

# Amateur RADIO

For all two-way radio enthusiasts

Operating in  
Scandinavia

Back to Basics –  
pass the RAE



On test:  
Icom IC3200E

**PROBLEMS IN RECEIVERS**

# R WITHERS COMMUNICATIONS



**584 HAGLEY ROAD WEST, OLDBURY, WARLEY  
B68 0BS (QUINTON, BIRMINGHAM) WEST MIDS.  
Tel: 021-421 8201/2 (24 HR ANSWERPHONE)**



**RWC SPECIAL OFFERS**



**PLEASE ASK ABOUT THE RWC CREDITCARD  
AVAILABLE NOW VIA LOMBARD TRICITY**

**M5  
JUNCT  
3**

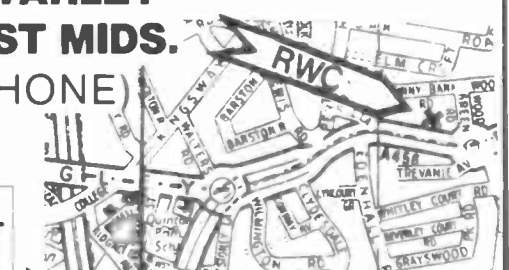

## R.W.C'S BARGAIN WINDOWS – ONCE ONLY OFFERS

|  |   |  |   |  |  |
|--|---|--|---|--|--|
| <p>2 Metre</p>   | <p><b>YAESU FT290R £349</b><br/>With free variable power supply, worth over <b>£40.00</b>. While stocks last. Charger &amp; Ni-Cads <b>£19.98</b> WHILE STOCKS LAST</p>                               | <p><b>TURN THAT BEAM KOPEK ROTATORS</b><br/>50KG LOAD-ING<br/>FULL 1 YEAR WARRANTY<br/>OUTSTANDING VALUE <b>£38.50</b></p>   | <p><b>GOOD QUALITY FIELD-STRENGTH VSWR METERS</b><br/>IN-LINE DESIGN WORK VERY WELL ON 2 METRES<br/><b>£9.50 inc post ONLY 50 AT THIS PRICE</b></p> | <p><b>VARIABLE BENCH POWER SUPPLIES</b><br/>0 to 15 Volts, 3 Ampere, IC Protected Normally over <b>£40.00</b>. RWC SPECIAL AT <b>£19.50</b> (+ £2.50 P&amp;P). 60 Only, UNREPEATABLE OFFER, GET YOURS QUICK...</p> |  |
| <p><b>NEW RANGE OF LINEAR AMPLIFIERS FROM RAYCOM LTD SEND SAE FOR FULL DETAILS</b></p>   | <p><b>10 METRE KIT LCL 2740 &amp; DNT 40FM COMP</b><br/>2 CRYSTALS<br/>1 CRYSTAL FILTER<br/>2 CAPACITORS &amp; FULL INSTRUCTIONS<br/>RWC BEST SELLER, STILL ONLY <b>£12.95</b> plus £1.00 p&amp;p</p> | <p><b>'R.W.C. Special' Revco RS 2000 Ext Coverage 60-179 &amp; 380-520MHz</b><br/>AM-FM<br/><b>£199.00 Ex-Demo "Final Reduction"</b></p>   | <p><b>THIS PRICE INCLUDES</b><br/>*70 MEMORIES<br/>*AC-DC SUPPLY<br/>*AUTO SEARCH<br/>*LOCK PRIORITY<br/>*Plus usual functions</p>                  | <p><b>5% OVER 5% 2 METRE COLINEAR BASE ANTENNA, TERRIFIC VALUE, ONLY £35.98, INCLUDING 5 STAR CARRIAGE TO YOUR DOOR.</b></p>   | <p><b>THE AMAZING NEW ARM MULTI-P6+ VHF-UHF MOBILE ANTENNA, THE MOST VERSATILE ANTENNA EVER MADE. ONLY £34.50</b><br/>+ £2.50 P&amp;P. Colinear element £4.75.</p>   |
| <p>ANOTHER RWC SCOOP PURCHASE. REGENCY HX-2000E HAND HELD SCANNING RECEIVERS – HIGH QUALITY. EXCEPTIONAL SENSITIVITY – FREQUENCY RANGE 60-89 MHz, 118-174 MHz AND 436-525 MHz, AM AND FM.<br/><b>* SPECIAL OFFER £235.00 + £3.00 p&amp;p * SCAN AND SEARCH</b></p> |   | <p><b>RAYCOM SUPER MODIFICATION FOR YAESU FT757QX HF</b><br/>MOBILE FIT THIS MOD YOURSELF, AND HEAR THE DIFFERENCE. ELIMINATES VCO GLITCH, IMPROVING VFO TUNING, AND AS AN ADDED BONUS, INCREASES TUNING SPEED TO 50KHz per DIAL REVOLUTION, SELECTABLE ON 500KHz STEP SWITCH. <b>£29.50</b>, post Free, FOR TESTED COMPLETE PCB AND FULL INSTRUCTIONS. SEE AD IN JUNE AMATEUR RADIO</p> |   | <p><b>WANTED</b><br/>FT225R D<br/>IC202E S FRG-7<br/>IC2E TR2300 BEST PRICES PAID - WORKING OR NOT</p>   |  |
| <p><b>"TEN METRES FM BOOSTER AMPLIFIERS"</b><br/>EX-C.B. BRAND NEW, RETUNED. UP TO 25/30 WATTS OUTPUT FROM YOUR 10 METRE COVERED C.B. UNIT <b>£19.50</b></p>   | <p><b>AKD WAVE METER A MUST FOR ALL VHF STATIONS</b><br/><b>£24.95 inc p</b><br/>THE BEST</p>   | <p>SEND SAE OR PHONE NOW FOR CATALOGUE AND THE FAMOUS RWC COMPUTER UPDATED SECONDHAND LIST!</p>  | <p><b>RWC'S HB9CV</b><br/>2 Mtrs <b>£6.99</b><br/>70cms <b>£5.99</b><br/>post &amp; pack <b>£1.00</b></p>   | <p><b>POWER MODULES FOR FDK YAESU ICOM TRIO</b><br/>ETC EG 25W 2 MTRT WRITE FOR FULL LIST FROM <b>£35.00</b></p>   | <p><b>PYE POCKETPHONE TRANSMITTERS &amp; RECEIVERS</b><br/>ABSOLUTELY AS NEW, ALREADY ON 70 CMS. (431.000 and also 447 MHz) less cases. SOME RECEIVER CASES AVAILABLE <b>£10.00 each, including post</b></p> |
| <p><b>STEEL QUAD SPIDERS FOR 2 ELE QUAD AERIALS ONLY £19.50</b></p>  | <p><b>TRAVELLING JIM</b><br/>2M<br/>70CMS<br/>INC LEAD 2M <b>£8.95</b><br/>- PL259 70CM <b>£8.95</b><br/>(inc post)</p>   | <p><b>SMC CBA</b><br/>10/11 METRE BASE ANTENNA <b>£19.50</b><br/>SMC II VII BASE ANTENNA <b>£27.50</b></p>   | <p><b>HIGH QUALITY RUGGED GUTTER MOUNTS USEABLE ON ALL SORTS OF ANTENNAS ONLY £4.98 £1.00 P&amp;P</b></p>   | <p><b>HI-Q BALUNS £10.00</b><br/><b>HI-Q INSULATOR TRAP-FORMER £9.99</b></p>   | <p><b>Q5RV HF MULTI-BAND DIPOLE ANTENNA</b><br/>FULL SIZE <b>£14.95</b> 1/2 SIZE <b>£12.95</b><br/>POST &amp; PACKING FREE!</p>  |
| <p><b>DATONG AND DRAE MORSE TUTORS £49.50</b><br/>EXCELLENT VALUE</p>  | <p><b>SUN MOBILE ANTENNAS FOR MOST BANDS</b><br/>2M-70cm<br/>10M-20M, 15M<br/>FROM <b>£13.50</b></p>  | <p><b>70 CENTIMETRES SINGLE CAVITY FILTERS</b><br/>BOTH RECEIVE AND TRANSMIT AVAILABLE £5.00 each, IDEAL FOR REPEATER DIPLEXING</p>  | <p>ALWAYS A LARGE RANGE OF SECONDHAND EQUIPMENT IN STOCK SEND LARGE SAE FOR LATEST LIST</p>   | <p><b>HF AERIAL TRAPS G8KW-W3DZZ TYPE HIGH QUALITY 7.1MHZ</b><br/><b>£8.95 PAIR POST FREE</b></p>  | <p><b>CCTV LENS</b><br/>39MM JAP 'C' TYPE FIXING 16mm FOCAL LENGTH <b>£7.50</b> £1.00 P&amp;P</p>  |
| <p><b>YAESU FT102 AM FILTERS XF 8.2 GA</b><br/>YAESU <b>£19.50</b></p>   | <p><b>RF TRANSISTORS OVER 20,000W IN STOCK FOR ALL HF/VHF/UHF RADIOS EG.</b><br/>2SC 1947 <b>£7.50</b><br/>2SC 2290 (in) <b>£24.00</b></p>  | <p><b>50 WATT DUMMY LOADS (100 WATTS INTERMITTENT) WITH LEAD AND PL259 CONNECTOR ONLY £15.00 INCLUDING POST. ALL TERMINATIONS SILVER PLATED</b></p>  | <p><b>HUGE RANGE OF AZTEC ANTENNAS PHONE NOW FOR FULL LIST!!</b></p>  | <p><b>YAESU FT101ZD AM UNITS ONLY £5.00</b></p>  | <p><b>HEAVY DUTY MAGNETIC MOUNT S0239 MOUNT 3M COAX - PL259 SPECIAL PRICE £8.95</b></p>  |

All offers subject to availability on a first come first served basis. Prices subject to change without notice. all correct at time of going to press. E&OE. **TERMS:** No COD. Barclaycard and Access accepted. Post free over £50, under £50 add £2.50 post and handling, unless stated. Please send SAE with all enquiries and for latest secondhand list.

# Amateur RADIO

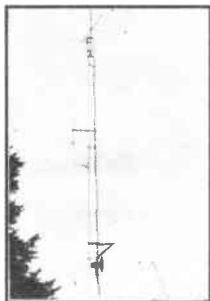
**Editor:**

Anita Ley

**Editorial Assistant:**

Jane Berry

**Advertisement****Manager:**

Margaret Hall

**Advertisement****Executive:**

Marian Vidler

**Subscriptions:**

01-684 3157

**Accounts:**

Clare Brinkman

**Publisher:**

Peter Williams

**On sale:** Fourth

Thursday of the month

preceding cover date

**Next issue:** Cover date

September 1985 on sale

29 August 1985

**Published by:** Amateur

Radio Magazines,

Sovereign House,

Brentwood, Essex CM14

4SE, England

(0277) 219876

**Printed:** In England

ISSN: 0264-2557

**News Trade Sales by:**

Argus Press Sales &amp;

Distribution Ltd, 12-18

Paul Street, London

EC2A 4JS.

01-247 8233

**Front cover:** Icom IC3200E

reviewed this month (p18) Photo

by Jay Moss-Powell G6XIB

Whilst every care is taken

when accepting

advertisements we cannot

accept responsibility for

unsatisfactory transactions.

We will, however, thoroughly

investigate any complaints.

The views expressed by

contributors are not

necessarily those of the

publishers.

Every care is also taken to

ensure that the contents of

Amateur Radio are accurate,

we assume no responsibility

for any effect from errors or

omissions.

© Copyright 1985  
Amateur Radio Magazines

**6 Longleat Mobile Rally**

If you weren't there this is small compensation. But who's fault is that anyway?

**8 Straight and Level**

All the latest news, comment and developments on the amateur radio scene

**14 Letters**

Your opinions on topics of interest

**16 DX Diary**

Don Field G3XTT with this month's DX news

**18 Angus McKenzie tests**

The Icom IC3200E dual band and the Yaesu FRG9600 multimode are scrutinised by G3OSS

**26 SWL**

Trevor Morgan GW4OXB reviews the DCRX receiver kit which gets you into the hobby for less than £25!

**29 Operating in Scandinavia**

How would you tackle portable operation from Denmark, Sweden and Norway? Three of our readers report on their experiences.

**36 Problems in Receivers**

The second part of Angus McKenzie's 'what to look for' feature

**40 On the Beam**

Glen Ross G8MWR with all the latest news from VHF, UHF and Microwaves

**41 Coming Next Month**

What's in store for you

**44 Back to Basics**

Bill Mantovani G4ZVB concludes the theory section of the RAE syllabus

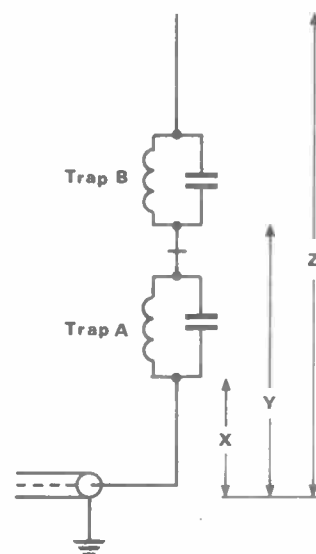
**49 Questions and Answers**

Multiple choice questions to test you on your knowledge of the RAE syllabus

**52 Secondhand**

An exhausted Hugh Allison G3XSE looks back at a few of this year's rallies

**54 Free Classified Ads**

The market for buying and selling

**SERVICES****17 Newsagents Order Form****24 Subscription Order Form****55 Free Classified Ad Form****58 Advertisers index****58 Advertising rates and information**







PHONE  
0474 60521  
3 LINES

**P.M. COMPONENTS LTD**  
AS FROM 1.7.85. SELECTRON HOUSE  
SPRINGHEAD ENTERPRISE PARK, SPRINGHEAD ROAD  
GRAVESEND, KENT DA11 8HD

TELEX  
966371  
TOS PM

VISA

**A SELECTION FROM OUR STOCK OF BRANDED VALVES**

|       |      |        |      |       |      |              |       |       |      |              |       |      |      |         |      |       |       |
|-------|------|--------|------|-------|------|--------------|-------|-------|------|--------------|-------|------|------|---------|------|-------|-------|
| EBCA1 | 1.05 | EL183E | 3.90 | MB151 | 5.50 | OV002-6      | 2.00  | U50   | 2.00 | 283Z         | 60.50 | 6AJ4 | 1.25 | 12AXAGT | 1.00 | 150B2 | 6.95  |
| EBOR1 | 1.90 | EL183P | 3.90 | MB162 | 5.50 | OV003-10/Mul | 0.70  | UB2   | 0.70 | OV003-10/Mul | 1.00  | 5AJ7 | 1.25 | 12AX7   | 1.00 | 150C2 | 1.90  |
| EBG91 | 0.80 | EL360  | 6.75 | MB163 | 5.50 | OV003-20     | 0.65  | UB191 | 0.65 | OV003-20     | 1.00  | 5AK5 | 1.70 | 12AY7   | 1.00 | 150C4 | 2.15  |
| EL500 | 1.40 | EL500  | 1.40 | MB190 | 4.50 | OV003-20B    | 2.00  | UB21  | 0.65 | OV003-20B    | 1.00  | 5ALS | 1.50 | 12AY7WA | 2.50 | 150C4 | 18.00 |
| EL510 | 0.85 | EL510  | 0.85 | MB195 | 6.50 | OV006-40A    | 32.00 | UB231 | 1.00 | OV006-40A    | 32.00 | 5AM4 | 4.50 | 12BA7A  | 1.95 | 27AA  | 15.00 |
| EL515 | 0.85 | EL515  | 0.85 | MB196 | 6.50 | OV007-30     | 27.00 | UB232 | 0.65 | OV007-30     | 27.00 | 5AM5 | 3.25 | 12BA7A  | 4.80 | 307   | 5.00  |
| EL520 | 0.85 | EL520  | 0.85 | MB221 | 4.50 | OV007-30     | 27.00 | UB233 | 0.65 | OV007-30     | 27.00 | 5AM6 | 1.80 | 12BA6A  | 1.95 | 326A  | 15.00 |
| EL525 | 0.85 | EL525  | 0.85 | MB222 | 4.50 | OV007-30     | 27.00 | UB234 | 0.65 | OV007-30     | 27.00 | 5AM7 | 1.80 | 12BA6A  | 1.95 | 326B  | 17.90 |
| EL530 | 0.85 | EL530  | 0.85 | MB223 | 4.50 | OV007-30     | 27.00 | UB235 | 0.65 | OV007-30     | 27.00 | 5AM8 | 1.80 | 12BA7A  | 2.75 | 401A  | 10.95 |
| EL535 | 0.85 | EL535  | 0.85 | MB224 | 2.00 | OV007-30     | 27.00 | UB236 | 0.65 | OV007-30     | 27.00 | 5AM9 | 2.15 | 12B7YA  | 2.75 | 401B  | 4.50  |
| EL540 | 0.85 | EL540  | 0.85 | MB225 | 2.00 | OV007-30     | 27.00 | UB237 | 0.65 | OV007-30     | 27.00 | 5AB8 | 0.65 | 12B7YA  | 2.75 | 431A  | 4.50  |
| EL545 | 0.85 | EL545  | 0.85 | MB226 | 2.00 | OV007-30     | 27.00 | UB238 | 0.65 | OV007-30     | 27.00 | 5AB9 | 0.65 | 12C6A5  | 1.95 | 5636  | 1.90  |
| EL550 | 0.85 | EL550  | 0.85 | MB227 | 2.00 | OV007-30     | 27.00 | UB239 | 0.65 | OV007-30     | 27.00 | 5AB0 | 0.65 | 12C6A5  | 1.95 | 5636  | 1.90  |
| EL555 | 0.85 | EL555  | 0.85 | MB228 | 2.00 | OV007-30     | 27.00 | UB240 | 0.65 | OV007-30     | 27.00 | 5AB1 | 0.65 | 12C6A5  | 1.95 | 5636  | 1.90  |
| EL560 | 0.85 | EL560  | 0.85 | MB229 | 2.00 | OV007-30     | 27.00 | UB241 | 0.65 | OV007-30     | 27.00 | 5AB2 | 0.65 | 12C6A5  | 1.95 | 5636  | 1.90  |
| EL565 | 0.85 | EL565  | 0.85 | MB230 | 2.00 | OV007-30     | 27.00 | UB242 | 0.65 | OV007-30     | 27.00 | 5AB3 | 0.65 | 12C6A5  | 1.95 | 5636  | 1.90  |
| EL570 | 0.85 | EL570  | 0.85 | MB231 | 2.00 | OV007-30     | 27.00 | UB243 | 0.65 | OV007-30     | 27.00 | 5AB4 | 0.65 | 12C6A5  | 1.95 | 5636  | 1.90  |
| EL575 | 0.85 | EL575  | 0.85 | MB232 | 2.00 | OV007-30     | 27.00 | UB244 | 0.65 | OV007-30     | 27.00 | 5AB5 | 0.65 | 12C6A5  | 1.95 | 5636  | 1.90  |
| EL580 | 0.85 | EL580  | 0.85 | MB233 | 2.00 | OV007-30     | 27.00 | UB245 | 0.65 | OV007-30     | 27.00 | 5AB6 | 0.65 | 12C6A5  | 1.95 | 5636  | 1.90  |
| EL585 | 0.85 | EL585  | 0.85 | MB234 | 2.00 | OV007-30     | 27.00 | UB246 | 0.65 | OV007-30     | 27.00 | 5AB7 | 0.65 | 12C6A5  | 1.95 | 5636  | 1.90  |
| EL590 | 0.85 | EL590  | 0.85 | MB235 | 2.00 | OV007-30     | 27.00 | UB247 | 0.65 | OV007-30     | 27.00 | 5AB8 | 0.65 | 12C6A5  | 1.95 | 5636  | 1.90  |
| EL595 | 0.85 | EL595  | 0.85 | MB236 | 2.00 | OV007-30     | 27.00 | UB248 | 0.65 | OV007-30     | 27.00 | 5AB9 | 0.65 | 12C6A5  | 1.95 | 5636  | 1.90  |
| EL600 | 0.85 | EL600  | 0.85 | MB237 | 2.00 | OV007-30     | 27.00 | UB249 | 0.65 | OV007-30     | 27.00 | 5AB0 | 0.65 | 12C6A5  | 1.95 | 5636  | 1.90  |
| EL605 | 0.85 | EL605  | 0.85 | MB238 | 2.00 | OV007-30     | 27.00 | UB250 | 0.65 | OV007-30     | 27.00 | 5AB1 | 0.65 | 12C6A5  | 1.95 | 5636  | 1.90  |
| EL610 | 0.85 | EL610  | 0.85 | MB239 | 2.00 | OV007-30     | 27.00 | UB251 | 0.65 | OV007-30     | 27.00 | 5AB2 | 0.65 | 12C6A5  | 1.95 | 5636  | 1.90  |
| EL615 | 0.85 | EL615  | 0.85 | MB240 | 2.00 | OV007-30     | 27.00 | UB252 | 0.65 | OV007-30     | 27.00 | 5AB3 | 0.65 | 12C6A5  | 1.95 | 5636  | 1.90  |
| EL620 | 0.85 | EL620  | 0.85 | MB241 | 2.00 | OV007-30     | 27.00 | UB253 | 0.65 | OV007-30     | 27.00 | 5AB4 | 0.65 | 12C6A5  | 1.95 | 5636  | 1.90  |
| EL625 | 0.85 | EL625  | 0.85 | MB242 | 2.00 | OV007-30     | 27.00 | UB254 | 0.65 | OV007-30     | 27.00 | 5AB5 | 0.65 | 12C6A5  | 1.95 | 5636  | 1.90  |
| EL630 | 0.85 | EL630  | 0.85 | MB243 | 2.00 | OV007-30     | 27.00 | UB255 | 0.65 | OV007-30     | 27.00 | 5AB6 | 0.65 | 12C6A5  | 1.95 | 5636  | 1.90  |
| EL635 | 0.85 | EL635  | 0.85 | MB244 | 2.00 | OV007-30     | 27.00 | UB256 | 0.65 | OV007-30     | 27.00 | 5AB7 | 0.65 | 12C6A5  | 1.95 | 5636  | 1.90  |
| EL640 | 0.85 | EL640  | 0.85 | MB245 | 2.00 | OV007-30     | 27.00 | UB257 | 0.65 | OV007-30     | 27.00 | 5AB8 | 0.65 | 12C6A5  | 1.95 | 5636  | 1.90  |
| EL645 | 0.85 | EL645  | 0.85 | MB246 | 2.00 | OV007-30     | 27.00 | UB258 | 0.65 | OV007-30     | 27.00 | 5AB9 | 0.65 | 12C6A5  | 1.95 | 5636  | 1.90  |
| EL650 | 0.85 | EL650  | 0.85 | MB247 | 2.00 | OV007-30     | 27.00 | UB259 | 0.65 | OV007-30     | 27.00 | 5AB0 | 0.65 | 12C6A5  | 1.95 | 5636  | 1.90  |
| EL655 | 0.85 | EL655  | 0.85 | MB248 | 2.00 | OV007-30     | 27.00 | UB260 | 0.65 | OV007-30     | 27.00 | 5AB1 | 0.65 | 12C6A5  | 1.95 | 5636  | 1.90  |
| EL660 | 0.85 | EL660  | 0.85 | MB249 | 2.00 | OV007-30     | 27.00 | UB261 | 0.65 | OV007-30     | 27.00 | 5AB2 | 0.65 | 12C6A5  | 1.95 | 5636  | 1.90  |
| EL665 | 0.85 | EL665  | 0.85 | MB250 | 2.00 | OV007-30     | 27.00 | UB262 | 0.65 | OV007-30     | 27.00 | 5AB3 | 0.65 | 12C6A5  | 1.95 | 5636  | 1.90  |
| EL670 | 0.85 | EL670  | 0.85 | MB251 | 2.00 | OV007-30     | 27.00 | UB263 | 0.65 | OV007-30     | 27.00 | 5AB4 | 0.65 | 12C6A5  | 1.95 | 5636  | 1.90  |
| EL675 | 0.85 | EL675  | 0.85 | MB252 | 2.00 | OV007-30     | 27.00 | UB264 | 0.65 | OV007-30     | 27.00 | 5AB5 | 0.65 | 12C6A5  | 1.95 | 5636  | 1.90  |
| EL680 | 0.85 | EL680  | 0.85 | MB253 | 2.00 | OV007-30     | 27.00 | UB265 | 0.65 | OV007-30     | 27.00 | 5AB6 | 0.65 | 12C6A5  | 1.95 | 5636  | 1.90  |
| EL685 | 0.85 | EL685  | 0.85 | MB254 | 2.00 | OV007-30     | 27.00 | UB266 | 0.65 | OV007-30     | 27.00 | 5AB7 | 0.65 | 12C6A5  | 1.95 | 5636  | 1.90  |
| EL690 | 0.85 | EL690  | 0.85 | MB255 | 2.00 | OV007-30     | 27.00 | UB267 | 0.65 | OV007-30     | 27.00 | 5AB8 | 0.65 | 12C6A5  | 1.95 | 5636  | 1.90  |
| EL695 | 0.85 | EL695  | 0.85 | MB256 | 2.00 | OV007-30     | 27.00 | UB268 | 0.65 | OV007-30     | 27.00 | 5AB9 | 0.65 | 12C6A5  | 1.95 | 5636  | 1.90  |
| EL700 | 0.85 | EL700  | 0.85 | MB257 | 2.00 | OV007-30     | 27.00 | UB269 | 0.65 | OV007-30     | 27.00 | 5AB0 | 0.65 | 12C6A5  | 1.95 | 5636  | 1.90  |
| EL705 | 0.85 | EL705  | 0.85 | MB258 | 2.00 | OV007-30     | 27.00 | UB270 | 0.65 | OV007-30     | 27.00 | 5AB1 | 0.65 | 12C6A5  | 1.95 | 5636  | 1.90  |
| EL710 | 0.85 | EL710  | 0.85 | MB259 | 2.00 | OV007-30     | 27.00 | UB271 | 0.65 | OV007-30     | 27.00 | 5AB2 | 0.65 | 12C6A5  | 1.95 | 5636  | 1.90  |
| EL715 | 0.85 | EL715  | 0.85 | MB260 | 2.00 | OV007-30     | 27.00 | UB272 | 0.65 | OV007-30     | 27.00 | 5AB3 | 0.65 | 12C6A5  | 1.95 | 5636  | 1.90  |
| EL720 | 0.85 | EL720  | 0.85 | MB261 | 2.00 | OV007-30     | 27.00 | UB273 | 0.65 | OV007-30     | 27.00 | 5AB4 | 0.65 | 12C6A5  | 1.95 | 5636  | 1.90  |
| EL725 | 0.85 | EL725  | 0.85 | MB262 | 2.00 | OV007-30     | 27.00 | UB274 | 0.65 | OV007-30     | 27.00 | 5AB5 | 0.65 | 12C6A5  | 1.95 | 5636  | 1.90  |
| EL730 | 0.85 | EL730  | 0.85 | MB263 | 2.00 | OV007-30     | 27.00 | UB275 | 0.65 | OV007-30     | 27.00 | 5AB6 | 0.65 | 12C6A5  | 1.95 | 5636  | 1.90  |
| EL735 | 0.85 | EL735  | 0.85 | MB264 | 2.00 | OV007-30     | 27.00 | UB276 | 0.65 | OV007-30     | 27.00 | 5AB7 | 0.65 | 12C6A5  | 1.95 | 5636  | 1.90  |
| EL740 | 0.85 | EL740  | 0.85 | MB265 | 2.00 | OV007-30     | 27.00 | UB277 | 0.65 | OV007-30     | 27.00 | 5AB8 | 0.65 | 12C6A5  | 1.95 | 5636  | 1.90  |
| EL745 | 0.85 | EL745  | 0.85 | MB266 | 2.00 | OV007-30     | 27.00 | UB278 | 0.65 | OV007-30     | 27.00 | 5AB9 | 0.65 | 12C6A5  | 1.95 | 5636  | 1.90  |
| EL750 | 0.85 | EL750  | 0.85 | MB267 | 2.00 | OV007-30     | 27.00 | UB279 | 0.65 | OV007-30     | 27.00 | 5AB0 | 0.65 | 12C6A5  | 1.95 | 5636  | 1.90  |
| EL755 | 0.85 | EL755  | 0.85 | MB268 | 2.00 | OV007-30     | 27.00 | UB280 | 0.65 | OV007-30     | 27.00 | 5AB1 | 0.65 | 12C6A5  | 1.95 | 5636  | 1.90  |
| EL760 | 0.85 | EL760  | 0.85 | MB269 | 2.00 | OV007-30     | 27.00 | UB281 | 0.65 | OV007-30     | 27.00 | 5AB2 | 0.65 | 12C6A5  | 1.95 | 5636  | 1.90  |
| EL765 | 0.85 | EL765  | 0.85 | MB270 | 2.00 | OV007-30     | 27.00 | UB282 | 0.65 | OV007-30     | 27.00 | 5AB3 | 0.65 | 12C6A5  | 1.95 | 5636  | 1.90  |
| EL770 | 0.85 | EL770  | 0.85 | MB271 | 2.00 | OV007-30     | 27.00 | UB283 | 0.65 | OV007-30     | 27.00 | 5AB4 | 0.65 | 12C6A5  | 1.95 | 5636  | 1.90  |
| EL775 | 0.85 | EL775  | 0.85 | MB272 | 2.00 | OV007-30     | 27.00 | UB284 | 0.65 | OV007-30     | 27.00 | 5AB5 | 0.65 | 12C6A5  | 1.95 | 5636  | 1.90  |
| EL780 | 0.85 | EL780  | 0.85 | MB273 | 2.00 | OV007-30     | 27.00 | UB285 | 0.65 | OV007-30     | 27.00 | 5AB6 | 0.65 | 12C6A5  | 1.95 | 5636  | 1.90  |
| EL785 | 0.85 | EL785  | 0.85 | MB274 | 2.00 | OV007-30     | 27.00 | UB286 | 0.65 | OV007-30     | 27.00 | 5AB7 | 0.65 | 12C6A5  | 1.95 | 5636  | 1.90  |
| EL790 | 0.85 | EL790  | 0.85 | MB275 | 2.00 | OV007-30     | 27.00 | UB287 | 0.65 | OV007-30     | 27.00 | 5AB8 | 0.65 | 12C6A5  | 1.95 | 5636  | 1.90  |
| EL795 | 0.85 | EL795  | 0.85 | MB276 | 2.00 | OV007-30     | 27.00 | UB288 | 0.65 | OV007-30     | 27.00 | 5AB9 | 0.65 | 12C6A5  | 1.95 | 5636  | 1.90  |
| EL800 | 0.85 | EL800  | 0.85 | MB277 | 2.00 | OV007-30     | 27.00 | UB289 | 0.65 | OV007-30     | 27.00 | 5AB0 | 0.65 | 12C6A5  | 1.95 | 5636  | 1.90  |
| EL805 | 0.85 | EL805  | 0.85 | MB278 | 2.00 | OV007-30     | 27.00 | UB290 | 0.65 | OV007-30     | 27.00 | 5AB1 | 0.65 | 12C6A5  | 1.95 | 5636  | 1.90  |
| EL810 | 0.85 | EL810  | 0.85 | MB279 | 2.00 | OV007-30     | 27.00 | UB291 | 0.65 | OV007-30     | 27.00 | 5AB2 | 0.65 | 12C6A5  | 1.95 | 5636  | 1.90  |
| EL815 | 0.85 | EL815  | 0.85 | MB280 | 2.00 | OV007-30     | 27.00 | UB292 | 0.65 | OV007-30     | 27.00 | 5AB3 | 0.65 | 12C6A5  | 1.95 | 5636  | 1.90  |
| EL820 | 0.85 | EL820  | 0.85 | MB281 | 2.00 | OV007-30     | 27.00 | UB293 | 0.65 | OV007-30     | 27.00 | 5AB4 | 0.65 | 12C6A5  | 1.95 | 5636  | 1.90  |
| EL825 | 0.85 | EL825  | 0.85 | MB282 | 2.00 | OV007-30     | 27.00 | UB294 | 0.65 | OV007-30     | 27.00 | 5AB5 | 0.65 | 12C6A5  | 1.95 | 5636  | 1.90  |
| EL830 | 0.85 | EL830  | 0.85 | MB283 | 2.00 | OV007-30     | 27.00 | UB295 | 0.65 | OV007-30     |       |      |      |         |      |       |       |

# LONGLEAT MOBILE RALLY



*Looking at the traders one could either assume that things were going very well or that they'd had more than enough time in the beer tent!*



*Ex-computer power supplies were one of the real bargains to be had. If there are any left you can find them at. The Computer Junk Shop, Widnes, Lancs. Tel: (051 420) 4590*



*While putting in a lot of work for the Radio Amateur Invalid and Blind Club, Brian and Cathy G1CQJ were celebrating their 6th wedding anniversary*



With an attendance of approximately 12,000 amateurs, XYLs and children, the Longleat Mobile Rally can only be described as an undisputed success.

The location was obviously

ideal for the family OM with a beautiful house, safari park and other activities to keep his non-amateur family amused while he went in search of a new toy for himself.

Business on the trade stands seemed to be brisk and society stands recruited a host of new members. The Microwave Society, for example, enrolled thirty new members and sold everything

they had!

Congratulations must go to the RSGB City of Bristol Group for a job well done in the organisation of the event.

We look forward to attending again next year.



*Morse tests were held on site; the location obvious from the huddle of nervous hopefuls outside. 70% of them needn't have worried however, as 27 out of the 33 candidates walked away with a certificate and a benign grin. The tests were organised by the Bristol Group and the examiner was Gavin Williams*



*See what I mean about the grin! Morris Weinstock was stuck with this specimen after passing his Morse test. Congratulations Morris.*



*Judging by the concentration on their faces these two are trying to work out how to explain this acquisition to the XYLs*

*The Ed seems to be confused here as she appears to be telling a fishing yarn to the Welsh contingent. How big was it?!*



# STRAIGHT &

# LEVEL

## DIGITAL ELECTRONICS

The highly successful *Introducing Microelectronics* package produced for the educational market by Educational Electronics Limited is now available to a broader market, being offered complete with the components, a circuit board and a 136-page course booklet, all needed to conduct a wide variety of investigations.

The course booklet, written by a leading authority on microelectronics, assumes no previous knowledge of the subject. It provides a self-study guide to basic digital electronics and computer building blocks.

The basic circuit board is cleverly designed to incorporate a range of features that enable the user to make rapid progress. It contains 4 IC socket pads, LED display diodes, a pulser button and a pulse 'clock'. Bit patterns can be set up using the integral bit set switches and the edge



connector port can be utilised for further experiments using a microcomputer.

The ideal medium for entering the world of electronics and digital micro-circuitry, in both academic and practical

terms, the *Intro* package is available at £59.50 inclusive of VAT, postage and packing from: *Educational Electronics Limited, 28 Lake Street, Leighton Buzzard, Beds LU7 8RX.*

## PHILIPS PM8154

Available from Electronic Brokers is the new Philips PM8154 six-colour graphics plotter which features writing speeds of 400mm per second on the X and Y axes and 200mm per second in all other directions.

Features include electrostatic paper hold-down, an accuracy of less than  $\pm 0.15\%$   $\pm 0.3\text{mm}$ , and a 0.1mm resolution. With a penlift frequency of five times per second, the PM8154 has a plotting speed of two characters per second and a positioning speed of 60cm per second.

The plotter accepts A4 format paper and has a plotting area of 230mm (X-axis) x 180mm (Y-axis). A choice of interface options is available including IEC-625/IEEE-488 and V24/RS232C.

The PM8154 is supplied with a dust cover, six nylon tip pens and paper sheets.

Optional accessories include a chart transport unit supplied with one roll of chart

and supporting consumables.

The plotter is ideal for a wide range of educational, engineering and business applications.

For further information contact: *Electronic Brokers Limited, 140-146 Camden Street, London NW1 9PB.*

## FIRST CASTLE

First Castle Electronics plc, with interests ranging from the consumer electronics industry to military and nuclear markets, has formed a new company to handle the sales and marketing of five component manufacturing companies in its electro-mechanical division.

The new company is First Castle Components Limited, which is based at Thundersley in Essex, and the Managing Director is Mr Mark Lee.

The five companies which come under the First Castle Components umbrella are: *Manby Electronics Ltd*, the Lincolnshire-based company,

whose main business is producing mains adaptors and PCB assemblies;

*Able Electrics Ltd*, of Thundersley, Essex, manufacturers of commercial harnesses for the domestic appliance and automotive industries and mains leads with moulded-on plugs;

*Darstan Ltd*, of Thundersley, Essex, producing capacitors and toroidal chokes for the automotive and consumer electronics markets;

*Ormandy and Stollery Electronic Components Ltd*, of Brightlingsea, Essex, who make wound products and power systems for the electrical, electronic and telecommunication industries;

*BRM Electronics Ltd*, of Maidstone, Kent, who produce wiring harnesses for the electronic, telecommunications and domestic appliance markets.

The new company's address is: *First Castle Components Ltd, 263 Church Road, Thundersley, Essex.*



# All the latest news, views, comment and developments on the amateur radio scene

## SPARK HAZARDS

The possibility that explosions at major plants such as oil rigs could accidentally be triggered by radio waves is to be the subject of an investigation by academic staff at the University of Bradford.

Dr Peter Excell, of the University's School of Studies in Electrical and Electronic Engineering, and Dr Alfred Keller, reader in industrial technology, have been awarded a £33,572 grant from the Science and Engineering Research Council.

Radio waves from high-powered transmitters can sometimes cause sparks to form on metal structures (unintended receiving antennas) located in a zone around the transmitter. Potentially hazardous conditions exist, for example, around oil and gas plants which are coincidentally located within the predicted 'hazard zone' around a radio transmitter.

The purpose of the work is to determine viable safety margins within which transmitters can be built and operated. This will be done by assessing the 'probabilistic

factors' – in other words, the likelihood of an explosion occurring, since a number of conditions must simultaneously exist, such as appropriate orientation, a spark-gap of the correct size, and flammable mixture at the optimum concentration around the spark-gap at the time of the spark.

A number of British Standards have been drawn up relating to 'hazard zones' around transmitters but these have proved unrealistically onerous for the needs of modern industry. This is because they have been based on the assumption that a number of unlikely events will occur simultaneously. By themselves, each of these events may be seen to be 'just possible', ie at the limit of reasonable probability. In fact, for a sequence of such events to occur simultaneously the probability would be so low as to be negligible compared with numerous other generally-accepted risks: the costs involved in elimination of the radio-frequency hazard would be better spent on more urgent safety matters,

such as improved scaffolding, or road safety.

The philosophy of assessing the overall probability of occurrence of a hazard, and comparing it with generally-accepted risks, is well-established in the chemical and nuclear industries but has never before been applied to radio-frequency hazards. It is hoped that, by using this approach, radio systems will be freed from some unnecessary restrictions, which may of themselves constitute a hazard to safety (eg restrictions on emergency radio transmitters on ships and oil rigs).

Dr Excell has been conducting research into radio frequency hazards since 1974 and Dr Keller has specialised in reliability and risk for some thirty years, having previously worked in the nuclear power industry. Their current work at Bradford is likely to influence future safety standards for radio frequency hazard zones. At the same time, a group of related hazards will be studied, such as the possibility of radio signals from many sources (eg CB radio) setting off electro-

explosive detonators, or interfering with aircraft guidance systems.

## PCB MOUNTING CONNECTORS

Klippon's BL/SL connector range with screw terminations for direct connection to PCBs has recently been improved.

It now features tin-lead metal parts, captive screws and enhanced shaping of the moulding for better insertion of the male section into the female.

Offering both vertical and horizontal connection facilities and a coding system to ensure correct polarisation, the range will accept cabling up to 1.5mm<sup>2</sup>.

Type dependent, between 2 to 15 poles, can be accommodated.

SL – the male connector – is offered with either open or closed ends, and has a voltage rating of 250V ac and a current rating of 8A.

For further details contact: *Klippon Electricals, Power Station Road, Sheerness, Kent ME12 3AB. Tel: (0795) 62440.*

## COUNTER-TIMER

A 100MHz universal counter-timer has been added to the range of low cost test instruments manufactured by Black Star Limited.

The model Apollo 100 is a compact mains operated unit, with an 8-digit LED display, for the measurement of frequency, period and period average, frequency ratio and time interval. Stop-watch, RPM and totalise modes are also provided within this model.

Full signal conditioning controls are provided on both inputs, including attenuation, edge selectors, trigger level and low pass filter.

Other controls include single measure, start/stop, reset, display hold and trigger hold-off.

A 10MHz timebase from a

crystal controlled oscillator provides a typical temperature stability of  $\pm 2.5$ ppm (10°C to 40°C) or an optional TCXO will improve the temperature stability to typically  $\pm 0.5$ ppm

(0°C to 40°C). A rear panel BNC socket allows access to the internal 10MHz oscillator or use of an external reference source.

The unit is priced at £285

(+VAT) and further details are available from: *M Black, Black Star Limited, 4 Stephenson Road, St Ives, Huntingdon, Cambs PE17 4WJ. Tel: (0480) 62440.*



## STRAIGHT & LEVEL



### 10 FUNCTION MULTIMETER

A high performance multimeter, offering ten measurement functions and a total of forty-eight ranges – the Pantec Challenger – is now available from Electronic and Computer Workshop Ltd.

With a voltage sensitivity of 40kohms/volt, dc/ac, the Challenger can measure voltages from 0.25 to 1000V dc and from 5 to 1000V ac. Current is measured from 25 $\mu$ A to 10A dc and from 0.5 to 10A ac. Accuracy is  $\pm 2\%$  at 20°C. Challenger also offers accurate measurement of resistance and provides a dB output as well as VBF and capacitance.

The instrument utilises a moving coil analogue meter movement, insensitive to

external magnetic fields and is contained in a high impact polycarbonate case. The rear panel has a magnet to allow Challenger to be fixed to any flat metallic surface.

Full protection is provided against misconnections and overloads using an internal discharging circuit and a quick blow fuse.

For further information please contact: *Electronic and Computer Workshop Ltd.* Tel: (0245) 262149.

### MAPLIN MAGAZINE

The latest edition of this electronics magazine, *Electronics – The Maplin Magazine*, is packed with new features and projects.

Included is a major feature

### DIGITAL MULTIMETER

An advanced digital multimeter that offers a wide range of automatic functions, mode and display switching, the Pantec Brisk, has been announced by Electronic and Computer Workshop Ltd (ECW).

The Brisk offers full auto-ranging and mode switching and has a 3½-digit LCD which provides clear, unambiguous data display with a range of extra indicators including mode, polarity, range, function, low battery and over-range symbols.

The autorange function operates over four measurement modes – ac voltages of

up to 600 volts, dc voltages of up to 1000 volts, ac/dc current of up to 10 amps and resistance of up to 2Mohms. A buzzer continuity test is included together with the capability of in-circuit resistance measurement.

Input resistance is 10Mohms and accuracy is from 0.5 to 0.7% on the dc voltage range.

The Pantec Brisk measures 155x85x30mm and is available from ECW at a price of £46.00 (plus £1.50 P&P and VAT).

For further information please contact: *Caroline Stewart, Electronic and Computer Workshop Ltd.* Tel: (0245) 262149.

### NAVY SPECIAL

Glenstar first introduced its 'Navy Special' range of mobile antennas last summer and the company have reported a very good response.

Now Glenstar have developed a compact system of home base station antennas which simply slip on to the top of a 1¼ inch OD alloy mast. These antennas are based on the well-tried Navy Special mobile resonators. They can be stacked in a relatively small space on the same pole to form an effective miniature multi-band

antenna system.

They are ideal for amateurs with limited space, and Glenstar envisage a slim vertical pole rising from the cabbage patch adorned at the top with a pair of Navy Special dipoles, one for 20 metres and one for 40 metres, both fed with a single 50 ohm coaxial cable and using a small tuner FC707 or similar.

This would make the 10, 12, 15, 17, 20, 30 and 40m bands available.

Further information is available from: *Glenstar, Newtown Road, Henley-on-Thames, Oxon RG9 1HQ.*

covering digital techniques in television receivers. The article, *The Digits are Coming*, suggests that with satellite and cable TV developments stalled, digital TV could be the next high technology product to hit the high street stores.

On the project side, full constructional details are provided for a compact expandable microcomputer system which can be used as a CPU-based controller in its own right or as the central processor for a more complex computer system, using the ubiquitous Z80 chip (kit price, £29.95).

An advanced level ultrasonic car (intruder) alarm system is also described in full detail.

With car thefts on the increase, such devices are becoming part of everyday life (kit price, £19.95). Com-

peting for attention with the ultrasonic car alarm is a powerful 6-channel guitar equaliser.

Each channel provides up to 10dB of signal boost (kit price, £26.95).

With the robot population on the increase, details are given enabling the Zero 2 Turtle Robot to be interfaced to the Spectrum, Commodore C-64 and BBC-B home microcomputers.

Regular features and editorial include the latest Maplin catalogue amendments, news on books and products, and a list of Maplin kits and books. *Electronics – The Maplin Magazine* is available at booksellers or from Maplin direct, price 75p.

For further information contact: *Maplin Electronic Supplies Ltd, PO Box 3, Rayleigh, Essex SS6 8LR.* Tel: (0702) 554155.





## CLUB NEWS

### RTTY and Amtor at Bristol

After the very hectic and successful Longleat Mobile Rally, which was organised by the RSGB City of Bristol Group on 30 June, things seem to be settling down again in that part of the country.

However, the group are as always very active and are holding some lectures in the next couple of months which readers might find interesting.

Ron Broadbent will be discussing satellites on 29 July and on 19 August Mark Goodfellow G4KUQ will be revealing the ins and outs of RTTY and Amtor.

Further information is available from: *Colin Hollister G4SQQ, 34 Battersby Way, Henbury, Bristol BS10 7SU. Tel: (0272) 508451.*

### RSGB HF Convention

The RSGB is arranging a convention for HF enthusiasts to take place on Sunday 29 September 1985 at the Belfry Hotel near Oxford.

The programme is provisional at the moment, but should include a twin lecture stream with lectures on: HF propagation and the USSR satellites. (G3IOR); ATUs - the least understood part of the station (G3RZP); The Sunspot Minimum, how long will it last? (G3LTP); DXpedition to Navassa Island (G3RFS); Introduction to contest operating (HF Contests Committee); G-QRP Club lectures; Applying for planning permission (RSGB Planning Committee).

Other attractions will include an HF and VHF contests forum, a display of QRP gear, DXpedition videos, RNARS QRQ CW tests, an RSGB bookstall, a car boot sale (£2 per pitch), an HF demo station (GB2HF) and, of course, a bar.

Talk-in (by Mid-Thames Raynet) will be on 160, 10 FM, 4, 2 and 70cm. BYLARA, G-QRP and other groups will have stands.

The Belfry Hotel is on the A40 close to Exit 7 of the M40. It can also be reached by bus from Oxford Bus Station (290 and 790 services, every hour). Doors open at 10am, and admission is £2 per person.

Further details, including talk-in frequencies, will be released nearer the time via

GB2RS and *Radio Communication*, or can be obtained by contacting the convention publicity officer (author of *DX Diary*): *Don Field G3XTT, 105 Shiplake Bottom, Peppard Common, Henley on Thames RG9 5HJ. Tel: (0734) 724192.*

### Brazilian contest

The Electrill Antenna factory in Sao Paulo, Brazil is sponsoring a contest to celebrate its silver jubilee.

The contest will take place on the 2, 10, 15, 20, 40 and 80m bands using CW and phone modes, from 0000 UTC on 9 November through to 2400 UTC on 10 November this year.

Operators are divided into two categories. For Category I (single operators) a total of 12 hours rest period has to be clearly indicated in the log (it can be subdivided). Category II consists of multiple operators, ie clubs and associations, and there is no rest period.

The call for CW operators is 'CQ test 25' and for phone is 'CQ 25 years contest'. Contestants are required to exchange RS/RST reports once they have a contact.

Each confirmed QSO counts for one point. There are no multipliers, but different band contacts with the same station count separately.

Logs should include details of the station worked, RST sent and received, QTR and UTC, band, mode and general remarks. Completed logs should be sent to: PO Box 22, Labre, Sao Paulo Section, SP-Brazil 01000 before 31 January 1986.

Electrill products will be awarded to the winners.

### Welsh club

Abergavenny and Nevill Hall Amateur Radio Club meets every Thursday at 7.30pm in Pen-y-Fal Hospital. Regular Morse classes are held on club nights and all newcomers are welcome.

The club will be operating a special event station at the Pen-y-Fal Hospital Fete on 3 August 1985.

The callsign will be GB2PYF and operation will be on HF and VHF.

Further information on the club and its activities is available from: *The Secretary, 109 Croesonen Parc, Abergavenny, Gwent NP7 6PF.*

### 'CQ-TV'

The British Amateur Television Club (BATC) have sent us the spring issue of their very informative and interesting magazine, *CQ-TV*.

This latest edition includes contributions from Andy Emmerson ( *SSTV Standards, Passive Repeaters* ) plus articles on various aspects of the hobby including *Interfacing the Spectrum, a Single Chip Colour Encoder, Contest News and Ideas for an FM-TV Transmitter.*

Membership and subscription enquiries should be sent to: *D Lawton GOANO, 'Grenehurst', Pinewood Rd, High Wycombe HP12 4DD.*

### Salisbury R & ES 2m Contest

On 18 August 1985 the Salisbury Radio and Electronics Society is holding a 2m contest between 900 and 1500GMT. The modes are SSB and CW only and power is limited to 250W ERP to make it fair for low power stations. A restriction on frequency allows amateurs who do not wish to participate in the contest to operate above 144.300MHz.

The awards consist of a specially endorsed award certificate which will be awarded to the top three contestants. Entries should include details of station, eg rig, antenna, antenna assembly and county, and an SAE for details of the results.

For full details of the rules send an SAE to: *M E Wright G4RLF, 27 Bulbridge Road, Wilton, Salisbury, Wilts.*

### SWL information group

The idea of an information exchange group was suggested in Trevor Morgan's SWL column in this magazine in 1984.

The suggestion was put forward that listeners with similar interests within the hobby or using similar equipment or techniques might like to exchange information with each other, thereby being of mutual assistance without the ties of joining a club or association.

The basis of the formation of the group is that it would be self motivating by the free exchange of information between interested parties.

However, as many listeners are, for security reasons, unwilling to publicise their personal details in a general way, it was suggested that a

'bureau' be operated to handle the mail.

To get the group under way, a list of listeners who have submitted information of their stations has been compiled but no full names or addresses have been included. The idea is that if you wish to correspond with a user of similar equipment as yourself, you do so by addressing the letter to, for instance, 'John 437' and leave the addressing to the bureau controller. As letters come in to the bureau they will be fully addressed and forwarded.

Of course, if you wish to take up correspondence directly with any member of the group you can mention this in the letter to him.

The procedure is that any member may write to the person of their choice, enclosing the letter in a sealed envelope and putting the member's number on the flap of the envelope.

All letters should be forwarded to Trevor Morgan at: *1 Jersey Street, Hafod, Swansea SA1 2HF*, where they will be addressed and sent on. Don't forget to put a stamp on the envelope please.

### Please note . . .

We have received information from the City and Guilds Institute that the RAE dates published in *Amateur Radio* in Bill Mantovani's *Back to Basics* series (June and July 1985) are erroneous.

The exams will only take place on Monday 2 December 1985 and Monday 12 May 1986, not as previously published on 14 August, 16 October and 4 December this year and 15 January, 19 March, 14 May, 9 July and 13 August 1986.

Our apologies go to the City and Guilds Institute and to any prospective RAE candidates - we didn't mean to confuse you!

The City and Guilds Institute can be contacted by telephoning 01-278 2468.

In addition to this, we managed to omit the last three answers from the Questions and Answers featured in the June issue.

Of course this was done purely to ascertain how many of you actually tackle the questions! Well, for the frustrated few who are anxious to know the answers to questions 33, 34, and 35 the answers were a, a and c respectively.

**AMATEUR ELECTRONICS UK**  
**06XBH** **R.A.S. (Nottingham)** **08UUS**  
**Radio Amateur Supplies**  
**Tel: 0602 280267**

**Visit your Local Emporium**  
 Large Selection of New/Used Equipment on Show

**AGENTS FOR:** **ACCESSORIES:**  
**F.D.K.** **Welz Range**  
**AZDEN** **Microwave Modules**  
**ICOM** **Adonis Mics**  
**YAESU** **Mutek Pre-Amps**  
**FORTOP ATV** **Serenco Mast Supports**  
**DRAE PSU and**  
**Wave Meters**

**AERIAL: Tonna, Halbar, New Diamond Range of Mobile Whips**  
**PLUS OWN**  
**'Special' Q.R.P. GW5 HF5 Band Beams**  
**JUST GIVE US A RING**  
 Monday: CLOSED Tuesday - Saturday: 10.00am to 5.00pm

**3 Farndon Green, Wollaton Park, Nottingham, Off Ring Road**  
**Between A52 (Derby Road) & A609 (Ilkeston Road)**

**CENTRE ELECTRONICS SPECIALISTS IN THE SALE AND SERVICING**  
**OF VALVE TYPE RADIO EQUIPMENT**

**OFFER** Brand new Eddystone Model 1590 (all solid state) general coverage receiver complete with full workshop manual one years works guarantee £790.00.

**OTHER RECEIVERS FOR SALE** include the following RACAL RA17 FROM £175, RA17/L FROM £195, RA117/E £250. EDDYSTONE MODELS 830/9 @ £155, 730/6 @ £145, 770U @ £115. Also a selection of Vintage Communication Receivers HRO's, AR88's, S27, 358X, S504 etc; LISTS OF OTHER RECEIVERS AND ITEMS ETC: AVAILABLE

**SPECIAL OFFER**  
 Hard to find bayonet fixing 6.3 volt  
 Panel light bulbs suitable for most vintage American radios and postwar Eddystone's etc. Pack of 10 only £1.00 pp paid  
 PRINTED CIRCUIT BOARD Double sided fibre glass, good for VHF-UHF, only £1.50 per sq ft, cut to size required, minimum order £5.00 pp paid. Also single side Paxalin 50p per sq ft.  
 Large stocks of assorted vintage components (1920's - 60's) to clear Callers only

**SPECIAL DOOR TO DOOR** **CENTRE ELECTRONICS**  
 345 STOCKFIELD ROAD, YARDLEY, BIRMINGHAM, W MIDLANDS  
**B25 8JP**  
**SHOP OPENING HOURS 10 - 5.30PM THURSDAYS, FRIDAYS,**  
**SATURDAYS ONLY. TELEPHONE ENQUIRIES 0676 32560**  
**ANYTIME**

**DELIVERY SERVICE**

**NEW FOR 1985**

**RADIO** **Amateur** **RADIO** **Prefix Award**

**AMATEUR RADIO**  
**HF PREFIX AWARD (TWO-WAY AND SWL)**

To qualify for an award you have to have worked/heard and logged:

250 prefixes for the Bronze award  
 500 prefixes for the Silver award  
 1000 prefixes for the Gold award

The opening date is 1 January 1985 and further details are available in SWL (page 26)

**AMATEUR RADIO**  
**MICROWAVE AWARD**

To qualify for an award on one of these bands you have to fulfil each category

|                | Countries | Counties | Squares | Distance |
|----------------|-----------|----------|---------|----------|
| <b>144MHz</b>  |           |          |         |          |
| Bronze         | 7         | 20       | 20      | 500 Km   |
| Silver         | 14        | 35       | 40      | 800 Km   |
| Gold           | 21        | 50       | 60      | 1200 Km  |
| <b>432 MHz</b> |           |          |         |          |
| Bronze         | 5         | 15       | 40      | 400 Km   |
| Silver         | 10        | 15       | 30      | 600 Km   |
| Gold           | 15        | 25       | 45      | 900 Km   |
| <b>1296MHz</b> |           |          |         |          |
| Bronze         | 3         | 10       | 10      | 300 Km   |
| Silver         | 6         | 15       | 20      | 500 Km   |
| Gold           | 9         | 20       | 30      | 700 Km   |

The opening date is 1 January 1985 and further details are available in *On the Beam* (page 40)

**KEEP IN TUNE WITH AMATEUR RADIO**  
**AND THE AMATEUR RADIO AWARDS**

Start working towards your chosen award now!  
 All winners will receive free certificates - and find their names in *Amateur Radio Magazine* (worth it for that alone).  
 All entries or queries should be sent to:  
 Trevor Morgan GW4OXB, Glen Ross G6MWR or Amateur Radio.

**The CM1600 Measurement and Control Interface**  
**from IMS Electronics**

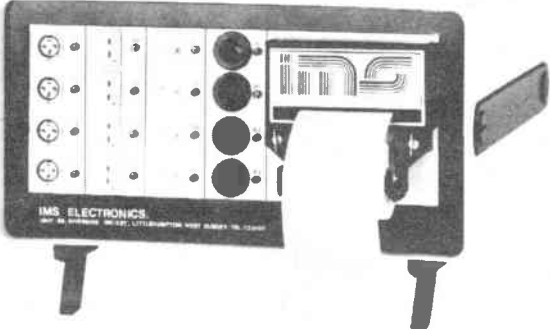

**Unique construction allows flexibility**  
**Four module positions, each with four channels**

Each module may be selected from an ever increasing list including:

- ± 10 volt outputs, 16 bit resolution
- ± 10V, 1V, 100 mV (Software Selectable) inputs, 16 bit resolution
- Thermocouple inputs (linearised)
- Single pole change over relays (mains rated)

**CHOICE OF IEEE-488 or RS 232C INTERFACE**  
**Z80 MICROPROCESSOR BASED**

Optional extras include:  
 Dot matrix panel printer (as illustrated)  
 32K RAM for assistance in data acquisition

**IMS Electronics**  
 Unit R6, Riverside Industrial Estate, Bridge Road,  
 Littlehampton, West Sussex BN17 5DF  
**SALES TELEPHONE (0903) 723492**

**AFFORDABLE TEST INSTRUMENTS**

**nombrex**

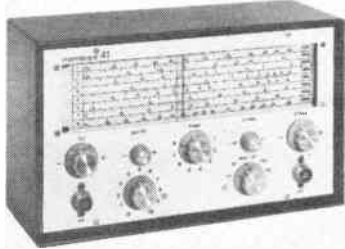

Model 41, R F Signal Generator, £106.96

One of a range of battery powered test instruments, offering professional standards of accuracy and reliability at an affordable price. R F Signal Generators, A F Sine/Square Generator, Frequency Meter, Inductance Bridge bench Power Supply etc. Send for full details of the Nombrex range to:

**Altair Electronics,**  
**Bridford, Exeter,**  
**Devon. EX6 7HT**  
**Telephone 0647 52594**

**Nombrex Instruments, designed and made in Devon.**



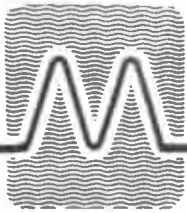

# MICROWAVE MODULES LTD

Microwave Modules Ltd. is a full time professional organisation, established over **16 years** ago in **1969**, and currently employs over **30 full time**, on site staff based in our two modern, purpose built factories. In addition, a similar number of 'Outworkers' are involved in assembly and mechanical operations.

## OUR EXTENSIVE RANGE . . .

Our product range now exceeds **50 individual items** in total and is the widest range available from any one manufacturing company. Our technical resources have enabled us to not only become the **largest** and **most successful** designer and manufacturer of R F Products, such as **Linear Amplifiers** and transverters, but also designers and manufacturers of **innovative** microprocessor and digital products such as **The Morsetalker**, MMSI, and the RTTY to TV decoder, MM2001.

## ALL BRITISH . . .

Every product in our range is designed and manufactured in the UK by our own employees, and wherever possible British Components are utilised.

## GUARANTEED . . .

All Microwave Modules Products are **Fully Guaranteed for 12 months**. This includes all semi-conductors and **PA Transistors**. We have built our reputation around our customer service and back-up and it is second to one.

## OUR RANGE OF LINEAR AMPLIFIERS . . .



MML144/30-LS



MML144/50-S



MML144/100-LS

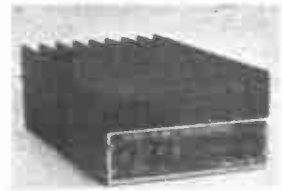

MML144/200-S

| PRODUCT       | INPUT POWER  | OUTPUT POWER | MODES OF OPERATION | Pre Amplifier |        | POWER REQUIREMENTS | RF * VOX | PRICE INC VAT        |
|---------------|--------------|--------------|--------------------|---------------|--------|--------------------|----------|----------------------|
|               |              |              |                    | GAIN          | NF     |                    |          |                      |
| MML144/30-LS  | 1 or 3W      | 30W          | SSB,               | 12dB          | <1.5dB | 13.8V @ 4A         | ✓        | £82.90 (p&p £3.50)   |
| MML144/50-S   | 10W          | 50W          | FM,                |               |        | 13.8V @ 6A         | ✓        | £82.00 (p&p £3.50)   |
| MML144/100-S  | 10W          | 100W         | AM,                |               |        | 13.8V @ 12A        | ✓        | £149.95 (p&p £4.00)* |
| MML144/100-HS | 25W          | 100W         | CW,                |               |        | 13.8V @ 12A        | ✓        | £149.95 (p&p £4.00)  |
| MML144/100-LS | 1 or 3W      | 100W         |                    |               |        | 13.8V @ 14A        | ✓        | £169.95 (p&p £4.00)  |
| MML144/200-S  | 3, 10 or 25W | 200W         |                    |               |        | 13.8V @ 30A        | ✓        | £299.00 (p&p £5.25)  |

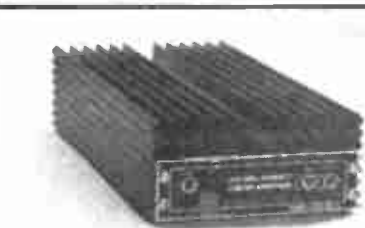

MML432/30-L



MML432/50

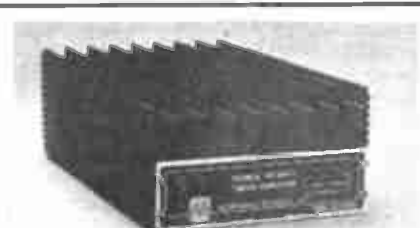

MML432/100

| PRODUCT     | INPUT POWER | OUTPUT POWER | MODES OF OPERATION | PRE AMPLIFIER |     | POWER REQUIREMENTS | RF* VOX | PRICE INC VAT       |
|-------------|-------------|--------------|--------------------|---------------|-----|--------------------|---------|---------------------|
|             |             |              |                    | GAIN          | NF  |                    |         |                     |
| MML432/30-L | 1 or 3W     | 30W          | SSB,               | 12dB          | 2dB | 13.8V @ 6A         | ✓       | £145.00 (p&p £4.00) |
| MML432/50   | 10W         | 50W          | FM,                | 12dB          | 2dB | 13.8V @ 8A         | ✓       | £129.95 (p&p £4.00) |
| MML432/100  | 10W         | 100W         | ATV,<br>CW,        | —             | —   | 13.8V @ 20A        | ✓       | £299.00 (p&p £5.25) |

\*THE RF VOX CAN BE OVERRIDDEN AND HARDWIRED.

## CONNECTORS . . .

144MHz Products — Our standard connector on these products is SO239. We use a high quality PTFE socket of superior quality, but we are able to supply the choice of BNC or 'N' type at no extra charge. Please specify

432 MHz Products — The MML 432/30-L's fitted with BNC connectors, 'N' type available, please specify. The MML432/50 and MML432/100 both have BNC input sockets and 'N' type output sockets. If this is not to your preference please specify when ordering.

## DATA SHEETS . . .

A full printed data sheet is available on each product, and is free on request.

## CATALOGUE . . .

A copy of our latest catalogue can be obtained free of charge on request.

## AVAILABILITY . . .

Our products are normally available from stock, either direct from ourselves or any of our 75 UK outlets.



WELCOME



## MICROWAVE MODULES (AR)

BROOKFIELD DRIVE, AINTREE, LIVERPOOL L9 7AN, ENGLAND

Telephone: 051-523 4011. Telex. 628608 MICRO G

CALLERS ARE WELCOME, PLEASE TELEPHONE FIRST

**HOURS:**  
**MONDAY-FRIDAY**  
**9-12.30, 1-5.00**  
**E & O.E.**

# L·E·T·T·E·R·S

## MISLEADING

I must write to point out one or two misleading statements made by Bill Mantovani G4ZVB in his June contribution, which is subtitled 'Practical Antennae'.

Bill says that end fed single wires can be of any length, but that optimum results are obtained if resonant lengths are used. This is certainly not the case and in fact such resonant lengths in an end fed system are best avoided. His advice that a length of 132ft is ideal is particularly misleading and one wonders what experience he has had with such a length? A later sentence alerting beginners to the fact that a problem with such a simple antenna is that it is prone to generating TVI is an oversimplification of the facts.

Resonant end fed wires will have high impedances and therefore high RF voltages at their far ends and at the shack end for they will contain one or more complete half wavelengths. The 'deadly' 132ft wire will have this condition on all the bands which are a multiple of 3.5MHz and will therefore have quite a high RF voltage in the shack and inside the house (if an indoor shack) on any band. This may give rise to many problems: 'hot' chassis or gear, absorption into the electric mains wiring, BCI, TVI and interference with hi-fi players, tape recorders, etc. Such a wire, even when used on 160 metres as a quarter wave antenna, will have its current maximum and therefore the point of greatest radiation indoors

where it can do no good!

I fail to understand where the myth of resonant lengths for end fed wires originated. Some writer obviously at some time confused half wave Hertzian antennas (dipoles) with other wire antennas. Such resonant wires had a spell of popularity in the 1930s when they were 'Zepp' fed with open wire transmission line. Even this system had the high voltage end of the radiator up in the air somewhere remote from the operating point. Can I please repeat a truism, 'any length of wire may be employed as an antenna'. The amateur is best advised to avoid lengths which contain one or more half wavelengths and go for a length which will have a shack end RF voltage somewhere between the minimum and the maximum. This will present a nice medium impedance to the station ATU which can be handled by this unit quite easily and also avoid RF in the shack. The ATU connected to a half wave end fed antenna in Figure 5 of Bill's article would require a very wide spaced capacitor to tune it because of the very high RF potential across it.

Readers may have noticed that the specifications for commercially built ATUs say they will cope with antenna impedances ranging between approximately 20 ohms and 500 ohms. This is especially true of all the motor tuned devices. By limiting the upper impedance to 500 ohms this ensures that the variable capacitor needed to tune the ATU need not have very wide

plate spacing and therefore it will be a much cheaper component.

Beginners are advised that the far end of any wire used as a single wire antenna will be at high RF voltage and high impedance. To find out the impedance at the feed end just work forwards in half wavelength steps; each half wave repeating the end high impedance point.

Finally I must put the record straight in saying that regular readers of *Amateur Radio* must have come across the many articles I have written for the magazine on wire antennas over the past few years. For some reason G4ZVB has a blind spot in remembering this fact!  
**John D Heys G3BDQ**

*Whilst not wishing to offend a fellow amateur and contributor to Amateur Radio, I would like to reply by saying that I feel Mr Heys has missed the point of my 'Back to Basics' feature. It is aimed at the prospective amateur who is probably still on the bottom rung of the ladder or who does have a basic knowledge of radio communication but wishes to brush up his theory before taking the exam. What may appear as an oversimplification of certain facts to the licensed amateur, who has been able to put radio and electrical theory into practice, may actually be all of the information deemed necessary for the purposes of passing the RAE.*

*Mr Heys makes a number of very valid points, but not, I feel, for this level of basic tuition. Some of the points*

*raised would only serve to confuse the beginner, not make things clearer. When first considering the objectives of 'Back to Basics', I had to decide where to draw the line on explaining a particular topic. Mr Heys goes beyond this line in his letter - if a reader of my series wishes to know more he can, as recommended, refer to the various other articles that have appeared in these pages, including those by Mr Heys, which I had most certainly not forgotten. Personally, I have referred to Mr Heys's articles on antennas many times when trying out my own experiments (including with the 'deadly' 132ft long wire that knocked the XYL's favourite TV programme out cold!), but I do not think that they are of as great a relevance to the prospective RAE candidate as the other articles mentioned in the issue in question.*

*As for 'an oversimplification of the facts' about TVI etc, I'm afraid Mr Heys has been just a little too quick off the mark - they are dealt with in more detail in the following month's conclusion to transmitter interference, as per the RAE syllabus. The above notwithstanding, please keep writing the practical articles Mr Heys; the wire antenna is one of my favourite subjects, too. For the record, despite the newness of my call, I am most certainly not a newcomer to amateur radio and prefer to build rather than buy any day.*

**Bill Mantovani G4ZVB**

## FB QSO IN MOSCOW!

An electronics exhibition is held in Moscow every two years, in the Economics Achievements Park, and one of its features is the exhibition short wave transmitting station run by members of the Moscow Radio Club.

When I walked through the door, my RSGB badge was immediately recognised by several radio amateurs, who invited me to operate the station - they could not have been more hospitable.

However, it certainly made

me wonder what the authorities in this country would have had to say if the boot had been on the other foot and a Russian radio amateur had visited a GB station in England, been handed the mic and invited to contact Moscow!

**Douglas Byrne  
G3KPO/GB3WM, Ryde, IOW**

## SUPPORT NEEDED

I am attached to my local Air Training Corps as a Civilian Instructor in Newark. A great deal of my time is spent

looking after radio equipment or in training boys aged between 14-18 years old to operate radio equipment. *Amateur Radio* magazine is therefore one which is often read in our workshop.

At present, training boys in sending and receiving Morse and in radio procedures is not a problem.

However, our Squadron funds, like most youth organisations, remain exceedingly small and radio equipment rather expensive or very difficult to obtain, so I wondered if any readers

could help us.

I contacted the RSGB's local clubs in Mansfield and Newark two months ago and although sounding very hopeful at first, they have been unable to help.

I desperately need two HF transmitters capable of operating between 3.200MHz and 3.800MHz and further up the band from 5.200 to 7.500MHz. (The frequencies we use are all crystal controlled).

Our power requirement is anything from 20W to 100W output with the facility to



# L·E·T·T·E·R·S

offer CW ((A1), AM (A3), and SSB (A3J) in transmit mode. Sets do not have to be in working condition for as long as parts are available we can repair them ourselves. Our new training year starts in September and we desperately need this equipment.

If you feel you can help us please contact:  
*J Gellatly,*  
11 Archers Drive,  
Bilsthorpe, Newark,  
Notts NG22 8SD.

## PROUD ex-CBer

The heading over M Shannon's letter (*Drivel*, AR July 1985) was very apt! Reading the first sentence, 'Rarely do I surface on 2 metres', I would surmise that like the fabled ostrich with its head stuck in the sand, he rarely surfaces at all! And even when he does the sand is still in his eyes. In case he has not been informed,

Queen Victoria is dead!

Most people *do* realise that obtaining a G callsign means that the holder is interested in the subject of radio enough to have taken a City and Guilds examination; whether or not they were on CB (legal or pirate) previously is of little importance.

A lot of information that I needed to pass the RAE came via CB and the remainder via Howard G3SFO, who is a lecturer in the RAE, which more than made up for any deficiencies in my basic knowledge, thus giving me an RAE class B pass.

May I point out that saying the multiple choice RAE 'encouraged thousands of people to drift into amateur radio' and 'ruin it for the more dedicated folk' is the sort of statement that would be repudiated by the majority of licencees, and to further declare that 'Black box operating should be stamped out' confirms the small-

minded attitude of G4GJN. Not everyone is adept with their fingers; what about those licensees who are disabled, blind or with a speech impediment and for whom amateur radio helps improve the quality of their life?

M Shannon seems hell-bent on changing amateur radio to suit himself only.

**A R Johns G1MSH, Yorks**

## PLEA

All of my family are CBers and my parents are also licensed to use 2m. In fact, my Dad is a G4, my Mum is a G6 and I hope to retake one part of the RAE in December after failing my first attempt last year.

My point is that my parents and many ex-CBers know more about operating procedures than many old-time HF men.

I agree that some CBers do use CB jargon on the air but I

think this is mainly from habit. I would also like to point out that CBers are not the only ones to use 'drivel' – the biggest offenders are sometimes those who know the most about electronics, radio and aerials.

Changing the examination procedures will not convert these offenders. In fact, passing such exams would only make them big-headed, as it has done for a certain amateur who will remain nameless.

Also, changing the exam would mean no licence for those, like me, who are very interested in amateur radio but find the ins and outs of such equipment beyond understanding.

I make two pleas to G4GJD. One, please do not generalise the attitudes of the majority by the actions of the few, and two, don't brag about your early achievements or you might trip over your own ego.  
**Karen Diss (aged 16), Essex**

For the latest thoughts about the communications of the future, and to find out what's happening now, buy **DIRECT LINE** and make it your guide to the new communications age.



Designed for easy reading

Introduces new communications systems

Read all about it in the first issue

Electronic mail, banking and shopping from your home

Cellular mobile telephones for calls wherever you are

Television by cable and satellite from around the world

Latest technology explained

Interactive computing – services at your fingertips

News of all the latest products

Exceptional value for money

**MAKE A DIRECT LINE TO YOUR NEWSAGENT ON JULY 18**



# DX DIARY

News for HF operators compiled by Don Field G3XTT

For DXers throughout the world June was marred by news of the passing of two outstanding operators, Don Wallace W6AM and Father Dave Reddy CE0AE. Don Wallace started his amateur radio career in 1910 and had been active ever since, his main interest being HF DX. His Rhombic Farm at Palos Verdes in California originally consisted of 13 rhombic antennas serving 26 directions. This was later reduced to 9 rhombics on 61 poles (10 of which were 140ft high), using 45 miles of wire.

Don led the DXCC Honor Roll for the last 25 years, no mean achievement in view of the intense competition between US DXers. Nevertheless, Don was always ready to try out new aspects of the hobby and, indeed, my own last contact with him was on the 10MHz band.

Father Dave gave many amateurs their first contact with Easter Island and could regularly be heard in Europe on all bands, 80-10. He was also responsible for encouraging a number of Easter Island residents to become radio amateurs. Father Dave had always been an active contester and DXer in his own right and will be a great loss to the airwaves.

## Rockall

Many readers will have followed the exploits of Tom McClean, who recently landed on the treacherous island of Rockall off the Scottish coast. Unfortunately Tom chose to appear on the amateur bands with fictitious

callsigns such as RR1TM and GR1TM and worked, among others, a number of British amateurs. In working him these amateurs were, of course, in breach of their licence.

There has been at least one attempt in the past to have Rockall accepted by the ARRL as a separate DXCC country, presumably on the basis of its distance from the mainland. As I recall the attempt failed because the ARRL looked at its distance from the nearest land (the Hebrides) rather than from the mainland proper. In any case, there is an ongoing dispute between Britain, Eire, Iceland and Denmark about the ownership of Rockall, although most of us would think of it as British.

## Sao Tome and Principe

Another relatively obscure part of the world which has featured in amateur radio circles recently is the tiny ex-Portuguese colony of Sao Tome (St Thomas) and Principe (Prince).

These are volcanic islands (together about 372 square miles) in the bend of the Gulf of Guinea. Sao Tome is as large again as the Isle of Man and rises to 7000ft. Principe is as large as Jersey and rises to 3000ft.

The Portuguese call the islands the 'Pearls of the Ocean'. The rich soil produces cocoa, coffee, coconuts and palm kernels as principal exports. The population, however, is only 86,000 and casual visitors are not allowed, so the islands are not well-known.

In amateur radio terms several CR5 stations used to be active before independence, for instance CR5SP and CR5LB. After independence in the early 70s the prefix was changed to S9, but there has been very little activity. This is because it is not possible to enter the country purely as a tourist (or therefore DXpedition operator), but visitors must be there to do a job of work.

Thus it was that Vince Thompson K5VT was able to operate in 1981 while he was travelling around Africa teaching medical techniques to local surgeons. Vince made many CW contacts as S9VCT and made lots of DXers, including myself, happy with a new country.

More recently, there was a very brief operation from Principe by PS7ABT/S9, visiting with his ship (Jose is with the Brazilian navy). This three-hour operation netted just 155 contacts in 30 countries, using the 20 and 15 metre bands. Clearly it did little to alleviate the enormous demand from newly-licensed DXers for a contact with S9.

And so to the present. Towards the end of June S92LB started to appear regularly on 20 metres in the late evenings, giving his address as PO Box 147, Sao Tome. It does rather look as though Luis CR5LB is back on the bands. Let's hope so. In the good old days Luis was never especially active, but keen DXers could rely on catching up with him sooner or later. Perhaps the same will be true again.

## AR in the year 2000

Readers will recall I invited contributions on this topic in the February column. I have to hand an interesting, though pessimistic, letter from G8SQS who listens on the HF bands from time to time. He points out that increasing access to satellite communications will mean that, before too long, the main users of the short wave spectrum will be amateurs, over-the-horizon radar, and a few remaining broadcasting stations.

HF amateur radio will be plagued by interference from the radar transmissions, amateurs will seek refuge in the much less interesting black box activities of VHF and will eventually lose interest in the hobby altogether, much as many newly-licensed class B operators seem to disappear forever off the bands after an initial honeymoon period.

The above scenario would be extremely sad for amateur radio, though I have to agree that we are already seeing signs of decreasing interest in the hobby especially among our more educated brethren. Many university radio clubs are but a shadow of their former selves.

Perhaps we push the idea of amateur radio as a self-teaching experience, as a community service, a bit too much? This, at least, is the theme of a recent editorial in the American *CQ Magazine*, where it is suggested that we should remind ourselves that the main virtue of our hobby is that it is fun! And HF operating is the most fun of all.



# DX DIARY

## HF Convention

Can I remind readers that the RSGB HF Convention takes place on Sunday 29 September at the Belfry Hotel on the A40 south of Oxford? There will be a wide ranging lecture programme as well as a range of other activities of interest to HF operators. No trade stands though; the idea is to focus on the social side and involvement in the activities. Doors open at 10am and the entrance fee is £2. For my sins I am on the organising committee, so if you need more details feel free to contact me. Otherwise, full information will appear in the September issue of *Radio Communication*.

## DX news

HB9APJ and HB9ASJ will be operational from Greenland signing their home calls /OX from 2-25 August. Frequencies will be 7020, 7080, 14050, 14180, 21050, 21180, 28050 and 28580kHz. QSL cards should be sent to their home calls.

The Madeira DX Club is planning an operation from the Selvagen (Salvage

Islands from 10-20 August. The islands, which count as Madeira for DXCC purposes, get their name because they are very treacherous and many a ship has come to grief there. If the operation takes place successfully the Islands-on-the-Air Award reference AF-47 will be allocated.

Another operation for island chasers will take place from 17-31 August. This will be from Rugen Island (IOTA reference EU-57) using the callsign Y24DO/P. Low power (only about 20W) will be used.

Further afield, HC10T hopes to operate as HC8E from the Galapagos Islands, commencing on 18 August. I have no other details on this one.

G3KQL/TT8 has been active from Chad, mainly on 15/20 metres SSB, and was expecting to be back there from 26 July for one month and then from 21 September until December. KA4JRY/TT8 has also been active from the same station. However, there seems to be some doubt as to whether either of these oper-

ators has proper written authorisation, so it is possible that the operations will not count for DXCC credit.

Readers may not be aware that when any of the American space shuttles are in orbit, the ground/space communications are relayed on 14295kHz.

One of the more unusual 'countries' on the DXCC list is the sacred community of Mount Athos on a Greek peninsula.

Readers may have seen the series of programmes about Mount Athos which appeared on Channel 4 TV a couple of months ago and showed a religious life-style among the all-male monastic population of the peninsula which has changed little in hundreds of years.

Although there has been occasional amateur radio operation in the past, it appears that the monks regard it as an example of 20th century corruption of their lifestyle and have now decided to ban it forever. I hope you worked this one while the going was good...

## Contests

Two international contests of note in August. The first is the Worked All Europe CW contest on 10/11th, run by the German DARC. The rules are quite complex but it is simple enough to join in and make a few contacts and exercise your CW. Another CW event is the All Asia CW Contest on 24/25 August, an opportunity to work lots of Japanese stations (if propagation is kind) as well as, occasionally, something a little more exotic.

Domestically, RSGB members can take part in the ROPOCO contest on 25 August.

The idea is to receive and pass on post-codes, some of which, in previous years, have ended up bearing no relation to how they started, having been passed from station to station for up to two hours! (like Chinese whispers).

Enjoy the remainder of your summer operating and do pass on any comments or news to me at: 105 Shiplake Bottom, Peppard Common, Henley RG9 5HJ.

## NEW NAVY SPECIAL BASE STATION COMPACT DIPOLE FOR 10, 15, 20 & 40m.

New Bands Available Shortly.

- ★ Each unit matched for 50 ohm feed impedance
- ★ Fits directly to 1¼" diameter mast
- ★ Ideal for limited space operation - maximum overall length 3m.
- ★ May be used without ATU.
- ★ Multi-band arrays require only one feeder.

Price per band: £29.99  
inc post & packing  
Please specify band(s) required.

**GLENSTAR ELECTRICAL MOTOR  
DISTRIBUTORS LTD**

**Newton Road, Henley-on-Thames,  
Oxon RG9 1HQ.**  
Henley (0491) 576591



## NEWSAGENT ORDER FORM

*Amateur*  
**RADIO**  
For all two-way radio enthusiasts

To (name of newsagent)

Please order a copy of *Amateur Radio* for me every month

NAME.....  
ADDRESS.....

Newstrade distributors: Argus Press, Sales & Distribution Ltd, 12-18 Paul Street, London EC2A 4JS. (Tel: 01-247-8233)

## Edwardschild Limited ELECTRONICS SERVICES

*Design and development*

\* PCB design and layout

\* Conventional PCB prototyping

\* Graphics

\* Manufacturing

28 Shenfield Crescent, Shenfield, Essex CM15 8BN

**Enquiries ☎ (0277) 216433**

# ANGUS MCKENZIE

---

## TESTS

---

### ICOM IC3200E DUAL BAND FM TRANSCEIVER

---



Hard on the heels of the Yaesu FT2700RH comes this magnificent miniature dual bander from Icom. It covers the whole of the 70cm band as well as 2m, and it can be internally modified to cover 140-150MHz. It is remarkably small and compact, and is especially suitable for a mobile installation, the mobile mounting sleeve having a padlockable latch on the side cheek.

It has just one antenna output covering both bands, a built-in diplexer coupling the two band sections together, so the rig is ideal for use with a dual band mobile antenna such as the Trio MA4000, which incidentally is limited to around 30W continuous power.

Last summer I managed to blow up my dual bander by transmitting 100W through it on 2m in GM, and this served me right! There are two VFOs and you can select the appropriate repeater shifts separately, thus 600kHz for 2m and 1.6MHz for 70cm.

The tuning knob rotates in light click steps and duplicates the up/down buttons on the electret HM15 mic supplied, which also includes PTT and a toneburst button which puts on burst and carrier. The toneburst circuit is in the mic and there is a separate one, somewhat curiously, in the rig itself.

#### Loudspeaker

The front panel buttons allow very comprehensive facilities, a second function key extending these considerably. Frequency and comprehensive status indications are provided on a liquid crystal display on the front panel, which is easy to see but not quite as good as that of the Trio TW4000A. One fascinating option is a speech synthesiser frequency readout, the UT23.

The loudspeaker is built into the front of the underneath panel but a 3.5mm jack socket on the back can be used to drive an external speaker. The rig operates off 13V dc, its captive short lead being provided with an in-line connector and an extension lead also being supplied with built-in fuses in both lines.

Two small rotary pots on the front panel provide Rx audio gain with power switching and squelch sensitivity, which

when pulled out reduces the power to around 3.5W. I am slightly concerned that this knob pulls out quite a long way and could possibly break with an accidental knock. The main front panel functions include microswitch operating buttons for VFO A/B, priority channel enable, memory recall, memory write, scan enable, a cycling button switching between simplex or  $\pm$  repeater shifts, call 1, which selects direct access to memory 8, and internal toneburst, which again also puts on carrier. MHz up/down buttons can also be used to switch memory channels when in that mode, the mic's buttons achieving this as well.

Internal switches, which can only be accessed by taking the top panel off, select whether the VFO knob can VFO from memory or not. Other switches select a pip tone on/off, which can sound when changing a channel by button pushing but not by changing the VFO knob, and a scan stop interval switch, which can hold a scan on a station or continue searching, the scanning speed itself also being selectable to fast or slow.

The second function button gives some extra facilities which include repeater offset frequency write, memory skip, offset frequency check, VFO lock, tuning step rate (12.5 or 25kHz channelling on both bands) and call 2, which gives instant access to the frequency in memory 9.

The microphone socket is mounted on the front panel, and incorporates 8 pins to the standard Icom wiring. The rig is well presented, extremely well laid out internally and includes separate PAs for the two bands with a very adequate heat-sink, although I am slightly concerned that no cooling fan is incorporated. This will mean that you will have to provide very adequate ventilation for the back of the rig when you mount it in your car. In the trials it did get extremely warm, but not ridiculously hot.

It is not possible to transmit on one

band and receive on the other, and if you require this facility you would have to consider the Yaesu, which is far more flexible, or the Trio, which does allow it but with difficulty (not duplex though).

It is quite clear that there is going to be heavy competition between the IC3200E, the Yaesu FT2700RH and the Trio TW4000A, for they all have strong points to commend them. The point about this little Icom is that it could be put into spaces that might not be large enough for the competitors, and if you want to be able to have a simple but effective installation for both bands its rather lower price may well swing the balance.

#### Berserk

I very much enjoyed using this rig as it has no serious failings. Although it takes a short time to accept a command to change frequency, I soon got used to it. However, if you tune the VFO knob too quickly the synthesiser goes berserk and you could end up going upwards when you want to go down, so you have to be slightly patient with it. The normal up/down functions, however, worked very well indeed. If you press either of these and hold it down, the rig steps channels quite rapidly.

I was rather annoyed with the MHz buttons, for these not only went from one band to the other, and thus provided the incorrect repeater shift, but when going through a band edge your kHz setting is replaced by noughts. It is so easy to press the wrong button absent-mindedly, and the Yaesu transceiver also had this problem. It is extremely useful to be able to move frequency from memory, and not many FM mobiles offer this facility, but unfortunately it is not available from either of the call access positions.

Although the displays on the front panel are back illuminated in a bright green colour, there is no illumination behind the VFO dial or the various buttons so the rig is not quite so easy to use in the dark. The instruction manual is



# G3OSS TESTS

very well laid out and provides adequate information for using the rig, lay-outs and circuit diagrams being incorporated.

The modulation quality was said to be very good, several amateurs commenting that speech was very clear, the microphone giving quite a bright reproduction with fairly low distortion overall. I have frequently moaned about the reproduced quality from Icom rigs, FM on many other Icoms being very muffled even on an external speaker as the result of too much Rx de-emphasis of the treble end. This rig is much better and I found that the received intelligibility was therefore very greatly improved, callsign gabblers being heard that much more clearly!

## Sensitivity

The receiver sensitivity seemed excellent on 2m but it was just a little poorer than average on 70cm which is rather a pity. This could well be due to the way in which the two bands are coupled together to feed one antenna socket. The SO239 line socket is on a short flying coaxial lead which feeds the two band sections in parallel. Each band has its own separate bandpass filter and Tx/Rx diode switching network. Not only are two separate PAs used, but each band has separate RF pre-amps and mixers, the mixer outputs being selected appropriately to a common IF strip. It is possible that the 144MHz filters are slightly loading down the 433MHz RF pre-amp input by interaction.

I experienced no problems with repeater access using the toneburst button on the mic, and the 25W power output on both bands enabled access to almost any audible repeater. The FM squelch control could be adjusted to allow very weak stations to open it, and the hovering characteristics were reasonably acceptable.

I have always found that second functions on the majority of controls tend to get a bit confusing, but they have been chosen quite carefully so that you should not have to use them very often. What is annoying however is that you have to take the lid off completely to get at the internal switches which you might well want to change for operating in different areas. For example, you might wish to scan rapidly in a more rural area but slowly in an urban one, or alternatively you might want to hold a scanned station where there are very few of them, whilst belting across many unwanted stations in a high density area.

I feel that Icom should have provided an easy to remove bug hutch cover on the top, or even used counter-sunk switches on the panel. The review sample was not fitted with the speech frequency read-out option, but I would assume that its quality would be fairly similar to those on other Icom rigs, which are adequate.

## Laboratory tests

The RF sensitivity on 2m measured very well, about the same as its latest competition. On 70cm though it was 4dB

less sensitive, which was disappointing, especially as you could not conveniently use an external pre-amp arrangement unless the pre-amp could pass 2m signals through it as well as 70cm on Tx.

Both the front end mixers gave a good performance, which did not deteriorate significantly when two strong carriers were very close to the wanted frequency. Furthermore, the synthesisers for both bands had relatively low sideband noise, thus giving a very good reciprocal mixing performance. A strong signal on the adjacent channel would not be likely to cause interference to the signal/noise ratio of a weak wanted signal, although the IF selectivity was none too good at 12.5kHz channelling.

Selectivity is quite important on 2m in urban areas, but I have not had problems on 70cm. Now that 25kHz channelling is in very regular use on 70cm, the addition of 12.5kHz channelling on that band is quite useful, although you should watch out carefully for commercial users who frequently use 12.5kHz offsets. It should be remembered that we are secondary users of the band, so I suggest that you avoid these offsets. 25kHz selectivity was excellent incidently.

Now we come to one of the most ridiculous S-meters that I have yet encountered, even on an FM rig. Not only is there a mere 9dB difference between S1 and 9, but Icom have got a strange idea about their dB above S9, since an RF level increase of only 3dB takes the meter from S9 to '9+60'. The meter is thus

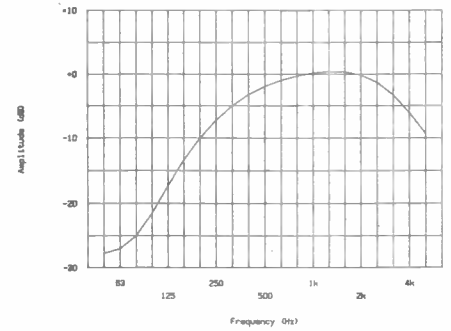

FM receiver response with 750µS pre-emphasis

only useful for indicating the presence of a signal which can be heard anyway, and I most certainly balk at an average of 1dB per S-point!

The discriminator distortion was unfortunately somewhat higher than usual, and although this does not affect communication it will mean that a very clean signal would sound just a little dirtier than it might do on another rig. However, the reproduced frequency response was superb, being almost flat from 400Hz to 3.2kHz with fairly steep roll offs outside these limits. Icom have clearly changed their philosophy to conform with the average pre-emphasis and de-emphasis characteristics of other manufacturers, which is excellent.

The maximum audio output power was just 2W into 8 ohms, but quite a bit more into a 4 ohm load. The built-in speaker was fairly efficient and quite adequate,

FM Tx response with 250µS de-emphasis. Max 3kHz deviation, 30Hz selective

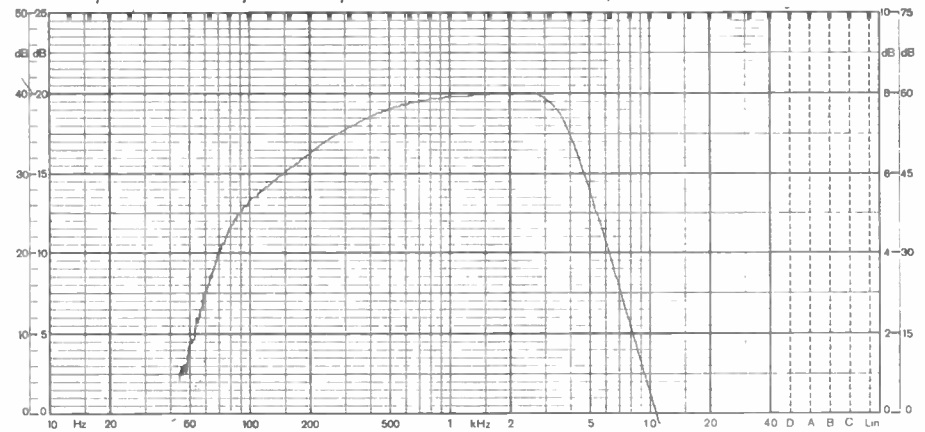

FM Tx response 750µS into limiting, 30Hz selective

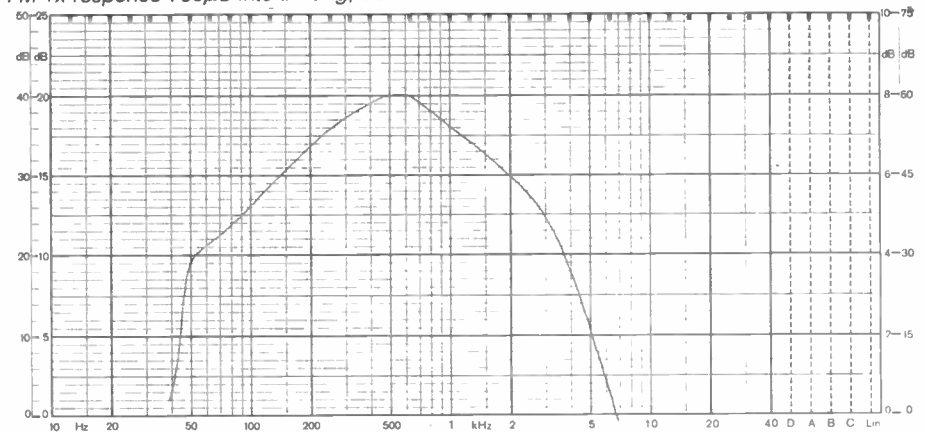

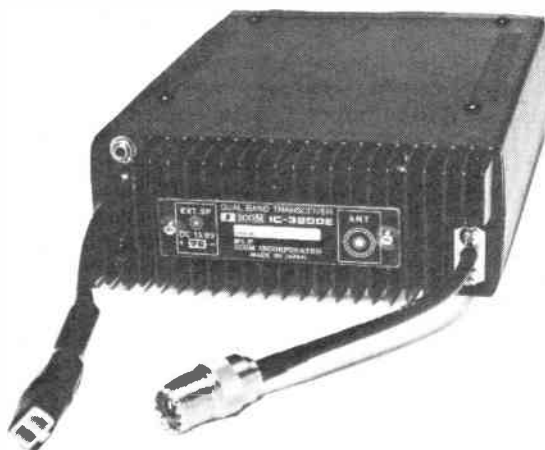

but since it faces downwards you would probably get a significant improvement by selecting a mini external speaker.

Whilst the rig was extremely well set up on the 2m band we noted a very slight unevenness in the IF selectivity on 70cm, but this should not affect 25kHz channelling or change the measured sensitivity. The unevenness was due to a very slight frequency error which caused a correct input transmission to be a little closer to one filter skirt than the other.

We checked the transmitter sections by dumping the power into a Rohde & Schwarz dummy load attenuator, measuring power on a Racal 9303 digital power meter. The rig was just about on spec, giving 25W output on 2m and 27.5W

on 70cm. The power reduced usefully to an average 3.5W on low power. We checked the FM deviation of the tonebursts and found that the oscillator in the mic was set correctly, its frequency also being precise, but the one in the rig, which is superfluous anyway, was just under 2Hz low and with deviation some 6dB lower than that from the mic, which is very curious.

Speech deviation peaked at around 4.6kHz normally, but even when extremely provoked the peak deviation hit just 5kHz, showing a superbly set up limiter. This was confirmed also by the frequency response transmitter, which checked well below limiting and into limiting.

The transmitted response from the mic input socket to the RF carrier after 750 $\mu$ S de-emphasis was almost ideal, being very flat indeed in the passband 400Hz-3.7kHz, the response falling extremely rapidly either side of this passband. The rig should therefore not pick up too much low frequency car noise, and yet the slightly extended response will make the sound quality that little bit better than that of other rigs, which are usually filtered a little lower, sometimes with a shallower cut off.

Transmitted frequency accuracy was extremely good on 2m and very good indeed on 70cm, and one might say that both were almost precisely 'on the nose'.

The maximum current drawn was 6.5A on 70cm, whilst the squelched current when receiving was down to 0.5A. The latter is slightly on the high side, so you will need to watch that you turn the rig off over a weekend! We checked quite carefully for RF harmonic and spurious outputs and none were seen, our noise floor for the test being just below -65dB.

## Conclusions

One has to weigh up the advantages and disadvantages of the three presently available dual band rigs, the IC3200E, the Yaesu FT2700RH, and the Trio TW4000A. The Trio is still my personal favourite because of its superb ergonomics, its one snag being the exclusion of 12.5kHz channelling. Having tried all three rigs the Trio seems easier to use, but you may find that since the separate antenna sockets are on the back panel itself, the 70cm one being slightly awkward to get to, the other two rigs with their short co-ax leads and sockets will be more convenient if you want to take the rig in and out of the car fairly frequently. The Trio has the best selectivity incidently.

The Yaesu, reviewed very recently in *Amateur Radio*, offers simultaneous Tx on one band and Rx on the other, which can be great fun. It too has excellent ergonomics, with just the odd awkward feature like the MHz button problem. I personally prefer the Trio transmit quality, although the Icom is very good as well.

If you want to obtain optimum performance on both bands, using separate antennas, you will have to exclude the Icom from consideration, especially as it would be very awkward to use an external linear pre-amp with it unless you only used one band at a time. However, for sheer convenience and simplicity the new Icom rig has so much going for it, allowing it to be very highly recommended. It is obvious that all three rigs are in the same top class and equally recommendable.

I would like to thank Thanet Electronics for getting me the review sample so quickly after it had come into the country, and Jonathan Honeyball G1LMS for helping with all the measurements and assessments. I will finally have to leave it to each individual reader to make his own choice, which is not going to be easy.

## Icom IC3200E Laboratory Results

(Results for 430MHz band are in brackets)

### Receiver Results

Sensitivity, for 12dB sinad

|            |         |                        |
|------------|---------|------------------------|
| 144.025MHz | -124dBm | (433.025MHz -120dBm)   |
| 144.95MHz  | -124dBm | (435.975MHz -120.5dBm) |
| 145.975MHz | -124dBm | (439.975MHz -120dBm)   |

Selectivity, off channel 3kHz deviation/3kHz modulation

|                       |             |          |
|-----------------------|-------------|----------|
| $\pm$ 12.5kHz spacing | 6.5/8.5dB   | (5/10dB) |
| $\pm$ 25kHz           | 71.5/73.5dB | 68/71dB  |

S-meter

|       |            |            |
|-------|------------|------------|
| S1    | -111dBm    | (-111dBm)  |
| S9    | -102dBm    | (-103dBm)  |
| S9+20 | -100dBm    | (-100dBm)  |
| S9+40 | not marked | not marked |
| S9+60 | -99dBm     | (-99dBm)   |

Distortion at 3kHz deviation

4%(5%)

Maximum audio output power (10%THD)

4 ohms 3.4W 8 ohms 2W

Calculated intercept point: 12dB sinad method

|                      |       |           |
|----------------------|-------|-----------|
| +100/+200kHz spacing | -8dBm | (-6dBm)   |
| +20/+40kHz spacing   | -8dBm | (-4.5dBm) |

Size

140 (W) x 50 (H) x 218 (D)mm

Weight

1.9kg

### Transmitter Results

Maximum output power (high/low)

25/3.7W (27.5/3.3W)

Harmonics and spuri

no harmonics or spuri above -65dB ref full output power on both bands

Tx accuracy

-50Hz (+210Hz)

Repeater shift accuracy

within 10Hz

Deviations (rig toneburst/mic toneburst/normal speech/provoked speech) 2.3/4.6/4.6/5KHz

Toneburst frequency accuracy

1750Hz on mic 1747Hz on rig

Current drawn at full output

6.5A



# Yaesu FRG9600 multimode receiver



Over the years many scanning receivers have come and gone, some being extremely poor whilst others have been just adequate. The exception was the AOR2001, which I reviewed about eighteen months ago in this magazine. The AOR2001 had quite good facilities and a performance well above any other available scanner, covering a range from 25MHz to well above 500MHz.

Although it performed well it had very poor ergonomics and a very nasty touch type keypad, a plastic membrane covering over the touch points. Even so, I gave it a good review but pointed out that what we all wanted was a receiver with far more facilities and with a proper tuning control.

When I first heard about the new Yaesu model I was delighted, since it seemed to have almost everything that one could want in such a receiver, except for the fact that the highest frequency covered was 905MHz and not 1GHz. A review sample arrived from Amcomm of Harrow, North West London, and whilst I was extremely impressed with all the facilities and ergonomics I have to say right now that the technical performance is extremely poor, in fact poorer in many ways than much of its competition. Before going into details of the performance, however, let's have a look at its comprehensive facilities.

The receiver is totally encased in metal, measuring 180 by 80 by 220mm and weighing 2.2kg. The loudspeaker is mounted in the top panel. The front panel includes an extremely easy to use 5 x 4 keypad, offering superb facilities. The frequency range is nominally 60 to 905MHz, frequency being entered on the keypad as required, a 0 being put in at the beginning for frequencies below 100MHz.

The mode button cycles between wide and narrow FM, wide and narrow AM (narrow AM uses an SSB filter, unfortunately) and upper and lower SSB. A cyclic step button selects 100Hz and 1kHz steps on SSB and AM narrow, 5, 10, 12.5 or 25kHz on wide AM and NBFM, and 100kHz steps on FM.

The keypad allows you to enter frequencies in between steps, the normal channelling reverting once you alter the up/down channel buttons, or the

tuning control. The tuning control itself gives click steps at the chosen channelling rate, which works extremely well, allowing one to belt up and down a particular band very rapidly, manual scanning of course being much faster than electronic scanning.

Above the tuning knob are up and down stepping buttons which can be used to select automatic up/down scanning. This, however, is rather slow. One hundred memories are incorporated, which include frequency and mode, and not only are these very easy to select, but you can transfer from memory to the VFO mode as well as putting any frequency found immediately into memory. A priority channel can be scanned every few seconds, if enabled.

An audio scan button will stop the receiver scanning only when a modulated channel is found, provided the squelch control is in use, concentrically mounted audio gain and tone controls also being provided. Additional buttons select clear entry, memory clear, antenna attenuator (20dB), and various clock functions. The front panel also includes a 3.5mm jack socket for headphone interconnection.

The back panel includes what seems to be the inevitably inappropriate SO239 socket for interconnecting a telescopic whip supplied or an external antenna,

this socket being ridiculous for the UHF range. A BNC socket would have given a better performance for frequencies above 500MHz. A 13.8V coaxial power socket has a positive inner pin, which you should note carefully as there are two standards for this. An external mains adaptor is available, type PA4C, which delivers 13.8V dc at up to 700mA.

Three phono sockets provide 8V dc (maximum 200mA), video output for use with an external adaptor, and a mute socket which mutes the receiver from external control. Three 3.5mm jack sockets are mounted for feeding a tape recorder at a fixed level (specified at 70mV into 50kohms), there's an 8 ohm external speaker, which mutes the internal one when in use, and an FM wide MPX output can be used to feed a stereo decoder externally, which you would have to make up yourself as Yaesu do not supply one.

A four pin molex socket provides binary band data for possible future Yaesu options. A six pin DIN socket can be used to feed an optional computer interface unit, Yaesu having the FIF232C and FIF65A available (Apple II etc). Two small presets can adjust video AGC and audio mute thresholds (the latter for FM wide).

You can thus see that this little receiver has some excellent facilities



and has been superbly ergonomically designed. Each time a button is pressed a pip sounds to show that the command has been accepted. Frequency entry is simplicity itself and operation is so much easier than on the AOR2001. The computer interfacing possibilities are fascinating and the receiver can also be used for video and data reception with the potential of excellent interfacing.

## Subjective tests

I interconnected the receiver with various antennas, including VHF and UHF discons, and the quality on NBFM and wide AM was quite reasonable for speech communication. Wide band FM seemed to be muffled though, and wide deviation programme peaks were very definitely distorted. In tuning around band II I was troubled by quite bad intermodulation products from the strongest FM radio stations, and unfortunately these extended well above and below the broadcasting section of the band.

The IM performance apparently improved when one switched in the attenuator, but the resulting desensitisation made it impossible to receive any but the very strongest mobile radio transmissions. The air band above 118MHz did come over quite well on AM, although sensitivity was a little lacking. However, as one tuned higher and higher the very poor sensitivity became more and more obvious, and by the 70cm band repeaters that should have normally be fully quieting were either inaudible or only just discernable.

The same situation arose for many PMR repeater and simplex channels below band IV television. I tried listening to CW and SSB and whilst the quality was tolerable at 144MHz, although clearly very subject to hiss modulation, by 432MHz many signals had an auroral quality caused by the appalling noise sidebands of the synthesised local oscillators.

Yaesu do not claim that the rig can be used for CW and SSB reception above 460MHz and I am not surprised, for carriers developed around the top end of the receiver did not produce a musical note at all, just an auroral hiss.

I am most dismayed that Yaesu's top frequency limit is 905MHz for they could, with advantage, have extended this to at least 960MHz, thus covering the 934MHz citizens' band and the cellular radio channels. However, by the time this review is published, Amcomm should be able to supply modified rigs receiving up to 960MHz, for at the time of writing they had already converted two rigs experimentally to cover the extended range.

If one bears in mind that there is obviously a colossal market, potentially of tens of thousands, for a receiver such as this with good ergonomics, it is very sad that the RF intermodulation, sensitivity and local oscillator noise performances are so very poor. Yaesu have been informed of my criticisms and have promised to look into the matter,

but surely they must have been aware of the set's deficiencies.

After I'd had a good moan about the first review sample a second one arrived from Alec, which proved to be a few dB better at 433MHz but was actually worse at 144MHz than the first sample, so it seems you cannot win.

We took very many sensitivity readings right across the frequency range, and many of them were considerably below specification. For example, the FM sensitivity around 433MHz of the first sample was some 10dB worse than spec, the specification itself being fairly poor. To overcome this you could put a broad band RF pre-amp in front, and I tried a number of these made by muTek, Datong and Packer. Indeed, the sensitivity improved more or less by the gain of the pre-amp, but of course the intermodulation performance was so severely degraded as to make the receiver almost unusable on several of the bands which contain strong signals amongst weak ones.

It strikes me that the front end is little better than the poorest typical ITV tuner types, and a hot TV front end would have been a lot better. This is not the right way to design a front end though, for what we really need are some switched front end very low noise pre-amps covering various frequency ranges, followed by a very good ring diode passive mixer feeding a very high frequency IF, which has a narrow roofing filter mixing down to a much lower frequency for the main amplification.

In these days of microprocessor controlled synthesisers it should be possible to design one to give a mixer feed of +10dBm (around 700mV), the injection level not varying much over the total frequency range. A front end such as I have described should give an overall sensitivity equivalent to the very best 144MHz FM black boxes, and what a

receiver this would then be.

Even so, there is a lot of fun to be gained from playing with this receiver and I have to emphasise that it is only because my standards are relatively high that I have been so critical. I suggest that you compare one of these receivers with the AOR2001 and a newer one which has just been announced, which incidentally is not the same as a much older model made by AOR for Regency, which also employs the very poor membrane type keypad.

## Laboratory tests

In the lab we checked the performance with the normal signal generator/analyser equipment that I use regularly for transceiver testing. FM sensitivity varied from an appalling -103dBm (1.6µV) at 433MHz to -120dBm (0.22µV) on 2m. At the top end of the range the sensitivity was only slightly better than at 433MHz and far below what it should have been. Curiously the SSB sensitivity at 144MHz measured quite well, certainly as good as average black boxes on the band.

The reciprocal mixing ratios at spacings close in to the wanted signal were very poor indeed, typically perhaps 20dB worse than a synthesised 2m rig, but at 1MHz and more distant spacings the measurement was very satisfactory. We used the Thorpe method for measuring the RF intercept point, for the normal methods gave ridiculous readings because of the dreadful local oscillator noise problem.

What can I say about a rig that gives measurements inferior to the poorest handhelds! It should have been possible for it to have been at least 20dB better and this is therefore a serious failing. Even the Thorpe method was unusable very close in because of measurement problems! There were indications, however, that the blocking performance was not too bad.

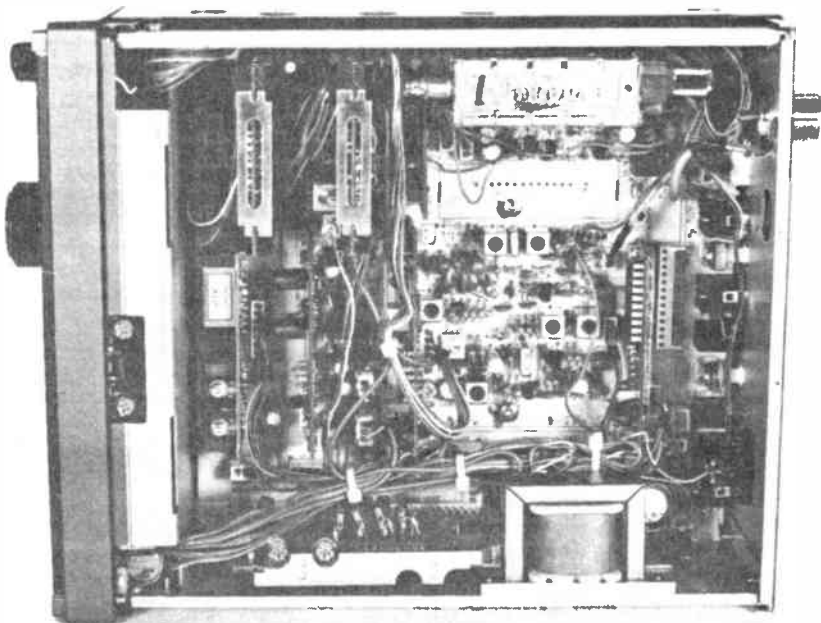



# G3OSS TESTS

We had a look at the SSB selectivity and found that the filter top was very broad, more so than the specification would suggest. 3.6kHz bandwidth for 6dB down is some 50% wider than it should have been. The 60dB selectivity was quite acceptable, though, showing reasonably good rejection of strong adjacent channel signals, provided these had not already demolished a weak wanted signal because of the reciprocal mixing problem!

The S-meter always showed at least an S1 signal and it only required a 9dB increase in RF level to go from S2 to S9 on SSB. Surprisingly, however, it showed more willing on FM, the same points requiring a lift of 26dB! For all the LEDs to come on required only 30µV on SSB, but a massive 11mV on FM – some signal! The SSB product detector distortion was poor, whilst NBFM discriminator distortion was tolerable. Wide band FM was rather poor, but the main problem here was that the de-emphasis was 75µS rather than the 50µS curve that is required in Europe. The antenna attenuator gave 23dB attenuation at 144MHz and I cannot see any point in attenuating an already insensitive rig. AM distortion was acceptable at middle frequencies and actually somewhat better than that of many other Japanese rigs, but the AM narrow selectivity created extremely muffled reproduction, although wide was quite reasonable. Low frequencies, however, produced quite bad audio distortion.

The rig gave an output of 1.8W for 10% distortion into 8 ohms, which is just about adequate, 2.4W being available into 4 ohms. A frequency error of 1.6kHz was noted at 144MHz on SSB, showing that the synthesiser crystal had not been set up too well. We took many measurements on the second sample, which was equally unsatisfactory, the average sensitivity being about the same, although not sinking to such low depths at 433MHz.

## Conclusions

I have to write that I am bitterly disappointed with this rig, which showed such promise when I first became aware of its facilities. If you are prepared to put up with all its deficiencies then I suggest that you could try one, but my advice is to wait a few months to see if Yaesu can get their act together and produce samples which can at least come up to specification, and hopefully surpass it. In the meantime it will be worth waiting for the new AOR model, which will have an extended coverage to 1.3GHz but exclude a chunk of frequencies between 550 and 800MHz approximately.

I would like to thank Amcomm very much indeed for their great help in providing both samples. They have promised to let me try one again if the performance eventually settles down to an acceptable one. Thanks also to Jonathan G1LMS for taking many of the measurements, and to Nigel G1LSA for helping me with many of the tests.

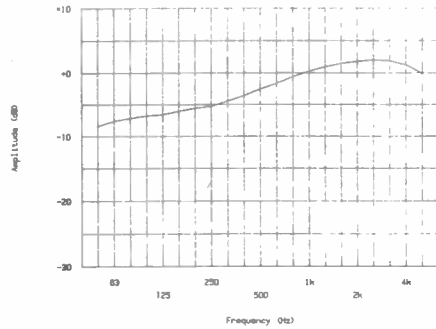

FM received audio response with 750µS pre-emphasis

AM received audio response

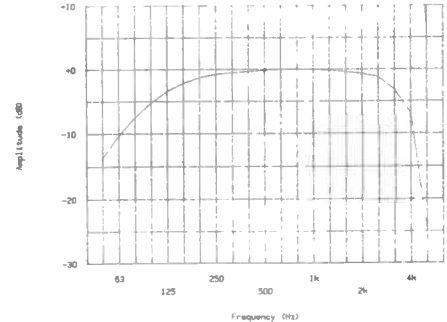

## Yaesu FRG9600 Laboratory Results

ALL RESULTS ARE FOR THE 144MHz BAND UNLESS OTHERWISE SPECIFIED

### Receiver results

Sensitivity NBFM for 12dB sinad result:

|            |         |
|------------|---------|
| 900.5MHz   | -105dBm |
| 600.5MHz   | -110dBm |
| 433.5MHz   | -103dBm |
| 300.5MHz   | -116dBm |
| 144.825MHz | -120dBm |
| 117.5MHz   | -115dBm |
| 100.5MHz   | -113dBm |
| 84.5MHz    | -117dBm |
| 60.5MHz    | -118dBm |

Attenuator

23dB

Sensitivity

SSB for 12dB sinad

-123dBm

144.3MHz

Selectivity

SSB, bandwidth for given level drop

3dB; 3kHz

40dB: 4.6kHz

6dB; 3.6kHz

60dB: 4.7kHz

RM ratio, SSB

105dB

+1MHz spacing

71dB

+100kHz

62dB

+50kHz

56dB

+20kHz

56dB

+10kHz

55dB

+5kHz

S-meter

FM

SSB

S1

always on

always on

S2

-99dBm

-96dBm

S9

-73dBm

-87dBm

Max LEDs

-26dBm

-78dBm

SSB product detector distortion

4.5%

FM audio distortion at 3kHz deviation

2.9%

AM distortion

AM narrow

AM wide

3kHz @ 90%

-

3%

@ 30%

-

3%

1kHz @ 90%

2.2%

1.9%

@ 30%

2.7%

3.5%

300Hz @ 90%

12.7%

13%

@ 30%

15%

16%

100Hz @ 30%

39%

-

Calculated intercept point

Thorpe method

+100/+200kHz spacing

-34dBm

+50/+100kHz

-34.5dBm

+20/+40kHz

-36.5dBm

+10/+20kHz

-35dBm

Size 180(W) x 80(H) x 220(D)mm

Weight 2.2kg





# R WITHERS

584 HAGLEY ROAD WEST, OLDBURY,  
QUINTON, B68 0BS BIRMINGHAM.

M5  
JUNCT  
3



BIRMINGHAM  
MAJOR INDEPENDENT  
SERVING THE UK

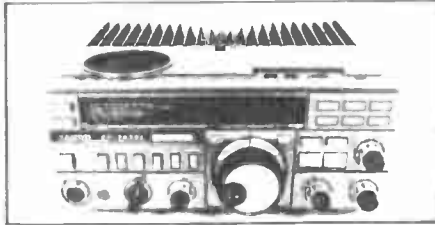

AN HF BEST  
SELLER  
FT757GX

\* 100 Watt multimode \* AM, FM, CW, SSB  
\* Gen coverage RX \* Computer compatible.

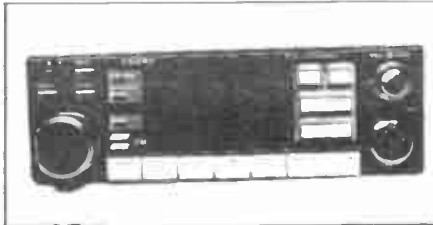

THE ULTIMATE  
2mtr/70cms  
MOBILE  
FT2700RH

\* Full duplex \* A big 25 watts on VHF/UHF.  
\* 10 channel memory \* Scanning \* LCD display/'S' meter

**NEW PRODUCTS EXCLUSIVE TO R.W.C.**

## RAYCOM MODULAR RF AMPLIFIERS

A complete range of linear and fm amplifiers for use with both VHF and UHF hand portables and multimode portables such as the YAESU FT290R and FT790R. Power output from 15W to 45W depending on model, (eight are available). All units feature Mitsubishi or Toshiba power modules as used in the majority of mobile and base radio transceivers. Two versions are also available for business radio applications.

PRICE from £39.50 for the 15W vhf model - £2.00 post

### UHF UNITS (430-440MHz)

| ORDER CODE       | PRICE  |
|------------------|--------|
| 25W FM CW        | £79.50 |
| 15W FM CW SSB AM | £89.50 |
| 15W FM CW        | £89.50 |

(FULL RANGE OF POWER MODULES IN STOCK)

### VHF UNITS (144-149MHz)

| ORDER CODE      | PRICE  |
|-----------------|--------|
| 45 FM/CW        | £82.30 |
| 35 FM/CW SSB AM | £59.50 |
| 25 FM/CW        | £48.50 |
| 15 FM CW SSB AM | £49.50 |
| 15 FM CW        | £39.50 |

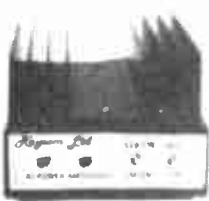

## 10 Mtr MOD BOARD

PRICE  
£22.50

+ £1.00 post free  
packing. Kit now  
available at £17.50



This is a complete modification board designed to fit all CB radios that incorporate the SANYO LC7137 series of synthesizer chip, the unit comprises of a small pcb with six microchips and fits almost all current legal (CB 27/81) radios, the unit is supplied with full fitting instructions and can be fitted easily by most enthusiasts, with the current upsurge in interest in this band demand has been high as this means that over 90% of current CB radios can now be used on 10 mtr amateur band. See other ads for more information. Over 300 sold in 2 months! Complete radios available & other kits.

We also sell and service Cellular Radio, and PMR (Business) radio equipment.

Tel: 021 421 8201 (24hr answerphone)

Telex: 334303 G TXAGWM



NEW EXCITING  
DUAL BANDER

IC3200E



\* Simplified front panel \* Simplex/Duplex memory  
\* Built in duplexer \* Smallest in its class



THE HIGH-TECH  
ALL BAND  
HF TRANSCEIVER

IC745



\* 16 tunable memories \* Gen coverage RX  
\* Scanning \* Deep IF notch filter \*

*Raycom Limited*



## A.R.M. MULTI P6 ANTENNA

Probably the most versatile  
Antenna ever designed

PRICE £39.25  
+ £2.50 carriage

This is one of the most exciting new products to be launched by RWC and is the result of many months of development by Antenna Research Manufacture based in Devon. The antenna has been designed to meet the growing popularity in multimode portable and mobile operation and is capable of being used on both vhf and uhf in both horizontal and vertical polarization modes, both portable and mobile. The antenna has the facility of being used as both omnidirectional modes as well as having capability of DF function. No ground-plane or radials are required and the antenna can therefore be used in a variety of applications on frequencies between 140-450 mhz. Colinear elements £4.75.

\* SEE THE REVIEWS \* or SAE LEAFLETS

## ANNOUNCING THE SUPER YAESU FT757GX - MOD BOARD UNIT from Raycom

- The modification serves two major purposes
- (1) to improve VFO tuning and eliminate 'TUNING GLITCH'
- (2) to increase tuning speed from 5khz per dial revolution to 50khz per dial revolution (selectable on the 500khz step switch)
- UK price is £29.50 for the built and tested pcb with complete fitting instructions and £39.50 plus carriage for a unit factory fitted and tested. Instant fitting service available. Phone now.

**£1000.00 instant credit available  
for licensed amateurs. Details upon  
request. Call now!**



HP/PERSONAL  
LOANS AVAILABLE  
(written details upon request)

**RWC CREDITCARD**

# SHORT WAVE LISTENER

TREVOR MORGAN GW40XB

Before carrying on with this month's column, I really must apologise for the abrupt ending to last month's offering. I was on the short list to enter hospital and had the admission notice as I was getting the article ready, so I had to rush things a bit.

Anyway, looking through it it's not too bad, but if you have any queries regarding the ATU feature please let me know.

Letters and entries for the *Prefix Awards* continued to sail in while I was away and I've had some catching up to do, but now I'm up to date again and letters are replied to by return of post.

Lots of enquiries have arrived regarding the Spectrum interface. I have had copies of the rewritten article made and this is available from me for an SAE.

## What an interesting batch

So to the mailbox... and what an interesting batch we have too.

Eric Parkes from Barnsley makes the comment that a lot of listeners (and licensed folk) are unemployed or retired etc, and because they can't afford those all singing and dancing black boxes have to make do with £50 second-hand rigs. He requests more information about the AR88s and how to fit accessories to rigs of that ilk.

Point taken Eric, but as I have said previously, there are others writing for the magazine who are doing a fine job with the older equipment (such as Hugh Allison with his *Secondhand* articles) and as I have had very little experience with valve type receivers I would not attempt to advise others.

Having made that statement, there are some excellent solid-state receivers around at that sort of price and a Lowe SRX30 with analogue scale was seen recently for £60, a Realistic DX160 plus

ATU and digital readout for £75, Trio JR500 for £50 etc. If you want to try homebrew there are some nice kits available (see later) at reasonable prices and you can improve or add to them as you go.

## Well used if not clapped out!

The AR88s and Eddystones were fine receivers, and many of them still are, but a lot of those coming onto the market are often well used, if not clapped out! If you've got the knowledge and skill to repair one, why not build your own?

So having said all that, up comes Philip Davies from Market Drayton with an award claim heard with an Eddystone 840A! Philip uses a folded dipole for 15 metres tucked away in the loft!

Next, a letter from John Jordan in Sheffield mentioning his bargain buy which got him interested in SWL. The receiver is a Skywood CX203 and John would be pleased to hear from anyone with any experience of this receiver. Anyway, he seems to be enjoying his new hobby using a long wire and hopes to get a G5RV up when the weather breaks.

## The old joystick

CH Fern wrote from Derbyshire about the old joystick antenna. He uses one in his flat and finds it most useful as he can't put up wires. These antennas were made by a company unfortunately now extinct, but an indoor antenna is still offered in design form for DIY by G2VF. An active antenna is available from Datong, among others, and Radio Nederland issue DIY plans amongst their excellent listeners' aids for an active antenna, so the flat dwellers are catered for.

Over to Eddie Brown in Wellingborough who asks about plotting his prefixes. The RSGB does a nice Amateur Prefix/Zone Map for

£2.53 and an up to date prefix list is available from Geoff Watts. The new Maidenhead locator maps are also useful and are well worth looking for.

Goff Curtis (not Geoff - sorry!) in South Harrow looks forward to working the new bands and hopes to hear more amateurs on them than at present. Goff listened intently recently when a 'no call-sign wallah' was being hunted by all and sundry. He was hoping for a long awaited Clipperton contact, only to find out, eventually, that it was DL8YR/ST2!

As he says, it's damned annoying when stations call 'QRZ' with no call-sign for 20 odd overs.

Goff also mentions his lively tape correspondence group, exchanging information and experiences using open reel tapes at 3 $\frac{3}{4}$ ips or cassettes. Listeners are welcome. Write to Goff at 45 Holyrood Avenue, South Harrow HA2 8UD.

## Who needs technical innovations?

A nice letter from John Gomer G8UNZ mentioned my write-up on receivers some months ago and he agrees that, although the amateur brands have all the technical innovations, many of the 'high street' receivers are quite excellent in use and sell at reasonable prices.

As I have often said, you don't need a Rolls Royce to get to the beach - it's just a bit more comfortable and a lot more expensive! And if you disagree with that just have a chat with Rev Dobbs and Co!

An enjoyable letter from Owen Cross (chairman of vice at the Cray Valley RS). They won the HF Field Day contest last year on SSB and were, in fact, the first G station to win it. Well done lads!

The Cray Valley RS 15th SWL Contest is being held on 7 September 1985 at 1800GMT until the same time on the 8th.

There are SSB and CW sections and 160, 80, 40, 15 and 10 metres can be used.

Log sheets and rules are available from: *Owen Cross G4DFI, 28 Garden Avenue, Bexley Heath, Kent DA7 4LF.* Please send a large SAE. Let's see a good entry from our readers this year!

## Prefix awards

On to the *Amateur Radio Prefix Awards*, and first on the list this month is Eric Parkes of Barnsley with his claim for a Bronze award which includes an XYL in VU2, 3B8, 5H3, AP2, 9Y2 and VQ9, to mention just a few.

S Lipscomb in Kings Lynn offered A71, A92, HH7, VQ9, ZC4, ZP5, and 9Y4 amongst his claim for Bronze heard on bands from Top Band to fifteen - just shows that they're there if you listen!

Charles Morgan of Croydon used his Eddystone 840C to good effect for a Bronze claim which included an FE running portable in TK land, a JA2 maritime mobile, a Canadian in 4U, ZB2 and ZZ5 to round it off.

KA Forward of Bognor Regis sent in 329 to make sure of the Bronze, including some nice ones from A92, AE4, DJ0/C6A, OE3/YK (a few lads had him), YT3, 4B3 and a mixed grill for the rest.

Next on the list this month is Gary Lee Hendricks in Letchworth who sends in a cracking list for the Gold award. His 1000 plus came neatly entered in a fourteen page book!

## Wires, loops and verticals

Gary's hunting was done using a Racal RA17 with FR101s as back-up and a multitude of antennas ranging from the old 5RV through to wires, loops and verticals. That's the way to catch 'em! CE2, CP8, D44, HL1, 8Q7, J73, J28, PJ2, P29, S83, TZ6 and ZD7, to name just a few of the choice catches in the list.



Jon Sales, now G0AZJ (congratulations Jon), is still waving the wires around and submits his 500 for the Silver to add to his shack decoration.

With 5H3, VP9, P29, 8P6, 8R1, J37 and 7S7 for starters and a nice collection of specials to make the number up, Jon comments on the drop-out of the bands for over a week. According to the reports, we're not at the bottom of the trough yet either!

Don Hollingsworth of Seaford submitted his first list for the Bronze, worked with a Yaesu FT200 feeding a half size G5RV, under G0AMH. Congrats on the new call Don.

It's a different kettle of fish working them if there's a pile up, but nevertheless Don submitted a good mixed bag including a nice collection of specials with LY4, VP9, YT3, 6W1, 7S0 and 5B4 thrown in for good measure.

John Simpson in Macclesfield used the award scheme as an excuse to dust off the FRG7 and strung out a 60 footer to capture his first 250. Not satisfied with run-of-the-mill SSB, John got his Vic 20 to work on RTTY to bag a few as well. Starting the list with A4X he neatly caught BY2, J37, J87, VQ9, VS6, YB5, YT6, 3A2, 5H3, 5T5 and 9N1 amongst the crowd.

Just pausing for a commercial to say that Geoff Watts' prefix/country/zone list is now backed up by an oblast list for those chasing Russian districts.

It's only 35p (the PCZ list is £1) and can be obtained from: 62 Belmore Road, Norwich NR7 0PU.

From Folkestone, Mike Hudson offers his Bronze claim which includes 5N8, A4X, AP2, HZ1, YB4 and ZC4 for starters and a nice mixed bag heard from 80 to 15.

### Just shows what can be done

Finally for this month, M Moss, RS86999, sends his Bronze claim commenting that he only had a DCRX on twenty until 15 March (note my previous comments about simple receivers) when he invested in an FT101E for future use. With A4X, JA2/MM, PP7, VE7, XT2, 5B4, 6Y5 and plenty of other nice

catches, it just shows what can be done with the simplest of receivers and a bit of wire.

The licensed fraternity have been kind to listeners during the D-Day celebrations and many special call-signs were to be heard in Britain and the USSR, with others in various countries giving us a nice selection of prefixes. The British GV series was operating throughout the D-Day week and an award was available for hearing GV0ISO, GV2ISO and GV4ISO, plus a number of service connected stations. Unfortunately, I didn't get GV4ISO but was informed that it was on regularly. That's the luck of the game.

The Russian stations are, I believe, on for the year so there are plenty of chances to work them as well as getting a few oblasts onto the list.

I'd like to run a series on the listeners, with your help of course. The idea is to present a small piece on a different listener each month with a picture of him or his shack with a brief outline of his listening history. If you would like to take part in this, could you let me have a clear picture (black and white or colour) and details of you and your station. I'll pay for each one published too!

### Remember the wood and wire constructions?

Now for the next set listening period. As you remember, we had an SLP for the new WARC bands in July. The 17 and 18 August are the dates and the times are from 0800 on Saturday to 2359 on Sunday.

We shall be interested in the activity on 10 metres this time so this is a chance to try out homebrew beams and suchlike which are easier to construct for this frequency.

Some of the old timers may remember the wood and wire constructions that had their devotees a few years ago. I had a lot of fun playing around with bow-tie monobanders and VK2ABQs. They're easy on ten as the dimensions are reasonable and the materials are cheap. Delta loops are a good bet on any band but on ten a two or three element job is feasible. *Simple Low Cost Wire Antennas* is a handy volume to have in the listen-

er's shack (RSGB...£6.83).

I mentioned earlier simple receivers and the building of the same. Well just before I went into hospital I received a Howes Communications DCRX kit which, while not the simplest receiver I ever built, is a very nice little direct conversion receiver and gives the newcomer to homebrew a chance to get on the listening game without spending a fortune, and learning a bit about construction into the bargain. I ordered the kit as part of their complete transceiver project but I'll only go through the receiver here.

### DCRX kits simple to construct

The Howes DCRX kit comes complete except for a couple of tuning capacitors, case and knobs. Suitable capacitors are available at £1.50 each and it's left up to you how big you build the finished article. Some prefer a fair sized cabinet for shack use while others may prefer a compact receiver for portable use. The circuit board is only 2½ inches square so it will go into a very small case.

The instruction sheets supplied make construction simple to follow and full details of the colour coding of the resistors and the markings on capacitors are given in the order in which you solder them to the board, which in the latter case saves you hunting around for references to identify components. Unless you were an experienced constructor you probably wouldn't know that a 0.01µF capacitor was marked 103Z or a 0.1µF was marked 104K.

All the coils (three of them in the 80m version) are pre-wound and the leads are clearly marked on the sheets, as are the pins of the transistors.

Following the instructions, you simply solder the components to the printed circuit board which, incidentally, has the positions of each component clearly marked on the non track side, in the order given.

Once you have soldered all the board mounted components into place, you check the track side of the board for

good solder joints and to make sure there are no bridges across the tracks. Adding the external components, such as the tuning capacitors and volume control etc, is clearly explained in the text.

### Tuning up

There just remains the tuning up of the receiver which can be done using another receiver by linking the antenna sockets and calibrating the tuning scale using a crystal calibrator.

The DCRX is very easy to construct and is extremely well presented making it a pleasure to build, especially for the newcomer to construction. There's no need to buy an expensive box, but if you wish you can make a plush job of it. It comes in three guises for 20 or 30m, 80m or 160m, which makes it handy for those with older receivers not having 30m or more modern receivers lacking Top Band.

How well does it work? Well, as I said, my version is part of the transceiver and I haven't finished the job yet, but it's looking good so far. However, to get a fair report on performance, let's look at the Bronze award claim by Martin Moss RS86999.

### Good going by any standards

Using the DCRX, Martin heard 112 prefixes and nearly 30 countries in just two months! As Martin works some awkward shifts his 'air' time is limited but that's good going by any standards.

Obviously a good little performer, I thoroughly recommend the DCRX to anyone who wants to get some listening in at little cost and do some solder bashing for the first time.

The DCRX kit costs £14.80 (or £19.90 assembled), so you can get into the hobby for less than £25! Available from: *Howes Communications, 139 Highview, Vigo, Meopham DA13 0UT*. My thanks to Martin for his unbiased report on the receiver.

Well, that's it for this month. Next time we'll look at some more awards and some different antennas to try. Good listening!

# C. M. HOWES COMMUNICATIONS

139 Highview,  
Vigo, Meopham,  
Kent DA13 0UT  
Tel: Fairseat (0732) 823129

**FUN TO BUILD KITS BY MAIL ORDER**



## FANFARE FOR NEW GOODIES!

**DcRx40 DIRECT CONVERSION RECEIVER** kit £14.80. Assembled PCB £19.90  
**CTX40 LOW POWER CW TRANSMITTER** kit £12.95. Assembled PCB £18.95  
**CVF40 EXTERNAL VFO** for DcRx and CTX40 kit £9.30. Assembled PCB £14.90

We are pleased to announce that we now have 40 metre band versions of our popular DcRx receiver, CVF external VFO and CTX transmitter. The 80M versions of these products have proved to be very popular indeed, so we have decided to add 40M versions to our product range. 40 metres is a great band for QRP (low power) CW working – a little goes a long way! Just listen to the huge signals surrounding the band under night time conditions, you can be many, many dBs weaker and still be S9! Fortunately, you can still find a space for CW working without too much trouble. We supply a crystal for the QRP calling frequency (7030kHz) with the CTX40 kit, but you can add the CVF40 VFO to give full band coverage if you wish. The CTX40 has adjustable output power, up to about 3W RF. All the kits will work from a 12 to 14V DC supply. You can use our new 40M kits on their own, or combine them to form a super little transceiver. They all have the usual HOWES features of course – easy to build – good quality parts – clear instructions.



Drop us a line enclosing an SAE for more details about any kit.  
 Delivery is normally within 7 days.

**PLEASE ADD 60p P&P to your total order value**

73 from Dave, G4KQH

# P.M. ELECTRONIC SERVICES

2 ALEXANDER DRIVE, HESWALL, WIRRAL, MERSEYSIDE L61 6XT  
 Telephone 051 342 4443 Telex 627371

## THE QUARTZ CRYSTAL SPECIALIST

AMATEUR RADIO CRYSTALS FROM STOCK

4m, 2m, 7cm and transverter/converter

**MICROPROCESSOR** from **MARKER**  
**CRYSTALS** stock **CRYSTALS**

DOUBLE BALANCED MIXERS M8 and M18  
 PIN compatible with MD108 and SBL1  
 but with superior spec available from stock.

WE CAN SUPPLY CRYSTALS TO MOST  
 COMMERCIAL AND PROFESSIONAL  
 SPECIFICATION INCLUDING COLD  
 WELD SPECS.

CRYSTAL SOCKETS for HC6/u, HC13/u  
 and HC25/u

### MADE TO ORDER SERVICE

OVER FREQUENCY RANGE 6KHz to 250MHz with  
 express service if required  
 For full details of the above services,  
 please send s.a.e.

SPEED CONTROL KIT FOR MINI-DRILLS includes completely assembled control unit in smart box with room for transformer. The only connections to make are 2 wires to a suitable transformer. The control unit will handle 2A continuous, 3A intermittent. £4.50  
 TRANSFORMER for above, 15V, 1A continuous (1.5A intermittent) for smaller type drill. £2.90  
 Brand new stock. The complete controller is advertised by major manufacturer for over £20!

HIGH TORQUE MOTOR FOR MINI DRILLS 12V to 18V, 40W 1000 rpm per volt, 5 pole rotor, Carbon brushes, 50x28mm dia, £2.90 (Fits any 35mm plastic film container!)

CHUCK & SET OF COLLETS to 2.5mm for above motor to make an inexpensive drill for PCB work. £2.00

HSS DRILL BITS WITH SHANKS 1.0mm-5 bits for £1.50 0.8mm or 0.6mm-5 bits for £2.50 or 2 of each size (8 bits) for £2.50 (Not recommended for glass fibre PCB)

COPPER CLAD s/s paxolin, 4 pieces (total 100 sq ins) £1.00

FERRIC CHLORIDE to make 500ml £1.10

CHARTPAK etch resist transfers, 1 sheet each (total 4) light & heavy lines, curves & dil pads £1.50

ETCH RESIST PENS (High quality pk of 2, fine & broad tips) £1.50  
 or 3 pks £4.00

NI-CAD RECHARGEABLE CELLS – AA – HP7 pack of 4, £1.50  
 or 4 packs for £5.00 Ex equipment, tested & guaranteed 500mA Hr, Bargain! NI-CAD CHARGER & 4 AA cells + holder. £5.00

ELECTRET MIC INSERTS 9mm dia x 6mm with integral amp. Requires normal 1.5V £1.10ea or 6 for £5.00

PRECISION THERMISTORS 5 types, any mix for £2.00 Approx resistance at 20 degrees C, 5MΩ, 1MΩ 300K 100K & 1KΩ

Please add 80p P&P per order  
 Many other items for callers or send sae for stock list  
 Goods normally sent by return

**CROYDON DISCOUNT ELECTRONICS**  
 40 Lower Addiscombe Road  
 Croydon CR0 6AA.  
 Tel: 01-688 2950

### EVERYTHING FOR 10 FM

**WANTED URGENTLY!**  
 2nd hand VHF+HF equipment, part X welcome

**SOUP OF THE DAY**  
 Lucas 10M FM RIG  
 Only £45.

### RAINBOW COMMUNICATIONS

68  
 Gorringe Park Ave  
 Mitcham Surrey

Ask for  
 Howard (G4VWR)  
 or W:N (xxxxxx)  
 01-640 1904

**OPEN TILL 8PM MON-FRI**

**SOUTH LONDON'S BUSIEST EMPORIUM**



# Operating in Scandinavia

The experiences of Mike G4ROM,

Khee G5MUR and Will G6TXA

The summer of 1984 saw Mike G4ROM, Khee, then G5MUR, and Will G6TXA embarking on a tour of Scandinavia by train. The countries visited were Denmark (OZ), Sweden (SM) and Norway (LA). Our train tickets were valid for one calendar month of travel throughout the rail network of Western Europe but work commitments dictated that we use up only three weeks of the month. Originally, plans were made to visit Finland (OH) as well, but they had to be dropped because of the lack of time.

What a super idea to be able to operate amateur radio from all the exotic Scandinavian locations that we were going to visit, we thought! Language problems? It is a well-known fact that English is widely spoken in the Scandinavian countries and this was proved to be correct later on.

## Limited

The amount of radio equipment that we could take was limited by the weight penalty that was imposed, and the amount of space available in our rucksacks. It is a well-known empirical fact that the weight of a rucksack increases with travelling time! Also, three weeks was a rather long period of time. Space was rather limited after the rucksacks (they were supposed to hold 60 litres each) had been filled with the essentials – clothing, sleeping-bags and photographic gear (photography being another interest that we share).

Therefore we decided to limit our radio gear to 2m hand-held transceivers and as few accessories as possible. The transceivers that we eventually took along were an Icom IC2E, a Yaesu FT203 and an FT208. The accessories were speaker microphones (which made operating and walking around with fully laden rucksacks more tolerable), a spare battery pack each, a battery charger and a multi-standard mains plug adaptor. A Sony ICF7600D with a long piece of wire was also taken along to monitor the amateur HF bands and for reception of the BBC World Service.

The application process for our reciprocal licences started about eight weeks before our departure date. We wrote to the RSGB for information regarding reciprocal licensing in the four countries that we wished to visit. In reply we received a computer listing of all the information they had, together with copies of the application forms from the respective licensing authorities. The information from the RSGB proved to be mostly accurate and we had no problems

with the licence applications, with the exception of Finland.

Our applications for Finnish reciprocal licences were returned to us with a letter from the licensing authorities saying that they only issue reciprocal licences for fixed station operations. This proved to be rather fortuitous as we had to drop Finland from our itinerary later on.

The nature of 2m operation in the countries that we visited proved to be very different from what we were used to in the UK. Owing to the sparse population, outside the major cities most QSOs on the band were through the extensive network of repeaters. There was no formal channelling system in the simplex portion of the band, with only 144.300 and 145.500MHz being designated as the SSB and FM calling frequencies respectively.

We only had a few simplex contacts and heard only two SSB contacts during the three weeks of travelling. However, the fact that we were only equipped with low power hand-helds with 'rubber-duck' aerials must be taken into consideration. Furthermore, little operating was done while we were travelling in the trains, even though it was not specifically prohibited in all three countries.

## Denmark

The first country that we visited was Denmark. The information that we received from the RSGB stipulated that there is no Danish licence which is equivalent to the British class B, so only G4ROM applied for a Danish reciprocal licence. It was only later when the licence for G4ROM/OZ was received that we discovered from the schedule that the Danish class D licence was equivalent to a British class B licence. The classes of Danish licence (there are four) and their technical and Morse code requirements are given in *Table 1*.

To obtain a Danish reciprocal licence, the completed application form (a copy of which is available from the Membership Services of the RSGB or direct from the Post og Telegrafvaesenet), together with a photocopy of the front page of one's licence and a letter from the RALU to confirm its validity, must be sent to the Post og Telegrafvaesenet. The RSGB recommended that we send our applications two months in advance. However, the licence for G4ROM/OZ arrived within a week of posting off the application.

The licence fee of DKr20 had to be paid by means of a Bank Giro transfer (similar

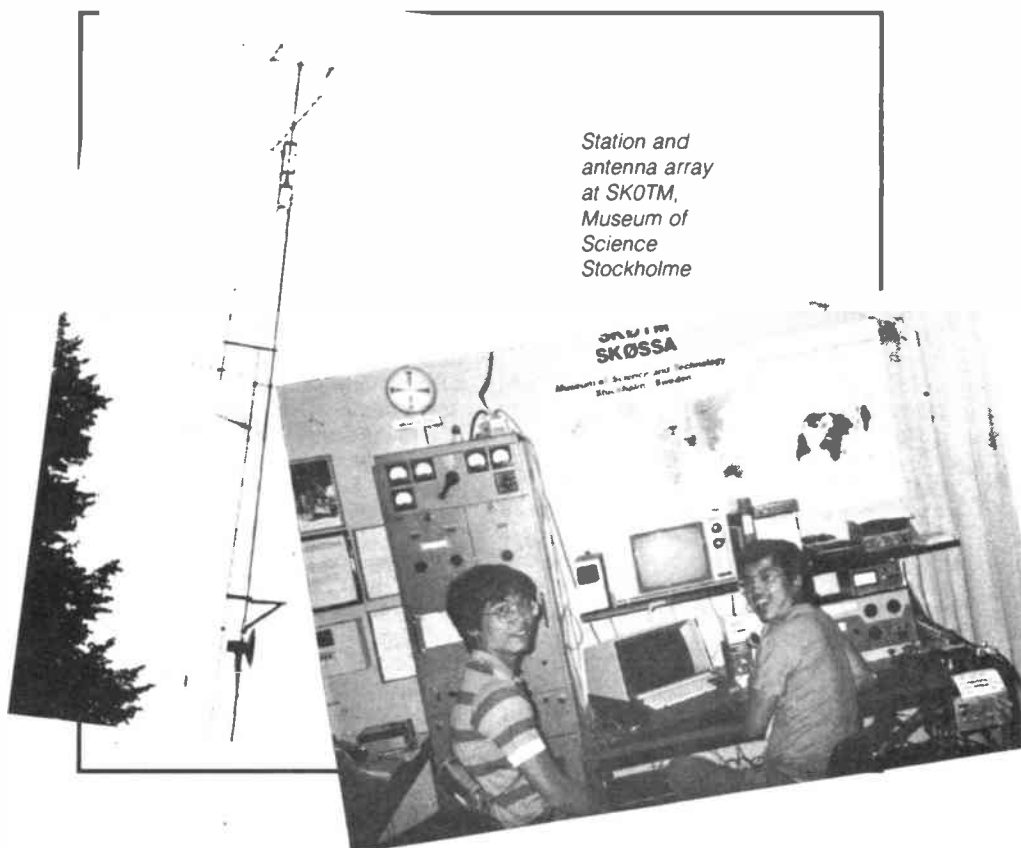

# OPERATING IN SCANDINAVIA



to the Bank Giro system here) upon arrival in Denmark. The Danish licensing authorities did not require a fixed address to be specified as the station address. The address of G4ROM/OZ was stated on the licence as 'mobile', because we were not sure where we would be staying in Denmark at the time of application. The reciprocal licence was valid for a period of up to three months.

Besides /M, operation as /A and /P are allowed along the same terms as the British licence. /M operation is also permissible from 'Private aeroplanes under visual flying conditions or in pleasure crafts'. The /MM prefix is only issued on special application together with the written approval of the shipowner. Unlike the British licence, where there is no mention of the language in which a QSO may be conducted, the Danish licence only permits Danish, Faroese, Greenlandic, Norwegian, Swedish, English, French, German and Spanish to be used.

Table 1 lists the bands and maximum power levels that are available to the different classes of licensees. There is no mention of the bands above 70cm, because a special permit has to be obtained to operate on the amateur bands 1.2 to 24GHz. Details of '... the nature and extent of experiments desired...' must be included in the application.

Copenhagen is a remarkably peaceful and relaxed city with none of the hustle and bustle of other major European capital cities. The only danger to the tourist on foot would be the cyclists. There are cycle lanes on all the main roads next to the pavement. We were nearly run down by cyclists a few times

while crossing the roads and alighting from buses.

We found operating 2m in Denmark, or to be more specific Copenhagen, rather disappointing. There seemed to be very few stations on the band, so few in fact that most stations did not bother to QSY from the calling frequency after establishing a contact. The scarcity of activity might partly be due to the fact that it was peak holiday season at the time of our visit, late July 1984. Furthermore, we were only in Denmark for three days and most of the time was spent in Copenhagen.

The repeaters that were accessible from Copenhagen on a 2m hand-held were OZ3REU on R3 and OZ9REE on R4. All Danish repeaters have the call sign OZ★R★ and most of the activity on the repeaters was from mobile stations going to and from work, with some fixed stations later in the evenings. We may have got a distorted picture of 2m in Denmark, after all, a visitor to this country working through the 2m repeaters in London would receive a bad impression of 2m operating in the UK!

The address of the Danish licensing authority is: *Post-og-Telegrafvaesnet, Radio Tilladelsessektionen, Islands Brygge 83C, DK-2300 Copenhagen S.*

## Sweden

The next country on our itinerary was Sweden. As in Denmark, there are four classes of amateur radio licences and the details are given in Table 2. From the table, it would appear that the nearest Swedish equivalent to a British 'B' licence is a class T. In practice however, the British class B licensees of our group were issued with Swedish class B reciprocal licences, thereby allowing

them to operate HF, albeit only on 10m. Later on we were told by Swedish amateurs that this is a common practice.

The suffixes /A and /P are no longer used in Sweden. When one is on the move then the appropriate suffix is /M, whether in a vehicle or on foot. When on board a vessel, however, the appropriate suffix is /MM. Instead of signing /A, a Swedish licensee signs /n, where n is the number of the radio district (see Table 3) in which the station is temporarily located. Similarly, a reciprocal licensee signs own-call/SMn.

The reciprocal licence is valid for a maximum period of three months in any twelve. A copy of an application form is available from the RSGB. The other documents that the Televerkets Radiodivision require are a copy of the front page of the home licence, proof of its current validity and a letter of good conduct either from the RSGB or the local police. At the time of our application, the licence fee was SEK80 and, like that for Denmark, was paid by Bank Giro transfer on our arrival in Sweden.

## Liberal

The Swedish licensing regulations are far more liberal than those of Britain. For example, anyone is allowed to operate the station as long as the licensee starts and finishes the QSO and is on hand to supervise. The Swedish licence permits /MM operation on board a ship or a private craft without a special licence, unlike the British licence. All that is required is the consent of the captain or the owner of the ship or craft. Operation on board public transport is also permitted.

Basically, amateur radio operation is allowed anywhere, as long as no interference is suffered by other users of the radio spectrum. These interesting items of information were not included in the rather brief booklet entitled *Memorandum on the rules applicable to amateur radio activities on the part of foreign nationals in Sweden* which was enclosed with our reciprocal licences. We only found out about them from the Swedish stations that we spoke to over the air. It seemed rather odd that a full English translation of the provisions of the Swedish amateur licence was not sent to us.

There is an extensive 2m repeater network in Sweden, from the southern tip to inside the Arctic Circle. In general, the remoter the location of the repeater, the more basic is its control logic. One repeater that we operated through while we were in the Arctic Circle was carrier accessed, as opposed to the more usual toneburst accessed machines elsewhere.

In Gothenberg, we could access three repeaters: SK6RFQ (R2), SK6RLV (R4) and SK6RKI (R6). SK6RFQ had a very fascinating control logic. A toneburst followed by audio within 15S was required to access the repeater. The maximum duration of the first over was 1 minute and subsequent overs were



# OPERATING IN SCANDINAVIA

limited to 2 minutes. If the 2 minute limit was exceeded a short recording of a marching tune was transmitted by the repeater when the offending station dropped carrier!

When the offending station has been transmitting through the repeater continuously for more than 3 minutes the repeater ceases talk-through, plays the tune and then closes down! This same repeater also has a time switch which shuts it down after 10pm to save power, as activity on the repeater is fairly low in the late evenings.

In Stockholm we had our first taste of operating 'Maritime Mobile', which, as mentioned earlier, does not require a special licence in Sweden. We were aboard a pleasure steamer (with a *real* steam engine) on the way to Våxholm, an island in the Stockholm archipelago. We managed to obtain permission from the first officer, whom it turned out came from Kingston-upon-Thames, after a brief explanation and assurance that the ship-board radio and navigational equipment would not suffer any interference from our transmissions.

Thus we were operating as G4ROM/SM0/MM, G5MUR/SM0/MM and G6TXA/SM0/MM (what a mouthful!) during the 2 hour return journey. We worked a number of stations who were /MM onboard their yachts and also OH5LX/MM, who was the radio operator of a ferry that was heading for Aland island (OH0). We also attracted a lot of attention from the crew members and the passengers on the steamer. In between QSOs we were explaining what amateur radio is all about and how it was that a group of foreigners, ie us, happened to be operating radios on board a Swedish vessel!

## SK0TM

Another memorable experience in Stockholm occurred while we were visiting the Museum of Science and Technology. The museum is similar to the Science Museum in London but it is smaller. There are two floors of an annex devoted entirely to telecommunications and an amateur radio station, SK0TM. We had noticed its antenna array earlier on when we passed the museum on a bus to visit the Kaknäs TV tower (one of the few places in Sweden from which radio amateurs may not transmit), and had therefore earmarked it as a place to visit.

We arrived at SK0TM only to discover that it was closed. We were told by the museum guide that it could only be operated by the authorised users, so we had to be content with peering through the glass partitioning at the very well equipped station. Luck was with us after all, for when we passed SK0TM again, about half an hour later, it was being opened up by Henning SM0EKG, who is one of the operators of the station. We quickly introduced ourselves and, to our delight, Henning said that we were welcome to operate the station; even unsupervised as we held Swedish amateur licences!

We found ourselves causing a pile-up on 20m because of the SK0 call, with a Drake TR7 driving an L4 linear amplifier into a TH6DXX tri-band beam. One call sign that rang a bell in G4ROM's memory (pun intended!) was G4UJS, Bob and it transpired that Bob was local to Manchester. Bob was prepared to ring up Murray, G2CAZ, Mike's dad, to let him know that Mike was on 20m. Father and son duly spoke to each other over the air, thereby enhancing the image of amateur radio in the eyes of Mike's mother; '... it is useful after all!'

SK0TM is also equipped for 2m with a Trio TR9100, a colinear and a 10 ele Yagi, and for RTTY with a VDU and a fairly new Philips electronic teleprinter. There were also other receivers of various sizes and vintages around the shack.

Looking through the station log most of the operators were visitors to the museum, a large proportion of whom were non-Swedish. Two months later G5MUR heard SK0TM on 20m, being operated by an HB9 visitor and he was also causing one almighty pile-up! SK0TM is certainly well worth visiting if you are ever in Stockholm, if not to see the other telecommunications exhibits, which are more comprehensive than those at the London Science Museum, then to experience the other end of a pile-up!

## Repeaters

Three repeaters were accessible with our hand-helds from the centre of Stockholm. However, none of them featured such exotic control logic as the one in Gothenberg. The repeaters were SK0RIX (R1), SK0RFO (R5) and SK0RDZ (R8). Activity on the repeaters was higher than in Gothenberg due to the higher radio amateur population; about one quarter of the total population of Sweden

live around Stockholm. /MM operation through the repeaters was quite common during the weekends, as it was summer then, especially between stations sailing in the Stockholm archipelago. From the number of yachts sailing or moored in the archipelago, it would seem that a yacht is like a second car to the Stockholmers.

Gothenberg is a charming little city. The wide boulevards are interspersed with tram-lines and the numerous little parks scattered here and there give an airy atmosphere to Gothenberg in the summer. The harbour is one of the busiest in Western Europe but nevertheless the water in the harbour was crystal clear!

Stockholm is spread over fourteen islands and like Copenhagen also lacks the hectic activities of a major European capital city. The long waterfront, the cleanliness, the immaculate orderliness and the abundance of uncrowded wide open spaces make Stockholm a very beautiful city in the summer.

On the whole, we found operating 2m in Sweden to be very enjoyable. The level of activity on the band was such that the repeaters were seldom busy and most of the simplex channels were available at all times! We received a wealth of helpful information and directions regarding the places of interest to visit in Stockholm and Gothenberg from other radio amateurs over the air (especially from Rogan SM0KJD, who is an expatriate Englishman), which made our visits all the more enjoyable. We had no language problems at all as all the Swedes spoke English very well!

From our experience the Swedish licensing authority works very quickly. We received our reciprocal licences only two weeks after sending off our application forms! English was used in all the

| Freq bands<br>KHz                                     | Groups of permitted classes of emissions                                    |              |              |
|---|---|--------------|--------------|
|   | A (max 500W)  | A (max 250W) | C (max 100W) |
| 3500 - 3600   | ii iii  |              |              |
| 3600 - 3800   | ii iii  |              |              |
| 7000 - 7040   | ii iii  |              |              |
| 7040 - 7100   | ii iii  |              |              |
| 14000 - 14100   | ii iii  |              |              |
| 14100 - 14350   | ii iii  |              |              |
| 21000 - 21350   | ii iii  |              |              |
| 21150 - 21450   | ii iii  |              | ii           |
| 28000 - 28200   | ii iii  | ii iii       |              |
| 28200 - 29700   | ii iii  | ii iii       |              |
| MHz   |   |              |              |
| 144 - 146   | ii iii iv   |              |              |
| 432 - 438   | ii iii iv v   |              |              |
| 1240 - 1300   | ii iii iv v   |              |              |
| 2300 - 2450   | ii iii iv v vi  |              |              |
| 5650 - 5850   | ii iii iv v vi  |              |              |
| MHz   |   |              |              |
| 10 - 10.5   | ii iii iv v vi  |              |              |
| 24 - 24.25  | ii iii iv v vi  |              |              |
| 47 - 47.2   | ii iii iv v vi  |              |              |
| 75.5 - 81   | ii iii iv v vi  |              |              |
| 142 - 149   | ii iii iv v vi  |              |              |
| 241 - 250   | ii iii iv v vi  |              |              |
| MHz   |   |              |              |
| The group of the classes of emissions are as follows: |   |              |              |
| Group i   | A1A, J2B, F1B   |              |              |
| Group ii  | A3E, H3E, J3E, R3E<br>8K00F3E, 9K00G3E                                      |              |              |
| Group iii   | H3C, J3C, J3D, R3C<br>3K00C3F, 3K00F3F                                      |              |              |
| Group iv  | A2A, A2D, H2D, J2D, R2D<br>F1A, F2A, F2B, F2D<br>A3C, F3C, 16K0F3E, 16K0G3E |              |              |
| Group v   | C3F, F3F, 36K0F3E, 36K0G3E  |              |              |
| Group vi  | F3E, G3E, P1A, P2A, K1E   |              |              |

Table 2 Frequency bands and groups of permitted classes of emission

Table 1 Classes of Danish amateur radio licences

| Class | Requirements  | Bands            | Power                |
|-------|---|------------------|----------------------|
| A     | Extended technical test. Morse at 12wpm.<br>Class B held for 1 year. Aged 18+   | HF<br>VHF<br>UHF | 500W<br>500W<br>500W |
| B     | Extended technical test. Morse at 12wpm.<br>Aged 15+<br>Or<br>Ordinary technical test. Morse at 12wpm.<br>Class C held for 1 year. Aged 16+ | HF<br>VHF<br>UHF | 100W<br>100W<br>100W |
| C     | Ordinary technical test. Morse at 12wpm.<br>Aged 15+  | HF<br>VHF<br>UHF | 10W<br>100W<br>100W  |
| D     | Either of the 2 tests. Aged 14+. Morse not required   | HF<br>VHF<br>UHF | 10W<br>100W<br>100W  |

HF = 80,40,20,15 and 10m  
Also CW only on 10.100-10.150MHz  
18.068-18.168MHz  
24.890-24.990MHz

VHF = 2m  
UHF = 70cm

# OPERATING IN SCANDINAVIA

correspondence. The address of the licensing authority is: *Televerkets Radiodivision, Frekvenssektionen, Tillstandkontore, S-123 86, Farsta, Sweden.*

## Norway

Norway was the last of the Scandinavian countries in our train journey. The Norwegian railway network passes through areas of immense natural beauty and wilderness. If you ever want a lesson in physical geography, especially one on the effects of glacial actions, then Norway is the country to visit for a firsthand experience. The fjords are really impressive and a must for any self-respecting visitor to Norway. Anyway, this article is supposed to be about amateur radio operating in Norway, not a promotional piece for the Norwegian Tourist Board (as if they needed any help!).

There are two classes of amateur licence in Norway. However, do not expect the Norwegian licensing authorities to issue you with a reciprocal licence if you only have a British class B licence as both classes require Morse capability. In addition, the rule that licences are only issued to nationals, whose countries have a reciprocal licensing agreement with Norway is strictly enforced, as we found out later in Oslo. This was unlike Sweden which also has no agreement with Malaysia; Will and Khee are Malaysians but have British licences.

The Norwegian class A licence is known as the 'General Licence' while the class B is known as the 'Beginner's Licence'. The class B licence is *only* valid for two years and is not renewable. Class A licensees have callsigns with the

prefix LA while those with class B licence have LB prefixes. A summary of the qualifications required and the privileges afforded by the two classes of licences can be found in *Table 4*.

The callsign issued to a foreign resident depends on his/her length of stay in Norway. For periods of residence of a year or more the callsign prefix is LA0 followed by two or three letters. For periods of less than a year, which would apply to most tourists, the callsign issued is own call/LA, /JW, /JX or /3Y. This licence is, however, issued only for periods of three months at a time. The cost of the reciprocal licence was NKr90 (July 1984).

Our first stop in Norway was at Narvik after a 22 hour journey through the whole length of eastern Sweden and the Arctic Circle, chugging through the amazingly beautiful scenery of the jagged mountains between Kiruna and Narvik (max elevation about 1500m asl). Our first 2m QSO in Norway was thus from the top of Fagernesfjell (literally, Fagernes Mountain) just above Narvik. It was a 10 minute ride to get to the cable-car station at the top, which is about 625m asl. The summit is at least another 100m higher.

## Impressive

The scenery of Narvik and the adjacent fjords was extremely impressive from the summit. Just like what a backdrop to *Peer Gynt* would be! There was still thick snow on the ground in the shade and there were even a number of mini-glaciers! We missed the midnight sun by a fortnight. When we were there the sun just took a dip behind the distant mountains for a while; it was still bright enough to read a book at 11pm.

At such height one would have thought that we would be working DX to our hearts' content. Alas it was not to be so because of the general lack of amateur stations in that part of the country. The local repeater is LA9NR (R5), situated on a small hill above Narvik, well below the summit of Fagernesfjell. Obviously most, if not all, of the local amateur population were away on their holidays as we did not hear a single QSO on the repeater during the day and a half that we were in Narvik.

From the summit of Fagernesfjell, LA7HR (R2) at Harstad, which is over 50Km to the west in the Lofoten Islands, was accessible with a couple of watts. Eventually, Mike had a QSO through it with LA9UH, Ray, who was on an island on the far western side of the Lofotens, a further 60Km away.

## Busier

The 2m airwaves were a bit busier in Oslo and Mike even had a few QSOs on simplex. Operating portable in Oslo was not very appealing at the time that we were there. It rained almost continuously for the first two days, and so most of our operating was done from the comfort of the youth hostel where we were staying, which is on a hill overlooking Oslo.

LA8FCA, Steinar, returned to one of Mike's CQs from the youth hostel and mentioned that he was rather shocked when he heard Mike's callsign. He said that he had just seen the callsign in *Practical Wireless*, in the club news column, as Mike had given a talk to the South Manchester Radio Club! *Practical Wireless* was the only English language radio magazine that we saw on general sale in Scandinavia. You may think it is expensive here but it was twice the UK price in Norway!

It was on the first rain soaked day that we paid a visit to the offices of the Teledirektoratet to enquire about the possibility of Will and Khee (who only have British class B licences) operating under Mike's licence. The person that we dealt with must have been a radio amateur himself and we had an interesting few minutes chat about radio equipment. He confirmed that all of us could use Mike's callsign, ie G4ROM/LA, and regretted that even if we had all had class A licences he would still have been unable to issue reciprocal licences to us because there is no reciprocal licensing agreement between Norway and Malaysia.

There are two local 2m repeaters serving Oslo. Activity on the repeaters was not high compared with Stockholm. One, LA6OR on R2, is within the city limits and the other is LA5OR on R6 at Enebakk, 20Km south west of Oslo. By now you will have deduced that all Norwegian repeaters have two letters after the number in the callsign. The first letter is usually related to the repeater location or the name of the nearest principal town, and the second letter is always 'R', to denote a repeater. A highly logical callsign system but it can be a nightmare when there are a number of

**Table 4**  
*Requirements and privileges of the Norwegian amateur licences*

| General Licence – class A   | Beginner's Licence – class B  |
|---|---|
| Basic general electronics theory and specific radio topics  | Basic general electronics theory only   |
| Knowledge of the treatment of electrical shocks   | Knowledge of the treatment of electrical shocks   |
| Knowledge of the licensing regulations  | Knowledge of the licensing regulations  |
| Ability to send and receive correctly in Morse code at a speed of 60 characters/min (12wpm), texts in code and Norwegian and English texts in plain language  | Ability to send and receive correctly in Morse code at a speed of 40 characters/min (8wpm), texts in code and Norwegian and English texts in plain language |
| Ability to send and receive correctly by telephony  | Ability to send and receive correctly by telephony  |
| Max power to final stage – 600W irrespective of CW or PEP. Output power must be easily reducible  | Max power to final stage – 15W irrespective of CW or PEP. Output power must be easily reducible.  |
| Freq bands: The bands allocated to both classes are the same and are similar to the British ones and there are plans to introduce 6m in the future. There is however no allocation for 180m nor as yet any of the post WARC '79 bands. Prior application to the Teledirektoratet is required before any amateur band above 70cm may be used |   |

**Table 3** *Amateur radio districts in Sweden*

| Distict no. | Extent of district  |
|-------------|---|
| 0           | Stockholm county  |
| 1           | Gotland county  |
| 2           | Counties of Norrbotten and Västerbotten                                       |
| 3           | Counties of Gävleborg, Jämtland and Västernorrland                            |
| 4           | Counties of Kopparberg, Örebro and Värmland                                   |
| 5           | Counties of Östergötland, Södermanland, Västmanland and Uppsala               |
| 6           | Counties of Älvsborg, Göteborg and Borhus, Halland and Skaraborg              |
| 7           | Counties of Blekinge, Jönköping, Kalmar, Kristianstad, Kronoberg and Malmöhus |



## OPERATING IN SCANDINAVIA

different repeaters serving the same locality or located in the same area.

Bergen was our next stop, in the heart of the Western Fjords. It is a more attractive place than Oslo, with cobblestoned lanes and a picturesque waterfront, and none of the skyscrapers and litter of Oslo. Apparently it has weather characteristics that are similar to Manchester, ie if it is not raining then it's going to, and hence it suffers from the same kind of jokes from non-residents as Manchester does. Well it only rained for one day out of the three that we were there, a better record than Oslo!

We had no problems accessing the local repeater in Bergen, LA5BR on R6. It was on a hilltop overlooking Bergen and the youth hostel we were staying at was halfway up the same hill. There was little activity on the band; probably most of the non-local traffic was obstructed by the terrain. In the evenings there were a number of QSOs on the simplex channels, but the only one we had through the repeater was with a station who was himself a visitor to Bergen.

After the hectic travelling of the previous three weeks we had a three day 'rest' (from travelling, anyway) at Arendal on the south eastern coast, before embarking on the 42 hour long train/ferry journey back to London via Oslo, Copenhagen, Hamburg, the Hook of Holland and Harwich.

Arendal is a little harbour which gets transformed into a sailing centre during the summer and it used to be the major centre for shipping and ship-building in the region. Nowadays its shipyards are mostly kept busy constructing oil production rigs for the North Sea oilfields.

Strange as it may seem, there was more activity on 2m around Arendal than in Bergen. We were rather bewildered by this until our Norwegian friend pointed out a large building with a tower bristling with aerials on a hilltop overlooking the town - a training school for maritime radio and radar operators. In fact, two of the local stations that we spoke to were instructors at the school.

Again, as in Sweden, we had no language problems, as most Norwegians could understand, if not speak, English. Unfortunately, we did not manage to locate Slartibarfast's signature despite a few trips through the fjords on the west coast!

### Restrictive

To round off, a few points of note about the Norwegian licensing conditions. Unlike the tone of liberalism of the Swedish amateur licence, the Norwegian one is rather restrictive. In fact, we consider it to be stricter than our British licences. For example, a Norwegian licensee may have his/her licence revoked for causing interference to other amateur stations by '... key-clicks, over-modulation or constant unstable signals...'. The licence even specifies the minimum frequency stability and the maximum amount of spurious emissions of an amateur transmitter.

One other aspect that most of us would consider to be extremely restrictive is the keeping of the station log. In addition to the usual details, the Norwegian licence requires the licensee to list all the equipment of the station in the log and to record any technical changes to the station. Furthermore, should any radio equipment be sold, lent, rented or otherwise transferred, a record is also required in the log.

The address of the Norwegian licensing authority is: *Teledirektoratet, Boks 6701, St Olavs Plass, Oslo 1, Norway.*

### Finland

This is going to be more of a footnote to our article. We had to drop our plans to visit Finland due to the pressure of time. With only three weeks available, we felt that a whistle stop tour would not have allowed us to explore the countries that we intended to visit in any detail, and as Finland was a bit out of the way and the train connections inconvenient, it was dropped from our itinerary.

As it turned out we had our application forms for Finnish reciprocal licences returned by the Finnish Amateur Radio League, who do the initial processing for the Finnish licensing authorities. Our applications were turned down because the Finnish licensing authorities only issue reciprocal licences for operations from a fixed location. Portable or mobile operating by reciprocal licensees is not permitted (possibly due to the proximity of the USSR!).

We cannot go into any great detail about the Finnish licence for obvious reasons. Nevertheless, here are some brief details about the application procedure. All radio amateurs in Finland must become members of the SRAL, except

for visitors staying less than a month. As mentioned earlier, all applications must be made via the SRAL (address below).

The cost (in June 1984) of the licence was 38 Finnish marks and an additional 20 Finnish marks handling charge is levied by the SRAL. However, no fee is payable at the time of application. It would appear that both British class A and class B licensees can obtain reciprocal licences in Finland but we have no details about the privileges of the different classes of amateur licence.

In addition to the completed application form, a certified photocopy of the front page of your passport and a letter certifying the validity and class of your licence from the RALU must be provided. The exact postal address of the station in Finland must also be stated.

We rather regret not being able to squeeze in Finland. The 'Land of a Thousand Lakes' and of Sibelius will have to wait for some other time. The address of the SRAL is: *Suomen Radioamatoorlito RY (SRAL), PO Box 306, SF-00101 Helsinki 10, Finland.*

### And finally . . .

We wish to thank the staff of Membership Services at the RSGB HQ for providing us with all our initial information about reciprocal licensing in the various Scandinavian countries. We also wish to thank those amateurs that we spoke to over the air for making us so welcome in their respective countries.

It is the firm view of the writers that to get away from the crowds in the summer, the countries in Scandinavia are ideal. If one prefers fresh air and peacefulness to lying in the sun (or even in addition to!), the great Scandinavian outdoors with its superb and unique scenery beckons.



# Thanet EI

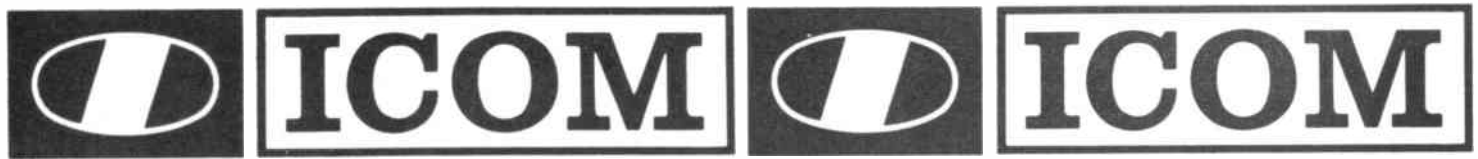

## IC-735, The Complete HF Radio

This new HF transceiver from ICOM is compact enough to make mobile or portable use a possibility. The IC-735 covers all Amateur frequencies from 1.8MHz to 30MHz including the three new bands 10, 18 and 24MHz. Modes include SSB, CW, AM and FM, all circuits are solid-state and output is approximately 100 watts.

Tuning ranges from 100kHz to 30MHz, made continuous by using a high-side IF and a CPU control system. RTTY operation is also possible. Dynamic range is 105dB with a 70.451 MHz first IF circuit. The direct feed mixer rejects spurious response and gives higher sensitivity and wider dynamic range. Pass-band tuning and a sharp IF notch filter provide clear reception even under duress. Preamp is 10dB and attenuator 20dB.

The new IC-735 from ICOM is easy to operate and versatile, it has various scanning functions, comprehensive LCD and 12 memories. Computer remote control is possible via the RS-232C jack.

Options include: the AT-150 automatic antenna tuner and shown here the PS-55 AC power supply and SM-8 desk mic.

Please contact Thanet Electronics or your local ICOM dealer for even more information on this latest HF transceiver - the IC-735.



## IC-290D/290E Mobile



290D is the state of the art 2 meter mobile, it has 5 memories and VFO's to store your favourite repeaters and a priority channel to check your most important frequency automatically. Programmable offsets are included for odd repeater splits, tuning is 5KHz or 1KHz.

The squelch on SSB silently scans for signals, while 2 VFO's with equalising capability mark your signal frequency with the touch of a button. Other features include: RIT, 1 KHz or 100Hz tuning/CW sidetone, AGC slow or fast in SSB and CW, Noise blanker to suppress pulse type noises on SSB/CW.

You can scan the whole band between VFO's/scan memories and VFO's. Adjustable scan rate 144 to 146 MHz, remote tuning with IC-HM10 and HM11 microphones. Digital frequency display, Hi/Low power switch. Optional Nicad battery system allows retention of memory.







# ≡ PROBLEMS IN RECEIVERS ≡

## PART 2

by Angus McKenzie G3OSS

### Audio distortion

Of the many factors affecting this parameter probably the most important ones are the detector distortion and the output capability of the set. However, the entire IF chain should be able to cope with short transients several dBs above the normal levels subject to AGC control through the system. After a pause, a sudden transient comes through before the AGC backs it down, and too many sets have a nasty click, which is transient distortion, on the leading edge of syllables or words. This shows insufficient IF dynamic range and poor AGC control.

Product detectors used for SSB and CW can be as good as 0.4% THD on a static measurement, but as bad as 10%. Under transient conditions distortion can be many tens of percent but it is extremely difficult to measure this, although the sound is all too familiar. What is particularly horrific is the shocking quality of reproduced AM from the average Japanese rig when at high modulation levels. I have noted up to 30% distortion, and when you compare this to a receiver having only one or two percent I can assure you that the audio differences are very startling.

The three finest AM receivers for sheer quality that I have measured are the old GEC BRT400, the Surrey Electronics modified Yaesu FRG7700 and the Lowe Electronics modified TS940S, all having less than 1% distortion; the worst was the Icom IC751 with 30% distortion at low frequencies. Sometimes the problem is not just with a very bad AM detector, for it can be due to inadequate IF dynamic range or distortion characteristics.

When you tune for AM stations it's best to have AGC short, but when you finally listen to the station you can get lower distortion with long AGC, which stops the AGC line from following the audio envelope. I suggest that many receivers do not back the gain off enough on AM signals, which is the reason for some of the trouble.

### Measuring RF Intercept point

If one is to avoid tearing a receiver apart and probing deep down into the innards, combined with modifying some parameters in order to measure radio frequency intermodulation distortion and blocking characteristics, one can use one of two simple methods for the measurement. I have learned by bitter experience that both the normal methods can give false results, but it is usually possible to choose one of them in an individual case which will give a fairly reliable answer.

The first method requires you to calibrate the S-meter very carefully, then measure the sensitivity at the required frequency, followed by a measurement of the off-channel carrier levels required to produce a given S-meter reading on channel.

This normally gives quite accurate measurements which allow one to calculate the intercept point when the two carriers are spaced well outside the IF roofing filter bandwidth, but problems occur if AGC is applied either to the RF stage, mixer or an IF stage acting before the roofing filter. The measurement gets very dodgy for carriers spaced closer than 20kHz off-channel.

The alternative method, after measuring basic 12dB sinad sensitivity, is to measure the levels of two identical carriers off-channel, as before, that give a 12dB sinad intermodulation product on-channel. This method works extremely well, even at close spacings, if the receiver has an excellent reciprocal mixing performance, but if it has a bad one the nearer off-channel carrier can create so much noise on-channel that it makes the sinad reading lower, which results in one having to increase the level of the two generators.

### Impossible to measure

As you increase the levels yet more noise is generated, but very slowly you will reach a 12dB sinad point as the intermodulation rises faster than the noise. The carrier levels can be perhaps 20dB higher than they really ought to be, so a close in figure has sometimes been stated to be 'impossible to measure'.

This has caused me much concern and various methods have been employed to rectify this, including using a narrow band spectrum analyser on the audio output in order to receive only the audio product. This is invalid as the reciprocal noise can start backing off the AGC line and invalidate the measurement.

I put the problem to John Thorpe, a post grad engineer from Cambridge University, who is now working at Lowe Electronics, and it was he who came up with a most effective solution and who should take all the credit for it.

Thorpe's technique involves the taking of three measurements in order to establish dynamic range and intercept point. The first measurement is to establish the on-channel 12dB sinad sensitivity, from which can be calculated the noise floor, assuming one knows the approximate filter bandwidth. The two generators are then connected as always via a coupler to the input of the receiver at spacings of X and 2X off-channel, and increased in level until an intermodula-

tion product is just audible. The generator which is furthest off frequency is then turned on and off at RF, and the point at which the audio output level of the receiver goes 3dB up and down is noted.

### Minor contribution

At this level the intermodulation product when both generators are on is at the same level as the reciprocal noise produced by the closer generator. There is a minor contribution, perhaps, of noise from the second generator, and there are methods for eliminating this which are more complex.

The third measurement requires one to change the frequency of the generator furthest out to the wanted channel and carefully introduce a 1kHz beat note. The original closer generator is kept on at the level established in test 2. The on-channel generator is reduced to inaudibility and then brought up again until there is a change of 3dB introduced when its RF is switched on and off. This gives the receiver noise floor very precisely in the presence of the strong off-channel signal.

The difference between tests 2 and 3 in dBs is then added to the basic noise floor of the receiver, and this figure is multiplied by 1.5. The resultant figure in dBs is the number of dBs that the approximate intercept point is above the receiver noise floor. If test 2 is at -30dBm and test 3 is at -120dBm, the difference is 90dB. Multiplying by 1.5 gives 135dB and adding this to a noise floor at -135dBm would then give 0dBm as the intercept point, which would be reasonably realistic.

The 12dB sinad method in this actual instance gave a figure of +12dBm, the S-meter method also giving a similar erroneous figure. I hope knowledgeable readers will write in to the Editor and make comments on this as I consider it quite important. It has already allowed me to measure blocking performance as close as 5/10kHz spacings on several rigs with marked reciprocal mixing problems, and the measurements tie in far better with subjective assessments on the bands than do the normal methods.

### Simplification

We have also tried a simplification of the new method which also seems to give consistent results. This method requires the measurement of a 12dB sinad product on-channel with the two off-channel carriers remaining on all the time. The method should also work with modulated FM carriers. Having noted the off-channel carrier levels required to produce a 12dB sinad IM product, the



# PROBLEMS IN RECEIVERS

more distant carrier should be put on-channel with modulation, if on FM, to give a 12dB sinad ratio in the presence of the closer off-channel carrier at the level reached in the previous check.

The approximate RF intercept point will then be 1.5 x the difference between the two test results added to the second result, ie half the difference added to the first result. You can compare the second result with the normal sinad measurement made without the off-channel carrier being present to obtain an indication of the reciprocal mixing problem that may exist in the receiver.

## Poor design

We may well have a completely clean band of signals coming out of the first mixer, but poor design even in the first IF stage can completely ruin what may otherwise be a good receiver. Gone are the days when the first IF was around 455kHz on short wave receivers with the attendant bad image problems which got worse as you tuned the set higher in frequency, and which could be really bad by the time you got to 28MHz.

Most sets now have a very high IF, somewhere between 40 and 70MHz. High IFs clearly have good image rejection but it is much more difficult and more expensive to provide switchable narrow filters at such a high frequency. For this reason most sets employ what is termed a roofing filter. If you are lucky they may be only 8kHz wide or so, but as often as not they can be up to 30kHz wide and have rather shallow skirts. The high IF is just there to remove the image problem and there should be hardly any amplification necessary to overcome the noise of the second mixer, after which one normally sees the main filtering.

The problem that I have noted on many modern sets is that of too much gain at the first IF, combined with hopelessly inadequate roofing filters. Strong off-channel signals therefore hit the second mixer and the increased gain with reference to the RF input causes blocking problems. The IC745 has a very good RF intercept point when tested with two carriers 100 and 200kHz off-channel. However, if the two carriers are within the roofing filter bandwidth, or one of them is not too far down the filter skirt, then the effective intercept point is very badly degraded.

The IC745 may have a far out intercept point of at least +10dBm, but how about a close in figure of -50dBm! In this case, although there are two roofing filters in the first IF there are also two amplifiers, both of which are subject to AGC. By the time the AGC point is reached only the wanted signal will cause it to shift, so the receiver can be working at very high gain and the off-channel interfering signals block out the wanted one.

In the IC751 there is but one amplifier in front of the second mixer, and in some earlier Icom designs the problem is even less marked. The Yaesu FT757 and some other Yaesu models also show blocking problems but one of the worst examples

was in a very old Trio TS700 2m multimode which blocked strong close off-channel signals badly, completely wrecking a weak on-channel one, despite the actual selectivity being superb.

If you look at the Ten-Tec Corsair or some of the earlier Drake receivers you will note a much lower first IF of around 9MHz, with the SSB filter following almost immediately after the first mixer. Some of these receivers have intercept points only a few dB worse at 5/10kHz spacing than they do at 100/200kHz spacing, and this is usually combined with a superb reciprocal mixing performance.

Filters do lose a few dB though and slightly more mixer gain is needed if it feeds straight into a filter, so sometimes a bomb-proof first IF amplifier, having quite a low gain, is then used to feed the filter.

In the old Collins KWM2 the mixer was driven from crystal controlled local oscillators so that the first IF was 200kHz wide, and an analogue VFO mixed this down to a 455kHz second IF. The Collins bandpass filter is quite a good one, but even so the image response is not ideal, although it is fascinating that there is no first IF amplifier, nearly all the sets' amplification being at the second IF.

Probably the finest overall transceivers today are the TS930S and the new TS940S reviewed last month. The TS930 has no FM facility. The first IF above 40MHz employs good filters, and thus the set has a good blocking performance as well as having an astonishing dynamic range.

## Selectivity

The ideal filter will have the appropriate pass-band at the top and either side the skirts should be as steep as possible. Since you may want to receive signals which may be coming into the set significantly below  $1\mu\text{V}$ , and there may be adjacent stations coming in some 80dB higher, skirt measurements down to -80dB are appropriate.

Unfortunately, this means pumping very strong signals near the skirt frequency in order to measure selectivity, but these signals mix with local oscillator noise and produce reciprocal mixing noise on-channel which can be so bad that the S-meter goes way up. The S-meter reading may be primarily RM noise, and not signal break-through. You can try other methods, but these are very tedious. Thus many selectivity measurements show that the effective filter bandwidth below -40dB widens out very appreciably.

The same TS700 which had a bad blocking performance had a superb RM one, and the filter itself was so splendid that we actually managed to measure the selectivity down to -100dB.

Poor selectivity, in the form of apparent widening, at say -60dB, can be due to another factor which is both fairly serious and difficult to fix. Either the filter itself opens out at the bottom of the

skirts or there is slight coupling between the input and the output of the filter caused by bad printed circuit board layout.

## Poor selectivity

In some cases the break-through can get through to the product detector but not to the S-meter circuit, so you hear poor selectivity but the measurements are good! This means you have to measure by another method and this was the case with both the Icom IC471 and 271 transceivers, in which the selectivity below -60dB virtually became that of the first roofing filter and not the SSB one.

Many words have been written about the ideal selectivity for FM, AM, SSB and CW but I suggest that there is no one ideal covering all uses for each mode.

Let's have a look at the requirements, though, in the context of modern band conditions. If an HF transceiver is not going to be used for driving transverters and FM is only required on 10m, then a filter bandwidth of around 8kHz will be ideal for coping with the 10kHz channelling around 29.6MHz. The frequency response of the system will be very limited as it is on 27MHz CB. You only need a wider filter to cope with 25kHz channelling on 144 and 432MHz etc. A 10kHz filter might be useful for 12.5kHz channelling on 144MHz but is not really essential if you already have the 8kHz one for 10kHz channelling. However, many of us like to extend the frequency response on FM.

The higher deviation of wider response transmissions, and thus with a 15kHz wide filter in the receiver, is particularly useful for a relaxed QSO on FM or VHF etc. I therefore suggest that the 15kHz filter could actually be part of the normal roofing filter system, whereas the 8kHz filter should be an extremely high quality one.

If we then consider AM, the 8kHz filter will be almost ideal for quality listening, but you will need a steeper one of say 5.5kHz bandwidth for extracting weak signals on a crowded band. I see no point in allowing the user to select the SSB filter for AM as the reproduction is so muffled as to be almost beyond any entertainment value, and if you are in a QRM situation then try listening to AM using the SSB mode and zero beat the carrier.

## SSB

When we come to SSB, the narrowest possible filter that one can use sensibly is around 1.8kHz, but as often as not a 2.1kHz filter is actually better as intelligibility is improved even if more adjacent break-through comes through. For most QSOs I suggest at least 2.4kHz is optimum to avoid the listening fatigue problem. There would therefore be a good point in having the ability to select either 2.1 or 2.7kHz, or better still the ability to close in from 2.7kHz using bandpass tuning systems such as those on the TS930 and some Yaesu rigs.

If you have never heard a fairly wide

# PROBLEMS IN RECEIVERS

response SSB transmission on a wide Rx filter then you have missed something, for the quality can be almost as good as FM in many respects.

If CW is to be considered, you have to accept that using just an SSB filter is almost hopeless on the LF and HF bands, and you will not be able to pick out much weak and allusive DX on the crowded CW band segments. You are therefore often faced with the choice of 500 or 250Hz filters, some of which have sharp side skirts whereas others are almost triangular shaped.

Personal preference shows wide differences here, and I much prefer a

500Hz bandwidth with very steep skirts to a narrower top. The precise tuning required with a very narrow filter is both tiresome to deal with and listen to, and once you have heard bad ringing on sharp filters you will know what I mean.

Once again the best alternative is to have a basic 500Hz filter with variable selectivity, such as is on the Trio TS930, perhaps combined with an audio peaking filter. You can, of course, try external filters such as those in the Datong range, but these don't stop strong close signals from backing AGC down.

There are few receivers indeed which look at the filter problem sensibly, for all

modes, but there is one more problem that I have encountered when various filters are switched in. The receiver's noise floor should vary with the bandwidth of the filter used, and if you change from the average SSB one to a 500Hz CW one you should notice the receiver noise floor reduce by around 7dB, and 10dB incidentally with a 250Hz one. Very narrow filters usually have more loss, as in the Ten-Tec Corsair where you do not see the noise floor reduce when you go to CW, and since this receiver does not have a good sensitivity on the 21 and 28MHz bands the CW sensitivity is that much poorer.



**4 + 11GHz SATELLITE TV RECEIVING EQUIPMENT**  
LNA's LNC's RECEIVERS, FEED HORNS ETC.

For further details contact  
**HARRISON ELECTRONICS**  
22 MILTON ROAD, WESTCLIFF-ON-SEA, ESSEX SSO 7JX Tel (0702) 332338

## RITTY and CW TRANSCEIVE with NO TERMINAL UNIT

This fantastic program interfaces direct with your rig, slashing the cost of previous systems. Split screen, type ahead, auto CR/LF, accurately preset baud rates and shifts (normal or reverse), QSO review, tracks and sends any CW speed up to 250wpm. Tape and kit for the very simple interface, including PCB and User Port connector, for only £20. Ready-made interfaces available. For CBM64, BBC-B, VIC20 (+ at least 8k). CW-only version for SPECTRUM (no interface needed, max speed 150wpm) £10.

**And for CBM64, VIC20, BBC-B, SPECTRUM, ZX81-16k**  
Morse Tutor Britain's best. Learn fast in easy stages from absolute beginner to over 40wpm. Join the hundreds who have succeeded with this program. Tape and full learning guide £8.

**RAE Maths** All the practice and testing you need. Tape and comprehensive reference sheet detailing all you need to know £8. VC20 needs expansion (any). Don't let maths make you fail. PASS with this program. Superb locator, logbook and contest log programs also available.

All programs are very easy to use and come with full instructions. Prices include p&p 1st Class by return. Add £1 per tape if outside UK or Ireland

### technical software (AR)

From, Upper Llandwrog, Caernarfon, Gwynedd LL54 7RF. Tel: 0286 881886

# Marshall's

A. MARSHALL (LONDON) LTD

A. Marshall (London) Ltd,  
Electronic Component Distributors  
85 WEST REGENT STREET  
GLASGOW G2 2QD  
TELEPHONE: 041 332 4133

## \* SPECIAL OFFER TO READERS OF AMATEUR RADIO \* SEND US ONLY 1/2 THE MARKED PRICE; ALL ITEMS EX STOCK

| TRANSISTORS | 2N3711 | 0.15    | AF106 | 0.15   | BC239C | 0.15   | BF183 | 0.30    | ZTX530 | 0.27     | SN7450 | 0.20      | DIODES | CV7227 | 0.55  | Z/DIODES | 30V    | 0.10  |      |        |      |      |
|-------------|--------|---------|-------|--------|--------|--------|-------|---------|--------|----------|--------|-----------|--------|--------|-------|----------|--------|-------|------|--------|------|------|
| 2N398       | 0.35   | 2N3771  | 1.70  | AF280  | 0.50   | BC250  | 0.15  | BF195   | 0.27   | ZTX531   | 0.27   | SN7451    | 0.20   | AA116  | 0.12  | CV7541   | 0.11   | 400mW | 39V  | 0.10   |      |      |
| 2N697       | 0.23   | 2N3772  | 1.90  | BC115  | 0.19   | BC251  | 0.15  | BF199   | 0.18   | IC's     | CA3034 | 1.20      | SN7453 | 0.20   | AA118 | 0.15     | DD0000 | 0.11  | 2V4  | 0.10   | 43V  | 0.10 |
| 2N698       | 0.80   | 2N3794  | 0.15  | BC116  | 0.19   | BC251B | 0.15  | BF225   | 0.24   | CA3034   | 1.20   | SN7454    | 0.20   | AA119  | 0.15  | GEX23A   | 0.10   | 2V7   | 0.10 | 47V    | 0.10 |      |
| 2N706A      | 0.22   | 2N3854A | 0.20  | BC118  | 0.19   | BC253  | 0.15  | BF255   | 0.20   | CD4000   | 0.18   | SN7460    | 0.20   | AA129  | 0.12  | ITT44    | 0.10   | 3V    | 0.10 | 1 Watt | 0.15 |      |
| 2N708       | 0.25   | 2N3856A | 0.25  | BC132  | 0.23   | BC256  | 0.15  | BF271   | 0.20   | CD4002   | 0.20   | SN7470    | 0.30   | AA144  | 0.12  | ITT920   | 0.10   | 3V3   | 0.10 | 3V3    | 0.15 |      |
| 2N718       | 0.27   | 2N3905  | 0.15  | BC136  | 0.15   | BC256A | 0.15  | BF451   | 0.30   | CD4012   | 0.20   | SN7472    | 0.28   | AA133  | 0.10  | ITT921   | 0.10   | 3V6   | 0.10 | 3V6    | 0.15 |      |
| 2N753       | 0.25   | 2N3962  | 0.25  | BC148B | 0.15   | BC260  | 0.15  | BFX13   | 0.42   | CD4017   | 0.50   | SN7483    | 0.60   | BA102  | 0.12  | ITT922   | 0.10   | 3V9   | 0.10 | 4V7    | 0.15 |      |
| 2N914       | 0.20   | 2N4059  | 0.15  | BC149C | 0.15   | BC262A | 0.23  | BFX86   | 0.40   | CD4025   | 0.20   | SN7484    | 1.20   | BA130  | 0.12  | ITT923   | 0.10   | 4V3   | 0.10 | 5V6    | 0.15 |      |
| 2N929       | 0.20   | 2N4060  | 0.15  | BC154  | 0.27   | BC262B | 0.23  | BSY28   | 0.30   | CD4069   | 0.20   | SN7491    | 0.63   | BA14C  | 0.12  | ITT2001  | 0.10   | 4V7   | 0.10 | 7V3    | 0.15 |      |
| 2N1131      | 0.30   | 2N4062  | 0.18  | BC158  | 0.15   | BC266  | 0.15  | BSY54   | 0.25   | CD4071   | 0.20   | SN7492    | 0.30   | BA144  | 0.10  | ITT2002  | 0.10   | 7V5   | 0.10 | 8V2    | 0.15 |      |
| 2N1507      | 0.15   | 2N4286  | 0.15  | BC159  | 0.15   | BC266A | 0.15  | BSY65   | 0.35   | CD4072   | 0.20   | SN7493    | 0.30   | BA154  | 0.12  | OA90     | 0.10   | 8V2   | 0.10 | 10V    | 0.15 |      |
| 2N1637      | 0.18   | 2N4288  | 0.15  | BC159B | 0.15   | BC266B | 0.15  | ME413   | 0.15   | CD4073   | 0.20   | SN7496    | 0.34   | BA155  | 0.12  | DA91     | 0.10   | 9V1   | 0.10 | 11V    | 0.15 |      |
| 2N1638      | 0.25   | 2N4898  | 1.40  | BC167  | 0.15   | BC308  | 0.15  | ME4101  | 0.15   | CD4075   | 0.20   | SN74107   | 0.28   | BA157  | 0.15  | DA95     | 0.10   | 10V   | 0.10 | 13V    | 0.15 |      |
| 2N1991      | 0.35   | 2N5033  | 0.40  | BC167B | 0.15   | BC308A | 0.15  | ME4104  | 0.15   | CD4082   | 0.32   | SN74141   | 0.58   | BA182  | 0.14  | DA200    | 0.10   | 11V   | 0.10 | 15V    | 0.15 |      |
| 2N2193      | 0.50   | 2N5129  | 0.15  | BC168B | 0.15   | BC308B | 0.15  | MJ430   | 1.75   | LF137414 | 0.40   | SN74155   | 0.60   | BA201  | 0.10  | QA202    | 0.10   | 13V   | 0.10 | 18V    | 0.15 |      |
| 2N2193A     | 0.55   | 2N5222  | 0.15  | BC168C | 0.15   | BC309  | 0.15  | MJ481   | 1.20   | LM348N   | 0.90   | SN74162   | 0.86   | BA202  | 0.15  | DAZ200   | 0.10   | 16V   | 0.10 | 22V    | 0.15 |      |
| 2N2217      | 0.25   | 2N5223  | 0.15  | BC169B | 0.15   | BC347  | 0.15  | MJ490   | 1.20   | LM716    | 0.95   | SN74180   | 0.85   | BA243  | 0.10  | DAZ204   | 0.10   | 18V   | 0.10 | 30V    | 0.15 |      |
| 2N2368      | 0.24   | 2N5246  | 0.32  | BC170B | 0.15   | BC350  | 0.15  | MPP103  | 0.36   | LM923    | 0.44   | SN74184   | 1.34   | BA316  | 0.10  | TV12     | 0.30   | 20V   | 0.10 | 33V    | 0.15 |      |
| 2N2714      | 0.15   | 2N5247  | 0.26  | BC171B | 0.15   | HC414  | 0.15  | MPS3638 | 0.15   | LM7824C  | 1.00   | SN74190   | 0.85   | BA317  | 0.10  | Z344     | 0.10   | 22V   | 0.10 | 39V    | 0.15 |      |
| 2N2923      | 0.51   | 2N5448  | 0.15  | BC172A | 0.15   | HC416A | 0.15  | MPSA    | 0.24   | SAS560   | 1.98   | SN74198   | 1.40   | BA318  | 0.18  | IN659    | 0.10   | 24V   | 0.10 | 43V    | 0.15 |      |
| 2N3133      | 0.25   | 2N6109  | 0.38  | BC173  | 0.15   | BC559  | 0.15  | TIS45   | 0.55   | SAS590   | 2.04   | SN741S27  | 0.75   | BAV19  | 0.10  | IN823    | 0.30   | 27V   | 0.10 | 51V    | 0.15 |      |
| 2N3392      | 0.15   | 40312   | 0.84  | BC173B | 0.15   | BC559B | 0.15  | TIS46   | 0.67   | SL701C   | 2.00   | SN74LS151 | 0.35   | BAV20  | 0.12  | IN916    | 0.10   | 24V   | 0.10 | 62V    | 0.15 |      |
| 2N3393      | 0.15   | 40316   | 0.75  | BC174B | 0.15   | BCY58  | 0.18  | TIS49   | 0.65   | SN7410   | 0.20   | SN74LS365 | 0.35   | BAW49  | 0.11  | IS131    | 0.12   | 30V   | 0.10 | 82V    | 0.15 |      |
| 2N3402      | 0.15   | 40363   | 1.20  | BC178B | 0.20   | BCY72  | 0.20  | TIS52   | 0.72   | SN7412   | 0.18   | SN74LS368 | 0.42   | BAV35  | 0.16  | IS131    | 0.12   | 30V   | 0.10 | 82V    | 0.15 |      |
| 2N3415      | 0.15   | 40389   | 0.73  | BC183A | 0.15   | BCY78  | 0.15  | TIS58   | 0.77   | SN7420   | 0.25   | SN76115   | 1.85   | BAV44  | 0.12  | IS132    | 0.18   | 30V   | 0.10 | 82V    | 0.15 |      |
| 2N3566      | 0.15   | 40512   | 0.50  | BC183C | 0.15   | BD116  | 0.75  | TIS64   | 0.50   | SN7423   | 0.25   | SN76116   | 1.75   | BAV93  | 0.10  | IS134    | 0.25   | 24V   | 0.10 | 51V    | 0.15 |      |
| 2N3638      | 0.15   | AC132   | 0.21  | BC213B | 0.15   | BD138  | 0.35  | TIS93   | 0.32   | SN7440   | 0.65   | SN76226   | 0.75   | BY134  | 0.30  | IS940    | 0.10   | 24V   | 0.10 | 51V    | 0.15 |      |
| 2N3642      | 0.15   | AC152   | 0.53  | BC213L | 0.15   | BD540A | 0.40  | TX107   | 0.15   | SN7441   | 0.20   | SN76666   | 0.70   | BY188  | 0.20  | IS941    | 0.10   | 24V   | 0.10 | 51V    | 0.15 |      |
| 2N3662      | 0.15   | AC188   | 0.30  | BC214  | 0.15   | BDY17  | 1.80  | ZTX109  | 0.17   | SN7446   | 0.45   | S042P     | 1.18   | CV5202 | 0.30  | IS961    | 0.15   | 24V   | 0.10 | 51V    | 0.15 |      |
| 2N3706      | 0.15   | ACY22   | 0.65  | BC214B | 0.15   | BF160  | 0.24  | ZTX303  | 0.24   | SN7447   | 0.45   | TCA160C   | 2.25   | CV7047 | 0.11  | BAX13    | 0.10   | 24V   | 0.10 | 51V    | 0.15 |      |
| 2N3708      | 0.15   | ACY30   | 0.86  | BC238B | 0.15   | BF177  | 0.25  | ZTX330  | 0.24   | SN7448   | 0.45   | TMS4116   | 1.00   | CV7071 | 0.11  |          |        | 24V   | 0.10 | 51V    | 0.15 |      |

TRADE ENQUIRIES WELCOME

ADD 60p FOR POST & PACKING + 15% VAT

### WHERE TO FIND US

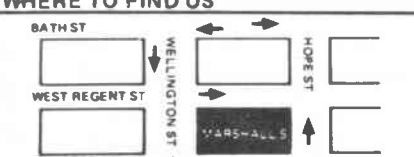

BATH ST  
WEST REGENT ST  
WEST GEORGE ST

### CALL IN AND SEE US

9-5.30 MON TO FRI  
9-5.00 SAT  
EXPRESS MAIL ORDERS  
ACCESS/BARCLAYCARDS  
WELCOME  
SAME DAY SERVICE



### MAIL ORDER

WE REGRET WE CANNOT ANSWER MAIL ORDER/ STOCK ENQUIRIES WITHOUT AN S.A.E. SAME DAY SERVICE TRADE AND EXPORT ENQUIRIES WELCOME

### TELEPHONE

MAIL ORDER  
041-332-4133  
SHOP AND STOCK ENQUIRIES  
041-332-4133  
TRADE  
041-332-4135



CHANCE PILKINGTON  
**Reactolite**  
**RAPIDE**

# Britain's fastest selling sunglasses

# NOW £5 OFF!

**Choice of 4 types – all at the amazingly low price of £7.95**

Last year a staggering 4 out of 10 sunglass wearers chose Reactolite Rapides.

This year, as an extra bonus, we are offering the readers of this magazine the opportunity to buy direct – a massive saving of £5 on the normal retail price of £12.95.

All 4 models have beautifully designed frames and genuine, optically ground, Reactolite Rapide lenses – the fastest reacting photochromic glass in the world!

**E93 Pilot Shape** The 'cut-away' sporting look. Superbly designed and built incorporating *soft, flexible nose pads* for total comfort and *optical quality hinges* (illustrated). Frames available in 3 colours.

**E96 Square Shape** High quality specification as above but with a more classical shape.

**E80 Unisex** Top of the fashion range with a beautifully sculptured 'tortoise shell' type plastic frame in brown and crystal.

**E116 Clip-On** Designed to fit almost any type of glasses and incorporating an ingenious 'flip-up' action.

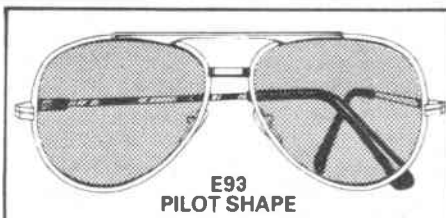

**E93  
 PILOT SHAPE**

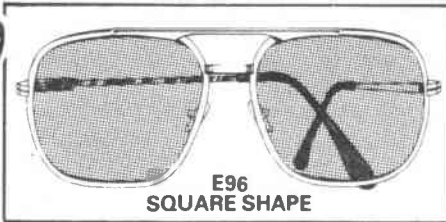

**E96  
 SQUARE SHAPE**



**E80  
 UNISEX**



**E116  
 CLIP-ON**

**FREE!**

Crushproof case with every pair ordered!



**TO: Amateur Radio**

Sunglasses Offer PO Box 211, Brentwood Essex NP4 5DY

Please send me the following pair(s) at £7.95 plus 65p P&P per pair.

NO REQUIRED

E93 in Gilt/Nickel/Black\* frame

E96 in Gilt/Nickel/Black\* frame

E80 in 'Tortoise Shell' frame

E116 in Gilt frame

\*Please delete.

I enclose cheque/P.O. for £ made payable to **Amateur Radio**

Name \_\_\_\_\_

Address \_\_\_\_\_

\_\_\_\_\_

\_\_\_\_\_

Post Code \_\_\_\_\_

**NO QUIBBLE MONEY BACK GUARANTEE!!**

Allow up to 14 days for delivery.

0885

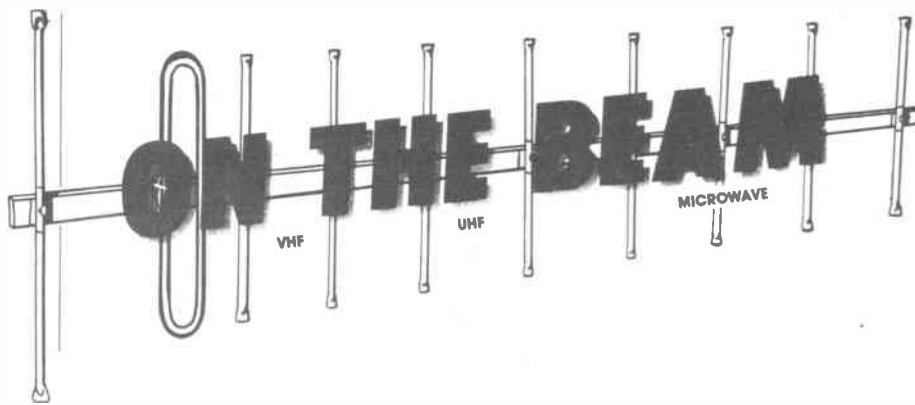

## News and comment from Glen Ross G8MWR

### IT'S OURS

After years of hope and a tremendous amount of back stage work by the RSGB it was announced in the House of Commons on 28 June that there is to be an amateur allocation between 50 and 50.5MHz.

No details were given at the time the statement was made as to who could use the band or any power limits that might be imposed; we will keep you posted as soon as information is available.

There is still some way to go until we can actually make use of the new band as we shall have to have amendments to licences etc. There can be no doubt that this is one of the most exciting pieces of news to hit the VHF scene for many years and gives everyone some exciting operating to look forward to.

I say everyone because the RSGB has always stated that they would negotiate on the basis of class A and B availability on the band. Three hearty cheers for them, yet another job well done.

### The Sporadics

They did arrive eventually but, as with the event last year, there seemed to be very little of it and not a lot to get very excited about. There is still time as I write this for more activity to arrive, so perhaps we should keep our fingers crossed and hope for better things to come.

One thing that has become obvious is that each year there are more and more British stations on the band waiting to grab whatever turns up, and that it is becoming more difficult to get a signal to the DX station due to the incredible amount of QRM that is flying about.

I managed a few contacts into Italy and Yugoslavia by getting the stations just as they were coming up out of the noise, but each time that I finished my contact all hell broke loose on the frequency. Various people have reported getting contacts into SV, 9H1, 9A, I, YU, HG, EA6 and YO. The stuff has been around but there have been none of the really immense openings that were common a few years ago.

### Other bands

All of the above activity took place on two metres, so what of the other bands? Conditions on 50 and 70MHz have been good in patches but the continental TV stations have been making life very difficult. As you will appreciate, the sporadic activity comes in earlier on those bands and stays around for a lot longer, so these high power broadcast stations, which have every right to be there, can make life very difficult. However, the 5B4CY beacons have been heard on both these bands and there are reports from America that both the GB3NHQ and GB3SIX beacons on the 50MHz bands have been received over there at a good strength at around 0200GMT. (Real night-hawk stuff, this!). The report on GB3NHQ is most interesting as this beacon runs around 15 watts to a pair of dipoles and is not well sited.

### New facilities

The first one to comment on is the news that the age at which you can hold an Amateur Radio Certificate has been reduced from 14 to 10 years. This is not the same as holding a licence, it simply means that anyone holding the certificate can operate your station under your supervision.

The one thing to bear in mind is that you have to have taken the Morse test to get the certificate but the requirement to hold an A licence is that the CW test must not predate your application by more than a year, so you could find yourself having to take the Morse test all over again.

Whilst on this subject it is nice to see the test being made available at so many rallies. It needed a lot of effort to get the powers that be to go along with this idea and the fact that they eventually did is due almost entirely to the man you write to for your time slot. You may feel that a word of appreciation would not come amiss.

### More good news?

The next piece of news to notice is the proposal for an intermediate licence, now before the authorities. To get this you would need to have the RAE and a Morse test at five words a minute (can you really use Morse at that speed)? This would then give you CW access to some of the HF bands.

Just what the specific terms of the licence will be are not yet known nor is it very obvious what the hoped for benefits are.

Surely if the VHF operator is up to five words a minute it does not take all that much more practice to get up to twelve and a full ticket. One thing is for sure, it certainly will not please all those who have been agitating for a 'free for all' novice licence.

### Certificates

We are up and running at last and the first batch of wallpaper has gone out.

One problem that has come up is that you all want your check logs back, but some of you did not put your call sign on the covering letter and I did not notice until it was too late. At least I have the names and from now on I shall check the call signs on the letter!

So far all the awards have been for two metre operation and the first bronze issued went to Mr J L Charnock of Wigan, who also has the honour of collecting the first Silver award issued. Only two other people have claimed both awards. The first was G1KHN of Chorley. Terry runs 50 watts to a pair of eight element Yagis and comments on the generally poor location.

The other one was G6IJM from Blackpool who submits a claim for SSB operation only. Still in the North (there must be some good vibrations up there), we have a bronze claim from G1KDF of Ormskirk. His was obtained using a Trio 9130 with a 160 watt amp and a nine element Tonna at 38 feet.

### Down south

Ian Morgan of Pontypool wades in for a Bronze using an FT290, a 30 watt amp and 10 ele beam, and he comments on having to work hard to get the counties. It's not worth having if it comes easy, Ian.

Another Ian, this time G1FXG of Bury St Edmunds, goes for Bronze with an identical set-up and, not to be out-done, Ian's friend Mike G1IPA, also claims the Bronze award.

His was achieved using a TS700G (one of the best two metre rigs ever available) running only eight watts to a 14 element yagi, no pre-amp, no linear, as he puts it. He also makes the comment that all the contacts were made in the space of sixteen days. On now to Chesterfield and G6PBW, who qualifies for the Bronze award with a beautifully presented check log.

The real optimist is G0BPS who claims a Bronze certificate and then asks if Moonbounce contacts can be counted towards the award! Not so surprising



## ON THE BEAM

when you find he has a 4CX250 and stacked parabeads! The answer is that any contacts other than those via repeaters count for the award, and that the certificate can be endorsed to your own requirement. If you think it is worth claiming an award for, then write and tell me.

One of the nicest things to come out of it so far is the number of people who say that they found the award worth working for and that it is a change from just chasing squares. That was the idea, lads.

### Top Band

These four metre lads are on the ball and not missing a chance to get some publicity for their activities. The main news this month is of an expedition from the Nottingham area, which is going up to North Ronaldsway from 8 to 16 August, from where it will live on YT square, the main activity on this band being scheduled for the Tuesday 13th.

The sporadic-E hit the band on 31 May and has continued ever since. There were massive disturbances during early June with ZB2VHF, the Gibraltar beacon, being regularly heard. No contacts with the Rock have been forthcoming. Another unusual spot heard from was Lundy Island in the Bristol Channel, in the shape of GB4LIE who was there as an expedition station.

From up North comes news that Nick

G4KUX has now got County Durham firmly on the four metre map. G4VOZ comments on the fact that our certificates are not issued for four metres. They could be issued for any band above 30MHz as the wording has been designed with extension possibilities in mind. How about telling us how you would set up the three grades for your particular band or interest? G4VOZ also asks us to say that all activity on four metres, irrespective of mode, is normally on horizontal polarisation.

### Repeaters

Last month I commented on the report of several repeaters possibly having to move to make way for GB3GD on the Isle of Man. This has brought in a tremendous amount of comment from you, nearly all of it agreeing with the comments I made. One thing that must be firmly kept in mind is that there seems to have been no firm decision made as yet and that the comments made were based on the thinking behind the projected move.

The one thing that is overwhelmingly apparent is that you all seem to be in agreement with the proposal to make use of 12.5kHz spacing. In the USA there has been a similar move to change repeater spacing and this has resulted in a lot of heated exchanges as to the merits or otherwise of making the move. It must come sooner or later, so why not

do it now and start getting the benefits as soon as possible?

### Odds and ends

Remember the Belgian fiasco of a few months ago when, as this magazine so delightfully put it, the question arose: 'Is ON off'? Well, it is back with us again with reports that they may lose some allocation above two metres. This is mainly due, it would seem, to lack of use; don't think it couldn't happen... use it or lose it.

Have you noticed the reluctance to use the new Maidenhead locators? People do not seem to like them and the Dutch have given them up completely. They were supposed to be mainly for the benefit of the HF bands (where?), but listening around down there they do not seem to be getting much use. Boris is still 145kms from Moscow rather than in whatever the square is.

The shuttle flight is on, probably around the 13th of the month, and the lads are over in Eire trying to work the States on two metres. The best of luck to both activities.

### The big switch

What a wide ranging column this month. Please keep your comments, news and certificate claims coming to me at: 81 Ringwood Highway, Coventry or on Prestel, as more of you are doing, on 203616941.

**NEXT  
MONTH**

*Amateur*  
**RADIO**

**all the regulars. . .**

DX Diary  
On the Beam  
Back to Basics  
SWL  
Straight and Level  
Your letters and  
features covering  
the whole of  
Amateur Radio

### ■ ANGUS MCKENZIE TESTS

Next month G3OSS reviews the Icom IC735 mobile HF transceiver and some bits and pieces for the 934MHz operator

### ■ BEGINNERS' WORKSHOP

A further instalment in Rev George Dobbs', G3RJV, construction series for the beginner

**DON'T MISS THE SEPTEMBER ISSUE**

On sale 29 August

## AFFORDABLE ACCURACY QUALITY MULTIMETERS FROM ARMON

### ANALOGUE

**HM-102BZ**  
10ADC Range, 20K $\Omega$ /VDC,  
Buzzer, Battery Test Scale  
**£13.00**

19 measuring ranges

**HM-102R**  
Low end voltage & current  
ranges, Jack for Audio o/p  
Voltages ..... **£11.00**  
20 measuring ranges.

**HM-1015**  
Rugged, Pocket sized meter,  
for general purpose use  
**£7.50**

16 measuring ranges

Battery, Test Leads and  
Manual included with each  
model.

### DIGITAL

**HC-6010** 0.5% Accuracy,  
Standard Model ..... **£33.50**

**HC-5010T** 0.25% Accuracy,  
TR Test Facility ..... **£39.50**

All models have full  
functions and ranges and  
feature:

3½ digit 0.5" LED display  
Low battery indication  
Auto zero & Auto polarity  
ABS Plastic Casing & Tilt  
Stand  
DC AC 10amp Range  
Overload Protection on all  
ranges.  
Battery, Spare Fuse, Test  
Leads and Manual

HC 5010  
0.25% accuracy  
rotary  
**£36.50**



HC 7030  
0.1% accuracy  
**£39.50**  
push button

HM 102 BZ  
**£13.00**

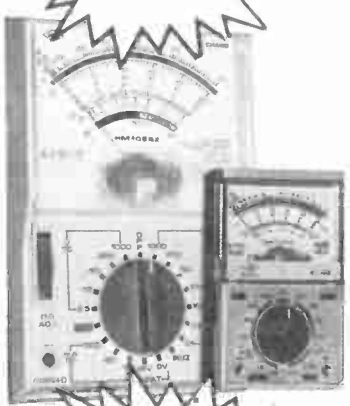

HM 1015  
**£7.50**

### FULL DETAILS ON APPLICATION FROM:- ARMON ELECTRONICS LTD

DEPT U HERON HOUSE, 109 WEMBLEY HILL ROAD,  
WEMBLEY, MIDDLESEX HA9 8AG  
TELEPHONE 01-902 4321 TELEX 923985  
PLEASE ADD 15% to your order for VAT. P&P Free of  
charge. Payment by cheque with order  
Offer applicable to mainland UK only  
Trade enquiries invited  
Please allow 28 days for delivery



# TECHNICIAN ENGINEERS COMMUNICATIONS AND ELECTRONICS

## A Planned Career in Technology in the Cotswolds

Salaries up to £11,445

- **VACANCIES** at both **TECHNICIAN ENGINEER** and **ENGINEERING TECHNICIAN** level.
- **CHALLENGING WORK** in the development and support of highly sophisticated communications and computer systems.
- **OPPORTUNITIES** for gaining experience in a wide variety of technical roles.
- **EXTENSIVE ENGINEERING FACILITIES**

- **CAREER PLANNING** aided by regular assessments of performance.
- **ADVANCEMENT** opportunities on the basis of proven ability.
- **OVERSEAS** service (voluntary).
- **FLEXIBLE** working hours with up to six weeks leave.
- **RELOCATION EXPENSES** in most cases.

Applicants for the higher grade of **TECHNICIAN ENGINEER** should normally possess a BTEC Higher National Certificate/ Diploma in electronics or other relevant subject; or a City and Guilds Full Technological Certificate, or an equivalent qualification. An aggregate of at least 8 years relevant training and

experience is required. Registration as a Technician Engineer (T.Eng) would be an advantage. **Salary Scale: £9,113 – £11,445**  
Applicants with BTEC ONC or equivalent and at least 4 years relevant training and experience are eligible for posts at the **ENGINEERING TECHNICIAN** level for which a structured training programme is provided. **Salary Scale: £6,599 – £9,135**

**INTERESTED?** Then for either post send for full details and application form to the address below, quoting Ref: T/6523/85

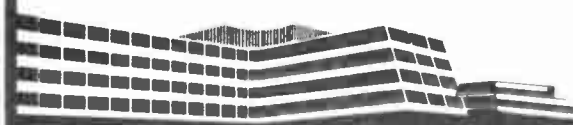

THE RECRUITMENT OFFICE, GCHQ, ROOM A/1108  
OAKLEY, PRIORS ROAD, CHELTENHAM, GLOS GL52 5AJ  
OR TELEPHONE (0242) 32912/3



# WOOD & DOUGLAS

## ★ NEW CATALOGUE ★ NEW PRODUCTS ★ NEW PRICES

| Package Prices                            |   | KH     |
|---|---|--------|
| 1. 500mW TV Transmitter                   | (70FM05T4 + TVM1 + BPF433)                    | 40.00  |
| 2. 500mW TV Transceiver                   | (As 1 above plus TVUP2 + PSI 433)             | 68.00  |
| 3. 10W TV Transmitter                     | (As 1 above plus 70FM10 + BDX35)              | 78.00  |
| 4. 10W TV Transceiver                     | (As 2 above plus 70FM10 + BDX35)              | 100.00 |
| 5. 70cms 500mW FM Transceiver             | (70T14 + 70R5 + SSR)                          | 80.00  |
| 6. 70cms 10W FM Transceiver               | (As 5 above plus 70FM10)                      | 118.00 |
| 7. 2M Linear/Pre-amp 10W                  | (144PA4/S + 144LIN10B)                        | 48.00  |
| 8. 2M Linear/Pre-amp 25W                  | (144PA4/S + 144LIN25B)                        | 48.00  |
| 2M Linear/Pre-amp 25W                     | (144PA4/S + 144LIN25C)                        | 81.00  |
| 9. 70cms Synthesised 10W Transceiver      | (R5 + SY + AX + MOD + SSR + 70FM10)           | 168.00 |
| 10. 2M Synthesised 10W Transceiver        | (R5 + SY + SY + 2T + SSR + 144FM10A)          | 128.00 |
| 11. 2M Crystal Controlled 10W Transceiver | (R5 + T3 + BPF + 144FM10 + SSR)               | 98.00  |
| 12. 70cms Linear/Pre-amp                  | (70LIN3 + 70PA2/S)                            | 47.00  |
| 13. 24cms FMTV Receive, video out (Kit)   | (VIDIF, 1250DC50 Boxed)                       | 108.00 |
| 14. 24cms FMTV Receive, video out (Ass)   | (VIDIF, 1250DC50 Boxed)                       | 120.00 |
| 15. 24cms FMTV Receive, Ch 36 out (Kit)   | (VIDIF, TVMOD1, 1250DC50 Boxed)               | 110.00 |
| 16. 24cms FMTV Receive, Ch 36 out (Ass)   | (VIDIF, TVMOD1, 1250DC50 Boxed)               | 128.00 |
| 17. 24cms FMTV Transmit (Kit)             | (UFM01, 70LIN3/LT, 70FM10, WDV400/1200 Boxed) | 140.00 |
| 18. 24cms FMTV Transmit (Ass)             | (UFM01, 70LIN3/LT, 70FM10, WDV400/1200 Boxed) | 170.00 |

| 70cms Transceiver Kits and Accessories | CODE      | ASSEMBLED | KIT   |
|--|-----------|-----------|-------|
| FM Transmitter (0.5W)                  | 70FM05T4  | 52.25     | 33.05 |
| FM Receiver (with PIN RF c/o)          | 70FM05R5  | 68.75     | 48.10 |
| Transmitter & Channel Adaptor          | 70MC06T   | 21.75     | 14.95 |
| Receiver & Channel Adaptor             | 70MC08R   | 28.95     | 18.90 |
| Synthesiser (2 PCB's)                  | 70SY25B   | 91.60     | 55.35 |
| Synthesiser Transmitter Amp            | A-X3U-06F | 36.40     | 24.30 |
| Synthesiser Modulator                  | MOD 1     | 9.10      | 5.75  |
| Bandpass Filter                        | BPF 433   | 8.95      | 5.65  |
| PIN RF Switch                          | PSI 433   | 7.90      | 5.60  |
| Converter (2M or 10M i.f.)             | 70R2/2    | 28.40     | 21.10 |

| 70cms Power Amplifiers (FM/CW Use)           |           |        |
|--|-----------|--------|
| 50mW to 500mW                                | 70FM1     | 24.60  |
| 500mW to 3W                                  | 70FM3     | 28.75  |
| 500mW to 10W                                 | 70FM10    | 48.10  |
| 3W to 10W                                    | 70FM3/10  | 27.05  |
| 10W to 40W                                   | 70FM40    | 78.50  |
| Combined Power Amp/Pre-Amp (Auto Changeover) | 70PA/FM10 | 53.50  |
| 500mW to 3W (Auto Changeover)                | 70FM3B    | T.B.C. |

| 70cms Linear                              |            |       |
|---|------------|-------|
| 500mW to 3W (Straight amp, no changeover) | 70LIN3/LT  | 31.40 |
| 3W to 10W (Auto Changeover)               | 70LIN3/10E | 47.20 |
| 1W to 7W (Auto Changeover)                | 70LIN10    | 50.15 |

| 70cms Pre-Amplifiers     |         |       |
|--------------------------|---------|-------|
| Bipolar Miniature (13db) | 70PA2   | 8.95  |
| RF Switched (30W)        | 70PA2/S | 26.30 |
| GaAs FET (16db)          | 70PA5   | 20.95 |

| AM TV Products                     |        |       |
|------------------------------------|--------|-------|
| Receiver Converter (Ch 36 Output)  | TVUP2  | 28.75 |
| Pattern Generator (Mains PSU)      | TVPG1  | 48.50 |
| TV Modulator (For Transmission)    | TVM1   | 10.35 |
| Ch 36 Modulator (For TV Injection) | TVMOD1 | 10.15 |

| 2M Transceiver Kits and Accessories  |          |       |
|--------------------------------------|----------|-------|
| FM Transmitter (1.5W)                | 144FM2T3 | 45.35 |
| FM Receiver (with PIN RF Changeover) | 144FM2R5 | 68.25 |
| Synthesiser (2 PCB's)                | 144SY25B | 84.10 |
| Synthesiser Multi/Amp (1.5W O/P)     | SY2T     | 30.95 |
| Bandpass Filter                      | BPF 144  | 6.85  |
| PIN RF Switch                        | PSI 144  | 7.90  |

| 2M Power Amplifiers (FM/CW Use) |          |       |
|---------------------------------|----------|-------|
| 1.5W to 10W (No Changeover)     | 144FM10A | 29.90 |
| 1.5W to 10W (Auto-Changeover)   | 144FM10B | 42.40 |

| 2M Linear                              |           |       |
|--|-----------|-------|
| 1.5W to 10W (SSB/FM) (Auto Changeover) | 144LIN10B | 42.70 |
| 2.5W to 25W (SSB/FM) (Auto Changeover) | 144LIN25B | 44.95 |
| 1.0W to 25W (SSB/FM) (Auto Changeover) | 144LIN25C | 48.20 |
| 1/3W to 30W (SSB/FM) (Auto Changeover) | 144LIN30  | 48.50 |

| 2M Pre-Amplifiers                       |          |       |
|---|----------|-------|
| Low Noise, Miniature                    | 144PA3   | 9.10  |
| Low Noise, Improved Performance         | 144PA4   | 13.45 |
| Low Noise, RF Switched, Full Changeover | 144PA4/S | 25.95 |

| General Accessories               |       |       |
|-----------------------------------|-------|-------|
| Toneburst                         | TB2   | 7.10  |
| Piptone                           | PT3   | 8.05  |
| Keytone                           | PTK3  | 9.45  |
| Relayed Keytone                   | PTK4R | 13.40 |
| Regulator (12V, low differential) | REG1  | 7.25  |
| Solid State Supply Switch         | SSR1  | 5.10  |
| Microphone Pre-Amplifier          | MPA2  | 6.00  |
| Reflectometer                     | SWR1  | 6.95  |
| CW Filter                         | CWF1  | 8.95  |
| TVI Filter (Boxed)                | HPF1  | 5.95  |
| Audio Amplifier                   | AF1   | 10.40 |

| FM TV Modules                              |             |       |
|--|-------------|-------|
| 50mW 42MHz Source (Video Input)            | UFM01       | 30.10 |
| 50MHz i.f. Processor                       | VIDIF       | 38.20 |
| Varactor Multiplier (Boxed)                | WDV400/1200 | 83.95 |
| 1250MHz Downconverter (50MHz i.f.) (Boxed) | 1250DC50    | 69.95 |
| 1250MHz Masthead Pre-amplifier             | 1250PA2/S   | —     |
| Transmit Sound Modulator                   | SCR-2       | —     |
| Receive Sound De-Modulator                 | SCR-2       | —     |

Details of these and other new products are included in our 1985 catalogue. This will be posted to you on receipt of an A5 stamped addressed envelope. Kits are usually available by return of post but please allow 28 days for any unforeseen shortages. Place your order by post or by telephone using your credit card. Please include £1.00 to cover order handling and postage.

Our products are kits or assembled kits consisting of circuit board and all components to mount on the board. We do not include external hardware such as boxes, connectors etc.

If your purchase does not work when assembled then apart from being surprised we will offer to service the module for a small charge depending on the complexity of the project. So please remember ...

**ANYONE CAN SELL A KIT . . . REPUTATION SELLS OURS**  
**UNIT3, YOUNGS INDUSTRIAL ESTATE**  
**ALDERMASTON, READING RG7 4PQ**  
**TEL: (073 56) 71444.**  
**TX: 848702**

# FIELD ELECTRIC LTD

3 SHENLEY RD, BOREHAMWOOD, HERTS. TELEPHONE 01-953-6009  
 ☒/OFFICIAL: ORDERS/OVERSEAS ENQUIRIES WELCOME  
 OPEN 6 DAY'S A WEEK 9.00am/5.00pm THUR.9.00am/1.00pm

|   |        |
|---|--------|
| 12" BLACK & WHITE 75Ω COMPOSITE VIDEO, HIGH RESOLO 80 CHARACTER IN BRUSHED ALI CASE. TESTED                     | £23.00 |
| SPECIAL OFFER 12" BLACK & WHITE 75Ω COMPOSITE VIDEO, HIGH RESOLO 80 CHARACTER. IN CASE NEW TUBES FITTED. TESTED | 16.95  |
| 9" HITACHI BLACK & WHITE 75Ω COMPOSITE VIDEO. HIGH RESOLO 80 CHARACTER IN CASE. TESTED                          | 45.00  |
| 12" GREEN PHOS. 75Ω COMPOSITE VIDEO. HIGH RESOLO 80 CHARACTER IN BRUSHED ALI CASE. TESTED.                      | 25.00  |
| SPECIAL OFFER 24" 75Ω COMPOSITE VIDEO. HIGH RESOLO. GREEN PHOS IN CASE. TESTED.                                 | 15.95  |
| ALL MONITORS 230 V.A.C. RING FOR CARRIAGE DETAILS   |        |
| 1 ONLY K.S.R. 33 230 V.A.C. RS232 TELETYPE. BRAND NEW. C/P 7 00   | 69.00  |
| M.P.I. 1/2" HEIGHT DISK DRIVE. SINGLE SIDED 40 TRACK. 5 1/2" NEW & BOXED. C/P 2.50                              | 65.00  |
| 1 ONLY LAMBDA 3 PHASE 0-36V 72 AMP 208 V A.C. C/P 16.00   | 60.00  |
| TEAC DATA CASSETTE MEC'S EX-EQUIP. C/P 2.00   | 10.00  |
| NRZ DATA CASSETTE MEC'S EX-EQUIP. C/P 2.00  | 10.00  |

PLESSEY 2/4 MEGABYTE (MAX) GENERAL PURPOSE RANDOM ACCESS MEMORY SYSTEM. CAN BE USED FOR MAINFRAME/MINI MICROPROCESSOR'S NEW & BOXED WITH DATA P.O.A.

AURALITE LIGHT WEIGHT HEADSET & MIC: IDEAL FOR COMMUNICATIONS EX-EQUIP. TESTED. C/P 2.00

|  |        |
|--|--------|
| ALL P.S.U. 200-250 V.A.C. INPUTS SWITCH MODE P.S.U. C/P 2.00 UNLESS STATED |        |
| 3.5V 10AMP D.C.  | £12.50 |
| ADVANCE 5V 20AMP D.C.  | 18.50  |
| 5V 30AMP   | 19.95  |
| 5V 40AMP D.C.  | 40.00  |
| 5V 60AMP D.C.  | 20.00  |
| FARNELL 6V 5AMP D.C. 145x87x32 M/M   | 20.00  |
| FARNELL 5V 20AMP D.C.  | 20.00  |
| 6V 40AMP D.C.  | 40.00  |
| FARNELL 24V 5AMP   | 35.00  |
| FARNELL 12V 10AMP  | 35.00  |

FARNELL FAN COOLED MULTI-RAIL SWITCH MODE +15V AT 15AMP -5V AT 1AMP + 12V AT 4AMP - 12V AT 1AMP GOULD MULTI-RAIL SWITCH MODE NEW 5V 40AMP - 12V 4AMP + 15V 11 AMP C/P 6 00 GOULD NEW & BOXED 6V 40AMP

COUTANT 0-7V 7AMP D.C. LINEAR NEW & BOXED GOULD PMA 47 12V 3AMP LINEAR COUTANT ESM LINEAR MULTI-RAIL 5V 13AMP D.C. ±12V 1.5AMP OR ±15V 1.5AMP 12V OR 24V 2AMP UNREGULATED COMPLETE BOOK CIRCUIT DIA NEW BOXED C/P 6 00

VOLTEX LINEAR MULTI-RAIL + 12V 600M/A + 5V 1AMP D.C. P.C. SUPPLY +5V 1AMP D.C. TOROIDAL T/X REGULATED

**WE ALSO BUY EQUIPMENT SURPLUS TO REQUIREMENT.**  
**SEND LIST OR PHONE**  
**ALL PRICES INC VAT 15% UNLESS STATED**

# RADIO AMATEURS EXAM? PASS FIRST TIME!

**Before you enrol check the benefits of RRC's unique Home Tuition Service**

RRC has helped thousands of students to success in their examinations with this unique system of postal tuition, one which guides you, step-by-step, to qualify in the shortest possible time. Only The Rapid Results College offers you all these advantages:

- A qualified personal tutor
- Study material prepared by specialists
- Completely self-contained courses
- Handy pocket-sized booklets
- Personal study programme
- Regular marked tests
- Courses regularly updated
- Stop-Press Bulletins
- Free advice before you enrol
- Telephone Helpline
- Free 'How to Study' Guide
- Instalment Plan
- Free Postage on course material
- Optional Reports for Employers
- Extra tuition free if you don't pass first time

**POST COUPON TODAY FOR FREE RADIO AMATEURS PROSPECTUS**  
 Please send me my prospectus as quickly as possible.

Mr/Mrs/Miss/Ms \_\_\_\_\_

Address \_\_\_\_\_

Postcode \_\_\_\_\_

**RRC** The Rapid Results College   
 Dept J57, Turtion House, London SW 19 4DS FREE ADVIC'E: 01 947 7272 (9am-5pm)  
 PROSPECTUS: 01 946 1102/24 hour Recordallocal Service quoting Dept No J57

# BACK TO BASICS

## Bill Mantovani G4ZVB concludes the technical part of the RAE syllabus with a final look at MEASUREMENTS

In concluding our look at measurements this month, we also come to the end of the technical part of the RAE syllabus, so let's get straight on with it.

### Frequency measurement

In order to ensure that an amateur transmission does not fall outside of the permitted frequency bands you must know how to check, with some degree of accuracy, the calibration of the transmitter. As well as avoiding causing interference to other users of the frequency spectrum, it also means that you will not be breaching the amateur licence conditions and so it is natural enough to expect to be questioned on this in the exam. Therefore, make sure you understand this part of the syllabus very well as it is quite important.

There are a number of ways in which the calibration of a transmitter can be checked, and one of them is by simply using a calibrated receiver. Obviously, if the receiver and transmitter are in extremely close proximity to each other, ie side by side in the shack, it would not be practicable to tune the receiver directly to the transmitter frequency, so instead the receiver is used to tune to the output frequency of the transmitter VFO. Once this frequency has been established it should be possible to calculate the output frequency of the transmitter. Using this procedure the tuning range of the VFO can be fully checked and adjustments made if necessary.

Remember, though, that with the above method, the accuracy of the results depends on the receiver itself being fairly accurately calibrated in the first instance. Also, even though the VFO will probably be screened (*should* be screened if you recall what we covered earlier on VFO stability etc), with the receiver very close to the transmitter the signal from the VFO may be strong enough to swamp the RF stage (or stages) of the receiver, and thus make accurate calibration difficult. If possible, the RF gain of the receiver should be turned right down, and it will certainly not be necessary to have the antenna connected.

So, we must first look at calibrating the receiver. This can be done in a number of ways, all with reasonable accuracy. (Please note at this point that the methods to be described are not necessarily suitable for all types of receivers, for reasons that will become obvious in a moment). One simple method of checking the calibration of a receiver is to tune to one of the standard frequency transmissions, such as WWV from the USA or our own MSF Rugby. These transmissions are made on accurate spot frequencies and a brief list of standard frequency stations is given in *Table 1*.

Unfortunately, there are a number of problems with using this method which

can detract from the accuracy of the eventual receiver calibration. Whilst the standard frequency transmissions are maintained to a very high accuracy, reception of the signals over long distances could be affected by fading (propagation would in this case be by sky-wave), and by a phenomenon known as the *Doppler Effect*. The latter can cause quite a large error in reception and occurs when the surface from which the sky-wave is being reflected is in motion.

This is particularly the case at the time when the various layers in the ionosphere are changing position, and is the same effect as seen on a television screen when a plane passes overhead and causes the picture to 'flutter'. To get over these problems it is preferable to use a low-frequency standard frequency transmission such as MSF Rugby on 60kHz, in which case propagation will be by ground (or surface) wave and so will not suffer from Doppler shift.

However, this may not always be possible, especially if the receiver only covers the amateur bands and does not receive even the standard frequency stations transmitting on short wave. Another more favoured method for accurately calibrating a receiver irrespective of its frequency coverage is by use of a separate crystal oscillator to produce beat notes. For example, the harmonics from a 100kHz crystal oscillator will produce beat notes every 100kHz in the receiver, which are used to calibrate the dial and thus mark the band edges.

This method can be used with both amateur and general coverage receivers alike but, with the latter, above about 4MHz the 100kHz markers may become difficult to resolve so additional crystal frequencies of 500kHz or 1MHz would also be required as appropriate. However, amateur bands only receivers or the current solid-state general coverage receivers have adequate bandwidth so that a 100kHz (together with possibly a 25kHz) crystal oscillator is perfectly adequate.

The crystal or crystals used in the calibration oscillator should be of close tolerance to ensure good accuracy. One way of checking a 100kHz crystal is to compare the second harmonic with the BBC's Droitwich transmitter on 200kHz long wave. This transmitter frequency is maintained very accurately and you may have sometimes come across digital clock circuits in magazines that actually use this transmitter as their time standard.

There are other ways of checking the receiver dial, for instance, using the various amateur beacons, which although not as accurate as that outlined above, will still serve to give an indication of whether the receiver dial is out of calibration. Once the receiver is properly calibrated the transmitter VFO can be checked against it.

Today, things tend to be a little bit easier than in the days before transceivers became popular. Because both transmitter and receiver share the same VFO then setting up the dial on receive using a crystal oscillator means that the

**Table 1** A brief list of some frequency stations

| Call sign | Frequency                                 | Location                    |
|-----------|---|-----------------------------|
| OMA       | 2.5MHz                                    | Prague, Czechoslovakia      |
| FFH       | 2.5MHz                                    | Paris, France               |
| IAM       | 5.0MHz                                    | Rome, Italy                 |
| IBF       | 5.0MHz                                    | Turin, Italy                |
| JJY       | 2.5, 5.0, 10.0<br>and 15.0MHz             | Tokyo, Japan                |
| MSF       | 2.5, 5.0 and 10MHz                        | Rugby, GB                   |
| MSF       | 60kHz                                     | Rugby, GB                   |
| WWV       | 2.5, 5.0, 10.0,<br>15.0, 20.0 and 25.0MHz | Fort Collins, Colorado, USA |
| WWVH      | 2.5, 5.0, 10.0,<br>15.0 and 20.0MHz       | Kekaha-Kauai, Hawaii        |
| WWVB      | 60kHz                                     | Fort Collins, Colorado, USA |



# BACK TO BASICS

| Advantages   | Disadvantages   |
|--|---|
| Very accurate. Precise readings will indicate if a transmitter is operating just outside or inside a band edge                             | In order to obtain this accuracy in readings, the cost of the meter becomes quite high  |
| By making use of harmonics, the meter can be used over a wide frequency range without changing coils                                       | Because of the presence of harmonics, this could produce extra beat notes with the frequency being checked, causing confusion |
| The meter is easy to couple to the receiver or transmitter   | A power supply is required  |
| Calibration of the meter can be easily checked against a major broadcasting station or standard frequency station such as WWV or MSF Rugby | The power supply must be voltage stabilised to ensure that the oscillator calibration remains accurate at all times           |

**Table 2** Advantages and disadvantages of the heterodyne frequency meter

transmitter will also be calibrated accordingly. Most commercial amateur transceivers and receivers have crystal oscillators fitted as standard but failing that, or if you are building your own equipment, a very simple crystal calibrator can very easily be built using a minimal number of components and housed in the once popular tobacco tin or more modern die-cast metal box.

Just one word of warning about using a crystal oscillator for calibrating a receiver. Because the signal injected from the oscillator into the receiver will be quite strong, a superhet receiver will often give several spurious positions on the dial at which a beat note will be heard and it may not always be immediately obvious which of these is the true beat note and which are in fact spurious.

### The absorption frequency meter

Having used a receiver to check the transmitter VFO frequency, we should now know what frequency our transmitter is operating on – or do we? In practice it could just be that the transmitter PA stage has in fact been inadvertently tuned to the wrong frequency; this can happen. For instance, consider the case where the transmitter is switched to the 7MHz band but the PA has for some reason been accidentally tuned up on 14MHz.

This is just one case where, although rare, the error may not become immediately apparent. To check that a transmitter is giving an output in the correct band, an *absorption frequency meter* (or *absorption wavemeter*) is used. This is a very simple device and consists of a coil and a variable capacitor. Some form of indicating the point of resonance can also be incorporated and two such simple circuits are shown in *Figure 1*.

If the unit is held very close to the tuned circuit to be checked and the capacitor varied, at the point of resonance some energy will be absorbed by the wavemeter from the circuit under test and the indicator will show that this point has been reached.

When checking that the PA stage is tuned to the right frequency, the absorp-

tion of power from the PA tuned circuit is also indicated by a small change in the feed current to that tuned circuit and so should show up to some degree on the meter incorporated in the PA collector or anode circuit. The scale of the wavemeter tuning capacitor is calibrated in frequency allowing a direct read-off of the resonant frequency of the circuit under test.

The wavemeter itself can be calibrated using a receiver as follows. With the meter loosely coupled to the antenna lead, the receiver is tuned to a suitable station and the wavemeter tuning is then varied until the signal strength of the said station appears to fall. This is caused by the wavemeter absorbing some of the incoming signal and so it must be tuned to the same frequency as the receiver. The wavemeter dial can thus be marked-up accordingly and the process repeated for different frequencies until the whole scale on the meter is marked up. To extend the range of the wavemeter so that it can cover a number of bands, plug-in-coils are used.

The absorption wavemeter does have a number of disadvantages, which I advise you to learn. It is an insensitive instrument and as such must often be held very close to the circuit under test in order to obtain an indication of resonance. This might serve to detune the circuit under test and if the circuit is screened or in a position where access is difficult it may not be possible to use the meter at all. The absorption wavemeter is not accurate enough to give a precise reading of

the frequency being checked, only the order of that frequency. Thus it can indicate if a transmission falls within a certain band, but it cannot be used to check whether a transmitter is operating just inside or just outside of the band edges.

These limitations are offset by quite a few advantages. An absorption frequency meter is simple to construct for very low cost. It can be made to be rugged, requires no power supply, and most important, the direct reading off the scale does away with any confusion over spurious beat notes. It is also a very useful instrument for checking that frequency multiplier stages are tuned to the correct harmonic. The circuit shown in *Figure 1b* is often referred to as the 'field strength meter' and it can be used to check that a transmitter is free from parasitic oscillations.

### The dip meter

For the absorption wavemeter to function, the circuit under test must always be energised but this is not the case with the *dip meter*. Originally consisting of a valve oscillator (hence the name *grid dip oscillator* or GDO), but now more commonly built using a FET oscillator, the dip meter is more flexible than an absorption frequency meter despite only having the same sort of accuracy.

It works as follows. The coil of the dip meter is placed close to the tuned circuit under test and the oscillator is tuned until a dip is indicated on the meter. This of course is where it gets its name from! The tuned circuit under test does not have to be energised; instead, at the point when the oscillator in the dip meter is tuned to the same frequency as the test circuit, power is absorbed *from* the oscillator producing a dip in source current in the case of a FET, or a dip in grid current for a valve GDO.

### The heterodyne frequency meter

Another type of frequency measuring meter that basically consists of an oscillator, though in this case crystal controlled or of limited range, is the *heterodyne frequency meter*. This meter is designed to be extremely accurate, its tuned circuit being very stable, and if the frequency range is variable, the scale and tuning capacitor drive will allow this frequency meter to be set with great

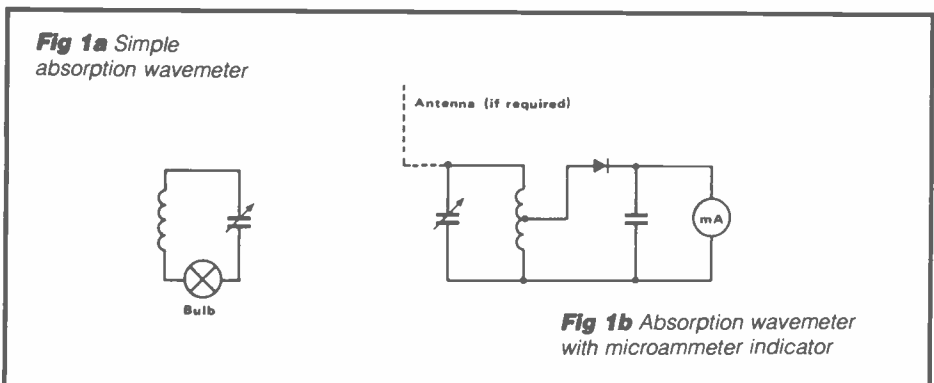

# BACK TO BASICS

precision. *Table 2* lists the advantages and disadvantages of the heterodyne frequency meter and, once again, it is in your interest to make sure you remember these for the RAE exam.

The RAE Manual gives the circuit diagram and explains the operation of such a frequency meter, but it is not absolutely necessary to remember all of this for the exam, what we have just covered above should suffice. A typical question would be centred around its advantages or disadvantages over other meters; you will not be asked to give a detailed explanation of how it works. Remember the basic circuit layout though, you might be presented with that and asked what the circuit is.

You can see from what we have just covered that the absorption and heterodyne frequency meters go hand in hand with each other, the first being used to ascertain roughly what order a frequency is and the latter to provide a more accurate frequency measurement.

## The digital frequency meter

Finally we come to the *digital frequency meter*, which is also covered in detail in the RAE Manual but about which you are only required, at this stage, to have a basic appreciation of. The digital frequency meter provides a simple but very accurate means of measuring frequency and, as its name suggests, uses integrated circuits to perform the frequency count and gives the readout on a digital display. It is also the easiest to use of the meters described.

Very briefly, the DFM measures frequency by first converting the signal applied to it into a square wave and then ANDing it with a very accurate clock signal. The output from the AND gate is counted and compared with the clock signal to give you the frequency of the input signal. The clock is crystal controlled and the oscillator usually generates a number of different duration clock pulses which allow the meter to be used over a wide frequency range.

## The oscilloscope

The oscilloscope is used for actually displaying the waveform we wish to examine. It has a cathode-ray tube, just like a TV set but much smaller, and as the electron beam inside the tube travels towards the screen it passes between two pairs of internally mounted parallel plates, one pair at right angles to the other. These plates are called the *X and Y deflector plates* and they cause the beam to be deflected as it passes between them by an amount dependent on the voltage applied to them. This may sound complicated, but it is all really quite simple.

The horizontal motion of the beam (from left to right across the screen) is performed by the X plates. A *timebase* circuit (usually inside the oscilloscope) generates a voltage that is proportional to time and this voltage is then applied to the X plates, causing the electron beam to scan horizontally at a speed dictated by the speed of the timebase. By making the speed of the timebase variable or switchable over a large range the oscilloscope can be made to cover a wide frequency band. With the beam now scanning horizontally, if an alternating voltage (ie the waveform to be examined) is applied to the Y plates the beam will trace out on the screen the waveform of that voltage.

The signal to be examined is usually very low level and if applied directly to the Y plates would produce almost no appreciable deflection. So, before the signal is fed to the Y plates it is amplified in the oscilloscope by the *Y amplifier* to bring it up to an appreciable level. Several amplification levels are often provided so that the oscilloscope can cope with input signals of different amplitude and each level is calibrated so that a set voltage applied at the input will give a known vertical deflection on the screen.

The screen itself will have calibration markings on it so that, for example, if the Y amplifier is switched to give a vertical

deflection of 1 volt per centimetre on the screen and an unknown alternating signal is applied at the input which deflects the beam by 2.5cm either side of the horizontal, that signal is being shown to have a peak to peak value of 5 volts. However, the Y amplifier does have a limited bandwidth and outside of this the calibration becomes invalid.

So that the display on the oscilloscope screen appears stationary and the waveform can be resolved, for every sweep of the beam the timebase must always be started at the same point on the waveform. This is achieved by either synchronising the frequency of the timebase with that of the input signal, or by using a *trigger* circuit.

If you think back to what we discussed about amplitude modulation and the problems that arise from over-modulation, you can see that the oscilloscope becomes a useful instrument for checking the modulated waveform in a transmitter to ensure that it does not exceed 100 per cent.

The method for doing this is explained in detail in the RAE Manual and need not be repeated here, for most of it is self-explanatory. Remember this use of the oscilloscope though, and make a note of the modulation waveforms you would expect for different levels of modulation.

## Power measurement of an SSB transmitter

Because the current drawn by the output stage of an SSB transmitter varies in accordance with the speech waveform, measuring the input power is not easy as a conventional meter movement is not able to accurately follow this rapid variation of input current. This is why, when we covered the topic of transmitters some months ago, we learned that the power rating for an SSB transmitter is normally expressed as PEP (*peak envelope power*). Put simply, this means the power that exists at the peaks of the speech waveform. Using an oscilloscope to look at the power being delivered by a transmitter (into a dummy load) the PEP of that transmitter can be measured as follows (refer to *Figure 2*).

Modulate the transmitter with two sinusoidal tones of equal amplitude (they must be non-harmonically related) and by measuring the current flowing through the load or the voltage across it, adjust the transmitter drive to give a mean power output into the dummy load of, say, 200W. Actually, any power level will do (or will have to do if you are checking a low-power transmitter), but the figure of 200W is used in the example because it conveniently corresponds to a deflection on the oscilloscope of 400W PEP (26dBW), which is the maximum power permitted by the UK amateur licence.

Note the peaks of the waveform shown on the oscilloscope. As the mean power (in this case 200W) being delivered into the load by the transmitter is equivalent to a PEP of twice this value, the points

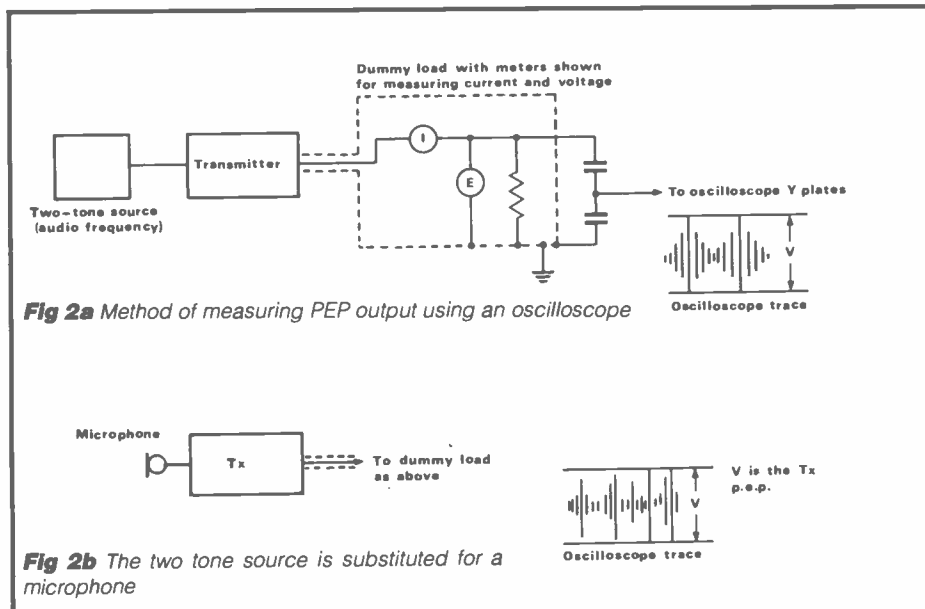



# BACK TO BASICS

noted on the oscilloscope represent a deflection corresponding to an output PEP, in our example, of 400W. Now that the PEP positions are marked on the oscilloscope, if we replace the two input tones with a microphone (*Figure 2b*) we can observe the output waveform from the transmitter and adjust the drive accordingly so that the peaks of the speech waveform do not exceed the marked points (ie 400W PEP).

The above method is also suitable for measuring the power output of a transmitter operating in a mode other than SSB, although in the case of AM mode a single tone source is all that is required for initial setting up. You are required to know of this recommended method of checking PEP for a transmitter because it is part of the RAE syllabus, but you will not normally find it necessary to have to do these measurements in practice unless you are contemplating using or building a transmitter or linear amplifier capable of giving an output which will exceed the legal limit. Most amateur equipment has outputs well inside this limit.

## VSWR measurement

Now we turn to the measurement of RF current. It is not possible to use the normal type of meter (milliammeter or voltmeter) to measure the RF current in a wire because, unlike a dc current, the RF current can vary depending upon where along the wire it is measured. Instead, to measure what the RF current is doing along the line we must look at something called the *voltage standing wave ratio* or VSWR. This VSWR is measured using a *reflectometer*, as shown in *Figure 3*. Using the reflectometer, which is more commonly referred to as a VSWR bridge or VSWR meter, the voltage standing wave ratio on the transmission line between transmitter and antenna can be checked as this then gives an indication of how well matched (or mismatched!) the system is.

The principle of the VSWR bridge is as follows. If the transmission line is not terminated in a load which matches its characteristic impedance, then some of the signal will be reflected back along the transmission line. The ratio of this reflected power to the power travelling in a forward direction along the transmission line is directly related to the VSWR, and is independent of where along the line the measurement is taken. This in theory means that irrespective of where the VSWR bridge is connected along the line, it will always produce the same result.

To explain briefly the circuit shown in *Figure 3*, a reflectometer bridge can be simply made by threading a piece of insulated wire down between the outer shield and the inner insulation of a short length of co-ax cable. The ends of the wire are each connected via a diode to a milliammeter. Part of the RF signal travelling down the co-ax in a forward direction is picked up by the wire, rectified by the appropriate diode and

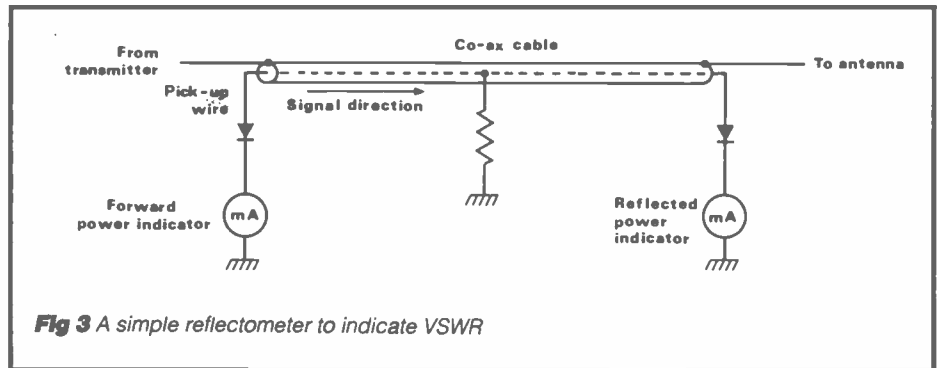

**Fig 3** A simple reflectometer to indicate VSWR

the resulting dc displayed on the meter. This is an indication of the so-called forward power. The same goes for the reflected signal, it being rectified by the other diode and the resulting dc displayed on the other meter. This is the 'reflected' power. The VSWR is then calculated from the ratio of these two readings.

This is just a simple (but nevertheless practical) VSWR bridge. Other more sophisticated reflectometers will incorporate a control (sometimes labelled 'calibration' or 'sensitivity') that allows the forward meter to be set to a calibration point, such as full scale deflection, so that the VSWR can then be directly read off the reflected power meter scale. Sometimes only one meter is used, with a switch to allow it to be used to read both forward and reflected power.

Finally, a very brief look at errors in measurements. In order to know how accurate a measurement is, we must know how accurate the actual measuring equipment is. When taking meter readings, for example, we must bear in mind the effect on our results of the inaccuracies or *tolerance* of the meter being used. The meter may actually be giving a slightly higher or slightly lower reading than is true, so this should be allowed for, especially when checking frequency. It might also be possible for a number of items in both the test equipment and the equipment under test to each have sufficient tolerance, so that when all the tolerance effects are added together the final reading may actually be quite inaccurate.

Tolerance can be expressed in any number of ways, but the more common are as a value (eg, plus or minus 100Hz) or as a percentage (eg, plus or minus 5 per cent). Two examples of how tolerance can affect actual readings are given in the RAE Manual and these should be studied along with any such questions you may come across (such as in R E G Petri's *Questions and Answers*, which appears in *Amateur Radio* most months), as these are the type of questions that you may have to answer in the RAE exam. Throughout this series I have tried to give some indication of the more popular type of questions that appear each time, so I hope you have been taking note. It is in no way possible to predict what there will be questions on but even the City

and Guilds appear to have their favourites.

Anyway, back to the examples in the manual for a moment. They are both easy to follow and need no further explaining here, save to say that they serve to indicate how the adding up of tolerances can affect a final result. Whilst the examples chosen are certainly extreme case ones in practice, it's just the sort of thing you might be asked to work out for the RAE.

The sample question about the lowest operating frequency for the transmitter in the 21MHz band is particularly interesting for it shows how a transmitter can still be inadvertently operated outside of the band edge, even if the operator thinks he is transmitting just inside it. It is sometimes forgotten that the transmission has bandwidth and that this must be taken into consideration when working very close to the band edges. The examiners however always seem to be well aware of this!

So you will now, no doubt, be relieved to know that we have concluded the 'technical' part of the RAE syllabus. All that remains is to cover the licence conditions, operating procedures and one or two other points that may be of benefit. This in no way means that the hard work stops here, for questions on the licence conditions take up almost two thirds of the first paper in the RAE exam and it is this part that many people actually fail on.

Next month then we will spend some time looking at the licence conditions, so do make sure that you have your copy of the publication *'How to become a radio amateur'*, which is available free of charge from: *The Radio Amateur Licensing Unit, Post Office Headquarters, Chetwynd House, Chesterfield, Derbyshire S49 1PF*. The licence conditions are also given in the RAE Manual, but there is other information in the RALU publication that we will look at, as well as the latter being recommended reading for the RAE.

**Acknowledgements and references**  
*Radio Amateurs' Examination Manual* – G L Benbow G3HB (RSGB).  
*Amateur Radio Operating Manual* – R J Eckersley G4FTJ (RSGB).  
*Radio Communication Handbook (fifth edition)* – RSGB.  
 City and Guilds of London Institute.

# S.E.M.

UNION MILLS, ISLE OF MAN

Tel: MAROWN (0624) 851277

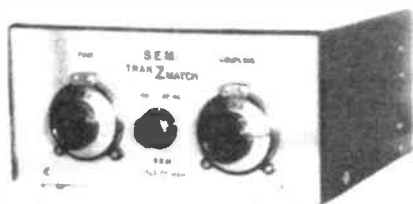

**SEMACT** We have at last overcome the enormous demand for our WAVEMETER and it's now in stock.

**S.E.M. TRANZMATCH.** The most versatile AERIAL MATCHING (Tuning) UNIT available. Matches 15 - 5,000ohms BALANCED or UNBALANCED feeders up to 1kw. Air coupled balun (no toroids) means no connection to equipment which can cure TVI both ways. An SO239 and screw terminals for CO-AX, END FED or TWIN FEED. They say "It will match anything". 8" x 4" x 7 1/4". 3 - 5.30MHz £89. 1 - 8.30MHz £99. The highly acclaimed EZITUNE built in (see below) £29.50 extra. All Ex stock.

**NEW SEM WAVEMETER.** Have you read your licence? Have you got a wavemeter? Covers 1.5-30MHz in 3 switched bands with a very nice meter readout. Only £29.50. Selling so quickly. But at last Ex stock.

**S.E.M. EZITUNE NEW CIRCUIT**

Gives MORE noise a bomb proof operation. Because no similar unit is made, its usefulness is not appreciated until you have used one. Eliminates need for S.W.R. bridge.

Clean up the bands by tuning up without transmitting. Increase your PA life by many times.

Connects in aerial lead, produces S9 + (1 - 170MHz) noise in receiver. Adjust A.T.U. or aerial for minimum noise. You have now put an exact 50Ohms into your transceiver. Fully protected, you can transmit through it, save your P.A. and stop QRM SO239s. 3" x 1 1/2" x 2". £38.00 Ex stock. P.c.b. to fit in any A.T.U. £29.50 Ex stock.

**S.E.M. IMABIC KEYSER.** No better fully auto keyer anywhere. Uses Curtis chip. R.F. proof. Sidetone etc. £38. A first class twin paddle key £17.50. Ex Stock.

**BRAID BREAKER/HI PASS FILTER.** Put in T.V. ant. lead to cure TVI. £6.50 Ex Stock.

**RF NOISE BRIDGE.** Adjustable 0-1,000ohms. 3" x 1 1/2" x 2" only. SO239s. 1-170MHz. Neat, accurate & economical. £34.50 Ex Stock.

**3 WAY ANTENNA SWITCH 1KW SO239s.** Good to 2metres. £17.50 Ex stock. Or 4th position to earth output £19.80 Ex Stock.

**S.E.M. 2 METRE TRANZMATCH.** 5 1/2" x 2", 3" deep. SO239s. £24.90 Ex stock.

**SENTINEL 2M LINEAR POWER/PRE-AMPLIFIERS**

Now feature either POWER AMP alone or PRE-AMP alone or both POWER AND PRE-AMP or STRAIGHT THROU when OFF. Plus a gain control on the PRE-AMP from 0 to 20dB. N.F. around 1dB with a neutralised strip line DUAL GATE MOSFET. (BF981).

Ultra LINEAR for all modes and R.F. or P.T.T. switched. 13.8V nominal supply. SO239 sockets.

Three Models:

- 1. 3/36. 12 times power gain. E.g. 3W in 36W out. £70.00.
- 2. 10/50. 10W in 50W out. £86.00.
- 3. 10/100. 10W in 100W out. £136.00.

All Ex stock

**POWER SUPPLIES** for our linears 12 amp £49.00. 6 amp £34.00.

**SENTINEL AUTO 2 METRE or 4 METRE PRE-AMPLIFIER**

RF switched. same spec. as in our linears. see above. 400W P.E.P. power rating. Use on any mode. 12V 25mA. £29.50 \* Ex stock.

**PA5.** Same specification as the Auto including 240V P.S.U. £33.00\* Ex stock

**SENTINEL 2 METRE PRE-AMPLIFIER.** No R.F. switch. £15.00\* Ex stock.

**S.E.M. AUDIO MULTIFILTER (A very good filter at a very good price)**

The most versatile filter available. Gives "passband" tuning, "variable selectivity" and one or two notches. Switched Hi-pass, Lo-pass, peak or notch. Selectivity from 2.5KHz to 20Hz. Tunable from 2.5KHz to 250Hz. PLUS another notch available in any of the four switch positions which covers 10KHz to 100Hz. 12V supply. Sizes: 6" x 2 1/2" front panel, 3 1/2" deep, all for only £65.00 Ex stock.

**SENTINEL AUTO H.F. WIDEBAND PRE-AMPLIFIER 2-40MHz, 15dB gain.** Straight through when OFF. 9-12V. 2 1/2" x 1 1/2" x 3". 200W through power. £19.55\* Ex stock.

**SENTINEL STANDARD H.F. PRE-AMPLIFIER.** No R.F. switching. £12.62\* Ex stock.

**12 MONTHS COMPLETE GUARANTEE INCLUDING ALL TRANSISTORS.**

Prices include VAT and delivery. C.W.O. or phone your credit card number for same day service.

\* Means Belling Lee sockets, add £1.90 for SO239s or BNC sockets. Ring or write for more information. Place orders or request information on our Ansaphone at cheap rate times.

Goods normally by return.

# New from ORYX-PORTASOL Portable Gas Soldering Iron

ORYX - market leaders in soldering irons and accessories introduce the revolutionary PORTASOL. This new approach to catalytic soldering iron technology is truly

pocket portable (173 mm) and independent of any external energy source. PORTASOL is powered by ordinary cigarette fuel and one filling lasts for 60 minutes continuous use.

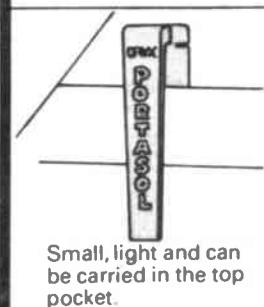

Small, light and can be carried in the top pocket.

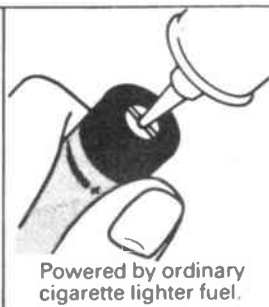

Powered by ordinary cigarette lighter fuel.

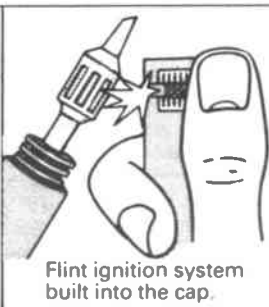

Flint ignition system built into the cap.



Adjustable temperature equivalent to electric soldering irons 10 to 60 Watt.

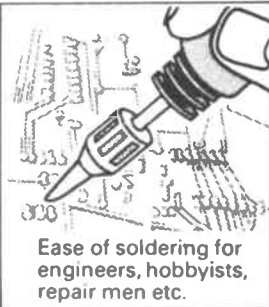

Ease of soldering for engineers, hobbyists, repair men etc.

- \* Portasol makes an ideal and present.
- \* Immediately available for use anytime anywhere.
- \* No problem with statics.

- \* Adjustable temperature for sensitive components.
- \* Portasol meets all safety standards.

**USE OUR EASYORDER SYSTEM NOW  
PRICE INCL. VAT. P + P**

ONLY  
**£17.95**



ORDER BY FREEPOST  
NO STAMP NECESSARY  
ALL ENQUIRIES, C.O.D  
ACCESS, VISA & AMEXP  
PLEASE PHONE  
01 889 1415  
TRANS CASH AT ANY  
POST OFFICE. CREDIT  
ACCOUNT NO 530 1556

SEND CHEQUE OR P.O.  
PAYABLE TO:

**J E M MARKETING**  
180 PRINCES AVENUE  
FREEPOST (DEPT AR)  
LONDON N13 6BR

**NO QUIBBLE MONEY  
BACK GUARANTEE** on  
goods returned within 7  
days in good condition.

OPEN MON - SAT  
10AM - 5PM  
24hr ANS/PHONE



# QUESTIONS & ANSWERS

RAE PRACTICE DEvised BY R.E.G. PETRI G8CCJ

1. The gain of a VHF antenna is described in a certain manufacturer's catalogue as having a gain of 10dBd. This means that the antenna gain is:
- 10dB over that of a half-wave dipole
  - 10dB over that of an isotropic radiator
  - 10dB below that of a standard unipole
  - 10dB below that of a half-wave dipole

Fig 1

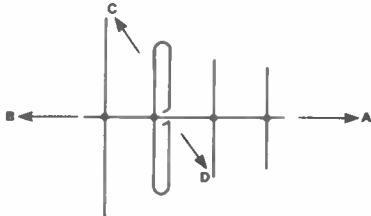

2. Figure 1 is a typical:
- yagi antenna
  - crossed dipole
  - wide band rhombic
  - delta matched dipole
3. Referring to Figure 1, what is the direction of maximum radiation?
- A
  - B
  - C
  - D
4. The antenna shown in Figure 1 is:
- bi-directional and unbalanced
  - directional and unbalanced
  - directional and balanced
  - omnidirectional and unbalanced
5. The antenna shown in Figure 1:
- must only be used vertically polarised
  - must only be used horizontally polarised
  - can be used for either horizontal or vertical polarisation
  - is only capable of circular polarisation

Fig 2

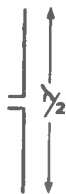

6. Figure 2 is that of a half-wave dipole. One of its characteristics is that:
- it is only suitable for operation on the VHF band
  - it is only suitable for operation on the HF band
  - it is only suitable for operation on bands above 70cms
  - it is capable of operation on all amateur bands
7. Using the formula:

$$\lambda = \frac{3 \times 10^8}{f}$$

and reducing the dipole length by 5% to allow for the difference between the velocity of propagation in the antenna elements to that in space, calculate the actual length of a half-wave dipole for operation at 1.2GHz (1200MHz).

- 1.18cm
- 11.88cm
- 1.2cm
- 23.75cm

8. Which one of the diagrams shown below is representative of the standing wave pattern on a half-wave dipole?

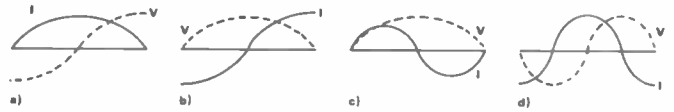

9. A vertical dipole, when operating with no nearby obstructions:
- must be fed with 600 ohm feeder
  - must be operated with a tuning stub to avoid interference
  - has a very narrow horizontal beamwidth
  - has an omnidirectional radiation pattern

Fig 3

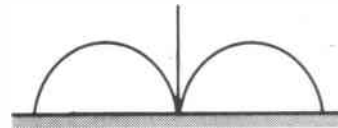

10. What type of antenna would you expect to exhibit the vertical-plane radiation pattern shown in Figure 3?
- a yagi with a gain of 6dB
  - an isotropic radiator
  - a half-wave dipole with an effective ground plane
  - a broadside array
11. The term 'feeder' is frequently used when talking about radio and transmission lines. What is a 'feeder'?
- The transmitter
  - The antenna feed point
  - The cable feeding the antenna from the transmitter
  - The mains power feed
12. What is a typical velocity factor (vf) and characteristic impedance ( $Z_0$ ) for a coaxial cable with a solid polythene dielectric?
- vf 0.35 -  $Z_0$  600 ohms
  - vf 0.95 -  $Z_0$  300 ohms
  - vf 0.40 -  $Z_0$  50 ohms
  - vf 0.65 -  $Z_0$  50 ohms
13. What is the effect of a mismatch between an antenna and its feeder?
- Too much power will be radiated
  - Power will be returned to the transmitter and standing waves will be set up
  - The velocity of the radiated signal will decrease to  $3 \times 10^8$  m/S
  - There will be a frequency shift due to the standing waves and the signal will be transmitted at one third of its original frequency
14. You are using an unbalanced feeder in conjunction with a balanced antenna. What precautions will you use to eliminate standing waves on the feeder?
- Use a balun and a correctly tuned antenna
  - Put a series of 90 degree bends in the feeder every 2 metres
  - Make sure that only the 'E' field is radiated
  - Use silver plated wire for the antenna elements
15. What is the type of antenna shown in Figure 4?
- A trap dipole
  - A bi-phase dipole
  - A radix radiator
  - A rhombic antenna

Fig 4

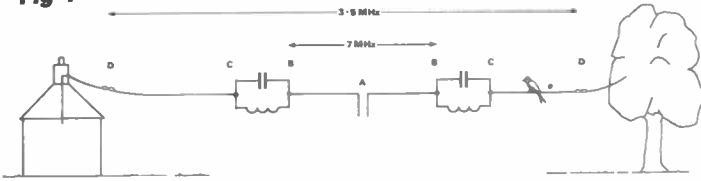

16. The inner section of the antenna shown in Figure 4 between points B-B is required to operate as a half-wave dipole at 7MHz. What is the approximate length of this section?

- a) 5m
- b) 10m
- c) 20m
- d) 40m

17. The antenna shown in Figure 4 is operated as a half-wave dipole at 3.5MHz, (80m). What is the approximate length between points D-D?

- a) 350m
- b) 160m
- c) 80m
- d) 40m

18. Referring to Figure 4, what is the resonant frequency of the traps?

- a) 3.5MHz
- b) 7.0MHz
- c) 14.0MHz
- d) 28.0MHz

19. You are using the antenna shown in Figure 4 on a frequency of 7.0MHz. A little bird (not Buzby) hops along the antenna with a suitable detecting device. At which points will he detect a voltage antinode (voltage maximum)?

- a) A-A
- b) B-B
- c) C-C
- d) D-D

20. Referring to the previous question and Figure 4. You QSY (change frequency) to 3.5MHz. Where will the little bird now detect the voltage antinode?

- a) A-A
- b) B-B
- c) C-C
- d) D-D

21. You are now using the antenna shown in Figure 4 at a frequency of 3.5MHz. To what frequency are the traps tuned?

- a) 1.8MHz
- b) 3.5MHz
- c) 7.0MHz
- d) 21.0MHz

22. Figure 5 shows a vertical trap dipole. The height of the lower section 'X' below trap 'A' is approximately 2.5m. What is the resonant frequency of trap 'A' likely to be?

- a) 7MHz
- b) 14MHz
- c) 21MHz
- d) 28MHz

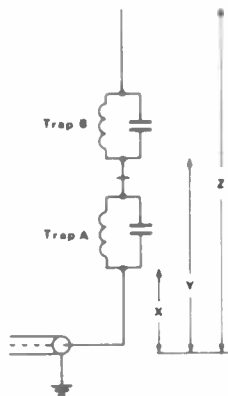

Fig 5

23. Ignoring harmonic operation, what frequency or band will use the full height of the antenna shown in Figure 5?

- a) The lowest design frequency of operation
- b) The highest design frequency of operation
- c) The shortest wavelength of operation
- d) None of the above

24. The input impedance or feedpoint impedance of the antenna shown in Figure 5 is about:

- a) 30-40 ohms
- b) 75 ohms
- c) 300 ohms
- d) 600 ohms

25. You are given the following choice of ground surfaces over which to erect your vertical antenna. Which one will make the best ground plane?

- a) Very dry heathland
- b) Dry rock with high resistance wires buried in it radially from the base of the antenna
- c) Moist high conductivity earth with copper wires buried in the ground and extending radially from the base of the antenna
- d) Dry low conductivity soil with a fair size glass fibre earth mat under the centre of the antenna

26. The vertical quarter-wave antenna with a good ground plane will:

- a) have a very good vertical take-off
- b) require increased ionisation densities
- c) give poor low angle radiation
- d) give good low angle radiation

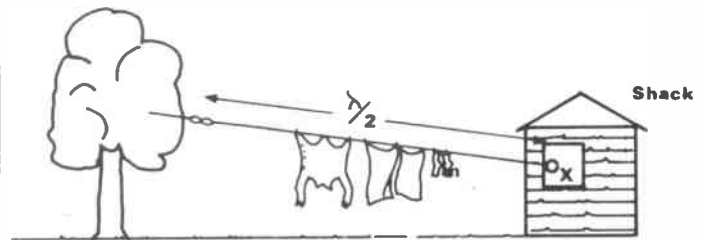
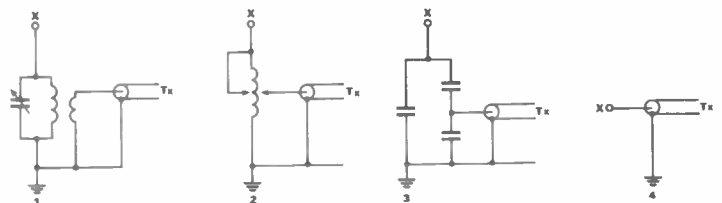

Fig 6

27. Which of the following arrangements would be the most suitable for feeding the end fed half-wave antenna shown in Figure 6?

- a) 1
- b) 2
- c) 3
- d) 4



28. Figure 7 shows an end fed antenna less than  $\lambda/4$  in length. It has an input impedance equivalent to a resistance and capacitive reactance in series. Select a suitable tuning or matching unit from those above.

- a) 1
- b) 2
- c) 3
- d) 4



**Fig 7**

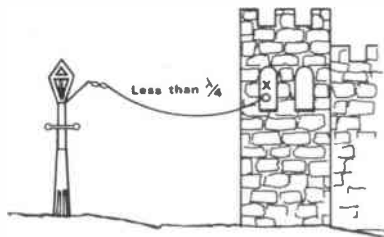

29. In order to obtain more antenna gain, you decide to phase and stack two identical 10dB yagi antennas. What gain figure will you be expecting?

- a) 10dB
- b) 13dB
- c) 16dB
- d) 20dB

30. Your recent RAE success is quickly followed by a pools win, and you are no longer satisfied with the array in the previous question. You contact a certain firm in Northampton, and soon you erect an array of four identical 10dB gain yagi antennas. What gain figure do you expect now?

- a) 10dB
- b) 13dB
- c) 16dB
- d) 40dB

**Fig 8**

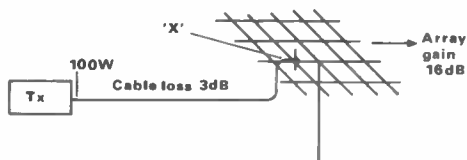

31. Use the figures shown in *Figure 8* to calculate the power supplied to the antenna at X, and the effective radiated power (ERP) respectively.

- a) 100W/16W
- b) 50W/16W
- c) 100W/1000W
- d) 50W/2000W

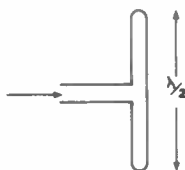

32. Which one of the following circuit configurations will be presented to the feeder cable by the folded dipole shown in *Figure 9* when operating at its resonant frequency?

- a) 1
- b) 2
- c) 3
- d) 4

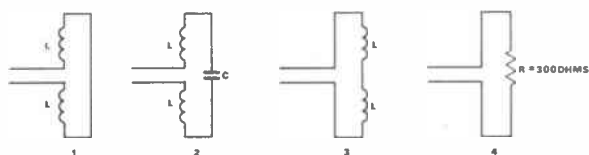

33. A type of coaxial cable is quoted as having a characteristic impedance of 50 ohms. What is the input impedance of an infinite length of this cable?

- a) zero
- b) 25 ohms
- c) 50 ohms
- d) very high

34. One advantage of using a yagi or beam antenna is that:

- a) it is the only antenna available that will directly match to 50 ohm feeder
- b) it has the ability to radiate power in a given direction
- c) it does not respond to interfering signals
- d) its wind loading is lower than that of a half-wave dipole

35. Another advantage of using a beam or yagi antenna is that:

- a) it is the only antenna available to directly match a 75 ohm feeder
- b) as well as a direction of maximum response it also has a direction of minimum response
- c) it is the cheapest antenna available
- d) once dimensioned, its impedance remains constant whatever the frequency change

For those of you that want the answers to *this month's* set of questions turn the magazine upside down etc.

However, if you are still waiting (in great anticipation, no doubt) for the answers to questions 33, 34 and 35 in the June issue, you'll find them in *Straight & Level*, page 11.

## ANSWERS

1-a; 2-a; 3-a; 4-c; 5-c; 6-d; 7-b; 8-a; 9-d; 10-c; 11-c; 12-d; 13-b; 14-a; 15-a; 16-c; 17-d; 18-b; 19-b; 20-d; 21-c; 22-d; 23-a; 24-a; 25-c; 26-d; 27-a; 28-b; 29-b; 30-c; 31-d; 32-d; 33-c; 34-b; 35-b.

## Once again (yawn) . . . . time to plug the book

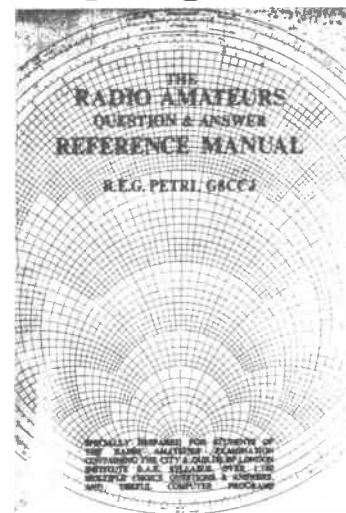

Now, just in case you've not already purchased it (or even heard of it!), I've written a Q&A book specially for the RAE student. It contains about 1,100 questions (with multiple choice answers of course). The questions have been divided into sections and selected to progress with each part of the RAE syllabus. It also contains the C&G syllabus for 1986-88 and some computer programs written in BASIC for the Commodore 64 (which will run on most machines with suitable mods) to assist with the RAE calculations and provide Morse tuition.

The book, *The Radio Amateurs' Q & A Reference Manual (Second Edition)*, is available at £5.95 plus £1 P&P (UK) from:

WP Publications,  
11 Wayville Rd,  
Dartford, Kent DA1 1RL.

It's all happening now, in fact your scribe has attended so many rallies lately he's forgotten what a free weekend is like! It was very interesting to note the complete change round at the Ipswich Wireless Revival. Three years ago the organisers were one of the founders of the 'car boot sale' area at a rally, and then only a couple of amateurs were brave enough to try it, whilst the bring-and-buy tent was packed solid. This year's Revival saw dozens of cars in the boot sale and only one taker for the flea market. In fact the rest of the tables were used, in the end, as an extension of the restaurant area.

#### Lucky with the weather

The Ipswich crowd were certainly lucky with the weather. Some visitors were sunbathing whilst watching the excellent model control flying display (including helicopters!), yet only ten miles away greenhouse windows were being smashed by hailstones the size of golf balls. Talk about the sun shining on the righteous. I wonder how many flea market tables, which were inside, would have been taken had the weather deteriorated?

The luxury of a car boot sale is that you can buy some real rubbish, and your scribe bought a van full (literally) at Ipswich, including a scruffy Hallicrafters S38 for £5 that cleaned up well and performs like a good 'un, and an FT290R for £15. No, that's not a misprint, an FT290R for £15. Before all owners start worrying about the resale value of their rigs, I had better explain that the good news was the price and the bad news was that the rig had been involved in a helicopter smash and, like the owner, had not survived the impact.

The main board is completely undamaged, which speaks volumes for the standards of construction when you consider that the case and front panel are virtually non-existent and the display is smashed. Apart from that the only electrical damage is the micro, which has cracked in half, and the back-up battery is broken. I now have a new respect for Yaesu reliability. I also have a long term restoration project!

#### BATC Convention

I don't know why, but the British Amateur Television Club event (it's not really a rally) always produces the bargains as well as the unusual. The organisers will probably not thank me for publicising it as it is held in a smallish annex of the Crick Posthouse Hotel and is more or less as crowded as it should get, but every year there are loads of unusual odds and ends to be picked up, and not all of them are video related.

I can well understand the comment by one newly arrived amateur at the hotel: 'There ain't much here'. Indeed, this would appear to be the case as there are only a dozen or so stands, but what there is seems, year after year, to be good stuff. The displays are also very interesting, including satellite weather, colour slow scan, slow-fast scan (ie limited bandwidth) and outside broadcast demonstrations, and it is a shame

# SECONDHAND EQUIPMENT GUIDE

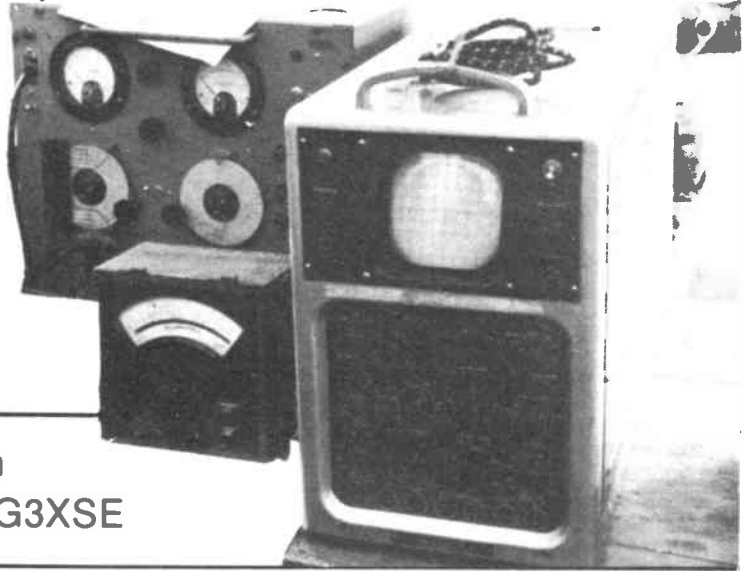

by Hugh  
Allison G3XSE

that a lot of people do not spot the advertisements for it. Perhaps 'convention' sounds boring, or perhaps because the announcement in *Radcom* is under 'other events' rather than 'mobile rallies' it puts people off.

Incidentally, there was a disabled persons meeting of some sort going on and the hotel had excellent facilities available for wheelchair bound visitors, with ramps up all stairways and special toilets etc, so this may be of interest to RAIBC members.

On the bargain front, your scribe bought a non-working Sony C6 front loading video for £20, and the subsequent injection of another £14 worth of odds and ends has made it better again. Another fascinating bargain, unfortunately bought by someone else, was a colour splitter from an early camera.

Having said above that the bargains were not confined to video related objects I have just mentioned two that were, but there was also a good selection of scopes, aerial masts and other goodies, so don't let me put you off.

#### Southend

This rally came from nowhere four years ago to become a force to be reckoned with. A few years ago it was in the small-time league, but now, after three changes of venue, it is into the 'well worth a visit' category. Your scribe was well pleased with a pristine Vibroplex 'presentation' mechanical bug key for £10 (they often fetch £25+ nowadays) and other assorted toys.

#### The Northampton AR boot sale

This one has been the only 'rally' disappointment for me this year. It's a splendid idea to have just the boot sale

without the rally, and I can't explain why it just didn't work this year. Perhaps it was that the date clashed with the BATC Convention (formation radio amateurs driving up and down the M1 were much in evidence), but it was sad to see that only about ten sellers participated. I heard a few moans on two metres about being charged to go in to view and your scribe had difficulty finding the place, but these are not real explanations as to why it failed to be a success. Maybe it too suffered from being advertised in *Radcom* as 'other events'. A great shame for Northampton radio amateurs and I wish you better luck (and more sellers) next year.

#### LA-Series linear amplifiers

I've noticed a lot of nondescript (ie unbranded) fairly large transistorised linear amplifiers at rallies lately. Apparently they were intended for extending somewhat dramatically the range of very naughty cordless phones. Your scribe recently bought one, bearing no name or frequency, for £2. I figured the case and heatsink were worth this, and was very pleasantly surprised when a dose of RF from a tracking oscillator/spectrum analyser gave positive indications of life at 160MHz. A quick tweak made it perform on 2 metres, 10 watts in, 100 out. I have since bought several more of these, all containing a single 2SC2630 (marked, in true Japanese fashion, C2630) and can find no correlation between model number and frequency (the 160MHz version was marked LA140). The only bad news is that these were not designed to switch to receive so a relay has to be added, but they certainly are cheap and potent and well worth keeping an eye out for.



# MICROBOX II THE 6809 SINGLE BOARD COMPUTER THAT YOU BUILD YOURSELF

**NOTE:** MICROBOX II WILL BOOT 'FLEX' FROM ANY STANDARD SYSTEM DISC.

**BARE PCB'S AND DOCUMENTATION  
+ SYSTEM SUPPORT MONITOR  
+ SYSTEM UTILITIES DISC – £95.00  
FLEX + EDITOR + ASSEMBLER £75.00**



Ex VAT

**8 SKILLICORNE MEWS · QUEENS ROAD · CHELTENHAM · GLOUCESTERSHIRE GL50 2NJ**  
Telephone: Cheltenham (0242) 510525

## Build yourself a **micron** transceiver at a price you can afford



**£241 FOR 6 BANDS/INTERNAL ATU/DIGITAL DISPLAY AND CASE**

OUR LATEST TRANSCEIVER KIT setting new standards in QRP performance. The MICRON is a 6 band CW only 8/10W output rig covering 80,40,30, 20,15 & 10 metres (bottom 200kHz of each). A 0.25uV sensitivity receiver with AGC, S Meter, very stable VFO with IRT, 1W AF o/p to speaker and 3 position LC filter + selectable attenuator. Silent solid-state Rx/Tx switching with fast semi break-in + sidetone. Fully variable RF power o/p + optional SWR metering. + 12v required.

PLUS fully finished smart CUSTOM CASE and hardware with UNIQUE facility for optional internal TRANSMATCH ATU and Full Frequency DIGITAL DISPLAY. The MICRON uses a high grade solder masked/screen printed pcb with comprehensive instructions using a step-by-step assembly manual designed for the relative newcomer. Mostly prewound coils and minimal test equipment needed for alignment.

**EXPORT A PLEASURE!**

PRICES FULL KIT with all options including Case/Hardware/ATU/Metering/Digital display at an all-in £241. Or, 6-band pcb kit complete at £145 or with case is £182.50 and the options of INTERNAL ATU at £37, and DISPLAY at £38.50

### QRP for under £40?

ONLY NEEDS +12v, SPEAKER + KEY/MIC TO BE ON THE AIR!

FOR THE LESS AMBITIOUS, why not try our DSB80 kit? A 2W + DSB or CW VFO controlled TRANSCEIVER kit for either 80 or 160m at a ridiculous £39.95 for a complete pcb kit - over 1000 sold to date! It has a very sensitive receiver and is ideal for beginners. Punched aluminium CASE and HARDWARE for the DSB80 at £25.95, and digital display at £29.50 - all three kits for £85.00

NEW! The MICRON MATCH ATU Kit, developed from the MICRON ATU, with its own case, connectors, etc Suitable for SWL or QRP (15W) from 1.8 -30Mhz. With air spaced capacitors for only £39.95 inc.

### 2M FM UNDER £70?

We also make a popular 2M FM T<sub>x</sub>/R<sub>x</sub> kit - 6 channel crystal control at 1W RF o/p. Receiver at £39.50 and Tx at £34.50 ex crystals - both for £69.95. Optional PLL VFO available at £38.50.

OTHER KITS: DSB2 - enhanced version of the DSB80 for any single band 160 - 15m, DSB/CW 2W+ at £69.50 basic kit. SPEECH PROCESSOR - very popular kit at £14.65 to help get the DX! ALPHA - our 50W monoband SSB/CW Transceiver with case and display at £179.95. OMEGA - 9 band 100W multimode for the specialist constructor - write for details.

Why not join the ranks of satisfied customers building our Projects? All of our kits come with copious instructions, all components, pcb, wire, pots, etc, and many are designed for beginners. Our Products are used world wide and can help YOU get on the air. KITS are sent in 7-10 days but please allow up to 28 days for popular items. All prices include VAT and Post. OVERSEAS - Europe use UK prices and Rest of World UK + 5% for carriage, etc. CREDIT CARD orders can be left on our 24hr Answering Service. For our 40+ page CATALOGUE please send 50p in stamps. Kit Debug service available.

**WPO COMMUNICATIONS**



**20 FARNHAM AVENUE, HASSOCKS G3WPO  
WEST SUSSEX BN6 8NS MAIL ORDER ONLY**  
24hr Anaphone 07918 6149

# FREE CLASSIFIED ADS

## FREE CLASSIFIED ADS CAN WORK FOR YOU

We are pleased to be able to offer you the opportunity to sell your unwanted equipment advertise your 'wants'.

Simply complete the order form at the end of these ads, feel free to use an extra sheet of paper if there is not enough space. We will accept ads not on our order form.

Send to: *Amateur Radio Classified Ads*, Sovereign House, Brentwood, Essex CM14 4SE.

## DEADLINE AND CONDITIONS

Advertisements will be published in the first available issue on a first come first served basis. We reserve the right to edit or exclude any ad. Trade advertisements are not accepted.

## FOR SALE

■ FT757GX mint includes YM38 base scanning mic, manual, boxed £575 ono. FTV107R complete, 70cm/2m modules fitted, modded by SMC for UK 70cm repeater. Operation includes FRB707 relay box for any Yaesu solid-state rig £285. Complete HF/VHF/UHF station for £825, would separate. 70cm module for £185. Also spare FRB707 box new £10. TR2400 £125. John G4WLD Tel: 01-857 8096

■ Exchange my Icom IC211E with muTek board and ICRM3 remote controller or my Yaesu FT707S with FM (not fitted) for Trio TW4000A or Icom IC402 or IC202S, or any combination of these, or sell both. Would prefer exchange. Both in 1st class condition, would consider other VHF, UHF gear also. Keith G6HHV (051) 327 5804 Merseyside, anytime

■ RTTY unit Dragon 64, plus disc drive, as new, edit plus 51 x 24, 6 months old, £300. M Morcher, 19 Lower St, Hoveton, St John, Norwich, Norfolk. Tel: (Wroxham) 3957

■ 2m colinear, 13ft cable, PL259, £45. Bags of semiconductors, ICs, resistors, capacitors, nearly all new, 50p to £3. Labgear UHF 2 output amp £8. Mains transformers £1.50 to £4. New valves PL509 etc. G8 manual £3. B and D saw attachment £6. Mullard, ITT, TI data books 50p. Box assorted comms, switches, caps, mic, coils, plugs, sockets etc, £6. Apple serial, parallel, dos cards, £2 to £10. Geoff, Tel: Hastings (0424) 442308 evenings, weekends

■ Rascal RA17L 5MHz-30MHz Rx in mint condition £300. Realistic PRO2002 VHF UHF scanner 54-512MHz as new, in box £130. Creed Mod 33 teleprinter with Redifon decoder. Choice of two from £30. Can deliver UK. Wanted, small scope or station monitor. B W Burt, 5 Dee Drive, Foxbar, Paisley PA2 0QL. Tel: (0505) 81 3528

■ Yaesu FT77 100W FM board fitted all bands. 11 metres fitted. Hardly used, as new £450. Tel: 01-876 1108

■ Trio TS700 2 metre multimode base station/mobile. Pre-amplifier fitted to improve front end. Also fitted fixed channels R2 R4 R5 R6 R7 & VOX-3, Mic handbook, excellent condition £300. Avanti Moonraker 4, AV140 four element beam for 11/10 metres. Excellent condition £65. Tel: Dave G1IDS (0442) 842243

■ FRV 7700 converter (to match FRG 7700). As new in original box. £40. No offers. I will pay carriage to buyer. With manual. Mr George Jacob, 23 Waterloo Gardens, Penylan, Cardiff CF2 5AA Tel: (0222) 487299

■ Icom 251E 2 metre base station, dealer fitted muTek board, all modes scanning memories, excellent for satellite reception, as new, manual, mic restrictions at new QTH, prompt sale, £450. John G6BGY Tel: Clevedon 871039

■ Pye mobile repeater system. 10 channel UHF, 10 channel VHF converted to amateur frequency and xtalled up. Excellent condition with manuals. Also with it is a Burndept 3 channel UHF hand portable. You can work 70cm to 2 metres and back again. This space isn't big enough to describe this system. No time wasters please. Price in the region of £2,000 or for £6,000 you can have the vehicle it is fitted in. Write to: J Hamilton, 25 Thornham Close, Armthorpe, Doncaster, S Yorks

■ Trio R2000 all mode receiver 100KHz, 30MHz, 114-174MHz, 10 VFO auto mem mode etc, with SW ATU PR40, super radio, £395 ono. Cost a lot more new! Ferro graph series six stereo reel to reel, £70. Like a tank Honda CBX250 B reg swap for good Trio 930S with auto ATU Wanted: D70 10FM. Mr Baines 53 Maple Road, London SE20

■ Sony ICF7600A FM/AM multiband receiver. SW dual conversion, good condition, little use, boxed, £55. Tel: Maidenhead 28940

■ Icom IC740 with FM and marker, also PS15 PSU SP3 spkr, SM5 desk mic. Welz SP15 SWR/power

meter and Welz AC38 ATU, £650 or exch Yaesu FT726. Microwave modules 432/28 MHz transverter 1.6 MHz shift and sat xtal £100 or exch for a 432/144 transverter. Tel: (0923) 44886

■ Trio TW4000A 25W 70cm 2m dual bander mint condition, £395.00. Yaesu FT230 25W FM mobile, I have two, one at £180.00, and £200.00, both very good mobile rigs. Trio TR2500 handheld mint condition, £195.00. ST2 base charger as new, £40.00 sold as a pair. Tel: 01-540 3959.

■ Yaesu FRG7 communications receiver with manual, mint condition, no modifications, original packing, can be seen in London or Essex, £125. Tel: Maldon (0621) 892755

■ Short Wave magazine 1954 to 1961, mostly complete volumes and some issues back to 1946. Radio manufacturing engineers RME69 0.5 to 30MHz receiver. Made in 1930s but in working order, some spare valves. Offers. Buyer collects. Tel: Malvern (06845) 61898

■ Attention Morse men! American Mc'Elroy automatic Morse machine. Keys and reads perfect CW from paper tape- 10 to 80 wpm. Real rare collectors item £25. One Bendix TA12 aircraft transmitter plus one TCS transmitter - both rough outside but full of good HF components for constructor, £15 each - all heavy, buyer collects. Still wanted, reel to reel tapes for 'Shibaden' video recorder - even from Dover! Write Nev Kirk G3JDK, 54 Allendale Road, Rotherham S65 3BY. Tel: Wickersley 541600 anytime

■ Mast 40ft lattice telescopic heavy duty wall mount, complete with 20ft extension pole, very good condition, £175 ono. Dave Rotherham Tel: (0709) 67471

■ Daiwa SR9 2m receiver 144-146MHz, VFO + 11 channels: R2, R5 (input) S19, S20, S21. Excellent condition, £50. Ideal for someone studying for RAE. Tel: Gravesend (0474) 26036

■ SB102 transceiver, hambands, 180W PEP SSB/CW, inc P/supply, spkr, mike, h/books, good clean working rig, £180. Looks similar to S line. SX62AU was Hallicrafters top Rx for gen coverage 550KHz - 108MHz, yes 108MHz ideal for BC band listener, clean powerful Rx, £70. No mods. Ex WD Eddystone UHF Rx 165-500 MHz (very interesting up there!) Works well £90. No mods, CTE speedy 240V 100W 26-30MHz linear £35. SX71 gen-cov Rx by Hallicrafters, scarce in UK, more so in good condx, 500KHz-55MHz, good on SSB, bands spread on ham bands, no mods, £75. SX24 'Defiant' also by Hallicrafters, 500KHz - 32MHz no mods, immaculate original order, I am 2nd owner since 1939, stored for 20 years (in dry shack), a good collectors Rx £65. BC348M, 240V 1 mod, dial lite switch instead of rotary, the cleanest one I have ever had, unmarked front panel, £60. Belcom LS102L 26-30MHz FB on SSB typically suffers from bleedover (CB) channels, £170, perfect clean order. BC906 freq meter, £8 in large wood case. Boonton USA Rx meter mod 250-A h/book £20. WW2 mine detector working and complete £15. All Rx except Belcom are valve jobs and heavy you must collect or arrange pick up. All gear ono. Tel: Milton Keynes (0908) 314095

■ Trio digital multimeter DL-705 bench type ac/dc, 2 volt - 1000V ±1% low-V 2V - 20 volt auto change over. Res-up to 20Mohm ±1.5% with carrying case. Also two constant voltage trans input 190 - 260 volts output 230V rms 50Hz 60W. One gardeners trans input 200-220-240 + 5% + 2.5% -- 2.5% at 440 volts 8MADC CIF 112 RA rms 6.3-4 amp 6.3-2amp and one at 200V-220-240V input 1-2-3-4-5-10-20 volt out at 4 amp rms 50Hz. Will swop all for audio multi-filter SEM or Daytong etc. All in first class condition. SA Deacon, 25 Moseley Road, Poulton Road Estate, Bebington, Wirral, Merseyside L63 9NT Tel: (051) 334 6859

■ Swap Acorn Electron (BBC BASIC) cassette deck, software, books, mags, cash adjustment if

needed, for 2m or 70cm FM or SSB rig or sell £110 ono. Also consider swap for FRG7 or R600 receiver or WHY. Please write KJ Argyle, 3 Gregory Close, Barlestone, Nuneaton, Warks CV13 0EP. All letters answered by return of post

■ Trio TR8400 70cm FM mobile mount PS10 PSU speaker. All boxed ½ mobile whip antenna all for £200 ono. Elvis Bailey G1HUY, 19 Northway Fleetwood, Lancs Fy7 8LE. Tel: 77636

■ Trio R600 receiver digital readout and boxed £200. CB transceiver ST9DX FM AM LSB USB £90. Hitachi cassette stereo recorder 4 band new and boxed £120. Tel: 01-207 0706 or 01-207 2326

■ Yaesu FT101E mint £360. FV101B £60. Trio TR700 £170. Belcom LS102L £160. Belcom LS20XE £120. FL902 £85. MS2000 £30. MM frequency counter £75. IC4E £200. 12V PSU £5. HF5 and radials £50. MM28MHz linear 100 watts £80. G3ZHI. Tel: (0709) 814911

■ Brems 30 £12. Icom 1050 £15. CB £10. J Brems 5 ele £8. International FM GUV0E £1. Tel: Ian G3ZHI (0709) 814911

■ Icom 701 accessory. Computerised remote control unit ICRM3 plus marker extension terminal ICX2 £75. Postage extra. Tel: (0202) 579115

■ President AR144, £20. Pye Westminster low band AM, working, £20. TRS80 pocket computer cassette interface, £10. Tel: Gainsboro (0427) 5848 (North Lincs)

■ FRG7700 general coverage receiver £200. Tel: Corby 65618

■ Yaesu 209RH NC18C charger, speaker, mic, 3 months old. As new £230 ono. Tel: Brighton 420609

■ Trio R600 communications receiver 0.30MHz and boxed, £190. CB transceiver FM, AM, LSB, USB, £90. Hitachi stereo cassette radio recorder, new and boxed, £120. Tel: 01-207 0706

■ Trio JR599 custom special (M) communication receiver. SSB, FM, CW, AM, solid state circuits. Crystal filters. 1.8MHz to 29.7MHz, amateur bands, including 144MHz converter, and WWV. Perfect condition complete with service manual, £150 ono. Also Lowe SRX30 communication receiver, .5MHz to 30MHz, AM, CW, SSB, amateur and BC bands. Complete with manual, excellent condition £85. Buyers collect and inspect both receivers. Tel: Leeds (0532) 686362

■ FM, AM, USB, LSB, gold coloured Marko Excalibur Mk II home base unit. Immaculate condition. Price around £175 ono. Would consider swap for Concorde 3 or Cobra, or receiver with digital counter readout. What have you for swap? No reasonable offer refused. Frank Kennedy, c/o 34 Church Brow, Bolton Le Sands, Carnforth Lancashire. Tel: Hest Bank 823603

■ Yaesu FT290R two metre portable rig. 144-148. Welz SP15M SWR power meter. LCL converted CB rig. 5 amp power supply. All good condition £250 ono. Mabe, 32 Byrefield Road, Guildford, Surrey GU2 6UB. Tel: Guildford 32705

■ Morse tutor on two hour cassette tapes. The easy way to get your A licence and still only £3.50. Price includes postage. Tel: Farnborough, Kent 58825

■ FT102/FM £565.00, FT7B £350.00 with digital, TS120S £430.00. C582M multimode £230, FT250R £230, TR2300 £110, KDK2030 £190, All mint condition Tel: (0792) 401058

■ Marconi wartime Admiralty radio type B28, W2835D, 60 kHz, 30 MHz, £75. Tel: Maidstone (0622) 861998

■ Suit amateur radio enthusiast requiring cheap printer. 1 Creed model 75 teleprinter working on level five Baudot Code £10. 2 Kode model S33 serial 20m/A loop teleprinter £20. Manual £5. Tel: Romford 40921



## FREE CLASSIFIED ADS

### WANTED

- FRG7 or similar HF receiver wanted, prefer unmodified. Rob Lloyd, Myrtle Cottage, Blakeney Hill, Blakeney, Glos GL15 4BS. Tel: Blakeney (059 451) 470.
- Starting from scratch. Any info on receivers, antennas etc (not transmitting equipment). Please contact: Mark Lichtarowicz. Tel: Harrogate (0423) 879202 (Answerphone) or write to: Leckhampton House, Hill Top Lane, Lund House Green, Harrogate, N Yorks HG3 1QG.
- Collins solid state digital receiver. Must be in mint condition. Tel: (0472) 58896.
- Looking for full service manual for Trio JR60. Can anyone sell or loan me a copy for photocopying? Many thanks. D Williams, 32/34 Carfin Street, New Stevenston, Motherwell ML1 4JL. Tel: (0698) 732403 after 6pm.
- Mains powered 2 metre valve linear 100 watts plus out. Please write. All letters answered. 70cm transverter. 2 metre drive. Ron Daly, 12 Stoney Lane, Newbury, Berks RG13 2NH.
- QST May 1981, loan or buy, expenses refunded. G4DJC. Tel: (0245) 262728.
- New listener in Dundee, would like a cheap gen cov recr. As I have little knowledge of what is needed, a full amount of items, aerial etc would be helpful in the package. Will pay carriage. Anything considered. Mr Andrew Burnett, 43 Harris Ter, Dundee. Tel: (0382) 456163.
- One SSB adaptor made by Grundig for Satellit receiver. Tel: (061) 743 1570.
- Exchange Sharp MZ711 64K colour micro, built-in recorder, 4 manuals, 6 software tapes, for Eddystone EA12, 770R or Yaesu FRG7 or similar Rx in vgc. Micro still boxed and as new. Tel: (021) 565 2498, evenings.
- FT101ZD or similar HF transceiver. Must be in good condition. Will pay good price. Tel: Nottingham (0602) 847728.
- One or two variable temperature compensating trimmers. F Lees, 6 Green Side Ave, Oldham, Lancs OL4 2QA. Tel: (061) 652 2628.
- FT225RD memory unit. Also microwave mod-

- ules transverter MMT432/28, in good condition. Graeme G6CSY, 19 Cowden Road, Orpington, Kent BR6 0TP. Tel: (0689) 29230 evenings.
- Digital frequency meter. 200MHz or higher, minimum 10Hz resolution. Also cassette with SSTV signals off air to test programme under development. Write: Daly, 12 Stoney Lane, Newbury, Berks. All letters answered.
- FRG7700, Trio R600 or similar modern solid-state digital Rx. Tel: (0642) 318328.
- Trio IC251E with or without muTek board. Also 400 watt linear for 2m (homebrew considered). Also, FM board (transceiver) for FT101E, and 2m transverter for FT101E. 15 Dickens Close, Hartley, Dartford, Kent DA3 8DP. Tel: (04747) 4563.
- Ham International 11m multimode, Grundy Newbrain computer model AD 32K, Realistic DX200 communication receiver 200KHz to 30MHz, AM, SSB. Exchange for 2m multimode - eg FT290 or similar. Tel: Dave (021) 458 3025 after 6.30pm.
- TS520HF, good price paid, or part/x for 1K HF linear. All letters answered. D Oates, 101 Ffordd y Castell, Maesgeirchen, Bangor, Gwynedd.
- BRL500 with a circuit diagram and which is forty. Tel: Farnborough 58825.
- Short wave Rx in gwo. FRG7, R600 or WHY? Swap for 26inch Ferguson Colorstar transistor TV, sliding doors, legs, vgw. Codar PR30 RF preselector as new, swap 2m ATV, LAR, SEM or SIM or 2m base ant. Mr Aldridge. Tel: 01-200 3825 (NW London).
- KDK2015 or KDK2016. CR150/6. Gerry G8TZW. QTHR. Tel: (021) 360 0817.
- Yaesu keyboard YK901. Also Yaesu YD-148 desk mic. Tel: Colchester 394336.
- Best HF rig exchange for Bronic ECTL camera 75mm lens, 2x converter, 50mm lens, spare back pentaprism filters, flash S/H valve £600. Dolphin, 3 Buckmore Avenue, Petersfield, Hants GU32 2EF.
- G2DAF Rx or AR88 Rx or similar. Campbell. Tel: Stevenage 820789.
- Exchange top range DX302 fully synthesised £289 2½ years ago, for any AR88, RA17, SP600, Eddystone 888, S27, SX28 or Collins 75A. Must be

- complete and working. Can collect Hull area, 10 miles. Tel: Terry (0482) 709761 after 6.30pm.
- Kenwood 430S, FT101ZD MKIII, FT707, all radios need some attention, fair price paid. Tel: Farnborough Kent 58825.
- Hallicrafter SX28A or Trio 9R59 in mint condition. Also 2,4 and 6 metre valve receiver in good condition. Tel: (051) 644 9185.
- Replacement motor for Sanyo reel to reel tape recorder model MR530. U/S recorder acceptable if motor is OK. Dobbs, 14c St Andrews Crescent, Leasingham, Sleaford, Lincs NG34 8LS. Tel: (0529) 303247.
- Digital frequency display unit type YC-7B for Yaesu FT7B. Tel: Pete Jenkins 01-393 9115 eves or (08926) 4489 daytime.
- Circuit diagram for Triple Tone stereo amplifier Gemini series 3. All expenses paid. S C Binge, 66 Swaines Way, Heathfield, East Sussex. TN21 0AN.
- German WWII electronics, parts, descriptions. WHY? Wanted for museum purposes. Will collect. Please give your tel number. OZ8RO R Otterstad, Vejdammen 5, DK 2840 Holte, Denmark.
- G4CLF/91600 PCB or Cirkit kit. 250 + 250PF air-spaced variable capacitor, 300-500PF variables for ATU. D Jones, Bee cottage, Abbey Street, Eynsham, Oxford. Tel: (0865) 881242.
- FRV7700 VHF converter to fit Yaesu FRG7700 receiver. Prefer type A B D or E for 2 metres and air band. Garry P Grigg (G1GPG) Tel: (061) 4286491.
- Codar AT5 Tx also 2m rig FDK700EX or similar. G4RIP, Mr Creasey, Rose Cottage 6 House, Bank West, Pinchbeck, Spalding, Lincs PE11 3QG.
- Can anyone provide me with copies of G3OSS tests about Rxs ICR70, ICR71, AOR2001, and FRG9600. Will defray costs and postage. Kremp, 40 Rue Des Seringas, 50200 Coutances, France.
- A 1362A type signal meter for my Marconi Atlanta general coverage marine receiver. Any reasonable price considered and all letters will be answered. This unit might not be too common, so any details will also be gratefully received. Please write to: Jonathan Baker, 67 East Street, Selsey, West Sussex. PO20 0BT.

## FREE CLASSIFIED AD FORM

*Classified Ad Form*

# Amateur RADIO SMALL ADS

**AKD** Armstrong  
Kirkwood  
Developments  
10, Willow Green, Grahame Park Estate, London, NW9.  
Tel: 01-205 4704

**VHF/UHF ABSORPTION WAVEMETER**  
Covers 120-450 MHz. Extremely sensitive. Low-profile. Requires PP3 battery ..... **£24.95**

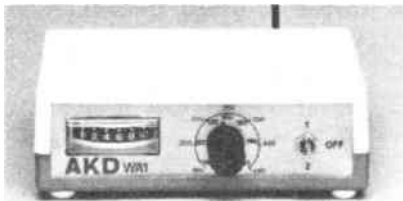

**HIGH PERFORMANCE RF FILTERS**  
SLIMLINE, ATTRACTIVE APPEARANCE  
Used by British Telecom, Thora-EMI, ITT, Telefusion, Granada etc.  
Standard range terminated in Belling Lee plug/socket (75ohms) - others to order  
Model TNF2 Tuned Notch Filters (Braid & Inner) for 2, 10, 15, 20 Metres & CB (state which) ..... **£7.75**

## MORSE TUTOR

**£4.00** on cassette. **£6.00** on microdrive for Sinclair Spectrum. 4 to 19 words per minute, variable spacing, variable groups of random letters, numbers or mixed; Random sentences, own message, single characters and variable pitch. Feedback on screen, printer, or speech (Currah Microspeech 48K only) and repeat facility, 16K and 48K versions on one cassette 48K only on microdrive.

**WD SOFTWARE**  
Hilltop, St. Mary, Jersey, C. Islands  
Telephone (0534) 81392

## XXX ADULT VIDEO CLUB

For the genuine adult films. Available only from ourselves. Ring

**0924-471811 (24hrs)**

For the intimate details or write  
**ADULT VIDEO CLUB**  
P.O. Box 12, Batley, W. Yorks.

## HEATHERLITE MOBILE MICS

Made to help you drive safely

Reasonably priced to suit your rig, head/neck band, electret mic, control box, variable mic gain, scanning buttons, plug fitted - superb quality. Priced from £20.50inc.

**FULLY GUARANTEED**

Ring for Details - Heather G5SAV (0401) 50921

## RTTY MORSE RADIO SOFTWARE

**RTTY/MORSE READER** For 48K Spectrum. The ultimate RX program, features include: 45.5 Baud RTTY reception - full character set supported. Morse reception - auto speed control (5-35 WPM), punctuation and wordspace. Also includes 40 page text memory, and copy facility for printer. No extra hardware required, simple connection to radio via computer EAR socket. Price £8.00.

**MORSE TX/RX Program** for 48K Spectrum. Allows full transceive operation, includes comprehensive morse tutor. No extra hardware required. Price £7.50.

**MORSE RX Program** for 16K Spectrum and 1K ZX81. Spectrum version includes comprehensive morse tutor. Price £5.20.

All above Programs 100% Machine Code  
Please add £1.00 to price if outside UK

P Anderson, Wellands, Pitton, Shepton Mallet, Somerset

## DW ELECTRONICS G3 XCF

Amateur Radio Supplies  
71 Victoria Rd, Widnes   
Tel: 051-420 2559

Open Mon-Sat 9.30-6 (closed 1.00pm Thurs)  
We supply Yaesu, ICOM, Tonna, Jaybeam,  
Microwave Modules, Datongs etc

## QSL Cards

Printed on white or colour gloss cards, printed to your own design.

Please send SAE for sample to:

**Caswell Press**  
21 Homethorpe Ave, Redhill, Surrey  
Tel: (Redhill) 71023

*Voucher*



**WANTED**

Test equipment, receivers, valves, transmitters, components, cable and electronic scrap and quantity. Prompt service and cash.

**M & B RADIO**  
86 Bishopsgate Street,  
Leeds LS1 4BB  
0532 435649

**Booth Holdings Bath**

**GOLF CLUBLANE**  
SALTFORD  
BRISTOL  
Tel: 02217 2402  
Open Tues-Sat 9am-9pm  
Closed Monday

**NEXT ISSUE ON SALE**

*Amateur*  
**RADIO**

**Thursday 29th August**



**USED AMATEUR EQUIPMENT? I Buy, Sell & Exchange!**

SELLING? I pay the BEST POSSIBLE PRICES for your Clean Used Equipment!

BUYING? I have the BEST SELECTION of top Quality Used Equipment Available!

For the Deal You've been Looking for, Phone Dave, G4TNY

ANYTIME ON HORNCHURCH (04024) 57722 or Send SAE

**G4TNY AMATEUR RADIO**  
132 Albany Road, Hornchurch, Essex RM12 4AQ

**\*\*\* TANGERINE OWNERS \*\*\***

6809 CPU board, Flex O/S, 14K RAM card overlay Tanex, 32K-RAM-EPROM-BATTERY BACKED BOARD address switchable page selectable all available from STOCK also all the hard to get Tangerine chips in stock, loads of FLEX programmes, power supplies, Access/Barclaycard, sae for details. Ralph Allen Engineering, Forncette-End, Norwich, NR16 1HT. Tel: 095389 420.

**SERVICE MANUALS**

Ham Concorde 2, Ham multimode 2, Ham Jumbo 2, Ham Viking, Ham Puma, Cobra 148 GTL DX, PC 879 and PB010. Colt 1600 DX, Tristar 777, York 863, York 861.

All above at **£6.00 + £1.00 p&p** each. Other, rigs and spare parts available. 10m conversion for FMCB rigs **£30 + £1.50 p&p**  
*Details on request.*

**CBT**

1 Prince of Wales Road, Swansea. Tel: (0792) 463821.



**There's more to the motor car than driving to work . . .**

Did you know that hundreds of people race each other all over Britain every weekend – legally? Fourteen permanent race tracks and 70 part-time sprint and hillclimb venues play host to 300 events every year.

Motor Racing Magazine will cover this world of high-performance motoring, along with the international glamour and excitement of Grands Prix, Le Mans and Monaco.

**MOTOR RACING SUBSCRIPTION ORDER FORM**

To: Subscription Department • Motor Racing • 513 London Road • Thornton Heath • Surrey • CR4 6AR  
Tel: 01-684 3157

NAME.....

ADDRESS.....

Postcode.....

**PLEASE SUPPLY:** (tick box) for 12 issues, all rates include P&P

Inland World-Surface Europe-Air World-Air  
£15.20 .....  £16.45 .....  £22.55 .....  £32.15 .....

**PAYMENT ENCLOSED:** £ - Cheques should be made payable to Motor Racing. Overseas payment by international Money Order, or credit card

**CREDIT CARD PAYMENT**

.....

Signature .....

# ADVERTISERS INDEX

|                                   |            |                                 |              |
|-----------------------------------|------------|---------------------------------|--------------|
| <b>Altair</b> .....               | <b>12</b>  | <b>Harrison Elec</b> .....      | <b>38</b>    |
| <b>Ariel Systems</b> .....        | <b>24</b>  | <b>C M Howes</b> .....          | <b>28</b>    |
| <b>Armon Elect</b> .....          | <b>42</b>  | <b>J E M Marketing</b> .....    | <b>48</b>    |
| <b>Centre Elec</b> .....          | <b>12</b>  | <b>Marco Trading</b> .....      | <b>IBC</b>   |
| <b>WPO Communications</b> .....   | <b>53</b>  | <b>A Marshall</b> .....         | <b>38</b>    |
| <b>P M Components</b> .....       | <b>4/5</b> | <b>Micro Concepts</b> .....     | <b>53</b>    |
| <b>Croydon Dis Elect</b> .....    | <b>28</b>  | <b>Microwave Module</b> .....   | <b>13</b>    |
| <b>Dewsbury</b> .....             | <b>OBC</b> | <b>RAS (Notts)</b> .....        | <b>12</b>    |
| <b>Edwardschild</b> .....         | <b>17</b>  | <b>Rainbow</b> .....            | <b>28</b>    |
| <b>IMS Electronics</b> .....      | <b>12</b>  | <b>Rapid Results</b> .....      | <b>43</b>    |
| <b>P M Electric Service</b> ..... | <b>28</b>  | <b>SEM</b> .....                | <b>48</b>    |
| <b>Field Elect Ltd</b> .....      | <b>43</b>  | <b>Technical Software</b> ..... | <b>38</b>    |
| <b>GCHQ</b> .....                 | <b>42</b>  | <b>Thanet</b> .....             | <b>34/35</b> |
| <b>Glenstar</b> .....             | <b>17</b>  | <b>R Withers</b> .....          | <b>2,25</b>  |
|                                   |            | <b>Wood &amp; Douglas</b> ..... | <b>43</b>    |

## Amateur RADIO

## ADVERTISING RATES & INFORMATION

| DISPLAY AD RATES      |             | series rates for consecutive insertions |          |          |           |
|-----------------------|-------------|---|----------|----------|-----------|
| depth mm x width mm   | ad space    | 1 issue                                 | 3 issues | 6 issues | 12 issues |
| 61 x 90               | 1/8 page    | £86.00                                  | £62.00   | £59.00   | £53.00    |
| 126 x 90 or 61 x 186  | 1/4 page    | £115.00                                 | £110.00  | £105.00  | £92.00    |
| 126 x 186 or 263 x 90 | 1/2 page    | £225.00                                 | £210.00  | £200.00  | £180.00   |
| 263 x 186             | 1 page      | £430.00                                 | £405.00  | £385.00  | £345.00   |
| 263 x 394             | double page | £830.00                                 | £780.00  | £740.00  | £660.00   |

| COLOUR AD RATES       |             | series rates for consecutive insertions |           |           |           |
|-----------------------|-------------|---|-----------|-----------|-----------|
| depth mm x width mm   | ad space    | 1 issue                                 | 3 issues  | 6 issues  | 12 issues |
| 126 x 186 or 263 x 90 | 1/2 page    | £305.00                                 | £290.00   | £275.00   | £245.00   |
| 263 x 186             | 1 page      | £590.00                                 | £550.00   | £530.00   | £470.00   |
| 263 x 394             | double page | £1,130.00                               | £1,070.00 | £1,010.00 | £900.00   |

| SPECIAL POSITIONS | Covers:<br>Bleed:<br>Facing Matter: | Outside back cover 20% extra, inside covers 10% extra<br>10% extra [Bleed area = 307 x 220]<br>15% extra |
|-------------------|-------------------------------------|--|
|-------------------|-------------------------------------|--|

| DEADLINES |                        |                          |              |               |
|-----------|------------------------|--------------------------|--------------|---------------|
| issue     | colour & mono proof ad | mono no proof & small ad | mono artwork | on sale thurs |
| Sep 85    | 1 Aug 85               | 7 Aug 85                 | 9 Aug 85     | 29 Aug 85     |
| Oct 85    | 29 Aug 85              | 4 Sept 85                | 6 Sept 85    | 26 Sept 85    |
| Nov 85    | 3 Oct 85               | 9 Oct 85                 | 11 Oct 85    | 31 Oct 85     |
| Dec 85    | 31 Oct 85              | 6 Nov 85                 | 8 Nov 85     | 28 Nov 85     |

| CONDITIONS & INFORMATION  |  |   |  |
|---|--|---|--|
| <p><b>SERIES RATES</b><br/>Series rates also apply when larger or additional space to that initially booked is taken.<br/>An ad of at least the minimum space must appear in consecutive issues to qualify for series rates.<br/>Previous copy will automatically be repeated if no further copy is received.<br/>A 'hold ad' is acceptable for maintaining your series rate contract. This will automatically be inserted if no further copy is received.<br/>Display Ad and Small Ad series rate contracts are not interchangeable.</p> | <p>If series rate contract is cancelled, the advertiser will be liable to pay the unearned series discount already taken.<br/><b>COPY</b><br/>Except for County Guides copy may be changed monthly.<br/>No additional charges for typesetting or illustrations (except for colour separations).<br/>For illustrations just send photograph or artwork.<br/>Colour Ad rates do not include the cost of separations.</p> | <p>Printed — web-offset.<br/><b>PAYMENT</b><br/>All single insertion ads are accepted on a pre-payment basis only, unless an account is held. Accounts will be opened for series rate advertisers subject to satisfactory credit references.<br/>Accounts are strictly net and must be settled by the publication date.<br/>Overseas payments by International Money Order or credit card.<br/><b>FOR FURTHER INFORMATION CONTACT</b><br/>Amateur Radio, Sovereign House, Brentwood, Essex CM14 4SE<br/>(0277) 219876</p> | <p>Commission to approved advertising agencies is 10%.<br/><b>CONDITIONS</b><br/>10% discount if advertising in both Amateur Radio and Radio &amp; Electronics World.<br/>A voucher copy will be sent to Display and Colour advertisers only.<br/>Ads accepted subject to our standard conditions, available on request.</p> |





# DEWSBURY



# ELECTRONICS



FRG 8800 £559



TRIO R600 £299



NRD 515 £965

## IF IT'S TRIO IT MUST BE DEWSBURY

A FULL RANGE ALWAYS IN STOCK

APPROVED  
**TRIO**  
DEALER



TRIO R2000 £479

APPROVED  
**TRIO**  
DEALER



IC - R 71E £699

### NEW PRODUCT NEWS

IF YOU'RE THINKING ABOUT C/W  
YOU MUST READ THIS!

- ★ Iambic Keyer ★ Dash/Dot Memory
- ★ Keying Speed 1 — 55 wpm
- ★ Built In Side Tone Oscillator And Speaker ★ Headphone Socket
- ★ Variable Weight Control ★ Side Tone Volume And Pitch Control
- ★ Switchable Automatic/Semi Automatic Keying/Tune Control ★ Operation From Internal Batteries Or 9 — 15v. External Supply ★ Low Current Drain
- ★ British Made 🇬🇧
- ★ Selectable Positives or Negative Keying

**5 YEAR GUARANTEE**

Only £49.95 + £3.00 P&P To Include External Power Leads And Plugs.



POCOMOTOR AFR2000  
RTTY ALL MODE DECODER

(Now with CW option) From £427



STAR MASTER — KEYER

Stockists of DAIWA — MET ANTENNAS — MUTEK — WOOD & DOUGLAS — TASCOS TELEREADERS — MICROWAVE MODULES — ICs AMTOR — AEA PRODUCTS — DRAE

Dewsbury Electronics, 176 Lower High Street, Stourbridge, West Midlands.

Telephone: Stourbridge (0384) 390063/371228

Telex: 337675 TELPES G



Instant finance available subject to status. Written details on request.

