

# Electronics & Technology Today

Canada's Magazine for High-tech Discovery

November 1987

\$3.95  
MM10884

The New  
Electronics Today!

## The Physics of Music

Beginning a new series

Build An Audio  
Analyzer!

Techniques of  
Artificial Intelligence

Avoiding PA Feedback

Tango PCB Software



# The BEST

## IBM PC, XT and AT Compatibles Des



### BEST AVX-386

**Basic System, Standard Features** • MS DOS and UNIX Compatible • Based on 32 bit INTEL 80386 Microprocessor • Phoenix BIOS • Overall AT compatibility with significant additional features **Software Selectable Speed** • 16MHz or 8MHz **Disk Storage: two Floppy 5 1/4 inch diskette drives** • Drive A: 1.2 Megabytes capacity • Drive B: 360 Kilobytes capacity **Memory Capacity** • 2 Megabytes of RAM or • 8 Megabytes of RAM **Standard Peripheral Interfaces** • One serial interface • Parallel Printer Interface • Game/Joystick port • AT Compatible Real Time Clock/Calendar with Battery Backup • Hardware Reset switch • 10 expansion slots: 6 IBM AT compatible expansion slots; 4 IBM PC compatible expansion slots **Power Supply** • 200 watt total power, 90 to 132 VAC-50/60HZ, 198 to 264 VAC-50/60HZ • Switched and fused Auxiliary power connector



### BEST COMPACT 286

**Basic System, Standard Features** • IBM AT Compatible • Based on 16 bit INTEL 80286 Microprocessor • Phoenix BIOS • 8MHz system clock speed **Disk Storage: one Floppy 5 1/4 inch diskette drive** • Drive A: 360 Kilobytes capacity **Memory Capacity** • 640 Kilobytes of RAM **Standard Peripheral Interfaces** • AT Compatible Real Time Clock/Calendar with Battery Backup • Hardware Reset switch • 7 expansion Slots: 2 IBM PC compatible expansion slots; 5 IBM AT compatible expansion slots **Power supply** • 130 watt total power, 90 to 132 VAC-50/60HZ, 198 to 254 VAC-50/60HZ • Switched and fused Auxiliary power connector



### BEST COMPACT 86

**Basic System, Standard Features** • IBM PC/XT Compatible • Based on 16 bit INTEL 8086-2 Microprocessor • Phoenix BIOS **Hardware Selectable Speed** • 8MHz or 4.77 MHz **Disk Storage: one Floppy 5 1/4 inch diskette drive** • Drive A: 360 Kilobytes capacity **Memory Capacity** • 256 Kilobytes of RAM **Standard Peripheral Interfaces** • Hardware Reset switch • 7 IBM PC/XT compatible expansion slots **Power Supply** • 130 watt total power, 90 to 132 VAC-50/60HZ, 198 to 264 VAC-50HZ

### BEST WARRANTY

## DESKTOP PUBLISHING

**BEST** Desktop Publishing Packages can be customized to your specific needs. With any of our systems, you can easily produce professional reports, documents and newsletters without the usual delay and aggravations. You and your creative ability are the only limits that a **BEST** Desktop Publishing system will encounter. Contact us for further information.



## Best Systems Corporation of Canada Inc.

**HEAD OFFICE** 6315 KESTREL ROAD MISSISSAUGA ONTARIO 1-800-387-6995 FAX (416) 673-1188

Circle No. 3 on Re

# BEST Range

Designed and Made in Canada



## BEST MARK III

**Basic System, Standard Features** • IBM PC/XT Compatible • Based on 8 bit INTEL 8088-2 Microprocessor • Phoenix BIOS **Hardware Selectable Speed** • 8MHz or 4.77MHz **Disk Storage: two Floppy 5 1/4 inch diskette drives** • Drive A: 360 Kilobytes capacity • Drive B: 360 Kilobytes capacity **Memory Capacity** • 640 Kilobytes of RAM **Standard Peripheral Interfaces** • Two serial interfaces • Parallel Printer interface • Real Time Clock/Calendar with Battery Backup • Hardware Reset switch • 7 IBM PC/XT compatible expansion slots **Power Supply** • 130 watt total power, 90 to 132 VAC-50/60HZ, 198 to 264 VAC-50/60HZ • Switched and fused Auxiliary power connector.



## BEST MARK IV

**Basic System, Standard Features** • IBM PC/XT Compatible • Based on 16 bit INTEL 8086-2 Microprocessor • Phoenix BIOS **Hardware Selectable Speed** • 3MHz or 4.77MHz **Disk Storage: two Floppy 5 1/4 inch diskette drives** • Drive A: 360 Kilobytes capacity • Drive B: 360 Kilobytes capacity **Memory Capacity** • 640 Kilobytes of RAM **Standard Peripheral Interfaces** • Two serial interfaces • Parallel Printer interface • Real Time Clock/Calendar with Battery Backup • Hardware Reset switch • 7 IBM PC/XT compatible expansion slots **Power Supply** • 130 watt total power, 90 to 132 VAC-50/60HZ, 198 to 264 VAC-50/60HZ • Switched and fused Auxiliary power connector.



## BEST AVT 10-286

**Basic System, Standard Features** • IBM AT Compatible • Based on 16 bit INTEL 80286 Microprocessor • Phoenix BIOS **Hardware Selectable Speed** • 10/6MHz or 10/6MHz **Disk Storage: two Floppy 5 1/4 inch diskette drives** • Drive A: 1.2 Megabytes capacity • Drive B: 360 Kilobytes capacity **Memory Capacity** • 640 Kilobytes of RAM or • 2 Megabytes of RAM expandable to 4 Megabytes **Standard Peripheral Interfaces** • Two serial interfaces • Parallel Printer Interface • AT Compatible Real Time Clock/Calendar with Battery Backup • Hardware Reset switch • 7 expansion slots: 2 IBM PC compatible expansion slots; 5 IBM AT compatible expansion slots **Power Supply** • 200 watt total power, 90 to 132 VAC-50/60HZ, 198 to 264 VAC-50/60HZ • Switched and fused Auxiliary power connector.

## NETWORKING

Let our qualified staff design a network configuration for your specific needs. We have a wide selection of **BEST** computers from which to choose along with our **BEST** Network Card, **BEST** 8-Port Active Hub and Passive Splitters, all locally manufactured and supported. Contact us for no-obligation advice and free, price-competitive estimate. We also provide **FREE** introductory seminars; full courses available. We have considerable experience in installing and commissioning complete systems.



# BEST

SEVERAL LOCATIONS TO SERVE YOU. JUST CALL (416) 673-5111

Order Service Card

## Our Cover

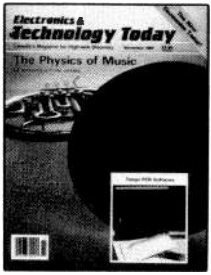

The French horn and Tango software were photographed by Bill Markwick and Ed Zapletal.

Electronics & Technology Today is Published 12 times a year by: Moorshead Publications Ltd. 1300 Don Mills Road, North York, Toronto, Ont. M3B 3M8 (416) 445-5600

Editor: William Markwick  
Assistant Editor: Edward Zapletal  
Director of Production: Erik Blomkwist  
Production Manager: Dolph Loeb  
Circulation Manager: Sharon Cernecca  
Advertising Manager: David Stone

Publisher: H.W. Moorshead; Executive Vice-President: V.K. Marskell; Vice-President - Sales: A. Wheeler; Vice President-Finance: B. Shankman; Production: Kevan Buss; Naznin Sunderji; Accounts: P. Dunphy; Reader Services: K. Parkinson, R. Cree; Advertising Services: B. Neilson.

Newsstand Distribution:  
Master Media, Oakville, Ontario

Subscriptions:  
\$22.95 (one year), \$37.95 (two years).  
Please specify if subscription is new or a renewal.

Outside Canada (US Dollars) U.S.A. add \$3.00 per year. Other countries add \$5.00 per year.

Postal Information:  
Second Class Mail Registration No. 3955.  
Mailing address for subscription orders, undeliverable copies and change of address notice is:  
Electronics & Technology Today, 1300 Don Mills Rd., Toronto, Ontario, M3B 3M8

Printed by Heritage Press Ltd., Mississauga  
ISSN 07038984.

Moorshead Publications also publishes Pets Magazine, Computing Now!, Computers in Education, and Government Purchasing Guide.

Circulation Independently Audited  
by MURPHY & MURPHY  
Chartered Accountants.

# Electronics & Technology Today

Canada's Magazine for High-tech Discovery

Volume 11, Number 11

November 1987

## Features

Parallel Systems in Man and Machine .....10  
*Developing artificial intelligence*

The Physics of Music .....36  
*Beginning a new series*

Circuit Theory .....50  
*The simplicity of Thevenin's theorem*

## Technology

Chemically Sensitive Transducers .....26  
*Making chemical sensors from microchips*

Avoiding Feedback .....30  
*Minimizing sound system howl*

A Battery Primer .....57  
*Reviewing the different types*

## Product Review

Tango PCB .....33  
*Printed circuit layout software for the PC*

## Projects

Automotive Multifunction Meter .....18  
*Find out what idiot lights don't tell you*

Audio Analyzer .....41  
*Build this comprehensive test set*

## INFORMATION

For Your Information ..... 5  
Next Month ..... 11  
Marketplace..... 23  
Classifieds ..... 24  
Advertiser's Index.....24

Software ..... 35  
Books .....48  
Order Form .....53  
Subscriptions .....54  
Binders .....55

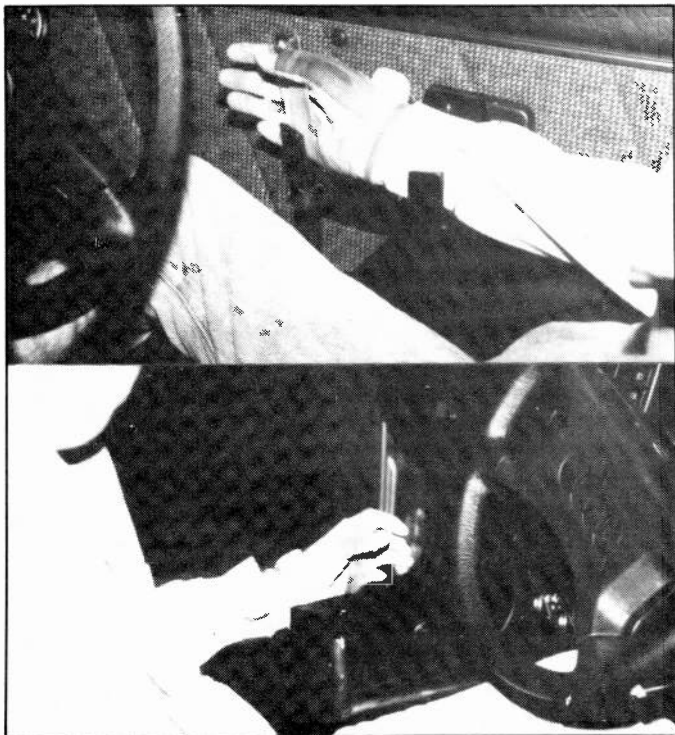

The remote control steering system evolved by Steering Developments Ltd, which can be operated by almost any limb movement. In this example it channels arm action for full driving control. The right hand operates a steering joystick, with elbow control for horn, wipers and indicators. The lefthand operation works the accelerator (push forward) and the brakes (pull back).

Remotely operated car controls are opening up a whole new world of independent travel for severely disabled people. Some of the disabilities are so extensive that the sufferers might have thought they would never be able to control a vehicle on the public roads, but advanced electronic systems from specialist manufacturers in Britain have made possible the "impossible". A perfect example of someone who thought she would never enjoy personal transport is a 22-year-old woman named Alison. She is a victim of the drug thalidomide and was born without arms and very short in stature.

However, the Steering Developments company of Eastman Way, Hemel Hempstead, near London, designed a remote control system that can utilize virtually any movement of the body. Alison can now steer a car through movements of a lever operated by her right shoulder.

## Safety Precautions

The system has been fitted into an Austin Metro sedan with automatic transmission made by Austin Rover. Tailored to her needs, all

controls other than steering are operated by the driver's feet through a specially built array below the instrument panel.

The steering control is a composite of hydraulics and electronics with the following features:

Hydraulic power assistance operated by a shoulder level/tiller connected to a rotary valve.

Hydraulic pressure is supplied via an engine driven pump incorporating a twin belt drive facility. This is, in itself, a safety back-up for the primary pump.

A speed sensitive characteristic of the hydraulic pumps ensures that, as the speed of the car increases, the sensitivity of the system reduces.

Various shapes and configurations of the lever/tiller are produced to meet individual needs. The positioning allows the use of any part of the body — arm, knee, shoulder, hand or foot — where there is some movement, however small.

Safety precautions are elaborate. The back-up system includes an electrically driven hydraulic pump activated by a sensor. This detects low oil pressure due to failure either of the primary pump, primary pump belt or the engine itself. The signal to the electrically

# Electronic Driving Systems and Disability

By Geoffrey Hancock

driven pump is instantaneous, and so maintains hydraulic pressure to the steering control valve.

## Driving Instruction

While such duplicated functions are essential to safety, it is important for the driver to know which components are in use. To avoid the driver being unaware of a substitution, a dual circuit delay timer is included. If the back-up system is called on for steering, both visual and audible alarms operate.

In this way the driver learns that the back-up system is operating and the primary one needs repair without delay. The fail safe back-up of key components means that even severely disabled people can drive.

Peter Roake, managing director of Steering Developments, says driving with the new remote control steering is unlike any other kind of driving experience. Since each system fitted is unique to the particular driver, new steering skills must be learned. "This will certainly require patience, dedication and a lot of practice," warns Mr. Roake.

It is recommended that learners have the assistance of a qualified driving instructor who is prepared to understand the special nature of the new system. Alison passed the official driving test at the first attempt, just three months after the system was fitted. A sympathetic instructor gave her driving lessons, first at the Banstead Place Mobility Centre and later on the open road, in a car initially fitted with an over-ride control.

## Paralyzed Legs

Alison is now able to do her motoring alone, thanks to the system and her own remarkable willpower. She

enters the car by opening the driver's door with her teeth, helped by a bracket on the handle. Once inside, she uses a stick with a hook on the end to close the door, again using her teeth. Another severely disabled person who can now drive is Mike who, two years ago, broke his spine when he was using a trampoline in preparation for the world skiing championships. He will never walk again but, after utter dejection at first, his spirits have soared because he now has the independence of being able to drive, thanks to Steering Developments' system.

With legs paralysed, he uses his arms and hands to drive the car. A forward push with the left hand works the accelerator while a pulling action brings on the brakes. A lever, or tiller movement, of the right hand operates the remote control steering. A sensor behind the elbow controls the horn, windscreen wipers and indicators.

## Cost of Conversion

A big advantage of the remote control steering system is that it can be fitted to most production cars with rack and pinion steering. Conversion prices for the system start at about \$3000 for cars like the Escort from Ford and the Astra and Ova from Vauxhall, all of which are obtainable with two doors. For easy getting in and out, these compare favourably with four door models where the doorway tends to be more restrictive. The major car companies in Britain operate special schemes for disabled people, including hire purchase and leasing arrangements.

Another new driving aid is an electronic two-axis joystick for the control of steering, brakes and ac-

## For Your Information

celerator, and capable of being positioned in a variety of places in a car to meet the needs of a particular disability, whether of hands or feet. It has been developed by the Department of Engineering Production at the University of Birmingham in the English midlands, with financial assistance from Motability, a registered charity that has the support of Queen Elizabeth II, the Prime Minister and the leaders of the major political parties, as well as the government's Department of Health and Social Security.

Neil Wood, production engineer in charge of the university project, says the aim is to give variable assistance to meet different disabilities using microprocessor controlled servo loops. Digital techniques, he said, make it very much easier to modify the characteristics of the steering.

### Minimal Physical Effort

Mr. Wood explained: "Another vital advance in the technology used is the development of power semi-conductors which are able to control more than one motor from a single 12 volt supply with a maximum of efficiency, which means low power loss. Such devices have been available only over the last year or so. Without them it would not be possible to utilize high energy electrical actuators. In the prototype vehicle the various controls have been integrated so that steering, brakes and accelerator can be controlled by the two-axis joystick".

The project, he said, had shown the feasibility of using modern technology to provide minimal-effort car control with a choice of applications to suit many needs. Steering, braking and acceleration can be controlled with "virtually zero effort".

Prospects of putting the system into production are under investigation.

### 42-inch Color Tube

Mitsubishi Electric Corporation has developed a 42-inch (diagonal) color picture tube, the industry's largest type direct-view tube. It will shortly start marketing the new huge color tubes at \$4,400 Cdn.

The 42-inch model uses fine pitches to achieve the high resolution of 560 lines horizontal. The adoption of a multiple-stage convergence large-caliber electron gun (new XF electron gun) has improved focusing capability, while a bright, sharp image and long life are provided by a scandium oxide dispersion cathode which can sustain four times larger current density than conventional cathodes.

Mitsubishi Electric Sales Canada Ltd., 8885 Woodbine Ave., Markham, Ontario L3R 5G1, (416) 475-7728.

## Advanced Technology Makes Wind Power Feasible

by John Webb

A huge experimental wind machine being assembled on Orkney island, off the northern tip of Scotland, will generate more electricity than any other in the world when it becomes operational later this year, it is confidently predicted. The 12 million pound wind turbine will have a 3MW rating and despite the fact that there are machines with rotors of much larger diameter than its 60 metres, it is expected to produce up to a record 9000MW/h of electrical power a year. The reason for the exceptionally high output of the new British machine is that it incorporates advanced technology in its rotor and control systems, and it is being erected on what has been described as the windiest wind turbine site yet used. Orkney has an annual average wind speed of 11m/s compared with 7m/s to 8m/s in the United States of America, where most of the world's modern wind turbines are clustered on farms in California.

The oil crisis of the 1970s provided a powerful boost to the creation of a wind power industry when the Carter administration backed the development of wind farming. Today there are 14,000 wind machines in California where not only American but also British and Danish companies have made it their showplace for a whole family of small-medium wind turbines. Over 100 British machines are now in service there, including the world's largest group of 75 medium power, 330kW turbines built by the James Howden group from Glasgow, Scotland.

### Latest Stage

While pioneering wind power, however, countries such as Britain, West Germany, Denmark, Sweden and the Netherlands have held back on the creation of kilowatt wind machine farms in their own countries because they believe the optimum machine may prove to be of megawatt size. Nevertheless, Denmark and the Netherlands have now decided to establish their own wind farms and Britain's Energy Department, which has spent 20 million pounds since 1979 on wind power research and development, is edging towards testing the economics of a United Kingdom wind farm.

British Aerospace and its partners in the Wind Energy Group (WEG) have done studies of a 100 metre diameter, 6MW wind turbine with the implications of a wind farm of 300 such machines sited off the coast. And England's Central Electricity Generating Board (CEGB) has said that provided wind power technology

continues to advance, it plans a future order or some ten wind turbines.

In the meantime, British Aerospace and the WEG are proceeding with an outline design study of a 70 metre machine that will produce up to 2.5MW on a mainland site. The study will be completed this year and is likely to be followed by a detailed design leading to the building of the machine in about three years time.

The machine will in fact be the latest stage of a development programme that started with a two-bladed, 20 metre diameter rotor machine being commissioned at Bugar Hill, Orkney, in September 1983. Known as the MS-1, it has a rated output of 250kW and during the past three years has generated power for almost 10,000 hours and produced over 850,000kW of electricity.

### Variable Pitch

The main aim of the 20 metre machine, whose rotor turns about 30 million times a year to produce enough electricity to supply 150 homes, was to prove the design and technology for the 60 metre turbine that will soon share its site on Bugar Hill. The prototype was closely monitored by over 200 sensors and proved so successful that it led to a 25 metre commercial version. Twenty of these MS-2 machines of 250kW rating are now in service on a wind farm near San Francisco.

British Aerospace, as a member of

the WEG responsible for building the 20 metre and 60 metre prototypes on Orkney, used its propeller and wing expertise to produce two-bladed rotors for them. Strangely, the MS-2 commercial machine has a three-bladed rotor but this was chosen because research showed it was the best option for a medium sized machine, whereas two-bladed rotors are better for large machines.

The outer 30% of the span of the 60 metre rotor, which has blades based on a steel spar with glassfibre outer shell, acts like a variable pitch propeller so that the tips can be feathered to reduce rotation speed in high wind.

Like the earlier 20 metre machine, the 60 metre sister turbine on Orkney will be closely monitored as part of the British Government's wind energy programme, as will a new 55 metre, three-bladed 1MW turbine soon to be built at Richborough, southeast England, by the Howden group.

### Vertical Axis

The latter project also involves the CEGB, the Energy Department and the European Commission, and is intended to explore the extent to which the successful medium sized wind turbine technology used in Howden machines built in California and Barbados can be scaled up and stretched to 1MW and beyond. It will have lightweight epoxy resin/wood composite blades and incorporate technical innovations designed to reduce

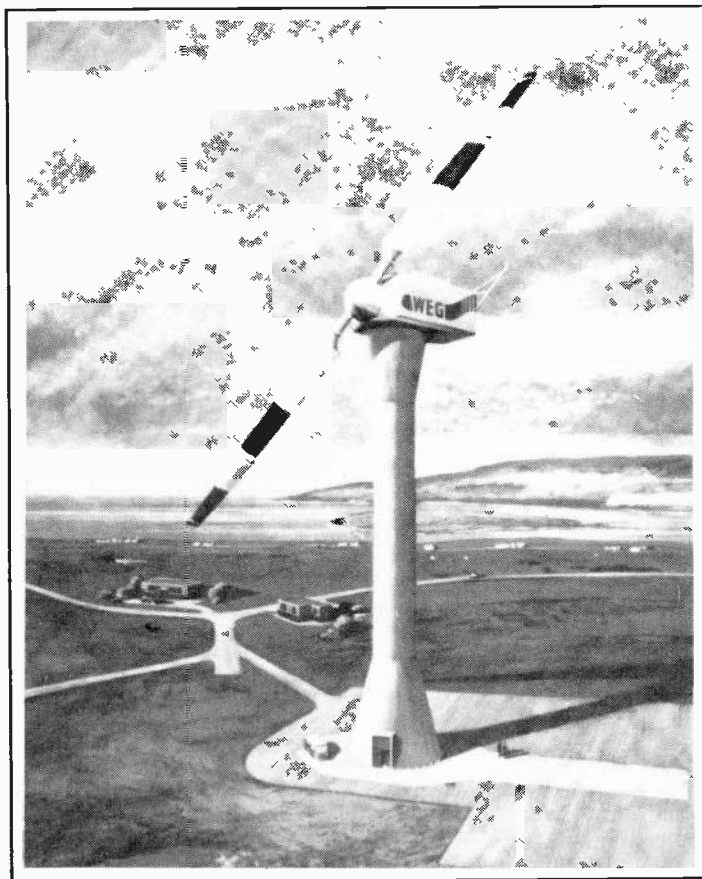

Continued on page 29

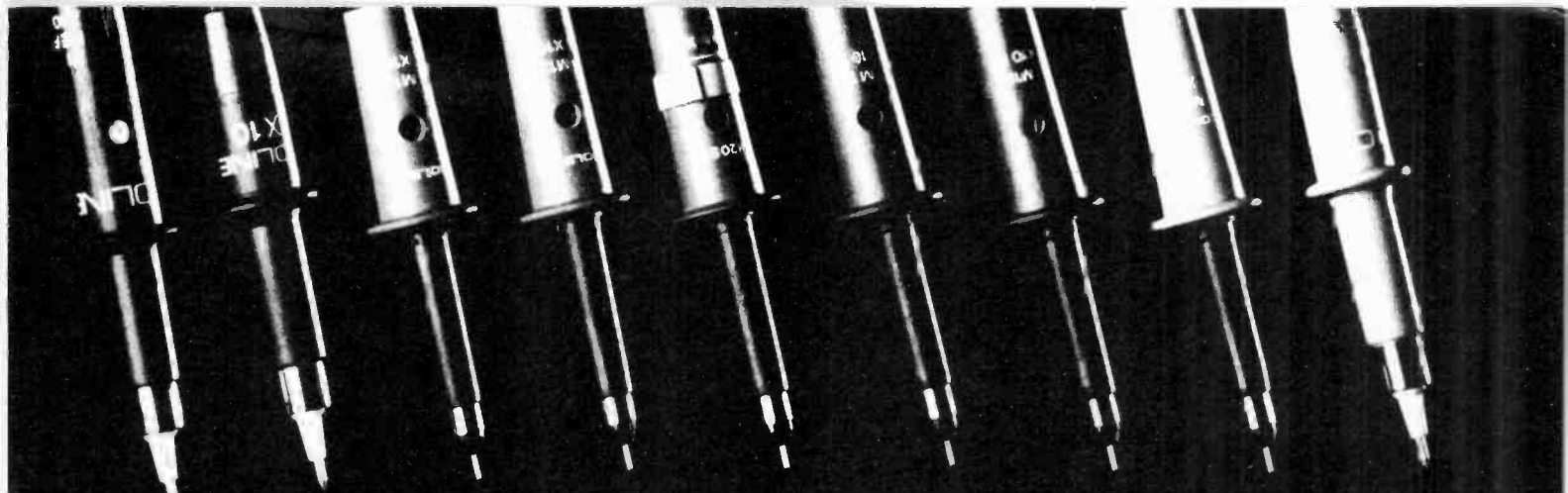

# Nine Test Probes with only one difference between them and your scope's original equipment

Manufacturers Scope	Original Probe	U.S. \$ Price	COLINE Equivalent	CDN Price	Manufacturers Scope	Original Probe	J.S. \$ Price	Coline Equivalent	CDN Price
<b>TEKTRONIX</b>					<b>PHILIPS</b>				
2300 Series	P6101A	\$53	M12X1	\$ 45.90	PM3267	PM8294	\$60	M12X1	\$45.90
	P6108A	\$75	M12X10	\$ 54.90	&				
2200 Series	P6121	\$100	M12X10AP	\$ 70.60	PM3256	PM892E	\$70	P100	\$36.20
	P6122	\$58	P100	\$ 36.20	PM3264	PM892E	\$95	M12X10	\$54.90
2400 Series	P6131	\$140	M15X10HFAP	\$105.90					
	P6133	\$115	M12X10AP	\$ 70.60	<b>HITACHI</b>				
400 Series	P6105A	\$93	M12X10AP	\$ 70.60	V-1100A	} AT-10AL.5	\$64	SP100	\$46.10
	P6106A	\$140	M15X10HFAP	\$105.90	V-670				
	P6130	\$130	M12X10AP	\$ 70.60	V-509				
<b>IWATSU</b>					<b>HEWLETT PACKARD</b>				
SS-5321	SS-0014	\$92	M12X10	\$ 54.90	1715A	10018A	\$135	M20X10	\$62.80
SS-5711	SS-0012	\$77	M12X10	\$ 54.90	1722B	10017A	\$130	M15X10HF	\$90.10
<b>LEADER</b>					1725A	10017A	\$130	M15X10HF	\$90.10
LBO-315	LP-060X	\$60	SP100	\$ 46.10	1740 Series	10041A	\$135	P100	\$36.20
LBO-518	LP-100X	\$76	SP100	\$ 46.10		10021A	\$85	IP20	\$31.90

Take up the Coline challenge and compare our prices with the probes you currently use. In many cases you can replace both probes on your dual trace scope at the cost of one probe from the scope manufacturer. Plus, bandwidth and overall performance of the probe typically exceed that of the original equipment. Satisfaction is guaranteed with a ten day return privilege. Coline - Specialists in probes for over 15 years.

IN CANADA  Coline Ltd PROBES & ACCESSORIES

distributed from your Canadian stocking source



980 Alness St. Unit 7.  
Downsview, Ontario  
M3J 2S2  
(416) 661-5585  
TELEX 065-28169

Circle No. 22 on Reader Service Card

## SPARTAN 64K COMPUTER

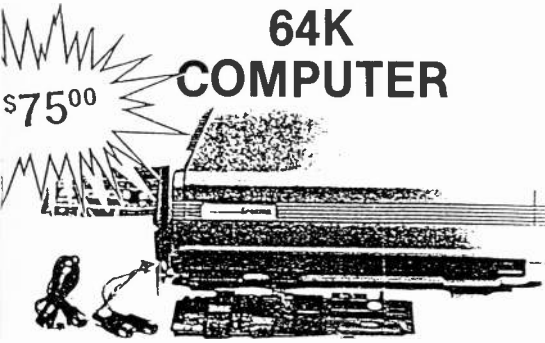

\$75<sup>00</sup>

Converts your Commodore 64 to run most Apple Type Hardware and Software  
The Spartan also can be used by adding any \*CPU Card, \*Manual

## ZX81 TYPE COMPUTER

ZK Z80 CPU 42 Keys  
Composite or TV Output

**\$49.00**

## LENSES

7cm Xerox 625967 ..... **\$6.00**

## TV PROJECTION

Focal length 114mm  
F.I.O. lens  
5" Dia.

**\$20**

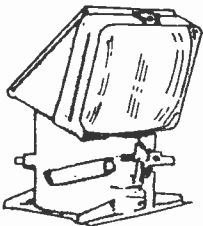

## REAR TV PROJECTION

Focal length 102.4mm  
F.I.O. lens  
5" Dia.

**\$25.00**

COPY LENS  
5.6-11



Schneider  
Kreuzach

**\$50.00**

## MOTION DETECTOR ALARM

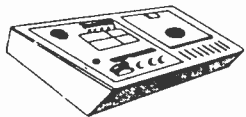

Photocell activates alarm  
Range up to 15'

**\$6.00**

## COLECO ADAM

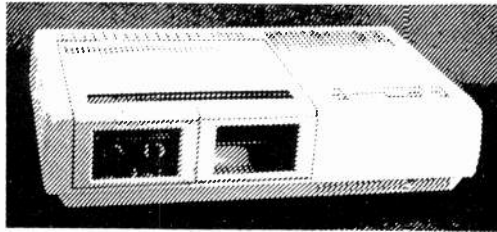

COLECO®  
ADAM™  
CPU

**\$79.00**

Adam™ CPU (memory console) for use in the ColecoVision™ family computer system... Features Z80/MC6801 processor technology with 80 K bytes of RAM and 40 K bytes of ROM with built-in digital data drive (256 K byte) with space for adding an additional drive.

## ASCII KEYBOARD

Mfd. for Coleco®  
Adam®

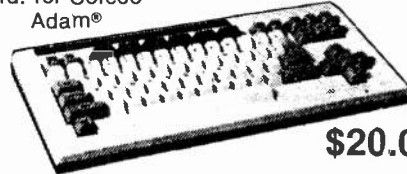

**\$20.00**

This 75 key unit with 21 user defined keys is ASCII 8 BIT serial output type. All connections via a 6 pin female modular connector at rear.

COLECO®  
GAME  
UNIT



JOYSTICK

**\$7.50**

DATA TAPE  
DRIVE

**\$35.00**

## SWITCHING

+ 5V 6A  
+ 12V 2A  
- 5V .7A  
- 12V .7A  
7 3/4" x 4 1/4" x 2"

**\$24.95**

+ 5V 7.5A  
+ 12V 1A  
- 5V 2A  
- 12V 1A  
+ 24 1.5A  
15" x 5" x 4"

**\$75.00**

## 6V Lead Acid Battery



4Ah - \$ 8.00  
8Ah - \$15.00  
10Ah - \$20.00

5.0 VDC STEPPING MOTOR  
Superior Electric  
Slo-Syn®  
M061-FD02  
4-PHASE  
1.0 Amp/Phase

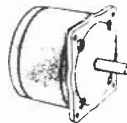

**\$15**  
(USED)

## 5 1/4 DISKETTES DSDD

Box of 10 \$ 6.50  
10 Boxes \$60.00

## POWER SUPPLIES

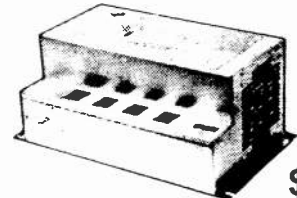

**\$50.00**

285W 472W

+ 5V 8A + 5V 13.5A  
+ 12V 2A + 12V 11A  
- 5V 1A - 5V 4A  
- 12V 2A - 12V 1.5A  
+ 24V 8A + 24V 5.5A  
12" x 8" x 6"



## MUFFIN FANS

3" \$10.00  
4 1/2" Whisper \$12.00

GEARED  
MOTORS  
5.76 rpm  
**\$35.00**

SPEAKERS  
Full Range  
8" 15W 8Ω  
**\$6.00**

61 rpm  
30 in/lb  
**\$35.00**  
(USED)

Logic Probe  
**\$18.00**  
(BUILT)

# Active Surplus Electronics

347 Queen St. W., Toronto, Ontario M5V 2A4 Tel: (416) 593-0967

Tested and working. All sales final. 7% Ontario sales tax. Visa, MasterCard, Certified Cheque. Shipping & Freight extra.



# Train with NRI for a high paying career servicing computers.



**DIGITAL MULTIMETER**—  
Professional test instrument  
for quick and easy  
measurements.

**LESSONS**—Clear, well illustrated  
texts build your understanding  
of computers step-by-step.

**DISK SOFTWARE**—  
including MS-DOS, GW  
BASIC, WordStar,  
and CalcStar.

**SANYO COMPUTER**— 8088  
CPU double-sided disk drive,  
256K RAM, 4.77 MHz and 8  
MHz turbo speed.

**MONITOR**—High resolution,  
green screen displays, crisp  
text and graphics.

**TECHNICAL MANUALS**  
—with complete specs on  
Sanyo computer and  
professional programs.

**DISCOVERY LAB**—Using it,  
you construct and test  
circuits like those used  
with computers.

**DIGITAL  
LOGIC  
PROBE**—  
Simplifies  
analyzing digital  
circuit operation.

## Get started now by building this fully PC compatible computer

Now you get it all... training for America's fastest growing career opportunity... training to service all computers... training on the newest total computer system, the Sanyo 880. Only NRI can give you the well-rounded training you need, because only NRI gives you a complete computer system... computer, monitor, disk drive, software, even test instruments like a digital multimeter and logic probe to work with and keep. It all adds up to training that builds the knowledge, competence, and ability you need to succeed as a computer service specialist.

### Get inside the newest Sanyo Computer—fully compatible with the IBM PC\*

As an NRI student, you'll get total hands-on training as you actually build your own latest model Sanyo 880 Series computer from the keyboard up. It's fully compatible with the IBM PC and, best of all, it runs programs almost twice as fast as the PC. As you assemble the Sanyo 880, you'll perform demonstrations and experiments that will give

you a total mastery of computer operation and servicing techniques. You'll do programming in BASIC language—even run and interpret essential diagnostic software.

### Understanding you get only through experience

You need no previous knowledge to succeed with NRI. You start with the basics, rapidly building on the fundamentals of electronics with bite-size lessons. You perform hands-on experiments with your NRI Discovery Lab and then move on to master advanced concepts like digital logic, microprocessors, and computer memories.

### Learn at home in your spare time

You train in your own home at your own convenience, backed at all times by your own NRI instructor and the entire NRI staff of educators and student service support people. They're always ready to give you guidance, follow your progress, and help you over

the rough spots to keep you moving toward your goal.

### 100 page free catalog tells more... send today

Send the postage-paid reply card today for NRI's 100 page catalog that gives all the facts about computer training plus career training in robotics, data communications, TV/audio/video servicing, and many other fields. If the card is missing, write to NRI at the address below.

\*IBM is a registered trademark of International Business Machines Corp.

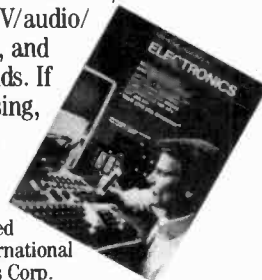

# **NRI** SCHOOLS

McGraw-Hill Continuing Education Center  
330 Progress Avenue  
Scarborough, Ontario M1P 2Z5  
or telephone 416-293-8787

We'll give you tomorrow



# Parallel Systems in Man and Machine

*Developing AI through the use of parallel processing*

By K. Tahir Shah

National programs, if anything else, are an indication of general scientific trends. Usually such wide scale programs are planned and implemented to achieve outstanding goals. In recent history, we have known projects like "Manhattan project" to build nuclear devices with destructive power not matchable, or NASA's Apollo project to put man on the moon. Whatever the objectives may be, good or evil, political or economical, a broad pure and applied research in many disciplines is required to successfully achieve these goals.

Since the early seventies, when LSI first became available, there has been a constant "technology race" between many nations. This technology race is a sort of thermometer to measure global priorities. What new scientific discoveries are going to be the technology of tomorrow? The two Japanese programs in information technology, and the fifth and sixth generation computer projects have brought tremors and excitement to all of us. Everybody is saying we are in the midst of an information revolution. Yes, that is true, but where are we heading?

What sort of information processing systems will we be using in a coming decade or two? There are no definite answers but knowing the present and the planned research projects worldwide, one gets a feeling that mankind is planning thinking machines possibly similar to our own brain. Thinking machines which are to be in our own image! Progress in neural as well as computer sciences drive this feeling to the level of rational prediction. The subject is too wide to be discussed in a few pages and thus I shall limit myself to only one fundamental aspect — parallel processing in the multi-processor computer and the brain.

## Sixth Generation Computers

A recent event encouraged to further my belief that the study of the human

and animal brain can enhance our design of artificial intelligence systems and computer hardware.

On the request by the Japanese Ministry of Science and Technology a report titled "Promotion of Research and Development on Electronics and Information Systems that may complement or Substitute for Human Intelligence" was published in 1985 by the Subcommittee on Artificial Intelligence of The Council for Aerospace, Electronics and other Advanced Tech-

**"The sixth generation shows a shift towards fundamental issues of the human thinking process."**

nologies. It was referred to as the "sixth generation computing proposal" by the Japanese press. The proposal differed remarkably from their fifth generation program which was mostly hardware and application oriented.

The sixth generation project shows a shift towards fundamental issues of the human thinking process. No doubt such a program will have a significant effect on research in artificial intelligence worldwide. The objective of this project is defined as advancement in the science and technology for clarifying advanced intelligent functions of the human being. More specifi-

cally that is recognition, learning, inference, and so on, while developing these functions technically for the construction of various systems. This brings it outside the conventional information technology with four major disciplines: Physiology, Psychology, Linguistics, and Logic as their target of research. The ultimate aim is the innovation in technologies, such as speech and pattern recognition, learning, natural language processing, deductive, analogical and inductive inference.

It is suggested that a brain model (in information processing paradigm) be constructed which approximates the human cognitive processes. The present state of knowledge in brain physiology suggests that:

1. The brain consists of independent functional regions.
2. Information processing in each region is hierarchical.
3. Regions exchange information to perform functions as part of a complex system.

## Understanding the Brain

Whatever is going on in our brain is certainly a very complex process but the development of advanced computing systems demand that we understand this process and resolve any difficulties associated with it. The program thus calls for research so that a computational model of the brain be constructed which approximates the human cognitive process.

The word model is used here in the sense of a theoretical description representing some process. Similarly the research and development of knowledge science in the psychology sector calls for studies on the nature of understanding, and modelling of intelligent functions e.g., visual perception, linguistic meaning, long term memory, and learning etc.

The human brain as we know contains about 100 billion neurons, about the same as the number of stars in our galaxy. The number of neural interconnections is itself an astronomical figure exceeding 100 billion. At present, there are many theories of memory, information retrieval and other brain functions. Each theory explains only part of the story.

From among the complexities of various explanations, one thing appears dominant: it is the interconnection network of neurons which is responsible for storage, retrieval, and the processing of information. It seems that the brain is, if I may use this term, a giant parallel machine with a complicated topology of its neural interconnections. The theory and the architecture of parallel machines has some curious similarity with what we know about the brain. It is this similarity which suggests that we are heading towards an era of artificial brain and artificial intelligence. The connection machine developed at Massachusetts Institute of Technology is only beginning of this epoch.

### Neural Hardware

The last few years of rapid progress in parallel models of computer hardware, associative network theories and VLSI technology, and equally rapid progress in biochemistry, brain theory, physiology of the brain and psychophysics of various sensory systems such as vision and motion perception, suggest now that the human and animal brain, and an associative parallel machine have many similar characteristics.

An associative parallel machine is a parallel processor which has interconnections in the form of an associative net. Despite this similarity, the physics of the two hardwares differs widely. Computers are electronic machines while brains are electrochemical machines. Although the exact chemical mechanisms are not yet fully understood, there is some qualitative knowledge of what sort of chemicals are involved. There is an impressive list of neurotransmitters for the central and sense-motory nervous systems.

Neurotransmitters are chemicals which are transferred from the synaptic ends of other neurons. They carry

some information in the form of chemical structure. There is also experimental evidence that some functions can be detected or stopped altogether with certain drugs, or organic chemical agents like puromycin. Like many pieces of a puzzle, the information about the chemistry and the physiology of the brain, and the memory and the learning mechanism, theories of artificial intelligence and parallel processing, can all be joined to postulate a practical model of what we may call a bio-computer. But such a venture at the commercial level is still far in the future. The Japanese sixth generation project is, however, aiming at such an achievement.

Professor Francis Crick, the discoverer of the DNA double helix structure, divides neural science research into two categories of topics. First, those which appear at least capable of explanation by known methods and techniques. The other category of problems appear to defeat all efforts to understand them. The chemical and electrical nature of neurons, habituation and sensitization, the effect of

## **Electronics & Technology Today**

Canada's Magazine for High-tech Discovery

**For advertising or subscriptions please call (416) 445-5600**

### **The Magic of MRI**

Magnetic resonance imaging is a method of scanning the interior of the human body without invasive techniques. We look at the technology and how it works.

### **The Physics of Music, Part II**

The ear is the most sophisticated hearing mechanism ever dreamed of. We examine many of the surprising facts about how we interpret the sounds around us.

### **Build a Basement Flood Alarm**

A simple, yet novel approach to an alarm circuit that lets you know if a basement pump isn't operating properly.

### **The PC Weather Station**

We review the Technology Marketing weather station that uses an IBM PC to record wind, pressure, temperature and rain.

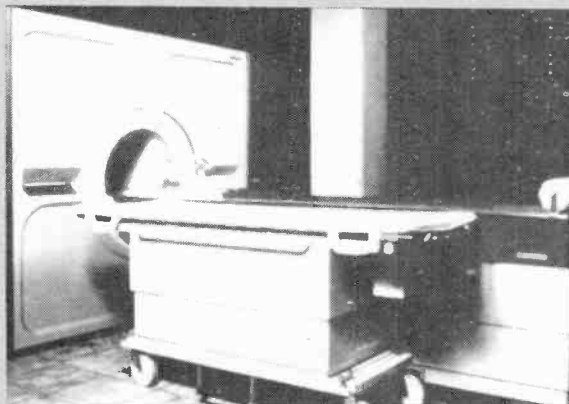

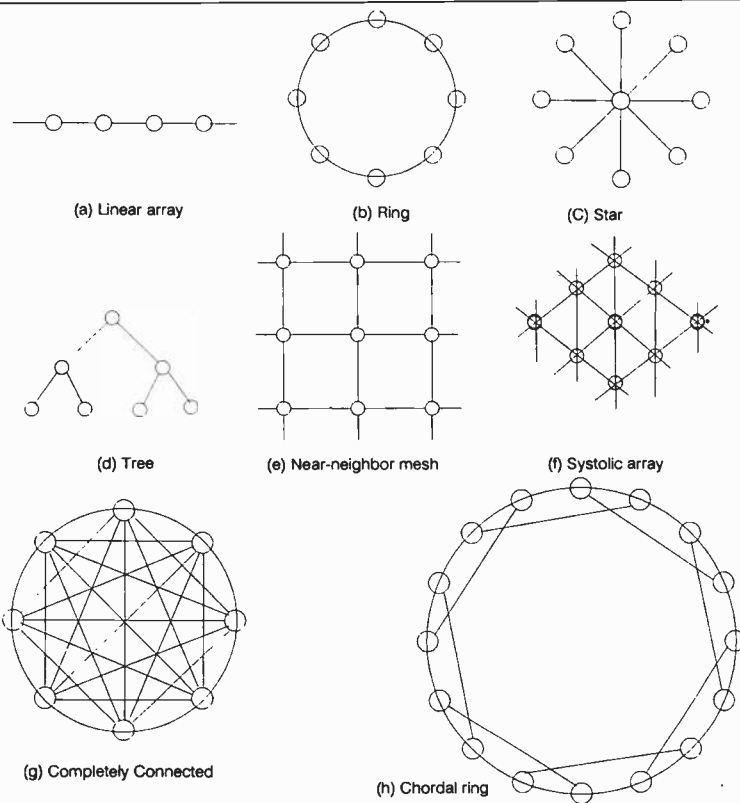

Fig. 1 Examples of static network topologies: one dimensional (top); two dimensional (middle); three dimensional (bottom).

of brain hardware. It is unlikely that the deletion of quite a few of them leads to any appreciable difference in processing ability. This is not true for a single CPU computer. A defect in a simple electronic gate can lead to a complete breakdown unless some auxiliary system is available for backup. This high level of fault tolerance, as we see in the brain, is possible to achieve only in a parallel, and thus confirming the parallel nature of brain. Because of this parallelism, and consequently non-deterministic processing, even partial information can be utilized to solve a problem but with lesser accuracy. The processing is non-deterministic in the sense that no serial time ordering is involved globally. Each processor has its own time scale and they perform their tasks according to their own schedule. This introduces a randomness in the whole process.

drugs etc., fall in the first category. In the second category comes the problems, such as perception, visual and speech understanding and other similar feats which are so effortlessly done by the brain whereas a computer is unable to achieve even a simple task of this type.

Theories of artificial intelligence deal with this category of problems. Artificial intelligence has progressed significantly in the last decade so as to explain some aspects of these problems in computational metaphors.

There is another puzzling aspect of neural hardware. Neurons are an unreliable piece

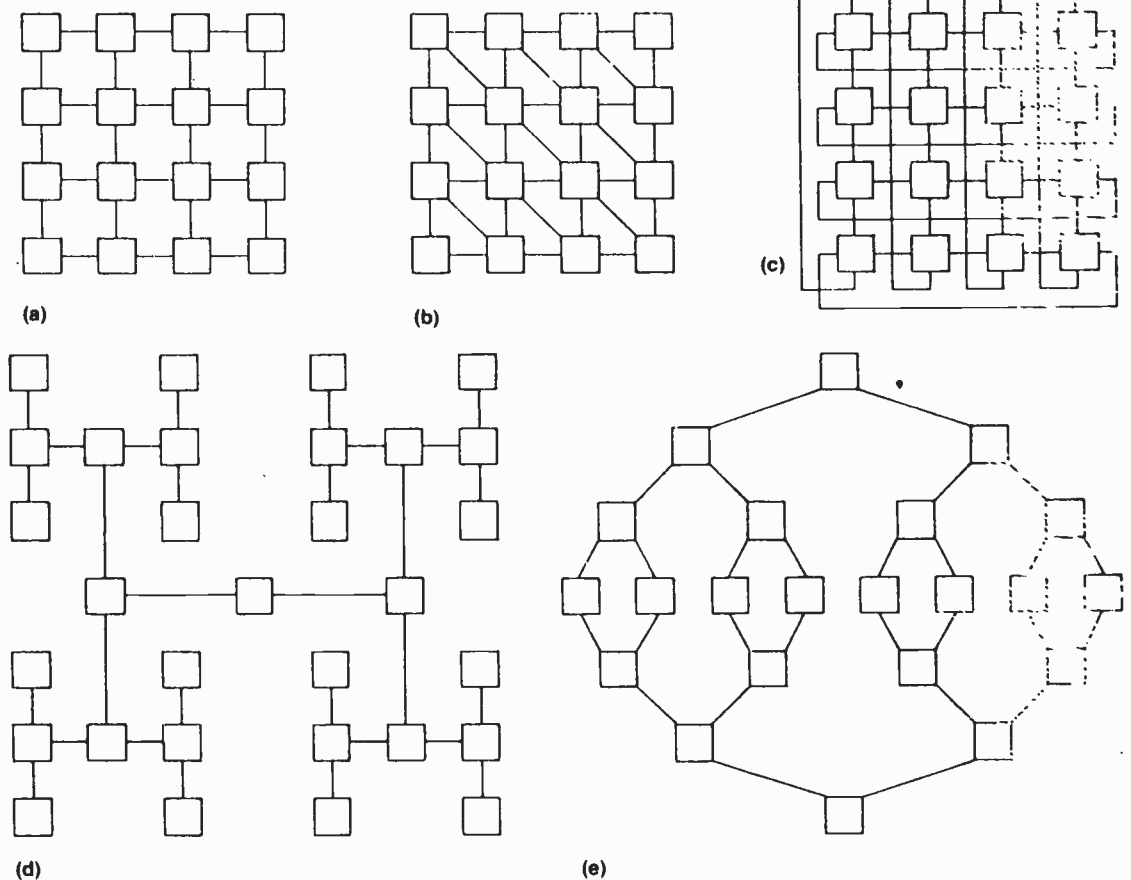

Fig. 2 Interconnection patterns for algorithmically specialized processors: (a) mesh, used for dynamic programming; (b) hexagonal mesh; (c) torus used for transitive closure; (d) binary tree for sorting; (e) double tree for searching.

**Interconnection and Hardwiring**

The functionality of parallel machines depends on their interconnection network. There is good evidence that sections of the brain are precisely hardwired. For instance, in inver-

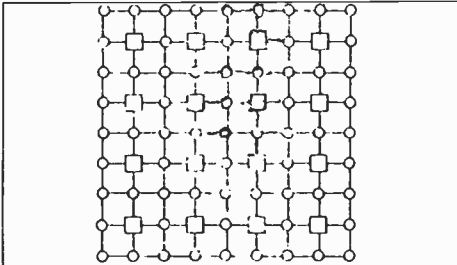

Fig. 3 A switch lattice structure. Circle represents switches; squares are CPUs.

tebrates such as Aplysia (a marine mollusk), the species has exactly 279 neurons wired, to a good approximation, in exactly the same way in every individual. Large number of neurons can also be precisely wired, particularly if the cellular pattern is repetitive, as at is in the fly's eye. These connections form topographical maps.

In the brain's connectionist model, an associative net is an abstract wiring diagram. Such a net has one or more sets of input channels and a set of output channels. The exact arrangement depends on the type of net being considered. The strength of the connection is adjusted "by experience" on the basis of certain well defined rules, so that pathways that are activated often are strengthened in some way. The higher nervous system appears to be a clever combination of associative nets and precision wiring. The wiring is usually organized in such a way that in some small localized region everything is connected to everything. The idea is similar to what is called partitioned semantic net, a knowledge representation scheme used in artificial intelligence.

During the last ten years or so neurobiologists and cognitive scientists have proposed many different models of parallel associative memory. A detailed survey can be found, for example, in a book edited by Geoffrey E. Hinton, of M.R.C. Applied Psychology Unit, Cambridge, England (presently at Carnegie-Mellon University) and James A. Anderson of Brown University. This survey does not deal with the processing because it is not understood whether the information processing

takes place in memory cells or in a separate part of the brain responsible for real-time processing — what we call thinking. Later, we shall remark on two interesting theories of associative memory, the holographic and the stochastic models.

These two models seem to be in the spirit of what is called the exact solution models in physics. Physicists have relied upon such exact solution models of physical reality for experimental testing and modification of their ideas and to achieve a fair degree of understanding of the phenomenon, which these exact solution models represent. In an exact solution model it is possible to formulate the mathematical equations of the system and solve them without simplifying assumptions.

Another idea quite popular in these models is what is called "content-addressable memory", which simply means that the partial contents of any item can be used to retrieve the remaining contents. This is something extremely difficult to implement on a Von Neumann machine because it accesses items in the memory using their

location (address) and it is time consuming if not impossible to discover the address of an item from an arbitrary subset (or partial information) of its content.

In an interconnection network the

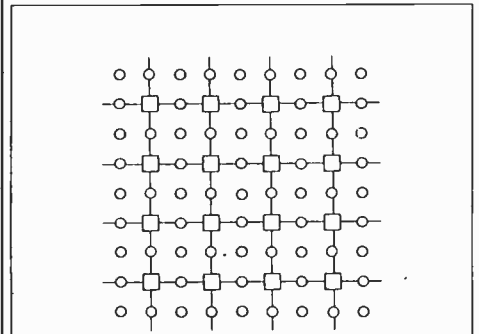
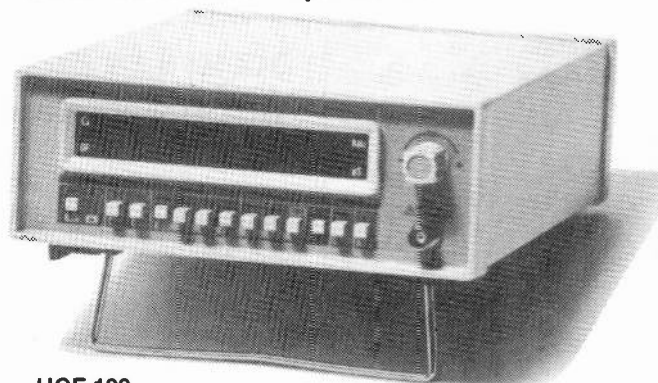

Fig. 4 The switch lattice of Fig. 3 configured into a mesh pattern

addressing problem is resolved by simply making one piece of data structure contain the address of the next piece or several pieces. Some researchers propose that addresses be replaced by specific hardware connections. According to Anderson & Hin-

**MULTI-FUNCTION COUNTERS**

Available in two capacities



**HCF-100**

Here's a compact, lightweight 10Hz to 100MHz counter with four function performances. The unit features eight digit LED display, low power consumption circuit with functions for frequency, period, totalize and self check.

Dimensions: 3" x 8" x 10-1/2"

**\$259.**

**HCF-1000**

Range 10Hz to 1GHz with 8-digit LED display, frequency, period, totalize and self check functions.

**\$495.**

Plus \$10 for shipping and handling.

Ontario residents add 7% P.S.T. Order by phone or mail.



**KB ELECTRONICS**

355 Iroquois Shore Road, Oakville, Ont. L6H 1M3  
(416) 842-6888 Telex: 06-982396 (KBEL OKVL)

ton the distributed representation seems to be a particularly appropriate method of coding highly parallel machines.

The evidence so far seems to be in favour of a highly parallel and dis-

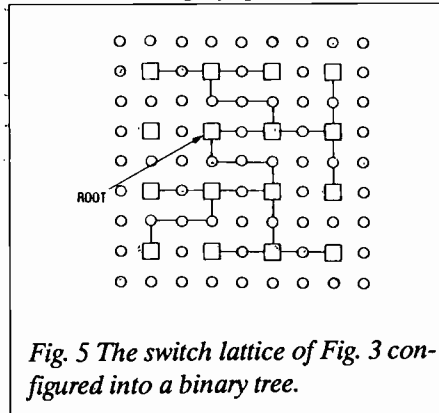

Fig. 5 The switch lattice of Fig. 3 configured into a binary tree.

tributed representation of the brain. The neo-cortex is highly parallel in the arrangement of basic units, for instance, a single cortical area containing millions of neurons seems to have a high degree of parallelism in its organization. Almost all cognitive functions can best be explained in a parallel model of processing and organization. At higher function levels the hypothesis of parallelism is also supported strongly by the evolutionary principle. Each functional unit developed at a different time during the history of evolution responds only to those specific signals for which it evolved.

### Brain Functions

The brain seems to have quite a bit of fluctuation at synopsis as dictated by the laws of quantum physics. It has some spontaneous and some stochastic (probabilistic) fluctuations. In some theories, like the "skeleton filters" model, are founded on the stochastic variation in the cerebral cortex. The physiological evidence obtained through experimentation and observation about this variation and randomness in the neural system support this essentially probabilistic approach.

Despite all the progress it is still a mystery as to how processing occurs in our brain and quite possibly we do not yet know the signal in the brain that encodes thought. What we do know is that the central nervous system somehow "knows" where each input originates just as a central telephone exchanges "knows" the origin of each

telephone line. There are various suggestions as to how this is achieved.

The arguments by Sejnowski, the founder of the skeleton filter model, suggest existence of a strong type of theoretical addressing mechanism from the peripheral to the central nervous system. Primary sensory areas of the brain appear to respond to sensory input in this way.

Recent research in a connectionist model deals with an abstract machine called the Boltzmann machine, named after a German scientist who is known for his fundamental work in statistical mechanics and thermodynamics. Because of the large number of neurons working in parallel and apparent absence of any clock mechanism in the brain, statistical mechanics turns out to be a good technique to study processes in the connectionist model.

The Boltzmann machine is a parallel computational organization that is well suited to constraint satisfaction tasks involving large numbers of "weak" constraints. In the connectionist system the long term knowledge is stored as the strengths of the connections between simple neuron like processing

example. When shown a partial example, the network can complete it by finding internal variable values that generate the partial example and using them to generate the remainder.

The machine is composed of primitive computing elements called "units" that are connected to each other by bidirectional "links". A unit is always in one of two states, ON or OFF and it adopts these states as a probabilistic function of the states of its neighboring units and the weight on its link to them. In a recent research paper published in the journal "Cognitive Science", Hinton and his collaborators describe a general parallel search method, based on statistical mechanics, and that it leads to a general learning rule for modifying the connection strength so as to incorporate knowledge about a task domain in an efficient way.

### Processing Elements

As we all know, present day computers are largely single Central Processing Unit (CPU) machines of, what is called, Turning Von Neumann type. A highly parallel or simply parallel

**"...it is still a mystery as to how processing occurs in our brain and quite possibly we do not yet know the signal in the brain that encodes thought."**

elements. These networks are clearly suited to tasks like vision that can be performed efficiently in parallel networks which have physical connections in just the places where processes need to communicate.

The Boltzmann Machine is capable of learning the underlying constraints that characterize a domain simply by being shown examples from the domain. The network modifies the strength of its connections so as to construct an internal generative model that produces examples with the same probability distribution as the examples it is shown. In the Boltzmann Machine, when shown any particular example, the network can "interpret" it by finding values of the variables in the internal model that would generate the

processing structure is composed of a large number of processing elements (PEs) with access to a common or public memory. In some cases each PE has also its own private memory. A parallel Machine (PM) is distinctly different from a single multi-tasking time shared CPU since in a parallel machine, all PEs solve part of the global problem simultaneously.

The concept of parallelism is always defined with respect to a some fixed reference. For example, in a PM, the parallelism refers to simultaneous and independent actions of many CPU's to solve a problem. The system, however, works serially within a CPU where all actions are governed by a clock in a strict time orderly fashion. Concurrent computation is possible in this case by

assigning CPU time in a manner so that each task gets some time share. This is obviously time sharing and not parallelism.

Similarly for instance, individual motor functions in higher animals is highly parallel, i.e. simultaneous action by many neurons or associative nets is necessary for coordinated movement of muscles. On the other hand, at a higher level the movement of muscles itself is a time ordered process. In a

tween the PEs. This interconnection network can be hardware fixed (i.e., fixed once and can not be changed in its operational life) or configurable with the help of programmable switches. In other words, the interconnection network topology can be fixed or variable. A PM with possible "variable topology" is also known as Configurable Highly Parallel Computer or CHiP.

There are many different PMs with

tolerance when the current configuration contains a faulty component. An efficient re-configuration technique should embed various network topologies with very short overheads, while utilization of resources remains very high. The re-configuration technique is particularly important in scheduling large scale system for high performance computation, since there is need for matching architecture and algorithm and for allocating both processor and communication resources.

In general, any given class of problems can be solved most optimally on a particular topology of network. For a class of problems, say linear problems, linear arrays are shown to be the most efficient configuration. It is called the optimization of architecture or network. The characteristics of any (highly) parallel machine with a large number of PEs with a shared memory, depends on the characteristics of its single PEs and the characteristics of its network.

For standard Von Neumann Type PEs (possibly with their own "private" memories) the main concentration of research has been on the network and coordination problem. The programs of such machines will also include synchronization instruction, i.e., programs oriented towards the coordinates use of all PEs. Thus research on PMs is roughly divided into two parts:

- Software - basically the coordination problem of PEs.
- Hardware - network design with fastest possible access to "public" memory.

Again, from the point of view of functionality and application, there are two broad classes of PMs, known as the SIMD (Single Instruction Multiple Data System) and the MIMD (Multiple Instruction Multiple Data System). Each of these classes is suitable for a different class of application. Since the functionality and application of both depend on the network's topology, we can classify them as either the fixed or variable topology type.

A SIMD machine consists of a control unit, and N processors along with N memory modules, all connected through a networks. The control unit broadcasts instructions to all processors, and all active processors execute the same instructions simultaneously.

---

**"...individual motor functions in higher animals is highly parallel, i.e. simultaneous action by many neurons or associative nets is necessary for coordinated movement of muscles."**

---

conventional digital computer many electrical events occur in parallel for each it of a byte, however, if the instructions are considered as units, they are executed sequentially. Systems which are mixed parallel and serial at various levels are called distributed systems.

In parallel processors the interconnection network consists of software and hardware entities that are designed to facilitate efficient inter process and inter processor communication. The interconnection network not only has a profound impact on the algorithm design, but it also greatly effects the system level control. The concept from the telephone switching systems and computer communication are heavily used in the design and analysis of interconnection networks. A good match between an algorithm and an architecture will result in a good correspondence between program graph and network topology. Consequently overhead time can be reduced.

### **Interconnection Networks**

A network can be depicted by a graph in which nodes represent switching points and edges represent communication links. The overall graph representation is called network topology; it is a key parameter in parallel architecture. We can now classify parallel machines according to their topology of interconnection network be-

fixed topology networks such as array processors, associative processors, data flow machines and some special purpose machines such as Systolic Arrays. However, the most interesting ones are with variable topology, i.e. CHiP. Sometimes this classification is given as static and dynamic topologies used commonly. In a static topology each switching point is connected to a processor, while in the dynamic case only those switching points in the in the input/output side are connected to processor which are needed to solve the problem.

This type of a machine, i.e., with variable topology, consists of processing elements as well as programmable switches with memory. On the software commands the switches change their state, and consequently various combinations of switch openings give rise to different topologies of interconnection networks. Why is this interesting? The efficiency of a given PM is closely related to the type of problems being solved.

Re-configuration techniques are used to allocate hardware resources, such as processors and communications witches, to a specific task. The hardware resources allocated are usually interconnected to form a suitable network topology for the task. The re-configuration is performed when a task requests a resource through a system controller. It can also be performed to provide fault

Each active processor executes the instructions about the data in its own associated memory module. Thus, there is a single instruction stream and a multiple data stream. Since the operation is the same on all PEs, there is no need for DO- WHILE ( $n = 1, 2, \dots, N$ ). However, on MIMD PMs, there can be many instructions as well as many data types. Both SIMD and MIMD PMs can be single stage or multi-stage.

Research in the software sector, especially the problem of coordination, is notable at New York University. The NYU's "Ultra Computer" project is being pursued at Courant Institute of Mathematical Sciences. The NYU network design achieves the following:

- Band width linear in N, the number of PEs.
- Latency, i.e., memory access time as long N in base 2.
- Only O ( $N \log N$ ) identical components.
- The routing decisions are local to each switch preventing a serial bottle neck.
- Concurrent access by multiple PEs to the same memory cell in-

curing no performance penalty, i.e., inter-processor coordination is not serialized.

An interesting aspect of this approach is the fact that messages are combined. For instance when concurrent "loads" and "stores" are directed at the same memory location and meet at a switch, they can be combined without introducing any delay. Since combined requests can themselves be combined, the network satisfies a key property. Any number of concurrent memory references to the same location can be accomplished in one access time to central memory.

On the hardware side the MIT's "Connection Machine" is notable. This is a 65,536 processor parallel machine with a hypercube topology. The interconnection topology is such that any processor can communicate with any other processor using only a 12-bit address. It can execute several billion instructions per second, making the connection machine one of the fastest computers ever built.

### Interconnection Similarities

One interesting common parameter is the topology of networks. It seems that nature selects specific topology of interconnection for a specific problem, concept or whatever. As it is pointed out in the connectionist model, the Boltzmann machine in its internal representation of some concept or object/problem it builds specific interconnections. It seems that the representation of some object/problem is done in a most efficient/optimal way depending on the problem algorithm. Once the network is there, the retrieval or future use remains as efficient as it was encoded. The switching mechanism is probably used to select the network for specific values of the variable, corresponding to an example.

In the brain, because of the availability of a large number of neurons, it is possible to have networks for large number of concepts in our long term memory. The importance (due to repetitive usage) of a concept resides in the strength of its interconnection. This is certainly not possible for man designed massively parallel machines because not only such a large number of CPUs are not possible to have in one machine, but also the strength of the connections remains unchanged. Perhaps future progress in topology will give us insight into why nature has chosen such a mechanism — an extremely large number of units interconnected to each other in some definite topological configuration.

*K. Tahir Shah is a consulting scientist in artificial intelligence and a freelance writer from Mississauga, Ontario ■*

## K.E.M. New model for IBM AT/XT/Turbo

Only K.E.M. original mighty SUPER EP-ROM TOASTER can support 1-chip CPU programmer & EP-Rom emulator adapter units.

### Special features:

- Program 2716 to 27512 including CMOS and A versions in Super high speed.
- Rom protection: with Over current protection and constant voltage circuitry.
- Can program 1-chip CPU 8748/8749/8751 with an optional adapter unit KEM-903.
- Also with an optional EP-Rom Unit KEM-902 this programmer becomes a powerful development tool.

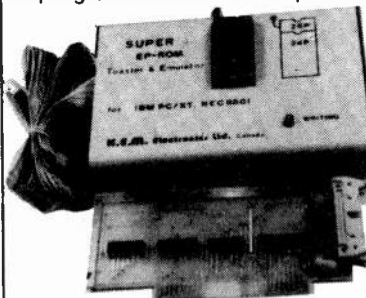

### Super EP-Rom Toaster

KEM-901SP(512K) for IBM . \$195  
 KEM-901(256K) for Apple . \$195  
 (Main unit, I/F card, cable and soft.)

EP-Rom Emulator adapter unit  
 KEM-902 (Max. 256K) . . . . \$130  
 (with soft.)

1-chip CPU programmer  
 adapter unit  
 KEM-903(8748/8749/8751) . \$145  
 (with soft.)

Intel HEX or Motorola format — Binary format convert software.  
 (to program from C-compiler, Assembler etc into EP-Rom . . . . . \$50

\$6.00 for shipping. Plus PST for B.C. residents. Plus C.O.D. fee if required. Sorry we have no facility for credit cards and do not accept invoice order.

### K.E.M. Electronics Ltd.

Mail to Box 69126 Station (K) Vancouver B.C. V5K 4W4  
 Office 879 E. Hastings Vancouver (604) 251-1514

### More Reasons to make

## Electronics & Technology Today

### Part of your Marketing Strategy.

80% of readers have purchased a product as a result of the advertisements in Electronics Today.

For advertising information  
 Call (416) 445-5600



# COMPUTER PARTS GALORE

316 COLLEGE ST. TORONTO M5T 1S3

SALES, SERVICE 1-416-928-2161

FAX # 1-416-924-0292

TOLL FREE ORDERS 1-800-387-1385

ENVOY100 ID: CPG

- \*80287 SOCKET
- \*CLOCK/CAL
- \*STD AT\*\* SIZE
- \*4 LAYER PCB
- \*6-16 BIT SLOTS
- \*2-8 BIT SLOTS
- \*U.S.A. BUILT
- \*VLSI CHIPSET
- \*8Mhz SI=7.7
- \*10Mhz SI=10.3



## OPTIONS

- EGA UPGRADE
- EXTENDED MEMORY
- EXPANDED MEMORY
- 80287 MATH CHIP
- 44 Meg 36ms HDISK
- 44 Meg 28 ms HDISK
- 72 Meg 28 ms HDISK
- 72 Meg 25ms HDISK
- MOUSE
- 80287 MATH CHIP
- MODEM

**CANADA'S  
COMPATIBLE  
COMPUTER  
SPECIALISTS**

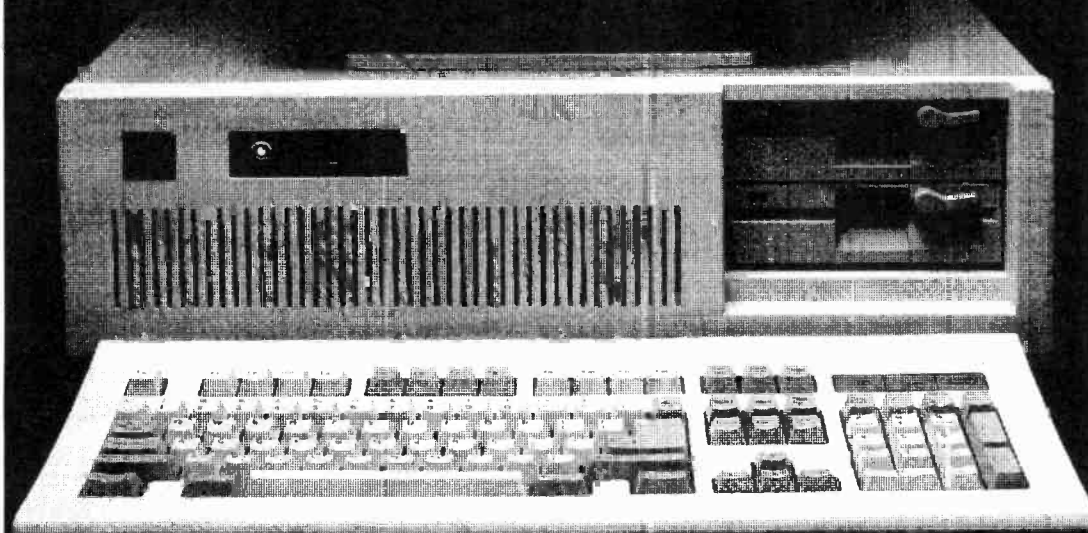

**AT BASIC SYSTEM\* INCLUDES: all for only \$1999.95**

- ATTAK286 MOTHERBOARD (6/8/10 Mhz)
- ATTAK MANUAL AND SCHEMATICS
- 640K (120ns) DRAM
- PHOENIX BIOS w/SETUP/SPEED SWITCH IN ROM
- FULL SIZE AT FLIP TOP CASE
- CGA or MGA VIDEO ADAPTER
- 200W POWER SUPPLY
- 6 DISK SET OF SYSTEMWARE SOFTWARE
- 5060 "TACTILE" KEYBOARD
- 16 BIT HARD/FLOPPY DRIVE CNTRL
- 1.2MEG and 360K FLOPPY DRIVES
- 1 YEAR PARTS/LABOR WARRANTY

### SYSTEM UPGRADES ADD TO BASIC PRICE

EGA Video Upgrade	\$199.95
EGAWONDER Upgrade	\$270.00
44 Meg 36ms Hdisk Seagate ST251	\$775.00
44 Meg 28ms Hdisk Mini-scribe 6053	\$1099.95
72 Meg 28ms Hdisk Mini-scribe 6085	\$1399.95
72 Meg 25ms Hdisk Tandon 3085	\$1125.00
Logitech Bus Mouse	\$149.95
MSDOS 3.21	\$94.95
2400 Baud Modem	\$399.95
3 Meg Extended Ram 0k	\$299.95
EGA 13" Monitor	\$575.00
80287-8	\$425.00
230W POWER SUPPLY	\$29.95

## BABY AT BOARDS - UPGRADE YOUR OLD PC or XT SYSTEM

- BABY AT #1 ONLY \$649.95** 6/8 Mhz. Fits in XT case. Runs all XT peripheral cards. 6-16 Bit slots. 2-8 Bit slots AWARD BIOS ZeroK ram. Directly replaces motherboard in std. clone system. With Basic AT SYSTEM Above \$1850.00
- BABY AT #2 ONLY \$849.95** 6/8/10/12 Mhz. Uses new CHIPS & TECH six chip chipset. Fits in XT case. Runs all XT peripheral cards. 6-16 Bit slots. 2-8 Bit slots. Expansion Bus runs at 8Mhz. Allows use 8Mhz peripheral cards. ZeroK ram. Ck/Cal. With Basic AT SYSTEM Above \$2050.00

## MONITORS

<b>GOLDSTAR 13" EGA MONITOR</b>	
640x350 res .31 dot pitch	\$625.00
<b>PACKARD BELL HI-RES TTL MONITOR</b>	
720x350 Swivel Base	\$149.95
<b>Amdek 410A HI-RES TTL MONITOR</b>	
720x350 Swivel Base	\$299.95
<b>ZENITH 1220 COMPOSITE B/W MONITOR</b>	
640x200	\$134.95

## CABLES

Cable type	6ft	10ft	20ft
Serial DB25 M-F, M-M, F-F	14.95	18.95	24.95
Par. DB25 F-Cent M	14.95	18.95	24.95
Parallel Extension	14.95	18.95	24.95
Monitor Extension	19.95	N/A	N/A
Keyboard Extension	9.95	N/A	N/A

## PAR/SER SWITCH BOXES

AB to C	\$49.95
ABC to D	\$54.95
ABCD to E	\$59.95

## ACCESSORIES

GENDER BENDER M-M, F-F, M-F	\$8.95
RS-232 JUMPER BOX	\$8.95
RS-232 TESTER	\$14.95
NULL MODEM ADAPT	\$8.95
FLOPPY CABLE	\$12.95
EXT. FLOPPY CABLE	\$14.95
3.5" FLOPPY CABLE	\$14.95
LARGE SWIVEL STAND	\$19.95
SMALL SWIVEL STAND	\$14.95
WIDE CARR. PRT STAND	\$39.95
STD SIZE PRINTER STAND	\$29.95
UPRIGHT STAND AT or XT	\$49.95
XT DUST COVER	\$9.95
GREY SCALE Adapter	\$19.95
DXY-85 DISKETTE HOLDER	\$14.95
GOLDSTAR DSD, 10 disks	\$12.95
GOLDSTAR SSD, 10 disks	\$10.95
GOLDSTAR 2HD 10 disks	\$32.95
GOLDSTAR 3.5" DSD	\$32.95
All GOLDSTAR disks have 100% Warranty	

## WIRED XT\*\* CARDS

Wired and tested, w/manual. Bare PCB's still available ASK\$\$\$ All cards have ZeroK ram, no disks except where noted.

COL OR GRAPHICS adapter /par.port	\$64.95
MONO/GRAPHICS-w/par.port	\$79.95
EGA Vidoe Adapter w/256k	\$269.95
MGA/MIO Hi-Res TTL Video Adapter w/ Drive Cntrlr, ser/par/clk/game	\$179.95
CGA/MIO Color/graph Vidoe Adapter w/ Drive Cntrlr, ser/par/clk/game	\$179.95
DISC CONTROLLER Std. 1 to 4 drives	\$39.95
XT 1.2M/360K Floppy Controller	\$99.95
MULTI I/O w/floppy/ser/par/game/disk	\$119.95
I/O-2 serial/clk/par/game w/disk	\$89.95
PRINTER Std parallel interface	\$39.95
RS-232 Std serial w/one port	\$44.95
CGAME Std 2 joystick ports	\$39.95
CLOCK/CALENDER w/disk	\$44.95
384K MULT w/ser/par/clk/game ZeroK	\$129.95
576K Ram Expansion ZeroK	\$54.95
2Meg Ram EMS card w/disk ZeroK	\$169.95
2Meg EMS & MULTIFUNCTION Card w/ser/par/clk/game ZeroK	\$219.95
1200 Baud Internal Modem	\$139.95
MIDI CARD for XT/AT	\$119.95
MIDI Source Book/Demo Software	\$19.95

## XT SYSTEMS

- Latest clone technology. 100% compatble. Legal BIOS. Fully tested and Burned-in.
- BASIC SYSTEMS INCLUDE:**
- 640K Ram on 8 slot Motherboard
  - 2 DSD 360K floppy and controller
  - AT/XT 5160 Tactile keyboard
  - Color or Mono/graphic Video Adapter
  - Hi-Res TTL or B/W Comp. Monitor
  - Clock / Cal, Serial, Parallel, Game Ports
  - 8 Slot Flip Top case
  - 150W Power Supply
  - 6 free disks of public domain Systemware
- Choose from these motherboard options.
- |                               |           |
|-------------------------------|-----------|
| (1) 4.77 Mhz Std.             | \$1075.95 |
| (2) 8 / 4.77 Mhz 2 Layer Pcb  | \$1099.95 |
| (3) 8 / 4.77 Mhz 4 Layer Pcb  | \$1175.95 |
| (4) 10 / 4.77 Mhz 4 Layer Pcb | \$1195.95 |
| (5) BABY AT 6 / 8 Mhz         | \$1549.95 |

**ADD TO BASIC SYSTEM PRICE**

-20 Meg Hdisk with Controller	\$479.95
-30 Meg RLL Hdisk w/ Controller	\$524.95
-Upgrade to EGA w/256k	\$189.95
-Upgrade to EGA monitor	\$560.00
-8087 5Mhz	\$199.95
-8087 8Mhz	\$299.95
-MS-DOS 3.21 with system	\$94.95

## DRIVES AND CONTROLLERS

PANASONIC JU455 DSD 360K	\$149.95
PANASONIC JU364 DSD 3.5" 720K	\$149.95
JU364 3.5" Drive with Mounting Kit	\$169.95
PANASONIC JU475 1.2M AT Drive	\$199.95
XT 20 Meg Hdisk w/controller	\$499.95
XT 20 Meg Hard Card	\$649.95
XT 30 Meg Hdisk RLL Controller	\$549.95
XT M-F-M Hdisk Controller (w/cables)	\$159.95
XT RLL Hdisk Controller (w/cables)	\$224.95
AT 4 Meg 36ms 1/2 height ST-251	\$799.95
AT 44 Meg 28ms Full height 6053	\$1099.95
AT 72 Meg 28ms Full height 6085	\$1399.95
AT 72 Meg 25ms Full height 3085	\$1150.00
AT 16 Bit Hard/Floppy Controller	\$289.95
AT 16 Bit Hard/Floppy RLL Controller	\$375.00
AT 16 Bit Low-Profile Hard/Floppy Controller for XT size cases	\$299.95

## FEWARE - CATCH THE WAVE

Catalog Disk 250+ Disk library-	\$2.00
Library disks each	\$5.00
10 or more library disks each	\$4.00
Feeware of the Month Club 1 Year	\$49.95

\*MONITOR not Included In Basic System Price \*\*IBM, XT and AT are Trademarks of IBM Corporation

Here is a project that will be of interest to those that have a vehicle with limited instrumentation. The circuit is partitioned so you can build only those parts that would be of interest to you. There is a dual range tachometer, a temperature measuring function with an over-temperature LED and a battery voltmeter. Information is also included to change the tachometer circuit ranges and to adapt it to 6 or 8 cylinder engines.

C5. This voltage is buffered by the amplifier connected to pins 4 and 10 and the internal transistor to provide a voltage at pin 5. R2 and R3 form a voltage divider to provide a reference for the comparator input pin 11.

C2 decouples pin 11 while R7 and R8 form a voltage divider that couples the nominal 12 volt pulses from the coil to pin 1. These pulses are extremely rough and contain a lot of high frequency ringing; hence the need for the

diodes in series to increase the change to about  $6\text{mV}/^\circ\text{C}$ , because that is a little easier to work with. The B section amplifies the voltage change by about 7 times as set by values of R18 and R19; the result at pin 1 drives the meter through R22 and RV3.

The voltage divider R16, RV4, RV5 and R17 is driven by the regulated voltage at pin 9 of the LM2917. RV4 is used to provide an offset voltage to section B that is equal to the voltage

across the diodes when they are at  $0^\circ\text{C}$ , thus the op-amp B will have 0 volts out at this temperature.

Section C designed to operate as a high temperature alarm. Here we have the diodes' voltage compared to the voltage from the wiper of RV5. Normally pin 7 is low so the LED is not lit. When a high temperature condition exists pin 6 will be more negative than pin 5 and pin 7 will go positive, driving current through the LED

via current limiting resistor R23. A small amount of positive feedback is supplied through R25 to ensure a snap-action voltage change at pin 7. Note negative feedback is also supplied through R21 and delay capacitor C7. After some delay (as C7 charges) pin 6 will again go more positive than pin 5 and pin 7 will switch back to ground, and the LED will turn off. This condition will not persist and as soon as C7 had discharged, pin 6 will again be more negative than pin 5 and the cycle will repeat, resulting in a slowly flashing LED (to get your attention). If the temperature goes higher, the LED will flash faster and if the temperature goes still higher, the flash rate becomes even more frantic until the LED stays on continuously. The other switch position is to measure the vehicle's system voltage. R5 and RV6 are scale adjusting resistors.

### Construction Hints

It is important to remember the finished unit will be used in a vehicle, where lots of vibration and large changes in temperature are commonplace.

# Auto Multifunction Meter

*Keep track of vital functions under the hood with this modular add-on*

*By Rick Leipert*

### Circuit Explanation

The zener diode, DZ1 and C1 will remove any high voltage transients that often appear in a vehicle's electrical system, particularly when the starter motor is operating. DZ1 will be forward biased, and conduct heavily if you inadvertently reverse the power supply leads; this of course will blow the fuse. R1, DZ2 and Q1 form a simple series voltage regulator, to reduce the 12 to 15 volts normally encountered in a vehicle to about 10.4 volts.

The tachometer circuit is built around the LM2917 IC. The following simplified explanation of the LM2917 should be sufficient for the constructor. Keeners can obtain full applications information from the part's manufacturer, National Semiconductor and others.

The comparator connected to pins 1 and 11, detects each operation of the ignition coil. This causes the charge pump connected to pins 2 and 3, to move a charge from C4 to the integrating filter R6 and C5 in turn causing a voltage that is proportional to the ignition coil's operating rate, to appear on

filtering action of C3. The LM2917 has a built-in shunt voltage regulator (like a zener diode) at pin 9. R4 is the required series resistor. R9, R10 and their associated variable resistors set the full scale meter reading to 5000 and 2000 RPM respectively.

The other IC LM2902, is used in the temperature measuring circuit. Section A is configured as current source. The voltage drop across R15 is forced by the op-amp to be about 6 volts, using the regulated voltage at pin 9 of the LM2917 as a reference. The constant voltage across R15 results in a constant current being forced through the diodes D1, D2 and D3.

The diodes are the temperature measuring devices. Silicone diodes have a forward voltage drop of about 0.65 volts. This voltage changes by about  $-2\text{mV}/^\circ\text{C}$  as the temperature of the diode increases, as long as the current through the diode is constant. The diodes will be put in close proximity to the engine's coolant and the resultant voltage across the diodes will be amplified to get a temperature reading on a meter. The circuit uses three

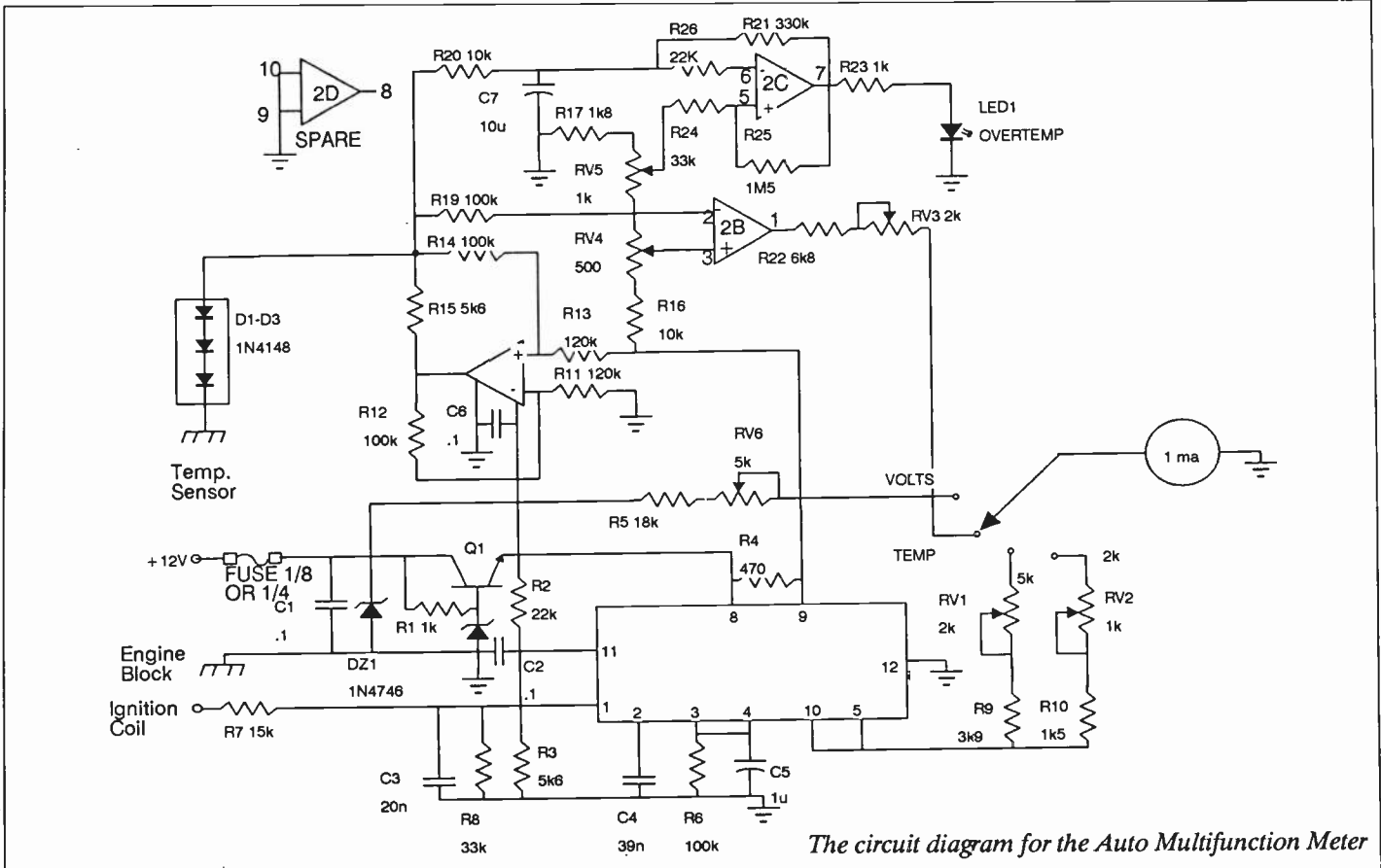

You should use a reasonable amount of care to insure mechanical stability of the finished assembly.

The electronic components can be mounted on perforated board using point to point wiring, strip board or other similar method. A circuit board layout is not provided because much of the final circuit details are the builder's choice. The board can then be firmly attached to the rotary switch or the meter terminals. Wiring to the vehicle can then be via an appropriate connector for ease in servicing or modification. (If you are like me, there always seems to be some good?? reason to get at the electronics to make that small improvement.) The circuitry can then be mounted in a plastic case.

You may wish to mount the meter in the dash, rather than in the case. I was fortunate enough to find a very good surplus meter that fit perfectly in an unused blank hole in the dash. You may also wish to make the calibration controls accessible through holes in the case so bear that in mind as you lay out the components.

The temperature sensor diodes must be mounted in a fitting suitable to be threaded into an unused hole in the

water jacket of the engine. The concept here is to have the body of the diodes in very close physical contact with the engine coolant. I will describe in detail one way to achieve this. I used an old, faulty fitting from an add-on temperature meter, from my junk-box; try an autowrecker for yours. I carefully removed the old thermister and other bits inside and was left with a hollow brass plug, with threads on the outside. The inside of the plug should

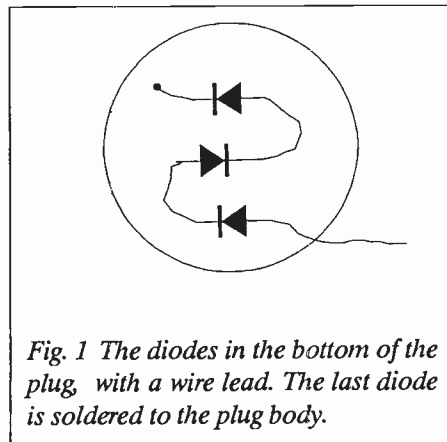

Fig. 1 The diodes in the bottom of the plug, with a wire lead. The last diode is soldered to the plug body.

be cleaned very well with sandpaper and then alcohol. Leave the inside

rough so the glue we use later will stick well.

The three diodes (Fig. 1) can be prepared by soldering them together in what best can be described as a "Z" shape. (Remember they must be in series electrically so observe polarity.) The outside or end leads should be left long at this time. The cathode end lead can then be soldered into the bottom of the plug. Leave the lead 10 to 15 mm long and use a heatsink on the diode lead because the plug will get very hot. After the plug cools, clean the residual flux away with alcohol. Carefully form the diodes to have their bodies as close to (touching if possible) the bottom of the plug but insure the leads are bent up so they can't short to the plug. Form the free anode end so it sticks up in roughly the middle of the plug. Check each diode for physical damage and then check each diode's electrical integrity by using an ohmmeter to compare its forward and reverse characteristics with a known good diode. Generally, any measurable resistance less than infinite in the reverse direction means the diode is damaged. Use a toothpick to work epoxy glue around the diodes then cover them completely,

to hold them in place and provide good thermal contact to the bottom of the plug. Set this aside so the epoxy can cure.

For the connection terminal, find a 3mm (6-32) bolt about 15mm long and three nuts to fit. Put one nut on the bolt and tighten it down hard against the bolt head. Put a short solder lug on the bolt and with another nut pinch the solder lug hard against the first nut. These bits must all be very tight. Bend the solder lug down past the bolt head. Now make a spacer using resilient material like rubber, to act as an expansion seam between the bottom (diodes) and the next epoxy layer we will be adding. Make a small hole in it to poke the diode anode lead through. Solder the diode anode lead to the

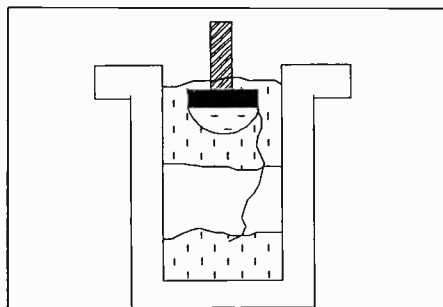

Fig. 2 Cross-section of the plug. The diodes and the terminal bolt are held with two layers of epoxy.

solder lug so that the head of the bolt is pointing into the cavity and the second nut is about 2mm above the plug. (See figure 2.) Set the plug on a flat surface with the open end up and fill it with two part epoxy glue or casting material. The epoxy should just come up to the exposed flat surface of the second nut. Set this aside so the epoxy can cure. You now have the temperature sensor complete with a terminal for electrical connection using the third nut. Many other sensor configurations are possible. I once made an engine oil temperature sensor by making a new dipstick out of copper pipe and put the diodes inside the pipe down at the oil end. With a little imagination you should be able to build a sensor for any job.

The surplus meter I used for this project had a 1mA full scale movement, that just happened to be scaled 0, 10, 20, 30, 40 and 50. I was able to disassemble it and add 0, 4, 8, 12, 16 and 20 with pressure sensitive lettering. The scales are used as follows:

x 100 for 2000 RPM full scale  
x 10 for 200°C full scale  
for 20V full scale

Most meters can be similarly modified as long as you work slowly and carefully, and don't get dirt or dust in the movement. I suggest you purchase only the type of meter that has a

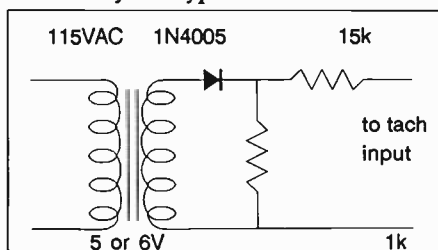

Fig. 3 A circuit to simulate ignition coil pulses. The output should not be allowed to go negative.

scale plate that is removable for adding scale numbers, otherwise the risk of damaging the pointer is too great. A meter with a sensitivity other than 1mA may be used as long as the series resistors for each range are changed. For example, if the chosen meter had a full scale current requirement of 0.5mA, the resistors would have to be doubled. Then R5 for instance, would become 36K, and RV6 would become 10K. 36K may be difficult to obtain, so 33K could be used. We can check these values easily by dividing the full scale voltage by the full scale current.

$$20V/0.5mA = 40Kohms$$

R5 plus an adjustable portion of RV6 plus the internal resistance of the meter will have to equal 40Kohms. This checks with the new values for R5 and RV6.

The choice of the meter is also determined by its expected use. It should be large and appropriately lit if you expect to use it to shift gears by.

All of the assembly work and calibration should be completed at a work bench prior to installation in a vehicle. Note R7 is to be mounted at the ignition coil. This helps to keep high level ignition noise off the lead that goes to the dash area and provides the added bonus of electrical isolation of inadvertent faults at our great electronic box from killing the ignition.

## Testing

The following tests will allow you to check each circuit section separately.

An unexpected result usually indicates a problem in the immediate circuit area that should be easy to locate. When the assembly work is done, double check all your wiring or have someone else check it.

When the checking is completed, temporarily attach short wires to the connector that will be installed in the vehicle. Better yet, buy and wire up a second connector that can be set aside for test purposes. Double check the pins used as it is very easy to get fouled up looking at a connector front to back.

Leave the ICs out of their sockets. Connect the temperature measuring assembly. Don't forget to connect its case to circuit common. Connect the meter, if it is to be mounted external to the case. Set the function switch to the voltage position. Connect a 12 volt DC power-supply to the power leads via a 1/4A fuse. Batteries will do here but a variable bench type supply is desirable. The meter should be reading about 1/2 to 3/4 full scale; check for about 10.6 volts at the emitter of the transistor. This voltage should change very little as the bench supply is changed be-

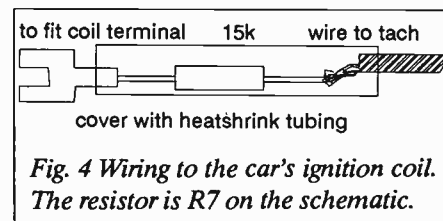

Fig. 4 Wiring to the car's ignition coil. The resistor is R7 on the schematic.

tween 12 and 15 volts. Check each pin of 2917 IC socket. Pins 8 and 9 should be about 10 volts and pin 11 should be about 2 volts. All the rest should be 0 volts. The 2902 IC should have about 10.6 volts on pin 4 and all the other pins should be very low or 0 volts. (Pin 12 could be up to about 5 volts, depending on the input resistance of your voltmeter.) RV4 should have about 1.8 volts on its wiper and RV5 should have about 1 volt on its wiper.

When you are sure all is well; turn off the power supply and insert the 2917 IC into its socket. Be careful with its pins and be sure to get pin 1 in the proper spot. Turn power on and measure pin 9. The voltage will be about 7.5 if the voltage regulator in the 2917 is working properly. Turn the function switch through the two tachometer ranges. You should see a 0 reading in both positions. Turn the power supply off and insert the 2902 IC

into its socket. Turn power on and turn the function switch to the temperature position. The meter should be adjustable around 1/8 scale with RV4. The LED should be off.

**Calibration**

The mechanical 0 on the meter may have been moved during relettering so check it and adjust as required. Turn the function switch to volts and turn the bench power supply on and adjust it to about 13.5 volts. With your most accurate meter, measure the power supply voltage. Adjust RV6 so the meter reads the same.

The calibration of the tachometer circuit requires ignition coil pulses to be simulated. These pulses should be unipolar going from 0 to about 10 volts. Those builders that have an accurate signal generator capable of generating this type of waveform probably have access to a 'scope and the expertise to check themselves, so please press on. I caution you however, the input signal must NOT be allowed to go negative. (Fig. 3) shows a test signal source that will work well but it requires temporarily wiring the primary of a power transformer to 117VAC, so be very cautious. The transformer's 5 or 6 volt secondary winding need only have a very low current rating. The 15Kohm resistor is to simulate the resistor that will be located at the vehicle's coil. Make sure the diode polarity is correct, then, connect the 15klohm resistor to the tachometer input. Turn power on. On each tachometer range, adjust the respective calibration resistor to obtain a reading of 1800 RPM.

Calibration of the temperature measuring circuit requires only ice water (0°C) and boiling water (100°C). It should be noted for those builders that are high (as in altitude not chemically), the boiling point of water decreases with altitude increase; roughly 4°C reduction for each 1000m above sea level.

You will need a container (about one cup) of mostly ice and just enough water to fill the spaces between the ice. The ice seems to melt very quickly when you are having fun and can be encouraged to stay longer if you put this container inside another slightly larger one with lots of ice in it. The boiling water need only be boiling slowly. Apply power and turn the function switch to the temperature position. Put

**Parts List**

**Resistors**

All 1/4W, 5% unless noted

R1,R23.....	1k0
R2,R26.....	22k
R3,R15.....	5k6
R4.....	470R
R5.....	18k
R6,R12,R14,R19.....	100k
R7.....	15k 1/2W or 1W
R8,R24.....	33k
R9.....	3k9
R10.....	1k5
R11,R13.....	120k
R16,R20.....	10k
R17.....	1k8
R18.....	680k
R21.....	330k
R22.....	6k8
R25.....	1M5
RV1,RV3.....	2k trim pot
RV2,RV5.....	1k trim pot
RV4.....	500R trim pot
RV6.....	5k trim pot

**Capacitors**

C1,C2,C6.....	0.1uF 50V cer. disc
C3.....	20nF 50V
C4.....	39nF stable foil type
C5.....	1uF 10V elect.
C7.....	10uF 10V elect.

**Semiconductors**

D1,D2,D3.....	1N4148
DZ1.....	1N4746 18V 1W zener
DZ2.....	1N4741 11V 1W zener
IC1.....	LM2917N DIL
IC2.....	LM2902N or LM324N DIL
LED.....	1/4" high intensity
Q1.....	2N4124, 2N2222 or 2N3904

**Miscellaneous**

SW1, 1 pole 4 position (more or less positions depending upon how many circuit sections you build); meter, 1mA movement with removable scale plate; Case to suit; case connector, good quality suitable for case mounting with 5 pins; cable connector to match above; fuse holder, inline type with 1/8 to 1/4A fuse.

the temperature sensor into the ice water and allow it to sit for a few minutes until it has cooled sufficiently, then adjust the meter to read 0 with RV4.

Move the temperature sensor into the boiling water and allow the temperature stabilize. Adjust RV3 so the meter reads the boiling temperature of the water. Check the operation of the over-temperature of LED circuit by adjusting RV5. As RV5 is adjusted from end to end, you should be able to have the LED flashing very rapidly or on continuously, to flashing slower and slower until the LED stops flashing. Leave RV5 set at the point where the LED has just stopped flashing. Now the LED should start flashing when the temperature just goes above boiling. This setting may have to be changed slightly on the vehicle to stop false

alarms. Some cooling systems operate above 100°C normally because they are pressurized and use a coolant mixture. Repeat the 0 and boiling point tests above as there may be some small interaction in the adjustments. Be sure to leave adequate time for the sensor to temperature stabilize before making any adjustments.

**Installation**

The wires that will be in the vehicle can be attached to their connector at the workbench. Be sure to leave a little extra wire length, it always seems to be necessary. The wires that pass through the fire wall can usually be routed through a rubber plug that fills an unused hole. Pierce the plug with a nail or drill bit, and ream it out so the wires can pass through. Reseal the rubber plug with silicone rubber. Install the appropriate connectors on the end of the wires, when their actual length is known. Remember a 15k resistor is required at the connector that attaches to the ignition coil. (See fig. 4.) The ground lead should be attached to the engine block to reduce the possibility of voltage drops in the ground of the temperature measuring circuit.

Power should come from a point that is hot when the ignition key is in the RUN or ACCESSORY position. Usually an appropriate terminal can be found on the fuse panel or in an unused accessory connector. If all else fails, tap into the radio's power wire. It can be located by probing through the insulation on the wires going to the radio with a thin needle connected to a voltmeter. An in-line fuse is recommended in the power lead to the electronics box.

**Modification**

The tachometer circuit was designed for a humble little four cylinder engine. The potential builder with a six cylinder or larger eight cylinder pavement burner can easily modify the tachometer circuit to suit their needs by just changing one capacitor value. The LM2917 has been cleverly designed so that the voltage at pin 3+4, follows a simple formula:

$$V_{OUT} = \text{Freq. in} \times 7.4 \times R6 \times C4$$

We can rearrange this to:

$$C4 = V_{OUT}/(\text{Freq. in} \times 7.4 \times R6)$$

The number of pulses from a four cycle engine's ignition coil, frequency, can be calculated from the formula:

## Auto Multifunction Meter

Freq = (engine RPM x # of cyl)/120  
 As an example lets apply this to the four cylinder that the design is for. We will use the highest engine speed to be registered, because that will determine the maximum voltage at pins 3 and 4. We want no more than about 5 volts. Substituting into formula 2, we have:  
 Freq. = (5000 RPM x 4)/120 = 166.7Hz  
 Substituting in to formula 1, we have:  
 C4 = 5V(max)/(166.7 x 7.4 x 100000) = 0.00000004F  
 = 40nF (use a standard 39nF capacitor)  
 This checks with the capacitor used in the design. A different number of cylinders or maximum RPM can be accommodated by plugging new numbers into the formulas.

### Other Ideas

Another voltage measuring position could be added to the function switch and wired to a test jack mounted on the electronics box. This provides a general purpose built-in voltmeter. I found it very useful to trouble shoot a misbehaving electric heater on the carb choke. The tachometer circuit could be limited to the high RPM range if the low range is not required for a tune-up. Conversely, the tachometer circuit could be mounted in a portable case, with expanded ranges to cover 6, 8, or 12 cylinder engines.

In a similar way, the temperature measuring circuit only could be mounted in a portable case; with a general purpose temperature measuring probe fitted. If this is done the 7.5

volt regulator in IC1 would have to be substituted with a zener diode regulator.

In either case above, the portable units could be battery powered because current drain is typically less than 10mA.

### Electronics & Technology Today

**SUBSCRIBE TODAY!  
 RECEIVE AN ALMOST  
 FREE SOFTWARE DISK  
 VALUE AT \$19.95  
 SEE ORDER FORM PAGE!**

## REVOLUTIONARY MULTIMETER | | | |

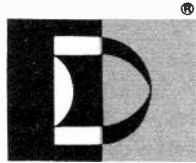

# DAETRON 4 IN 1 MULTIMETER

MADE IN CANADA

"THE HIGH PRODUCTIVITY MULTIMETER"

MEASURE **4** VOLTAGES  
 AT THE SAME TIME WITH  
**3 1/2** DIGIT DISPLAYS

1.9999V 1.9999V  
 1.9999V 1.9999V

OR

**2** VOLTAGES  
 AT THE SAME TIME WITH  
**4 1/2** DIGIT DISPLAYS

1.9999V  
 1.9999V

### ALL AUTORANGING

CAN ALSO DISPLAY 3 VOLTAGES AND 1 CURRENT AT THE SAME TIME WITH MANY OTHER COMBINATIONS AVAILABLE INCLUDING OUR 4 1/2 DIGIT WITH HIGH RESOLUTION

### ANALOG BARGRAPH DISPLAY

### PANORAMIC PSEUDO 7 DIGIT RESOLUTION

191.990.00  
 V mV uV

ALSO INTRODUCING  
 A NEW CONCEPT

OTHER FEATURES:  
 \* RELATIVE REFERENCE (100% FULL SCALE)  
 \* HOLD FUNCTION

\* CONTINUITY BEEPER ON RESISTANCE CHECK  
 \* MANUAL RANGING ON ALL FUNCTIONS  
 \* COLOR CODED INPUTS TO AVOID CONFUSION  
 \* PROGRAMMABLE SETPOINTS

\* ONE YEAR PARTS + LABOUR WARRANTY  
 \* STILL MANY MORE FEATURES



MODEL MM100

**\$ 189.95**

DAETRON

935 THE QUEENSWAY, BOX 641  
 TORONTO, ONTARIO M8Z 5Y9

(416) 676-1600

DEALER ENQUIRIES INVITED

[ ] (QTY) MM100 (INCLUDES 1 RED AND 1 BLACK TEST LEADS AND MANUAL) @ \$189.95 \$ \_\_\_\_\_

TO AVOID CONFUSION IN READING MANY VOLTAGES AT ONCE WE HIGHLY RECOMMEND ONE OF THE FOLLOWING SETS WHICH ARE MATCHED TO THE COLOR CODED INPUTS OF THE MM100

[ ] TL220 SET OF 6 COLOR COATED LEADS WITH EZ HOOKS @ \$39.95 \$ \_\_\_\_\_

[ ] TL230 SET OF 6 COLOR COATED LEADS WITH ALLIGATOR CLIPS @ \$39.95 \$ \_\_\_\_\_

[ ] CARRYING CASE, TOUGH LEATHER LIKE AND LARGE ENOUGH TO CARRY A SET OF TL220 OR TL230 LEADS AND INSTRUCTION MANUAL @ \$34.95 \$ \_\_\_\_\_

[ ] AC ADAPTOR @ \$11.00 \$ \_\_\_\_\_

SHIPPING: CHECK ONE OF THE FOLLOWING .....

[ ] UPS (SERVICES TO VICTORIA, VANCOUVER, ONTARIO & MONTREAL ONLY) ADD 2.5% \_\_\_\_\_

[ ] 1ST CLASS MAIL ADD 3%, [ ] COURIER PREPAID ADD 10% \_\_\_\_\_ \$ \_\_\_\_\_

[ ] COURIER COLLECT (BUSINESS ONLY) \_\_\_\_\_ \$ COLLECT

ONTARIO RESIDENTS ADD 7% SALES TAX \_\_\_\_\_ \$ \_\_\_\_\_

[ ] CHECK [ ] MONEY ORDER [ ] VISA [ ] MASTERCARD TOTAL \_\_\_\_\_ \$ \_\_\_\_\_

[ ] CARD NO. \_\_\_\_\_ EXPIRY DATE \_\_\_\_\_ SIGNATURE \_\_\_\_\_

NAME \_\_\_\_\_ TELEPHONE NUMBER \_\_\_\_\_

ADDRESS \_\_\_\_\_

CITY \_\_\_\_\_ PROV. \_\_\_\_\_ POSTAL CODE \_\_\_\_\_

# MARKET PLACE

For Advertising Information  
Call (416) 445-5600

## AD-PCM method solid state Tapeless tape recorder Kit

- Max. recording time 128 sec (at 8KBps) with 256K x 4 pcs D-Ram controlled by new technological 60 pin CPU
- 500mW audio Amp and 600ohm/10Kohm MIC Amp built-in
- Host computer control available

Assembled & Tested (without SP, MC) ..... \$98.00

## Voice (speech) recognition 5CH (Max. 20CH) control SW Kit

- Can control 5 relays on/off with your voice
- State-of-the-art special 60pin CPU control
- With additional circuit can extend more 15CH
- Your voice memory backed up by S-Ram and battery

Complete Kit with 5 relays ..... \$149.00

## Digital Capacitance Meter Kit

- 3 digit large size LED display 9V battery operation
- Wide range 10pF to 999uF, Accuracy 2%

Complete Kit (without case) ..... \$39.00

## Max. 500MHz 8-digit Frequency Counter Kit

- 10Hz to 500MHz, 6 combination measurements
- Large size high bright 8-digit LED
- Up to 10MHz 30mV, 10MHz to 500MHz 100mV. Accuracy 0.005%

Complete Kit (without case) ..... \$145.00

## 12CH (MAX. 32CH) Infrared Tx, Rx Remote-control switch Kit

- Max. control distance 40 feet indoor
- 38KHz modulated and 16 bit serial coded signal
- 86dB high gain Amp. with IR sensor and bandpass filter
- Special function CPU control

Complete Kit ..... \$87.00

## Stepping motor driver Kit come with mini motor

- Good for driving small motor. Max. 12V 1.2A, 3000 pps
- Manual control or computer control are selectable.

15% Special price ..... \$68.00

## High Speed EP-Rom erasing UV 1 amp Kit

- High intensity type. To erase 20 pcs Rom in 5 to 10 minutes
- Also P.C. Board exposing UV lamp sold by K.E.M.

1 set ..... \$37.98

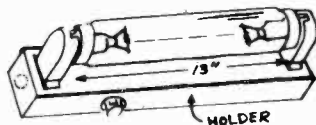

\$6.00 for shipping. Plus PST for B.C. residents. Plus C.O.D. fee, if required. No invoice order acceptable.

## K.E.M. Electronics Ltd.

Mail to Box 69126, Station (K),  
Vancouver, B.C. V5K 4W4  
Office 879E, Hastings, Vancouver  
(604) 251-1514

## PRO AUDIO and STAGE LIGHTING

- \* Faders all values and tapers.
- \* Rotary and trim pots. - \* Knobs all sizes.
- \* NEUTRIK audio connectors. - \* Chemicals.
- \* Resistors and capacitors all values.
- \* Led's, diodes, transistors and IC's.
- \* Tone generators 1 Hz-100 kHz.
- \* Pink noise generator. - \* Summing, line and preamps.
- \* Level indicators. - \* LCD panel meters
- \* Phantom power supply circuit boards.
- \* Regulated power supply circuit boards for all Radio Shack and Hammond 161 and 229 series transformers. - \* Power supply kits.
- \* Low distortion digitally or manual controlled audio attenuators.
- \* High headroom noiseless electronic switches with remote.
- \* 3 wire communication module compatible with others.
- \* RFI filter chokes 10-200amps. - \* Triacs 15-40A. SCR's 3-150A.
- \* 1, 4 and 8 ch. 120 vac dimmer cards.
- \* 4, 6 and 10 ch. solid state relay boards 15 - 40A RMS.
- \* 10 scene 12 ch. programmable solid state relay controller with ch. bump and push on push off switches. - \* 2-8 ch. chaser board with speed and level control.
- \* 24 ch. random generator.
- \* 4 ch. color organ with active filters.
- \* Rate controlled auto fade with presets and remote control.
- \* 4 wire analog multiplexer compatible with others.
- \* All circuits operate at standard levels.

Send \$2.00 (refunded with initial order) for complete catalog with pricing and detailed specs of circuits to:

## PATOR COMPONENTS

P.O. Box 80671, S. Burnaby, B.C. V5H 3Y1

## Classifieds ADVERTISING FORM

**Rates:** The basic one time insertion rate is \$1.50 per word (Minimum 25 words). The rate of \$3.50 per word allows your advertisement to run in all three publications (Computing Now!, Electronics Today, and Computers in Education) Headings, logos and reverse advertisements are available for an additional \$10.00.

Special discount rates are available for multiple insertions. They are as follows:

- 25% for 12 consecutive insertions
- 15% for 6 consecutive insertions
- 10% for 3 consecutive insertions

These rates apply only to the prepayment of the entire sum

Send a cheque (deduct applicable discounts) along with this order form

Please contact: **Moorshead Publications**  
1300 Don Mills Rd., Don Mills, Ontario M3B-3M8  
**(416) 445-5600**

## DO DREAMS COME TRUE? SALES MANAGEMENT TRAINEES AND SALES REPS

Dreams can come true if you "Get Active".

Our remuneration and benefits package is well above average. Our Managers and Sales Representatives have unlimited earnings potential! If you dream of the "good life", we can help you realize that goal.

Due to our accelerated expansion program, we have immediate openings for qualified candidates to be trained to manage our branches. Our comprehensive training program will teach you all that is necessary to run them.

The entrepreneurial spirit lives on at Active Electronics. Active is one of the fastest growing electronic retailer/MRO distributors in North America. We plan on opening new branches from coast to coast, and need management trainees and sales reps to help us grow. This is a once in a lifetime opportunity that will appeal to the person who would like the next best thing to running one's own business!

If you are an above average person, with a great deal of ambition and drive, prior experience in sales, telemarketing, management, or electronics, we would like to hear from you!

Forward your resume to:

**Hank Boyer, General Manager**  
Active Electronics  
237 Hymus Boulevard  
Pointe Claire, PQ H9R 5C7

# Active

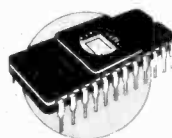

## THE NEW 65/9028 VT ANSI VIDEO TERMINAL BOARD!

★ FROM LINGER ENTERPRISES ★

A second generation, low cost, high performance, mini sized, single board for making your own RS232 Video Terminal. This highly versatile board can be used as a stand alone video terminal, or without a keyboard, as a video console. VT100, VT52 Compatible.

### FEATURES:

- ★ Uses the new CRT9128 Video Controller driven by a 6502A CPU
- ★ On-Screen Non-Volatile Configuration
- ★ 10 Terminal Modes: ANSI, H19, ADM-5, WYSE 50, TVI-920, KT-7, HAZ-1500, ADDS 60, QUME-101, and Datapoint 8200
- ★ Supports IBM PC/XT, and Parallel ASCII Keyboards
- ★ Supports standard 15.75 kHz (Horiz.)
- ★ Composite or Split Video (50/60 Hz)
- ★ 25 X 80 Format with Non-Scrolling User Row
- ★ Jump or Smooth Scroll
- ★ RS-232 at 16 Baud Rates from 50 to 19,200
- ★ On Board Printer Port
- ★ Wide and Thin Line Graphics
- ★ Normal and Reverse Screen Attributes
- ★ Cumulative Character Attributes: De-Inten, Reverse, Underline and Blank
- ★ 10 Programmable Function Keys and Answerback message
- ★ 5 X 8 Character Matrix or 7 X 9 for IBM Monitors
- ★ Mini Size: 6.5 X 5 inches
- ★ Low Power: 5VDC @ .7A, ± 12VDC @ 20mA.

### MICRO SIZE!

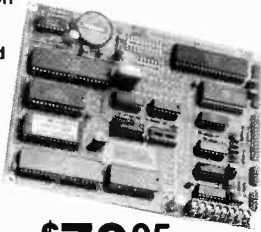

**\$79<sup>95</sup>**

**FULL KIT**

w/100 Page Manual  
ADD \$40 FOR A&T

OPTIONAL EPROM FOR  
PC/XT STYLE SERIAL  
KEYBOARD: \$15

SOURCE DISKETTE:  
PC/XT FORMAT  
5 1/4 IN. \$15

## Digital Research Computers

P.O. BOX 381450 • DUNCANVILLE, TX 75138 • (214) 225-2309

Call or write for a free catalog on Z-80 or 6809 Single Board Computers, SS-50 Boards, and other S-100 products.

TERMS: Add \$3.00 postage. We pay balance. Orders under \$15 add 75¢ handling. No C.O.D. We accept Visa and MasterCard. Texas Res. add 6-1/4% Tax. Foreign orders (except Canada) add 20% P & H. Orders over \$50 add 85¢ for insurance.

Circle No. 7 on Reader Service Card

## Advertisers' Index

Active Electronics .....	23
Active Surplus Electronics .....	8
BCS Electronics Ltd. ....	7
Best Systems Corp. of Canada Inc. ....	2, 3
Brunelle Instruments Inc. ....	28
Computer Parts Galore .....	17
Daetron .....	22
Digital Research Computers .....	24
Hitachi Denshi Ltd.(Canada) .....	61
Information Unlimited .....	47
Kaientai Electronic Merchants .....	16, 23
KB Electronics .....	13
McGraw Hill .....	9
National Technical Schools .....	25
Omnitronix Ltd. ....	63
Pator Components .....	23
Solen Inc. ....	34
Techkit .....	47
Technology Marketing Inc. ....	56
Tektronics Canada Inc. ....	64
Universal Cross-Assemblers .....	56

For Advertising Information

Call 445-5600

# Classifieds

## Where Buyers Find Sellers

### DESIGNERS ENGINEERS, hobbyists:

Looking for that hard-to-find circuit? Try search on bibliographic data base. Thousands of practical circuits from dozens of journals. Many scientific applications. Ask for manual. **CIRCUIT SEARCH**, P.O. Box 268, Breslau, Ontario NOB 1M0.

**CABLE TV DESCRAMBLIGN TECHNIQUES.** 56 pages. \$13.95. Channel 3 notch filter \$39.95. Amazing see-in-the dark infra-red night viewer kit \$295. SCA backround nd music kit \$49.95. Catalogs \$1. **OCTE(J)**, Box 173, Montreal, H3X 3T4. 514-739-9328.

**FULL** featured; High quality - pocket sized HIOKI 3217 Digital Multimeter. Ideal for automotive, educational, maintenance and home applications. Specifications include: 3-1/2 digital LCD display, Autoranging, AC, DC volts from 2V full scale to 450V max., Ohms from 2k full scale to 2M, continuity tester, 1 millisecond continuity response, Diode test plus more. Comes in its' own compact case. \$49.95. **Telephone: 445-5600.**

**"HAM" AMATEUR RADIO LICENCE** supereasy with correspondence course. Pass DOC exam or money back! Free Details: **NORTHLAND ACADEMY**, Dept. 821, Box 3532, Thunder Bay, Ontario P7B 6E2.

**SOFTWARE**, Hardware and Peripherals of IBM, Atari, Macintosh and Amiga systems - all includes in one directory. Computing Now! Volume 5 No. 2. Also a special section on software and output devices for the revolutionary Desktop Publishing. Only \$4.95. To receive your rush copy **Telephone: 445-5600.**

**ATTENTION Educators!** Computers in Education presents The Canadian Educational Microcomputer Directory Volume II. Program descriptions listed by subject including, Economics, Mathematics, Chemistry, Geography and much much more. Includes a complete index for software listings and computer product suppliers for easy reference. Only \$4.95. **Telephone: 445-5600.**

**KEEP** all of your valuable back issues of Computing Now! in one convenient location - with strong and durable CN! Binders. You'll never have to search for your favourite magazine again. Only \$9.95/tax. Holds up to 12 issues. **Telephone: 445-5600.**

**SOFTWARE** Software Software - Almost Free Software, for the PC. Includes descriptions of over 350 programs. Also 8 brand new programs available for your enjoyment. Get your catalogue and be well on your way to receiving some of the very best program software offered anywhere. Free. **Telephone: 445-5600.**

**ROLL** up your sleeves and purchase Electronics & Technology Today, Project Book No. 3. Includes 39 favourite projects guaranteed to thrill any electronics hobbyist. Contains detailed instructions and illustrations to guide the enthusiast through each project. \$3.95. **Telephone: 445-5600.**

For Advertising Information Call  
(416) 445-5600



# IF YOU WANT TO GET INTO PC SERVICING, YOU HAVE TO GET INTO A MICROCOMPUTER!

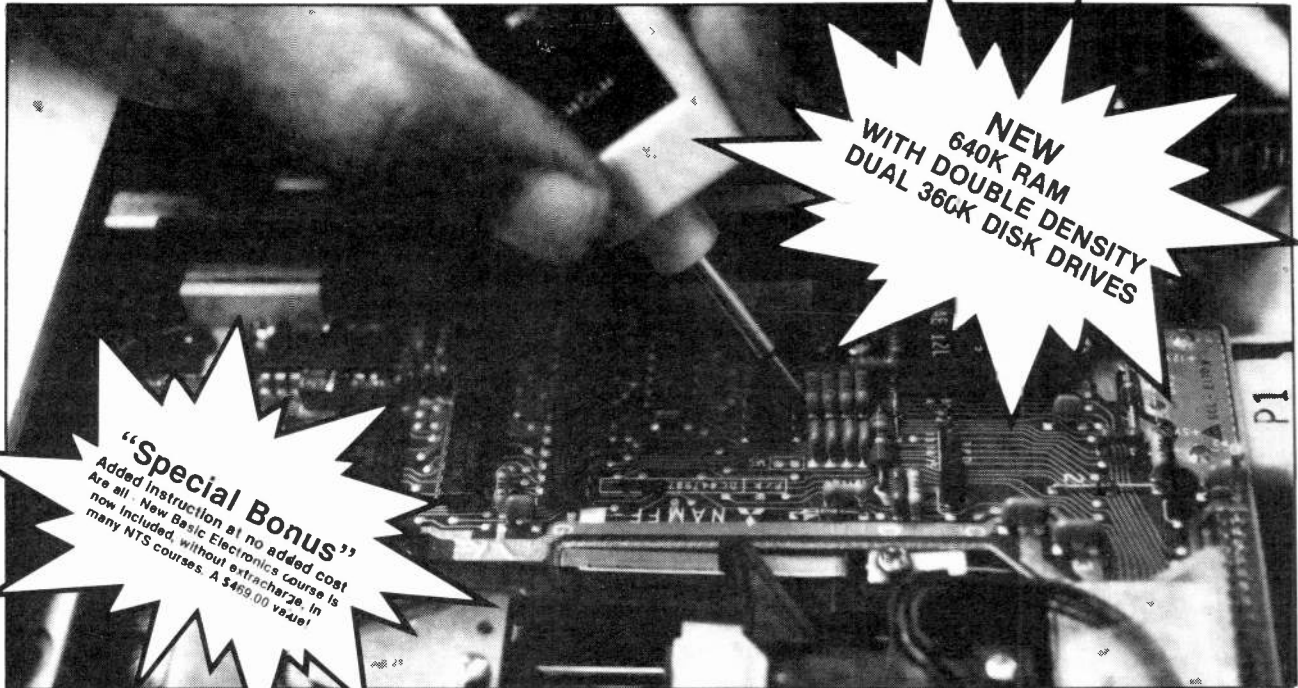

## Learn PC Servicing By Building Your Own Desk-Top Computer!

NTS Intrinsic Home training gets you right down into the heart of computer circuitry. Learn how microprocessors function, how they operate and are used to solve problems. Your program includes a wide variety of tests and projects you perform as you build your own PC, circuit board by circuit board unit by unit.

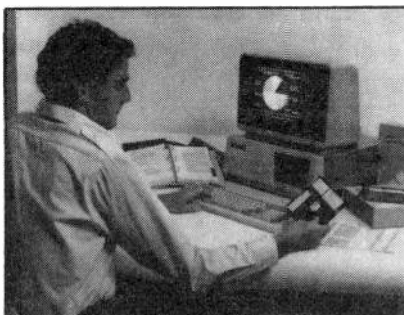

SEND FOR "FREE COLOUR CATALOGUE"

## Hand-On Training With Your (IBM Compatible) PC-XT Puts You At The Leading Edge Of Technology!

This remarkable desk-top PC is the most powerful and versatile ever offered in any home study course. Advanced features of this PC-XT include:

- 16 Bit 8088 microprocessor for IBM compatibility
- 640 K RAM for high speed performance
- 8 expansion slots
- 135 watt power supply
- Dual 360K double density floppy disk drives
- Colour graphics/printer adapter card
- Operating system included: MS-DOS with GW Basic

IBM is a Registered Trademark of International Business Machine Corp  
MS is a Registered trademark of Microsoft Corp

## NTS Offers Many Additional Courses in Electronic and Other Fields:

- Robotics
- Video Technology
- TV & Radio Servicing
- Industrial Technology & Microprocessor
- Basic Electronics



National Technical Schools  
Canadian Office  
517 Bohemia Crescent  
Oakville, Ontario L6J 2K7

(416) 842-8383

School Head Office:  
456 W. Martin Luther King Jr. Blvd.,  
Los Angeles, CA 90037



# Chemically Sensitive Transducers

## Making chemical sensors from microchips

By Dr. H. Virani

Much of the progress now being made in developing miniature sensors for chemical variables can be attributed to microlithography the same technology employed in manufacturing micro processor and other integrated circuit chips.

In this process, thin films of metals, dielectrics, and semiconductors are vacuum-deposited on silicon substrates. A pattern is formed in a film layer by applying a light-sensitive organic coating. If the organic coating is

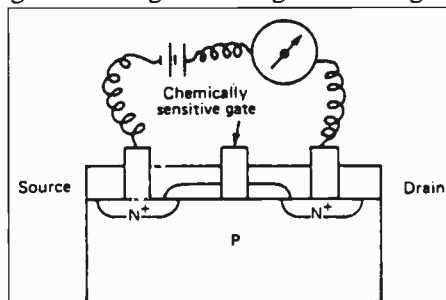

Fig. 1 A basic representation of a chemically sensitive FET.

illuminated through a mask, the exposed areas become more soluble and can be washed away. The entire film is then subject to an etching batch, which removes the portion of the film not covered by the organic coating. The procedure is repeated to create multiple layers.

Various types of solid-state chemically sensitive devices can be formed in this manner. Operation is based on modulation of the current in the circuit by an interaction between deposited material and chemicals with which it comes into contact.

### Chemical FETs

Chemically-sensitive field effect transistors (CHEMFETs), or in-sensing

field effect transistors (ISFETs) are illustrated in Fig. 1.

A voltage is applied across the source and drainage is applied across the source and drain contacts, the current flow is then modulated by the field at the gate. In an ordinary FET, the gate is an electrode, whose field is varied by applying a control voltage. In A CHEMFET or ISFET, the gate is a metallic film coated with an ion-sensitive material (2). Interaction between ions in solution and this material affects the field at the gate and therefore alters the drain current. Applications of prototype devices have included systems to monitor solutions and reducing gases as well as to detect enzymes and antibodies. Advantages, include small size, low output impedance, and response close to that predicted by the Nernst equation for common ions such as  $H^+$ ,  $H^+$ ,  $Ca^{++}$ ,  $C^-$ ,  $I^-$ , and  $CN^-$ .

### Ion-Controlled Diodes

In ion-controlled diodes, p-n junctions coated with ion-sensitive membranes, are in contact with metal oxide semiconductor capacitors as shown in Fig. 2. Changes in diode properties caused by interactions of the coating with ions in the monitored solutions, are measured using admittance bridge circuits. Present applications include detecting potassium and hydrogen ions.

An advantage of these devices is that the electrical connections are on the opposite sides of the elements from the ion-sensitive coatings. This simplifies fabrication-leading to low cost and high reliability. It also allows encapsulation of all components except for the membrane exposed to the monitored solution.

### Schottky Diodes

Schottky diodes illustrated in Fig. 3, have small metallic areas in contact

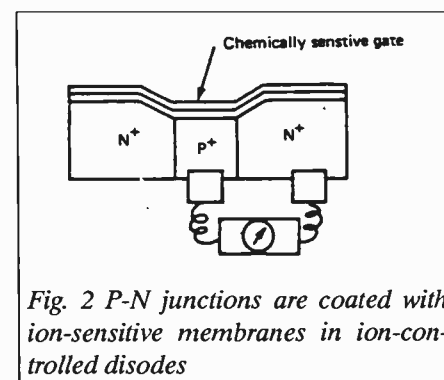

Fig. 2 P-N junctions are coated with ion-sensitive membranes in ion-controlled diodes

with semi-conductors.

Elements fabricated of PdT1102, Pd-cds, Pd-ZnO, PbS-Si and PdSiO<sub>2</sub>-Si are sensitive to low molecular weight gases such as H<sub>2</sub>, H<sub>2</sub>S, NH<sub>3</sub> and CO. A

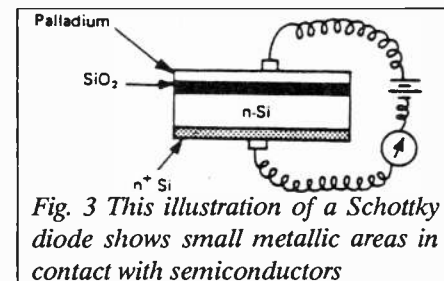

Fig. 3 This illustration of a Schottky diode shows small metallic areas in contact with semiconductors

limitation is that selectivity is low. Schottky diodes with organic semiconductors are also under investigations. These may prove effective for detecting organic vapours with relatively high molecular weights.

### Chemiresistors

The electrical resistance of some organic semiconductors is affected by ambient gases and vapours. The inherent resistivity of suitable material is high; early devices therefore required

excessive voltages to obtain measurable output currents, and were also susceptible to drift caused by reactions at the semiconductor-metal interface. To avoid these problems, elements are being fabricated with the semiconductor films coated on inter-

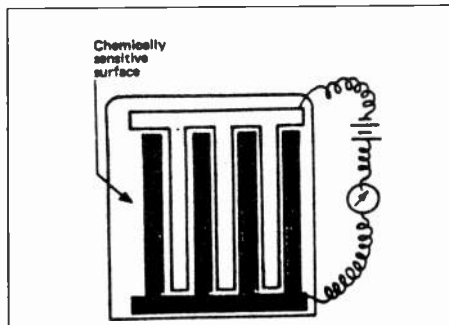

Fig. 4 The interleaved electrodes of this chemiresistor provide a high ratio of electrode perimeter to interelectrode distance.

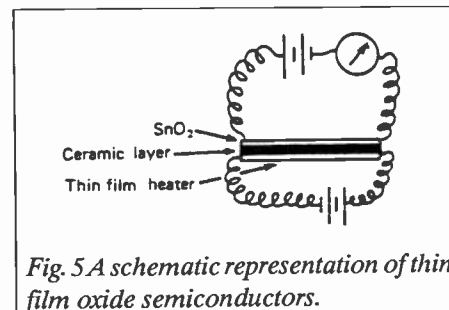

Fig. 5 A schematic representation of thin film oxide semiconductors.

digitated electrode structures as suggested in Fig. 4; this provides a high ratio of electrode perimeter to interelectrode distance.

### Thin Film Tin Oxide Sensors

Thin film oxide semiconductors are shown schematically in Fig. 5.

When the semiconductor material is heated, reducing or oxidizing gases react with absorbed oxygen on the surface and produce measurable conductivity changes. Units based on sintered semiconductor blocks are commercially available for a number of gas detection applications. For instance, methane-sensitive units are marketed for flammable vapour monitoring, devices that respond to carbon monoxide are employed for combustion hazard warning, and units that detect ethanol are incorporated in breath alcohol testers.

The reverse side of the substrate has electrodes with a resistive film deposited over them to serve as a

heater. Selectivity is poor in present devices, but research is being conducted to overcome this limitation by doping the semiconductors with noble metals or metal oxides.

### Micro-Dielectrometers

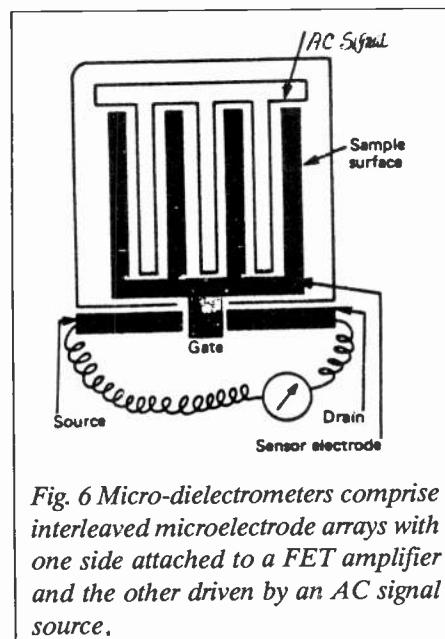

Fig. 6 Micro-dielectrometers comprise interleaved microelectrode arrays with one side attached to a FET amplifier and the other driven by an AC signal source.

A number of analytical measurements can be performed by monitoring the dielectric constant of a medium. This technique lends itself to miniaturization with devices like that illustrated in Fig. 6. Elements comprise planar interdigital microelectrode arrays, with one side attached as a floating gage to an FET charge amplifier and the other driven by a sinusoidal voltage. The complex impedance of the medium in contact with the electrode is determined by measuring the amplitude and phase difference between the input and output signals.

Integration of a FET and the microelectrode on a single chip permits small currents to be measured and yields dielectric information over a wide frequency range. Elements with on-chip temperature sensors are being used to monitor the cure of epoxy resins. Micro-dielectrometers coated with hygroscopic aluminum oxide films also show promise for humidity sensing.

### Surface Acoustic Wave Sensors

Surface acoustic wave (SAW) sensors, illustrated in Fig. 7, consist of piezoelectric substrates with an inter-digital array of electrodes microfabricated at

each end to serve as a transmitter and a receiver. When the transmitter is excited at resonant frequency, Rayleigh waves are induced in the substrate.

Wave propagation characteristics depend on properties of the first 100U or so of surface material. Variations in surface characteristics due to phenomena such as absorption or condensation therefore produce measurable shifts in the output frequency.

### Pyroelectric Heat Flux Sensors.

Pyroelectric heat flux sensors shown in figure 8, are sensitive to thermally-induced desorption.

Elements have been fabricated of LiTaO<sub>3</sub> substrates with two gold electrodes on one side and gold contacts on the other. An operational amplifier measures the potential difference between the measuring and reference electrodes. A resistance

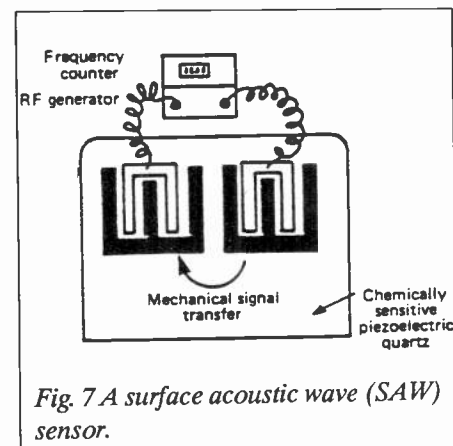

Fig. 7 A surface acoustic wave (SAW) sensor.

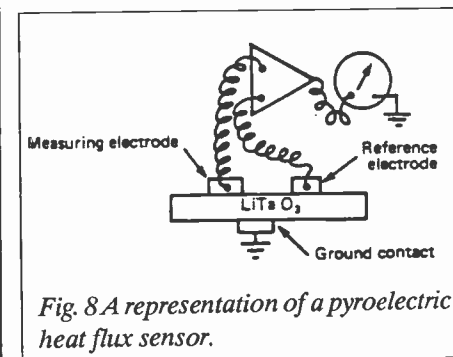

Fig. 8 A representation of a pyroelectric heat flux sensor.

heater raises the temperature of the element and desorbing gases then produce a measurable change in heat flux between the electrodes. The devices are used to perform differential thermal analyses and to measure phase transitions and decompositions in small samples.

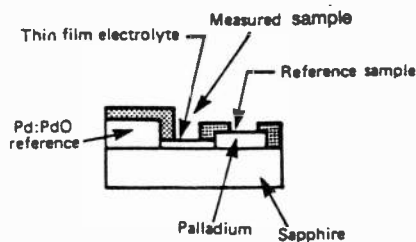

Fig. 9 Potentiometric gas sensor

### Potentiometric Gas Sensors

Potentiometric gas sensors are formed as electrochemical cells as indicated in Fig. 9.

The approach is widely used with large scale zirconium oxide sensors for oxygen measurement. Cells can be miniaturized and employed with electrolytes suitable for gases such as H<sub>2</sub> and SO<sub>2</sub> as well as oxygen. Integral heaters are needed to obtain reasonable conductivity from solid-state electrolytes.

### Fibre Optic Miniaturization

Miniature fibre optic electrodes or optrodes are also being developed for analytical sensing applications. One approach involves use of a reagent at the end of the fibre which changes in colour or other optical properties in

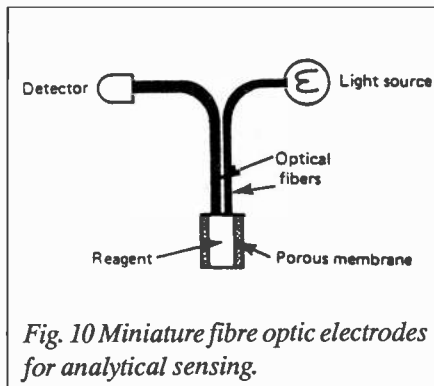

Fig. 10 Miniature fibre optic electrodes for analytical sensing.

the presence of the substance to be detected. The reagent phase does not have to be in physical contact with the fibre; for instance, it can be in a sealed transparent cell, or on the surface of a moving target. A typical configuration is shown in Fig. 10.

Advantages over electrochemical elements include insensitivity to electrical noise and no requirements for a reference electrode. Optrodes can be highly cost effective because a number of sensors may be multiplexed by a single spectrometer and different wave lengths can be scanned to monitor several components in the same solution. Small size is another benefit.

Limitations of current devices, include interference by ambient light, which can be overcome by optical isolation, difficulties in finding stable reagents for particular determinations that respond rapidly on exposure to the substance to be analyzed, and narrow dynamic range.

Dr H Virani is a freelance writer from Mississauga Ontario. ■

### Electronics & Technology Today

For advertising information call

(416) 445-5600

## When Accuracy Counts... You Can Count On Us... Since 1977

THE BRUNELLE

### Commander

SERIES

#### Model 2300 Digital L/C Meter

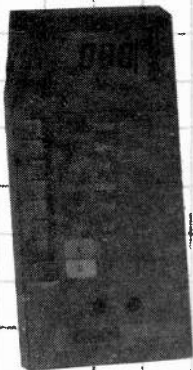

\$221.76  
FST Included

The Digital L/C Meter, you've been waiting for... at the price you've been hoping for!

#### Featuring:

- Input overload protected
- LSI circuitry for high reliability and durability
- 3-1/2 digit LCD display for long battery life
- 5 inductance ranges - 2mH to 20H
- 6 capacitance ranges - 2nF to 200uF
- 1 year part/labor warranty
- Power Requirement: 9V battery
- Battery Life: Up to 200 hours typical with Alkaline.
- Accessories Supplied: Test Lead (1) spare fuse (1), instruction manual (1) 9V Battery.

Circle No. 8 on Reader Service Card

#### Model 600 Video Head Tester

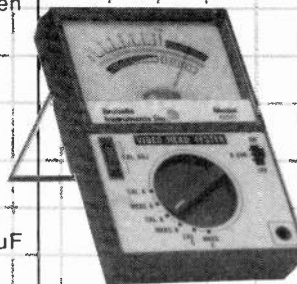

Circle No. 9 on Reader Service Card

The Video Head Tester you've been waiting for... at the price you've been hoping for.

#### Featuring:

- Fast testing of VCR heads.
- Three ranges to cover all VCR Heads, Bridge measuring system.
- Frequency range 1 Mhz.
- Battery operated (9v)
- Rugged and lightweight.
- 600B 'beta', 600V 'vhs'
- Comes complete with test leads, battery, carrying case and 1 year warranty.

\$99.50

FST Included

• Quality + Price + Service = BRUNELLE

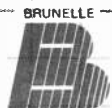

**Brunelle Instruments Inc.**  
73-6th Range South  
St. Elie, D'orford, Quebec, J0B 2S0  
Tel: 1-819-569-1408 Telex: 05-836266

Available from Distributors Coast to Coast contact us for the nearest to you.

**CALL COLLECT: 1-819-569-1408**

costs and improve efficiency and reliability.

These conventional horizontal axis, windmill-type turbines, however, are under attack themselves from a new type of machine. What is described as the world's first variable geometry vertical axis wind turbine was originally conceived more than a decade ago Dr. Peter Musgrove of Reading University, west of London. He realized that if the blades of vertical axis wind turbines could be hydraulically reefed towards the horizontal in strong winds they would be subjected to much lower stresses than those of more conventional aerogenerator designs. A 1.8 million pound, 25 metre diameter, quarter scale prototype of such a machine has now been built by the Vertical Axis Wind Turbines company and was inaugurated last November at a former power station site at Carmarthen Bay in Wales, which has become a test ground for prototype wind machines.

### Giant Power Wheel

The moving part of the 135kW machine, which resembles a giant H-shaped television aerial sitting on top of a 25 metre tall concrete tower, has been popularly nicknamed the "aerial egg-beater". The crossbar of the H is a 25 metre box section, steel member which supports 18 metre long elliptical blades that are hinged halfway.

The aim of this unusual design is to remove the need to swivel the machine to is to remove the need to swivel the machine to face the wind, while retaining the ability of conventional machines to alter the pitch of their blades according to wind strength. The blades of the new machine can be inclined through 70 degrees by a mechanism in the crossbar.

The claim that vertical axis machines can be built to much larger sizes than horizontal axis wind turbines is based on the fact that their blades are not subject to the same cyclical stresses during rotation. One of the main purposes of the Energy Department's monitoring of the prototype is to establish whether this claim is justified.

While the machine is tested to see if it has a future offshore, yet another idea has been put forward to tap the offshore wind: a giant power wheel, 183 metres in diameter, which could produce 20MW of electricity.

The 14 million pound machine, which looks like a Ferris funfair wheel with high technology blades acting as the spokes, is a giant version of the tiny wind wheels used since the 18th century for local water pumping in various parts of the world. In this case the monster machine would have a series of 5MW asynchronous generators built into the hub of the wheel.

**E & TT November 1987**

### DOC Seeks Public Comment on RF Use

Ottawa — Communications Minister Flora MacDonald has called for public comment on future directions for management of the radio spectrum. The request for input is contained in a background paper entitled "Utilization of the Radio Frequency Spectrum in the Range 30.01-890 MHz." This range is the most heavily-used and congested portion of Canada's airwaves.

The Department of Communications' review of the use of this spectrum is part of an overall policy review of radio spectrum frequencies in Canada. This range contains the frequency bands currently used for television, FM radio stations, air traffic control, radar, radio astronomy, amateur (ham) radio, and virtually all land and maritime mobile radio operations including taxi, police, fire, ambulance, shipping and cellular radio systems.

The release of the paper is the first stage in a three-part public consultation process that will assist the Department of Communications (DOC) in preparing a spectrum utilization policy for this range of the spectrum. The policy will serve as a road map for government spectrum managers and the public and facilitate the development of services into the 21st century.

The Department of Communications will use public response to the background paper in formulating proposals for the use of this section of the spectrum. These proposals will be published and further comments sought before a final spectrum utilization policy is announced.

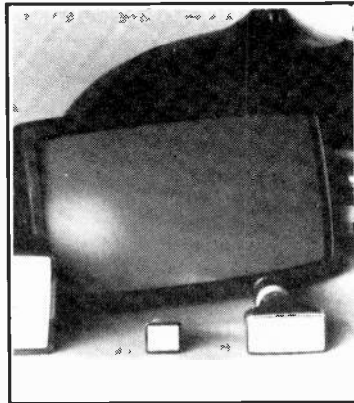

### New Data Display Tube

ECG Canada Inc., a North American Philips Company, has introduced a new product, the replacement data display tube. ECG has been appointed the exclusive manufacturer's stocking representative in Canada for Video Display Corp., the largest U.S. manufacturer and distributor of replacement tubes for computer display and monitor applications.

The high resolution colour or monochrome tube features dark glass, direct etch options, and is available in popular colours ranging from Black-and-White to European Amber.

With over 3,000 tube types, ECG can supply the exact replacement tube for computers, medical instrumentation, surveillance equipment and most other monitor applications for nearly all brands and at less than the OEM cost.

For further information on the data display tube and other products available from ECG Canada call (514) 685-5800.

Circle No. 11 on Reader Service Card

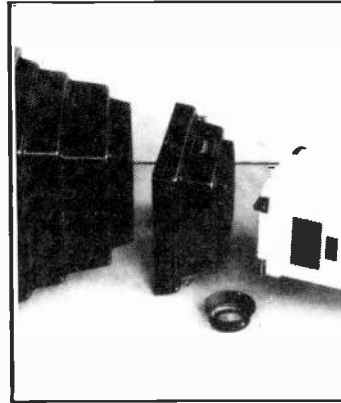

### Polaroid Screen Recording

Shackman's new 7007 Polaroid Autofilm System is a combination of units for direct screen recording. This camera is for all engineers, scientists, and technicians who require an accurate recording of instrument displays, quickly and reliably.

Major features include a high performance, four element glass lens and two different Polaroid film backs. Choice of either mechanical (1s to 125th sec with "B") or electric (16s to 1/60th sec with "X") contact shutter.

The 7007 body is made of high quality ABS moulding and can be cleaned easily making the camera ideally suited to medical, laboratory, or sterile environments. The 7007 camera can be matched to any one of over 70 custom made oscilloscope, CT, and ultrasound instrument adaptors, enabling it to be used on almost all instruments on the market today. Contact BCS Electronics Ltd., 980 Alness St., Downsview, Ontario M3J 2S2, (416) 661-5585.

Circle No. 12 on Reader Service Card

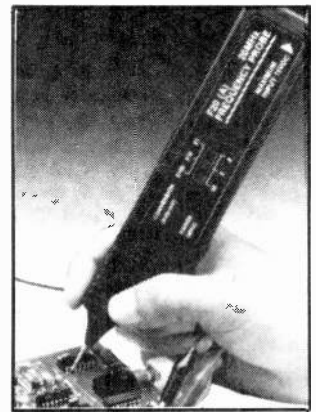

### Frequency Probe

I.M. Instruments of Brantford, Ontario presents two new handheld probes to accurately meter frequencies from 200Hz to 20MHz. The probes are designed for use with 3 1/2 or 4 1/2 digit DVMs to accurately monitor frequencies within  $\pm 5.02\%$  (20MHz) or  $\pm .05\%$  (2MHz). These probes, powered by the circuit under test, offer low cost alternatives to expensive test equipment.

The F-2(A) and F-20(A) IMP Frequency Probes will be available at major distributors this fall. For further information, including literature, please contact I.M. Instruments, Brantford, Ontario N3S 3E1, (519) 756-3770.

Circle No. 13 on Reader Service Card

Copyright — all material is subject to worldwide copyright. PCB designs are copyright and may not be sold without permission.

Liability — no responsibility whatever is accepted for failure of projects to perform for any reason, and no responsibility is accepted for any injury or damage caused by any fault in design.

EDITORIAL QUERIES — written queries must be accompanied by a stamped, self-addressed envelope, relate to recent articles and must not involve research.

*We cannot answer telephone queries.*

PCB Suppliers — we do not supply PCBs or kits or keep track of stocks. Please contact the following:

K.S.K. Associate, P.O. Box 266, Milton, Ont. L9T 4N9.

B—C—D Electronics, P.O. Box 6326, Stn. F., Hamilton, Ont. L9C 6L9.

Danocinths Inc., P.O. Box 261, Westland MI 48185 USA.

Spectrum Electronics, 14 Knightswood Crescent, Brantford, Ontario N3R 7E6.

*Continued on page 40*

**READER SERVICE CARDS**

You'll get FREE response fast!

# Avoiding Feedback

*Feedback should come from your audience, not your PA.*

*By Vivian Capel*

**H**ave you ever been to a meeting or function where the speeches were punctuated by hoots, howls and squeals (from the system, not the audience)? Maybe you have had to fix up the sound yourself and found that as soon as the volume was turned up the howling started. If you turned it back down there were complaints that the volume wasn't loud enough.

The problem is acoustic feedback. Sound from the loudspeakers is picked up by the microphones, reamplified, emerges from the speakers at a higher level and re-enters the microphones to be further amplified. The slightest sound starts off the cycle which rapidly builds up to the familiar squeal. How then can this be avoided?

The simple answer is that it can't. Whenever a loudspeaker and a microphone occupy the same volume of air there will be a level of amplification at which feedback will take place. This is known as the *feedback level* or *feedback point*. The trick is to make that level as high as possible.

## Microphone Choice

The single most important factor affecting feedback level is the type of microphone used. For best results the type chosen must satisfy certain requirements regarding directional characteristics and frequency response.

A directional microphone is one which is more sensitive to sounds arriv-

ing from some directions than from others. With a little care, a directional microphone can be positioned so that its most sensitive face is positioned towards the sound source while its least sensitive side faces the loudspeaker. This gives an enormous improvement compared with omnidirectional microphones.

One of the most common directional patterns is the cardioid response. As its name suggests, the response pattern is heart-shaped, with a large bulge (maximum sensitivity) at the front, gradually tailing off along the sides towards the back where there is minimum sensitivity. A variant of this is the hypercardioid, which has a slimmer heart shape bought at the expense of a small response lobe at the back of the microphone. The slimmer pickup pattern of the hypercardioid means that it is more directional than the cardioid and therefore better able to reject sound from the sides while picking up sound from the front.

The directional qualities of a microphone are sometimes ex-

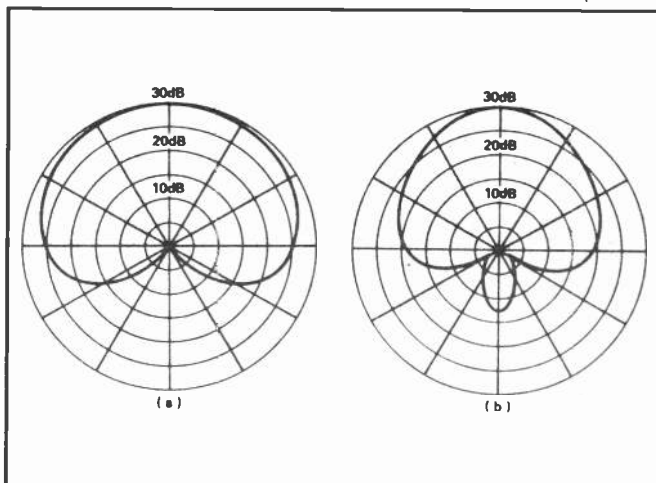

Fig. 1 (a). Cardioid microphone polar diagram and (b) hypercardioid polar diagram. These show the response at 1kHz. Lower frequencies are less directional.

pressed in terms of the ratio between the maximum and minimum sensitivities. The figure is usually known either as the *directivity factor*, the *rejection ratio* or the *front-to-back ratio* and typically values are around 15-20 dB.

A more practical figure is one that gives the ratio of sound picked up from the forward direction compared with that picked up from all other directions, because reflections from the loudspeakers usually arrive from a variety of directions. This figure is obtained by comparing the acoustic power received by an omnidirectional microphone in a reverberant environment with that picked up by the directional microphone. The ratio is squared and the result termed the *directivity index*. For a cardioid, the index is about 3 and for a hypercardioid it is 4.

Taking the square root of this index (which is the original acoustic power ratio) gives the distance from the source at which the same proportion of ambient sound compared to the omni will be received. For a cardioid the distance is about 1.75 times, and the hypercardioid is twice that of the omni. For public address work this means that for the same feedback level the cardioid can be positioned 1.75 times the distance from the user as an omni, while the cardioid can be positioned twice as far away. Alternatively, the microphone could be used at the original distance from the user and the feedback point will be that much higher.

The rifle microphone is better still, having directivity indices of 6-10 depending on length. However, it is rather unwieldy to use on a microphone stand and the high directivity can be a two-edged sword. The user needs to stand right in front of it or the volume will drop considerably with any deviation. The hypercardioid is thus the most practical choice for sound-reinforcement purposes.

The other microphone parameter which considerably affects feedback is the frequency response. The important thing here is not an extended frequency response, but a flat one.

A glance at Fig. 2 will show the principle. The straight horizontal line represents the feedback point of the system, while curve A is the frequency response of a microphone having a pronounced peak in its higher

midrange. Although the general level of the curve is below the feedback point, the peak exceeds it, so feedback will occur.

Curve B is that of a flat response microphone and the whole curve remains below the feedback level, so it will operate at a higher volume and still not run into feedback. Even when it is operated on the feedback point it will not go suddenly and violently into feedback like the peaky microphone of curve A. Rather, it starts to give an echoing effect called *ringing* after each spoken sentence and so gives due warning that feedback is near.

A big problem here is that nearly all moving-coil microphones have a peak in their response from about 2-5kHz. This is due to the mass of the resonance diaphragm and the coil. Some of the better instruments have the peak damped to a degree, but the laws of physics cannot be circumvented and the peak is still there.

What is required is a microphone with a moving element that is very light and so has its resonance into or above the treble region where a little treble cut on the amplifier can tame it. Capacitor microphones of studio quality have this characteristic, but they are expensive and need a polarizing power supply. They are rather out of the class for sound reinforcement work.

Electret microphones are another possibility. These are cheap and have light diaphragms, working on a similar principle to the capacitor, but with a

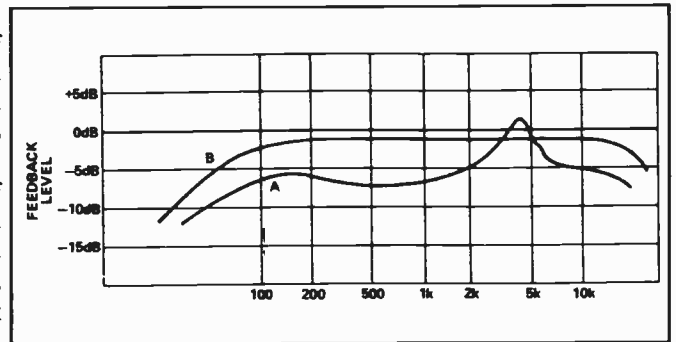

Fig. 2. A peak in the response of microphone A exceeds the feedback level. With microphone B, the response is flat, allowing operation at a higher level without crossing the feedback line.

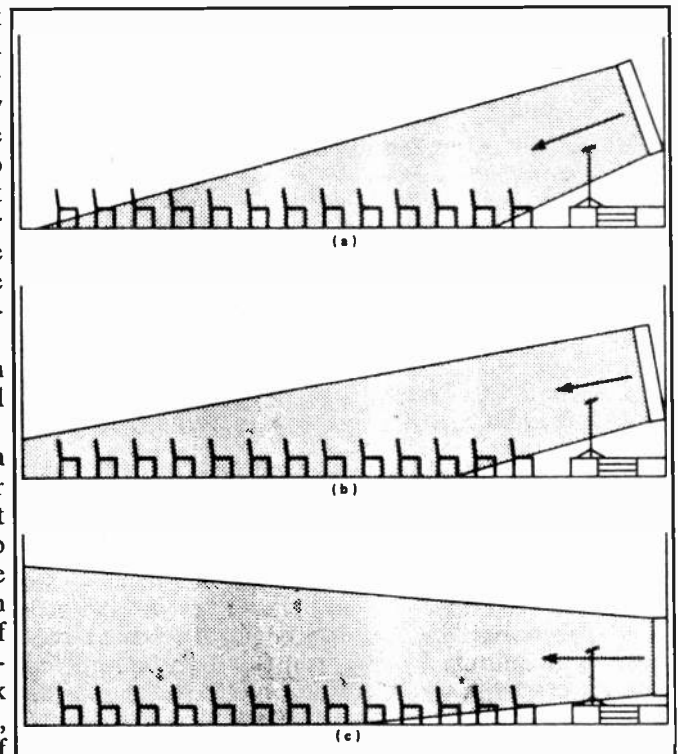

Fig. 3 (a). A high-mounted line-source speaker can be tilted to direct sound into the audience, but the angle of incidence limits the seating area covered. In (b) a lower position requires less tilt and gives better coverage. With a still lower position (c), having the bottom of the column at audience shoulder height, no tilt is needed.

built-in polarizing charge. Unfortunately, their cheapness seems to preclude high-grade construction and there can be problems with the internal battery connections, the power switch and the adverse effect of atmospheric humidity on the stored charge. Furthermore, only a few exhibit the smooth response that they should be capable of in theory.

Another type of unit is the ribbon microphone. This has a low mass and

is capable of a flat response, but some models have peaks purposely introduced by the makers to give a brighter effect. Ribbons are generally more fragile than moving-coil units, but a few are remarkably robust and prove themselves capable of standing up to rough usage.

Of all the hundreds of microphones that are now available, few have all the characteristics necessary for the inhibition of feedback. The author's own favorite is the Beyer M260 N80 ribbon, which has proved itself in many difficult acoustic conditions. The only snag is the high cost.

### Loudspeakers

The type and positioning of loudspeakers can play a major part in the avoidance of feedback.

Single-unit loudspeakers radiate sound in a wide cone-shaped pattern from the front, and if the back of the cabinet is not fully blocked off, they will radiate a similar though restricted pattern from the rear. Much of this sound energy is thereby directed toward the ceiling and the upper walls from where it is bounced to be reflected back into the microphone and produce feedback. If the sound could be beamed into the audience these reflections could be avoided.

This can be achieved by the column or line-source loudspeaker. It consists of a number of units mounted vertically in a narrow cabinet, the sound distribution pattern produced being that of a wide-angled beam having a flat top and bottom. The beam diverges to a very limited extent and it can be considered for practical purposes to be of the same height as the column itself. Divergence is greater when there are fewer units in the column, making it less effective. Five or six units give good results and four is the minimum to achieve line-source characteristics.

Another useful feature of the column loudspeaker is that the sound pressure produced at a single point actually increases as that point is moved away from the speaker up to a certain maximum distance. This means that the volume level is sufficiently high at a distance without being deafening at close quarters.

The important factor is the positioning of the columns. If mounted high, they must be angled forward so

as to direct the sound into the audience. The higher the position, the greater the inclination, but this will cover only part of the audience effectively.

A greater coverage will be obtained by a lower position and narrower angle. Often though, it is more conveniently to mount them vertically, in which the column bottom should be at about the shoulder height of a seated audience.

### Acoustics

One thing that can nullify much of the advantage obtained from applying the above information is the back wall of the platform. Sound from the auditorium is reflected from it right into the front of the microphones, thus making them virtually omnidirectional.

The answer is to hang a heavy curtain in deep folds along the back platform wall. If possible, it should go the whole length of the wall, but if not, it should extend at least six to eight feet from either side of the microphone position.

Another factor is the audience itself. The clothed human body is highly sound absorbent, so nearly all the sound directed into the audience by the column speakers will be absorbed when there is a capacity crowd. Feedback problems are therefore less.

When attendance is poor and there are many empty seats, more sound is reflected back and feedback is greater. In an empty hall feedback is at a maximum and many an installer has sweated to improve it, only to find the problems disappearing as the hall fills up. If the feedback level is reasonable when you install the equipment, it can only get better.

One useful tip is to try reversing the loudspeaker phasing. All the speakers should be connected in the same phase, or there could be blind spots where the sound from two out-of-phase columns overlap. However, the combined speaker wiring can be connected either way around, and it may be found that feedback is less in one position than in another. There may be little difference, but it's worth a try, especially if it's made convenient by using a double-pole switch for the reversal.

### Frequency Shifting

Another solution to the feedback

problem is provided by a device known as a frequency shifter. This is inserted somewhere in the amplifying chain (usually between the mixer and the power amps) and raises all the signal frequencies passing through it by a few Hertz. This works well with speech, and the slight difference between sound heard directly from the person speaking and the sound heard from the loudspeakers is too small to be noticed.

Frequency shifting prevents feedback because there are no reinforcements of the original sound. Each signal from the microphone will emerge from the loudspeakers at a higher frequency. If it is picked up by the microphone again, it will then re-emerge from the loudspeakers at yet another frequency. The result is that potential feedback is rapidly swept upwards in frequency until it is above the upper frequency limit of the system. This allows far more gain to be used before feedback becomes a problem and the effects are less obtrusive when feedback does occur.

The disadvantages are the cost and complexity of the hardware and the fact that it does not work well with music, particularly in the bass register. Because all signals are increased by a fixed amount (usually around 5Hz), the effect is to apply a larger proportional increase to the lower notes than to the higher ones. Adding 5Hz to a 100Hz note or less will raise the note by a semitone or more, while adding 5Hz to the next octave will raise the notes by about a quarter of a tone. This introduces a discordant relationship between the fundamentals and harmonics.

Because of these drawbacks, frequency shifting should be looked on as something of a last-ditch solution when all else has failed. It should not be used as a substitute for good anti-feedback design in the choice and use of microphones, speakers and stage furnishings. Shifters should always be fitted with a bypass switch so they can be removed from the signal path if problems develop. ■

**READER  
SERVICE  
CARDS**

You'll get  
**FREE**  
response  
*fast!*



# Tango PCB Software

*Using the power of the computer for designing printed circuit boards.*

*By Bill Markwick*



If you design more than a few printed circuits and you do it by hand, with graph paper and tape, you're missing out on the power and flexibility available from today's PCB planning software. One such program is Tango PCB, from Accel Technologies of San Diego. If you have a PC/XT/AT or compatible, you can save an enormous amount of time drawing up any type of board, from the simplest single-sided to the most complex multi-layer type.

Using a mouse in much the same way as in a CAD program, you can place pads, tracks, DIP outlines and more in seconds. The Tango program uses a rubber-band line for tracks, and they're placed either horizontally or vertically; going around corners is automatically worked out for you using 45-degree angles. There are full editing functions for changing or moving anything, and you can surprise yourself at how easy it is to turn out precision board layouts in a fraction of the time it takes by hand.

### System Requirements

The Tango software will run on any PC-DOS or MS-DOS machine, but as usual, we advise a machine faster than a normal PC for any program more complicated than a word processor. An economical choice would be a 8MHz turbo-type PC, and best of all is an AT or compatible. The great drawback with the ordinary PC running any type of CAD is the length of time required to regenerate drawings whenever you zoom or pan. Tango PCB does not require a math coprocessor chip such as the 8087, since it uses all

integer calculations to plot its vectors (it's object-oriented, much like AutoCAD).

You'll need two floppies or one floppy and a hard drive; memory requirement is 256K or greater. The software includes batch files to configure it for either the CGA- or EGA-type video cards. There is no driver for the Hercules-style hi-res or other monochrome card, because Accel expects you to be using a colour monitor. We used it successfully with a green monitor and a CGA card, but that was only for purposes of the review; I only drew small test PCBs. If you're going to be making double-sided or multi-layer board, colour will avoid any confusion about which side you're working on.

And, of course, you should have a mouse, one that's compatible with the Microsoft Mouse drivers (most are, or at least have suitable software drivers included), though you can use the cursor keys. The printout is best done on a plotter; Tango supports the HP-GL, DM-PL and Roland DXY 800 plotter languages. In addition, you can print out a fairly rapid check print on Epson FX and LQ dot-matrix printers, and those compatible with the Epson graphics format.

One point of contention with Tango is the copy-protection scheme. I have no problem with manufacturers wanting to protect their investment, but Accel uses a half-card PCB which must be inserted in one of the bus slots. It contains logic gates which supply a keycode when the software requests it; no keycode, no program

load. It's annoying to have to open a computer, especially if it has a sliding-type case rather than a fliptop, and it uses up one of the slots rapidly being filled by today's various accessories. In addition, the software is no longer transportable; it runs only on your computer. The PLOT function, fortunately, is not protected and will run on other machines.

Further, Tango Route, which is a separate autorouter program, requires a protection device to be inserted into the parallel port. This is too much fiddling with hardware. If we have to live with protection schemes, I prefer the ones that let the master program be copied once for a backup. This lets you install the software on a hard disk and eliminates gadgetry.

But that's my only serious complaint.

### Starting Up

If you start the program and load the included demonstration program, you'll see the demo PCB appear as a tiny rectangle in the lower left corner of the screen. There's a zoom key with six levels of magnification that quickly redraws the PCB to the desired size. You can also put the cursor on any part of the PCB and the screen can be zoomed with that part as the centre. Even complex boards are zoomed and redrawn very rapidly, much faster than, say, the Columbia shuttle outline as drawn by AutoCAD. You can also interrupt the re-drawing at any point and specify something else.

When you try moving the mouse here and there, you'll notice that it

snaps along grid coordinates. There are nine grid sizes from 1 to 200 mils in size, making it easy to move from one component to the another without jiggling the cursor for an exact lineup.

Try putting in some pads and tracks. The function keys are used for the most-often-used features, such as inserting pads, tracks and components; they're also used along with Alt and Shift, so the included keyboard template is welcome. You'll find that the rubber-band line and function keys let you rocket along drawing a layout faster than you've ever done before.

The software contains a library file with pads, DIP layouts, SMD pads, edge connectors and others. It's like using those self-adhesive PC symbols, except that it's a whole lot faster. You can also move pads to your heart's content, with or without the tracks stretching to fit. Try doing that with a sticker.

### Components

In addition to the multilayer feature, Tango also makes up a component-location silkscreen master as you go. To implement this feature, the cursor

is placed at a desired location, a function key pressed, and the component selected and described. For instance, you might select a 24-pin DIP for IC location U13, using a 2716 chip. At any time during a drawing session you can cursor to the pad and press the Identification function key to see "U13 2716 DIP24". The labelling also appears on the silkscreen label layer.

The library also includes axial and radial-lead components of various sizes and shapes so you can put down most available types of resistors, capacitors and diodes (the latter two can be marked for polarity as well). There's also an editing function to let you create whatever components you need for you PCB.

If all the components and labels start getting in the way, you can shut off the label layer (or any layer).

### Lists

The software keeps track of all the components and locations and can print out a component list. The Netlist is an abbreviated form used for input to other programs (such as the auto-router) and the Wirelist is a printable

file with components and nodes. It can be used for manually checking the PCB against a schematic. Incidentally, some schematic-drawing programs produce output files which are compatible with Tango; if you have one, you can load it into Tango and maybe never have to use your pencil again. Information is included in the manual for editing lists into the required format, should you have to.

### Plotting

For final output, a precision pen plotter is required; the maximum size of PCB Tango will produce is 32 by 19 inches. Once you're ready to go, you can print any or all of: the Component side layer, the Solder side layer, the three Middle Layers, the Power plane, the Ground plane, the Solder Mask, the Pad Master (pads only, for quick checking) and the Silkscreen Overlay. In addition, if you have a multi-pen plotter, you can have a quick color multilayer plot with everything on one sheet. There's a Bill of Materials listing all components, and as mentioned, you can do a quick check plot on a dot matrix printer.

### In Conclusion

We didn't have time before we went to press to fully test the Tango Route program. However, we did manage to make up a simple netlist using Tango PCB, and fed it into the router to see what would happen. It designed a small PCB before you could say "Pass the X-Acto knife". Then we loaded in the netlist from the large demonstration PCB that comes with Tango. This wasn't quite as fast, but a 6-layer board was routed in under ten minutes; imagine doing that with tape.

The software is very easy to learn and use, the manual is excellent, and the good editing functions make it very easy to change and correct your drawing. If you've never used any type of vector CAD before, you may find the object-oriented editing a little odd at first (you can't erase part of a line — you have to "break" it first), but you'll soon develop speed in using it. Tango is from local dealers, or contact Accel Technologies, 7358 Trade Street, San Diego, CA 92121, (619) 695-2000. The Tango PCB program and Tango Route are each priced at a manufacturer's selected list of \$495US. ■

Circle No. 6 on Reader Service Card

# SPEAKERS DRIVERS IN CANADA

vifa



FOTAL

DYNAUDIO®

## CROSSOVER, SPEAKER COMPONENTS

### SOLEN CROSSOVERS

Custom Computer Design  
Passive Crossover for Professional, Hi-Fi and Car Hi-Fi  
Application, Power up to 1000 Watt.

### SOLEN INDUCTORS

Perfect Lay Hexagonal Winding Air Cored  
Values from .10 mH to 30 mH,  
Wire Sizes from #20 AWG to #10AWG

### CHATEAUROUX CAPACITORS

Metallized Polypropylene (Non-Polarized)  
Values from 1.0 mfd to 200 mfd,  
Voltage Rating: 250 VDC / 150 VAC

### CROSSOVER, SPEAKER PARTS

Mylar Capacitors, Power Resistors, Crossover Terminals,  
Nylon Ty-Wrap, Binding Post, Banana Plugs, Speaker Terminals,  
Grill Cloth, Plastic Grill Fast Snap, Neoprene Gasket, Misc. Parts.

### COMPUTER AIDED DESIGN FOR ENCLOSURE AND CROSSOVER AVAILABLE TO CUSTOMER

Product specifications and prices available upon request.



**SOLEN INC.**  
5851 Cousineau Blvd.,  
St. Hubert, Que.  
J3Y 7P5 Canada

**ORDERS**  
Tel: (514) 656-2759

# ALMOST FREE PC SOFTWARE VOLUME XXVIII

**ASTROLAB** This is a very sophisticated program for working out the conjunction of the planets for any day in history. It's not much use if you believe in a flat earth, but handy for horoscopes.

**BASERES** Yet another resident utility, this thing will accept numbers in any base and show them to you in all the other commonly used notations. In other words, it will convert decimal to hex and back again... great for people with only ten fingers.

**BREAKON** This is a utility to make just about any program exitable with control-break. It has multiple levels of urgency... three hits gets you out of anything short of the end of civilization as we know it. Assembler source included.

**CROSSWRD** If you've ever wanted to generate your own crossword puzzles, this is the code for you. Fill it full of words and it finds places for them... keeps track of the clues, too.

**DIMMER** The smallest screen blanker yet... two hundred and seventy one bytes.

**EPSONSIM** Even people with laser printers occasionally have to deal with plebes. This program is a DOS filter to make a PostScript printer behave like an Epson.

**FASTBIOS** This is a pair of programs which will extend your keyboard buffer... without hanging your system... and increase the speed of your screen dramatically. When was the last time you had a little drama in your computer?

**FREERAM** This will tell you the truth about how much useable memory is available to your programs. A painful thing, the truth...

A few good programs can change the way you use your computer. This month we've gone looking for things to plug into your system and warp your life with. This collection includes a really spectacular game, some invaluable utilities and a number of pop up resident things to make your universe run more smoothly.

There's also a music program, because the universe just wouldn't be the same without computer music.

Whether you're into gambling, tunes, puzzles or just getting your PC to do what you tell it, you won't want to miss this volume of software. As with all of our almost free software disks, this one has been scrupulously checked for trojans and other nasties, so you can run it knowing that your hard drive won't wind up being blasted into hyperspace.

This disk is available for a mere

**\$19.95**

plus seven percent Ontario oxide tax

from

**Moorshead Publications**  
1300 Don Mills Road  
Toronto, Ontario  
M3B 3M8

or you can order it by phone. Call

**(416) 445-5600**

during business hours. Please have your Visa, MasterCard or American Express card handy.

**LASERGRID** This is an ASCII game, but a rather good one. Place your bets and hope the aliens leave you alone.

**VMUSIC** This is a small three voice music player which handles its scores in BASIC music notation. Comes with several songs, and you can easily create your own tunes with a text editor.

**IDCKEYS** This is an assembly language program to set up the function key redefinitions under ANSI.SYS. It's great if you like to have keyboard macros under DOS without a keyboard redefinition program installed. Requires an assembler to use.

**IDCKILL** This will go through an entire hard drive... including all your subdirectories... and kill files that match a given specification. A bit nasty if you use it improperly, but great, say, for snuffing BAK files.

**LW86** This is an extensive pop up reference card for assembly language programmers. It includes explanations of the op codes, what the assembler directives do and so on, all at the touch of control shift.

**SPACE** Find out how much useable space is on your hard drive instantly. Includes assembly language source.

**YESNO** A really useful thing to create complex interactive batch files, this little program returns an error level code basic on the ASCII value of a key press. Assembly source included.

Fine Print: All of the programs on this disk have been collected from public domain bulletin boards, and are believed to be in the public domain. All of them have been tested to make sure that they work and don't do anything weird. Please note that these programs may behave unpredictably on computers which are not wholly PC compatible.

We cannot be responsible for any loss or damages resulting from your use of this software, however caused. If you are unable to use these programs as a result of disk errors, please return the disk to use for an immediate free replacement.

IF YOU ENCOUNTER PROBLEMS WITH THIS SOFTWARE, PLEASE NOTE THAT OUR TECHNICAL SUPPORT LINE IS AVAILABLE BETWEEN 9:00 AND 10:00 EASTERN STANDARD TIME MOST MORNINGS.

# Part One

## The Physics of Music

*Beginning a new series on  
how sound waves become  
the most complex and  
subtle art form.*

*By Bill Markwick*



The Merriam-Webster dictionary defines music as “the science or art of combining tones into a composition having structure and continuity”, a definition loose enough to encompass just about anything as music. The *Oxford Companion to Music* bypasses the problem of any concise interpretation; oddly, there is no entry under “music”. If you try pinning it down by means of an informal survey, you’ll probably find that few people agree. This is a good thing for the ever-changing world of music, though it makes for arguments that are often dull: “Heavy metal? You call that *music*?”

We’ll leave any attempts at strict definitions to the musicologists. This new series, which will be written by various authors, examines the physical rules and regulations that govern the production of musical sounds, from the sound of tapping your fingers to the most complex of orchestral instruments or electronic synthesizers.

In this initial part, we’ll begin with the basics of sound production, each point of which we hope to cover in more depth as the series progresses.

### Introduction

All music comes into our perception by means of vibrations of a medium. In the great majority of cases, this means pulsations of the air between the source or sources and the ear. Though some sound may be transmitted through conduction in other materials (Beethoven’s deafness required him to place his ear against the piano, allowing conduction from the wood to the bone structure), we can safely concentrate on sounds that come to us through the air.

The standard highschool experiment to demonstrate sound was (and probably still is) to strike a tuning fork and hold it to a microphone connected to an oscilloscope. The resulting pure tone produced a sine wave display that diminished in amplitude with time. All sound is made like this, regardless of its origin. You can thump your fist on the table and the same rules apply to the very different-sounding noise you’ll get. The tuning fork just happens to be a special case; it’s mechanically designed to produce that pure sound wave.

If we review the various instru-

ments in an orchestra, or a rock band, or any other musical source of any type, we can come to the conclusion that definite pitch is a prerequisite for music, because our brains seem to prefer this kind of ordering of sound. The rule of pitch may not seem to apply to drumming, which is a cousin of thumping on the tabletop, but pitch does play an important part in percussion that we’ll come back to later. We can probably say then that all musical sounds originate in one way: an object is mechanically designed to make the air pulsate regularly. If it’s tuned to a certain pitch or pitches, it’s said to *resonate* at that pitch.

Breaking this idea down a bit, we can say that all musical sounds originate from one of four mechanical objects: the string, the reed, the tube and the diaphragm. The most complex electronic synthesizer in the world is mute until it moves the diaphragm of a speaker or headset. Simple pan pipes and massive pipe organs use resonating tubes in the same way.

Sometimes the instruments use several of these ideas together. The vibrating string, for instance, just



doesn't like to impart its energy to the surrounding air, so a diaphragm, the soundboard, is used to couple this energy to the surrounding air molecules. It's rather like making oars for your rowboat; if you make the blades three feet across, you'll never be able to move them in the water, and if you make them two inches across, they'll just slice through the water and waste your energy. The ideal relationship between the acoustic instrument's strings, soundboard and the air has been worked out by trial and error over the centuries (with "ideal" meaning that the instrument suits musicians well enough — no one will ever agree on the perfect instrument). The vibrating reed of the clarinet and the trumpet player's lips share the same problem of sound not being particularly loud, so various types of tubes are used to increase the efficiency.

Any one of the above points can and should be expanded into a larger explanation, and we'll do just that as the series continues, but for now, a review of the terminology used in acoustics.

### Pitch

When the tuning fork is struck, it swings back and forth at a rate determined by its mechanical design. As the bars swing toward you, they compress the air, and as they retreat the air is rarified. The resulting sound waves are then alternating compressions and rarefactions; they're called transverse waves and spread out spherically from the fork.

If we look at the oscilloscope signal produced by a microphone near the fork, we see a graphic representation of these waves, with vertical axis (X axis) representing the amplitude (strength) of the signal and the horizontal axis (Y axis) representing time. The waveform from a tuning fork is the familiar sine wave that begins at zero, rises in a smooth curve to a positive peak (compression), falls smoothly to zero, and then duplicates this positive half-cycle in the negative direction (rarefaction). The name comes from the fact that the amplitude at any point is proportional to the sine of the angle, where a full cycle goes from zero to 360 degrees; the sine of zero is zero (the beginning

of the cycle), the sine of 90 is one (full positive amplitude), and so on.

The usual pitch for a tuning fork is 440 Hertz, or 440 complete cycles of compression and rarefaction per second. This value is used to put instruments into *concert pitch*, where the A note above middle C is 440Hz, and this value was arrived at by international agreement. As with most international agreements, it took centuries to arrive at; tuning forks from the past indicate a wide variety of systems have been used. Handel's tuning fork shows that 18th century musicians (in England, at least) used 422.5Hz as concert pitch, or almost one semitone lower than today (A-flat is 415.3Hz). The problem with the numerous pitch systems in the past seems to have stemmed from improvements in instruments; for instance, makers of woodwinds in the 18th century preferred a lower pitch for the newly developed instruments, but the church organs of the time were fixed at a higher one.

Remarkably, it was as late as 1939 before the present standard of A440 was agreed upon.

## Frequency

Pitch and frequency are often used interchangeably, but as author Tom Robbins said, there are no synonyms. Pitch is our subjective reaction to a frequency, which consists of a certain number of cycles per second. Frequency is a measurement that can be done easily and precisely with lab instruments.

## Why piano tuners are paid to put pianos out of tune.

In general, the relationship between pitch and frequency appears linear to us: twice the frequency seems to give twice the pitch and so on, but this is true only for a narrow range of frequencies. Our ear/brain hearing mechanism begins to stray from this 1:1 ratio at either end of the audible spectrum. If a piano is tuned using exact octaves right across its range, the upper and lower octaves will sound just a bit flat, even though they may look correct to a frequency counter. Piano tuners compensate for this by tweaking the extreme octaves until they sound right. Chances are that no two people have exactly the same variance at the extreme octaves, so tuners probably encounter fussy piano players who insist it still isn't right, even though the tuner is satisfied. Any variation would be extremely small, though, and you'd need highly trained hearing before you could detect what they're arguing about (besides, the upper octave of a piano consists of more impact noise than string tone).

For the above reasons, instruments with extreme range (such as pianos and organs) have a unique scale. More on the derivation of musi-

Threshold of hearing.....	0
Average living room .....	40
Conversation at 3'.....	70
Traffic .....	80
Factory .....	100
Point of pain .....	120
Jet plane at 150' .....	140

Intensity levels of sound in dB for some typical situations. Each 10dB multiplies the sound power level by 10.

cal scales will be forthcoming in a future issue.

## Decibels

The most popular unit for measuring is the ubiquitous decibel. It's the favorite level measurement of both sound and electronics technicians, and it's used for sound, voltage levels and power. It states the signal strength coming from your cassette deck, the micropower levels in your cable TV feed, and the level of sound produced by loudspeakers. Yet it's poorly understood outside the ranks of those who work with it all the time; newspapers always avoid technical discussions of the decibel by saying that it's "the smallest difference detectable by the human ear", which is only one-tenth of the story and not totally accurate at that.

The reluctance of the media is understandable when you consider what a wide range of functions of decibel covers, and each one requires an understanding of the application and how the decibel is modified to suit.

The whole problem with quantifying sound levels is that our ears are capable of a staggering dynamic range; the intensity of the loudest sound we can hear (at the threshold of pain) is about one trillion times that of the softest sound we can detect under ideal conditions. To avoid having to work with enormous numbers all the time, the difference in the intensity levels is expressed as a base-10 logarithm, giving us the ratios of the

powers. If you increase the power going into your loudspeakers by 10 times, the intensity of the sound is 10 times, and the log is one; 100 times the power gives a log of two and so forth. Note carefully that *intensity*, a physical quantity, is not the same as *loudness*, a subjective auditory sensation; the relationship between the two is complex and will be covered below.

Our new unit for compressing large numbers is called the *bel*, after Alexander Graham Bell, a pioneer in hearing studies as well as inventor of the telephone. Its formula is simply:  $\log P1/P2$ , where  $P1$  is the larger power and  $P2$  is the smaller.

However, the bel is still a bit coarse for small changes, so it's customary to use the decibel, 0.1 bel and abbreviated dB. Now the standard formula for comparing sound powers becomes:

$$10\log P1/P2$$

Try it out. All you need is a simple scientific calculator that can do logarithms. If the softest sound we can detect (in a very quiet soundproof chamber) is  $10^{-16}$  watt/cm<sup>2</sup>,

and the loudest is  $10^4$  watt/cm<sup>2</sup>, divide the larger by the smaller, take the log, and multiply by 10. You should get 120dB, and this is the typical figure given for the human ear's dynamic range, a truly amazing phenomenon that beggars the very best of digital recording methods, considered a technological miracle because its dynamic range is 80 to 90dB.

Another confusing fact about the dB is that zero does not mean zero in the usual sense. Instead, 0dB is used as some desired reference or starting

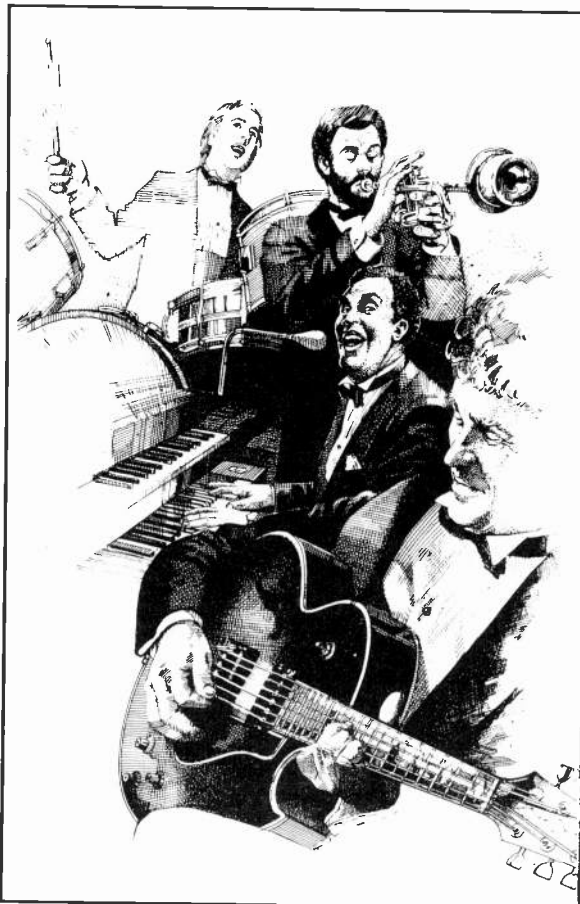

point, with negative decibels representing levels less than the reference and positive decibels representing larger ones. The most familiar example of this is the VU meter on your tape deck (the VU, volume unit, can be treated as a decibel). Zero on your meter represents a standard output level, usually near 3/4 volt on home equipment. Levels like -20dB indicate a lesser signal.

### Any calculator with a log function will help you demystify the dB.

Using your calculator again, you can work backwards with our decibel formula and find the change in power level. First, divide by 10, giving 2. Take the antilog of this ( $10^x$  on most calculators) and you'll get 100.

It's worth a digression to note that if your signal at 0VU is driving your power amplifier to its maximum, say 100 watts, the signal at -20 is only one watt. I've met people who have "upgraded" their amplifiers to about 1/2 again the power, and were disappointed that they couldn't hear much difference. Using our dB formula, this is only 1.76dB more level that they've obtained, so if audio experts tell you that you need more power to handle the new digital dynamic range, they mean *lots* more power.

So what do the newspapers mean when they say that a measured sound had a level of 60dB? What they never explain is that sound researchers use the threshold of hearing as 0dB, a value taken as  $10^{-16}$  watt/cm<sup>2</sup>, more often stated in terms of a sound pressure level of 0.0002 dyne/cm<sup>2</sup>. This sound level is only encountered in special soundproof, anechoic (non-reflecting) chambers. I've never been in one that was silent to that level, but people who have say that you can hear a hissing sound; this turns out to be the motion of air molecules against the eardrum.

One last point on decibels, one that often leads to some confusion. The dB can be both a *relative* and an *absolute* measurement. Used in the relative sense, the decibel can compare one sound level to another, or compare two voltages, and so forth. This lets the technician know the relationship between two quantities. In the ab-

solute sense, zero dB is defined as a point of reference and all other measurements compared to that. In acoustics, 0dB is 0.0002 dynes/cm<sup>2</sup>; in electronics, the power level of a 600 ohm line is measured by taking 0dBm as one milliwatt, and so on.

### Loudness vs Intensity

As mentioned above, loudness and intensity do not bear a simple relationship to each other. The perceived loudness for a given intensity depends on the frequency of the sound, and on the intensity itself.

If a person (the famous "average listener") listens for the threshold of audibility in an anechoic chamber, it will usually agree with the 0dB level of  $10^{-16}$  watts/cm<sup>2</sup>, but only in the middle frequencies of 1 to 4kHz. If the frequency of the tone is lowered or raised outside this approximate range, the intensity must be increased for the sound to be barely audible. For instance, at 100Hz the intensity must be raised to about 30dB for audibility.

Next, if we raise the overall intensity in equal steps, the apparent change in loudness between the steps increases as the intensity increases. Very little power increase is necessary for the perception of change at high levels, and conversely, the ear is very insensitive even to large changes at very low listening levels. And just to complicate it more, it varies with frequency: turn down your stereo and the bass and high treble just die away.

This variation of apparent loudness with frequency is why hifi manufacturers put loudness controls on preamps. The ideal loudness control consists of a bass and treble boost which increases as the volume control is turned *down*, compensating for the ear's requirement for extra intensity outside the midrange at low levels. As the volume control is turned up, the boost circuit has less and less effect, until the output response of the amplifier is flat (equal intensity at all frequencies) at high listening levels. Of course, the ideal loudness control is difficult to implement and calibrate if you want exact compensation for the ear's frequency/intensity variations, so on many preamps you may find only a simple bass and treble boost. Besides, people like the punchy sound of the loudness circuit and tend to overuse it, producing a boomy bass sound.

And what about the often-heard claim that the dB is the smallest difference we can detect? Well, it's only a rough guide to how the ear hears changes of one decibel. Detection of the smallest difference, as we've seen, is governed by the frequency and intensity of the tone. If the tone generator is set to a person's most sensitive frequency range, under ideal conditions people have detected changes of less than 0.5dB. If the tone generator is set to a low frequency, it might require 6 to 10dB for a change to be noticeable at low levels. And if you use music instead of pure tones, it gets even more complicated because the ear is more sensitive to changes in the middle frequencies. @SUBHEAD = And next... In the next issue, we'll take a look at the basics of how the ear perceives musical sounds, with an expanded explanation of the above discussion on loudness and intensity. We'll also explain the SPL meter, the sound-pressure-level meter used for measuring the output level of speakers. Point it at a speaker and you have a number you can use for comparisons. Or do you? Some of the pitfalls of making sound measurements are included, along with the difficulties of making valid A-B tests when you're comparing equipment. ■

### DID YOU RECEIVE YOUR COPY?



This catalogue is a comprehensive description of the Almost Free Software available from Moorshead Publications.

If you would like a copy of this catalogue, please mail your request to:

**Moorshead Publications  
Software Services**  
1300 Don Mills Road  
Toronto, Ontario  
M3B 3M8

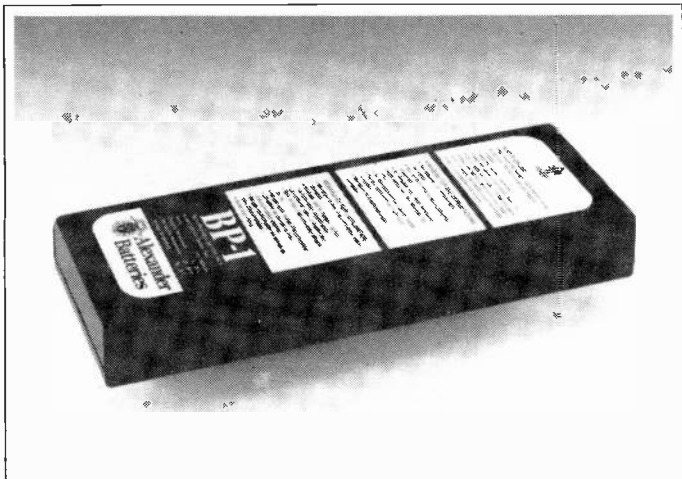

### New NP-1 Replacement Battery

Alexander Manufacturing has announced the availability of a direct replacement for the Sony NP-1 battery.

Called the BP-1, it is a 12 volt nickel cadmium rechargeable battery with 1500 mAh capacity.

Alexander also produces batteries for video cameras and recorders, emergency and biomedical equipment, cellular phones, pagers, radios and radio controlled models. A full line of chargers, analyzer/conditioners, battery belts and other accessories are also offered.

For further information contact: Sales Department, Alexander Manufacturing Company, P.O. Box 1508, Mason City, IA 50401 1-515-423-8955

Circle No. 15 on Reader Service Card

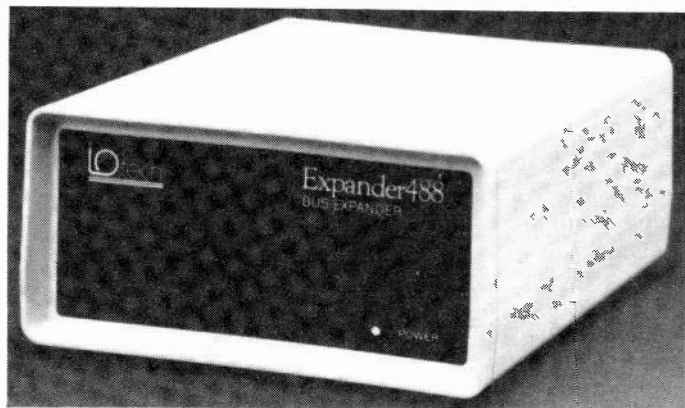

### IEEE 488 Bus Expander

Test engineers can double the number of devices they can use on the IEEE bus through IOtech's new Expander488.

The Expander488 will link as many as 30 instruments, printers, plotters and other devices in a system. It functions entirely transparent to the system's controller and has no effect on bus transfer rates. Maximum data transfer rate is 1Mbyte/second.

Since IEEE bus has built-in support for 30 valid primary bus addresses, no special software or bank-switching is necessary to access the additional 15 devices allowed by the Expander488.

Two IEEE ports are provided on the Expander488 box: one that attaches directly to the host computer IEEE devices.

IOtech designs and manufactures advanced interface bus products used in personal computer-based test and measurement systems. Its products are found in university and corporate research facilities and are sold throughout the world.

For more information on Expander488 and on other IOtech products, call Tom DeSantis, 216-439-4091

Circle No. 16 on Reader Service Card

The Ministers of Communications of Canada and Quebec, Flora MacDonald and Richard D. French, recently announced in Rimouski the two governments' contribution to a pilot project based on the integration of communications technologies. The pilot was announced in the presence of Monique Vezina, Minister of Supply and Services Canada and Member of Parliament for Rimouski-Temiscouata, and Michel Tremblay, member of the Quebec national assembly for Rimouski.

The project will be carried out by a new consortium, Consortel, which includes a Montreal electronic equipment manufacturer, CVDS, and two service companies, Quebec Telephone from the telephony sector and Spectavision of Trois-Rivieres, a part of the Cogeco group of companies, from the cable television distribution sector. This partnership will make it possible to develop and perfect common compatible infrastructures offering a complete range of telecommunications services on an experimental basis. Cable distribution, telephony and teleinformatics are among the services that will be available to various categories of clients. At present, these services are distributed on different networks.

With a \$9-million budget, the project will be jointly funded by Consortel (\$4.5-million) and by the governments of Canada (\$ 2.25 million) and Quebec (\$ 2.25 million). The companies involved have undertaken to reinvest in Consortel, by December 31, 1991, \$ 4.5 million from the funds generated through marketing of products resulting from this research and development project.

In economic terms, the project will create 90 research and development jobs. As well, it is expected that 200 new production jobs will be created during the first two years after the project is completed.

"This project ties in well with the government's aim of improving telecommunications services in Canada," Miss MacDonald, Canada's Minister of Communications, said. "Not only will it help create jobs, but it will provide better communications and information services in urban as well as rural areas."

Richard D. French, Minister of Communications of Quebec, is also pleased that the pilot project is being carried out in the region. "This meets my department's goal of providing a complete range of adequate communications services to all regions of Quebec, particularly those that, because of distance, or accident of geography, are less well served."

The experiment will provide some interesting opportunities. Besides contributing to the development of Quebec-based know-how in new communication systems, the expertise acquired will give project sponsors easier access to certain national and international markets, not only in areas such as consulting services, but also in manufacturing and sales of high-technology equipment.

The two communications Departments are making their contributions through the Canada-Quebec Subsidiary Agreement on Communications Enterprises Development, reached under the Canada-Quebec Economic and Regional Development Agreement (ERDA) of 1984. The purpose of the subsidiary Agreement is to encourage research and promote innovation.

### Simple-To-Use Circuit Tester

A Residual Current Circuit Breaker (RCCB) testing device from Britain features a novel polarity circuit which eliminates the need for additional controls.

The RC500D is simple to use and complies with existing 15th Edition IEE Wiring Regulations. It has facilities for testing time-delay breakers and the sensitivity of residual-current devices to pulsating DC.

Several neon indicators warn of any wiring connection problems. A large rotary dial selects one of eleven currents covering all common RCCBs and 50% of their rated trip currents. Information is also indicated on a large liquid-crystal display.

The device's reversal circuit automatically switches the instrument from a zero degree start point on the AC scale, to 180

degrees, on each alternate test. The operator can select either a standard AC test, or a pulsating DC position. This will automatically apply one half cycle for the first test and then reverse the polarity for the second test, providing instant information on the sensitivity of the breaker to a DC component.

Completely self-powered, the instrument is housed in a polycarbonate case measuring 180 mm x 95mm x 45mm. It is supplied with a sleeved 3-pin plug, hard carrying case, test harness and comprehensive operating instructions.

Enquiries to: Norm Furness, Atlas Electronics, 50 Wingold Avenue, Toronto, Ontario M6B 1P7 (416) 789-7761

Circle No. 17 on Reader Service Card

### Amiga-Atari Review

We regret that due to scheduling problems, the head-to-head review of the Amiga and Atari computers has been delayed until next month.



# Audio Analyzer

*A useful educational device with a multiplexed display*

By R.A. Penfold

The unit described in this article is a straightforward design which has an eight bargraph display with ten LEDs per bargraph and logarithmic scaling. Each bargraph corresponds to an audio band approximately one octave wide. In order to reduce the cost and complexity of the unit the display is a multiplexed type having just a single bargraph driver, but this does not compromise results in any way. This section of the unit could easily act as the basis for other projects which require a multiple bargraph display.

## System Operation

At the input there is a high gain amplifier which enables the unit to be fully driven from practically any microphone, including low and medium impedance dynamic types, and crystal microphones. The sensitivity is adjustable, and it can be backed off to the point where the unit will operate properly with line level input signals.

Eight bandpass filters are used to split the amplified signal into octave bands (actually each band has to be marginally more than one octave in order to cover the full audio range in

eight bands). The blocks marked as bandpass filters in Fig. 1 also provide rectification and smoothing so that the output signals are DC levels proportional to the AC input. In common with other types of audio level indicator, the smoothing circuit has a fast attack time of a few milliseconds, and a slow decay time of a few seconds. This gives a stable and easily read display and it also ensures that brief transients do not pass unnoticed.

An eight-way analog switch is used to feed the DC signals through to the input of the bargraph driver one at a time, and is continuously cycled by a clock oscillator at over 100Hz via three stages of a seven-stage binary counter.

Multiplexing the input signal is only half the problem solved, and the eight bargraphs must somehow be driven from the single bargraph driver. They must also be synchronized properly with the analog switch so that each analog input consistently drives the right bargraph.

This is achieved by driving the cathodes of the bargraphs from a one-of-eight decoder which provides a path to the negative supply for one bargraph at a time and is itself driven from the same clock used for the analog switch.

A common reset pulse for the binary counter and the one-of-eight decoder sets them at a predictable and repeatable starting point, so that each channel always drives the appropriate bargraph.

## Construction

Apart from the input socket, power transformer and controls, the components are all fitted on to four PCBs. The display driver and filter boards (Figs. 2 and 3, respectively) are the two most complex boards, but offer little out of the ordinary as far as construction is concerned. Bear in mind that ICs 2,3 and 4 on the display card are CMOS types, and require normal antistatic handling precautions. ICI is not a particularly cheap device, and it is worthwhile fitting this on a socket even if none are used for the other non-MOS types.

There is a complication with the filter board in that some components are repeated in each filter, and appear on the board in eight different locations. These components have been given numbers on the overlays to indicate which channel they are in, and channel 1 is the lowest frequency channel.

Table 1 indicates the value of the filter components themselves which vary from channel to channel. To avoid confusion over the right quantities, the parts list shows the total number of each value or type required in brackets, while Table 1 lists the components not individually itemized in the parts list.

Details of the power supply board are shown in Fig. 4. Fuse FS1 is mounted on the board in a pair of 20mm fuseclips, and you should ensure that these are properly inserted before soldering them in place. IC5, the 12V regulator, must be fitted with a small heatsink.

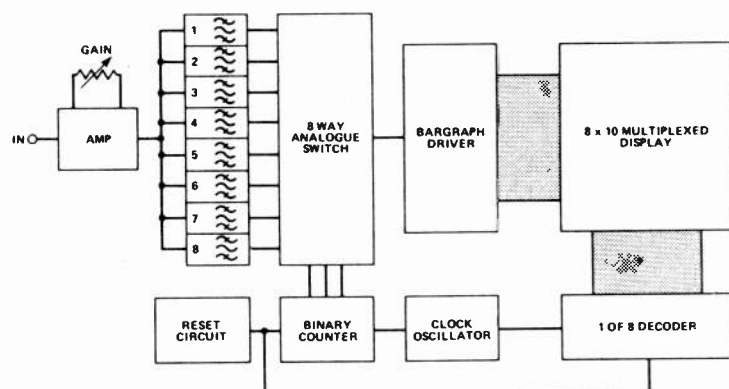

Fig. 1 Block diagram of the analyzer.

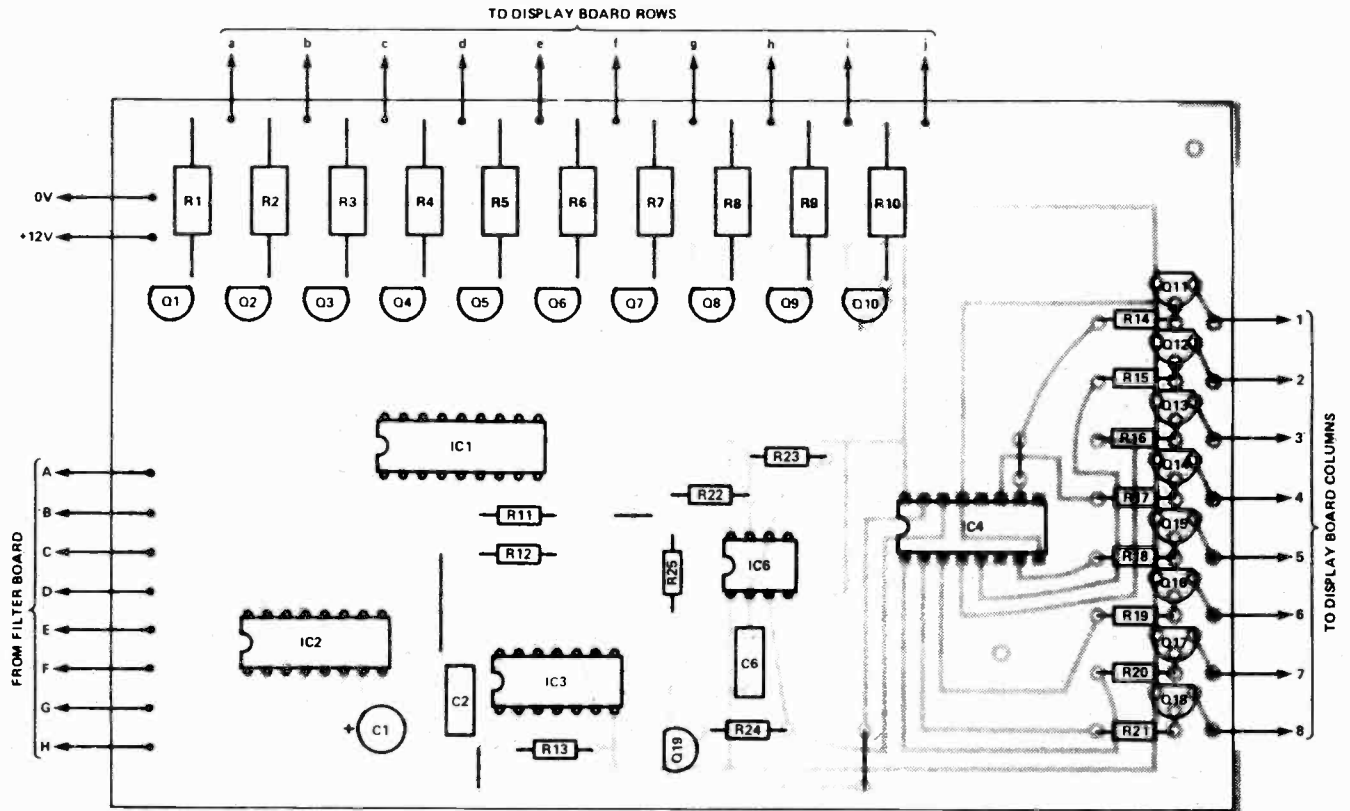

Fig. 2 Component overlay for the display driver board (clock included).

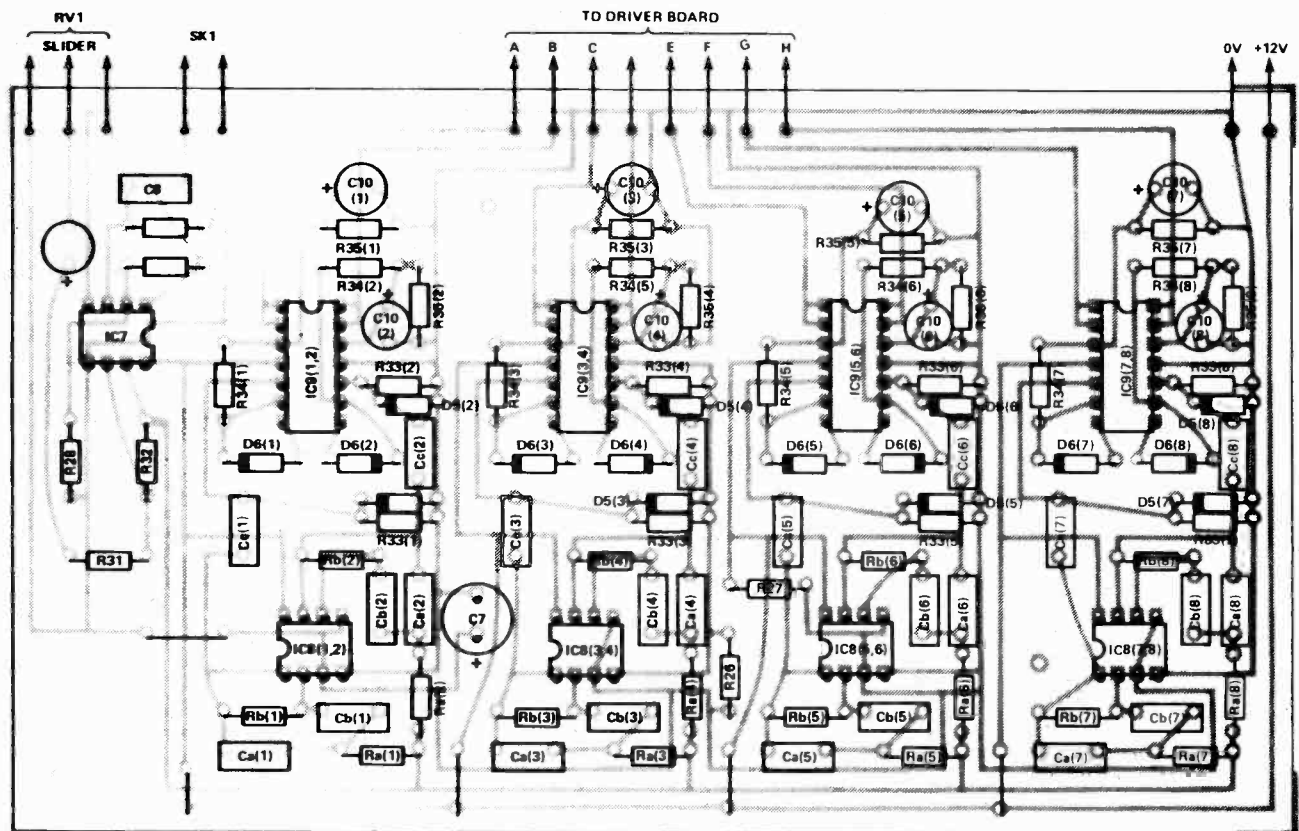

Fig. 3 Component overlay for the filter board (note the number of repeated components).

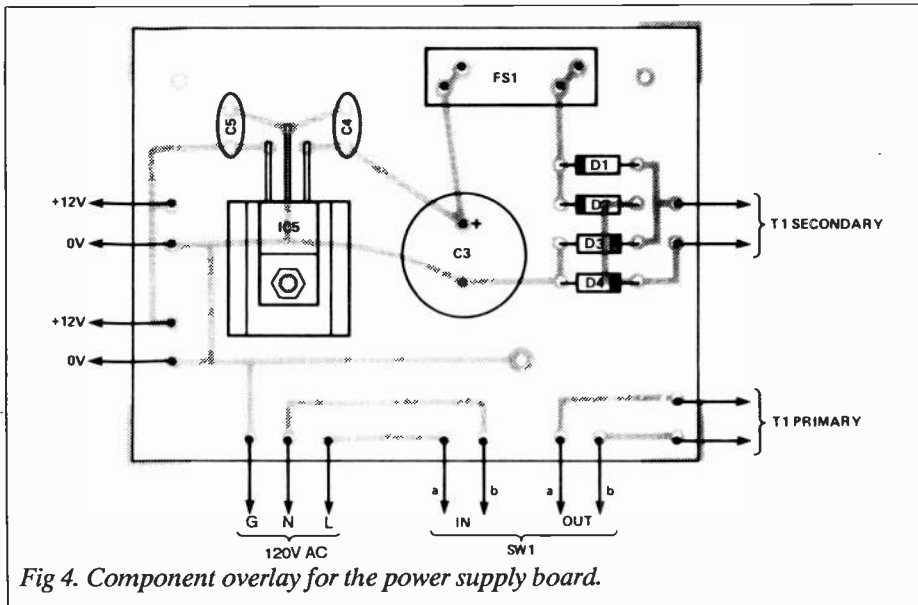

Fig 4. Component overlay for the power supply board.

The display board is probably the most difficult from the construction point of view, and details of this board are provided in Fig. 5.

It is best to start by fitting the 32 necessary wire links. The LEDs are then fitted, taking great care not to fit any the wrong way around (note the alternate anode-cathode, cathode-anode orientation of the columns). It is probably best to work through the LEDs one column at a time, checking each completed column for errors using a multimeter before progressing to the next one. It could be a little awkward to correct errors in the middle of the board after completion. Try to make the board as neat as possible, including keeping the LEDs at a consistent height above the board. The LEDs should not be allowed to protrude any further above the board than is really necessary or it might be difficult to find sufficient space to accommodate the completed board inside the case, and mounting it could be difficult.

All boards are fitted with pins at the points where interconnections will be made. Connections are made to the rear (copper) side of the display board, and so double-sided pins should be used on this one.

### Case

A metal instrument case having approximate outside dimensions of 300 x 150 x 100mm will comfortably take the four boards and other components. The prototype has the power supply at the right, looked at from the front. The

display is to left of centre on the front panel with RV1 and SK1 to its left. The display driver board is on the base panel to the left of the power supply, and the filter board is on the rear panel adjacent to the display driver board. Wiring up is quite easy with this arrangement and it keeps the sensitive wiring at the input of the unit well separated from the power supply.

The display board must be mounted behind and looking through a window cut in the front panel, about 77mm wide by 74mm high. This can be cut using a fretsaw or a miniature round file. Spacers are used over the board's mounting bolts so that the tops of the LEDs are brought flush with the front panel. Red display window material could be fixed in place in front of the LEDs to give a neat finish.

The unit is completed by hard-wiring the boards using multicoloured ribbon cable except for the lead to SK1 which must be a screened type and the power lead.

### In Use

When the analyzer is switched on, some of the bargraphs will show a strong initial indication, soon falling back to zero. As a quick check of the unit, connect an input lead to SK1 and touch the non-ground side. This will probably cause all the display LEDs to light up at first. By carefully backing off RV1 it should be possible to obtain a strong indication from the two lowest frequency channels, with little or no response from the others (since the signals picked up in your body will be

predominantly low frequency AC hum).

With each bargraph having ten LEDs at 3dB intervals the unit covers a fairly wide dynamic range, but for optimum results in some applications it is still necessary to adjust RV1 carefully. Best use of the available dynamic range is made by advancing RV1 just far enough to cause the top LED in one of the bargraphs to light up on signal peaks. Of course, in some applications the idea is to adjust things so that an equal response is obtained from all eight bargraphs, and RV1 can then simply be given any setting that results

### Parts List

#### Resistors

All 1/4W 1% metal film unless noted

R1-R10.....	180R 1W 5% carbon
R11,12,23,24,30.....	18k
R14-R21.....	1k0
R22.....	4k7
R25.....	3k9
R26,27.....	3k3
R28,31.....	10k
R29,32,35.....	1M0 (10 req)
R33.....	220k (8 req)
R34.....	6k8 (8 req)
Ra,Rb.....	See Table 1
RV1.....	10k log pot

#### Capacitors

C1.....	10u 16v rad. elec.
C2.....	100u polyester layer
C3.....	2200u 25V rad. elec.
C4,5.....	100n cer.
C6.....	47n poly. layer
C7,8.....	220u 16V rad. elec.
C9.....	2u2 63V rad. elec.
C10.....	1u 63V rad elec (8 req)
Ca,b,c.....	See Table 1

#### Semiconductors

IC1.....	LM3915N
IC2.....	4051BE
IC3.....	4024BE
IC4.....	4022BE
IC5.....	7812
IC6.....	NE555
IC7.....	LF353
IC8.....	1458C (4 req)
IC9.....	LM324 (4 req)
Q1-10.....	2N5819 or BC327 (10 req)
Q11-18.....	2N5818 or BC337 (8 req)
Q19.....	2N5818 or BC547
D1-4.....	1N4002 (4 req)
D5,6.....	1N4148 (16 req)
LED1-80.....	5mm red LEDs (80 req)

#### Miscellaneous

SW1.....	Rotary power switch
SK1.....	3.5mm jack socket
T1.....	117V prim., 12V 1A sec.
FS1.....	20mm 1A quick blow
Metal instrument case about 300 x 150 x 100mm; PCBs; two control knobs; two 16-pin DIL IC holders; five 14-pin DIL IC holders; six 8-pin DIL IC holders; one 18-pin DIL IC holder; pair of 20mm fuse clips; small finned heatsink (plastic power type); ribbon cable, power lead.	

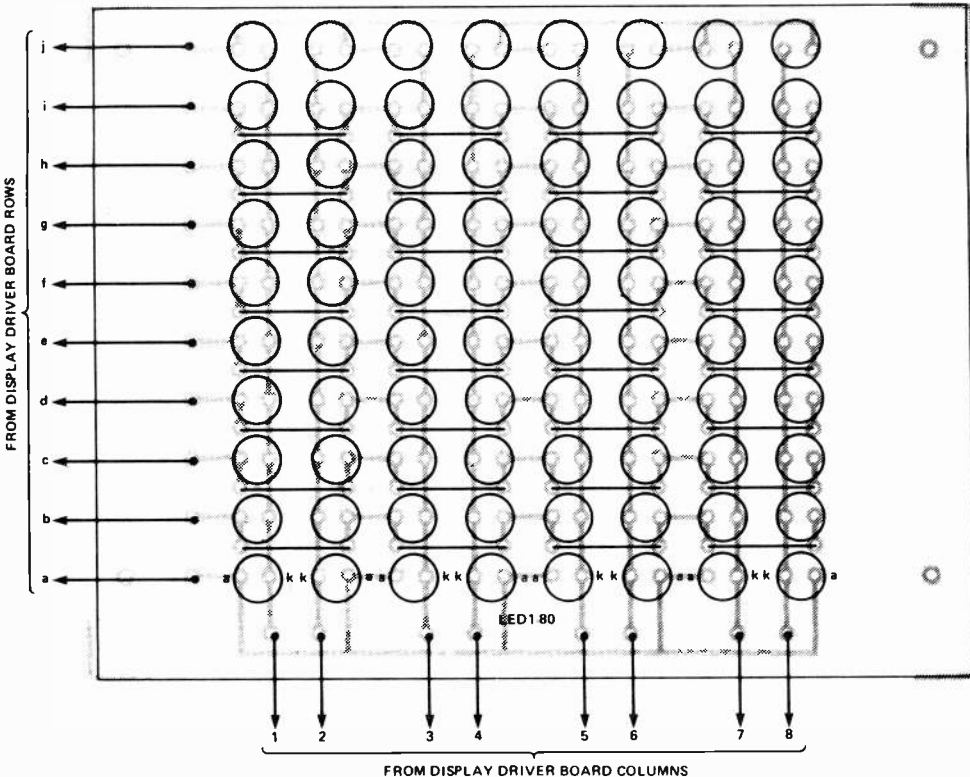

Fig. 5 Component overlay for the LED display.

Table 1

FREQUENCY	Ra	Rb	Ca	Cb	Cc	CHANNEL
50HZ	33k	330k	33n	33n	330n	1
10HZ	33k	330k	15n	15n	150n	2
225HZ	33k	330k	6n8	6n8	100n	3
500HZ	33k	330k	3n3	3n3	33n	4
1kHz	33k	330k	1n5	1n5	22n	5
2.2kHz	22k	220k	1n0	1n0	10n	6
4.8kHz	10k	100k	1n0	1n0	4n7	7
10kHz	10k	100k	470p	470p	2n2	8

**RESISTORS**

2x10k, 1x22k, 5x33k, 2x100k, 1x220k, 5x330k

**CAPACITORS**

2x470p (polystyrene); 4x1n0, 2x1n5, 1x2n2, 2x3n3, 1x4n7, 2x6n8, 1x10n, 2x15n, 1x22n, 3x33nf, 1x100n, 1x150n, 1x330n (all polyester layer).

in a few LEDs in each bargraph lighting up.

The unit will operate with most types of microphone, but with some types the high input impedance of the unit is less than ideal. However, this is easily corrected by adding a resistor across SK1 to shunt the input impedance to the required figure. Operation with line level inputs is possible, but an external attenuator will be needed for signal levels of more than about 3V peak-to-peak in order to avoid overloading the input amplifier.

**How it Works**

The display driver circuit is shown in Fig. 6 and is built around ICI, an LM3915N bargraph driver (the logarithmic version of the popular LM3914N device). The logarithmic scaling provides indications at 3dB intervals, and enables a reasonably wide dynamic range to be covered with a ten LED display. The device supports both dot and true bargraph operation. The latter is used here, giving a relatively high level of current consumption. Bar mode provides a much clearer form of

display, especially in a multiple bargraph applications.

ICI can sink up to 30 mA per output, which is inadequate in this case and the current may be shared between eight LEDs - giving only 3.75 mA per LED. Q1 to Q10 are used to roughly double the drive current, and they also effectively convert ICI from a current sink to a current source.

IC2 is the 8-way analog switch, and IC3 provides the one-of-eight decoder action, but provides an inadequate output current capability and is therefore buffered to the display by switching transistors Q11 to Q18. C2 and R13 form the common reset circuit for IC3 and IC4.

The power supply and clock circuits are shown in Fig. 7, and these are both quite conventional. The power supply uses bridge rectification and a monolithic voltage regulator IC5 to give a well smoothed and stabilized 12 volt output. A current of over 500mA can be drawn when all 80 LEDs are turned on, but the supply is well capable of providing this.

The clock oscillator is a standard 555 astable circuit. Since IC3 and IC4 require antiphase clock signals in order to achieve proper synchronization, Q19 acts as an inverter which generates the second clock phase.

The input amplifier circuit (Fig.8) consists of a low gain non-inverting amplifier ahead of the gain inverting type following it. The voltage gain ahead of RV1 has to be kept low in order to maintain reasonable headroom for high level signals, and the main purpose of the input stage is to act as a buffer to give the unit a high input impedance of 1M0.

IC8 operates as a bandpass filter and is repeated eight times for each channel. The circuit is a standard opamp configuration and gives reasonable performance without needing large numbers of components. The Q value of the filter is made quite low so that there is no significant variation in gain over its frequency range, a factor which is crucial if the unit is to give good results. An inevitable consequence of this is that there is some overlap between one filter and next, and with a signal at the centre of one passband the adjacent channels will respond to it to some extent. This is something that has to be tolerated in a low cost design, but with about 16dB or so of attenua-

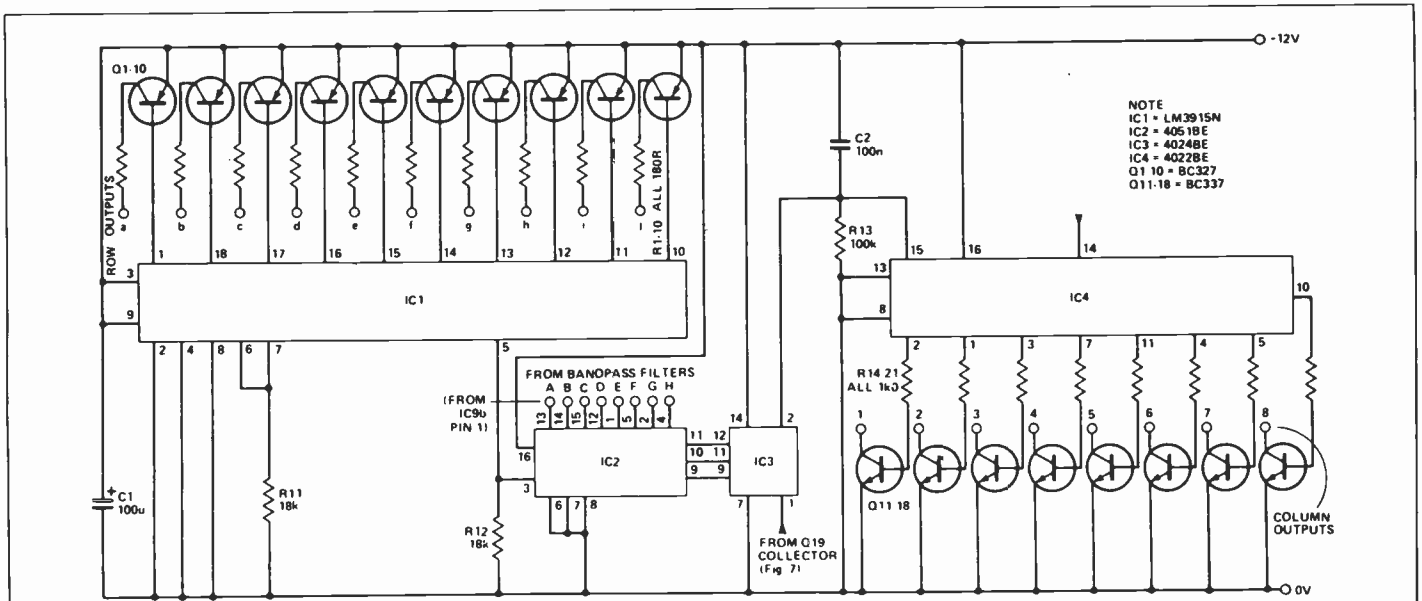

Fig. 6 Circuit diagram of the display driver.

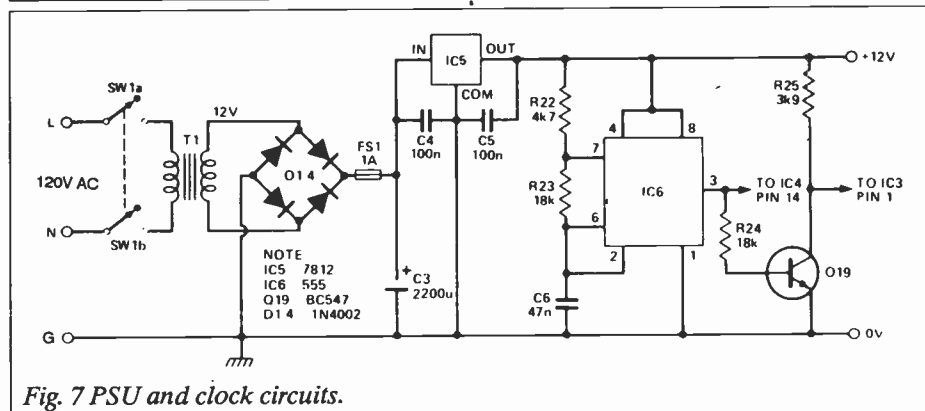

Fig. 7 PSU and clock circuits.

tion (equivalent to a range of about 5 or 6 display LEDs) from the centre of one pass and to the next, the level of performance compares quite well with other low-cost analyzers.

Each filter feeds into a separate precision half-wave rectifier (IC9a) and buffer amplifier (IC9b). The

values in these provide the required fast attack and slow decay times. Note that the LM324 is suitable for single supply rail operation - an essential feature of this circuit.

The LED display circuit (Fig.9) is an ordinary 8 x 10 diode matrix built up from individual 5mm diameter red

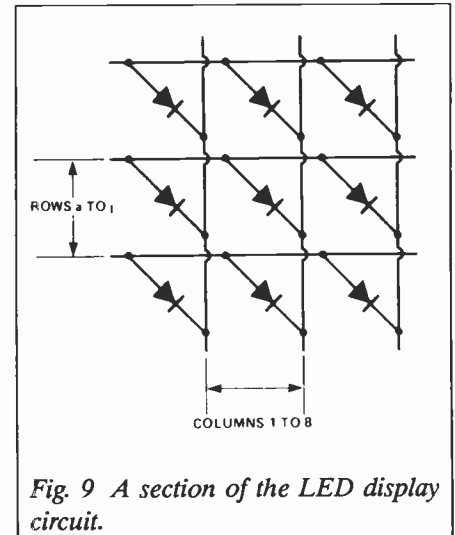

Fig. 9 A section of the LED display circuit.

LEDs (suitable ready made displays seem to be unobtainable).

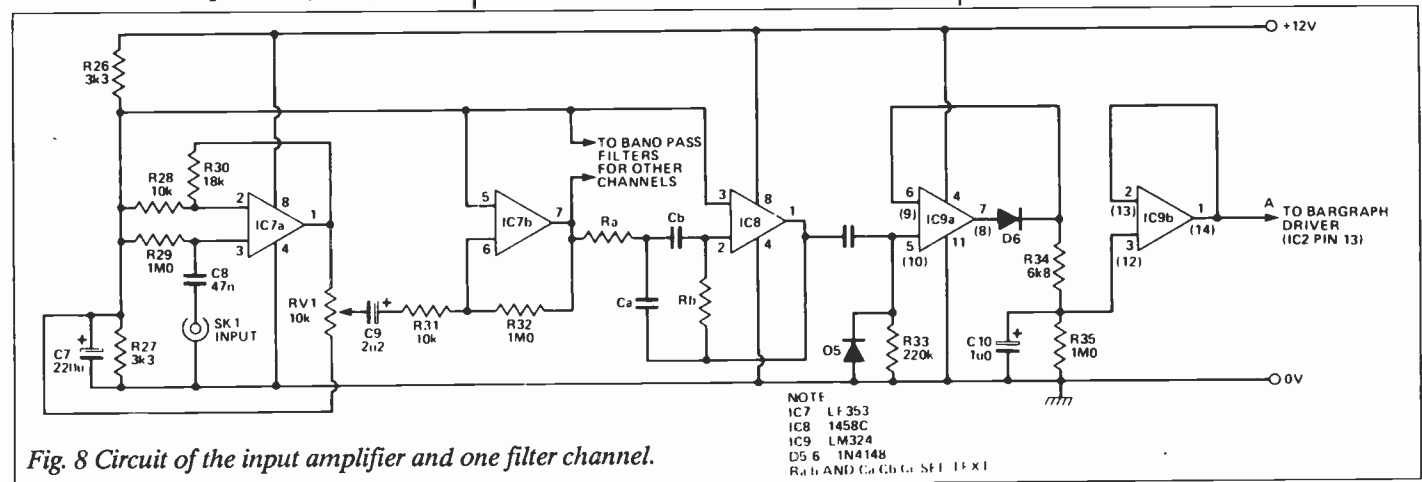
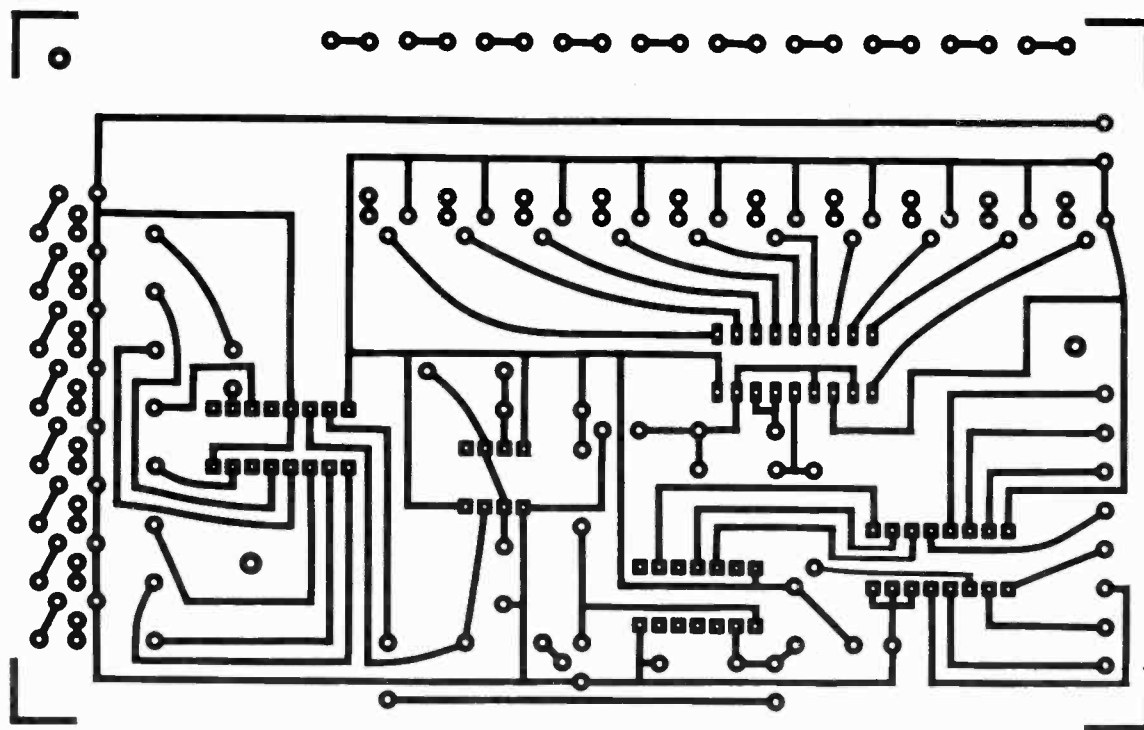
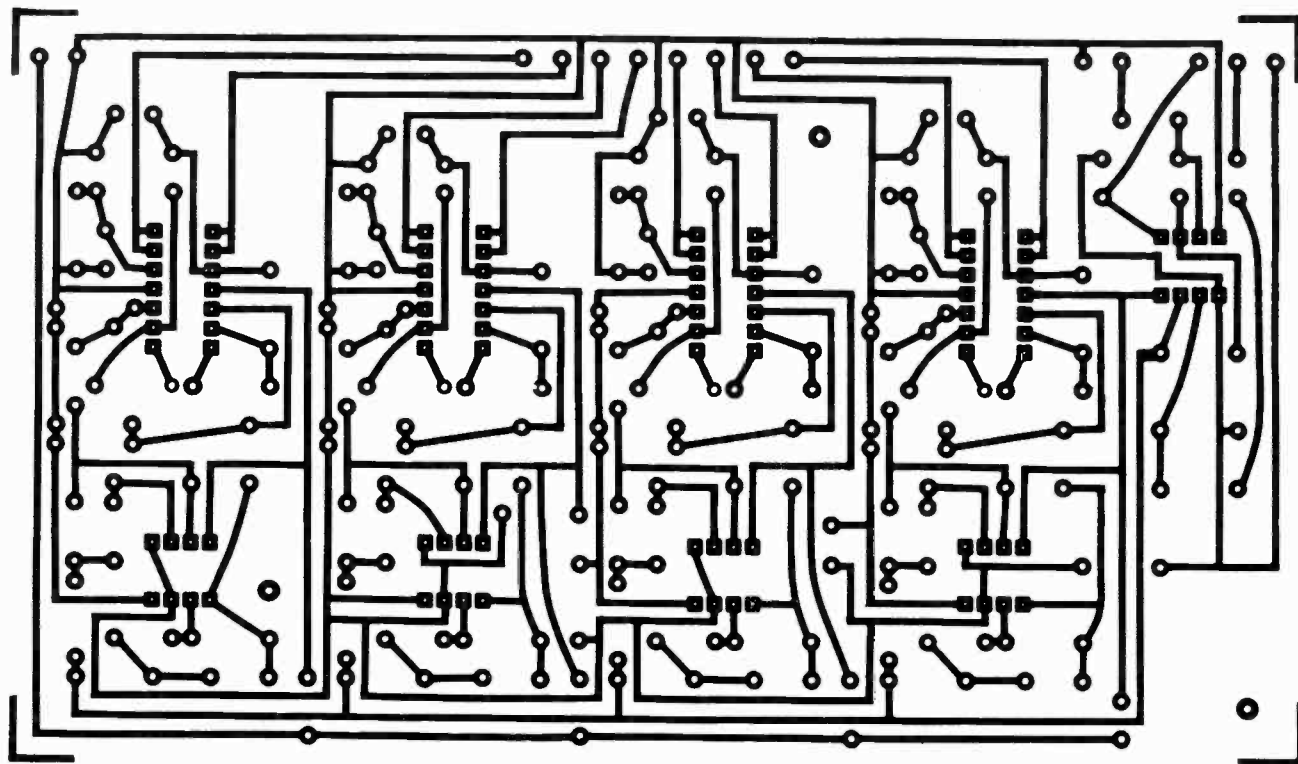
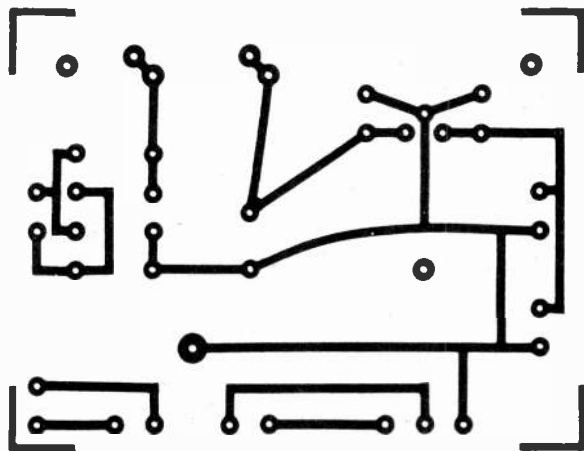

Fig. 8 Circuit of the input amplifier and one filter channel.

NOTE  
IC7 - LF 353  
IC8 - 1458C  
IC9 - LM324  
D5 6 - 1N4148  
R<sub>a</sub> and C<sub>a</sub> C<sub>b</sub> C<sub>c</sub> SFT 1 x 1



Audio Analyzer filter board (top) and display driver (bottom) PCB artwork.



Analyzer PSU

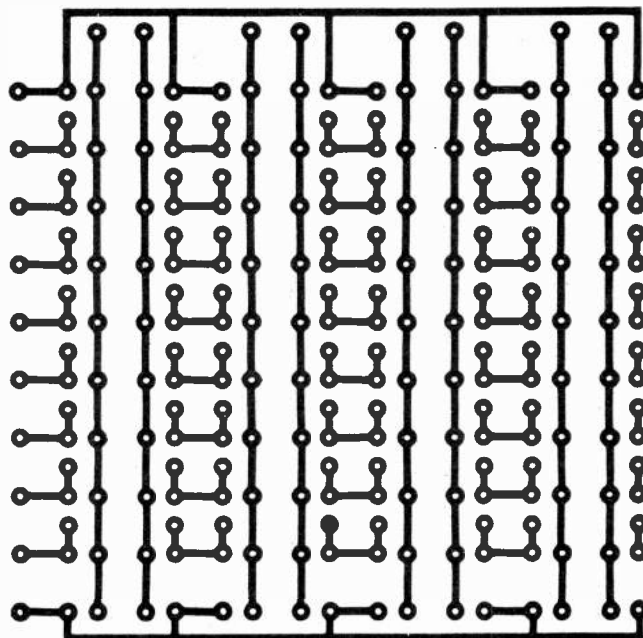

the display driver PCB artwork.

# AMAZING SCIENTIFIC & ELECTRONIC PRODUCTS

PLANS—Build Yourself—All Parts Available in Stock

- LC7—BURNING CUTTING CO<sub>2</sub> LASER ..... \$ 20.00
- RUB4—PORTABLE LASER RAY PISTOL ..... 20.00
- TCC1—3 SEPARATE TESLA COIL
- PLANS TO 1.5 MEV ..... 20.00
- KG1—ION RAY GUN ..... 10.00
- GRA1—GRAVITY GENERATOR ..... 10.00
- EML1—ELECTRO MAGNET COIL GUN/LAUNCHER ..... 6.00

## KITS

- MFT1K—FM VOICE TRANSMITTER 3 MI RANGE ..... 49.50
- WVPMSK—TELEPHONE TRANSMITTER 3 MI RANGE ..... 39.50
- BFC3K—250,00 VOLT 10-14" SPARK TESLA COIL ..... 199.50
- L-4C2K—SIMULATED MULTICOLOR LASER ..... 39.50
- BLS1K—100,000 WATT BLASTER DEFENSE DEVICE ..... 69.50
- ITM1K—100,000 VOLT 20' AFFECTIVE RANGE INTIMIDATOR ..... 69.50
- PSP4K—TIME VARIANT SHOCK WAVE PISTOL ..... 59.50
- PTG1K—SPECTACULAR PLASMA TORNADO GENERATOR ..... 149.50
- MYPK SEE IN DARK KIT ..... 199.50

## ASSEMBLED

- PG70H—MULTICOLORED VARIABLE MODE PLASMA GLOBE "T" ..... 199.50
- BTC10—50,000 VOLT—WORLD'S SMALLEST TESLA COIL ..... 44.50
- LGU40—1MW HeNe VISIBLE RED LASER GUN ..... 199.50
- TAT20 AUTO TELEPHONE RECORDING DEVICE ..... 24.50
- GPV10—SEE IN TOTAL DARKNESS IR VIEWER ..... 349.50
- LIST10—SNOOPER PHONE INFINITY TRANSMITTER ..... 189.50
- IPG70—INVISIBLE PAIN FIELD GENERATOR—MULTI MODE ..... 74.50

• CATALOGS CONTAINING DESCRIPTIONS OF ABOVE PLUS HUNDREDS MORE AVAILABLE FOR \$1.00 OR INCLUDED FREE WITH ALL ABOVE ORDERS.

PLEASE INCLUDE \$3.00 PH ON ALL KITS AND PRODUCTS PLANS ARE POSTAGE PAID. SEND CHECK, MO, VISA, MC IN US FUNDS.

## INFORMATION UNLIMITED

P.O. BOX 716, DEPT. ET AMHERST, NH 03031

Circle No. 18 on Reader Service Card

## WIRELESS VIDEO TRANSMITTER KIT

Specially designed to modulate and transmit a video/audio signal to a TV/UHF channel. Provides great versatility when used with your VCR, home computer, video camera, etc. Requires 9 VDC adapter.



ORDER NOW!  
limited quantities

- Channel 14 or 15 UHF operation (please specify one)
- Case, parts, PCB incl.
- Pre-assembled modulator
- Full instructions

### MAIL ORDER

Cheque, money order, certified cheque. Add \$5.00 postage and handling. Quebec residents add 9% PST.

### Techkit

8007 Rene Descartes  
Montreal Que. H1E 3E2  
or  
P.O. Box 216  
Ville D'Anjou Que. H1K 4G6

Circle No. 100 on Reader Service Card

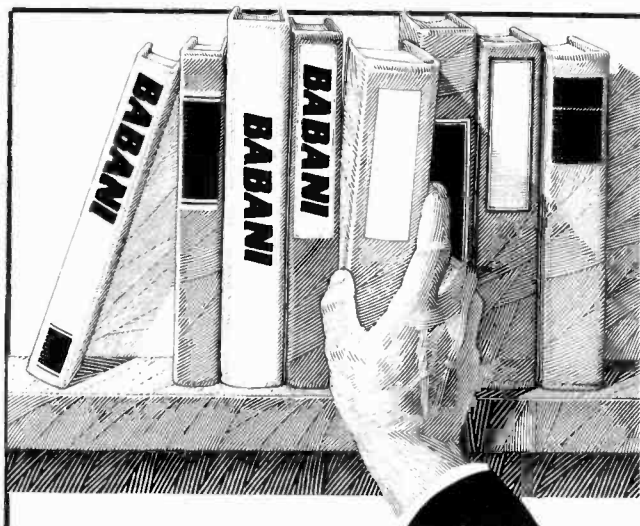

# BABANI book offer

Exclusively available in  
Canada from  
Moorshead Publications.

EXCELLENT  
CHRISTMAS  
GIFT!

## PROJECTS

### BP74: ELECTRONIC MUSIC PROJECTS \$10.00

R.A. Penfold  
Although one of the more recent branches of amateur electronics, electronic music has now become extremely popular and there are many projects which fall into this category. The purpose of this book is to provide the constructor with a number of practical circuits for the less complex items of electronic music equipment, including such things as a Fuzz Box, Waa-Waa Pedal, Sustain Unit, Reverberation and Phaser-Units, Tremelo Generator etc.

### BP24: TRANSISTOR SELECTOR GUIDE \$15.00

Listings of British, European and eastern transistor characteristics make it easy to find replacements by part number or by specifications. Devices are also grouped by voltage, current, power, etc., includes surface-mount conversions.

### BP50: IC LM3900 PROJECTS \$4.25

The purpose of this book is to introduce the LM3900 to the Technician, Experimenter and Hobbyist. It provides the groundwork for both simple and more advanced uses and is considerably more than just a collection of simple circuits or projects.

### BP75: ELECTRONIC TEST EQUIPMENT CONSTRUCTION \$5.25

This book covers in details the construction and use of a wide range of test equipment for both the electronics hobbyist and radio amateur. The projects are fairly simple to build and the components are inexpensive and easily obtainable.

### BP92: ELECTRONICS SIMPLIFIED - CRYSTAL SET CONSTRUCTION \$5.25

This is a book written especially for those who wish to participate in the intricacies of electronics.

### BP101: HOW TO IDENTIFY UNMARKED IC's \$1.95

An unusual and fascinating chart that is highly recommended to all those interested in electronics and which will hopefully pay for itself many times over, by enabling the reader to use IC's that might otherwise have been scrapped.

### BP121: HOW TO DESIGN AND MAKE YOUR OWN PCBs \$5.85

The purpose of this book is to familiarise the reader with both simple and more sophisticated methods of producing printed circuit boards. The emphasis of the book is very much on the practical aspects of printed circuit board design and construction.

### BP180: ELECTRONIC CIRCUITS FOR THE COMPUTER CONTROL OF MODEL RAILWAYS \$9.00

Shows how home computers can easily be applied to the control of model railroads and other quite sophisticated control. A variety of projects are discussed as well as circuits for train position sensing, signal and electric points control etc.

### BP185: ELECTRONIC SYNTHESIZER CONSTRUCTION \$9.00

With this book a relative beginner should be able to build, with the minimum of difficulty and at a reasonably low cost, a worthwhile monophonic synthesiser and also learn a great deal about electronic music synthesis in the process.

## COMPUTERS

### BP72: A MICROPROCESSOR PRIMER \$5.25

In an attempt to give painless approach to computing, this inexpensive book will start by designing a simple computer and then the shortcomings of this simple machine will be discussed and the reader is shown how these can be overcome. A glossary of microprocessor terms is at the end of the book.

### BP78: PRACTICAL COMPUTER EXPERIMENTS \$5.25

The aim of this book is to enable the reader to simply and inexpensively construct and examine the operation of a number of basic computer circuit elements and it is hoped gain a fuller understanding of how the mysterious computer "chip" works.

### BP86: AN INTRODUCTION TO BASIC Programming Techniques \$5.85

This book is based on the authors own experience in learning BASIC and also in helping others, mostly beginners to programming, to understand the language.

### BP115: THE PRE-COMPUTER BOOK \$5.85

Aimed at the absolute beginner with no knowledge of computing, this entirely non-technical discussion of computer bits and pieces and programming is written mainly for those who do not possess a microcomputer but either intend to one day own one or simply wish to know something about them.

## CIRCUITS

### BP42: 50 SIMPLE L.E.D. CIRCUITS \$5.85

Contains 50 interesting and useful circuits and applications, covering many different branches of electronics, using one of the most inexpensive and freely available components.

### BP85: INTERNATIONAL TRANSISTOR EQUIVALENTS GUIDE \$9.00

This book is designed to help the user find possible substitutes for a popular user-oriented selection of modern transistors and includes devices produced by over 100 manufacturers.

### BP140: DIGITAL IC EQUIVALENTS AND PIN CONNECTIONS \$15.00

Shows equivalents and pin connections of a popular user orientated selection of Digital Integrated Circuits. Includes European, American and Japanese devices.

## RADIO AND COMMUNICATIONS

### BP7: RADIO AND ELECTRONICS COLOUR CODE AND DATA CHART \$3.00

Opens out to Wall Chart approximately 584 x 457 mm. Includes many Radio & Electronics Colour Codes in use in UK, USA, Europe and Japan. Covers Resistors, Capacitors, Transformers, Field Coils, Fuses, Battery Leads etc.

### BP100: AN INTRODUCTION TO VIDEO \$5.85

This is a book for the person who has just, or is about to buy or rent some video equipment but is not sure what it is all about.

### BP125: 25 SIMPLE AMATEUR BAND AERIALS \$5.85

This book describes how to build 25 amateur band aerials. The designs start with the simple dipole and proceed to beam, triangle and even a mini-rhombic.

### BP136: SIMPLE INDOOR AND WINDOW AERIALS \$7.00

People living in apartments who would like to improve shortwave listening can benefit from these instructions on optimising the indoor aerial.

### BP147: AN INTRODUCTION TO 6502 MACHINE CODE \$10.00

The popular 6502 microprocessor is used in many home computers; this is a guide to beginning assembly language.

### BP225: A PRACTICAL INTRODUCTION TO DIGITAL ICs \$7.00

This book deals mainly with TTL type chips such as the 7400 series. Simple projects and a complete practical construction of a Logic Test Circuit Set are included as well as details for a more complicated Digital Counter Timer project.

### BP47: MOBILE DISCOTHEQUE HANDBOOK \$7.80

Divided into six parts, this book covers such areas of mobile "disco" as: Basic Electricity, Audio, Ancillary Equipment, Cables and Plugs, Loudspeakers, and Lighting. All the information has been considerably subdivided for quick and easy reference.

### BP131: MICRO INTERFACING CIRCUITS - BOOK 2 \$9.00

Intended to carry on from Book 1, this book deals with practical applications beyond the parallel and serial interface. "Real world" interfacing such as sound and speech generators, temperature and optical sensors, and motor controls are discussed using practical circuit descriptions.

### BP141: LINEAR IC EQUIVALENTS AND PIN CONNECTIONS ADRIAN MICHAELS \$23.80

Find equivalents and cross-references for both popular and unusual integrated circuits. Shows details of functions, manufacturer, country of origin, pinouts, etc., includes National, Motorola, Fairchild, Harris, Motorola, Intersil, Philips ADC, AMD, SGS, Teledyne, and many other European, American, and Japanese brands.

### BP156: AN INTRODUCTION TO QL MACHINE CODE \$10.00

The powerful Sinclair QL microcomputer has some outstanding capabilities in terms of its internal structure. With a 32-bit architecture, the QL has a large address range, advanced instructions which include multiplication and division. These features give the budding machine code programmer a good start at advanced programming methods. This book assumes no previous knowledge of either the 68008 or machine code programming.

### BP59: SECOND BOOK OF CMOS IC PROJECTS \$7.80

This book carries on from its predecessor and provides a further selection of useful circuits, mainly of a simple nature, the book will be well within the capabilities of the beginner and more advanced constructor.



**BP32: HOW TO BUILD YOUR OWN METAL & TREASURE LOCATORS****\$7.80**

Several fascinating applications with complete electronic and practical details on the simple, and inexpensive construction of Heterodyne Metal Locators.

**ELECTRONIC THEORY****BP108: \$7.00**

Cross-references European American and Japanese diode part numbers. Besides rectifier diodes, it includes Zeners, LEDs, Diacs, Triacs, SCRs, OCIs, photodiodes and display diodes.

**BP144: FURTHER PRACTICAL ELECTRONICS CALCULATIONS AND FORMULAE \$15.00**

This book covers many aspects of electronics where a knowledge and familiarity of the appropriate formulae is essential for a fuller understanding of the subject. An essential addition to the library of all those interested in electronics be they amateur, professional or student.

**ELEMENTS OF ELECTRONICS - AN ON-GOING SERIES****F.A. WILSON, C.G.I.A., C.ENG., BP62: BOOK 1. THE SIMPLE ELECTRONIC CIRCUIT AND COMPONENTS \$11.70**

**BP77: BOOK 4 MICROPROCESSING SYSTEMS AND CIRCUITS \$11.80**  
Although written especially for readers with no more than ordinary arithmetical skills, the use of mathematics is not avoided, and all the mathematics required is taught as the reader progresses.

Each book is a complete treatise of a particular branch of the subject and therefore, can be used on its own with one proviso, that the later books do not duplicate material from their predecessors, thus a working knowledge of the subjects covered by the earlier books is assumed.

**BOOK 1.** This book contains all the fundamental theory necessary to lead to a full understanding of the simple electronic circuit and its main components.

**BOOK 2.** This book continues with alternating current theory without which there can be no comprehension of speech, music, radio, television or even the electricity utilities.

**BOOK 3.** Follows on semiconductor technology, leading up to transistors and integrated circuits.

**BOOK 4** A complete description of the internal workings of micro-processor.

**BOOK 5** A book covering the whole communication scene.

**PROJECTS****BP180: ELECTRONIC CIRCUITS FOR THE COMPUTER CONTROL OF MODEL RAILWAYS \$9.00**

The projects in this book consists of various types of controller, including a high quality pulse type, as well as circuits for train position sensing, signal and electronic points control and many more.

**BP194: MODERN OPTO DEVICE PROJECTS \$9.00**

This book provides a number of practical designs for beginners and experienced project builders. These projects utilize a range of modern opto-electric devices, including such things as fibre optics, ultra bright LEDs and passive IR detectors.

**BP37: 50 PROJECTS USING RELAYS, SCRs & TRIACS \$7.80**

**F.G. RAYER, T.ENG.(CEI), ASSOC. IERE**  
Relays, silicon controlled rectifiers (SCR's) and bi-directional triodes

(TRIACs) have a wide range of applications in electronics today. This book gives tried and practical working circuits which should present the minimum of difficulty for the enthusiast to construct. In most of the circuits there is a wide latitude in component values and types, allowing easy modification of circuits or ready adaptation of them to individual needs.

**BP71: ELECTRONIC HOUSEHOLD PROJECTS \$7.00**

**R.A. PENFOLD**  
Some of the most useful and popular electronic construction projects are those that can be used in or around the home. The circuits range from such things as '2 Tone Door Buzzer' intercom, through Smoke or Gas Detectors to Baby and Freezer Alarms.

**BP90: AUDIO PROJECTS \$7.80**

**F.G. RAYER**  
Covers in detail the construction of a wide range of audio projects. The text has been divided into preamplifiers and mixers, power amplifiers, tone controls and matching and miscellaneous prospects.

**BP44: IC 555 PROJECTS \$10.00**

**E.A. PARR, B.Sx., C.Eng., M.I.E.E.**  
Every so often a device appears that is so useful that one wonders how life went on before without it. The 555 timer is such a device included in this book are Basic and General Circuits, Motor Car and Model Railway Circuits, Alarms and Noise Makers as well as a section on the 556, 558 and 559 timers.

**BP82: ELECTRONIC PROJECTS USING SOLAR CELLS \$7.60**

A collection of simple circuits which have applications in and around the home using the energy of the sun to power them. The book deals with practical solar power supplies including voltage doubler and tripler circuits, as well as a number of projects.

**BP49: POPULAR ELECTRONIC PROJECTS \$10.00**

**R.A. PENFOLD**  
Includes a collection of the most popular types of circuits and projects which, we feel sure, will provide a number of designs to interest most electronics constructors. The projects selected cover a very wide range and are divided into four basic types. Radio Projects, Audio Projects, Household Projects and Test Equipment.

**BP94: ELECTRONIC PROJECTS FOR CARS AND BOATS \$7.80**

**R.A. PENFOLD**  
Projects, fifteen in all, which use a 12V supply are the basis of this book. Included are projects on Windscreen Wiper Control, Courtesy Light Delay, Battery Monitor, Cassette Power Supply, Lights Timer, Vehicle Immobiliser, Gas and Smoke Alarm, Depth Warning and Shaver Inverter.

**BP95: MODEL RAILWAY PROJECTS \$7.80**

Electronic projects for model railways are fairly recent and have made possible an amazing degree of realism. The projects covered include controllers, signals and sound effects: striboard layouts are provided for each project.

**BP93: ELECTRONIC TIMER PROJECTS \$7.80**

Windscreen wiper delay, darkroom timer and metronome projects are included. Some of the more complex circuits are made up from simpler sub-circuits which are dealt with individually.

**BP84: DIGITAL IC PROJECTS \$7.80**

**F.G. RAYER, T.ENG.(CEI), ASSOC. IERE**  
This book contains both simple and more advanced projects and it is hoped that these will be found of help to the reader developing a knowledge of the workings of digital circuits, to help the newcomer to the hobby the author has included a number of board layouts and wiring diagrams. Also the more ambitious projects can be built and tested section by section and this should help avoid or correct faults that could otherwise be troublesome. An ideal book for both beginner and more advanced enthusiast alike.

**BP99: MINI - MATRIX BOARD PROJECTS \$7.60**

**R.A. PENFOLD**  
Twenty useful projects which can all be built on a 24 x 10 hole matrix board with copper strips. Includes Door-buzzer, Low-voltage Alarm, AM Radio, Signal Generator, projector Timer, Guitar Headphone Amp. Transistor Checker and more.

**BP103: MULTI-CIRCUIT BOARD PROJECTS \$7.80**

**R.A. PENFOLD**  
This book allows, the reader to build 21 fairly simple electronic projects, all of which may be constructed on the same printed circuit board. Wherever possible, the same components have been used in each design so that with a relatively small number of components and hence low cost, it is possible to make any one of the projects or by re-using the components and P.C.B. all of the projects.

**BP107: 30 SOLDERLESS BREADBOARD PROJECTS - BOOK 1 \$9.00**

**R.A. PENFOLD**  
A "Solderless Breadboard" is simply a special board on which electronic circuits can be built and tested. The components used are just plugged in and unplugged as desired. The 30 projects featured in this book have been specially designed to be built on a 'Verobloc' breadboard. Wherever possible the components used are common to several projects, hence with only a modest number of reasonably inexpensive components it is possible to build, in turn, every project shown.

**BP106: MODERN ON AMP PROJECTS \$7.80**

**R.A. PENFOLD**  
Features a wide range of constructional projects which make use of op-amps including low-noise, low distortion, ultra-high input impedance, high slew-rate and high output current types.

**CIRCUITS****BP127: HOW TO DESIGN ELECTRONIC PROJECTS \$9.00**

Although information on stand circuit blocks is available, there is less information on combining these circuit parts together. This title does just that. Practical examples are used and each is analysed to show what each does and how to apply this to other designs.

**BP122: AUDIO AMPLIFIER CONSTRUCTION \$6.75**

A wide circuits is given, from low noise microphone and tape head preamps to a 100W MOSFET type. There is also the circuit for 12V bridge amp giving 18W. Circuit board or stripboard layout are included. Most of the circuits are well within the capabilities for even those with limited experience.

**BP98: POPULAR ELECTRONIC CIRCUITS, BOOK 2 \$9.00**

**R.A. PENFOLD**  
70 plus circuits based on modern components aimed at those with some experience.

**BP179: ELECTRONIC CIRCUITS FOR THE COMPUTER CONTROL OF ROBOTS \$12.00**

The main stumbling block for most would-be robot builders is the electronics to interface the computer to the motors, and the sensors which provide feedback from the robot to the computer. The purpose of this book is to explain and provide some relatively simple electronic circuits which bridge the gap.

**BP39: 50 (FET) FIELD EFFECT TRANSISTOR PROJECTS \$7.00**

**F.G. RAYER, T.ENG.(CEI), ASSOC. IERE**  
Field effect transistors (FETs), find application in a wide variety of circuits. The projects described here include radio frequency amplifiers and converters, test equipment and receiver aids, tuners, receivers, mixers and tone controls, as well as various miscellaneous devices which are useful in the home.

This book contains something of particular interest for every class of enthusiast - short wave listener, radio amateur, experimenter or audio devotee.

**BP88: HOW TO USE OP AMPS \$11.80**

**E.A. PARR**  
A designer's guide covering several op amps, serving as a source book of circuits and a reference book for design calculations. The approach has been made as nonmathematical as possible.

**BP65: SINGLE IC PROJECTS \$6.00**

**R.A. PENFOLD**  
There is now a vast range of ICs available to the amateur market, the majority of which are not necessarily designed for use in a single application and can offer unlimited possibilities. All the projects contained in this book are simple to construct and are based on a single IC. A few projects employ one or two transistors in addition to an IC but in most cases the IC is the only active device used.

**BP118: PRACTICAL ELECTRONIC BUILDING BLOCKS - BOOK 2 \$7.60**

**R.A. PENFOLD**  
This sequel to BP117 is written to help the reader create and experiment with his own circuits by combining standard type circuit building blocks. Circuits concerned with generating signals were covered in Book 1, this one deals with processing signals. Amplifiers and filters account for most of the book but comparators, Schmitt triggers and other circuits are covered.

**BP83: VMOS PROJECTS \$7.60**

**R.A. PENFOLD**  
Although modern bipolar power transistors give excellent results in a wide range of applications, they are not without their drawbacks or limitations. This book will primarily be concerned with VMOS power FETs although power MOSFETs will be dealt with in the chapter on audio circuits. A number of varied and interesting projects are covered under the main headings of: Audio Circuits, sound Generator Circuits, DC Control Circuits and Signal Control Circuits.

**ORDER BY TELEPHONE (416) 445-5600**

# Circuit Theory: Thévenin's Theorem

*Simplifying circuit representations to discard all but the irrelevant information*

By Paul Chappell

Imagine you are choosing a new hi-fi system. You've got the turntable, CD player, cassette deck and speakers all sorted out. You've also bought a power amp but you don't fancy the pre-amp that goes with it. Instead, you find the pre-amp of your dreams elsewhere, and it has all the excellent characteristics that you would want.

To find out, you check the data sheet to find the nominal output signal level and output resistance of the pre-amp. In other words, your view of the pre-amp shrinks down to the equivalent circuit shown in Fig.1a. Gone are the direct central-register tonal complexes, the front-end nascent ramifications and the bi-valved molluscs. Your view of the pre-amp for matching purposes is nothing more than a signal generator and resistor.

This is quite a feat of simplification when you consider that to reduce the pre-amp to a two terminal network, the box must contain its entire circuitry, the CD player and its internal circuitry, the power supply and so on.

Of course, the signal source and resistor model does not attempt to explain what goes in inside the box. It just gives a representation of the way the box "looks" to anything connected to its terminals. The model you use in any given situation depends on just what information you need. In other circumstances the four-terminal representation of Fig.1b would be a better way to think of your amplifier.

Some of the simplifications you regularly perform are more subtle. When you buy a TL071 you have every confidence that at its terminals it will behave as if there were an op-amp inside the plastic lump. You know that what's really in there is a silicon crystal with a few odds and ends of impurities diffused into it. You know that anything approaching a full explanation of what the IC is really doing would involve an extensive understanding of semiconductor physics. For

the purposes of circuit design you ignore all this. Your attention is focussed on the way it looks to anything connected to its terminals. The way it looks is like an op-amp.

Even the fact that it needs a power supply can fade from your mind. In circuit diagrams the power connections are more often than not left out completely. It's all part of the process of discarding irrelevant information. The idea of simplifying a circuit or component to concentrate on the essentials is not new to you. All I hope to do in this article is to refine it a little.

Figure 2b is the fantasy version containing a single voltage source (which work's by magic) and a resistor. If Thévenin's theorem is correct, there should be no way you can tell, short of opening the boxes, which circuit is which.

First of all we have to decide what values to give to V and R. The open-circuit output voltage of Fig. 2a is clearly 5V, so if the fantasy box is going to fool anybody the value of V must also be 5V. If the output terminals of the real divider are shorted together, the current flowing between them will be 1mA (10V across 10k), so the fantasy box must also have a short-circuit of 1mA, giving R a value of 5k0.

That's all very well. They match under open-circuit and short-circuit conditions but will they still match in between? If I get a 20V supply and use it to stuff current into the output terminal, what then? Do the two circuits still behave in the same way? The short answer is that being linear circuits, they will always match. If you are not convinced, try a few resistors, currents or voltages at the output and see what happens. A 5k0 resistor across the fantasy box will give an output voltage of 2.5V, for instance. The "real" box should give the same; check it with a calculator to be sure.

In general, for resistor networks, the Thévenin voltage will be the "real" open circuit output voltage and the resistor will be the open circuit output voltage divided by the short-circuit current.

## D to A Converter

A simple way to make a D to A converter is the weighted resistor network shown in Fig. 3a. The problem with this approach is that a variety of non-standard resistor values are needed if

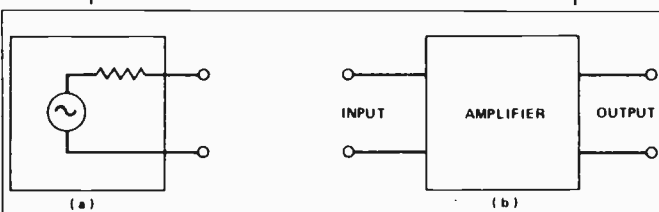

Fig. 1 Two and four-terminal representations of an amplifier.

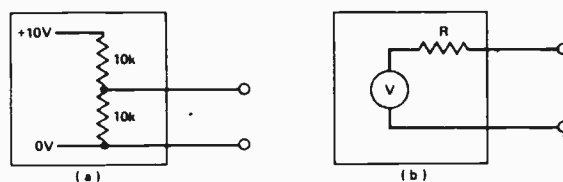

Fig. 2 A real potential divider network and the Thévenin fantasy box equivalent.

## Thévenin's Fantasy Box

The circuit theory which says it's OK to represent linear two terminal networks as a source and impedance is Thévenin's theorem. It's something you already use when you talk about the output impedance of an amplifier, the internal resistance of a battery and so on. Let's take a look at a few examples and see what it can do for us.

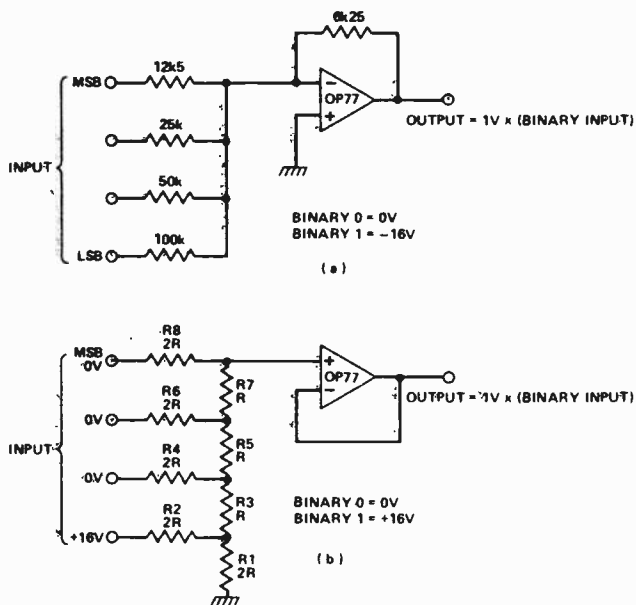

Fig. 3a & 3b Two possible resistor networks for D to A conversion.

reasonable accuracy is to be achieved. It also imposes widely differing loads on the digital inputs, which could be a problem if the circuit is driven directly from a CMOS IC.

Another way of tackling the problem is shown in Fig. 3b. This circuit imposes equal loading on all inputs and only requires one resistor value. (The 2R resistors can be made from two Rs in series or the Rs from two 2Rs in parallel.) For a precision network, it is a lot easier to select resistors all of one value (without knowing exactly what that value is) than it is to manufacture or measure them to a specified resistance. A simple resistor bridge will do the trick.

If you haven't seen the R-2R network before, I think you'll agree that it's not immediately obvious why it works. At first sight it's clear that the less significant bits have to "go through more resistors" but that's about all.

Suppose that the LSB is set to 1 and all the rest to 0. We can open a fantasy box for the LSB voltage and resistors R1 and R2 in just the same way as for the potential divider of Fig. 2. Inside

the box will be a voltage source of 8V and a resistor of value R (Fig. 3c).

Now we can draw R3 into the fantasy box. It has the effect of increasing the resistor value from R to 2R (Fig. 3d). To suck R4 into the box halves the voltage again and sends the resistor value back down to R. Adding in R5 sends it back up to 2R (Fig. 3e).

Now we begin to get the picture. Each step up the ladder halves the voltage and always gives a loading of 2R to the following stage. Having got the gist of it, we can

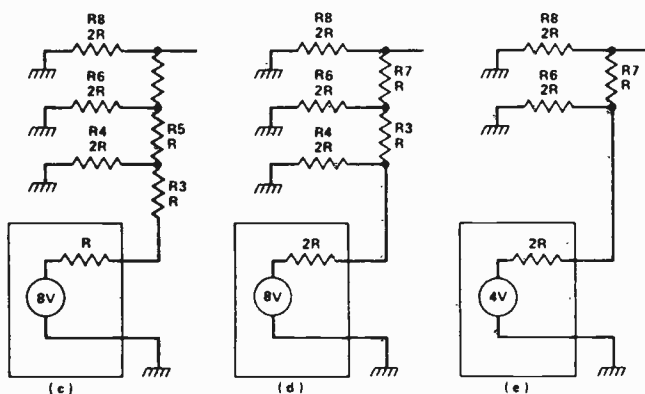

Fig. 3c - 3e, 3f and 3g (below) Thévenin fantasy box eats resistors

quickly stuff the rest of the network into the fantasy box. Figure 3f shows the penultimate stage and Fig. 3g the ultimate simplification of the network with the LSB set.

Suppose the bit above the LSB is 1 and all the rest are zero. Notice that R1, R2, and R3 give a resistance to ground of 2R to this stage just as R2 did for the LSB. The same process of feeding the network into the fan-

tasy box, starting one stage higher up gives Fig. 3h. The voltage is twice as big. For the next stage it will be 4V and for the final stage 8V.

Now, all this applies to the case when only one bit is set up at a time. Do we need to go through all 16 possible inputs? (Or through all 256 for an 8-bit converter?) Not at all. Superposition tells us that the result of several bits being 1 (several voltages applied) is simply the sum of the voltages given by the individual switches, so we're done.

The output (for this example) is a voltage equal to the binary number represented by the input.

If the operation of stuffing the circuit into the fantasy box doesn't make its operation any clearer to you, don't panic. Like anything new, it takes time to get used to it. If you are not familiar with fantasy boxes it won't help at all. Meditate in this example for a while and you'll come to an understanding of Thévenin's theorem. Use the theorem a few times and it will become clear as daylight.

Apart from the direct reduction of a complicated circuit to a simple one, there are many other reasons for representing a circuit in fantasy form. One might be that the actual mode of operation of the device is not particularly enlightening or helpful when it comes to designing circuits.

Take transistors, for instance. Most engineers have a naive appreciation of the physics involved: a garbled electrons and holes mode, perhaps. Most will be aware of some of the limitations imposed on performance by transistor geometry. Some may even

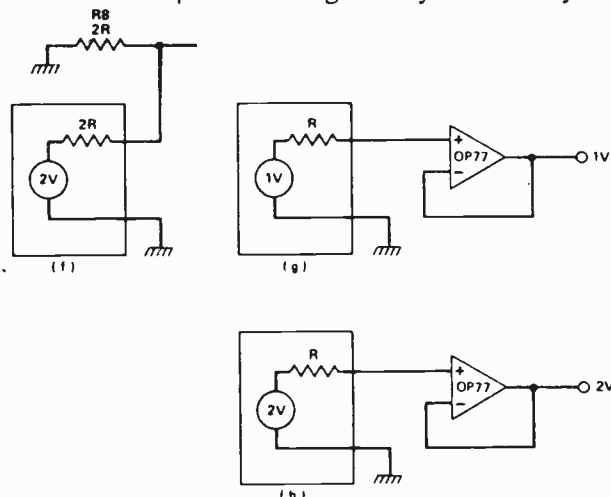

Fig. 3h The result of the same simplification beginning one step further up the network (bit 1 set instead of bit 0).

have taken the trouble to come to terms with the current state of the art in semiconductor physics. How many actually use physical models to design circuits? Not one, I venture to suggest.

The reason is not that the models are incorrect, incomprehensible or boring, simply that they contain far too much irrelevant stuff from a circuit design point of view. Engineers have their own kinds of fantasy boxes for semiconductors, containing things that they feel much more at home with.

Transistor fantasy boxes are really a special case of those used for general four terminal networks. (Spot the deliberate "mistake" Four terminals?) When you think about it, a good many electronic circuits have a two wire input and a two wire output and so can be conveniently put inside a four terminal box (the amplifier representation of Fig. 1a, for example).

For two terminal networks, there are a number of ways of describing how it looks at the terminals. If the network contains only resistors, a simple Ohm's law description is quite enough. If it has capacitors and inductors too, it can still be summed up by an AC equivalent of Ohm's law. If we allow sources too, there's the Thévenin equivalent, and also the Norton equivalent, in which the circuit is summed up as a current source in parallel with an impedance.

All these aim to give the simplest possible description of the appearance of the network at its terminals but not to describe what goes on inside.

With a four terminal network, there are many more possibilities for the simple reason that there are more terminals to apply inputs to and take outputs from. For a passive two terminal network, you can apply a voltage and measure the current, or apply a current and measure the voltage and that just about exhausts the possibilities. With a four terminal passive network it is usual to stimulate it from both ends at once, giving rise to three sets of parameters according to whether the stimulus is two voltage sources (giving

the g- or conductance parameters) two current sources (giving the r- or resistance parameters) or one of each, which gives the h- or hybrid parameters.

Figure 4a shows a general four terminal resistor network being excited by a current  $I_1$ , applied to the left hand side and a voltage  $V_2$  to the right. The

can look on the 1 in the subscript as meaning "input" and the 2 as meaning "output".

The physical interpretation of the parameters is quite simple.  $h_{11}$  will be the input resistance with a short circuit at the output,  $h_{12}$  is the reverse voltage gain,  $h_{21}$  is the forward current gain and  $h_{22}$  is the output conductance with

the input open-circuit. Now you can see the reason for the name "hybrid" - two are dimensionless, one is a resistance and one is a conductance.

The simplest fantasy of what could be inside the box to give these results is shown in Fig. 4b. Having said that this applies to resistor networks, how can it be of any use for representing transistors? Well, the parameters can obviously be used for any circuit which doesn't mind having a current imposed on its input and a voltage on its output and a transistor falls into this category. Furthermore, the behaviour of a transistor under certain circumstances turns out to be very much like a resistor network with a gain. It was originally called a "transfer resistor" after all.

The IEEE recommend a slightly different set of subscripts from the ones shown above. For 11, use i for input, for 22 use o for output, for 21 use f for forward transfer, for 12 use r for reverse transfer. In addition, for transistors a second subscript b,e or c is used to indicate common base, common collector or common emitter configuration. So the input resistance of a transistor in common emitter configuration is called  $h_{ie}$ , the forward current gain will be  $h_{fe}$  and so on.

For FETs, by the way, it is usual to use the g-parameters since they are happier responding to a voltage than to a current. You may have seen  $g_{fs}$  and  $g_{os}$  in data sheets - I'm sure you can work out the interpretation. The h-parameter transistor model appears in a number of guises, some simpler than the one shown, some considerably more complicated. ■

only way the circuit can respond to give a certain voltage  $V_1$  at the left and a current  $I_2$ , could be caused by either or both of the stimuli, the most general summing up of the situation is:

$$V_1 = h_{11}I_1 + h_{12}V_2 \quad I_2 = h_{21}I_1 + h_{22}V_2$$

The various h's are the hybrid parameters, the subscripts are according to the convention adopted by most electrical engineering text books; you

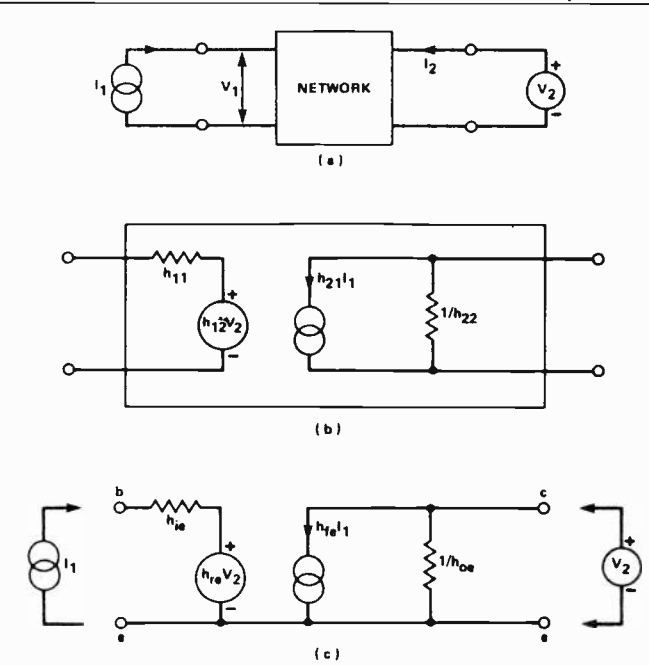

Fig. 4 (a) general four-terminal resistor network stimulated by current  $I_1$ , and voltage  $V_2$  "outputs" are  $V_1$  and  $I_2$  (b) One idea of what could be inside the box to give rise to the h-parameters. A model without sources is also possible. (c) A simple h-parameter model for a transistor in common-emitter mode. This is an AC model (no static DC currents and voltages are shown in particular,  $h_{12}V_2$  does not represent the 0.6V base emitter voltage drop). It applies to signals small enough for the non-linearity of the base-emitter junction to be neglected, and low enough in frequency for internal capacitances to be ignored. There are a number of models derived from this. The source  $h_{re}V_2$  is often left out since at normal operating currents it is negligible in comparison with  $h_{ie}I_1$ . A typical value of  $h_{re}$  for a small signal transistor operating at a collector current of 1mA would be around  $10^5$  to  $10^6$ .

# Electronics & Technology Today

Canada's Magazine for High-tech Discovery

## Order Form

### Subscriptions:

Please complete reverse side of order form to start or renew subscription.

### SOFTWARE — Order Form

..... \$ .....  
 ..... \$ .....  
 ..... \$ .....  
**Sub Total** \$ .....  
**Tax (Ontario Residents)** \$ .....  
**Postage** \$ .....  
**Total Enclosed** \$ .....

### BOOKSHELF — Order Form

..... **Code** ..... **Title** ..... **Price** .....  
 (e.g. BP12) Short-form is O.K.)  
 .....  
 .....  
 .....  
 .....  
 .....  
 .....

### SPECIAL PUBLICATIONS

ITEM	QTY	AMOUNT
Book of Computer Music	\$4.95	\$ .....
Project Book No. 3	\$3.95	\$ .....

Orders from the Bookshelf are tax exempt. Please add \$1.00 for postage. Remember to put your name and address on reverse side. See over for mailing details. Specials and Software add 7% PST.

### Back Issues:

\$4.00 each; Ontario residents add 7% sales tax.  
 Please circle issued desired.

### Binders:

Moorshead Publications, Electronics Today  
 \$9.75 each plus 7% P.S.T.

1977	1978	1979	1980	1981	1982	1983
February July	May June September November December	January February March April May July August September October November	January March May June November December	January February March April June July August September October November December	January March April May June July August October	January February March April August October December
1984	1985	1986	1987	1988	1989	1990
January February March April May June July August September October November December	January February March April May June July September October December	January February March April June July August September October November December	January February March April May June July August September October			

**BE SURE OF YOUR ISSUE EACH MONTH.  
SUBSCRIBE TODAY.**

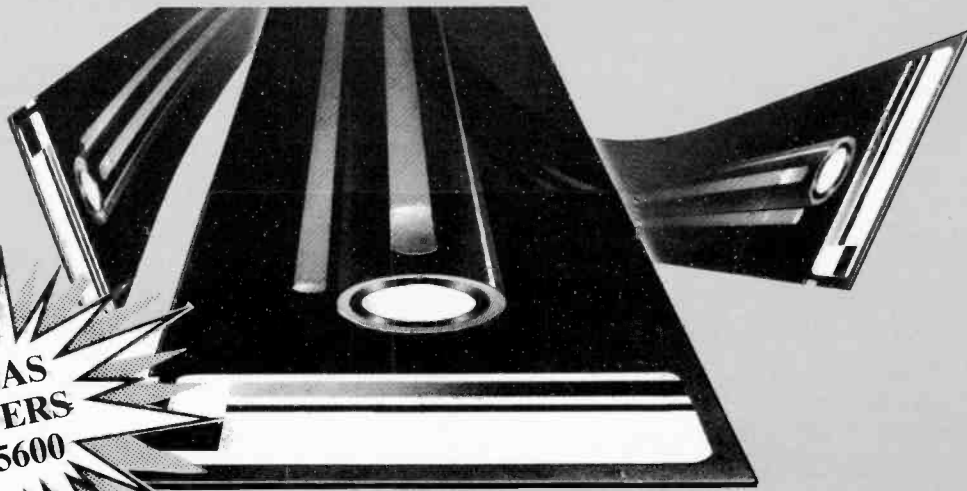

**CHRISTMAS  
GIFT ORDERS  
(416) 445-5600**

**Bonus!**  
**Almost Free Software Sample Disk**

Subscribe today and receive a sampler disk filled with great public domain software programs (IBM PC/MS DOS format only). This disk contains great games like Pango and Pitfall, as well as a fantastic Chess program and some great DOS utilities. See what you've been missing!

**Regular value: \$19.95. Time Limited Offer**

**MERCHANDISE ORDER**  Please fill out form overleaf.

**SUBSCRIPTIONS:**  NEW SUBSCRIPTION  RENEWAL

**Electronics & Technology Today:**  One year (12 issues) \$22.95  Two years (24 issues) \$37.95

**Computing Now!**  One year (12 issues) \$22.95  Two years (24 issues) \$37.95

**Computers in Education:**  One year (10 issues) \$25.00  Two years (20 issues) \$45.00

**Outside Canada (US Dollars)**

For U.S. please add \$3.00 per year  Other countries add \$5 per year

NAME \_\_\_\_\_ ADDRESS \_\_\_\_\_

TOWN/CITY \_\_\_\_\_ PROVINCE/STATE \_\_\_\_\_

CODE \_\_\_\_\_ DATE \_\_\_\_\_ POSTAL CODE \_\_\_\_\_

Cheque enclosed DO NOT send cash

MasterCard Account No. \_\_\_\_\_  Visa Account No. \_\_\_\_\_  American Express Account No. \_\_\_\_\_

Expiry Date \_\_\_\_\_ Signature \_\_\_\_\_

**Moorshead Publications, 1300 Don Mills Road, North York, Toronto, Ontario M3B 3M8**

# COMPUTING NOW! MICROCOMPUTER DIRECTORY VOLUME II

Finding the hardware or software one wants for one's microcomputer applications is very often an exercise in finding out what exists. Following this, one must locate what one has chosen, often through a labyrinth of dealers and suppliers. Conventional magazine directories and surveys can help with all of this... somewhat.

Most directories are constructed so as to be easy to compile. This one has been designed to be easy to use. Rather than selecting arbitrary categories, the items in the directory will be classified by system and within each system, in a tree structure dividing them into subclassifications.

This will result in a large directory with a lot of duplication in it. However, it will be a reference highly valued by its readers because of its resulting ease of use. It will be the essential reference work for anyone involved in microcomputers, from single system end users to small and mid-sized businesses.

For additional copies @ \$4.95 per copy  
call (416) 445-5600

Group rates on request.



## Of Shoes and Ships and Binders...

Alice stretched herself up on tiptoe and peeped over the edge of the mushroom and her eyes immediately met those of a large blue caterpillar, that was sitting on top, having a milkshake.

"Who are you?" said the Caterpillar.

"I hardly know, Sir," stammered Alice, "but I'm looking for a way to keep magazines tidy and convenient."

"Moorshead binder," said the Caterpillar.

"Pardon?" asked Alice.

"Moorshead magazine binders. Cleverly worked out, with spring rods to hold the magazines without cutting or punching," the Caterpillar replied.

"Oh," said Alice.

"They lay flat for reading or photocopying," he added.

What does he mean? *What* lays flat? thought Alice to herself.

"The binders," said the Caterpillar, just as if she'd said it aloud, and in another moment he was out of sight.

Moorshead binders are available for \$9.75 each (Ontario residents please add 7% provincial sales tax). Send to:

**Binders,**  
*Electronics & Technology Today,*  
Moorshead Publications,  
1300 Don Mills Road,  
Toronto, Ontario,  
M3B 3M8.



## CROSS-16 META ASSEMBLER

- Table based 8/16 bit cross-assembler.
- Uses manufacturer's assembly mnemonics.
- Tables & Example Source files are included for ALL of the following processor families:

1802	3870	64180	6502
65816	6801	6805	6809
6811	68000	7000	8048
8051	8085	8086	8096
COP800	SUPER8	Z8	Z80

- Users may modify or create new tables for additional processors.
- Produces listing, symbol table, and 8/16 bit binary, Intel and Motorola hexcode.
- 5" DSDD for PC/MS-DOS 2.0 or greater.  
\$99.95 US      \$139.95 CDN
- Portable C sourcecode is available.

Worldwide shipping (AIRMAIL) & handling included. Credit Card orders (\$139.95 CDN) please specify: Card number, name on card and expiry date.



### Universal Cross-Assemblers

P.O. Box 384, Bedford, N.S.  
Canada B4A 2X3

Circle No. 20 on Reader Service Card

## PC Weather Pro. A gift for all seasons.

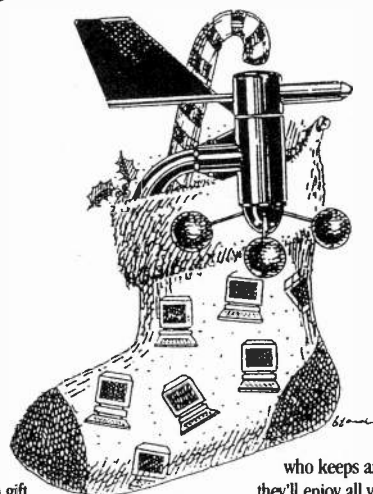

Know someone who keeps an eye on the weather? This is a gift they'll enjoy all year long.

PC Weather Pro comes with anemometer, temperature probes, rain gauge and software. It monitors wind speed and direction, inside and outside temperature, barometric pressure, wind chill factor and rainfall... all with just the push of a key on an IBM PC or compatible. They'll be able to check present conditions and keep a perpetual record of weather data. Plus, set alarms to alert them to specific changes. It's the perfect gift... useful, educational and just plain fun.

Only **U.S. \$575** VISA/MC/AMEX Accepted

Technology Marketing Inc.

4000 Kruse Way Place 2-120, Lake Oswego, OR 97035  
1-800-247-5712 In Oregon, (503) 635-3966

Circle No. 21 on Reader Service Card

## ASUKA AT/XT SYSTEM (Your source for High Quality Japanese products)

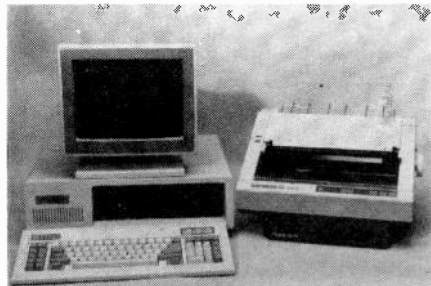

### ASUKA XT TURBO SYSTEM

4.77 MHz/8MHz Dual Speed  
640K Memory  
360K Panasonic Drive  
Colour or Monochrome Graphic Card  
150W CSA Power Supply  
Asuka AT Style Keyboard  
Parallel, Serial, Time, Game Port  
Composite or TTL Monitor  
One Year Warranty (Phoenix or Award Bios)  
Optional: 20 M Hard Drive **\$425.00**  
30 M Hard Drive **\$500.00**  
MS DOS 3.2 \$ 99.00

ASUKA 8088 4 LAYER **\$1099<sup>00</sup>**  
TURBO



### ASUKA AT 80286 SYSTEM

640K Memory 6, 10 MHz Speed  
1.2 M Drive Hard Drive with Controller  
AT 3000 EX Enhanced Keyboard  
Monochrome Graphic & Printer Port  
200 W CSA Power Supply  
One Year Warranty  
(Phoenix or Award Bios)

Optional: ATI Graphic Solution Card  
Add \$ 199.00  
MS DOS 3.2 \$ 99.00

ASUKA 80286 4 LAYER **\$1750<sup>00</sup>**  
TURBO

DEALER INQUIRIES WELCOME.  
Institutional P.O.'s Accepted.

A  
S  
U  
K  
A

## Kitstronic International Ltd.

4051 Sheppard Ave. East, Agincourt, Ontario  
M1S 1S8 (416) 298-3280 Fax (416) 298-2093

Circle No. 23 on Reader Service Card

### MITSUBISHI MONITOR

RGB 1409C	\$ 499.00
EGA 1430C	\$ 750.00
Autoscan AM1371A P.G.A.	\$ 950.00
Samsung Flat Screen/Swivel base Amber	\$ 169.00
Datatrain Swivel base Amber	\$ 145.00

### PRINTERS

Roland 1012 w/cable	\$299.00
Roland 1212 w/cable	\$525.00
Roland 1215 w/cable	\$725.00

### PERIPHERAL CARDS

Colour Card	\$ 79.00
Dual Display RGB, Monochrome Graphic Card	\$109.00
Monochrome Graphic Card	\$ 89.00
Multi I/O Ser Per Clock Controller	\$ 99.00
EGA Card	\$299.00
ATI Wonder Card	\$399.00

### KEYBOARDS

Asuka AT/XT Auto Sensing	\$119.00
Asuka Enhanced AT/XT 3000 EX	\$149.00

### HARD DRIVE

20 M XT Miniscribe	\$ 475.00
30 MXT Miniscribe	\$ 525.00
40 M AT Miniscribe 28MS	\$1050.00
40 M AT Seagate 36MS	\$ 795.00
40 M AT Tandem 40MS	\$699.00

### MODEMS

Datatrain Hayes compatible external	\$199.00
EPM Hayes Comp. external	\$189.00



# A Battery Primer

*Sorting out the many available types of dry batteries.*

*By Andrew Armstrong*

In the design of electronic equipment, the power supply often used to be left until last and then designed almost as an afterthought by the most junior member of the design team. Nowadays there are specialist engineers and companies concerned only with power supplies, and it is recognized that the choice of power supply can influence the over equipment design very significantly.

So it is with batteries. Increasing numbers of electronic products need a portable power source, and the correct choice of battery can determine the product's viability. Of course, there have been specialists in the design and

manufacture of batteries since they started to be manufactured commercially, but this is a discipline allied to chemistry rather than electronics.

Because chemists design batteries and engineers design the batteries into machines, the choice of battery type is sometimes less well informed than it might be. The two types of experts do not speak the same language, so it is not surprising if the criteria for choice are imperfectly understood.

## Chemistry

A detailed knowledge of the chemistry involved in an electric cell is not necessary for the electronics design-

er, but a knowledge of what goes into a cell and how it is assembled is useful background information.

The basic idea behind an electric cell is to have two chemicals reacting in an ionic form, such that "spare" electrons accumulate at one side of the reaction. If the physical construction of the cell is such that the electrons can only return to the other side via an external circuit, then useful energy can be extracted. This effect is illustrated most simply by the reaction used in a mercury cell (Fig. 1.).

On the left we see an oxygen ion  $O^-$  leaving the mercuric oxide cathode and taking with it two electrons from

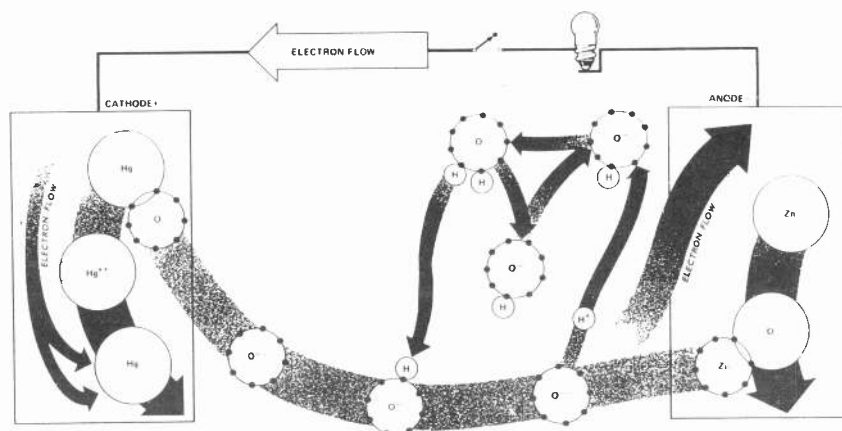

Fig. 1. The chemical reaction which takes place inside a mercury cell.

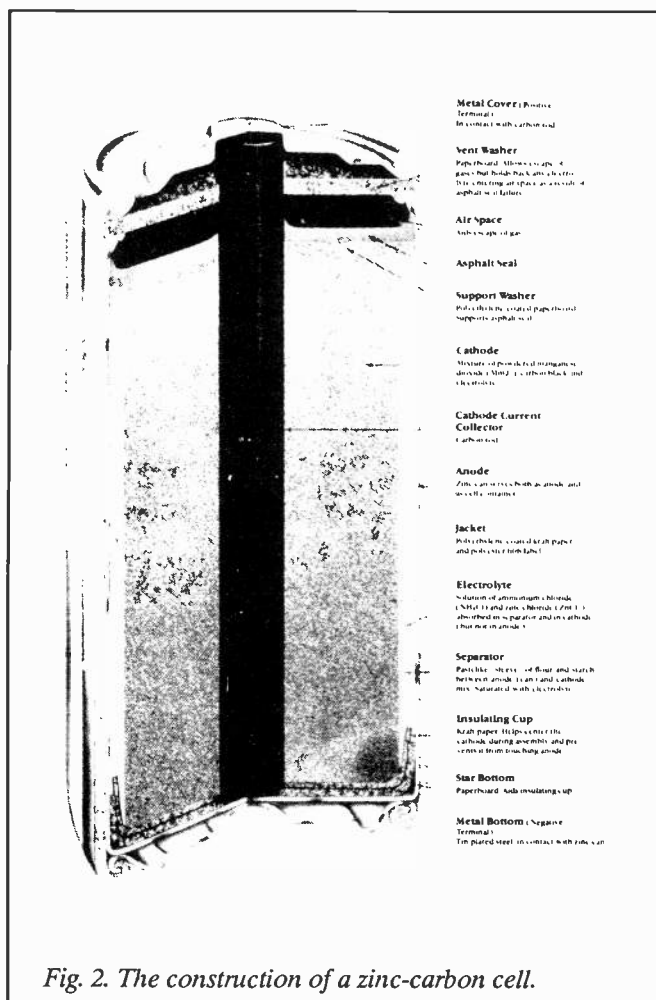

Fig. 2. The construction of a zinc-carbon cell.

the mercury atom. This oxygen is being attracted towards the zinc anode, which has a greater affinity for oxygen than the mercury.

Once it has left the cathode, the oxygen reacts with a molecule from the water electrolyte to form two hydroxyl ions, OH<sup>-</sup>. One of these joins with the zinc and the hydrogen is released, leaving behind its electron. The hydrogen, H<sup>-</sup>, rejoins the second hydroxyl ion, reforming the water molecule. Now the cathode has lost two electrons, the anode has gained two, and the water is unchanged.

Assuming that no external circuit is connected, this reaction will continue until the electrostatic repulsion between the excess electrons on the anode and the hydroxyl ions balances the extra affinity of zinc for oxygen compared with mercury. The point at which this occurs determines the EMF of the cell.

If an external circuit is connected, the reaction proceeds and the spare

electrons on the anode flow through the circuit to replace those missing on the cathode.

It is not easy to give within the scope of this article a deeper explanation. In general, atoms of elements consist of a nucleus containing protons (with one positive charge) and neutrons (with no charge) and a number of electrons equal to the number of protons. Thus, the charges balance.

The electrons are arranged in shells — groupings of similar energy states — and for maximum stability each shell should con-

tain its full complement of electrons. Most elements do not have the exact number of electrons to fill all the shells used, so the outer shell (in which the electrons have the highest energy level and are least strongly bound to the nucleus) is often short of a few electrons. Elements combine into chemical compounds to complete their outer shells by sharing their electrons.

Why then should oxygen prefer to share two electrons with zinc rather than with mercury? The answer is that zinc has 30 electrons as

### Primary Cell Types

against mercury's 80. This means that the zinc's outer shell is closer to the nucleus (lower in energy) than that of mercury. If all else is equal, systems try to attain the lowest energy levels (like a ball rolling to the bottom of a hill), which explains the direction of the reaction in mercury cell.

In practice, cells are more complicated than the mercury cell illustration. Other chemicals are added to assist the reaction, prevent deterioration, etc. We will take a look at some of the main types of cells, beginning with primary (non-rechargeable) cells. The zinc-carbon cell is perhaps the most widely used in consumer applications. The anode is made of zinc, the active surface of which is amalgamated with mercury. The zinc electrode forms the outer case of the battery as well, though some manufacturers add an outer steel case.

The cathode is made of man-

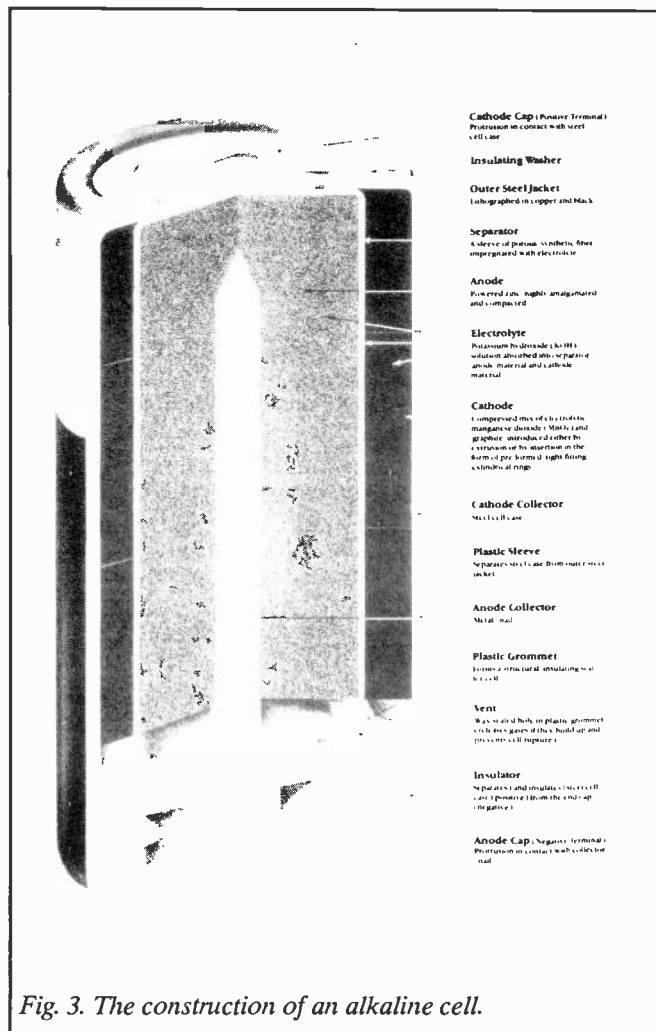

Fig. 3. The construction of an alkaline cell.

ganese dioxide, with a carbon rod to collect the current. The electrolyte is a solution of ammonium chloride (NH<sub>4</sub>Cl) and zinc chloride (ZnCl<sub>2</sub>), which is acidic.

The **heavy-duty zinc-carbon** cell is very similar to the ordinary variety, but the difference is that its electrolyte is zinc chloride only. This gives an increased ability to provide heavy currents, though it has no greater energy storage.

The **alkaline-manganese** cell uses similar electrode materials, but its electrolyte and construction are different from the zinc-carbon cell. The anode is made of powdered zinc amalgamated with mercury, and the current is collected by a metal collector instead of a carbon rod. This provides a low internal resistance for the cell.

The electrolyte is potassium hydroxide, an alkaline solution which is highly conductive. The cathode is made of electrolytically-produced manganese dioxide, which is purer and has more oxygen per unit than the naturally-occurring substance. This means that the energy content of the cell per unit volume is greater than that of the zinc-carbon type.

These are the most commonly used cells, but a number of other types are used where other qualities are needed. Most of these are button cells, designed to meet special needs. The mercury button cell and its basic chemical reaction has already been described. Its output is 1.3V. A cell with a silver oxide cathode provides 1.6V, and can be used where the extra voltage is needed, or where the environmental effects of disposing of mercury cells are unacceptable. The silver cell is even more expensive than the costly mercury cell.

**Zinc-air** cells have been around for some time, but have not turned out to be the panacea that some people initially believed them to be. Their major advantage is that they get their oxygen from the air rather than from an oxygen-bearing chemical, so that for a given energy level they are smaller and lighter than many other types of cell.

They have two main disadvantages. One is that zinc-air cells require air to operate, so they cannot function in a sealed environment such as watches. The other difficulty is that once the air seal is removed to allow the cell to operate, the electrolyte

begins drying out. Normal cells remain usable for about three months, although some special low-drain ones are meant to last for three years. Rumour has it that these are not always satisfactory.

The **lithium** cell has been heralded as a major advance in battery technology. In fact, there is not one type of lithium cell, but about a dozen variations. Some examples of these are lithium copper oxide, lithium sulphur oxide and lithium thionyl chloride.

The energy per unit weight is high because lithium is a light metal, the third lightest element in the periodic table after hydrogen and helium. Lithium is extremely reactive, which you might think would result in a rapid or explosive self-discharge of the cell. What actually happens is that the surface forms a non-reactive oxide layer which prevents any unwanted reaction. The result is that the cells have a long shelf life, typically ten years.

### Secondary Cells

So far all the cells mentioned have been the primary, or non-rechargeable type. Secondary (rechargeable) cells have been around for some time now, and they are being used more and more. The first widely used rechargeable cell was the lead-acid car battery, but this is not practical for use in portable electronic equipment.

When a cell is recharged, current is forced through it in the reverse direction. The oxygen leaves the anode, restoring it to its metallic state, and returns to the cathode. Small primary cells are not capable of this process to a worthwhile degree, because the anode swells up as it oxidizes like rust on a car, its shape is distorted and pieces may break off.

In the **nickel-cadmium** (NiCad), this problem is largely solved by containing the anode and cathode materials in porous, conductive plates. The individual particles of electrode material can change size without seriously changing the shape of the overall structure, so recharging is possible.

Nickel cadmium cells may be stored in any state of charge, but if they are completely discharged for long periods, a problem can arise. There is a tendency for crystalline cadmium "whiskers" to grow towards the opposite plate of the battery. If a cell contains a charge, then a short circuit will melt the whisker back onto the anode. If there is no charge, this cannot occur, and it is possible to reach the stage where no practical amount of current fed into the cell will remove the whisker. The cell is then of no further use.

**Sealed lead-acid** cells and batteries are also available and are widely used in industrial emergency lighting and backup supply systems. They are also to be found in some professional

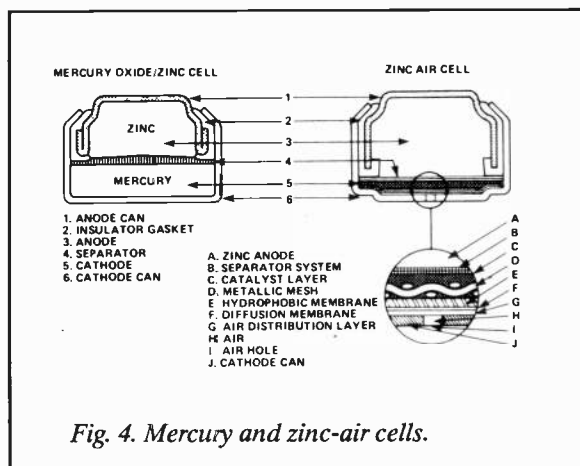

Fig. 4. Mercury and zinc-air cells.

portable tape recorders and are beginning to appear in domestic equipment.

Sealed lead-acid cells have a nominal operating voltage of 2.2V, so they cannot be substituted directly for zinc-carbon or manganese-alkaline cells. They come in two types, the flat-plate type, normally supplied as 6V or 12V batteries, and the cylindrical cell supplied individually. Both types should be stored in a charged state.

Less commonly available are **silver-zinc rechargeable** cells. These have about double the energy density of Ni-Cads, and a constant voltage over most of their output. They are little used in amateur or consumer equipment.

Of more future interest are the **rechargeable lithium** cells, which provide double the energy density of NiCads and weigh less. The anode is made of lithium foil and the cathode is molybdenum disulphide powder bound to a substrate. The electrolyte

acts only as a carrier for ions and does not react chemically with the electrode materials.

There appears to be no oxygen involved in the reaction, which is significant. As mentioned above, the lithium electrode in a lithium primary cell forms a non-reactive layer on its surface, which prevents the untimely discharge of the cell. This would also prevent the lithium from being plated back on the anode, so a rechargeable cell must use a very different system.

The charge retention of these cells is good for a rechargeable type; approximately 10% charge loss over a year at 22 degrees C. This would remove the need for float charging in some applications.

An interesting characteristic is that the discharge curve is well-defined, and the voltage falls from 2.25V to 1.3V predictably (although not linearly) as the cell discharges. This makes a state of charge indicator possible. Unfortunately, it can also cause problems for equipment which requires a constant voltage.

Currently these cells are very costly, and it is likely to be a while before the price falls enough for anyone to consider using them in consumer applications.

The main reason why an electronics designer should want to consider the subject of batteries seriously is to be able to choose a battery for a given application. For this reason, we need to know about the discharge characteristics of primary cells, and both charge and discharge characteristics of secondary cells.

### Primary Choice

The choice between zinc-carbon and alkaline manganese cells is fairly simple. Fig. 5 shows the relative energy recovered from two cells plotted against current drain. This shows a maximum of seven times as much energy from the alkaline cell at a fairly high current drain, but much less at lower current drains. If cost is the criterion, then the break-even point is shown by the dotted lines, and alkaline cells are more cost-effective at higher currents than that shown.

In practice, this means that ordinary transistor radios could well be powered by zinc-carbon cells, but cassette players, due to the current consumption of the motor, should be

powered by alkaline cells.

Another consideration is the shelf life of the battery. In many cases flashlights are left in a cupboard or glovebox for a long time until needed. For this type of use, it might be tempting to choose zinc-carbon cells because the whole capacity of the cell is unlikely to be required. However, alkaline cells deteriorate much slower than zinc-carbon cells do, largely because of the alkaline electrolyte.

If, though, the flashlight is to be used regularly but for brief periods (for example, by a meter reader), then the use of alkaline cells gives little or no advantage. Without a sustained heavy current drain, the high power of the alkaline cell is of no advantage, and regular use means that shelf life is not a problem.

There is one area in which the choice of cells is clear. It is widely recognized that the alkaline-manganese cells are appropriate for personal stereos. As I sit here listening to mine, I'm contributing to a growing, though yet unquantified environmental problem. This type of cell contains mercury in an amalgamated form, and there is obviously at least some risk that after disposal this could get into drinking water or even food. It's likely that

without the personal stereo, too few alkaline cells would have been used to constitute a problem, but if the trend continues, the environmental impact will likely require some consideration. It's interesting to note that mercury cells, which contain more mercury, are no longer used in Japan.

The choice between primary and secondary systems follows a different set of criteria. NiCad batteries, the most commonly available secondary system, store about a quarter as much energy as alkaline cells of the same size. Some of the cells on sale to the public store only an eighth as much, which necessitates irritatingly frequent charging. They also supply only 1.2V instead of 1.5V, which can occasionally cause problems. The charge retention of NiCads is also unimpressive, with a

self-discharge rate of 20% to 30% of the remaining charge each month.

On the plus side, the internal resistance of the NiCad is much less than that of the alkaline cells, so with a higher current load, the available voltage from the NiCad may be higher than that from the alkaline cells.

In addition, there is the obvious advantage that considerable saving can be made in applications requiring many charge/discharge cycles. The equipment should not completely discharge the equipment between cycles.

### Rechargeable Choice

The three varieties of rechargeable cells available to the consumer are the

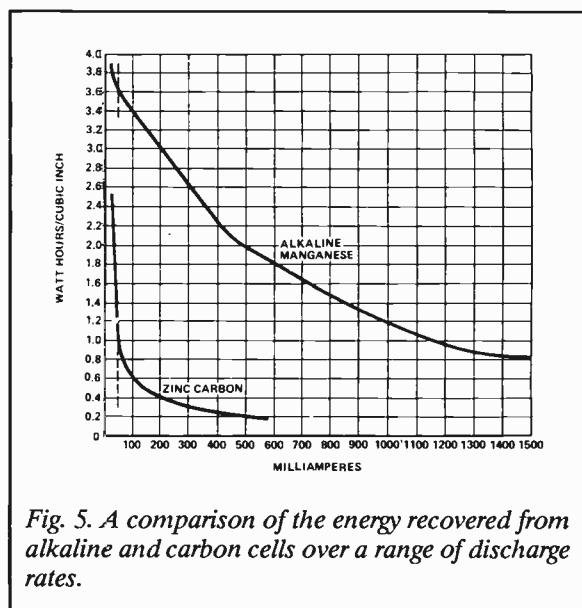
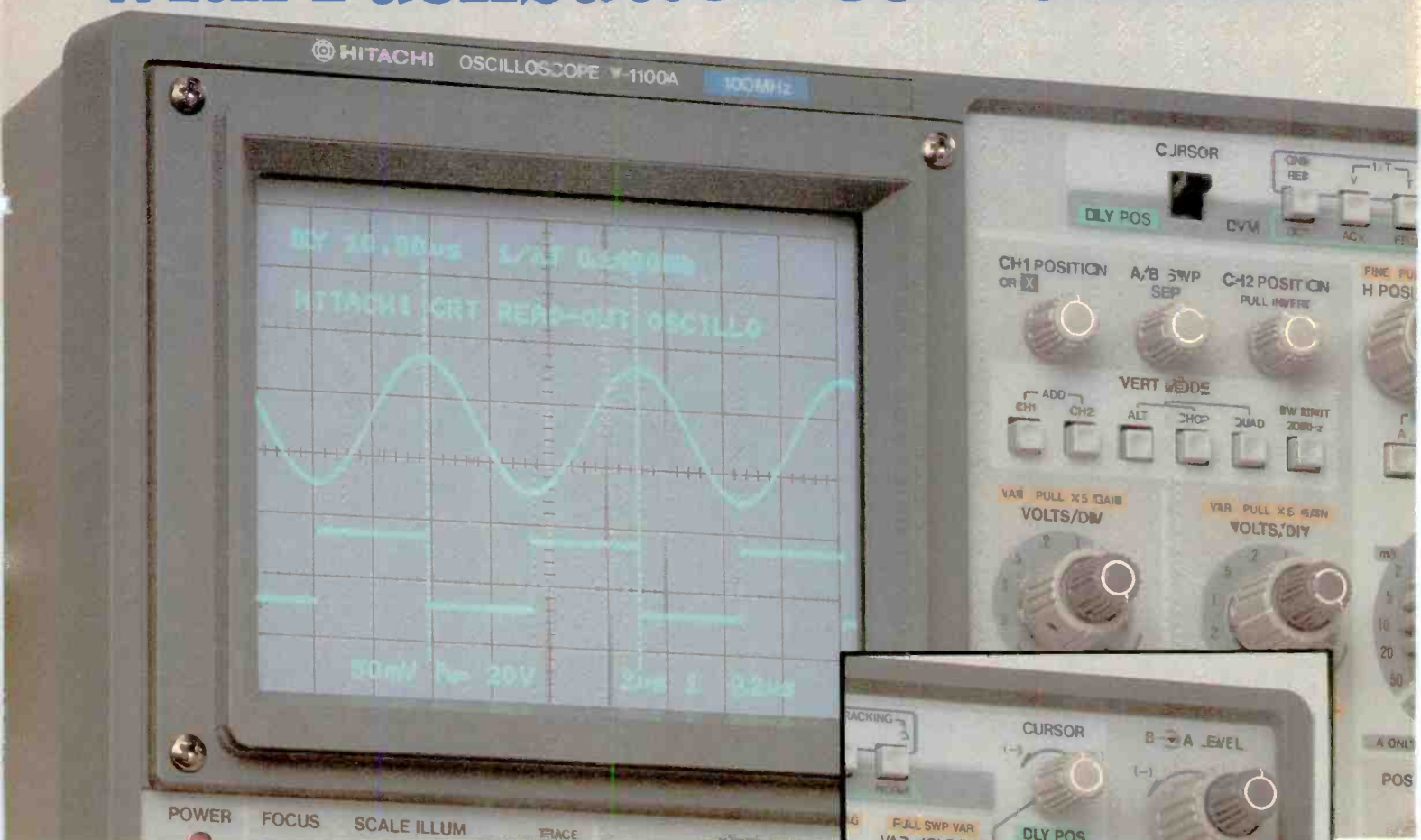

Fig. 5. A comparison of the energy recovered from alkaline and carbon cells over a range of discharge rates.

NiCad, the flat plate lead acid and the cylindrical lead acid cell. They are all suitable for different uses and need to be charged differently. For off-the-shelf equipment designed to function within ordinary cells, NiCads are the obvious choice because they're available in the same range of sizes. If equipment is to be designed from scratch, the choice is no longer so constrained.

For an application requiring a high discharge current and frequent deep discharges, NiCads are almost always the most suitable. The sintered plate cells can be routinely charged at rates of up to 10C, with pulses up to 100C (C is the rate to charge or discharge the cell in one hour, so 10C would discharge it 6 minutes, provided that the capacity is undiminished at

# Get the Whole Picture with Pushbutton Convenience



## The V-1100A by Hitachi.

Finally, there is a full feature 100 MHz oscilloscope that gives you the whole picture, at a glance. The V-1100A's CRT shows you scope setting information, cursor locations and values, DVM measurements and fully programmable text, all on the CRT.

A new illuminated pushbutton array allows easy character input and trigger mode selection.

We are sure that once you talk to your Hitachi representative about the V-1100A you won't be satisfied with anything less than the whole picture.

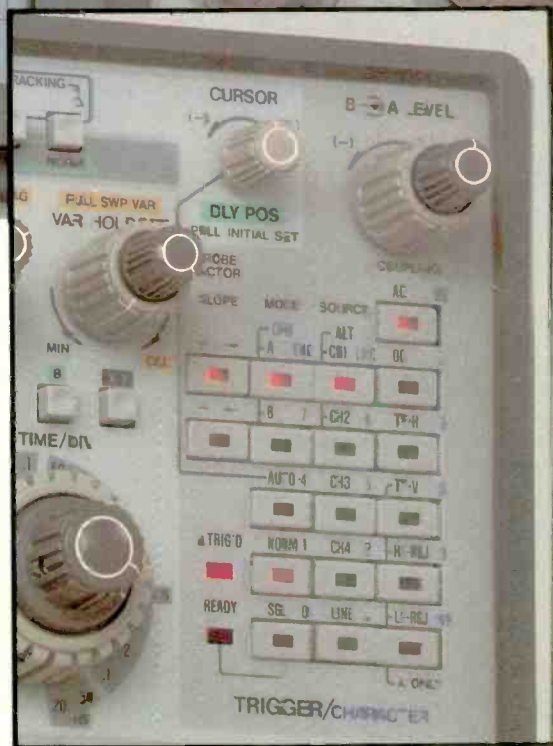

# Hitachi Denshi, Ltd. (Canada)

Circle No. 24 on Reader Service Card

## Performance Proven Electronics

### Head Office:

65 Melford Drive, Scarborough  
Ontario M1B 2G6  
Tel: (416) 299-5900

### Ottawa Office:

159 Colonnade Road, Unit 3  
Nepean, Ontario K2E 7J4  
Tel: (613) 727-3930

### Eastern Office:

8096 Route Trans Canadienne  
St. Laurent, Quebec H4S 1M5  
Tel: (514) 332-6687

### Western Office:

3433-12th Street N.E.  
Calgary, Alberta T2E 6S6  
Tel: (403) 291-4388

this high discharge rate).

NiCad button cells cannot match this performance, but they can provide high currents, and are the only choice for small rechargeable packs.

NiCads exhibit a "memory" effect is they are repeatedly cycled over a certain fraction of their total capacity and eventually reach a stage where the voltage on load will fall long before the rated capacity is used up. One deep discharge cycle may remove this effect. The problem is that the voltage may fall to such an extent that the equipment no longer functions, and the battery will have to be discharged with a resistor.

Lead acid cells have a shorter life than NiCads if they are subjected to deep discharge, or kept discharged for a long time. They are much better suited than NiCads to float charge applications because of their charging requirements.

**Charging**

The standard charging technique for cylindrical NiCads is to charge them at

C/10 for 14 hours. At this rate prolonged overcharge is possible without significant damage.

In some cases much faster charging is possible. If the cell is completely discharged and the temperature is maintained within the range of 10 to 40 degrees C, the following rates are possible: C/5 for 7 hours, C/3 for 4 hours, and C for 85 minutes. Limited overcharge is possible for rates below C/2.5, but a timer-controlled charger is recommended for fast charging.

In addition, between 15 and 30 degrees C, ultrafast charging is possible, though the recoverable capacity will be 25% to 80% of normal. As an example, a 500mAH cell could be recharged at 5A for 3 minutes, after which almost 250mAH would be recoverable. The charging requirements for NiCad button cells are similar to those of cylindrical cells, but overcharging is more detrimental. The maximum charge rate is C for 50 minutes.

Sealed lead acid cells should be charged from a constant voltage

source rather than a constant current. On float charge 2.25V per cell should be used at temperatures between 15 and 25 degrees C. In cyclic applications, 2.45V per cell is appropriate. If the discharge cycle is only a small proportion of that available, then it is best to limit the charge current as well as to reduce the overcharge on each cycle.

**More Reasons to make**  
**Electronics & Technology Today**  
**Part of your Marketing Strategy.**

Readers of **Electronics Today** value their magazine highly, in that **75% report that they retain their copies indefinitely.** A further **15%** retain them for **12-24 months** and **8%** retain **6-12 months.** That's **98%.**

For advertising information  
**Call (416) 445-5600**

**The Christmas Gift that keeps on giving...**

As a reader you know the value of the magazine you hold. Regular monthly features on computers and electronics, articles and news on the rapidly changing technology of computers, and more.

You are kept informed and even a step ahead to help your buying decisions and increase your general knowledge.

When considering a Christmas gift for a friend or associate this year perhaps the answer is in your hands. It is a gift that will keep on giving for twelve months and is a monthly reminder of you the giver. It is a special and thoughtful gift needed.

PLEASE SEND THE FOLLOWING CHRISTMAS GIFTS. I HAVE INDICATED THE MAGAZINE OF MY CHOICE.

**From:**

Name/Title \_\_\_\_\_

Address \_\_\_\_\_

City \_\_\_\_\_ Province \_\_\_\_\_

Postal Code \_\_\_\_\_ Telephone \_\_\_\_\_

**Christmas Gift Rates**

Computing Now! .....	<b>\$17.95</b>	<del>\$22.95</del>
Electronics & Technology Today ...	<b>\$17.95</b>	<del>\$22.95</del>
Computers in Education .....	<b>\$17.95</b>	<del>\$25.00</del>

- My cheque is enclosed.
- Charge my  Visa  MasterCard  American Express.
- Account Number \_\_\_\_\_ Expiry Date \_\_\_\_\_



**To:**

Name \_\_\_\_\_

Address \_\_\_\_\_

City \_\_\_\_\_ Province \_\_\_\_\_

Postal Code \_\_\_\_\_ Publication \_\_\_\_\_

**To:**

Name \_\_\_\_\_

Address \_\_\_\_\_

City \_\_\_\_\_ Province \_\_\_\_\_

Postal Code \_\_\_\_\_ Publication \_\_\_\_\_

**Send to:**

Moorshead Publications  
 1300 Don Mills Road, North York,  
 Toronto, Ontario M3B 3M8

**CHRISTMAS GIFT RATE TIME LIMITED**

# LEADER

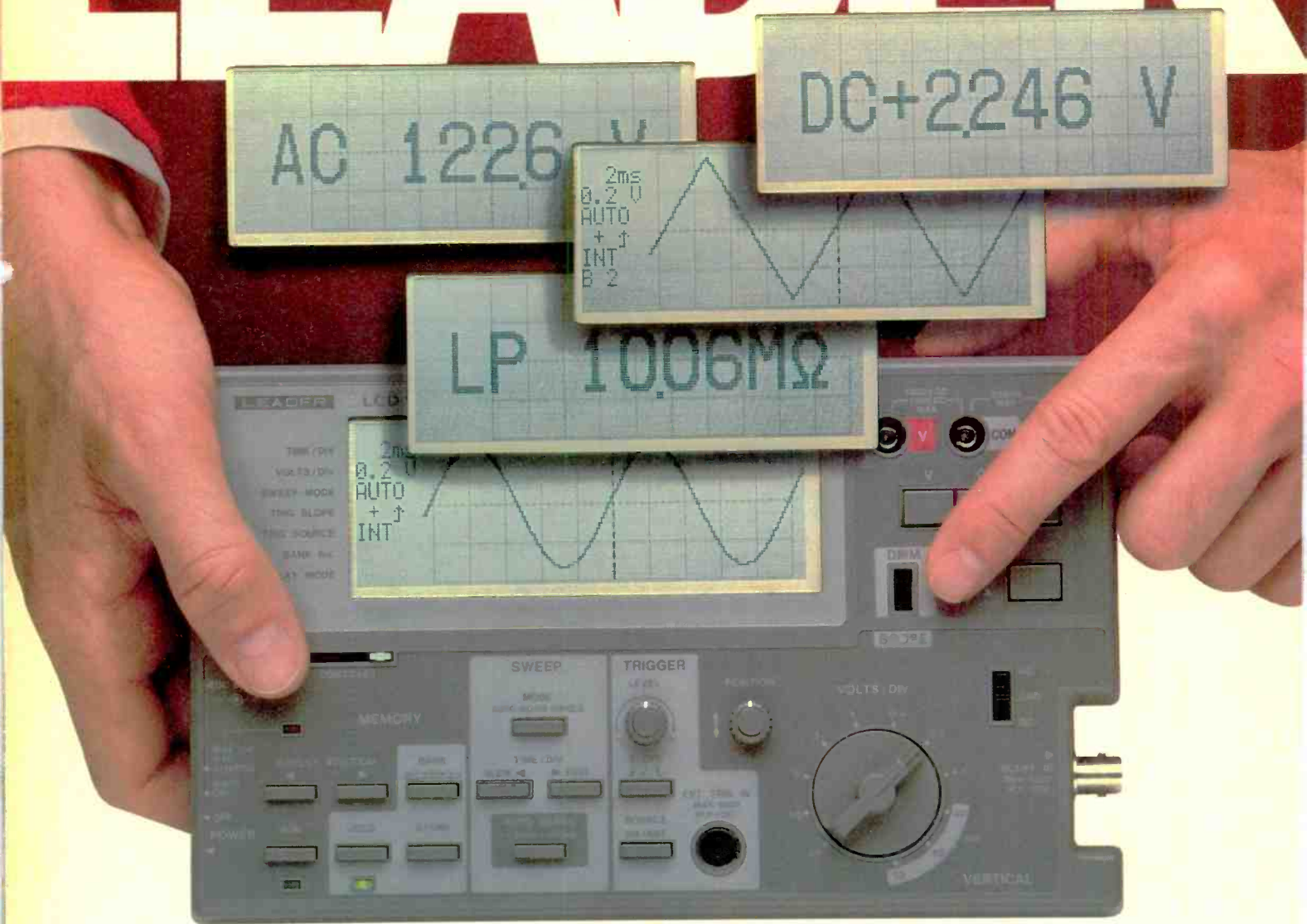

## Portable Problem Solver

### Ultra-compact Digital Storage Oscilloscope-Multimeter.

Easily carried in a tool kit or attache case—powered by batteries or supplied ac adaptor—this 2-in-1 lightweight is always ready for hand-held action.

### Multi-function, 200-kHz DSO.

Just flip the switch from DMM to SCOPE and the performance of a professional Digital Storage Oscilloscope is at your fingertips. Lets you capture and analyze single-shot and very slow phenomena. Stores up to three waveforms, and has such top-of-the-line features as auto-ranging time base setting, pre-trigger, roll mode, and on-screen readout of setting conditions. Low-power indicator

alerts you when batteries need recharging, while a separate back-up system protects memory.

### Full-function, 3½-digit DMM.

Precise measurement of ac/dc voltage, current and resistance is easy to see on the large, high-contrast, display. Automatically selects range which provides greatest accuracy and resolution.

### Perfect for many applications.

LCD-100 is a unique combination instrument that can confirm that its DMM is measuring a desired signal. Better by far than a DMM alone... more useful in the field than any benchtop DSO in this bandwidth, LCD-100 is ideal for service-  
Circle No. 25 on Reader Service Card

ing a broad range of electromechanical, electrical and electronic systems.

Ask for an evaluation unit, more information, or our latest Catalog.

**B.C./Alberta Call**  
(604) 985-6707

**Saskatchewan/Manitoba Call**  
(204) 775-3354

**Ontario Call**      **Quebec Call**  
(416) 828-6221      (514) 337-9500

**Omnitronix Ltd.**  
Instruments that measure up.

2410 Dunwin Drive, Unit 4, Mississauga,  
Ontario L5L 1J9 Telex 06-22324

8100 F, Trans-Canada Hwy., St. Laurent,  
Quebec H4S 1M5 Telex 05-824151

# New GPS Series: Tek sets the pace with SmartCursors™ and push-button ease.

Work faster, smarter, with two new general purpose scopes from Tektronix. The four-channel, 100 MHz 2246 and 2245 set the new, fast pace for measurements at the bench or in the field. They're easy to use and afford, by design.

**On top: the 2246 with exclusive integrated push-button measurements.** Measurements are accessed through easy, pop-up menus and implemented at the touch of a button. Measure peak volts, peak-to-peak,  $\pm$  peak, dc volts and gated volts with new hands-off convenience and on-screen readout of values.

SmartCursors™ track voltmeter measurements in the 2246 and visually indicate where ground and trigger levels are located. Or use cursors in the manual mode for immediate, effortless measurement of waveform parameters.

**Both scopes build on performance you haven't seen at the bandwidth or prices.** Lab grade features include sweep speeds to 2 ns/div. Vertical sensitivity of 2 mV/div at full

Features	2246	2245
Bandwidth	100 MHz	100 MHz
No. of Channels	4	4
Scale Factor Readout	Yes	Yes
SmartCursors™	Yes	No
Volts Cursors	Yes	No
Time Cursors	Yes	No
Voltmeter	Yes	No
Vertical Sensitivity	2 mV/div	2 mV/div
Max. Sweep Speed	2 ns/div	2 ns/div
Vert/Hor Accuracy	2%	2%
Trigger Modes	Auto Level, Auto, Norm, TV Field, TV Line, Single Sweep	
Trigger Level Readout	Yes	No
Weight	6.1 kg	6.1 kg
Warranty	3-year on parts and labor including CRT	

bandwidth for low-level signal capture. Plus trigger sensitivity to 0.25 div at 50 MHz, to 0.5 div at 150 MHz.

Accuracy is excellent: 2% at vertical, 2% at horizontal. And four-channel capability includes two channels optimized for logic signals.

**Best of all, high performance comes with unmatched convenience.** You can see it and feel it—in the responsive controls and simple

front-panel design, in extensive on-screen scale factor readouts, and in simplified trigger operation that includes Tek's Auto Level mode for automatic triggering on any signal.

Contact the Tektronix office nearest you for complete details.

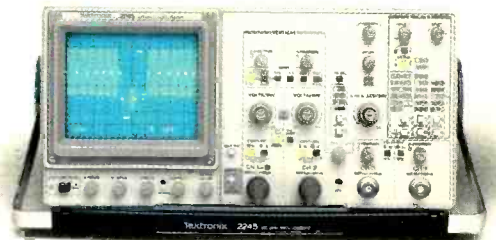
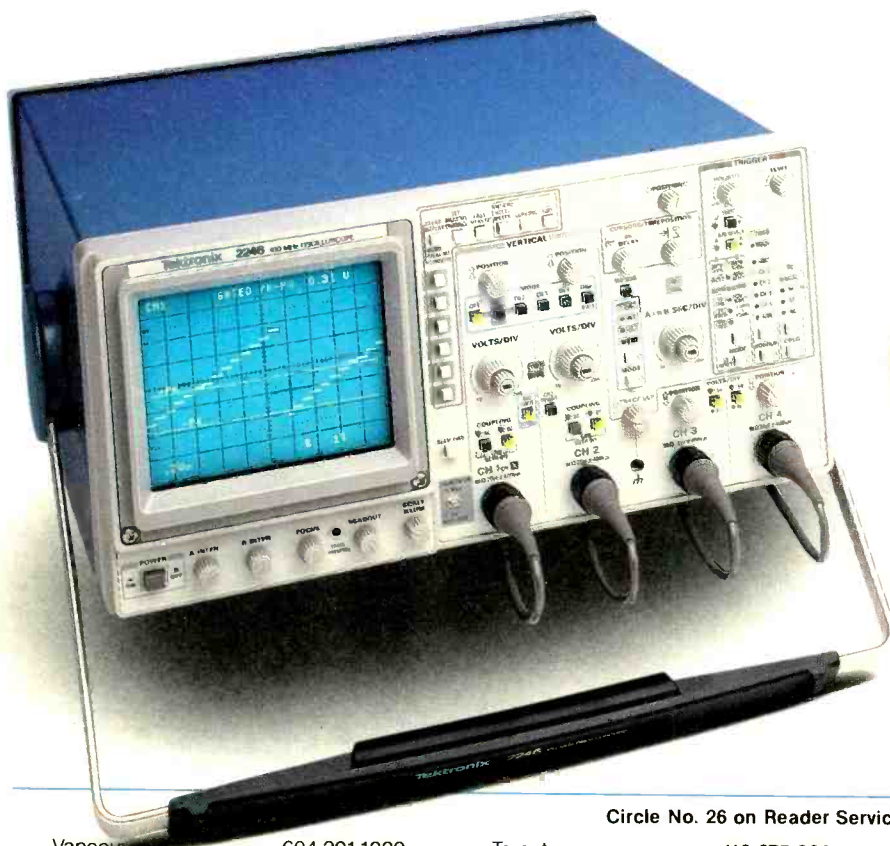

Featuring four channels, flexible triggering, extensive CRT readouts and push-button ease of use, the new Tek 2246 (left) and 2245 (above) bring high-quality, low-cost analysis to diverse applications in digital design, field service and manufacturing.

Copyright © 1987, Tektronix, Inc. All rights reserved. TTA-687

Circle No. 26 on Reader Service Card

Vancouver 604-291-1222  
 Calgary 403-250-7583  
 Edmonton 403-434-9466  
 Manitoba & Sask. 1-800-663-1047

Toronto 416-675-3865  
 Ottawa 613-225-2850  
 Montreal 514-697-5340  
 Dartmouth 902-469-9476

**Tektronix**  
 COMMITTED TO EXCELLENCE