

stations in the news

Cogeco Bids For Quebec's Pathonic Inc.

Trois-Rivieres-based Cogeco Inc. has emerged as a bidder for Ste-Foy-based Pathonic Network Inc. in a takeover bid valued at \$64.7-million.

But before it can be successful Cogeco will have to persuade the Canadian Radio-Television and Telecommunications Commission to approve the deal involving companies that control competing television stations in two cities in Quebec.

Pathonic's major properties include TV stations CFCM Quebec City, CHLT Sherbrooke, CHEM Trois-Rivieres and CFER Rimouski, all affiliates of the French-language TVA network. It also owns CKMI-TV, the CBC English-language affiliate in Quebec City.

Among Cogeco's growing holdings are CKTM-TV and CKFM-TV in Trois Rivieres, which are, respectively, affiliates of the CBC French service and the Quatre Saisons Network. Cogeco also owns CKSH-TV and CFKS-TV, the CBC and Quatre Saisons affiliates in Sherbrooke.

Cogeco chairman, chief executive and controlling shareholder Henri Audet acknowledged getting the go-ahead from the CRTC will be difficult. But he said Cogeco and Pathonic are discussing a number of possible strategies to deal with the concentration of ownership issue involving the Sherbrooke and Trois-Rivieres television stations. He refused to say if this would involve selling any of the combined stable of TV stations. He also said that Pathonic's controlling shareholders, chairman and chief executive Paul Vien and vice-chairman Pierre Lessard, have a commitment "to accept our offer and only our offer."

Appeal Court Upholds Asper in CKVU Dispute

The British Columbia Court of Appeal has rejected an appeal by CKVU-TV Vancouver founders Darryl Duke and Norman Klenman of a B.C. Supreme Court ruling of July, 1987 that awarded I.H. (Izzy) Asper control of the station.

The decision came six days after Asper's CanWest Group of Companies formally took over the Vancouver independent television station.

But two more issues affecting the station still remain to be decided.

The first concerns a dispute between Asper, chairman and major shareholder of Winnipeg-based CanWest Communications Corp., and Edmonton broadcaster Dr. Charles Allard over his nine per cent stake in CKVU. Dr. Allard launched a suit claiming CanWest must sell its 76 per cent stake in CKVU to his company. Mr. Asper contends Dr. Allard must sell his stake to CanWest subsidiary CanWest Broadcasting Ltd.

The second issue still in dispute in the melodrama surrounding CKVU concerns a suit for damages that CanWest launched against Duke and Klenman alleging breach of contract and other complaints. The B.C. Supreme Court is expected to begin hearing those claims Oct. 29.

Also facing CKVU in October is an appearance before the CRTC when the television station will seek a five-year renewal of its broadcast licence.

Seeing is listening

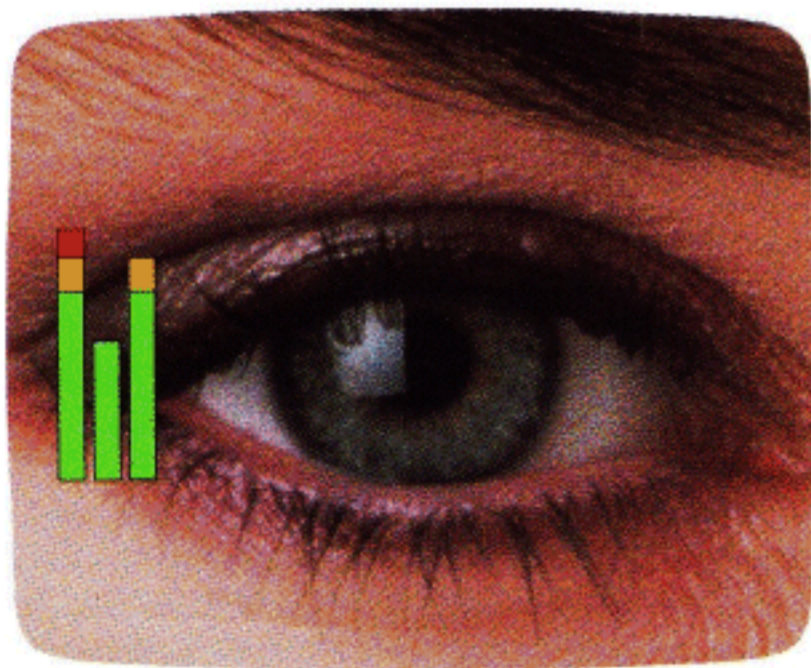

Canadian distributor



TELE-SYN
VIDEO INC.

No longer do you have to listen to broadcast sound levels to make sure they're what they should be. In fact, with the new SOL-20/20 you don't ever have to take your eyes off the screen.

The SOL-20/20 lets you "listen" in silence by displaying a stereo audio level meter in the form of three bar graphs right on the screen. They let you see instantly all you need to know about sound on either channel as well as phase information. And if the sound isn't what it should be, blinking dots and an audible warning signal alert you immediately.

The SOL-20/20...a quiet step forward.

SOLUTEC

H.A. SOLUTEC LTD.

MONTRÉAL/STE-MARTHE 24, 5e avenue, CP 389 Ste-Marthe-sur-le Lac, Québec J0N-1P0, 514-472-7231 Télécopieur (Fax): 514-472-5321
MONCTON Place Héritage Court, Fondery, suite 440 Moncton N.B. E1C-5H7, 506-859-7208 Télécopieur (Fax): 506-859-7208

AM Band Expansion In The Works For Canada

Communications Minister Flora MacDonald has announced expansion of the AM radio band, paving the way for hundreds of new radio stations to start up across the country.

Canada recently signed an international agreement with the United States and 20 other countries in South and Central America to open up the AM band from 1605 to 1705 kHz. Key element of the agreement will give Canada 10 new AM frequencies starting July 1, 1990.

Communications Department spokesman Michel Lucas said that although broadcasters haven't been beating down the doors demanding new frequencies, he expects there will be a fair number of applications to open new AM radio stations. He also said the airwaves over most cities with populations of more than 200,000 are almost full.

CRTC Streamlines To Better Serve Industry

The Canadian Radio-Television and Telecommunications Commission is being streamlined to better handle its job of regulating the airwaves.

The commission, in a July announcement, said its broadcasting section will be broken into three units to handle television, radio and cable.

The major reorganization was to affect about half of the 400 people who work at the CRTC.

Two top jobs were eliminated in the July 5 shuffle. Gone are the positions of executive director, broadcasting, held by Larry Durr, and director-general of broadcast operations, held by Gilles Courtemance.

But three new directorates, each reporting directly to CRTC chairman Andre Bureau, have been created: Television, headed by Robert Armstrong; Radio, headed by Peter Fleming; and Cable, Pay and Specialty Services, headed by Lisa de Wilde.

Also created in the reorganization was a Licensing Directorate, headed by Brien Rodgers, and a Corporate Analysis Directorate, headed by Bob Tyre. Each reports to the secretary-general of the commission.

The changes are reported to have been in the works for months.

And for the first time in almost a year the commission now has a full roster of full-time commissioners with the naming of three commissioners to seven-year terms in late June. The new commissioners are Frederic Arsenault, a long-time New Brunswick civil servant; Adrian Burns, an anchor and writer for CFCN-TV Calgary; and Edward Ross, a veteran advertising marketer who headed his own consulting firm. There are still three-part time vacancies on the commission to fill.

CRTC Unveils New Network Policies

Radio listeners will get more Canadian program variety from expanding radio networks as part of a policy proposed by the Canadian Radio-Television and Telecommunications Commission.

Canadian radio stations, particularly small ones, are able to buy programs from networks to boost their regular

TV Stereo Sound So Superior Engineers Prefer It!



TZ-30 TV STEREO GENERATOR

Broadcast engineers naturally are the most critical and discerning listeners when it comes to stereo sound. Here's what they had to say about the Broadcast Electronics' TZ-30 TV Stereo Generator.

"According to a viewer, Citytv produces the best Dolby Stereo Surroundsound around. That means our TV stereo amplitude and phase has to be right on."

Ron Reid, Dir. Oper. & Engring.
Citytv/MuchMusic/MusiquePlus
Toronto, Ontario

"Good, reliable unit with a very stable injection level."

Bruce Cowan, Trans. Spvr., Citytv

"The TZ-30 has remained very stable since we installed it a year and a half ago. A representative of the Communications Ministry recently checked it and it did not need to be adjusted."

Gerald Landry, Tech. Dir.
CFVS-TV, Rouyn, Quebec

"Built-in calibrator and Composite Equalizer Controls simplify set-up."

Gordon Langdon, Systems Engr.
Imagineering Ltd., Ontario, Canada

For more information on the TZ-30, contact the Broadcast Electronics' Representative nearest you.

AVR Communications, Ltd.
Scarborough, Ontario
(416) 297-9377

Marketing Marc Vallee Ltd.
St-Sauver-des-Monts, Quebec
(514) 227-1828

Nortec West Ltd.
Calgary, Alberta
(403) 243-5525

Nortec West Ltd.
Vancouver, BC
(604) 872-8525

BE [®] **BROADCAST ELECTRONICS INC.**

4100 N. 24th ST., P.O. BOX 3606, QUINCY, IL 62305, (217) 224-9600, TELEX: 250142, FAX: (217) 224-9607

We do it all!



- Guyed Towers: up to 2,300 feet
- Self-Support Towers: Light Duty VHF up to Heavy Duty in all height ranges
- Antennas and Combiners
- Flexible and Rigid Coaxial Lines
- Ancillary products for towers
- Grounding devices, connectors, switches
- Pneumatic telescoping masts

A complete line of products and services enables us to design, fabricate, erect, install, test, commission, service, and repair RF Transmission and Communications Systems of all types and sizes.

Ask us for full details.

Circle #160 on Reader Service Card



LeBLANC & ROYLE TELCOM INC.

"Much More Than Towers!"

514 Chartwell Road, P.O. Box 880
Oakville, Ontario L6J 5C5.

(416) 844-1242 • TLX: 06-982226 LR TOWERS OKVL.

VANCOUVER, EDMONTON, WINNIPEG,
OAKVILLE, MONTREAL, TRURO, ST. JOHN'S.

schedule against competition from larger stations, which can afford to produce expensive music and documentary programs.

Aware of the growing trend, the CRTC proposed a new policy and asked for comments from the radio industry. A public hearing is expected to be called once the commission has digested the comments it has received.

The policy proposed by the CRTC laid out for the first time general criteria for licensing network operations which, the commission says, have become a central component to Canadian broadcasting.

"There are small, independent syndicators popping up all over the country with creative ideas and there's been sort of a renaissance, particularly with network and syndications," said Mike Ferras, a CRTC economic and regulatory analyst.

The commission said the nature of networks and other syndicated programming arrangements is "uniquely capable of reaching, informing and entertaining Canadians with high quality, diverse programming." It said local and regional radio programs are still the main responsibility of AM and FM stations, but the new network proposals aim at allowing stations to combine their programs with the best of acquired programs picked up from other parts of the country.

The CRTC also asked for comment on proposed new television network policies that would "clarify and simplify" its policy framework for networks.

Selkirk Expands to Quebec Radio Market

Toronto-based Selkirk Communications Ltd. is expanding into the Quebec market with a deal to acquire two French-language radio stations from Radio Futura Ltd. of Verdun.

The purchase of rock station CKOI-FM and middle-of-the-road CKVL from Jack Tietolman, who founded CKVL in the 1940s and held 95 per cent of all shares of Radio Futura, is subject to approval by the CRTC. No purchase price has been announced. CKVL is ranked fourth in the Montreal market while CKOI is the No. 1 FM station.

In announcing the acquisition, Selkirk president George Meadows said Selkirk plans to invest \$7-million to upgrade the Verdun studio facilities and equipment of Radio Futura. A new

building will be built to house the two stations.

In a related move, Selkirk appointed Walter Machny as director of operations for Montreal. Currently president and general manager of Selkirk's Calgary radio station CFAC, Machny will co-ordinate the application to the CRTC seeking approval for purchase of the Montreal stations. He also will guide the transition of the ownership and assume responsibility for operations of the two stations.

A bilingual native of Montreal, Machny spent 18 years there in radio and television. He retains his positions at CFAC.

Group Makes Second Bid for Ottawa Licence

A group of Ottawa business people is making a second attempt to bring a new television station to the nation's capital.

Metro TV Ltd. has filed an application with the Canadian Radio-Television and Telecommunications Commission for a licence to operate an independent station in the market.

Spearheading the bid is Ted Billo, a Groupe Lavalin communications consultant who helped win the original independent licence for Baton Broadcasting Inc. Baton subsequently abandoned the licence when it bought CJOH-TV, the Ottawa CTV affiliate.

No details of the new application have yet been released.

If the CRTC decides to consider the application it will call for competing applications. And George Lund, vice-president and general manager of Mid-Canada Communications, owners of CHRO-TV Pembroke, said his company plans to compete with Metro TV for the licence.

NewCap To Buy Radio Stations in B.C.-Alberta

Newfoundland Capital Corp. plans to purchase the three radio stations of CFCW Ltd. of Edmonton--CFCW Camrose, CKRA-FM Edmonton and CHRK-FM Kamloops, B.C.

The proposed purchase is subject to approval by the CRTC.

CFCW was founded 35 years ago in Camrose by Hal Yerxa as a 250-watt country radio station. →

Newfoundland Capital operates a number of stations in eastern Canada through its subsidiary, NewCap Broadcasting. The firm is waiting approval of its recent purchase of seven Newfoundland radio stations from CHUM Ltd.

Allarcom Bids To Buy CKRD-TV Red Deer

Television station CKRD in Red Deer, Alta., will be sold to Allarcom Ltd. of Edmonton, says Bill Yuill, president of Monarch Broadcasting Ltd.

Allarcom, which owns Edmonton's independent CITV, will also operate an independent CITV station in Red Deer which is expected to go on air in May of next year. The sale must be approved by the CRTC. No price has been announced.

Allarcom also owns pay TV's Super-channel and has a 50 per cent interest in a children's channel.

Investor Seeks To Add To Radiomutuel Stake

A holding company controlled by the chairman of BCE Mobile Communications Inc. wants to buy about 25 per cent of the equity of Radiomutuel Inc. for approximately \$9.2-million. Radiomutuel owns five AM and seven FM radio stations in Quebec as well as 50 per cent of a newly-licensed French-language music video television service.

Charles Sirois, who is a director of Radiomutuel, said he isn't planning to try to take over the Montreal-based broadcasting company. He said buying 25 per cent of Radiomutuel will allow the holding company he controls to consolidate the holding in its accounts and give it about 43 per cent of Radiomutuel A shares outstanding. That would translate into about 15 per cent of the votes.

Radiomutuel chairman and chief executive Normand Beauchamp and executive vice-president Paul-Emile Beaulne would continue to control the company through their holding of B shares, which do not trade publically.

BROADCAST TECHNOLOGY

A BUYER'S GUIDE TO FIELD PRODUCTION PRODUCTS

Designed to work well when you're miles away from anything

Shure Field Production products are made specifically for out-of-studio film, remote recording, and video work. They're not "general" audio products that might (or might not) work when you're outside the studio. They are singularly rugged and reliable, eminently portable, and professional performers in every way.

FP51—Gated compressor/mixer

Rides gain automatically for a quieter, smoother, better-balanced sound. Eliminates background noise and "pumping" effect common to many compressors. Switchable mic/line inputs and outputs.

FP31



Industry standard mono mixer

This is the trail-blazing mini mixer that set a new standard for small size coupled with utter dependability. 3 inputs, 2 outputs.

FP32



Portable stereo mixer

First choice of field crews because of its light weight, easy-to-use controls, and convenient shoulder harness, 3 inputs, 2 outputs.

FP42



Stereo mixer

Simplifies mic cueing so important to sports. Pan pots enable you to mix down stereo in post production. 4 balanced inputs, 2 balanced outputs.

FP16



Distribution amp

A one-by-six distribution amplifier with transformer isolator and link jacks. Ideal as a portable press bridge.

FP11



Mic-to-line amp

The problem solver for long line situations with up to 84db of gain. Converts any mic to line level. Built-in limiter.

FP12



Headphone bridging amplifier

Keeps shotgun and boom operators on target without need for return line. Great for monitoring, troubleshooting, or intercom.

PROFESSIONAL CIRCUITRY PRODUCTS



A.C. Simmonds & Sons Limited

975 Dillingham Road, Pickering, Ontario LIW 3B2 (416) 839-8041

Circle #262 on Reader Service Card

CRTC Approves Two Cogeco Applications

The Canadian Radio-Television and Telecommunications Commission has approved two of three applications from Cogeco Inc. for the purchase of Quebec radio stations.

The commission approved the application by Cogeco to purchase Radio St. Hyacinthe (1978) Ltee, licensee of CKBS and CFEI-FM Saint-Hyacinthe, and the purchase of Radio Cote-Nord Inc., licensee of CHLC and CKDO-FM Baie Comeau and of CFRP Forestville.

However, an application by Cogeco that would have given it effective control of Radio Drummond (1980) Inc. and Communications Grantham Inc., licensees of CHRD and CJDM-FM Drummondville. The Commission said that Cogeco had not satisfactorily proven that the proposed transfers of control of the stations would yield "significant" benefits for the communities and would not be in the public interest.

Radio Drummond acquired CHRD, established in 1954, in 1981. CJDM-FM began broadcasting Aug. 15, 1987.

Cogeco Inc., through its subsidiaries, operates four Quebec television stations and two other radio stations. The company also has indirect interest in a number of cable undertakings that make it the third largest cable operator in the province as well as interests in pay television services and a private production company.

In other recent decisions, the CRTC:

* Renewed the licence of CKWK Corner Brook, Nfld., for only two years so it can assess the station's performance, particularly its local and regional news service, and its adherence to regulations concerning Canadian content and for providing proper logger tapes.

* Renewed for three-years the licence of CHER Sydney, N.S., so it can assess the station's overall performance, particularly its adherence to provision of logger tapes and to the amount of local and regional news that had been broadcast by the station. The station had told the commission that, under new management, it has increased its news staff and its commitment to provision of local news programming.

* Approved power increases from 24,000 to 100,000 watts for CKGL-GM Kitchener, Ont.; from 5,000 watts to 25,000 watts for CKEC New Glasgow, N.S.; from 1,000 to 5,000 watts for CKGA Gander, Nfld.; and from 28,200 to 39,000 watts for CKRO-FM Inkerman, N.B.

* Approved a CBC application for an FM station at Middleton, N.S. at 93.3 MHz with a power of 8,000 watts, to rebroadcast programs of the CBC English-language FM (Stereo) network.

New Montreal Facility For Radio-Canada

Radio-Canada has reached agreement with Prodevco Lavalin to build a \$50 million film and television production centre in Montreal. The centre, to be located adjacent to the east-end Maison de Radio-Canada building, will house three studios and an ultra-modern post-production facility as well as office space.

The 105,000-square-foot production centre will include a special effects studio and facilities for radio production. Work on the project is expected to begin this fall and is expected to take two years.

In other news from CBC:

* The CBC and Radio Nord Inc. have applied to the CRTC to disaffiliate CHAD Amos, CKRN Rouyn-Noranda, CKVD Val d'Or and CKLS La Sarre, all Quebec, from Radio-Canada, the CBC French-language AM radio network.

* CBC has applied to the Commission to change the frequency of CBCO-FM Orillia, Ont., from 105.9 to 91.5 MHz, relocate its transmitter site and reduce its power. The request is in line with the CBC policy of moving to educational FM channels where possible and free up commercial channels for use by private broadcasters. The CBC would cease operation of CBCM-FM Penetanguishene, Ont., if the application is approved.

* And CBC's new London, Ont., station replaced now-independent CFPL-TV as of September 4. CBC claims its six rebroadcasters in the region increase its potential audience by 1.2 million viewers.

BT

Our job is to keep you on the air

Continental Electronics has reliable and efficient transmitters and the same quality of service. We offer:



- Telephone assistance 24 hours a day, 365 days a year;
- Field service engineers skilled at troubleshooting;
- Critical parts orders shipped the same day;
- Technical training for all transmitters available;
- No charge for telephone assistance.

We're here to help keep you transmitting. For further information, contact:



varian®
continental electronics division

P.O. Box 270879 Dallas, Texas 75227
Telephone: 214-381-7161 Fax: 214-381-4949

Howard Christensen's column:

'Good Humor Makes Most Things Tolerable...'



PEOPLE AND STATIONS . . .

My western colleague, BN Gen. Exec. **Jerry Fairbridge** says **Mel Friesen** is president and GM at CKCK-TV Regina... **Howard Cooper** is new president and GM at CFQC-TV Saskatoon... **Leon Brinn**, the former CFQC ND, is GM at CKBI-TV and CIPA-TV, Prince Albert... **Brent Seely** is OM for both CILA-FM and CJOC Lethbridge... **Ray Telford** is GM at CKNL Fort St. John/CFNL Fort Nelson, taking over from **Brent Fitzpatrick**, now at CKGY Red Deer... Over at CFOK Westlock, **Phyllis Sheppard** is GM after **Len Novak** got bumped up to managing director. Len's overseeing operations at CFOK, CKNL/CFNL, CHLW St. Paul, CILW Wainwright, CKWA Slave Lake and CJOI Wetaskiwin... And **Jim Yount**, formerly at BCIT, is now ND at CKXY Vancouver.

The WAB has established a scholarship in honor of **Dr. G. R. A. Rice**, the broadcasting pioneer who built CJCA Edmonton and later began CFRN... The association also named **Blair Nelson** of Russwood Broadcasting (CFQC Saskatoon, CKBI and CIPA-TV Prince Albert, CKCK-TV Regina and CICC/CKOS-TV Yorkton) as its Broadcaster of the Year.

Dennis O'Neill is VP & GM at CFBC/CJYC-FM Saint John after a stint at CKNG-FM Edmonton... Former GM **Ralph McLenaghan** is VP, radio development for CFBC owner Fundy Broadcasting... **Paul Schurrman** and CJRW Summerside staff are celebrating their 40th anniversary... GM **John Mackey** left CJLB Thunder Bay for other broadcast pursuits in Toronto... **Charlie Russell** is the proud owner of a pre-owned radio station, taking over CJCJ Woodstock from boss **Bruce Groh**... CKVR-TV Barrie ND Barrie **Tony Panacci** is driving a new VW Jetta, replacing his old Toyota. Volkswagen Canada's **Ingrid Christensen** ("Pardon me, but your face is familiar!") put her training and development skills to work on him.

CJCB Sydney ND **Dave Wilson**, at a Calgary RTNDA executive meeting, didn't know what to make of a dinner companion who thought the bowl of ice cubes was meant for dipping his fingers. Turns out the 'finger bowl' got there ahead of the prawns, but not before the anonymous one stuck his hands in... The neighborhood bistro is too small. How small is it? It's so small you can hardly squeeze in on some nights. But when you do, it's great to find familiar faces like CFRB Toronto talker **Ed Needham**, his wife **Louise**, and Easy97 Toronto ass't GM **Bill Ballantine**... Speaking of Easy97 (CJEZ-FM), **Erin Davis** moved from CKO to join their lineup of on-air personalities.

John Enright, ND at Bracebridge's new FM'er, takes delight in letting anyone know that CFBG-FM's address is Balls Drive... JC55 and I-98 Kamloops have moved former OM **Rick Arnish** upstairs into the GM's job, replacing retired **Dave Clark**. Moving to OM, while holding onto his ND duties, is **Doug Collins**... At CFTR Toronto VP-PD **Sandy Sanderson's** house, wife **Anne** controls the budget. So it was tough for Sandy to squirrel cash away over a six month period. But it was worth it. For Anne's birthday, Sandy had enough to fly both of them to Paris. There they met friends from Ireland before all four boarded the Orient

Express. Sandy didn't tell Anne about it until the very last day.

In it's editorial about CKFM Toronto's CRTC hearing (over the hits/non hits ratio), the Globe and Mail reported that Standard Broadcasting boss **Allan Slaight** had called the affair "a sobering and mortifying experience." Said the Globe; "Sobered, mortified and stung for too much Sting." The piece went on: "The CRTC was acting in the name of variety, as it must, but so often comedy comes out instead." The Globe's definition of the FM Regs? "To prevent pandering to pedestrian persons perversely prone to popular products."

Rock 103 Moncton receptionist **Penny Osborne** says she enjoyed reading the piece here a while back about the contribution made by radio & tv receptionists. All she could think of as she read it, she says, was: "Ain't that the truth." But Penny wasn't too thrilled with my flip response to a letter from CFYN Sault Ste. Marie receptionist **Victoria Ozols**. In Penny's words, "Get your own G.D. coffee."

Former CHOO Ajax GM **Lorna Braid**, and husband **Reg**, were attending their last CCBA convention, this one at Kingston. Lorna has since retired. Both are now 'fifth wheeling' (trailing) in Texas. **Dave Hughes** is running the shop for **Elmer Hildebrand's** Golden West Broadcasting... The CRTC's **George Coates**, trying to open a window on a bus, was moving buttons the wrong way. Someone yelled, "You're doing it backwards," to which CKSL/CIQM-FM London GM **Gord Hume** quipped, "Typical!" (He was just kidding, George. Honest)... Telemedia Ontario's **Bob Templeton**, based at Sudbury, is learning to fly. Last word was that Bob is having trouble with crosswind landings.

Jerry Stevens says he's happy in his new PD posting at W1310 Ottawa after so many years in London... CFOB Fort Frances president **Don Fawcett** got a short gig as a vaudevillian on a Kingston showboat. If you want him, he works under the stage name, "Harry Herkimer". (Incidentally, Don's stations at Kenora (CJRL) and Dryden (CKDR) are celebrating anniversaries this year. CJRL is 50 and CKDR turned 25)... CHEZ-FM Ottawa president **Harvey Glatt**, and his wife **Louise**, were on the same cruise. Harvey even shared a cookie... BN GM **John Rea** was a bit pooped. It was his third convention that week; WAB in Jasper, RTNDA at Calgary, and then Kingston... **Andy Sparling** of Belleville's Loyalist College straightened me out on the difference between the *Mr. Ed* and *Flipper* themes ("A fish is a fish, of course, of course.").

Al MacKay, VP, station manager and all-round good guy at CJOH-TV Ottawa, has a wonderful fable about an elephant trapped in a pit and a mouse with a BMW. Anyone interested should check with Al for the moral... Mid-Canada Radio guys from Sudbury -- **Gerry Clifford**, **Chuck Babcock** and **Paul Scott** -- made for fun dinner companions at a Wolfe Island restaurant ("Buns? What buns?").

A note to **Bill Morton** of CJBQ Belleville; I won't be forgetting your name again... CFPL London's **Bill Brady** told a great story about literally falling over comedian **George Burns** at a Texas airport.

CKLC Kingston was named *Radio Station of the Year* for its *Music Project* to develop and promote local Canadian talent. Next day, CFFX Kingston announced the victory and congratulated the market competitor... **Michael Caine** of CHWO Oakville, at the President's Dinner, inadvertently coined a new word I kinda like, 'sinseriously.' Give Michael credit; he stuck with it.

Most touching event was a posthumous presentation to **Paul Mulvihill**, the co-winner of the Ruth Hancock Friend of the Industry award. Accepting were **Margaret Mulvihill** and son, **Joe**. **Joe's** speech didn't leave a dry eye in the house... **Roy Caley** of CHOK Sarnia won honors as *Broadcaster of the Year*. Listening to his acceptance speech, you understood why. Roy has a magnificent talent to actually, wait for it, COMMUNICATE!.

R.K. (Bob) Macdonald, VP & GM at CKOC/CKLH-FM Hamilton, won this year's Howard Caine Memorial Award. Armadale people seem to have a lock on the honor. Over the past few years, CKOC PD **Nevin Grant** and CKLH-FM morning driver **Paul Hanover** also won. Incidentally, **Bob Macdonald** is now VP of Radio Development for Armadale and **Wolf von Raesfeld**, ex SM at CFRB Toronto, is new CKOC GM.

You'll want to know that the new CCBA President is CJSS Cornwall GM **Keith Clingen** for whom things continue to modulate... **John** and **Joanne Manol** from CKPT Peterborough, with some help from Major Market Broadcasters'

Larry and Joan Lamb, helped sort through my breakfast selection the morning after the night before.

NEWS HANDLING . . .

Leading a story, "A young offender has been charged ..." convicts before trial. Although we haven't found a succinct phrase to cover the mouthful which includes reference to the Young Offenders' Act, perhaps you or your station has. Are "teenager" or "juvenile" (for those under 13) appropriate single word substitutions? If you've got the answer, let me know.

CFNB Fredericton reporter **Ken MacGillivray**, doing police checks, engaged the person who answered the phone in the usual reporter repartee, "How ya doin'? What's goin' on?" Turned out the guy on the other end of the line began talking about provincial Progressive Conservative affairs. Amazingly astute, Ken picked up on the fact that maybe things weren't quite what they should be. In the course of going through the Rolodex on a quiet day, Ken had misdialed, by one digit, and instead of getting the police he'd reached the office of Richard Robertson, the president of the New Brunswick Tories. And he got a story, too.

When at your next news conference/interview and you're getting bafflegab, bring the subject back to earth with this: "Explain it to me as if you were talking to your mother."

Fred Berns, of Washington-based The Berns Bureau, provides news to Canadian stations on such things as B.C. lumber, Quebec syrup, Saskatchewan potash, fishing disputes and extradition treaties, not to mention International Trade Commission investigations (which I just mentioned). As well as providing the stories, Fred's besieged by Canucks wanting souvenirs. He's tracked down and answered requests for Redskins sweatshirts, Pentagon studies, Congressional directories, FBI tours, hotel accommodations and has supplied information about theatrical events at Kennedy Center. Fred's most recent request came from CKUA Edmonton assignment editor **Ken Regan**, who wanted a poster of the Paul Gauguin exhibit at the National Gallery of Art. If you've got a need for Washington coverage (or you're looking for some goodies), check Fred at (202) 484-1840.

MARKETING . . .

In May, I told you about Virginia radio sales rep **Carolyn McCollum** and how she'll keep a lead-generated prospect on the phone a bit longer to develop a rapport, no matter how small, before visiting. Carolyn's attitude is that it's easier to deal with a friend. A recent edition of Sales Upbeat had more news of her.

Carolyn recognizes that everyone loves being the centre of attention and she uses that knowledge to her advantage. When prospects say they aren't interested in advertising for one reason or another, then turn a deaf ear, she'll end the conversation on a polite note: "Thanks for your time. Is it all right if I give you a call in a few weeks, just to keep in touch?"

She then spends some time thinking about what the prospect said. Most objections, she finds, come from misinformation, either about her station or about radio advertising in general.

DIRECTOR'S CASE



► When calling on a client, attending a conference or trade show, there's room to spare, with easy access slip pockets, secure zippered pocket and velcroed script or file pocket... then the detachable pouch to carry an SLR or small camcorder and accessories to take on location while scouting a scene. Call for more information.



K&H Products, Ltd.

Box 246 PHONE 802-442-8171
North Bennington FAX 802-442-9118
Vermont 05257 TLX5106005222 K AND H

Then Carolyn writes a personal letter to the prospect, explaining her side of the story: "I understand your hesitation to advertise on the radio, so I have enclosed some information that may clear up some of your questions . . ."

The response is usually favorable.

In fact, she won a national account that way! The man to whom she wrote called after sending the order to say he had been impressed by the fact that she took the time to write. He felt the letter showed she cared about his business and his interests.

PROGRAMMING . . .

It's not often a radio station wins a prize. But that's exactly what happened for OM-FM Windsor. PD **Ian Davies** and promotions type **Keith Chinnery** flew off to England thanks to Pepsi Canada to see Michael Jackson at Wembley Stadium. OM-FM won the trip for most entries per market capita in the "Bad in Britain" promotion.

CJCB Sydney threatened listeners with taking *The Unfriendly Giant* off the air. PD **Donnie Graham** says the reaction was unbelievable; even a petition circulated at an area high school protesting.

QUICKIES . . .

MITV (Maritime Independent Television Network) is polishing the act, getting set for their debut this month from

their Dartmouth studios... CIWW/CKBY-FM Ottawa ND **Brian Crawford** is recuperating nicely after a stroke suffered last Spring. He's now back at work... New ND at CFTR Toronto is **Larry Silver**. Heading upstairs to take over CHFI-FM's news department is **John Hinnen**.

At CKX-TV and Radio, Brandon, **Bob Neeve** is now ND. Bob has worked in "The Wheat City" under the name **Bob Bruce** for upwards of nine years after radio stints in Ontario... Former CFOR Orillia ND **Kevin Kanne** moved back to his home town, taking over the ND duties at CJTT New Liskeard... **Erin Mills**, former ND at CJKL Kirkland Lake, is now working for CBC Radio in Sudbury.

Willy Percy and **Larry Hennessey**, who'd been doing AM Drive at CKPR Thunder Bay the past three years, have been recruited as the new morning drivers at CFOX Vancouver. CKPR PD **Ray Dee** had mixed emotions, glad Larry and Willy made such a fabulous move but sorry to be stuck looking for new morning talent. Ray says Moffat Communications consultant **Chuck McCoy** calls the pair the "freshest thing" he's heard in Canadian radio.

John Badham, ex of CFRA Ottawa, is prepping and reading morning news for CHEX Radio at Peterborough. And **Lauren Lee**, co-anchor of CHEX-TV's evening news, moved to CFPL-TV London to cover the late package there... New reporter/editors at Broadcast News in Toronto include **Geri Smith**, ex of CHYM Kitchener; **Colin Perkel** from CBC-TV; **Ralph Leven** from CJSB Ottawa; and **Mark LaVigne** from Toronto's CJEZ-FM.

Carol Weir, VP at RBC for six years, has moved to All-Canada as Manager-Radio Marketing Services... CHYM Kitchener ND **Don Grose** moved into retail sales at the station... At CHOK Sarnia, **Linda Tracey** from part-time at CJBK London, is on-board while **Mike DeJong** moved to CKNX Wingham... Long-time ace right-hand woman to **Bob Redmond** at CHSC St. Catharines, **Stephanie Kalynka**, is getting married this month to Ottawa free-lance sales/consultant **Clyde Ross**. All the best, Steph.

KICKER . . .

A certain radio station has an absentee owner who shows up only occasionally. When he does, he checks in with his GM, then browses around the shop. This fellow doesn't really have too great an understanding of what broadcasting is all about. In a recent bid to develop camaraderie with the engineer, Mr. Owner sidled up to the hapless techie and asked, "So, how are things going out at the old transistor site?"

Let me know what's going on at your place...who got promoted, who left, who bloopered, who arrived, interesting promotions, unique programming. Send it to me c/o Broadcast News Ltd., 36 King St. East, Toronto, ON, M5C 2L9.

VIDEO DESIGN

EQUIPMENT RENTALS

CHYRON 4100-EXB

- Standard System for Network Sports.
- Complete Air Package.
- Dual Channel Fully Loaded Sports Configured.
- Background Graphics Capability.

CHYRON SCRIBE

- The Ultimate Text Generator.
- Full 3D Graphic Capability.
- Variable Light Source Shading/Texture Mapping.
- Logo Compose.

CHYRON VP2

- Standalone Low Cost Character Generator.
- 35ns Resolution.
- Internal Keyer.
- Palette Animation.

CMX 100

- Great ENG/EFP Portable Editing System.
- Complete with Built-In Switcher and Mixer.

Call Us Today For Daily, Weekly and Monthly Rates.

(416) 677-5461

Watch for BT's coverage of CCBE Oct. 18-20 in Ottawa; CAB/WABE Nov. 6-8 in Winnipeg.

New Frequency And Facilities for CHSJ



CHSJ's New Production Room



The New Control Room at CHSJ

by Steve Wilson

CHSJ Saint John, New Brunswick, commenced broadcasting in March, 1934. Originally known as CFBO, it had a power output of only 100 watts.

In 1940, the decision was made to increase the transmitter power to 1,000 watts, providing a better service to the growing community. The transmitter site was moved to Coldbrook, as the original location on top of the Capital Theatre was no longer suitable.

In 1947 the power output was increased to 5,000 watts, and the building -- still on the site -- was constructed. In 1960, power was again increased, to 10,000 watts, the present level.

When the Coldbrook site was chosen, no houses or businesses were in the area.

But that was 48 years ago

Today, with the city having expanded all around the Coldbrook area, and the ground system having completely disintegrated, a new transmitter site had to be found.

Move to 700 kHz

With CRTC approval for broadcast on 700 kHz, CHSJ's search for a new transmitter site commenced in earnest. In the summer of 1987, a site was located 30 km to the south-west of Coldbrook.

As most of the electronic equipment was of early '60s vintage, it was necessary to replace 95 per cent of it with new AM stereo equipment. And, of course, it wouldn't be right to have all of this great-looking equipment sitting in old control rooms.

New Production Room

First, scale models were made of the new rooms.

Construction then started on the production room first, so that all the stereo music could be carted and ready to go when the other facilities were completed. The production room construction took approximately three weeks, then equipment installation took one week.

Equipment in the new production room includes a McCurdy SS8816 console, two Technics SP10MKII turntables, four ITC Delta series cart machines (two with record capability), a Delta ESL-V erasure splice finder, two Denon CD players, two Revox PR 99MKII, one Technics RS-B905 cassette deck, Studer/Revox telephone hybrid, four custom switching panels, one Bryston stereo amplifier, two EV

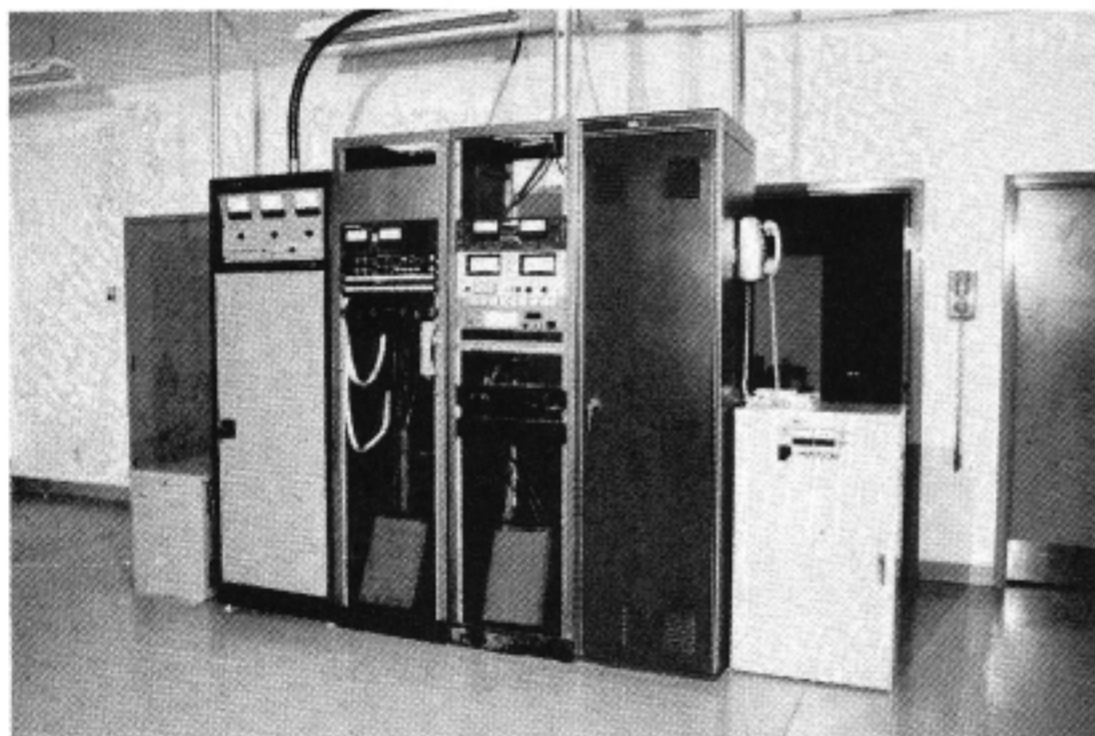

A look Inside the New Transmitter Building



News booth in renovated CHSJ studios

100 speakers, Sennheiser mics and headphones, and a Garner 105A bulk eraser.

Most of the equipment was supplied through Maruno Electronics Limited. Yamaha provided an REV-7 digital reverb. The rooms were designed by Steve Wilson, console woodwork was by MEL Cabinet Systems, while the woodwork in the studios was done by Ted Johnson.

Control Room Rebuilt

Once the production facilities were in operation, the former production area was gutted so that the new control room could be constructed. After another couple of weeks, this room was ready for equipment installation.

The new control room is equipped with a McCurdy SS8816, one Technics turntable, six ITC Delta cart machines, two Denon CD players, two Revox PR 99MKII, one Technics cassette deck, Studer/Revox telephone hybrid, one Bryston stereo amplifier, two EV 100 speakers, Sennheiser mics and headphones, and CRL audio processor, supplied by Maruno. Remote control is a Moseley DRS 1.

New Xmitter Building

While all this activity was taking place, work crews were busy completing the transmitter site. (Work had started in October -- lots of trees down there!)

Not only was the building new, so was much of the equipment, as the photo on the preceding page shows. From left in the photo are: the 208VAC step-down transformer, a Nautel 10 kw transmitter, exciter and processor rack, monitor rack, N.B. Telephone LD1 digital audio rack and battery charger.

Equipment at the transmitter site includes N.B. Tel LD1 PCM audio system, CRL audio processors, Motorola C-QUAM stereo generator, 10 kw dummy load, vector phasing equip-

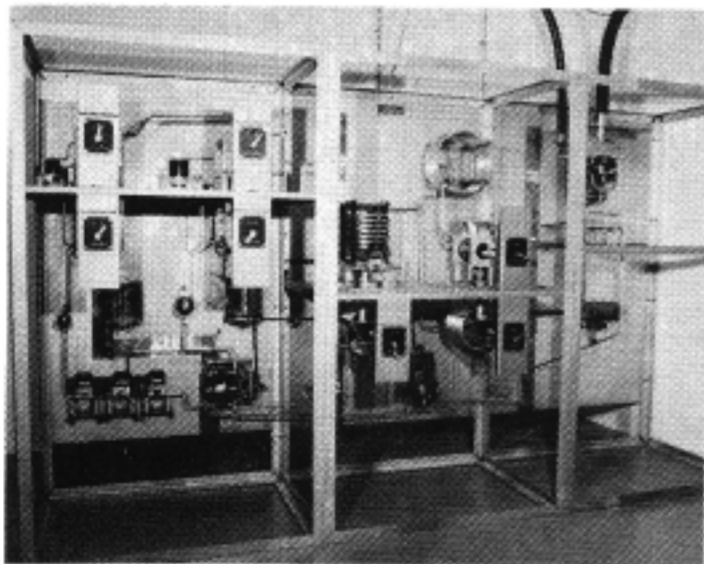

Main Phasor at Transmitter Site

ment, three Tylon towers and a diesel back-up generator.

The grounding system for the three towers consists of a 20-foot square copper mesh, with 120 equally-spaced radials. The copper mesh provides a more stable ground-wave pattern.

Work Was Worth It

Many long, hard hours were put in by the CHSJ staff to see this project completed, with very few technical

problems. When the transmitter switch was flipped on for the first time everything worked perfectly!

CHSJ's move to 700 kHz with AM stereo took effect on February 25, 1988 and has been followed by numerous reports of improved reception in many parts of New Brunswick and Atlantic Canada.

(Editor's note: Our thanks to Steve Wilson and the CHSJ staff for their cooperation in preparing this article for Broadcast Technology.)

DENON
CD CART PLAYER™
DN-950F

DENON Sets New Standards for Easy
Operation with the World's First
CD CART PLAYER™

DENON Canada Inc.
17 Denison Street, Markham, Ontario L3R 1B5
Telephone: (416) 475-4085
FAX: (416) 475-4159

BROADCAST BEAT

by Phil Stone

Summer Summary:

Sad news was the passing of **Dol McCreath**, wife of Selkirk VP **Ross McCreath**, with whom we are working in the gathering of audio interviews for the broadcasting industry's archives...**John DeForest**, president of the Radio Sales Bureau, reminds one and all that the annual Radio Awards presentation will be held Tuesday, October 25th in Toronto's Roy Thomson Hall...TVB'S annual Sales management Conference (SAC), will be held on the 28th of this month through the 30th at Banff...French, Canadian and American TV producers got together to produce *Champagne Charlie* a four-hour TV mini-series spotlighting champagne company founder **Charles Heidseick**. Director is Canadian **Allan Eastman**. The programs will be aired by CTV this fall...**Jim Black** left Toronto's Q107 to join the Neil Martin Group as an account supervisor...**Rena Krawagna** became program advisor for CBC Television's Office of Independent Production in Toronto...CKVR Television in Barrie did an outstanding job of promoting its summer calendar of Classic TV programs and movies...It is 25 years since the Alliance of Canadian Cinema, Television and Radio Artists (ACTRA) became a national body...Once a copy writer at CFOX Montreal, and then a major figure in the ad agency world, **Jane Williams** became vp/management director at Young and Rubicam...**Nancy Brown** became gm at CFGM Richmond Hill/Toronto, succeeding **Barry Trebell**.

It was a boy, her first child, for **Hana Gartner**, co-host of CBC-TV's *the fifth estate*...**Andrew Shapiro**, director of

marketing for TVOntario, says that sales of new product and services around the world in the past fiscal year grossed \$3.8 million...**John Saunders**, once of CITY-TV sports, Toronto, is now happily ensconced with ESPN where he chairs the nightly *Sports-Center*...**Sandi Rinaldo** started her career with CTV as secretary for news director **Don Cameron** before making it on air.

The recent passing of **Bill Byles**, at 73, took away a man who had truly been a colorful legend in broadcasting and advertising. He was an imaginative, inventive pioneer whose mark will live long in media history. One of his landmarks was bringing a young comedy team to radio. They were originally billed as Shuster and Wayne...CKO's **Bob McLean** became a member of the Variety Club of Ontario, as did **Nigel Watts** of MCA-TV...**Mimi Fullerton**, director-general of TVOntario, announced the appointment of **Donald Duprey** as managing director, English Program Services...**Wolf von Raesfeld**, who had been gm at CFRB Toronto, became gm of CKOC and CKLH-FM Hamilton, owned by Armadale Communications Ltd. According to Ad News he replaces **Bob Macdonald**, who will be devoting himself full-time to duties involving Armadale's radio operation in three markets.

Deryl Ring was appointed Co-ordinator of National Sales Activities at the Saskatchewan Television Network...**Fernand Seguin**, the veteran broadcaster who died at 66, wrote and moderated the first scientific telecast in French...**Ralph Mellanby**, the Canadian Football League's director of broadcasting, joined Vickers and Benson to form a production company that will broadcast and film sports events...We had a note from **Glen Barnett**, president of KWCY AM/FM Palm Springs, telling us that **Alyce Walker**, whom we profiled in a recent issue of BT, had retired from the station after 20 years service.

Elwy Yost, the popular TVOntario movie man, will host on a cruise for film buffs departing in October on S.S. Rotterdam. Guest lecturer for this Caribbean cruise is a yesteryear movie star, **Virginia Mayo**...We heard that CBC has 220 people in Seoul for their 10-hour-a-day coverage of the Olympics...**Edward (The Equalizer) Woodward**, told the Globe and Mail's **John Haslett Cuff** that he thinks British TV is better than the North American version because it "maintains a higher standard of writing and developed out of a theatrical tradition, while the U.S. industry grew out of radio, where the concept of 'product' was already well entrenched"...

Doug Ward became station manager for CBO Ottawa...The main stage at Toronto's Young People's Theatre is being named after **Susan Douglas Rubes**, founder of YPT. She was later head of radio drama for CBC and is now president of the new pay TV feature, Family Channel...It's estimated that 48-year-old ABC-TV personality **Ted Koppel**, who has been with the network for 25 years, earns \$1.5 million annually...CJEZ-FM Toronto newsman **Neal Sandy**, spells it that way, not Neil...Speaking of names, **J. D. Roberts**, of CITY-TV Toronto anchor, was christened John David. According to **Susan Ferrier-MacKay**, who recently profiled J.D., he entered the University of Toronto at 16 intending to become a dental surgeon but, after becoming involved with the university's radio station, decided instead to go into broadcasting and got started in CFOS Owen Sound before moving to CHUM in Toronto and then to CITY.

A NALPAK CASE FOR YOUR VALUABLE EQUIPMENT



QUICKSHIP
ATA type reusable shipping containers by Bel Air.

SOFT-PAK
Shock proof, durable, stain resistant tripod bag.

TRIPAK
Strong and durable tubular cases.

DRY-PAK
Strong, durable, water tight professional equipment protection.

TRAVEL KART
Lightweight, compact, all purpose carrier.

CINEQUIP INC.

Write for details
275 MacPherson Ave.,
Toronto, Ont.
M4V 1A4

(416) 920-5424
Telex 06-23752
Fax 969-9835

Sales • Rentals • Service

OR SEE THEM AT DIMENSIONS 88 - BOOTH 1313

Circle #121 on Reader Service Card

Jester Hairston, who plays the blunt church elder Rolly Forbes on *Amen*, is said to be the oldest sitcom regular at age 87.....**CHCH-TV** Hamilton, became the second Toronto-area TV station to program 24-hours a day when it decided to broadcast throughout the night...**Erin Davis**, whom we earlier reported as leaving CKO for CJEZ-FM Toronto, is working weekends as an on-air personality...Singer **Kenny Rogers** will host a daily syndicated TV talk show, scheduled for telecast this fall...**Bob McCown** returned to CJCL Toronto to host a sports talk show. He'd been with the station until 1981 when he moved to Global to get its late-night *Sportsline* underway...It should be noted that earlier this year, **E. R. Jarman**, industry pioneer and Chancellor of Canadian Cable Television Association's Honor List, was saluted by the University of Western Ontario. The school conferred upon him an Honorary Doctor of Law degree...**Al Waxman** was elected chairman of the Academy of Canadian Cinema and Television... CTV plans to expand its weekly amount of closed captioned programming to 20 hours from 17 as the result of a new in-house captioning service...After a spell with Glen-Warren Broadcast Sales, **Paul Sweeney** has returned to Radio-Television Representatives in Toronto. He is with the TV sales force.

If it hasn't happened yet, look for the marriage of *The National's* host **Peter Mansbridge**, 39, to **Wendy Mesley**, 31, a CBC parliamentary reporter in Ottawa. Previously married, Peter has two teenage children...**Suzanne Legue** of CKVR-TV Barrie's public affairs program *Close-Up* was the subject of a rave by the Toronto Star's respected TV writer, **Jim Bawden**. In part he said that Suzanne "runs rings around the network competition" at the Barrie station...**Peter Trueman** lost his father, **Albert Trueman**, a distinguished educationist who in his time served as chairman of the National Film Board, director of the Canada Council and chancellor of the University of Western Ontario...**Elaine Ali**, appointed assistant gm at Winnipeg's CKND Television, is also continuing as Director of Finance & Administration of STV, CanWest Capital Group of Companies' two independent stations in Saskatchewan.

A reminder that the joint convention of the Canadian Association of Broadcasters and the Western Association of Broadcast Engineers will be held in November at the Winnipeg Convention Centre. In the meantime there is the Atlantic Association of Broadcasters convention, at the Algonquin Hotel in St. Andrew-by-the-Sea, N.B. Sept. 23-25; the Ontario Cable Telecommunications Association Conference, to be held at the Constellation Hotel, Toronto, October 18-20; and the Central Canada Broadcast Engineers convention at the Westin Hotel, Ottawa, October 18-20...It is expected that the handsome new building **Johnny Lombardi** is having erected to house his CHIN radio stations, and other enterprises, will be ready for occupancy this November. It is located across College Street in Toronto from the present CHIN facilities.

Peter Reback, executive producer of CTV's *W5* has authored a book, *Undercover Agent* to be published next month by McClelland and Stewart...**Ronald Corey**, the former journalist, broadcaster and radio and television producer, has been made president of a division created by Molson's to co-ordinate its sponsorship of sports and entertainment events. Corey, who is president of the Montreal Canadiens hockey club which Molson's owns and for whose games Molson's has the broadcast rights, is also vice-chairman of the NHL.

BROADCAST TECHNOLOGY

Create with Your TBC



Your video production creativity soars to new heights with ALTA's Cygnus. Our infinite window TBC/Synchronizer and its palette of special effects transform your video production dreams into reality.

With Cygnus' **Digital Picture Freeze**, strobos, variable posterizations, colorizations and variable mosaics, your creative limits vanish. And ALTA takes your video production dreams one step beyond with full 8-bit resolution, proc amp controls, 4 x 1 video/stereo audio switching and separate vertical and horizontal image enhancement controls. You master the entire spectrum with finger-tip ease.

Video visions materialize with Cygnus, ALTA's unbelievably economical creation for only \$8,500. Contact us for complete details.

TELE SYN, Quebec 514-472-7231 VIDEOSCOPE, Ontario 416-449-3030 WESTERN CINEVISION, Alberta 1-800-661-1542 MATRIX, B. C. 604-875-6301

Cygnus ALTA GROUP, INC

535 Race St. San Jose, CA 95126 408-297-2582

Photo by Paul Topley. Compliments of San Jose Cleveland Ballet.

Circle #237 on Reader Service Card

Dining on Toronto's Danforth Avenue one night this summer we ran into **Harry Rasky**, whose weekly documentaries on CBC-TV have been winning him fresh accolades. One of his first jobs in broadcasting was in news at CHUM in the early 50s...1989 will see the beginning of construction on a \$50-million centre for movie and TV production on CBC land in east-end Montreal...Because of falling movie house attendance, French TV stations are limited to showing two movies a week in prime time - that's 8:30 to 10:30 p.m. in France...Canadian Home Shopping Network, which markets a variety of consumer products through a televised shop-at-home service to Canadian cable subscribers coast-to-coast, has a new leader. He is **E. S. Ted Rogers**, chief executive officer of Rogers Communications Inc. He replaced **John Goldberg** as chairman. Goldberg will continue as a director and consultant for the company for the next three years.

After six years of dedication and contribution, **Carol Weir** left the Radio Bureau to go with All-Canada Radio & Television...While continuing as host of TVOntario's highly popular *Saturday Night At The Movies*, **Elwy Yost** will appear with the Scarborough Philharmonic's 1988-89 subscription series, joining music director **Chris Kitts**...**Richard Ian Laidlaw**, whose broadcasting career spanned 30 years died, in Charlottetown at age 60. He was likely best known for his terse, caustic views of life in Ontario aired on CBC Radio in the 70s...In a streamlining move, the CRTC will be broken into three units to handle radio, television and cable...**Linden MacIntyre**, who has hosted CBC Radio's *Sunday Morning* for the past two years, left the program to return to CBC-TV as a journalist producer with *The Journal*...**Murray Marchant**, who had been vp, finance at First Choice, is now with Astral Bellevue Pathe Inc., Montreal. His successor is **Richard (Rick) Miller**, who had been with Columbia Records, City-TV., CFMT-TV, and Cybermedix...Fox Broadcasting will carry a two-hour program in late November covering the induction of newly-elected personalities to the Academy of Television Arts & Sciences Hall of Fame. They will include **Jack Benny**, **George Burns** and **Gracie Allen**, **Chet Huntley** and **David Brinkley**, **Red Skelton**, **Davis Susskind** and **David Wolper**...**Karen Bryant**, director of promotions at CKGM Montreal, was elected an executive vp of the Advertising and Sales Executives Club of Montreal...D'Arcy Masius Benton and Bowles, Toronto, named **Virginia Smith** senior broadcast producer.

Elmer Hildebrand, the Western Association of Broadcasters' secretary-treasurer, let us know that the 55th WAB Convention will be held next year in Jasper, June 4th to 7th. **Verne Trill** is the 1988-89 president of the Association, having succeeded **John Cochrane**...**Ted Eadinger**, who had been president of CFQC-TV Saskatoon, became vp and gm of CFPL-TV London

CCBA Retrospective:

When we returned from Kingston last June from the 38th annual Central Canada Broadcasters Conference, it was too late for us to get our personal notes into the July issue of *BT*...But it's never too late to play catch-up when you're writing about interesting, warm people present at an outstanding event...One of the highlights of the CCBA gatherings is always the presentation of the *Howard Caine Award*, honoring a very special man whom we all loved and admired.

Three generations of the Caine family were present for the presentation: **Jean Caine**; her son **Michael**; and Michael's wife **Annette** and their three children, **Matthew**, 13; **Natalie**, 7; and **Travis**, 3. As Michael is following in the footsteps of his late father, so we feel will his children, learning at an early

age how their heritage is interlocked with Canadian broadcasting...*BT* was well represented at the Conference. Among those present were columnists **Howard Christensen** and **Howard English** as well as sometime contributor **Wayne Stacey**, and this writer. Howard English had an exhibit there for Randal-English Consulting. He told us that **Ted Randal** had dropped out of the firm, was doing some teaching at Humber College and living on his boat. Working with Howard was attractive **Kellie Edgar**, serving as Music Director and handling Client Relations. Howard said his firm now has 27 clients. He was part of the panel that discussed "New Technologies Which Can Effect the Bottom Line", one of the many interesting and informative events on the CCBA agenda.

Al Brooks said of **Flora McDonald's** pursuit of more Canadian programming on Canadian TV stations: "That's fine, I'm in favor of it. But how do you get Canadians to watch Canadian programming?"...Loyalist College of Belleville, just down the road from Kingston, was the host college for the conference and **Brian Olney** did a great job of seeing that people were enjoying themselves. He did get a lot of ribbing for waking people up to attend breakfast sessions, but no one threw him off the ship (boat?) that took us on a delightful cruise to a delightful restaurant on Wolfe Island. On the way back there was great entertainment and Brian demonstrated a mean Twist...**Ross Kentner**, the outgoing president of CCBA who is manager of CFOS Owen Sound, said that their new FM station, at 96.5, could be on the air at about this time. The AM station, Ross reported, is also being rebuilt...

More CCBA:

The chairman of the Conference was **Keith Clingen**, now the CCBA president and he worked hard to bring about a successful get together. As always, too, **Gerry Acton** and his wife **Helen**, along with CAB staffers **Giselle Kite** and **Eva Gauthier**, did sterling duty...**Bill Hutton**, serving on one of the panels, said that he started in radio as a newsman but had he started 30 years later, he opined, he would have been a journalist.

During the time we ran the Radio Broadcasting course at Humber College, eight couples who had met in our classes, married. One such twosome was **Tony Orr** and **Joy Colangelo**. Tony has been News Director at CKLC Kingston for many years and we renewed our friendship at the conference.

We chatted with a real fan of *BT*, **Neil Aitchison**, who told us that all the staff at CKKW/CFCA-FM Kitchener are avid readers of the magazine. As our old colleague **Larry Mann** says on the Telecom commercials, "Aren't they clever?"...A nice honor was the one given to **Herb Young**, the retiring president of Loyalist College, for his support of the broadcasting courses at the school.

We met many old friends and acquaintances at the Conference - **Ralph Hart**, **John Manol**, **Barry Howard**, **Dave Sovereign**, **Bob French** (he's the fine young man associated with Target Tuning), **Bob McDonald**, **Don MacDonald**, **Bob McKeown**, **Frank Gardiner**, **Bob Quinn**, **Linda Benoit**, **Bill Hawkins**, **Chuck Babcock**, **Wayne Bjorgan**, **Bill and Mary Ann Brady**, **Norm Bonnell**, **Jim Boyle**, **Ross Hamilton**, **Jack and Nancy Gillespie**, **Larry Smith**, **Barry Howard**, **Harvey Glatt**, **John Read**, **Barry Sarazin**, **Bob Templeton**, **Don Willcox**, **Harry McDonald**, **Bob Norton**, **Larry Cameron**, **Cam Finley**, **Alma and Baxter Ricard**, **Gord Hume**, **Larry Lamb**, **Mike and Sherry Hanson**, **Dick Bowman**, **Bob Elsdon**, **Jane Bonisteel**, **Earle Toppings**. →

There were over 190 registrants in all, one of the highest figures in CCBA history...Great sessions, great food, great time...Great to represent *BT* at a major function.

The CAB/WABE joint conference and trade show to be held in Winnipeg, November 6-9, will feature the first annual Canadian Radio Syndication Awards. They will be presented at a luncheon hosted by Selkirk Communications on Sunday, Nov. 6. Tickets are available from Dick Drew, Drew Marketing, 435 Trunk Rd., Duncan, B.C., V9L 2P5, phone (604) 748-1500. The tickets are \$30...Our thanks to **Bev Edwards** of Toronto's CFRB for the help he provided in arranging interviews at the station with people qualified for inclusion in the broadcasting industry's library of audio interviews, which are being preserved in the National Archives at Ottawa...**Elwy Yost** showed a couple of old Alan Ladd movies recently on his *Saturday Night at the Movies* program on TVOntario. Watching we were reminded that Ladd's brother, **Phil Ladd**, worked for CHUM as p.d. during its early days as a hit parade station.

New at *Farm Equipment Quarterly* magazine as a sales rep is **Pam Sugden**. She had earlier been a print promotion specialist in marketing services for CFPL-TV London, Ont...**Alan Butler** of All-Canada Radio & Television was elected a director of the National Advertising Benevolent Society of Canada, as was **Pat Grierson** of United Broadcast Sales...Many broadcasters will be familiar with the name of **George Murray**, media director at Ogilvy & Mather. Word is that he has left that shop...**Pam Hewitt** left her position as a research analyst at the Radio Bureau of Canada to

return to school, where she apparently will study nutrition...AdNews reports some changes in Baker Lovick's media services department: **Doug Scott** has moved from senior broadcast buyer to broadcast supervisor/manager broadcast research; **Joy McNevin** has become senior broadcast buyer, and **Stephen Mills-Hughes**, a former media assistant, has become a broadcast buyer.

When **Bart Gibb** was in Toronto from his Vancouver base on some RTVR business he gave us a call and we chatted about people with whom we had worked. We were sorry to learn from him that **Earl Bradford**, with whom we had worked at CHUM many moons ago, died a while back of lung cancer. As Bart put it, he was an outstanding broadcaster...In search of Canadian contestants, the game show *Wheel of Fortune* held a screening for applicants in Toronto. More than 6,000 applied, 300 names were drawn at random and that was pared down to a short list of 40. Finally ten contestants were chosen, each receiving a free trip to Hollywood, \$500 in expense money, a tour of Columbia Pictures' studio and, perhaps most important, a chance to win big money on the show.

The CRTC is now at its full strength of nine full-time commissioners. For a time, due to terms expiring, resignations, and the death of Real Therrien, the number of full-time commissioners had been reduced to six. The latest additions are **Adrian Burns**, a former Calgary broadcaster; **Ed Ross**, a Montreal radio marketing executive; and **Frederick Arsenault**, whose background was with government in Atlantic Canada...Telemedia Broadcasting Systems has picked up the Canadian Football League broadcasts of the Toronto Argonauts dropped by CFRB Toronto. Veteran football play-by-play announcer **John Badham**, now a newscaster at CHEX Peterborough, Ont., calls the games for Telemedia with **Bill Watters**, analyst for radio broadcasts of the Toronto Maple Leaf hockey team, as color commentator.

At Ontario's Global Television, **Richard Brown** has taken over as anchor of the evening news following the retirement of Peter Trueman. **Mike Anscombe** replaces Brown on the late night newscast. Speaking of Anscombe, he's taking a stab at writing fiction...Ever wonder how many television stations there are in the world? **Moses Znaimer** of Toronto's CITY-TV says he thinks there may be between 15,000 and 17,000.

Peter Gzowski's latest literary effort is *The Private Voice, A Memoir In The Form Of A Journal*, which is a history of his activities over a year...**Kay Levine**, who broadcasts games of the Toronto Blue Jay's farm team in Syracuse, N.Y., has a distinguished writing career. He has written 15 episodes of *Cheers*, winning an Emmy and a Writers' Guild Award. He wrote scripts for *M*A*S*H* for four years and the movie *Volunteer*, which starred Tom Hanks. He also served as executive producer of the *New Mary Tyler Moore Show* and, later, of the *Tracy Ullman Show*. Voicing the Syracuse games gave him something to do during the summer, particularly with the writers strike...**Vaughn Bjerre**, the former manager of Toronto's CHFI-FM, lives in South Parde Island, Texas. His letterhead reads *Tropical Condominium Services - Sales - Management - Rentals*.

Mike Forrester at CFMX-FM, the classical music station headquartered in Cobourg, Ont., advises us that the station has opened a Toronto sales office at 468 Queen Street East. (Note to Mike: Kindly send future releases for me to the address published at the end of this column)...Some may remember **Moe Carter**, the colorful Toronto-Hamilton broadcaster. One of the things he is doing these days is play-by-play on Rogers Cable of the Hamilton Redbirds and the St. Catharines Blue Jays, Ontario teams in the Class A New York-Penn baseball league.

BREAKTHROUGH VIDEO TRIPOD

Remarkable specifications. Inspired engineering. A fanatical dedication to quality and value. Test one at your Manfrotto dealer real soon. 'Cause soon everyone will be wanting one.

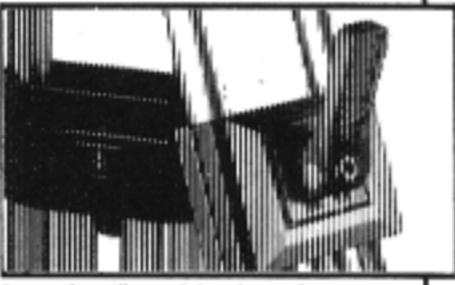

Large handle, quick release leg extenders. Fast. Simple. And reliable.

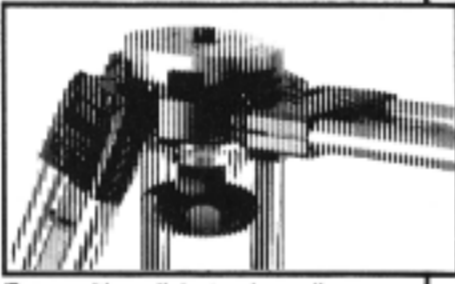

Two-position click stop legs allows even extra low angles.

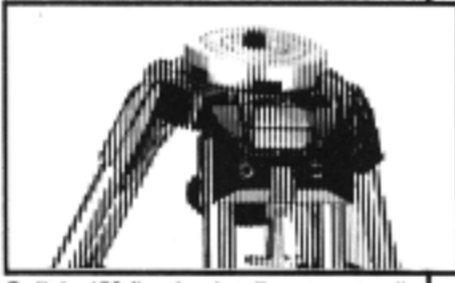

Built-in 15° floating leveller accepts all major fluid heads.

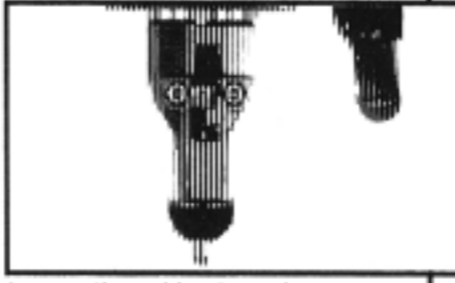

Lever action rubber to spoke converter. New versatility at every location.

Distributed by Amplis Foto Inc.

The Travelling Show hosted by **Bob Rice** on the CKO Radio Network, has been sold to the Independent Travel Professionals (ITP) making possible a weekly audience of 500,000 listeners, according to AdNews...**William French**, vp and managing director of Toronto's Agincourt Productions, is president-elect of the International Television Association of Canada...**Bill Terry**, who had been head of drama and features for CBC Radio, has been named director, program operations and regional development...If you think **Season Hubley** of the television program *Blue Skies* has an unusual name, consider that she has a brother named **Whip** and a son named **Boston**.

Point of correction: He spells it **Allan Slaight**, not Alan...**Mike Duffy**, CBC-TV's well-known Ottawa correspondent, has left the corporation to go with CJOH-TV Ottawa, where he is to have his own program - *Mike Duffy, Sunday Edition*...**Bill Roberts**, who was with the CRTC as a senior policy analyst and then with the Canadian Association of Broadcasters as senior vp, television, has joined TVOntario as senior managing director of external relations...Out of the 21 new shows scheduled to be seen on television this coming season only three seem destined to be hits, according to Young and Rubicam's annual prediction -- NBC's *Dear John* and *Empty Nest*, and ABC's *Roseanne*...**Dwayne Van Horne**, son of Montreal Expos' broadcaster **Dave Van Horne**, has been drafted and signed by the Cincinnati Reds

Gary Parkhill phoned to let us know that he has retired from Conestoga College in Kitchener, Ont., where he had served with distinction as head of the radio-television course. But he's not loafing; indeed, he's likely busier than ever. Gary is working with CBC Radio network news; teaching part-time at Loyalist College in Belleville, Ont.; continuing his two television shows; and working on the new home he is building at Warkworth, Ont. ...CHUM Toronto dj **Ingrid Shumacher** has given birth to a son, her second. Father is *Blue Rodeo* drummer **Cleave Anderson**

Susan Anton-Clark, a teaching master in Toronto's Seneca College radio-television broadcasting course, is serving as co-ordinator of the Broadcast Educators Association of Canada conference at Winnipeg which, as usual, leads up to the annual CAB gathering. She told us there are many highlights scheduled by the BEAC for its conference, which begins November 3, that will be of interest not only to educators but also to broadcasters, ranging from Copyright to Free Trade. For further information and registration contact Susan at Seneca College, (416) 491-5050, Extension 4864.

We had an interesting letter from **Steven J. Cutway**, the station manager at the Queen's University stations in Kingston, Ont. He tells us he has been at the stations for over 14 years, a record in the "campus/community" industry. We heard from Steven because he had conducted an excellent interview with **Terry French** for the broadcast industry's library of audio interviews we are gathering for the archives...**Bob** and **Willa McLean** provided the announcement that **Peter McCarthy** has been appointed gsm at CKO Montreal. A Montreal native, his background includes radio sales time in Miami and Windsor, Ont.

Phil Stone welcomes your news for Broadcast Beat. Write c/o 2350 Bridletowne Circle, #1601, Scarborough, ON, M1W 2E6. Please address information for other departments and staff at Broadcast Technology to P.O. Box 420, Bolton, ON, L7E 5T3.

BROADCAST TECHNOLOGY

IT'S ABOUT TIME!

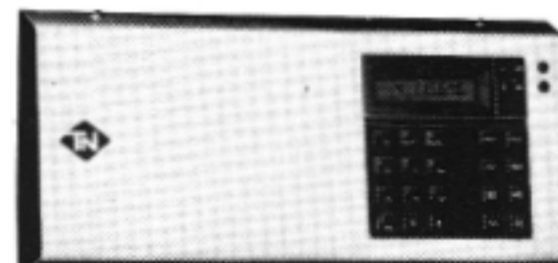

When every minute counts, you need clocks and time control systems you can count on.

We offer a complete line of precise electronic time service control equipment: computer controlled quartz master clocks and a wide range of analog and digital remote slave clocks. For both indoor and outdoor installations. For all applications.

Call or write today for free colour literature. The time is right.



MARUNO ELECTRONICS LIMITED

VANCOUVER (604) 872-0636
Toll Free 1-800-663-2433
TORONTO (416) 255-9108
Toll Free 1-800-268-2241
MONCTON (506) 859-1414
Toll Free 1-800-561-3940

Circle #459 on Reader Service Card

people in the news

All-Canada Radio & Television--**Suzanne Carpenter** has been promoted to Group Manager, National Cable Advertising Sales; **Cheryl Whitehouse** and **Val Meyer** as television representatives.

CAB--**Emmanuelle Gattuso** has been appointed vice-president, communications. Prior to her appointment she had been director of the communications branch of the Office of the Commissioner of Official Languages.

CBC Radio--**Bill Terry** has been named director, program operations and regional development. He was most recently head of drama and features for CBC Radio.

CBC Television--**Ron Smith** has been appointed head of CBC Television Sports for the English network, effective Oct. 10, replacing Don MacPherson, who will step down after the Summer Olympics in Seoul. **Rena Krawagna** has been appointed program advisor of CBC-TV's Office of Independent Production in Toronto. She had previously been a program purchasing officer with the corporation.

Central Dynamics--**Christian Tremblay** has been appointed product development manager at Montreal. He formerly was with CBC Engineering, most recently as manager, Digital Group.

CFAC Calgary--**Dennis Stiles** has been appointed operations manager.

CFMX-FM Cobourg, Ont.--**Jamie Crookston** has been appointed sales manager and **Douglas Kay** account

executive in the station's new Toronto sales office. Both had previously been with Standard Broadcasting Toronto stations CFRB and CKFM-FM.

CFPL-TV London, Ont.--**E.W. (Ted) Eadinger** has been appointed vice-president and general manager of the station. He previously was president of CFQC-TV Saskatoon.

Channel One--**Ted Jones** has joined the company's TVRO sales team at Toronto. He joins Channel One from Platinum Communications Systems Inc., where he was sales manager.

CKO Montreal--**Peter McCarthy** has been appointed general sales manager.

CTV Television Network--**Gary Maavara** has been appointed vice-president of the network. He had practiced law with a major Toronto firm prior to joining CTV.

CTV Sales--**R.F. (Rick) Lee** has been appointed Toronto Sales Manager.

CTV Ottawa--**Craig Oliver** has been appointed Ottawa bureau manager after eight years as Washington correspondent. He replaces **Pamela Wallin**, who has become national affairs correspondent in Toronto.

Directors Guild of Canada--**Alan Erlich** has been elected president. He also was president in 1984-85 and 1985-86.

First Choice Canadian Communications Corp.--**Ellen Davidson** has been re-appointed director of communications.

Groupe Andre' Perry--**Eric Guaglione** has been appointed creative director, **Alfred Kamajian** art director, and **Jeff Wood** technical director of the company's new post-production centre in Washington.

Groupe Cogeco--**Jean Fortier** has been appointed vice-president, television. He joins the company from Radio-Canada, where he had been host of a business affairs program.

Hewlett-Packard (Canada) Ltd.--**Malcolm Gissing**, president and general manager since 1977, has announced he will take early retirement effective Nov. 20. He will be replaced by **George Cobbe**, currently president and general manager of a Hewlett-Packard joint venture in Korea.

Northern Cable Services Ltd.--**Morry E. Brown** has been named director of programming responsible for all of Northern Cable's community and public affairs programming, based in Sudbury.

ITVA Canada--**William French** has been elected president-elect of the International Television Association of Canada. s. He is vice-president and managing director of Toronto's Agincourt Productions.

Radio Canada--**Adreanne Bour-nival** has been named director of television programming. She had been in charge of purchasing and planning programming from independent producers.

Just for a moment, let's talk bang for the buck.

Bang:

1. 8, 12, 16 or 24 channels
2. Balanced inputs
3. Separate mic (XLR) and line (1/4") inputs
4. Phantom power
5. Input trim controls
6. Channel clip indicators
7. 3 band channel EQ
8. Channel inserts
9. 3 send busses
10. Channel PFL (solo)
11. 2 return busses
12. Internal reverb
13. Reverb to monitor
14. Headphone gain
15. Separate left, right, mono, monitor outputs
16. L and R inserts
17. Gooseneck lamp connector

18. LED bar level meters
19. 20-20kHz ± 1 dB response
20. .05% THD @ +4dBu
21. +24dBu maximum input
22. -75dB crosstalk
23. Completely modular construction

Buck:

- 8 channels - under \$1,500
- 12 channels - under \$1,800
- 16 channels - under \$2,400
- 24 channels - under \$3,000

Any questions?



Electro-Voice®

BK 32 STEREO MIXERS

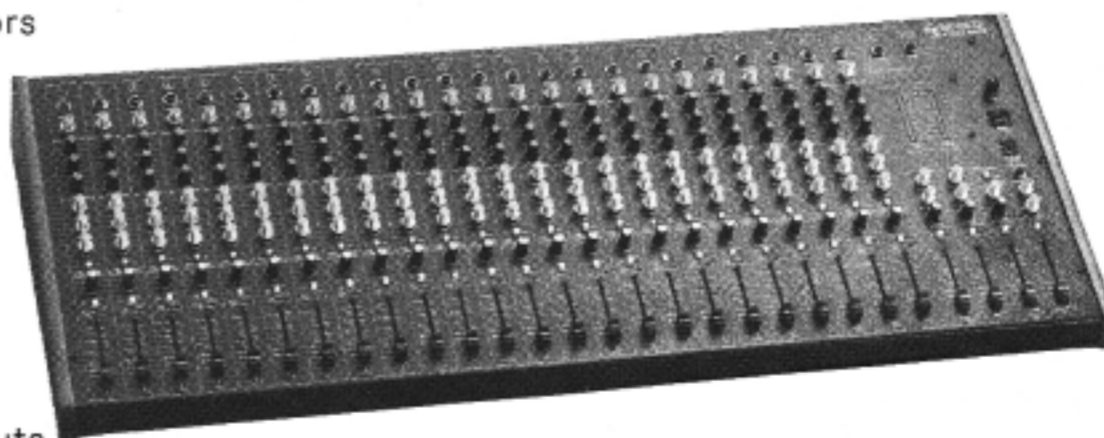

AVI
COMMUNICATIONS LIMITED

We make studios happen.

Phone: (416) 297-9377
Fax: (416) 297-4757

Rogers Cablesystems--**Angie Bavosa** has been named manager, marketing services, Toronto. She will be responsible for development and execution of corporate marketing programs.

Selkirk Broadcasting Ltd.--**Walter Machny** has been appointed director of operations for Montreal, overseeing the application to the CRTC for approval of the purchase of CKVL and CKOI-FM Verdun and operations of the stations. Machny remains president and general manager of Selkirk-owned CFAC Calgary.

Telefilm Canada--**Edmund Bovey** has replaced Jean Sirois as chairman. In other moves: **Marcel Choquette** has been appointed director of human and material resources at Montreal; **Sam Wendel** has replaced Lorraine Good-Samson as director of the Los Angeles office; **Judy Watt** has been appointed manager, Business Affairs, **Bill Niven** manager of program development and **Helen Paul** project co-ordinator, all in the Ontario office.

Tele-Metropole Inc.--**Lino Bramucci** has been appointed general sales manager.

Tele-Radio Systems Ltd.--**Stephen Rice** has been appointed regional sales representative, telecom division, and **Timothy Kwan** has been appointed regional sales representative, data communications division, both in the Toronto office.

TVOntario--**Bill Roberts** has been appointed senior managing director of external relations, responsible for dealings with government, corporate relations, marketing, information and publications services. He was previously senior vice-president of television for the CAB. And **Donald Duprey** moves to managing director of English programming services from the same position in French programming services at the network.

Marketing magazine and then worked on the account side at several agencies. He was best known for Stoven-Byles Television, the broadcast rep house he owned later in his career. By the time he retired in 1974 he had also been chairman of the Association of Canadian Advertisers and of the Canadian Association of Advertising.

Fernand Seguin

A pioneer in bringing science to on radio and television died June 19 in Montreal at the age of 66. He began his career in broadcasting in 1947 with a series of scientific talks for the CBC's French-language service, Radio-Canada. When television arrived in the early 1950s, he wrote and moderated the first scientific telecast in French. He continued in both radio and television and also took part in more than 250 films. In 1977 he received the Kalinga prize awarded by the United Nations Educational, Scientific and Cultural Organization and the Olivar-Asselin and Judith-Jasmin prizes for journalism. He was also the first francophone to receive the Sandford-Fleming medal from the Royal Institute of Canada.

IN MEMORIAM

William D. (Bill) Byles

A pioneer in Canadian broadcast advertising who helped found the Broadcast Executives Society died June 22 in Toronto. He was 73. He started his career in 1930 with a brief stint at

GOULD MARKETING ANNOUNCES 5 NEW PROFESSIONAL DIVISION APPOINTMENTS

Graham Hallett, Executive Vice President of Gould Marketing Inc., is pleased to announce the appointments of Claude Sabourin as National Sales Manager, Professional Division; Carlo Roletti as Marketing Manager and Toronto Sales Representative for studio and broadcast products; Paul Kinney as Ontario Sales Representative; Al Belliveau as Maritime Sales Representative; and Larry Medwin as British Columbia and Alberta Sales Representative.



Claude Sabourin

Claude Sabourin has been Quebec Professional Sales Representative for Gould for 7 years; his promotion to Sales Manager reflects his success and achievements, including winning the Gould Salesman of the Year Award 3 times (1982, 1984, 1987). Claude is based at Gould's head office in Montreal, (514) 342-4441.



Carlo Roletti

Carlo Roletti, who was recently the Marketing Manager for AKG Acoustics in Canada, continues his role within Gould as Marketing Manager for all broadcast and studio products, including AKG. Carlo will also handle Toronto broadcast and studio sales and can be reached at (416) 890-2330.

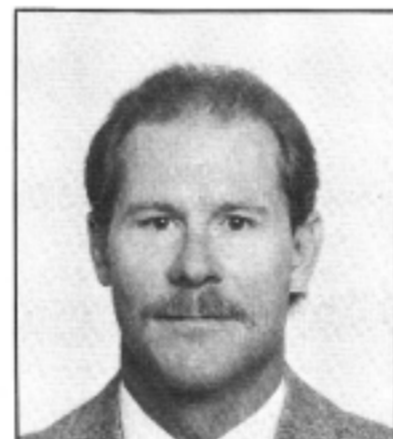

Paul Kinney

Paul Kinney, an experienced professional audio sales rep, is well-known in the Ontario region. In joining Gould, Paul will continue representing AKG throughout Ontario in addition to the other Gould professional products — Otari, JBL, Lantek, Sanken and Seck. Paul can be reached at (416) 691-3037.



Al Belliveau

Al Belliveau, a native of Moncton, joins Gould with an extensive audio background as a representative, a retailer, and in running his own sound contracting business. In addition to professional products, Al will also be representing the consumer lines carried by Gould. He can be reached at (506) 854-5453.



Larry Medwin

Larry Medwin is 'returning to the fold,' having worked for Gould in Toronto 10 years ago. Since moving west he has been in audio marketing, both consumer and professional, and will now bring Western Canada a new high level of professional support and service. Larry can be reached at (604) 733-9562.

Gould

GOULD MARKETING INC., 6445 COTE DE LIESSE, MONTREAL, QUEBEC H4T 1E5

Cees Bruynes, who had held the top post at North American Philips, becomes chairman and chief executive of the new subsidiary, Consolidated Electronics Industries Corp. The new subsidiary includes the Magnavox defence contracting business as well as a variety of peripheral businesses, including Magnavox cable television equipment.

* Abroyd Communications--has completed construction of eight 360-foot towers for CFGM Richmond Hill, Ont. The towers incorporate LEC's (Lightning Dissipation Array) into the design of the towers to provide 100 per cent protection against lightning. CFGM is expected to begin transmitting from the new Beamsville, Ont., transmitter site in mid-September with 50 Kw of AM stereo on a new frequency of 640 kHz.

* Comlink Systems Inc.--was awarded a contract for provide a Toronto video uplink for Rogers Network Services, a newly-created division of Rogers Cablesystems Inc. Under the contract Comlink engineered, supplied and installed a three channel KU Band uplink, with one channel of hot standby, at Rogers' York Mills facility in Toronto. It will provide video uplink for the new YTV (Children's Channel) and Le Club (French-language Home Shopping) services.

* Gould Marketing Inc.--has been appointed exclusive distributor for Aphex Systems, originators of the Aural Exciter signal enhancement systems. Further information can be obtained from Gould Marketing Inc., 6445 Cote de Liesse, Montreal, PQ, H4T 1E5, (514) 342-4441.

* Sigmacom Systems Inc.--has been appointed exclusive distributor of products manufactured by RF Technology Inc., Norwalk, Connecticut, manufacturers of fixed and mobile microwave equipment for transmission of video, voice and data.

* Sonotechnique PJI Inc.--will hold their annual exhibition of equipment September 13-15 at the Hotel de la Montagne, 1430 de la Montagne, Montreal. Contact Micheline at Sonotechnique PJI Inc., 2565 Bates Road, Suite 300, Montreal, PQ, H3S 1A9, (514) 739-3368.

New Books, Literature Available

* GNB Batteries (Canada) Inc.-has published a new four-page corporate brochure detailing its wide range of batteries and chargers. The Fort Erie, Ont., company provides batteries designed for standby power in microwave, telecommunications and other standby applications such as emergency lighting. Free copies are

available from GNB Batteries (Canada) Inc., 275 Lewis Street, Fort Erie, Ont., L2A 5N6, (416) 871-5600.

* ECCO Inc.-has a new brochure providing information on the PCAT-300 single slot IBM compatible board for level IV interactive video for use in such applications as audio archiving, sound effects, etc. Copies can be obtained by contacting Robert E. Yablonski, 1601 E. Chestnut Ave., P.O. Box 659, Santa Ana, CA 92702-0659, (714) 953-3769.

(Cont'd P. 85)

SPACE PROBLEMS?

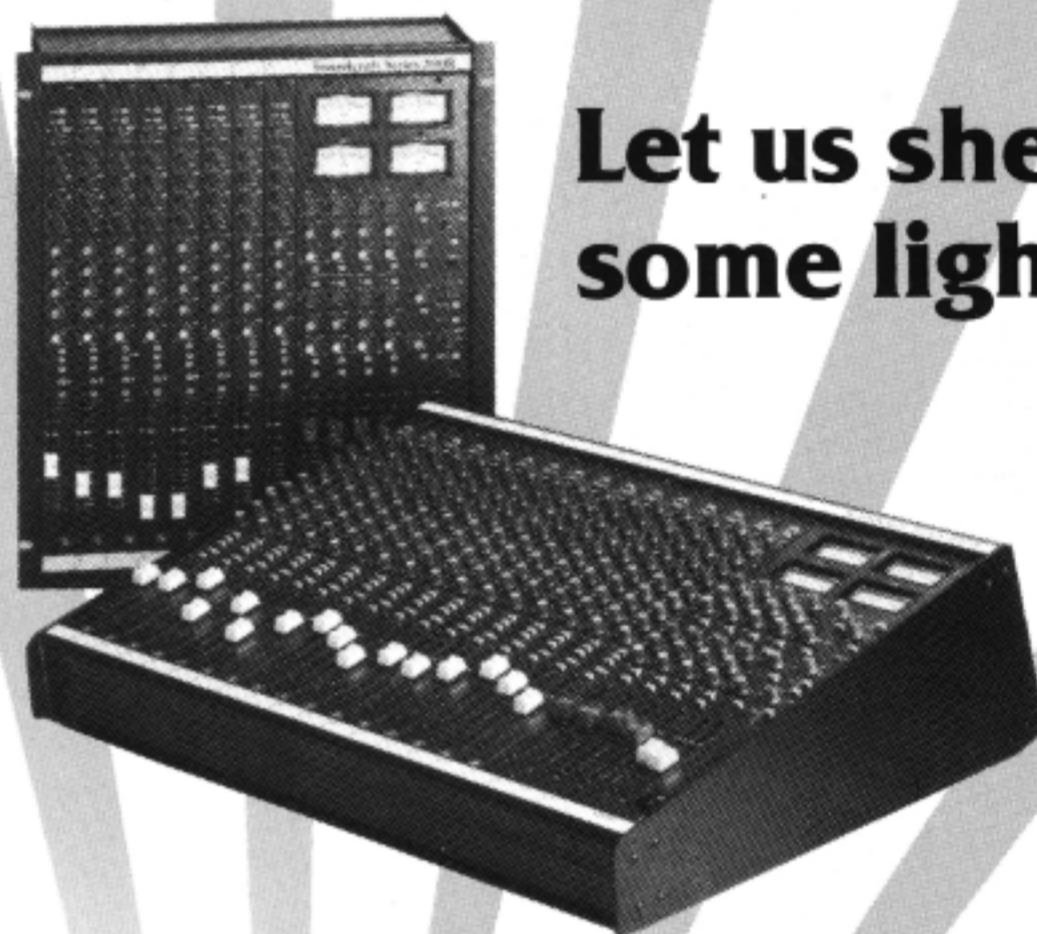

Let us shed some light...

The Soundcraft Series 200B

Versatile. Professional. Compact.

Inputs are assignable to four subgroup busses, and stereo mix buss, with four auxiliary sends which are pre/post EQ, pre/post fader. Electronically balanced line/mic inputs, 48V phantom power with individual channel switching and 4 band eq with operating levels of -10 dBV or +4 dBV make this Soundcraft rackmountable console suitable as a centerpiece in broadcast or multitracking or a discreet backup for digital applications.



6 Banigan Drive, Toronto, Ontario M4H 1E9 (416) 421-9080