

104
5/17



MILTON S. KIVER

TELEVISION

Simplified

Sixth Edition

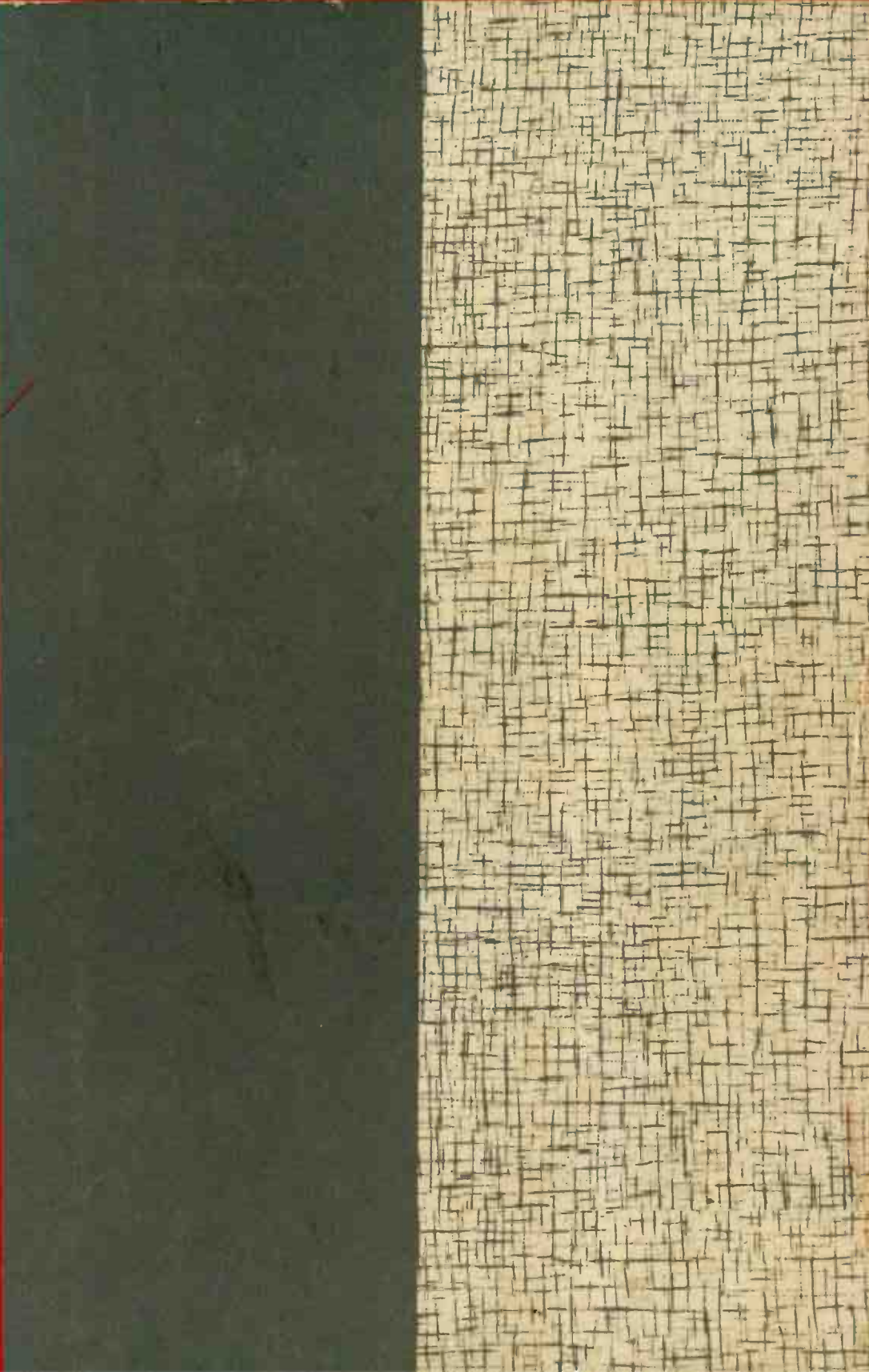

MILTON S. KIVER

TELEVISION

Simplified

Sixth Edition



D. VAN NOSTRAND COMPANY, INC.

Princeton, New Jersey

Toronto

New York

London

D. VAN NOSTRAND COMPANY, INC.
120 Alexander St., Princeton, New Jersey (*Principal office*)
24 West 40 Street, New York 18, New York

D. VAN NOSTRAND COMPANY, LTD.
358, Kensington High Street, London, W.14, England

D. VAN NOSTRAND COMPANY (Canada), LTD.
25 Hollinger Road, Toronto 16, Canada

Copyright © 1946, 1948, 1950, 1954, 1955, 1962, by
D. VAN NOSTRAND COMPANY, Inc.

Published simultaneously in Canada by
D. Van Nostrand Company (Canada), Ltd.

No reproduction in any form of this book, in whole or in part (except for brief quotation in critical articles or reviews), may be made without written authorization from the publishers.

09665150

PRINTED IN THE UNITED STATES OF AMERICA

TELEVISION

Simplified

BY THE SAME AUTHOR

F—M Simplified, 3rd Ed.

Television Receiver Servicing, 4th Ed.

Introduction to UHF Circuits and Components

Preface

Television Simplified has been completely revised for its sixth edition. The important advances which have occurred in television receivers since the publication of the fifth edition (1955) have been incorporated in the present volume. In addition to a thorough updating of the various circuits and components that are normally found in television sets, a new chapter on Remote Control Systems has been added. These devices are the most significant recent advance that has occurred in television, and their extensive use makes it imperative that the reader be familiar with them.

The presentation in this sixth edition follows the pattern established in previous editions. Little is assumed beyond an elementary knowledge of the operation of home sound receivers, and upon this knowledge is built an understanding of the modern television receiver with its highly integrated synchronizing circuits. Chapter 1 presents an outline of the various stages that combine to form a television system. It attempts to answer those pertinent questions which always arise when any subject is first investigated and which, if left unanswered, soon begin to interfere with the smooth accumulation of subsequent information. With each succeeding chapter a different section of the television receiver is discussed, starting at the input end of the set and traveling along the same path as the incoming signal. The function of every part, both within its stage and within the receiver as a whole, is carefully noted.

Illustrations are extensively employed, and in nearly all circuit diagrams representative parts values are included. These values enable the reader to develop a "feel" for the type of component and its size which may be expected in various sections of the receiver. The author believes that this ability is necessary if the reader is to possess more than a superficial understanding of the subject.

While most of the emphasis in the book is necessarily devoted to circuit operation, receiver servicing has not been overlooked. In Chapter 16 a step-by-step approach to the isolation of defects in a television receiver is detailed, complete with symptomatic illustrations of the most common troubles. The use of appropriate test instruments is also covered.

A set of questions is included at the end of each chapter for those who wish to gauge their progress through the book. The questions are straightforward and are drawn wholly from the text material.

No book represents the sole effort of one person. Grateful acknowledgment is due to the Radio Corporation of America; the General Electric Company; the Zenith Corporation; Howard W. Sams & Co., Inc.; Central Television Service, Chicago, Illinois; and Motorola, Inc., for their generous aid in furnishing illustrations and data that were essential in the preparation of the book.

MILTON S. KIVER

Contents

CHAPTER	PAGE
1. THE TELEVISION FIELD	1
2. HIGH-FREQUENCY WAVES AND THE TELEVISION ANTENNA	42
3. WIDE-BAND TUNING CIRCUITS—RF AMPLIFIERS	66
4. THE HF OSCILLATOR AND MIXER—TV TUNERS	88
5. VIDEO IF AMPLIFIERS	119
6. VIDEO DETECTORS AND AGC CIRCUITS	151
7. VIDEO AMPLIFIERS	180
8. D-C REINSERTION	221
9. CATHODE-RAY TUBES	234
10. TELEVISION RECEIVER POWER SUPPLIES	281
11. ADDITIONAL NOTES ON INTERCARRIER SYSTEMS	303
12. SYNCHRONIZING-CIRCUIT FUNDAMENTALS	316
13. DEFLECTION SYSTEMS	354
14. FREQUENCY MODULATION	402
15. TYPICAL TELEVISION RECEIVERS—ANALYSIS AND ALIGNMENT	436
16. SERVICING TELEVISION RECEIVERS	470
17. REMOTE-CONTROL SYSTEMS FOR TELEVISION RECEIVERS	517
18. UHF TELEVISION	548
19. COLOR TELEVISION	576
GLOSSARY	622

The Television Field

Introduction. Television, the science of transmitting rapidly changing images from one place to another by electromagnetic waves, is today as significant a factor in home entertainment as the radio broadcast.

This change in media has brought with it a corresponding change in the operating techniques of the service technician. Because of the considerably greater complexity of the television receiver, a whole new array of test equipment and of servicing methods has evolved. These have not supplanted the instruments and service techniques employed with broadcast radio receivers since much of what is done to a radio receiver to isolate a defect can be applied as well to television receivers. Rather, these basic service methods have been expanded to encompass the newer circuits which television receivers possess and which have no counterpart in radio. This situation has led to a natural upgrading in the knowledge and skill of the service technician, and a corresponding increase in his financial earning power. Thus, television is more enjoyable to the user and more profitable to the serviceman.

Television receivers are housed in large console cabinets, in table-model enclosures, Fig. 1-1, or in cases small enough to be carried from place to place. All contain practically the same circuits. The larger models generally possess a somewhat greater number of tubes and, perhaps, an additional speaker or two. Picture-tube screens range from 8 to 10 inches for the smaller sets (found only in portable receivers) to 24 inches for larger sets. At one time, 27- and 30-inch picture-tube screens were available, but these are no longer used. They were too large and too bulky and presented many manufacturing difficulties. In addition, the larger picture was not found to be appreciably more desirable than the picture obtained with 23- and 24-inch screens.

Controlwise, television receivers are only slightly more complex than

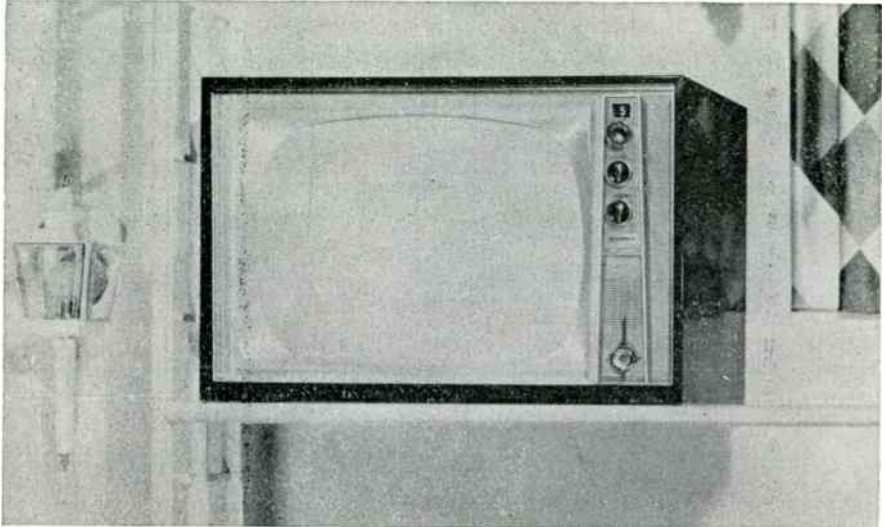

Courtesy Motorola

FIG. 1-1. A table-model television receiver. A 21-inch screen is employed.

radio-broadcast sets. For the sound section of the television receiver, conventional on-off volume control, supplemented frequently by a tone control, is used. These parts perform the same functions that they do in a radio receiver. For the video, or image-producing, section of the television receiver, a complete new set of front-panel controls are required. There are only a few controls and they are easily manipulated.

The primary control is the station selector, a rotary switch with 12 positions. Seven of these positions will have local stations, which is all any one community may be allotted. This number will be found only in very large cities, for example, New York and Chicago. Smaller cities have fewer stations, sometimes only one or two. Another control, associated with the picture, is the contrast control which adjusts the intensity of the image detail. Turning the control clockwise causes the picture detail to become darker; rotating the control counterclockwise reduces detail intensity, sometimes to the point where the picture disappears completely.

Still another control is the brightness control, which regulates the overall shading of the picture and establishes the "tone" of an image, that is, whether it is light, medium, or dark. Finally, there is the "fine-tuning" control, which is basically a vernier-tuning adjustment. The main tuning circuits used in television receivers are relatively fixed, and the desired station is obtained by means of the selector switch. In addition, the proper oscillator coil and capacitor are selected at the same time. If a change should occur in the resonant properties of these circuits and no adjustment were

provided, it could readily happen that the sound would become distorted and the images would not be faithfully reproduced. To prevent this, a fine-tuning control is placed on the front panel. Within limits, this control permits the observer to center the entering signal so that the proper frequencies are obtained at the video and audio IF amplifiers.

Controls which deal with the vertical and horizontal synchronization of the picture may also be found on the front panel of a television receiver. How these controls are manipulated will be discussed later. Generally, only those controls which must be manipulated frequently are placed on the front panel; others that require less frequent adjustment are positioned either on the back panel of the chassis or in a small covered recess in front. In any event, while the mechanism of a television receiver may be quite complex use of the few necessary controls can be readily learned, even by those entirely unfamiliar with the technical aspects of the system. This must be so, else television would not have become so popular.

In this chapter, the overall operation of the present-day television system is explained, with particular emphasis on the methods used to transform light rays into equivalent electrical impulses. After that, chapter by chapter and section by section, the operating principles of the receiver are presented, assuming only a basic knowledge of the operation of present superheterodyne AM receivers.

Desirable Image Characteristics. Since the image is the final product of the television system, and everything centers about the production of this image, here is the most logical place to begin. In order for a picture to be satisfactory from the observer's point of view, the following minimum requirements should be obtainable:

1. The composition of the image should be such that none of the elements that go into its make-up is visible from ordinary viewing distances. The image should have the fine, smooth appearance of a good photograph.

2. Flicker must be totally absent. To accomplish this, it is necessary for the cathode-ray beam to sweep across the fluorescent screen in time to cause light to be emitted before the previous image has lost its effect in the viewer's mind. The scenes then follow each other in rapid succession and the action appears continuous.

3. The picture should be large enough in size to permit comfortable viewing by several people at distances of 10 feet or more from the screen.

4. To meet the changing requirements for viewing the screen either by day or by night, an adequate amount of light must be available from the cathode-ray screen. Naturally, less is necessary when the room illumination is low than when it is high.

5. An effective contrast range is desirable. Contrast refers to the ratio between points of maximum to minimum brightness on the same screen.

In broad daylight, for example, the contrast ratio between areas in bright sunlight to shaded areas may run as high as 10,000:1. On fluorescent screens, however, the amount of light that can be emitted is definitely limited, and only contrast ratios between 50:1 and 100:1 are obtainable ordinarily. These, however, prove quite satisfactory.

The foregoing requirements have been listed with only a slight explanation advanced for each. There are limitations which affect these conditions, but before any extensive discussion is undertaken, it is necessary to gain a more detailed knowledge of the overall operation of present-day television systems.

Outline of Stages of Television Transmitters and Receivers. An outline of the various stages of a television transmitter is shown in Fig. 1-2.

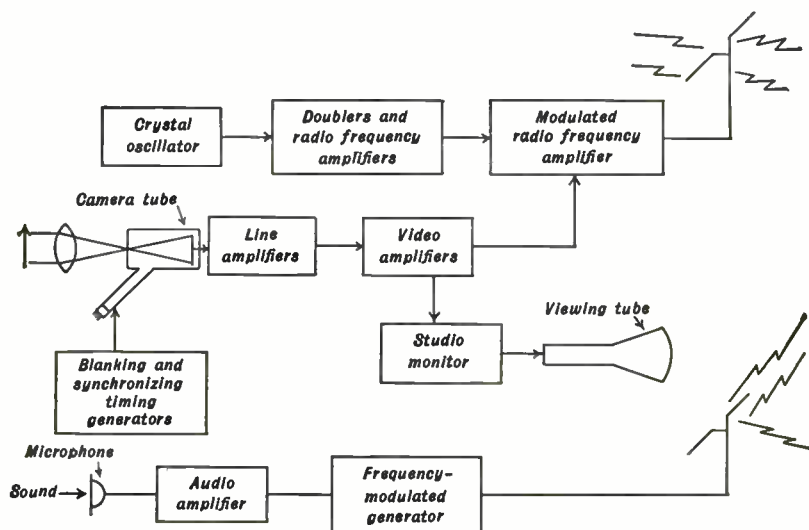

FIG. 1-2. A modern television transmitter.

The scene to be televised is focused on the photosensitive plate of the camera tube by means of a lens. At the tube the light rays are transformed into equivalent electrical impulses. Thereafter amplifiers and the regular amplitude-modulating sequences form the final television signal. To synchronize the position of the electron beam at the receiver-viewing tube with the beam in the camera tube, synchronizing pulses are also inserted into the television signal.

Aside from the synchronizing pulses, the action in a television transmitter is entirely analogous to the corresponding action in a sound transmitter. In one, the object is to transform audio vibrations in the surrounding air to

equivalent electrical variations. A microphone accomplishes this simply. In the other, light rays are to be changed into equivalent electrical variations and a camera tube is employed. In either case, once the currents have been formed, essentially the same procedure is followed to form the final amplitude-modulated RF signal. It is well to keep in mind the correspondence between the purpose of the microphone and the camera tube, for this will aid in visualizing the overall operation of television transmitters.

The sound made by the actors in the scene being televised is kept separate from the video electrical currents. The sound is frequency modulated and sent out by another transmitter at a frequency that lies close to the edge of the band of frequencies utilized by the image signals. So far as the transmitters are concerned, two separate units are necessary: one for the sound, the other for the image signals. A single transmitting antenna may be used, however, since the two signals are close enough in frequency to be broadcast from the same array.

At the receiver, shown in Fig. 1-3(A), the video and audio carriers are received simultaneously by wide-band amplifiers. After amplification by an RF stage, the composite signal is applied to the mixer tube where it combines with a high-frequency oscillator voltage. The desired IF values are produced by this action and, at the output of the mixer stage, the video and sound signals are separated and fed to their respective IF amplifiers.

The audio signal is frequency modulated and, although the IF amplifier stages found in FM receivers do not differ radically in construction from the corresponding amplifiers in AM sound superheterodyne receivers (except for frequency), the detector is entirely new. In the FM set, a discriminator is necessary in order to convert the FM signal into the equivalent audio variations. (A brief description of the operation of FM receivers is given in Chapter 14.) Once past the FM detector, the ordinary audio stages amplify the signal until it is suitable for application to a loudspeaker.

Returning to the video signal, we find that, after separation from the audio voltage, it passes through several IF amplifiers (the number ranging from two to four) before the diode detector is reached. Either half-wave or full-wave rectification is employed at the detector. At some point beyond the detector, part of the signal is applied to the synchronizing section of the receiver. Here, the synchronizing pulses are separated from the picture detail and used to control the frequency of oscillators that directly control the position of the electron beam in the cathode-ray tube. In this manner, the exact point where the electron beam impinges on the fluorescent screen is kept related to the electron beam in the studio camera tube. Only vertical and horizontal synchronizing pulses are required for black and white images.

The remainder of the video signal, containing the detail information,

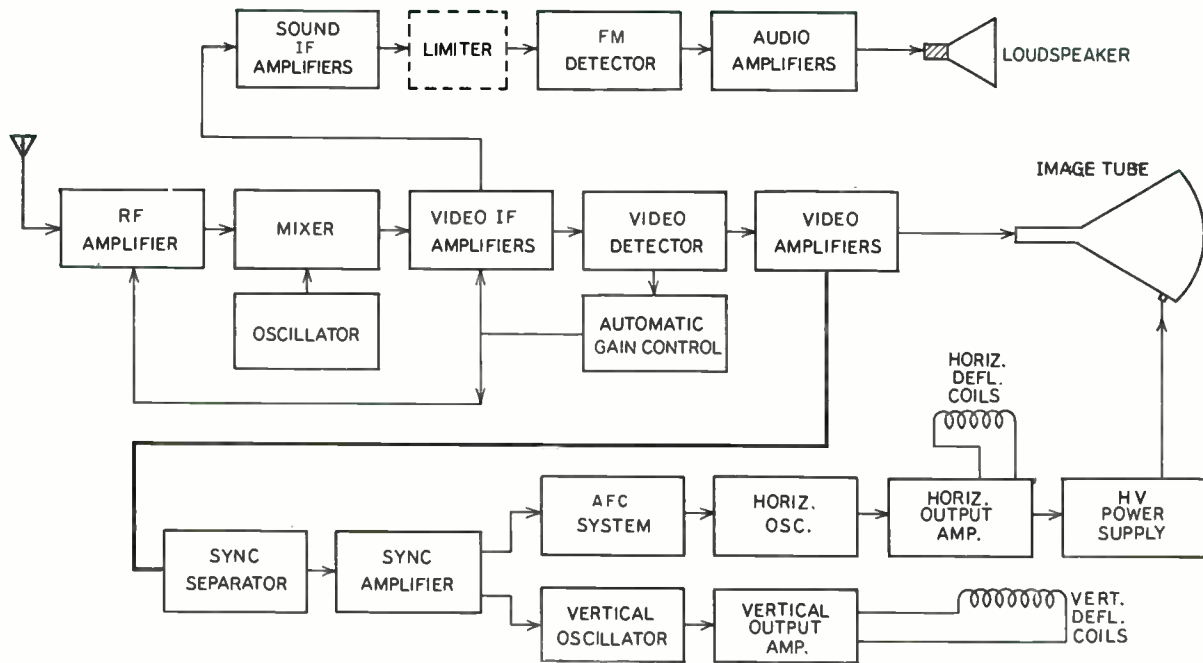

FIG. 1-3(A). A block diagram of a television receiver operating under the split-sound system.

is amplified by the video amplifiers and then applied to the picture tube. The amplitude of the input voltage varies the intensity of the electron beam, while the deflecting plates (or coils) swiftly move the beam from one side of the screen to the other. The result is an image on the screen, produced by approximately 500 distinct lines. The eye of the viewer integrates these lines so that they blend, and the image assumes the smooth appearance of a photographic picture.

After the scanning beam forms an image in this manner, a second picture, a third, and so on are formed in such rapid succession that the blending of each into the next becomes even and continuous as in the movies. When the system is operating properly, the viewer is not aware of each individual picture.

Intercarrier TV Receivers. The foregoing discussion was centered about the block diagram in Fig. 1-3(A). This is a split-sound television receiver and was the form employed by the first sets. However, in 1948, a television circuit operating on a somewhat different principle was introduced and is now almost exclusively employed. The new system is known as the "intercarrier system." It is illustrated in block form in Fig. 1-3(B).

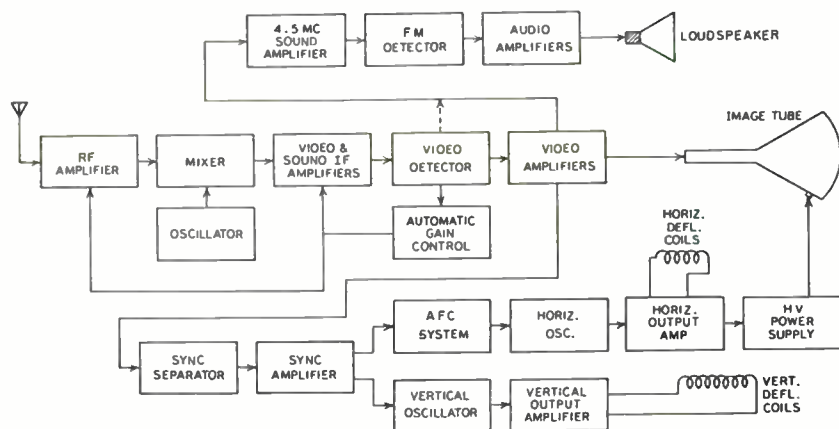

FIG. 1-3(B). A block diagram of an intercarrier set.

The RF stages of the receiver are identical with the RF section of the split-sound set. The incoming signal is received, amplified, and then converted to the lower intermediate frequencies. The entire signal—sound and video—now enters the IF system where both are amplified. There is this important difference, however. The video signal receives its normal amount of amplification, but the sound signal is permitted to receive only 5 per cent of the total available amplification. This relationship is purposely

maintained to prevent the sound signal from producing visible interference on the picture screen.

The intercarrier system has no sound take-off point in the mixer or the video IF system. Hence, both signals remain together until the video second detector. In this stage a beating, or mixing, takes place between the video and sound IF carriers, producing a difference frequency of 4.5 mc.* If we wish, we can consider the video carrier as being equivalent to the local oscillator, and the audio carrier as acting as the incoming signal. The result of the mixing is a 4.5-mc beat note. In addition, we also obtain all of the 0-4 mc video frequencies from the amplitude-modulated video carrier.

The 4.5-mc beat note contains all of the sound information. This part of the signal may now be transferred to its own sound system or the separation may be further delayed until both sound and video signals have passed through one or more video amplifiers. Once the separation is effected, the sound signal goes through one or two 4.5-mc sound IF amplifiers, through an FM detector, and on to several audio amplifiers and the speaker.

The video signal, for its part, travels through the video amplifiers to the picture tube. Here, its information is displayed visually.

The vertical- and horizontal-deflection systems are synchronized by a part of the signal obtained from some point in the video amplifiers. In this respect, both split-sound and intercarrier receivers are alike; therefore whatever was stated previously concerning the operation of these systems applies here, too.

The principal difference, then, between split-sound and intercarrier receivers is the point where the video and sound signals separate. In the split-sound set, this must occur *before* the video detector; in the intercarrier set, the separation takes place *after* the video detector.

Television Camera Tubes. The foregoing is an outline of present-day television systems. With this in mind, let us investigate the important operation of the studio camera tube in greater detail, for it is what this tube "sees" and converts into equivalent electrical impulses that will determine the form of the image finally reproduced at the receiver. Faithful reproduction of the scene being televised is necessary for high-quality images at the receiver.

Consider an ordinary photograph, such as is shown in Fig. 1-4. This picture was obtained from a negative that contained a large number of grains originally sensitive to light. So long as the picture, or positive, obtainable from the negative is not greatly enlarged or examined too closely, the granular structure of the photograph is not evident and the photograph appears smooth and continuous. However, if the picture is more and more

* In every television signal, the frequency difference between the sound and the video carriers is 4.5 mc.

enlarged, a point is reached where the granular structure of the picture does become visible. These grains, then, are the elements that combine to form the picture.

A fine-grain photograph, with many grains per unit of area, is capable of greater enlargement than a coarse-grain picture before these elements become discernible. With television images, the same kind of situation prevails. In the receiver, each picture element is just as large as the area of the



FIG. 1-4. A television studio scene developed from an ordinary negative.

circular beam impinging on the fluorescent screen of the cathode-ray tube. The light that is seen when observing a cathode-ray-tube screen is derived from the energy given off by the impinging beam to the particles of the fluorescent coating on the inner face of the tube. If the points of light are closely spaced, the observer will integrate them and their character as separate points will disappear. Hence, one of the first considerations for a television picture that is to reproduce any amount of fine detail is an electron beam of small diameter. This requirement is as important at the receiver screen as it is at the camera tube.

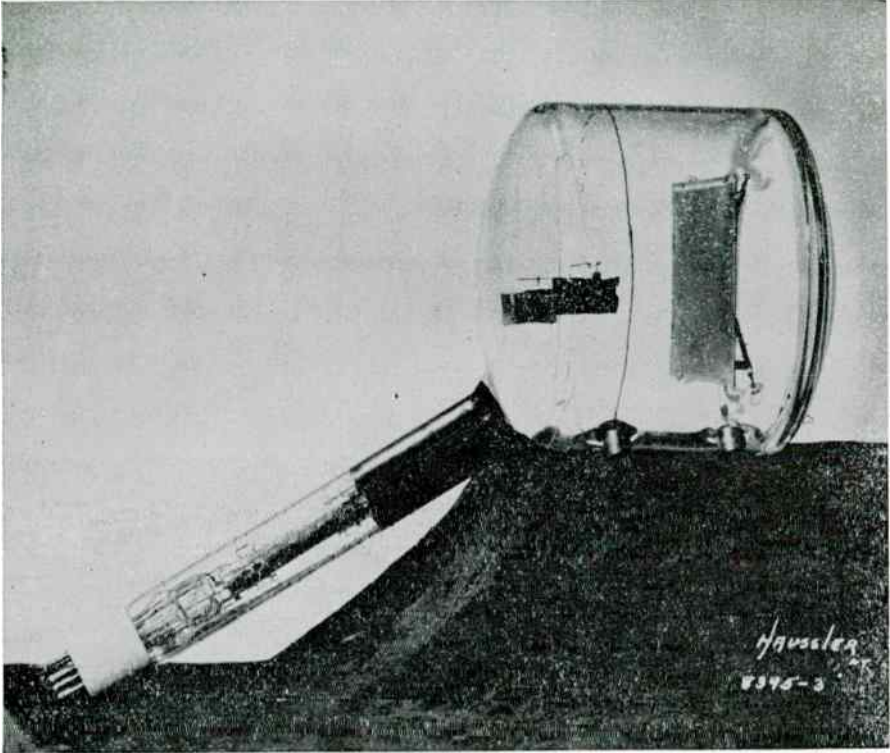

FIG. 1-5. An iconoscope camera tube.

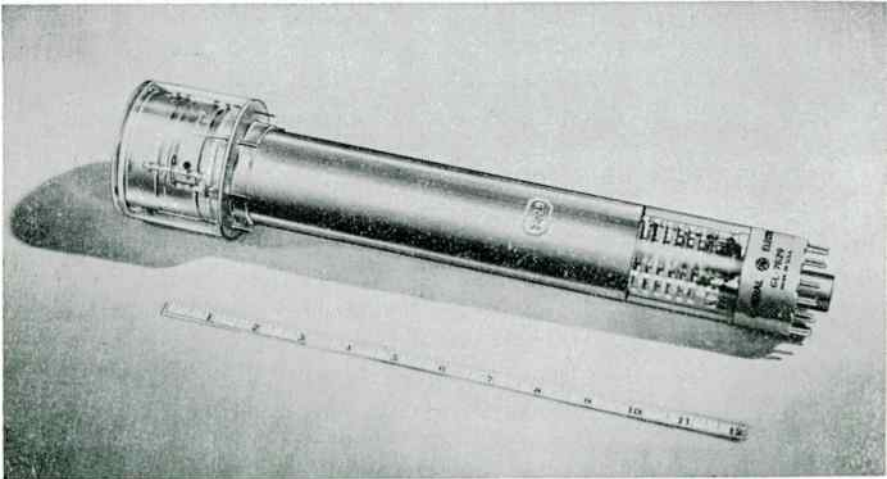

FIG. 1-6. An image-orthicon camera tube.

Three types of camera tubes have been widely used in this country: the iconoscope, the image orthicon, and the vidicon. They are shown in Figs. 1-5, 1-6, and 1-7. The iconoscope was the first of the three to be developed and employed commercially, and while it is still in use in a few broadcast stations, principally in film cameras, it has generally been replaced by either an image orthicon or a vidicon. Both of the latter tubes are in general use at the present time. Since the iconoscope was the earlier tube, it will be considered first.

The iconoscope has the internal construction shown in Fig. 1-8. Within the tube is a relatively large rectangular plate upon which all the light from the scene is focused. The plate consists of a thin sheet of mica (an insulator) upon the front of which has been deposited many microscopic globules of a sensitized caesium-silver compound. Because of the manner in which the globules have been placed on the mica plate, they do not come in actual contact. Each tends to form its own little island. Between these separate globules, of course, is the surface of the mica. On the reverse side of the plate, a continuous layer of a conducting substance is deposited and an electrical connection is brought from here to the external circuit.

It will be recognized that actually a capacitor is formed by the foregoing method of construction. Each globule forms one separate plate, with the back side of the mica acting as the common second plate for all the globules. The dielectric is the mica.

The object is focused on the face of the plate (commonly called "the mosaic"). Due to their silver-caesium composition, the globules emit electrons in proportion to the light intensity reaching that particular point. Thus each globule assumes a different positive charge, caused by this loss of negative electrons, with each element retaining this charge since it is insulated from all the other elements. The mica likewise prevents the charge from leaking off to the conducting layer on its other side. Essentially, we now have a charged capacitor, but the charge varies from globule to globule because of the difference in light intensity that fell on these various points.

By having the amount of charge on each globule vary in proportion to the light at that globule, we accomplish the first step of our process, namely,

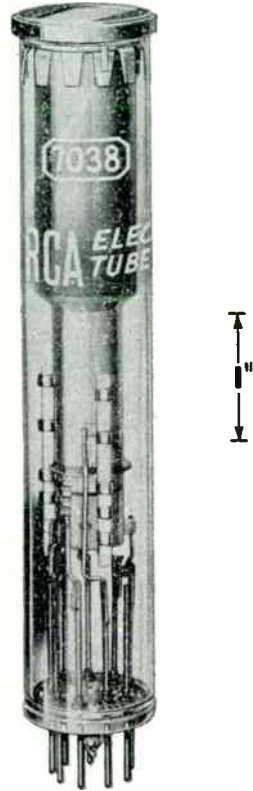

Courtesy RCA

FIG. 1-7. A vidicon camera tube.

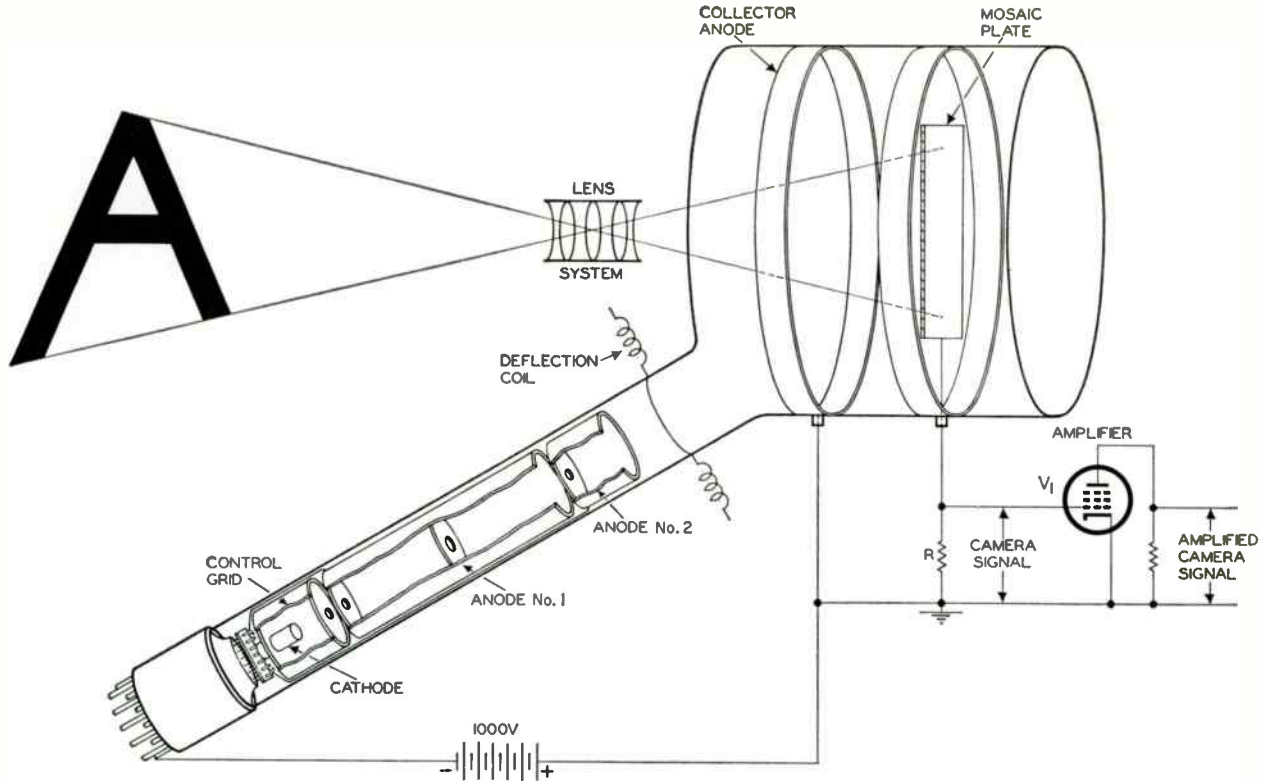

Fig. 1-8. The internal construction of an iconoscope.

conversion of light rays into equivalent electrical charges. It remains to convert these charges into electrical currents.

The similarity between the above action and the photographic process of taking a picture is striking. With more globules deposited on the mosaic, it should be possible to obtain a finer structure for the final reproduced image. This possibility will depend on the size of the electron beam and the scanning process used. The latter is associated with the method employed to convert the various differences in globule charge into corresponding electrical impulses. For the reproduction of fine detail in photographic films a fine-grain structure is necessary. For the iconoscope mosaic, caesium-sensitized globules correspond to the grains on a film negative. The more globules that are deposited on the mosaic, the smaller the detail that may be distinguished. The number of globules, in itself, however, is not the only deciding factor. Important, too, is the diameter of the scanning electron beam. A large round beam covers many globules at one time, and an average current, determined by the average of the charges on all these globules, results. Any detail that is too fine will blend with the surrounding objects and become obscured. On the other hand, with a small beam it is possible to contact smaller groups of globules and cause separate electrical currents to flow for each. The finer detail will be more evident now.

Electron-Beam Scanning. In order to transmit a picture, it is possible to send all the elements that compose this picture at one time, or to send each element separately in orderly sequence. Because of the complexity of the system that would be required if an attempt were made to transmit all the elements simultaneously, the second method (sending each element separately) has been universally adopted. Even with these alternatives, there is still a choice of scanning sequence. For example, it is possible to divide the image into a series of narrow horizontal strips and transmit one after the other, starting at the left-hand side of the uppermost strip. Another method is to dissect the image into vertical strips and transmit these in order. A third means employs spiral scanning. Each is illustrated in Fig. 1-9. Of practical interest, however, is horizontal scanning, since it is closest to the process currently employed.

At the start of the horizontal-scanning process in the iconoscope, an electron beam is formed, focused in the neck of the tube, and accelerated toward the upper left-hand corner of the mosaic plate (point *A* in Fig. 1-10). There, under the influence of varying voltages applied to the deflecting coils of the iconoscope (positioned on the neck of the tube), the electron beam moves to the right, passing over the charged globules which have been exposed to the focused rays of light from the televised scene, and which are located across the top of the image. As each globule, or group of globules, is reached, enough electrons are supplied by the electron beam to restore the

globule to its previously neutral potential. This action automatically releases any charge on the opposite conducting surface of the mosaic that was held there by the positive globules. With the release of this charge, a small pulse of current passes through resistor R of Fig. 1-8. The strength of this current is proportional to the amount of positive globule charge neutralized, which in turn is proportional to the intensity of the light striking this point of the mosaic plate.

Thus the second phase of our task has been accomplished and we have

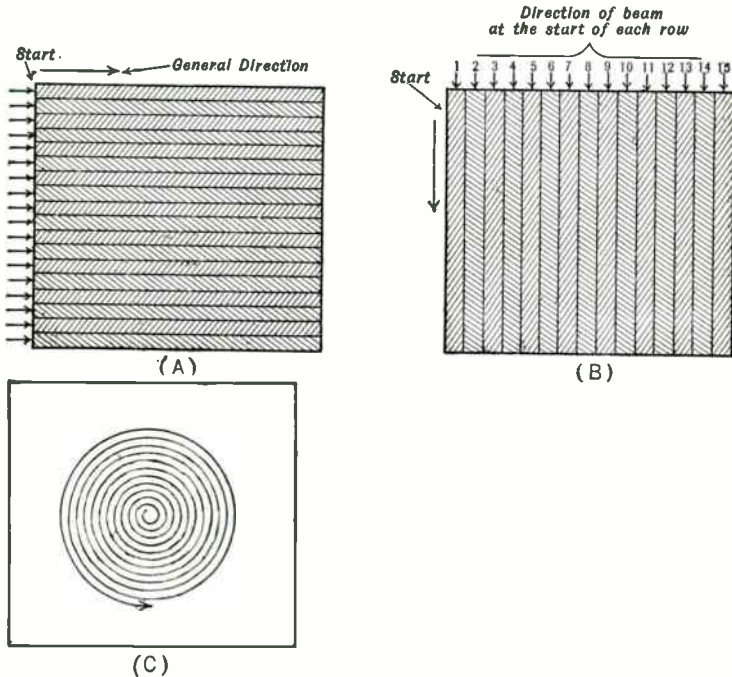

FIG. 1-9. Three possible methods of scanning an image: (A) horizontal scanning, (B) vertical scanning, and (C) spiral scanning.

transformed light rays into equivalent electric currents. The voltage developed across R will be proportional to the varying pulses of current passing through it. Tube V_1 will then amplify the fluctuating voltage and forward it to the stages that follow.

Returning to the scanning process, the beam continues along the first line until the end (point B) is reached. Here a generator connected to the camera tube will cut off or blank out the beam while the deflection coils bring it rapidly back again to point C at the left-hand side of the mosaic. This point is slightly below the first line. The blanking voltage is now

removed, and again the cathode-ray beam moves toward the right, neutralizing the positively charged globules along this horizontal line and causing electrical impulses to pass through *R*.

The sequence recurs until the end of the lowermost line is reached (at point *D*). The beam is blanked out and returned to the starting point *A*. The entire process is now ready to be repeated.

It should be noted that each globule has been storing up a charge (or giving off electrons) during the time the electron beam is busy passing over other globules. Thus, if it takes the beam 1 min to scan the entire image, the globules are being exposed to the focused light rays during all of this time. The resultant emission of electrons causes the positive charge to increase. With the arrival of the beam, a neutralization takes place; but, at the next second, with the passage of the beam, the storage process begins anew. While 1 min is mentioned as an arbitrary period, in practice the beam passes over each globule every $\frac{1}{30}$ sec. Hence 30 complete pictures are sent every second.

In actual equipment, the motion of the scanning electron beam, as described above, must be modified somewhat for two reasons. First, it is extremely difficult to generate a voltage that will cause the beam to drop suddenly from the end of one line to the level of the next one directly beneath it. It is simpler to have the beam move down to the level of the second line gradually, as is illustrated in Fig. 1-11.

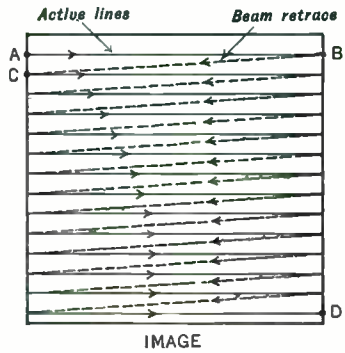

FIG. 1-10. The motion of the electron beam in one form of horizontal scanning.

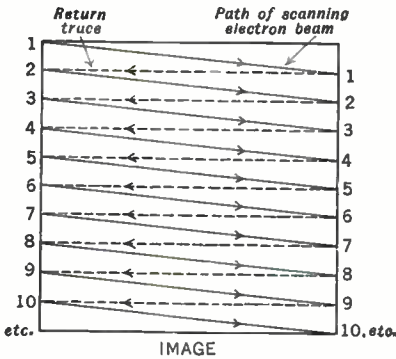

FIG. 1-11. In actual equipment it is easier to have the electron beam travel in the manner indicated above than in Fig. 1-10.

Second, it is extremely difficult to generate a voltage that will cause the beam to drop suddenly from the end of one line to the level of the next one directly beneath it. It is simpler to have the beam move down to the level of the second line gradually, as is illustrated in Fig. 1-11.

To obtain this type of motion for the electron beam, both horizontal- and vertical-deflection coils in the iconoscope tube are utilized. Without going into an extensive discussion at this time of the operation of the electron gun located in the neck of the iconoscope, let us state simply that the horizontal-deflection coils can move the electron beams horizontally across the screen from left to right and back again. The vertical-deflection coils can cause the beam to move vertically. Between them, and with different amounts of currents

passing through each set of coils, it is possible to move the electron beam across the screen to reach any desired point.

In the foregoing type of motion (with the beam moving across the screen slantwise), we have the equivalent of a fast-acting voltage on the horizontal plates quickly forcing the beam straight across, while a slow-acting voltage at the vertical plates is forcing the beam down. The result is shown in Fig. 1-11. When the beam reaches the end of a line, it is quickly brought almost straight across (with the blanking signals on) where it is in correct position to start scanning line 2 when the blanking voltage is removed. The remainder of the lines follow in similar fashion. At the bottom of the picture, after the last line has been scanned, a longer blanking signal is applied while the beam is returned to the top of the picture. The purpose of the blanking voltages is simply to prevent the beam from impinging on the screen when there is nothing to impart, and the beam is merely moving into position for the next scanning run.

A possible current that could be used for the horizontal- and vertical-deflection coils is the familiar sawtooth wave illustrated in Fig. 1-12. This current rises gradually to a fixed level and then suddenly drops (almost vertically) to zero to begin the process over again. More will be mentioned about

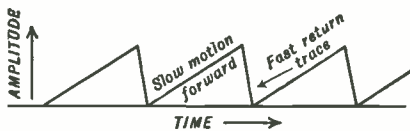

FIG. 1-12. A sawtooth current, as illustrated here, when passed through a set of deflecting coils, will cause the electron beam to move slowly from left to right and then retrace rapidly from right to left.

motion appears continuous. The eye can do this because of a phenomenon called "persistence of vision." Due to this property of the eye, visual images do not disappear as soon as their stimulus is removed. Rather, the light appears to diminish gradually, taking, on the average, about $\frac{1}{30}$ sec before it disappears entirely. In motion pictures, this situation is very fortunate, for otherwise this method of entertainment would be impossible.

It has been found that when theater films are presented at a rate of 15 stills per second, the action appears continuous. However, at this speed, flicker is still detectable and detracts from the complete enjoyment of the film. The flicker is due to the sensation in the viewer's mind decreasing to too low a value before the next film is presented on the screen. Increasing

sawtooth-wave generators when the television receiver is discussed. For the second reason why the horizontal scanning process had to be modified we must examine more closely the human eye and its action when observing motion on a screen.

Flicker. If a set of related still films follow each other fairly rapidly on a screen, the human eye is able to integrate, or combine, them, and the

the rate at which the stills are presented will gradually cause the flicker to disappear. At 50 frames per second there is no trace of flicker, even under adverse conditions. The rate is not absolute, however, but depends greatly upon the brightness of the picture. With average illumination, lower frame rates prove satisfactory.

In the motion-picture theater, 24 individual still films (or frames) are flashed onto the screen each second. Since at this rate, flicker is somewhat noticeable, a shutter in the projection camera breaks up the presentation of each frame into two equal periods. (The fundamental rate has now been increased to an effective rate of 48 frames per second.) This is accomplished by having the shutter move across the film while it is being projected onto the screen. Thus we are actually seeing each picture twice. By this ingenious method, all traces of flicker are eliminated.

In television, a fundamental rate of 30 images (or frames) per second was chosen because this frequency and the effective rate are related to the frequency of the a-c power lines. Practically, this choice of frame-sequence rate necessitates less filtering in order to eliminate a-c ripple, which is called "hum" in audio systems. With 24 frames per second, for example, any ripple that was not eliminated by filtering would produce a weaving motion in the reproduced image. Less difficulty is encountered from a-c ripple when 30 frames per second are employed.

To eliminate all traces of flicker, an *effective* rate of 60 frames per second is employed. This is accomplished by increasing the downward rate of travel of the scanning electron beam so that *every other line* is sent instead of every successive line. Then, when the bottom of the image is reached, the beam is sent back to the top of the image, and those lines that were missed in the previous scanning are now sent. Both of these operations, the odd- and even-line scanning, take $\frac{1}{30}$ sec; therefore 30 frames is still the fundamental rate. However, since all the even lines are transmitted in $\frac{1}{60}$ sec and the same is true of the odd lines, they add up, of course, to $\frac{1}{30}$ sec. To the eye, which cannot separate the two, the *effective* rate is now 60 frames per second, and no flicker is noticeable.

To differentiate between the actual fundamental rate and the effective rate, we say that the frame frequency is 30 cps, whereas the effective rate (called the field frequency) is 60 cps. This method of sending television images (Fig. 1-13) is known as "interlaced scanning."

Thus, as the standards for television images now stand, each complete scene is sent at a rate of 30 frames per second. To obtain the desired amount of detail in a scene, the picture is divided into a total of 525 horizontal lines. The technical reasons behind the choice of 525 lines are related to these requirements:

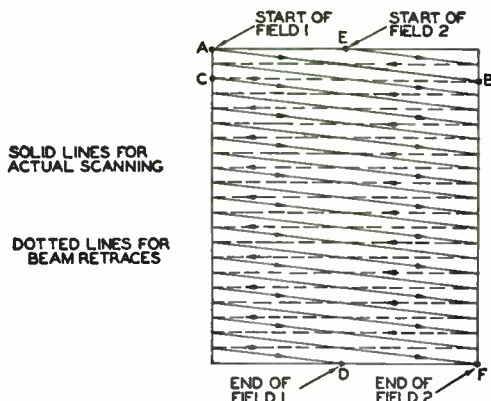

FIG. 1-13. The path of the electron beam in interlaced scanning.

1. The frequency bandwidth available for the transmission of the television signals. As will be shown later, the required bandwidth increases with the number of lines.

2. The amount of detail required for a well-reproduced image.

3. The ease with which the synchronizing (and blanking) signals can be generated for the horizontal- and vertical-deflection plates.

With each frame divided into two parts (because of interlaced scanning), each field will have one-half of 525 lines, or $262\frac{1}{2}$ lines, from its beginning to the start of the next field. (As a matter of definition, a complete picture is called a "frame.") With interlaced scanning, each frame is broken up into an even-line field and odd-line field. Each field contains $262\frac{1}{2}$ lines, whereas a frame has 525, the full amount.

The Complete Scanning Process. From the foregoing discussion it becomes possible to reconstruct the entire scanning process. Although only the movement of the electron beam at the television camera will be considered, an identical motion exists at the receiver screen.

At the start of the scanning motion at the camera-tube mosaic, the electron beam is at the upper left-hand corner, point *A* of Fig. 1-13. Then, under the combined influence of the two sets of deflection coils, the beam moves at a small angle downward to the right. When point *B* is reached, the blanking signal acts while the beam is rapidly being brought back to point *C*, the third line, as required for interlaced scanning. The blanking signal then relinquishes control and the electron beam once again begins its left-to-right motion. In this manner every odd line is scanned.

When the end of the bottom odd line has been reached (point *D*), the blanking signals are applied while the beam is brought up to point *E*. Point *E* is above the first odd line of field 1 by a distance equal to the thick-

ness of one line. The beam is brought here as a result of the odd number of total lines used (525). Each field has $262\frac{1}{2}$ lines from its beginning to the start of the next field and, when the beam reaches point *E*, it has moved through the necessary $262\frac{1}{2}$ lines from its starting point *A*. From here the beam again starts its left-to-right motion, moving in between the previously scanned lines, as shown in Fig. 1-13. The beam continues until it reaches point *F* and from here is brought to point *A*. From point *A* the entire sequence repeats itself.

Thus, as matters stand, the electron beam moves back and forth across the width of the mosaic $262\frac{1}{2}$ times in going from point *A* to point *D* to point *E*. The remaining $262\frac{1}{2}$ lines needed to form the total of 525 are obtained when the beam moves from point *E* to point *F* back to point *A*. The process may seem complicated but actually it is carried out quite readily and accurately at the transmitter (and receiver). A more detailed analysis, including the number of horizontal lines that are lost when the vertical synchronizing pulse is active, is given in Chapter 12.

The Image Orthicon. Of the three camera tubes mentioned previously, the iconoscope has already been described in detail. It is not without defects, the two most serious being its poor efficiency and its tendency to produce background shading that is not found in the original scene. The latter defect arises from the fact that the impinging scanning beam has sufficient force to dislodge secondary electrons from the surface of the globules over which it may be passing. Some of these electrons, once freed from their globules, may be attracted to the positive collector ring or fall back on the mosaic plate. In either case, the true, original form of the charge distribution of the mosaic plate is altered. This distortion, for that is what it is, generally appears on the screen as a darkened background. Correction voltages can be inserted into the signal in an effort to eliminate the distortion. Actually the voltages from the shading generator are 180 deg out of phase with the distortion voltages, and their elimination is thus effected. It may appear to the reader that almost an infinite number of shading signals would be required. Fortunately this is not so. Experience with iconoscopes reveals that relatively simple correcting voltages are required and these are readily generated and injected into the voltage wave.

A camera tube which is considerably more sensitive than the iconoscope is the image orthicon. See Fig. 1-6. The greater sensitivity of this tube gives it the following advantages:

1. The ability to televise scenes too dark to establish an acceptable image with other camera tubes.
2. A greater depth of field, permitting the inclusion of background that will otherwise be blurred or obscured on the receiver screen.

Physically, the tube looks like an elongated image-projection tube. It is

approximately 15 inches long and 3 inches in diameter at the head. Electrically, the tube is divided into three parts: the image section, where the equivalent distribution of charge over a photosensitive surface is formed; a scanning section, consisting of the electron gun, the scanning beam, and deflection coils; and a multiplier section where, through a process of secondary emission, more current is generated than is contained in the returning beam. Figure 1-14 illustrates all three sections of the image orthicon.

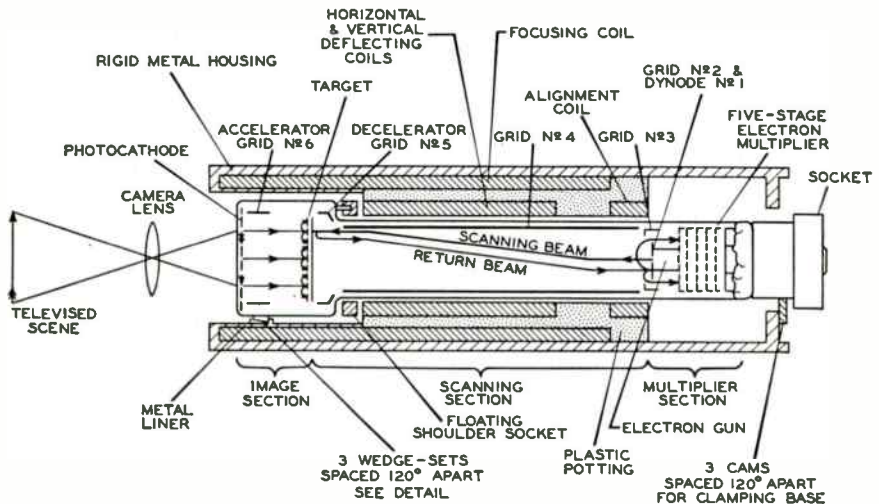

Fig. 1-14. The internal construction of the image orthicon.

In operation, light rays from the scene to be televised are focused by an optical lens system onto a transparent photosensitive plate. At the inner surface of this plate, electrons are emitted from each point in proportion to the incident light intensity. Note that the light rays must penetrate the transparent plate to reach the photosensitive inner surface.

The emitted electron image (in which, at each point, the density of the electrons corresponds to the light at that point) is drawn to the target by a positive wall coating. At the target, the arriving electrons produce secondary emission and thus develop a pattern of positive charges directly proportional to the distribution of energy in the arriving electron image. The target is not photosensitive, but is capable of emitting secondary electrons.

By this method of forming a charge distribution on the target plate, we obtain a more intense degree of positive charge distribution than would be obtained if the light rays themselves were the activating agent, as in the iconoscope.

The back of the target plate is scanned by a low-velocity electron beam,

which is slowed down just short of the plate and at each point gives up sufficient electrons to neutralize the positive charge at that point. The remainder of the electrons in the beam then return to an electron-multiplier arrangement where several electrons are produced for each impinging electron. The result—at the output—is a current amplified many times greater than the current in the return beam.

It is evident that the most positive points on the plate return the least number of electrons from the original scanning beam. Hence, the voltage developed across the output-load resistor is inversely proportional to the positive charge intensity on the target. As we shall see presently, this corresponds to negative phase polarity in the signal.

In order to function effectively, the two-sided target must be able to conduct between its two surfaces but not along either surface. The logic of this is evident. Whatever charge appears on one side of the target due to the focused image must likewise appear on the other side. It is this second side which is scanned and it is from here that the video signal is obtained. Hence, a conducting path must exist between the front and back sides. However, nothing must disturb the relative potential that exists throughout the charge pattern, as deposited on the front side of the target. Hence, no conduction is permissible between the various elements of any one side of the target plate. If this does occur, the charge differences between the various points on the image disappear.

Until very recently, the two-sided target used in the image orthicon was a thin sheet of low-resistivity glass. The resistivity between the front and back sides was sufficiently low that by placing opposite charges on the sides, complete neutralization (by conduction) would occur in less than $\frac{1}{30}$ sec. In this way, one frame was prevented from affecting the next frame.

The thin sheet of glass was about $1\frac{1}{2}$ in. in diameter. It was placed about $\frac{2}{1000}$ in. from a flat fine-mesh screen, the purpose of which was to collect secondary electrons that were knocked off the target when the photoelectrons impinged upon it. In order not to interfere with the oncoming photoelectrons, the mesh contained 500 to 1,000 meshes per linear inch, an open area of from 50 to 75 per cent, and a considerable accuracy of spacing.

Recently, another type of material, magnesium oxide, has been developed for target use in image orthicons. This material is said to overcome one of the major objections to glass targets, namely, the tendency to become "sticky" after several hundred hours of use. The term "sticky" refers to the increasing tendency of glass targets to retain the image for longer and longer periods of time. When stickiness becomes noticeable by causing images of a previous scene to smear over the new scene, the tube must be discarded. Stickiness has been a major cause of tube replacement.

Another limitation of glass targets is their susceptibility to permanent

damage from what is called "burn-in," which is caused by aiming the camera at a bright, stationary highlight for too long a time. When this happens, the target acquires a permanent afterimage, or burn, which is evident in all transmitted pictures from that time on. Burn-in is another cause of tube replacement.

The ability of magnesium oxide targets to overcome these difficulties stems from the fact that the oxide uses a different principle of conduction between front and back sides. In the glass target, conduction occurs by the movement of sodium ions. This is not a reversible action because the sodium which travels from one side of the target to the other does not return to its original position. In time, the ions are exhausted and the useful life of the tube ceases.

With magnesium oxide targets, only electrons travel from the rear to the front. This process is reversible and the life of a tube is not limited by the exhaustion of charged carriers. Thus, the problems caused by stickiness and burn-in are virtually eliminated, and the expected life of the tube is appreciably extended. Furthermore, camera tubes using these targets possess a higher sensitivity because magnesium oxide yields a higher secondary electron emission (for the electrons reaching the target from the photosensitive plate).

A major reason for the high sensitivity of the image orthicon stems from the use of an internal electron multiplier. In this multiplier, the electrons in the return beam are captured and then increased manyfold through a process of secondary emission to provide an output current which is several hundred times stronger than it would be without a multiplier.

The multiplier structure in the image orthicon consists of a series of circular screens set one below the other around the gun. See Fig. 1-15. The return beam is directed to dynode no. 1 (this is also grid no. 2) of a 5-stage electron multiplier. For each electron that strikes this electrode, two or more electrons are dislodged secondary electrons are then directed (by the electric field of grid no. 3 and the higher voltage of dynode no. 2) to dynode no. 2. This latter element is a 32-blade pinwheel mounted directly

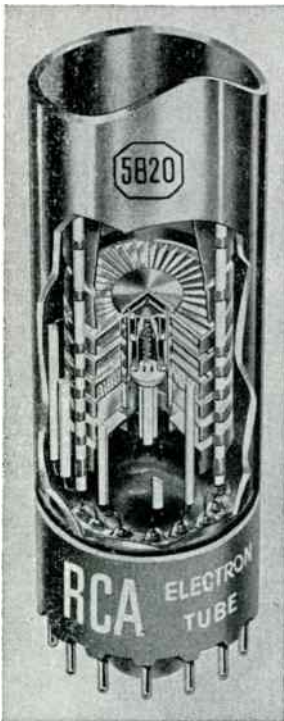

Courtesy RCA

FIG. 1-15(A). Cut-away view of image orthicon showing construction of multiplier section.

from its surface. These electric field of grid no. 3 and the higher voltage of dynode no. 2) to dynode no. 2. This latter

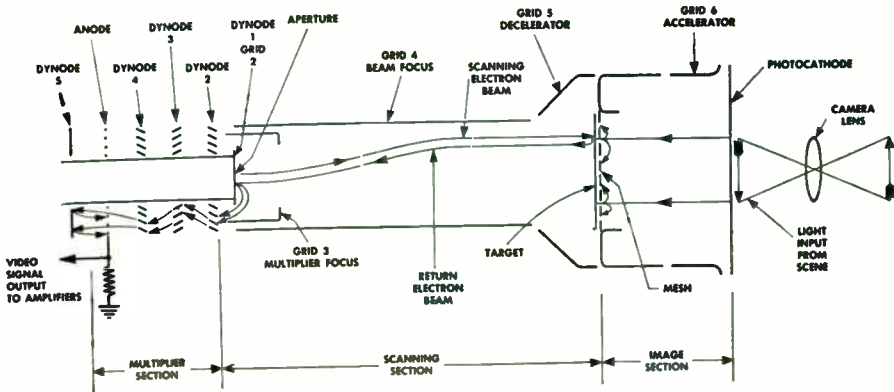

FIG. 1-15(B). The path of the electrons as they travel through the screens of the multiplier section (at left side of illustration).

below dynode no. 1. The arriving electrons strike the blade of dynode no. 2, causing secondary electrons to be emitted, which are drawn through the slots to the next stage.

This multiplying process continues at each successive dynode, with an ever-increasing stream of electrons, until those emitted from the final dynode are collected by an anode and made available to the output circuit.

An amplification of 500 or more electrons is achieved in this fashion. The multiplication so obtained maintains a high signal-to-noise ratio. The gain of the multiplier is sufficient to raise the output signal above the noise level of the video amplifiers to which the signal is fed so that the amplifiers contribute no noise to the final video signal.

The Vidicon. The iconoscope and the image orthicon both depend on the principal of photoemission, wherein electrons are emitted by a substance when it is exposed to light. The vidicon, on the other hand, is a television camera tube that employs photoconductivity; that is, a substance is used for the target whose resistance shows a marked decrease when exposed to light.

The operating principal of the vidicon camera tube is illustrated in Fig. 1-16. The target consists of a transparent conducting film (the signal electrode) on the inner surface of the face plate and a thin photoconductive layer deposited on the film. Each cross-sectional element of the photoconductive layer is an insulator in the dark that becomes slightly conductive when it is illuminated, and acts like a leaky capacitor, having one plate at the positive potential of the signal electrode and the other floating. When light from the scene or film being televised is focused on the surface of the photoconductive layer next to the face plate, each cross-sectional illuminated layer element conducts slightly, the current depending on the amount of

TELEVISION SIMPLIFIED

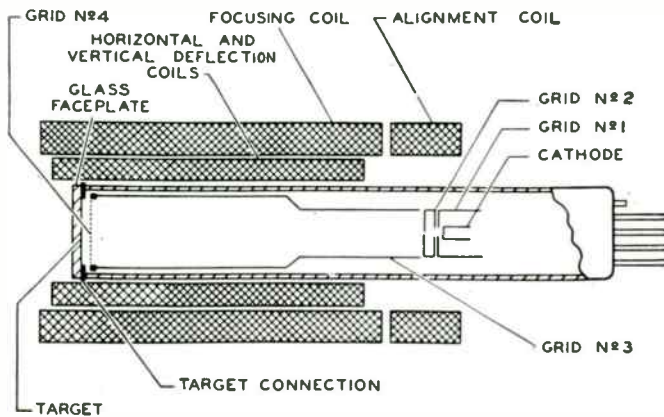

FIG. 1-16. Internal construction of a vidicon.

light reaching that element. This causes the potential of its opposite surface (i.e., the gun side) to rise to the signal electrode potential in less than the scanning time of one frame. Hence, there appears on the gun side of the entire layer surface a positive potential pattern composed of the various element potentials corresponding to the pattern of light which is focused on the photoconductive layer.

The gun side of the photoconductive layer is scanned by a low-velocity electron beam produced by the electron gun. When the gun side of the photoconductive layer, with its positive-potential pattern, is scanned by the electron beam, electrons are deposited from the beam until the surface potential is reduced to that of the cathode. This action produces a change in the difference of potential between the two surfaces of the element being scanned. When the two surfaces of the element, which in effect form a charged capacitor, are connected through the external target (signal-electrode) circuit and a scanning beam, a capacitive current is produced. This current constitutes the video signal. The amount of current flow is proportional to the surface potential of the element being scanned and to the rate of the scan. The video-signal current is then used to develop a signal-output voltage across the load resistor. The signal polarity is such that for highlights in the image, the grid of the first-video amplifier tube swings in the negative direction. In the interval between scans, wherever the photoconductive layer is exposed to light, the migration of charge through the layer causes its surface potential to rise toward that of the signal plate. On the next scan, a sufficient number of electrons are deposited by the beam to return the surface-to-cathode potential.

The electron gun contains a cathode, a control grid (grid no. 1), and an accelerating grid (grid no. 2). The beam is focused on the surface of the

photoconductive layer by the combined action of the uniform magnetic field of an external coil and the electrostatic field of grid no. 3. Grid no. 4 serves to provide a uniform decelerating field between itself and the photoconductive layer, so that the electron beam will tend to approach the layer in a direction perpendicular to it, a condition which is necessary for driving the surface-to-cathode potential. The beam electrons approach the layer at low velocity because of the low-operating voltage of the signal electrode. Deflection of the beam across the photoconductive substance is obtained by external coils placed within the focusing field.

Photoconductive substances are capable of producing far greater currents per lumen of incident light than photoemissive substances. Consequently, the vidicon is considerably more sensitive than either the image orthicon or the iconoscope, and does not require an electron multiplier. Thus, the vidicon is more simple structurally and can be built in a much smaller glass envelope. Miniature vidicon pickup tubes have been built which are only $\frac{1}{2}$ in. in diameter and 3 ins. long. In contrast, an image orthicon has an average bulb diameter of 3 in. and an overall length of somewhat more than 15 in.

Vidicons are employed principally for film and slide pickup in television broadcast stations, although a few stations use vidicons for live pickup, primarily for newscasts and shows of a similar type having little action. Because of its small size and much lower cost (than image orthicons), the vidicon is almost exclusively employed for industrial application.

Camera tubes designed for studio use are housed in large rectangular cases, then placed on dollies to allow the entire assembly to be moved from one position to another quickly and quietly. The necessity for employing the relatively large cases is due to the extremely small video currents generated in the camera tubes, even under the most favorable conditions. If these tiny currents were sent into the long connecting coaxial cables, they would be too small to override the noise inherent in the system by the time the transmitter was reached. To prevent this situation, several amplifiers are built into the camera assembly along with the camera tube. Consequently, the small video currents are amplified immediately and then sent into the connecting transmission line.

Figure 1-17 shows a present-day television studio camera. A television studio camera in use is shown in Fig. 1-18.

Blanking and Synchronizing Signals. The cathode-ray beam at the receiver must follow the transmitter action at every point. For example, each time the camera-tube beam is blanked out, the same process must occur at the receiver and at the proper place on the screen. It is for this purpose that blanking pulse signals are sent along with the video signals, those that contain the image details. These blanking pulses, when applied to the

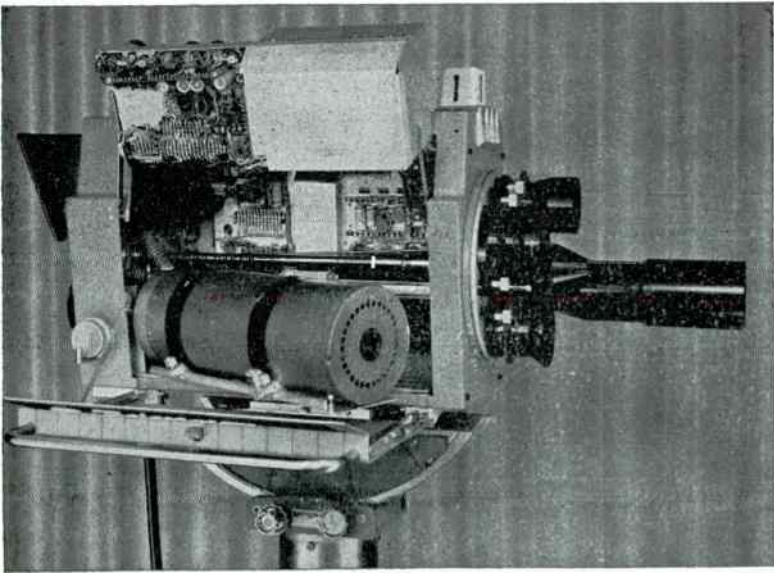
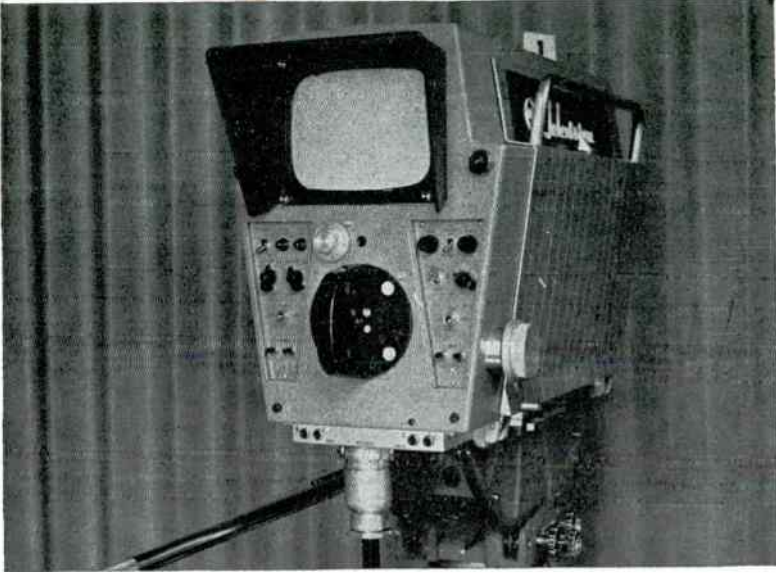

Courtesy RCA

FIG. 1-17. A modern television camera. (Top) Rear view showing the various controls that govern camera operation. (Bottom) Inside of television camera. The camera tube fits inside the large cylinder shown at the bottom of the cabinet.



Courtesy RCA

FIG. 1-18. A television studio camera in use.

control grid of a cathode-ray tube, bias it to a large negative value, sufficient to prevent any electrons from passing through the grid and on to the fluorescent screen.

Blanking voltages, while preventing the electron beam from impinging on the fluorescent screen during retrace periods, do not cause the movement of the beam from the right- to the left-hand side of the screen, or from bottom to top. For this, another set of pulses, superimposed over the blanking signals, control oscillators at the receiver and these, in turn, control the position of the beam. The pulses are called "synchronizing pulses." A horizontal pulse at the end of each line causes the beam to be brought back to the left-hand side, in position for the next line. Vertical pulses, at the end of each field, are responsible for bringing the beam back to the top of the image.

The Video Signal. In order to see how the picture detail, blanking signals, and synchronizing pulses are all combined to form the complete

video signal, refer to Fig. 1-19. Here three complete lines have been scanned. At the end of each line the blanking signal is imposed on the beam and automatically prevents the electron beam from reaching the mosaic at the camera or the fluorescent screen at the receiver. With the blanking signal on, a synchronizing pulse is sent to cause (in this instance) the horizontal-deflection coils to move the position of the electron beam from the right side of the picture to the left. This movement accomplished, the job of the synchronizing pulse is completed and a fraction of a second later the blanking control releases its negative bias on the control grid of the cathode-ray tube and the electron beam starts scanning again. The process continues until all the lines (odd or even) in one field have been scanned.

The vertical motion ceases at the bottom of the field and it is necessary to bring the beam quickly to the top of the image so that the next field

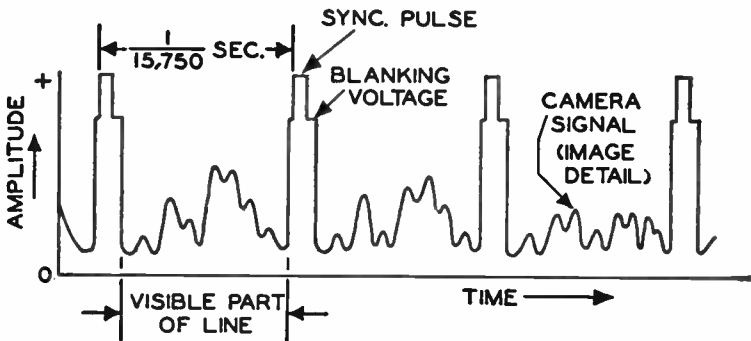

FIG. 1-19. The complete video signal for three scanned lines.

can be traced. Since the vertical-triggering pulse and retrace require a longer period of time than the horizontal-triggering pulse and retrace, a longer blanking signal is inserted. As soon as the blanking signal takes hold, the vertical-synchronizing pulse is sent. The form that this takes is shown in Fig. 1-20. Because the horizontal-synchronizing pulses must not be interrupted, even while the vertical-deflection coils are bringing the electron beam to the top of the field, the long vertical pulse is broken into appropriate intervals. In this manner it is possible to send both horizontal and vertical pulses at the same time, each type being accurately separated at the receiver and transferred to the proper deflection system. Greater detail is given on this point in Chapter 12. The term used for the series of synchronizing pulses that combine to make up the total vertical signal is "serrated vertical impulses." This type of waveform has been established as standard in the United States.

Under the action of the vertical-deflection coils the beam is brought to

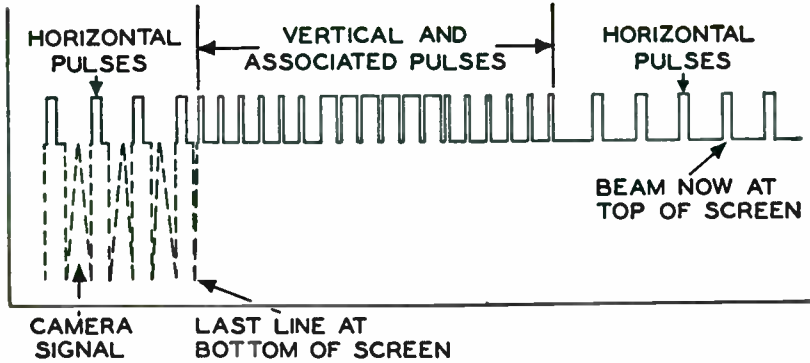

FIG. 1-20. The form of the vertical-synchronizing pulses.

either point *A* or point *E* (Fig. 1-13) and then the usual camera action starts anew.

Negative and Positive Video Polarity. A closer inspection of a video signal (Fig. 1-21) reveals that of the total (100 per cent) amplitude available, from 75 to 80 per cent is set aside for the camera-signal variations. At the level where the camera signal ceases, the blanking voltage is inserted. The remaining 20 to 25 per cent of the amplitude is reserved for the horizontal- or the vertical-synchronizing pulses. It will be noticed that, no matter where the camera signal happens to end, the blanking level and the synchronizing pulses always reach the same amplitude. This is done purposely at the transmitter, and several operations in the television receiver depend upon this behavior. It must be remembered, however, that this action does not necessarily have to be used, but is specifically employed because of resulting simplicity at the receiver.

Figure 1-21 illustrates the form of the video signal as it is used in the United States. From the relative polarity marked on the side (or vertical) scale, it is seen that the brightest portions of the camera signal cause the least amount of current to flow, or the voltage has the least amplitude. This action

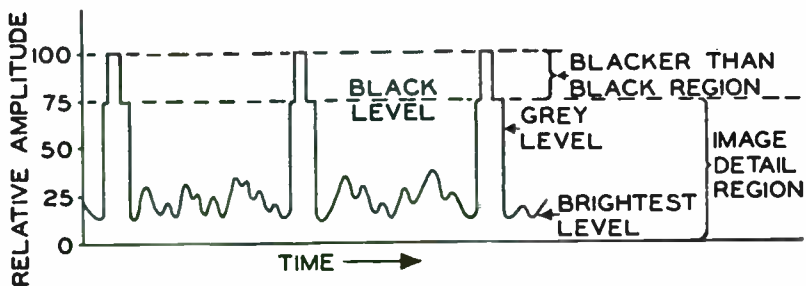

FIG. 1-21. The various proportions of a video signal.

is exactly the opposite of the action at the iconoscope, as explained earlier in this chapter. The signal-voltage (or current) values have been completely reversed. The blanking voltage, which should be more negative than any part of the camera signal, is actually more positive. And the synchronizing pulses give the largest voltage and current of all.

Transmitting the signal in this form is known as "negative picture transmission," and the picture is said to be in the "negative picture phase." If the video signal is reversed so that it assumes the form of Fig. 1-22, it is called

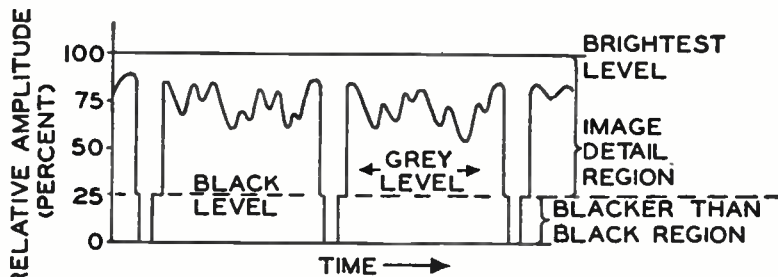

FIG. 1-22. The form of the video signal in positive transmission.

the positive picture phase" and, if transmitted, is known as "positive transmission." In the United States negative RF transmission is employed; in England the other form is preferred. It is claimed here that less interference is visible on the viewing screen with negative transmission and that better all-round reception is obtained under adverse conditions. Be that as it may, one standard has been decided upon, and all receivers must be constructed to receive this signal. If a receiver designed for negative-picture-phase signals receives a positive-picture-phase signal, all the light values of the image are reversed on the viewing screen. The bright portions appear dark, the dark portions appear light. The result is similar to a photographic negative, in which the values are likewise reversed.

In the receiver, before the video signal is applied to the control grid of the cathode-ray tube, the signal must possess the proper, or positive, picture phase. The grid of the cathode-ray tube is then biased by enough negative voltage that, when the blanking voltage section of the signal does act at the grid, the electron beam is automatically prevented from reaching the fluorescent screen. With the positive picture phase, the camera-signal voltages are all more positive than the blanking pulse and, on these portions of the video signal, the electron beam is permitted to impinge on the screen with varying amounts of electrons. A bright spot in the received image causes the grid to become more positive than when the voltage of a darker spot is applied. More electrons in the beam mean that more light is emitted

at the screen, and the various shades and light gradations of the image are formed by different voltages.

The purpose of the blanking voltage in the video signal is to prevent the electron beam from reaching the fluorescent screen. This fact is well known by now. The point in the video wave where the blanking signal is located occurs in the region where the currents corresponding to the very dark portions of the image are found. By the time the blanking voltage acts at the control grid of the viewing tube, the beam is entirely cut off and nothing appears on the screen. The blanking level is then properly called the "black region," because nothing darker appears on the fluorescent screen. By nothing darker, we mean no light at all appears.

Now, consider the video signal of Fig. 1-22. With the blanking level we find the synchronizing pulses. When applied to the viewing-tube control grid along with the rest of the wave, the pulses drive the grid to a negative voltage even greater than cutoff. The pulse region, for this reason, is labeled blacker than black, because the position of the blanking signal has been labeled black. The unwanted synchronizing pulses that ride through the video amplifiers with the necessary video signal need not be removed because they do not interfere in any way with the action of the control grid at the cathode-ray tube. As will be shown presently the complete video wave is applied, after the detector, to the synchronizing- and video-amplifier circuits simultaneously. The synchronizing clipper tube permits only the pulses to pass through, whereas the video amplifiers allow the entire signal to pass.

Why Television Requires Wide Frequency Bands. In dealing with television receivers, it will be found that extensive use is made of wide-band amplifiers designed to receive signals extending over a band 4 to 6 megacycles (mc) wide. The different forms which these amplifiers may assume and their characteristics are discussed in later chapters; however, the reason for the extremely wide bandwidth may be appreciated now.

In the foregoing paragraphs on television images, it was brought out that the more elements in a picture, the finer the detail that is portrayed. The picture can also stand closer inspection before its smooth, continuous appearance is lost. Each $\frac{1}{30}$ sec, 525 lines are scanned, or a total of 15,750 lines in 1 sec. If each horizontal line contains 700 separate elements, then $15,750 \times 700$, or 11,025,000, elements or electrical impulses are transmitted each second. In order to attain full advantage of the use of this number of elements, it is first necessary to determine what relationship exists between two quantities: number of elements and bandwidth.

Consider, for example, that the mosaic plate in the iconoscope is broken up into a series of black and white dots, each dot representing one element. The resulting pattern is shown in Fig. 1-23(A). As the scanning

beam passes over each element in turn, a pulse of current flows every time a white dot is reached, for this element has a large deficiency of electrons. At the next element, the current drops to zero, for theoretically a black dot represents an element that has received no light at all. It therefore requires

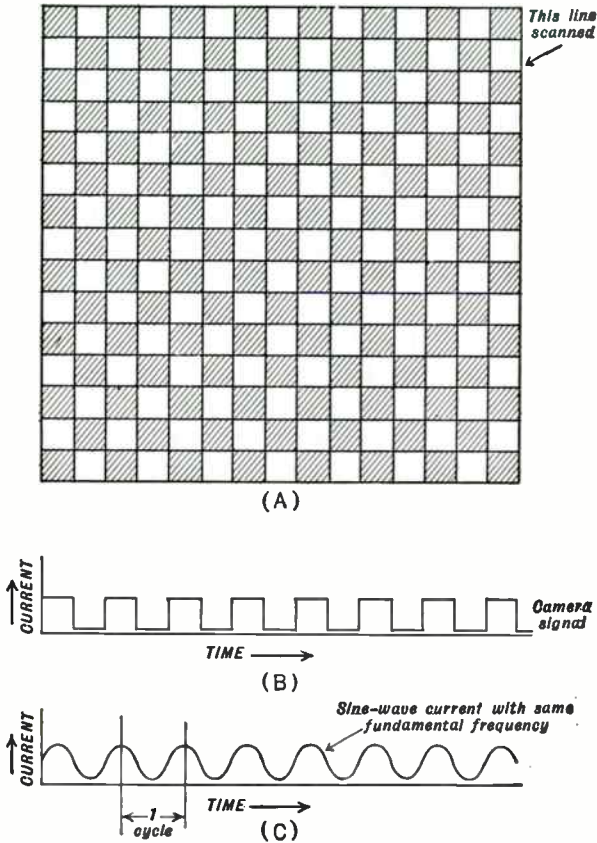

FIG. 1-23. The basic relationship between the number of elements in an image and the width of the frequency band required.

no additional replacement of electrons. In one complete horizontal line, the electric pulses of current would have the shape shown in Fig. 1-23(B).

If one maximum point in the wave is combined with its succeeding minimum point, one complete cycle is obtained. The same situation prevails in any sine wave. See Fig. 1-23(C). Since each white dot represents a maximum point and each black dot a minimum point, taking the total number of white and black dots on a line and dividing their sum by 2 gives the number of cycles the current goes through when one horizontal line is

scanned. With 700 elements (dots, in this case) on a line, a fundamental frequency of 350 cycles is generated.

Under present standards, 525 lines are scanned in $\frac{1}{30}$ sec, or a total of 15,750 in 1 sec. Employing 700 elements per line, 11,025,000 picture elements are sent each second, which, for our analysis, results in a frequency of $\frac{11,025,000}{2}$ cps, or 5.51 mc. In actual practice, a band width of 4 mc is allowed.

Thus, for the video section alone, this extremely large bandwidth must be passed by all the tuned circuits of the television receiver.

The above situation would seldom, if ever, be found in practice. However, the figures obtained by this reasoning yield results that have been found satisfactory, and the method, from this viewpoint, is justified.

Although 4 mc are required to accommodate the video information alone, the bandwidth set in practice is 6 mc. Of the extra 2 mc, the FM audio carrier uses 50 (kc). Apparently considerable bandwidth is not utilized. The reason for the extra space is found in the process whereby the television video carrier is generated.

On ordinary broadcast frequencies, it is common knowledge that most stations occupy a 10-kc bandwidth, or ± 5 kc about the carrier position. Thus, if a station is assigned to the frequency of 700 kc, it transmits a signal that occupies just as much frequency space on one side of 700 kc as on the other. Under existing FCC regulations, the maximum deviation is 5 kc (or 5,000 cycles) on either side of the carrier position of 700 kc. Technically, we say that these side frequencies are "side bands" for the present illustration, each side band may have a maximum deviation of 5 kc about the mean, or carrier, position. The information of the signal is contained in the side bands, since they are not generated until speech or music or other sounds are projected into the microphone. At the receiver, the variations in the side bands are transformed into audible sounds and heard by the radio listener.

It can be shown that those side bands that are generated with frequencies higher than the carrier frequency contain the same information as the side bands with frequencies lower than the carrier. In other words, if one set of side bands (either above or below the carrier) were eliminated, we could still obtain all the necessary information at our receiver. The only reason one side band is not eliminated is for economic reasons. A transmitter naturally generates both side bands, and it is cheaper to transmit both than to try to eliminate one by expensive and complicated filters. However, single side-band transmission does exist for certain communication facilities.

Now, let us turn our attention to the video signal. This signal is generated by fundamentally the same type of apparatus that is employed at the sound broadcast frequencies. Since 4 mc are needed for the picture detail, a sig-

nal would be generated that extended 8 mc, or ± 4 mc about the carrier. And this bandsread does not include the sound. An 8-mc band is undesirable because of the ether space occupied and the difficulties inherent in transmitting a signal of this bandwidth. Hence, the need arises for removing one side band, since, as noted above, only one is required.

The undesired side band is removed by filters that follow the last amplifier of the television transmitter. But filters are not easily constructed that will cut off one side band sharply and completely, and leave only the one desired. Furthermore, in the process of elimination, nothing must occur that changes the amplitude or phase of any of the components in the desired side band. As a compromise arrangement, most, but not all, of one side band is removed and in this way the remaining side band is least affected by the filtering. Thus part of the 2 mc of the total 6-mc bandwidth is occupied by what may be called the "remnants" of the undesired side band. This method is known as "quasi-single-side-band" or "vestigial-side-band" operation.

In Fig. 1-24(A) is the television video signal as it appears with both side bands present, and Fig. 1-24(B) shows the signal as it appears after passage through filters that partially remove one side band. The frequency of the carrier is found 1.25 mc above the low-frequency edge of the television signal. Then for 4 mc above this, we have the television video signal with the desired picture information. See Fig. 1-24. A 0.5-mc bandwidth separates the high-frequency edge of the video signal and the FM carrier. The space is left for the purpose of preventing undesirable interaction between the two, for example, cross-modulation, which would lead to distortion of the video signal. In this manner the allotted 6 mc are distributed.

Effect of Loss of Low and High Video Frequencies. While uniform response over a 4-mc band may be required in the picture IF and video amplifiers, this is not easily attained in practice. Special circuit designs must be resorted to; these are more fully explained at the appropriate places in later chapters. For the moment, it is only necessary to point out the effects of poor response at the high- or low-frequency ends of the band.

In the preceding analysis we have seen that a greater number of elements requires a greater bandwidth if advantage is to be taken of the increase. Since detail is determined mainly by the number of very small elements, any decrease in the response at the higher frequencies will result in less fine detail available at the receiving cathode-ray screen. The picture will lose some of its sharpness and may even appear somewhat blurred if the high-frequency response is degraded enough. In commercial television receivers, a video passband of from 3.3 to 4.0 mc is generally considered good, while anything below 3.0 mc is not too desirable.

At the low-frequency end of the band, poor frequency response results in obliterating the slow changes that occur in background shading. However, with the manually adjustable brightness control (to be described later) it is possible to counteract to some extent the bad effects of the poor response.

Frequency Allocations. With a maximum bandwidth set at 6 mc, it is clear that in order to operate even as few stations as five in any one area, a band 30 mc wide must be provided. With most of the lower fre-

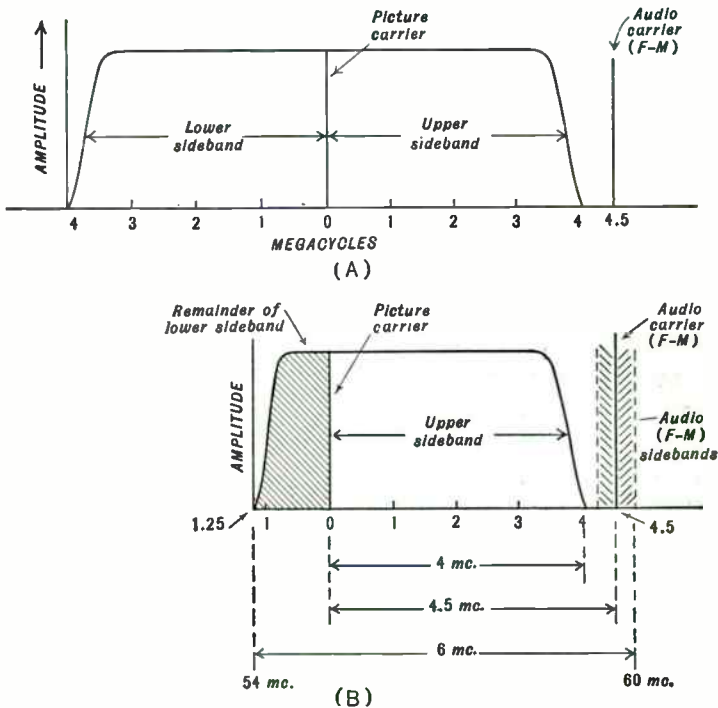

FIG. 1-24. (A) Double-side-band and (B) vestigial-side-band transmission of television signals. B is standard in the United States and represents the signal as sent.

quencies already occupied by existing services, television was allotted space at the high frequencies—from 54 mc up. The advantage of using the higher frequencies lies in the vast amount of free ether space that is available. The chief disadvantage of using the higher frequencies is the limited area over which these waves are effective. In most localities, a receiver should be within 60 miles of the transmitting tower to receive enough signal to develop a satisfactory picture. And even then, such obstacles as hills and mountains may obstruct the free travel of the signal sufficiently to prevent any reception at all. The antenna at the receiver plays an important

role in developing satisfactory reception. Chapter 2 is devoted entirely to a study of television antennas.

Signal distribution from station to station across the country is made by coaxial cables and microwave relays. A section of a transmission cable (Fig. 1-25) contains eight independent coaxial cables, together with 49 paper-insulated wires for testing and maintenance purposes. A pair of the

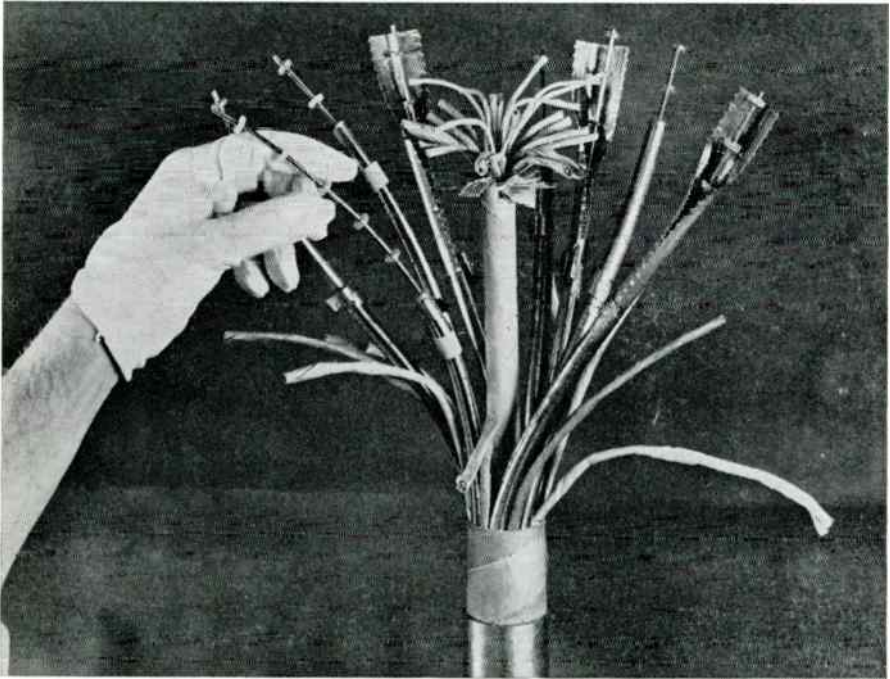

FIG. 1-25. A coaxial transmission cable with the outside lead and paper covering removed to show the eight coaxial tubes and also the paper-insulated wires. Held between the gloved fingers are the plastic discs which separate and insulate the inner wire from the outer copper tube.

concentric cables fully terminated by the proper repeater stations is capable of handling about 600 simultaneous telephone conversations, or one television program in each direction. Each of these copper tubes is about the diameter of a man's small finger. Running down the center of each tube is a copper wire about the size of a pencil lead, held in place by round insulating discs. Both the copper tube and the wire inside have the same axis, hence the name "concentric," or "coaxial" cable.

Microwave systems, which may be used for long-distance telephone calls

as well as television, make use of very short radio waves (about 4,000 mc). These microwaves are free from static and most manmade interference and shoot off into space instead of following the curvature of the earth. Therefore, the waves are gathered into a beam and aimed at towers, usually located atop high buildings or hill-tops. Microwaves are focused in narrow beams from one point to another by huge horn-shaped antennas. Microwaves can be beamed over distances of from 30 to 40 miles, just as long as there is no interference in its line-of-sight path. Typical of the microwave-relay stations on hilltops is the one located along the Bell System radio-relay route in Colorado. See Fig. 1-26.

Figure 1-27 shows the Bell System's coaxial-cable and radio-relay system as it exists now. While not shown separately, some parts of the routes use microwave relay and other sections use coaxial cable. For example, the link between Boston and New York consists entirely of microwave-relay stations, while from New York, southward and westward, there is coaxial cable. There is a microwave-relay system between New York and Chicago to supplement the coaxial cable between these two cities. Other systems besides the Bell System are in operation, but the latter is the most extensive.

The allocation of channels for television broadcasting, as it now stands, is shown on page 39.

When television allocations were first made in 1946, 13 channels were assigned to television broadcasting. These included the 12 VHF channels listed on page 39 plus channel 1 at 44 to 50 mc. At the same time, nongovernment fixed and mobile radio services were permitted to share television channels 1 through 5 and 9 through 13. However, it did not take long to demonstrate that sharing was impractical because of serious interference to television reception. It was then decided to allot channel 1 entirely to nongovernment fixed and mobile services and to eliminate sharing of television channels 1 through 5 and 9 through 13.



FIG. 1-26. A radio relay tower used for the reception and transmission of television signals.

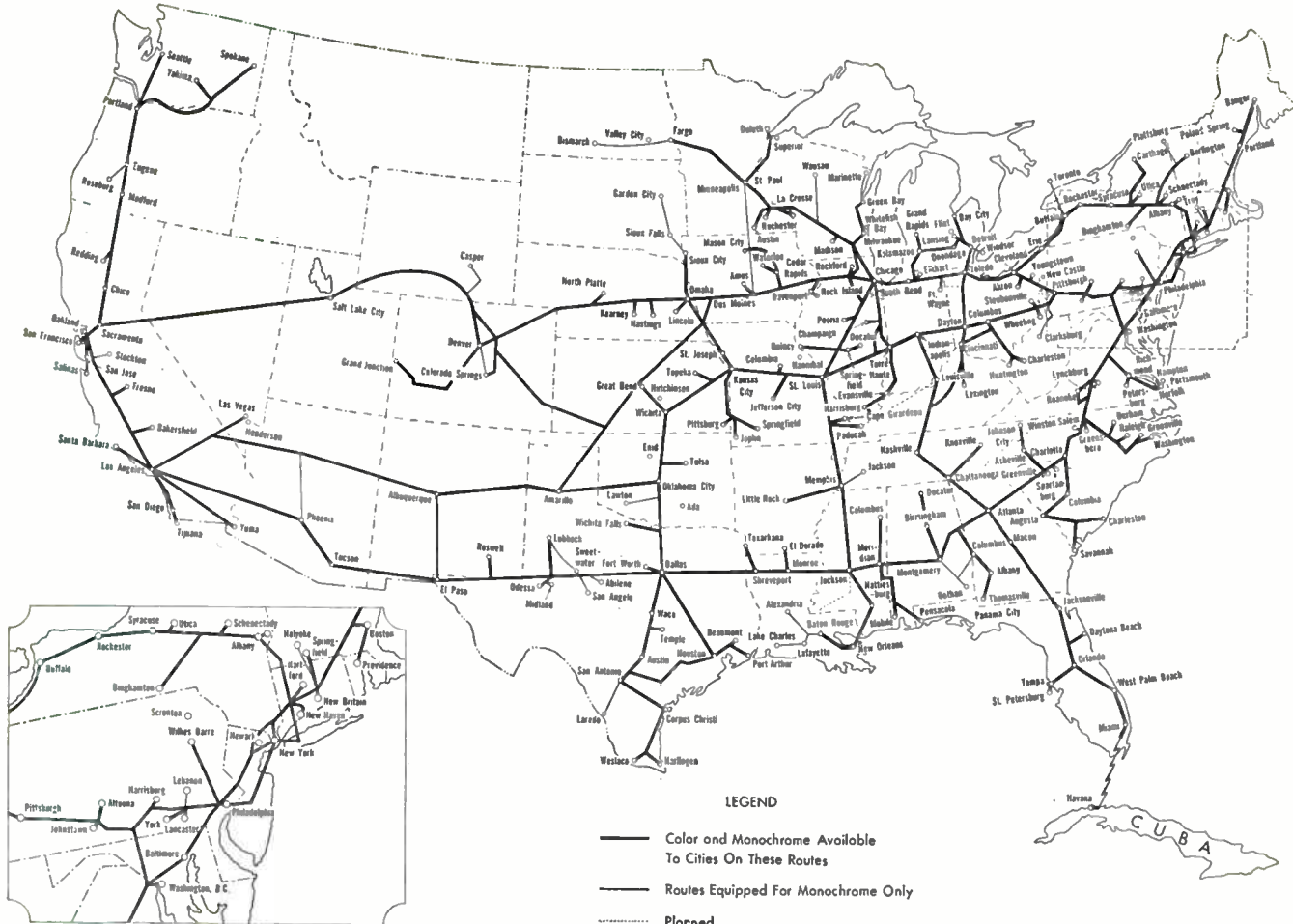

FIG. 1-27. The Bell System coaxial-cable and microwave-relay routes.

<i>Channel</i>	<i>Channel Freq. (mc)</i>	
2	54-60	} lower VHF band
3	60-66	
4	66-72	
5	76-82	
6	82-88	
7	174-180	} upper VHF band
8	180-186	
9	186-192	
10	192-198	
11	198-204	
12	204-210	
13	210-216	

UHF Band

Channel No.	Channel Freq. (mc)	Channel No.	Channel Freq. (mc)	Channel No.	Channel Freq. (mc)
14	470-476	38	614-620	62	758-764
15	476-482	39	620-626	63	764-770
16	482-488	40	626-632	64	770-776
17	488-494	41	632-638	65	776-782
18	494-500	42	638-644	66	782-788
19	500-506	43	644-650	67	788-794
20	506-512	44	650-656	68	794-800
21	512-518	45	656-662	69	800-806
22	518-524	46	662-668	70	806-812
23	524-530	47	668-674	71	812-818
24	530-536	48	674-680	72	818-824
25	536-542	49	680-686	73	824-830
26	542-548	50	686-692	74	830-836
27	548-554	51	692-698	75	836-842
28	554-560	52	698-704	76	842-848
29	560-566	53	704-710	77	848-854
30	566-572	54	710-716	78	854-860
31	572-578	55	716-722	79	860-866
32	578-584	56	722-728	80	866-872
33	584-590	57	728-734	81	872-878
34	590-596	58	734-740	82	878-884
35	596-602	59	740-746	83	884-890
36	602-608	60	746-752		
37	608-614	61	752-758		

The UHF band, containing channels 14 to 83, was opened to commercial broadcasting on July 1, 1952 and a number of stations are now operating in this band.

FM for Audio Transmission. When standards were established for commercial television broadcasting, it was directed that FM was to be

used for the audio portions of the television signal, and amplitude modulation for the video portion of the signal. FM for the audio offers noise-free reception and higher fidelity because of the possible use of audio frequencies up to 15,000 cycles. This type of modulation, however, has been found to give poorer results for the video signal, and amplitude modulation has been retained for two reasons.

Let us consider, for example, an antenna receiving two waves from the same transmitter. One ray traveled directly from transmitter to receiver, while the other ray (which we shall call "the reflected ray") arrived at the receiver by a longer, more indirect path. This could have occurred if the second ray was moving in some other direction, hit an obstacle in its path, and was reflected toward the receiving antenna. Because the reflected ray traveled a longer path to reach the receiving antenna, it arrived a small fraction of a second after the direct ray. During the interval between received rays, the electron beam traveled a short distance across the fluorescent screen. The end result is two similar images, slightly displaced with relation to each other. This condition is known as "ghosts" and occurs when AM is used. The same situation with FM also produces a ghost image, but the two contrasts are more prominent and prove more distracting than the ghost images of AM.

Another advantage of AM over FM for the video signal is the better synchronizing action observed. When there are several paths that a signal may follow in reaching the receiving antenna, or when there are other types of interference, the synchronizing pulses tend less to become obliterated in the AM signal. Loss of the synchronizing pulses means no control of the motion of the electron beam as it moves across the screen. The image, under this condition, would appear streaked at points where the synchronizing action was lost.

The distance over which the signal can be transmitted directly is the same, whether FM or AM is employed. Frequency, and only frequency, is the determining factor. As explained in Chapter 2, the usable range at these high frequencies is governed by the height of the receiving and transmitting antennas above the ground.

QUESTIONS

1. Why do television receivers have more panel controls than sound receivers?
2. What is a fine-tuning control? Why is it necessary in most television receivers?
3. What are some of the desirable characteristics that an image should possess? Explain each briefly.
4. *a.* Draw a block diagram of a split-sound television receiver. *b.* Where do intercarrier and split-sound television receivers differ?

5. Of what does a complete television signal consist?
6. State briefly the function of each stage in a television receiver.
7. What is the purpose of synchronizing pulses?
8. Name three types of television cameras. Explain briefly the operation of one of these tubes.
9. Define scanning. What type of scanning is standard today? Why?
10. Define frame frequency, field frequency, and line frequency. Give values for each.
11. What would happen to the receiver image if blanking voltages were not employed in the video signal?
12. Discuss negative and positive picture polarity.
13. How do English and American television signals differ? What effect does this difference have on the reproduced image? What would happen if an American-made receiver received English television signals?
14. Explain why video signals require wide frequency bands.
15. What effect does the bandwidth of the television signal have on the form of the final transmitted signal? Explain.
16. List all the VHF channels currently assigned to television broadcasts, giving frequencies in each instance. How many UHF channels are there?
17. What is the visual effect of a loss of high video frequencies? Low video frequencies?
18. Why is FM employed for sound transmission and AM for video-signal transmission?
19. What relationship exists between flicker and the method employed for scanning?
20. Discuss in detail the motion of the electron beam in interlaced scanning.
21. How is horizontal synchronization maintained while the vertical pulses are active? What is this called?
22. What is the horizontal-scanning frequency? The vertical-scanning frequency? Explain how each figure is arrived at.
23. What is meant by vestigial side-band transmission? How does this differ from the type of transmission employed in standard broadcast practice?
24. Are relay stations necessary for television transmission? Where are relay stations useful?
25. List the video front-panel controls that are generally used in commercial television receivers. State their function briefly.
26. Why must amplifiers be included with a camera unit?
27. Draw two lines of a complete video signal including two blanking and sync pulses. Draw the video in positive picture phase.
28. What is an electron multiplier? Where is it used?
29. What is the time, in microseconds, for one complete horizontal line?

High-Frequency Waves and the Television Antenna

Introduction. The antenna of a television receiver requires much more attention and care, especially with regard to placement, than the antenna of the ordinary sound receiver. In order to obtain a clear, well-formed image on the cathode-ray-tube screen, the following requirements must be met:

1. Sufficient signal strength must be developed at the antenna.
2. The signal must be received from one source, not several.
3. The antenna must be placed well away from manmade sources of interference.

In sound receivers, a certain amount of interference and distortion is permissible. If not excessive, reception of the broadcast is satisfactory. For television, however, the standards are more strict, and added precautions must be taken to guard against almost every type of interference and distortion. Hence, the need for more elaborate antenna receiving systems.

The position of the antenna must be chosen carefully, not only to give additional signal strength, but to avoid the appearance of so-called "ghosts" on the image screen which are due to the simultaneous reception of the same signal from two or more directions. For an explanation of this form of interference, refer to Fig. 2-1, in which a television dipole antenna is receiving one signal directly from the transmitting tower, while another ray strikes the same antenna after following a longer, indirect path. Reflection from a building or other large object could cause the indirect ray to reach the antenna.

Because of the longer distance the reflected ray travels, it will arrive a small fraction of a second later than the direct ray. With sound receivers, the ear does not detect the difference. On a television screen, the scanning beam has traveled a short distance by the time the reflected ray arrives at

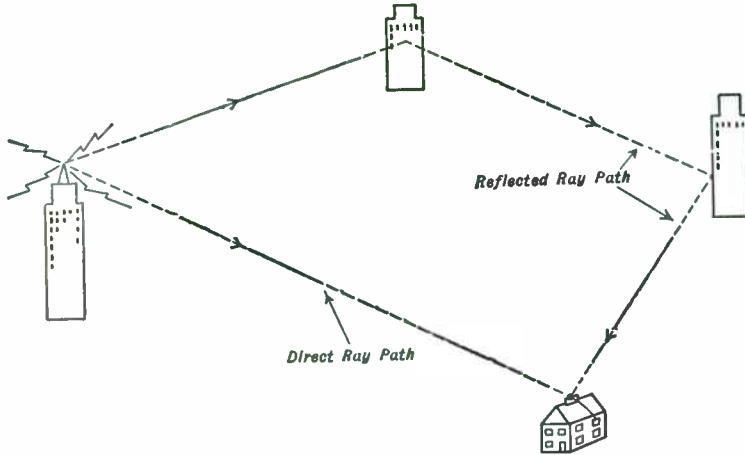

FIG. 2-1. The reflected ray and the direct ray arrive at the receiving antenna and form double images, or "ghosts."

the receiver. Hence, the image contained in the reflected ray appears on the screen displaced a short distance from similar detail contained in the direct ray. The result is shown in Fig. 2-2. When the effect is pronounced, a complete double image is obtained and the picture appears blurred. To correct this condition, it is necessary to change the position of the antenna until only one ray is received. The antenna should not be turned to favor the reflected signal unless it is impossible to obtain a clear image with the direct ray. The properties of reflecting surfaces change with time, and there is no certainty that a good signal will always be received.

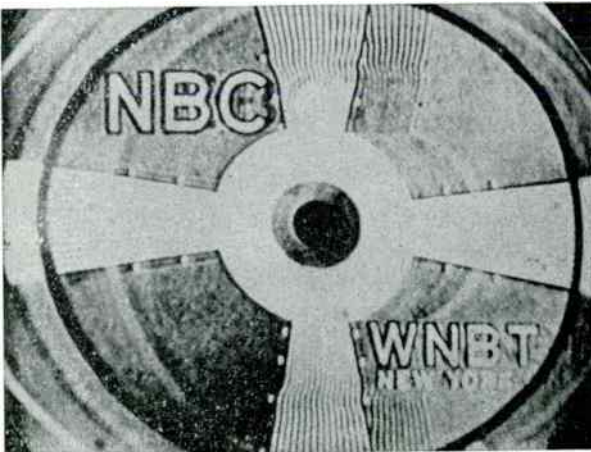

FIG. 2-2. A "ghost" image on a television viewing screen.

The placement of the antenna is generally the most difficult operation of a television installation. To obtain optimum results, it is necessary for the serviceman or other person erecting the antenna to have a good understanding of the behavior of radio waves at the high frequencies.

Radio-wave Propagation. Transmitted radio waves at all frequencies may travel in either of two general directions. One wave closely follows the surface of the earth, whereas the other travels upward at an angle which is dependent on the position of the transmitting radiator. The former is known as the "ground wave," the latter as the "sky wave." At the low frequencies, up to approximately 1,500 kc, the ground-wave attenuation is low, and signals travel for long distances before they disappear. Above the broadcast band, ground-wave attenuation increases rapidly, and all extensive communication is carried on solely by means of the sky wave.

The sky wave leaves the earth at an angle that may have any value from 3 to 90 deg, and travels in almost a straight line until the ionosphere is reached. This region, which begins about 70 miles above the surface of the earth, contains large concentrations of charged gaseous ions, free electrons, and uncharged, or neutral, molecules. The ions and free electrons act on all passing electromagnetic waves and tend to bend these waves back to earth. Whether the bending is complete (and the wave does return to the earth) or only partial depends on several factors:

1. The frequency of the radio wave
2. The angle at which the wave enters the ionosphere
3. The density of the charged particles (ions and electrons) in the ionosphere at that particular moment
4. The thickness of the ionosphere at the time

Extensive experiments indicate that, as the frequency of a wave increases, a smaller entering angle is necessary in order for complete bending to occur. As an illustration, consider waves *A* and *B* in Fig. 2-3. Wave *A* enters the ionosphere at a small angle and, hence, little bending is required to return it to earth. Wave *B*, subject to the same amount of bending, heads outward, however, because its initial entering angle was too great. Naturally, the latter wave would not be useful for communication purposes.

By raising the frequency still higher, the maximum incident angle at the ionosphere becomes smaller, until finally a frequency is reached where it becomes impossible to bend the wave back to earth, no matter what angle is used. For ordinary ionospheric conditions, this frequency occurs at about 35 to 40 mc. Above such frequencies, the sky wave is useless so far as radio communication is concerned. Only the direct ray is of any use. Television bands starting above 40 mc fall into this category. By direct ray (or rays), we mean the radio waves that travel in a straight line from transmitter to

receiver. Ordinarily, at lower frequencies, the radio waves are sent to the ionosphere and from there to the receiver at a distant point. With high frequencies, the ionosphere is no longer useful, so the former sky waves must be concentrated into a path leading directly to the receiver. If not intercepted by the receiver, they finally strike the ionosphere and are lost. It is this restriction to the use of the direct ray that limits the distance in which high-frequency communication can take place.

There are present, at times, unusual conditions which cause the concentrations of charged particles in the ionosphere to increase sharply. At these

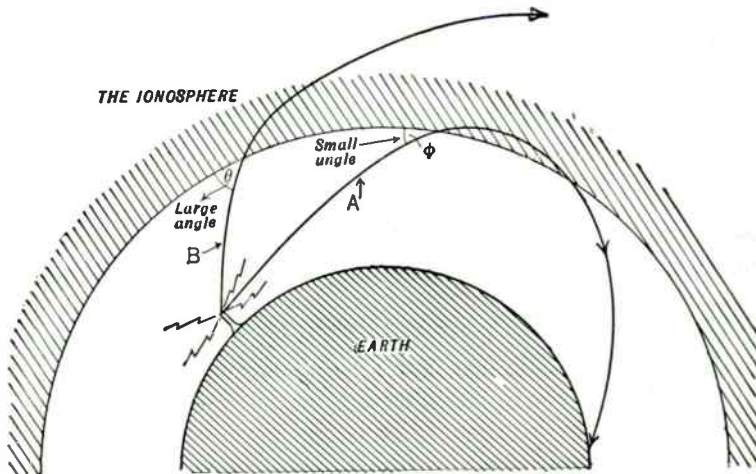

FIG. 2-3. At the higher frequencies a radio wave must enter the ionosphere at small angles if it is to be returned to earth.

times, it is possible to bend radio waves of frequencies up to 60 mc. The exact time and place of these phenomena cannot be predicted and hence are of little value for commercial operation. They do explain to some extent the distant reception of high-frequency signals that may occur.

Line-of-sight Distance. At the frequencies employed for television, reception is possible only when the receiver antenna directly intercepts the signals as they travel away from the transmitter. These electromagnetic waves travel in essentially straight lines, and the problem resolves itself into finding the maximum distance from the transmitter where the receiver can be placed and still have its antenna intercept the rays. This distance may be computed as follows.

In Fig. 2-4, let the height of the transmitting antenna be called h_t , the radius of the earth R , and the distance from the top of the antenna to the

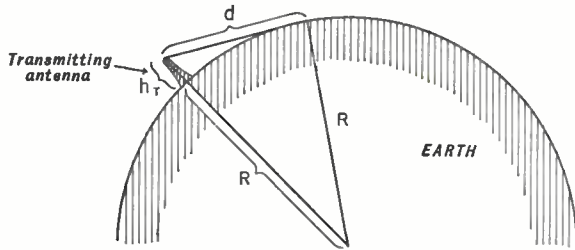

FIG. 2-4. Computation of the line-of-sight distance for high-frequency radio waves.

horizon d . These give us a right triangle. From elementary geometry it is possible to write the following equation:

$$(R + h_t)^2 = R^2 + d^2 = R^2 + 2Rh_t + h_t^2$$

Since h_t is very small compared with the radius of the earth, the h_t^2 term may be neglected. This leaves

$$d^2 = 2Rh_t$$

The value of R is approximately 4,000 miles. Substituting this value in the above equation, and changing h_t from miles to feet, we obtain

$$d = 1.23\sqrt{h_t}$$

where d is in miles, h_t is in feet. The relationship between d and h_t for various values of h_t is shown in graph form in Fig. 2-5.

The coverage for any transmitting antenna will increase with its height. The number of receivers capable of receiving the signals will likewise increase. This fact accounts for the placement of television antennas atop tall buildings (for example, the Empire State Building, New York City) and on high plateaus.

The signal range thus computed is from the top of the transmitting antenna to the horizon. By placing the receiving antenna some distance in the air, it should be possible to cover a greater distance before the curvature of the earth again interferes with the direct ray. Such a situation is depicted in Fig. 2-6. By means of simple geometrical reasoning, the maximum distance between the two antennas now becomes

$$d = 1.23(\sqrt{h_t} + \sqrt{h_r})$$

where h_r is the height of the receiving antenna in feet.

Unwanted Signal Paths. While the foregoing computed distances apply to the direct ray, there are other paths that waves may follow from the transmitting to the receiving antennas. All of these other rays are undesirable because they tend to distort and interfere with the direct-ray image on the screen. One method, reflection from surrounding objects, has

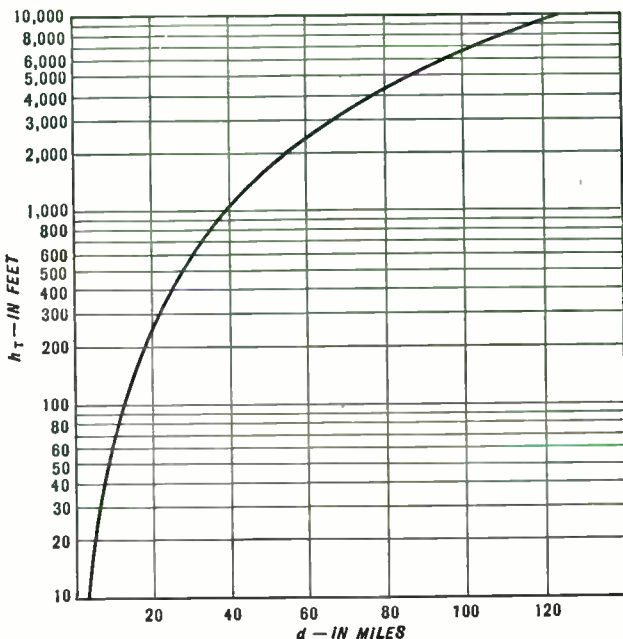

FIG. 2-5. The relationship between the height of the transmitting antenna in feet and the distance in miles from the antenna that the ray may be received.

already been discussed. Another ray may arrive at the receiver by reflection from the surface of the earth. This path is shown in Fig. 2-7. At the point where the reflected ray impinges on the earth, phase reversals up to 180 deg have been found to occur. This phase shift thus places a wave at the receiving antenna which generally acts against the direct ray. The overall effect is a general lowering of the resultant-signal level and the appearance of annoying ghost images.

There are, however, compensating conditions that act against the decrease due to the ground-reflected ray. One is the weakening of the wave strength by absorption at the point where it grazes the earth. The other results from the added phase change (not that just mentioned) arising from the fact that the length of the path of the reflected ray is longer than that of the



FIG. 2-6. Increase in the line-of-sight distance from the receiving antenna to the transmitter achieved by raising both structures as high as possible.

TELEVISION SIMPLIFIED

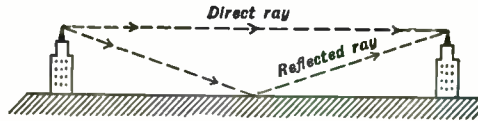

FIG. 2-7. The reflected radio wave, arriving at the receiving antenna after reflection from the earth, may lower the strength of the direct antenna considerably.

direct ray. Thus there is a ground-phase shift plus whatever else may have been added because of the longer distance. All combine to lower the direct-ray strength less than would at first be expected.

It has further been observed that the received signal strength increases with the height of either *antenna* or both. For television signals, this increase is most important. Placement of the antenna and utilization of its directive properties help in decreasing (and many times in eliminating) all but the desired direct wave.

Wave Polarization. The height of the antenna is important, but the manner in which it is held, either vertically or horizontally, must also be considered. The position of the antenna is affected by the nature of the electromagnetic wave itself.

All electromagnetic waves have their energy divided equally between an electric field and a magnetic field. In free space these fields are at right angles to each other. Thus, if we were to visualize these fields and represent them by their lines of force, the wavefront would appear as in Fig. 2-8. The fields represent the wave; the arrows the direction in which the forces are acting. The mode of travel of these waves in free space is always at right angles to both fields. As an illustration, if the lines of the electric field are

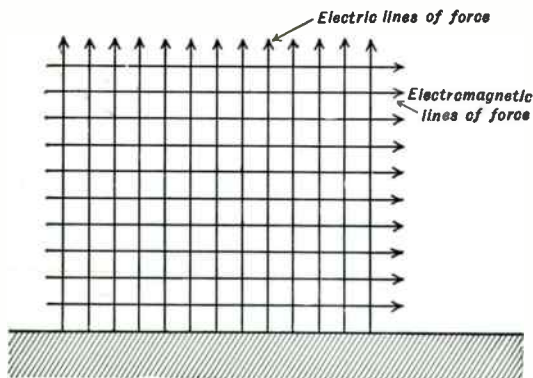

FIG. 2-8. The components of an electromagnetic wave. The wave travels at right angles to the lines of force. In this illustration direction of travel is forward, out of the paper.

vertical and those of the magnetic field are horizontal, the wave travels forward.

In radio, the sense of a radio wave has been taken to be the same as the direction of the electric lines of force. Hence a vertical antenna radiates a vertical electric field (the lines of force are perpendicular to the ground), and the wave is said to be vertically polarized. A horizontal antenna radiates a horizontally polarized wave. Experience has revealed that the greatest signal is induced in the receiving antenna if it has the same polarization (is held in the same manner) as the transmitting antenna.

Concerning the relative merits of horizontal versus vertical polarization, it has been found that, for antennas located close to the earth, vertically polarized rays yield a better signal. On raising the receiving antenna about one wavelength above ground, this difference generally disappears and either type may be employed. Further increase in height, up to several wavelengths, has shown that the horizontally polarized waves give a more favorable signal-to-noise ratio and are desirable. In television, the wavelengths are short and the antennas are placed several wavelengths in the air. Hence, horizontally polarized waves have been taken as standard. All television receiving antennas are mounted in the horizontal position.

Tuned Antennas.* The need for good signal strength at the antenna has led to the general use of tuned-antenna systems. A tuned antenna, which is a wire cut to a specific length, is equivalent in its properties to any resonant circuit. The radio waves passing the antenna will induce voltages along the wire. For equally powered waves, the maximum voltage is developed when its resonant frequency is equal to that of the passing wave. A large signal at the antenna means a greater input to the receiver.

Half-wavelength Antennas. An ungrounded wire which is cut to one-half the wavelength of the signal to be received represents the smallest length of wire that can be made to resonate at that frequency. The half-wavelength antenna is the most widely used since it represents the smallest antenna for its frequency and consequently requires the least amount of space. In troublesome areas it may be necessary to erect more elaborate arrays possessing greater gain and directivity than the simple half-wave antenna. They are, however, more costly.

A simple half-wave antenna is erected and supported as indicated in Fig. 2-9. Metallic rods are used for the antenna itself, mounted on the supporting structure and placed in a horizontal position (parallel to the ground). Each of the rods is one-quarter of a wavelength, the total equal to the necessary half-wavelength. In this arrangement, which is also known as a "dipole antenna," the transmission lead-in wire is connected to the rods, one wire of the line to each rod. The line then extends to the receiver. Care must

*UHF antennas will be considered separately in Chapter 18.

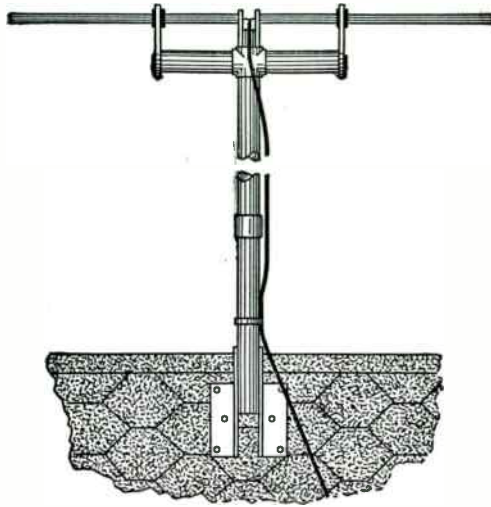

FIG. 2-9. Dipole-antenna assembly used extensively for television receivers.

be taken to fasten the line at several points to the supporting mast with stand-off insulators so that it does not interfere with the operation of the antenna. Fastening the line also prevents it from flapping back and forth in the wind. Any such motion could weaken the connections made at the rods.

When the properties of a dipole antenna are investigated, it is found that signals are received with greatest intensity when the rods are at right angles to the approaching signal. This arrangement is illustrated in Fig. 2-10(A). On the other hand, signals approaching the antenna from either end are very poorly received. To show how waves at any angle are received, the graph of Fig. 2-10(B) is commonly drawn. It is an overall response curve for a horizontally held dipole antenna in the horizontal plane.

With the placement of the antenna as shown in the diagram, the strongest signal would be received from direction *A*. As the signal angle made with this point is increased, the strength of the received signal decreases, until at point *B* (90 deg) the received signal voltage is at a minimum (or zero). By inspection of the graph the reader can determine the reception for waves coming in at other angles. Notice that good signal strength is obtained from two directions and, because of this, the dipole may be called "bidirectional." Other systems can be devised that are unidirectional or nondirectional, or that have almost any desired properties. For each system, a response curve quickly indicates its properties in any direction.

As stated, an antenna must be tuned in order to have the strongest signal develop along its length. Hence it becomes necessary to cut the wires (or

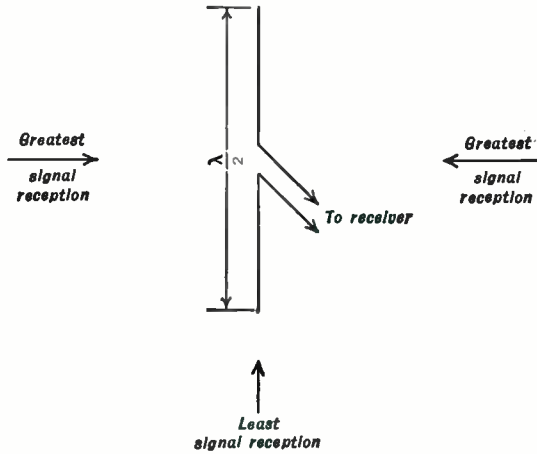

FIG. 2-10(A). Dipole antennas of the type shown receive signals best from the directions indicated.

rods) to a specific length. The length will vary with each different frequency, longer at the lower frequencies and shorter at the higher frequencies. It might be supposed, then, that a television set capable of receiving signals with frequencies ranging from 54 to 88 mc would need several antennas, one

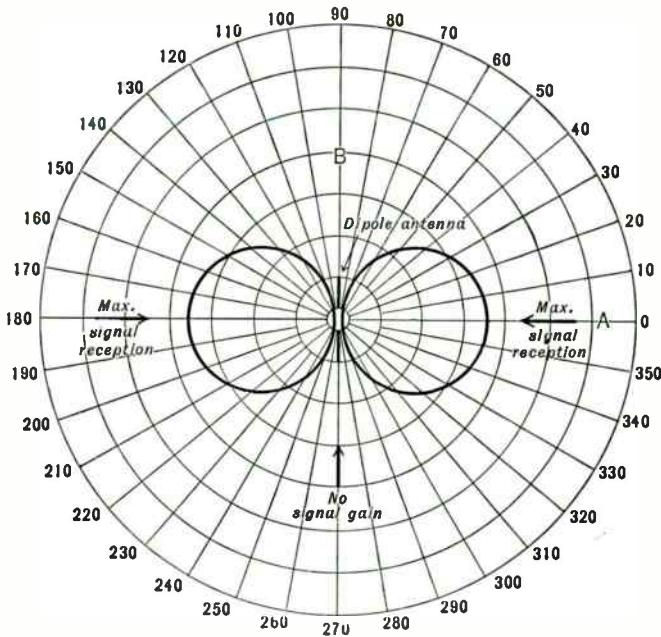

FIG. 2-10(B). The directional response curve of a dipole antenna.

for every channel. It is not necessary, however, to go to such extremes; in practice, one antenna is sufficient, if tuned to a middle frequency.

Antenna-length Computations. With the foregoing range of frequencies, a middle value of 65 mc might be chosen. While an antenna cut to this frequency will not give optimum results at the other bands, the reception will still be quite satisfactory.

To compute the length needed for the 65-mc frequency half-wave antenna, the following formula is used:

$$L_{\text{in feet}} = \frac{468}{f_{\text{mc}}}$$

With f set equal to 65 mc, the length would be equal to $468/65$, or 7.2 feet. Practically, 7 feet might be cut, with each half of the half-wave antenna 3.5 feet long. For a full-wavelength antenna, approximately 14 feet are needed. In congested areas, antenna length must be as short as possible, and only half-wave-antenna systems are generally found. At the present time, most television stations are located in urban areas in order to reach the greatest number of sets. Emphasis, then, is on short antennas, such as the half-wave type. If longer lengths are desired, the equation should be modified by the proper factor. A full-wavelength antenna requires a factor of 2; a wavelength and a half requires a factor of 3, etc.

Half-wave Dipole with Reflector. The simple half-wave system provides satisfactory reception in most locations within reasonable distances of the transmitter. However, the signals reaching receivers situated in outlying areas are correspondingly weaker, and noise and interference have a greater distorting effect on the image. For these locations more elaborate arrays must be constructed—systems that have greater gain and directivity and provide better discrimination against interference.

A simple yet effective system is shown in Fig. 2-11. The two rods are mounted parallel to each other and spaced about $.15\lambda$ -. $.25\lambda$ apart. The action of the second wire, which is not connected, is twofold. First, because of its position, it tends to concentrate signals reaching the front wire. Second,

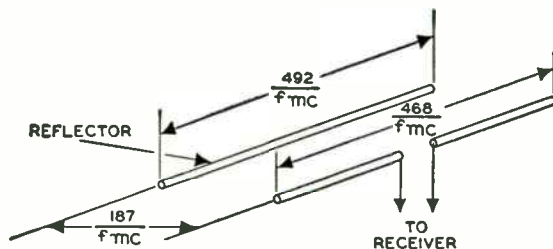

FIG. 2-11. Dipole receiving antenna and reflector.

it shields the front antenna from waves coming from the rear. The gain of the array is generally 5 db greater than that obtainable from a single half-wave antenna.

Besides the additional gain that is observed with this 2-wire system, Fig. 2-12 shows that the angle at which a strong signal may be received

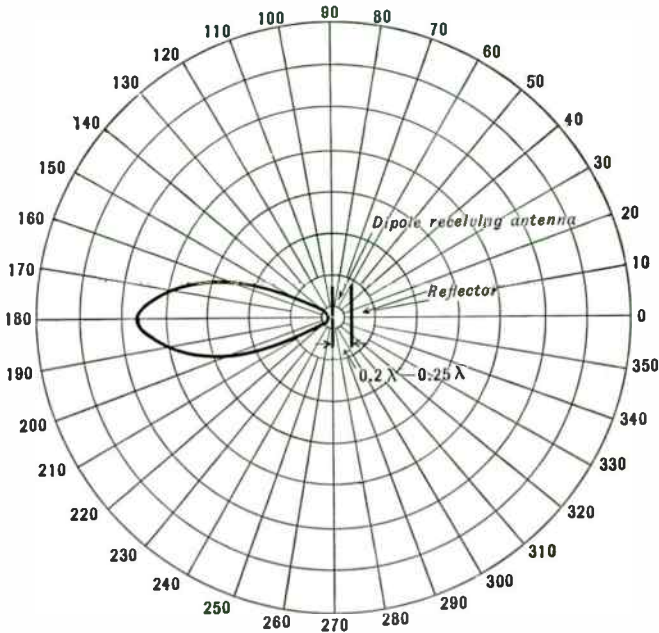

FIG. 2-12. The directional response curve for a half-wave antenna with a reflector.

now is narrower. This is also advantageous in reducing the number of reflected rays that can affect the antenna. Finally, partial or complete discrimination is possible against interference, manmade or otherwise. (The curve in Fig. 2-12 is an ideal representation. The response curve of an actual array would have small lobes extending in the direction of the reflector, which indicates that reception of signals approaching the array from the rear can occur, although to a considerably less extent than signals arriving from the front.)

Dipoles with Reflector and Director. Additional gains and directivity can be obtained from a dipole if, besides the reflector, a director element is added. See Fig. 2-13. Like the reflector, the director is merely a rod or wire to which nothing is attached. Unlike the reflector, however, its length is slightly less than that of the dipole and it is positioned in front of the dipole. When the dipole is placed broadside to the direction of the incoming signal,

the director is the first element of the combination to intercept the oncoming signal. The director picks up part of the signal and then reradiates this signal with such a phase relationship that it strengthens any signal arriving from the front of the array and partly cancels any signal reaching the antenna from the rear. The net result of this action is to make the forward response of the dipole more directive, and to reduce the ability of the array to pick up signals reaching the unit from the rear.

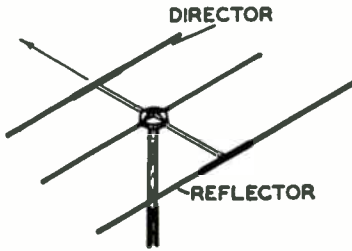

FIG. 2-13. A dipole with reflector and director.

In general, then, the reflector has its greatest effect in reducing the response of an antenna to signals approaching it from the rear, whereas directors produce their greatest effect by increasing the directivity of an antenna to signals approaching it from the front.

Other Antennas. An antenna widely used by servicemen and recommended by television-receiver manufacturers is the folded dipole shown in Fig. 2-14(A). This antenna consists principally of two dipole antennas connected in parallel with each other. The separation between the two sections is from 3 to 5 in. The folded dipole has the same bidirectional pattern as the simple dipole and approximately the same gain. The input impedance is now 300 ohms (at the frequency for which it was cut) against 72 ohms for the simple dipole. However, the response of a folded dipole is more uniform over a band of frequencies than that of the simple dipole.

The directivity of the folded dipole can be increased by the addition of a reflector. See Fig. 2-14(B). The unit now possesses the same directional pattern as the simple dipole with reflector. The length and spacing of the reflector can be determined by the formulas previously given for the simple dipole and reflector.

In the remaining illustrations of Fig. 2-14, other popular types of television antennas are shown. Nearly all of these are elaborations of the basic dipole or folded dipole. In Fig. 2-14(C), we have a stacked-dipole array with reflectors. (This antenna is sometimes referred to as a "lazy H" because of its similarity to the letter H lying on its side.) Two half-wave dipoles are placed at the front of the assembly, one mounted above the other. The center terminals of each dipole are connected by means of a parallel-wire transmission line. Each conductor of the lead-in line to the television receiver is attached to a conductor of this connecting transmission line at a point midway between the dipoles. A reflector is mounted behind each dipole.

In Fig. 2-14(D), there are two folded dipoles, with reflectors, mounted one above the other. The upper dipole is cut for a resonant frequency ap-

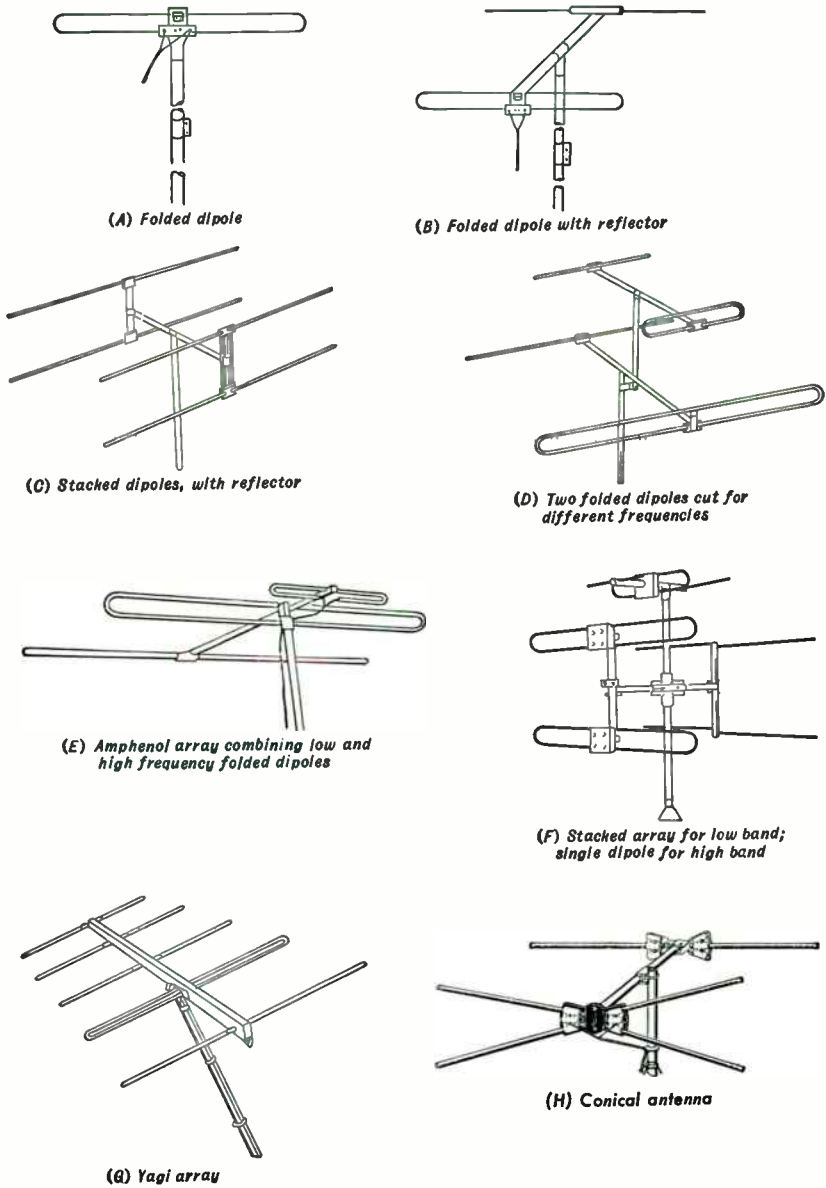

FIG. 2-14. Types of popular television receiving antennas.

proximately in the center of the upper VHF-TV band (174-216 mc), and the longer folded dipole is resonated at the center frequency of the lower television band. A short length of 300-ohm transmission line connects the upper dipole to the lower. From the lower antenna, a 300-ohm line feeds the signals to the receiver. With this assembly, each antenna can be oriented independently for best reception from stations within its band, providing the receiver with good coverage on both bands. Figure 2-14(E), is essentially the same arrangement as Fig. 2-14(D), except that the longer folded dipole acts as the reflector for the shorter folded dipole. The two folded dipoles are connected in the same manner as the array in Fig. 2-14(D). Independent orientation of each folded dipole is not possible in the array of Fig. 2-14(E). The unit in Fig. 2-14(F), is an elaboration of that shown in Fig. 2-14(D).

The antenna of Fig. 2-14(G) contains a folded dipole with one reflector and three directors. It is known as a "yagi" array and possesses sharp unidirectional directivity. This high-gain antenna is generally employed in low signal areas. Because of its sharp directivity, it must be carefully positioned.

The final array, shown in Fig. 2-14(H), is one which has been extensively used because of its ability to receive low and high VHF band signals. The front elements are bent or veered forward, while the rear elements (the reflectors) generally extend straight out. Because of the shape of the front elements, the response pattern contains only one major lobe on all channels (as shown in Fig. 2-12). This response is an improvement over the conventional dipole where an element cut for the low frequencies will have a multi-lobed pattern on the high channels, and an element cut for the high frequencies will have a poor response on the low channels. With the conical antenna, one array suffices for all VHF channels.

Conical antennas may come either singly or stacked two or four high. The same is true of most other antennas. In installations within 10 miles of the transmitter, the simple dipole and the folded dipole, each aided perhaps with a reflector, will frequently prove completely satisfactory. Beyond 10 miles, stacked arrays are generally required. Conditions, of course, will vary in different localities and no set rule will always work. But, as a start, the technician can follow the foregoing suggestions.

Fringe-area Antennas. In fringe areas where the signal level is exceedingly low, high-gain antenna arrays are needed. Since the gain of an antenna increases with the number of elements it possesses, fringe-area arrays have many more elements than the antennas used where the signal is strong. A representative group of high-gain antennas is shown in Fig. 2-15. The power gain of each is at least 10 db, and with some it reaches 15 db or more. Most high-gain combinations are sharply directional; hence, each must be carefully aimed, otherwise the captured signal will be much lower than it could be.

Table 2-1 reviews the properties of the basic television antennas, together with their dimensions.

After the antenna has been chosen, the following points should be kept in mind before installing it:

1. The higher the antenna, the stronger the signal received.
2. The antenna should be set-tested with an actual connection to its receiver before the supports are fixed in place permanently.

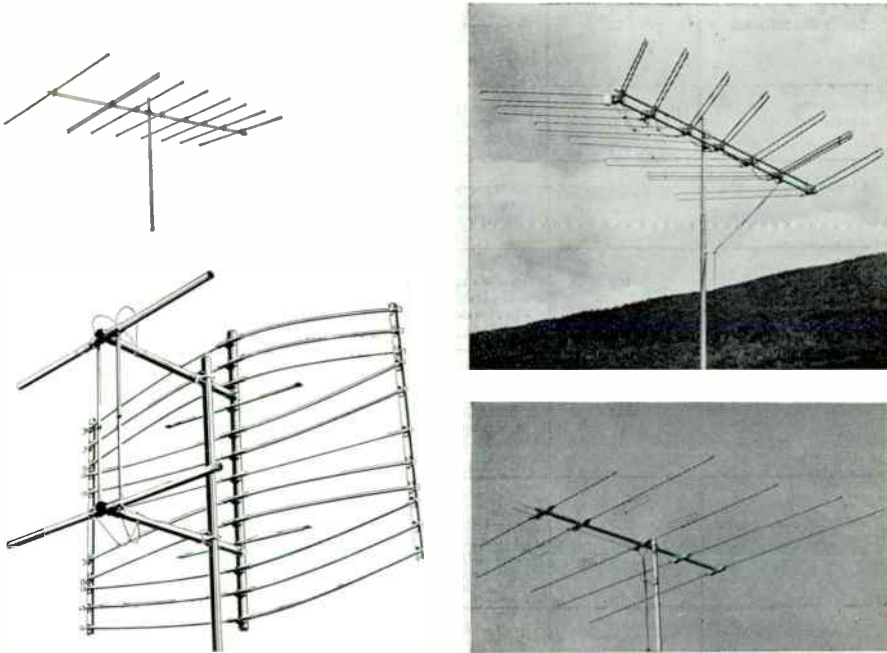



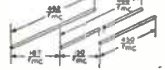



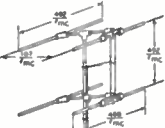
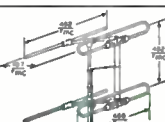

FIG. 2-15. Four representative high-gain antenna arrays designed specifically for weak-signal (fringe) areas.

3. When more than one station is to be received, the final placement of the antenna must, of necessity, be a compromise. In extreme cases, it may be desirable, or even necessary, to erect several antennas.

Indoor Antennas. In strong signal areas it is entirely feasible to use an indoor antenna for signal reception if the receiver is sufficiently sensitive. These antennas come in a variety of shapes, some of which are shown in Fig. 2-16. Types A, D, E, and G have selector switches which can modify the response pattern and raise the frequency of the antenna so as to minimize interference and ghost signals. Generally, the switch is rotated (with the antenna connected to a receiver and a signal being received) until the

TABLE 2-1. Characteristics of common television antennas.

ANTENNA TYPE	APPROXIMATE CHARACTERISTIC IMPEDANCE [ohms]	DIRECTIVITY	DIMENSIONS [feet]	GAIN [COMPARED TO DIPOLE]	
				db	voltage
Plain dipole	72	Bi-directional; broadside to elements		-	Unity
Folded dipole	300	Bi-directional; broadside to elements		-	Unity
Dipole and reflector	50	Uni-directional; broadside to radiator		5	1.78
Folded dipole and reflector	250	Uni-directional; broadside to radiator		5	1.78
Dipole, reflector, and director	25	Uni-directional; broadside to radiator		7	2.24
Folded dipole, reflector and director	100	Uni-directional; broadside to radiator		7	2.24
Stacked dipoles	40	Bi-directional; broadside to elements		5	1.78
Folded stacked dipoles	150	Bi-directional; broadside to elements		5	1.78
Stacked dipoles and reflectors	25	Uni-directional; broadside to elements		10	3.16
Folded stacked dipoles and reflectors	100	Uni-directional; broadside to elements		10	3.16

best picture is obtained on the screen. With the exception of the unit shown in Fig. 2-16(C), the dipole rods can be adjusted in length and position for best reception. When not in use, the rods can usually be telescoped.

In Fig. 2-16(H), the antenna is mounted directly on the back of the receiver. Its swivel base permits it to be manipulated into a number of posi-

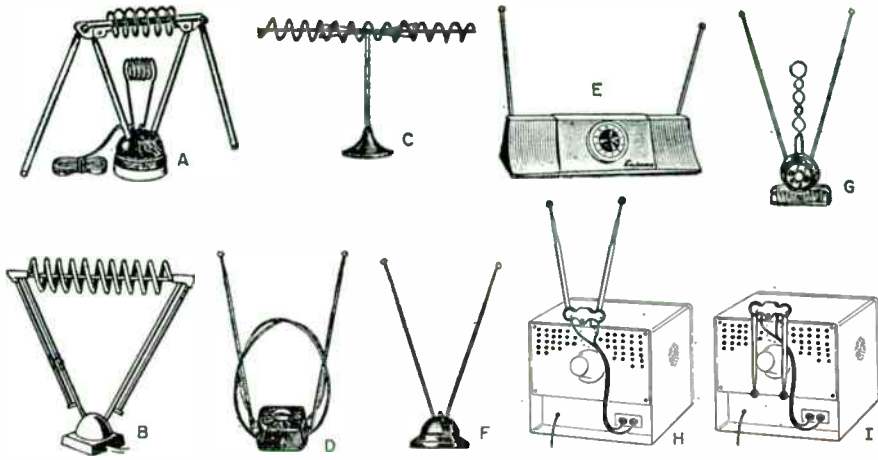

FIG. 2-16. Types of indoor TV antennas.

tions in order to capture the best possible signal. When not in use, the arms are telescoped inward and then turned down behind the receiver cabinet.

Multiple-set Couplers. It is not unusual to find that many homes and apartments have more than one television set, and it is desirable to use the signal provided by one antenna array for all these receivers. This arrangement can be made with 2-, 3-, or 4-set couplers. See Fig. 2-17. The lead-in from the antenna is connected to the input terminals of the coupler; the signal is then split into 2, 3, or 4 parts according to the design of the unit. Each receiver is then connected to an appropriate set of input terminals.

By this method, each set will receive less signal than it would receive if it were connected directly and solely to the antenna. However, in medium and strong signal areas, enough signal power is available to provide completely satisfactory signals for each receiver. In weak signal areas, separate antennas may be required or a master-antenna distribution system employing special high-frequency preamplifiers may be required. The latter method is more expensive, but it can provide signals to an almost unlimited number of receivers.

Transmission Lines. With the antenna system in position, the trans-

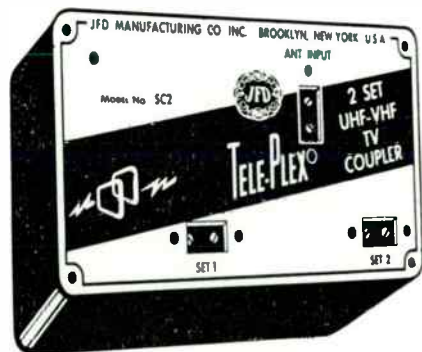

FIG. 2-17. A 2-set coupler which enables one antenna to supply a television signal to two receivers.

mission line that conducts the signal from the antenna to the receiver is considered next. Although many differently constructed transmission lines have been designed, only two general types find any extensive use in television installations: the parallel-wire types and the concentric or the coaxial cable.

From the standpoint of convenience and economy, one antenna should be capable of receiving all the VHF television stations. It should have, therefore, a fairly uniform response of 54 to 216 mc. A resonant dipole presents an impedance, at its center, of 72 ohms. To obtain maximum transfer of power, the connecting transmission line should match this value. However, when we attempt to use the same dipole for a band of frequencies, we find that the 72-ohm value is no longer valid. A dipole cut for 50 mc presents a 72-ohm impedance. At 100 mc, the impedance has risen to 2,000 ohms. It is clear that the best transmission-line impedance is no longer 72 ohms, but a higher value which will serve as a compromise. It is desirable to use as high an impedance value as possible, because line loss is inversely proportional to characteristic impedance. On the other hand, such factors as the size of line and wire gage must also be considered. It is current practice to design the input circuit of the television receiver for a 300-ohm transmission line. It has been found that a 300-ohm line used with a half-wave dipole produces a broad-frequency response without too great a loss due to mismatching. A folded dipole has an impedance close to 300 ohms at its resonant frequency, and a much more uniform response is obtained with this antenna.

The flat, parallel-wire transmission line shown in Fig. 2-18(A), is probably the most popular lead-in line in use today. The wires are encased in a plastic ribbon of polyethylene which is strong, flexible, and unaffected by

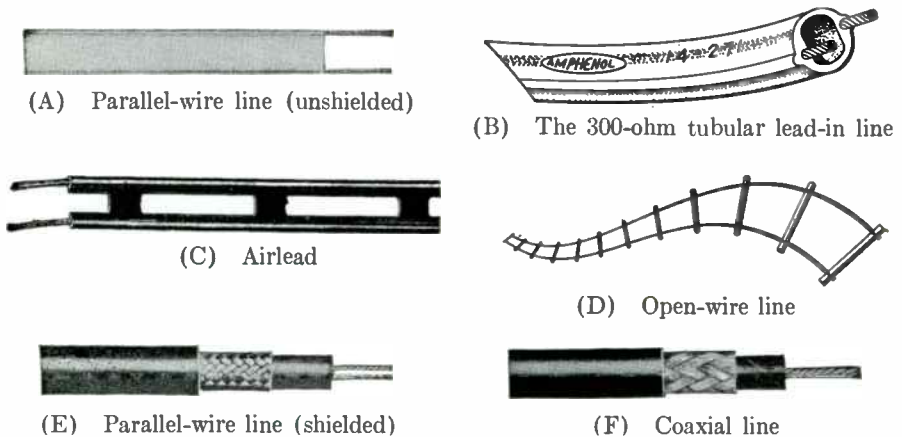

FIG. 2-18. Types of popular transmission lines used for FM and television installations.

sunlight, water, cold, acids, or alkalis. At 100 mc, the line loss is on the order of 1.2 db per 100 ft of line. Its characteristic impedance ranges from 75 ohms to 300 ohms. The line is balanced, which means that both wires possess the same average potential with respect to ground. It is, however, unshielded and therefore not recommended for use in extremely noisy locations.

A companion tubular twin-lead line is also available, shown in Fig. 2-18(B), which, while somewhat more expensive than the flat twin-lead, possesses the advantage of being less affected by adverse weather conditions than the flat line. Rain, sleet, snow, etc., may not physically affect the flat line, but electrically these serve to increase its attenuation. Thus, at 100 mc, flat and tubular lines under dry conditions possess equal attenuations of 1.2 db. When wet, however, the loss on a flat line rises to 7.3 db, whereas that on a tubular line is only 2.5 db. In strong signal areas this loss might not be important, but imagine what it would do to a picture in a weak signal area.

A third type of parallel-wire line is shown in Fig. 2-18(C). Known commercially as "airlead," it has 80 per cent of the polyethylene webbing removed, which is said to reduce the loss, or db attenuation, by at least 50 per cent. Line impedance is still 300 ohms.

The fourth parallel-wire line, shown in Fig. 2-19(D), is one which is completely open, being held together by small polystyrene spacers placed approximately 6 in. apart. The attenuation of this line is only of the order of 0.35 db per 100 ft. at 100 mc. It is relatively unaffected by changes in weather. Impedance of this line is 450 ohms.

A parallel-wire transmission line that is completely shielded is shown in Fig. 2-18(E). The two wires are enclosed in a dielectric, possibly polyethylene, and the entire unit is shielded by a copper-braid covering. As a protection against the elements, an outer rubber covering is used. Grounding the copper braid converts it into a shield which prevents any stray interference from reaching either conductor. Furthermore, the line is balanced against ground. It can be built with impedance values ranging from 50 ohms up, but a 225-ohm line has found greatest use in television installations. Attenuation of this line is 3.4 db at 100 mc and this is considerably higher than the attenuation of any of the unshielded lines. Because of this, and because of its greater cost, the shielded line is used only where the surrounding noise is particularly severe.

The final transmission line is the coaxial, or concentric, cable shown in Fig. 2-18(F). It contains an insulated center wire enclosed by a concentric metallic covering which generally is flexible copper braid. The inner wire is kept in position by a solid dielectric chosen for its low-loss properties. The signal carried by the line is confined to the inner conductor, with the outer

copper-braid conductor grounded so as to serve as a shield against stray magnetic fields. This arrangement causes the line to be unbalanced, and the input coil of the receiver must be connected accordingly. Coaxial cables are available in a range of impedances from 10 to 150 ohms.

At the receiver, the connections for balanced and unbalanced lines differ, as shown in Fig. 2-19. For a balanced line, the input coil is center-tappeded

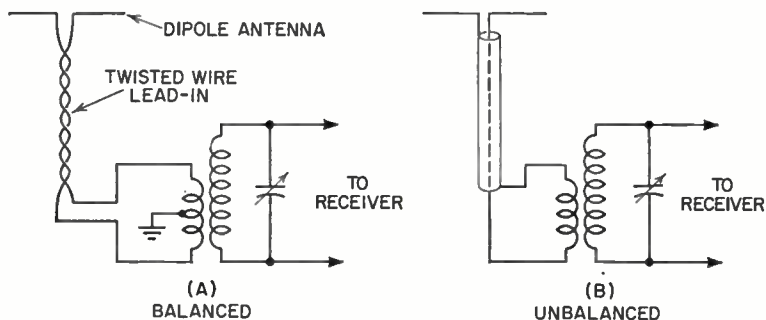

Fig. 2-19. Methods of connecting lead-in wires to the input coil of a receiver.

and grounded at this tap. Stray fields, cutting across both wires of a balanced line, induce equal voltages in each line. The similar currents that flow because of the induced voltages are in the same direction on the two conductors of the line and neutralize each other.

Antenna Installation. A complete installation is illustrated in Fig. 2-20(A). Stand-off insulators should be mounted on the side of the building to prevent the transmission line from rubbing against the wall. It is good practice, also, to install a lightning arrester at the point where the line enters the building. See Fig. 2-20(B). The other ends of the arrester should be connected securely to an iron pipe sunk into the earth. From the lightning arresters, the transmission line is led into the building to the receiver.

Lightning Arresters. Since the outdoor TV antenna is a slender rod that usually extends above the level of a roof of a building and therefore represents the highest point at that location, it is good practice to install a lightning arrester at the time the antenna itself is being installed. The thin, pointed antenna rods are especially attractive to the static charges contained in thunder clouds and are more vulnerable to a sudden disrupting discharge than the large, relatively flat surfaces of the building. The antenna thus serves as a focal point for lightning flashes, and a lightning arrester is worth its weight in gold as a protector of the set, the property, and human life.

Lightning arresters come in several different forms, some of which are shown in Fig. 2-21. In the unit shown in the upper right-hand corner, there are two-minute spark gaps. The transmission line (twin lead) is placed in a

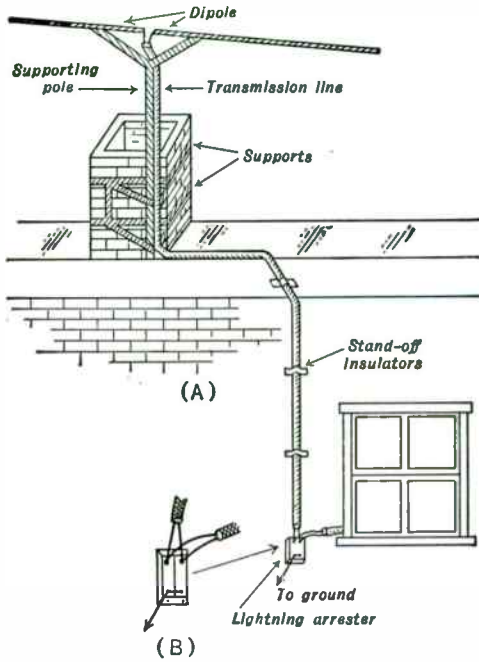

FIG. 2-20. An antenna installation for a television receiver. The ground from the lightning arrester should be as short and direct as possible.

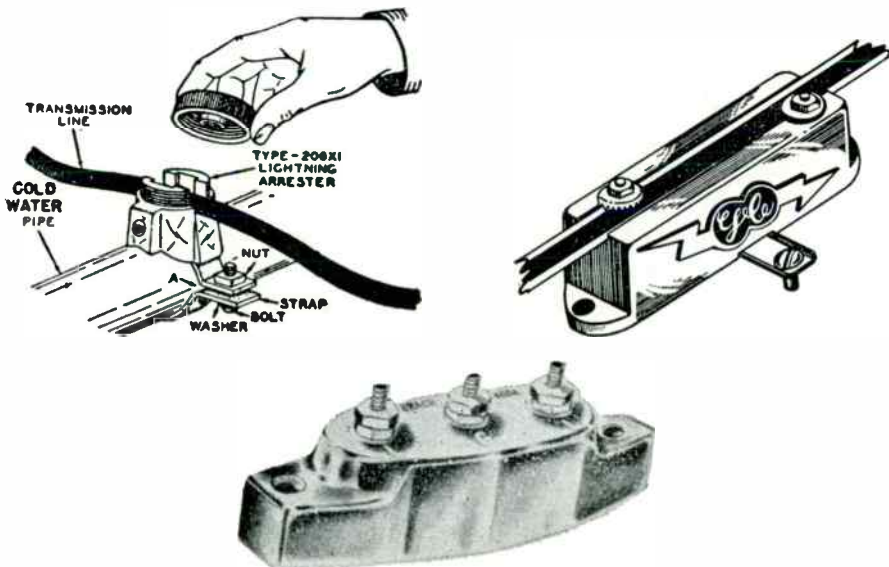

FIG. 2-21. Several types of lightning arresters.

groove along the top of the arrester. At one end of this groove is a clamp which, when fastened down tightly by its holding nut, grips the polyethylene covering the twin lead in close proximity to the 1-wire conductor. There is a similar arrangement at the opposite end of the groove, where another clamp is positioned near the other twin-lead conductor.

A heavy wire is run close to each clamp, with the separation between the heavy wire and the clamp constituting the spark gap. The wire is then run to ground and represents the discharge path. Any electrical charge which accumulates on the transmission line can, when it becomes strong enough, jump across the gap at each clamping screw and be conducted down to ground.

Other types of lightning arresters contain neon gas, neon bulbs, or high-valued static draining resistors. Availability and price generally determine which type is used by any service company.

The best place to install a lightning arrester is outside the house or building at the point where the transmission line enters the structure. A good position for the arrester is underneath a window ledge where it will be partly out of sight.

The ground lead from the arrester should be connected securely to a stake driven into the earth at the foot of the structure. In place of a stake, a cold-water pipe may be used. The grounding lead should be attached to the pipe or stake by means of a ground clamp, and the connection should be made as close as possible to the point where the pipe enters the earth. Use wire size no. 10 or larger for the grounding leads. If the distance from the lightning arrester to the ground is long, the grounding lead should preferably be kept away from the structure by means of supporting insulators.

Many servicemen ground the antenna mast since the mast will also attract lightning static discharges. When the mast is on the roof, grounding is usually achieved by fastening it to one of the vent pipes that extend above the roof level. In most instances, no harm will come from this procedure, but it does not afford maximum safety. It is more desirable to run a heavy insulated wire from the mast down to the ground; it is generally not wise to run static-discharge conductors through the house itself.

QUESTIONS

1. Why are antennas more important to television receivers than to standard AM broadcast receivers?
2. What happens if the same signal is received from several directions? What is this called?
3. What is the importance of the ionosphere in signal transmission?

4. What factors determine whether or not radio waves are returned to earth from the ionosphere?
5. How are television signals sent? Explain.
6. What is the horizon distance for a television antenna mounted atop a tower 450 ft high?
7. How much is the above distance increased if the antenna is raised an additional 100 ft?
8. A receiver is located 30 miles *beyond* the horizon distance computed in Question 6. How high should the receiver antenna be raised to receive signals from this transmitter?
9. What is meant by wave polarization? How does it affect the installation of a television receiving antenna?
10. What are the disadvantages of using any length of wire for the reception of a television signal?
11. Indicate the materials required to construct and erect a half-wave dipole antenna.
12. A half-wave antenna is to resonate at 70 mc. What should its overall length be?
13. How are the directional characteristics of antennas obtained?
14. Name and sketch five different types of antennas that could be employed to receive television signals.
15. What precautions must be observed in choosing and installing a transmission line?
16. Name and describe four types of transmission lines.
17. Where could each type of line be used? Give reasons for each choice.
18. Define antenna gain and antenna directivity.
19. Must a signal always be received directly from the transmitter to be useful? Explain.
20. A half-wave dipole antenna designed for 80 mc is to be used on 192 mc. By how much should it be altered?
21. Illustrate a balanced- and an unbalanced-input system.
22. In what respects do high-gain antennas differ from antennas employed to pick up strong, local signals?
23. Describe the construction of a lightning arrester. Where should one be positioned?
24. What can be done to use a single array to feed adequately more than one receiver?

Wide-Band Tuning Circuits—RF Amplifiers

The Bandwidth Problem. The television signal occupies a 6-mc bandwidth in the radio spectrum, a range far greater than anything we have to receive with the ordinary radio set. The problem must be met at the television receiver in the RF and mixer stages. The response of the tuned receiving circuit should be uniform throughout the 6-mc band and yet be selective enough to discriminate against unwanted image frequencies or stations on adjacent bands. Before the circuits of the RF and mixer stages are considered, it will be helpful to discuss wide-band tuning circuits.

Ordinary Tuning Circuits. A single coil and capacitor, connected as shown in Fig. 3-1 (A), form a parallel tuning circuit. At or near the resonant frequency, the variation of impedance which this combination presents is given by the graph of Fig. 3-1 (B). At frequencies below the resonant frequency, the parallel combination acts as an inductance with a lagging current, and the impedance here drops off quite rapidly to a fairly low value. Above resonance, the effect is capacitive with a leading current. Again, the impedance decreases quite rapidly. At the resonant point, capacitive and inductance reactances cancel each other, the impedance becoming high and wholly resistive.

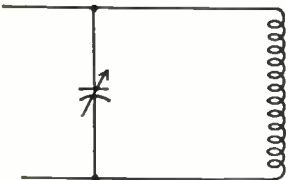

FIG. 3-1(A). A parallel tuning circuit. The response curve for this circuit is shown in Fig. 3-1(B).

While Fig. 3-1 (B) shows the general shape of the resonant curve, more specific information is necessary. Hence, in Fig. 3-2, several resonant curves have been drawn, each for a circuit having a

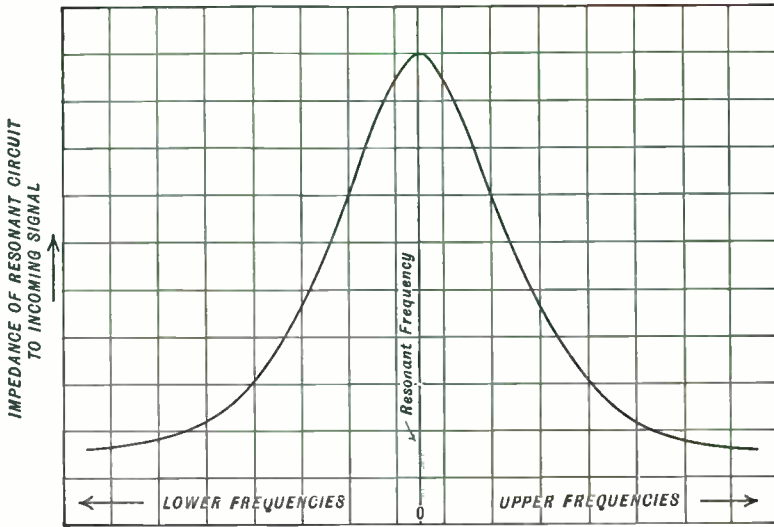

FIG. 3-1(B). The response curve for the tuning circuit shown in Fig. 3-1(A).

different value of Q . Q , which is the ratio of inductive reactance to coil resistance, may be taken to indicate two things:

1. The sharpness of the resonant curve in the region about the resonant frequency. This, of course, is the selectivity of the tuning circuit.
2. The amount of voltage that will be developed by the incoming signal across the resonant circuit at resonance.

For any given circuit, the greater its Q value, the more selective the response of the circuit, and the greater the voltage developed. While these factors may be highly desirable, they are useful only if they do not interfere with the reception of radio signals. At the broadcast frequencies, each station occupies a bandwidth of 10 kc. Within this region, uniform response is desirable. However, the sharply peaked curve of Fig. 3-1(B) does not produce equal response at all points within this region. The portion of the signal exactly at the resonant frequency, for example, would develop a greater voltage across the resonant circuit than those frequencies at

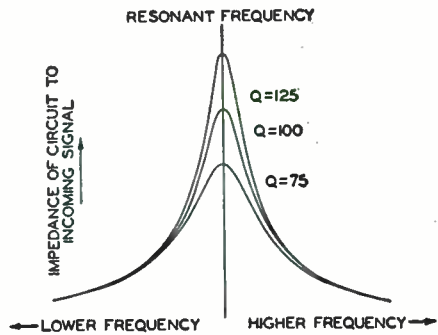

FIG. 3-2. The variation in the response curve with different values of Q .

the outer fringe, plus and minus 5 kc away. A coil and capacitor combination having a lower Q would give a more uniform response and might be chosen over one with a higher value of Q . Less voltage results from this change, but, with the advent of high-gain tubes, amplification is not too serious a problem. The emphasis now can be shifted to fidelity, which is especially necessary for the reproduction of images in television receivers.

Transformer Coupling. Whereas the simple circuit already described is sometimes used by itself for tuning, a more common combination is the untuned primary coil inductively coupled to a tuned secondary. See Fig. 3-3. With this form of coupling, additional gain may result by having

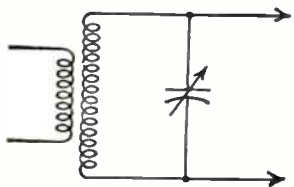

Fig. 3-3. A common form of transformer-coupled tuning circuit used in radio receivers.

more turns in the secondary than in the primary coil. The stepped-up voltage applied to the grid of the next stage is larger than that obtained with only the single coil and capacitor by a value dependent upon the design of the coils.

The shape of the response curve of the primary circuit depends to a great extent upon the degree of coupling between the coils. When the coefficient of coupling k is low (i.e., when the coils are relatively far apart), the interaction between coils is small. The secondary response curve will retain the shape shown in Fig. 3-1(B).

As the coupling coefficient k is increased, the secondary circuit reflects a larger impedance into the primary. The primary current is affected more by variations in the tuning of the secondary capacitor. This, in turn, changes the number of flux lines which cut across the secondary coil, and the end result is a gradual broadening of both primary and secondary response curves. With very close coupling, the secondary response curve may continue to broaden and even develop a slight dip at the center. The dip, however, will never become too pronounced. It must be remembered that the discussion, so far, has dealt with coupled circuits where the primary is untuned. Hence, no matter how close a coupling is effected, the secondary will retain essentially the same curve shape given in Fig. 3-1.

On the other hand, with two *tuned* circuits coupled together, such as IF transformers, the effect of each circuit on the other becomes more pronounced. With close coupling, the familiar double-humped curve of Fig. 3-4 is obtained. The closer the coupling, the broader the curve and the greater the dip at the center.

For television reception, none of these combinations provides the necessary uniform bandwidth. Loose coupling produces a curve that is too sharp and lacking in uniformity over its range. Tight coupling tends to decrease the voltage of the frequencies near resonance because of the dip. Between

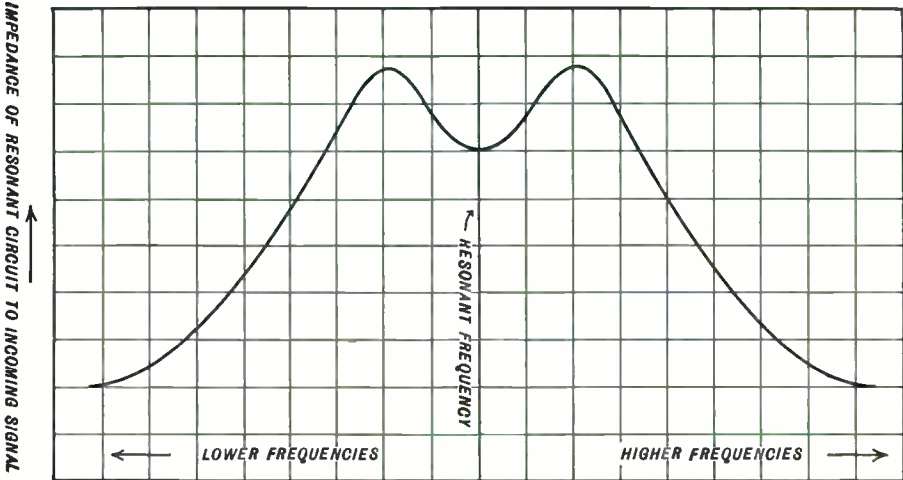

FIG. 3-4. Close coupling between two tuning circuits produces this type of response curve.

these two extremes we may obtain a semblance of uniform response about the center point of the curve, but never for a 6-mc spread. However, if a low-valued resistor is shunted across the coil and capacitor, we can artificially flatten the curve to receive the necessary 6 mc. The extent of the flat portion of the response curve will depend inversely on the value of the shunting resistor. The higher the resistor, the smaller the width of the uniform section of the curve. Hence, what we could not accomplish with a coil or a capacitor, we can do with a combination of these two with resistance.

One of the undesirable results of increasing the width of a response curve by the resistor method is the lowered Q that is obtained. As the value of Q decreases, the voltage developed across the tuned circuit becomes smaller for the same input. An inevitable reduction in output results. There are many ways of combining the tuned circuits and loading resistors to achieve the optimum gain and selectivity. Several of the more widely used circuits will be discussed in the section on RF amplifiers.

Special Tubes for Television Receivers. A number of special tubes have been developed for the RF-amplifier stage in television receivers. These include pentodes, tetrodes, and triodes. All are of the miniature variety, and are used not only to achieve compactness in the tuner, but also because in a miniature tube, interelectrode capacitance is smaller and the connecting leads between the elements and the base pins are shorter. The latter introduces less inductance into the circuit, a factor which is particularly desirable since the inductance in the tuning network, itself, is small.

Pentodes. From the standpoint of gain from a single tube, pentodes offer the best solution, and a number of them have been developed and extensively employed. These include 6AG5, 6AK5, 6BC5, and 6CB6. When these pentodes are used, it is the usual practice to shunt resistors having values between 1,500 and 10,000 ohms across the tuning circuit to attain the necessary bandwidth. (The pentode, itself, is not very helpful in this respect because it possesses a high internal resistance.) Because of the shunting resistor, however, stage gain is not very high, generally on the order of 20 to 25. The reason for this can be seen from the following.

A tuning circuit, when connected in the output of a tube, is essentially in series with the plate resistance of the tube. This is illustrated in Fig. 3-5,

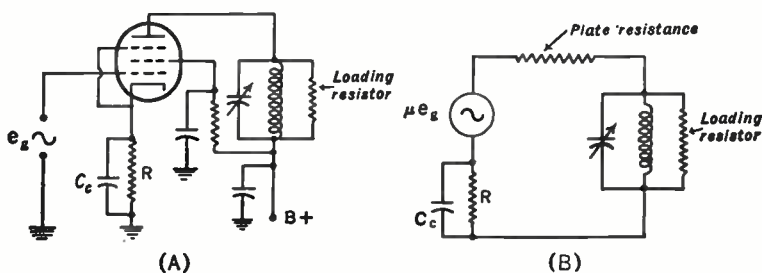

FIG. 3-5. (A) An amplifier stage and (B) its equivalent circuit.

where the actual schematic and its electrical equivalent are shown. At resonance, the resistance of the tuning circuit itself may be high, but due to the low-shunting resistor, the total value of the combination becomes low. The plate resistance, on the other hand, is very high (in pentodes), and most of the output voltage is lost in the tube. Only a small portion of the total voltage appears across the tuning circuit to be transferred to the next stage.

Mathematically, the gain of the pentode stage can be expressed closely by the relation:

$$\text{Gain} = g_m \times Z_L$$

where g_m = mutual conductance of the tube (in mhos)

Z_L = load in output circuit (in ohms).

For a 6AG5 tube, g_m is 5,000 micromhos. With a plate load of 2,000 ohms, we obtain

$$\begin{aligned} \text{Gain} &= \frac{5,000}{1,000,000} \times 2,000 \\ &= 10. \end{aligned}$$

The 5,000 is divided by 1,000,000 to convert it from micromhos to mhos.

To obtain more amplification per stage, the mutual conductance of the tube must be increased. g_m , it will be recalled, represents the change in plate current caused by a change in grid voltage. To effect an increase in this ratio, tubes were designed in which the grid possesses greater control over the space charge near the cathode. This was done by moving the grid closer to the cathode. Although the change caused an increase in grid-to-cathode capacitance, it increased the mutual conductance even more. This design is exemplified in the 6AG5, 6AK5, 6CB6, and 6BC5.

As an example, the 6AG5 has a mutual conductance of 5,000; the 6AK5 likewise has a g_m of 5,000, and the 6BC5 has a g_m of 6,000. Compare these values with older RF and IF pentode voltage amplifiers, for example, the 6SK7, 6D6, 6S7, and the 6SJ7, which have mutual conductances of 2,000, 1,200, 1,750, and 1,600 micromhos respectively. If the gain of the stage is computed and these values of mutual conductance are used, a voltage amplification much less than 10 is obtained.

Triodes. The ability of a receiver to amplify a signal is governed not only by the amplification obtained from the tubes, but also by the noise generated in the tubes and in the associated receiver networks. Furthermore, the noise that is developed by the first stage (the RF amplifier) is actually the most important because at this point in the system the level of the incoming signal is more nearly on a par with the noise level than it is at any other point in the receiver. (Once the signal becomes much larger than the noise, it can easily override the noise and hence mask its presence.) Whatever noise voltage appears at the grid of the RF amplifier is amplified along with the signal. To obtain a picture as free of noise spots as possible, we need to have as much signal and as little noise as possible at the front end of the set.

The best choice for a low-noise tube is a triode RF amplifier. This is because noise originating in a tube varies directly with the number of positive elements within that tube and a triode has fewer such elements than a pentode. Hence, a triode is more desirable from a noise standpoint than a pentode. It is for this reason that high-frequency triodes have been employed in the RF amplifier.

A triode normally provides less gain than a well-constructed high-frequency pentode. For this reason, special dual triodes have been developed for use in a circuit known as a "cascode amplifier," in which the two triodes are connected in series. In this arrangement they are capable of providing about as much gain as a pentode. This enables the designer to achieve the desired amplification at a lower noise level. Cascode amplifiers will be discussed at length presently.

Recently, a significant change has taken place in high-frequency triode construction. In an effort to achieve higher efficiency and reduced plate-to-

grid capacity, extra elements called "grid-guides," or "shield plates," have been inserted in the region between the grid and the plate. An internal view of the 6ER5, a tube of this new group, is shown in Fig. 3-6(A). The grid

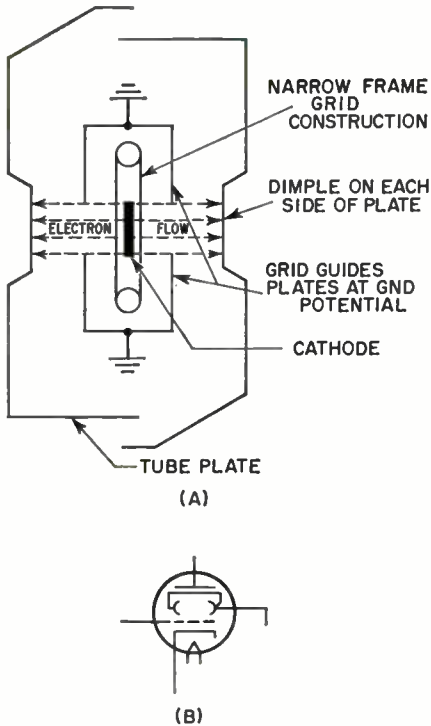

Fig. 3-6(A). Internal view and schematic symbol of 6ER5 RF triode.

which is formed by welding metal cross-braces between sturdy upright grid supports. This construction makes it possible to wind the grid with very fine wire under higher than normal tension. The result is a flatter (front-to-back) overall assembly which permits the grid to be positioned closer to the cathode. This closer positioning, with the closer spacing between grid wire turns, enable the grid to exercise considerably greater control over the current flow, which, in turn, means a higher mutual conductance.

Tetrodes. High-frequency tetrode tubes, for example, the 6CY5, have also been developed specifically for use as RF amplifiers in television receivers. These tubes possess high mutual conductances (on the order of 8,000 to 10,000) and they do not develop much more internal noise than triodes. The high g_m is achieved by using fine (8-mil) wire for the control grid; the low noise level is partly due to the fact that the plate takes con-

centrated into a smaller area, striking the plate only at an indented section called a "dimple." This concentration discourages sideways or random travel of electrons, and reduces the noise which such undesired flow produces. Note that the grid-guide plates do not themselves intercept any electrons traveling from cathode to plate, hence they are not basically another element, which is why these tubes are still considered triodes. The dimples on the plate structures permit a closer spacing between this element and the grid. This reduces electron transit time, a desirable feature at VHF.

Higher gain is achieved by the use of a newly developed frame grid,

siderably more current than the screen grid (approximately in the ratio of 7:1). Since current division is one of the governing factors of internal noise in a tube, the relatively small percentage of the total current captured by the screen grid helps to keep the noise level low.

One of the principal reasons why tetrodes have been generally avoided in all types of circuits in the past has been their tendency to produce more current flow in the screen-grid circuit than in the plate circuit for certain low values of plate voltage. The oncoming cathode electrons strike the plate electrode with sufficient force to dislodge several electrons from the plate structure for each arriving cathode electron. Because of the close proximity of the screen-grid wires and their higher positive voltages, these electrons are drawn to the screen grid rather than to the plate, with the result that more current flows in the screen-grid circuit than in the plate circuit. The effect of this is to present a negative resistance in the plate circuit, leading to amplifier instability.

In the newer tetrodes, this tendency is largely reduced through element design. For example, in the 2CY5 and 6CY5, the interelectrode spacing has been shaped so that electrons arriving from the cathode develop a space charge in the region between the screen grid and the plate.* The negative electrostatic field of this concentration of electrons blocks the escape of the secondary electrons from the plate. It also prevents cathode electrons which have reached the vicinity of the plate from returning to the screen grid when the plate voltage swings below the screen-grid voltage in normal operation. (It is possible for the negative-resistance effect to appear if the plate voltage is driven to 30 volts or so. This is carefully avoided, however, so that no difficulty develops from this source.)

Figure 3-6(B) shows a sectional view of a 2CY5. As indicated by the broken lines in the illustration, the stream of electrons is divided into sheets or "beams" which tend to pass between the wires of the screen grid. Thus, relatively few electrons impinge on the screen grid. Also, by carefully spacing the various electrodes, a space-charge effect is created in the darkly shaded region.

RF Amplifiers. The typical television RF stage, shown in Fig. 3-7, is very similar to the same stage in amplitude-modulated broadcast receivers. It has three functions. First, it provides

* In pentodes the suppressor grid serves this purpose.

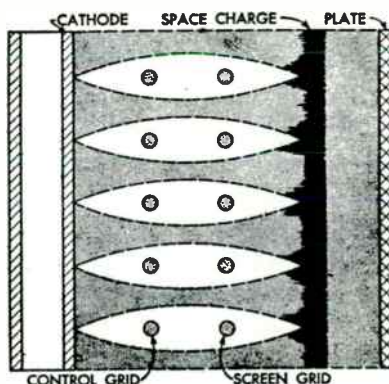

FIG. 3-6(B). Electron paths in the 2CY5 tetrode.

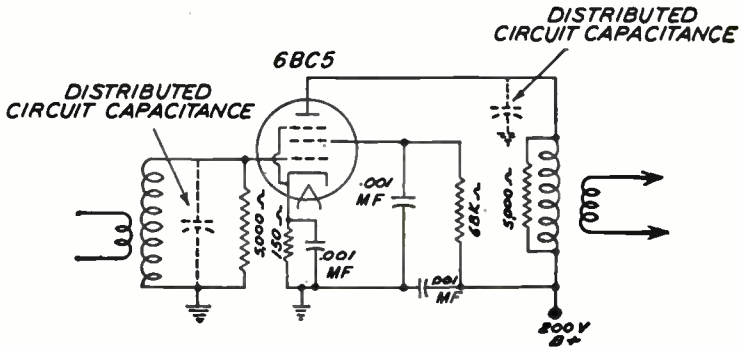

FIG. 3-7. A typical television RF amplifier.

signal amplification in a part of the set where the signal is at its lowest value. In outlying regions or noisy locations, this extra amplification may be the deciding factor in obtaining satisfactory reception. Second, it provides greater discrimination against signals lying in adjacent bands. This is especially applicable for image frequencies. A properly designed RF stage will help the signal to override any small interferences that are produced in the tubes themselves. The latter boost applies only to the first tube or two where the signal may be comparable to the internal disturbance voltage. In audio systems, the internal tube disturbance is known as "noise." In television receivers these disturbances are amplified along with the video signal and, if stronger than the received signal, will appear as small white spots on the image screen. (These spots are often referred to as "snow," or "masking voltages.") Finally, the RF amplifier also reduces local oscillator radiation, which can be quite offensive to neighboring receivers.

The tube employed in the RF stage, besides having a low noise content and a high mutual conductance value, should also possess a remote cutoff characteristic. With remote cutoff properties, the stage does not distort as readily when large input signals are received. Furthermore, automatic gain-control * voltage may be applied to the tube, materially aiding amplifier stability and tending to maintain a steady signal output.

Some of the forms that the RF stage may assume are shown in the accompanying diagrams. In Fig. 3-7, transformer coupling is used in the input and the output circuits of the RF amplifier. Each transformer is loaded down by a shunting resistor so that its response will be fairly uniform over a 6-mc bandwidth. The resistor value is chosen with the idea of maintaining the stage gain as high as possible. On the upper VHF channels (7-13) and throughout the UHF band, sufficient loading is usually provided

* AGC in a television receiver is similar to AVC in a radio receiver.

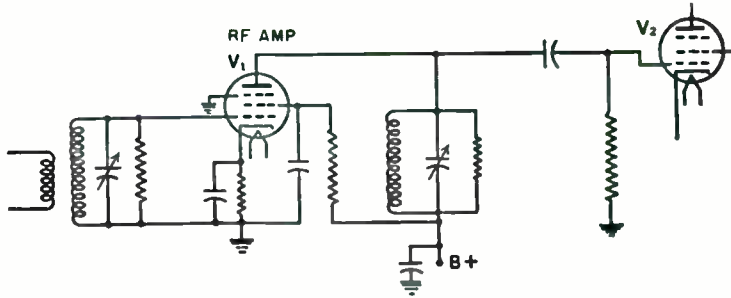

FIG. 3-8. Another RF-amplifier stage. One tuned circuit is common to the plate of V_1 and the grid of V_2 .

by the tube itself so that external resistors are not needed. When triodes or tetrodes are used, loading resistors may be omitted because the lower internal impedances of these tubes provide sufficient loading to achieve the desired bandwidth.

In Fig. 3-8, a single-tuned circuit instead of a transformer is used between the plate of the RF amplifier and the mixer tube. The tuning capacitance shown in each of these diagrams might be either a small variable trimmer capacitor or the stray-circuit-wiring and tube capacitance always present in the circuit. In the latter instance, adjustment of the tuned circuit would not be accomplished by varying the capacitance (since the wiring and tube capacitances are not adjustable), but by using movable cores within the coil. Thereafter a selector switch or some other tuning arrangement is used. Although only one set of coils is shown in some of these diagrams, there would be similar arrangements for each of the channels.

There are a number of variations of the coupling network between V_1 and V_2 of Fig. 3-8, two of which are shown in Fig. 3-9. In the first illustration, Fig. 3-9(A), the plate load for V_1 is a resistor. L_1 is the resonant

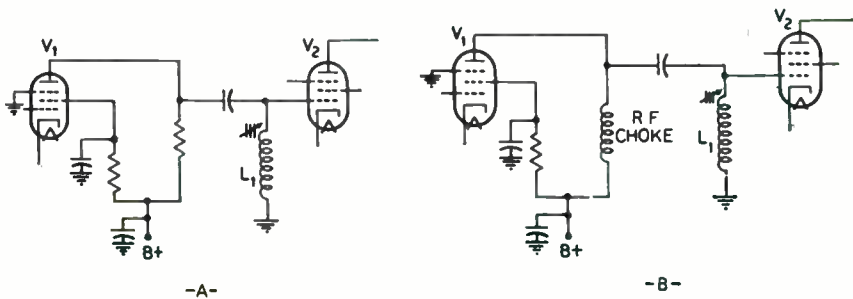

FIG. 3-9. Two additional interstage coupling networks between the RF amplifier (V_1) and the mixer (V_2). Either triodes or pentodes can be employed.

circuit between the two tubes and it is placed in the grid circuit of V_2 . In Fig. 3-9(B), the plate load for V_1 is an RF choke. It might also be another resonant circuit.

An approach sometimes practiced is to insert an overcoupled transformer in the input circuit and a single-peaked circuit in the plate circuit of the stage. One such circuit is shown in Fig. 3-10. The primary winding of T_1 is untuned and matches the transmission-line impedance. The grid winding is tuned by the grid-input capacitance of the tube, plus whatever stray capacitance is inevitably present in the circuit. The third winding

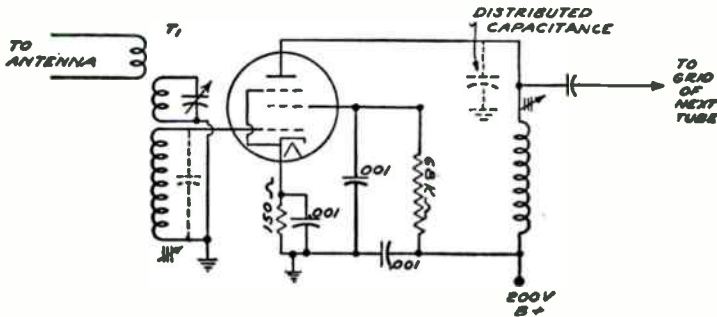

FIG. 3-10. An RF amplifier which combines the response characteristics of grid- and plate-tuned circuits to obtain a 6-mc overall spread.

contains a small trimmer to permit adjustment, although in some instances it is nothing more than a 1- or 2-turn winding which functions as a link coupling between the input and grid coils. The combination of these three coils results in a double-peaked response curve, as shown in Fig. 3-11(A). In the plate circuit of the stage, and serving as an impedance coupling between circuits, is a single-tuned coil. Its response is single-peaked, as illustrated in Fig. 3-11(B). By properly adjusting the peaks of these circuits, we can achieve an essentially overall flat response of 6 mc for the stage, as is shown in Fig. 3-11(C). (The word "essentially" is used because it seldom occurs that the RF response curve has an absolutely flat top. In practice, up to a 30-per cent dip in the center of the curve is permissible.)

Another method of coupling between stages in order to achieve a broad bandpass is shown in Fig. 3-12. Here, a small capacitor connects the primary and secondary windings. The value of this capacitance is low (10 to 20 mmf) and governs the extent of the bandwidth; increasing the capacitance increases the bandwidth.

In Fig. 3-13, mutual capacitive coupling between the RF amplifier and the mixer is achieved in still another way. L_A and L_B are two coils which are coupled to each other *only* through the common capacitance C_4 . In

other words, their magnetic fields do not interact. Each coil is pretuned to the same frequency by means of a brass slug. C_A represents the output capacitance of the 6AG5 RF amplifier plus other circuit capacitances; C_B is the input capacitance of the following tube plus the distributed wiring capacitance of the circuit.

In this type of tuned circuit, the bandwidth is determined by the degree of coupling and the Q 's of L_A and L_B . The degree of coupling is controlled by the value of C_4 . The smaller this capacitance, the greater the mutual impedance and the greater the bandwidth. The value of C_4 is chosen to provide a bandpass of approximately 6.0 mc. To maintain a constant bandwidth, C_4 has a value of 250 mmf on the lower channels and a value of 140 mmf on the higher channels. This value compensates for the change in coil Q 's with frequency. For each channel a new pair of coils is switched into the circuit.

Another feature of Fig. 3-13 is the provision for either 75- or 300-ohm-input transmission lines. This is accomplished by using the full primary winding of the input transformer for the 300-ohm line and half of the winding for the 75-ohm coaxial line. Inductance of a coil is proportional to the square of the number of turns. Doubling the number of turns produces four times the inductance and, at

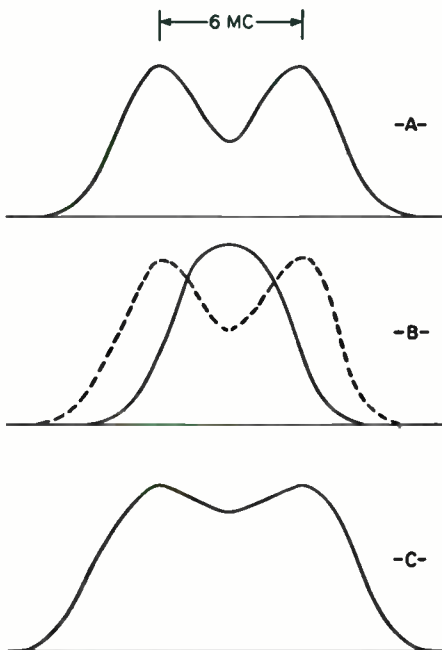

FIG. 3-11. The combination of two tuning circuits to produce a flat-topped overall response. (A) Grid-circuit response; (B) plate-circuit response; (C) overall response.

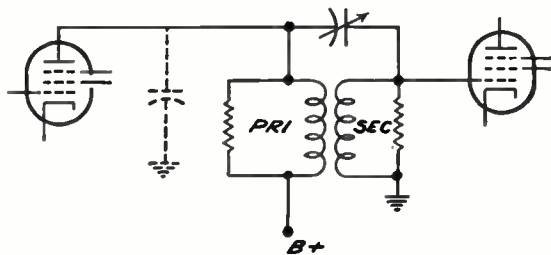

FIG. 3-12. One method of increasing the coupling between two tuned circuits to achieve broad bandpass.

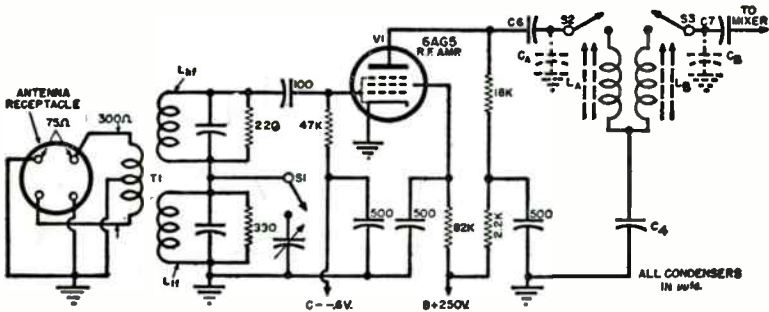

FIG. 3-13. Mutual capacitive coupling, C_4 , is used between L_A and L_B .

the same frequency, four times the impedance; 300 ohms is four times 75 ohms.

Triode RF Amplifiers. The low-noise qualities of triodes always make them attractive for the RF amplifier stage, and a number of different circuits have been designed which use these tubes. The simplest approach employs a single triode, as shown in Fig. 3-14(A). The 6BN4A is a specially built triode possessing a mutual conductance of 8,000 mhos and a plate resistance of 5,400 ohms. The low plate resistance loads the tuning circuits sufficiently to achieve the desired bandwidth without the need for any external shunting resistors. The high g_m helps to achieve a fairly good gain even at these frequencies.

A triode tube, when used as shown in Fig. 3-14(A), requires a neutralizing network in order to prevent regeneration at high frequencies. This need stems from the relatively large capacitance that exists between the plate and grid elements inside the tube. At sufficiently high frequencies, the output signal can use this capacitance to travel from the plate to the grid and

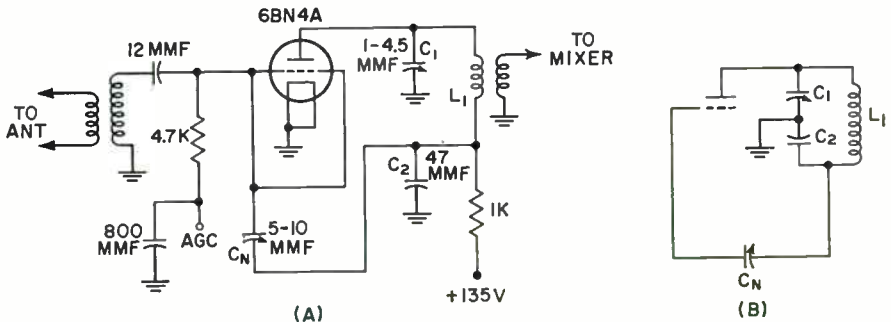

FIG. 3-14. (A) Triode RF amplifier. (B) Rearrangement of plate circuit to better reveal how out-of-phase voltage for neutralization is developed.

reduce the stage gain. By feeding an out-of-phase signal of the same amplitude back to the grid, the first signal can be effectively neutralized and the degenerative condition avoided.

The required out-of-phase voltage for the grid is obtained at the bottom end of the plate coil (L_1). One way of looking at L_1 to see how the out-of-phase voltage is developed is to consider capacitors C_1 and C_2 as providing a capacitive network across L_1 which establishes an RF ground at some point on this coil. See Fig. 3-14(B). With this condition, the RF voltage at the plate end of the coil is 180 deg out of phase with the voltage at the other end. Capacitor C_N then feeds back to the grid as much out-of-phase voltage as is needed to neutralize the signal voltage reaching the grid by way of the interelectrode capacitance.

The 6BN4A (or its 2-volt counterpart, the 2BN4A) is shown in Fig. 3-14(A) to indicate the fact that the tube actually possesses two grid leads and two cathode leads. This is done to minimize lead inductance in order to permit a single neutralization adjustment that will serve suitably throughout the entire VHF band. If such inductances were permitted to become high enough, operation on channels 7 to 13 would require one neutralizing adjustment and channels 2 to 6 would require another. More will be said about tube lead inductance presently.

Push-pull Triode Amplifiers. Push-pull amplifiers have also been used in the RF section of television receivers. The circuit schematic is shown in Fig. 3-15. The transmission line from the antenna feeds directly into the grids of a 6J6 push-pull triode amplifier. To match the impedance of the line, two 150-ohm resistors are connected in series to provide the total of 300 ohms. T_1 is a center-tapped coil used to prevent low-frequency signals from reaching the grids of the RF amplifier. C_1 and C_2 are antenna-isolating capacitors.

In the plate circuit of the RF amplifier, starting with L_{26} and progressing down to L_1 , we have a series of inductances that may be considered as sections of a quarter-wave transmission line. The switch, as it moves progressively to the left, brings in more inductances, thus decreasing the channel frequency. In position 13, only L_{25} and L_{26} are in the circuit and the receiver is set for the highest VHF-TV channel. At position 2, the set will receive the lowest channel. (Position 1 was for the now obsolete channel 1.) At various points along the line, adjustments may be made by changing the position of the tuning slugs. The physical construction of each of the small inductances, L_{13} to L_{26} , is a small, fixed silver strap between the switch contacts. Each strap is cut long enough to introduce a 6-mc change in frequency. In order to make the transition from the lowest high-frequency channel, 174-180 mc to the highest low-frequency

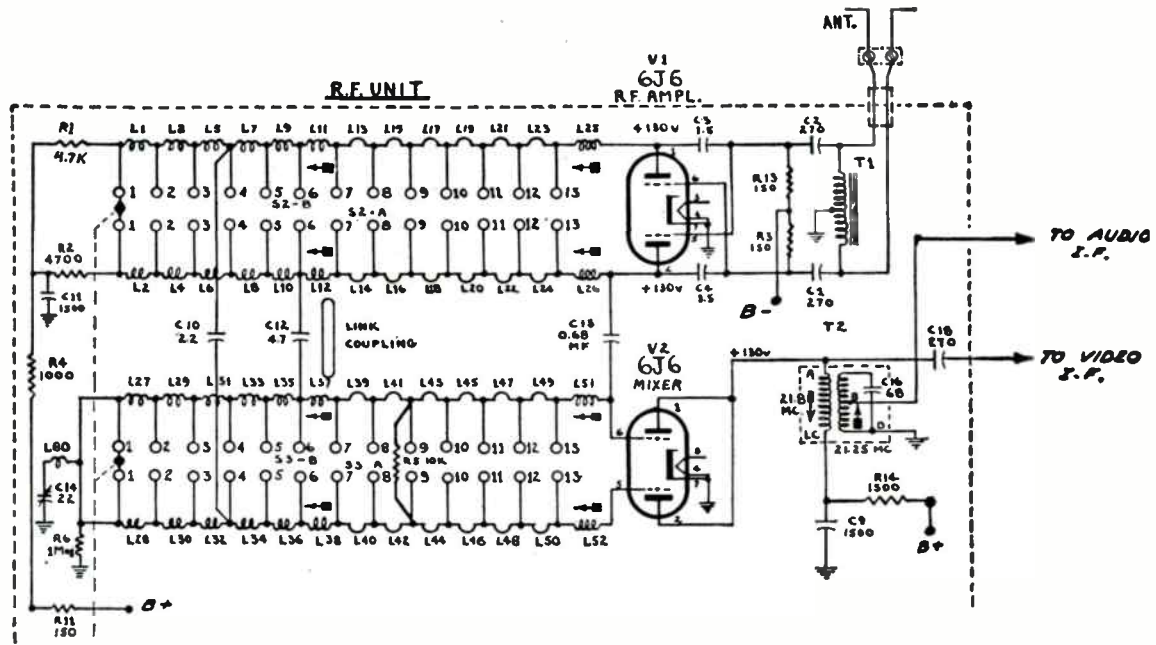

Fig. 3-15. A quarter-wave transmission line used for tuning the RF stages of a television receiver.

channel, 82-88 mc, adjustable coils L_{11} and L_{12} are used. Coils L_1 to L_{10} are more substantial in appearance than coils L_{13} to L_{26} , being wound in figure-8 fashion on fingers protruding from the switch assembly.

Since each section of the 6J6 is a triode, neutralizing capacitors are necessary to counteract the grid-to-plate capacitance. This is the function of C_3 and C_4 .

Coupling between the quarter-wave line of the RF amplifier and a similar section in the grid circuit of the mixer tube is twofold: by direct capacitance connection and by link coupling. The response characteristic of these RF circuits extends the full 6 mc. In addition, a 10,000-ohm loading resistor is placed across a portion of the mixer tuning circuits to provide the necessary bandwidth. (In Fig. 3-15 the resistor is effective only for channels below 9.)

Grounded-grid Amplifiers. Triode RF amplifiers are often employed in an arrangement known as the "grounded-grid amplifier." This type of amplifier is contrasted with the conventional amplifier in Fig. 3-16. Note

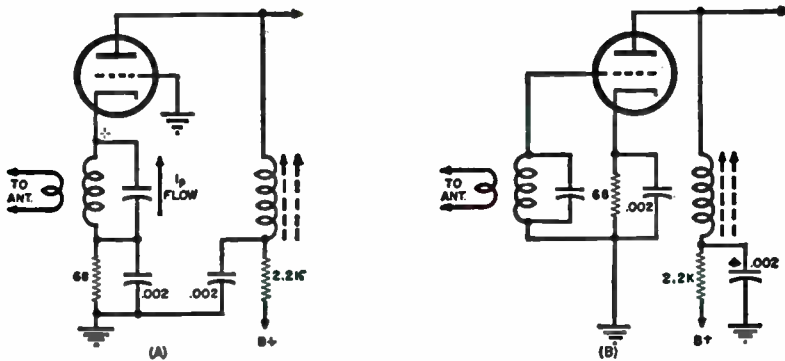

FIG. 3-16. (A) A comparison between the grounded-grid and (B) conventional RF amplifier.

that the grid of the tube is at RF ground potential and that the signal is fed to the cathode. The tube still functions as an amplifier because the flow of the plate current is controlled by the grid-to-cathode potential. Instead of varying the grid potential and maintaining the cathode fixed, the grid is fixed and the cathode potential is varied. The net result is the same. In addition, the grid, being grounded, acts as a shield between the input and output circuits, thereby preventing the feedback of energy which is so essential to the development of oscillations.

The grounded-grid amplifier also offers low input impedance, enabling the amplifier to match the antenna transmission-line impedance. The low

impedance provides a broader bandpass response curve which is particularly desirable for 6-mc television signals.

A commercial application of a grounded grid RF amplifier is shown in Fig. 3-17. The antenna is connected into the cathode circuit of the RF amplifier. L_1 is a simple high-pass filter designed to reject all low-frequency signals, especially those at the intermediate frequency. The cathode chokes, L_2 to L_6 , are placed in series with the cathode resistor to prevent the input impedance from being lowered by the shunting effect of any stray ca-

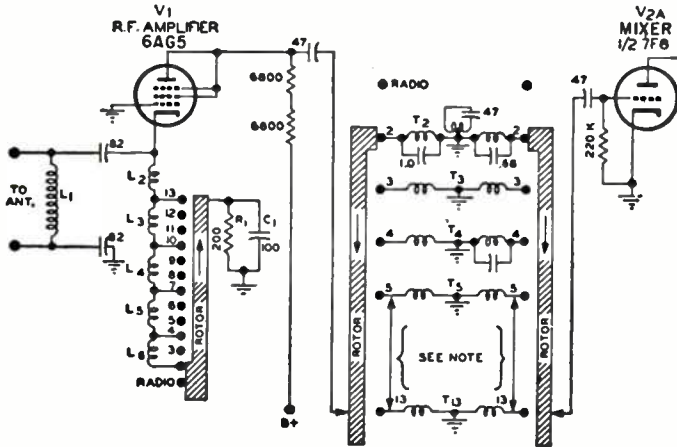

FIG. 3-17. The grounded-grid RF amplifier stage used in a television receiver. (Note: RF coils and switch points for channels 6 through 12 are not shown. Coils T_6 through T_{12} correspond to channels 6 through 12 and are connected the same as T_5 .)

pacitance to ground due to the cathode of the tube. The choke value is changed with frequency. R_1 and C_1 provide cathode bias.

The RF amplifier is coupled to the mixer tube through a wide-band transformer. One such unit is provided for each channel. The windings are self-tuned by the distributed and tube capacitances to provide maximum gain through a high L/C ratio. The RF coils for each channel are placed physically near the oscillator coils of the same channel (not shown) in order that both voltages will combine at the mixer grid.

Cascode Amplifier. Still another RF amplifier arrangement that makes use of triodes is the cascode amplifier. See Fig. 3-18. Here two triodes are connected in series, that is, the plate of the first section goes directly to the cathode of the second section. The same current flows through both tubes and the amplitude of this current is controlled by the d-c bias on the first triode.

The input-tuned circuit of this series amplifier connects to the control

grid of the first triode; the output-tuned circuit is in the plate lead of the second triode. The first stage is operated as a conventional amplifier, that is, with the signal applied to the grid and the output signal obtained from the plate. The second stage is employed as a grounded-grid amplifier. The inductance, L_1 , between both stages helps to neutralize the grid-to-plate capacitance of the first triode (with help from capacitor C_1), and it is designed to resonate with the grid-cathode capacity of the second section on the high VHF channels. While L_1 thus aids the stability of this combination, it is

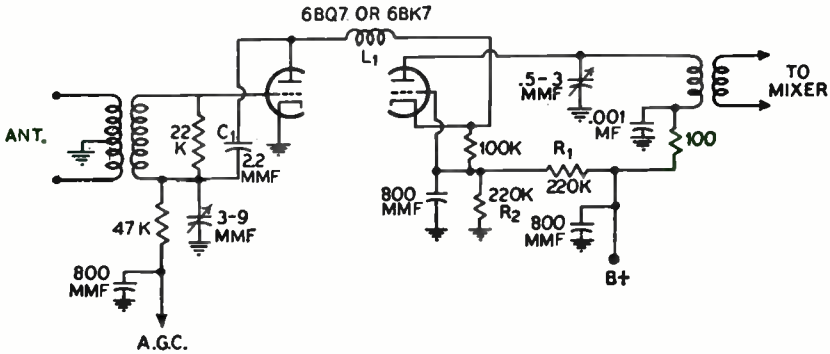

FIG. 3-18. A cascode RF amplifier.

also largely responsible for the low-noise qualities of the cascode circuit.

The role that C_1 plays in helping neutralize the input triode to prevent it from oscillating can be seen perhaps more clearly by noting that it connects from the plate of the first triode to the bottom end of the coil in the grid circuit. Thus, it feeds its signal to the bottom end of this coil at the same time that the grid-to-plate capacity within the first triode feeds back its signal to the top of the coil. In this way we achieve the 180 deg phase reversal required for the two voltages to counterbalance and neutralize each other.

Direct coupling is used between the first triode plate and the second triode cathode. With cathode feed to the second triode, C_2 is used to place the grid at RF ground potential. Since the two triode sections are in series across a common plate supply, the cathode of the second triode is 125 volts positive with respect to chassis ground. A divider across the plate supply, consisting of R_1 and R_2 , places the grid of the second triode at a sufficiently positive potential (with respect to its cathode) for proper operating bias.

The cascode circuit is widely employed and a number of special twin-triode tubes—for example, the 6BZ7, 6BK7-B, and 6BQ7-A—have been developed for this particular purpose. All have basically similar electrical characteristics but different internal connections to facilitate the placement

of the components and the layouts found in the various television tuners. The cascode arrangement gives an overall gain which is somewhat less than that obtainable from a well-designed high-frequency pentode. However, the noise figure of a cascode combination is considerably better than that of a pentode.

Internal Tube Capacitances. Just as important as the mutual conductance of a tube are its interelectrode capacitances. It has already been noted that the gain of a stage is equal to the product of the mutual conductance of the tube and the load impedance. The load impedance, in turn, is essentially equal to the value of the resistor shunting the tuning coil and capacitor. And, as we shall see in a moment, it is the value of the L -to- C ratio of the tuning circuit which determines how high a resistor can be used.

For greatest gain over any band, a high L -to- C ratio should be maintained in each resonant circuit. The capacitance which shunts the coil includes the interelectrode capacitance of the tube. As we make this capacitance smaller, the gain increases correspondingly. In addition, the value of the resistance R needed to load a tuned circuit is proportional to the reactance of the capacitance across the coil. Thus, with a smaller capacitance, we obtain a higher capacitive reactance and the loading resistor is higher in value. The end result is greater gain.

For the RF input stage, the minimum capacitance is determined by

1. The grid-to-cathode capacitance, C_{gk}
2. The grid-to-plate capacitance, C_{gp}
3. The stray capacitance, C_s

The total capacitance is equal to

$$C_{\text{total}} = C_s + C_{gk} + C_{gp}(1 + G)$$

where G is the gain of the stage, usually about 15-30 in these amplifiers.

For the 6AK5, C_{gk} is equal to 4 mmf, C_{gp} amounts to 0.015 mmf, and the gain of the stage may be taken as 20. The stray capacitance will depend upon the manner in which the stage is wired and may amount to an additional 10 mmf. The total, or 14.3 mmf, would then represent the minimum capacitance of the stage and would have to be considered as an addition to any tuning capacitor inserted across the coil (Fig. 3-19).

At the broadcast frequencies (500 to 1,500 kc) in the ordinary home receiver, these tube and wiring capacitances are never serious when compared with the size of the tuning gang employed. However, when frequencies of 100 mc or more are to be received, the tuning capacitor may be even smaller than these additional capacitances and they can no longer be disregarded.

Whereas the wiring and tuning capacitances remain fixed once the set

has been completed, no such happy state of affairs exists for C_{gk} or C_{gp} $(1 + G)$. The latter values will vary as the gain of the stage varies, which occurs every time the input voltage changes. C_{gk} will change its value as the electron current is altered. The effect of the variation, if great enough, is sufficient to detune the stage. Again, these small items, insignificant in themselves, may become very influential as the frequency increases and the size of the coil and capacitor decreases.

We have considered only the capacitance in the input circuit. A similar line of reasoning may be applied to the plate circuit, where the total minimum capacitance is composed of the following:

1. The output capacitance, C_o , as obtained in any tube manual
2. The wiring capacitance

The list is short because it has been assumed that the output circuit is inductively coupled to the next grid. This coupling tends to separate the input capacitance of the next tube from the plate circuit of the preceding tube. However, if a direct connection is made to the next tube, the additional input capacitances must be taken into account.

From the foregoing brief discussion, it is evident that in designing RF television amplifiers of all types, tubes should be selected that have

1. High mutual conductance values
2. Low input and output capacitances

It has been suggested that the usefulness of a tube may be determined by the ratio of (1) to (2), or

$$\frac{g_m}{C_{in} + C_o}$$

This ratio is called the "figure of merit" of a tube. Large values are desirable. It should be noted that both numerator and denominator of the ratio are important at the high frequencies. At the low frequencies, the tube capacitances have less importance and only g_m needs to be considered.

Tubes with Two Grid and Two Cathode Terminals. The 6BN4A in Fig. 3-14 possesses two cathode terminals and two grid terminals. It has been found that the input impedance of vacuum tubes, which is ordinarily so

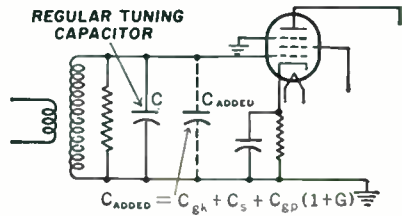

FIG. 3-19. At the higher frequencies the stray-wiring and internal-tube capacitances represent an appreciable part of the total circuit capacitance and hence must be included in all computations.

high as to be considered infinite, begins to decrease as we raise the frequency of the signal. In the television channels above 50 mc, this tube loading on the attached tuned circuits causes a reduction in the gain and Q of the circuit. One of the causes for this reduction in tube input impedance is due to the inductance of the cathode leads within the tube itself. Why this is so can be seen from the following explanation.

The current of a tube must flow through the cathode lead wires and in so doing develops a voltage across the inductance of these wires. Note that this inductance is of importance only when the signal frequency is high. The average or d-c component of the current does not enter into this consideration. The voltage produced across the lead inductance, although due to the plate current, is impressed between the grid and the cathode. As a result, the effective signal voltage acting at the grid of the tube is lowered because of the opposition of the cathode-lead voltage. The situation is analogous to inverse feedback, except that the lead-inductance voltage is present even though the cathode of the tube is grounded directly to the tube socket. The lead inductance occurs within the tube itself.

Note that the voltage which is developed across the cathode-lead inductance is due to the plate current. So far as the plate circuit is concerned, this voltage is of little significance. It is at the grid, where the signal is applied, that the voltage is important.

To eliminate the effect of the lead-inductance voltage on the input-grid circuit, they have been designed with two wires leading directly from the cathode structure inside the tube to the tube base. In this manner, one terminal is available for the grid-circuit return and one for the plate circuit and its current, and the two circuits are divorced from each other. In the circuit of Fig. 3-20, the RF amplifier tube possesses two cathode terminals. Even though both cathode terminals are grounded, pin 2 is connected to the grid coil and capacitor. Pin 7 is the cathode connection for the plate circuit. To it is connected the screen-grid and plate bypass capacitors. The d-c plate

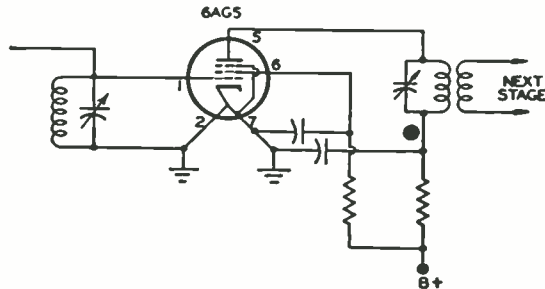

FIG. 3-20. The use of two cathode wires to eliminate the adverse effect of cathode inductance.

current divides between both cathode terminals, but this is of no consequence since it does not contribute to the degenerative effect.

In RF triodes, for example, the 6BN4A, two control grids are also made available in order to reduce the lead inductance in this circuit as well. This reduction permits one neutralization adjustment to suffice over the entire VHF range. As indicated previously, if the control-grid inductance becomes too large, separate neutralization adjustments would be required for the low and high ends of this range. In tubes not requiring neutralization, such as tetrodes or pentodes, two control-grid leads are generally not employed.

In this chapter we have been concerned solely with the basic RF-amplifier circuits found in television receivers. Nothing has been said about the tuner mechanisms themselves. This discussion will be deferred until after high-frequency oscillators and mixers have been covered, because all three stages are contained within the tuner housing.

QUESTIONS

1. How are wide-band tuning circuits achieved by using conventional tuning circuits?
2. What is the difference in behavior between transformer-coupled tuning circuits using tuned and untuned primaries?
3. Why is the gain low in RF television circuits?
4. What is the usual reason for including RF amplifiers in receivers?
5. Why are RF amplifiers especially useful in television receivers?
6. What desirable characteristics should RF amplifier tubes possess? Explain your answers.
7. Illustrate several types of RF coupling networks used in television receivers.
8. What is the advantage of using an overcoupled transformer in the input circuit and a single-peaked tuned circuit in the plate circuit of an RF amplifier?
9. Explain the operation of the RF circuit shown in Fig. 3-15.
10. Draw the circuit of a grounded-grid amplifier. Explain briefly how it operates.
11. Explain the origin of all the capacitances associated with an RF amplifier.
12. Explain the term "figure of merit" as it pertains to tubes. Why is it useful?
13. Why is the cathode-lead inductance important in high-frequency tubes?
14. Draw the circuit of an amplifier in which the effect of cathode-lead inductance is minimized.
15. Explain what effect a narrow frequency response in the RF tuned circuits has on the reproduced image.
16. Why do some tubes, for example, the 6BN4A, possess two cathode terminals?
17. Draw the basic circuit of a cascode amplifier. Explain briefly how it operates.
18. Why have RF tetrodes recently become popular?
19. What precautions should be noted when constructing an RF amplifier for use in a television receiver?
20. What effect would an inoperative RF-amplifier tube have on the image? Explain your answer.

The HF Oscillator and Mixer—TV Tuners

Converters—The Effect of High Frequencies. Present-day sound superheterodyne receivers obtain the conversion of the radio frequencies to the intermediate frequencies either at the first or at the second stage, depending upon whether or not an RF amplifier is employed. The least expensive method of obtaining the conversion is through the use of a single tube operating as a mixer and an oscillator. A typical circuit is given in Fig. 4-1. The desired intermediate frequencies appear in the plate

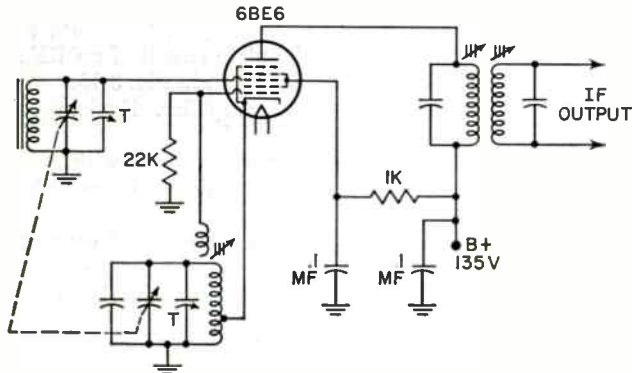

Fig. 4-1. A typical low-frequency pentagrid converter stage.

circuit and are inductively transferred by the IF transformers to the appropriate amplifiers. In early sets, separate oscillators were widely employed; however, with the development of special tubes of the pentagrid-converter type, only one tube is required now.

The interchangeable use of the words “mixer” and “converter” is common practice, although there exists a definite technical difference. A tube is a mixer only when a separate oscillator is used. Its action then merely mixes or combines the RF input and oscillator signals to obtain the difference frequency, or IF. A converter combines the action of mixing and generating the oscillator voltage within one envelope.

With increase in frequency, the stability and output of the oscillator section of a converter decrease. At the relatively high frequencies required for television, the *conventional* converter becomes unsatisfactory. The oscillator has a tendency to drift, and its output voltage is not constant. The only suitable method of obtaining sufficient oscillator voltage, without appreciable frequency drift, is to separate the oscillator from the mixer. See Fig. 4-2.

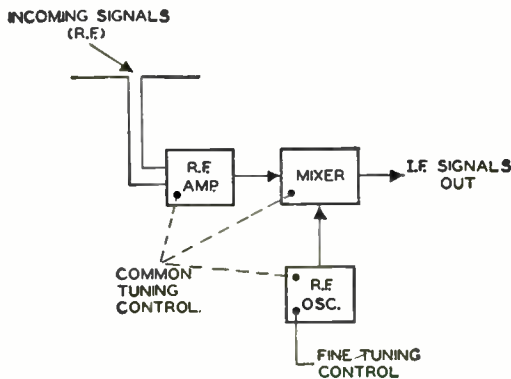

FIG. 4-2. A block diagram of the front end of television receivers.

Miniature high-frequency triodes and pentodes are employed as mixers in television receivers. From the standpoint of noise, triodes are superior to pentodes and the latter are superior to pentagrid converters because each positive element within a tube introduces a certain amount of noise into the circuit. In this respect, diodes would be the best tube of all to use, if the additional amplification provided by triodes and pentodes did not outweigh whatever noise reduction diodes provide. Of late, pentodes are being favored because of the greater gain which they provide the signal and because of the improvement in gain and lower noise of the newer RF-amplifier tubes. With the latter stage providing higher gain, the incoming signal reaches the mixer with greater amplitude; hence it is in a better position to override whatever noise may exist in the mixer.

For the oscillator, triodes are almost universally used. Special combination triode-pentode high-frequency tubes have been developed so that they

can perform the functions of generating an oscillator signal and mixing with a single tube. Each section in the tube, however, is physically and electrically independent of the other.

Energy from the oscillator may be capacitively or inductively coupled to the mixer. Two frequently used methods are shown in Fig. 4-3. Interaction between the input signal and the oscillator outside the mixer tube is kept

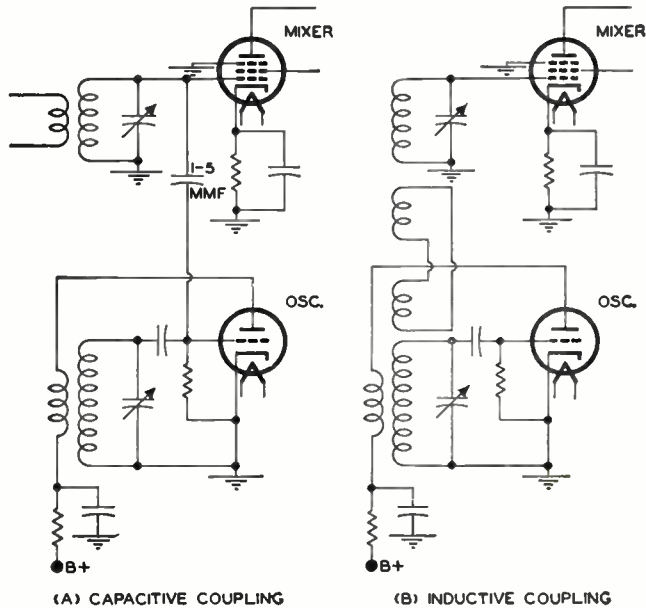

FIG. 4-3. Coupling energy from the oscillator to the mixer by inductive or capacitive means.

as low as possible to prevent any changes from occurring in the oscillator frequency and to minimize oscillator radiations from appearing at the antenna.

It has been observed that any considerable amount of radiated signal can produce a complete loss of contrast or even a negative picture in near-by television receivers. When the interfering frequency is close to the picture carrier of the station being received by the other sets, the "beat" interference produces vertical, horizontal, or slanted stripes across the screen. Beat interference refers here to the difference frequency signal obtained when the interfering signal and the picture carrier of the station being received mix with each other in the second detector stage of the receiver.

In Fig. 4-3(B), an intermediate coil is employed to transfer the generated oscillator energy to the mixer. If it is possible to position the oscillator

coil physically close to the mixer grid coil, the inductive transfer of energy may occur directly and the intermediate coil can be dispensed with.

Within the mixer of the television receiver, the received signal and the oscillator voltage both modulate the electron stream to form the desired audio and video IF voltages. In nearly all sets, the signal from the RF amplifier is transformer- or impedance-coupled to the mixer. The oscillator voltage, as indicated, is transferred to the mixer tube either capacitively or inductively.

Oscillators. Perhaps the most frequently employed oscillator circuit in present-day television receivers is the circuit shown in Fig. 4-4(B), which is known as the "ultraudion." It is equivalent in its action to the well-known Colpitts circuit. See Fig. 4-4(A). In the ultraudion, the voltage division across the tank circuit is accomplished through the grid-to-cathode (C_{gk}) and the plate-to-cathode (C_{pk}) capacitances within the tube. The feedback voltage which sustains oscillations is developed across C_{gk} . In some television receivers, the oscillator stage has the actual form shown in Fig. 4-5(A) and the equivalent network indicated in Fig. 4-5(B). The voltage-dividing capacitance network consists of the effective capacitance of C_{gk} in series with the parallel combination of C_{pk} and C_1 , while C_t represents the combination of the grid-plate capacitance, the distributed capacitance, and C_2 . C_2 is a temperature-compensating capacitor and helps reduce oscillator drift. In spite of this, drift does occur, and C_1 is provided to permit the user of the set to adjust the oscillator frequency to the best sound output. Because C_1 is actually a vernier adjustment, it is labeled "fine-tuning control" and placed on the front panel. Any shift in oscillator frequency immediately alters the IF produced as a result of the mixing action. The effect is the same as detuning the receiver. By means of the fine-tuning control, the oscillator frequency can be readjusted to its proper value. Capacitors C_3 and C_4 keep the d-c plate voltage off the ex-

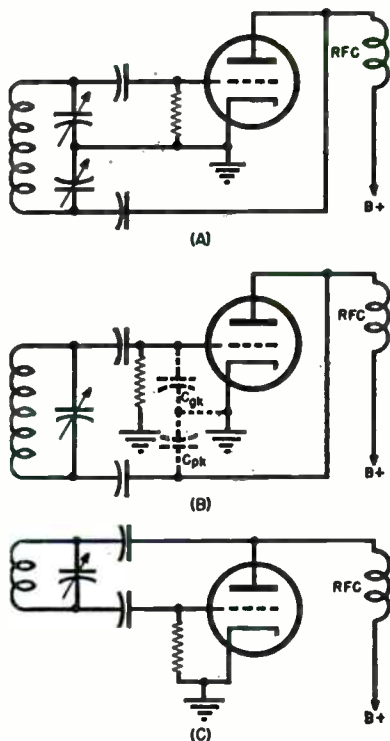

FIG. 4-4. Circuit diagrams showing similarities between (A) the Colpitts and (B) the ultraudion oscillators. (C) The circuit diagram illustrates how the ultraudion is usually drawn.

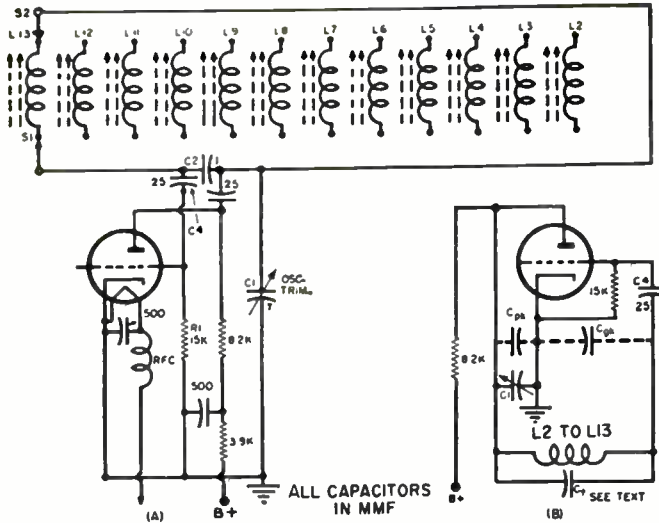

FIG. 4-5. (A) The ultraudion-oscillator arrangement as employed commercially and (B) its equivalent circuit.

posed coils. C_4 also makes it possible for the oscillator to develop grid-leak bias across R_1 . A separate coil is brought in for each channel, and each coil can be adjusted individually as to frequency. This adjustment is necessary because the oscillator frequency must be accurately set for each channel.

Modified Ultraudion. In the Colpitts oscillator of Fig. 4-4(A), it is possible to shift the placement of the ground connection from the cathode to the plate end of the tuning coil without affecting the operation of the oscillator. Now, however, we must provide a different d-c path from the cathode to ground, otherwise the electron flow of the tube will be interrupted. For this, we can use an RF choke which provides the necessary d-c path but still maintains the cathode at the required RF potential. The corresponding shift in ground point can be applied to the ultraudion circuit, with the result shown in Fig. 4-6.

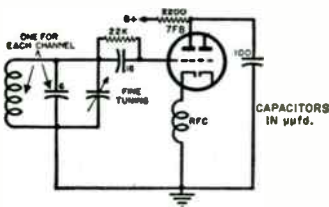

FIG. 4-6. A modified ultraudion circuit.

frequency. For tuning, brass screws are placed near the high-frequency tuning straps L_{14} , L_{16} , L_{18} , L_{20} , L_{22} , L_{24} , and L_{26} , and brass cores are adjusted

Push-pull Oscillator. In conjunction with the push-pull RF amplifier of Fig. 3-15, there is a push-pull oscillator and a push-pull mixer. See Fig. 4-7. The channel switch, as it progressively moves down the line, adds more and more inductance to the line, effectively lowering the tank frequency.

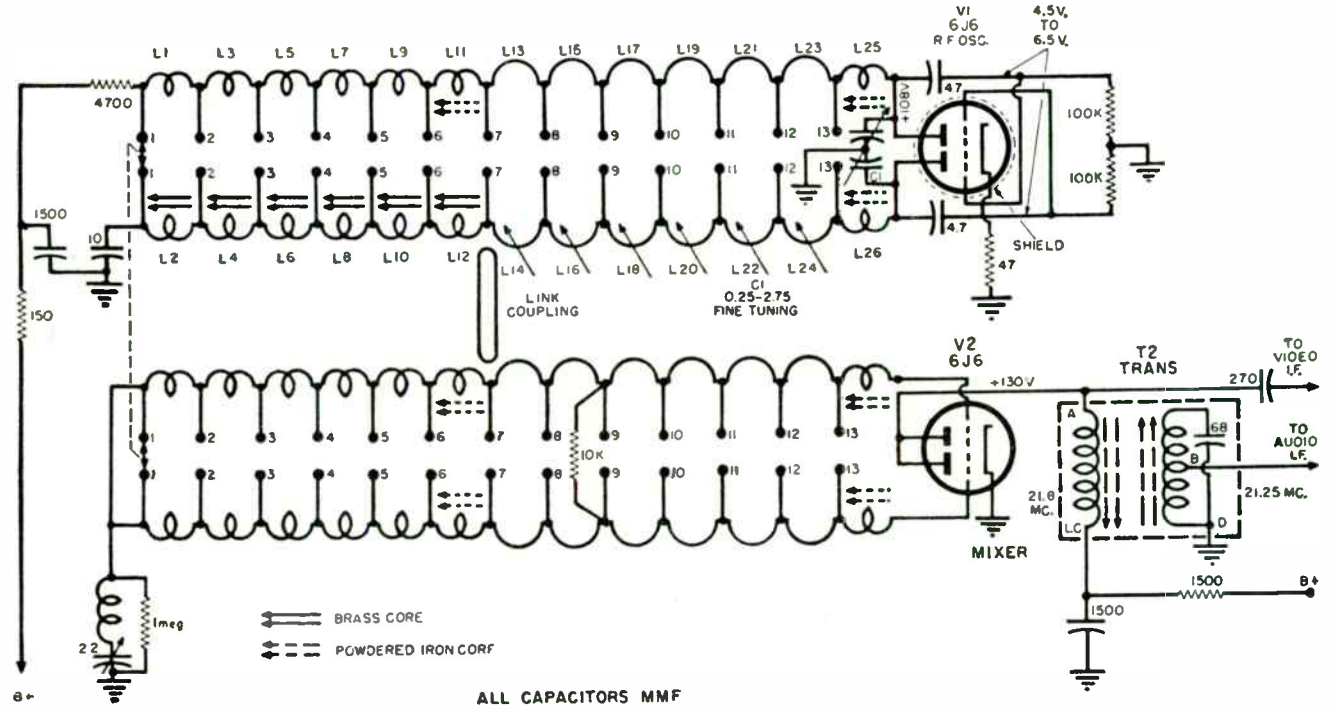

FIG. 4-7. Push-pull oscillator and mixer circuits. These are used in conjunction with the circuit shown in Fig. 3-15.

through coils L_2 , L_4 , L_6 , L_8 , L_{10} , and L_{12} . For keeping the two sections of the line as closely balanced as possible, L_{11} and L_{25} are provided.

C_1 is a fine-tuning control which is connected across the entire tuning circuit. It provided a frequency variation of approximately plus or minus 300 kc on old channel 1, and this increases to plus or minus 750 kc on channel 13. Coupling between the oscillator and the mixer is accomplished by a single turn of link coupling and by physically placing the oscillator-tuning circuit close to the converter grid-tuning circuit.

Oscillator Frequencies. In design, the oscillator frequency is generally placed above the incoming sound and video frequencies.* By being located above both signals, the highest IF produced will be that of the video signal. Refer to Chapter 1 where it was shown that, in a 6-mc television channel, the audio carrier was 4.5 mc higher than the video carrier. For channel 2, 54-60 mc, the video carrier will be at 55.25 mc. (The remnants of the other sideband are from 54.00 mc to 55.25 mc, but these are useless and rapidly attenuated in the circuits.) From the video carrier, the picture sidebands extend for 4 mc to 59.25 mc. The audio carrier would then be located at 59.75 mc.

Now suppose that the oscillator frequency is 101.00 mc. In the mixer tube, the 54- to 60-mc signals will combine with the oscillator frequency to form the following IF signals:

1. For the video, the IF will range from 41.75 mc to 45.75 mc. This is the difference between 101.00 mc and 55.25 to 59.25 mc. Actually, the IF generated will extend to 47 mc. However, the vestigial sideband remnants are from 45.75 mc to 47 mc and are not desired. The IF bandpass tuning circuit eliminates them.

2. For the sound, the IF will be centered at 41.25 mc. FM is employed for the audio transmission, resulting in a frequency variation of plus and minus 25 kc about this center (41.25 mc) position.

In Chapter 1, Fig. 1-24 (B), a characteristic curve of the video transmission is shown. The remnants of the lower sideband are permitted to remain because of the difficulties encountered in attempting to separate the lower sideband entirely from the upper sideband without affecting the phase or amplitude characteristics of the desired upper sideband. At the receiver, the remaining or vestigial, lower sideband must be attenuated; otherwise it will produce unequal response at the video-detector output. This occurs because the lower video frequencies are contained in both the upper sideband

* This placement is used in all receivers employing a split-sound television system and in most intercarrier sets. However, in certain intercarrier receivers, the oscillator frequency is placed below the sound and video frequencies. Where this is true, the sound and video signals retain the same relative position they had when broadcast. This does not affect operation of the receiver so long as the video IF system is designed for this condition.

and the remnants of the lower sideband. The higher video frequencies are present only in the upper sideband, having been eliminated from the lower sideband. If the transmitted signal waveform is permitted to remain intact, there will be proportionally more low-video-frequency voltage produced at the second-detector output than high-video-frequency voltage. To prevent this, a receiver-response characteristic, such as is shown in Fig. 4-8, is gener-

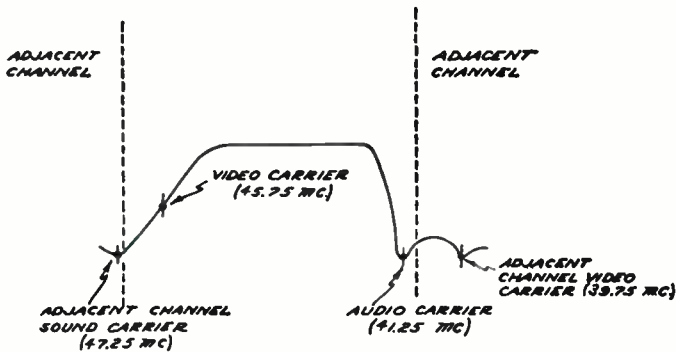

FIG. 4-8. An overall video IF response curve.

ally employed. At the carrier frequency, the response is 50 per cent down, increasing linearly toward the higher frequencies and decreasing toward the lower frequencies. Roughly speaking, the lower video frequencies, for which there are two sidebands, receive half the amplification accorded those higher frequencies for which there is only one sideband. The overall result is an equal response for both the low and the high video frequencies.

The characteristic shown in Fig. 4-8 is the response curve of the IF system of the receiver. In any superheterodyne, it is the IF stages which chiefly determine the selectivity and sensitivity of the receiver.

Indicated, too, in Fig. 4-8 are other frequencies which are attenuated by means of trap circuits inserted in the various IF amplifiers. The reason these circuits are used will be given presently.

RF Tuners. Now that RF amplifiers, oscillators, and mixers have been discussed we can turn to modern television tuners and see how these circuits are combined electrically and mechanically to receive one incoming signal to the exclusion of all others.

A number of methods for tuning television stations have been developed. All systems can be classified roughly as continuous tuning or selector-switch tuning. In the first, which is somewhat similar to that used in radio receivers, the dial is rotated until the station is tuned in. Dial rotation is continuous from station to station by turning the dial knob clockwise or counterclockwise. With selector-switch tuning, each channel is assigned a fixed and

definite set of contacts on the switch. Each position of the switch is numbered. To receive a desired channel, the switch is rotated until the channel position is reached. Contact is here made with the tuning circuits of this channel, and any signal present is received.

Within each of these two categories there are various types of tuners that have been developed. The more important of these will be discussed.*

Selector-switch Tuning. Turret tuner. The turret tuner, illustrated by popular Standard Coil units, is shown in Figs. 4-9 and 4-10. The coils for

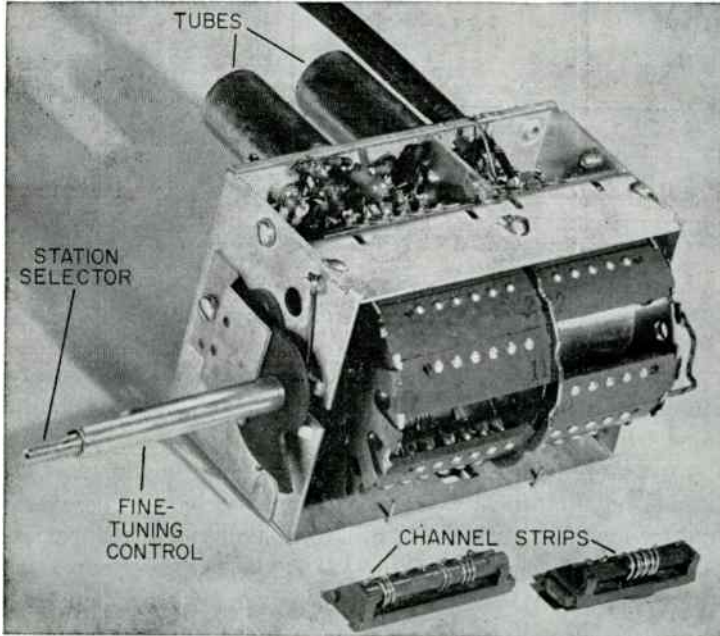

Courtesy Standard Coil Products

FIG. 4-9. An early form of a turret tuner. The two sets of coils for each channel are shown separately.

each of the 12 VHF channels are snapped into position on a rotatable circular drum. Separate coils are used for each channel. In earlier units, exemplified by the tuner shown in Fig. 4-9, the antenna coil and the RF-amplifier input coil were mounted on one form, while the RF-amplifier output coil, the oscillator coil, and the mixer input coil were grouped together on another form. These two units then constituted the complete set of coils for one channel. In more recent versions of this tuner (Fig. 4-10), all the coils are mounted on a single form for each channel. The forms are of the snap-in type and can be removed readily, if necessary.

* UHF-tuning methods will be described in Chapter 18.

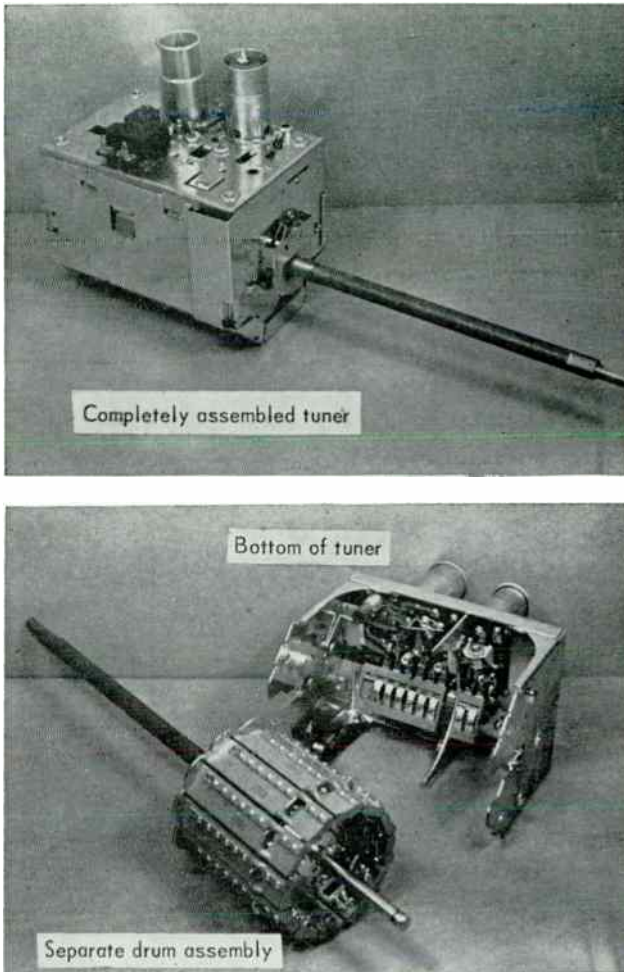

Courtesy Standard Coil Products

FIG. 4-10. A recent turret tuner. One strip holds all of the tuning coils for a channel.

A number of different circuits, particularly in the RF-amplifier stage, have been employed in turret tuners. These include pentodes, tetrodes, duotriodes in a cascade arrangement, and single neutralized triodes, or neutrodes. All possess a similar basic circuitry, but it may be desirable to examine each of these different arrangements in order to become familiar with them.

A schematic diagram of a pentode tuner is shown in Fig. 4-11. The input circuit is balanced with an impedance of 300 ohms. It is purposely designed to match the 300-ohm twin-lead line. However, by using one end terminal

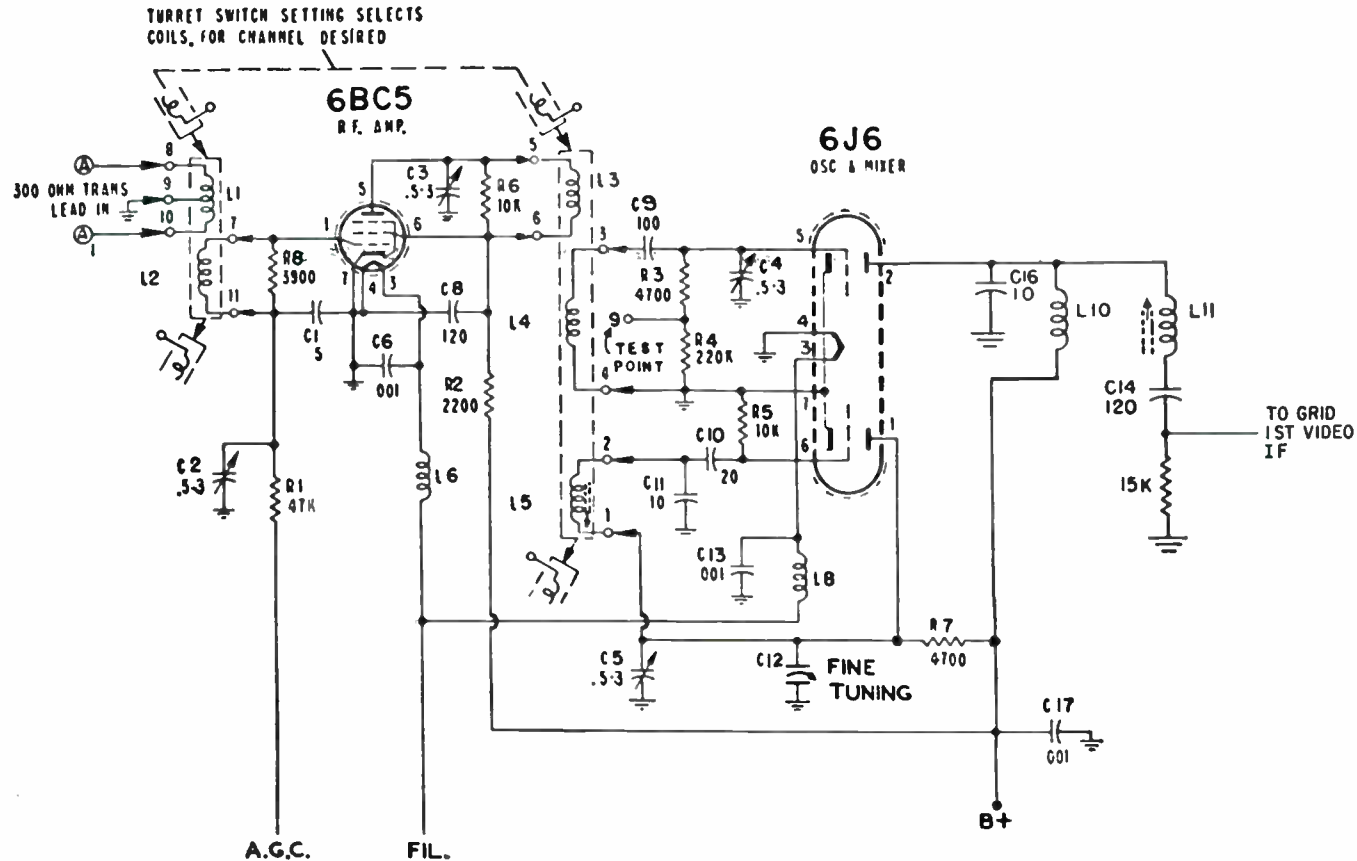

FIG. 4-11. Schematic diagram of a turret tuner using a pentode in the RF amplifier.

and ground, the input impedance becomes 75 ohms, and a shielded coaxial cable can be connected to the receiver without mismatch. The RF-amplifier tube may be a 6AG5, a 6CB6, or a 6BC5. These tubes have similar characteristics that are interchangeable, except for the slightly different pin connections of the 6CB6.

The secondary winding of the input circuit (L_2) is tuned by the input capacitance of the RF-amplifier tube in series with the parallel combination of C_1 and C_2 . Trimmer C_2 is used for alignment. The 3900-ohm resistor (R_8) across L_2 is inserted for the purpose of broadening the response of the input-tune circuit to the necessary bandwidth.

We might digress here for a moment to show more clearly how C_2 can influence the tuning of the input coil L_2 . If we were to draw the input circuit of the 6BC5, including the input capacitance which the tube itself presents, then a simplified arrangement of this input circuit would appear as shown in Fig. 4-12. From the diagram, we can see that the tube and stray capacitance, (C_s), and capacitance C_2 are in series with each other across L_2 . Variation of C_2 will then alter the total series capacitance of C_2 and C_s , and consequently affect the resonant frequency of the input circuit. Another interesting feature of this arrangement is that since both C_2 and C_s are in series, a change in C_s when a tube is changed or a

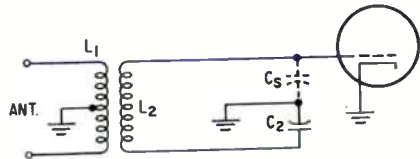

FIG. 4-12. C_2 (of Fig. 4-11) and the input and stray capacitance, C_s , are in series across L_2 .

variation in the operating characteristics of the tube will have less effect in detuning L_2 than if C_2 had not been present. To demonstrate this, assume C_s has a value of 7 mmf and that C_2 has a similar value. The value of the two capacitors in series is 3.5 mmf. If, now, because of a change in the RF-amplifier tube or because a new RF-amplifier tube is employed, the value of C_s decreases by 1 mmf, the total capacitance will change to 3.23 mmf. This represents a change of only 0.27 mmf. Since a change of 0.27 mmf is considerably smaller than a change of 1 mmf, we see how this particular arrangement minimizes changes in tube capacitance and its effect on the tuning circuit.

Returning to Fig. 4-11, the plate load of the RF amplifier is L_3 in conjunction with C_3 plus whatever tube and stray capacitance may be present here. R_6 is again a loading resistor designed to widen the bandpass characteristics of the tuned circuits. The gain of the stage is controlled by an AGC voltage fed to the control grid through a 47,000-ohm resistor.

The signal is transferred from the plate of the RF amplifier to the mixer grid by inductive coupling between L_3 and L_4 . The combination of R_3 and

R_4 across L_4 is not for loading, but rather to provide a terminal (test point 9) where an oscilloscope can be attached to observe the response pattern of the RF-amplifier tuned circuits. Also, test point 9 can be used as an injection point for video-IF-test signals. (In the tuner, this test terminal projects above the top deck where it may readily be reached.)

R_3 and R_4 , together with C_9 , develop grid-leak bias for the mixer stage. Trimmer C_4 is used for alignment. The output of the mixer stage is coupled to the first-video IF amplifier by means of the low-pass network composed of C_{16} , L_{10} , L_{11} , and C_{14} . Capacitor C_{14} is a d-c-blocking capacitor.

Oscillator coil L_5 is inductively coupled to mixer-grid coil L_4 to enable the oscillator signal to reach the mixer circuit. Capacitor C_{11} is in series with the parallel combination of C_5 and C_{12} to form the split-capacitor of a Colpitts oscillator. Trimmer C_5 is an RF-oscillator adjustment, while C_{12} , a variable-dielectric-type capacitor, functions as the fine-tuning control. Grid-leak bias for the oscillator is developed by R_5 and C_{10} . The oscillator plate is shunt-fed by means of R_7 .

Tetrode Tuner. A tuner employing a tetrode in the RF stage would be practically identical to the circuit shown in Fig. 4-11. As a matter of fact, since the 6BC5 in Fig. 4-11 contains no external suppressor connection, the two circuits would be exactly the same with the possible exception of a difference in component values.

Cascode Amplifiers. The schematic diagram of a tuner using a cascode circuit in the RF-amplifier stage is shown in Fig. 4-13. VHF signals are inductively coupled from the balanced 300-ohm antenna coil L_1 to a tuned circuit composed of L_2 , C_1 , and the grid-to-cathode interelectrode capacitance of the first-triode section of V_1 . R_1 is connected in parallel with the tuned circuit to provide the desired bandpass. C_3 neutralizes the effect of signal feedback through the interelectrode capacitance of the tube.

The plate load of the first-triode section and the cathode impedance of the second-triode section of V_1 is L_3 . Since the grid of the second-triode section of V_1 is held at RF ground by C_4 , and this section is cathode-driven, it is essentially a grounded-grid amplifier. The plate-output circuit consists of L_4 . Neutralization of this second triode is not required because the grid is placed at RF-ground potential by C_4 and the signal is applied to the cathode.

Since the two triode sections are in series, the plate potential of the first section is also the cathode potential of the second section. This condition makes it necessary that a positive voltage be applied to the grid of the second section. R_3 and R_4 form a voltage-divider network to accomplish this.

AGC voltage is applied to the grid of the first-triode section of V_1 through R_2 . When a negative-going voltage is impressed on this grid, the

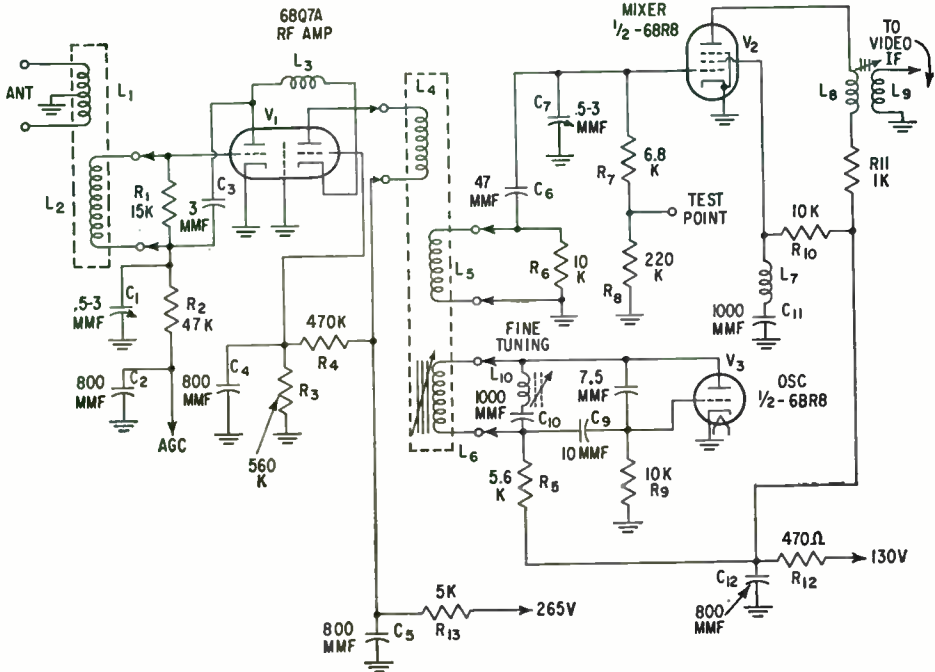

FIG. 4-13. An RF tuner using a cascode RF amplifier.

plate-current flow decreases and the plate voltage increases. This higher d-c potential is also present at the cathode of the second-triode section. Since this results in a smaller d-c-voltage difference between the plate and cathode of the second section, amplification of the second stage decreases, hence AGC is effectively applied to both RF amplifiers. C_2 prevents RF energy from entering the AGC circuits.

The remainder of the circuit in Fig. 4-13, containing the mixer, V_2 , and the oscillator, V_3 , possesses essentially the same form and functions in the same manner as the comparable stages in the tuner circuit of Fig. 4-11. There are two differences, however, that call for additional comment. First, in the oscillator, an inductive fine-tuning control (L_{10}) is employed to vary the oscillator frequency instead of the capacitive control shown in Fig. 4-11. This approach helps to stabilize the oscillator because combining L_6 and L_{10} in parallel produces a lower inductance than L_6 produces alone. With a lower inductance, more capacitance can be employed for a desired resonant frequency and this, in turn, helps to mask changes in tube capacitance.

C_{10} is a d-c-blocking capacitor. Between channels, when L_6 is not in position, the capacitor disables the oscillator by preventing d-c from reaching the plate of V_3 . This disabling is desirable because with only L_{10} in the cir-

cuit, the higher frequency generated might be in a range which would cause interference to other sets and services in the vicinity.

The second difference shown in Fig. 4-13 occurs in the screen-grid circuit of V_2 . Here, in place of a bypass capacitor alone, we also find a coil (L_7). This coil introduces a slight amount of regeneration (through in-phase feedback) for more constant tuner gain on all channels.

Neutrode Tuner.* An example of a neutrode RF amplifier as it would be employed in a turret tuner is shown in Fig. 4-14. It is followed by a pentode

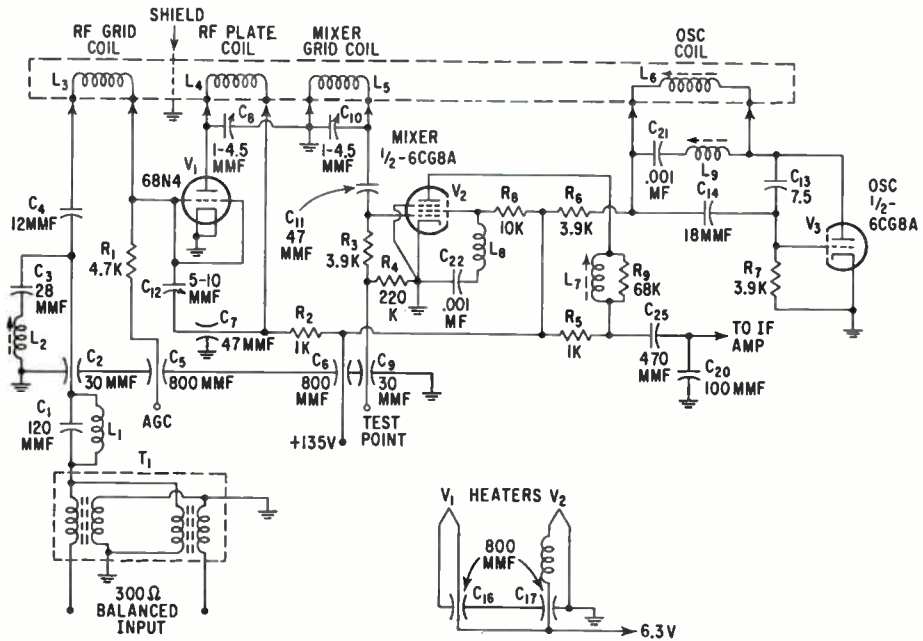

FIG. 4-14. An RF tuner using a neutrode RF amplifier.

mixer and a triode oscillator. A 6CG8A contains the pentode and triode sections in one envelope.

The operation of a neutrode RF amplifier has already been discussed, but the input circuit of Fig. 4-14 contains a number of features which have not been previously analyzed and which are quite common in present-day television receivers. For example, T_1 is a matching transformer designed to do two things: it converts the 75-ohm-input impedance of the RF-amplifier stage to 300 ohms; second, it provides a balanced input of 300 ohms, whereas the RF-amplifier input is unbalanced. A 300-ohm balanced input is desired to match twin-lead transmission lines currently in use.

* Neutrode is a short term for "neutralized triode."

Two types of baluns (as these matching transformers are called) are in popular use: 300-ohm balanced input to 300-ohm unbalanced output and 300-ohm balanced input to 75-ohm unbalanced output. Each type appears schematically in Fig. 4-15(A) and in Fig. 4-16(A). While these are shown as transformers, transformer action, as we commonly know it, does not take place. Instead, a balun consists of two sets of parallel lines, each with a characteristic impedance of 150 ohms. These lines are closely wound fine wire, evenly spaced, on a suitably long form (Fig. 4-17), or they are con-

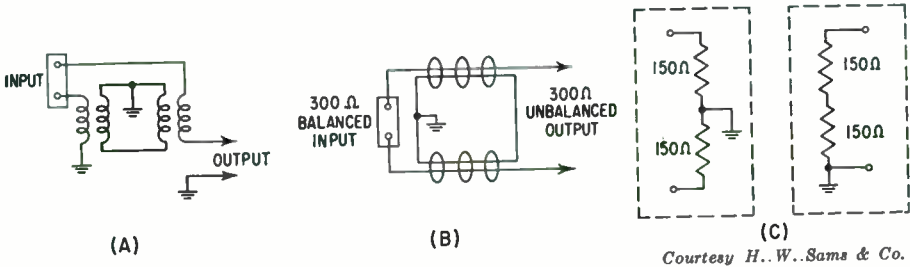

FIG. 4-15. Balun used to match 300-ohm balanced and unbalanced impedances.

structed as a toroid with a ferrite core. The lines are shown in the schematics, Fig. 4-15(B) and Fig. 4-16(B). Part (C) in each illustration demonstrates by means of resistors how the input and output impedances and the balance arrangements can be obtained. It should be recognized that these latter illustrations are for explanatory purposes only and are not to be taken literally.

Returning to Fig. 4-14, L_1 and C_1 form a parallel-resonant trap, while L_2 and C_3 form a series-resonant trap, both peaked for slightly different frequencies between 41 and 46 mc. Their purpose is to prevent interfering signals in the IF range from penetrating the RF amplifier and reaching the mixer and, beyond it, the IF system where it is not possible to reject them.

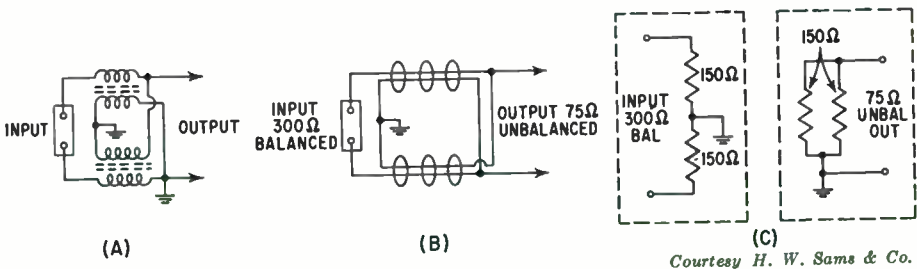
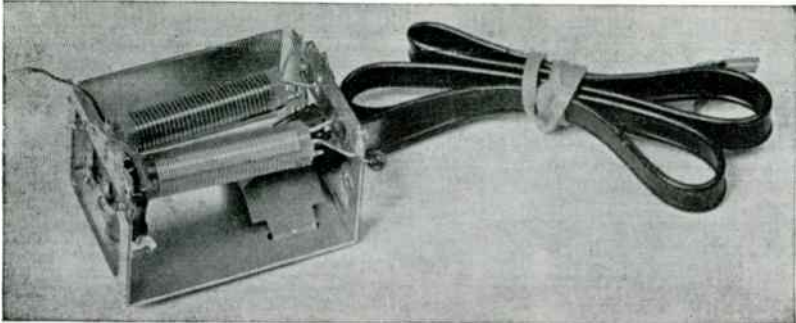

FIG. 4-16. Balun used to match 300-ohms balanced and 75-ohms unbalanced impedances.



Courtesy H. W. Sams Co.

FIG. 4-17. A balun, or input-matching, transformer.

L_2 is adjustable and can be set for a specific frequency to be rejected. L_1 is factory adjusted and ordinarily is not touched in the field.

If we disregard the two foregoing traps, then the input-resonant circuit appears as shown in Fig. 4-18. It is essentially a low-pass pi-type filter consisting of C_2 , C_4 , L_3 , and C_{IN} , the latter representing the input capacitance

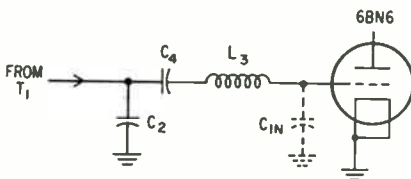

FIG. 4-18. Input-resonant circuit.

of the 6BN4 tube. Since C_2 and C_4 are both much larger than C_{IN} , their impedance will be smaller than that of C_{IN} . Consequently, a greater amount of the signal voltage will appear across C_{IN} . This acts as a voltage step-up arrangement just as effectively as if we had employed a step-up transformer.

L_3 is changed for each channel, enabling the circuit to resonate to the required input frequency of that channel. Generally, the circuit is designed to peak at the mid-frequency of the specific channel.

C_4 , in addition to the function noted above, also serves as a d-c-blocking capacitor. This is required because of the presence of a negative AGC voltage at the grid of the RF tube. This AGC voltage is brought in through R_1 ; C_5 , in the AGC line, prevents any RF signal from reaching the AGC line beyond the tuner.

The output-tuning circuit of the RF amplifier consists of L_4 , C_8 , and whatever stray and output capacitance of V_1 might be present. R_2 is the plate-decoupling resistor, while C_7 functions as an RF-bypass capacitor. However, C_7 is small enough so that it does not completely bypass all of the RF signals voltage away from R_2 . A small RF voltage does appear across R_2 and is fed back to the grid of V_1 by the neutralizing capacitor C_{12} .

The remaining two stages of the tuner, the mixer and the oscillator, which have already been discussed in preceding tuners, are conventional in design.

In Fig. 4-14, capacitors C_2 , C_5 , C_6 , C_7 , C_9 , C_{16} , and C_{17} are all somewhat different from the other fixed capacitors in the same diagram. The difference resides in the fact that these are feedthrough capacitors. Such capacitors are constructed by taking a dielectric material and shaping it into the form of a small cylindrical tube. One metal plate is then deposited around the inner diameter of the cylinder, while the second plate is deposited over the outer surface. Wires are then attached to both ends of the inner plate. When the capacitor is inserted in a circular opening of one of the metal walls, or shields, of the tuner, the outer plate is automatically grounded. Filament and d-c voltages can then be brought into the tuner by way of the inner plates of several feedthrough capacitors. If the capacitance values of these units are large enough, then RF voltages traveling out along these same supply lines are bypassed to ground.

Feedthrough capacitors are employed extensively in TV tuners because of the convenient way in which they enable voltages to enter and leave tuner housings. These capacitors are also useful between tuner sections separated by shield walls.

In television receivers designed to operate without a power transformer, the resistor-capacitor isolation network, shown in Fig. 4-19, is inserted between the antenna terminals and the matching balun. The purpose of the resistors in this network is to provide a leakage path for static voltages developed by the antenna. In addition, they isolate the "hot" chassis from earth ground and prevent shock if the antenna and earth ground are touched at the same time. Without the resistors, the conduction path would be completed through the low-resistance balun coils.

The capacitors shunting the resistors provide a low-impedance path for arriving signals.

Wafer-switch Tuners. Another type of selector-switch tuning arrangement is the wafer-switch tuner. This unit employs rotary switches with a tuning coil mounted between each set of switch contacts. To accommodate the different RF-oscillator, and mixer tuning circuits, multisection switches are employed. Each section then contains various coils for one tuning circuit over the 12 television channels.

A number of wafer-switch tuners are in use, but an examination of a few of the more important ones will serve to indicate their physical and electrical appearance. Wafer-switch tuners are sometimes also called "wafer-

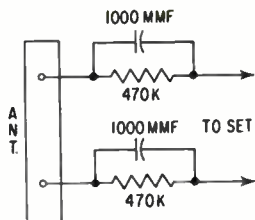

FIG. 4-19. An isolation network employed at the antenna inputs of some television receivers.

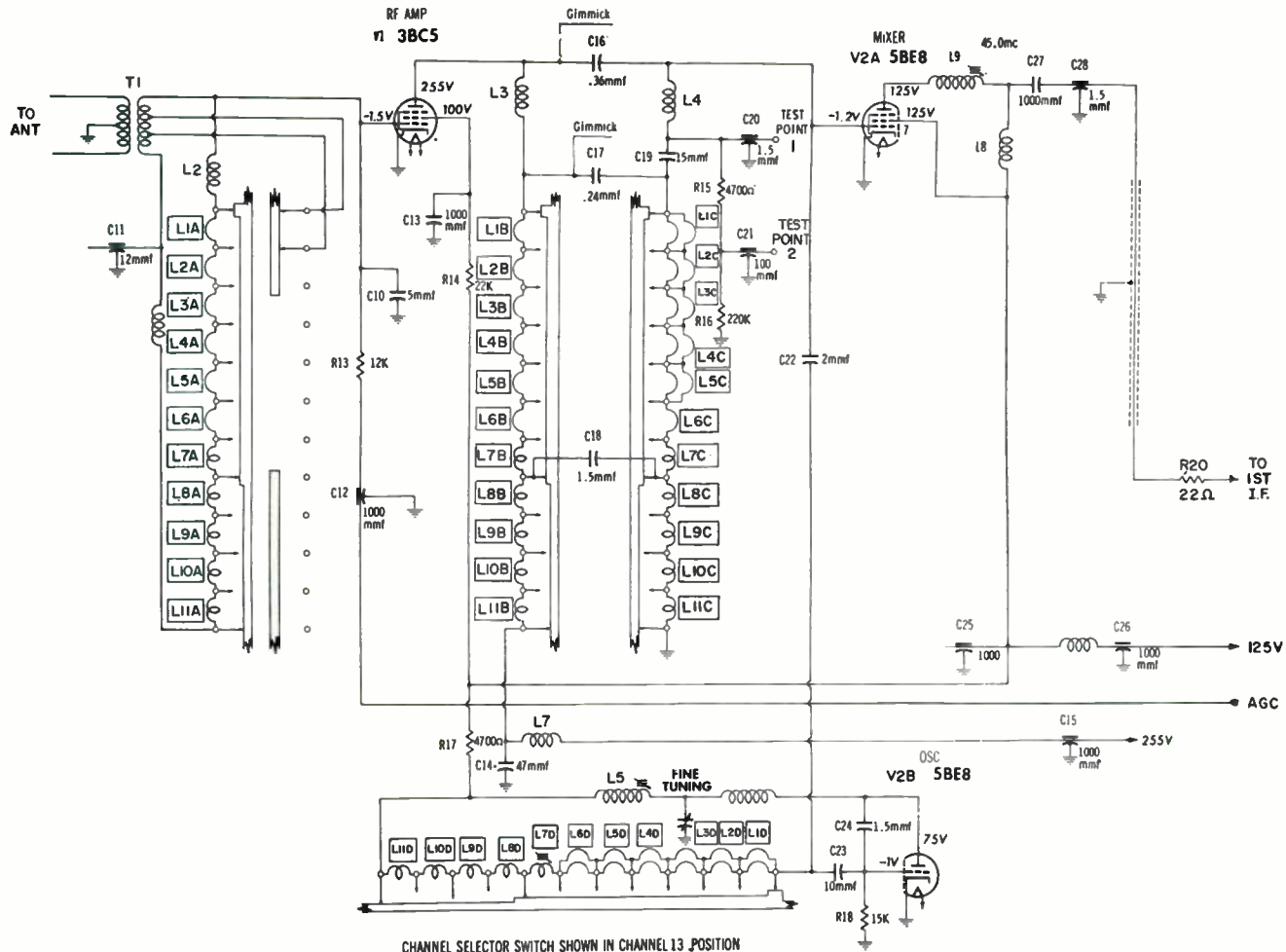

FIG. 4-20. Schematic diagram of the G.E. wafer-switch tuner shown in Fig. 4-21.

Courtesy H. W. Sams & Co.

tier tuners." The word "wafer" refers to the switching arrangement; the word "tier" indicates that the switch contains several sections, or tiers. A circuit diagram of a commercial wafer-switch tuner is shown in Fig. 4-20. Physically, the tuner appears as indicated in Fig. 4-21. If this illustration is examined closely, four wafer sections, or tiers, will be seen, each one containing a different set of coils. For example, the wafer tier at the back of the tuner contains all of the coils present in the grid circuit of the RF amplifier,

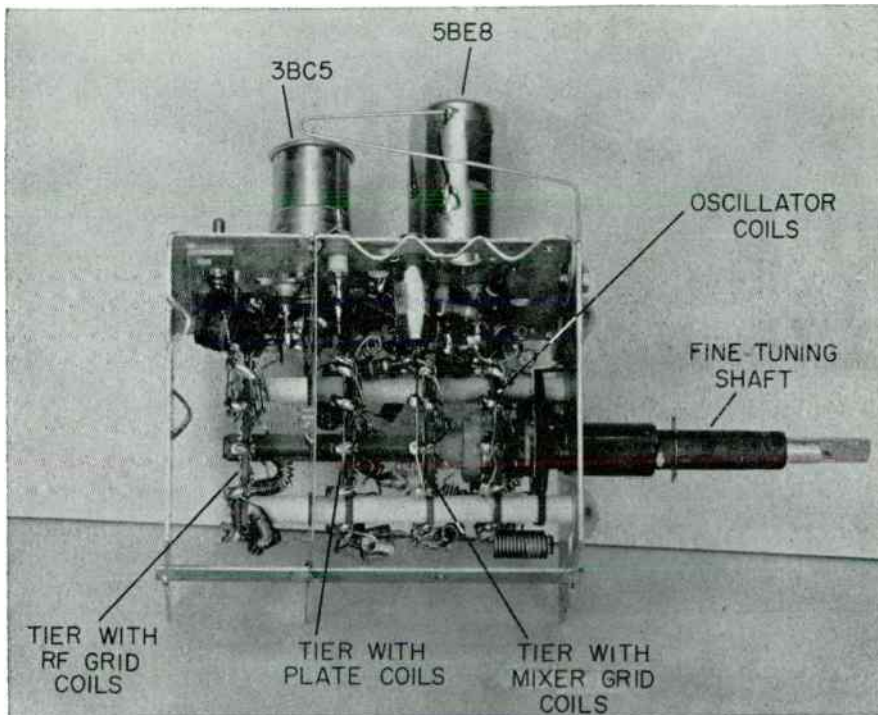

FIG. 4-21. General Electric wafer-switch tuner. The four wafer tiers are indicated, and the coils which are mounted on these supports can be seen.

V_1 . The second tier from the rear contains the RF-amplifier plate coils. The third section (farther forward) holds the mixer-grid coils, while the wafer closest to the front of the tuner carries the oscillator coils. Clustered around these coils are the various resistors, capacitors, and other inductances comprising the tuner circuitry. The closeness of the various components to each other is revealed clearly.

Electrically, the tuner consists of a pentode RF amplifier, a pentode mixer, and triode oscillator. (The RF amplifier could actually be any of the circuits previously discussed, that is, a cascode arrangement, a neutrode, a tetrode, or the pentode circuit shown in Fig. 4-20. All types have been em-

ployed with this tuner.) The mixer and oscillator tubes are combined within one envelope, adding to the compactness of the tuner assembly. All of the coils in each tuning circuit are series-connected and the amount of inductance which is active rises as the selector switch is turned toward lower and lower channels. Thus, for channel 13, the highest VHF television channel, all of the coils, L_{1A} - L_{11A} , L_{1B} - L_{11B} , L_{1C} - L_{11C} , and L_{1D} - L_{11D} , are shorted and removed electrically from the circuit, leaving only L_2 , L_3 , L_4 , and L_5 to tune the various circuits to resonance on channel 13.

When the selector switch is turned to channel 12, the top three switch sections (Fig. 4-20) move down one position and the switch section in the oscillator circuit moves (as shown in the diagram) to the left. In each instance, one inductance coil is added to each tuning circuit, thereby lowering the resonant frequency. In a similar manner, rotation of the selector switch gradually adds more active inductance to each circuit as the operating frequency is lowered. Note that on the high-band channels, some of the coils have parallel windings. This is done physically to develop the desired amount of inductance.

In all of the switches, shorting of the unused coil sections takes place at more than one point. This prevents the shorted coils from resonating with the active coils, thereby forming a trap circuit. Should this occur, it would tend to absorb energy from the active portion of the tuning circuit and reduce the signal available to the RF amplifier and mixer. When absorption traps are discussed subsequently, this behavior will be described in greater detail.

The secondary winding of input transformer T_1 has part of its turns shorted on all of the high VHF band channels. This is achieved by a shorting bar mounted at the rear of the wafer which controls the active coils of the L_{1A} - L_{11A} group. On the lower five channels (2 through 6), the secondary of T_1 is utilized in full to provide a more efficient transfer of signal through T_1 .

The RF amplifier has an AGC voltage applied to its grid through R_{13} . C_{12} is a feedthrough capacitor, whereas C_{10} is simply a bypass capacitor of conventional form. The output circuit of V_1 consists of L_3 and L_{1B} through L_{11B} . $B+$ voltage is brought to the plate by these coils, by L_7 , and by a feedthrough capacitor (C_{15}). L_7 and C_{15} combine to prevent any RF signal from passing out of the tuner and onto the $B+$ line.

The RF signal at the plate of V_1 is transferred to the grid of the mixer by a capacitance which is formed by wrapping a small section of insulation wire around a similar section leading to V_2 . This physical arrangement, known as a "gimmick," provides a capacitive coupling equal to 0.36 mmf. This arrangement serves the same function as a capacitor having a value

this low. Hence, a capacitor symbol is shown, although no such physically recognizable component is present.

Examination of the circuit between the RF plate and the mixer grid reveals that another gimmick capacitor, C_{17} , is used, together with the physical capacitor C_{18} . The coupling is thus totally capacitive, there being no magnetic coupling between the L_{1B} - L_{11B} coils and those in the L_{1C} - L_{11C} string. These capacitors are chosen and positioned in the circuit so that the desired bandpass of 6-mc is attained on all channels. Note that in order to achieve the uniform 6-mc bandpass, C_{18} is added for channels 2 through 6; for channels 7 through 13, C_{18} is effectively shorted out of the circuit.

In the mixer-grid circuit, bias is developed by the injection of the oscillator voltage through C_{22} . This biases the tube so that the desired mixing takes place between the oscillator and incoming signals, producing sum-and-difference frequencies. For the IF system, the difference frequencies are desired.

Test points are available in the grid circuit of the mixer to enable the grid bias to be measured and also to permit connection of an oscilloscope for viewing the response of the RF stage or for injecting a sweep or AM signal, when the video IF system is to be aligned. Test point 2 is used for the alignment work, while test point 1 is primarily available for measuring the grid bias of the mixer. The latter is a useful point to check whenever defective tuner action is obtained.

The output of the mixer is transferred to the video IF system by way of L_9 , L_8 , C_{27} , C_{28} , and R_{20} . L_8 is an RF choke serving as the direct plate load of V_{2A} . It also brings the B+ voltage to the plate of this tube. L_9 is the first of the video-IF-tuning circuits, with a resonant frequency of 45.0 mc. C_{27} is a coupling capacitor and C_{28} is a small feedthrough capacitor which brings the signal through the wall of the tuner. C_{27} also serves to block the d-c voltage at the mixer plate from reaching the IF system.

The oscillator circuit is of the ultraudion variety, with the tuning circuit between the grid and the plate. The frequency of any given channel can be varied by the fine-tuning capacitor, which is controlled by a sleeve over the selector switch and functions by moving a section of dielectric material between two fixed plates. One of these plates is actually the tuner case; the other is secured a short distance from the tuner wall by an insulated bushing. As the sleeve is turned, it alters the amount of dielectric between these capacitor plates, thereby varying the capacitance across the oscillator tuning circuit.

L_5 and L_{7D} in the oscillator circuit have movable slugs which can be adjusted from the front of the tuner. The slug in L_5 primarily controls the setting of the high-VHF-band coils (channels 7 to 13), while the L_{7D} slug con-

trols the low-VHF-band operation (channels 2 to 6). If the circuit is functioning normally, adjustment of these coils should be all that is required for the oscillator to produce the correct frequencies at each channel position. If any channel is slightly off frequency, it will be necessary to remove the tuner shield and, with a knife blade, either carefully compress the turns of a coil or spread them apart until the correct oscillator frequency for that channel is attained.

Another wafer-switch tuner is shown in Fig. 4-22. Circuits in various

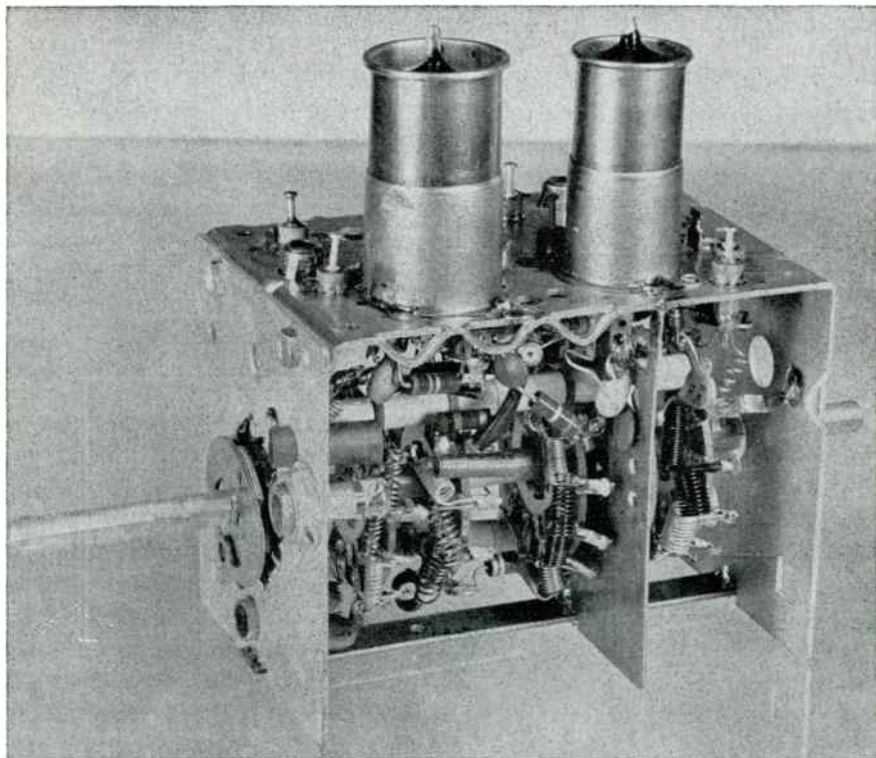

FIG. 4-22. A wafer-switch tuner designed and produced by Sarkes-Tarzian.

tuners differ, but the line-up of stages and the physical arrangement of the coils remain basically the same.

Disc-type Tuners. The disc-type tuner (Fig. 4-23) is a cross between a turret and a wafer-switch tuner, employing some of the mechanical and electrical features of each.

A circuit of a disc-type tuner is shown in the diagram of Fig. 4-24. A cascode RF amplifier is employed here, followed by a pentode mixer and a

triode oscillator. It is also possible to use a pentode RF amplifier or a neutralized triode, followed either by the arrangement shown or by a duo-triode. The significant departure electrically of the disc-type tuner lies in the tuning circuits and how they are arranged. For example, on the RF-input disc, a series of coils is employed between channels 2 and 6 that has the same form as a wafer-switch tuner; that is, the coils are in series with each other and are brought into the circuit actively, as needed, by a set of contacts. How-

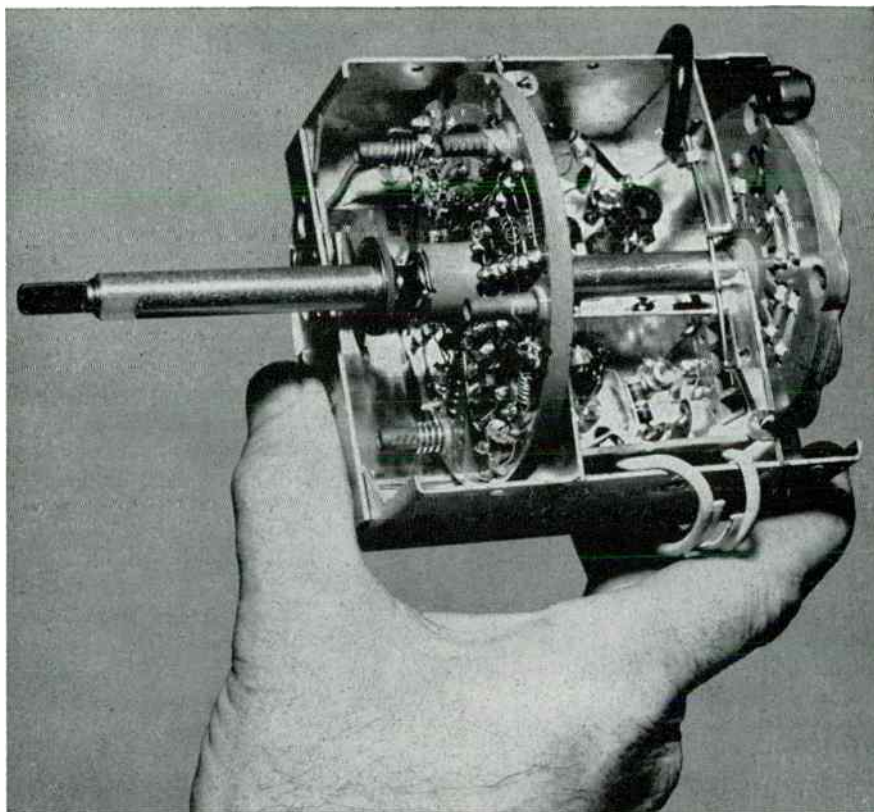

FIG. 4-23. A disc-type tuner.

ever, for channels 7, 8, and 9, a completely different set of coils is brought into the circuit. The same is true for channels 10 and 11 and, again, for channels 12 and 13. In each case, the two coils are mounted on a rotary disc which is moved into position to make electrical contact with dual-switch points.

All tuned circuits are switched in a similar manner. The RF-amplifier plate and the mixer-grid circuit are mounted on a larger disc which is positioned at the front of the tuner. The oscillator coils are mounted around the

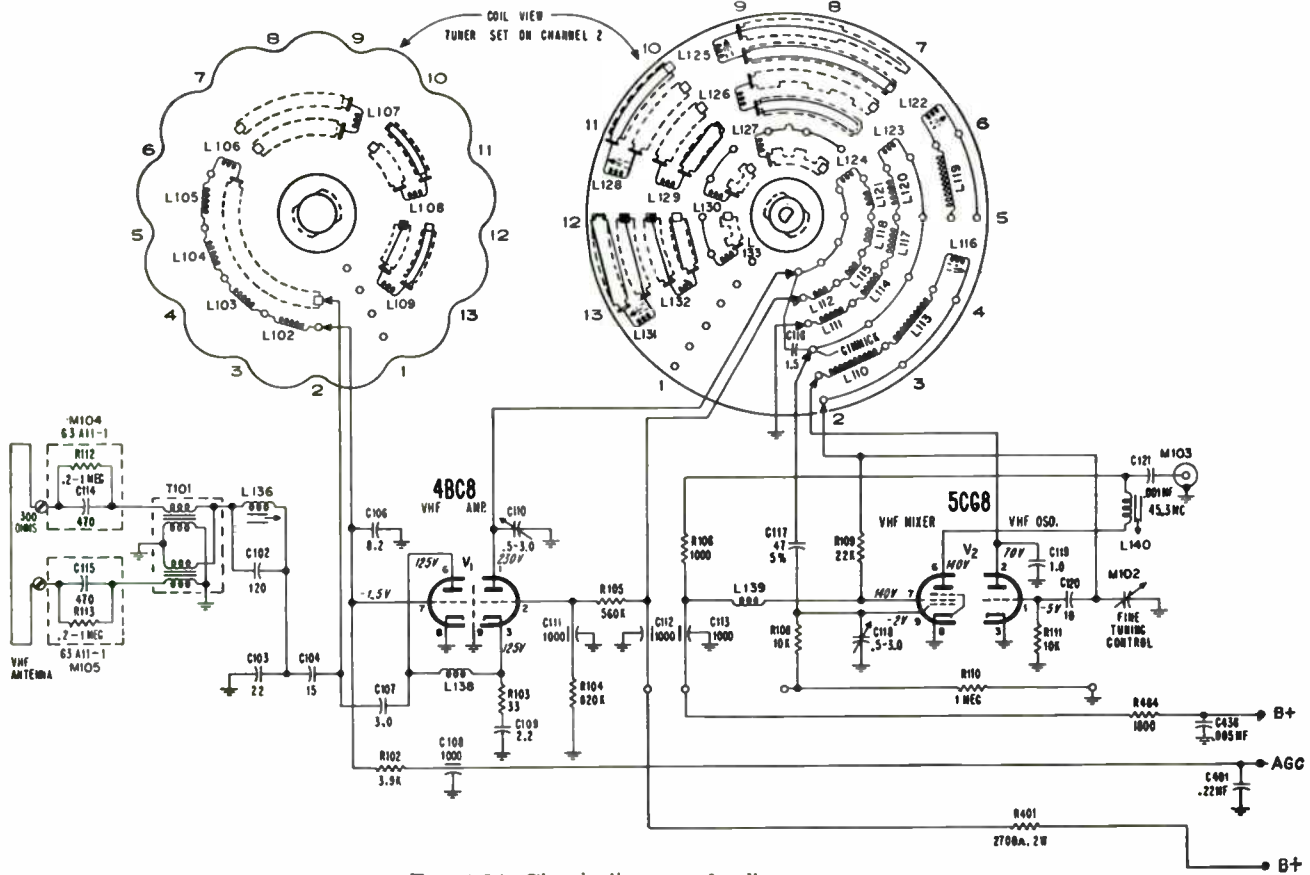

FIG. 4-24. Circuit diagram of a disc-type tuner.

outer edge of the disc and, as in other tuners, these coils have tuning slugs which can be reached from the front of the receiver. The other tuning coils on this larger disc are positioned farther in from the edge. These coils come in groups of channels—2 to 6, 7 to 9, 10 and 11, 12 and 13—just as they are in the input-circuit disc. None of these inner ring coils are adjustable, although external capacitors are available for peaking (generally on channel 10). In this respect, these circuits follow the practice employed in other tuners.

Signal-coupling between the RF-amplifier-output circuit and the mixer-grid-input circuit is provided by a capacitor and a gimmick for the low channels. For the high channels, the individual coils at the end of each strip of connected coils are coupled to each other.

Electrically, the disc-type tuner resembles the wafer-switch arrangement in that it has groups of coils in series with each other for several channels. It also resembles the drum-type turret tuner because different sets of coils are employed for some channels.

Mechanically, the rotation of the discs with their tuning circuits resembles the rotation of the drum-type turret tuner, in which all the circuits are moved into position to make contact with a fixed set of contacts. The disc-type tuner is fairly simple to disassemble, to repair, and to align. It is ruggedly constructed, made possible by self-winding springs and solid molded discs. A detent spring and its roller ride directly on the scalloped edge of the smaller disc. A steel plate is rivoted to this disc to provide it with the necessary stability, rigidity, and ruggedness.

Continuous Tuning. Continuous tuning over the 12 television channels is well liked by some people because it not only does away with the fine-tuning control, but also enables the receiver to pick up the FM signals that are located in the 88- to 108-mc band.

Several continuous tuners have been used at one time or another, although at present this form of tuning is not popular. Of those that have been used, the Inductuner, shown in Fig. 4-25, has enjoyed perhaps the greatest popularity. In one form, shown in Fig. 4-25(A), this unit consists of three separate inductances mounted on a common shaft. The coils, each containing 10 turns, are wound on ceramic forms; movable trolley sliders make contact at each point on the coil.

Each trolley is grounded and, as it moves along, more and more turns of each coil section are short-circuited, progressively raising the frequency of the circuit. The inductance can thus vary from 0.02 to 1.0 microhenry, permitting a tuning range from 44 to 216 mc.

In later versions, shown in Fig. 4-25(B) and (C), the contact arm moved around a spiral instead of along a solenoid. The advantages gained were greater compactness, lower cost, and increased mechanical stability.

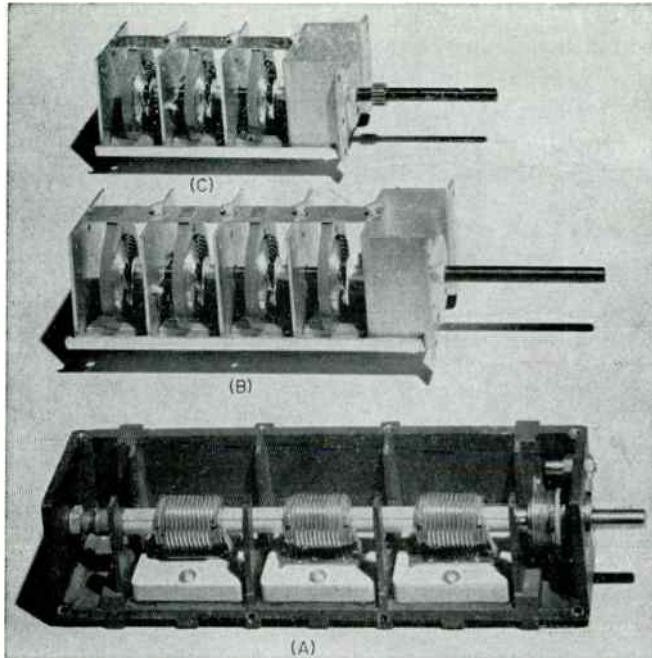

FIG. 4-25. A continuous type of tuner. (A) represents an early version, (B) and (C) newer versions.

Other types of continuous tuners included a permeability tuner and a capacitance tuner. In the permeability tuner, the movable slugs of each coil were mechanically ganged together and moved in or out of the coils when the front-panel knob was rotated. There was one set of coils for the low band and one set for the high band. A special switch on the front panel permitted the changeover from one band to the other. The capacitance tuner was similar to radio-receiver tuners, employing a number of variable capacitors ganged together by a common shaft.

Television Boosters. Owners of television receivers located in areas where the signal strength is weak often attempt to improve the quality of the pictures by adding an external booster to their sets. Boosters are basically nothing more than RF amplifiers, and when one is attached to a set, it means, in effect, adding one or more RF amplifiers to that already existing in the receiver.

The purpose in adding a booster is to strengthen the incoming signal to such an extent that it will produce a picture possessing the full contrast range and, at the same time, improve the signal-to-noise ratio so that the

picture will be clear and free of annoying noise spots. Of these two objectives, the improvement of the signal-to-noise ratio is the more difficult to attain, but it is the more important. So let us pause and examine the relationship between noise and weak signals.

As stated previously, the ability of a receiver to amplify a signal is not limited by the amplification obtained from vacuum tubes but by the noise arising from the tubes and the associated receiver networks. This noise is known as "random noise" because it possesses no fixed frequency, but extends from zero to frequencies far above the television bands.

The noise that is developed in a receiver comes from two sources: thermal agitation in conductors and electron flow through tubes. Thermal agitation arises from the random motion of electrons within a conductor. No external voltage is applied, but the electrons, using their own energy, move to and fro along a conductor. This movement of electrons constitutes a current flow. Since, at any given instant, a few more electrons are moving in one direction than in the other, a voltage is set up in the conductor which is proportional to the net current flow and the value of the conductor resistance. The polarity of the voltage due to thermal agitation changes constantly, causing electrons to move first in one direction and then in another. Because of this, there is no definite pattern to the random voltage, or, for that matter, any one frequency at which the energy changes. It has been found that the energy of this disturbance is distributed uniformly throughout the entire frequency spectrum used for communications.

The second source of receiver noise is developed in the tubes. While several components make up this noise, the most important is the shot effect. The current that flows in a tube is not a continuous fluid but a moving aggregation of separate particles, the electrons. Noise voltages are produced, even when so-called "steady currents" are flowing, because at any single instant the number of electrons impinging on the plate differs from the number reaching this electrode at any other instant. Over a measurable period, the current is steady, but at any one instant it fluctuates rapidly because of the nonfluid nature of electrons. These instantaneous fluctuations are the noise.

In a receiver, the noise that is developed by the first stage (the RF amplifier) is actually the most important because at this point in the system the level of the incoming signal is more nearly on a par with the noise level than it is at any other point in the receiver. Whatever noise voltage appears at the grid of the RF amplifier is amplified along with the signal; hence, to obtain the best noise-free picture, we want to have as much signal and as little noise as possible at the front of the set.

From these facts concerning noise, we see that in selecting a booster we

desire one which has a low-noise figure. This characteristic is certainly as important as gain. We can have all the gain in the world, yet if a large noise voltage exists at the grid of the first-amplifier stage of the booster, the noise-voltage output will be high. And nothing we can do thereafter will reduce the noise.

Boosters are designed with two aims in mind: to improve the signal-to-noise ratio and to amplify the weak incoming signal. Both are important and both are needed. A booster capable of high gain but incapable of providing a good signal-to-noise ratio will give a picture filled with disturbing noise spots. A booster possessing a minimum of internal noise but capable of little gain will not amplify the signal sufficiently to permit it to override the noise of the set. Again, the picture will be covered with noise spots. The booster must have both attributes or it might as well have none.

There is a reason why a booster may not always help the set. Assume that in the regular TV receiver (without a booster) the noise voltage existing in the RF amplifier is 10 mv and the received signal is 30 mv. The signal-to-noise ratio then is 3:1. We decide that, if we place a booster ahead of our set, we will get a clearer picture. This may not be so.

Suppose the booster develops a noise voltage of 20 mv in its input circuit. The incoming signal is still 30 mv. If the booster gain is 10, then what the RF amplifier will receive is 200 mv of noise and 300 mv of signal. What is the signal-to-noise ratio now? It is 3:2, which is not as good as 3:1. In this instance, this booster has not helped to improve the quality of the picture.

If, however, the noise existing in the RF amplifier of the booster is less than 10 mv and the same signal of 30 mv is received, then the signal-to-noise ratio will improve and, with it, the quality of the picture.

Before we leave this subject of noise, it should be pointed out that nothing has been said about noise generated outside of the set or the booster. This noise, if present, comes down the transmission line with the signal and is indistinguishable from the signal so far as the booster is concerned. To overcome this noise it must be attacked at its source, or, if this is not feasible, try to keep as little of it as possible from reaching the signal via the antenna or the lead-in line. Standard methods of attack include increasing antenna height, antenna replacement, and the use of shielded lead-in line. It has also been found helpful to position the booster at the antenna (or at least as close to the antenna as possible), where it will strengthen the signal before it has been subjected to the noise and enables it, with its amplified strength, to overcome better the adverse effects of the noise. Here again we have attempted to improve the signal-to-noise ratio.

A commercial booster, shown in Fig. 4-26, is connected between the receiver and the antenna. All boosters are self-powered, developing their own d-c voltage from the a-c power lines. The RF-booster circuits are similar



FIG. 4-26. A television booster.

to the RF amplifiers already discussed. The trend, at present, is toward the use of the newer triodes, although cascade amplifiers and pentodes are also in use.

QUESTIONS

1. Why are pentagrid converters seldom, if ever, found in television receivers?
2. What is the difference, technically, between a mixer and a converter?
3. Draw the circuit of an ultraudion oscillator.
4. Indicate the differences in circuit between an ultraudion oscillator and a Colpitts oscillator.
5. Explain the purpose of a fine-tuning control.
6. Where is the fine-tuning control placed electrically in the circuit? Draw a circuit using this control.
7. Illustrate two methods of coupling the oscillator signal to the mixer.
8. Using a single tube how is the oscillator frequency for each channel obtained? Illustrate your answer.
9. What is the mathematical relationship between the oscillator frequency and the video and audio frequencies?
10. Explain why the video carrier is placed where it is on the video IF response characteristic.
11. What is the difference between a turret-type tuner and a wafer-tier type tuner?
12. Name several types of continuous TV tuners.
13. Why do we sometimes find an inductance in the screen-grid circuit of a pentode mixer?

14. Draw the circuit of a cascode RF amplifier.
15. What is a booster and where is it used?
16. Explain why a booster may not always be beneficial to a television receiver.
17. Identify two sources of noise within a television receiver which determine the quality of the reproduced picture.
18. In what ways does a disc tuner resemble a turret tuner? In what ways does a disc tuner resemble a wafer-tier tuner?
19. What is a gimmick capacitor? In which diagrams in this chapter are such capacitors employed?
20. What is a feedthrough capacitor? Explain its physical structure. Where are such capacitors principally found?

Video IF Amplifiers

Choice of Intermediate Frequencies. The television signal at the output of the mixer has been reduced to its IF values. The change occurs in the mixer where the incoming signals are beat against the local oscillator signal. The IF amplifiers will now amplify these voltages and then transfer them to a detector where the intelligence originally imparted to the signal will be removed.

In order to understand why the particular IF values were chosen, let us pause and determine what factors are most important in the design of an IF system. There are three basic factors to consider:

1. Frequency of the IF stages
2. Gain
3. Selectivity

The procedure is to select the operating frequency first and then consider the problems of gain and selectivity together.

The choice of an intermediate frequency may appear, at first, to be quite simple since we know that at the lower frequencies it is easy to construct amplifiers which have high gain. However, there is a limit to how low a frequency can be used because of the stability of the circuits ahead of the IF system and because of the bandwidth required by the television signal itself. When a set is first turned on, it may require as much time as an hour before the oscillator frequency stops drifting. When ordinary parts are used in the construction of a receiver, the oscillator may drift as much as 0.2 per cent in frequency. At 60 mc, this means a drift of 120 kc. Although a shift of this magnitude may not noticeably affect the reproduced image, it can certainly affect the television sound. This shift is especially true of split-sound television receivers where the sound and video signals separate before the video second detector. Hence, the stability of the oscillator and

RF circuits will be governed by the FM audio-signal considerations. In the interest of stability, a low IF value is indicated. However, there are the requirements of the video IF amplifier to consider.

The IF tuned circuits must pass a band of frequencies 4 mc wide. Suppose we use the IF values which were used in the television receivers of 1939—8.75 mc to 12.75 mc. At the second detector, the demodulated video-frequency voltages extending from 0 to 4 mc would have to be separated from the IF values 8.75 to 12.75 mc. To effect a clear-cut separation between the video frequencies and the IF, it is desirable to have their ratio as high as possible. At the low broadcast frequencies, the sound "spread" is only 5 kc, which is a small fraction of the 455 IF. Thus, no difficult problem exists here. But in a television receiver, as noted above, the separation between the desired and undesired frequencies is considerably less, and the problem becomes more difficult. A high IF is desirable as this would simplify the problem of separation. As the IF value rises, it becomes more difficult to achieve high gain and maintain good stability.

In addition to the above, there are various types of spurious responses capable of affecting a receiver and they, too, influence the choice of an intermediate frequency. The more important of these spurious responses are:*

1. Image response
2. Response to two stations separated in frequency by the IF value
3. Direct IF response

Image Response. Image response is due to the mixing of an undesired signal with the local oscillator signal in the mixer stage to produce a voltage at the intermediate frequency. Since a frequency equal to the intermediate frequency is produced, this signal will be accepted and passed by the IF amplifiers. As an illustration, suppose a television receiver had an IF carrier value of 12.75 mc. This means that its bandpass extends from 12.75 mc to 8.75 mc. Further, suppose the set is tuned to the 54-60 mc television channel, no. 2. With the IF value specified, the local oscillator would be operating at 55.25 mc plus 12.75 mc, or 68.00. If a powerful station is operating at the same time, in the 76-82-mc channel, its signal will, in some measure, appear at the mixer-stage input. Mixing of this signal with the oscillator voltage within the mixer tube will produce signal voltages which will be at or sufficiently close to 12.75 mc to be accepted by the IF amplifiers. The result at the cathode-ray tube is distortion.

By choosing an IF value greater than half the entire band to be covered, it is possible to eliminate image response from that band entirely. For the widest VHF television band (174-216 mc) this requires an IF value in excess

* One more spurious response which stems from neighboring television receivers is discussed on p. 122.

of 21 mc. (The UHF band, of course, is even wider, being 420 mc wide. However, the IF chosen for a receiver should not be greater than the lowest frequency to be received, in this case, channel 2, 54 mc.)

Stations Separated by the Intermediate Frequency. A second source of interference is caused by stations separated by the intermediate-frequency value. In this situation, one incoming signal acts as the mixing oscillator for the other signal, their difference frequency appearing at the output of the mixer, or converter, stage at the intermediate frequency.

There are two solutions to this problem. One is to provide sufficient discrimination in the circuits preceding the mixer so that they will reject two signals so widely separated in frequency. The other is to provide a high IF, one which is slightly greater than the entire band. In the upper-frequency (VHF) television band, this would be 42 mc.

Direct IF Response. The third form of spurious response stems from direct reception of a signal equal in frequency to the IF itself. To avoid the need of incorporating special filters, wave traps, and shielding to prevent interference from this source, an IF is chosen with a frequency that is not used to any appreciable extent for commercial or amateur transmissions. This accounts for such seemingly odd values as 10.7 and 9.1.

The foregoing by no means exhausts the subject of spurious responses. However, the important contributing factors have been covered and it is possible to see how they affect receiver design and operation. For the video IF, a high value is indicated, and to a certain point, the higher the better. This will not only reduce interference from spurious responses but also simplify the problem of filtering the video signal in the detector output from the IF. Opposing the use of a high IF are the disadvantages of reduced gain, necessity for greater care in selecting components to prevent excessive losses, additional shielding, and greater tendency of feedback through the tubes and adjacent circuits and the relatively narrow bandwidths of the audio FM circuits. For the latter, stability in the local oscillator is highly important, and since stability is more readily achieved at the low frequencies, a low IF is desirable. With all these considerations and in view of the fact that, at the moment, it is more important to reduce spurious responses and other outside interferences from reaching the screen, a relatively high IF is used.

When television was introduced commercially in 1946, the Radio and Television Manufacturers Association (RTMA)* recommended a video-carrier IF frequency between 25.75 and 26.4 mc. If 25.75 mc was chosen (and it was extensively used), then the complete video signal extended from 25.75 mc to 21.75 mc—a 4-mc range. The corresponding sound IF value was 4.5 mc lower than the video carrier IF value. In this instance 25.75 mc — 4.5

* Now known as the Electronic Industries Association (EIA).

mc gives a value of 21.25 mc. At the time these recommendations were made it was felt that these frequencies were high enough to minimize the amount of interference to which a TV set would be subjected and yet not so high that manufacturing obstacles would be difficult to overcome.

For a number of years, these video IF values were employed with considerable success. There was a certain amount of interference from medical and industrial electronic equipment operating in the 21-to-27-mc range and from harmonics of near-by amateur stations. FM stations (88-108 mc) also caused some image interference. However, what was somewhat unexpected, and what proved to be very annoying, was the interference that came from neighboring television receivers.

Suppose your set is tuned to channel 5 (76-82 mc) and a neighbor's set is tuned to channel 2 (54-60 mc). If his video IF value is 25.75 mc, then his local oscillator is operating at 81.0 mc, because 55.25 mc (video RF carrier) beating against 81.0 mc produces the difference frequency of 25.75 mc. Now, if some of this 81.0-mc voltage is radiated from your neighbor's antenna to your antenna, a series of fine stripes will appear across your screen.

By similar reasoning it can be shown that interference can be produced also on channels 6, 11, 12, and 13. In each case, of course, the interfering receiver would have to be tuned to a different channel. With the growing concentration of television receivers in large cities and suburban areas, this problem became a serious one to the TV owner. There are ways by which a certain amount of relief can be achieved by slightly altering the IF values of the interfering receiver. However, this alteration represents an added expense to a TV owner and from a commercial standpoint is not desirable.

In view of this situation, studies and research were carried on to determine IF values which would eliminate some of these undesirable interferences. The results revealed that a sound IF of 41.25 mc and a video IF of 45.75 mc would serve much better. These frequencies are now recommended by the EIA and extensively employed. The circuits for either set of frequencies are similar and will be referred to interchangeably in the discussion that follows.

Separation of Video and Sound Signals. The television signal in the plate circuit of the mixer has been reduced to its IF values. What happens to the video and sound signals now depends upon the type of system being employed in the receiver. In the intercarrier type of set, both sound and video signals remain together, at least until the video second detector. In the split-sound receiver, separation of the video and sound signals takes place *before* the video second detector. The separation may occur at the plate of the mixer or it may occur in any one of the video IF amplifiers. But wherever the separation, only the video signal remains by the time the video second detector is reached.

Since signal separation in split-second receivers must take place before the video second detector, it may be instructive to briefly examine typical separation methods. In one method, the mixer transformer (T_1 in Fig. 5-1) is a combination video IF transformer, sound trap, and sound IF transformer. The primary winding of T_1 is peaked at 21.8 mc, but since its frequency response is fairly wide, all the video and sound frequencies appear across it. The secondary of T_1 is a high- Q resonant circuit, sharply peaked

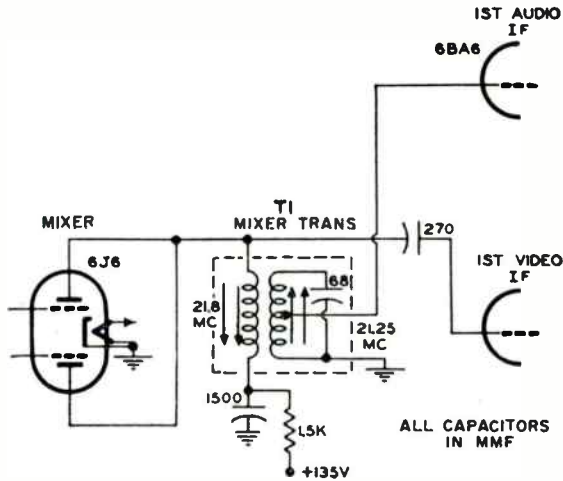

FIG. 5-1. A signal separation network.

to 21.25 mc, the sound carrier IF value. The resonant circuit absorbs the sound IF component from the primary, transferring it to the grid of the first IF amplifier. The rest of the signal on the primary of T_1 is unaffected by the trap and continues on into the video IF system.

It should be noted that although the secondary of T_1 absorbs a considerable portion of the sound IF voltage appearing across the primary, it does not absorb all of it. Hence, a second and sometimes a third sound trap will be found at a subsequent point in the video system.

Signal separation by means of a series-resonant circuit is shown in Fig. 5-2. C_1 in conjunction with L_1 forms a series-resonant path from the plate of the mixer to ground at the sound intermediate frequency. (C_2 shunted across L_1 is used to achieve another effect, which will be discussed in a subsequent section dealing with trap circuits.) In any series-resonant circuit, the opposition offered to an applied voltage is low when its frequency is equal to the resonant frequency of the circuit. Maximum current then flows through each component in this series branch. Moreover, and this is important, the voltage across each component at resonance is Q times the ap-

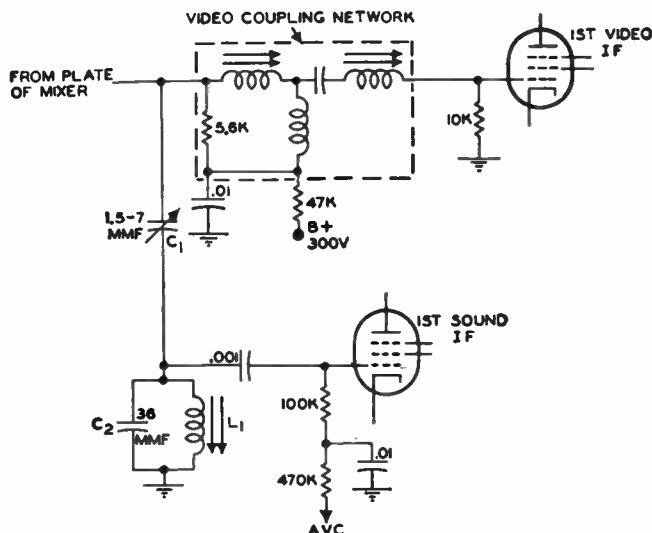

FIG. 5-2. A series resonant circuit, C_1 and L_1 (the latter in conjunction with C_2), separates the sound and video IF voltages.

plied voltage, where Q is the Q of the circuit (generally this means of the coil). Thus, if the applied voltage is 5 and the Q is 5, the potential across the series capacitor and inductance, each, will be 25 volts. It is true, of course, that the voltage across the coil is 180 deg out of phase with the voltage across the capacitor, and these, taken together, nullify each other. However, if we consider each component by itself, the rise in voltage is considerable. In the circuit of Fig. 5-2, the voltage fed to the grid of the first

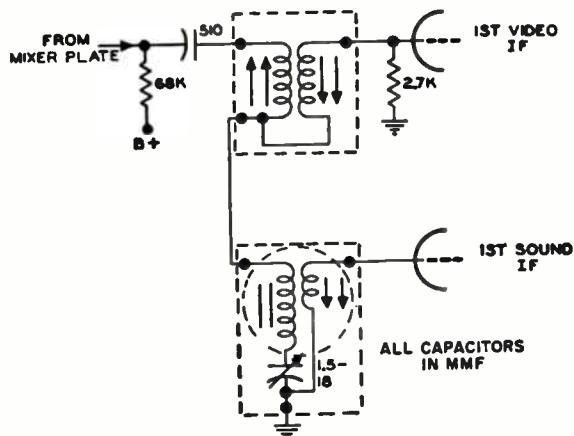

FIG. 5-3. Sound- and video-signal separation using two tuned circuits in series.

sound IF amplifier is developed across the coil of the series-resonant circuit. At the sound intermediate frequency, a resonant rise in voltage occurs, providing a sizable voltage for the grid of the first sound IF amplifier. At the same time, C_1 , C_2 , and L_1 form a trap, reducing the amount of sound IF signal that is penetrating the video IF system.

Still another method of signal separation is exemplified by the circuit shown in Fig. 5-3. Two tuned circuits are connected in series in the plate circuit of the mixer. The top resonant circuit receives the Video IF signal while the lower resonant circuit is sharply tuned to the sound IF. Currents of both signals pass through both coils, but the greatest voltage drop in the top coil will be at the video IF and the greatest voltage drop in the lower coil will be at the sound IF. The signal in each resonant circuit will then transfer to its respective system.

In some receivers, separation of the signals does not occur until the output of the first IF amplifier or even later. Thus, in Fig. 5-4, the signal is first passed through the first IF amplifier, whereupon a third winding is coupled to the interstage transformer and the energy it absorbs is fed to the control grid of the first sound IF. Sometimes the manufacturer labels this first stage as the first-video IF. Actually, a better designation would be, simply, first IF, since both video and sound IF signals are amplified.

Most split-sound receiver designers effect the video and sound IF separation at the output of the first IF stage. However, some receivers delay this operation until the second IF or even the third IF amplifier. By delaying the separation, the advantages of additional amplification are gained, which can be employed to reduce the number of sound IF amplifier stages. On the other hand, there is danger that enough sound FM voltage will reach the video second detector to produce interference across the video screen.

Video IF Amplifiers.* In any superheterodyne circuit, the major portion of the overall gain and selectivity is contributed by the IF amplifiers. See Fig. 5-5. Consequently, it is most important for all those working with television receivers to be familiar with the shape of the IF response characteristic and to understand why this particular form was chosen. The reason, as we shall see, lies with the signal transmitted by the broadcast station.

*The video-IF-amplifier section remains essentially the same for split-sound and intercarrier operation. Such differences that do exist will be brought out as we proceed.

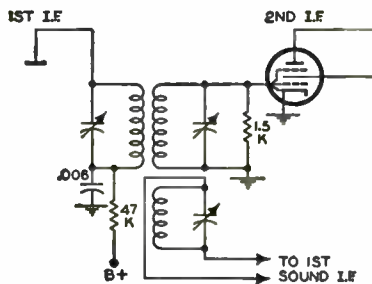

FIG. 5-4. Sound- and video-signal separation by means of a third winding on the interstage transformers.

TELEVISION SIMPLIFIED

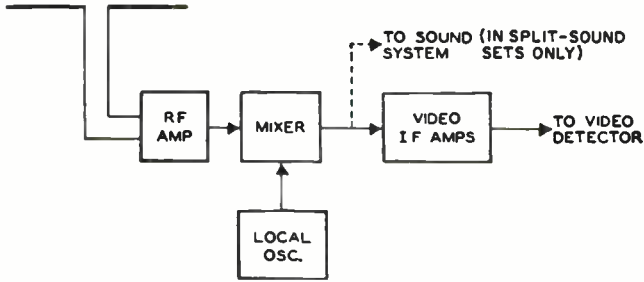

FIG. 5-5. The position of the video IF amplifiers in the television receiver.

A television signal, when broadcast, has the form shown in Fig. 5-6. It is amplitude-modulated, but differs from conventional AM signals by having essentially only one sideband. The other sideband, of which remnants are still present, has been effectively suppressed. This is known as “vestigial sideband transmission” and is the standard in modern television. When any carrier is amplitude-modulated, an upper and a lower sideband form automatically. However, because identical information is contained in each sideband, only one sideband is required at the receiver.

Complete suppression of the lower sideband is the goal, but it is not economically achievable. It is impossible to eliminate completely one sideband by means of simple filters without, at the same time, distorting near-by portions of the remaining sideband. As a compromise between economy and easily adjustable circuits on the one hand and minimum distortion and band-pass on the other, it was decided to remove all but 1.25 mc of the 4.0-mc

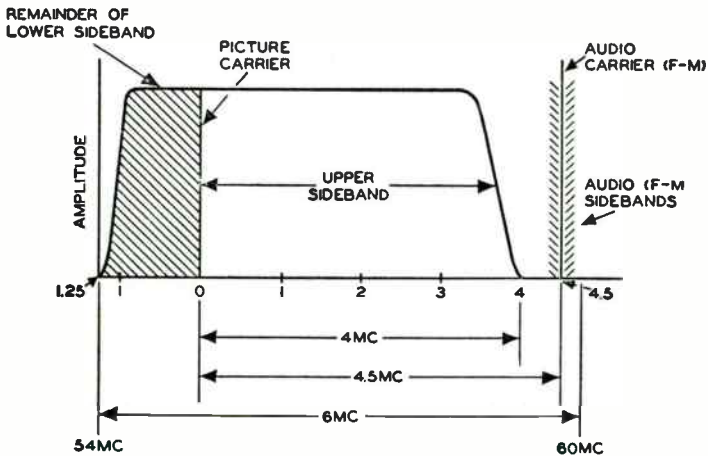

FIG. 5-6. The distribution of the television signal as broadcast by a television station.

lower sideband of the video signal. The transmitted signal, then, consists of this 1.25 mc plus the carrier plus 4.0 mc of the upper sideband. With the addition of the near-by audio carrier and its sidebands, the full 6.0 mc allotted each television station are obtained.

Within the receiver we must take the upper sideband, together with the remnants of the lower sideband, and provide a response characteristic in which all sideband frequencies will have available an equal amount of amplification. In sound AM sets this presents no great problem because both sidebands are alike. But things are different in the television signal. Here, there is 1.25 mc of the lower sideband and 4.0 mc of the upper sideband. The lower video frequencies (those having frequencies close to the carrier) are contained in both the upper sideband and the remnants of the lower sideband. However, all video frequencies above 1.25 mc are present only in the upper sideband, having been suppressed in the lower sideband. If both the low and the high video frequencies are accorded equal amplification in the receiver, proportionately more low-video-frequency voltage will be developed at the second-detector output than high-video-frequency voltage. It is to prevent this situation that the receiver response characteristic shown in Fig. 5-7 is generally employed. At the carrier frequency the response is 50

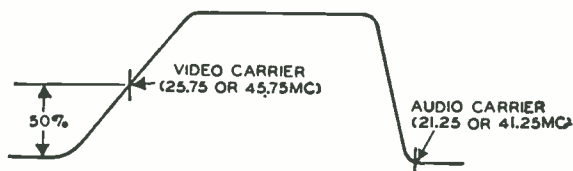

Fig. 5-7. The desired response curve of the video IF system.

per cent down, increasing linearly toward a maximum for the higher frequencies and decreasing for the lower frequencies. Roughly speaking, the lower video frequencies, for which there are two sidebands, receive half the amplification accorded all video frequencies above 1.25 mc. In this way, we equalize the response for the low and the high video frequencies. To the serviceman, the shape of this curve is important in his work on television receivers. When aligning the IF stages, he must be careful to place the video carrier close to the 50-per cent point. At the same time, the circuits should be adjusted to provide the maximum bandpass. Detail in a television image is dependent upon the strength of the high video frequencies present. When the response curve drops at the upper end of the curve, fine detail becomes fuzzy and indistinct. Poor low-frequency response gives rise to poor synchronizing action, smearing, and a generally darker image.

The response curve in Fig. 5-7 is an ideal curve. Much more common in

present video IF systems is the response curve shown in Fig. 5-8. The two curves are seen to differ slightly, principally across the top. In Fig. 5-7 the top of the curve is flat; in Fig. 5-8 the top is rounded, and the shape of the overall curve is more symmetrical. From the standpoint of fidelity, the first curve will result in a truer reproduction of the original scene televised at the broadcast station. The difference is so slight, however, that without the original for comparison, the viewer is unaware of any deterioration. The symmetrical response curve is also easier to develop when only three IF stages are employed. More and more receiver manufacturers are therefore designing their video IF systems to develop the more symmetrical response curve. (This second curve is sometimes called a "gaussian curve" because of its resemblance to gaussian probability curves used by statisticians.)

FIG. 5-8. A common form of video-IF-response curve found in present commercial TV receivers.

The important feature of these gaussian curves is the position of the video carrier (50-per-cent point) and the position of the sound carrier (about 5-per-cent point).

Video Interstage Coupling. Video IF systems can be conveniently classified according to the type of interstage coupling employed. All systems can be placed in at least one of the following categories (some make use of two) :

1. Transformer coupling
2. Stagger-tuned coupling
3. Complex coupling

Transformer Coupling. Typical of the transformer-coupled video IF systems is the circuit shown in Fig. 5-9. Transformers T_1 and T_2 are over-

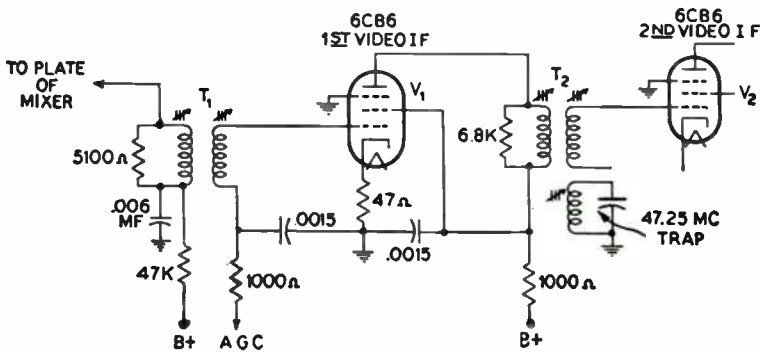

FIG. 5-9. A typical transformer-coupled video IF amplifier. The addition of the trap circuit to T_2 does not alter the operation of this stage.

coupled and loaded with resistance to provide approximately a 4-mc band-pass-frequency characteristic. A third winding on T_2 functions as a trap to attenuate certain undesirable frequencies. (A complete discussion of trap circuits will be given presently.) The overall response of the video IF system (of which Fig. 5-9 is one stage) is shown in Fig. 5-10.* The curve is approximately 4.0 mc wide, extending from 41.75 mc to 45.75 mc. The IF value of the video carrier is 45.75 mc and as such receives only 50 per cent of the total amplification. The video frequencies containing the image information then extend from this point to 41.75 mc.

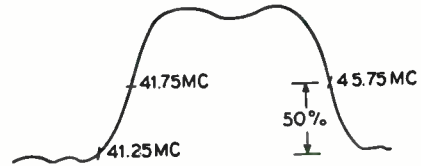

FIG. 5-10. The overall response of a complete transformer-coupled IF system.

While a 4.0-mc bandpass is to be preferred, little loss in picture quality will be noted for pass bands of 3.5 mc. In many sets, the response begins to fall at 3.0 mc. A narrower bandpass permits the manufacturer to effect economies in design and, in a field as competitive as television, cost is always an important consideration. Of course, this practice cannot be carried too far, or picture quality will be materially degraded.

In Fig. 5-9, only a single IF stage is shown. Actually, there would be three or four, this number being required to provide sufficient amplification for the signal. One such complete system is shown in Fig. 5-11. Three

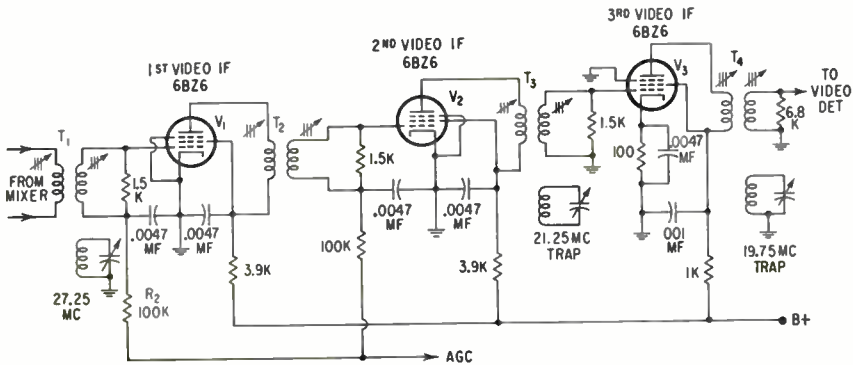

FIG. 5-11. A transformer-coupled video IF system.

stages are employed, with four interstage coupling transformers. Each set of transformer windings is overcoupled and resistor-loaded. A third winding

* Video IF response curves may be shown either with the frequency increasing from left to right (as in Fig. 5-10) or with the frequency rising from right to left (as in Fig. 5-7). Both types of presentations are used extensively and interchangeably throughout the industry.

in three of the transformers serves as a trap to prevent certain undesirable frequencies from passing through the system.

Two of the three IF stages, V_1 and V_2 , are AGC-controlled. The final IF stage employs cathode bias and does not tie into the AGC network.

The trap circuits shown in Fig. 5-11 play an important role in the operation of this and other video IF systems. Let us therefore consider in greater detail their form, mode of operation, and purpose.

Trap Circuits for Television Receivers. Television receivers are continually beset by a host of interfering signals, any one of which is easily capable of distorting or completely destroying the desired image. Fortunately, many of these interfering signals never get beyond the input tuner and, consequently, are suppressed before harm is done. Some, however, are so close to the channel frequency to which the set is tuned that they are able to penetrate the RF defense and reach the video IF system. This system actually constitutes the main bulwark against all interference and once a signal passes through these stages successfully, there exist few stopgaps between the video detector and the cathode-ray tube. Every effort must be made to suppress any signal which is capable of distorting the reproduced image.

In order to receive a 6-mc band of frequencies, the RF and converter tuning circuits are designed with a low Q , which means that the sides of the input curve are not very steep, like the sides of a rectangle, but tend to taper off gradually. Figure 5-12(A) illustrates a typical input characteristic of a modern television receiver. With a response of this type, voltages at the frequency of the sound carrier of the next lower channel or the picture carrier of the next higher channel could penetrate through the RF stages and reach the video IF system. Unless trap circuits are inserted in the video IF system (or even beyond), the effect of these interfering signals will be detrimental to the image.

To ascertain the frequency of the most important interfering signals, suppose the receiver is tuned to channel 3 (60-66 mc) and the video carrier IF value is 45.75 mc. The sound carrier of the next lower channel (54-60 mc) is at 59.75 mc. A signal at this frequency when mixed with the local oscillator (107.00 for channel 3) will develop a difference frequency of 47.25 mc. This is the frequency of one interference signal.

The second interference signal is the picture carrier of the next higher channel (66-72 mc). When this beats with the same local oscillator, a difference frequency of $107.00 - 67.25$ mc, or 39.75 mc, is produced.

The two frequencies—(1) sound from the next lower channel (47.25 mc) and (2) picture carrier from the next higher channel (39.75 mc)—must be eliminated from the video signal before it reaches the cathode-ray tube. Channel 3 is used in this illustration, but any other channel could have been

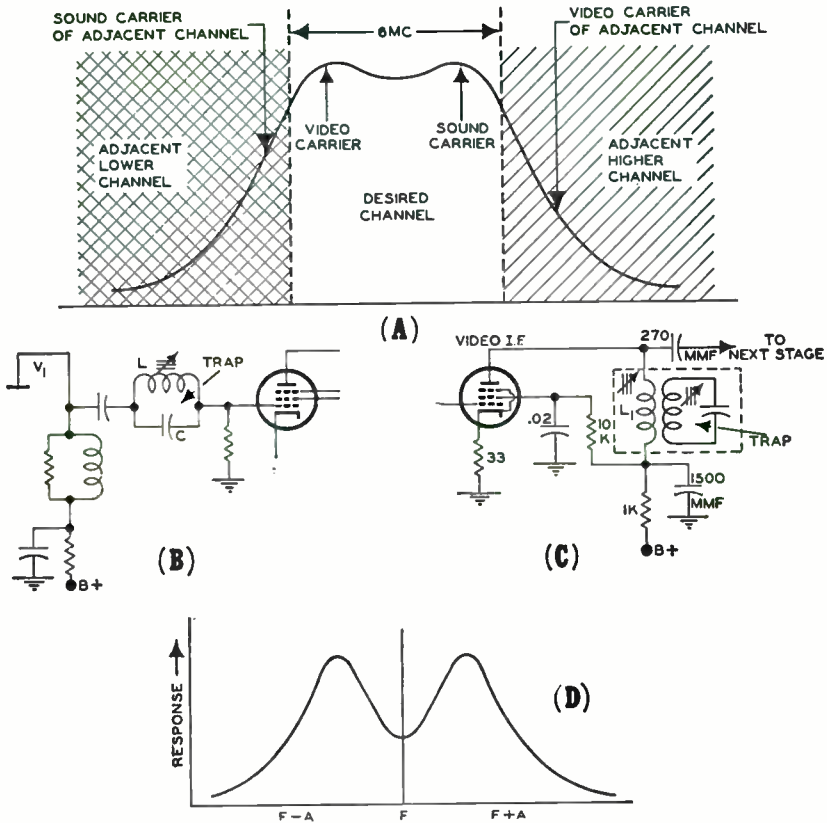

FIG. 5-12. (A) The RF response curve of most television receivers. Note that signals from adjacent channels can be received. (B) A series trap circuit. (C) An absorption trap circuit. (D) The double-humped response curve characteristic of closely coupled circuits.

chosen. In all cases where closely adjacent channels exist, the two interfering frequencies will be 47.25 and 39.75 mc for this receiver. Note, however, that there are channels which are not subject to such interference. Thus, channel 2 (54-60 mc) does not possess an adjacent lower channel; on the other hand, channel 4 does not possess a closely adjacent higher channel. By "closely adjacent" is meant channels which follow each other without any frequency separation. Channel 4 is followed by channel 5, but the end of channel 4 and the beginning of channel 5 are separated by 4 mc. Channel 4 is 66-72 mc; channel 5 is 76-82 mc. This 4-mc separation is sufficient to prevent any of the frequencies in channel 5 from adversely affecting channel 4. However, channel 2 (54-60 mc) is closely followed by channel 3 (60-66 mc), and interference is possible. The same is true of many of the other

channels—hence the importance of using these traps. The trap frequencies will vary with the video and audio IF values employed in the circuit. The purpose of the traps, however, remains unchanged.

The objection may be raised that traps are not really necessary because under existing regulations adjacent channels are not assigned to *any one community*. This is true. However, communities which are located comparatively near one another are assigned adjacent channels. Thus, consider New York and Philadelphia, only 90 miles apart. New York is assigned VHF channels 2, 4, 5, 7, 9, 11, and 13; Philadelphia is assigned VHF channels 3, 6, and 10. Any set situated between these two cities would certainly be subject to considerable interference and would definitely require trap circuits. This same situation is true in many other parts of the country.

Adjacent channel traps could be used in split-sound and intercarrier receivers.* On the other hand, there is one additional trap that is always used in split-sound receivers and frequently used in intercarrier sets. This trap is designed to attenuate the sound IF voltage and prevent it from reaching the picture tube. It will be remembered that sound- and video-signal separation in split-sound receivers occurs before the video second detector. However, while a substantial portion of the sound signal is removed at the separation point, enough energy does remain to cause interference to the picture. Indications of sound interference are the appearance of either a wormy, fine-line pattern (Fig. 7-32) or a series of dark horizontal bars (Fig. 7-33), or both. (See p. 216 for details on these patterns.)

In split-sound receivers this trap is more important than any of the other traps because adjacent channel stations are not always present, but the sound of the same channel is.

In intercarrier receivers a sound trap is also used. Here its purpose is not to reject the sound IF signal completely, but rather to make certain that it is kept at its proper low level. When a sound trap is not used, it generally means that the overall response curve of the normal tuning circuits is sufficiently far down at the sound IF value to attenuate the sound carrier to the desired 5-per cent level.

Type of Traps. A series trap circuit is shown in Fig. 5-12B. It is placed between two IF stages and tuned to the frequency to be rejected. Trap circuits are sharply tuned networks, designed to reject one frequency or, at most, a narrow band of frequencies. When a signal at the trap frequency appears at the plate of V_1 (Fig. 5-12B), the impedance offered by LC is high, absorbing most of this interference voltage. A negligible amount appears across the input circuit of the following IF amplifier. At all other

* Whether or not a receiver contains these traps is largely a matter of design and economics. Some sets have one or the other trap; some have both; and a few have none.

frequencies, the resonant circuit offers negligible impedance, and the desired signal passes easily.

The *absorption trap*, shown in Fig. 5-12C, is the most widely used type of rejection circuit. It consists of a coil (and parallel fixed capacitor) inductively coupled to the plate load of an IF amplifier. When the IF amplifier receives a signal at the resonant frequency of the trap circuit, a high, circulating current develops in the trap (as a result of the coupling between the trap and the plate coil), and the voltage in the video coil, at the trap frequency, becomes quite low. Consequently, very little of this interference voltage is permitted to reach the next amplifier.

To explain this action more fully, two resonant circuits closely coupled will give a double-humped curve, such as is shown in Fig. 5-12(D). Note the sharp decrease in primary current at the center frequency. In the case of the two tuned circuits of Fig. 5-12C L_1 is tuned to a band of frequencies while the secondary is sharply set at one frequency. Since the primary band coverage includes this one frequency, there is a sharp drop in primary voltage at this frequency, due to the presence of the trap. It is this interaction between coils which produces the marked decrease in voltage at the trap frequency. The other frequencies in this signal are unaffected by the trap.

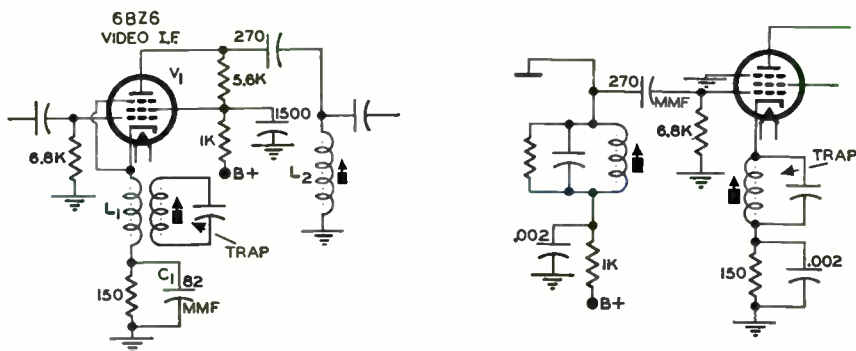

FIG. 5-13. Two types of cathode, or degenerative, trap circuits.

A *cathode, or degenerative, trap*, shown in Fig. 5-13(A), is a sharply tuned parallel-resonant circuit coupled to a coil in the cathode leg of a tube. Coil L_1 in series with C_1 forms a broadly tuned series-resonant circuit to the same range of frequencies as L_2 , which permits V_1 to function as a normal amplifier for all signals within this frequency range. However, at the resonant frequency of the trap, a high impedance is reflected into the cathode circuit (by the trap), and the gain of this stage is reduced by degeneration.

Another type of cathode trap, illustrated in Fig. 5-13(B), places the

parallel circuit directly into the cathode leg. At the resonant frequency of the trap the impedance in the cathode leg will rise, producing a large degenerative voltage and reducing the gain of the amplifier. At all other frequencies, the impedance of this parallel network is low, and only a small degenerative voltage appears. There is thus only a slight loss in gain.

Parallel traps are series-resonant circuits which are placed across (or in shunt with) the circuit. See Fig. 5-14. At the frequency for which it is

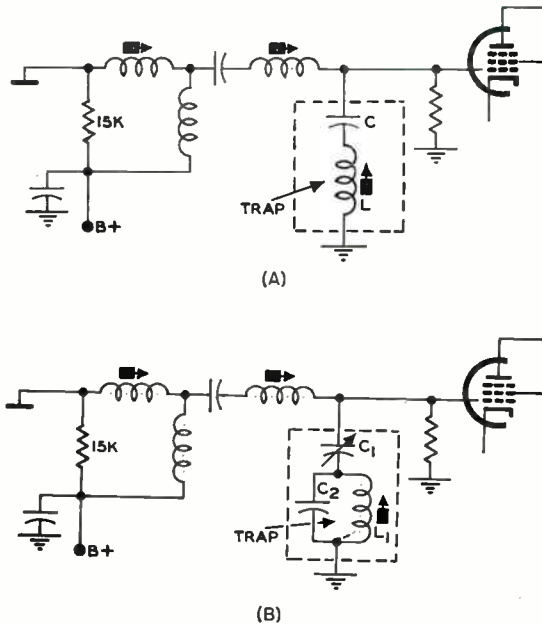

Fig. 5-14. Two types of parallel trap circuits.

set, the trap acts as a short circuit, bypassing all signals of the same frequency to ground and preventing their further penetration into the circuit. At other frequencies the trap circuit presents a relatively high impedance, permitting these signals to proceed farther into the circuit.

The simplest type of parallel trap is illustrated in Fig. 5-14(A). A capacitor and a variable coil, in series with each other, are connected across the signal path. Any signal possessing the same frequency as the trap will "see" a virtual short circuit upon reaching this portion of the circuit. The simple capacitor-and-coil trap is effective if the Q of this network (principally the coil) is quite high. However, when the Q is low, the tuning of the network is broad and more than one frequency is attenuated. A more efficient parallel trap is shown in Fig. 5-14(B).

At first glance, the trap network appears as a parallel-resonant circuit rather than a series-resonant circuit. Let us, however, analyze its operation. The example, Fig. 5-14(B), is taken from a commercial television receiver. It is designed to bypass or trap the audio-carrier voltage of the signal being received. In this instance the IF frequency is 41.25 mc.

If we consider first L_1 and C_2 , ignoring C_1 for the moment, then we have a parallel-resonant circuit, tuned to 42.25 mc. The coil Q is 200, and a fairly large voltage is developed across the combination at this frequency. Now, it is easily demonstrated that, for all frequencies lower than its resonant frequency, a parallel resonant circuit appears inductive. (At the resonant frequency, of course, it presents a purely resistive impedance.) For frequencies above resonance, the impedance presented is capacitive. This latter fact can be understood by noting that for higher frequencies, the parallel capacitor offers less impedance than the coil. Consequently, most of the current flows through the capacitor, and the circuit current possesses a leading phase. Since the audio IF of 41.25 mc is below the 42.25-mc resonant frequency of L_1 and C_2 , the parallel combination appears inductive to the audio IF signal. By resonating this inductance with C_1 , we obtain a series-resonant path for the audio IF signal, and the audio IF voltage is bypassed.

By providing a parallel-resonant circuit (L_1 and C_2) for 42.25 mc, we obtain a sharp rise in voltage just beyond 41.25 mc. Since the 42.25-mc value is included in the range of the desired video frequencies (they extend from 45.75 mc down to 41.75 mc), we insure that the video frequencies are passed by the trap with negligible attenuation while, at the same time, forcibly suppressing the undesired audio carrier IF.

Bridged-T Traps. A fifth trap, which is more complex than any of the foregoing circuits but also more effective, is the *bridged-T trap* shown in Fig. 5-15(A). L_1 , C_1 , and C_2 are resonated to the frequency of the signal to be rejected. Now, if the value of the resistor R is properly chosen, the attenuation imposed upon a signal to which L_1 , C_1 , and C_2 are resonated will be great. Ratios of 50 and 60 to 1 are easily attainable using components which possess manufacturing tolerances.

Some understanding of the operation of this trap can be obtained if we take the bridged-T network shown in Fig. 5-15(B) and transform it into the equivalent network of Fig. 5-15(C). This is called a "delta-wye transformation" and can be readily accomplished with well-known electrical theorems. If the various components of the bridged-T network C_1 , L_1 , and C_2 are properly chosen, Z_1 will have a negative value. If we make R equal to Z_1 , then the total impedance between points 1 and 2 will become zero, effectively short-circuiting signals of the frequency to which the bridged-T network is tuned. For all other frequencies the trap offers little shunting effect and the signals pass through with negligible attenuation.

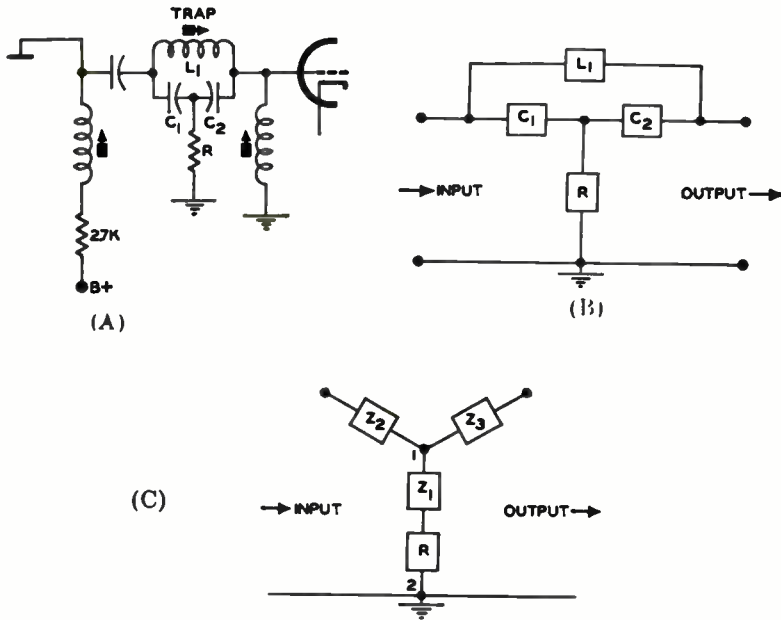

FIG. 5-15. (A) A bridged-T trap. (B) The same circuit shown in block form. (C) An equivalent electrical network.

Tuning the Traps. To adjust the traps to their proper frequencies, the following procedure is employed:

1. Connect an AM signal generator to the grid of the mixer.
2. Connect a vacuum-tube voltmeter across the load resistor of the video second detector.
3. Set the signal generator to the trap frequency.
4. Using an alignment screwdriver or wrench, change the capacitance or inductance of the proper trap until a minimum voltage is registered at the detector. Consult the manufacturer's instructions for the resonant frequency of each trap circuit.
5. Follow the same procedure for each trap, each time altering the signal-generator frequency to correspond.

(Always check the manufacturer's instructions to determine whether a certain bias should be applied to the controlled video IF stages during trap alignment. This is frequently done.)

For most television receivers, the traps are adjusted before any video IF alignment is begun. During the video-alignment process, the adjustment of the traps should be rechecked because they are affected to some extent by changes in the associated video IF tuning coils and transformers.

Stagger-tuned IF Systems. The majority of present-day television re-

ceivers employ tuning circuits in the video IF system which are stagger-tuned in frequency, that is, the various tuning circuits are peaked individually to different frequencies within the bandpass of the system. It may be that two circuits in different stages are tuned to the same frequency, but never will all of the tuning circuits peak to one frequency. In short, there is a spread of frequencies, but when the individual responses are combined, they produce an overall curve which is similar to the curves of Fig. 5-8.

A simple stagger-tuned IF system is shown in Fig. 5-16. One tuned coil, located between the first- and second-video IF stages, is peaked (in

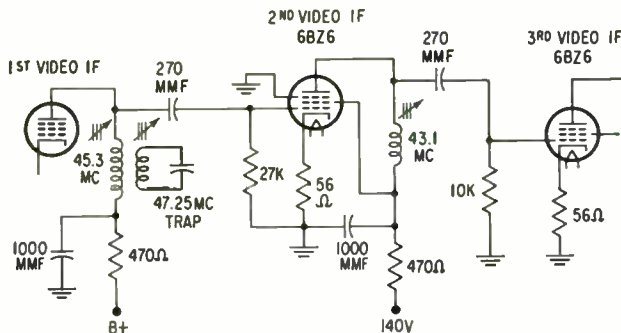

FIG. 5-16. A simple stagger-tuned video IF system.

this circuit) to 45.3 mc. Inductively coupled to this coil is an absorption trap resonated at 47.25 mc, which is the frequency that the sound carrier of an adjacent lower channel would produce if its signal entered the receiver. The trap will absorb any such signal voltage present and prevent it from proceeding further through the IF section. The remainder of the video signal will be unaffected by the trap and continue through the system. The second coil, between the second- and third-video IF amplifiers, is peaked to another frequency (here 43.1 mc) within the video bandpass. In similar manner, by adding two or three more IF stages, each possessing a coil tuned to a different frequency, we can achieve the desired video bandpass, whether it is 3.0, 3.5, or 4.0 mc.

The number of video IF amplifiers employed in any set is determined chiefly by the price of the set. In quality receivers, possessing the full 4.0-mc bandpass, there might be five stagger-tuned coils, using four video IF stages. In other sets, where a 3.0-mc spread is common, three or even two video IF amplifiers might be employed. Regardless of the number of stages used, the basic operation remains the same.

Stagger-tuning. Stagger-tuning is employed so extensively in video IF systems that it might be instructive to analyze these circuits in greater detail. As a first step in this analysis, let us define bandwidth.

A typical resonance curve for a parallel tuning circuit is shown in Fig. 5-17. The response is not uniform but varies from point to point. At the resonant frequency (labeled F_0 in the diagram) the response of the circuit is at its peak, or maximum. From this point, in either direction, the response

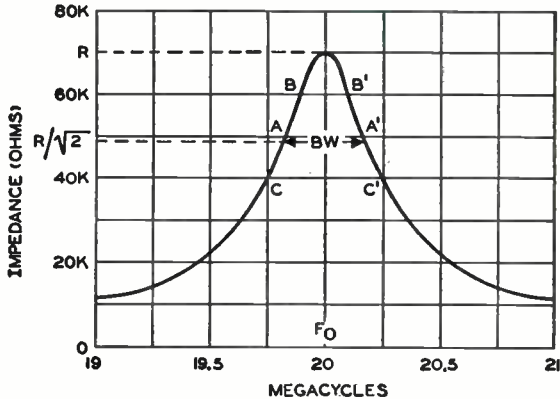

Fig. 5-17. The accepted definition for bandwidth of a tuned system.

tapers off until it soon becomes negligible. With a characteristic of this type, what would you say the bandwidth was? Obviously the answer to this question is arbitrary. We could say, for example, that all frequencies between the points B and B' on the curve should be considered as part of the bandwidth. Or, we could choose points C and C' and say that all frequencies which receive an amplification equal to that of points C and C' or greater, should be considered as within the bandpass of the circuit. Note that this does not prevent other frequencies—those that receive less amplification—from passing through the circuit.

The arbitrary definition generally accepted for bandwidth is illustrated in Fig. 5-17. The bandwidth of a circuit is equal to the numerical difference in cycles between the two frequencies at which the impedance presented by the tuning circuit is equal to 0.707 of the impedance presented at F_0 (i.e., the maximum impedance). Thus, in the response curve shown in Fig. 5-17, the impedance at points A and A' is 0.707 (or $1/\sqrt{2}$) of the impedance offered by the circuit at F_0 . In this particular illustration, Fig. 5-17, the bandwidth is 0.4 mc.

A further note of importance is that, if the gain of the circuit is considered equal to 1 at F_0 , it is down 3 db at points A and A' . That this is so can be seen from the following:

The definition of decibel is given by $\text{db} = 20 \log (E_1/E_2)$, where E_1 here would be the voltage at F_0 , and E_2 would be the voltage at points A

and A' . For the sake of simplicity, let us assign a value of 1 volt to E_1 . At either point A or point A' the impedance offered to the same signal is $1/\sqrt{2}$, or 0.707 times as great. The voltage developed at either of these two points will therefore be 0.707 volts. Substituting these values in the formula we have $\text{db} = 20 \log (1/0.707)$, or $\text{db} = 20 \log 1.414$, or about 3 db.

Points A and A' are also known as the "half-power" points because $P = E_1^2/R$, and since $E_2 = E_1/\sqrt{2}$, then $P_{A-A'} = E_1^2/2R$, which is one-half the power developed across R at F_0 , the peak of the curve.

With this concept of bandwidth in mind, let us consider two single-tuned amplifiers, both tuned to the same frequency. If these two amplifiers are in cascade (i.e., follow each other), then the overall bandwidth is not equal to the bandwidth of either circuit, as one might expect, but to 64 per cent of this value. The reason for the shrinkage in bandwidth will be apparent from the following:

The response curve of the first amplifier, shown in Fig. 5-18(A), has a maximum value of amplification of 1 at F_0 , its peak, and 0.707 at the ends of the bandpass. Let us say that the mid-frequency is 10 mc, while the

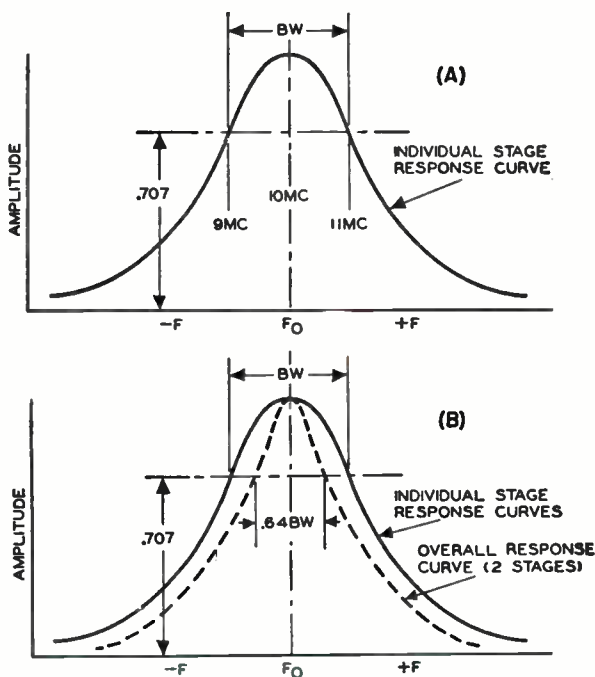

FIG. 5-18. Two tuned circuits, each peaked to the same frequency, produce an overall response in which the bandwidth is less than that of either curve taken separately.

end frequencies of the bandpass are 9 and 11 mc respectively. If each of these three frequencies has an amplitude of 1 volt at the input to this tuned stage, then at the output they would possess the following values: at 9 mc, $1 \times 0.707 = 0.707$ volt; at 10 mc, $1 \times 1 = 1$ volt; and at 11 mc, $1 \times 0.707 = 0.707$ volt.

These same three frequencies are now passed through the second tuned circuit. Since this second circuit possesses the same characteristics as its predecessor, here is the result at its output: at 9 mc, $0.707 \times 0.707 = 0.49$ volt; at 10 mc, $1 \times 1 = 1$ volt; and at 11 mc, $0.707 \times 0.707 = 0.49$ volt. After passage through the two amplifiers, 9 mc and 11 mc are no longer within the 0.707 region about the resonant frequency of 10 mc. To find frequencies with voltages equal to at least 0.707 of the 10-mc voltage we must move *closer* to 10 mc. The result, of course, is a narrower bandpass; more accurately, 36 per cent narrower. See Fig. 5-18(B).

Now let us consider two single-tuned amplifiers, each with the same bandwidth, but with their peaks separated (or staggered) by an amount equal to their bandwidth. See Fig. 5-19. The result is a response in which

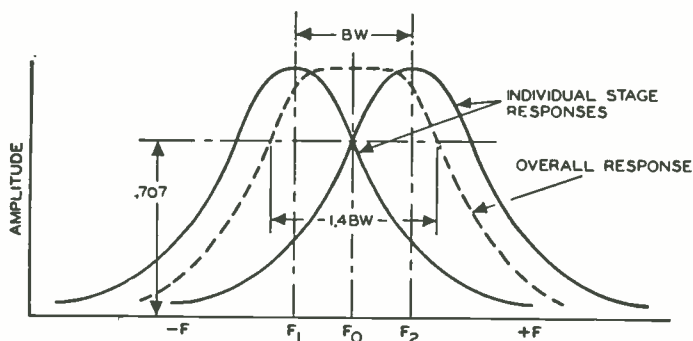

FIG. 5-19. By stagger-tuning two tuned circuits we obtain a wider bandpass.

the overall bandwidth (to the 0.707 point) is 1.4 times the bandwidth of a single stage. The overall gain, however, is now only one-half that of the two stages tuned to the same frequency. This is so because at the center frequency of the overall response curve, the individual stage responses are only 0.707 of their peak response. The product of the stage gains is approximately one-half ($0.707 \times 0.707 \cong 0.5$). This would be stagger-tuning.

Now, to progress one step further. We have seen that by stagger-tuning two tuned circuits, we achieve 1.4 times the bandwidth of a single stage but with only one-half of the gain. Suppose, however, we retain stagger-tuning, but we decrease the bandwidth of each individual tuned circuit. The overall bandwidth of the stagger-tuned system will still be 1.4 times the bandwidth of the individual stages. However, because we have decreased bandwidth

of the individual coil 1.4 times, this new figure will be less than 1.4 times the figure obtained when each individual bandwidth was greater. The advantage of this method is that we still get a greater bandwidth than if we had not stagger-tuned the circuits, and the overall gain remains high.

A simple illustration will make this clearer. Suppose that the bandwidth of each individual stage is decreased to 0.707 of its original value. To do this, we raise the individual circuit Q 's to 1.4 times their previous value which will provide an increase in gain of 1.4 times. Now, when the stages are staggered by an amount equal to this reduced bandwidth, the overall gain is one-half the product of 1.4 times 1.4. The answer is approximately 1. Thus the overall gain is now the same as that obtained with the previous amplifier with both circuits tuned to the same frequency.

Other systems can give high gain and bandwidth, but the primary advantage of the stagger-tuned amplifier is its ease of alignment.

An important relationship, and one to be remembered, is that bandwidth of any parallel-resonant circuit (or an ordinary resistance-coupled amplifier) is inversely proportional to the amplification of that system. Expressed a little differently, we can say that $\text{bandwidth} \times \text{gain} = \text{constant}$. Thus, if we increase the bandwidth of a system 1.5 times, we decrease its gain the same amount. For any individual tuning coil, $\text{bandwidth} = F_0/Q$, where F_0 is its resonant frequency, and Q is the figure of merit of the coil. This expression tells us that, for any given resonant frequency, increasing the bandwidth can only be accomplished by decreasing the Q of the coil a proportional amount. However, if we raise the resonant frequency of the coil, maintaining Q constant, then the bandwidth will increase in like measure.

Commercial Stagger-tuned IF Systems. The interstage tuning circuits commonly employed in stagger-tuned IF systems are either single coils or bifilar coils. Fig. 5-20 shows a typical IF system using stagger-tuned single coils. Four IF stages are used, with two of the coils peaked to one frequency and two peaked to another frequency. (If the designer wishes, all

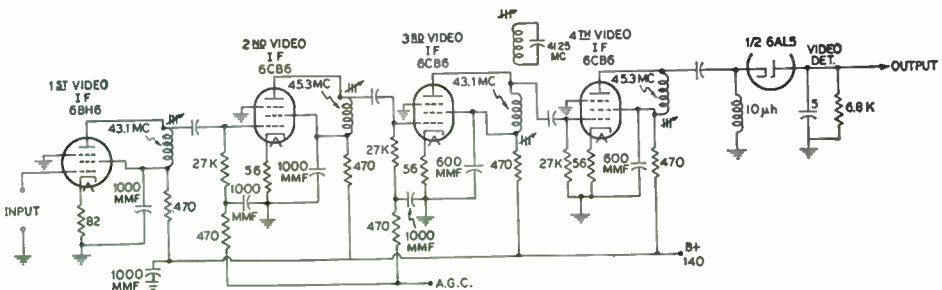

FIG. 5-20. A stagger-tuned video IF system using single-tuned coils.

may be tuned to different frequencies, that is, there may be a total staggering of frequencies or the coils may be staggered in pairs.)

Each coil contains a powdered-iron core whose position is adjustable, and by proper adjustment, the coil can be tuned to the desired resonant frequency. Because relatively high frequencies are employed, actual capacitors are not placed across each coil, although capacitance is present. It arises from the capacitance which is inherent in the coil, plus the capacitance which the tubes and the connecting circuit wires themselves possess.

Each stage in Fig. 5-20 uses cathode bias; in addition, the second and third stages receive an AGC voltage which varies their gain in accordance with the strength of the incoming carrier. The final amplifier feeds the signal to a half-wave second detector where it is rectified, the video intelligence is recovered, and the carrier is discarded.

It is common practice, when using single coils in a staggered arrangement, to place them in the plate circuit while the following grid circuit uses a coupling resistor. In short, each plate coil and the following grid resistor are in parallel, and by using low-valued resistors, the response of the tuning coils is broadened. This arrangement is needed to achieve an overall passband of 3 or 4 mc, when the individual responses of all the coils are combined.

There is little more to add to the analysis of Fig. 5-20 since it is basically quite simple in construction and operation. It is also quite simple to align. A signal generator is connected to the grid of the tube preceding the coil to be adjusted and is set for the proper frequency. The tuning slug in the coil is then adjusted for maximum deflection on a VTVM connected across the second-detector load resistor, here 6,800 ohms. The same equipment is employed in aligning any traps that may be present in the system, except that all traps are adjusted for minimum meter deflection.

In Fig. 5-20, only one trap circuit is employed. It is located between the second- and third-video IF stages and is inductively coupled to the 43.1-mc tuning coil. Trap frequency is 41.25 mc, the sound IF carrier of the channel being received. Since this is an intercarrier system, the purpose of the trap is not to eliminate the 41.25-mc signal completely, but rather to attenuate it to the desired level. Whether a trap circuit substantially eliminates a signal or simply reduces it to a lower, but still usable, level, depends primarily on the Q of the trap circuit. With a high Q circuit, substantial elimination is possible; with a medium Q circuit, the signal is simply lowered in amplitude, but is not completely eliminated.

The form of an IF system does not change with a moderate change in intermediate frequency. The circuit in Fig. 5-20 is designed for the 40-mc range but with suitable tuning circuits, it works satisfactorily in the 20-mc range.

Bifilar IF Coils. A bifilar coil, shown in Fig. 5-21, consists of two windings which are positioned so close together that the degree of coupling is near unity. The result is that practically all of the voltage developed across one winding, acting as the primary, is transferred to the other winding, acting as the secondary. A movable iron core, inside the coil form, tunes both windings simultaneously. In most instances, the tuning rod extends above the top side of the chassis, where it can be reached in alignment.

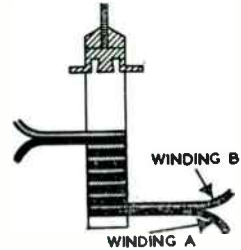

FIG. 5-21. A bifilar coil.

The circuit diagram of a video IF system employing bifilar coils is shown in Fig. 5-22. The system contains four IF stages and bifilar coils are employed in all of them. The circuit between the tuner output and the first IF stage is basically a low-pass filter consisting of a coil (primary winding of T_1) plus a circuit capacitance on each side of it. In addition, an absorption trap tuned to 39.75 mc is coupled to this winding (i.e., the secondary of T_1), while a second parallel-resonant trap, L_1 , C_1 , and C_2 , is placed in series with it. Three other absorption traps are also found in this IF system, one each in the second, third, and fourth stages. The traps tune to the sound IF carrier of the channel being received (41.25 mc), the video carrier of the adjacent higher channel (39.75 mc), and the sound carrier of the adjacent lower channel (47.25 mc). AGC voltage is applied to the first two stages.

Note that trap circuits, whether they are coupled to bifilar coils or single coils, always have their own adjustable cores. Also, when an absorption trap is coupled to a bifilar coil, it is usually placed above or below the bifilar winding on the same coil form. It is possible also to wind the trap coil on a separate form and then slip it over the tuning circuit; however, this arrangement is frequently costlier and is generally avoided for that reason.

By comparing Figs. 5-20 and 5-22, we see that use of the bifilar coils makes it possible to eliminate all the interstage coupling capacitors found in Fig. 5-20. In addition, the RF choke found in the second-detector input circuit is also eliminated. Thus, a system employing bifilar coils is more economical than a system utilizing single-tuned coils. In addition, bifilar coil circuits are less responsive to noise pulses.

Alignment of video IF systems using bifilar coils is accomplished in the same manner as alignment of IF stages possessing single-tuned coils. Stagger-tuning of the coils plus loading resistors provide the necessary bandwidth.

A system may employ all single-tuned coils or all bifilar coils, or it may use both types. Of late, the tendency has been toward the latter—one

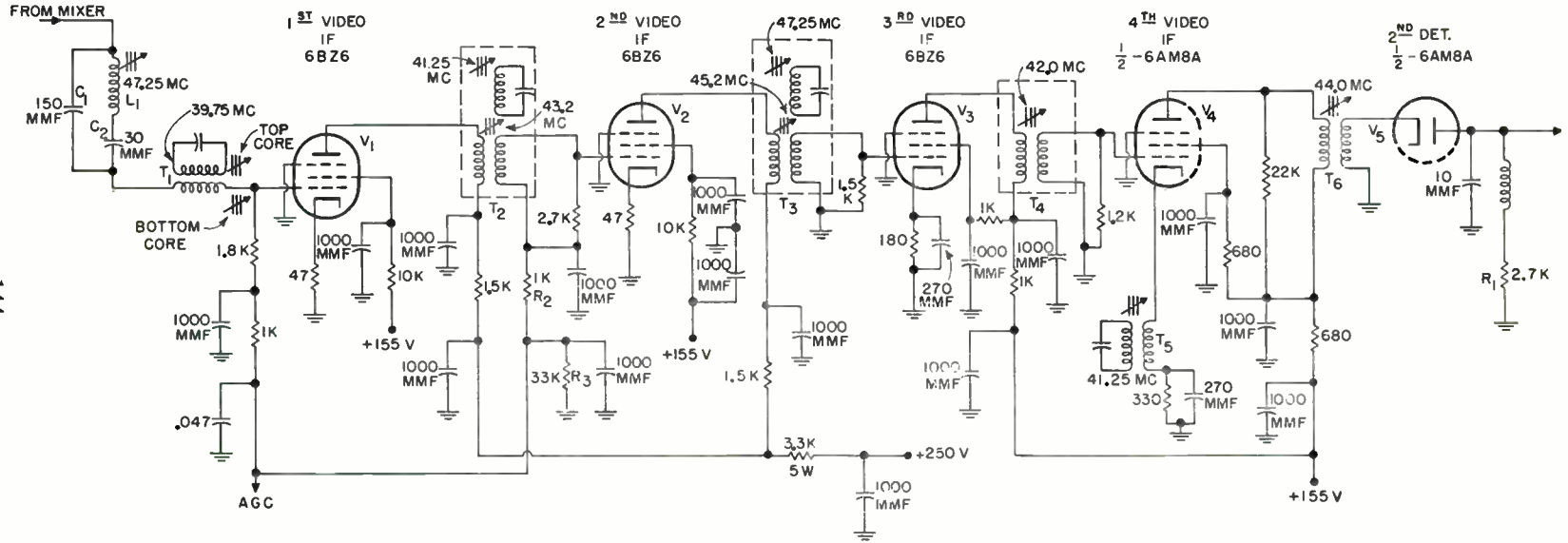

FIG. 5-22. A video IF system employing bifilar coils between stages.

or two single-tuned coils between the mixer and first IF stage, and bifilar coils throughout the remainder of the system.

Again, all the video IF systems discussed may be used for the older 21-26-mc IF band or for the newer 41-46-mc range. The form remains practically the same; only the inductance and capacitance values of the tuning circuits change. Also, intercarrier and split-sound receivers use basically the same video IF systems. The differences are minor. They consist chiefly in whether the sound signal is to be completely suppressed before it reaches the video second detector (in split-sound systems) or whether a small amount of the sound signal is to be permitted to reach the video detector (in intercarrier systems). Farther on, we will indicate more fully why this difference exists between the two systems.

The IF systems dealt with to this point each have four stages, providing a considerable amount of gain with a bandpass at, or close to, 4 mc. It is possible, however, to produce acceptable pictures with systems having bandwidths of only 3.0 or 3.2 mc, and, in such instances, three or even two IF amplifiers may be used, provided the level of the received signal is high enough. (High signal levels are generally found in most cities having television stations, because of the high-transmitting power achievable with modern television equipment.) As a matter of fact, in some receivers using screens of 14 in. or less, the overall IF bandwidth may even drop slightly below 3 mc. This is because the smaller the screen, the less need there is for exceedingly fine pictorial detail, unless the viewer wishes to sit very close to the screen. Generally this is not true, and the detail lost by the reduced bandwidth is not noticed.

Representative 2- and 3-stage IF systems are shown in Figs. 5-23 and 5-24. In form, these follow the pattern of the IF systems previously discussed. In each, there are single-tuned coils between the tuner mixer and the first IF stage, while bifilar coils are utilized in the remainder of the system. The number of trap circuits generally decrease as the system band-

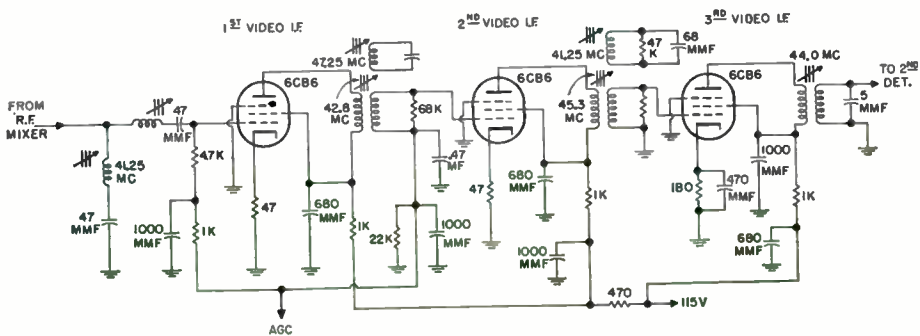

FIG 5-23. A 3-stage video IF system.

pass becomes narrower. This decrease is due to two reasons; first, the narrower bandpass systems are found in lower priced sets and this necessitates paring the circuit of as many components as possible consistent with a certain minimum level of performance. Second, with a narrower bandpass, the circuit will itself impose attenuation on signals from adjacent channels, thereby lessening the need for traps. As a matter of fact, many 2-stage IF systems possess no traps at all and rely solely on the IF tuning circuits to attenuate the undesirable signals.

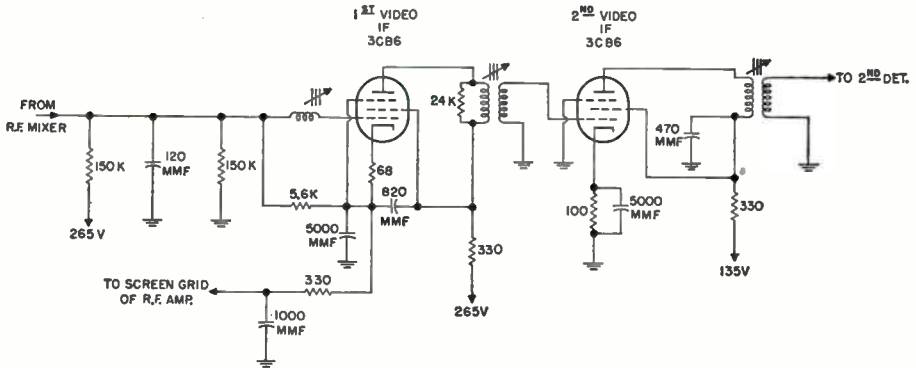

FIG. 5-24. A 2-stage video IF system. Note that there are only three peaking adjustments, and these, in conjunction with another one in the mixer plate circuit, would be adjusted for the desired response. The reason for the connection from the bottom of the cathode circuit of the first video IF to the screen grid of the RF amplifier is explained in the text.

In 3- and 4-stage systems, AGC is applied to at least one stage (the first) and frequently to the second as well. However, in 2-stage IF systems, AGC is applied only to the first stage and sometimes the matter of accomplishing this is indirect. For example, in Fig. 5-24, the AGC line (not shown) goes only to the control grid of the RF amplifier in the tuner. Here it controls the gain of the stage. However, the bottom end of the cathode resistor of the first IF stage is directly connected to the screen grid and the plate circuits of the RF amplifier. When a strong signal is received, the AGC voltage becomes more negative, reducing the current through the RF tube. This, in turn, raises the positive potential of the screen grid and plate of this tube. Since the bottom end of the first IF cathode is connected to the latter element in the RF-amplifier tube, it, too, will have its positive potential increased. This arrangement is equivalent to a negative increase in grid bias for the video IF tube and the gain of the stage will decrease. Thus,

by this indirect approach, automatic gain control of the first IF stage is achieved.

Complex Coupling. Thus far, we have considered transformer-coupled and stagger-tuned video IF amplifiers; now let us turn our attention to complex-coupled systems.

In the video IF system of Fig. 5-25 all interstage circuits are capacitively coupled. Thus L_1 leading to the input IF amplifier transfers its energy

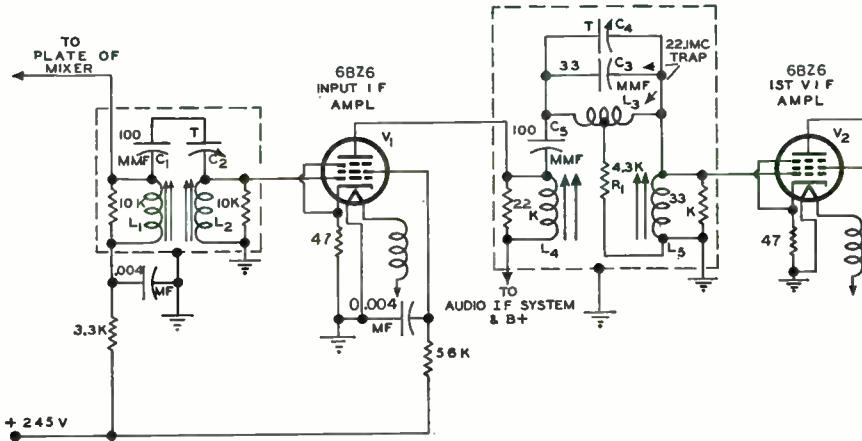

FIG. 5-25. A complex-coupled video IF system.

to L_2 through C_1 and C_2 . (L_1 and L_2 are not inductively coupled.) For alignment, L_1 and L_2 are peaked to different frequencies, and then C_2 is adjusted to provide the desired bandwidth. The idea here is to achieve the proper bandwidth without permitting any appreciable dip to appear in the center of the response curve. In this input network, all signals between 28.1 and 22.1 mc are permitted to reach the amplifier tube 6BZ6. The audio IF signal is then transferred to the audio system from the plate of the input IF amplifier. In the second coupling network located between V_1 and V_2 , the accompanying audio IF voltage is sharply attenuated by the trap consisting of L_3 , C_3 , C_4 , and R_1 . (The reader will recognize this as a bridged-T network.) L_4 , L_5 , and C_5 form the video IF coupling network similar to L_1 , L_2 , C_1 , and C_2 . The bandpass of this network is restricted to the 4.0 mc required by the video intermediate frequencies. The remaining video IF amplifiers of this system (not shown) are similar to the first two stages.

A second complex-coupled network is shown in Fig. 5-26. The common inductance L_2 couples the signal energy from the mixer plate to the grid

of V_1 . The mixer load circuit is L_1 plus L_2 . The input circuit for V_1 is L_2 plus L_3 . L_2 is thus the common element in both arms of this network and functions as the transferring agent. L_1 and L_3 possess variable cores in order that the bandpass of this network may have the proper width (4.0 mc). C_1

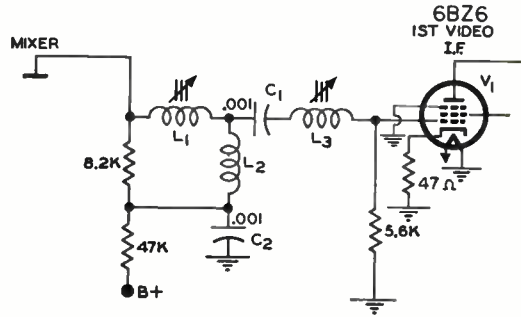

FIG. 5-26. A complex-coupled stage using the common inductance, L_2 , to transfer the signal from the plate of the mixer to the grid of V_1 .

is a d-c blocking capacitor, preventing the mixer B+ plate voltage from reaching the grid of V_1 . C_2 is an ordinary bypass capacitor. An 8,200-ohm plate resistor broadens the response of the network to insure a 4.0-mc spread.

Some readers will recognize the foregoing circuit as the familiar "T" network employed in some filters. Another complex arrangement is the "pi" circuit shown in Fig. 5-27. Although a large number of such circuits are

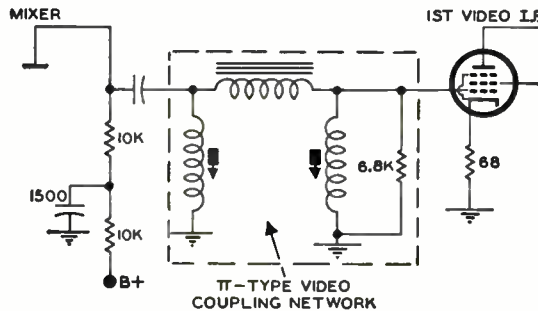

FIG. 5-27. A pi-type video coupling network.

possible, few, besides the ones shown, are ever employed. Circuits more complex than these are usually too costly and too difficult to adjust to permit their adaptation to mass-produced television receivers.

The cores of the IF coils and transformers discussed in this chapter require several alignment tools. One type of core, shown in Fig. 5-28(A), has

a hexagonal hole. A small, 6-sided rod is needed for its adjustment. The sides of the rod are visually aligned with the sides of the hole, inserted into the opening, and then slowly rotated.

A second type of core, shown in Fig. 5-28(B), has a partial slot, whereas the core in Fig. 5-28(C) has a full slot. For these cores, narrow metal, fiber, or plastic tipped screwdrivers are required. It is particularly important that the blade exactly fits the slot; otherwise the slot may be damaged and it may be difficult or even impossible to turn the core.

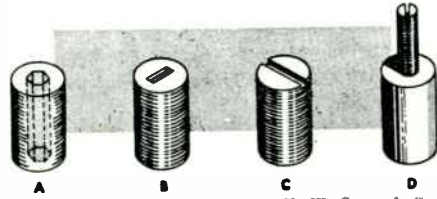

Courtesy H. W. Sams & Co.

FIG. 5-28. Types of cores used in IF coils.

The fourth type of core, shown in Fig. 5-28(D), has a brass screw imbedded in it. The open end of the screw is slotted, requiring a thin screw-driver blade for turning.

QUESTIONS

1. Draw the standard response curve for the IF system of a television receiver. Indicate the position of the video carrier.
2. What basic factors govern the design of an IF system?
3. How is the IF chosen for a system?
4. What is a spurious response?
5. List and explain two types of spurious responses.
6. Illustrate two methods for separating audio and video IF voltages from each other in split-sound sets.
7. When are video and audio IF signals separated from each other? Explain for both split-sound and intercarrier systems.
8. Why are trap circuits used in video IF amplifiers?
9. In a split-sound receiver employing 45.75 mc for the video carrier IF and 41.25 mc for the audio carrier IF, what trap frequencies should be employed? Explain how your answers were obtained.
10. When is the audio signal of the adjacent television channel not important? Why?
11. Draw three types of trap circuits commonly found in television circuits.
12. Given that the video carrier IF is 45.25 mc for a certain receiver. List the oscillator frequencies for each of the thirteen channels.
13. Draw the circuits of two different types of IF amplifiers.
14. Explain why capacitor tuning is seldom found in video IF tuned circuits.
15. A video IF signal extends from 45.75 mc to 41.25 mc. What effect would attenuation of the frequencies around 45.75 mc have on the image? Around 43.25 mc?
16. Explain the reason why the EIA recommended that the video IF carrier be raised to 45.75 mc and the sound IF carrier value be raised to 41.25 mc.
17. How are the trap circuits of a video IF system adjusted?
18. Explain the principle behind stagger-tuning.

19. Wherein does a bifilar coil differ from conventional transformer coupling?
20. The video IF system shown in Fig. 5-24, does not contain any trap circuits. Explain why this is possible in this case without the receiver becoming unduly susceptible to interference from adjacent channels?
21. What is the function in C_2 in Fig. 5-25?

Video Detectors and AGC Circuits

Detection of the Video Signal. In accordance with the general line-up that is peculiar to superheterodynes, the second detector follows the last IF amplifier. Detection in television receivers is carried out in much the same manner as in any ordinary sound broadcast receiver. The single diode, connected as shown in Fig. 6-1, is typical. The demodulated video signal with

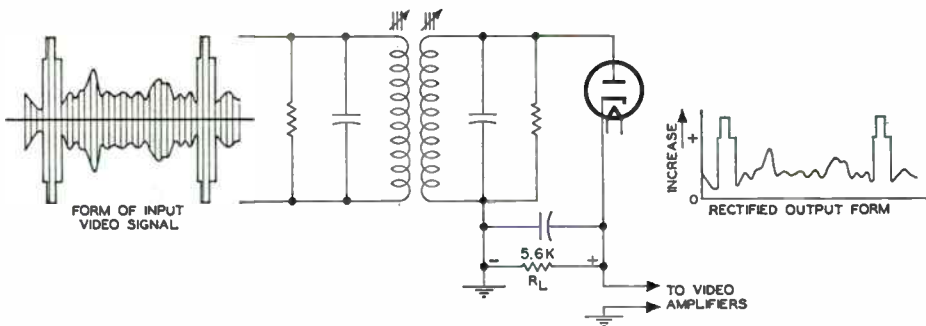

FIG. 6-1. A diode detector for a television receiver.

its blanking and synchronizing peaks is developed across R_L . The form of the signal when it enters the second detector is shown to the left of the figure. The rectified resultant is illustrated at the right.

As is true of diode operation, plate current flows only when the plate is positive with respect to the cathode. The effect of this action is to eliminate the negative portion of the incoming signal. Since the positive and negative sections of the modulated video signal are exact duplicates of each other, either one may be used. Instead of a half-wave rectifier it is also possible to use the full-wave arrangement shown in Fig. 6-2 with a 6AL5 double diode.

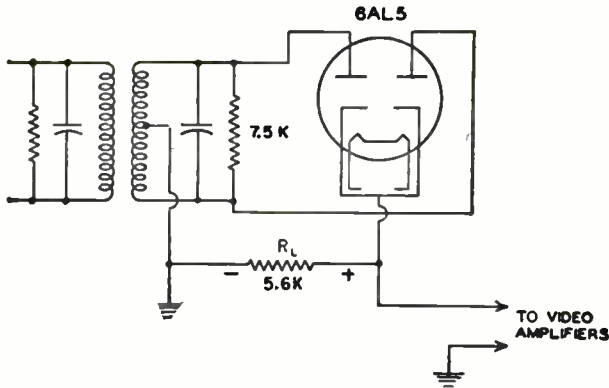

FIG. 6-2. A full-wave detector.

Positive and Negative Picture Phases. At this point it is necessary to consider the effect of the relative polarity of the voltage drop across the load resistor R_L . It will be recalled from Chapter 1 that, for American television systems, negative picture transmission is standard. This means that the brightest elements cause the least amount of current to flow, while maximum current is obtained when the blacker than black region of the synchronizing signal is reached. This method of transmission was adopted because it was felt that better overall reception would be obtained.

The signal in the negative picture-phase form, as shown in Fig. 6-3(A) however, cannot be applied directly to the grid of the picture tube. It first has to be reversed to the form shown in Fig. 6-3(B). That this is necessary

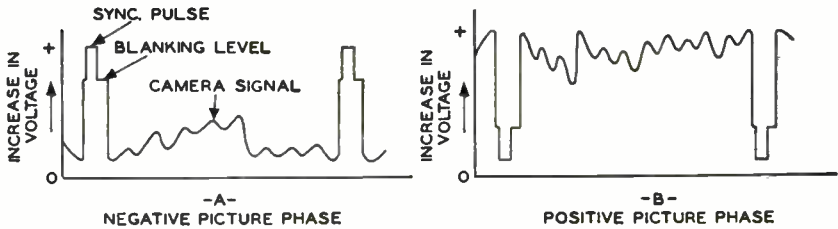

FIG. 6-3. Rectified video signals may be obtained from the output of the detector in either one of the two forms shown, depending upon how the detector is connected.

is easily seen, for the blanking and synchronizing signals, when applied to the control grid of a picture tube, must bias it to cutoff. The objective can be attained only if the signal has the form given in Fig. 6-3(B). The television engineer calls this latter form of the television signal the positive picture phase. It is interesting to note that, if the negative phase of the signal is applied to the control grid of the picture tube, all the picture values

will be reversed and the observed scene will be similar to a photographic negative.*

In sound receivers, no attention is given to the relative phase of the audio signal because our ears are insensitive to all but gross phase differences. Television, on the other hand, deals with visual images, and reversal of phase produces noticeable effects. Possible ways of altering the phase of the video signal are discussed in the following paragraphs.

Turning to the half-wave detector circuit of Fig. 6-1, let us investigate the voltage developed across R_L . The incoming signal has the same form as at the antenna, with the synchronizing pulses giving rise to the greatest voltages. At the diode rectifier, these synchronizing signals cause the plate to become the most positive, resulting in a greater voltage drop across R_L and having the polarity as shown. On the other hand, those portions of the video signal representing the bright segments of the image will have the least positive voltage at the diode plate, with a smaller resultant voltage drop at R_L . Thus, with this circuit hookup, point *A* of resistor R_L will still give rise to a large positive voltage for the synchronizing signals, which means that the signal is still in the negative picture phase. The signal is unsuitable for direct application to the grid of the viewing tube.

The direction of the current flow through R_L may be altered quite easily to give the opposite polarity. Simply reverse the connections between the diode tube and the input transformer, as shown in Fig. 6-4. Rectification now

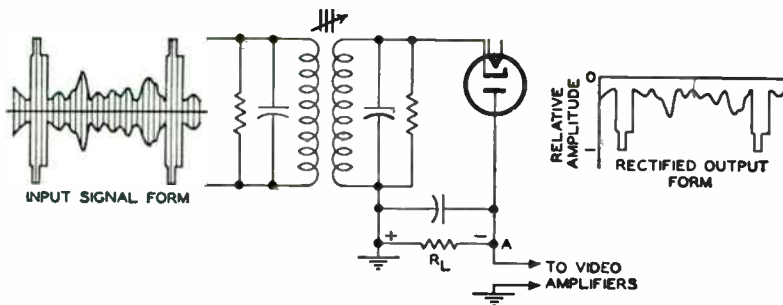

FIG. 6-4. A diode detector connected to give a positive-picture-phase output signal. Note that, with an inverted diode detector, only the negative half of the input signal is rectified. In Fig. 5-1 the opposite is true.

eliminates the positive half of the modulated carrier and leaves the negative half. Since both contain the same information, nothing is lost. Point *A* becomes more strongly negative for the blanking and synchronizing por-

* Another widely used method of distinguishing between signal polarities is to employ the designation of sync pulse positive (Fig. 6-3(A)) or sync pulse negative (Fig. 6-3(B)).

tion of the video signal, while the bright elements cause A to become less negative. When the signal is applied in this form between the grid and the cathode of the image tube, the largest current will flow for the bright sections of the image and a bright spot will appear on the fluorescent screen. For the blanking and synchronizing parts of the signal, the voltage at the grid (from point A) will be highly negative and the electron beam will be cut off, as it should be.

The strength of the signal that is developed at the diode load resistor is not strong enough to use directly at the picture tube. Hence, further amplification is necessary. The following video amplifiers, which are generally of the resistance-coupled type, are capable of reversing by 180 deg the polarity of any signal sent through them. Thus, if the video signal had a positive picture phase at the diode load resistor, it would have a negative picture phase at the output of the first video amplifier. With another stage of amplification, the picture would be brought back to the positive phase again. As a general rule, then, an even number of video amplifiers is required if the picture phase across R_L in the detector is positive. For a negative picture phase at R_L , an odd number of video amplifiers is needed, this time for a positive picture to appear at the grid of the image tube. These conditions are illustrated in block form in Fig. 6-5.

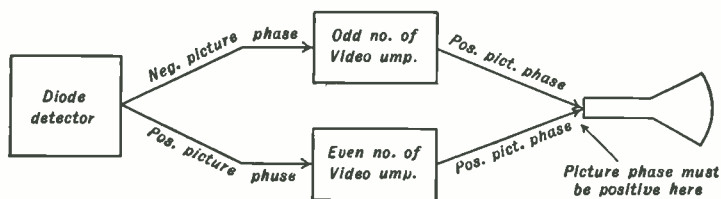

FIG. 6-5. An illustration of why the number of video amplifiers after the detector is dependent upon the polarity of the signal obtained from the detector.

The circuit of the video detector and the video amplifier in Fig. 6-6 appears at first glance to violate the foregoing rules. Examination of the video signal developed across R_1 reveals it to be positively phased. This would require 0, 2, 4, or some other even number of video amplifiers. Actually only one is present. The mystery is resolved when we note that the output of the video amplifier is fed not to the control grid of the cathode-ray tube but to its cathode. The foregoing rules were drawn up with the tacit understanding that all incoming signals are applied to the control grid of the picture tube. To produce similar results, signals applied to the cathode of a tube should differ by 180 deg from the same signals applied to the control grid.

Detector Filtering and Peaking. The frequencies present in the detector circuit include the intermediate-frequency values and the actual video

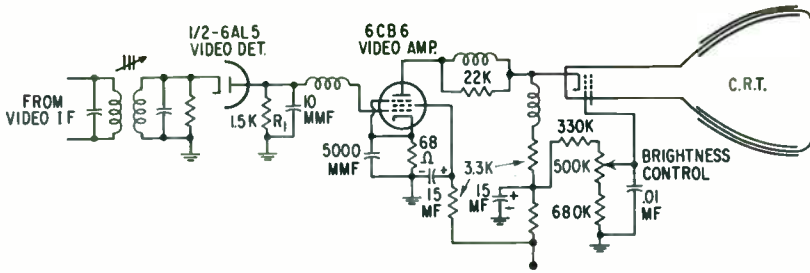

FIG. 6-6. A video detector and video amplifier feeding the signal to the cathode of the image tube.

signals themselves, 0-4 mc. The latter voltages are to be passed on to the video amplifiers and strengthened to the point where they are able to modulate the electron current in the cathode-ray tube to produce an image on the screen. At the detector output, the intermediate frequencies must be properly shunted around the load resistor to prevent their reaching the following video amplifiers. In the receivers currently being produced, the problem of filtering the IF voltages has been made comparatively simple through the use of fairly high IF values. The rectified video signal has a maximum frequency of 4 mc. In early television receivers, the IF values ranged from 8.75 to 12.75 mc, and considerable filtering was required because of the low order of separation between the desired frequencies (0-4 mc) and those which were to be bypassed (8.75 to 12.75 mc). However, by increasing the separation between the two, we have simplified the problem considerably. Current recommended values for the video IF are between 40 and 46 mc. Adequate filtering can be obtained through the arrangement shown in Fig. 6-7. The rectified current passes through the low-pass filter composed of C_1 , L_1 , R_1 , L_2 , R_2 , and C_2 . C_1 is a small fixed capacitor of 5 mmf, but actually there exists additional capacitance across this point produced by the tube and the wiring. At the other end of the filter, C_2 is shown in dotted form because no such component is inserted. However, the sum of the stray wiring capacitance plus the input capacitance of the following video amplifier produces the equivalent of an actual capacitor of 10 to 15 mmf. The two coils, L_1 and L_2 , while forming part of the low-pass filter, at the same time maintain a good frequency response to 4 mc, thereby counteracting any tendency of the circuit to attenuate these higher video frequencies. More will be noted on this point in the succeeding

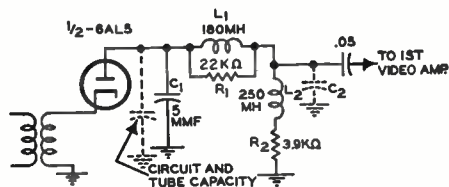

FIG. 6-7. A video detector circuit with a low-pass filter and load resistor.

chapter on video amplifiers. The 39,000-ohm resistor shunted across L_1 is used to prevent the response of the coil from rising abruptly at the higher video frequencies because of a natural resonant circuit formed by the coil and its inherent capacitance. The detector load resistor is R_2 (3,900 ohms).

In place of a diode tube, many television receiver designers use one of the germanium crystal detectors, 1N34, 1N54, 1N55, 1N60, and 1N295, among others. A typical circuit using a germanium crystal is shown in Fig. 6-8.

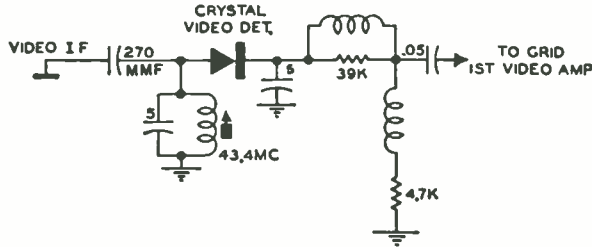

Fig. 6-8. A germanium crystal as a video detector.

Shunt Video Detectors. All of the video detectors discussed thus far are of the series type, in which the rectifier (tube or semiconductor diode), the input-tuned circuit, and the load resistor are all in series. It is also possible to achieve detection by placing the diode in shunt with the tuned circuit and the load resistor. The basic circuit is shown in Fig. 6-9(A) and the complete circuit, with the low-pass filter, is shown in Fig. 6-9(B).

The circuit of Fig. 6-9(A) operates in the following manner. When the positive half of the IF video signal is active, 1N295 germanium diode conducts. Electrons travel up through the diode to the right-hand plate of C_1 , charging this side of the capacitor negative. At the same time, an equivalent number of electrons leave the other plate of C_1 and travel down through L_1 and R_2 to B+ and thence to ground, completing the circuit. Because of the low resistance of the diode while it is conducting, C_1 will charge to the peak of the applied voltage.

During the succeeding half-cycle, when the signal voltage is negative, the diode becomes nonconductive. C_1 , however, finds a complete discharge path through R_L and electrons travel from the right-hand plate of C_1 through R_L to ground, then up through V_1 to the other plate of C_1 . This flow places the full value of the voltage of C_1 across R_L . Thus, we obtain all of the IF variations across R_L , as well as the modulation signal (which represents the video information), and an average d-c voltage, because rectification has taken place. Additional filtering is required to remove the IF portion of the voltage. What happens to the d-c voltage depends on the suc-

ceeding circuit. If it is desired to retain the d-c voltage, then a d-c path is maintained to the next tube (a video amplifier). However, if this d-c voltage is not desired, the signal across R_L can be capacitively coupled to the next stage.

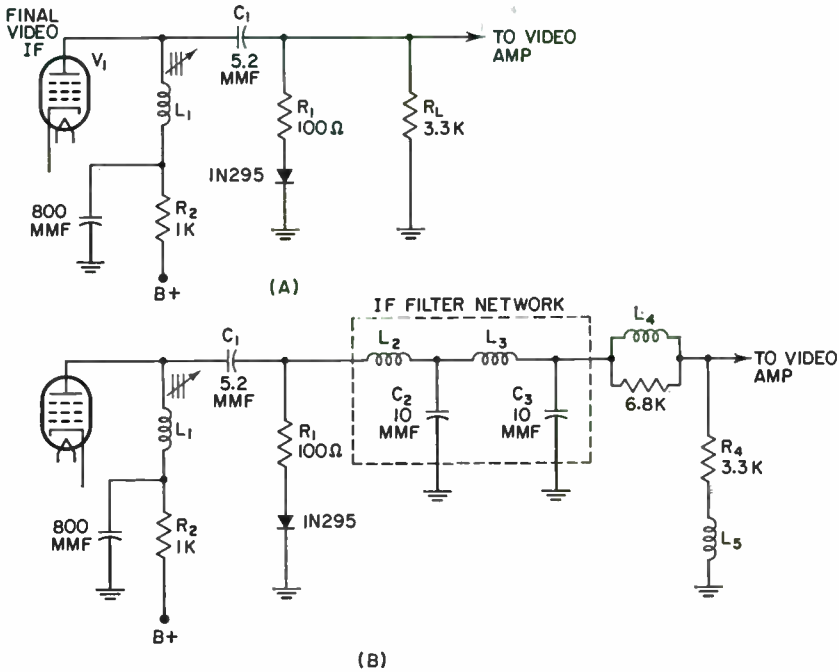

FIG. 6-9. (A) Basic circuit of shunt video detector. (B) Complete circuit with low-pass filter and video-peaking coils.

A full-shunt-detector circuit, complete with a low-pass filter, is shown in Fig. 6-9(B). L_2 , L_3 , C_2 , and C_3 form the filter, while L_4 and L_5 serve as the video-peaking elements. R_1 is a current-limiting resistor, designed to protect the 1N295 diode. Note that in this arrangement the low-pass filter is placed before the load resistor, R_L . It could have been positioned after R_L , but the arrangement shown is the more efficient approach.

Before we leave video detectors, it might be instructive to see how a video signal would appear as seen on the screen of an oscilloscope. A typical presentation is given in Fig. 6-10. To obtain a stationary pattern, the sweeping rate in the oscilloscope should either be 15,750 cycles or, for two full lines, as shown in Fig. 6-10, 7875 cycles. How clearly the sync pulses appear will depend on the overall response of the vertical amplifiers in the oscilloscope. If this response is too narrow, the sync pulses will appear with rounded

corners; however, even with the limited response of fairly low-cost oscilloscopes, the form of the video signal will be clearly discernible.

AVC and AGC. Automatic volume control (actually this should be called "automatic gain control") in a radio receiver serves to keep the output constant while wide variations occur in the input signal. Once the manual volume control has selected the output level that is desired, the AVC system tends to keep it there. In addition, when tuning to other stations, no adjustments are necessary to prevent blasting. For television receivers, automatic gain control (AGC) is advantageous in keeping the picture intensity fixed at one level while the actual video signal at the input of the set may be varying. The eye is far

more critical of changes than the ear, and anything that minimizes unwanted variations in image intensity is very desirable. AGC is advantageous when switching from one station to another, for again input-signal strengths may differ. Finally, more stable synchronizing is obtained if the signal fed to the synchronizing circuits is constant in amplitude.

In a radio receiver, the AVC voltage is obtained at the second detector. The necessary audio signal is developed across the load resistor. A circuit frequently used is illustrated in Fig. 6-11, with the polarity of the AVC voltage and the filter circuit included. It will be recalled that the object of the AVC is not to feed back the instantaneous audio variations but rather an average voltage that depends upon the carrier level back to the RF and

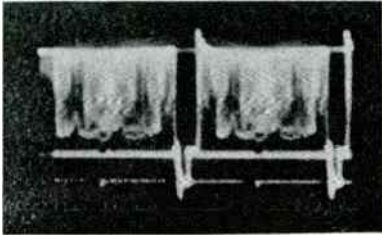

FIG. 6-10. Two lines of a video signal, as observed on the screen of an oscilloscope.

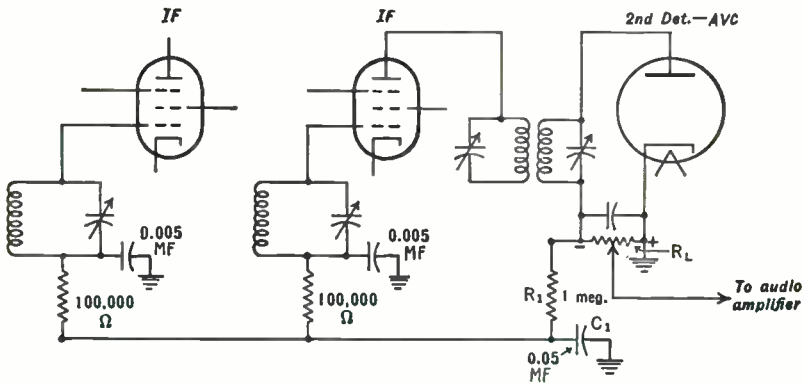

FIG. 6-11. A conventional AVC circuit found in radio receivers.

IF stages. If the audio variations were sent back to the preceding tubes, all musical passages, for example, would be heard with the same intensity, in itself a form of distortion.

The desired AVC voltage is obtained from the average voltage developed across the load resistor by the rectified carrier signal. The incoming signal, both before and after rectification by the diode detector, is shown in Fig. 6-12. The detector output consists of a pulsating d-c voltage that contains

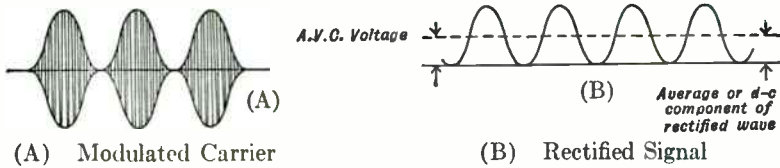

FIG. 6-12. The AVC voltage developed across R_L represents the average value of the incoming wave.

a varying audio voltage, and an average d-c voltage dependent upon the carrier strength. The audio signal, since it is varying as much above the average value as below, contributes nothing to the d-c voltage. The only way the average d-c voltage can be changed is to alter the strength of the carrier. This is demonstrated in Fig. 6-13, where different levels of carrier signals are shown, all having the same audio component. The d-c voltage is then fed to the various controlled IF and RF stages. The purpose of filter capacitor C_1 and resistor R_1 of Fig. 6-11 is to prevent (or at least minimize) any audio voltage from reaching the controlled tubes.

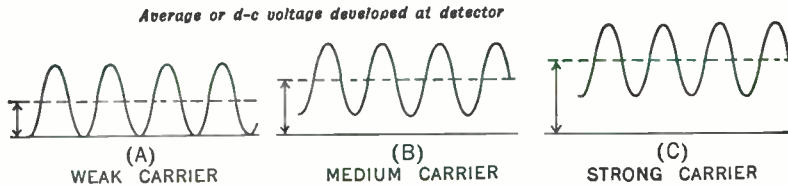

FIG. 6-13. These diagrams illustrate how the AVC voltage is dependent upon the strength of the incoming signal, and not upon its modulation.

The objectives in television receivers, through the use of automatic gain control, are similar to those of radio broadcast sets. The means of obtaining the necessary voltage, though, is somewhat different, because of the difference in the make-up of the video signals. A study of the television-modulated signal in Fig. 6-14 reveals that, so far as AGC is concerned, the rapidly varying camera signal is of little use to us. We desire some point

which will be indicative of the strength of the carrier and which does not change with anything but the carrier.

With the present system of transmission, the carrier is always brought to the same level when the synchronizing pulses are inserted. Thus, so long as the signal being received is constant in strength, the level of the synchronizing pulses will always reach the same value. If something should affect

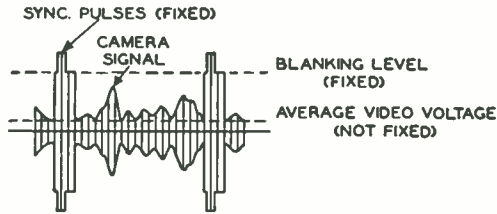

FIG. 6-14. An amplitude-modulated television signal. The fixed voltage levels are suitable for AGC control since these voltages vary directly with signal strength.

the carrier level, these pulses would likewise change. With the change, the gain of the set would require adjustment to maintain the previous level at the detector. Hence, the strength of the synchronizing pulses will serve nicely as a reference level for the AGC system. It should be noted that the level of the blanking pulses (immediately below the top of the synchronizing pulse) is likewise fixed and may also be used.

To the present, three general methods have been employed to develop AGC voltage: peak, average, and keyed. Each will be considered in turn.

Peak AGC Systems. In peak AGC systems, the designer uses the sync-pulse tips to establish the AGC voltage. A separate diode rectifier is employed which receives the same video IF signal as the second detector. Diode conduction occurs during one-half cycle (positive or negative) and during this period a capacitor is charged to the full voltage of the arriving sync pulse. It is this voltage which is then employed for automatic gain control.

A typical peak-detector circuit is shown in Fig. 6-15(A). The AGC diode is one section of a 6AL5 and receives the incoming signal from the video IF system through a 0.5-mf capacitor, C_1 . The load for the AGC tube is R_1 , a 1-megohm resistor. To understand the operation of this circuit, consider the equivalent diagram shown in Fig. 6-15(B). (The cathode resistor and capacitor are omitted from the equivalent diagram because they do not affect the AGC-voltage development.) The AGC tube will not conduct until its plate is driven positive with respect to its cathode. When this occurs, electrons flow from the cathode to the plate of the diode and into C_1 , where the negative charge is stored. Very few electrons attempt to go through R_1 because of its high value. On account of the low impedance

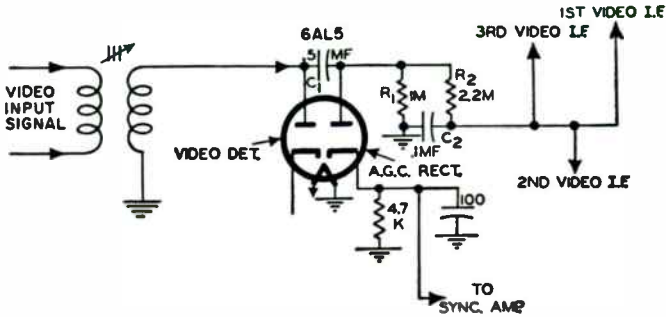

(A)

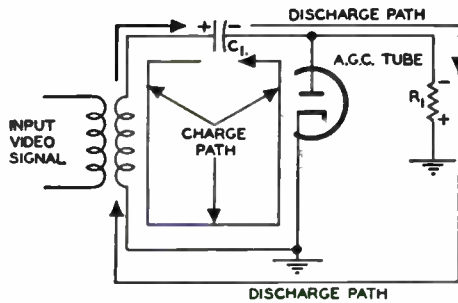

(B)

FIG. 6-15. (A) A simple peak AGC network. (B) The equivalent circuit, showing the charge and discharge paths of C_1 .

offered by the tube when it is conducting, C_1 charges up to the peak of the applied voltage, which is the value of the synchronizing pulses.

During the negative excursion of the incoming signal, the plate of the diode is driven negative with respect to its cathode and no conduction through the tube occurs. However, if we examine Fig. 6-15(B), we see that a complete circuit exists with C_1 , R_1 , and the input coil all in series. Since a voltage exists across C_1 and a complete path is available, current will flow, with the upper end of R_1 becoming negative with respect to ground. Because of the long time constant of R_1 and C_1 , the charge accumulated across C_1 will discharge slowly through R_1 , so slowly, in fact, that only a small percentage of the voltage across C_1 will be lost during the interval when the tube is not conducting.

When the incoming signal becomes positive again, the tube does not immediately conduct because the applied signal voltage must first overcome the negative voltage existing across C_1 . Since C_1 has lost little of its voltage, tube conduction will occur only at the very peak of the positive cycle. These peaks, of course, are the synchronizing pulses. Thus, the voltage across

C_1 is governed entirely by the sync pulses, which is what we desire. The negative voltage across R_1 is filtered by R_2 and C_2 to remove the 15,750-cycle ripple of the horizontal sync pulse, and then fed to the video IF amplifiers as the control voltage. It is interesting to note that the same diode can also supply the sync pulses to the horizontal and vertical sync systems. Since current flows through this diode only at the sync pulses, voltage pips will appear at these times across the 4,700-ohm resistor in the cathode leg of the tube. These pips are tapped off and applied to the sync-separating circuits.

Instead of using a separate diode to develop the AGC voltage, the sync separator can be designed to provide this voltage as well as to separate the sync pulses from the rest of the video signal. (The latter aspect of its behavior will be discussed in a subsequent chapter.) A suitable circuit appears in Fig. 6-16. The entire video signal (containing signal voltages and sync

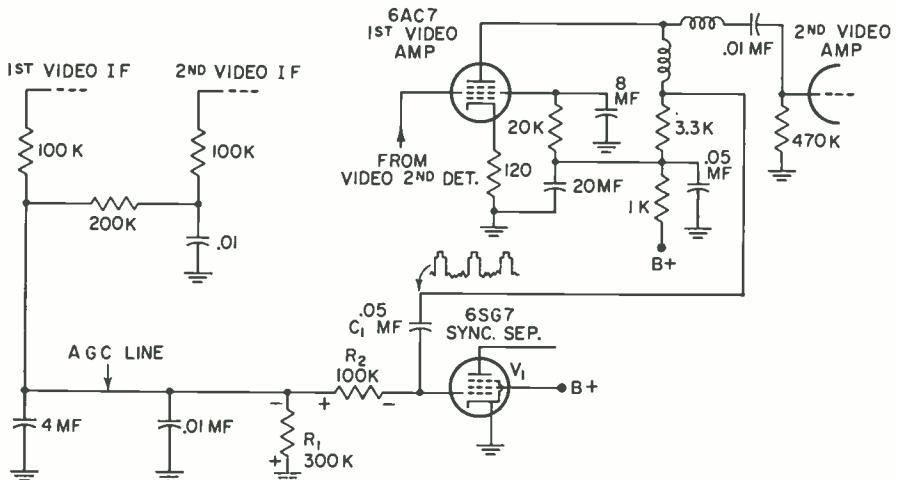

FIG. 6-16. An AGC network employed in some television receivers.

pulses) is tapped off from the output circuit of the first video-frequency amplifier and applied to a 6SG7 sync-separator tube. The AGC voltage is developed at the grid of V_1 as a result of the grid-leak-biasing arrangement employed here. V_1 has no fixed bias of its own. Hence, when a signal is applied through C_1 , grid current flows for the positive portions of the signal, the amount depending upon the strength of the signal voltage. Because of the high value of R_1 and R_2 , the grid electrons flow into C_1 , charging it to the peak value of the applied signal. This peak value is set by the sync pulses. The charge developed across C_1 then discharges slowly through R_1 and R_2 , developing a bias voltage across these two resistors which is nega-

tive with respect to ground. Because of the long-time constant of the grid network, the charge on C_1 leaks off slowly, and only the sync pulses can overcome its negative charge and cause current to flow in the 6SG7. Thus, the voltage developed across R_1 and R_2 is governed by the sync pulses. The voltage across R_1 is applied, through a suitable filter network, to several video IF amplifiers as an automatic bias. The 6SG7 is a sync separator because only the sync pulses appear in its output. The rest of the video signal is without effect because of the high negative grid-leak bias.

A system which is more complex and involves the use of a special AGC amplifier is shown in Fig. 6-17. As before, the incoming video signal is

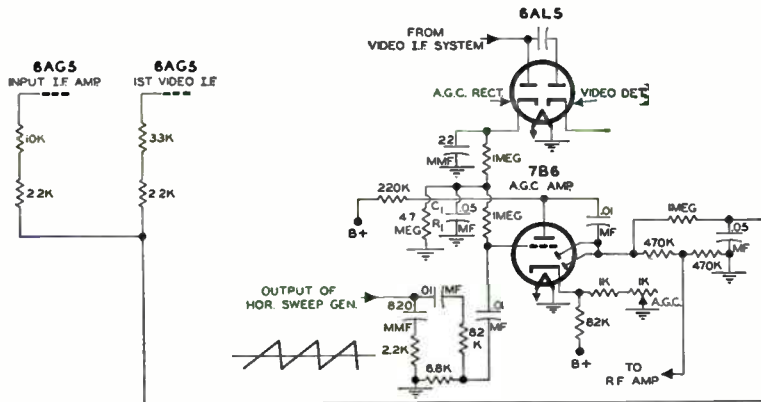

Fig. 6-17. An AGC network that uses an amplifier.

received from the video IF system and applied to the video second detector and the AGC rectifier. In the cathode leg of the AGC diode section of the 6AL5, we have the long-time-constant network of R_1 (4.7 meg) and C_1 (0.05 mf). Initially the capacitor charges up to the peak value of the incoming sync pulses and thereafter discharges slowly through R_1 during those intervals when the diode tube does not conduct. Since the discharge is very slow, because of the time constant of the circuit, much of the voltage established across C_1 will remain. Hence, current will flow through the tube only at the sync-pulse tips. The voltage thus established across C_1 and R_1 will be governed by the level of the sync pulses in the incoming signal.

As a result of the path of current flow through the AGC rectifier tube, the voltage at the ungrounded end of R_1 is positive. This voltage is fed to the grid of the triode section of the 7B6 AGC amplifier. This positive voltage, however, is offset by an even greater positive voltage that is obtained from the B+ power supply and applied to the cathode. Thus, the

effective control-grid bias for the AGC amplifier is negative, although the value of this negative voltage varies with the voltage obtained from R_1 and C_1 . The purpose of this arrangement is to vary the bias of the 7B6 with the strength of the incoming signal and yet maintain the overall bias negative.

A second voltage applied to the grid of the AGC amplifier is obtained from the horizontal-deflection system. This voltage is amplified in the 7B6 and then rectified by the diode section of the same tube. It is this rectified voltage which is finally employed as the AGC voltage to control the gain of the RF, input IF, and first-video IF amplifiers.

When the signal level increases, the AGC rectifier develops more voltage across C_1 and R_1 . This means more positive voltage for the AGC amplifier (7B6) and a greater output from this tube because of the increased gain. The horizontal-deflection voltage fed into the tube remains constant at all times and a more positive bias for the tube will produce a greater output. This means that more rectified AGC voltage is fed to the controlled stages. However, since the final AGC voltage is negative, the gain of the controlled stages decreases, counteracting the increased video signal and reducing the output to the normal level.

When the signal level decreases, less positive voltage appears across C_1 and R_1 and the AGC amplifier bias becomes correspondingly more negative. Less gain in this tube provides less voltage at its output, and the negative AGC voltage decreases. As a result, the gain of the controlled stages rises, and the signal level is again brought back to the normal level.

Whereas in the previous AGC system, the output of C_1 and R_1 was used as the controlling AGC voltage, here it is used to control the bias of the AGC amplifier. The final product of both systems is the same, but this arrangement is more sensitive to carrier changes because of the addition of the amplifier. A divider network at the output of the diode section of the 7B6 feeds less AGC voltage to the RF amplifier than to the IF stages. The potentiometer in the AGC system permits it to be adjusted for desired sensitivity.

Average AGC Systems. Average AGC systems employed in television receivers operate in exactly the same manner as the conventional AVC system illustrated in Fig. 6-11, that is, one diode functions as the video second detector and AGC rectifier, providing both voltages at its output. A typical circuit is shown in Fig. 6-18. V_1 , the diode section of a 5AS8 tube, is connected as a series detector. If we remove R_2 , C_2 , then the circuit is a conventional video detector possessing a low-pass filter network and peaking coils. The voltage that appears across R_1 is composed of the rectified video signal plus a d-c component which is an average voltage governed by the strength of the incoming signal and its picture content. The video segment is transferred to the video amplifier that follows the detector; the d-c

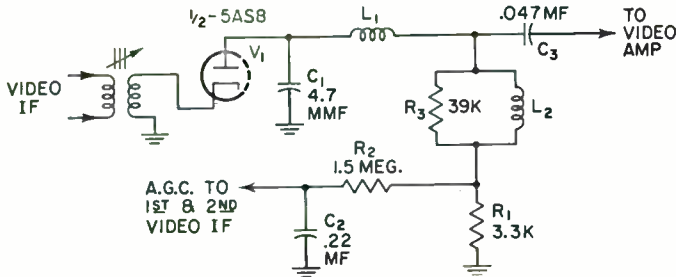

FIG. 6-18. Circuit diagram of a typical AGC system.

component is passed through the low-pass filter of R_2 , C_2 and applied to the control grids of the first- and second-video IF amplifiers to control the gain of these stages.

R_2 , C_2 serve several purposes. First, they prevent any video signal from entering the AGC line. Second, by their relatively long-time constant (here 0.33 seconds), they act to smooth out any sudden noise pulses that may be received. In this way, the AGC system responds only to the slow changes in signal level and not at all to momentary noise pulses.

The system is extremely simple in operation and the most economical of all the AGC systems in use. It does, however, suffer from several disadvantages. The amount of AGC voltage which it develops is quite small because of the relatively low level of the signal at the video detector. This small amount of voltage makes it difficult to control remote cutoff video IF tubes, the 6BZ6, for example. (In strong-signal areas, remote cutoff tubes are required in the video IF system to prevent overloading.)

A second disadvantage is the fact that the d-c voltage, shown across R_1 of Fig. 6-18, depends not only on the signal strength (which is desirable), but also on the picture content (which is undesirable). To illustrate the latter point, consider two identical signals, both possessing the same video detail but differing in background brightness. These signals are shown in Fig. 6-19. Note that the darker signal in Fig. 6-19(A) has the video detail

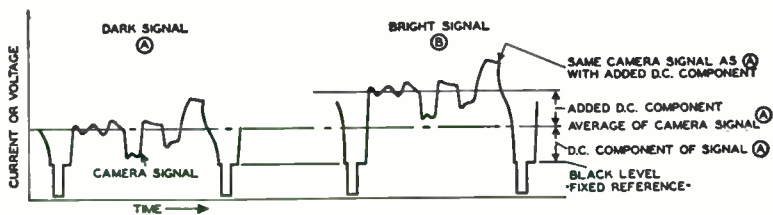

FIG. 6-19. Two video signals containing the same detail (a-c component) but different background brightness (d-c component).

closer to the peaks of the sync pulses; consequently this signal will develop a greater negative d-c voltage across R_1 than the higher signal shown in Fig. 6-19(B). A larger d-c voltage across R_1 means less gain in the video IF system. Hence darker scenes will come through even darker, and lighter scenes even lighter.

In the average AGC system, there is no way to avoid this difficulty and this is one of its major drawbacks. In a strong-signal area, the lighter scenes may readily lead to set overloading. However, the system is exceedingly economical and this is the major reason why it is employed.

Sometimes an effort is made in average AGC systems to reduce the dependency of the control voltage on changes in scene brightness by the arrangement shown in Fig. 6-20. Here, part of the AGC voltage is obtained

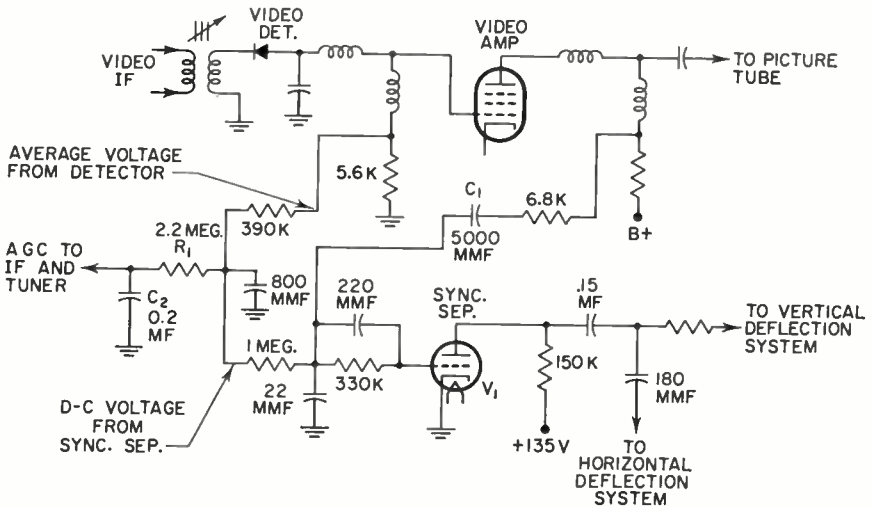

Fig. 6-20. The AGC voltage in this circuit is obtained by combining the average d-c voltage from the detector and the peak voltage developed across C_1 by V_1 .

from the video detector by averaging, and part of it from the grid of the sync separator, V_1 . Composite video with sync positive polarity is fed from the video amplifier to V_1 , where the grid and cathode function as a peak diode detector which conducts only when the sync pulses are active. The current that flows in the grid circuit of V_1 charges C_1 negatively to approximately the peak value of the sync pulses. Because of the fairly long-time constant of the grid network, C_1 does not appreciably discharge between pulses. Hence current flows in V_1 only at the sync-pulse tips, because only then is the signal voltage strong enough to overcome the negative voltage of C_1 .

The voltage from C_1 is combined with the average d-c voltage developed

by the video detector, filtered by R_1 , C_2 , and fed to the IF and RF stages. The presence of this peak-dependent voltage tends to make the overall AGC voltage less sensitive to changes in scene brightness than an AGC voltage totally obtained by averaging.

A number of receivers combine a "local-distant" switch with the AGC system to provide a degree of flexibility under varying signal conditions. The function of the switch is to have the full AGC voltage in use when the incoming signal is strong (that is, "local" conditions), and to reduce the control voltage when the received signal is weak (that is, "distant" conditions). There are a number of ways to achieve this flexibility, but the method shown in Fig. 6-21 is fairly typical.

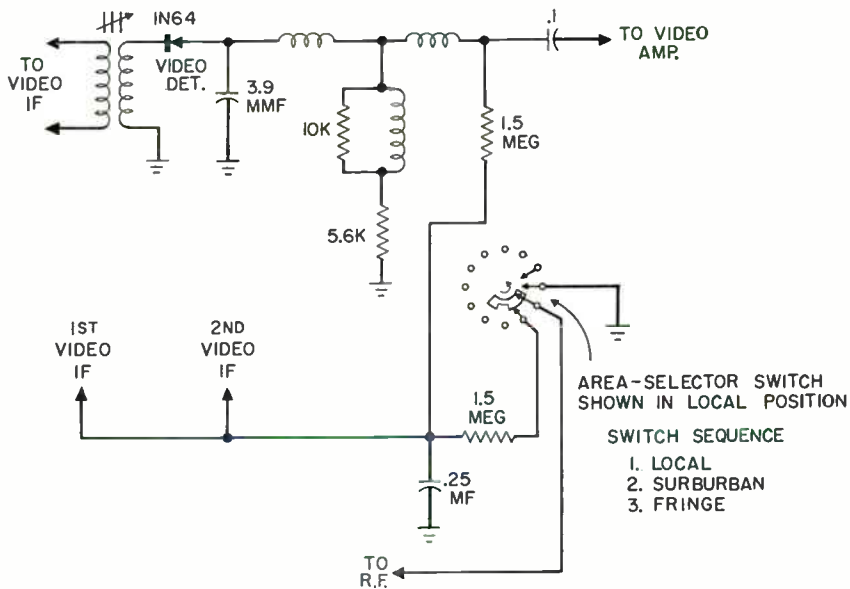

FIG. 6-21. An AGC system in which the control voltage can be varied to suit local reception conditions.

The AGC voltage is developed by a germanium diode (together with detection of the video signal) and fed via two 1.5-megohm resistors to the first and second IF amplifiers and the RF amplifier. A 3-position rotary selector switch is connected with this circuit so that it can alter the AGC-voltage distribution. When the switch is in the "local" position, all the controlled stages (IF and RF) receive the full AGC voltage. When the switch is in the "suburban" position, where the received signal is somewhat weaker, the AGC line to the RF amplifier is grounded. The two IF stages, however, still receive the full AGC voltage. Finally, in the "fringe" position, both IF

amplifiers have their AGC voltage cut in half. The AGC voltage to the RF amplifier remains at zero.

By the foregoing arrangement, the AGC voltage can be regulated according to the strength of the incoming signal. This method of control can be applied also to the peak AGC system.

Keyed AGC Systems. Keyed AGC systems represent still another approach to the problem of adequate control of the gain of a receiver. Although of fairly recent origin, they are already widely used.

If we examine the AGC filter network in any of the circuits discussed thus far, it will be seen that fairly high-valued resistors and capacitors are used. This means that the capacitors charge up and discharge slowly. High-valued resistors and capacitors are required not only because they must smooth, or filter, out a 15,750-cycle ripple arising from the horizontal pulses which actuates the circuit, but because they must also smooth out a 60-cycle ripple produced by the vertical pulses. If the 60-cycle fluctuation is not removed, the bias on all controlled tubes will rise during the vertical sync interval and act to depress these pulses.

For slow changes in signal strength, these filter network arrangements are satisfactory. But what happens when a very fast change in signal level occurs? If such changes do not occur frequently, they will have very little noticeable effect on the AGC bias. But if the changes occur rapidly and continuously (or frequently), they will affect the bias and, through this, the picture. Thus, for example, when an airplane passes overhead, the picture intensity will rise and fall (flutter). Again, if the noise level is high, the preceding AGC systems will react to large noise pulses by developing more bias than they will if they respond solely to the signal. The result will be less amplification for the signal. If the signal itself is quite weak, this decreased amplification may cause it to be lost altogether.

Both of these disturbances adversely affect the television image. In fringe areas, the weak signal and the surrounding noise are the most important considerations; in areas near airports, airplane flutter is important. Before we describe how a keyed AGC system overcomes both these annoyances, let us briefly determine the reason for airplane flutter.

Picture flutter occurs whenever an airplane passes overhead or near-by. The picture intensity rises and falls, becoming light and dark in turn at a fairly rapid rate. This effect might last from 15 to 30 sec, depending upon how long it takes the airplane to pass.

The intensity pulsation is caused by the airplane acting as a reflector. Some of the television signals striking the metallic surface of the airplane bounce off and reach the television antenna. If these reflected television signals arrive in phase with the normal signal that the set antenna receives, they will add to the desired signal and strengthen it. If the reflected sig-

nal arrives out of phase with the normal signal, the strength of the normal signal will be reduced. Since this rapid increase and decrease in strength of the received signal cannot be counteracted by the usual slow-acting AGC filter, the picture on the screen will vary in intensity, producing the aforementioned flutter.

A keyed AGC system is able to overcome this flutter because of two facts: first, the AGC system is receptive to incoming signals only at certain specific times; second, the resistance and capacitances comprising the AGC filter are lower in value than the corresponding components in conventional AGC systems. Therefore a keyed AGC network can react instantly to a fairly rapid signal fluctuation, such as that produced by airplanes, and can change the AGC bias fast enough to counteract this signal change.

A simplified illustration of a keyed AGC system is shown in Fig. 6-22.

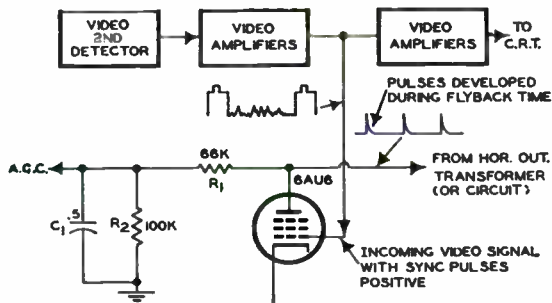

FIG. 6-22. A simplified diagram of the components of keyed AGC systems.

A 6AU6 pentode is so connected that a portion of the detected video signal is applied to its control grid. The signal is in the negative picture phase, which means that the sync pulses are most positive. The plate of the 6AU6 is connected to a winding on the horizontal-output transformer and receives from this transformer a positive pulse of voltage at the end of each horizontal line.

Now, the 6AU6 is so biased that it will not conduct unless the grid and plate are simultaneously active. If just one of these voltages is present, the 6AU6 does not ordinarily conduct.

The pulses applied to the grid are the horizontal-sync pulses. When these pulses arrive, the electron beam traveling across the face of the picture tube is about to start its retrace. At the moment it begins, a large pulse of voltage is developed in the horizontal-output transformer and a portion of this pulse is fed to the plate of the 6AU6. With both positive pulses of voltage present, the 6AU6 AGC tube is keyed into conduction and the AGC bias is established.

Note the foregoing sequence of events carefully because they contain the key to the operation of this system. Positive pulses must be present at both control grid and plate of the 6AU6 in order for the tube to pass current and establish the proper AGC bias. The plate receives no positive voltage other than that furnished by the horizontal-output transformer.

Since the 6AU6 conducts only when the sync pulses are active at its grid and inactive throughout the remainder of the video signal, it is evident that the AGC tube and consequently the AGC network is responsive to undesirable noise pulses for only a very short time. Actually, the sync pulses occupy but 5 per cent of the composite video signal, and therefore only 5 per cent of the total noise can be effective.

Contrast this with AGC systems other than the keyed type. While they are supposed to be unresponsive to all but the sync-pulse tips, this is true only if the amplitude of the sync pulses is greater than any of the noise pulses present. Any noise signal possessing a greater amplitude than the sync pulses will cause current to flow in the AGC tube and consequently will develop a greater negative biasing voltage in the AGC network than that obtained from the sync pulses. Until this greater negative voltage diminishes and the normal sync pulses again resume control, the gain of the set will be down.

When the 6AU6 conducts, current flows from the tube cathode to plate, then through R_1 and R_2 to ground, and finally back to the cathode of the 6AU6. C_1 is charged to the voltage developed across R_2 . The values chosen for the R_2 , C_1 combination are designed to remove the 15,750-cycle ripple of the plate-current pulses. No provision need be made to filter out a 60-cycle ripple since none exists in this AGC system. It is the use of small R , C values that largely accounts for the ability of a keyed AGC system to act fast in overcoming airplane flutter.

Before we progress further, there is probably one question which will occur to many readers: Why do the other AGC networks develop a 60-cycle ripple, while the keyed AGC networks do not? To understand why, refer to Fig. 1-19 (Chapter 1) where horizontal-sync pulses and vertical-sync pulses are shown. Note that the duration of a horizontal-sync pulse is much shorter than the duration of the vertical-sync pulse. In the conventional AGC system, this inequality in pulse duration results in a larger charge being developed across the AGC capacitors by the vertical-sync pulses. Hence, every $\frac{1}{60}$ sec, more current will flow through the AGC tube because of the greater width of the vertical-sync pulses. As a result, the AGC biasing voltage will have a 60-cycle ripple in addition to the 15,750-cycle variation caused by the horizontal-sync pulses themselves.

In the keyed AGC system, the 6AU6 is "fired" by a combination of a positive plate pulse and a positive grid pulse. The plate pulse, however, is

constant in duration since it is obtained from the horizontal-output transformer where the pulses do not change. Hence, whether the grid pulse is a horizontal-sync pulse or a vertical-sync pulse, the 6AU6 conducts for the same length of time. It is because of this behavior that only a 15,750-cycle ripple is present and needs to be filtered in keyed AGC systems.

In applying the sync pulses to the grid of the 6AU6 tube, care must be taken to see that they are all aligned to the same level. This alignment is necessary because the amount of current flowing through the AGC tube is determined in large measure by the amplitude of the sync pulses. As these vary, so will the current and, with this, the AGC bias will be developed across R_2 , C_1 and fed to the controlled tubes. Hence, it is important that the video signal contain its d-c component, for when the d-c component is removed, the sync pulses of the same signal are no longer aligned. To feed the latter type of signal to the AGC tube would result in a variation in bias with picture background and would not provide true reproduction of the original signal.

Commercial application of the keyed AGC system is shown by the circuit of Fig. 6-23. The video signal developed at the second detector has a complete d-c path to the grid of the video-amplifier tube and therefore the d-c component is present in the video signal. Hence this requirement is satisfied.

Second, inspection of the diagram reveals that the video signal which is

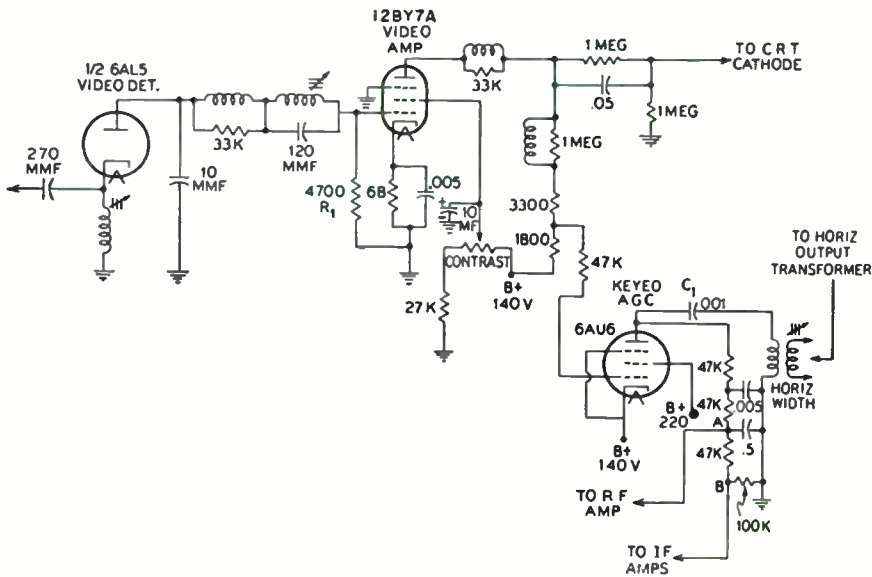

FIG. 6-23. A commercial application of the keyed AGC system.

applied to the 6AU6 AGC tube is obtained from the plate circuit of the 12BY7A video amplifier. At this point the sync pulses are positive. (This would have to be true, of course, since the signal from here is fed directly to the cathode of the cathode-ray tube.) A decoupling network consisting of a 3,300-ohm resistor, a 1,800-ohm resistor, and a 47,000-ohm resistor directs part of the video signal to the 6AU6 AGC tube. The decoupling network is designed to minimize the shunting effect of the 6AU6 on the video-amplifier network. This is required to uphold the video response of the amplifier-coupling network.

The cathode of the AGC tube is connected directly to the 140 volts B+ point. This is necessary because of the high positive potential present on the control grid of the 6AU6. Actually, with the AGC tube in operation, the control grid is approximately 25 volts less positive than the cathode, and hence the tube does not conduct except when the horizontal-sync pulses are active.

The screen grid of the 6AU6 AGC tube has applied to it a positive potential of 220 volts. The flyback pulse for the plate is taken from a special winding placed over the normal horizontal width coil. (This coil is connected across the secondary of the horizontal-output transformer.) Whenever the AGC tube conducts, current flow is through the three 47,000-ohm resistors and the 100,000-ohm resistor in its plate circuit. The polarity of the voltage developed at points *A* and *B* is thus negative with respect to ground and this is the AGC-regulating bias sent to the grids of the controlled tubes.

Under normal conditions, the AGC voltage measured at the control grid of any of the video IF amplifiers in this circuit will be approximately -4.5 volts. This voltage will vary slightly with signal-input and contrast control-setting. The latter control adjusts the screen grid voltage of the 12BY7A between the limits of 65 and 140 volts. At 65 volts the video signal is cut off completely; at 140 volts it receives its maximum amplification.

The foregoing has indicated the advantage of a keyed AGC system and its manner of operation. There are certain disadvantages to this system, too. First, when the horizontal sweep is not in step with the incoming signal, the pulses at the AGC tube will be also out of step and the AGC bias will vary rapidly. Hence it is most important that the horizontal-sync system be stable.

Another factor which will influence the operation of this AGC network is the timing of the horizontal-sweep pulse with respect to the incoming sync pulses of the signal. The interval during which both must be active is very limited, being at most 10 microseconds, and this tends to make the operation of a keyed AGC system more critical than that of an ordinary AGC system. However, this criticalness cannot be reduced since it is inherent

in the operation of this circuit. Actually, to make the system less critical the 6AU6 would have to conduct for a longer period of time, and this, in turn, would cause the set to be more susceptible to noise pulses. Thus, a choice must be made and the operation of the circuit, as outlined above, provides very good results when it is functioning properly.

In place of a pentode keying tube, a triode is occasionally employed. A pentode will provide more gain, but if the signal is first passed through the video amplifiers, the additional gain will not be required, and a triode will provide all the AGC voltage desired.

Diode Clampers in AGC Systems. Before we consider other keyed AGC networks, recognition should be given to a method which varies the AGC voltage fed to the RF amplifier differently from the AGC voltage applied to the video IF stages. The reason for this difference stems from the need to operate the RF amplifier, under weak signal conditions, at maximum gain until the input signal has reached a value of about 500 mv. This is desirable in order to present as much signal to the mixer as possible since the mixer is one of the greatest sources of noise in the receiver. With a large input signal, the output signal-to-noise ratio will be more favorable than it would be if the gain of the RF amplifier were less than its maximum.

Actually, what we are seeking to do is to delay the application of an AGC voltage to the RF amplifier, at least until the input signal has attained a level of 500 mv. Thereafter, the AGC voltage at this stage should rise fairly rapidly to avoid any overloading. Figure 6-24 shows the desired

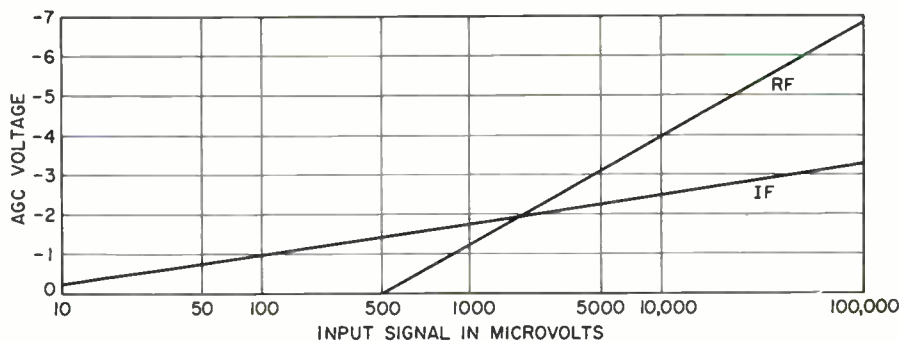

FIG. 6-24. The desired variation of AGC voltage versus input signal for the controlled RF and IF stages.

variation of AGC voltage versus signal for the RF and IF stages. The IF control is initiated immediately; the RF control is first delayed and then made to rise quite sharply.

One method of obtaining RF delay is shown in Fig. 6-25. Tube V_1 is the keyed AGC tube which operates in the same fashion as the 6AU6 of

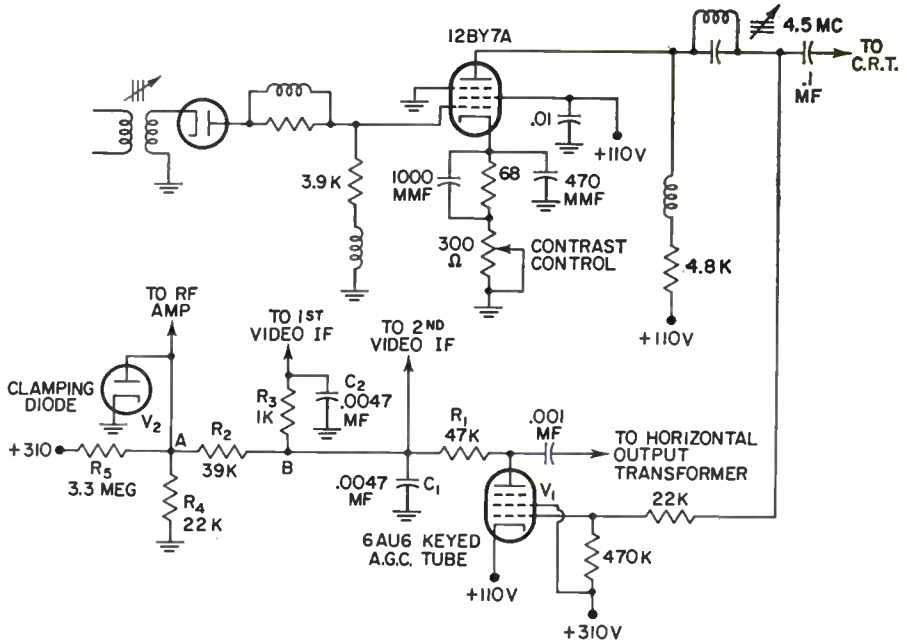

FIG. 6-25. An AGC system containing a clamping diode.

Fig. 6-23. The AGC voltage which V_1 develops appears across C_1 , and from this point it is distributed to the video IF and RF stages through R_2 , R_3 , R_4 , and R_5 . Of these components, R_3 and C_2 are readily recognizable as a decoupling filter for the AGC voltage fed to the first-video IF stage. R_2 is an isolating resistor designed to keep the AGC variations at the RF tube distinct from the AGC variations occurring at the video IF tubes.

R_4 , R_5 , and diode V_2 all connect to the line that goes to the RF amplifier at point A. If, we first concentrate only on R_4 and R_5 and disregard V_2 , then the +310 volts that are applied to one end of R_5 divide between R_5 and R_4 . However, since R_5 is so much larger than R_4 , all but 2 volts appear across R_5 . Thus, point A becomes 2 volts positive with respect to ground. If diode V_2 were not present, these +2 volts would be applied to the control grid of the RF amplifier. By connecting the plate of V_2 to point A, and the cathode of V_2 to ground, the tube conducts. Plate resistance of V_2 under these conditions is low enough so that resistor R_4 is practically shunted by a short circuit, and the voltage at point A drops to zero. Furthermore, point A remains fairly close to zero so long as point A is positive.

While all this is happening at point A, point B remains at whatever negative voltage V_1 develops across C_1 . It is the purpose of R_2 to provide some isolation between points A and B. However, as the signal level rises

and point *B* becomes increasingly negative, point *A* becomes less and less positive until the voltage across C_1 is strong enough to make point *A* negative. At this moment, V_2 stops conducting and the voltage at point *A* increases in the negative direction as the generated AGC voltage rises. By properly proportioning the resistive dividers in the RF and IF branches, the AGC voltage at point *A* can be made to rise faster than the AGC voltage reaching the video IF stages.

The important thing to remember is that when the incoming signal is weak, the AGC negative bias is small and the potential at point *A*, because of the presence of the clamping diode, is zero. The controlled video IF amplifiers, under the same signal condition, have a bias close to -1 volt. But as the signal strength increases, so does the negative AGC bias, and part of it overcomes the slight positive potential at point *A*, driving the clamping diode into nonconduction, and raising the negative grid bias of the RF amplifier.

After the principle of the clamping diode had been employed for some time, it was discovered that the same clamping effect could be achieved by removing the diode and using the cathode and control grid of the RF amplifier itself. When the positive voltage is applied to the RF-amplifier control grid, grid current flows, reducing the grid-to-cathode impedance to a low value. If the cathode is grounded, we have essentially zero-bias voltage on the RF tube. This method can be employed because the small amount of grid current flowing (less than $50 \mu\text{a}$) does not noticeably increase the noise factor of the tube. This delayed AGC principle can be applied to any AGC system.

Sync-pulse Keyed AGC. An alternate form of keyed AGC, in which the keying is done by the sync pulses themselves, has been developed for a special tube, the 6BU8. This tube (Fig. 6-26) is a twin pentode possessing a common cathode, a common control grid, and a common screen grid. Only grid no. 3 and a plate are established separately for each pentode section.

Plate current for each half of the tube is controlled by either grid no. 1 (the control grid) or grid no. 3 (normally the suppressor grid). Furthermore, each pentode is designed to have a sharp cutoff characteristic in order to effect good, clean sync separation and to develop suitable AGC operation.

One pentode section serves as a noise-immune sync separator and clipper tube, which will be examined in a later section. The other pentode section provides the AGC voltage, which will be discussed here.

One arrangement of the 6BU8 to develop AGC is shown in Fig. 6-27. The cathode is grounded and a positive voltage is applied to grids no. 1

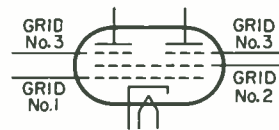

FIG. 6-26. A 6BU8 twin pentode tube.

and 2. Grid no. 2, the screen grid, receives a positive potential of 75 volts. Grid no. 1 receives its positive potential through a 2.7-megohm resistor and the ensuing current flow causes almost all of the 75 volts to be dropped across R_2 , leaving grid no. 1 almost at zero volts. (If a large resistor, for example R_2 , is similarly positioned in the grid no. 2 circuit, the same effect

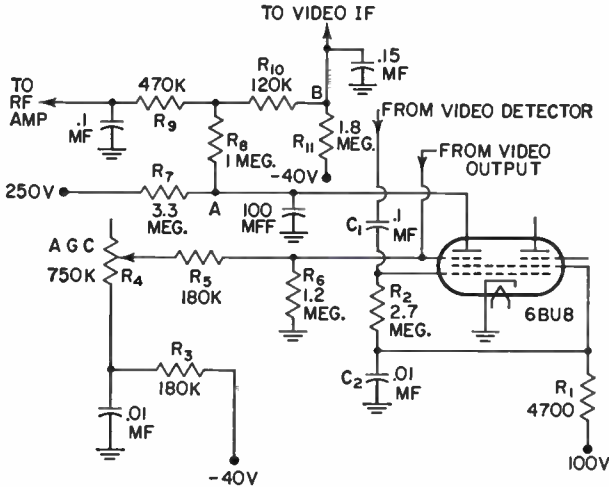

FIG. 6-27. An AGC system utilizing the 6BU8 tube.

will occur here.) A video signal, with the sync pulses negative, is then brought to grid no. 1 by capacitor C_1 . The video signal, which is obtained from the output of the video detector, has an overall peak-to-peak amplitude of about 1.5 volts. This amplitude will have little effect on tube conduction. However, if a strong noise pulse should come along, it would drive grid no. 1 negative enough to cut off the tube momentarily.

Grid no. 3 receives a negative d-c voltage through R_3 , R_4 , R_5 , and R_6 . R_4 is made variable to permit the d-c level at the grid to be altered to suit local receiving conditions. A video signal with positive-going sync pulses is also brought to grid no. 3 from the output circuit of the video amplifier. D-c coupling is employed to insure that all of the sync-pulse tips will be aligned at the same level. (A d-c-coupling path is also provided from the video detector to this amplifier.) Since the sync-pulse tips represent the most positive portion of the signal, R_4 is adjusted so that conduction through the tube occurs principally when the sync pulses are active. In essence, these sync pulses turn the tube on. At all other times, the negative d-c voltage at grid no. 3 keeps the tube cut off.

The plate of the tube receives a positive voltage through R_7 . This posi-

tive voltage is also applied to the grid of the RF amplifier through R_8 and R_9 . Tapping into the same network are resistors R_{10} and R_{11} , and the voltage that appears at the junction of these two resistors is applied to the video IF stages. This voltage is negative because R_{11} ties into a source of negative voltage at its other end. Thus, in the absence of a signal, the RF amplifier receives a slightly positive voltage and the video IF amplifiers receive a slightly negative voltage.

When a signal appears, current flows through the tube at each horizontal pulse. This flow of current reduces the plate voltage, which, in turn, drives both the RF and the IF AGC voltage more negative. When the signal level rises above 500 mv, the plate voltage has dropped enough that even the RF AGC voltage is negative.

To summarize, the signal at grid no. 1 is designed to cut off the tube whenever a strong noise pulse appears. The signal at grid no. 3 is the keying or pulsing signal. Thus, with these two watchdogs, very little noise voltage reaches the AGC system.

Combination Keyed AGC. In recent receivers, a combination keyed AGC has been employed in which the actions of the two preceding keyed systems have been applied to the 6BU8. See Fig. 6-28. This circuit is connected in practically the same fashion as the AGC circuit shown in Fig. 6-27, with the addition of strong keying pulses for the plate. These pulses,

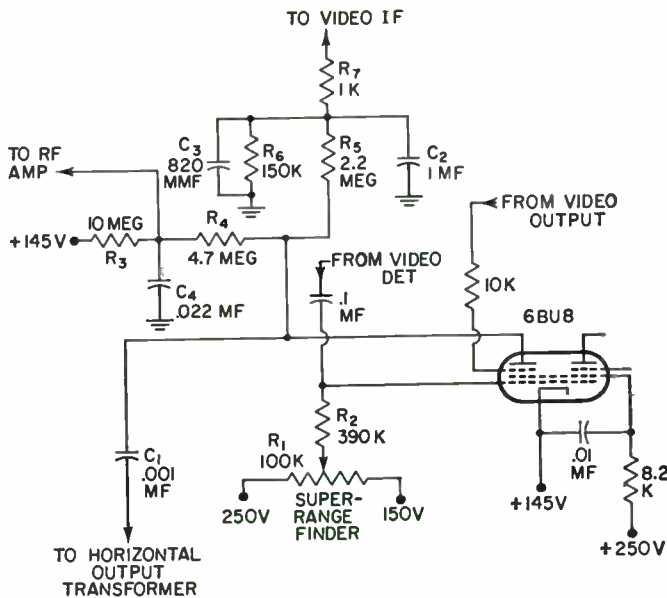

Fig. 6-28. A combination-keyed AGC system.

with a peak-to-peak value of 400 or more volts, are obtained from the horizontal-output transformer. The d-c voltage reaching the plate of the tube from R_3 and R_4 is close to zero, so that in the absence of any keying pulses very little current passes through the tube even if the voltages on grids no. 1 and 3 are favorable to such flow. However, when a positive triggering pulse reaches the plate through C_1 , current will flow, provided grids no. 1 and 3 permit this to happen.

Resistor R_1 permits the d-c voltage at grid no. 1 to be adjusted to the noise conditions present at that particular location. It should be set so that the normal signal does *not* cut off the tube, but noise pulses will. (The video signal here is in the negative sync-pulse phase, similar to the circuit of Fig. 6-27.) Grid no. 3 is directly connected to the plate circuit of the video-output amplifier, receiving a video signal from here, with the sync pulses extending in the positive direction. With no signal being received, the positive d-c voltage at grid no. 3 is some 20 volts less than the cathode. This amount is enough to bias the tube to cutoff. When a signal is received, the sync pulses are strong enough to permit plate current to flow if the plate is being pulsed at the same time.

In the plate circuit, one AGC branch goes to the RF amplifier and the other branch goes to the video IF. The video IF always receives a negative AGC voltage, whereas the RF amplifier, due to R_3 and the +145 volts, operates at zero voltage until the incoming signal reaches a high enough level to drive this line negative.

This combination AGC system is more noise-immune than either of the two keyed circuits previously mentioned and because of this, is being employed widely.

QUESTIONS

1. Draw the circuit of a television diode detector which will produce a negative picture-phase signal.
2. Show how the above circuit can be modified to produce a positive picture-phase signal.
3. Explain the difference between positive and negative video signals. What phase must the video signal possess when applied to the grid of the cathode-ray tube? Why?
4. How can a video signal, which is phased positively, be converted to the negative phase? Explain your answer.
5. Besides picture phase, what other precautions must be observed in video detector circuits?
6. What advantages are gained by the use of AGC in a television receiver?
7. What portion of the incoming signal is useful in regulating the AGC voltage? Why?
8. What three types of AGC systems have been employed in television receivers? Which system is the most economical? Which possesses the best noise immunity?

9. Describe briefly how the AGC system of Fig. 6-16 operates.
10. Draw the diagram of the most economical AGC system and explain how it functions. What disadvantage does it have?
11. What relationship exists between the polarity of the signal at the video detector output and the number of permissible video amplifiers?
12. Would your answer remain unchanged if the signal is applied to the cathode of the picture tube rather than to its control grid? Explain.
13. Why is it important to maintain a good frequency response in the coupling network between the video second detector and the video amplifiers?
14. Describe briefly how a keyed AGC system operates.
15. What advantages does a keyed AGC system possess over the system shown in Fig. 6-15?
16. Why is the AGC voltage to the RF amplifier frequently prevented from varying in the same manner as the IF AGC voltage?
17. Show how the action described in question 16 can be achieved in a circuit. Explain the operation of this network.
18. How do the circuits of Figs. 6-23 and 6-27 differ in operation?
19. What function does the super-range finder of Fig. 6-28 serve?
20. What effect would an open circuit in R_3 of Fig. 6-28 have on the operation of the receiver? What would be the effect if R_3 shorted?

Video Amplifiers

Introduction. Up to this point, the television signal has been received and amplified by an RF stage, converted to another frequency by means of a mixer, further amplified by the IF stages, and rectified by the diode detector. We now have the video signal in a form that can be applied to the picture tube. However, as shall be seen, the signal amplitude at the output of the video second detector is not great enough to drive the picture tube directly. Hence, further amplification is necessary and this is provided by the video amplifiers.

As a first step in determining the characteristics that a video amplifier must possess, let us look ahead to the picture tube and see what its requirements are. With these established, we can better determine how the video amplifiers should meet these needs.

Video-signal Requirements of Picture Tubes. In order for a video signal to produce a suitable image on the screen of the picture tube, it must possess certain attributes. First, it must contain the video information in the same form that it had when it was originally developed at the studio. Any change in shape or any loss of frequency will result in an alteration in the image produced on the picture-tube screen. This video information requires frequencies from near 30 cycles to 4 mc to produce a high-quality picture. Second, the signal must possess the proper phase polarity, otherwise it will produce a negative picture at the picture tube. Finally, the video signal must be strong enough to vary the intensity of the picture-tube scanning beam sufficiently to produce a suitable range from bright to dark light values on the screen. Without a suitable variation, the image on the screen will appear washed out, because it lacks sufficient contrast to provide a satisfactory image. These three requirements are basic to every picture tube, although the extent to which they are met will frequently vary from

receiver to receiver. In order to appreciate more fully the relative importance of each characteristic let us examine each in more detail.

Video-signal Bandwidth. The video signal which is developed by the second detector and then passed through one or more video amplifiers before being applied to the picture tube contains the blanking, synchronizing, and picture information, and has a bandwidth extending from 30 cycles to 4 mc. The synchronizing pulses are not required by the picture tube. Their function is to synchronize the vertical- and horizontal-sweep systems and at some point before the video signal reaches the picture tube some of this signal is diverted to the sync-separator system. The blanking and the video information, however, are directly employed by the picture tube. The blanking pulses cut off the picture-tube beam at the end of every line and every field in order to mask the movement of the beam as it quickly swings from the right-hand side of the screen to the left-hand side, or from the bottom to the top. The video information deals directly with the detail which forms the picture. The low frequencies in the video signal produce the larger objects in the scene, while the high frequencies in the video produce the fine detail. It is important for a video amplifier to have a uniform response over the entire range, otherwise either or both ends of the video spectrum will suffer. We shall learn in our subsequent study of video-amplifier circuits what precautions are taken to insure that the response does not fall off too soon at either the high or the low ends. We shall see also why certain manufacturers purposely restrict the video bandwidth, particularly at the high end, because of economy or because of the small size of the picture-tube screen itself.

It will be appreciated that the demands on a video amplifier for a uniform bandwidth of from approximately 30 cycles to 4 mc are unusually severe, particularly in comparison with any high-fidelity audio amplifier where the response is uniform for only some 20,000 to 30,000 cycles. Obviously, the conventional resistance-capacitance-coupled amplifier is not suitable for video signals. Before it can be suitable, modification is necessary.

Video-signal Polarity. It was previously noted that the video signal must possess a certain polarity when applied to the picture tube, otherwise a reverse, or negative, image will be produced on the screen. See Fig. 7-1. Several lines of a typical video signal are shown in Fig. 7-2. The signal is drawn with the black level most negative. Whether it possesses this particular polarity at the output of the video second detector depends on the detector circuit. This we have already seen. When the video signal reaches the cathode-ray tube with this polarity, it must be applied to the control grid. The black level will serve to cut off the beam while the video variations, being relatively more positive, permit electrons to pass the control



Courtesy Sylvania Electric

FIG. 7-1. A negative picture.

grid and reach the screen. The brightest portion of the video signal will be produced by the most positive voltages in this signal. These represent the highlights in the image.

It is also permissible to apply the video signal to the cathode of the picture tube and, in this case, it is necessary that the video-signal polarity be reversed 180 deg; that is, the sync pulses will be most positive and the video-signal variations relatively more negative. The bias between the grid and the cathode of a tube depends on the voltage between these two elements. If we wish to increase the number of electrons which pass the

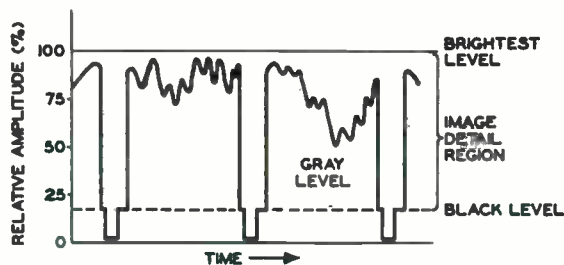

FIG. 7-2. Several lines of a typical video signal.

grid, then the grid must be made more positive than the cathode; or, looking at it another way, the cathode must be made more negative than the grid. Consequently, if we apply a video signal to the cathode, holding the grid at some fixed bias voltage, any signal variation which makes the cathode more negative will cause more electrons to travel through the tube. In the present case, we want the video signal to produce more electrons than the blanking pulses. Consequently, we will have the video signal drive the cathode more negative than the blanking pulses.

The video signal, at the output of the video second detector, may possess either a positive or a negative picture phase. This means that the sync pulses may be either relatively negative or relatively positive with respect to the video variations. The signal is then passed through one or more amplifiers before being applied to the picture tube. Each time the signal passes through an amplifier, its phase is reversed by 180 deg.

To show that this reversal occurs, consider the simple amplifier circuit shown in Fig. 7-3. A sine-wave signal is applied to the control grid and the

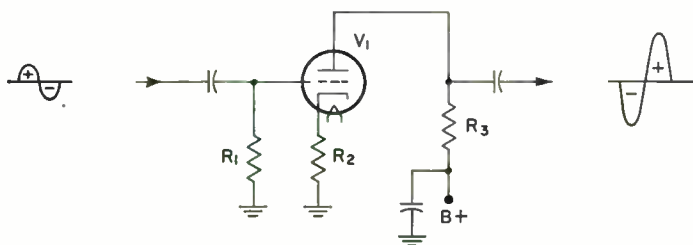

FIG. 7-3. A simple amplifier circuit.

amplified version is obtained at the plate. Assume, now, that the positive half of the sine wave is active at this moment. This positive-going voltage will drive the control grid more positive, increasing the flow of current through the tube, which, in turn, will produce a greater voltage drop across the load resistor R_3 , making the top end of R_3 relatively more negative than the bottom end. Thus, this positive increase in grid voltage has produced a negative increase in output voltage. By the same token, for the negative half of the input signal, the grid becomes relatively more negative than it was, and this tends to reduce the flow of current through the tube. The reduced current produces a lower voltage drop across R_3 , enabling the potential at the top of R_3 to become more positive. Again, we see that a 180-deg phase reversal has occurred.

The vacuum tube in the illustration is a triode. The same behavior, however, occurs with pentodes. The phase reversal holds so long as the input signal is applied to the grid and the output signal is obtained from

the plate. A phase reversal does not occur if the input signal is fed to the cathode and the output signal is obtained from the plate. The latter is known as a "grounded-grid amplifier." No phase reversal occurs in cathode followers either, where the signal enters the stage at the control grid and leaves at the cathode. However, the latter two circuits are seldom employed in the video section of a television receiver.

Between the video second detector and the picture tube, d-c amplifiers are also employed, and these operate on the signal in the same manner that a resistance-capacitance coupled amplifier operates, that is, a signal applied to the grid appears at the plate inverted 180 deg. It may be instructive to follow a signal through a 2-stage d-c-coupled video amplifier to see what happens at the grid and plate of each tube. For this discussion the circuit shown in Fig. 7-4 will be used. Note the direct coupling between the

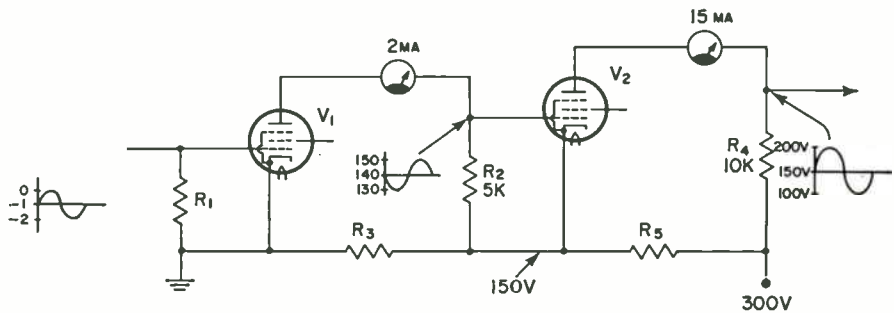

FIG. 7-4.

plate of one tube and the control grid of the next without intervening coupling capacitors. The circuit consists solely of tubes and resistors.

Let us assume that a sine-wave signal having a peak amplitude of 1 volt is applied to the control grid of V_1 . This wave is shown at the left of the illustration and can be seen to vary from -1 volt to zero at its positive peak and from -1 volt to -2 volts at its negative peak. The average voltage is -1 volt, and it is at about this level that the sine-wave variations take place. The -1 volt represents a d-c bias. For this bias, 2 ma of current flow through the tube and through R_2 , producing a drop of 10 volts across the resistor. Since the bottom end of R_2 connects to a point which has a d-c potential of 150 volts, the top end of R_2 will have a potential of 140 volts. These 10 volts across R_2 act as a 10-volt bias on V_2 . Furthermore, since the top end of R_2 is less positive than the bottom end, the control grid of V_2 is more negative than its cathode. Thus, V_2 has the necessary bias for its purpose.

Now let us see what happens when the 1-volt peak-to-peak sine-wave

signal is applied to the control grid of V_1 . If we assume that initially the signal goes positive, then the bias between the control grid and cathode of V_1 will decrease, increasing the current flow through the tube. This increase will raise the voltage dropped across R_2 . If we assume that the current increases to 4 ma, then 20 volts will be dropped across R_2 and the control grid of V_2 will now receive 130 volts in place of the previous 140 volts. Since the cathode of V_2 is kept at a constant 150 volts, the total bias between control grid and cathode is now -20 volts. This represents a 10-volt change from the previous condition.

By the same token, when the signal at the control grid of V_1 becomes more negative, perhaps to -2 volts, the plate current decreases. If we assume a 2-ma decrease in current for this voltage, then at the negative peak of the input signal the plate current through V_1 will drop to zero. This drop will produce no voltage drop across R_2 and bring the full 150 volts to the control grid of V_2 . The bias on this tube is now zero. Thus, a 1-volt peak variation at the control grid of V_1 produces a 10-volt peak variation at the control grid of V_2 . The stage has provided an amplification factor of 10.

If we follow the signal through one more stage, we can see what variations occur across the output load resistor R_4 . When the control grid voltage on V_2 is 140 volts, let us assume 15 ma of current will flow through V_2 , producing a voltage drop of 150 volts across R_4 . This voltage, subtracted from the power-supply voltage of 300 volts, leaves 150 volts at the plate of V_2 . When the control grid of V_2 is driven more negative, the current through V_2 decreases, reducing the voltage drop across R_4 and raising the plate voltage. In our example, we are assuming that, at this time, the current through V_2 decreases to 10 ma and that this current, flowing through R_4 produces a 100-volt drop. This voltage, subtracted from 300, leaves 200 volts at the plate of V_2 .

By the same token, when the grid of V_2 is driven more positive, the increased plate current will produce a greater drop across R_4 and lower the plate voltage of V_2 . In this example, we assume that the plate current will increase to 20 ma and produce a 200-volt drop across R_4 . These 200 volts subtracted from the 300 volts of the power supply leaves 100 volts at the plate of V_2 .

For the entire amplifier, a 1-volt peak variation at the input of V_1 produces a 10-volt peak variation at the input of V_2 , which, in turn, produces a 50-volt peak variation at the output of V_2 . Furthermore, whenever the grid of V_1 goes positive, the grid of V_2 goes negative, and the plate of V_2 goes positive. Thus, passage of the signal through a tube causes its polarity to be reversed by 180 deg.

In the video section of television receivers, d-c amplifiers are employed because they possess certain advantages. There is an economic advantage

because no coupling capacitors are required. Second, such amplifiers permit the d-c component of the video signal to remain, which helps in the subsequent presentation of the image. More will be said on this point later. Note, however, that when we employ a 2-stage d-c amplifier, the power-supply voltage must become increasingly large as we move through the system because of the direct connection between the plate of one tube and the grid of the next. For example, since the plate of V_1 directly connects to the grid of V_2 , we must return the cathode of V_2 to a point in the power supply where it will receive a higher voltage than its control grid, in order to present this tube with an overall negative grid bias. By the same token, if we directly connect the plate of V_2 to the control grid of a following stage, then the cathode of this following tube will have to be placed at an even higher voltage in order to again maintain the proper bias between control grid and cathode. This is one of the difficulties of using d-c amplifiers in cascade; generally, when a d-c amplifier is employed, there is only one stage.

Video-signal Amplitude. The amplitude of the signal which is applied to the picture tube governs the contrast of the image which appears on the screen. To gain a better appreciation of this dependence, consider the typical transfer-characteristic curve shown in Fig. 7-5. This curve shows the relationship between the control-grid voltage and the intensity of any spot produced on the screen by the electron beam. For example, if the control-grid

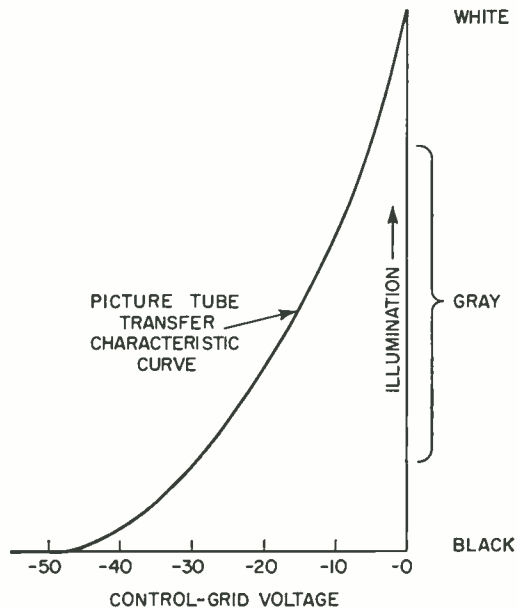

Fig. 7-5. A typical curve of a picture-tube transfer characteristic.

voltage is -50 volts (with respect to the cathode), the beam is completely cut off and nothing is seen on the screen. This is the condition when the screen is black. If we lower the grid voltage to -20 volts, the screen illumination produced can be determined in the following manner. Start at the -20 -volt point on the horizontal axis and draw a straight line vertically until the curve is reached. Then draw to the right. A line so drawn will fall within the area marked "gray." If we continue to reduce the control-grid voltage, perhaps to -10 volts, then, according to the above procedure we see that the screen will become brighter.

It is the purpose of the incoming video signal to vary the control-grid bias of the picture tube so that the desired variation of screen brightness is produced. The first step is to establish the proper operating bias for the picture tube. Let us say that without any incoming signal, this bias is adjusted to 25 volts. See Fig. 7-6. The video signal is now applied and it will distribute itself about the operating point so that as much signal area appears on one side of the point as on the other. This distribution is also indicated in Fig. 7-6. Actually, the operating bias is adjusted so that the blanking voltage just reaches the cutoff level of the beam. If we examine the video-signal variations and the brightnesses which they produce on the screen, we see that maximum white is produced on the screen for the video

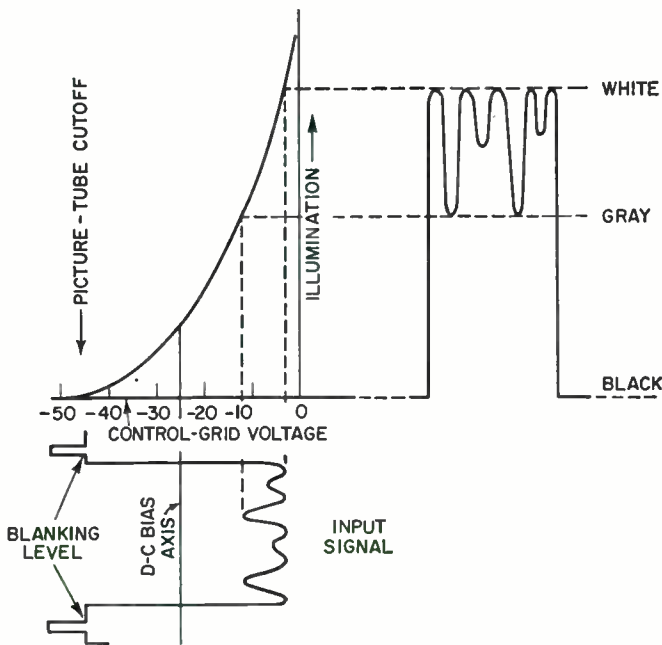

FIG. 7-6. The effect of a video signal at the control grid of a picture tube.

signal which extends farthest to the right. For that portion of the video signal which does not extend quite as far, less screen illumination is produced and the signal falls, perhaps within the gray areas. Finally, whenever the blanking pulses appear, the voltage on the tube reaches the -50 volt cutoff point and the screen goes black.

If a smaller video signal is received, the situation shown in Fig. 7-7

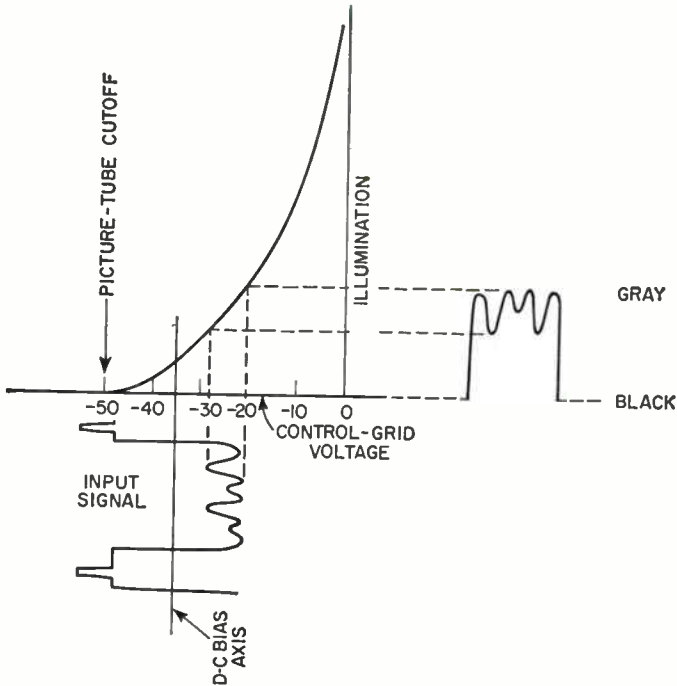

FIG. 7-7. The effect of a small video signal at the control grid of a picture tube.

prevails. First, the d-c bias on the tube would be adjusted as before, until the blanking level of the incoming signal plus the d-c bias voltage reaches the cutoff point. Once this is done, the signal variation to the right of the cutoff point will produce varying levels of illumination on the screen. In this case it is interesting to note that, since this video signal has a smaller peak-to-peak variation than the preceding signal, we shall not obtain the range of screen illumination that we did with the preceding signal. The present signal extends from cutoff to a point less than halfway between maximum white and gray. The result, in the picture, is that there is less contrast between the dark and light areas. If the video-signal amplitude is further reduced, we shall eventually have a washed-out picture.

Conversely, if too strong a signal is applied to the picture tube, and the d-c bias is adjusted so that the blanking voltage just cuts off the beam, then for a considerable range of the video-signal variation, the screen illumination will not vary much. This condition will occur for the most positive values of the video signal and tend to wash out some of the detail because of the inability of the electron beam to produce a suitable change in screen-brightness variation for a corresponding variation in video signal. For best operation of the picture tube, the applied video signal should be restricted so that it varies the bias on the picture tube from approximately -5 volts to -50 volts. Any greater signal variation does not produce as pleasing a picture and anything less does not provide the best range of contrast.

Two controls in the video system help the viewer produce the best-appearing picture. One is the contrast control which regulates the peak-to-peak amplitude of the video signal reaching the picture tube. The other is the brightness control which establishes the d-c bias for the tube. If the brightness control is set so that the control-grid voltage applied to the picture tube is not sufficiently negative, then we are really shifting the operating point of the tube to the right. See Figs. 7-6 and 7-7. This shifting will produce an image with insufficient contrast because the background illumination will tend to be too light. If we make the control-grid bias too negative, then much of the signal will be lost in the cutoff region and the overall appearance of the image will be darker than normal. The proper setting for the brightness control is at that point where the image possesses its most pleasing contrast.

Screen Size and Video-signal Detail. It may not be immediately apparent, but the size of the screen on which an image is placed will also govern how much fine detail the image should possess. While it is true that 525 lines can be placed on a 5-inch screen as well as on a 23-inch screen, the amount of detail necessary for the smaller tube is not as great as for the larger screen. The reason stems from the resolving power of the human eye.

The "resolving power" of the eye is the ability of the eye to distinguish between objects that are placed close together. As an example, consider the card, shown in Fig. 7-8, with two narrow lines located side by side. So long as the card is held fairly close to the eye, it is possible for an observer to see each line separately. As the card is slowly

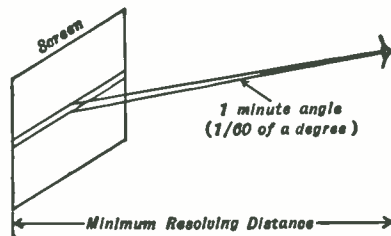

FIG. 7-8. The power of the human eye to resolve or separate two objects that are closely spaced depends upon the distance from the eye to the objects. If the objects subtend a 1-min angle at the eye, they may be seen separately.

moved farther and farther away, it becomes increasingly difficult to see each line distinctly. Eventually a point is reached where the eye is just capable of distinguishing between them. This point is the limit of the resolving power of the eye for these two lines.

Quite obviously, the farther apart the lines are, or the wider apart they are, the more easily they can be separated at any given viewing distance. For the average person, it is claimed that so long as the two objects subtend an angle of 1 min or more at the observer's eye, they can be seen as distinct units. This angle is known as the "minimum resolving angle of the eye" and is illustrated in Fig. 7-8. The reader can determine how wide a 1-min angle is by dividing any circle into 21,600 equal wedge-shaped parts. The angle of any small section at the wedge end would then equal 1 min, or $\frac{1}{60}$ deg.

The distance that the observer must be from the objects in order to have the 1-min angle subtended at his eye is known as the "critical resolving distance." If the observer is farther away than this distance, the two objects merge into one. With television, it is necessary for the observer to remain outside the critical resolving distance. Coming closer only reveals the separate scanning lines and this hampers the illusion of continuity.

From the foregoing line of reasoning, it would seem possible to calculate the exact viewing distance for an object of any size. Actually, with television images, an observer can approach the screen closer than the calculated figure and still be unable to distinguish one line from another. This is possible because the resolution of two lines, for example, depends not only on their separation, but also on the amount of light of the lines and their relative motion. The stronger the light, the more clearly they stand out. Under these conditions, the critical resolving distance increases.

On the other hand, the introduction of motion tends to make the line of demarcation less clear-cut and the objects blend into each other at much smaller distances than if they were stationary. The latter condition prevails for television images and hence the observer may view the screen from closer distances than he could if the motion was absent. In addition, because of the impossibility of obtaining perfect synchronizing action, the positions of the lines of the picture tend to change slightly during each scanning run, and this further obscures any clear division between lines.

Placing the same 525 lines on a 19-in. screen as on a 7-in. screen means that the proper viewing distance for the larger screen is greater than that for the smaller screen. With the smaller screen, the ideal viewing distance is generally so short that the observer ordinarily never comes this close to the screen. Therefore many of the finer details of the picture are not seen, even though they are present on the screen. Manufacturers take advantage of this fact to design small-screen receivers with bandwidths less than 4 mc

By the same token, as the picture-tube screens become larger, it becomes more important to have the bandwidth wider.

Although it is possible to sacrifice some response at the high-frequency end of the 4-mc signal, the amplifier should possess a flat characteristic at the low end. This provides uniform response to 30 cycles. Since amplifiers do not cut off sharply at any one frequency, but tend rather to decrease gradually, it is necessary for a flat response at 30 cycles to have the curve extend downward to 10 cycles, or even less.

To ascertain what loss of response at the low frequencies would mean, let us examine the camera signal, for it contains the information of the picture. A section of the signal which might be obtained from the scanning of one line is shown in Fig. 7-9. On either end of the line we find the blanking

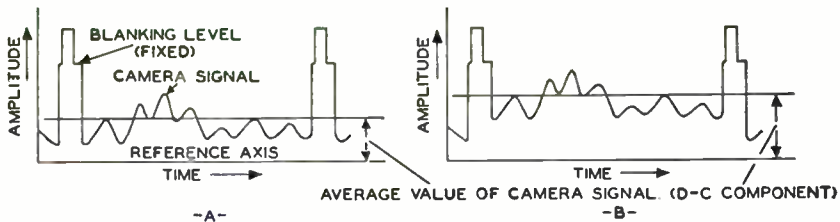

FIG. 7-9. The height of the camera-signal variations above the reference axis represents the amount of background illumination that the line (or scene) will possess. This average value is known as the d-c component of the video signal.

and synchronizing pulses. These have a fixed level, always reaching the same voltage (or current) value whenever they are inserted into the signal. The elements of the image itself are represented by the varying voltages between the pulses and naturally differ from one line to the next. The engineer refers to these changing voltages as the "a-c variations of the television signal."

In addition to the a-c variations, the synchronizing and blanking pulses of the video signal, there is another component, referred to as the "d-c component." Examine the two video signals placed side by side in Fig. 7-9. The blanking levels of both are of the same height and the a-c variations of each signal are identical. The only difference is in the average level of the a-c variations of Fig. 7-9(A), as compared with the average level of the a-c portion of the signal of Fig. 7-9(B). That of B is the greater of the two. This average level represents the background illumination of the scene at that line and is the d-c component of the video signal. The background illumination may vary from line to line, but this situation is unusual. Generally it changes slowly over the entire scene, and adjacent lines will have almost equal d-c components.

When the value of the d-c component is high, as in Fig. 7-9(B), the peo-

ple and objects in the scene being televised will appear against a dark background. This is true because with negative transmission every value is reversed. The darker the scene (or element), the greater the current. As the scene becomes brighter, there is correspondingly less current, and the a-c variations of the video signal move closer to the zero axis. Hence, as the d-c value is less in Fig. 7-9(A) than in Fig. 7-9(B), the background illumination of (A) will be brighter. Neither the people nor the objects, however, have changed. A lighted background will convey to the viewer of a television scene the impression of daylight, sunshine, and clear weather. A darker background, on the other hand, will give the viewer the impression of night.

At the transmitter, the d-c component can be inserted manually by an operator viewing the scene from a monitor, or automatically by using the average current derived from the viewing tube, when this is possible. If the latter cannot be accomplished, the light from the scene is allowed to fall onto a photoelectric tube and the d-c component is derived in this manner. Once obtained, it is inserted into the video signal, raising the a-c component to the desired level.

From the discussion of the d-c component, which for the present is sufficient, we can see that the average illumination of a scene may change with each frame, or 30 times a second. Of course, if the exact scene is televised without any variations, the average illumination remains constant. Actually, each frame scanned at the camera has a somewhat different average value. In order to obtain the correct shading of the image background at the receiver, it is necessary that all transmitting and receiving circuits be capable of passing 30 cps without too great attenuation. Any poor response would result in incorrect values for the background illumination and, as shown later, left-to-right stretching or smearing of large objects.

Phase Distortion. Frequency response is an important consideration in video amplifiers, but not the only one. Phase distortion, which can be tolerated in an audio amplifier, is capable of destroying the image on the cathode-ray-tube screen and must also be given careful attention when an amplifier is designed. Since phase distortion is very seldom considered in audio amplifiers, a brief discussion at this point may be helpful.

Phase distortion is produced when the time or angle relationship of electric waves to each other changes as they pass through any electrical system. For a simple example, let us consider the two sine waves shown in Fig. 7-10.

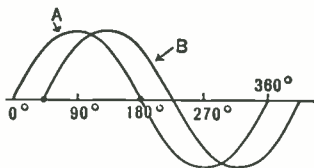

FIG. 7-10. Two waves, 45 deg out of phase with each other.

Curve A reaches its maximum value a short time before curve B and curve A is said to lead curve B by a number of degrees. The actual number depends on the manner in which these curves

were generated. Suppose that, in this case, curve *A* leads curve *B* by 45 deg. If, after the output of the electrical system is reached, there is still this relationship between the two waves, no phase distortion has been introduced. On the other hand, if the value of the angle is altered, the network has introduced some phase distortion.

As another example, consider the wave shown in Fig. 7-11(A), which is actually composed of a fundamental wave in combination with its third harmonic. See Fig. 7-11(B). If the network has a different effect on each of

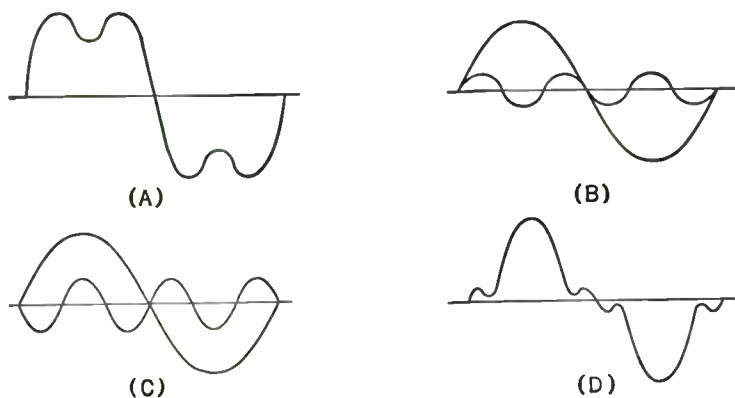

FIG. 7-11. The effect of phase distortion in changing the shape of a wave. The composite wave (A) can be broken down into two waves (B). If these two component waves change their relative phases (C), then (D) shows one result. There may be other combinations than the ones shown.

these waves, the two waves may appear as in Fig. 7-11(C), where the third harmonic wave has changed its position with respect to the fundamental, that is, its phase has changed. The resultant of the latter waves now assumes the shape given in Fig. 7-11(D), which is certainly different from the original form of Fig. 7-11(A).

How Phase Distortion Is Introduced. Now that the effect of phase distortion in changing the shape of a wave has been illustrated, let us see how the circuits found in video amplifiers may bring about such distortion. A resistance-coupled amplifier is used, as it is the only type that can be easily and economically adapted to satisfy the stringent requirements of wide-band amplifiers. A typical circuit is shown in Fig. 7-12. We are concerned here initially only with the low-frequency response of the circuit, which means that in Fig. 7-12, we will deal only with R_L , C_c , and R_g . C_s , representing the wiring, tube, and stray capacitances, has too low a value to be significant and can be disregarded.

When an alternating voltage is applied to the input of V_1 , an amplified version of this voltage will appear across R_L . It is desired to transfer this

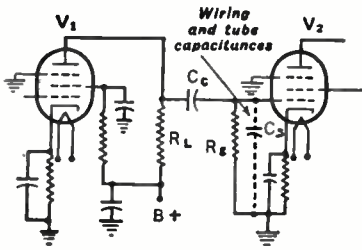

FIG. 7-12. A resistance-coupled amplifier.

a-c voltage to the grid of V_2 , and this is accomplished through the series combination, C_c and R_g . How much of the total voltage of R_L will appear across R_g is dependent on the opposition (or impedance) C_c presents to the a-c current flowing in this circuit. At low frequencies, the opposition of the capacitor is high and a large part of the a-c voltage is lost. Less is available for R_g . This condition is responsible for the poor low-frequency response of resistance-coupled amplifiers.

Increasing the frequency will result in less voltage being lost across C_c and more will be available for R_g .

The phase of the voltage at R_g is governed by the opposition C_c offers to the a-c wave passing through the circuit. Consider, for example, what the phase of the a-c current would be if only C_c were present in the circuit. The current flowing would be 90 deg ahead of the voltage. Now, add a resistor in series with the capacitor. The current flowing in the circuit becomes less than 90 deg out of phase with the applied voltage. The voltage drop across the resistor is in phase with the current flowing through it; hence it would also be less than 90 deg out of phase with the applied voltage. The situation is shown in Fig. 7-13, where E_g is a little less than 90 deg out of phase with E_L .

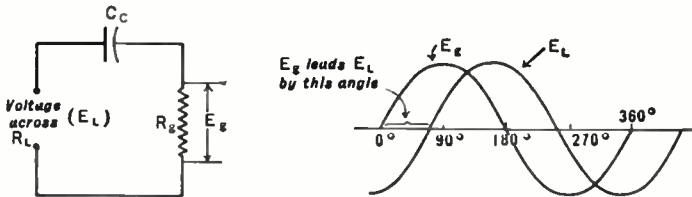

FIG. 7-13. At the low frequencies E_g is out of phase with E_L because of the coupling capacitor C_c .

As the opposition that C_c offers to the current in the circuit becomes less and less (say, with increasing frequency), R_g becomes more important and the current approaches closer and closer in phase with E_L . At the middle range of frequencies, the opposition of C_c may be neglected entirely and E_g is in phase with E_L , which is similar to any other completely resistive circuit.

We see, then, that when voltages of many frequencies, and with no phase difference, are applied at E_L , the voltages appearing across E_g have

different phase relationships, the degree being dependent upon each frequency.

The lowest frequency will have the greatest phase angle introduced while it is traveling from the output of the tube to the input of the next stage. As the frequency rises, the phase difference becomes less, gradually reaching zero. This behavior of a resistance-capacitance-coupled amplifier is illustrated by the bottom curve in Fig. 7-14.

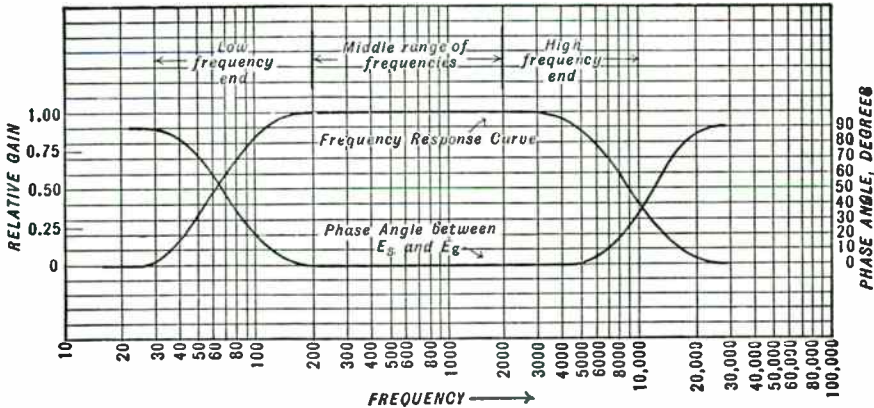

FIG. 7-14. The frequency and phase response of a resistance-capacitance-coupled amplifier.

A complex wave, which contains many frequencies, will have its shape altered when it passes through a resistance-capacitance-coupled amplifier network. With a change in shape, the effect of the wave at the grid of the picture tube must certainly be different and the resulting image is distorted to some extent. By distortion, we mean that the image is not an exact duplicate of the original. The amount of change introduced into the picture detail depends on the degree of phase distortion.

In the middle range of frequencies, from 200 to 2,000 cycles, C_c has no effect on the passing waves and can be disregarded. Since only resistances are involved, there is no phase shift introduced between the voltages at R_L and R_g .

At the high frequency end of the band, the shunting capacity, C_s , becomes important and must be considered. C_s has the effect of offering an easy shunting path for the a-c voltages around R_g , and the voltage appearing across this resistor decreases with increasing frequency. Note that C_s forms a parallel combination with R_g . As the frequency increases, more and more current flows through C_s rather than through R_g and soon the current becomes wholly a capacitive one. Again we see E_g and E_s differing by 90 deg,

but in this case the phase angle increases with frequency, whereas for the low frequency action the opposite was true. However, for both cases, the result is phase distortion. The graph in Fig. 7-14 shows how the phase angle between input and output voltages of the resistance-capacitance-coupled network changes with frequency.

Results of Phase Distortion. To correlate phase distortion and its effect on the television picture, let us study the dependence of phase distortion and time delay. It has been noted that at the low frequencies the phase angle between input and output voltages increased to a maximum of 90 deg as the frequency decreased. Suppose that a video signal is sent through this *R-C* network containing (among others) two frequencies, say of 40 cycles and 90 cycles. From the preceding discussion, we know that the 40-cycle wave will receive a greater phase delay than the 90-cycle wave. Assume that the 40-cycle wave is shifted 45 deg and the 90-cycle wave, 10 deg. Obviously the two waves will no longer have the same relationship at the output that they had at the input, and by simple mathematics it is possible to compute their difference.

A 40-cycle wave takes $\frac{1}{40}$ sec to complete one full cycle, or 360 deg. With $\frac{1}{40}$ sec for 360 deg, it will take $\frac{1}{320}$ sec for the wave to change 45 deg; $\frac{1}{320}$ sec is approximately 0.003 sec. Thus there will be this time difference between a maximum occurring at the input to the next tube and that occurring at the output of the preceding tube. The appearance of one will lag behind the other by 0.003 sec.

The 90-cycle wave, we know, has a 10 deg phase angle introduced into it. One cycle, or 360 deg, of a 90-cycle wave occurs in $\frac{1}{90}$ sec. Ten degrees would require only $\frac{1}{3240}$ sec, or approximately 0.0003 sec. Thus the input and output variations will differ by this time interval for the 90-cycle wave.

At the cathode-ray screen, the electron beam moves across a 12-in. screen a distance of 1 in. from left to right in about 0.000,007 sec. The time interval is extremely short and, if waves containing the 40 and 90 cycles receive the time displacements computed above, the end result is a displacement of the picture elements that they represent. In actual television practice, the background illumination is determined by the low frequencies, and phase distortion in the video amplifiers causes a change in this shading. If, for example, the background transmitted from the studio is perfectly white, by the time it appears at the receiver screen phase distortion will have altered it. It will now vary from white to gray, or will even be black in some parts.

Any large objects or letters in the picture are distorted, too, by poor low-frequency response. They appear to be smeared across the image like fresh paint. The smearing effect is derived from the action described in the last paragraph, where we learned that phase distortion and time delay are

directly related. A slight time delay causes certain parts of the object to be displaced from the correct position. The visible consequence of this displacement is smearing. Since the beam moves from left to right, the extended stretching of large objects will always be toward the right, or in the direction that the beam is moving. Only large objects are affected, because they are the only ones represented by the lower frequencies.

At the high-frequency end of the video signal, phase distortion results in the blurring of the fine detail of the picture. The larger the size of the cathode-ray-tube screen, the more evident this defect. This is another reason why the larger sets require more careful design and construction. Phase distortion can be eliminated if the phase difference between the input and output voltages is zero, or if a proportional amount of delay is introduced for each frequency. Thus, a phase delay of 45 deg at 60 cycles is equivalent to a 90 deg delay at 120 cycles, etc. The first introduces a delay of approximately 0.002 sec, similar to 90 deg at 120 cycles. The net result is that all the picture elements are shifted the same amount, and correction is attained by positioning the picture. Phase shifts introduced by the electrical constants of one stage are to be added to those of any other stage. The total phase delay of a system is equal to the sum of all the individual phase delays.

Video-amplifier Design. The preceding paragraphs have indicated the requirements necessary for high-fidelity transmission and reception of television images. The methods whereby these requirements are met in practice represent an important consideration in television today.

The type of amplifier that can be used to give the necessary 4-mc bandwidth is restricted, almost without exception, to resistance-capacitance-coupled networks. Transformers and inductances, even when they are built with a 4-mc width, involve a disproportionate expense. On the other hand, *R-C* amplifiers have the advantage of small space and economy, and are universally employed.

From knowledge of conventional resistance-coupled amplifiers that the reader possesses he knows that a flat response is obtained in the middle range of frequencies (say from 200 cycles up to approximately 2,000 cycles), with ordinary circuits. A frequency-response curve is illustrated in Fig. 7-14 and applies to any conventional *R-C* amplifier. As we are also interested in phase response, this, too, is indicated in Fig. 7-14. The frequency and phase characteristics of the amplifier, throughout the middle range, are suitable for use in video amplifiers, and this section of the curve requires no further improvement. However, the responses at either end of the curve are far from satisfactory and corrective measures must be taken. Fortunately, any changes made in the circuit to improve the high- or low-frequency responses of the curve will generally not react on each other (with one limitation noted later), and each end can be analyzed separately and independently. How-

ever, before we see what can be done to extend the high- and low-frequency ends of the response curve, let us derive the gain equation for amplifiers.

Amplifier Gain. The gain of an amplifier, and by this we mean voltage gain, is the ratio of the output signal to the input signal. We particularly stress voltage gain because it is also possible to obtain power gain in an amplifier; however, in most vacuum-tube applications, voltage gain is the figure of merit, and this is the value to be considered here.

The gain of a stage is dependent upon the μ or amplification factor of the tube as well as the value of the load which is employed in the plate or output circuit. The μ value is governed largely by the tube construction as well as the operating voltages applied to the various elements, particularly the screen grid and plate. The output load of an amplifier is much more than simply the resistance or impedance which may be found directly connected to the plate. It also includes the impedance of any circuit to which the plate may be connected. In most instances, this impedance includes the control-grid-input circuit of the following stage.

In order to appreciate better the roles which the two foregoing factors play in determining the gain of an amplifier, it is desirable to analyze the amplifier circuit by means of an equivalent diagram. The purpose of an equivalent diagram is to provide a circuit which contains only those components essential to the operation of the amplifier insofar as the signal is concerned. It is important that the latter distinction be carefully noted, because equivalent circuits do not possess d-c voltages, it being assumed that the proper voltages are applied and the tube is operating in the desired manner. Generally, this means that the stage operates as a linear amplifier.

Figure 7-15(A) contains the diagram of a triode amplifier in its simplest form, with the input signal applied between grid and cathode, while the output signal appears across Z_L . Grid bias is established by a battery in-

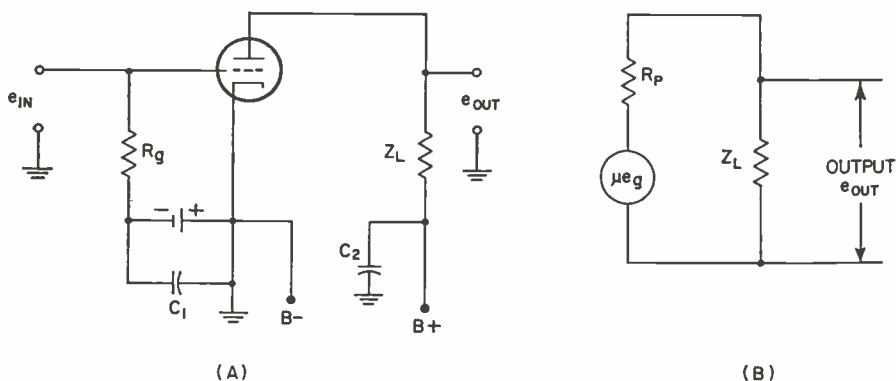

FIG. 7-15. (A) A triode amplifier and (B) its equivalent circuit.

serted between the cathode and the grid. Plate voltage is obtained from a power supply which applies B+ to the bottom end of Z_L , while the negative side of the supply connects to ground and the cathode.

In any amplifier, such as the one shown in Fig. 7-15(A), a small a-c voltage inserted between grid and cathode will develop a much larger voltage across the output-load impedance. In an equivalent diagram, Fig. 7-15(B), we can represent this amplifying action of the tube by a generator producing a voltage of μe_g . In this equation, μ is the amplification factor of the tube and e_g is the input a-c voltage.

The μe_g generator is placed in series with the plate resistance of the tube (R_p) and the output-load impedance, Z_L . The plate resistance must be included because we know such a resistance exists and when current flows through the tube, a certain voltage drop is developed across the resistance, i.e., across the tube.

The circuit of Fig. 7-15(B) thus becomes the equivalent circuit of the amplifier in Fig. 7-15(A). Note that capacitors C_1 and C_2 do not appear in the equivalent circuit because their purpose is simply to provide a low-impedance path for signal current flowing around the bias battery in one case and the power supply in the other. Since it is not their purpose to impede the flow of current, and since their a-c impedance is, or should be, negligible, they need not be shown in the equivalent diagram. Also, we can disregard completely the grid circuit of the tube because the signal voltage here is multiplied by the μ of the tube and is represented by the generator, μe_g . Furthermore, there is ordinarily no current flow in the grid circuit and this, too, is a good reason why the grid circuit itself is not shown separately in the equivalent diagram. Thus, all we have left is the small generator μe_g , the plate-load resistance, and the tube internal resistance. We know that Z_L and R_p must be in series with each other because any current that flows through the tube, and hence, R_p , must also flow through the load impedance, Z_L . Z_L is designated as an impedance rather than as a resistance because resistors are not always employed as the load. To make the discussion general, at least at the start, the load is being considered as an impedance.

To derive the equation for the gain of this amplifier, we proceed as follows. Since this is a simple series circuit, we can indicate its governing equation as

$$\mu e_g = i_p \times (R_p + Z_L) \quad (1)$$

Solving this equation for i_p , we obtain

$$i_p = \frac{\mu e_g}{R_p + Z_L} \quad (2)$$

The next step is to multiply the plate current, i_p , by the load impedance, Z_L , to obtain the voltage developed across Z_L . This gives us

$$\begin{aligned}
 e_{\text{out}} &= i_p Z_L & (3) \\
 &= \frac{\mu e_g}{R_p + Z_L} \cdot Z_L
 \end{aligned}$$

The over-all gain of the amplifier, which is defined as the ratio of e_{out} to e_g , can now be obtained.

$$\text{Gain} = \frac{e_{\text{out}}}{e_g} \quad (4)$$

$$\begin{aligned}
 &= \frac{\mu e_g Z_L}{(R_p + Z_L) \cdot e_g} \\
 &= \frac{\mu Z_L}{R_p + Z_L} & (5)
 \end{aligned}$$

From equation (5), we see that the over-all gain of the amplifier will always be less than μ because of the fraction that it is multiplied by: $Z_L/R_p + Z_L$; unless Z_L becomes much larger with respect to R_p , this fraction will always have a value which is less than 1. Hence, the gain will always be less than the theoretical amplification factor μ of the tube that is employed. It can also be seen that in order to obtain maximum gain, the plate-load impedance should be as high as possible. However, if this happens to be a resistor, then, obviously, the larger this resistor, the lower the plate voltage (for any given value of B+). With a lower plate voltage, less signal can be handled by the tube without distortion. In a practical design, a compromise is reached between the power-supply voltage and the value of the plate-load resistance.

When a pentode tube is employed, we obtain the same equivalent circuit. However, a better appreciation of stage gain for this tube can be obtained in the following manner. In a pentode, the plate-load resistance is exceedingly high, certainly much higher than it is in a triode. Under these conditions, R_p completely swamps Z_L in the denominator of equation (5) and the result is

$$\text{Gain} = \frac{\mu Z_L}{R_p} \quad (6)$$

We see that μ is multiplied by the ratio of load impedance to plate resistance of the tube. Now, μ and R_p are values determined by the tube which is being employed. Furthermore, these two quantities are related to each other by $g_m = \mu/R_p$. This relationship is true of every tube, whether it is a triode, tetrode, or pentode. If g_m is substituted for the ratio μ to R_p , the gain equation for an amplifier is given by

$$\text{Gain} = g_m \cdot Z_L \quad (7)$$

This equation is much more convenient to work with when the internal

plate resistance of the tube is considerably greater than the load resistor. We also see why equation (7) would not be correct for triodes unless the same conditions hold. In recognition of the preceding relationship, tube manuals are more likely to list g_m values for pentodes than μ values.

Thus, as a rough measure of the amplification of an amplifier, it is necessary simply to multiply the mutual conductance of the tube in question by the impedance or the resistance of the plate load. The reason this does not always give an accurate value stems from the presence of other impedances which affect the plate circuit and which frequently have a decided effect on the total value of impedance that the tube sees as a load. However, the foregoing procedure can be used as a rough indication. Also, in the discussion to follow, we shall consider the plate load as being purely resistive and use R_L in place of Z_L . This is permissible for video amplifiers.

The g_m , or mutual conductance, of a tube is governed by the particular tube used and the plate current flowing through the tube. The latter is dependent upon the B+ applied to the plate. The second part of equation (7) is the load resistance into which the tube works. To see what fully constitutes this load, consider Fig. 7-16. Here we have the coupling network

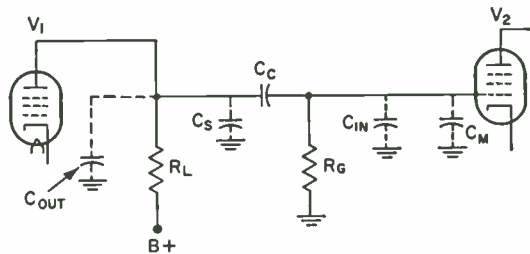

FIG. 7-16. The complete coupling network between two amplifiers.

between the output of one amplifier and the input of the following stage. In addition to the plate-load resistor, R_L , we also see C_c , the coupling capacitor, and R_G , the grid resistor of the following tube. These three components are those that are ordinarily wired into the circuit. Also present, but not physically wired into the circuit by the designer, is the output capacitance of the first tube, C_{out} , the input capacitance of the following tube, C_{in} , plus two additional shunt capacities, C_s and C_M . C_s is the stray capacitance which exists across the circuit because of the wiring between stages, the capacitance that R_L or R_G may have with respect to the chassis, and any capacitance that C_c itself may develop with respect to the chassis. This stray capacity, while it is seldom greater than 5 or 6 mnf, must be taken into account when dealing with the high frequencies which pass through a video amplifier. C_M is a capacitance which is reflected from

the plate of V_2 to its grid circuit. We shall discuss the value of this capacitance in a moment.

Thus, what initially appeared to be a fairly simple circuit, consisting of two resistors and a coupling capacitance, actually turns out to be a fairly complex network containing three additional capacitances which are ordinarily not visible. These capacitances, with the resistances, combine to make a complex quantity, Z_L . As we shall see, however, not all of these components need be considered when dealing with any specific section of the overall video response. This fact will become evident as we consider the operation of these amplifiers, first at the high-frequency end, then over the mid-frequency section and, finally at the low-frequency end. Let us start with the high-frequency response of an amplifier.

High-frequency Behavior of Video Amplifiers. When considering the high-frequency operation of a resistance-coupled amplifier, we need not include the coupling capacitor C_c . The reason for this is that C_c will generally have a value of approximately 0.1 mf and the high-frequency end of a video-amplifier-response curve generally falls about 1 mc or above. At these frequencies, C_c has negligible impedance. All we need include are the two resistances, R_L and R_G , plus the shunt capacitances which are present in the circuit. The high-frequency version of the network between V_1 and V_2 is now as shown in Fig. 7-17. We could, if we wish, simplify this circuit even more

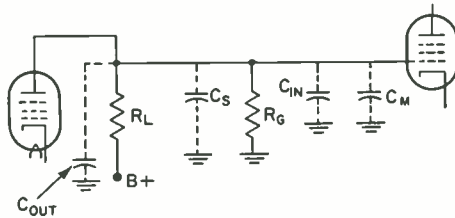

FIG. 7-17. The high-frequency equivalent of the interstage coupling network.

by showing only R_L and omitting R_G . This simplification can be made because R_G is considerably higher in value than R_L and the two resistances in parallel will provide a total resistance very close to the value of R_L . However, for the sake of those instances when R_G may not be negligible in its effect on R_L , we shall retain R_G .

To determine the high-frequency gain of an amplifier with the interstage network shown in Fig. 7-17, we must take not only R_L into consideration, but also the four shunt capacitances, C_{out} , C_s , C_{in} , and C_M . Since all of the capacitances are in parallel, their total value is equal to the sum of the separate units, that is,

$$C_T = C_{out} + C_s + C_{in} + C_M$$

To evaluate C_T numerically, we must know the exact values of each of its four components. The values of C_{out} and C_{in} can be obtained from a tube manual. A typical value of C_{out} is 3 mmf, and for C_{in} it is 7 mmf. C_s will vary with the circuit, but generally it falls about 6 mmf. Still remaining is the determination of C_M . This capacitance is an addition to the input capacitance of a tube due to the grid-to-plate capacitance of the tube plus the presence of a larger signal (generally) on the plate than on the grid. As a matter of fact, the plate signal is A times larger, A being the amplification of the stage.

If we examine Fig. 7-18, we see that C_{gp} has applied to it, on the grid side,

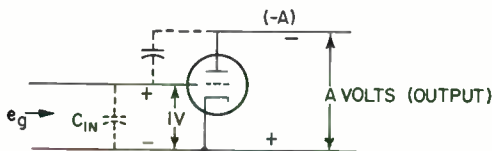

FIG. 7-18.

the incoming signal voltage. Let us assume this is 1 volt. On the other side of C_{gp} the amplified signal is present. If the stage gain is A , then $-A$ volts appears at the plate side of C_{gp} . (The minus sign takes into account the phase reversal that occurs in the tube.) Hence, the two voltages, so far as C_{gp} is concerned, are series aiding, or $(A + 1)$. Now, the grid-to-plate capacitance, C_{gp} , is in series with the normal-input capacitance of the tube, C_{in} , and the charging current that flows through C_{gp} will affect C_{in} . If we keep the voltage across C_{in} constant, in this case the input signal, e_g , but increase the effective charging current, then the over-all effect is equivalent to an increase in capacitance. This effect can be seen from the equation which governs capacitor charge and capacitance,

$$Q = CV \quad (8)$$

where Q is the capacitor charge, C is the capacitance, and V is the voltage across the capacitor. If V is kept constant, but Q increases, then C must become larger to maintain equation equality.

Thus, because of the presence of C_{gp} , the input capacitance of a tube rises above the published value of C_{in} , which represents the capacitance between the control grid and cathode, heater, grid no. 2, grid no. 3, and any internal shield that may be employed. This additional increase is equal to

$$C_M = C_{gp}(1 + A) \quad (9)$$

where A is the stage gain. If we assume a value for C_{gp} of 0.05 and a stage gain of 20, then this additional capacitance is equal to

$$C_M = 0.05(1 + 20) \\ = 1.05 \text{ mmf}$$

Now, we can compute the value of C_T .

$$C_T = C_{out} + C_s + C_{in} + C_M \\ = 3 + 6 + 7 + 1.05 \\ = 17.05 \text{ mmf}$$

This capacitance is evidently not negligible; therefore it will certainly affect the total plate impedance at the high-frequency end of the video-response curve. The plate-load resistor, R_L , and C_T are in parallel with each other (Fig. 7-19). It is useful to determine at what frequency the impedance of C_T equals R_L . When this point is reached,

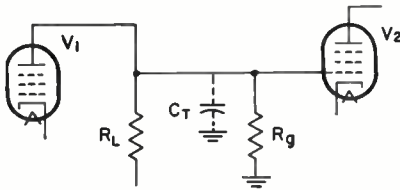

FIG. 7-19. The plate-load resistor R_L and C_T are in parallel with each other. Coupling capacitor C_c has been omitted because it does not enter into high-frequency gain calculations.

$$R_L = X_{CT}$$

or

$$R_L = \frac{1}{2\pi FC_T}$$

and

$$F = \frac{1}{2\pi C_T R_L} \quad (10)$$

At this frequency (F), the total impedance in the plate circuit is $\frac{1}{\sqrt{2}}$ * of its value at lower frequencies, when X_{CT} is so large it can be disregarded. The expression $\frac{1}{\sqrt{2}}$ is equal numerically to 0.707. In terms of decible loss, 0.707 represents a decrease of 3 db. Hence, at frequency F the amplifier gain is 3 db down from its gain at lower frequencies.

It is apparent from equation (10) that in order to raise frequency F , either C_T or R_L must decrease in value. The curves in Fig. 7-20 demonstrate how the bandwidth of a video amplifier is broadened by lowering the value

* This can be seen readily. Let us assume that R_L and X_c each have a value of 1 ohm. Then, since both are in parallel and since one is a resistor and the other is a reactance,

$$Z = \frac{R \cdot X_c}{\sqrt{(R)^2 + (X_c)^2}} \\ = \frac{1 \cdot 1}{\sqrt{(1)^2 + (1)^2}} \\ = \frac{1}{\sqrt{2}}$$

of the plate-load resistor. This, then, is the primary reason why low-valued load resistors are used in video amplifiers. Unfortunately, Fig. 7-20 reveals that lower load resistors also provide less stage gain. Hence, while this method of increasing the response of a stage frequencywise is useful, it cannot be carried too far if any useful gain from the stage is to be achieved.

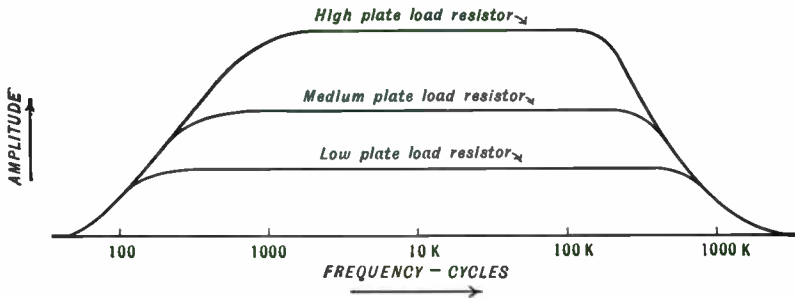

FIG. 7-20. By lowering the plate-load-resistor value, it is possible to increase the extent of the flat portion of the response curve.

Shunt Peaking. A method which is useful in extending the high-frequency response of an amplifier is the addition of a small inductance in series with the load resistor. The inductance is designed to neutralize the effect of the shunting capacitances, at least to the extent that we can improve the amplifier response at the upper frequencies. This method is known as "shunt peaking."

A circuit diagram using this compensating inductance is shown in Fig. 7-21. The impedance of the combination of L , R , and C_T is given as

$$Z = \sqrt{\frac{X_L^2 X_{C_T}^2 + R_L^2 X_{C_T}^2}{R_L^2 + (X_L - X_{C_T})^2}} \quad (11)$$

If the value of X_{C_T} is made equal to R_L , and X_L is equal to half of R_L , then we find that

$$\begin{aligned} Z &= \sqrt{\frac{\left(\frac{R_L}{2}\right)^2 R_L^2 + (R_L^2)^2}{R_L^2 + \left(R_L - \frac{R_L}{2}\right)^2}} \\ Z &= \sqrt{\frac{R_L^2 \left(\frac{R_L^2}{4} + R_L^2\right)}{R_L^2 + \frac{R_L^2}{4}}} \\ &= R_L \end{aligned}$$

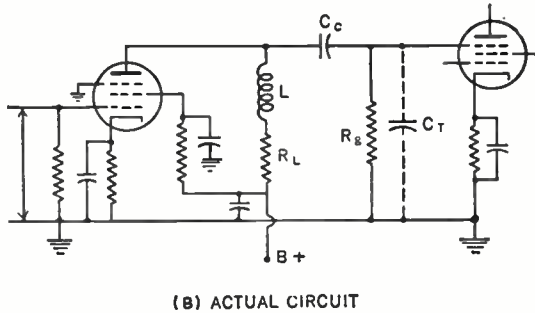
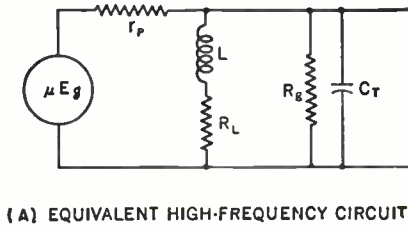

Fig. 7-21. High-frequency compensation for an R-C amplifier.

Thus, under the conditions specified, the impedance of the plate circuit is the same as the impedance it possesses at mid-frequency. This is certainly a desirable situation, since it means that the response of the circuit remains flat up to frequency F , the frequency at which X_{C_T} equals R_L . In an uncompensated amplifier, at frequency F , the response is down 3 db from its mid-frequency value. By the addition of the inductance L , we have raised the gain 3 db at F .

The procedure for finding actual values for R_L and L is as follows. First, the highest frequency at which it was desired to have the response remain flat would be specified. In a video amplifier, this would occur between 3 and 4 mc. Then R_L would be determined from the equation

$$R_L = \frac{1}{2\pi F C_T}$$

Also, since X_L is to have a value equal to one-half R_L ,

$$X_L = 0.5R_L = \frac{0.5}{2\pi F C_T}$$

Also, since $X_L = 2\pi F L$,

$$2\pi F L = \frac{0.5}{2\pi F C_T}$$

or

$$L = \frac{0.5}{4\pi^2 F^2 C_T} \tag{12}$$

and

$$L = 0.5 C_T R_L^2 \tag{13}$$

The value of C_T would be calculated from the circuit or would be actually measured. Typical values of R_L range from 4,700 ohms to 6,800 ohms.

Figure 7-22 demonstrates the effect of too high an inductance value for L (curves 3 and 4) and too low a value (curve 1). A small amount of over-

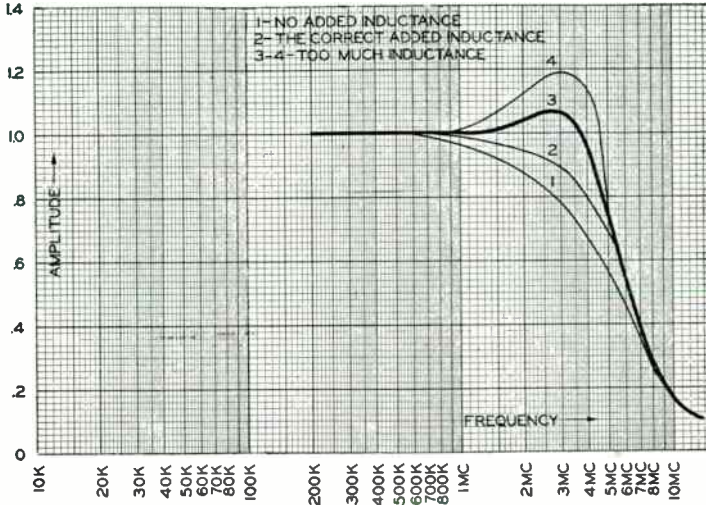

FIG. 7-22. The effect on amplifier response of the insertion of various amounts of peaking inductance in the plate load.

peaking may sometimes be employed to sharpen the fine detail in the picture. Too much peaking, however, will lead to ringing, a condition where multiple lines follow the edge of an object. This is sometimes confused with ghosts.

Series Peaking. A second method of improving the high-frequency response is to insert a small coil in series with the coupling capacitor, as illustrated in Fig. 7-23. This method gives higher gain and better phase re-

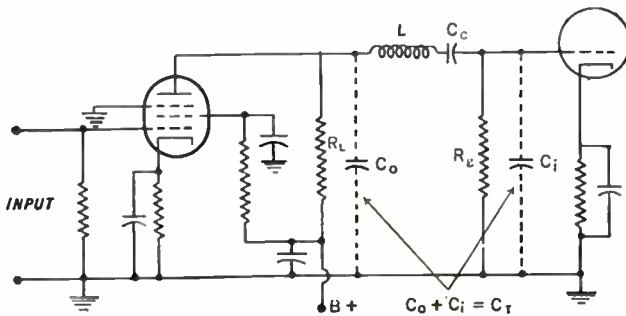

FIG. 7-23. High-frequency compensation by means of a series peaking coil.

sponse than shunt peaking. The improved gain of this type of coupling is due to the fact that the components of C_T are no longer lumped together in one unit, but are separated. On the left-hand side of the series inductance is the output capacitance of the preceding tube, and on the other side is the input capacitance of the following tube. With this separation, the load resistor R_L may be higher in value because only C_0 is directly across it and not the larger C_T . As C_0 is smaller than C_T , its capacitive reactance is greater, and it will have less of a shunting effect on R_L . A larger value of R_L is then possible, actually 50 per cent larger. Thus,

$$R_L = \frac{1.5}{2\pi f C_T} \quad (14)$$

C_T is the total capacitance shunting R_L (that is, $C_0 + C_i$ in Fig. 7.23).

It has been found that best results are obtained when the ratio of C_i to C_0 is approximately 2. The value of the series coil, L , is given as

$$L = 0.67 C_T R_L^2 \quad (15)$$

Series-shunt Peaking. It is further possible to combine shunt and series peaking and obtain the advantages of both. The shunt coil is designed to neutralize the output capacitance of the preceding tube, while the series coil combines with the input capacitance (and stray wiring capacitance) of the next tube. With this double combination, it is possible to achieve 1.8 times more gain than can be derived through the use of shunt peaking alone. Furthermore, the phase distortion of the coupling network is lower than either of the two preceding types. An amplifier using shunt and series peaking combined is shown in Fig. 7-24. A resistor is shunted across the series

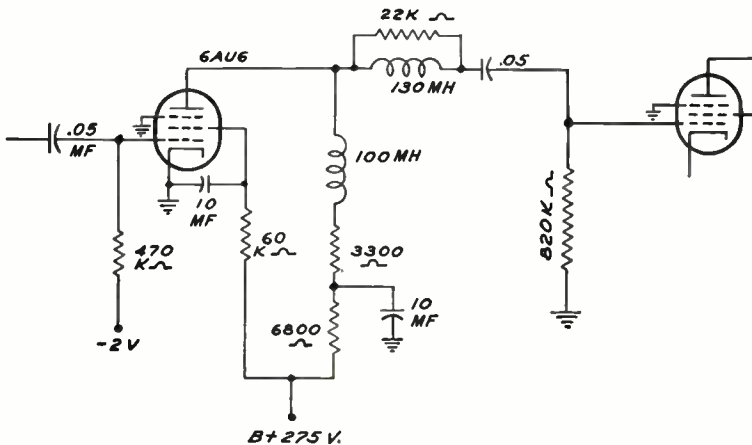

FIG. 7-24. A video amplifier employing series-shunt peaking combined.

coil to minimize any sharp increase in circuit response due to the combination of the series coil inductance and its natural or inherent capacitance. The coil is designed to have a natural frequency considerably above the highest video frequency. In production, however, a certain number of coils will be produced with natural resonant frequencies within the range covered by the amplifier. The effect is a sharp rise in response, similar to curve 4 in Fig. 7-22. It is to prevent this peak from occurring that the shunting resistor is used. Its value is generally 4 or 5 times the impedance of the series coil at the highest video frequency.

For the combination circuit, the values of L_s , L_c , and R_L are obtained from the following relationships:

$$R_L = \frac{1.8}{2\pi F C_i} \quad \text{where } C_T = C_i + C_o \quad (16)$$

$$L_s = .12 C_T R_L^2 \quad (\text{shunt coil})$$

$$L_c = .52 C_T R_L^2 \quad (\text{series coil})$$

F is the highest frequency at which the response remains uniform.

Low-frequency Compensation. With the high-frequency end of the response curve taken care of, let us determine what changes can be made to improve the low-frequency response. At this end of the band, it is possible to disregard the shunting capacitances since their reactance, given by

$$X_c = \frac{1}{2\pi f C}$$

is very high, and they do not affect the low-frequency signal voltages in any way. Now, however, it becomes necessary to include the coupling capacitor. The equivalent low-frequency circuit can be represented as shown in Fig. 7-25. The operation of the circuit, as explained in conjunction with Fig. 7-12, shows that the lower the frequency, the greater the effect of the coupling capacitor. The response gradually falls off because the reactance of C_c

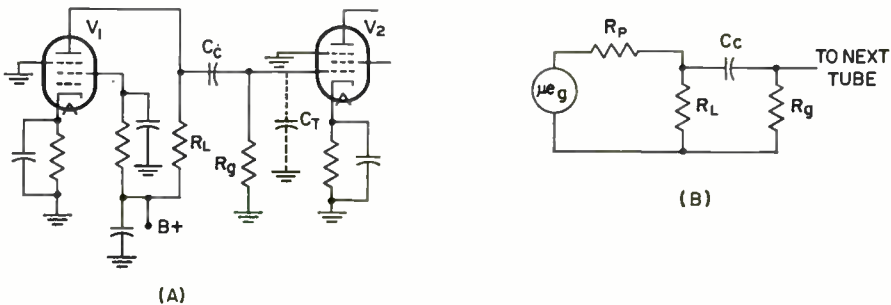

FIG. 7-25. (A) An RC-coupled amplifier and (B) its low-frequency equivalent circuit.

soon becomes dominant and a large portion of the output voltage of V_1 is lost. The phase delay of the signal begins to change, eventually approaching 90 deg. As a result, the background illumination of the reproduced image is affected.

To increase the linear response at the low frequencies, either C_c should be made larger (so that it will have less reactance) or R_p should be made larger. The limit of the size of either C_c or R_p is governed by several factors:

1. Too large a value of C_c increases the stray capacitance to ground, and is certain to interfere with the high-frequency response.
2. Larger coupling capacitors generally have higher leakage currents. This permits the positive power-supply voltage on the preceding plate to affect the grid of the following tube and to bias it positively.
3. A large value of R_p proves detrimental if the tube to which it is attached has even a slight amount of gas.
4. Finally, high values of R_p and C_c have a tendency to produce motorboating (oscillations), because of the slow building up and leaking off of charge across the combination.

By inserting a resistor and capacitor in the plate circuit of tube V_1 , as indicated in Fig. 7-26, it is possible to improve the low-frequency response without making either R_p or C_c too large. R_f and C_f are the two added components. They form the low-frequency compensation circuit. Through the addition of this resistor and capacitor, the impedance in the plate circuit is increased for the lower frequencies and greater gain results. At the high frequencies, C_f bypasses R_f and effectively nullifies it. Furthermore, C_f and R_f serve as a decoupling filter which aids in stabilizing the stage by preventing any low-frequency oscillations, or motorboating, from feedback between stages by way of the power supply.

The value of C_f in Fig. 7-26 is obtained from the expression:

$$R_L C_f = C_c R_p \quad (17)$$

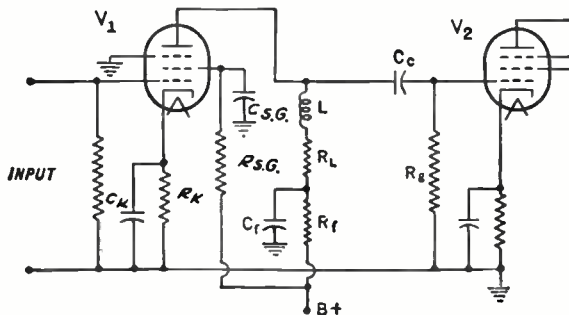

FIG. 7-26. Low-frequency compensation (R_f, C_f) of an R-C amplifier.

where R_L , C_c , and R_g have previously been assigned values. R_L will be determined by the highest frequency to be passed by the amplifier and C_c and R_g will be as large as possible but within the limitations noted above. Finally, R_f should have a resistance which is at least 20 times larger than the impedance of C_f at the lowest frequency to be passed.

C_f and R_f provide the greatest amount of compensation, but there are additional factors which influence the extent of the low-frequency response. One of these is the screen-grid dropping resistor and bypass capacitor. For best results, R_{sg} and C_{sg} should have a time constant which is at least 3 times as long as the period ($1/f$) of the lowest video frequency to be passed by the amplifier. A second governing factor is the cathode resistor, R_k , and the cathode bypass capacitor, C_k . These should be chosen so that they satisfy the following expression:

$$R_k C_k = R_f C_f \quad (18)$$

Admittedly, the latter two circuits are not quite as important as the decoupling resistor and capacitor, R_f and C_f , but they should be considered in the amplifier design.

In the design procedure of video amplifiers, the values of the high-frequency compensating components are selected first. These include R_L , L_s , and L_c . Next, the low-frequency compensating components, C_f and R_f , are computed, then R_{sg} and C_{sg} , and, finally, R_k and C_k . The values of each of the latter three resistors must fall within the operating characteristics of the tube as recommended by the manufacturer. This requirement imposes a limitation. However, since we are concerned with a time constant in each instance (as $C_f \times R_f$, $R_{sg} \times C_{sg}$, and $R_k \times C_k$) rather than the individual value of each part, we can usually satisfy all the required conditions.

When the high- and low-frequency compensating circuits are applied to a video amplifier, the result appears as shown in Fig. 7-24. The fre-

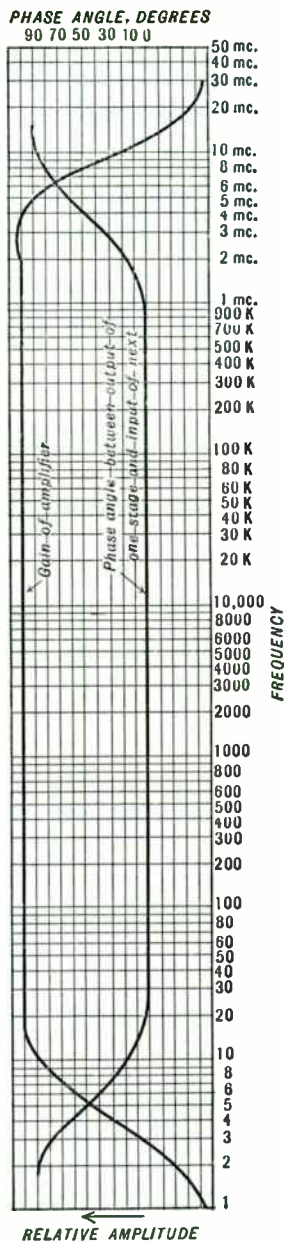

FIG. 7-27. The frequency response of a fully compensated resistance-coupled amplifier.

quency-and-phase response of this amplifier is plotted in Fig. 7-27. The number of such stages required between the video detector and the cathode-ray tube will depend upon the polarity of the signal at the output of the detector. If the picture phase is negative, its current or voltage increases as the picture elements become darker; an odd number of video amplifiers must be used because each amplifier changes the signal by 180 deg. Hence, if the picture phase is negative, one stage will convert it to a positive phase and the signal in this form can then be applied to the grid of the viewing tube. Of course, three, five, or any other odd number of stages will also answer the purpose. For a positive picture polarity at the output of the detector, an even number of stages is necessary.

It is well to remember that this 180-deg-phase reversal in a tube has nothing at all to do with any phase distortion caused by the coupling-capacitor or shunting-tube capacitances. The tube reversal merely has the effect of changing a positive picture phase into a negative picture phase, or vice versa. The voltage output is still in step with the wave at the input and there is no time delay introduced at all.

Mid-frequency Compensation. In the middle range of frequencies, extending from several hundred cycles to several thousand cycles, the capacitances which caused so much trouble at either end of the frequency curve can usually be disregarded. Thus, C_o and C_i of Fig. 7-23, so troublesome at the higher frequencies, still present sufficiently large impedances in the mid-range that they introduce little shunting effect. On the other hand, the coupling capacitor, C_c , which affected the low-frequency response, presents a negligible impedance in mid-range. It, too, can be disregarded here. The result is a basic interstage coupling network of R_L and R_g , and since their impedance (or resistance) remains constant, no variation in gain results. Hence, a flat response curve is obtained and no special compensatory steps need be taken throughout this range. As a matter of fact, the mid-range level, or gain, is taken as the reference level of the stage and the high and low ends are raised to meet this gain.

Video Amplifier Tubes. The ability to provide high gain and to handle signals up to 4 mc are the primary considerations in the selection of tubes for use as video amplifiers. To achieve high gain, pentodes and beam-power tetrodes are the favored types, although occasionally a triode or a dual triode (for example the 12AU7) is utilized. The 6AW8A, 12BY7A, 6AU8, 8BQ5, and others have mutual conductances (in their pentode sections) ranging from 6,000 to more than 12,000 micromhos, values which are considerably higher than those ordinarily found in triodes. In addition, the pentode sections of these tubes are capable of handling relatively large signal swings without introducing excessive amplitude distortion.

The requirement of amplifying signals up to 4 mc is met by low inter-

electrode capacitance, particularly between plate and grid. As was noted earlier in Chapter 3, the figure of merit of a high-frequency tube is given by the expression

$$\frac{g_m}{C_{in} + C_{out}}$$

To the denominator should be added C_M (or its equivalent $C_{gp}(1 + A)$), since this appears in parallel with C_{in} . Hence, the expression becomes

$$\frac{g_m}{C_{in} + C_{out} + C_{gp}(1 + A)} \tag{19}$$

The larger the value of this expression, the better the tube for use as a video amplifier. Sometimes, the power need is the more important requirement. In such cases the interelectrode capacitance is sacrificed, because higher power requires a larger tube structure and this, in turn, leads to greater interelectrode capacitances.

Contrast Controls in Video Amplifiers. The purpose of a contrast control is to regulate the amount of video signal reaching the picture tube. It is manually operated and is adjusted by the viewer until the picture intensity suits his taste. If the room is light, he may want to turn the contrast control up. If the room has been darkened, he may want to decrease the picture intensity.

Regulation of picture intensity may be accomplished in several ways. Variation of the bias of one or more video IF amplifiers will vary the gain of these stages and this variation, in turn, will control the signal amplitude at the picture tube.

Signal gain can also be varied in the video-amplifier stages following the video second detector. In the circuit of Fig. 7-28, a contrast control is placed in the screen-grid lead of the 6CB6 video amplifier. By regulating

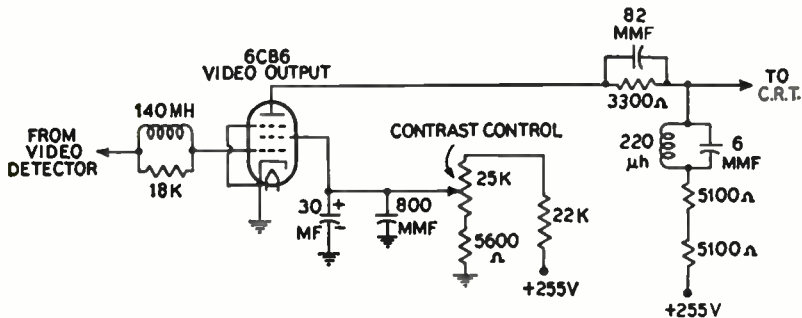

FIG. 7-28. A video amplifier stage containing a contrast control in the screen grid circuit.

the screen-grid voltage, we can vary the gain of the amplifier and of the signal that passes through.

Another approach to video-signal-amplitude control is shown in Fig. 7-29. Here the contrast potentiometer is placed in the cathode leg of the

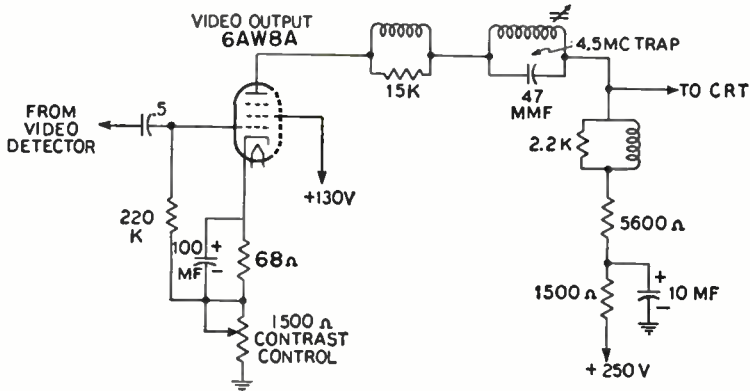

FIG. 7-29. A video amplifier with the contrast control in the cathode leg of the 6AW8A.

stage. At first thought it might appear that the control varies the bias on this stage and thereby varies the signal gain. Actually, because the 220,000-ohm grid resistor ties in to the bottom of the 150-ohm cathode resistor, the bias of the stage is only slightly affected by the contrast control. What the control really does is to determine how much of the video signal appears across the 5,600-ohm resistor in the plate circuit and how much of the signal appears across the 2,500-ohm contrast control. Naturally, the more the control receives, the less there is available for the 5,600-ohm resistor and the cathode-ray tube to follow.

Variation of the negative feedback voltage to achieve gain control is obtained in the circuit shown in Fig. 7-30. The 270-ohm resistor is shunted

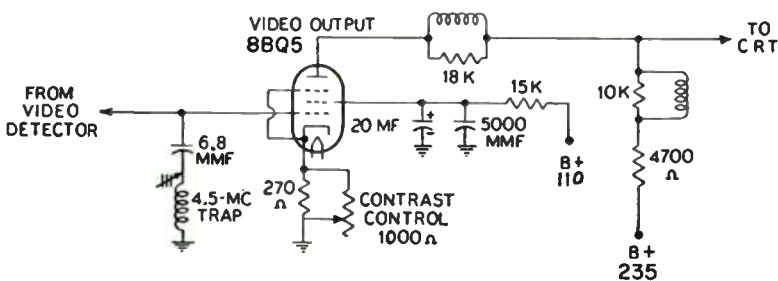

FIG. 7-30. Bias variations to achieve control of signal amplitude.

across the 1,000-ohm contrast control to prevent the total cathode resistance from exceeding 225 ohms (approx.). To do so would result in picture distortion. The signal receives maximum gain when the cathode resistance is zero.

A number of sets have employed the contrast-control arrangement shown in Fig. 7-31. The video signal which is amplified by the 12BY7A video amplifier appears across the contrast control (and the 33,000-ohm resistor below it). The amount of the signal which then actually reaches the picture tube depends upon the position of the center arm of the control. This action is quite similar to that of the volume control in a radio receiver.

Inspection of the diagram will also reveal that the control has three small, fixed capacitors branched across it. These serve to equalize the response of this unit so that all a-c and d-c voltages receive similar treatment. A potentiometer (or any other resistor, for that matter) acts as a pure resistance only at very low frequencies. At high frequencies, stray capacitance across sections of the control offer alternate paths for high-frequency signals with the result that the proportion of this voltage reaching the picture tube is not the same as it is for d-c and low-frequency voltages. For example, when the control arm is two-thirds of the way up the potentiometer, the picture tube receives two-thirds of the d-c and low-frequency voltage that is present across the control. However, it receives less than half of the high-frequency voltage because of the shunting capacities.

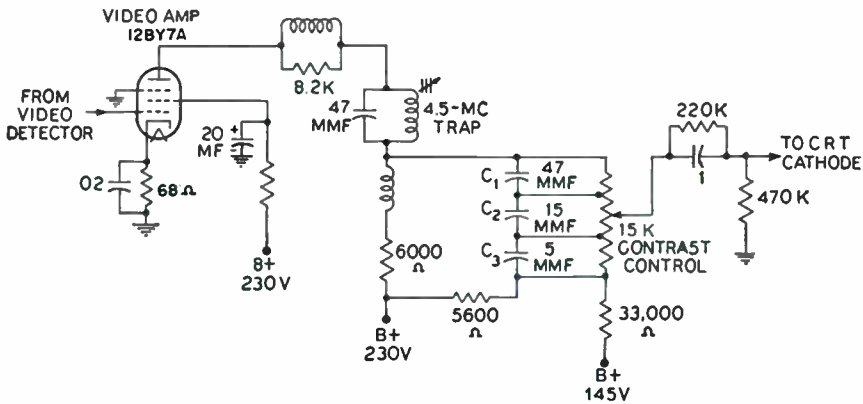

Fig. 7-31. A compensated contrast-control arrangement.

To equalize the response of the control, additional small capacitances are branched across the potentiometer in the manner shown in Fig. 7-31. These units are so chosen that the picture tube receives the same proportion of low- and high-frequency voltages when the movable arm is at the top of the potentiometer as when it is at the two tapped positions. At intermediate

positions, the equalization is not complete, but the fall-off is not sufficient to produce a noticeable effect on the picture.*

The addition of the three capacitors across the video circuit tends to degrade its high-frequency response. However, this degradation is overcome by increased peaking in the video-frequency amplifier.

4.5-mc Traps in Video Amplifiers. In intercarrier receivers, both the video and sound IF signals reach the video second detector. Within this tube a beating, or mixing, takes place between the video and sound carriers, and a 4.5-mc beat note is produced. The sound intelligence is contained within this signal and is subsequently removed from the video system and transferred to the sound system. As a precautionary measure, it is customary to insert a 4.5-mc trap in the video amplifiers beyond the separation point to insure that none of this 4.5-mc voltage reaches the picture tube. (Should this occur, it would produce a fine-line pattern on the screen similar to that shown in Fig. 7-32.)

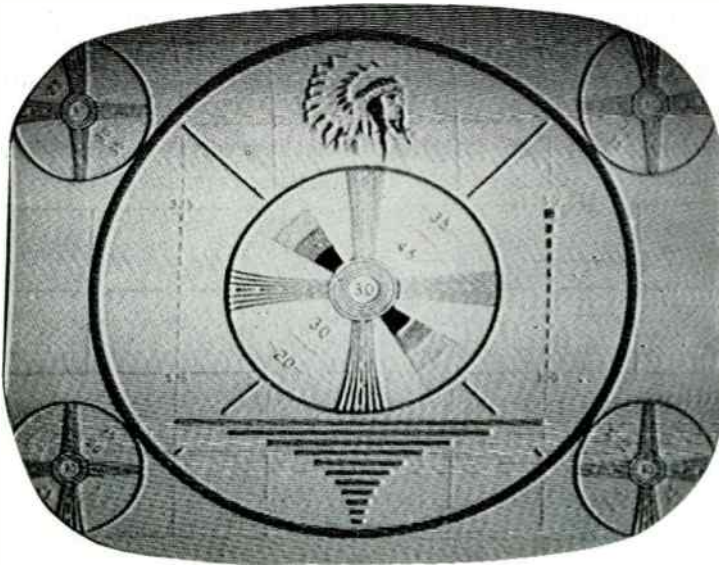

Courtesy H. W. Sams & Co.

Fig. 7-32. The appearance of a 4.5-mc signal on the screen.

The trap circuits are either parallel resonant as shown in Fig. 7-29, or series resonant as indicated in Fig. 7-30. Note again that they are placed in the video system *beyond* the sound-separation point.

Split-sound receivers also utilize a 4.5-mc trap because it is usually im-

* Note that the picture tube does not receive the same *amount* of voltage in all three positions.

possible (or impractical) to prevent completely some sound-IF-carrier voltage from reaching the video detector, in spite of the fact that these sets have sound traps in their video IF system.

It is interesting to note that when the sound IF signal reaches the video detector, two actions can occur. First, there is the formation of the 4.5-mc beat note (provided the video carrier is also present). Any amount of sound IF voltage will produce this effect. Second, the FM sound signal may itself be detected to release the audio voltages it contains. This process is called "slope detection." * These audio voltages are comparatively low in frequency, and so the visual effect they produce on the screen will differ from that of the 4.5-mc signal. Figure 7-33 is a picture affected by low-frequency



FIG. 7-33. The visual result when sound voltages reach the cathode-ray tube.

sound voltages. The voltages appear as a number of horizontal black bars. The intensity of the bars varies with the sound amplitude, and the thickness of the bars depends upon the sound frequency. No bars are present when no sound is being heard.

The appearance of the sound bars will occur only when the amplitude of the sound signal reaching the video detector is quite large, certainly much larger than is required for the operation of an intercarrier system. Hence, when these bars are observed on the screen, it is an indication that either

* See the author's *F-M Simplified*, D. Van Nostrand Co., Inc., 1960.

the video IF system (and its traps) is misaligned or that the fine-tuning control is grossly misset.

Direct-coupled Video Amplifiers. Direct-coupled amplifiers have been known and used for many years, even before the advent of television. Recently they have been employed in television receivers, too, and it might be instructive to see what form they take and how they differ from *RC* coupled amplifiers.

A video system with a d-c path from the video second detector to the picture tube is shown in Fig. 7-34. The 12BY7A amplifier receives the video

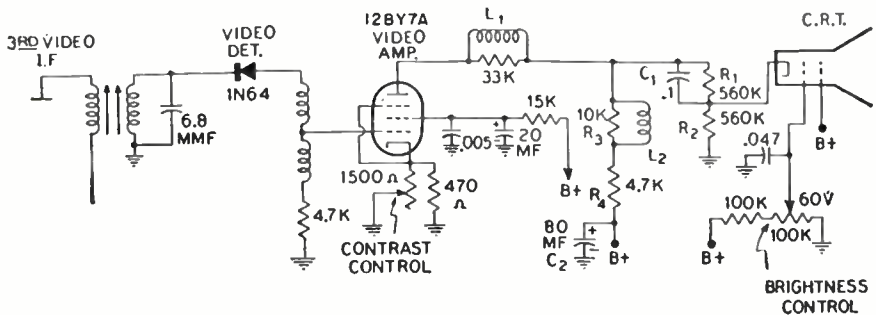

Fig. 7-34. A direct-coupled video amplifier system.

signal direct from the video detector, amplifies it, and then feeds it to the cathode of the picture tube. Because of the direct coupling, the cathode of the picture tube has a fairly high positive potential. In this case it is 82 volts. Partly to offset this, the control grid of the picture tube is also given a positive voltage. (The exact value will be determined by the setting of the brightness control. The 60 volts indicated in the diagram is an average value.) In this way we still maintain the control grid negative with respect to the cathode, as is required for the proper operation of the tube.

Elimination of the coupling capacitor extends the amplifier response down to d-c or zero frequency. It was the presence of this capacitor, it will be recalled, that caused the response of an amplifier to drop off at the low frequencies. High-frequency compensation is still necessary. L_1 and L_2 of Fig. 7-34 serve this purpose.

The presence of C_1 , R_1 , and R_2 requires explanation because they are related to the fact that direct coupling is used between the video amplifier and the picture tube.

If we tie the plate of the 12BY7A directly to the cathode of the picture tube, the positive voltage at this cathode will be close to 195 volts (in this circuit). To offset this, the control grid of the picture tube will also have to have a high positive voltage. And finally, since the second grid (or first anode) of the picture tube should be from 300 to 350 volts more positive than

the control grid, its voltage in this case will have to exceed 500 volts. To avoid using voltages this high (which are obtained from the low-voltage power supply), the following system is employed.

In the plate circuit of the 12BY7A, the load presented to the a-c component of the video signal is a combination of L_2 , R_3 , and R_4 . The load for the d-c portion of the signal, however, includes not only these three components but also the resistance formed by C_2 and the power supply. C_2 , an electrolytic capacitor, may represent a short circuit to a-c, but to d-c its impedance is very high. Therefore this impedance in parallel with the power-supply impedance must also be considered in computing the load seen by the d-c component of the video signal.

Since the d-c load of the amplifier is greater than its a-c load, the d-c component will receive more amplification than the a-c component. To equalize the response, a d-c voltage divider consisting of R_1 and R_2 is formed. From the value of these resistances it is seen that slightly less than half of the d-c component reaches the picture tube. The 0.1-mf capacitor prevents the a-c signals from being attenuated by shunting them around R_1 .

The voltage-dividing action of R_1 and R_2 also reduces the d-c plate voltage reaching the cathode of the picture tube, and thereby reduces the amount of B+ required by the control grid and second grid of the CR tube.

A 2-stage, direct-coupled video-amplifier system is shown in Fig. 7-35. Note how the voltages start at -130 volts at the grid of V_1 and work up to $+225$ volts at the plate of V_2 . This increase in operating voltages from stage to stage is characteristic of direct-coupled amplifiers. If we add another stage after V_2 , the grid of this third stage will be positive because of its connection to the plate of V_2 . This, in turn, means that the cathode and plate of this third tube will have to be even more positive. By adding enough stages, the B+ voltage required soon rises to extremely high values. Fortunately, television receivers seldom require more than two stages of video amplification, and hence direct coupling can be successfully employed.

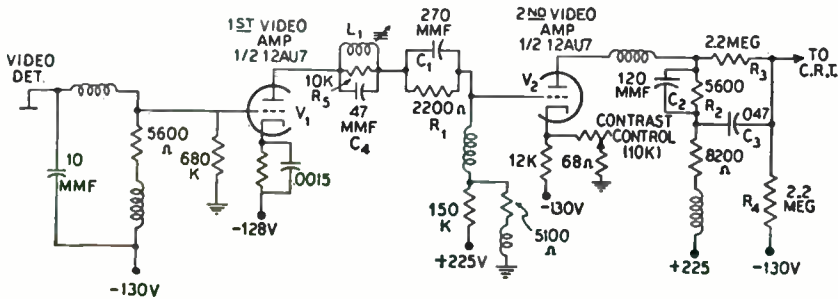

Courtesy RCA

FIG. 7-35. A two-stage direct-coupled video-amplifier system.

In the circuit of Fig. 7-35, the balance between the amplification accorded the a-c and d-c components is carefully maintained. C_1 and R_1 form one equalizing network wherein the a-c component is left alone while the d-c component is reduced. C_2 , C_3 , R_2 , R_3 , and R_4 form another such network. Finally, L_1 , C_4 , and R_5 constitute a 4.5-mc trap to remove any 4.5-mc signal that may be present in the circuit.

QUESTIONS

1. Why must we modify a high-fidelity audio amplifier before it can be used as a video amplifier?
2. Must the full 4.0-mc video signal be used in all television receivers? Explain.
3. What governs the minimum viewing distance of a television screen?
4. What purpose does the d-c component of a television signal serve?
5. What occurs to the image when the d-c component is removed?
6. Why is phase distortion important in television? Why is it unimportant in sound receivers?
7. Explain how phase distortion occurs in a television circuit.
8. What particular components are responsible for low-frequency phase distortion? Why?
9. What is the effect of high-frequency phase distortion?
10. What is the visual effect of low-frequency phase distortion?
11. What factors tend to reduce the high-frequency amplification of an audio amplifier?
12. Draw the equivalent high- and low-frequency circuits of an audio amplifier.
13. What is a peaking coil? Why is it useful in video amplifiers?
14. Draw the circuit of a video amplifier containing high-frequency compensation.
15. Explain and illustrate the differences between series peaking, shunt peaking, and a combination of the two.
16. Why can we disregard all shunting capacitances when designing the low-frequency compensation network?
17. Without adding any additional components to an audio amplifier, how can we partly improve its low-frequency response? What limitations exist to this method?
18. Draw the circuit of a video amplifier containing low-frequency compensation.
19. Specify the various points in an amplifier where low-frequency compensation can be applied. Indicate the compensation suggested in each instance.
20. What would be the visual effect of overpeaking? Underpeaking?
21. A video amplifier is to use a single shunt-peaking coil. The response is to extend to 4.0 mc. If the load resistor is 2,000 ohms and the total shunting capacitance is 20 mmf, what value should the peaking coil have?
22. In the same video amplifier, the coupling capacitor (C_c) has a value of 0.1 mf and the grid resistor of the following stage a value of 250,000 ohms. What value should C_f have in the low-frequency compensation network?
23. Explain how the low-frequency compensation networks accomplish their purpose.

D-C Reinsertion

The D-C Components of Video Signals. The video signal contains several distinct components, each of which serves a definite purpose. There is, first of all, the a-c component and this represents the detail in the image. Second, there is the d-c component and this governs the over-all background shading of the picture. Both components are separate, and each may be varied independently of the other. Finally, there are the blanking and synchronizing pulses and these are included in the signal for the purpose of shifting the scanning beam from one side of the screen to the other precisely, without producing any visible trace on the screen which reveals this position shift.

The preceding chapter dealt with video amplifiers which are primarily concerned with the a-c component of the video signal. In this chapter, we will consider the d-c component, its function within the video signal, and what happens when it is removed from the signal.

Several lines of a typical video signal are shown in Fig. 8-1. Between every two successive synchronizing and blanking pulses, we have the camera-signal variations, ranging from white (at the most positive value) to black at the level of the blanking pulse. The signals are shown in the posi-

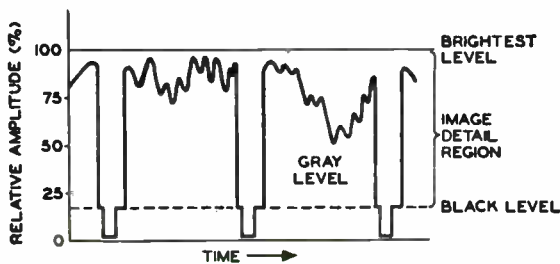

FIG. 8-1. Several lines of a typical video signal.

tive picture-phase form. When applied to the control grid of a cathode-ray tube, each different value of video voltage produces a different spot intensity on the cathode-ray tube screen and from all these light gradations we obtain the image.

Suppose, now, we take a video signal and, while maintaining the same camera-signal variations, we first move these variations closer to the blanking-pulse level, shown in Fig. 8-2(A), and then shift the same variations as far away as possible from the blanking pulses, shown in Fig. 8-2(B).

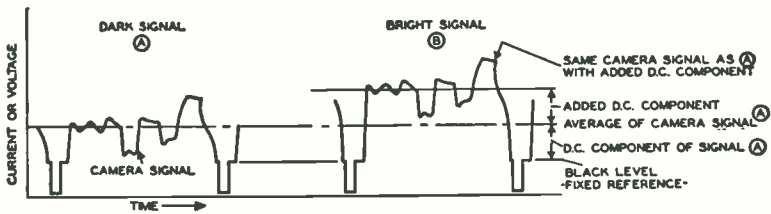

FIG. 8-2. Two video signals containing the same detail (a-c component) but different background brightness (d-c component).

What will be the visual result in each instance? Since the blanking level represents the point at which the cathode-ray-tube beam is supposed to cut off, moving the video signal closer to this level means that the overall background of the image will become darker. On the other hand, when the video signal variations are farther away from the blanking level, the background of the image becomes brighter. Note, however, that because the video-signal variations are identical in each instance, the same scene is obtained. The only thing we have altered by shifting the relative position of the video signal is the background brightness. In the first instance it is dark; in the second, it becomes bright. We can simulate the same condition in a room by increasing or decreasing the intensity of the electric lights. This change does not affect the objects in the room; it merely affects the overall brightness of the scene.

To distinguish between the camera-signal variations and the average level of these variations (or the average distance of these variations from the blanking level), it has become standard to call the latter the d-c component and the former the a-c component of the video signal. The average level of the signal can be altered by the insertion of a d-c voltage, thereby raising or lowering the average level of the video signal and changing the background brightness of the image.

At the transmitter, the level of the blanking pulses is established as the dark level, at which point the electron beam in the receiver cathode-ray tube is to cut off and the screen, for that point, is to become dark. When the a-c

video-signal variations obtained from the camera tube are combined with this blanking voltage and the sync pulses, we have a complete video signal. At any point along the program line, the distance between the average level of the a-c video signal and the blanking level may be varied (through insertion of a d-c voltage) to produce the desired shading or background brightness as dictated by the program director. Note that, since the d-c voltage moves the video-signal variations closer to or farther away from the blanking level, we are using this level as a reference. Therefore, the level of the blanking pulses must remain fixed, and the signal is transmitted with this relationship maintained.

The second-detector output in the receiver contains the full video signal, as shown in Fig. 8-1. The blanking pulse of each line is aligned to the same level. However, when the signal is passed through *R-C* coupled video-frequency amplifiers, the blanking pulses of the various lines are no longer lined up because the coupling capacitors cause the video signal to possess equal positive and negative areas about the zero axis.

This situation has been encountered by the serviceman, although in slightly different form. Suppose we take three 60-cycle a-c voltages and three d-c voltages and combine them to form the signals indicated in Fig. 8-3(A). (Voltages of this type are frequently found in power supplies where the a-c wave represents the ripple.) For the sake of this discussion, we have provided enough d-c voltage so that the positive peaks of all three waves reach the same level. Now, let us pass these voltages through a capacitor. The result is shown in Fig. 8-3(B). By removing the d-c voltages, each wave has as much area above the axis as below and, because of this, the positive peaks of the waves are no longer at the same level.

Let us look at the equivalent situation in a television system. In Fig. 8-3(C) there are shown three video signals taken at different moments from a television broadcast and representing three lines. One line is almost white, one is grey, and one is dark or black. As they come out of the video second detector, all the blanking voltages are aligned to the same level. After passing these three signals through a coupling capacitor, the signals possess the form indicated in Fig. 8-3(D). For each signal, the area above the axis is equal to the area below the axis. But because of this distribution, the blanking voltages of the signals are no longer at the same level. In this condition, we say that the d-c component of the video signal is missing. The question now is: What effect will this variation in blanking level have on the image produced on the screen?

Each blanking pulse represents the dark level of each line. Since all lines in an image should have the same reference (or black) level, all blanking pulses should have the same voltage value. This was true of the video signal when it left the transmitter and it was true in the receiver just before we

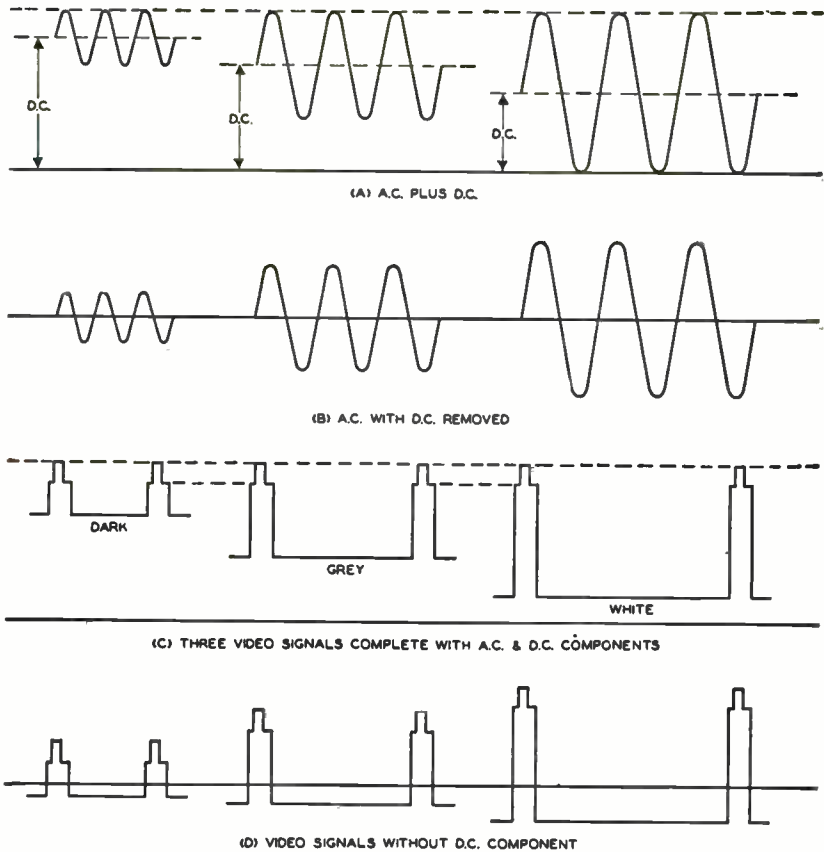

FIG. 8-3. An illustration of the effect of removing the d-c component from the video signal.

passed the detected video signal through a coupling capacitor in the video-frequency amplifier system. After passage through this capacitor, the blanking pulse levels were no longer aligned to the same level. If now we apply the three signals to an image tube (reverse polarity of Fig. 8-3(D)) here is what happens.

When the signal corresponding to a white line reaches the cathode-ray-tube grid, we manually adjust the brightness control (which controls the bias for the image tube) to the point where the blanking-pulse level just drives the tube into cutoff. Thus, as long as this signal remains, the negative voltage of the blanking pulse, added to the negative bias set by the brightness control, will darken the screen at the blanking-pulse level.

If now the grey video signal comes to the cathode-ray tube, we see that its blanking-pulse level is less negative than the blanking-pulse level of the

previous video signal. Hence, here, the beam will not cutoff at the blanking pulse, and the beam retrace will be visible. We could produce the proper cutoff conditions by increasing the negative bias on the image tube, but this is impractical for several reasons. First, in any changing scene, the background shading changes too rapidly to be adjusted manually by the viewer. As a result, if the brightness control is set for a very bright picture, we will see the retrace lines when a darker picture arrives. Conversely, if the brightness control is set for a darker image, then, when a lighter image is viewed, part of the detail will be lost because of the greater cathode-ray-tube grid bias.

Finally, the situation is aggravated even more when a dark video signal arrives. Now, we require an even greater negative bias and, when the brightness control is set correctly for this signal, it is much too negative for any of the two previous signals. If either of these two other signals is viewed with the bias set for this last signal, the image will appear too dark. On the other hand, when it is correctly set for a white picture, a black picture will appear too light, with even the retrace lines visible. The only solution to this state of affairs is to return all blanking voltages to the same level again, just as we found them in the incoming signal. *This, then, is the function of the d-c restorer in the receiver.*

Every cathode-ray tube has a definite characteristic curve. For a certain input voltage, a definite amount of light appears on the screen. All blanking pulses are purposely placed on the same level in order that the cathode-ray tube will react to them in the same manner throughout the entire reception of the signal. The same is true of white, grey, black, or any other shade that is transmitted to the scene. Any one shade must produce the same illumination on the cathode-ray-tube screen each time its corresponding voltage is present on the control grid of the tube. However, this cannot occur unless all video signals have the same reference level. It is here that the usefulness of the d-c component becomes apparent. Through the use of this inserted voltage, all blanking and synchronizing pulses are leveled off and the image detail attached to these pulses is likewise correctly oriented.

To operate the television receiver properly, then, a method must be devised whereby the a-c video signals which appear at the cathode-ray tube are again brought to the same relative level that they had before the removal of the d-c component in the intervening video amplifiers. The problem resolves itself into one of reinserting a d-c voltage that will take the place of the one removed. Note that in direct-coupled video amplifiers there are no coupling capacitors and hence the d-c component is not removed. Consequently there is no need here for special d-c reinsertion networks.

It might be noted here that most AGC systems (except the average type) use the sync-pulse level to establish the AGC voltage. Here, too, it is im-

The time constant of the grid resistor R_g and the grid capacitor C_c must be long enough so that the bias developed will last for at least one complete horizontal line, or from pulse to pulse. In practice, however, it may last longer, perhaps for several lines, since the average brightness of the background illumination seldom changes that rapidly. Values of R_g range from about 400,000 ohms up to 1 megohm. C_c would be chosen so that the time constant ($T = R \times C$) is equal to the duration of one or more lines. Each line lasts approximately 1/16,000 sec.

The output of V_1 , shown in Fig. 8-4, is applied directly to the control grid of the cathode-ray tube. Direct coupling is necessary since a capacitor will remove the d-c component just inserted. At the grid of the cathode-ray tube, a fixed bias between the grid and cathode is obtained from the power supply. This bias sets the operating point for the tube and, in conjunction with the video blanking and synchronizing pulses, cuts off the electron beam at the proper moments. The setting of this bias will depend upon the strength of the signal reaching the grid. A signal of small amplitude, say from some distant station, requires more fixed negative bias on the grid than a stronger signal.

The dependency of the cathode-ray-tube grid bias on the strength of the arriving signal is illustrated in Fig. 8-5. For a weak signal, the bias must be advanced to the point where the combination of the relatively negative blanking voltage plus the tube bias drives the tube into cutoff. However, with a strong signal, the negative grid bias must be reduced; otherwise some of the picture detail is lost.

The Brightness Control. Since the bias of the cathode-ray tube may require adjustment for different stations, or even for various conditions on the same station, a potentiometer is connected into the bias circuit, brought out to the front panel, and called the "brightness control." By its use, the observer is able to adjust the bias on the grid of the picture tube in order that blanking pulses drive the grid only to cutoff and no retrace is visible on the screen.

The effects of the brightness control and the contrast control previously described overlap to some extent. If the setting of the contrast control is increased so that the video signal becomes stronger, the brightness control must be adjusted to meet the new condition, which means, of course, that no retraces are visible. Too small a value of negative grid bias allows the average illumination of the scene to increase and permits part of the return traces to become visible. In addition, the image assumes a thin, watery, washed-out appearance. Too low a setting of the brightness control, which will result in a high negative bias on the picture-tube grid, will cause some of the darker portions of the image to be eliminated, and the average illumination of the scene will decrease. To correct this latter condition, either the

brightness control can be adjusted or the contrast-control setting can be advanced until the correct position is obtained. Finally, the focusing action of the tube may also be affected by either the brightness control or the contrast control and requires a slight adjustment, although normally this will not occur.

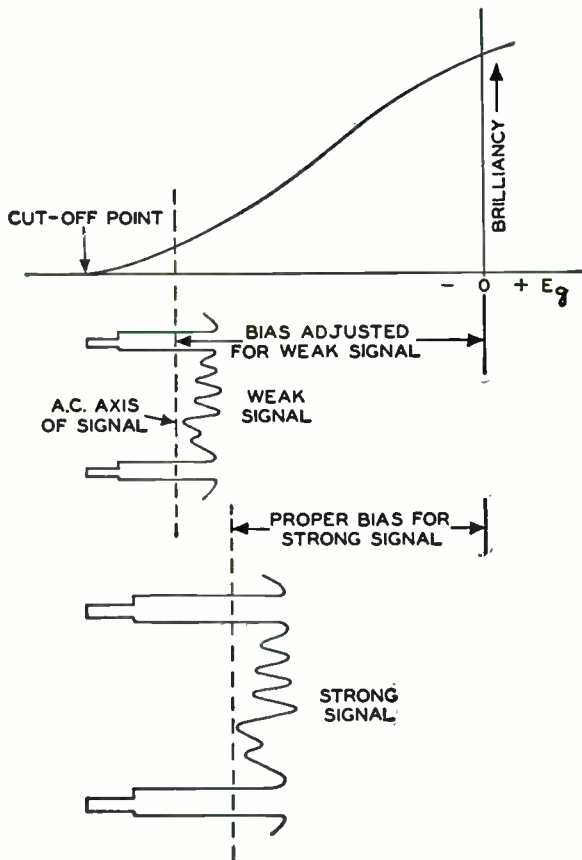

FIG. 8-5. Illustrating why the brightness control must be adjusted to suit the incoming signal.

D-C Reinsertion with a Diode. The foregoing method of d-c reinsertion is attained simply and produces good results. It has, however, one limitation: the B+ potentials on the screen grid and plate must be reduced in order that excessive current does not flow when no signal is being received. This reduces the overall gain available from this stage. Further, it is important that the screen-grid voltage be well regulated, otherwise the d-c restoring action will be impaired.

Another method of d-c reinsertion requires the addition of a diode tube, but removes the highly positive voltage from the control grid of the cathode-ray tube. See Fig. 8-6. The signal here is in its a-c form until it reaches the input to the d-c restorer, composed of capacitor C_1 , resistor R , and the diode tube. The form of the signal, at this point, is the positive phase since no further reversals take place before the grid of the cathode-ray tube is reached.

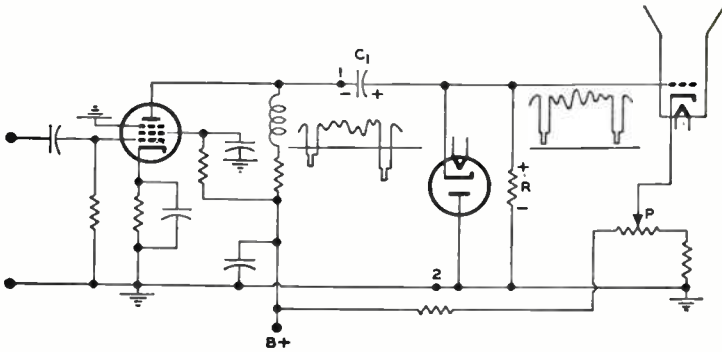

FIG. 8-6. D-c reinsertion with a diode.

In the signal applied to the restorer, the blanking and synchronizing pulses are below the zero line. When applied to points 1 and 2, the signal will cause point 1 to become negative with respect to 2. This follows from the action of an a-c wave. The other portion of the signal, which contains the image information, is above the line and, when applied across points 1 and 2, it will make 1 positive with respect to 2. The diode in the circuit conducts only when its plate is positive with respect to its cathode, or when point 2 is positive with respect to point 1.

The action of the d-c restorer is simple. When the polarity of the video signal at point 1 is negative, point 2 and the plate of the diode are positive. A flow of current will occur through the tube, and capacitor C_1 will charge to a value dependent upon the strength of the signal acting at points 1 and 2. The polarity of the charge is indicated in Fig. 8-6. During the positive portions of the video signal at the input of the circuit, capacitor C_1 will discharge through R , since the diode plate is now negative, and the tube is non-conducting. The value of R is high, about 1 megohm, and C_1 discharges slowly.

The values of C_1 and R are so designed that the voltage on the capacitor remains fairly constant throughout an entire horizontal line, or during the time that the positive a-c signal is acting on the picture tube grid. Note that this charge is between the grid and ground, or cathode, and hence acts as a

variable bias in series with the a-c signal. When the negative portion of the signal (which is due mostly to the blanking and synchronizing pulses) acts at the input, the plate of the diode again becomes conductive. The charge on C_1 will now be automatically adjusted to the amplitude of the negative pulse. A bright line will place a larger positive voltage on the capacitor C_1 than a darker line (positive picture phase here). The positive voltage will cause the grid to become more positive and the line will receive its correct value. The bias will raise each line until the blanking pulses are lined up again. Thus, in this instance, a bias develops which is proportional to the impulse amplitudes, which are, in turn, governed by the average brightness of the line, as previously explained. Potentiometer P is available, and its adjustment will cause the grid to cut off on the application of all blanking pulses.

A slightly modified version of the foregoing circuit is used in some television sets. The circuit, given in Fig. 8-7, reveals that the diode tube is not

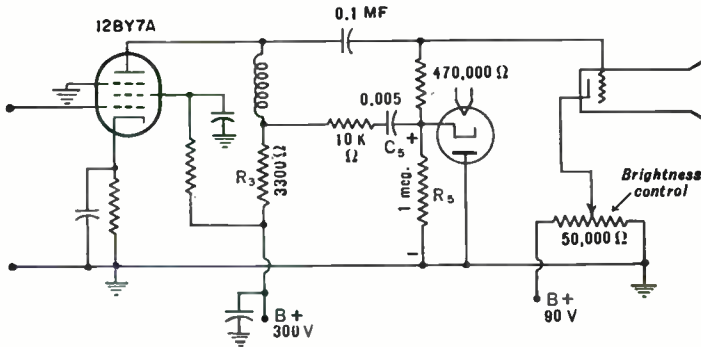

Fig. 8-7. A d-c reinsertion circuit employed in commercial receivers.

placed across the entire plate output of V_1 , but merely across a portion of it, obtained from resistor R_3 . The action of the a-c video signal across C_5 , R_5 , and the diode results in C_5 charging to the peak value of the pulses. It then discharges partly through the 1-megohm resistor, and the effect of the capacitor charge is to place its stored voltage in series with the a-c video signal so that the necessary d-c component is reinserted into the signal. The amount of charge on the capacitor will naturally vary from line to line.

Instead of using a diode tube for the d-c reinsertion, a germanium crystal can be substituted. Since crystal and vacuum-tube diodes function in the same manner, the entire previous discussion can be applied here.

Diode restorers also can be used to function as clippers to separate the sync pulses from the rest of the video signal and then to transfer these pulses

to the horizontal- and vertical-sweep systems. A typical circuit is shown in Fig. 8-8. Between every two horizontal sync pulses, C_1 discharges slightly through R_1 , setting up the d-c restoration voltage here. Upon the arrival of a sync pulse, a short flow of current takes place through the tube and R_2 since this latter resistor is in series with the tube. These pips of current represent the sync pulses since they appear only when the peak pulses are present across the circuit.

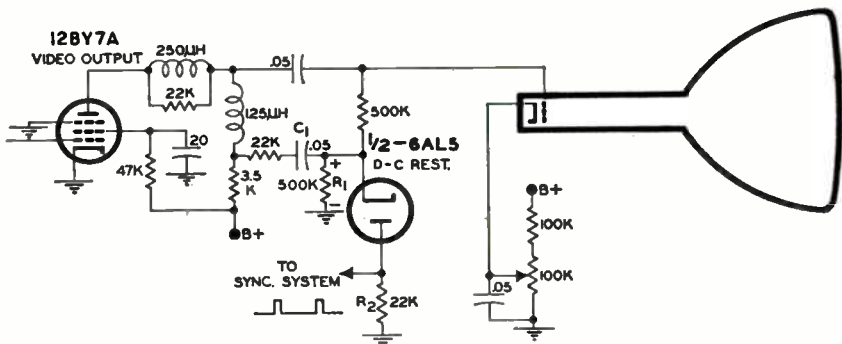

FIG. 8-8. A diode d-c restorer serving also as a sync clipper.

Television Receivers without D-C Restoration. Cost is a strong determining factor in the design of commercial television receivers and if it is possible to reduce the cost of a set without compromising picture quality too much, this sacrifice is frequently made. There are a number of receivers on the market today that do not employ d-c restoration, nor do they possess a d-c path between the video second detector and the picture tube. In other words, the d-c component is removed from the signal and never reinserted.

As the preceding discussion has indicated, loss of the d-c component will tend to make the overall picture darker. To counteract this, the viewer generally turns up his brightness control. This, in turn, frequently causes the vertical retrace lines to become visible. The continued presence of these lines during normal broadcasts will prove to be annoying. To rid the screen of these retrace lines, it has become standard practice to apply a negative pulse to the grid of the picture during the vertical retrace interval. (A positive pulse fed to the picture-tube cathode will achieve the same results. Generally the pulse is applied to the element not receiving the video signal.) The pulse biases the tube to cutoff, prevents electrons from passing through the tube, and effectively removes the vertical retrace lines for any normal position of the brightness and contrast controls.*

* More information concerning the origin of these pulses will be given at a subsequent point.

It is true that removal of the d-c component will reduce the contrast range of the image. However, this has been partly offset by the development of screen phosphors possessing wider contrast ranges, and it is doubtful whether any viewer can tell the difference when the d-c component is missing.

QUESTIONS

1. What is meant by d-c reinsertion? Why is it necessary?
2. Explain the difference between the a-c and d-c components of a video signal.
3. How is the d-c component removed? Why is it possible to reinsert this voltage?
4. Must a television receiver contain a d-c restorer? Explain.
5. Explain the operation of the grid-leak-bias method of d-c reinsertion.
6. What is the brightness control? Where is it situated in the circuit?
7. Explain the need for the brightness control.
8. What is the difference between the brightness and contrast controls?
9. What would happen to the image if the grid-leak d-c reinsertion network had a time constant of 1 microsecond?
10. Draw the schematic circuit of a diode d-c reinsertion network.
11. Explain how the circuit in question 10 operates.
12. Explain what happens when the d-c component of a video signal is removed.

Cathode-Ray Tubes

Introduction. The cathode-ray tube, which is the very heart of the television receiver, is in many respects quite similar to the ordinary receiving tube. Like the receiving tube, it, too, has a cathode that emits electrons because of heat received from the heater wires. The flow of electrons, and hence the number, is regulated by the voltage on the electrodes in the same manner as in any other tube. Once past the control grid, however, the electrons are narrowed down to a fine beam and subjected to focusing and deflecting forces until the beam strikes a fluorescent screen located at the far end of the tube. At each point where the electron beam impinges on the screen, a spot of light appears. If the points follow in rapid succession, the motion can be made to appear continuous due to the persistence-of-vision phenomenon of the human eye.

For television receivers, the video signal containing the image detail is applied to the control grid or cathode, while the synchronizing impulses control sawtooth oscillators that connect to deflecting coils. Under the influence of these changing voltages, the beam is swept across the screen in step with the scanning beam in the camera tube at the studio.

The formation of the electron beam starts naturally at the cathode. The emitting surface, composed of thoriated tungsten or barium and strontium oxides, is restricted to a small area in order that the emitted electrons progress only toward the fluorescent screen. They would serve no useful purpose in any other direction. The emitting material is thus deposited on the end of the nickel cathode cap that encloses the heater in the manner shown in Fig. 9-1 for a typical construction. The electrons, after emission, are drawn by the positive anode voltages into electric or magnetic lens systems. These form and focus the electrons into a sharp, narrow beam that finally impinges on the fluorescent screen in a small round point.

The use of the word "lens" may puzzle the reader who thinks of this term

only in connection with light rays, not electron beams. The purpose of a glass lens is to cause light rays either to diverge or to converge to a point. The same results can be achieved electronically; hence the reason for the carryover of the name.

The First-lens System. In the first lens we find the cathode, the control grid, and the first anode arranged in the manner shown in Fig. 9-2. The grid, it is noticed, is not the familiar mesh-wire arrangement found in ordinary tubes. For the present purpose it is a small hollow cylinder with only a small pinhole through which the electrons may pass. This restricts the area of the cathode that is effective in providing electrons for the beam and aids in giving the beam sharpness. Following the grid cylinder is the first anode. Here again baffles permit only those electrons near the axis of the tube to pass through.

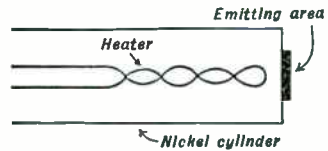

FIG. 9-1. Cathode and heater construction for a cathode-ray television tube.

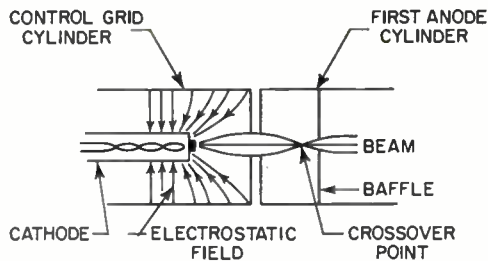

FIG. 9-2. The first lens system of a cathode-ray tube.

Because of the energy imparted to them by the heated cathode, the electrons leave the cathode surface with a small velocity. With no positive electric force (or field) to urge them forward, the electrons tend to congregate in the vacuum space just beyond the cathode and form a space charge. Eventually, just as many electrons will leave the heated cathode surface as are repelled by the negative space charge, and a state of equilibrium will exist. This condition can be overcome and a flow of electrons allowed to take place down the tube if a high positive voltage is placed on the first anode.

The first anode, which is a hollow cylinder, does not have its electric field contained merely within itself; it also reaches into the surrounding regions. To be sure, the farther away from the anode, the weaker the strength of the field. With zero and low negative potentials on the control grid, the influence of the positive anode field extends through the baffle of the control grid right to the cathode surface. Electrons leaving this surface are urged on by the positive electric field and accelerated down the tube, with the baffle

restricting the direction of the electrons to very small angles with the axis of the tube.

Figure 9-2 shows the distribution of the electrostatic lines between cathode and control grid. It is interesting to note that these lines are not straight, but tend to curve, the amount of curvature being influenced by the distance from the first anode and the control grid and by the voltages on these elements. Cathode-ray-tube design engineers use such field distribution diagrams to determine the effect of each electrode on the electrons at the cathode and in the beam.

As a result of the bending of the electric field at the cathode, it can be proved by means of vectors that all electrons passing through the small hole in the control-grid baffle will come to a focus or converge toward a small area located just inside the first anode. This region is on the axis of the tube and is known as the "crossover point." The effect of the electric field is such that electrons near the outer edges of the control-grid opening travel at an angle in order to get to the crossover point, whereas electrons on the axis of the lens move straight forward to this point. The direction of some of the electrons is shown in Fig. 9-2.

It is well to keep in mind that the shape of the electric field is determined by the placement of the electrodes and the voltages applied to them. The electrons are forced to converge toward the crossover point because this point can more readily serve as the supply source of the beam electrons than the cathode from which they initially came. The area of the crossover point is more clearly defined than the relatively larger cathode surface, and it has been found that the electron beam is easier to focus if the crossover area is considered as the starting point rather than the cathode itself. The electrons that compose the final beam are then drawn from the crossover point while other electrons come from the cathode to take their place. The greater the number of electrons drawn from this point, the brighter the final image on the fluorescent screen.

For ordinary purposes, a negative bias is placed on the grid. In the larger cathode-ray tubes, the bias may rise as high as -60 volts. With a negative voltage on the control grid, the extent of the positive electric field is modified and it no longer affects as large an area at the cathode surface as it did previously with zero grid volts. Now, only electrons located near the center of the cathode are subject to the positive urging force, and the number of electrons arriving at the crossover point is correspondingly less. The intensity of the final electron beam likewise decreases. In the television receiver, the video signal is applied to the control grid and the resulting variations in potential cause similar changes in electron beam intensity.

For the beam arriving at the screen to remain in focus once the controls have been set, the position of the crossover point must remain fixed. With

normal variations of control-grid voltage, this condition is obtained. With large variations, however, the position of the crossover point tends to change, moving closer to the cathode as the grid becomes more negative. Thus a certain amount of defocusing will take place. Proper design generally keeps this at a minimum, and for most of the voltage variations encountered in television work, defocusing is scarcely noticeable.

To summarize the purpose of the first-lens system: We see that electrons leaving the cathode surface are forced to converge to a small area near the anode. This offers a better point for the formation of the beam and its subsequent focusing.

The Second-lens System. The second-lens system draws electrons from the crossover point and brings them to a focus at the viewing screen. The system consists of the first and second anodes, as shown in Fig. 9-3. The second anode is operated at a higher potential than the first anode, is larger in diameter, and frequently overlaps the first anode to some extent. It is at the point of overlap of the two anodes that the second lens is effective, and it is here that the focusing action of the electron beam takes place. Electrons, when drawn from the crossover point established by the first lens system, are not all parallel to the axis of the tube. Some leave at various small angles. The beam thus tends to diverge and it is due to the second lens that these diverging electrons alter their path and meet at another point on the axis. This second point is at the screen. Those electrons moving straight along the axis of the tube are not affected, in direction, by the focusing action of the second lens.

The operation of the second lens depends upon the different potentials that are applied to the first and second anodes and the distribution of the resulting electric field. The equipotential lines for this lens are drawn in Fig. 9-3. It is to be noted that the curvature of these lines changes at the intersection of the two anodes. On the left-hand side, the electric-field lines are convex to the approaching electron beam, while to the right of the intersection the lines are concave. The effect of these oppositely shaped electric-field lines on the beam is likewise opposite. Since we have seen that some of the electrons tend to diverge after they leave the crossover point, the field distribution must be designed to overcome such a tendency. In action, the convex equipotential lines force the electrons to

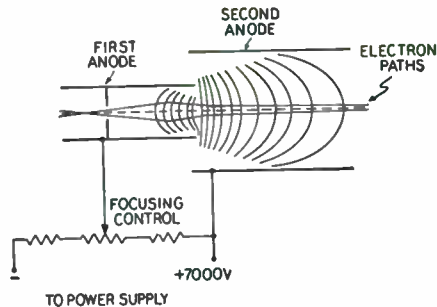

FIG. 9-3. The second lens system. Focusing of the electron beam at the viewing screen is accomplished by varying the voltage at the first anode.

converge to a greater extent than the concave lines cause the electrons to diverge. Inasmuch as the convergence exceeds the divergence, the net result is a focusing of the electrons on the screen.

The ratio of the voltages, the size of the anode cylinders, and their relation to each other will determine the distribution and curvature of the electric lines of force; the latter, in turn, will determine the amount and the point at which the focusing takes place. In cathode-ray tubes, the ratio of the first to the second anode voltages ranges from 3 to 1 to 6 to 1 or more.

In order that the electron beam leaving the crossover point shall not diverge too much, a baffle is placed just beyond this point, similar in construction to the baffle previously described for the control grid. The baffle again limits the width of the electron beam to the desired size. Practically, focusing control can be accomplished by varying the voltage on the first anode by an arrangement shown in Fig. 9-3. This is one way of altering the voltage ratio between the first and second anodes and, with it, the distribution of the electric lines of force of the lens system. An approximate optical analogy of the lens system is shown in Fig. 9-4 and may prove helpful in indicating the operation of the electric system.

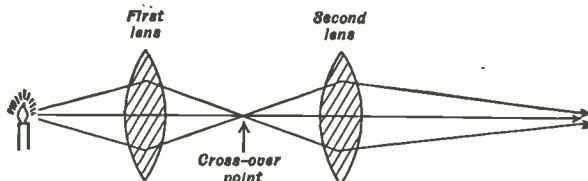

Fig. 9-4. The glass lenses used in focusing light rays illustrate the similarity between light-wave and electron-beam focusing.

Electrostatic Deflection. Once past the second anode, the electron beam speeds toward the fluorescent screen. However, to present an image on the screen, a means of deflecting the beam is in order. This deflection may be achieved electrostatically by using two sets of plates, or electromagnetically by using two sets of coils. Let us consider electrostatic deflection first.

To deflect the beam electrostatically, two sets of plates are mounted at right angles to each other. One set is known as the horizontal deflection plates, the other as the vertical deflection plates. In television receivers, sawtooth oscillators are electrically connected to these plates, and the electron beam is subjected to changing voltages that force it to move across and up (or down) the screen. The 525 lines of each frame are swept out in this manner. The synchronizing pulses control the action of the sawtooth oscillators in order to keep the original and reproduced images synchronized with each other. The same action of deflection can also be accomplished with coils and will be described presently.

In commercial television receivers, two methods of applying the deflection voltages to the deflecting plates are employed. In one method, one deflecting plate of each set is connected directly to the second anode while the other plate receives the varying deflection voltages. When this voltage is zero, both plates (of each set) are at the same potential, which in this case is equal to the second anode voltage. The electron beam is therefore not subjected to any deflecting force and passes unmolested through the center of the system. The deflecting plates are at second anode potential because of their position in the tube. The beam, in leaving the second anode, must not be slowed down. Any voltage difference between the second anode and the deflecting plates not only changes the velocity of the beam but also produces defocusing at the screen. To avoid these difficulties, the deflecting plates and the second anode are electrically connected.

With one plate permanently attached to the second anode and the other to the deflecting voltage, we have an unbalanced arrangement as in Fig. 9-5(A). The plate with the varying potential will deflect the beam an amount

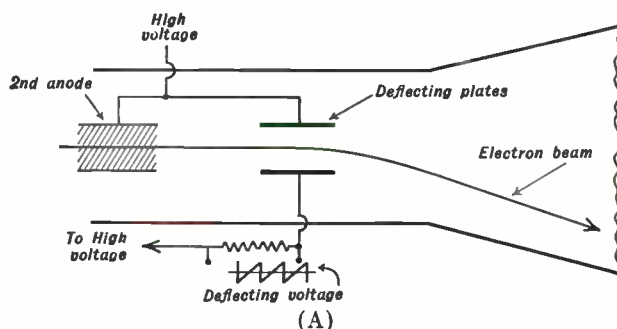

FIG. 9-5(A). Deflection of electron beams. This unbalanced method, while simple in construction, does not always give a clearly defined beam on all parts of the fluorescent screen.

proportional to the acting voltage. For small voltage variations, the operation is satisfactory. At higher deflecting voltages (in larger tubes), a defocusing of the beam occurs. This effect is sometimes called "astigmatism."

The reason for the defocusing action may be explained as follows: The electron beam, once it leaves the second anode, is traveling toward the screen where it should come to a focus. Any electrical disturbances not part of the focusing action will tend to destroy the sequence. When varying voltages are applied to the deflecting plates, their average potential varies above and below the second anode voltage. The result, when the difference between the two becomes sufficiently great, is to throw the beam out of focus. In small tubes the voltage difference is not large enough to cause

defocusing, but in larger tubes definite defocusing is observed. This is especially noticeable when the beam is at the ends of the screen, for it is at such points that the required deflection voltage is greatest.

The more desirable method, which is a balanced one, is shown in Fig. 9-5(B). The voltages on both plates change, and uniform force is exerted

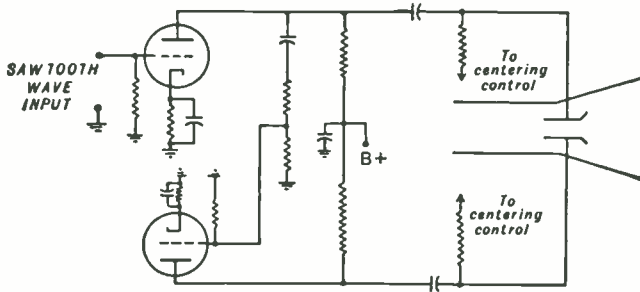
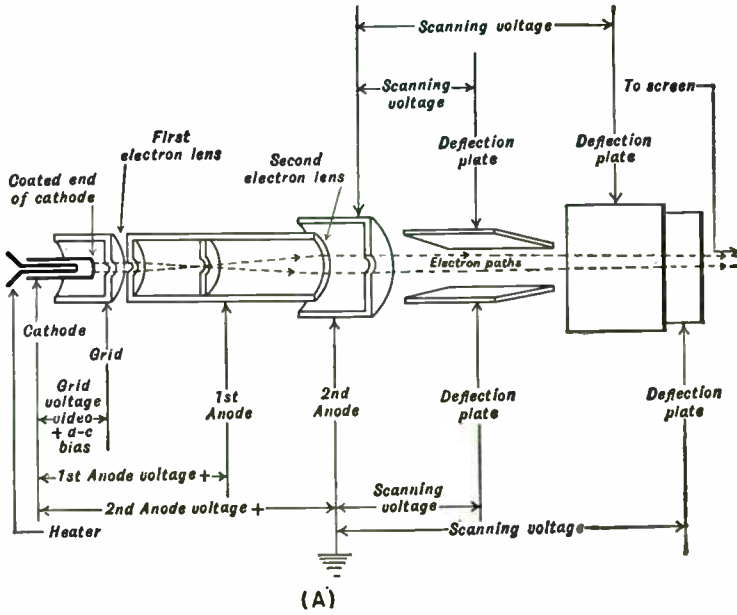

Fig. 9-5(B). A balanced deflection system.

by the plates on the beam. As both deflection-plate voltages vary in an opposite manner, the average *change* in voltage is zero. However, now two tubes are required (push-pull) to develop the deflection voltage, and this increases the cost of the set. Despite the latter fact, this method is the one used in receivers that employ electrostatic deflection.

To obtain maximum deflection of the beam without having it strike the edges of the plates, the plates are flared slightly at the ends. The basic elements of a cathode-ray tube employing electrostatic deflection and focusing are shown in Fig. 9-6(A). An example of this type of tube is the 5JP4. Seven- and 10-inch electrostatic deflection tubes generally incorporate one additional element not present in Fig. 9-6(A). The new element is placed between the control grid and the focusing (first) anode. Internally, it connects to the accelerating (or second) anode. See Fig. 9-6(B). The introduction of this new element serves to reduce further interaction between beam focus and voltage variations at the control grid. As the screen area becomes larger, beam-defocusing defects become more apparent and more precautions must be taken to prevent them.

Cathode-ray tubes also possess a conducting aquadag coating entirely around the inside of the glass, extending from the first or the second anode almost (but not quite) to the fluorescent screen. An important function of this aquadag coating is to prevent the collection of free electrons that would otherwise accumulate on the glass walls of the tube. In addition, it serves as a collecting anode for the secondary electrons which are emitted from the fluorescent screen when the electron beam impinges on the screen. If we removed the aquadag coating, the secondary electrons would land on the



(A)

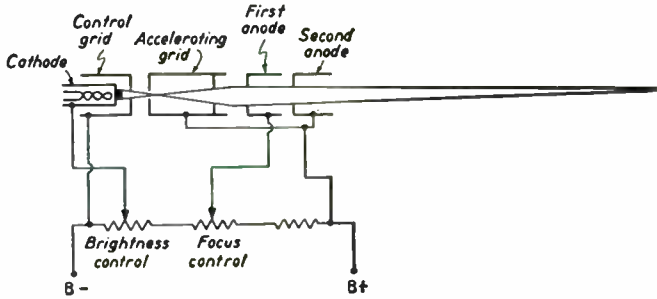

(B)

FIG. 9-6. (A) The basic elements of a cathode-ray tube using electrostatic focusing and deflection. (B) Modified construction of electron gun in 7- and 10-inch electrostatic deflection tubes.

glass walls of the tube and remain there. Eventually, sufficient charge would develop to prevent proper functioning of the beam. By coating the inside of the tube with aquadag and giving it a positive potential, we remove all of this undesirable charge. Internally, the coating is connected to the second anode. Furthermore, through the use of this dark coating, less light is reflected from the screen into the tube and then back to the screen again. This reduction in reflection improves the contrast range available from a fluorescent screen.

Amount of Deflecting Voltages Necessary. The amount of voltage that must be applied to the deflection plates in order to force the beam to travel from one side of the screen to the other will depend to a great extent upon the accelerating voltage of the second anode and the width of the screen. A larger voltage will accelerate the electrons more strongly and hence make a large voltage on the deflection plates necessary. The faster an electron travels, the less time it spends between the plates and the greater the deflection voltage required to bend it. The deflection factor, which is given for each electrostatic tube in its characteristic data, then increases. On the other hand, lowering the second-anode voltage will permit the deflection plates to exert greater control over the electron beam for the same deflection voltage.

In characteristic charts of cathode-ray tubes, the deflection factor may be stated directly or another unit, known as the "deflection sensitivity," may be given. Many times both are given, although it is possible to compute one if the other is given. To illustrate, consider the 7JP4 tube. The deflection factor is given as 31 to 41 d-c volts/in./kv. This means that, with 1,000 volts on the second anode (1 kv), a difference of from 31 to 41 d-c volts between a set of deflection plates will move the beam 1 in. on the screen. The range of 31 to 41 volts is given because of manufacturing tolerances; 36 volts can be used as an average value. If 2,000 volts are placed on the second anode, the deflection force becomes less effective, and 62 to 82 d-c volts are required to produce the same 1 in. of deflection. In general, increasing the second-anode voltage by a certain amount decreases the distance the beam is deflected by a proportionate amount (assuming no voltage change on the deflection plates). To overcome this decrease, we must increase the deflection voltage accordingly.

The deflection factors of the vertical and horizontal plates need not necessarily be the same. In the 7JP4, for example, the foregoing figures (31 to 41 volts) represent the deflection factor of the vertical plates. The horizontal plates have a deflection factor of 25 to 34 d-c volts/in./kv.

Deflection sensitivity is given as 0.71 mm/volt/kv for the vertical plates of a 7JP4. This means that with 1,000 volts on the second anode, 1 volt of difference between the vertical deflection plates will move the beam 0.71 millimeter on the screen. The average value of 0.71 is equivalent to a deflection factor of 36 volts.

To change from one set of units to the other, take the deflection factor in d-c volts/in./kv and divide it into 25.4 (the number of millimeters in one inch). The result is the deflection sensitivity in mm/volt/kv. To convert from the deflection sensitivity (in mm/volt/kv) to the deflection factor, we divide 25.4 by the deflection sensitivity. In other words,

$$\frac{25.4}{\text{Deflection factor}} = \text{Deflection sensitivity}$$

D-c volts are specified to avoid the confusion which might exist if a-c voltages were stated without specifying whether the values were peak, average, or rms. As an indication of the total amount of deflection voltage necessary, the 7JP4 tube requires 186 to 246 d-c volts to move the electron beam 1 in. horizontally, with a second-anode voltage of 6,000 volts. To cover the entire 7 in. the large value of 1,302 to 1,722 volts would be required. With alternating voltages, this is the peak-to-peak value, because the positive portion of the signal swings the beam across one half the screen and the negative portion of the signal swings it through the other half.

Centering Controls for Electrostatic Deflection Tubes. The electron beam, when not subject to any deflecting voltages, should hit the fluorescent screen at its center. In this position, a symmetrically placed image will result when the deflecting voltages are applied to the plates. In practice, stray electric and magnetic fields, or distortions of fields within the tube itself, may interfere and cause the beam to be displaced from the center position. In order to correct this condition, positioning controls for the vertical and horizontal plates are generally available at the back of the receiver.

A popular method for applying correcting voltages to electrostatic deflection plates to center the beam is shown in Fig. 9-7. A high fixed voltage is placed on one vertical and one horizontal deflection plate from a tap be-

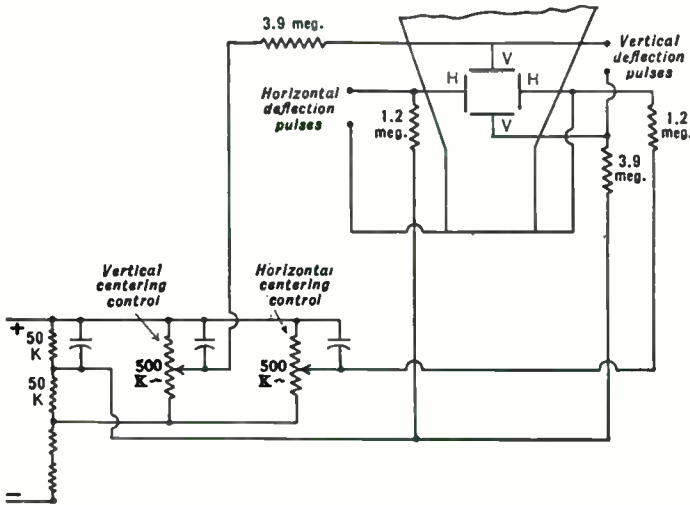

FIG. 9-7. Vertical and horizontal centering controls.

tween two 50,000-ohm resistors. In parallel with these two resistors are two 500,000-ohm potentiometers, the center arm of each going to the other vertical and horizontal deflection plates. When the arms of the potentiometers are in the center position, there is no d-c potential difference *between* the plates of the horizontal and vertical sets. A balance exists. Any change in the position of these potentiometer arms, however, will make one plate more positive than the other of the set and bend the electron beam in the desired direction. The deflection voltages for the image are applied separately, as shown, with large resistors placed in the centering leads to act as connecting resistors to couple the deflection voltages to the plates themselves.

Magnetic Focusing. The preceding discussion has been concerned with electrostatic methods of focusing and deflecting the electron beam. The same operations may be performed as well magnetically. However, before any circuits are discussed, it would perhaps be advisable to review the action of magnetic fields on moving electrons.

It is well known that a wire carrying a current has a circular magnetic field set up around it, as shown in Fig. 9-8(A). Suppose the wire is placed

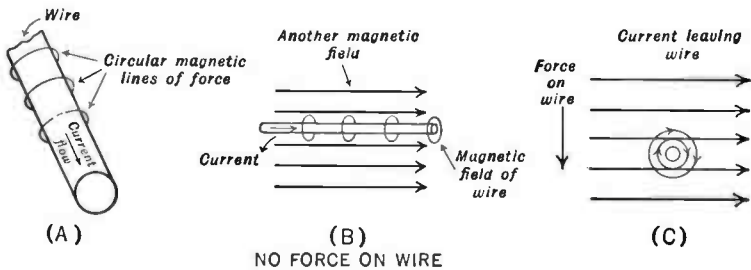

FIG. 9-8. The action of a wire carrying current when placed in a magnetic field.

in a magnetic field parallel to the magnetic lines of force. See Fig. 9-8(B). There will be no interaction between the magnetic lines of the field and those set up by the wire. Why? Because the two *fields* are at right angles to each other.

For the opposite case, illustrated in Fig. 9-8(C), the current-carrying wire is placed at right angles to the field lines of magnetic force. Above the wire the lines of both fields add; underneath the wire they oppose and tend to cancel. Experiment indicates that a resulting force will act on the wire in such a way that it moves from the stronger part of the magnetic field to the weaker part. This is indicated in the figure. The illustration represents the two extreme angles that the wire and the field can make with each other. Intermediate positions (those between zero and 90 deg) will cause intermediate values of force to act on the wire.

The transition from a wire carrying electrons to the electrons themselves, without the wire, is quite simply made. With only electrons moving through space, the same circular magnetic field is set up about their path. From the preceding discussion, we know that electrons traveling parallel to the lines of force of an additional magnetic field experience no reaction from this field. On the other hand, if they enter the magnetic field at an angle to the flux lines, a force will be brought to bear on them and their path will be altered.

It is well to reiterate that for an electron to react with a magnetic field: (1) the electron must be moving, otherwise it does not generate a magnetic field; and (2) the moving electron must make an angle with the magnetic field in which it is traveling.

Now let us apply these considerations to magnetic focusing. The focusing coil is slipped over the neck of the cathode-ray tube and placed beyond the first anode. The first-lens system remains essentially as in the electrostatically controlled tubes previously described; it still converges electrons to the crossover point. From this point, the electrons spread out and the focusing action of the coil begins to function. The focus coil, then, represents the second lens in electromagnetic tubes. An accelerating anode (anode no. 2) is positioned close to anode no. 1 to accelerate the beam down the tube and also to provide a means of removing ions from the beam. (More is given on this point presently.) The accelerating anode is connected internally to the aquadag coating (Fig. 9-9) and receives its voltage from the coating. The latter, in turn, obtains its potential via a metal cavity or a ball-insert terminal located on the side of the glass bulb.

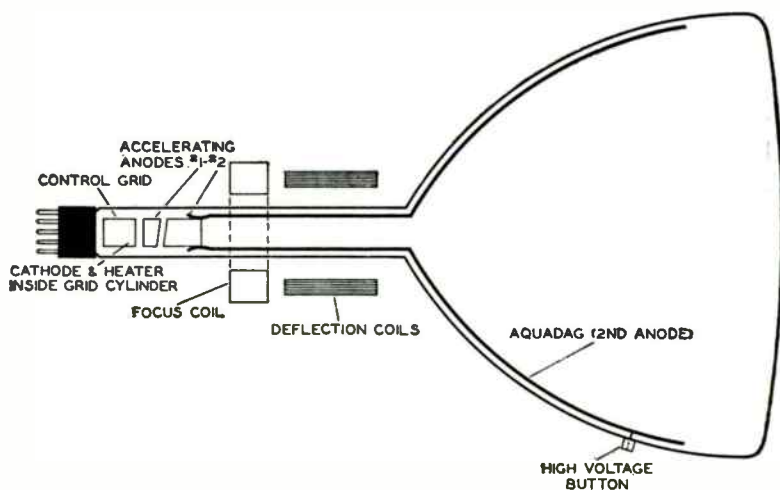

FIG. 9-9. The internal construction of an electromagnetic deflection-and-focus tube.

The field of the focusing coil is parallel to the axis of the tube and is generated by direct current flowing through the coil. So long as the electrons leave the crossover area and travel down the tube along the axis, the magnetic lines do not interfere with their motion. However, many electrons tend to spread out beyond the crossover region, and it is on these electrons that the magnetic force reacts because they are moving at a small angle to the magnetic flux lines.

The path taken by electrons that are acted on by a magnetic field can be more easily understood if it is recalled that the resulting force on the electrons is at right angles to both its motion and the magnetic field. This force, as shown in Fig. 9-10(A), causes the electrons to move in a circular

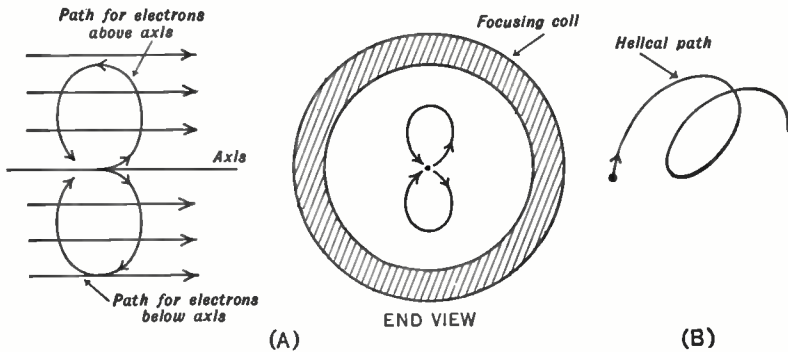

FIG. 9-10. (A) Electrons cutting across magnetic lines of force are made to move in a circular path. (B) If, however, they are also subjected to an electrical force urging them forward, their resultant path will be helical.

path. In this way the force on the electrons, the electron motion, and the magnetic force are always at right angles to each other.

Apply these ideas to the action inside the cathode-ray tube. As the electrons leave the crossover point at small angles to the magnetic field, they are subjected to a force that tends to make them turn in a circle. But at the same time that they are being forced to travel this circular path, they are also speeding forward. The resulting motion of the electrons is known as "helical" and is similar to the action of a screw being turned into a piece of wood. It rotates while moving forward. Figure 9-10(B) may aid the reader to visualize the motion.

The electrons that are acted on by the magnetic field all come from the crossover point that is situated on the axis of the tube. The minute they leave this point at an angle, the magnetic force starts to act, forcing them to move in a circular path back to the axis again. In the cathode-ray tube they are, at the same time, also moving forward; hence when the circular path is completed the electrons will again be on the axis of the tube some

distance away. The exact position down the tube where the electrons return to the axis is dependent upon the strength of the magnetic force and the forward velocity.

By suitable variation of the intensity of the magnetic field, it is possible to have the electrons return to the axis of the tube exactly at the screen. The beam is now focused. The greater the speed of the electrons, the stronger the magnetic field required. Thus, any changes that affect the velocity of the electrons, for example, varying the first-anode voltage, will also require readjustment of the current through the focusing coil.

To review the process, we find that the magnetic field causes the outgoing electrons from the crossover region to travel in helical paths that will force them back to the axis again. With proper adjustment of the magnetic-coil current, the electrons complete their circular path at the screen. Here they meet the other electrons that travel straight along the axis (and are not affected by the magnetic field) and a well-defined spot results.

At other values of the magnetic field defocusing occurs. As an exception to this statement, it should be mentioned that by continually increasing the strength of the magnetic field, the electrons can be made to do two (or more) complete revolutions before striking the screen. As each complete revolution brings the beam to the screen, a focused spot will appear. This process can be continued as long as the magnetic coil will carry current.

It would appear from the preceding discussion that the magnetic field must extend all along the tube in order that the electrons will always be under its influence. Their path will then be helical, as described. However, for practical applications, only a small iron-core coil is slipped over the neck of the tube. This is shown in Fig. 9-11. The electron beam is thus

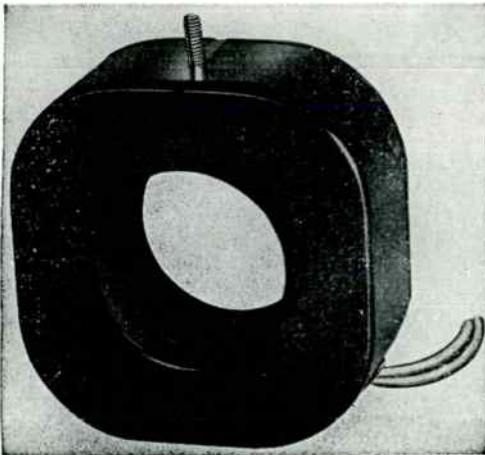

FIG. 9-11. A focusing coil.

subjected to the magnetic force for only a short time. During this period it is given enough of a twist so that it will move toward the axis; the forward motion then keeps it traveling along this path. The motion now is not truly helical, but the end result is satisfactory.

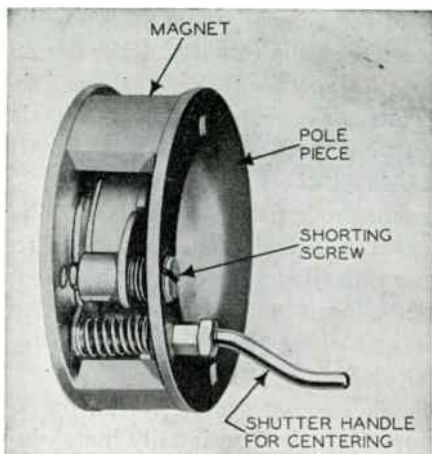

FIG. 9-12. A permanent magnet (PM) focus unit. The additional shutter handle permits centering of the picture.

It will occur to the reader that magnetic fields need not necessarily be obtained from coils only. Permanent magnets (PM) are also suitable and these are extensively used. One type of PM focus magnet is shown in Fig. 9-12. The unit consists of three (sometimes four) small bar magnets which are placed along and around the axis of the tube neck. The magnets are equally spaced and held in position by two dislike pole pieces made of a low-carbon steel. The magnets are mounted with similar poles at the same end. Thus, the flux lines

joining the ends of the magnets pass through the tube along its axis. Focusing is accomplished by the interaction of these flux lines with the electron beam passing down through the tube.

To permit variation of the magnetic focusing field, one or two shorting screws are threaded into one of the end discs. The screw provides a path of lower magnetic resistance (i.e., less reluctance) for the lines of force, thereby tending to shunt them away from the tube. The magnetic field through the center of the device decreases as the screw is turned in. Turning the screw out has the opposite effect.

Another type of permanent focus magnet is shown in Fig. 9-13. It is similar to the unit in Fig. 9-12, except that flux variation through the tube is achieved by a sliding steel collar controlled by a lead screw at the end of a flexible shaft. By rotating the knurled screw at the end of the shaft, either clockwise or counterclockwise, the steel collar can be moved back and forth. The end of the screw drive extends beyond the back cover of the receiver, permitting focus adjustments to be made without the necessity of removing the back cover.

Electromagnetic Deflection. It is possible to deflect electrons by either magnetic or electrostatic fields. Electrostatic deflection has already been described and magnetic deflection will now be considered. Actually, little new need be added to understand the action of deflection coils on the elec-

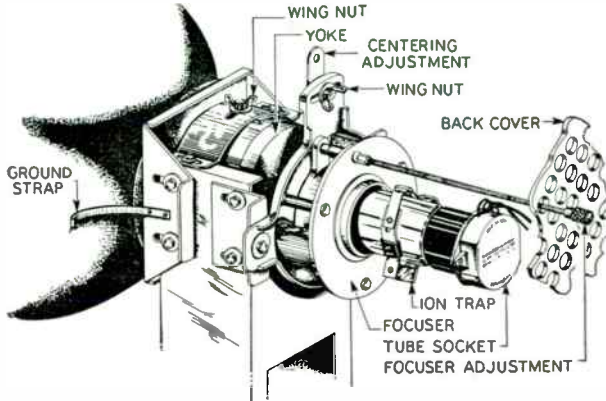

FIG. 9-13. A PM focusing unit using a movable collar for focus adjustment.

tron beam. Two sets of coils are placed at right angles to each other and mounted on the section of the tube neck where the electron beam leaves the focusing electrode and travels toward the screen. There are four coils in all (two in each set), with opposite ones comprising one set. These are connected in series in order to obtain the proper polarity. See Fig. 9-14(A).

Figure 9-14(B) shows the actual physical placement of the deflection coils. For horizontal deflection, the coils are vertically placed, whereas, for vertical deflection, the coils are horizontally mounted. This reverse placement of the coils is due to the fact, stated above, that the force on traveling electrons in a magnetic field is at right angles to both the direction of motion and the lines of the field. After the coils have been oriented, sawtooth-shaped current variations are sent through them. The magnetic-field flux follows these current changes and causes the electron beam to move back and forth (or up and down) across the screen, sweeping out the desired pattern.

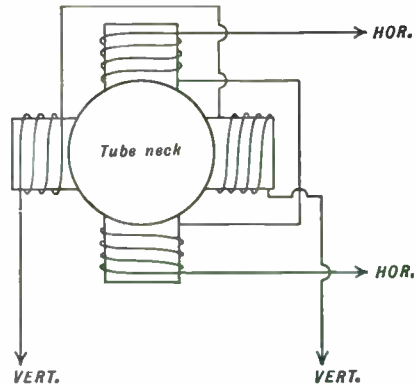

FIG. 9-14(A). Arrangement of coils for electromagnetic deflection.

The entire assembly of deflection coils is known as a “deflection yoke.” Two typical commercial units are shown in Fig. 9-15. Note how the forward windings lap over the front edge of the yoke housing. The yoke is thus positioned right up against the flare of the tube in order to achieve complete coverage of the full screen area. This is particularly important for wide-angle tubes (110 deg or more).

The deflection windings in Fig. 9-14(B) are shown wound uniformly; that is, there is no variation in winding thickness from end to end. This type of winding was characteristic of the yokes employed when narrow-angle picture tubes were prevalent. As the deflection angle increased, it was found that the magnetic field produced was not uniform, particularly when the beam was deflected toward the edges of the raster. Visually, an elongated spot was produced, tending to develop an out-of-focus condition.

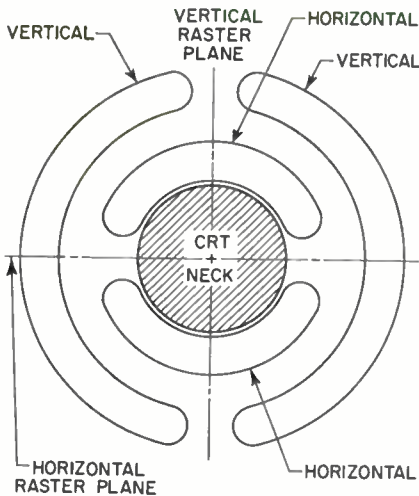

FIG. 9-14(B). The actual physical placement of the deflection coils about the neck of the picture tube.

A more uniform field is developed when a cosine-type winding is employed. In this arrangement (Fig. 9-16) the thickness of a deflection winding varies as the cosine of the angle from a central reference line varies. (For horizontal windings, the reference line is the horizontal line through the center of the yoke. For vertical windings, it is the vertical line.)

Nearly all present-day yokes are wound in this manner or in a cosine-squared fashion.

The reader should not become confused by the seemingly different actions of the focusing and deflection coils. At first glance it might appear that one

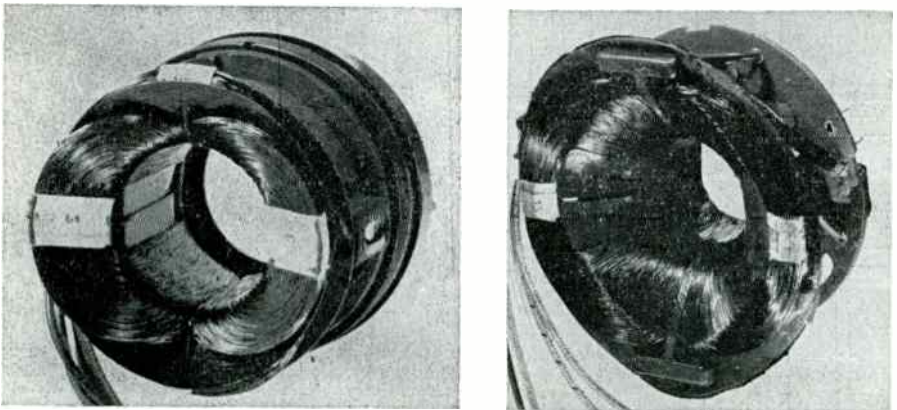

FIG. 9-15. Two typical deflection yokes. (Left) A 70-deg deflection unit is shown. (Right) A 110-deg unit. Note how the 110-deg yoke windings flare out.

coil (the focusing coil) twists the electron beam around so that it ends up at the screen in focus, while the other coils (the deflecting coils) only cause the beam to move either to the right or left or up and down. Actually the action of all the coils is the same; the only difference lies in the manner in which they affect the beam. At the focusing coil, the magnetic lines of flux are parallel to the axis of the tube and the electrons that are moving away from the axis of the tube are subjected to a strong twisting force that turns them back to the axis. Their forward motion, given to them by the positive first anode, and sometimes by an intensifier ring, keeps them moving toward the screen.

At the deflection coils, the magnetic fields are at *right angles* to the path of the beam. The beam, in moving through these fields, has a force applied which is at right angles to the forward motion of the electrons and the direction of the magnetic lines of force. Here the effect of the field is not as great as at the focusing coil, and the beam is merely deflected rather than bent all the way around into a circular path. The influence of the field ends when the electrons pass the yoke, but any sideward or up-and-down motion imparted to the electrons while in the field is retained. By varying the direction of the flow of current through the vertical- and horizontal-deflection coils, it is possible to reach all points on the screen. This type of deflection is used with all present-day television picture tubes.

When a yoke is inserted over the neck of the picture tube, it is very easy to position it so that the image is not properly oriented. This is indicated in Fig. 9-17. In this case, correction may be accomplished by rotating the yoke until the image is again properly positioned.

Figure 9-18 illustrates the proper positions for focus, deflection, and ion-trap coils on the neck of a picture tube. The ion trap will be discussed presently.

Beam-centering in Electromagnetic Tubes. In electrostatic deflection and focus tubes, beam-centering is accomplished as shown in Fig. 9-7. This is essentially the only method employed. In electromagnetic tubes, a number of beam-centering methods have been employed.

In one system, a small d-c voltage is applied to the horizontal-deflection windings of the yoke. The amount of voltage actually impressed across the coil windings is regulated by a potentiometer. The current resulting from

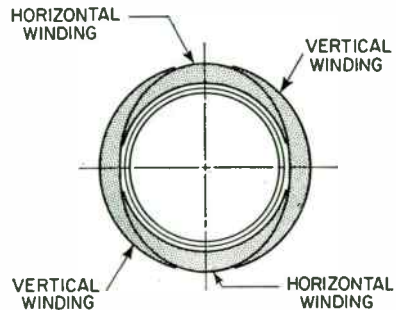

FIG. 9-16. The appearance of cosine windings in a deflection yoke. Note the uneven thickness of each winding.



FIG. 9-17. Image incorrectly positioned because of improper placement of deflection yoke.

this voltage will produce a magnetic field, and the strength and direction (or polarity) of this field will cause the beam to move. If the current flows in one direction, the beam will be shifted one way; if the current flows in the other direction, the beam shift will likewise reverse. A similar arrangement in the vertical-deflection winding enables the user of the set to shift the beam up or down.

Note that this d-c centering current is in addition to the vertical- and horizontal-deflection currents that also flow through the yoke windings and swing the beam across the screen. The d-c current is steady, and the beam shift it introduces is fixed. The reader may consider this is analogous

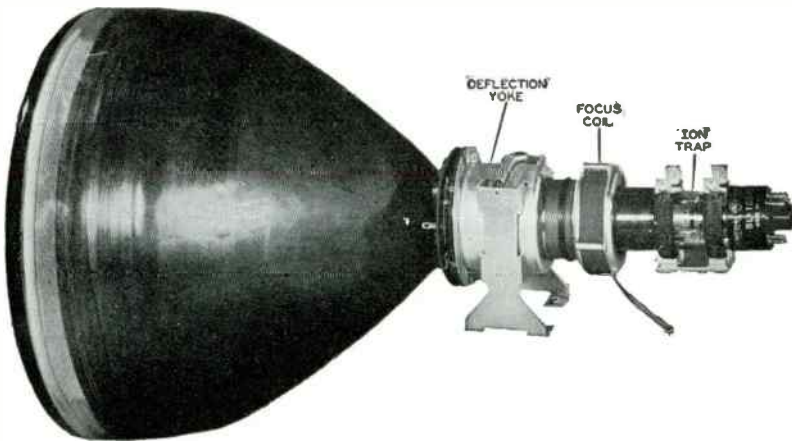

FIG. 9-18. The positions for a deflection yoke, focus coil, and ion trap on the neck of a cathode-ray tube.

to the d-c bias on a tube. Incoming signals then vary above and below this bias.

Picture-centering can also be accomplished by mechanical positioning of the focus coil. In the arrangement shown in Fig. 9-19, three centering screws enable the serviceman to tilt the axis of the focus coil (or magnet) in one of several different directions until the focus-magnet field directs the beam to the center of the screen.

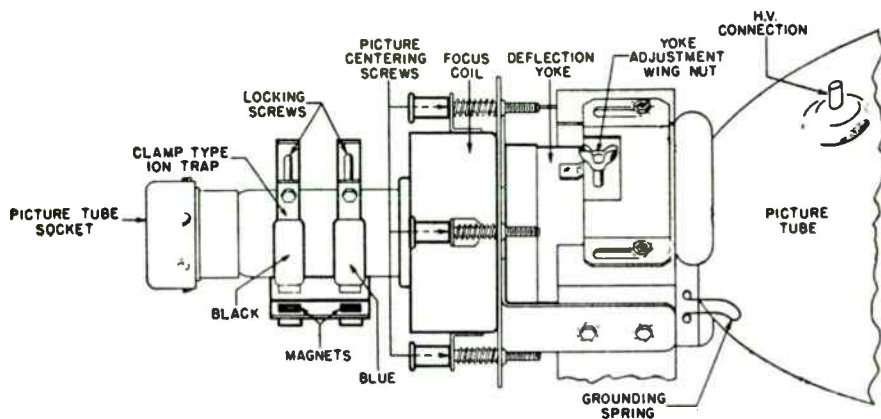

FIG. 9-19. Three centering screws permit the axis of the focus coil to be tilted in one of several directions until the beam is centered.

A system of centering widely used with permanent magnets is shown in Fig. 9-13. A metal plate is fastened onto the focus magnet. Some centering plates contain a locking screw which must be loosened before centering; others are held in position by friction. Up-and-down adjustment of the plate moves the picture from side to side; sidewise adjustment shifts the picture up and down. Electrically, the plate modifies (i.e., distorts) the distribution of the PM field until the desired beam-shifting is achieved.

Magnetic Deflection with Electrostatic Focus. When commercial television was getting started in the United States, in 1946, electrostatic focus and deflection tubes were manufactured in great quantity. The most popular of these tubes were the 7JP4 and, to a lesser extent, the 10HP4.

The chief drawback of electrostatic deflection (as compared with electromagnetic deflection) is that, for tubes with screens larger than 7 in., the amount of deflection voltage required is considerable. Since it is cheaper to develop high currents rather than high voltages, the trend turned toward electromagnetic deflection.

However, in late 1950, the outbreak of hostilities in Korea forced the government to issue orders restricting the use of certain critical metals.

Among these were aluminum, nickel, cobalt, and copper, all of which are required in the manufacture of focusing magnets. Faced with this limitation on the manufacture of receivers, the television industry set about finding ways of eliminating magnetic focusing. The result was a tube which retained electromagnetic deflection, but combined this with electrostatic focusing. This approach has proved so successful that it is now the most widely used method employed in television picture tubes. Electrostatic focusing is particularly suited to wide-angle tubes because the beam produced by the gun is smaller in diameter and there is less defocusing when the beam is swung to the edges of the raster. Also, this form of focusing is useful to short guns by eliminating the external focus magnet.

A cross-sectional view of an electrostatic focus gun is shown in Fig. 9-20.

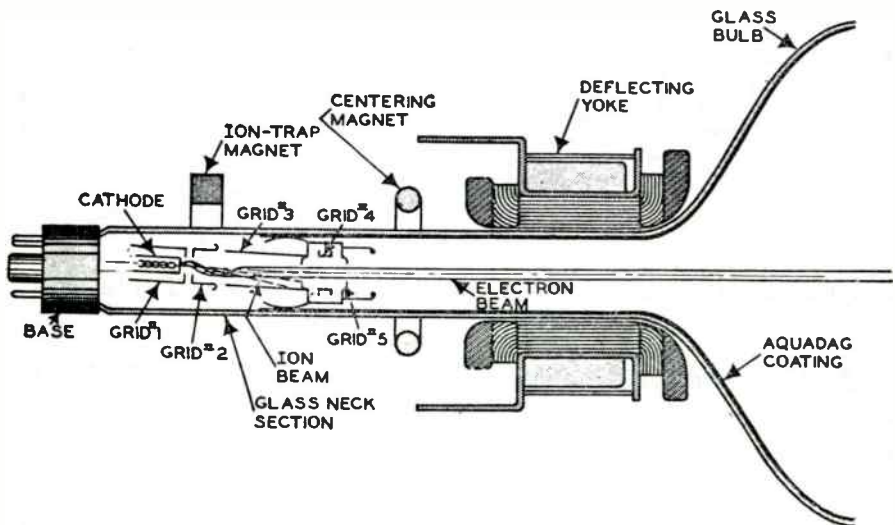

FIG. 9-20. Internal structure of new electrostatic focus tube. Deflection is accomplished magnetically.

Grid no. 1 is the control grid. Grid no. 2 is the same as anode no. 1 previously shown.* Grid no. 3 serves the same purpose as the accelerating anode in Fig. 9-9. It contacts and operates at the high potential of the aquadag coating.

The new elements, grids no. 4 and 5, provide the focusing field which focuses the electron beam. The voltage applied to grid no. 4 is lower than

* The labeling of the various elements in the gun assembly as consecutive grids is done frequently to simplify identification. Thus, the control grid is grid no. 1. The first anode following this is grid no. 2. The second anode is grid no. 3, etc. Note that this change in name does not in any way alter the function or construction of the electrodes.

that which grids no. 3 or 5 receive and it is frequently made variable to permit adjustment of the focus voltage to the proper value. Grid no. 5 (which structurally surrounds grid no. 4) is connected internally to grid no. 3 and operates at the same potential as no. 3.

The voltage applied to grid no. 4 depends upon the manner in which grids no. 3, 4, and 5 are constructed. The first electrostatic focus tubes manufactured required that the potential of grid no. 4 be on the order of 20 per cent of the accelerating (or second-anode) voltage. This meant that voltages between 2,000 and 3,000 volts had to be made available. A special potentiometer, inserted in this circuit, permitted adjustment of this voltage for sharpest picture focus.

In subsequent designs it was found that, by constructing grids no. 3, 4, and 5 to closer tolerances, the necessary focusing action could be obtained with voltages on the order of 300 to 400 volts. These latter values can be obtained directly from the low-voltage power supply, avoiding the special circuit required when several thousand volts are needed.

It is also possible, by modifying the structure of grids no. 3, 4, and 5 to the form shown in Fig. 9-21, to obtain the proper focusing action with zero potential on grid no. 4. Now, no external voltage or focusing potentiometer need be used.

Since the focus magnet is dispensed with on electrostatic focus tubes, a new centering magnet is provided to center the picture on the screen. See Fig. 9-22. The magnet assembly is in the form of two rings mounted on a nonmagnetic form which is placed around the neck of the picture tube and at a distance of about $\frac{3}{8}$ in. back of the deflection yoke.

Guns for Short-neck Tubes. As we shall see presently, the deflection angles in picture tubes have increased steadily in order to permit the overall length of the tube to be reduced. See Fig. 9-25. In time, attention also was directed toward reducing the length of the neck of the tube where the electron gun is housed. To achieve this reduction in length, it became necessary to modify the gun structure itself. Several modified gun assemblies have been developed and undoubtedly others will follow. However, it is of interest to know what has been done, and this is discussed below. In both instances, electrostatic focusing and electromagnetic deflection are retained.

Philco has been able to reduce the overall length of the gun structure shown in Fig. 9-23(A) by almost 2 in. The first step in achieving this was obtained by mounting the filament, cathode, and control grid (G_1) hori-

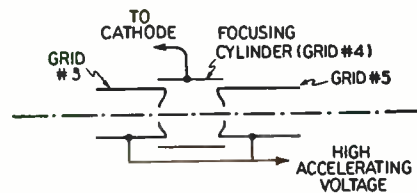
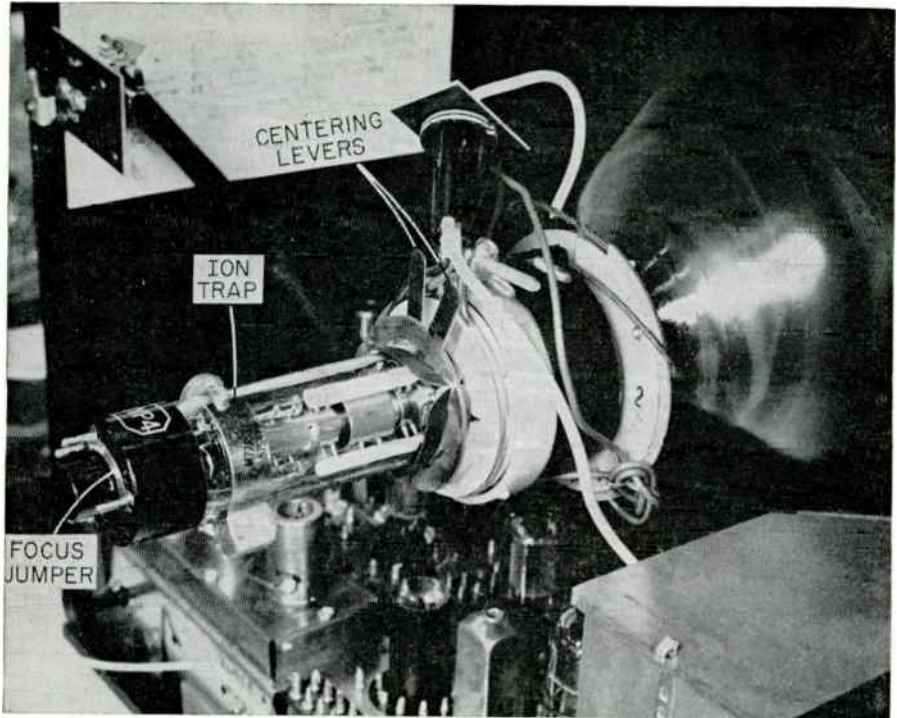

FIG. 9-21. The modified arrangements of grids no. 3, 4, and 5 in the zero-focus tube.



Courtesy G.E.

FIG. 9-22. Close-up view showing centering device for electrostatic focus tubes. Ion trap is also evident at left.

zontally rather than vertically. See Fig. 9-23(B). The cathode structure is similar to that used in a receiving tube. Two spaced mica plates provide support for the elements. This helps remove about $\frac{7}{8}$ in. from the conventional gun structure. The remaining savings is obtained by shortening G_3 and G_5 .

As an interesting sidelight, it was found that as the neck of the cathode-ray tube is shortened and the gun elements approach the yoke, a point is reached where the deflection field interacts with the focusing field produced by the electrostatic lens; as a result, the picture appears soft and defocused near its edges. To reduce this effect, cylinders G_2 and G_3 are made out of permeable steel. The permeable steel acts as a magnetic short circuit for the yoke field, preventing it from reaching the electron beam which travels unmolested inside the cylinders.

A slightly different approach is taken by Sylvania tube engineers. They utilize the arrangement shown in Fig. 9-24. The cathode and control grid

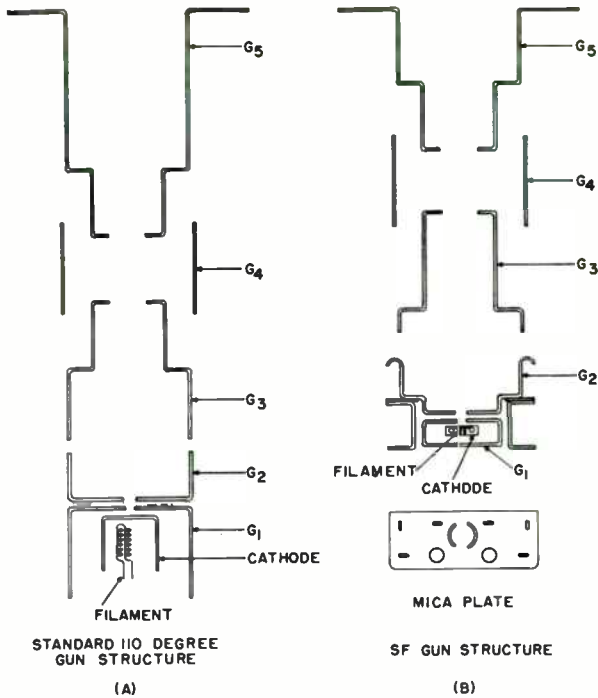

FIG. 9-23. Philco was able to reduce overall length of standard 100-deg gun structure (A) by almost two inches to produce gun structure in (B).

(G_1) resemble these same elements in any of the previous guns. These are then followed by a cup-shaped no. 2 grid, a short cylindrical no. 3 grid, and a cylindrical anode. Each of these elements has a different voltage, with the final grid connecting to the internal conductive coating of the tube.

The voltages applied to G_2 , G_3 , and the anode all determine the focusing of the beam. It is possible to apply fixed voltages to any two elements and vary the third voltage to focus the beam at the screen. For optimum receiver design, this focus voltage is best obtained from a potentiometer. The size of the beam spot at both low and high current is about the same as in standard tubes.

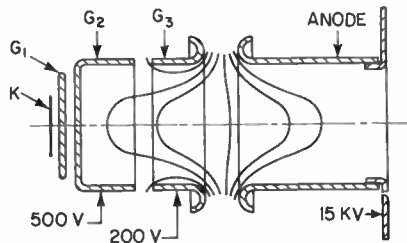

FIG. 9-24. The gun structure developed by Sylvania for their short-neck tubes.

Tube Length. In electromagnetic deflection tubes used before World War II, the deflection angle of the electron beam was 40 deg. Following

the war, the deflection angle was raised to 50 deg, then 60 deg, 70 deg, 90 deg. Nearly all the tubes now made are 110 deg. See Fig. 9-25. The increased deflection angle results in a shorter overall length and therefore permits the use of relatively large screen tubes in exceedingly compact cases. True, the increase in deflection angle means greater deflection currents, but this has been met in large measure by improved operating efficiency in the deflection circuits.

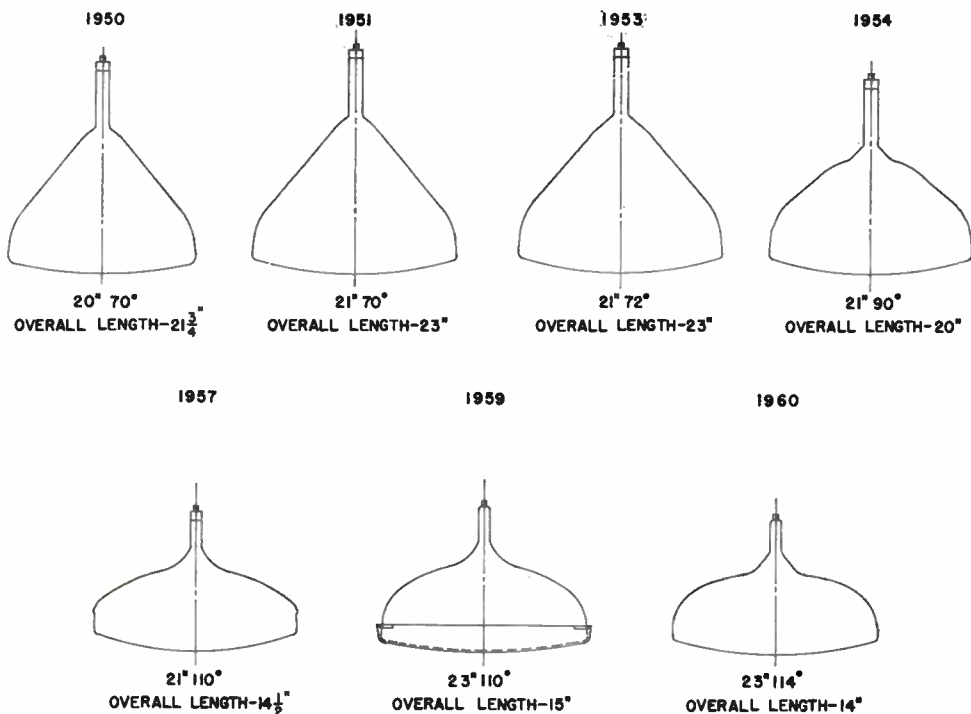

FIG. 9-25. An illustration of how the physical dimensions of picture tubes have changed through the years.

Cathode-ray-tube Screens. Everything that has been done to the electron beam in the discussion thus far has been done with two ideas in mind: to have the beam focus properly on the screen and to send it to different parts of the screen as well. Now let us consider the screen itself.

An electron gun, once constructed, can be subjected to considerable misuse without being permanently affected. On the other hand, failure to grasp the significance of certain precautions required to protect the fluorescent screen can readily result in a shortened period of usefulness and/or unsatisfactory operation throughout the life of the tube.

The phenomenon by which certain substances convert the energy of an electron beam into visible light is known as "luminescence." Luminescence is further divided into "fluorescence" and "phosphorescence." Fluorescence is luminescence which ends when the exciting agent is removed. Phosphorescence is luminescence which exists after the exciting agent is removed. Technically, then, the screens used in television should be called "phosphorescent screens," and, indeed, the crystalline substances used for these screens are known as "phosphors." Unfortunately, however, the word "fluorescent" has become so widespread that one seldom hears the other, proper name. A tabulation of the most common phosphors in use in oscilloscopes, television receivers, and radar equipment is given in Table 9-1. For television, a

TABLE 9-1. Common phosphors used for oscilloscopes, television receivers, and radar equipment.

Phosphor	Emission Color		Persistence	Application
	Fluorescence	Phosphorescence		
P-1	Yellowish green	Yellowish green	Medium	Cathode-ray oscillographs and radar
P-2	Yellowish green	Yellowish green	Medium	Cathode-ray oscillographs
P-3	Yellowish orange	Yellowish orange	Medium	
P-4	White	White	Medium to medium short	Monochrome television picture tubes
P-5	Blue	Blue	Medium short	Photographic recording
P-7	White	Yellowish green	Blue, medium short, Yellow, long	Radar
P-12	Orange	Orange	Long	Radar
P-15	Green	Green	Visible, short Ultraviolet, very short	Television pick-up of photographs by flying-spot scanning
P-18	White	White	Medium	Low-frame rate television
P-19	Orange	Orange	Long	Radar
P-22	Tricolor phosphor screen		Medium	Color television
P-24	Green	Green	Short	Flying-spot scanner tubes
P-26	Orange	Orange	Very long	Radar
P-27	Reddish orange	Reddish orange	Medium	Color television monitor service
P-28	Yellow green	Yellow green	Long	Radar

Courtesy Electronics Magazine

combination of zinc sulphide and zinc beryllium silicate is used, this combination giving higher conversion efficiency than most other known compounds. It is interesting to note that the electron beam remains at any one point for approximately $0.1 \mu\text{s}$, yet the light emission continues $\frac{2}{100}$ to $\frac{3}{100}$ sec, indicating that the zinc sulphide and zinc beryllium silicate are responsible through their phosphorescence for practically all of the emitted light seen by the observer. A typical persistence curve for zinc sulphide is shown in Fig. 9-26.

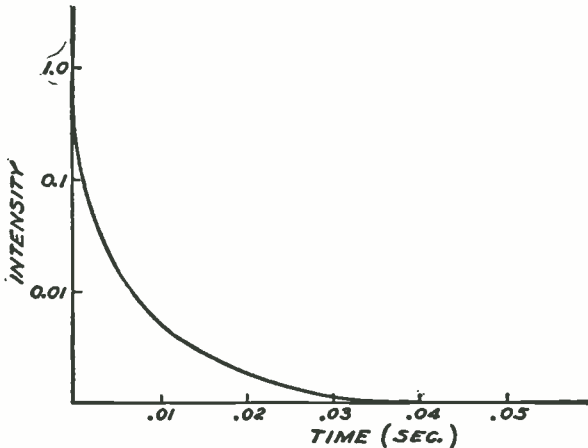

FIG. 9-26. A persistence curve for zinc sulphide, commonly used in P4 television screens.

The principal objective in the design of a cathode-ray tube is the production of an image having good brightness and high contrast. When the electron beam strikes the back side of the fluorescent screen, the light which is emitted distributes itself in the following approximate manner:

50 per cent of the light travels back into the tube

20 per cent of the light is lost in the glass of the tube by internal reflection

30 per cent of the light reaches the observer

Thus, of all the light produced by the electron beam (and this, itself, is a highly inefficient process), only 30 per cent reaches the observer.

Image contrast is impaired because of the interference caused by light which is returned to the screen after it has been reflected from some other points. Some of these sources of interference are given here in the order of their importance:

1. Halation
2. Reflections due to the curvature of the screen

3. Reflections at surface of the screen face
4. Reflections from inside the tube

Halation. If we take a cathode-ray tube and minutely examine the light pattern produced by a stationary electron beam, we find that the visible spot is surrounded by rings of light. These rings of light are due to a phenomenon known as "halation." See Fig. 9-27. The light rays which leave

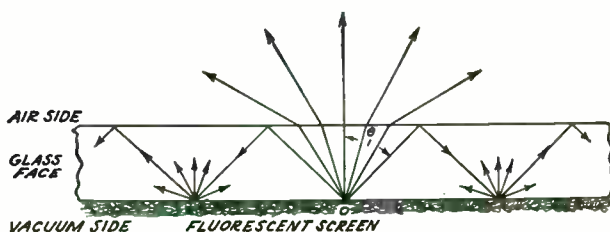

FIG. 9-27. Reflections between the two sides of the glass can cause halation.

the fluorescent crystals at the inner surface of the tube face travel into the glass and are refracted. Those rays which make an angle greater than θ do not leave the glass when they reach the outer surface, but instead they are totally reflected back into the glass. At each point where these reflected rays strike the fluorescent crystals they scatter, and it is this scattering of the rays that produces visible rings on the screen. These rings cause a hazy glow in the region surrounding the beam spot and reduce the maximum possible detail contrast. Contrast, it will be recalled, is the ratio of the brightness of two points, one of which is being bombarded by the electron beam, the other of which is under cutoff conditions. It is desirable to have this ratio as high as possible in order to achieve "rich-looking" or high-quality images. Due to the scattering of the light, however, areas which should be in total darkness receive some light, and the result is a reduction in the contrast ratio. A distinction is usually made between the detail-contrast ratio, and the over-all field contrast. The field-contrast ratio compares two sections of the screen which are widely removed from each other. Halation affects only detail contrast.

Reflections Due to the Curvature of the Screen. Reflection arising from the curvature of the screen, as shown in Fig. 9-28, cause loss in contrast. The remedy is the

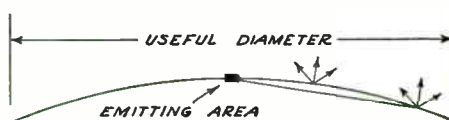

FIG. 9-28. Diffusion effects in nonflat screen.

use of a flat screen. Much progress has been made in this direction since the screen curvature greatly restricts the useful image area.

Reflections at Surface of the Screen Face. Light rays, when traveling from one medium to another, always lose a certain amount of energy at the intersection of the two media. At the cathode-ray-tube screen, some light is reflected when it reaches the dividing surface between the air and the glass of the tube. The reflected light travels back to the inner surface and then back to the outer surface again. At each dividing surface, some of the light continues onward and some is reflected back into the glass. Absorption and dispersion quickly reduce the strength of these rebounding rays.

Reflections from Inside the Tube. In Fig. 9-29 we see how reflections from the inside surfaces of the tube can act to decrease the field contrast of the image. The loss in contrast from this source of interference can be made quite low by a special shaping of the walls of the bulb, as shown in Fig. 9-29, and the use of the black aquadag coating.

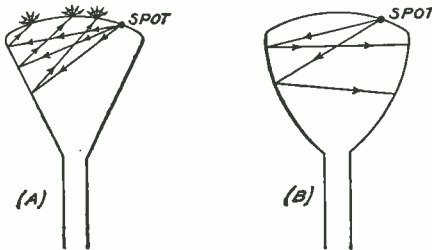

FIG. 9-29. The shape of the tube can reduce internal reflections.

as shown in Fig. 9-29, and the use of the black aquadag coating. The aquadag coating is also useful for electrical purposes; it acts as a shield and a path for the return of the secondary electrons emitted from the fluorescent screen. Secondary electrons must be emitted by the screen, otherwise the

negative charge accumulation on the screen would soon become great enough to prevent the electron beam from reaching it.

One step taken toward improving screen brightness and contrast has been the addition of an extremely thin film of aluminum on the back of the fluorescent screen. The film is sufficiently thin to permit the electrons in the scanning beam to reach the fluorescent crystals. It will prevent, however, any of the light which is generated by the screen crystals from traveling back into the tube. This is shown in Fig. 9-30. The light which previously went back into the tube is now reflected toward the observer. This is one improvement. In addition, the overall field contrast is improved as much as 10 times. However, the detail contrast is not noticeably affected since it is governed primarily by halation, and the addition of the aluminum layer does not affect this condition.

The metal film is extremely thin, being on the order of $3,500 \times 10^{-8}$ /cm thick. Since even a layer this thin interposes a barrier in the path of the electron, it is essential that sufficiently high accelerating voltages be used. In Fig. 9-31 is shown the variation in the efficiency curves of screens having the metallic layer and those which do not. At low accelerating voltages, the loss of energy by the electrons in penetrating the layer decreases their

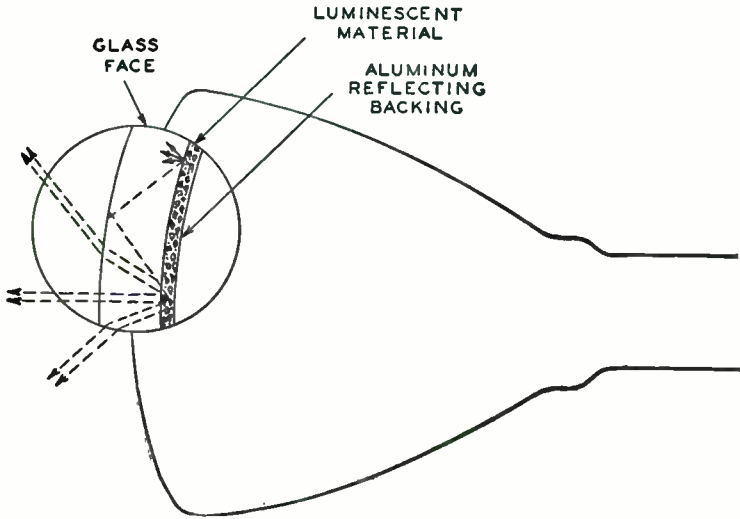

FIG. 9-30. An aluminum backing over the fluorescent screen prevents light from traveling back into the tube.

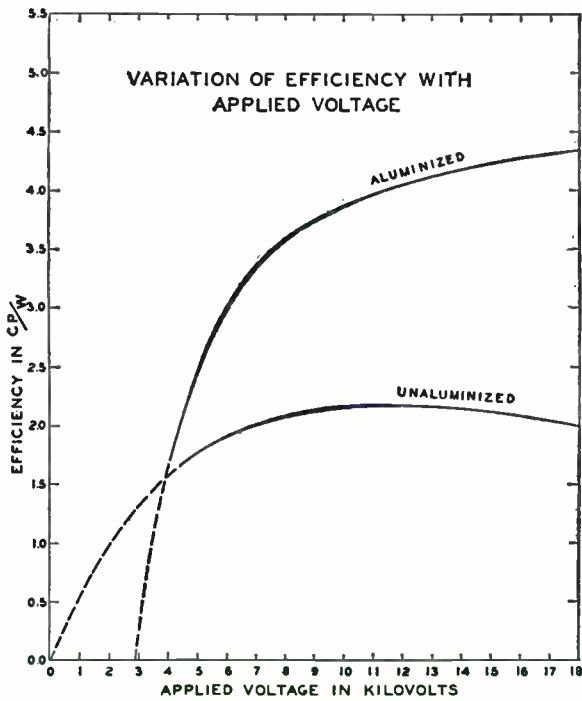

FIG. 9-31. Variation in efficiency of aluminized and unaluminized screens.

efficiency* below that of similar electrons in tubes not possessing this layer. The poorer efficiency continues until the curves intersect. Beyond this region, the screen with the metallic layer proves to be quite superior to the ordinary tube. The rapid rise in efficiency is due to a decrease in energy lost at the metallic barrier plus an increase in the overall brightness due to the light-resisting characteristics of the layer itself.

Sticking Potentials. An additional purpose which the aluminum film serves is to prevent undesirable effects due to poor secondary emission from the screen. The electrons in the beam, where they strike the screen, must somehow be brought back to the cathode. The fluorescent crystals themselves are essentially nonconductors. If the electrons from the beam were allowed to accumulate on these crystals, a point would soon be reached where a negative charge would accumulate sufficiently to prevent any additional electrons from reaching the screen. Originally, when tubes were first built, a thin metal film was deposited on the glass face of the tube and the fluorescent screen coated on this film. The metal film was connected to the second anode, thereby assuming the same potential. When the electrons hit the fluorescent coating, they continued through to the metal film.

Further investigation revealed that, without the metal film, the tube would still work because of the secondary emission from the screen. When they hit the fluorescent screen, the beam electrons imparted sufficient energy to the screen electrons to cause them to leave the screen. These emitted electrons reached the aquadag coating on the walls of the tube and by this path were conducted back to the cathode. The removal of the metal film was a significant step forward toward obtaining a brighter image.

The return of the electrons by secondary emission was not without limitations. First, the number of secondary electrons emitted depended upon the velocity of the arriving beam electrons. If their velocity was too low, there was no secondary emission and the tube would not function in a satisfactory manner. With the stepping up of the beam velocity, secondary electrons are emitted, with good tube operation, to the point where there are just as many electrons arriving at the screen as are leaving. Beyond this, additional increase in beam velocity will produce no corresponding increase in light output. If it is found, for example, that the number of arriving and the number of emitted electrons at the screen are equal when the second-anode potential is 8,000 volts, then raising this voltage to 12,000 volts will produce no greater light output, despite the higher voltage. This critical potential, at which the ratio of secondary electrons to beam electrons becomes equal to 1, is known as the "sticking potential." Any further increase in beam velocity will cause

* Efficiency is expressed here in candle power of illumination attained for each watt of electrical power expended. CP/W is an abbreviated notation for candle power per watt.

the ratio to decrease below 1, with the result that the screen accumulates sufficient negative charge to reduce effectively its potential to the critical point. No matter what the accelerating potential on the second anode may be, the effective screen potential cannot exceed its critical value. Thus, if the accelerating voltage is 12,000 volts, and the critical potential of the screen is 8,000 volts, then the light emitted from the screen will be on the basis of 8,000 volts, not 12,000 volts.

From the standpoint of screen manufacture it is desirable to have the critical potential as high as possible, certainly above the operating potentials of the tube. The method of providing an aluminum film corrects many of the defects due to secondary emission difficulties and greatly increases the range of substances which can be used for screen phosphors. Previously, each material had to be carefully examined to determine whether its sticking potential was of a suitable value.

Ion Spots. Another matter of considerable importance is the elimination of the ion spot in tubes using electromagnetic deflection. No matter how carefully a tube is degassed or how well a cathode-coating is applied, it will be found that ions are present in the electron beam. These ions are either gas molecules which have acquired an electron or else molecules of the outside coating material of the cathode. These ions possess the same charge as the electrons and are sensitive to the same accelerating voltages. In tubes employing electrostatic deflection, the ions and the electrons are similarly deflected and for all practical purposes may be considered as one. However, when electromagnetic deflection is employed, it will be found that these heavier ions are hardly deflected. As a result, they strike the center of the screen in a steady stream and, in time, deactivate the fluorescent material in this area. When the electrons in the scanning beam subsequently pass over this section of the screen, no light is emitted. To the observer this section appears as a dark patch.

The reason for the difference in deflection characteristics of the ion can be obtained from the equations governing electromagnetic and electrostatic deflection. For electromagnetic deflection, we have

$$d = \frac{DLeH}{mv}$$

- where d = distance the beam is deflected on the screen
 D = distance from the deflection field to the screen
 e = charge of particle deflected
 H = strength of magnetic field
 v = velocity of traveling particle
 L = length of magnetic field
 m = mass of particle

For electrostatic deflection, the expression is

$$d = \frac{1}{2} \cdot \frac{V}{E} \cdot \frac{S}{h} \left(D + \frac{S}{2} \right)$$

- where d = distance the beam is deflected on the screen
 V = potential difference between the deflecting plates
 E = forward accelerating voltage of the tube (i.e., second anode)
 S = length of the deflection plate
 h = separation of the deflection plates from each other
 D = distance from the end of the deflection plate to the screen

In electromagnetic deflection the mass of the deflected particle appears in the equation; in electrostatic deflection it does not. Hence, the ions, because of their greater mass, will receive less displacement than electrons in electromagnetic systems. However, when the mass of the particle is not important, ions and electrons receive similar treatment.

Bent-gun Ion Trap. Several means are used to prevent the ions from reaching the screen. First there is the bent electron gun, shown in Fig. 9-32(A). The cathode, when heated, will emit ions and electrons and these will be accelerated to the first and second anodes. However, the cathode is inclined at an angle to the rest of the gun structure and both ions and electrons would, if permitted to travel in a straight line, impinge on the side of the electron gun and never reach the screen. If a strong magnetic field is placed in the path of the particles, it is possible to alter the paths of the electrons sufficiently so that they travel toward the screen. The heavier ions, however, are not sufficiently deflected and as a result they hit the side of the electron gun. The magnetic field which causes this separation of ions and electrons is obtained from a small coil or permanent magnet placed on the outside of the neck of the tube, above the cathode. The ion-trap magnet (or "beam bender," as it is sometimes called) is clamped onto the neck of the tube in the position shown in Fig. 9-32(A).

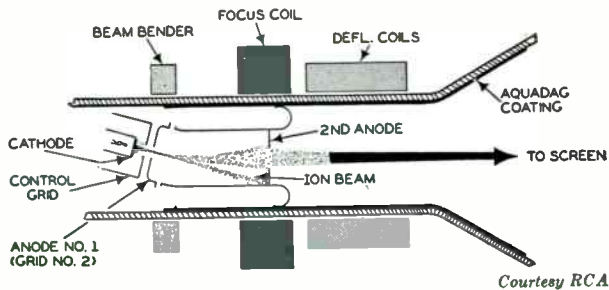

FIG. 9-32A. A bent-gun ion trap.

Diagonal-cut Ion Trap. Another approach to the prevention of ion spots is the diagonal-cut ion trap. See Fig. 9-32(B). The electrons and ions are emitted by the electron gun and are accelerated forward. The first and second anodes are so designed that the gap between them is oblique. The first anode has a low positive voltage; the second anode has a high positive voltage. The electrons, as they leave the cathode, are attracted forward by

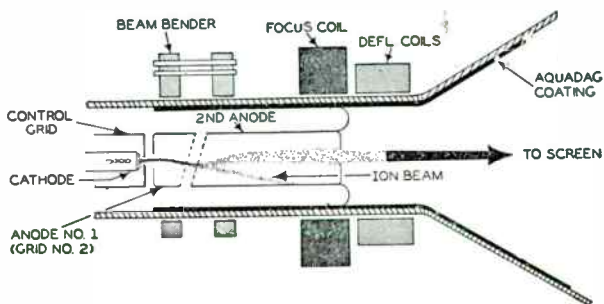

FIG. 9-32B. A diagonal-cut (or slash-field) ion trap.

the first anode. However, the oblique gap between the first and second anode causes the electric field here to become warped and the electrons and ions crossing the gap are bent in toward the second anode. With no other forces applied, the electrons and ions will strike the second anode and be prevented from reaching the screen.

However, if a magnetic field is introduced at right angles to the electrode, the electrons receive a counterforce deflecting them upward and permitting them to continue through the gun. The ions, because of their greater mass and because the magnetic field scarcely deflects them, strike the second anode and are removed from the beam path.

The magnets are clamped on the tube stem in the manner illustrated in Fig. 9-18.

The ion trap may operate electromagnetically, with current flowing through the front and rear ion-trap coils to provide the necessary magnetic field, or the trap may contain fixed magnets of Alnico (Fig. 9-33).

It should be noted that the diagonal-cut (or slash-field) gun requires a double magnet, whereas the bent gun utilizes a single magnet. In every complete listing of picture tubes information concerning the type of magnet to use is generally included.

Four types of PM double magnet-ion traps are in use. These are shown in Fig. 9-34.

1. One type is held in place with two clamps, colored black and blue, and tightened onto the neck of the tube with two screws.

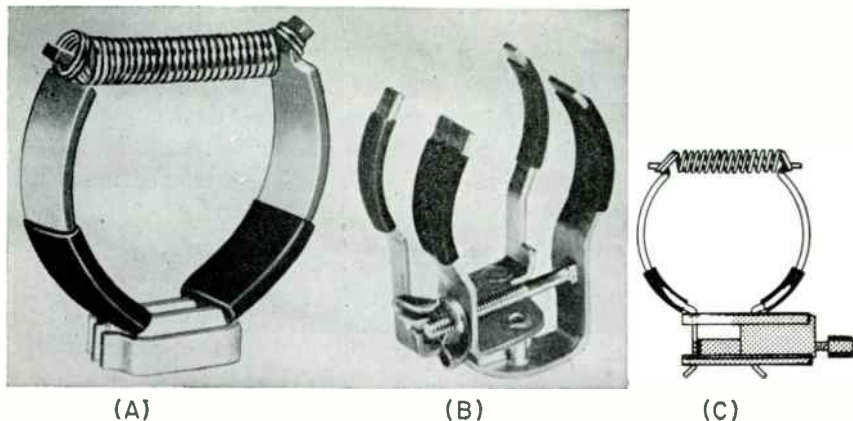

FIG. 9-33. Fixed ion-trap magnets. (A) Single ion trap (B) Double ion trap (Courtesy Quam-Nichols) (C) Adjustable single ion trap (Courtesy J. W. Miller Co.).

2. Another type is a ring containing a large and a small circular magnet which slip over the neck of the tube.

3. A bar type has two square bar magnets that slip over the neck of the tube.

4. A fourth is a friction-clamp type of trap.

The ion-trap unit should be placed on the neck of the tube with the stronger of the two magnets over the first anode. In some units, the stronger magnet will also be the larger one. In other units, the color code markings indicated in Fig. 9-34 will guide the serviceman. Sometimes an arrow will be found stamped into the holding plate of the magnet and, in such instances, the unit should be positioned so that the arrow points toward the tube screen.

After the magnet is in position, the set is turned on and allowed to warm up.* Now turn up the brightness control and adjust the magnet by moving it forward or backward, at the same time rotating it around the tube neck until the brightest raster is observed on the screen. Keep reducing the brightness control as the system is brought into line. When adjustment is complete, make certain that the ion trap is held tightly in position.

It may happen that when the raster is brightest, shadows will appear at its sides or corners. Never correct for a shadowed raster with the ion-trap magnet if such correction results in decreased brightness. The ion-trap magnet must always be adjusted for maximum brightness and, if shadows occur at this setting, they should be eliminated by adjusting the focus and deflection coils.

Sometimes two brightness maxima are obtained in moving the ion trap

* The adjustment procedure given here is the same for single or double magnet traps.

back and forth along the neck. The correct position to use is the one which is closest to the base of the tube. The second maximum is usually obtained when the ion-trap magnet is close to the focus coil or magnet. The interaction of the two magnetic fields is such that a brightness maximum is obtained in this incorrect location. Tubes should not be operated with the ion-trap magnet in this second position since possible damage to the tube may result.

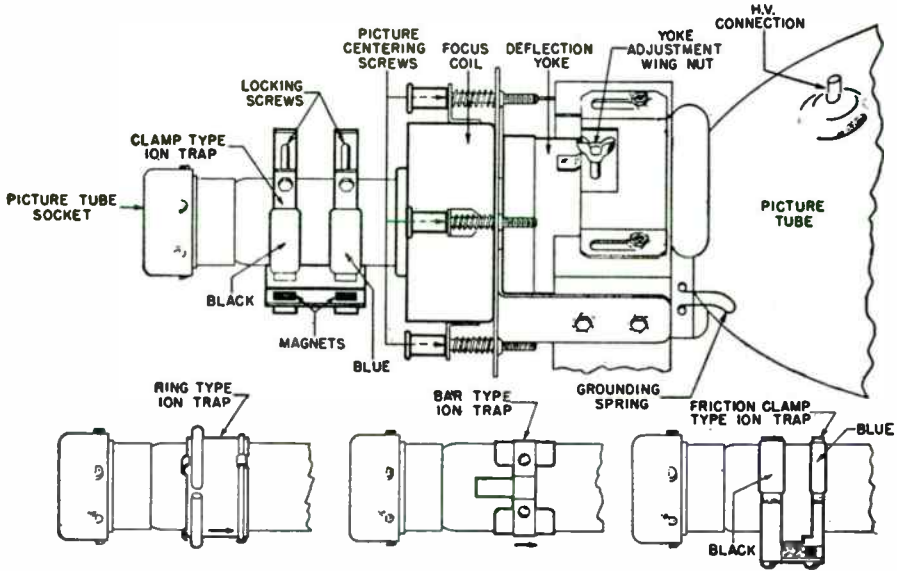

Fig. 9-34. Types of ion-trap magnets.

Metal-backed Screen Tubes. The third method of preventing ions from reaching the screen uses the aluminum layer mentioned previously. The depth of penetration of any particle is governed by the relationship,

$$\text{Depth of penetration} = \frac{K(Ve)}{m}$$

where K = constant

Ve = energy of particle

m = mass of particle

Since an ion has considerably more mass than an electron, its depth of penetration is less. By properly proportioning the thickness of the metallic screen, the ions are excluded but the electrons in the beam are able to pass through.

The trend, of late, has been to aluminize all screens and, in most instances, eliminate the ion trap. This tendency has been accelerated particularly by the use of short guns.

Some of the more popular cathode-ray tubes are listed in Table 9-2, together with their characteristics. All are of the "direct-viewing" type, so-called because the images produced on their screen are viewed directly by the user of the set. Note that in all these tubes the accelerating voltages are far higher than those normally encountered, and extreme caution should be exercised when working with them.

Rectangular Screens. It had been recognized for many years that a rectangular image on a circular screen is wasteful not only of screen area, but of cabinet space as well. The sensible solution was a rectangular screen dimensioned in the standard 4:3 ratio of the transmitted image. At first, manufacturing difficulties and obstacles presented by the rectangular shape of the tube prevented mass production, but in time these were overcome and rectangular tubes are now used almost exclusively.

A rectangular tube with a 21-in. screen is shown in Fig. 9-35(A). This has a fairly long neck and a conventional socket base. A 110-deg picture

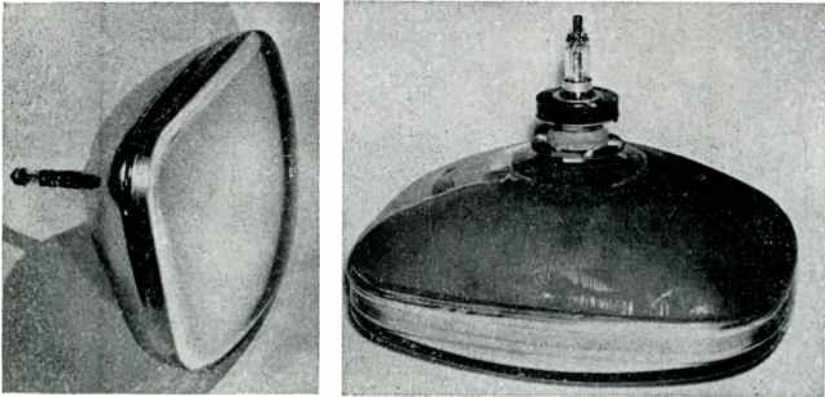
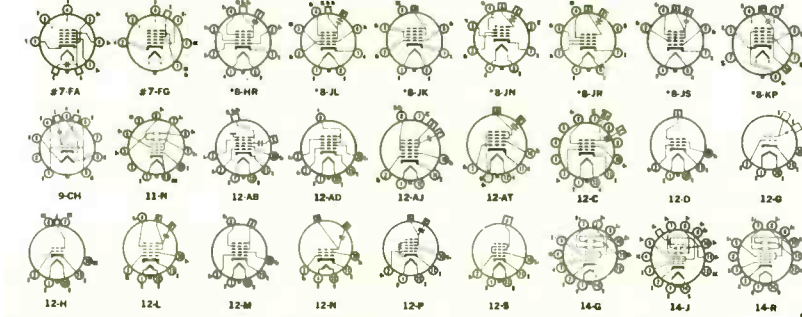

FIG. 9-35. (Left) A rectangular picture tube with a 21-inch screen. Deflection angle is 90-deg. (Right) A 110-deg picture tube possessing a shortened neck and a modified plastic base. Note deflection yoke on neck.

tube possessing a shortened neck and a modified plastic base is shown in Fig. 9-35(B). With the deflection yoke in place, as shown, not much room remains for additional components. This can be compared with the tubes shown in Figs. 9-18 and 9-22 where longer guns (and hence longer necks) are employed.

Tube Shields. In most TV receivers, a plate-glass shield is mounted close and in front of the picture tube as a safeguard to the viewers against possible serious injury should the tube implode. This shield, however, is not always easily removable, making it difficult to remove dust or fog from

Table with 5 main columns and 15 sub-columns each, detailing TV picture tube characteristics. Columns include: TYPE, HEATER, FACE, BODY, FOCUS, DEFL ANGLE, ANODE VOLTS, MAG ING, ION TRAP, NOM INAL LENGTH, and MAG. Each sub-column contains specific technical data for various tube models.



NOTES: All Sylvania television picture tubes feature a controlled heater warm-up time of 11 seconds for operation in receivers employing a series heater string. Design - Maximum Ratings - limiting values of operating and environmental conditions applicable to B body tube, that should not be exceeded under the most probable conditions. 110" types have a nominal neck diameter of 1 1/4". All other Magnetic Deflection types have a nominal neck diameter of 1 1/8".

TABLE 9.2. TV picture tube characteristics. World Radio History Courtesy Sylvania Electric

either the tube face or the inner shield surface. There is also a loss of contrast stemming from light reflections between the shield and the tube.

Recently, the separate safety shield has been replaced by a flat sheet of glass possessing the same contour as the external surface of the tube screen and permanently bonded to this screen by an epoxy resin. See Fig. 9-36.

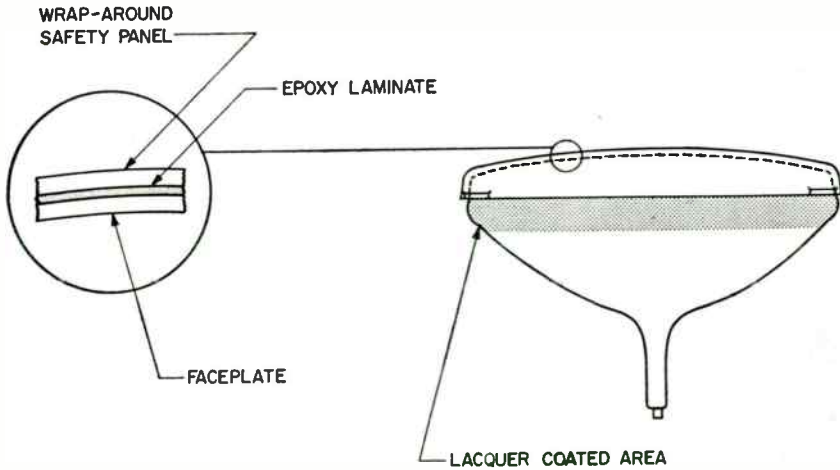

Courtesy Sylvania

Fig. 9-36. Cross section of tube possessing a bonded shield. Lacquer band protects critical area of the bulb behind the wrap-around panel.

The result is a virtually implosion-proof tube that is easy to keep clean, produces a brighter, sharper image, and permits a picture shaped more nearly rectangular. Finally, use of this technique has made it possible to design a bulb having a flatter face, which reduces distortion at wide viewing angles.

Nomenclature of Cathode-ray Tubes. In an effort to standardize the nomenclature used for cathode-ray tubes, the following system has been adopted:

1. The first number, whether of one or two digits, represents the diameter of the screen. To have the numbering system of screen sizes of rectangular tubes conform to that employed for circular screens, it is standard procedure to use the diagonal length of the rectangular screen as the screen size. Thus, the 21-in. tube shown in Fig. 9-35(A), has a diagonal length (from one corner to the opposite corner) of 21 in. The reader can, from elementary geometry, then figure out that the screen sides will be somewhat greater than 12 in. high and 16 in. wide.
2. The letter P, with the number following it, indicates the type of fluorescent screen that the cathode-ray tube contains.

3. Any other letters found between the first number and P is used to distinguish between tubes that may be just as large as each other, with identical screens, but possess other differences. These differences may consist of the addition of another element (for example, an accelerating grid), a differently shaped-bulb, a different tube socket, etc.

4. The letters A, B, C, and D frequently follow the screen type (P4). These indicate that the screen glass of the tube is either of special texture or construction or that it has been specially tinted to help improve picture contrast. When the letter A is used (as in 16HP4A), it frequently indicates that a special light-absorbing glass (known commercially as "Gray Glass," "Filterglas," or "Teleglas") is being used for the screen plate. When the letter B is found, it indicates that the screen face has been frosted; which tends to diffuse the reflections of bright lights in the room, thereby lessening their annoyance to the viewer. This frosting, in combination with Filterglas, helps to improve picture contrast considerably.

Occasionally the letters C and D will be found. In the 19AP4C, for example, Grey Glass is used and, in addition, the fluorescent side of the screen is coated with a thin layer of aluminum. This tends to increase the light output considerably. In the 19AP4D, a frosted glass is used. This distinguishes it from the 19AP4D which employs a frosted Grey Glass.

Some variations of the above letters (A, B, C, D) will be found because it is becoming standard practice to incorporate some of these additional features in the newer tubes. Where this is occurring, the letters may be omitted or otherwise modified.

There are different types of screens, depending upon the purpose to which the cathode-ray tube is put. In television, a white trace is desirable with a persistence that might be termed "medium." This would be labeled P4. For oscillographic work, either a P1 or a P2 screen, having a green trace, might serve better. Green is used here, in preference to white, because it gives a brighter trace with the same accelerating potentials. This feature is desirable as it is often necessary to observe oscilloscopes where the surrounding illumination is high. For long periods of viewing, however, white results in less strain on the eyes.

The P1 trace has a shorter persistence than the P2 trace, the latter being employed in oscilloscopes where transients are to be viewed. The P5 fluorescent coating is especially suited where photographs are made of the pattern on the viewing screen. The radiation given off by this fluorescent screen is blue in color and of short persistence. Other types of screens have different properties that make them suitable for other particular applications. See Table 9-1.

Projection Television Systems. In the picture tubes discussed thus far, the images swept out on their screens are designed for direct viewing by the set owner. Under these circumstances the size of the picture will be governed by the size of the screen. It is possible, however, to use this image to produce a larger picture by projecting it through a lens system onto a screen. Projection systems have been designed specifically for television and have been commercially used to a limited extent.

In the first system that appeared, the image was formed on the screen of a small cathode-ray tube and then enlarged by means of several projection lenses similar to those employed in motion-picture equipment. See Fig. 9-37. The chief disadvantage of this method is its poor efficiency. Specially treated lenses, having a large aperture and good transmission of light, deliver to the viewing screen only about 6 per cent of the light present on the screen of the cathode-ray tube. Consequently, even with intense images developed on the cathode-ray screen, the final image is bound to be dim and difficult to see.

As an illustration, consider the 5-in. projection tube, with its 3- by 4-in. image. The total area here is 12 sq. in. If the image is enlarged to fill a screen 15 by 20 in., the total area becomes 300 sq. in., and the light which was originally concentrated in an area of 12 sq. in. is now spread over an area of 300 sq. in. The brightness is thereby reduced by the ratio of 300/12, or 25:1. This, of course, assumes 100-per cent transmission. If now we take into account that the transmission efficiency is only 6 per cent, then the brightness is decreased by a factor of 400 to 1 rather than 25 to 1.

Increasing the brightness of the image developed on the tube screen is a partial solution to this problem, but the cost involved can readily place the equipment in the same expensive class as large cathode-ray tubes. A second approach to the problem, and one with greater possibilities, is to increase the efficiency of the lens system.

The first attempt in this direction was directed toward the lens system shown in Fig. 9-37. Several difficulties were immediately encountered. In order to capture as much light as possible being emitted from the screen,

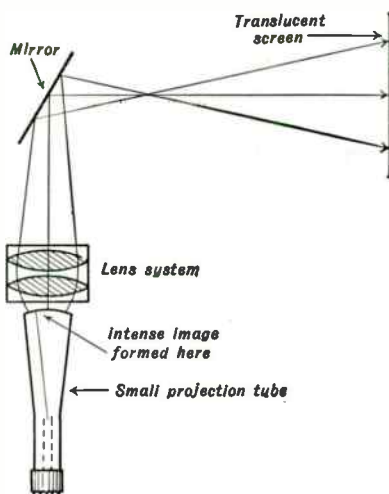

FIG. 9-37. Projection system to obtain large images.

the lens should be as large as possible. However, as the lens becomes larger, the number of distortions or "aberrations" multiply. (There are principally six aberrations that must be corrected: chromatic aberration, spherical aberration, coma, astigmatism, curvature of field, and distortion.) To correct for these aberrations in a fairly satisfactory manner requires several lens elements, say possibly three. However, in a wide-angle system, more than three lens elements should be used. As more elements are added, the cost of the system rises. The greater the number of lenses in a system, the greater the total loss of light at the intersecting surfaces and the lower the overall efficiency. Finally, with large lenses, elimination of some aberrations is accompanied by a greater accentuation in others.

This impasse faced television engineers until the Schmidt reflective optical system was adapted to television. Schmidt, an instrument maker at the Hamburg, Germany, Observatory, invented his optical system in 1931. The system, originally designed for astronomical telescopes, was built around a large spherical reflecting surface or mirror. See Fig. 9-38. Use of this type of reflecting surface offered the following advantages:

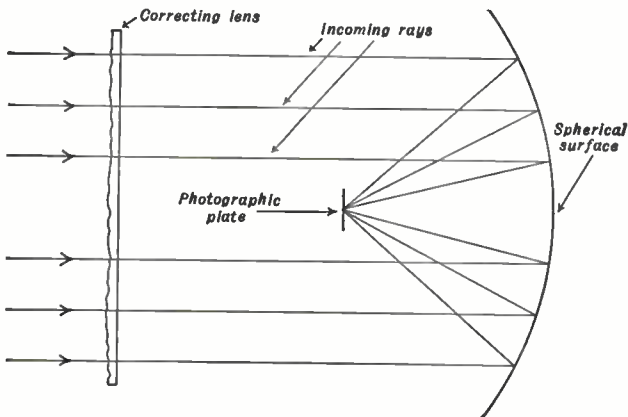

FIG. 9-38. Original arrangement of the Schmidt lens system.

1. Mirrors are completely free of chromatic aberrations.
2. Under comparable design of focal distance and diameter, a spherical mirror has a spherical aberration one-eighth that of a single lens. The need for correction is still present, but the problem is now considerably simplified.
3. By placing a small aperture at the center of the curvature of a spherical mirror, all the monochromatic aberrations (except spherical aberration) are eliminated.

We are thus left with two problems to solve. One is spherical aberration and the other is curvature of the field. The latter is quite simply resolved

by curving the screen of the projection tube to suit the curvature of the mirror. To eliminate spherical aberration, a special correcting lens is employed. The correcting lens introduces into the beam an amount of spherical aberration which is equal to that introduced by the mirror but opposite in sign. As a result, the two neutralize each other, effectively removing the last great defect of the spherical mirror. With this lens in place, we have an optical system possessing an efficiency of 25 per cent with magnification of 5. Compare this with the meager 6 per cent obtainable from the refractive lens system of Fig. 9-37.

For use in television receivers, there are several modifications of the original Schmidt lens system as designed for astronomical use. The optical mirror is mounted at the bottom of the cabinet with its axis vertical, projecting the image straight up and onto a flat mirror inclined at 45 deg. to the beam of light and throwing the image onto a translucent screen. See Fig. 9-39. The throw or distance between the correcting lens and the spherical mirror will depend upon the diameters of the correcting lens and the spherical mirror. To increase the size of the projected image, the distance, or throw,

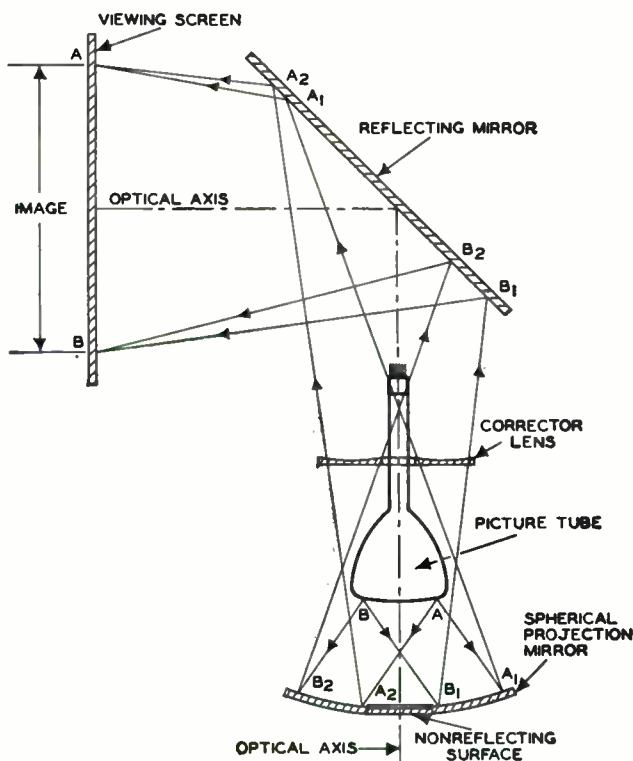

FIG. 9-39. Adaption of the Schmidt optical system to projection television receivers.

must increase, necessitating large cabinets, a larger mirror, and a larger correcting lens. Eventually the optical system becomes awkward and bulky.

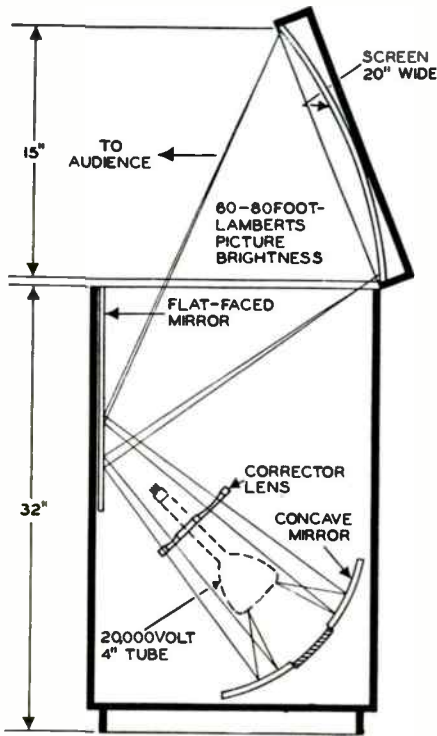

Fig. 9-40. The optical system of another projection television receiver.

picture tube would appear on the screen as a trapezoid (the image would have sloping sides with the top larger than the bottom). See Fig. 9-41. On the other hand, by projecting a trapezoidal image from the tube, we obtain a rectangular image on the screen.

Formation of the trapezoid pattern is achieved by applying a magnetic field at right angles to the electron beam. To produce this magnetic field, two oppositely polarized permanent magnets are mounted opposite each other on the end of the projection tube. See Fig. 9-42. A piece of iron pole, curved to fit the sides of the tube, is attached to each magnet and is used to produce a strong field for deflecting the electron beam upward near the tube face.



Fig. 9-41. A trapezoid.

A compromise is thus necessary between the size of the final image and the cost and size of the set. Each different throw or magnification requires a different correcting lens. This, it will be noted, differs from a refractive lens system, where the size of the projected image can be increased merely by changing the position of the lenses and the screen.

A slightly different arrangement is shown in Fig. 9-40. The distance between the correcting lens and the screen is $33\frac{1}{2}$ in., and variations of plus or minus 10 per cent are permissible without leading to any serious deterioration of image quality. The reflecting-plane mirrors in all these optical systems are front-surfaced mirrors to prevent ghosts which would occur from reflections at the surface of the glass of a rear-surfaced mirror.

Since the optical system is mounted at an angle and projects onto the screen at an angle, a rectangular image projected from the face of the

The oppositely polarized ends of the magnets farthest from the tube face cause a lesser and downward deflection of the beam before it is deflected upward. The result is the same as that which would be produced if the face of the tube were tilted inward; the distance the beam travels to the bottom of the image is reduced and the distance to the top is increased. This creates the desired trapezoidal pattern. The magnets are adjusted for the proper keystone pattern by moving them toward (parallel to the tube neck) or away from the tube (at right angles to the tube neck).

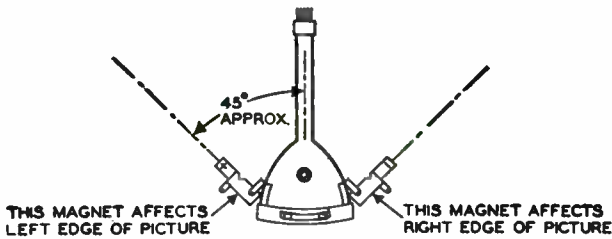
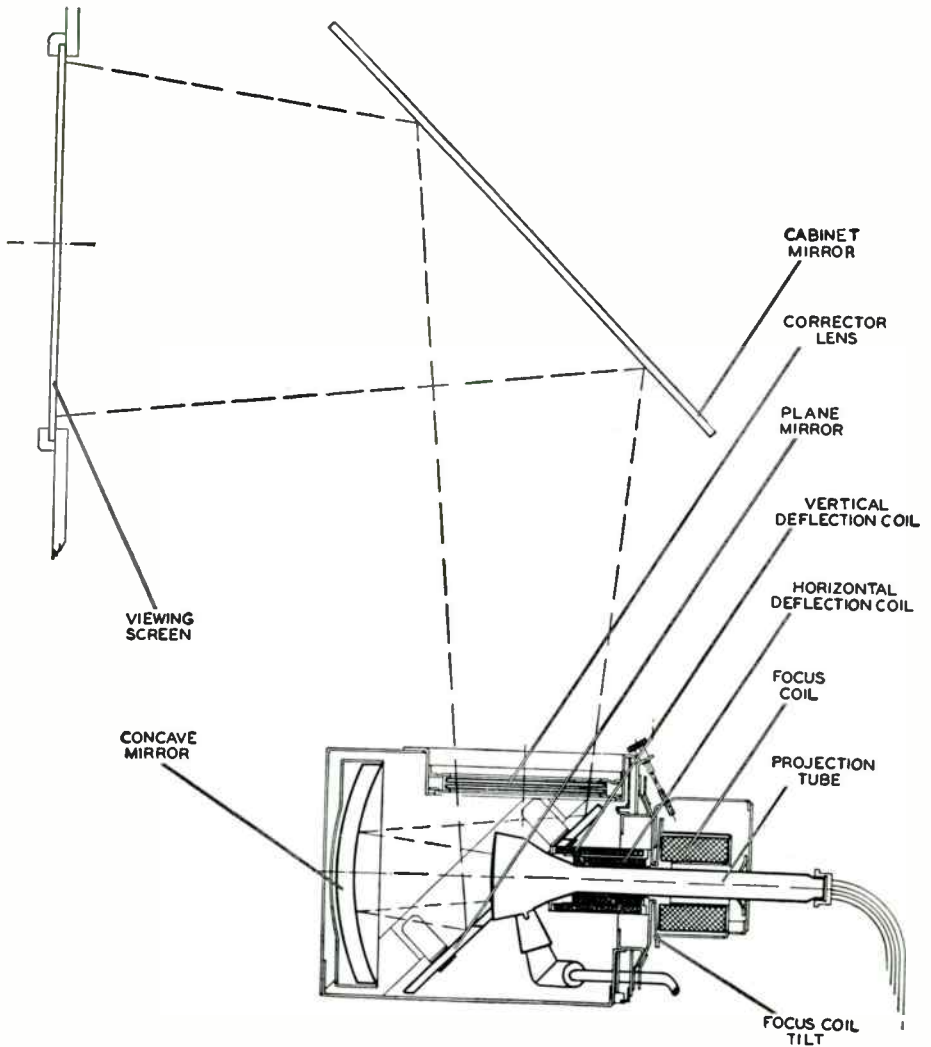

FIG. 9-42. The special magnets mounted on the cathode-ray tube in projection receivers.

Another variation of the Schmidt optical system as adopted for television is that devised by North American Philips. The system, known by the trade name "Protelgram," is an adaptation of the "folded" Schmidt system and occupies only half the space of a conventional arrangement. Since the light path is folded, it is possible to mount the projection tube with its optical system within a small metal box, thereby producing a compact and dustproof arrangement. The actual metal case measures only $8\frac{1}{2}$ by $8\frac{1}{2}$ by 9 in. It contains three optical elements: (1) a 6-in. spherical mirror, (2) an aspherical correcting lens, and (3) a special plane mirror to "fold" the light beam. See Fig. 9-43. The light emitted from the face of the tube is gathered by the spherical mirror, reflected to the plane mirror, and then projected upward through the correcting lens. A throw distance of 31 in. from the correcting lens to the viewing screen is required to produce an image 12 by 16 in.

A special, small-sized cathode-ray projection tube (3NP4) was designed for this unit. The diameter of the tube screen is 2.5 in. and a 1.4 by 1.86-in. picture is obtained. It appears that 2.5 in. constitute the smallest practical size from which an enlarged image can be obtained. The tube uses magnetic deflection, magnetic focusing, and 25,500 volts for acceleration. The spot diameter at the tube face is 0.003 in., which permits a 450-line resolution to be obtained. The high-voltage anode terminal consists of a button in a glass



Courtesy North American Philips

Fig. 9-43. The various components of the optical unit of the North American Philips projection system.

cup sealed to the cone of the tube. The glass cup lengthens the external leakage path from the high-voltage contact to the coils, thereby minimizing any tendency for arc-over to occur. The outside of the cone and part of the neck are covered with a conductive coating that can be grounded. This

outer coating, together with the conductive coating inside the tube, form a 300-mmf capacitor which can be utilized for filtering the high voltage.

QUESTIONS

1. Indicate briefly how a cathode-ray tube differs from a conventional pentode.
2. Which elements of the cathode-ray tube are contained in the first lens system?
3. Explain what occurs to the electron beam in the first-lens system.
4. Which elements are contained in the second-lens system? What occurs to the electron beam in this section of the electron gun?
5. What is a crossover point and what is its purpose?
6. What type of electrodes is employed in the electron gun? Why?
7. Explain, with illustrations, how the deflection plates bend the electron beam.
8. Name all the basic elements of an electrostatic deflection cathode-ray tube.
9. What is the purpose of an aquadag coating inside the walls of the cathode-ray tube?
10. Why is balanced deflection preferred to unbalanced deflection? List the advantages of each method.
11. Draw the circuit of a balanced electrostatic deflection system.
12. Why are vertical and horizontal centering controls necessary?
13. Show how centering controls are placed in the circuit.
14. Define deflection sensitivity and deflection factor. How can one be converted to the other?
15. Explain what happens when an electron enters a magnetic field.
16. Explain how an electron beam is focused magnetically.
17. Explain how a beam is deflected magnetically. Indicate the placement of the deflection coils at the cathode-ray tube.
18. What is the purpose of the fluorescent screen? What is its composition? What is the difference between fluorescence and phosphorescence?
19. What happens to all the light that is generated at the fluorescent screen?
20. Define image contrast. Why does the scattering of light reduce image contrast?
21. Explain halation briefly.
22. How can reflections inside the cathode-ray tube interfere with the image on the screen?
23. What is the reason for coating the back side of the fluorescent screen with aluminum?
24. What do we mean by sticking potential? When does it occur?
25. What is an ion spot? Why does it occur only in tubes using electromagnetic deflection?
26. Illustrate and explain two methods frequently used to prevent ion spots.
27. How are cathode-ray tubes identified? Explain in detail the system used.
28. Explain the difference between tubes using electromagnetic focus and deflection and tubes using electrostatic deflection and focus. Illustrate the differences in their internal construction.
29. Name the elements in an electromagnetic deflection, electrostatic focus tube. What advantage does this tube offer over an all-electromagnetic tube?

30. How are ion-trap magnets adjusted? What precautions must be carefully observed?
31. Explain, with illustrations, how a simple lens-type projection system operates.
32. What is the Schmidt optical system? How has it been adapted for television?
33. Why is the Schmidt optical system superior to a simple lens-type projection system?

Television Receiver Power Supplies

The power requirements of a television receiver differ from those of radio sets. The difference is due, in part, to the higher voltages required for the operation of the cathode-ray tube. In a television receiver we are confronted with the task of supplying 300 to 400 volts to the plates of the receiving tubes, while the picture tube must have voltages that range up to 25,000 volts.

It is possible to construct one supply for both or to employ two separate supplies. In the latter case, one would be used for the picture tube and the other for the remainder of the set. If one supply is decided upon, it must be capable of an output of 400 volts at 200 to 300 ma for the ordinary tubes and up to 25,000 volts at 1 ma for the picture tube. In one case we have low voltage, high current, while in the other instance there is the opposite combination. For one composite unit, then, there would have to be available 25,000 volts at 1 ma and 400 volts at 300 ma. The unit would be bulky, expensive, and quite out of proportion with other sections of the set.

Low-Voltage Power Supplies. A more effective solution is two separate supplies. The low-voltage, high-current unit could then take its familiar form as in Fig. 10-1. A 5U4GB operates as a full-wave rectifier, developing an output voltage of 335 volts. (This value will vary with the set.) In place of one of the filter chokes, the field coil of an electrodynamic speaker may be substituted. Voltages of 230, 130, and 90 volts are also made available by using suitable dropping resistances. Note that there are five filter capacitors in this supply. The more filtering the voltage receives, the more nearly it will approach the desired pure d-c state. A poorly filtered d-c voltage in the audio stages will produce an audible hum. The same voltage in the video amplifiers will distort the picture.

Examining Fig. 10-1 further, we notice that the primary of the power

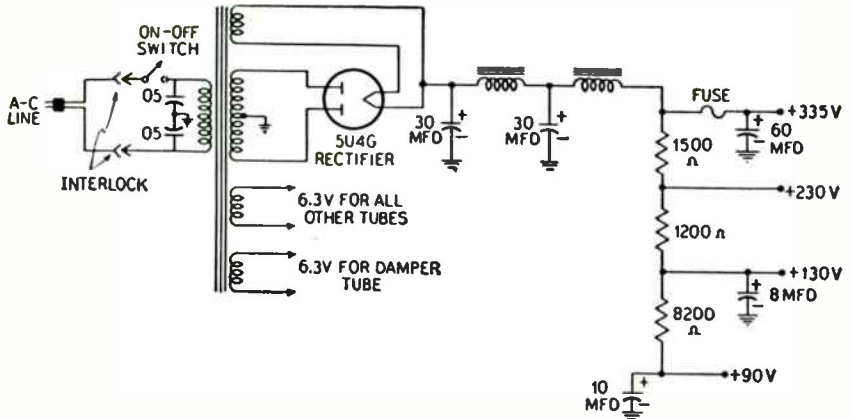

Fig. 10-1. The low-voltage power supply for a television receiver.

transformer contains an on-off switch plus an interlock switch. The interlock is a safety feature designed to prevent unauthorized tampering with the set and also to protect anyone who accidentally removes the back cover of the cabinet. The interlock is so devised that when the back cover of the set (or, in some instances, the back cover of the high-voltage section) is removed, the a-c plug pulls out along with it. For the serviceman who has work to do on the set, there are available extension cords with female plugs which will fit onto the male plug left in the set and serve to reintroduce power into the set.

Filament power for the tubes is, in this instance, obtained from two 6.3-volt windings on the power transformer. This means that the tubes are connected in parallel. The tubes in the RF section of the receiver plus some or all of the tubes in the video IF stages generally require RF chokes and/or bypass capacitors in their heater circuits to prevent any of the high-frequency currents present in these tubes from interacting with each other or with other tubes. By the same token, these filters prevent disturbances in other parts of the set from affecting the critical RF and video IF stages. This precaution is not required in the broadcast AM radio because of the low-frequency signals dealt with in these circuits. Filament RF chokes and bypass capacitors generally appear when the signal frequencies exceed 10 mc.

A separate 6.3-volt heater winding is required for the damper tube because of the high d-c voltage present on the cathode of this tube. To forestall possible breakdown between heater and cathode, the two are frequently connected and then the heater must be provided with a separate winding in order that the heaters of other tubes will not be subjected to the same high d-c voltage. In most tubes the cathode is only slightly above ground

potential, and were we to establish a high difference of potential between the heater and the cathode, breakdown of the insulation resistance between these elements would frequently occur.

A somewhat more extensive power supply is shown in Fig. 10-2. The supply employs 5U4GB and 5Y3GT rectifier tubes, each acting independently of the other. The 5U4GB, being connected across the full secondary of the power transformer, develops a d-c output voltage of 360 volts. The

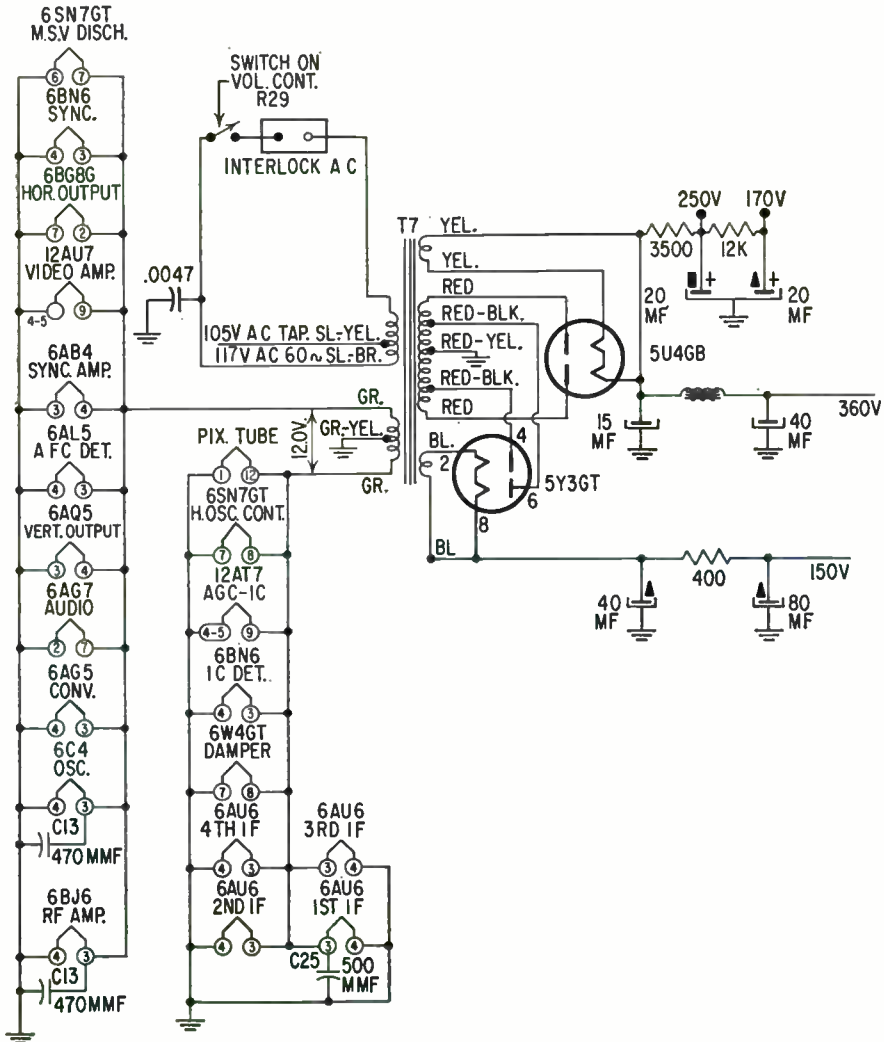

FIG. 10-2. Another low-voltage power supply.

5Y3GT, connected across a smaller portion of the secondary winding, develops only 150 volts. In this lower voltage section, a series resistor serves in place of a filter choke.

Also connected to the 5U4GB is a resistance-capacitance filter network which is used exclusively to feed voltage to the audio-power amplifier. Values of +250 volts and +170 volts are obtainable from this particular section. Separation of the two filter sections of the 5U4GB helps to prevent interaction between those audio and video stages which receive their power from this source.

Filament power for the various tubes is obtained from a single 12.6-volt winding on the transformer. The center of the winding is grounded, producing two equal halves containing 6.3 volts each. One string of tubes is fed from one half and one string of tubes from the other half. In this way, any one tube receives only its required 6.3 volts.

In many television receivers, both negative and positive voltages are required. Voltages of both polarities can be obtained from the same supply by the method shown in Fig. 10-3.

A bleeder is connected across the output terminals of the power supply, and then a ground is placed at some point along the bleeder. That ground point represents zero potential. From the ground point up, the voltages are positive; from the ground point down, the voltages are negative. By dividing the bleeder into a series of resistors, various positive and negative voltages can be obtained. The most positive voltage that can be obtained from the supply, as shown in Fig. 10-3, is +280 volts. The most negative voltage is -100 volts. This gives us a total of 380 volts over the entire bleeder.

Now, what would happen if we shifted the ground point up, say from point *A* to *B*? We would have less resistance between the ground point and the top of the bleeder string. Since the total amount of resistance in the bleeder is unchanged, the current flowing through it will also remain unaltered. This means that the amount of positive voltage now existing from the ground point to the top of the bleeder string will be less. By the same token, the negative voltage will have increased because of the greater amount of resistance between the ground point and the bottom end of the bleeder. Thus, all we have accomplished by moving the ground point up is to transform some of the positive potential into negative potential. We could have increased the positive voltage and decreased the negative voltage by moving the ground point down.

To anyone who has been accustomed to the fairly simple AM sets, especially the midget radios, the large number of filter capacitors frequently found in television-receiver power supplies may appear to be a waste of money. However, there is a good reason for these capacitors. The television picture seen on the screen is developed by the split-second timing of many

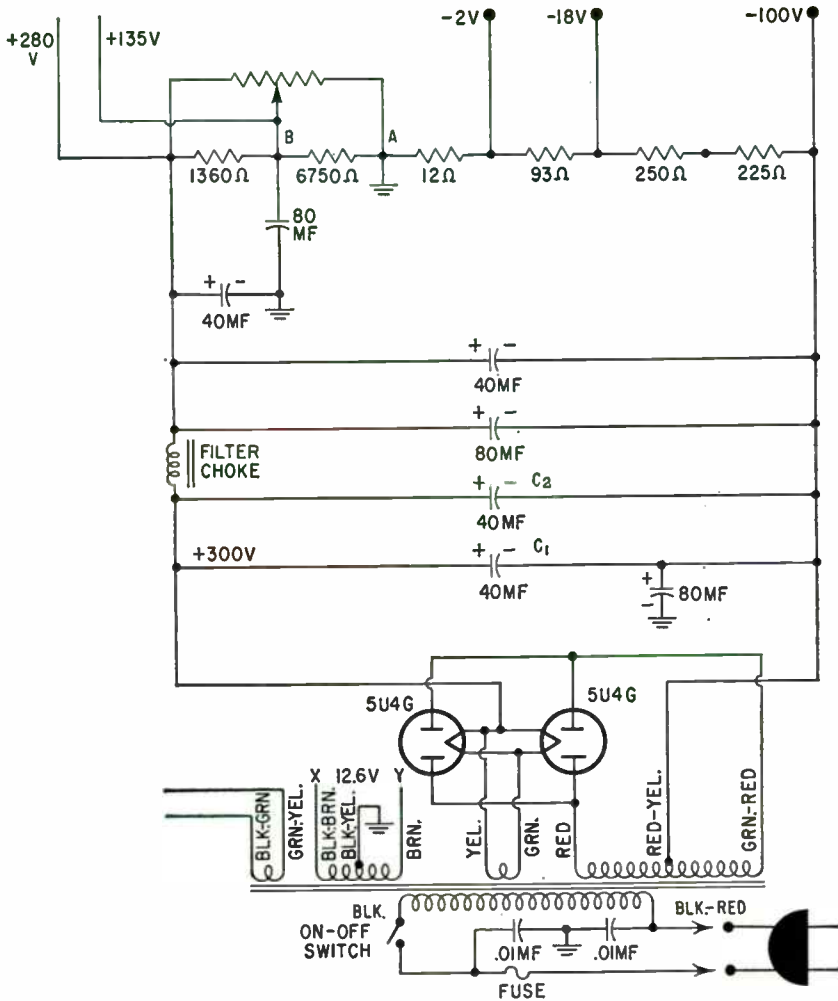
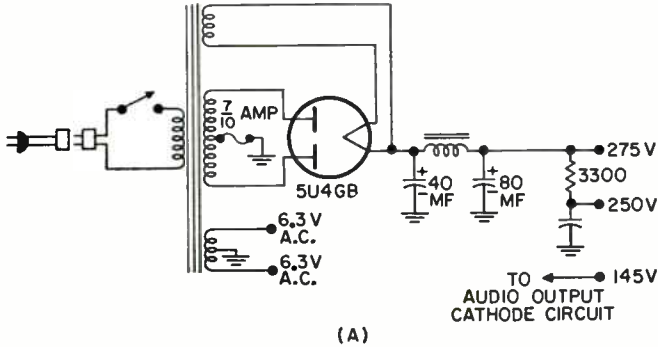

Fig. 10-3. A power supply capable of providing positive and negative voltages.

circuits which can be achieved only if each circuit is functioning properly. One way to achieve this goal is to power the circuits with a well-filtered d-c voltage, filtered not only to remove the alternating component of the line voltage but also to prevent one circuit from affecting any of the other circuits through the common power supply. We want signals from one circuit to travel to adjacent circuits through the proper channels, and coupling achieved through the power supply is decidedly not desired. It is the purpose of these filter capacitors to see that this undesirable coupling is kept at a minimum.

In nearly all of these power supplies, one or two 0.01- to 0.05-mf capacitors are generally bridged across the a-c line leading into the power transformer. They serve to remove or filter out interference that might be present on the line because of other electrical devices.

Another practice that is being widely followed is illustrated in Fig. 10-4(A). This power supply contains two output voltages: one of 275 volts



(A)

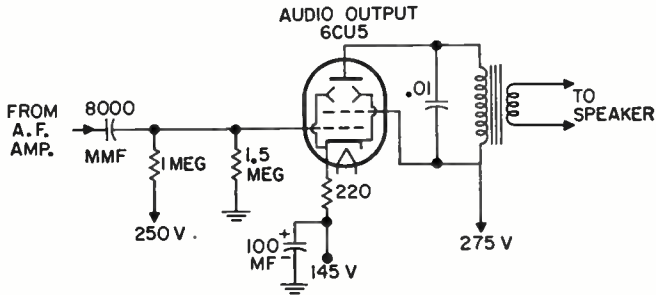

(B)

FIG. 10-4. In many receivers the internal resistance of the audio-output tube is employed for voltage dropping.

and the other of 250 volts. There are also +145 volts indicated, although this voltage has no direct outlet at the power supply. The question is, "Where does this voltage come from?" It will be found, on tracing through the circuit, that the +145 volts originate at the cathode of the audio-output amplifier tube. See Fig. 10-4(B). The 275 volts are applied to the plate circuit of this tube. Of this amount, 130 volts are dropped across the 6CU5, leaving 145 volts at the cathode. This voltage is then applied to a number of other stages in the receiver. Thus, the 6CU5 audio amplifier is in series with the parallel combination of all those stages that operate from the 145-volt line. All of the series current passes through the audio-output tube, which is designed

to handle large currents. The tubes on the 145-volt lines are all in parallel with each other and they merely divide the current as they need it.

One consequence of this arrangement is that, since the cathode of the audio-output tube is positive by 145 volts, the control grid of this tube must also be made positive, although by a somewhat lesser value. This is done in Fig. 10-4(B) by bringing the 250-volt line into the grid circuit through a 1-meg-ohm resistor. The net result is to make the grid negative with respect to the cathode by about 5 volts.

Using the audio-output amplifier tube in the foregoing manner saves the expense of additional bleeder resistors; the internal resistance of the tube now serves in their place. However, because of its key position in the B+ distribution line, any change in operation of this tube will cause many side-effects heretofore never associated with this stage. For example, failure of the tube to conduct not only will kill the sound completely but will also remove the operating voltage from those tubes connected across the 145-volt line. This generally includes the mixer, RF oscillator, video IF stages, and sound IF stages. Thus, the set will also lose its picture.

Or, suppose the bias on the audio-output tube increases negatively. This will raise the internal resistance of the 6CU5 and increase the B+ voltage drop across the tube. The result will be less voltage available at the tube cathode, and this will adversely affect the operation of those stages tied into the 145-volt line.

In some receivers, the B+ distribution can become quite involved, as is demonstrated by the two simplified circuit diagrams shown in Fig. 10-5. Note how a number of resistive voltage dividers are hung across the major B+ line, with some of the subbranches feeding as many as four tubes. By breaking up the voltage network in the manner shown, the designer of the set is able to use inexpensive low-wattage resistors for voltage dropping. He is able to fashion the voltages at each point to values best suited to the stage in question. However, this complexity does increase the technician's work when he tries to track down a defective resistor or filter capacitor.

Selenium Rectifiers. Selenium rectifiers are being used in increasing numbers in the low-voltage power supply of a number of television receivers. A typical selenium rectifier is shown in Fig. 10-6. These units take the place of vacuum-tube rectifiers and offer the advantages of compactness, reduced power consumption due to absence of filament power for the rectifier, and generally better voltage regulation than comparable rectifier tubes. In the amount of reverse voltage they can withstand, they are, however, more limited than tubes.

Selenium rectifiers have two distinct poles, positive and negative. These correspond to the plate and cathode of the vacuum tube. The positive side, indicated by a red dot of paint or a plus sign, is equivalent to the cathode.

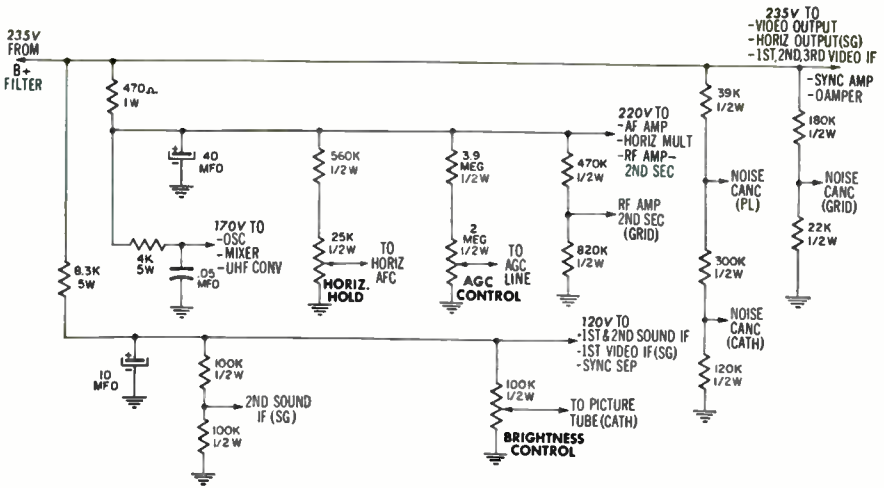

A

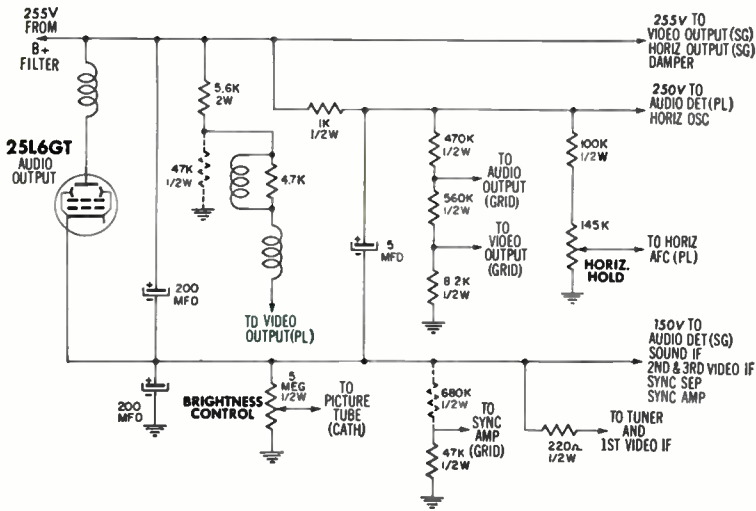

B

Courtesy H. W. Sams & Co.

Fig. 10-5. Simplified illustrations of the B+ distribution network of two television receivers.

The negative side, indicated by a yellow dot, or a minus sign functions as the plate.

In addition to selenium rectifiers, silicon and germanium rectifiers have also appeared on the market in recent years. These newer devices possess

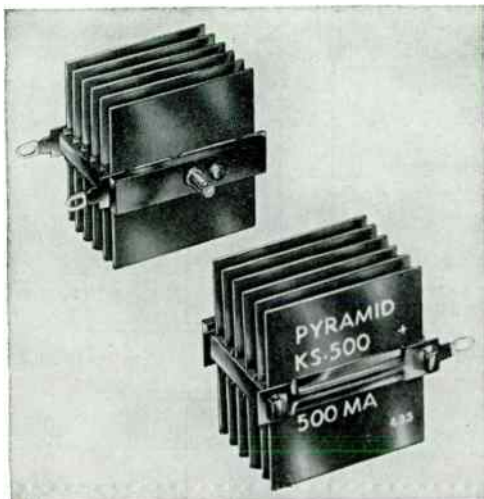

Courtesy Pyramid Electric

FIG. 10-6. A typical selenium rectifier.

lower forward resistances and higher backward resistances than either the selenium rectifier or a diode vacuum tube. For this reason, much less power is lost in the rectifier when current passes. There is also less leakage of current during the nonconductive cycle and, consequently, a higher rectifying efficiency.

It might be informative, at this point, to note the difference in construction of selenium rectifiers and silicon and germanium rectifiers. In the selenium unit, a thin steel or (more generally) aluminum plate serves as a base. This plate is chemically etched and then electroplated with a very thin coat of nickel. The undercut etch serves to mechanically bond the selenium layer to the base plate during the subsequent pressing operation. The nickel-plating governs crystal growth and orientation in the selenium layer.

High-purity selenium is next sprinkled over the nickel-plated base and the entire unit is then subjected to high temperature and high pressure. This treatment not only produces the proper crystallization in the selenium, but also causes a very thin barrier layer to form on the exposed side of the selenium. It is here that current rectification occurs.

To provide positive contact to the barrier layer, a low-melting-point alloy (cadmium, tin, bismuth, or zinc) is sprayed over the barrier surface. This forms one terminal of the rectifier cell and the aluminum plate forms the other. Individual cells are then combined (i.e., stacked) according to the amplitude of the a-c voltage to be rectified and the current to be passed.

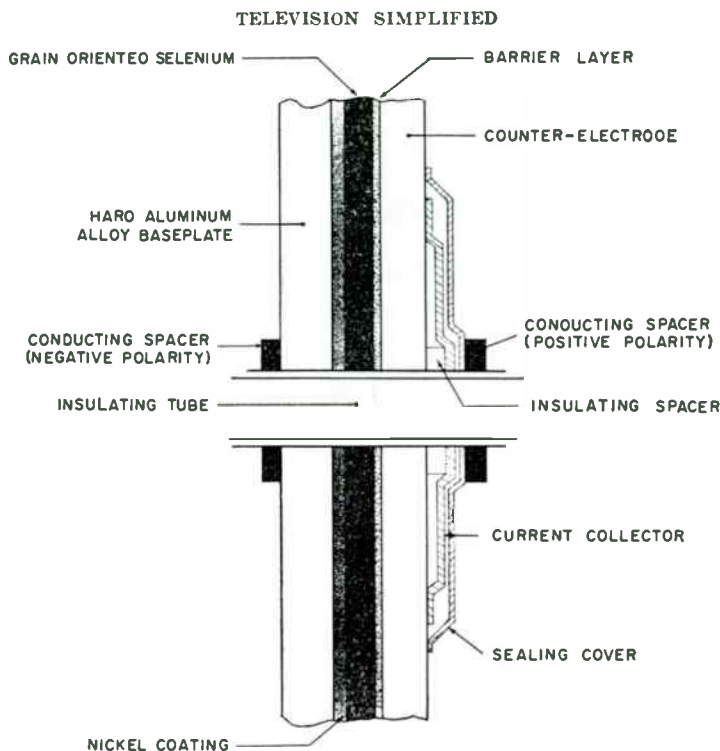

FIG. 10-7. Cross-sectional view of a selenium rectifier cell.

A cross-sectional view of a selenium rectifier is shown in Fig. 10-7.

The construction of silicon and germanium diodes is also quite different. For example, in the silicon rectifier, a small wafer of silicon is securely fastened, generally by welding, to a copper plate which then is attached to the rectifier housing. See Fig. 10-8(A). This terminal is the cathode, and the copper serves to make electrical connection to the silicon. By connecting the copper to the rectifier case, and then mounting the case to a chassis, an efficient heat dissipator is produced.

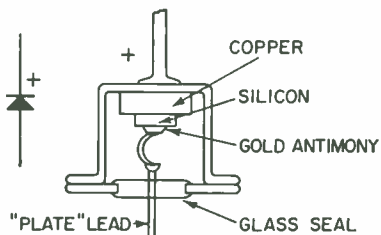
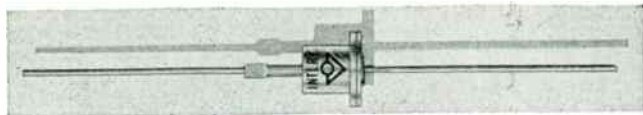

FIG. 10-8A. Internal construction of a silicon or germanium rectifier diode.

The other terminal of the rectifier is formed by alloying a small dot of gold antimony into the opposite face of the silicon wafer. Electrical connection is then made to this dot, and this lead, brought

out of the case, but insulated from it, becomes the plate of the rectifier. Figure 10-8(B) illustrates a typical silicon rectifier.



Courtesy International Rectifier Corp.

FIG. 10-8B. A silicon rectifier. These units are available also in slightly different shapes.

In germanium rectifiers, germanium is employed instead of silicon, but the same type of overall construction prevails.

Selenium, silicon, and germanium are employed most frequently as half-wave rectifiers, shown in Fig. 10-9(A), or as voltage doublers (Fig. 10-9(B)). The small protective series resistor in these circuits frequently serves a dual purpose. First, it tends to prevent burnout of the rectifiers and filter components by limiting the amplitude of any surge currents that may occur. Second, if a short circuit should develop in the receiver, the resistor will

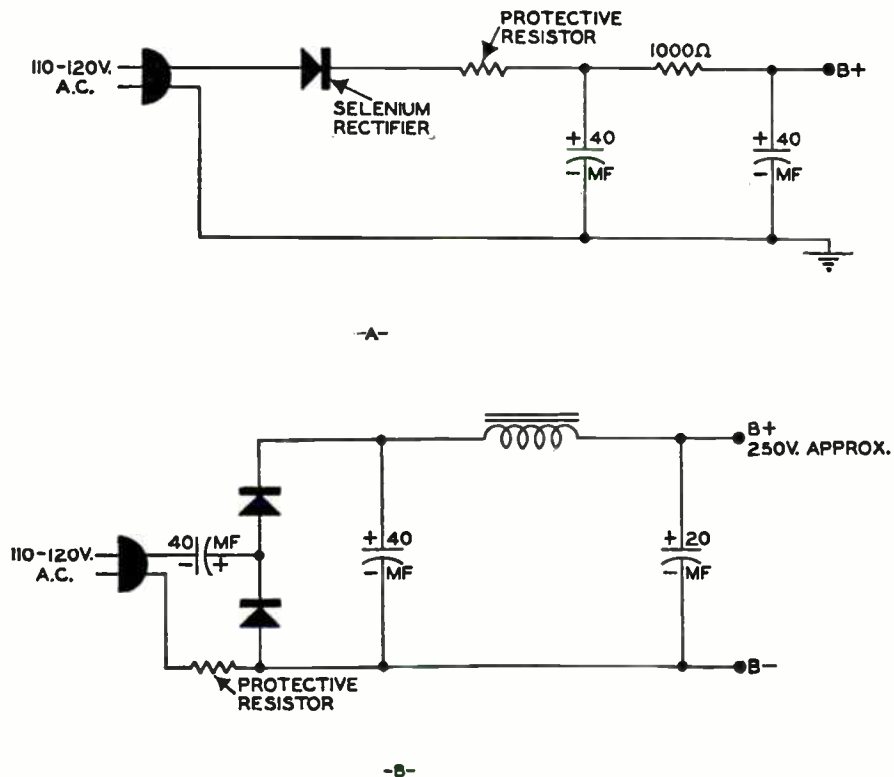

FIG. 10-9. Selenium, silicon, or germanium rectifiers used (A) in a half-wave power supply and (B) in a voltage doubler circuit.

function as a protective fuse by burning out. For this reason, the resistor is mounted so that it can be easily replaced.

A typical application of these rectifiers in a television receiver is shown in Fig. 10-10. The two rectifiers are connected to function as a voltage

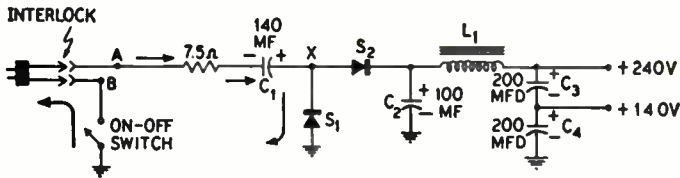

Fig. 10-10. A typical application of selenium, silicon, or germanium rectifiers in a television receiver.

doubler. Briefly this action is as follows: Assume initially that S_2 is disconnected from the circuit. When point B of the power line is more positive than point A , current will flow around the circuit as indicated by the solid arrows. During this time, C_1 will charge up with the polarity as shown. When the a-c input voltage reverses in polarity so that point A is positive with respect to point B , S_1 does not conduct. However, now the a-c voltage adds to the voltage across C_1 , making point X positive with respect to ground by a value equal to the sum of both these voltages. If now S_2 is connected into the circuit, the voltage between point X and ground tends to charge C_2 to the peak voltage existing at X . This is generally about twice the peak of the applied a-c voltage.

L_1 , C_3 , and C_4 provide filtering for the voltage across C_2 . The use of C_3 and C_4 in series not only permits capacitors with smaller voltage ratings to be used (for economy) but also provides a 140-volt line for use in the set. Actually, the voltage division provided by C_3 and C_4 in series is determined more by the resistance of the circuits shunted across these capacitors than by the relative microfarad values of the unit themselves.

Selenium, silicon, or germanium rectifiers are frequently used in transformerless receivers, although transformers can and are being used. When there is no transformer to supply filament voltage to the various tubes, then an arrangement such as that shown in Fig. 10-11 must be employed. All the filaments are connected in series and a suitable voltage-dropping resistor absorbs any excess line voltage. A simple series connection of tube filaments is finding increasing favor because of the trend toward smaller chassis where space limitations severely restrict the use of a power transformer. Another assist for this arrangement is the development of tubes requiring the same filament current and the same time to reach operating temperature. For many years, different tubes had widely varying warm-up characteristics,

resulting in frequent filament burnouts during the warm-up interval when the set was just turned on and the voltage distribution in the filament path fluctuated widely. With the development of a uniform warm-up period among all tubes, this voltage variation is now eliminated and filament burnout from this cause has been reduced substantially.

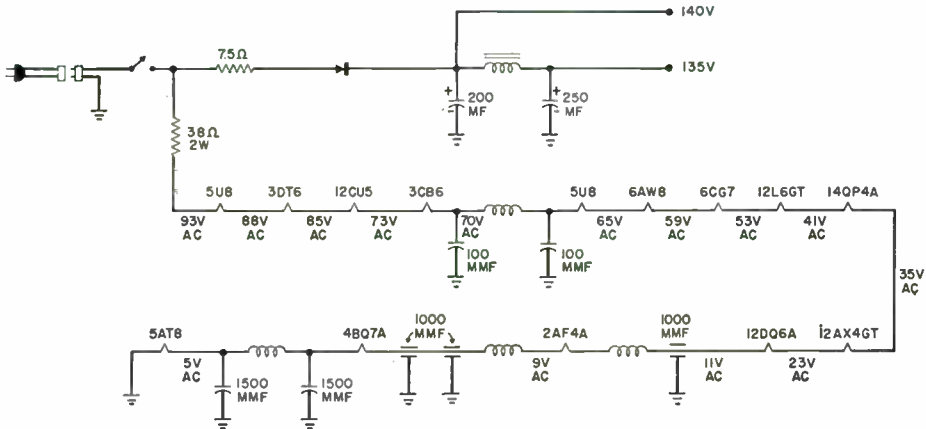

FIG. 10-11. A series filament string. The a-c voltage at various points along the string is given.

Another assist toward extending the life of tubes has been the development of special voltage-dropping resistors. One popular type of resistor, with a negative-temperature coefficient, acts as a surge limiter during the initial warm-up interval; that is, it starts out with a relatively high resistance of several hundred ohms (which is higher than needed), and gradually decreases in value as the tubes (and the resistor) warm up. At operating temperature, its resistance may be on the order of 20 ohms or less.

High-voltage Power Supplies. To use the 60-cycle a-c directly for the development of high voltages, we proceed a little differently. Since the voltage required is very high, a half-wave rectifier is used. For a full-wave rectifier to give the same voltage output, twice as many turns would be necessary on the transformer. Although each half of the secondary will now carry half as much current, permitting the use of a smaller sized wire, the cost of the transformer would still be higher. In addition, it is found that the filtering problem is not appreciably increased if the rectified current contains a 60-cycle ripple instead of a 120-cycle, obtained from a full-wave rectifier. The reason is that the value of current drain is low. Hence, half-wave rectification is almost always employed.

Ordinary rectifier tubes cannot be employed in the cathode-ray-tube power supply because of the high inverse peak voltage. The 5-volt tubes,

such as the 5U4G, 5T4, 5V4G, and 5Y4G, will withstand only about 1,600 volts, a voltage that is much too low for the present purpose. Suitable tubes are the 2X2, 2Y2, 2V3, or 879, to mention a few. These have high inverse-peak-voltage ratings, generally one and one-half to two times more than is required.

The filtering section of the high-voltage power supply, if built along conventional lines, would also become too expensive. Electrolytic capacitors, designed to withstand these high voltages, would be large, costly units. It has been found more economical to solve the filtering problem with small capacitors and large filter chokes (or resistors) rather than with large capacitors and small chokes, as in low-powered units. The capacitors used range in value from 0.01 mf to 1 mf, with a working voltage dependent upon the output of the transformer. The choke need not be unnecessarily large, despite the high inductance, because the current flowing is small and fine wire can be used. In many sets, a series resistor rather than a choke is used.

In addition to the single pi-type filter, a bleeder resistor is connected across the circuit. As before, this acts to stabilize the voltage output of the power supply and permits various taps to be made; for example, for the focusing anode and the cathode brightness control. The value of the bleeder resistor depends upon the current drain of the several electrodes of the tube. Since the current drain is small, and the voltage large, the resistance will be correspondingly large, generally several megohms in value. Because of the small current, a low wattage rating will suffice.

One tapped resistor might conceivably be used, but this is never done. It is more economical to insert small resistors in series, each with a 1-watt rating. A disadvantage of using one resistor is the tendency of a carbon resistor to develop an internal arc if subjected to this high voltage. With several resistors, the voltage across each is proportionately less and arcing does not appear. Potentiometers of suitable value, giving the desired voltage variation, are used for the focusing control, the brightness control, and the horizontal- and vertical-positioning controls. A typical high-voltage supply evolved by the foregoing design is shown in Fig. 10-12.

RF Power Supplies. As we increase the value of the voltage desired from the high-voltage supply, we find that the cost and the bulkiness of the unit increase too, but at a much greater rate. In an effort to evolve a more economical solution, research has been directed toward other avenues of approach. From these investigations, two power supplies have been developed which offer relief from the cost and the bulkiness of the conventional supply. One unit develops RF oscillations, sustained by a relatively small 60-cycle power supply. The output of the RF oscillator is then rectified, and the high

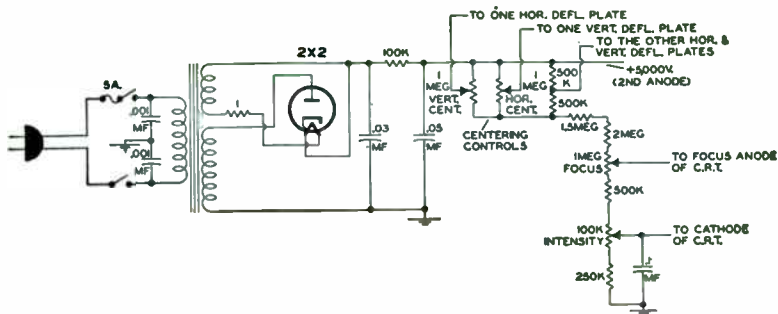

FIG. 10-12. A high-voltage power supply designed in the same manner as the conventional low-voltage power supply. This supply would be suitable for electrostatic picture tubes.

voltage is thus obtained. The other unit obtains its voltage from the inductive kickback of the horizontal-deflection coils.

The first type of RF power supply is shown schematically in Fig. 10-13. A 5V4G full-wave rectifier operating from the 60-cycle line supplies the 300-350 volts necessary to drive the 6Y6G oscillator tube. The oscillator itself is a conventional tuned-plate, untuned-grid-ticker-coil arrangement. Frequencies of oscillation vary from 85 kc to 300 kc. The secondary coil, L_2 , which contains more turns than the tuned primary, steps up the low oscillator voltage to approximately 10 kv. Voltage step-up is set at one-half maximum obtainable in order to provide high efficiency and good voltage regulation.

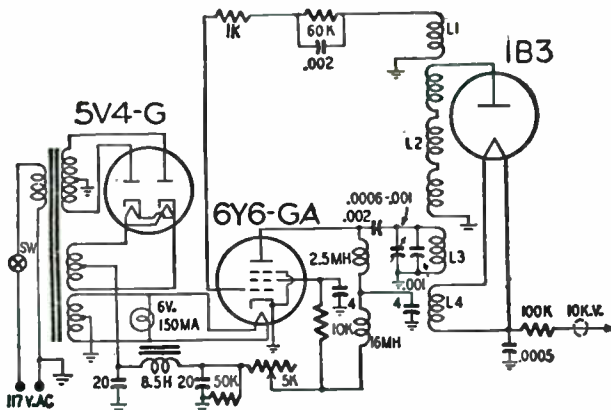

FIG. 10-13. An RF power supply. The filament of the 8016 rectifier also operates on RF.

The feedback coil, L_1 , to sustain oscillations is coupled to L_2 , instead of to L_3 directly, to obtain greater stability. The oscillator tube is biased for class-C operation and hence has relatively low plate-voltage loss. This is in the interest of efficiency. The 6Y6GA beam power tube is capable of developing 15 watts of power with 80 per cent efficiency at 350 volts. The screen-grid voltage is made self-regulating by a series resistor. Screen-grid voltage, under operation, varies from approximately 65 volts at no load to 120 volts at full load.

The high-voltage rectifier is a half-wave unit employing a specially designed 1B3 tube. At the high frequency of the oscillator, a 500-mmf capacitor and a 100,000-ohm resistor provide sufficient filtering.

The Inductive Flyback Power Supply. The second high-voltage power supply is based on an idea conceived by P. T. Farnsworth about 1930. It was, however, with the advent of television that a good, practical model was evolved. The voltage induced in any inductance is governed by the relationship.

$$e_L = -L \frac{di}{dt}$$

where e_L = the induced voltage

L = the inductance

$\frac{di}{dt}$ = the change in current in the time interval of dt

As the time interval, dt , is made smaller, e_L becomes greater. In the horizontal-deflection coils, the retrace interval, dt , is on the order of 7 microseconds and a large voltage is produced. By rectifying the pulse, voltages to 30 kv can be obtained.

The diagram of an "inductive kick" power supply is shown in Fig. 10-14. The horizontal-multivibrator tube, V_2 , is kept cut off during most of the oscillator cycle, enabling C_1 to charge slowly. This charging occurs because C_1 is in series with the B+ supply through R_1 at one end and R_2 at the other. Near the end of the cycle, the tube is brought sharply into conduction. This,

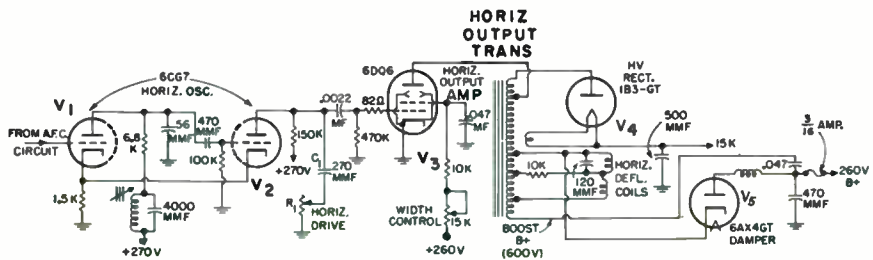

FIG. 10-14. A horizontal-deflection system using a flyback type of high-voltage supply.

in effect, places a low-resistance circuit across C_1 , which discharges quickly. The conduction interval is quite short and when the capacitor has been substantially discharged, the tube is once again plunged into cutoff. The capacitor then starts charging again for the next cycle. In the horizontal system of a television, this process takes place 15,750 times a second.

The deflection waveform produced by C_1 and R_1 series will, when applied to the deflection coils (after amplification by the 6DQ6 stage), produce a linear left-to-right movement of the electron beam across the face of the picture tube, and a rapid retrace. The output tube is the driving tube for the deflection transformer, the high-voltage rectifier, the deflection coils, and the damper tube. The 6DQ6, a beam-power tetrode, is controlled by the deflection voltage it receives from C_1R_1 .

The shape of the deflection wave applied to the grid of V_3 is shown in Fig. 10-15. During the interval AB , this voltage is rising, causing the current through the horizontal-output transformer to rise steadily, and forcing the beam to move across the screen of the image tube at an even rate of travel. At point B , the grid voltage drops sharply, cutting off the plate current of the tube. The magnetic field, which has been steadily building up in the output transformer, collapses quickly, inducing a large positive pulse of voltage in the primary winding. The plate of the 1B3GT rectifier is connected to the top of the primary winding, and the positive pulse of voltage is rectified, filtered, and fed to the second anode of the cathode-ray tube. Since 15,750 such pulses appear each second, adequate filtering can be achieved by using a single 500-mmf capacitor. Filament power for the 1B3GT is obtained from a 2-to-3-turn secondary winding on the same transformer. A photograph of the output transformer is shown in Fig. 10-16.

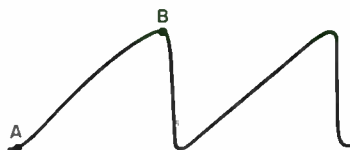

FIG. 10-15. The shape of the deflection wave at the grid of the horizontal output tube.

In both the RF and flyback methods of developing high voltages, failure of the low-voltage power supply will automatically remove the high voltage from the circuit. As an added precaution in the flyback system, failure of the horizontal-sweep system to develop the proper deflection wave will have the same effect. This eliminates the possibility of a stationary spot appearing on the image screen, with subsequent burning and insensitizing of the screen.

High-voltage Doubling. It is possible to double the output high voltage by connecting two 1B3GT rectifier tubes as shown in Fig. 10-17.* During

* The circuit is shown here in simplified form. Aside from the additional filament winding for the second 1B3GT, the horizontal output transformer would be similar to the one shown in Fig. 10-14.

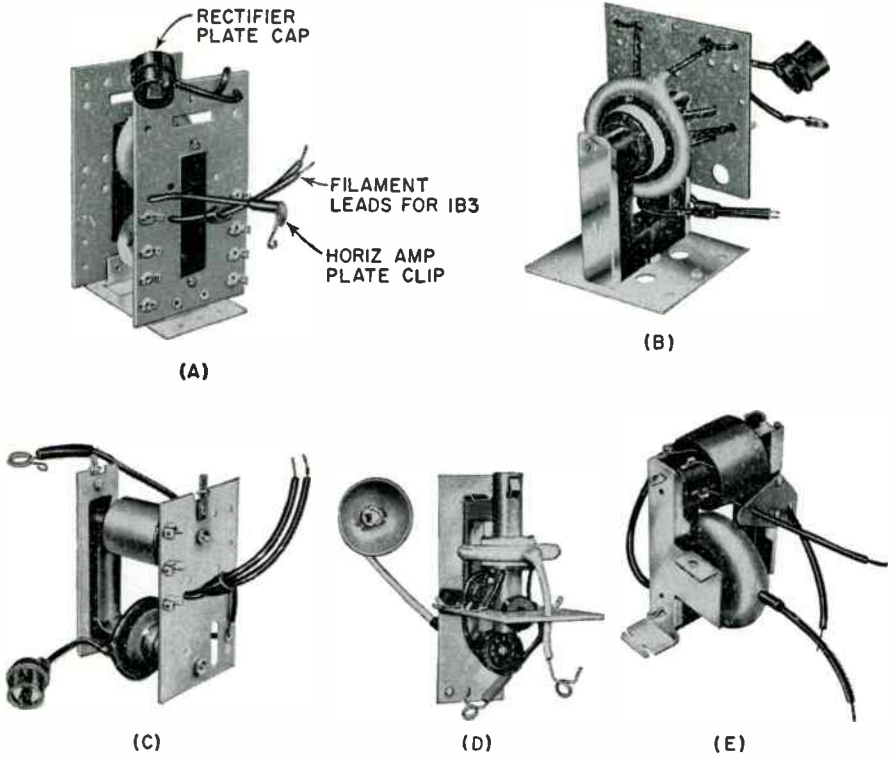

FIG. 10-16. (A) A typical horizontal-output transformer for the high-voltage fly-back systems. (B) Another view of same transformer. (C)-(E) Other horizontal-output transformers.

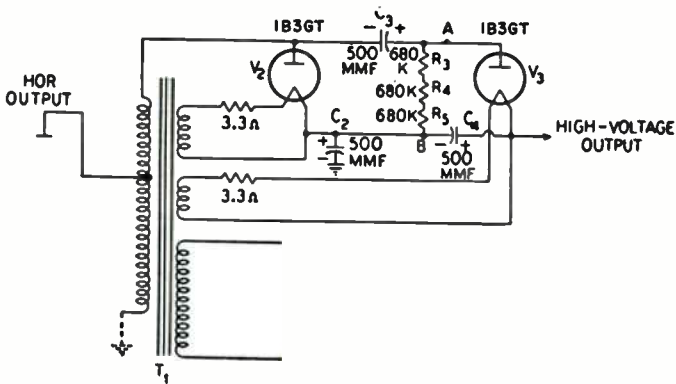

FIG. 10-17. A high-voltage doubler circuit. The bottom end of the primary of T_1 is not actually grounded but is assumed to be for purposes of circuit explanation.

the retrace interval, the voltage developed across the full secondary of the output transformer rises sharply to, say, 9,000 volts. This rise causes V_2 to conduct, and C_2 charges to 9,000 volts (after the first few cycles) with the polarity as indicated. In the longer interval between retraces, C_2 and C_3 are seen to be essentially in parallel with each other through the primary winding of T_1 and R_3 , R_4 , and R_5 . Hence, C_3 also charges up to the full 9,000 volts.

At the next retrace interval, 9,000 volts once again appear across the transformer. If we pause at this moment and add up the voltages existing between points A and B , we see that the transformer voltage and the voltage across C_3 are equal to 18,000 volts. Opposing this voltage are the 9,000 volts across C_2 . Thus, between points A and B there are 9,000 volts with point A positive with respect to point B . This potential is applied to V_3 , causing this tube to conduct, and C_4 charges to 9,000 with the polarity indicated. If now we use the voltages across C_2 and C_4 , we can obtain an output voltage of 18,000 volts. Losses in the circuit plus the current drain on the power supply by the picture tube usually reduce the output voltage to a value less than twice the peak of the applied pulse.

Pulse-type High-voltage Supply. North American Philips has developed a pulse-type high-voltage supply for use with its projection system described in the previous chapter. This supply differs from the fly-back system in that a separate pulse generator is utilized, operating at a frequency considerably lower than the horizontal-sweep frequency.

The circuit of the power supply shown in Fig. 10-18 consists of a blocking oscillator, a driver amplifier, and a three-tube cascaded high-voltage rectifier. The blocking oscillator is conventional in form and operates at a frequency of about 1,200 cps. It produces a sawtooth voltage which is

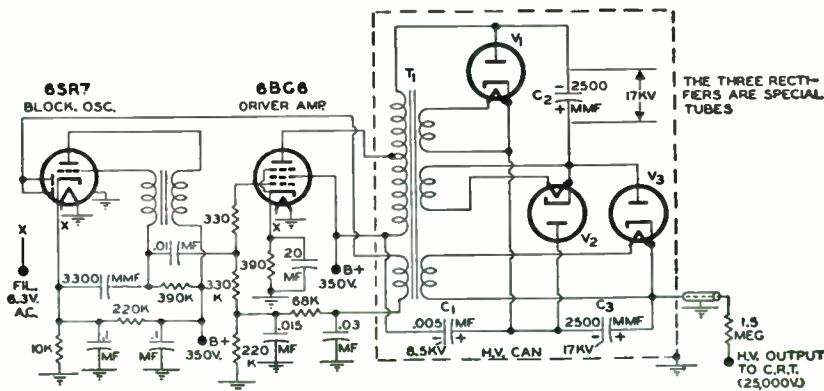

FIG. 10-18. Schematic diagram of the high-voltage unit of the North American Philips projection system.

applied to the grid of the following 6BG6 driver amplifier. The grid of this tube is biased beyond cutoff so that its plate current flows only at the peaks of the sawtooth. See Fig. 10-19. At the tip of the sawtooth, the grid voltage of the 6BG6 drops sharply back into cutoff, stopping the flow of plate current and shock-exciting the transformer. Because of the inductance in the

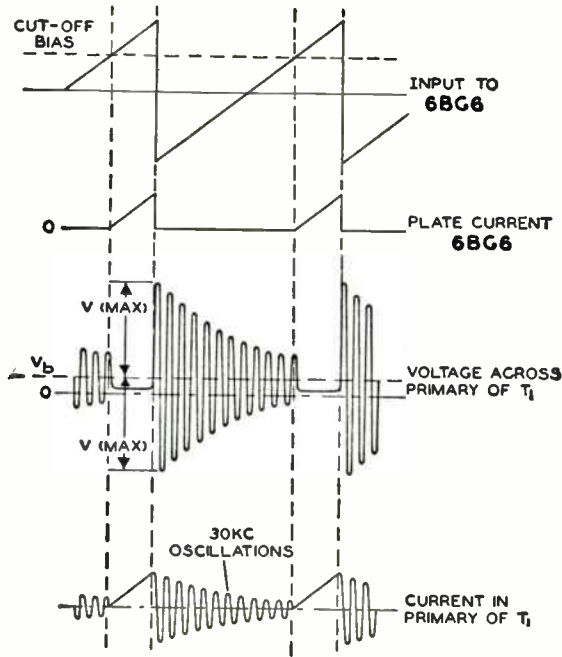

FIG. 10-19. Current and voltage waveforms in circuit of Fig. 10-18.

transformer windings and the stray capacitance across them, the system is shocked into oscillations. The values of these components were chosen to produce transient oscillations having a frequency of about 30 kc. These oscillations continue until the next flow of plate current from the 6BG6, as indicated in Fig. 10-19. In the flyback system, a damping tube placed across the output transformer damped out all but the first cycle of oscillations. In this circuit no such damping occurs, and the oscillations are present throughout the interval between plate-current pulses of the 6BG6. At these moments the conducting 6BG6 loads down the circuit, stopping the oscillations. The sudden stoppage of the plate current at the end of each plate-current pulse shock-excites the transformer into oscillations at its natural frequency of 30 kc.

The voltage developed across the full primary winding of the output transformer is rectified by the three 1B3 tubes to provide an output voltage

of 25,000 volts. Since the high voltage is developed here a little differently than in the previous high-voltage systems discussed, a brief explanation is given here.

On the first positive oscillation peak (8,500 volts) current flows through V_1 and C_1 , charging the latter capacitor to the full-peak voltage with the polarity as shown. On the first negative peak, the voltage across the transformer primary winding adds to the voltage across C_1 to cause V_2 to conduct and charge C_2 to a peak value which is twice the transformer voltage, or 17,000 volts. Current, in this instance, flows from the cathode of V_2 to its plate, through C_1 and the transformer primary, to C_2 and thence back to the cathode of V_2 . On the next positive peak, C_3 is charged by current flowing through V_3 and C_2 , the transformer primary, and C_1 to C_3 , and then back to the cathode of V_3 again, completing the circuit. The voltage across C_2 adds to the voltage across the transformer primary to feed a positive voltage to the plate of V_3 . Opposing this voltage is the potential across C_1 . The total positive voltage at this instant is $2V$ (from C_1) plus V (from the transformer), or $3V$. Opposing this voltage is V from C_1 . Hence, C_3 receives $2V$ ($3V - V$), or 17,000 volts. By using the voltages across C_3 and C_1 we can obtain an output voltage of 25,500 volts. Actually, the output voltage is somewhat lower than this.

The output transformer contains another winding, which is used for regulation purposes. The voltage developed in this winding is fed to the diode section of the 6SR7 tube, where it is rectified and applied as a negative voltage to the grid of the 6BG6 by virtue of the voltage drop across the 220,000-ohm resistor in the grid circuit of this tube. If the output voltage tends to increase, more negative bias is applied to the 6BG6, reducing its interval of conduction and thereby reducing the amount of energy imparted to the transformer. This will tend to lower the amplitude of its oscillations and reduce the high voltage. On the other hand, a reduction in high voltage will cause less negative bias to appear at the grid of the 6BG6, increasing its interval of conduction and resulting in oscillations of greater amplitude in the transformer.

With this self-regulating arrangement, the voltage output is maintained constant within the limits set for this design. An external low-voltage power supply is needed to provide B+ at 350 volts for the 6SR7 and 6BG6 plus 6.3-volts a-c for their filaments.

QUESTIONS

1. Draw the circuit for a low-voltage power supply (using vacuum-tube rectifiers) suitable for a television receiver.
2. Indicate how the same power supply can provide positive and negative voltages.

3. Explain the operation of a selenium rectifier voltage doubler.
4. What differences exist in the choice of components between 60-cycle low-voltage and high-voltage power supplies?
5. Explain briefly the operation of an RF type of high-voltage power supply.
6. Draw the schematic diagram for a suitable RF high-voltage power supply.
7. On what principle does the flyback type of power supply operate?
8. What is the purpose of placing a damping tube across the horizontal deflection coils?
9. How does a high-voltage doubler operate?
10. What differences exist between the operation of the circuit of Fig. 10-14 and the circuit of Fig. 10-18?
11. Why is it possible to use a 500-mmf filter capacitor in the flyback power supply when low-voltage power supplies require much larger filter capacitors?

Additional Notes on Intercarrier Systems

Introduction. Now that we have followed the video signal from antenna to picture tube, we can pause and examine in greater detail the difference between split-sound and intercarrier television receiving systems. In split-sound systems, the sound signal is separated from the video signal prior to the video second detector. In intercarrier systems, this separation does not occur until *after* the video detector. These are two directly conflicting requirements and yet practically the same circuitry is employed in both. To appreciate the reasons for this apparent contradiction, let us analyze both systems.

Split-sound Television Receivers. Consider first the split-sound system, shown in Fig. 11-1. The incoming audio and video signals, after passage through a mixer, are reduced to their IF values. At some point after the mixer and before the video second detector, the sound IF signal is removed from the video IF system and fed to a separate set of IF amplifiers which are peaked to the sound IF value. After two or three IF stages, the audio

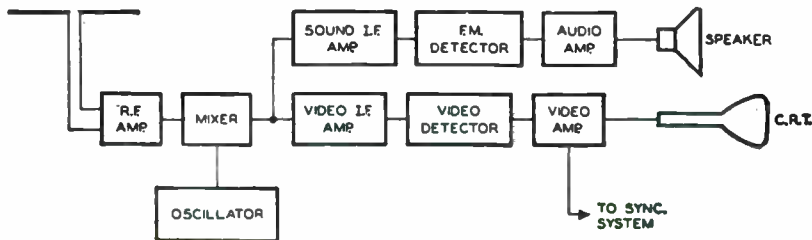

FIG. 11-1. A block diagram of a receiver employing the split-sound television system.

signal is fed to an FM detector where it is converted to audio frequencies. This is then followed by one or more stages of audio amplification after which the signal is powerful enough to drive a loudspeaker. Once the two signals have been separated, trap circuits are placed in the video system to prevent any sound voltage from reaching the video detector and the subsequent cathode-ray tube.

This system will operate successfully when properly designed, but it possesses several disadvantages when cost becomes an important design factor. Thus, one of the most important stages in the television receiver, the local oscillator, is also one of its weakest points. We know that the sound IF value is the difference between the frequency of the local oscillator and the frequency-modulated sound carrier. If the frequency of the local oscillator should drift, either during the warm-up period when the set is first turned on or during the operation of the receiver, then the difference frequency produced by the mixer will change too. Thus, consider a television receiver tuned to channel 3 and designed for a sound of 41.25 mc. On channel 3, the audio-carrier frequency is 65.75 mc and since the oscillator frequency is above this by an amount equal to the sound IF, the oscillator frequency will be 65.75 mc plus 41.25 mc, or 107.00 mc. The sound carrier is frequency-modulated, and the modulation shifts the audio-carrier frequency ± 25 kc. In other words, the total audio signal for channel 3 can be expressed as 65.75 mc ± 25 kc.

In the sound IF system (including the input discriminator coil), the bandpass is from 200 to 300 kc wide, although generally the discriminator response is linear only for about 150 kc. If the local oscillator should drift by as little as 75 kc, it is possible for the sound IF signal to shift to a nonlinear portion of the discriminator characteristic, thereby causing audio distortion. Now, a drift in frequency of 75 kc, with the oscillator functioning at 107 mc, represents a change of less than 0.07 per cent; at 200 mc, the same frequency drift represents a change of 0.035 per cent. Using conventional components, combined with the station-selector rotary switches, it is difficult to prevent the local oscillator from drifting even this amount during warm-up and subsequent operation. To meet this situation oscillators are provided with fine-tuning controls which, extended to the front panel, permit the observer to correct for oscillator drift. While such controls remedy the drifting temporarily, it is annoying to have to use this control several times during each set operation. Furthermore, the oscillator frequency is extremely sensitive to tube capacitance, and it is not unusual to find that the oscillator frequency is altered sufficiently by a tube change to require a complete realignment of the oscillator circuit. Finally, in time, the resistive and capacitive components themselves will change sufficiently in value, even without a tube change, to require a complete realignment also.

The local oscillator is the source of other annoyances. Any inadequate filtering of the B+ voltage used by the local oscillator will cause the oscillator frequency to vary at a 60-cycle or 120-cycle rate. This results in phase and frequency modulation of the local oscillator, which passes through the sound IF system and FM detector and appears as an audible hum. The only remedy for this situation is complete filtering of the power supply. We also obtain phase and frequency modulation when acoustic feedback from the speaker causes oscillator coils, capacitors, and tube elements to vibrate. Vibrations of the cores in permeability or slug-tuned coils or in the plates in a capacitor can be a difficult annoyance to eliminate.

Solutions to all the foregoing problems are not unknown, but they usually involve sufficient additional expense to make them unattractive in today's competitive market. The intercarrier system does offer a remedy to this situation and consequently it has gained wide favor.

Basic Principles of the Intercarrier System. In sets employing the intercarrier system, the various stages follow the sequence shown in Fig. 11-2.

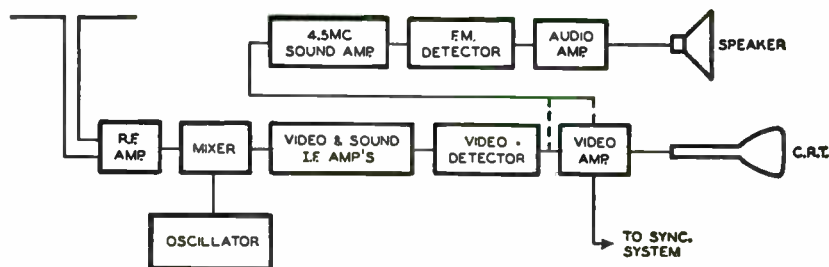

Fig. 11-2. A block diagram of a receiver using the intercarrier system.

A comparison of this illustration with that of Fig. 11-1 reveals that separation of the audio and video signals does not occur until both signals have passed through the video second detector and possibly one or more video amplifiers. Thus, at first glance, every precaution which was previously taken to insure that the sound voltage did not reach the cathode-ray tube is now seemingly ignored. How, then, does the intercarrier system prevent the sound signals from reaching the picture tube and interfering with the image presentation? The answer is given in the paragraphs that follow.

In Fig. 11-2 it is seen that the audio and video signals are received by the RF stages of the receiver, lowered in frequency at the mixer by beating with the local oscillator voltage, and then passed together through the IF system.

The carrier IF values after passage through the mixer are the same as they would be if the split-sound system of Fig. 11-1 were used. The intermediate frequencies assigned to each carrier are a function only of the local

oscillator setting and to this point in the receiver both systems are identical. The first departure appears in the IF system. Although the video IF response characteristic for a split-sound receiver is as shown in Fig. 11-3, it must now be widened to include the sound IF signal as well. However, instead of providing the sound carrier with as much amplification as the video signal re-

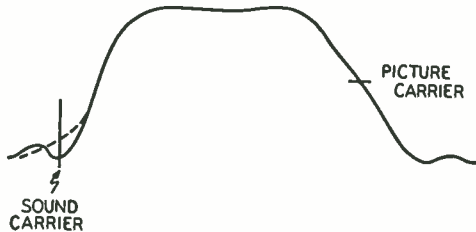

FIG. 11-3. The solid line represents the response curve for the IF system in a split-sound television system. The dotted curve represents the modification needed to adapt the response to a receiver operating on the intercarrier system.

ceives, it is provided with considerably less amplification, and it is specifically because the sound carrier receives this lesser amount of amplification that the system is able to function. This point is important, for if the level of the sound carrier is not kept considerably below the level of the video signal, the latter signal becomes completely unusable.

To understand why the sound-carrier level must be considerably below the video-signal level, let us look ahead to the video detector in Fig. 11-2. The video and sound IF signals reach this point, in the intercarrier system, after passage through the IF system. Now, a detector (such as that used ordinarily for the video second detector) operates basically in the same manner as the previous mixer. In both, a mixing process occurs. Thus, in the mixer stage (which has long been known as the "first detector"), the local oscillator voltage beats with the incoming signal or signals to produce the IF signal. At the video second detector, a beating or mixing takes place between the video and sound IF carriers with the result that a 4.5-mc beat note is produced. In this case we could consider the video carrier as being equivalent to the local oscillator and the audio carrier as the incoming signal. The result of the mixing is a 4.5-mc beat note. In addition, we obtain all of the 0-4 mc video frequencies from the video signal, produced when the video carrier beats with each of the video sidebands.

The reason for keeping the level of the sound carrier low can now be given. Consider the two carriers shown in Fig. 11-4(A) and (B). Assume the larger one to be the video carrier and the smaller one to be the audio carrier. If these two signals are mixed, a ripple will be produced in the resultant wave, as shown in Fig. 11-4(C), which will have a frequency equal to the

difference between the carrier frequencies—in this case, 4.5 mc. So long as the *amplitudes* of the two carriers differ considerably, the amplitude of the 4.5-mc beat note will remain small and unaffected by any amplitude modulation contained in the video carrier. Here is one of the pivotal points in the intercarrier television sound system. *By maintaining the sound carrier small*

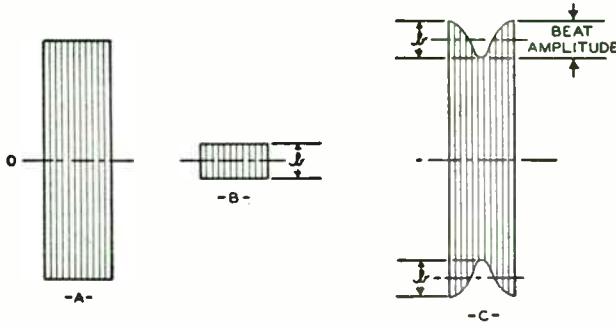

FIG. 11-4. (A) The video carrier, (B) the sound carrier, and (C) the resultant wave.

in comparison to the video signal, we obtain a 4.5-mc beat note which contains only the frequency modulation of the original sound RF carrier and practically none of the video modulation.

The sound carrier is continually shifting back and forth between the limits of ± 25 kc. In the mixing process in the video second detector this frequency modulation is imparted by the sound IF carrier to the 4.5 mc beat note. The 4.5-mc signal represents the difference between the video and sound IF carriers. The frequency of the video carrier is fixed, but the frequency of the sound carrier continually shifts back and forth. This changes the value of the beat note. Thus, while we speak of 4.5 mc as the beat note, we actually mean a beat note having a center frequency of 4.5 mc, but shifting back and forth about this value to the limits of ± 25 kc. This frequency shifting, remember, represents the sound intelligence of the television broadcast.

Now let us see how the foregoing is employed to make the intercarrier television sound system workable. When the video carrier (with its amplitude modulation) and the audio carrier are received at the receiver, they have substantially the same amplitude. (The FCC regulations state that the power of the sound carrier must be 50 to 150 per cent of the power of the video carrier when transmitting synchronizing pulses. However, most stations transmit equal sound and maximum-amplitude video carriers.) After passage through the mixer stage, the two signals are converted to their IF values and are ready to pass through the IF system. If we are to keep the

degree of amplitude modulation of the beat-note signal to a minimum, it is desirable to keep the level of the sound carrier at least 26 db below the peak video-carrier level at the second detector. This means that the amplitude of the sound carrier should be reduced to about 5 per cent of the maximum amplitude of the picture carrier. In order to achieve this, the IF system through which both signals pass is designed to have the response characteristic shown in Fig. 11-5. At the frequency of the sound IF carrier, the response curve is 26db down from the video-carrier frequency point.

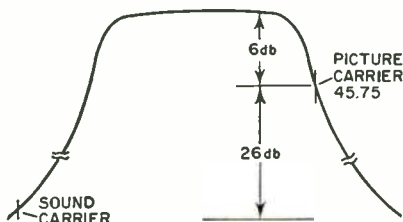

FIG. 11-5. The proper IF response curve for intercarrier receivers.

After passage through the IF system, the signals are fed to the video detector, where the IF frequencies are removed, leaving only the video frequencies, which extend from 0 to 4.0 mc, and the 4.5-mc beat note that is produced when the two carriers beat against each other.

At the output of the video second detector the complete signal, including the 4.5-mc voltage, is usually passed through the video-frequency amplifiers. The sound signal, it must be remembered, was reduced considerably in the IF system and thus requires a corresponding increase in amplification following the video second detector in order to bring it back to a usable value. Even after passage through the video-frequency amplifiers, its average level seldom exceeds 1 or 2 volts. Thus, what is done is to transfer this voltage out of the video system into an audio IF amplifier, tuned to 4.5 mc, and after one stage of amplification, apply it to an FM detector for conversion into audio frequencies. Thereafter, one or two audio amplifiers bring the signal to the desired strength for normal operation of a loudspeaker.

To remove the 4.5-mc voltages from the video system, a variety of methods can be employed. In Fig. 11-6, the sound IF signal is fed to the sound system from the plate of the video amplifier. A parallel-resonant 4.5-mc trap, L_1, C_1 , is then placed in the signal path leading from the video-amplifier tube to the picture tube. The trap, sharply tuned to 4.5 mc, will prevent any of the sound signal from reaching the picture tube, while permitting the video signal (0-4 mc) to pass through. L_2 , which follows L_1, C_1 , is a video-peaking coil.

The video system in Fig. 11-7 has a series-resonant 4.5-mc trap connected between the control grid of the video amplifier and the ground. The sound IF take-off point is just ahead of the video amplifier. L_2, R_1 , between the trap circuit and the sound take-off point, serves two purposes: it isolates the take-off network from the low-impedance trap, and it serves as a video-

peaking circuit. If L_1, C_1 were connected directly at the sound take-off point, obviously there would be very little sound IF voltage available for the sound system.

A third method of preventing the sound signal from reaching the picture tube is shown in Fig. 11-8. Here, the 4.5-mc trap is placed in the cathode

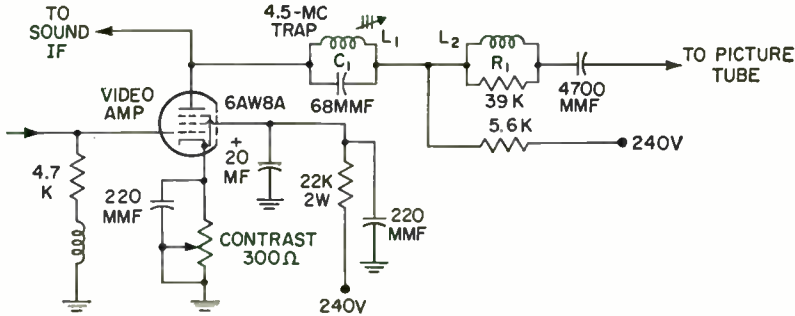

FIG. 11-6. A widely used method for sound take-off.

circuit of the video amplifier following sound take-off. This circuit functions in the same manner as the cathode trap previously shown in Fig. 5-13. At 4.5 mc, a high impedance is developed in the cathode circuit, producing a large degenerative voltage and reducing the gain of the amplifier at this frequency only. At all other frequencies, the impedance of the trap

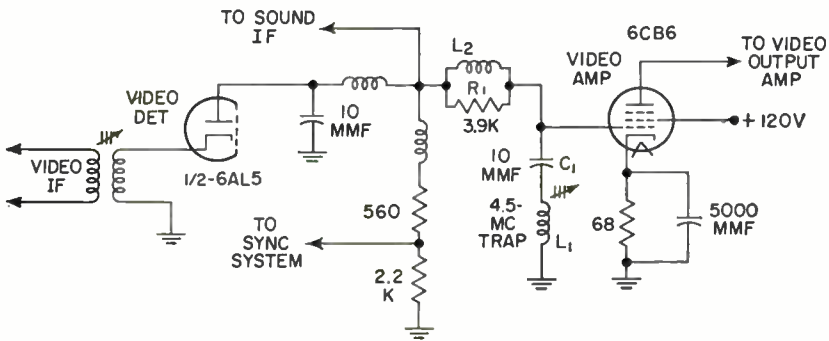

FIG. 11-7. Sound take-off in this circuit is accomplished in the video detector.

circuit is low and only a small degenerative voltage appears. There is thus only a slight loss in gain.

The final sound take-off method for intercarrier receivers is shown in Fig. 11-9. The entire video signal is passed through L_1, C_1 on its way from the video output stage to the picture tube. L_2 is closely coupled to L_1 , and since L_2, C_2 are sharply resonant to 4.5-mc, this resonant circuit will act as

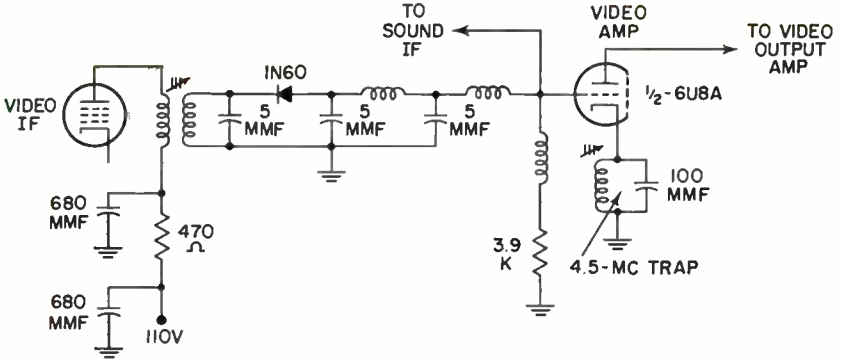

FIG. 11-8. The sound trap in the cathode of the video amplifier functions by degeneration.

an absorption trap, removing the 4.5-mc segment from the video signal. The 4.5-mc voltage thus removed is transferred to the sound IF system, while the remainder of the video signal continues on to the picture tube.

C_3 is added between the top ends of L_1 and L_2 to provide the proper bandwidth of this network and to assist in the transfer of the 4.5-mc signal between the two resonant circuits.

We are now in a position to appreciate fully the reasons for the reduction in sound carrier prior to the video second detector. First, if the video and audio carriers are comparable in strength when they reach the video second detector, the resultant 4.5-mc beat note will contain a considerable amount of amplitude modulation. Also, the amount of this amplitude modulation will vary as the modulation of the video carrier changes. Since no FM detector now in practical use is able to remove completely or to ignore ampli-

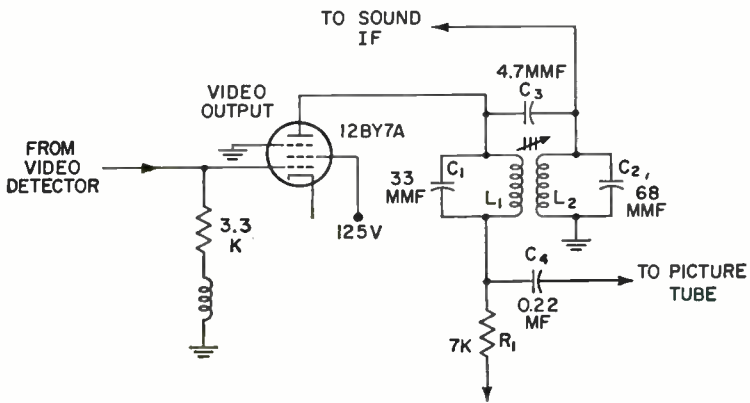

FIG. 11-9. Still another type of sound take-off circuit.

tude modulation in an FM signal, the audio output will be distorted to an extent dependent upon the amount of amplitude modulation is present in the signal. Even the use of a limiter ahead of the detector does not altogether alleviate this trouble. With the amplitude of the sound carrier reduced to about 5 per cent of the video carrier, the 4.5-mc beat-note amplitude remains substantially constant as the level of the video carrier varies between 15 and 100 per cent of its peak value.

Another consideration related to the use of comparable audio and video carriers is the manner in which the audio voltage can affect the picture. Since the sound carrier is frequency modulated, one way to convert an FM signal into an audio voltage is by means of slope detection. Now, if the sound signal receives 26 db less amplification than the video signal in the IF system, it will be quite small and, even if 30 per cent of this signal is converted into audio voltage* at the video second detector, the interference from this source will be approximately 36 db below the video signal and generally unnoticeable. However, if the audio signal is large at the detector, then even 10-per-cent slope detection will produce enough audio voltage to develop horizontal bars across the screen. It will probably be found that with a large audio signal, more than 10-per-cent slope detection occurs, further aggravating the situation.

If the 4.5-mc signal itself reaches the control grid of the cathode-ray tube, a fine-line pattern will appear on the screen, as shown in Fig. 11-10. This will occur if the audio signal is strong at the video detector output and does not receive the proper amount of reduction. However, if the audio signal is reduced by the 26 db already specified, then its effect, after the shunting effect of the series-resonant pick-off circuit, will again be so small as to be negligible.

Thus, we see from the foregoing why it is mandatory for the video carrier to be considerably stronger than the audio carrier at the video detector, if the intercarrier system is to function properly. It also explains why the presence of the sound signal, even as far as the last video-frequency amplifier, does not materially affect the image on the screen.

Advantages of the Intercarrier System. Now that we have examined the underlying principles of the intercarrier system and noted its application to commercial receivers, it might be well to evaluate its advantages and limitations. One big advantage of the intercarrier system is its relative independence of many of the difficulties which beset the local oscillator and which affect the quality of the output in split-sound television receivers. Thus, consider what happens when the oscillator frequency drifts. In both

* FM signals can be detected by detuning an AM detector and using the slope or sides of the AM response curve to obtain the audio modulation from the FM signal. This is known as slope detection. It is not a very efficient method but it will work.

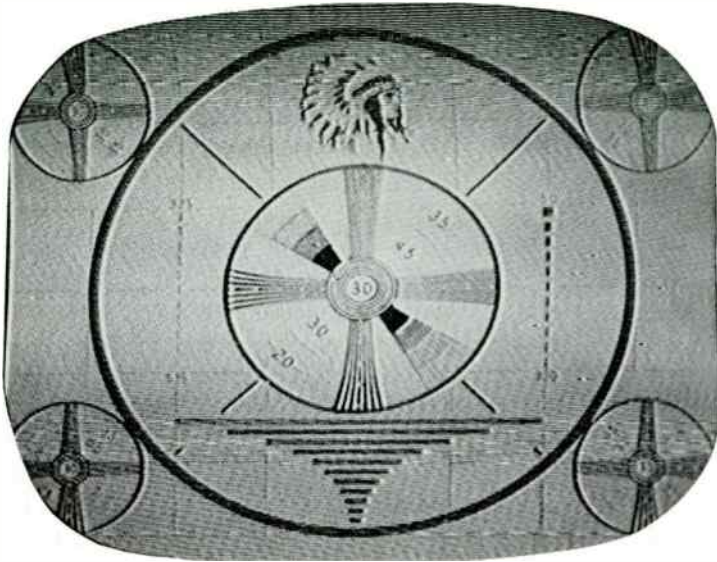

Courtesy H. W. Sams & Co.

FIG. 11-10. The appearance of a 4.5-mc signal on the screen.

systems, the resultant video and sound IF values will shift. Suppose that this shift is 200 kc. In a receiver employing the split-sound system, the video signal will be negligibly affected because a 200-kc shift is unimportant when compared with the total video spread of 4.0 mc. In the sound IF system, however, the discriminator linearity extends usually for ± 100 kc on either side of the IF carrier frequency, and a shift of 200 kc will remove the signal from the linear portion of the characteristic, distorting or causing the complete loss of audio output.

Compare this with the same effect in a receiver employing the inter-carrier system. Since separation of the two signals does not occur in the IF system, the only effect this produces is to shift the position of the two signals along the IF response curve. This will alter somewhat the amplification accorded these signals, but not to an appreciable extent since 200 kc is negligible compared with the 4.5-mc bandpass. When the two signals reach the video second detector, the resultant 4.5-mc beat note will be obtained since the difference between the two carriers is fixed at the transmitter and nothing that occurs at the receiver can alter this relationship. The 4.5-mc beat note will then pass through the video-frequency amplifiers and into the sound system, unaltered by the local oscillator change in frequency.

Shifting of the local oscillator frequency due to hum or microphonics

will likewise have a negligible effect in the intercarrier system because, no matter how the oscillator frequency changes, the difference between the two carrier frequencies remains 4.5 mc, and it is from this difference that the sound output is obtained.

Thus, small changes in oscillator frequency will have less noticeable effect in intercarrier receivers than in split-sound sets. However, if a sizable frequency change occurs in an intercarrier system, the entire signal will shift along the video-response curve because of the shift in IF values caused by this change. The usual consequence of this action is to lower the oscillator frequency, thereby raising the IF values produced in the mixer. On the curve of Fig. 11-5, this will move the sound carrier up the left-hand side of the response curve, providing more than normal gain for the sound signal. This shift will disrupt the 26-db relationship necessary for intercarrier operation and lead to sound interference bars in the picture. To avoid this interference, intercarrier receivers are designed with fine-tuning controls as well as split-sound receivers.

Disadvantages of the Intercarrier System. The intercarrier system is not without disadvantages, however. The appearance of the sound at the loudspeaker is dependent upon the mixing action that occurs in the video second detector. If something should happen to prevent the transmission of the video carrier—and this can and has happened—then no output at all is obtained at the receiver. Note that this is peculiar to intercarrier systems and is not true in sets employing the split-sound system. While it may be argued that the foregoing set of conditions seldom occurs, yet there is another manifestation of the same effect that appears more frequently. Thus, when a white line or series of white lines is being transmitted, the video-signal level drops down to a low value. If care is not observed at the transmitter, the level may easily drop to zero (corresponding to 100-per cent modulation), resulting momentarily in no video signal. This causes the sound to disappear, also momentarily. This is usually repeated at line frequency (15,750 cycles) or field frequency (60 cycles) producing a 60-cycle buzz or a 15,750-cycle note in the receiver. (The 60-cycle buzz is more evident because many people cannot detect a note as high as 15,750 cycles.) To prevent this situation it is necessary to monitor transmitter modulation carefully.

Another factor that requires careful observance is the incidental phase or frequency modulation that sometimes develops in the video carrier when it is receiving the video intelligence. It has been found that under some circumstances, the video carrier will receive a small amount of phase or frequency modulation while it is being amplitude-modulated at the transmitter. In the subsequent mixing that occurs in the video second detector at the re-

ceiver, this phase or frequency modulation is passed on to the 4.5-mc sound signal and is not removed at the FM detector. The result again is a 60-cycle buzz or a 15,750-cycle squeal.

Precautions are necessary in receivers, too. Here, the greatest single factor affecting proper operation is the relative magnitude of the video and sound carriers at the time they are mixed in the video detector. If the amplitude of the video carrier is very large compared with that of the sound carrier, then the amplitude of the beat note is very nearly independent of the amplitude of the video signal. This means that the FM 4.5-mc beat note will not be affected by any modulation contained on the video carrier. Now, this stress on keeping the amplitude of the beat note as constant as possible arises chiefly because the FM detector and the limiter which precedes it are not insensitive to amplitude modulation when such modulation appears in a sizable amount. Most servicemen believe that an FM detector and limiter will not respond at all to amplitude modulation, which is true if the amplitude modulation is small and the detector is fully aligned. However, if the amplitude modulation is not small, it will affect the output of the FM detector and distort the audio signal.

The value of 26 db as the difference between the amplification accorded the video and sound IF carriers will insure that the 4.5-mc beat note receives little amplitude modulation.

Finally, there is the problem of attempting to maintain the sound limiter and detector tuned circuits at precisely 4.5 mc. Any deviation from this value, due to altered components, usage, humidity, etc., will cause the sound signal to be displaced to a nonlinear portion of the detector characteristic, thereby producing a distorted output. In sets using the split-sound system, this condition can be corrected by retuning the local oscillator, using the fine-tuning control.

QUESTIONS

1. Indicate, in block diagram form, the difference between split-sound television receivers and those employing the intercarrier system.
2. What has the phenomenon of signal mixing to do with the operation of intercarrier television sets?
3. What are some of the disadvantages of the split-sound system and how does the intercarrier system avoid them?
4. Compare the IF response curves of split-sound and intercarrier sets and explain any differences.
5. In intercarrier sets, what prevents the audio signal from reaching the cathode-ray tube?
6. Where does video and audio signal separation occur in an intercarrier receiver? Draw a typical separation circuit.

7. Which would require the greatest number of additional parts: transforming a split-sound receiver to the intercarrier system or converting an intercarrier set to the split-sound system? Explain your answer in detail.

8. Upon what major fact is the intercarrier system based?

9. Detuning a receiver has the greatest effect on which of the two types of receivers? Why?

10. Under what conditions would a split-sound receiver produce a sound output whereas an intercarrier set would not? Explain.

11. What precautions must be observed at television broadcast stations in order that intercarrier sets will operate properly?

12. List the advantages and disadvantages of intercarrier sets.

13. What happens in intercarrier sets when the audio carrier becomes comparable in strength to the video carrier? What precautions are taken to avoid this condition?

14. List several ways in which the servicing procedure of an intercarrier set might differ from that of a split-sound set.

15. Why can the sync systems of both of these receivers be identical?

16. Describe the passage of a signal through an intercarrier set, starting at the antenna and ending at the image tube and loudspeaker.

17. In what way does the mixing of a frequency-modulated signal with a single-frequency voltage differ from the mixing of an amplitude-modulated signal and the same single-frequency signal?

18. Why is the value of the audio IF frequency the same in all intercarrier sets while this is not true in split-sound television receivers?

19. What troubles might conceivably arise in an intercarrier set that could not occur in a split-sound receiver?

20. Why do intercarrier receivers possess fine-tuning controls?

21. Show two ways of removing the 4.5-mc sound signals in an intercarrier system.

Synchronizing-Circuit Fundamentals

Synchronizing Pulses. Up to this point we have studied the action of the various stages of the television receiver in amplifying and changing the form of the video signal so that it will finally be suitable for application to the grid of the picture tube. Nothing, however, has been said so far about the method of supplying the proper voltages to the deflection plates, or coils, so that the image will be swept out properly on the cathode-ray screen. To accomplish this, we must obtain the synchronizing pulses from the video signal and apply them to other circuits that will eventually connect directly to the deflection system of the picture tube. Since each line has a separate synchronizing pulse, it becomes possible to lay the lines out on the screen in their proper position exactly as they were scanned in the camera tube. The synchronizing pulses responsible for the correct positioning of the various lines are referred to as the "horizontal synchronizing pulses," or, perhaps more simply, as the horizontal pulses. These pulses are diverted to amplifiers that control the action of the horizontal-deflection coils.

After the electron beam sweeps out the correct number of horizontal lines and arrives at the bottom of the picture, a vertical synchronizing pulse is applied to the vertical-deflection plates, and the beam is rapidly brought back to the top of the screen again. This vertical pulse is transmitted together with the horizontal pulses in the video signal, separated by filters at the receiver, and applied to a set of amplifiers that terminate at the vertical-deflection plates. The block diagram of Fig. 12-1 illustrates the general path of the synchronizing pulses within a television receiver.

Pulse Separation from the Rest of the Signal. Before they can be used, the pulses of a video wave must first be separated from the other portions of the signal. The separation may occur anywhere from the video detector to the last video stage before the cathode-ray tube. In practice, designers of sets have generally chosen to obtain the input for the synchroniz-

ing stages from a point beyond the video detector, usually at the output of one of the video amplifiers. At such points, the signal has sufficient amplitude and is in proper form for controlling horizontal- and vertical-deflection oscillators with a minimum of additional stages. For example, circuit designers often do not apply the video signal to the sync separator until it has passed through the first-video amplifier. In this way an extra pulse amplifier is eliminated.

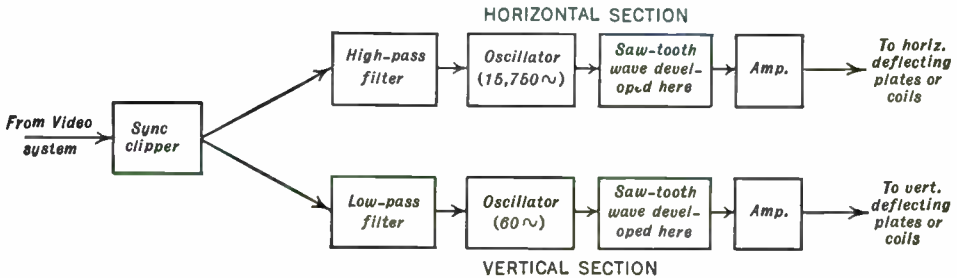

FIG. 12-1. Basic diagram of the synchronizing section of a television receiver.

Since it is necessary to obtain the synchronizing pulses from the incoming wave, it is first imperative that the signal be in its d-c form. This should be evident by reference to the figures of Chapter 8, where the a-c and d-c forms of a video signal are illustrated. While the signal is always in its d-c form at the output of the detector, it may not be so if it is obtained from the plate circuit of an amplifier that follows. In this case, d-c restoration is necessary.

The tube that separates the sync pulses from the rest of the video signal is called the "clipper" or "sync separator." Both horizontal and vertical synchronizing pulses are clipped by this tube; the further separation of these two pulses then occurs at another point beyond this stage. The type of tube that may be utilized for the synchronizing separation is not restricted. Practically every type is suitable since the action consists merely in biasing the tube so that only the top portions of the video wave (where the pulses are found) cause current to flow.

Diode Clippers. A possible diode-clipper circuit is shown in Fig. 12-2. The video signal is applied between plate and ground, while the output voltage is developed across the diode load resistor, R_L . The small battery is inserted with its negative end toward the plate, which prevents current from flowing until the video signal acting on the tube becomes sufficiently positive to counteract the negative biasing voltage. Current then flows. With the circuit constants properly chosen, current should flow only at the synchronizing pulses which are the most positive for a signal having negative

phase, and the output will consist only of these short pulses of current. The picture phase at the input of this diode must be negative, as in Fig. 12-2.

By inverting the diode, as in Fig. 12-3, it is possible to apply a positive-picture phase to the tube and again obtain only the pulse tips across R_L .

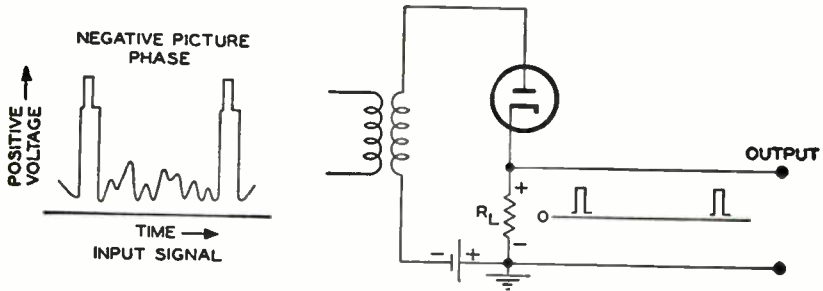

FIG. 12-2. A diode clipper operating with input signals having negative phases.

The d-c biasing voltages necessary for these diodes may be taken from the low-voltage power supply.

It is generally not practical to use a bias battery or power-supply d-c voltage for the diode-clipper tube. We require an arrangement that is completely automatic in its operation, altering its operating point as the amplitude of the received carrier varies. A simple, yet effective, circuit is shown in Fig. 12-4(A). The diode clipper uses the time constant of R and C to bias the tube so that all but the synchronizing pulses are eliminated. Capacitor C and resistor R form a low-pass filter with a comparatively long-time constant, equal to approximately 10 horizontal lines. Therefore, the voltage developed across R (and C) will be determined by the highest voltage applied across the input terminals. This, of course, means the synchronizing pulses. Throughout the remainder of the line, although the video voltage is active, the plate is never driven sufficiently positive to overcome the positive cathode bias.

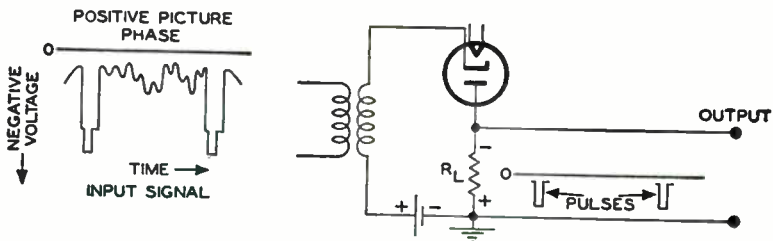

FIG. 12-3. An inverted diode clipper, suitable for input signals having a positive picture phase.

A commercial application is shown in Fig. 12-4(B). One half of a 6AL5 is used for picture signal detection (not shown), while the remaining half is devoted entirely to pulse rectification and clipping. R_1 and R_2 are the pulse-detector load and here the rectified signal is developed. The time constant of the load is set by R_1 and C_1 . At the arrival of each pulse to the tube, a short flow of current occurs, recharging C_1 , and, at the same time, producing

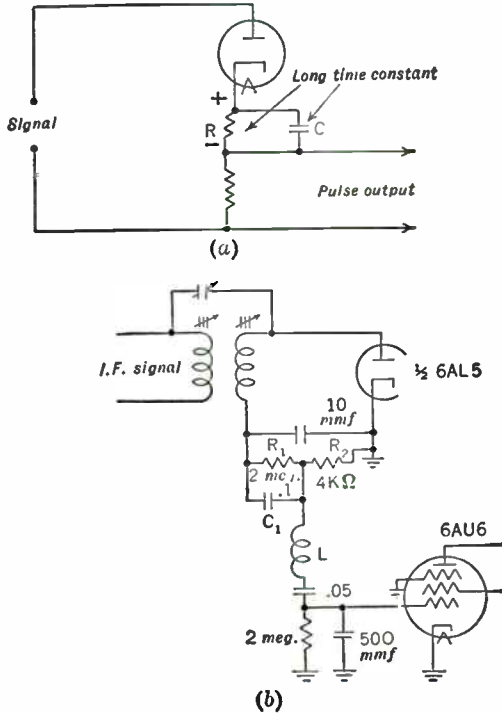

FIG. 12-4. (A) Fundamental diode-clipper circuit. (B) A commercial application.

a pulse across R_2 . This voltage is passed on to a 6AU6 synchronizing-pulse amplifier. The series inductance L maintains a good response in the connecting network to the higher-frequency components of the square-shaped pulses. Any decrease in high-frequency response here would have the effect of rounding out the steep sides of the synchronizing pulses, thereby destroying the effectiveness of their triggering action. It can readily happen that the synchronizing oscillators will trigger at slightly differing intervals, causing sections of the image to "tear out." The appearance of such an image is identical with that obtained when interference is active in the circuit.

Another common application of the diode sync separator uses the circuit

shown in Fig. 12-5. The composite video signal is applied across terminals *A* and *B*. As a start, we shall assume that C_1 is uncharged. Upon the application of a signal, electrons flow from cathode to the plate of the tube and thence to the nearest plate of C_1 .

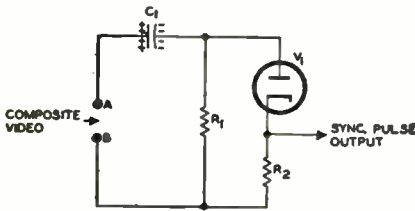

FIG. 12-5. Another common application of a diode as a sync separator.

From the other plate of C_1 , an equal number of electrons will flow to terminal *A*, through whatever circuit is connected between this point and terminal *B*, up through R_2 , and back to the tube again. C_1 will become charged, its potential equal to the peak potential of the applied video signal. During the second and all subsequent lines, V_1 will not conduct until the applied signal is able to overcome the negative charge existing across C_1 . This will be true only when the sync pulses are active. At these moments, current flows through the circuit in the manner described above and a pulse of voltage appears across R_2 . At all other times V_1 will be kept at cutoff by the negative charge across C_1 . When V_1 is not conducting, C_1 discharges through R_1 , and it is actually this discharge through R_1 that makes the plate of the diode negative with respect to its cathode. As before, the time constant of C_1 and R_1 is made sufficiently long so that only the sync pulses cause current flow through the circuit.

Triode Sync Separators. Since a triode (or a pentode) can do anything a diode can, and provide amplification as well, it is natural to find these tubes used as sync separators. An application involving a triode sync separator is shown in Fig. 12-6. The triode, V_1 , is biased by grid-leak bias developed across C_1 and R_1 . The pulses in the video signal fed to the sync separator triode V_1 possess the most positive polarity of the signal. Electrons will then flow in the grid circuit, charging C_1 . Because of the high value of R_1 , the charge on C_1 will leak off slowly, causing a fairly steady bias voltage to develop across the grid resistor. This bias voltage prevents plate current from flowing except for the most positive values of the incoming signal, which are the synchronizing pulses. A fairly low plate voltage causes V_1 to saturate readily, thereby tending to square off the sync pulses and to limit any noise pulses that may appear in the signal.

Resistor R_2 serves to isolate, or decouple, the sync-separator tube from the video amplifier where the signal is obtained. In this way, the input circuit of V_1 and its capacity do not unduly load the video-amplifier-plate circuit with subsequent deterioration of the image quality. R_3 and C_2 are inserted into the circuit to help minimize the effect of any noise pulses that may be present in the received signal. If a strong noise pulse (extending in the positive direction) should come along and R_3 and C_2 were not present,

the resulting electron flow in the grid circuit of V_1 would charge C_1 to a fairly high negative voltage. Because R_1 is so large in value, the time required by C_1 to discharge enough through R_1 to enable the regular signal to again produce a current flow through V_1 might be so long that the set would lose synchronization. To avoid this, R_3 and C_2 are placed in the grid circuit. Now,

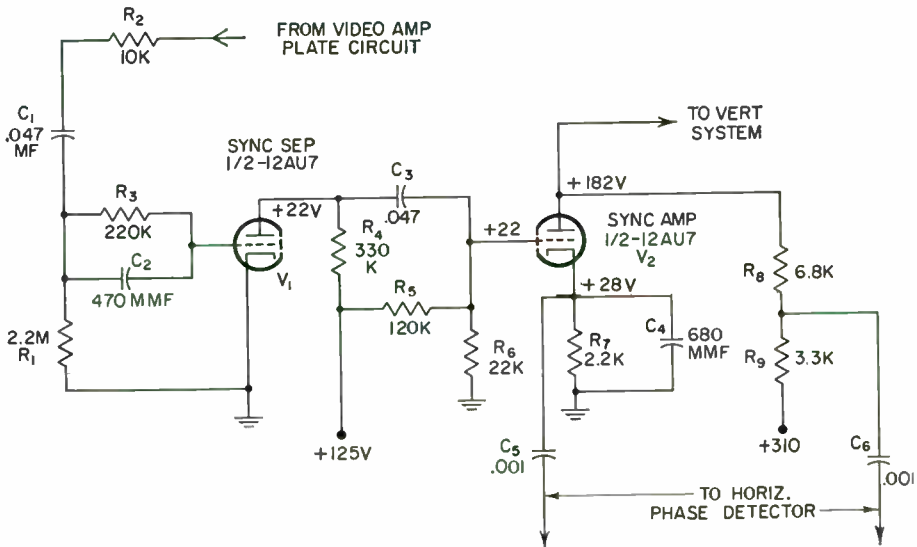

FIG. 12-6. A triode (V_1) sync separator.

when a noise pulse comes along, C_2 absorbs the additional current flow it produces. C_2 then discharges fairly quickly through R_3 , which has a value one-tenth the value of R_1 .

The video signal arriving at the grid of V_1 has an overall, or peak-to-peak, amplitude of 60 volts. See Fig. 12-7. However, the grid-leak bias developed by C_1 , R_1 , permits V_1 to conduct only when the sync pulses are active. For the remainder of the video signal below the sync pulses, the tube is cut off by the bias. Also assisting in this action is the low-plate voltage of the tube.

Note that not all of the sync pulse produces a corresponding change in the plate circuit. Near the peak of the pulse, the grid is almost at zero bias and the tube is passing as much current as it can with the low level of plate voltage. In other words, it is operating at saturation and a further rise in input voltage produces little additional output voltage. This is the reason why the very tip of the sync pulse in Fig. 12-7 is shown unshaded. This small upper section does not develop much additional output voltage. In essence, this tends to square off the top of the output pulse.

From V_1 , the sync pulses, which are now negative-going, travel to V_2 , the sync amplifier. The grid of this tube is made 22 volts positive by R_5 , which causes a considerable amount of current to flow in the grid and plate circuits, both currents returning to the cathode by way of R_7 . The result is 28 volts at the cathode. This makes the grid negative with respect to the

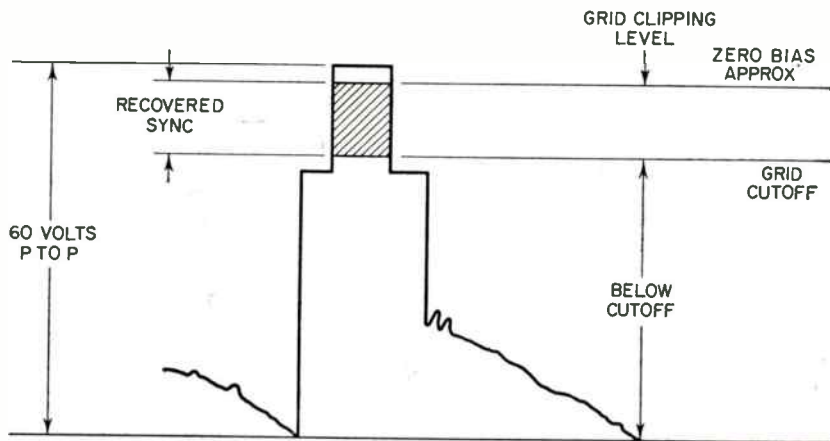

FIG. 12-7.

cathode by 6 volts. This voltage, together with the negative portion of the sync pulse from V_1 , quickly drives V_2 into cutoff and helps to square off this end of the applied pulses. By the same token, since the grid already has a positive voltage (from $B+$), the positive portion of the pulses from V_1 cannot drive the grid far before current saturation is reached. Thus, the positive portion of the signal is also clipped.

The sync amplifier effectively clips both positive and negative extremes of the sync pulse fed to it from V_1 . This amplifier section operates at considerably higher plate voltage, and the output is consequently greater than that of the sync-separator stage alone.

The sync pulses at the plate of V_2 are in the positive direction and are fed to the vertical-integrator network. At the same time, positive pulses from R_9 and negative pulses from the cathode are fed to the horizontal-phase detector.

Another triode sync-separator circuit is shown in Fig. 12-8. The first triode, V_1 , is a normal voltage amplifier. Its output is the complete video signal and is applied to the grid of V_3 with the sync peaks in the positive direction. In the input circuit of V_3 , a diode, V_2 , is connected from grid to ground. This diode has -14 volts applied to its plate terminal and will not conduct until the 14 volts are neutralized by a signal which is at least

14 volts above zero-reference level (ground). When this occurs, the diode conducts, effectively preventing the signal at the grid from rising any further. The grid of V_3 is biased by the same -14 volts, preventing the tube from conducting until part of this voltage has been neutralized. The variations in video-detail voltage of the incoming signal are unable to over-

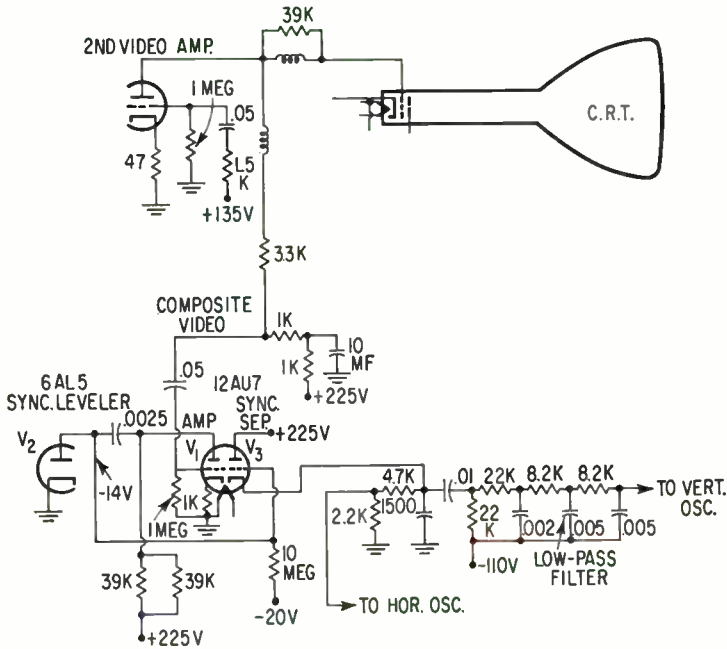

FIG. 12-8. Another triode sync-separator circuit.

come this negative bias and thus the video-detail voltage up to approximately the blanking level is removed. Only sync pulses which extend in the positive direction are able to force V_3 to conduct, producing positive pulses in the cathode circuit which are then fed through appropriate filters to the vertical and horizontal blocking oscillators.

V_2 serves as a sync leveler, tending to provide a constant-pulse output. Because of the amplification accorded by V_1 , the sync pulses of all normal signals reaching V_3 extend more than 14 volts above the zero-reference axis. Hence, all sync pulses drive the diode into conduction, preventing further rise of the pulse beyond 14 volts and leveling off the tips of all sync pulses. For signals too weak to develop sufficient voltage at the output of V_1 to drive V_2 into conduction, leveling does not occur, and the sync amplitude variations reach the sweep oscillators, providing less positive sync control.

Triode Sync Separator with Noise Canceller. The sync-separation system of Fig. 12-9 incorporates a noise canceller which actually removes noise pulses rather than simply cancel them out. A part of the video signal is d-c coupled to the sync amplifier V_1 , where it is amplified before being fed to the sync clipper V_3 . Tied directly across the plate of the sync amplifier is the noise-canceller circuit V_2 . This tube has a fixed grid bias and a positive bias applied to its cathode by R_1 and R_2 .

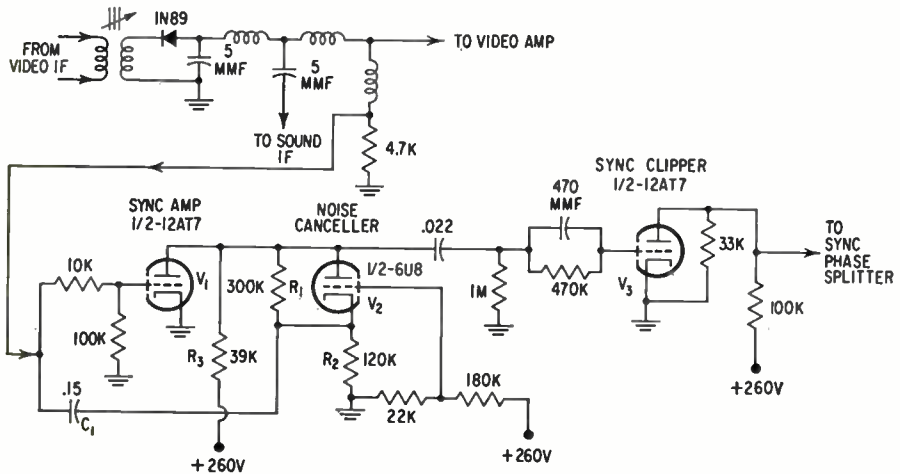

FIG. 12-9. A sync-separator system with a noise canceller.

Since the sync-amplifier-plate signal and d-c level will vary with the strength of the received signal, and because the cathode of V_2 derives a part of its positive bias from the plate, the plate and cathode voltages tend to change with the signal, thereby making allowances for varying signal levels. These voltages combine to keep the noise-canceller tube cut off under low-noise conditions.

Negative sync pulses are fed to the cathode of the noise canceller through C_1 from the detector. When a noise pulse appears with an amplitude that exceeds the sync-tip level, it lowers the canceller cathode potential, causing the tube to conduct. This action produces a negative pulse in the plate circuit of V_2 (across R_3). At the same time, the noise pulse from the detector enters the grid of V_1 and appears as a positive pulse across R_3 . Thus, the negative pulse that V_2 develops across R_3 cancels the positive pulse that V_1 establishes here and little or no noise voltage reaches V_3 .

If a noise pulse appears during a normal sync interval, it causes the sync pulses to be removed also. At these times, the inertia of the sweep oscillators or "flywheel" effect is relied upon to keep the picture in sync.

Pentode Sync Separators. To obtain clean-cut sync separation, sharp cutoff pentodes are frequently more satisfactory than either triodes or diodes. Complete pulse separation is achieved by the 3-stage system shown in Fig. 12-10, containing a pentode sync amplifier, a pentode sync separator, and a second triode sync amplifier or limiter. Let us analyze each in turn.

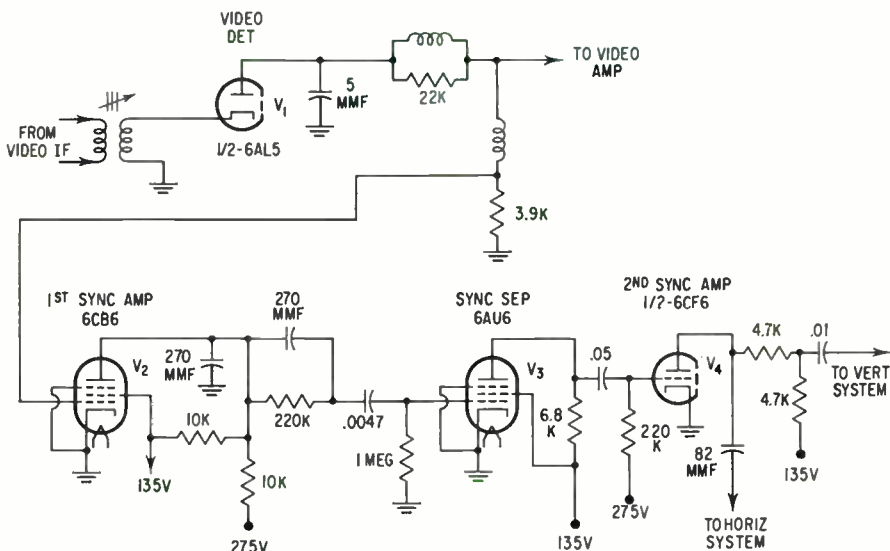

FIG. 12-10. A 3-stage system used to obtain complete pulse separation.

The first sync amplifier is a 6CB6 pentode which has a sharp cutoff characteristic. The signal received from the d-c restorer network has a polarity such that the sync pulses are in the negative direction, which tends to drive the tube toward plate cutoff. With a weak signal, such as S_1 of Fig. 12-11, the sync pulse operates over the relatively high-gain portion of the curve. With the large signals, such as S_2 , the sync pulse extends into the low-gain portion of the tube characteristic. The result is a more constant sync-pulse output. Noise pulses tend to be suppressed by this action, improving the sync-to-noise ratio.

The sync-separator stage, V_3 , clips the signal just above the blanking level and removes all the video portion of the signal. This is accomplished by using the sync pulses of the signal to drive the grid of V_3 positive and by establishing a negative grid-leak bias. The 6AU6 tube in this stage also has a sharp cutoff characteristic.

The second sync amplifier, V_4 , has a positive d-c voltage applied to its grid through a 220,000-ohm resistor. The ensuing grid-current flow causes practically all of the 275 volts to be dropped across this resistor, leaving the

grid at essentially zero volts. In this condition, the tube is operating close to current saturation. When the sync pulses now arrive from V_3 , they are sufficiently strong to swing V_3 from saturation to cutoff. This serves to produce output sync pulses from V_4 which are essentially flat-topped.

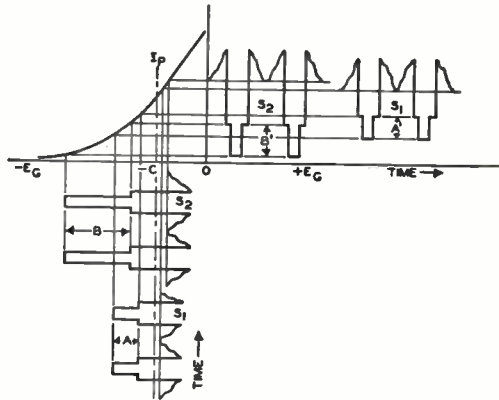

FIG. 12-11. The action of V_2 in Fig. 12-10 in stabilizing the sync-pulse output of V_1 .

Special Single-stage Sync Separators. In recent circuit designs several new methods of achieving sync separation have been employed. In one approach, a 6CS6 pentagrid tube is the sole sync-separator stage employed. See Fig. 12-12. Grid no. 1 receives the output of the video detector. The signal here, with the sync pulses negative, is on the order of 2 volts peak to peak. A potentiometer, labeled the "fringe lock control," applies a small positive voltage to grid no. 1. The control is adjusted so that the bias applied to grid no. 1 is close to zero, thereby preventing the negative video signal from cutting the plate current off in the tube.

In the same tube, grid no. 3 receives the video signal after it has been amplified and inverted by the first video amplifier. The signal now has an amplitude of 40 volts peak to peak and the sync pulses are positive. Initially, grid no. 3 has zero bias. When the 40-volt peak-to-peak video signal is applied to it, grid-leak bias is developed by C_1 and R_1 to an average value of -10 volts. This bias is maintained by the positive sync pulses, and only when the sync pulses are active can electrons flow past grid no. 3. For the more negative portions of the signal containing the video information, the grid voltage is too negative to permit electrons to pass. Under these conditions, no current reaches the plate of the tube.

At grid no. 1, electrons are normally able to pass because the fringe lock control is adjusted so that electrons pass grid no. 1 even at the sync-pulse

tips which are most negative. However, grid no. 3 permits electrons to pass it only when the sync pulses are active. Effectively, therefore, it serves to clip the sync pulses from the rest of the video signal. Both grid no. 1 and no. 3 must be in condition to allow electrons to pass, otherwise none will reach the plate.

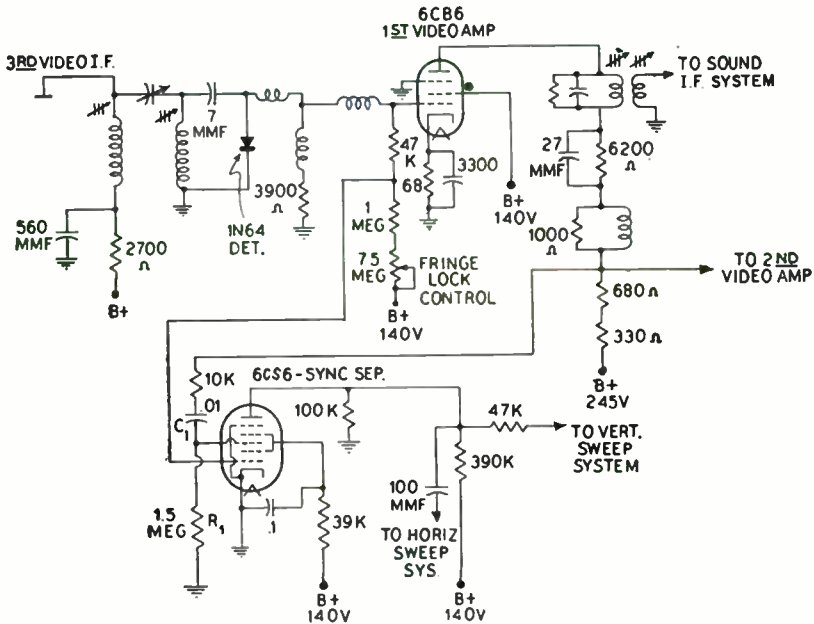

FIG. 12-12. A 6CS6 pentagrid employed as a sync separator.

If a noise pulse drives grid no. 1 beyond the 2-volt level, plate-current cutoff occurs, and the noise pulse cannot get through to trigger the sweep oscillators falsely. On rare occasions, a strong noise pulse may occur at the time of the sync pulse and the tube likewise will cut off. However, the flywheel action of the sweep oscillators will maintain sync during this brief period. The entire fringe-lock control system is based on the fact that the loss of an occasional sync pulse is to be preferred to having a noise pulse get through to trigger the sweep oscillators falsely.

An approach which is related to the circuit of Fig. 12-12 is illustrated in Fig. 12-13. A 3BU8 duo-pentode functions as a combined sync separator, AGC keyer, and noise limiter. The operation of this tube was discussed in Chapter 6, where it was seen to possess a common cathode, a common control grid, and a common screen grid. Only grid no. 3 and a plate are established separately for each pentode section.

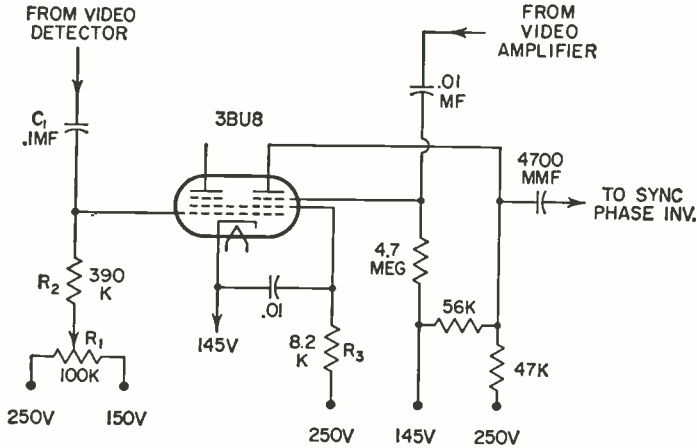

FIG. 12-13. A noise-immune sync separator.

The half of the 3BU8 employed for keyed AGC also was described in Chapter 6. For sync separation, the second half (shown in Fig. 12-13) functions as follows. A positive voltage is applied to grids no. 1 and 2. Grid no. 2, the screen grid, is given a positive potential of 210 volts. Grid no. 1 receives a positive voltage of about 145 volts. The same voltage is applied to the cathode, therefore the bias on grid no. 1 is practically zero. A video signal, with the sync pulses negative, is then brought to grid no. 1 by capacitor C_1 . This signal, obtained from the output of the video detector, has an overall peak-to-peak amplitude of about 1.5 volts and it has little effect on tube conduction. However, if a strong noise pulse should come along, it would drive grid no. 1 negative enough to cut off the tube momentarily.

Grid no. 3 connects directly to the plate circuit of the video-output amplifier, receiving a video signal with the sync pulses extending in the positive direction. When no signal is received, the positive d-c voltage at grid no. 3 is some 20 volts less than the cathode and this is enough to bias the tube to cutoff. When a signal is received, however, the sync pulses are strong enough to cause plate current to flow.

Thus, the signal at grid no. 1 will cut off the tube whenever a strong noise pulse appears, irrespective of the signal on grid no. 3. When strong noise pulses are not present, current will flow through the tube whenever the sync pulses are active at grid no. 3. Since the 3BU8 has sharp cutoff characteristics, good, clean sync separation can be achieved.

Pulses and Their Form. So far, only general terms have been used when discussing the synchronizing pulses of video waves. Their purpose has been stated time and again, but nothing definite has been stated about how their objective is accomplished. There is nothing in sound receivers that

even closely resembles this action, and a detailed examination becomes necessary. Discussion of the pulses, separated from the rest of the wave as outlined above, will be held in abeyance while we develop in greater detail the form and functions of the horizontal and vertical pulses.

It is already known that, as each horizontal line signal arrives at the grid of the picture tube, the electron beam should be in correct position, ready to sweep out the information contained in the signal. The position of the electron beam is controlled by sawtooth oscillators. In order for the oscillator to have the beam in the correct position, horizontal synchronizing pulses are inserted into the video signal. These could have been sent separately, but the present method is cheaper and simpler in operation. It should be noted and kept in mind that the function of the horizontal synchronizing pulses is to trigger an oscillator in order to bring the electron beam from the right-hand side of the screen to the left-hand side. Once the beam is at the left-hand side, the oscillator is no longer directly under the control of a pulse and goes about its normal function of sweeping the beam across the screen. Thus each horizontal pulse that precedes the line detail sets up the beam in readiness for the scanning of this information. The next pulse arrives when the beam is at the far right-hand side of the screen, at the end of a line.

There are 525 lines sent out every $\frac{1}{30}$ sec. In one second, then, we have 525 times 30, or 15,750 lines. This means that the frequency of the horizontal pulses is 15,750 per sec, or one arrives every $\frac{1}{15,750}$ sec. The time interval is quite small, being only 0.000064 sec.

In similar manner, the vertical pulses serve the purpose of bringing the electron beam back to the top of the screen for the beginning of each field. With interlaced scanning (described in Chapter 1), every other line is scanned, each field ($\frac{1}{2}$ frame) taking $\frac{1}{60}$ sec. The beam next sweeps out the lines that were missed, this also in $\frac{1}{60}$ sec. The total frame, with all lines, is completed in $\frac{1}{60}$ plus $\frac{1}{60}$ sec, or $\frac{1}{30}$ sec. Thus we see that the vertical pulses must occur once every $\frac{1}{60}$ sec, or 60 times in one second. This frequency is considerably less than that of the horizontal pulses, and it is because of this fact that they can be separated with comparative ease.

With the preceding ideas in mind, let us closely examine the construction of the video signal with its synchronizing pulses. In Fig. 12-14 several lines of an image are shown, complete with the detail information, blanking voltages, and horizontal synchronizing pulses. The blanking and synchronizing voltages occupy approximately 20 to 25 per cent of the total signal amplitude. Note that the blanking voltage retains its control over the cathode-ray-tube grid for some time before and after each synchronizing pulse. This is done to make certain that no beam retrace is visible at all on the screen. As soon as the blanking voltage relinquishes control of the

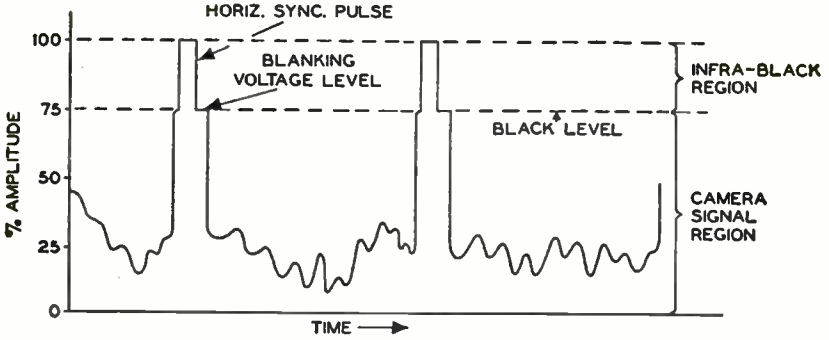

FIG. 12-14. A video signal with its synchronizing (horizontal) pulses.

grid, the line detail becomes active again. All the lines of one field follow this form; the only difference occurs in the camera detail of the various sections of the image.

At the bottom horizontal line, it is necessary to insert a vertical impulse that will bring the beam back to the top of the screen again. During the period that the vertical pulse is active, it is imperative that the horizontal oscillator not be neglected. For, if this did occur, the horizontal generator would slip out of synchronization. To avoid this, the vertical pulses are arranged in serrated form and accomplish vertical and horizontal synchronization simultaneously.

Serrated Vertical Pulses. To understand the form of the vertical pulse that has finally been evolved, start with the voltages shown in Fig. 12-15. At the bottom of the image, a long vertical pulse is inserted into the signal. This controls the vertical synchronizing oscillator and forces the beam to be brought back to the top of the screen. No provision is made in the signal, in this preliminary form, for horizontal-oscillator control while the vertical pulse is acting. Such a condition is undesirable as it permits the

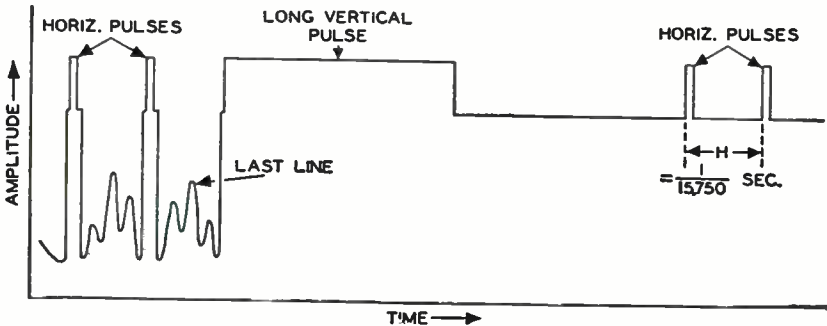

FIG. 12-15. The basic form of the vertical synchronizing pulse.

horizontal oscillator to slip out of control. To prevent this, the vertical pulse is broken up into smaller intervals, then both actions can occur simultaneously. The vertical synchronizing pulse, in the modified form, is shown in Fig. 12-16 and is known as a "serrated vertical pulse."

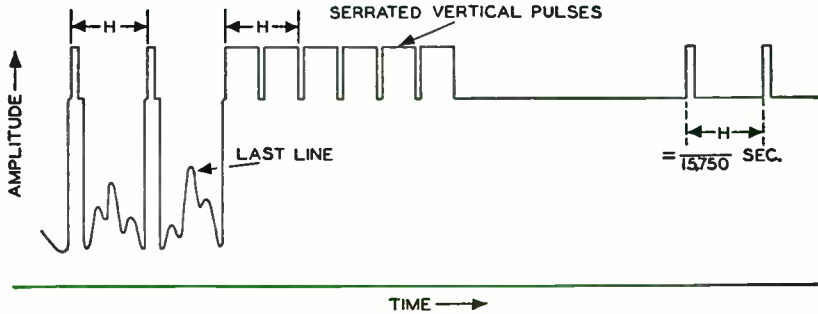

FIG. 12-16. The serrated vertical synchronizing pulse.

While the vertical pulse is broken up to permit the horizontal synchronizing voltages to continue without interruption, the effect on the vertical pulse is substantially unchanged. It still remains above the blanking-voltage level practically all of the time it is acting. The interval is much longer than the preceding horizontal pulse frequency. The two pulses are still capable of separation because their waveforms are different, as is evident from Fig. 12-19.

Because an odd number of lines is used for scanning, the form of the signal just prior to the application of the serrated vertical pulse must be still further modified. With an odd number of lines, 525, each field contains $262\frac{1}{2}$ lines from the beginning of its field to the *start* of the next. This fact is important but has not been overly stressed before. Fig. 12-17, reprinted from Chapter 1, indicates that the end of the visible portion of each field occurs at the bottom of the image. However, the actual end of that field is not reached until the beam has been brought back to the top of the screen again. At the end of the visible portion of the first field, the beam must be interrupted at point *D* and the vertical synchronizing pulse inserted. Point *D*, we see, occurs in the middle of a horizontal line. From *D*, the beam is brought up to point *E*, and the second field is begun. The visible portion of the latter field is completed at point *F*, the end of a complete horizontal line, and is returned to point *A* to repeat the entire sequence. These actions are mentioned here for review. The reasons for employing this particular method of scanning were explained in Chapter 1.

When the beam is blanked out at the bottom of an image and returned to the top, it does not move straight up; instead it moves from side to side

during its upward swing. This movement is due to the rapidity with which a horizontal line is traced out as compared with the vertical retrace period. In

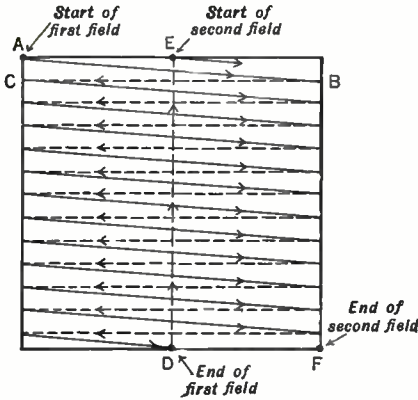

FIG. 12-17. The motion of the electron beam in interlaced scanning. For simplicity, the retrace from point D to point E has been shown as a straight line.

fact, there are approximately 20 horizontal lines traced out while the vertical synchronizing pulses are bringing the beam back to the top of the picture. Thus, in each field, 20 horizontal lines are lost in the blanking interval between fields. Of the 525 lines which are sent out, only $525 - 2(20)$, or 485, are actually effective in forming the visible image.

The method of arriving at 20 horizontal lines is quite simple. The electron beam is blanked out for approximately 1,250 microseconds between fields while the beam is being shifted from bottom to top of the image. During this interval, the horizontal sweep oscillator is also active. Thus, the beam, while it moves up under the in-

fluence of the vertical-deflection voltage, is also moving back and forth because of the horizontal-deflection oscillator. One horizontal line requires $1/15,750$ sec, or 64 microseconds. Dividing this 64 into 1,250, we find that approximately 20 horizontal lines are traced out. In a frame, which contains two fields, 40 lines are thus lost. To see these retrace lines, turn up the

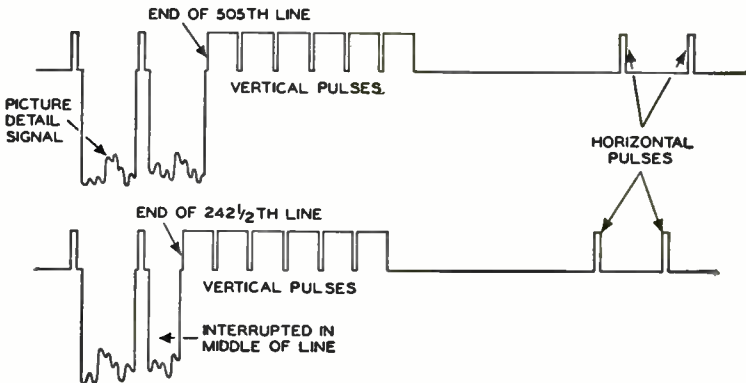

FIG. 12-18. The form of the video signal at the end of $242\frac{1}{2}$ and 505 lines. The equalizing pulses are not shown.

brightness control on a television receiver when no station is being received and only the scanning raster is visible.

The fact brought out above, that the vertical pulse is once inserted into the video signal when a horizontal line is half completed and once at the end of a complete line, necessitates a further modification of the video signal just prior to the arrival of the vertical pulse. A serrated video signal for each case is illustrated in Fig. 12-18. The half-line difference between the two diagrams may not affect the horizontal-synchronizing-generator operation, but it can cause the vertical oscillator to slip out of control.

To have the vertical pulse oscillator receive the necessary triggering voltage at the same time after every field, a series of six equalizing pulses is inserted into the signal immediately before and after the vertical synchronizing pulses. These equalizing pulses, shown in Fig. 12-19, do not disturb the

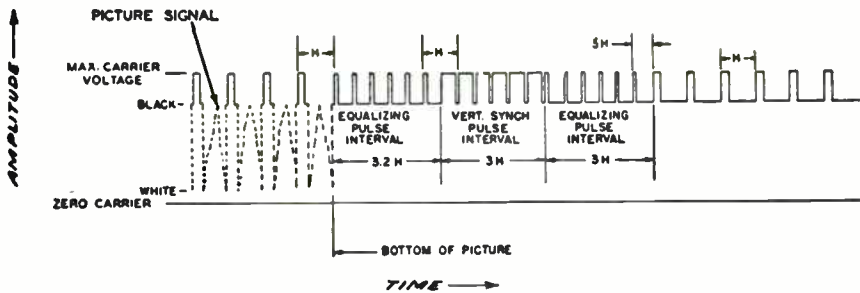

FIG. 12-19. The position of the equalizing impulses in the video signal.

operation of either oscillator (as will be shown later), yet they do permit the vertical pulse to occur at the correct time after every field.

Once the serrated vertical pulse is ended, the six equalizing pulses are again inserted into the signal, and the line detail assumes control while the next field is swept out. One vertical pulse occurs at the end of every $262\frac{1}{2}$ lines, while a horizontal pulse appears at the end of each line.

Vertical and Horizontal Separation. The separation of the vertical and horizontal pulses from each other is based on their frequency (or waveform) difference and not on their amplitude since the latter is the same for both. The two pulses are shown in Fig. 12-20. Note that the horizontal pulse is much shorter in duration than the vertical pulse, rising and falling in 5 microseconds. Essentially, then, a low-pass filter will develop the vertical-pulse voltage at its output, while a high-pass filter will have only the horizontal-pulse voltage at its output. These two distinct pulses can then be fed to their respective oscillators, controlling them in accordance with the requirements of the signal being received.

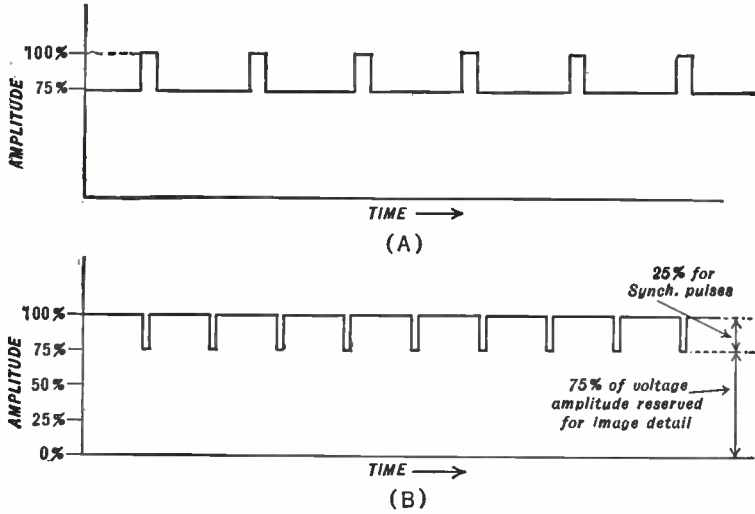

FIG. 12-20. Differences in waveforms of (A) horizontal and (B) vertical pulses.

Filters and Time Constants. The filters which are employed to separate the vertical and horizontal sync pulses consist of resistors and capacitors. When voltage is applied to such a combination (Fig. 12-21) by closing

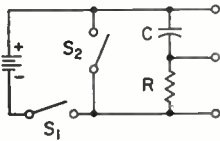

FIG. 12-21. A filter employed to separate vertical and horizontal sync pulses.

switch S_1 , current starts to flow and the capacitor begins to charge. Just how rapidly the capacitor charges is depicted by curve 1 in Fig. 12-22. We see that initially, when the voltage is first applied, the capacitor charge increases rapidly to the point marked 63 per cent. At this point, the voltage across the capacitor is equal to 63 per cent of the applied voltage. Thereafter the voltage increase across the capacitor slows down, and considerably more time is required before the capacitor attains full charge.

Along the time scale, there is the notation of RC , $2 RC$, $3 RC$, etc. RC is a common expression when dealing with resistance-capacitance filters and is one which the reader should become familiar with. By definition, the time (in seconds) which a capacitor requires to charge to about 63 per cent (actually 63.2 per cent) of the applied voltage is called the RC time. This time is found by the formula

$$T = RC$$

where

- T = the time in microseconds
- R = the resistance in ohms
- C = the capacitance in microfarads

Thus, if R is 100 ohms and C is 1 mf, the RC time is

$$T = RC = 100 \times 1 = 100 \text{ microseconds}$$

It would require 100 microseconds for the capacitor to reach 63 per cent of the applied voltage. If the voltage is 100 volts, then in 100 microseconds, the voltage across the capacitor will be 63 volts. If the applied voltage is 80 volts, then in 100 microseconds, the capacitor voltage will be 50.4 volts.

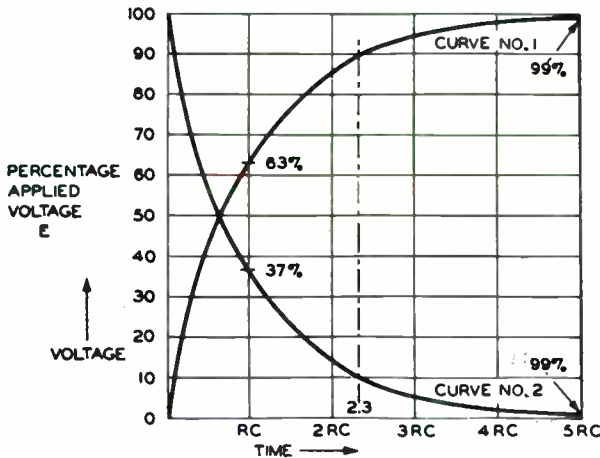

FIG. 12-22. Curves showing the time required for a capacitor to charge and discharge when it is connected in series with a resistance.

From the graph in Fig. 12-22, it is evident that it will require 2.3 RC time, or 230 microseconds, to charge up to 90 per cent of the applied voltage and 5 RC time, or 500 microseconds, to charge up to 99 per cent of the applied voltage.

Obviously, the larger R or C is, the longer it will take C to reach any given voltage.

The second curve in Fig. 12-22 represents the discharge curve of a capacitor. Thus, if C in Fig. 12-21 has charged and we open S_1 and close S_2 , the capacitor will complete a circuit and begin to discharge. In RC time, the capacitor voltage will decrease to 37 per cent of its original value. In 2.3 RC time, the charge will drop to 10 per cent of the original charge. And in 5 RC time, the capacitor voltage will be only 0.1 per cent of the value it originally possessed.

From the foregoing, we can formulate the following rule: *When a voltage is applied to an RC network, the voltage across the capacitor cannot rise instantaneously. Instead, it rises at a rate determined by the amount of resistance in the circuit and by its own capacitance value.*

Now let us consider a high-pass filter and its effect on the horizontal sync pulses which are fed to it. See Fig. 12-23. The filter in the diagram has a time constant of

$$\begin{aligned} T &= RC \\ &= 2000 \text{ ohms} \times 50 \text{ mmf} \\ &= 2000 \text{ ohms} \times .00005 \text{ mf} \\ &= 0.1 \text{ microseconds} \end{aligned}$$

A time of 0.1 microseconds is short compared with the 5-microseconds duration of the horizontal sync pulse.* At the application of the first edge of the horizontal pulse in Fig. 12-23, known as the "leading edge," a momen-

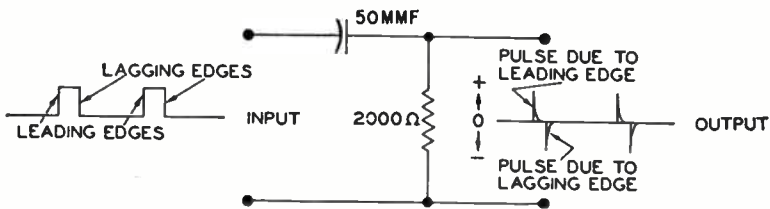

FIG. 12-23. A high-pass filter and its effect on the horizontal-synchronizing pulses.

tary flow of current takes place through the resistor to charge the capacitor to the full-pulse voltage. Once the capacitor has become fully charged, nothing further occurs all along the flat portion of the pulse because a capacitor (and hence, a capacitor and resistor in series) reacts only to changing or a-c voltages, not to steady or d-c voltages. At the next, the lagging edge of the pulse, where the voltage drops suddenly, another short flow of current takes place, this time in the opposite direction, discharging the capacitor. The result of the application of the square-wave sync pulse to the input of the high-pass (or short-time constant) filter is the output wave indicated in Fig. 12-23.

Each incoming synchronizing pulse gives rise to two sharp pulses at the output of the filter, with one above and one below the reference line. This, of course, is due to the fact that one is obtained when the front edge of the incoming pulse acts on the filter, and one when the lagging edge arrives.

For control of the sweep oscillator, only one of these two output pulses is required. If the first pulse at the output of the filter is negative (below the line) and a positive pulse is required, the conversion is readily made. Merely apply these pulses to an amplifier and the first pulse becomes positive. The amplifier introduces a phase shift of 180 deg, which is equivalent

* Any time constant one-fifth the duration of an applied pulse is said to be short with respect to that pulse. By the same token, any time constant 5 times longer than the duration of an applied pulse is said to be a long-time constant.

to reversing every value in a wave. The oscillators that are used, either the blocking or the multivibrator type, respond to the first pulse, becoming insensitive immediately thereafter to other pulses that do not occur at the *proper point* in the oscillator frequency interval. When the next horizontal pulse arrives, it is again in position to control the oscillator action. In this manner, any pulse occurring at an intermediate interval is without effect. One or two exceptions will be noted later.

The foregoing action of a high-pass filter indicates how the serrations of the vertical pulse permit control of the horizontal synchronizing oscillator during the application of the vertical pulse. In Fig. 12-24 are shown the in-

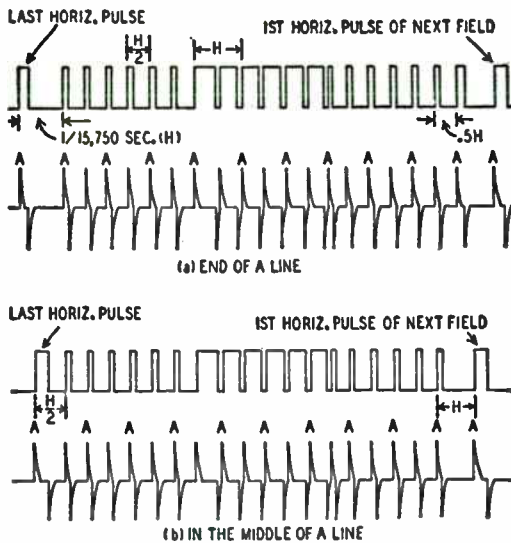

FIG. 12-24. Conditions during vertical pulses. The pips labeled A control the horizontal sweep oscillator.

put wave and the output pulses of a high-pass filter. Of all those present, only the positive pulses that occur at the proper time ($1/15,750 \text{ sec}$) affect the horizontal oscillator. These active pulses are indicated by A in the figure. Note that all active pulses are evenly spaced and differ $1/15,750 \text{ sec}$. The conditions shown in Fig. 12-24(A) occur only when the vertical pulses are inserted at the end of a line. Figure 12-24(B) shows the situation when the field ends on a half line. Now the same equalizing and serrated pulse pips are not active in controlling the horizontal oscillator. Because of the difference in field ending, the control has shifted to those pips which were shown to be inactive in Fig. 12-24(A). However, the shift has in no way interfered with the timing in the control pips. This shift from field to field

illustrates why all the equalizing and vertical pulses are designed to produce pips twice in each horizontal-line interval.

The long vertical pulses are without effect on this filter because of its short-time constant and, further, because the output is obtained from across the resistor. As soon as a vertical pulse is applied across the terminals of the filter, a short, sharp current fully charges the capacitor. With the capacitor charged to the full voltage value, no further current flows through the resistor until another change occurs. The output is taken from across the resistor and, with current flowing only a very short time, a short, sharp pulse of voltage is obtained. At the lagging edge of the input wave, another quick flow of current brings the capacitor voltage back to its previous value and again a voltage pulse develops across the resistor. Hence, only *changes* in the input wave appear across the output resistor, because it is only at these times that a current flows in the filter, either to charge or to discharge the capacitor. The serrations inserted in the vertical pulse provide the changes that cause current to flow in the high-pass filter. Thus control can be maintained at the horizontal oscillator even when the vertical pulse is acting.

Vertical-pulse Filters. For vertical-pulse separation, we use a low-pass or long time-constant filter of the type shown in Fig. 12-25. This appears

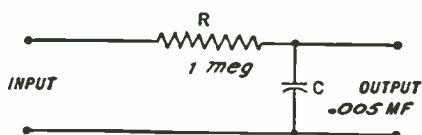

FIG. 12-25. A low-pass filter. The capacitor combines (or integrates) all the serrated vertical pulses until the output voltage rises to the level necessary for the vertical sync oscillator to react.

identical with the high-pass filter, except that the positions of the capacitor and resistor have been interchanged and the output is obtained from the capacitor. Besides the difference of position, the time constant of the capacitor and resistor is much greater than that of the previous filter. A long-time constant means that the capacitor will charge and discharge slowly and will not respond as readily as a short-time constant filter to rapid changes in voltages. Hence, when a horizontal pulse arrives at the input of this filter, its leading edge starts a *slow* flow of current through the resistor, and the capacitor begins to charge. But this charging process is slow and, almost immediately afterward, the lagging edge of the wave reaches the filter and reverses the current flow, bringing the capacitor back to its previous value. Very little change has occurred during this short time interval. And the vertical synchronizing oscillator is designed so that it does not respond to these small fluctuations.

What is true of the effect of the horizontal pulses on the vertical filter is even more true with respect to the equalizing pulses, which rise and fall

much more rapidly. Essentially, then, we have eliminated the possibility of the higher frequency pulses affecting the operation of the vertical synchronizing generator. Figure 12-26 shows the output voltage of the filter on the application of these higher frequency waves. Their voltage level is below the dotted line, which represents the point that the voltages must reach in order to affect the generator.

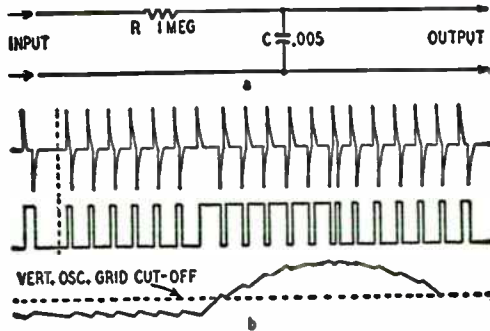

FIG. 12-26. (A) Low-pass filter for separating the vertical and horizontal pulses; (B) waveform of the rise in voltage across the capacitor due to vertical pulses.

The building up of the voltage across the capacitor for the output begins when the serrated vertical pulses are reached. Even though the pulse is serrated, it still remains above the reference line for a relatively long time. The capacitor charges slowly in the manner indicated in Fig. 12-26. The small notches in the wave are due to the serrations. At these points, for a fraction of a second, the voltage drops and then rises again. As previously noted, these changes affect the horizontal filter but leave the vertical-filter output substantially unchanged because of their rapid disappearance.

Equalizing Pulses. We can pause for a moment here and determine more clearly the reason for the equalizing pulses. In Fig. 12-27 is shown the build-up of vertical-deflection voltage across the output of the vertical filter, once for the vertical pulse that comes at the end of a line, and once for the pulse that comes in the middle of a line. In the top illustration of Fig. 12-27, we see that each horizontal pulse causes a slight rise in voltage across the output of the vertical filter, but this is reduced to zero by the time the next pulse arrives. Hence there is no residual voltage across the vertical filter due to the horizontal pulses. Only when the long, serrated vertical pulse arrives is the desired voltage increase obtained.

However, the situation in the lower illustration of Fig. 12-27 is slightly different. Here the last horizontal pulse is separated from the first vertical pulse by only half a line. Any horizontal voltage developed in the vertical filter will thus not have as much time to reach zero before the arrival of

TELEVISION SIMPLIFIED

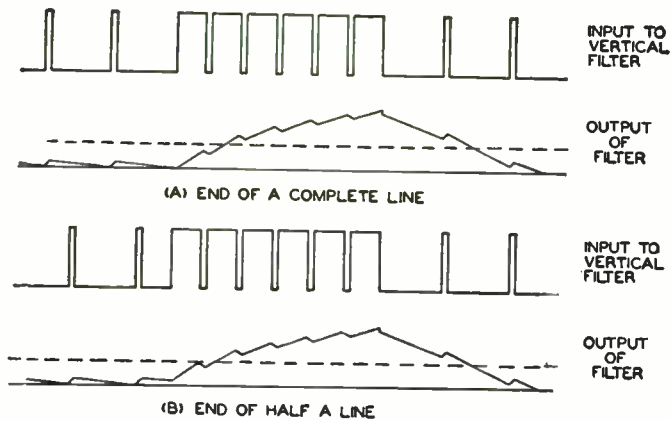

FIG. 12-27. The difference in voltage conditions before a vertical pulse when no equalizing pulses are used.

the first vertical pulse, which means that the vertical build-up does not start from zero, as in the top illustration, but from a low voltage value. As a result, the dotted line is reached sooner than it would be reached if the voltage rise had started from zero. Since the dotted line represents the firing point of the vertical oscillator, we see that the oscillator is triggered a fraction of a second too soon. The actual time involved is quite short, but it does prove sufficient to upset the precision interlacing of modern television images.

With the insertion of equalizing pulses before and after every vertical pulse, the voltage level established before the start of each vertical serrated pulse is essentially the same, and the vertical oscillator is triggered at the proper moment in each instance.

After the complete vertical pulse has passed through the filter, the charge on the capacitor output gradually returns to the small value it had previously, the voltage due to the horizontal pulses (Fig. 12-26). These pulses develop a very small voltage, far from sufficient to affect the vertical oscillator. Only the larger, longer vertical pulse $\frac{1}{60}$ sec later accumulates enough voltage to trigger the oscillator.

From a comparison of the vertical- and horizontal-pulse forms shown in Figs. 12-23 and 12-26, we may get the impression that the vertical pulse is not very sharp. The reason is the vertical pulse is shown extended over quite a few horizontal pulses and the comparison exaggerates the extent of the vertical pulse. If the vertical pulse were drawn to a larger interval, then it too would appear sharp. So far as the vertical synchronizing oscillator is concerned, this pulse occurs rapidly and represents a sudden change in voltage.

The polarity of the pulses, as obtained at the output of their respective filters, may or may not be suitable for direct application to the controlled synchronizing oscillators. It all depends upon the type of oscillator to be controlled. For a blocking oscillator the leading pulse must be positive. If a multivibrator type of oscillator is employed, either a positive or a negative pulse may be used, depending upon where it is introduced. This point will be more fully developed presently.

Synchronizing Oscillators. From the block diagram of the components of the synchronizing section of a receiver (Fig. 12-1), we see that the oscillator is the next stage in the path of the synchronizing pulse. Before studying the operation of the stage itself, let us first review its function.

The electron beam must move across the screen at the regular rate of 15,750 times a second. Its path, as explained in Chapter 1, is not straight across the screen, but tilted slightly downward. At the end of the line, it is brought rapidly back to the left-hand side of the screen. The type of voltage at the horizontal- and vertical-deflection plates that will accomplish this distinct motion is the sawtooth wave shown in Fig. 12-28. This wave gradually rises linearly and then, when it reaches a certain height, returns rapidly to its starting value.

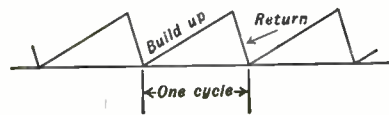

FIG. 12-28. A sawtooth wave. Either the voltage or the current may assume this form.

A capacitor, connected to a battery (or other source of supply) through a resistor, will initially charge in a manner approximately as shown in this figure. When the capacitor voltage reaches a predetermined value, a pulse from the oscillator completely discharges it and the voltage build-up begins again. Without going much further into the sequence at this point, we see that the pulse from the synchronizing oscillator controls the action of the charging capacitor and, through it, the action of the electron beam across the screen. The oscillator itself is controlled by the pulse in the television signal. In this way the entire network is tied together and coordinated.

The Blocking Oscillator. The blocking oscillator is one of two popular synchronizing oscillators used in television receivers. In common with all oscillators, feedback of energy from the plate to the grid must occur. A transformer is employed for this purpose. Any change of current in the plate circuit will induce a voltage in the grid circuit which will aid this change. To examine the situation in detail, consider the operation of the oscillator when a disturbance occurs in the circuit which increases the plate current. To aid this increase, a positive voltage is induced in the grid through transformer *T* (Fig. 12-29(A)). With the grid more positive than before, more plate current will flow, resulting in the grid becoming rapidly very positive. A positive grid means that electrons will flow in the circuit, charg-

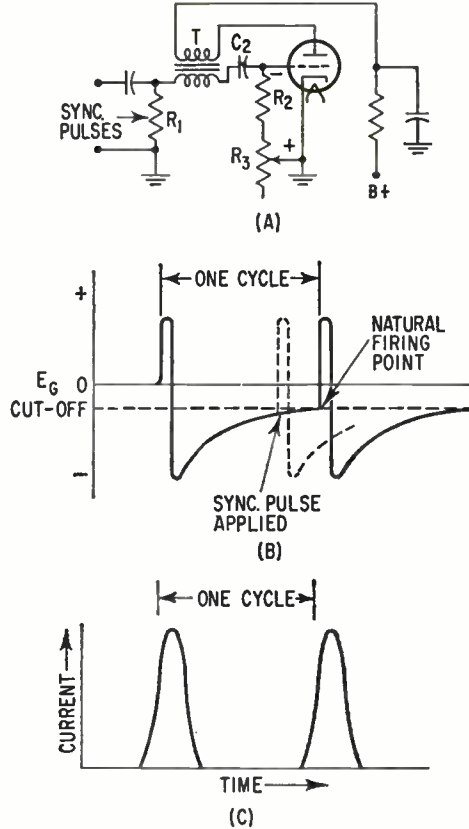

FIG. 12-29. (A) A blocking oscillator. (B) The grid voltage variations. (C) The form of the plate current.

ing capacitor C_2 . The electrons reaching the grid pile up on the right-hand plate of C_2 . With resistors R_2 and R_3 low in value, the charge on the capacitor leaks off rapidly and the action of the oscillator continues. In practice, however, R_2 and R_3 are made high, combining with C_2 to give a long-time constant. The electrons on C_2 discharge slowly to the cathode, placing a negative voltage on the grid, as shown in Fig. 12-29(A).

Because of the slow discharge of C_2 , electrons which have accumulated on the grid remain there in sufficient numbers to give it a large negative bias, sufficient to block or stop the plate-current flow. Gradually the electrons accumulated on C_2 pass through R_2 , R_3 , and R_1 back to the other plate of C_2 . Then the negative bias on the grid slowly becomes less. When the discharge is almost complete, electrons from the cathode once again reach the plate,

plate current starts up, quickly reaches its high value, drives the grid positive, and the process repeats itself. Thus, during every cycle there is a short, sharp pulse of plate current, followed by a period during which the tube blocks itself until the accumulated negative charge on the grid leaks off again. The frequency of these pulses is determined by C_2 , R_1 , R_2 , and R_3 .

The form of the voltage drop across R_2 and R_3 is shown in Fig. 12-29(B). In C , the plate-current pulse occurs once in every cycle. It is possible to control the frequency of this oscillator if a positive pulse is injected into the grid circuit at the time indicated in Fig. 12-29(B). To be effective, the frequency of the controlling pulse must be near and slightly higher than the free frequency of the oscillator. By free frequency is meant the natural frequency at which it will oscillate if permitted to function alone. This frequency is controlled by C_2 , R_1 , R_2 , and R_3 .

The point at which the synchronizing pulse should be applied to the grid of the oscillator is illustrated on the curve of Fig. 12-29(B). A positive pulse, applied to the oscillator grid when it is at this point of its cycle, will bring the tube sharply out of cutoff and cause a sharp pulse of plate current to flow. Then, at the application of the negative pulse of the horizontal synchronizing voltage which follows immediately, the oscillator is no longer in any position to respond. The grid has now become so negative that it is unaffected by the second negative synchronizing pulse. It is only when the grid capacitor C_2 is almost completely discharged that any pulse will *effectively* control the frequency of the oscillator. This accounts for the firm control of the correct horizontal pulses. Equalizing pulses which occur at the halfway point in the oscillator cycle do not possess sufficient strength to bring the tube out of cutoff. It also explains why a positive synchronizing pulse is required.

In short, then, the synchronizing pulse controls the start of the oscillator cycle. If left alone, the oscillator would function at its natural period which, more often than not, would not coincide with the incoming signal. Through the intervening action of the synchronizing pulse, both oscillator and signal are brought together, in step. Naturally, for effective control, both synchronizing pulse and oscillator frequency must be close enough together to permit locking-in.

Resistor R_3 is made variable in order to provide adjustment of the oscillator frequency. It is commonly known as the "hold control" since it can be varied until the frequency of the blocking oscillator is held in synchronism with the incoming pulses.

The output from the oscillator can be taken from either the plate or the grid circuit and used directly on the charge and the discharge capacitor, or it can be applied through another tube. The simplest method of obtaining

the sawtooth deflection waves is shown in Fig. 12-31. But before this diagram is analyzed, it may be helpful to discuss briefly the sawtooth wave and its properties.

Sawtooth Waves. The desired shape that the sawtooth waves should have is shown in Fig. 12-28: a long, straight, gradual rise in voltage until a predetermined value is reached; then a quick, sudden drop to the initial starting level. The process then repeats itself, 15,750 times a second for the horizontal oscillator and 60 times a second for the vertical oscillator.

Practically, the simplest way of obtaining the gradual rise in voltage followed by a sudden drop is by charging and discharging a capacitor. If a capacitor is placed in series with a resistor and a source of voltage, the flow of current through the circuit will cause the voltage across the capacitor to rise in the manner shown by the curve of Fig. 12-30. This curve is not

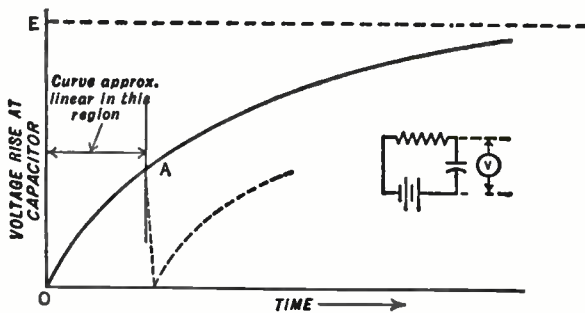

Fig. 12-30. The manner in which a voltage across a capacitor increases when a potential is applied through a series resistor.

linear along its entire length, but the approximation to linearity at the beginning section of the curve is close enough for most practical purposes. Hence, if the capacitor is discharged just as it reaches point *A* on the curve, we will have a satisfactory sawtooth wave suitable for application to the deflection plates of a cathode-ray tube. The discharge of the capacitor should be as rapid as possible since during the time the capacitor is discharging the electron beam is blanked out at the tube and no picture detail is appearing on the screen. The shorter the time spent in discharging the capacitor, the greater the interval during which the useful portion of the video signal may be acting at the screen.

A simple and inexpensive method of charging and discharging a capacitor to produce the necessary sawtooth waves is given in Fig. 12-31. Triode V_1 is connected as a blocking oscillator, and the charge-discharge capacitor is placed in the plate circuit. From the preceding discussion of the operation of these oscillators, we know that a short, sharp pulse of plate current

flows once in every cycle. During the remainder of the time, the grid is negatively biased beyond cutoff and no current flows in the plate circuit.

During the time no plate current is flowing, C_1 is charging, because one side of this capacitor connects to the positive terminal of the power supply through resistors R_1 and R_4 , and the opposite side is attached to ground. The charge the capacitor absorbs assumes the polarity shown in Fig. 12-31.

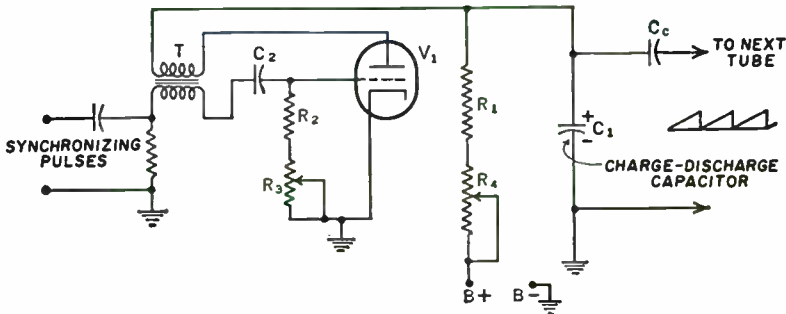

FIG. 12-31. A simple method of obtaining a sawtooth voltage from a capacitor.

When plate current starts to flow, it is only for a very short period, and during this time the resistance of the tube becomes very low. Capacitor C_1 , which is actually in parallel with the tube, then quickly discharges through this low-resistance path. At the end of the short pulse of plate current, the grid has been driven very negative by the accumulation of electrons in C_2 and the tube becomes nonconducting again. C_1 no longer has this easy path for discharging and slowly starts to charge, as previously explained. The sawtooth variation in voltage across C_1 is transmitted to the next tube, an amplifier, through coupling capacitor C_c . The process repeats itself, either at the horizontal scanning frequency or at the vertical frequency, depending upon the oscillator constants.

It will be noted from the foregoing action that the instant the synchronizing pulse arrives at the oscillator, it triggers the oscillator, the tube becomes conducting, and the capacitor developing the sawtooth voltage discharges. Hence, whenever a pulse arrives at the grid of the blocking oscillator, the capacitor discharges and the electron beam is brought back from the right-hand side of the screen to the left-hand side. This action is true in all such synchronizing oscillators.

Resistor R_4 is made variable to permit adjustment of the width of the picture. As more of its resistance is placed in the circuit, the amount of charging current reaching C_1 is lessened, with a subsequent decrease in the voltage developed across C_1 during its period of charging. A small voltage

variation at C_1 means, in turn, a small voltage applied to the deflection plates. The length of the left-to-right motion of the electron beam is consequently shortened, resulting in a narrower picture at the viewing screen. This is the reason for calling R_4 the "width control." In the vertical synchronizing circuit, this same control will affect (and adjust) the height of the picture. Here it will be labeled the "height control."

One blocking-oscillator variation that finds a significant amount of use is shown in Fig. 12-32. The oscillator transformer, T_1 , is here connected

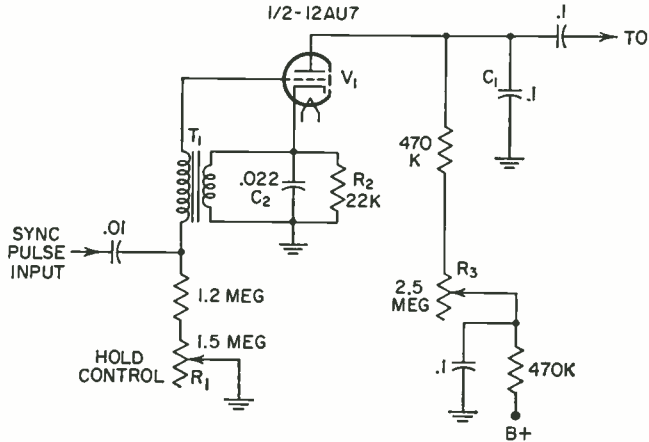

Fig. 12-32. A blocking oscillator in which feedback takes place between cathode and grid rather than between grid and plate.

between grid and cathode, and it is between these two elements that the energy transfer takes place. Overall operation of the stage is still essentially the same as that in the circuit of Fig. 12-31, since the same current flows in the plate and cathode circuits of V_1 .

The values shown for the various components in Fig. 12-32 are for a vertical oscillator operating at 60 cycles. R_1 is the hold control and it regulates the operating frequency of the oscillator. R_3 serves as the height control. C_2 and R_2 , across the cathode winding of T_1 , help to shape the pulse which is fed back to the grid. C_2 resonates with the transformer inductance, while R_2 prevents the pulse from rising to too high a value. Without these two components, the oscillator would tend to be less stable, and the sharp pulses which developed during the feedback interval would tend to shorten the life of T_1 and V_1 .

Multivibrator Synchronizing Oscillators. Multivibrator generators are also employed as synchronizing oscillators. Essentially, the multivibrator is a 2-stage resistance-coupled amplifier, with the output of the second

tube fed back to the input of the first stage. Oscillations are possible in a circuit of this type because a voltage at the grid of the first tube will cause an amplified voltage to appear at the output of the second tube, which has the same phase as the voltage at the grid of the first tube. This is always the case with an even number of resistance-coupled amplifiers, but never with an odd number. The output of an odd number of such stages is always 180 deg out of phase with the voltage applied at the input of the first tube. The two voltages thus oppose, rather than aid, each other.

The operation of a multivibrator is best understood if we trace the voltage and current changes through the various circuit elements. To start, assume that the power supply has just been connected across the circuit. See Fig. 12-33. Due perhaps to some slight disturbance in the circuit, the plate current of tube V_1 increases. This produces an increase in the voltage across R_1 , with the plate end of the resistor becoming more negative. Capacitor C_1 , which is connected to R_1 , at this point, likewise attempts to become more negative, and the grid of V_2 also assumes the same potential. The net result is a lowering of the current through V_2 and R_2 .

The lowered voltage across R_2 means that the plate end of this resistor becomes less negative, or relatively positive to its previous value. Capacitor C_2 transmits this positive increase to the grid of V_1 and, consequently, even more plate current flows through R_1 . The process continues in this manner, with the grid of V_1 becoming more and more positive and driving the grid of V_2 increasingly negative by the large negative charge built up across R_3 and C_1 . The plate current of V_2 is rapidly brought to zero by this action.

Tube V_2 remains inactive until the negative charge on C_1 discharges and removes some of the large negative potential at the grid of V_2 . The path of discharge of C_1 is through the relatively low resistance r_p of tube V_1 and the relatively high resistance R_3 . When C_1 has discharged sufficiently, plate current starts to flow through V_2 , causing the plate end of resistor R_2 to become increasingly negative. This now places a negative charge on the grid of V_1 , and the plate current through R_1 decreases. The lessening of the voltage drop at R_1 causes the plate end of the resistor to increase positively, and the grid of V_2 (through C_1) receives this positive voltage. The increased current through R_2 quickly raises the negative grid voltage on V_1

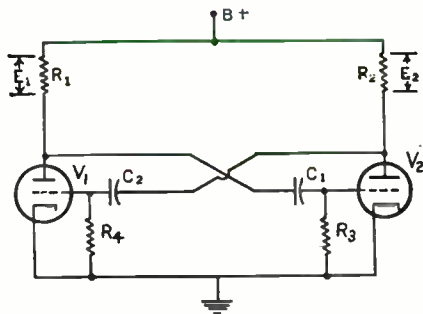

FIG. 12-33. The fundamental multivibrator circuit.

(through C_2) and drives this tube to cutoff. When the excess charge on C_2 leaks off, the process starts all over again. C_2 loses its accumulated negative charge by discharge through r_p of V_2 and R_4 . Contrast this path with that of C_1 .

The entire operation may be summed up by stating that first the plate current of one tube rapidly rises, driving the second tube to cutoff. This condition remains until the second tube is released from its cutoff state and commences to conduct. It is now the first tube which is cutoff. When the first tube is again permitted to conduct, the second tube is driven into nonconduction. The switching continues in this manner, with the frequency largely determined by the grid resistors and capacitors, R_4 , R_3 , C_1 , and C_2 .

If a synchronizing pulse is applied to either of the grids, and if its frequency is close to the natural frequency of the oscillator, it is possible to control the period of the multivibrator effectively.

Figure 12-34 illustrates how the multivibrator can control the charge and discharge of a capacitor, thereby developing the required sawtooth voltages.

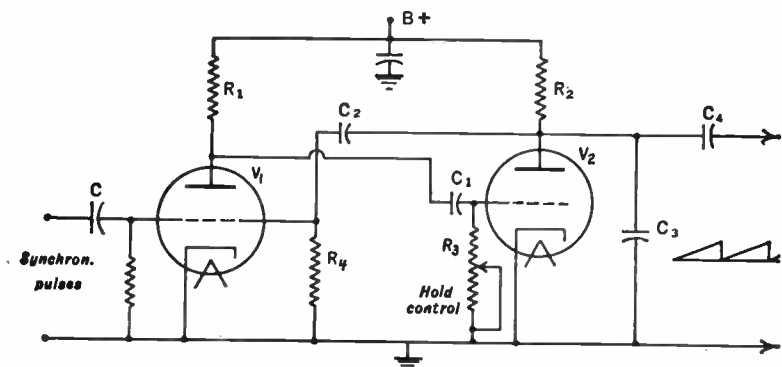

FIG. 12-34. How a multivibrator may be connected to control the charging and discharging of a capacitor to derive sawtooth waves.

The same multivibrator is used, with the addition of the charge-discharge capacitor C_3 . When tube V_2 is not conducting, the power supply will slowly charge C_3 through resistor R_2 . The moment that the grid voltage of V_2 reaches the cutoff point of the tube, the tube starts to conduct and its internal resistance decreases. Capacitor C_3 then discharges rapidly through the tube. During the next cycle, V_2 is again nonconductive, and again C_3 slowly charges. C_4 transmits the voltage variations appearing across C_3 to the next amplifying tube. Resistor R_3 is made variable to permit adjustment of the multivibrator so that it can be locked in with the synchronizing pulses. Hence R_3 is the hold control.

TYPICAL VALUES OF COMPONENTS SHOWN IN FIG. 12-34

<i>60 Cycles</i>	<i>15,750 Cycles</i>
V_1 — $\frac{1}{2}$ 6SN7GTB	V_1 — $\frac{1}{2}$ 6SN7GTB
V_2 — $\frac{1}{2}$ 6SN7GTB	V_2 — $\frac{1}{2}$ 6SN7GTB
R_4 —2.2 megohms	R_4 —220,000 ohms
R_3 —1.0 megohms	R_3 —100,000 ohms
R_1 —100,000 ohms	R_1 —47,000 ohms
R_2 —2.2 megohms	R_2 —500,000 ohms
C_3 —0.1 mf	C_3 —500 mmf
C_1 —.01 mf	C_1 —.001 mf
C_2 —.05 mf	C_2 —.005 mf

The desired form of the sawtooth synchronizing pulses is a slow rise in voltage, followed by a rapid decrease. Toward that end, C_1 and R_3 of Fig. 12-34 are designed to have a considerably longer time constant than C_2 and R_4 . C_1 and R_3 will discharge slowly, maintaining V_2 in cutoff while C_3 slowly charges. During this interval, V_1 is conducting. Upon the application of a negative synchronizing pulse to the grid of V_1 , this tube is forced into cutoff, while V_2 rises sharply out of cutoff and into conduction. C_3 now discharges rapidly. Because C_2 and R_4 have a small-time constant, V_1 does not remain cut off very long and as soon as C_3 has discharged, V_1 begins to conduct, again cutting off the plate current of V_2 . The ratio of the time constants of C_1, R_3 and C_2, R_4 is approximately 9:1.

In many commercial receivers, a slightly altered form of multivibrator circuit is used, although the basic operation remains the same. This oscillator is shown in Fig. 12-35. Feedback between tubes is accomplished in two ways: through the coupling capacitor C_1 and the unbypassed cathode resistor, which is common to both tubes.

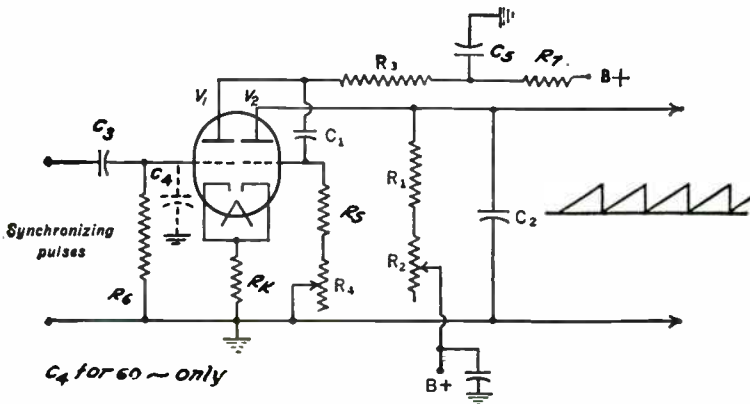

FIG. 12-35. Another widely used form of multivibrator, known as a cathode-coupled multivibrator.

The charge-discharge capacitor C_2 is placed in the plate circuit of the second triode. During the portion of the multivibrator cycle when V_2 is not conducting, C_2 is practically across the power supply and charges through resistors R_1 and R_2 . When a sharp negative pulse of voltage is applied to triode V_1 , the plate current of this tube decreases, causing the plate end of resistor R_3 to become increasingly positive. As the grid of V_2 is connected to this part of R_3 , it too will become more positive. The plate current through V_2 will rise sharply, developing enough voltage across the common cathode resistor to bring V_1 to cutoff. V_2 , however, continues to conduct because its grid has received sufficient positive voltage from the potential variation across R_3 to counteract partly this high negative cathode bias. V_1 , not having this positive grid voltage, is forced into cutoff. During this period, when V_2 is conducting heavily, its internal resistance is low and C_2 discharges through it.

The high positive voltage on the grid of V_2 , which resulted in a large plate current flow for an instant (and permitted C_2 to discharge), makes the grid draw current. This immediately biases the grid to cutoff (similar to the blocking oscillator), brings V_1 out of cutoff, and permits C_2 to charge again. Resistor R_4 is made variable to permit adjustment of the frequency of the multivibrator. R_2 controls the amount of the charging current flowing into C_2 , and this in turn regulates the extent of the electron beam sweep across the screen. R_2 is the width control.

TYPICAL VALUES OF COMPONENTS SHOWN IN FIG. 12-35

<i>60 Cycles</i>	<i>15,750 Cycles</i>
V_1 } 6SN7GTB	V_1 } 6SN7GTB
V_2 }	V_2 }
R_1 —1.0 megohm	R_1 —470,000 ohms
R_2 —2.0 megohms	R_2 —500,000 ohms
R_3 —100,000 ohms	R_3 —47,000 ohms
R_4 —1.2 megohms	R_4 —50,000 ohms
R_5 —1.2 megohms	R_5 —33,000 ohms
R_6 —2.2 megohms	R_6 —2,000 ohms
R_7 —100,000 ohms	R_7 —100,000 ohms
C_1 —.01 mf	C_1 —.001 mf
C_2 —.1 mf	C_2 —500 mmf
C_3 —.01 mf	C_3 —50 mmf
C_4 —.001 mf	C_4 —not necessary
C_5 —.1 mf	C_5 —.006 mf
R_k —470 ohms	R_k —470 ohms

Here, as before, the incoming synchronizing pulses serve to alter slightly the time at which a changeover from one tube to the other takes place. Without these pulses, each tube would conduct for a portion of the cycle, just as in the case of the previous multivibrator.

While a negative synchronizing pulse at the grid of V_1 will cause C_2 to discharge, we may obtain the same effect if a positive synchronizing pulse were fed to the grid of V_2 . The negative pulse, however, results in a more stable arrangement and is generally used. This fact explains the statement made several paragraphs before when it was pointed out that either a positive or a negative synchronizing pulse could be used to actuate a multivibrator. For the blocking oscillator, it will be remembered that a positive pulse was required.

The phrase "synchronizing an oscillator" is quite frequently used in describing the operation of television circuits. There are, however, many technicians who are not completely clear as to the exact mechanism of this synchronization. To clarify this point the following explanation is offered.

In a television receiver, the pulses of the incoming signal take control of the free-running sweep oscillators and lock them into synchronism with the pulse frequencies. We are referring, of course, to the horizontal and vertical synchronizing pulses. It is highly improbable that the first pulse, when it reaches the oscillator, arrives at such a time as to force the free-running oscillator exactly into line. Generally, this does not occur until several pulses of the incoming signal have reached the sweep oscillator. Let us examine the means whereby the receiver oscillator is gradually forced into synchronization with the incoming pulses.

In order to synchronize an oscillator, the pulses must be applied to the oscillator input. In Fig. 12-36 we have the grid-voltage waveforms of a

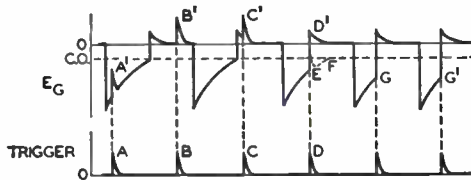

FIG. 12-36. How the incoming pulses lock in the synchronizing oscillators.

multivibrator and, beneath them, the triggering pulses as they are received from the preceding pulse separator networks. Suppose the first pulse, *A*, arrives at a time when the grid is quite negative and thus this pulse is unable to bring the tube out of cutoff. The second pulse, *B*, arrives when the tube is conducting. Thus, it drives the grid more positive and has very little effect on its operation. The conditions for the third pulse are similar to those for the second pulse. The fourth pulse, *D*, arrives at a time when the grid of the tube is negative. However, this pulse is able to drive the grid positive, thereby initiating a new cycle. Thereafter, each succeeding pulse arrives at a time when it will bring the tube out of cutoff and the

sweep oscillator is securely locked in as long as the pulses are active. It is important that the pulse reach the grid of the oscillator when it can raise the tube above cutoff. Unless it can do this, it will be without power to lock in the oscillator.

One final word about the foregoing oscillators. As the grid voltage approaches the cutoff value, it becomes increasingly sensitive to noise pulses which may have become part of the signal. A sufficiently strong interference pulse, arriving slightly before the synchronizing pulse, could readily trigger the oscillator prematurely. When this occurs, the electron beam is returned to the left-hand side of the screen before it should be and the right-hand edge becomes uneven. Severe interference causes sections of the image to become "torn." See Chapter 16. To prevent this form of image distortion, television-receiver manufacturers use synchronizing systems which respond only to long-period changes in the pulse frequency. Since interference flashes seldom have regular patterns, they cannot affect these special systems. Several such systems are analyzed in Chapter 13.

QUESTIONS

1. Do the horizontal and vertical synchronizing pulses ever reach the control grid of the cathode-ray tube? Explain.
2. Draw a diagram of a complete video signal, indicating where the horizontal synchronizing pulses are located.
3. Illustrate the path taken by all synchronizing pulses in a television receiver.
4. State specifically the action of the horizontal and vertical synchronizing pulses in controlling the motion of the electron beam.
5. Explain what precautions must be observed before the pulses can be separated from the rest of the video signal.
6. Draw the circuit of a diode clipper. Explain how it operates.
7. Why are pentode and triode clippers more desirable than diode clippers?
8. Draw the circuit of a pentode-clipper stage, indicating the values to be assigned to the B+ voltage.
9. Why do the blanking voltages last longer than either the vertical or the horizontal synchronizing pulses? What would happen if the blanking voltages were too short?
10. Explain why serrated vertical pulses are employed. Draw a serrated vertical pulse, indicating its duration in microseconds.
11. What is an active line? What is the approximate number of active lines per frame? Indicate how your figure was obtained.
12. Indicate the position and time duration of the equalizing pulses.
13. Why are equalizing pulses necessary? Illustrate your answer by means of diagrams.
14. Draw the diagram of a differentiating network and explain its operation.
15. Draw an integrating network and explain its operation.
16. Do the same vertical and equalizing pulses trigger the horizontal oscillator after every field? Explain.

17. Illustrate the action of a vertical pulse in triggering the vertical sweep oscillator.
18. How are sawtooth deflection voltages developed? What are the limitations of this method?
19. Draw a diagram of a blocking oscillator.
20. Explain the operation of blocking oscillators.
21. To control effectively the sweep oscillator, should the pulse frequency be higher or lower than the oscillator frequency? Why?
22. Draw the circuit of a cathode-coupled multivibrator.
23. Explain briefly how a multivibrator functions.

Deflection Systems

An Electrostatic Deflection System. An electrostatic deflection system has been chosen for analysis which is representative of many of the electrostatic deflection systems which have been used in television receivers. A schematic of this system is shown in Fig. 13-1.

Horizontal and vertical sync pulses (from a sync section, not shown) are applied to the horizontal and vertical oscillators. To insure that only the proper sync pulses reach each system, integrating and differentiating filters are inserted before the vertical and horizontal oscillators, respectively. The differentiating network inserted in the grid circuit of the horizontal multivibrator consists of a 220 mmf capacitor and a 4,700-ohm resistor. The integrating network placed in the signal path leading to the vertical-sweep oscillator (also a multivibrator) consists of two 4,700-ohm resistors and two 0.005-mf capacitors.

Turning our attention first to the horizontal-sweep system, we see that it consists of two duo-triodes (12SN7GTB). One 12SN7GTB is the multivibrator, operating at a frequency of 15,750 cycles. A 250,000-ohm potentiometer permits variation of the horizontal frequency and is the hold control. The sawtooth deflection voltage is developed across C_1 in the plate circuit of the second triode section of V_1 . A width control regulates the amount of voltage developed across the capacitor. One triode section of V_2 receives the sawtooth voltage, amplifies it, and applies it to one horizontal-deflection plate of the 7JP4 picture tube. The same triode also feeds a small portion of this voltage to the second triode section of V_2 of which plate is connected to the other horizontal-deflection plate in the cathode-ray tube. In this manner, push-pull deflection is achieved.

The vertical system, containing V_3 and V_4 , is almost identical in design. A 1-megohm potentiometer in the multivibrator circuit controls the vertical-sweep frequency, and a 10-megohm potentiometer regulates the height of the

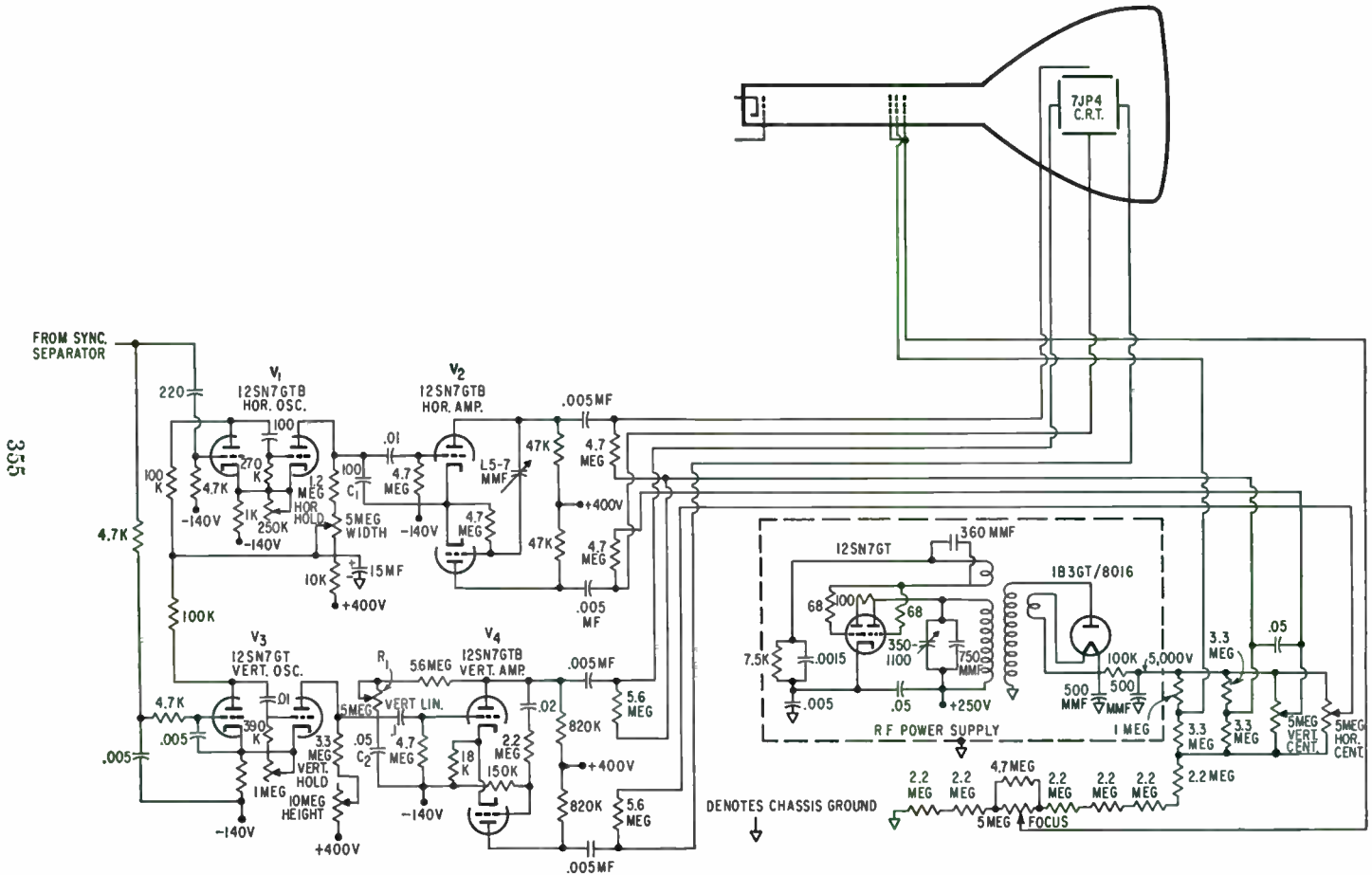

FIG. 13-1. A complete electrostatic deflection system.

image. C_2 is the charge-discharge capacitor, developing the necessary sawtooth-deflection voltage which, after passage through V_4 , is applied equally, but in opposite phase, to the vertical-deflection plates in the 7JP4. A variable resistor, R_1 , serves as the vertical-linearity control. Its function is to correct the shape of the sawtooth waves so that they rise more linearly. The name of the control is derived from this action. The need for correction arises from the tendency of the charging voltage across C_2 to increase in a manner not quite linear. This fact was pointed out in a preceding paragraph where it was stated that, if only a very small portion of the curve is used, the resulting wave will be satisfactory. The situation is still true. However, if only the most linear portion of the charging curve is used, the voltage developed across the charging capacitor is small. This requires a considerable amount of amplification, accomplished only with additional amplifiers. As a practical solution it is customary to permit the voltage across the charging capacitor to extend somewhat beyond the linear portion, and to compensate for this nonlinearity by a special control. Good results are obtained and one push-pull stage of amplification following the charge-discharge capacitor is usually sufficient.

In this system, R_1 regulates the amount of voltage fed back from the output of the vertical-sweep amplifiers to the input and in this way is able to offset tapering or rounding off of the deflection voltage developed across C_2 .

In both multivibrators (V_1 and V_3), the grid and cathode of each triode section are each returned to -140 volts instead of to ground. Since the voltage is applied equally to both elements, it does not constitute a grid-bias voltage. Instead, it is used here in conjunction with a positive 400 volts applied to the plates of the tubes to provide an effective plate voltage of 540 volts. Thus a fairly linear sawtooth voltage of large amplitude can be developed across C_1 and C_2 .

In addition to the sawtooth deflection voltages, each of the deflection plates receives a d-c voltage for the purpose of centering the electron beam. Two centering controls, one for the vertical set of plates and one for the horizontal set, permit variation of the d-c voltage on one of the deflection plates of each set. The d-c voltage on the other plate is kept constant.

The high-voltage power supply shown at the bottom of Fig. 13-1 is of the RF type described in Chapter 10. It develops 5,000 volts, which are applied to the centering controls and a bleeder network. At appropriate points along the bleeder network, voltages are tapped off for the accelerating electrode in the 7JP4 and for the first anode. The latter voltage is variable, in order to provide a focusing adjustment of the electron beam. Low voltages (those applied to the remaining tubes in the set) are developed by a separate power supply which uses diode and selenium rectifiers. Voltages

available are +250 volts, +400 volts, +120 volts, and -140 volts. The +250 volts is used solely for powering the high-voltage RF supply.

ELECTROMAGNETIC DEFLECTION SYSTEMS

In electrostatic deflection systems, the objective is to develop sufficient deflection voltage to swing the electron beam completely across the screen, from side to side, and from top to bottom. In electromagnetic deflection systems, the driving force in the picture tube is a magnetic field and, to develop such fields, current is required. Just as a sawtooth deflection voltage was needed, so now a sawtooth deflection current is required. However, in order to achieve a sawtooth-current flow through the deflection coils, we frequently must apply to these coils a voltage that possesses a modified sawtooth form.

The form of the voltage wave to be applied to the deflection coils is derived by analyzing the components of the coils and their action when subjected to voltages of various shapes. Each coil contains inductance plus a certain amount of resistance. So far as the resistance is concerned, a sawtooth voltage will result in a sawtooth current. For the inductance, considering a pure inductance, a voltage having the form shown in Fig. 13-2(B)

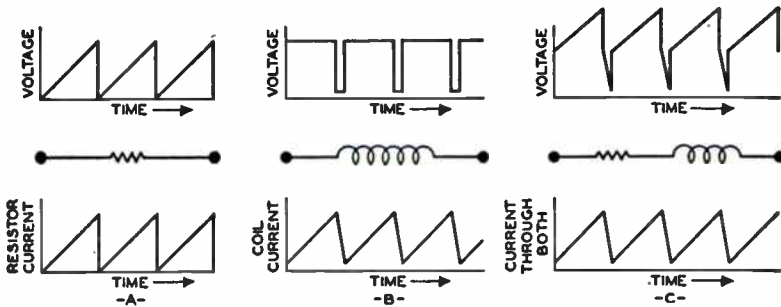

FIG. 13-2. By applying the voltage shown above the electrical component, the sawtooth waves shown below the component are obtained.

is needed for sawtooth-current flow. Combining both voltage waves, the result obtained varies in the manner shown in Fig. 13-2(C). A voltage of this type, when placed across the deflection coils will give a sawtooth current, and the magnetic flux, varying in like manner, will force the electron beam to sweep across the screen properly. Note carefully that the resultant wave is not obtained by combining the two voltage waves in *equal* measure. If the deflection circuit contains more inductance than resistance, the resultant wave will be closer in form to Fig. 13-2(B). On the other hand, if the resistance predominates, then the resultant wave will more closely resemble

Fig. 13-2(A). Hence, one may expect to find variations of this horizontal-deflection wave ranging from almost a pure sawtooth wave to that shown in Fig. 13-2(C).

The next problem is to generate this voltage. It was found that this could be accomplished readily by obtaining the output from the charging capacitor and a series resistor in place of the capacitor alone. The circuit is shown in Fig. 13-3. In the diagram, the capacitor is charged by the current passing

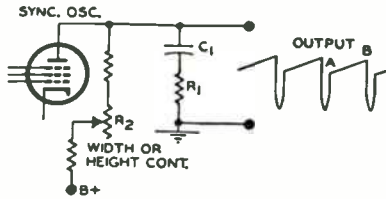

Fig. 13-3. A common method of generating deflection voltages suitable for application of deflecting coils.

through resistor R_2 from the battery. During this period the voltage is rising from A to B. When the oscillator tube is triggered and the tube is conducting heavily, the plate voltage drops nearly to cathode potential. Capacitor C_1 discharges during this time. The conduction time, however, is short and C_1 is unable to discharge completely before the tube is again cut off. The plate voltage does not have to rise slowly from cathode potential; instead, it rises immediately to

whatever voltage still remains across the capacitor. Thereafter, it rises slowly in a fairly linear manner until the arrival of the next pulse. R_2 is made variable to permit adjustment of the output voltage so that the proper image size may be attained.

The only difference, it is noted, between the methods for generating suitable deflection voltages for electrostatic and electromagnetic systems is the components at the output terminals. For electrostatic deflection, the output is taken from a capacitor alone; for electromagnetic deflection, a series resistor is included. Either combination may be used with the blocking oscillator or the multivibrator.

Vertical-electromagnetic-deflection Systems. The two basic oscillator circuits discussed in Chapter 12 are employed in the vertical-deflection system of current television receivers. A number of typical circuits are analyzed here to show the exact form of complete vertical-deflection systems.

Blocking-oscillator Systems. The circuit shown in Fig. 13-4 consists of a blocking oscillator followed by an output amplifier. The oscillator and the output simplifier each utilize one-half of a 6CM7 tube, which is a dual triode with each section fashioned for the particular service it is to perform. For example, the triode which functions as the vertical-output amplifier has considerably higher transconductance and plate dissipation ratings than the other triode section. This enables it to carry (and provide) more power, which is necessary for an output stage, and also permits the design of a 1-tube vertical-deflection system.

Positive sync pulses are obtained from a sync amplifier and passed through an integrating network consisting of R_1 , R_2 , C_1 , and C_2 . In the diagram, four components are enclosed in a dotted box to indicate that they are encased in a single housing having three external leads. Capacitor C_3 , which follows the integrating network, also contributes to the integrating action.

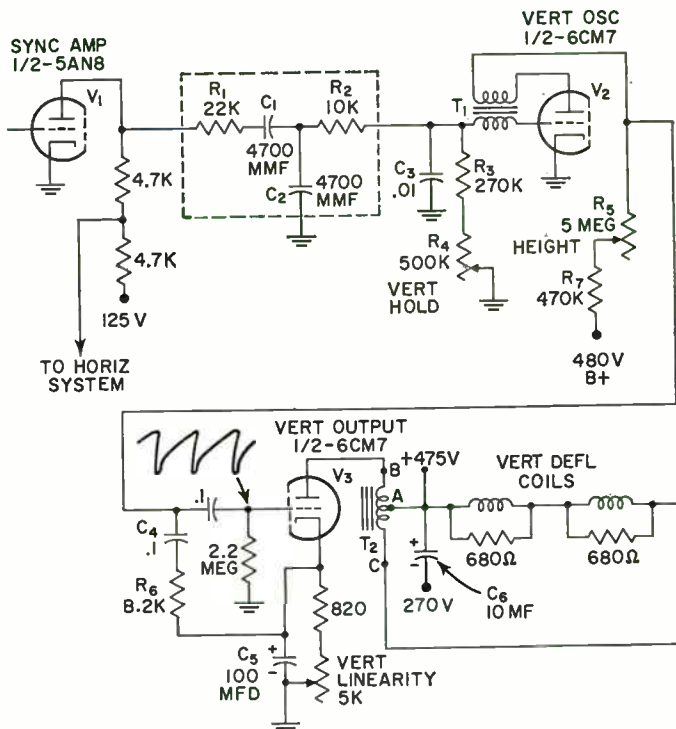

FIG. 13-4. A commercial vertical-deflection system employing a blocking oscillator.

The sync pulses are applied to the grid of V_2 , which is a conventional blocking oscillator with T_1 providing feedback from the plate to the grid. R_4 is the vertical hold control, and with it we can vary the operating frequency of the oscillator. Another potentiometer, R_5 , in the plate circuit controls the amplitude of the voltage developed across C_4 . This, then, is the "HEIGHT" control. Note that the bottom end of R_6 connects to C_5 , the large bypass capacitor in the cathode network of the vertical-output tube, V_3 . This has the same electrical effect as if R_6 had been directly connected to ground.

The waveform which is developed across C_4 and R_6 , and which is transmitted to the grid of V_3 , is shown just above this point. It possesses a

gradual sawtooth rise, followed by a sharp drop representing the retrace period. Because C_4 does not completely discharge, the next cycle starts above ground. This is in keeping with the type of waveform required for electromagnetic deflection. Furthermore, since V_3 is a triode and therefore possesses a relatively low internal plate resistance, the inductance of the output transformer dominates the circuit. Consequently, a peaked waveform is needed for deflection.

The waveform V_3 received from the vertical-oscillator circuit is amplified and applied to the vertical-autotransformer output. The vertical-deflection coils are connected across part of the transformer and carry the sawtooth current necessary to deflect linearly the electron beam in the picture tube. B+ is brought to the plate of V_3 from point A, a tap on the output-transformer winding. Insofar as V_3 is concerned, its plate load consists of the winding between points A and B. The bottom half of the transformer, between points A and C, is the output section of this unit and it is across points A and C that the vertical-deflection coils are connected.

Point A on transformer T_2 is almost at a-c ground potential because of the presence of electrolytic capacitor C_6 . One end of C_6 connects to point A, while the other end connects to a +270-volt point in the power supply. This arrangement is used, rather than have C_6 return to ground directly, because the positive potential at point A is close to 475 volts. If C_6 is returned directly to ground, it must possess a voltage rating in excess of 475 volts, and an electrolytic capacitor with a voltage rating this high is fairly expensive. By returning C_6 to 270 volts, this capacitor needs a voltage rating of 475 volts minus 270 volts, or somewhat over 200 volts. Such electrolytic capacitors are considerably cheaper. However, insofar as the grounding action of

C_6 on point A is concerned, the same results are obtained as if C_6 had been tied directly to ground.

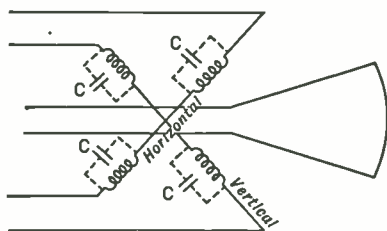

FIG. 13-5. The distributed capacitance inherent in deflection coils.

Each of the vertical-deflection coils has a 680-ohm resistor shunting it. In winding these coils, it is impossible to eliminate distributed capacitance between turns. Hence, the inductance of the coils and this distributed capacitance form a parallel resonant circuit (Fig. 13-5). Every $\frac{1}{60}$ sec, a sharp pulse of voltage develops across the circuit. If one

of the frequency components of this pulse is near the resonant frequency of the coil, oscillations will be set up. The visual effect on the screen is the appearance of spurious lines at the top of the image. These occur here because

the oscillations are set up immediately after the voltage pulse appears across the coils, and the beam, after the pulse, is at the top of the screen.

By inserting relatively low-valued shunting resistors in parallel with the deflection coils, it is possible to damp quickly any oscillation that might be set up. As in any other parallel resonant circuit, oscillation amplitude will be reduced if a relatively low resistance is placed across the circuit. The action resembles the loading of the input-tuning circuits in the RF and IF stages. Sometimes, a resistance in series with a capacitance is used for this damping function. Note that the preceding vertical-output-amplifier triode, V_3 , is also connected across T_2 and its relatively low plate resistance is reflected across the deflection coil. This also assists in the damping action.

In the horizontal-deflection system, where the pulses have higher component frequencies, it is even more important that stringent measures be taken to eliminate all unwanted oscillations. Suitable damping circuits for the horizontal system will be examined presently.

A vertical-linearity control is located in the cathode circuit of V_3 . By varying the cathode-circuit resistance, we can shift the operating point of the tube, moving it from one point of its characteristic curve to another where the curvature is different. In this way, we are able to use the non-linearity of the characteristic curve of V_3 to counteract any nonlinearity that may develop in the sawtooth section of the deflection wave. This can be done successfully because the curvature of the tube characteristic is in a direction opposite the curvature which develops in the deflection wave. If such correction is not made, sections of the image will crowd together. Note that overcompensation will lead to the opposite distortion in which sections of the image are stretched out.

To gain some idea of the magnitude of the deflection voltages present in this circuit, the deflection wave present at the grid of V_3 has a peak-to-peak amplitude of 70 volts. When this signal is amplified by V_3 , and applied to the vertical-deflection coils, it is sufficient to sweep the beam completely across a 17-in. picture tube.

A second vertical-deflection system which contains basically the same circuit arrangement as that of Fig. 13-4 is shown in Fig. 13-6. Two interesting variations occur in this circuit. First, height control is achieved by resistor R_1 , in which the center arm taps off whatever voltage is required by V_2 in order to attain the necessary picture height. This arrangement closely parallels that of volume control in a conventional radio receiver. With the arrangement of Fig. 13-6, the deflection voltage developed across capacitor C_1 remains constant. This voltage, which here is practically sawtooth in form, is then passed on to R_1 , which governs the peak-to-peak deflection signal fed to the output tube.

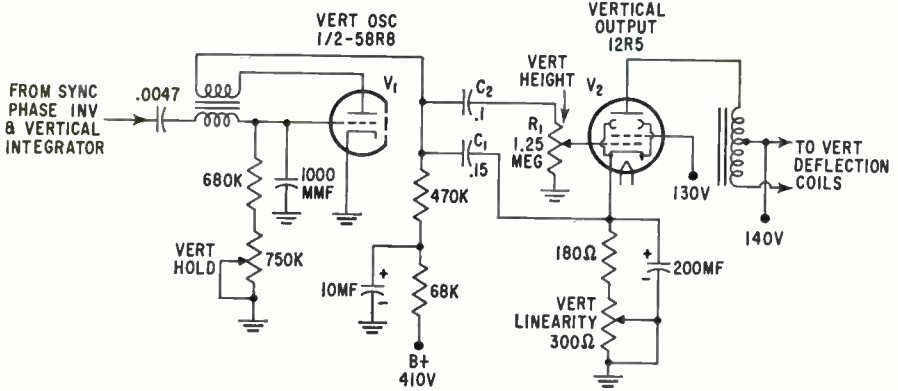

Fig. 13-6. A second vertical system employing a blocking oscillator.

A fairly linear sawtooth-wave deflection voltage is developed across C_1 ; the peaking resistor employed in the previous circuit is not found here. This arrangement is possible because V_2 has a high internal resistance which completely dominates the output circuit. For a circuit that is essentially resistive, even though it contains a small amount of series inductance, a sawtooth voltage will produce a sawtooth flow of current. As indicated before, the deflection voltage applied to the output circuit will vary from a pure sawtooth to one which is peaked, depending upon the proportion of resistance and inductance in the output circuit.

Multivibrator Systems. The third vertical-deflection system (Fig. 13-7)

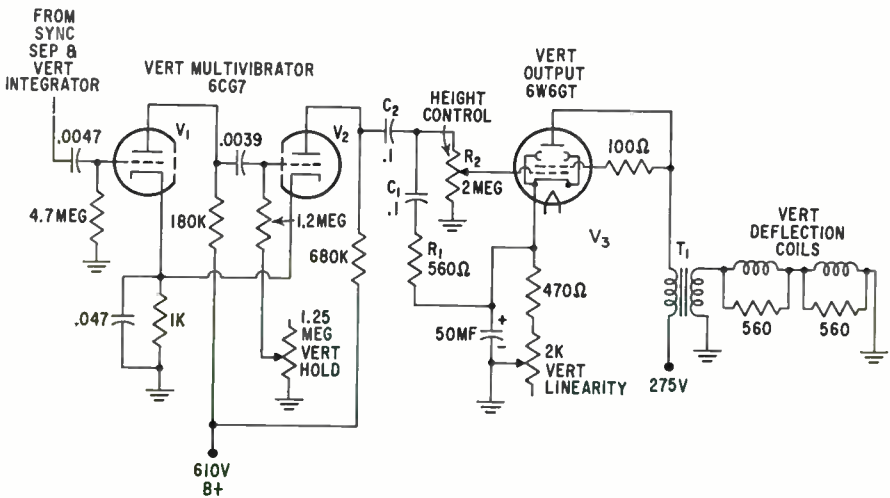

Fig. 13-7. A vertical system utilizing a multivibrator.

contains a cathode-coupled multivibrator as the oscillator. The deflection voltage is developed by C_1 and R_1 and transferred to the vertical-output tube, which is connected here as a triode. The amount of voltage required to develop the necessary picture height is controlled by potentiometer R_2 in an arrangement similar to that shown in Fig. 13-6. The vertical-deflection wave at the grid of the output tube has an overall peak-to-peak amplitude of about 90 volts. This wave is amplified and applied across the primary of output transformer T_1 . Then, by transformer action, the necessary current wave is developed in the secondary and sent through the vertical-deflection coils.

By using V_3 as a triode-connected tetrode, we obtain some of the power-sensitivity advantages of the tetrode with the lower-distortion feature of a triode. A beam-power tetrode, such as the 6W6GT, can introduce a fair amount of distortion into the deflection signal which it amplifies. By connecting the screen grid and plate, the tube is operated as a triode, with a resulting characteristic curve which is more linear and, hence, develops less distortion than it would if the tube were used as a beam-power tetrode. However, by connecting it as a triode, some of the power sensitivity is lost.

The positions of C_1 and R_1 in the circuit may appear puzzling since they fall to the right of C_2 rather than to the left. Insofar as the a-c variation produced across C_1 is concerned, it makes little difference whether C_1 is to the right or to the left of C_2 . With the present arrangement, both C_2 and C_1 will charge during the time that V_2 is cut off. However, it is the voltage across C_1 which is then transmitted to V_3 . During the retrace period, when V_2 is conducting strongly, both C_1 and C_2 discharge through V_2 and continue this discharge until V_2 is thrown back into cutoff. At this instant, whatever voltage appears across C_1 and R_1 determines the level from which the next cycle commences.

The fourth vertical-deflection system is shown in Fig. 13-8. Here, two tubes serve as the multivibrator and output amplifier, an arrangement made possible by using the output tube to complete the multivibrator circuit. If the circuit is examined, it will be seen that there is a feedback path from the plate of V_2 to the grid of V_1 . This path is formed by R_1 and C_1 and by transferring back energy which arrives in phase at the grid of V_1 , the oscillating action of a multivibrator is achieved. At the same time, a transformer in the plate circuit of V_2 feeds output signals to the vertical-deflection coil. Thus, by utilizing the output tube as the second multivibrator tube, we accomplish both functions with only two triodes. In this case, since each triode is one-half of a 12BH7A, the entire vertical system contains only a single tube. This arrangement is very economical and for this reason has found widespread use.

The rest of the circuit is fairly conventional and follows the previous

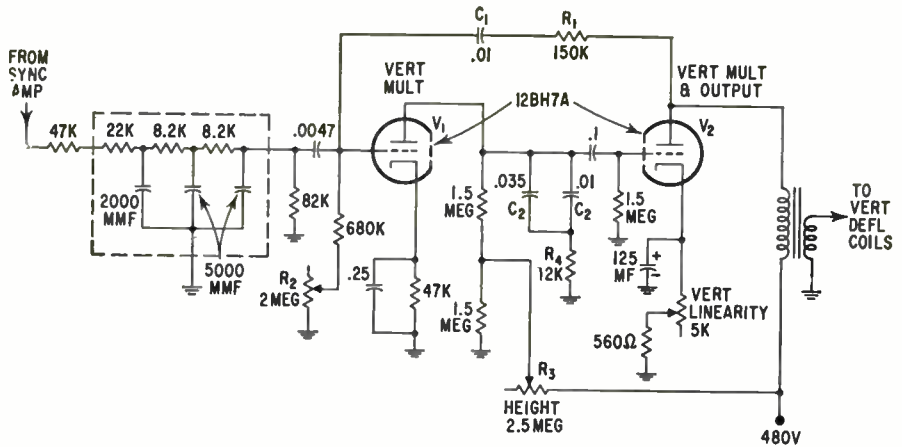

FIG. 13-8. The output tube in this system is also part of the multivibrator.

circuit quite closely. A potentiometer, R_2 , in the grid circuit of V_1 serves as the vertical hold control. A second potentiometer, R_3 , in the plate circuit of V_1 varies the amount of voltage fed to capacitors C_2 and resistor R_4 . R_3 is thus the height control. The peak waveform which is developed across C_2 and R_4 is then transferred by C_3 to the grid of the output tube, where it is amplified and then applied to the vertical-deflection coils. Part of this wave is fed back through R_1 and C_1 to the grid of V_1 to keep the multivibrator oscillating. Vertical linearity is accomplished conventionally by a potentiometer in the cathode leg of V_2 . Despite the fact that V_2 is employed as the second half of the multivibrator, the vertical-linearity control functions in exactly the same fashion as it did in any of the previous circuits where the output tube is a straight amplifier.

It is possible to control vertical linearity by varying the grid bias of the output tube directly. Such a method is illustrated in Fig. 13-9. A negative voltage which is developed at the grid of the first multivibrator tube is fed through R_1 to the vertical-linearity control, R_2 . The position of the arm on the vertical-linearity control determines the negative bias which the grid of V_2 receives. Resistor R_1 , which precedes the vertical-linearity control, is used to isolate the control from the grid of V_1 . Capacitor C_1 , in the network leading to the grid of V_2 , also assists in the filtering action so that the voltage fed to V_2 is essentially d-c.

Figure 13-9 also demonstrates that the vertical multivibrator does not need to be formed by two tubes of similar type. In this case, V_1 is a triode and V_2 is a beam-power tetrode. Just so long as there is sufficient feedback voltage from the output of V_2 to the input of V_1 , the circuit will oscillate. It is not necessary that V_1 and V_2 be similar electrically.

There are other variations of vertical-deflection circuits. However, the circuits that have been shown in Fig. 13-4 through Fig. 13-9 demonstrate the more important arrangements found in present commercial television receivers. Whether we are using a blocking oscillator or a multivibrator, the basic operation of the circuit remains unchanged. It is the function of the oscillator not only to provide the proper frequency, but also to develop a wave which will suitably deflect the beam from top to bottom of a picture tube. It is the purpose of the output amplifier to amplify the signal so that

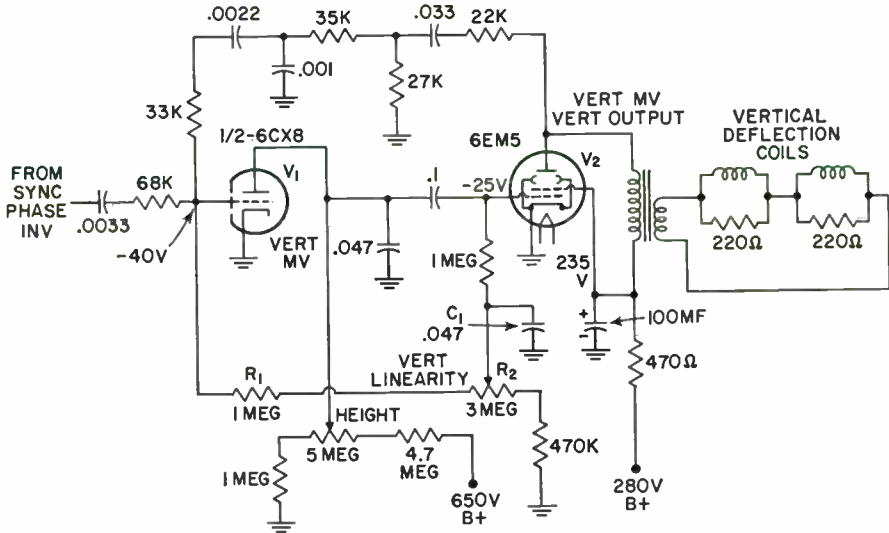

FIG. 13-9. The grid bias of V_2 is controlled directly for vertical linearity in this system.

the complete screen will be covered by the image. A nonlinearity control is generally incorporated in the output circuit to counteract any distortion that might arise either because of the nonlinear charging of the charge-discharge capacitor or because of the nonlinear characteristics of the output tube itself.

Horizontal-electromagnetic-deflection Systems. The basic form of the horizontal-deflection system is roughly similar to that of the vertical-deflection system. Both contain an oscillator followed by an output amplifier. However, the horizontal oscillator is almost invariably preceded by an automatic-frequency-control (AFC) network the sole purpose of which is to keep the oscillator on frequency while shielding it from noise pulses that might enter the receiver. This network is an important adjunct to the horizontal-deflection system and, to a considerable extent, governs the stability of this system.

Figure 13-10 shows a block diagram of a horizontal-deflection system. The horizontal sync pulses from the sync separator (or sync amplifier or sync-phase inverter) are fed to the AFC circuit. With these pulses and others which will be discussed in a moment, the AFC circuit determines whether or not the horizontal oscillator is on frequency. If it is not, then the AFC block develops a d-c voltage which it applies to the horizontal oscil-

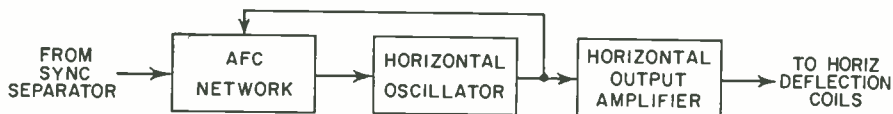

FIG. 13-10. Block diagram of a typical horizontal-deflection system.

lator and which serves to bring the oscillator frequency back into line. The oscillator develops an appropriate deflection voltage which is then passed on to the output amplifier and, from there, to the horizontal-deflection coils.

This, then, is the overall action of a typical horizontal-deflection system. Since the AFC network is the first stage of this system, let us analyze more closely why it is required and how it functions.

AUTOMATIC-FREQUENCY-CONTROL SYSTEMS

Use of the incoming sync pulses to trigger and control the vertical- and horizontal-sweep oscillators represents the simplest, most economical, and most direct method of controlling the motion of the electron beam in the image tube. Unfortunately, however, this method possesses limitations and disadvantages which outweigh its economy and simplicity. Perhaps the greatest disadvantage is its susceptibility to noise disturbances arising from electrical apparatus and equipment operating in the vicinity of the receiver. The noise pulses, combining with the video signal and extending usually in the same direction as the desired sync pulses, pass through the same stages as the pulses and arrive at the sweep oscillators. They do their greatest damage when they arrive during the interval between sync pulses. If the amplitude of the noise pulses is sufficiently great, they will trigger the sweep oscillator, initiating a new cycle prior to its proper time. When the vertical oscillator is so triggered, the picture will move vertically either up or down, until the proper sync pulses in the signal can again assume control. If the horizontal oscillator is incorrectly triggered, a series of lines in a narrow band will be jumbled, giving the appearance of streaking or tearing across the image. When the interference is particularly heavy and persistent, the entire picture becomes jumbled and may even be thrown out of horizontal sync permanently, requiring manual adjustment of the horizontal hold control.

Of the two sweep systems in a television receiver, interference is par-

ticularly destructive to the horizontal system. To understand why this is so, we must examine the nature of most interference voltages and their effect upon the vertical- and horizontal-sweep oscillators.

Whenever a blocking oscillator is triggered, for example by a sync pulse, its grid, after a short period of conduction, becomes highly negative as a result of an accumulation of electrons on the grid capacitor. This negative voltage is sufficient to keep the tube beyond cutoff until the charge on the grid capacitor has decreased to a value at which current is permitted to flow again through the tube. In most circuits now in use, the capacitor discharge occurs in the manner shown in Fig. 13-11. At the start, the discharge is fairly linear. However, as the amount of charge contained in the capacitor decreases, the discharging rate decreases exponentially. In Fig. 13-11, the region, usually called non-linear, extends from points *A* to *B*.

Now, when the negative charge existing on the grid capacitor is large, the oscillator is relatively immune to incoming positive pulses. With continued discharge, however, the immunity decreases. Experience has indicated that off-cycle triggering

of the oscillator is generally concentrated in the last 15 per cent of its discharge cycle. This is true regardless of the frequency at which the oscillator is operating. Hence, one would expect to experience equal difficulty with both deflection systems in the receiver. That this is not so is due to the nature of the noise pulses and the type of filters inserted before each sweep oscillator.

Noise pulses which are the most troublesome to television receivers possess high amplitude, but are narrow in width or, what is the same thing, are of short duration. (The energy in noise pulses is distributed over a wide range of frequencies. In order for a peak to occur, the phase relationship among the various frequencies must be such as to permit them to add, forming the high-amplitude pulse or peak. This condition, however, usually exists only for a brief interval, which explains the narrow width of these pulses.) When the pulses reach the path leading to the horizontal-sweep oscillator, they are readily passed because of the short-time constant of the filter leading to the horizontal system. A short-time-constant filter is necessary because the horizontal sync pulses themselves have a duration of only 5 microseconds. On the other hand, the filters leading to the vertical system have a long-time constant and automatically act to suppress the effects of

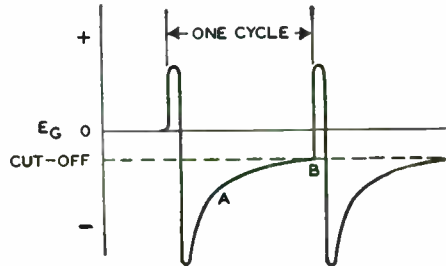

FIG. 13-11. The manner in which the grid voltage of a blocking or multivibrator oscillator varies.

all horizontal sync pulses and noise pulses of short duration. The presence of this low-pass filter (the integrating network) is largely responsible for the greater immunity to noise pulses enjoyed by the vertical system. Of course, when a wide noise pulse is received, it contains enough energy to cause off-time firing of the vertical oscillator, but the annoyance caused the viewer from this source is seldom great. To reduce the susceptibility of the horizontal-sweep system to noise pulses of any type, several automatic-frequency- (and phase-) control systems have recently been developed.

In each of these special control systems an oscillator is set to operate at 15,750 cps, and the output of the oscillator controls the horizontal motion of the electron beam across the screen of the image tube. The next step is to synchronize the frequency of this sweep oscillator with the incoming horizontal sync pulses of the signal. This step is accomplished through an intermediate stage known by one of the following names: control tube, AFC phase detector, or horizontal sync discriminator. Whatever the name, the function of this intermediate network is to compare the frequency of the incoming horizontal sync pulses with the frequency of the receiver horizontal sweep oscillator. If a difference exists, then a d-c voltage is developed which, when fed back to the horizontal-sweep oscillator, is used to change its frequency until it is exactly equal to that of the incoming pulses.

Note that the incoming sync pulses are not applied directly to the sweep oscillator. They are merely compared (in frequency) with the output of the sweep oscillator and, if a frequency difference exists, then a d-c voltage is developed which, when fed back to the sweep oscillator, forces its frequency back into line with that of the sync pulses.

Now (and here is the crux of the whole matter), by having the d-c control voltage pass through a long-time-constant filter before it reaches the sweep oscillator, we can eliminate the effects of any noise impulses and permit only relatively slow changes in frequency of the sync pulses (which may occur at the transmitter) to affect the sweep oscillator. Thus a long-time-constant filter somewhat similar to that present in the vertical-sweep system is incorporated into the horizontal-sweep system.

Remember, it was the long-time-constant filter in the vertical-sweep system that gave this network its immunity from most noise pulses (which have a short-time duration). A long-time-constant filter could not be used directly in the horizontal system because it would have prevented the desired horizontal sync pulses (as well as the noise pulses) from reaching the horizontal-sweep oscillator. Hence the need for the indirect method outlined above.

Now let us analyze the various automatic-frequency-control systems currently in use.

Horizontal AFC Systems. One of the first AFC systems to be used is shown in block form in Fig. 13-12. In this circuit, a stable Hartley oscillator is set at 15,750 cps. Connected to the oscillator is a synchronizing discriminator circuit which receives the pulses of the incoming television signal and

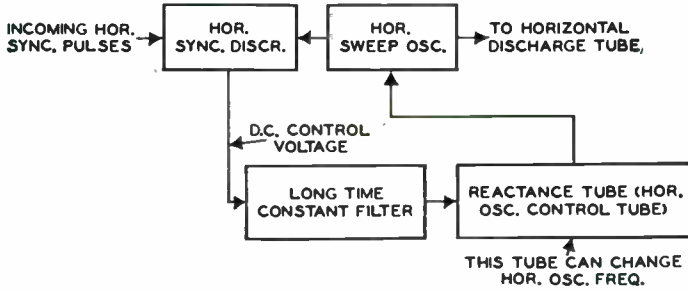

FIG. 13-12. A block diagram of the AFC system shown schematically in Fig. 13-14.

compares the frequency and phase of these synchronizing pulses with the generated sine wave of the Hartley oscillator. Any slight variations between the two will produce a d-c voltage which is applied to the grid of a reactance tube after passing through a long-time-constant filter. The plate circuit of this reactance tube is connected across the tuning circuit of the Hartley oscillator, and, as the d-c voltage at the grid of the reactance tube varies, it will alter the plate current of this tube and with it the oscillator frequency.

Since the reactance tube plays such a vital role in this and other AFC circuits, let us pause here and determine how a tube can simulate the action of a resistance, a capacitance, or an inductance.

In Fig. 13-13(A), a tube is connected with normal plate and grid voltages, so that plate current is flowing through the tube. When we increase the plate voltage, the plate current will increase and the two will be in step within fairly wide limits of plate-current flow. The same is true of a plate-

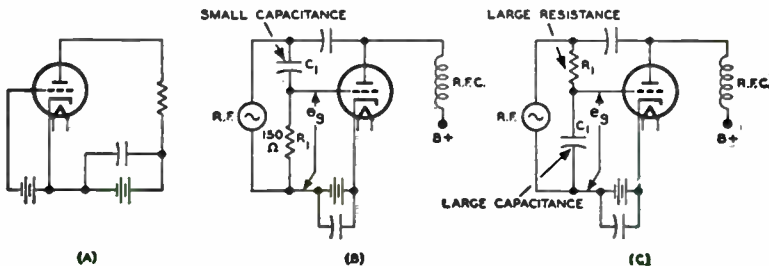

FIG. 13-13. Circuit diagrams showing how a vacuum tube can be made to appear as (A) a resistor, (B) a capacitor, or (C) an inductor.

voltage decrease; the current will decrease in step. Since the two follow each other directly, we obtain practically the same action as the voltage and current in a resistor, and consequently the tube is functioning as a resistor, although, at some voltages, it acts as a nonlinear resistor.

Now, let us alter the circuit to the form shown in Fig. 13-13(B). A source of RF voltage is connected to the plate of the triode and the B+ voltage now reaches the tube through an RF choke. The choke prevents the RF component of the plate current from passing through the d-c voltage source. In the same circuit, a small capacitor and resistor transfer part of the RF voltage to the grid of the tube. Let us investigate this section of the circuit more closely.

Since C_1 and R_1 are placed directly across the RF voltage source, an RF current will flow through both components, the amount of current being governed by the impedances of C_1 and R_1 . In the diagram it is specified that C_1 is small, resulting in a large impedance. The resistor, on the other hand, is low in value. Thus, the circuit impedance will be largely capacitive, and the current flowing through C_1 and R_1 will lead the RF voltage by approximately 90 deg. The RF current, flowing through R_1 , will develop a voltage, e_g , which is in phase with the RF current, and which leads the RF voltage from the generator by 90 deg. It is also true that since e_g is also the alternating grid voltage for the tube, the plate current will lead the applied RF voltage by the same 90 deg. Whenever any electrical component exhibits the property of having the current through it lead the voltage applied across it by 90 deg, it is said to act like a capacitance. Thus, by properly connecting the tube, we have made it appear to the circuit as a capacitor. The tube will have this effect on any circuit in which it is placed.

To indicate how a tube can be made to function as an inductance, we can employ the circuit in Fig. 13-13(C). Now we find that R_1 and C_1 have been interchanged and the impedance of R_1 greatly exceeds the impedance of C_1 , at the operating frequency of the RF-voltage generator. The current now through R_1 and C_1 will be in phase with the applied RF voltage. However, across any capacitor, the voltage always lags 90 deg behind the current and, therefore, the RF grid voltage, in Fig. 13-13(C), will lag the current through R_1 and C_1 by 90 deg. By the same token, it will lag the RF generator voltage by 90 deg. Within the tube, the plate current, being in phase with the grid voltage, will also lag the RF voltage by 90 deg. To the circuit, the tube will appear as an inductance in which the current lags 90 deg behind the applied RF voltage. (If desired, a high resistance can be shunted across C_1 to provide a leakage path for any electrons accumulated at the grid. With a high value of resistance, the circuit operation remains as indicated.)

In each of the foregoing instances, the amount of inductance and capaci-

tance that the tube injects into the circuit will depend upon the amount of plate current flowing through the tube. If we increase the d-c bias for the tube in the positive direction, the plate current will increase and its reactive effect on the circuit will likewise increase. With a greater negative d-c bias, the opposite action and effect will occur.

With the foregoing in mind, let us analyze the circuit of which Fig. 13-12 is the block diagram. This circuit is shown in Fig. 13-14 and consists of the following:

1. A horizontal-sync-discriminator circuit using V_{1A} and V_{1B}
2. A horizontal-sweep oscillator (V_2)
3. A reactance or horizontal-oscillator-control tube (V_3)
4. A long-time-constant network using C_3 , C_4 , and R_4

The sweep oscillator (V_2) is the well-known Hartley. The oscillator coil T_2 is inductively coupled to the horizontal sync discriminator by means of a center-tapped primary winding, T_1 . Each diode in the discriminator circuit is connected across half of T_1 , receiving sine-wave voltages which are equal in amplitude but opposite in phase. Disregarding R_1 for the moment, the voltages appearing across T_1 will affect this circuit in the following manner.

During one-half cycle, the top end of T_1 is positive, forcing V_{1A} to conduct. Its current flows from cathode to plate, through the top half of the coil, through R_1 and R_2 back to the cathode again. The voltage developed across R_2 is such that the bottom end is negative and the cathode end is positive. Throughout this interval, V_{1B} is nonconductive because the sine-wave voltage applied to its plate is negative.

During the next half cycle, V_{1B} conducts and V_{1A} is cut off. Current now flows through this tube, up through the bottom half of the primary winding, T_1 , through R_1 and R_3 back to V_{1B} again. The voltage developed across R_3 is such that its top end is negative. If the circuit is operating properly, the voltages across R_2 and R_3 will be equal. However, when these two voltages are added, the resultant will be zero because of the back-to-back placement of the two resistors. In this circuit the voltages are added, which means that no output voltage will be obtained, using this network alone. However, inspection of the circuit reveals that the horizontal sync pulses are also added to this circuit by means of C_2 and R_1 . C_2 connects to the output of the sync separator and transfers the horizontal pulses appearing here to R_1 where both V_{1A} and V_{1B} receive this pulse voltage in equal amplitude and phase. Now, let us see how this alters circuit operation.

A horizontal sync pulse can arrive at one of three times. It can appear across R_1 when the sine-wave voltage at T_1 is zero; it can arrive when

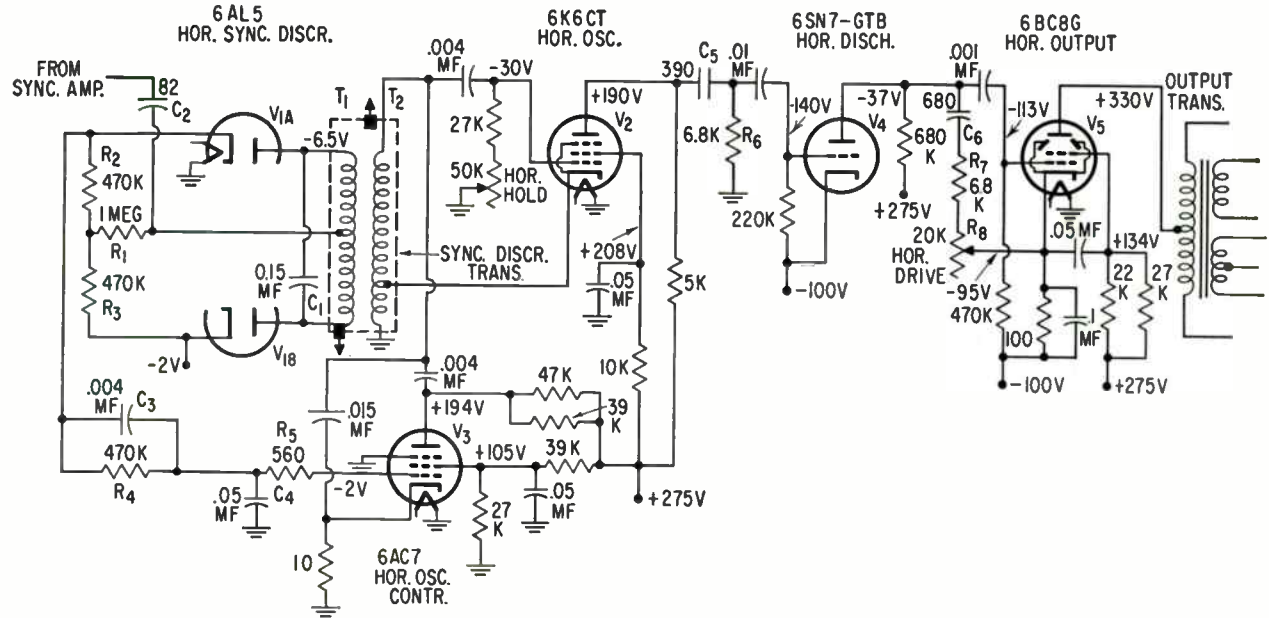

FIG. 13-14. An automatic-frequency-control system used in television receivers.

V_{1A} is conducting; or it can arrive when V_{1B} is conducting. If the pulse arrives when the sine wave applied to each tube is passing through zero, there will be no change in circuit conditions. The incoming synchronizing pulse appears across R_1 and combines with the sine-wave voltage from each half of the secondary coil, T_1 , to form the driving voltage for each diode. If the pulses arrive when the sine-wave voltage across T_1 is zero (Fig. 13-15(A)), then each diode will receive the same pulse voltage, and the same amount of rectified voltage will appear across the diode load resistors R_2 and R_3 . The total net output from both tubes will be canceled because their load resistors are connected in opposition (back-to-back).

Note again that the reason each diode produces equal voltages across R_2 and R_3 at this moment is that there is no sine-wave voltage and each tube receives the same synchronizing-pulse voltage from R_1 .

Suppose, however, that the pulse arrives at some other instant. Two such situations are shown in Fig. 13-15(B) and (C). In Fig. 13-15(B), the pulse arrives when the top diode is positive (and conducting) and the bottom diode is cut off. Obviously, then, on the average, more voltage will be developed across R_2 than across R_3 . The average voltage, over one cycle, will be positive, and this, fed to V_3 , will make its grid more positive. On the other hand, if we consider the situation of Fig. 13-15(C), we see that R_3 will receive the greater voltage and that, on the average, the voltage from the combination will be negative. The effect on V_3 will be different in each instance. It is seen, therefore, that the double-diode arrangement of V_1 is a very sensitive phase discriminator and will develop an output voltage which may be negative, zero, or positive, depending upon the phase of the pulses with respect to the voltage generated by the Hartley oscillator.

The d-c voltage developed in the phase discriminator, together with a fixed negative-bias voltage (-2 volts), is applied through the long-time-constant filter of C_3 , R_4 , and C_4 to the grid of a reactance tube, V_3 . This tube is so connected that its plate current is 90 deg out of phase with the voltage across it, and consequently it appears as a reactance. (Note that a .015-mf capacitor is connected from the plate circuit of V_3 to the 10-ohm cathode resistor. Here, the reactance of the capacitor far exceeds the re-

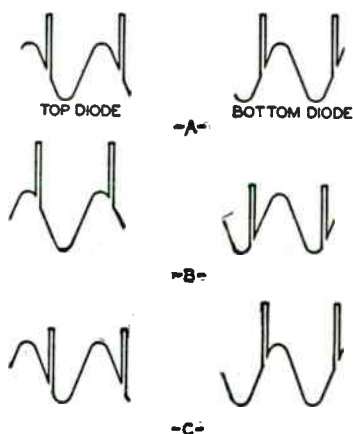
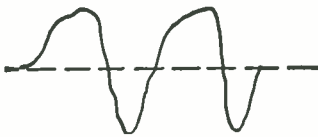

FIG. 13-15. How the horizontal synchronizing discriminator operates.

sistance of the 10-ohm resistor.) Since V_3 is connected directly across the tuning coil of the Hartley oscillator, changes in its plate current will produce changes in the frequency of the oscillator and force the oscillator to operate at the frequency of the synchronizing pulses. The d-c voltage developed at the phase discriminator is fed directly into the grid of the reactance tube and thereby controls the plate-current flow. In this manner, all differences in frequency between the synchronizing pulses and the Hartley oscillator are instantly corrected.

C_3 , R_4 , and C_4 form a long-time-constant filter to block the passage of rapid changes in d-c from the phase discriminator produced by noise pulses. Only the relatively slow changes in frequency caused by differences between the Hartley oscillator and the incoming horizontal sync pulses are permitted to reach V_3 . A hold control is available in case the Hartley oscillator frequency should be too far from the frequency of the incoming pulses.

Horizontal Discharge. A horizontal discharge tube, V_4 , follows the horizontal oscillator and produces, in its plate circuit, the peaked deflection voltage which will drive the horizontal deflection coils. In V_2 , the Hartley oscillator is connected between the screen grid and the cathode. The plate circuit contains only a resistance, and consequently the waveform found here is not the symmetrical sine wave that would be produced by a resonant circuit; rather it has the form shown in Fig. 13-16(A).



(A) Plate of horizontal oscillator 225 volts peak-to-peak



(B) Input to horizontal discharge tube 100 volts peak-to-peak

FIG. 13-16. (A) Plate of horizontal oscillator 225 volts peak-to-peak. (B) Input to horizontal discharge tube 100 volts peak-to-peak.

The peak-to-peak voltage on the grid of V_2 is approximately 100 volts. This grid swing produces a square wave in the plate circuit, with a peak-to-peak voltage of 225 volts. The square wave is differentiated by C_5 and R_6 , resulting in the waveform shown in Fig. 13-16(B). The positive portion of the differentiated wave is sufficiently sharp to trigger the discharge tube. The discharge tube is normally at cutoff due to bias produced by grid rectification of these pulses from the oscillator. The positive pip of the pulse overcomes this bias and drives the tube into heavy momentary conduction. During this period, the plate voltage of V_4 falls to cathode potential, and C_6 does not discharge completely because of R_7 and R_8 , both of which are in series with C_6 . When V_4 becomes non-conductive again, its plate voltage rises

quickly to a value determined by the charge remaining on C_6 . From this point the plate voltage rises slowly, and we get the desired deflection waveform. This is transferred to the horizontal output tube V_5 .

Phase-detector AFC Systems. Phase-detector AFC systems, as currently employed, fall into two general categories. These are diode and triode systems, according to the type of tube used. Even within each category there exist several different methods of achieving the desired output-control voltage, although in most instances the general operation remains the same.

Diode Phase-Detector. An early diode phase-detector circuit is shown in Fig. 13-17. Two diodes are connected so that they receive horizontal sync

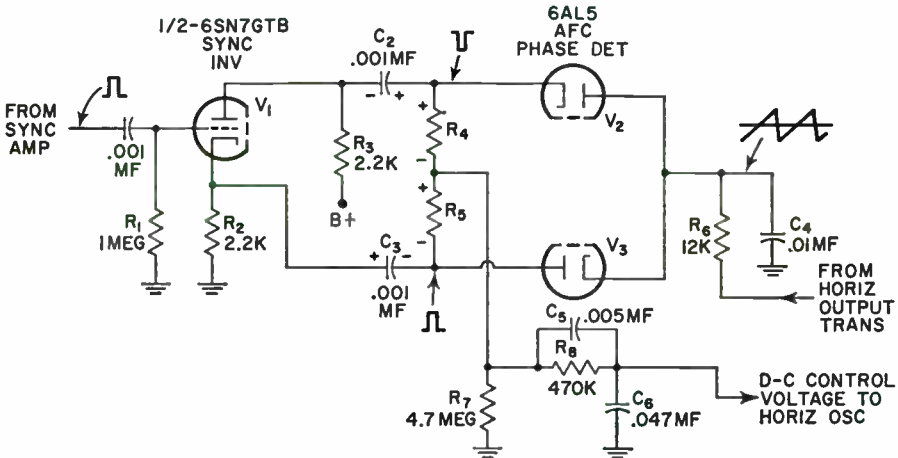

FIG. 13-17. A double-diode-phase detector.

pulses in phase opposition and a sawtooth wave in common. From the interaction of these waveforms, a d-c voltage is developed across R_7 that is governed by the relative-frequency difference between the incoming sync pulses and the sawtooth wave.

In detail, the network functions as follows. When sync pulses are received by V_1 , positive and negative pulses of equal amplitude are applied to both diode sections of the phase detector. The cathode of V_2 receives a negative pulse at the same time that the plate of V_3 receives the positive pulse. These pulses cause both diode sections to conduct. The current flowing through V_2 charges C_2 to approximately the peak value of the applied pulse, while the current flowing through V_3 charges C_3 . The polarity of each voltage is indicated in Fig. 13-17. During the interval between pulses, each capacitor discharges, the electrons moving from C_3 up through R_5 , then down through R_7 to ground, and up through R_2 to the other plate of C_3 . This current thus develops a negative voltage across R_5 and R_7 . C_2 also discharges and its electrons travel down through R_3 to ground (by way of the power supply), then up through R_7 to the junction of R_4 and R_5 , and then up through R_4 to the

other plate of C_2 . The result of these two currents through R_7 is that the voltage produced by one current cancels the voltage produced by the other current, leaving a net potential of zero volts. This is desirable since these two pulses, alone, should produce no net control voltage.

Because of the slow discharge of C_2 and C_3 through their respective networks, the voltages developed across R_4 and R_5 keep V_2 and V_3 from conducting until the arrival of the next pulse.

Coming into the phase detector is yet another voltage, a sawtooth wave which is developed across C_4 from pulses applied to it from the secondary of the horizontal-output transformer. This sawtooth voltage possesses the same frequency as the horizontal oscillator since it is the oscillator which drives the horizontal-output amplifier. The sawtooth voltage is applied equally to each tube; thus, the plate of V_2 and the cathode of V_3 receive the same polarity voltage (of the sawtooth wave) at the same time. Hence, at the phase detector, we have both ingredients needed to check the oscillator frequency against the frequency of the incoming pulses.

Comparison of the two frequencies is possible only at the instant the sync pulses arrive, because it is only at this moment that V_2 and V_3 conduct and are in a position to respond to the sawtooth voltage. Three situations are possible.

First, if the sync pulses arrive at a time when the sawtooth voltage is passing through zero, current will flow through V_2 and V_3 , replenishing any charge that C_2 and C_3 may have lost during the interval between pulses. No net voltage will appear across R_7 , as was indicated previously. This condition is the desired one because the frequency of the sweep oscillator and the sync pulses are in step with each other.

The second situation occurs when the sync pulses arrive and the sawtooth voltage is negative at this instant. (This occurs when the horizontal oscillator is running slowly.) Now V_3 will receive a positive pulse at the plate and a negative sawtooth voltage on the cathode and, hence, conduct more strongly than usual, producing a larger than normal voltage across R_7 . At the same time, conduction through V_2 is reduced because the negative sawtooth voltage at the plate partly offsets the negative sync pulse at the cathode. The reduced current flow through V_2 cannot offset the voltage which the current of V_3 develops across R_7 . Hence, a resultant negative voltage is developed which is fed to the horizontal oscillator, and its frequency is altered (in this case, speeded up).

In the third situation, the pulses arrive when the sawtooth voltage is positive. Now, V_2 conducts more strongly than V_3 and a resultant positive voltage is developed across R_7 . This voltage, fed to the controlled horizontal oscillator, acts to slow it down or lower its frequency to bring it in line with the frequency of the incoming pulses.

Filters C_5 , C_6 , and R_8 respond only to slow changes in voltage level, preventing fast-acting noise pulses from affecting the operation of the horizontal oscillator. In this way, we tend to stabilize the circuit and avoid the false triggering that can happen when sync pulses are fed directly to the horizontal oscillator.

D-C Control of Oscillator Frequency. The horizontal oscillator to which the d-c control voltage developed in Fig. 13-17 is applied is shown in Fig. 13-18. This oscillator is a cathode-coupled multivibrator containing a special

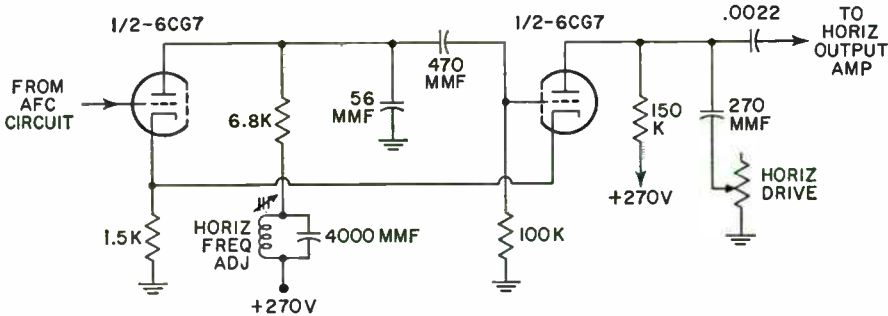

FIG. 13-18. A cathode-coupled multivibrator to which the AFC circuit of Fig. 13-17 would be connected.

resonant-stabilizing circuit in the plate circuit of the first triode. More will be said on this point later.

To understand what happens when the d-c control voltage is applied directly to an oscillator, consider the operation of a cathode-coupled multivibrator. It was noted previously that in this oscillator, the first triode conducts throughout the operating cycle. The second triode conducts only during "retrace" time. Since the cathodes are tied to ground through a common resistor, the operating bias of the second triode is affected by the cathode voltage developed by the first triode.

The grid of the first triode is usually bypassed to ground and is not part of the feedback loop. This leaves the grid available as the controlling element of the system.

If the correcting voltage on the grid of the first triode is made positive (by the automatic-frequency-control network), current flow through the tube will increase and the cathode voltage will rise. This extends the cut-off time of the second triode. Since the time is lengthened before the retrace time occurs, the oscillator frequency is lowered.

Similarly, any negative voltage applied to the first-triode grid lowers the cathode potential and shortens the time of the RC discharge of the second triode grid circuit. This change increases the firing rate and raises the frequency of the system.

It is possible, by reversing the polarity of the sawtooth voltage which is fed to the phase detector to obtain control voltages of opposite polarity, for the conditions of a fast or a slow oscillator. The oscillator is the controlling factor. For a cathode-coupled multivibrator, the required control voltages should possess the polarity indicated. For a blocking oscillator, an opposite set of polarity voltages would be needed.

In place of vacuum-tube diodes, germanium diodes may be utilized with identical results. The diagram of such a circuit is shown in Fig. 13-19.

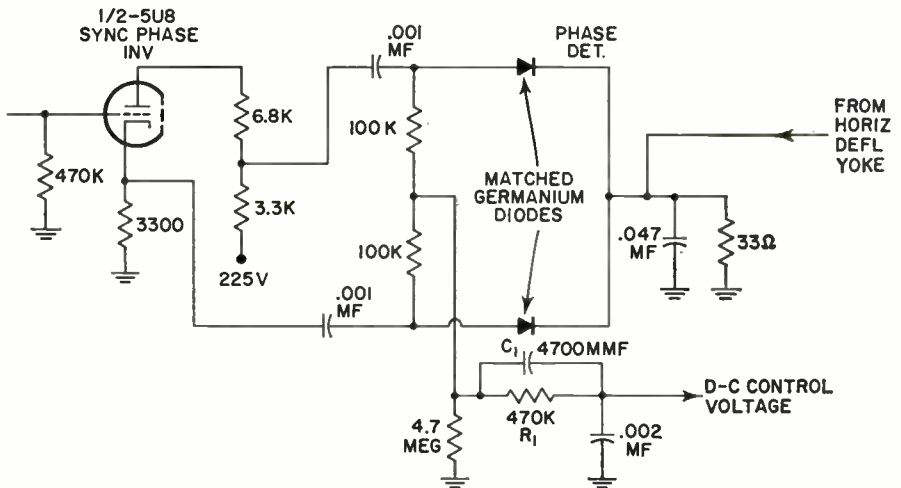

FIG. 13-19. Germanium diodes employed in a phase detector in place of vacuum-tube diodes.

One very important precaution that must be observed here is to select closely matched diodes, otherwise the circuit will become unbalanced and will not operate properly. If one diode becomes defective and must be replaced, it is usually desirable to replace both units.

The use of diodes in the phase detector just discussed requires horizontal sync pulses of positive and negative polarity. A two-diode circuit in which only one set of sync pulses is required is shown in Fig. 13-20. The two cathodes of the diode (in this case, germanium diodes) are connected and a negative-going sync pulse is applied at their junction. This arrangement applies the sync pulse equally across D_1 and D_2 because C_3 and C_4 are so much greater than C_1 that D_1 and D_2 are effectively connected in parallel. This being the case, current will flow in each diode, causing equal currents to flow in load resistors R_1 and R_2 . The currents, of course, flow in opposite directions and the voltage drops across R_1 and R_2 will have opposing polarities and, therefore, will cancel out, producing zero-volt output.

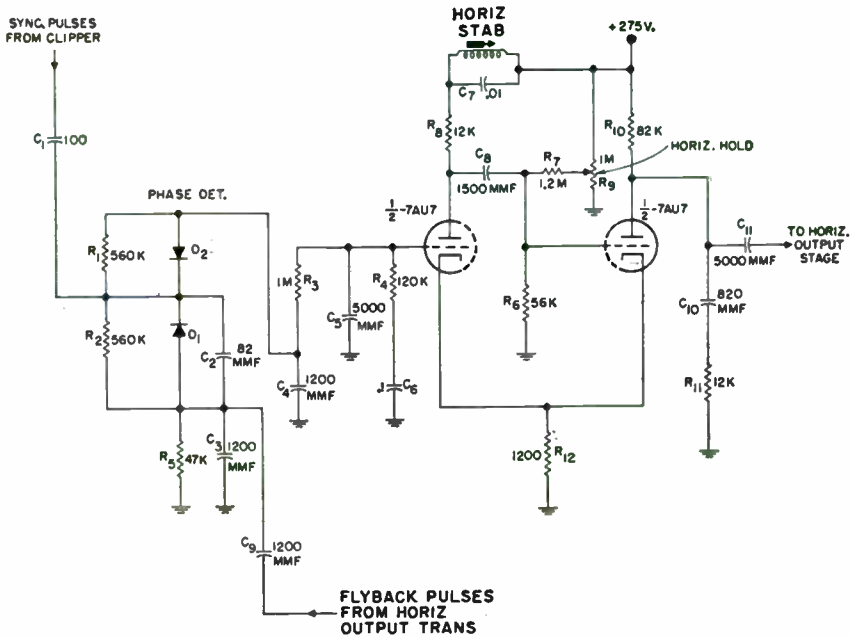
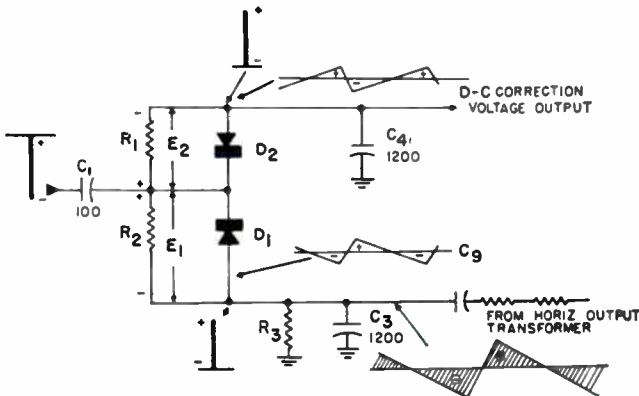

FIG. 13-20. A phase detector using germanium diodes and requiring only one set of input sync pulses.

The sawtooth wave which is formed from the flyback pulses received at the horizontal output stage is a sample of the horizontal oscillator frequency. This voltage is applied across D_1 and D_2 , effectively bringing one-half of the original sawtooth wave across each diode. It can be shown that the saw-



Courtesy G.E.

FIG. 13-21. A simplified diagram of the phase detector in Fig. 13-20, showing the waveforms in the circuit.

tooth wave across D_1 will be going positive when the voltage across D_2 is going negative, and vice versa (Fig. 13-21). The currents of both diodes will be equal but opposite in polarity, so equal and opposite voltages across R_1 and R_2 will produce a zero-volt output.

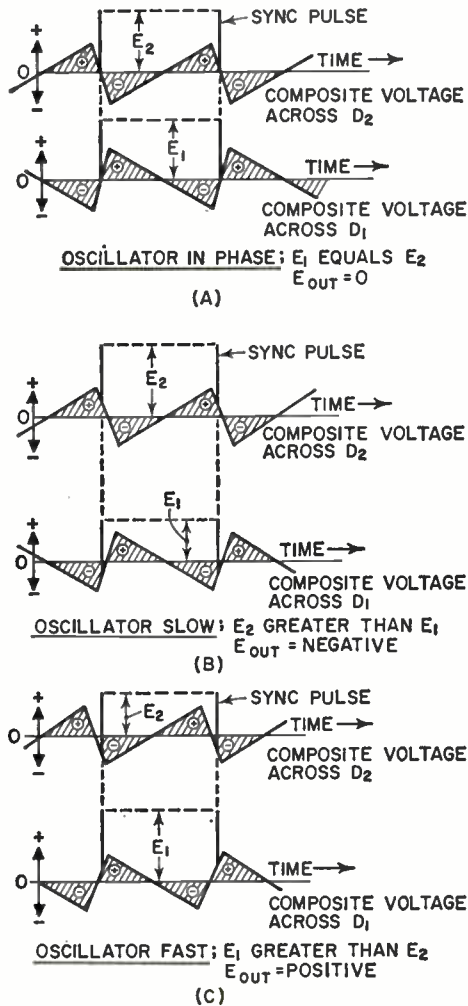

Courtesy G.E.

Fig. 13-22. Operation of the phase detector of Fig. 13-20 when the sync-pulse frequency and the oscillator frequency are (A) equal and (B and C) unequal.

Thus, the incoming sync pulses alone will not cause the phase detector to produce any voltage output. In like manner, the sawtooth wave alone will not cause the phase detector to produce any voltage output.

The sync pulse, possessing a much greater amplitude than the sawtooth wave, keeps the diodes biased so that they conduct only when the sync pulse is applied to them. Therefore, only that portion of the sawtooth wave that occurs at the instant of the sync pulse has any effect on the output of the phase detector.

Now, if the sync pulse occurs in the exact center of the sawtooth retrace (i.e., retrace passing through its a-c axis), equal but opposite currents will flow and no output voltage will be developed. See Fig. 13-22(A).

If the oscillator is slow, the sync pulse will arrive before the sawtooth retrace passes through its a-c axis. See Fig. 13-22(B). On D_2 , therefore, part of the sawtooth voltage will be added to the sync-pulse voltage because the sawtooth voltage is on the positive half of its cycle when the sync pulse occurs. Part of the sawtooth voltage on D_1 will be subtracted from the sync-pulse voltage because the sawtooth retrace here is still in the negative half of its cycle. The output voltage of the phase detector in this case will be a negative one because the voltage drop across R_1 is greater than the drop across R_2 .

If the oscillator is fast, the sawtooth retrace will pass through its a-c axis before the sync pulse occurs. See Fig. 13-22(C). On D_2 , therefore, part of the sawtooth voltage will be subtracted from the sync pulse. On D_1 , part of the sawtooth voltage will be added to the sync pulse, producing a higher voltage drop across R_2 than across R_1 . This will produce a positive output voltage which slows down the horizontal oscillator.

Triode Phase Detector. It is possible, through the action of a single triode, to achieve the same measure of control as with the double-diode circuits previously described. Two variations of triode AFC circuits are described below.

One triode phase detector is shown in Fig. 13-23. Positive and negative sync pulses of equal amplitude are required, the positive pulses going to the grid of the triode and the negative pulses going to the cathode. In addition,

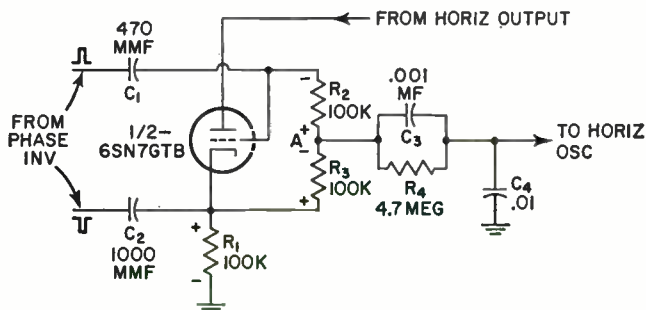

FIG. 13-23. A triode phase-detector circuit.

a sawtooth wave is applied to the plate. By the interaction of these voltages, an AFC voltage is developed at point *A* which can be used to control the frequency of a suitable horizontal oscillator.

Consider the action of the circuit when only the sync pulses are active. Simultaneous positive pulses to the grid and negative pulses to the cathode drive the tube into conduction and produce a current flow that charges capacitors C_1 and C_2 . During the interval between pulses, the charged capacitors, with their voltages in series aiding, cause a current to flow around the circuit. This current travels from C_1 and R_2 , to R_3 , then C_2 , and back to C_1 via the external circuit between the two capacitors. This flow produces a voltage drop across R_2 and R_3 , with the top ends of the resistors negative with respect to their bottom ends. The voltage remains quite constant because the applied sync pulses will normally remain fixed in amplitude.

In addition to the foregoing voltages, a potential is also developed across R_1 , the cathode resistor. This voltage is due to the current which reaches the plate of the tube during the instants the tube is pulsed into conduction by the applied sync pulses. The value of this voltage varies with the condition of the plate voltage at the instant the pulses arrive.

Now, if we examine the voltage polarities across R_1 and R_3 , we see that they are in opposition to each other and, if equal, will cancel out, leaving the potential of point *A* zero with respect to ground. This is the desired condition when the sync pulses and the frequency of the sweep oscillator are in step with each other. For, under this condition, the sawtooth wave will be going through zero when the pulses trigger the triode.

Consider what happens when the horizontal oscillator is running slow. At the time the pulses arrive, the sawtooth wave is negative at the plate. This condition will reduce the current reaching the plate and, consequently, the average voltage across R_1 will decrease. This decrease will leave a net negative voltage at point *A*. On the other hand, if the sawtooth wave is positive at the plate when the tube conducts, more current will flow, increasing the positive voltage developed across the cathode resistor. The net voltage at point *A* now becomes positive and is fed to the cathode-coupled multivibrator that follows. Thus, a full range of voltage values is obtained to speed up or slow down the sweep oscillator as required.

A second triode-phase detector circuit is shown in Fig. 13-24. Its chief distinguishing feature is its need for one source of sync pulses rather than two. The sync pulse is applied to the cathode and its phase is negative. The sawtooth wave is still applied to the plate of the tube while the d-c control voltage is obtained from the grid. Over-all circuit operation is as follows.

When a sync pulse arrives, it drives the cathode sharply negative or, what is the same thing, it makes the grid and plate positive with respect to

the cathode. Current then flows in both circuits, through the paths indicated in Fig. 13-24. The voltages developed across R_1 and R_2 have the polarities indicated and, if the resistor values are correctly chosen, the two voltages will be equal and will cancel each other. (Actually, C_2 and C_5 charge first when the current flows and then discharge between pulses. It is during the discharge interval that the voltages across R_1 and R_2 are developed.)

When the oscillator frequency is too low, the sawtooth wave lags behind the sync pulses. Hence, when the pulses arrive, the sawtooth voltage at the

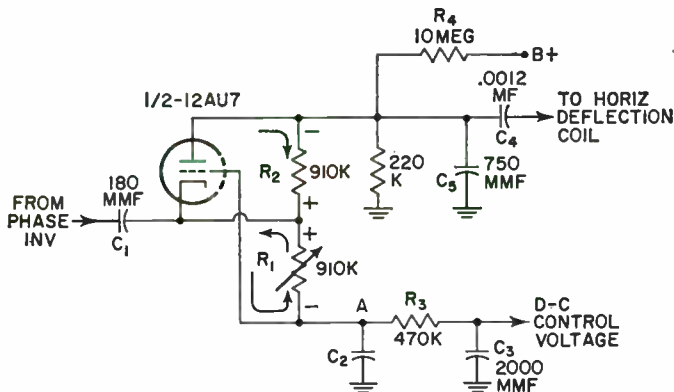

FIG. 13-24. Another triode phase-detector circuit. Here, one source of sync pulses is required rather than two, as in Fig. 13-23.

tube plate is negative. This reduces the current flowing in the plate circuit, and, in consequence, the voltage developed across R_2 . The voltages across R_1 and R_2 no longer cancel and a net negative voltage appears at point A and is transferred to the horizontal-sweep oscillator.

Conversely, if the oscillator frequency is higher than the sync-pulse frequency, the sawtooth wave is positive at the tube plate when the sync pulses arrive. Now, the voltage across R_2 rises above normal and the d-c control voltage is positive.

Resistor R_1 is made variable so that it can be adjusted to accommodate tubes whose plate-current characteristics may differ. Such variations can occur even for tubes of the same type.

Circuit Adjustments. In the foregoing AFC circuits there are practically no variable controls. Hence, there is actually nothing to adjust. Variable components, however, are found in the horizontal oscillator which is almost always a cathode-coupled multivibrator. This circuit is preferred because it provides a convenient input for applying the AFC-control voltage and it operates with good stability, particularly when it has a stabilizing resonant circuit in the plate circuit of the first triode.

The cathode-coupled multivibrator employed with phase-detector-AFC systems may have one or two adjustments. If there are two adjustments, one is a horizontal hold control and the other is the movable core in the stabilizing coil. The multivibrator of Fig. 13-20 is representative of this group. The hold control is accessible on the front or rear panels of the receiver and may be adjusted from time to time, as required. In a number of sets, however, the hold control is dispensed with and the only adjustment then is the movable core of the stabilizing coil. Figure 13-18 is an example of this approach. In both arrangements, the coil core should not require any attention once it is adjusted, unless some component changes value in the circuit and the stabilizing circuit is unable to keep the multivibrator in sync. The adjustment is quite simple and requires only that the core be rotated until the picture is properly synced in. If a hold control is present, it is set to the center of its range before the coil core is moved.

Synchroguide AFC System.* Another AFC circuit which has gained wide acceptance is that shown in Fig. 13-25. It consists of a single control

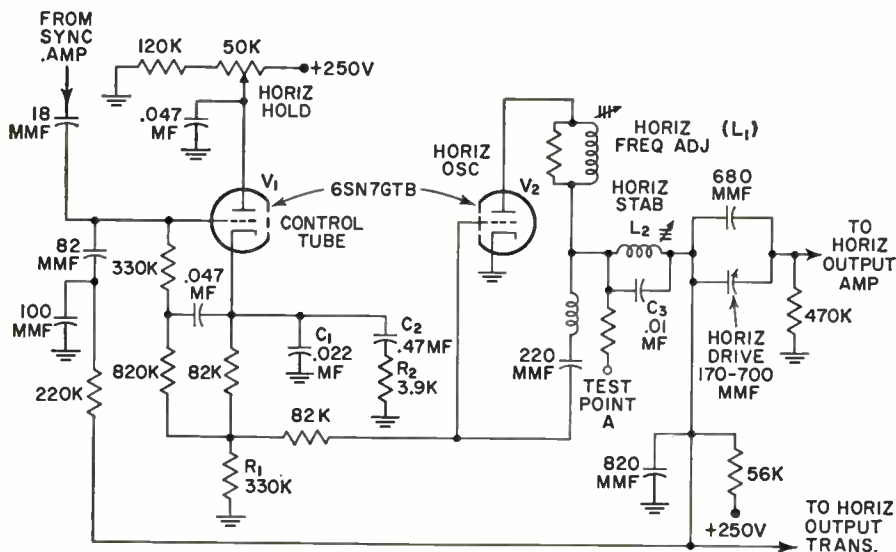

FIG. 13-25. The synchroguide AFC system.

tube, a long-time-constant filter, and a blocking oscillator. Basically, the horizontal oscillator is a free-running oscillator and discharge circuit. It does not receive the incoming pulses directly, but should its frequency differ from that of the pulses, then the control tube, V_1 , will alter the negative bias on the grid of the blocking oscillator and thereby change its frequency. It can do this because the cathode resistor, R_1 , of the control tube is common

* Also known as the pulse-width system.

to the grid of the blocking oscillator. The incoming sync pulses, positive in polarity, are applied to the grid of V_1 through an 18-mmf capacitor. This grid also receives a wave from the horizontal-output transformer which possesses a shape which is a cross between a parabolic wave and a sawtooth wave. This wave combines with the incoming sync pulses to maintain the blocking oscillator on frequency.

The combined wave is specifically designed to have fairly steep sides (Fig. 13-26) in order that any difference in frequency between the blocking oscillator and the incoming sync pulses will have a marked effect on the circuit. Here is how this occurs.

The control tube, V_1 , is given enough negative bias to keep it cut off except when the incoming sync pulse is high on the slope of the combined waveform, as shown in Fig. 13-26(B). If the blocking oscillator changes phase so that the pulse arrives at a time when it is down along the slope, the amount of time during which V_1 conducts will decrease. This decrease is indicated in Fig. 13-26(C) by the narrow width of the waveform extending above the cutoff point of the tube V_1 . On the other hand, if the blocking-oscillator frequency changes so that the sync pulse arrives at a time when it is closer to the top of the combined wave (Fig. 13-26(A)), then the plate conduction time of V_1 will increase. When the control tube conducts, C_1 and C_2 in its cathode circuit will charge to a d-c potential proportional to the length of time that current flows through the tube. This d-c potential is applied as a bias to the grid of the blocking oscillator, altering its frequency and tending to bring it back into line. The components of the cathode circuit of V_1 form a long-time-constant filter which averages out the plate current pulses.

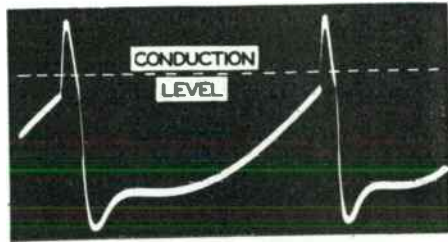

(A) Oscillator Slower Than Normal.

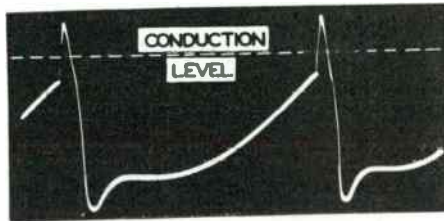

(B) Oscillator in Phase.

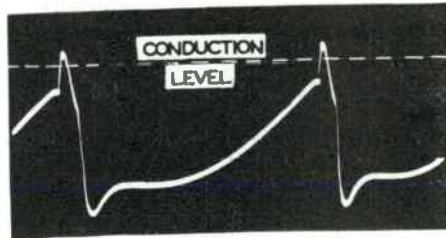

(C) Oscillator Faster Than Normal.

Courtesy H. W. Sams & Co.

FIG. 13-26. The waveforms at the grid of V_1 , Fig. 13-25, for different oscillator frequencies.

Three controls are associated with this circuit: (1) The blocking oscillator transformer, L_1 , is slug-tuned to permit coarse adjustments in oscillator frequency. (2) The horizontal hold control will affect the plate voltage of the control tube and, in this manner, affect the amount of voltage developed across R_1 . This is the only front-panel control of the group. (3) The core of coil, L_2 , is adjustable to permit tuning this resonant circuit to the frequency of the oscillator. This control is the most difficult to adjust.

L_2 and C_3 serve to stabilize the oscillator operation and thereby render it more immune to signal or circuit disturbances that may occur from time to time. The manner in which it accomplishes this in the circuit of Fig. 13-25 is as follows.

The oscillator, being a blocking oscillator, is cut off during more than 90 per cent of the cycle and conducts heavily 10 per cent of the cycle or less. Let us consider the oscillator when it is conducting heavily. During this interval, the heavy current drawn through L_2 and C_3 prevents this circuit from oscillating. At the same time a voltage is developed across these components with the polarity indicated in Fig. 13-27(A).

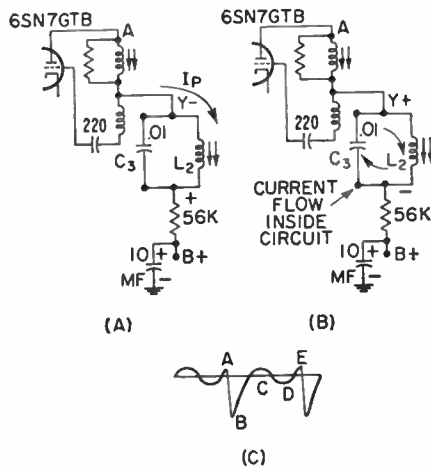

FIG. 13-27. Diagrams illustrating how L_2 and C_3 (of Fig. 13-25) help to stabilize the pulse-width AFC system.

When the blocking oscillator drops into cutoff, the current flowing through the tube and the resonant circuit, L_2 , C_3 , ceases abruptly. This sudden stoppage of current excites L_2 , C_3 into resonance, the coil attempting to maintain the flow of current. The polarity of the voltage developed across the coil required to do this is shown in Fig. 13-27(B).

Referring to the waveform developed in this circuit at point *Y*, at time *A* in Fig. 13-27(C) the blocking oscillator drops into cutoff, and at time *B* the resonant circuit reverses its voltage polarity in an attempt to maintain the flow of current. Thereafter, the current in the resonant circuit L_2 , C_3 flows first into the lower plate of C_3 , then reverses and flows into the upper plate. The frequency of the circuit is close to 15,750 cps, and so it has time to complete one cycle before the blocking oscillator again conducts heavily at time *E*, damping out the oscillations in L_2 and C_3 .

The ability of this additional resonant circuit to improve the noise immunity of the blocking oscillator is due to the fact that near the end of the discharge cycle, when the cutoff voltage on the oscillator grid is low, the voltage developed across L_2 , C_3 is negative. In Fig. 13-27(C) this is the region C-D. This negative voltage opposes the B+ voltage from the power supply and, in so doing, reduces the susceptibility of the blocking oscillator to any noise pulses that may appear at this time. Here is why this is so.

When the plate voltage of a triode decreases, the grid voltage required to cut off the plate current decreases. In other words, the cutoff point approaches closer to zero volts. With the B+ plate voltage going down (because of the opposition voltage across L_2 and C_3), we achieve the same effect as bringing the cutoff level of the tube closer to zero. See Fig. 13-28.

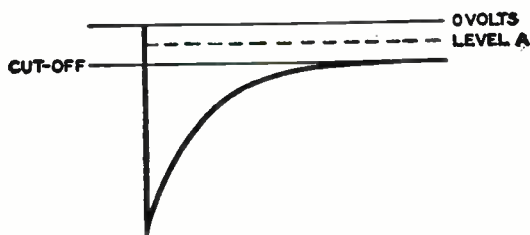

FIG. 13-28. See text for explanation.

With the cutoff level thus moving upward, it will require a stronger noise pulse to raise the grid voltage to this new cutoff level in order to have current flow through the tube again for the start of the next cycle.

On the other hand, in the region near *E* in Fig. 13-27(C), the voltage across L_2 and C_3 is going in the positive direction, aiding the B+ voltage and preparing the plate circuit for the arriving triggering pulse.

Resonant-stabilizing circuits have been used in the multivibrator as well as in the blocking oscillator. One such circuit was shown in Fig. 13-18. The additional resonant coil and capacitor are placed in the plate circuit of the first triode and adjusted to 15,750 cps. The presence of this circuit

alters the manner in which the grid of the second triode comes out of cutoff. In Fig. 13-29(A) the waveform appears at the plate of the first triode in the absence of the stabilizing circuit. Fig. 13-29(B) shows the grid waveform of the second triode under the same condition. Now, when we insert the stabilizing circuit, its waveform, shown in Fig. 13-29(C), will add to those existing in the circuit to produce the modified waveforms shown in Fig. 13-29(D) and (E). Of particular importance is the grid waveform of

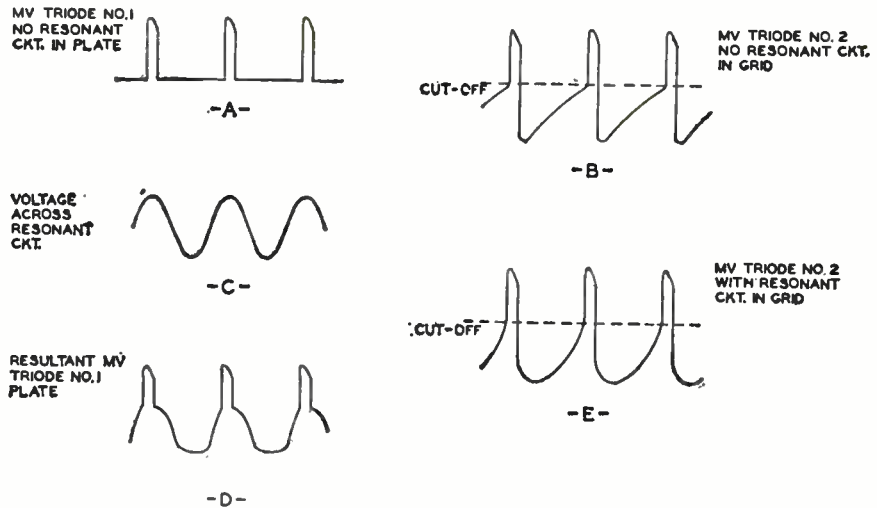

FIG. 13-29. The effect of a resonant stabilizing circuit on the operation of the multi-vibrator shown in Fig. 13-18.

the second triode. Note that it now comes out of cutoff quite sharply. A considerably stronger noise pulse will be required to trigger this tube prematurely than would have been needed without the stabilizing circuit.

Gruen AFC Circuit. The Gruen AFC system is in some respects a cross between the system shown in Fig. 13-14 and the phase-detector networks just discussed. The basic circuitry and associated block diagram are shown in Fig. 13-30. The horizontal oscillator is an electron-coupled Hartley in which the output or plate circuit is coupled to the oscillator section of the tube through the electron stream. L_1 , in the resonant circuit, is the coarse-frequency control. Shunted across L_1 are *three* capacitors which, with the coil, serve to establish the frequency at which the circuit operates. The most apparent capacitance is C_1 (1,000 mmf), and this is fixed in value. The second capacitance is C_2 (270 mmf), and this unit, in conjunction with R_1 and R_2 , also affects the oscillator frequency. The variation, of course, is achieved by the horizontal hold-control potentiometer. As this places

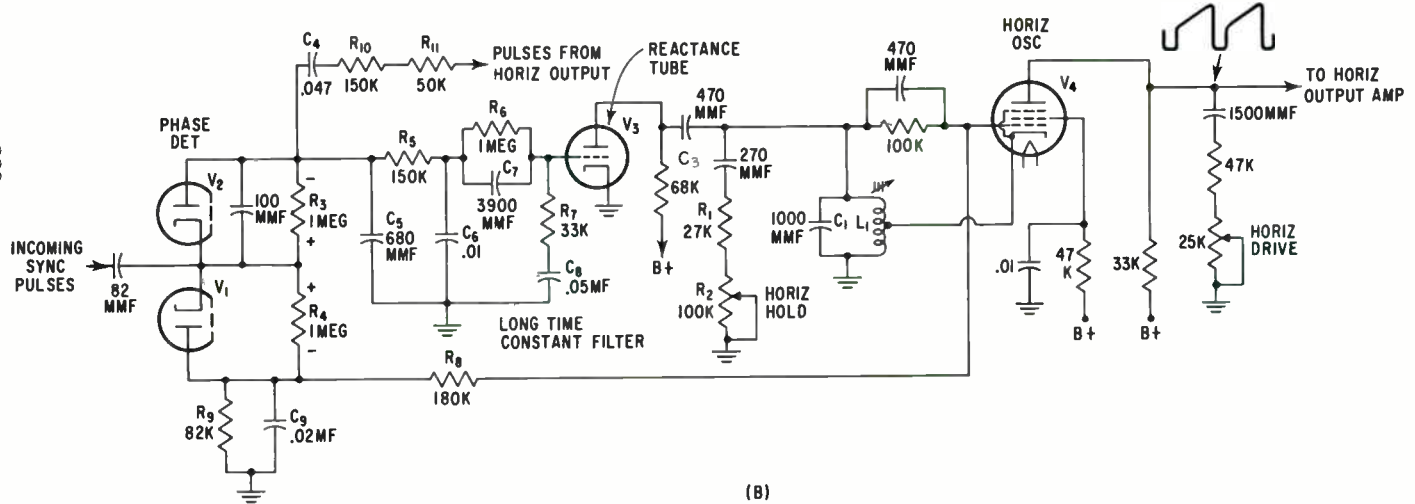
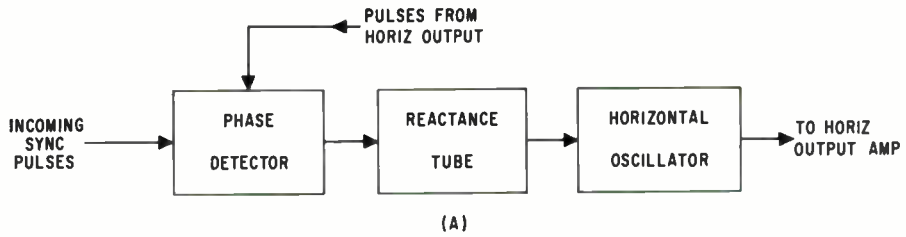

FIG. 13-30. (A) Block diagram and (B) schematic circuit of Gruen AFC system.

more or less resistance in the circuit, it changes the effect of C_2 on the resonant circuit and, in consequence, alters the frequency.

The third capacitance across the tuning circuit is C_3 (470 mmf), and this, like C_2 , is in series with a resistor. In this case, however, the resistance is that contained within V_3 , and just what value this resistance is will be determined by the bias on the tube. Thus, V_3 is the automatic control of the oscillator frequency, and it is V_3 which receives the d-c control voltage from the phase detector.

V_1 and V_2 form the phase detector where the incoming sync pulses are compared in frequency with pulses obtained from the plate of the damping tube. If the frequency relationship is not right, a resultant d-c voltage will be produced which will be used to regulate the resistance of V_3 . This, in turn, will vary the Hartley oscillator frequency.

In the phase-detector circuit, the incoming sync pulses are applied to the cathodes of V_1 and V_2 in negative polarity. Since a negative pulse at the cathode of a tube is equivalent to a positive pulse at the plate, tube conduction will occur. Both tubes will conduct equally, resulting in equal voltage drops across their respective plate-load resistors, R_3 and R_4 . (R_3 is for V_2 , R_4 is for V_1 .) However, both resistors are placed back-to-back, with the result that their net voltage is zero.

Also applied to V_1 and V_2 is a series of pulses fed back from the damper plate (or any other point *after* the sweep oscillator). These pulses are converted into sawtooth waves by R_{10} , R_{11} , C_4 , and C_5 . Thus, we have here somewhat the same condition as that existing in the previous sawtooth AFC system. V_1 and V_2 compare the sawtooth wave with the incoming pulses and develop from this a resultant d-c voltage in the manner described for the previous AFC system. This d-c control voltage is fed through a long-time-constant filter C_5 , R_5 , and C_6 and then through an antihunting circuit, R_6 , R_7 , C_7 , and C_8 , before it is applied to the grid of V_3 . The purpose of the antihunting circuit is to prevent the voltage from overswinging or hunting back and forth. Hunting will occur when a correcting voltage is fed to the control circuit.

The purpose of R_8 , R_9 , and C_9 is to feed into the control circuit enough d-c bias to place V_3 at the correct operating point. The voltage developed by the phase detector then shifts V_3 above or below this point, as is required. Part of the large negative bias developed at the oscillator grid is employed for this purpose.

At the control grid and cathode of V_4 a sine waveform is present. At the plate of the tube, however, we obtain the waveform illustrated in Fig. 13-30(B). The most important segment of this wave, insofar as beam deflection is concerned, is the sawtooth portion rising linearly. The negative pulse

just preceding this sawtooth rise is wide and flat-bottomed, differing considerably from the sharp-pointed pulse ordinarily found here. See Fig. 13-3. This difference has no effect on the output amplifier because, as shall be seen presently, the tube does not begin to conduct until some time after the retrace pulse has ended.

Horizontal-output Circuits. The sawtooth deflection waveform is produced in the output circuit of the horizontal-sweep oscillator and then transferred via an RC network to the grid of the output amplifier. In this coupling network, however, there is usually a variable capacitor or resistor which will regulate the amount of deflection signal reaching the output tube. It is the drive control. If this control is set so that too much deflection voltage reaches the output tube, the picture may be distorted; it will have one or more white vertical lines down the middle of the picture. If it is set too low, the picture may not fill the screen. Also, too little drive will reduce the negative bias on the output tube, permitting more plate current to flow and leading eventually to tube overheating and failure. (A bias voltage develops at the grid because the deflection wave, at its peak, drives the grid positive and causes grid current to flow. This charges the coupling capacitor, which then discharges through the grid resistor, providing the bias voltage.)

Three common methods of achieving drive control are illustrated in Fig. 13-31. In Fig. 13-31(A), C_2 and C_3 form a voltage-divider network for the voltage waveform developed across C_1 . C_3 is the drive control and, as its capacitance is reduced, the impedance rises and more voltage is developed across it and passed on to the output amplifier. The unit is usually a small trimmer capacitor adjustable by means of a screwdriver.

In Fig. 13-31(B) the drive control is a 150,000-ohm potentiometer which varies the amount of plate voltage on the preceding oscillator. This, in turn, will regulate the amplitude of the deflection voltage developed across C_1 and R_1 .

In the third circuit, shown in Fig. 13-31(C), the drive capacitor is placed in series with the signal path between oscillator and output amplifier. Less capacitance means less driving voltage at the output tube and more capacitance means more voltage. The variation here is seen to be directly opposite to the variation in Fig. 13-31(A).

The Horizontal Output Amplifier. The sawtooth-deflection voltage, after it has been formed, is applied to the grid of the horizontal-output-amplifier tube. The deflection voltage is shown as E_1 in Fig. 13-32(B).* A portion of this signal is below the cutoff level and during this time the tube does not

* The important part of this wave rises straight. In some circuits the design is such that this wave has almost a perfect sawtooth form. In other circuits there is a pronounced negative pip, as shown in E_1 .

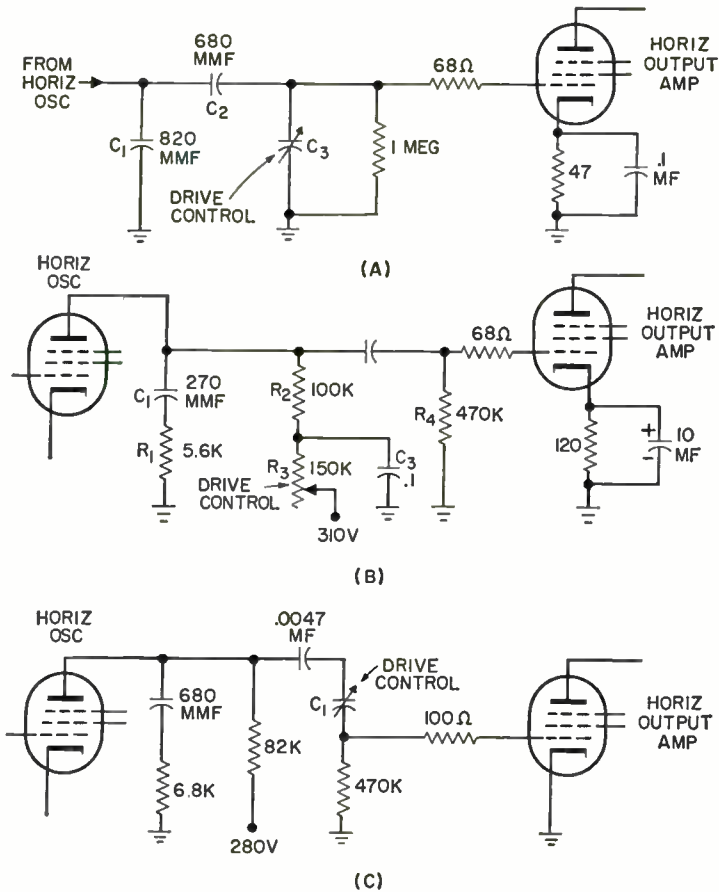

FIG. 13-31. Three different methods of controlling the drive voltage to the horizontal-output amplifier.

conduct.* The grid comes slowly out of cutoff at time 2 and drops into cutoff at time 3. At time 1, V_1 is cut off and no current is flowing through L_2 . At time 2, V_1 starts to conduct, current flows through L_2 , and a field builds up around L_2 . This expanding field cuts L_3 , L_4 , and L_1 , inducing a voltage in each. At time 3, the tube is driven sharply into cutoff, plate current drops to zero, and the field built up around L_2 collapses suddenly, inducing a high voltage in L_1 , L_2 , L_3 , and L_4 . The voltage induced across L_1 and L_2 is on the order of 15,000 volts or more, peak-to-peak. The collapsing field shock-

* The output-amplifier tube is cut off approximately 30 per cent of the time and conducts 70 per cent of the time. This behavior will be referred to again in connection with the servicing of certain horizontal-linearity defects.

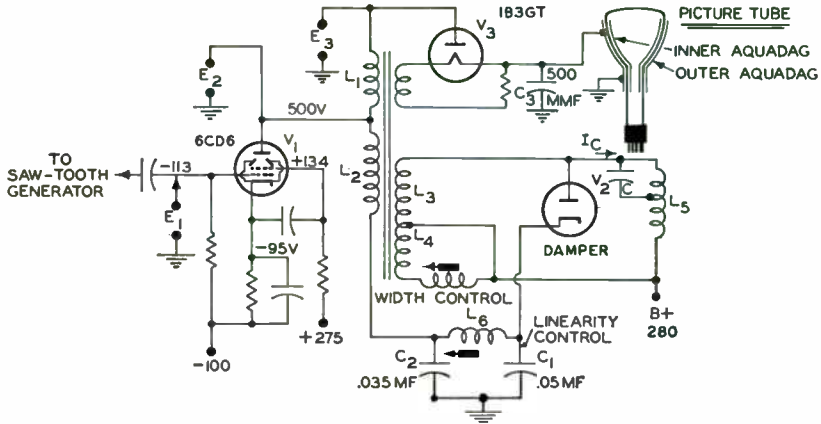

FIG. 13-32A. A horizontal-output amplifier and high-voltage power supply circuit.

excites the tank circuit, composed of L_3 , L_4 , L_5 , and C , into oscillation. The resonant frequency of this network is such that the period of $\frac{1}{2}$ cycle of oscillation is about 5 to 7 microseconds, which is equal to the flyback time of the horizontal sweep. Thus, during the first half-cycle of this oscillation, the beam, which is at the extreme right-hand side of the screen, is brought back to the left-hand side. The oscillations have now served their purpose and must be stopped; otherwise they would continue until the appearance of the next line and interfere with the proper motion of the beam. An expedient method of damping the oscillations quickly is accomplished by means of V_2 .

At about time 3, when V_1 is cut off and the field collapses about L_3 , the top of L_3 and the plate of V_2 become negative, with the current flowing down through the deflection coil (L_5). When the current in the deflection coil reaches its negative peak, the voltage at the top of the coil begins to go positive because the current lags the voltage by 90 deg in an inductance. As soon as the voltage on the plate of V_2 becomes positive, the tube conducts and, in so doing, offers a low-resistance path for the deflection current into capacitor C_1 , which thus becomes charged. The charging process is quite

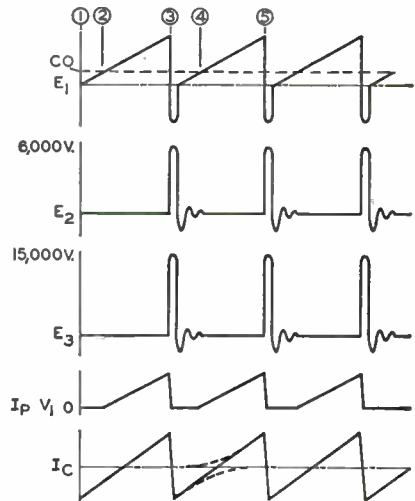

FIG. 13-32B. Waveforms in the horizontal-output circuit. See text.

rapid at first, gradually slowing down as the voltage across C_1 rises. This slowing down is reflected in the gradual dying out of the current, as is indicated by the bottom dotted line in I_C . However, as the current approaches zero, V_1 comes out of cutoff and a field again builds up around L_2 . This growing field induces a voltage in L_3 , causing the current to build up to its maximum peak as at time 5 in I_C . In this way, a linear sawtooth current is generated.

Note that the voltage on the plate of V_2 is equal to the 280 volts from the power supply plus the deflection voltage which is developed across L_3 , L_4 . The greater the deflection voltage, the greater the voltage applied to the plate of V_2 , and the greater the charge which C_1 receives.

The charge across C_1 produces a voltage across the capacitor in which the top plate is positive and the bottom plate is negative. (This polarity is due, of course, to the fact that the electrons in V_2 flow from cathode to plate, through L_5 to B+, from here to ground in the power supply, and from ground to C_1 .) Thus, the voltage across C_1 will be greater than the B+ voltage and the difference can be as much as several hundred volts. The name given this augmented voltage is "boost B+." In Fig. 13-32(A) it is applied to the plate of V_1 by way of L_2 . In addition, it is frequently used to provide higher voltages for other stages in the receiver besides the horizontal-output amplifier.

V_2 conducts for about 30 per cent of the sweep. When it conducts, the voltage across C_1 and C_2 builds up. When V_2 stops conducting, the voltage across C_1 and C_2 falls. This rise and fall constitutes an a-c ripple on the plate of V_1 . By shifting the phase of this ripple voltage, it is possible to compensate for some of the nonlinearity of the current waveform in the deflection coil. This change of phase is affected by the variable inductance (L_6). L_6 is called a "linearity control."

Both V_1 and V_2 in Fig. 13-32(A) should be regarded as switches. V_1 is turned on when the electron beam is about one-third the way across the screen while the image is being traced out. It remains on until the beam reaches the far right-hand side of the screen when retrace starts. During all this time, V_2 is off. When retrace starts, V_1 is also turned off and the partial oscillation in the yoke brings the beam back to the left-hand side of the screen. Now, V_2 is turned on and the gradual die-out of energy (through absorption by C_1) brings the beam about one-third the way across the screen. V_2 now lapses into cutoff and V_1 is turned on.

(V_2 can conduct only when its plate voltage is greater than its cathode voltage. This means that the plate needs not only the B+ from the power supply, but also the deflection voltage across the yoke coils. This condition occurs only during the retrace interval while the beam is being swung from the right-hand to the left-hand side of the screen. For the rest of the cycle,

the plate voltage of V_2 is lower than its cathode voltage and no conduction takes place.)

Modifications of Horizontal-output Circuit. The horizontal-output circuit and the attendant method of obtaining high voltage stem originally from the first television receiver marketed back in 1946. This circuit is very similar to the circuit shown in Fig. 13-32(A). The horizontal-output transformer employed a fairly large powdered iron core. The original circuit was designed principally for 53 deg picture tubes requiring an accelerating potential of about 9,000 volts. The tube most frequently used in the horizontal-output amplifier was the 6BG6-G, a husky beam-power tube capable of delivering a sizable amount of power.

As the television industry expanded, and the demand for large-screen tubes grew, the 10-inch screen gave way to the 12½-, 14-, 15-, 16-, 17-, and 21-inch and even larger screens. In order to keep the length of these large screen tubes within reason, the deflection angle was increased, first to 60 deg, then 66 deg, 70 deg, 90 deg, and currently 110 deg.

Now, increasing the deflection angle does reduce the overall length of the picture tube, but more high voltage and greater driving power are required. By employing two 1B3 rectifiers as voltage doublers, the high voltage can be increased; by paralleling horizontal-output tubes, the driving power can be made greater. These solutions provide the necessary deflection power and high voltage, but they add components and result in higher costs.

Through research and development, the television manufacturers have developed a higher-efficiency output transformer using a small ferrite core. See Fig. 13-33. Also, output tubes have been developed which are capable of

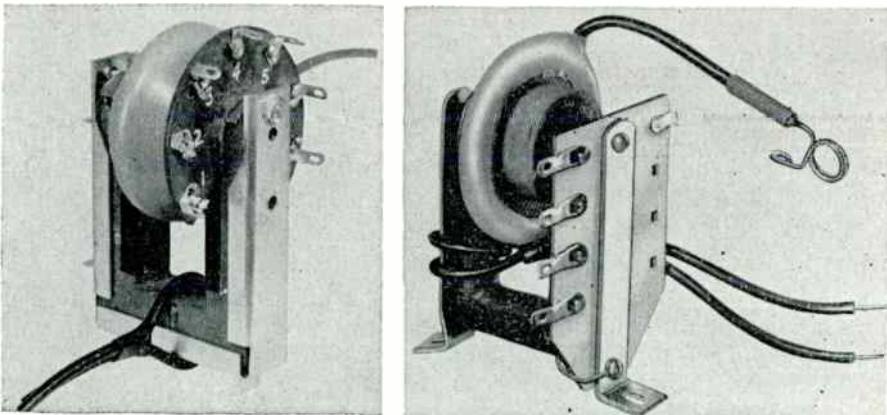

Courtesy Merit Coil & Transformer and Standard Transformer

FIG. 13-33. Two typical horizontal-output transformers. The single-loop turn at the bottom of each unit provides the filament voltage for the high-voltage rectifier.

greater power with less current drain on the B+ supply. With these improved components, it is now possible to develop voltages as high as 20,000 volts and to obtain sufficient power to sweep an electron beam over the entire area of a 110 deg deflection tube.

In addition to the changes that were being made in the construction of the output transformer, changes were also appearing in the horizontal-output circuit itself. One popular approach is shown in Fig. 13-34.

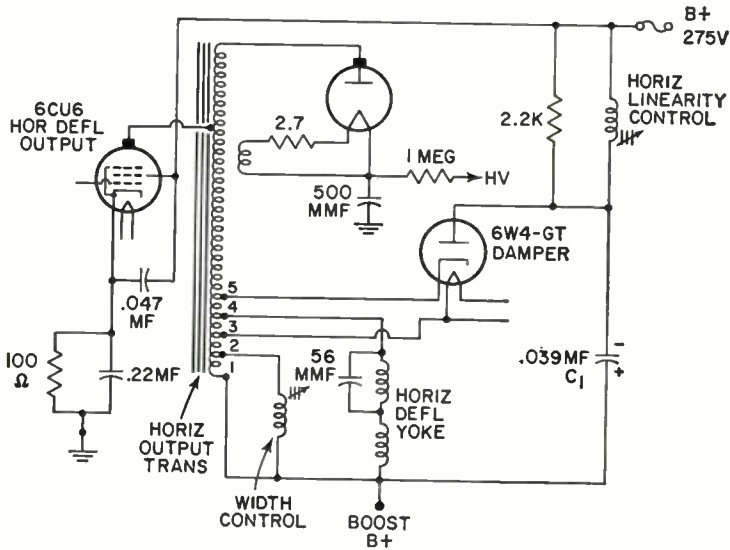

FIG. 13-34. A horizontal-output amplifier using an autotransformer.

The horizontal-output transformer in Fig. 13-34 contains one winding to which are connected the 6CU6 horizontal-output tube, the 1B3GT high-voltage rectifier, the 6W4 damper tube, the horizontal-deflection yoke, and the width coil. Filament power is supplied to the 1B3GT tube by a single-turn loop placed close to the transformer winding.

In this autotransformer, the horizontal-deflection winding is connected across terminals 1 and 4, these being the terminals across which the horizontal-deflection winding of the yoke best matches the autotransformer impedance. The 6W4 damper tube connects between points 1 and 5. Note that with the removal of the secondary windings, the damper tube is inverted. The 180 deg-phase shift between primary and secondary windings is no longer present and, to have the 6W4 damper tube operate properly, it must be inverted. The energy which the damper tube is able to rectify and convert into direct current is developed across the 0.039-mf capacitor con-

connected from the plate of the 6W4 tube to terminal 1 of the output transformer. The polarity of the rectified voltage developed here is shown in Fig. 13-34. To add this voltage to that of the low-voltage power supply, the B+ terminal of the low-voltage power supply connects to the negative end of the 0.039-mf capacitor through a horizontal-linearity coil. The other (or positive) terminal of the 0.039-mf capacitor connects to the bottom of the autotransformer, applying the boosted B+ to the plate of the 6CU6 output amplifier.

Figure 13-35 compares the coupling methods employed to connect loudspeakers to audio-output stages and the methods used to couple the deflection yoke to the horizontal-output tube.

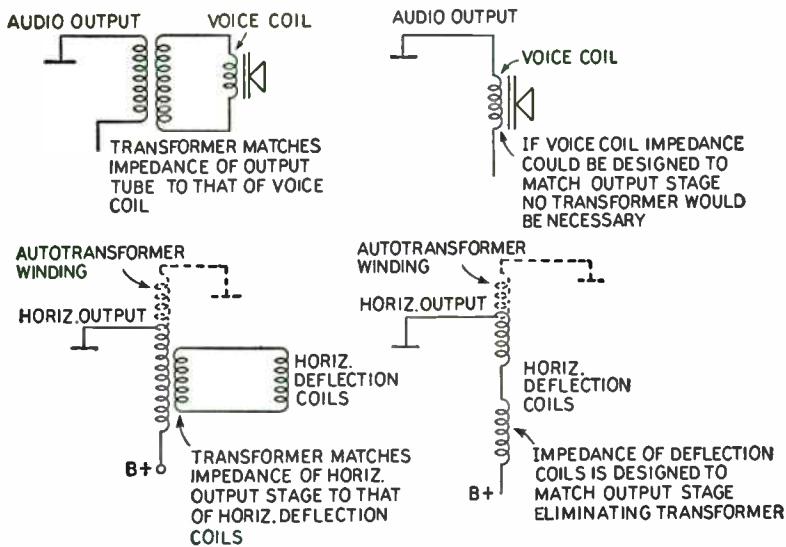

Courtesy RCA

FIG. 13-35. The coupling methods employed to connect loudspeakers to audio-output stages and the methods used in the horizontal-output amplifier.

For the 90 deg and 110 deg tubes, the horizontal-output circuits shown in Fig. 13-36 have been employed. In illustration (A) the yoke windings are still connected in series across a portion of the horizontal-output transformer. However, a connection is made between the point where two half-sections connect and a suitable tap on the transformer. The 4,700-ohm resistor in this lead is designed to minimize ringing effects in the yoke and also to help balance the two yoke sections. The 0.15-mf capacitor in series with the yoke is for d-c blocking.

In this circuit, the added voltage is developed across C_1 with the polarity

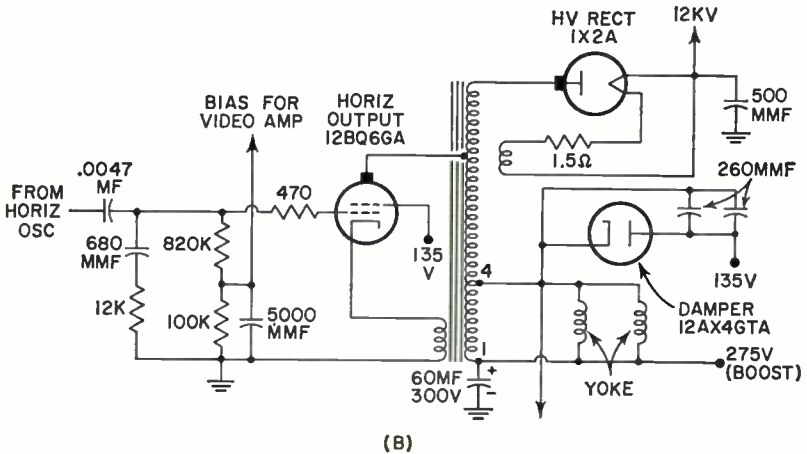
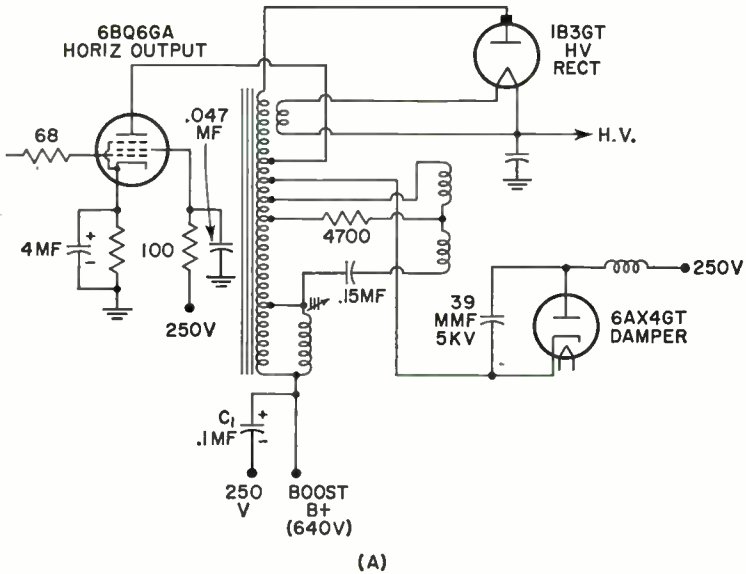

FIG. 13-36. Two additional horizontal-output circuits that have been used with 90-deg and 110-deg picture tubes.

indicated. Note that the bottom end of this capacitor connects to the plate circuit of the damper tube since both attach to the 250-volt terminal in the power supply. The added voltage developed across this capacitor is equal to almost 400 volts, since the bottom end of C_1 has a potential of 250 volts and the top end provides a boost B+ of 640 volts.

In Fig. 13-36(B), the two horizontal-yoke windings are connected in

parallel. This arrangement eliminates the need for any balancing resistors or capacitors, but it does require more driving current (about 4 times as much). An interesting feature of the circuit is the horizontal-transformer winding that is connected to the cathode of the output tube. During retrace, a positive pulse of voltage is developed here, which helps to keep the 12BQ6 cut off during this interval.

The grid circuit of the 12BQ6 is also somewhat unusual in that it possesses a voltage divider consisting of an 820,000-ohm and a 100,000-ohm resistor. The voltage developed here is used, in part, as bias for the video-output tube. The 5,000-mmf capacitor at the tap-off point bypasses the 15,750-cps signal present here to prevent pickup by the video-output tube.

Use of this point as a bias source is possible because, under normal condi-

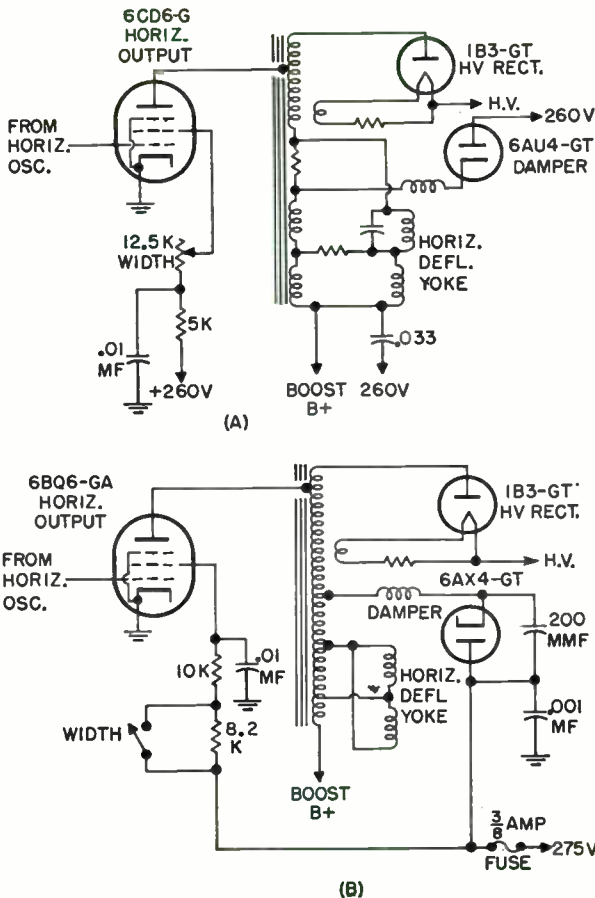

FIG. 13-37. Two methods of achieving width control.

tions, the negative voltage developed here is quite steady. It will change only when a defect occurs in the horizontal system, and this, of course, would tend to disrupt the normal functioning of the receiver anyway.

Width Controls. In many of the horizontal-output circuits previously discussed, control of picture width is accomplished by varying the inductance of a special coil shunted across a section of the horizontal-output transformer. By changing the inductance of the width coil through a movable core, we alter the amount of deflection current flowing through the deflection coils and thereby vary the width of the raster. In this fashion, picture width can be varied by $1\frac{1}{2}$ inches or more.

Width coils come in a variety of inductance values—from as low as 0.05 mh to as high as 30 to 35 mh. Whatever the inductance, it must be matched to the transformer winding. Should any defect lead to a mismatch, such as a shorted turn in the transformer or in the width coil, it will be reflected in a picture which is either too narrow or distorted, or both. Even as little as one shorted turn can have a marked effect, particularly in low-inductance width coils.

Additional methods of width variation are shown in Fig. 13-37. In (A), a potentiometer in the screen-grid circuit of the horizontal-output amplifier varies the gain of the stage and, with it, the deflection voltage (and current) fed to the yoke. In (B), the same method is employed, although here a fixed resistor is brought into or cut out of the circuit by a simple toggle switch.

Certain manufacturers vary picture width by using an output transformer with a variable air gap in its core. This gap can be made larger or

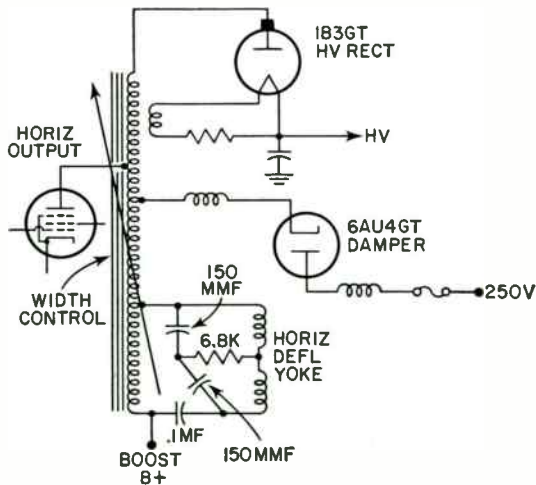

Fig. 13-38. Width control can also be achieved by varying the air gap in the core of the horizontal-output transformer.

smaller by a width-control shaft, thereby altering the inductance of the fly-back-transformer windings. This, in turn, affects the picture width. The symbolic notation for this type of width control is shown in Fig. 13-38; it consists of an arrow through the center of the horizontal-output transformer.

QUESTIONS

1. List and explain the purpose of every variable resistor and capacitor found in the circuit of Fig. 13-1.
2. Draw a low-voltage power supply which would be suitable for the deflection system of Fig. 13-1.
3. If the upper triode section of V_4 (Fig. 13-1) stopped functioning, how would it affect the image?
4. The video signal is reaching the control grid of the cathode-ray tube, but the clipper tube breaks down. What is the effect on the screen?
5. If a vertical line is obtained on the screen when the set is turned on, indicate all the possible points where the trouble could exist. Use Fig. 13-1.
6. What is the purpose of the linearity control in Fig. 13-1?
7. Why do sawtooth voltage waves generally have to be modified when used with deflection coils?
8. How is the proper deflection voltage for deflection coils developed?
9. Why are automatic-frequency-control systems usually found only in the horizontal-sweep system and not in the vertical sweep system?
10. How does the AFC system of Fig. 13-14 operate?
11. What does the horizontal-discharge tube of Fig. 13-14 do?
12. What is a damper tube? Why do we use a damper tube only in the horizontal-deflection system? What is used in the vertical-deflection system to accomplish the same purpose?
13. In Fig. 13-17 what purpose do C_5 , C_6 , and R_8 serve?
14. How is the frequency of the multivibrator in Fig. 13-18 speeded up by an AFC-phase detector? How is it slowed down?
15. Explain how the phase detector of Fig. 13-20 functions.
16. Draw the circuit of a triode phase detector. Explain briefly how it operates.
17. Where is the long-time-constant filter of the synchroguide AFC system located? List its components.
18. What is the purpose of an antihunting network? Where is one located in the circuits described in this chapter?
19. In what ways does the Gruen AFC system resemble the circuit of Fig. 13-14? In what ways does it resemble phase-detector AFC systems?
20. Explain how the oscillator frequency in a Gruen system is controlled.
21. (a) In a horizontal-output circuit, when are both the output-amplifier and the damper tubes cut off? (b) When does the horizontal-output-amplifier tube function alone? (c) When does the damper tube become active?
22. Explain fully how a damper tube functions.
23. How is boost B+ developed?
24. In what three ways can the width of an image be varied?
25. What can happen if not enough drive voltage is fed to the horizontal-output-amplifier tube? If too much drive voltage is applied?

Frequency Modulation*

General Outline. The audio portion of all television programs is transmitted by frequency modulation. This choice was the result of several factors. Of the two broadcasting systems in use today, AM and FM, the latter has been proved capable of better reception under adverse conditions. It is easier to minimize interference from other near-by stations operating on the same frequency with frequency modulation than with amplitude modulation. Second, there is the matter of cost, a factor especially applicable to transmitters. Because of the arrangement of the circuits in a frequency-modulated transmitter, a given wattage signal can be developed more economically with this equipment than with amplitude-modulation equipment. Specifically, the large difference in cost between the two systems lies in the audio power required to produce a certain strength signal. With AM, the audio power is generally 50 per cent of the carrier power, and this may entail many thousands of watts for a powerful station. In FM, on the other hand, the audio required represents only a fraction of the output power and is more easily generated.

The power relationship that exists in an amplitude-modulated wave between the sidebands and the carrier is in the ratio of 1:2 for 100 per cent modulation. This is only the average power and, when the equipment is designed, it must be capable of handling the much higher peak (or surge) power. Naturally, this requirement materially increases the cost of the station. In FM transmission, the power output does not increase with modulation and no additional provision for handling excess power need be made.

The matter of fidelity is not stressed because, contrary to popular opinion,

* Due to space limitation, only the most important aspects of FM can be considered here. For a more detailed analysis, the reader is directed to M. S. Kiver, *F-M Simplified*, 3rd Edition, published by D. Van Nostrand Co., Inc., 1960.

just as much fidelity is available with AM as with FM. It is only on the present crowded broadcast band (500 to 1,500 kc) that space is not available to permit the full 10,000 or 15,000 audio cycles to be reproduced. Given sufficient spectrum space, both systems have equal fidelity.

AM and FM differ in many respects and this is perhaps best revealed by the following table:

<i>Factor</i>	<i>FM</i>	<i>AM</i>
Amplitude of signal	Remains constant	Varies with percentage of modulation
Audio voltage	The frequency spread of signal is determined by the strength of the audio voltage	Determines the amplitude of the wave
Audio frequency	The frequency of the audio modulating voltage will determine how rapidly the FM wave will change from one frequency to another	The audio frequency controls the speed with which the amplitude of the wave changes
Signal spread	The number of sidebands depends upon the amplitude of the modulating signal. In television, this spread is restricted to 25 kc on either side of carrier	Limited to 5 kc on either side of the carrier frequency. It is determined by the frequency of the audio modulating wave

The ordinary amplitude-modulated waveform, as it might appear for 100 per cent modulation, is shown in Fig. 14-1(A). The audio-modulating signal adds to or subtracts from the amplitude of the carrier. When the modulating signal becomes too strong, overmodulation occurs and the carrier

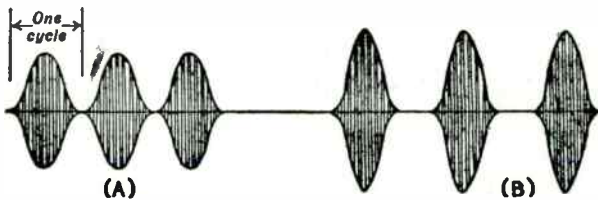

FIG. 14-1. Amplitude-modulated waves. (A) 100-per-cent modulation, (B) over-modulation.

is driven to zero for a short time. This is illustrated in Fig. 14-1(B). Note that, whereas the amplitude of the wave may increase as much as possible, it can only decrease to zero. Whenever overmodulation occurs, the waveform becomes distorted and the greater number of frequencies that are generated by this process causes the bandwidth of the station to increase. Hence all commercial broadcasting stations are careful to see that their output never reaches 100-per-cent modulation.

A frequency-modulated wave is constant in amplitude, but varies in fre-

quency. It would appear as pictured in Fig. 14-2. The property of constant amplitude makes the frequency-modulated wave so important. Most of man-made and natural interference has been found to affect the amplitude of a wave much more than its frequency. For the AM signal, the



FIG. 14-2. Frequency-modulated wave. The changing spacing between cycles indicates different modulating frequency intensities.

interference distorts the waveform and, with this, the intelligence contained therein. FM, on the other hand, contains its intelligence in its changing frequencies. At the FM receiver, one of the IF stages, acting as a limiter, smooths any irregularities in the amplitude of the incoming signal and by this process eliminates the interference.

The frequency bandwidth of an FM wave depends upon the strength of the impressed audio voltage. At the transmitter, the carrier frequency is fixed by a self-excited oscillator. This frequency is the mean, or center, frequency of the broadcast station. When the sounds that are to be transmitted are fed into the microphone, the mean frequency of the transmitter is varied. The louder the audio signal, the greater the deviation. For example, a frequency deviation (or change) of 50 kc in the output might occur for a strong audio voltage, whereas only a 1-kc change would occur if the audio voltage were weak. In the AM case, the amplitude and not the frequency of the wave changes for different audio sound levels.

The rapidity with which the FM transmitter frequency moves from one point to another is determined by the frequency of the modulating sound. A high-pitched sound will cause the frequency of the FM transmitter to change more rapidly than when 60 or 100 cycles are used.

One definite advantage obtained with frequency modulation is due to the observed (and calculated) fact that, if two signals are being received simultaneously, the effect of the weaker signal will be eliminated almost entirely if it possesses less than half the amplitude of the other stronger signal. This means that for one signal to completely override another at the receiver, their amplitudes needs to be in the ratio of 2:1, or more. With a good antenna, it is frequently easy to tune in one station in sufficient

strength so that the other interfering station or stations are eliminated entirely. No such situation exists with AM signals, where interfering stations can be heard when even a 100:1 relationship exists between the different carrier amplitudes.

Transmitters. It would be difficult to analyze the functions of a frequency-modulated transmitter by comparing it with the more familiar amplitude-modulated transmitter because of the great dissimilarity between them. Consider the two basic methods used to develop an FM signal shown

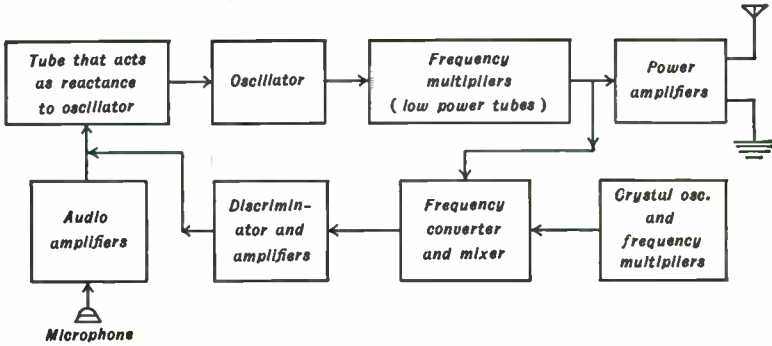

FIG. 14-3. Crosby system, or reactance-tube method, of producing FM waves.

in block form in Figs. 14-3 and 14-4. In Fig. 14-3 we have the reactance-tube, or Crosby, system, whereas in Fig. 14-4 we have the Armstrong method of frequency-modulated transmission. Although both systems are highly involved and mathematically complex in design, a sufficiently simple ex

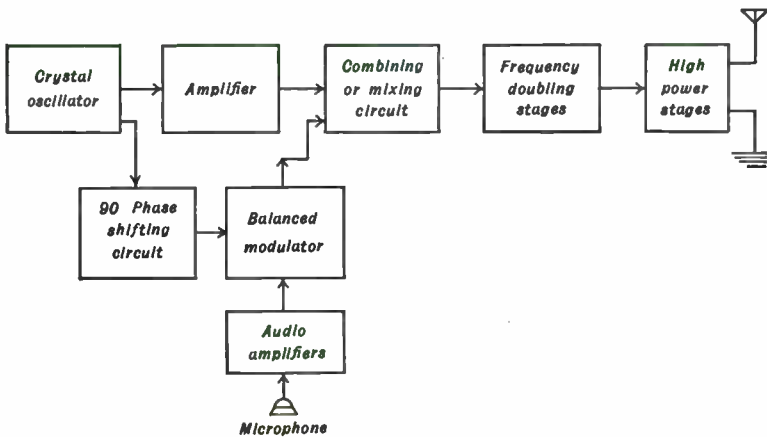

FIG. 14-4. Armstrong system of frequency modulation.

planation is possible to indicate the general functions of the various stages of each of the systems.

In the Crosby transmitter, the heart of the process is in the reactance tube. This tube and its circuit are directly connected to a single-frequency oscillator, the latter being perhaps some form of Hartley oscillator. So long as no audio signal is impressed on the grid of the reactance tube, no plate-current variations will occur in the output of the tube, which is directly connected across the tuning coil of the oscillator. Under such conditions, the oscillator generates its mean, or carrier signal, frequency. Any receiver tuned to this transmitter would not, at this particular moment, receive any audio output.

Upon speaking into the microphone, however, a varying voltage is generated which is amplified by conventional audio stages and placed on the grid of the reactance tube. These audio variations cause the reactance-tube plate current to assume different values. Because the plate current must pass through the oscillator coil and because of the phase relations of the associated circuit, the reactance tube may be made to appear either inductive or capacitive to the oscillator, thus causing its frequency to increase or decrease. This is the first step in the formation of a frequency-modulated signal. The audio variations have directly affected the frequency of the oscillator, with a stronger audio signal causing a greater change in frequency than a weaker audio signal.

The frequency variations or deviations from the mean, or carrier, frequency are at this point quite small. For example, with a mean frequency of 1 mc, the audio voltage may cause a frequency variation of perhaps ± 10 kc about the 1 mc. Feeding this signal into a doubler stage will result in an output of 2 mc having a frequency deviation about the carrier value of ± 20 kc. By employing a number of these multipliers, a final carrier frequency is obtained having a frequency variation of ± 100 kc (200 kc in all). While the values used here as illustrations may not be the exact figures found in practice, they do illustrate how the final signal spread is obtained. In any one stage, the frequency range must be a small percentage of the mean, or carrier, frequency at that point in order to prevent distortion.

The other sections of the transmitter shown are concerned with keeping constant the mean frequency of the self-excited oscillator. How this is accomplished is indicated in Fig. 14-3. A crystal oscillator generates a single, fixed frequency. The output from the crystal oscillator is passed through a sufficient number of frequency-multiplier stages so that a frequency equal to the exact carrier frequency of the transmitter (as fixed by the FCC) is reached. This signal from the crystal-oscillator section is then fed to a mixer where it combines with the actual carrier of the transmitter itself. If no difference exists between these two values, no voltage is sent back to

the reactance tube. However, if something causes the carrier frequency of the transmitter to drift, a resultant voltage will be obtained from the discriminator, and the bias of the reactance tube will be varied accordingly. A positive change in bias of the reactance tube will affect the oscillator frequency one way; a negative change will result in the opposite reaction. In either case, the output of the discriminator will always act so as to bring the mean frequency of the main oscillator back to its correct value. With careful adjustment, the transmitter carrier will always remain at its assigned value, the limits being determined by the correcting crystal oscillator.

A second system commonly used for producing frequency modulation is shown in block diagram form in Fig. 14-4. In this transmitter, the fundamental frequency is determined by a crystal-controlled oscillator operating at about 200 to 300 kc. A part of the output of this oscillator is fed to an amplifier while the other part is sent through a 90 deg phase-shifting circuit and a balanced modulator. The modulator merely combines the phase-shifted carrier with the audio-modulating voltage. Due to the action of a balanced modulator, sidebands are generated, just as in any ordinary amplitude-modulated transmitter. The one difference, however, lies in the fact that the carrier is automatically suppressed and only the sidebands appear at the output of the stage. These sidebands, when recombined with the original carrier, will cause frequency modulation, although at this point the amount of frequency variation about the carrier is not very great.

From this point on, frequency multipliers increase the amount of frequency deviation obtained until it is as large as desired. Then isolating power amplifiers increase the strength of the signal and feed it to the transmitting antenna. The heart of this system is in the 90 deg phase-shifting network, for it is through its action that frequency modulation is obtained.

In the description of the two systems, only the basic outlines have been given. The number and type of stages that are found depend upon the output power desired and the frequency of the transmitter. However, except for the last few power amplifiers, the intervening tubes may be of the small, inexpensive receiving type commonly found in home sets. Thus we can see that the audio power required in either one of these two systems is very small, much less than the amount necessary with amplitude modulation.

FM Receivers. Although it is difficult to draw a comparison between AM and FM transmitters, it is possible to show the similarity between the respective receivers. The FM receiver is a superheterodyne in all instances, although tuned-radio-frequency (TRF) sets are also possible. The superheterodyne offers so many more advantages than a tuned-radio-frequency receiver that the latter is seldom used.

The block diagrams in Fig. 14-5 illustrate the differences between AM and FM superheterodynes. Besides the limiter and discriminator stages in

the FM receiver, both sets appear to be exactly alike, and indeed might easily be taken for each other in an ordinary schematic. Up to the limiter stage, the primary difference between the two types of receivers resides almost wholly in the tuning circuits that connect each stage. In FM, these circuits must be capable of receiving higher frequencies and of passing a wider band of side frequencies associated with the FM carrier. In the

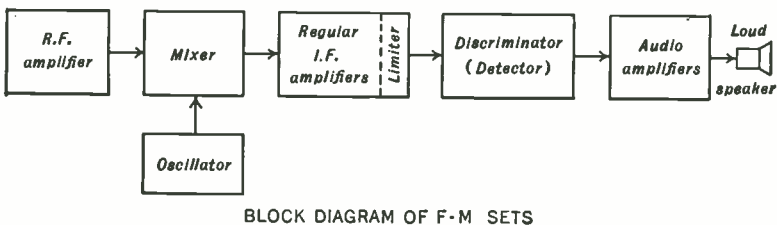
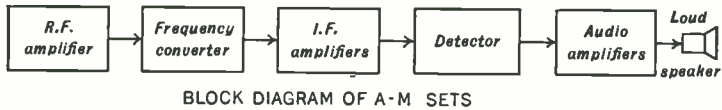

FIG. 14-5. A comparison of the block diagrams of AM and FM receivers.

ordinary FM receiver, designed for use between 88 and 108 mc, each station is allowed sidebands ranging up to 75 kc on both sides of the carrier. For television audio, merely 25 kc is used, the narrower bandwidth simplifying somewhat the problem of receiving both the video and the audio carriers simultaneously.

One feature common to most FM receivers is the use of a separate oscillator that feeds the mixer tube and helps generate the IF. At the higher frequencies employed for the television audio, drifting by the oscillator produces more marked effects than it does in the lower-frequency-broadcast receivers. At 60 mc, 2 per cent frequency drift would shift the signal beyond the bandpass of the audio IF circuits; at 1 mc, the same percentage shift is only 20 kc and would not shift a signal beyond the bandpass of circuits designed for a ± 75 -kc signal spread. The separate tube arrangement results in greater stability, with drift reduced to a smaller fraction than would be present in designs using the same tube for mixing and generating the oscillator voltage. Often, such additional devices as compensating ceramic capacitors are placed in the oscillating-tank circuit in order to counteract tendencies on the part of the other frequency determining components to change with operating conditions.

The most common IF in use today for the FM receiver (not associated with television) is 10.7 mc. Sound IF values in television intercarrier re-

ceivers is always 4.5 mc. In split-sound systems, its value is governed by the video IF. Common values are 21.25 mc and 41.25 mc.

Limiters. The first significant difference between the AM and FM superheterodynes is noted at the limiter stage or stages. Essentially, the purpose of a limiter is to eliminate the effects of amplitude variations in the FM signal. While it may have been true that the frequency-modulated signal left the transmitter with absolutely no amplitude variations, this is almost never true by the time the signal reaches the limiter.

To digress for a moment, let us see where, in the receiver itself, various parts of the FM signal could have received more amplification than other parts of the signal. An ideal response curve for a tuned circuit is shown in Fig. 14-6(A). With such a characteristic, each frequency within the signal

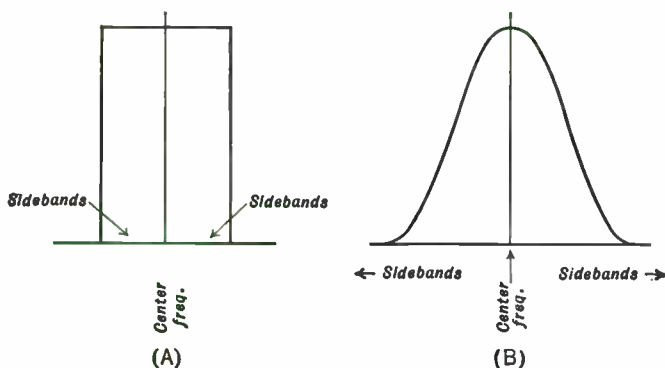

FIG. 14-6. Receiver response curves. (A) is the ideal curve, (B) a typical practical result.

receives uniform amplification. Such a happy situation, however, is seldom encountered in practice. The more usual state of affairs is illustrated by the curve in Fig. 14-6(B). Here it is apparent that the center frequencies receive more amplification than those located farther away. Hence, even if the incoming signal is perfectly uniform, by the time it arrives at the limiter amplitude variations would be present. The result is distortion if this wave is allowed to reach the speaker. It is for the limiter to remove the amplitude variation.

A typical limiter stage is shown in Fig. 14-7. Inspection reveals that low plate and low screen voltages are used, in addition to grid-leak bias in the input or grid circuit. The low electrode voltages cause the tube to reach current saturation with moderate signals at the grid. The use of grid-leak bias aids in keeping the output-plate current (and hence the output signal) constant for different input-voltage levels. It is readily apparent that, with FM signals of different amplitudes arriving at the grid of the limiter, a

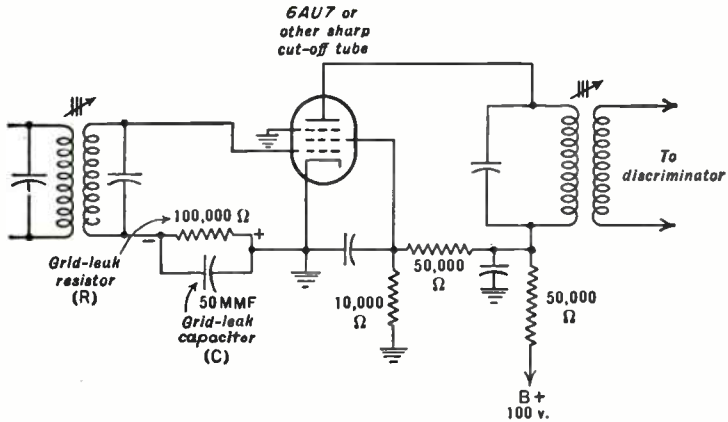

FIG. 14-7. A limiter circuit.

constant output for each would mean the elimination of any amplitude distortion, which is exactly what is desired. With the limiter so designed that it will easily saturate, amplitude variations can be eliminated and, with them, most disturbing noises. This is all possible because of one fact, namely, that much man-made or natural interference affects the amplitude of the radio signal more than it does its frequency. By the simple device of smoothing out the amplitude differences of the incoming waves (without affecting their fundamental frequency), we eliminate the noise or interference. This constitutes one reason for the extensive use of FM.

A limiter characteristic curve is shown in Fig. 14-8. Notice that the output signal of the tube increases with input signal until a certain voltage is reached. Beyond this point, known as the "knee" of the curve, point A, the plate current of the limiter remains substantially constant for all stronger input voltages. Since complete limiting begins at this point, the signals at the antenna of the receiver must receive sufficient amplification to force the limiter tube to operate beyond point A. From this point, the output of the limiter will remain constant. Any signal which is so weak that it is unable to operate the tube beyond OA will

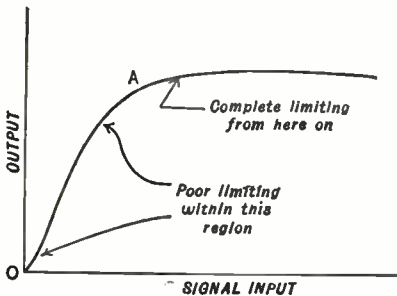

FIG. 14-8. The characteristic curve for a limiter.

have its noise appear in the limiter output.

The situations for weak and strong signals can be shown graphically. The curve OAB in Fig. 14-9 shows the relationship between the input grid

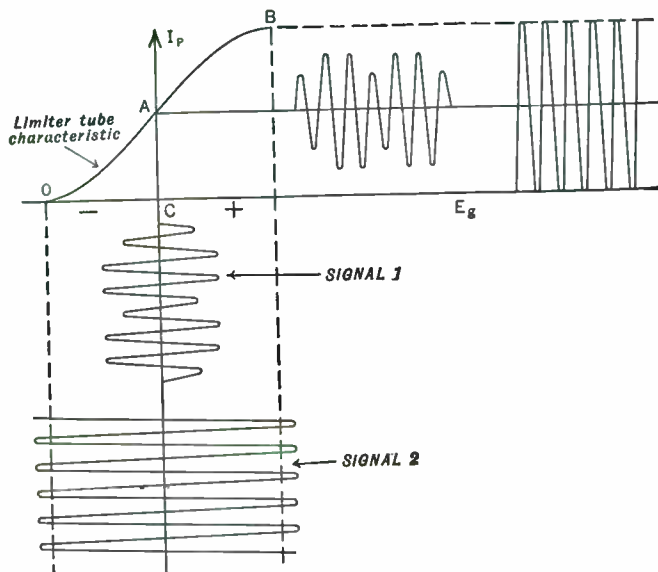

FIG. 14-9. These curves illustrate that the incoming signal must reach a certain amplitude before the limiter stage will saturate.

voltage, or signal, and the resulting plate current in the output of the limiter. With the tube biased to point C , the input-signal voltage will vary about this point. Consider the first small signal coming in. As it varies the grid bias, corresponding changes take place in the plate circuit and at no time will the plate current be forced to its saturation value. This means that any noise and amplitude distortion contained in this signal will be amplified and reproduced in the plate circuit and, from here, go to the discriminator.

Now consider the voltage of the second signal. At all peak points of the signal, plate-current saturation is reached on the positive peaks, while current cutoff is responsible for smoothing out the negative peaks. In the output circuit, all amplitude distortion has been clipped or eliminated. When this signal is fed to the discriminator, it should give noise-free operation. Thus, while a limiter provides FM with its greater advantages, care must be taken to see that it is properly operated; otherwise its usefulness is lost. The FM receiver must be so designed that all desired signals to the input receive sufficient amplification. When this is done, the plate current of the limiter will give constant output.

It should be mentioned that, by clipping off the top of the waves in order to have them all reach the same level, we are introducing amplitude distortion into the signal. Ordinarily this would be objectionable but, in the

present case, the new frequencies generated by this clipping are harmonics of the frequencies arriving at the limiter, and the resonant circuit in the output of the stage does not react to them. Thus the harmonics are filtered out and can cause no damage. Only signals with frequencies within the band-pass limits of the resonant coil and capacitor develop sufficient voltage to be passed on to the next inductively coupled circuit.

It is possible to design limiters on the basis of low plate and low screen voltages alone, but better results and more amplification are obtained if grid-leak bias is added to this combination. See Fig. 14-7. With the insertion of grid-leak bias, it is possible to raise the electrode voltages, somewhat increasing the gain. The tube initially has zero bias with no signal at the grid. As soon as a signal acts, the grid is driven slightly positive, attracts electrons, and charges the capacitor C (Fig. 14-7). This capacitor attempts to discharge through R but, due to the relatively long-time constant of R and C , the discharge occurs slowly. Because of current flow through R , a voltage is developed, with the end nearest the grid becoming negative. This voltage will act as a bias, varying in value as the incoming signal varies and in this way tending to keep the plate current steady within rather wide limits of input voltage. A strong signal causes the grid to become more positive, resulting in a greater current flow through R . A larger bias is developed. A weaker signal will cause less voltage, resulting in essentially the same amount of plate current. Usual values of C range from 30 to 60 mmf and, for R , between 50,000 and 200,000 ohms.

Because the voltage across R , the grid-leak resistor, will vary with the amplitude of the incoming signal, this point of the limiter is generally used for aligning the preceding IF amplifiers.

Although one limiter stage serves satisfactorily, better results can be obtained with two stages, one following directly after the other. The circuit of two limiters in cascade is shown in Fig. 14-10, and their characteristic curve is given in Fig. 14-11. With two limiters, the knee of the resulting curve becomes sharper and provides better limiting action. In all limiter

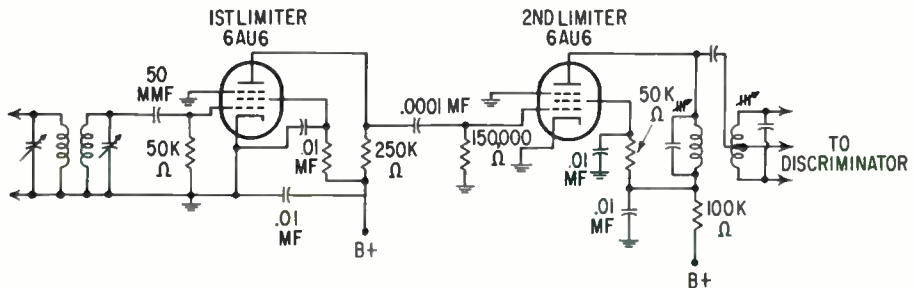

FIG. 14-10. A dual limiter circuit.

circuits, sharp cutoff pentodes are used, with tubes having the highest values of G_m preferred.

The Discriminator. The purpose of the second detector in an amplitude-modulated set is to obtain the audio variations from the incoming modulated signal. The same stage in a frequency-modulated receiver must derive the audio variations from the different incoming frequencies. Thus, although the end product in both cases is the same, the methods used are quite different. We know that with FM a large frequency deviation from

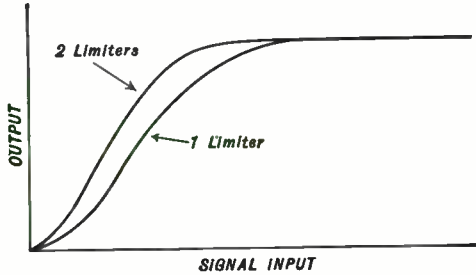

FIG. 14-11. Comparison of limiter characteristic curves for single and dual stages.

the carrier means a loud audio signal, whereas a small frequency deviation means a weak audio note. Hence, some circuit must be devised that will develop voltages proportional to the deviation of the various incoming frequencies about the carrier.

A simple circuit that discriminates against various frequencies is the elementary parallel- (or series-) resonant circuit. As is well known, this circuit will develop maximum voltage at the resonant frequency, with the response falling off as the frequency separation increases on either side of the central or resonant point.

One of the first discriminators used in FM receivers contained two resonant circuits in an arrangement as shown in Fig. 14-12. The primary

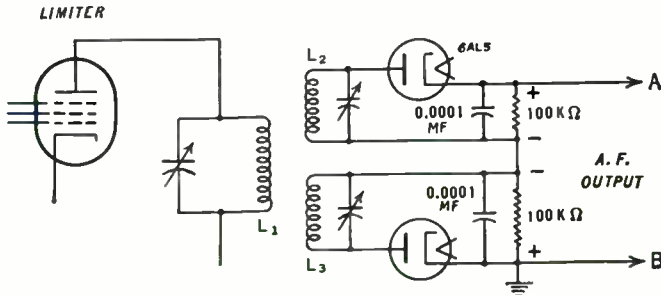

FIG. 14-12. A simple discriminator circuit.

coil, L_1 , is inductively coupled to L_2 and L_3 , each of which is connected to a diode tube. Each tube has its own load resistor, but the output of the discriminator is obtained from the resultant voltage across both resistors.

In order to determine the frequencies to which L_2 and L_3 must be tuned, it should be recalled that when an audio-modulating signal alters the frequency of an FM transmitter it varies this frequency above and below one central, or carrier, value. Thus, for a sine wave, the maximum positive portion would increase the frequency, say by 40 kc, while the maximum negative section would decrease the carrier frequency by the same amount. At intermediate points, less voltage would cause correspondingly less frequency deviation.

To have the discriminator function in a similar manner over the same range, L_2 and L_3 are each peaked to one of the two end points of the IF band. For example, if the IF band-spread extends from 4.40 mc to 4.60 mc (with 4.50 as the mean, or carrier, frequency), L_2 could be peaked to 4.40 mc, and L_3 to 4.60 mc. The response curves would then appear as in Fig. 14-13.

The two curves are positioned in the manner shown because of the way their load resistors are connected in the circuit. According to the arrangement, the voltages developed across them tend to oppose each other, as indicated by the polarities across the resistors in the circuit shown in Fig. 14-12.

At the center frequency, point A of Fig. 14-13, the two voltages devel-

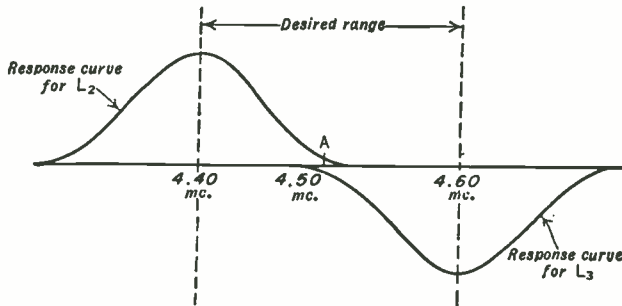

FIG. 14-13. The overall response curve for the discriminator of Fig. 14-12.

oped across the load resistors cancel each other and the resultant voltage is zero. Similarly, by adding the voltages at other points about the carrier, we obtain the overall resultant curve shown in Fig. 14-14. This is the familiar S-shaped curve of all frequency discriminators which shows how the output voltage of the second detector will vary as the incoming frequencies change. Specifically, suppose the signal acting at the input to the dis-

criminator at any one instant has a frequency of 4.56 mc. The amount of voltage developed at the output is given by point *A* on the vertical axis. Then, at the next instant, if the frequency should change to 4.44 mc, the output voltage is indicated by point *B*. Notice that all frequencies below 4.50 mc result in positive output voltages, whereas all those above 4.50 mc result in negative output voltages.

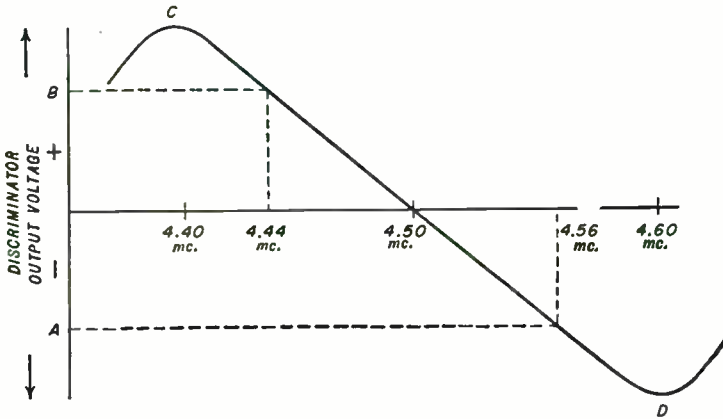

FIG. 14-14. The resultant S-shaped discriminator characteristic curve obtained by adding the two separate curves of Fig. 14-13.

mc give rise to negative output voltages. In this way, the audio voltages that modulated the carrier frequency at the transmitter are extracted in the receiver.

The useful segment of this characteristic curve of the discriminator is the linear portion included between the two maximum points, *C* and *D*. Any nonlinearity along this section of the curve would produce amplitude distortion in the output audio signal. When discriminators are designed, the maximum points *C* and *D* are generally set much farther apart than is required in the particular receiver. This insures a linear curve at those frequencies that are actually used, since the response characteristic has a tendency to curve near the maximum peaks. By utilizing a smaller range, amplitude distortion in the output signal is kept to a minimum. The sections of the curve of Fig. 14-14 beyond points *C* and *D* are completely disregarded. The frequency of the output voltages is determined by how rapidly the frequency of the incoming IF signal varies. A large frequency deviation in the input signal gives rise to a strong output wave, and the rapidity with which this incoming frequency changes determines whether the strong output will be pitched high or low.

A Modified Discriminator. One may wonder why the preceding circuit was described in such detail if it is not used in modern receivers. The

reason lies simply in the ease with which this circuit brings out the fundamental conversion process at the second detector of an FM receiver and because it is basically the same as the present-day discriminator of Fig. 14-15. Instead of employing two separate capacitors for the secondary circuits, only one is used. R_1 and R_2 are the load resistors, one for each diode, and the resultant output audio voltage is still obtained across points *A* and *B*. The use of one capacitor, instead of two, results in greater ease in aligning the circuits and economy in construction. The tap divides the secondary coil into two identical coils, L_2 and L_3 .

Circuit operation depends upon the voltages developed across L_2 and L_3 for the various incoming frequencies. The voltages add vectorially to the voltage in the primary coil L_1 , which is brought over to the secondary circuit through capacitor C_3 . A complete discussion of the operation of this circuit would involve determining the phase relationships between the various coils, for it is only in this way that the different voltages appearing at the output of the discriminator can be computed. The different phase relations are brought about by the changing frequencies that enter the discriminator. For example, at resonance the secondary tuning circuit acts purely resistive to an incoming signal. For frequencies above resonance, the inductive reactance of the secondary circuit predominates whereas, for frequencies below resonance, the capacitive reactance determines the phase of this circuit. As these phase relations fluctuate, the output voltage taken from across R_1 and R_2 likewise changes. A characteristic curve similar to the S-shaped one in Fig. 14-14 is obtained for this discriminator.

One variation of the foregoing circuit which is used frequently is shown in Fig. 14-16. Its popularity stems from its slightly lower cost which is due to the elimination of one capacitor across the output resistor.

The need for limiter stages arises because the discriminators noted in the preceding paragraphs are sensitive to the amplitude of the incoming signal. In other words, these discriminators are not pure FM detectors. There are other FM detectors, however, which are sufficiently immune to amplitude variations to enable the limiter to be dispensed with. These detectors are discussed below.

FM Ratio Detector. To understand why a ratio detector enjoys greater immunity from AM distortion in the incoming FM signal, let us compare its operation with that of the ordinary discriminator.

In the discriminator circuit of Fig. 14-15, let the signal coming in develop equal voltages across R_1 and R_2 . This would occur, of course, when the incoming signal is at the IF center value. Suppose that each voltage across R_1 and R_2 is 4 volts. When modulation is applied, the voltage across each resistor changes, resulting in a net output voltage. Say that the voltage across R_1 increases to 6 volts and the voltage across R_2 decreases

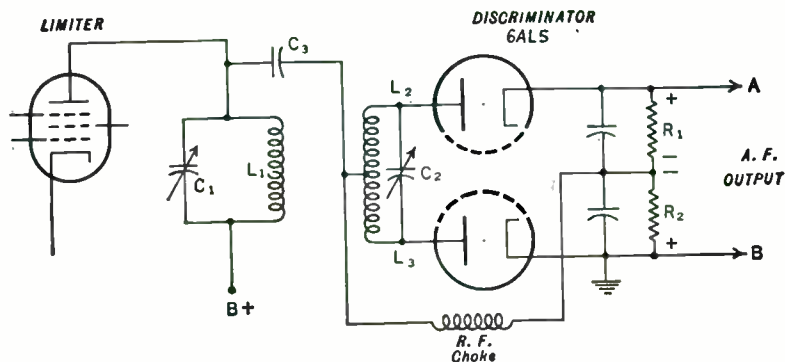

FIG. 14-15. A common discriminator in FM receivers.

to 2 volts. The output voltage would then be equal to the difference between these two values, or 4 volts.

However, let us increase the strength of our carrier until we have 8 volts, each, across R_1 and R_2 , at midfrequency. With the same frequency shift as above, but with this stronger carrier, the voltage across R_1 would rise to 12 volts and that across R_2 decrease to 4 volts. Their difference, or 8 volts, would now be obtained at the output of the discriminator in place of the previous 4 volts. Thus the discriminator responds to both FM and AM. It is for this reason that limiters are used. The limiter clips all amplitude modulation off the incoming signal and an FM signal of constant amplitude is applied to the discriminator.

When unmodulated, the carrier produced equal voltages across R_1 and R_2 . Let us call these voltages E_1 and E_2 respectively. With the weaker carrier on modulation, the ratio of E_1 to E_2 was 3:1 since E_1 became 6 volts and E_2 dropped to 2 volts. With the stronger carrier on modulation, E_1 became 12 volts and E_2 dropped to 4 volts. Their ratio was again 3:1, the same as with the previous weaker carrier. Thus, while the difference voltage varied in each case, the ratio remained fixed. This example demonstrates,

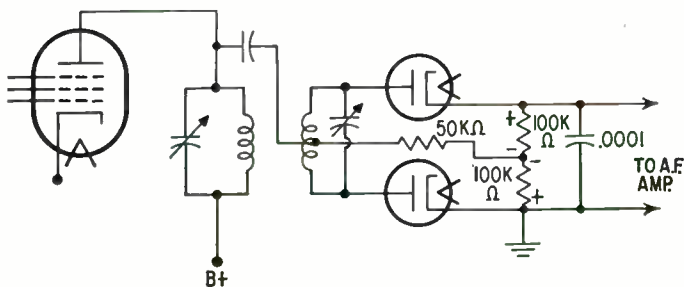

FIG. 14-16. A variation of the FM detector of Fig. 14-15.

in a very elementary manner, why a ratio detector could be unresponsive to carrier changes.

An elementary circuit of a ratio detector is shown in Fig. 14-17. In this form, the detector is similar to the detector in Fig. 14-12, where each tube has a completely separate resonant circuit. One circuit is peaked slightly above the center IF value (say T_1); the other is peaked to a frequency

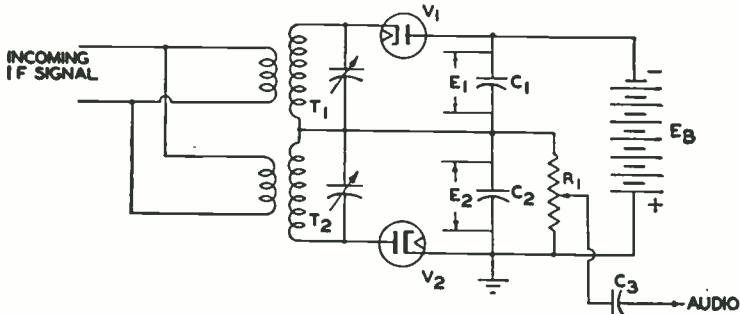

FIG. 14-17. Preliminary form of the ratio detector.

below the center (say T_2). The output voltage for V_1 will appear across C_1 and the output voltage for V_2 will be present across C_2 . The battery, E_B , represents a fixed voltage. Since C_1 and C_2 are in series directly across the battery, the sum of their voltages must equal E_B . Also, due to the manner in which the battery is connected to V_1 and V_2 , no current can flow around the circuit until a signal is applied. Now, while $E_1 + E_2$ can never exceed E_B , E_1 does not have to equal E_2 . In other words, the ratio of E_1 to E_2 may vary. The output voltage is obtained from a resistor connected across C_2 .

When the incoming signal is at the IF center value, E_1 and E_2 will be equal. This is similar to the situation in the previous discriminator. However, when the incoming signal rises in frequency, it approaches the resonant point of T_1 and the voltage across C_1 likewise rises.

For the same frequency, the response of T_2 produces a lower voltage. As a consequence, the voltage across C_2 decreases. However, $E_1 + E_2$ is still equal to E_B . In other words, a change in frequency does not alter the total voltage, but merely the ratio of E_1 to E_2 . When the signal frequency drops below the IF center point, E_2 exceeds E_1 . The sum, however, of $E_1 + E_2$ must equal E_B . The audio variations are obtained from the change of voltages across C_2 . Capacitor C_3 prevents the rectified d-c voltage in the detector from reaching the grid of the audio amplifier. Only the audio variations are desired.

The purpose of E_B in this elementary explanatory circuit is to maintain

an audio output voltage which is purely a result of the FM signal. E_B keeps the total voltage ($E_1 + E_2$) constant, while it permits the ratio of E_1 to E_2 to vary. So long as this condition is maintained, we have seen that all amplitude variations in the input signal will be without effect.

The problem of selecting a value for E_b is an important one. Consider, for example, that a weak signal is being received. If E_B is high, the weak signal is lost because it cannot possess sufficient strength to overcome the negative polarity placed by E_B on the tubes V_1 and V_2 . The tubes, with a weak input voltage, could not pass current. If the value of E_B is lowered, then powerful stations are limited in the amount of audio voltage output from the discriminator. This is due to the fact that the voltage across either capacitor, C_1 or C_2 , cannot exceed E_B . If E_B is small, only small audio output voltages are obtainable. To get around this restriction, it was decided to let the average value of each incoming carrier determine E_B . Momentary increases could be prevented from affecting E_B by a circuit with a relatively long-time constant.

The practical form of the ratio detector is shown in Fig. 14-18. The de-

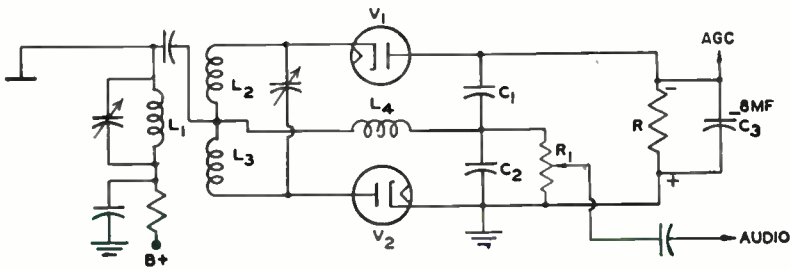

Fig. 14-18. Practical form of the ratio detector.

tor uses the phase-shifting properties of the discriminator of Fig. 14-15. R and C_3 take the place of E_B and the voltages developed across R will be dependent upon the strength of the incoming carrier. Note that V_1 and V_2 form a series circuit with R (and C_3) and any current flowing through these tubes must flow through R . However, by shunting the 8-mf electrolytic capacitor across R we maintain a fairly constant voltage. Thus, momentary changes in carrier amplitude are merely absorbed by the capacitor. It is only when the *average* value of the carrier is altered that the voltage across R is changed. The output audio-frequency voltage is still taken from across C_2 by means of the volume control.

Since the voltage across R is directly dependent upon the carrier strength, it may also be used for AGC voltage. The polarity of the voltage is indicated in Fig. 14-18.

Ratio-Detector Modifications. Another form of the ratio detector is shown in Fig. 14-19. L_4 , instead of receiving its voltage from the primary L_1 through a direct capacitive connection, is now coupled inductively to L_1 . Circuit operation remains unchanged because the voltage across L_4 still depends directly upon the voltage existing across L_1 .

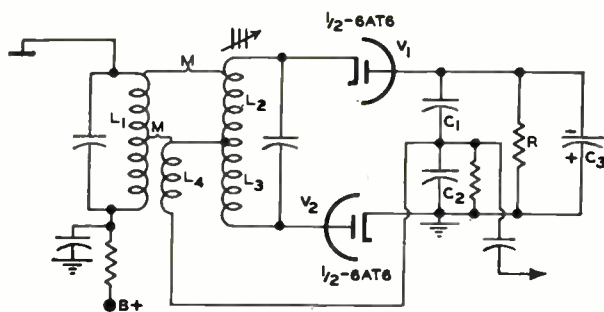

FIG. 14-19. In this ratio detector, L_4 receives its voltage from L_1 by inductive coupling.

The two foregoing ratio detectors (Figs. 14-18 and 14-19) are "unbalanced" circuits, so-called because V_1 and V_2 are not equally balanced against ground. We can transform these circuits into a balanced ratio detector by moving the position of the ground connection, as shown in Fig. 14-20. In

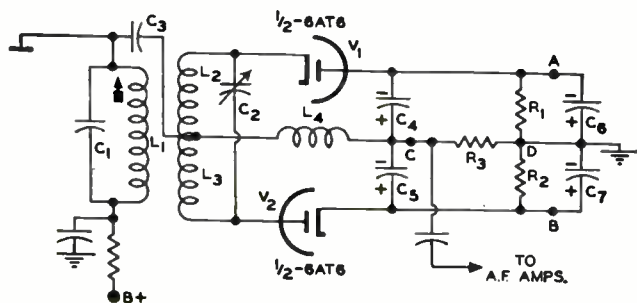

FIG. 14-20. A balanced ratio detector.

place of one stabilizing capacitor, C_3 , and resistor, R , we now have two of each. Their function, however, remains the same.

To see how this circuit works, let us assume that the voltage coming in is at the IF midfrequency. Equal voltages will be applied to V_1 and V_2 , and equal voltages will appear across C_4 and C_5 , with the polarity noted. At the same time, there will be a voltage developed across A-B equal to the

average value of the signal. Half this voltage will appear across R_1C_6 , and half of the total voltage will be across R_2C_7 . Since C_4 is in parallel with R_1 and C_6 , all will have the same voltage. The same is true of C_5 , R_2 , and C_7 . As a consequence of these conditions, there will be no *difference of potential* between points C and D and no audio output. This, again, is similar to the previous discriminators.

Now let the signal frequency swing below the IF midvalue. V_1 will receive more voltage than V_2 and more voltage will develop across C_4 and less across C_5 . The carrier amplitude has not changed, however, because this is an FM signal, and consequently the voltage between points A and B remains the same. To use numerical values, assume that the voltage across R_1, C_6 is 6 volts. Because of the signal-frequency shift, the voltage across C_4 rose from 6 to 9 volts, while the voltage across C_5 dropped from 6 to 3 volts. Since E_{C_4} is now greater than E_{R_1} , and E_{C_5} is less than E_{R_2} , currents will flow in these circuits. These currents, flowing through R_3 , will develop a voltage drop of 3 volts here, with point C positive and point D negative. If now we add the voltages around both branches, we see that they check out. The rise in voltage across R_3 results in an audio output. When the signal swings in the opposite direction, C_5 receives more voltage than C_4 , and the polarity of the voltage across R_3 reverses. In this manner, for signal frequency swings above and below the center point, positive, zero, and negative voltages will develop across R_3 . This is the audio output voltage. At all times, the sum of the voltages across C_4 and C_5 must equal the average carrier voltage present between points A and B. Changes in frequency do not alter the total voltage but merely the ratio of E_{C_4} to E_{C_5} . That is why this is known as a "ratio detector." Changes in signal amplitude will not change the ratio of E_{C_4} to E_{C_5} .

To illustrate this, consider the example used in the foregoing paragraph. A signal-frequency shift caused the voltage across C_4 to rise from 6 to 9 volts, while the voltage across C_5 dropped from 6 to 3 volts. The ratio of E_{C_4} to E_{C_5} is 9:3 or 3:1. Now let us assume that the carrier amplitude is doubled, momentarily. This would double both sides of our ratio but leave the value of the ratio unchanged. Thus, $9:3 = 18:6 = 3:1$.

Any momentary increase in carrier will affect the numerator and denominator of this ratio in like measure and consequently leave the basic value of the ratio unaltered. The same is true of carrier decreases. Actually, because of the presence of the long-time-constant network of R_1, C_6 and R_2, C_7 , the momentary changes in carrier amplitude only *tend* to make the voltages across C_4 and C_5 go up or down. By the time the voltage in the circuit actually changes, the pulse or disturbance has passed.

Another balanced ratio detector commonly encountered is shown in Fig. 14-21. R_1 is inserted to provide better balance between both halves of the

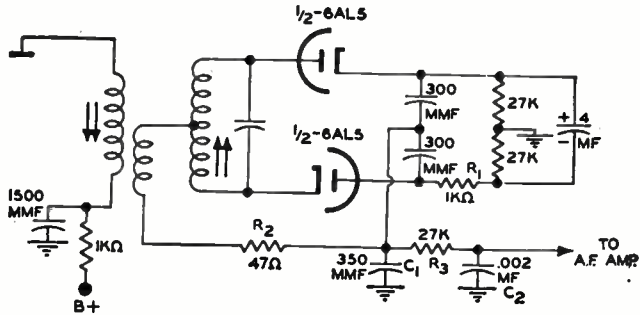

FIG. 14-21. A common variation of the balanced ratio detector.

circuit, and R_2 limits the plate current drawn by each diode section of the 6AL5. C_1 shunts IF voltages away from the audio output, while R_3 , C_2 is a de-emphasis filter to equalize the audio signal back to its original form. More will be said on this point in a moment. An ACG voltage can be obtained from the negative side of the 4-mf stabilizing capacitor.

The urge to simplify these circuits and thereby reduce the cost is ever present among designers of television sets. Such simplification is possible with the ratio detector, as revealed by the design shown in Fig. 14-22. This arrangement possesses fewer capacitors than the ratio detector of Fig. 14-21. In spite of the reduction, the circuit still functions satisfactorily. However, with fewer capacitors, the reader may fail to see how the difference voltage is established to provide the necessary audio output signal.

To understand how the circuit in Fig. 14-22 operates, it has been drawn with lettered identification points. Current that flows through V_1 can take one of two paths. In one path, the current flows from the cathode of V_1 to the plate, to points B , C , F , E , A , and then back to the cathode again. The second path is: cathode to plate, to points B , C , then to ground, and up through C_1 to point D , then to point E , A , and finally back to the cathode again.

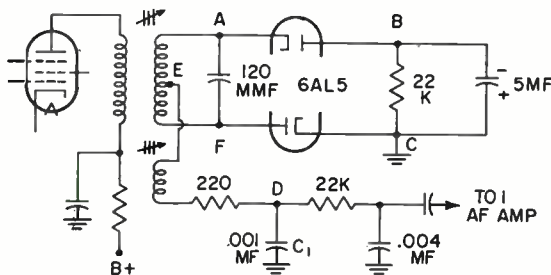

FIG. 14-22. An economical ratio detector that is widely used.

Now consider V_2 . One path for its current is: cathode to plate, to F, E, A , through V_1 to B, C , and back to the cathode again. The second path is from cathode to plate to F, E , and down to point D , through capacitor C_1 to ground, then to point C and back to the cathode again. Note then that part of the current of V_1 flows up through C_1 while part of the current of V_2 travels down through the same capacitor. It is from these two opposing currents that the difference is established, this difference representing the audio output voltage of the detector.

The 6BN6 Gated-Beam Tube. Another approach to a limiter-discriminator combination, one that differs considerably from any of the previous circuits, is provided by the 6BN6 gated-beam tube. This tube, designed by Dr. Robert Adler of the Zenith Radio Corp., possesses a characteristic such that when the grid voltage changes from negative to positive values, the plate current rises rapidly from zero to a sharply defined maximum level. This same maximum value of plate current remains no matter how positive the grid voltage is made. Current cutoff is achieved when the grid voltage is about 2 volts negative.

The reason for this particular behavior of the tube stems from its construction. See Fig. 14-23. The focus-electrode and first accelerator slot

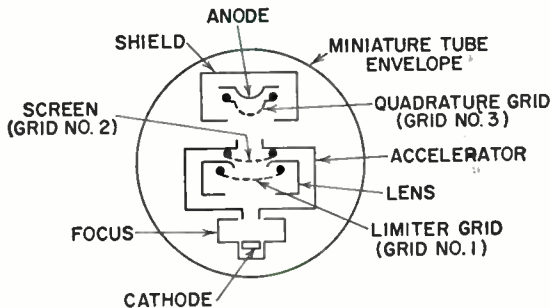

FIG. 14-23. The internal construction of the beam-gated tube 6BN6.

together form an electron gun which projects a thin-sheet electron stream upon grid no. 1. The curved screen grid, together with the grounded lens slot, and aided by the slight curvature of grid no. 1, refocuses the beam and projects it through the second accelerator slot upon the second control grid. This grid and the anode which follows are enclosed in a shield box. Internally, the focus, the lens, and the shield electrodes are connected to the cathode. The accelerator and the screen grid receive the same positive voltage because both are connected internally.

The foregoing design is such that electrons approaching the first grid do so head-on. Hence, when grid no. 1 is at zero potential or slightly positive,

all approaching electrons pass through the grid. Making the grid more positive, therefore, cannot further increase the plate current. When, however, grid no. 1 is made negative, those electrons that are stopped and repelled toward the cathode do so along the same path taken in their approach to the grid. Because of the narrowness of the electron beam and its path of travel, electrons repelled by the grid form a sufficiently large space charge directly in the path of other approaching electrons, thus causing an immediate cessation of current flow throughout the tube. In conventionally constructed tubes, the spread of the electron beam traveling from cathode to grid is so wide that those electrons repelled by the grid return to the cathode without exerting much influence on other electrons which possess greater energy and therefore are able to overcome the negative grid voltage. It is only when the control-grid voltage is made so negative that no emitted electrons possess sufficient energy to overcome it that current through the tube ceases. These differences between tubes can be compared to the difference between the flow of traffic along narrow and wide roads. On narrow roads, failure of one car to move ahead can slow down traffic considerably; along wide roads, where there is more room, the breakdown of one car has less effect.

The electron beam leaving the second slot of the accelerator approaches grid no. 3 also in the form of a thin sheet. Thus, this section of the tube can also serve as a gated-beam system. If this second grid is made strongly negative, the plate current of the tube is cut off no matter how positive grid no. 1 may be. Over a narrow range of potential in the vicinity of zero, the third grid can control the maximum amount of current flowing through the tube. However, if the third grid is made strongly positive, it also loses control over the plate current, which can never rise beyond a predetermined maximum level.

Now, let us see how this tube can be made to function as a limiter-discriminator. A typical circuit is shown in Fig. 14-24.

It has been noted that when FM signals reach the discriminator they contain amplitude variations. When the 6BN6 gated-beam tube is used, these signals are applied to control grid no. 1. If the signal receives sufficient prior amplification, it will have a peak-to-peak value of several volts. Upon application to grid 1, current through the tube will flow only during the positive part of the cycle and will remain essentially constant no matter how positive the signal may become, or what amplitude variations it may contain. Thus, signal-limiting is achieved in this section of the tube; the electron beam is passed during the positive half-periods of the applied signal and cutoff occurs during the negative half-periods. The groups of electrons that are passed then travel through the second accelerator slot and form a periodically varying space charge in front of grid no. 3. By electrostatic

induction, currents are made to flow in the grid wires. A resonant circuit is connected between the grid and ground, and a voltage of approximately 5 volts is developed in grid no. 3. The phase of this voltage is such that it will slow down the input voltage in grid no. 1 by 90 deg, assuming that the resonant circuit is tuned to the intermediate frequency. (Because of this 90

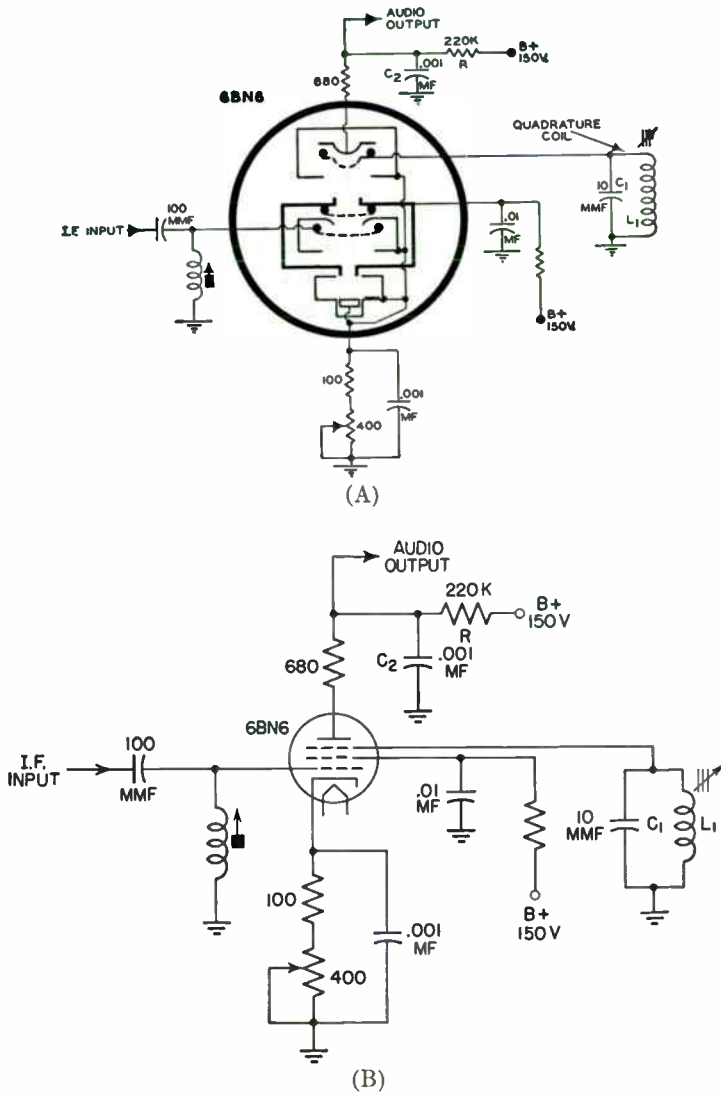

FIG. 14-24. The beam-gated tube connected as a limiter-discriminator. (A) Tube shown in pictorial form. (B) Tube drawn schematically.

deg difference between grid voltages, grid no. 3 is often referred to as the "quadrature grid.")

Electrostatic induction, referred above, may be new to the reader. Whenever a group of electrons approach an element in a tube, electrons at that element will be repelled, resulting in a minute flow of current. By the same token, electrons receding from an element will permit the displaced electrons to return to their previous position. Again a minute flow of current results, this time in a direction opposite that of the first flow. If a sufficient charge periodically approaches and recedes from an element, the induced current can achieve substantial amplitudes. This is precisely what occurs at grid no. 3 in the 6BN6.

In the gated-beam tube, grids no. 1 and no. 3 represent electron gates. When both are open, current passes through the tube. When either one is closed, there is no current flow. In the present instance, the second gate lags behind the first. Plate-current flow starts with a delayed opening of the second gate and ends with the closing of the first gate. Now, when the incoming signal is unmodulated and L_1 and C_1 of Fig. 14-24 is resonated at the intermediate frequency, the voltage on grid no. 3 will lag the voltage on grid no. 1 by 90 deg. However, when the incoming signal is varying in frequency, the phase lag between the two grid voltages will likewise vary. This, in turn, varies the length of time during which plate current can flow. See Fig. 14-25(A). Thus, plate current varies with frequency. The circuit is

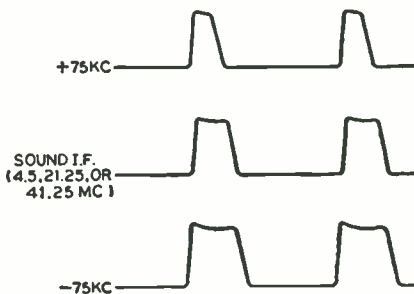

FIG. 14-25(A). The variation in current pulse duration with different incoming frequencies in a 6BN6.

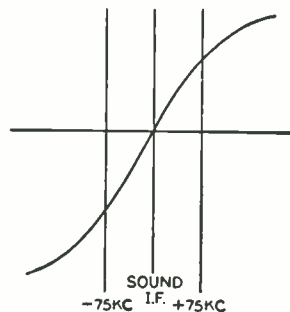

FIG. 14-25(B). Discriminator response of the 6BN6 when connected as shown in Fig. 14-24.

designed so that the current varies in a linear manner. By placing the resistor in the plate lead, R of Fig. 14-24, we can obtain an audio voltage to drive the audio amplifier that follows.

A typical response for a 6BN6 FM detector is shown in Fig. 14-25(B). Note that this curve does not possess any sharp bends (such as are in Fig.

14-14), at frequencies beyond the range of normal signal deviation. This makes the receiver easier to tune.

In the circuit of Fig. 14-24, a 680-ohm resistor is inserted between the load R and the plate of the tube. Bypassing the IF voltage is accomplished by C_2 , but since this capacitor is placed beyond the 680-ohm resistor, a small IF voltage appears at the anode of the tube. Through the interelectrode capacitance that exists between the anode and grid no. 3, the IF voltage developed across the 680-ohm resistor is coupled into L_1 and C_1 . The phase relations existing in this circuit are such that this feedback voltage aids in driving the tuned circuit.

Bias for grids no. 1 and no. 3 is obtained by placing a resistor in the cathode leg of the tube. Since amplitude rejection, especially at low input signals near the limiting level, is a function of the correct cathode bias, the cathode resistor is made variable. This permits adjustments to be made in order to compensate for tube or other component changes.

The 6DT6 Detector. The 6BN6 tube is, as we have seen, of special construction. Recently another tube, a 6DT6, has been similarly employed, although its internal structure is more like that of an ordinary pentode. However, in the new tube the control and suppressor grids are both capable of sharply cutting off the plate current. For this reason, they resemble grids no. 1 and no. 3 of the 6BN6. The circuit of an FM detector using a 6DT6 (or a 3DT6) is similar to the 6BN6 circuit. See Fig. 14-26. So long as the

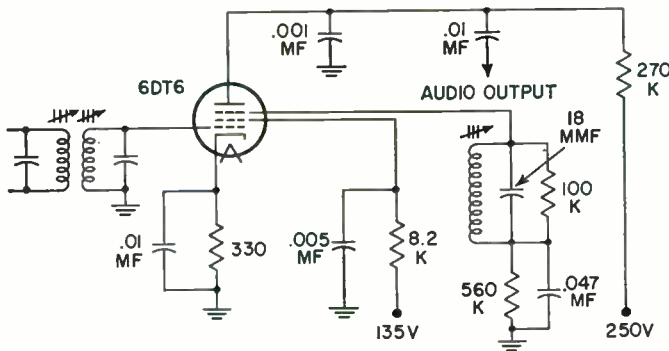

FIG. 14-26. A FM-detector circuit using a 6DT6.

incoming signal is moderately strong, quadrature-grid detection takes place essentially as it does in the 6BN6 arrangement.

On weak signals, the 6DT6 circuit has a tendency to break into oscillation at the IF value. This serves to maintain the detected output signal constant in spite of the fact that weak signals tend to vary considerably in amplitude because of noise and fading. The oscillations arise because of

the feedback which takes place between suppressor grid and control grid within the tube. The incoming signal at grid no. 1 locks in with these oscillations and actually causes them to shift in frequency as the modulation moves the signal frequency back and forth. Normal quadrature-grid detection takes place in the oscillating detector. This oscillation boosts the sensitivity of the circuit to weak signals, causing it to deliver a clearer output under adverse conditions. However, if the applied signal becomes extremely weak, the oscillator will become unlocked, resulting in a loss of detection. Locking will occur only over a limited range of weak signal strength.

When moderate or strong signals are received, the control grid draws grid current and this loads down the circuit of the input tube. This loading not only kills any tendency to oscillate, but it also broadens the tuning response, all of which tend to limit these signals, thereby providing a certain amount of limiter action. The strong signal tends to drive the tube from plate-current cutoff to plate-current saturation. Thus, the current flow in the plate circuit will be essentially the same as that of a square-wave, and limiting action is produced. In the 6BN6, limiting is achieved by the characteristics of the tube itself.

De-emphasis Network. There is one other circuit found in FM receivers that is not used in AM sets—the so-called “de-emphasizing filter.” It was required because the greatest amount of audio-frequency noise is generated in the transmitter at the higher frequencies—from 5 kc up. To reduce the effect of the noise, a pre-emphasis network is inserted in the audio system of the transmitter. The function of the circuit is to favor the frequencies above 1500 cycles. It accomplishes this by proportionately attenuating the lower frequencies more than the higher frequencies of the signals passing through the network. A typical accentuator filter is shown in Fig. 14-27(A). The

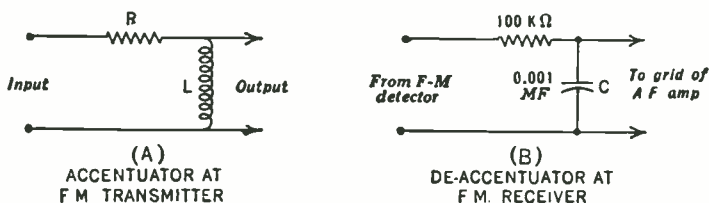

FIG. 14-27. Two circuits that help maintain the fidelity of the higher audio frequencies in FM systems.

higher frequencies, in passing through the network, lose less voltage than the accompanying low frequencies.

Pre-emphasis is applied to the audio signals at the first audio amplifier. Beyond this network, the audio voltages combine in the usual manner with whatever noise is present in the system. At the receiver there is a de-empha-

sis circuit shown in Fig. 14-27(B), with the reverse properties of the pre-emphasis circuit. The frequencies above 1500 cycles are reduced to their original values. At the same time a similar reduction in noise occurs. The overall effect is a return of the signal to its proper relative proportions, but with a considerable reduction in noise.

The audio amplifiers that follow the discriminator are engineered for flat response up to 15,000 cycles. This frequency-response extension is easier to achieve here than in video amplifiers, and little change in basic amplifier form will be noticed. A single, or push-pull, power amplifier provides sufficient power to drive 12-in. speakers.

Audio Systems in Television Receivers. Typical audio systems found in television receivers are shown in Figs. 14-28 to 14-33. Each contains a different feature which is generally typical of receivers employing similar circuitry. In the circuit shown in Fig. 14-28, a fairly elaborate arrangement is employed, consisting of two sound IF amplifiers, a limiter, a combined discriminator and first audio-voltage amplifier, and a power-output stage. This arrangement is representative of the sound systems found in split-sound receivers where the sound signal is separated rather early from the video signal and then requires considerable amplification to bring it to the desired level at the loudspeaker.

Little more needs be said about this system since each stage is straightforward for the purpose it serves. The resonant frequency of the tuned circuits will be determined by the video IF frequency and will be 4.5 mc below this. Common values of sound IF are 21.25 mc and 41.25 mc. The limiter, V_{12} , uses grid-leak bias and low plate and screen voltages to cause the tube to saturate easily. The limiter grid resistor is kept small, so that the grid time constant will be low. In this way, the effect of sharp pulses of interference are reduced or eliminated.

The 6S8GT serves the dual function of discriminator and first audio amplifier. R_1 and R_2 are the discriminator load resistors which develop the audio-signal voltage. This is then passed through the de-emphasis network of R_3 and C_1 and applied to the 1-megohm volume control, R_4 . The desired amount of signal is tapped off of R_4 and fed to the triode section of the 6S8GT. From here, the signal travels to the output amplifier and the loudspeaker.

Note that the screen-grid bypass capacitor and the cathode resistor and bypass capacitor of V_{14} return to -110 volts rather than to ground. This is done to provide a greater voltage differential across this tube in order to obtain a higher output.

C_2 , C_3 , and R_5 form a tone-control network while R_6 and C_3 provide loudness compensation at low volume.

A sound system which has been extensively employed in intercarrier sets

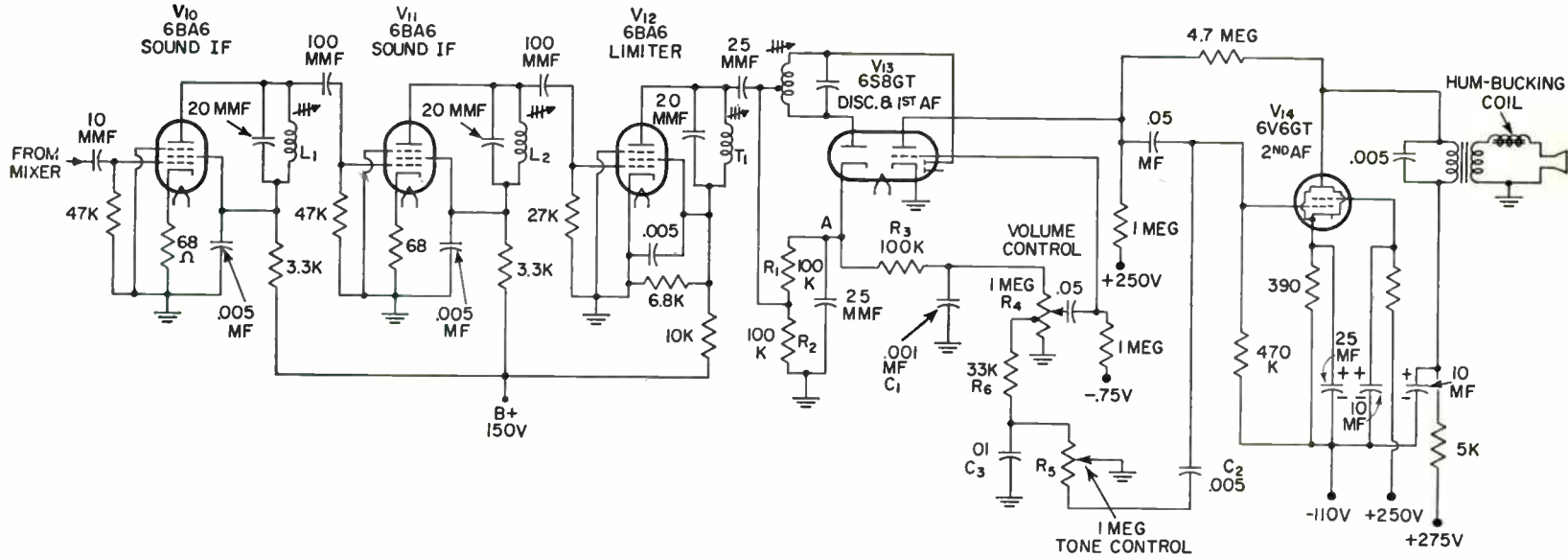

FIG. 14-28. The complete audio system of a television receiver using an FM discriminator.

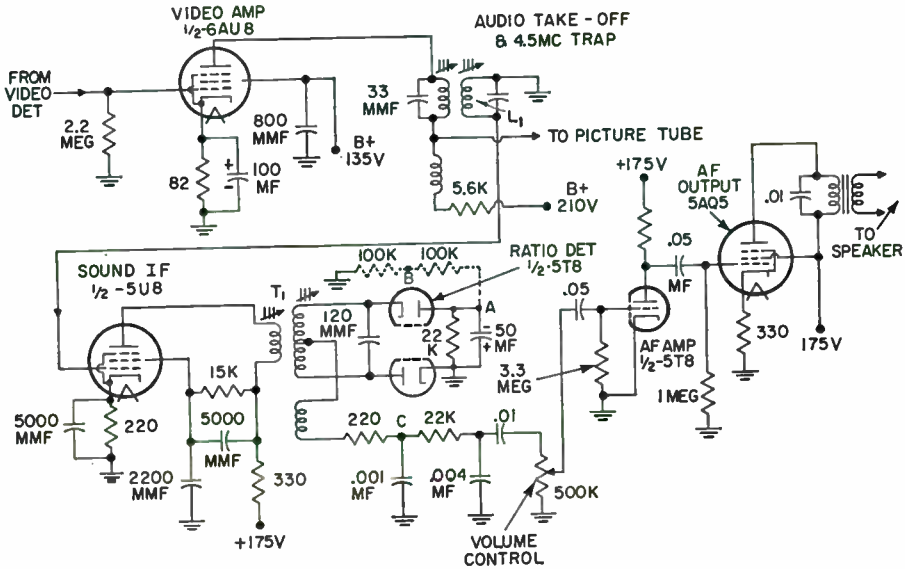

FIG. 14-29. A sound system of a television receiver employing a ratio detector.

is shown in Fig. 14-29. One stage of IF amplification (at 4.5 mc) precedes an unbalanced ratio detector. The detected audio signal then is amplified by a triode amplifier, an audio power amplifier, and fed to a loudspeaker.

Occasionally, matched germanium diodes are employed in the FM detector circuit in place of vacuum tubes. See Fig. 14-30. The biggest obstacle to the successful operation of this arrangement is the ability to obtain matched diodes. This requirement requires special handling when the set is built and when it is subsequently serviced. Without such matching, the output tends to be distorted and its AM suppression qualities are poor.

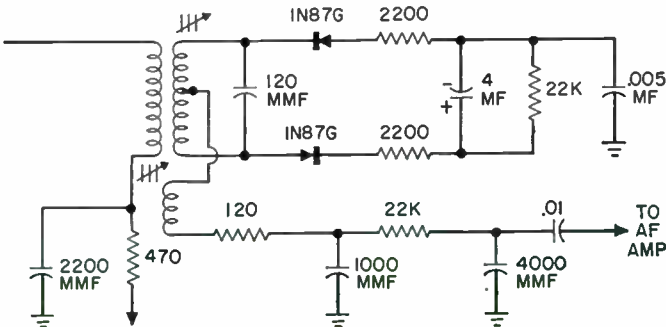

FIG. 14-30. A ratio detector using germanium diodes.

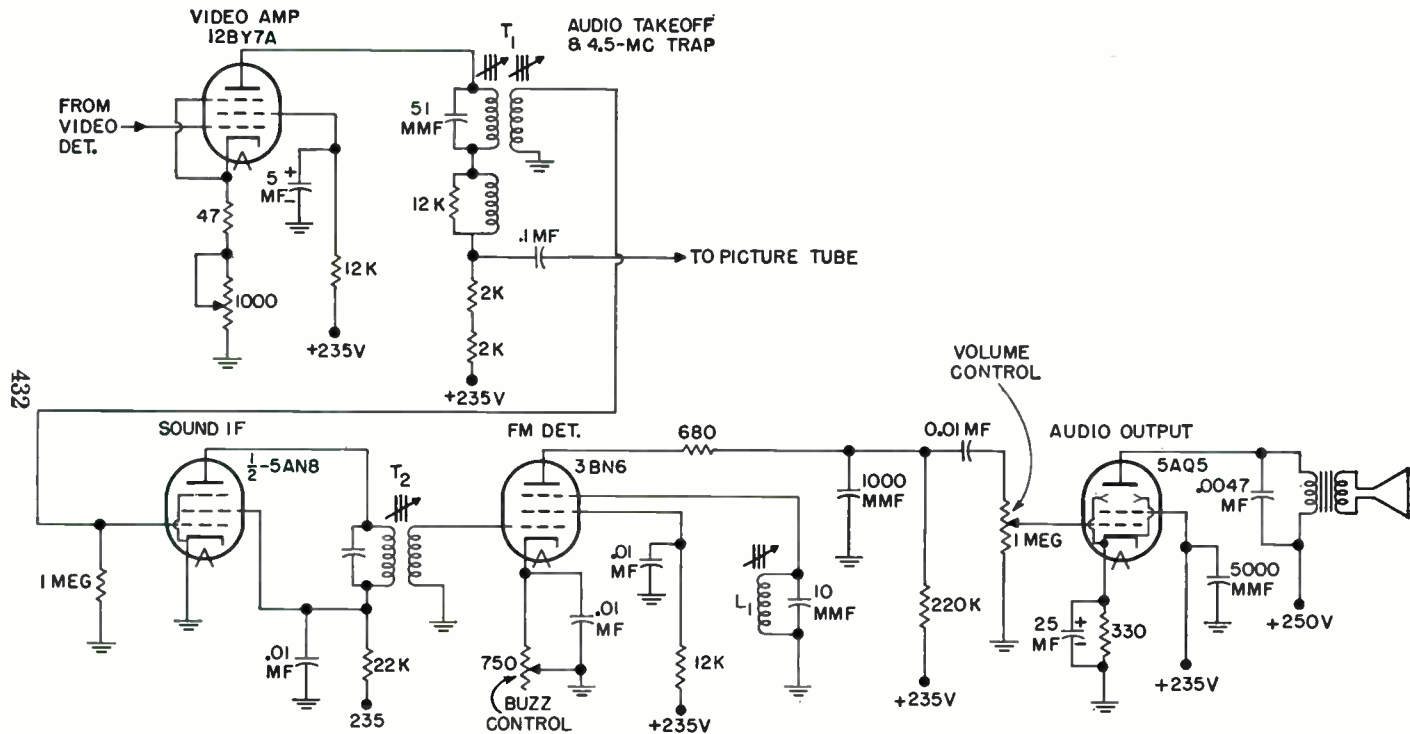

Fig. 14-31. The sound system of a television receiver using a 3BN6 beam-gated tube.

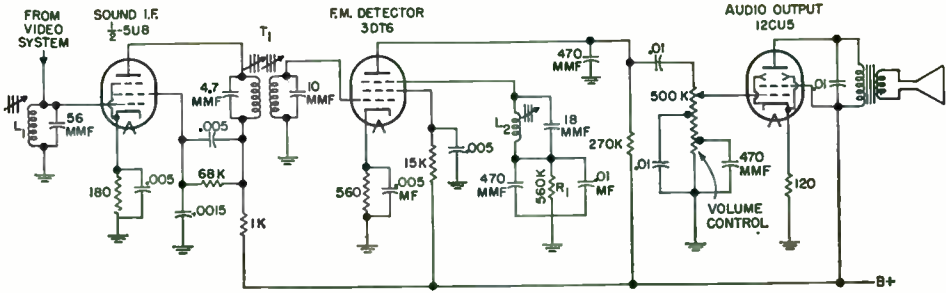

FIG. 14-32. A television sound system employing a 3DT6 tube.

The fourth circuit (Fig. 14-31) utilizes a 3BN6 gated-beam tube. Since this FM detector is capable of supplying amplification, its output can be fed directly to a power-output stage without requiring an intermediate voltage amplifier. A similar arrangement is usually found when a 3DT6 detector is used (Fig. 14-32); both systems operate in essentially the same manner previously described.

The fifth circuit (Fig. 14-33) has a novel feature which has found considerable application. If the output of the ratio detector is checked, it will

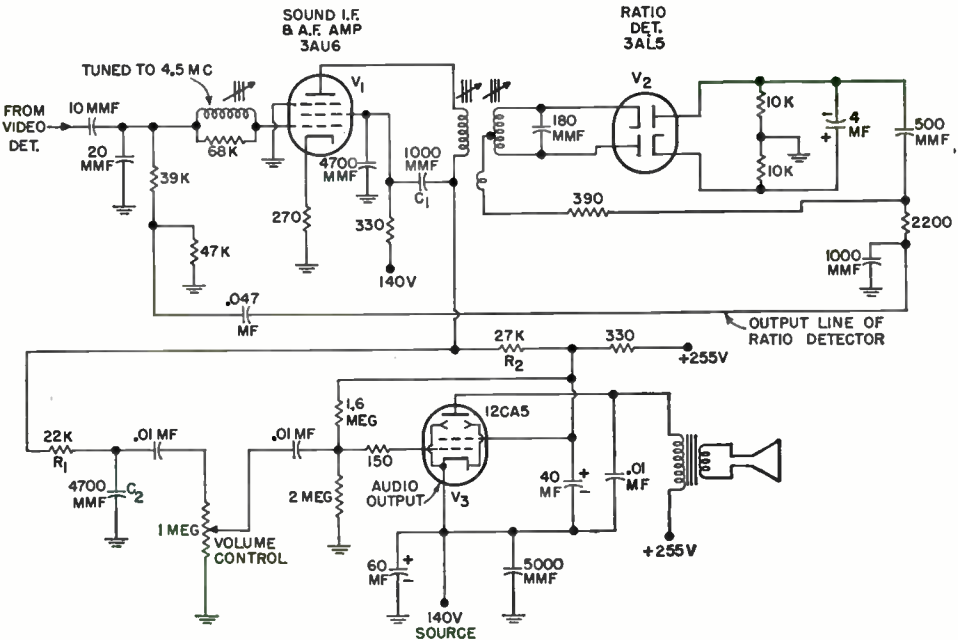

FIG. 14-33. A television sound system in which one tube, V₁, serves as a 4.5mc IF amplifier and also as the first audio amplifier.

be seen to connect to the control grid of the input 3AU6 IF amplifier. In short, the 3AU6 is not only used as a 4.5-mc sound IF amplifier, with suitably tuned circuits, but it is also used to amplify the audio output of the ratio detector. The two signals are kept separate from each other because of the considerable difference in their frequencies. The 4.5-mc signal activates the plate-tuned circuit and is kept out of the audio output stage by bypass capacitors C_1 and C_2 and series resistor R_1 . The audio signal, on the other hand, is not affected by the IF-tuned circuits, seeing them only as connecting wires. The load resistor for this signal is R_2 and it is the voltage developed here that is transferred to the audio-output amplifier through the volume control.

In spite of the twofold purpose that V_1 serves, its double action operation is fairly straightforward.

QUESTIONS

1. In an AM wave, where is the intelligence contained? How does this differ from the conditions prevailing in frequency modulation?
2. What is a discriminator?
3. What influence does the audio-modulating signal frequency have in the production of an FM signal?
4. Where do the FM sidebands obtain their power? Contrast this with the situation existing in an AM signal.
5. Differentiate between phase modulation, amplitude modulation, and frequency modulation.
6. What is the significance of the 2:1 ratio in FM reception?
7. Why is oscillator stability so important in a high-frequency receiver?
8. What purpose do the IF amplifiers serve in a superheterodyne?
9. What advantages are obtained through the use of an IF amplifier?
10. Why are limiters necessary in FM receivers?
11. Do all FM receivers require limiters? Explain.
12. What advantage do double limiters possess over single limiters?
13. Explain the operation of a grid-leak-bias limiter.
14. In what other circuits in radio do we find grid-leak bias?
15. What effect does the use of lowered voltages have on tube operation?
16. Contrast the purpose of an AM detector with an FM detector. State clearly why each should differ.
17. Draw the schematic diagram of an early type of discriminator which employed two secondary windings.
18. Explain the operation of the circuit drawn for Question 17.
19. Would the foregoing discriminator function if one of the diodes became inoperative? Give the reasons for your answer.
20. Draw the circuit of a discriminator widely used today.
21. Draw the circuit of a ratio detector.
22. Explain briefly the operation of a ratio detector.
23. What is the Armstrong system of generating frequency modulation? Why is it useful?

24. Draw a block diagram of the basic Armstrong system. Explain the function of each stage.
25. What properties of a 6BN6 enable it to be used as a limiter? In what other section of a television receiver could these same properties be put to use?
26. In what ways does a 6DT6 FM detector differ from a 6BN6 FM detector? In what ways are they alike?
27. Locate the de-emphasis network in the circuit of Fig. 14-28. In Fig. 14-29. What is the time constant of each?
28. Explain how the circuit of Fig. 14-33 operates. Discuss the entire circuit.

Typical Television Receivers—Analysis and Alignment

Television Receiver Cabinets. Television receivers come in a variety of cabinet styles ranging from a floor-standing console to a portable unit designed to be moved readily from place to place. In many instances, a manufacturer will use the same basic chassis for all or most of his different models, changing only the picture tube and, perhaps, the loudspeaker system. Thus, the portable model might have a 17-in. picture tube, while the console model would use a 23-in. tube. Circuitwise, however, they would be very similar.

Occasionally, a television receiver will incorporate an additional AM and FM chassis to take care of the other broadcast services available to the public. Usually both AM and FM signals are handled by a single combination circuit which receives the sound signals, converts them down to suitable intermediate frequencies, amplifies them, and then detects them. After this, the demodulated voltages are transferred to the audio section of the television receiver where they subsequently reach the loudspeaker.

Receiver Operating Controls. The front-panel controls of television receivers fall into two categories: those dealing with the audio section of the receiver and those associated with the video chassis. Straddling both groups would probably be the regular tuning control and the fine-tuning control, adjusting the reception of both signals simultaneously. Of the audio controls, little need be added to what is already known. One volume control and one tone control permit all the variation ordinarily desired, even with the greater audio range available with FM.

For adjustment of the video portion of the television receiver, the number of front-panel controls varies with each manufacturer. Certain manufacturers provide only contrast and brightness controls; others include the hold controls. All try to keep the number of front-panel controls to a minimum;

anything that will simplify the operation of the receiver for the user is desirable and certain to make the television receiver a more popular instrument.

Contrast. An important video control on the front panel is the contrast control. This adjustment on a television set is similar in its action to the volume control on a sound receiver. The greater the strength of the video voltage applied to the control grid of the cathode-ray tube, the more intense will be the image on the screen. A high setting might be desirable if the surrounding light is strong, or at least bright enough to interfere with the clear perception of an ordinary lighted screen.

In some receivers, the contrast control does not vary the output voltage directly. Rather, it accomplishes this by controlling the gain of several tubes throughout the set. If the control is advanced too far, the regulated tubes are placed on a part of the characteristic curve that is not linear. The result is distortion. It is a well known fact that the human eye is more critical of distortion than the ear. In sound receivers, distortion can run as high as 15 per cent and still be tolerated. In the case of the eye, this percentage would prove disturbing.

Brightness Control. Another panel adjustment for the video section of the television receiver is a "brightness control" which works in close conjunction with the contrast control, and it should not be set until the contrast potentiometer has been adjusted to the desired point. It will be recalled that the brightness potentiometer varies the bias on the grid of the cathode-ray tube and, in this manner, the operating point of the tube. With a strong video signal, it seems reasonable that the bias on the grid of the viewing tube should not be the same that it is when the incoming signal is weaker. The correct setting of the brightness control will just bias the cathode-ray tube so that the blanking voltage level causes the electron beam to be cut off. Refer to Chapter 8. Too low a setting causes the picture to appear washed out; too high a setting eliminates part of the darker detail of the image.

Hold Control. The hold controls, one for the vertical system and one for the horizontal system, enable the viewer to bring the picture back into sync if the need should arise. Nearly all sets manufactured today possess automatic frequency control of the horizontal oscillator. When this is functioning properly there should be little need for adjustment of the horizontal hold control. If the manufacturer feels that the horizontal system is sufficiently stable to require only occasional adjustment, he may place the horizontal hold control on the rear panel. Another favorite place for it is behind a recessed panel on the front of the cabinet. However, if he feels that the hold control will be needed more than occasionally, he may place it on the front panel.

The vertical system, because of the integrating network that precedes it, is less susceptible to disturbances than a free-running horizontal system.

The vertical oscillator may fall out of sync momentarily, causing the picture to roll, but it usually locks itself in again. As a general practice, the vertical hold control is placed near the horizontal hold control.

Fine Tuning. In addition to the controls just described for the video chassis, and the two for the audio chassis, there is another knob labeled "fine tuning." This is a vernier variable capacitor or inductance connected across the oscillator tuning circuit. With it, small variations in the oscillator frequency can be compensated. This control is especially necessary at the high frequencies where small percentage variations mean greater frequency changes. The regular tuning is accomplished by means of a selector switch.

Secondary Controls. The other controls associated with the video chassis of the television receiver are placed within easy reach at the rear of the set. They are placed there only for the convenience of the serviceman and are generally not to be touched by the user of the set. A list of these rear secondary controls includes the following:

1. Vertical linearity
2. Horizontal linearity
3. Vertical centering (if used)
4. Horizontal centering
5. Vertical size (height control)
6. Horizontal size (also known as width or drive control)

The exact number of controls found will, of course, depend upon the elaborateness of the receiver design. No discussion of the action of the controls is necessary here as it would merely be a repetition of what has been given in previous chapters.

A Modern Television Receiver. A typical example of a modern television receiver is shown in Fig. 15-1. This receiver employs a 21-in. tube for direct viewing. Twelve channels are covered, with an FM sound system. The various oscillator frequencies for each of the twelve channels are as follows:

<i>Channel Number</i>	<i>Channel Freq. Mc</i>	<i>Picture Carrier Freq. Mc</i>	<i>Sound Carrier Freq. Mc</i>	<i>Receiver RF Osc. Freq. Mc</i>
2	54-60	55.25	59.75	101
3	60-66	61.25	65.75	107
4	66-72	67.25	71.75	113
5	76-82	77.25	81.75	123
6	82-88	83.25	87.75	129
7	174-180	175.25	179.75	221
8	180-186	181.25	185.75	227
9	186-192	187.25	191.75	233
10	192-198	193.25	197.75	239
11	198-204	199.25	203.75	245
12	204-210	205.25	209.75	251
13	210-216	211.25	215.75	257

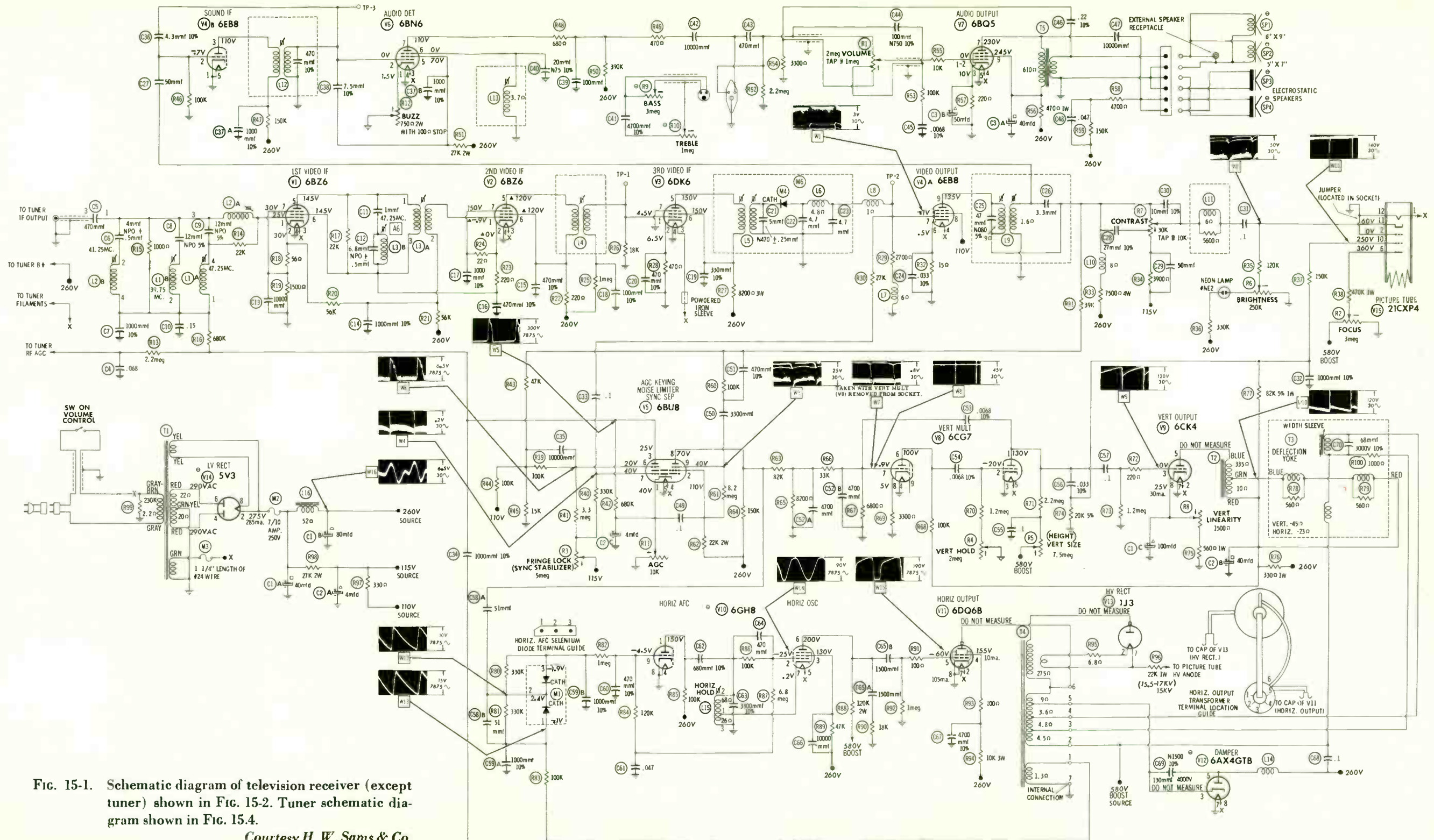

FIG. 15-1. Schematic diagram of television receiver (except tuner) shown in FIG. 15-2. Tuner schematic diagram shown in FIG. 15.4.

Courtesy H. W. Sams & Co.



Courtesy Zenith Radio Corp.

FIG. 15-2A. The television receiver whose schematic is shown in Fig. 15-1.

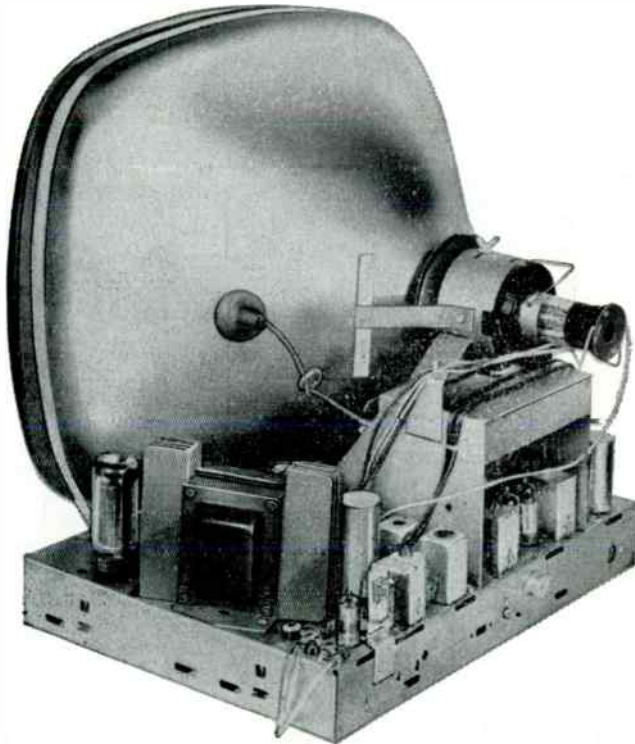

Courtesy Zenith Radio Corp.

FIG. 15-2B. The television receiver of Fig. 15-1 shown without its cabinet.

Primary operating controls (those that are exposed on the front panel) are shown in Fig. 15-2(A).

Channel selector	}	Dual control knobs
Fine tuning		
Sound volume and on-off switch	Single knob
Bass	Knob
Treble	Knob

The secondary operating controls (those which are mounted behind a hinged plate at the front of the chassis) include:

Height	Focus
Vertical hold	Brightness
Horizontal hold	Vertical linearity
Fringe lock	Contrast

In addition, there is also a "buzz" control and an AGC control on the rear of the chassis. The purpose and use of each of the controls will become evident as the analysis of the circuit proceeds.

A block diagram of the receiver is shown in Fig. 15-3. The full schematic

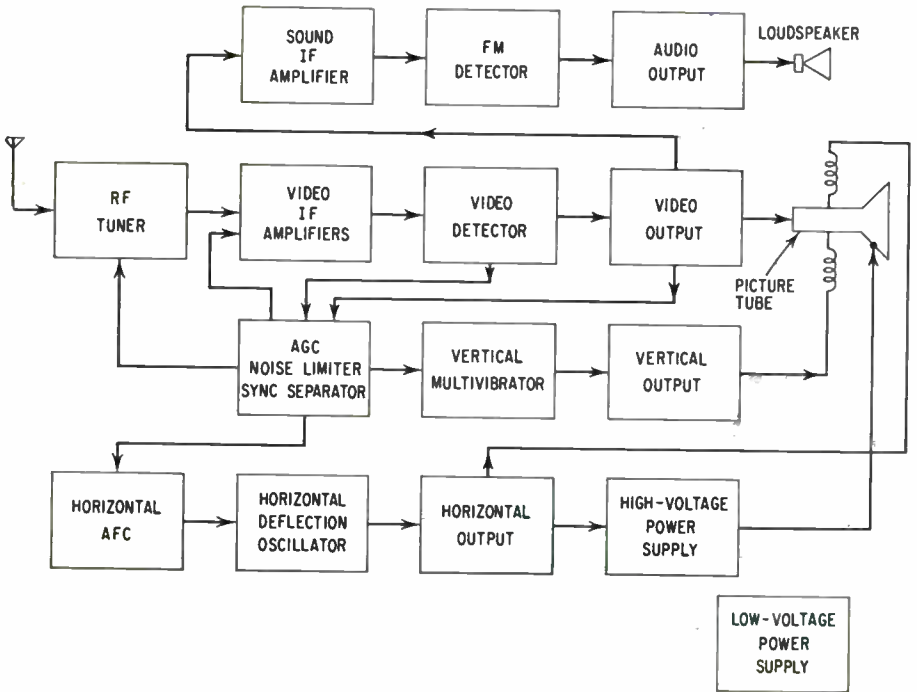

Fig. 15-3. A block diagram of the television receiver of Fig. 15-1.

is shown in Fig. 15-1. In the explanations that follow, it is recommended that both diagrams be consulted.

RF Tuner. The tuner employed in this receiver is a cascode turret tuner with a 6BK7B RF amplifier and a 6EA8 mixer-oscillator. See Fig. 15-4. Different coils are brought in for the various tuning circuits on each channel throughout the VHF range (channels 2 to 13). Provision also exists for tuning in selected UHF stations by removing suitable VHF strips and substituting UHF strips. This facet of tuner operation will be discussed more fully in Chapter 18.

Between the antenna input terminals of Fig. 15-4 and the RF-amplifier grid coils, there is a high-pass trap designed to attenuate all signals below channel 2. Particularly troublesome would be signals at or near the video IF. These could pass quite easily through the RF amplifier and mixer, and reach the video IF system. After this, they could not be stopped, and could cause considerable interference on any pictures developed on the screen.

The cascode RF amplifier, the pentode mixer, and the triode oscillator closely resemble the tuner presented in Fig. 4-13. For further details refer to this figure. The circuit shown in Fig. 15-4 differs in several respects. These differences are discussed below.

Between grid capacitor C_1 and the RF-input tuning coil is a 470,000-ohm resistor, R_1 , which brings B+ to this part of the circuit. In the diagram, this B+ serves no useful purpose until a UHF tuning strip is substituted for the present VHF coils, then this B+ is necessary. In Chapter 18 dealing with UHF TV, this point will be examined more fully.

L_1 in the output circuit of the 6BK7B is an auxiliary adjustment just as C_2 is. By having L_1 in this circuit and L_2 in the mixer-grid circuit, it is more readily possible to achieve a uniform response on each of the 12 VHF channels. In the mass production of this tuner, differences in inductance and capacitance occur in the same circuits of different units. It is the purpose of L_1 , L_2 , C_2 , and C_3 to help equalize the various tuners so that uniform results are obtainable.

Video IF Systems. Three stages of amplification are employed in the video IF system of this receiver. See Fig. 15-1. The output of the tuner, in traveling from the plate of the mixer tube to the grid of the first video IF stage, must pass three shunt-trap circuits, each tuned to a different frequency. The first trap, resonant at 41.25 mc, is designed to reduce the sound IF frequency. It is not the purpose of this trap to eliminate completely this frequency from the overall signal, but simply to reduce it in amplitude so that it is equal to no more than 5 per cent of the video-IF-carrier amplitude. The second trap circuit is tuned to 39.75 mc. This is the IF frequency of the video carrier of the next higher channel and the trap is designed to eliminate

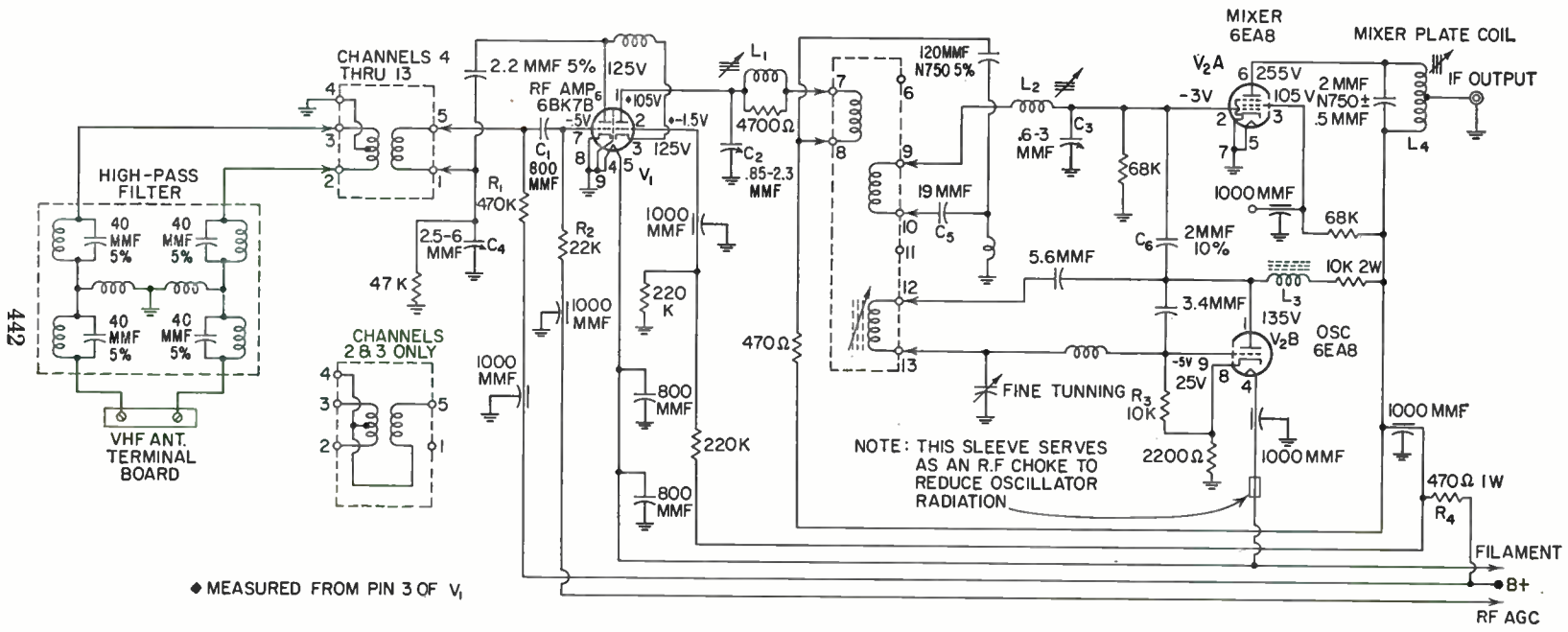

FIG. 15-4. Schematic diagram of RF tuner employed with receiver of Fig. 15-1

any signals that may be received from a station operating on this (the next higher video) channel. The third shunt trap is resonant to 47.25 mc, which is the frequency of the sound carrier of the next lower channel, should such a signal be received.

Note that a second 47.25-mc trap also exists in the plate circuit of the first-video-IF stage. Apparently the designers of this receiver felt that greater interference can come from the video carrier of an adjacent higher channel than from the sound carrier of an adjacent lower channel.

The signal for the grid of the first-video-IF stage is obtained from a tap on the mixer-plate coil. This is done in order to match the impedance of the coaxial cable which connects the two circuits. The same IF input circuit contains a second tuned circuit which, in conjunction with the various capacitances present here, tends to provide a fairly broad response over the video IF range. A second tuning circuit exists between the plate of V_1 and the grid of V_2 . This bifilar coil, L_{3A} , is shunted with a 22,000-ohm resistor to broaden its response.

The bias arrangement for V_1 differs somewhat from conventional amplifier circuitry. The cathode of the tube possesses a voltage of +30 volts, which is obtained in part by the plate and screen flow through the cathode resistors, R_{18} , R_{19} , and in part from the tie-in to the B+ line through resistor R_{20} . The suppressor grid also connects to the cathode. Consequently it, too, has a voltage of about +30 volts. All this is necessary in order to counteract the +25 volts which are present on the grid of this tube and which are derived from the AGC keying tube. With 30 volts on the cathode, the control grid, with its 25 volts, is 5 volts less positive (or more negative) and this establishes the proper bias for this particular tube.

The second video IF stage is straightforward insofar as the input and output tuning circuits are concerned. However, when we examine its B+ network, we find that V_2 and V_1 are essentially in series with each other. This can be seen by noting that the cathode of V_2 does not return to ground but, rather, to the bottom end of the plate circuit of V_1 . Consequently, any current which flows through V_1 travels down through its resonant tuning circuit, up through the cathode of V_2 to the plate of this tube, and through L_4 (primary) to the 260-volt terminal of the power supply. This arrangement, where the current of V_1 is made to flow completely through V_2 , represents a series combination. By operating the two tubes in series, it is possible to control the gain of both tubes by applying AGC bias to the first tube only. Thus, if we reduce the current in V_1 , we automatically cause the current in V_2 to be reduced similarly. Conversely, if we increase the current through V_1 , we automatically increase the current through V_2 . With this arrangement, considerable care must be taken by the technician when measuring voltages at the various elements of V_2 . For example, the cathode of V_2 is

about 150 volts above ground. This amount, if taken at face value, would be an unusual figure since the cathode voltage of most amplifiers is ordinarily not much above zero. Therefore, in order to bring the voltage of V_2 in better perspective, the value at each element is shown with respect to pin 7 (the suppressor). Since pin 7 ties directly to pin 2, the cathode, it is essentially the reference element. The plate, then, is 120 volts positive with respect to the suppressor grid and cathode; the same is true of the screen grid. Finally, the control grid is 0.9 of a volt less positive, or more negative, than the cathode. Whenever an arrangement such as this is encountered, it is always best to use the cathode as the reference rather than the chassis.

The signal from the second video IF stage passes through another bifilar coil on its way to the control grid of a third IF amplifier. This stage is fairly conventional in the way it handles the signal, although here again a somewhat different biasing voltage arrangement is found. For example, since the cathode has a fairly high voltage (as cathode voltages go), a small amount of offsetting positive voltage is fed to the grid. However, it is important to note that the control grid is about 2 volts negative with respect to the cathode and therefore normal operation will be achieved.

From the third video IF tube, the signal passes through a transformer to the video second detector. This interstage coupling transformer has a separate tuning slug for each winding, therefore we can expect that its response will be much broader than the response of any of the preceding bifilar coils.

Video Second Detector. The video second detector, a germanium diode, is connected to produce a positively phased signal. In this form, the synchronizing pulses possess the most negative polarity and the brightest portions of the image possess the most positive polarity. This particular arrangement is required because the signal is fed ultimately to the cathode of the picture tube where the sync pulses must extend in the positive direction and there is only one amplifier between the video second detector and the picture tube.

The diode load resistor, R_{29} , is 2,700 ohms. The circuit is fully compensated, employing both series and shunt-peaking with L_6 , L_7 , and L_8 . The response of the low-pass filter between the detector diode and video amplifier decreases rapidly above 4 mc, preventing the video IF signal from reaching the video amplifier. Part of the demodulated video signal is obtained from R_{29} and L_7 and fed to the sync separator and keyed AGC tube. A series isolating capacitor, R_{30} , reduces the loading of this additional side circuit on the grid input of the video-output tube. Note that there is a direct or d-c connection between the video detector and the video-output amplifier. The amount of negative voltage which develops across R_{29} is so small that a direct connection can be made without upsetting the bias ar-

rangement of V_{4A} . A test point, TP_2 , enables the technician to check the waveform being developed here if he has any reason to suspect the circuit up to this point. A full video signal should be found at TP_2 , including pulses and the video information.

Video Amplifiers. In this receiver, only one stage of video amplification is employed between the video second detector and the picture tube. This stage provides not only the video signal for the picture tube, but also the 4.5-mc sound IF signal for the sound section. L_9 is a sound takeoff transformer, containing a secondary winding which acts as an absorption trap resonant to the sound IF frequency. The voltage which this trap develops is then passed on to V_{4B} , the sound IF amplifier. Since L_9 is peaked to 4.5 mc, it does not affect the normal video signal. Resistor R_{33} is the plate load for V_{4A} .

Contrast variation of the image is achieved with a potentiometer connected between V_{4A} and the cathode of the picture tube. This arrangement is similar to the volume control in a sound receiver, except that the contrast control is more fully compensated because of the wider range of frequencies that have to be passed. This type of control has been previously discussed (pp. 215 and 216). Note that there is another peaking coil, L_{11} , beyond the contrast control designed to maintain the high-frequency response of the overall network. The circuit arrangement between V_{4A} and the cathode of the picture tube may appear complicated, but actually it is not. To help simplify the circuit, it is best to keep each of the elements separately oriented. Thus, the sound takeoff coil at the plate of V_{4A} serves primarily to provide 4.5 mc signals for the sound system. This is then followed by the plate load resistor and its peaking coil, then the contrast control, then another peaking coil, after which the signal is brought to the cathode of the picture tube. There is also a brightness control at the cathode of V_{15} . This control varies the bias on the tube. The control grid of V_{15} is tied to ground; hence it is negative with respect to the cathode.

The brightness control circuit is somewhat unusual in that it has a series neon lamp between the brightness control and R_{36} , a 330,000-ohm resistor which connects to the 260-volt terminal of the power supply. So long as the circuit is functioning normally and the proper amount of voltage is being applied to the circuit, the neon lamp fires and presents little resistance. However, when the set is turned off, the 260 volts are immediately removed. Their removal opens up the path through the neon lamp and effectively cuts off the brightness control from the B+ circuit where residual voltage (in an electrolytic capacitor) may still be present. This is done to prevent any lingering bright spots that may occur after the power has been removed and the deflection voltages have been reduced to zero. It is not unusual to find, after the power has been turned off, that the cathode in the

picture tube is still emitting electrons and that there is enough accelerating voltage present to cause the beam to continue impinging on the screen. With the sweep-deflection voltages no longer in action, the beam narrows down to a spot which, if permitted to remain for any appreciable length of time, will burn or insensitize the fluorescent screen material at that point. Removal of the B+ voltage from the cathode allows speedy discharge of the high voltage through the brightness control to ground.

Synchronizing Separator and Noise Limiter. A 6BU8 duo-pentode is employed as a combination sync-separator, noise limiter, and keyed AGC. The noise-limiting feature of this tube is applied in equal measure to both pentode sections. Therefore, both the AGC circuit and the sync-separator benefit from it. If we concentrate on the right-hand pentode section, we find that the video signal, with sync pulses negative, is applied to grid no. 1, whereas grid no. 3 receives the video signal with sync pulses positive. The tube is so biased that with a normal video signal on grid no. 1 and with no noise pulses present or passing through the circuit, the sync pulses will be clipped and will appear in the plate circuit. However, if a strong noise pulse should come along, it would drive grid no. 1 so negative that current flow through the tube would cease. Nothing would appear in the plate circuit during this interval. The video signal, with sync pulse positive, which is applied to grid no. 3 is strong enough to establish a negative bias on this grid * so that current flows through the tube only during the sync-pulse interval and at no other time. In this way, we achieve clean separation of the sync pulses from the video signal.

An AGC control is available in the cathode to establish the proper AGC voltage, developed by the left-hand pentode, for the particular area in which this set is being employed. The fringe lock control in the circuit of grid no. 1 is adjusted so that with a normal signal, grid no. 1 will permit current to flow through the tube. Then, when a stronger noise pulse comes along, it will drive the tube to cutoff. If this control is incorrectly adjusted, the picture will possess jitter or fall easily out of sync.

Vertical-deflection System. The output of the sync separator consists of a series of vertical and horizontal synchronizing pulses. Separation of the two sets of pulses is made by an integrating network which stands at the input to a vertical multivibrator. This network, consisting of R_{65} , C_{52A} , R_{66} , C_{52B} , and R_{67} , removes the effects of the horizontal sync pulses and permits only the vertical sync pulses to attain sufficient amplitude to trigger the vertical multivibrator. The sync pulses, which are fed to the first tube of the vertical multivibrator, are negative and on their arrival they drive the tube into cutoff, which permits the second tube of the multivibrator combination to conduct strongly, discharging capacitor C_{56} . The multivibrator

* It is negative with respect to the cathode.

circuit is fairly conventional, with a vertical hold control at the grid of V8B and a vertical size, or a height control, in the plate circuit of the same tube. Feedback between the output of the second multivibrator tube and the input of V8A is accomplished by capacitor C_{53} . This arrangement is very simple and one that is almost trouble-free.

The deflection waveform developed across C_{56} and R_{74} is coupled to the grid of the vertical-output tube by C_{57} . Here, further amplification takes place, then the deflection signal is applied to T_2 , the output autotransformer. The vertical-deflection coils of the yoke are connected across the bottom half of this transformer while V_9 connects across the top half. A vertical linearity control, in the cathode leg of V_9 , serves to correct any nonlinear distortion which may be developed in the waveform either by the discharge circuit (C_{56} and R_{74}) or by V_9 .

One additional item of interest in this circuit is the fact that the voltage which appears across R_{74} is passed on to one of the anodes in the picture tube. This is a negative pulse, the purpose of which is to cut off the picture tube during vertical retrace. In this way, the vertical retrace lines are eliminated; otherwise they would be seen on the screen at certain settings of the brightness control. Capacitor C_{32} , in this network, tends to broaden the pulse so that the blanking action will last throughout the entire vertical-retrace interval. Without the capacitor, not all of the retrace lines would be removed. B+ voltage is brought into this network and to the picture-tube anode through R_{77} .

Sound System. The input for the sound IF amplifier is obtained from the sound take-off coil in the plate circuit of the video-output tube. The arriving signal is amplified by V4B, then fed through a bifilar coil to the 6BN6 beam-gated FM detector. This circuit, the operation of which was previously described, contains a variable control in the cathode leg, called a "buzz control," which is adjusted under weak-signal conditions to establish the proper limiting action for the tube. How this is done will be described later.

The audio output from the FM detector is fed through a bass- and treble-tone control circuit to a volume control and, from there, through the audio-output amplifier to an arrangement containing two electromagnetic and two electrostatic speakers. The volume control has a tap for loudness compensation at low-volume levels. Also present is a negative feedback circuit from the output transformer to the resistor, which is connected to the bottom of the volume control. This feedback helps to lower the distortion produced by the 6BQ5 audio-output tube. Even though there are only three tubes in the sound system, sufficient volume is developed to drive four speakers adequately. This volume is caused by the high level of signal which is fed into the system from the video-output stage and to the amplification.

which the 6BN6 provides. Amplification is one advantage which the 6BN6 holds over the discriminator circuit or over the ratio detector. In the two latter detectors, diodes are employed and the output signal is weaker than the input signal. Such FM detectors as the 6BN6 or the 6DT6 are used largely because they can provide amplification.

Before we leave the sound system, note that since V_{4B} is a triode operating at a fairly high frequency, it requires neutralization, which is achieved with C_{36} , connected between the secondary of L_{12} and the grid of V_{4B} .

Horizontal-deflection System. Horizontal sync pulses are applied to the horizontal AFC phase discriminator from the output of the 6BU8 sync separator. The 51-mmfd capacitor, C_{58A} , in conjunction with R_{81} , serves as a differentiating network that reacts only to the steep front and rear sides of each sync pulse. Also feeding into the AFC phase detector are pulses obtained from a separate winding on the horizontal output transformer, T_4 . These pulses are converted by C_{59A} and R_{83} into sawtooth waves which are applied in equal measure to both germanium diodes. The result of mixing the horizontal sawtooth wave with the incoming sync pulses is a net output voltage which is then passed through the long-time-constant filter C_{59B} , R_{82} , and C_{60} to V_{10A} , the horizontal AFC reactance tube. This tube, acting with the horizontal oscillator, forms a Gruen AFC network, the operation of which has been described previously. V_{10A} and C_{62} shunt the resonant circuit of the horizontal oscillator. Actually, what the reactance tube does is to furnish a variable resistance in series with C_{62} . When the resistance of V_{10A} is increased by a more negative voltage at its grid, the effectiveness of C_{62} in altering the frequency of the resonant circuit is reduced. Conversely, when more current is permitted to flow through V_{10A} by the bias on its grid, then its resistance value decreases and C_{62} becomes more effective in changing the frequency of the oscillator. Thus, by varying the grid voltage of V_{10A} above and below a certain level, the oscillator operating frequency can be raised or lowered.

The fixed grid bias for V_{10A} is obtained in large measure from the horizontal oscillator. A fairly large negative voltage is ordinarily developed at the grid of the oscillator and part of this voltage is brought to the grid of V_{10A} by R_{87} , C_{61} , and R_{84} . Negative voltage is also obtained from the phase detector. However, the phase detector does not develop voltage sufficiently negative to provide the necessary bias by itself. Capacitor C_{61} is used in the feedback path to prevent anything but the d-c voltage present at the grid of V_{10B} from reaching the grid of V_{10A} .

The deflection wave is developed by C_{65} and R_{90} in the output of V_{10B} . These components will produce the peaked sawtooth wave needed to deflect the beam across the screen properly. Note that the part of the wave just before the point where it starts its linear rise has a fairly wide base. This

has no effect upon V_{11} because the tube is cut off until the linear rising portion of the wave becomes effective. This was previously discussed.

An autotransformer is employed between the plate of V_{11} and the horizontal-deflection yoke. The yoke windings themselves are connected between pins 2, 3, and 4 of the transformer. The damper tube goes to pins 5 and 2 and the energy which this tube removes from the circuit is stored in capacitor C_{68} where the boost B+ voltage is developed. Two hundred and sixty volts of the boost B+ are obtained from the low-voltage power supply while the damper tube adds 320 volts, for a total boost B+ of 580 volts. This voltage is employed at the plate of the horizontal-output amplifier, at the plate of the second-vertical-multivibrator tube, and at the focus control for the picture tube. Variation in the width of the picture is achieved by a non-ferrous metallic sleeve which fits over one of the horizontal-deflection-yoke coils. By changing the position of the sleeve, the inductance which the coil presents to the output transformer is altered, thereby changing the width of the picture. This sleeve is readily accessible at the back of the receiver.

From the high-voltage rectifier 15,000 volts are obtained and applied to the second-anode aquadag coating of the cathode-ray tube. Little filtering is necessary here since the ripple frequency (15,750 cycles). The filter capacitance does not exist as a separate component in the circuit; rather, it is provided by the conductive coatings that exist between the inner and outer surfaces of the picture-tube bulb. The stored energy is small, preventing the high voltage from proving fatal if it should be touched accidentally. The remaining potentials required by the cathode-ray tube are supplied either by the low-voltage power supply directly or by the boost B+ circuit.

Low-voltage Power Supply. The low-voltage power supply furnishes the power for every stage of the receiver, including the low-voltage electrodes of the cathode-ray tube. The design of this supply is conventional, with a 5V3 rectifier and capacitive input filters. The maximum output voltage is 260 volts, although 115 volts and 110 volts are also available. Two fuses are employed in the supply network; one, a 0.7-amp unit, is in the B+ line while the other, a 1¼-in. length of no. 24 wire, protects the heater line. These are two worthwhile protective measures which prevent extensive damage to the power supply in case of component failure. Unfortunately, too many receivers are built without this simple protection in the interests of economy.

Cathode-ray Tube. The cathode-ray tube employs magnetic deflection and electrostatic focusing. Centering is accomplished by a nonmagnetic plate mounted on the case of the deflection yoke. There is no ion trap because the screen has an aluminum back. Focusing is achieved by varying the voltage on the focusing electrode within the tube. The entire arrangement is simple to adjust because of the small number of external components. A

brightness control in the cathode circuit varies overall screen illumination.

Keyed AGC System. A keyed AGC voltage is furnished by one section of a 6BU8 duo-pentode tube. Noise-limiting is applied to this section of the tube as well as to the sync-separator half. Operation of the tube depends not only on the video signal which is fed to grid no. 1 and grid no. 3 but also on a 300-volt peak-to-peak pulse which is applied to the plate from a separate winding on the horizontal output transformer. In order for the tube to conduct, this pulse must be present as well as the sync pulse at grid no. 3. These conditions are normally met in practice and the resulting flow of current in the plate circuit travels through the load resistor, R_{42} . A voltage is developed here which is governed by the amplitude of the sync pulse at grid no. 3; this, in turn, is determined by the strength of the incoming signal and the amplification which the signal has received prior to its demodulation in the detector.

The AGC voltage produced by the 6BU8 is applied to the grid of the first video IF amplifier and, through a 2.2-megohm isolating resistor, to the grid of the RF amplifier. Since the first- and second-video IF stages are in series, any AGC voltage applied to the grid of the first tube will also alter the current flowing through the second tube. Actually, then, two video IF stages are AGC controlled, together with the RF amplifier.

If a noise pulse should occur when the 6BU8 is being triggered, no current will flow because the electrons leaving the cathode are repelled by the high negative voltage on control grid no. 1. This is done to prevent noise pulses from developing large negative AGC voltages which tend to reduce substantially the gain of the receiver. A momentary reduction in gain could perhaps be tolerated, but, because of the time constants of the AGC line and other circuits, the effect of this excessive negative voltage might remain long enough to throw the picture out of sync. By not permitting the noise pulse to reach the vertical- and horizontal-deflection systems, this behavior is prevented.

A 10,000-ohm potentiometer in the cathode leg of the keyed AGC tube enables the bias of the tube to be adjusted. This adjustment will alter the amount of plate current when the AGC section is keyed on, thereby altering the amount of AGC voltage developed. In an area where the incoming signal is fairly weak, a lower-than-normal AGC voltage is desired; in an area where the signal strength is particularly high, a higher-than-normal AGC voltage is required. This difference in conditions can be taken care of by the setting of the AGC control.

The AGC voltages developed by this system are somewhat unusual. With no signal being received, a d-c voltage of about +25 volts will be developed at the plate of the AGC keyer tube. In the first video IF stage, the +25 volts, at the grid, are offset by the +30 volts at the cathode. See

Fig. 15-1. In the RF amplifier tube, the +25 volts are applied through a 2.2 megohm resistor and the resulting grid-current flow produces essentially zero volts at the grid of the first-triode section of the 6BK7B. Actually, the voltage may be slightly negative.

As the input-signal level rises, the AGC voltage becomes less positive, increasing the negative bias on V_1 . See Fig. 15-1. Eventually, with a sufficiently strong signal, the AGC voltage will actually become negative and, in time, the amplification of V_1 will be reduced to zero.

In the RF amplifier, the grid bias remains close to zero so long as the AGC voltage is positive. It is only when the AGC voltage drops below zero volts that the bias on the RF amplifier becomes more negative. In essence, then, we have here delayed AGC.

Alignment of the Receiver—Equipment Required. For the proper alignment of television receivers, the following basic pieces of test equipment are required: a cathode-ray oscilloscope, a wide-band sweep oscillator, a signal generator, a vacuum-tube voltmeter, and a marker signal generator that is capable of indicating specific frequency points on the test pattern swept out on the oscilloscope screen. The latter may be available as a separate instrument or it may be incorporated in the sweep generator.

Oscilloscope. The cathode-ray oscilloscope is today a necessary piece of test equipment among the serviceman's electrical testing apparatus. Its greatest use, that of observing waveforms of different voltages and frequencies in the receiver, provides the repairman with a positive means of determining rapidly exactly what is occurring at all points in the circuit under test. It eliminates guesswork and permits accurate adjustments to be made until the correct operating conditions are attained. For a television receiver, satisfactory images are observed only if the various intervening circuits are functioning properly. The requirements become stricter as the size of the screen increases and small defects become more readily apparent.

The cathode-ray oscilloscopes that are at present on the market differ little from each other for the same size screen. As the size of the screen is made larger, the number of controls available on the front panel increase, but the basic operation of the instrument remains the same. The advantage of the larger-sized oscilloscopes is their greater possible viewing screen area and the improved frequency response of the vertical and horizontal amplifiers. For television alignment work, however, even a small 3-in. oscilloscope will prove satisfactory. A popular 5-in. model is shown in Fig. 15-5.

Sweep Generators. Because of the wide bandwidths that are peculiar to television receivers, the familiar signal generator, in which only one frequency is available at any one time, is not fully suitable, by itself, for receiver alignment. With a single frequency entering the circuit, it is possible to determine only one point on the frequency response curve. To

do this for a 6-mc or even 4-mc band would require too much time for ordinary service, where time is an important factor in determining the cost of the job. To meet the special requirements imposed by television receivers,



Courtesy Triplet

Fig. 15-5. A modern service oscilloscope.

special sweep oscillators, similar to the unit illustrated in Fig. 15-6, have been developed.

These generators are designed to provide an output signal that sweeps across a range of frequencies and continuously repeats this sweeping at a

rate of 60 cps. If this type of signal is applied to the video IF system of a television receiver, and an oscilloscope is connected across the output of the system (at the video detector, for example), then the pattern produced on the scope screen will represent the response curve of that system.

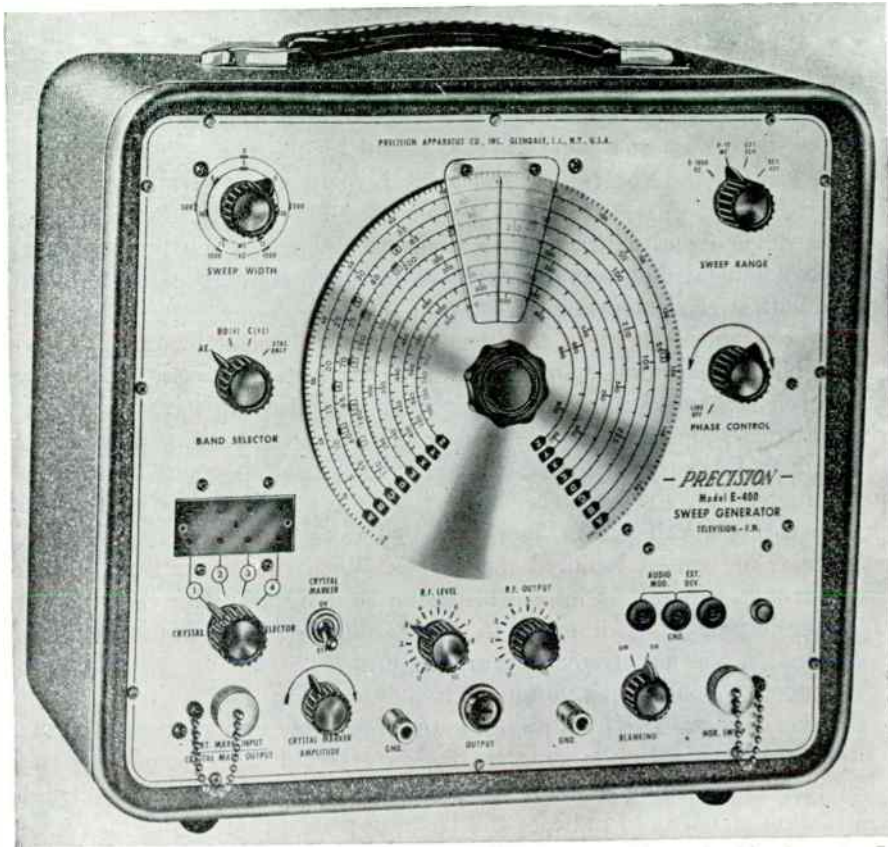

Courtesy Precision Apparatus Co.

FIG. 15-6. A sweep-signal generator covering the FM and television bands.

The range of frequencies obtainable from a sweep generator varies with the instrument. Some are designed to cover only the video IF frequencies, say from 20 to 50 mc. Others cover this and the RF frequencies as well. In all of these instruments, there is a sweep-width control which permits adjusting the range of frequencies swept out at any setting of the tuning dial. For example, suppose the generator is set for 25 mc. Then the amount by which the output signal sweeps above and below 25 mc can be varied from zero (when there is no sweep and the output frequency is 25 mc) to, say,

± 5 mc. This means the output signal varies periodically from 20 mc (25 mc - 5 mc) to 30 mc (25 mc + 5 mc).

For circuit alignment, sweep generators are indispensable. This is especially true of the video IF system.

Single-signal Generators. Although the television receiver employs wide-band tuning circuits, the conventional amplitude-modulated signal generator is not entirely without application. In the receiver just analyzed, some of the IF single-tuned circuits are peaked with such a signal generator. This is particularly true of the trap circuits. Signal generators which generate one frequency at a time are also useful for marker points, as will be seen presently, and for testing the local high-frequency oscillator of the receiver. Finally, in emergencies when no wide-band signal generator is on hand, a single signal generator can frequently permit a fairly satisfactory receiver alignment. For best results, however, single signal generators should be used with sweep generators.

Vacuum-tube Voltmeters. The vacuum-tube voltmeter has always been a very handy instrument to have around, and with television receivers it becomes even more important. The vacuum-tube voltmeter, when properly constructed, has a negligible loading effect on the circuit across which it is placed. In this respect it gives a truer indication of the conditions in the circuit under test. Furthermore, by the use of special auxiliary probes, it will measure d-c voltages as high as 50,000 volts and RF voltages having frequencies of several hundred megacycles. With the conventional 1,000-ohms-per-volt meter it is impossible to do this. Finally, the vacuum-tube voltmeter is practically immune to overloading, a feature for which even experienced servicemen frequently are grateful.

A modern vacuum-tube voltmeter is shown in Fig. 15-7.

Marker Signals. The final piece of apparatus may be incorporated either in the sweep generator or supplied by an external signal generator that is capable of providing a single accurately calibrated signal. The purpose of a marker signal is to indicate the frequency at various points in the response curve observed on the oscilloscope screen. This will aid in adjusting the tuning slugs in the resonant circuits to the desired bandpass characteristics.

As an example, consider the response curve of Fig. 15-8, which is the response curve for the video IF system of a television receiver. This curve would be observed if we connected a sweep generator to the mixer grid and if the generator were set to sweep through the IF range. The oscilloscope would be connected across the video-detector load resistor. What we desire to do, once we obtain the response curve, is to determine the frequencies at various points to insure that the curve rises where it should and falls where it should. It is here that the marker signal comes in handy.

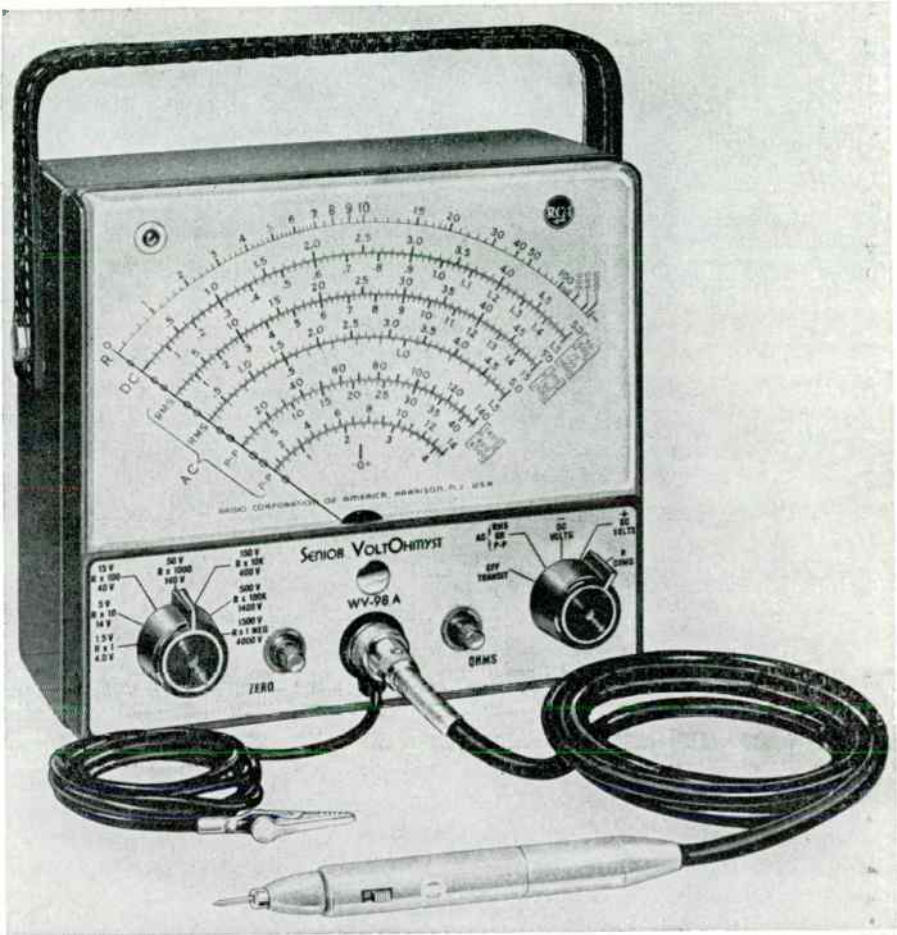

Courtesy RCA

FIG. 15-7. A vacuum-tube voltmeter.

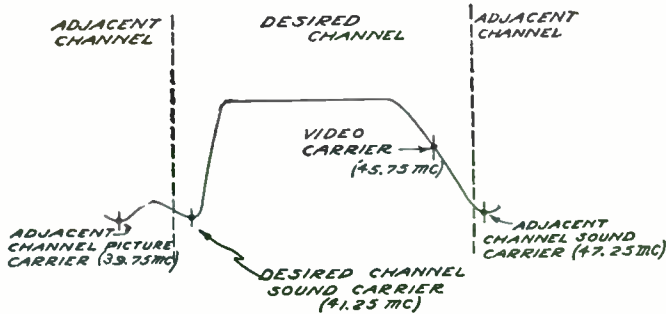

FIG. 15-8. The overall video IF response curve of a television receiver.

If a manufacturer states in his service data that the video-carrier IF is 45.75 mc and the other end of the response occurs at 41.75 mc, then the curve obtained should be checked for the position of these two frequencies. To obtain marker points on the oscilloscope screen, two methods are generally employed. In the simplest method, the sweep signal generator contains an internal oscillator that superimposes its signals on the IF being swept out (40 to 50 mc). The indication of the marker point in the visible pattern is either a slight wiggle or else a dip in the curve at this point. See Fig. 15-9. Note that while two marker points are indicated in Fig. 15-9, only one is

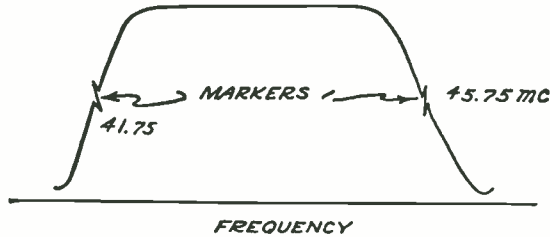

FIG. 15-9. The use of marker points for indicating definitely a frequency on a response curve.

seen at a time. First the marker oscillator is set to 45.75 mc and its position noted on the curve and then set to 41.75 mc and its position checked again.

The above-mentioned video IF band limits, 41.75 mc and 45.75 mc, represent the entire 4 mc that can be employed to transmit the details of the televised scene. Many receivers are designed to pass only 3 mc in the IF amplifiers. In these instances, reference to the manufacturer's instructions will quickly indicate the band limits, and the marker frequencies can be changed accordingly.

If the sweep oscillator does not contain an internal device for supplying the marker points, these can be obtained by the following method. Take another signal generator and place its output leads in parallel with those of the sweep generator, using a 50-mmf isolating capacitor* in the signal lead of the marker generator. Set the frequency of this second oscillator accurately to one of the frequencies that is to be checked on the response curve, say 45.75 mc. With the equipment turned on, a wiggle (or pip) will appear on the overall response curve at 45.75 mc. Note whether the response at this point is that indicated by the manufacturer in his service manual.

*It may be found that attaching the marker generator directly to the sweep generator lead will cause the response curve to alter its shape. If this occurs, try inserting an isolating resistor of 10,000 ohms in the signal line of the marker together with the 50-mmf capacitor. The value of the capacitor is not critical and values between 20 mmf and 200 mmf have been suggested by various manufacturers.

Now change the marker frequency to 41.75 mc and note where this appears on the response curve. In this particular receiver (Fig. 15-1), 45.75 mc represent the video carrier, and 41.75 mc the end of the video bandpass. Other frequencies that should be checked are the trap frequencies. See Fig. 15-8. These include 41.25 mc, the sound carrier of the same channel and 47.25 mc, the lower adjacent channel sound carrier. At each of these points the response should be very low. In other sets that will be encountered, other frequency values may be used. The procedure, in any event, remains the same and requires only changing the frequency of the marker signal to these values. It is advisable not to turn the amplitude of the indicating signal generator too high, but to keep it as low as possible to still obtain a marker line.

The second method is highly flexible. While the sweep oscillator is moving back and forth across the band, the marker-signal generator is set at one frequency. The setting of the marker generator can be altered at will, providing the serviceman with a means for identifying each point on the visible curve.

The alignment procedure for a typical television receiver, such as the one shown in Fig. 15-1, will now be considered in detail. Variations in circuits may cause certain variations in alignment procedure, but the basic approach and the goal to be attained generally remain the same. Thus, by fully understanding the alignment procedure for a typical receiver, the reader will be the better able to carry out the alignment on almost any television receiver, even when certain variations are required.

Alignment Procedure. Whether the alignment for the receiver in Fig. 15-1 starts in the video IF system or in the sound system is not important. However, after one section is completed, the other is begun. The manufacturer of the set shown in Fig. 15-1 recommends that the video IF system be aligned first, then the sound IF system. In the discussion below, this alignment order will be followed.

To start, the signal from an AM signal generator is injected into the mixer tube. One of the simplest ways of doing this is as follows. Connect the generator ground lead directly to the receiver chassis. Then take the "hot," or signal, lead of the generator and attach it to the shield covering the mixer tube. However, to bring a signal into the tube effectively, it is necessary to unground the shield. This is done by lifting the shield until it no longer makes contact with the base, and then tilting it sideways slightly until it rests on and is supported by the tube envelope. In this position, the entire shield will serve as a radiating surface for the signal, and cause part of the signal to reach the inner mixer elements and, from here, the mixer circuit. This method is highly useful when injecting a signal into circuits (for example, the RF mixer) which are ordinarily inaccessible to clip leads.

Next place a vacuum-tube voltmeter across the video-second-detector load resistor, R_{2B} , of Fig. 15-1. The top of this resistor is available also at a special test point identified as $TP-2$. The signal generator is now set, in turn, to each of the following frequencies and the appropriate coil is tuned for a minimum indication on the VTVM.

L_{2B}	41.25 mc
L_{1B}	39.75 mc
L_{1A}	47.25 mc
L_{3B}	47.25 mc

Next, the video IF tuning circuits are aligned. For this, a sweep generator is required and also an internal marker oscillator or an external marker signal provided by an AM generator. As the first step in preparing for this alignment, slowly turn the front panel channel selector until the tuner rotor rests between two channels. This prevents any spurious signals from entering the system and appearing on the oscilloscope screen, thus interfering with the alignment curve. The sweep-signal lead of the sweep-signal generator is then connected to test point $TP-1$, which is at the control grid of the third video IF amplifier. A 470-mmf capacitor is placed in series with the sweep-generator lead. The ground side of the sweep generator connects to the chassis. Finally, a 56-ohm carbon resistor is connected across the sweep-generator output in order to effect a match between the external impedance which the generator "sees" and its internal impedance. An external carbon resistor is required because the input impedance of the third video IF stage is far too high to provide this match. The video sweep generator is then set for a center frequency of 44 mc with a 10 mc sweep, that is, it will sweep from 39 mc to 49 mc, or 5 mc on either side of 44 mc.

For the next step, connect an oscilloscope, through a 10,000-ohm isolation resistor, to test point $TP-2$. The ground terminal of the oscilloscope connects to the chassis at the point where L_7 connects to ground. Adjust the amplitude of the sweep generator for an oscilloscope pattern having an amplitude of 3 volts peak-to-peak. The phase control on the sweep generator should be rotated until a single pattern appears on the scope screen. The internal sawtooth deflection voltage ordinarily used by the scope to sweep the beam across the screen is turned off. In its place, a 60-cycle sinusoidal voltage, obtained from the sweep generator, is applied to the horizontal input terminals of the scope. This step is taken to match the sinusoidal sweeping signal which the sweep generator feeds into the video IF system, thereby providing a response pattern which is properly proportioned frequencywise across the screen.

Before any adjustments are made, a marker frequency of 45.75 mc is required. If this is available from the sweep generator internally, it should be

brought into the system. However, if the sweep generator does not contain its own marker oscillator, then an AM generator should be set at 45.75 mc and its signal lead placed in parallel with that of the sweep generator. Generally, it is desirable to insert a series resistor of between 10,000 and 25,000 ohms in the hot lead of the AM generator to isolate the two generators from each other. Another method, which is just as effective and frequently less disturbing on the response curve, is to insert a marker signal indirectly. This can be done by placing the hot lead of the marker generator near the circuit under test or by clipping this lead onto the body of a capacitor or resistor in the circuit. Since the component body is composed of an insulating material, direct electrical contact with the circuit is avoided. The signal, by direct radiation from the lead clip plus some extraneous capacitive coupling, reaches the test circuit, combines with the sweep signal, and appears on the oscilloscope screen. See Fig. 15-9. It is also permissible to inject the marker signal at the control grid of a preceding video IF tube. Whatever the method of injection, be absolutely certain that the level of this signal is kept as low as possible consistent with some indication on the scope screen. The output of the sweep-signal generator should also be kept as low as possible. As a simple test, disconnect the marker generator from the circuit and notice if the shape of the response curve changes in any way. If it does, the marker-generator coupling to the circuit should be decreased.

With the equipment set up and in operation, adjust both of the cores of interstage-coupling transformer L_5 for maximum gain and symmetry of the response curve with the 45.75-mc marker positioned as shown in Fig. 15-10. If the desired response cannot be obtained, check to see that the cores are entering their respective windings from opposite ends of the coils. Once the 45.75-mc marker has been properly positioned, change the marker frequency to 39.75 mc and note its position on the curve. The 39.75-mc marker can fall within ± 0.5 mc of the point indicated. Finally, shift the marker frequency to 41.25 mc and again see whether this falls where it should. See Fig. 15-10.

The next step in the alignment procedure is to check the response curve of the entire video IF system. For this, the sweep signal is fed in at the mixer tube, passed through the IF stages, demodulated in the second detector, and observed, with an oscilloscope, at the detector load resistor.

To inject the sweep signal at the mixer, lift up the shield of the mixer tube and support it on the tube itself. Then, clip the generator-signal lead

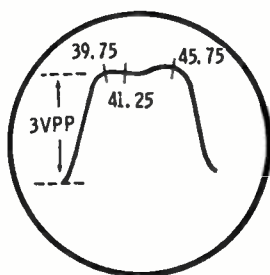

Courtesy H. W. Sams & Co.

FIG. 15-10.

to the shield. Attach the generator-ground lead to the receiver chassis. The generator frequency remains at 44 mc with a 10-mc sweep. Also the oscilloscope is left connected across the video detector load resistor.

Before the alignment is begun, the AGC voltage must be removed from the first video IF stage. To accomplish this, connect a clip lead from the bottom of R_{30} to the chassis. This effectively prevents any signals from reaching the AGC system. Next, connect a clip lead from the top of R_{16} to the junction of R_{18} and R_{19} . These three resistors are in the grid and cathode circuits of the first video IF stage. With this connection, zero grid bias is effectively established on the stage. Turn the scope gain as high as it

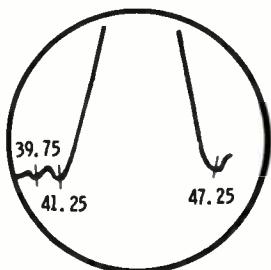

Courtesy H. W. Sams & Co.

FIG. 15-11.

will go, in order to enlarge the sections of the response curve where the trap frequencies are located. Now set the marker signal at 39.75 mc and note whether it falls at the point indicated in Fig. 15-11. If it does not, then the 39.75-mc trap adjustment in L_{1B} should be rotated until the proper position is achieved. Next, the marker frequency is set to 41.25 mc and its position observed. Finally, a 47.25-mc marker is developed and its position on the response curve is noted. If any adjustments are required, they are made with the appropriate core or cores.

Remove the clip lead between R_{16} , R_{18} , and R_{19} and connect it from the top of R_{16} to the chassis. Now adjust the cores of L_4 , L_{3A} , and L_{2A} and the core in the mixer-plate coil for maximum gain and symmetry of the response curve, as shown in Fig. 15-12. With the marker generator, check the various frequency points indicated in this illustration to make certain they appear at the proper points. Note that the core in L_{3A} affects the low side of the curve while the core in L_4 affects the high side. Once the proper response curve has been developed, all of the clip leads are removed from the circuit.

In the adjustment of coils L_4 , L_{3A} , and L_{2A} and the coil in the mixer-plate circuit, zero AGC bias was applied to the video IF system. This is necessary in order that the maximum gain can be achieved from the system under the weakest signal conditions. However, the AGC system is left untouched where the interstage transformer between the third video IF amplifier and the video detector is adjusted. Since no AGC line connects to the third video IF stage, it has no effect on the alignment of this amplifier.

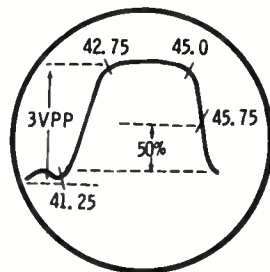

Courtesy H. W. Sams & Co.

FIG. 15-12.

If a manufacturer desires another value of fixed bias voltage during alignment, it will be indicated in the service manual. This is an important point to check and certainly one to be followed carefully; otherwise the circuit will be misaligned because changing the grid bias on a tube alters the input capacitance of the tube, which, in turn, affects the resonant frequency of any tuning coil that may be connected across the input circuit. To obtain the response curve indicated by the manufacturer, it is important that the suggested bias conditions be established.

Sound-system Alignment. Alignment of TV sound systems utilizing 6DT6 or 6BN6 tubes are generally made without the use of any instruments. Only the input signal from a near-by station is utilized. However, in order to employ this signal properly, it must be made quite weak. This can be achieved by disconnecting the antenna transmission line from the receiver-input terminals and then laying the transmission line across the input terminals without any direct electrical connection. If the signal level is still fairly high, slowly move the line away from the receiver until a hiss is heard. Another method is to insert a resistive attenuation pad between the transmission line and the receiver-input terminals. A suitable attenuator pad is shown in Fig. 15-13. Use those resistor values that provide a signal weak enough to cause a hiss to be heard in the speaker, together with the sound of the broadcast station. It is important that both the sound and the hiss be heard. Without the sound, it is impossible to determine when the best alignment is reached. Without the hiss, the signal is strong enough to prevent the detector from operating below its limiting level.

Once the proper conditions have been achieved, adjust coils L_0 , L_{12} , and L_{13} to achieve maximum sound and the best quality. Throughout all this adjusting, it must be cautioned again that both the hiss and the sound should be heard. Next, adjust the buzz control in the cathode circuit of the 6BN6 for minimum buzz.

The sound and video IF sections of the receiver in Fig. 15-1 are now fully aligned. Before turning to the RF tuner, let us note what alignment procedures are required if a 4.5-mc trap is employed in the video section.

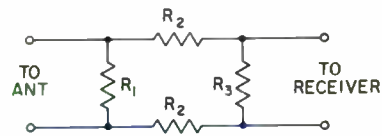

DB ATTENUATION	R_1	R_2	R_3
6	1000	100	1000
12	470	300	470
18	390	560	390
24	330	1000	330
30	310	2200	310

FIG. 15-13. Balanced 300-ohm attenuator pad. Chart shows relationship between resistance values and attenuation imposed by network.

It might also be instructive to examine the alignment steps for other types of FM detectors.

Adjustment of 4.5-mc Trap. A number of receivers contain a 4.5-mc trap beyond the point where the sound take-off occurs. This, for example, is true of the circuit shown in Fig. 15-14. To adjust the trap, proceed as follows.

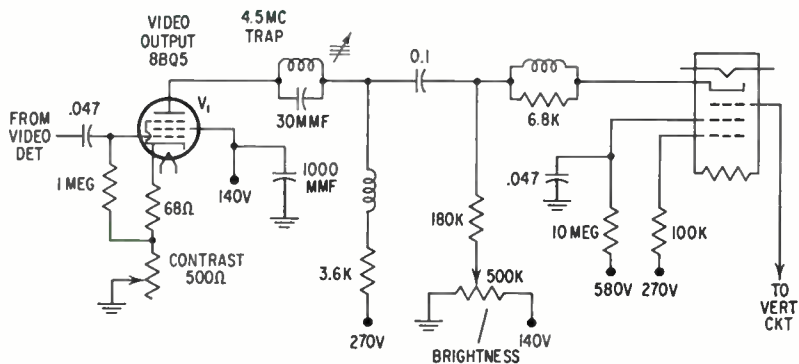

FIG. 15-14. Diagram of a circuit containing a 4.5-mc trap.

A signal generator is connected to the grid of V_1 and its frequency is set to 4.5 mc. For an indicator two devices are needed: a VTVM and a germanium crystal detector. The latter device is needed to rectify the 4.5-mc signal so that an indication can be obtained on the VTVM. The meter will not respond directly to 4.5-mc voltage.

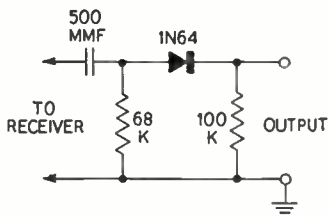

FIG. 15-15. A crystal detector network.

If the VTVM possesses an RF probe, it may be used. Otherwise, the crystal detector shown in Fig. 15-15 can be used. The input terminal of the crystal detector connects to the electrode at the picture tube, grid, or cathode, where the video signal is applied. The other input lead goes to the receiver chassis. The detector output is fed to the d-c terminals of the VTVM. Use the lowest scale possible.

Now, with the generator turned up, adjust the 4.5-mc trap for minimum meter indication.

Alignment of Other FM Sound Systems. The alignment of two additional FM sound systems will now be considered. One system employs a discriminator circuit (also known as a "Foster-Seeley discriminator") and the other has a ratio detector.

FM Discriminator. A sound system employing a Foster-Seeley discriminator was shown earlier in Fig. 14-28. The following alignment will be

written for this circuit. (Although the network shown is employed with a split-sound receiver, the procedure for an intercarrier receiver is the same, except for frequency values.)

As a first step, an AM signal is connected to the control grid of the first sound IF stage, V_{10} . A VTVM is then connected between point A and the chassis and set to operate on its lowest range of d-c volts. The AM generator is set to deliver a signal at the IF frequency. Then, with everything in operation, detune the secondary of T_1 by turning its tuning slug several turns, either clockwise or counterclockwise. (The direction is not important; the purpose is simply to detune the secondary.)

Now, adjust the cores of L_1 and L_2 for maximum reading on the VTVM. It is important to keep the signal level as low as possible in order that the limiter stage can not be driven to saturation, for if this should occur it will be impossible to find the proper resonant point for L_1 and L_2 .

Next adjust the primary of T_1 for maximum indication on the VTVM. Then slowly adjust the secondary of this transformer for a zero reading on the VTVM. (A positive and a negative reading will be obtained on either side of the correct setting.)

Ratio Detector. A typical ratio-detector sound system was shown in Fig. 14-29. To align this circuit, apply a 4.5-mc unmodulated signal, preferably crystal-controlled, to the control grid of the video-output amplifier. The VTVM is connected between point A and the chassis in the ratio-detector circuit. At the same time this connection is made, two 100,000-ohm resistors (± 1 -per-cent accuracy) are connected in series between the same point A and chassis. These resistors will be used in the next step of the alignment.

With the setup as indicated and the power turned on, adjust the tuning slug in L_1 for maximum deflection on the VTVM. Then do the same for the primary of the ratio-detector transformer. Next, connect the d-c probe of the VTVM to point B (at the intersection of the two precision 100,000-ohm resistors) and the common lead of the instrument to point C . Now adjust the secondary slug of T_1 until the meter reads zero. A positive and negative reading will be obtained on either side of the correct setting. After this, repeat the first two steps to make certain that they are still centered at the optimum point.

The foregoing procedure is for an unbalanced ratio detector. In a balanced circuit a center point is already available and there is no need to create one artificially by the addition of two resistors. In all other respects, the two circuits are aligned similarly.

Alignment of the RF Tuner. The most critical circuit in the front end of the RF tuner is the oscillator. Here, a single frequency per channel is generated, and any shift in this frequency automatically results in a shift of every intermediate frequency developed in the mixer. Fine-tuning con-

trols are carried in every television receiver to enable the user to correct such oscillator frequency changes within certain limits. Should the oscillator frequency change more than this, then an adjustment of the oscillator tuning circuit becomes necessary.

Alignment of the RF Oscillator. Assuming that the FM sound system has been properly aligned, let us turn our attention to the RF-oscillator stage. The oscillator must be precisely set to each of twelve frequencies, one in each channel. To do this, an AM signal generator that can be set accurately to the desired frequency is needed.

There are three possible methods of adjusting the high-frequency oscillator of a television receiver:

1. With the sound and video IF systems in alignment, adjust the RF oscillator in the set against an incoming signal. This method is the most popular, but it must be recognized that it will work only on those channels where signals are available.

2. Check the high-frequency oscillator against the known signal of a separate signal generator, noting the indication on an oscilloscope.

3. Use a sweep generator, a marker signal, and an oscilloscope. Each method is examined below.

First Method. The first method is useful when the receiver is otherwise operating satisfactorily and an off-the-air signal is available. It is simple to perform and will provide excellent results.

A typical adjustment procedure is to turn on the receiver and allow it to warm from 10 to 15 min. Set the channel selector for the highest channel to be received. Set the fine-tuning control in the center of its range; then adjust the other controls for normal picture and sound. Now remove the channel selector and fine-tuning knobs. Using a flexible, nonmetallic tool with a $\frac{1}{8}$ -in. blade, carefully adjust the channel slug in the tuner for the best picture and sound. Repeat this procedure for each lower frequency channel received until all have been adjusted.

Second Method. In the second method of checking the oscillator frequency, the apparatus is connected as shown in Fig. 15-16. The calibrating signal of the generator must be capable of being accurately set. The oscillator signal and the generator signal beat against each other and the beat signal is visible on the oscilloscope screen. The oscillator is adjusted until its frequency is equal to that of the signal generator. At this point, the beat frequency decreases to zero and only a straight horizontal line is visible on the screen. The same procedure is followed for each television channel. This method is applicable to *all* types of television receivers.

Third Method. The third method involves the use of a sweep generator, an accurately calibrated signal generator, and an oscilloscope. Connect the oscilloscope to the output of the video detector. Connect the sweep generator

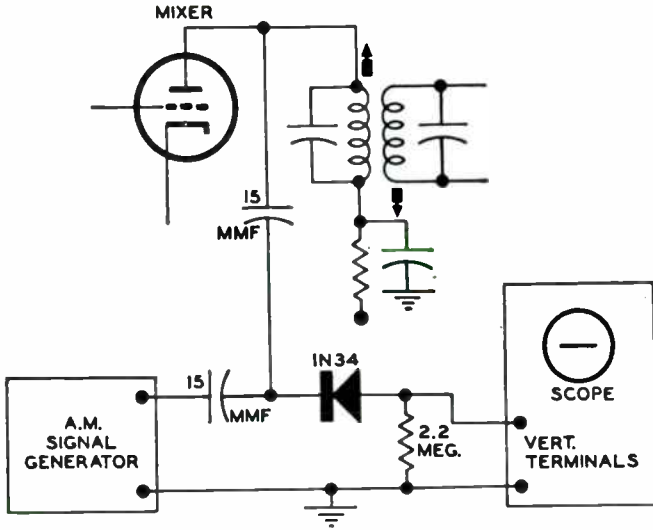
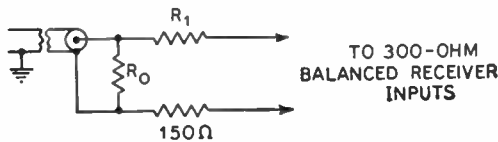

FIG. 15-16. The second method of checking the oscillator frequency as described in the text.

to the antenna terminals of the receiver through a suitable matching network. (See Fig. 15-17). If the instrument does not possess a marker generator, then an external AM signal generator is loosely coupled to the sweep unit. Set the receiver controls to channel 13 and adjust the sweep generator so that it sweeps across this channel. Set the fine-tuning control to the center of its range. The marker generator (either internal or external) is set at the RF video-carrier value for this channel (i.e., 211.25 mc). The response pattern obtained on the scope screen is the normal video IF response for this receiver. Somewhere on this curve is a pip, produced by the marker signal.



GENERATOR IMPEDANCE	R_0	R_1
50 Ω	56 Ω	120 Ω
72 Ω	82 Ω	110 Ω
92 Ω	110 Ω	100 Ω

FIG. 15-17. How to match signal generator output impedance to balanced receiver input (300 ohms).

The receiver-oscillator coil is adjusted until the pip falls exactly on the 50-per-cent point.

Repeat this procedure for each successively lower channel until all of the oscillator slugs have been adjusted.

Be careful to connect a portion of the synchronized sweep voltage from the sweep generator to the horizontal input of the scope for horizontal deflection. The need here is the same as it was for a sweep alignment of the video IF system.

Sweep Alignment of the RF Stages. The front-end section of a television receiver possesses a greater overall bandpass (6 mc) than either the video or sound IF stages that follow it. To attain this bandpass, the tuning circuits are loaded by a combination of shunting resistors and the relatively low-input impedance of vacuum tubes at high frequencies. In the receiver of Fig. 15-1 a turret tuner is used, which contains separate, removable RF and oscillator coils for each of the twelve VHF channels. See Fig. 15-4. There are three capacitive adjustments (C_2 , C_3 , and C_4) and two inductive adjustments (L_1 and L_2) for the RF coils on all channels. The oscillator coils have a tuning slug for each channel. This number is required since the oscillator generates a single frequency per channel and it is relatively easy for this frequency to drift too far to one side or the other.

Alignment of the RF stages carries with it a number of precautions that must be observed if the job is to be properly carried out. First, there is the matter of matching the sweep-signal generator to the receiver-input terminals. Most sweep-signal generators have an unbalanced output, with impedances ranging between 50 ohms and 100 ohms. On the other hand, television receivers possess either a 75-ohm unbalanced input or a 300-ohm balanced input. The 75-ohm unbalanced receiver input can usually be connected directly to a generator the output of which is similarly unbalanced and the impedance lies between 50 and 100 ohms without causing appreciable mismatching. However, when an attempt is made to connect such a sweep generator directly to the input terminals of a 300-ohm balanced receiver, the response pattern will be sufficiently affected to result in misadjustment of the circuit trimmers. (The input tuning circuits of a television receiver contribute to the shape of the overall RF response curve and, when the proper matching is not employed between instrument and receiver, the tuning curve of this input circuit is affected. This, in turn, alters the overall pattern.)

To match an unbalanced sweep generator to a 300-ohm balanced television receiver, an arrangement such as is shown in Fig. 15-17 can be employed. One series resistor has a fixed value of 150 ohms; the other series resistor has a value which depends upon the impedance of the sweep-generator output. Such a dependence is true also of the shunt resistor, R_0 . The

resistors should be of noninductive variety, preferably carbon, or of composition construction.

Note that many sweep generators come with special matching networks, in which case these would be used instead of the resistive pad of Fig. 15-17.

It is never good practice to align an unfamiliar tuner without having the manufacturer's alignment instructions at hand if possible. Certain tuners must be removed from the receiver for alignment, because only by removal can certain necessary adjustments be made. For other tuners, special jigs are required. Finally, the sequence in which adjustments are made is frequently of great importance, and this information usually is available only from the manufacturer. Other factors which should be checked carefully in RF alignment are: the value of bias recommended for the RF amplifier, whether or not the local receiver oscillator is to be cut off, and whether the mixer-plate tuning circuit is to be shorted or otherwise modified to prevent it from affecting the RF response. In one of its sets, RCA states that the tuner is to be aligned by using zero AGC bias and that the output coaxial cable which connects the mixer plate to its tuned circuit is to be disconnected from this transformer and terminated by a 39-ohm resistor. In some models Philco uses -1.5 -volt bias and shunts a 300-ohm resistor across the first IF coil to eliminate the absorption effect of this coil on the response curve. Pay particular attention to these special instructions or you will not obtain the response curve indicated in the service manual.

To align the RF tuning circuits of the tuner shown in Fig. 15-4, proceed as follows. Connect the sweep generator to the receiver input terminals through an appropriate matching network. The vertical input terminal of the scope is attached to the test point shown in the screen-grid circuit of the mixer. (In some tuners, this test point is in the mixer control-grid circuit.) The scope ground attaches to the receiver chassis.* The scope beam should be driven by a 60-cycle sine-wave voltage obtained either from the sweep generator or from the oscilloscope if the latter contains a phase control. The marker signal, when it is needed after a response curve has been obtained, is loosely coupled to the sweep generator, either by a connection made through a small (5- to 10-mmf) capacitor, or by laying the marker generator-output cable across the resistive matching network.

The negative terminal of a -2.5 -volt battery is clipped onto the AGC wire and the positive terminal goes to the chassis. If it is difficult to obtain a curve of sufficient amplitude, remove the battery and simply ground the AGC wire to the receiver chassis.

With the equipment in operation after an appropriate warm-up interval

*The mixer, being essentially a detector, provides the oscilloscope with a demodulated voltage. This voltage is available at the control grid or at the screen grid. Here, the manufacturer elects to obtain it at the screen grid.

of from 10 to 15 min., the receiver is tuned to channel 4. The response curve sought for this channel is shown in Fig. 15-18.

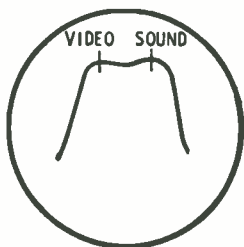

FIG. 15-18.

If the curve observed does not possess this form, adjust C_2 , C_3 , and C_4 . Adjusting C_2 will generally shift the center of the response curve in relation to the video- and sound-carrier markers. C_3 and C_4 should be alternately adjusted for best gain with flat-top appearance. The response curve should have maximum amplitude and flat-top appearance consistent with proper bandwidth and correct marker location. Do not broaden the curve too much, as this will result in a loss of sensitivity.

Next, the channel selector is turned to channel 11 and the sweep-generator frequency is similarly altered. Marker frequencies of 199.25 mc (to identify the sound-carrier position) and 203.75 mc (to identify the video-carrier position) are also added. Now, adjust the cores of L_1 and L_2 for maximum gain and symmetry of a response curve similar to that of Fig. 15-18. Repeat this step and the previous one until the best overall symmetry is obtained.

The foregoing steps represent the alignment procedure for one type of tuner; other units have other methods of approach. In all RF alignments, follow the manufacturer's instructions.

QUESTIONS

1. Explain the function and operation of the focus, contrast, brightness, and fine-tuning controls.
2. What controls are generally classified as secondary controls? Where is their position on the television receiver chassis?
3. What type of RF tuning system is used in the receiver of Fig. 15-1? Explain how it operates.
4. What is the function of each of the following components in the RF tuner of Fig. 15-1: R_3 , L_4 , L_3 , R_4 , R_2 , C_8 and C_5 ?
5. What would happen if R_2 opened up?
6. Explain why there is an oscillator adjustment for each channel, yet C_2 , C_3 , C_4 , L_1 and L_2 are the only adjustments for the RF circuits for all channels.
7. List all the trap circuits in the video IF system, together with their resonant frequencies. Explain how each trap circuit achieves its purpose.
8. Describe the operation of the contrast control of Fig. 15-1.
9. List the high-frequency compensating components in the stages following the video second detector of the circuit of Fig. 15-1.
10. Explain how the horizontal AFC controls the frequency of the horizontal sweep oscillator (Fig. 15-1).
11. What type of oscillator is used in the vertical synchronizing system? Explain its operation.

12. Explain the operation of the horizontal output system, using the proper waveforms.
13. How does the vertical linearity control function?
14. What equipment would be needed to align thoroughly this receiver?
15. What is a marker signal? Why is it useful? How are marker signals generated?
16. Explain in detail the alignment procedure for video IF trap circuits.
17. Outline the alignment procedure for the video IF system.
18. How is the sound IF system aligned?
19. By what method can the oscillator be adjusted?
20. What adjustments are made in aligning the RF amplifier and mixer?
21. A receiver is brought in for repair with the complaint that dark bars appear across the screen. It is later determined that this is true only when a signal is being received. What components are at fault and how can they be corrected?
22. What components form the vertical retrace suppression circuit in Fig. 15-1?
23. If you obtained sound on this receiver but no picture, where would you start first? Explain the reason for your choice. (Assume a raster is present.)
24. In the absence of both sound and picture, what stages would you check?
25. Draw a B+ voltage-distribution diagram for the complete receiver discussed in this chapter. Use blocks to represent each of the various stages. Show actual value of B+ being applied at each stage.

Servicing Television Receivers*

Introduction. Television receivers are critical mechanisms that require accurately adjusted circuits if the viewer is to derive maximum enjoyment. Indiscriminate replacement of component parts, a popular practice for many sound receivers, will generally cause more harm than good and should be discouraged. Careful adherence to manufacturer's values is especially important in the timing circuits of the receiver deflection systems. Hold controls permit some variation of the oscillator's frequency, but the limits are fairly narrow. Wide discrepancy between the values of the replacement parts and those specified by the manufacturer would render synchronization impossible.

Experienced servicemen utilize the indications (or lack of them) obtained from the loudspeaker of a sound receiver to their greatest extent. Probably the best example of the usefulness of the indications from the speaker in servicing work is the hoarse, rasping sound obtained when a filter capacitor in the power supply becomes defective. The set continues to operate, but with reduced volume and the characteristic distortion of sound. In the hands of an expert serviceman, a receiver with this trouble would be repaired in less time than it takes to describe the defect. The greatest difficulty, however, in trouble-shooting is experienced when the set operates intermittently, the defect appearing and disappearing without any apparent reason.

A television receiver, in addition to having a loudspeaker for its sound, has another, better source of indication, the viewing screen. The eye is a more critical judge than the ear, and defects in television sets reveal their causes far more readily than comparable defects in sound receivers. The two

* The reader's attention is also directed to the author's *Television Receiver Servicing*, 4th Edition, 1959, published by D. Van Nostrand Co., Inc. Here will be found more detailed servicing procedures than can be conveniently handled in this textbook.

(sound and sight) combine to facilitate television service work to a remarkable degree. True, a certain amount of experience is necessary, but it can be acquired in a relatively short time. With the basic principles (as presented in previous chapters) clearly in mind, a technician should be able to associate the various distortions of the image with specific circuits throughout the receiver.

Servicing Guide Points in Television Receivers. All television receivers can be divided into two groups, the split-sound and intercarrier sets. Each system, in turn, contains sound and video sections, and it is important to know where the separation of the signals occur. The servicing significance of the separation point can be realized by the fact that, up to the separation point, both signals travel side by side. What affects one signal will also affect the other. Beyond the separation point, however, each signal travels alone.

Thus, suppose a receiver exhibits a distorted picture accompanied by a distorted audio output. This situation immediately tells the serviceman that the defect is located in a circuit through which both signals pass, and it directs attention to the stages preceding the separation point. On the other hand, when only one signal appears distorted at the output, then obviously this distortion must have occurred in a circuit dealing solely with this signal. If the audio is defective, then all attention is centered on the audio stages *following* the point of separation. If the image is distorted, only the video stages *beyond* the separation point need be examined. With these simple facts in mind, tracking down troubles in television receivers can be simplified considerably.

When servicing a receiver, the first step is to locate the signal separation point. In intercarrier receivers you know that this occurs at the video second detector or beyond; in split-sound sets, signal separation must take place between the mixer and some point before the video second detector. A rapid procedure for locating the stage where the signals separate is to start at the video second detector. Pull this tube from its socket and note what has been affected. If only the picture is gone, it indicates the set is of the split-sound type and the separation point exists prior to the video second detector. On the other hand, if both sound and video are affected, the set uses the intercarrier system.

To locate the exact separation point, proceed to pull tubes in the video IF system—provided the set is of the split-sound type—until you reach the stage where tube removal affects both sound and video. In an intercarrier set, tube-pulling would be directed toward the video amplifier stages following the video second detector. This method will work well on all television receivers except those in which the filaments are series-wired. In these sets, removal of one tube in a string will affect all others in the string and prob-

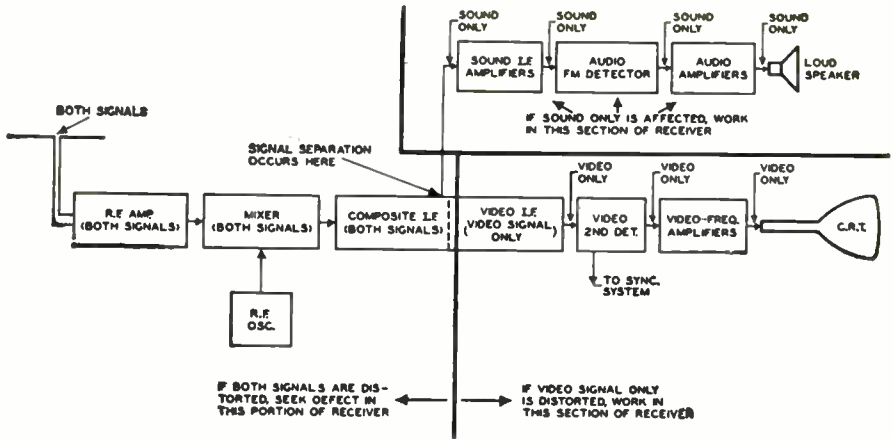

Fig. 16-1. A block diagram of a split-sound television receiver, illustrating the significance of the signal separation point.

ably prevent the signal from reaching the picture tube or loudspeaker. Under these conditions, actual circuit-tracing or reference to the schematic of the set is necessary to locate the separation point.

Fig. 16-1 illustrates, in a block diagram, the method just described for localizing defects using the signal separation position in split-sound sets. Figure 16-2 does the same for intercarrier receivers.

Once the defect has been traced to a specific section of the receiver, the next step is to analyze that particular section with a view toward further

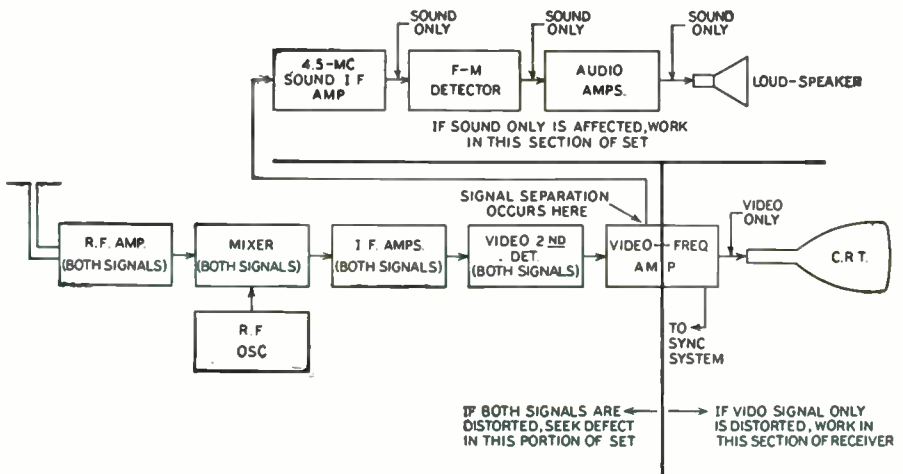

Fig. 16-2. A block diagram of an intercarrier television receiver, illustrating the significance of the signal separation point.

localization. This brings us to the block diagrams shown in Figs. 16-3 and 16-4. In the audio system, the general breakdown consists of the IF amplifiers, the FM detector, the audio amplifiers, and the loudspeaker. In the video system we have, in addition to an IF section, a second-detector and video amplifiers, the vertical and horizontal sweep systems. Furthermore, most television receivers have the high-voltage power supply located at the output of the horizontal sweep system.

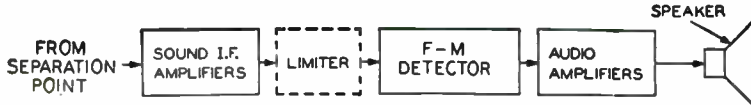

FIG. 16-3. A block diagram of the audio section of a television receiver.

Once the difficulty has been traced to a particular system in the receiver, we are in a position to conduct a further analysis of our defective receiver. In the video system, for example, breakdown of the signal path in sections A, B, or C will prevent the video signal from reaching the cathode-ray tube. If the sound-separation point is prior to the breakdown, sound will be unaffected. If it is after the breakdown, it will also be lost. In either instance, the picture-tube screen will contain a raster, but no sound. The scanning raster is due to the sweep oscillators which continue to function because they are self-oscillating. These oscillators are not being triggered, but they do oscillate.

As another example, suppose the circuit opens up in section D. The sync pulses will be prevented from reaching the sweep oscillators; consequently the oscillators will not be controlled by the incoming signal. On the other

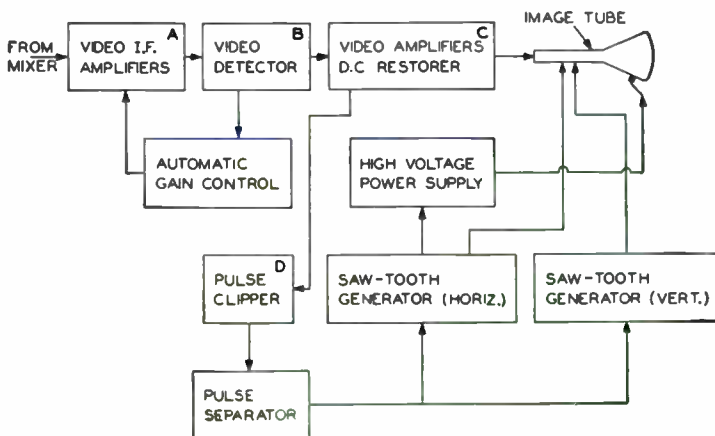

FIG. 16-4. A block diagram of the video section of a television receiver.

hand, image signals are reaching the cathode-ray tube. The visual result is a scrambled picture caused by the various sections not being placed on the screen in proper sequence. The audio section will be unaffected.

These are two of the many clues that the serviceman receives each time the set becomes defective. In this chapter we will undertake the analysis of many common clues encountered in defective television receivers. Recognition and interpretation of these signposts will help the serviceman in 90 per cent of his work.

RF SYSTEM

A defect in the RF section of a television receiver will affect both the sound and the video outputs. If the signal is prevented from passing through completely, no sound will be heard from the loudspeaker and no image will be seen on the screen. However, what will be visible is a scanning raster. See Fig. 16-5.

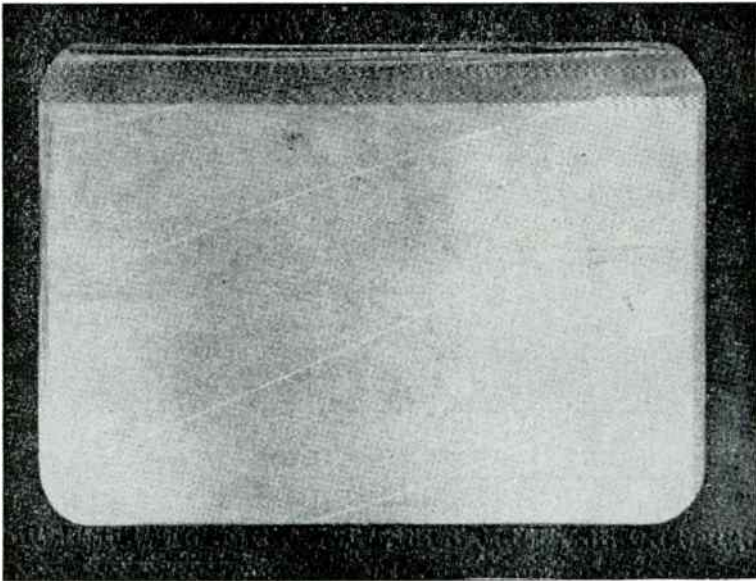

FIG. 16-5. A scanning raster.

Since tubes are, by far, the greatest source of trouble in any section of a television receiver, they should be checked first. If the tubes are good, the trouble lies elsewhere in this section—either in the tuning circuits or in the resistors and capacitors.

The serviceman should know the method of tuning that is employed in the particular set because this fact will help him determine whether or not the tuned circuits are at fault. For example, in the Standard Coil tuner, a

completely separate tuning circuit is switched in for each channel. When all channels are affected, a common component, such as a tube or resistor, must be at fault. If the tubes have already been checked, then make a voltage and resistance test to find any faulty resistors.

In wafer-switch tuners, Fig. 4-20, all of the tuning coils are in series. An open coil in any tuning line will disrupt operation for its channel and all lower ones. It will not, however, interfere with the operation of higher frequency channels because the B+ of the unaffected portion of the tuning line can reach the tube through the shorting bar. A resistance check will reveal the open coil. The approach to each different tuner will be governed by its design, and no general rules can be set up to cover all tuners. However, first determine whether the tuning circuits for the various channels are independent of one another or whether what happens to one coil will affect others. This information is basic and will help immeasurably in any subsequent analysis of tuner trouble.

Several signal tests are useful in indicating whether or not a signal can get through the front-end stages. A rough test, but one which will reveal whether or not a signal can get through, is to detach the transmission line from the receiver input terminals and brush the line leads across the input-terminal posts. Bursts of noise will be heard in the speaker (even with FM) and flashes of light will appear in the scanning raster. If the signal cannot get through the RF stages, these indications will not be obtained. Admittedly this is a rough test, but it is surprising how well it works. On certain sets, even disconnecting the transmission line is unnecessary. Merely turn the contrast control to its maximum clockwise position. Noise will be heard from the speaker, and snow with light flashes will be seen on the screen.

One problem which might arise is how to distinguish between a defect in the front-end stages and the complete absence of any signal reaching the television receiver. The latter may occur if there is a break in the transmission line leading from the antenna to the receiver. A simple method for checking the front-end stages is to use an AM signal generator. Connect the instrument across the input terminals and set the generator frequency to a value about 1 mc above the video-carrier frequency for that channel. Turn on the AM modulation in the generator. If dark bands appear across the screen of the image tube, then a signal is able to pass through the RF stages. Notice that the signal generator will not produce any indication on the screen if the receiver oscillator is inoperative.

The foregoing tests will indicate whether or not the tubes are at fault and whether the tuned circuits are in operating condition. The tests can be applied in a few minutes. If the tests indicate that the tubes are O.K. but the set is completely dead on all channels, then only a voltage and a resistance check will reveal the source of trouble.

Voltage and Resistance Checks. In the RF system trouble is most likely to originate in the oscillator. Hence, the first step in checking this section is to measure the d-c voltage at the oscillator grid with a vacuum-tube voltmeter. Typical values range from 2 to 10 volts, depending upon the design of the circuit. This voltage should be checked on all channels, since it is quite possible for the oscillator to function at some frequencies but not at others. If the voltage measured differs appreciably from the value specified by the manufacturer, further checking is indicated. The tube may require replacement or the B+ voltage may be low. Both defects are capable of reducing the d-c grid voltage.

If an oscillator-grid voltage is present, we know the circuit is oscillating. Of course, this does not mean that the oscillator is on frequency, and it may very well happen that it is sufficiently far off frequency to give the same effect as it would if the circuit were inoperative. Usually this does not happen, but it can. A check of the oscillator frequency, employing one of the methods described in Chapter 15, will reveal whether or not this is so.

After the oscillator, the plate and grid voltages of the RF amplifier and mixer should be checked. Ninety-nine per cent of the difficulties arising in these stages will be found by means of one of the tests described. Also useful but not as widely employed is signal-tracing. An AM signal generator is connected to the input terminals of the receiver and is set to a frequency about 1 mc above the video-carrier frequency for that channel. (The mid-frequency for the channel is another good value to use.) A high-frequency probe in conjunction with a sensitive VTVM or an oscilloscope may then be used to trace the signal through the RF stages. If the VTVM is used, an unmodulated signal is obtained from the generator. If the oscilloscope is used, the signal must be modulated. The set oscillator should be disabled in order to insure that any signal picked up by the probe is that of the AM generator only. Presence of the signal at the RF amplifier plate, at the mixer grid, and at the mixer plate can be determined by placing the probe at these points and noting what indications, if any, are obtained on the oscilloscope or the VTVM.

To obtain definite indications, the signal generator should be capable of putting out at least 0.1 volt of signal. At the higher frequencies, this may not always be the case. Also, it may not readily be possible to reach the desired points in the RF circuits because of the compact construction of the tuner.

THE VIDEO CIRCUITS

The next group of circuits through which the signal passes are the video circuits. These include all of the video IF stages, the video detector, and the video frequency amplifiers. Let us consider each in turn.

Failure in the video IF system will cause the image to become distorted or to disappear entirely from the screen, but it may or may not affect the sound. If the sound passes through part of the video IF system, thus passing through the affected stage, then it will suffer together with the video signal. But if the sound is separated *before* the defective stage, then it will be heard without distortion. The importance of knowing where signal separation occurs in a receiver thus becomes evident.

As with other sections of the television receiver, tubes are the greatest offenders. Hence, these should be checked first, preferably by substitution. Gassy tubes and microphonic tubes are especially suited to this method since they will not always be detected by a tube tester. Microphonic tubes in the video system produce a "bouncy" picture. The picture bounces whenever the set is jarred.

Gassy tubes produce a variety of effects, of which overloading appears to be the most common. When the stage becomes overloaded, the sync pulses are either depressed or clipped off entirely, which causes the set to lose synchronization. Tonal values in the picture frequently reverse so that a negative picture is produced. A gassy tube can cause a positive voltage to develop in the grid circuit. And if the AGC network connects to this grid, the entire AGC voltage will be disrupted. Also, gassy tubes have been known to introduce 60-cycle hum from the filament to the cathode circuit. Visually, this will distort the picture as shown in Fig. 16-6.

Gassy tubes may sometimes reveal themselves by a bluish glow, although the absence of a glow does not mean that the tube is not gassy.

Another common tube trouble is a cathode-to-heater short, which definitely introduces a 60-cycle hum in the picture. See Fig. 16-6. Tube substitution will bring this defect to light, too.

In addition to tubes, any of the other components—resistors, capacitors, and coils—can be the cause of failure. To locate the defective unit, several methods of approach are possible. First, there is voltage checking. With a voltmeter or VTVM, measure the voltages at the screen, plate, and control grid of the various IF tubes. Then compare these with the manufacturer's values. This method is effective and frequently successful.

Incidentally, if it is discovered that all the B+ voltages in a system are low, trouble in the B+ system is indicated, and the trouble is not necessarily in the stages where the voltage measurements are being made. A filter capacitor in the power supply may be leaky, or the rectifier tube emission may be low, or a shorted bypass capacitor may be at fault. In an effort to determine the one branch containing the defective component, your job now may be the tedious one of disconnecting various branches leading off the B+.

Voltage tests are most successful in detecting open resistors, shorted capacitors, and incorrect AGC voltages. This latter voltage is most important

because an improper AGC voltage can completely disrupt set operation. When this voltage is too low, the controlled stages run "wide open," resulting in signal overloading. When this voltage is too high (negatively), the tubes cut off and no signal gets through. Hence, pay particular attention to AGC voltage. In fact, if you suspect that the trouble lies in the AGC system, pull out the AGC tube. If this is impractical, remove the AGC volt-

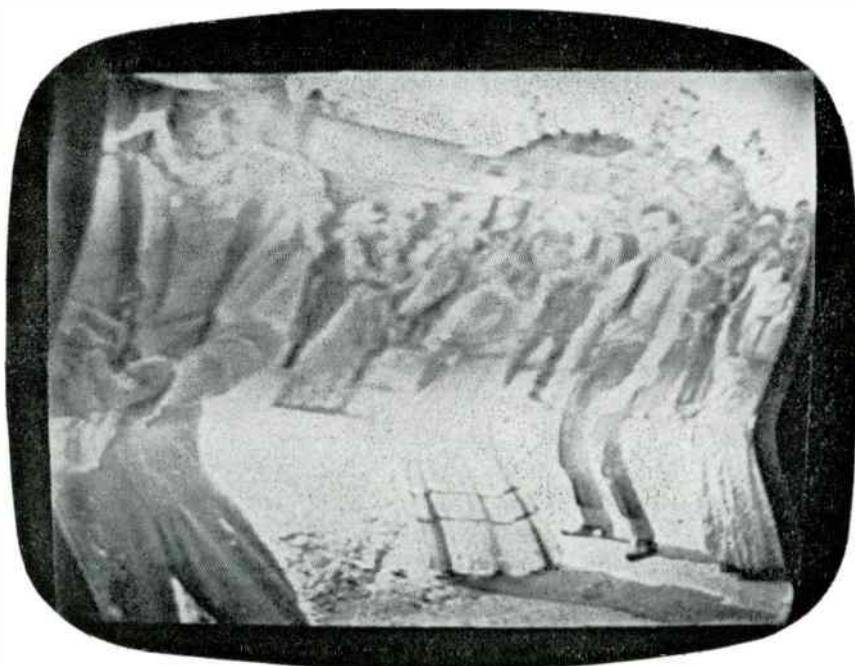

FIG. 16-6. The visual effect of a 60-cycle voltage reaching the video-signal path.

age, possibly by breaking this circuit at the point where it leaves the AGC tube. Then in its place insert a small 3-volt battery with the negative terminal connecting to the AGC line and the positive terminal going to the chassis. If the set returns to normal operation, you know that the video system is all right and that the trouble lies in the AGC circuits.

A defect that will not be found by voltage checks (such as an open capacitor or a shorted coil) may be brought to light by injecting a signal into the circuit. Take an AM generator and connect it to the control grid of the last video IF amplifier. (This stage is just before the video second detector.) Set the frequency to the mid IF value and turn on the modulation. If this stage is functioning (and all the others that follow it), then black and white horizontal bars will appear across the face of the picture.

The generator can be moved back, stage by stage, until the point of failure is located. This method is simple, requires only an AM signal generator, and is readily carried out.

If you have a sensitive oscilloscope and an RF probe, you may be able to trace the video signal as it travels through the IF system. Connect the probe to the vertical input terminals of the oscilloscope and turn the vertical gain up as far as it will go. This places the oscilloscope in its most sensitive condition. Now touch the probe tip to the grid of the second video IF amplifier and see if you obtain the video-signal waveform on the scope screen. A normal indication is shown in Fig. 16-7. (The same waveform, only reversed 180 deg, is also acceptable. The phase of the pattern depends upon the probe circuit and the number of vertical amplifiers in the oscilloscope.) If you obtain a normal indication, move on to the grid of the next IF amplifier, and so on. Continue until you lose the signal or it becomes distorted.

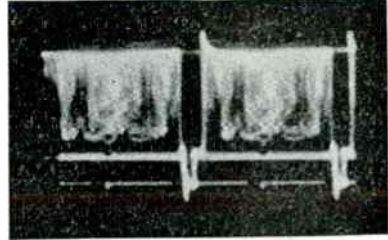

FIG. 16-7. The appearance of a normal video signal as seen on an oscilloscope screen.

When you reach the video second detector, the RF probe is no longer required. Detector action will be furnished now by the video detector. Signal-tracing can be very effective, provided you have a sensitive scope and can distinguish between a normal-appearing video signal and a distorted one. Overloading in any of the video IF amplifiers as well as a-c hum in the signal is clearly brought to light by this method. See Figs. 16-8 and 16-9. Signal-tracing with an oscilloscope is used extensively in the video amplifiers (those beyond the video detector) and in the vertical- and horizontal-sweep systems.

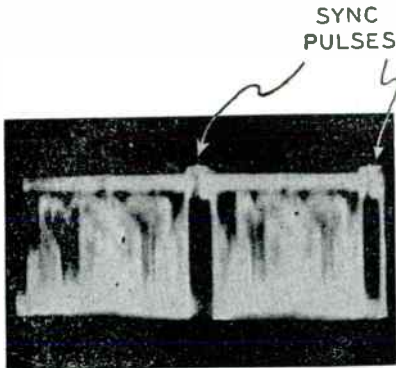

FIG. 16-8. A video signal in which the sync pulses have been partly compressed. Note that the video signal extends up to the level of the pulses.

frequently with germanium crystals than with vacuum tubes.

Following the video second detector are the video amplifiers. Unless a

video amplifier becomes completely inoperative, in which case no image at all is obtained on the screen, indications of other defects will be evident only by their effect on the image. In a video-frequency amplifier tube and its circuit, the following defects may be found:

1. A defective low-frequency compensating network
2. A defective high-frequency compensating network
3. Improper voltages at the tube electrodes
4. An inoperative tube or a defective component

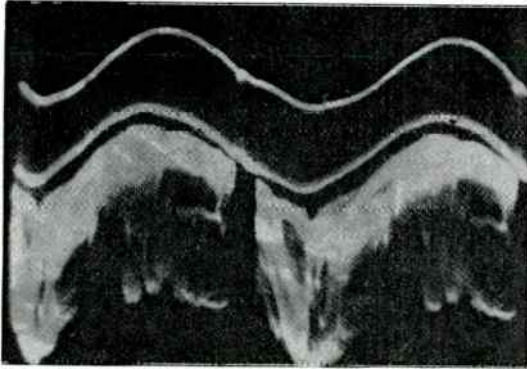

FIG. 16-9. 60-cycle hum in video signal.

When the low-frequency compensation network is defective, the background shading of the image becomes darker and the larger objects in the image "smear." See Fig. 16-10. Check bypass capacitors, load, dropping, and cathode resistors. Capacitors are highly vulnerable components, and frequently open. A fast method of checking for open capacitors is to shunt a suspected unit with another capacitor of equal value, that is known to be good. Also useful are in-circuit capacitor checkers which reveal a defective unit without first requiring that it be partly or totally removed from the circuit.

Smearing can also occur when the bias voltage is too low. Hence, measure the grid voltage at each video-amplifier tube. Gassy tubes and leaky interstage coupling capacitors are two causes for low grid-bias voltage. Low plate and screen voltages produce smearing because under these conditions the tube is readily overloaded. Look, too, for a plate-load resistor that has increased considerably in value or a grid resistor that is quite low. A tube with a low g_m is another cause of smearing.

A more difficult defect to detect is the loss of fine detail caused by poor high-frequency response of the video stages. High-frequency compensation is provided by the series and shunt peaking coils in the video amplifiers and

by using low-valued plate resistors. The peaking coils are frequently shunted by a resistor to prevent them from sharply increasing the amplifier gain at their resonant frequency. Should this resistor increase substantially in value or perhaps open, its shunting effect would be removed and transient oscillations would develop in the coil and in its distributed capacitance whenever the signal frequency fell within this range. The oscillations would appear on the screen as ghost lines (or multiple lines) after any small object or sharply defined line or edge in the picture. Their presence is most noticeable in test



Courtesy RCA

FIG. 16-10. A visual indication of poor low-frequency response in a video system.

patterns. This effect, also known as “ringing,” can be distinguished from ghost signals by the fact that the various lines are evenly spaced. Also, each successive line becomes progressively fainter.

Ringling may also be caused by replacing a defective coil with one whose value is not correct for that circuit.

When a peaking coil is not shunted by a resistor and the coil opens, the B+ path to the tube is broken and the stage becomes inoperative. When the coil is shunted by a resistor and the same condition occurs, one of two things can happen. In the case of a shunt-peaking coil, the gain of the stage rises sharply because the load impedance of the tube has increased greatly, thus causing the picture to become much brighter. However, the response of

the stage is narrowed and the high-frequency response suffers. Picture quality is well below normal and often accompanied by smearing.

An open-series peaking coil with a shunt resistor also results in a marked increase in stage gain. However, the signal transferred to the next stage is taken from a point below this resistor, so actually *less* signal is available for this stage. As a result, the picture becomes dimmer, requiring a higher setting of the contrast control, in order to bring back its former intensity. At the same time, the frequency response is reduced by the increased plate load and the picture quality deteriorates. High-frequency loss is best evaluated when a test pattern is being received. For example, when the response of a system extends the full 4.0 mc, then the lines in the vertical wedge of a test pattern, such as the one shown in Fig. 16-11, will be clearly discernible down to the circles at the center. (This is true of the particular pattern shown in Fig. 16-11, the information for which was supplied by its originator, NBC.



FIG. 16-11. A typical test pattern.

The National Broadcasting Company and many of its affiliates use this or similar patterns. When other patterns are employed, other specifications may be used, and the engineers of each station should be consulted if possible.)

If, however the lines in the vertical wedge should start blending at a point above the center, then less than a 4.0-mc bandpass is indicated.

With an image, the appearance of poor high-frequency response is not as readily observable, unless the overall response becomes quite narrow.

If the signal is not passing through a video amplifier, as is indicated by no image on the screen (only a scanning raster), then a quick check to locate the inoperative stage is in order. Apply a 400-cycle audio signal, obtained from an audio-signal generator, across the load resistor of the video second detector. Alternate black and white bars will appear across the screen if the video amplifiers are working. If the screen remains blank, move the audio generator toward the cathode-ray tube, one stage at a time, until the defective amplifier is found. Voltage, resistance, and tube checks will then quickly reveal the defective component.

Another approach to video-amplifier servicing when no signal is reaching the picture tube is to tune in a station, then follow the video signal from the second detector to the point where the break occurs. The oscilloscope is an ideal instrument for this purpose. Place the vertical-input leads of the scope across the plate-load resistor of the second detector. Set the scope-sweeping frequency either to 30 cycles (to observe two fields) or to 7875 cycles (to observe two lines). Typical field and line patterns of video signals are shown in Fig. 16-12. Whether the polarity of the observed signals is as shown

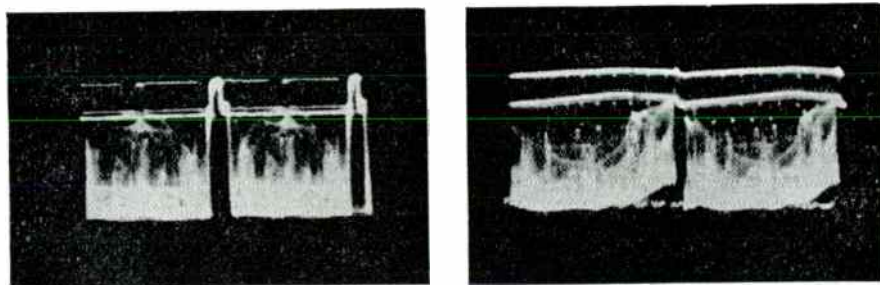

FIG. 16-12. Typical line (left) and field (right) patterns of video signals.

in this figure or reversed depends upon how the detector is wired. In any event, it is the presence of the signal that is important and not its polarity.

Once the signal is observed at the output of the second detector, it can be traced to the grid and plate of each succeeding video amplifier until it disappears or becomes distorted. Where this occurs represents the location of the defect, and voltage and resistance measurements should then bring it to light.

Another signal-tracing method is to *listen* for the signal instead of viewing it on an oscilloscope screen. The presence of the low-frequency, 60-cycle, vertical sync pulses in the video signal make this detection possible. To hear them, simply take a 0.1-mf capacitor and connect one end to the volume

control in the audio section of the receiver. To the other end of the capacitor attach a long wire with an alligator clip. Then use the clip as a probe, hooking into that part of the video-amplifier system where it is desired to check for the presence of the video signal. If the signal is present, a loud buzzing sound will be heard in the loudspeaker. If the signal is absent, no sound will be heard. By this simple expedient, breaks in the video-signal path can be readily discovered.

Additional Video-Amplifier Defects. Dimness in a picture, or one that lacks good contrast, can be caused by a weak video-amplifier tube, low-plate or screen-grid voltages, or grid bias that is too high (i.e., too negative). A dim picture may also stem from a defective picture tube or one having too high grid-bias voltage.

On the other hand, excessive contrast—when, the picture is quite dark and the grays are missing—may be caused by a gassy tube, bias which is too low, a leaky coupling capacitor, a shorted cathode bypass capacitor, or an improperly functioning d-c restorer, if one is employed. (D-c restorers are discussed later in this chapter.) Too strong a signal from the video second detector, due perhaps to a defective AGC system, will also produce the same symptom.

A negative picture (Fig. 16-13) represents a greater aggravation of the conditions that lead to excessive contrast. In this case, the tube is well overdriven, resulting in the reversal of picture values, as is indicated in the illustration. Picture tubes often cause this trouble; they may be either quite gassy or have an internal short.

We have previously discussed the purpose of a 4.5-mc trap in the video-amplifier system and how this circuit is adjusted. When out of adjustment, a 4.5-mc beat will appear in the picture. It will also be found if any of the components in the trap circuit become defective.

The foregoing malfunctionings, when they are reflected on the screen, are frequently recognizable immediately as stemming from a defect in the video system. Sometimes, however, they are obscured by other, more striking distortions, such as loss of synchronization or horizontal pulling. In one case, the picture cannot be locked-in vertically or horizontally (or both ways), and in the second instance, the top of the picture waves from side to side or develops "tears." When these symptoms appear, the technician may not notice that the image contains other defects, such as poor detail or hum bars, or excessive contrast. Failing to see these other telltale signs, he may never consider the video system in his investigation.

To determine if the loss of synchronization is being caused by trouble in the video-amplifier section, check the video signal at the point where it leaves this section for the sync-separator stage. A normal-appearing signal will indicate that the defect lies beyond the take-off point, possibly in the

sync-separator section. However, if the video signal is distorted, and the sync pulses are depressed or missing entirely, then another check through the video system is indicated.

Horizontal pulling, arising from sync compression or the presence of a noticeable 60- or 120-cycle a-c voltage in the video signal, is tracked down in the same manner.



Courtesy Sylvania News

FIG. 16-13. A negative picture in which all the tonal values are reversed.

SERVICING PICTURE-TUBE CIRCUITS

The proper presentation of an image on the screen of a picture tube depends upon the following conditions: first, a signal being present at the grid (or cathode) of the tube, second, the correct d-c voltages being applied to the various electrodes, third, the neck-mounted coils and magnets being properly positioned, and finally, sufficient deflection power being available. Failure of any one of these conditions will either distort the picture or result in its absence. Let us consider each condition separately to see what its effect will be on the picture.

A. No Video Signal. In the absence of a signal, only a raster will be seen on the screen. The raster indicates that the high voltage plus all the other voltages are operating normally. It will indicate also that the hori-

zontal- and vertical-deflection systems are delivering the necessary deflection currents to the yoke. And from the sharpness of the raster lines and the absence of any shadows over the screen, you will know that the focus action and ion trap are functioning properly.

B. Loss of High Voltage. The surest indication of high-voltage failure is the appearance of a perfectly blank screen. If a blank screen is accompanied by normal sound output, then we know that the low-voltage power supply is operating and we can concentrate on the high-voltage system. However, a blank screen and no sound are more likely caused by a defective low-voltage supply which should be tackled first.

High-voltage power-supply failure will cause a dark screen but there may be other reasons for the same condition. What these are will depend upon the manner in which the high voltage is generated. Thus, if the receiver possesses an RF high-voltage power supply, then a dark screen generally will be due to failure of the high voltage or a defective cathode ray tube. If the filament of the picture tube is lit, check the high-voltage system. If a kilovoltmeter is available, measure the output of the high-voltage power supply. If the voltage is low or missing, replace the oscillator and/or high-voltage rectifier tubes. Measure the d-c voltages in the oscillator circuit. As a final step, make resistance (continuity) checks in the high-voltage system.

When the high voltage is developed by the inductive "flyback" method, the number of factors that can produce a blank screen increases. There is not only the high-voltage unit itself and the cathode-ray tube, but, in addition, the horizontal deflection system. To determine where the trouble exists in this system, first measure the voltage at the output of the high-voltage supply with a kilovoltmeter. If the voltage is zero, determine whether the horizontal deflection system is operating by checking the waveform at the grid of the horizontal output amplifier.

If the waveform and its peak-to-peak value are normal, check the waveform at the cathode of the tube. A normal condition here will indicate that the tube is functioning as it should. Concentrate now on the horizontal amplifier-output circuit, particularly the output transformer, the damper tube, and its associated components, and also the high-voltage rectifier circuit.

The absence of any deflection waveform indicates that the trouble exists in the horizontal-deflection system, which is best checked with an oscilloscope. Note the waveforms at various points, and compare them with those given by the manufacturer. Note that a distorted waveform may still cause a high voltage to be produced, although this voltage will be low. A distorted deflection waveform will visibly affect the horizontal linearity of any image appearing on the screen.

It is well to distinguish between a dark screen, which is due to no high

voltage, and a screen containing a scanning raster but no image. The latter difficulty, when accompanied by a normally functioning audio system, indicates a defective video system. In this case, the horizontal deflection system and the high-voltage power supply are both operating satisfactorily as revealed by the appearance of the scanning raster.

C. Defective Picture Tube. The picture tube is undoubtedly the most expensive single item in the television receiver. Because of this, the owner of the set is understandably very much concerned with its condition. Fortunately, these tubes are ruggedly built and most of them can be expected to last 24 months or longer. However, defects in them do arise and it behooves the serviceman to be familiar with them.

The brightness of the raster (and the picture) depends upon the number of electrons striking the fluorescent screen. This, in turn, depends upon the bias between cathode and control grid and upon the number of electrons emitted from the cathode. If a tube is improperly constructed or after it has had long use, it is possible that less than the normal number of electrons will be emitted from the cathode. The result will be a dim picture, even for advanced settings of the brightness control.

A tube with low emission should generally be replaced. However, it has been found that raising the filament voltage above its normal value will frequently cause enough additional electrons to be emitted to restore brightness of the picture. It can be expected, of course, that in time the emission will again decrease below a usable value, but in the meantime useful service is being obtained from a normally unusable tube. Devices which enable the serviceman to increase picture-tube filament voltage are commercially available.

An incorrectly positioned ion trap can also be responsible for reduced brightness. Owners who tamper with their sets may also bring about a reduction in brightness. Or, in moving a set about the house, the ion trap magnet may have been jarred out of position. Or, an inexperienced technician might have had difficulty arranging the deflection yoke and centering device to obtain a shadowless picture, and might have "solved" the problem by shifting the ion-trap magnet from its optimum position.

Incidentally, when the ion trap is not correctly positioned, it can lead to the eventual development of ion spots. An ion spot is an area on the screen where the picture brightness is reduced and the picture is discolored. The color of these areas is brown. They appear most often in the center of the screen, but may develop at other points.

When a picture tube becomes gassy, several things can happen. It may develop negative pictures. See Fig. 16-13. Negative pictures may be due to a bad picture tube or to an excessively strong signal. If the signal is the cause, then negative pictures should be obtained only on the channel where

this signal is being received. On all other channels, normal pictures should be seen. If the tube is at fault, of course, all stations will be affected.

One instance when negative pictures can be received on all stations and the tube not be defective arises when the AGC network is defective and zero bias is placed on all controlled tubes. If all received signals are of moderate strength it is possible that, with the set running "wide open," all will cause overloading with subsequent negative pictures. Measuring the grid bias of the AGC-controlled tubes will reveal whether the bias voltage is normal or not.

A tube which is somewhat gassy may sometimes cause picture-blooming, a condition which causes the picture to expand in all directions as the brightness control is turned up. Blooming is accompanied by loss of focus and sometimes by complete loss of picture and raster. The blooming or spreading out of the picture is due to a decrease in high voltage applied to the tube. If the tube is gassy, it may be drawing an excessive amount of current, and this drain on the high-voltage supply can cause a considerable reduction in high voltage.

Another cause of blooming is a rise in value for the filter resistor which is employed between the high-voltage rectifier and the picture tube. A common value for this resistor is between 470,000 ohms and 1 megohm. If this resistor rises sharply in value, it will decrease the high voltage made available to the tube, and blooming will result. A defective high-voltage rectifier tube also can be responsible for blooming.

Another source of picture-tube trouble is a cathode-to-heater short. In sets where the cathode is externally connected to the filament, there will be no noticeable effect. However, in many television receiver circuits, the brightness control is placed in the cathode circuit of the picture tube. See

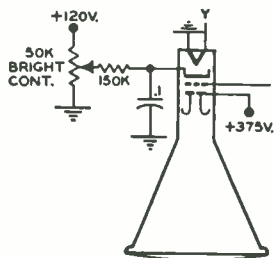

FIG. 16-14. A brightness control in the cathode circuit of a picture tube.

Fig. 16-14. One side of the heater is usually grounded. Hence, when a cathode to-heater short develops, the cathode is placed at ground potential, and no variation of the brightness control will be able to alter this.

There are two solutions to this problem. One is to replace the picture tube. The other is to retain the same picture tube, but to use a special filament transformer for the picture-tube heater. In this way the ground connection is removed from the heater and the d-c potential on the cathode is permitted to vary with the brightness control. Note, however, that this particular tube could be used again without change in those television receivers where cathode and filament are connected externally.

D. Picture Distortions Due to Defective Picture-Tube Components.

Associated with the picture tube are the deflection yoke, a centering plate, and perhaps an ion trap. Improper placement of any of these components will have an adverse effect on the picture. By the same token, any defect within these components will also tend to distort the picture or even prevent it from appearing on the screen.

When a picture is not in proper focus the cause may be: a defect in the electron gun (in electrostatically focused tubes), the application of an incorrect voltage to the focus electrode (again, in electrostatically focused tubes), an improperly adjusted focus control, a defective focus coil (in electromagnetically focused tubes), or a resistive change in the focus circuit. When a focus coil is employed, it must have a certain amount of current flowing through it. Too much or too little current will produce defocusing. If the set uses a permanent-magnet focus unit, poor focus indicates improper placement of the magnet or possibly a weakened magnet. In Fig. 16-15, the ion trap is out of position. In Fig. 16-16, the deflection yoke is not as close to the cone or bulb of the picture tube as it should be. Fig. 16-17 reveals distorted images which stem from the same source—a short in the deflection yoke.

Besides the two sets of windings in the deflection-yoke housing, there will be found several damping resistors (across the vertical windings) and a small capacitor (across one of the horizontal windings). Should any of these components become defective, picture distortion will be produced. A typical appearance of the image is shown in Fig. 16-18, in which several ripples at the left side of the screen cause the pattern to appear wrinkled.

SERVICING LOW-VOLTAGE POWER SUPPLIES

Since the low-voltage power supply of a television receiver is, in many respects, similar to the power supply in a radio receiver, the same types of troubles will be encountered in both. The following discussion will discuss what effects can be expected from defective components.

A. Tubes. A rectifier tube is designed to pass a considerable amount of current. In many television receivers these tubes are pushed to the limit of their capacity. If, after being in use for some time, the emission level of the rectifier tube decreases somewhat, it will have an immediate effect on the value of voltage developed. Lowered voltages can lead to dim pictures, unstable picture hold-in, decreased volume, and a decrease in set sensitivity, to name several of the more obvious results. It is frequently difficult from a number of symptoms to point directly to the power supply and say that here lies the cause of the trouble. However, when the trouble cannot be corrected by tube replacement, then a check should be made of the B+ voltage to determine if this possesses its normal value.

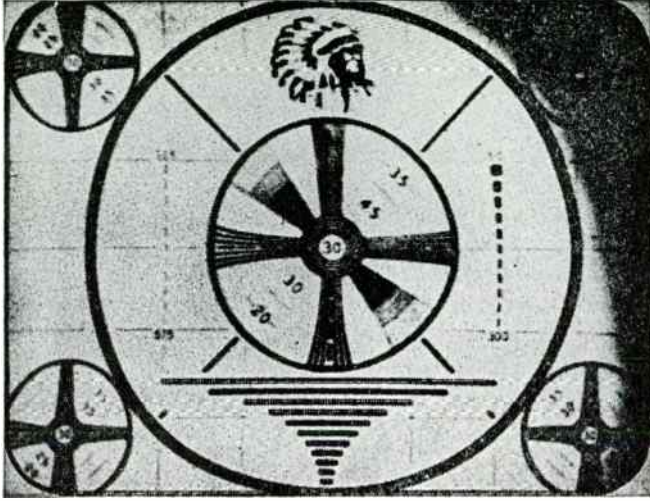

FIG. 16-15. Improper placement of ion trap.



Courtesy Sylvania News

FIG. 16-16. The shadow around the outer edge of the pattern is caused by a deflection yoke which is not as close to the cone of the tube as it will go.



FIG. 16-17(A). Distortion as produced by a short across part of the deflection-coil windings. Short circuit is across part of horizontal deflection yoke windings.

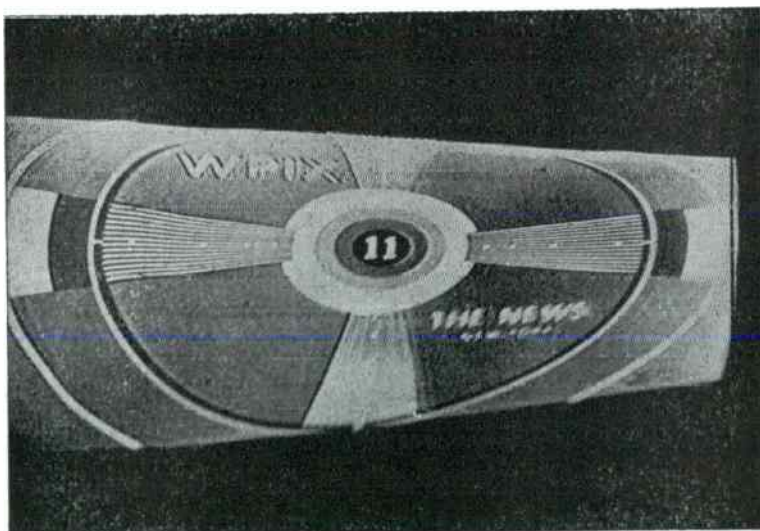

FIG. 16-17(B) Short is in vertical section of yoke windings.

Besides lowered filament emission, rectifier tubes can burn out or short. If the set is not fused, a shorted rectifier tube in it can result in a burned-out transformer or even generate enough heat to set the receiver on fire. Most manufacturers fuse their sets, but it is astonishing how many do not take this simple precaution.

It will also be noted that when some manufacturers fuse their sets, they do not provide sufficient room for momentary current surges or for line



Courtesy Sylvania News

FIG. 16-18. Ripples caused by an open or wrong value of capacitor across half of the horizontal winding of the yoke.

voltages which are slightly above normal. Servicemen sometimes deal with this situation by replacing the existing fuses in the set with others possessing higher current ratings. This practice is frequently dangerous unless it is definitely known that the circuit is underfused. Generally the only source of this information is the manufacturer's service manager or his design engineers.

A better procedure and one which will generally be satisfactory is the use of a slo-blo, or time-lag, fuse having the same rating as the original

fuse. These fuses are designed to withstand momentary surges of current, but they will blow if the overload current persists. Littlefuse makes the slo-blo fuse and Buss makes the time-lag Fusetrons.

In receivers utilizing selenium or silicon rectifiers, a small-series protective resistor frequently serves as a fuse, burning out whenever the current drain on the rectifier becomes excessive. Some of these resistors are even soldered into special plugs that facilitate their removal from the set.

The use of series-filament arrangements complicates location of a defective tube when the defect stems from an open filament. When one tube goes out, the series chain is broken and all tubes go out. The technician is thus faced with the prospect of checking 14 or more tubes individually, either by using a tube tester or by performing a continuity check on each filament. Either procedure takes considerable time.

If the technician is unwilling to remove the chassis from the cabinet, he may be forced to check each tube individually, as outlined above. An alternate procedure is to remove one tube at a time and insert the test probe of an a-c voltmeter into the heater-socket holes. With the power on, the meter will show a line voltage of 120 volts when the socket containing the tube with the open filament is reached. If the tube filaments are good, there will be no indication on the meter. Each socket can be checked in a similar manner until the position of the defective tube is uncovered. Notice that after a position has been checked and found to be satisfactory, the tube is replaced before the next one is removed.

The behavior just discussed is due to the fact that when the line voltage is applied to a string of tubes and each filament is intact, then each will have a voltage across its filament terminals equal to its rated value. However, when an open filament develops, no current will flow in the circuit and the full-line voltage will appear across the open filament end and nowhere else. Hence, removing the defective tube and checking the voltage at its filament terminals will produce a 120-volt reading on the meter.

If the underside of the chassis is available, the foregoing test can be performed without removing the tubes from their sockets. Simply place the probes of an a-c voltmeter across each set of filament terminals until the meter records the line voltage. At this point, the open elements are located.

B. Semiconductor* Rectifiers. Semiconductor rectifiers are widely used in television receivers because they will perform the same function as vacuum-tube rectifiers but with greater efficiency. They are small in size, rugged, comparatively cool in operation, and have a long, useful life. How-

*Selenium, silicon, and germanium belong to a class of materials known as "semiconductors." These same materials, particularly silicon and germanium, are used also for transistor construction.

ever, from time to time, these units will become defective and require replacement.

These semiconductor rectifiers are sometimes tested by measuring their forward and reverse resistances. This is done by placing the ohmmeter leads across them and noting the resistance, then reversing the ohmmeter leads and again measuring the resistance. The readings will normally show greatly different values in each direction. However, what these resistance values are will depend on the ohmmeter voltage and scale. Because of this, ohmmeters should be used *only* to determine whether current can flow through the rectifier. They should never be used to gauge how well the unit will perform.

Whenever B+ voltage is below normal and no other obvious defects exist, many servicemen simply substitute other rectifiers for the ones in the receiver. In performing the changeover, the following precautions should be observed:

(1) The soldering iron or solder should not be brought into contact with the rectifier body. Also, the iron should not be applied to the soldering terminals any longer than necessary.

(2) Mount the rectifier in the same manner as its predecessor, and see that it receives adequate ventilation.

C. Electrolytic Capacitors. Electrolytic capacitors in the low-voltage power supply provide most of the filtering. They are not a permanent part of electronic equipment and, like the vacuum tube and the battery, may have to be replaced periodically.

When making a visual inspection of a receiver during any servicing job, the serviceman should check the filter capacitors for signs of corrosion, dripping, or scaling around the base of the capacitor. The capacitor may still work perfectly, but these signs will indicate that the capacitor is about to fail. It should be replaced. The failure of a filter capacitor usually produces excessive hum (in the speaker), low-volume output, and heavy black bars on the face of the screen.

Effects of Shorted or Leaky Filter Capacitors. A shorted filter capacitor can cause the rectifier tube to burn out. It will cause the fuses to blow (if the circuit is fused).

With a leaky filter capacitor, the voltage output of the power supply is low, there is hum in the speaker, dark horizontal bars appear on the pictures, and the transformers and chokes overheat.

Effects of Open Filter Capacitors. An open filter capacitor produces most of those symptoms caused by leaky capacitors except the heating of parts. It will lower the B+ voltage. This is especially true if the capacitor in question is the input capacitor of the filter network. If the capacitors in the filters are in parallel, one open capacitor may not noticeably affect the operation of the receiver. (This will depend upon the design tolerances of

the receiver. In television receivers it is very important that the power supply be well filtered. Therefore, the power supplies frequently contain enough capacitance that failure of one unit may not be noticed.)

Open Filter Chokes. Open filter chokes can be isolated quite simply. For example, if the filter choke of Fig. 10-3 were to open, there would be no output voltage and a higher than normal voltage across C_1 and C_2 . When operating normally, the filter choke should be cool to warm. It should not become so hot that the hand cannot be held on it for several minutes.

One visual effect of an improperly filtered power supply is shown in Fig. 16-19. The distortion in Fig. 16-19 is due to ripple in the voltage reach-

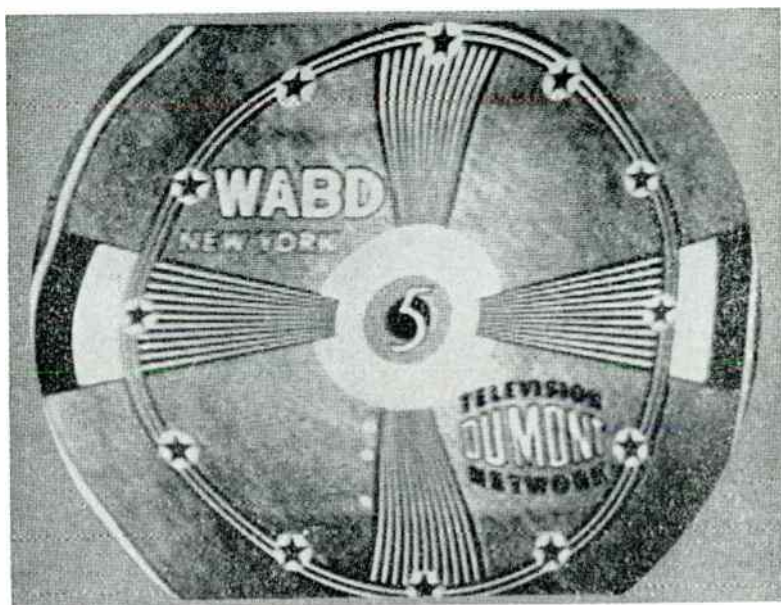

FIG. 16-19. Visual effect of poorly filtered power supply. The distortion is due to ripple in the voltage reaching the horizontal deflection system.

ing the horizontal deflection system. The image weaves slowly from side to side. When the ripple frequency is 60 cycles, the pattern shown is observed. The curvature at the edge of the image represents one cycle of a sine wave laid on its side. If the ripple voltage is raised to 120 cycles, then the number of "bends" is similarly doubled. The visual effect of ripple in the vertical-deflection system is an alternate spreading and crowding of the image in the vertical direction. Generally this distortion is not stationary, but moves slowly up and down the image.

Sound vs. Filter Ripple. Sound signals reaching the cathode-ray tube produce an effect which is similar in certain respects to a-c ripple. Each defect causes black bars to appear across the screen, but those caused by the sound voltages are more numerous and their intensity changes in step with the amplitude of the applied audio. See Fig. 16-20. The black bars produced by hum in the power supply seldom exceed two, are much wider than the audio bars, do not vary in intensity, and are visible on all channels.



Fig. 16-20. The visual effect of sound voltages in the video system.

Sound voltages reaching the cathode-ray tube may arise from two sources: improper alignment of the trap circuits in the video IF system or incorrect setting of the fine-tuning control. As a first step toward removing the sound bars, adjust the fine-tuning control. In a receiver functioning normally, this adjustment should be enough to remove the sound bars from the image without distorting the sound output. If the sound bars cannot be removed or the sound becomes fuzzy when they are removed, then alignment of the circuits should be checked.

Transformerless Receivers. Television receivers which use semiconductor rectifiers do not often use a power transformer, which means that the serviceman must be careful not to ground the chassis of such receivers unless he is certain that the side of the power line to which the chassis is connected is also at ground potential. Unless this precaution is observed, it is quite possible that a fuse will be blown and any equipment connected to the receiver will be damaged. For this reason, isolation transformers should always be used when servicing receivers without transformers.

Before returning a receiver of any kind to the owner, the service technician must thoroughly test the unit to be certain that it is completely safe to operate without danger of electrical shock. Do not use a line-isolation transformer when making this test. In addition to practicing the basic fundamental electrical safety rules, the following test, which is related to the minimum safety requirements of the Underwriters Laboratories, should be performed by the technician before any receiver which has been serviced is returned to the owner.

For the test, a 1,000 ohm-per-volt a-c voltmeter is shunted with a 1,500-ohm, 10-watt resistor. One meter probe is held against any portion of the receiver exposed to the consumer or operator, for example, the cabinet trim, hardware, controls, and knob, while the other probe is held in contact with a good "earth" ground, for example, a cold-water pipe. The a-c voltage indicated by the meter should not exceed $7\frac{1}{2}$ volts. A reading exceeding $7\frac{1}{2}$ volts indicates that a potentially dangerous leakage path exists between the exposed part of the receiver and the "earth" ground. Such a receiver presents a potentially serious shock hazard to the operator.

The test should be repeated with the receiver-power plug reversed in its connection to the power line. Also, as a matter of safety to the voltmeter which is used in the test, start with the instrument set to the 150-volt scale. Then, switch to a lower range. When making the safety test on receivers with external connections (remote-controlled and motorized tuners, or special accessories, including indoor antennas), be sure that all units are operating and functioning at the time of the test. The safety test should be applied to all receivers, whether or not the design incorporates a power transformer with line-isolating winding. Receivers damaged by lightning, flood, accidents, or other causes require careful examination of all the isolating components and circuitry to insure that they are in good condition.

SERVICING HIGH-VOLTAGE POWER SUPPLIES

A good indication of high-voltage failure is the appearance of a dark screen. If the dark screen is accompanied by normal sound, then the low-voltage power supply is operating normally, and we can concentrate on the high-voltage system. However, a blank screen and no audio is generally due to a defective low-voltage supply.

As a first step in checking the high-voltage supply, measure the voltage at the end of the second-anode connector (after the connector has been removed from the tube). If there is no high voltage, a likely source of trouble is the high-voltage rectifier. Substitute another tube and see if the voltage returns. If the tube is not at fault, then the next step depends upon the manner in which the high voltage is developed. In the flyback type of supply, a check should be made with an oscilloscope to determine whether

the proper deflection voltage is reaching the grid of the horizontal output amplifier. If this wave does not have the proper shape and peak-to-peak amplitude, work back toward the sweep oscillator to find out why the proper wave is not being developed.

When the drive voltage is normal, a check should be made of the horizontal-output tube. Also, the damper tube may be faulty. The important thing is to determine whether the trouble is arising from the output circuit or from insufficient drive on the output amplifier. This will then direct you to the proper circuit.

Within the high-voltage system the usual causes of failure are the tube, the filter capacitor, and the series filter resistor. If the capacitor shorts, there will be no high voltage. If it opens, there will be some high voltage, but not very much. A common trouble developed by the series filter resistor is an increase in value. This does not remove the high voltage, but it does decrease it and produces an effect known as "blooming." As the brightness control is turned up, the picture begins to lose brightness and starts expanding. It is possible for the picture to disappear altogether at some setting of the brightness control.

A rectifier tube with low emission can also be responsible for blooming.

RF Power-supply Servicing. A defective rectifier tube, filter capacitor, or filter resistor will produce the same effects in the RF-type of power supplies that they do in the flyback type. The RF supply differs in the manner in which it develops its high voltage. The RF power supply is a self-contained unit, requiring only low voltage from the television receiver. Therefore, what happens in the horizontal-deflection system is usually of no immediate importance to the RF power supply. When high voltage is missing and the low-voltage B+ is normal, then the trouble lies within the high-voltage circuit. Tubes should be tested first, preferably by substitution. Next, determine if the RF oscillator is operating. Measure the grid bias on the oscillator tube. If it is low, oscillations are weak. Try adjusting the trimmer capacitor across the oscillator coil to see if the amplitude of oscillations can be increased. Do this carefully, for frequently it is easy to throw the circuit out of oscillation. If this does not help, check circuit resistances and capacitors. Sometimes a number of turns in the oscillator coil become shorted, but this may or may not be detectable by a resistance check because of the low coil resistance.

SYNC-SEPARATOR STAGES

The sync-separator stages stand between the vertical and horizontal sweep systems and the video system.

A defect in the sync-separator stages of a television receiver will almost always cause both vertical and horizontal sections to fall out of sync. The

picture on the screen will be found to roll aimlessly both vertically and horizontally. See Fig. 16-21. While it may be possible to lock the picture in momentarily by adjusting the vertical and horizontal hold controls, the picture will soon fall out of sync again.

The best way to check through a sync circuit in search of a defect is by tuning in a signal and then using an oscilloscope to check pulse waveforms at the grid and plate of each of the sync stages. The point at which to start is the input to the sync-separator section. The waveform here will generally

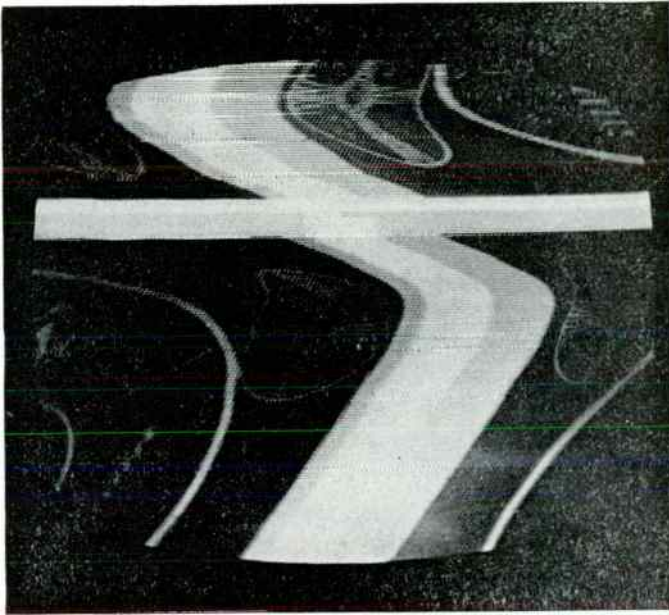

Courtesy H. W. Sams & Co.

FIG. 16-21. Loss of vertical and horizontal lock-in.

be the video signal complete with video voltage and sync pulses. See Fig. 16-22(A). At the output of the first sync separator (V_2) in Fig. 12-10 the vertical and horizontal waveforms will appear as shown in Fig. 16-22(B) (The oscilloscope sweeping rate used to observe the vertical sync pulses is 30 cycles; the horizontal sync pulses, 7875 cycles.) Note how much the video signal has been suppressed (or even eliminated) while the sync pulses are being amplified. At the output of the second sync-separator stage, V_3 , the pulses are more clearly defined and the percentage of video signal has been further reduced. See Fig. 16-22(C). The separation of sync pulses from video signal becomes substantially complete at the plate of the third

Horizontal

Vertical

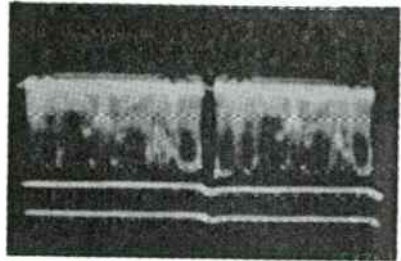
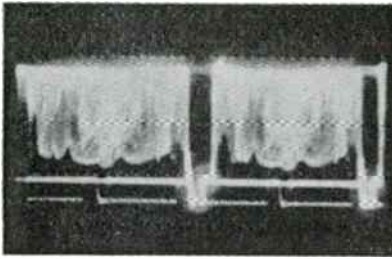

A - At Input To Sync Separator System.

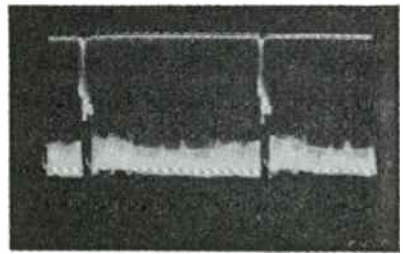
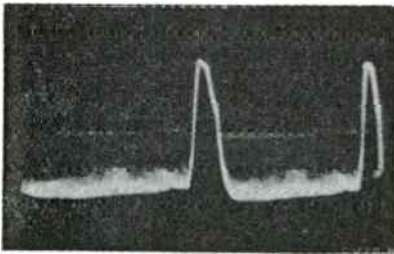

B - At Output Of First Sync Separator.

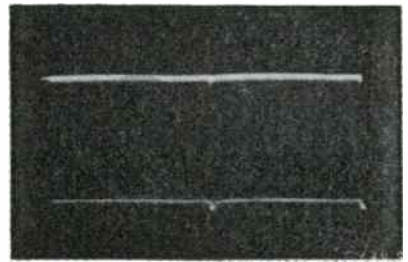
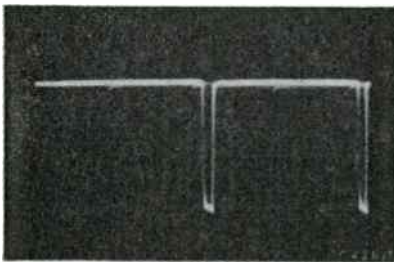

C - At Output Of Second Sync Separator.

Fig. 16-22. An illustration of how the sync-separator stages separate the sync pulses from the video signal.

separator stage, V_3 . The sync pulses are now ready to be transferred to their respective sweep systems.

When observing sync pulses on an oscilloscope screen, the serviceman will find that the horizontal pulses stand out clearer and more distinctly than the vertical pulses. One reason for this is that the horizontal pulse is simpler in structure than the serrated vertical pulse. Also, the horizontal sync pulse occupies a greater proportion of a line than the vertical sync pulse does of a field. Hence there is more of the pulse to be observed when the scope-scanning rate is set to the proper value. These facts are borne out by the oscillograms of vertical and horizontal sync pulses shown in Fig. 16-22.

It is important to observe carefully the composite video signal which is applied to the input of the sync-separator section. If, for example, it is found that the sync pulses have been compressed (Fig. 16-23) and it is difficult to keep the picture in sync, then it can be surmised that it is not the sync-separator stages that are at fault, but the preceding video system. It is quite possible that the defect exists in the AGC network, wherein the controlled RF and IF amplifiers are being permitted to operate at higher than normal gain because of insufficient bias. This can readily lead to overloading with subsequent sync-pulse compression. When this signal reaches the sync separators, there is a considerable amount of video signal operating at the same level as the sync pulses, and consequently it becomes impossible to effect a clear-cut separation. In the vertical system, this will show up as unstable or critical hold-in. The picture will have a tendency to roll. In the horizontal system, the automatic frequency-control network may hold the picture more firmly in place. However, the hold-in range will undoubtedly be smaller than normal. Also, a bend may appear at the top of the picture. Vertical lines or objects in the picture will be found to curve to the right or to the left. In extreme cases, the top of the picture will "flag-wave," that is, will move rapidly from side to side.

If it is found that sync pulses are being compressed or clipped entirely before they reach the sync-separator stages, then the path of the video signal should be traced back to the video second detector with the oscilloscope. Sync-limiting or compression may occur at almost any point from the RF

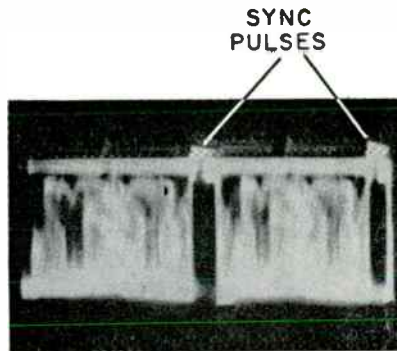

FIG. 16-23. A video signal in which the sync pulses have been partly compressed. Note that the video signal extends up to the level of the pulses.

amplifier to the sync take-off point in the video amplifiers. A gassy tube, a defective AGC system, a signal which is too strong, a change in operating voltages or in component values can all be responsible. Examine the signal in the video second detector. If it looks normal, then the preceding RF and IF stages are operating normally. If the sync pulses are absent or have been compressed, the trouble exists prior to the video second detector. Check the plate, screen, and grid-bias voltages on the video IF tubes first. Pay particular attention to low AGC voltages since these are a frequent source of trouble. Gassy tubes—sometimes identifiable by a blue glow—are also common causes; cathode-to-heater shorts are also. The servicing procedure now follows along the lines previously outlined for video IF amplifiers.

When poor sync action has been traced to the sync-separator stages, the oscilloscope is employed first to localize the defective stage. Thereafter voltage and resistance checks will be required to isolate the component. Of course, in *any* section of the receiver, tubes should be checked first. If checking them does not clear up the trouble, then turn to voltage and resistance measurements.

VERTICAL-DEFLECTION SYSTEM

Difficulties in the vertical-deflection system are perhaps the easiest to analyze because the voltages developed here deal only with the vertical sections of the image. There are no high-voltage-power supplies associated with this system, such as we find in the horizontal-deflection system. When only the vertical-deflection system is affected, analysis of the source of the defect is simple and straightforward.

1. The most positive indication of complete failure of the vertical-deflection system is the appearance of a narrow, horizontal line on the cathode-ray-tube screen. See Fig. 16-24. The first components to check are the vertical oscillator and amplifier tubes. If these are working, check the vertical sweep waveforms with an oscilloscope, starting at the vertical-oscillator tube and progressing forward to the vertical-output amplifier. Once the defective stage is located, voltage and resistance checks should reveal the defective component. Keep in mind, when making the

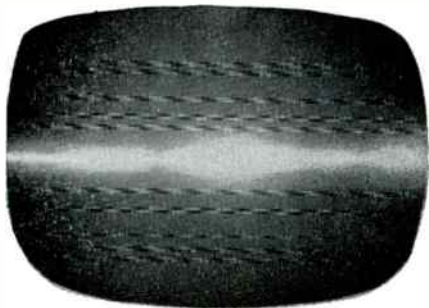

FIG. 16-24. Complete loss of vertical deflection.

foregoing tests, that an open in the windings of the vertical-deflection coils is also a possibility. This does not usually occur, but it can.

2. The picture may fail to lock-in vertically. See Fig. 16-25. Ordinarily, if the vertical hold control is rotated, a point will be found where the frequency of the oscillator is brought close enough to the incoming vertical synchronizing pulses to permit lock-in. The picture then becomes stable. However, if the oscillator is not functioning properly, or the vertical synchronizing pulses are not reaching the oscillator, then perfect lock-in will not occur. Hence, when the vertical hold control proves ineffective, make the following tests:

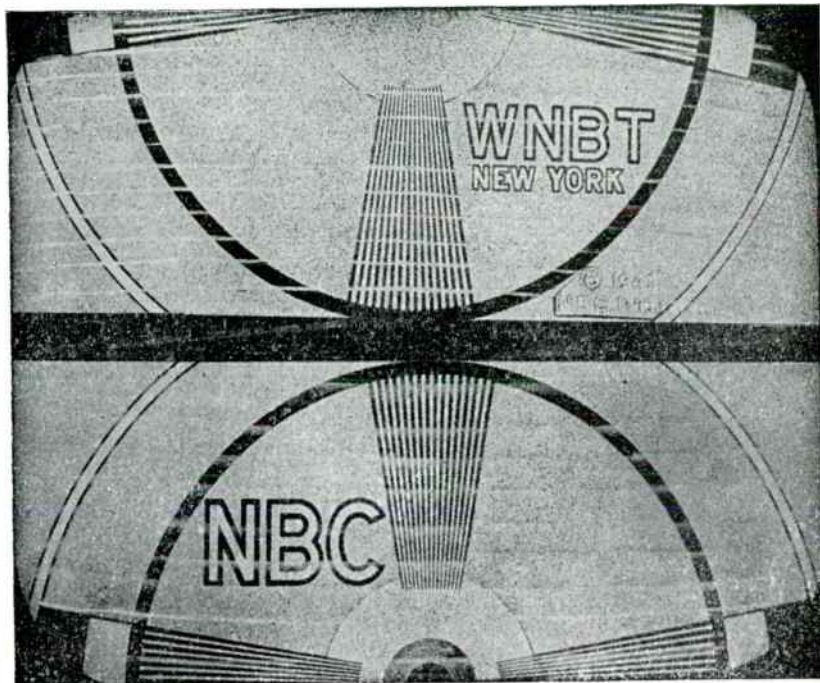

FIG. 16-25. Effect of an incorrect setting of vertical hold control.

a. Check the waveform at the input to the vertical sweep oscillator. Determine whether the pulses reaching the vertical sweep oscillator are sufficiently strong to maintain control. It is quite possible that the path from the sync-pulse separator to the vertical oscillator does not transmit the full vertical pulse. Defective coupling capacitors, open resistors, or components which have changed value appreciably may be the causes. Resistors can be checked by measurement and capacitors by substitution. Check, too, the amplitude of the complete video signal at the point where the sync-pulse separation occurs. The image on the screen will also help determine whether sufficient signal strength is present.

b. If the foregoing test produces normal results, check the waveform at the output of the vertical sweep oscillator. Note whether variation of the vertical hold control has any effect on the frequency of the observed waveform. A lack of such frequency variation indicates an open resistor in the grid circuit containing the hold control. Check the resistors and capacitors to find the defective component.

c. Sometimes poor vertical lock-in comes from a completely unsuspected source. In one set brought into the shop the picture could not be held vertically. All tubes and suspected parts were checked and found to be O.K. However, when the serviceman started repositioning some of the wires near the vertical-sweep oscillator, it was found that a lead from the vertical system had moved near the filament leads of another tube. The 60-cycle field radiated by the filament wires induced sufficient voltage in the vertical sweep-oscillator circuit to trigger this circuit prematurely, resulting in lock-in instability. When the offending filament leads were dressed away from the vertical-sweep oscillator, the set returned to normal operation.

3. The picture may "bounce" when the set is jarred. In this case check all the tubes in the vertical synchronizing system for microphonics. Merely by tapping each tube, while it is in the set will be inconclusive. The best test is to replace each tube, in turn, with one known to be good.

Incidentally, too strong a signal or too high a setting of the contrast control can produce a jumpy picture. When this condition is present, the tubes are driven to saturation, thus compressing or otherwise distorting the synchronizing pulse waveforms. The result is poor sync control of the sweep oscillators. In sets where the horizontal sweep system employs some form of automatic control, noise disturbances or a weak signal will affect the vertical sweep system to a greater degree than the horizontal sweep system. However, when such control is absent, both will be affected almost equally.

4. The height of the picture may be insufficient. In a receiver functioning normally, rotation of the height control will produce the proper picture height. Inability to obtain this result may be caused by one or more of the following conditions:

- a. Weak vertical-output-amplifier tube
- b. Lowered plate and screen voltages on vertical oscillator and vertical-amplifier tubes
- c. Low line voltage
- d. Improper placement of the deflection yoke

Items *c* and *d* will affect the width of the image, too. If the width is normal, these items can be disregarded.

5. The picture may be compressed at the top. This is an indication of

poor linearity of the vertical-deflection voltage. The vertical saw-toothed deflection wave is developed in the plate circuit of the vertical sweep oscillator, amplified by the vertical output amplifier, and then applied to the vertical-deflection coils. If this wave does not have the proper form, if parts of it curve or bend more than they should, then the electron beam in the cathode-ray tube will not travel down at an even rate. The visual result will be a bunching of lines in some sections of the image and the spreading apart of them in others. This is known as "poor linearity." When the image displays this type of distortion, the trouble is in the vertical sweep and amplifier circuits.

To correct the defect, try adjusting the vertical-linearity control. If this adjustment fails, change the vertical output tube. If the nonlinearity still persists, check (preferably replace) the capacitor and/or resistor which develop the deflection wave. In Fig. 16-26, these would be C_{75} , and R_{65} . Check, too, R_{70} , R_{72} , R_{71} , and C_{48C} , because these also influence the shape of the deflection wave. Finally, grid, plate, and screen voltages of the vertical output amplifier should be checked against the manufacturer's recommended values. Line overlapping and image compression can arise from lowered tube potentials.

A precise vertical linearity check can be made with an audio oscillator. Place the receiver in operation but have it tuned so that no signal is being received. This will leave the screen with a blank raster. Now connect the audio oscillator across the load resistor of the video second detector and set the frequency to 660 cycles. As the output of the generator is turned up, a series of alternate black and white stripes will appear. See Fig. 16-27. If the bars are evenly spaced, we know that the scanning of the screen is linear. On the other hand, a nonlinear scanning rate will cause the bars to bunch together at some points.

The figure 660 was suggested because it is an integral multiple of the 60-cycle vertical scanning rate. Almost any multiple of 60 may be used, although it is desirable to have at least 10 or more bars on the screen.

The audio signal was injected at the video second detector because this same signal will also lock-in the vertical sweep system and produce a steady pattern. The sync signals are almost always taken from some point beyond the second detector and in this way part of the injected signal will reach the vertical sweep oscillator and lock it in.

6. Inability to center image vertically.

a. Electromagnetic-deflection Cathode-ray tubes. Test for an open resistor in the centering network if such a circuit is employed. If the position of the focus coil or magnet is the sole method of centering in the receiver, check this. Where a centering potentiometer is employed, measure the volt-

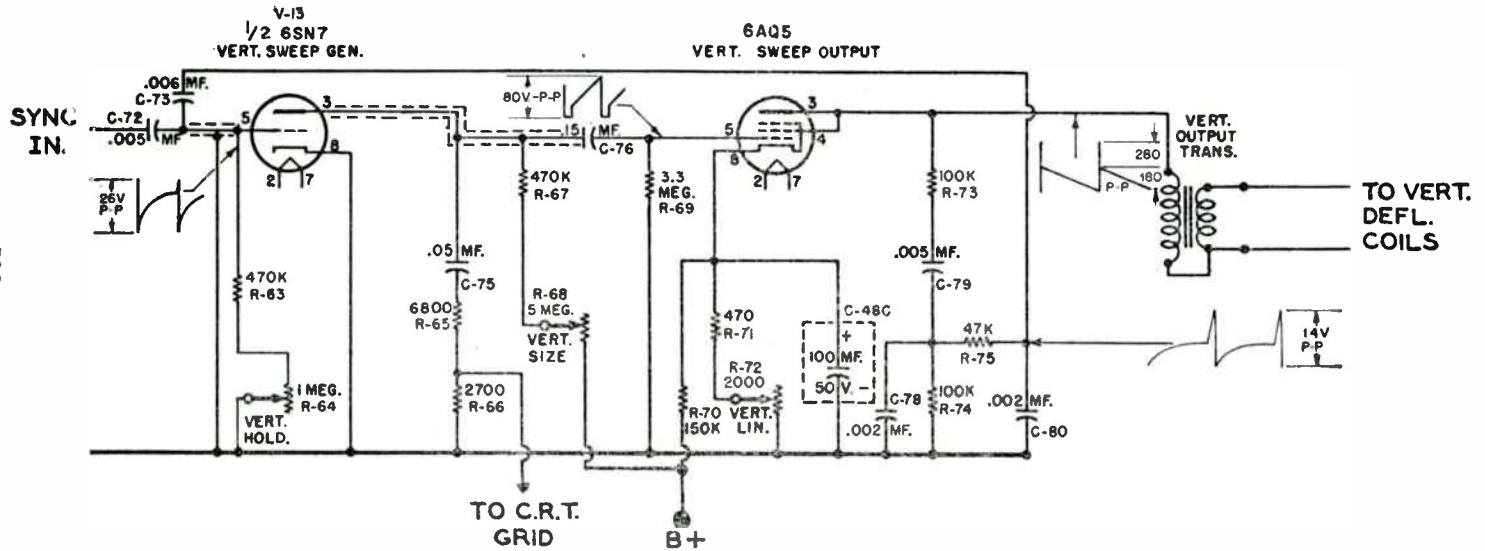

FIG. 16-26. A vertical deflection system.

age across this control. If it is low, measure the voltage of the low-voltage power supply. A low voltage at either point will produce a restricted centering range. Check the position of the ion trap. Finally, if all these tests do not reveal the trouble, check the cathode-ray tube itself. The electron gun may have become tilted because of a sudden jarring of the tube.

b. *Electromagnetic-deflection, Electrostatic-focus tubes.* In these tubes, the component that governs the picture position is a magnetic centering device, the arms of which must be properly oriented with respect to each other. Check the manufacturer's service manual for the proper procedure to follow. Also examine the position of the ion trap.

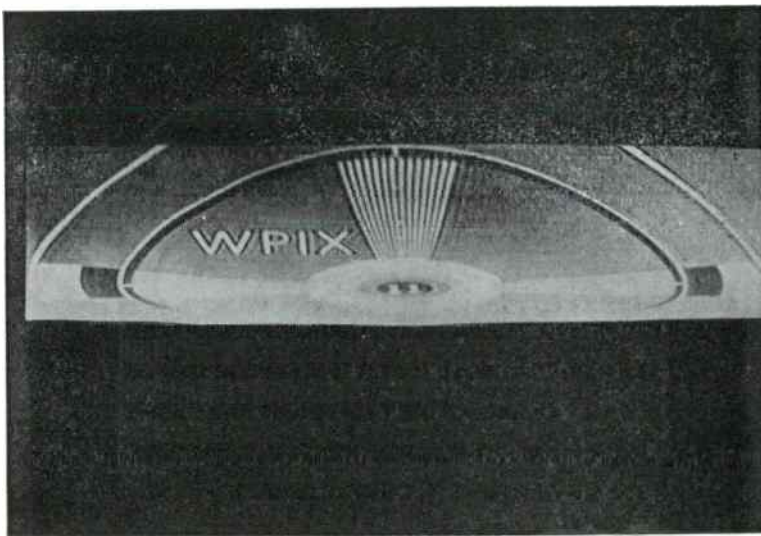

FIG. 16-27. Black and white horizontal bars for checking vertical linearity.

7. Vertical foldover in a picture might be considered as an aggravated case of nonlinearity. In form, the picture will appear somewhat as shown in Fig. 16-28. The bright horizontal stripe across the bottom of the image represents the point where the scanning beam stopped moving downward. This condition generally arises from some defect between the output circuit of the vertical oscillator and the grid circuit of the output tube. Thus, a leaky coupling capacitor between oscillator and output amplifier or a substantial decrease in the value of the grid resistor will often be responsible. It might also be wise to check the filter capacitor in the cathode leg of the output amplifier. Finally, a gassy output tube is also a distinct possibility and a new tube should be tried.

Sometimes a condition will be obtained in which there is a bright horizontal line across some intermediate point in the picture. This is usually due to heater-to-cathode leakage in the vertical-output tube.

8. Shorted turns in the vertical-output transformer will result in a loss in picture height. It may sometimes give the same indication that insufficient driving voltages gives to the vertical output amplifier. This type of trouble is usually difficult to detect because it reveals itself neither to normal voltage or to resistance checks. If the shape and the peak-to-peak amplitude of the deflection wave are correct at the input to the vertical output amplifier and if the amplifier appears to be operating normally, then the output transformer is a logical suspect.



Courtesy Sylvania Electric

FIG. 16-28. An illustration of vertical foldover.

Measuring the peak-to-peak value of a wave can be a very powerful method of servicing, especially in the sweep sections of a television receiver. Make it a habit to measure this value at the input to the output amplifier. Then compare the value with that recommended by the manufacturer.

Shorted turns in the vertical-deflection coils will produce the trapezoidal or keystone-shaped pattern shown in Fig. 16-29. (Which side is wider depends upon which section of the coils contains the short.)

HORIZONTAL-DEFLECTION SYSTEM

It is evident from what has been discussed in Chapter 13 that distinctive waveforms are produced at each point in the vertical- and horizontal-deflection systems. It is also clear that the reception of a signal does not appreciably alter the shape of these waves.

What better method is there to compare the wave shapes of the voltages

in the defective receiver with the corresponding waveforms given by the manufacturer in his service manual. For example, refer to the waveforms shown in Fig. 16-30. These are the proper waveforms present in the vertical and horizontal circuit of this receiver when everything is operating normally. The peak-to-peak voltage values are also important in waveform checking and these should be carefully noted. When the wave amplitudes are found to be appreciably smaller than recommended by the manufacturer, tubes and the B+ power-supply voltages should be checked. On the other hand, distorted or improperly shaped waves usually indicate defective capacitors and/or resistors in the circuits.

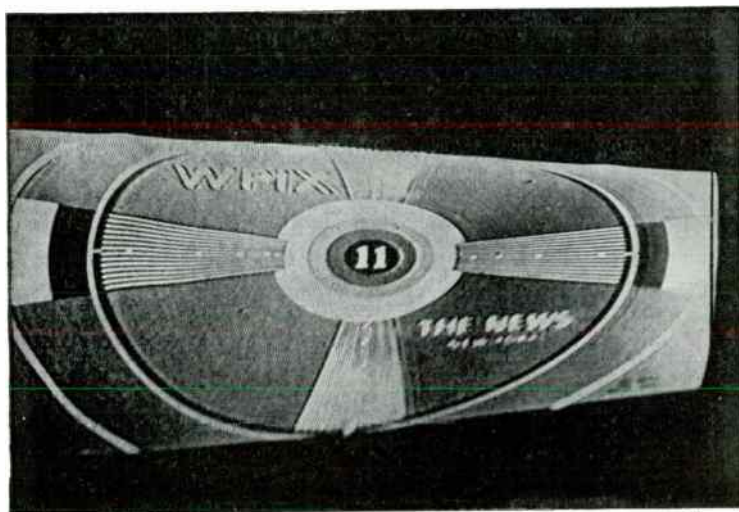

Courtesy Sylvania Electric

FIG. 16-29. Vertical keystoneing.

It has been stated before but it is well to repeat that tubes are, by far, the most important source of trouble in present-day television receivers. Again—when trouble is traced to the deflection systems, check the tubes first. If the tubes test O.K., then the next job is the waveform check.

Take an oscilloscope and connect the grounded vertical input terminal to the receiver chassis. Connect a test prod to the other vertical input terminal. Then, starting at the plate of the synchronizing oscillator, check plate and grid waveforms of each tube, working toward the deflection plates or coils of the cathode-ray tube. At the point where the waves disappear or are not in their proper form, voltage and component checks should be made to determine the reason for the change or disappearance of waves. It is desirable to use a ruled plastic mask for the oscilloscope screen and note

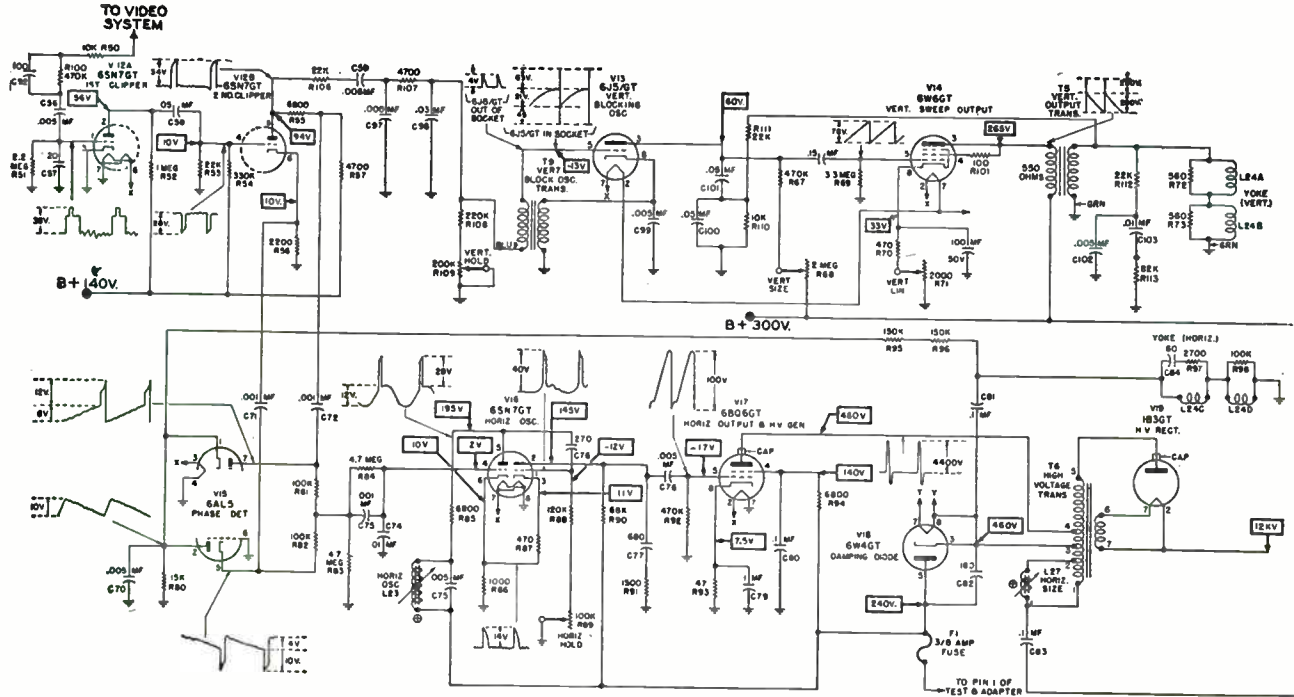

Courtesy Motorola

FIG. 16-30. The sync separator and vertical and horizontal sweep systems of a television receiver, together with the normal waveforms found in these circuits.

approximately the peak-to-peak voltage values of each of the waveforms checked. Variations of from 10 to 15 per cent from the recommended values can be accepted since the adjustment of various controls can readily affect the wave amplitude by this amount.

Loss of Synchronization. Loss of horizontal synchronization is indicated when the picture assumes the distorted appearance of Fig. 16-31.

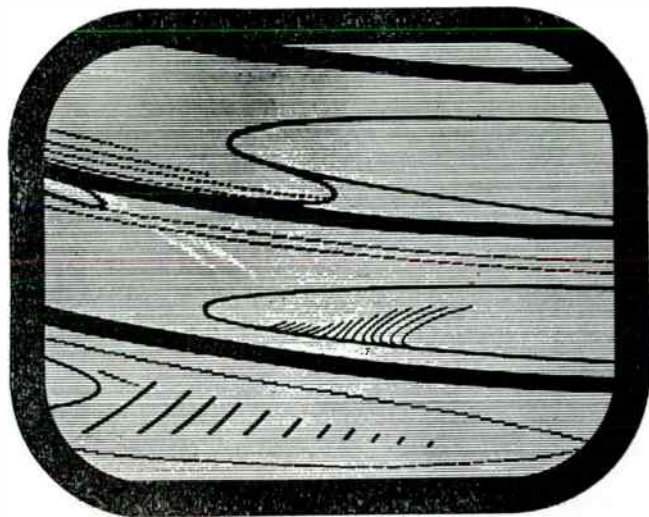

Fig. 16-31. Loss of horizontal synchronization.

In the latter, the image appears to slip in a horizontal direction. If the slippage is great enough, it results in several images overlapping, and no detail can be clearly distinguished. In the absence of too large an input signal, slow rotation of the horizontal hold control will bring the oscillator back to the correct operating frequency at which one stationary image is again visible. Failure of the hold control to correct the oscillator frequency generally indicates a faulty component in this generator or in its automatic control network.

Other Horizontal Defects. A fairly common type of picture defect, and one which gives many technicians a considerable amount of trouble, is horizontal nonlinearity. The picture may be compressed or elongated at the left- or right-hand sides (Fig. 16-32). There may be a series of ripples across a part of the screen (Fig. 16-18), or the picture may possess two or three closely spaced dark lines (Fig. 16-33).

To track down the part of the horizontal circuit most likely to contain the seat of the trouble, the technician must recall something that was stated previously: that the first 30 to 40 per cent of horizontal beam travel is con-

trolled by the damper tube (and its circuit) while the remaining 60 or 70 per cent of beam travel across the screen is controlled by the horizontal-output amplifier.

From this we can see that, if the picture is impaired on the left-hand side, the defect is most likely to exist in the damper-tube circuit (i.e., from the plate of the horizontal output amplifier to the deflection yoke). If it is the right-hand side of the picture which is distorted, the most likely place to look for the defect is in that portion of the horizontal sweep system extending from the horizontal oscillator up to and including the output tube.



Courtesy RCA

Fig. 16-32. An image possessing horizontal nonlinearity.

Thus, from the foregoing reasoning, ripples in the picture caused by a defective capacitor in the deflection yoke, or foldover caused by a defective damper tube, or light and dark stripes caused by misadjustment of the linearity coil, all quite naturally fall at the left-hand side of the picture because they arise from the damper-tube circuit. In place here, too, are the dark stripes of Barkhausen oscillations* since these occur after the output tube has been cut off and the beam has just been returned to the left-hand side of the screen. Foldover or compression at the right-hand side of the picture is produced when the value of the grid resistor of the horizontal output tube is decreased sharply.

Most frequent defects in the damper stage include the damper tube, any capacitors that may be used, and the linearity coil.

* These are spurious oscillations set up within the horizontal output amplifier tube just after the tube has been cut off.

In the horizontal output stage, check the following:

1. Lowered grid-resistor value
2. Defective screen-grid by-pass capacitor
3. Leaky coupling capacitor at stage input
4. Bad horizontal output tube
5. Defective cathode-bias resistor or capacitor

In most instances the general location of the defect, as revealed by the section of the picture which is affected, is fairly well defined. However, be-



Courtesy Radio News

FIG. 16-33. The visual effect of a Barkhausen oscillation.

cause a B+ boost voltage developed by the damper tube is fed back to the horizontal output tube (and frequently to other tubes in the horizontal system as well), a certain amount of interaction between the various sections is bound to occur. For example, changes in the B+ boost filter-network components will have an effect on both sides of the picture, although the left-hand side will be the section principally affected. Or, again, insufficient driving voltage applied to the grid of the output tube will have its greatest effect on the right-hand side of the picture. But since the B+ boost voltage developed depends upon the drive voltage, the left-hand side of the picture will suffer, too. Thus, while the circuits directly associated with each part of the picture will have their greatest effect on that section, the close

relationship between all circuits will produce disturbances in other sections of the picture as well.

There is still another feature of horizontal-sweep-system operation that is worth noting and this is the peak-to-peak amplitude of the driving voltage fed to the grid of the output amplifier tube. The width of the picture is governed by this voltage as well as the high-voltage for the picture tube and the B+ boost in the damper circuit. It is an important check point in the horizontal-sweep system and measuring its value early in the servicing analysis is strongly recommended.

SERVICING AFC CIRCUITS

The purpose of the AFC circuit in the horizontal sweep system is to keep the horizontal oscillator locked-in with the incoming sync pulses. When this system is operating properly, random noises and momentary disturbances will have no visible effect on the horizontal-sync stability; the picture will remain securely in place. However, when the system is not operating normally, it may slip out of synchronization occasionally, or the setting of the horizontal hold control will be critical, or the picture may refuse to be locked-in at all.

Failure of the AFC system to maintain the picture in synchronization may arise from a defect in the control circuit or from a defect in some prior circuit. If the latter is true, then the sync pulses reaching the control tube are distorted in some manner or they may even be missing altogether.

If it is determined that the proper pulses are reaching the AFC circuit, then any reason for sync instability must be caused by faulty operation of the control circuit itself. To localize the source of the trouble, several methods of approach are open to the serviceman. As a start, he can measure the voltages within the control circuit. This lends itself quite readily to the location of fairly obvious defects caused by resistances which are either open or have changed radically in value and leaky capacitors. Tubes are not mentioned because it is assumed that these will receive first attention whenever work is done on *any* circuit.

Another approach to the service problem is by waveform checking within the AFC circuit. To check waveform effectively, the serviceman should be familiar with the correct waveforms. The various waveforms in each of the more popular AFC systems were shown in Chapter 13. Perhaps a better place to find what the waveform should be for a particular receiver is in the manufacturer's service manual. Slight variations in the circuit will frequently cause some modifications in the wave shapes developed therein.

Another item to check in your examination of an AFC system is whether the d-c control voltage is being fed to the controlled tube. Connect a VTVM between the d-c control path and chassis. Then, with a signal coming in,

slowly rotate the horizontal hold control from end to end. In a properly operating system, the needle on the VTVM should swing back and forth in step with the hold-control variation. This indicates that the control network is developing corrective voltages to offset the changes in horizontal-sweep frequencies produced by rotating the hold control. Failure to observe these voltage swings on the VTVM indicates that either no d-c control voltage is being developed or that the amount developed is not reaching the controlled stage.

Changes in component values are frequently the cause of instability in AFC systems. Be especially mindful of this fact when making voltage and resistance checks.

QUESTIONS

1. What is the significance of the separation point of the video-sound signal in a television receiver?
2. What indications would be obtained if each of the following defects occurred in a television receiver? (Consider each one separately.)
 - a. No vertical-deflection voltage
 - b. The RF amplifier tube became defective
 - c. The clipper tube became inoperative
 - d. No low voltage
 - e. The horizontal-deflection yoke opened up
 - f. A coupling capacitor in the video amplifier system opened
 - g. The AGC line accidentally grounded
 - h. The horizontal oscillator stopped functioning
3. What is the visual effect of low-voltage a-c ripple in the video amplifiers? How do we distinguish between this effect and that obtained when sound voltages reach the cathode-ray tube?
4. Describe a method for measuring the amount of ripple in the low-voltage power supply.
5. What controls are associated with the horizontal-deflection system? Consider that a pulse-width AFC system is being employed.
6. How would you go about checking an AFC system which you believed was defective? Use the system in Fig. 15-1 as your example.
7. In checking through a horizontal- or vertical-deflection system, what do you look for?
8. Which controls are associated with the vertical-deflection system? State the visual effect of an improper adjustment of each control (considered separately).
9. How can we distinguish between vertical and horizontal nonlinearity?
10. What possible image distortions are due to defects in the video IF system?
11. List the equipment which should be on hand for thoroughly testing a television receiver.
12. What is the significance of the position of any horizontal nonlinearity in a picture? How does this provide a clue to the location of the defect?
13. Outline several tests which will indicate whether or not a signal can get through the front-end stages.

14. What visual effects do gassy tubes produce? (Do not include picture tubes.)
15. Why is it frequently important to measure the AGC voltage early in an analysis?
16. What defects can occur in a video amplifier?
17. Indicate some of the troubles you might encounter with picture tubes.
18. Outline your servicing approach to a receiver containing no high voltage. Assume a flyback system is employed.
19. What will cause picture-smearing?
20. List some of the causes of insufficient picture height.

Remote-Control Systems for Television Receivers

Introduction. Within the last few years, a number of remote-control devices for television receivers have been developed by the various receiver manufacturers. These devices offer considerable convenience to the set user, who is thus able to change volume, picture, and station without leaving his chair. The public has shown that they favor such controls and are willing to pay extra for their incorporation into the receiver. Manufacturers have responded by introducing a variety of remote-control methods and these are now in fairly wide use.

The complexity of a control device depends on the number of functions it performs. Its most important function is station-changing, since this is the major reason why most viewers leave their chairs and go to the receiver. Next, it is useful to alter the sound level, preferably in a series of steps, although even the two conditions of on and off are useful. Turning the receiver on and off is also a desirable control function, and, finally, if not too costly, the control of contrast and/or brightness. Obviously, the more functions to be altered from this remote position, the more complex the circuitry of the control device. This, in turn, directly regulates the cost of the unit.

One of the simplest and most direct approaches to remote control is to connect the control unit to the receiver by a long cable containing a number of wires. This was the path taken in the first remote-control devices that were developed. However, this physical attachment between remote control and receiver tended to limit the usefulness of the system and in time was discarded for methods not requiring wire connections between the remote-control device and the receiver.

One signaling method employs a light beam between the remote control

and a photoelectric cell at the receiver. This method suffers from the disadvantage that the receiver must be able to discriminate between the light which the remote-control device develops and any light ordinarily present in the room in which the television set is located. In order to make certain that the receiver responds only to the remote control, it is necessary to make the actuating light very bright or the photoelectric cell highly directional. Either approach does not provide the strong positive control so desirable in this type of function, and the optical method of actuating a television receiver has been discontinued. It is generally costly to develop a powerful source of light; on the other hand, if the receiver is made highly directional, it requires too much time and effort to aim the remote-control device to hit directly the photoelectric cell at the receiver. The optical system, however, possesses the advantage that it does not interfere with television receivers in other rooms or in adjacent apartments that may also be remotely controlled.

Electromagnetic signaling devices have also been developed and are currently being used by some manufacturers. This type of remote-control device is simple to fabricate, economical in cost, and easy to operate. However, considerable care must be taken to see that the generated signal does not travel beyond the area where it is being used; otherwise, it can falsely trigger receivers in other locations. Generally, when such devices are employed, their transmitting frequency is below the radio broadcast band, that is, below 500 kc.

The most recent signaling method which has been developed employs ultrasonic sound. In this method, a signal above the audible range is developed and directed toward the receiver, where it is picked up by a suitable microphone. This form of control is advantageous in that it can be confined by the walls of the room, with little possibility of interference to receivers in other rooms or beyond the receiver at which it is aimed. Furthermore, it is quite simple to generate acoustic signals by purely mechanical methods; there is no need for a battery or other type of powering mechanism in the transmitter. This is not true of optical and electromagnetic signaling systems.

In the acoustic signaling system, the operating frequency has generally been kept in the 40-kc range. This is sufficiently high above the audible range not to annoy the user. It is also sufficiently low so that air absorption does not seriously restrict signal range. As the acoustic frequency increases, air absorption also increases, and this can be a serious limitation on the system.

ELECTROMAGNETIC REMOTE-CONTROL SYSTEMS

General Electric System. The General Electric remote-control system shown in Fig. 17-1 employs an RF-modulated signal which is beamed from

the transmitter to the receiver. At the transmitter, there are four push-buttons, each concerned with a separate function. These functions are: television channel selection, volume increase, volume decrease, and television receiver turn-on and turn-off. When any button is depressed, the same RF carrier is transmitted; however, a different audio-modulation frequency is employed for each function. It is this difference in modulating frequencies which enables the remote-control receiver at the television set

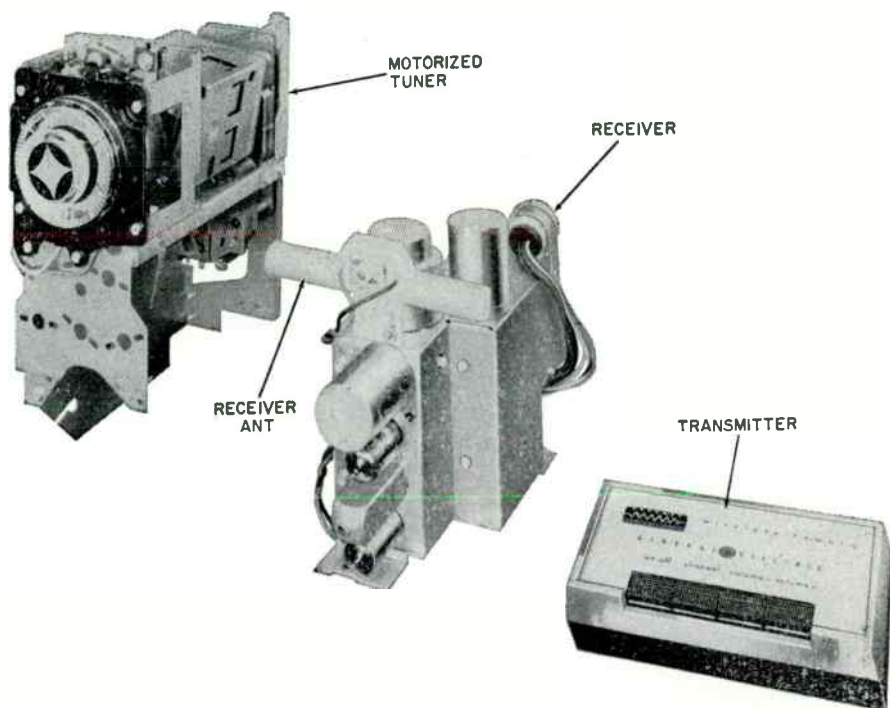

Courtesy G.E.

FIG. 17-1. Components of the General Electric remote-control system.

to distinguish between the various desired functions. The receiver antenna picks up the signal from the transmitter, amplifies it, detects it, and then applies it to the coils of a reed relay assembly. This assembly has four vibrating reeds, each designed to respond to one of the audio-modulating frequencies used. When one of the reeds is made to vibrate, a corresponding sensitive relay is activated and the desired function is carried out.

The transmitter employs the circuit shown in Fig. 17-2. A single PNP triode transistor is connected in what is known as a "common-emitter arrangement." If we consider this circuit simply from the point of view of

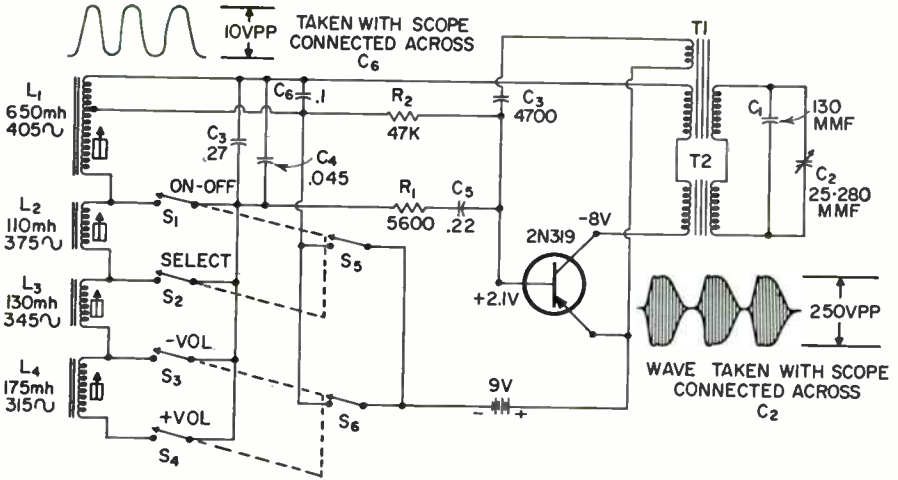

FIG. 17-2. Transmitter circuit for G.E. remote-control system shown in Fig. 17-1.

an RF-carrier oscillator, then its basic circuit has the form shown in Fig. 17-3. When a button is depressed, the collector circuit of the transistor is connected to the negative side of a 9-volt battery, which activates the transistor and causes the RF-carrier frequency to be generated. At the same time, by virtue of the switching arrangement, a distinctive audio modulating frequency is developed.

The amplifying device employed in this oscillator is a transistor, and for those who have not had experience with this device, circuit operation will be made clearer if the transistor element marked base is considered equivalent to the grid of a triode tube, the collector element is considered equivalent to the plate, and the emitter element is equated with the filament or cathode. If we now redraw the circuit, using a corresponding vacuum-tube triode, we can see from Fig. 17-4 that this is a fairly straightforward oscil-

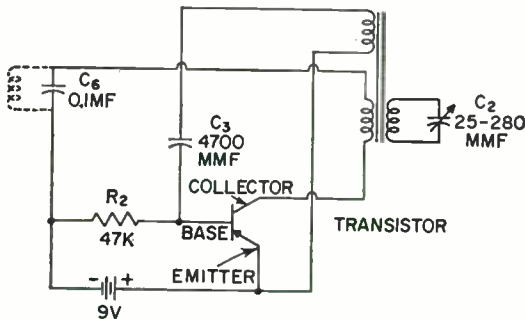

FIG. 17-3. Basic circuit of transmitter RF carrier oscillator.

lator, with feedback between the plate and grid circuits to sustain oscillations.

The tuned circuit consists of both secondary windings of T_1 and T_2 operating in conjunction with the two capacitors C_1 and C_2 . See Fig. 17-2. The governing factor in the amount of feedback is the coupling between the windings of the two transformers, while the actual feedback voltage

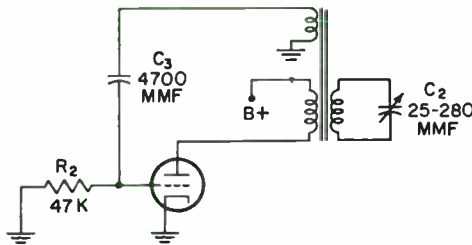

FIG. 17-4. Vacuum-tube equivalent of Fig. 17-3.

is applied by the tickler winding on T_1 . Operating frequency of the oscillator is in the vicinity of 323 kc, although a usable RF bandspread of ± 31.5 kc is available. This bandspread not only provides the necessary width for the modulation frequencies but also enables the RF carrier to be altered slightly, if it should be found that another remote-control unit is operating near-by and interference between the two develops.

It was mentioned earlier that the same oscillator also develops an audio-modulation signal. Figure 17-5 shows the portion of the circuit which is effective for this purpose. Basically, what we have here is a Hartley oscillator, and again it might be helpful to replace the base by the grid of a triode tube, the collector by a plate, and the emitter by a cathode. Although only one coil is shown in this simplified diagram, the actual audio-oscillator part of the transmitter possesses four separately slug-tuned coils. These coils are connected in series so that, in the final analysis, one large coil is available with three taps. Each tap represents one of the audio frequencies, while the total inductance represents the fourth audio frequency. The audio modulation ranges from 315 to 405 cycles, in 30-cycle steps. The Hartley oscillator tuned circuit consists of L_1 through L_4 and capacitors C_3 and C_4 .

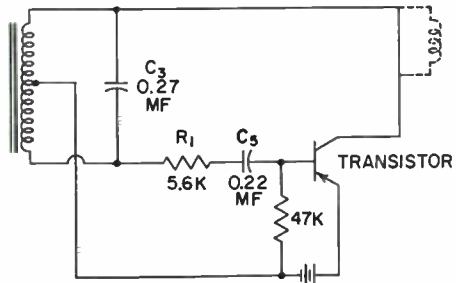

FIG. 17-5. Basic circuit of audio oscillator in transmitter.

See Fig. 17-2. Voltage from the plate or collector circuit is developed across the upper part of the inductance, inducing a voltage of sufficient amplitude and of the right phase in the grid or the base circuit to sustain oscillation. This feedback voltage is coupled to the base or grid through C_5 and its amplitude is governed by R_1 .

Since there is only a single electron stream through the transistor, the RF-carrier frequency is modulated at an audio rate by the audio-oscillator portion of the transmitter circuitry.

It would require an extended discussion to examine transistor operation fully; still, a basic operating knowledge of this device is needed because it is employed in some of the remote-control systems currently in use. Transistors, in their most common form, possess three elements. First, there is the emitter, where the electrical carriers that travel through the transistor originate; this is equivalent to the cathode of a vacuum tube. Second, there is the element to which these carriers travel; this is known as the "collector." Third, there is the element which is physically between the emitter and the collector; this is known as the "base." The relative voltage which is applied between the base and the emitter determines the amplitude of the current flowing through the transistor. Basically, then, we can compare the amplifying action of a transistor with that of a triode tube.

Transistors come in two varieties—PNP and NPN. These letters indicate whether the majority carriers in each section are positive (P) or negative (N). The negative carriers are the familiar electrons which form the current flow through vacuum tubes. The positive carriers, known as "holes," are somewhat more difficult to understand.

In a transistor, an excess of electrons can be developed in a section by selectively adding certain impurities to the germanium or the silicon forming that section. When this is done, the section assumes a designation of "N." It is also possible, by adding other impurities to germanium or silicon, to develop a deficiency of electrons. This does not mean that electrons are removed from the germanium, but rather that one or more electrons are needed to complete the bond between the impurity and the germanium.

At each point where there is such insufficiency, a positive charge is developed. It is this positive charge that is known as a "hole." Although the reader is undoubtedly familiar with the flow of electrons through a circuit, the idea that positive charges in the form of holes can similarly travel through a circuit will come as a surprise. However, this has actually been shown to be true and is the action that takes place in PNP transistors. What happens is that the hole will rob an electron from a near-by point, causing that point to become positive while the hole that receives the electron no longer has a positive charge. Thus, the "robbed" electron, by moving into the hole, neutralizes the positive charge there. At the same time, a new

hole is formed at the spot from which the electron was taken. In essence, then, the hole has moved from its original position to the second position.

In PNP transistors, holes leave the emitter, travel through the base, and reach the collector. Here they combine with an equivalent number of electrons drawn from the external battery producing a flow of electrons through the external circuit. Thus, although there is a flow of positive charges inside the transistor, externally there is a flow of negative electrons, the conventional flow we are all familiar with. In an NPN transistor, the emitter produces electrons which then travel through the base section to the collector and on through the remainder of the external circuit back to the emitter. In the NPN transistor, we come closest to duplicating the action that occurs in a vacuum-tube triode.

The application of voltages to these transistors is carried out as shown in Fig. 17-6. For a PNP transistor, a voltage which makes the emitter

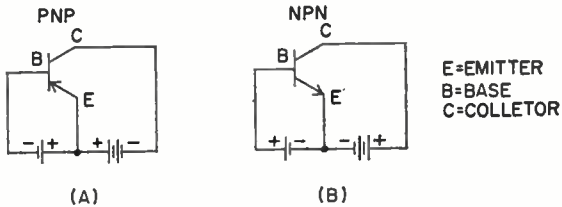

FIG. 17-6. (A) PNP transistor with suitable voltages. (B) NPN transistor. Note the difference in voltage polarities for the two units. Note, too, the difference in symbols.

positive with respect to the base is applied between these elements, whereas a negative voltage is connected to the collector element. In an NPN transistor, the emitter is made negative with respect to the base, while the collector is made positive with respect to the base. If we then examine the NPN transistor, we find that the electrons travel through the base to the collector, where they are attracted by the positive battery voltage at this element. In PNP transistors, the positive holes which leave the emitter travel through the base and then are attracted by the negative collector voltage. In this way, we achieve the necessary current flow through these devices. By varying the amplitude of the voltage provided between the base and the emitter, we can control the number of carriers which leave the emitter. We thus achieve amplification just as we do in a triode tube where the grid controls the number of electrons which leave the cathode and travel to the plate.

Although the foregoing is a brief discussion of transistor operation, it will provide the reader with sufficient background knowledge to deal intelligently with any remote-control circuits in which these devices are em-

ployed.* If service work has to be done on remote-control devices which employ transistors, the voltages in the circuit should be measured first. If these are found to be within the normal range, the transistors themselves can be removed and tested on a transistor checker. In this respect, transistor circuits lend themselves basically to the same servicing approach employed in vacuum-tube circuits. Perhaps the principal difference between the two circuits will be found in the level of the actuating d-c voltages. In vacuum-tube circuits, it is usual to find voltages between 30 and 300 volts. In transistor circuits, voltages applied to the collector seldom exceed 15 volts. This significant difference should be kept in mind when making voltage measurements on these circuits.

Remote-control Receivers.** The receiver employed with the foregoing remote-control system is shown as a block diagram in Fig. 17-7 and as a

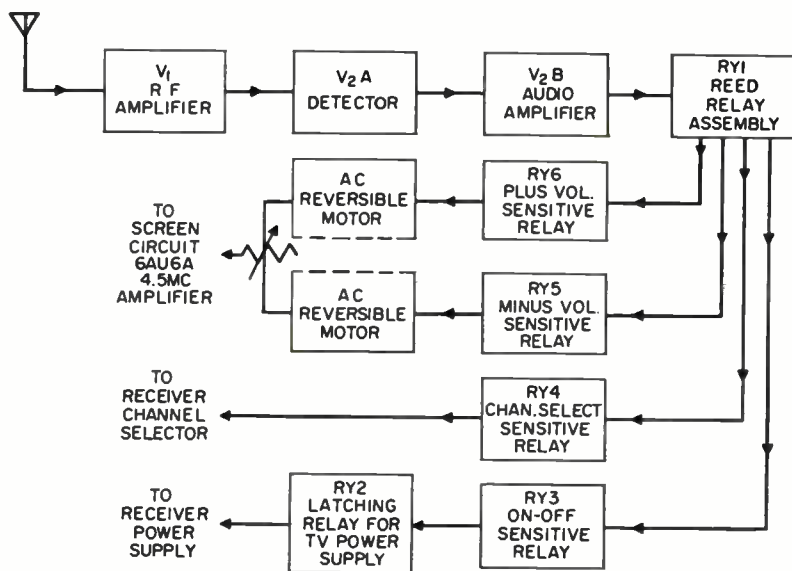
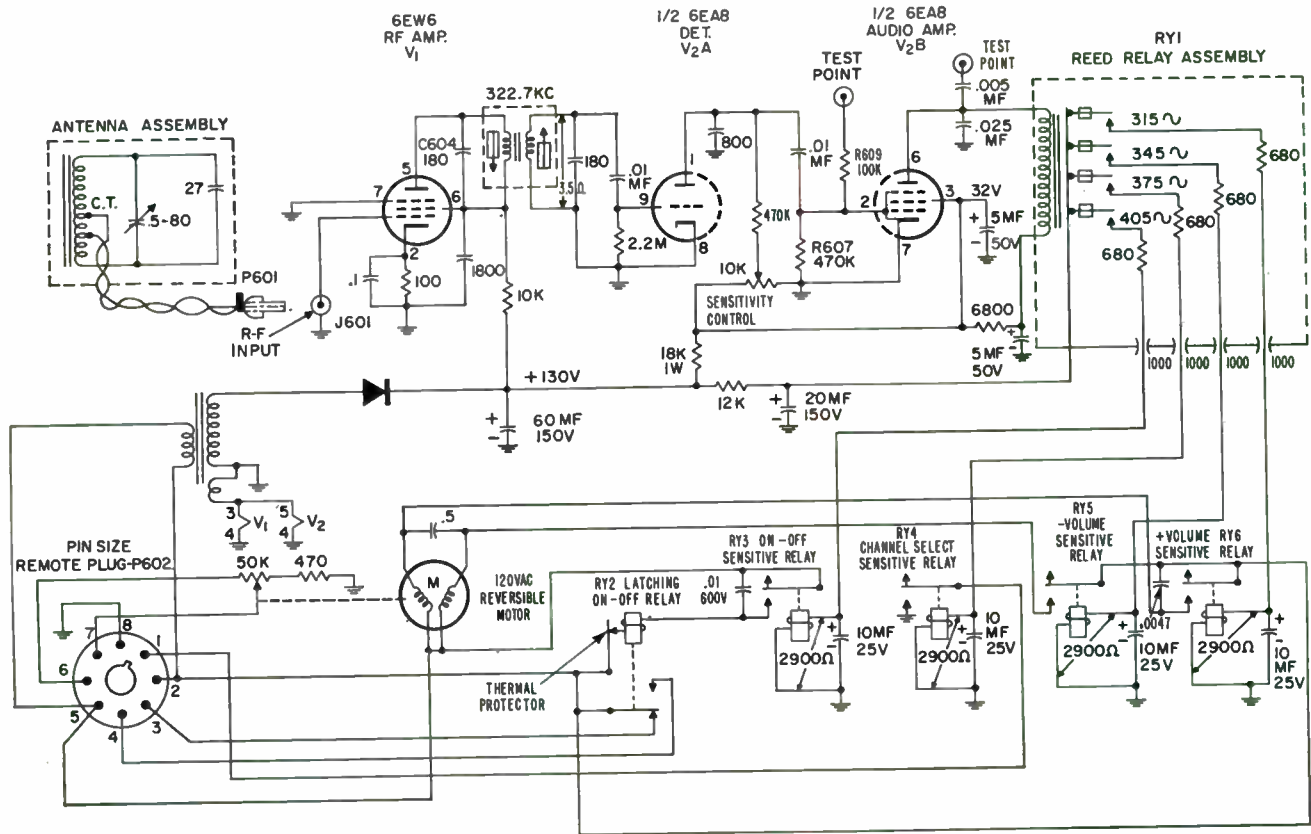

Fig. 17-7. Block diagram of receiver use din G.E. remote-control system.

schematic in Fig. 17-8. Two tubes, a 6EW6 and a 6EA8, provide two stages of amplification and a bias detector. The incoming signal is picked up by a ferrite rod antenna which is mounted with the receiver unit. A variable trimmer capacitor is available across this antenna to permit adjustment of the frequency, should this become necessary. The incoming signal is fed to

* For a more comprehensive treatment of transistors, see Milton S. Kiver, *Transistors in Radio, Television, and Electronics*, McGraw-Hill Book Co., New York, 1962.

** General Electric Company, *Techni-Talk*, Feb., 1960, and Mar-May, 1960, issues.



REMOTE-CONTROL SYSTEMS FOR TELEVISION RECEIVERS

Fig. 17-8. Schematic diagram of receiver used in G.E. remote-control system.

a 6EW6 RF amplifier whose output is tuned sharply to 322.7 kc. The amplified RF signal is coupled to the triode section of a 6EA8 by a high Q double-tuned interstage transformer. This triode functions as a bias detector in which the grid and the cathode serve as a demodulation diode, while the plate section provides an amplified output signal which is then passed on to the pentode section of the 6EA8. The triode also provides limiting, and toward this end, a sensitivity control in the plate circuit permits the voltage here to be adjusted so that plate saturation will occur with a predetermined amplitude of input signal to the receiver.

After detection, the audio signal is amplified, further limited by a power-amplifier stage formed by the pentode section of the 6EA8, and then applied across the coil of the reed-relay assembly. The audio signal causes a magnetic field to develop in the relay coil, which is modulated at an audio rate.

Since the metal reeds are positioned within the magnetic field of the coil, one of the reeds with resonant frequency corresponding to the selected audio frequency is made to vibrate rather strongly. Each of the four reeds in the assembly is resonant to a different frequency 30 cycles apart. Therefore, each of the individual reeds corresponds to a different function of the remote-control system.

The reed-contact points are connected to a corresponding sensitive relay coil, and when the system is idling, the reed-contact points are normally open. However, when the audio-modulation magnetic field excites one of the reeds and causes it to vibrate, the reed contact closes for each half-cycle of reed vibration. This action causes a current to flow through the corresponding sensitive relay coil and the magnetic field built up in the relay coils causes the sensitive relay arm to be pulled in. This action closes the contact point of the relay, initiating the proper function.

A two-position latching relay coil in the remote-control receiver performs the on-off function. It operates in conjunction with the on-off switch of the television receiver. The channel-selector function is performed by completing the a-c power loop needed to supply power for the power-tuning motor mounted on the TV receiver. Each time the motor is activated, it rotates the RF tuner until the next active channel in that area is reached. Then the motor is deactivated. The function of increasing or decreasing volume is performed by supplying power to an a-c reversible motor. The motor is mechanically coupled to a variable potentiometer which, when varied, changes the screen voltage available to the 4.5-mc sound IF-amplifier tube in the receiver.

The remote-control-receiver unit contains its own transformer power supply, utilizing a germanium diode in a half-wave rectifier circuit for the B+ voltage. An octal plug and socket interconnects the receiver with the

TV receiver and pins 2 and 5 of the socket are used for the 120-volt a-c supply to the remote-control unit.

The power to the remote-control unit can be turned on or off by a slide switch located just above the antenna input terminals on the back of the TV receiver. Under normal conditions, the receiver unit should be left turned on so that it will receive any control signals sent by the transmitter unit. If, however, the unit will not be used over an extended period of time, it can be turned off.

The straightforwardness of the transmitter and the receiver in this remote-control combination makes it relatively simple to track down any defects that develop. For example, if the receiver does not respond to any of the remote-control positions, it is possible that no RF signal is being transmitted. As a simple check, bring the remote-control transmitter close to a radio receiver which is turned on and tuned somewhere around the second harmonic of the transmitter. This would be around 645 kc. If no sound or buzz is heard in the receiver, it can be assumed that no transmitter signal is being emitted. By the same token, if the remote control actuates the receiver in certain positions but not in others, then the circuits which deal exclusively with the nonoperating positions should be checked. It is also possible, by using a calibrated audio-signal generator, to check each reed at its resonant frequency to determine if any are defective. The procedure would simply involve injecting the proper audio frequency at the grid of the pentode section of the 6EA8 and noting whether the attendant control function takes place. By changing the frequency of the audio generator to each of the different reeds, each position can be quickly checked.

Thus, while the remote-control systems add additional components to the normal television receiver, these systems are here fairly simple in form and should pose no difficult problem insofar as servicing is concerned.

ACOUSTICAL REMOTE-CONTROL SYSTEMS

In acoustical remote-control systems, the actuating transmitter signal is an ultrasonic sound that can be produced by a number of devices ranging from cylindrical aluminum rods to a mechanically operated bellows that force air through a small opening. The sound produced is picked up by a suitable microphone, converted into equivalent electrical signals, amplified, and then employed to actuate relays which perform the desired functions. The overall action is fairly straightforward, although sometimes the receiver circuitry tends to become involved. By analyzing typical circuits, the reader will soon become familiar with the more common methods that have been developed.

Zenith Remote-control System. In the Zenith remote-control system (and several others), the transmitter consists of a cylindrical aluminum rod

which vibrates in its longitudinal mode. If such a rod is struck on one end by a hammer moving along its axis, it emits a sustained note which has a definite frequency. For example, an aluminum rod $2\frac{1}{2}$ in. long has a fundamental resonant frequency of about 40 kc. The internal damping of the aluminum is so slight that a large part of the vibrational energies, stored in the rod after the original blow of the hammer, is radiated. A single rod of a specified length will produce a certain resonant frequency. Therefore, to control three or four functions within a television receiver, three or four rods of slightly different lengths are employed. See Fig. 17-9. In the illustra-

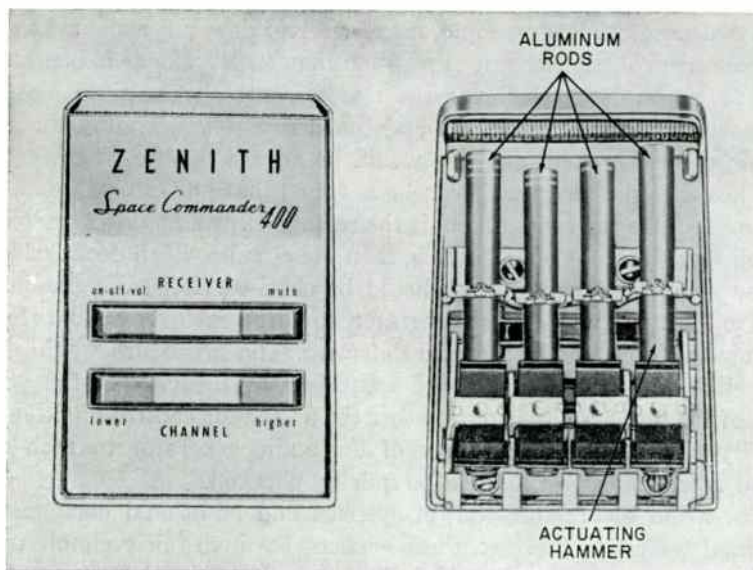

Courtesy Zenith Radio Corp.

FIG. 17-9A. External appearance and internal construction of ultrasonic transmitter for remote control of a TV receiver.

tion we see the working parts of the transmitter. A hammer, a steel cylinder weighing about $2\frac{1}{2}$ grams, is located at one end of the cylindrical rod. When a button is pressed, the hammer is pushed away from the rod by the force of a spring. As the button is further advanced, the spring is suddenly released and the hammer strikes the rod. Generally, if more than one rod is employed, the difference in frequencies of the various rods may be on the order of 1,000 cycles or so.

Once a rod has been struck and the energy transmitted, it is then desirable to dampen the remaining energy as quickly as possible. For this purpose, a mechanical damping method is employed. In the unit shown in Fig. 17-9, damping is achieved by a small piece of spring wire, covered by a

plastic sleeve, which protrudes through the mounting and touches the rod. When the button is pressed, the damper is withdrawn; when it is released, the sleeve again makes contact with the rod.

At the receiver, the ultrasonic energy is picked up by a microphone formed by using barium titanate. This material, when cut in the form of a small bar or plate and placed between two conducting electrodes, will generate a voltage when the bar or plate is mechanically strained. Conversely, when a voltage is applied across the two electrodes, the barium titanate will be mechanically strained. This is the well-known piezoelectric effect.

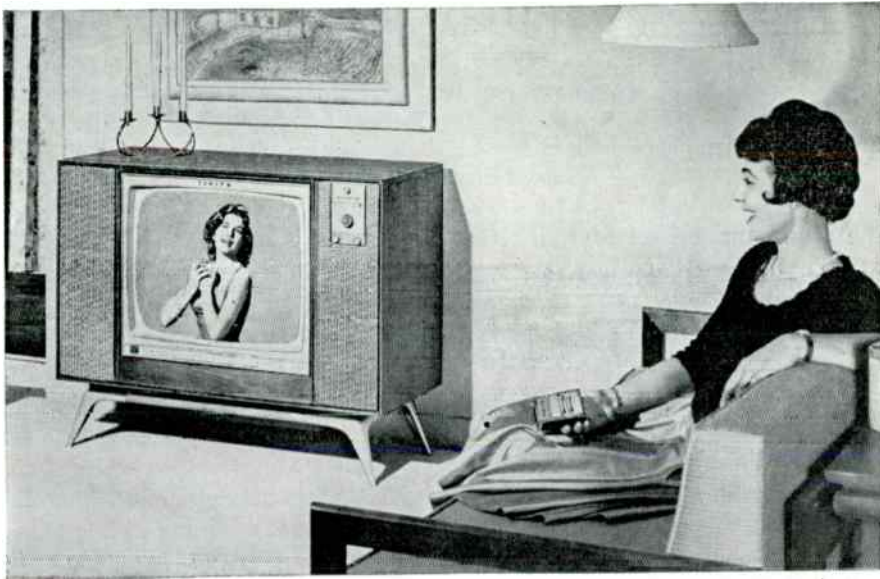

Courtesy Zenith Radio Corp.

FIG. 17-9B. Ultrasonic transmitter of Fig. 17-9A in use.

In the Zenith microphone, two thin rectangular wafers of barium titanate are combined, as shown in Fig. 17-10(A).^{*} Silver (the conducting electrode) is applied over a small section of each end of each wafer. These electrodes are indicated in Fig. 17-10(A) by the dark segments at each end of the assembly. Between the two wafers, at the nodal points of vibration, two thin metal strips are cemented which serve as electrical contacts and as mechanical suspension.

To broaden the response of this transducer, a small U-shaped piece of aluminum is added to the assembly, as shown in Fig. 17-10(B). This

^{*} "A High Sensitivity Ultrasonic Microphone," by P. Desmares and R. Adler. 1959 IRE National Convention Record, Part 7.

now is the electrical equivalent of two tuned circuits closely coupled together. It enables ultrasonic frequencies from 37.75 kc to 41.25 kc to be picked up and converted into equivalent electrical signals.

Figure 17-10(C) shows the entire microphone in cross section. From left to right, there is a supporting piece which carries the barium titanate wafers by means of the two thin metal strips mentioned above. Next is

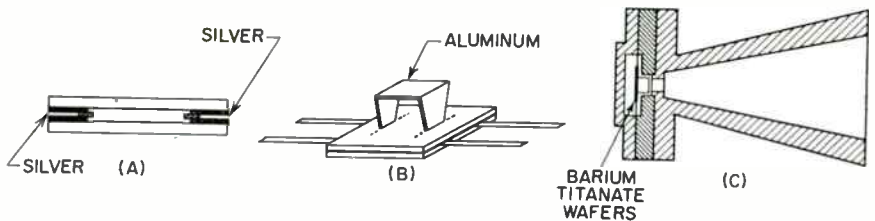

Fig. 17-10. Microphone utilized by Zenith to pick up ultrasonic sound of transmitter shown in Fig. 17-9.

the aluminum bridge to which the wafers are cemented, together with a plastic piece and a rectangular window which fits closely around the bridge. Beyond the bridge, there is a space equal in length to one-quarter wavelength at about 40 kc and, beyond this, a rectangular horn 2-in. long. Both the one-quarter wavelength space and the horn serve to match the impedance of the barium titanate assembly to the air. Or, to state it another way, the horn and the one-quarter wavelength space help to couple the wafers to the air.

The combination of mechanical transmitter, microphone, and amplifier in this system provides sufficient sensitivity to make aiming of the transmitter quite unnecessary in most homes. Sound reflected from the floor, walls, ceiling, or furniture make it possible to operate the receiver controls positively with the transmitter in almost any desired position—held in the hand or resting on a table or chair. Line of sight and approximate aiming of the transmitter become important only at maximum range—a distance of 40 ft, which is rarely encountered.

Remote-control Receiver. A schematic diagram of the remote-control receiver used in conjunction with the foregoing transmitter is shown in Fig. 17-11. The incoming signal is received by the ultrasonic microphone. The voltages developed by these sound waves become the input signal to V_1 , the first amplifier. V_1 and V_2 form a dual high-gain amplifier. Once the signal has passed through these stages, it is tripled in frequency by V_3 . Also, because of the way V_3 is operated, clipping occurs at the positive and negative peaks, so that the following FM discriminator receives signals of constant amplitude for the various actuating frequencies. It will be recog-

FIG. 17-11. Schematic diagram of Zenith remote control receiver.

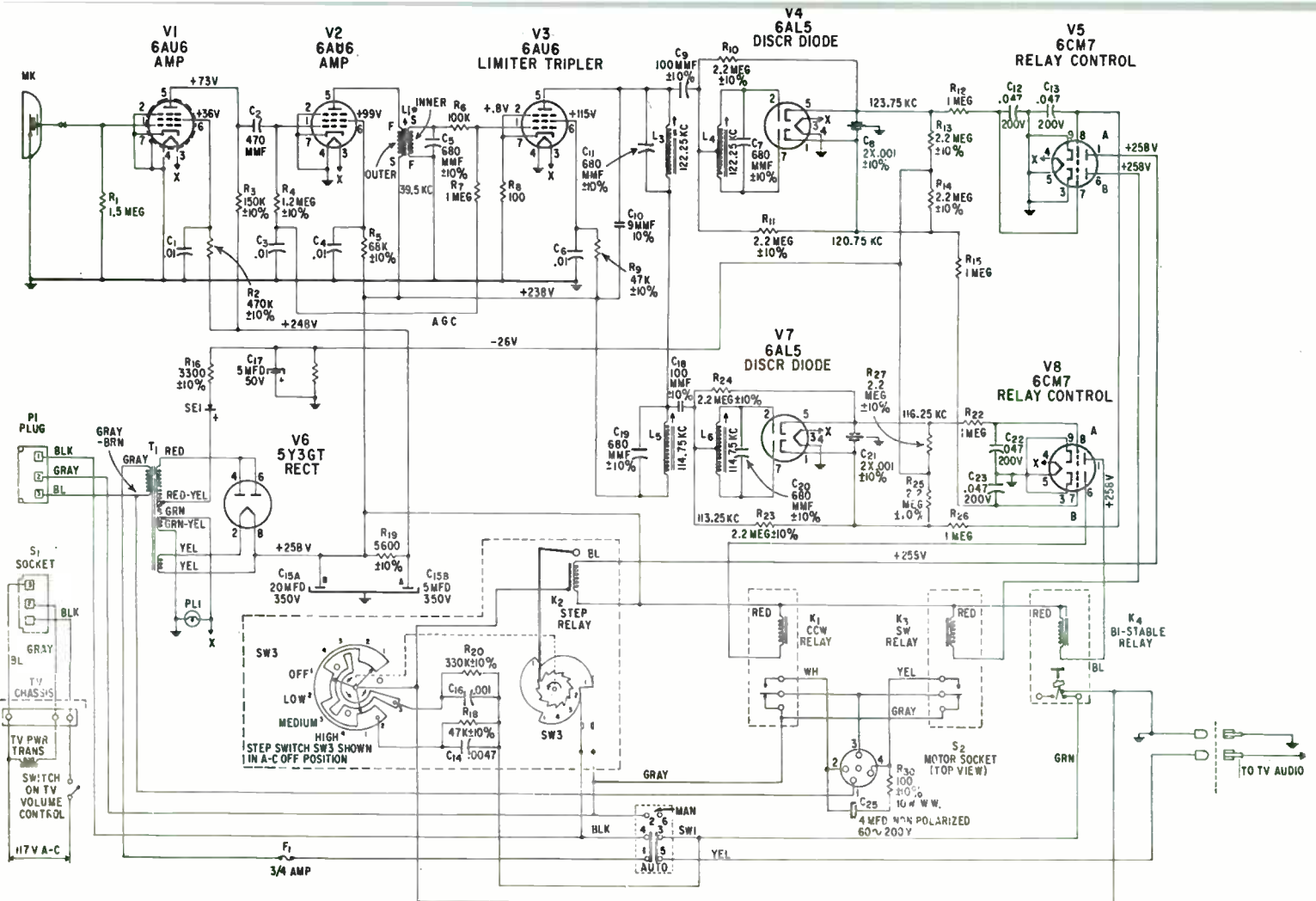

nized that this is a requirement for the proper functioning of an FM discriminator.

The signal is tripled in V_3 because it is easier to design the following discriminator and achieve the necessary circuit "Q" and coil size. It also reduces the amplification required at the fundamental 40-kc frequency, decreasing the possibility of any spurious regeneration.

In the output circuit of V_3 , there are two tuned circuits in series. One of these, the bottom circuit, is tuned to a center frequency of 114.75 kc, while the other is resonated to a center frequency of 122.25 kc. Each tuned circuit has connected to it an FM discriminator.

These discriminators are employed to separate and discriminate between the fairly close incoming frequencies generated by the transmitter. Here is how this is done. The discriminator formed by V_7 is tuned to a center frequency of 114.75 kc. The signal which the transmitter produces when the on-off volume button is depressed (37.75 kc) will develop 113.25 kc at the discriminator. This is 1.5 kc below the center frequency of the discriminator. By the same token, the signal which is emitted when sound-muting is desired (38.75 kc) produces a signal frequency of 116.25 kc at this discriminator. This is 1.50 kc above the center frequency of the discriminator. Now, with the discriminator accurately adjusted, its response curve will possess the familiar S-shape shown in Fig. 17-12. Note that one peak comes

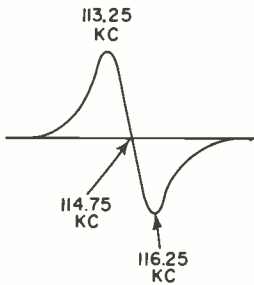

FIG. 17-12.

at 113.25 kc, the other at 116.25 kc. Thus, when the on-off signal is sent, a positive voltage will be produced across the output load resistor, R_{27} , of the distributor. By the same token, when the mute signal is sent, it will produce a positive voltage across the other load resistor, R_{25} . In this way, it is possible for the circuit to differentiate between input signals, and to react accordingly.

The second FM discriminator (formed by V_4) has a center-operating frequency of 122.25 kc. A distance of 1.5 kc below this frequency is the signal "tune lower," or counterclockwise tuner rotation; 1.5 kc above this frequency is the "tune higher," or clockwise rotation signal. Here again we differentiate between these two functions by the positive voltages produced across the output load resistors of the discriminator. Two sets of discriminator circuits are needed because four different actions are to be controlled by this remote-control device. If only two functions were desired, one of the FM discriminator circuits could be dispensed with.

The output across each half of each discriminator is passed through an integrating circuit before it is applied to a specific relay-control tube. This is

done to suppress the effects of any accidental noise or random noise that might fall within the range of frequencies accepted by this receiver unit. Unless a random noise possesses the proper frequency and lasts long enough to build up the necessary voltage across the integrating network, it will not actuate the relay tubes which are biased to cut off. Most of the time it will be found that interference signals fall within the proper bandpass of the receiver unit, but they do not develop sufficient voltage across the integrating network to affect the relay-control tubes. Hence, they cannot accidentally trigger the receiver mechanism.

Without any signal applied, a negative d-c voltage on the order of -26 volts is applied to each of the relay-control triodes, effectively biasing them far below cutoff. When a button at the transmitter is depressed, say the one that requests "tune-higher," it will develop a positive voltage and consequently cause V_{5B} to conduct. The current from V_{5B} flows through the relay marked "CW relay." When this relay is actuated, its contacts close, activating the motor which controls the clockwise rotation of the tuner mechanism. If it is desired to turn the station selector in the opposite direction, the "tune-lower" button on the transmitter is depressed. This action develops at point *C* a positive voltage which is fed to V_{5B} . The ensuing tube conduction will activate the relay marked "CCW relay" and cause the tuner motor to turn in the opposite direction. Once the tuner motor starts rotating, it continues to do so even though the actuating relay drops out because of contacts on the turret drive assembly which parallel the relay contacts. The contacts stay closed until they are opened by an extending finger on the index wheel. When this happens, the motor stops. Desired channel stops are selected by turning corresponding index tabs from a tangential to a radial position. An index tab set in a radial position causes a link lever and pawl to open the contacts and stop the motor. A brake counteracts rotor inertia, preventing overtravel and assuring positive channel-selector indexing. When a tab for a particular channel is adjusted for bypassing, it prevents the cam from turning the pawl when the tuner passes a position to be skipped. The motor switch thus remains closed and the motor still runs.

For sound-muting control, a bistable-type relay is used; this has a toggle switch operated by a plunger which is attached to the relay armature. When the relay is energized, the switch is thrown to one position, say with the sound OFF. It remains here until the relay is energized again, then it goes to the sound ON position. For receiver power and volume control (labeled ON-OFF VOL on transmitter) a stepping switch is actuated by V_{5A} . By pressing this button at the transmitter we can drive the stepping switch from OFF to LOW to MEDIUM and then to HIGH volume. Continued actuation of the transmitter button will then bring the stepping switch back to OFF

again, when the power to the receiver is removed. This cycle can be repeated indefinitely.

The control-receiver unit contains its own power supply, which develops -26 volts bias and $+258$ volts B+.

Motorola Remote-control System. Motorola employs a system which is quite similar to the foregoing in that it also uses an ultrasonic transducer with an aluminum rod resonant to the 40-kc range. This aluminum rod is made to transmit by means of a spring-loaded, manually operated hammer. Two remote-control units are available. One is a two-function unit making use of a single frequency. The principal function of this remote-control transmitter (Figs. 17-13(A) and (C)) is to cause the channel to change. The second function, that of on-off, is provided in the TV receiver by a break switch which is activated when channel 1 is tuned in. Thus, if the set user desires to turn the receiver off, he moves the receiver mechanism along (using the remote control) until channel 1 is reached. This turns the receiver proper off. However, it still leaves the remote-control system powered, so that by actuating the remote control, the set can be returned to operation. To completely turn off both TV receiver and its remote-control system, the on-off switch on the front panel of the receiver must be used.

The ultrasonic radiation provided by the transmitter is picked up by a magnetostriction-type microphone which, in conjunction with capacitor C_1 , forms a resonant input circuit tuned to 40 kc. See Fig. 17-14. This signal is fed through two identical stages of amplification, each having a plate load tuned to 40 kc. The output signal is then coupled through C_7 to a diode detector, D_{2B} , which is one-half of a dual-diode selenium rectifier connected in such a way that the presence of a signal causes the end of C_7 , tied through R_9 to the grid of the relay tube V_3 , to swing positive. This increases plate current and causes the relay coil to energize, initiating the channel-change function.

The conduction point of the relay tube V_3 may be controlled by an adjustable negative bias supply, consisting of D_{2A} and a voltage divider network of R_7 and R_8 . R_8 acts as a range control and determines the sensitivity and the distance from which the transmitter can be used. The voltage at the grid of the relay tube is then the sum of the positive voltage developed by rectifying the incoming signal and the negative voltage developed by D_{2A} and R_8 .

The range of the receiver is adjusted for each specific location by adjusting the bias on the relay tube so that the set can be triggered from the farthest location from which the transmitter will normally be used. This provides maximum protection against false triggering.

The single diode selenium rectifier D_1 acts as an AGC rectifier. The signal from the output of V_2 is coupled through C_8 and fed to the diode which rectifies the signal and develops a negative d-c voltage. This voltage

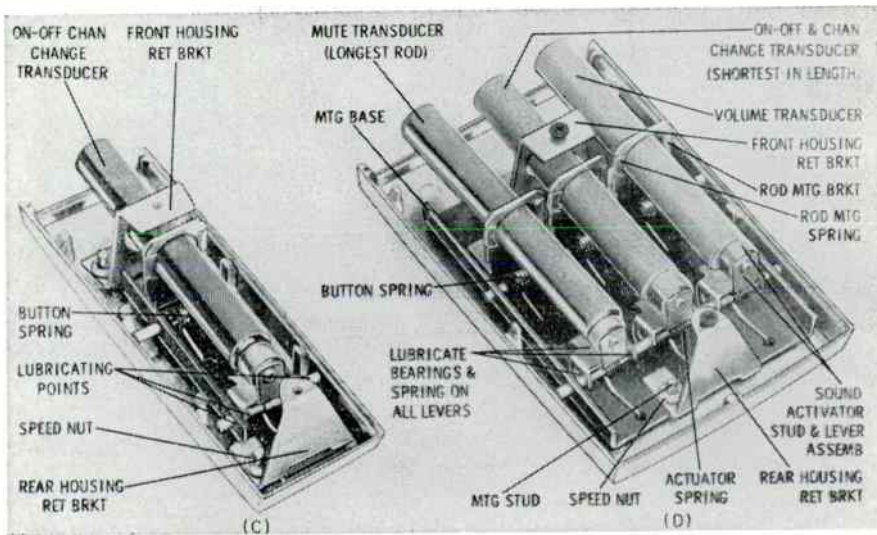
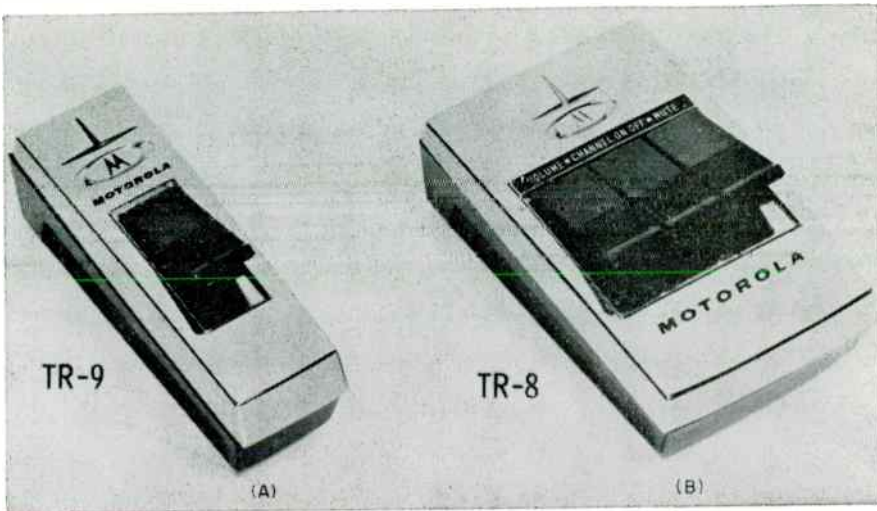

Courtesy Motorola, Inc.

FIG. 17-13. Two television remote control transmitters employed by Motorola, Inc. (A) and (C) are external and internal construction of transmitter having a single aluminum rod. (B) and (D) show transmitter having three rods.

is fed to the grid of V_1 through a suitable filter network, thus keeping the incoming signal at a constant level. The time constant of the filter is relatively short and the AGC voltage develops rapidly. This prevents skipping of channels, regardless of how long the transducer rod rings. A damper spring is also provided on the transducer rod to give further protection

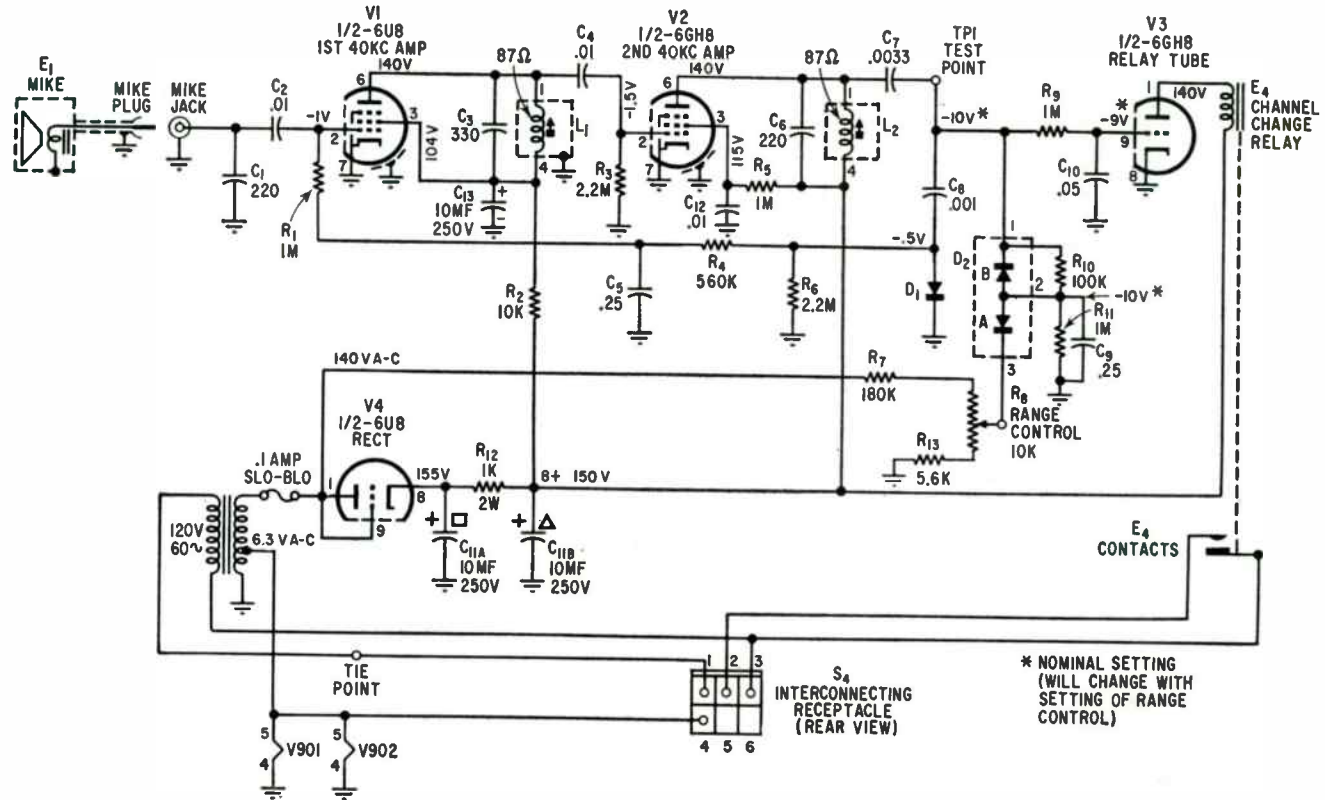

FIG. 17-14. Remote control receiver for single-rod transmitter.

against channel-skipping by muting the rod when the activating button is released.

The bandwidth of this remote-control system is extremely narrow, making it immune to false triggering from spurious signals, and frequencies other than 40 kc.

It is apparent that for remote control of an RF tuner, each station selected must be tuned in exactly, insofar as the fine-tuning control is concerned. Ordinarily, when a tuner is adjusted manually, the station is first selected and then the fine-tuning control is rotated until the best picture is obtained. When channel selection is done remotely, it is apparent that the fine-tuning control cannot be similarly adjusted readily. To take care of this situation, auxiliary mechanical adjusting systems, such as that shown in Fig. 17-15, have been devised. If the reader will look at the tuner shaft,

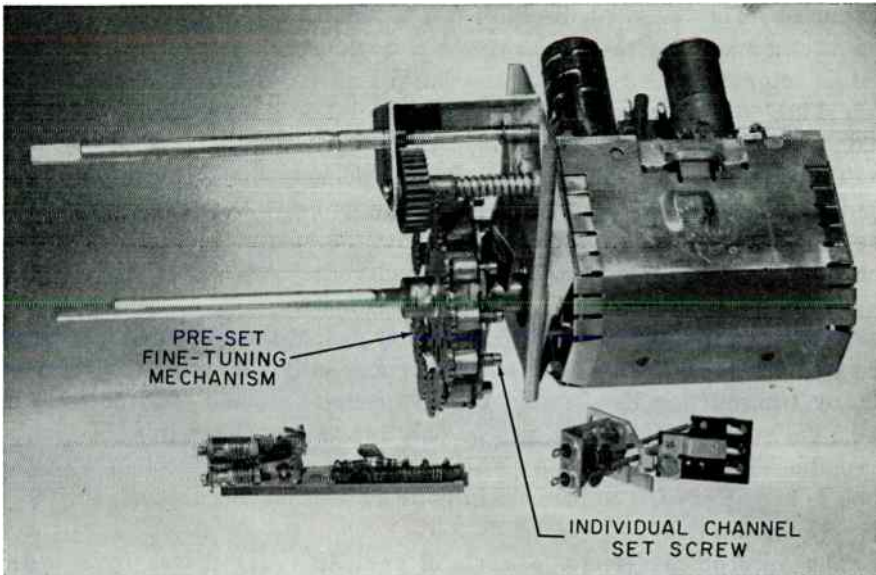

FIG. 17-15. A television tuner possessing an auxiliary mechanical adjusting device to maintain the fine-tuning control properly set for each channel.

he will see that a series of preset fine-tuning adjustments can be made on each channel. At each position, the extent to which a small screw protrudes from the assembly is adjustable. The head of the screw butts up against a plate which, in turn, controls the position of the core of the fine-tuning coil. As each station comes into position, the screw causes the position of the plate connected to the fine-tuning control to change. It is this change in

position which enables the exact fine-tuning position to be preset prior to any remote use of the tuner.

Each of the preset fine-tuning screws can be individually adjusted from the front panel. For example, here are the instructions which are typically given with a receiver:

"To adjust the fine-tuning, turn the channel selector to a usable channel, push the fine-tuning knob toward the cabinet and rotate slightly until the preset screw actuator engages with the preset fine-tuning screws. Hold the knob in this engaged position and rotate to obtain the clearest and most stable picture with sound. After the desired picture and sound have been obtained, release the knob. Repeat this procedure on all usable channels."

A four-function remote-control receiver employed by Motorola consists of three stages of amplifiers operating at approximately 40 kc. See Fig. 17-16. The third stage drives a differential detector and a balanced discriminator. The balanced discriminator is similar in form and function to the discriminator for the Zenith receiver previously described. The differential detector drives a relay-closing control tube for the channel-change action. The balanced discriminator drives two relay-closing control tubes for audio muting and volume change.

The discriminator will produce opposite polarity d-c voltages across the load resistors (in reference to some voltage value at the center tap) when the incoming frequency is above or below the center frequency to which the discriminator is tuned. Also, the load-voltage polarities will reverse, depending on whether the incoming signal is above or below the center frequency. Thus, by transmitting a frequency below the center frequency of the receiver (38.5 kc), we can effectively key only the muting relay tube. Or, by transmitting the frequency above center frequency of the receiver (39.5 kc), we can effectively turn on only the volume-relay tube. Keying is accomplished by producing a positive voltage at the control grid of the tube to be triggered. The increase in plate current flowing through the relay tube closes the relay.

The differential detector consists of a diode (V_{4A}) driven by a tuned tank (L_3 resonated at 41.5 kc) and a diode (V_{4B}) driven by the voltage developed across a pure resistance (R_1). Resistor R_1 is insensitive to frequency, producing approximately the same voltage across diode V_{4B} regardless of the frequency being received. Conduction of V_{4B} develops a voltage across R_2 of approximately the same value for all frequencies. This voltage is added to that of the bias power supply and merely increases the cutoff point of the channel-change relay tube. At any frequency other than the resonant frequency of coil L_3 , practically no voltage is developed across the tank and little voltage is applied to diode V_{4A} . No voltage is developed across the diode load resistor, R_3 , and there is no change in the bias applied to the

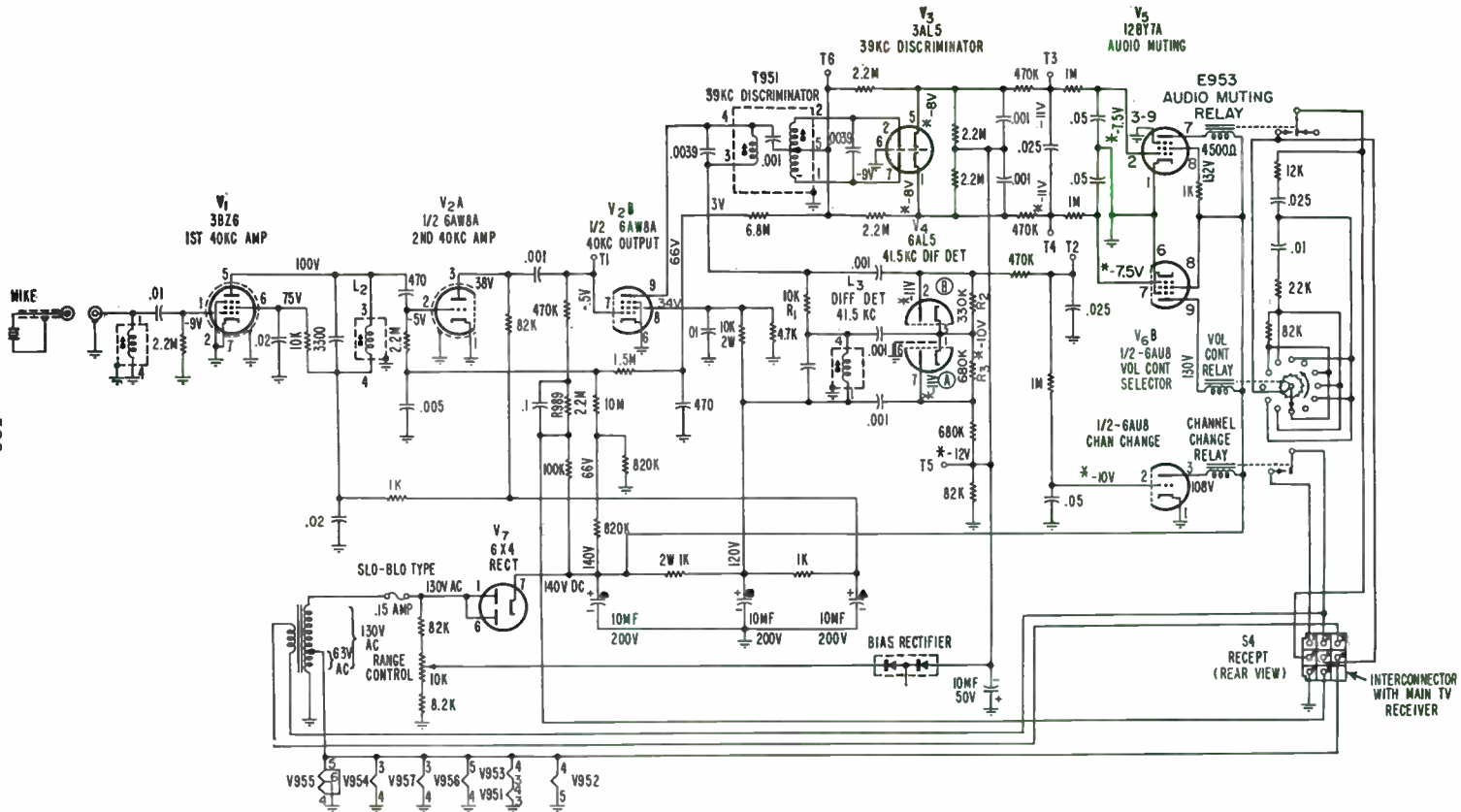
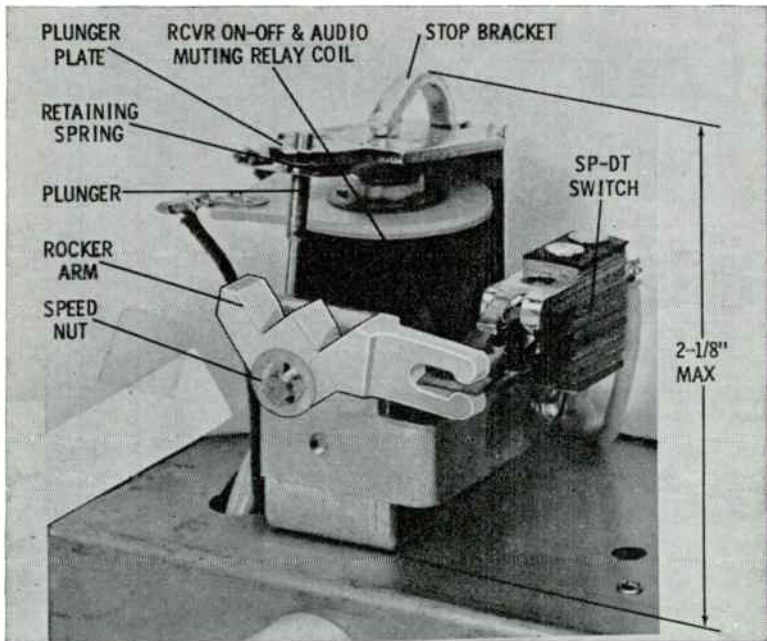

FIG. 17-16. Receiver for a four-function remote control developed by Motorola.

control grid of channel-change relay tube and the tube remains cut off. This condition exists when a frequency of 38.5 kc or 39.5 kc is received from the transmitter for muting or for changing volume. Upon receipt of 41.5 kc, the resonant frequency of L_3 , a sizable voltage is developed across L_3 and applied to the diode. Conduction of the diode develops a voltage across load resistor R_3 of such polarity as to reduce or overcome the negative voltage being applied to the control grid of the channel-change relay tube. Actually, the control-grid voltage is driven positive and the tube conducts, closing the audio-muting relay.



Courtesy Motorola, Inc.

FIG. 17-17. A locking-type relay having two operating positions.

The rectified d-c output voltages of the FM discriminator and the differential relay are applied, by way of integrator networks, to the control grids of the relay-control tubes. The R , C values of the integrated circuits are designed so that signals of comparatively long duration and continuous frequency are required to pass through the trigger tubes. Such exact signal requirements can usually be supplied only by the type of waveform produced by the remote-control transmitter. Sharp noise pulses of short duration cannot charge the integrating capacitor to the voltage level required to trigger the relay tube.

The channel-change relay is of the conventional momentary-contact type, which makes contact during power application and then returns to its normal "resting" position when power is removed from the relay. A relay of this type is satisfactory for the channel change, since all information at the channel number is held by the channel-indexing mechanism of the TV receiver.

The second type of relay used in these remote-control receivers is of the locking type which has two operating positions. See Fig. 17-17. The contacts of the locking-type switch alternately change positions with each succeeding relay pull-in. The relay position thus remains locked into the last position utilized.

Pneumatic Signaling Devices. A pneumatic ultrasonic signaling device for a low-cost remote-control system has been developed by the Warwick Manufacturing Company of Chicago.* The ultrasonic whistle, shown in Figs. 17-18 and 17-19, is basically a miniature organ pipe with an air column tuned to quarter-wave resonance at approximately 39 kc. It consists of a notched tube with a flatted plug or palate in one end providing a constricted air inlet, and a threaded plug in the other end with a slotted head for adjusting the length of the air column.

The whistle is press-fitted into a molded hard-plastic housing. Because the radiation from the whistle is not as sharply directional as is desirable in order to beam the energy efficiently to the receiver over long distances, a large part of the interior surface of the housing around the whistle is shaped as a parabolic reflector to concentrate the beam. The radiating orifice of the whistle is positioned at the focal point of the paraboloid. A guard, shaped like a four-pointed star, extends across the face of the housing in front of the whistle to prevent damage to the latter from rough handling. A hole through the center of the guard provides access to the slotted head of the frequency-adjusting plug.

The air chamber is a molded soft-plastic squeeze bulb designed to lie easily in the palm of the hand. When the whistle is used, pressures up to 8 psi can be developed, depending on how hard the bulb is squeezed. It has been determined that a comparatively light squeeze, such as that given



Courtesy Warwick Mfg. Corp.

FIG. 17-18. A pneumatic ultrasonic signaling device.

*"A Pneumatic Ultrasonic Transmitter for a Low-Cost Remote Control," by P. W. Tappan, A. C. Vaccaro, and L. Babcock. IRE Transactions of the Professional Group on Broadcast and Television Receivers (PGBTR), July, 1960.

by a woman or a child, would result in 3 or 4 pounds of pressure. Three and a half pounds was the pressure chosen for the tuning of the whistle.

A small pressure-actuated check valve is incorporated in the housing. The valve consists of a ball bearing held captive in a small cavity. At one end of the cavity is an outlet communicating with the interior of the bulb. On the other end is an outlet leading out of the unit to open air. As the bulb is compressed, air pressure forces the ball bearing to close the exterior out-

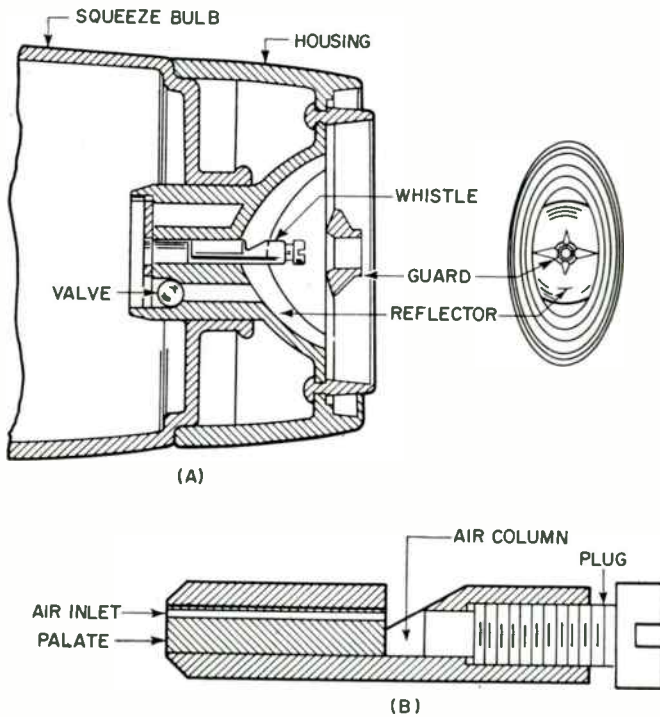

Fig. 17-19. (A) Internal construction of the pneumatic transmitter shown in Fig. 17-18. (B) Construction of the whistle.

let, so the compressed air must escape through the whistle orifice. When the bulb is released, outside air pressure, which is then greater than that inside the bulb, forces the ball bearing away from its seat and allows easy passage of air back into the bulb.

The complete transmitter has approximately twice the peak output of many competitive mechanical resonators. Moreover, instead of instantaneous bursts of energy that decay exponentially, the device sustains peak output for well over one second by applying a slow, steady pressure to the bulb. By permitting a reduction in receiver sensitivity, these features enhance the im-

munity of the system to ambient ultrasonic noises, for example, key jangling.

The receiver which operates with this transmitter is fairly conventional in form. It consists of three 39-kc amplifiers, a germanium diode-rectifier, and a relay-trigger tube. The relay-control tube has a relay in its plate circuit and when the tube is actuated, the relay contacts close, connecting a power supply to the motor coupled to the tuner in the TV set. A wheel is mounted on the back end of the tuner shaft and turns with it. The periphery of the wheel carries 13 metal clips, 12 of which correspond to television channels. When the set is installed, the user pushes in those clips corresponding to the channels he wishes to receive. When a clip is in the pushed-in position, a bump on it passes under a spring-loaded lever arm attached to a program motor switch in parallel with the relay contacts. The switch is opened when a bump is pressing against the lever arm. When the relay is energized, it remains closed long enough to allow the motor to move the bump out from under the arm, thereby closing the program motor switch to keep the motor running after the relay opens. The motor continues to turn the tuner shaft until the next pushed-in clip is brought under the lever arm, opening the switch and shutting off the motor.

The thirteenth clip is provided to allow the set to be turned on and off by remote control. It may be inserted in any one of the 13 channel positions around the periphery of the wheel. It has a higher bump than the other 12, and forces the arm up far enough to open a switch in series with the power line to the TV receiver.

Magnavox Remote-control System. Magnavox has developed a remote-control system which also uses a pneumatic signaling device. The transmitter unit possesses mechanically operated bellows that force air through a small tuned port. See Fig. 17-20. The bellows are compressed by a lever attached to the "function" button as the button is depressed. Compression of the bel-

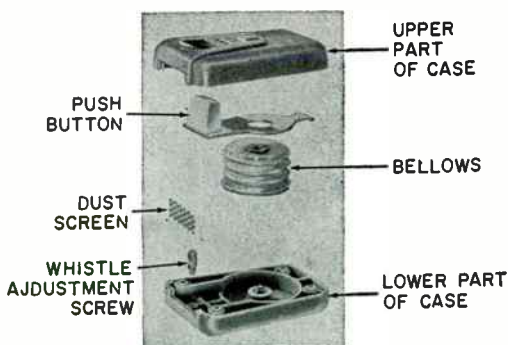

FIG. 17-20. Exploded view of a transmitter in which a mechanically operated bellows force air through a whistle.

lows forces air through a channel in the bottom of the transmitter case into the resonator, or "whistle." The resonator has a small adjustment screw which is set to tune the resonator to 37 kc. The entire transmitter unit is housed in a small plastic case designed to fit comfortably in the hand.

The receiver unit employs two 12AX7 tubes and one 12AU7, plus a selenium rectifier and a silicon rectifier. See Fig. 17-21. The chassis receives its a-c power from the TV chassis. Tube heaters are connected in series and the chassis pan is above ground and thus is isolated from the TV-chassis ground by insulated mounting grommets.

The two 12AX7 tubes form a 4-stage resistance-capacitance coupled broadband amplifier. The first half of the 12AU7 tube (V_{3A}) is an inductively tuned circuit, tuned to 37 kc. The second half of the 12AU7 (V_{3B}) is a trigger tube to actuate the channel-selector relay. A silicon rectifier (D_1), in a half-wave circuit, develops B+ potentials for the receiver circuits. A selenium rectifier (D_2) is a shunt rectifier in the grid circuit of the trigger tube and acts to clamp this circuit to a reference-bias level. The signal applied to the trigger tube will be the positive half-cycles of the 37-kc signal originating at the transmitter, picked up by the microphone, and amplified through the preceding stages of the remote receiver. Selenium rectifier D_2 also develops an AVC bias which is fed back to the RC-coupled amplifier stages V_1 and V_2 .

Trigger tube V_{3B} is normally biased to cutoff. When an incoming signal is received, it provides a positive pulse at the grid of this stage, causing the tube to conduct and current to flow through the relay coil which actuates the channel-selector relay. The relay contacts close the motor circuit and the motor rotates the tuner in a clockwise direction. At the same time, relay actuation removes the ground connection at the junction of R_{23} and R_{24} , placing a positive potential on the grid of the trigger tube. As the motor begins to rotate, the program switch (S_2) closes and this brings B+ to C_{14} , charging the capacitor and driving the grid more positive. This positive potential on the grid keeps the trigger tube conducting and this holds the channel-selector relay down. A program wheel, attached to the rear of the motor, is fitted with 13 nylon pins, each of which is mounted so as to pivot eccentrically on its own axis when turned. See Fig. 17-22. The pins correspond to the 13 positions of the tuner and each pin may be set to open the program switch as the two pass each other or to bypass the switch and leave it in the closed position. As the program wheel approaches a channel that has been programmed to "stop," the corresponding nylon pin makes contact with the program switch, opening it. When this switch opens, capacitor C_{14} discharges rapidly, developing a sharp negative-going pulse at the grid of the trigger tube. This cuts off the tube, releases the channel-selector relay, and stops the motor.

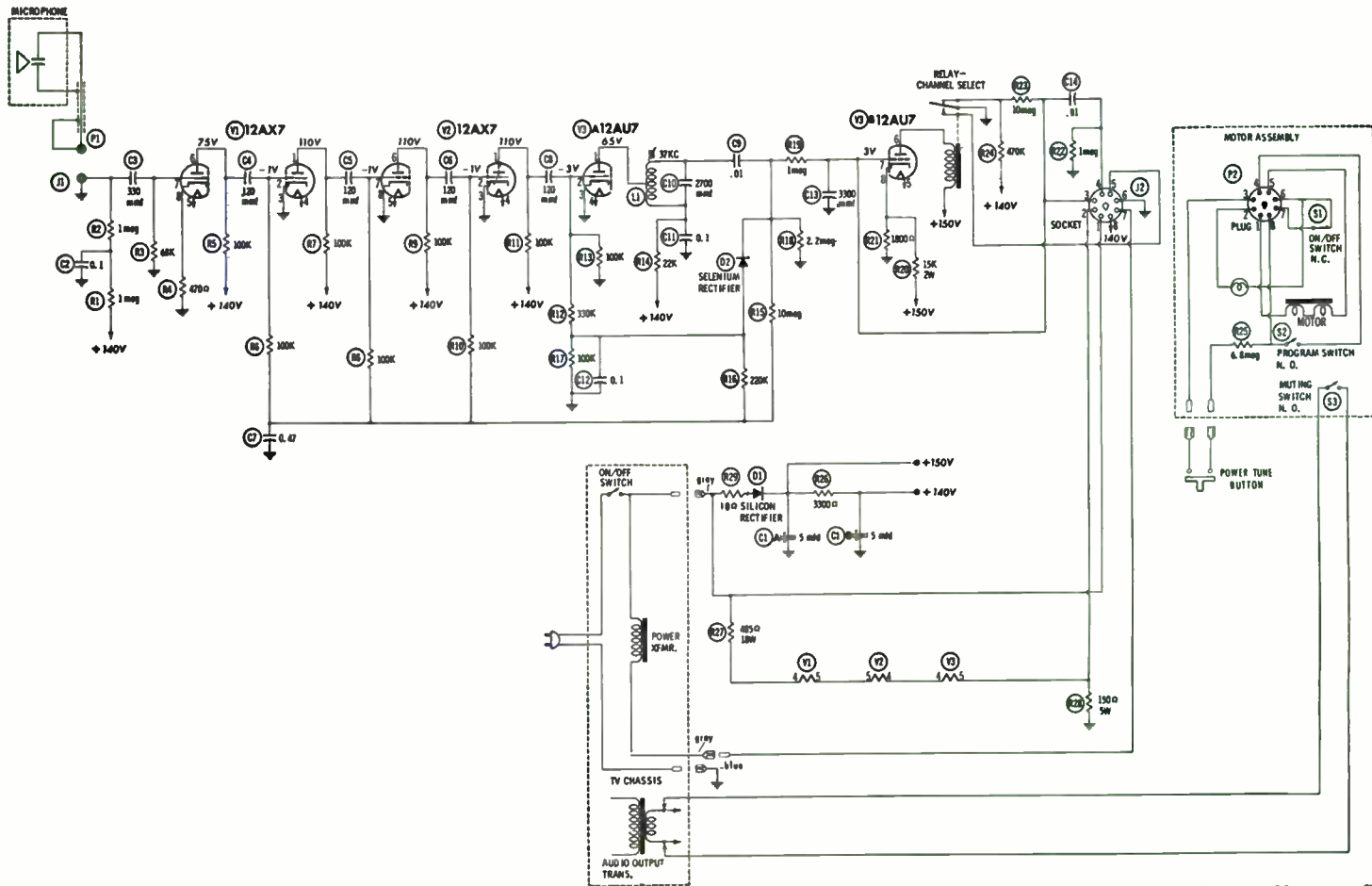
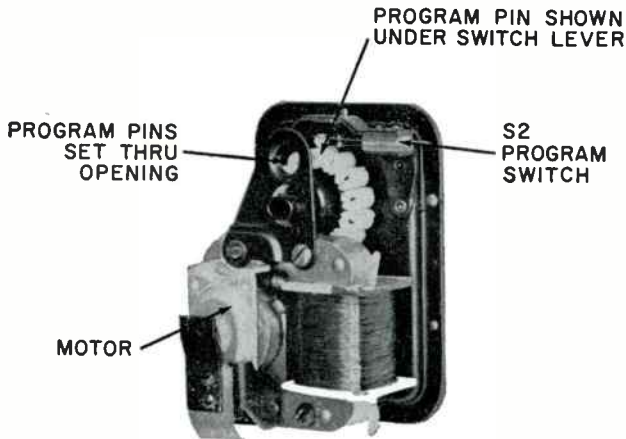

FIG. 17-21. Schematic diagram of the remote-control receiver employed with the signaling device shown in Fig. 17-20.

Courtesy Magnavox Co.

The power-tuning button mounted on the front of the instrument serves the same function as the transmitter. In this case, depressing the power-tuning button momentarily places a positive potential on the grid of the trigger tube, causing it to conduct and producing the same sequence just explained. Instrument power shutoff is accomplished by a nylon lever which is attached to the motor shaft in such a position that when the tuner is in



Courtesy Magnavox Co.

Fig. 17-22. Program wheel with 13 nylon pins to determine those stations to be received. The driving motor is shown below the wheel.

the “UHF” position, this lever contacts the on-off switch (S_1), causing power to be removed from the TV chassis. The remote receiver, of course, remains on. The on-off switch on the front of the instrument will turn off both the TV chassis and the remote receiver.

An audio-muting switch (S_3) is mounted on the rear of the motor assembly and is actuated by the motor shaft. The rotor is fitted with a spring which pushes the rotor and shaft out toward the rear when the motor is not running, thus holding the switch open. When the motor is energized, the rotor pulls in allowing the audio-muting-switch contacts to close, placing a short across the audio-output-transformer secondary on the TV chassis.

QUESTIONS

1. What are the advantages and disadvantages of a remote-control system using light as the actuating element?
2. What frequency limitations have been observed in remote-control systems using electromagnetic signals? Why?

3. What operations of a television receiver are almost always controlled remotely (when such an additional facility is provided)? What other functions may or may not be controlled?
4. Describe a remote-control system using RF signals.
5. Describe briefly how transistors operate.
6. How are four separate signals developed in the circuit of Fig. 17-2?
7. Trace the path, starting at the antenna, taken by a signal which actuates the on-off relay in Fig. 17-8.
8. How does the Zenith remote-control transmitter in Fig. 17-9(A) develop four different frequency signals?
9. How is the signal in the Zenith system received? Describe the receiving device briefly.
10. How does the Zenith system guard against spurious signals?
11. How does the Zenith remote-control receiver differentiate between the four signals it can receive?
12. What functions can the circuit of Fig. 17-14 perform through remote control? Describe briefly the operation of this circuit.
13. How is the fine-tuning control adjusted for remote operation?
14. The remote-control receiver in Fig. 17-16 utilizes a differential detector. How does this circuit work?
15. Compare the signaling device employed in Zenith remote-control systems with the pneumatic device shown in Fig. 17-18.
16. Explain briefly the operation of the circuit shown in Fig. 17-21.
17. Can a receiver possessing the remote-control system of Fig. 17-21 be operated manually? Explain how.

UHF Television

In its original allocation plan issued in 1946, the Federal Communications Commission set aside 12 channels* for commercial television broadcasting. It did not take long to demonstrate that this was far too few channels for extensive nationwide coverage and, in 1952, an additional 70 channels in the UHF band (470-890 mc) were added.

The problems facing the television serviceman in the UHF band do not differ in principle from those presently facing him in the VHF bands. They do, however, differ in degree. Thus, he must still erect an antenna system to capture as much signal as possible except that UHF signals reaching the antenna are weaker and the losses presented by transmission lines are greater. Within the receiver, UHF signals are first fed to a mixer crystal where they are converted to a much lower frequency and then are amplified by suitable amplifiers. Note that there is no stage of preamplification before the mixer (as in VHF receivers) simply because tubes capable of operating in the UHF range are, at the present time, quite expensive. Thus, for the moment, we again find UHF reception at a disadvantage, and this portion of a television receiver will be less sensitive than the VHF section. Where the sensitivity of a VHF receiver might be on the order of 10 microvolts, its sensitivity when tuned to UHF would be perhaps 100 microvolts.

In order to present as much UHF signal to the receiver as possible, careful erection of the antenna is necessary. This means that you not only have to find the best spot horizontally, but you also have to determine what the best height is. In the choice of antennas, the serviceman has a considerable number from which to pick, and, fortunately, high-gain arrays are more feasible at UHF because antenna dimensions are smaller. Thus, a half-wave dipole at 550 mc will have roughly $\frac{1}{10}$ the overall dimensions of a

* At first 13 channels were allocated, but channel 1 (44-50 mc) was subsequently dropped.

half-wave dipole at 55 mc. This means that more elements can be added to the UHF array without causing it to become unwieldy. Since the gain of an antenna generally rises with the number of elements, higher gain can be expected from UHF arrays.

ANTENNAS

Fan Dipole.* The half-wave dipole is the simplest type of VHF antenna and also it is the simplest UHF antenna. See Fig. 18-1. By using triangular sheets of metal instead of rods, the unit becomes a broadband affair, capable of receiving all signals within the UHF band. The response pattern of a fan dipole is a figure-8 unless a screen reflector is placed behind the array. See Figure 18-2. In this case it becomes unidirectional.

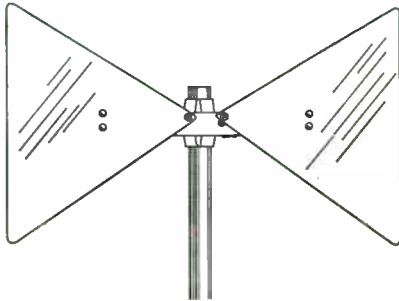

FIG. 18-1. A UHF fan dipole.

The impedance of a fan dipole possessing a corner angle of 70 deg is about 300 ohms. Overall length for greatest gain is of the order of 16 inches. Fan dipole gain is slightly higher than that of a rod dipole, and for this reason

these units provide satisfactory reception only in strong signal areas where there are relatively few ghost signals.

Fan dipoles can be stacked two high and four high to provide increased gain and better discrimination against ground-reflected signals. The latter property is useful in reducing the number of interfering signals capable of affecting the receiver.

Note that the di-fan reflector in Fig. 18-2 is a mesh screen instead of a rod, as is customary at VHF. Screens are considerably more efficient reflectors than rods and the only reason they are not used extensively at VHF is because they would prove too bulky. Mesh screens are as effective as solid metallic sheets, provided the mesh openings are on the order of 0.2 of a wavelength or less at the highest operating frequency. Reflector dimensions

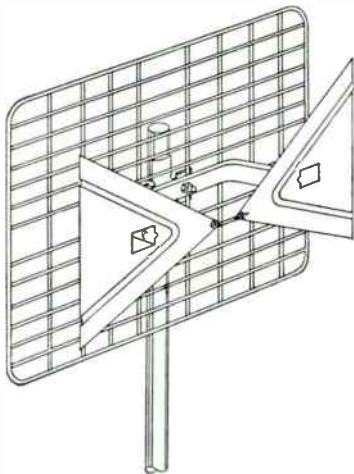

FIG. 18-2. A fan dipole with a screen deflector.

wavelength or less at the highest operating frequency. Reflector dimensions

* Also known as a "bow-tie" antenna and as a "di-fan" antenna.

are not critical, but the edges should extend a little beyond the dipole elements.

Rhombic Antennas. The rhombic antenna, Fig. 18-3, has been used to some extent for VHF reception in weak signal areas. It has broad band-pass properties, is unidirectional, possesses a sharply defined directivity

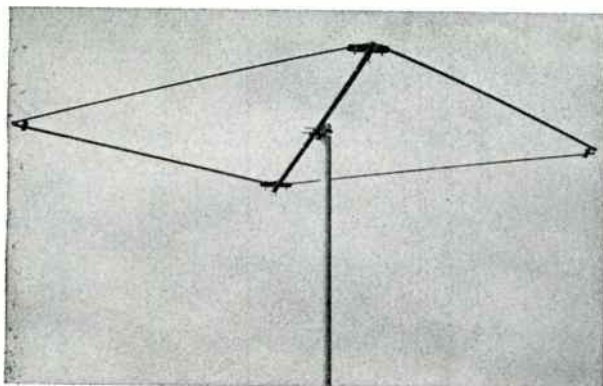

FIG. 18-3. A rhombic UHF antenna.

pattern, and is capable of good gain. The length of each of the four sides (also known as legs) should be at least several wavelengths. In fact, the longer each side, the greater the gain and the sharper the horizontal directivity pattern of the array. In order to obtain the unidirectional effect, a resistor having a value of 470 to 500 ohms is inserted at one end of the array (Fig. 18-4). The input impedance at the other end is equal in value to

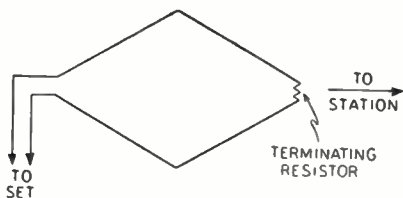

FIG. 18-4. By inserting a resistor in one end of a rhombic antenna, a unidirectional pattern is obtained.

this resistor, but connecting a 300-ohm line here will, for all practical purposes, serve very nicely with only a slight loss in gain.

In the UHF band, it is customary to make each leg length equal to two or more wavelengths. Suitable mechanical support can be obtained by a crossarm mast mounted at the top end of a pipe. The array is then oriented with the resistor end pointing in the direction of

the station. Stacking of rhombic antennas provides increased gain and is employed in weak signal areas.

Cylindrical Parabolic Reflector. Probably everyone is familiar with the fact that the headlights of a car have parabolic reflectors in order to provide a high concentration of light. In much the same fashion, parabolic

reflectors can be (and have been) used to receive and transmit radio waves with high gain and sharp directivity.

Instead of using an entire parabolic reflector, it is possible to use only a section. The cylindrical parabolic reflector in Fig. 18-5 alone can provide a gain of 8 db over a resonant half-wave dipole. The vertical directivity of this antenna structure is sharp, but the horizontal directivity is somewhat broad. Where high gain is desired and the ghost problem is not serious, this array will provide excellent results.

Corner Reflectors. Instead of using curved surfaces as reflectors, it is possible to use two flat surfaces so positioned as to intersect at an angle, forming a corner. This type of reflector, shown in Fig. 18-6, is known as a "corner reflector" antenna. The receiving element, usually a dipole antenna, is placed at the center of the corner angle and at some distance from the vertex of the angle.

The response pattern of this array depends not only on the corner angle but also on the distance between the antenna and the vertex of the reflector corner. If the antenna is positioned too far from the vertex, the response pattern will have several lobes. If it is brought in too close, the vertical response will be broadened and the susceptibility of the array to ground reflected signals will increase.

The corner angle in the commercial array of Fig. 18-6 is 90 deg, and a similar bend is placed in the accompanying fan dipole. Gain over the entire UHF-TV band is high, ranging from about 7 db at 500 mc to 13 db at 900 mc.

Combination Antennas. In many parts of the country, both VHF and UHF stations will be in operation, and for those areas combination antennas, if suitable, would serve to simplify the installation problem. A number of combination VHF-UHF arrays are available, and the ones shown in Fig. 18-7 are indicative of what the technician will find.

The array shown in Fig. 18-7(A) consists of a low-band conical antenna for VHF signals and a broad-band fan dipole for UHF signals. A single lead-in line delivers signals to the receiver through the use of a special coupling device which is mounted directly at the antenna itself.

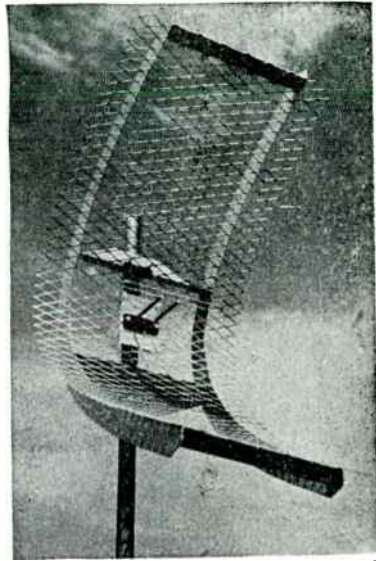

Courtesy TACO

FIG. 18-5. A cylindrical parabolic reflector.

V-type arrays have appeared in a number of forms, of which the one shown in Fig. 18-7(B) is typical. The antenna contains four rods: two at the front and two at the rear. The two front rods may be considered the directors; the two rear rods the active elements, supplying the signal to the receiver via a 300-ohm transmission line. However, in distinction to other

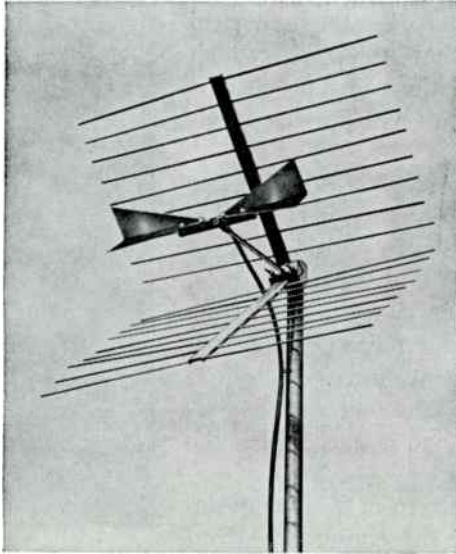

Courtesy Walter L. Schott Co.

FIG. 18-6. A corner reflector for UHF antenna.

arrays containing directors, the two front rods (Fig. 18-7(B)) are electrically connected to the two rear rods. The purpose of the connecting rods is twofold.

First, the rods serve as a transmission line to conduct to the two rear rods whatever signal is picked up by the two front rods. In addition, the two rear rods also pick up that portion of the signal which passed over the front rods and combine it with the energy received from the front rods via the transmission line.

Second, the connecting rods support both front and rear rods and produce a mechanically sturdy array.

It is characteristic of these antennas that the longer each side of the V becomes as compared with the operating frequency of the signal, the narrower the angle between the sides must be made for best gain and a single-lobe pattern. This means that, for low-band operation, the sides are spread out farther, generally until the included angle is 90 deg. For the high-band operation, the sides are brought in closer, generally to 60 deg or even 45 deg.

The best angle for a particular installation is determined at the time the antenna is erected. A good compromise angle is 60 deg for both VHF and UHF signals, although if signals above 750 mc are to be received, a smaller angle may be necessary.



Courtesy J.F.D.

FIG. 18-7. (A) A combination VHF-UHF antenna consisting of a low-band conical and a broad-band fan dipole.

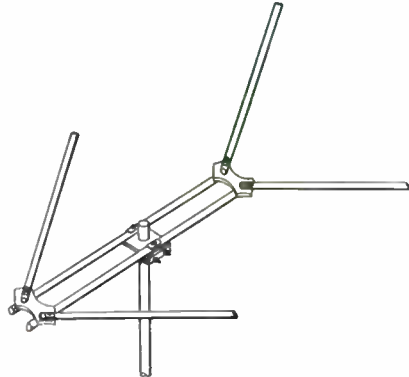

Courtesy J.F.D.

(B) A V type of antenna which will receive VHF and UHF signals.

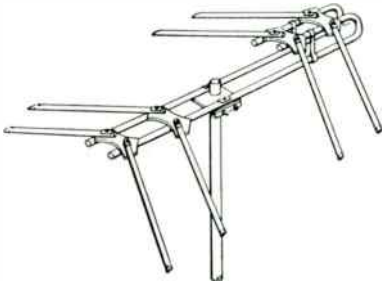

(C) Another combination antenna derived from the basic V.

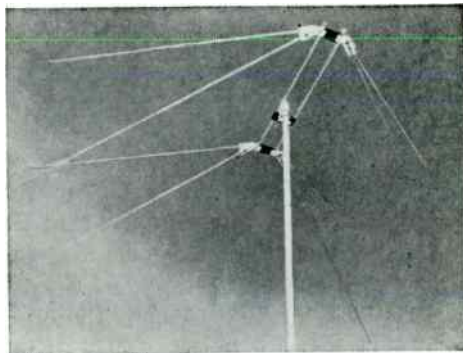

(D) Another combination VHF-UHF antenna.

Two variations of the V-type array are shown in Fig. 18-7(C) and Fig. 18-7(D). Stacking of the sections increases the gain (about 2 db per additional section) and sharpens the vertical directivity.

Other Antennas. While not specifically so stated in this discussion, any of the antennas described in Chapter 2 can be used. Of course, the size of these antennas would have to be scaled down to the proper dimensions, but

other than that no other changes are required. Design formulas remain unaltered, too.

Because of the smaller dimensions of UHF antennas, stacking of arrays is more common than with VHF arrays. A 4-bay array designed for reception at 60 mc would be about 8 ft wide and 16 ft high. At 500 mc, it would be only 1 ft wide and 2 ft high, certainly a considerable difference! And since the more elements used in an array, the greater the gain obtained from it, the trend toward more elaborate structures is understandable.

TRANSMISSION LINES

Transmission lines in common use at VHF frequencies include a 450-ohm open-wire line, 300-ohm flat and tubular lines, and two coaxial cables, the RG-59U and RG-11U. All these lines, including the more recent 300-ohm tubular, are illustrated in Chapter 2. The tubular line is shown here in Fig. 18-8. At 100 mc, the signal loss per 100 ft of the open-wire line is 0.35



Courtesy Amphenol

Fig. 18-8. 300-ohm tubular twin-lead transmission line.

db, in the 300-ohm line it is about 1.2 db, in the RG-11U cable it is 1.8 db, and in the RG-59U it is 3.8 db. The open-wire line has, by far, the lowest attenuation and, thus, is eminently suitable for fringe area installations. Its characteristic impedance is 450 ohms, and this high value may sometimes require a matching network between the line and the usual 300-ohm receiver input impedance. That it does not always do so stems from the fact that receiver impedances may vary considerably from their stated value of 300 ohms.*

The 300-ohm line (flat) is the one which is most extensively employed in VHF because it is economical, it matches receiver input impedances directly, and its attenuation is still low. In areas where the surrounding noise is high, use of the unshielded open-wire or 300-ohm lines becomes impractical and one of the coaxial cables must be employed.

With increase in frequency, line db attenuation also rises. Thus, at 500 mc, the open-wire loss mounts to 0.78 db, the 300-ohm line loss becomes 3.2 db, RG-11U attenuation increases to 5.0 db, and RG-59U loss reaches

* Recently a 375-ohm open-wire line was announced. This brings the line impedance closer in value to the 300-ohm receiver input and it is doubtful whether a matching network will ever be required.

the rather high figure of 9.4 db. Comparative figures at 100 mc, 500 mc, and 1000 mc are given in Table 18-1, and it can well be understood why

TABLE 18-1. Transmission Line Loss
(db loss per 100 ft)

Type of line	100 mc		500 mc		1000 mc	
	Wet	Dry	Wet	Dry	Wet	Dry
450-ohm open-wire*	...	0.35	...	0.78	...	1.1
300-ohm tubular	2.5	1.1	6.8	3.0	10.0	4.6
300-ohm flat	7.3	1.2	20.0	3.2	30.0	5.0
RG-59U	...	3.8	...	9.4	...	14.2
RG-11U	...	1.8	...	5.0	...	7.6

* Estimated dry values—unknown for wet conditions.

the amount of line needed should be figured closely in order that no more than necessary is used.

An interesting sidelight on line attenuation is the rapid rise in this value in unshielded lines when they become wet. The 300-ohm flat line appears to be most vulnerable, jumping from a value of 3.2 db (at 500 mc) when the line is dry to 20.0 db when it becomes wet. What this rise will do even to a strong signal is quite obvious. The 300-ohm tubular line is considerably better in this respect and hence would be more desirable for installation purposes. No data are available on the attenuation increase in wet open-wire lines, although it is not considered to be appreciable. Shielded cables, such as the RG-11U and RG-59U, are not affected by inclement weather.

An important factor in keeping down overall attenuation is the careful routing of the line from antenna to receiver. This is especially true in the case of unshielded lines. Keep the line away from gutters, pipes, or other metal objects as much as possible. Avoid sharp bends in the line. If a bend must be made, have it occur gradually. Finally, secure the line tightly by means of stand-off insulators so that it does not sway in the wind or otherwise alter its position.

Impedance matching at the antenna and, more importantly, at the receiver will require more careful attention in UHF installations. Mismatching at the receiver results in energy being reflected back along the line with resultant standing waves. It has been found that the attenuation of a line may be increased by as much as 2 db over its normal rating when standing

waves are present. In strong signal locations the additional loss may not be serious, but in moderate and weak signal areas it can mean the difference between usable and unusable pictures.

UHF TUNING METHODS

The allocation of television channels in the UHF region was not announced until the spring of 1952 and the actual granting of station permits did not occur until July of the same year. By that time, VHF television, on channels 2 to 13, had been in operation for six years or more and nearly 18 million receivers had been manufactured and sold. None of these sets were equipped to receive UHF signals, and unless some method was evolved to adapt these sets for UHF reception, they would, in time, become obsolete.

The industry attacked the problem in several ways. The most flexible solution was the construction of converters. These receive the UHF signal, convert it down in frequency to one of the VHF channels, and then transfer this signal to the input terminals of a VHF receiver, where it is treated as any other VHF signal. Converters are housed in separate cabinets and contain their own power supply. For convenience in operation, they can be placed on top of the VHF receiver cabinet. The incoming UHF signals are fed to a suitable terminal at the rear of the converter and then the transformed signal is routed to the VHF receiver by another line.

A second solution for adapting VHF receivers to UHF reception was the addition of auxiliary tuning elements to the VHF tuner. Examples are the UHF channel strips that can be substituted for unused VHF strips in turret tuners. Zenith and Standard Coil are advocates of this approach because their tuners are of the turret variety. Also popular are auxiliary continuous UHF tuners which are electrically and frequently mechanically linked to the VHF tuner. These units tune across the entire UHF band in essentially the same fashion as the tuners found in radio receivers. They can be used with turret and wafer-type VHF tuners.

With either of the foregoing methods, both VHF and UHF signals can be received. For those receivers which are sent to areas containing UHF stations, combination VHF-UHF reception is provided. However, for the many areas where there are no UHF stations, only VHF tuners are built into the receiver.

UHF Converters. UHF converters is the designation usually reserved for self-contained, self-powered units which lower all UHF signals received to one of the VHF channels. The output of the converter is then applied to the antenna input terminals of a VHF receiver, where it is treated as any other VHF signal.

UHF converters find their greatest use with sets which are not equipped

to receive UHF signals. These may be older sets for which UHF auxiliary tuners are not available or recent receivers where the owner does not wish to go to the trouble of installing a UHF tuner. Whatever the reason, UHF converters are available for those who want them at relatively low cost.

In use, the converter is usually positioned somewhere near the VHF receiver. The transmission line from the UHF antenna is then connected to the converter input terminals and a 300-ohm line connects the converter output to the receiver input. A switch on the converter determines the signals which the VHF receiver is given. If a UHF station is being received, it is the stepped-down, or converted, UHF signal which is sent to the VHF receiver. On the other hand, if a VHF signal is desired, the selector switch is placed in the VHF position and the signal on the VHF lead-in line is switched directly to the VHF receiver. During this time, the converter is usually made inoperative. This may be accomplished either by removing all power from the converter or by removing only the B+ voltages, and permitting the filaments to remain lighted. In the latter situation, switching back to UHF enables the converter to return to operation immediately; no warm-up period is required.

A typical UHF converter and its block diagram are shown in Fig. 18 9. Following preselector-tuned circuits, the UHF signal enters a crystal-mixer stage where it combines with an oscillator signal of suitable frequency. Since the converter is to be self-contained, it possesses its own local oscillator operating at a frequency *below* the incoming signal. This is necessary so that the video-carrier frequency, after mixing, will remain below the sound-carrier frequency. In other words, the relative position of the two incoming carriers must not be altered.

The signal at the mixer output is applied now to an IF amplifier. The notation of IF is borrowed from the superheterodyne circuit, where the amplifiers following the mixer are known as IF amplifiers. Actually, here the IF amplifier will have a frequency equivalent to the RF amplifier of the VHF television receiver which follows the converter. This distinction between the converter IF and video IF should be kept in mind to avoid confusing the two.

Beyond the converter IF amplifier, the signal is transferred to the VHF receiver input, where it is accepted through one of the normal channels (2

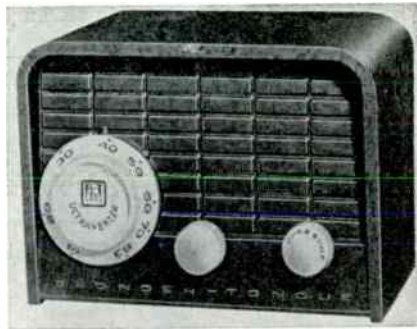

Courtesy Blonder-Tongue Labs, Inc.

FIG. 18-9A. A UHF converter.

to 13) of the set. Thereafter it is treated in the same manner as any other VHF signal.

An RF amplifier is not used ahead of the mixer because the additional expense would be high. Not only would the stage require a relatively expensive tube, but it would also introduce another tuned circuit which would have to be varied in conjunction with the oscillator and mixer-tuned circuits. Since a converter is only an auxiliary piece of equipment to a standard receiver, it is desirable that its cost be kept as low as possible.

The practice of using crystals for the mixer stage in place of vacuum tubes is widespread despite the fact that crystals introduce an 8- to 10-db loss in the signal. A triode used as a mixer would provide some gain, but the crystal has a better noise factor. In addition, crystals are cheaper and their circuits simpler.

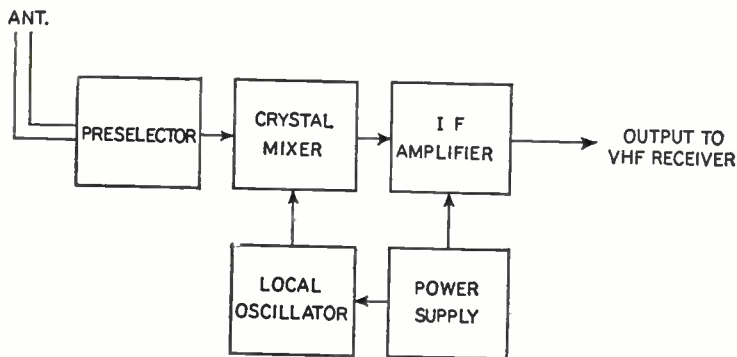

FIG. 18-9B. Block diagram of converter.

When a crystal mixer is used in a UHF converter, the noise factor of the entire unit is determined in large measure by the frequency which is selected for the IF amplifier following the mixer. For this converter IF amplifier, the noise factor becomes poorer as the intermediate frequency rises; consequently, it is best to choose as low a value as possible. Of course, since the converted signal is to be fed into a VHF receiver, the channel 2 frequency (54-60 mc) represents the lowest converter IF values that can be used.

Working against the selection of a low IF value is the fact that the amount of power which an oscillator will radiate through the antenna varies inversely as the square of the converter IF value. Thus, by doubling the converter IF value, the power radiated by the antenna decreases by one-fourth. Finally, a high IF value will increase the ability of the converter to overcome image response, cross modulation, and other undesirable spurious responses.

The compromise IF value which is chosen by most converter manufacturers is 76 to 88 megacycles. It covers channels 5 and 6 of the VHF band and enables the set owner to select either one to receive the converted IF signal. The channel chosen will be the one which is not in VHF use in that particular locality.

It is also possible to design a UHF converter without the IF amplifier shown in Fig. 18-9(B). In this case, the IF signal developed by the mixer is then fed directly to the VHF receiver antenna input terminals. Such an arrangement will work satisfactorily if the level of the incoming UHF signal is not too low and the VHF receiver is sensitive.

The circuit diagram of such a UHF converter is shown in Fig. 18-10.

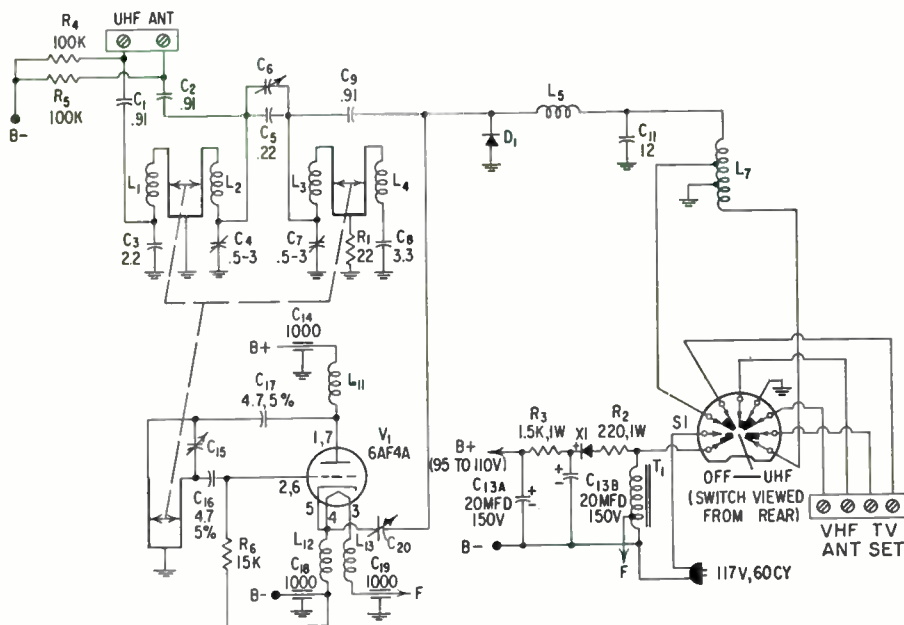

Courtesy Blonder-Tongue Labs, Inc.

FIG. 18-10. Schematic diagram of a UHF converter that does not possess an IF stage.

Basically, the circuit consists of a double-tuned preselector input circuit, an oscillator, a crystal mixer, and an output circuit which is connected directly to the input of the VHF receiver to which it is connected.

In detail, incoming UHF signals are applied to a balanced-input circuit having an impedance of 300 ohms. The input-tuning circuit, called a preselector, is basically a quarter-wave shorted section of a parallel-wave transmission line. Two such tuning circuits are employed here. Frequency variation is achieved by changing the position of the shorting bar and the

highest frequency is obtained when the shorting bar is closest to the upper end of the quarter-wave section. As this shorting bar is moved down toward the grounded end, the resonant frequency decreases, until the lowest frequency is obtained when the shorting bar is in contact with the grounded end of the line. Actually, when the shorting bar is at the very top of the quarter-wave section, the only active tuning elements in the circuit are L_1 , C_1 , C_2 , C_3 , and C_4 . These establish the highest frequency to be received, in essence representing the minimum inductive and capacitive loading on the circuit.

A second tuning circuit, similar in all respects to the input-tuning circuit, follows next, with the signal transfer between the two circuits governed by trimmer capacitor C_6 . This arrangement forms a double-tuned input network which provides enough selectivity so that only the desired signals reach the mixer stage.

C_4 and C_7 are small variable capacitors for adjusting the input-tuning circuits so that they track with the oscillator over the tuning range. In addition, C_6 adjusts the coupling between the two tuned circuits and therefore regulates the overall bandwidth of the combined network.

The shorting bars of each quarter-wave parallel-wire transmission line are mechanically ganged to the same tuning shaft, together with the shorting bar of the oscillator-tuning circuit. This enables the three circuits to be varied in step with each other. If the circuits are properly adjusted, they will track with each other across the full tuning range. If the tracking is faulty, it can be corrected by adjusting C_4 and C_7 .

Since this converter does not possess a power transformer, two resistors are added to the UHF antenna terminals to provide a leakage path for any static voltages which develop on the antenna or transmission line.

Following the preselector-tuned circuits, the signal is fed to mixer D_1 . At the same time, an oscillator circuit utilizing a similar quarter-wave parallel-wire transmission line and a 6AF4A triode develops a suitable oscillator signal which is also fed to this diode. The two signals mix here, producing a signal which falls in either channel 5 or channel 6. The signal is then fed through the low-pass filter L_5 and C_{11} to the output-tuned circuit, L_7 . This output circuit presents a balanced 300-ohm impedance, matching the input impedance of the VHF receiver which would be connected to the converter. The oscillator circuit is basically an ultraudion circuit with the tuned circuit connected between the plate and grid. Note that the necessary oscillator voltage is taken from the cathode and fed through a small capacitor, C_{20} , to the germanium diode mixer, D_1 . The amount of voltage which reaches the mixer is controlled by the value of C_{20} .

S_1 , a 2-position switch, does two things. When the switch is in the UHF position (as shown in Fig. 18-10), the output of L_7 goes directly to the two

terminals on the output strip marked "TV set." Thus, in this position, the converter output is being fed to the television receiver. The other two terminals on the terminal strip, marked "VHF ant," would be the point where the VHF antenna is connected. If S_1 is turned to the off position, the VHF antenna connects directly to the TV-set terminals. In other words, the signal enters the VHF antenna terminals, passes through the switch and enters the TV set. In this position, the a-c voltage to the converter power supply is turned off.

A transformerless, half-wave power supply using a selenium rectifier develops the B+ voltages required by the 6AF4A oscillator tube. The voltage needed by the tube for its filaments is obtained from a tap on what is essentially a choke connected across the power line.

This converter is exceedingly simple and actually represents the minimum circuitry that could be employed to achieve the conversion desired. To receive the output of the converter, the VHF television receiver is tuned to either channel 5 or channel 6. There is basically little that can go wrong with this converter because of the simplicity of its circuit. Occasionally, the 6AF4A oscillator tube will require replacement, but beyond this the system should be fairly trouble-free.

A more extensive UHF converter using the same tuning circuitry is shown in Fig. 18-11. The only significant difference is that this converter uses a power transformer, eliminating the need for resistors R_4 and R_5 . In all other respects, the double-tuned preselector, the oscillator, and the mixer are identical with the circuits of the preceding illustration. Beyond the mixer, the signal is passed through a low-pass filter consisting of L_5 , L_6 , and C_{10} . This signal, which is now in the channel 5-channel 6 range, is fed to V_1 , a 6ER5 triode. This triode was described earlier in conjunction with VHF tuner circuits, where it was indicated that its unique guide plates and other internal features produce high gain with low noise and a low feedback capacity between the plate and the grid. The output of the amplifier then is coupled to a tuned circuit (L_9) which is grounded at its midpoint to provide a 300-ohm balanced-output impedance. L_9 connects to the transfer switch. This output circuit is fairly broad-tuned to encompass the 12 mc required by the spread from channel 5 through channel 6. This broad range is in large measure achieved by the 4,700-ohm resistor, R_5 , shunted across L_8 .

In examining the manner in which d-c voltages are applied to V_1 , it will be seen that the cathode receives a negative potential of 102 volts while the plate is essentially at zero voltage since it is directly grounded through L_8 . This arrangement will produce the same effect within the tube as it would if the cathode were grounded and the plate had been given a positive potential of 102 volts. By using this arrangement, all B+ voltages are kept away from the output circuit, thus minimizing the danger of this voltage acci-

562

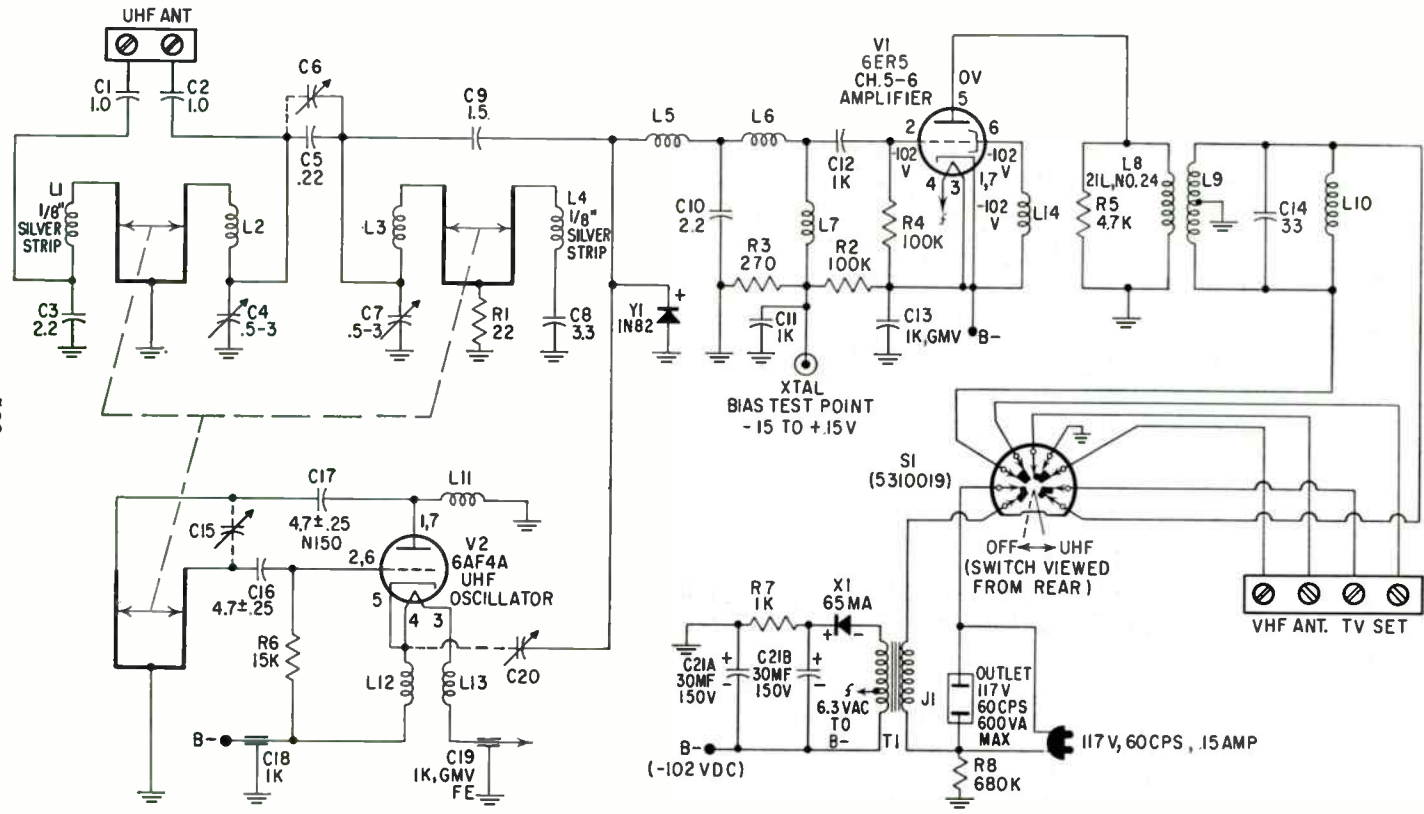
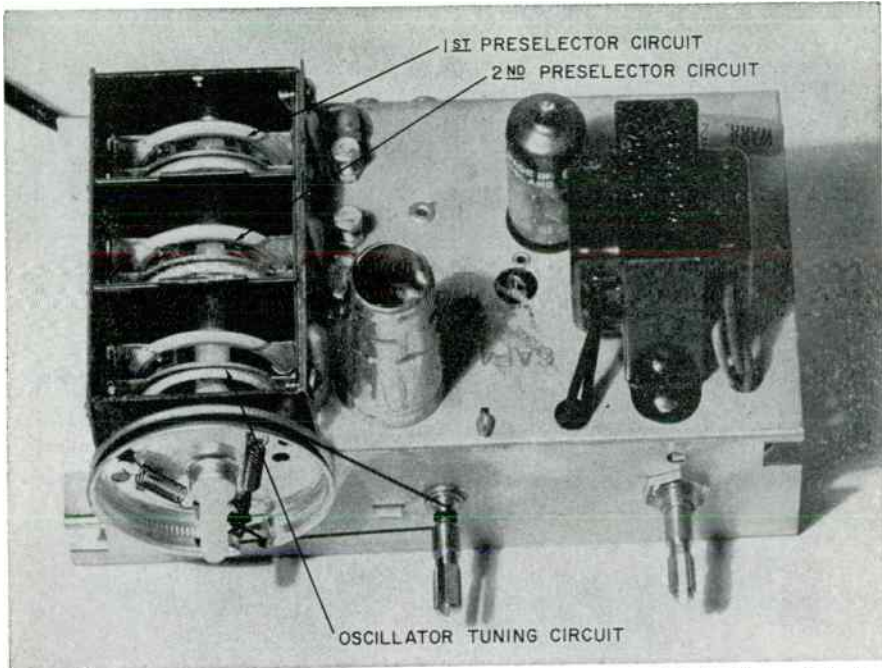

FIG. 18-11. The schematic diagram of a UHF converter possessing an IF amplifier stage.

Courtesy Blonder-Tongue Labs, Inc.

dentally reaching the transfer switch and, from here, the input to the VHF receiver. The same type of voltage arrangement is employed in V_2 , the oscillator, where again the plate is at d-c ground while the cathode is 102 volts negative.

A photograph of this UHF converter showing the construction of the tuning elements is shown in Fig. 18-12. Instead of having the quarter-wave



Courtesy Blonder-Tongue Labs, Inc.

FIG. 18-12. Actual appearance of converter shown in Fig. 18-11.

parallel-wire transmission lines held as shown in the schematic diagram, the two elements of each line are curved to provide a more compact arrangement. The movable shorting bar connects to a plastic tuning shaft.

Tuner Strips. The second approach to UHF conversion is by means of tuner strips. There are, on the market, turret tuners in which the RF-tuning elements are mounted on strips which are removable from the tuner drum. In the Standard Coil tuner, shown in Fig. 18-13, there is one strip for each VHF channel. In any one locality, however, the maximum number of VHF stations is seven. This then leaves five unused strips and these may be taken out and UHF strips inserted in their place. One UHF strip will be required for each UHF station to be received.

In the illustration of Fig. 18-13, the UHF tuner strip is shown in the lower left-hand side of the photograph. Next to it, at the right, is the antenna assembly which fits into a slot at the top of the tuner deck. This unit serves two purposes. It physically holds the antenna-input filter which acts to attenuate all signals below the UHF band. The unit also provides the antenna terminals to which the transmission line from the UHF antenna is connected. Note that these terminals are separate and distinct from the VHF terminals.

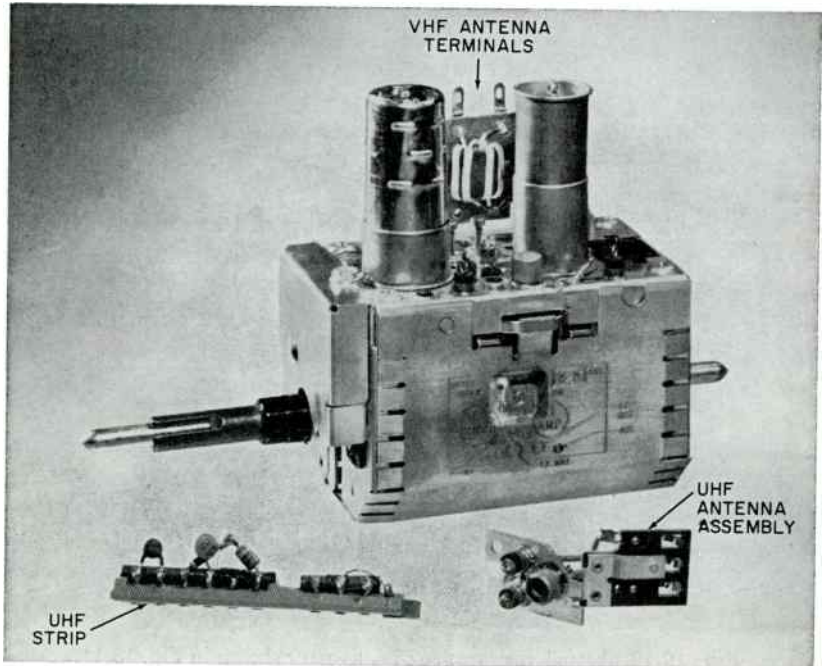

Fig. 18-13. A Standard Coil turret tuner with a UHF strip (lower left).

The block and schematic diagrams of the circuits contained on the Standard Coil UHF strip appear in Fig. 18-14(A) and (B). Referring to the block diagram first, the incoming signal from the antenna is applied initially to a preselector circuit which emphasizes the signals of one UHF channel and attenuates all other UHF signals. In addition, as mentioned above, many manufacturers (such as Standard Coil) add a special filter ahead of the preselector to take care of all signals below the UHF band.

The next stage to receive the incoming signal is the mixer, and in all current UHF equipment this is a crystal. Also feeding into the mixer circuit is a locally generated signal which beats with the received signal to produce

the difference frequency. This oscillator signal could be developed by a separate UHF oscillator, but for the sake of economy, the VHF oscillator already in the set is utilized. What happens is this. The VHF oscillator is set to oscillate at some appropriate frequency. Let us say that this is 258.5 mc. This frequency is then passed through a crystal (not the mixer) where harmonics of 258.5 mc are produced. A multiplier-tuned circuit is peaked to the appropriate harmonic frequency, insuring that this frequency voltage will be stronger than the other harmonic voltages. In the present case, it is desired to accentuate the second harmonic, although the second, third, or fourth can be employed. With the second harmonic, a frequency of 517 mc is obtained. This signal beats with the incoming signal to produce a difference

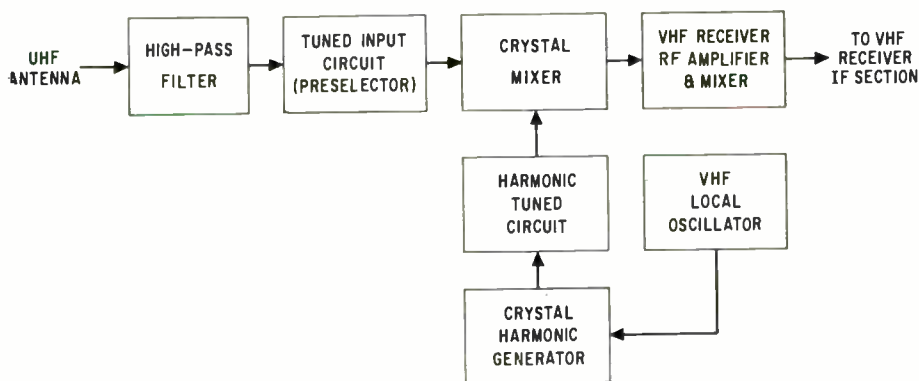

FIG. 18-14A. Block diagram of the UHF circuits contained on the Standard Coil plug-in strip.

frequency equal to the video IF frequency of the VHF receiver. The normal RF amplifier of the VHF tuner is converted into an IF amplifier by suitably tuned circuits. The same is true of the mixer. Thus, both the RF amplifier and the RF mixer now become straight video IF amplifiers, adding two more IF stages to the receiver when the UHF tuner strip is in place and in operation.

To take a specific example, assume that a channel 27 signal is to be received. For this channel, the frequency range is 548 mc to 554 mc. The video RF carrier is at 549.25 mc, and the sound carrier is at 553.75 mc. The VHF oscillator would, by means of the specially tuned circuits on the UHF tuner strip, be set for a fundamental frequency of 198.33 mc. When this signal is passed through the harmonic multiplier, which is here peaked to the third harmonic, an output frequency of 595 mc is obtained. This 595-mc signal beats with the video-carrier signal of 549.25 mc and with the

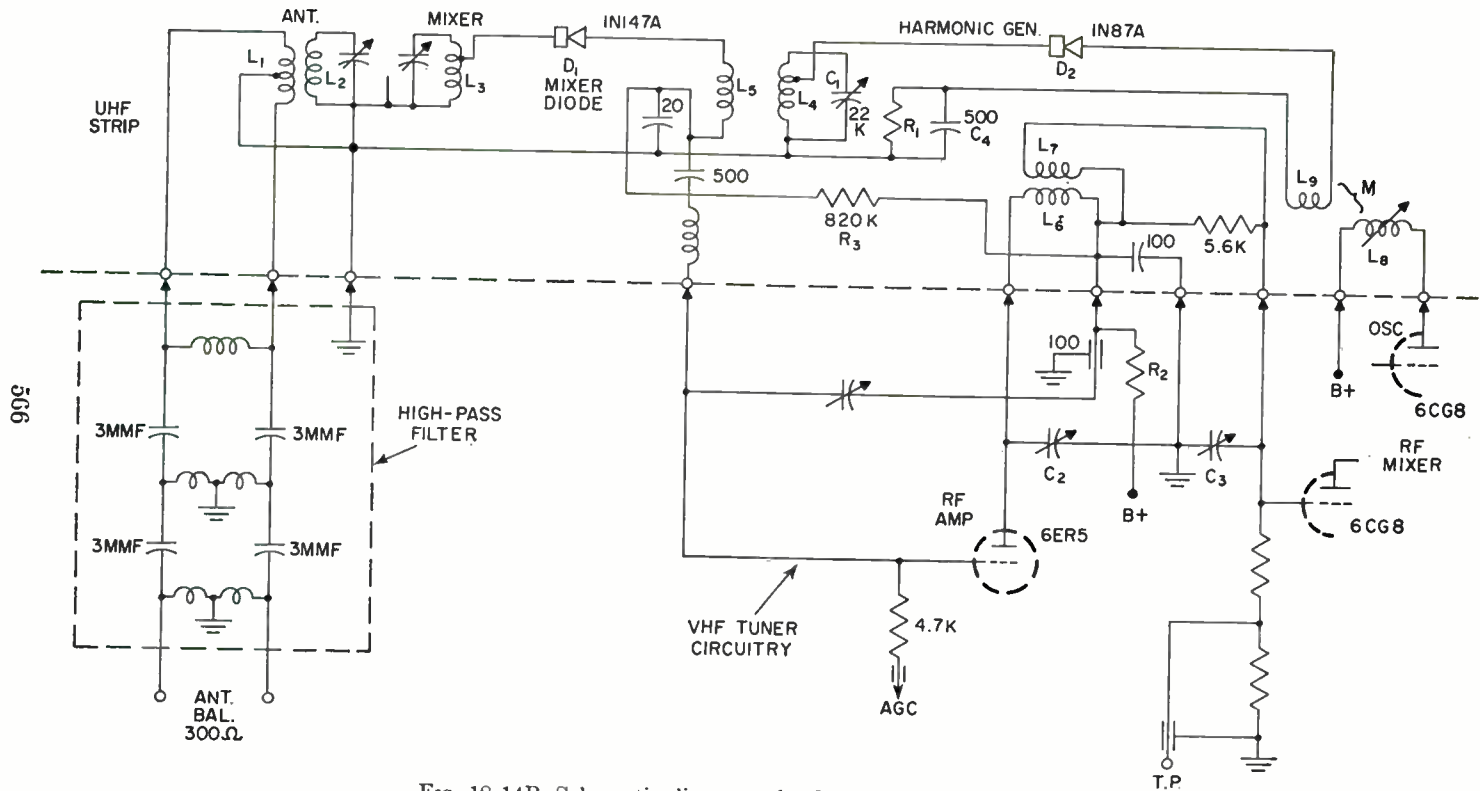

FIG. 18-14B. Schematic diagram of a Standard Coil UHF strip.

sound-carrier signal of 553.75 mc. This gives the following difference frequencies:

For the video carrier

$$595.00-549.25 = 45.75 \text{ mc}$$

For the sound carrier

$$595.00-553.75 = 41.25 \text{ mc}$$

These two signals are then accepted by the RF amplifier, amplified, and fed to the VHF mixer where they are again amplified. Both stages have been converted to straight 41- to 46-mc amplifiers by means of auxiliary coils on the UHF-tuner strip. Beyond the mixer, the signal is transferred to the regular video IF strip of the television receiver and dealt with in exactly the same way as any conventionally received VHF signal.

From the figures used in this example, several interesting facts come to light. First, use of a harmonic of the VHF oscillator frequency does away with the need for a separate UHF oscillator. A simple germanium crystal produces the desired harmonics from the VHF-oscillator signal.

Second, since the strip determines the circuitry of the VHF RF amplifier, mixer, and oscillator circuits, the frequencies of these stages can be set at any desired value. In the foregoing example, the VHF oscillator operated at 198.33 mc, while the RF amplifier and mixer were tuned to accept a frequency band extending from 41 to 46 mc. For other UHF channels, the fundamental frequency of the oscillator will be altered, but in all cases, the RF amplifier and mixer will still function as IF amplifiers.

It might appear that the manufacturer of these strips and the parts jobbers who stock them would have to have 71 different strips, one for each of the UHF channels 14 through 83. Actually, it will be found that each UHF-tuner strip can be adjusted to any one of several adjacent channels. For example, channels 14 through 18 could be accommodated by the same UHF strip by suitable adjustments on the strip. The next UHF strip might cover channels 19 through 23; a third strip could handle channels 25 through 28, and so on. Occasionally, because of certain interference signals that may be present, it is necessary to design a strip specifically for one channel only. However, in general, 12 different UHF strips will suffice to cover the 71 channels of the UHF-band.

With this preliminary discussion, let us examine in detail the actual circuits on the Standard Coil UHF strip. See Fig. 18-14(B). The UHF antenna is connected across the two antenna terminals and a transmission line having a 300-ohm balanced impedance is employed. Following this, there is a high-pass input filter designed to attenuate signals below channel 14. Then, the signal is applied to a double-tuned input circuit labeled "Ant." and "Mixer." The coupling between the two circuits is by mutual inductance.

(This is not evident from Fig. 18-14(B), but the two coils are positioned to permit this coupling.) The short vertical line which is shown between the variable tuning capacitors of the antenna and mixer-tuned circuits is designed to help the coupling between the two circuits and to see that the proper bandwidth is achieved. Thus, the input signal is transferred from L_1 to L_2 by mutual inductive coupling and from L_2 to L_3 in the same manner. The mixer crystal is tapped down on L_3 (for best impedance match); consequently it receives whatever signal is present in this circuit. Also feeding into the mixer circuit is a harmonic of the oscillator signal. L_4 and C_1 are resonated to the harmonic which it is desired to pass on to the mixer. Transfer of the oscillator harmonics to the crystal mixer occurs by inductive coupling between L_4 and L_5 .

Both signals are now mixed and the difference frequency is forwarded to the grid of the normal RF amplifier of the VHF receiver. Here, the signal is amplified, and then transferred to the VHF mixer where it is further amplified. The transfer from the plate of the RF amplifier to the grid of the mixer is accomplished through the inductive coupling which exists between L_6 and L_7 . Capacitors C_2 and C_3 are alignment adjustments provided to make certain these coils are resonant to the proper frequencies.

The multiplier crystal receives its oscillator voltage by mutual coupling between L_8 and L_9 . The crystal distorts the oscillator current to develop a series of harmonics. These currents flow through L_4 and C_1 , where the desired harmonic is accentuated and then transferred to L_5 for mixing with the incoming signal. A small positive voltage is applied to mixer crystal D_1 through resistor R_2 and R_3 . Its purpose is to select an operating point for D_1 where the noise level (developed by D_1) is at a minimum.

It should be noted that when a UHF strip is in position, the front-panel fine-tuning control will vary the oscillator frequency. This enables the user of the set to tune in the desired signal accurately. In short, the fine-tuning control functions in the same way with UHF strips as it does with VHF strips. However, the knob must be turned more slowly and more carefully because the same rotation of the knob with a UHF-tuner strip in place will alter the oscillator frequency considerably more than when a VHF station is being tuned in. In all other respects, however, the use of the fine-tuning control remains the same.

Continuous UHF Tuning. Still another approach to UHF tuning is shown in Fig. 18-15. This tuner, which is coupled mechanically to the regular VHF tuner, provides continuous tuning over the entire UHF television band. When the VHF channel selector dial is rotated so that a window, located between numbers 2 and 13, is on top, then the UHF tuner output is electrically connected to the VHF tuner. This position, which is the now-abandoned

channel 1 spot, contains electrical circuits which transform the normal VHF RF amplifier and mixer into amplifiers tuned to the 40-mc band, that is, 41 to 46 mc. The VHF oscillator is rendered inoperative and is without effect on the signal during UHF operation. Tuning of the UHF unit is done with the fine-tuning knob.

Figure 18-16 shows one arrangement which has been employed. The UHF continuous tuner is mounted in front of the VHF tuner, with the fine-tuning rod extending through the UHF tuner. The front channel-selector

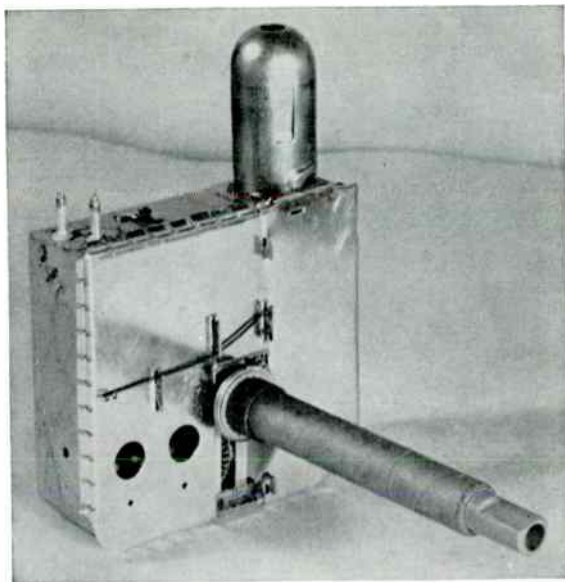

Courtesy Sarkes-Tarzian

FIG. 18-15. A UHF continuous tuner.

knob can then be rotated to the VHF various channels. However, when it gets to the channel 1 position, the output of the UHF tuner becomes electrically active and is fed into the VHF tuner by the loop which extends between the two units. The fine-tuning knob can now be turned, and as it rotates from one end of its range to the other, the output of the UHF tuner will vary from channels 14 to 83. On the unit shown in Fig. 18-16, the position of channel 14 is indicated on the fine-tuning control so that the user will know at what point he is in the UHF range. Separate antennas are employed for the UHF and VHF sections.

Arrangements have also been developed in which the UHF tuner is physically separate from the VHF tuner and actually has its own front-

panel dial. See Fig. 18-17. The electrical output of this tuner is fed to the VHF tuner. However, the latter unit must be in the channel 1 position (or whatever the channel between 2 and 13 is called) in order for it to be receptive to any signal from the UHF tuner.

The circuit diagram of a UHF tuner is shown in Fig. 18-18. Basically it consists of two preselector-tuned circuits, an oscillator, and a mixer. Since we are dealing with ultra-high frequencies, a tuning circuit which is most

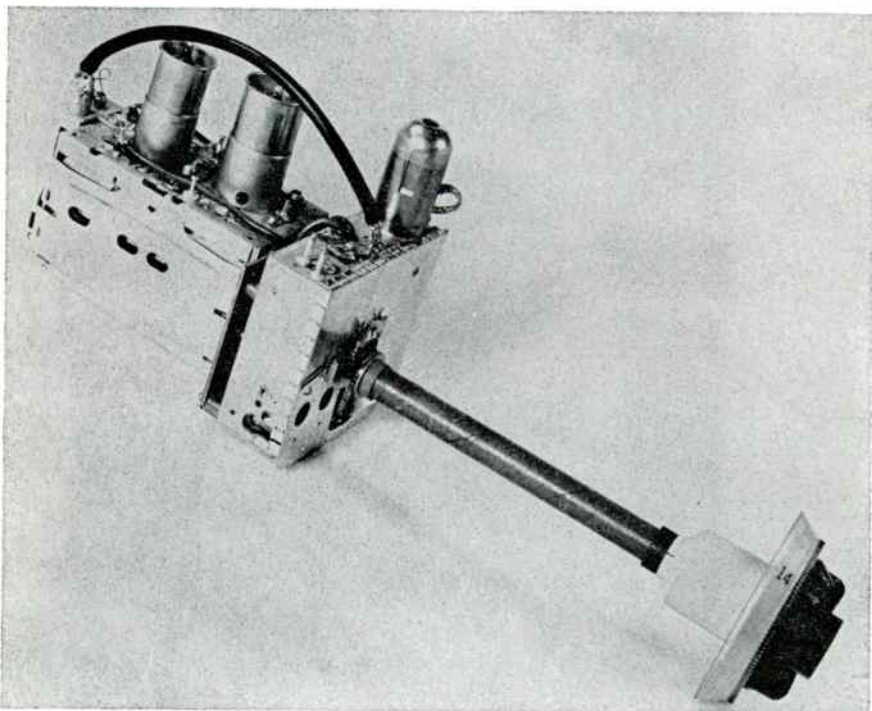

Courtesy Sarkes-Tarzian

FIG. 18-16. The UHF tuner of Fig. 18-15 is mechanically and electrically linked to the VHF tuner behind it.

efficient in this range must be employed. In the present case, this is accomplished in the antenna or preselector circuits by modified coaxial lines. The outer conductor of each line is a rectangular metal compartment. See Fig. 18-19. The inner conductor is a quarter-wavelength shorted stub formed by a metallic rod. The tuning is accomplished in each preselector circuit by rotation of a variable capacitor (C_{1A} or C_{1B}) connected between the open end and its outer shield. In effect, we are resonating the inductance of the line by varying the capacitance across the line. In addition, a high-frequency

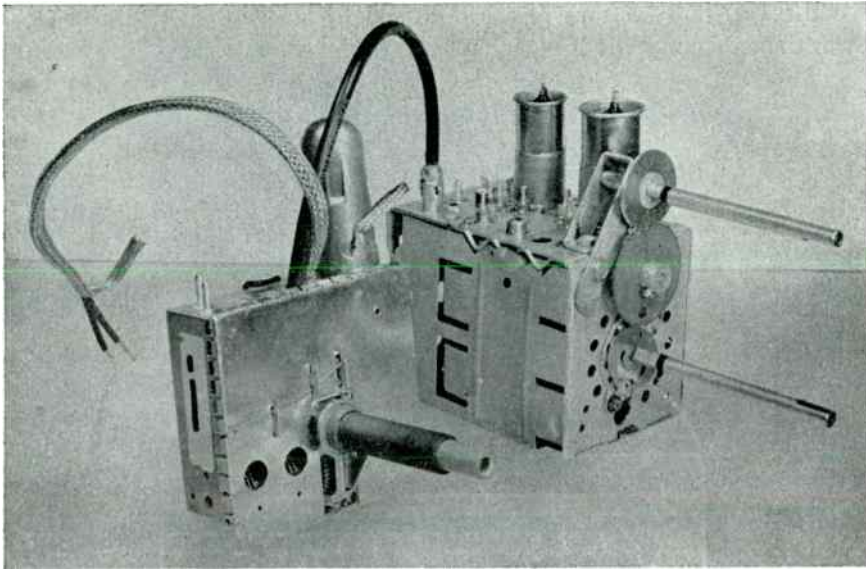

Courtesy Sarkes-Tarzian

FIG. 18-17. In the arrangement shown here, the UHF tuner is mechanically separate from the VHF tuner.

trimmer tab is located near the open end of each line for the initial high frequency alignment.

The antenna signal is applied to a small loop which is coupled to the internal stub of the first-preselector section. This loop is positioned so that it matches the impedance of the coaxial line. Coupling between the first- and

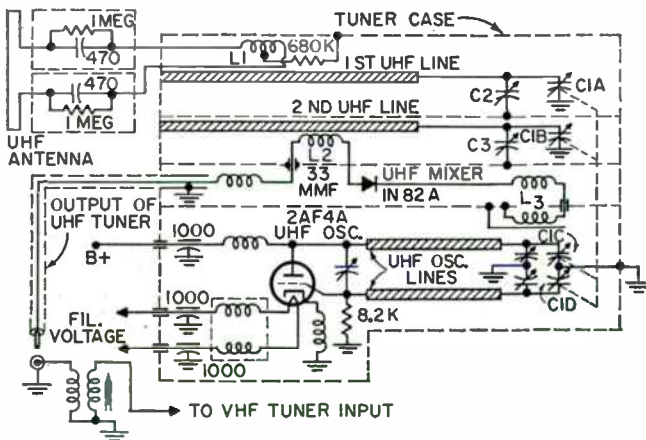

FIG. 18-18. Schematic diagram of UHF tuner shown in Fig. 18-19.

second-preselector sections is accomplished by a coupling slot or opening cut in the common plate between the two compartments. This is an interesting and effective way of coupling two high-frequency circuits; it establishes a definite linkage between them through the high-frequency energy which escapes through the slot and moves from one compartment to the other. Sometimes a wiper blade, mounted on the tuning shaft, varies the effective width of the opening with rotation, thereby changing the coupling over the

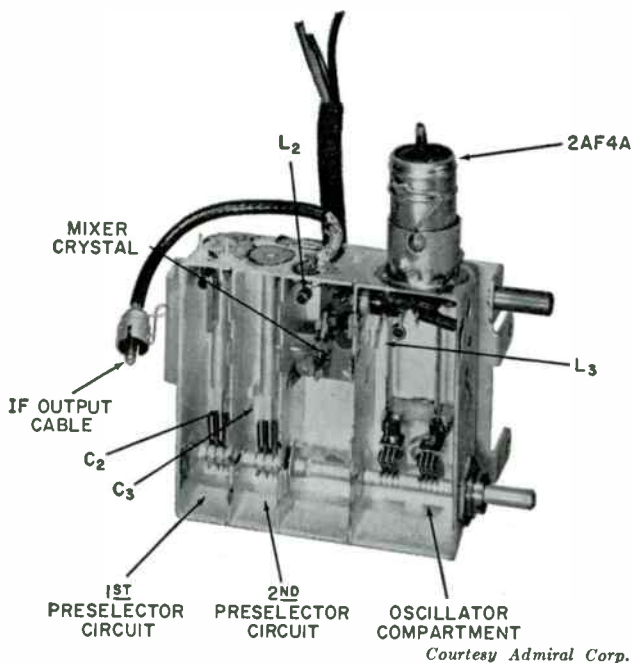

FIG. 18-19. A continuously tuned UHF tuner. Resonant frequency variation is accomplished by rotating the variable capacitors shown at the bottom of the several compartments. All are ganged on one shaft.
Courtesy Admiral Corp.

frequency band. The purpose of this arrangement is to maintain uniform coupling and to keep the bandwidth constant.

The signal which is developed in the second-preselector section is coupled to the mixer crystal by a small loop positioned near its center stub. Also feeding into the mixer circuit is a signal obtained inductively from the oscillator tuning circuit by loop L_3 . (In Fig. 18-18, L_2 and L_3 are represented as coils, which is what they really are.) The two signals combine in the mixer crystal and a resulting difference signal in the 40-mc band is developed. This signal is transferred to the grid of the RF-amplifier tube. The latter stage, together with the VHF-mixer tube, now functions as a

straight 40-mc amplifier. Beyond these stages, the signal goes to the video IF section of the receiver where it is treated as any normal VHF signal.

The local oscillator is of the balanced, tuned-line type, operating as a modified Colpitts and utilizing the internal capacity of the tube as part of the split-capacity feedback system. With tuning capacitors C_{1C} and C_{1D} in the fully open position, the oscillator generates its highest frequency. The frequency then drops as more capacity is brought into the circuit. Use of lines as tuning elements provide a high Q in the oscillator circuit and a simple mechanical means of tracking the oscillator with the antenna section.

The oscillator has two adjustments, one at each end of the tuning line. The trimmer nearest the tube has the greatest effect on the lower UHF channels. The trimmers at the far end of the line have the greatest effect on UHF channels above number 50.

In the oscillator circuit of Fig. 18-18, there are small RF chokes in the B+ plate lead and in the two filament leads. These prevent any of the RF energy in the oscillator circuit from reaching the rest of the receiver through the B+ line or through the a-c filament voltage line. The cathode also possesses a small RF choke, but its purpose here is simply to keep the cathode above RF ground potential, which is necessary for the proper functioning of the oscillator circuit.

In dealing with UHF circuits, it becomes necessary to modify the usual conception of what certain components look like. This is especially true when dealing with inductances. A straight piece of wire which is ordinarily disregarded in conventional low-frequency circuits, in UHF circuits, possesses all the necessary inductance required by the circuit. When two circuits are inductively linked together, there is generally no more than a single-turn loop between these circuits. Or, as we have just seen, a slot in the wall separating two tuning circuits will adequately couple them together.

A capacitor in a high-frequency circuit, particularly a variable capacitor, may be no more than the head of a screw, the position of which with respect to another part of the circuit is altered. Or, the capacitance may be formed by wrapping the ends of two wires together, with the insulation kept intact to serve as a dielectric. These are methods in addition to more conventional variable capacitors, such as those shown in Fig. 18-19.

Figure 18-20 demonstrates a slightly different tuning arrangement that has also been employed. Here, frequency variation is achieved by movable shorting bars. The active segment of each tuning line is the distance between the shorting bar and the open end of the line. The shorter this distance, the higher the operating frequency. Also present across the two preselector circuits are small trimmer capacitors, C_3 and C_5 . These serve to align the tuning lines at the low-frequency end of the UHF band. For the high-frequency-end alignment, L_1 and L_2 are the adjusting elements.

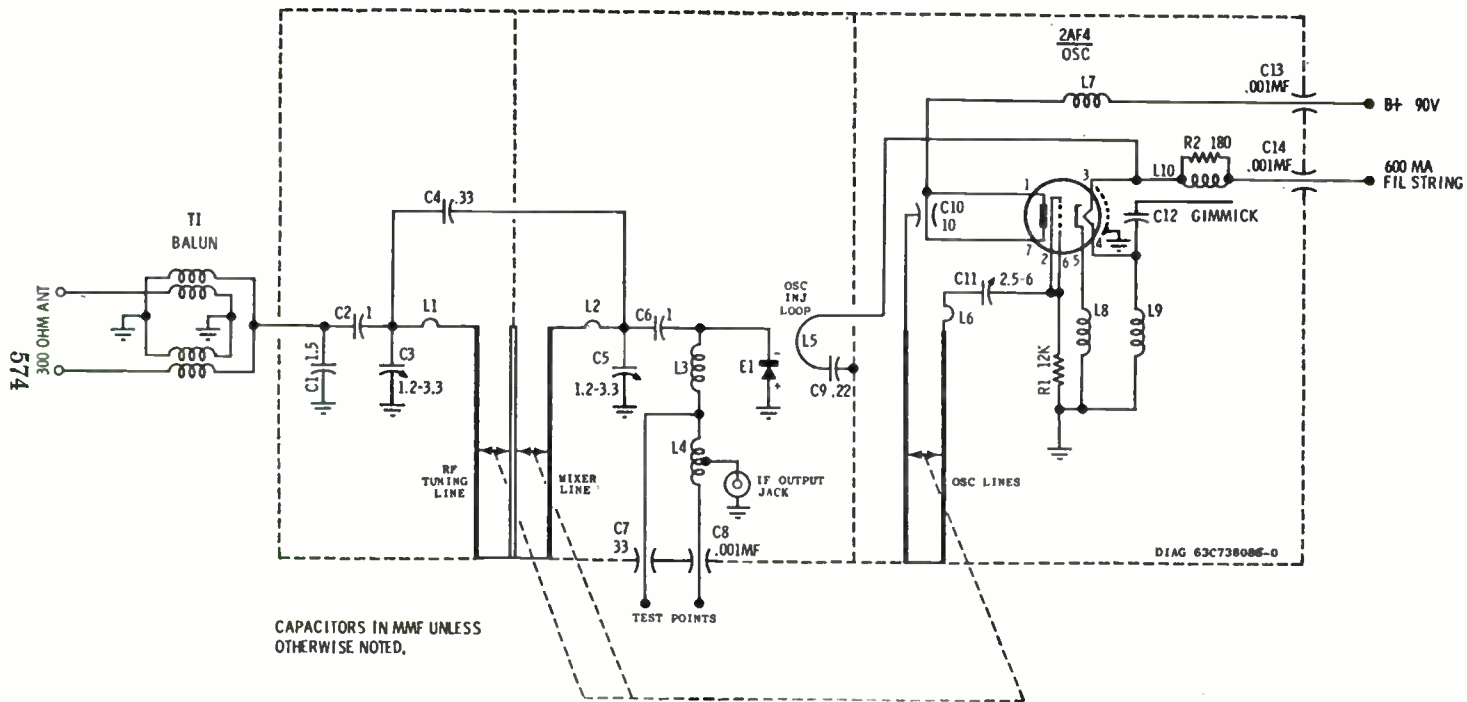

FIG. 18-20. Another UHF continuous tuner.

The variable or movable shorting bars required by this UHF tuner might take the same physical form as the shorting bars in the UHF converter previously described.

The remainder of the circuit follows the arrangement of Fig. 18-18 quite closely. The incoming signal reaches the crystal mixer by way of two pre-selector tuning lines. Transfer of energy between these lines is achieved with C_4 . The oscillator voltage is brought to the mixer by an injection loop which simply radiates the oscillator signal into the mixer compartment.

All shorting bars are ganged to the same shaft and all are rotated at the same time. The output of the mixer is in the 40-mc IF band and this signal is fed to the input grid of the VHF RF amplifier. From this point, system operation is identical to that employed with the previous UHF tuner.

QUESTIONS

1. Why are multiple element antennas more feasible at UHF than at VHF?
2. List four UHF antennas. Briefly outline the properties of each.
3. Why is a 300-ohm flat twin-lead transmission line less suitable for UHF application than the 300-ohm tubular line?
4. What two general approaches did the television industry adopt to enable VHF sets to receive UHF signals?
5. Describe in detail how a Standard Coil VHF turret tuner can be converted to receive UHF signals.
6. Describe the operation of a UHF converter.
7. What type of tuning elements does the converter of Fig. 18-10 employ? Indicate briefly how they operate.
8. Explain the operation of the circuit in Fig. 18-18. Indicate what changes have to be made in a VHF receiver to which this circuit is connected.
9. Why are UHF installations more difficult to perform than VHF installations?
10. Describe a VHF-UHF combination antenna.

Color Television

Introduction. Emphasis throughout the preceding chapters has been directed entirely to the underlying principles of transmission and reception of so-called black-and-white images. In such a system, only black, white, or intermediate shades appear on the receiver viewing screen. The result is similar in all respects to the ordinary motion picture. Although the reproduced image is certainly far from being an exact duplicate of the full-colored scene originally televised at the studio, it imparts sufficient information to prove entertaining. The public has long been accustomed to black-and-white pictures in the motion-picture theater and accepts with little or no objection the same type of image in a television receiver.

The appeal of color television lies in its greater naturalness. We live in an environment that contains many shades of color, and to desire the same lifelike qualities in television is quite understandable. Color in an image heightens the contrast between elements, brightens the highlights, deepens the shadows, and appears to add a third dimension to a flat reproduction. More detail appears to be present in colored images containing fewer lines than corresponding black-and-white pictures. Perhaps many readers have noticed the remarkable differences between color motion films and ordinary motion pictures. Similar differences are observed with television.

The FCC has been investigating color television since 1946. At first it rejected all systems shown to it as being unsuitable for commercialization. For a time the question of color television lay dormant; then it was revived, and after long months of hearings and viewing demonstrations, the FCC in October, 1950, adopted a field-sequential system proposed by the Columbia Broadcasting System (CBS). This system was known as a noncompatible system because its line and field frequencies differed from those of the

black-and-white television receivers. Noncompatibility meant that, if a station was broadcasting a CBS color signal, a black-and-white picture could not be properly presented on a black-and-white television receiver unless certain changes were made in the receiver circuitry.

The adoption of the CBS color system met with opposition from the public and the television manufacturers, chiefly because of its incompatibility, and the system did not progress very far. Almost concurrently with the FCC decision, the Korean War broke out, and in the interests of national defense (and the conservation of critical materials) all commercial manufacturing of color television receivers was temporarily discontinued. When the ban was lifted several years later, CBS admitted that industry opposition to its system was too great to be overcome by CBS singlehandedly; hence CBS indicated it would be willing to go along with whatever system received the backing of the industry. This turned out to be the National Television System Committee (NTSC) system, which, in December, 1953, superseded the CBS system.

In order to appreciate fully the basic principles of the NTSC color system, let us refresh our memory concerning certain elementary aspects of color.

Elements of Color. Color, physicists tell us, is a property of light. If we take sunlight and pass it through a glass prism, a variety of colors are produced. White sunlight contains all colors, but, owing to the limitations of the human eye and the fact that the colors produced by a prism blend into one another, we can count only six fairly distinct colors (red, orange, yellow, green, blue, and violet). Upon closer inspection of this color distribution, numerous fine gradations can be distinguished, both between different colors and within any one color itself. For example, red, when it first becomes definitely distinguishable from its neighbor, orange, possesses a different shade than that at the other end of the red band where infrared wavelengths are approached.

It is a common experience with all persons who are not color-blind to find that objects which possess one color under an electric light may assume a considerably different color when examined in the sunlight. The difference is due to the fact that the color of an object is a function of the wavelengths of the light which the object does *not* absorb. Thus, if we shine white light on a body and none of it is absorbed, we see a white body. However, if under the same white light the object appeared blue, then the object would be absorbing all the other components of white light and reflecting blue.

To see the true color of an object, we must examine it under a light which contains all the wavelengths of the visible spectrum. Thus, a blue object appears much darker under an ordinary incandescent lamp than it

does in sunlight. This is because the lamp has an excess of red light and a deficiency of blue. Since a blue object will reflect only blue rays, it will reflect less light under an incandescent lamp and give a darker appearance. In sunlight, blue and red are present to the same extent and the object assumes its proper color.

With objects that are transparent, the color is determined by the light which is transmitted through the object. Thus, in a green piece of glass, green is permitted to pass through, whereas the other colors are absorbed.

Color Primaries. Anyone who has ever experimented with projector lamps has discovered that when differently colored lights from several projectors are combined, the resultant color seen by an observer will differ in hue from any of the projected lights. Thus, for example, yellow can be formed by combining red and green light; white light can be produced by combining red, green, and blue. The color of the mixed light will appear to the eye as a complete color, and the eye will be unable to distinguish the various components of the mixture that produced that color.

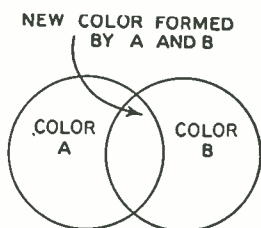

FIG. 19-1. Two circles of light, A and B; where they overlap, they form a third color different from either A or B.

This method of color formation is illustrated in Fig. 19-1. Two circles of colored light are projected onto a screen and positioned so that they overlap to some extent. Within the overlapping region, a new color will be produced by the addition of color A and color B. Where the circles of light do not overlap, each light will retain its original color.

If a third circle of light is added, as shown in Fig. 19-2, then additional colors can be obtained. These colors are

Color A	Color D (formed from A and B)
Color B	Color E (formed from A and C)
Color C	Color F (formed from B and C)
	Color G (formed from A, B, and C)

and each differs from the others. In the areas where the circles of light overlap, the eye is not able to distinguish each of the colors forming the mixture, but instead sees the final color produced. Furthermore, as we vary the relative intensities of colors A, B, and C, we see that colors D, E, F, and G likewise vary in shade.

The number of different colors that can be formed by the use of three colored lights depends upon the colors chosen. Experience has indicated that the colors red, blue, and green, when combined with each other in various proportions, will produce a wider range (or gamut) of colors than

any other combination of three colors. Note, however, that, if we use four different colors in our mixing process, we can produce an even wider range of different colors. With the addition of more and more colors to our mixing scheme, the reproducible range will increase somewhat. Obviously, however, a line must be drawn, and the use of three colors has become standard. The three colors chosen—red, green, and blue—are thus referred to as the “primary colors.”

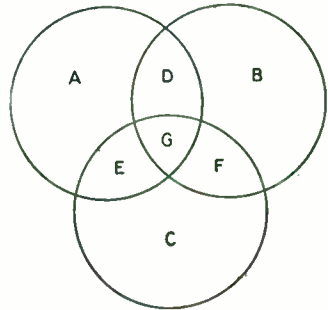

FIG. 19-2. The mixing of three colors—A, B, and C—results in four new ones: D, E, F, G.

Chromaticity Chart. A diagram which is convenient to use for color mixing is the tongue-shaped (or horseshoe-shaped) curve shown in Fig. 19-3. This is known as a “chromaticity chart.” The positions of the various spectrum colors from blue at one end to red at the other are indicated around the curve. Any point not actually on the solid-line curve but within the area enclosed by the curve represents not a pure spectrum color but a *mixture* of spectrum colors. Since white is such a mixture, it, too, lies in this area, specifically at point C. This

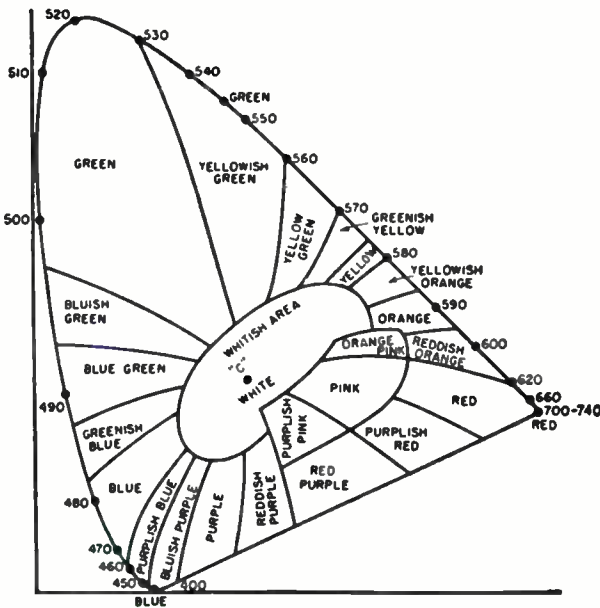

FIG. 19-3. A chromaticity diagram. The numbers listed around the perimeter of the chart represent the wavelengths of the various colors in millimicrons.

particular point was chosen at an international convention in England and is generally referred to as "illuminant C." Actually, of course, there is no specific white light; sunlight, skylight, and daylight are all forms of white light and yet the components of each differ considerably. The color quality of a conventional black-and-white television receiver tube is represented by a point in the central region of the diagram about point *C*.

If Fig. 19-3 were reproduced in full color, it would be seen that the color changes gradually from point to point. The deepest and most intense colors are obtained at the outer edge of the diagram. Here we find the real deep red, deep blue, and deep green shades which we actually see very seldom in everyday life. More familiar are the lighter colors, appearing as we move in toward the center. These are the pastels such as pink, light green, and pale blue. Finally at the center come the whites with point *C* as the reference white, or, for our purpose here, the "whitest" white. Actually this is a rather nebulous shade, entirely arbitrary in value and simply chosen for certain conveniences.

The chromaticity chart lends itself readily to color-mixing because a straight line joining any two points on the curve will indicate all the color variations that can be obtained by combining these two colors additively. Thus, in Fig. 19-4 consider the line connecting points *R* and *G*

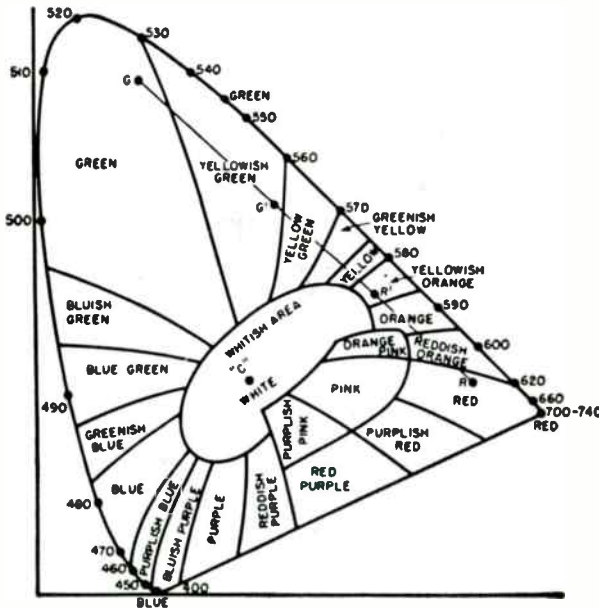

FIG. 19-4. The line drawn between points *R* and *G* passes through all the colors that can be obtained by mixing these two shades of the red and green hues.

representing certain shades of red and green respectively. If there is more red light than green light, the exact point representing the new color will lie on the line, but be closer to *R* than to *G*. Point *R*¹ might be such a color. On the other hand, if a greater percentage of green light is used, the new color will still lie on the line connecting *R* and *G*, but will now be closer to *G* than to *R*. Point *G*¹ might be such a color. This method of combining colors can be carried out for any two colors on the chart.

It is possible to specify the purity of a color by its distance from point *C*. Consider point *B* in Fig. 19-5. This is halfway along the line between

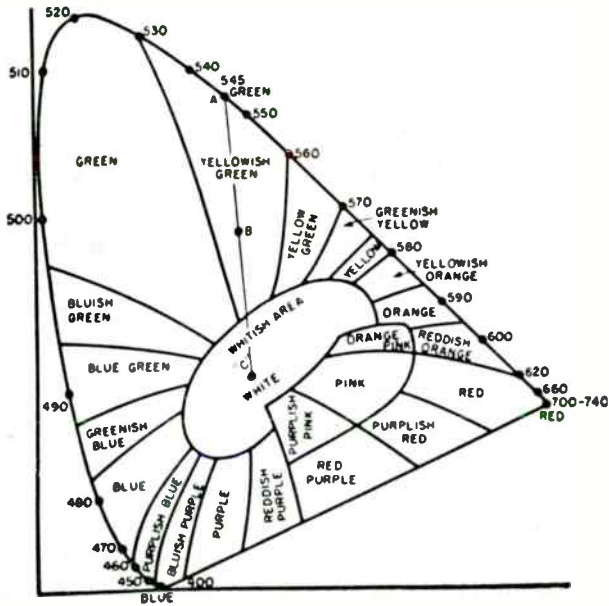

FIG. 19-5. When moving from *A* to *C*, the green becomes less and less saturated, or lighter in intensity.

point *C* (white) and point *A* (green). Hence, point *B* represents a mixture of green diluted 50 per cent with white light, and we can say that the purity of this color is 50 per cent. Had the distance between point *C* and point *B* been 75 per cent of the total distance between point *C* and point *A*, we would have stated that the purity of the color at point *B* was 75 per cent. As point *B* moves closer and closer to the spectrum curve, the purity of the color it represents increases until it becomes 100 per cent at the curve—point *A*. As point *B* moves closer to point *C*, its purity decreases. At point *C*, the purity is said to be zero.

In place of purity, the word “saturation” is frequently used. Any point

located on the tongue-shaped curve is said to be completely saturated. As we leave the curve and approach closer to point *C*, more and more white light is added to the color and it becomes less saturated or, what is the same thing, more desaturated. And, at point *C*, the saturation is zero.

In connection with saturation, the word "hue" is frequently heard. Hue represents color, such as red, green, and orange. The term is associated with color wavelength, and when we call a certain color green, or orange, or red, we are specifying its hue. Thus, hue refers to the "basic" color as it appears to us, while saturation tells us how "deep" the color is. If the color is highly saturated, we say that it is a deep color, such as deep red or deep green. If it contains a considerable amount of white light, we say it appears "faded," as a faded red or a faded green.

THE NTSC COLOR TELEVISION SYSTEM

We are now ready to study the NTSC color television system, the system officially adopted by the FCC. This system has been so designed that its signal occupies no more than 6 mc (video and sound) and it carries not only the full black-and-white (or monochrome) signal but, in addition, the color information.

The question is: How is all this information compressed into a 6-mc bandsread? The answer is to be found in the nature of a television signal. It was discovered as far back as 1929 that a video signal does not occupy every cycle of the 4 mc assigned to it. Rather, it appears in the form of "clusters" of energy located near harmonics of the 15,750-cycle line—scanning frequency. The energy is grouped around these points, with relatively wide gaps between them. See Fig. 19-6. Since these empty spaces are not being used, they can be employed for the transmission of additional information, and here is specifically where the color information of the NTSC color-television signal is placed. See Fig. 19-7. The practice of placing

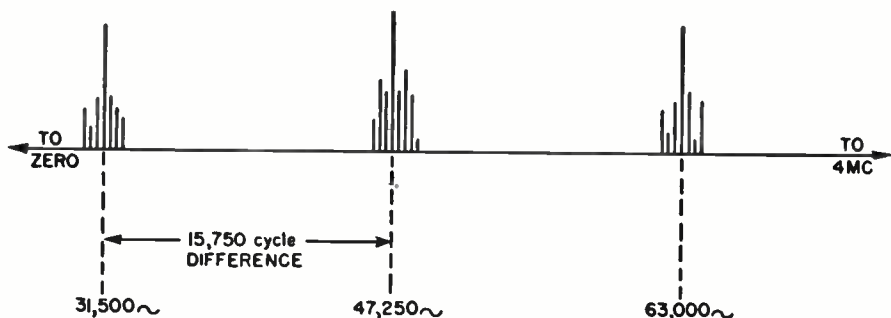

FIG. 19-6. Partial spectrum distribution of a monochrome signal.

the energy of one signal between the clusters of energy of another signal is known as "interleaving."

Thus, a total color signal consists of two components—a monochrome signal and the signal which carries information concerning the color. Let us examine each component, separately.

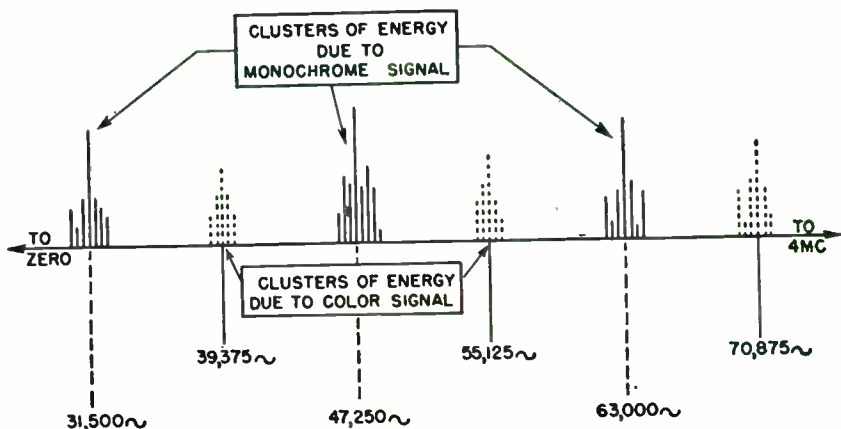

FIG. 19-7. The energy of the color signal is inserted in the gaps between the energy of the monochrome signal.

The Monochrome Signal. The black-and-white, or monochrome, portion of the total color signal is equivalent in all respects to present black-and-white signals. It is formed by combining the red, green, and blue signals from their respective color cameras in these proportions:

$$Y = 0.59G + 0.30R + 0.11B$$

- where
- Y = a mathematical symbol representing the monochrome signal
 - G = green signal
 - R = red signal
 - B = blue signal

This particular proportion was chosen because it closely follows the color sensitivity of the human eye. That is, if you take an equal amount of green light, an equal amount of red light, and an equal amount of blue light and superimpose the rays from these lights on a screen, you will see white. However, if you then look at each light separately, the green will appear to be twice as bright as the red, and from 6 to 10 times as bright as the blue. This is because the eye is more sensitive to green than to red and more sensitive to red than to blue. It is in recognition of this fact that the proportions given above were chosen.

Thus, the monochrome signal is composed of 59 per cent green signal (that is, 59 per cent of the output of the green camera), 30 per cent red, and 11 per cent blue, and contains frequencies from 0 to 4 mc. (The use of the letter *Y* to denote the monochrome portion of the color signal is a common practice and should become familiar to the reader.)

Other names for this monochrome signal are luminance signal and brightness signal. These terms were chosen because they indicate more clearly the action of this signal. Every monochrome video signal contains nothing but the variations in amplitude of the picture signal, and these amplitude variations, at the picture tube, produce changes in light intensity at the screen.

The Color Signal. The second component of the television signal is the color signal itself. This, as we have just seen, is interleaved with the black-and-white signal. To determine what information this portion of the total signal must carry, let us first see how the eye reacts to color, since it is the eye, after all, for which the color image is formed.

A number of men have investigated the color discerning characteristics of the human eye, and, briefly, here is what they found. The typical human eye sees a full color range only when the area or object is relatively large. When the size of the area or object decreases, it becomes more difficult for the eye to distinguish between colors. Thus, where the eye required three primary colors, now it finds that it can get along very well with only two. That is, these two colors will, in different combinations with each other, provide the limited range of colors that the eye needs or can see in these medium-sized areas.

Finally, when the detail becomes very small, all that the eye can discern are changes in brightness. Colors cannot be distinguished from gray, and, in effect, the eye is color-blind.

These properties of the eye are put to use in the NTSC color system. First, only the large- and medium-sized areas are colored; the fine detail is rendered in black and white. Second, as we shall see later, even the color information is regulated according to bandwidth. That is, the larger objects receive more of the green, red, and blue than the medium-sized objects.

The color signal takes the form of a subcarrier and an associated set of sidebands. The subcarrier frequency is approximately 3.58 mc. This represents a figure which is the product (approximately) of 7875 cycles multiplied by 455. The value 7875 is one-half of 15,750, and if we use an odd multiple (1, 3, 5, etc.) of 7875 as a carrier, then the frequency will fall midway between the harmonics of 15,750 cycles. If we used even multiples of 7875, we would end up with 15,750 cycles or one of its harmonics, and this would place the color signal at the same points (throughout the band) as those occupied by the black-and-white signal. Refer back to Fig. 19-7. By

taking an *odd* multiple of 7875, we cause the second signal to fall in between the bundles of energy produced by the first signal, and the two do not interfere.

Now that we have a color carrier (or "subcarrier," as it is known), the next step is to provide it with enough modulation to enable the receiver to develop a color picture. Ordinarily, the information required would consist of *R*, *G*, and *B*, since these are the three primary colors from which all other colors are derived. This means modulating the color subcarrier with three different voltages. Actually, however, we can do the same job by using only two quantities if we resort to the following modification. Take the *R*, *G*, and *B* voltages and combine each with a portion of the monochrome signal after the latter has been inverted 180 deg. This produces $R - Y$, $G - Y$, and $B - Y$ signals. We can do this by taking a portion of the brightness signal (*Y* signal) and passing it first through a low-pass filter. See Fig. 19-8.

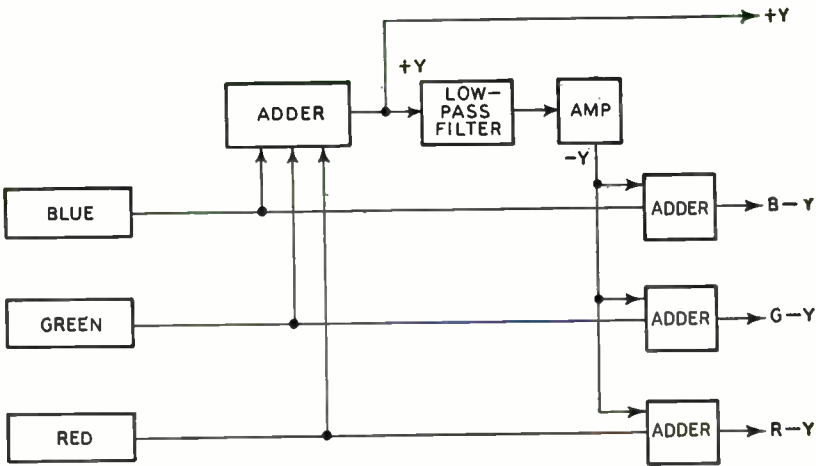

FIG. 19-8. Block diagram illustrating how color-minus-brightness signals are formed.

This permits only the low-frequency components to get through, which is satisfactory since the color signals are also concerned only with the low frequencies. Then the brightness signal is passed through an amplifier where it is inverted. This gives us the desired $-Y$. This is then added to each of the three color signals or voltages to produce a $G - Y$, an $R - Y$, and a $B - Y$ signal.

At the receiver, the original *R*, *G*, and *B* can be reobtained by adding *Y* to $G - Y$ to obtain *G*, by adding *Y* to $R - Y$ to get *R*, and by combining *Y* with $B - Y$ to get *B*.

Thus far, it would seem that we have only exchanged *R*, *G*, and *B* for

$R - Y$, $G - Y$, and $B - Y$. However, once this is done, it turns out that, instead of requiring the three color-difference signals, all we really need are two, say $R - Y$ and $B - Y$. This is so because G information is already present in the Y , or brightness, signal since the latter contains voltages from all three colors ($Y = 0.59G + 0.30R + 0.11B$). Hence, if we send along only $R - Y$ and $B - Y$ in the color signal to the receiver, we can use these to obtain the $G - Y$ information that we need.

We now have only two pieces of color information to send, and somehow the 3.58-mc color subcarrier frequency must be modulated by $R - Y$ and $B - Y$ voltages without conflict with each other.

The best solution to this problem, designers have found, is to take the $B - Y$ and $R - Y$ signals and apply each to a separate modulator. At the same time, 3.58-mc carriers are also applied to each modulator, but with this difference. Their frequencies are the same, but one carrier is 90 deg out of phase with the other. After the carriers are amplitude-modulated, they are then combined to form a resultant carrier. This is best illustrated by means of vectors.

In Fig. 19-9(A), the $B - Y$ vector represents the $B - Y$ modulated carrier; the $R - Y$ vector represents the carrier modulated by the $R - Y$ volt-

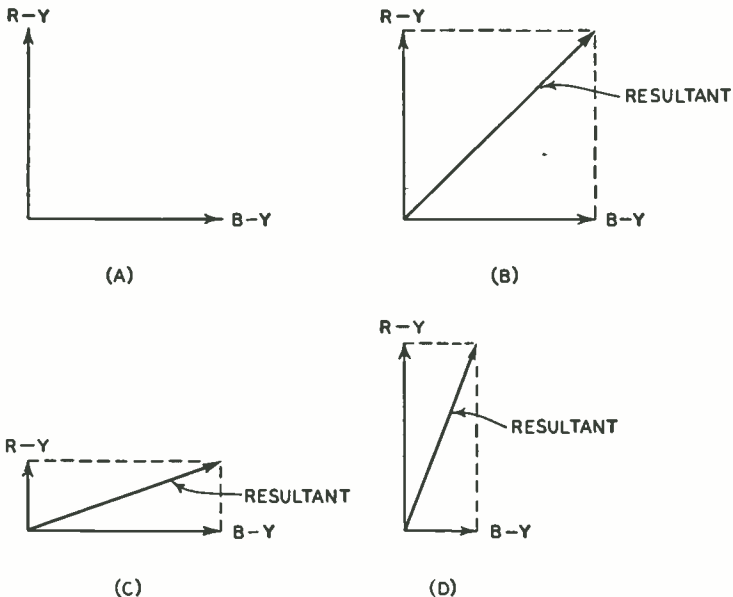

FIG. 19-9. The angular position and amplitude of the resultant carrier for various amplitudes of $B - Y$ and $R - Y$; (A) the $R - Y$ and $B - Y$ vectors; (B) the resultant when $R - Y$ and $B - Y$ are equal; (C) the resultant when $B - Y$ is stronger than $R - Y$; and (D) the resultant when $R - Y$ is stronger than $B - Y$.

age. When these voltages, or signals, are combined, a resultant is formed. If the $R - Y$ and $B - Y$ signals are equally strong, the resultant will occupy the position shown in Fig. 19-9(B). If the $B - Y$ signal is predominant, the resultant will be drawn closer to it. See Fig. 19-9(C). On the other hand, if the $R - Y$ signal is the stronger, the position of the resultant vector will shift toward it. See Fig. 19-9(D). Thus, we can see that the phase angle of the resultant will be governed by the coloring or hue of the picture, whereas the amplitude (or length) of the vector will determine the saturation of the colors.

This particular fact is of great importance in the receiver. If we should change the phase of the resultant with respect to $B - Y$ or $R - Y$, then the colors reproduced on the screen will be incorrect. Hence, present circuit designs incorporate a special phasing control which enables us to compensate for any phase shift that may occur. The position of this control in the circuit will be discussed presently.

Note that the $B - Y$ and $R - Y$ signals amplitude-modulate their separate carriers prior to the addition, and that therefore each modulated signal possesses a 3.58-mc carrier and a series of sidebands (like every AM signal). When the resultant is formed, the sidebands are brought along with it.

If we pause and reconstruct our total color signal, here is what we find. First, there is the Y , or monochrome, signal and it extends over the entire video-frequency range from 0 to 4.0 mc. Second, there is a color sub-carrier, with a frequency of 3.58 mc. This carrier is modulated by the $R - Y$ and $B - Y$ signals, and the modulation intelligence is contained in a series of sidebands that extend above and below 3.58 mc. Just how far above and below depends on the band of frequencies contained in the $R - Y$ and $B - Y$ modulating voltages. It was discovered that the eye is satisfied by the color image produced if we include color information only up to 1.5 mc, while the portion of the image from 1.5 mc to 4.0 mc is rendered in black and white. Hence the sideband frequencies of the color-modulating voltages (so far, $R - Y$ and $B - Y$) need extend only from 0 to 1.5 mc. Furthermore, we can even modify this set of conditions somewhat because the three primary colors are required only for large objects or areas, say, those produced by video frequencies up to 0.5 mc. For medium-sized objects, say, those produced by video frequencies from 0.5 to 1.5 mc, only two primary colors need be employed.

In other words, to take advantage of this situation, we need two color signals: one which has a bandpass only up to 0.5 mc, and one which has a bandpass from 0 to 1.5 mc. The next problem, then, is to determine the composition of these two color signals.

To understand the answer to this problem, let us return to the vector

diagram (Fig. 19-9) which shows the $R - Y$ and $B - Y$ signals. This diagram is redrawn in Fig. 19-10(A), and we have added the equivalent equation for Y .

$$Y = 0.59G + 0.30R + 0.11B$$

For $R - Y$, then, we have

$$R - Y = R - 0.59G - 0.30R - 0.11B$$

or

$$R - Y = 0.70R - 0.59G - 0.11B$$

and, for $B - Y$, we obtain

$$B - Y = B - 0.59G - 0.30R - 0.11B$$

or

$$B - Y = 0.89B - 0.59G - 0.30R$$

This means that the $R - Y$ and $B - Y$ vectors contain R , G , and B voltages in the proportions shown.

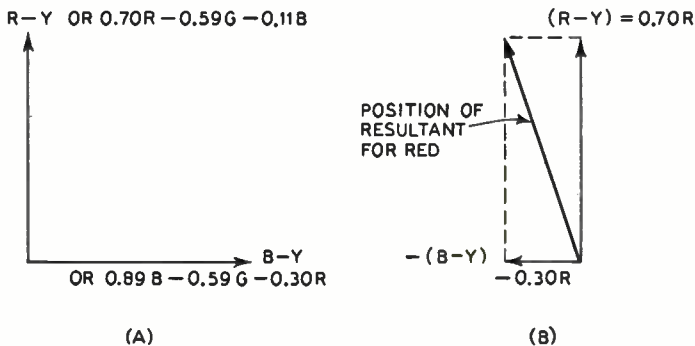

FIG. 19-10. How color determines the position of a resultant vector. (A) Equations showing compositions of $B - Y$ and $R - Y$ in terms of R , G , and B ; (B) position of signal vector when red field is being scanned.

Now, let us suppose that the color camera is scanning a scene containing only red. Then, no green or blue voltages will be present and the $R - Y$ signal becomes simply $0.70R$, while the $B - Y$ signal is reduced to $-0.30R$. This set of conditions is shown in Fig. 19-10(B), with the position, too, of the resultant vector. In other words, this is the position the resultant vector will occupy when red only is being sent.

By following the same process, we can obtain the position that the resultant vector occupies when only green is being sent, or blue, or any other color formed by combining the three primary colors in any combina-

tion. A number of colors are shown in Fig. 19-11, and we see, perhaps more clearly than before, how the phase of the color subcarrier changes as the color to be transmitted varies. To reiterate: The phase angle of the resultant is governed by the coloring of the picture, whereas the amplitude (or length) of the vector determines the saturation of the colors.

The designers of the NTSC system found that, while they could use $R - Y$ and $B - Y$ for the color signals, better system operation would result if they chose two other signals situated not far from the $R - Y$ and $B - Y$ signal.* These two other signals were labeled I and Q , and their position with respect to $R - Y$ and $B - Y$ is shown in Fig. 19-12.

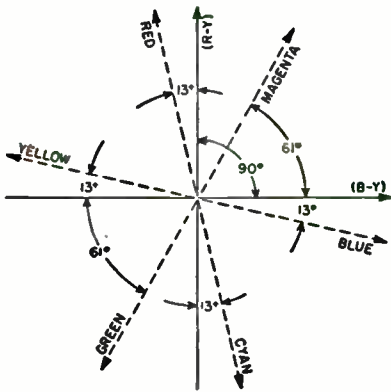

FIG. 19-11. The phase of the color subcarrier depends upon the color to be sent.

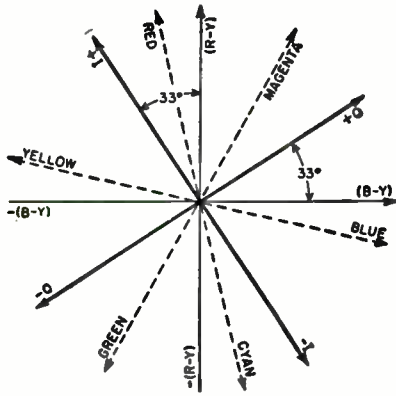

FIG. 19-12. The positions of the I and Q signals with respect to $R - Y$ and $B - Y$.

Thus, where before we had $R - Y$ and $B - Y$ voltages modulating the 3.58-mc color subcarrier, we now substitute I and Q signals. Furthermore, the Q signal possesses frequencies up to 0.5 mc, whereas the I signal is permitted to have sidebands up to 1.5 mc.

Now, what do we gain from this? For all color-signal frequencies up to 0.5 mc, both I and Q are active and since they are 90 deg apart, as were $R - Y$ and $B - Y$, they will act just the way $R - Y$ and $B - Y$ acted. That is, they will produce, in combination with each other, all of the colors shown in Fig. 19-12. Hence, whether we use I and Q or $R - Y$ and $B - Y$ as our modulating voltages for color-signal frequencies up to 0.5 mc, we obtain precisely the same results.

Consider, however, the situation for color-signal frequencies from 0.5

* Some receivers operate as $R - Y$, $B - Y$ systems or variations thereof. In this way they gain certain advantages of economy. More will be said on this point later. I - Q sets, however, produce truer color pictures.

mc to 1.5 mc. The Q signal drops out, and only the I signal remains to produce color on the picture-tube screen. From Fig. 19-12 we see that positive values of the I signal will produce colors between yellow and red, or actually a reddish orange. On the other hand, negative values of I will produce colors between blue and cyan, or, in general, in the bluish-green range. Hence, when only the I signal is active, the colors produced on the screen will run the gamut from reddish-orange to bluish-green.

But why do we want this arrangement? If you go back to an earlier paragraph, you will recall that, for medium-sized objects (say, those produced by video signals from 0.5 mc to 1.5 mc), the sensitivity of the eye is reduced. Actually, for medium-sized objects, it was found that the eye is sensitive principally to the bluish-greens or the reddish-oranges. The NTSC signal (via its I component) is fashioned to take advantage of this fact by producing only blue-greens or reddish-oranges for medium-sized objects.

We are now in a position to consider the color signal in all its aspects:

1. There is a monochrome signal with components that extend from 0 to 4 mc. This is the Y signal.
2. The color subcarrier frequency is set at 3.58 mc (actually it is 3.579545 mc).
3. This color subcarrier is modulated by two color signals called the I and Q signals.
4. The Q signal has color frequencies that extend from 0 to 500 kc, or 0.5 mc. This means that the upper Q sideband extends from 3.58 mc up to $3.58 + 0.5$, or 4.08 mc. The lower Q sideband goes from 3.58 mc down to $3.58 - 0.5$, or 3.08 mc.
5. The I signal has color frequencies that extend from 0 to 1.5 mc. When this modulates the color subcarrier, upper and lower sidebands are formed. The lower sideband extends from 3.58 mc down to $3.58 - 1.5$, or 2.08 mc. If the full upper sideband were permitted to exist, it would extend all the way up to $3.58 + 1.5$, or 5.08 mc. Obviously this would prevent the use of a 6.0-mc overall band for the television signal (video and sound). To avoid this spilling over beyond the limits of the already-established channels, the upper sideband of the I signal is limited to about 0.6 mc. This brings the upper sideband of the I signal to 4.2 mc. The video pass band then ends rather sharply at 4.5 mc. See Fig. 19-13.

There is one further fact of importance in the make-up of a color television signal and this concerns the color subcarrier. We know that the 3.58-mc carrier is modulated by the I and Q color signals. Now, in conventional modulation methods, both the carrier and the sidebands are present when the signal is finally sent out over the air. The intelligence (or modulation) is contained in the sidebands and actually is all that

interests us. However, the carrier is sent along because it is required in the receiver in order to reverse the modulation process and recreate the original modulating voltages.

In the NTSC color system, the color subcarrier is not sent along with its sidebands (after the latter have been formed). Instead, it is suppressed by means of a balanced modulator. This particular practice is followed for two reasons. First, by suppressing the color subcarrier, we reduce the formation of a 920-kc beat note between it and the 4.5-mc sound carrier, which is also part of every television broadcast. This 920-kc beat note would appear as a series of interference lines on the face of the picture tube. Now, it is true that the color sidebands are present and that they can (and do) beat with the 4.5-mc sound carrier to produce similar low-frequency beat notes. However, in any signal, the carrier usually contains far more energy than any of its sidebands; hence, when we suppress the carrier, in effect we are suppressing the chief source of this interference. Whatever other interference may be produced by some of the stronger sidebands near 3.58-mc can be more easily dealt with by using traps in the IF system. This will be seen when we examine the circuitry of a receiver.

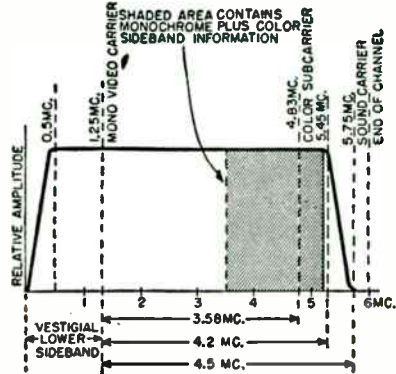

Fig. 19-13. The distribution of the full color signal within its allotted band.

The second reason for using the suppressed-carrier method is that it leads to an automatic removal of the entire color signal when the televised scene is to be sent wholly as a black-and-white signal. When this occurs, *I* and *Q* decrease to zero, and since the balanced modulators suppress the carrier, no color signal at all is developed.

With these advantages of carrier suppression comes one disadvantage. When the color sidebands reach the color section of the receiver, a carrier must be reinserted in order to permit detection to take place. Offhand, one might suppose that an oscillator operating at 3.58 mc will be needed. This is one requirement. A second and vitally important consideration is the phase of this reinserted carrier. Remember that, at the transmitter, attention was given to the phase of *I* and *Q* as they were introduced into the modulator. If the same relative phase is not maintained in the reinserted carrier, the colors obtained at the output of the color circuits will not possess the proper hue.

To provide information concerning the frequency and phase of the missing color subcarrier, a color burst is sent along with the signal. This burst follows each horizontal pulse and is located on the back porch of each blanking pedestal. See Fig. 19-14. It contains a minimum of 8 cycles of

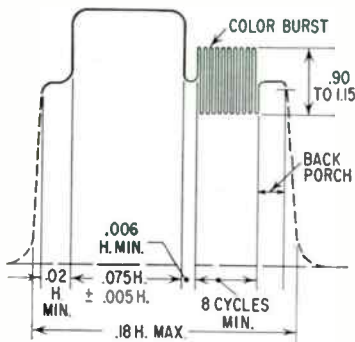

FIG. 19-14. The position of the color burst for subcarrier oscillator sync on the back porch of a horizontal sync pulse.

the subcarrier and is phased in step with the color subcarrier used at the station. In the receiver, this burst is used to lock in the frequency and phase of a 3.58-mc oscillator, and thus we are assured at all times that the reinserted carrier will do its job correctly when it recombines with the color sidebands.

COLOR TELEVISION RECEIVERS

A block diagram illustrating the major divisions of a color television receiver is shown in Fig. 19-15. Roughly there are ten such divisions.

1. RF tuner
2. Video IF system
3. Sound IF, FM detector, and audio system
4. Video detector and video amplifiers
5. Chrominance channel
6. Color sync section
7. Sync separators and AGC
8. Vertical- and horizontal-deflection systems

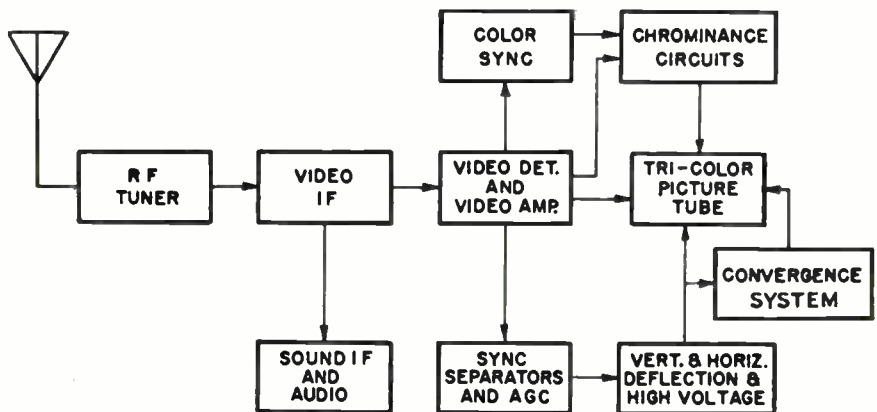

FIG. 19-15. Master block diagram of color television receiver.

9. High-voltage circuits

10. Tri-gun color picture tube and associated convergence circuits

If we compare this diagram briefly with that of a conventional black-and-white receiver, we see that all sections with the exception of 5, 6, and 10 are common to both types of receivers. Therefore, the circuitry in sections 1, 2, 3, 4, 7, 8, and 10 should contain many familiar aspects to anyone who has worked with black-and-white receivers. That this is so will become evident as we proceed through a detailed description of a color television receiver.

(The actual circuits that the blocks represent are given in Fig. 19-41 at the end of this chapter. After the material has been covered once, reread the chapter, this time linking each block with its associated section of the receiver.)

1. RF Tuner. The RF tuner consists of an RF amplifier, an oscillator, and a mixer stage. See Fig. 19-16. This section of the receiver is similar to

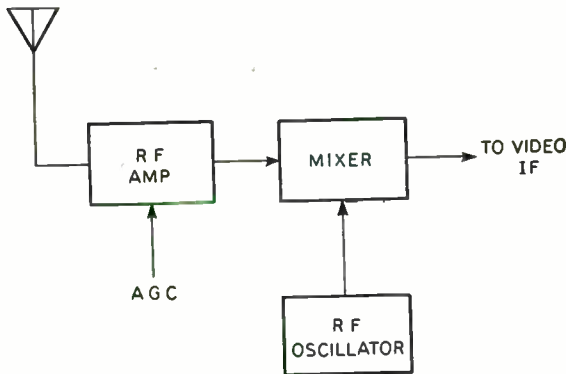

FIG. 19-16. Block diagram of RF tuner for color receiver.

that employed in the black-and-white receivers since the RF requirements of both types of sets are alike. However, the allowable tolerance in the RF frequency response is more critical. A tilt or slope up to 30 per cent in the response curve of a tuner might be satisfactory for monochrome reception, but for color TV reception it would cause a degradation in picture quality due to the unequal amplification. As shown in Fig. 19-17, the RF response curve of a tuner for color reception must have a more uniform characteristic within the signal portion of the band.

If a tuner possessing the response of Fig. 19-17(A) is employed for color reception, the color subcarrier will be attenuated as much as 20 to 30 per cent compared with the picture and sound carrier. The response of Fig.

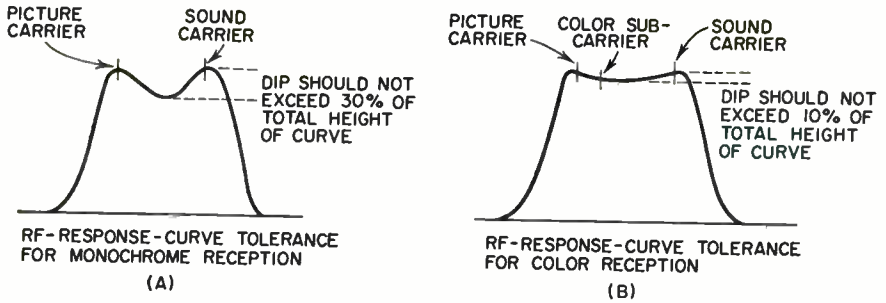

FIG. 19-17. RF-response curves. (A) Suitable for monochrome reception. (B) Required for color reception.

19-17(B) is required on all channels since any station now sending monochrome signals is permitted by the FCC to send color broadcasts, provided the necessary additional equipment is installed at the studio and the transmitter.

In Fig. 19-41, a cascode amplifier is employed for the RF amplifier. The mixer is formed by the pentode section of a 6EA8, and the triode half of the tube provides the oscillator. The resonant circuits themselves are mounted on a wafer-switch tuner.

The circuits employed in the tuner consist of an RF amplifier and a modified Colpitts circuit for the oscillator. The mixer combines both incoming and oscillator signals and from them produces the difference, or IF signals. These are then fed to the video IF system.

No UHF tuning circuits are shown in Fig. 19-16, but they would be treated in the same way as they are in black-and-white receivers.

2. Video IF System. The video IF system in color television receivers, in general, contains three or four separate amplifiers. See Fig. 19-18. In form these closely resemble the IF section of a monochrome receiver because the change to color reception in no way has altered the basic function

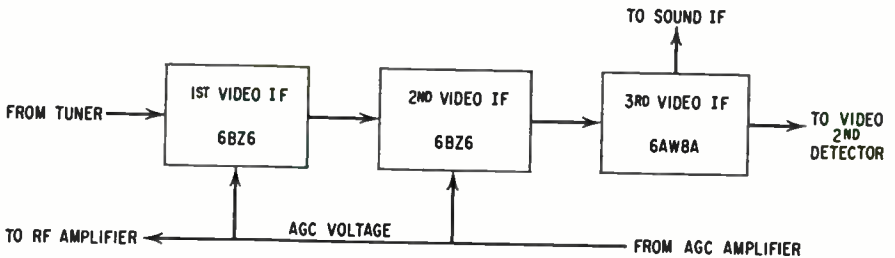

FIG. 19-18. A typical video IF system. Note similarity to video system of monochrome receivers. In most color receivers one or two additional IF stages may be used.

of this section of the receiver, namely, that of establishing the overall bandpass and sensitivity of the receiver.

The stages in the video IF system are stagger-tuned, generally in the 41-to-46-mc range, with suitable traps for the accompanying sound (41.25 mc), for the sound carrier of the adjacent lower channel (47.25 mc), and for the video carrier of the adjacent higher channel (39.75 mc). The adjacent channel traps generally have an attenuation of 55 to 60 decibels. The sound carrier of the same channel (41.25 mc) may have more than one trap to insure that this signal is kept down at the proper level. Failure to observe this precaution will tend to produce a noticeable 920-ke beat on the picture-tube screen, especially in those sections where the colors are highly saturated.

Typical IF-response curves for color reception are shown in Fig. 19-19. These curves differ mainly in the location of the color subcarrier. In Fig. 19-19(A), the color subcarrier is shown near the top of the curve with 41.6

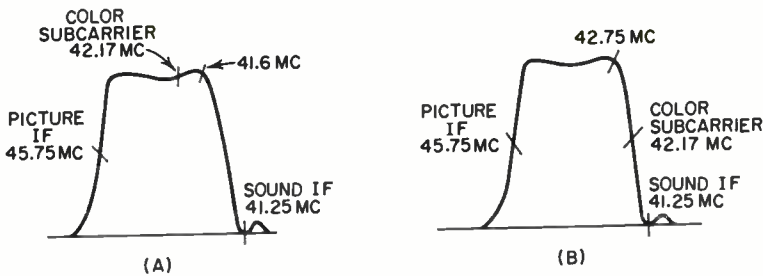

FIG. 19-19. Typical IF-response curves for color receivers.

mc at the "knee," or limit of the response. This curve is typical of many early receivers.

The overall IF-response curve extends to approximately 4.2 mc (at the 50-per-cent points) in order to include the color subcarrier and all its sidebands. It will be remembered from the preceding discussion that the upper sidebands of the color subcarrier extend about 0.6 mc above 3.58 mc, or up to 4.2 mc. Hence, to reproduce the picture in full and true color, it is necessary that the upper color sidebands be permitted to pass. Beyond 4.2 mc, the IF response drops sharply to the level of the sound carrier.

The IF response shown in Fig. 19-19(B) is of more recent design and is typical of later model receivers of some manufacturers. The same general shape of the response curve is maintained except for a slight decrease in sharpness of the slope on the color subcarrier side. Also, the color subcarrier signal is carried through the IF stages at an amplification level equal to the picture IF (50 per cent or 6 db). This design further reduces the tend-

ency toward a 920-kc beat pattern on the picture-tube screen. However, other effects created by this approach are compensated for in the video amplifier and chroma bandpass stages discussed later.

AGC voltage is applied to all the IF amplifiers, except the last, in order to control their gain in accordance with the level of the received signal. If the last IF stage is AGC-fed, excessive attenuation will result. A portion of the same voltage is also fed to the control grid of the RF amplifier for similar control.

From the video IF system, the signal is generally applied to two points: the video second detector and the sound system. Let us consider the latter first.

3. Sound IF, FM Detector, and Audio System. It is the practice in color television receivers to separate the sound and video carriers just as soon as it becomes feasible to do so. This generally occurs at the last IF stage. The purpose, of course, is to keep the amount of 920-kc beat interference voltage as small as possible so that its effect on the screen will be negligible.

The practice generally followed is to employ a separate detector (usually a germanium crystal diode) in which the sound and video carriers are mixed to produce the 4.5-mc sound IF signal. This signal is then amplified by one or two IF-amplifier stages and applied to a sound-detector stage (usually of the quadrature-grid type employing a 6DT6 tube). From the sound detector, the original audio intelligence is recovered and fed to one or two audio-amplifier stages and finally to the speaker. The system is identical in all respects to the sound section of many present-day monochrome receivers. See Fig. 19-20.

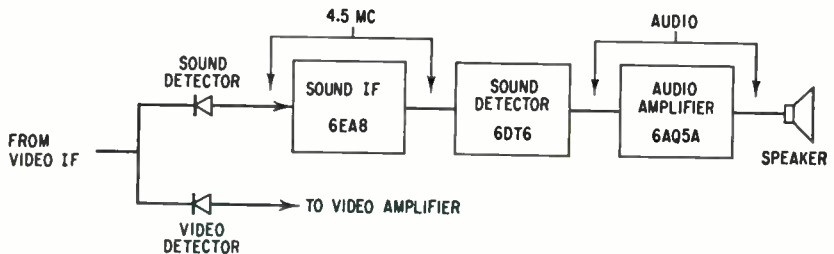

Fig. 19-20. Sound-IF, detector, and audio-amplifier stages.

4. Video Detector and Video Amplifiers. Returning to the video system, we find that the signal enters the video second detector after leaving the IF stages. Here the signal is demodulated, giving back the 0-to-4-mc monochrome or luminance signal, and the color sidebands. Present, too, are the various synchronizing pulses plus the color burst. The latter, it will be

recalled, is needed to reestablish the proper frequency and phase of the missing color subcarrier.

At the video detector output, a number of things must occur. First, the brightness portion of the total signal must be fed to a separate amplifier. Second, the color sidebands must be separated from the full signal and transferred to a separate chrominance section. Third, the color burst must be made available to the color sync circuits. And, finally, there are the sync separator and AGC system that must also be tied into the signal path.

There are a number of different ways in which all the foregoing functions can be carried out. The block diagram in Fig. 19-21 illustrates one

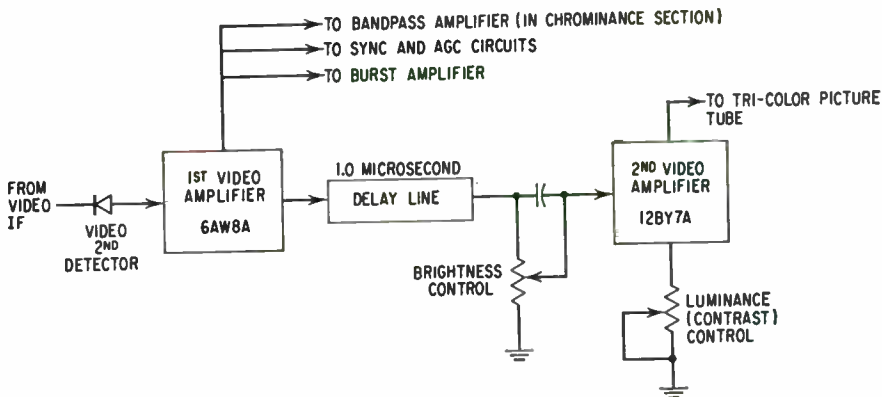

FIG. 19-21. Block diagram of video second detector and video amplifier (brightness channel). Color receivers may use one or two video amplifiers.

method. The signal from the video second detector is fed to a video amplifier. Here both chroma and monochrome signals are amplified. The monochrome signal is then transferred to a video second amplifier and from this stage either to a matrix network or to the cathodes of the picture tube. The chroma signal is taken from the first video amplifier and coupled to a bandpass amplifier in the chrominance section. A color receiver may employ one or two bandpass amplifiers. The chroma signal is also fed to a burst amplifier, which, by means of accurate gating, separates the burst signal from the chroma signal. The brightness and contrast controls are also associated with the video-output stage just as in monochrome receivers. The contrast control in the receiver of Fig. 19-41 is in the cathode circuit and varies the amount of cathode bias (degeneration) applied to the tube and hence the amplification of the video signal passing through the tube. The brightness control also varies a potential applied to an element of the video-output tube, regulating the over-all operating point of the tube. This control, although

generally located in the input circuit of the video-output stage (control grid), may also be in the screen or plate circuit. A time-delay line (approximately 1.0 microsecond) is inserted between the first and second video amplifiers. The need for the delay line arises from the fact that the color signal passes through a rather narrow bandpass filter in its system which acts to slow down its passage. To insure the simultaneous arrival of the *Y* (or brightness) signal with the color signal at the matrix (or picture-tube grids), an artificial delay line having a delay of from 0.6 to 1.0 microsecond (depending on receiver design) is inserted in the *Y* channel.

It is interesting to note that the bandpass of the *Y* channel beyond the color take-off point is usually reduced below 3.58 mc. This is done to minimize further any visual dot pattern which the 3.58-mc color subcarrier signal may develop on the face of the picture-tube screen.

5. Chrominance Channel. We come now, for the first time, to a section of the receiver which has no counterpart in any monochrome receiver—one which is completely devoted to color. This section is usually known as the “chrominance channel” and covers several stages. The number of stages used in this section and the type of circuitry employed to accomplish its function vary considerably among TV sets. However, regardless of the type of circuitry employed, the principal function remains the same: the section must demodulate the color signal in such a way that the original red, green, and blue components of the chroma signal are reobtained faithfully as originally seen by the color camera tube. Essentially, the chrominance channel amplifies the chrominance signal, demodulates (detects) the individual red-, green-, and blue-signal components, and by a matrixing, or signal-adding, network, couples the correct portions of these signal components to the tri-color picture tube. This, then, is the function of the chrominance channel.

Now, let us study this system in greater detail.

Many color receivers produced in 1954 and 1955 utilized the *I, Q* system shown in Fig. 19-22. Although this system is functionally identical with recent receivers, it is similar in only certain aspects to present circuit design. This similarity will be discussed later. Let us start with this earlier system.

The full color signal (Fig. 19-22) is obtained from the video system and fed to a bandpass amplifier. Also applied to the bandpass amplifier is a gating pulse which keys off the amplifier by applying a pulse derived from the horizontal-deflection output transformer. The pulse arrives only during the horizontal retrace interval when the color burst is passing through the system. By gating out the burst from the bandpass amplifier, we prevent color background unbalance in the picture tube. This unbalance may arise if the d-c restorers in the chrominance channel clamp onto the color bursts rather than onto the tips of the sync.

The bandpass amplifier also receives a d-c biasing voltage from a stage

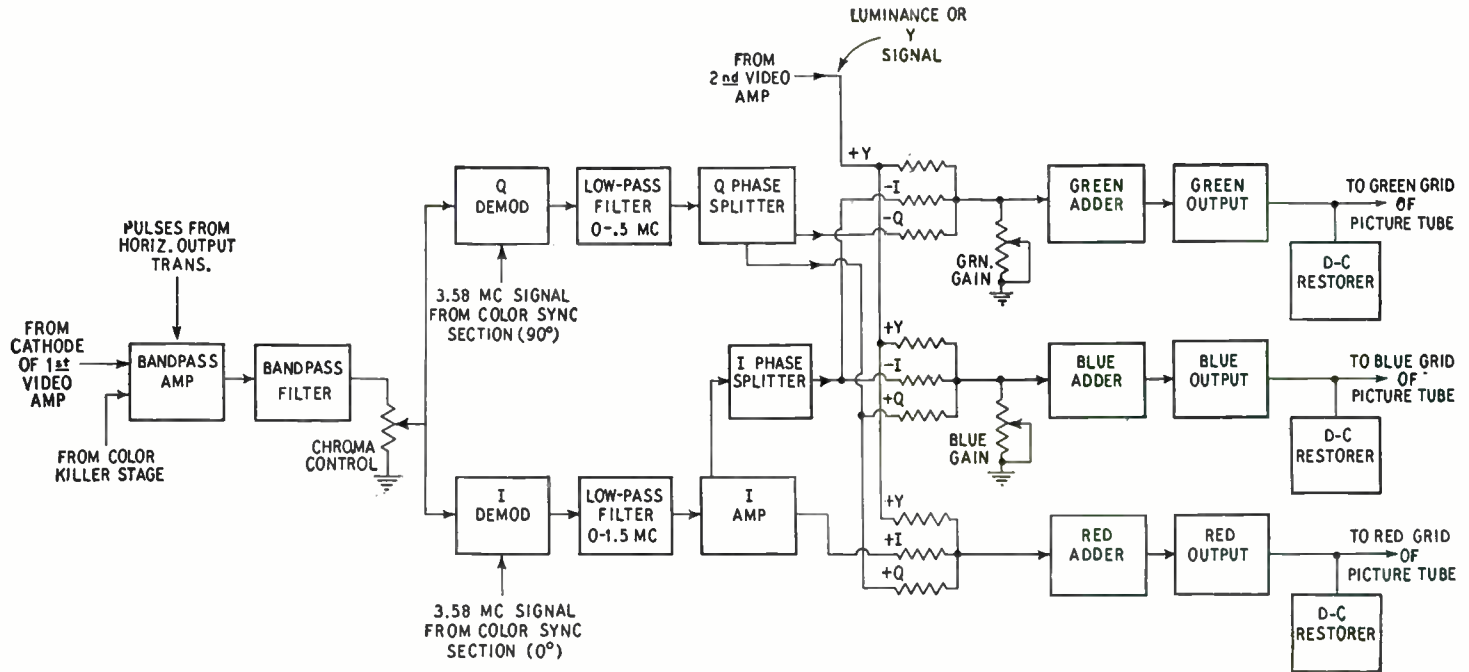

FIG. 19-22. The chrominance section of a color receiver employing *I, Q* demodulators. No special delay line is shown for the *I* stages because the required delay is in distributed form.

known as a "color killer." This stage is located in the color-sync section of the receiver, and its purpose is to bias the bandpass amplifier to cutoff in the absence of a color signal (that is, when black-and-white signals only are being received). This precaution is taken to insure that no random color appears on the picture-tube screen during a monochrome transmission. Such random color would be produced by noise or monochrome signals reaching the *I* and *Q* demodulators.

In the plate circuit of the bandpass amplifier there is a bandpass filter which permits signals from 2.1 to 4.1 mc to pass, but strongly attenuates all others. This filter thus serves to separate that portion of the signal containing the color sidebands from the section of the signal containing only monochrome information.

The bandpass filter is terminated in a color-intensity control (called the "chroma control") from which point we can take as much of the color signal as we feel is required and feed it to the following chroma amplifier. This control actually determines how saturated (deep) the colors appear on the screen. It is a front-panel control which the user of the set can adjust as he sees fit. (It is also labeled "chroma," "color intensity," "color saturation," or "color." Regardless of the name used, its function is the same in any color receiver.)

The chroma stage following this control amplifies the color signal and then feeds it, in equal measure, to the *I* and *Q* color demodulators. Also arriving at these demodulator stages is another voltage—a 3.58-mc signal.

The 3.58-mc signal represents the missing color subcarrier and it must be recombined with the color signal of the demodulators so that the original *I* and *Q* signals can be detected. Both *I* and *Q* stages receive a 3.58-mc voltage, the only difference being that one 3.58-mc voltage lags behind the other 3.58-mc voltage by 90 deg. This particular phase relationship is required because the color signal was modulated this way at the transmitter and demodulation is the reverse process.

With a color signal being received, the entire chrominance channel is operative, and the output of the two demodulators represents the original *I* and *Q* color signals that were originally developed at the transmitter. The *I* signal, then, is passed through a 0 to 1.5-mc bandpass filter and a special 0.5-microsecond delay line. Then it may receive additional amplification before being made available to the adding, or matrix, network in positive and negative polarity. The double-polarity *I* signals are required in the final mixing process from which red, green, and blue voltages are re-created. A single phase splitter provides the positive and negative *I* signals.

The use of a 0.5-microsecond delay network in the *I* channel again stems from the narrow 0-to-0.5-mc bandpass filter through which the *Q*

signal is sent. The *Y* signal, it will be remembered, had to be delayed 1 microsecond for the same reason. The difference in delay between the *Y* and *I* signals arises from the different characteristics of their respective networks. In the *Y* channel, the bandpass of the circuits extends from 0 to 3.5 or 4.0 mc. In the *I* channel, the bandpass extends only from 0 to 1.5 mc. The narrower bandpass introduces some delay, requiring less additional delay in order to slow the *I* signal down to the *Q* signal.

In the *Q* channel, the demodulated *Q* signal passes through a 0-to-0.5-mc bandpass filter and reaches a phase splitter from which positive and negative *Q* signals are made available to the matrix.

We now have at the matrix the *I*, *Q*, and *Y* signals and, by properly combining them, we can re-obtain the red, green, and blue voltages that were originally combined to form the *I*, *Q*, and *Y* signals.* The addition is carried out in rather simple fashion by using a series of resistors connected as shown in Fig. 19-23. At the output of the matrix section, each of the

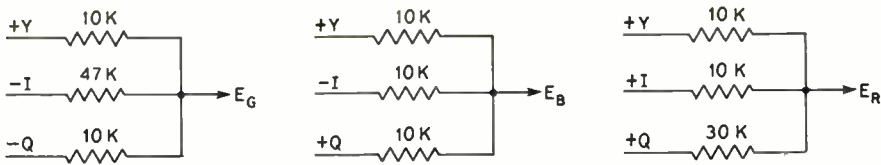

FIG. 19-23. Typical matrix network of an early color receiver which adds *I*, *Q*, and *Y* signals to re-create original red, green, and blue signal voltages.

three color voltages is separately amplified by triode or pentode amplifiers and then transferred via separate d-c restorers to the appropriate control grid of the tri-gun picture tube.

The demodulators in color receivers which reproduce the original *I* and *Q* components from the chroma signal are usually low-level demodulators, that is, demodulation is performed at a low color-signal level and, by necessity, the signals must be further amplified following demodulation.

At this point, it may be desirable to say a few words about color demodulators. The *I*, *Q* system just described, when properly designed, provides excellent color reproduction. However, price is an important aspect of receiver sales, and if it is possible to achieve acceptable results at lower cost, most circuit designers will use the more economical system. That is why the *I*, *Q* method is no longer being used; instead, several other systems have been developed.

* Remember that the original *R*, *G*, and *B* voltages at the transmitter were manipulated to form the *I*, *Q*, and *Y* signals. Here, in the receiver matrix, the reverse action is taking place.

For example, $R - Y$ and $B - Y$ color demodulators have been used, with both channels possessing an identical bandpass, generally 0-5 mc. While this method does not color as much of the picture as the I, Q system, the visual results are acceptable. (In the narrower system, only the larger objects are in color; medium and small detail are rendered in black and white only.) By this modification, no time-delay networks are needed in the chrominance section, although the time-delay filter in the Y section is still retained. The change also permits other simplifications which are economically advantageous.

$R - Y$ and $B - Y$ systems have been used with low-level and high-level demodulators. In high-level demodulation, the $G - Y$ signal is formed in a cathode circuit which is common to both $R - Y$ and $B - Y$ demodulators. See Fig. 19-24. The detected $R - Y, B - Y,$ and $G - Y$ color signals are then

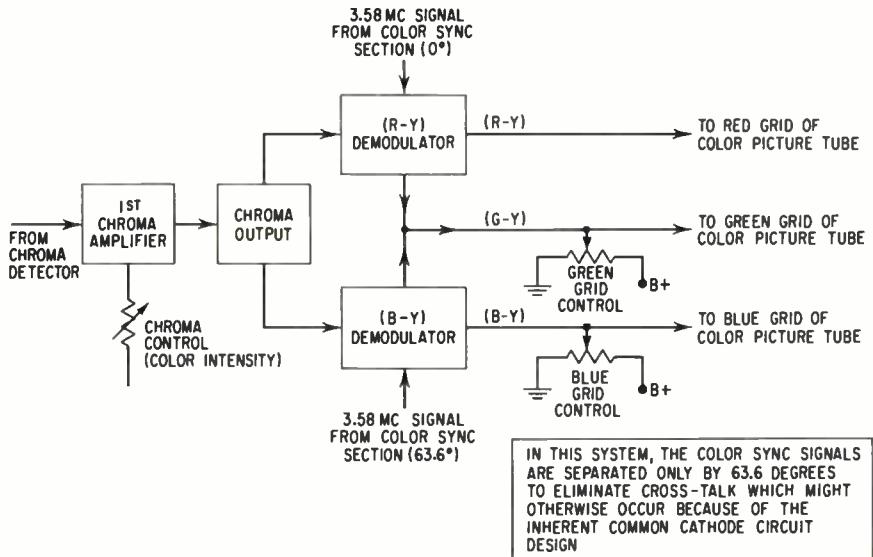

FIG. 19-24. The chrominance section of a color receiver employing $R - Y$ and $B - Y$ demodulators. Note that bandwidths for the two demodulators are equal and that no delay line is required.

fed directly to the grids of the picture tube. This is what we mean by high-level demodulation; no additional amplifiers are needed beyond the demodulators. In such a system, the 3.58-mc carrier that is reinserted with the two color sidebands does not possess the same 90-degree relationship previously indicated for the I, Q system or even when low-level $R - Y, B - Y$ detection is employed. This stems from the fact that a common cathode is being utilized at the demodulators to provide the $G - Y$ signal. If a 90-deg phase

separation between the 3.58-mc carriers being applied to each demodulator is maintained, cross-talk will occur and cause improper coloring of the image. That is, the colors sent to each grid of the picture tube will not be as pure as they could be.

When low-level $R - Y$ and $B - Y$ demodulation is carried out and the $G - Y$ signal is formed in a separate circuit that appears later in the circuit, the reinserted 3.58-mc carriers more nearly possess a 90-deg phase relationship.

In some receivers, $R - Y$ and $G - Y$ are demodulated and a portion of each is added to obtain $B - Y$. This is feasible because if we can add $R - Y$ and $G - Y$ to obtain $B - Y$, we can also use $R - Y$ and $G - Y$ to derive $B - Y$. It should be noted, however, between the 3.58-mc signals sent to that if we employ this method, a different phase relationship is required the demodulators. This can be seen from Fig. 19-25.

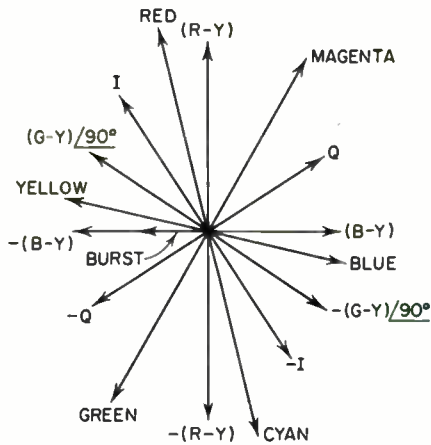

FIG. 19-25. The phase relationships between the various color signals, including $R - Y$, $B - Y$, and $G - Y$.

Still another low-level modulation system uses what are called X and Z demodulators. See Fig. 19-26. This is basically an $R - Y$, $B - Y$ system, but the angular separation of the reinserted 3.58-mc carrier signals is 57.5 deg and not 90 deg. The output from the X demodulator is $R - Y$ and the output from the Z demodulator is $B - Y$. From

the common cathode of the following amplifiers, the $G - Y$ signal is obtained, amplified, and then transferred to the appropriate grid of the color-picture tube. Notice that the terms X and Z have been selected arbitrarily to identify the demodulators; they have no other significance.

This matter of color demodulation in which phase angles other than 90 deg are employed in the reinserted 3.58-mc carrier often puzzles the serviceman working with color circuits. The precise angle selected depends upon the way the circuits have been designed to handle the color signals. Demodulation can be performed in a variety of ways, each with its own phase requirements. The point to remember in all these systems is that pure $R - Y$, $B - Y$, and $G - Y$ signals are provided at their respective grids at the color-picture tube.

In the receiver shown in Fig. 19-41, an X , Z low-level demodulation system is employed. In the circuit of Fig. 19-41, the chrominance signal is fed

to the control grids of the two demodulators through a transformer. The 3.58-mc reference voltages from the oscillator are also fed through a transformer to the cathode of each tube, with a separation of 57.5 deg. The output of each demodulator is the result of detection within the tube and appears as $R - Y$ voltage in the X demodulator output, and $B - Y$ voltage in the Z demodulator output. Since the signal must be further amplified, $R - Y$

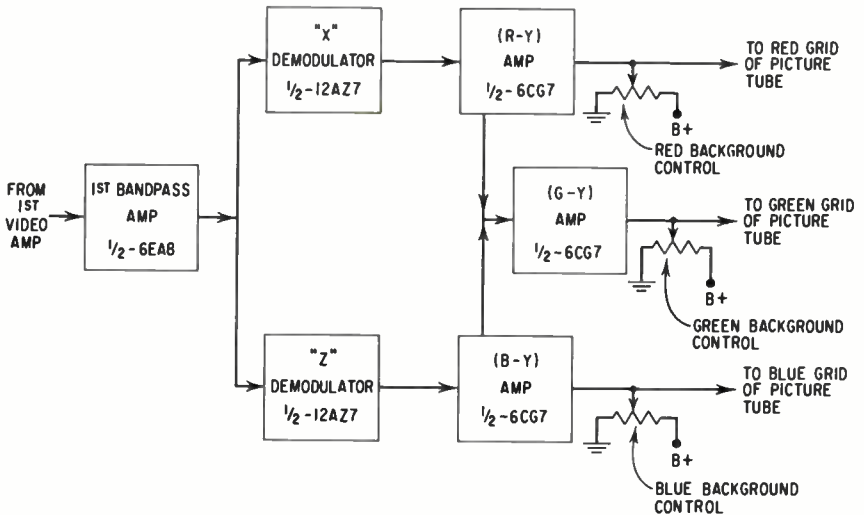

FIG. 19-26. The chrominance section of the color receiver in Fig. 19-41. This employs X and Z demodulators.

and $B - Y$ amplifiers are used, as well as a $G - Y$ amplifier. The X demodulator output is fed to the grid of the $R - Y$ amplifier and the output of the Z demodulator is fed to the grid of the $B - Y$ amplifier. The common cathode circuit of the two amplifiers is also common to the $G - Y$ amplifier. Thus, when $R - Y$ and $B - Y$ currents are flowing, the correct amount of $G - Y$ voltage will appear in the plate of the $G - Y$ amplifier.

The three color-difference signals are then applied to the grids of the tri-color-picture tube at the same time that the luminance (or Y) signal is fed to the three cathodes of the picture tube. Thus, matrixing is actually performed within the tri-color tube itself. When the Y signal (appearing on the "red" cathode) is added to the $R - Y$ signal appearing on the "red" grid, a voltage (bias) results that represents R alone; the $B - Y$ and $G - Y$ signals are added in the same manner to the Y signal, resulting in the correct voltage and beam current for B and G . Peaking coils in the output circuits of the demodulators are resonant to 3.58-mc, preventing this frequency from reaching the picture-tube grids.

6. Color Sync Section. Stability of the 3.58-mc carrier signal reinserted into the chroma demodulators is an important factor in the reproduction of the original red, green, and blue voltages. It is the function of the color-sync section to develop a stable 3.58-mc signal, and to make certain it possesses the proper frequency and, what is equally important, the proper phase. If the phase is wrong, the reproduced color will likewise be wrong, and in a color television system this is a very noticeable form of distortion.

A block diagram of the color sync section of a color receiver is shown in Fig. 19-27. The input to this section is obtained from some point in the

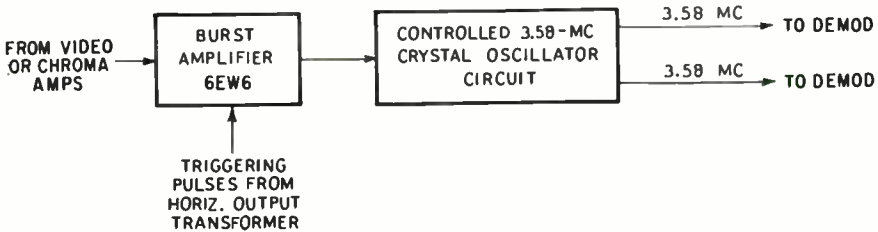

FIG. 19-27. An abbreviated block diagram of the color sync section of a color receiver.

luminance system or from some other point where the chroma signal is complete, for example, the bandpass (chroma) amplifiers. What the color sync section is primarily designed to obtain is the color burst which is placed on the back porch of every horizontal sync pulse. See Fig. 19-14. It is this burst which contains information concerning the proper frequency and phase of the color subcarrier. The 3.58-mc burst take-off point varies in different receivers, but it is always from some point where the full chroma signal is present. In some receivers, the take-off point might be at a resonant coil or transformer in the plate circuit of one of the video amplifiers. In another receiver, it might be at one of the chroma amplifiers.

The voltage developed by the take-off circuit is applied to a burst amplifier which is gated by a pulse obtained from the horizontal output transformer. That is, the stage is cut off except when gated by the pulse, and during this interval the color burst should be active in the system and hence pass through the burst amplifier. At the end of the gating pulse, the burst amplifier once again lapses into cutoff.

At the output of the burst amplifier, the color burst may be applied either to a crystal-ringing circuit or to an automatic phase control (APC) circuit. Some of the early receivers employing *I, Q* demodulation systems used a crystal-ringing circuit but nearly all present-day receivers use an automatic phase-control circuit. Both systems are described here.

The Crystal-ringing Circuit. This system uses a quartz crystal which, when excited by the color burst at the start of each horizontal line, will continue to “ring” or oscillate at its natural frequency (here 3.58 mc) for the duration of the line. A typical circuit is shown in Fig. 19-28. The burst

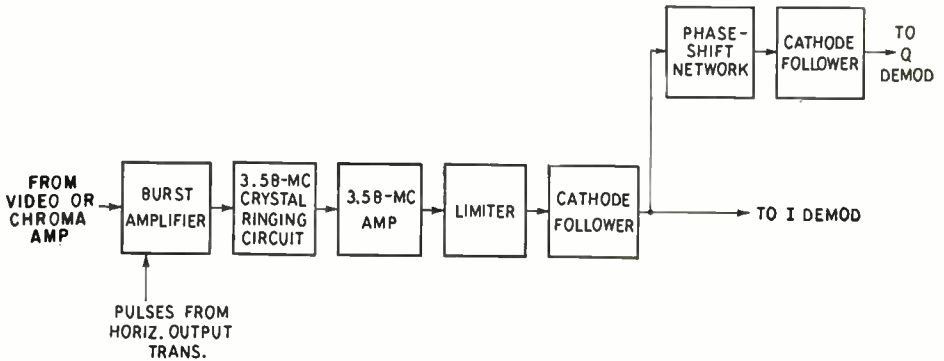

FIG. 19-28A. Block diagrams of a crystal ringing system for generating 3.58-mc oscillations.

from the burst amplifier activates the quartz crystal and, because of its extremely high Q , it continues to oscillate with very little decrease in amplitude until the next burst arrives. The trimmer in series with the crystal can change its resonant frequency by several hundred cycles and thus take care of crystal tolerances.

The stage following the crystal is an amplifier stage, and the stage

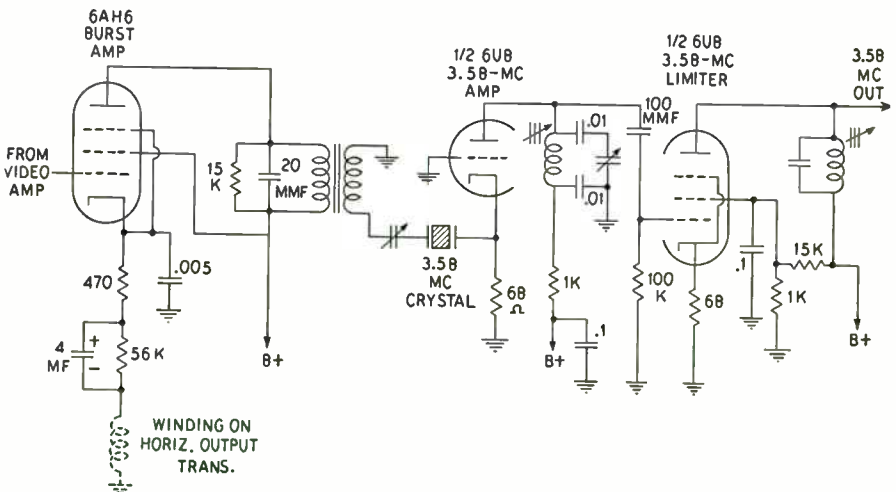

FIG. 19-28B. Partial schematic circuit of crystal ringing system.

beyond that is generally a limiter to smooth out variations in output of the ringing circuit. Output from the limiter may be used as one of the 3.58-mc driving voltages for the *I* or *Q* demodulators, while the same output, passed through a 90-deg phase-shift network will provide the reference voltage for the other demodulator.

Automatic Phase-control System. A second approach to the development of a 3.58-mc subcarrier whose frequency and phase are locked in to that of the color burst is by means of an automatic phase-control system. This system, shown in Fig. 19-29, is dominant in present-day receivers. It

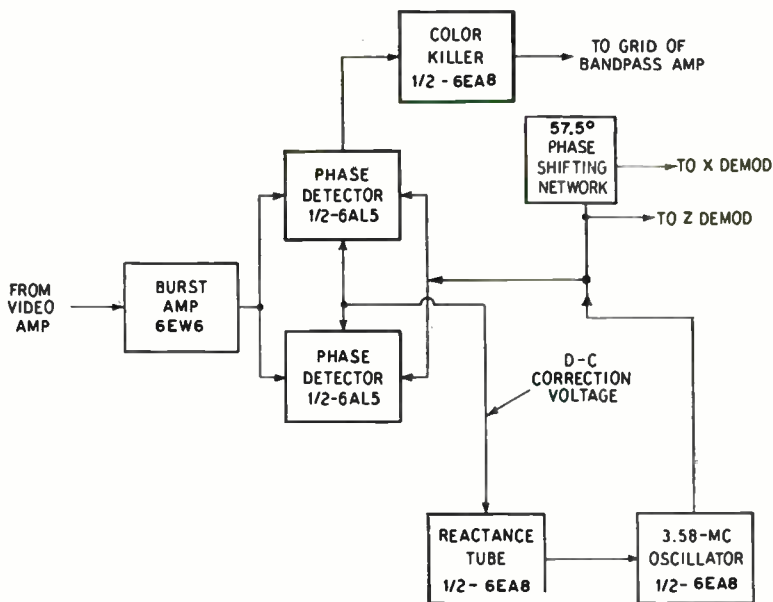

FIG. 19-29. A color sync section using an automatic phase-control system. This is the method employed in the receiver of Fig. 19-41.

closely resembles the horizontal AFC systems currently employed in black-and-white receivers, that is, the frequency and phase of the color burst are compared with the frequency and phase of the signal developed by a free-running, 3.58-mc oscillator. If a difference exists between the two, a corrective d-c voltage is developed and applied to a reactance tube which is connected across the resonant circuit of the oscillator. The reactance tube, in response to the correction voltage, varies its plate current in such a way as to bring the oscillator frequency in line with the color burst.

The oscillator output is fed to a 3.58-mc tuned circuit from which is obtained signals for the phase detector and the two color demodulators.

and vertical sync pulses from the rest of the video signal. Once this is accomplished, the pulses are applied to the horizontal and vertical sweep systems through appropriate integrating and differentiating networks.

Linked with the sync separator is a noise inverter which serves to prevent noise pulses from affecting the vertical and horizontal sweep systems. In the circuit of Fig. 19-41, the cathode of the noise inverter is connected to the cathode of the first video amplifier. The grid-bias level for the inverter is set by the noise-inverter-threshold control, which obtains a negative d-c voltage from the grid circuit of the horizontal-deflection oscillator. This voltage is constant in value and therefore suitable for the purpose. The bias is adjusted so that any noise appearing at the cathode will appear amplified at the plate of this tube. Also present at the plate, but of opposite polarity, is the video signal with the same noise pulses. If the noise-inverter-threshold control is properly selected, the two sets of noise pulses will cancel each other and a noise-free signal will be forwarded to the sync separator.

For the AGC section, any method which has been employed in monochrome sets may be utilized in color receivers. At the present time, keyed AGC is favored, but this preference stems not from the fact that color television is being used, but from the inherent characteristics of keyed AGC itself.

The tubes controlled by the AGC voltage include the RF amplifier and one or more video IF stages. Clamping of the AGC voltage fed to the RF amplifier may also be employed.

8. Vertical- and Horizontal-deflection Systems. In the horizontal- and vertical-deflection circuits we again encounter circuits similar to those found in monochrome receivers. See Fig. 19-32. The vertical system consists of a

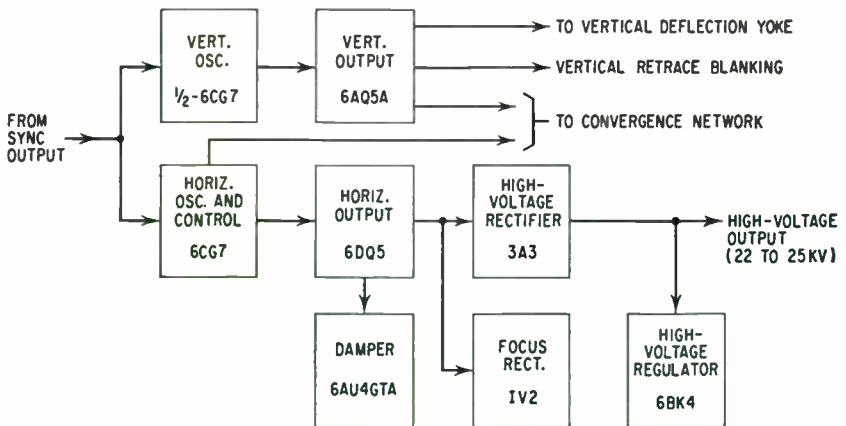

FIG. 19-32. Block diagram of the vertical- and horizontal-deflection systems of the color receiver of Fig. 19-41.

multivibrator with an output amplifier. In the horizontal section, the oscillator is preceded by an automatic frequency-control system. Beyond the oscillator there may or may not be a discharge tube, after which we have the output amplifier and the horizontal output transformer. A damper tube is connected across the horizontal windings of the deflection yoke to eliminate oscillations which may occur during beam retrace. The energy absorbed by the damper tube in this process is converted into an additional voltage which, when added to the normal B+ voltage, results in a boost B+.

A horizontal-retrace-blanking circuit is included in the receiver of Fig. 19-41. This is provided by the triode (V705-B) labeled "blanker." Horizontal retrace blanking is incorporated to prevent the 3.58-mc burst from reaching the grids of the color-picture tube. This burst, we have seen, follows the horizontal sync pulse and if it were permitted to reach the picture tube, it would develop a yellow stripe during the horizontal blanking interval.

The blanker triode has its cathode connected in parallel with the cathode of the first bandpass amplifier. During the horizontal retrace interval, a positive pulse is applied to the grid of the blanker tube from the horizontal output transformer, which drives V705-B strongly into conduction and raises its cathode voltage so high that the first bandpass amplifier is cut off, thus preventing any signal from passing through the chrominance section and reaching the picture tube.

The foregoing action produces an amplified negative pulse at the plate of V705-B, which is coupled to the common cathodes of the $R - Y$, $B - Y$, and $G - Y$ amplifiers. Each of these tubes conducts strongly, lowering its respective plate voltage to a very low value. Since the plates of these tubes are direct-coupled to the control grids of the picture tube, the net effect is to momentarily kill each of the beams in the tube.

9. High-voltage Circuits. The high-voltage requirements of the three-gun, shadow-mask picture tube are considerably more critical than they are for a conventional black-and-white picture tube. The color tube requires up to 25,000 volts at a maximum current drain of 1500 microamperes. There also must be available to the tube a focus voltage variable between 5 to 8 kv.

The heavy requirements of the picture tube in regard to beam current result in some serious problems in the designing of a combination deflection and high-voltage system. Since the power used by the high-voltage circuit is an appreciable portion of the total, changes in beam current due to changes in picture brightness can cause variations in scanning linearity and in the various operating potentials of the tube itself.

To avoid such variation it is necessary to maintain the high-voltage load constant whether the picture is bright or dim. A simple method of achieving this stabilization is to use a special vacuum-tube triode, a 6BD4A or a 6BK4. The plate of the tube connects to the output of the high voltage

system (22,000 to 25,000 volts), while the cathode is returned to a positive low-voltage point, 375 to 400 volts. See Fig. 19-33. The grid is then tapped into a bleeder network hung between boost B+ and ground. The operation of the circuit is as follows: Any variation in picture content (light areas, dark areas, etc.) causes a corresponding change in picture-tube beam current. Light areas produce a higher beam current than dark areas, with a corresponding change in boost B+. Since the control grid of the regulator tube connects to this supply, conduction of the regulator tube will also

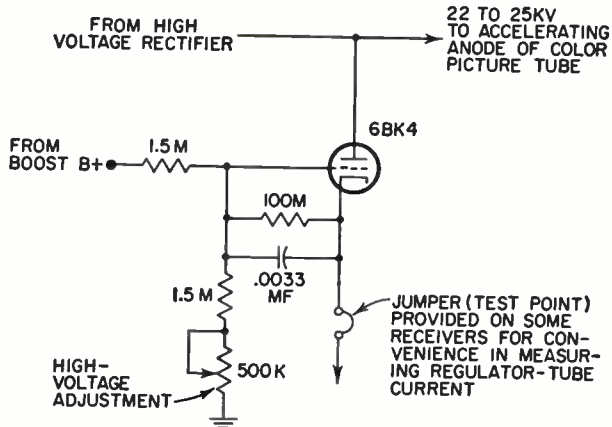

FIG. 19-33. A schematic diagram of part of a high-voltage regulator stage.

change, either increasing or decreasing plate current. Specifically, if picture-tube beam current increases, high voltage decreases; in turn, boost B+ decreases, causing increased grid bias on the regulator tube, and less plate current. Since the regulator tube is directly across the high-voltage supply, the decreased plate current counteracts the increased beam current of the picture tube, and high voltage is maintained at its correct level. If the beam current of the picture tube decreases, the reverse action occurs.

Focus voltage for the picture tube is furnished by a separate rectifier (5 to 8 kv is required), because of the current requirements of the focusing anode. A 1V2 tube is often employed as well as a focus control to adjust the pulse amplitude applied to the plate of the tube.

The last section in the color receiver diagram of Fig. 19-15 that needs to be described is a block labeled "convergence circuits." Why these are needed and what they do are best discussed after certain features of the tri-gun color picture tube have been examined.

10. Tri-gun Color Picture Tubes and Associated Circuits. The color receivers which have been marketed thus far have employed a tri-gun, tri-

color picture tube. The tri-gun portion of the name indicates that the tube possesses three electron guns. The conventional black-and-white tube employs only one electron gun.

The second half of the name, tri-color, reveals that the screen of the tube possesses three different color-emitting phosphors. This, of course, is basic to the entire color television system since we employ the three primary colors—red, green, and blue—to synthesize the wide range of hues and tints required for the satisfactory presentation of a color picture.

The tie-in between the three electron guns and the three different types of screen phosphors now becomes evident. Each gun is concerned with one type of phosphor. Thus, one of the electron guns develops an electron beam which strikes, say, the phosphor which emits red light. This gun may be labeled the “red gun.” A second electron gun directs its beam only at the green phosphor dots and it is the “green gun.” The third gun is concerned in similar manner only with the blue dots. Note that in each case, it is not the color of the phosphor to which we refer, but the light which this phosphor gives off when actuated by an electron beam. The actual color of the substance and the color of the phosphorescent light it emits do not necessarily bear any relationship to each other.

The overall color that is seen on the screen is determined by two general factors: (1) the phosphors which are being bombarded by the three guns and (2) the number of electrons which are contained in each beam. Thus, suppose you turn one beam off completely—say, the beam from the red gun. Then, only the blue and green dots will be emitting light, and what you see is a mixture of blue and green light which can range from a greenish blue to a bluish green. The exact color is determined by which of the two beams is the stronger.

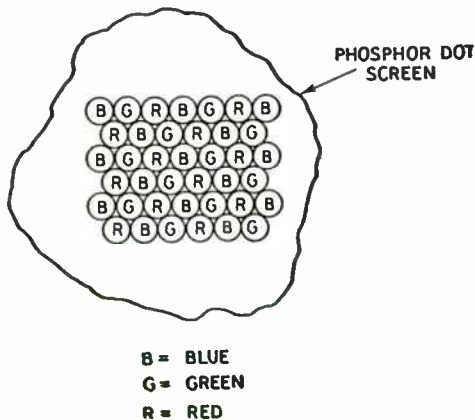

FIG. 19-34. The phosphor dot screen of a 21CYP22 tri-gun color picture tube.

In the same way, we could cut off the green gun, leaving only the red and blue guns in operation. Now the screen color would fall somewhere in the purplish range. If the blue gun were stronger than the red gun, the color would appear closer to blue, say, bluish purple. On the other hand, if the red beam were made more intense, the resultant color would be nearer a purplish red.

It is, of course, not necessary to turn any gun off. All three may be operating simultaneously and, when they do, you generally see the lighter or pastel shades on the screen. This is because red, green, and blue combine in some measure to form white, and, although white may not be predominant, it will mix with whatever colors are present and serve to lighten or desaturate them.

The phosphorescent dots which produce the colored light are arranged on the screen in an orderly array of small triangular groups, each group containing a green-emitting dot, a red-emitting dot, and a blue-emitting dot. See Fig. 19-34. The actual number of such dots, for a 21-in. screen, is somewhere in the neighborhood of 1,071,000.

With 1,071,000 dots on the screen, there are 357,000 trios. Each dot has a diameter of approximately 16 mils. If all three dots in a group are bombarded at the same time, the combined red-, green-, and blue-light output will present one color to the observer's eyes.

Electron-gun Structure. At the other end of the color picture tube there are three parallel, closely spaced electron guns which produce three independent electron beams. See Fig. 19-35. Each gun consists of a heater, a cathode, a control grid (grid no. 1), an accelerating (or screen) grid (grid no. 2), a focusing electrode (grid no. 3), and a converging electrode (grid no. 4). The heaters of all three guns are in parallel and require only two external connections to the tube base. Each control

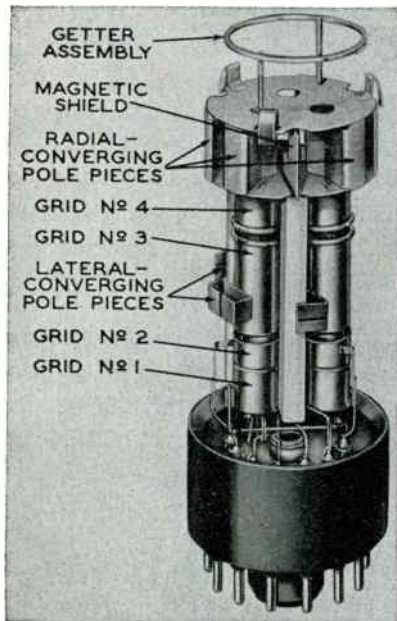

Courtesy RCA

FIG. 19-35A. Electron-gun assembly of 21-in. color picture tube, 21CYP22; Three electron-gun structures are employed, although only two are clearly visible.

grid has its own base pin, and the same is true of each screen electrode. The focusing electrodes (grid no. 3) of all the guns are electrically connected

because one overall voltage variation will bring all three beams to a focus at the phosphor dot screen.*

The final electrode in the gun structure is grid no. 4, the converging grid. This is a cylinder of small diameter, which is internally connected to (and operated at the same high potential as) the aquadag coating (20,000 to 25,000 volts). Also associated with each no. 4 grid is a pair of pole pieces.

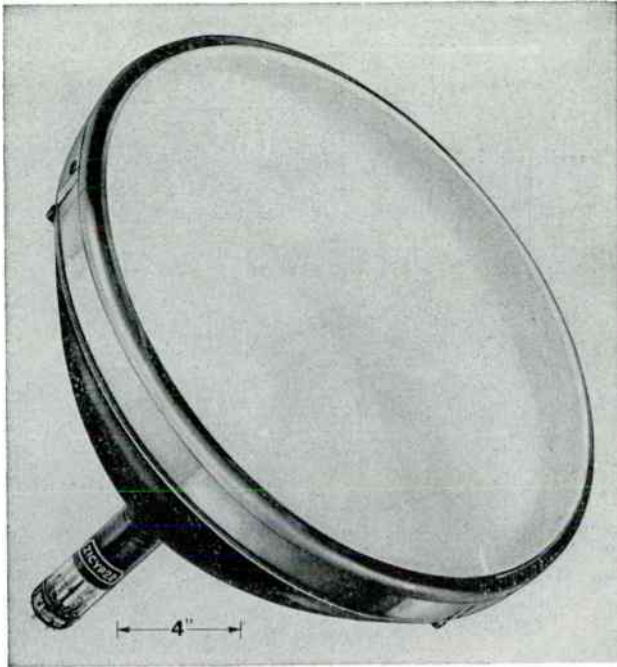

Courtesy RCA

FIG. 19-35B. 21CYP22 color-picture tube.

These are mounted above each grid. External coils on the neck of the tube induce magnetic fields in each set of pole pieces, as shown in Fig. 19-36. These fields force the three beams to converge so that each beam will strike the proper phosphor dot in the same group at any one instant of time; that is, one beam will strike the red dot, a second beam will strike the green dot, and the third beam will hit the blue dot, all three dots being in the same group. The three dots are bunched so close together that the light they

* Grid no. 3 of the blue gun has two special built-in pole pieces. These function in conjunction with an external magnet to assist in converging the beams at the center of the screen.

produce combines and appears to the eye as a single color. In the absence of this converging action, it is possible for the beams to hit phosphor dots at sufficiently separated points so that an observer sees three individual points of light. Under these conditions, mixing of colors to obtain different hues is not possible.

The Shadow Mask. Proper beam convergence is an important aspect of tri-gun picture-tube operation. Thus, to insure that each beam strikes only one type of phosphor dot, a mask, called a "shadow, or aperture, mask,"

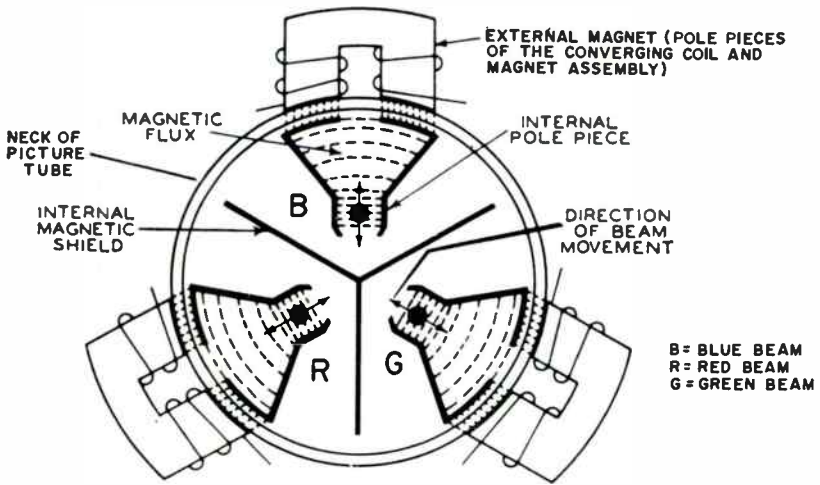

FIG. 19-36. External coils mounted on the neck of the picture tube induce magnetic fields in each set of pole pieces. These fields force the three beams to converge so that each beam will strike the proper phosphor dot in the same group at any one instant of time.

is inserted between the electron guns and the phosphor dot screen. See Fig. 19-37. The mask is positioned in front of and parallel to the screen. It contains circular holes, equal in number to the dot trios. Each hole is so aligned with respect to its group that any one of the approaching beams can "see" and therefore strike only one phosphor dot. The remaining two dots of the trio are hidden by the mask, that is, the two other dots are in the "shadow" of the mask opening—hence the name of shadow mask.

What is true for one beam is true for the other two beams. Each can also see one phosphor dot. In this way, we are able to minimize color contamination which occurs when a beam either hits the wrong dot or overlaps several dots at the same time.

Static and Dynamic Convergence. In the foregoing introductory discussion, beam convergence was covered in a general manner. Actually, as

we shall see, there are two types of convergence: static convergence and dynamic convergence. In static convergence, we adjust the positions of the beams, using either fixed d-c voltages or fixed magnetic fields. As a further aid in this action, the electron guns are tilted inward slightly. If the adjustments are made carefully, the beams will converge properly over the central area of the screen.

To maintain this converged condition of the beams as they swing away

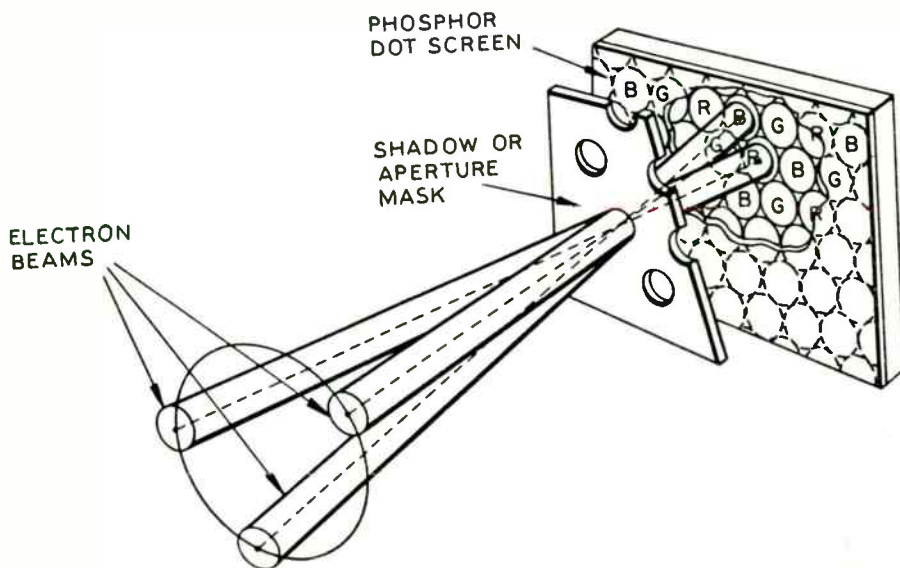

FIG. 19-37. Diagrammatic illustration of the mask and screen, showing the convergence of the three beams at a single hole in the shadow (aperture) mask. Note that the converged beams pass through the hole and strike their respective phosphor dots.

from the center, it is also necessary to vary their relative angles slightly. This process of changing the beam angle so that it will be in step with the scanning is referred to as "dynamic convergence." It is required because the distance traveled by the beams increases as they swing away from the center of the screen. The swing away from the center, in turn, occurs because the curvature of the screen is not perfectly spherical, and beams which are converged at the screen center will tend to converge in front of the shadow mask at points away from the center. See Fig. 19-38.

A moment's reflection will reveal that the extent of convergence changes the farther the beams are from the center of the screen. Furthermore, there is a direct relationship between the convergence needed at any

one point and the instantaneous horizontal- and vertical-deflection-voltage values. Thus it is possible to obtain whatever correction voltages are needed from the vertical and horizontal deflection systems. These additional voltages are known as dynamic convergence voltages to distinguish them from the

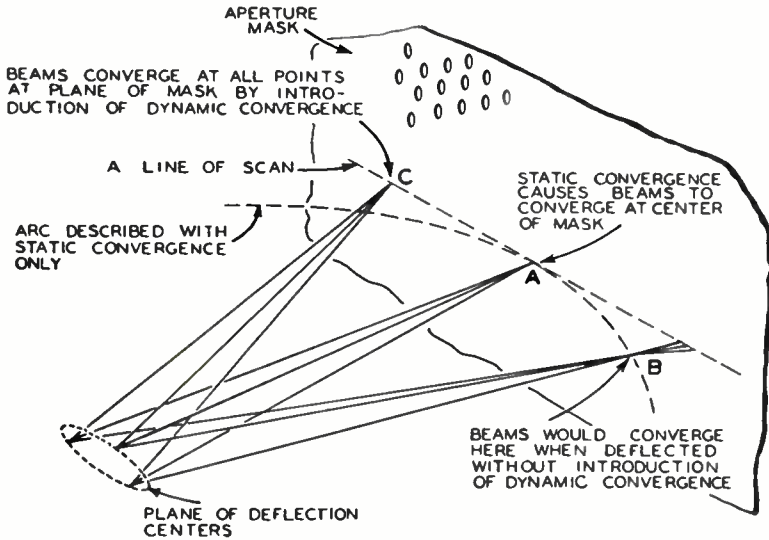

FIG. 19-38. Dynamic convergence voltages are required to cause the three beams to converge at the picture edges because the screen and the aperture (or shadows) mask are not perfectly spherical.

d-c or static convergence adjustment which is made over the central area. Where magnetic convergence means are employed, the static adjustment is made with a permanent magnet. The dynamic convergence is then achieved by introducing varying magnetic fields via converging coils mounted on the neck of the picture tube.

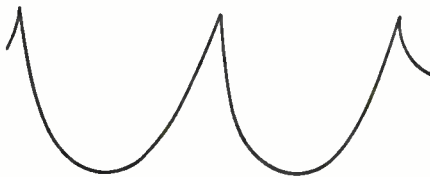

FIG. 19-39. The form of the dynamic convergence voltage (or current) is parabolic.

The basic form of the correcting current is parabolic, as shown in Fig. 19-39. When the three beams are in the center of the screen, the correction current is zero. On either side of the center, however, the current varies, and the combined effect of the correction (that is, dynamic

and static fields) is to keep the beams properly converged at every point of the screen.

We can now understand what purpose the block labeled "convergence circuits," shown in Fig. 19-15, serves. In Fig. 19-41, a voltage appearing

at the cathode of the vertical output tube, 6AQ5A, and a horizontal pulse voltage from a winding on the horizontal output transformer are coupled to a convergence circuit network. On many late model receivers the convergence circuitry and controls are contained on a separate, small panel which is easily removed and positioned for convenience in performing convergence adjustments. Connection to the main chassis is made via a cable-and-socket arrangement. Generally, there are six controls for adjusting vertical dynamic convergence and six controls for adjusting horizontal dynamic convergence.

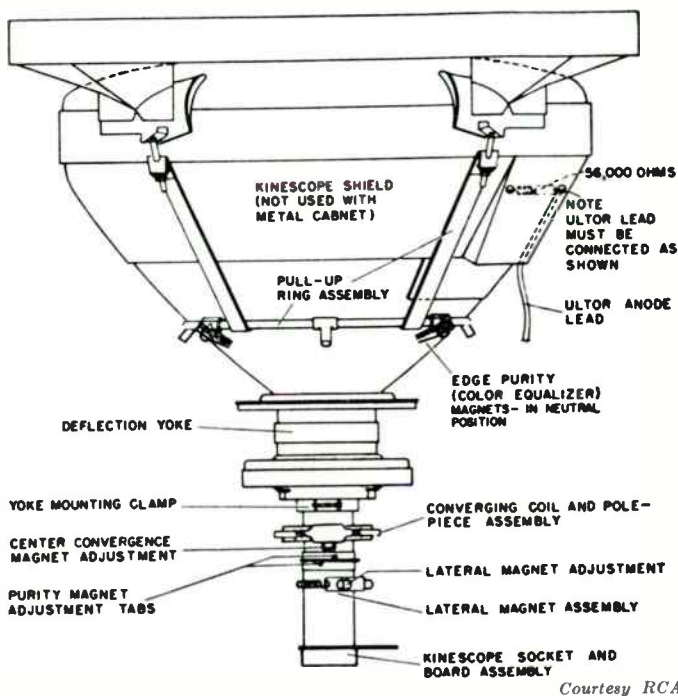

Fig. 19-40. Location of external components on neck of 21CYP22 tri-color picture tube.

External Picture Tube Components. We come now to the components which are mounted on the neck of the tri-gun, tri-color picture tube. See Fig. 19-40. The first item that we recognize is the deflection yoke. This is, to a considerable extent, similar to the deflection yoke used with a black-and-white tube. However, its design is more complex because three beams must be deflected instead of one, and it is of the utmost importance that a symmetrical and uniform magnetic field be maintained throughout the deflection area.

Another component found on the neck of the color-picture tube is the

purity-magnet assembly. This device adjusts the axis of each electron beam so that it approaches each hole in the shadow mask at the proper angle to strike the appropriate color phosphor dot. In other words, the purity magnet provides for the proper alignment of the three beams with respect to the phosphor-dot plate and the shadow mask. When this component is properly set, a uniform color field will be obtained for each gun. For example, with only the red gun in operation a uniform red raster should be observed. Any departure from pure red at any point on the screen indicates that the beam is striking phosphor dots other than red. Similarly, when only the green gun is in operation, a uniform green raster should be obtained, and when only the blue gun is active, a blue field should be visible.

The larger screen color tubes utilize magnetic convergence and, toward that end, employ three sets of convergence coils, each positioned directly over the pole pieces which are internally associated with each grid no. 4. The magnetic fields set up by the coils are coupled through the glass neck of the tube to the internal pole pieces. The latter serve to shape and confine the fields so as to affect only the particular electron beams to which the individual pole pieces correspond. For example, the change in convergence angle of the red beam is a function only of the current through the external coil which couples to the internal set of pole pieces adjacent to the red beams. Similarly, the currents through the green and blue external magnets affect respectively only the green and blue beams.

Each external coil possesses two separate windings to provide for horizontal- and vertical-dynamic-convergence correction. For the static-convergence adjustment, each coil has associated with it a small permanent magnet, the position of which can be varied.

A diagram of the individual static-convergence-control magnets is shown in Fig. 19-36. The heavy dots represent the individual electron beams as they pass through the gun on their way to the screen. The arrows at these beams indicate their direction of movement. Note that the red and green beams are confined to paths which make an angle of 30 deg on either side of a perpendicular axis. The blue beam, on the other hand, can move only vertically (up or down).

Now it can readily happen that, although the color dots of the green and red beams fall within the trio of phosphors, those of the blue beam do not. This means that, while we can always cause the red and green beams (or color dots) to converge, it may not be possible to have the blue beam meet the other two. Still another adjustment is required, that of being able to move the blue beam from side to side (or laterally). To effect this, a special blue-beam lateral-positioning magnet is also found on the neck of the tube. Now perfect convergence of the three beams at the center of the screen is always achievable.

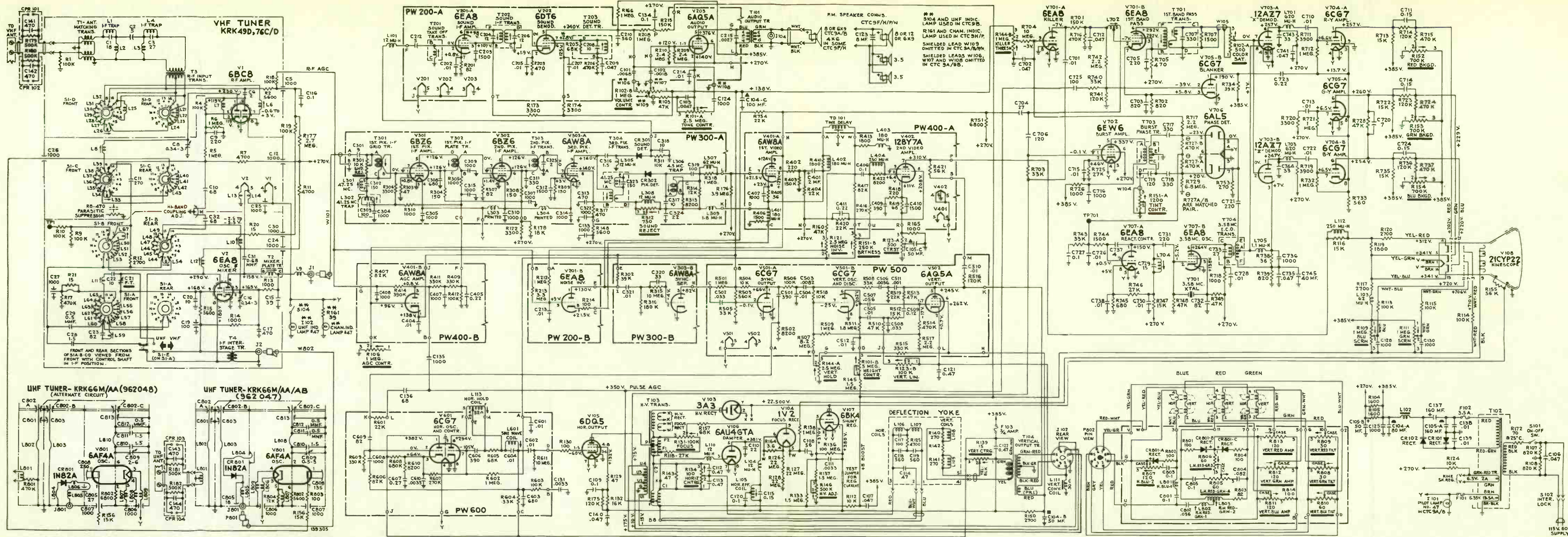

The schematic is shown in the latest condition at the time of printing. All resistance value in ohms. K = 1000.

All capacitance values less than 1 in MF and above 1 in MMF unless otherwise noted.

FIG. 19-41. Schematic diagram of RCA color television chassis CTC9A.

Courtesy RCA

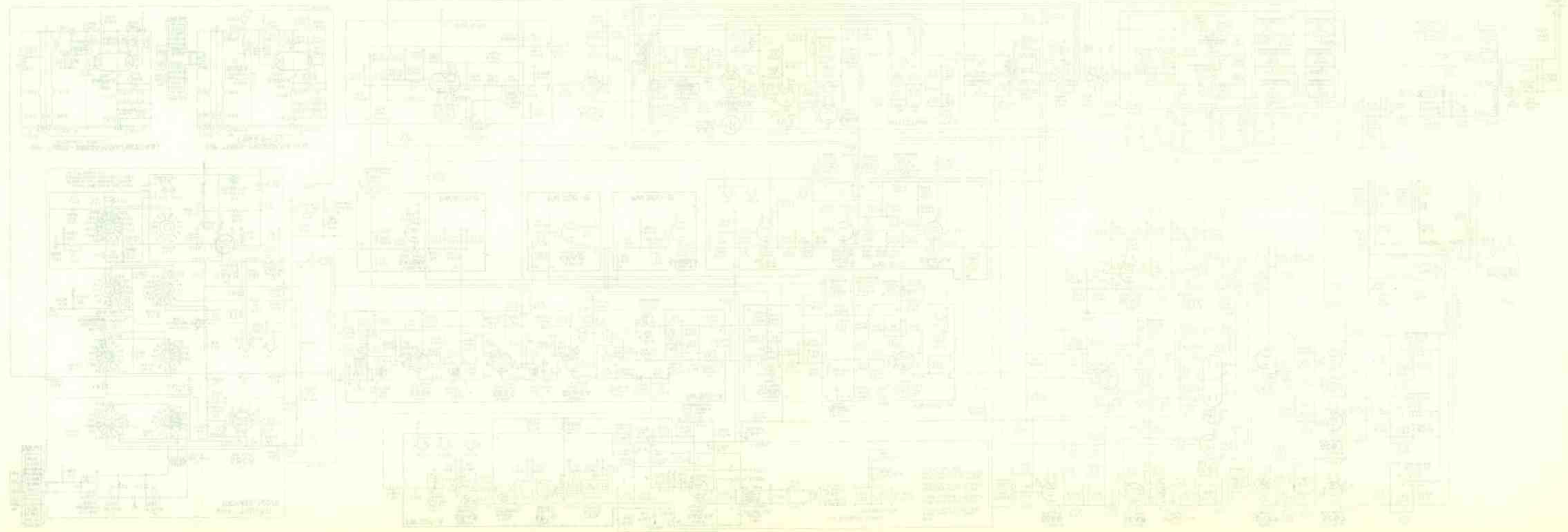

No ion traps are used in this tube because the color screen is aluminized. The layer of aluminum presents a barrier to any oncoming ions and prevents them from reaching and damaging the screen. Electrons, having only $\frac{1}{1800}$ th of the mass of an ion, encounter little difficulty in passing through this aluminum layer.

QUESTIONS

1. What advantages are offered by the use of color in presenting a television picture?
2. Name the primary colors. What is their significance?
3. What is a chromaticity chart and what purpose does it serve?
4. What colors are found near the edges of the chromaticity chart? What colors near the center?
5. Explain the meanings of hue, saturation, and purity.
6. Does the normal eye see color equally well in large as well as small areas? Explain.
7. When we say that a television signal extends from 0 to 4 mc, do we mean that it occupies every cycle of the 4-mc band? Explain.
8. How is it possible to transmit a full color signal in the same space as that occupied by a monochrome signal?
9. What information does the monochrome signal carry? the color subcarrier and its sidebands?
10. Why are *I* and *Q* signals better suited to color rendition than *R - Y* and *B - Y*?
11. How is information concerning the frequency and phase of the missing subcarrier supplied to the receiver?
12. Draw a block diagram of a color television receiver using a tri-gun picture tube.
13. Which sections of the color block diagram would not be found in a monochrome receiver? Explain why in each instance.
14. What precautions must be observed with respect to sound take-off from the video system?
15. List all of the sections in the receiver to which a portion of the detected video signal must be fed.
16. With which portion of the incoming signal is the color sync section specifically concerned? How does it use this information?
17. Trace the path of the monochrome portion of a color video signal from the second detector to the picture tube.
18. What is the function of the chrominance section of the receiver?
19. Describe where each of the following stages are found and indicate what they do:

1. bandpass amplifier(s)	3. color killer
2. burst gate amplifier	4. chrominance demodulators
20. Describe briefly two methods of developing suitable 3.58-mc subcarrier signals.
21. Why are special convergence circuits required in the color receiver?

Glossary of Television Terms

A

- Active Lines**—In scanning an image, those lines that are responsible for imparting the information of the image. The beam is inactive when moving rapidly from right to left, or from the bottom of the picture to the top.
- Amplitude Modulation**—The process of varying the amplitude of a carrier in accordance with the amplitude of the intelligence (sound or video) to be broadcast.
- Aquadag**—A substance composed of graphite in solution. A coating of this substance is usually placed on the inside of a cathode-ray tube to prevent the accumulation of electrons on the walls of the tube.
- Array**—A group or combination of two or more antenna elements, functioning as a unit. Antenna arrays are generally designed to provide greater directivity and gain than are available from a single-element antenna.
- Aspect Ratio**—The ratio of the image width to the image height.
- Automatic Frequency Control**—A method of automatically maintaining the frequency of an oscillator at a desired value. In television receivers, automatic frequency control is extensively applied to the horizontal sweep oscillator.
- Automatic Gain Control (AGC)**—A method whereby the overall gain of a television receiver is automatically adjusted to produce a constant output signal for varying input signals.

B

- Back Porch**—The section of the synchronizing signal extending from the back end of the horizontal sync pulse to the start of the next line.
- Band**—A group of frequencies having definite upper and lower frequencies.
- Bandwidth**—The numerical difference between the highest and lowest frequencies passed by an electrical circuit.
- Beam**—When referring to television, a stream of electrons traveling in a vacuum tube. The tube to which this expression is most generally applied is the image tube.
- Bidirectional**—A term that applies to the response characteristic of an antenna and signifies that signals may be received from (or transmitted to) two different directions.
- Blacker-than-Black Region**—The region where the blanking and synchronizing voltages are found in the video signal. The voltages in this region prevent any

electrons in the cathode-ray tube from reaching the viewing screen. The result is an absence of light on the screen.

Black Level—The point in the video signal at which the electron beam in the image tube is cut off or prevented from reaching the screen. This point normally occurs at 75 per cent of the maximum amplitude of the signal.

Blanking Pulses—Sharp rises in voltage that bias the viewing tube control grid beyond cutoff. This action, when properly correlated with the brightness control, prevents the electron beam retraces from appearing on the viewing screen.

Blooming—The mushrooming of an electron beam (with consequent defocusing).

Boost B+—The additional B+ voltage developed in the damper circuit by utilizing the excess deflection energy developed during the horizontal retrace interval.

Booster Amplifier—An RF amplifier which is not an integral part of a television receiver but which is connected to the front end of the set in order to "boost" or raise the strength of the received signal. Booster units may contain more than one RF amplifier.

Brightness Control—A potentiometer control that varies the average or background illumination of the image on the picture tube screen. When properly set, this control prevents any beam retraces from appearing on the screen.

Brilliance Control—Another name for the brightness control.

C

Camera Tube—A tube with the ability to transform incoming light rays into equivalent electrical charges. A scanning beam then utilizes these charges to produce a video signal.

Cathode-ray Tube—A vacuum tube that contains a fluorescent screen at one end. By directing an electron beam at this screen, visible traces are formed and a combination of these gives rise to the reproduced image. Also known as a Kinescope.

Centering Control—A device which enables the viewer to move the image back and forth or up and down on a screen.

Channel—the range of frequencies over which the video and audio signals may be transmitted. Each television channel is 6 mc wide.

Chromaticity Chart—A horseshoe-shaped chart which reveals the relationships between various spectral colors or mixtures thereof.

Chrominance—The hue (or shade) and saturation (or purity) of a color.

Clamping Circuit—Another name for a d-c restorer. Clamping circuits in American television receivers maintain the tips of the sync pulses at a common level.

Clipper—A circuit which does not permit the positive (or negative) level of signal to exceed a certain value. The most extensive use of clippers in television receivers is the separation of the sync pulses from the rest of the video signal.

Coaxial Cable—A transmission line in which one conductor (the outer) completely surrounds the other conductor (the inner). The two conductors are separated by air or some other insulator.

Color Control—An adjustment that varies the intensity of the colors seen on the screen of a color television picture tube.

Color Intensity Control—Another name for the color control.

Color Saturation Control—Another name for the color control.

Contrast—The ratio between the brightest and darkest portions of an image.

Contrast Control—A potentiometer that permits variations of the intensity of the

various elements of an image. May be used to accentuate the highlights and shadows in an image.

Cross-over Area—In an electron gun, a region in the first-lens system where the cathode-emitted electrons are brought together under the influence of electric (and sometimes magnetic) fields.

D

Damping Tube—A tube used with magnetic deflecting coils to prevent any transient oscillations from being set up in the coils or the associated circuits.

D-c Reinsertion—The readjusting of the video signal at the image tube to the form it possessed when transmitted by the broadcast station. Passage of the video signal through the a-c coupling networks of the video amplifiers results in the removal of the d-c component of the signal. A d-c restorer circuit just prior to the cathode-ray tube reinserts this missing d-c component.

Deflection—The shifting of the electron beam in a cathode-ray tube away from the center of the screen.

Demodulation—Another name for detection, or abstracting the intelligence contained in a signal from the carrier.

Detail—the smallest or minutest portions of an image that can be distinguished from each other.

Differentiating Circuit—A grouping of components that possess the ability to produce an output voltage proportional to the rate of change of the input signal.

Dipole—An antenna wire, one-half wavelength long at the frequency it is to be used. It is usually divided into two equal quarter-wave sections.

Directive Antenna—Any antenna system that tends to receive signals best from one or more but not all directions.

Director—An antenna wire placed in front of a dipole. Its purpose is to sharpen the directivity of the dipole and increase its gain.

Discharge Tube—A tube which is biased to cutoff and therefore nonconducting except when triggered by a positive pulse. A capacitor, connected in the plate circuit of the tube, charges when the tube is nonconducting and discharges when the tube is triggered and forced into conduction.

Discriminator—The second detector in an FM superheterodyne receiver. The frequency variations in the FM signal are here converted to amplitude variations, suitable to be heard on a loudspeaker.

Driven Element—The wire or wires of an antenna which connect to the receiver (or transmitter).

E

Electric Field—The region surrounding charged particles. An electric field is set up also whenever a magnetic field varies. Radio waves traveling through space are composed of electric and magnetic fields.

Electromagnetic Deflection—Deflecting an electron beam by applying varying currents to coils mounted on the neck of a cathode-ray tube.

Electromagnetic Deflection Coil—A circular coil placed around the neck of some cathode-ray tubes to cause deflection of the electron beam. Generally enclosed in an iron core known as a yoke.

Electron Gun—The cathode, grid, and cylindrical plates in a cathode-ray tube that produce the electron beam.

- Electron Multiplier**—A series of anodes used in camera tubes to increase the intensity of the output video signal.
- Electron Scanning**—The periodic deflection of an electron beam across the screen of a cathode-ray tube, following a definite pattern.
- Electrostatic Deflection**—Deflecting an electron beam by applying varying voltages to plates mounted inside the glass envelope of a cathode-ray tube.
- Equalizing Signals**—A series of six pulses before and after a serrated vertical pulse. The action of these pulses causes the vertical deflection to start at the same time in each interval.

F

- Field Frequency**—This term is used in interlaced scanning and refers to the portion of a complete frame when either the even or odd lines are scanned. Requires 1/60 sec.
- Flicker**—The variation in brightness that can be seen by the human eye when the images presented on a screen do not follow each other with sufficient rapidity.
- Fluorescent Screen**—The coating located at one end of the cathode-ray tube on which the image is produced.
- Flyback**—The rapid retrace motion of an electron beam after every horizontal line from the right-hand to the left-hand side of the image and after every field, from the bottom to the top of the image.
- Focusing Control**—The control whereby the electron beam is made to meet the fluorescent screen in a small, well-defined spot.
- Folded Dipole**—A half-wave antenna consisting of two dipoles in parallel with each other. Connection to the array is made at the center of one of the dipoles.
- Frame Frequency**—The rate at which a complete image is scanned. This includes both even- and odd-line fields. The rate is 30 frames per second.
- Frequency Modulation**—A means of transmitting radio intelligence by varying the frequency of the wave.
- Front Porch**—The part of the synchronizing signal extending from the end of a line to the start of the horizontal sync pulse.

G

- Gamma**—The ratio of brightness variation in the reproduced image to the brightness variation in the original scene.
- Ghost Image**—A second image appearing on the receiver screen, superimposed on the desired signal. These images are caused by reflected rays arriving at the receiving antenna some small time interval after the desired wave.
- Grounded-Grid Amplifier**—An amplifier in which the control grid is at RF ground potential and the signal is fed into the cathode circuit.
- Ground Wave**—A radio wave that travels close to the earth.

H

- Halation**—A ring or halo of light surrounding a point where an electron beam is impinging and producing a dot of light. The ring is due to multiple reflections between the front and back surfaces of the glass screen.

- Height Control**—The control whose setting determines the vertical amplitude of the image.
- Hold Control**—The variable resistor that permits adjustment of the synchronizing oscillator until the latter frequency nearly equals that of the incoming synchronizing pulses.
- Horizontal Blanking**—The interruption of the electron beam during horizontal retrace.
- Horizontal Centering Control**—A control that enables the operator to move the television image in a right or left direction across the screen.
- Horizontal Line Frequency**—The number of horizontal lines per second: 15,750.
- Horizontal Resolution**—The number of light variations or picture elements along a line which can be distinguished from each other.
- Horizontal Retrace**—The rapid right-to-left motion of the electron beam at the end of each line.
- Hue**—The basic color as we see it. For example, a red apple has a red hue, while a green leaf has a green hue.

I

- Iconoscope**—An image camera tube that receives the light rays of the scene being televised and converts this energy into electrical charge.
- Image Orthicon**—A highly sensitive camera tube used extensively for indoor and outdoor telecasting.
- Implode**—The action of the highly evacuated cathode-ray tube when the glass envelope is suddenly broken. Due to the atmospheric pressure against all sides of the tube, the sides move inward with tremendous force.
- Impulse**—A sudden rise and fall of current (or voltage) in an electrical circuit.
- Integrating Circuit**—A circuit, consisting generally of capacitors and resistors, whose output voltage is equal to the sum of a number of input pulses.
- Intercarrier System**—A system in which the 4.5 mc difference between video and sound carriers is used as the IF of the sound system.
- Interlaced Scanning**—A method whereby an image is scanned first along the odd-numbered lines and then along the even-numbered lines. The result of interlaced scanning is an apparent increase in the rate at which the picture is sent. Flicker, by this means, is reduced to a minimum.
- Ion Spot**—An area on the fluorescent screen of a picture tube which has become desensitized because of a bombardment by ions in the electron beam.
- Ion Trap**—An arrangement whereby the ions within an electron beam are prevented from bombarding the screen and producing an ion spot.

L

- Limiters**—The last IF stage (or two) in an FM receiver. The purpose of this stage is to eliminate all amplitude distortion or variation in the FM signal.
- Linearity Control**—An adjustment that tends to correct any distortion in the sawtooth current or voltage waves used for deflection.
- Line-Scanning Frequency**—The rate at which the lines or sections of an image are scanned. Present standards set the rate at 525 horizontal lines for each 1/30 sec, or 15,750 per second.
- Luminance Signal**—Another name for a black-and-white video signal.

M

- Marker Pip**—An identification pulse which is superimposed over a response curve to indicate the position of a definite frequency.
- Monitor**—An auxiliary circuit containing a cathode-ray tube upon which appears the image being broadcast by the transmitter. The use of this auxiliary circuit permits the engineers in the station to maintain a continual check of the signal being transmitted.
- Monoscope**—A television camera tube that contains a fixed pattern within the tube. The tube is used to produce prebroadcast test patterns for testing and alignment purposes.
- Mosaic**—The photosensitive surface in an iconoscope or orthicon camera tube. It is here that the light rays are transformed into equivalent electrical charges.
- Multivibrator**—An oscillator used to generate sawtooth or square voltage (and current) waves.

N

- Negative Picture Modulation**—A method of transmitting the television video signal in which all the picture values are reversed. The brightest portions of the image are represented by the least amount of voltage, while the dark sections of the image have large voltage (or current) values.
- Noise**—Undesirable voltages, either generated in the set or received from some external source, which produce a multitude of very small black and white spots over the entire image. These spots are often referred to as "snow."
- NTSC System**—The color television system which meets the specifications established by the National Television Systems Committee of the Electronic Industries Association. This is the system which has been officially approved by the FCC for commercial broadcasting in the United States.

P

- Pairing**—An effect in which the lines of one field do not fall exactly between the lines of the next field. When the effect is pronounced, the lines of the two fields fall directly over each other, effectively reducing the vertical definition in half.
- Peaking Coil**—A coil inserted in the video amplifier circuits for the purpose of improving its high-frequency response.
- Pedestal**—The level of the video signal at which blanking of the beam occurs.
- Period**—The time of one complete cycle of an alternating wave.
- Persistence of Vision**—A phenomenon of the human eye whereby variations in light intensity, occurring sufficiently close, tend to blend into each other and appear continuous.
- Phosphor**—The fluorescent material coated over the inside surface of the viewing end of a cathode-ray tube.
- Pickup Tube**—Another name for camera tube.
- Picture Elements**—The smallest portions of an image that are distinguishable from each other.
- Picture Frequency**—This term is synonymous with frame frequency.
- Positive Picture Modulation**—A method of transmitting video signals in which the brightest portions of an image are represented by the most positive voltages. Opposite to negative picture modulation.

- Pulse**—Another term for impulse and denotes a sudden rise and fall of voltage.
- Pulse-Repetition Rate**—The number of times a pulse reappears each second.
- Pulse Width**—The time duration of a pulse.

R

- Raster**—The pattern of a television screen that is traced out by the electron beam. When no image is being received and the brightness control is turned up, the various lines comprising the raster can be plainly seen.
- Ratio Detector**—A circuit which is capable of converting frequency-modulated signals into equivalent audio signals.
- Reactance Tube**—A tube which is so connected that it appears as an inductance or capacitance to its circuit.
- Reflector**—An antenna wire placed behind a dipole and designed to improve the directional characteristics and gain of the dipole.
- Relaxation Oscillator**—An oscillator through which current flows strongly for part of a period and then ceases to flow entirely for the remainder of the period. Blocking and multivibrator oscillators perform in this manner and hence fall within this category.
- Resolution**—A term which refers to the smallest detail which can be distinguished or seen separately in a television image. Resolution is generally expressed as the maximum number of alternate black and white lines which can be distinguished in a test pattern.
- Response Characteristic**—The manner in which a circuit reacts to a set of signals. In an antenna, the response characteristic refers to the manner in which signals arriving from different directions are received. In a receiver, this same phrase refers to the way certain frequency signals are received and amplified while others are rejected.
- Retrace**—The return of the electron beam either from the right-hand side of the image to the left-hand side, or from the bottom to the top of the picture.

S

- Saturation**—The purity or intensity of a color. A completely pure color, undiluted by any other colors, is said to be fully saturated. A vivid green, for example, is more saturated than a pale green.
- Scanning**—The process of breaking down an image into a series of elements or groups of elements and transmitting this information in a logical manner.
- Schmidt Optical System**—An optical system employing reflectors and a corrective lens to magnify an image produced on a small cathode-ray-tube screen.
- Secondary Electrons**—Electrons that are obtained from a substance because of the intensity with which other electrons (known as primary electrons) impinge on the surface of this substance. The primary electrons arrive with sufficient force to knock loose one or more secondary electrons.
- Separation Circuit**—A circuit which will separate signals having different properties, such as amplitude, frequency, etc.
- Serrated Vertical Pulse**—The manner by which the relatively long vertical pulse is broken up into a series of pulses to permit simultaneous control of vertical and horizontal synchronizing oscillators.
- Single Side-band Transmission**—See vestigial side-band transmission.

- Smear Ghost**—Ghost images which follow the desired image so closely that the overall effect is one of smearing.
- Spurious Signal Voltages**—These are the voltages caused by the secondary emission effects of a mosaic plate.
- Staggered Tuning**—The peaking or resonating of each of the tuned circuits in an IF system to different frequencies. This is done to achieve a broad response.
- Subcarrier**—A secondary carrier of information in a complete signal. In a color television signal, the subcarrier contains the color information.
- Synchronizing Pulses**—Voltage (and current) waveforms that maintain the electron beam at the receiver in step with the camera tube electron beam.

T

- Tearing**—A synchronizing circuit disruption which causes the displacement of lines from their normal position. The visual effect is as though portions of the image had been physically torn away.
- Televisé**—To train a television camera on a scene and convert the light reaching the camera into equivalent video signals.
- Test Pattern**—A special chart on which lines and other detail are so arranged as to indicate certain characteristics of the system through which the television signal obtained from this chart passes.
- Time Constant**—The time required for the voltage or current in a circuit to rise to 63 per cent of its final value or fall to 37 per cent of its initial value.
- Time Delay**—The time required by a specific voltage or current to travel through a circuit.
- Transmission Line**—A set of two conductors possessing evenly distributed resistance, capacitance, and inductance and employed for transporting electrical energy from one point in a system to another.
- Trigger**—To set off or initiate a certain action in an electrical circuit by the application of a pulse of voltage.

U

- UHF**—An abbreviation for ultra-high frequencies. By definition, these extend from 300 to 3,000 mc.

V

- Vertical Blanking**—The interval in which the electron beam is being shifted from the bottom of the image back to the top and the electron beam is prevented from reaching the screen.
- Vertical Centering Control**—An adjustment control for moving the image up or down on the viewing screen.
- Vertical Resolution**—The number of active lines in an image.
- Vertical Retrace**—The return path of the electron beam during the vertical blanking interval.
- Vestigial Side-band Transmission**—A method of transmission whereby one set of side bands is eliminated from the modulated transmitted signal.
- VHF**—Abbreviation for very high frequencies. By definition, these extend from 30 to 300 mc.

Video Amplifiers—Any amplifier having a uniform frequency response over a wide range. Generally this range starts at 20 cycles and extends for several megacycles.

Video Frequency—Any frequency obtained from the scanning of a camera tube. At the present time, the highest value is restricted to 4 mc, but it could be higher.

W

Wedge—Those portions of a test pattern containing a series of lines which converge at one end, this end generally positioned at the center of the pattern.

Width—The horizontal dimension of an image. It is generally expressed in inches or feet.

Width Control—The electrical component or circuit that controls the width of the image.

Y

Y Signal—Another name for the monochrome or black-and-white video portion of a color signal.

Yoke—The frame upon which is wound the horizontal- and vertical-deflection coils.

Index

- Active lines, 622
- Adjacent channel interference, 130
- AGC stages in color television, 609
- Amplifier,
 - cascode, 100
 - d-c video, 219
 - grounded-grid, 81
 - IF, 119, 136, 629
 - RF, 66, 73
 - triode, 78
 - video, 180, 596
- Amplitude modulation, 622
- Antenna, 42
 - array, 55, 56, 622
 - bow-tie, 549
 - conical, 55, 56
 - corner reflector, 55
 - cylindrical parabolic, 550
 - dipole, 51, 53, 58
 - fan dipole, 549
 - folded dipole, 54
 - fringed area, 56
 - half-wave length, 49, 52
 - high-gain, 56
 - indoor, 57, 59
 - installation, 62
 - length computations, 52
 - rhombic, 550
 - rods, 62, 524
 - stacked, 55, 56
 - tuned, 49
 - UHF, 56, 548
 - Yagi, 55, 56
- Aquadag, 206, 622
- Aspect ratio, 622
- Audio system in TV receiver, 429, 447, 596
 - alignment, 461, 462
 - detector, 444, 596
- Automatic frequency control, 366, 622
 - circuit servicing, 514
 - Gruen circuit, 388
 - phase-detector, 375
 - pulse-detector system, 375
 - reactance tube system, 369
 - saw-tooth voltage waves, 375
- Automatic gain control (AGC), 622
 - average, 164
 - combined keyed, 177
 - keyed, 168, 450
 - peak, 160
 - stage of the color receiver, 609
 - with diode clampers, 173
- Back porch, 622
- Band, 622
- Bandwidth, 31, 622
- Barkhausen oscillations, 513
- Beam, 13, 622
 - convergence, 616
 - scanning, 221, 628
- Beam centering in picture tubes, 251, 616
- Beam-gated tube, 423
 - 6BN6, 423
- Bidirectional, 622
- Bifilar IF coils, 143
- Black and white signal, *see* Monochrome signal
- Black level, 26, 623
- Blacker-than-black region, 28, 29, 622
- Blanking signal, 25, 221, 623
 - horizontal, 626
 - vertical, 629
- Blocking oscillators, 341, 358, 365, 367
- Blooming, 488, 623
- Boost B+, 623
- Booster amplifier, 623
- Boosters, 114

- Brightness control, 1, 228, 437, 487, 623
 signal, 437
 Brightness signal, *see* Monochrome signal
 Brilliance control, *see* Brightness control
- Camera tube**, 8, 623
 iconoscope, 10
 image dissector, 10
 image orthicon, 10
 vidicon, 11
- Capacitor**, 494
 electrolytic, 494
 filter, 494, 495
- Cascode amplifier**, 100
- Cathode-ray tubes**, 234, 449, 623
 beam-centering, 251
 centering controls, 243, 251
 cross-over point, 236
 defective, 487
 electromagnetic deflection, 238, 248, 505
 electrostatic deflection, 238, 507
 first lens system, 235
 guns, 255, 611
 halation, 261
 ion spots, 265
 lengths, 259
 magnetic focusing, 244, 253
 metal-backed screen, 269
 nomenclature, 271
 phosphors, 613
 projection, 273
 reflection from screens, 258, 261, 262
 second lens system, 237
 servicing, 487
 shields, 270
 sticking potentials, 264
- CBS color television system**, 576
- Centering controls**, 436, 623
- Chromaticity chart**, 579, 623
- Chrominance**, 623
 channel, 598, 600
- Clamping circuit**, 173, 623
- Clamping diodes for AGC**, 174
- Clipper circuits**, 232, 316, 623
 diode, 317
 pentode, sync separator, 325
 special single-stage sync separators, 326
 triode sync separation, 320
- Coaxial cable**, 36, 623
- Color**, 577
 elements of, 577
 intensity, 578
 primaries, 578
 saturation, 581
- Color control**, 600, 623
- Color signals**, 582, 584
 monochrome, 583
 subcarrier, 584
 phase relationship, 603
- Color television**, 576
 additive process, 578
 automatic phase control circuit, 605, 607
 CBS system, 576
 chromaticity chart, 579
 chrominance channel, 598
 crystal ringing circuit, 606
 control, 600
 high-voltage circuits, 611
 NTSC system, 577, 582
 picture tube, 611, 613, 619
 receivers, 592, 595
 screen, 613
 shadow mask, 616
 signals, 582, 584
 sync section, 604
 sync separators, 609
 video amplifier, 596
 video detector, 596
 video IF system, 594, 597
- Complex-coupled IF system**, 147
- Contrast control**, 213, 623
- Controls**
 front panel, 436
 rear, 438
- Converters**, 88
 UHF, 556
- Corner reflectors**, 55
- Couplers**, 59
 multiple-set, 59
- Cross-over area**, 236, 624
- Cylindrical parabolic antenna**, 550
- Damper tube**, 396, 513, 611, 624
- Damping**, 528, 624
- D-c reinsection**, 221, 624
 brightness control, 228
 circuits, 226
 components of video signals, 221, 226
 with a diode, 229

- D-c restorer, 225, 230, 232, 623
D-c video amplifiers, 226
Deflection electrostatic, 238, 354, 625
 angles, 269
 balanced, 240
 coils, 249, 357, 365
 electromagnetic, 248
 factor, 243
 sensitivity, 243
 yoke, 250
Deflection systems, 354, 502, 511, 624
 automatic frequency control, 365, 511
 circuit adjustments, 383, 476
 d-c control of oscillator frequency, 377
 detector, 375
 electromagnetic deflection, 357, 505
 electrostatic deflection, 354
 Gruen AFG, 388
 horizontal, 448, 508, 610
 horizontal, AFC, 369
 horizontal output circuit, 374
 horizontal electromagnetic, 365
 horizontal electrostatic, 354
 phase detector, 375, 381
 servicing, 502, 511
 synchroguide AFC, 384
 vertical, 416, 502, 610
 vertical electromagnetic, 358
 width control, 400
Demodulation, 598, 624
Detail, 189, 624
Detectors,
 diode, 151
 FM ratio detector, 416, 420, 423, 427
 germanium, 156
 video, 596
Differentiating circuit, 334, 624
Dipole antenna, 49
 directional, 49
 folded, 55
 lazy-H, 54
 length computations, 51
 stacked, 55
 with director, 53
 with reflector, 53
Directive antenna, 49, 53, 624
Director, 53, 624
Discharge tube, 624
Discriminator, 413
 alignment, 462
 Foster-Seeley, 462
 FM, 462, 532
 modified, 415
Driven element, 624
Electron beam scanning, 13, 625
 methods, 14
Electron gun, 11, 15, 24, 448, 613, 621, 624
 structure, 614
Electron multiplier, 21, 625
Electromagnetic deflection, 248, 357, 365, 624
Electrostatic deflection, 238, 253, 354, 357, 625
Elements of color, 577
Equalizing pulses, 333, 339, 625
Fan dipole antenna, 549
Field frequency, 17, 625
Fine-tuning control, 1, 3, 438, 537
Flicker, 16, 625
Flyback, 296, 625
F-M audio signal, 40
Folded dipole antenna, 54, 625
Focus control, 236, 245, 248, 625
Focusing, 236
 coil, 245
 electrostatic, 236
 magnetic, 244
 P-M, 248
Foldover, 507
Frame frequency, 17, 625
Frequency modulation, 402, 625
 Armstrong system, 405
 comparison with A-M, 402
 Crosby system, 405
 discriminator, 413
 general principles, 403
 limiters, 409
 ratio detector, 417
 receivers, 407
 transmitters, 405
Front porch, 625
Gamma, 625
Ghosts, 42, 625
Ground wave, 47, 625
Grounded-grid amplifiers, 81, 625
Halation, 261, 625
Half-wave antenna, 49

- Height control, 346, 348, 626
- High-frequency response of amplifiers, 195
 shunt peaking, 205
- High-voltage power supplies, inductive flyback, 296
 pulse-type, 299
 RF, 294
 servicing of, 497
- Hold control, 343, 346, 354, 359, 364, 503, 626
- Horizontal AFC systems, 369
 Gruen, 388
 pulse-width, 384
 reactance-tube, 369
 saw-tooth, 379
 syncroguide, 384
- Horizontal centering control, 438, 626
- Hue, 582, 626
- Iconoscope**, *see* Camera tube
- IF amplifiers, 119, 125
 complex-coupled, 147
 responses, 120, 121
 response curve, 127, 129
 separated stations, 121
 separation of signals, 122
 stagger-tuned, 137, 141
 trap circuits, 132, 134, 135
 transformer coupling, 128
 sound detector, 566
- Image,
 characteristics, 3
 contrast impaired, 260
 response, 120
- Image dissector, *see* Camera tube
- Image-Orthicon, *see* Camera tube
- Implosion, 626
- Impulses, serrated vertical, 26
 synchronizing, 26
- Integrating circuit, 338, 626
- Intercarrier receivers, 7, 303
 advantages, 311
 basic principles, 305
 comparison with conventional receivers, 303
 disadvantages, 313
 split-second, 303, 471
- Intercarrier system, *see* Intercarrier receivers
- Interference from adjacent channels, 113
- Interlaced scanning, 300, 626
- Interlock switches, 282
- Ion spots, 265, 626
- Ion traps, 626
 bent-gun, 266
 diagonal-cut, 267
- Ionosphere, 45
- Keyed AGC system**, 450
- Kinescope, *see* Cathode-ray tubes
- Lightning** arrester, 62, 524
- Limiter, 409, 446, 626
- Linearity control, 626
 check, 505
 horizontal, 438
 vertical, 356, 361, 438, 507, 511
- Line frequency, 17
- Line-of-sight distance, 45, 47
- Line-scanning frequency, 626
- Loss of high and low frequencies, 34
- Low-frequency response of amplifiers, 209
- Low-voltage power supply, servicing of, 281, 449, 489
- Luminance signal, 626
- Magnetic** focusing, 244
- Marker signal (pip), 454, 627
- Metal-back picture tubes, 269
- Mid-frequency response of amplifiers, 213
- Mixers, *see* Converters
- Monitor, 627
- Monochrome signal, 583
- Monoscope, 627
- Mosaic, 11, 627
- Multivibrator, 446, 627
- National Television System Committee** (NTSC), 577, 582
- Noise, 446, 610, 627
- NTSC color television system, 577, 582, 627
- Oscillator**, 91
 alignment of RF, 464
 blocking, 91, 341, 358
 cathode-coupled multivibrator, 349
 frequencies, 94, 377
 multivibrator synchronizing, 92, 346

- push-pull, 92
- ultradion, 91, 92
- Oscilloscope, 451
- Pairing**, 627
- Peaking**, 205
 - series, 207
 - series-shunt, 208
 - shunt, 205
- Peaking coils, 627
- Pedestal, 627
- Period, 627
- Persistence of vision, 627
- Phase distortion in amplifiers, 192
- Phosphor, 259, 613, 627
- Pickup tube, 627
- Picture elements, 627
- Picture frequency, 17, 627
- Picture phase, 627
 - negative, 27, 152
 - positive, 27, 152
- Picture tube, *see* Cathode-ray tube
- Picture-tube servicing, 485
 - defective tube, 487
 - distortion, 489
 - no signal, 485
 - voltage loss, 486
- Power supply, 281
 - high-voltage, 49, 293
 - inductive flyback, 296
 - low-voltage, 281, 449
 - pulse-type, 299
 - RF, 294, 489
 - selenium rectifier, 287
 - transformerless, 292, 489, 496
 - voltage-doubling, 297
- Projection television systems, 273
 - North American Philips, 278
 - Schmidt, 274
- Pulse, *see* Synchronizing pulse
 - repetition rate, 628
 - width, 384, 628
- Quasi-single side band**, 34
- Radio waves**, 44
 - propagation, 44, 48
 - paths, 46
 - grounded, 47
- Raster, 474, 487, 628
- Ratio detector, 416, 628
 - modification, 420
 - FM, 416
 - tubes, 423, 427
- Reactance tube, 369, 628
- Receiver alignment, 451
 - discriminator, 413
 - equipment required, 451
 - marker signals for, 454
 - oscilloscope, 451
 - procedure for, 457
 - RF mixer, 88
 - RF oscillator, 464
 - RF stages, 466
 - RF system, 463
 - RF tuner, 463
 - single system generators, 454
 - sound IF stages, 466
 - sweep generator, 451
 - traps, 462
 - video IF stages, 441
- Receiver panel controls,
 - brightness, 228, 437, 623
 - centering, 243, 251
 - contrast, 213, 437
 - focus, 236, 245, 247
 - hold, 343, 346, 359, 364, 437, 626
 - linearity, 361, 438
 - size, 438
- Receiver servicing, 470
 - amplifier defects, 484
 - AFC circuits, 511, 514
 - checks, 474, 476
 - guide points, 411
 - high-voltage power supplies, 497
 - horizontal deflection system, 508
 - low-voltage power supplies, 489
 - ripples, sound vs. filter, 496
 - RF system, 470, 498
 - semiconductor rectifiers, 493
 - servicing guide, 410
 - sync separator stages, 488
 - transformerless, 496
 - vertical deflection system, 502
 - video circuits, 476
 - video amplifier defects, 484
- Receivers
 - AM, 40, 403
 - color television, 592, 598
 - de-emphasis network, 428

- FM, 407, 428
 - remote control, 530
- Reflector, 628
 - cylindrical parabolic, 550
 - corner, 551
- Relaxation oscillator, 628
- Relay stations, 37
- Remote control signaling methods, 517
 - electromagnetic, 518
 - operation, 518
 - optical, 518
 - pneumatic, 541
 - ultrasonic, 518, 527, 541
- Remote control systems
 - General Electric, 518
 - Zenith, 527
 - Magnavox, 543
- Resolution, 189, 628
- Resolving power, 189
 - minimum angle, 190
- Response characteristic, 628
- Retrace, 628
- RF amplifiers, 73
- Ripple, 492
 - sound vs. filter, 496
- Saturation, 628**
- Saw-tooth waves, 341, 344, 354, 355
- Scanning, 18, 628
 - beam, 221
 - interlaced, 17
 - methods, 13
 - raster, 474
- Schmidt optical system, 274, 628
- Selenium rectifiers, 287, 493, 534
- Semiconductor rectifier, 493
- Separation circuit, 628
- Separation of video and sound signals, 122
- Serrated vertical pulse, 28, 330, 628
- Signal generators, 454
- Single side-band transmission, 628
- Smear ghost, 629
- Sound-muting control, 533
- Sound system, 447, *see* Audio system in TV receiver
 - alignment, 461, 462
 - color television, 596
- Spurious signal voltages, 629
- Stagger-tuned IF amplifier systems, 119, 136, 629
- Studio cameras, 26, 27
- Subcarrier, 629
- Sync clippers, 231, 317
 - diode, 231, 317
 - pentode, 325
 - servicing, 499
 - special, 326
 - triode, 320
- Sync separator, 498, 510, *see* sync clipper
- Synchronizing oscillators, 341
 - blocking, 341, 358
 - cathode-coupled multivibrator, 349
 - multivibrator, 346, 356
- Synchronizing pulses, 4, 27, 316, 629
 - differentiation, 333
 - equalizing, 332, 339
 - form, 328
 - horizontal, 27, 330, 511
 - integrating network, 338
 - separation from video signal, 316, 446
 - serrated vertical, 28, 330
 - separation of horizontal from vertical, 28, 333
 - vertical, 330
- Synchronizing separator, 316, 446, 498, 510, 609
- Tearing, 366, 629**
- Television camera tubes, 8
 - iconoscope, 11
 - image dissector, 11
 - image orthicon, 11
- Television receivers, 436, *see* Receivers
 - alignment, 451, 457
 - audio systems, 429
 - cabinet, 436
 - conventional, 1
 - front panel controls, 436, 438
 - intercarrier, 268
 - modern, 438
- Test pattern, 629
- Time constant, 629
- Time delay, 629
- Tone control, 3
- Transformer coupling, RF, 68
 - amplifiers, 68
 - IF amplifiers, 125
- Transformerless receiver power supply, 292, 489, 496
- Transistor, 519, 522

- Transmission lines, 59, 519, 629
 - airlead, 61
 - coaxial, 61
 - lead-in, 61
 - open, 61
 - parallel-wire, 60
 - shielded, 61
 - UHF, 60, 552, 554
- Trap circuits, 130
 - adjustment of, 136, 462
 - coupled with bifilar coils, 143
 - types of, 132, 134, 135, 216
- Trigger, 629
- Trigger tubes, 544
- Triode sync clippers, 317
- Tubes for television, 69
 - internal tube capacitance, 84
 - pentodes, 70
 - tetrodes, 72
 - triodes, 71
 - two-cathode terminals, 85
 - two-grid terminals, 85
- Tuned antennas, 49
- Tuner strips, 563
- Tuners, 95
 - continuous, 113, 568
 - disc, 110
 - neutrode, 102
 - RF, 593
 - rotary wafer switch, 105, 475
 - standard coil, 564
 - tetrode, 100
 - turret, 441, 463
- Tuning,
 - circuits, 68, 559
 - continuous, 113
 - preselector, 559
 - staggered, 629
 - strips, 563
 - UHF methods of, 556
- UHF television, 548, 629
 - antennas for, 548
 - channels, 548
 - converters, 556
 - transmission lines for, 60, 552, 554
 - tuner strips, 563
- Ultraudion oscillator, 91, 560
- Vacuum-tube voltmeters, 455
- Vertical blanking, 629
- Vertical centering control, 438, 629
- Vertical linearity control, *see* Linearity control
- Vertical resolution, 629
- Vertical retrace, 629
- Vertical sync pulses, 27, 330
 - separation from horizontal pulses, 333
- Vestigial side band transmission, 31, 629
- VHF, 629
- Video amplifiers, 441, 445
 - contrast controls, 213
 - design, 183, 197
 - direct coupled, 218
 - 4.5 mc traps in, 216
 - high-frequency compensation, 202
 - high-frequency response, 202
 - low-frequency compensation, 202
 - low-frequency response, 202
 - mid-frequency compensation, 212
 - phase distortion, 193
 - requirements, 181
 - servicing, 484
- Video frequency, 119, 630
- Video IF amplifiers, 119, 125, 180, 445, 630
 - alignment, 457
 - complex coupled, 147
 - intermediate frequencies, 119
 - response curve, 95, 127
 - servicing, 484
 - stagger-tuned, 136
 - transformer coupling, 128
- Video signal, 25, 27
 - band width, 31, 329
 - polarity, 29
 - positive phase, 28
- Volume control, 3
- Wedge, 630
- Width control, 346, 348, 354, 400, 630
- Y signal, 630
- Yoke, 249, 396, 484, 630

