



**RECORDING DEPARTMENT**



INDEX OF CONTENTS

Master Reference Book For Disc Recording

|         |  |  |
|---------|--|--|
| Sec. #1 | "Microphones"                            |  |
| I       | S-851882                                 | Plane Wave Freq. Response Velocity Microphone for Disc Recording   |
|         | No Number                                | Correction in Pressure Response of Veloc. Mic. in Spherical Sound Wave   |
|         | 1B-2582                                  | MI-3027 Instruction Book   |
|         | 1B-2583B-1                               | MI-4040B Type 77-A Uni-Directional Microphone  |
|         | S-839869                                 | 77-B Uni-Directional Mic. Freq. Response   |
|         | 1B-37022                                 | Aerodynamic Microphone Instruction Book  |
| Sec. #2 | "Filter and Compensation Units Data"     |  |
| II      | S-851767                                 | Lateral Compensation Freq. Response "Domestic Recording"<br>Note: This is equivalent to pre amp equalization.  |
|         | S-851766                                 | Orthoacoustic Compensation "Transcription Recording"   |
|         | S-851845                                 | 45 cycle Hi Pass (MI-10107) Freq. Response   |
|         | ⊗ S-851774                               | XT-2727A L.P. Filter "Home Recording"  |
|         | S-851773                                 | XT-2544 Telephone Effects Filter (Sound Effects)   |
|         | S-851802                                 | XT-914B Voice Freq. Filter Response 500 <sup>w</sup> circuit   |
|         | 2R6-5.2                                  | M3119 MI-10101 Re-recording Compt. Instruction Book  |
|         | 1B-25839                                 | 56A Line Equalizer "Schematic Diagram"   |
|         | No Number                                | 56A (MI-4167) Instruction Book   |
| Sec. #3 | "Microphone and Re-recording Mixer Data" |  |
| III     | III-1                                    | Instruction Sheet Disc Rec. Mixer Console<br>8500 c.p.s. L.P. Filter<br>Var. L.F. Atten. (Voice Freq. Filter) XT-914B<br>Volume Indicator to be WU Meter |
|         | W-302627                                 | Wiring for Console used in Disc Recording  |
|         | 2R6-8.1                                  | MI-3108-3108A Instructions re-Recording Mixer  |
|         | 2R6-2.1                                  | MI-3116 Input Mixing Panel Instructions  |
|         | 2R6-3.1                                  | MI-3120 Combining Network Instructions   |
| Sec. #4 | "Amplifier Data"                         |  |
| IV      | 1B-23837                                 | Bridging Amp. MI-3223 Instructions   |
|         | 2R1-3.1                                  | Bridging Amp. MI-3223C Addenda Sheet   |
|         | 1B-23891                                 | Mic. Amp. MI-3230 Instructions   |
|         | 2R1-6.2                                  | Mic. Amplifiers MI-3230A & B Addenda Sheet   |
|         | 2R1-4.1                                  | Booster Amp. Instructions  |
|         | 2R1-3.2                                  | DC Bridging Amp. MI-3233A Instructions   |
|         | 2R1-9.1                                  | Vol. Compressors MI-10201 MI-10206 Instructions  |
|         | 1V-7a                                    | Mod. of MI-10206 Range Control for Disc Recording.<br>Change from Compressor to Limiter.   |



Sec. #5  
V

"Monitor Equipment-- Meters, Loudspeakers, etc."  
2R15-1.1 Volume Indicator MI-3115 Instructions  
2R15-1.1A " " " Addenda  
S-85182 Var. Atten. for use with Weston VU 30B (301)  
V-3 Instruction Sheet Disc Rec. Monitor Speaker  
MI-3429 with MI-3404 Baffle

Sec. #6  
VI

*check over  
copy* →

"Recorders, Pickups & Related Accessories"  
⊗ S-851770 Wax Calibration Freq. Response (Optical Calib.) Issue 2  
46286 Photo. Wax Recorder with advance ball mounted  
46285 Photo. Wax Recorder Mounting Saddle

Sec. #7  
VII

"Power Supplies"  
2R9-3.1 "B" Supply MI-3526  
IB-24196 " " " Addenda  
2R9-6.1 "A" Supply MI-3527  
IB-24195 " " MI-3527A Addenda

Sec. #8  
VIII

"Recording Machines"  
VIII-1.1 Scully Recording Machine Instructions  
⊗ Lubrication & Oiling  
General Instructions  
Change of Recorded Pitch  
Recorded Dia. Scale & Indicator Lamp  
Carriage Feed  
Clutch Lever  
Screw & Lock Nut  
Microscope Scale  
Saddle Pivots  
⊗ Recording  
Power Switch  
⊗ Recorder Adjustment  
⊗ Advance Ball Adjustment  
46282 Photo. Scully Recording Machine  
46282 " " " " Motor & Drive Unit  
W-300457 Wiring Diagram

Sec. #9  
IX

"Turntables"  
IB-24121-1 70B Turntable Instructions  
S-839817 Freq. Response 70B Transcription Turntable  
⊗ LX-2 Proper Setting of 70B Eq. for Reproduction of  
RCA Recordings

Sec. #10  
X

"Test Equipment"  
1B-32001 Type 68B Oscillator Instructions  
1B-23362-4 Type 69A Distortion Meter Instructions  
1B-23365 Type 89A Atten. Panel Instructions  
2R1-2.3 MI-3222, MI-3222A Rec. Amp. Instructions  
X-5 Standard Test Records  
S-851899-2 Freq. Response of 78 and 33-1/3 Test Records



Sec. #11  
XI

"Transmission and Schematic Diagrams"  
T-613261 Trans. Diagram Disc Rec. Equip. N.Y. & Chicago

Sec. #12  
XII

"Equipment Assembly and Inter-unit Wiring Dia."  
W-302705 Typical Inter-unit Wiring N.Y. & Chicago  
W-303171 Wiring Diagram N.Y. and Chicago "Studio Rack"

Sec. #13  
XIII

"Testing and Maintenance of Equipment"  
XIII-1 Disc Recording Equipment  
Test and Maintenance Instructions  
XIII-1.1 Daily Routine  
XIII-1.2 Weekly Routine  
XIII-1.3 Monthly Routine  
XIII-1.4 Miscellaneous  
XIII-1a Cleaning Attenuators & Amplifier Volume Controls  
XIII-1b Checking RCA-845 Power Tubes  
XIII-1c.1 Standards for Measuring Freq. Response Curves  
XIII-1c.2 Chart MX-243536 Standard Setup for Making Freq. Response Curves  
XIII-1d Procedure for Making Freq. Response or "Xmas Tree" Patterns of Wax Recorders  
No Number Disc Recording Equipment Weekly Test Data (Sample Chart) (4 sheets)  
No Number (Sample) Weekly Response Check Studio 1, N.Y.  
S-851791 Compression Curve MI-10208 Used as Limiter  
S-851772 Compression Curve MI-10208 Used as Compressor

*Review as to possible routine.*

Sec. #14  
XIV

"Operation Standards"  
XIV-1 "Jack Bay Patching" for Various Types of Disc Recordings  
(XIV-2) Recording Standards Sheet for Studio Domestic Recording With Compression (3 sheets)  
(XIV-3) Recording Standards Sheet for Studio Domestic Recording - No Compression (3 sheets)  
(XIV-4) Recording Standards Sheet for Studio Orthacoustic Recordings (3 sheets)  
(XIV-5) Recording Standards Sheet for Wire Line Orthacoustic Recordings (4 sheets)  
XIV-6 Recording Standards Re-recording from Records. Preliminary.

*Review as to possible standard as to have same thing each time.*

Sec. #15  
XV

"Frequency Response and Performance Data"  
S-851768 Wax Recording Amp. Response Mixer-Input to Power Amp. Out  
S-851769 Freq. Response Mixer-Input to UI Amp. Out  
S-851803 Freq. Response Mixer-Input to Monitor Out  
S-851804-1 Overall Channel Response Studio Domestic Recording Using "Lateral" Compensator  
S-851805-1 Overall Channel Response Studio Domestic Recording Using Compensated Pre Amps (Non Standard)  
S-851806-1 Overall Channel Response Studio Orthacoustic Recording Mic. Amp. Input to Power Amp. Output  
S-851807-1 Overall Channel Response Wire Line Orthacoustic Recording Mixer Input to Power Amp. Out  
S-851808-1 Overall Channel Response Transcription Recording with "Lateral" Compensation



Sec. #16 "Material and Dimensional Data on Recording Blanks and Records"  
XVI T-607517 Record Dimensions 1936  
P-76308 General Recording 10" & 12" 78 RPM Records  
P-76331 " " 16" 33-1/3 RPM Records  
P-718138 Dimensions of 4-1/2" Recording

Sec. #17 "Individual Studio Data"  
XVII

Sec. #18 "Acoustic Data"  
XVIII

Sec. #19 "Addenda"  
XIX



MASTER REFERENCE BOOK  
FOR  
Disc Recording

-----  
For use by RCA employees only  
-----

Book Number 5

Issued To:

RCA Recording Studio  
1016 North Sycamore Avenue  
Hollywood, California  
USA

February 1940

Issued by the Recording Department, RCA Manufacturing Company, Inc.,  
Camden, New Jersey, USA

## INTRODUCTION

This Master Reference Book has been prepared to serve as a centralized, authoritative and timely source of technical and operations information on our Company's disc recording activities.

The book contains, in addition to this comprehensive information, specific operating and maintenance instructions on the high fidelity equipments in use in our Chicago and New York studios. Our Hollywood equipment differs slightly in layout but its operation is in accordance with the same standards.

While the instructions in the Master Reference Book refer generally to these equipments, the operation standards and the overall performance information are intended to serve as basic reference data for all of our disc recording studios.

Our Company enjoys a position of leadership in this field but in order to maintain and improve upon this position we must adhere to certain fundamental standards and profit mutually by the experiences of all those engaged in disc recording activities.

Our continued progress in the art of sound recording depends greatly upon the interest and cooperation of all concerned. Your experiences and suggestions as well as your adherence to our basic performance standards will do much to further a technical policy which will insure our production of a uniform, high quality record having a widespread acceptance.

Recording Department

A. Pulley  
Chief Recording Engineer

Camden, New Jersey  
March 11, 1940



## DISTRIBUTION

A list of the departments, studios and subsidiaries of this company receiving copies of the Master Reference Book appears below for your information in the exchange of information among these groups.

| Book Number | Issued to  |
|-------------|--|
| 1           | Recording Department, Camden, (Master Copy)                      |
| 2           | Engineering Department, Camden.                                  |
| 3           | Record Manufacturing Department, Camden.                         |
| 4           | Recording Studio, Chicago, Ill.                                  |
| 5           | Recording Studio, Hollywood, Calif.                              |
| 6           | Recording Studio, New York, N. Y.                                |
| 7           | RCA Victor Argentina, Buenos Aires, Argentina.                   |
| 8           | RCA Victor Brasileira, Rio de Janeiro, Brazil.                   |
| 9           | RCA Victor Chilena, Santiago, Chile.                             |
| 10          | RCA Victor Mexicana, Mexico City, Mexico.                        |
| 11          | RCA Victor Company Limited, Montreal, Canada.                    |
| 12          | RCA Manufacturing Company, Far East Branch,<br>Hong Kong, China. |
| 13          | Sound Engineering Division, Camden.                              |
| 14          | Home and Auto Receiver Design, Camden.                           |
| 15          | Recording Department, Camden.                                    |

## DATA CHANGES

The data in this book should not be altered or removed except by instructions from the Recording Department in Camden.

Additions, revisions and replacements for the data book will be distributed for each book as required, along with appropriate instructions for the changes.

New ideas and methods regardless of origin will be cleared through the Camden office. If tests in the studios show them to be worthy of adoption, the necessary information will be distributed to all the interested parties.



MASTER REFERENCE BOOK FOR DISC RECORDING - SECTION INDEX

| Section | Contents  |
|---------|---|
| I       | Microphone Data   |
| II      | Filter, Equalizer and Compensator Data                  |
| III     | Mixer Data  |
| IV      | Amplifier Data  |
| V       | Monitor Devices - Meters, Loudspeakers, Etc.            |
| VI      | Recorder and Pickup Data                                |
| VII     | Rectifier and Power Supply Data                         |
| VIII    | Recording Machine Data                                  |
| IX      | Reproducing Turntable Data                              |
| X       | Test Equipment Data and Information                     |
| XI      | Transmission and Schematic Diagrams                     |
| XII     | Wiring Diagrams of Overall Equipment                    |
| XIII    | Standards for Equipment Testing and Maintenance         |
| XIV     | Operation Standards                                     |
| XV      | Overall Performance Data and Response Curves            |
| XVI     | Dimensions and Materials - Records and Recording Blanks |
| XVII    | Individual Studio Data                                  |
| XVIII   | Accoustic Data  |
| Addenda | Miscellaneous Technical Information                     |

The Pages immediately following are devoted to a detailed index of each of the above sections.

Issued March 11, 1940

MASTER REFERENCE BOOK FOR DISC RECORDING - INDEX - SECTION I

Microphone Data

| Number | Subject  | Identification |
|--------|--|----------------|
| 1      | Velocity Microphone for Disc Recording                                   | I-1            |
| 1a     | Frequency Response Curve - Velocity Micr.<br>for Disc Recording          | S-851882       |
| 1b     | Effect of Source Distance upon Velocity<br>Microphone Frequency Response | S-851127       |
| 2      | Instruction Book - Velocity Microphone<br>Type MI-3027                   | IB-25842       |
| 3      | Instructions- 77A Unidirectional Microphone                              | IB-25838       |
| 4      | Instructions- 77B Unidirectional Microphone                              | IB-26509       |
| 4a     | Frequency Response- 77B Microphone                                       | S-839869       |
| 5      | Talkback Microphone (Aerodynamic-MI-6226A)                               | IB-37022       |

Issued March 11, 1940



MASTER REFERENCE BOOK FOR DISC RECORDING - INDEX - SECTION II

Filter, Compensator and Equalizer Data

| Number | Subject  | Identification |
|--------|--|----------------|
| 1      | Data Sheet - "Lateral" Compensator                                   | S-851767       |
| 2      | Data Sheet - "Orthacoustic" Compensator                              | S-851766       |
| 3      | Data Sheet - 45 cycle Hi-pass Filter                                 | S-851845       |
| 4      | Data Sheet - XT-2727A, 8500 cycle Lo-pass Filter                     | S-851774       |
| 5      | Data Sheet - XT-2544, "Telephone Effect" Filter                      | S-851773       |
| 6      | Data Sheet - XT-914B "Voice Frequency" Filter                        | S-851802       |
| 7      | Instruction Book - MI-3119 and MI-10101<br>Re-recording Compensators | 2R6-5.2        |
| 8      | Instruction Book - 56A Line Equalizer                                | IB-25839       |

Issued March 11, 1940

MASTER REFERENCE BOOK FOR DISC RECORDING - INDEX - SECTION III

Mixer Data

| Number | Subject   | Identification |
|--------|---|----------------|
| 1      | Disc Recording Mixer Console Description<br>(Includes Data References, Photographs<br>and Wiring Diagram) | III-1          |
| 2      | MI-3108 and MI-3108A Mixer Instruction Book   | 2R6-8.1        |
| 3      | MI-3116 and MI-3116A Mixer Instruction Book   | 2R6-2.1        |
| 3a     | Correction Sheet for 2R6-2.1  |                |
| 4      | MI-3120 Combining Network Instruction Book  | 2R6-3.1        |

Issued March 11, 1940



MASTER REFERENCE BOOK FOR DISC RECORDING - INDEX - SECTION IV

Amplifier Data

| Number | Subject  | Identification |
|--------|--|----------------|
| 1      | MI-3223 and MI-3223A Monitor Amplifier-<br>Instruction Book                                | IB-23837       |
| 1a     | MI-3223C Monitor Amplifier Instruction Sheet-<br>Addenda to IB-23837                       | 2R1-3.1        |
| 2      | MI-3230 Microphone Pre-amplifier Instruction<br>Book                                       | IB-23891       |
| 2a     | MI-3230A and MI-3230B Microphone Pre-amplifier<br>Instructions - Addenda to IB-23891       | 2R1-6.2        |
| 2b     | Instruction Sheet - MI-3230B Modified for Disc<br>Recording                                | IV-2b          |
| 3      | MI-3232 and MI-3232A Booster Amplifier Instruct.<br>(Voltage Amplifier for Disc Recording) | 2R1-4.1        |
| 4      | MI-3233A Driver (Bridging) Amplifier Instruction<br>Book                                   | 2R1-3.2        |
| 5      | MI-4250A Power Amplifier Instruction Sheet   | 2C3-3.5        |
| 6      | MI-4255A Power Amplifier Instruction Sheet   | 2C3-3.5A       |
| 6a     | Correction Sheet for 2C3-3.6A  | 2C3-3.6B       |
| 7      | MI-10201 and MI-10206 Electronic Range Control<br>(Volume Compressor) Instruction Book     | 2R1-9.1        |
| 7a     | Modification of MI-10206 for Disc Recording  | IV-7a          |

MASTER REFERENCE BOOK FOR DISC RECORDING - INDEX - SECTION V

Monitor Devices, Meters, Loudspeakers, Etc.

| Number | Subject   | Identification |
|--------|---|----------------|
| 1      | MI-3115 and MI-3115A Meter Volume Indicator<br>Instruction Book | 2R15-1.1       |
| 2      | VU Meter Volume Indicator-Connections and<br>Information        | S-851812       |
| 3      | Disc Recording Monitor Loudspeaker Instructions                 | V-3            |

Issued March 11, 1940

MASTER REFERENCE BOOK FOR DISC RECORDING - INDEX - SECTION VI

Recorder and Pickup Data

| Number | Subject  | Identification |
|--------|--|----------------|
| 1      | Frequency Response and Limits of Standard Wax Recorder | S-851770       |
| 2      | Recorder Photograph showing Advance Ball               | 46286          |
| 3      | Recorder Mounting Saddle                               | 46285          |

Issued March 11, 1940

MASTER REFERENCE BOOK FOR DISC RECORDING - INDEX - SECTION VII

Rectifier and Power Supply Data

| Number | Subject   | Identification |
|--------|---|----------------|
| 1      | MI-3526 Plate Power Supply Instruction Book     | 2R9-3.1        |
| 2      | MI-3527 Filament Power Supply Instr. Book       | 2R9-6.1        |
| 2a     | MI-3527A Instruction Sheet (Addenda to 2R9-6.1) | IB-24195       |

Issued March 11, 1940



MASTER REFERENCE BOOK FOR DISC RECORDING - INDEX - SECTION VIII

Recording Machine Data

| Number | Subject   | Identification |
|--------|---|----------------|
| 1      | Instructions for Operation and Maintenance<br>of the Scully Recording Machine | VIII-1         |

Issued March 11, 1940

MASTER REFERENCE BOOK FOR DISC RECORDING - INDEX - SECTION IX

Turntable Data

| Number | Subject   | Identification |
|--------|---|----------------|
| 1      | Instruction Book - 70B Transcription Type<br>Turntable                  | IB-24121-1     |
| 1a     | Frequency Response of the 70B Turntable                                 | S-839817       |
| 2      | Standard Settings of 70B Compensators for<br>Reproducing RCA Recordings | IX-2           |

Issued March 11, 1940

MASTER REFERENCE BOOK FOR DISC RECORDING - INDEX - SECTION X

Test Equipment Data

| Number | Subject  | Identification |
|--------|--|----------------|
| 1      | 68A (or 68B) Beat-frequency Oscillator -<br>Instruction Book   | IB-32001       |
| 2      | 69A Distortion Factor Meter - Instruction Book   | IB-23362-4     |
| 3      | 89A Attenuator Panel (Gainset) - Instruction Book  | IB-23365       |
| 4      | MI-3222 Recording Amplifier (Used as a Test Ampli-<br>fier in Disc Recording Studios - Instructions) | 2R1-2.3        |
| 5      | Standard Test Records  | X-5            |
| 5a     | Frequency Response Curves of Standard Test Records   | S-851899       |

Issued March 11, 1940

MASTER REFERENCE BOOK FOR DISC RECORDING - INDEX - SECTION XI

Transmission and Schematic Diagrams

| Number | Subject   | Identification |
|--------|---|----------------|
| 1      | Transmission Diagram - Studio Recording<br>Equipment - New York and Chicago Studios | T-613261       |

Issued March 11, 1940



MASTER REFERENCE BOOK FOR DISC RECORDING - INDEX - SECTION XII

Wiring Diagrams

| Number | Subject   | Identification |
|--------|---|----------------|
| 1      | Typical Interunit Wiring Diagram of Studio<br>Recording Equipment | W-302705       |
| 2      | Main Amplifier Rack Wiring Diagram                                | W-303171       |

Issued March 11, 1940

MASTER REFERENCE BOOK FOR DISC RECORDING - INDEX - SECTION XIII

Standard Methods and Procedure  
for  
Equipment Testing and Maintenance

| Number | Subject  | Identification |
|--------|--|----------------|
| 1      | Test and Maintenance Instructions                | XIII-1         |
|        | Daily Test Routine                               | XIII-1.1       |
|        | Weekly Test Routine                              | XIII-1.2       |
|        | Monthly Test Routine                             | XIII-1.3       |
|        | Miscellaneous Tests                              | XIII-1.4       |
| 1a     | Cleaning Mixer Attenuators and Volume Controls   | XIII-1a        |
| 1b     | Checking UV-845 power tubes                      | XIII-1b        |
| 1c     | Standards for Measuring Frequency Response Curve | XIII-1c        |
| 1d     | Procedure for Making Recorder Frequency Patterns | XIII-1d        |
| 2      | Specimen Data Sheets for Routine Tests           | XIII-2         |
| 3      | Adjusting and Balancing the MI-10206 ("ERC")     | XIII-3         |
| 3a     | Adjusting the MI-10206 as a Limiter              | XIII-3a        |
|        | Limiter Characteristic of MI-10206               | S-851771       |
| 3b     | Adjusting the MI-10206 as a Compressor           | XIII-3b        |
|        | Compression Characteristics of MI-10206          | S-851772       |

MASTER REFERENCE BOOK FOR DISC RECORDING - INDEX - SECTION XIV

Operation Standards

| Number | Subject   | Identification |
|--------|---|----------------|
| 1      | Jack Bay Patching - Main Amplifier - for<br>All Types of Recording    | S-851777       |
| 2      | Standard Setup - Studio Domestic Recording<br>with Compression        | XIV-2          |
| 3      | Standard Setup - Studio Domestic Recording<br>with No Compression     | XIV-3          |
| 4      | Standard Setup - Studio Orthacoustic Recording<br>(with Limiter)      | XIV-4          |
| 5      | Standard Setup - Wire Line Orthacoustic Record-<br>ing (with Limiter) | XIV-5          |
| 6      | Standard Setup - Re-recording from Records                            | XIV-6          |

Issued March 11, 1940

MASTER REFERENCE BOOK FOR DISC RECORDING - INDEX - SECTION XV

Performance Data and Response Curves

| Number | Subject  | Identification |
|--------|--|----------------|
| 1      | Mixer Input to Power Amplifier Output -<br>Frequency Response ("No Comp" Pad In)   | S-851768       |
| 2      | Mixer Input to VI Amplifier Output - Frequency<br>Response ("No Comp" Pad In)  | S-851769       |
| 3      | Mixer Input to Monitor Amplifier Output -<br>Frequency Response ("No Comp" Pad In)   | S-851803       |
| 4      | Microphone Amplifier Input to Power Amplifier<br>Output - "Lateral" Compensator - Flat Mic.<br>Amps.-Frequency Response. (Studio Domestic)       | S-851804       |
| * 5    | Microphone Amplifier Input to Power Amplifier<br>Output - Compensated Mic. Amps. - Frequency<br>Response. (Studio Domestic)                      | S-851805       |
| 6      | Microphone Amplifier Input to Power Amplifier<br>Output - "Orthacoustic" Compensator - flat<br>Mic.Amps.-Frequency Response. (Orthacoustic Rec.) | S-851806       |
| 7      | Mixer Input to Power Amplifier Output -<br>"Orthacoustic" Compensator - Frequency Response<br>("Orthacoustic" Wire Line Recordings)              | S-851807       |
| 8      | Mixer Input to Power Amplifier Output - "Lateral"<br>Compensator - Frequency Response - (Non-<br>Orthacoustic Wire Line Recordings)              | S-851808       |

\* Item 5 is a Non-Standard Setup and should only be used in case of failure of the Lateral Compensator or for experimental recordings.

Issued March 11, 1940



MASTER REFERENCE BOOK FOR DISC RECORDING - INDEX - SECTION XVI

Record Dimensions and Record Materials

| Number | Subject   | Identification |
|--------|---|----------------|
| 1      | Standard Dimension Sheet for all Records                    | T-607517       |
| 2      | General Dimensions for 10" and 12" Commercial Records       | P-76308        |
| 3      | General Dimensions for 16" Transcription Records            | P-76331        |
| 4      | General Dimensions for 4 $\frac{1}{2}$ " Advertising Record | P-718138       |

Issued March 11, 1940

MASTER REFERENCE BOOK FOR DISC RECORDING - INDEX - SECTION XVII

Individual Studio Data

Note: This section is reserved for the use of the studio to which this copy of the Master Reference Book is issued. It may be used to file data pertinent to the particular equipment only.

| Number | Subject | Identification |
|--------|---------|----------------|
| 1      |         |                |
| 2      |         |                |
| 3      |         |                |
| 4      |         |                |
| 5      |         |                |

Issued March 11, 1940

MASTER REFERENCE BOOK FOR DISC RECORDING - INDEX - SECTION XVIII

Accoustic Data

Note: This section of the book is reserved for information about the various studios (reverberation time etc.) and general sound and accoustic data.

| Number | Subject | Identification |
|--------|---------|----------------|
|--------|---------|----------------|

Issued March 11, 1940

MASTER REFERENCE BOOK FOR DISC RECORDING - INDEX - ADDENDA

This section of the book is reserved for chemical, electrical and mechanical data which does not apply directly to the operation of the recording equipment but which is of general interest to the studio personnel.

Number

Subject

Identification

Issued March 11, 1940

SECTION I  
Microphone Data

Master Reference Book  
Disc Recording



INSTRUCTION SHEET  
VELOCITY MICROPHONE FOR DISC RECORDING

## GENERAL:

The velocity or ribbon microphone is to be considered the standard type for disc recording. When other microphones are used for special reasons, their performance should be referred to in terms of its relation to that of the velocity.

## TYPE:

No specific type number has been assigned to the standard disc recording microphone. However, most of these now in use were PB-144's or 44A's originally and have been modified to agree with the standards here described. All microphones not in agreement with these standards should be modified as soon as possible and where doubt exists, the microphone should be returned to Camden for recalibration.

## FREQUENCY RESPONSE:

The attached curve, S-851882, shows the standard response of the disc recording microphone.

## SENSITIVITY:

The sensitivity of the disc recording microphone is:-

-63 db (0.006w) output for a 10 bar input (open circuit)

NOTE 1:- Curve S-851127 (attached) shows the effect upon the frequency response of the microphone for a variation of distance from the sound source to the microphone.

NOTE 2:- The disc recording standard velocity microphone has essentially the same frequency response as that of the newer types MI-3027 or 44B when these microphones are connected on the "MUSIC" position. The disc recording microphone is not provided with a "VOICE" connection.

NOTE 3:- Because of the mechanical and electrical similarity between the disc recording microphone and the MI-3027 an instruction book covering the MI-3027 has been included in the Master Reference Book as an aid in studying the disc recording model.

NOTE 4:- The Sensitivity of the disc recording microphone is 6 db less than that of the MI-3027 or the 44B.

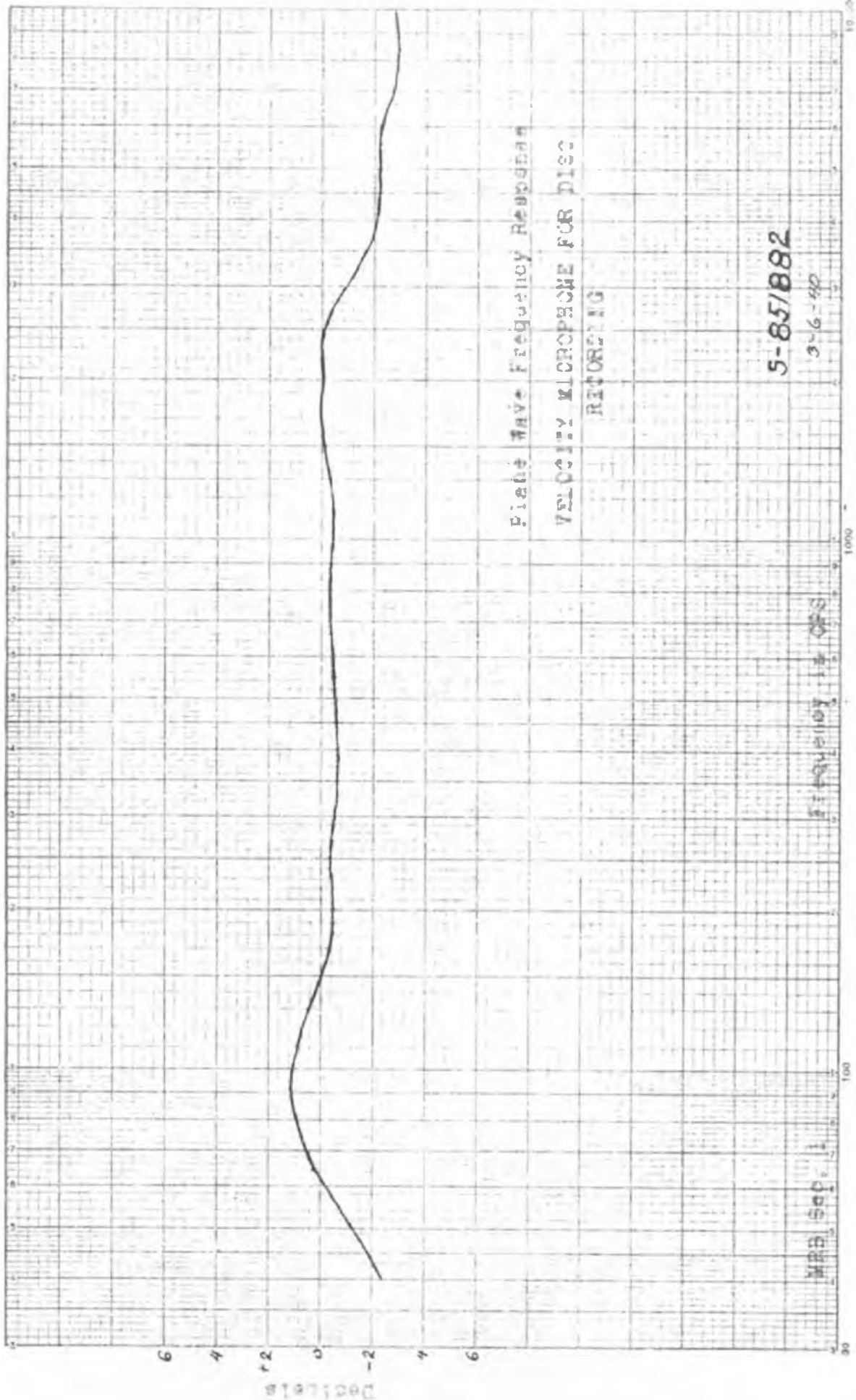
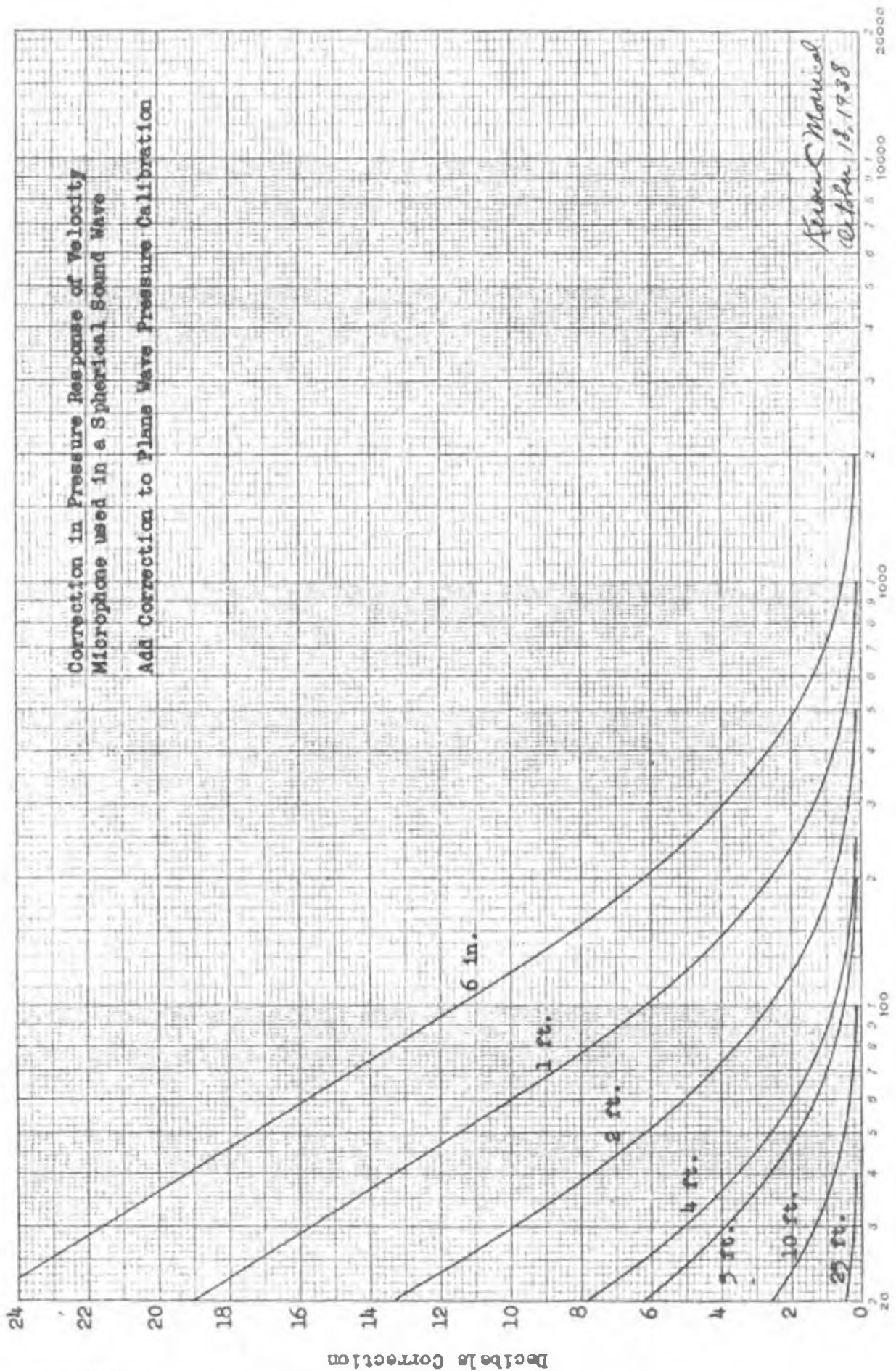

Plate Wave Frequency Response  
 VELOCITY MICROPHONE FOR DISC  
 RECORDING

5-85/882

3-6-40

S-851127



FREQUENCY IN CYCLES PER SECOND

**RCA PHOTOPHONE  
VELOCITY MICROPHONE**

**MI-3027**

**WITH  
ACCESSORIES**

---

**I N S T R U C T I O N S**

---

Copyright 1936 by

**RCA Victor Division  
RCA Manufacturing Company, Inc.  
CAMDEN, N. J., U. S. A.**

**A N R C A S E R V I C E**



# RCA PHOTOPHONE VELOCITY MICROPHONE

MI-3027

WITH  
ACCESSORIES

## PART I - DESCRIPTION

1. INTRODUCTION - The velocity microphone is the result of several years of intensive research and development toward the improvement of the characteristics of microphones as used for recording purposes, and is entirely different in principle and construction from other microphones now in use.

Instead of a "diaphragm" (in the commonly accepted meaning of the word), the velocity microphone contains a thin metallic ribbon suspended between the poles of a permanent magnet with its length perpendicular to, and its width in the plane of, the magnetic lines of force. The opposite ends of the ribbon are connected to a transformer which matches the impedance of the ribbon to a 50 or 250 ohm line. Sound waves reaching the ribbon vibrate it within the magnetic field set up by the magnet. The vibration of the ribbon is in exact accordance with the sound vibrations and, occurring as it does within the magnetic field, sets up corresponding alternating electric potentials across the primary of its associated transformer. These minute voltages are subsequently amplified to the power level required for recording. The microphone amplifier may be located remotely from the microphone unit when necessary or desirable.

2. DESCRIPTION - The MI-3027 microphone unit is furnished with a suspension fitting (Type UP-4212-A) to permit the unit to be suspended overhead. This location of the microphone is that generally used in sound motion picture recording. See Figure 1. The microphone may also be mounted on a program or announce stand as shown in Figures 2, 3, and 4.

The transmitter is enclosed within a perforated metal casing which serves to protect it from mechanical injury and adverse wind effects. The line coupling transformer is contained in a metal case as a part of the microphone unit.

3. SENSITIVITY - With an input sound pressure of 10 dynes per square centimeter perpendicular to the plane of the ribbon, the ribbon microphone unit will deliver 800 microvolts across a 250 ohm load, which is equivalent to an output level of -67 db. as compared with a zero level of 12.5 milliwatts, or -64 db. as compared with a zero level of 6 milliwatts.

On an open circuit basis of measurement, i.e., with an input of 1 dyne per square centimeter (1 bar) perpendicular to the ribbon, the output of the microphone across an open circuit is the equivalent of -81 db. with reference to a zero level of 12.5 milliwatts, or -78 db. with reference to a zero level of 6 milliwatts.

4. QUALITY OF RESPONSE - The operating range of the microphone extends from 30 cycles to 15,000 cycles.

When a velocity microphone is placed close to a source of sound, the low frequency response is accentuated. In view of this fact, provision is made in the MI-3027 microphone to enable the user to alter its frequency response in such a manner as to suit best the particular purpose desired; viz., the pick-up of voice (i.e., within 2 feet of the microphone), or the pick-up of music (which takes place at greater distances from the microphone). Emphasis is here placed on the fact that this feature of the MI-3027 microphone is not provided with the intention that such alterations in frequency response be made at will; i.e., between scenes; but is furnished for the sole purpose of supplying a microphone with the best possible characteristics for voice pick-up or for musical pick-up. It is recommended that the frequency response be adapted to either of these types of pick-up and the use of the microphone be restricted to that type of pick-up only.

To alter the frequency response proceed as follows:

A small circular hole will be found in the cover plate of the transformer casing. Through this hole will be visible the letter "V" (voice) or the letter "M" (music), depending on whether the microphone is at the time adapted for voice pick-up or for musical pick-up.

Voice pick-up requires the use of a jumper (upon which appears the letter "V"), which is to be placed across the two terminals marked "M" (music), located on the terminal block within the transformer housing. Access to this terminal block is obtained by removing the cover plate of the transformer housing.

When the jumper "V" is used, it connects a reactor in parallel with a part of the transformer winding (when the 250-ohm output connections are used), or with all the transformer winding (when the 50-ohm output connections are used). See the schematic diagram, Figure 5.

A response curve taken with and without the "V" jumper is shown in Figure 6. As will be observed from examination of this curve, there is a sharp decline at the low frequency end of the curve when the "V" jumper is used. It is to be noted that this curve was taken in a plane wave field, and that the curve is flat when the speaker is located at a distance of 1 foot from the microphone.

5. DIRECTIONAL CHARACTERISTICS - One of the most important characteristics of the velocity microphone is its directional property. Since the ribbon is suspended in free space, sound waves approaching the microphone from a direction in the same plane as the ribbon have no effect upon it. Sound waves FROM EITHER DIRECTION along an axis perpendicular to the plane of the ribbon have the maximum effect. For equal distances from the transmitter, the relative response to sound originating at various angles to the axis perpendicular to the ribbon is shown in Figure 7.

It is at once apparent that this characteristic is of considerable value in the solution of some of the difficulties usually encountered in reverberant locations by the reduction of the effect of undesired sound reflections, and in the increased possibilities of obtaining better balance, clarity, naturalness, and selectivity in sound pick-up. Extraneous direct or reflected sounds approaching the microphone from side directions will have little effect, and therefore background noises and reflected sounds in the recording are considerably reduced, which increases, by comparison, the quality of the direct sounds reproduced. The degree of sound-proofing necessary for sound originating within the "dead zone" is, of course, dependent upon the reflecting surfaces present which may return the undesired sound to the microphone from such directions that response may be obtained.

For the same allowable reverberation pick-up, the operating range of the velocity microphone is approximately 1.7 times greater than a non-directional microphone having the same sensitivity.

Sound concentrators and baffles used with condenser or inductor microphones are unnecessary with and inapplicable to the velocity microphone because of the fundamental difference in the principle of its operation. The transmitter must be used in free space where the flow of air particles is unimpeded. However, "pick-up" from the rear direction of the microphone may be eliminated by placing a baffle or shield of heavy sound absorbing material, such as heavy felt, at a distance of not less than three feet from the transmitter and so confine the "pick-up" to the area in front of the microphone.

## PART II--OPERATION

6. MICROPHONE ASSEMBLY. - The microphone, as supplied by the manufacturer, is equipped for suspension mounting. For this purpose, a suspension fitting is attached to the yoke of the microphone fork by means of three machine screws, eyelets are likewise provided at the extremities of the fork.

NOTE:- When the microphone is suspended, see that its weight is carried by the suspension fitting with no strain on the microphone cable.

(a) STAND MOUNTING - If stand mounting is desired, the manufacturer is prepared to furnish program stand Type AZ-4090 (MI-4056) or announce stand Type AZ-4191 (MI-4058-A). When either of these stands is to be used an adapter (MI-3033) will be required. To mount the adapter on the microphone fork, remove the suspension fitting, pass the spindle of the adapter through the hole in the yoke and put on the flat washer, the spring washer and the clamping nut. If the program stand is to be used, screw the adapter assembly (the flange of which is drilled and



threaded for this purpose) to the top of the stand. If the announce stand is to be used, remove the cable clamp from the barrel and the flange from the bottom of the adapter, insert the barrel in the hole in the stand and fasten it in place by means of the three screws.

(b) CABLE CONNECTIONS - Remove the cover plate of the transformer housing.

Loosen the two screws in the cable clamp and pass the end of the cable through the clamp.

At one side of the terminal block are mounted four terminals. Of these four terminals, the two outside are output terminals. Between the two terminals nearer the center is engraved the number 250 (i.e., 250 ohms). Between each outside terminal and the nearer of each centrally located terminal is engraved the number 50 (i.e., 50 ohms).

If the microphone is to feed a 250-ohm line, the two small jumpers should be placed, one over the other, across the two centrally located (250-ohm) terminals.

If the microphone is to feed a 50-ohm line, one of the two small jumpers is to be placed across each pair of terminals marked 50.

No change is necessary in microphone cable terminal connections.

Solder the ground lead from the cable shield to the cable clamp.

The cable is to pass through the slot in the cover plate of the transformer housing.

Figure 12 shows the location of the various numbered contacts of both plugs and receptacles, and, in conjunction with the schematic wiring diagram, will serve to indicate the proper connections of the various leads when testing, repairing, or replacing any electrical part.

(c) PHASING - When more than one microphone is used in a single pick-up, it is possible that the output of the various microphone circuits may not be in phase when fed into a common circuit. The microphone circuits include the microphones themselves, microphone pre-amplifiers, microphone attenuators (mixers) and the necessary connecting lines. The output of the microphone attenuators (mixers) when fed into the overall attenuator (mixer) must be in phase, or varying degrees of distortion will result, depending upon the relative placement of the microphones. If two microphones are placed close together, the result will be practically zero output if their circuits are out of phase at the overall mixer.

For this reason each unit of all RCA recording equipment is carefully wired in accordance with a definite wiring color scheme in

order that they will always be in phase when the inter-unit connections have been made according to a uniform plan; i.e., where the "±" connection of ONE microphone is connected to a certain input terminal of its pre-amplifier, then the "±" connection of ALL microphones must be connected to a corresponding terminal of their respective pre-amplifier and so on through the system up to the overall mixing control.

In set-ups in which velocity microphones are used, it is possible to phase them by turning those out of phase through 180 degrees. This is not possible with any pressure operated microphone.

It is particularly important that the phasing problem be borne in mind when inspecting, testing, repairing or replacing any unit or component thereof, and care be taken to see that the internal connections of the various units are made strictly in accordance with their wiring diagrams.

7. TECHNIQUE OF VELOCITY MICROPHONE PLACEMENT - The proper placement of the microphone is essential in order to realize fully its inherent advantages. For this reason, the following instructions should be carefully studied, and close attention be given to the results of any special placement with a view towards future improvement of the technique. These instructions can of course only serve as a guide, and a study should be made to determine the best microphone placement for each condition.

(a) GENERAL CONSIDERATIONS FOR STAGE SET-UP - The directional characteristic and greater sensitivity of this microphone are especially important in sound recording for motion pictures. Because of the necessity of constructing sound stages for sight as well as sound, the acoustic properties of the set are frequently sacrificed in favor of the scenic properties, whereupon more difficulty is experienced in controlling the effect of undesired echoes and reverberations. Also, because the microphone cannot be in the field of view of the cameras, the microphone must be located farther from the actors than is the case in a broadcasting studio. With the increased distance between the sound source and the microphone, the reverberation, echo and background noise effects are more troublesome. Furthermore, there are always people and machinery in motion on the set other than those in the picture and sounds caused by them must not be picked up.

Also because of the usually more distant location of the microphone, it is unlikely that the connection of the microphone for voice pick-up, as described in section 4, will be used; although it may become desirable because of special recording conditions.

Previous to the production of the velocity microphone, it has been necessary with other microphones to use microphone baffles, sound concentrators, acoustic treatment of sets and studios, camera "blimps," etc. The use of these devices as aids to the perfect reproduction of sound and

picture with the proper illusion of naturalness has not been entirely eliminated through the use of the velocity microphone, but has been greatly minimized.

As mentioned in section 5, a felt baffle may be placed so as to cut off the "pick-up" of sound from directions opposite to the source of desired sound. The microphone, in many cases, may be placed so that an imaginary plane coincident with the plane of the ribbon will pass through sources of undesired sound, either direct or reflected, and so minimize the effects of extraneous or reverberant sound.

The necessity of highly sound-proofed booths and "blimps" is evidently reduced if cameras are operated in positions in the "plane of zero sound"; and the degree of sound-proofing necessary for sound originating within the "dead zone" is, of course, dependent upon the reflecting surfaces present which may return the undesired sound to the microphone from such directions that response may be obtained. A camera, for example, may be operated outside of a booth and without a "blimp" if it is placed in the plane of zero sound, providing that none of the camera noise is returned to the microphone from any other direction by reflecting surfaces, which condition may be most generally realized in out of door recording. See Figure 11.

(b) GENERAL INSTRUCTIONS - The source of sound, speaker, artist or musical instrument, should not be placed closer to the microphone than 2 feet and a distance of 3 to 4 feet is to be preferred. At shorter distances there is a tendency toward accentuation of low frequencies, which may result in making voices sound "boomy." In this respect, the use of the velocity microphone differs greatly from that of the condenser microphone with which the speaker or soloist has usually worked at a distance of 4 to 6 inches.

The placement of a speaker or musical instrument off from the center line of the microphone will in no way affect the quality of pick-up, but will merely attenuate the direct sound pick-up, thereby raising the ratio of reverberation to direct "pick-up".

For the most satisfactory results, the microphone should not be placed closer than 3 feet to any solid reflecting surface. This statement is, of course, general and specific conditions may require otherwise.

In order further to eliminate adverse wind effects, it is advisable to employ a suitable wind screen when the microphone is used out-of-doors.

The diagrams referred to in the subsequent paragraphs and the discussion concerning them can only serve to indicate some of the possible placements under particular conditions. The final decision as to what constitutes the proper placement must rest with someone who is competent to judge the quality of the results as reproduced by the monitor speaker.

It is recommended that the side of the microphone OPPOSITE the cable entrance bushing, always be turned toward the source of desired sound.

(c) SOLOIST WITH PIANO - Interesting effects may be obtained by changing the angle of the microphones with respect to the piano, thus changing the ratio of reverberation to direct "pick-up". The distance between the soloist and microphone should be determined by the strength of his (or her) voice, and the piano should be placed accordingly. The general arrangement is shown in Figure 8. Under no conditions should the soloist be less than 2 feet from the microphone.

(d) DANCE ORCHESTRA - The diagram (Figure 9) is self-explanatory, the only precaution necessary being to keep the soloist at least 2 feet, and preferably 3 feet, from the microphone.

Due to the fact that artists cannot work close to the microphone, some difficulty may be experienced in obtaining the proper balance between the artist and the orchestra. This difficulty can be overcome quite satisfactorily by using two microphones, one to pick up the orchestra and the other to pick up the artist. The artist's microphone should be located so that its "dead zone" is toward the orchestra. By properly setting the mixing controls, the level of the orchestra can be controlled so that a satisfactory back-ground accompaniment of music is obtained.

In locating the microphone with respect to an orchestra, care should be taken to avoid reflected "pick-up" from hard surfaced floors. Such reflections can be avoided by the use of carpets or similar material on the floor.

(e) LARGE ORCHESTRA - An arrangement for a large orchestra is shown in Figure 10. Two microphones may be used to advantage for such an assembly. See also paragraph (d) above. The arrangement shown in Figure 10 was used successfully in the RCA recording studios in Camden, N. J. It must be borne in mind, however, that this arrangement will not necessarily be the best in all studios because of differences in their acoustic properties. Changes in this arrangement should not need to be very extensive in order to give excellent results.

(f) "LONG SHOT" AND "CLOSE-UP" SOUND - The nearer a microphone may be placed to the subject within the limits of the foregoing paragraphs, the more natural will be the quality of recorded sound. This statement is made without regard to "long-shot" sound which is deliberately made poorer in order to produce the desired match between picture and sound. An indefinable quality of "presence" is the principle difference between "long-shot" and "close-up" sound and this quality is rapidly lost as the microphone is moved farther from the subject. In many cases, two cameras are trained on the subject simultaneously and at least that portion of the sound used with the close-up picture should have "presence" to match the picture. The increased field of view of

the long-shot camera precludes the possibility of placing a microphone close enough to the subject to give the desired close-up sound except through the use of the velocity microphone and by taking full advantage of its directional characteristics and increased sensitivity.

(g) UNI-DIRECTIONAL PICK-UP - Should it be found desirable to utilize pick-up from but one direction, pick-up from the opposite direction may be made ineffective by placing a baffle or shield of heavy sound absorbing material, such as felt, approximately 3 feet from the microphone on the side from which the sound is to be blocked. The felt should be approximately 6 to 10 feet square.

(h) BI-DIRECTIONAL PICK-UP - The bi-directional characteristic of the microphone may be used to its fullest advantage in some cases by grouping the artists about the microphone at such positions that their voice levels match to form the desired composite.

When the microphone is used by a speaker located at a table or desk, the microphone should be so placed that it picks up direct sound from the speaker rather than reflected sound from the surface of the table, desk or manuscript.

In most cases of this sort, it is necessary to conceal the microphone.

8. OPERATION. - In general, the microphone will operate satisfactorily and require very little attention. It should give the normal output listed in section 3.

The microphone may also be mounted on a program or floor stand (MI-4056) or on an announce or desk stand (MI-4058-A). An adapter (MI-3033) is required when using either type of stand. The program or floor stand is adjustable as to height. The center of the velocity microphone may be located at any height from 56 to 81 inches above the floor. In order to raise or lower the stand, the vertical column clamping screw should first be loosened. If it is desired to raise the microphone, all that is necessary is to lift it to the desired point and there it will lock itself automatically. Usually, it will remain fixed at this position unless there is vibration or the microphone and stand are moved around. This movement may cause the stand to slide slowly downward. The clamping screw is provided in order to prevent this. However, if the microphone does not tend to creep, then it is not necessary to use the clamping screw. When it is desired to lower the microphone stand, the clamping screw should first be loosened, then the inner tube of the microphone stand should be raised slightly while pressing the sliding column latch which projects at the side of the locking device. This will release the lock and allow the microphone to be lowered to the desired position, at which point the latch should be released and the stand will automatically lock itself. Then the clamping screw may be tightened if desired.

It is not recommended that the customer attempt to repair the microphone, but, rather that it be returned to the RCA Manufacturing Company, Inc. for repair. This may be done by writing to the RCA Manufacturing Company, Inc. for a "RETURNED APPARATUS" tag and "REPORT BLANK." Before doing this, however, make absolutely certain that the trouble is in the microphone and not elsewhere in the circuit.

#### 9. LIST OF PARTS AND ACCESSORIES.---

##### ACCESSORIES

| <u>Description</u>   | <u>Type</u>             | <u>Stock No.</u>       |
|--|-------------------------|------------------------|
| Velocity Microphone (with Suspension Fitting) . . . .<br>(see Figure 1)      |                         | MI-3027                |
| Program Stand (see Figure 2) . . . . .                                       | AZ-4090                 | MI-4056                |
| Announce (Desk Type) Stand (see Figure 4) . . . . .                          | AZ-4191                 | MI-4058-A              |
| Adapter, for Program and Announce Stands (see Figure 3)                      |                         | MI-3033<br>(or 16831)  |
| Suspension Fitting (for MI-3015-B) . . . . .                                 | UP-4212-A               | MI-4071-A              |
| Cable and Plug (18-inch cable with<br>a Cannon Type P3-CG-12 plug) . . . . . |                         | MI-3055                |
| *Cable (2-conductor, shielded extension cable) . . . . .                     |                         | MI-62                  |
| Flush Type Wall Receptacle (see Figure 12) . . . . .                         | Cannon<br>Type P3-13    | MI-4622                |
| Surface Type Wall Receptacle (see Figure 12) . . . . .                       | Cannon<br>Type P3-17    | MI-4621                |
| Flush Type Wall Receptacle (see Figure 12) . . . . .                         | Cannon<br>Type P3-35    | MI-4625                |
| Female Cord Connector (see Figure 12) . . . . .                              | Cannon<br>Type P3-CG-11 | †MI-4620<br>‡MI-4620-A |
| Male Cord Connector (see Figure 12) . . . . .                                | Cannon<br>Type P3-CG-12 | †MI-4630<br>‡MI-4630-A |

NOTES:- \*Length of cable must be specified when ordering

†Aluminum, Bronze finish.

‡Aluminum, Natural finish.

REPLACEMENT PARTS

| <u>Description</u>  | <u>Stock No.</u> |
|---|------------------|
| Microphone Screen . . . . .                                       | 16825            |
| Swivel Clamping Nut . . . . .                                     | 16826            |
| Washer - Used under swivel clamping nut. . . . .                  | 16827            |
| Transformer - Microphone Output Transformer . . . Type RT-435 . . | 16828            |





FIGURE 1— MI-3027 VELOCITY MICROPHONE SUSPENDED



FIGURE 2— MI-3027 VELOCITY MICROPHONE ON PROGRAM STAND

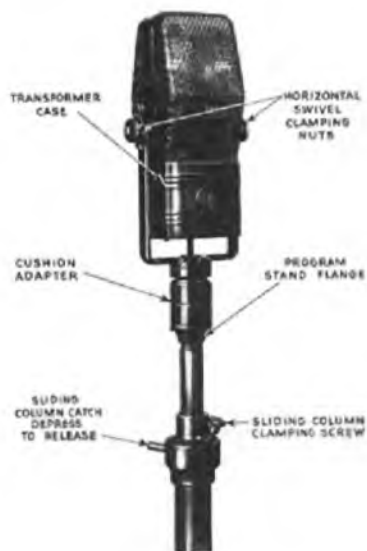

FIGURE 3—CLOSE-UP OF MICROPHONE ON PROGRAM STAND, SHOWING CUSHION ADAPTER



FIGURE 4—MICROPHONE ON ANNOUNCE (OR DESK) STAND.

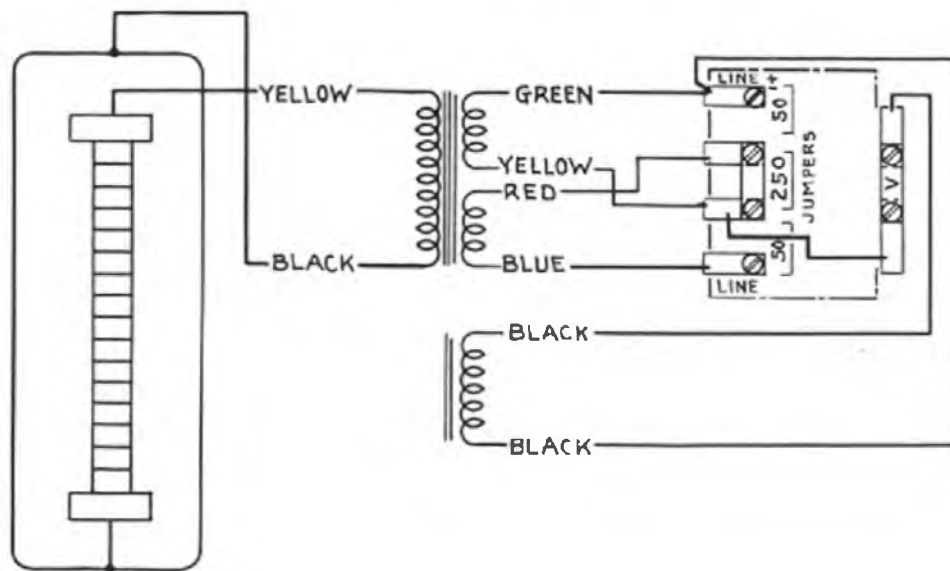

FIGURE 5—SCHEMATIC DIAGRAM OF VELOCITY MICROPHONE

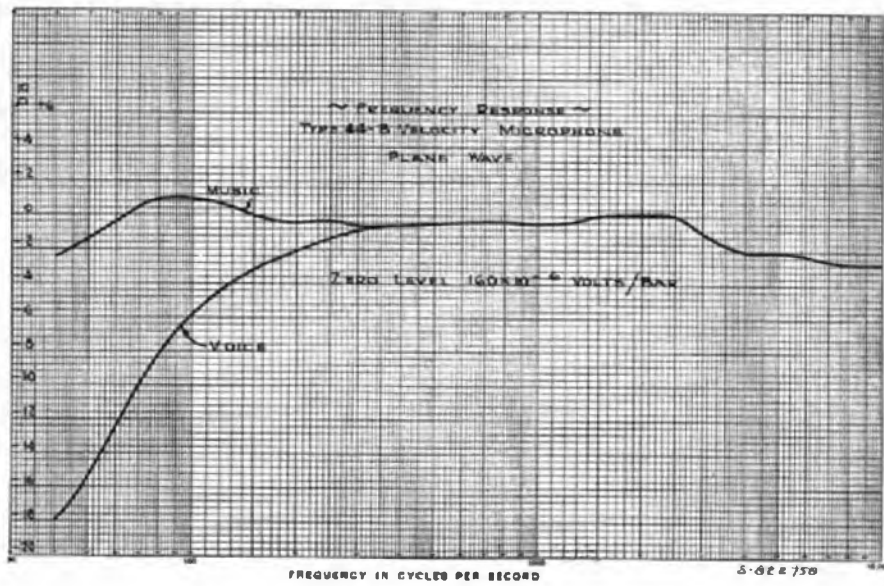

FIGURE 6—RESPONSE CHARACTERISTICS OF VELOCITY MICROPHONE

$\rho$  = LOSS IN DB BELOW RESPONSE OBTAINED ALONG AXIS NORMAL TO PLANE OF RIBBON.

$\sigma$  = ANGULAR POSITION IN DEGREES OF SOURCE OF SOUND WITH RESPECT TO AXIS NORMAL TO PLANE OF RIBBON.

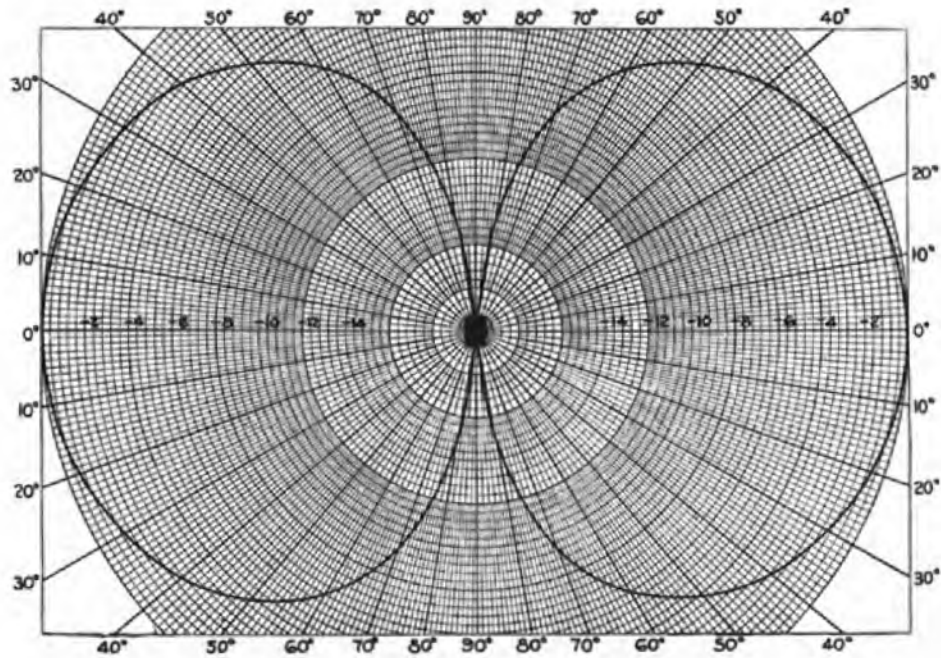

FIGURE 7—DIRECTIONAL CHARACTERISTICS OF VELOCITY MICROPHONE

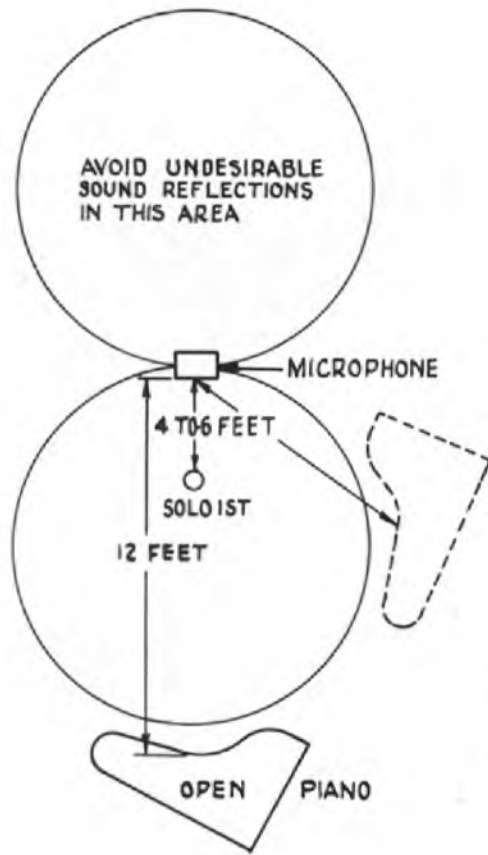

FIGURE 8 -MICROPHONE SETUP FOR SOLOIST WITH PIANO

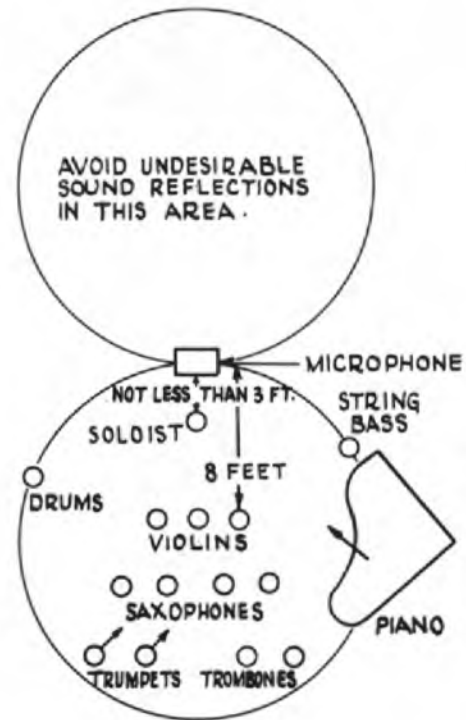
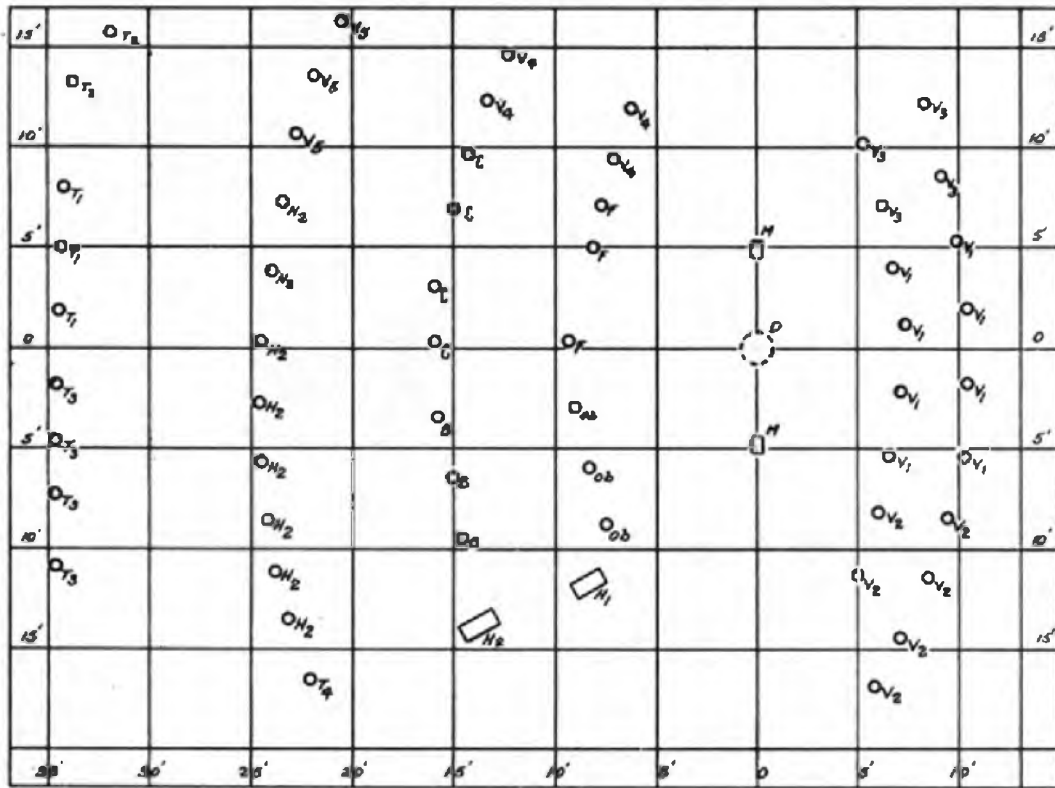

FIGURE 9 -MICROPHONE SET-UP FOR DANCE ORCHESTRA



**LEGEND**

- D Director
- M 2 Velocity Microphones
- 
- V1 8 First Violins
- V2 6 Second Violins
- V3 4 Violas
- V4 4 Cellos
- V5 3 String Bass
- F 3 Flutes
- Ob 3 Oboes
- H1 2 Harps
- H2 8 French Horns
- C 4 Clarinets
- B 3 Bassoons
- T1 3 Trumpets
- T2 2 Tympani and Traps
- T3 4 Trombones
- T4 1 Tuba
- Total--58 Musicians

**FIGURE 10 - MICROPHONE AND ORCHESTRA SET-UP FOR SYMPHONY ORCHESTRA**

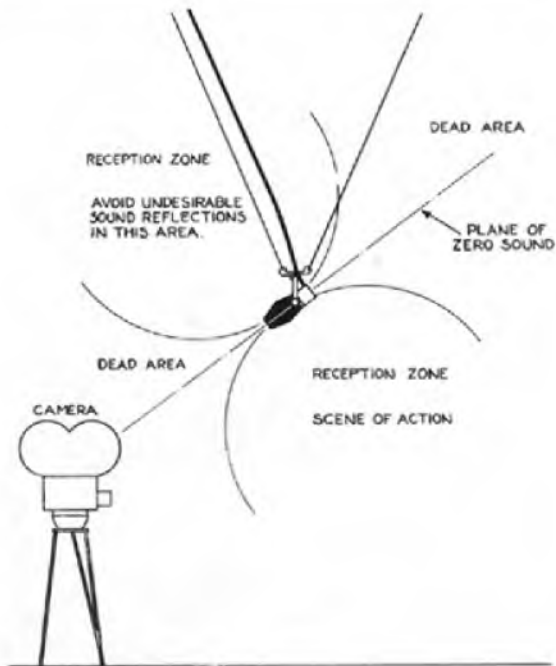

**FIGURE 11 - CAMERA LOCATION WITH RESPECT TO MICROPHONE**

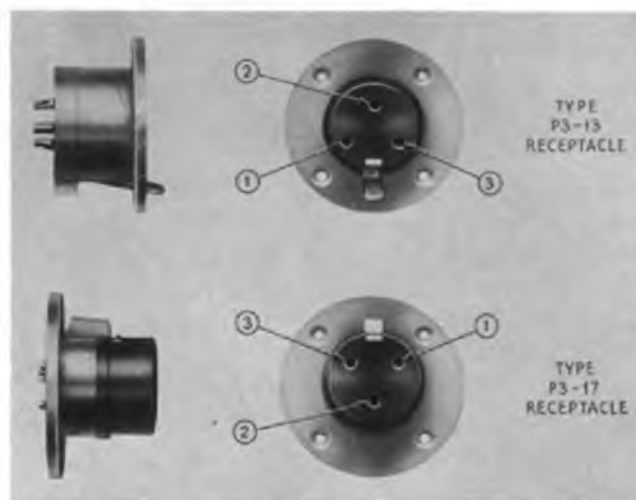
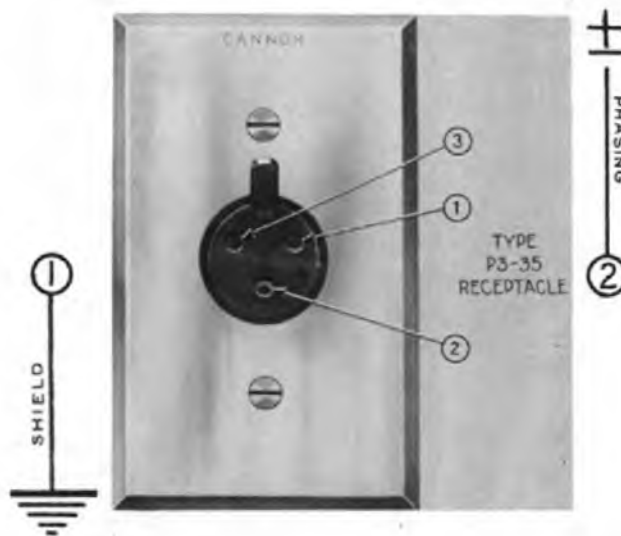

FIGURE 12 -PLUGS AND RECEPTACLES FREQUENTLY USED FOR MICROPHONE CONNECTIONS

**INSTRUCTIONS**  
*for*  
**UNI-DIRECTIONAL MICROPHONE**

**TYPE 77-A**  
(MI-4040B)



**RCA Victor Division**  
**RCA Manufacturing Company, Inc.**  
**Camden, N. J., U. S. A.**

Copyright 1937 by the RCA Manufacturing Company, Inc.

Instructions IB-25838-1



# OPERATING INSTRUCTIONS FOR UNI-DIRECTIONAL MICROPHONE TYPE 77-A (MI-4040B)

## PART I—DESCRIPTION

1. **Introduction.**—The RCA Type 77-A uni-directional microphone is an entirely new type of sound pick-up device—a microphone with a directional pick-up pattern wholly different from that of any other microphone. While it resembles the velocity microphone in appearance and construction, and is, in fact, evolved from research and development work on the latter, the RCA Type 77-A uni-directional microphone combines the principles of velocity and pressure operation. For this reason, it possesses in a surprising degree the best features of each and overcomes the disadvantages inherent in both. In view of the fact that the unit is designed to pick up sound arriving from one direction—or, more accurately, from one side—while almost completely rejecting sound from the other side, it is admirably adapted to studio pick-up, public address and sound reinforcement applications.

Instead of a diaphragm (in the commonly accepted meaning of the word), the uni-directional microphone contains a thin metallic ribbon suspended between the poles of a permanent magnet with its length perpendicular to, and its width in the plane of, the magnetic lines of force. The ribbon is rigidly clamped at the center, as well as at the top and the bottom. The lower half is open front and back and operated as a regular velocity microphone. In order to make the upper half of the ribbon operate as a pressure microphone, it is, of course, necessary that the rear of this section of the ribbon be enclosed. At the same time it is not possible just to block this section off, as such a contrivance would result in a response increasing with the frequency. Rather, it is necessary to present an acoustic impedance to the back part of the ribbon. An infinitely long tube would be the ideal impedance; but this, of course, is impossible. Instead, an ingenious labyrinth, which gives practically the same effect, is used. While this labyrinth has a finite length, the desired damping of reflection is obtained by filling it very loosely with sound-absorbing material. The result is that the upper half of the ribbon becomes an efficient pressure-operated microphone.

The vibration of each part of the ribbon is in exact accordance with the sound vibrations and, occurring as it does within the magnetic field, sets up corresponding alternating electric potentials across the primary of its associated transformer. Since the two microphones (*i. e.*, the velocity-operated section and the pressure-operated section of the Type 77-A microphone) are a part of the same ribbon, the voltages developed in the two sections are, of course, in series, and the output level is

obtained from the ends of the ribbon in essentially the same manner as in the case of the velocity microphone.

2. **Description.**—The uni-directional microphone shown in Figure 1 consists of a microphone unit mounted in a horizontal swivel on the top of a program stand. "Aiming" is accomplished partially by means of this swivel and partially by rotating the vertical column of the program stand. The transmitter is enclosed within a circular, perforated metal casing, so designed as to conform to the circular construction of the labyrinth, which occupies the lower part of the unit.

The labyrinth consists of a series of circular sections, the interior of each section having a spiral partition, an opening at the beginning or the end of which communicates with the beginning or the end, respectively, of the section of the labyrinth that immediately precedes or immediately follows it. The sections occupying the upper part of the labyrinth are so designed as to provide a cavity to accommodate the line coupling transformer, which thus forms a part of the microphone unit.



Figure 1—Close-up of Microphone on Program Stand



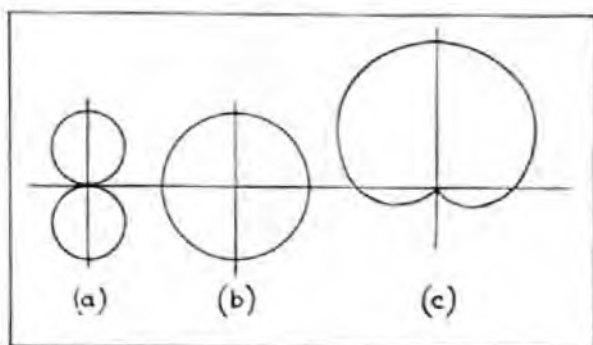

Figure 2—Development of Directional Pattern

The Type 77-A microphone unit is supported in a mounting yoke (containing the aforementioned horizontal swivel), which permits it to be tilted as desired. This mounting yoke is supplied with a threaded stand flange to fit a standard Type AZ-4090 program type microphone stand. A suspension mounting (Type UP-4212-A) is supplied to permit the suspension of the unit overhead when desired.

The microphone program stand (Type AZ-4090) is of the adjustable single vertical column type with a three-point base. The height of the transmitter may be adjusted to maximum and minimum heights of 84 inches and 59 inches respectively.

3. **Sensitivity.**—With an input sound pressure of 10 dynes per square centimeter perpendicular to the plane of the ribbon, the Type 77-A uni-directional microphone will deliver 317 microvolts across a 250-ohm load, which is equivalent to an output level of -75 db, as compared with a zero level of 12.5 milliwatts, or -72 db, as compared with a zero level of 6 milliwatts.

On an open circuit basis of measurement, *i. e.*, with an input of 1 dyne per square centimeter (1 bar) perpendicular to the ribbon, the output of the microphone on open circuit is the equivalent of -89 db, with reference to a zero level of 12.5 milliwatts.

4. **Quality of Response.**—The operating range of the microphone extends from 60 cycles to 10,000 cycles. When the microphone is located less than 2 feet from the source of sound the low frequency response is increased somewhat, and when operated at a greater distance (up to 4 feet) the low frequency response is slightly attenuated. Beyond the 4-foot operating distance the response characteristic is unchanged by changes in the operating distance. The frequency response is essentially unchanged by the direction of the incident sound over an angle of 150 degrees at the front of the microphone.

5. **Directional Characteristics.**—One of the most important characteristics of the Type 77-A microphone is its uni-directional property. On the front, or operating side, of the microphone the response is very uniform, while at the rear of the microphone sounds are attenuated an average of 20 db., thus giving a 10-to-1

ratio of desired to undesired pick-up. Sound waves originating in front and along an axis perpendicular to the plane of the ribbon will, naturally, have the maximum effect.

The outstanding advantage of the Type 77-A microphone is derived from the fact that the unit combines the action of a velocity-operated and a pressure-operated microphone and results from the manner in which the velocity-operated and the pressure-operated parts of the ribbon add together.

Without going into mathematical expressions for these voltages, it is possible to obtain a picture of the action from a consideration of the three patterns shown in Figure 2. In this illustration (a) is the directional pattern of a velocity microphone, (b) is the directional pattern of a pressure microphone. While these figures are the theoretical or idealized patterns, they correspond, for ribbon microphones, quite closely to actual measured characteristics.

When these patterns are added, the forward lobe of the figure-8 pattern adds to the circular pattern, while the rear lobe, which is 180 degrees out of phase, opposes. The result is the same as that obtained when the signals of a vertical antenna and a loop antenna are added; *viz.*, a cardioid of revolution, as shown at (c). In practice, the actual measured response of the Type 77-A uni-directional microphone, as shown in Figure 3, approaches this cardioid very closely. For all frequencies up to 6,000 cycles the cancellation is very good. At higher frequencies a small "tail" occurs because of the slight phase displacement that begins to become noticeable in this range.

It is at once apparent that the uni-directional characteristic is of considerable value in the solution of some of the difficulties encountered in reverberant locations by the reduction of the effect of undesired sound reflections, and the increased possibilities of obtaining better balance, clarity, naturalness and selectivity in sound pick-up. Extraneous direct or reflected sounds approaching the microphone from side directions and from the rear will have little or no effect and there-

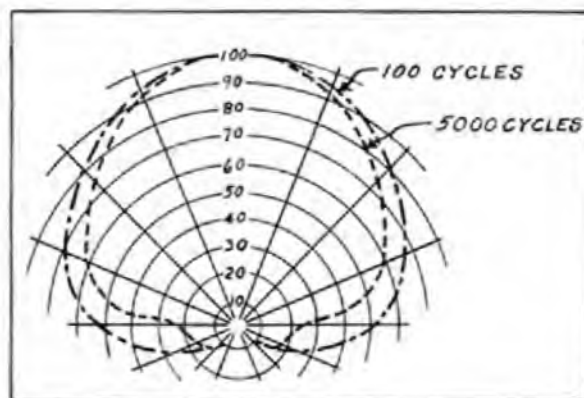

Figure 3—Cardioid Pattern of Microphone

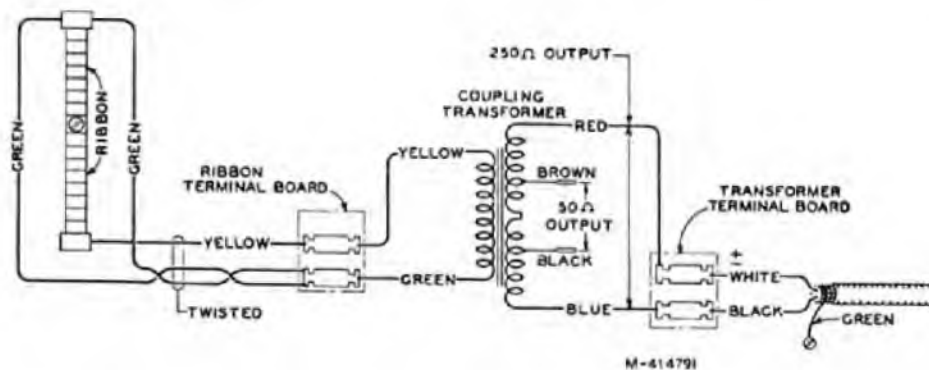

Figure 4—Schematic Wiring Diagram of Microphone

fore background noises and reflected sounds in the broadcast are considerably reduced, which increases, by comparison, the quality of direct sounds reproduced. The amount of sound-proofing necessary for sound originating within the "dead zone" can be greatly reduced—and, in many cases, "dead end" construction can be entirely eliminated.

For the same allowable reverberation pick-up the operating range of the uni-directional microphone is approximately 1.73 times greater than a non-directional microphone having the same sensitivity.

When used for public address and sound reinforcement purposes the directional characteristic is of considerable value in reducing feed-back effects between the microphone and the loudspeaker.

Sound concentrators and baffles used with condenser microphones are unnecessary with and inapplicable to the uni-directional microphone because of the fundamental difference in the principle of its operation. The transmitter must be used in free space where the flow of air particles is unimpeded. "Pick-up" from the rear of the microphone is eliminated by the design and construction of the unit.

## PART II — OPERATION

6. **Microphone Assembly.**—The Type 77-A uni-directional microphone is shipped with the stand flange attached by means of three screws to the microphone mounting yoke. The suspension fitting is shipped in an envelope in the box with the microphone unit.

(a) **Stand Mounting.**—If it is desired to mount the microphone unit on a program stand, it is necessary merely to screw the microphone (using the stand flange) securely to the stand column. See Section 9, List of Parts and Accessories, for the type of stand recommended for this purpose.

(b) **Suspension Mounting.**—If it is desired to suspend the microphone overhead, the stand flange must be removed from the microphone mounting yoke and replaced with the suspension fitting, which contains the eyelets for cord attachment. The fitting must be attached securely to the yoke by means of the three screws formerly used for mounting the stand flange.

NOTE.—When the microphone is suspended see that its weight is carried on the suspension fitting, with no strain on the cable.

(c) **Cable Connections.**—The microphone is shipped connected for 250-ohm output. Transformer connections for 50-ohm output are shown in Figure 4. The transformer taps and terminal board are rendered accessible for inspection or service by taking out the three screws located about the microphone screen mounting flange and removing the screen.

(d) **Phasing.**—When more than one microphone is used in a single pick-up, it is possible that the output of the various microphone circuits may not be in phase when fed into a common circuit. The microphone circuits include the microphones themselves, microphone pre-amplifiers, microphone attenuators (mixers) and the necessary connecting lines. The output of the microphone attenuators (mixers) when fed into the overall attenuator (mixer) must be in phase, or varying degrees of distortion will result, depending on the relative placement of the microphones. If two microphones are placed close together, the result will be practically zero output if their circuits are out of phase at the overall mixer.

To check the phasing of two or more microphones connected in a single pick-up, place the units close together, two at a time, with the attenuators (mixers) turned to the off position. Turn on the attenuator of one microphone to some arbitrary position where the output will be distinctly audible or register definitely on the volume indicator meter, if such a device is used. Talk into the microphone and note the output volume. Now, without disturbing the setting of the attenuator of the microphone just used, turn on the attenuator of the second microphone to the same setting. Talk into the two microphones and note the result. If there is an increase in volume, the microphones are in phase. If there is a decrease in volume, remove the screen of one microphone and reverse the connections at the microphone cable terminal board. If more than two microphones are employed, using one microphone as a reference, check the other units against it, one at a time, in the manner outlined above. If any are found to be out of phase, reverse the cable connections, at the

microphone cable terminal board, of the lesser number of microphones necessary to bring all the units into phase. A thirty-foot cable is furnished as part of the microphone equipment. The microphone plug must be furnished by the customer. For microphone connections refer to Figure 4, Schematic Wiring Diagram.

**7. Technique of Uni-Directional Microphone Placement.**—The proper placement of the microphone is essential in order to realize fully its inherent advantages. For this reason, the following instructions should be carefully studied, and close attention should be given to the results of any special placement, with a view toward future improvement of technique. These instructions can, of course, serve only as a guide, and a study should be made to determine the best microphone placement for each condition.

(a) *General.*—The Type 77-A uni-directional microphone has a pick-up angle of approximately 150 degrees. The source of sound, speaker, announcer, actor or musical instrument, should not be placed closer to the microphone than 2 feet, and a distance of from 3 to 4 feet is to be preferred. At shorter distances there is a tendency toward accentuation of low frequencies, which may result in making voices sound "boomy." In this respect the use of the uni-directional microphone differs greatly from that of the condenser microphone, with which the soloist usually works at a distance of from 4 to 6 inches. As a point of useful information, it may be mentioned here that the uni-directional microphone may be used as a close-talking microphone by talking in the plane of the ribbon. In this position, only the pressure-operated part of the ribbon is used.

The placement of a speaker or musical instrument off from the center line of the microphone will in no way affect the quality of pick-up, but will merely attenuate the direct sound pick-up, thereby raising the ratio of reverberation to direct pick-up.

The microphone is uni-directional. Speakers, instruments or players may be placed on the operating side of the microphone only. The diagrams (Figures 5, 6, 7 and 9) will serve as examples which arise from the uni-directional characteristic.

For most satisfactory results, the microphone should not be placed closer than 3 feet to any solid reflecting surface. This statement is, of course, general and specific conditions may require otherwise.

The diagrams referred to in the subsequent paragraphs and the discussion concerning them can only serve to indicate some of the possible placements under particular conditions. The final decision as to what constitutes the proper placement must rest with someone who is competent to judge the quality of the results as reproduced by the monitor speaker.

(b) *Soloist with Piano.*—Interesting effects may be obtained by changing the angle of the microphone with respect to the piano, thus changing the ratio of reverberation to direct pick-up. The distance between the soloist and the microphone should be determined by the strength of his (or her) voice, and the piano should be placed accordingly. The general arrangement is shown in Figure 5. Under no condition should the soloist be less than 2 feet from the microphone.

(c) *Stage Plays.*—In the case of stage plays and those pick-ups of the type that occur in the case of auditorium-type studios, where a sizable audience is present—and in remote pick-ups at theatres, night clubs and the like, where audience noise presents a serious problem, the use of the uni-directional microphone possesses a distinct advantage. By placing the microphone with its dead-side toward the audience and close to the footlights, or in an equivalent position, the 20 db. discrimination will provide the desired attenuation of audience noise, while the broad pick-up angle—useful through nearly 150 degrees—will afford pick-up of the whole stage, or that part of the studio where the artists are located. See Figure 6.

(d) *Dance Orchestra.*—The set-up for dance orchestra is similar to that just outlined for stage plays, the dead-side of the uni-directional microphone being toward the dance floor. The diagram (Figure 7) is self-explanatory, the only precaution necessary being to keep the soloist at least 2 feet, and preferably 3 feet, from the microphone.

In locating the microphone with respect to an orchestra, care should be taken to avoid reflected pick-up

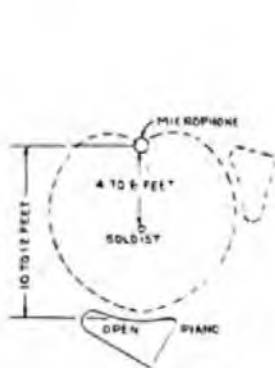

Figure 5—Soloist with Piano

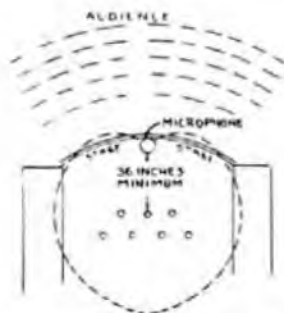

Figure 6—Plays



Figure 7—Dance Orchestra

VARIOUS MICROPHONE ARRANGEMENTS

from hard surfaced floors. Such reflections can be avoided by the use of carpets or similar material on the floor.

(e) *Large Orchestra.*—An arrangement for a large symphony orchestra is shown in Figure 9. It is to be noted that the wide angle of coverage (150 degrees) of the uni-directional microphone will permit a satisfactory pick-up in many cases, such as that shown, with but one microphone. It must be borne in mind, however, that the physical proportions and acoustic properties of the studio have a direct bearing on the arrangement of the orchestra and the placement of the microphone. Where space considerations do not govern, changes from the arrangement shown should not necessarily be very extensive in order to give excellent results under the usual acoustic conditions.

(f) *Public Address.*—For public address use the microphone can usually be placed near the loudspeakers (within 3 or 4 feet). It is important to see that the dead-side of the microphone is toward the loudspeaker system—more specifically, the microphone should not be placed in front or directly behind the loudspeakers—to prevent acoustic feedback. If the speaker must have latitude of movement on the stage, it may be necessary to have a microphone installed at each side to obtain satisfactory pick-up.

(g) *Sound Reinforcing.*—Microphones used for this purpose must generally be concealed and may be successfully operated in the wings, flies, etc., or at the front of the stage, where some simple method may be devised for their concealment. Such a system usually requires the use of a number of microphones and their detailed location is largely determined by their exact use, the constructional details of the stage and other conditions so numerous as to preclude any definite statement of rules or methods of application. The uni-directional feature of the microphones may be utilized to great advantage in eliminating undesirable noise emanating from the audience area. It is also to be noted that, because of the wide pick-up angle of the uni-directional microphone, fewer units of this type than of any other will be required for proper coverage.

8. *Operation.*—In general, the microphone will operate satisfactorily and require very little attention. It should give the normal output listed in Section 3.

The microphone may be suspended or it may be mounted on a program or floor stand. This stand is adjustable as to height. The center of the uni-directional microphone may be located at any height from 59 to 84 inches above the floor. In order to raise or lower the stand, the vertical column clamping screw should first be loosened. If it is desired to raise the microphone, all that is necessary is to lift it to the desired point and there it will lock itself automatically. Usually it will remain fixed at this position unless there is vibration or the microphone and stand are moved around. This moving may cause the stand to slide slowly downward. The clamping screw is provided in order to prevent this. However, if the microphone does not tend to creep, it is not necessary to use

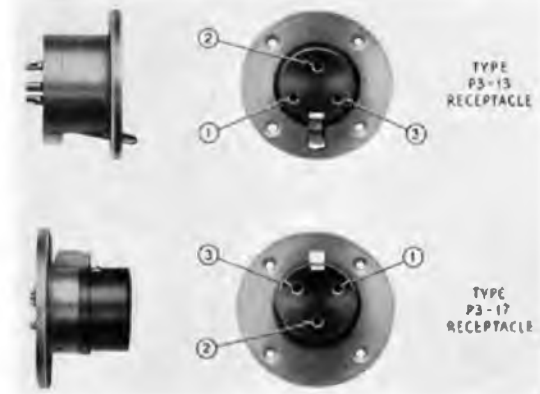
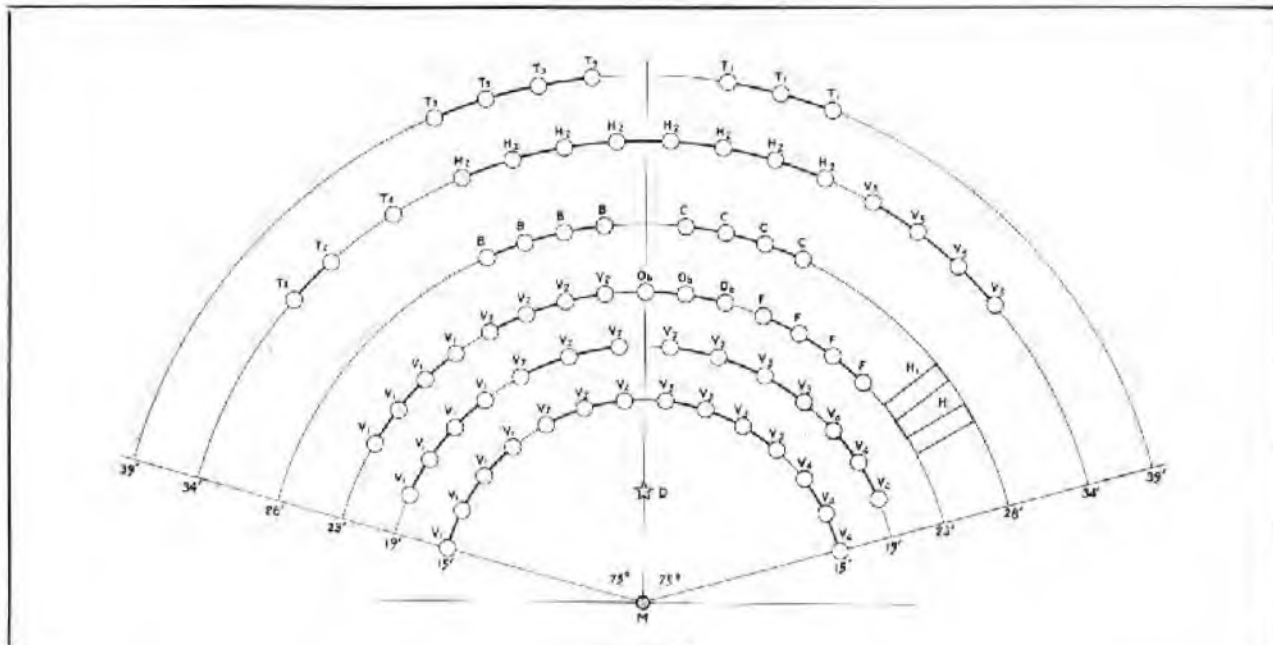

Figure 8—Plugs and Receptacles

the clamping screw. When it is desired to lower the microphone stand, the clamping screw should first be loosened, then the inner tube of the microphone stand should be raised slightly while pressing the sliding column latch which projects at the side of the locking device. This will release the lock and allow the microphone to be lowered to the desired position, at which point the latch should be released and the stand will



LEGEND

- |               |                   |                        |                    |
|---------------|-------------------|------------------------|--------------------|
| D Director    | F 4 Flutes        | T2 2 Tympani and Traps | V3 8 Violas        |
| M Microphone  | H1 2 Harps        | T3 4 Trombones         | V4 6 Cellos        |
| B 4 Bassoons  | H2 8 French Horns | T4 1 Tuba              | V5 4 String Bass   |
| C 4 Clarinets | Ob 3 Oboes        | V1 12 First Violins    | Total 75 Musicians |
|               | T1 3 Trumpets     | V2 10 Second Violins   |                    |

Figure 9—Microphone and Orchestra Arrangement for Symphony Orchestra

automatically lock itself. Then the clamping screw may be tightened if desired.

It is not recommended that the customer attempt to repair the microphone, but, rather, that it be returned to the RCA Manufacturing Company, Inc., for repair.

This may be done by writing to the RCA Manufacturing Company, Inc., for a "RETURNED APPARATUS" tag and "REPORT BLANK." Before doing this, however, make absolutely certain that the trouble is in the microphone and not elsewhere in the circuit.

9. List of Parts and Accessories.—

| Description                                  | Type          | Stock No. |
|--|---------------|-----------|
| Uni-Directional Microphone.....              | 77-A          | MI-4040-B |
| Program Stand.....                           | AZ-4090       | MI-4056   |
| Suspension Fitting.....                      | UP-4212-A     | MI-4071-A |
| Stand Flange.....                            |               | 16857     |
| Microphone Screen Assembly.....              |               | 17156     |
| Swivel Clamping Nut.....                     |               | 16478     |
| Washer (used under Swivel Clamping Nut)..... |               | 16827     |
| Microphone Cable.....                        |               | MI-62*    |
| Microphone Plug.....                         | Cannon        | MI-4630   |
|  | Type P3-CG-12 |           |
| Female Cord Connector.....                   | Cannon        | MI-4620   |
|  | Type P3-CG-11 |           |
| Flush Type Wall Receptacle.....              | Cannon        | MI-4622   |
|  | Type P3-13    |           |
| Surface Type Wall Receptacle.....            | Cannon        | MI-4621   |
|  | Type P3-17    |           |
| Flush Type Wall Receptacle.....              | Cannon        | MI-4625   |
|  | Type P3-35    |           |

\* Length of cable must be specified when ordering.



# UNI-DIRECTIONAL MICROPHONE

TYPE 77-B

MI-4042

## DESCRIPTION

The Uni-Directional Microphone consists of two different ribbon type microphones operating in a common airgap. One of the units is responsive to the pressure gradient of the sound wave, and is commonly called a velocity microphone. The other unit responds to the pressure in the sound wave. The outputs of the two microphones are connected in series and the resultant vector addition of the generated voltages produces a directional characteristic as shown in Figure 1 (c). Characteristics of the velocity section and of the pressure section are shown at "a" and "b" respectively. The construction of the velocity section follows the conventional arrangement. The pressure operated section is open on one side and terminated on the other in a folded tube packed with sound absorbing material. This arrangement produces a pressure operated microphone which is essentially resistance controlled over the range. This feature is necessary in this type of microphone since both the phase and magnitude of the output voltages of both sections must maintain a correct relation over the entire operating range.

The ribbon and magnet assembly is enclosed in the perforated housing at the top of the assembly. This screen serves the triple purpose of providing wind screening, protection against dust and mechanical injury. The folded tube associated with the pressure section is contained in the cylindrical body part of the microphone, and the impedance matching transformer is located in the hemispherical shell at the bottom of the microphone.

The cushion mounting is threaded to fit any of the microphone stands having a 1/2-inch pipe thread. Removal of the cushion mounting will allow the microphone to be used with stands having a 1/8-inch pipe thread.

**SENSITIVITY** - With an input sound pressure of 10 dynes per sq.cm., the output on the axis of maximum response will be  $1070 \times 10^{-6}$  volts open circuit across the 250 ohm terminals. Using this voltage value, the output levels will be as follows: -61 db with reference to 6 mw zero level and -64 db with reference to 12.5 mw zero level. If the microphone is operated into a 250 ohm load, these levels should be dropped by 6 db.

**RESPONSE CHARACTERISTICS** - The operating range of the microphone extends from 50 cycles to 10,000 cycles. When the microphone is located less than two feet from the source of sound, the low frequency response will be somewhat increased though to a much smaller extent than experienced with a velocity microphone. Beyond three feet, the variation becomes negligible. The frequency response is essentially unchanged by the direction of the incident sound over an angle of 150 degrees at the front of the microphone.

**DIRECTIONAL CHARACTERISTICS** - One of the most important characteristics of

the Type 77-A microphone is its uni-directional property. On the front, or operating side, of the microphone the response is very uniform, while at the rear of the microphone sounds are attenuated an average of 14-20 db, thus giving approximately a 10-to-1 ratio of desired to undesired pick-up. Sound waves originating in front and along an axis perpendicular to the plane of the ribbon will, naturally, have the maximum effect.

The actual measured response of the uni-directional microphone, as shown in Figure 2, approaches a cardioid very closely. For all frequencies up to 4,000 cycles the cancellation is very good. At higher frequencies a small "tail" occurs because of the slight phase displacement that begins to become noticeable in this range.

For the same allowable reverberation pick-up, the operating range of the uni-directional microphone is approximately 1.73 times greater than a non-directional microphone having the same sensitivity.

## ASSEMBLY

**MOUNTING** - As previously mentioned, the microphone may be used with stands having either a 1/2-inch pipe thread or 1/8-inch pipe thread, by removing the cushion mounting.

**CABLE CONNECTIONS** - The microphone is shipped connected for 250 ohms output. Transformer connections for 50 ohm output are shown in Figure 3. The terminal board is made accessible by removing the hemispherical bottom shell.

**TRANSFORMER CONNECTIONS** - By removing the screws in the transformer primary lugs and rotating the assembly to the points indicated and reassembling the screws, the microphone may be converted to either a pressure or velocity microphone with an attendant loss of 3 db in sensitivity and no change in output impedance.

**PHASING** - When the output of two or more microphones are fed into a common mixing circuit, it is important that their respective output currents be in phase with relation to each other; otherwise, they will cancel each other, resulting in a reduction in output instead of a gain.

To check the phasing of two microphones or more, first turn their respective attenuators to zero. Place two microphones side by side and adjust the attenuator of one, while speaking into the microphone, to a normal output level as indicated by a volume indicator, if one is available; otherwise, note the volume level from the speakers, by ear. Next turn up the attenuator of the second microphone to approximately the same position as the first and note whether the output level increases or diminishes. If it increases, the two microphones are in phase; if it decreases, the two microphones are out of phase. If the microphones are out of phase, remove the screen cover of one microphone and reverse the cable connections at the terminals.

If more than two microphones are to be used in the same mixing circuit, the phasing test should be repeated with each microphone, using the first micro-

phone as a reference for each of the others. After each microphone is phased, its attenuator should be returned to zero so that it will not affect the testing of the next microphone. When more than two microphones are being phased, it is a pretty good idea to check the phasing of all of the microphones before changing the connections of any, then reverse the connections of the minority group to save unnecessary labor.

REPLACING RIBBONS - It is not recommended that the customer attempt repairs other than the replacement of screens, transformers and mounting parts. For new ribbons, etc., it is recommended that the unit be returned to the RCA Manufacturing Company for repair.

This may be done by writing to the RCA Manufacturing Company, Inc., for a "RETURNED APPARATUS" tag and "REPORT BLANK". Before doing this, however, make absolutely certain that the trouble is in the microphone and not elsewhere in the circuit.

38-16-9

### PARTS LIST

| Description                             | Type     | Stock No. |
|---|----------|-----------|
| Uni-Directional Microphone              | 77-B     | MI-4042   |
| Program Stand                           | AZ-4090  | MI-4056   |
| Program Stand (Chrome and Black)        | 90-A     |           |
| Light Program Stand (Chrome and Black)  |          | MI-4068-A |
| Boom Stand                              | 90-B     |           |
| Portable Microphone Stand               | 59-A     |           |
| Microphone Screens                      |          | 18225     |
| Output Transformer                      |          | 18226     |
| Cushion Assembly                        |          | 18227     |
| Fork                                    |          | 18228     |
| Clamping Nut                            |          |           |
| Cushion Washer                          |          |           |
| Cushion Washer                          |          | 18229     |
| Clamping Washer                         |          |           |
| Microphone Cable                        |          | MI-59     |
| Microphone Plug                         | P3-CG-12 | MI-4630   |
| Female Cord Connector                   | P3-CG-11 | MI-4620   |
| Flush Type Wall Receptacle              | P3-13    | MI-4622   |
| Surface Wall Receptacle                 | P3-17    | MI-4621   |
| Flush Wall Receptacle (in switch plate) | P3-35    | MI-4625   |



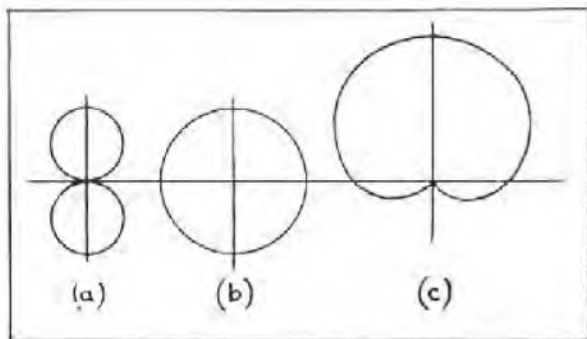

FIGURE 1 - DEVELOPMENT OF  
DIRECTIONAL PATTERN

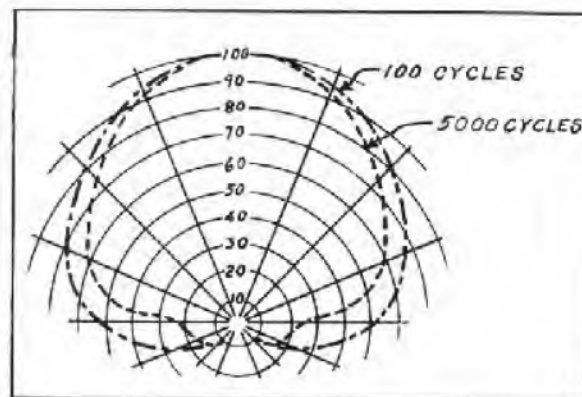

FIGURE 2 - CARDIOID PATTERN OF  
MICROPHONE RESPONSE

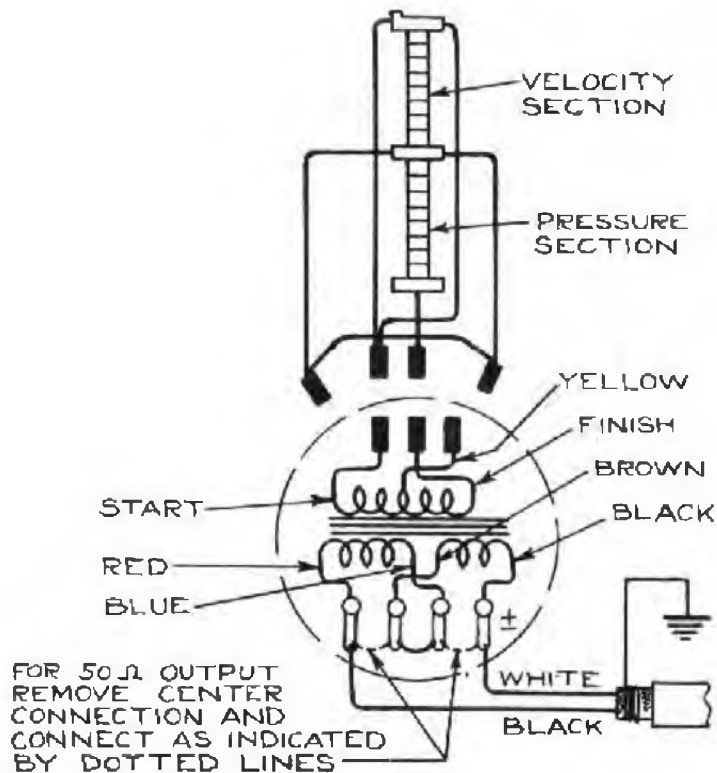

FIGURE 3 - MICROPHONE CIRCUIT  
(Schematic K-844226)

Manufactured by  
RCA MANUFACTURING COMPANY, INC.  
Camden, N.J., U.S.A.

Printed in U.S.A.

IB-26509

S-839869

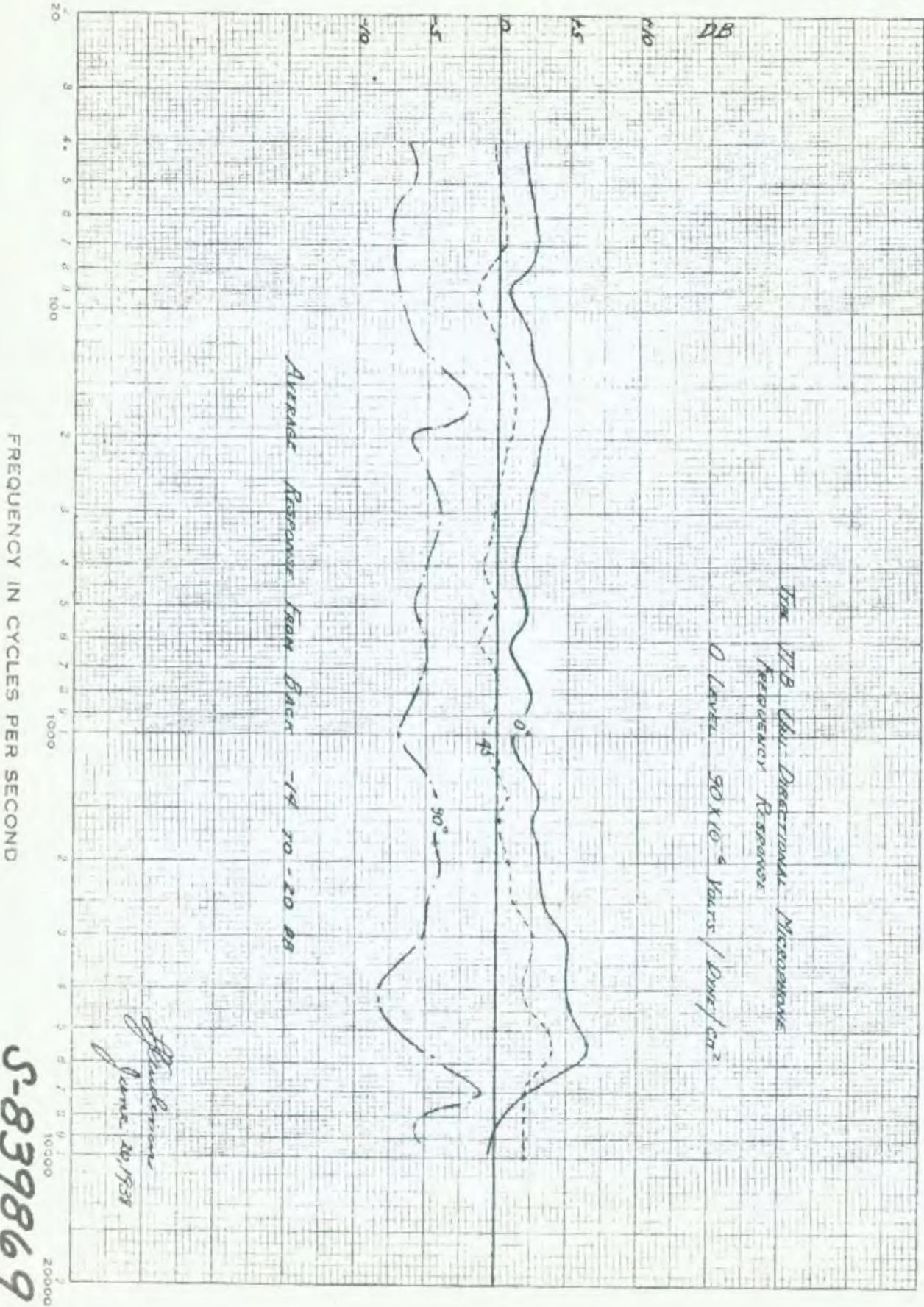

# **AERODYNAMIC MICROPHONE**

## **INSTRUCTIONS**

Manufactured by  
**RCA Manufacturing Company, Inc.**  
Camden, N. J., U. S. A.

Printed in U.S.A.

16-37022

## AERODYNAMIC MICROPHONE

MI-6226-D  
MI-6226-E

MI-6226-G  
MI-6228-B

MI-6228-D  
MI-6228-E

### DESCRIPTION

The Aerodynamic Microphone is of the pressure operated type and is designed for use with public address systems, amateur radio transmitters, and the like, where an inexpensive yet efficient microphone is desirable. The Aerodynamic Microphone is extremely compact and of modern design. It is relatively insensitive to mechanical shock and wind disturbances. It is weather resistant but not waterproof, and will withstand exposure to moisture or rain, but will not withstand immersion or the equivalent.

**SENSITIVITY** - With an input sound pressure of 10 dynes per square cm., the following output levels will be obtained.

Output in volts =  $650 \times 10^{-6}$ , open circuit, 250-ohm terminals  
Output in volts =  $8250 \times 10^{-6}$ , open circuit, 40,000-ohm terminals  
-68 db 12.5 mw zero level  
-65 db 6 mw zero level  
-57 db 1 mw zero level

If the microphone is operated into a matched load, these levels should be lowered by 6 db.

**RESPONSE CHARACTERISTICS** - The operating range of the MI-6226-D and the MI-6228-B extends from 100 to 8000 cycles. The range of the MI-6226-E and the MI-6226-G and that of the MI-6228-D and the MI-6228-E has been restricted. These latter microphones are intended for work in reverberant locations where the noise level is very high. The shape of the response curve is affected only very slightly by proximity to the source of sound. The angle of coverage varies approximately as follows: Below 2000 cycles the microphone is practically non-directional; at 4500 cycles the average coverage is about 180 degrees and at 7000 cycles about 90 degrees.

**IMPEDANCE** - The output impedance of the MI-6226 series is 250 ohms and that of the MI-6228 is 40,000 ohms. The MI-6226 series may be used with any amplifier designed to operate from a 250 ohm source, and having a gain of 100 db or over. A typical amplifier is the Type PG-114 Public Address Amplifier. The MI-6228 series may be used with any amplifier system having an input impedance of 40,000 ohms or over.

**MOUNTING** - The Aerodynamic Microphone is supplied with a 1/8-inch straight pipe female thread for mounting purposes. An adapter MI-6229 is supplied so that the microphone may be used with stands having a 5/8-27 thread.

### OPERATION

The technique of the RCA Aerodynamic Microphone is similar to that employed with any other microphone of the pressure-operated type.

**Phasing** - When more than one microphone is used in a single pickup, it is



possible that the microphone circuits may not be in phase when fed into a common circuit. Provided that the microphone case has not been opened and the internal connections of the microphone disturbed, two or more microphones should be in phase when the cable leads of each microphone are connected in parallel, with the black leads connected together at the same amplifier input terminal and the white leads connected together at the same amplifier input terminal.

To check the phasing of two or more microphones, connect one microphone to the amplifier input, set the amplifier volume control at some arbitrary point where the amplifier output is distinctly audible and note the result. Without disturbing the volume control setting, connect the second microphone in parallel with the first, place the two microphones together and talk into them. If there is a decrease in volume, reverse the connection of one of the microphone cables at the amplifier input terminals.

## MAINTENANCE

**Transformer or Cable Replacement** - Under normal operating conditions no difficulty should be experienced with the Aerodynamic Microphone. Excepting for the replacement of the microphone transformer or the microphone cable, it is not recommended that the customer attempt to repair the microphone, but, rather, that it be returned to the RCA Manufacturing Company, Inc., for repair. This may be done by writing the RCA Manufacturing Company, Inc., Camden, N.J., for a "Returned Apparatus" tag and "Report Blank". Before doing this, however, make absolutely certain that the trouble is in the microphone and not elsewhere in the circuit.

To open the microphone case for transformer or cable replacement, proceed as follows:

- (a) Take out the two retaining screws in the front cover screen of the microphone and remove the cover screen.
- (b) Loosen the gland nut through which the microphone cable passes into the microphone case.
- (c) Lift the transmitter unit and the transformer from the microphone case.
- (d) Unsolder the necessary connections at the transformer and make the required replacement, making sure that the connections are restored in their original order.

## LIST OF PARTS AND ACCESSORIES -

| Description   | Stock No. |
|---|-----------|
| Aerodynamic Microphone - with 30 feet of cable but less plug - 250 ohms output. | MI-6226-D |
| Aerodynamic Microphone - same as above except response range limited.           | MI-6226-E |
| Aerodynamic Microphone - same as above except response range limited.           | MI-6226-G |

| Description  | Stock No. |
|--|-----------|
| Aerodynamic Microphone - with 30 feet of cable but less plug - 40,000 ohms output.           | MI-6228-B |
| Aerodynamic Microphone - same as above except response range limited.                        | MI-6228-D |
| Aerodynamic Microphone - same as above except response range limited.                        | MI-6228-E |
| Adapter - 1/8" -32 to 5/8" - 27 thread   | MI-6229   |
| Cable - Microphone Cable - 30 feet long  | 32583     |
| Cap - Front cap for Microphone, with screen  | 31452     |
| Diaphragm Assembly   | 33751     |
| Stand - Desk Stand   | MI-6227   |
| Stand - Floor Program Stand  | MI-4074   |
| Swivel - Swivel joint, 1/8" to 1/8" thread   | 30842     |
| Transformer - Microphone Transformer (RT-510) for use in the MI-6226 series of microphones.  | 14143     |
| Transformer - Microphone Transformer (XT-2651) for use in the MI-6228 series of microphones. | 30052     |

40-1-19

# UNI-DIRECTIONAL MICROPHONE

TYPE 77-B1

MI-4043

## DESCRIPTION

The Uni-Directional Microphone consists of two different ribbon type microphones operating in a common airgap. One of the units is responsive to the pressure gradient of the sound wave, and is commonly called a velocity microphone. The other unit responds to the pressure in the sound wave. The outputs of the two microphones are connected in series and the resultant vector addition of the generated voltages produces a directional characteristic as shown in Figure 1 (c). Characteristics of the velocity section and of the pressure section are shown at (a) and (b) respectively. The construction of the velocity section follows the conventional arrangement. The pressure operated section is open on one side and terminated on the other in a folded tube packed with sound absorbing material. This arrangement produces a pressure operated microphone which is essentially resistance controlled over the range. This feature is necessary in this type of microphone since both the phase and magnitude of the output voltages of both sections must maintain a correct relation over the entire operating range.

The ribbon and magnet assembly is enclosed in the perforated housing at the top of the assembly. This screen serves the triple purpose of providing wind screening, protection against dust and mechanical injury. The folded tube associated with the pressure section is contained in the cylindrical body part of the microphone, and the impedance matching transformer is located in the hemispherical shell at the bottom of the microphone.

The cushion mounting is threaded to fit any of the microphone stands having a 1/2-inch pipe thread. Removal of the cushion mounting will allow the microphone to be used with stands having a 1/8-inch pipe thread.

**SENSITIVITY** - With an input sound pressure of 10 dynes per sq. cm. the following output levels will be obtained:

Output in volts:  $800 \times 10^{-6}$  open circuit 250 ohm output terminals  
-63 db 6.0 mw zero level  
-66 db 12.5 mw zero level  
-55 db 1.0 mw zero level

If the microphone is operated into a matched load, these levels should be lowered by 6 db.

**RESPONSE CHARACTERISTICS** - The operating range of the microphone extends from 50 cycles to 10,000 cycles. When the microphone is located less than two feet from the source of sound, the low frequency response will be somewhat increased though to a much smaller extent than experienced with a velocity microphone. Beyond three feet, the variation becomes negligible. The frequency response is essentially unchanged by the direction of the incident sound over an angle of 150 degrees at the front of the microphone.



**DIRECTIONAL CHARACTERISTICS** - One of the most important characteristics of the Type 77-B1 microphone is its uni-directional property. On the front, or operating side, of the microphone the response is very uniform, while at the rear of the microphone sounds are attenuated an average of 14-20 db, thus giving approximately a 10-to-1 ratio of desired to undesired pick-up. Sound waves originating in front and along an axis perpendicular to the plane of the ribbon will, naturally, have the maximum effect.

The actual measured response of the uni-directional microphone, as shown in Figure 2, approaches a cardioid very closely. For all frequencies up to 4000 cycles the cancellation is very good. At higher frequencies a small "tail" occurs because of the slight phase displacement that begins to become noticeable in this range.

For the same allowable reverberation pick-up, the operating range of the uni-directional microphone is approximately 1.73 times greater than a non-directional microphone having the same sensitivity.

## ASSEMBLY

**MOUNTING** - As previously mentioned, the microphone may be used with stands having either a 1/2-inch pipe thread or 1/8-inch pipe thread, by removing the cushion mounting.

**CABLE CONNECTIONS** - The microphone is shipped connected for 250 ohms output. Transformer connections for 500 and 50 ohm outputs are shown in Figure 3. The terminal board is made accessible by removing the hemispherical bottom shell.

**PHASING** - When the outputs of two or more microphones are fed into a common mixing circuit, it is important that their respective output currents be in phase with relation to each other; otherwise, they will cancel each other, resulting in a reduction in output instead of a gain.

To check the phasing of two microphones or more, first turn their respective attenuators to zero. Place two microphones side by side and adjust the attenuator of one, while speaking into the microphone, to a normal output level as indicated by a volume indicator, if one is available; otherwise, note the volume level from the speakers, by ear. Next turn up the attenuator of the second microphone to approximately the same position as the first and note whether the output level increases or diminishes. If it increases, the two microphones are in phase; if it decreases, the two microphones are out of phase. If the microphones are out of phase, remove the screen cover of one microphone and reverse the cable connections at the terminals.

If more than two microphones are to be used in the same mixing circuit, the phasing test should be repeated with each microphone, using the first microphone as a reference for each of the others. After each microphone is phased, its attenuator should be returned to zero so that it will not affect the testing of the next microphone. When more than two microphones are being phased, it is a pretty good idea to check the phasing of all of the microphones before changing the connections of any, then reverse the connections of the minority group to save unnecessary labor.

**REPLACING RIBBONS** - It is not recommended that the customer attempt repairs other than the replacement of screens, transformers and mounting parts. For new ribbons, etc., it is recommended that the unit be returned to the RCA Manufacturing Company for repair.

This may be done by writing to the RCA Manufacturing Company, Inc., for a "RETURNED APPARATUS" tag and "REPORT BLANK". Before doing this, however, make absolutely certain that the trouble is in the microphone and not elsewhere in the circuit.

39-12-14

**PARTS LIST**

**UNI-DIRECTIONAL MICROPHONE -**

| Description  | Stock No. |
|--|-----------|
| Cable, microphone cable                            | 19700     |
| Clamp, cable clamp                                 | 19828     |
| Cushion, cushion mounting assembly, less thumb nut | 19699     |
| Fork, support fork                                 | 18228     |
| Nut, thumb nut for cushion mounting                | 18454     |
| Nut, thumb nut and washers for top of fork         | 18229     |
| Ribbon, microphone ribbon                          | 27973     |
| Screen, screen assembly complete                   | 18225     |
| Transformer, output transformer                    | 19698     |

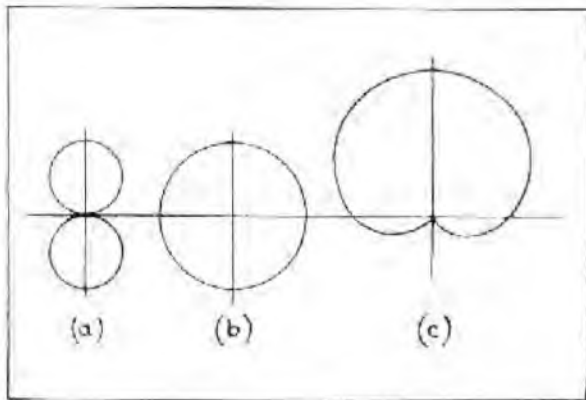

FIGURE 1 - DEVELOPMENT OF DIRECTIONAL PATTERN

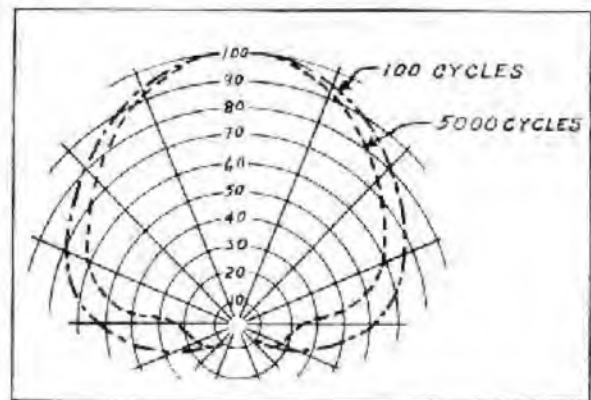

FIGURE 2 - CARDIOID PATTERN OF MICROPHONE RESPONSE

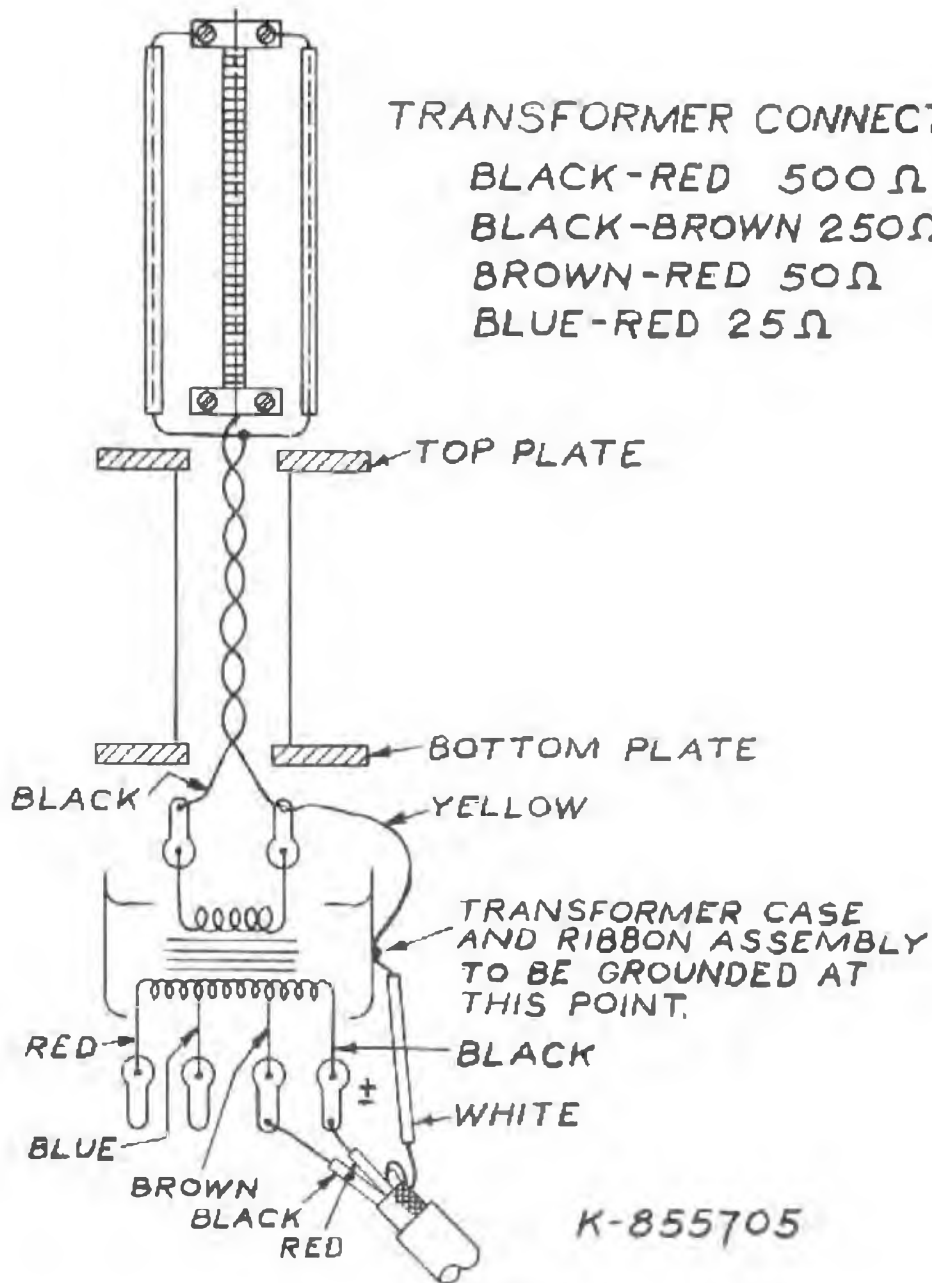

FIGURE 3 - MICROPHONE CIRCUIT

Manufactured by  
 RCA MANUFACTURING COMPANY, INC.  
 Camden, N.J., U.S.A.

Printed in U.S.A.

5-37026

INSTRUCTIONS  
for  
VELOCITY MICROPHONE  
TYPE 44-BX  
MI-4027-B

TECHNICAL DATA

**OUTPUT LEVEL**

\* -55 vu at 1000 cycles when terminated into a matched load.  
1800 x 10<sup>-6</sup> volts open circuit across 250 ohm tap. (with an input sound pressure of 10 dynes per square centimeter.

**FREQUENCY RESPONSE**

30-15000 cycles  
(See curve Figure 3)

**OUTPUT IMPEDANCE**

250 and 50 ohms  
Connected for 250 ohms when shipped

**PHYSICAL CHARACTERISTICS**

Overall length including mounting 12 "  
Overall width 4-3/4"  
Overall depth 3-3/8"  
Weight unpacked including cushion mounting 8-1/2 lbs.

**DIRECTIONAL CHARACTERISTICS**

Bi-directional - Figure 8 pattern  
(See Figure 2)

DESCRIPTION

The Type 44-BX Microphone, is a ribbon microphone which operates on the pressure gradient principle, and was especially designed to provide a microphone capable of reproducing sound with the fidelity required for modern radio broadcasting.

The moving element is a very thin, corrugated, aluminum ribbon, suspended between the poles of a permanent magnet with its length perpendicular to, and its width in the plane of, the lines of magnetic force. The ends of the ribbon are connected to the primary of a transformer which matches the impedance of the ribbon to either a 50 or 250 ohm line. The ribbon is open to sound waves both front and back. Movement of the ribbon is due to the small instantaneous pressure differences existing between the two faces of the ribbon. These pressure differences are caused by the difference in acoustic path lengths which sound must traverse in reaching each face.

Because of the lightness of the ribbon, it moves exactly in accordance with the small pressure differences appearing between the faces, and since the moving ribbon crosses the magnetic lines of force, the voltage induced in it,

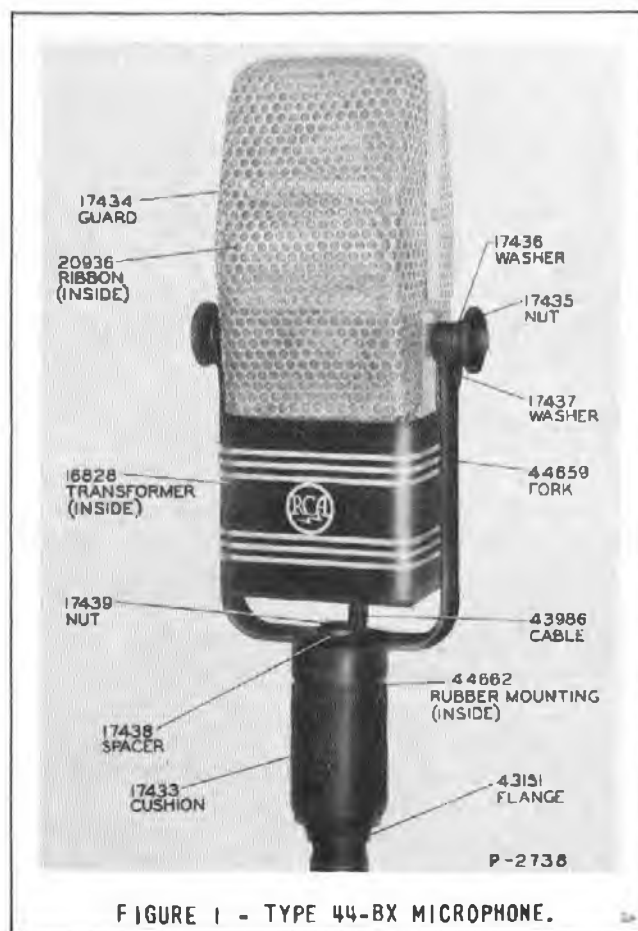

FIGURE 1 - TYPE 44-BX MICROPHONE.

\* 0 vu = .001 watt.

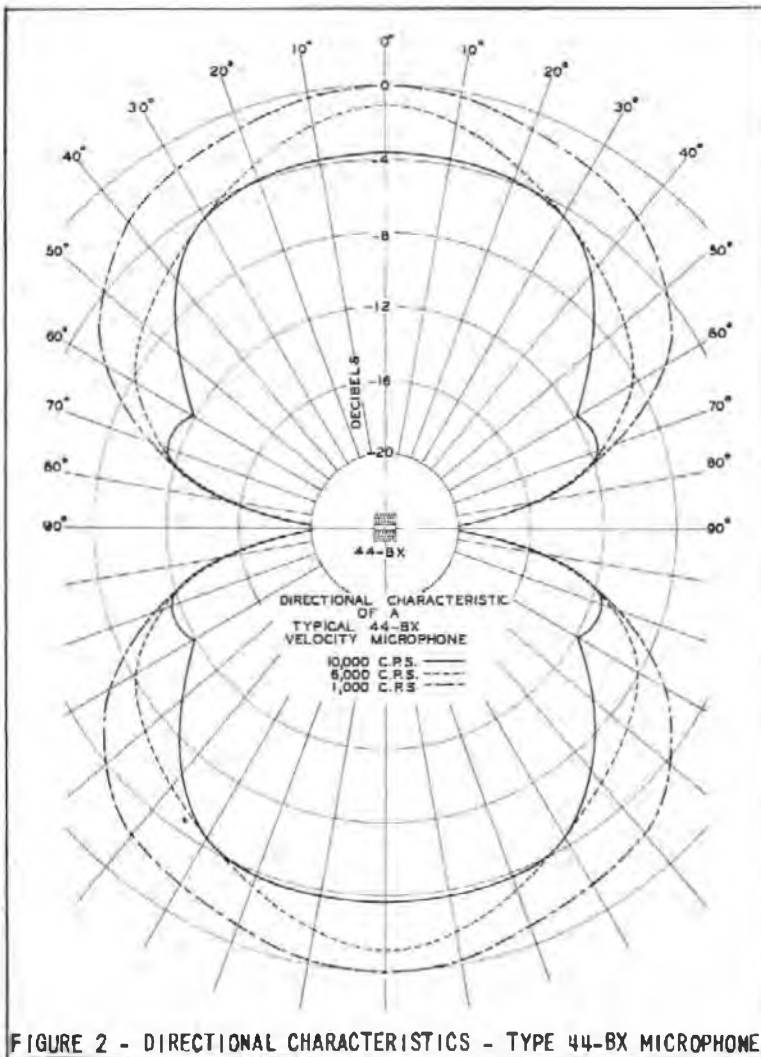

FIGURE 2 - DIRECTIONAL CHARACTERISTICS - TYPE 44-BX MICROPHONE.

and appearing across the primary of the impedance matching transformer, is a faithful reproduction of the sound waves by which the ribbon is actuated.

Measurements have shown that a microphone of this type provides a sound responsive device with an exceptionally uniform frequency response throughout the audio range employed in radio broadcasting.

The output level of the Type 44-BX (as shown under Technical Data) is of an order which compares favorably with other high quality microphones used in radio broadcasting. It is comparatively rugged and because of the type of construction, its sensitivity and frequency response are practically unaffected by changes in temperature, humidity, and barometric pressure.

The ribbon and magnet assembly is contained in a perforated housing which provides protection against mechanical injury. The output transformer is contained in a lower housing and the terminal board of the transformer is accessible by removing the cover plate of this housing. Output impedances of 250 and 50 ohms may be secured. As shipped, the microphone is connected for 250 ohms output.

The MI-4027-B Microphone is finished in polished black enamel trimmed with chromium. The Microphone has a shock-proof cushion mounting assembled when shipped, and packed separately, a suspension hanger (MI-4071-A) which may be assembled to replace the cushion mounting if it is desired to suspend the microphone instead of mounting it on a program stand. The cushion mounting is tapped to fit a 1/2 inch pipe thread.

## RESPONSE CHARACTERISTIC

The response of the microphone can be altered to provide the characteristic most suitable for either music or speech. This is accomplished by connecting a reactor in parallel with all or part of the transformer output winding (across entire winding when connected for 50 ohms output impedance and across part of the winding when the 250 ohm connection is used) for voice operation. For reproduction of music the reactor is not connected. This reactor is enclosed in the same case with the output transformer and connections within the case to the output terminal board are such that the response can be adapted to either voice or music merely by changing a jumper connection on the output terminal board.

A small circular hole is provided in the cover plate of the transformer casing. Through this hole may be seen the letter "V" (voice) or "M" (music) depending upon whether the microphone is adapted for voice or music.

Vocal pickup requires the use of the jumper marked "V" which is placed across the two terminals marked "M" (music) on the output terminal board. (See Figure 4) thus connecting the reactor as described above. With the jumper in place the letter "V" is visible through the small hole, while removal of the

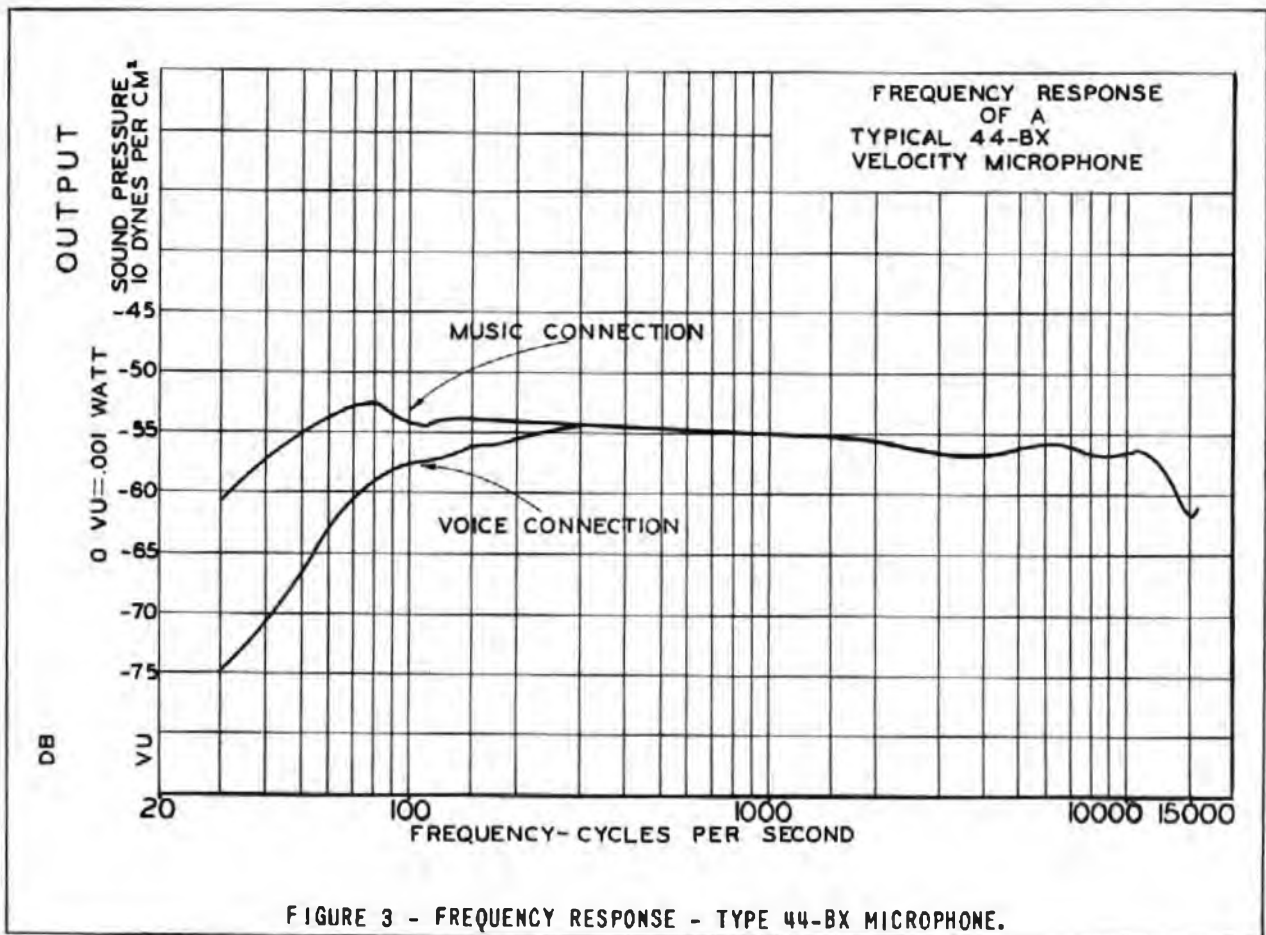

jumper exposes the letter "M" on the terminal board and at the same time disconnects the reactor. A response curve taken with and without the "V" jumper is shown in Figure 4. This reactor is employed to provide the proper low-frequency equalization required by radio broadcasting channels when the microphone is used for voice reproduction.

*IMPORTANT:* It is not intended that alterations in response will be made between numbers on a program. The response adjustment feature is incorporated for the sole purpose of supplying a microphone with the best possible characteristics for either vocal or musical pickup, and it is recommended that the response be adjusted for one of these types of service, and the use of the microphone restricted to that type of service.

#### DIRECTIONAL CHARACTERISTIC

One of the most important characteristics of the velocity microphone is its directional property. Sound waves approaching the microphone from a direction in the same plane as the ribbon have little effect upon it. Sound waves from either direction along an axis perpendicular to the plane of the ribbon have the maximum effect. For equal distances from the microphone, the relative response to sound originating at various angles to the axis perpendicular to the ribbon is shown in Figure 2.

A directional characteristic of this type results in a considerable reduction in the pickup of background noise and reflected sounds because such sounds from side directions will have little effect. By comparison, the quality of the direct sounds reproduced is improved, which means that for the same allowable reverberation pickup the operating distance of the velocity microphone is approximately 1.7 times that of a non-directional microphone of the same sensitivity.

When used for public address or sound re-enforcing purposes the directional characteristic is of considerable value in reducing feed-back effects between the microphone and loudspeaker.



## INSTALLATION

### ASSEMBLY

Packed in the box with the MI-4027-8 Microphone units proper, are three machine screws, three lockwashers, and a suspension hanger. The machine screws and lockwashers are used for attaching the suspension hanger to the microphone yoke. Assembled to the microphone yoke as shipped, is a cushion assembly for mounting the microphone on a program stand. This assembly is to be removed if suspension mounting is desired, and replaced with the suspension hanger provided.

**IMPORTANT:** When suspension mounting is used the weight of the microphone should be carried by the hanger, with no strain on the cable.

### CONNECTIONS

With the cover plate on the transformer housing removed, the output terminal board will be exposed. Four terminals are located on one side of the block. The two outside ones are the output terminals. Between the two center terminals is engraved the number 250 (i.e., 250 ohms). Between each outside terminal and the adjacent center terminal is engraved the number 50 (i.e., 50 ohms). See Figure 4. If the microphone is to feed a 250 ohm line, place the two small jumpers, one over the other, across the two center terminals (250 ohm). If the microphone is to feed a 50 ohm line, connect one of the jumpers across each pair of terminals marked 50. No change is necessary in microphone cable terminal connections. The cable should pass through the slot in the transformer housing. Solder the ground lead from the cable shield to the cable clamp.

### PHASING

When the outputs of two or more microphones are fed into a common mixing circuit, it is necessary that their respective outputs be in phase, otherwise, the output of one microphone will buck the output of the other, resulting in a reduction in output instead of a gain, and introducing varying degrees of distortion.

A velocity microphone may be reversed in phase by rotation of the microphone through a  $180^{\circ}$  arc. However, this method of phasing is not possible with other types of microphones.

## OPERATION

The velocity microphone is especially well adapted to studio use where its directional characteristics and excellent response may be utilized to the best advantage. Since broadcasting studios are usually constructed so that there is a minimum of sound reflection within the room, the problem of echoes and reverberations is not a serious one. More attention may be directed to the placement of the microphone so as to accentuate certain sounds and reduce others by means of the directional characteristic of the velocity microphone. Interesting effects can be secured by different arrangements of instruments and performers about the microphone.

In order to secure the best results it is essential that performers and instruments be grouped properly, and that all sources of sound be placed relative to the microphone so that each person or

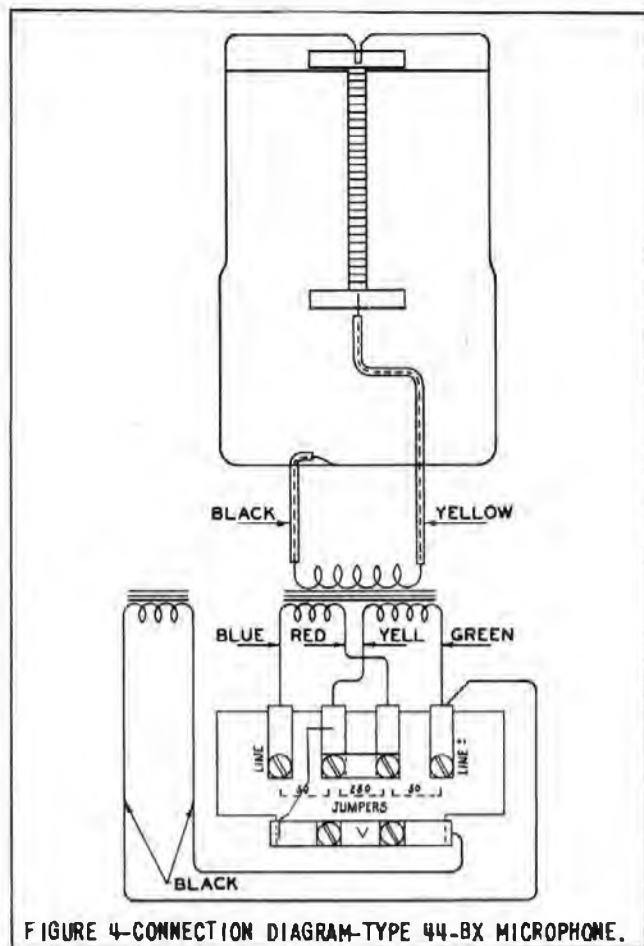

FIGURE 4—CONNECTION DIAGRAM—TYPE 44-BX MICROPHONE.



instrument will register with the proper relative intensity. The correct grouping and placement will be determined best by experience, since the requirements of individual set-ups vary widely. The following general rules may be helpful in developing the necessary microphone technique for any particular situation.

1. Never place artists, speakers, or singers nearer than approximately one foot to the microphone. Usually the best results are secured if the performer is three to four feet from the microphone. The low frequency response is increased if the source of sound is within about three feet of the microphone, and it is desirable to maintain this distance unless special effects are desired. Voices tend to become boomy and unnaturally deep-throated if the performer is too close to the microphone. Beyond three feet the response is as shown by the curve. (Figure 3).
2. Place the microphone so that the source of sounds that it is desired to reproduce will be either to the front or back of the microphone. Also, position the microphone so that the source of unwanted sounds is toward the sides of the microphone, where such sounds will be attenuated.
3. Place instruments having a low frequency range at greater angles with the perpendicular to the microphone ribbon, while instruments having higher frequency ranges may be placed in line with this perpendicular or removed from it only by small angles. The mid-frequency instruments are, of course, spaced in between these having the higher and lower ranges. Reference to the chart (Figure 2) showing the directional characteristic of the microphone will assist in placement of the various instruments and performers to the best advantage. Determine the exact placement by means of the following factors:
  - A. Wishes of Orchestra Leader, or Band Leader.
  - B. Number of performers and number and type of instruments.
  - C. Size and construction of studio room.
  - D. Peak volume swings as indicated by a volume level indicator.
  - E. Results as determined by actual monitoring with a pair of RCA high fidelity headphones, or by a suitable loudspeaker connected to the monitoring output of the amplifying system.Experimental placement of performers and instruments is usually necessary in order to obtain the best results.
4. Protect the microphone from strong winds or loud explosive type sounds. Such sounds may stretch the microphone ribbon abnormally and necessitate replacement of the ribbon.
5. Always place the microphone so that direct sound from the subject is received rather than reflected sound from tables, walls, etc.

### REPAIRS

It is not recommended that the customer attempt repairs of microphones other than the replacement of transformers, cables, and mounting parts. For new ribbons, etc., it is recommended that the unit be returned to the RCA Manufacturing Company for repair. Ribbons are carried in stock to cover special cases.

If it is definitely determined that trouble exists in the microphone and not elsewhere in the circuit, a "Returned Goods" tag and "Report Blank" should be secured from the RCA Manufacturing Company, Inc., before returning the apparatus.

REPLACEMENT PARTS LIST

The following parts list is included to provide proper identification when ordering replacement parts. When ordering, specify the item by its Stock Number and Description.

| <u>DESCRIPTION</u>   | <u>STOCK NO.</u> |
|--|------------------|
| Cable - 2-conductor, flexible, shielded, rubber covered cable<br>less strain relief (specify length desired) . . . . . | 43986            |
| Cushion - Mounting assembly, less flange . . . . .   | 17439            |
| Flange - Cushion mounting flange . . . . .   | 43151            |
| Fork - Microphone support fork . . . . .   | 44659            |
| Guard - Complete microphone guard (both sections) . . . . .  | 17434            |
| Mounting - Rubber shock mounting for cushion assembly . . . . .  | 44662            |
| Nut - Swivel clamping nut . . . . .  | 17435            |
| Nut - Thumb nut on cushion mounting assembly . . . . .   | 17439            |
| Ribbon - Microphone ribbon . . . . .   | 20935            |
| Spacer - Spacer used under nut stock #17439 . . . . .  | 17438            |
| Transformer - Microphone transformer (RT-435) . . . . .  | 16828            |
| washer - Locking washer for yoke clamping nut . . . . .  | 17437            |
| washer - Stop washer for yoke clamping nut . . . . .   | 17436            |

ACCESSORIES

| <u>DESCRIPTION</u>  | <u>STOCK NO.</u> |
|---|------------------|
| Program Stand . . . . .   | M1-4090          |
| Announce Stand (Desk Type) . . . . .  | M1-4058-A        |
| Cable - 2-conductor shielded extension cable (order length desired) . . . . . | M1-62            |

R C A V I C T O R D I V I S I O N  
R C A M A N U F A C T U R I N G C O M P A N Y , I N C.  
Camden, N. J. U. S. A.

A SERVICE OF THE RADIO CORPORATION OF AMERICA

Printed in U. S. A.

SECTION II

Filter and Compensator Units - Data

Master Reference Book  
Disc Recording

Decibels

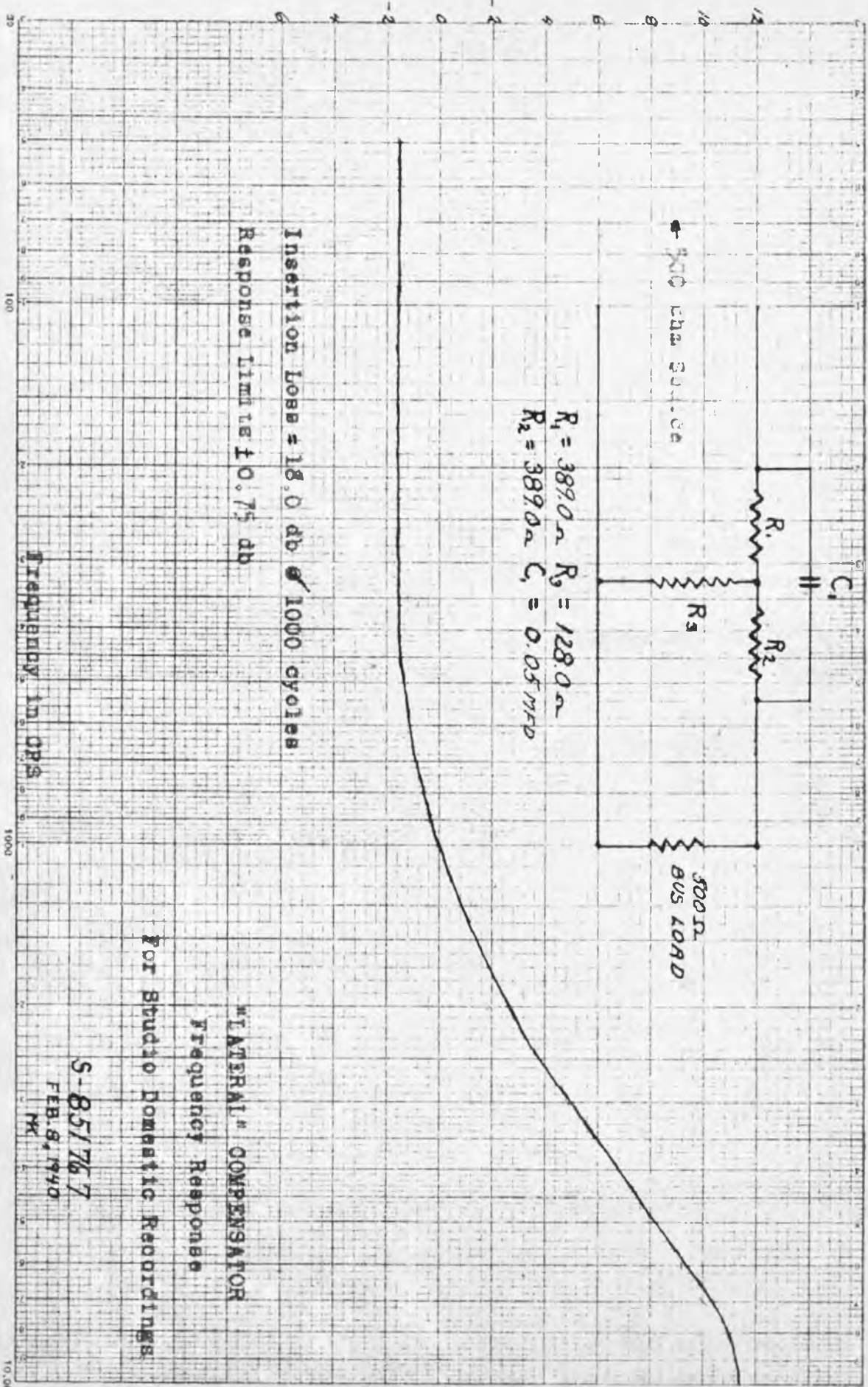

Insertion Loss = 18.0 db @ 1000 cycles  
 Response limits +/- 0.75 db

$R_1 = 3890 \Omega$   $R_2 = 1280 \Omega$   
 $R_3 = 3890 \Omega$   $C_1 = 0.05 \text{ MFD}$

500  $\Omega$   
 BUS LOAD

LATERAL COMPENSATOR  
 Frequency Response  
 For Studio Domestic Recordings

S-85/767  
 FEB. 8, 1940  
 MK

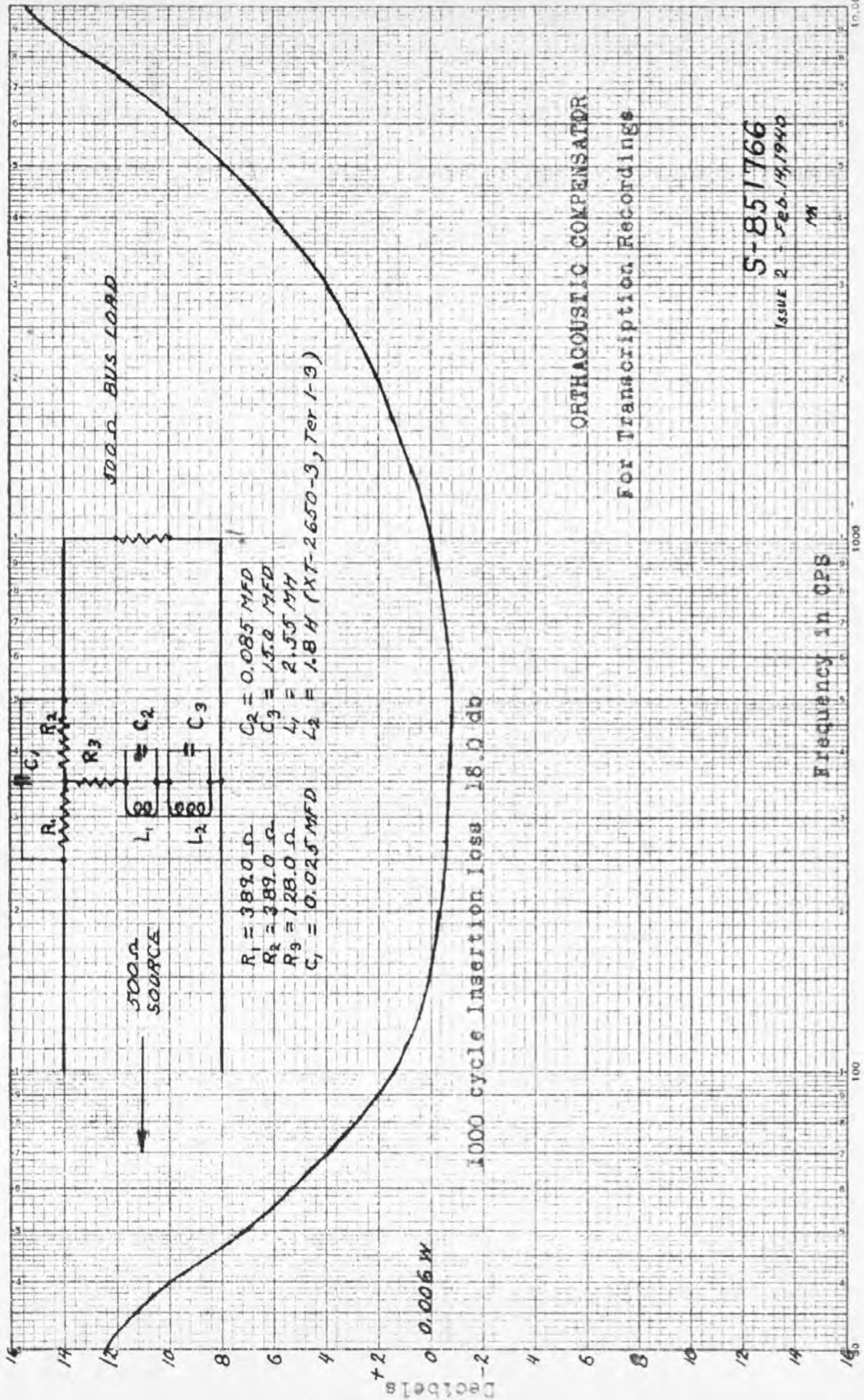

ORTHACOUSTIC COMPENSATOR  
 For Transcription Recordings

5-851766

ISSUE 2 - FEB. 14, 1940

MM



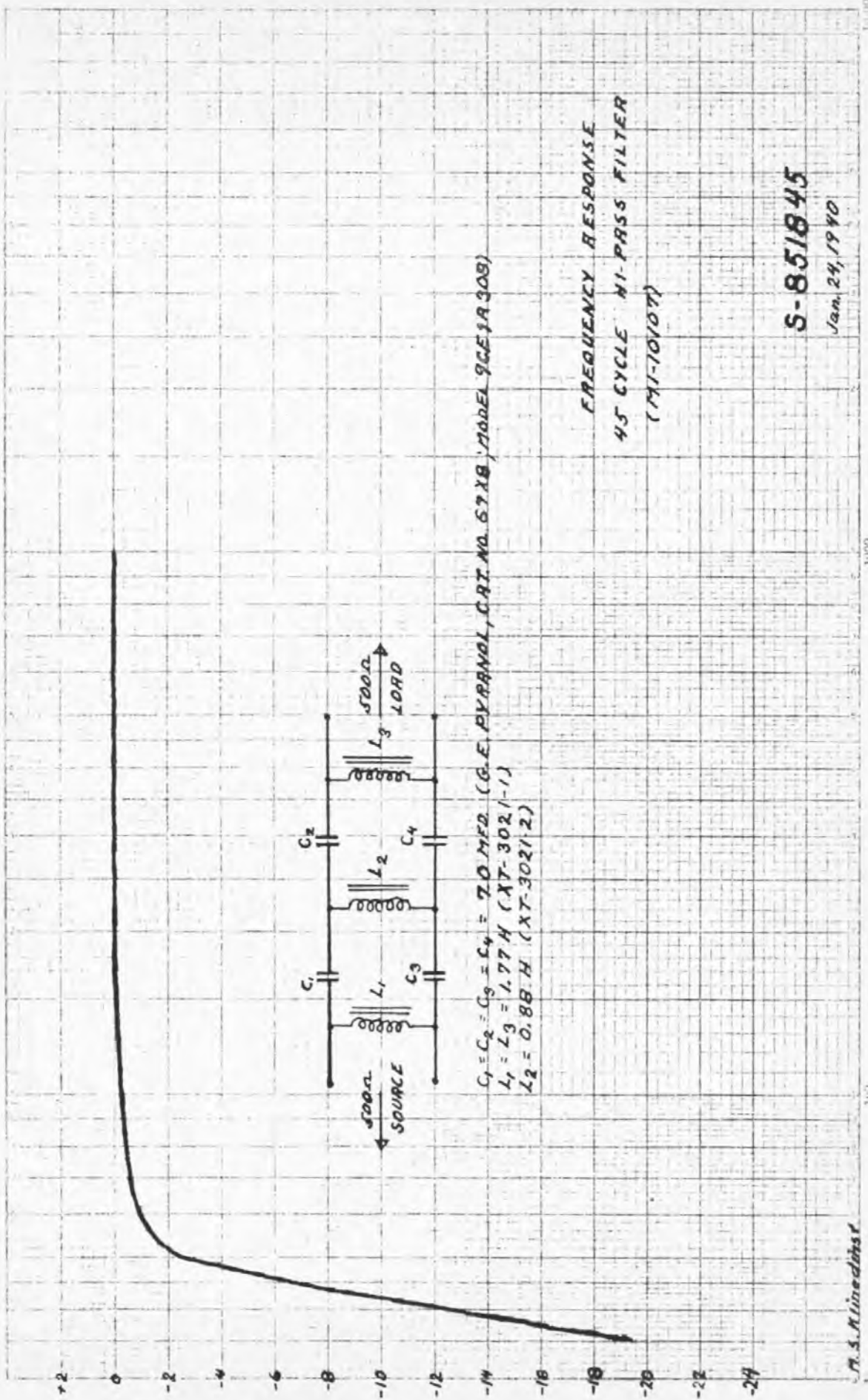

$C_1 = C_2 = C_3 = C_4 = 70 \text{ MFD (G.E. PYRAMOL, CRT. NO. 67XB, MODEL 9CE1A308)}$   
 $L_1 = L_3 = 1.77 \text{ H (XT-3021-1)}$   
 $L_2 = 0.88 \text{ H (XT-3021-2)}$

FREQUENCY RESPONSE  
 45 CYCLE 41-PASS FILTER  
 (MI-10107)

S-851845  
 Jan. 24, 1940

M. S. Klinedtst





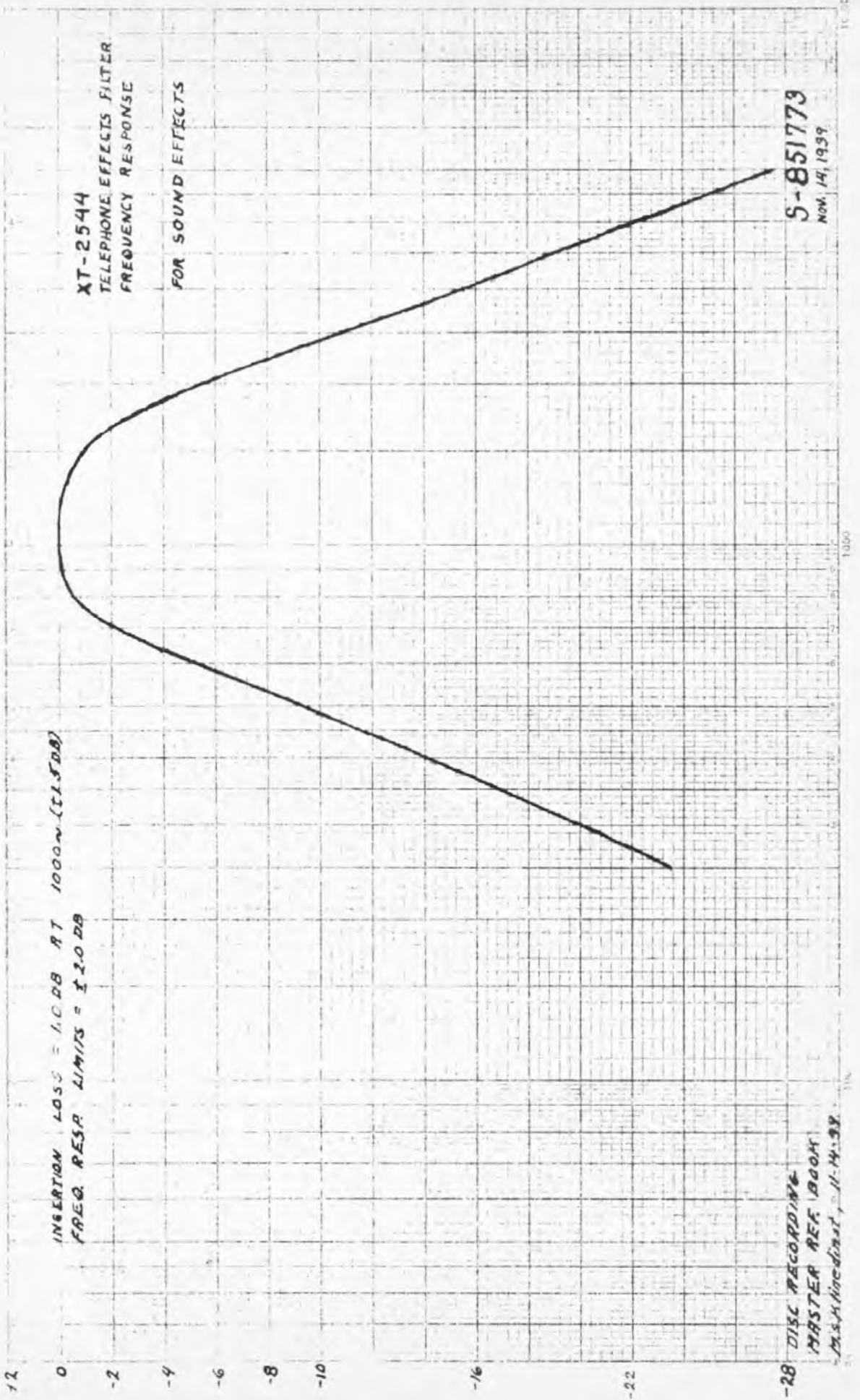

INSERTION LOSS = 1.0 DB AT 1000 Hz (11.5 DB)  
 FREQ. RESP. LIMITS = ± 2.0 DB

XT-2544  
 TELEPHONE EFFECTS FILTER  
 FREQUENCY RESPONSE  
 FOR SOUND EFFECTS

-28 DISC RECORDING  
 MASTER REF BOOM  
 M.S. Alford, 11-14-38

S-851773  
 NOV. 14, 1939

IMPEDANCE: USE IN 500 Ω LINE  
INSERTION LOSS: 0.5 DB TYPICAL  
RESPONSE LIMITS: ±1.0 DB ALL FREQ

X7-914B

VOICE FREQUENCY FILTER  
FREQUENCY RESPONSE

S-851802  
NOV. 30, 1959

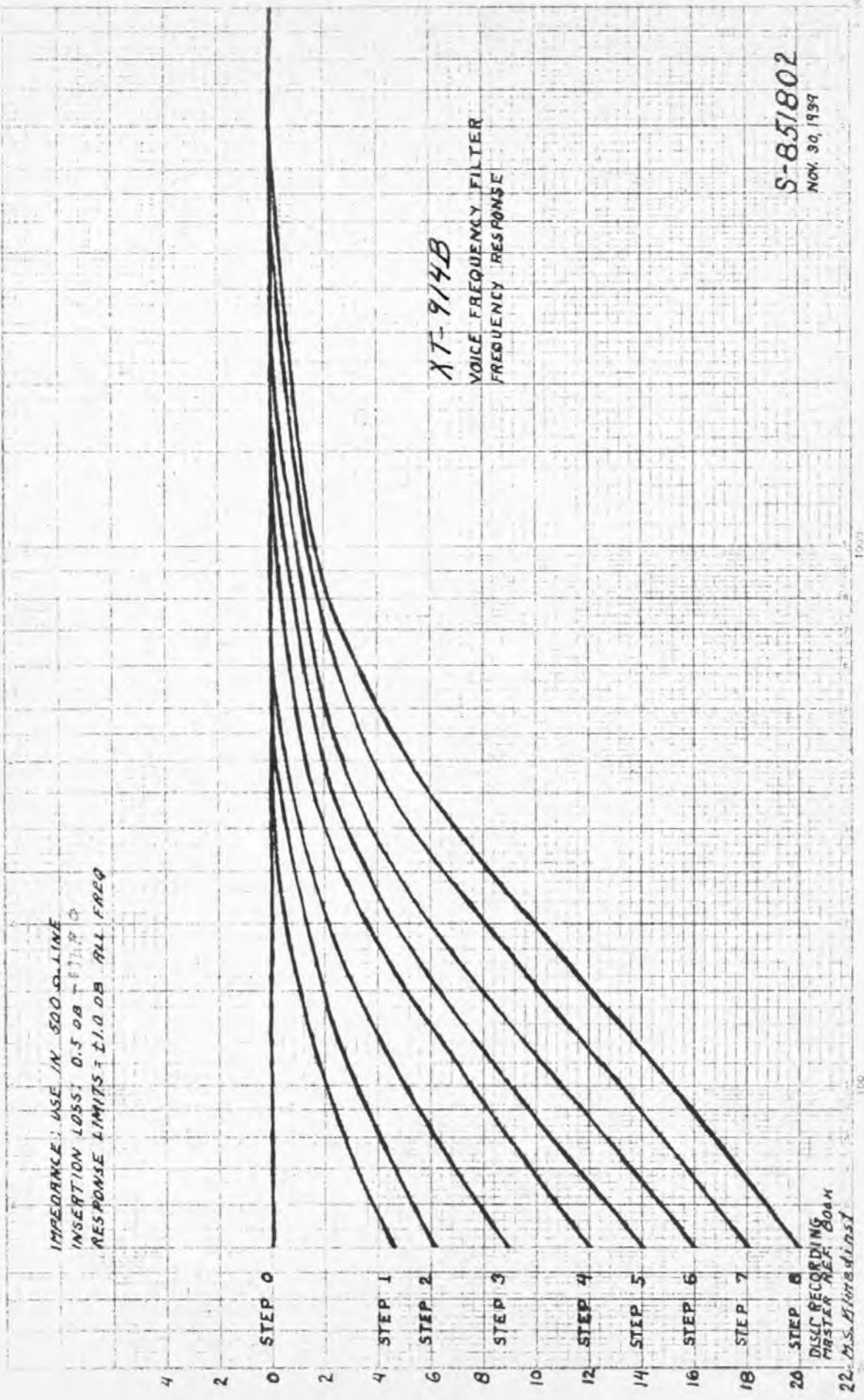

DISC RECORDING  
FIRST AER. BOAM  
22-MS. Hittaldinst

56A LINE EQUALIZER - Used in Disc Recording Studios  
 To equalize telephone line losses in the transfer of  
 programs from radio broadcast studios to the recording  
 studios.

IB-25839  
 Sheet 1 of Sheets  
 Date Feb. 20, 1940

(This instruction book reprinted from IB-25839)



FIG. 1. Front Panel - 56 A Equalizer

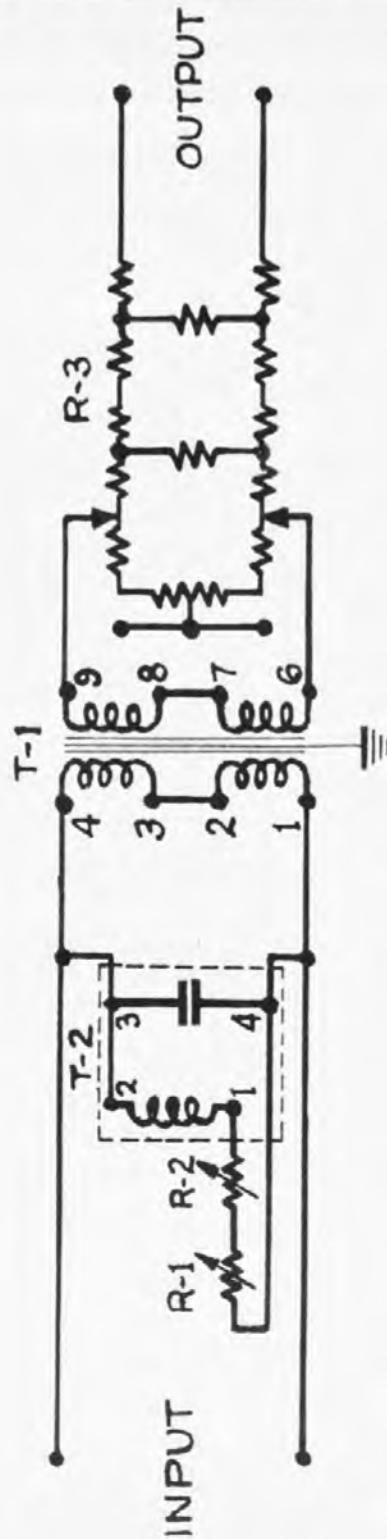

FIG. 2. Schematic Diagram - 56A Equalizer

# OPERATING INSTRUCTIONS

for

## LINE EQUALIZER

Type 56-A  
(MI-4167)

### PART I - INTRODUCTION

The RCA line equalizer, Type 56-A, is intended for equalizing the non-linear frequency transmission characteristics of non-loaded telephone lines of appreciable length, but not exceeding a length of ten miles. It consists of a tuned equalizing circuit, isolating repeat coil, and attenuation network.

The primary of the repeat coil is connected across the input terminals. Connected across these same terminals is the equalizing circuit, consisting of two resistance decades and an air-core reactor in series, with a capacitor shunted across the combination. The secondary of the repeat coil is connected through a balanced ladder pad to the output terminals. The equalizer panel is designed to operate between impedances of five hundred ohms.

The schematic wiring diagram and a front view of the panel are shown in Figures 1 and 2.

### PART II- SPECIFICATIONS

Source impedance.....500 ohms

Load impedance.....500 ohms

Volume control range.....38 db. in 19 steps of 2 db. each.

Frequency characteristic:

Without equalizer circuit.....Flat  $\pm$  1 db. 25 to 15,000 cycles.

With equalizer circuit.....Will equalize lines up to 10 miles in length to within  $\pm$  1 db. to 8,000 cycles and  $\pm$  2 db. to 10,000 cycles.

Resistance of 1st decade.....90 ohms in steps of 10 ohms.

Resistance of 2nd decade.....9 ohms in steps of 1 ohm.

Repeating coil.....1:1 transformer.

The Type 56-A line equalizer is designed to equalize the non-linear frequency characteristics of non-loaded telephone lines for frequencies ranging as high as 10,000 cycles.

The volume control consists of a balanced ladder pad and is connected between the secondary of the repeating coil and the output terminals. It has a range of 38 decibels, covered in 19 steps of 2 decibels



each. Contact "0" short-circuits the secondary of the repeating coil, thus constituting of "off" position for the equalizer panel. A detent is provided to prevent the stopping of the arm between contacts.

The repeating coil is a 1:1 transformer, with each winding made in two balanced sections with all leads brought out. It is connected as shown in the schematic diagram (Figure 2). There is an electrostatic shield between the primary and secondary coils. This is connected to ground through a separate terminal.

The variable resistor decades in the equalizing circuit are so arranged that the resistance varies from 0 to 99 ohms in 1 ohm steps. One decade varies in tens to 90 ohms, and the other in units to 9 ohms.

### PART III - INSTALLATION AND OPERATION

#### (a) Installation

The line equalizer should be mounted on the rack with two bolts on each side of the panel. Remove the rear cover by pulling it straight back.

Connect the leads from the line or pick-up apparatus to the input terminals of the panel. The leads to the apparatus receiving the equalized signal are connected to the output terminals. There must be a good connection from the equalizer panel to ground. This may be accomplished by carefully grounding the rack upon which the panel is mounted.

#### (b) Operation

The equipment necessary for operation consists of:

- (a) Beat Frequency Oscillator
- (b) Volume Indicator or Thermocouple Voltmeter

Assume that a "nemo" line is to be equalized at the receiving end, where the oscillator, equalizer, and metering devices are located. Since two lines are usually available on "nemo" circuits, the oscillator signal should be fed out over the spare line to the "nemo" point. There the signal should be fed through a "nemo" amplifier, the characteristics of which are known, and back at constant level through the line to be equalized. Send a 1,000 cycle tone (usually not more than +2 decibels) out over the line and adjust the "nemo" amplifier until the proper level is obtained on the volume indicator. The equalizer volume control should also be set at the desired operating point. After noting the reading on the volume indicator, change the oscillator output to 8,000 cycles. Adjust the decade resistors on the equalizer until approximately the same volume indicator reading is obtained for both 1,000 cycles and 8,000 cycles, taking into account the characteristics of any amplifiers that may be in the circuit. A complete characteristic check should now be made from 50 cycles to 8,000 cycles. It may be necessary to further adjust the equalizer decade resistors until the proper characteristic is obtained.

It is always desirable to reverse the input leads to the equalizer to check the line for turnover, or balance, at 5,000 cycles.

The rear cover may then be replaced.

The volume control may be adjusted in steps of two decibels over a range of 38 db., or until the desired signal strength is obtained.

(c) Maintenance

Little maintenance is likely to be needed. After installation, the only regular attention necessary is to keep all contacts on the decade resistors and volume control clean and coated with a good grade of light machine oil to prevent corrosion.

PART IV - LOCATION OF TROUBLES

(a) No Output

No output may be caused by a short-circuited condenser in the equalizer; by an open-circuit in the repeating coil; by a defect in the volume control or by a defective connection.

The defect may be located by connecting a pair of headphones across the input terminals, terminals 1 and 4, and 6 and 9 on the repeating coil, and the output terminals, in the above order, and noticing where the signal stops.

(b) No Equalizing Action

When the decade resistors have no effect on the line frequency characteristic the reactor in the equalizer may be open. Any open-circuit in the equalizing circuit may be located by checking continuity through the various components of the unit.

When it is impossible to equalize the frequency characteristics within approximately the given limits, it is possible that the line is defective, or that either the input or output terminals are not connected to the correct impedance (500 ohms). This trouble may also be caused by short-circuited turns in the reactor, by an open capacitor, or by defective resistors in the decades.

(c) Noisy Action

Noisy action is probably caused by rough contacts on the switch, a decade resistor or the volume control. This may be avoided as mentioned above, by keeping the contacts clean and coated with a good grade of light machine oil.

(d) Irregular Control of Volume

Irregular control of volume is probably caused by a defective resistor in the volume control.



PART V - REPLACEMENT PARTS

The following parts list is included to provide proper identification when ordering replacement parts. When ordering, specify the item as called for in Figure 2, followed by description and reference drawing number, where given.

| <u>ITEM</u> | <u>DESCRIPTION</u>                                 | <u>REF. D'WG NO.</u> |
|-------------|--|----------------------|
| T-1         | Repeating Coil - Type XT-1313                      |                      |
| T-2         | Equalizer - Type XT-1314                           |                      |
| R-1         | Decade Resistor - 90 ohms                          | K-814350 P-2         |
| R-2         | Decade Resistor - 9 ohms                           | K-814350 P-1         |
| R-3         | Volume Control<br>(Balanced ladder pad, 500 ohms.) | M-406596 G-502       |

SECTION III

Microphone and Re-recording Mixer Data

Master Reference Book  
Disc Recording

INSTRUCTION SHEET  
DISC RECORDING MIXER CONSOLE

DESCRIPTION:

The Mixer Console illustrated on photographs 47813, 47814 and 47815 was designed and built especially for disc recording. It consists of two four channel mixer units, each with its master or overall control, electrically combined so as to form, effectively, a single eight position mixer. The combination of the two units is effected by means of a network electrically identical with the MI-3120 Combining Network.

In addition to the mixer units the console is provided with four microphone pre-amplifiers, a booster amplifier, a pre-amplifier for the talk-back microphones, a talkback microphone, several filters and a volume indicator meter.

MIXERS:

The right hand group of four mixer controls is generally used for direct studio recording along with the associated studio microphones and the normally connected pre-amplifiers. (When recording a wire line program the line is connected to the mixer by patching which automatically disconnects the pre-amplifiers) This right hand mixer group is electrically identical with the MI-3116A Recording Mixer, including the compensation available for each channel.

The left hand group of four mixers is used for re-recording from record. This left hand group is electrically identical to the MI-3108A Re-recording Mixer. Between the output of this group and the Combining Network there is a single section of the MI-10101 Re-recording Compensator and its associated Booster Amplifier (MI-3232A) to provide the frequency response control necessary in re-recording.

8500 CYCLE LO-PASS FILTER:

This unit is provided for reducing the extreme high frequency response for domestic recordings by essentially cutting off all frequencies above 8500 cycles. It is "normalled" in the circuit through jacks between the main amplifier input line (console output) and the Voice Frequency Filter.

VOICE FREQUENCY FILTER:

This unit is provided for use ONLY if the low frequency response of a vocal or orchestra is abnormally accentuated and can be corrected in no other way. It is connected in the circuit between the output of the combining network and the input to the 8500 cycle lo-pass filter. Is disconnected by turning the control knob to the "0" position. Varying degrees of low frequency attenuation are available - the attenuation increasing as the control is rotated clockwise.

METER VOLUME INDICATOR:

This meter is provided to monitor the level of the signal being recorded. It will be (at the present time) either a standard MI-3115 Volume Indicator Meter (Zero level 0.0125 watts-500 ohms) or a VU meter (0.001 watts-600 ohms). The VU meter is to be standard because of the necessary tie up with broadcast stations using VU meters and as soon as possible all studios not now equipped with VU meters will be so equipped.

INSTRUCTION SHEET - DISC RECORDING MIXER CONSOLE

TALKBACK MICROPHONE AND SWITCHING:

Provision is made for the use of two talkback microphones. One of these microphones is permanently located in the console on the Meter VI panel and the other is usually located on the director's table.

The microphones are fed, through a common pre-amplifier (MI-3230B) to the studio playback amplifier.

The "press-to-talk" switches for these microphones are so connected that they short circuit the input to the monitor meter and the monitor loudspeaker when they are pressed. This avoids damage to the monitor meter and acoustic feedback. Since this part of the circuit is amplifier isolated from the recording circuits, the recording will not be spoiled if the switch is pressed accidentally - providing of course that no sound from the talkback speaker enters the recording microphones.

ADDITIONAL DATA ON CONSOLE AND UNITS:

1. Schematic diagram - See T-613261 (Part labelled Mixer Console)
2. Wiring Diagram - See W-302627, See MRB Sec. III
3. Microphone Mixer, MI-3116A, See MRB Sec. III
4. Re-recording Mixer, MI-3108A, See MRB Sec. III
5. Combining Network, MI-3120, See MRB Sec. III
6. Talkback Microphone, MI-6226A, See MRB Sec. I
7. Microphone Pre-Amplifier, MI-3230B, See MRB Sec. IV
8. Booster Amplifier, MI-3232A, See MRB, Sec. IV
9. VI Meter, MI-3116, See MRB Sec. V
10. VU Meter See MRB Sec. V
11. Voice Frequency Filter, XT-914B, See MRB Sec. II
12. 8500 cycle Lo-Pass Filter, XT-2727A, See MRB Sec. II
13. Telephone Effect Filter, XT-2544, See MRB Sec. II
14. Re-recording Compensator, MI-10101, See MRB Sec. II

NOTE: "MRB Sec. I", refers to the "Master Reference Book, Section I".

3  
2  
1





35





5  
2  
5  
2



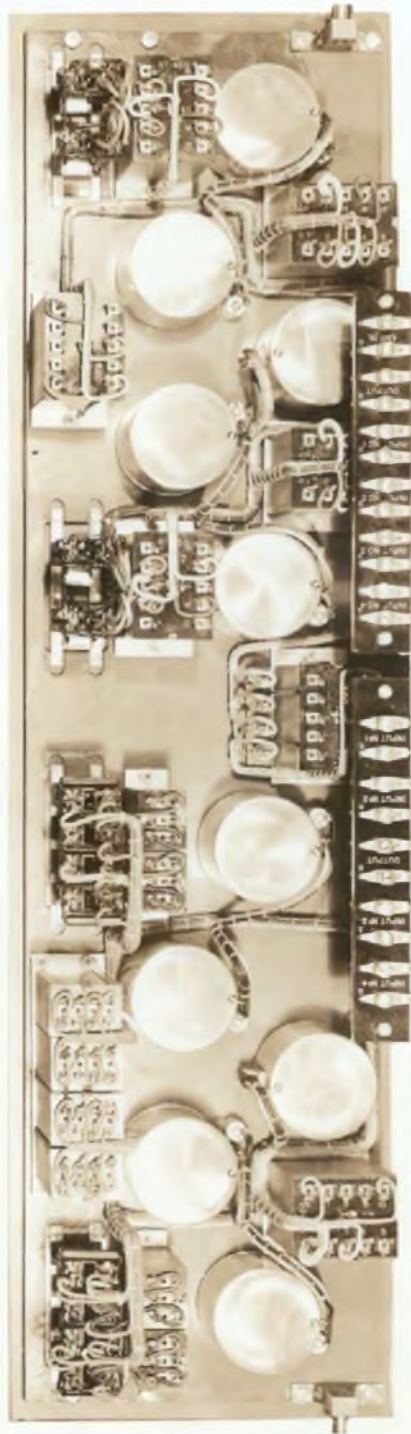

47816



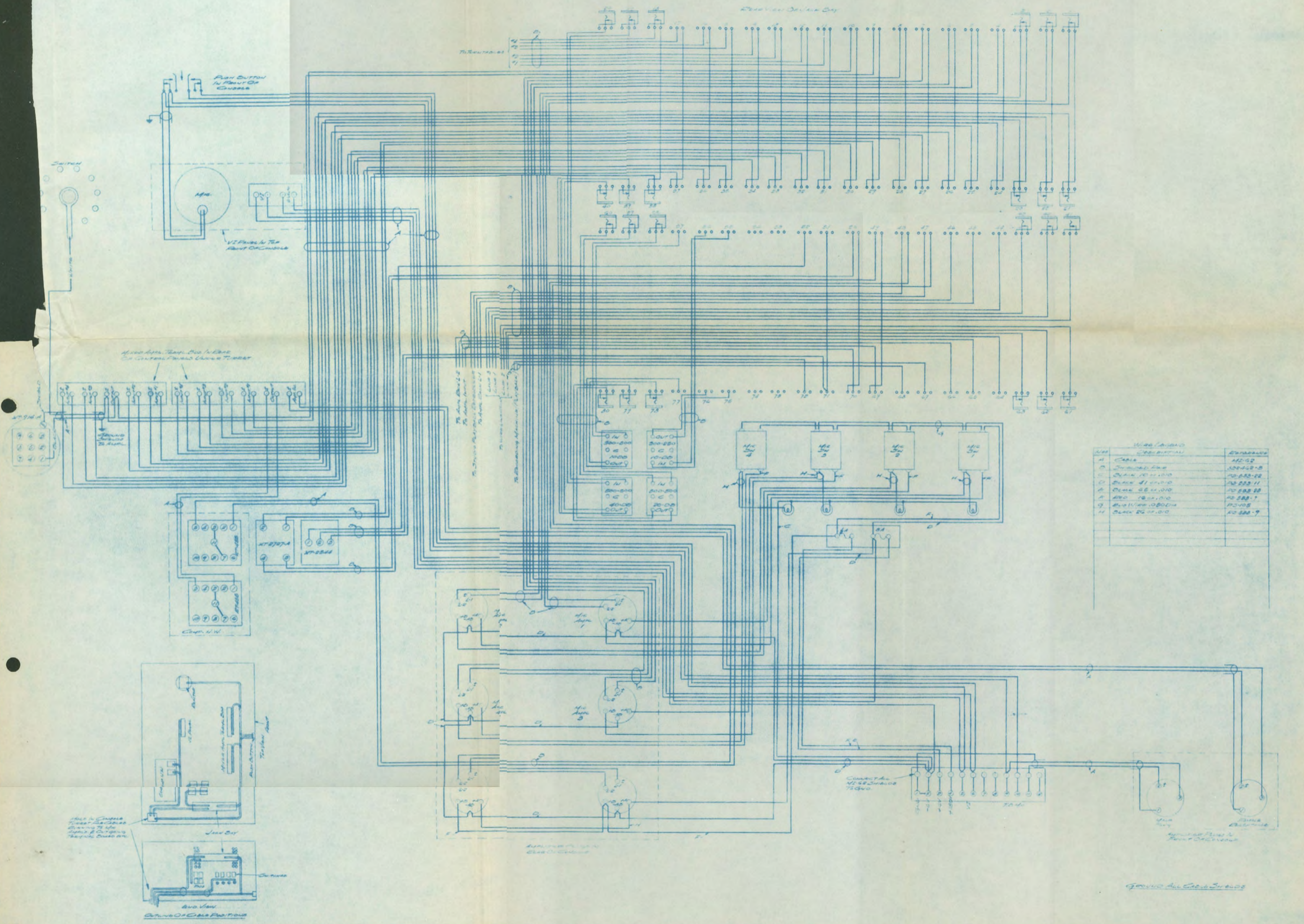

| Wire Color | Designation    | Quantity  |
|------------|----------------|-----------|
| A          | Cable          | 142-62    |
| B          | Shielding Wire | 100-42-8  |
| C          | Black 16 AWG   | 50-550-10 |
| D          | Black 18 AWG   | 50-550-11 |
| E          | Black 22 AWG   | 50-550-12 |
| F          | Black 24 AWG   | 50-550-13 |
| G          | Black 26 AWG   | 50-550-14 |
| H          | Black 28 AWG   | 50-550-15 |

**WIRING FOR CONSOLE  
USED IN DISC RECORDING**

W-302627



**MI-3108  
MI-3108-A**

**RERECORDING MIXERS**

---

**RCA PHOTOPHONE  
RECORDING INSTRUCTIONS**

---

First Edition

Photophone Division  
RCA Manufacturing Co., Inc.  
Camden, N. J., U. S. A.

A Service of the Radio Corporation of America

**MI-3108****MI-3108-A****RCA PHOTOPHONE  
RERECORDING MIXERS**

Number of Channels ..... 4  
 Input Impedance ..... 250 (can be wired 500) ohms  
 Output Impedance ..... 250 or 500 ohms  
 Minimum Insertion Loss ..... (reference level 0.006 watt) 10 db  
 Weight ..... 44 pounds

## Overall Dimensions

|        | <u>With False<br/>Panel</u> | <u>For Std. Relay<br/>Rack Mounting</u> |
|--------|-----------------------------|---|
| Length | 20 inches                   | 19 inches                               |
| Height | 11-13/16 inches             | 10-1/2 inches                           |
| Depth  | 5-9/16 inches               | 5-5/16 inches                           |

PART 1 DESCRIPTION

The RCA MI-3108 and MI-3108-A Rerecording Mixers are identical in electrical circuits. They differ only in the type of attenuation pads used. Each consists of a four (4) channel input equipped with input transformer, key switch, dummy load resistor, and bridged "T" pad attenuator, and a one (1) channel output equipped with output transformer, and bridged "T" pad attenuator.

Each of the five attenuators in the MI-3108 has 21 steps. The first 15 steps each increase the attenuation by 1-1/2 db. The next 5 steps increase the attenuation by tapering amounts up to a total of 60 db. The last step opens the circuit.

Each of the five attenuators in the MI-3108-A has 31 steps. The first 26 steps each increase the attenuation by 1-1/2 db. The next 4 steps increase the attenuation by tapering amounts up to a total of 60 db. The last step opens the circuit.

Each input channel on both the MI-3108 and MI-3108-A is equipped with a key switch having positions marked "LOCK, OFF, NON-LOCK." In either the "LOCK" or "NON-LOCK" position the input is connected directly to the primary of the input transformer. In the "OFF" position the input circuit is opened, one side of the input circuit is grounded, and a 250 ohm resistor is connected across the primary of the input transformer.

The attenuator terminals on the MI-3108 and marked "1," "2," and "3" respectively. Corresponding terminals on the MI-3108-A attenuators are marked "In," "C," and "Out."

The panel is finished in gray wrinkle, with chromium trim. For relay rack mounting the aluminum false panel and the hinge blocks may be removed.

### PART 2 CIRCUIT

Figure T-607647 shows the schematic circuit and figure T-607585 shows the wiring diagram of the MI-3108-A. Both these diagrams are applicable to the MI-3108 since the only difference is in the type of "T" pad attenuators used.

These amplifiers are shipped from the factory with the input circuits connected for operation on 250 ohm lines. If operation on 500 ohm input lines is desired move the wires now connected to terminals number 2 and 4 on the RT-455 input transformers (T1, T2, T3, T4) to terminals 1 and 5.

Figure S-822878 shows the frequency characteristic of the MI-3108. The frequency characteristic of the MI-3108-A is identical to this.

### PART 3 REPLACEMENT PARTS

The following parts list is included to provide identification when ordering replacement parts. When ordering specify the item by description and reference drawing number.

#### Parts used in both MI-3108 and MI-3108-A

| <u>Item No.</u> | <u>Description</u>   | <u>Reference Dwg. No.</u> |       |
|-----------------|----------------------|---------------------------|-------|
| R 1             | Resistor 250 ohms    | K-35861                   | P-38  |
| R 2             | Resistor 250 ohms    | K-35861                   | P-38  |
| R 3             | Resistor 250 ohms    | K-35861                   | P-38  |
| R 4             | Resistor 250 ohms    | K-35861                   | P-38  |
| R 10            | Resistor 188 ohms    | K-35861                   | P-40  |
| R 11            | Resistor 188 ohms    | K-35861                   | P-40  |
| R 12            | Resistor 188 ohms    | K-35861                   | P-40  |
| R 13            | Resistor 188 ohms    | K-35861                   | P-40  |
| S 1             | Key Switch           | M-414234                  | P-3   |
| S 2             | Key Switch           | M-414234                  | P-3   |
| S 3             | Key Switch           | M-414234                  | P-3   |
| S 4             | Key Switch           | M-414234                  | P-3   |
| T 1             | Transformer (RT-455) | M-68985                   | G-502 |
| T 2             | Transformer (RT-455) | M-68985                   | G-502 |
| T 3             | Transformer (RT-455) | M-68985                   | G-502 |
| T 4             | Transformer (RT-455) | M-68985                   | G-502 |
| T 5             | Transformer (RT-456) | M-68985                   | G-503 |



Parts used only in MI-3108

| <u>Item No.</u> | <u>Description</u>       | <u>Reference Dwg. No.</u> |
|-----------------|--------------------------|---------------------------|
| R 5             | Bridged "T" Pad 250 ohms | P-705944 G-504            |
| R 6             | Bridged "T" Pad 250 ohms | P-705944 G-504            |
| R 7             | Bridged "T" Pad 250 ohms | P-705944 G-504            |
| R 8             | Bridged "T" Pad 250 ohms | P-705944 G-504            |
| R 9             | Bridged "T" Pad 109 ohms | P-705944 G-503            |

Parts used only in MI-3108-A

| <u>Item No.</u> | <u>Description</u>       | <u>Reference Dwg. No.</u> |
|-----------------|--------------------------|---------------------------|
| R 5             | Bridged "T" Pad 250 ohms | M-414583 P-3              |
| R 6             | Bridged "T" Pad 250 ohms | M-414583 P-3              |
| R 7             | Bridged "T" Pad 250 ohms | M-414583 P-3              |
| R 8             | Bridged "T" Pad 250 ohms | M-414583 P-3              |
| R 9             | Bridged "T" Pad 109 ohms | M-414583 P-2              |

# RERECORDING MIXER MI-3108

## FREQUENCY CHARACTERISTIC WITH POTENTIOMETERS ON STEP 10

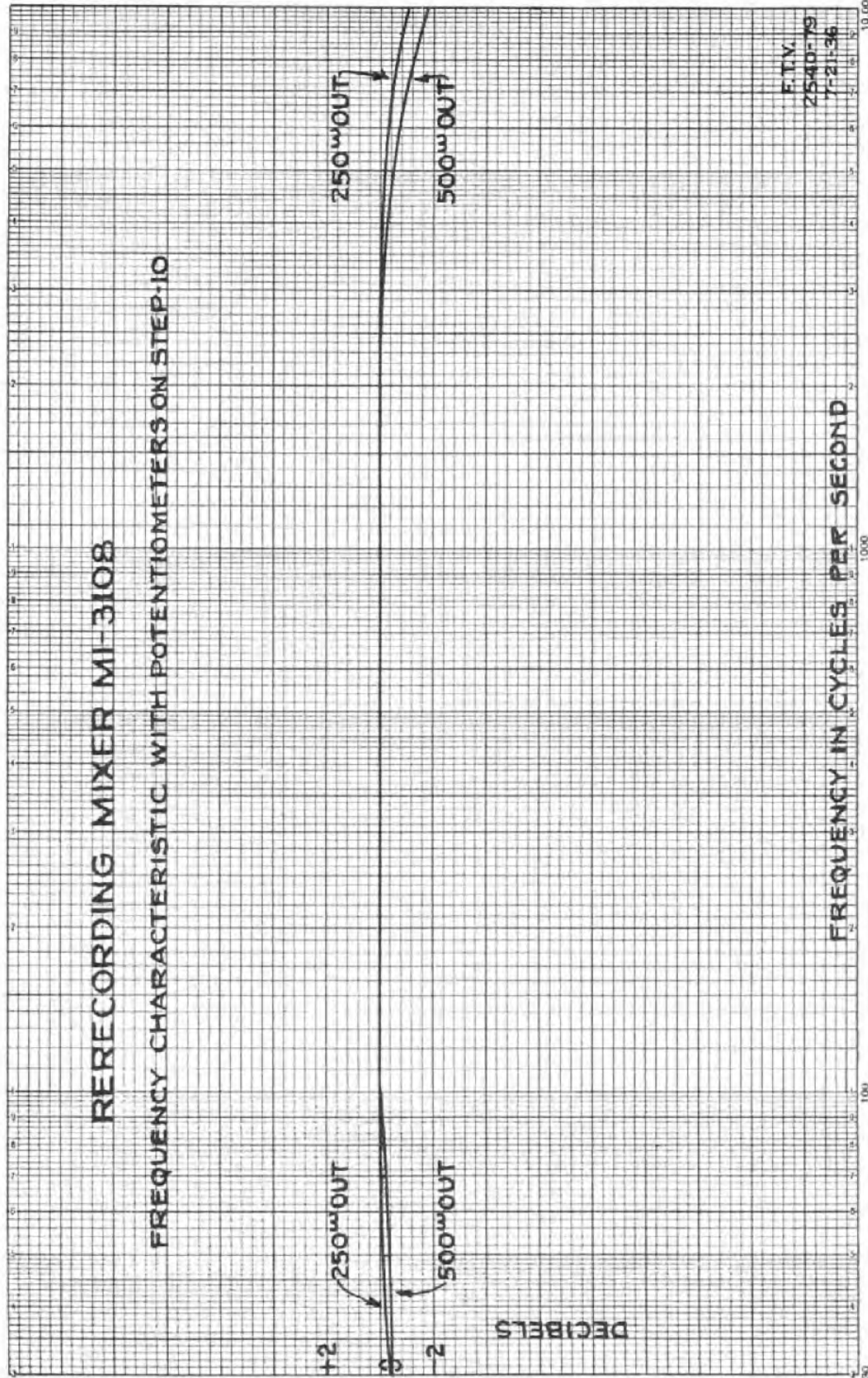

F.T.V.  
2540-79  
7-21-36

# S-822878

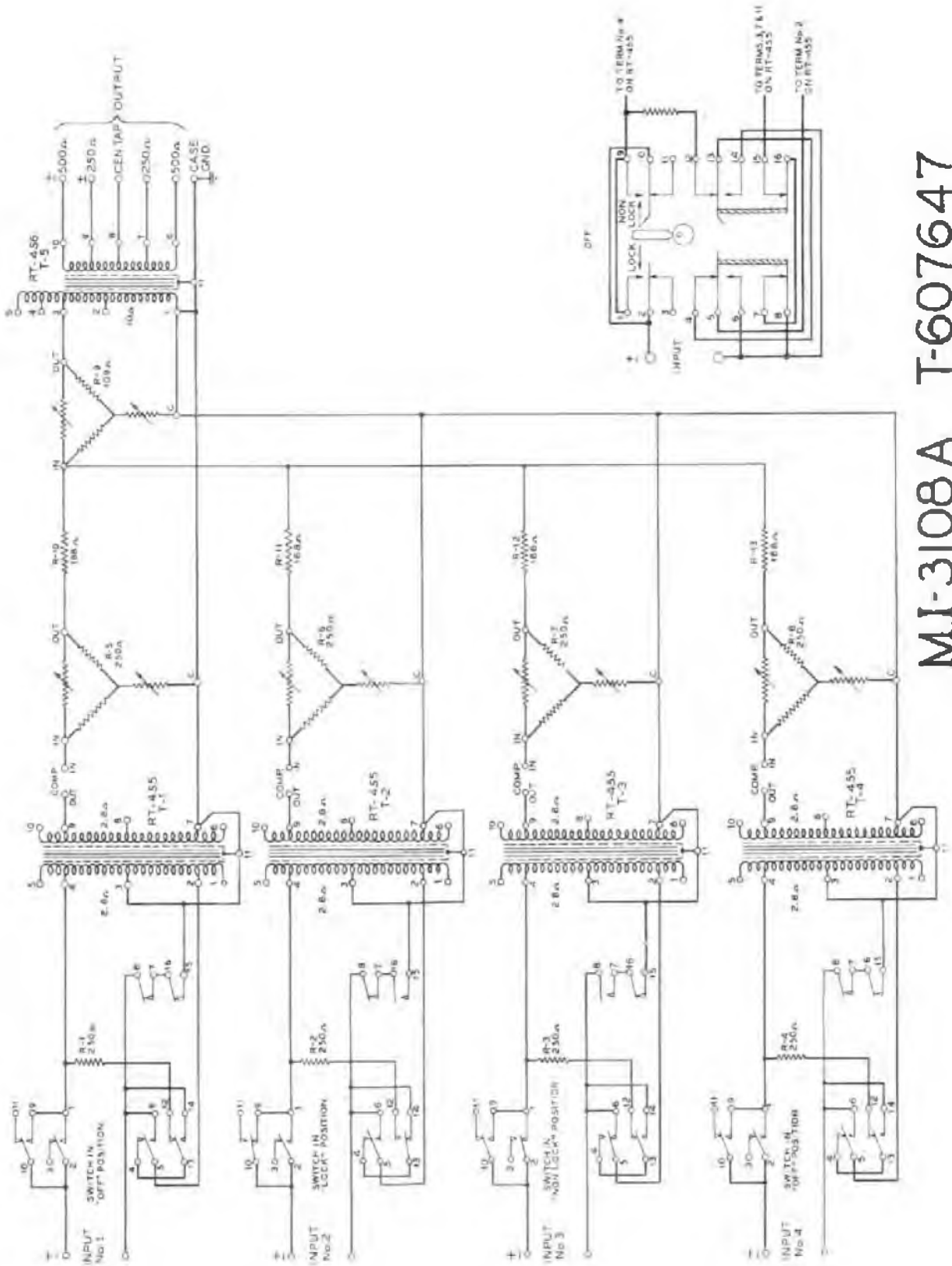

M.I-3108A T-607647



MI-3116  
MI-3116A

RCA PHOTOPHONE  
INPUT MIXING PANELS

---

R E C O R D I N G  
I N S T R U C T I O N S

---

RCA Victor Division  
RCA Manufacturing Company, Inc.  
CAMDEN, N. J., U. S. A.

A N R C A S E R V I C E



# RCA PHOTOPHONE INPUT MIXING PANELS

MI-3116  
MI-3116A

## DATA SHEET

|                            |   |
|----------------------------|---|
| Input Impedance            | 250 ohms.   |
| Output Impedance           | 500 ohms. (250 ohms also available<br>in MI-3116-A)   |
| Number of Channels         | 4   |
| Number of Controls         | 1 mixing attenuator for each channel<br>1 high frequency compensator<br>switch for each channel<br>1 low frequency compensator<br>switch for each channel<br>1 overall attenuator   |
| Control Range              |   |
| Attenuators                | 19 steps of 1 db. per step and<br>zero position of infinite<br>attenuation for each control<br>(in MI-3116 only)<br>26 steps of 1.5 db. per step to 39<br>db., followed by 3 steps tapered<br>to 60 db. and a zero position<br>of infinite attenuation (in MI-3116-A<br>only) |
| Low Frequency Compensator  | 4.5 db., 8.5 db. or 13 db. atten-<br>uation at 100 cycles (see<br>accompanying curves)  |
| High Frequency Compensator | 9 db. attenuation at 10,000<br>cycles (see accompanying<br>curves)  |

Frequency Range

Without Compensation  
With Compensation

30 to 10,000 cycles  
(See accompanying curves)

Mounting

Rack or console

Dimensions

For rack mounting (without  
top panel)

19" wide x 3 23/32" high x  
4 15/16" deep

For console mounting (with  
top panel)

19 7/8" wide x 10 13/16" high x  
5 3/16" deep

Weight

MI-3116  
MI-3116-A

36 pounds

# RCA PHOTOPHONE INPUT MIXING PANELS

MI-3116  
MI-3116A

## PART I - DESCRIPTION

1. INTRODUCTION - The use of more than one microphone pre-amplifier in any recording system entails the use of some device for switching from one microphone pre-amplifier to another, for mixing the outputs of the microphone pre-amplifiers and, irrespective of number, the control of the overall volume of sound currents fed into the main recording amplifier. It is for this purpose that the input mixing panel was designed.

In the problem of sound recording there are certain factors that render necessary the use of compensation. Before entering upon a discussion of the RCA Photophone input mixing panels, these factors will be briefly considered, with a view of emphasizing the importance of the compensator circuits of these panels as a part of the recording network.

The introduction of low frequency attenuation in the recording has been necessitated by the continued practice of reproducing speech in the theatre at a higher volume than that at which it was recorded.

Music is usually reproduced in the theatre at the recorded level, or slightly lower, while speech is reproduced at a considerably higher level than that at which it was recorded. Under the latter conditions, attenuation is required at both the high and low frequencies. This compensation corrects for the change in frequency response of the human ear with an increase in sound intensity; thereby making it possible to amplify the recorded speech to the desired level without appreciably changing its quality as compared with the original. Such compensation is similar in principle, but the reverse in application, to the tone compensated volume control used in radio receivers and phonographs, since, in these instances the broadcast speech and music are reproduced at abnormally low rather than abnormally high volume levels.

Some attenuation, of approximately equal amounts, is required at both low and high frequencies when recording lectures or announcements. When recording conversational speech or dialogue, somewhat more attenuation is required at the low frequency end of the range. While this statement is true in general, experience and varying field conditions may dictate some deviation from this method of procedure.

In addition to providing for attenuation of the higher frequencies so as to maintain an overall balance between high and low frequencies when considerable low frequency compensation is used, the high frequency compensator also provides a convenient control for reducing the effects of excessive sibilants, etc.

Actors and actresses who have had stage training sometimes speak with excessive sibilants which are very difficult to record without a control of this kind.

2. DESCRIPTION - This instruction book covers the installation, operation and maintenance of two types of input mixer panels; i.e. the MI-3116 and the MI-3116-A. The MI-3116 and MI-3116-A contain the same arrangement of controls, four mixing and one overall attenuators and a set of high and low frequency attenuators for each mixing attenuator. They differ in that the MI-3116 mixing and overall attenuators provide 19 steps of 1 db. per step with a zero position of infinite attenuation, while the MI-3116-A mixing and overall attenuators provide 26 steps of 1.5 db. per step out to 39 db. followed by 3 steps tapered to 60 db. and a zero position of infinite attenuation. With these exceptions, and unless otherwise specified, the instructions which follow apply equally to both of these input mixing panels.

These units fulfill all the fundamental requirements of high quality input mixing panels in that:-

(a) The input impedance of each microphone circuit in the panel matches the output impedance (250 ohms) of the microphone pre-amplifier circuit to be coupled to it.

(b) The output of the panel matches the input impedance (500 ohms) of the recording amplifier to which it is to be coupled.

(c) It is possible to control the frequency response of any input circuit without affecting the frequency response of any other input circuit or that of the succeeding amplifier.

(d) It is possible to control the volume from each individual microphone pre-amplifier without affecting either its frequency response characteristic or that of any of the other amplifiers connected to the input of the panel or that of the succeeding amplifier.

(e) It is possible to control the volume from the individual microphone pre-amplifiers without affecting the volume of output from any of the other pre-amplifiers.

(f) It is possible to control the volume of the overall output from the panel without affecting its frequency response characteristic or that of the succeeding amplifier.

(g) The overall frequency response characteristic of the mixing panel is uniform within  $\pm 0.5$  db. from 30 to 10,000 cycles from any and all of the input circuits (when the high and low frequency attenuators are not in the output circuit).

(h) The operation of the various controls is mechanically smooth and electrically silent.

3. ELECTRICAL CIRCUIT - The audio circuits from the microphone distribution panel are brought into the mixing panel through a terminal board on the bottom of the mixing panel. From the input terminals of each channel the signal is carried to the "HIGH" and "LOW" compensation control switches of that channel. If no compensation is desired; i.e., when both switches are placed in the "OFF" position, the signal passes without change to the mixing control of its respective channel.

The four sets of three-position key switches are mounted on the front of the amplifier panel in two groups of two sets each. Each set of switches is labeled with its respective channel designation. The switch marked "LOW" is provided for the control of the low frequency compensation, and the switch marked "HIGH" is provided for the control of the high frequency compensation of its respective channel. While both switches are of the three-position type, the "HIGH FREQUENCY" switch has in reality but two effective positions; that is, in the "OFF" position no high frequency compensation is provided, and in both of the other positions the same amount of high frequency compensation is introduced into the circuit.

Mixing circuits from four microphone pre-amplifiers are included. A coupling transformer is used to match the impedance of the mixing circuits to that of the recording amplifier. The "Tee" pad volume control, for controlling the overall volume output of the mixing panel, is connected in the output circuit of the coupling transformer in MI-3116 and in the primary circuit of the coupling transformer in MI-3116-A.

The output transformer of MI-3116-A is normally connected to operate into a 500-ohm circuit (transformer terminal 6 and 10) but may be connected to operate into a 250-ohm circuit (transformer terminals 7 and 9).

The circuit, as just described, embracing a terminal strip providing for four input circuits, four mixing controls with their associated compensator circuits, a coupling transformer, an overall volume control and a two contact output terminal strip, comprises input mixing panels MI-3116 and MI-3116-A.



## PART II - INSTALLATION AND OPERATION

4. INSTALLATION - These input mixing panels are designed to fit a standard RCA Photophone recording rack, and the MI-3114, 3114-A, 3117-A and MI-3117 mixing consoles. The units, with the exception of the control knobs, are inclosed in a sheet metal case. Special instructions for the assembly of the input mixer panels in the mixing consoles are contained in the instruction books for the respective consoles.

Care must be taken, at the time of installation, to see that the units are properly phased. See section 6.

5. OPERATION - There are no hard and fast rules for the use of compensation, the most advantageous effects being obtained as a matter of experience and judgment. However, it may be said that, whenever possible, it is advisable to use the full recording range (no compensation). When recording the human voice, or any type of sound in which there is a predominance of lows or highs, the proper amount of low or high frequency compensation should be used. See also section 1.

If high frequency compensation only is desired, the "LOW" frequency compensation switch will remain in the "OFF" position and the "HIGH" frequency compensation switch will be moved to position "1" or position "2". This introduces a reactor and a series capacitor (compensator pack, Type RT-261) in parallel with the circuit. With high frequency compensation in the circuit, attenuation begins at approximately 2,500 cycles and becomes increasingly effective as the frequency is raised. See the accompanying curve Figure 6 for detailed information as to the effect of high frequency compensation as the frequency is raised.

The "LOW" frequency compensation switch has, in addition to the "OFF" position (in which position no low frequency compensation is introduced into the circuit), two positions in which such compensation is introduced into the circuit.

When the "LOW" frequency compensation switch is in position "1" two capacitors (those connected to terminals 3 and 4 of the capacitor pack CP-134) are connected in parallel and shunted by a resistor, the entire combination being connected in series with one side of the compensator panel circuit. With the switch in this position, attenuation commences to become effective at approximately 1,000 cycles and becomes increasingly so as the frequency is lowered, being down 8.5 db. at 100 cycles.

When the switch is in position "2", one capacitor (that connected to terminal 4 of the capacitor pack CP-134) is connected in series with one side of the compensator panel circuit. With the switch in this

position, attenuation begins to become effective at approximately 1,500 cycles and becomes increasingly so as the frequency is lowered, being down 13 db. at 100 cycles. See the accompanying curve, Figure 7, for detailed information as to the effect of low frequency compensation as the frequency is lowered.

**IMPORTANT** - As the input panels are shipped, they are connected for maximum low frequency compensation, and the figures given above apply to this method of connection.

The amount of low frequency compensation, however, may be varied in such a manner that when the "LOW" frequency compensation switch is in position "1", compensation begins to become effective at approximately 500 cycles and is down about 5.25 db. at 100 cycles; and when the "LOW" frequency compensation switch is in position "2", compensation begins to become effective at approximately 1,000 cycles and is down about 8.5 db. at 100 cycles. Refer to the accompanying curve, Figure 8, for detailed information as to the effect of minimum low frequency compensation as the frequency is lowered.

For channels in which change in low frequency compensation is desirable, proceed as follows:

- (a) Remove the wire from terminal 3 and connect it to terminal 2 of the capacitor pack (CP-134) of that respective channel.
- (b) Connect terminals 3 and 4 of the capacitor pack (CP-134) by means of a jumper.

### PART III - TESTING

In the field, testing of these units involves a check of their phasing and frequency response. A method of making each of these tests is outlined below:

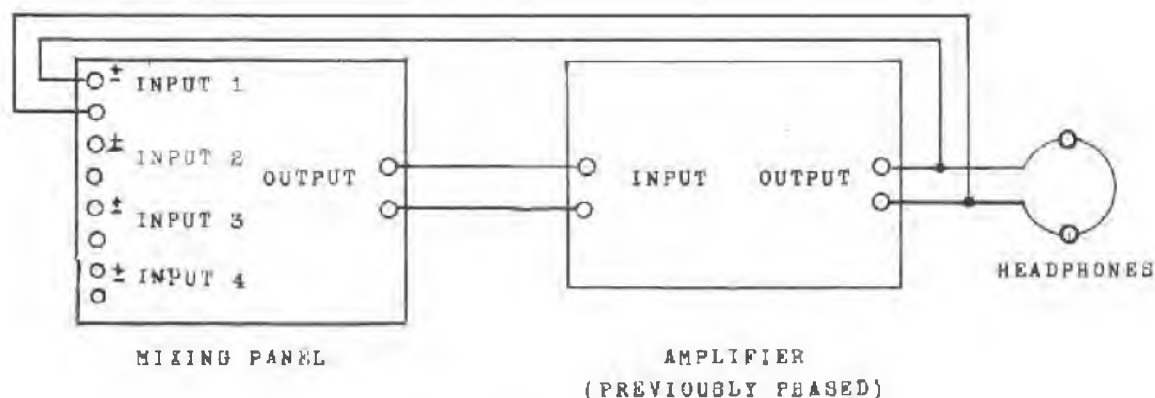

Figure 1 - Connections for Phasing

6. PHASING - The panel should be connected in the circuit "in phase". To facilitate this, one terminal of each set of input terminals and one terminal of each set of output terminals is identified by means of a  $\pm$  sign. Since this means of terminal identification is common to all units of RCA equipment, phasing is generally a matter of connecting like terminals to like terminals. However, in the event of parts replacement, it is possible that such internal connections might result in the unit being "out of phase".

To check the phasing, proceed as follows:

(a) Check the circuit from the input terminal board through the several units to the output terminal board in accordance with Figure 7 or 8. The various connections should be strictly in accordance with this diagram.

(b) Connect the "OUTPUT" of the mixer of the "INPUT" of an amplifier which has been "Phased", making sure that the phasing marks ( $\pm$ ) are connected together. (See Figure 1.)

(c) Connect one of the "INPUTS" of the mixer to the "OUTPUT" of the amplifier, making sure that the phasing marks ( $\pm$ ) are connected together. Connect a pair of headphones across these terminals.

(d) If the respective channel of the mixing panel is properly phased, the mixing panel and the amplifier will "motorboat" or will produce a strong low frequency signal. If the combination is silent or produces a weak high frequency signal the channel is not "in phase". Make this test for all switch positions, and reverse the internal connections as may be found necessary to phase each channel in all switch positions.

11. FREQUENCY RESPONSE - A check on the frequency response will indicate whether the mixer is properly connected, and/or whether it contains any parts which are electrically defective. Without compensation, the frequency response characteristic should be flat  $\pm 0.5$  db. from 30 cycles to 10,000 cycles. The frequency response characteristic may be taken as follows:

(a) Connect a calibrated source of audio frequency signal to one of the mixer input terminals as indicated in Figure 2. A 250-ohm resistor should be connected in series with the side of the audio line which is connected to the input terminal marked " $\pm$ ". The other side of the audio line should be grounded, since the mixer input is not balanced with respect to ground.

(b) The mixer input control to which the signal generator is connected and the overall control both should be set on position "10" since this is a normal setting for recording. The rest of the mixer input controls should be set on position "0".

(c) Connect an output measuring circuit and an external load resistor across the output terminals. The output measuring circuit and the load resistor should, in combination present a 500-ohm load across these terminals. A 500-ohm resistor with a vacuum tube voltmeter may be used, or a voltmeter shunted across a resistor of such value that the combined resistance is 500 ohm, or a milliammeter in series with a resistor of such value that the meter and resistor in series have a resistance of 500 ohms may also be used.

(d) With an input signal to the MI-3116 of 3 volts, and one input and the overall controls both set on position 10, the output voltage will be approximately 0.07 volts (or -27.8 db. using a reference level of 0.006 watts). With an input signal to the MI-3116-A of 3 volts, and one input and the overall control both set on position "26" the output voltage will be approximately 0.0062 volts (or -49.2 db., using a reference level of 0.006 watts). In case the available instrument will not measure the output, a calibrated amplifier, having 500 ohms input impedance, may be used and the input voltage to the mixer, the amplification of the amplifier and the output voltage and measuring circuit may be adjusted until normal readings are obtained.

(e) The response characteristic obtained by using the high frequency compensator and the several connections of the low frequency

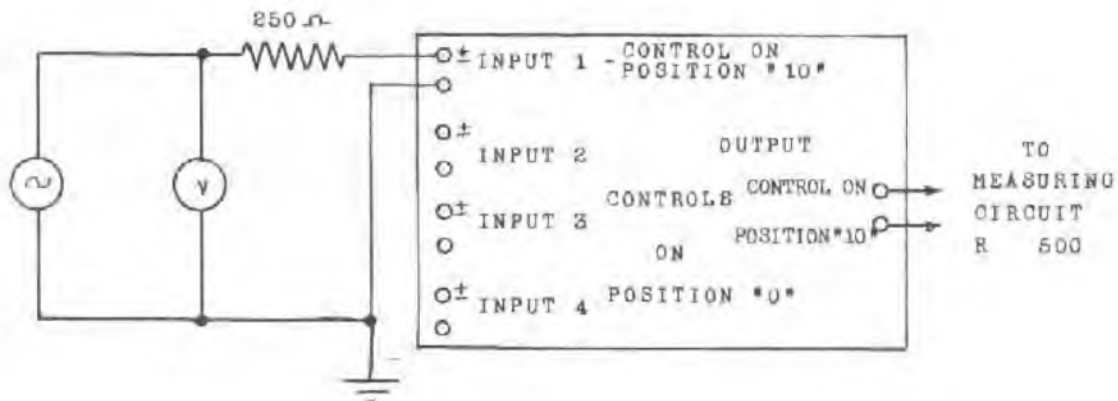

Figure 2

compensator are shown in Figure 5. The particular connections to be used for low frequency compensation will be determined by local recording conditions. At the present time, the high frequency compensation is the same for both position 1 and position 2 of the frequency compensation switch.

PART IV REPLACEMENT PARTS

The following parts list is included to provide proper identification when ordering replacement parts. When ordering specify the item as called for in the schematic diagram followed by a description and reference drawing as follows:

| <u>Item</u> | <u>Description</u>                          | <u>Reference D'w'g No.</u> |
|-------------|---|----------------------------|
| C-1         | Capacitor pack (CP-134)                     | M-66198 G-501              |
| C-2         | Capacitor pack (CP-134)                     | M-66198 G-501              |
| C-3         | Capacitor pack (CP-134)                     | M-66198 G-501              |
| C-4         | Capacitor pack (CP-134)                     | M-66198 G-501              |
| L-1         | Compensator pack (RT-261)                   | M-406235 G-501             |
| L-2         | Compensator pack (RT-261)                   | M-406235 G-501             |
| L-3         | Compensator pack (RT-261)                   | M-406235 G-501             |
| L-4         | Compensator pack (RT-261)                   | M-406235 G-501             |
| R-1         | Resistor --- 500,000 ohms                   | K-817472 P-10              |
| R-2         | Resistor --- 500,000 ohms                   | K-817472 P-10              |
| R-3         | Resistor --- 500,000 ohms                   | K-817472 P-10              |
| R-4         | Resistor --- 500,000 ohms                   | K-817472 P-10              |
| R-5         | Resistor --- 188 ohms                       | K-30176 P-28               |
| R-6         | Resistor --- 188 ohms                       | K-30176 P-28               |
| R-7         | Resistor --- 188 ohms                       | K-30176 P-28               |
| R-8         | Resistor --- 188 ohms                       | K-30176 P-28               |
| *R-9        | Mixing Attenuator --- 250 ohms              | P-705944 G-501             |
| *R-10       | Mixing Attenuator --- 250 ohms              | P-705944 G-501             |
| *R-11       | Mixing Attenuator --- 250 ohms              | P-705944 G-501             |
| *R-12       | Mixing Attenuator --- 250 ohms              | P-705944 G-501             |
| *R-13       | Overall Attenuator --- 500 ohms             | P-705944 G-502             |
| **R-9       | Mixing Attenuator --- 250 ohms              | M-414554 G-501             |
| **R-10      | Mixing Attenuator --- 250 ohms              | M-414554 G-501             |
| **R-11      | Mixing Attenuator --- 250 ohms              | M-414554 G-501             |
| **R-12      | Mixing Attenuator --- 250 ohms              | M-414554 G-501             |
| **R-13      | Overall Attenuator --- 109 ohms             | M-414554 G-502             |
| S-1         | Key switch --- Stromberg-Carlson Type 172-A | K-817472 P-9               |
| S-2         | Key switch --- Stromberg-Carlson Type 172-A | K-817472 P-9               |
| S-3         | Key switch --- Stromberg-Carlson Type 172-A | K-817472 P-9               |
| S-4         | Key switch --- Stromberg-Carlson Type 172-A | K-817472 P-9               |
| S-1         | Key switch --- Stromberg-Carlson Type 172-A | K-817472 P-9               |
| S-2         | Key switch --- Stromberg-Carlson Type 172-A | K-817472 P-9               |
| S-3         | Key switch --- Stromberg-Carlson Type 172-A | K-817472 P-9               |
| S-4         | Key switch --- Stromberg-Carlson Type 172-A | K-817472 P-9               |

\*For MI-3116 only      \*\*For MI-3116-A



\*T-1 Transformer --- Type XT-374 EX-280233 G-1  
 \*\*T-1 Transformer --- Type RT-456 K-68985 G-503

## \*DETAILED PARTS LIST OF MIXING CONTROLS R-9, R-10, R-11 AND R-12

| <u>Resistor No.</u> | <u>Resistance</u> | <u>Reference D'w'g No.</u> |
|---------------------|-------------------|----------------------------|
| 1                   | 250 ohms          | K-35528 P-1                |
| 2                   | 242 ohms          | K-35528 P-2                |
| 3                   | 216 ohms          | K-35528 P-3                |
| 4                   | 192.5 ohms        | E-35528 P-4                |
| 5                   | 171.6 ohms        | E-35528 P-5                |
| 6                   | 152.9 ohms        | E-35528 P-6                |
| 7                   | 136.3 ohms        | K-35528 P-7                |
| 8                   | 121.4 ohms        | K-35528 P-8                |
| 9                   | 108.2 ohms        | K-35528 P-9                |
| 10                  | 95.5 ohms         | K-35528 P-10               |
| 11                  | 86 ohms           | K-35528 P-11               |
| 12                  | 76.5 ohms         | K-35528 P-12               |
| 13                  | 68.3 ohms         | E-35528 P-13               |
| 14                  | 60.8 ohms         | K-35528 P-14               |
| 15                  | 54.3 ohms         | K-35528 P-15               |
| 16                  | 48.4 ohms         | K-35528 P-16               |
| 17                  | 43.1 ohms         | K-35528 P-17               |
| 18                  | 38.4 ohms         | K-35528 P-18               |
| 19                  | 34.2 ohms         | K-35528 P-19               |
| 20                  | 30.5 ohms         | K-35528 P-20               |
| 21                  | 250.1 ohms        | K-35528 P-21               |
| 22                  | 1024 ohms         | K-35528 P-22               |
| 23                  | 360 ohms          | K-35528 P-23               |
| 24                  | 178.6 ohms        | K-35528 P-24               |
| 25                  | 106.3 ohms        | K-35528 P-25               |
| 26                  | 70 ohms           | K-35528 P-26               |
| 27                  | 49.4 ohms         | K-35528 P-27               |
| 28                  | 35.5 ohms         | K-35528 P-28               |
| 29                  | 27.9 ohms         | K-35528 P-29               |
| 30                  | 21.9 ohms         | K-35528 P-30               |
| 31                  | 17.6 ohms         | K-35528 P-31               |
| 32                  | 14.3 ohms         | E-35528 P-32               |
| 33                  | 11.7 ohms         | K-35528 P-33               |
| 34                  | 9.8 ohms          | K-35528 P-34               |
| 35                  | 8.26 ohms         | K-35528 P-35               |
| 36                  | 7.0 ohms          | K-35528 P-36               |
| 37                  | 5.95 ohms         | K-35528 P-37               |
| 38                  | 5.13 ohms         | K-35528 P-38               |
| 39                  | 4.4 ohms          | K-35528 P-39               |
| 40                  | 31.6 ohms         | E-35528 P-40               |

\*For MI-3116 only

\*\*For MI-3116-A

## \*DETAILED PARTS LIST OF MIXING CONTROL R-15

| <u>Resistor No.</u> | <u>Resistance</u> | <u>Reference D'w'g No.</u> |
|---------------------|-------------------|----------------------------|
| 1                   | 500 ohms          | K-35532 P-1                |
| 2                   | 484 ohms          | K-35532 P-2                |
| 3                   | 432 ohms          | K-35532 P-3                |
| 4                   | 385 ohms          | K-35532 P-4                |
| 5                   | 343 ohms          | K-35532 P-5                |
| 6                   | 305.3 ohms        | K-35532 P-6                |
| 7                   | 272.6 ohms        | K-35532 P-7                |
| 8                   | 242.9 ohms        | K-35532 P-8                |
| 9                   | 216.5 ohms        | K-35532 P-9                |
| 10                  | 193 ohms          | K-35532 P-10               |
| 11                  | 172 ohms          | K-35532 P-11               |
| 12                  | 153.3 ohms        | K-35532 P-12               |
| 13                  | 136.6 ohms        | K-35532 P-13               |
| 14                  | 121.8 ohms        | K-35532 P-14               |
| 15                  | 108.5 ohms        | K-35532 P-15               |
| 16                  | 96.7 ohms         | K-35532 P-16               |
| 17                  | 86.2 ohms         | K-35532 P-17               |
| 18                  | 76.8 ohms         | K-35532 P-18               |
| 19                  | 68.5 ohms         | K-35532 P-19               |
| 20                  | 61 ohms           | K-35532 P-20               |
| 21                  | 500.1 ohms        | K-35532 P-21               |
| 22                  | 2162 ohms         | K-35532 P-22               |
| 23                  | 712 ohms          | K-35532 P-23               |
| 24                  | 357.3 ohms        | K-35532 P-24               |
| 25                  | 212.5 ohms        | K-35532 P-25               |
| 26                  | 140 ohms          | K-35532 P-26               |
| 27                  | 98.8 ohms         | K-35532 P-27               |
| 28                  | 72.9 ohms         | K-35532 P-28               |
| 29                  | 55.8 ohms         | K-35532 P-29               |
| 30                  | 43.7 ohms         | K-35532 P-30               |
| 31                  | 35.1 ohms         | K-35532 P-31               |
| 32                  | 28.5 ohms         | K-35532 P-32               |
| 33                  | 23.5 ohms         | K-35532 P-33               |
| 34                  | 19.5 ohms         | K-35532 P-34               |
| 35                  | 16.5 ohms         | K-35532 P-35               |
| 36                  | 14 ohms           | K-35532 P-36               |
| 37                  | 11.9 ohms         | K-35532 P-37               |
| 38                  | 10.25 ohms        | K-35532 P-38               |
| 39                  | 8.8 ohms          | K-35532 P-39               |
| 40                  | 63.2 ohms         | K-35532 P-40               |

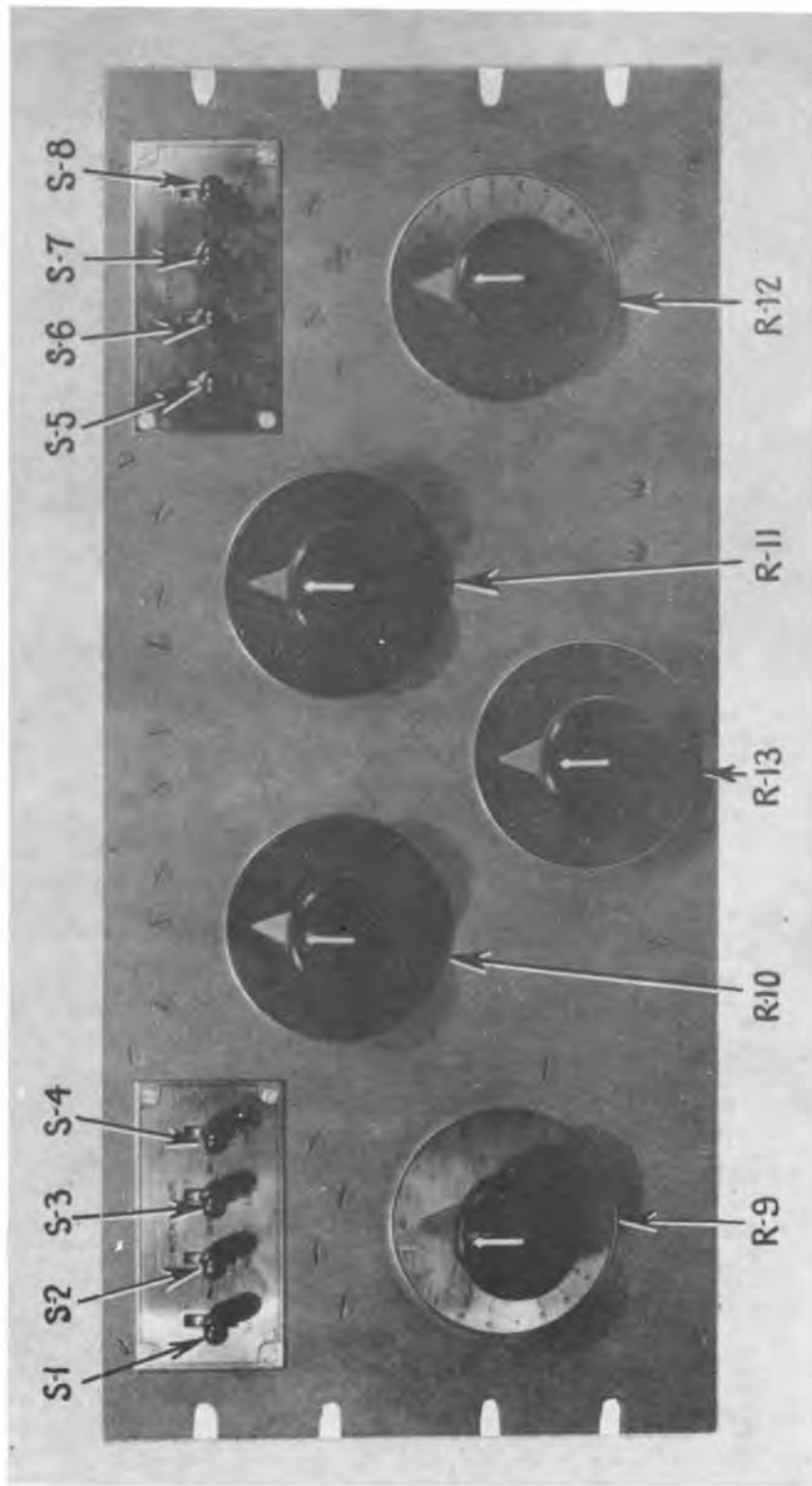

Figure 1 - MI-3116 MIXER - Location of Controls

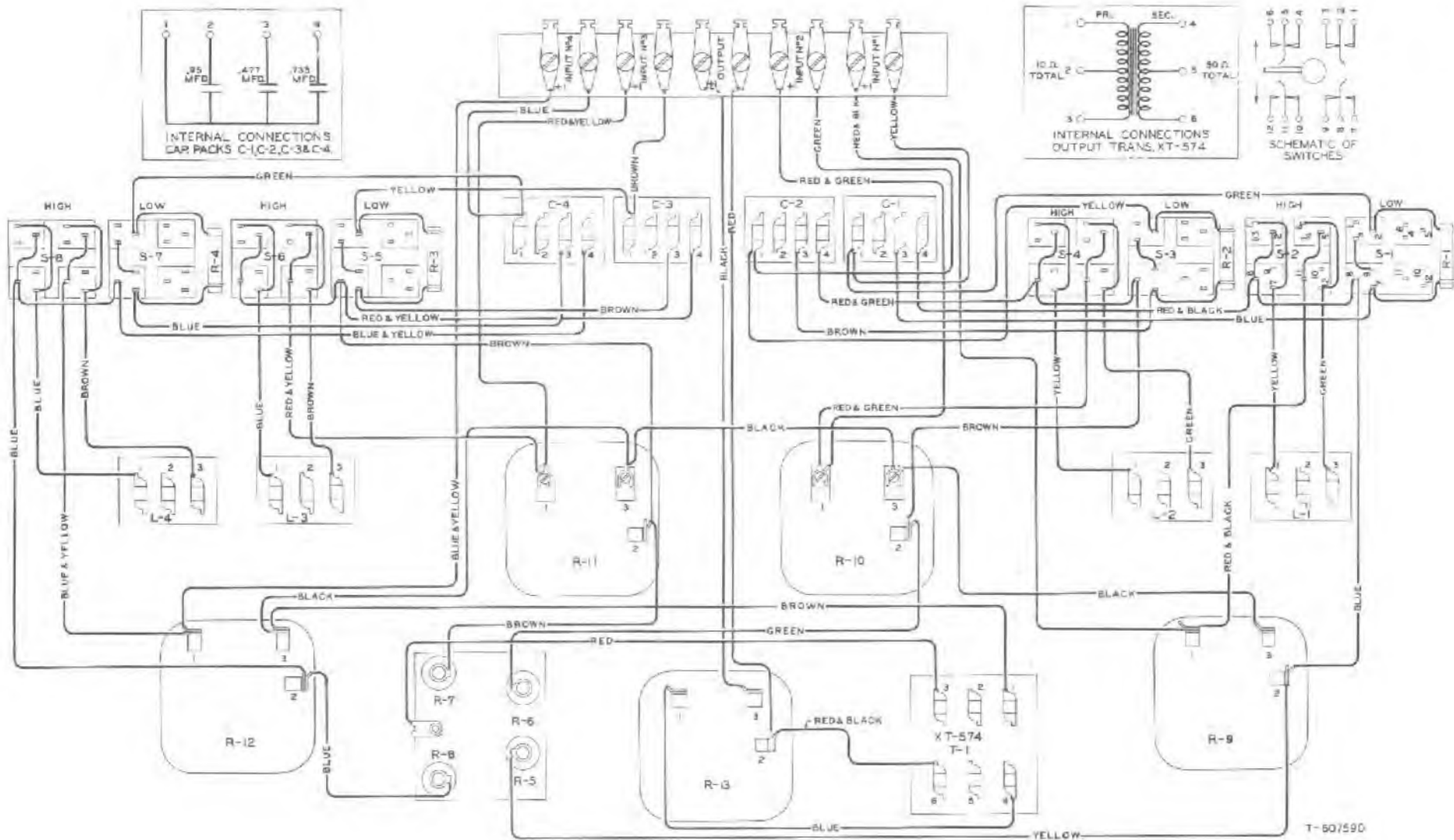
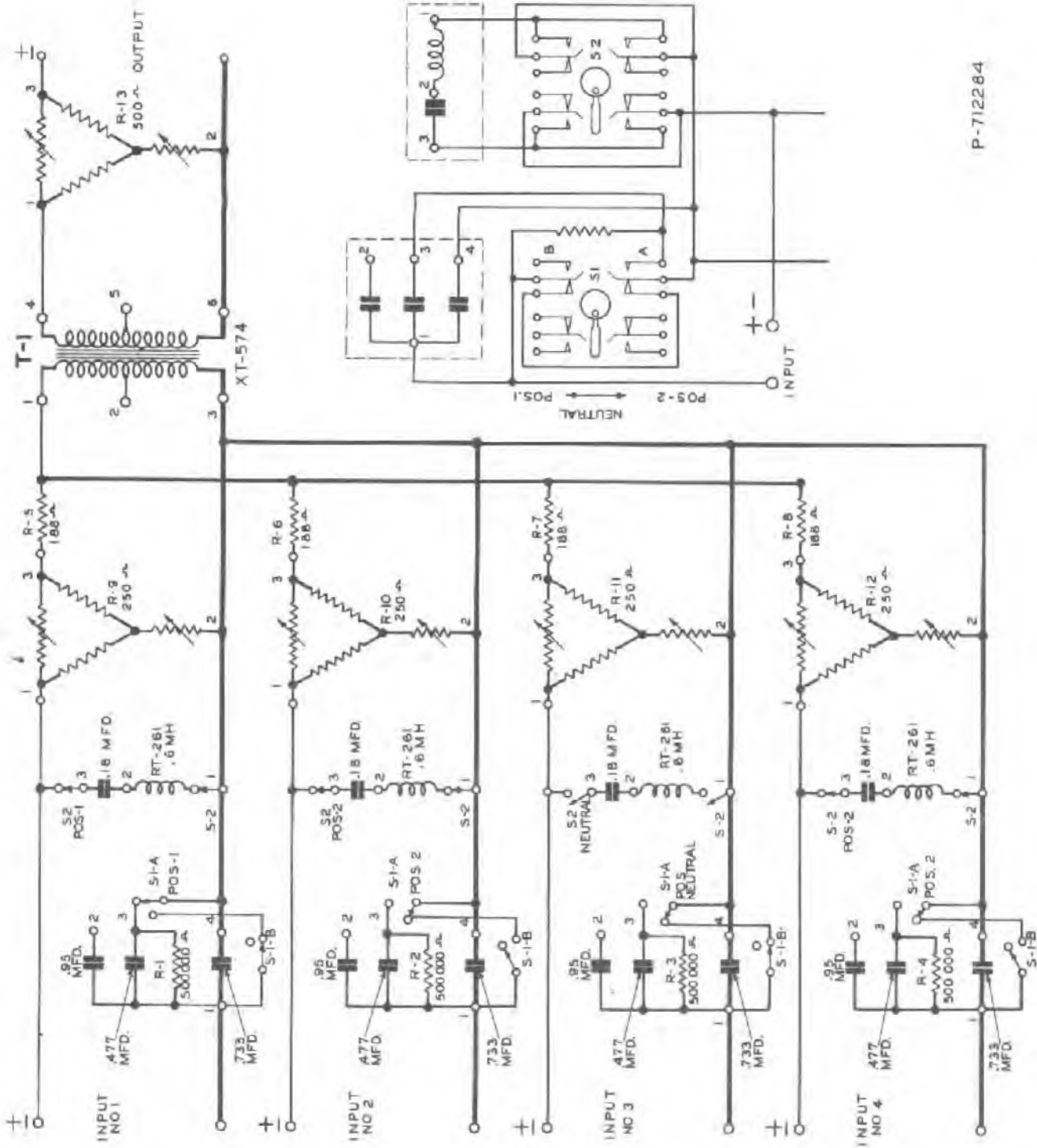

Figure 2 - Wiring Diagram - MI-3116



P-712284

Figure 3 - Schematic Circuit Diagram - MI-3116



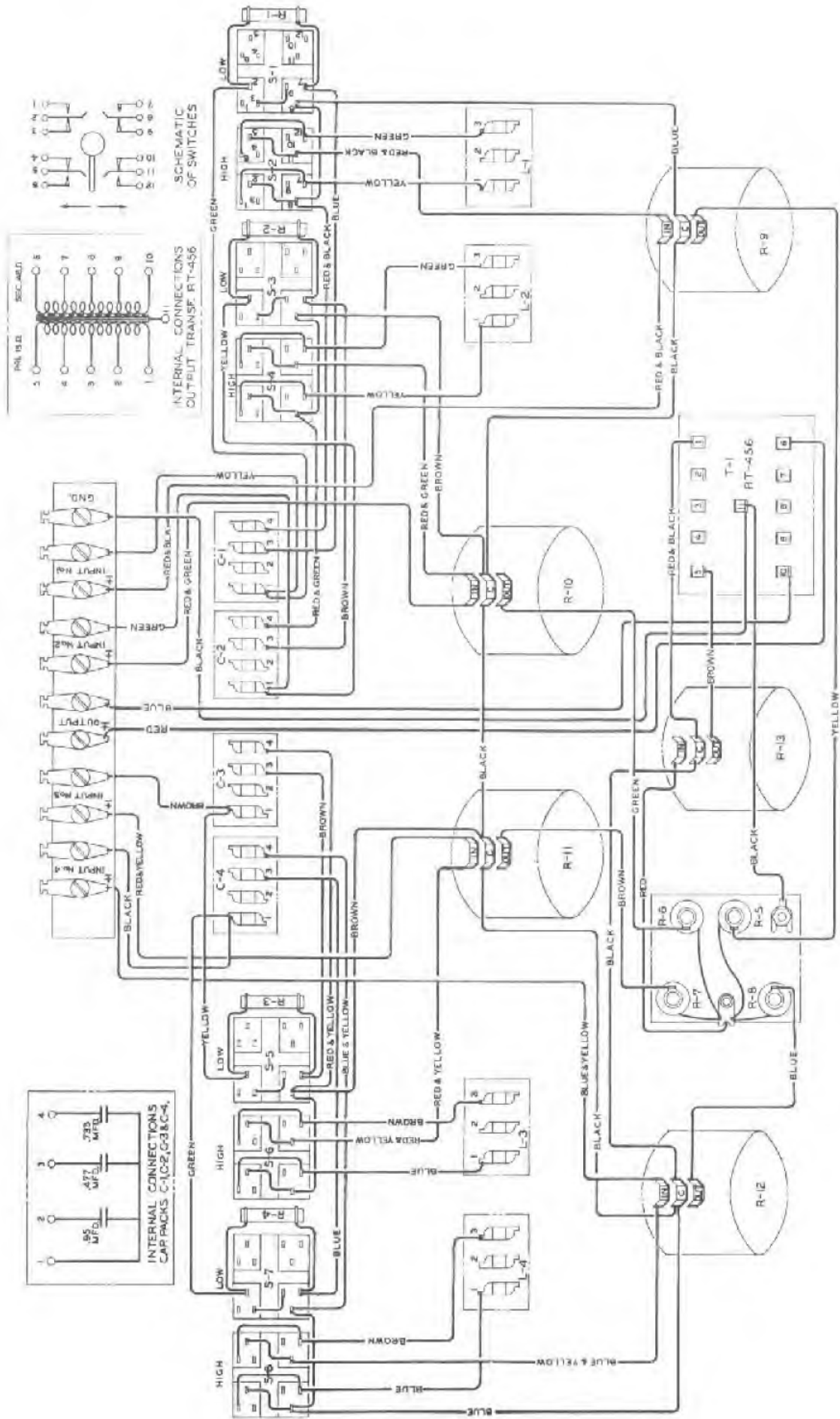

T-ED7601

Figure 4 - Wiring Diagram - MI-3116-A



Addenda Sheet

MI - 3116

MI - 3116A

Photophone Recording Instructions, Instruction Book 23895, mention characteristic curves for the MI-3116 and MI-3116A microphone mixers. These curves were omitted from IB-23895 and are now supplied herewith.

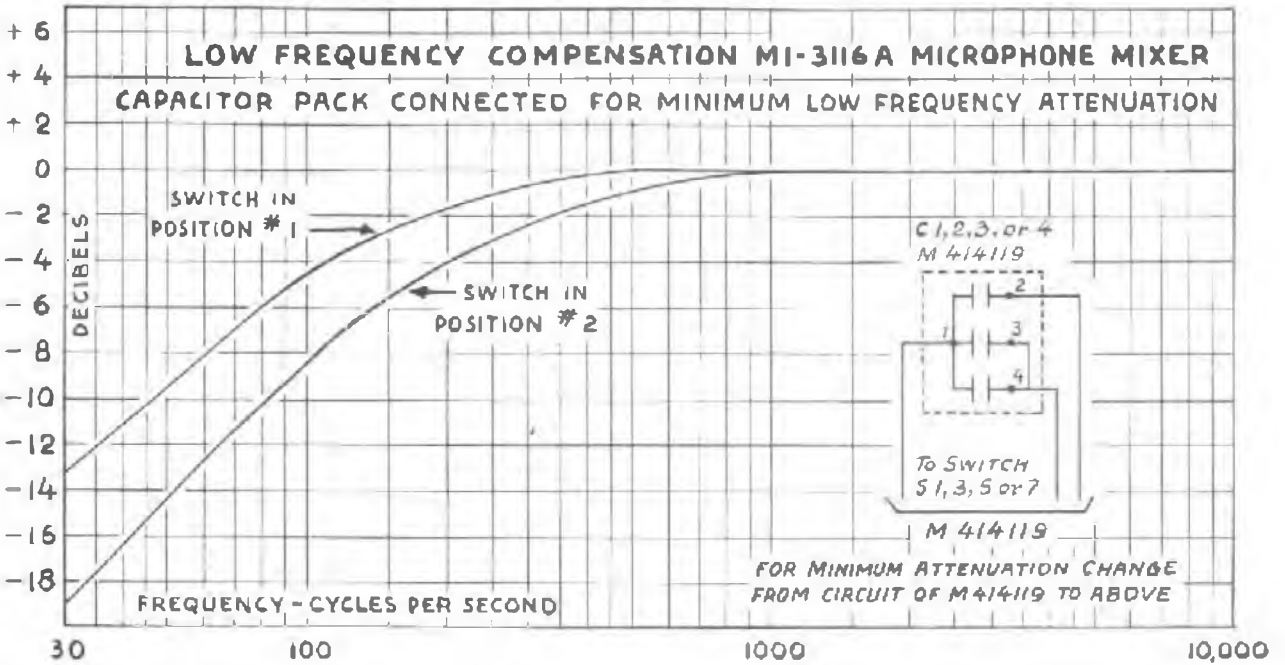

3-P-30 - Minimum Low Frequency Compensation - MI-3116A

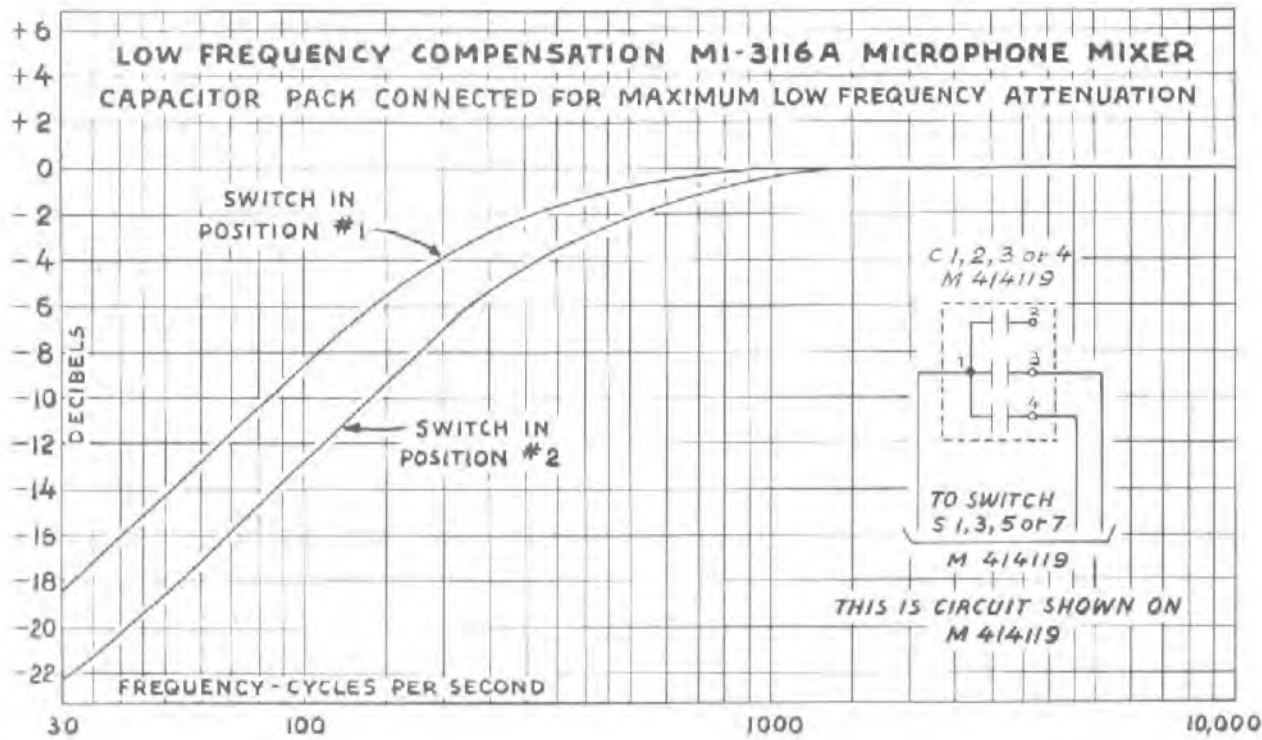

P-30-A - Maximum Low Frequency Compensation - MI-3116A

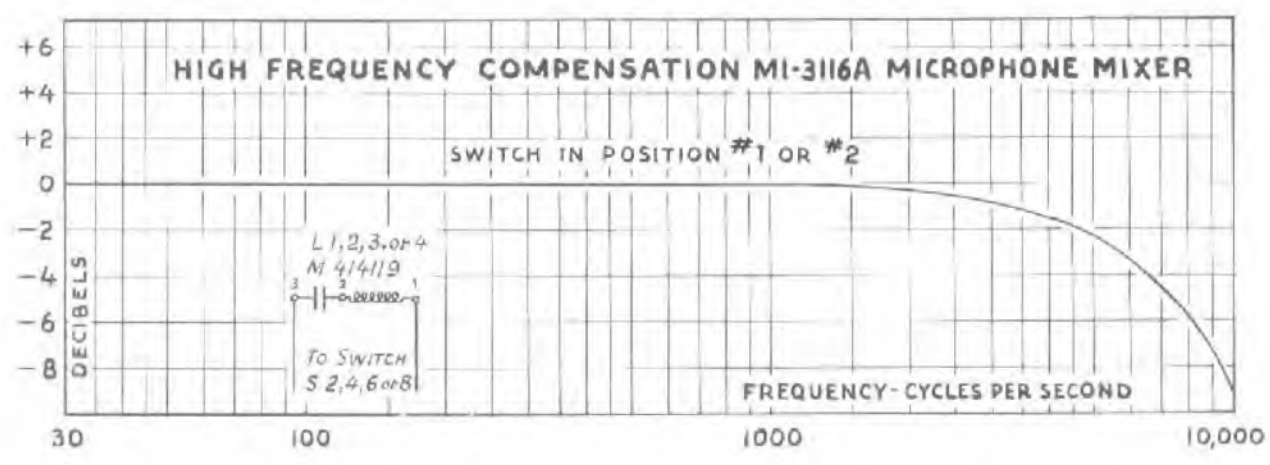

P-31 - High Frequency Compensation - MI-3116A

MI-3120

# COMBINING NETWORK

---

## RCA PHOTOPHONE RECORDING INSTRUCTIONS

---

IB-25864

First Edition  
Copyright 1937  
RCA Mfg. Co., Inc.

Photophone Division  
RCA Manufacturing Co., Inc.  
Camden, N. J., U. S. A.

A Service of the Radio Corporation of America





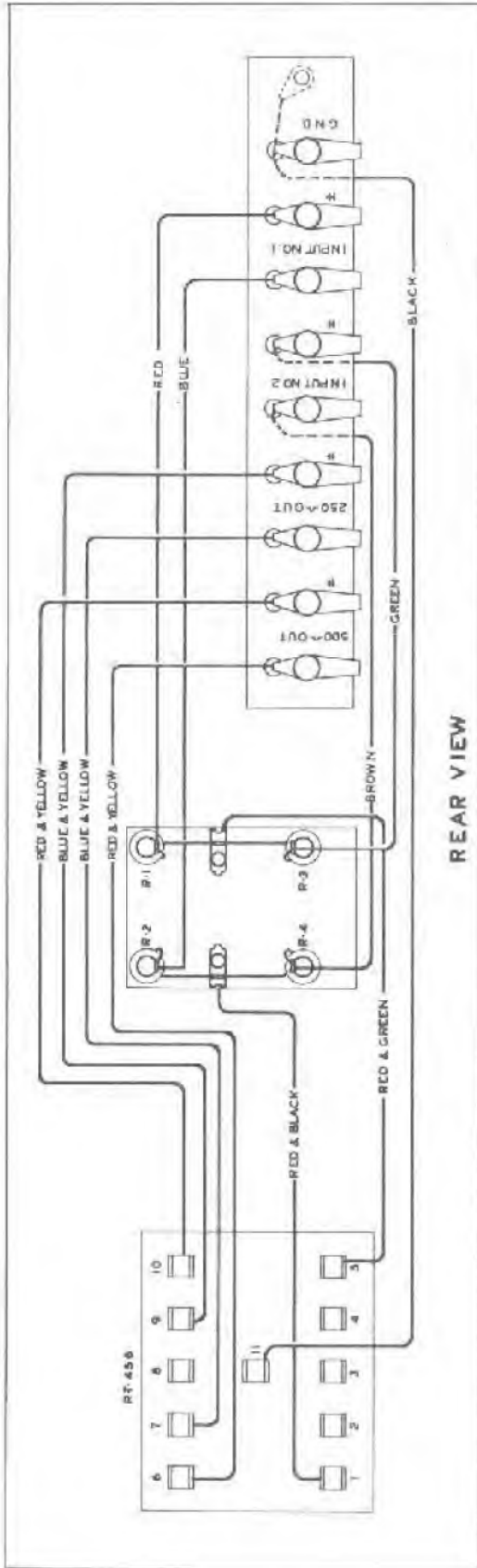

WIRING DIAGRAM

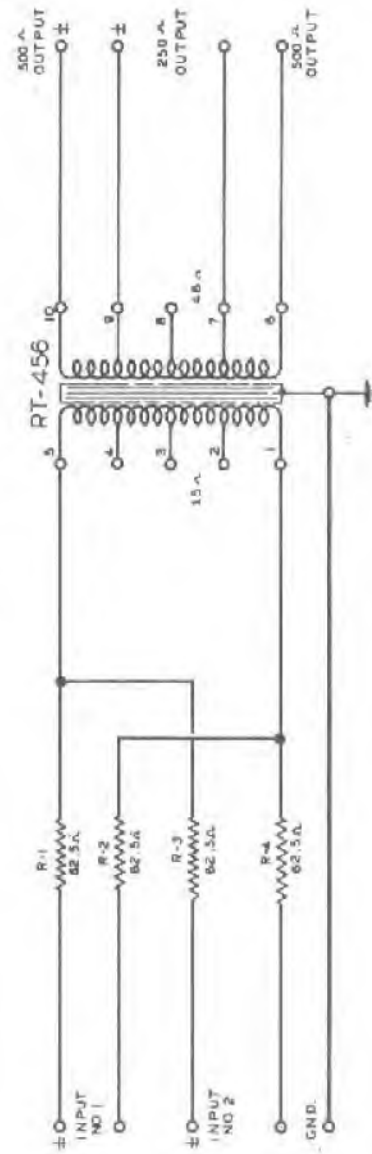

T-60759I

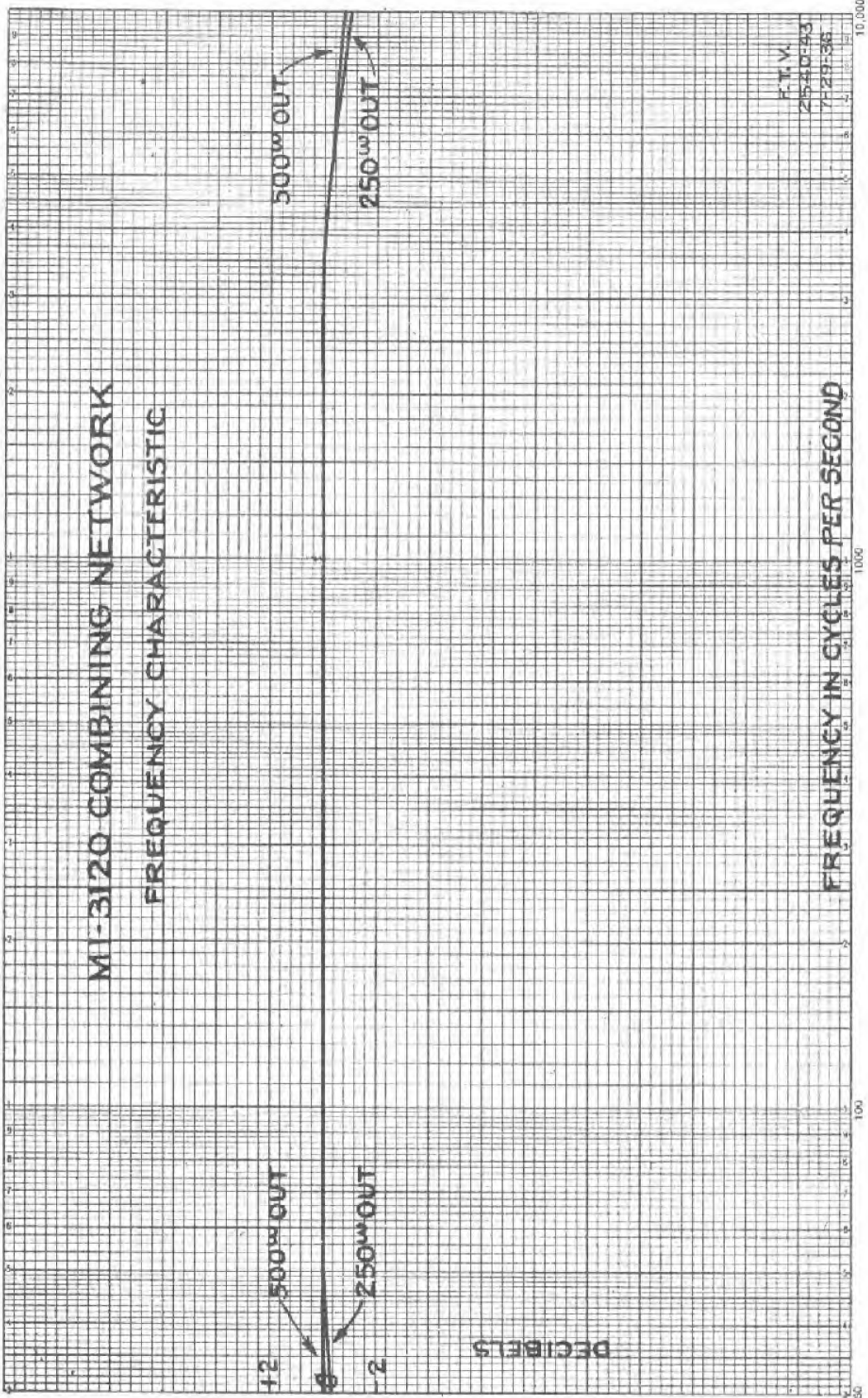

**S-822879**

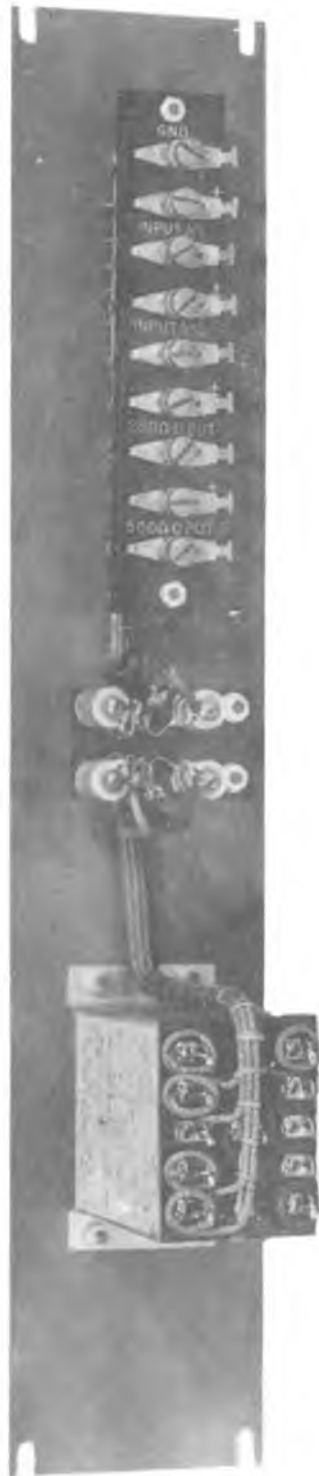

43061

SECTION IV  
Amplifier Data

Master Reference Book  
Disc Recording



**RCA PHOTOPHONE  
BRIDGING AMPLIFIER**

**TYPE PA-109**

(MI-3223 - 110-Volt)  
(MI-3223-A - 110/220-Volt)

---

**INSTRUCTIONS**

---

[Second Edition]

**RCA VICTOR DIVISION  
RCA MANUFACTURING COMPANY, INC.  
CAMDEN, N. J.,**

**AN RCA SERVICE**

# ERRATUM

IB-23837 MI-3223 and MI-3223-A BRIDGING AMPLIFIER

Refer to parts list on Page 7. R-12 and R-13 change Reference Drawing Number from K-817616-P1 to K-817616-P6. Note this is a tapped resistor.

## DATA SHEET

### RADIOTRONS

|           |                      |
|-----------|----------------------|
| 1st stage | 1 RCA-37             |
| 2nd stage | 1 RCA-37             |
| 3rd stage | 2 RCA-45 (push-pull) |
| Rectifier | 1 RCA-80             |

### Pilot Lamp

1 Mazda No. 40 6 volt, 0.15 amp.,  
Cat. #3030

### Fuses

1 W.E. non-alarm type, Code 24-B  
 $\frac{1}{2}$ -ampere

1 W.E. non-alarm type, Code 24-B  
2-ampere (for 110-120 volt  
operation) or,

1 W.E. non-alarm type, Code 24-B  
1-ampere (220-230 volt operation,  
MI-3223-A only)

### Power Supply

|               |                |
|---------------|----------------|
| For MI-3223:  | For MI-3223-A: |
| 110-120 volt, | 110-120 or     |
| 50-60 cycle,  | 220-230 volt,  |
| single-phase  | 50-60 cycle,   |
| 85 watts      | single-phase,  |
|               | 85 watts       |

### Source Impedance

0-30,000 ohm

### Input Impedance

30,000 ohms

### Output Impedance

250 or 500 ohms

### Load Impedance

250 or 500 ohms

### Overall Gain

38 db.

### Undistorted Power Output

2 watts

### Field Supply

100 volts, 100 milliamperes

### Plate Supply

275 volts for Type PS-132 Neon Volume  
Indicator

# RCA PHOTOPHONE BRIDGING AMPLIFIER

TYPE PA-109  
(MI-3223 - 110-Volt)  
(MI-3223-A - 110/220-Volt)

DATA SHEET

RADIOTRONS

|           |                      |
|-----------|----------------------|
| 1st stage | 1 RCA-37             |
| 2nd stage | 1 RCA-37             |
| 3rd stage | 2 RCA-45 (push-pull) |
| Rectifier | 1 RCA-60             |

Pilot Lamp

1 Mazda No. 40 8 volts, 0.15 amp.,  
Cat. #3030

FUSES

1 W.E. non-alarm type, Code 24-B  
½-ampere

1 W.E. non-alarm type, Code 24-B  
2-ampere (for 110-120 volt  
operation) or,

1 W.E. non-alarm type, Code 24-B  
1-ampere (220-230 volt operation,  
MI-3223-A only)

Power Supply

|               |                |
|---------------|----------------|
| For MI-3223:  | For MI-3223-A: |
| 110-120 volt, | 110-120 or     |
| 50-60 cycle,  | 220-230 volt,  |
| single-phase  | 50-60 cycle,   |
| 66 watts      | single-phase,  |
|               | 66 watts       |

Source Impedance

0-30,000 ohm

Input Impedance

30,000 ohms

Output Impedance

250 or 500 ohms

Load Impedance

250 or 500 ohms

Overall Gain

38 db.

Undistorted Power Output

2 watts

Field Supply

100 volts, 100 milliamperes

Plate Supply

275 volts for Type PB-132 Neon Volume

DATA SHEET (CONT'D)

Main Volume Control

2 db attenuation steps above setting  
No. 5

4 db attenuation between setting No. 5  
and No. 4

5 db attenuation between setting No. 4  
and No. 3

3 db attenuation between setting No. 3  
and No. 2

12 db attenuation between setting No. 2  
and No. 1

Infinite attenuation between setting  
No. 1 and 0

Panel Dimensions

19" wide x 10 $\frac{1}{2}$ " high x 9 $\frac{1}{4}$ " deep

Weight

78 lbs. unpacked, including tubes

# RCA PHOTOPHONE BRIDGING AMPLIFIER

TYPE PA-109  
(MI-3223-B - 110/220-Volt)

## ADDENDA SHEET (IB-23837-A)

1. DESCRIPTION OF MI-3223-B BRIDGING AMPLIFIER - The MI-3223-B Bridging Amplifier is identical with the MI-3223-A Bridging Amplifier described in the Instructions IB-23837 with the exception that a hum balancing potentiometer of 20 ohm resistance is connected across the filament winding of each output tube (one across terminals 10 and 12 and one across terminals 13 and 15 of the power transformer, T-4) and the cathode return circuit for each of these tubes is made through the arm of its respective potentiometer instead of through the filament winding center taps (terminals 11 and 14, respectively, of the power transformer, T-4).

2. HUM ADJUSTMENT OF MI-3223-B BRIDGING AMPLIFIER - The hum content of the MI-3223-B amplifier is approximately 53 db. below zero level (12.5 mw). The predominant hum is at 60 cycles, the harmonics of this frequency being much lower. For this reason, the adjustment of the hum potentiometers by means of a pair of headphones connected across the output of the MI-3223-B amplifier is difficult if not impossible. The accuracy of the adjustment will depend, of course, upon the conditions of operation of the unit. When used in the ordinary manner as a monitoring amplifier to drive directly a monitoring loudspeaker, it is only necessary to turn the volume control to its "0" position and to adjust the hum potentiometers to give the minimum hum as heard from the loudspeaker. When more accurate adjustment is required, the procedure should be as follows:

- (a) Set up and connect the necessary power supply to the MI-3223-B Bridging Amplifier and to another amplifier (such as the Type PA-108 Recording Amplifier) having sufficient amplification to drive the hum voltage within the range of a conveniently available low range voltmeter. (Note: - The amplification of the Type PA-108 Recording Amplifier is sufficient to provide a satisfactory reading on any 1000 ohm per volt voltmeter on which a fairly accurate reading of about 10 volts or less can be taken.)
- (b) Connect the 500-ohm output terminals of the MI-3223-B Bridging Amplifier to the 500-ohm input terminals of the Type PA-108 Recording Amplifier.
- (c) Connect an A.C. meter across the output of the Type PA-108 Recording Amplifier.



- (d) Turn the volume control of the Type PA-109 Bridging Amplifier to its "0" position.
- (e) Adjust the volume control of the Type PA-103 Recording Amplifier so as to obtain a reading of the output meter that is sufficiently high on the meter scale to be easily readable and to indicate readily comparatively small changes in value.
- (f) Turn the hum control potentiometers, one at a time, through their ranges and set each at the point at which the smallest reading of the output meter is obtained.

3. FREQUENCY RESPONSE MEASUREMENTS OF TYPE PA-109 AMPLIFIERS - It should be noted that the test circuit shown in Figure 1, Page 6 of Instructions IR-23337 for the Model PA-105A1 Bridging Amplifier (MI-3223) and the MI-3223-A Bridging Amplifier will result in the taking of a response curve under conditions equivalent to the operation of the amplifier from a source of zero impedance. To obtain a curve the equivalent of operation from a source of known impedance, insert in this test circuit two resistors, each of one-half the source impedance, one in series with each side of the amplifier input line and between the input voltmeter and the amplifier. The response curve shown in Figure 7 was taken under the equivalent condition of zero source impedance i.e., using the circuit shown in Figure 1. Over the range of source impedance from 0 to 30,000 ohms, the response will not vary more than about 1 db. at 30 cycles and 10,000 cycles. (The amplifier is normally operated from source impedances of 250 to 1,000 ohms.)

4. REPLACEMENT PARTS - The hum potentiometers used in the MI-3223-B Bridging Amplifier may be ordered, if replacement should become necessary, as follows:-

| <u>Item</u> | <u>Description</u>      | <u>Ref. Drawing No.</u> |
|-------------|-------------------------|-------------------------|
| R-24        | Potentiometer - 20 ohms | K-832602 P-2            |
| R-25        | Potentiometer - 20 ohms | K-832602 P-2            |

# RCA PHOTOPHONE BRIDGING AMPLIFIER

## TYPE PA-109

### PART I - DESCRIPTION

1. GENERAL - One of the primary uses of the Type PA-109 bridging amplifier is for monitoring. When used for this purpose, in conjunction with a loudspeaker placed in the booth, the recordist is able to check aurally the results of his manipulations of the mixing controls and speech compensator panel so that the recording when properly reproduced in the theatre, will be a true reflection of the impressions, moods, and ideas which the director and recordist desire to create. The Type PA-109 amplifier may also be used for bridging purposes such as is required when two or more film or wax recorders are to be operated from the 500-ohm output or the intermediate output of the recording amplifier. Its use for either purpose requires that it be of the highest quality and properly operated.

2. ELECTRICAL CIRCUITS - The Type PA-109 amplifier is a small, compactly built unit completely operable from any single-phase, 50-60 cycle power supply of the proper voltage rating. The amplifiers of the earlier production, designated as MI-3223, were designed for operation only from a nominal line voltage of 110; but the later production, designated as MI-3223-A, were designed for operation from a nominal line voltage of either 110 or 220. The latter model is wired, when shipped, for operation from a 220-volt line, the transfer of a single wire from one transformer tap to another being all that is necessary to change the unit from one voltage rating to the other.

The input transformer is designed to operate from the intermediate output provided on the recording amplifier or for bridging any 500 ohm bus.

The first audio stage employs an RCA-37 Radiotron resistance-capacitance coupled to the second stage which also utilizes an RCA-37 Radiotron. The output of this second stage is resistance-capacitance coupled to a push-pull transformer which furnishes audio voltage to the grids of two RCA-45 Radiotrons. A calibrated volume control is supplied in the grid circuit of the first RCA-37 Radiotron providing a two db. change in attenuation for each step above No. 5. Below setting No. 5 the attenuation increases rapidly so as to give 60 db. attenuation in No. 1 position. The position corresponding to zero setting of the indicator provides infinite attenuation. (See data sheet for values of attenuation per step).

The output transformer of the amplifier has provision made for either 500-ohm or 250-ohm matching. The frequency response characteristic

is flat, being within  $\pm 0.5$  db. from 30 to 10,000 cycles.

The three stages of amplification employed in the Type PA-109 bridging amplifier provide a total amplification of 33 db. The amplifier plate supply circuit, utilizing an RCA-80 Radiotron, furnishes 100 milliamperes DC at 100 volts for one loudspeaker field supply, if required. When no external speaker field is required, a reactor included in the power equipment of the amplifier may be connected in the plate circuit by proper placement of the fuse provided for this purpose in the tube compartment.

The meter and cord supplied with the recording amplifier may be used for checking the operation of the tubes. Provision is made for metering the plate current of all tubes and the plate supply voltage. The circuits employed with these metering facilities use open-circuit jacks so that no amplifier circuits are made or broken during the metering process. Reference to Figures 8 and 9 will show that the metering is actually the measurement of voltage drop across appropriate resistors.

An interstage output is provided by a tertiary winding on the secondary of the push-pull input transformer to provide a means of supplying a uniform input over the audio frequency range to the noise reduction amplifier, neon volume indicator and monitoring system when the Type PA-109 amplifier is used as a bridging unit. If necessary, as many as six bridging loads of 30,000 ohms each may be operated from this output. A total load of less than 5,000 ohms should not be used and the capacity of the various connections to these bridging loads should be kept below 0.0045 mfd. This capacity is approximately equivalent to 100 feet of twin lead cable or 100 feet of E-conductor shielded microphone cable.

3. CONSTRUCTION - The amplifier is so constructed that it may be readily serviced while it is still connected and in position. It is no longer necessary for the operator to unsolder numerous wires and remove a number of screws in order to place the panel in a suitable position for service or inspection. The entire front panel is hinged on the side to permit its swinging open toward the front. This is easily accomplished by the loosening of two thumb-screws on the left of the panel which permits the unit to be rotated, out of its stationary metal container, through approximately  $180^\circ$ . The entire amplifier assembly is mounted on the back of the front panel with each part easily accessible.

Connections between the amplifier and the terminal strips on the inside of the stationary metal container are made with flexible cables as is clearly shown in the photographs. A loop of sufficient size is provided to permit the panel to swing fully open without allowing any strain to come on the connectors.

The external connections to the unit are made directly to the stationary terminal strips through openings in the walls of the metal housing. A schematic wiring diagram is glued to the rear of the shield

can and all components are numbered, corresponding to the numbers and values on the diagram.

#### PART II - INSTALLATION

4. MOUNTING - The Type PA-109 amplifier is designed for mounting in a standard 19" relay rack; however, any equivalent structure may be used that will provide rigid support for the panel. It is important that the panel be firmly supported in position before attempting to open the unit on its hinges.

5. LOCATION OF FUSES - After mounting the amplifier in a suitable rack, remove the cover plate from the tube compartment and place the power supply fuses in their holders. In the MI-3223 or MI-3223-A amplifier, a W. E. 2-ampere fuse (non-alarm type, Code 24-B) should be inserted between the right center terminal and the right upper terminal (engraved "110" or "LOW") for 110-volt operation or between the right center terminal and the right lower terminal (engraved "120" or "HIGH") for 120-volt operation. Never put a fuse in each position at the same time as this will short circuit a portion of the transformer primary and burn out one or both fuses. In the MI-3223-A amplifier only, when operated on a power supply of a nominal rating of 220 volts, a W. E. 1-ampere fuse (non-alarm Type, Code 24-B) should be inserted between the "LOW" terminals for 220-volt operation or between the "HIGH" terminals for 230-volt operation.

If no external loudspeaker field is to be energized, a W. E. 1/2-ampere fuse (non-alarm Type, Code 24-B) should be connected between the left center terminal and the left upper terminal. The word "REACTOR" is marked between these terminals and indicates that when the fuse is in this position, a substitute reactor is included in the circuit.

If a loudspeaker field is to be fed from the amplifier this fuse should be connected between the left center terminal and the left lower terminal. The word "SPEAKER" is marked between these terminals and indicates that with the fuse in this position an external speaker field must be connected.

6. RADIOTRONS - After putting the fuses in their proper places, insert the Radiotrons in their respective sockets as called for by the markings adjacent to each tube location. For best results the two RCA-45 Radiotrons in the output stage should be chosen such that their plate currents are approximately the same value. Screw the Mazda No. 40 pilot lamp in its socket behind the red bezel and replace the cover of the tube compartment.

7. ELECTRICAL CONNECTIONS - Loosen the thumb nuts on the left side of the panel and swing the amplifier open on its hinges. When the unit is used to supply plate voltage to the Type PE-132 Neon Volume Indicator, care should be taken to inspect the terminal board mounted on the back of the swinging panel to ascertain if the 12,000 ohm bleeder resistance lead is removed from the terminal marked "+ B SUPPLY" and connected to the terminal

marked "+ SPEAKER FIELD". This removes the bleeder from the circuit. If the amplifier is not used to supply plate voltage for the Type PB-132 Neon Volume Indicator, the bleeder resistance lead should be connected to the terminal marked "+ B SUPPLY". This lead is easily located as it is the only lead with a spade terminal going to the terminal board.

The MI-3223-A amplifier is wired, when shipped, for operation from a power supply of 220-230 volts. This is done as a safety precaution. If the amplifier is to be operated from a power supply of 110-120 volts, unsolder the black lead, having a red tracer, connected to terminal "C" of the power transformer, T-4, and solder this lead to terminal "1" of this transformer. For the location of these terminals, refer to Figure 11.

No "C" batteries are required as all grid voltages are obtained from the voltage drop across appropriate resistors.

The input connections can be made to the interstage output of the recording amplifier or to a 250 or 500 ohm bridge bus, depending on the particular application.

If the amplifier is used to drive a film recorder, the noise reduction amplifier, neon volume indicator and monitor amplifier should be connected to the interstage output. (See section 2, regarding load). Both 250 and 500 ohm output terminals are provided. When the Type PA-109 amplifier is used to drive a film recorder the recorder input should be connected to the terminals marked "500 OUT". When making all input and output connections be sure to maintain the proper phasing by connecting the "+" terminal of any particular input or output pair to the "+" terminal of the preceding or succeeding unit.

If the amplifier is used to supply plate current to the neon volume indicator, the leads carrying this supply should be connected to the two terminals marked "+" and "-" on each side of the words "E SUPPLY". The leads carrying field supply to the speaker should be connected to the two terminals marked "+" and "-" on each side of the indication "SPKR FLD". It will be noted that one of these terminals is common to both the plate current supply and the speaker field.

Turn "off" the power switch on the front of the panel, connect the 110- or 120-volt AC power supply to the two top terminals marked "AC", and close the amplifier.

#### PART III - OPERATION AND MAINTENANCE

8. CHECKING TUBE OPERATION - After completing all connections outlined in section 7, the amplifier is ready to be turned "on".

Allow a few seconds for the tubes to warm up. Then check the plate currents of each tube and the plate supply voltage, using the meter and cord supplied in the Type PA-108 Recording Amplifier. The approximate



values to be obtained at each test jack are given below in the order in which the jacks are arranged on the panel, from left to right:

| <u>Jack</u> | <u>Reading</u> | <u>Multiplication<br/>Factor</u> | <u>Indication</u> |
|-------------|----------------|----------------------------------|-------------------|
| MA-1-V      | 1.3            | 1                                | 1.3 milliamps.    |
| MA-2-V      | 3.2            | 1                                | 3.2 "             |
| MA-3-V      | *1.5           | 20                               | 30 "              |
| MA-4-V      | *1.5           | 20                               | 30 "              |
| B-V         | 2.9            | 100                              | 290 volts         |

\*These readings should balance within 15%.

The tubes should be checked occasionally with a reliable tube tester.

9. CARE OF VOLUME CONTROL - The volume controls may be taken out for inspection or cleaning by removing only the four screws in the outer corners of the escutcheon plate and carefully pulling the unit straight out so as not to scrape the wire-wound resistors. The controls should be cleaned occasionally by using a small quantity of light, high-grade, machine oil such as camera or watch oil. (CAUTION: - Never use sandpaper or harsh abrasives to clean the contacts as these surfaces have been carefully and accurately lapped at the factory.) Using a toothpick, apply a drop of oil to the surface of several contacts and rotate the arm back and forth until the oil is thoroughly worked in and becomes dirty. Then use a soft cloth and thoroughly wipe off the contacts. Repeat this procedure until the oil ceases to become discolored. When complete, all oil should be thoroughly wiped off with a clean cloth.

#### PART IV - TESTING

10. PHASING - It is important that all inputs and outputs be properly phased. In other words the instantaneous voltage at corresponding input and output terminals should be of the same polarity. For convenience one terminal of each input and output pair is marked "+" to indicate this polarity relation.

All units of RCA recording equipment bear this "+" indication on the input and output terminals so that all equipments can be similarly connected. This system insures consistent results on all similar channels with the same operating technique.

The phasing of this amplifier may be checked by the feedback method and, although the unit has been completely checked and tested at the factory, the following information is supplied as a matter of information to assist in maintenance and repair.

When the phasing is correct, the amplifier will "motorboat" when the "input" terminals are connected across any one of the three "output" pairs with the "+" terminals of the "input" and particular "out-

put" pair connected together. A pair of headphones connected across the "input" terminals will serve to indicate this "motor-boating" sound. If the amplifier is not properly phased, either no sound or a very high frequency whistle will be heard. If the volume controls are set too low, no sound will be heard in either case. At volume control settings above the spill-over point, the frequency of the oscillation will decrease somewhat.

Should these tests indicate the amplifier to be out of phase, it may be corrected by reversing the INTERNAL connections to the input or output terminals, whichever involves the least changing, in order that all outputs are in phase with the input.

11. FREQUENCY RESPONSE - A check on the frequency response and load characteristics will indicate whether the amplifier is properly connected and/or whether it contains any parts that are electrically defective. The frequency response characteristic may be taken under various operating conditions as follows:

A. CONNECTIONS - Connect a calibrated source of audio frequency signal to the amplifier input terminals as indicated in Figure 1. An RCA TMV52E beat frequency oscillator is very desirable for this work.

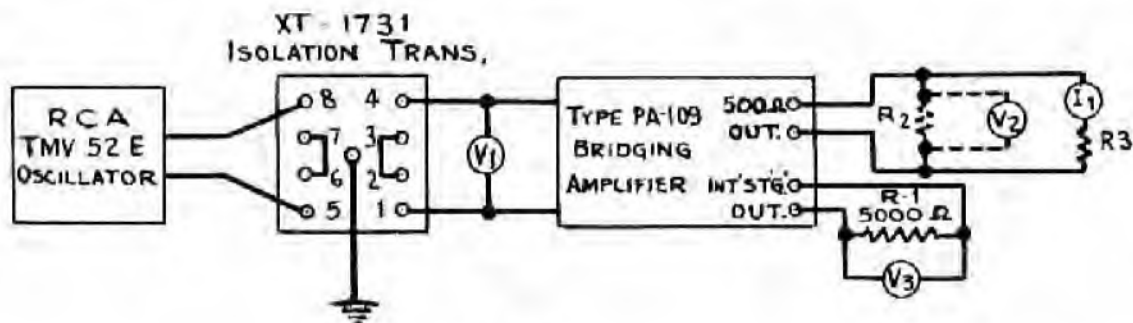

FIGURE 1

Although suitable source impedances for this amplifier are from 0-30,000 ohms, a 500-ohm input loading is usually most convenient.  $V_1$  may be measured with a voltmeter or db. meter connected across the input. Rectox type meters may be used if desired, but care should be taken to use them in pairs. That is, if the input is read with a rectox meter, the output should also be read with a rectox meter. The output may be measured by either a high resistance voltmeter across a 500 ohm load,  $R_2$ , as shown dotted or a milliammeter in series with a load resistor  $R_3$ . Resistor  $R_3$  should be of such a value that its resistance plus the resistance of the meter is 500 ohms. A voltmeter covering the range of 20-50 volts or a milliammeter covering the range of 40 to 100 ma. is satisfactory.

B. FREQUENCY RESPONSE - Curve #1 Full Gain Setting - Intermediate Output Unloaded.

With the volume control set at maximum adjust the input at

1000 cycles until the output reads 20 volts ( $V_2$ ) or 40 ms. ( $I_1$ ) and take output readings for each frequency, keeping the input voltage constant. Figure 7 shows a representative curve obtained under these conditions.

C. FREQUENCY RESPONSE - Curve #2 Full Gain Setting - Intermediate Output loaded with 5000 ohms.

Hold the same output as in Curve #1 and read output on the 500-ohm output and on interstage output for each frequency with constant input voltage. Figure shows a representative curve obtained under this condition. The output of the interstage ( $V_3$ ) may be measured with a vacuum tube voltmeter across the 5000-ohm load or, if a Type 13-C volume indicator panel is available, it may be used for this purpose.

If the 250-ohm output is used, curves should be taken as described for Curve #1 except that the output circuit should be 250 ohms rather than 500 and the meter readings will be altered proportionally.

12. LOAD CURVE - The load characteristic (output voltage against input voltage) should be a straight line up to an output voltage of 32 volts. As with any load curve, it is essential that the metering equipment be very accurate over the range used.

12. REPLACEMENT PARTS - The following parts list is included to provide proper identification when ordering replacement parts. When ordering specify the item as called for in the schematic diagram followed by description and reference drawing as follows:

| <u>Item</u> | <u>Description</u> | <u>Ref. D'w'g No.</u>     |
|-------------|--------------------|---------------------------|
| R-1         | Volume Control     | 50,000 ohms M-406366 G-1  |
| R-2         | Resistor           | 20,000 ohms K-819789 P-10 |
| R-3         | "                  | 3,500 ohms K-819789 P-7   |
| R-4         | "                  | 50,000 ohms K-819789 P-1  |
| R-5         | "                  | 75,000 ohms K-819789 P-11 |
| R-6         | "                  | 500,000 ohms K-819789 P-3 |
| R-7         | "                  | 20,000 ohms K-819789 P-10 |
| R-8         | "                  | 3,500 ohms K-819789 P-7   |
| R-9         | "                  | 25,000 ohms K-819789 P-12 |
| R-10        | "                  | 500,000 ohms K-819789 P-3 |
| R-11        | "                  | 500,000 ohms K-819789 P-3 |
| R-12        | "                  | 26,000 ohms               |
| R-13        | "                  | 20,000 ohms K-817616 P-1  |
| R-14        | "                  | 13,700 ohms K-819789 P-14 |
| R-15        | "                  | 500,000 ohms K-819789 P-3 |
| R-16        | "                  | 61 ohms K-819789 P-16     |
| R-17        | "                  | 61 ohms K-819789 P-16     |
| R-18        | "                  | 104 ohms K-819789 P-13    |
| R-19        | "                  | 104 ohms K-819789 P-13    |
| R-20        | "                  | 50 ohms K-819789 P-15     |

| <u>Item</u> | <u>Description</u>  | <u>Ref. D'w'g No.</u> |
|-------------|---|-----------------------|
| R-21        | Resistor 50 ohms  | K-819739 F-15         |
| R-22        | " 12,000 ohms   | K-817616 P-2          |
| R-23        | " 25,000 ohms   | K-819789 F-12         |
| C-1         | Capacitor 0.1 mfd. CP-86  | M-64565 G-1           |
| C-2         | " 1 mfd. Term. 13-14  | } CP-135 M-68568 G-1  |
| C-3         | " 3 mfd. Term. 1,7-2,8  |                       |
| C-4         | " 2 mfd. Term. 9,15-10,16   |                       |
| C-5         | " 1 mfd. Term. 17-18  |                       |
| C-6         | " 3 mfd. Term. 5,11-6,12  |                       |
| C-7         | " 2 mfd. Term. 3-4  |                       |
| C-8         | " 3 mfd. Term. 1,5,9,13-2,6,10,14   |                       |
| C-9         | " 3 mfd. Term. 3,7,11,15-4,8,12,16  |                       |
| L-1         | Reactor RT-259, R <sub>11</sub> =1,000 ohms   | M-406230              |
| L-2         | " RT-311, R <sub>1-2</sub> /R <sub>1-3</sub> =<br>245 ohms/250 ohms   | M-406417 G-1          |
| L-3         | " RT-310, R <sub>1-3</sub> =1000 ohms   | M-406405 G-1          |
| S-1         | Fuse, 0.5-ampere (W.E. non-alarm type Code 24-B)  |                       |
| S-2         | Fuse, 2-ampere ( " " " " " " ) or.<br>Fuse, 1-ampere ( " " " " " " )  |                       |
| S-3         | Switch D.P.S.T. power switch  | K-55679 P-1           |
| T-1         | Input Transformer RT-307,<br>R <sub>1-4</sub> /R <sub>5-8</sub> =2000 ohms/2590 ohms                                      | M-403091 G-2          |
| T-2         | Interstage Transformer RT-308,<br>R <sub>3-4</sub> /R <sub>5-8</sub> /R <sub>9-11</sub> =<br>1690 ohms/5070 ohms/255 ohms | M-403026 E-1          |
| T-3         | Output Transformer, RT-309,<br>R <sub>1-4</sub> /R <sub>5-12</sub> =525 ohms/38 ohms                                      | M-403097 G-1          |
| T-4         | Power Transformer RT-313, R <sub>1-2</sub> /R <sub>1-3</sub> /R <sub>2-6</sub> =<br>(Used in MI-3223 only)                | M-406418 G-1          |

| <u>Item</u> | <u>Description</u>   | <u>Ref. D'w'g No.</u> |
|-------------|--|-----------------------|
| T-4         | Power Transformer RT-423, R <sub>0-3</sub> /R <sub>1-3</sub> /R <sub>4-3</sub> /<br>R <sub>7-2</sub> /R <sub>10-12</sub> /R <sub>13-15</sub> /R <sub>16-17</sub> =9.15 ohms/<br>4.165 ohms/0.213 ohms/476 ohms/<br>0.094 ohms/0.083 ohms/0.154 ohms<br>(Used in MI-3223-A, only) | M-406418 G-502        |
| Meter       | As used in recording amplifier<br>for metering purposes, 0-8 volts<br>1000 ohms/volt   | K-35558 P-4           |
| Meter Cord  |  | K-35558 P-5           |
|             | <u>Test Equipment</u>  |                       |
|             | Isolation Transformer  | XT-1731               |
|             | RCA Beat Frequency Oscillator<br>(20-17000 cycles)   | TMV52E                |





FIGURE 2—FRONT VIEW OF MODEL PA109A1 BRIDGING AMPLIFIER (MI-3223)

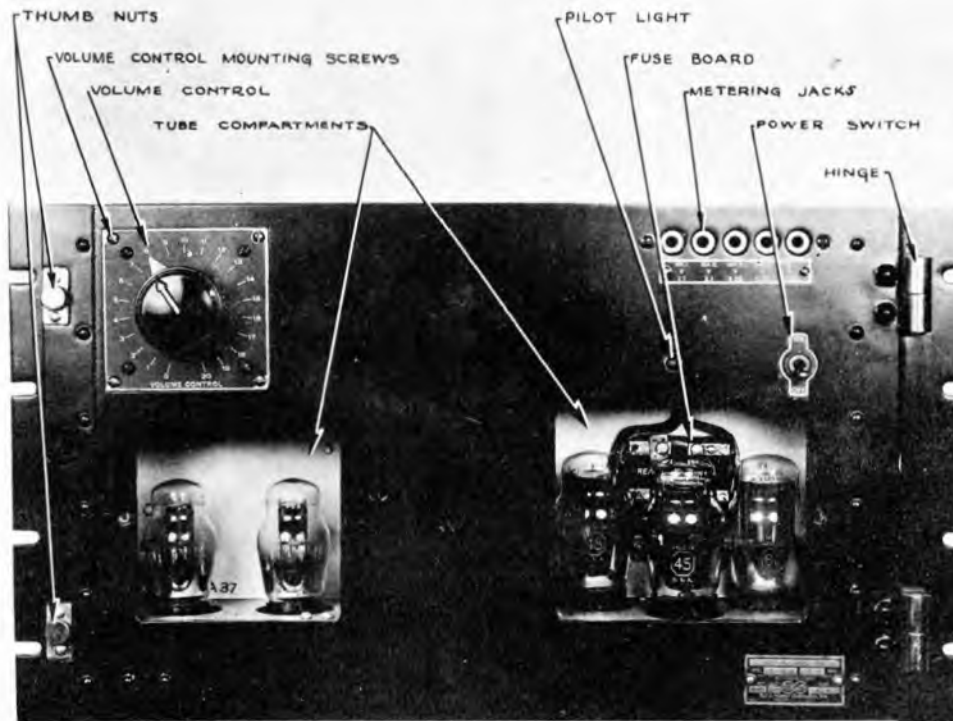

FIGURE 3—FRONT VIEW OF MODEL PA109A1 BRIDGING AMPLIFIER (MI-3223)  
WITH TUBE COMPARTMENT COVER REMOVED

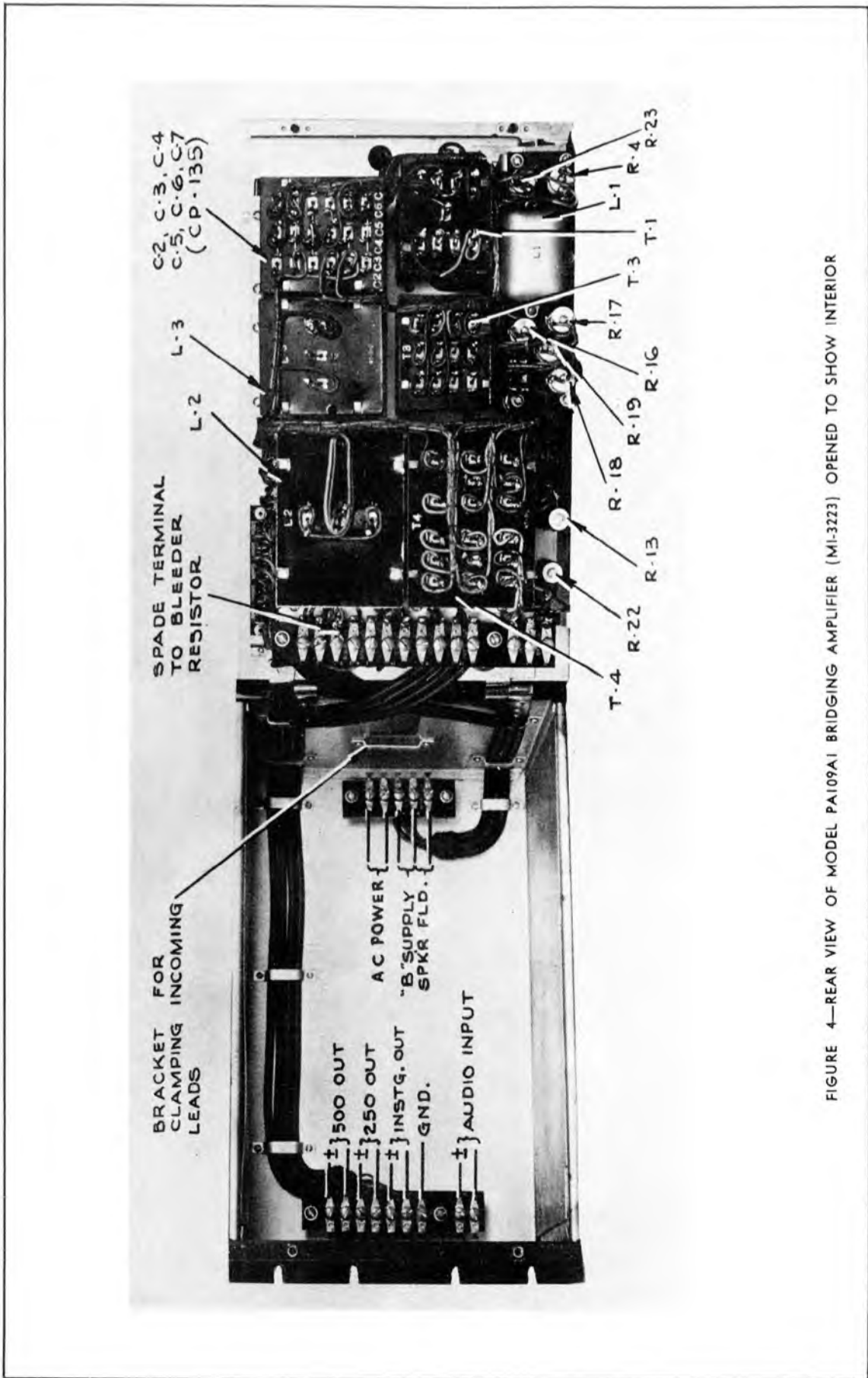

FIGURE 4—REAR VIEW OF MODEL PA109A1 BRIDGING AMPLIFIER (MI-3223) OPENED TO SHOW INTERIOR

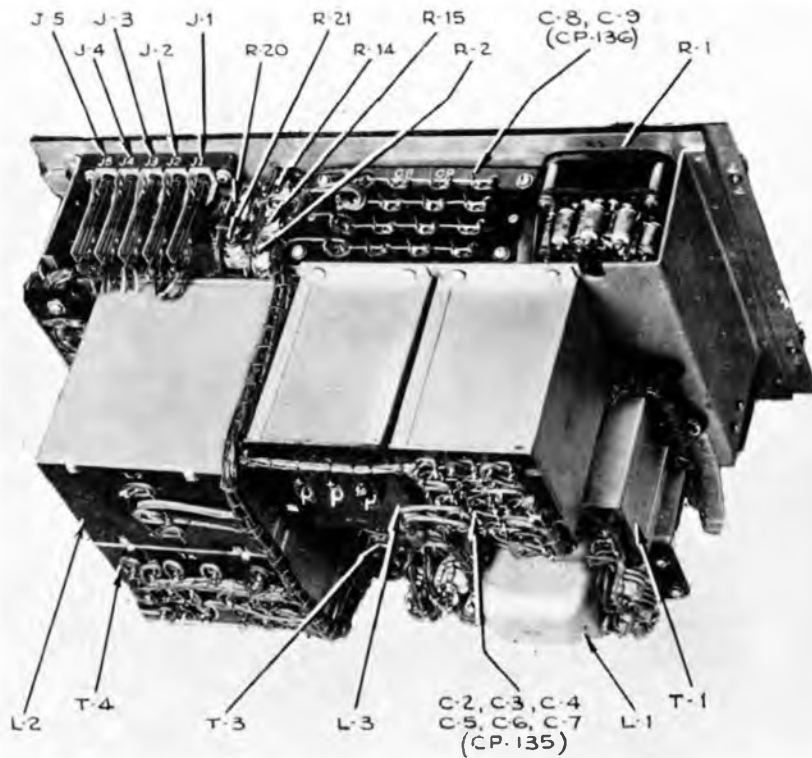

FIGURE 5—TOP VIEW OF MODEL PA109A1 BRIDGING AMPLIFIER (MI-3223)

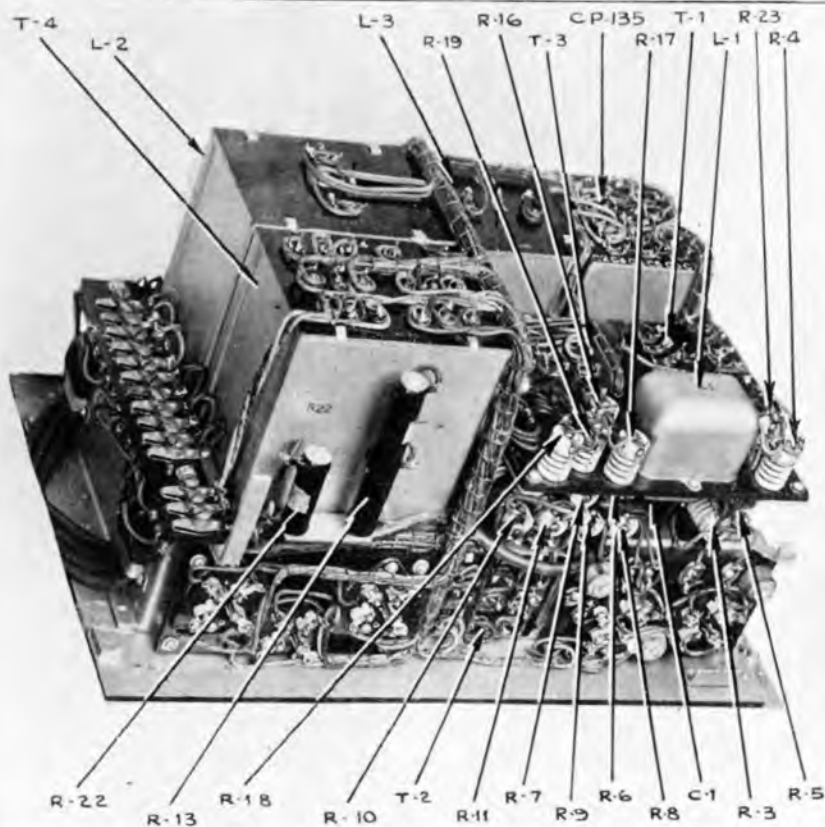
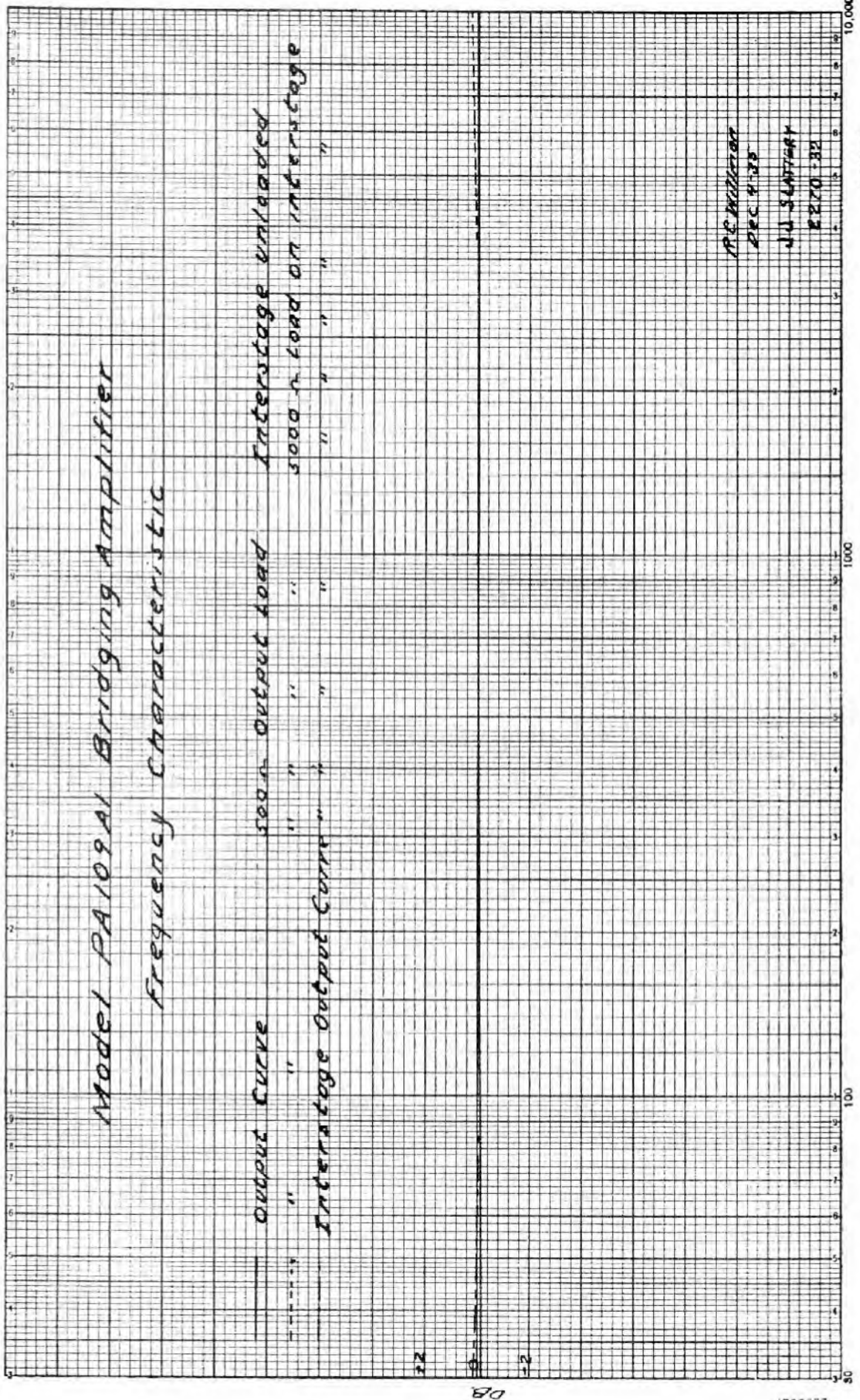

FIGURE 6—BOTTOM VIEW OF MODEL PA109A1 BRIDGING AMPLIFIER (MI-3223)



FREQUENCY IN CYCLES PER SECOND

FIGURE 7-

S-822431







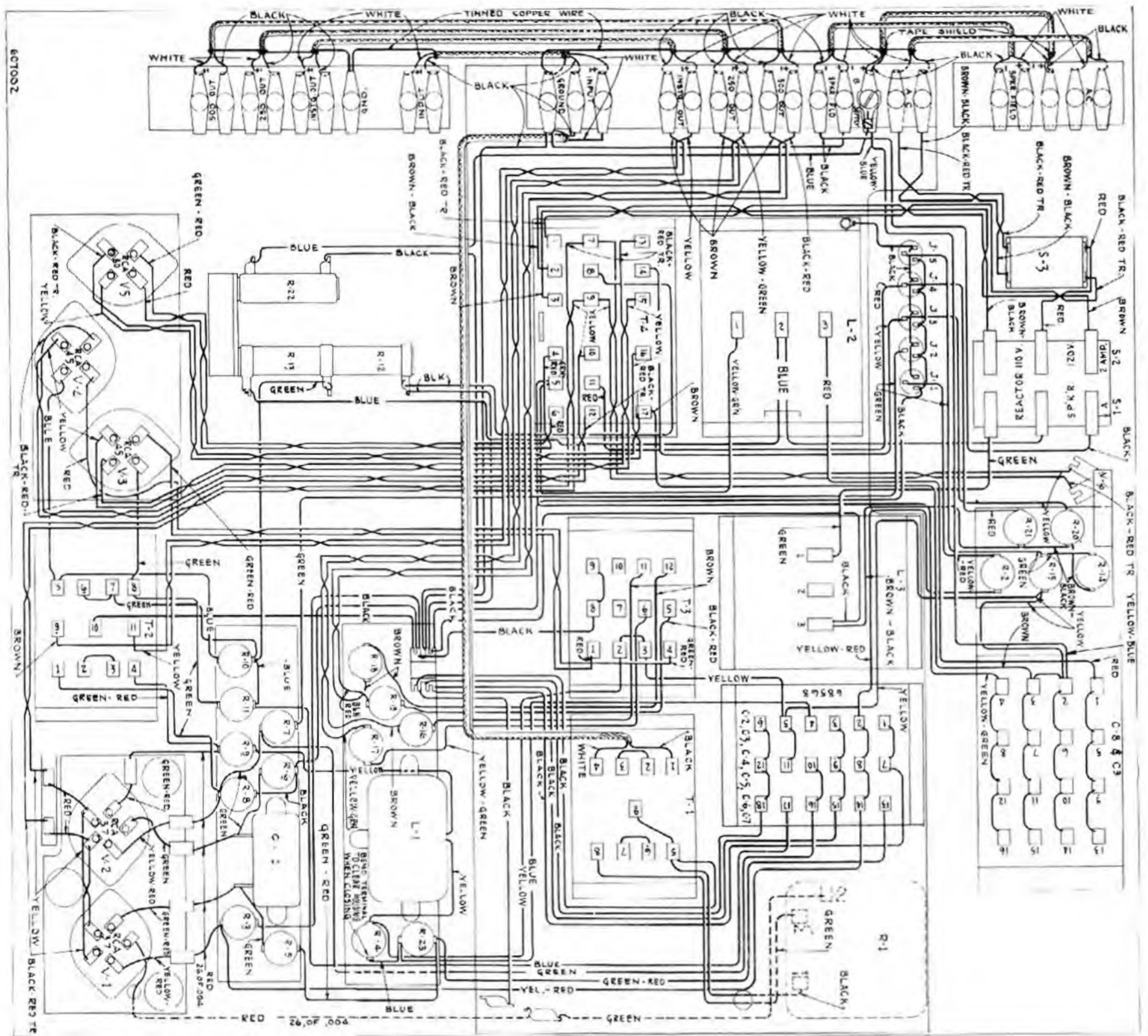

FIGURE 10—WIRING DIAGRAM OF MODEL PA109A1 BRIDGING AMPLIFIER (MI-3223)

T-607002

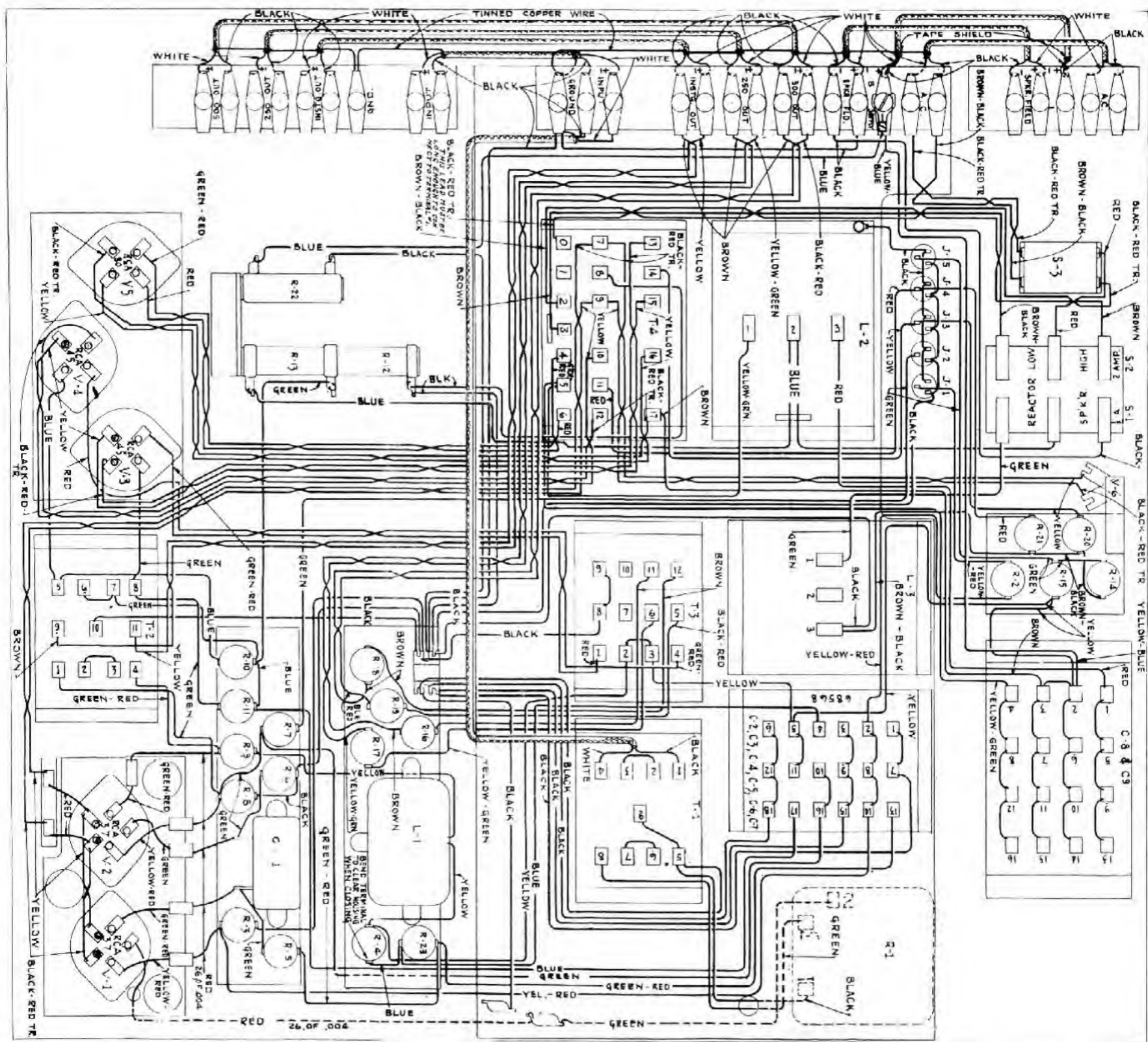

FIGURE 11 - WIRING DIAGRAM OF MI-3223A BRIDGING AMPLIFIER

## ADDENDA SHEET

(MI-3223-C, 110 - 220 volt)  
**RCA PHOTOPHONE  
 BRIDGING AMPLIFIER**

1. Description of MI-3223-C Bridging Amplifier

The MI-3223-C Bridging Amplifier is identical with the MI-3223-B Bridging Amplifier described in Addenda Sheet IB-23837-A except for a rearrangement of the parts and changes in shielding to further reduce hum.

2. Circuit

Figures 1 and 2 attached show respectively the schematic and wiring diagrams for the MI-3223-C Bridging Amplifier.

3. Replacement Parts

Most replacement parts for the MI-3223-C Bridging Amplifier are listed in the Instruction Book for the MI-3223 and MI-3223-A and also in the Addenda Sheet for the MI-3223-B. The other replacement parts are listed below.

| <u>Item</u> | <u>Description</u>             | <u>Ref. Drawing No.</u> |
|-------------|--------------------------------|-------------------------|
| C-1         | Capacitor 0.1 mfd.             | P-72017 G-532           |
| C-10        | Capacitor 0.25 mfd.            | P-72017 G-536           |
| C-11        | Capacitor 0.25 mfd.            | P-72017 G-536           |
| C-12        | Capacitor 0.25 mfd.            | P-72017 G-536           |
| C-13        | Capacitor 0.1 mfd.             | P-72017 G-532           |
| R-1         | Volume Control 50,000 ohms.    | K-830184 P-1            |
| T-2         | Interstage Transformer RT-308A | K-900391 G-501          |

**ERRATA**

2R1-3.1 MI-3223-C BRIDGING AMPLIFIER

Refer to parts list on Page 1. R-1 change reference Drawing  
 Number K-850184-P1 to K-850184-P1  
 Copyright © 2009 Roy A. Royburn - All Rights Reserved



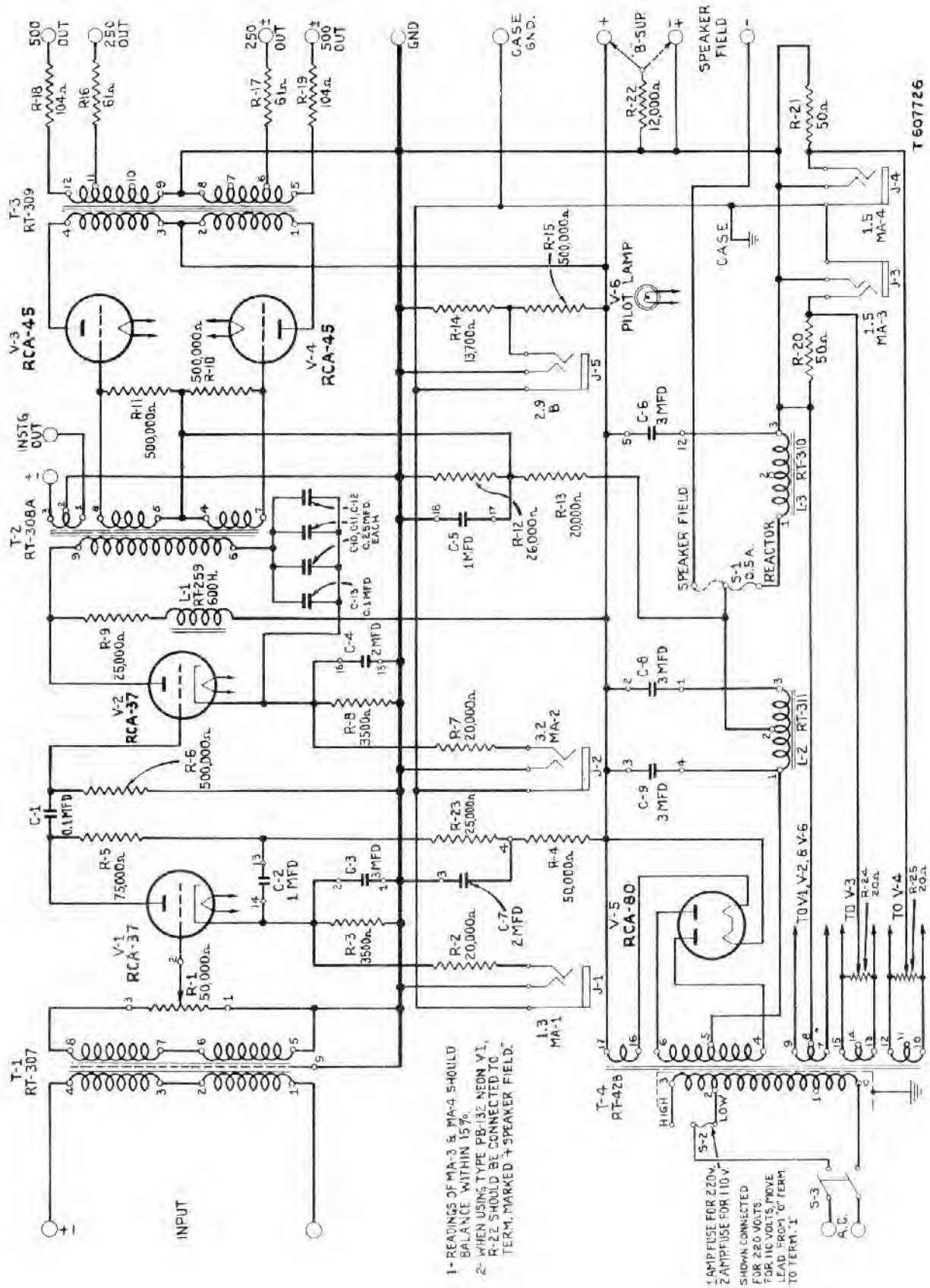

1- READINGS OF MA-3 & MA-4 SHOULD BALANCE WITHIN 15%  
 2- WHEN USING TYPE PB-132 NEON V-1, R-22 SHOULD BE CONNECTED TO TERM. MARKED + SPEAKER FIELD.

1- AMP FUSE FOR 220V, 2 AMP FUSE FOR 110V  
 SHOWN CONNECTED FOR 220 VOLTS  
 FOR 110 VOLTS, MOVE LEAD FROM 1 TO TERM. 1

Figure 1





## INSTRUCTIONS

### for MODIFIED MI-3230 MICROPHONE AMPLIFIER

#### TECHNICAL DATA

##### POWER SUPPLY REQUIRED

"A" SUPPLY  
5 - 8 Volts 0.6 Ampere DC

"B" SUPPLY  
225 Volts 5 ma.

RADIOTRONS  
2-RCA-1620

INPUT  
250 or 50 ohms  
INPUT LEVEL (at 1000 cycles)  
Minimum for Rated Output  
250 ohm Input 250 ohm Output  
- 14 db

OUTPUT IMPEDANCE  
250 ohms

LOAD IMPEDANCE  
250 ohms

##### RATED OUTPUT

+6 db (0.004 W. Ref. level  
with less than 1% distortion  
at 400 cycles)

##### GAIN (NORMAL RESPONSE)

50 db  
(250 ohm bal. source, 250 ohm  
load).

##### FREQUENCY RESPONSE

Flat Position  
±1 db 30 - 10000 cycles  
With high frequency compensation  
+6.8 - db at 10000 cycles.

##### PHYSICAL SPECIFICATIONS

Width - 4-1/2 inches  
Height - 6 inches  
Length - 13-1/2 inches (overall)  
Weight - 16 pounds

#### DESCRIPTION

The MI-3230 Microphone Amplifier made according to M-411077 has been re-designed to permit of a higher output level with the same amount of distortion. Schematic diagram K-859641 together with photographs, Nos. 52888 and 52889, show the circuit and the arrangement of parts in the modified unit. Otherwise the amplifier has the same physical dimensions as the MI-3230 and is interchangeable therewith.

## INSTALLATION

### AUDIO INPUT CONNECTIONS

The audio input connections are made through a small three conductor Cannon plug as follows:

|         |   |                  |
|---------|---|------------------|
| Pin No. | 1 | Shield & Chassis |
| " "     | 2 | 250 ohm input    |
| " "     | 3 | 250 ohm input    |

When shipped the amplifier is connected for use with a source impedance of 250 ohms. In addition, taps are provided on the input transformer for an input impedance of 50 ohms. When it is desired to use this value of input impedance, the lead on tap one should be changed to tap 2 and the lead on tap 6 to tap 5 on the input transformer (XT-2383).

### POWER INPUT AND AUDIO OUTPUT CONNECTIONS

The audio output and power supply connections are made through a 5-contact Cannon Type "F" male connector on the opposite end of the amplifier case. This connector and all mating connectors are clearly marked, showing the "+A," "-AB," "+B," "L1" and "L2" connections, on the INNER SIDE of each pin. Where additional markings appear on the outer sides of the pins, they should be disregarded.

### High Frequency Compensation

To obtain curve 2 on S-853607 connect R-1 to ground and C-1 to R-2 as indicated on K-859641.

## MAINTENANCE

The only maintenance work required is a periodical check of the Radiotrons and cleaning of the tube socket, tube cap, and plug contacts. These various contacts should be cleaned with alcohol at least once every 3 months to insure noiseless operation. It is suggested that the Radiotrons be tested at weekly intervals or ~~often~~ as usage requires.

The suggested method of checking the frequency response is to connect an oscillator through an isolation transformer and suitable balanced H pads to the input of the amplifier. A 250 ohm load and indicating meter is connected to the output. The input voltage is held constant while varying the frequency over the desired range. Curve S-853607 shows the frequency response with the amplifier in the flat position and with the high frequency end accentuated.

Curve S-853609 shows the distortion characteristic at several frequencies.

## REPLACEMENT PARTS

| SYMBOL |             |     | DESCRIPTION |                    |
|--------|-------------|-----|-------------|--------------------|
| C-1    | Capacitor   | -   | .015 mfd.,  | P-72017-514        |
| C-2    | "           | -   | .25 mfd.,   | " -536             |
| C-3    | "           | -   | .10 mfd.,   | " -532             |
| C-4    | "           | -   | .25 mfd.,   | " -536             |
| C-5    | "           | -   | .25 mfd.,   | " -536             |
| C-6    | "           | -   | .025 mfd.,  | " -518             |
| C-7    | "           | -   | .25 mfd.,   | " -536             |
| C-8    | "           | - 2 | -1.0        | P-72024-502        |
|        |             |     |             |                    |
| R-1    | Resistor    | -   | 1,000       | ohms, 1 watt       |
| R-2    | "           | -   | 1,800       | ohms, 1 watt       |
| R-3    | "           | -   | 1,200,000   | ohms, 1 watt       |
| R-4    | "           | -   | 100,000     | ohms, 1 watt       |
| R-5    | "           | -   | 220,000     | ohms, 1 watt       |
| R-6    | "           | -   | 470,000     | ohms, 1 watt       |
| R-7    | "           | -   | 100,000     | ohms, 1 watt       |
| R-8    | "           | -   | 100,000     | ohms, 1 watt       |
| R-9    | "           | -   | 20          | ohms, 1 watt       |
| R-10   | "           | -   | 150,000     | ohms, 1 watt       |
| R-11   | "           | -   | 10,000      | K-811847-8         |
| R-12   | "           | -   | 23 ohms     | K-811847-16        |
| R-13   | "           | -   | 23 ohms     | K-811847-16        |
|        |             |     |             |                    |
| T-1    | Transformer | -   | KT-2383     | Input Transformer. |
| T-2    | "           | -   | KT-328      | Output Transformer |

**Note:**

All Resistors except R-11, R-12 and R-13 are carbon.



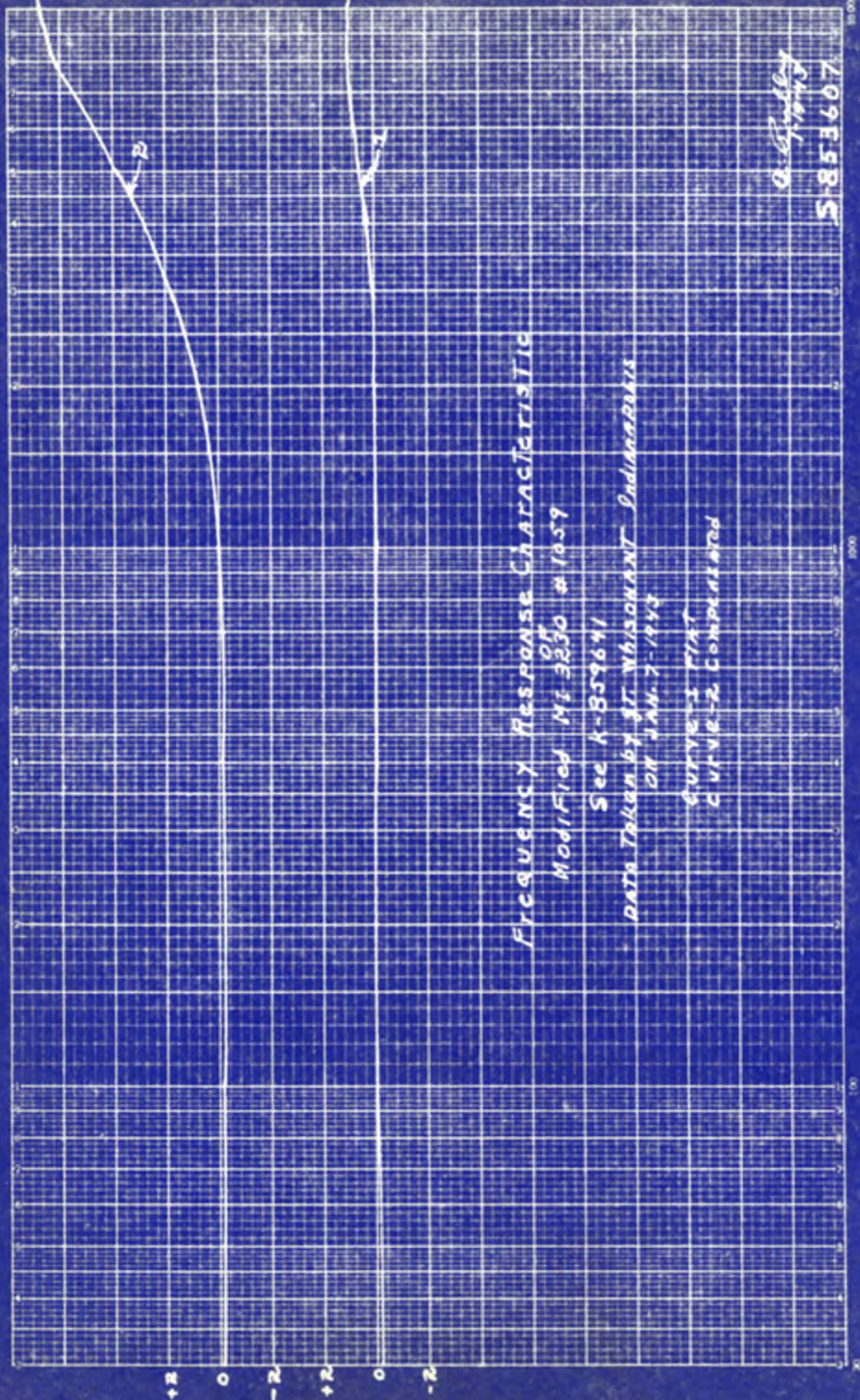





18044-11

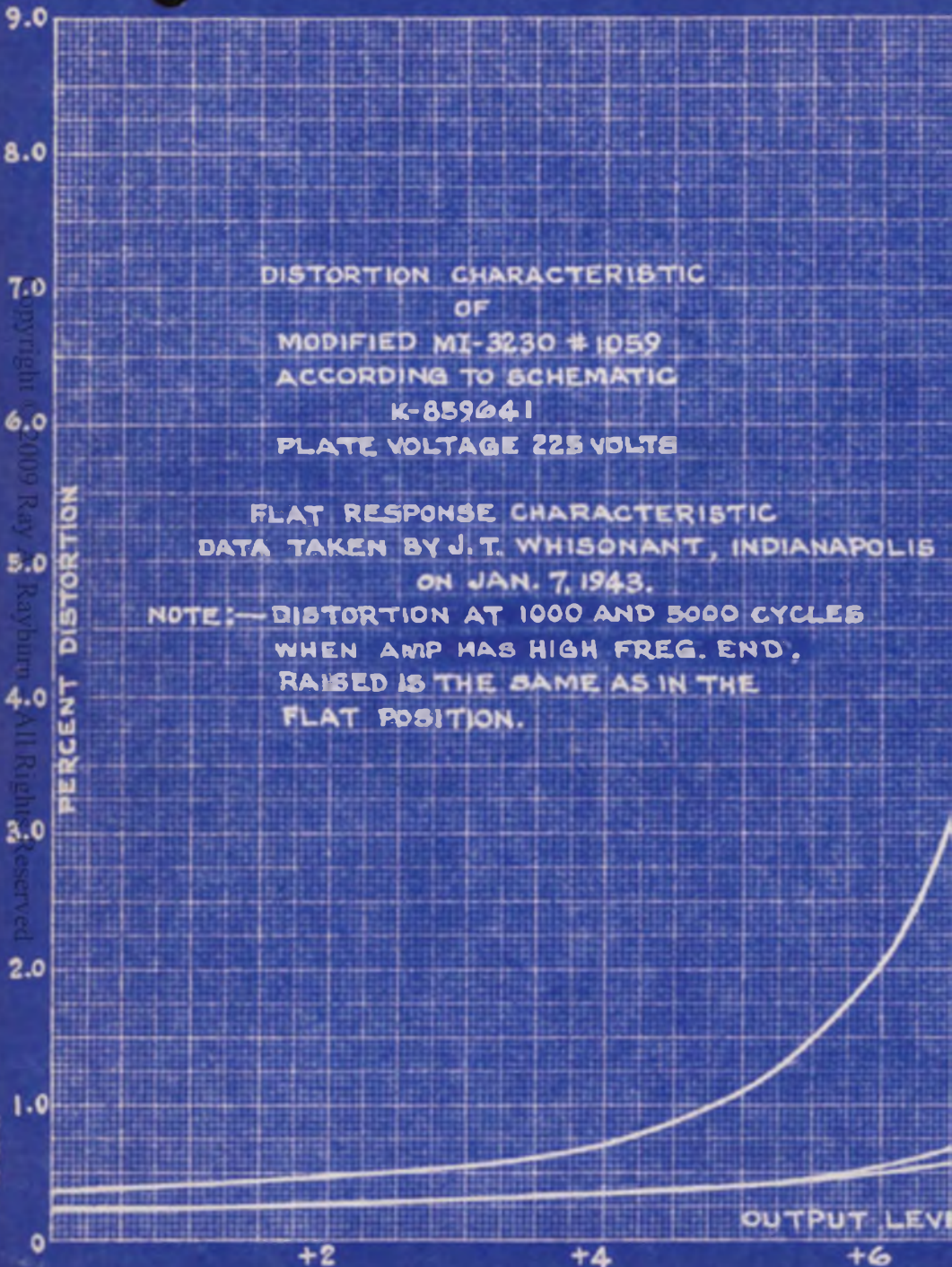

Copyright © 2009 Raytheon Company. All Rights Reserved.

18044-11



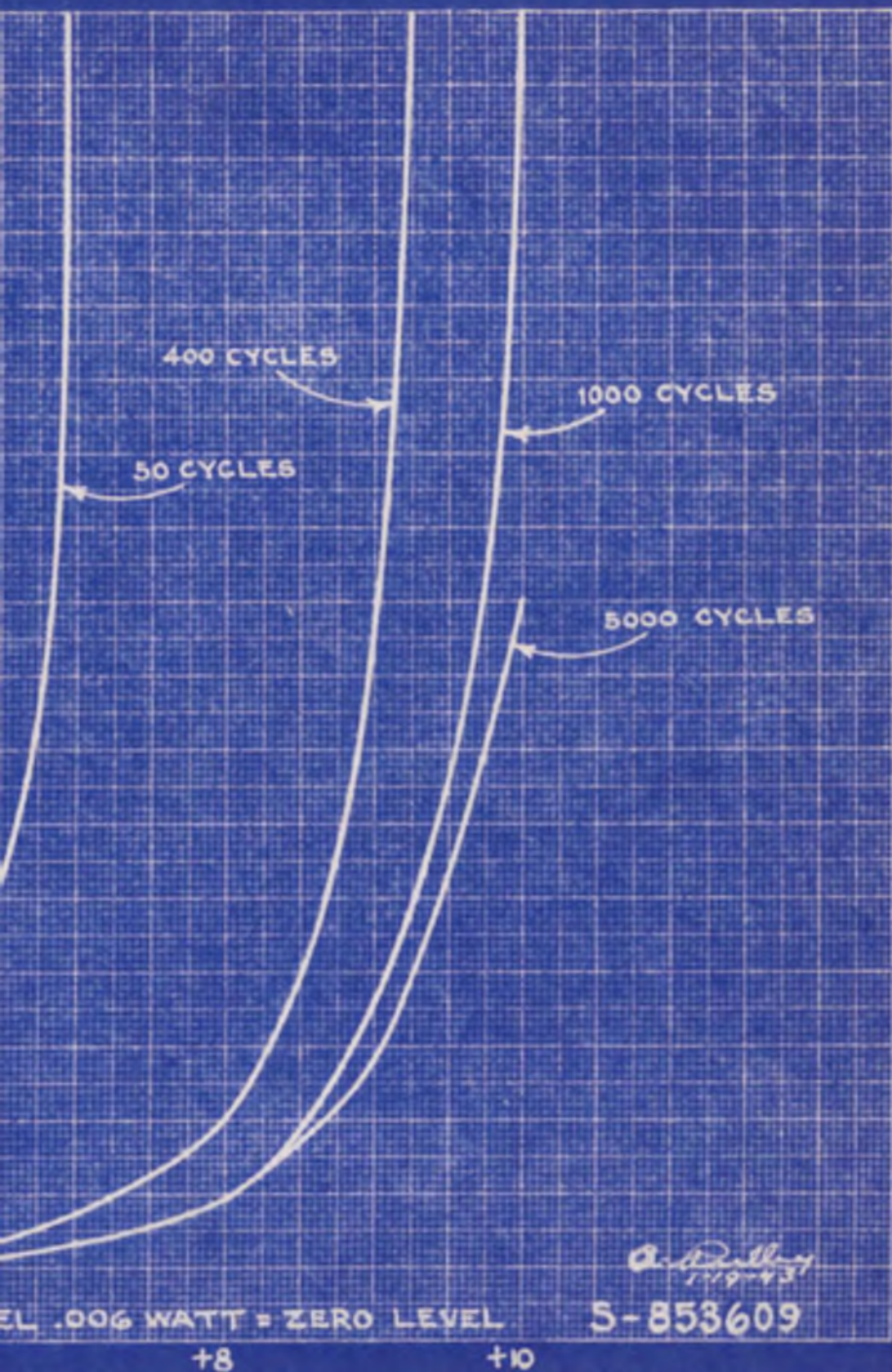

LEVEL .006 WATT = ZERO LEVEL

+8

+10

*A. D. Kelly*  
1/19/43

5-853609

**K-859641**

Copyright © 2009 Ray A. Rayburn - All Rights Reserved

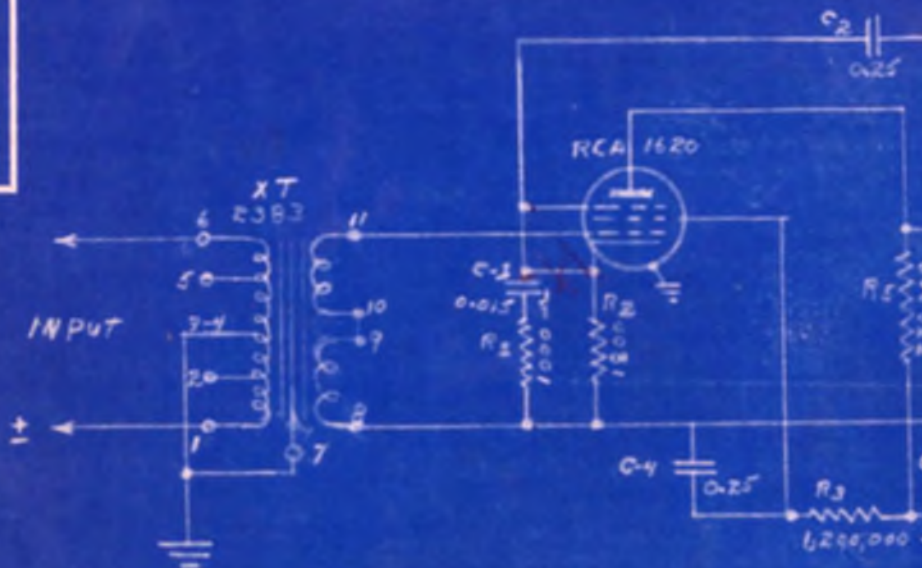

SUB NUMBER

AP. BY

AP. MFG.

Terminal No. added **1**  
 G. Buckley T-23-42



Dimensions in Inches.

Variations on Finish Dimensions unless otherwise marked

| Basic Dimensions         | Fractional Dimensions | Decimal Dimensions |
|--------------------------|-----------------------|--------------------|
| Up to $\frac{1}{4}$      | $\pm \frac{1}{32}$    | $\pm .005$         |
| Above $\frac{1}{4}$ to 6 | $\pm \frac{1}{64}$    | $\pm .005$         |
| Above 6 to 24            | $\pm \frac{1}{32}$    | $\pm .010$         |
| Above 24                 | $\pm \frac{1}{16}$    | $\pm .015$         |

See Purch. Spec. for Stock Tolerances

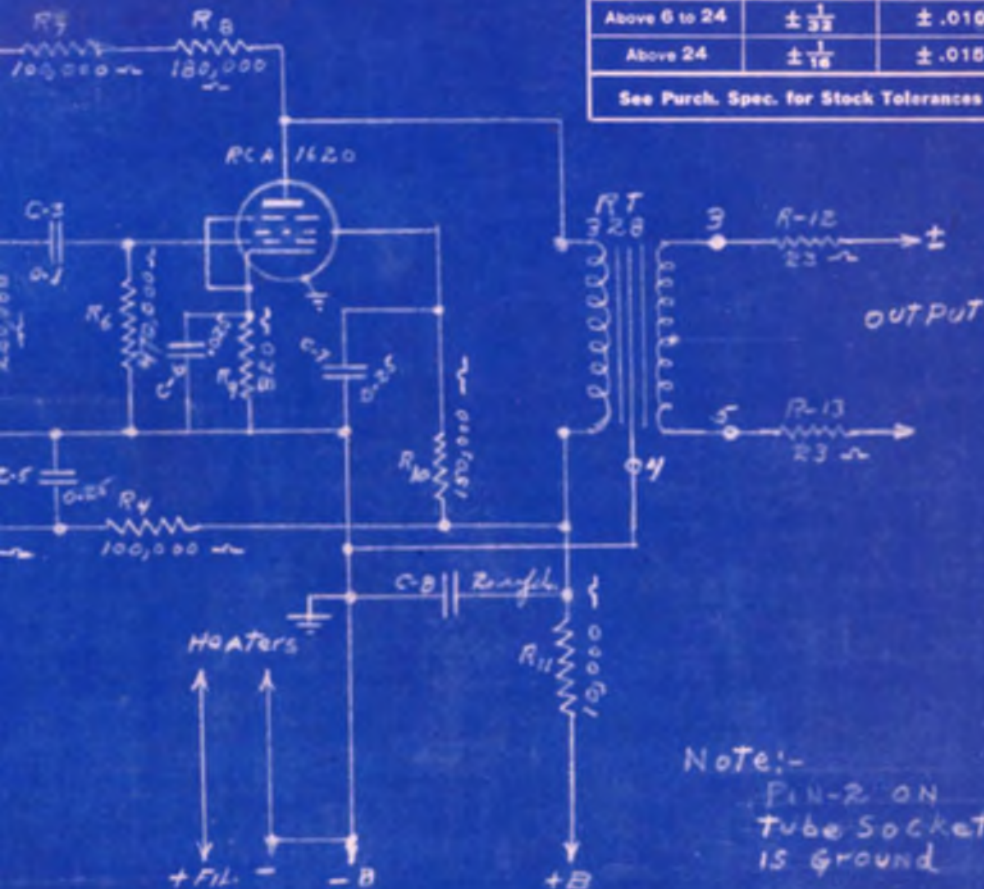

SCHEMATIC  
DIAGRAM

FIRST MADE FOR MODIFIED MZ 3230

DRAWN BY G. Pullley 8-12-91

MATERIAL

TRACED BY

CHECKED BY

RCA Manufacturing Co. Inc.  
RCA Victor Division

K-859641

859641





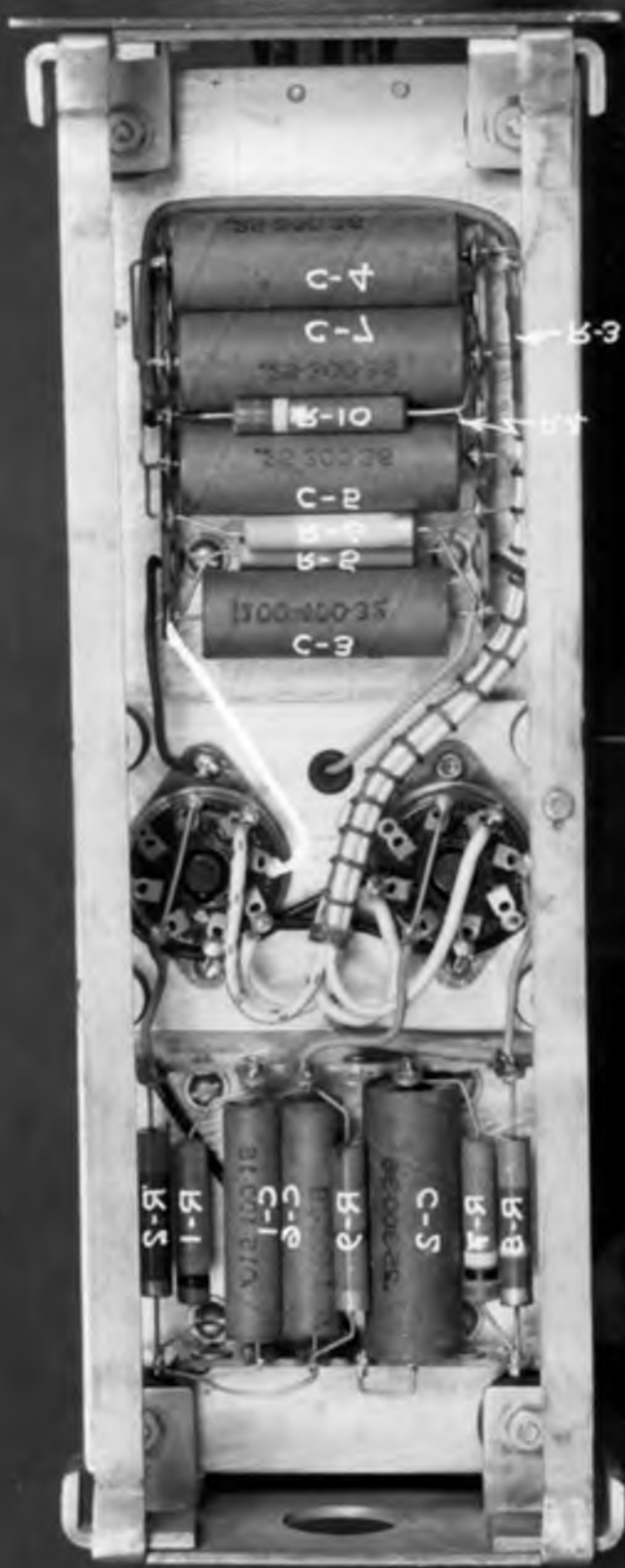

C-4

C-1

R-10

C-2

R-9

R-8

C-3

B-3

B-4

S-2

C-1

C-2

R-3

C-3

R-4

R-5

S-1

R-1

R-2

R-6

R-7

R-8

R-9

**MI-3232 and MI-3232-A**

**BOOSTER AMPLIFIER**

---

**RCA PHOTOPHONE**  
**RECORDING INSTRUCTIONS**

---

**First Edition**

**Photophone Division**  
**RCA Manufacturing Co., Inc.**  
**Camden, N. J., U. S. A.**

**A Service of the Radio Corporation of America**

# ERRATA

2R1-4.1 MI-3232 and MI-3232-A BOOSTER AMPLIFIER

Refer to Replacement Parts List. R-6 change Reference Drawing Number K-811847-P15 to K-819789-P17. C-6 change P-72024-G502 to K-82406-P2. C-7 change P-77024-G502 to K-82406-P2.

## DATA SHEET

### Radiotrons

|           |                     |
|-----------|---------------------|
| 1st stage | RCA-77 (MI-3232)    |
|           | RCA-1603 (MI-3232A) |
| 2nd stage | RCA-37              |

### Power Supply

|            |  |
|------------|--|
| "A" supply | 6 or 8 volts d.c. Total drain 0.6 amperes (MI-3527 "A" supply or equivalent may be used) |
|------------|--|

|            |  |
|------------|--|
| "B" supply | 180 volts d.c. Total drain 8 milliamperes (MI-3526 "B" supply or equivalent may be used) |
|------------|--|

|                         |                  |
|-------------------------|------------------|
| <u>Input Impedances</u> | 250 and 500 ohms |
|-------------------------|------------------|

|                          |                 |
|--------------------------|-----------------|
| <u>Source Impedances</u> | 250 or 500 ohms |
|--------------------------|-----------------|

|                          |                  |
|--------------------------|------------------|
| <u>Output Impedances</u> | 250 and 500 ohms |
|--------------------------|------------------|

|                        |                 |
|------------------------|-----------------|
| <u>Load Impedances</u> | 250 or 500 ohms |
|------------------------|-----------------|

|                     |  |
|---------------------|--|
| <u>Overall Gain</u> | (at 1000 cycles - compensation included) |
|---------------------|--|

|                   |       |
|-------------------|-------|
| "High" connection | 41 db |
|-------------------|-------|

|                  |       |
|------------------|-------|
| "Low" connection | 33 db |
|------------------|-------|

|                                 |   |
|---------------------------------|---|
| <u>Undistorted Power Output</u> | less than 2% harmonic distortion (0.006 watt reference level) |
|---------------------------------|---|

|         |      |
|---------|------|
| MI-3232 | 0 db |
|---------|------|

|          |      |
|----------|------|
| MI-3232A | 6 db |
|----------|------|

|                   |                              |
|-------------------|------------------------------|
| <u>Dimensions</u> | 4½" wide, 6" high, 13½" long |
|-------------------|------------------------------|

|               |           |
|---------------|-----------|
| <u>Weight</u> | 16 pounds |
|---------------|-----------|

# RCA PHOTOPHONE BOOSTER AMPLIFIER MI-3232 and MI-3232A

## DATA SHEET

### Radiotrons

|           |                     |
|-----------|---------------------|
| 1st stage | RCA-77 (MI-3232)    |
|           | RCA-1603 (MI-3232A) |
| 2nd stage | RCA-37              |

### Power Supply

|            |   |
|------------|---|
| "A" supply | 6 or 8 volts d.c. Total drain 0.6 amperes<br>(MI-3527 "A" supply or equivalent may be used) |
| "B" supply | 180 volts d.c. Total drain 8 milliamperes<br>(MI-3526 "B" supply or equivalent may be used) |

### Input Impedances

250 and 500 ohms

### Source Impedances

250 or 500 ohms

### Output Impedances

250 and 500 ohms

### Load Impedances

250 or 500 ohms

### Overall Gain

(at 1000 cycles - compensation included)

|                   |       |
|-------------------|-------|
| "High" connection | 41 db |
| "Low" connection  | 33 db |

### Undistorted Power Output

less than 2% harmonic distortion  
(0.006 watt reference level)

|          |      |
|----------|------|
| MI-3232  | 0 db |
| MI-3232A | 6 db |

### Dimensions

4½" wide, 6" high, 13½" long

### Weight

16 pounds

### DESCRIPTION

MI-3232 booster amplifier has an RCA-77 Radiotron and a 220-ohm bias resistor in the first stage. MI-3232-A has an RCA-1603 Radiotron and a 420-ohm bias resistor. These changes result in approximately 6 db greater power output for MI-3232-A. In other respects, the amplifiers are identical. (Existing MI-3232 amplifiers should be converted to MI-3232-A.)

The amplifier may be used in any 250- or 500-ohm line. As shipped, the amplifier is connected for 500-ohm source impedance and 500-ohm output load. Provision is made for changing to a 250-ohm input and/or a 250-ohm output, as specified in the schematic diagram P-712391.

The amplifier has plug connectors and a handle for ease in handling and connecting in the circuit. It may be mounted in the mixer console, or on an MI-3290 panel for rack mounting. Care should be taken in locating the amplifier so that it will not be subject to shock, vibration, or strong a-c fields.

### EXTERNAL CONNECTIONS

INPUT CONNECTIONS are made through a 3-contact Cannon type "P" plug. Connect the input signal pair to pins 2 and 3 (pin 2 being the "+" or phasing terminal). Connect shield of input cable to pin 1.

AUDIO OUTPUT AND POWER SUPPLY CONNECTIONS are made through a 5-contact Cannon type "F" male connector. Connect the output signal pair to pins "L1" and "L2" ("L1" being the "+" or phasing terminal). Corresponding "+" terminals on all units of RCA Recording Equipment should be connected together.

### INTERNAL CONNECTIONS

HEATER VOLTAGE ADJUSTMENT. The heater voltage at the Radiotron sockets must be maintained between 5.5 and 7.0 volts. One or more sections of the tapped resistor R16 may be shorted out to maintain these limits. The adjustment should be re-checked if the "A" supply voltage or the length of supply cable is changed appreciably.

REDUCING OVER-ALL GAIN. As shipped, the amplifier is connected for its maximum gain of 41 db. This may be reduced to 33 db by connecting the green lead from the grid of the second tube to the "low" terminal between R8 and R9. This change should be avoided when possible, because the performance of the amplifier is best with the "high" gain connections.

### TESTING

A check of the phasing, frequency response, and load characteristics will show if the amplifier is properly connected and functioning normally.



-2-

PHASING. Phasing may be checked by the feed-back method. Connect the input terminals to the output terminals, with "+" terminals connected together. Connect headphones across the input terminals. A "motorboating" sound will be heard if the phasing is correct. If it is incorrect, no sound, or a very high-frequency whistle will be heard, and in this case, reverse the INTERNAL connections to either the input or output terminals.

GAIN AND FREQUENCY RESPONSE. The frequency response of the booster amplifier is shown in curve S-822923.

The suggested method of checking response consists of first setting up and determining the response of the equipment as shown in figure 1. An "H" pad and the booster amplifier are then inserted, as shown in figure 2, and the response of the complete system is determined. The difference between this and the previous response indicates the response of the booster amplifier.

The purpose of the "H" pad is to provide attenuation to compensate approximately for the gain of the booster. The pad should be thoroughly shielded, and the shield grounded to the booster amplifier.

The purpose of the mixer (which is calibrated in decibels) is to show the relative gain or loss of the system with respect to the gain at 1000 cycles (the input voltage being maintained constant by adjustment of oscillator control, and the output being maintained constant by adjustment of the mixer controls).

The load resistor and meter should total 500 ohms. If rectox meters are employed, they must be used for input and output and be of similar type.

LOAD CHARACTERISTICS. Distortion curves for the MI-3232 are shown in S-822929, and for the MI-3232-A in S-839519.

REPLACEMENT PARTS - The following parts list is included to provide identification when ordering replacement parts. When ordering specify the item by description and reference drawing number.

REPLACEMENT PARTS

| <u>Item</u>          | <u>Description</u>               | <u>Reference Drawing Number</u> |
|----------------------|----------------------------------|---------------------------------|
| <u>RESISTORS</u>     |                                  |                                 |
| R-1                  | 220 ohms (MI-3232)               | K-811847 P-17                   |
| R-1                  | 420 " (MI-3232A)                 | " P-22                          |
| R-2                  | 20,000 "                         | " P-13                          |
| R-3                  | 20,000 "                         | " P-13                          |
| R-4                  | 420,000 "                        | K-841326 P-4                    |
| R-5                  | 150,000 "                        | " P-1                           |
| R-6                  | 100,000 "                        | K-811847 P-15                   |
| R-7                  | 750,000 "                        | T-607416 P-10                   |
| R-8                  | 300,000 "                        | K-841326 P-3                    |
| R-9                  | 200,000 "                        | " P-2                           |
| R-10                 | 3,000 "                          | K-811847 P-3                    |
| R-11                 | 10,000 "                         | " P-8                           |
| R-12                 | 75.0 "                           | " P-19                          |
| R-13                 | 25.0 "                           | " P-18                          |
| R-14                 | 75.0 "                           | " P-19                          |
| R-15                 | 25.0 "                           | " P-18                          |
| R-16                 | 3.3 "                            | K-825113 P-2                    |
| R-17                 | 1,075 "                          | K-811847 P-20                   |
| R-18                 | 50,000 "                         | " P-5                           |
| <u>CAPACITORS</u>    |                                  |                                 |
| C-1                  | 2.0 mfd.                         | (2) M-68535 G-502               |
| C-2                  | 1.0 "                            | " "                             |
| C-3                  | 1.0 "                            | " "                             |
| C-4                  | 0.025 "                          | K-36026 G-584                   |
| C-5                  | 56.0 mmfd.                       | M-80342 G-521                   |
| C-6                  | 1.0 "                            | P-72024 G-502                   |
| C-7                  | 1.0 "                            | " "                             |
| <u>MISCELLANEOUS</u> |                                  |                                 |
| T-1                  | Input Trans. RT-306              | M-403091 G-501                  |
| T-2                  | Output Trans. XT-2335            | K-900213 G-501                  |
| V-1                  | Radiotron RCA-77 (MI-3232)       |                                 |
| V-1                  | Radiotron RCA-1603 (MI-3232A)    |                                 |
| V-2                  | Radiotron RCA-37                 |                                 |
| P-1                  | Input plug (Cannon P3-14)        | K-817515 P-1                    |
| P-2                  | Output receptacle (Cannon F5-54) | K-819218 P-4                    |

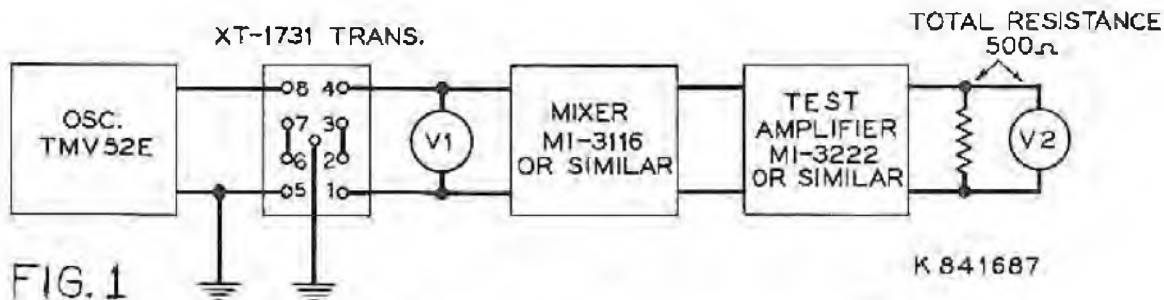

FIG. 1

OSCILLATOR MID-TAP MUST BE REMOVED FROM GROUND

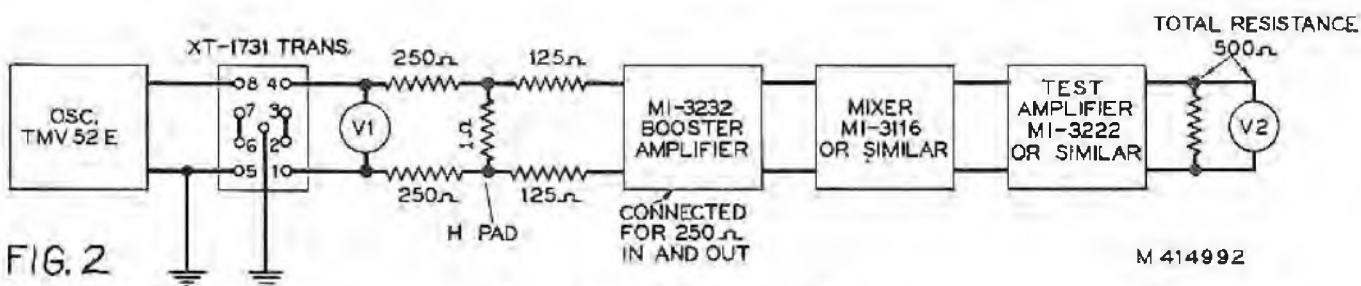
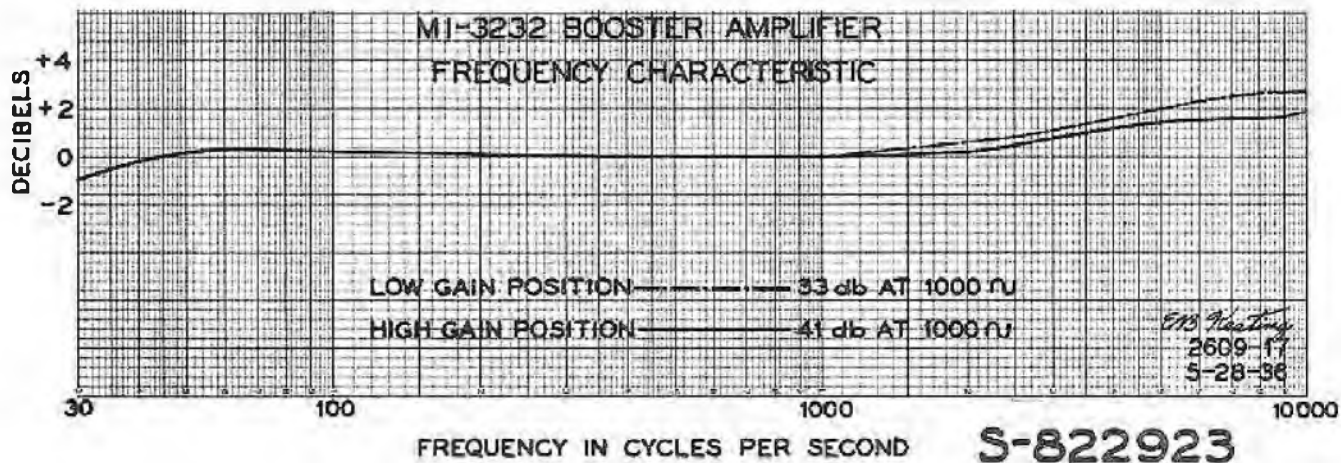
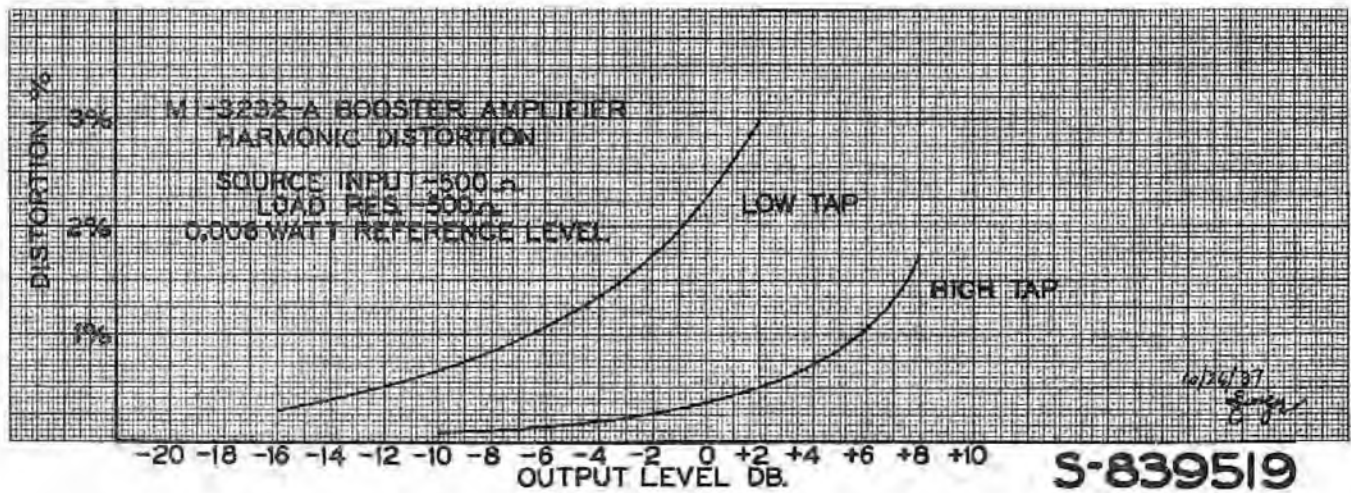
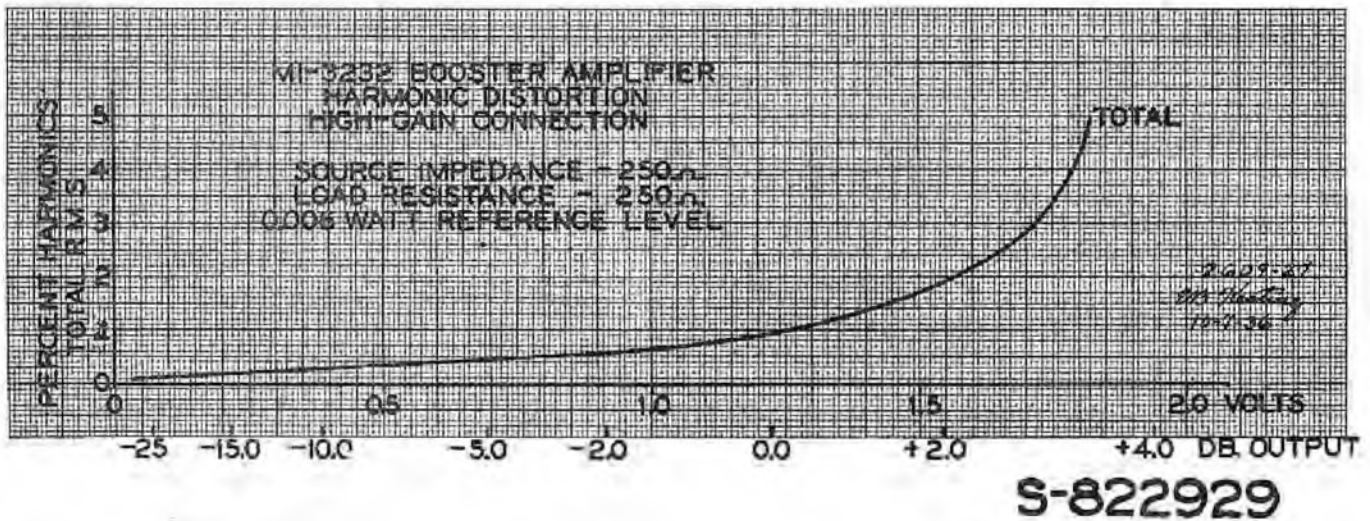
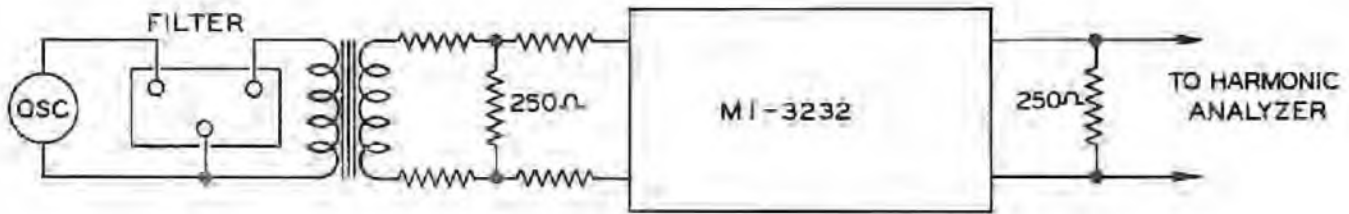

FIG. 2

OSCILLATOR MID-TAP MUST BE REMOVED FROM GROUND





2R1-4.1

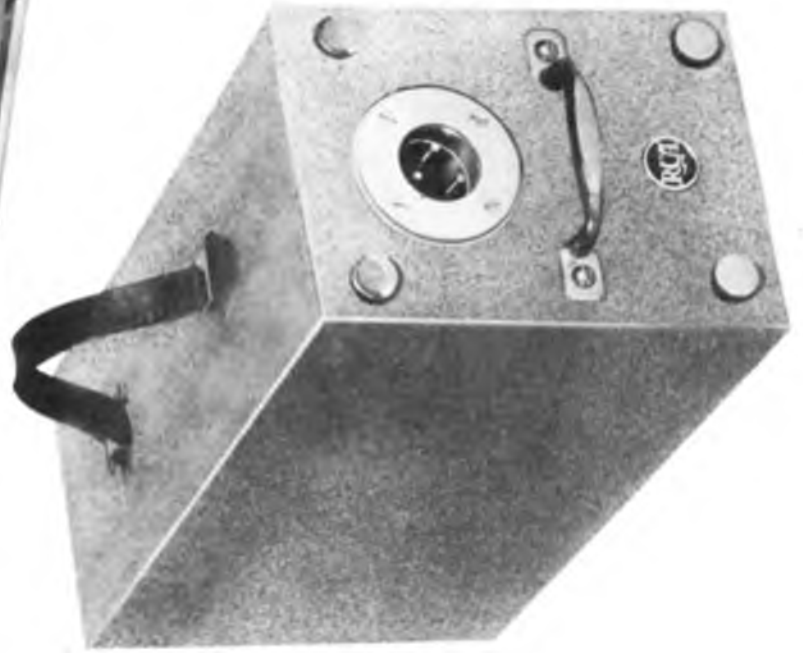

MI-3232

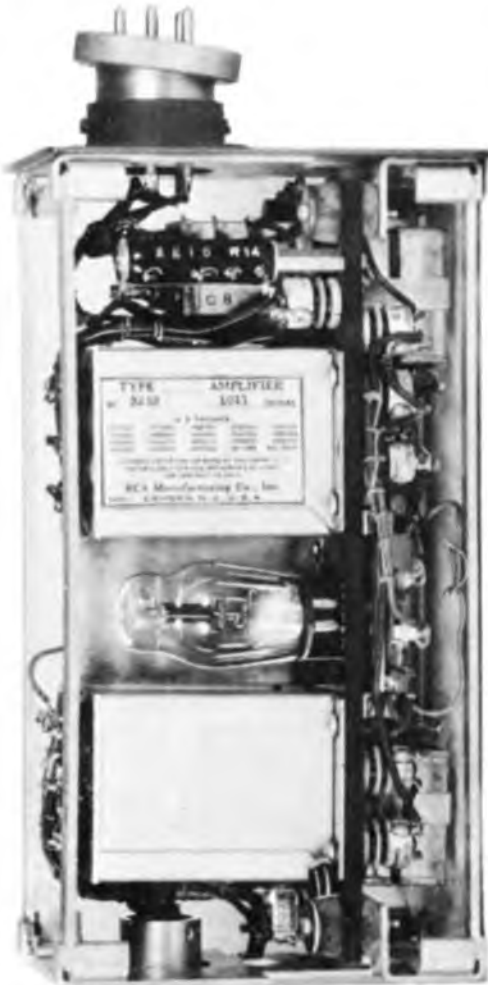





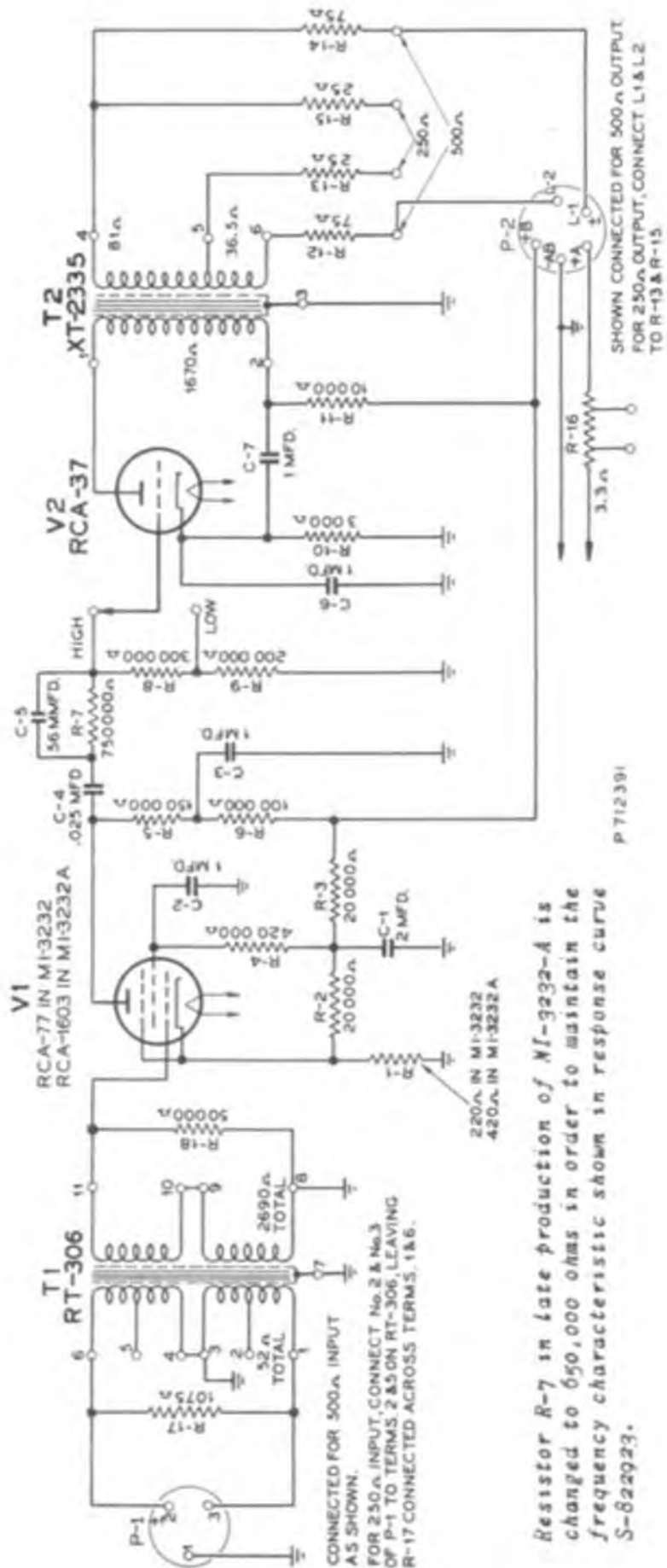

Resistor R-7 in late production of MI-3232-A is changed to 650,000 ohms in order to maintain the frequency characteristic shown in response curve S-822023.

MI-3233, -A

## D-C BRIDGING AMPLIFIER

---

### RCA PHOTOPHONE RECORDING INSTRUCTIONS

---

First Edition

Photophone Division  
RCA Manufacturing Co., Inc.  
Camden, N. J., U. S. A.

A Service of the Radio Corporation of America

# MI-3233 *A*

## D-C BRIDGING AMPLIFIER

### DATA SHEET

#### Radiotrons

1st stage                    1 RCA-6C5  
 2nd stage                    2 RCA-6F6 (push pull)

#### Pilot Lamp

1 Mazda No. 40, 6-volt, 0.15 ampere,  
 Cat. No. 3030

#### Fuses

"A" supply circuit            1 W.E. non-alarm Code 24-B, 5 ampere  
 "B" supply circuit            1 W.E. non-alarm Code 24-B,  $\frac{1}{2}$  ampere

#### Power Supply

"A" supply                    6 or 8 volt storage battery. Total  
    drain 1.83 amperes

"B" supply                    180 or 225 volt "B" battery. Total  
    drain 21 milliamperes at 180 volts  
    or 28 milliamperes at 225 volts

"C" supply                    18 or 22 $\frac{1}{2}$  volts depending on "B"  
    voltage used. Burgess No. 5156,  
    Eveready No. 768 or equivalent

#### Source Impedance

0 - 30,000 ohms

#### Input Impedance

30,000 ohms

#### Output Impedance

250 or 500 ohms

#### Load Impedance

250 or 500 ohms

#### Over-all Gain

32 db (bridging input)

#### Undistorted Power Output

180 volt "B" supply            0.75 watt (less than 2% total rms distortion)  
 225 volt "B" supply            1.25 watt (less than 2% total rms distortion)

#### Volume Control Range

19 steps of 2 db each, and cutoff

#### Weight

44 $\frac{1}{2}$  lbs. with tubes and "C" Battery

#### Dimensions

Height                    6  $\frac{15}{16}$  inches  
 Width                    19 inches  
 Depth                    10  $\frac{5}{8}$  inches

## PART 1 - DESCRIPTION

**ELECTRICAL CIRCUITS** - The MI-3233 D-C Bridging Amplifier is designed essentially for monitoring purposes and to drive a recording galvanometer. It is a two stage amplifier incorporating an RCA-6C5 Radiotron in the first stage and a pair of RCA-6F6 Radiotrons in push-pull in the second stage. It has an input impedance of 30,000 ohms and the output impedance can be either 250 ohms or 500 ohms, according to which terminals are used. The ground post is connected inside the amplifier to the negative "B" supply post and these terminals are in no way connected to the main frame of the unit. A separate case ground which is connected to the frame of the unit is also brought to the main terminal strip thus providing a very flexible grounding arrangement whereby the entire case can be grounded and either side of the "A" supply grounded or not as desired. Jacks are provided on the front panel for measuring heater voltage, "B" supply voltage, and plate current drawn by each individual tube. The voltage drop across appropriate resistors is measured through the use of open circuits jacks so that no amplifier circuit are made or broken during this measuring process. Within this instruction book will be found schematic circuit diagram M-414685, wiring diagram T-607698, frequency response characteristic curve S-839437, distortion curves, S-839436, load curves S-839435, and two photographs of this amplifier.

**POWER SUPPLY** - Either 6 volt or 8 volt "A" battery supply may be used with this amplifier. The drain on the "A" battery is 1.83 amperes regardless of which voltage is used. This includes the pilot lamp drain. Either 180 volt or 225 volt "B" battery supply may be used. At 180 volts the total current drain is 21 milliamperes. At 225 volts the total current drain is 28 milliamperes.

**CONSTRUCTION** - The MI-3233 D-C Bridging Amplifier has all its essential parts mounted upon the front panel which is hinged at the right hand end. The case to which the hinge is fastened should be permanently fastened to a standard relay rack and is built in the form of a stationary metal container which serves as a dust and electrostatic shield over the entire amplifier when it is swung in its closed position. When open, all parts are readily accessible for servicing. Cables connecting to the front panel and associated parts are of sufficient length so that no lead need be disconnected in order to open the front panel.

## PART 2 - OPERATION

**MOUNTING** - The Model MI-3233 D-C Bridging Amplifier is designed for mounting in a standard 19-inch relay rack. It should not be opened on its hinges unless the case is firmly and rigidly supported.

**LOCATION OF FUSES** - After mounting the amplifier in a suitable relay rack remove the cover plate from the tube compartment and install the "A" and "B" supply fuses in their holders. A W.E. non-alarm, code "24-B" 1/2 ampere fuse should be placed in the "B" supply circuit (which is the left-hand fuse mounting). A similar type 5 ampere fuse should be installed in the "A" supply



circuit (which is the right-hand fuse mounting). For 5 volt "A" supply operation this fuse goes in the two upper clips and for 8 volt operation it goes in the two lower clips. The terminal board is marked to indicate correct positions of both fuses.

**RADIOTRONS** - The proper Radiotrons should now be placed in their respective sockets (as marked opposite each tube location). Screw the Mazda No. 40 pilot lamp in its socket behind the red indicator bezel and replace the tube cover plate.

**POWER SUPPLY AND GROUND CONNECTIONS** - Open the amplifier case and install the "C" battery in the space provided. This should be a Burgess No. 5155, Eveready No. 768, or equivalent. Connect the leads to the "C" battery taps providing 18 volts if 180 volt "B" supply is used; or connect these leads to the taps providing 22-1/2 volts if 225 volt "B" supply is used. The "A" and "B" batteries should now be connected to their respective terminals on the main terminal board and a jumper connected between negative "B" and whichever side of the "A" battery will agree with the system ground being used. A ground connection should also be made to the case ground.

**INPUT AND OUTPUT CONNECTIONS** - The input terminals of this amplifier are usually connected to the inter-stage terminals of either an MI-3222 or MI-3222-A Recording Amplifier. In some installations the D-C Bridging amplifier input terminals may be connected in parallel with a 500 ohm resistor which, in turn, is connected across the 500 ohm output terminals of the Recording Amplifier. Corresponding "-" terminals on all units of RCA recording equipment should always be connected together. The output of the MI-3233 D-C Bridging Amplifier is normally connected to either a loudspeaker, to RCA High Fidelity Headphones, or a recording galvanometer; a suitable matching transformer is frequently used to make these connections. Either the 250 ohm or 500 ohm output terminals should be used in order to obtain the best possible impedance match. It is advisable to shield the input leads to the MI-3233 D-C Bridging Amplifier.

**SIGNAL INPUT LEVEL** - This amplifier is designed for operation with signal input levels of -40 db (0.006 W zero reference level) and greater; it is not recommended for operation from signal inputs below this level.

**CHECKING TUBES AND BATTERIES** - After allowing a few moments for the tubes to warm up, check the plate current, heater voltage, and "B" voltage by means of the jacks provided on the front panel. The 0-8 d-c voltmeter provided on the main recording amplifier will be found convenient for this purpose. Below is shown a tabulation of the readings to be obtained in these jacks when all voltages and currents are normal. The jack designation and the two top lines reading across in this tabulation are the markings appearing on the front of the panel. The bottom line reading across in this tabulation indicates a multiplying factor which when applied to the above readings will indicate the actual value of voltage or current as the case may be. The plate current readings will vary somewhat with individual tubes.

| <u>MA 1</u> | <u>MA 2</u> | <u>MA 3</u> | <u>H</u> | <u>B</u> |                    |
|-------------|-------------|-------------|----------|----------|--------------------|
| 2.8         | 1.1         | 1.1         | 6.0      | 4.5      | ("B" supply 225 V) |
| 2.2         | 0.8         | 0.8         | 6.0      | 3.6      | ("B" supply 180 V) |
| 2           | 10          | 10          | 1        | 50       |                    |

The push-pull output tubes RCA-6F6 should be chosen so that the plate currents drawn by these two tubes do not differ more than 15%. It is usual practice to allow the "B" batteries to drop approximately 15% below their initial value before replacing them. As this voltage drops the taps on the "C" battery should be changed in order to maintain at all times a "C" voltage as near 10% of the "B" voltage as possible. The "C" battery should be replaced when its voltage has dropped 10% below its initial value or sooner if it becomes noisy.

The Radiotrons should be tested occasionally by means of a reliable tube tester.

**CARE OF VOLUME CONTROL** - The volume control may be taken out for inspection or to clean the contacts by removing only the four screws in the outer corners of the escutcheon plate and carefully pulling it straight out. The contacts should be cleaned occasionally by using a small quantity of light, high-grade machine oil such as camera or watch oil. (CAUTION: - NEVER USE SANDPAPER OR HARSH ABRASIVES TO CLEAN THE CONTACTS AS THESE SURFACES ARE CAREFULLY AND ACCURATELY LAPPED-IN AT THE FACTORY). Using a toothpick, apply a drop of oil to the surface of several contacts and rotate the arm back and forth until the oil is thoroughly worked in and becomes dirty. Then use a soft cloth and thoroughly wipe off the contacts. Repeat this procedure until the oil remains clean. When cleaning is complete, all oil should be wiped off with a dry cloth.

### PART 3 - TESTING

A check of the phasing, frequency response, and load characteristic will show if the amplifier is properly connected and functioning normally.

**PHASING** - It is important that all inputs and outputs be properly phased. In other words the INSTANTANEOUS voltage at corresponding input and output terminals should be of the same polarity. For convenience, one terminal of each pair has been marked " $\pm$ " to indicate this polarity relation. All units of RCA Recording Equipment bear this " $\pm$ " indication on the input and output terminals so they can be properly connected. This system insures consistent results on all recording channels with the same operating technique. This amplifier has been carefully phased at the factory but during maintenance and repair work in the field a double check may easily be made by using the feedback method. This is accomplished by connecting the input terminals to the output terminals with the corresponding " $\pm$ " terminals connected together. A pair of headphones should be connected across the input terminals and the volume control should be well advanced. A "motorboating sound" will be heard if the phasing is correct. If it is incorrect either no sound or a very high frequency whistle will be heard. Should this test indicate the amplifier to be out of phase it may be corrected by reversing the INTERNAL connections to either the input or output terminals.

**FREQUENCY RESPONSE** - The frequency response characteristic of this amplifier should be within plus or minus 1/2 db from 30 to 10,000 cycles as shown on the attached curve S-839457. This may be checked as follows: Connect a calibrated source of audio frequency signal such as an RCA type TMV-52-E Beat Frequency Oscillator and a volume indicator through an H-pad attenuator, having an attenuation of at least 20 db, to the input of the amplifier. Connect a load resistor and volume indicator across the output of the amplifier. The values of load resistor and volume indicator should be such that their combined resistance equals 500 ohms. If preferred, a milliammeter may be connected in series with a resistor and used across the output. If this is done the total resistance of the meter and resistor must likewise equal 500 ohms. A diagram of connections for such a test equipment set-up is included on curve S-839437. (CAUTION: - IF RECTOX METERS ARE EMPLOYED, THEY MUST BE USED FOR BOTH INPUT AND OUTPUT READINGS AND BE OF A SIMILAR TYPE SO AS TO PREVENT METER CHARACTERISTICS FROM AFFECTING THE RESULTS.)

**LOAD CHARACTERISTICS** - For all values of volume control setting the load characteristic (output voltage plotted against input voltage) should be a straight line up to an output voltage of 24-1/2 volts with 225 volt "B" supply; or 19 volts with 180 volt "B" supply. These load characteristics are shown on attached curve S-839435.

Included within this booklet are harmonic distortion curves S-839436. When making distortion measurements, it is essential that the voltmeter used for measuring output should be of the thermocouple type whenever possible. If a rectox meter is used, it must be removed from the circuit when taking actual distortion measurements since this type of meter will introduce some distortion. This condition is most noticeable at low values of amplifier output.

**REPLACEMENT PARTS** - The following parts list is included to provide identification when ordering replacement parts. When ordering specify the item by description and reference drawing number.

| <u>Item</u> | <u>Description</u>              | <u>Ref. Drawing No.</u>                   |
|-------------|---------------------------------|---|
| C-1         | Capacitor 4.0 mf (CP-137)       | M-68566-501                               |
| C-2         | Capacitor 4.0 mf (CP-137)       | M-68566-501                               |
| L-1         | Reactor (RT-259)                | M-406230-501                              |
| R-1         | Volume Control 50000 ohms       | <del>K-836935-P1</del> <i>K-836184-P1</i> |
| R-2         | Resistor 1350 ohms              | K-819789-P45                              |
| R-3         | Resistor 8000 ohms              | K-819789-P30                              |
| R-4         | Resistor 500000 ohms            | K-819789-P3                               |
| R-5         | Resistor 500000 ohms            | K-819789-P3                               |
| R-6         | Resistor 101.5 ohms             | K-819789-P2                               |
| R-7         | Resistor 101.5 ohms             | K-819789-P2                               |
| R-8         | Resistor 392000 ohms            | K-819789-P19                              |
| R-9         | Resistor 0.92 ohms              | K-819789-P6                               |
| S-1         | Switch (D.P.S.T.)               | K-65679-P1                                |
| T-1         | Input Transformer (RT-307)      | M-403091-502                              |
| T-2         | Interstage Transformer (RT-308) | M-403096-501                              |
| T-3         | Output Transformer (RT-309)     | M-403097-501                              |

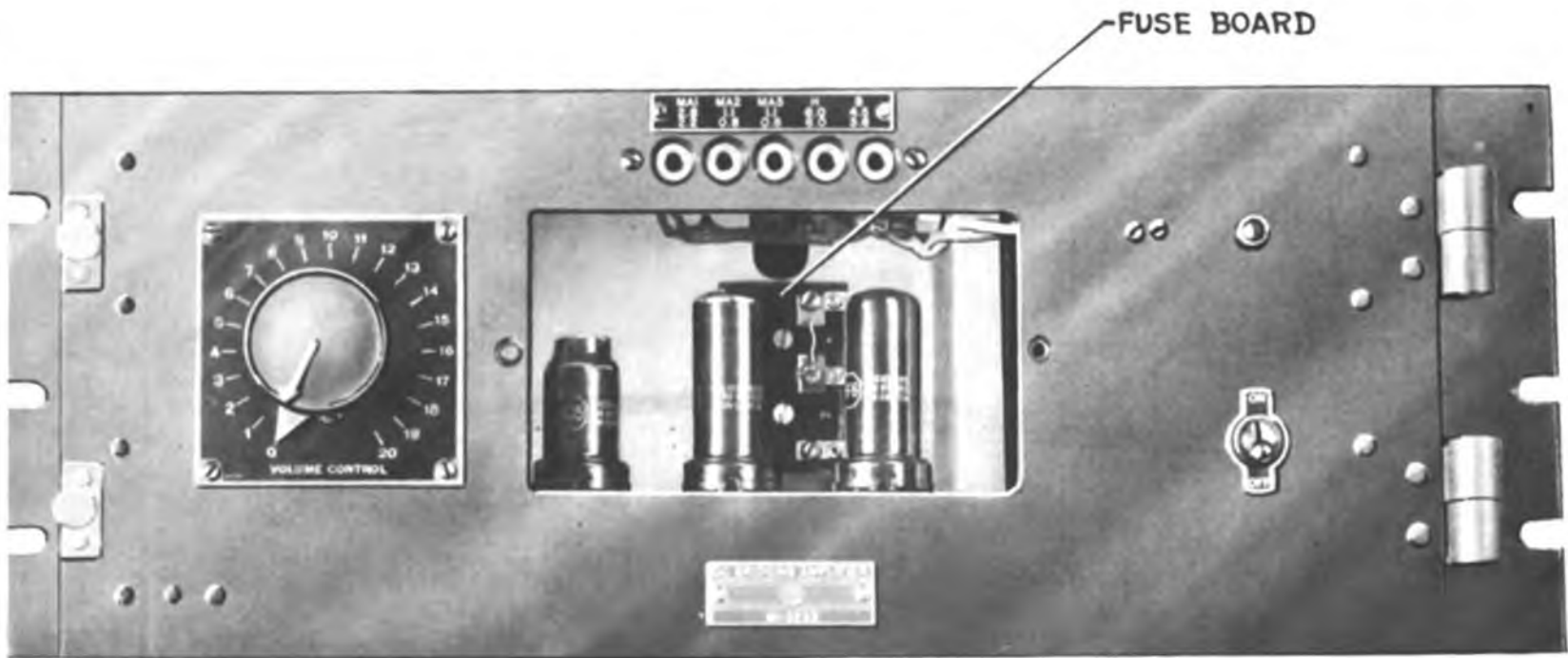
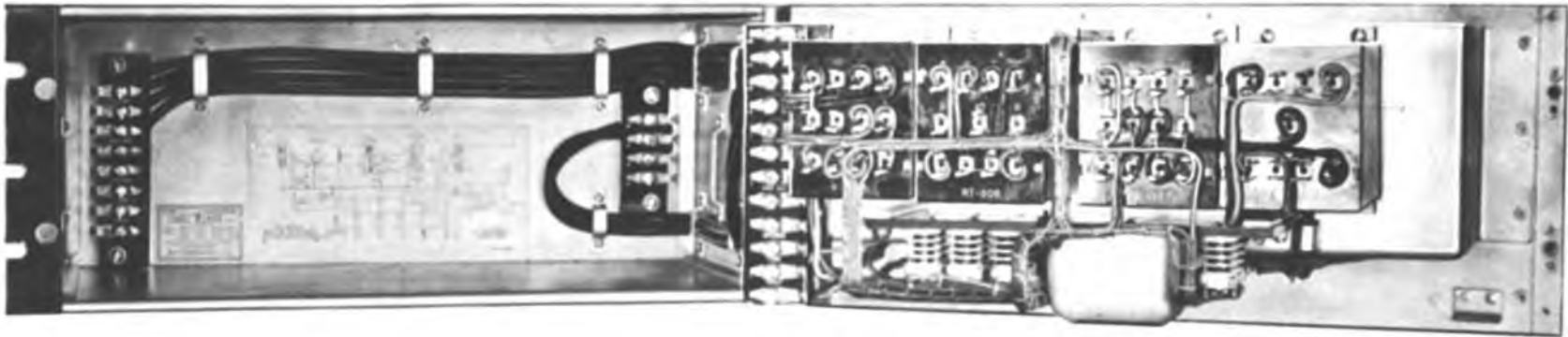

FUSE BOARD

MI-3233 D.C. BRIDGING AMPLIFIER



S-839435

S-839435

# MI-3233 DC BRIDGING AMPLIFIER

## LOAD CURVES FOR 60 AND 1000 CYCLES

### 500 OHM OUTPUT

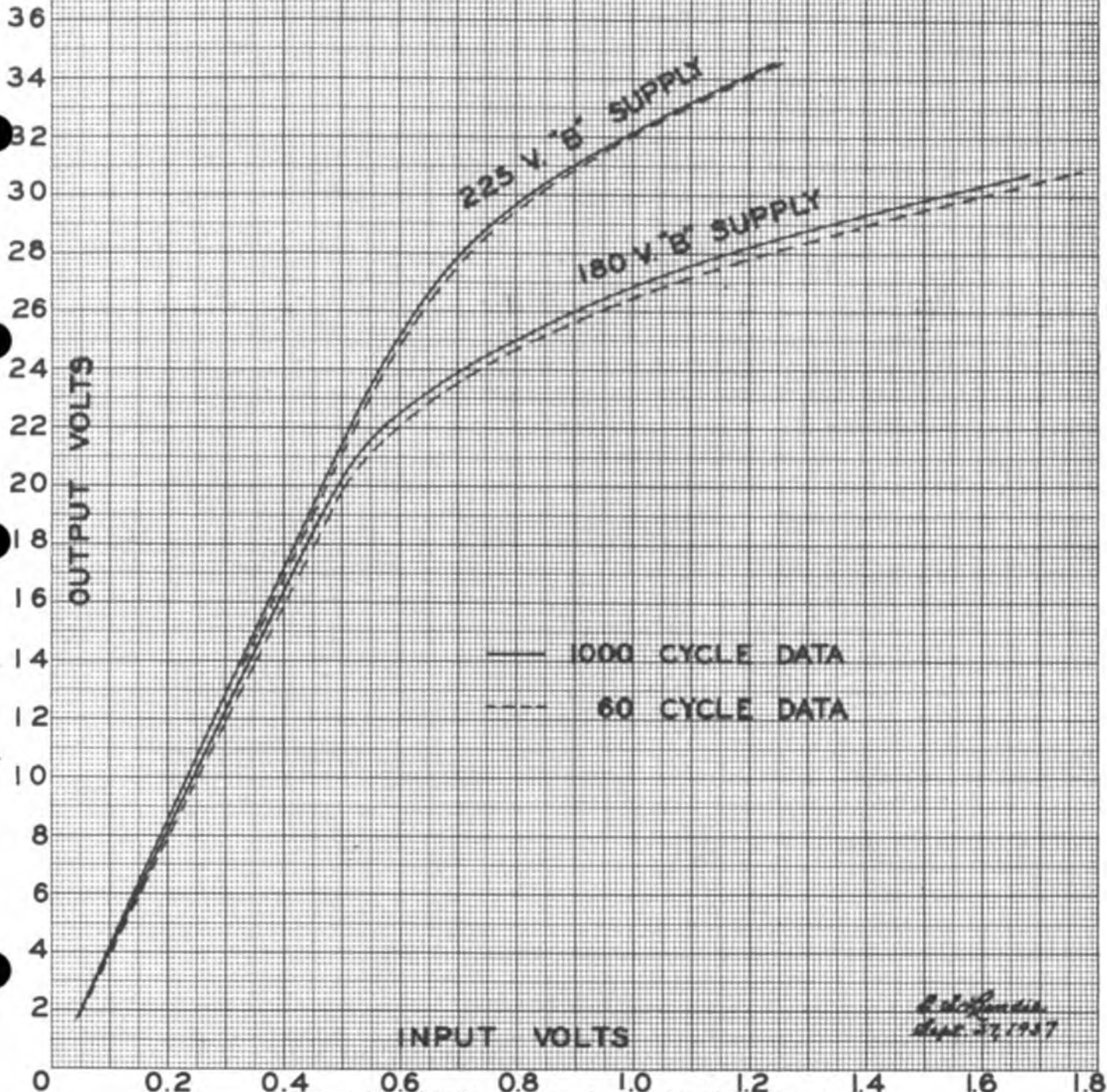

*E. Hoffmann*  
Sept. 27, 1957



MI-3233 D.C. BRIDGING AMPLIFIER  
PERCENT HARMONICS VS POWER OUTPUT (0.006 W. REF.)  
400 CYCLE FUNDAMENTAL FREQUENCY

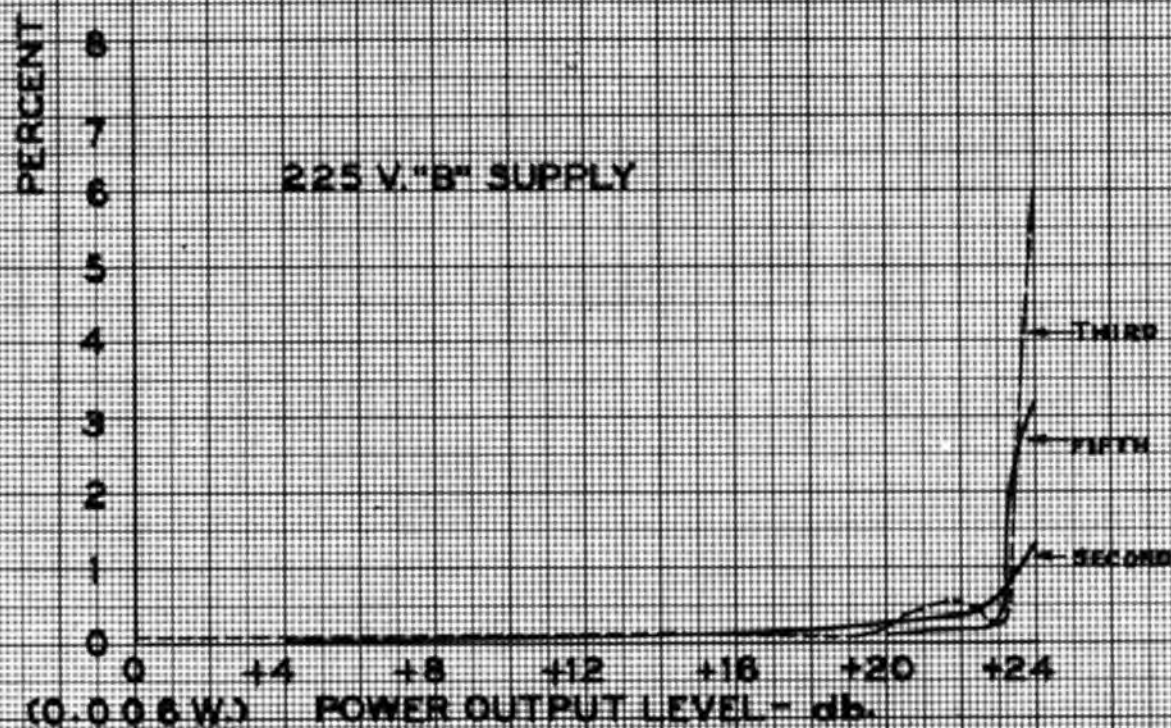
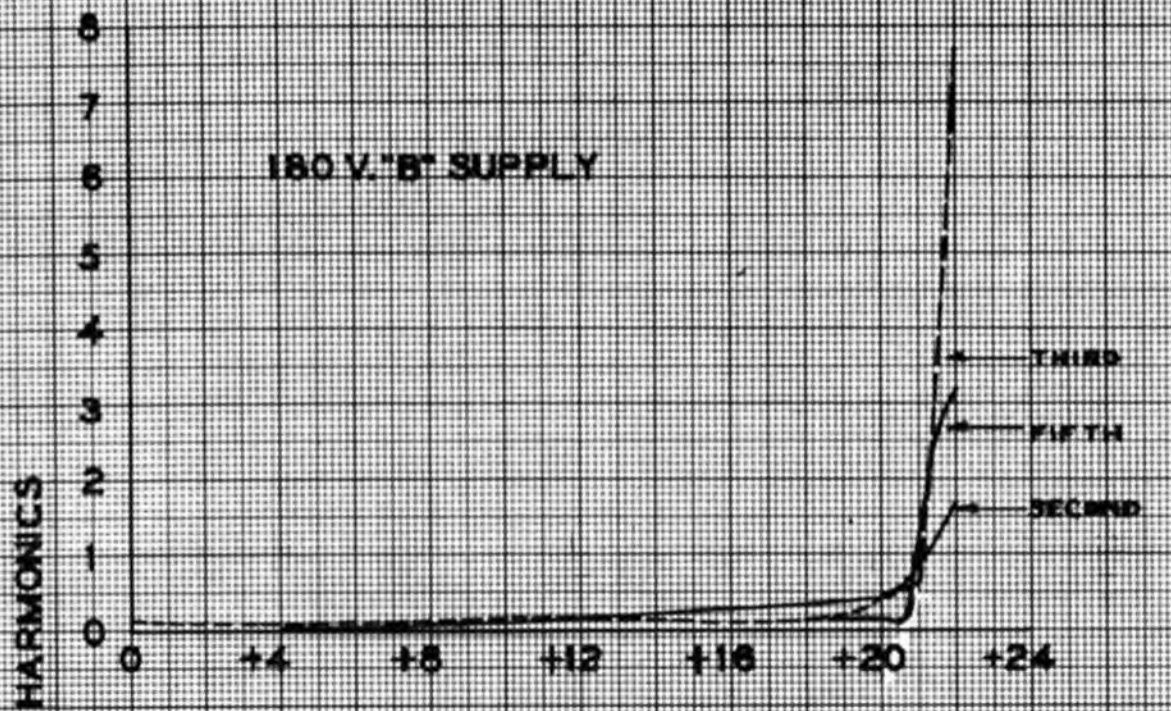

(0.006 W.) POWER OUTPUT LEVEL - db.

*[Signature]*  
APR 28, 1957

# MI-3233 D.C. BRIDGING AMPLIFIER FREQUENCY CHARACTERISTIC

34  
32  
30

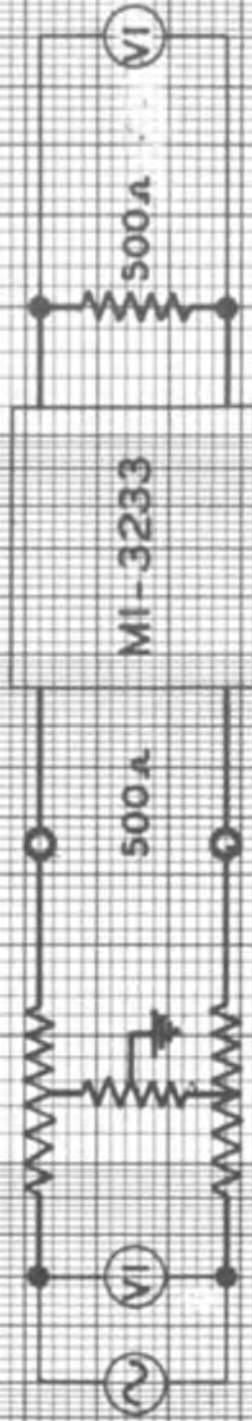

500 OHMS OUTPUT LOAD  
500 OHMS SOURCE IMPEDANCE

*Handwritten:*  
R. J. Collins  
MAR 27 1957

FREQUENCY-CYCLES PER SECOND

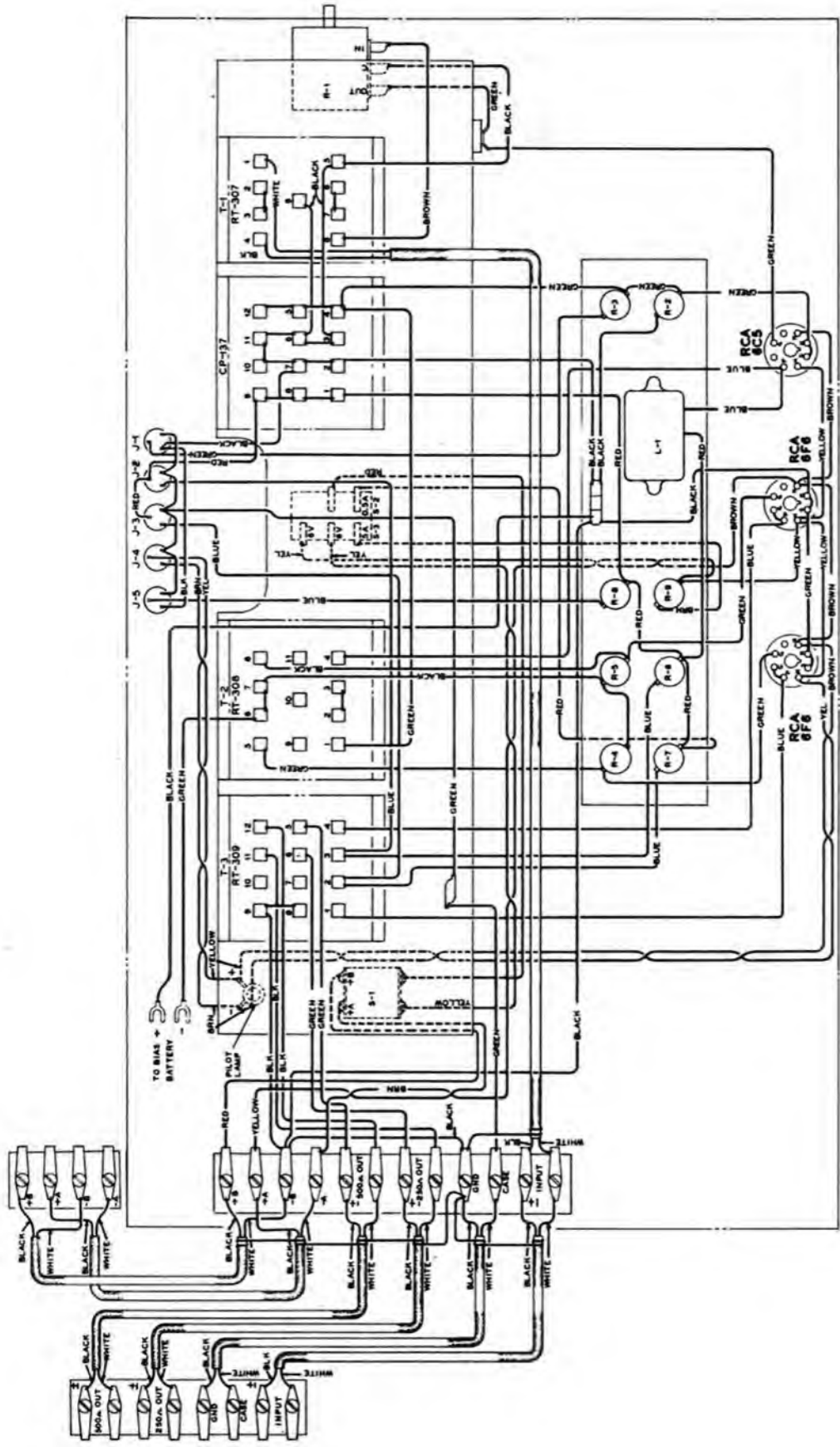

M.I:3233 T-607698





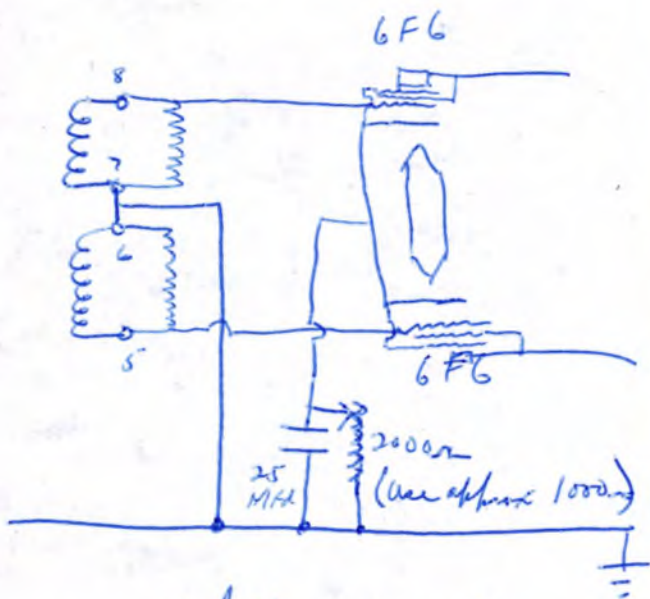

adjust current  
plate current for  
"B" voltage being used.



Dimensions in inches

Dimensions on Finished Dimensions unless otherwise marked

| Basic Dimensions | Fractional Dimensions | Decimal Dimensions |
|------------------|-----------------------|--------------------|
| Up to 1/4        | ± 1/32                | ± .005             |
| Above 1/4 to 6   | ± 1/64                | ± .005             |
| Above 6 to 24    | ± 1/32                | ± .010             |
| Above 24         | ± 1/16                | ± .015             |

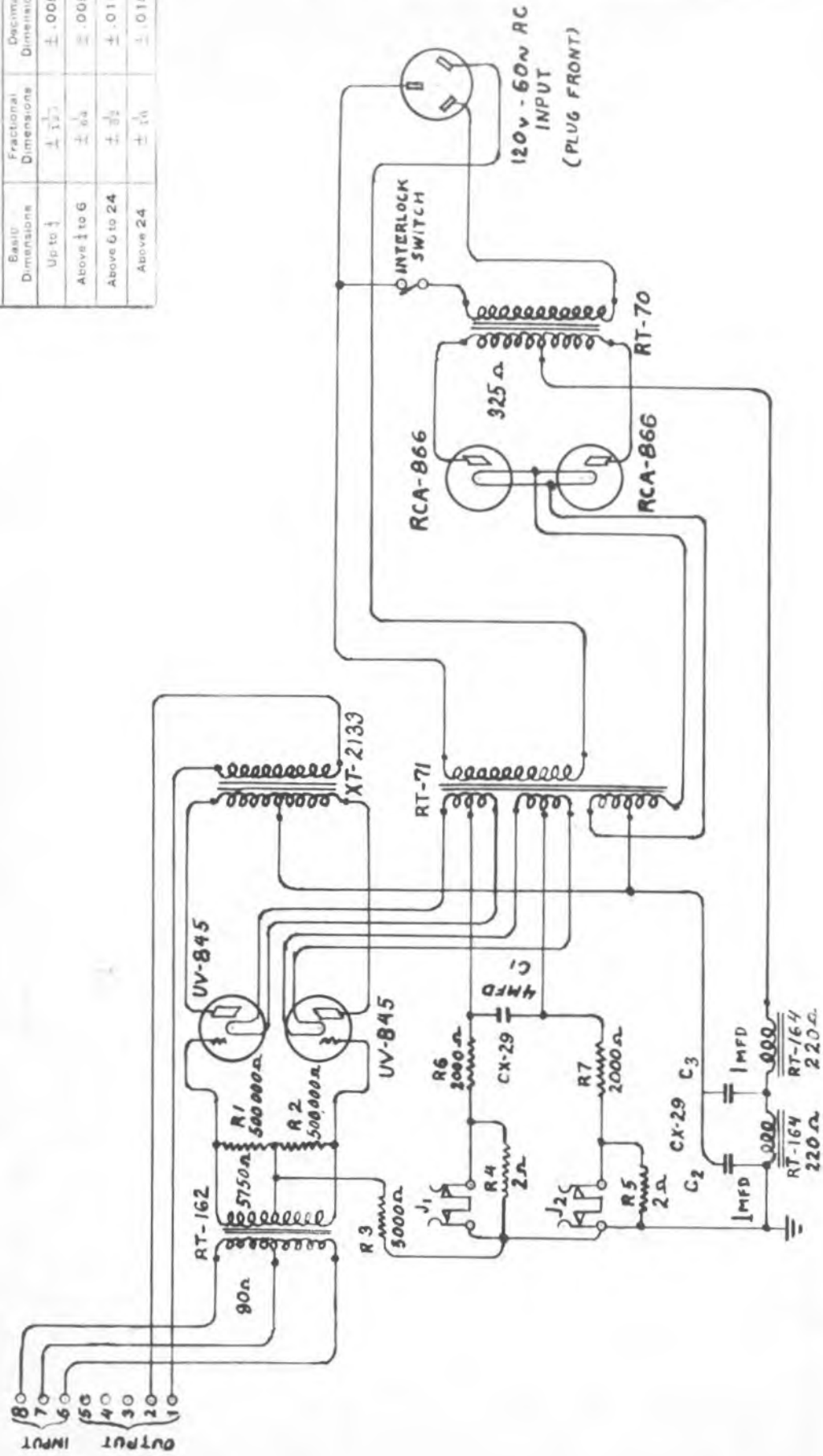

**SCHEMATIC DIAGRAM OF MI-4250A**  
Modified for Disc Recording

FIRST MADE FOR Master Reference Book.  
DRAWN BY MSK Feb. 12, 1940 MATERIAL

TRACED BY \_\_\_\_\_  
CHECKED BY \_\_\_\_\_

RCA Manufacturing Co. Inc.  
RCA Victor Division

**KX-380132**

**KX-380132**



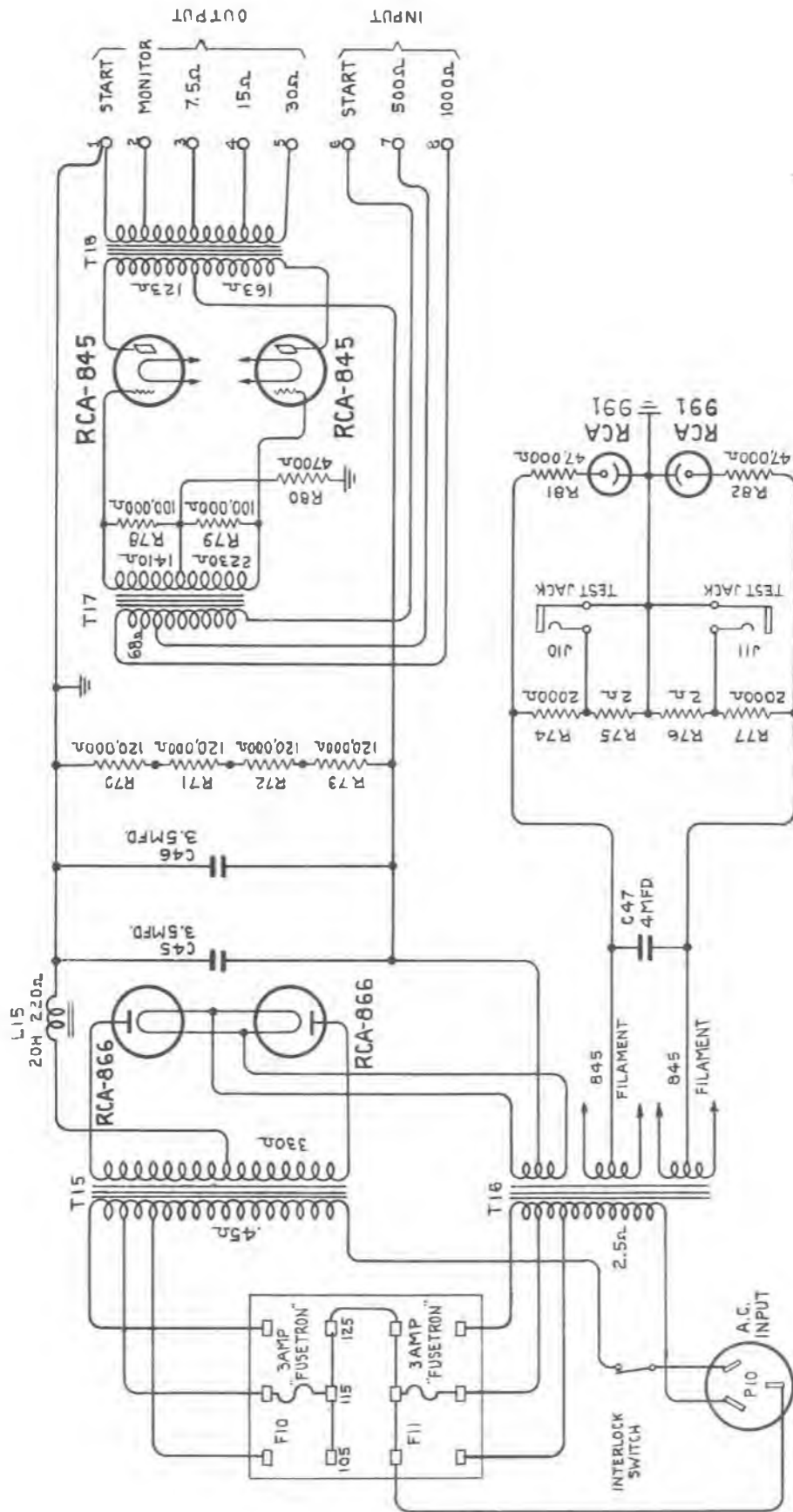

Figure 1 - Schematic Circuit Diagram - MI-4255A

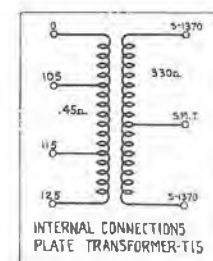
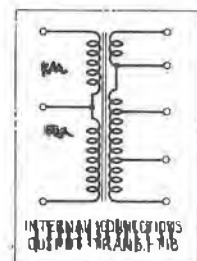
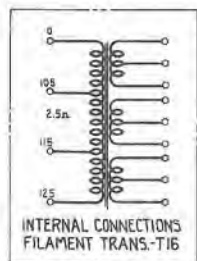
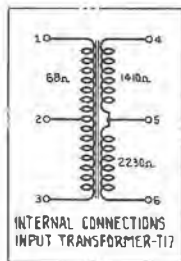
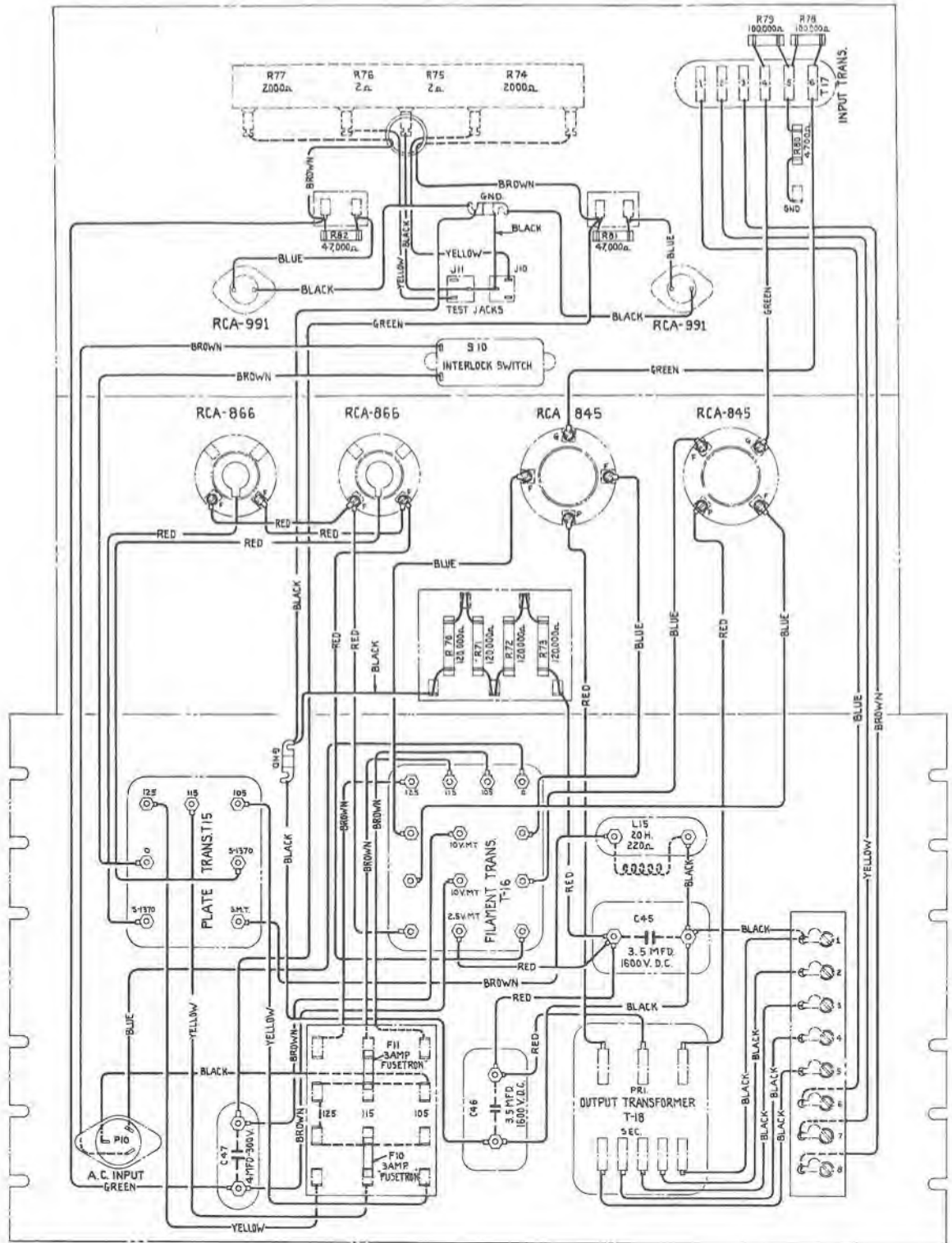

Figure 2 - Wiring Diagram - MI-4255A

## RADIOTRONS UV-845

To measure the plate current of the Radiotron UV-845 a low-range voltmeter or a millivoltmeter is required. The meter should be connected to a Yaxley No. 75 phone plug, or a similar plug, and the plug inserted into the plate-current metering-jacks on the base of the power amplifier. The normal plate current is between 60 and 75 milliamperes.

An internal shunt of suitable value is provided so that two millivolts read on the test meter equals one milliampere of plate current.

## RADIOTRONS RCA-866

During shipment the mercury in the Radiotrons RCA-866 may splash on the filament and plate, and therefore, when this type of tube is first placed in operation, *the filament should be heated for thirty minutes with no plate voltage applied to the tube* in order to drain mercury to the base of the envelope, prior to application of plate potential.

## REPLACEMENT PARTS

### Power Amplifier MI-4255A

| DESCRIPTION  | STOCK NO.        |
|--|------------------|
| BOARD - Fuse board complete with 12 clips and terminals .....  | 26204            |
| BOARD - Input and output terminal board .....  | 25393            |
| BOARD - Terminal board complete with 2 terminals .....   | 22865            |
| CAPACITOR - 3.6 Mfd. capacitor - C45, C46 .....  | 26162            |
| CAPACITOR - 4 Mfd. capacitor - C47 .....   | 26163            |
| FUSE - 3.2 amp. cartridge fuse - F10, F11 .....  | 23559            |
| JACK - Meter jack - J10, J11 .....   | 22616            |
| REACTOR - Filter reactor - RT-164 (L15) .....  | 25380            |
| RECEPTACLE - 3 contact receptacle - P10 .....  | 23553            |
| RESISTOR - 47,000 ohm 1/4 watt carbon resistor - R81, R82 .....  | 23432            |
| RESISTOR - 4,700 ohm 1/2 watt carbon resistor - R80 .....  | 8072             |
| RESISTOR - 100,000 ohm 1/2 watt carbon resistor - R78, R79 .....   | 6185             |
| RESISTOR - 120,000 ohm 2 watt carbon resistor - R70, R71, R72, R73.  | 11366            |
| RESISTOR - 4,004 ohm porcelain resistor, tapped at 2,000, 2,002 and<br>2,004 ohms - R74, R75, R76, R77 ..... | 26206            |
| SCREWS - One set of two special thumbscrews for fastening perforated<br>cover .....                          | 20058            |
| SOCKET - Indicator lamp socket .....   | 23555            |
| SOCKET - Porcelain base socket for UV-845 Radiotron .....  | 26442            |
| SOCKET - Porcelain base socket for RCA-866 Radiotron .....   | 26483            |
| SWITCH - Interlock switch - S10 .....  | 23552            |
| TRANSFORMER - Filament transformer - RT-71 (T16) .....   | 27397            |
| TRANSFORMER - Input transformer RT-375 (T17) .....   | 26203            |
| TRANSFORMER - Output transformer <del>RT-375 (T17)</del> ..XT-2183 .....                                     | <del>27398</del> |
| TRANSFORMER - Plate transformer - RT-70 (T15) .....  | 27398            |



INSTALLATION AND SERVICE DIVISION

MI-4255-A

RCA MANUFACTURING CO., INC.

CAMDEN, N. J.

CLASSIFICATION Technical - Photophone - Amplifiers

DATE Dec. 16, 1937

SUBJECT: REPLACEMENT TUBE SOCKETS FOR MI-4255-A

NUMBER SL-2C3-3.6B

TO: A-5, B-1, B-2, B-3, B-4, C-7, D-7, E-7, F-7, G-1, G-2, G-3, G-4, H-7

Because of difficulty in obtaining delivery, Stock No. 26442 (UV-845 Radiotron socket) and No. 26483 (RCA-866 Radiotron socket) used in MI-4255-A will no longer be stocked.

When replacement sockets are necessary in the MI-4255-A, the standard porcelain base sockets (No. 7166 and No. 17306) used in the MI-4255-B should be ordered. The sockets are interchangeable except for mounting holes. Figure 1 shows the location of the mounting holes to be drilled in the lower shelf of the MI-4255-A amplifier chassis to accommodate the replacement socket. Each socket is mounted by means of two one-inch #10-32 machine screws with the necessary flat washers and lock washers.

(NOTE: Stock No. 7166 UV-845 socket is identical to and supersedes No. 24475 stocked for MI-4255.  
Stock No. 17306 RCA-866 socket is identical to and supersedes No. 25075 stocked for MI-4255.)

Figure 1  
Layout of Mounting Holes for Porcelain Base Sockets in MI-4255-A

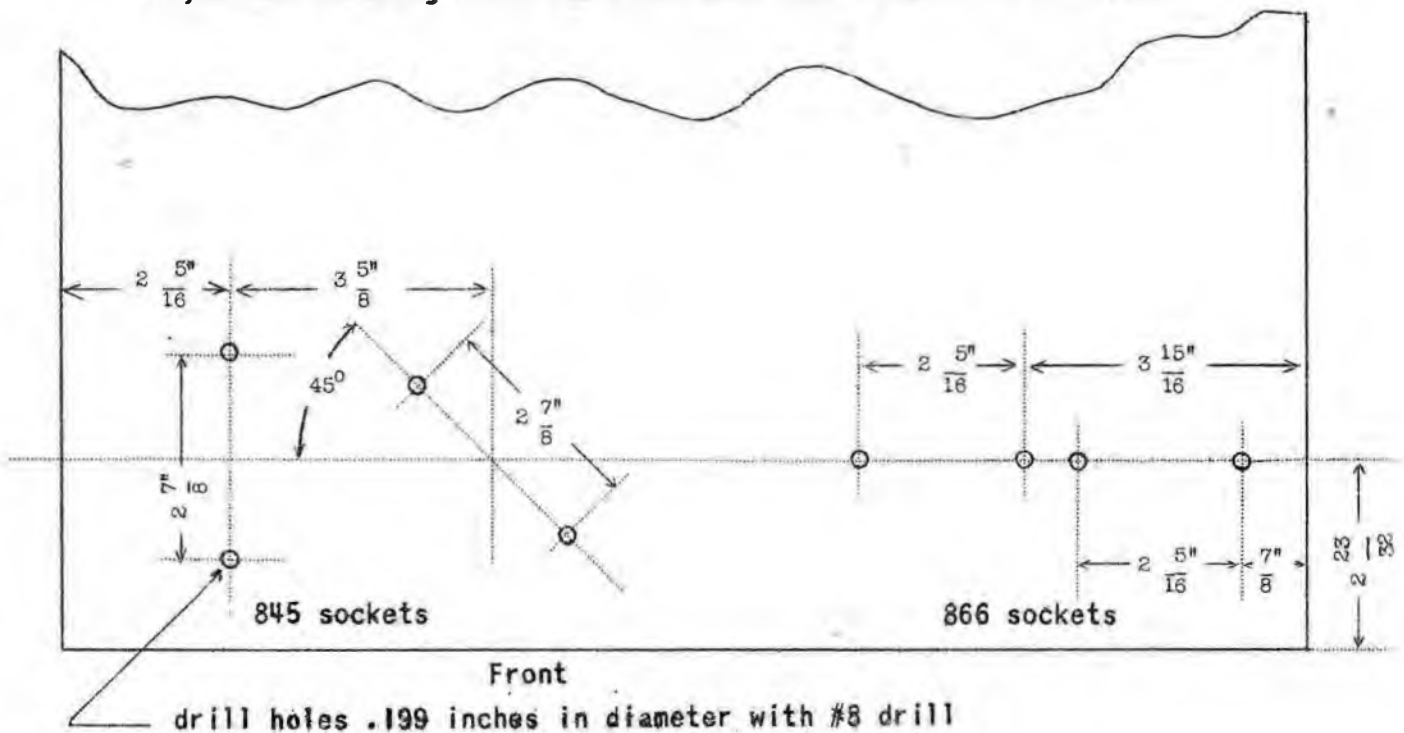

## (PRELIMINARY)

## Instruction Sheet

Modification of MI-10206 (or MI-10206A) Electronic Range Control  
for Disc Recording.

## GENERAL:

The unit used for disc recording is actually an MI-10206A which differs from the MI-10206 only in having two balancing potentiometers instead of one as shown on the accompanying instruction book 2RI-9.1.

For disc recording these two potentiometers should be 50,000 ohms each - one for the 6K7 tubes and one for the 6C5 tubes.

In addition the input loss pad, indicated on the schematic diagram must be changed from 39 db to 15 or 20 db according to the use of the unit. (See Schematic diagram T-613261, MRB Sec. XI and setup instructions MRB Sec. XIII-3a and 3b).

## CHANGEOVER FROM COMPRESSOR TO LIMITER:

The unit may be easily modified for quick changeover from compressor to limiter action if required by substituting fixed resistors for the two sections of both P-1 and P-2. Procedure is as follows:

After P-1 and P-2 have been adjusted according to Section 3a and 3b of this book - measure the resistances from each end of the potentiometers to the arms. Note these eight values (they should be measured on an accurate resistance bridge) and remove the two potentiometers from the circuit. Substitute eight resistors for these four potentiometer sections. These resistors should be one half watt, non-inductive wire wound resistors and should be within one per cent of the exact measured value of the potentiometer section resistances.

Now connect a four-pole two-position switch so that changing the switch from one position to the other will change from limiting to compressing action.

Note: This data is offered for use in case it is necessary to use the same MI-10206 as both a limiter and a compressor. Since this condition does not exist generally as yet, detailed data including a schematic is not yet available. Such information will be made available as soon as studio conditions require it.

Issued March 11, 1940

SECTION V

Monitor Equipment - Meters, Loudspeakers Etc.

Master Reference Book  
Disc Recording

## INSTRUCTIONS

for

### STUDIO TALKBACK & PLAYBACK EQUIPMENT

#### GENERAL

The Talkback and Playback Equipment are for use in communication between the Control Room and Clients Room and the Studio, also for playback in the Studio.

#### COMPONENTS OF EQUIPMENT

- 1 PA-82-C1 (MI-11209-B) Amplifier modified as per information stated in paragraph "Changes made to Standard Parts."
- 1 Type 64-B (MI-4400-B) Monitoring Speaker equipped with one MI-4410 Permanent Magnet Speaker Mechanism modified as stated in paragraph "Changes made to Standard Parts."
- 1 MI-4405-B Base for Type 64-B Monitoring Speaker.
- 1 XT-2831 or GW-171 Transformer.

#### CHANGES MADE TO STANDARD PARTS LISTED IN ABOVE PARAGRAPH

The gain of the PA-82-C1 (MI-11209-B) Amplifier is reduced in accordance with the instruction given on page nine of IB-24247.

MI-4410 Speaker Unit is modified by disconnecting one of the capacitors placed across a portion of the voice coil leaving only one capacitor in use.

#### ASSEMBLY OF THE SEVERAL COMPONENTS

The PA-82-C1 Amplifier is mounted in the MI-4405-B Speaker Base and fastened with screws or bolts.

The Type 64-B (MI-4400-B) Speaker Cabinet is then assembled on the base and fastened with screws using the holes in base provided for same.

Remove the back of the speaker cabinet and install the XT-2831 transformer. Short terminals 1A and 1B also 3A and 3B. Connect terminals 4 and 6 to the wires going to the voice coil, first removing them from plug on back of speaker cabinet. Connect pair of wires from terminals Nos. 1A and 3B to plug in speaker cabinet back and also drill several holes through wood partitions in the speaker cabinet and connect a second pair of wires from the same transformer terminals (1A and 3B) to the 500-600 ohm output terminals on the PA-82-C1 terminal board.

Note: In several cases a GW-171 Transformer is used instead of the XT-2831. When used, terminals remote from the GW number are to be connected to the voice coil leads and the terminals nearest the GW number to the plug and output of the PA-82-C1.

Install the MI-4410 Speaker Mechanism according to instructions given on page 4 of IB-30021.

Bridge a 250 ohm resistor across the input terminal of the PA-82-C1 and then connect a pair of shielded wires from these same terminals to the line running to the console and labeled "Audio to Studio Playback Amplifier" on inter unit wiring diagram W-302705.

A pair of 10000 ohm one watt resistors must be connected between the tips and springs of jacks, Nos. 47 and 48, on the console jack bay (see wiring diagram W-302627). This permits the PA-82-C1 to be bridged across the V1 driver bridge bus for playback purposes and normaled across the talkback pre-amplifier for talkback purposes. It is realized that there will be a mismatch in impedance between the output of the talkback pre-amplifier and the input of the PA-82-C1 under these conditions but for the purpose for which it is used, it is satisfactory.

February 10, 1943



INSTRUCTIONS  
for  
RCA MONITORING AMPLIFIER  
TYPE 82-C1  
(MI-11209-B)

TECHNICAL DATA

POWER SUPPLY

105-125 Volts  
50-60 Cycles  
110 Watts

FUSE

a-c Line, 2-Ampere

RADIOTRONS

1st Stage, 1 RCA-1620 or \*1 RCA 6J7  
2nd Stage, 1 RCA-1620 \*1 RCA 6J7  
3rd Stage, 2 RCA-1620 \*2 RCA 6J7  
4th Stage, 2 RCA-1622 (Push-Pull) \*2 RCA 6L6  
Rectifier, 1 RCA-5U4G

\*May be used when maximum uniformity of characteristics and minimum of microphonics, hum, and distortion are not required.

SOURCE IMPEDANCE

250 or 30 Ohms

INPUT IMPEDANCE

Unloaded transformer

LOAD IMPEDANCE

500-600/250/15/7.5/5 Ohms

OUTPUT IMPEDANCE

140/70/3.5/2.0/1.4 Ohms (Approx.)

FEEDBACK

15 db @ 1,000 Cycles

POWER OUTPUT

Rated power output: 12 watts (+40.8 db\*) with less than 3% total rms distortion 50 to 7,500 cycles.)

OVERALL GAIN

- (a)  $105 \pm 2.0$  db (250-ohm source to a 15 ohm load)
- (b) 70 db (with bridging volume control, 500-600 ohm terminated line to a 15 ohm load)

NOISE LEVEL

Maximum -18 db\* (unweighted) with input terminated.

FREQUENCY RESPONSE

$\pm 2.0$  db (1,000 cycle reference) from 30 to 15,000 cycles with 250 ohm source and a 15 ohm load.

GAIN CONTROLS

- (a) Internal, Potentiometer in the grid circuit of 2nd stage.
- (b) External Bridging Control.

PHYSICAL SPECIFICATIONS

Width - 16 inches  
Depth - 11 inches  
Height - 8 inches  
Weight - 26 pounds (unpacked)

MOUNTING

Shelf-Mounting, may be rack-mounted by means of the Type 36-A or Type 36-B Panel and Shelf Assemblies.

\*Note: 0 db = 0.001 Watts



FIGURE 1 - TYPE 82-C1 MONITORING AMPLIFIER - MI-11209-B.

**DATA WHEN CONVERTED FOR HIGH  
AND LOW FREQUENCY COMPENSATION**

**AMPLIFIER FREQUENCY RESPONSE**

(1,000 Cycle Reference)  
+5.0 db at 60 cycles  
+6.0 db at 15,000 cycles. See Figure 6

**AMPLIFIER HUM AND NOISE LEVEL**

(Unweighted, with  
input terminated)  
-14 db\*

**AMPLIFIER GAIN**

(At 1,000 Cycles)  
105 db, from a 150-ohm source to a 15  
ohm load.

**RATED POWER OUTPUT**

12.0 Watts (+40.8 db\*) with less than 3%  
total R.M.S. distortion 50 to 7,500 cycles.  
Note: The power output at 60 cycles is 12  
watts (amplifier rating) when the output  
at 1,000 cycles is 3.8 watts.

**DESCRIPTION**

The RCA Type 82-C1 Amplifier has been designed primarily for monitoring purposes, although it may be used during emergencies in the program channel of the transmitter. The amplifier employs metal tubes in the signal circuit and comprises four stages, with an interstage volume control, and phase inverter driving push-pull output tubes. The remote volume control is designed to be used externally for bridging a line.

Plug-in type electrolytic capacitors are used in the MI-11209-B Amplifier Assembly. This type of capacitor is fabricated with an octal type base on its end (similar to that used in radio tube construction), and capacitor leads are brought out to pins in the base. These capacitors are inserted into octal sockets on the chassis base. Circuit connections are made to the sockets. It is obvious that this

type of electrolytic capacitor construction very much simplifies servicing the equipment, and loss of service due to capacitor failures is practically eliminated.

## INSTALLATION

### LOCATION AND MOUNTING

The amplifier may be conveniently mounted on Type 36-A or Type 36-B Panel and Shelf Assemblies. Avoid placing the amplifier near microphone pre-amplifiers or other units operating at extremely low signal levels. Place plug-in capacitors into sockets, the marking on capacitor and socket to be alike.

### VOLUME CONTROL AND AUDIO INPUT CONNECTIONS

- (a) The amplifier is connected to operate from a 250-ohm source, and the amplifier "INPUT" terminals will be found connected to the terminals #1 and #4 of the input transformer, T-1. Should it be desired to operate from a 30-ohm source, disconnect input wire to terminal #1 and connect to terminal #2, and disconnect input wire to terminal #4 and connect to terminal #3.
- (b) If the amplifier is to bridge a 500-600 or 250-ohm line it will be necessary to use the remote volume control (supplied with the amplifier) in the input circuit. This control is comprised of a 500-ohm dual potentiometer with two 4,700-ohm resistors, connected one to each arm (moving contact) and to a pair of terminals on a terminal block attached to the potentiometer. The two outer terminals of the potentiometer are shunted with a 470-ohm resistor.

Connections should be made as follows:

1. Connect the two outer terminals (shunted by the 470-ohm resistor) on the dual potentiometer to the "INPUT" terminals of the amplifier.
2. Connect the two inner terminals shunted together on potentiometer to ground."
3. Connect the two terminals on terminal block to the 500-600 or 250-ohm line.

\*Note: In some cases, it may be found desirable to:

- (a) Connect these terminals to the amplifier ground.
- (b) Remove the ground connection to the primary center tap of the input transformer, T-1, (in type 82-C1 Amplifier) when the remote volume control is grounded at a remote point.
- (c) If the Type 82-C1 Amplifier is used to amplify the output of an RCA-MI-4875-A, MI-4875-C Combination Pickup Kits or Type 70-C1 Transcription Turntable, the output of these equipments may be connected directly to the Input of the amplifier. It will only be necessary to remove the ground lead from the input transformer center tap (terminal #6) and connect instead to terminal #1.

If it is desired to use the Type 82-C1 Amplifier with a device which is intended to work into 250-ohms (unbalanced) such as the RCA Types 70-B or 70-C Transcription Turntables or Type 71-C Vertical pickup, proceed as follows:

1. Remove the ground lead connection on the input transformer primary from terminal #6.
2. Connect the input to the amplifier as shown in Figure 2.

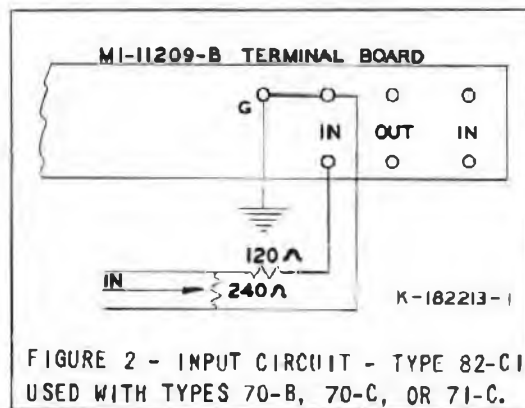

FIGURE 2 - INPUT CIRCUIT - TYPE 82-C1 USED WITH TYPES 70-B, 70-C, OR 71-C.

All audio input leads should be MI-6 $\mu$  shielded cable, or a shielded twisted pair, insulated for 200-volts, and need not be larger than No. 19 A.W.G. To prevent undesirable pickup, the leads should



not be run adjacent to, or laced in with, a-c or loudspeaker field supply leads.

### AUDIO OUTPUT CONNECTIONS

The amplifier is designed to supply a nominal audio output of 12 watts to various types of load. It may operate into a 500-600-ohm or 250-ohm line, or drive one or more loudspeakers. Terminals are provided and connected for 500-ohm and 15-ohm output. To adapt the amplifier to the type of load into which it is to operate, the amplifier "OUTPUT" terminals must be connected to the proper output transformer leads as follows:

| <u>LOAD</u>             | <u>TRANSFORMER (T-2) LEADS</u> |
|-------------------------|--------------------------------|
| 500-600-ohms (balanced) | Blue and Red                   |
| 250-ohms (unbalanced) * | Blue and Red/Black             |
| 15-ohms                 | Black and Red/Black            |
| 7.5-ohms                | Black and Red/Yellow           |
| 5.0-ohms                | Black and Brown                |

\*Note: When using 250 ohm tap the ground connection to the Black lead may be disconnected and connected to the Blue lead. Do not disturb the feedback circuit on the Black/Brown and Black-Red tracer leads.

The output leads to each speaker, or to the line should be individual MI-64 Shielded Cable, or No. 19 A.W.G. shielded, twisted pair, insulated for 200-volts (MI-63-A).

### AC POWER CONNECTIONS

The a-c power connections are made to the amplifier through the two terminals marked "AC". The power transformer (T-3) is designed for normal operation at 115 volts and contains taps for 125-volt operation and 105-volt operation. The transformer is connected at the factory for 115-volt operation. For 125-volt operation the 115-volt primary lead (black and red 50/50) may be disconnected and taped, and the 125-volt primary lead (black with red tracer) may be connected in its place. For 105-volt operation the 115-volt primary lead (black and red 50/50) may be disconnected and taped, and the 105 volt primary lead (black) may be connected in its place.

Note: In some amplifiers it may be found that the 115 volt primary lead is red with black tracer instead of black and red 50/50.

### HIGH AND LOW FREQUENCY COMPENSATION

#### GENERAL

Included with the Type 82-C1 Amplifier are the following parts:

| <u>SYMBOL NO.</u> | <u>DESCRIPTION</u>       | <u>STOCK NO.</u> |
|-------------------|--------------------------|------------------|
| C-1B              | 1 Capacitor, .015 Mfd.   | 30856            |
| C-2B              | 1 Capacitor, .005 Mfd.   | 30852            |
| R-1B              | 1 Resistor, 750-ohms     | 3382             |
| R-2B              | 1 Resistor, 56,000-ohms  | 30650            |
| R-3B              | 1 Resistor, 150,000-ohms | 30493            |
| R-4B              | 1 Resistor, 56,000-ohms  | 30650            |
| R-5B              | 1 Resistor, 82,000-ohms  | 8064             |
| R-6B              | 1 Resistor, 1,000-ohms   | 34766            |

To obtain replacement parts order by Stock Number and Description.

These parts are included with the Type 82-C1 Amplifier so that, if desired, the customer may convert his amplifier so as to provide a high and low frequency boost in the response. The low frequency boost is accomplished by adding a resistance capacity network into the plate circuit of the second stage. The high frequency boost is accomplished by adding a resistance capacity network into the cathode circuit of the third stage.



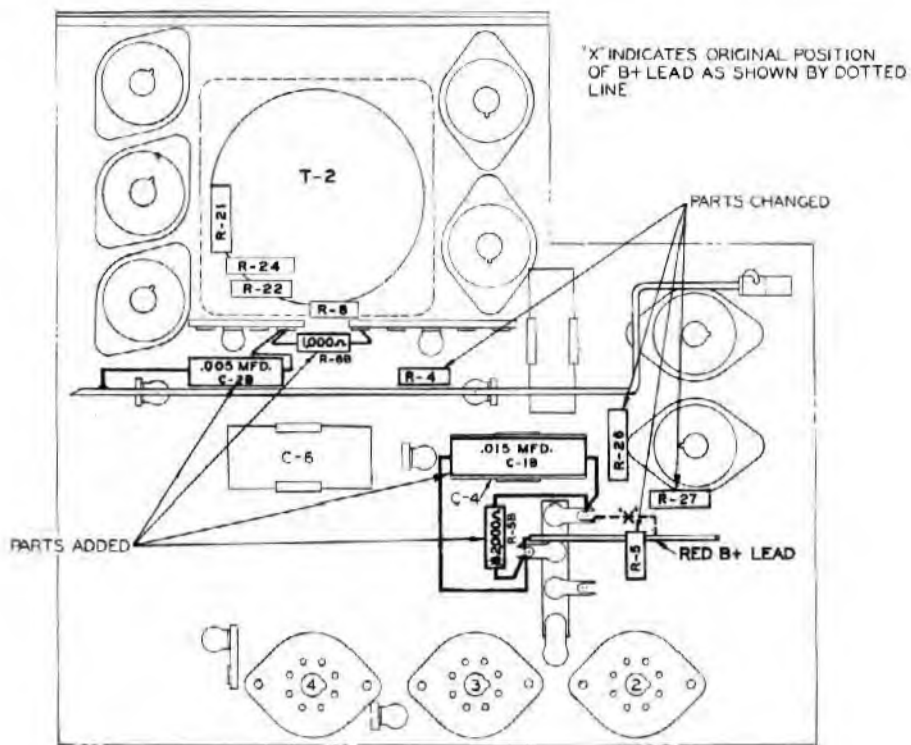

P-170738-1

FIGURE 4 - WIRING - FREQUENCY COMPENSATION ADDED TO TYPE 82-C1 AMPLIFIER.

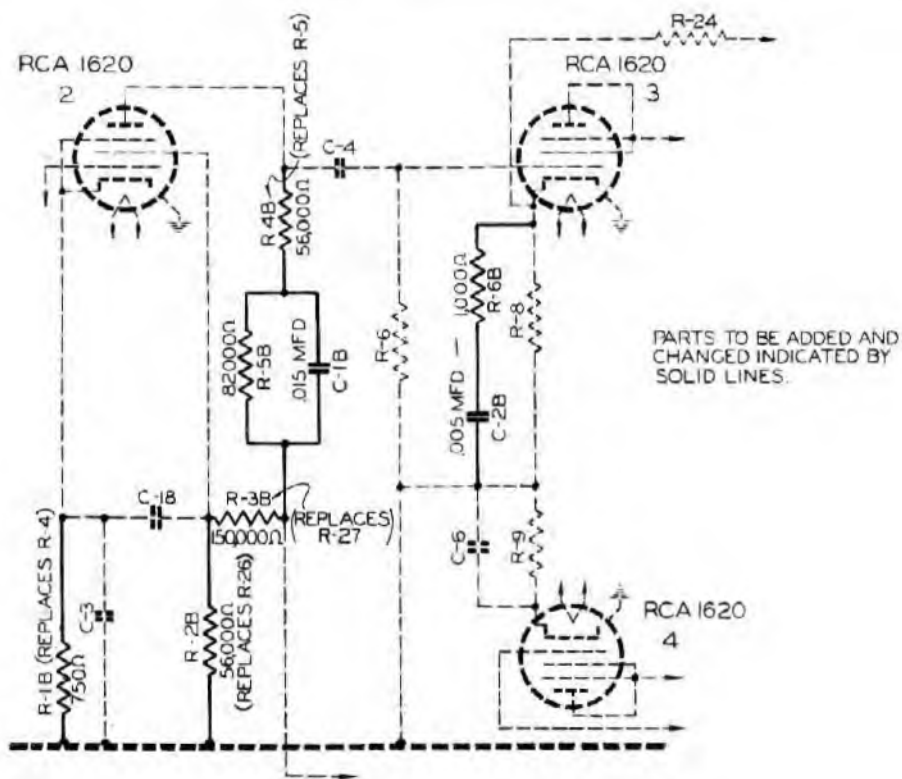

P-170739-1

FIGURE 5 - SCHEMATIC - FREQUENCY COMPENSATION ADDED TO TYPE 82-C1 AMPLIFIER.

## TO ADD FREQUENCY COMPENSATION

Refer to the Parts Location Figure 4 and Schematic Diagram Figure 5, and proceed as follows:

### (A) Parts to be changed in the Type 82-C1:

1. Replace R-4 with the 750-ohm resistor, R-16.
2. Replace R-26 with one of the 55,000-ohm resistors, R-2B.
3. Replace R-27 with the 150,000-ohm resistor, R-3B.
4. Replace R-5 with the other 55,000-ohm resistor, R-4B.
5. Disconnect the Red B- wire from the top terminal (on terminal strip that supported R-5) and connect it to the spare terminal on strip.

### (B) Parts to be added in the Type 82-C1:

1. Connect one side of the 82,000-ohm resistor, R-5B, to the Red B+ wire that was connected to spare terminal in section A-5, and the other side to the top terminal on this strip where one side of the 56,000-ohm resistor was connected in section A-4.
2. Place the .015 Mfd. capacitor, C-1B, in the mounting clamp holding C-3 and C-4 and connect it across the 82,000-ohm resistor added in section B-1.
3. Connect one side of the 1,000-ohm resistor, R-6B, to the junction of R-24 and R-8, and the other side to spare terminal on terminal strip supporting R-21.
4. Connect one side of the .005 Mfd. capacitor, C-2B, to the spare terminal that the 1,000-ohm resistor was connected to in section B-3, and the other side to the ground buss wire.

The amplifier will now have a high and low boost in the frequency response as shown in Figure 6.

The approximate potentials on the 2nd RCA-1620 tube with the 82-C1 converted for frequency compensation are as follows, when using a voltmeter of 20,000-ohms per volt:

| <u>2nd RCA-1620</u> |          |
|---------------------|----------|
| Ep                  | 50 Volts |
| Esg                 | 42 Volts |
| Ecath               | 1.0 Volt |

Note: All voltages should be measured to ground in order to correspond with tabulated figures.

## OPERATING VOLTAGES

Refer to Figure 7 for the tube operating voltages. To obtain the values listed, the a-c line voltage should be 115 volts, and all except heater voltages should be measured to ground using a voltmeter of 20,000-ohms per volt. The voltages listed are nominal, and readings taken should not vary more than about 5% of the values given. The total rectified voltage (across resistors R-19 and R-20) is approximately 350 volts.

**CAUTION:** If the voltmeter used has a meter resistance less than 20,000-ohms per volt, most readings taken will vary accordingly, the amount of variation depending upon the circuit in which the meter is connected.

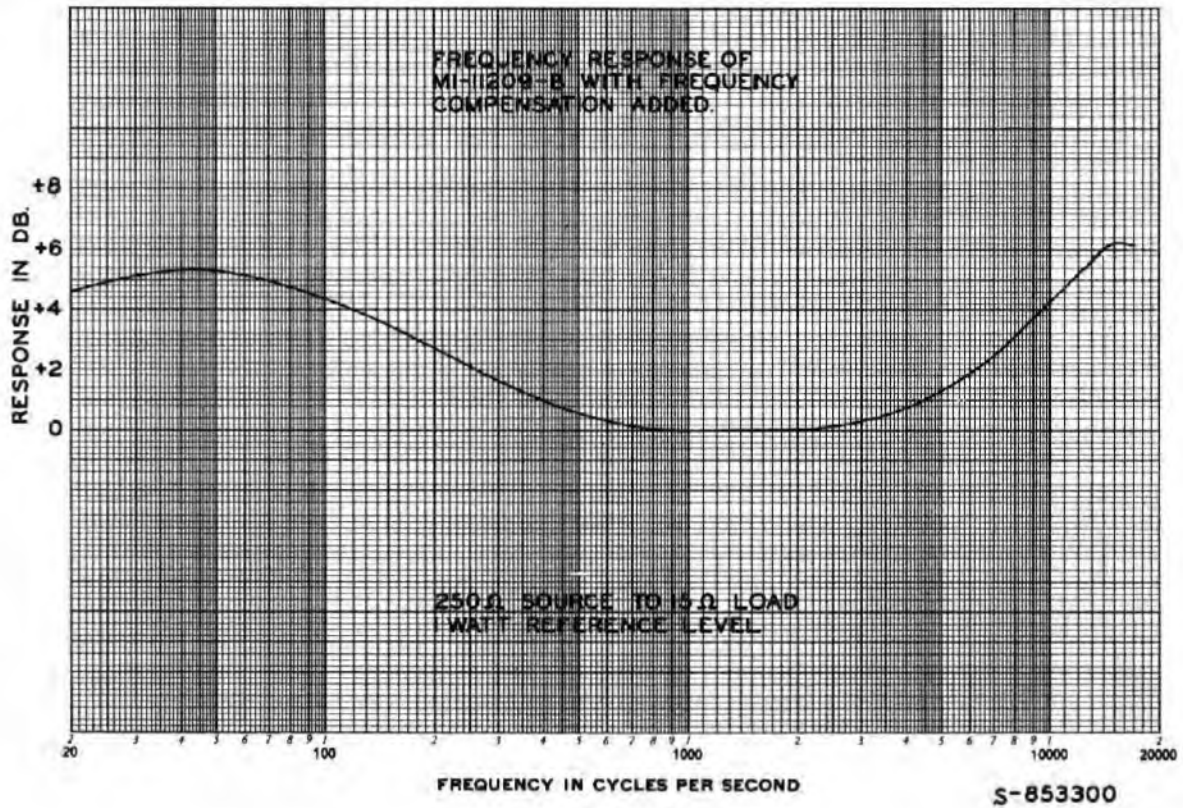

FIGURE 6 - RESPONSE CURVE OF TYPE 82-C1 AMPLIFIER WITH COMPENSATION.

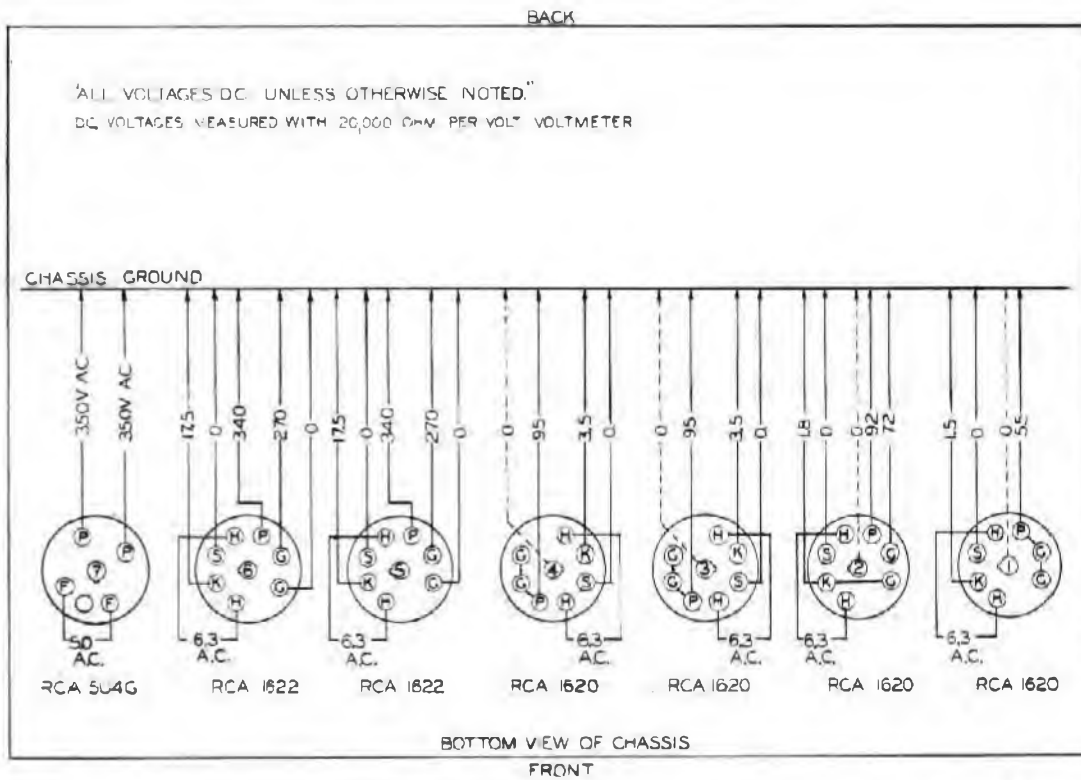

FIGURE 7 - TUBE SOCKET VOLTAGES - TYPE 82-C1 AMPLIFIER.

## MODIFICATIONS TO SECURE A REDUCTION IN OVERALL GAIN

TECHNICAL DATA: (Showing changed characteristics only)

### RADIOTRONS

1st Stage, 1 RCA-1620 or \*1 RCA 6J7  
2nd Stage, 2 RCA-1620 \*2 RCA 6J7  
3rd Stage, 2 RCA-1622 (Push-pull) \*2 RCA 6L6  
Rectifier, 1 RCA-504G

\*May be used when maximum uniformity of characteristics and minimum of microphonics, hum, and distortion are not required.

### NOISE LEVEL

Maximum -40 db with input terminated  
(0.001 watt reference)

### MAXIMUM INPUT

-25 db (For either 3 or 4 stage connections  
(0.001 watt reference)

### OVERALL GAIN

71 db @ 1000 cycles  
(250 ohm source to 15 ohm load)  
36 db @ 1000 cycles  
(with bridging volume control,  
500-600 ohm terminated line to  
a 15 ohm load).

### FREQUENCY RESPONSE

Unchanged

### POWER OUTPUT

Unchanged

### DESCRIPTION

For special applications it may be desired to operate the Type 82-C1 Amplifier at a lower gain. For such applications the gain may be reduced by omitting the second stage of the amplifier. This may be accomplished in the following manner.

1. Remove the grid lead from the grid cap of V-2 (The second stage RCA-1620).
2. Remove V-2 from its socket.
3. Remove the grid lead from the grid cap of V-3 (The 1st RCA-1620 in the 3rd stage).
4. Connect the grid lead removed from the cap of V-2 to the grid cap of V-3.

After these changes have been made the Type 82-C1 will have become a three stage amplifier having the same characteristics as specified for the normal (no compensation) Type 82-C1 four stage amplifier, except for the tube complement, gain, and noise level which are as specified above.

The interstage volume control should be operated near maximum in order to obtain rated power output.

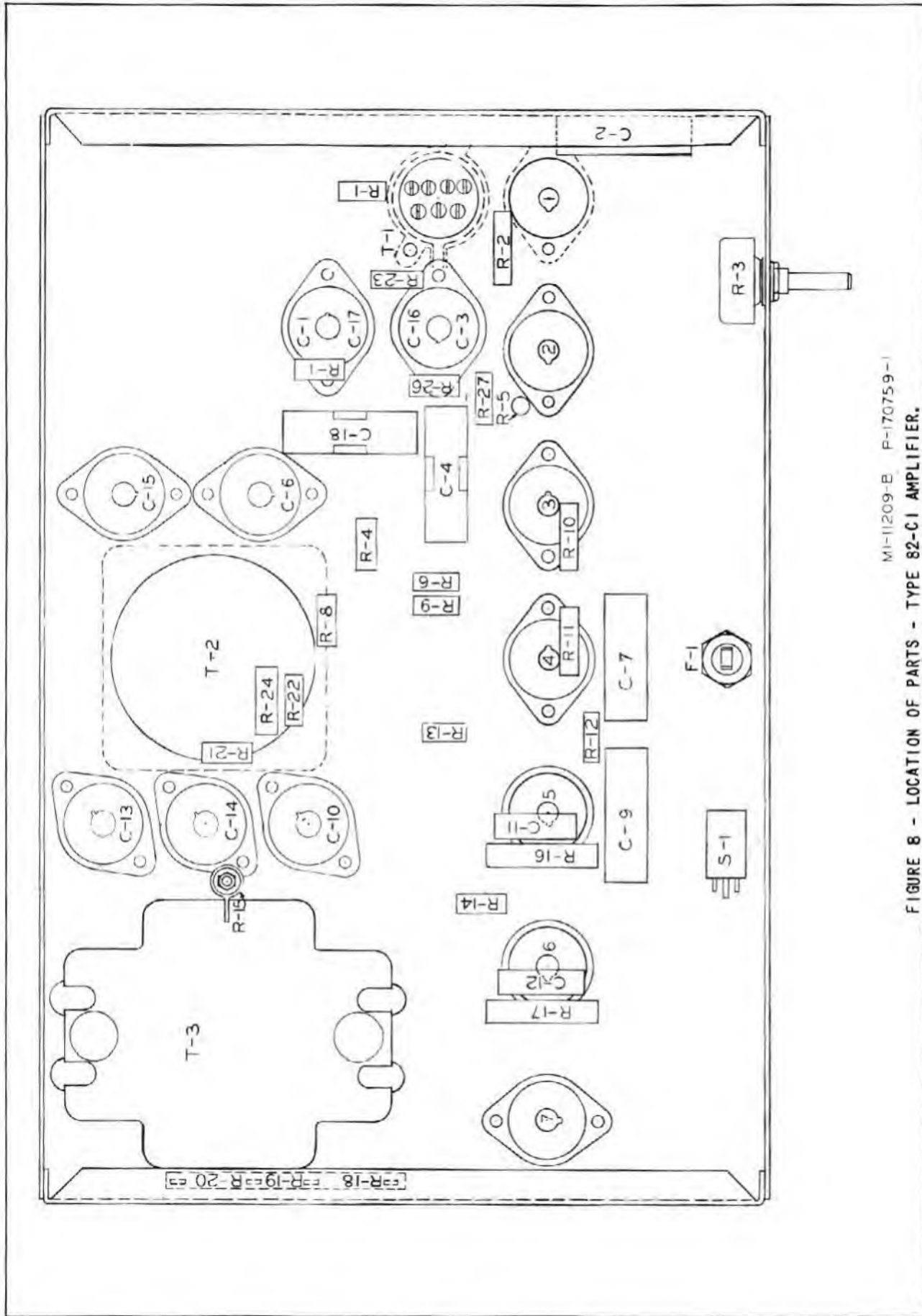

MI-11209-B P-170759-1  
 FIGURE 8 - LOCATION OF PARTS - TYPE 82-C1 AMPLIFIER.



## REPLACEMENT PARTS

The following parts list is included to provide identification when ordering replacement parts. When ordering, specify the item by its Stock Number and Description.

| <u>SYMBOL</u>            | <u>DESCRIPTION</u>  | <u>STOCK NO.</u> |
|--------------------------|---|------------------|
| C-1,C-3 . . . . .        | Capacitor - 10 mfd., 450 volts, & 40 mfd., 25 volts . . . . .                                     | 39461            |
| C2,C-4 . . . . .         | Capacitor - 0.1 mfd., 500 volts . . . . .   | 30848            |
| C-6 . . . . .            | Capacitor - 40 mfd., 150 volts . . . . .  | 39459            |
| C-7,C-9 . . . . .        | Capacitor - 0.1 mfd., 500 volts . . . . .   | 30848            |
| C-10 . . . . .           | Capacitor - 40 mfd., 150 volts . . . . .  | 39459            |
| C-11,C-12 . . . . .      | Capacitor - .0025 mfd., 1000 volts . . . . .  | 30850            |
| C-13,C-14 . . . . .      | Capacitor - 40 mfd., 450 volts . . . . .  | 39457            |
| C-15 . . . . .           | Capacitor - 20 mfd., 450 volts . . . . .  | 39597            |
| C-16,C-17 . . . . .      | Capacitor - 10 mfd., 450 volts, & 40 mfd., 25 volts . . . . .                                     | 39461            |
| C-18 . . . . .           | Capacitor - 1 mfd., 150 volts . . . . .   | 18416            |
|                          |   |                  |
| F-1 . . . . .            | Fuse - 2 ampere, 200 volt fuse . . . . .  | 3883             |
| - - . . . . .            | Holder - Fuse holder complete . . . . .   | 32059            |
| - - . . . . .            | Mounting - Floating socket mounting cushions, screws, and nuts. . . . .                           | 28413            |
|                          |   |                  |
| R-1 . . . . .            | Resistor - 1500 ohms, 1/2 watt . . . . .  | 30654            |
| R-2 . . . . .            | Resistor - 100,000 ohms, 1 watt . . . . .   | 3058             |
| R-3 . . . . .            | Control - 250,000 ohms variable control . . . . .   | 44153            |
| R-4 . . . . .            | Resistor - 1000 ohms, 1/2 watt . . . . .  | 34766            |
| R-5 . . . . .            | Resistor - 47,000 ohms, 1 watt . . . . .  | 30495            |
| R-6 . . . . .            | Resistor - 470,000 ohms, 1/2 watt . . . . .   | 30648            |
| R-8,R-9 . . . . .        | Resistor - 2700 ohms, 1/2 watt . . . . .  | 30730            |
| R-10,R-11 . . . . .      | Resistor - 82,000 ohms, 1 watt . . . . .  | 30435            |
| R-12,R-14 . . . . .      | Resistor - 150,000 ohms, 1/2 watt . . . . .   | 30493            |
| R-13 . . . . .           | Resistor - 12,000 ohms, 1/2 watt . . . . .  | 30436            |
| R-15 . . . . .           | Resistor - 180 ohms, 10 watt . . . . .  | 44154            |
| R-16,R-17 . . . . .      | Resistor - 470 ohms, 2 watt . . . . .   | 43506            |
| R-18,R-19,R-20 . . . . . | Resistor - Voltage divider comprising - 170 ohms, 3000 ohms,<br>and 18,000 ohms section . . . . . | 44155            |
| R-21,R-22,R-23 . . . . . | Resistor - 10,000 ohms, 1 watt . . . . .  | 13097            |
| R-24 . . . . .           | Resistor - 24,000 ohms, 1 watt . . . . .  | 17247            |
| R-26 . . . . .           | Resistor - 100,000 ohms, 1 watt . . . . .   | 3058             |
| R-27 . . . . .           | Resistor - 82,000 ohms, 1 watt . . . . .  | 30435            |
|                          |   |                  |
| - - . . . . .            | Socket - 8 contact ceramic type socket . . . . .  | 18007            |
| - - . . . . .            | Socket - 8 contact phenolic type socket for chassis mounting . . . . .                            | 31319            |
| - - . . . . .            | Socket - 8 contact phenolic type socket for cushion mounting . . . . .                            | 28413            |
| - - . . . . .            | Socket - 8 contact wafer type socket. . . . .   | 33084            |
| - - . . . . .            | Socket - Capacitor socket . . . . .   | 45368            |
|                          |   |                  |
| - - . . . . .            | Switch - S.P.S.T. toggle switch . . . . .   | 28322            |
|                          |   |                  |
| T-1 . . . . .            | Transformer - Input transformer . . . . .   | 19987 46420      |
| T-2 . . . . .            | Transformer - Output transformer . . . . .  | 43679            |
| T-3 . . . . .            | Transformer - Power transformer . . . . .   | 44068            |
|                          | <i>Trans. Adapter plate</i>   | 46680            |

(Parts list continued on page 12)

REPLACEMENT PARTS

| <u>SYMBOL</u>                  | <u>DESCRIPTION</u>                              | <u>STOCK NO.</u> |
|--------------------------------|---|------------------|
| REMOTE VOLUME CONTROL ASSEMBLY |   |                  |
| - - . . . . .                  | Knob - Volume control knob . . . . .            | 17268            |
| R-1A . . . . .                 | Resistor - 470 ohms, 1/2 watt . . . . .         | 30499            |
| R-2A, R-3A . . . . .           | Control - Dual 250 ohm volume control . . . . . | 18552            |
| R-4A, R-5A . . . . .           | Resistor - 4700 ohms, 1/2 watt . . . . .        | 30494            |

PARTS INCLUDED FOR FREQUENCY COMPENSATION

|                      |                                   |       |
|----------------------|-----------------------------------|-------|
| C-1B . . . . .       | Capacitor - .015 mfd. . . . .     | 30856 |
| C-2B . . . . .       | Capacitor - .005 mfd. . . . .     | 30852 |
| R-1B . . . . .       | Resistor - 750 ohms . . . . .     | 3382  |
| R-2B, R-4B . . . . . | Resistor - 56,000 ohms . . . . .  | 30650 |
| R-3B . . . . .       | Resistor - 150,000 ohms . . . . . | 30493 |
| R-5B . . . . .       | Resistor - 82,000 ohms . . . . .  | 8064  |
| R-6B . . . . .       | Resistor - 1,000 ohms . . . . .   | 34766 |

R C A V I C T O R D I V I S I O N  
R C A M A N U F A C T U R I N G C O M P A N Y , I N C .

Camden, N. J.                      U. S. A.

A SERVICE OF THE RADIO CORPORATION OF AMERICA

Printed in U. S. A.

# **MONITORING LOUDSPEAKER**

**TYPE 64-B**

## **INSTRUCTIONS**

Manufactured by

**RCA Manufacturing Company, Inc.**

**Camden, N. J., U. S. A.**

Printed in U.S.A.

18-30021

A SERVICE OF THE RADIO CORPORATION OF AMERICA



*FIGURE 1 - TYPE 64-B MONITORING LOUDSPEAKER CABINET*

# MONITORING LOUDSPEAKER

## TYPE 64-B

### TECHNICAL SUMMARY

#### ELECTRICAL CHARACTERISTICS -

Input Impedance, Loudspeaker Mechanism, MI-4410, MI-4411 . . . . . 15 ohms  
Frequency Range, Loudspeaker Mechanism, MI-4410, MI-4411. 60 to 10,000 cycles  
Field -  
Loudspeaker Mechanism, MI-4410 . . . . . Permanent Magnet  
Loudspeaker Mechanism, MI-4411 . . . . . 100 volts, 100 ma

#### MECHANICAL SPECIFICATIONS -

| Dimensions -                                       | Height | Width  | Depth  |
|--|--------|--------|--------|
| Loudspeaker Mechanism, MI-4410 (overall) . . . . . |        | 8-1/8" | 6-1/4" |
| Loudspeaker Mechanism, MI-4411 (overall) . . . . . |        | 8-1/8" | 7-3/8" |
| Loudspeaker Cabinet, MI-4400, -A, -B, -C . . . . . | 33"    | 29 "   | 19 "   |

#### Weight -

Loudspeaker Mechanism, MI-4410 . . . . . 11 pounds  
Loudspeaker Mechanism, MI-4411 . . . . . 12 pounds  
Loudspeaker Cabinet, MI-4400, -A, -B, -C . . . . . 78-1/2 pounds

#### EQUIPMENT

(Optional)

Permanent Magnet Loudspeaker Mechanism . . . . . MI-4410  
Electro-Magnet Loudspeaker Mechanism . . . . . MI-4411  
Loudspeaker Cabinet (Two-tone Gray) . . . . . MI-4400  
Loudspeaker Cabinet (Transmitter Gray) . . . . . MI-4400-A  
Loudspeaker Cabinet (Black) . . . . . MI-4400-B  
Loudspeaker Cabinet (Walnut) . . . . . MI-4400-C

The manufacturer is prepared to furnish, as supplementary equipment, a base upon which the cabinet may be placed. See Figure 2. This base is designated as MI-4405, MI-4405-A, MI-4405-B or MI-4405-C, corresponding in finish to the cabinet of similar letter designation in the MI-4400 cabinet series.

#### DESCRIPTION

The RCA Type 64-B Monitoring Loudspeaker is a high fidelity unit that has been especially designed for use in studios, control booths, clients' listening rooms and small auditoriums. It consists of a permanent magnet loudspeaker mechanism (or an electro-magnet loudspeaker mechanism, if desired) with a sound distributor housed in one of the attractively finished cabinets listed.



The MI-4410 mechanism is an 8-inch loudspeaker of the double voice coil type, having a permanent magnet field. The MI-4411 mechanism is an 8-inch electro-magnet loudspeaker of the double voice coil type.

A counter-bore is provided in the left side of the cabinet for mounting a loudspeaker volume control. The volume control, however, is not furnished by the manufacturer but when desired may be installed by the customer. All holes drilled by the customer for mounting the volume control and running the wires must be sealed with wax so that air cannot leak thru them after the parts are in place.

The loudspeaker cabinets are of the "folded horn" type. The loudspeaker mechanism is to be mounted in a recess in the upper part of the cabinet. The high-frequency radiation is from the front side of the loudspeaker cone, which is protected by a silk-covered grille. Low-frequency radiation is obtained from the rear of the loudspeaker cone which feeds into an accoustical labyrinth, or "folded horn", of exponential proportions. This folded horn terminates behind a rectangular grille in the lower part of the cabinet.

## INSTALLATION

**LOUDSPEAKER** - To install the loudspeaker mechanism in the cabinet lay the cabinet on its back and proceed as follows:

1. Remove the upper front grille of the cabinet by taking out the six screws with which it is attached.
2. Fasten the two leads from the "VOICE" receptacle on the rear panel of the cabinet to the terminals on the loudspeaker terminal strip.
3. Place the loudspeaker mechanism and diffuser in its recess in the loudspeaker cabinet and secure it in position by means of the six mounting studs furnished for the purpose.

*NOTE - Care should be taken when assembling the speaker mechanism to the cabinet that the felt ring under the speaker mechanism is in proper position to completely seal the two together so that air from the back of the speaker mechanism cannot leak to the front except thru the long "folded horn" path.*

4. Replace the upper front grille of the loudspeaker cabinet.

**USE OF MI-4411 ELECTRO-MAGNET MECHANISM** - If it is desired to use the MI-4411 electro-magnet double voice coil loudspeaker, it will be necessary for the customer to install another plug receptacle in the back panel to supply the field current. Except for this additional operation, the installation is the same as described above.

40-3-25

## PARTS LIST

| Description   | Stock No. |
|---|-----------|
| <b>LOUDSPEAKER</b>  |           |
| Permanent magnet type loudspeaker (mechanism only)            | MI-4410   |
| Capacitor, 1.75 mfd for MI-4410                               | 16728     |
| Cone and housing assembly for MI-4410                         | 43201     |
| Electro-magnet type loudspeaker (mechanism only)              | MI-4411   |
| Capacitor, 1.75 mfd for MI-4411                               | 16728     |
| Coil, field coil for MI-4411                                  | 43203     |
| Cone assembly for MI-4411                                     | 43202     |
| <b>CABINET</b>  |           |
| Two-tone gray finish  | MI-4400   |
| Transmitter gray finish                                       | MI-4400-A |
| Black finish  | MI-4400-B |
| Walnut finish   | MI-4400-C |
| Plug, two-prong female plug for loudspeaker cabinet           | 32661     |
| Receptacle, two-prong male receptacle for loudspeaker cabinet | 32660     |
| <b>BASE</b>   |           |
| Base for MI-4400 loudspeaker cabinet                          | MI-4405   |
| Base for MI-4400-A loudspeaker cabinet                        | MI-4405-A |
| Base for MI-4400-B loudspeaker cabinet                        | MI-4405-B |
| Base for MI-4400-C loudspeaker cabinet                        | MI-4405-C |



*FIGURE 2 - MONITORING LOUDSPEAKER CABINET WITH BASE  
(Front View)*

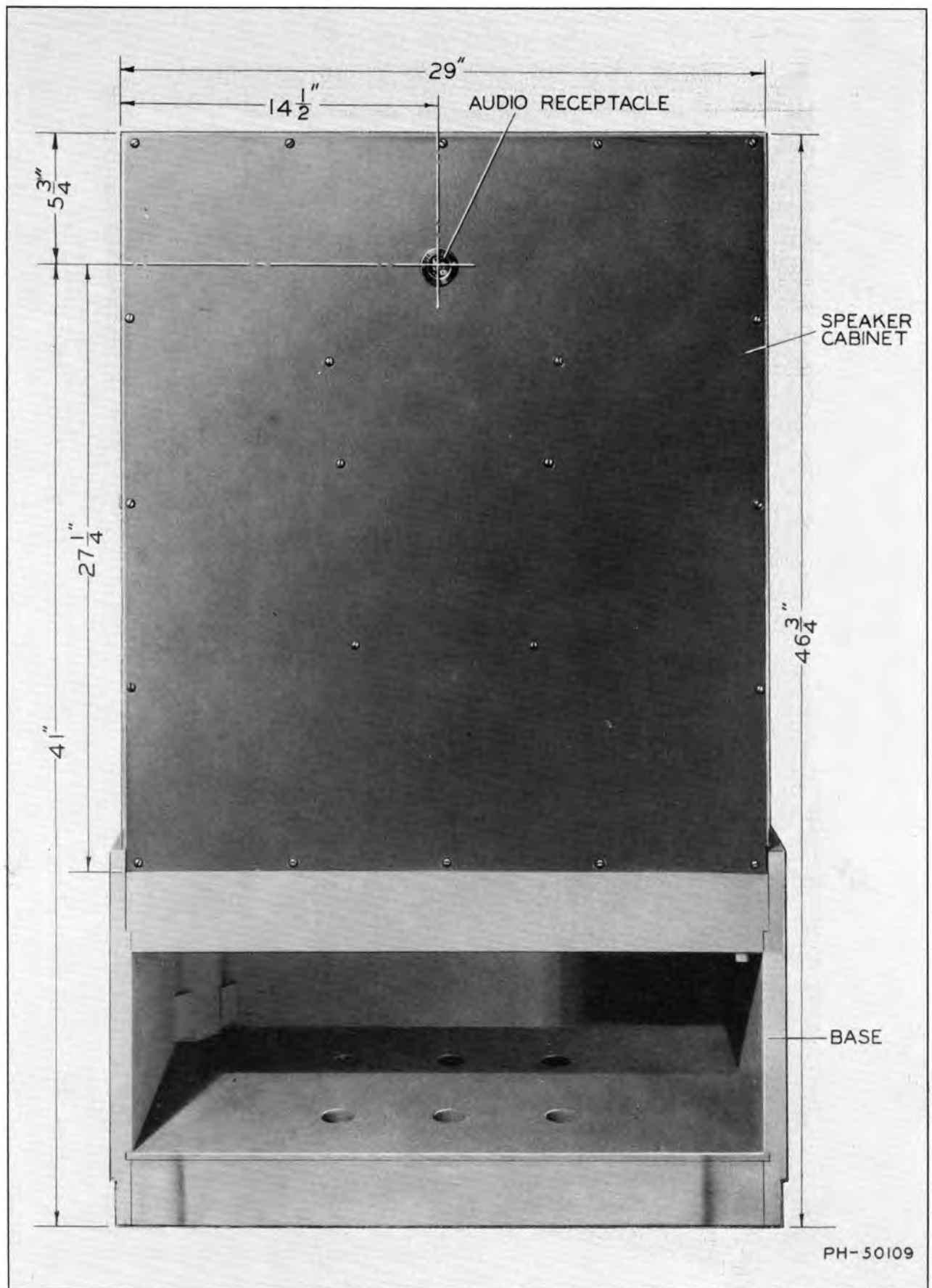
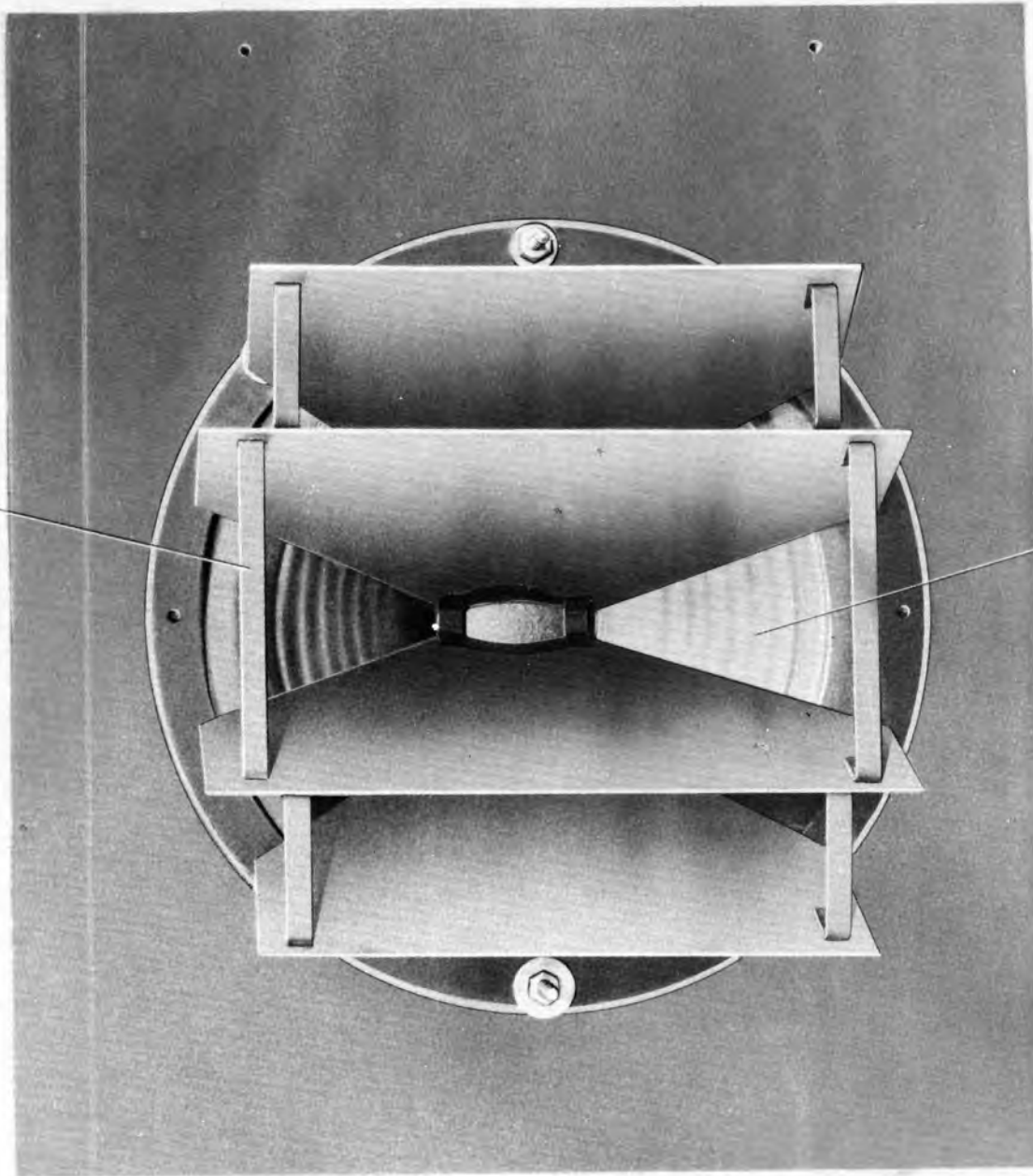

FIGURE 3 - MONITORING LOUDSPEAKER CABINET WITH BASE  
(Rear View with Dimensions)

DIFFUSER



DIAPHRAGM

PH-50111

FIGURE 4 - MONITORING LOUDSPEAKER UNIT



**MI-3115**

**MI-3115A**

**VOLUME INDICATOR  
(METER TYPE)**

---

**RCA PHOTOPHONE  
RECORDING INSTRUCTIONS**

---

**First Edition  
Copyright 1937  
RCA Mfg. Co., Inc.**

**Photophone Division  
RCA Manufacturing Co., Inc.  
Camden, N. J., U. S. A.**

**A Service of the Radio Corporation of America**

**MI-3115**  
**MI-3115 A**  
**VOLUME INDICATOR**  
**(METER TYPE)**

**TECHNICAL INFORMATION**

|   | <u>MI-3115</u>          | <u>MI-3115-A</u> |
|---|-------------------------|------------------|
| Line Impedance .....                    | 500 ohms .....          | 500 ohms         |
| Range .....                             | minus 6 to plus 16 db-- | 0 to plus 30 d   |
| Reference Level .....                   | .0125 watts .....       | .006 watts       |
| Extension Meters (Permissable to use) . | None .....              | Two (Max.)       |
| Pad .....                               | Rheostat .....          | Variable "L"     |
| Load Presented to Line .....            | 3,000 ohm (Min.).....   | 5,000 ohms       |

**MECHANICAL SPECIFICATIONS**  
**(MI-3115 and MI-3115A)**

|                       |              |
|-----------------------|--------------|
| Height .....          | 3-1/2 inches |
| Width .....           | 19 inches    |
| Depth (Approx.) ..... | 3-1/2 inches |

**GENERAL INFORMATION - MI-3115**

The MI-3115 meter-type volume level indicator has been designed to operate across a 500-ohm audio line to provide a visual means of checking signal strength. Incorporated in the unit are two 6.3-volt pilot lamps which can be connected to an external battery if it is desired to illuminate the meter. A rheostat is connected in series with a 2,500-ohm meter, giving a minimum load impedance of 3,000 ohms across a 500-ohm line. The rheostat is calibrated in steps of 2 db each and affords a range of from minus 6 db to plus 16 db, with a zero reference level of .0125 watts. Provision is not made in this unit for connecting external meters, however the MI-3115-A affords this feature if it is desired.

**GENERAL INFORMATION - 3115A**

The MI-3115-A, a modified design of the MI-3115 volume level indicator, has also been designed for use across a 500-ohm line. A variable "L" pad incorporated in the unit provides a means of varying the range in 2 db steps from 0 to plus 30 db, with .006 watts as the zero reference level. This unit offers a constant load impedance of 5,000 ohms to a 500-ohm line.

**EXTENSION METERS** - A Maximum of two remote meters, having suitable characteristics, and having a DC resistance of 500 ohms each, can be connected to the

MI-3115-A indicator. Two 500-ohm resistors are mounted adjacent to the terminal board, and when external meters are used, either or both resistors can be selected or rejected, depending upon whether one or two meters are connected to the volume level indicator.

Meters suitable for this purpose should meet the specifications of the RCA Engineering Department, and information as to the exact type of meter should come from that source.

MCOUNTING - Either of the above units is designed to mount in the RCA type MI-3114 or type MI-3117 Mixer Consoles. It is also possible to use standard relay rack mounting.

### REPLACEMENT PARTS

|  |               |
|--|---------------|
| Attenuator (For MI-3115) .....                               | K-819891-P1   |
| Attenuator (For MI-3115-A) .....                             | K-180089-P1   |
| Knob (Attenuator Knob).....                                  | M-414778-G506 |
| Lamp (6-volt pilot lamp) .....                               | K-61114-P2    |
| Lamp Socket Assembly .....                                   | K-67842-G501  |
| Meter (Volume level meter for MI-3115) .....                 | P-705580-P4   |
| Meter (Volume level meter for MI-3115-A) .....               | K-180090-P1   |
| Resistor - (500-ohm wire wound resistor for MI-3115-A) ..... | K-819789-P25  |

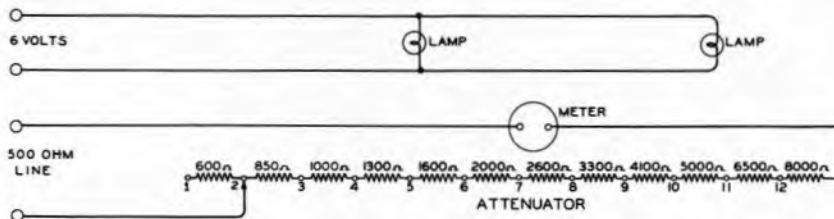
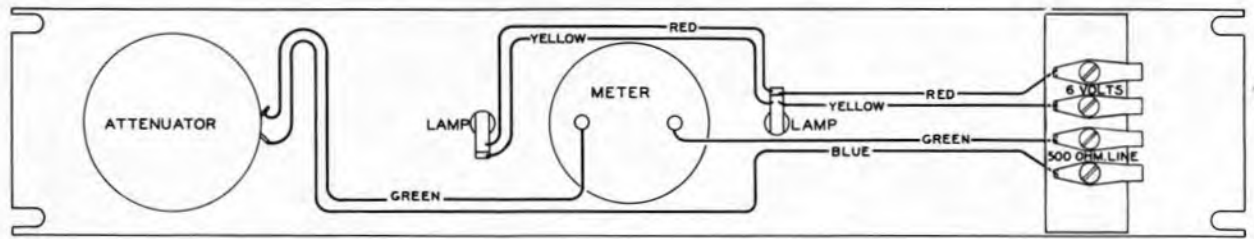

P 712312

Figure 1 - Schematic and Wiring - MI-3115

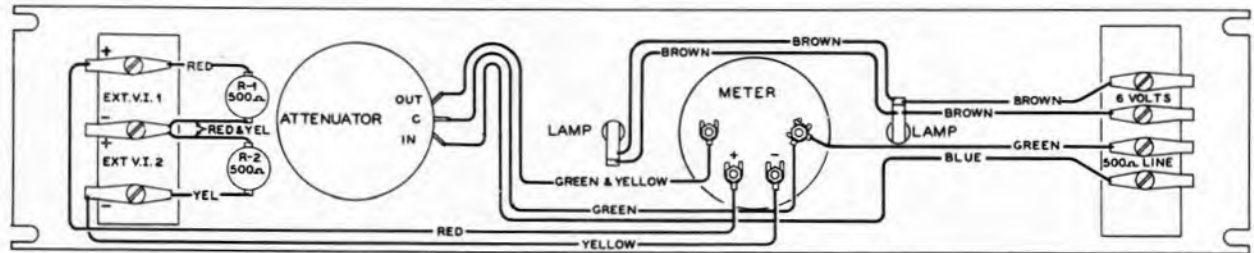

P712 433

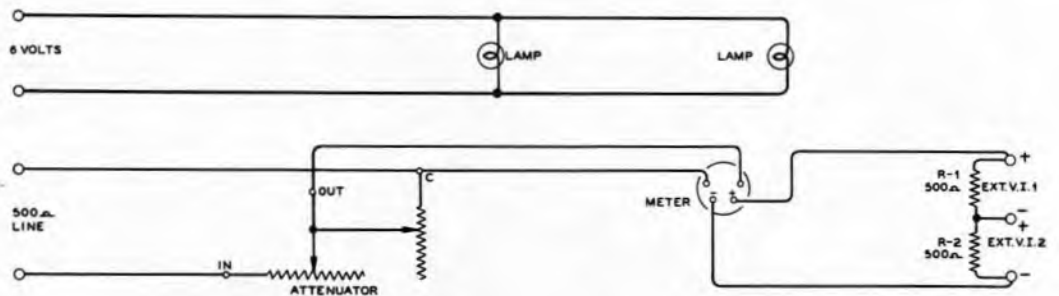
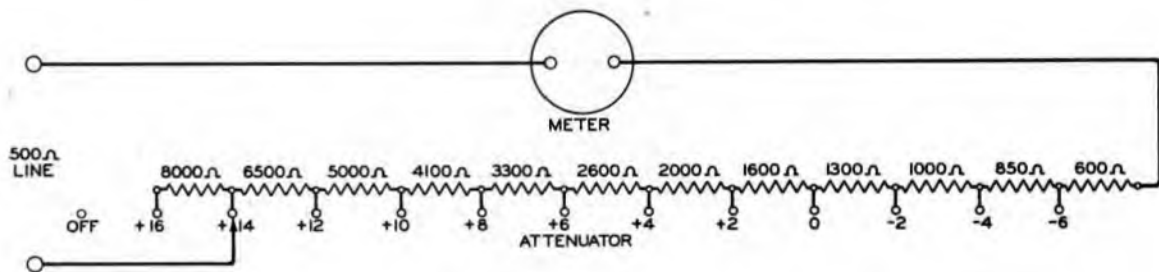

Figure 2 - Schematic and Wiring - MI-3115-A

## ADDENDA SHEET

# MI-3115, MI-3115-A RCA PHOTOPHONE VOLUME INDICATOR (METER TYPE)

Instruction book IB-23898-1 (2R15-1.1) showed the resistors comprising the attenuator in reverse order on the schematic circuit diagram of MI-3115. Below is shown a correct schematic circuit diagram of this unit.



When ordering a remote Volume Indicator Meter for use with the MI-3115-A it should be specified by Reference Drawing Number K-841703.

Printed in U.S.A.  
November 26, 1937.

RCA MANUFACTURING CO., INC.,  
CAMDEN, NEW JERSEY, U.S.A.



5-851812

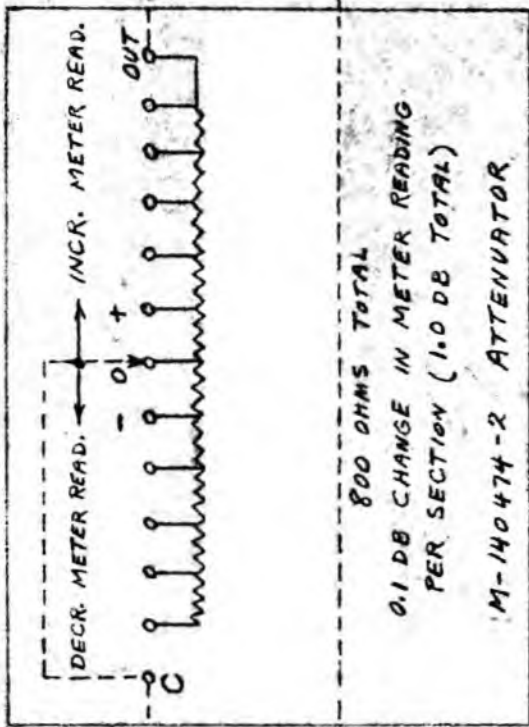

800 OHMS TOTAL  
0.1 DB CHANGE IN METER READING  
PER SECTION (1.0 DB TOTAL)

M-140474-2 ATTENUATOR

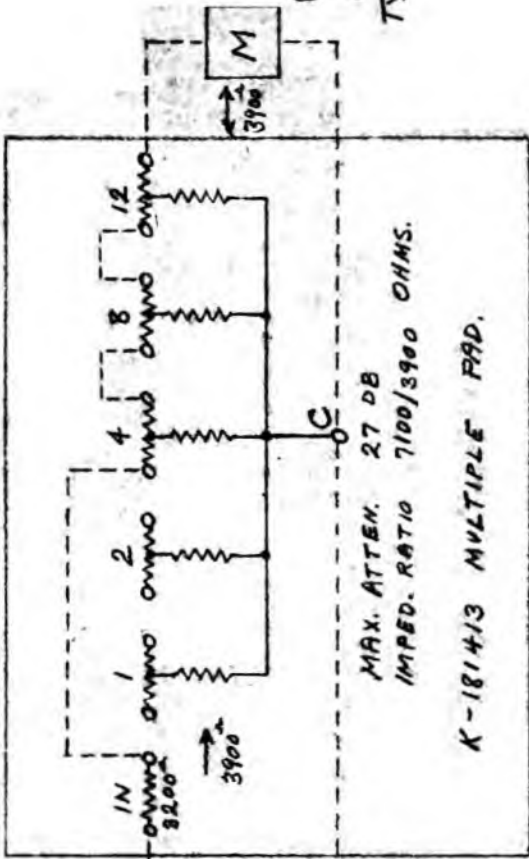

MAX. ATTEN. 27 DB  
IMPED. RATIO 7100/3900 OHMS.

K-181413 MULTIPLE PAD.

ANY FIXED LOSS FROM 1 TO 27 DB (IN 1 DB STEPS)  
MAY BE OBTAINED BY ADDING OR REMOVING  
JUMPERS BETWEEN PAD SECTIONS.

--- EXTERNAL CONNECTIONS

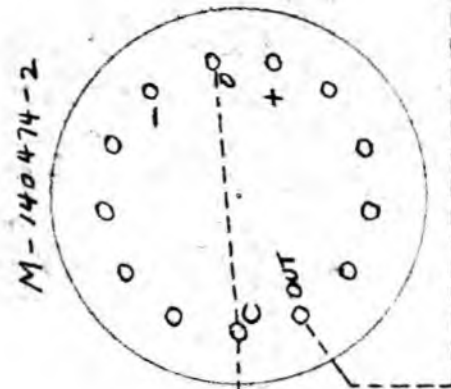

K-181413

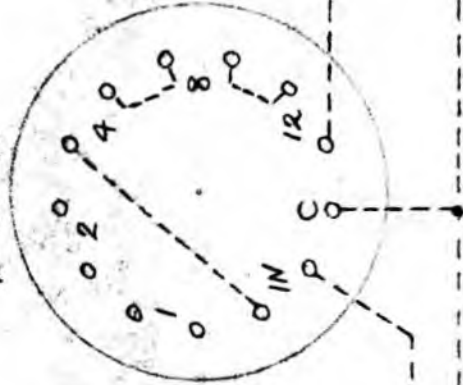

CONNECTIONS SHOWN  
FOR 24 DB ATTEN.

M

C FILE

VARIABLE ATTENUATORS FOR USE WITH WESTON VU METER TYPE 308 Made 301  
TOTAL ATTEN. AVAILABLE: 28 DB (IN 0.1 DB STEPS).

J.P. O'Neil  
12-4-39

5-851812

Instruction Sheet — Disc Recording Monitor  
Loudspeaker

No. V-3

Sheet 1 of 1 Sheets

Date Feb. 21, 1940

MI-3429 Loudspeaker Mechanism with MI-3403 Compound Baffle

Cutaway Schematic Diagram.

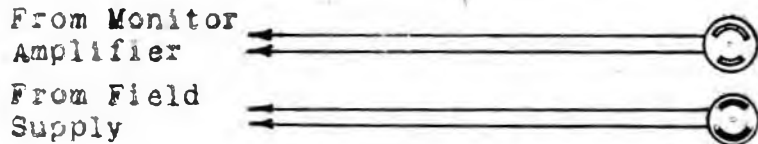

Monitor Amplifier: MI-3223, MI-3223A or MI-3223B (500 ohm output)

Field Supply: MI-3223, MI-3223A or MI-3223B.

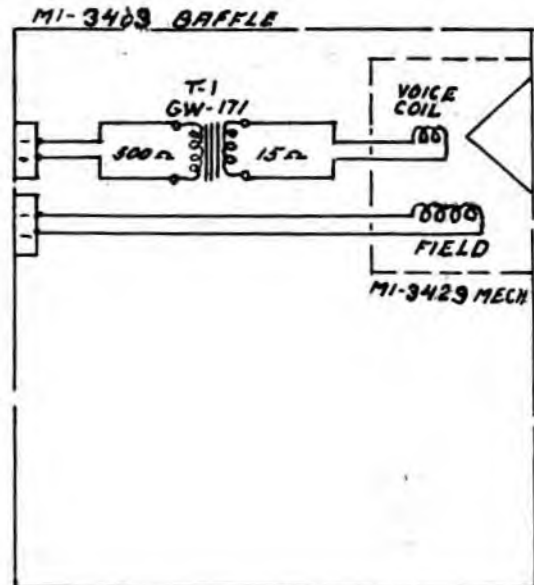

Parts List

1. Loudspeaker Baffle MI-3403 (Includes Plugs and Coupling Transformer) Dwing T-607238, G-501
2. Loudspeaker Mechanism MI-3429 (Single Voice coil) 100 volt, 1000 ohm Field. Dwing P-705833, G-501
3. T1, Coupling Transformer, 500 to 15 ohms Type GW-171

SECTION VI

Recorders, Pickups and Related Accessories

Master Reference Book  
Disc Recording

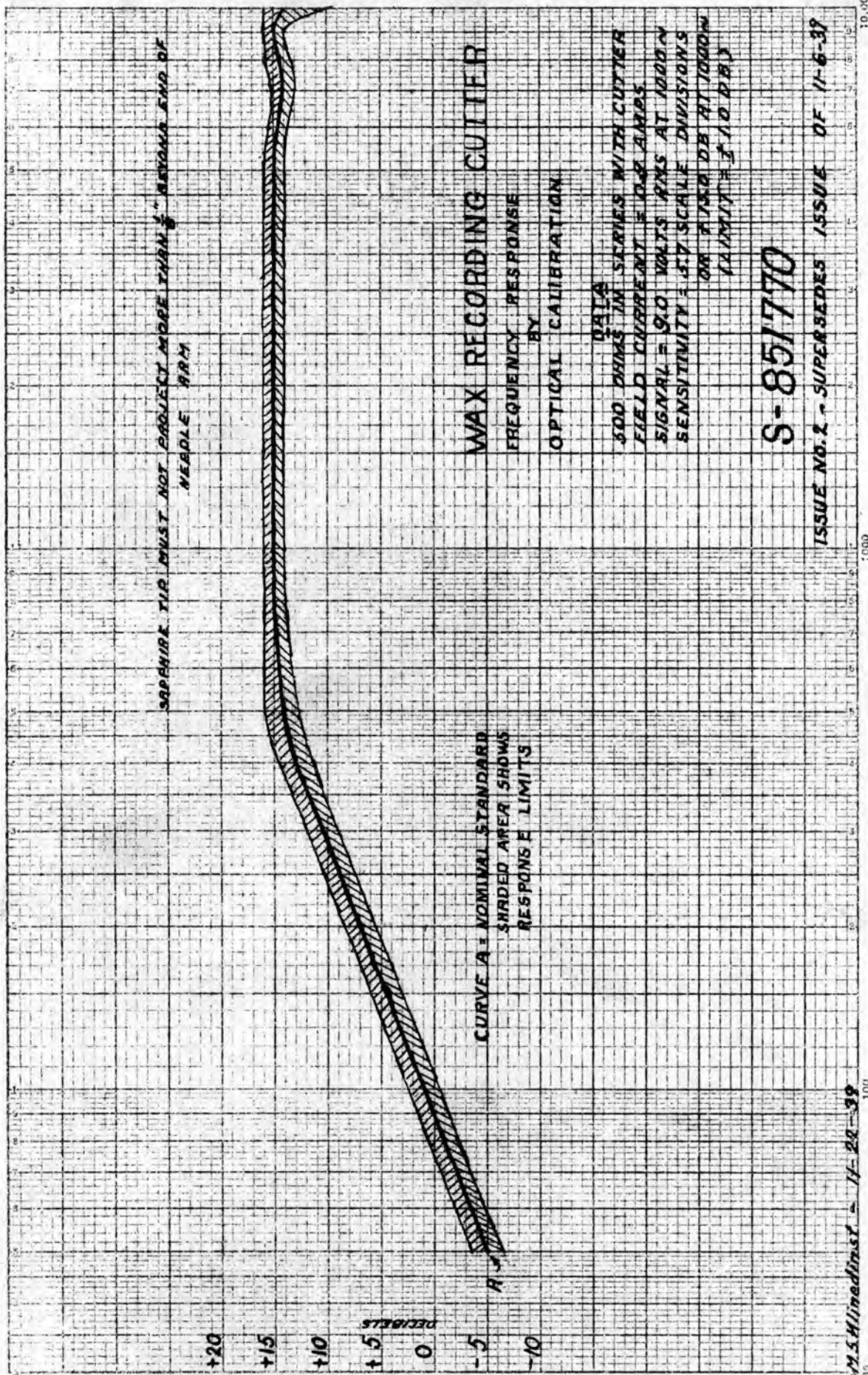

SAPPHIRE TIP MUST NOT PROJECT MORE THAN 1/8" BEYOND END OF NEEDLE ARM

**WAX RECORDING CUTTER**

FREQUENCY RESPONSE  
BY  
OPTICAL CALIBRATION

**DATA**

500 OHMS IM SERIES WITH CUTTER  
FIELD CURRENT = 0.8 ARMS  
SIGNAL = 9.0 VOLTS RMS AT 1000 HZ  
SENSITIVITY = 37 SCALE DIVISIONS  
OR 1.15 DB AT 1000 HZ  
(LIMIT = 3.10 DB)

**S-851770**

ISSUE NO. 2 - SUPERSEDES ISSUE OF 11-6-37

M.S. Hines Inc. - 11-22-39

100

10,000



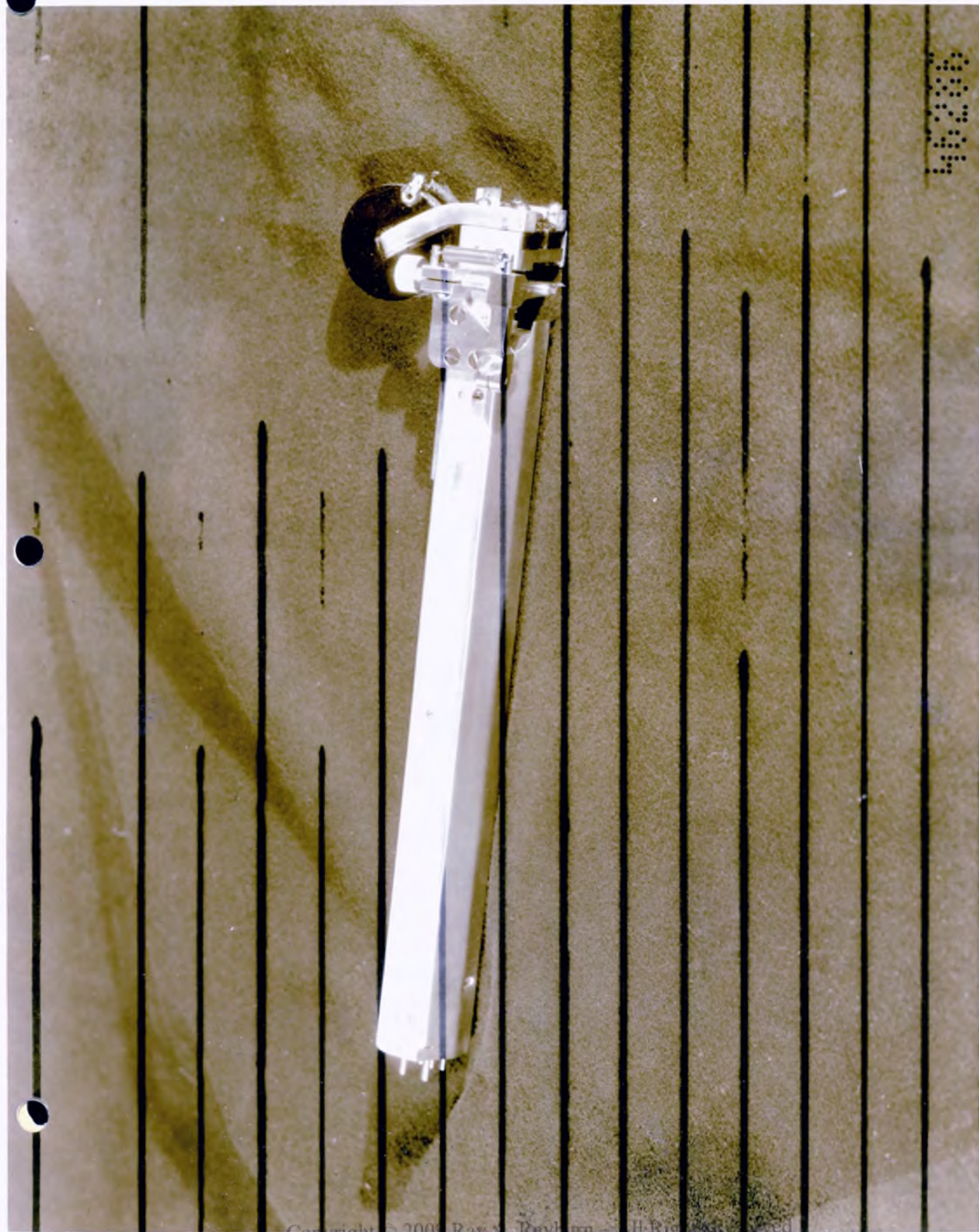



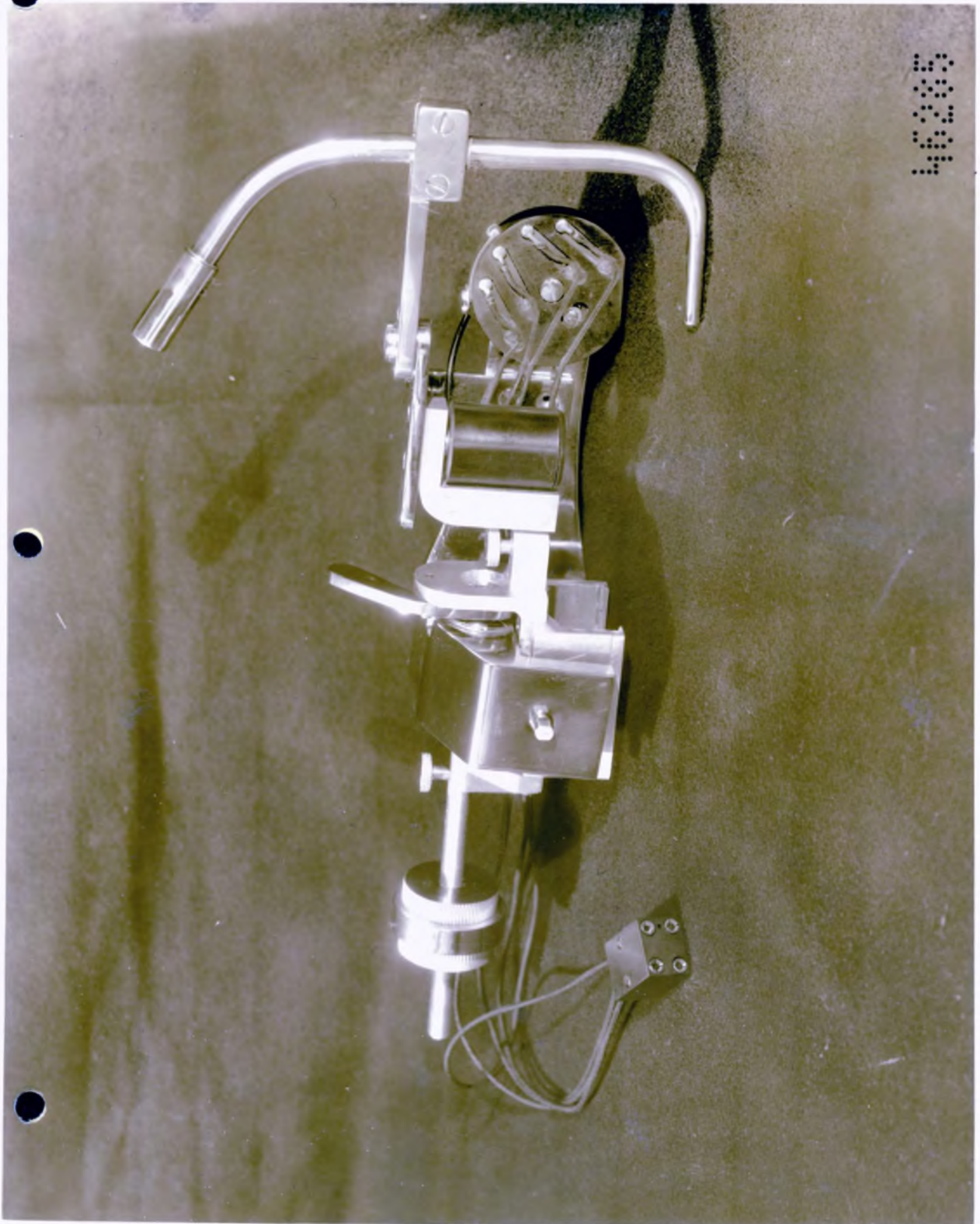

SECTION VII  
POWER SUPPLIES

Master Reference Book  
Disc Recording

SECTION VIII

Recording Machines

Master Reference Book  
Disc Recording

## SGULLY RECORDING MACHINE INSTRUCTIONS

## MAINTENANCE

## Lubrication and Oiling:

Note: The SAE # 10 and SAE #50 oils specified below should be Quaker State, Pennzoil or Kendall Motor Oils.

1. GEAR SHIFT BOX - should be filled with SAE #50 oil up to the level of the rear petcock.
2. WORK GEAR BOX - should be filled to the level of the petcock with SAE #50 oil. Do not remove or disturb the filter drum during this oiling.
3. FILTER DRUM - should be filled with SAE #10 oil - enough should be used to fill the unit and allow a small surplus over the vanes.

The turntable speed will not vary more than 0.5% at most and under all normal operating conditions should be less than 0.3%. The filter drum must be carefully filled with oil, especially to avoid air bubbles, if this accuracy is to be maintained.

4. TURNTABLE SPINDLE BEARING - should be lubricated with "Nyoil", a light, non-gumming oil available from the Recording Department.
5. MOTOR - motors with wool packed bearings have been lubricated at the factory but additional oil may be added as required through the oilers above the motor bearings.

Grease packed ball bearings are lubricated for about two years of operation. At the end of that time the bearings should be removed, cleaned and repacked.

6. IDLER - the clutch belt tension idler should be removed occasionally and recoiled with "Nyoil".

## General

7. RUBBER MOUNTING FEET - must be kept free of oil to prevent disintegration of the rubber.
8. FLEXIBLE COUPLING - must be checked from time to time and when it has become stretched or otherwise distorted it should be replaced.
9. FUSES - should be checked immediately if the motor does not start. It must be remembered that if one of the phases of a three phase line blows a fuse, the motor may continue to run as a single phase motor but will not start.
10. MOTOR CLEANING - the motor should be kept free of dust and oil. It should be wiped regularly and from time to time the dust should be blown out with an air hose. (Be sure there are no waxes exposed while blowing out the motor.)

## OPERATION

## Use of the Controls

1. CHANGE OF RECORDED PITCH - is accomplished by simultaneous shifting of the lever on the right front end of the carriage base and sliding the rod at the extreme right end of the base near the handwheel.

Pitches of 88, 96, 104, 112, 120, 128, and 136 lines per inch may be cut with the Scully machine as normally supplied.

2. RECORDED DIAMETER SCALE AND INDICATOR LAMP -

Scale: - A scale is provided on the top right-hand end of the carriage, which with its associated pointer indicates the record diameter in inches at which the recorder is recording at any given instant. This scale is adjustable and must be reset and checked each time a change is made in the recorder or recorder saddle location.

Indicator Lamp:- The indicator lamp with its associated contacts is adjusted to flash at three points on each of three types of records. The lamp flashes at the outside diameter, at the maximum recorded diameter and at the point at which the recorder is lifted by the pick-up magnet. Contacts are provided to flash the lamp for 10", 12" and 16" records. The trigger arm which makes the connection with the contact pins to flash this lamp is located on the front top edge of the carriage base, and is adjustable so that it may be corrected for a change in recorder position.

3. CARRIAGE FEED -

Normal Feed:- After the proper pitch has been set according to item 1, the recorder carriage is set to feed as follows: On the top left face of the carriage just under the saddle arm, are two levers which engage the half-nut with the feed spiral. One of these levers is for outside-in feed, the other is for inside-out feed. A slotted bar is provided which can be locked in place to prevent engaging both levers at the same time. Pulling the proper lever forward engages a half-knut and causes the carriage to feed at the pitch previously set.

Rapid Feed:- Automatic rapid feed is provided which can be set to feed at an increased rate of speed continuously, or to feed at an increased rate of speed for a radial distance of about  $\frac{3}{8}$ " and then to resume feeding at the correct pitch. This short rapid feed is provided for recording the lead-in spiral from the outside edge of the record to the first music groove. This short rapid feed is accomplished by throwing the clutch control that is the fourth control from the left on the front of the carriage base to the right - when the indicator pointer - second from left - is pointing up. The machine will then feed at a rapid rate for  $\frac{3}{8}$ " and resume a normal feed. This change over to a



rapid feed may be made with the machine not in operation, in which case, the rapid feed will take effect immediately upon starting the machine or when the machine is in operation.

To maintain the rapid feed, it is necessary, to pull out the cam pin - third control from the left - and turn it to the right engaging in the slot provided.

Hand Feed: - A hand wheel is provided on the extreme right hand end of the carriage base which enables the operator to feed at a rate dependent entirely upon the speed of revolution on the hand wheel. This hand wheel is usually used to feed the lead-in spiral and to cut this spiral from the last music groove and the eccentric groove. Particular care must be taken in recording this last spiral as too rapid a feed-that is too steep a pitch,-will result in reproducer "howling", as the needle follows this groove on the finished record.

4. CLUTCH LEVER - the left hand control on the front of the carriage base engages the feed mechanism to the pulley which is driven by an endless belt from the motor drive unit.

#### General

5. SCREW AND LOCK NUT - the adjustment for the half-nuts which engage the lead screws should be carefully made to avoid binding between the half-nuts and lead-in screws.
6. MICROSCOPE SCALE - is calibrated in decimal parts of an inch, each division representing 0.001 of an inch.
7. SADDLE PIVOTS - are accurately ground to permit the recorder or playback to follow slight undulations in the wax surface. These pivots should never be disturbed unless they bind, and then they must be removed and replaced with considerable care to avoid damage to the points. "Nycil" oil should be used to lubricate these pivot points.
8. RECORDING -  
Note: - the machine MUST ALWAYS be started in the 33-1/3 rpm turn table speed position and allowed to warm up for about 20 minutes, then the machine may be stopped completely, and the gears shifted to 78 rpm position.
9. POWER SWITCH - two switches are provided for starting the Scully Recording Machine. One switch is labeled "one-two". With this switch in the number 1 position, the other, or "on-off" switch controls only the machine on which the switches are located. With the switch in the number 2 position, and an adjoining machine also having its switch in the number 2 position the "on-off" switch of either machine will start both machines.

10. **RECORDER ADJUSTMENT** - place the wax on the turntable. Put the wax recorder with the advance ball attached in its saddle, adjust the recorder so that the stylus arm is central with the saddle supporting arm. Tighten the holding screws and attach the saddle to the machine. With the lateral axis of the recorder parallel to the wax surface, run the recorder in toward the center of the turntable and observe that the stylus arm travels along a true radius of the turntable. If, it does not, adjust it by sliding the recorder in the horizontal sliding ways of the saddle. With the recorder thus correctly tracking, adjust the counter-balancing weight so that the recorder cuts a groove of standard width with the advance ball NOT in contact with the wax.
  
11. **ADVANCE BALL ADJUSTMENT** - Two types of advance balls are normally used with the recorder. The one most generally used is provided with a spherical tip sapphire which glides along the surface of the wax, and prevents the recorder from jumping from the surface of the wax with slight variation or with irregularities of the wax surface. To accomplish this, it is sometimes necessary to slightly unbalance the recorder, that is to allow the advance ball to carry some of the weight and adjust the counterbalancing weight accordingly. This unbalance should be kept at a minimum because the advance ball will smear the wax and this smear must be polished off the matrix thus effecting the high frequency response.

Some models have been made of a new advance ball, which it is hoped will soon replace the type just described. This advance ball is similar to the other with these two important differences. First, the sapphire is ground to a narrow wedge, and therefore, leaves a minimum trace of approximately three mills (0.003"). The second, difference is that the advance ball mounting is so constructed that it may be adjusted easily for changes in recorded pitch. The sapphire is first set so that for any given pitch, it will ride ahead of the recording sapphire exactly a fixed number of grooves. Therefore, as the recording sapphire proceeds toward the center of the record, it will cut out the trace left by the advance ball, and, only a few spirals of advance ball smear will be left on the record, and these will be inside the recorded diameter where polishing will not affect the quality of the record. A scale is provided so that when the recorded pitch is changed the advance ball may be changed also and the recording sapphire will still trail it exactly. The trace for this style of advance ball must be adjusted so that its width is from three to four mills, in order that the recorder will be able to cut out the entire trace.
  
12. **RECORDER FIELD SWITCH** - For recording this switch must be closed lighting the pilot lamp and the field current should be adjusted to 0.9 amperes. Observe the recorder stylus arm to be sure that it does not change position when the switch is turned on, as this indicates poor centering in the magnetic field and requires a readjustment of the recorder.

The Scully Recording Machine

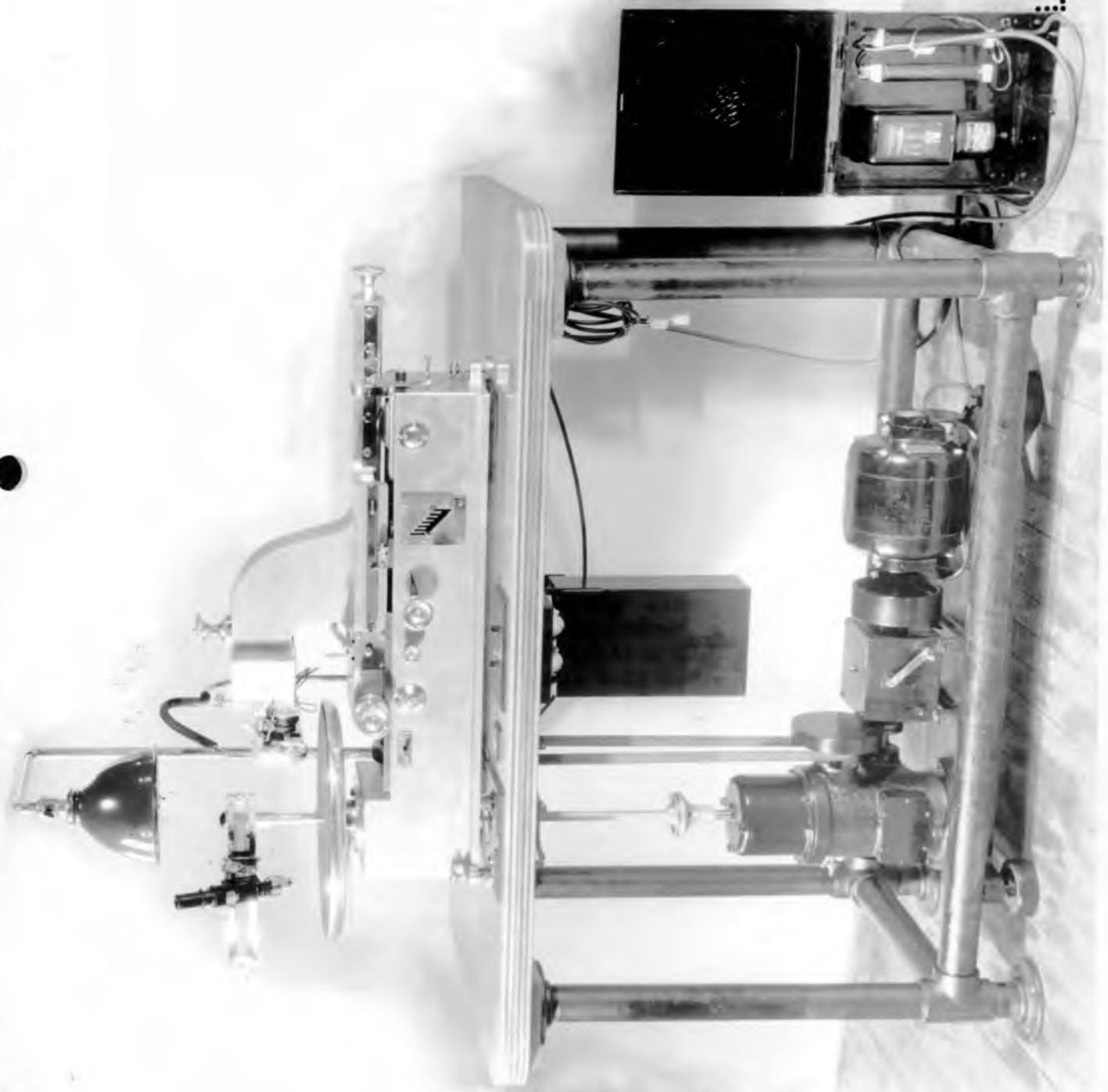

Copyright © 2009 Ray M. Rayburn All Rights Reserved



46284

Sully Recording Machine - Motor and Drive Unit

46284







SECTION IX

Turntables

Master Reference Book  
Disc Recording

## INSTRUCTIONS

for

### RCA TRANSCRIPTION EQUIPMENT

#### TYPE 70-B TURNTABLES

MI-4858, (BLACK, 60 CYCLES)  
MI-4858-A, (GRAY, 60 CYCLES)  
MI-4858-B, (MI-4858 WITH TONEARM LIFT)  
MI-4858-C, (MI-4858-A WITH TONEARM LIFT)  
MI-4859, (BLACK, 50 CYCLES)  
MI-4859-A, (MI-4859 WITH TONEARM LIFT)  
MI-4859-B, (MI-4859-A IN GRAY)  
MI-4860, (BLACK, 25 CYCLES)  
MI-4860-A, (MI-4860 WITH TONEARM LIFT)  
MI-4860-B, (MI-4860-A IN GRAY)

#### POWER SUPPLY

105-125 Volts  
60 Cycles for MI-4858, -A, -B, -C.  
50 Cycles for MI-4859, -A.  
25 Cycles for MI-4860, -A.  
35 Watts

#### MOTOR SPEED REGULATION

0.6 Per Cent at 33-1/3 R.P.M.  
0.4 Per Cent at 78 R.P.M.

#### FREQUENCY RESPONSE

30 to 9,000 Cycles

#### OUTPUT LEVEL

0.0043 Volts across 250 Ohms  
(minus 52 db\*)

#### OUTPUT IMPEDANCE

To operate into a circuit of  
from 200 to 250 Ohms.

#### TURNTABLE DIAMETER

15 Inches

#### TURNTABLE SPEEDS

33-1/3 and 78 R.P.M.

#### PHYSICAL SPECIFICATIONS

(Approximate)

|        |     |        |
|--------|-----|--------|
| Width  | 27  | Inches |
| Depth  | 22  | Inches |
| Height | 34½ | Inches |
| Weight | 150 | Pounds |

**CAUTION:** The lateral reproducer has been accurately adjusted and carefully inspected at the factory. Extreme care should be exercised when assembling the reproducer to the arm and when lowering the reproducer onto the record. Failure to observe these instructions may result in a broken diamond point.

#### DESCRIPTION

The Type 70-B Transcription Turntable with the new high fidelity lateral pickup has been designed for use with the new high fidelity transcriptions, as well as with other transcriptions. The component units have been designed so that the combination, together with the transcription, produces an excellent frequency characteristic. The new lateral pickup uses a diamond point stylus, thereby eliminating the necessity for changing needles. A selector switch (designated "FILTERS") is conveniently located on the top of the cabinet so that the high frequency response is a maximum, or may be attenuated in three values of

(Continued on page 3.)

\*Note: 0 db - 0.0125 Watts

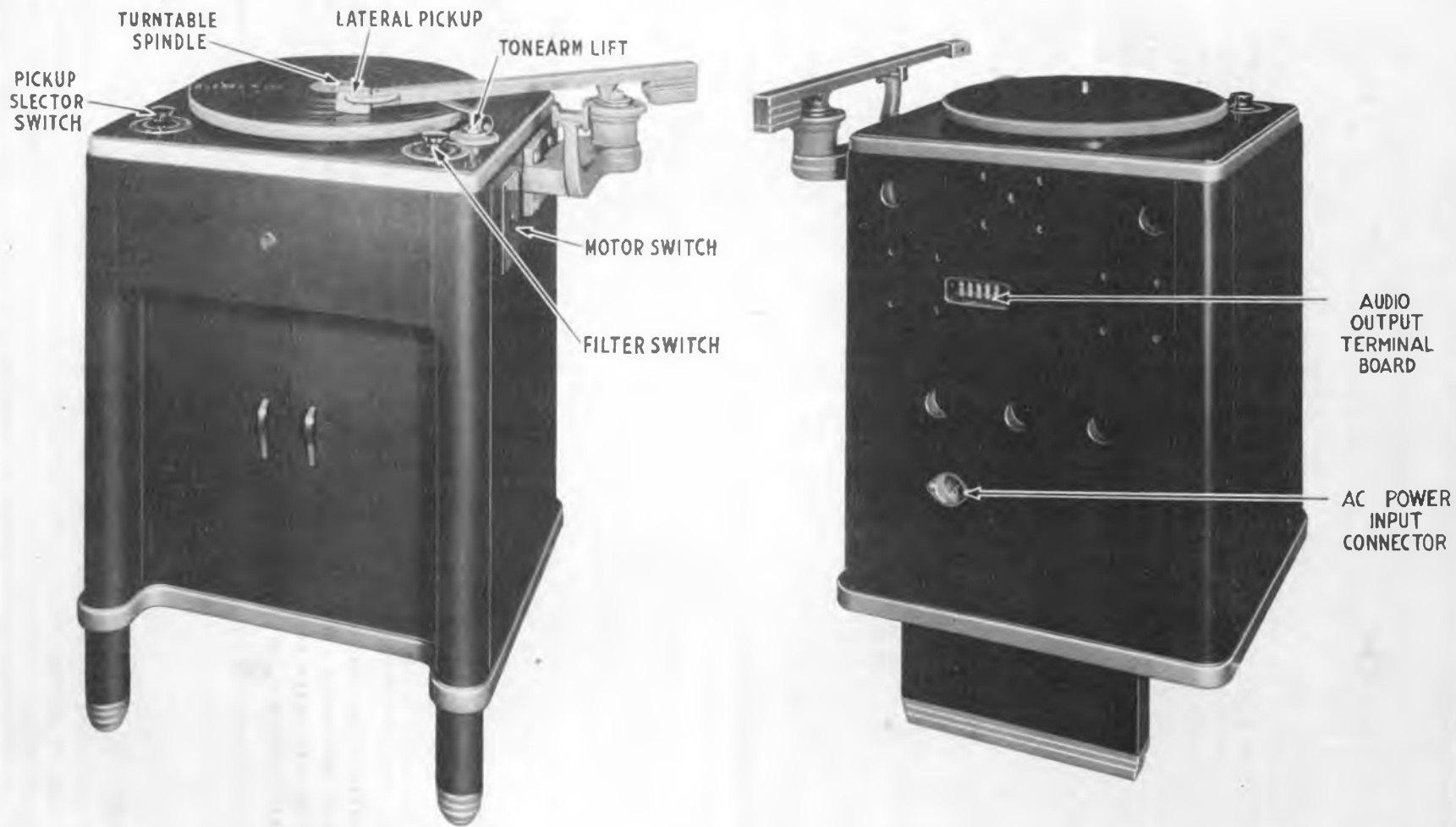

FIGURE 1 - FRONT AND REAR VIEWS OF TYPE 70-B TRANSCRIPTION TURNTABLE.

cutoff. In order to obtain the desired bass response, a selector switch is provided inside the cabinet. The dial of the bass compensator is marked "1,2,3,4" and the maximum amount of low frequency attenuation is obtained when the switch is at position 1.

The Type 71-B Vertical Pickup Kit (MI-4852-A) and its accessory kit (MI-4855) may be ordered for use with the Type 70-B Turntable. The pickup selector switch is located on the top and left of the cabinet, and is marked "VERTICAL-LATERAL".

A high-torque synchronous motor of the capacitor type is mounted horizontally in the bottom of the cabinet. A damper (mechanical filter) mechanism is mounted on the end of the motor gear box vertical shaft and coupled to the turntable drive shaft by means of two semi-flexible couplings between which are interposed a coupling shaft and over-running clutch. The clutch disengages the turntable shaft from the driving shaft whenever the turntable and flywheel are revolving at a greater speed than the motor. This occurs when the motor power supply is turned "off" or when the turntable is advanced by hand. The turntable shaft always revolves at a speed of 78 r.p.m., speed constancy being maintained by means of a heavy flywheel. This shaft, together with its associated flywheel and the turntable (record plate), is entirely supported by means of a cushioned bearing housing mounted in the top of the turntable cabinet. This housing also contains the ball bearing speed reduction mechanism by means of which the turntable speed may be reduced to  $33\frac{1}{3}$  r.p.m. from the constant flywheel-and-shaft speed of 78 r.p.m. The speed shifting lever is located in a slot in the top of the turntable (record plate).

The MI-4858-B, MI-4858-C, MI-4859-A, MI-4860-A are provided with tonearm lift attachments. The lift arm must be swung back clearing the turntable when records are changed.

The lateral pickup tonearm bracket is mounted at the right side of the cabinet. The frequency response characteristic of this unit is sloped to a degree closely complementary to the response characteristics of present day recordings. This compensation results in an overall record reproduction characteristic almost uniform throughout the range.

The vertical pickup tonearm bracket (when used) is mounted at the rear of the cabinet. As in the case of the lateral pickup, the frequency response characteristic is made closely complementary to the response characteristics of present day recordings. The combined characteristic of the vertical pickup and the record is nearly uniform over the frequency range.

The audio and power connections to the turntable unit are made to a terminal board and a recessed male connector, respectively, located on the rear of the cabinet.

The AC power switch is a mercury tube switch of the tumbler type and is located on the right-hand side of the cabinet.

The pickup selector switch is located at the left and on top of the cabinet. When this switch is set in its right-hand position, the lateral pickup is connected to the output terminals of the cabinet; when set in the left-hand position, the vertical pickup is connected to the output terminals; or, when only one pickup is mounted on the cabinet, the switch is so wired that this pickup is connected in both switch positions. The switch is provided with a detent for the assurance of contact and position.

The speed shift control in the turntable (record plate) is plainly marked in two colors as well as with numerals corresponding to the two speeds.

## INSTALLATION AND OPERATION.

### (a) UNPACKING

When unpacking the equipment, extreme care should be exercised in removing the crating which is used to protect the top of the turntable in shipping. The card-board cap that covers the turntable should be lifted off carefully, and in such a manner that the turntable is not raised or disturbed in any way. Remove any shipping wedges that may be under the turntable.

(Continued on page 5.)

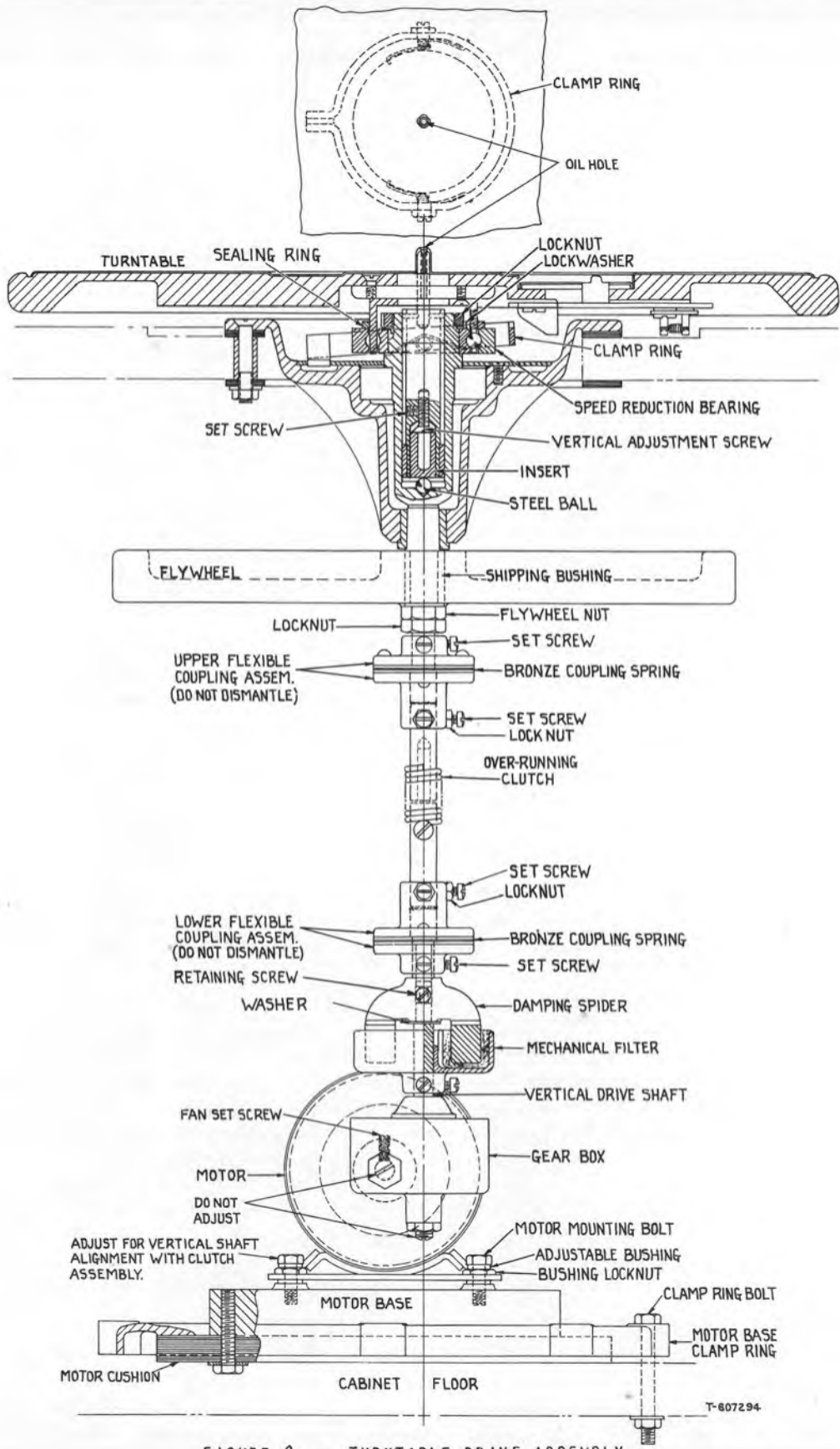

FIGURE 2 - TURNTABLE DRIVE ASSEMBLY.



CAUTION: Do not at any time, whether during unpacking, assembly or operation, lift the turntable or remove it from its spindle except as noted in "MAINTENANCE".

All wrappings and shipping wedges should be carefully removed from the tonearm.

The flywheel is packed in a cardboard carton beside the cabinet. In this location will also be found, tied in place, a box containing the pickup. Unpack these very carefully.

When dusting the equipment, subsequent to unpacking, and at all other times, take particular care that dust is not brushed or blown underneath the turntable and thus conveyed to the turntable bearings. The use of an oiled cloth for dusting purposes is recommended.

(b) ASSEMBLY.

Open the two doors of the cabinet, thus gaining access to the driving mechanism; namely, the motor, the mechanical filter (just above the motor gear box), and the flywheel shaft which extends downward out of the bearing and speed reduction housing, and upon which the flywheel, the drive shaft and flexible couplings are to be mounted.

The motor and base are fastened to the cabinet floor by means of wooden clamps and carriage bolts for protection during shipping. Remove and discard these wooden clamps and carriage bolts before proceeding further.

CAUTION: The motor and the entire drive shaft assembly are carefully aligned at the factory. Under no circumstances attempt to realign the assembly by loosening the motor mounting bolts or the bolts in the motor mounting ring. The horizontal and the vertical shaft thrust bearing adjustment screws in the motor gear box are likewise carefully adjusted at the factory, and under no circumstances should they be disturbed.

Remove the two hexagon nuts and the shipping bushing from the flywheel shaft. Place the flywheel, with the recessed side up, on the flywheel shaft and secure it in position by means of the two hexagon nuts removed in the previous operation, and make sure that it is securely clamped. In order to assemble the flywheel on the shaft, it is necessary to tilt the flywheel above the cross-piece over the cabinet doors, lining up the flywheel hole with the shaft, carefully raising the flywheel into place, then securing as explained above. The flywheel will slip into place on the shaft easily when in position and it must not be forced or damage to the shaft may result.

Refer to Figure 2. The turntable drive assembly is shipped unassembled. CAUTION: Exercise extreme care when handling the shaft and flexible couplings to avoid springing or forcing the couplings in such a way as to cause injury to the bronze spring-washers that form a part of their assembly.

Place the coupling shaft and flexible coupling assemblies in position at the drive assembly, slide the upper flexible coupling upon the flywheel shaft and the lower flexible coupling down on the drive shaft (see Figure 2). Space the couplings equally on the shafts and then tighten the set screws and lock nuts. Note that the flywheel shaft and the short shaft projecting upward from the mechanical filter are "spotted" for the cone point set screws and that both ends of the coupling shaft are provided with "flats" for the accommodation of their respective set-screws in the collars of the flexible couplings. Observe also that the coupling shaft consists of two members (male and female), the joint of which is concealed by the spring of the over-running clutch. The shaft should be replaced in such a manner that the retaining screw of this spring is toward the bottom of the shaft. Be sure that the two members of the shaft are completely engaged, one with the other. Do not force the shaft assembly on the flexible couplings when replacing the assembly.

See that all set-screws involved in the foregoing operation are properly seated and tightened.

(c) LUBRICATION

Pour the entire contents of the bottle of oil (Cat. No. 15914), shipped with the equipment, into the oil well or cup-like receptacle (mechanical filter mechanism). The purpose

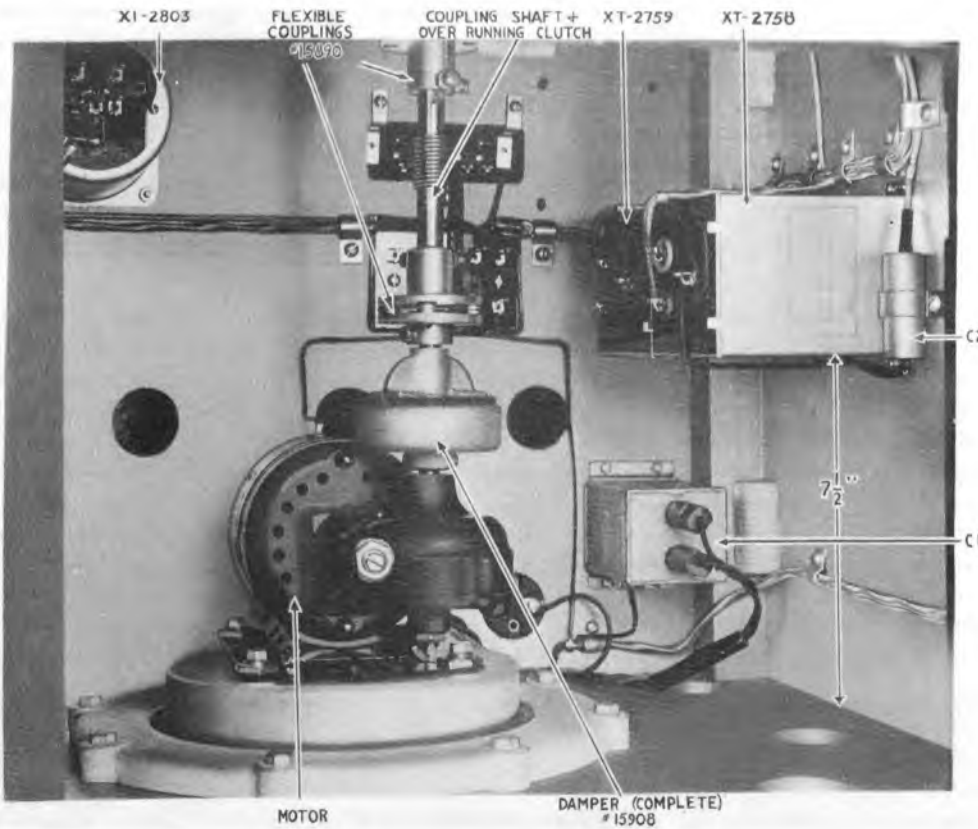
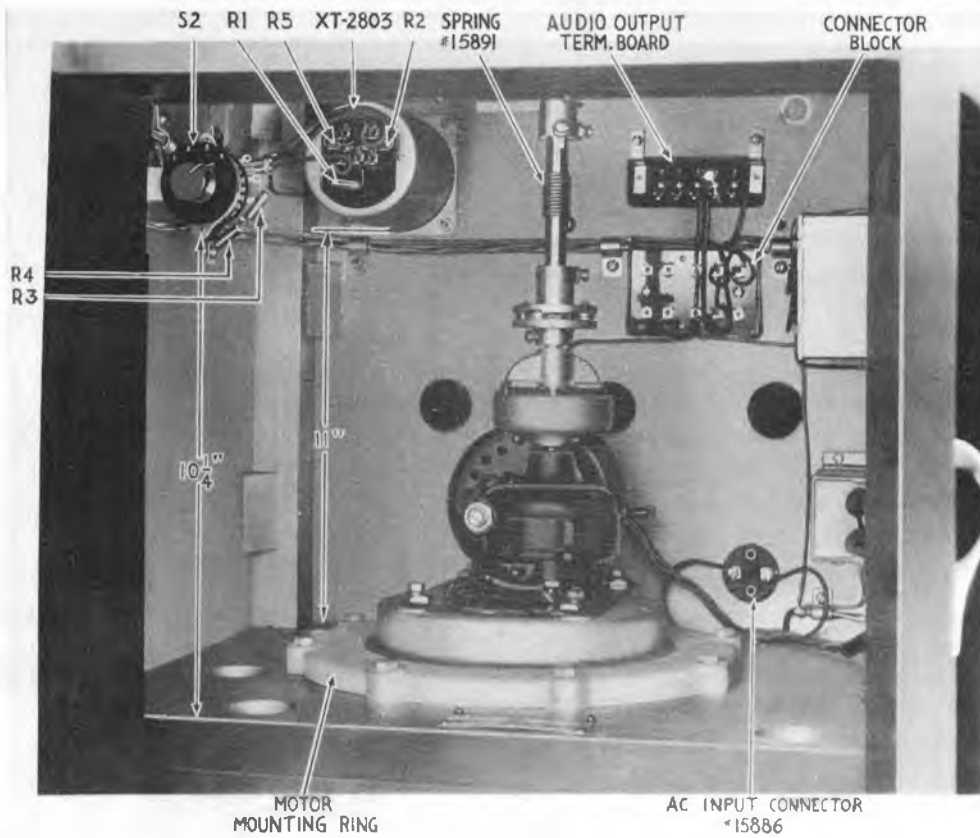

FIGURE 3 - INTERIOR VIEWS OF TYPE 70-B TRANSCRIPTION TURNTABLE.

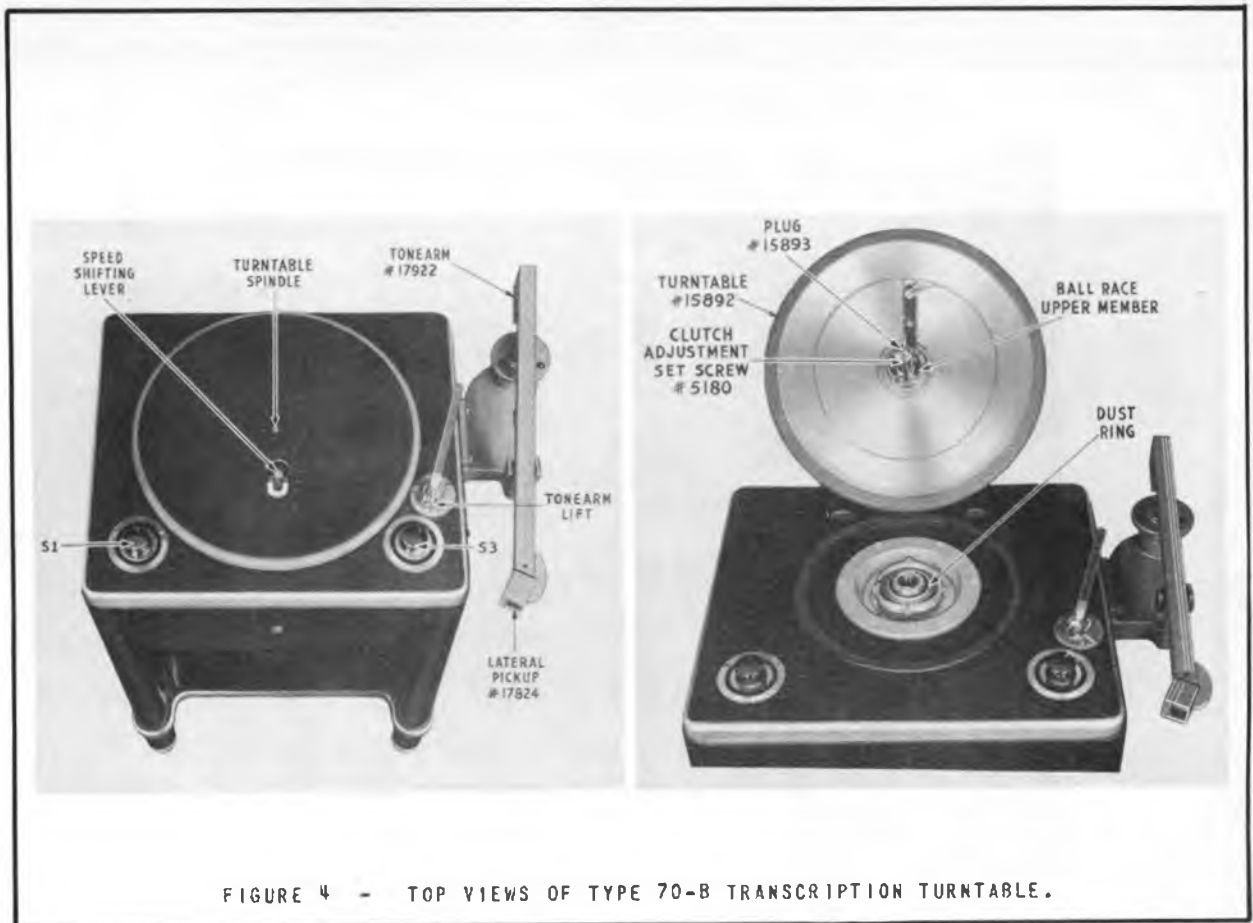

FIGURE 4 - TOP VIEWS OF TYPE 70-B TRANSCRIPTION TURNTABLE.

of this oil is to saturate the felt cushions accommodating the two driving vanes and thus lubricate the assembly. Under normal operating conditions, it should not be necessary to renew this lubricant. If, however, circumstances arise making such lubrication necessary, use a similar quantity of Vacme "AA" oil or its equivalent (S.A.E. 60).

Two holes are provided, one in each end-bell, for the lubrication of the motor bearings. Use a light, high-grade, non-gumming machine oil (S.A.E. 20), and lubricate at intervals of not more than six months.

An oil hole is provided in the center of the record spindle for the lubrication of the turntable bearings. Use a light, high-grade, non-gumming machine oil (S.A.E. 20) and apply six or seven drops at intervals of one month.

(d) ELECTRICAL CONNECTIONS.

The equipment is now completely set up, lubricated and ready for installation. In order to match the pickup output, the amplifier input impedance should not be less than 200 ohms or more than 250 ohms. Reproducing quality will not, however, be noticeably affected when the output is fed into 500 ohms. Install the equipment as follows:

See that the turntable is level. A three-point method of support is provided to eliminate the possibility of the turntable rocking when the floor is uneven.

See that the motor starting switch is in the "off" position.

The female cord connector furnished should be fitted with a suitable power cord, as this is not supplied as a part of the equipment. Make the required connections to a 105- to 125-volt, AC power supply of the frequency specified on the name plate. No other type of power supply may be used.

(Continued on page 9.)

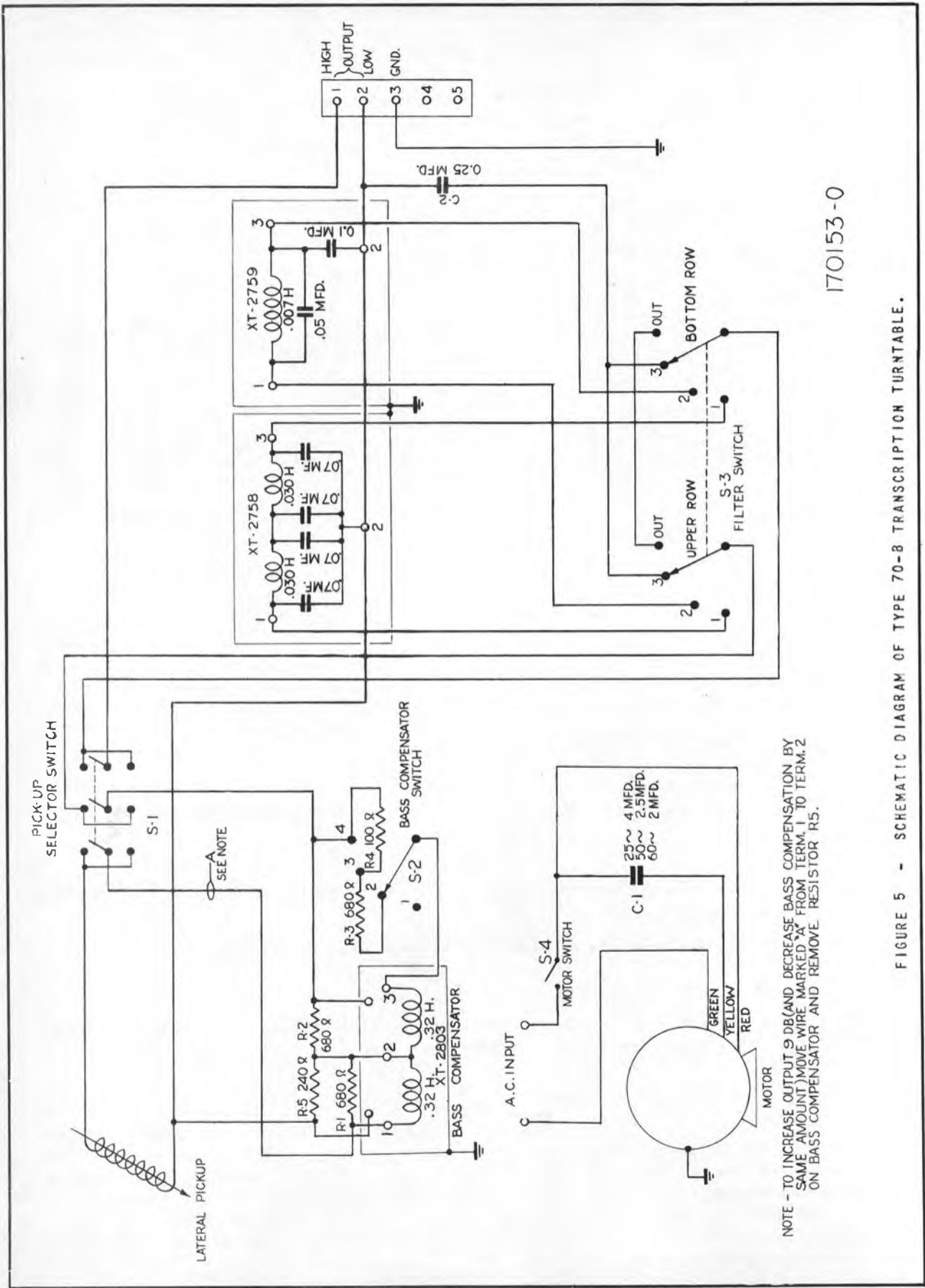

170153-0

NOTE - TO INCREASE OUTPUT 9 DB (AND DECREASE BASS COMPENSATION BY SAME AMOUNT) MOVE WIRE MARKED "A" FROM TERM. 1 TO TERM. 2 ON BASS COMPENSATOR AND REMOVE RESISTOR R5.

FIGURE 5 - SCHEMATIC DIAGRAM OF TYPE 70-B TRANSCRIPTION TURNTABLE.

A terminal board, containing the two audio output terminals and the ground terminal, is accessible through an opening in the back of the cabinet. Terminals #1 and #2 are the output terminals; terminal #3 is the ground terminal; terminals #4 and #5 are not used. Make the required connections to the amplifying equipment. It is recommended that a shielded, twisted pair of No. 19 A.W.G. be used for the output connections, and the low side of the audio output (terminal #2) should preferably be grounded at the amplifier to which it is connected. The shield of this audio cable should also be grounded.

(e) ROUTINE OPERATION

In order to insure stability of operation, it is recommended that the motor starting switch be turned "on" and the motor allowed to run independently for at least five minutes before playing records. This precaution should be observed especially when the instrument has been idle for an appreciable period, (such as overnight), but is not essential between operations separated by intervals of short duration.

With the external amplifier turned on, the routine operating procedure for the Type 70-B equipment as follows:

1. See that the motor switch is in the "off" position.
2. Set the speed shifting device for the speed of the record to be used (either 33-1/3 r.p.m. or 78 r.p.m.). Engage the speed shifting mechanism by rotating the turntable slowly by hand. The speed change becomes effective in less than one revolution.
3. Place the record on the turntable and place over it the record weight.
4. If necessary, set the pickup head selector switch for the type of pickup to be used. In the case of the Type 70-B equipment which is designed to reproduce lateral cut records only, both positions on this switch are common and no previous setting of the switch is required. In the case of the Type 70-B equipment which is adapted for the use of both the vertical and the lateral cut recordings, clockwise, or right-hand, setting of the selector switch closes the circuit of the lateral pickup head, while the left-hand setting closes the circuit of the vertical pickup head.
5. Start the motor and lower the pickup arm onto the record in accordance with the usual studio practice.
6. When the record has been played, lift the pickup and replace it in the tonearm rest.
7. Move the motor starting switch to the "off" position.

CAUTION: The pickup should never be left resting on the record or the turntable when through playing.

It is recommended that the equipment be covered when not in use.

M A I N T E N A N C E

Lubricate the equipment in accordance with instructions given in "INSTALLATION AND OPERATION". Do not oil the over-running clutch, as lubrication of this device has been properly taken care of at the factory.

Never blow dust from beneath the record plate. Wipe it from this space with a lint-free and slightly oily cotton cloth--WHILE THE RECORD PLATE IS STATIONARY. The speed reduction bearing is protected against the normal accumulation of dust from above, but is liable to contamination if fairly large particles of dust are blown upward from the recess in the turntable cabinet in which the bearing is located.

(Continued on page 10.)



The lateral pickup arm should ride parallel to the plane of the record. Should this at any time not be the case, adjustment may be made by loosening the set-screw at the back of the tonearm pivot, sliding the tonearm up or down on the pivot until the correct adjustment is obtained, and tightening the set-screw.

As a result of the continued demand for higher and higher quality in the reproduction of broadcast transcriptions, the transcription turntable has been developed, through engineering refinements, into a device in the class with precision instruments and should be treated as such. With reasonable care and proper lubrication, as outlined in this Instruction Book, it should give years of constant service without noticeable increase in speed variation. Therefore, do not tamper with, or alter in any way, any parts of the turntable drive assembly or record plate (except as described in "INSTALLATION AND OPERATION", or change any adjustments of this mechanism, unless it is absolutely necessary because of a known defect.

Should any adjustments or repairs to the drive mechanism become necessary, it is advisable to have the RCA Manufacturing Company's service man make the required adjustment of the device. However, in cases of extreme necessity and with the provision that the work be performed by an experienced machinist, the following repairs and adjustments may be made in the field. Refer to Figure "TURNTABLE DRIVE ASSEMBLY" for part identification.

(a) CLUTCH ADJUSTMENT OF SPEED CHANGING MECHANISM.

Do not remove the turntable unless this adjustment ( or that described in (b) below) is necessary.

The turntable may be removed from its bearing and re-adjustment of the clutch mechanism may be made in the following manner:

1. Grasp the turntable with the hands at diametrically opposite points on its circumference and withdraw it from its bearing by exerting a straight, upward pull. When doing this be sure to hold the turntable in a level position until its spindle is entirely clear of the bearing. Otherwise, damage to the bearing may result.

The steel ball which serves as a thrust bearing under the end of the turntable spindle may adhere to the grease on the spindle and be removed from its seat. Be careful not to lose this ball.

2. Place the turntable, face down, on a clean level surface.
3. Remove the cylindrical plug in the end of the turntable spindle.
4. A vertical bearing adjustment, slotted to accommodate a screw-driver, will be found at the bottom of the hole from which the plug has been removed. A set-screw in the side of the shaft serves to clamp this adjustment.
5. Loosen this set-screw, back out or screw in the adjustment and insert the plug.
6. See that the steel ball thrust bearing is in its seat in the turntable spindle bearing in accordance with instructions given, in (c) below, and test for correct adjustment, the conditions for which are given in sub-paragraph 7, below.
7. The clutch engagement should be accomplished in the first revolution of the turntable, and the equipment must not be operated if the clutch slips.

(Continued on page 11.)

(b) CLEANING THE SPEED REDUCTION BEARING.

If the equipment is not kept clean or is improperly cleaned, dust may become lodged in the speed reduction bearing. If the dust is permitted to remain and accumulate, excessive wear, and possible speed variation, will result. Dust in the speed reduction bearing will be indicated by a faint knocking or grinding noise, heard directly from the mechanism when running at 33-1/3 r.p.m. To remedy this condition, it is necessary to remove the bearing and clean it thoroughly.

Do not raise the turntable or remove the bearing unless it is necessary to perform this work (or that described in (a) above). The procedure is as follows:

1. Remove the turntable as described above.
2. Unlock the bearing nut by bending the lock washer tabs outward and away from the notches in the bearing nut.
3. Remove the bearing nut by means of a spanner wrench.
4. Remove the lock washer and sealing ring.
5. Lift the speed reduction bearing clear of the bearing housing without removing the clamp ring.
6. Clean all parts on the top of the housing of the mechanism and remove all dust from the top of the cabinet.
7. Soak the speed reduction bearing thoroughly in clean kerosene oil, turning the steel balls and ball races to be sure that no dirt or lint remains on the assembly.
8. Wash the bearing in a second rinse of clean kerosene and shake off all kerosene possible. Do not attempt to dry the bearing with a cloth, as this operation may reintroduce lint to the bearing parts and cause a repetition of the trouble.
9. Apply a thin coating of pure, clean, white-vaseline to the ball race. Vaseline sold in a tube-type container is suggested, since there is almost no possibility of its becoming contaminated or dirty.
10. Replace the bearing on the bearing shaft. (See that the notch in the clamp ring is uppermost when the assembly is in position.)
11. Place the lockwasher on the bearing shaft.
12. Place over the lock washer a clean piece of paper, having in its center a round hole the size of the bearing shaft.
13. Screw the nut in place and tighten it with a spanner wrench.
14. Lock the nut by bending a lock washer tab into a notch in the bearing nut.
15. Place the sealing ring in position on top of the speed reduction bearing and center it.
16. Clean the under side of the turntable and replace it on the spindle as described below.

(Continued on page 12.)

(c) REPLACEMENT OF TURNTABLE.

If, for any reason, the turntable has been removed from its bearing in the main drive spindle, replace it in the following manner:

1. Engage the turntable spindle with the female bearing of the drive spindle, align the spindle, and lower the turntable slowly until the upper member of the ball race, which is attached to the turntable, comes into contact with the balls. When performing this operation make certain that the dust ring, which rests on the top of the spindle, is concentric with the bearing.
2. While still holding the turntable, rotate it slowly until the openings in the upper member of the ball race engage the balls, and then lower it slowly and carefully into position.

(d) WOWS.

A variation in the speed of rotation of the turntable, sometimes referred to as "wows", can be caused by a loose flywheel. Be sure that the flywheel nut and its lock nuts are well tightened.

(e) CHANGING THE MOTOR.

To replace the drive motor, disconnect electrically and proceed as follows:

1. Loosen the lock screws on the upper and lower flexible coupling units and on the spider of the mechanical filter.
2. Remove the four motor mounting bolts.
3. Raise the entire spider and coupling assembly to clear the vertical drive shaft and set the upper flexible coupling lock screws and spider lock screws so as to hold the assembly clear of the vertical drive shaft.
4. Carefully lift out the motor.
5. Remove the mechanical filter from the vertical drive shaft and place it in the same position on the vertical drive shaft of the new motor.

NOTE: A washer in the mechanical filter is shown in Figure 2. This washer can be forgotten, or lost, before the reassembly is started. Therefore, be sure to locate this washer and set it safely aside at the time of removing the old motor.

6. Place the new motor carefully on the motor base and lock the mechanical filter to the vertical drive shaft. Flats are provided on the shafts for the lock screws.
7. Align the vertical shaft with the coupling shaft and start, but do not tighten the motor mounting bolts.
8. Loosen the upper flexible coupling and spider lock screws and lower the coupling unit assembly into place so that the spider engages the female section of the mechanical filter.

(Continued on page 13.)

9. Lock the lower and upper flexible coupling lock screws to the flats of the shafts to which they fit.
10. Make electrical connections to the new motor. See "INSTALLATION AND OPERATION."
11. Oil the new motor as described previously.
12. Start the motor and observe the bronze coupling spring in the lower flexible coupling unit. The spring will run horizontally between the coupling unit sections and will appear as a plane surface when the motor is properly aligned. If the motor is not correctly in line, the bronze spring will show a definite undulation as it turns.
13. Adjustable motor base bushings with lock nuts are supplied on the motor. These bushings permit the raising or lowering of any corner of the motor and must be adjusted for the alignment of the vertical drive shaft and clutch assembly. The bushings should be locked after they have been set for alignment as described.
14. Tighten the motor mounting bolts while watching the bronze coupling spring with the motor running. Any variation in the bronze coupling spring movement will indicate that further adjusting of the motor base bushings will be necessary.
15. When the adjustable bushings are set so that the tightening of the motor mounting bolts does not throw the vertical drive shaft and clutch assembly shaft out of line, they are correctly set.

NOTE: The over-running clutch must be absolutely free to turn in the clockwise direction and must not bind. It must lock when turned counter-clockwise.

(f) TONEARM MOUNTING DETAILS.

Should it become necessary to remove the tonearm from the mounting casting, it should be replaced as shown in Figure 6.

(g) TONEARM LIFT ADJUSTMENT.

A set screw is provided in the lower part of the main casting which, when loosened, allows the bearing and lift mechanism to be adjusted higher or lower. If it should become necessary to change the vertical adjustment in order to properly lift the tonearm from the record, remove the woodscrews securing the tonearm lift to the cabinet, loosen the set screw mentioned above, adjust the bearing, and lift the mechanism slightly higher or lower as necessary, tighten the set screw, and then replace the mechanism on the cabinet. The procedure should be repeated if the first adjustment does not produce the desired results.

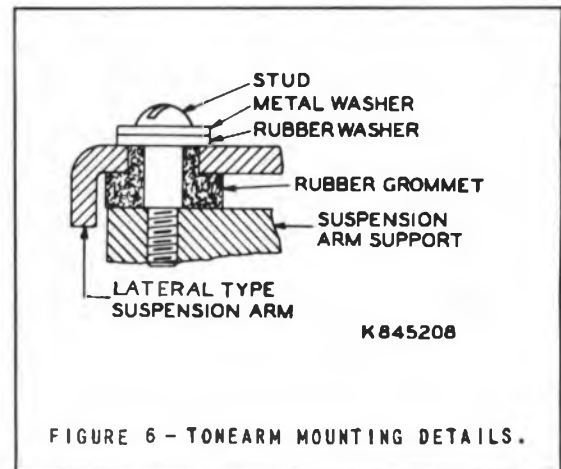

REPLACEMENT PARTS LIST

The following parts list is included to provide proper identification when ordering replacement parts. When ordering, specify the item by its symbol (wherever possible) as shown in the diagrams, followed by description and catalog number.

Insist on genuine factory-tested parts which are readily identified and may be purchased through Authorized Dealers, or from the Factory.

| <u>SYMBOL</u> | <u>DESCRIPTION</u>                     | <u>CATALOG NUMBER</u> |
|---------------|--|-----------------------|
| C-2           | Capacitor, 0.25 Mfd.                   | 30849                 |
| C-1           | " For 60 Cycle Motor                   | 12051                 |
| C-1           | " For 50 Cycle Motor                   | 30398                 |
| C-1           | " For 25 Cycle Motor                   | 13101                 |
| ---           | Pickup - Lateral Pickup                | 17824                 |
| ---           | Motor, 60 Cycle (for MI-4858,-A,-B,-C) | 16362                 |
| ---           | Motor 50 Cycle (for MI-4859,-A,-B)     | 16804                 |
| ---           | Motor, 25 Cycle (for MI-4860,-A,-B)    | 16805                 |
| R-1           | Resistor, 680 Ohms                     | 31024                 |
| R-2           | " 680 Ohms                             | 31024                 |
| R-3           | " 680 Ohms                             | 31024                 |
| R-4           | " 100 Ohms                             | 30540                 |
| R-5           | " 240 Ohms                             | 30619                 |
| ---           | Bass Compensator, XT-2803              | 17653                 |
| S-1           | Pickup Selector Switch                 | 17670                 |
| S-2           | Bass Compensator Switch                | 17672                 |
| S-3           | Filter Switch (High Frequency)         | 17671                 |
| S-4           | Motor Switch                           | 15885                 |
| ---           | Filter Assembly, XT-2758               | 17651                 |
| ---           | Tone Arm                               | 17822                 |
| ---           | Filter Assembly, XT-2759               | 17652                 |
| ---           | Knob for S-2                           | 30075                 |
| ---           | Knob for S-3                           | 17268                 |
| ---           | Connector, Cord Connector and Cap.     | 15886                 |
| ---           | Coupling, drive shaft coupling         | 15890                 |
| ---           | Damper, (mechanical filter), complete  | 15908                 |

(Continued on page 15.)



REPLACEMENT PARTS LIST (Con.)

| <u>SYMBOL</u> | <u>DESCRIPTION</u>   | <u>CATALOG NUMBER</u> |
|---------------|--|-----------------------|
| --- .....     | Insert, thrust bearing insert (plug)<br>in bottom of turntable spindle .....   | 15893                 |
| --- .....     | Screw, adjustment screw, for adjusting<br>the clutch of the speed reduction mechanism,<br>(located in turntable spindle) ..... | 5181                  |
| --- .....     | Screw, set-screw for clamping the clutch<br>adjustment screw .....   | 5180                  |
| --- .....     | Spring, coupling shaft, torsional<br>spring .....  | 15891                 |
| --- .....     | Turntable, complete with spindle and<br>speed shift lever .....  | 15892                 |
| --- .....     | Tonearm Lift Attachment (Complete) .....   | MI-4861               |

RCA VICTOR DIVISION

RCA MANUFACTURING COMPANY, INC.

Camden, N. J.      U. S. A.

A SERVICE OF THE RADIO CORPORATION OF AMERICA

Printed in U. S. A.

TYPICAL OVERALL FREQUENCY RESPONSE  
 OF  
 TYPE 70-B TRANSCRIPTION EQUIPMENT  
 AND TEST RECORD #2346-1 (12" DIA. 33.3 R.P.M.)

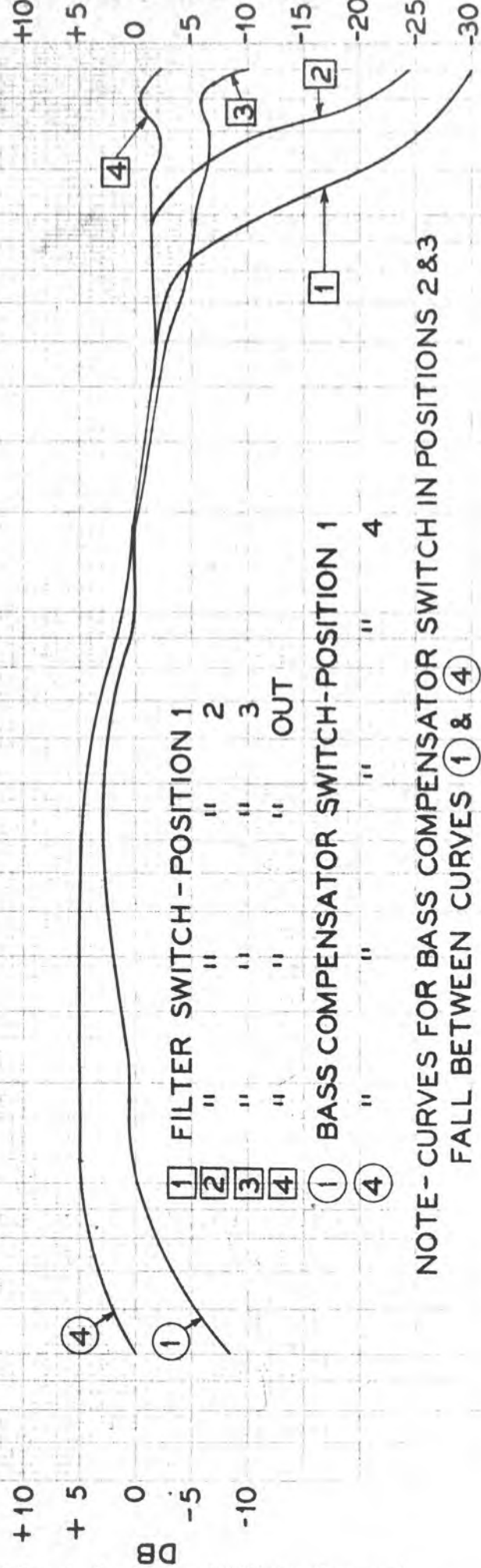

NOTE - CURVES FOR BASS COMPENSATOR SWITCH IN POSITIONS 2 & 3  
 FALL BETWEEN CURVES 1 & 4

100 500 1000 2 3 4 500 1000 2 3 4 500

5-839817

PROPER SETTINGS OF 70B EQUALIZERS FOR  
REPRODUCTION OF RCA RECORDINGS

|       |               |
|-------|---------------|
| No.   | IX-2          |
| Sheet | 1 of 1 Sheets |
| Date  | 2-13-40       |

- \*1. Reproduction of 10" and 12" commercial recordings. (Red Seal, Victor Black Seal and Bluebird)
  - a. Low frequency equalizer on step 2.
  - b. High frequency equalizer on step 3.
  
- \*2. Reproduction of "Orthacoustic" recordings.
  - a. Low frequency equalizer on step 2.
  - b. High frequency equalizer on step 3.

\* Note:— These settings are for the 70B turntable with the MI-4856 Lateral Reproducer and a flat amplifier such as the 82- or 94- series of broadcast monitors or their equivalents. The loudspeaker should be an MI-3429 (Recording Monitor) or a 64A Broadcast Monitor with a single voice coil cone.

SECTION X

Test Equipment

Master Reference Book  
Disc Recording





# **DISTORTION METER**

**TYPE 69-A**

Manufactured by  
**RCA Manufacturing Company, Inc.**  
Camden, N. J., U. S. A.

**"A SERVICE OF THE RADIO CORPORATION OF AMERICA"**

# INSTRUCTIONS

---

## DISTORTION METER

---

**TYPE 69-A**

Manufactured by

**RCA Manufacturing Company, Inc.**  
Camden, N. J., U. S. A.

**"AN RCA SERVICE"**

Printed in U. S. A.

1B-23362-4

PH-45880



FIGURE 1 - DISTORTION METER  
(Type 69-A)

# DISTORTION METER

TYPE 69-A

MI - 7512

## ELECTRICAL CHARACTERISTICS

Frequency Range: 50 to 22,000 cycles  
Distortion Range: 0.3% to 100% r-m-s  
Noise Level Reading To: -85 db  
Power Supply: 110/120 volts, 25/60 cycles  
Power Drain: 50 watts  
Fuse Protection: 1.5 amperes  
Tube Complement:  
3 RCA-6C5 Voltage Amplifiers  
1 RCA-6N7 Power Amplifier  
1 RCA-6C5 R-F Rectifier  
1 RCA-5Z4 Power Rectifier

## MECHANICAL CHARACTERISTICS

| Dimensions      | Rack Type     | Cabinet Type  |
|-----------------|---------------|---------------|
| Height          | 8-3/4 inches  | 9 inches      |
| Width           | 19 inches     | 19-1/4 inches |
| Depth           | 10-1/4 inches | 12 inches     |
| Shipping Weight | 49 pounds     | 60 pounds     |

## DESCRIPTION

The Type 69-A Distortion Meter was developed to meet the demand for an accurate and reliable instrument for measuring the harmonic distortion and noise level in the output of radio transmitters, audio amplifiers, or modulated radio frequency equipment of any type.

Distortion or noise measurements are read directly from the meter scale which is calibrated for several ranges.

When used with the Type 68-A Low Distortion Oscillator, distortion measurements may be made at any frequency from 50 to 7000 cycles per second or higher. The distortion meter measures all components up to 25,000 cycles with full accuracy. Reliable readings as low as 0.3 percent may be made on any equipment having normal phase characteristics, that is, less than 180 degrees phase shift throughout its frequency range, since under these conditions the inherent distortion in the oscillator of approximately 0.1 percent r-m-s will have negligible effect upon the distortion meter readings. Under the worst possible phase conditions, a residual reading of approximately 0.2 percent would be obtained. Distortion measurements may be made



at frequencies down to 30 cycles per second with reasonable accuracy if the amount of distortion to be measured is not too small.

Distortion as low as 0.3 of one percent may be read where the phase shift is less than 180 degrees.

Using 12.5 mw as a zero reference level, distortion can be measured at volume levels as low as -15 db, and noise levels may be measured as low as -85 db.

In making distortion measurements, the meter indicates the distortion factor; i.e., the ratio of r-m-s total distortion to fundamental amplitude. This is accomplished by suppressing the fundamental frequency component of the wave in question and measuring the r-m-s total of the remaining components. Elimination of the fundamental frequency component is accomplished by adding to the distorted wave, a sine wave of the same frequency, equal in amplitude to the fundamental component, and 180 degrees displaced in phase. This voltage is secured from the same oscillator which supplies the signal to the equipment under test, and is adjusted in amplitude and phase by controls on the panel of the Distortion and Noise Meter. (See Figure 1). Distortion readings directly in percent of fundamental amplitude are secured by first adjusting the Distortion Meter to read full scale (100%) with only the sine wave input connected.

Measurements of noise level are made by adjusting the meter to read full scale at the desired equipment output level and then removing the input signal from the equipment under test. The remaining noise and hum is amplified until a readable deflection of the meter is obtained. The noise level is then read directly in decibels from the meter and attenuator scales.

## INSTALLATION

The Type 69-A Distortion Meter is supplied in two models, the cabinet model and the rack model. The cabinet model is supplied in a substantial metal cabinet, while the rack model is supplied with a standard relay rack mounting panel and dust cover. In every other respect, both models are identical.

The power cable should be connected between the a-c receptacle of the meter and a power supply receptacle furnishing 110/120 volts 25/60 cycles and capable of delivering 50 watts.

Terminals for connecting the Distortion and Noise Meter with the associated equipment are located in the rear of the chassis and are plainly marked, with parallel connected jacks located on the front panel. These terminals may also be identified from the illustration in Figure 2.

## OPERATION

**METER RANGE** - Distortion and noise measurements are read from the same meter, which is calibrated to the following full scale readings:



| Distortion | Noise Level |
|------------|-------------|
| 1%         | -60 db      |
| 3%         | -50 db      |
| 10%        | -40 db      |
| 30%        | -30 db      |
| 100%       |             |

The desired meter range is selected through the meter range switch which is controlled by means of the large knob and scale. The desired distortion range may be selected by rotating the knobs over the left-half of the scale. The desired noise level range may be selected by rotating the knob over the right-half of the scale.

**INPUT LEVELS** - For accurate distortion or noise measurements, the input level should not be lower than that tabulated below for specific cases:

Modulated Radio Frequency from Equipment Under Test -

- Minimum 10 volts carrier for distortion measurements
- Minimum 0.6 volt carrier for noise level measurements
- Maximum 100 volts carrier

Audio Frequency from Equipment Under Test -

1. Bridging input terminals or jacks (balanced)
  - Minimum 0.5 volts or -15 db below 12.5 mw on 500 ohm line
  - Maximum 8 volts or +10 db above 12.5 mw on 500 ohm line
  - This voltage must be at least 10 db higher than the voltage taken from the oscillator.
2. Audio and ground input terminals (unbalanced)
  - Minimum 0.6 volts
  - Maximum 100 volts
  - This voltage must be at least 5 times as great as the voltage taken from the oscillator.

Audio Frequency from Low Distortion Oscillator -

- Minimum 0.1 volts or -25 db below 12.5 mw on 500 ohm terminals
- Maximum 8.0 volts or +10 db above 12.5 mw on 500 ohm terminals

**COUPLING METHODS** - Modulated radio frequency voltages to be measured are obtained through inductive coupling. The pickup coil should be designed with a low audio frequency impedance in order to eliminate any a-c hum component that may be picked up.

When the Distortion and Noise Meter is to be used in conjunction with a balanced audio line having an impedance of 600 ohms or less, a bridging transformer having an impedance of 20,000 ohms is used. This impedance is sufficiently high to have no appreciable effect upon the low impedance line.

The three transformer input connections terminate in three binding posts, marked "BRIDGING", located at the rear of the chassis, and a pair of parallel connected jacks located on the front panel. The center tap of the transformer winding is not grounded.

For an unbalanced audio line having an impedance up to 20,000 ohms, connections may be made to the "AUDIO" and "GROUND" terminals at the rear of the meter chassis. The input circuit at these terminals consists of a 0.2 mfd capacitor in series with approximately 250,000 ohms resistance. Measurements should be taken with the equipment under test operating under normal load conditions.

Interstage distortion and noise measurements may be made by connecting the distortion meter direct to the plate of the stage being measured. In this way the origin of the major portion of distortion in an amplifier may be located.

The audio frequency voltage supplied by the low distortion oscillator must be coupled to the meter through a balanced line of 500 ohms or less. Three connections, center tap and both side connections, must be made in order to properly operate the phase shifting network. The center tap terminal of the distortion meter oscillator input is grounded.

**CONNECTIONS** - Following are tabulated the correct connections to be made for distortion and noise measurements under various conditions:

For Modulated Radio Frequency Input - Connect the pickup coil between the "R-F" and "GROUND" terminals at the rear of instrument and remove all connections from the audio terminal. Set the "INPUT" switch to "R-F" position.

For Audio Frequency Input Balanced Lines, Up To 600 Ohms - Connect the audio line either to the "BRIDGING" terminals at the rear or to the "BRIDGING" jacks on the front panel. The center tap connection may be connected, left open or grounded as desired. Set the "INPUT" switch to "BRIDGING" position.

For Unbalanced Audio Frequency Input - Connect the audio line to the audio and ground terminals. Set the "INPUT" switch to "AUDIO" position.

For Distortion Measurements - Connect the 250 or 500 ohm and center tap terminals to the three terminals at the rear of the distortion meter marked "OSCILLATOR", or to the pair of jacks on the front panel marked "OSCILLATOR".

**CALIBRATION** - The meter may be calibrated for noise level and distortion measurements in the following manner:

For Noise Level Measurements -

1. Set the "RANGE" switch to reference level (REF.) position.
2. Adjust the output of the equipment under test to the desired reference level, making certain that the voltage applied to the Distortion and Noise Meter is within the limits given above.
3. Set the meter to full scale, zero db, by means of the "CALIBRATION" control and the "COARSE AMPLITUDE" control. In case the "CALIBRATION" control has previously been adjusted for distortion measurements, its setting should not be changed.

For Distortion Measurements -

1. Set the "RANGE" switch to "CALIBRATE" (CAL.) position.
2. Adjust the output from the oscillator to some value within the limits given under "INPUT LEVELS".
3. Adjust the output from the equipment under test to the desired level.
4. Set the meter by means of the "CALIBRATION" control to read full scale.
5. Turn the "RANGE" switch to reference level (REF.) position and adjust the "COARSE AMPLITUDE" control for full scale meter deflections.

**PRELIMINARY ADJUSTMENTS** - Where the Distortion and Noise Meter is used for distortion measurements over a large range of frequencies and output levels, it will be desirable to adjust the output voltage from the oscillator to give approximately the recommended maximum value, 8 volts, at the distortion meter terminals, and to adjust the equipment under test so that full output is obtained with this setting of the oscillator "OUTPUT" control. Distortion measurements at lower output levels may then be made by readjusting only the oscillator "OUTPUT" control and the distortion meter "CALIBRATION" control.

In installations where the Distortion and Noise Meter is permanently associated with the equipment to be measured, such as in the case of a broadcast transmitter, and where it is to be used for routine checking of distortion and noise at a particular output level, the "CALIBRATION" and "COARSE AMPLITUDE" controls can be permanently set in the following manner.

Adjust the transmitter output to the desired reference level and calibrate the distortion meter by setting the "RANGE" switch to "CALIBRATE" position and adjusting the "CALIBRATION" control to full meter scale deflection. Turn the range switch to "REFERENCE LEVEL" position and adjust the meter to full scale deflection by means of the "COARSE AMPLITUDE" control. The "COARSE AMPLITUDE" control as well as the "CALIBRATION" control may be left permanently in these positions. A check of the accuracy of these settings can be made at any time by adjusting the equipment again to the same output level. Permanent calibration settings will enable the operator to obtain readings in the shortest time.

**NOISE LEVEL MEASUREMENTS** - After calibrating the equipment for noise level measurements as outlined under "CALIBRATION", reduce the input signal to the equipment under test to zero, in the case of a transmitter reduce the modulation to zero, turn the "RANGE" switch toward the -60 db position until a readable deflection of the output meter is obtained. The sum of the "RANGE" switch reading and the "METER" reading gives the noise level in decibels below the reference level.

Noise levels are ordinarily measured in decibels below the rated output or below 100% modulation. Calibration at these levels will enable measurements down to -70 db. This range may be extended to -80 db, -90 db or further by setting the reference level 10, 20, or more decibels below rated output.

**DISTORTION MEASUREMENTS** - After calibrating for distortion measurements as outlined under "CALIBRATION", turn the range switch to the 100% position and adjust the "PHASE" controls to secure *minimum* meter deflection. The

"COARSE PHASE" control provides 360 degree phase shift in 48 overlapping steps in two complete revolutions of the knob. The "FINE PHASE" control provides continuous phase shift between steps. The position of the "COARSE PHASE" control should be carefully selected to provide minimum meter deflection and the "RANGE" switch advanced to the 30% position. If the correct position of the "COARSE PHASE" control has been selected, a minimum meter deflection should be found within the range of the "FINE PHASE" control. If minimum deflection is obtained with the "FINE PHASE" control at one end of its range, the "COARSE PHASE" control should be advanced in this direction. For example, the meter reading may decrease steadily with rotation of the "FINE PHASE" control until the right hand stop is reached. This indicates that the "COARSE PHASE" switch should be moved to the right. The "RANGE" switch should be set back to the 100% position before changing the position of "COARSE PHASE" control. In some instances it may be necessary to advance the "PHASE" switch by two or more points from the preliminary point owing to the overlapping ranges. If the "COARSE PHASE" switch reaches the stop and cannot be advanced further in the desired direction, the correct position will be found by rotating the knob two complete revolutions in the opposite direction.

When a balance has been found within the range of the "FINE PHASE" control, the "AMPLITUDE" controls should be adjusted for minimum meter deflection and the "RANGE" switch advanced to a more sensitive position, that is, select a lower percent range. After obtaining an exact balance the amount of total distortion is obtained by reading both the "METER" and "RANGE" scales. After a reading has been taken, the "RANGE" switch should be returned to the "CALIBRATE" position before making any adjustments to the equipment, in order to protect the meter.

**DISTORTION ANALYSIS** - Analysis of components of a modulated radio frequency wave may be made if a wave analyzer or an oscillograph is connected across the "AUDIO" and "GROUND" terminals of the distortion meter. The output of the detector is available at these terminals. Well shielded leads should be used to avoid pickup of extraneous voltages. Any equipment connected to the "AUDIO" terminals while the detector is in use must have an impedance of at least 100,000 ohms, and be coupled through a capacitor in order to keep direct current out of the circuit.

By the use of an oscillograph such as the Type TMV-122-B an analysis may be made to determine whether the major part of the distortion consists of second, third, or other order harmonic. To make this measurement, connect the oscillograph vertical amplifier across the meter terminals (inside the distortion meter) or from the 6N7 tube plate to ground and connect the horizontal amplifier to the oscillator. When the distortion meter is balanced, the vertical deflection of the oscillograph represents only the distortion components. Thus the resulting oscillograph trace may be examined to determine the ratio of the distortion frequency to the input signal frequency. A slight unbalance of the distortion meter controls gives a vertical deflection containing a small amount of the fundamental frequency. With the oscillograph timing axis in use, the result is a pattern showing the wave shape of the output of the equipment under test with the amount of distortion greatly exaggerated.

## CIRCUIT DESCRIPTION

The schematic diagram of the Distortion and Noise Level Meter circuit is shown in Drawing T-611070.

When operating as a noise level meter, the instrument utilizes a radio frequency rectifier or detector, followed by three stages of audio frequency amplification, the output stage being coupled to the meter. An attenuator system comprising the "RANGE" switch, the "CALIBRATION ADJUSTMENT" control, and the "COARSE and FINE AMPLITUDE" controls, is used to vary the gain of the amplifiers.

The output of the detector is fed through a variable resistor and the "FINE AMPLITUDE" control to an attenuator composed of two sections of the five gang "RANGE" switch. The output of this attenuator is connected, through the "COARSE AMPLITUDE" potentiometer, to the first amplifier tube. The output of this stage is transformer coupled to the "CALIBRATION ADJUSTMENT" control, through an attenuator using another section of the "RANGE" switch, to the second amplifier tube.

The output of the second stage is resistance-capacitance coupled to an attenuator using the front section of the "RANGE" switch. The input to the final amplifier stage is taken from the attenuator. The final stage is transformer coupled to the output meter.

For making distortion measurements, some additional circuits are required. The input voltage introduced at the oscillator terminals is adjusted in phase by the "COARSE PHASE" switch and the "FINE PHASE" potentiometer. The grid of an additional 6C5 tube is connected either to ground or to the phase shifting network by means of the rear section of the "RANGE" switch. The output of this tube is added to the output of the first amplifier stage by means of a third winding on the interstage transformer. All amplifier tubes are individually self-biased by means of cathode resistors. The plate supply is of conventional design.

The attenuation in db for various positions of the "RANGE" switch is as follows:

| Switch Position | Sections 2 & 3 | Section 4 | Section 5 | Total | Voltage Ratio |
|-----------------|----------------|-----------|-----------|-------|---------------|
| -60 db          | 0              | 0         | 0         | 0     | 1.00          |
| -50 db          | 0              | 0         | 10        | 10    | 3.16          |
| -40 db          | 0              | 0         | 20        | 20    | 10.0          |
| -30 db          | 0              | 10        | 20        | 30    | 31.6          |
| Ref. Level      | 20             | 20        | 20        | 60    | 1000.0        |
| Calibrate       | inf.           | 20        | 20        | inf.  | inf.          |
| 100%            | 20             | 20        | 20        | 60    | 1000.0        |
| 30%             | 20             | 9.5       | 20        | 49.5  | 300.0         |
| 10%             | 20             | 0         | 20        | 40    | 100.0         |
| 3%              | 20             | 9.5       | 0         | 29.5  | 30.0          |
| 1%              | 20             | 0         | 0         | 20    | 10.0          |



These values are obtained by maintaining a constant output meter reading and measuring the modulated r-f or audio input, using the -60 db position as reference. Correct setting of the range switch should provide infinite attenuation for the oscillator input in all noise level positions and zero attenuation in all distortion positions.

The frequency characteristic is flat within 1 db from 50 to 25,000 cycles for all positions of the "RANGE" switch when the audio (unbalanced) input is used. When the bridging input is connected, the frequency characteristic is flat from 50 to 15,000 cycles.

## MAINTENANCE

In case the distortion and noise meter fails to function in the normal manner, all external connections should be inspected and if the difficulty is not located, the a-c power should be shut off and the tubes removed from the chassis and tested in a reliable tube tester. Defective tubes and tubes of low emission characteristics should be replaced.

In cases of failure which cannot be traced to poor connections or defective tubes, a systematic socket to socket voltage test should be made using a high resistance voltmeter or reliable radio receiver set analyzer. For this test, the tubes should be in their respective sockets and the a-c power turned on. The readings obtained should closely approximate the values given in the table.

A small 1-ampere cartridge fuse is used in the primary circuit of the power transformer. This fuse should not be short-circuited or replaced by one of higher rating. Fuse failure may originate from a power supply surge but the cause will more likely be found in the equipment protected. Heat generated at the clip contacts may cause failure. These points should be kept clean and in firm contact with the fuse.

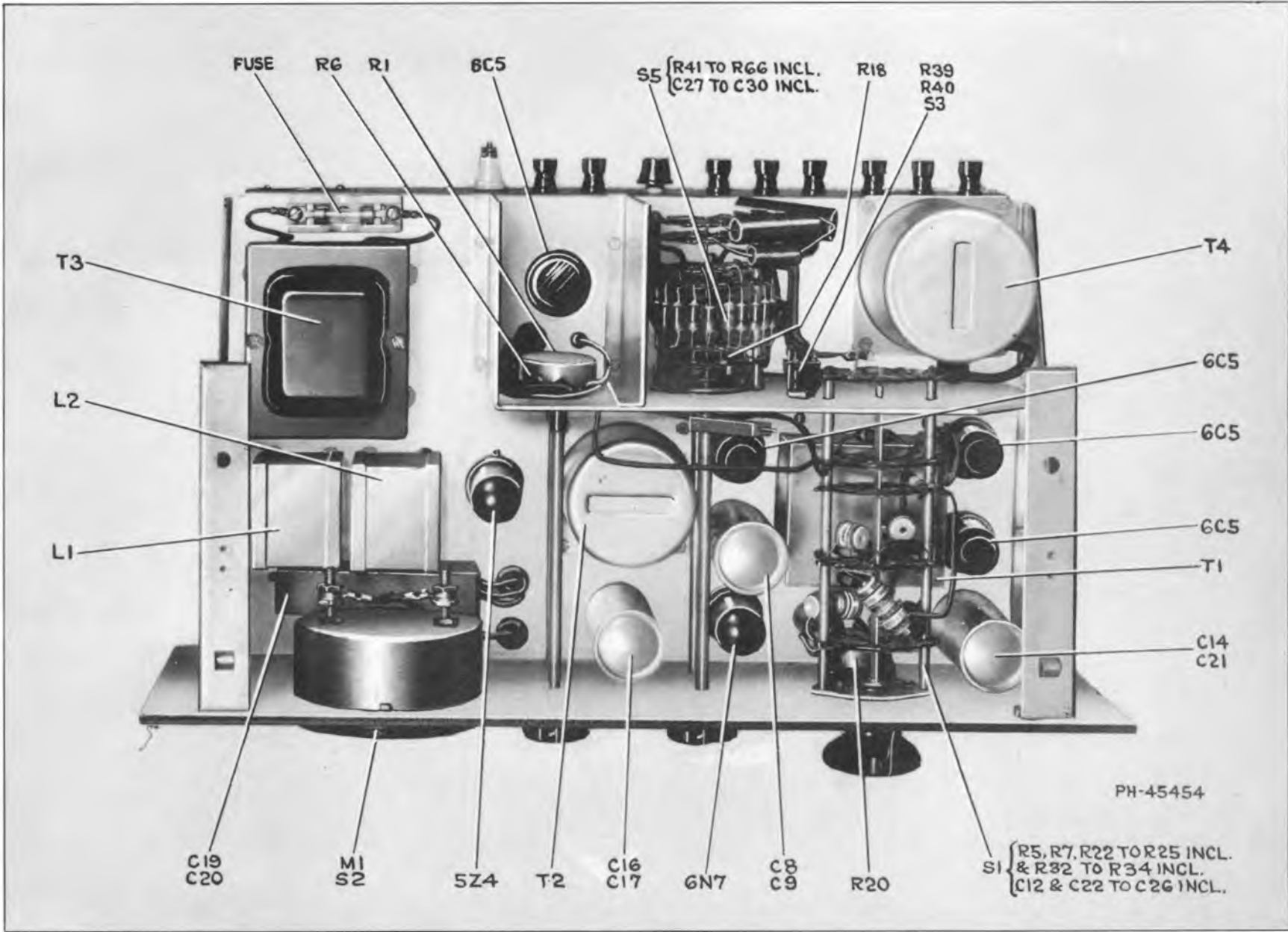

PH-45454

Figure 2 - Chassis Top View

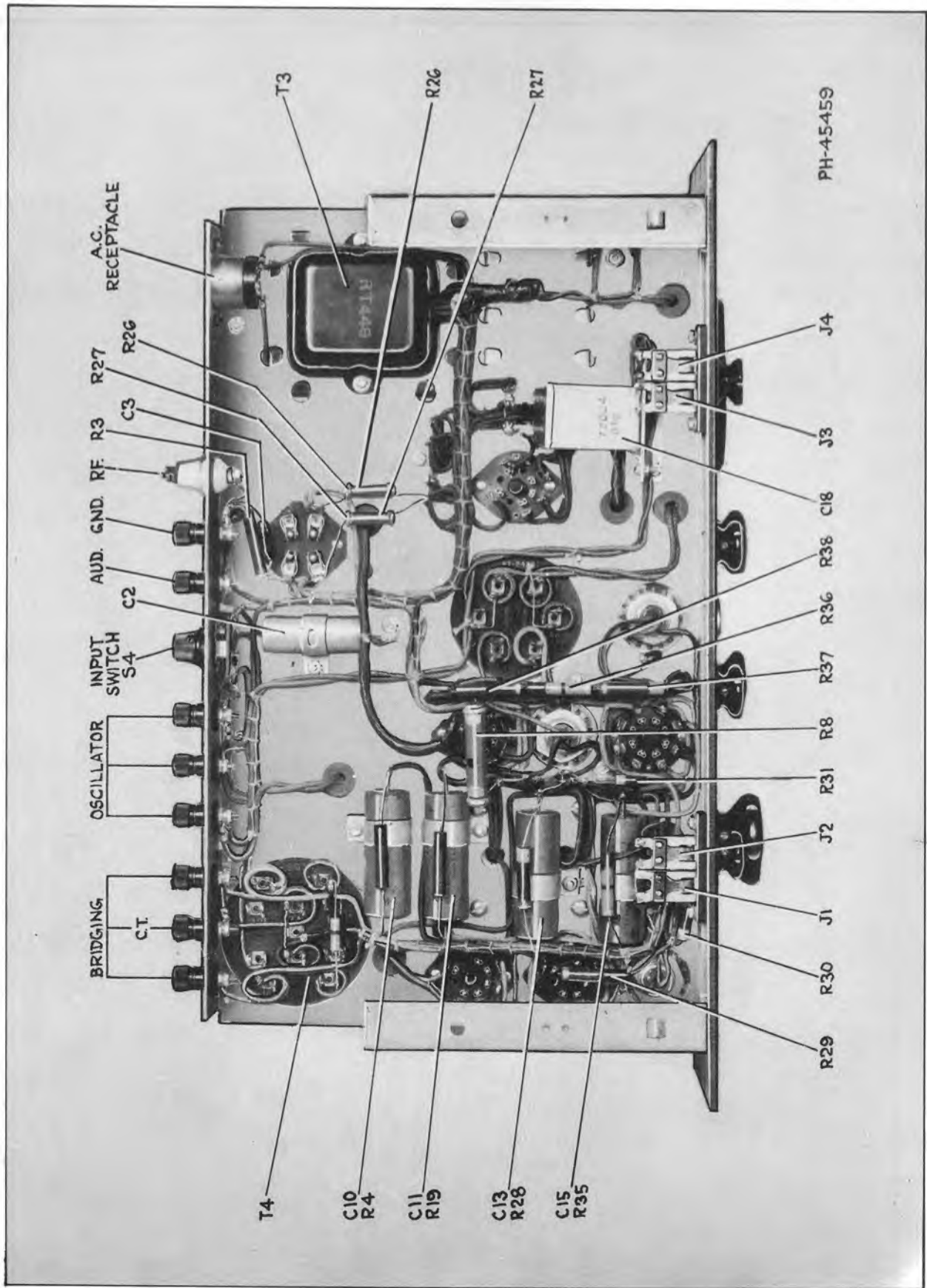

Figure 3 - Chassis Bottom View

| MI-7512        |                                   | PARTS LIST       |               | TYPE 69-A                       |           |
|----------------|-----------------------------------|------------------|---------------|---------------------------------|-----------|
| Symbol         | Description                       | Stock No.        | Symbol        | Description                     | Stock No. |
| C26            | Capacitor 27 mmfd                 | 13605            |               | Tube Socket Insulator           | 13787     |
| C3, C23        | Capacitor 150 mmfd                | 12725            | L1, L2        | Reactor                         | 6431      |
| C24            | Capacitor 100 mmfd                | 12720            | M1            | Meter Weston A-C Rectifier Type | 17173     |
| C22            | Capacitor 12 mmfd                 | 13002            |               | Galvanometer (Bakelite Case)    |           |
| C25            | Capacitor 470 mmfd                | 14082            |               | RCA Monogram                    | --        |
| C18            | Capacitor 1 mfd                   | 17178            | R63           | Resistor 15,000 ohms            | 12695     |
| C10, C11,      | Capacitor 20 mfd (Electrolytic)   | 13611            | R57           | Resistor 22,000 ohms            | 13998     |
| C13, C15       |                                   |                  | R31, R39, R40 | Resistor 27,000 ohms            | 12738     |
| C16 & 17       | Capacitor (Electrolytic) 3 units  | 7776             | R50, R7       |                                 |           |
| C14 & 21       |                                   |                  | R42, R58, R64 | Resistor 33,000 ohms            | 12454     |
| C8 & C9        |                                   |                  | R51, R65      | Resistor 39,000 ohms            | 12266     |
| C19 & C20      | Capacitor (Electrolytic) 1 unit   | 13611            | R52, R59      | Resistor 56,000 ohms            | 12286     |
| C27            | Capacitor 1000 mmfd               | 13593            | R66           | Resistor 82,000 ohms            | 14023     |
| C28            | Capacitor 0.01 mfd                | 17179            | R43           | Resistor 150,000 ohms           | 14020     |
| C29            | Capacitor 0.1 mfd                 | 17180            | R49, R56, R62 | Resistor 12,000 ohms            | 30128     |
| C30            | Capacitor 0.25 mfd                | 17181            | R55, R61      | Resistor 10,000 ohms            | 14559     |
| C12            | Capacitor 0.1 mfd                 | 4839             | R41, R48, R54 | Resistor 8,200 ohms             | 14075     |
| C2             | Capacitor 0.2 mfd                 | 17182            | R47, R53, R60 | Resistor 6,800 ohms             | 12265     |
| J1 & 2, J3 & 4 | Jack Assembly (2 units)           | 17171            | R45, R46      | Resistor 4,700 ohms             | 30146     |
|                | Knob                              | <del>30147</del> | R44           | Resistor 3,900 ohms             | 12955     |
|                | Knob                              | 30075            | R5            | Resistor 220,000 ohms           | 12264     |
|                | Knob                              | 30142            | R30           | Resistor 39,000 ohms            | 30147     |
|                | Dial Escutcheon                   | 17172            | R26, R27      | Resistor 56 ohms                | 5034      |
|                | Fuse Block G.E. Cat. #42412       | * --             | R8            | Resistor 6,800 ohms             | 30148     |
|                | Connector G.E. Cat. #2711         | * --             | R36           | Resistor 8,200 ohms             | 30149     |
|                | Insulator Birnbach #458           | 16767            | R38           | Resistor 3,300 ohms             | 30150     |
|                | Binding Post Eby Jr. Pr 1/32 Ext. | * --             | R37           | Resistor 18,000 ohms            | 30151     |
|                | Fuse 1 ampere                     | 14133            | R4, R19       | Resistor 1,000 ohms             | 30152     |
|                | Power Cord                        | 30080            | R35           | Resistor 820 ohms               | 30153     |
|                | Tube Sockets (Octal Base) 6 prong | 11197            | R28           | Resistor 2,700 ohms             | 14421     |
|                | Tube Sockets (Octal Base) 8 prong | 11196            | R29           | Resistor 100,000 ohms           | 30154     |
|                | Tube Sockets (Octal Base) 5 prong | 11195            |               |                                 |           |

| PARTS LIST (continued) |   |           |
|------------------------|---|-----------|
| Symbol                 | Description                                   | Stock No. |
| R3                     | Resistor 10,000 Ohms                          | 13097     |
| R24                    | Resistor 133,300 ohm $\pm$ 1%<br>(I.R.C. WW3) | 17183     |
| R23                    | Resistor 3,470 Ohms (I.R.C. WW3)              | 17184     |
| R22,R33                | Resistor 43,200 Ohms (I.R.C. WW3)             | 17185     |
| R34                    | Resistor 136,800 Ohms (I.R.C. WW3)            | 17186     |
| R25,R32                | Resistor 20,000 Ohms (I.R.C. WW3)             | 17187     |
| R18,R6                 | Potentiometer 250,000 Ohms                    | 30143     |
| R1                     | Potentiometer 10,000 Ohms                     | 30144     |
| R20                    | Potentiometer 250,000 Ohms                    | 30145     |
|                        | Cabinet Assembly                              | MI-7514   |
| S4                     | Switch Yaxley, similar to #3700 series        | 17174     |
| S2                     | Switch S.P.S.T (Rotary Type)                  | 30073     |
| S3                     | Switch D.P.D.F. Cutler-Hammer                 | 17175     |
| S1                     | Switch (Range) Yaxley 5 gang special          | 17176     |
| S5                     | Switch (Phase) Yaxley 6 gang special          | 17177     |
| T1                     | Transformer (Interstage) RF-499               | 17169     |
| T2                     | Transformer (Output) XT-2432                  | 17170     |
| T3                     | Transformer (Power) RF-499                    | 13518     |
| T4                     | Transformer (Input) XT-1963A                  | 17157     |

\* Order by Description



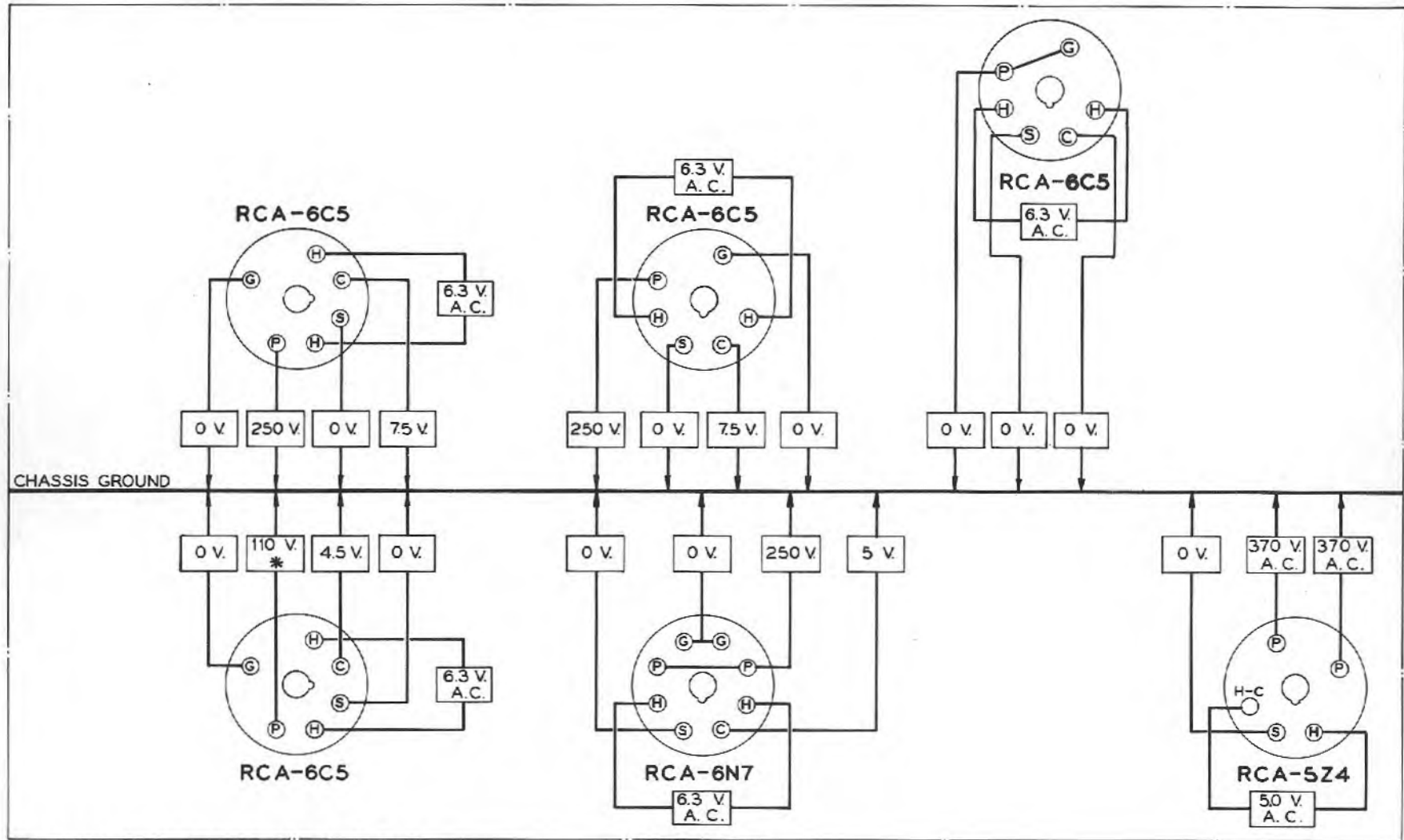

\*MEASURED WITH 300,000 OHM VOLTMETER

FRONT PANEL  
BOTTOM VIEW

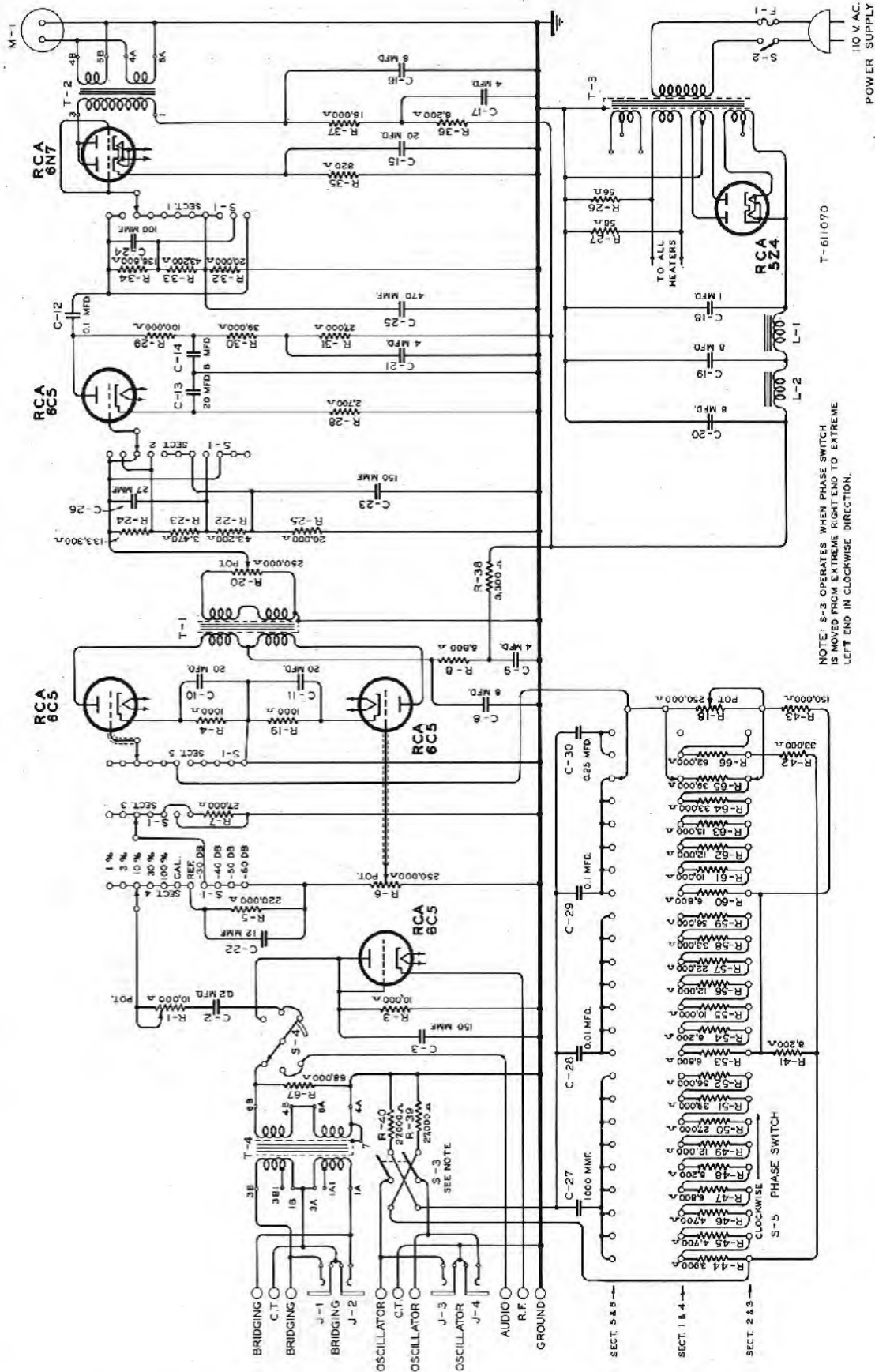

Schematic Diagram, T-611070

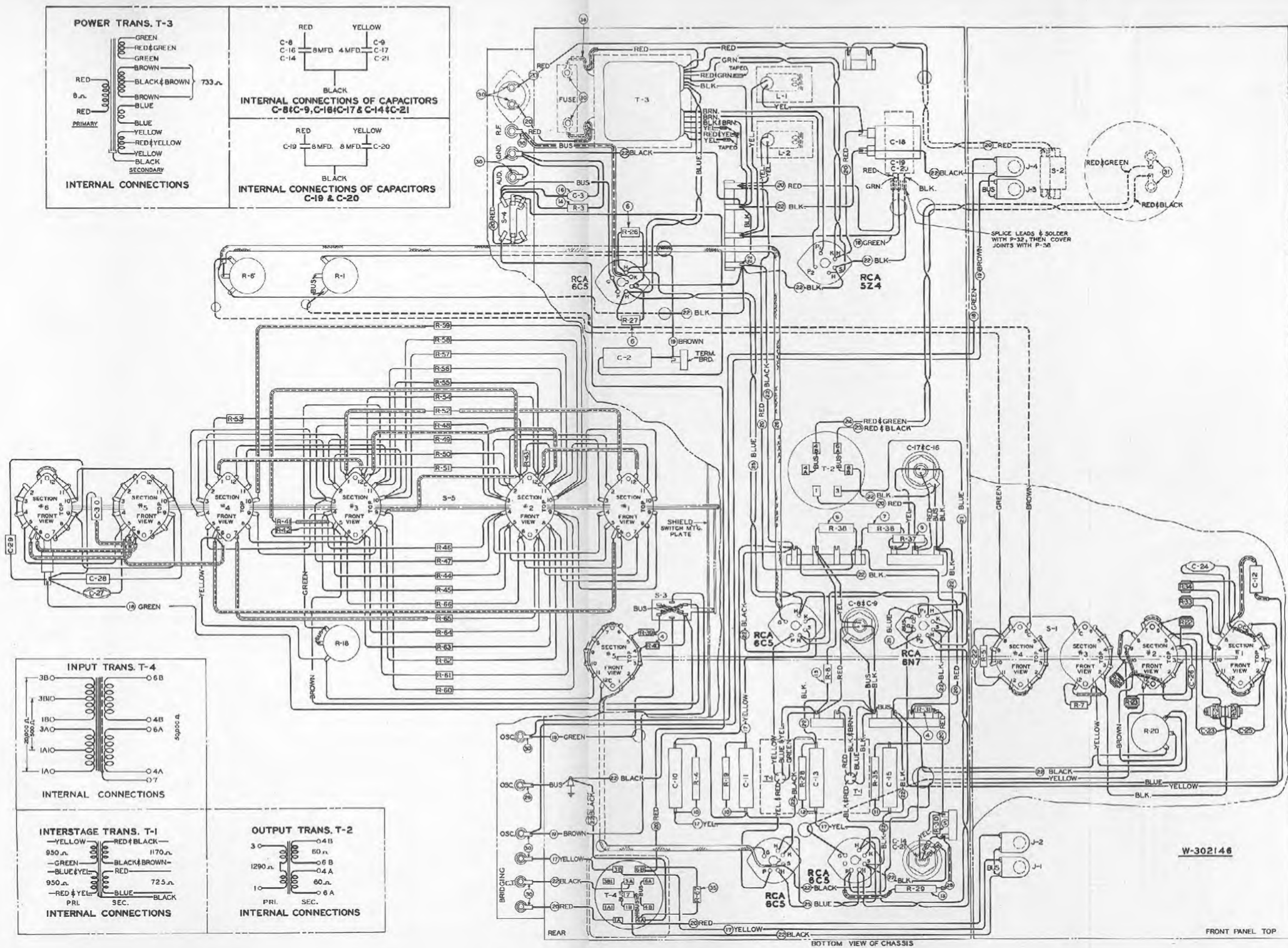

SUPPLEMENT  
TO  
INSTRUCTIONS IB-23362  
DISTORTION METER  
TYPE 69-A

The following information is intended to supplement the instructions contained in instruction book IB-23362, on the installation and operation of the type 69-A Distortion Meter.

The pickup circuit used in measuring modulated r-f signals must provide a low resistance d-c path between the r-f and ground terminals of the distortion meter as well as low audio frequency impedance. These conditions will be met by the use of a small, several turn pickup coil. Capacitive coupling or an antenna may be used if a radio frequency choke or a parallel resonant circuit is connected across the r-f and ground terminals. A low resistance, untuned coil, is most desirable for this purpose, as it is least likely to introduce hum into the circuit or to cause frequency discrimination.

The chassis of the distortion meter should be well grounded and it may be found advisable to ground the Beat Frequency Oscillator chassis. Since a ground connection through the pickup circuit may not always be adequate, it is advisable to provide a heavy ground strip from the Distortion Meter chassis to ground.

When making distortion measurements, a connection must be completed between the center tap terminal on the beat frequency oscillator, which is not grounded, and the ground terminal on the distortion meter which is grounded to the distortion meter chassis. This connection can also be made by means of three-wire patch-cords connected between the jacks on the two instruments. Block diagrams showing typical installation will be found in Figures 3, 4 and 5.

**CIRCUIT LOADING** - The output of the type 68-A Beat Frequency Oscillator should terminate in the correct impedance in order to secure minimum distortion of the oscillator signal. The correct terminating impedance is indicated at each pair of output terminals. For example; an impedance of 500 ohms should be connected between the two terminals marked 500, or an impedance of 250 ohms between each terminal marked 500 and the center tap terminal. The type 89-A Attenuator Panel will provide proper impedance loading.

The equipment under test should feed into the correct impedance load when making either distortion or noise measurements, in order to observe the true operating conditions. The distortion meter input circuits are designed to have negligible loading effect upon the equipment under test.

**EFFECT OF NOISE ON DISTORTION MEASUREMENTS** - The type 69-A Distortion Meter indicates the r-m-s total of all components of the input signal



which fall within the limits of the frequency range (normally 50 to 21,000 cycles; 50 to 15,000 cycles for the Bridging input) except the fundamental frequency component, which is cancelled by the voltage taken directly from the oscillator. The reading of the distortion meter will therefore include the following components:

| Name   | Frequencies for 1000 cycle modulation<br>(60 cycle power supply)  |
|--|---|
| (1) Harmonics  | 2000, 3000, 4000 . . . . 20,000, etc.   |
| (2) Modulation cross products<br>between hum and fundamental | 1000 + 60 cycles = 1060<br>1000 - 60 cycles = 940<br>1000 + 120 cycles = 1120<br>1000 - 120 cycles = 880<br>1000 ± 180 cycles, etc.   |
| (3) Modulation cross products<br>between hum and harmonics   | 2000 ± 60 cycles = 2060 and 1940<br>2000 ± 120 cycles = 2120 and 1880<br>2000 ± etc.<br>3000 ± 60 cycles = 3060 and 2940<br>3000 ± 120 cycles =<br>3000 ± etc.<br>4000 ± etc. |
| (4) Hum Components   | 60, 120, 180, etc.  |
| (5) Noise Components   | All frequencies   |

The distortion meter sums all these quantities and thus indicates, as percent distortion, the ratio of the sum of all unwanted components to the fundamental frequency component. If it is desired to determine the distortion due to the harmonic and cross product components alone, either of two methods may be used. One method is to operate the equipment under test at a high output level, thus making the hum and noise components negligible compared to the other components. Another method is as follows:

- (1) Measure distortion in the normal manner at the desired output level.
- (2) Measure the noise level in decibels using the same output level as a reference level.
- (3) Convert the reading in decibels to percent: example, -40 db = 1%,  
-60 db = 0.1%
- (4) These values may then be substituted in the following equation:

$$H = \sqrt{D^2 - N^2}$$

where H is the total harmonic and cross product distortion in percent.

D is the distortion percent obtained as per (1).

N is the noise (in percent) obtained as per (2) and (3).

When making distortion measurements, it should be kept in mind, that the noise level in the output of the beat frequency oscillator is approximately 60 db below 12.5 milliwatts (57 db below 6 milliwatts) and is substantially independent of the actual oscillator output voltage. While the design of the distortion meter is such that the effects of noise and distortion pre-



sent in the oscillator output tend to be cancelled out, in most cases the cancellation will be more complete for the distortion than for the noise components. Therefore, it is desirable to operate the oscillator at as high an output as practicable, thus improving the signal to noise ratio to the point where the noise output of the oscillator (expressed in percent of signal) is small compared to the percent distortion being measured. High oscillator output may not always be consistent with the input voltage requirements of the distortion meter as given in the instruction book and repeated here, but this difficulty can be readily overcome by the use of one or two attenuators.

The input voltages to the distortion meter should always lie between the following limits:

- (1) Modulated Radio Frequency from Equipment under Test -
  - Minimum 10 volts carrier for distortion measurements
  - Minimum 0.6 volts carrier for noise level measurements
  - Maximum 100 volts carrier
  
- (2) Audio Frequency from Equipment under Test -
  - (a) Bridging input terminals or jacks (balanced)
    - Minimum 0.5 volts or -15 db below 12.5 mw on 500 ohm line
    - Maximum 8 volts or +10 db above 12.5 mw on 500 ohm line
    - This voltage must be at least 10 db higher than the voltage taken from the oscillator.
  - (b) Audio and Ground input terminals (unbalanced)
    - Minimum 0.6 volts
    - Maximum 100 volts
    - This voltage must be at least 5 times as great as the voltage taken from the oscillator.
  
- (3) Audio Frequency from Low Distortion Oscillator
  - Minimum 0.12 volts or -25 db below 12.5 mw on 500 ohm terminals
  - Maximum 8.0 volts or +10 db above 12.5 mw on 500 ohm terminals

From the above limits it can be seen that the equipment under test must have a voltage gain of at least 5 (3.16 when bridging input is used) if the same oscillator terminals supply both the distortion meter and the equipment under test, and that the distortion meter may be operated with as low as 0.12 volts, supplied at its "OSCILLATOR" input terminals, enabling measurements of distortion in signals as low as 0.6 volts.

To secure the same voltages at the distortion meter terminals and at the same time operate the oscillator at high output level, it is only necessary to insert an attenuator between the oscillator and the distortion meter. Such an attenuator is provided, with others, in the type 89-A Attenuator Panel. This attenuator, shown in Figure 1, provides a voltage ratio of approximately 1/18 or 25 db. Thus, the oscillator may be operated at zero level output while the signal supplied to the distortion meter is -25 db. Additional attenuators may be provided between the oscillator and the equipment under test if desired.

**OPERATION WITH THE OSCILLATOR LOCATED AT A POINT REMOTE FROM THE DISTORTION METER** - This type of operation is not recommended in general, since the effects of noise and distortion in the line may be great enough to seriously affect the accuracy of the measurements. If the equipment under test is located close to the distortion meter and a long line is used to supply a signal from the oscillator to the distortion meter and equipment under test, the effects of noise and distortion in the line may be considered as being present in the oscillator. Thus the same considerations previously discussed also apply in this case; accurate measurements being obtainable only if the noise and distortion at the output of the line are small compared to the distortion being measured.

**MEASUREMENTS NEAR 0 OR 180 DEGREES PHASE SHIFT** - The phase shifting network contained in the distortion meter, has two small gaps in its range; one near 0 degrees and the other near 180 degrees. Normally a balance cannot be obtained at frequencies which are transmitted through the equipment under test with phase shifts which fall within these narrow limits. With most equipment, this is not a serious disadvantage since the phase shift is usually progressive with frequency and a small change in frequency will cause the phase angle to fall outside the "blind" angle. The effect becomes more noticeable when making measurements on equipment whose phase shift is more nearly constant with frequency and happens to fall within the blind angle. This disadvantage may be completely overcome by introducing a phase shift at any of the following points in the circuit:

- (1) In the equipment under test.
- (2) Between the output of the equipment under test and the distortion meter.
- (3) Between the output of the oscillator and the distortion meter.
- (4) Between the input of the equipment under test and the oscillator.

The simplest method is to insert a capacitor in series with one of the two outside terminal connections (not the center tap) between the distortion meter and the oscillator. The value of the capacitor and the choice of which connection to use is best decided by trial.

**ERRATA** - See page 9 of instruction book IB-23362. The headings of the second, third and fourth columns of the table at the bottom of the page should be corrected to read:

|          |         |         |
|----------|---------|---------|
| Sections | Section | Section |
| 3 and 4  | 2       | 1       |

See page 13 of IB-23362. Items C19 and C20 should have their stock number corrected to 30910.

**R-F INPUT LEVEL** - To secure maximum accuracy in measuring the distortion of modulated radio frequency signals the carrier frequency input to the distortion meter should be between 20 and 50 r.m.s. volts. This voltage can be measured conveniently by inserting a direct current milliammeter in series with the r-f input circuit. The direct current will be approximately 0.1 ma per r.m.s. volt of carrier input. Thus the r-f input should be adjusted to give from 2 to 5 milliamperes d-c in the pickup circuit. Under these conditions the detector will introduce less than 0.3% total distortion up to 95% modulation. For modulation below 90% this distortion consists almost entirely of third harmonic; at higher modulation the second harmonic becomes appreciable. At 10 volts carrier input up to 85% modulation may be used without introducing more than 0.3% distortion. Less than 10 volts is not recommended for distortion measurements unless the modulation is low.

**R-F RECTIFIER** - Improved performance of the r-f rectifier, resulting in reduced errors when measuring the distortion of modulated radio-frequency signals, can be obtained by using an RCA-6X5G tube in place of the RCA-6C5 originally used for this purpose. No changes in connections are required. The r-f rectifier socket is located in the shielded compartment at the rear of the instrument.

The recommended range of carrier-input voltage is from 40 to 80 r.m.s. volts. This voltage can be measured conveniently by inserting a direct-current milliammeter in series with the r-f input circuit. The direct current will be approximately 0.125 ma per r.m.s. volt. Thus, the r-f pickup should be adjusted to give from 5 to 10 milliamperes d.c. in the pickup circuit.

This change has been made in some of the production units.

TYPICAL ATTENUATOR  
FOR INSERTION BETWEEN  
OSCILLATOR AND  
DISTORTION METER

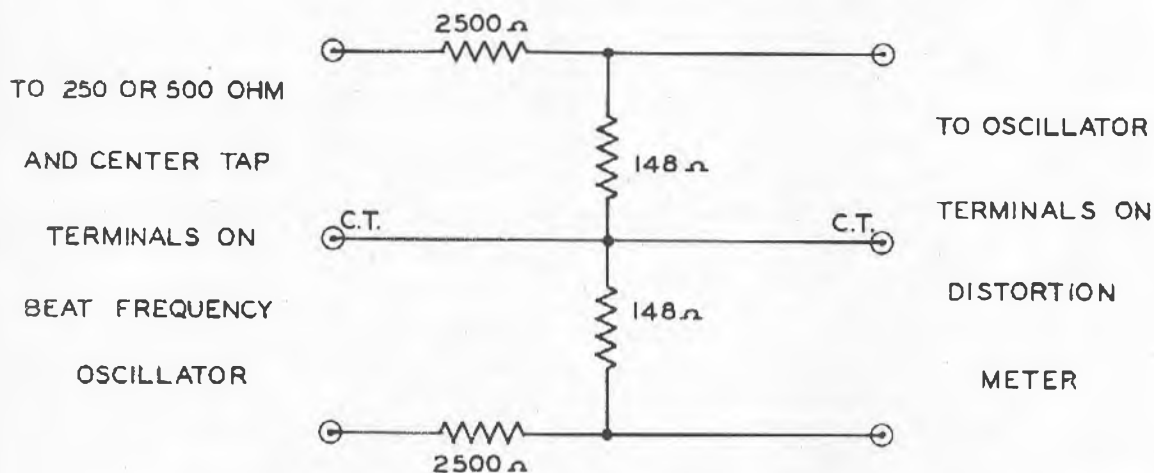

FIGURE 1 - TYPICAL ATTENUATOR  
(Schematic K-841775)

PERMANENT INTERNAL CONNECTIONS OF  
DISTORTION METER

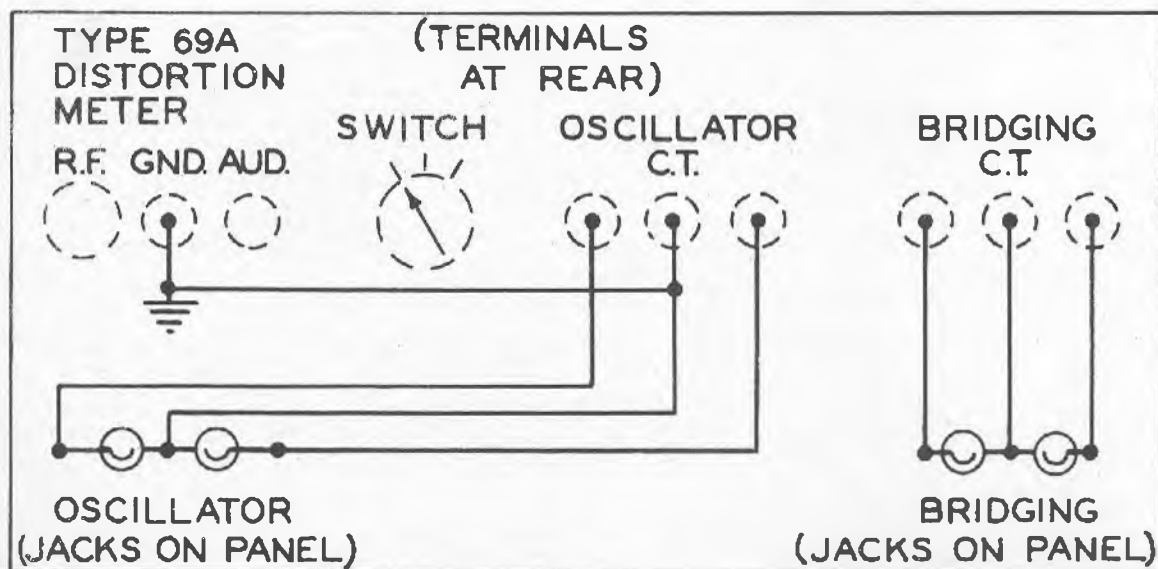
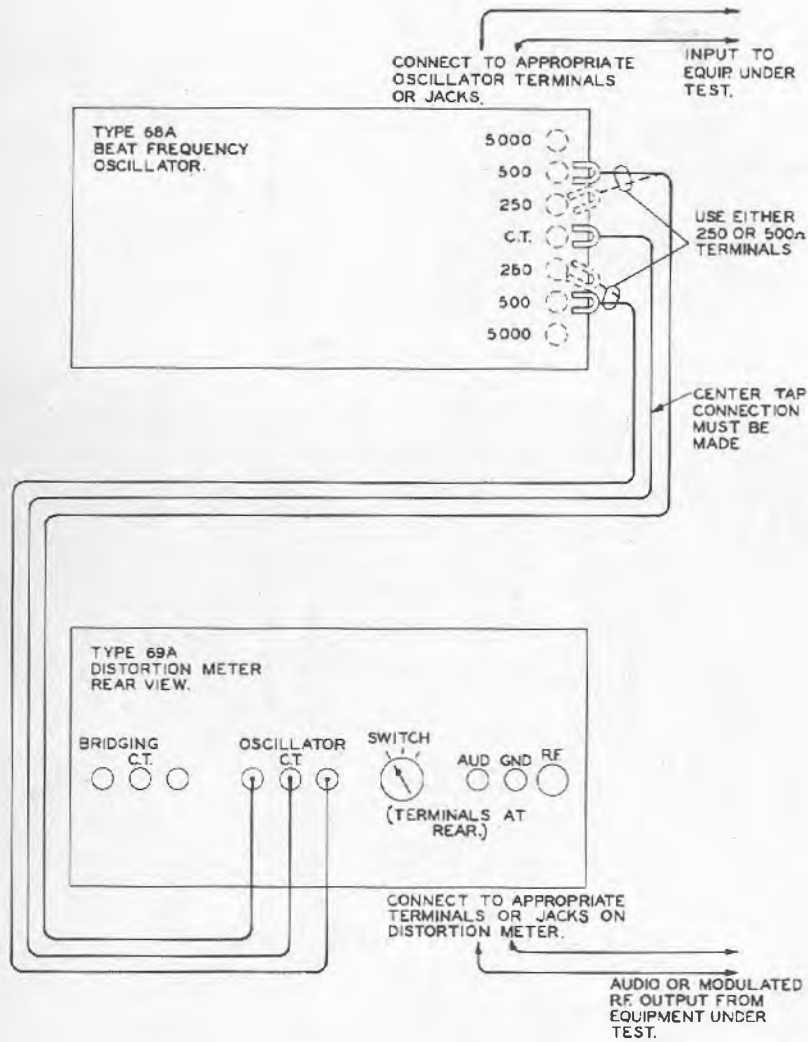
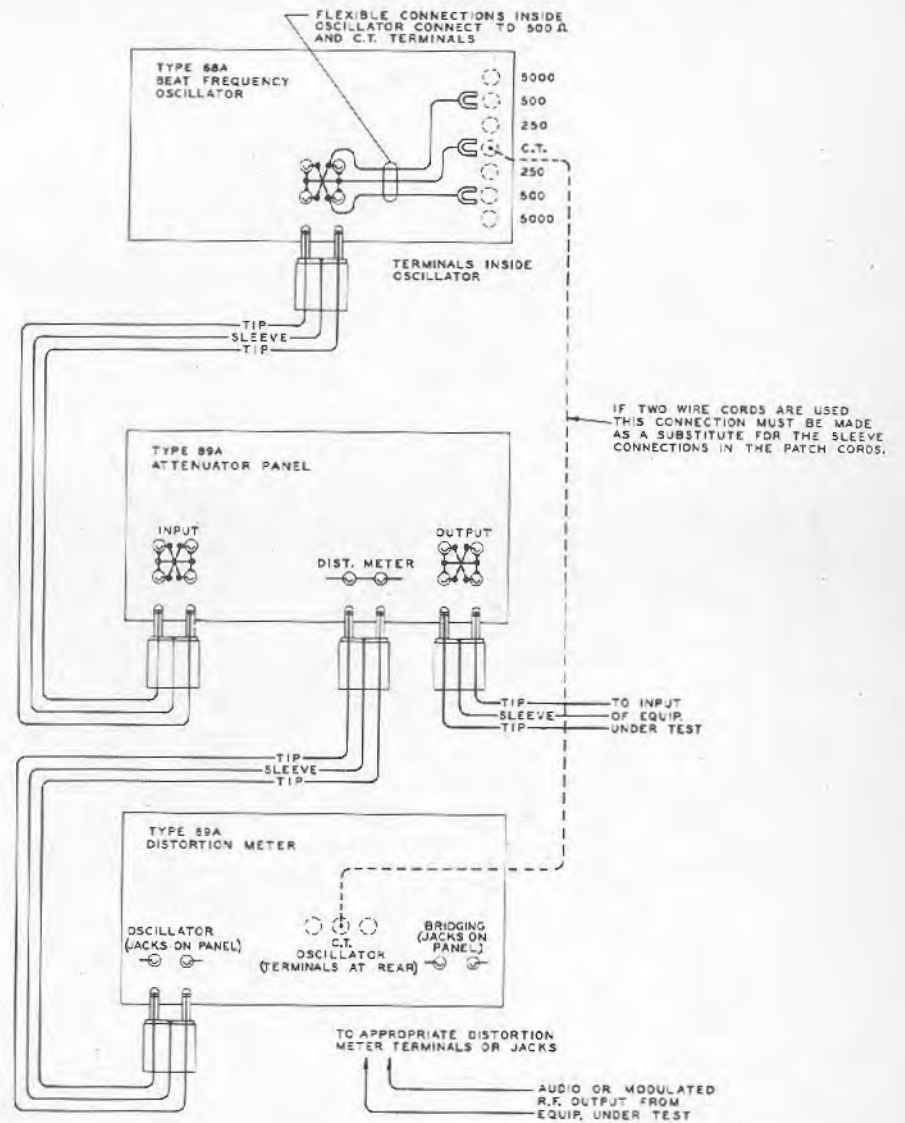

FIGURE 2 - INTERNAL WIRING  
(Connections K-841774)



DISTORTION METER CONNECTIONS  
USING DIRECT WIRING

FIGURE 3 - EXTERNAL WIRING  
(Connections M-417050)



DISTORTION METER CONNECTIONS  
USING TYPE 89-A ATTENUATOR PANEL

FIGURE 4 - TYPE 89A ATTENUATOR PANEL  
(Connections P-712616)



**INSTRUCTIONS**

---

**ATTENUATOR PANEL**

**TYPE 89-A**



Manufactured by

**RCA Manufacturing Company, Inc.**

**Camden, N. J., U. S. A.**

**"AN RCA SERVICE"**

Printed in U. S. A.

IB-23365



FIGURE 1 - ATTENUATOR PANEL  
(Front View)

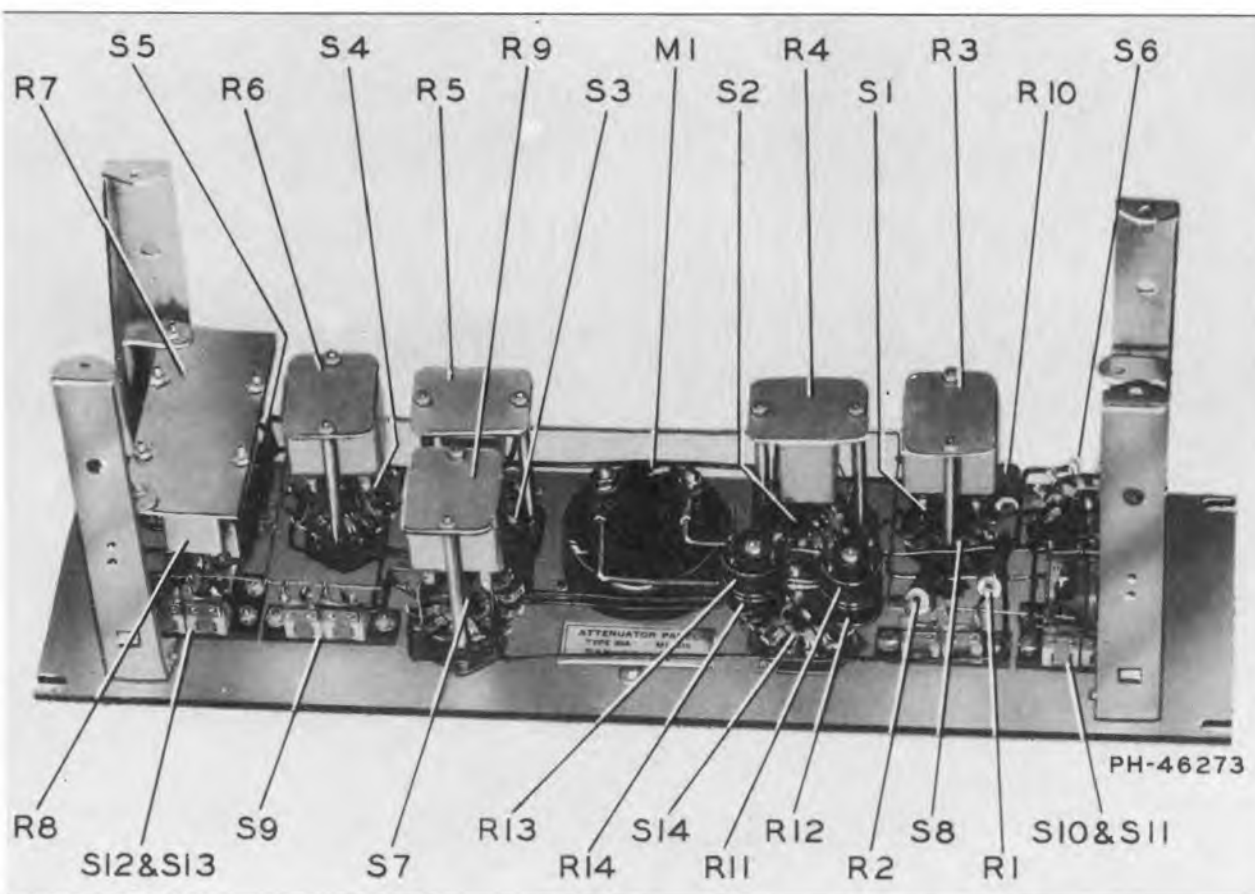

FIGURE 2 - ATTENUATOR PANEL  
(Rear View)

# ATTENUATOR PANEL

TYPE 89-A

MI-7515

## ELECTRICAL CHARACTERISTICS

|                            |                     |                     |
|----------------------------|---------------------|---------------------|
| Frequency Range            | . . . . .           | 30 to 17,000 cycles |
| Input: . . . . .           | Impedance . . . . . | Power Level *       |
|                            | 500 ohms . . . . .  | -10 to +12 db       |
| Output . . . . .           | Impedance . . . . . | Power Level *       |
|                            | 500 ohms . . . . .  | -85 to +12 db       |
|                            | 250 ohms . . . . .  | -95 to + 2 db       |
|                            | 50 ohms . . . . .   | -105 to - 8 db      |
| Volume Indicator Impedance | . . . . .           | 20,000 ohms         |
| Volume Indicator Range     | . . . . .           | -10 to +12 db       |

\*Reference Level = 12.5 milliwatts

## MECHANICAL SPECIFICATIONS

| Dimensions       | Rack Type              | Cabinet Type  |
|------------------|------------------------|---------------|
| Height . . . . . | 5-1/4 inches . . . . . | 5-1/2 inches  |
| Width . . . . .  | 19 inches . . . . .    | 19-3/8 inches |
| Depth . . . . .  | 7 inches . . . . .     | 8-5/16 inches |
| Weight . . . . . | 16 pounds . . . . .    | 18 pounds     |

## DESCRIPTION

The Type 89-A Attenuator Panel is an accessory equipment designed primarily to facilitate measurements with the Type 68-A Beat Frequency Oscillator and the Type 69-A Distortion Meter. It consists essentially of a volume indicator and an attenuator system. The indicator permits direct reading of the input and output levels of the equipment under test while the attenuator system serves to control the amplitude of signals supplied by the oscillator to the equipment being tested and to the distortion meter. All operating limits are shown in tabular form under the preceding section entitled "Electrical Characteristics".

## INSTALLATION

The Type 89-A Attenuator Panel (MI-7515) is intended for mounting in a stand-

ard 19-inch relay rack, requiring 5-1/4 inches of panel space, and is enclosed by a dust cover. For portable service, a durable metal cabinet (MI-7520) is available in which the panel may be installed upon removing the dust cover. All connections are brought out to standard double jacks on the front panel.

**CONNECTIONS** - External connections as shown in the following tabulation are required when using the panel in conjunction with the Type 68-A Beat Frequency Oscillator and Type 69-A Distortion Meter for making distortion measurements on audio-frequency equipment.

| Cord | To                   |                    | From                 |                     | Number of Wires |
|------|----------------------|--------------------|----------------------|---------------------|-----------------|
|      | Equipment            | Jacks or Terminals | Equipment            | Jacks or Terminals  |                 |
| 1    | Att. Panel           | "INPUT"            | B-F Osc.             | "OUTPUT" (500 ohms) | 3 *             |
| 2    | Dist. Meter          | "OSCILLATOR"       | Att. Panel           | "DISTORTION METER"  | 3 *             |
| 3    | Equipment under test | Input              | Att. Panel           | "OUTPUT"            | 2 or 3          |
| 4    | Att. Panel           | "VOLUME INDICATOR" | Equipment under test | Output (500 ohms)   | 2               |
| 5    | Dist. Meter          | See IB-23362       | Att. Panel           | "VOLUME INDICATOR"  | 2               |

\* *These jack connections should be made with 3-wire cords in order that the chassis of the distortion meter will be connected to the center tap of the oscillator output circuit. If such cords are not available, use the 2-wire type and make a direct connection between the center-tap terminals at the rear of both chassis.*

For measurements of gain or frequency characteristics, the external connections are as outlined above except that those to the distortion meter (cords 2 and 5) are not required. The panel may be used as a power-level indicator only by connecting to the jacks marked "VOLUME INDICATOR" and setting the correspondingly marked switch to the "JACKS" position. In the latter application, power levels of from -10 db to +12 db may be measured. The input impedance of the volume indicator is 20,000 ohms and its readings are correct only for measurements on 500-ohm circuits, although correction can be made when used across circuits of other impedance.

## OPERATION

**CONTROLS** - The operating controls of the Type 89-A Attenuator Panel serve the following purposes.

"VOLUME INDICATOR" Switch: In the "INPUT" position, the volume indicator is connected to the input circuit of the attenuator system; in the "JACKS" position, it is connected to the "VOLUME INDICATOR" jacks for external measurements; the "OFF" position is self-explanatory.

"VOL. IND. LEVEL" Control: This control is a two-position attenuator for sensitivity adjustment of the volume indicator. The level required to pro-

duce zero db reading may be changed from 0 db to +10 db. Combined with the meter-scale range of from -10 db to +2 db, therefore, the volume indicator operates over a range of from -10 db to +12 db.

"DECIBELS" Attenuator Switches: The four controls so designated enable insertion of four balanced H-type attenuator pads, either singly or in cascade, between the "INPUT" and "OUTPUT" jacks. These pads offer attenuations of 5, 10, 20 and 40 db respectively as marked, thus affording a total range of from 0 to 75 db in 5-db steps.

"OUTPUT" Impedance Switch: Three positions are provided for adjusting the output impedance to operate into loads of 500, 250 or 50 ohms as indicated. These positions offer losses of zero, 10 and 20 db respectively which must be added to the settings of the attenuator switches. Failure to set this switch properly or to use the proper load impedance will cause a mismatch and result in incorrect readings of the attenuators.

"DISTORTION METER" Input Switch: This control affords two levels of input to the "OSCILLATOR" jacks or terminals on the distortion meter, as denoted by the markings "HIGH" and "LOW". These represent zero and approximately 25-db attenuation, respectively.

MEASUREMENT PROCEDURE - Proper use of the Type 89-A Attenuator Panel obviously depends upon the intended application. The following paragraphs, which describe those applications most frequently employed, should serve as a basis of operating procedure.

DETERMINATION OF INPUT LEVEL - The input power level to the attenuator panel is obtained by adding algebraically the readings of the meter and the "VOL. IND. LEVEL" control. Thus, for example, if the meter should read -1 db with the "VOL. IND. LEVEL" control at the 10-db position, the input level would be +10 -1 db or +9 db. As noted heretofore, such readings are referred to a reference level of 12.5 milliwatts.

DETERMINATION OF OUTPUT LEVEL - The output level of the attenuator panel is obtained by subtracting the total number of decibels, as indicated by the settings of the attenuator switches, from the input power level. For example: With a load impedance of 500 ohms, the four attenuator switches are set to 5, 10, 0 and 40 db respectively, and the volume indicator shows an input level of +3 db. The output level is then +3 -5 -10 -0 -40 db or -52 db.

If the load impedance is other than 500 ohms, this computation must include the loss in the output circuit. With the "OUTPUT" impedance switch at the 250-ohm position, the loss is 10 db, while at the 50-ohm position, the loss is 20 db. Thus, in the above example, if the load impedance were 50 ohms, the output level would then be -52 -20 db or -72 db.

MEASURING FREQUENCY CHARACTERISTICS - Unusual accuracy in taking frequency characteristics can be obtained with the Type 89-A Attenuator Panel since the same meter is employed to measure both input and output levels. In this way, the frequency characteristic of the meter is cancelled out. Maximum accuracy is obtained when the input voltage to the attenuator panel is equal to the output voltage of the equipment being tested. To take frequency



characteristics at constant input or constant output level, correction should be made for the frequency characteristics of the meter. In all cases, the equipment under test should be operated into its normal load.

**MEASURING DISTORTION** - After making the connections as outlined under "Installation", the output of the equipment under test should be adjusted to the desired level by means of the attenuators and beat frequency oscillator "VOLUME" control. If the output level of the equipment under test is 10 db or more higher than the input to the attenuator panel, the switch on the attenuator panel marked "DISTORTION METER" should be turned to the "HIGH" position. If the output level of the equipment under test is less than 10 db higher than the input to the attenuator panel, this switch should be set at the "LOW" position. When measuring low values of distortion, the volume indicator should be removed from the circuit since some error may be introduced by the meter rectifier. This may be accomplished simply by turning the "VOLUME INDICATOR" switch to the "OFF" position.

**REPLACEMENT PARTS**  
**MI-7515**  
**TYPE 89A ATTENUATOR PANEL**

Insist on genuine factory tested parts, which are readily identified and may be purchased from authorized dealers.

| Symbol        | Description                             | Stock No. |
|---------------|---|-----------|
| R1, R2        | Resistor - 27.1 ohms                    | 17520     |
| R10           | Resistor - 20,000 ohms                  | 17521     |
| R3            | Attenuator Pad - 500/500 ohms 5DB       | MI-4180A  |
| R4            | Attenuator Pad - 500/500 ohms 10DB      | MI-4176A  |
| R5            | Attenuator Pad - 500/500 ohms 20DB      | MI-4177A  |
| R6            | Attenuator Pad - 500/500 ohms 40DB      | MI-4178A  |
| R7            | Attenuator Pad - 500/500 ohms 10DB      | MI-4175A  |
| R8            | Attenuator Pad - 500/500 ohms 20DB      | 17522     |
| R9            | Attenuator Pad - Special                | 17523     |
| R12, R13, R14 | Attenuator Pad - 10DB for V.I. Meter    | 17524     |
| S1, S4, S7    | Switch - 4 pole, 2 throw                | 17525     |
| S2, S3        | Switch - 4 pole, 2 throw                | 17526     |
| S5, S6        | Switch - 4 pole, 3 throw                | 17527     |
| S8, S9, S10,  |   |           |
| S11, S12, S13 | Jack                                    | 30079     |
| M1, R11       | Meter and External Resistor (9875 ohms) | 17528     |
| S14           | Switch - 4 pole, 2 throw                | 17529     |

7

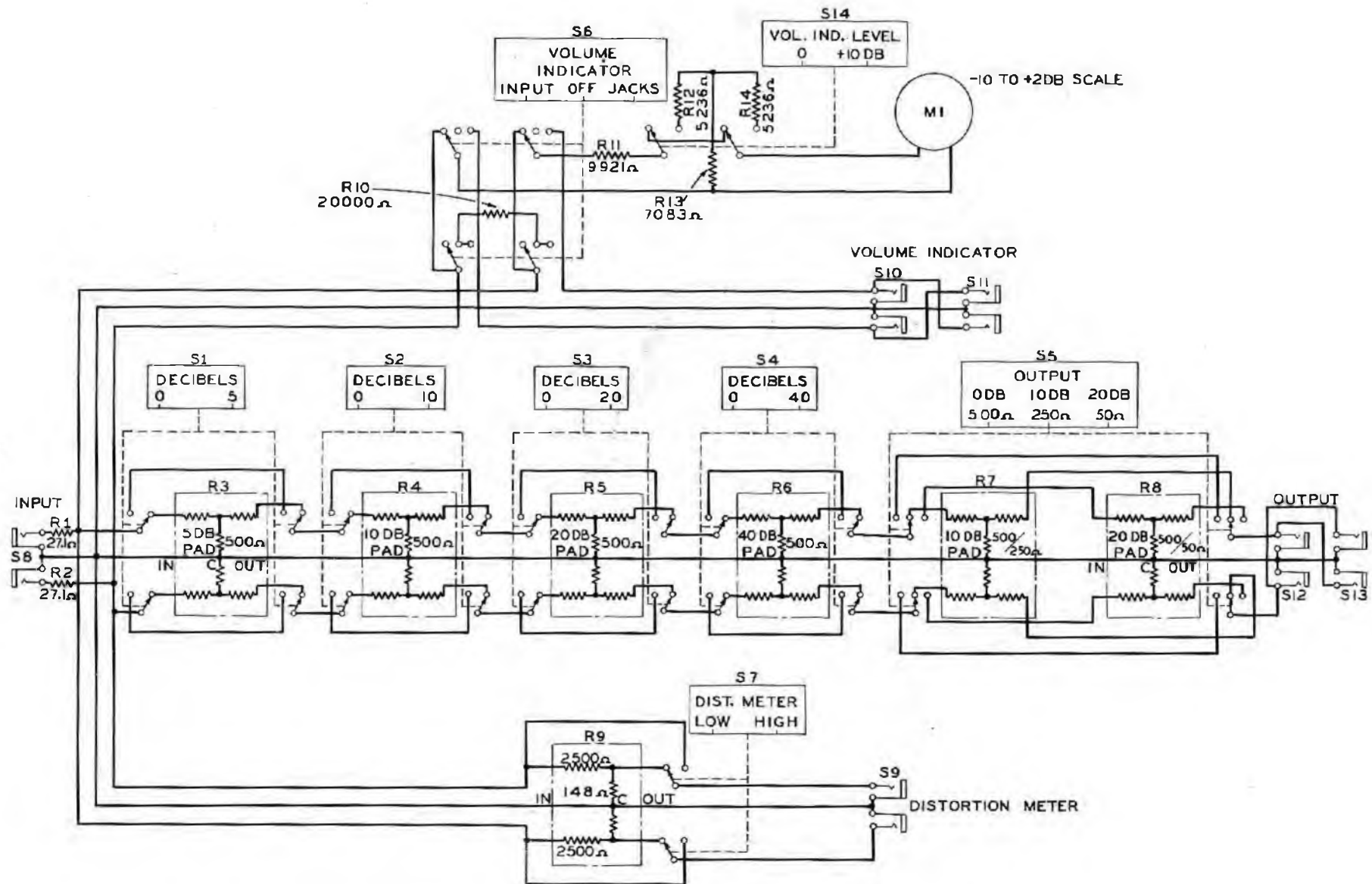

ATTENUATOR PANEL  
(Schematic P-712407)

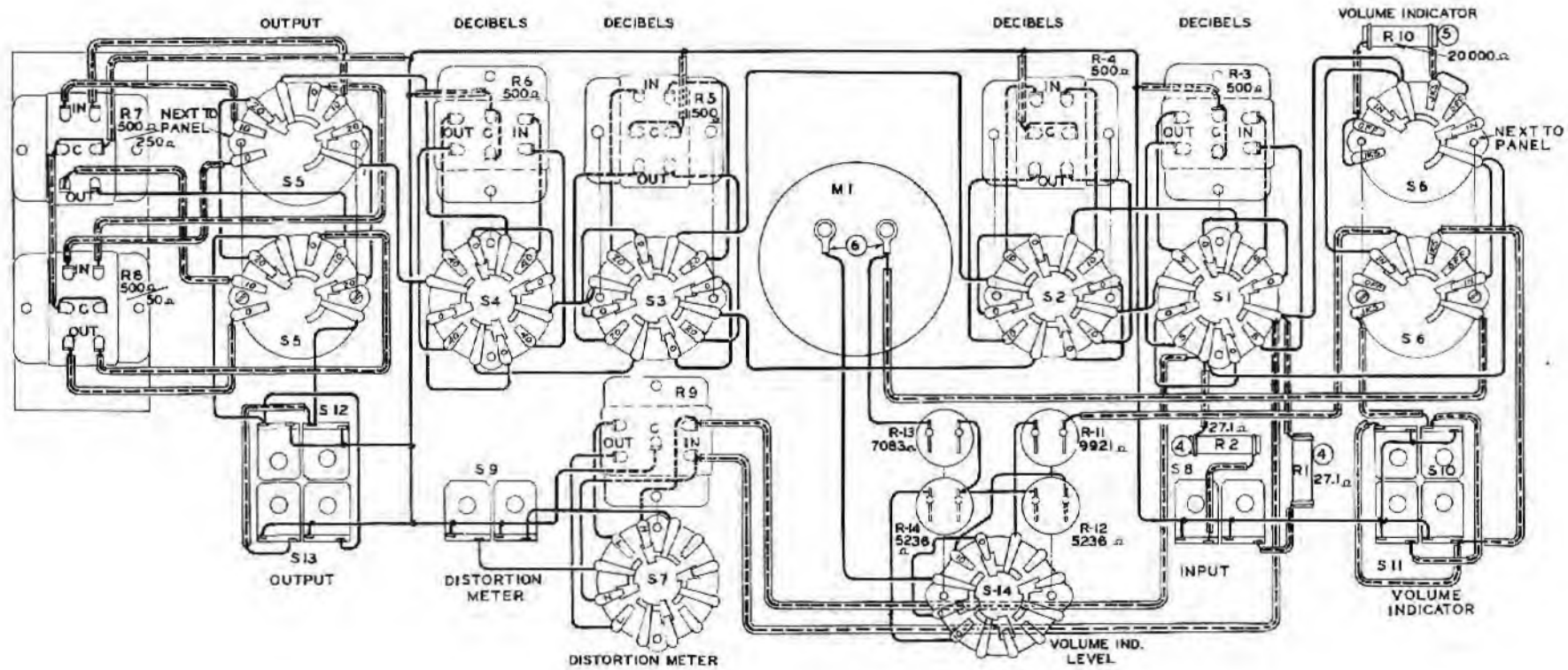

ATTENUATOR PANEL  
(Connections T-611076)

MI-3222  
MI-3222-A

## RECORDING AMPLIFIERS

---

### RCA PHOTOPHONE RECORDING INSTRUCTIONS

---

First Edition

Photophone Division  
RCA Manufacturing Co., Inc.  
Camden, N. J., U. S. A.

A Service of the Radio Corporation of America

## ADDENDA

2R1-2.3 MI-3222 and MI-3222-A RECORDING AMPLIFIERS

Refer to Data Sheet on Page 1. Under column headed Radiotrons add at bottom, "Oscillator Stage," and in corresponding horizontal position at bottom of column headed MI-3222-A add, "1 RCA-955".

Refer to parts list, Page 10. T-2 should be Reference Drawing Number M-403096. T-3 should be Reference Drawing Number M-403097.

### DATA SHEET

| <u>Radiotrons</u>                   | <u>MI-3222</u>  | <u>MI-3222-A</u> |
|-------------------------------------|---|------------------|
| 1st stage                           | 1 RCA-37  | 1 RCA-76         |
| 2nd stage                           | 1 RCA-77  | 1 RCA-77         |
| 3rd stage                           | 1 RCA-37  | 1 RCA-76         |
| Power stage                         | 2 RCA-71-A  | 2 RCA-71-A       |
| <br><u>Pilot Lamp</u>               | 1 Mazda No. 40, 6-volt, 0.15-ampere,<br>Cat. No. 3030   |                  |
| <br><u>Fuses</u>                    | 1 W.E. non-alarm Code 24-B,<br>5-ampere<br>1 W.E. non-alarm Code 24-B,<br>1/2-ampere                |                  |
| <br><u>Power Supply</u>             |   |                  |
| Plate voltage                       | 180 volts DC with battery bias, or<br>225 volts DC with self bias                                   |                  |
| Bias voltage                        | Requires two 22-1/2-volt "C" bat-<br>teries, Burgess No. 5156 or Eveready<br>No. 768, or equivalent |                  |
| Plate current                       | 42 milliamperes   |                  |
| Heater and filament supply          | 6 or 8 volts DC   |                  |
| Heater and filament current         | 1.55 amperes  |                  |
| <br><u>Sources Impedance</u>        | 250 or 500 ohms   |                  |
| <br><u>Input Impedance</u>          | 250 or 500 ohms   |                  |
| <br><u>Intermediate Output Load</u> | Above 5000 ohms and less<br>than 0.0045 mf.   |                  |
| <br><u>Output Impedance</u>         | 250 or 500 ohms   |                  |
| <br><u>Load Impedance</u>           | 250 or 500 ohms   |                  |
| <br><u>Over-all Gain</u>            | MI-3222 85 db   | MI-3222-A 90 db  |



MI-3222  
MI-3222-A  
**RCA PHOTOPHONE  
RECORDING AMPLIFIERS**

DATA SHEET

| <u>Radiotrons</u>                   | <u>MI-3222</u>  | <u>MI-3222-A</u> |
|-------------------------------------|---|------------------|
| 1st stage                           | 1 RCA-37  | 1 RCA-76         |
| 2nd stage                           | 1 RCA-77  | 1 RCA-77         |
| 3rd stage                           | 1 RCA-37  | 1 RCA-76         |
| Power stage                         | 2 RCA-71-A  | 2 RCA-71-A       |
| <br><u>Pilot Lamp</u>               | 1 Mazda No. 40, 6-volt, 0.15-ampere,<br>Cat. No. 3030   |                  |
| <br><u>Fuses</u>                    | 1 W.E. non-alarm Code 24-B,<br>5-ampere<br>1 W.E. non-alarm Code 24-B,<br>1/2-ampere                |                  |
| <br><u>Power Supply</u>             |   |                  |
| Plate voltage                       | 180 volts DC with battery bias, or<br>225 volts DC with self bias                                   |                  |
| Bias voltage                        | Requires two 22-1/2-volt "C" bat-<br>teries, Burgess No. 5156 or Eveready<br>No. 768, or equivalent |                  |
| Plate current                       | 42 milliamperes   |                  |
| Heater and filament supply          | 6 or 8 volts DC   |                  |
| Heater and filament current         | 1.55 amperes  |                  |
| <br><u>Sources Impedance</u>        | 250 or 500 ohms   |                  |
| <br><u>Input Impedance</u>          | 250 or 500 ohms   |                  |
| <br><u>Intermediate Output Load</u> | Above 5000 ohms and less<br>than 0.0045 mf.   |                  |
| <br><u>Output Impedance</u>         | 250 or 500 ohms   |                  |
| <br><u>Load Impedance</u>           | 250 or 500 ohms   |                  |
| <br><u>Over-all Gain</u>            | MI-3222 85 db   | MI-3222-A 90 db  |

Volume Control Range

|                           |                                      |
|---------------------------|--------------------------------------|
| Main control MI-3222 only | 2 db steps above setting No. 5       |
|                           | 4 db attenuation from No. 5 to No. 4 |
|                           | 6 db " " No. 4 to No. 3              |
|                           | 8 db " " No. 3 to No. 2              |
|                           | 12 db " " No. 2 to No. 1             |
|                           | Infinite " " No. 1 to 0              |

|                             |                         |
|-----------------------------|-------------------------|
| Main control MI-3222-A only | 2 db steps for 20 steps |
|                             | Infinite for 1 step     |

|   |        |        |      |
|---|--------|--------|------|
| Intermediate control:<br>MI-3222 or MI-3222-A | LOW    | INT.   | HIGH |
|   | -28 db | -14 db | 0 db |

|                                 |                                   |
|---------------------------------|-----------------------------------|
| <u>Undistorted Power Output</u> | 400 milliwatts with 1% distortion |
|                                 | 800 milliwatts with 2% distortion |

|                   |                                 |
|-------------------|---------------------------------|
| <u>Dimensions</u> | 19" Wide x 10½" High x 9¼" Deep |
|-------------------|---------------------------------|

|               |                                       |
|---------------|---------------------------------------|
| <u>Weight</u> | 58 lbs., less tubes and "C" batteries |
|---------------|---------------------------------------|

Trademark "Radiotron" Reg. in U. S. Pat. Office by RCA Mfg. Co., Inc.

PART I - DESCRIPTION

ELECTRICAL CIRCUITS - The RCA Model MI-3222 or Model MI-3222-A constitutes the heart of the amplifying system of the RCA "High Fidelity" Recording Channel. These amplifiers are compactly built, include many advancements in design, construction, and ease of operation, and respond faithfully to all frequencies from 30 to 10,000 cycles within plus or minus 1 db. These recording amplifiers are designed to operate from either a 250-ohm or 500-ohm impedance input line and to furnish ample power for the operation of an RCA film recorder. Each employs four stages of amplification and has an output terminal board containing connections to match into either a 250-ohm or 500-ohm impedance line. One volume control is located in the grid circuit of the first amplifier stage and an intermediate volume control is located in the grid circuit of the second stage. The attenuation for each step of both these volume controls is given in the data sheet in the front of this booklet.

Schematic circuit diagrams, wiring diagrams, and distortion curves for both MI-3222 and MI-3222-A amplifiers are included in the back of this booklet.

Model MI-3222 uses a microphone hummer (oscillator) for use in adjusting the noise reduction amplifier preliminary to recording. This hummer operates at a frequency of approximately 1000 cycles per second and receives its power supply from the amplifier filament battery. It may be turned "ON" or "OFF" by means of a rotary switch mounted on the front panel. This switch shaft is slotted and may be turned by the use of a coin or screwdriver.

Model MI-3222-A uses an oscillator employing an RCA-955 tube for adjustment of the noise reduction amplifier preliminary to recording. This oscillator delivers a frequency of approximately 400 cycles per second and receives its filament and plate supply from the main batteries used to supply the amplifier. This oscillator may be turned "ON" or "OFF" by means of a rotary switch equipped with control knob mounted on the front panel.

The jacks and d-c meter make it possible to measure the plate current of each tube except the 955 tube used in MI-3222-A amplifier. The jacks also make possible measuring heater voltage, plate supply voltage, and bias voltage on the power stage. Actually, the voltage drop across appropriate resistors is measured through the use of open circuit jacks so that no amplifier circuits are made or broken during the measuring process. The meter used is a zero to 8 volts d-c voltmeter having an internal resistance of 1000 ohms per volt. On Model MI-3222 the markings over these metering jacks are simply a multiplying factor which when applied to the meter readings will indicate the actual voltage or current as the case may be. On Model MI-3222-A amplifier the actual meter readings are marked above each jack.

An intermediate output is provided by a tertiary winding on the push-pull input transformers to provide a means of supplying a uniform input over the audio frequency range to the noise reduction amplifier, neon volume indicator and monitoring system. If necessary, as many as six bridging loads of 30,000 ohms each may be operated from this output. A total bridging load of less than 5,000 ohms begins to affect the frequency response of the amplifier and

should not be used. Drawing S-822428 shows the overall frequency characteristic of the MI-3222 and MI-3222-A amplifiers as measured across both the output and interstage-output terminals under different loading conditions. When operating with bridging amplifiers at a distance from either the Model MI-3222 or Model MI-3222-A amplifier, the total capacity of the various connecting cables should be kept below 0.0045 mf. This is equivalent to approximately 100 ft. of twin lead cable or 100 ft. of five conductor shielded microphone cable.

**CONSTRUCTION** - Both the MI-3222 and MI-3222-A Recording Amplifiers have all the essential parts mounted upon the front panel which is hinged at the right hand end. The framework to which the hinge is fastened should be permanently fastened to a standard relay rack and is built in the form of a stationary metal container which serves as a dust and electrostatic shield over the entire amplifier when it is swung in its closed position. When opened, all parts are readily accessible for servicing. Cables connecting to the front panel and associated parts are of sufficient length so that no leads need be disconnected in order to open the front panel.

This booklet includes front-view and internal photographs of the MI-3222 Amplifier. The MI-3222-A is almost identical in appearance.

**POWER SUPPLY** - Either six volt or eight volt "A" battery supply may be used with these amplifiers. The "A" current drain is 1.55 amperes at either voltage. Wherever possible these amplifiers should be operated with battery bias applied to the output stage, in which case 180 volts of "B" supply is necessary. By making a slight wiring change at the amplifier terminal board these amplifiers can be made to operate with self bias in which case the plate voltage should be 225 volts. In either case the total "B" battery drain is 42 ma.

**CAUTION:-** WHEN OPERATING EITHER AMPLIFIER WITH SELF BIAS IT IS NECESSARY TO OPERATE THE AMPLIFIER FROM A SEPARATE "A" SUPPLY WHICH MUST NOT BE CONNECTED TO OTHER UNITS OF THE RECORDING EQUIPMENT OR TO GROUND.

## PART II - OPERATION

**MOUNTING** - The Models MI-3222 and MI-3222-A Recording Amplifiers are designed for mounting in standard 19-inch relay racks. They should not be opened on their hinges unless the panel is firmly and rigidly supported.

**LOCATION OF FUSES** - After mounting either amplifier in a suitable rack, remove the cover plate from the tube compartment and install the "A" and "B" supply fuses in their holders. A W.E. non-alarm, code "24-B," 1/2 ampere fuse should be placed in the "B" supply circuit (which is the left hand fuse mounting). A similar type 5 ampere fuse should be installed in the "A" supply circuit (which is the right hand fuse mounting). For 6 volt "A" supply operation this fuse goes in the two upper clips and for 8 volt operation it goes in the two lower clips. The terminal board is marked to indicate correct position of the fuse.

**RADIOTRONS** - The proper Radiotrons should now be placed in their respective sockets (as marked opposite each tube location). Screw the Mazda No. 40 pilot lamp in its socket behind the red indicator bezel and replace the tube cover plate.

INTERCONNECTION OF "A" AND "B" SUPPLY - Since battery bias is preferred, for recording with this type of amplifier, it is necessary to connect "-A" and "-B" together by means of a jumper. "+A" instead of "-A" may be connected to "-B" if necessary to agree with the system ground. To do this, loosen the two thumb nuts on the left side of the panel and swing the amplifier open. The terminal strip on the right hand side in the back of the shield container is now available and clearly marked "+B, -A, -B, +A."

CAUTION: - BEFORE CONNECTING OR CHANGING ANY BATTERY LEADS TURN OFF POWER SWITCH AND TURN OFF HUMMER OR OSCILLATOR AS THE CASE MAY BE.

OPERATION WITH "B" BATTERY BIAS - With all power switches and other battery leads disconnected, install two 22½ volt "C" batteries (Burgess #5156, Eveready #768, or equivalent) in the "C" battery container located along the rear top portion of the amplifier. Connect these batteries to give 39 volts if the "-A" supply is grounded. If "+A" is grounded, connect them to supply 45 volts. Due to the type of filament circuit used the test meter will show an indication of 42 volts in either case. When using "C" battery bias the plate voltage supplied to the amplifier must be 180 volts.

OPERATION WITH SELF BIAS CIRCUIT - For self bias operation the "C" batteries must be removed from their compartment and the leads which normally would connect to them must be connected together. Care must be taken that these leads do not come in contact with ground. The "B" supply must be 225 volts. A SEPARATE "A" BATTERY MUST BE USED AND MUST NOT BE CONNECTED TO GROUND OR TO THE "B" SUPPLY CIRCUIT IN ANY WAY.

INPUT AND OUTPUT CONNECTIONS - The input terminals of the amplifier should be connected to the output of the mixer panel, low pass filter, or other unit, with the corresponding "±" terminals of each unit connected together. It is advisable to shield the input leads. These amplifiers are shipped from the factory with the input circuit connected for operation on 500-ohm impedance lines. For operation from 250-ohms impedance lines, it is only necessary to remove the two wires coming from the main input terminal board from terminals #6 and #1 of the input transformer, T-1, and reconnect them to terminals #5 and #2. The input loading resistor, R-1, should remain connected across terminals #1 and #6 as before.

The 500-ohm output terminals should be connected to the input of the recorder, or other unit as the case may be, with the "±" terminals of each connected together. The ground noise reduction amplifier, monitoring amplifier, or other units, should be bridged across the intermediate output being careful not to load down this intermediate output circuit too much as noted above.

In some installations these units may be connected in parallel with a 500 ohm resistor which, in turn, is connected across the 500 ohm output terminals.

CHECKING TUBE OPERATION - After allowing a few moments for the tubes to warm up, check the plate current, filament voltage and grid bias voltage by means of the meter and cord provided.



Below are shown two tabulations indicating approximate readings which should be obtained from the various jacks in the order in which the jacks appear on the panel from left to right. The first tabulation refers to the MI-3222 and the second tabulation refers to the MI-3222-A. In order to maintain the proper balance in the push-pull output stage the readings of jacks "MA-4" and MA-5" should not differ more than 15%. It may be necessary to try several Radiotrons, RCA-71-A, in order to find a proper balance.

MI-3222

| Jack   | Reading   |              | Multiplication<br>Factor | Indication              |
|--------|-----------|--------------|--------------------------|-------------------------|
|        | Self Bias | Battery Bias |                          |                         |
| MA 1   | 1.0       | 0.8          | 1                        | 1.0 or 0.8 milliamperes |
| MA 2   | 0.6       | 0.5          | 1                        | 0.6 or 0.5 milliamperes |
| MA 3   | 2.8       | 2.3          | 1                        | 2.8 or 2.3 milliamperes |
| HEATER | 6.0       | 6.0          | 1                        | 6.0 volts               |
| MA 4   | 1.9       | 1.9          | 10                       | 19 milliamperes         |
| MA 5   | 1.9       | 1.9          | 10                       | 19 milliamperes         |
| BIAS   | 4.2       | 4.2          | 10                       | 42 volts                |
| B      | 4.5       | 3.6          | 50                       | 225 or 180 volts        |

MI-3222-A

| Jack   | Reading with<br>Battery Bias | Multiplication<br>Factor | Indication       |
|--------|------------------------------|--------------------------|------------------|
| MA 1   | 0.8                          | 1                        | 0.8 milliamperes |
| MA 2   | 0.5                          | 1                        | 0.5 milliamperes |
| MA 3   | 1.9                          | 1                        | 1.9 milliamperes |
| HEATER | 6.0                          | 1                        | 6.0 volts        |
| MA 4   | 1.9                          | 10                       | 19 milliamperes  |
| MA 5   | 1.9                          | 10                       | 19 milliamperes  |
| BIAS   | 4.2                          | 10                       | 42 volts         |
| B      | 3.6                          | 50                       | 180 volts        |

NOTE:- When operating the MI-3222-A amplifier as a self biased unit without the use of bias batteries the above readings will be approximately the same with the exception of the "B" reading which will be 4.5 indicating a plate voltage of 225.

OPERATING NOTES - The amplifier should be operated at as low a volume control setting as is consistent with good range of control at the mixing panel. The intermediate volume control should be kept as low as possible using the master control to increase the volume.

When the amplifier is operated from dry "B" batteries, it usually becomes necessary to allow the "B" voltage to drop within certain limits. The grid bias voltage as supplied by the "C" batteries should be decreased proportionately. In general, the "B" batteries should be replaced when their voltage has dropped 15% below its initial value. As the "B" battery voltage decreases, the taps on the "C" batteries should be changed so that the voltage reading obtained in jack marked "Bias" will be as near as possible to 23-1/3% of the voltage reading obtained in jack marked "B".

The "C" batteries should be replaced when the delivered voltage drops 10% below rated value, or sooner, if they become noisy.

The Radiotrons should be tested occasionally by means of a reliable tube tester.

CARE OF VOLUME CONTROLS - The volume controls may be taken out for inspection, or to clean the contacts, by removing only the four screws in the outer corners of the escutcheon plates and carefully pulling them straight out. The contacts should be cleaned occasionally by using a small quantity of light, high-grade machine oil such as camera or watch oil. (CAUTION:- NEVER USE SANDPAPER OR HARSH ABRASIVES TO CLEAN THE CONTACTS AS THESE SURFACES ARE CAREFULLY AND ACCURATELY LAPPED IN AT THE FACTORY.) Using a toothpick, apply a drop of oil to the surface of several contacts and rotate the arms back and forth until the oil is thoroughly worked in and becomes dirty. Then use a soft cloth and thoroughly wipe off the contacts. Repeat this procedure until the oil remains clean. When cleaning is complete, all oil should be wiped off with a dry cloth.

ADJUSTMENT OF THE HUMMER OSCILLATOR POTENTIOMETER ON MODEL MI-3222 AMPLIFIER - Whenever any changes are made to the 1000 cycle hummer oscillator of the potentiometer, R-3, an adjustment of the potentiometer is necessary in order that the output of the amplifier when excited by the oscillator will be sufficient to modulate the recorder light beam 100% at an average setting of the volume control. To make this adjustment, connect a 500 ohm resistor across the output of the amplifier and across this resistor connect a volume indicator having a total resistance of 5000 ohms or greater and capable of measuring a level of + 22 db or greater. Set intermediate volume control at its mid-position and the main volume control at 20. Adjust the movable contact arm on the potentiometer until the amplifier output reading is + 21 db. (0.006 watts = 0 level).

ADJUSTMENT OF THE VACUUM TUBE OSCILLATOR IN MODEL MI-3222-A RECORDING AMPLIFIER - A combined power switch (S-1) and output control (R-3) for the 400 cycle vacuum tube oscillator is located on the front panel of the Model MI-3222-A amplifier. Rotating the knob clockwise closes the switch, S-1, which turns on this oscillator. Rotating the same knob further increases the output of the oscillator so that any desired output may be obtained.

### PART III - TESTING

A check of the phasing, frequency response, and load characteristic will show if the amplifier is properly connected and functioning normally.

PHASING - It is important that all inputs and outputs be properly phased. In other words the INSTANTANEOUS voltage at corresponding input and output terminals should be of the same polarity. For convenience, one terminal of each pair has been marked " $\pm$ " to indicate this polarity relation. All units of RCA recording equipment bear this " $\pm$ " indication on the input and output terminals so they can be properly connected. This system insures consistent results on all recording channels with the same operating technique.

The phasing of this amplifier may be checked by the feed-back method and, although the unit has been completely checked and tested at the factory, the following information is supplied to assist in maintenance and repair.

When the phasing is correct, the amplifier will "motor-boat" when the input terminals are connected across any one of the three output pairs with the "+" terminals of the input and output pair connected together. A pair of headphones connected across the input terminals will serve to indicate this "motor-boating."

If the amplifier is not properly phased, either no sound or a very high frequency whistle will be heard. If the volume controls are set too low, no sound may be heard in either case. At volume control settings above the "spill-over" point, the frequency of oscillation will decrease somewhat.

Should these tests indicate the amplifier to be out-of-phase it may be corrected by reversing the INTERNAL connections of the input or output terminals, whichever involves the least changing in order that all outputs are in phase with the input.

In some cases it may be more convenient to use the monitoring equipment in place of headphones in which case the bridging amplifier for the monitor should be left connected across the interstage output.

**FREQUENCY RESPONSE** - The frequency response characteristic should be flat plus or minus 1 db, from 30 to 10,000 cycles as shown on S-839416 and may be taken as follows:

Connect a calibrated source of audio frequency signal such as an RCA Type TMV-52-E Beat Frequency Oscillator through an isolation transformer such as type XT-1731, a volume indicator, and a 50 db "H" pad attenuator to the amplifier "input" terminals. Connect a 5000-ohm resistor across the "interstage output" terminals. Connect a volume indicator and a 500-ohm resistor across the "output" terminals. These connections are shown on curve S-839416.

**CAUTION:-** IF RECTOX METERS ARE EMPLOYED, THEY MUST BE USED FOR BOTH INPUT AND OUTPUT READINGS AND BE OF A SIMILAR TYPE SO AS TO PREVENT METER CHARACTERISTICS FROM AFFECTING THE FINAL RESULT.

Adjust the input level to + 8 db; the main volume control to maximum; and the intermediate volume control to "LOW". Under these conditions the output level will be approximately + 20 db (0.006 watt = 0 level) which level should not be exceeded during the taking of characteristic curves.

When making such measurements at higher gain settings on an amplifier whose input transformer is mid-tapped to ground, the measuring circuit should be checked for balance at 8000 to 10,000 cycles by observing the output when the input polarity is reversed at the amplifier terminals. The output should not change when this reversal is made or when a ground is made or broken to the mid-point of the "H" type attenuator. The attenuation network should be kept near the amplifier and the leads to the amplifier should be shielded.

**LOAD CHARACTERISTICS** - The load characteristics (output level plotted against input level) should be a straight line up to an output level of +21 db (0.006 watts = 0 level) for all values of volume control settings. However, the most critical test of linearity of the first stage is noted when the intermediate volume control is in its "LOW" position. As with any load curve it is essential that the metering equipment be very accurate over the range used.

In the distortion curves (S-839417 for MI-3222 and S-839418 for MI-3222-A) the meter used for measuring output should be of the thermocouple type whenever possible. If a rectox meter is used, it must be removed from the circuit when taking actual distortion measurements since this type of meter will introduce some distortion. This condition is most noticeable at low values of amplifier output.

REPLACEMENT PARTS - The following parts list is included to provide identification when ordering replacement parts. When ordering specify the item by description and reference drawing number.

PARTS USED IN BOTH MI-3222 AND MI-3222-A

| <u>Item</u> | <u>Description</u>          |              | <u>Ref. Drawing No.</u> |
|-------------|-----------------------------|--------------|-------------------------|
| R-1         | Resistor                    | 1,075 ohms   | K-819789-P21            |
| R-5         | Resistor                    | 20,000 ohms  | K-819789-P10            |
| R-6         | Resistor                    | 3,500 ohms   | K-819789-P7             |
| R-7         | Resistor                    | 75,000 ohms  | K-819789-P11            |
| R-8         | Resistor                    | 25,000 ohms  | K-819789-P12            |
| R-9         | Resistor                    | 50,000 ohms  | K-819789-P1             |
| R-10        | Intermediate Volume Control | 500,000 ohms | M-406387                |
| R-11        | Resistor                    | 9,600 ohms   | K-819789-P20            |
| R-12        | Resistor                    | 2,200 ohms   | K-819789-P18            |
| R-13        | Resistor                    | 100,000 ohms | K-819789-P17            |
| R-14        | Resistor                    | 500,000 ohms | K-819789-P3             |
| R-15        | Resistor                    | 50,000 ohms  | K-819789-P1             |
| R-16        | Resistor                    | 100,000 ohms | K-819789-P17            |
| R-17        | Resistor                    | 500,000 ohms | K-819789-P3             |
| R-18        | Resistor                    | 20,000 ohms  | K-819789-P10            |
| R-19        | Resistor                    | 3,500 ohms   | K-819789-P7             |
| R-20        | Resistor                    | 16,700 ohms  | K-819789-P8             |
| R-21        | Resistor                    | 50,000 ohms  | K-819789-P1             |
| R-22        | Resistor                    | 500,000 ohms | K-819789-P3             |
| R-23        | Resistor                    | 500,000 ohms | K-819789-P3             |
| R-24        | Resistor                    | 72,000 ohms  | K-819789-P22            |
| R-25        | Resistor                    | 1,100 ohms   | K-817616-P4             |
| R-26        | Resistor                    | 100 ohms     | K-817616-P5             |
| R-27        | Resistor                    | 0.92 ohms    | K-819789-P6             |
| R-28        | Resistor                    | 0.92 ohms    | K-819789-P6             |
| R-29        | Resistor                    | 1.32 ohms    | K-817616-P3             |
| R-30        | Resistor                    | 101.5 ohms   | K-819789-P2             |
| R-31        | Resistor                    | 101.5 ohms   | K-819789-P2             |
| R-32        | Resistor                    | 35 ohms      | K-819789-P5             |
| R-33        | Resistor                    | 35 ohms      | K-819789-P5             |
| R-34        | Resistor                    | 82 ohms      | K-819789-P4             |
| R-35        | Resistor                    | 82 ohms      | K-819789-P4             |
| R-36        | Resistor                    | 392,000 ohms | K-819789-P19            |
| C-1         | Capacitor 0.1 mf. (CP-86)   |              | M-64565-G1              |
| C-2         | Capacitor 0.1 mf. (CP-86)   |              | M-64565-G1              |
| C-3         | Capacitor 0.001 mf.         |              | K-35558-P7              |

PARTS USED IN BOTH MI-3222 AND MI-3222-A CON'T

| <u>Item</u> | <u>Description</u>   | <u>Ref. Drawing No.</u> |
|-------------|--|-------------------------|
| C-4         | Capacitor 4 mf. term. 3, 6, 11-4, 5, 12 )                                |                         |
| C-6         | Capacitor 2 mf. term. 1-2 )- - - - -                                     | (CP-137)                |
| C-7         | Capacitor 1 mf. term. 9-10 )   | M-68566                 |
| C-8         | Capacitor 1 mf. term. 7-8 )  |                         |
| C-5         | Capacitor 2 mf. term. 1-2 )  |                         |
| C-9         | Capacitor 3 mf. term. 3, 6-4, 5)- - - - -                                | (CP-137)                |
| C-10        | Capacitor 1 mf. term. 11-12 )  | M-68566                 |
| C-11        | Capacitor 1 mf. term. 7-8 )  |                         |
| C-12        | Capacitor 1 mf. term. 9-10 )   |                         |
| C-13        | Capacitor 0.1 mf. (CP-86)  | M-64565-G1              |
| L-1         | Reactor 600 H. (RT-259)  | M-406230                |
|             | d-c resistance 11,000 ohms   |                         |
| S-2         | Switch D.P.S.T. for amplifier power                                      | K-65679-P1              |
| S-3         | Fuse 5-amp. (W.E. non-alarm type<br>Code 24-B)                           |                         |
| S-4         | Fuse 1/2-amp. (W.E. non-alarm type<br>Code 24-B)                         |                         |
| S-5         | Bias Battery two 22-1/2 volt Burgess<br>#5156 Eveready 768 or equivalent |                         |
| T-1         | Input transformer (RT-306)   | M-403091                |
|             | taps 1-6 52 ohms   |                         |
|             | taps 8-11 2,690 ohms   |                         |
| T-2         | Interstage transformer (RT-308)  | M-403097                |
|             | taps 3-4 1,690 ohms  |                         |
|             | taps 5-8 5,070 ohms  |                         |
|             | taps 9-11 255 ohms   |                         |
| T-3         | Output transformer (RT-309)  | M-403096                |
|             | taps 1-4 525 ohms  |                         |
|             | taps 5-12 38 ohms  |                         |
| --          | Patch cord   | K-35558-P5              |
| --          | Meter 0-8 volt 1000 ohm/volt   | K-35558-P4              |

PARTS USED IN MI-3222 ONLY

| <u>Item</u> | <u>Description</u>                  | <u>Ref. Drawing No.</u> |
|-------------|-------------------------------------|-------------------------|
| R-2         | Volume control 50,000 ohms          | M-406366                |
| R-3         | Resistor 20 ohms                    | K-35558-P2              |
| R-4         | Resistor 82 ohms                    | K-30176-P14             |
| C-14        | Capacitor 0.25 mf.                  | P-72017-G36             |
| C-15        | Capacitor 0.25 mf.                  | P-72017-G36             |
| S-1         | Switch D.P.S.T. for Hummer          | K-35544-P1              |
| T-4         | Oscillator transformer (1000 cycle) | M-403084                |



PARTS USED IN MI-3222-A ONLY

| <u>Item</u> | <u>Description</u>                                    |             | <u>Ref. Drawing No.</u> |
|-------------|---|-------------|-------------------------|
| R-2         | Volume control<br>(combined with S-1)                 | 50,000 ohms | K-836184-P1             |
| R-3         | Potentiometer   | 600 ohms    | K-180315-P1             |
| R-4         | Resistor  | 50,000 ohms | K-30176-P1              |
| R-37        | Resistor  | 2,200 ohms  | K-814062-P22            |
| R-38        | Resistor  | 50,000 ohms | K-30176-P1              |
| R-39        | Resistor  | 50,000 ohms | K-819789-P1             |
| C-14        | Capacitor   | 0.01 mf.    | P-72017-G512            |
| C-15        | Capacitor   | 0.1 mf.     | P-72017-G532            |
| C-16        | Capacitor   | 0.025 mf.   | P-72017-G518            |
| C-i7        | Capacitor   | 0.025 mf.   | P-72017-G518            |
| S-1         | Switch D.P.S.T. for oscillator<br>(combined with R-2) |             | K-836184-P1             |
| T-4         | Oscillator transformer (400 cycle)                    |             | K-68373-G501            |
| --          | Oscillator assembly complete (400 cycle)              |             | M-140060-G501           |

TEST EQUIPMENT

| <u>Item</u> | <u>Description</u>   |
|-------------|--|
|             | Isolation Transformer (XT-1731)  |
|             | RCA Beat Frequency Oscillator (20-17,000 cycles)<br>Type TMV-52-E or TMV-171-A |

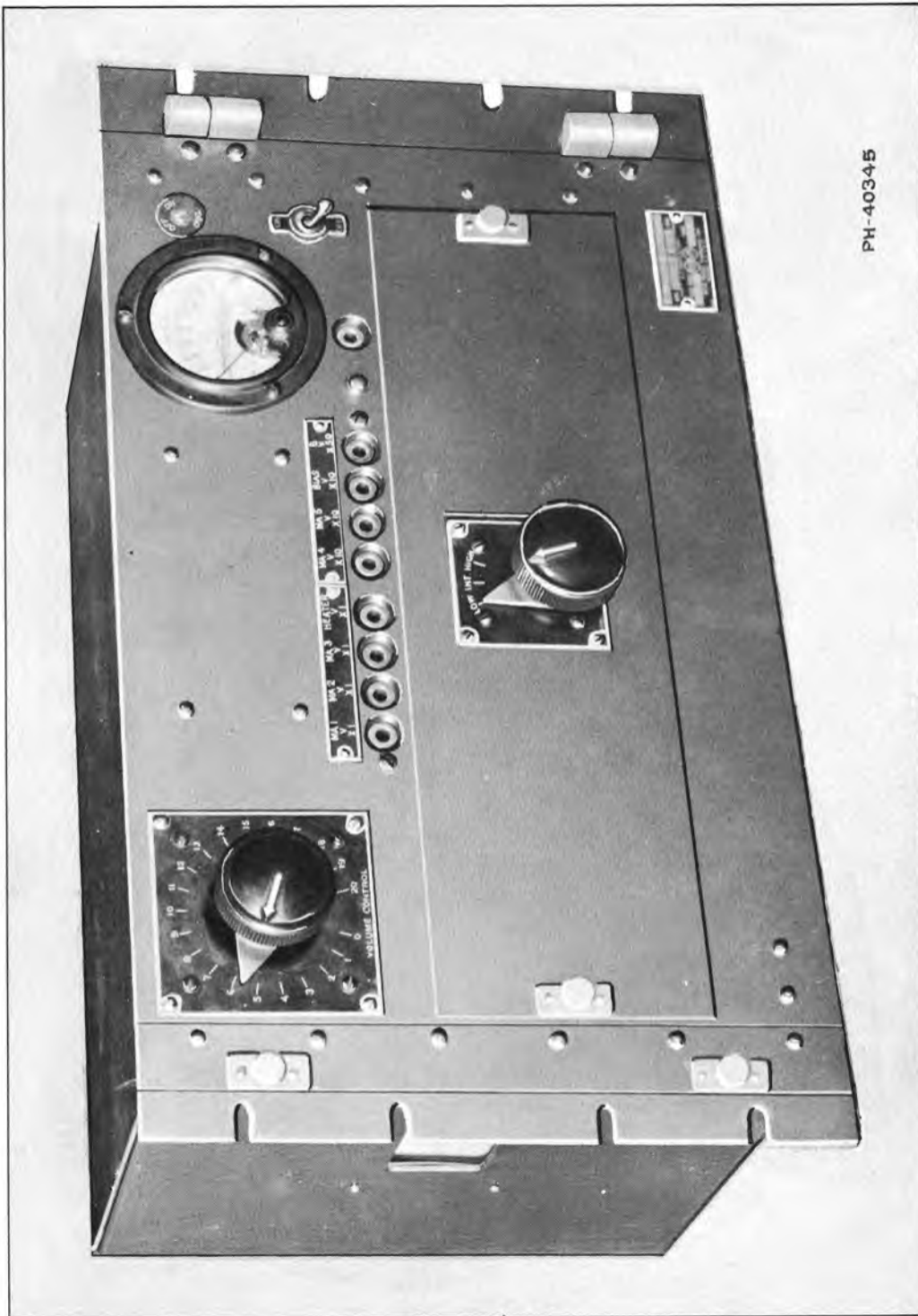

PH-40345

## MI-3222 RECORDING AMPLIFIER

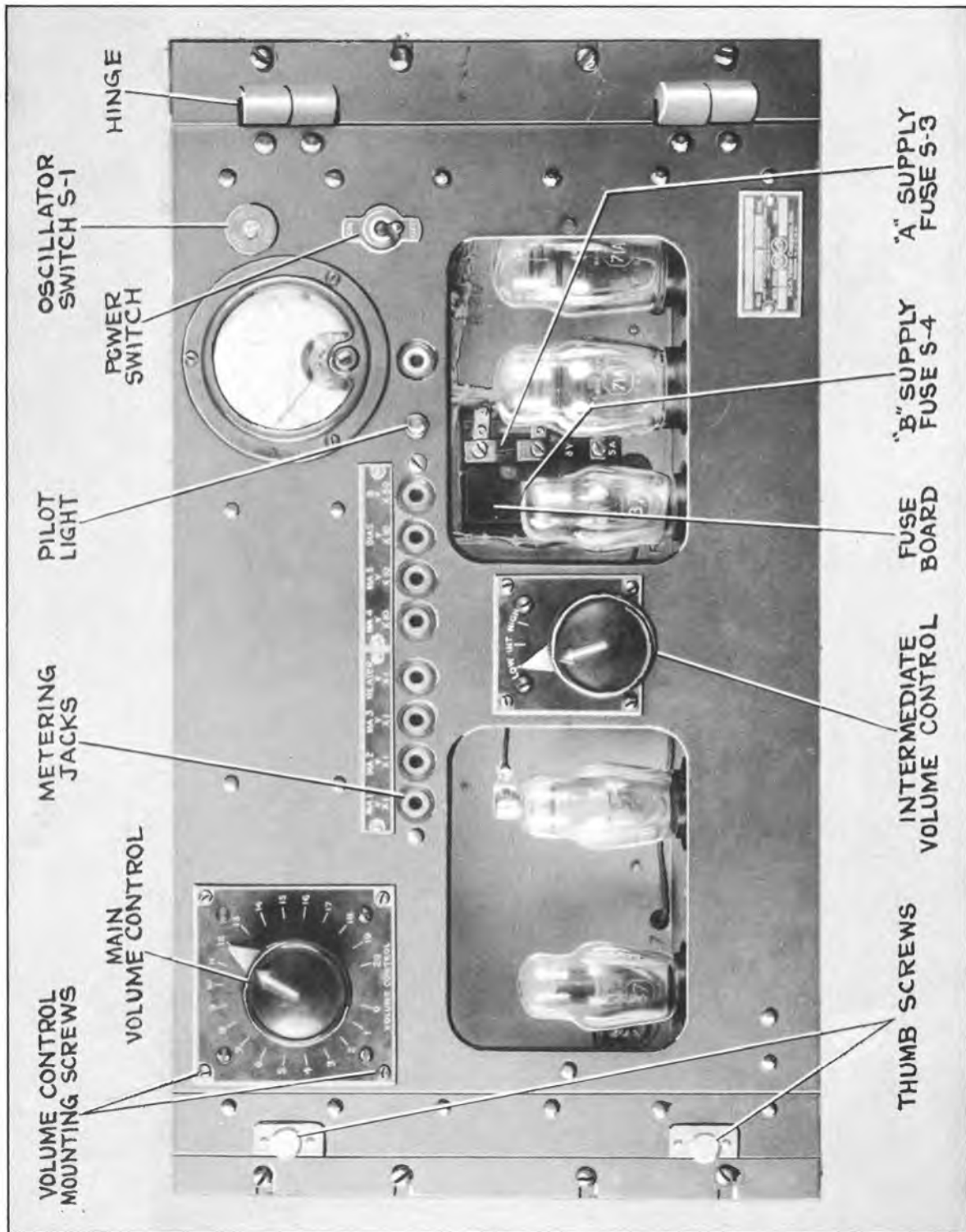

MI-3222 RECORDING AMPLIFIER

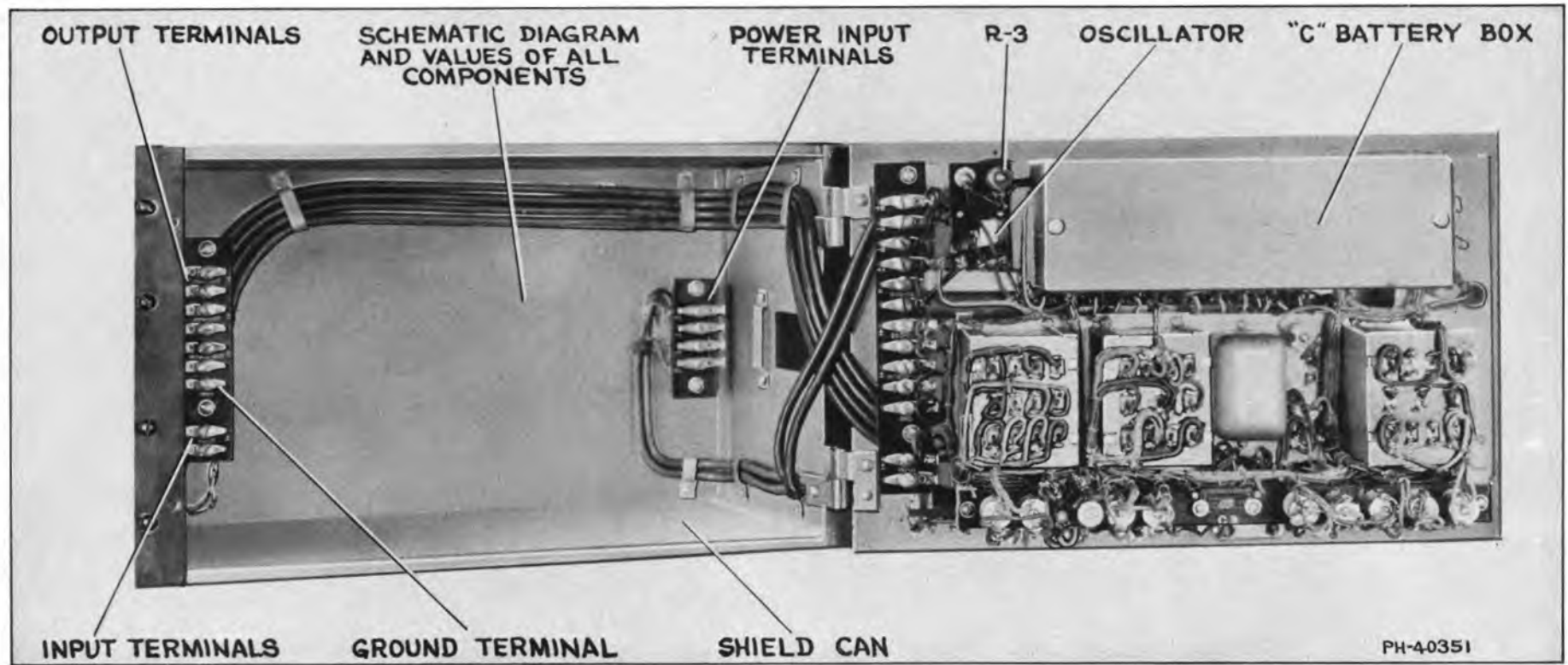

MI-3222 RECORDING AMPLIFIER



# M.I. 3222 RECORDING AMPLIFIER

DISTORTION V.S. POWER OUTPUT AT 400 CYCLES

$E_{in} = 160$  V.

$E_{out} = 5.6$  V.

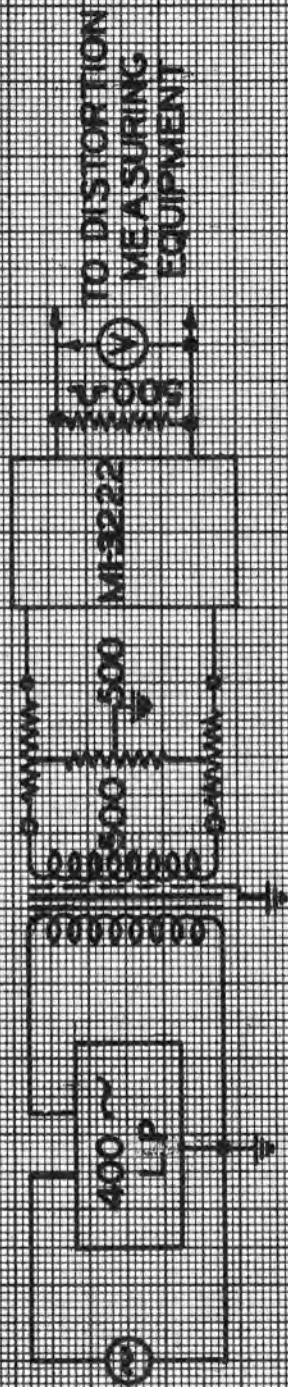

PERCENT DISTORTION - TOTAL RMS

0 +2 +4 +6 +8 +10 +12 +14 +16 +18 +20 +22

POWER OUTPUT LEVEL - D.B.  
ZERO REFERENCE = 0.00 W

S-839417



# MI 3222A RECORDING AMPLIFIER

## DISTORTION V.S. POWER OUTPUT AT 400 CYCLES

$E_b = 180 \text{ V.}$

$E_s = 5.8 \text{ V.}$

PERCENT DISTORTION - TOTAL RMS

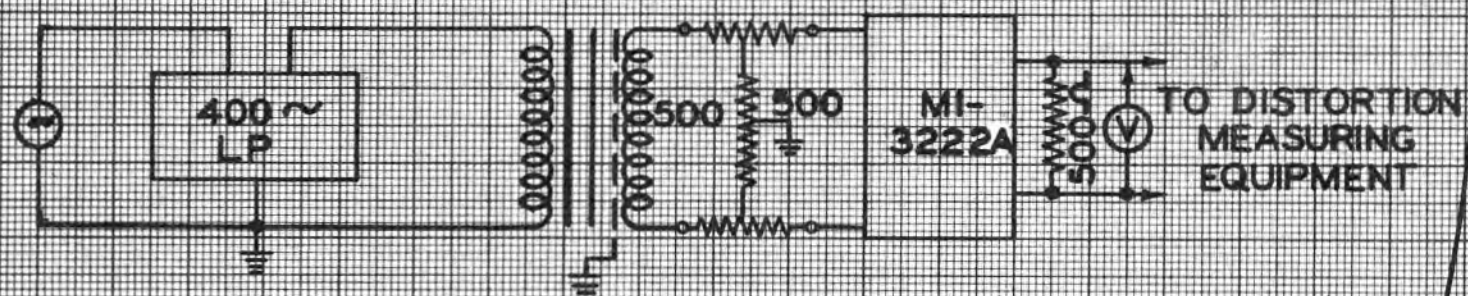
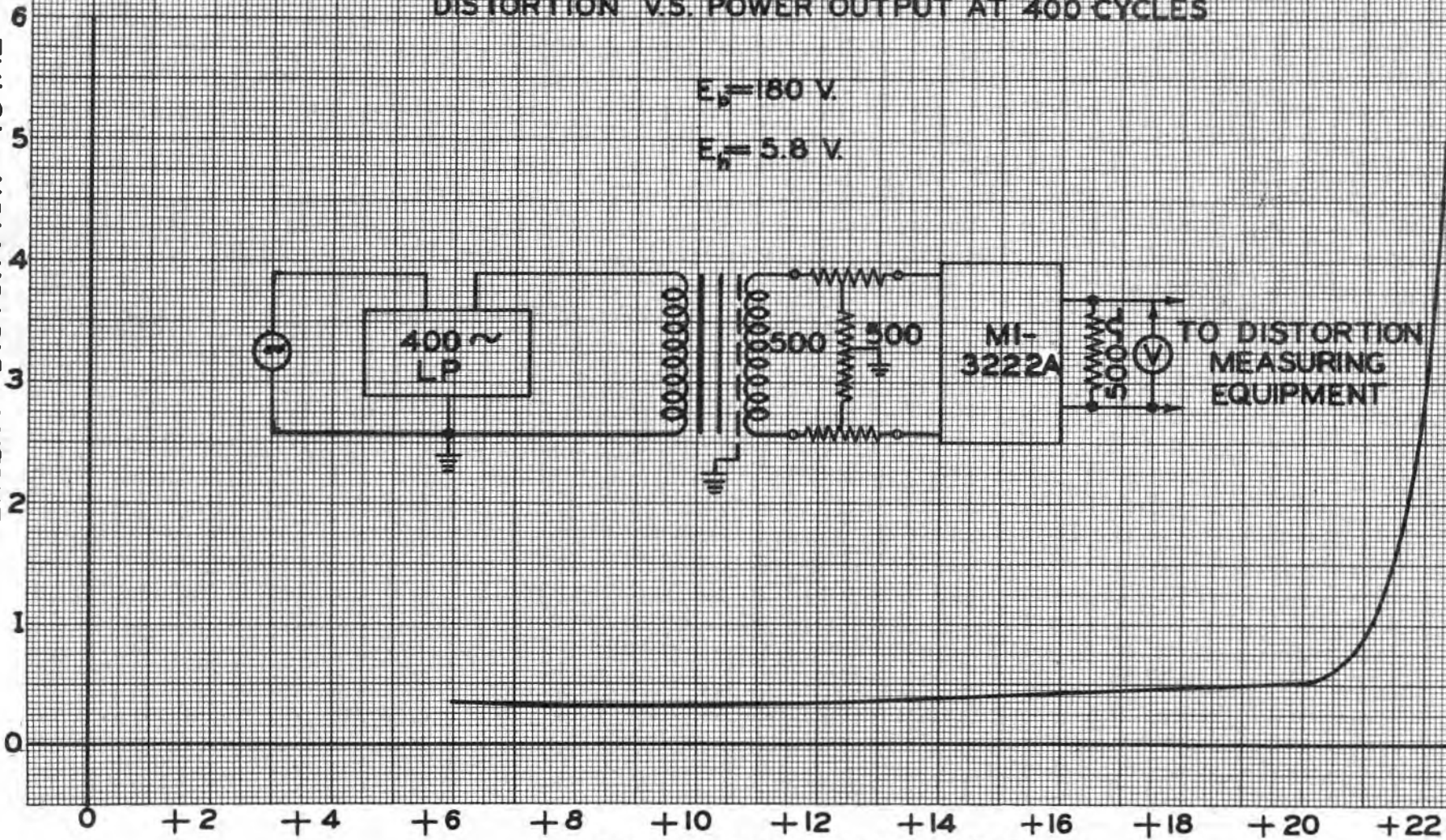

POWER OUTPUT LEVEL - D.B.  
(ZERO REFERENCE=0.006 W)

S-839418

# MI-3222 AND MI-3222-A RECORDING AMPLIFIER FREQUENCY CHARACTERISTIC.

OUTPUT CURVE INTERSTAGE UNLOADED  
 OUTPUT CURVE 5000 Ω LOAD ON INTERSTAGE  
 INTERSTAGE OUTPUT CURVE 5000 Ω LOAD ON INTERSTAGE  
 ALL CURVES:- 500 Ω SOURCE IMPEDANCE, 500 Ω OUTPUT LOAD.

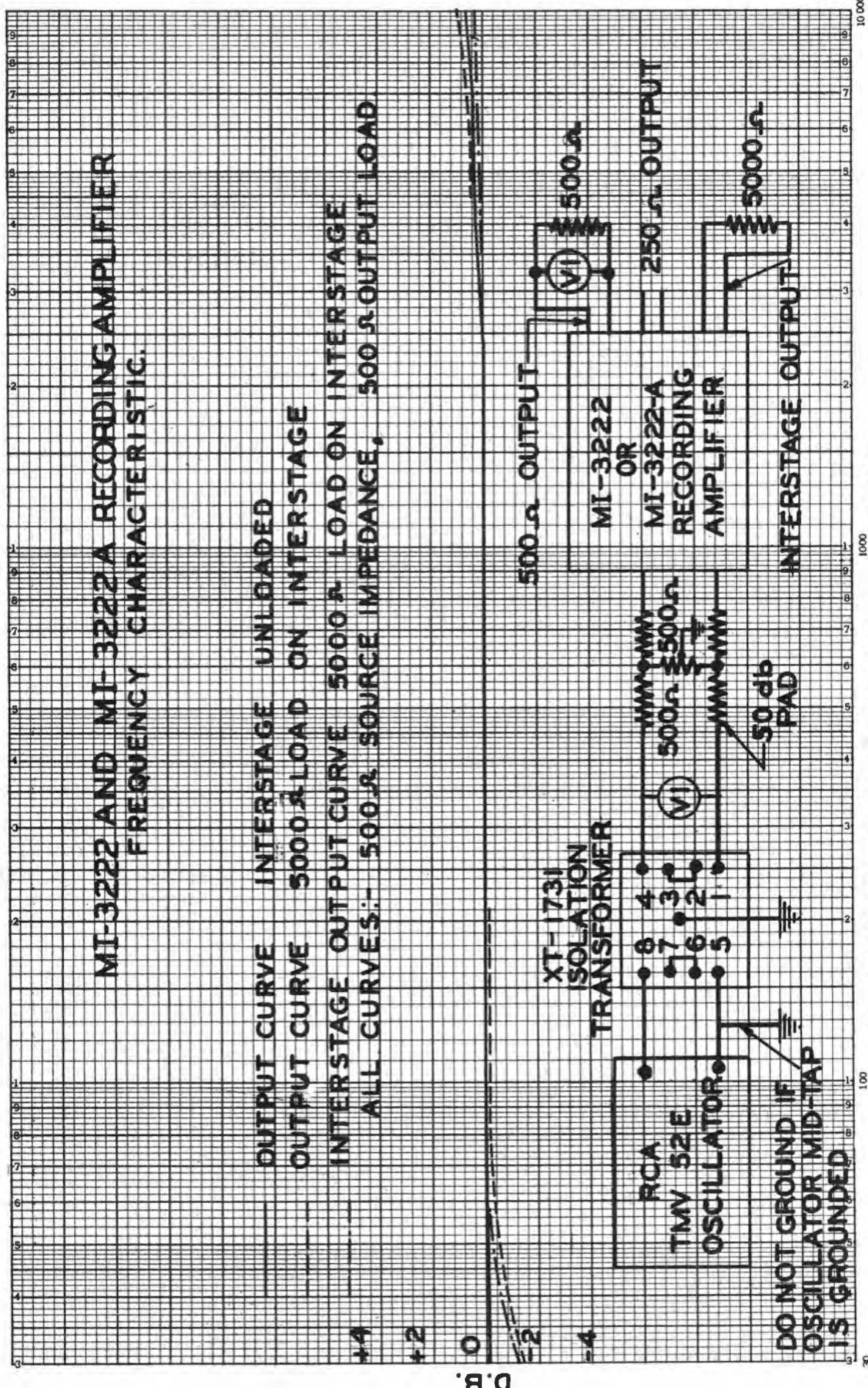

DO NOT GROUND IF  
OSCILLATOR MID-TAP  
IS GROUNDED

FREQUENCY IN CYCLES PER SECOND.

S-839416

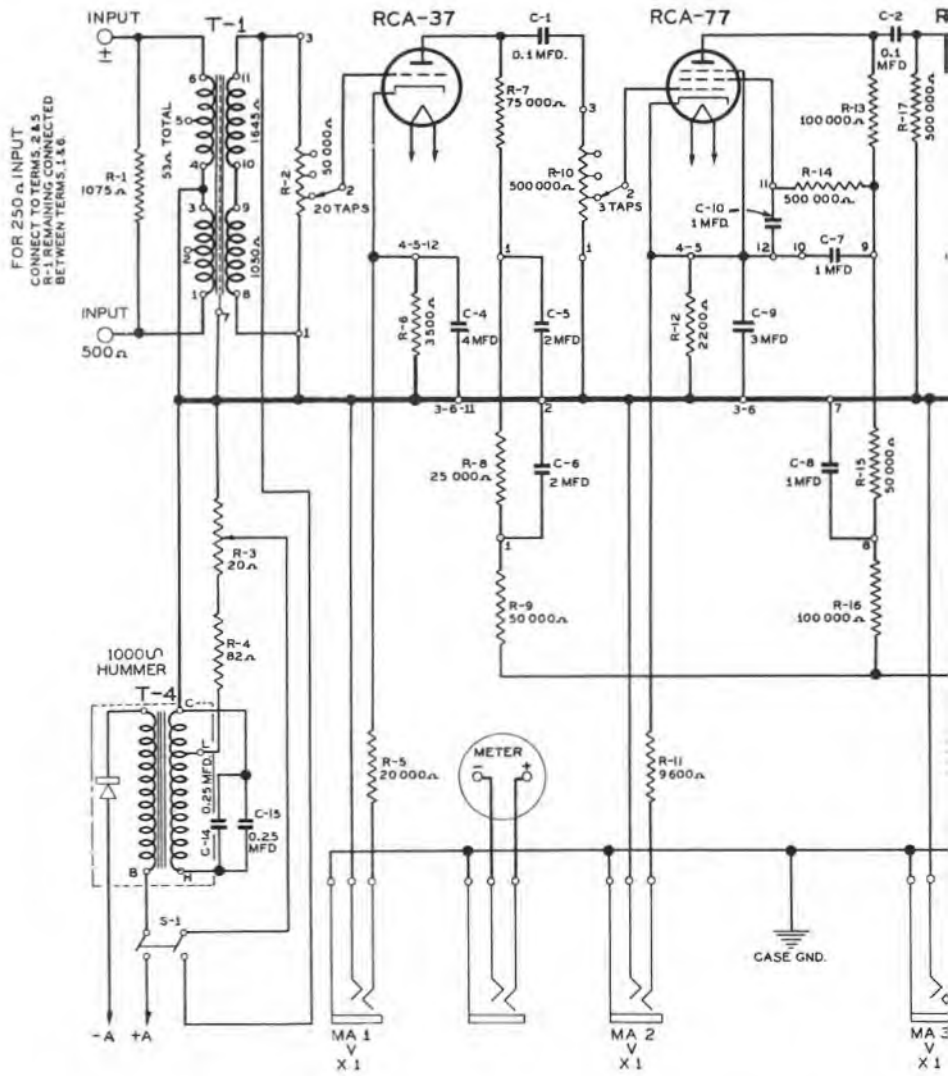

M.I. 3222



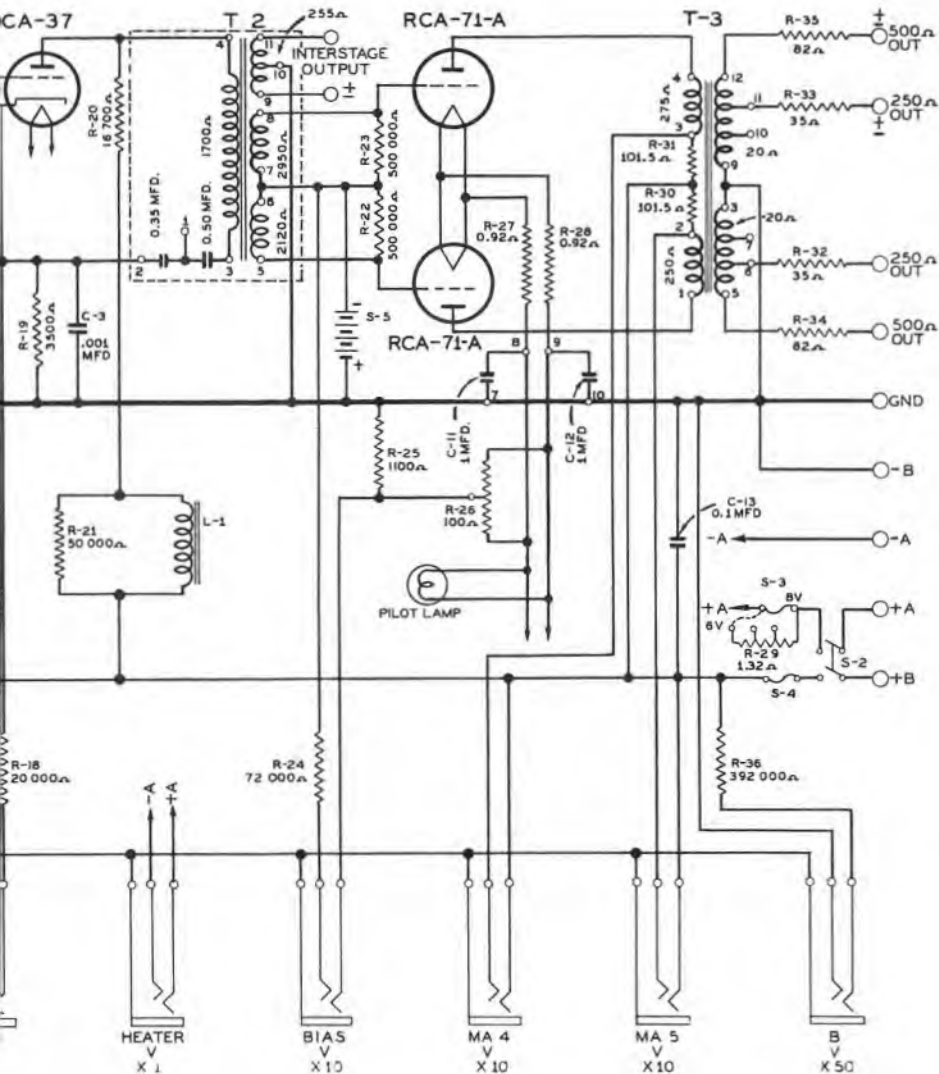

T-607642

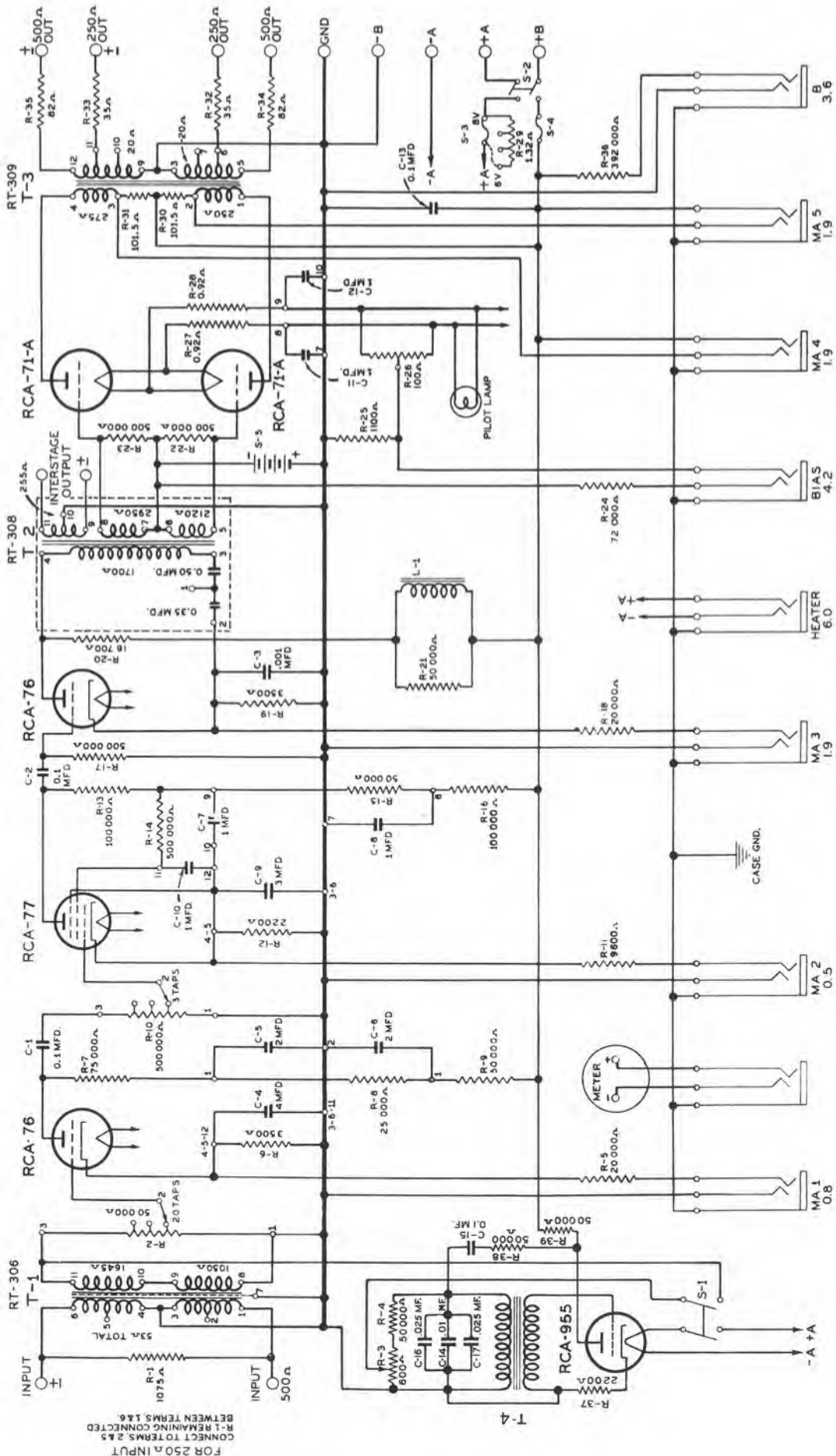

M.I.3222A. T-607718



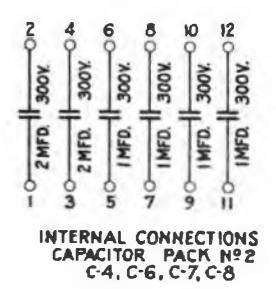
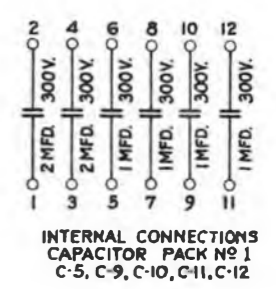
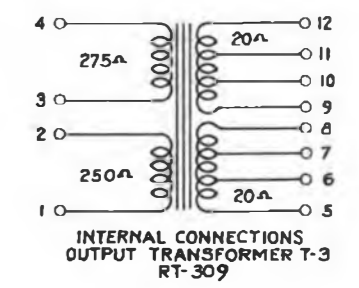
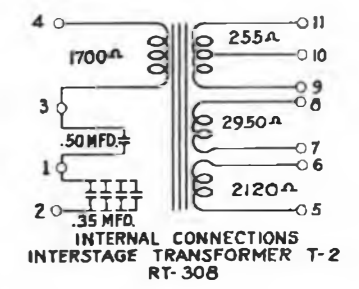
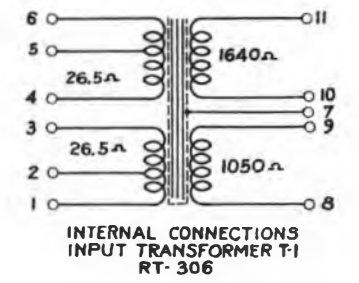
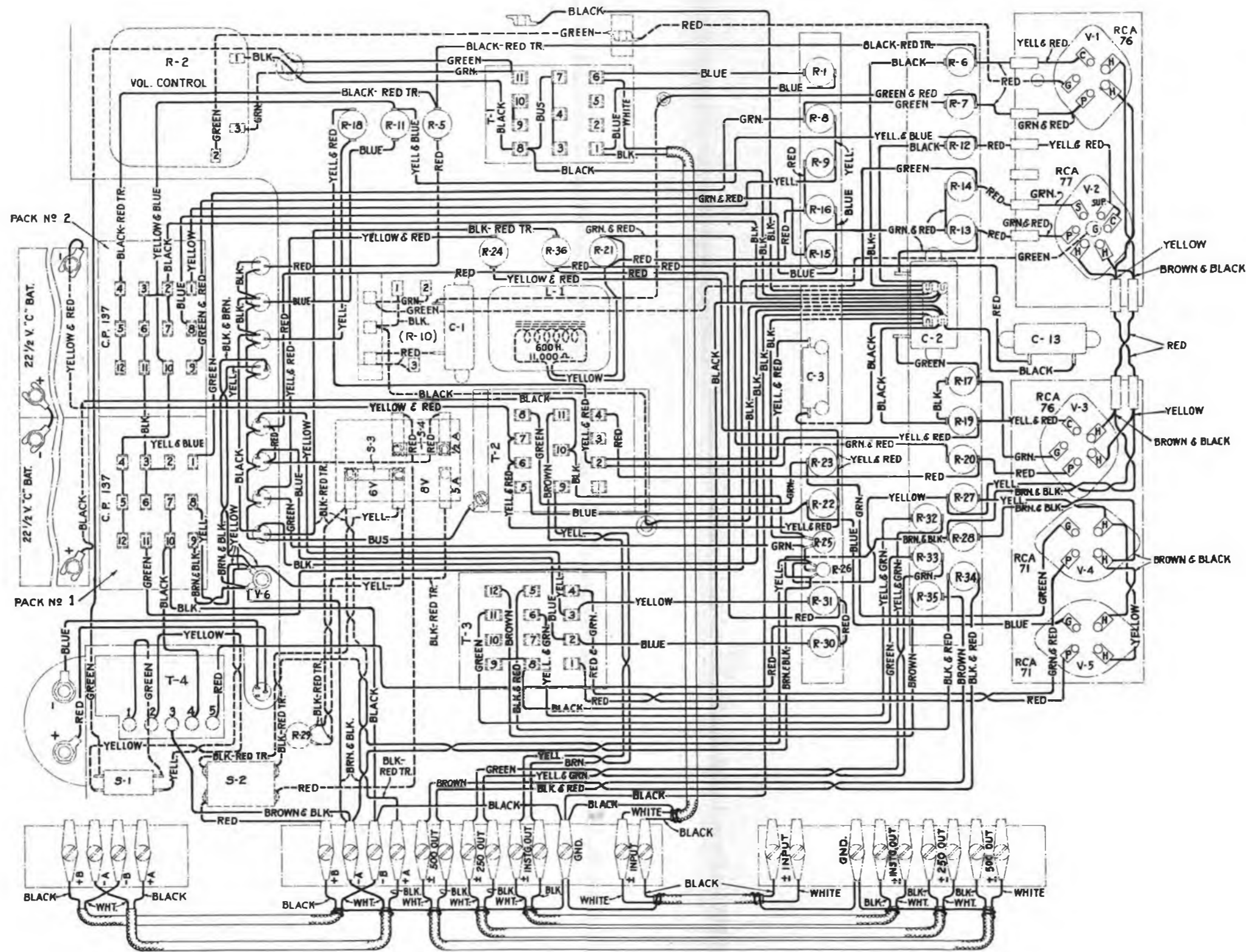

M.I. 3222-A W-302066

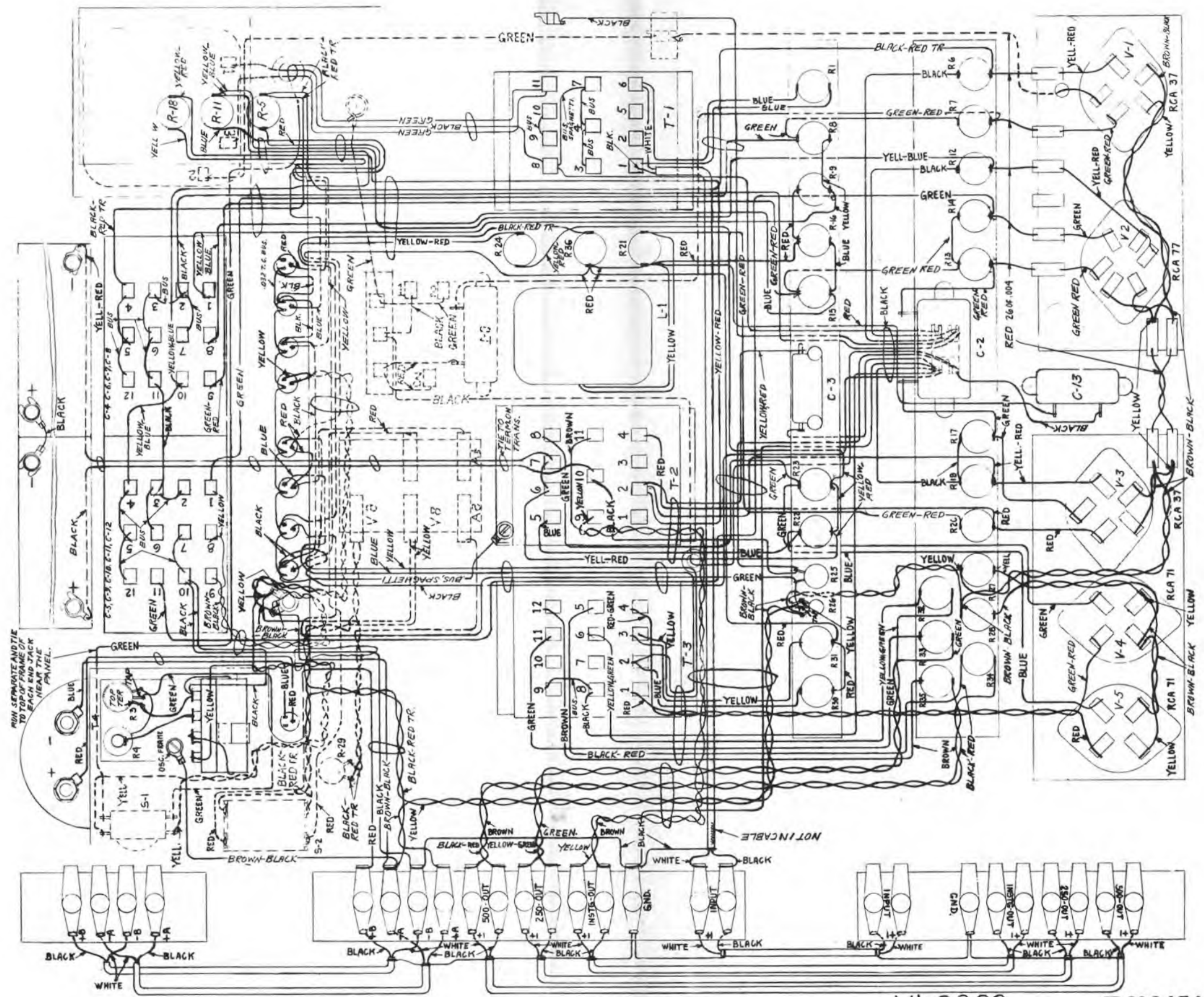

MI-3222

T-600474



## STANDARD TEST RECORDS

|         |             |
|---------|-------------|
| No.     | X-5         |
| Sheet 1 | of 7 Sheets |
| Date    | 3-11-40     |

| Record Number | Speed    | Description   |
|---------------|----------|---|
| CS-T-2346-1   | 33.3 rpm | Frequency record used for response curves on 70B Transcription Turntable ( 88° stylus ) |
| CS-T-2221-1   | 33.3 rpm | Frequency record (Bands) made with high fidelity recorder with 70° stylus.              |
| CS-T-2222-1   | 78. rpm  | Frequency record (Bands) made with high fidelity recorder with 70° stylus.              |
| CS-T-2484-5   | 78 rpm   | Frequency record (Bands) made with high fidelity recorder with 88° stylus.              |
| CS-T-2485-2   | 33.3 rpm | Frequency Record (Bands) made with high fidelity recorder with 88° stylus.              |

See also Response curves , S-851899-2

Note: Records 2221, 2222, 2484 and 2485 above were recorded at constant amplitude from 50 to 500 cycles and constant velocity from 500 to 10,000 cycles. The recordings on each of these records from outside in are as follows:

1. Blank groove -  $\frac{3}{8}$  inch or about 30 seconds
2. Frequency bands - 10 seconds each - 10,000, 9,000, 8,000, 7,000, 6,000, 5,000, 4,000, 3,000, 2,000, 1,000, 500, 300, 200, 100 and 50 cycles per second.
3. Repeat 1,000 cycle signal - same level as above.
4. Repeat 1,000 cycle signal - 2 db lower level.
5. Repeat 10,000 cycle signal - same level as above.

SEE CURVE S-851899 for response of above records.

Note: Record 2346 is no longer a standard test record but is listed because it was used in taking the response curves for the 70B

Note: The frequency response curves shown on the following page for records 2221, 2222, 2484 and 2485 were taken with a flat amplifier and with the diamond point pickup MI-4856. The pickup was matched at 250 ohms and no compensation was used. A 70B turntable was used.

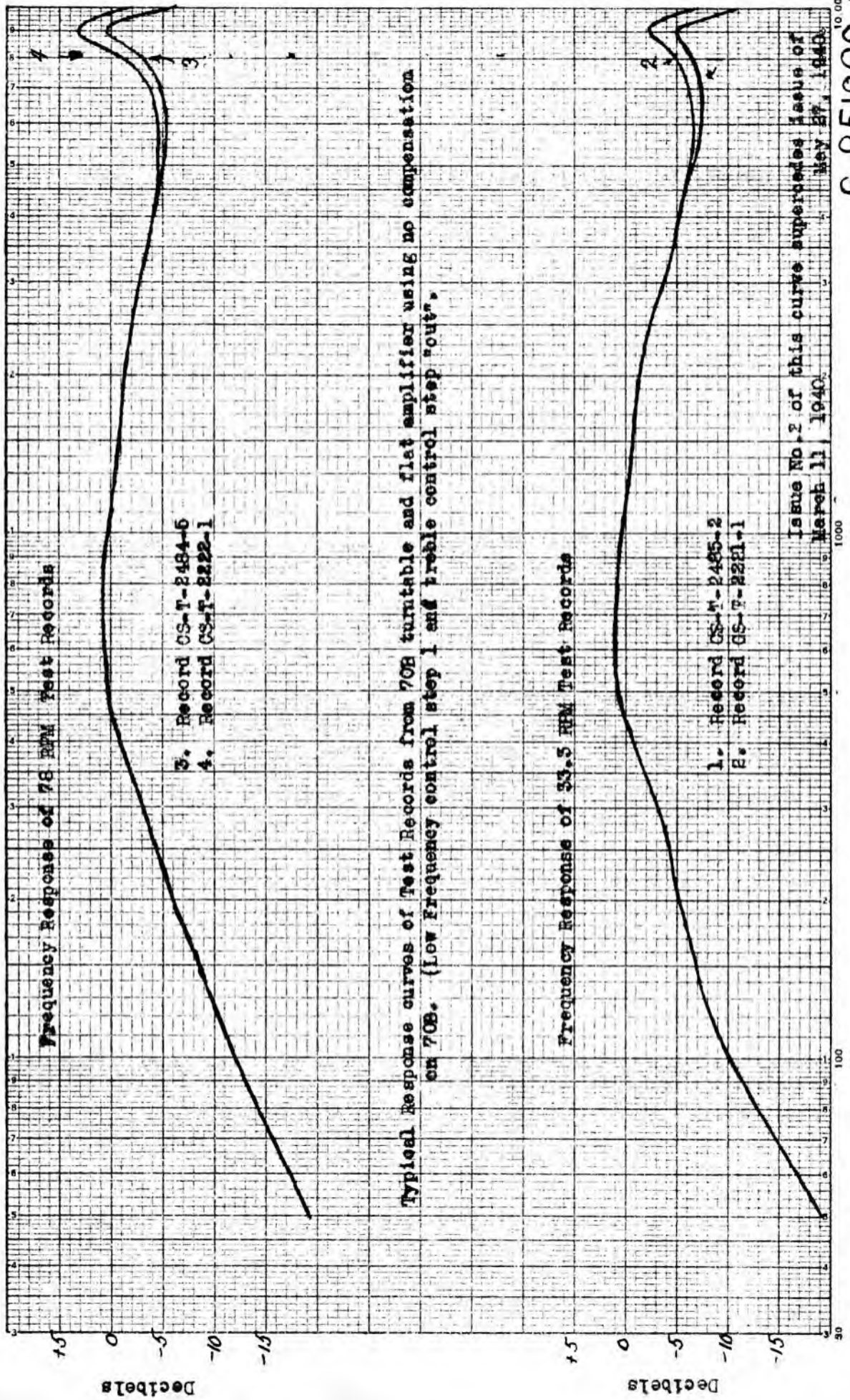

Typical response curves of Test Records from 70B turntable and flat amplifier using no compensation on 70B. (Low Frequency control step 1 and treble control step "out".)

S-851899-2

SECTION XI

Transmission and Schematic Diagrams

Master Reference Book  
Disc Recording







SECTION XII

Equipment Assembly and Inter-unit Wiring Diagrams

Master Reference Book  
Disc Recording



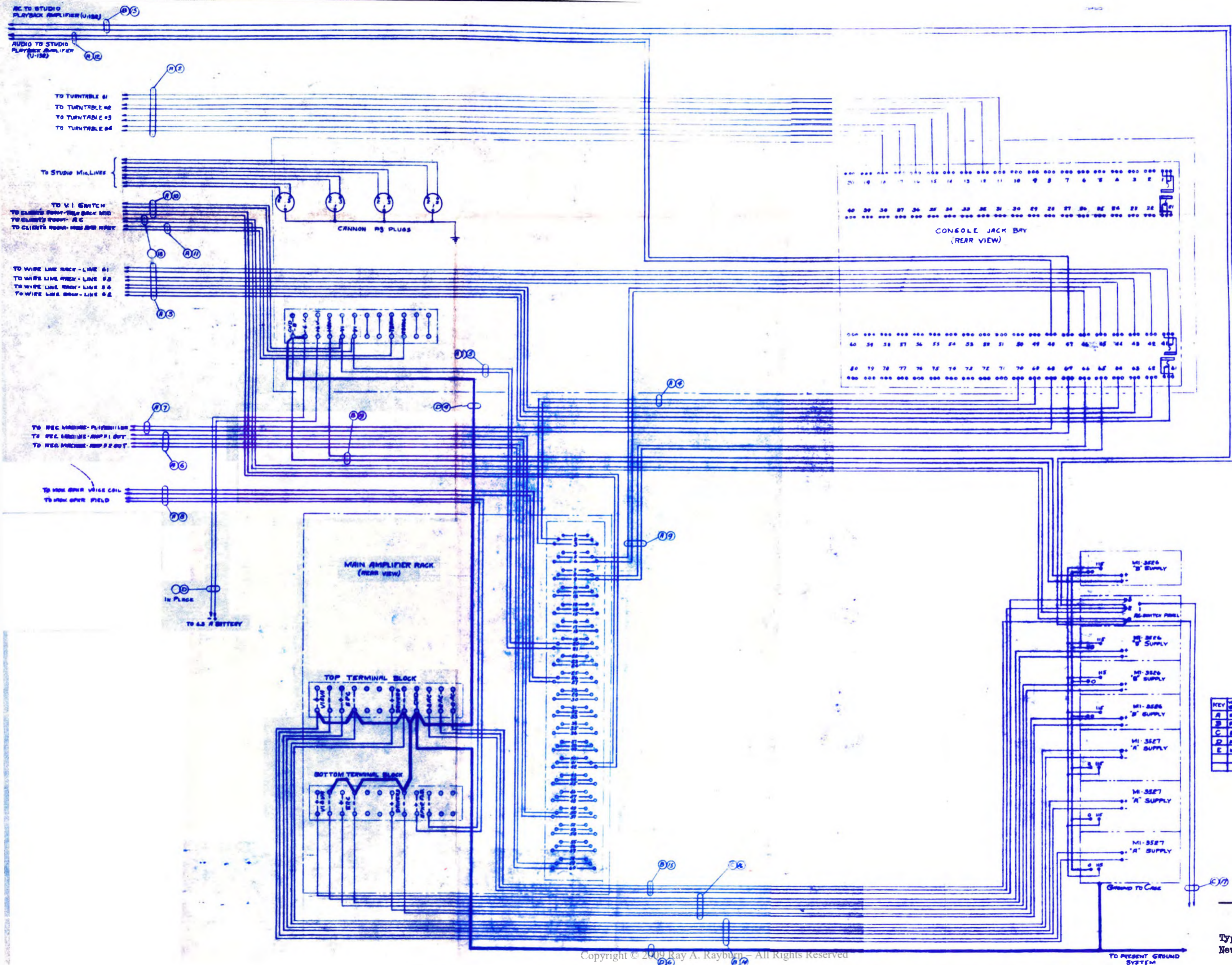

| REV | WIRE NO. | NO. WIRE | DESCRIPTION                |
|-----|----------|----------|----------------------------|
| A   | 819      | 2        | 10-3526B-3 Tw Shield Cable |
| B   | 816      | 1        | 1 Cond Solid R&B Trayalt   |
| C   | 818      | 1        | 1 Cond Solid R&B Trayalt   |
| D   | 810      | 1        | 1 Cond Solid R&B Trayalt   |
| E   | 818      | 1        | 1 Cond Solid R&B Trayalt   |
|     |          |          |                            |

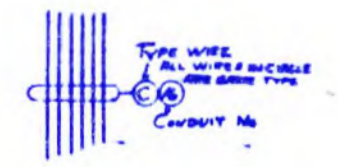

EXPLANATION OF WIRE MARKINGS

W-302705

Typical Inter-unit Wiring  
New York and Chicago Studios



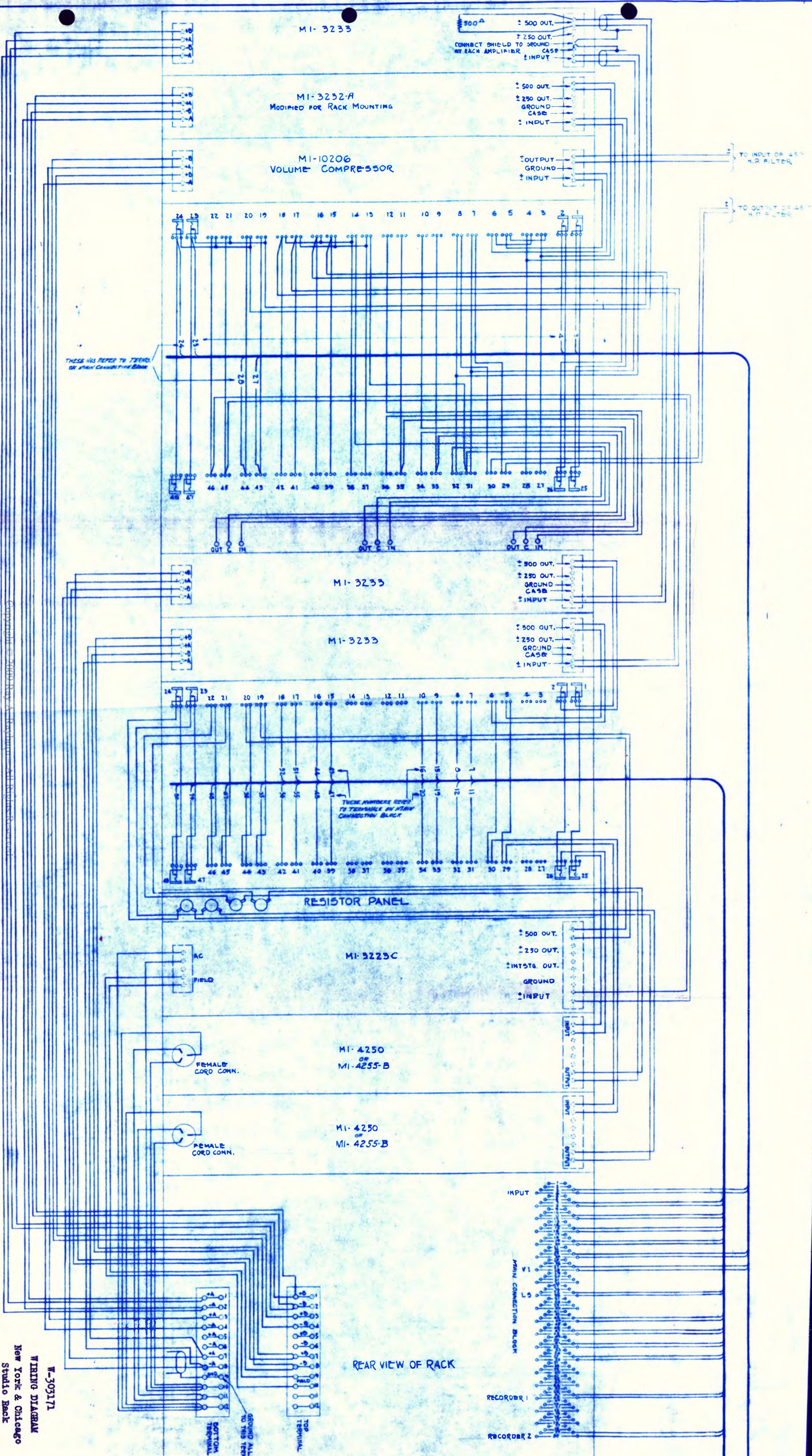

MI-3233

500 OUT.  
250 OUT.  
CONNECT SHIELD TO GROUND BY EACH AMPLIFIER.  
GROUND CASE  
INPUT

MI-3232-A  
MODIFIED FOR RACK MOUNTING

500 OUT.  
250 OUT.  
GROUND CASE  
INPUT

MI-10206  
VOLUME COMPRESSOR

OUTPUT  
GROUND  
INPUT

TO INPUT OF 45" H.P. FILTER

TO OUTPUT OF 45" H.P. FILTER

THESE WIRTS REFER TO TERMINALS ON MAIN CONNECTION BLOCK

MI-3233

500 OUT.  
250 OUT.  
GROUND CASE  
INPUT

MI-3233

500 OUT.  
250 OUT.  
GROUND CASE  
INPUT

RESISTOR PANEL

MI-3225C

500 OUT.  
250 OUT.  
INSTG. OUT.  
GROUND  
INPUT

MI-4250  
OR  
MI-4255-B

FEMALE CORD CONN.

MI-4250  
OR  
MI-4255-B

FEMALE CORD CONN.

REAR VIEW OF RACK

INPUT  
V1  
L5  
MAIN CONNECTION BLOCK

RECORDR 1

RECORDR 2

GROUND ALL WIRTS TO THIS TERMINAL

TOP TERMINAL DO.

W-303171  
WIRING DIAGRAM  
New York & Chicago  
Studio Rack

Copyright © 1960 RCA Victor Records. All Rights Reserved.



SECTION XIII

Testing and Maintenance of Equipment

Master Reference Book  
Disc Recording



Disc Recording Equipment  
Test and Maintenance Instructions

The following pages describe in detail the testing and maintenance work required to insure trouble-free and uninterrupted operation of the disc recording equipment.

The testing and maintenance work has been divided into groups to make certain that each part of the equipment receives its proper attention at the proper time. These groups consist of four definite routines, namely, daily, weekly, monthly and miscellaneous. The miscellaneous tests consist partly of periodic tests and partly of tests required only when some change has been made to the equipment. The tests in the various groups are described in considerable detail on the following pages in the order in which they should be performed. Several of the tests requiring more detailed information have been separately described on instruction sheets which are also included in the following pages.

The daily tests, which give a general indication of the equipment's condition from day to day, should be performed by the operating personnel using the equipment. No permanent record need be made of the results of these tests.

The weekly test routine is the basic routine by which the condition of the equipment is determined at regular intervals and by which it will be possible to anticipate and thus avoid failures of component parts. The weekly test should be performed by the maintenance engineer with the assistance of the operating personnel and the results of the test should be noted on the Data Sheets provided, copies of which will be found in this section of the Master Reference Book.

The other routines will usually be performed by the maintenance engineer and records of the results will be kept in the Engineer's Notebook provided for the particular studio being tested.

Disc Recording Equipment  
Test and Maintenance Routine - DAILY

A. AMPLIFIERS

1. FILAMENT VOLTAGES:- Check all filament voltages in the console and amplifier rack. The filament voltage under operating conditions should be from 6.0 to 6.8 volts.
2. PLATE VOLTAGE:- Check all plate voltages. The plate voltage for the "ERC" should be 250 volts; and for all other amplifiers except the power amplifier, plate voltage should be 180 volts.
3. PLATE CURRENTS:- Check all plate currents where jacks are provided for this purpose. Refer to instructions, Section XIII-1b for proper testing of UV-845.
4. NOISE:- Listen to the monitor speaker for noise in the amplifier system ahead of the amplifier stages.
5. HUM-ELECTRICAL:- Check the hum level of the power amplifier outputs by listening to the output of each in turn with the Western Electric head Phones. Be sure that no microphones are connected when making this test. Adjust the balancing potentiometers in the MI-3223B monitor amplifiers where used.
6. GAIN:- Observe the position of the gain controls each day. Any change in the position of gain controls for a particular set of recording conditions should be regarded as abnormal and a test should be made to determine the reason for this difference.
7. PATCH CORD PLUGS:- Clean all jack plugs with a rubber eraser (preferably a Ruby eraser), or a fine silver polishing cloth.
8. Check and note the balance of the MI-10206 "ERC" unit when it is used. (See Sec. XIII-3)

B. MIXER

1. MIXER CONTROLS - NOISE:- The mixer controls should be checked over their entire range to be sure there are no noisy steps. Every month - or more often if they are found noisy - they should be cleaned in accordance with the instructions in Section XIII-1a.

C. MICROPHONES

1. QUALITY AND SENSITIVITY:- Listening tests should be made before each recording session to determine if the quality and the sensitivity of each microphone is up to standard. This test is usually made by listening to the microphones in pairs, determining that each two are essentially identical to the ear.

## Daily Maintenance Routine (cont)

## D. RECORDING MACHINE

1. OILING AND OIL LEAKAGE:- Oil in accordance with instructions outlined in Scully Recorder Instructions, Sec. VIII and note oil leakage. Any serious leakage should be called to the attention of the maintenance engineer for immediate correction.
2. RECORDER SADDLE: - Check adjustment of recorder mounting saddle- especially of the pivot points. Be sure the recorders are properly balanced in their saddles.

## E. RECORDERS

1. RECORDER BALANCE:- Check the recorder balance by determining that the recording sapphire does not change position when the field switch is turned on and off while the recorder is cutting wax.
2. STYLUS POINTS:- Examine the stylus points on all recorders several times daily to be sure they are not nicked or dulled.
3. ADVANCE BALLS:- Be sure the advance ball is free of dust and wax chip and properly adjusted for the record pitch in use.

## F. TURNTABLES (when used)

1. WARM UP:- Allow each turntable being used to run for 15 minutes at 78 rpm.
2. TONE ARM:- Examine the tone arm to be sure that it is free to rotate along its entire travel and that the pivot points are snug but not binding.
3. EQUALIZERS:- Be sure that the turntable equalizers are in their proper positions for the job to be done. Refer to standards sheet XIV-6, for re-recording standards; and to Section IX-2 for reproduction standards.

Disc Recording Equipment  
Test and Maintenance Routine - WEEKLY

A. RECTIFIERS

1. VACUUM TUBES:- The tubes from the plate supply rectifiers MI-3526 must be removed from the units and tested in a tube tester. Care should be taken to return the tubes to the same sockets from which they were removed. Particular attention should be paid to the emission of the type '59 tubes and type '57 tubes.
2. TUNGAR TUBES:- Observe Tungar tubes in MI-3527 units for flicker and unusual brightness as either condition is often a warning of early failure.
3. VOLTAGE:- Be sure that output voltage of all rectifiers is steady under load.  
DO NOT CHANGE THE ADJUSTMENT OF THE TAPPED RESISTOR ON THE MI-3527 UNITS TO CORRECT FOR AGING TUBES.

B. AMPLIFIERS

1. TUBES - VACUUM:- Remove from their respective amplifiers and test all vacuum tubes in a tube tester. Be sure to replace all tubes in the same amplifier in the same position in that amplifier.
2. FILAMENT VOLTAGE:- Check all filament voltages in the console and amplifier rack. The filament voltage under operating conditions should be from 6.0 to 6.8 volts.
3. PLATE VOLTAGE:- Check all plate voltages. The plate voltage for the "ERC" should be 250 volts; and for all other amplifiers except the power amplifier, plate voltage should be 180 volts.
4. PLATE CURRENTS:- Check all plate currents where jacks are provided for this purpose. Refer to instructions Section XIII-1b for proper testing of UV-845 tubes.
5. HUM - ELECTRICAL:- Check the hum level of the power amplifier outputs by listening to the output of each in turn with the Western Electric head phones and observe on a cathode ray oscillograph. Be sure that no microphones are connected when making this test. Adjust the balancing potentiometers in the MI-3223B monitor amplifiers.
6. HUM- MECHANICAL:- Occasionally, the filter reactors or some other mechanical parts will cause mechanical hum or audible vibrations. Although not necessarily serious as far as the electrical operation of the equipment is concerned, this condition should be eliminated when it arises by changing the offending reactor or part.

## Weekly Maintenance Routine (Cont)

7. NOISE:- Listen to the monitor speaker for noise in the amplifier system ahead of the power amplifier stages.
8. VOLUME CONTROLS:- Test all amplifier volume controls for noisy operation. Clean if necessary.
9. JACKS:- Test all jacks normally used for noisy or poor contact.
10. PATCH CORD PLUGS:- Clean all patch cord plugs, used in testing with a rubber eraser (preferably a Ruby eraser), or a fine silver polishing cloth.
11. Check the balance of the MI-10206 unit according to directions Sec. XIII-3.
12. Check Limiting or Compression characteristic according to Sec. XIII-3a and -3b.

## C. MIXER

1. MIXER CONTROLS - NOISE:- The mixer controls should be checked over their entire range to be sure there are no noisy steps. Every month - or more often if they are found noisy - they should be cleaned in accordance with the instructions in Section XIII-1a.
2. MIXER CONTROLS - ATTENUATION:- The mixer controls must be checked for attenuation. This is done by impressing an oscillator signal into each mixer input in turn and, with an output meter, checking the attenuation of each step on controls. The attenuation should be as follows:-

| <u>Individual Channel Control</u>               | <u>Master Control</u>                           |
|---|---|
| Step 30 to step 5 -- $1\frac{1}{2}$ db per step | Step 30 to step 4 -- $1\frac{1}{2}$ db per step |
| Step 5 to step 4 -- $2\frac{1}{2}$ db           | Step 4 to step 3 -- $2\frac{1}{2}$ db           |
| Step 4 to step 3 -- 5 db                        | Step 3 to step 2 -- 6 db                        |
| Step 3 to step 2 -- $7\frac{1}{2}$ db           | Step 2 to step 1 -- $12\frac{1}{2}$ db          |
| Step 2 to step 1 -- $8\frac{1}{2}$ db           | Step 0 -- infinite                              |
| Step 0 -- infinite                              |   |

Attenuators not having this attenuation must be replaced.

3. KEY SWITCHES:- Key switches should be checked for bad contact and cleaned by operating the switch approximately fifty times in rapid succession to shake off loose dirt particles. If they cannot be cleaned this way, they may be cleaned by inserting a piece of heavy wrapping paper between the contacts and sliding this paper through the contacts while they are closed.

## D. GAIN AND FREQUENCY RESPONSE

1. GAIN:- The gain of the entire recording system should be checked by impressing an oscillator signal into the microphone amplifier measuring the power amplifier output. The correct connections



## D. GAIN AND FREQUENCY RESPONSE (cont)

2. FREQUENCY RESPONSE CURVES:- The frequency response curves listed below should be taken in accordance with instructions appearing in Section XIII-1c.

NOTE:- -Curves a to g inclusive measured with "Lateral Comp" IN, 8500 cycle lo-pass OUT, "ERC" unit OUT and all other compensation OUT.  
 Curve h - repeat curve g with 8500 cycle Lo-pass IN.  
 --Curve i is measured with "Orthacoustic Comp" IN, 8500 cycle lo-pass OUT, "ERC" unit in as a LIMITER and all other compensation OUT.  
 --Curve j is measured with "No Comp" pad IN, 8500 cycle lo-pass OUT, "ERC" unit IN as a COMPRESSOR and all other compensation out.

Take the following curves:-

|    |                |          |                  |                              |
|----|----------------|----------|------------------|------------------------------|
| a. | Mic.amp. No. 1 | input to | Volume Indicator | Meter                        |
| b. | " "            | No. 1    | " "              | power amplifier No. 1 output |
| c. | " "            | No. 1    | " "              | " " No. 2 "                  |
| d. | " "            | No. 2    | " "              | " " No. 1 "                  |
| e. | " "            | No. 3    | " "              | " " No. 1 "                  |
| f. | " "            | No. 4    | " "              | " " No. 1 "                  |
| g. | " "            | No. 4    | " "              | monitor amplifier output     |
| h. | " "            | No. 4    | " "              | power amplifier No. 1 output |
| i. | " "            | No. 4    | " "              | " " No. 1 "                  |
| j. | " "            | No. 4    | " "              | " " No. 1 "                  |

Use the following frequencies for the above curves:-

|           |             |
|-----------|-------------|
| 50 cycles | 3000 cycles |
| 100       | 5000        |
| 200       | 7000        |
| 500       | 8000        |
| 1000      | 10000       |

After the above overall curves have been taken, check the following compensator units as indicated.

- k. Re-recording compensator using frequencies shown on Data Sheet.  
 l. Mixer high frequency attenuators using frequencies shown on Data Sheet. Mixer low frequency attenuators (2 positions each) using frequencies shown on Data Sheet.

## E. VOLUME INDICATOR

1. METER ACCURACY:- The accuracy of the volume indicator meter may be checked by impressing a constant frequency tone upon the system and changing the level of this tone in steps of 2 db meanwhile, noting the amount of change indicated by the meter.

## F. LOUDSPEAKER

1. FIELD VOLTAGE:- Measure the field voltage of the loudspeaker supply at the amplifier with the loudspeaker connected. This voltage should be from 100 to 120 volts.  
 2. NOISE AND DISTORTION:- The Monitor loudspeaker should be checked periodically at normal operating level with an oscillator signal. This is done by running through the complete frequency range from 30 cycles to 10,000 cycles and listening to the speaker for rattles, buzzes and resonances at all frequencies. The speaker should produce a single, clean tone at all frequencies.

## Weekly Maintenance Routine (cont)

At extremely low frequencies, the speaker may distort slightly since the power level is far greater for constant tone than that normally encountered in recording. It should be remembered that this test is a far more rigorous than normal recording operations and, therefore; if the speaker operates satisfactorily during the test, it will be satisfactory for recording.

## G. MICROPHONES

1. QUALITY AND SENSITIVITY:- Listening tests should be made to determine if the quality and the sensitivity of each microphone is up to standard. This test is usually made by listening to the microphones in pairs, determining that each two are essentially identical to the ear.

## H. RECORDING MACHINE

The maintenance of the Scully recording machines is discussed in some considerable detail in Section VIII of this book. In addition, the following points should be observed:-

1. STARTING:- The machine should start smoothly without notable jerks or "bucking".
2. GEARS:- The gear box should be observed for any increase in the noise coming from the gears.
3. SPEED:- Listen to the motor and gear box to be sure motor is not "hunting".
4. OILING:- Check all oiling points and oil according to instructions in Section VIII.
5. VACUUM LINES:- Be sure that the vacuum lines are clear and all hose connections tight.
6. RECORDER SADDLE:- Check the adjustment of the recorder saddle especially of the pivot points.

## I. RECORDER

1. STYLUS POINTS:- Examine the stylus points on all recorders to be sure they are not nicked or dulled.
2. ADVANCE BALLS:- Observe the operation of all advance balls to be sure that all adjustments are free and that the advance ball has not become damaged.
3. RECORDER BALANCE:- Check the recorder balance by determining that the recording sapphire does not change position when the field switch is turned on and off while the recorder is cutting wax.

## Weekly Maintenance Routine (cont)

4. FREQUENCY PATTERNS:- A frequency pattern or "Christmas Tree" should be recorded for each recorder each week. The waxes made one week should be saved until the following week and compared with the new set before they are destroyed. Periodically, these patterns should be checked against a standard frequency record to insure against cumulative errors in observing the patterns on wax. See XIII-1d

## I. 70B TURNTABLES

1. OILING:- Oil the turntable at the points called for in the instruction book, paying particular attention to the oil-damped felt filter.
2. TONE ARM:- Examine the tone arm to be sure that it is free to rotate along its entire travel and that the pivot points are snug but not tight.
3. LEVELING:- Check the turntable with a spirit level to be sure that it is level in both planes.
4. NEEDLE PRESSURE:- Measure the needle pressure with the tone arm in the playing position. This pressure should be 2 ounces.
5. SPEED:- Observe the speed characteristic of the turntable in the 78 rpm position with a stroboscopic disc and neon lamp.
6. LISTENING TEST:- Listen to a standard frequency record for distortion and high frequency flutter.

Use Record CS-T-2484-5

Disc Recording Equipment  
Test and Maintenance Routine-- Monthly

A. MIXERS

1. MIXER ATTENUATORS:- All mixer attenuators should be cleaned once each month as outlined in Section XIII-1a.
2. FREQUENCY RESPONSE:- The frequency response of all the various compensating units on the console should be checked,

These are as follows:

- a. Telephone effects filter
- b. Voice frequency filter.
- c. Lo-pass filter.

B. AMPLIFIERS

1. VOLUME CONTROLS:- Clean all volume controls in accordance with instruction sheet XIII -1a.

C. RECORDERS

1. OPTICAL RESPONSE CURVE:- An optical response curve should be made of each recorder every month.

D. TURNTABLES

1. RESPONSE:- Measure the frequency response of the turntables and their various equalizers using a standard test record.

Use Record CS-T-2484-4  
Refer to Curve S-851899-2

Disc Recording Equipment  
Test and Maintenance Routine - Miscellaneous

The following tests are comprised of three groups. The first two groups consist of tests or changes which should be made at regular intervals other than the previously described routine. The third group of tests consists of tests which are made only when some change is made in the overall equipment or in the particular unit which must then be tested.

A. TEST TO BE MADE EVERY THREE MONTHS

1. Change the bias batteries on all amplifiers once every three months. Make a note of the date when this change is made on the battery or on a piece of paper attached to the amplifier near the battery.

B. TEST TO BE MADE EVERY SIX MONTHS

1. All recorders should be returned to Camden for recalibration and adjustment every six months.
2. All microphones should be returned to Camden for test adjustment and recalibration.

C. MISCELLANEOUS TESTS TO BE MADE WHEN EQUIPMENT CHANGES REQUIRE

1. MICROPHONE PHASING:- Whenever the cables have been removed from the microphones for any purpose, or when the microphones have been returned to Camden for recalibration; they should be "phased" before being put into service again. To phase a microphone, proceed as follows: Select a microphone which is already properly phased with the recording system and place the microphone to be tested beside the selected standard. The two microphones may then be phased by listening to their output over the monitor system using a male voice pickup as a sound source. When the microphones are properly phased, the tone quality will be unchanged when the volume of either one of the microphones is cut to zero. When they are out of phase, the low-frequency response will be noticeably increased by turning the volume of either microphone to zero. When phasing velocity microphones, this test may be checked by reversing one of the microphones 180 degrees and comparing opposite sides. Velocity microphones should be phased so that the front of all of them is the name plate side.
2. VOLUME INDICATOR PHASING:- The volume indicator is phased by means of an asymmetrical sound source. A male voice will supply such a sound wave. The speaker should be in front of the microphone and must read or speak in a monotone so that changes in level resulting from voice changes will be a minimum. The reading of the volume indicator meter should be observed for peak amplitudes. Then reverse the polarity of the volume indicator meter with a patch cord and with the same sound level again observe the reading of the volume indicator meter. With a non-symmetrical wave form, the peak reading of the meter will be greater for one polarity than the other. Connect the meter permanently in the position giving maximum volume indicator meter reading to insure the proper observation of peak amplitudes while recording.

It must be remembered that this test should only be made after the microphones are properly phased and with the speaker in front of the microphone.



## Instruction Sheet

## CLEANING MIXER ATTENUATORS AND AMPLIFIER VOLUME CONTROLS

Periodically, generally once a month except in dusty locations, it is advisable to clean the contacts of the mixer attenuators. The amplifier volume controls, being normally pre-set and not changed during recordings will require less frequent cleaning but may be cleaned in the same manner outlined below for mixer attenuators.

The attenuators should be cleaned and lubricated with Daven attenuator oil which has been prepared especially for this purpose and will not "gum" or form an insulating film.

DO NOT USE ANY ABRASIVE, HOWEVER FINE, ON THE CONTACTS.

DO NOT USE CARBON TETRA-CHLORIDE OR ANY COMMERCIAL CLEANING FLUID TO CLEAN THE CONTACTS AS MOST OF THESE FLUIDS WILL FORM AN INSULATING FILM OVER THE CONTACTS WITH CONTINUED APPLICATIONS.

Use a clean, lint-free, soft cloth for wiping the contacts. "Cheese cloth" is to be preferred.

The cleaning procedure is as follows:

1. Remove dust cover from attenuator.
2. Wipe with soft cloth to remove loose dirt particles.
3. With a tooth-pick or similar soft, fine-pointed applicator apply oil to the attenuator contacts, touching every third contact and applying a very small drop of oil with each touch of the tooth-pick.
4. Rotate the attenuator arm to smear the oil over contacts and continue rotation until the dirt and oil have formed a dark film over the contacts.
5. Wipe off this dirty film with the cloth.
6. Repeat operations 3, 4, and 5 until the last wiping shows the dirt to be removed.
7. After wiping carefully with the cloth, a thin film of oil will still remain on the contacts. Except in extremely dusty locations this film should be allowed to remain on the contacts as it will prevent corrosion and offer a certain amount of lubrication. However, in very dusty locations it has been found advisable to wipe very carefully and remove all of the oil so that it will not serve as a dust-collector. Under these conditions of course it will be necessary to clean the contacts more frequently.

Issued March 11, 1940

## CHECKING RCA-845 POWER TUBES

The RCA-845 power output tubes as used in the power amplifier of the recording system have proven, in eight years of service in similar amplifiers, to be extremely dependable and trouble free. However, when they are used for such a critical job as driving a recorder it is advisable that the two tubes in the push-pull output stage be very carefully balanced and that this balance be maintained.

A satisfactory operating check of these tubes may be accomplished by the simple expedient of measuring the plate currents of the tubes to determine the degree of balance and, over a period of time, to determine when the tube has reached the end of its safe useful life.

When a set of 845's is inserted in an amplifier the plate currents of the tubes should be measured on the meter supplied for this purpose. The plate currents should be written on a piece of white film tape and the tape attached to the amplifier base near the tube sockets in such a manner that it is visible, but not obtrusively so, through the protective grill. The tubes should be designated as left and right facing the front of the amplifier.

Tubes whose plate currents fall between the values of 60 MA and 75 MA are satisfactory for use. Tubes whose plate currents are more than 75 MA or less than 60 MA should not be used but should be returned to Camden for replacement.

In addition to falling within the specified limits, the currents of the tubes should be balanced. In no case should two tubes be used together when their currents vary more than 5% referred to the larger current. That is if the current of one tube is 70 MA the other tube must have a plate current of not less than 66.5 MA.

The plate currents of these tubes should be checked weekly to insure continued balance in the output stage. When the plate currents of these tubes vary more than 5% the tube having the lower plate current should be replaced and returned to Camden for exchange.

When the plate current of either or both tubes drops below a value of fifteen (15) % less than its initial value the tube or tubes should be replaced.

Particular care should be taken to note if one of the tubes ages more rapidly than the other or if one tube has a sudden drop in plate current from one week to the next. In either case the offending tube must be assumed to be bad and replaced with a properly matched tube.

### Standards for Measuring Frequency Response Curves

The following curve, MX-243536, on sheet XIII-1c.2 shows the necessary connections for making all of the required frequency response curves on the overall equipment.

When making recorder wax patterns, use the setup shown for oscillator direct into the mixer, eliminating the microphone pre-amplifier. In this case the 500 ohm load resistor on the output of the power amplifier will be eliminated and the recorder connected in its stead (as in normal recording).

Response curves of individual units are made by the substitution method and the individual unit response determined by the difference in response between the various parts of the system with the unit in question in and out.

The "Standard Frequencies" noted on MX-243536 are those required to duplicate the reference curves mentioned. It will be noted that fewer frequencies are specified for routine tests. These fewer frequencies will speed up the tests and give a sufficiently accurate picture of the performance of the equipment to make any changes in operation apparent. Needless to say, when using fewer points on the curve, great care must be taken to be sure that all variations over previous curves are noted and investigated.



Chart MX-243536  
 Standard Setup for Making Frequency  
 Response Curves

XIII-1c.2

HOWN DOTTED - FOR STANDARD CURVES

| INPUT IMPED. | MIC AMP | MIC. AMP COMPENS.   | 8500 $\omega$ LO-PAS | MI-10206 | MI-10206 SETTING      | COMPENSATION | OUTPUT VI | EXT LOAD     | OUTPUT LEVEL-1000 $\omega$ |
|--------------|---------|---------------------|----------------------|----------|-----------------------|--------------|-----------|--------------|----------------------------|
| 250 $\Omega$ | OUT     | NONE                | OUT                  | OUT      | —                     | "NO COMP"    | I         | 500 $\Omega$ | +14.5                      |
| 250 $\Omega$ | OUT     | NONE                | OUT                  | OUT      | —                     | "NO COMP"    | II        | NONE         | +3.0                       |
| 250 $\Omega$ | OUT     | NONE                | OUT                  | OUT      | —                     | "NO COMP"    | III       | 500 $\Omega$ | +17.0                      |
| 250 $\Omega$ | IN      | NONE                | IN                   | IN       | POWER ON<br>COMP. OFF | "LATERAL"    | I         | 500 $\Omega$ | +14.0                      |
| 250 $\Omega$ | IN      | +8.0 19000 $\omega$ | IN                   | IN       | POWER ON<br>COMP. OFF | "NO COMP"    | I         | 500 $\Omega$ | +14.5                      |
| 250 $\Omega$ | IN      | NONE                | OUT                  | IN       | POWER ON<br>COMP. OFF | "ORTHA."     | I         | 500 $\Omega$ | +14.0                      |
| 250 $\Omega$ | OUT     | NONE                | OUT                  | IN       | POWER ON<br>COMP. OFF | "ORTHA."     | I         | 500 $\Omega$ | +14.0                      |
| 250 $\Omega$ | OUT     | NONE                | IN                   | IN       | POWER ON<br>COMP. OFF | "LATERAL"    | I         | 500 $\Omega$ | +14.0                      |
|              |         |                     |                      |          |                       |              |           |              |                            |
|              |         |                     |                      |          |                       |              |           |              |                            |
|              |         |                     |                      |          |                       |              |           |              |                            |
|              |         |                     |                      |          |                       |              |           |              |                            |

SEE ALSO LEVEL DIAGRAMS SEC XIV

FREQUENCY RESPONSE MEASUREMENTS  
 STANDARD SETUP

FIRST MADE FOR MASTER REFERENCE BOOK FOR DISC RECORDING

BEGUN BY *M. S. Klinedinst - 11-29-37*

TRACED BY

FINISHED BY

CHECKED BY

RCA Manufacturing Co. Inc.  
 RCA Victor Division

**MX-243536**



FOR JACK AND CONNECTION DETAILS SEE TRANSMISSION DIAGRAM T-613261 - FOR JACK BAY PATCHING SEE S-851777

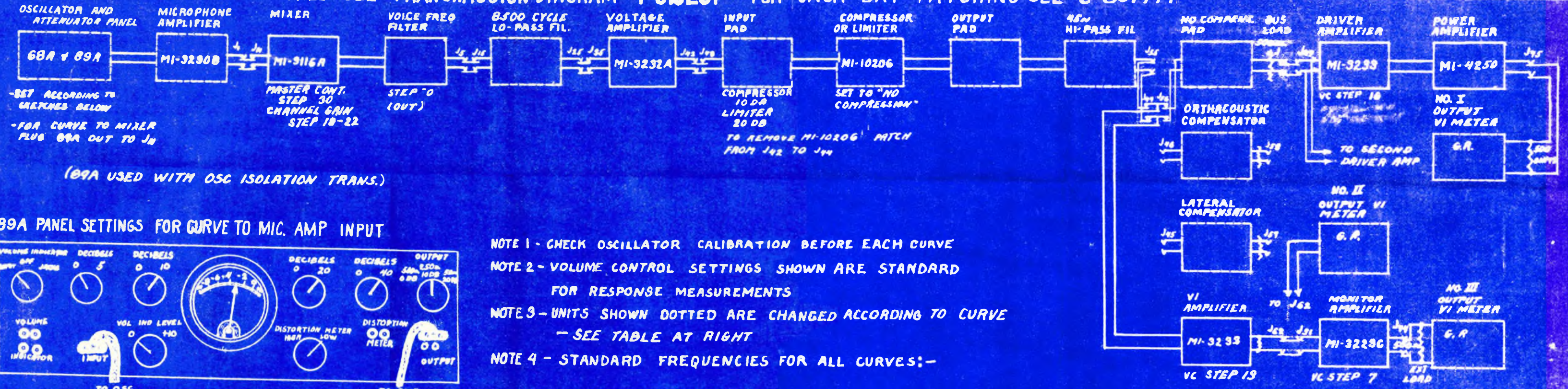

-SET ACCORDING TO SKETCHES BELOW  
-FOR CURVE TO MIXER  
PLUG 89A OUT TO J<sub>4</sub>

(89A USED WITH OSC ISOLATION TRANS.)

1. 89A PANEL SETTINGS FOR CURVE TO MIC. AMP INPUT



METER READING = -3.0 DB (12.5mW) OR 0 DB (0.06w)  
INPUT LEVEL TO MIC. AMP. = -30.0 DB (0.06w REF)

2. 89A PANEL SETTINGS FOR CURVE TO MIXER INPUT

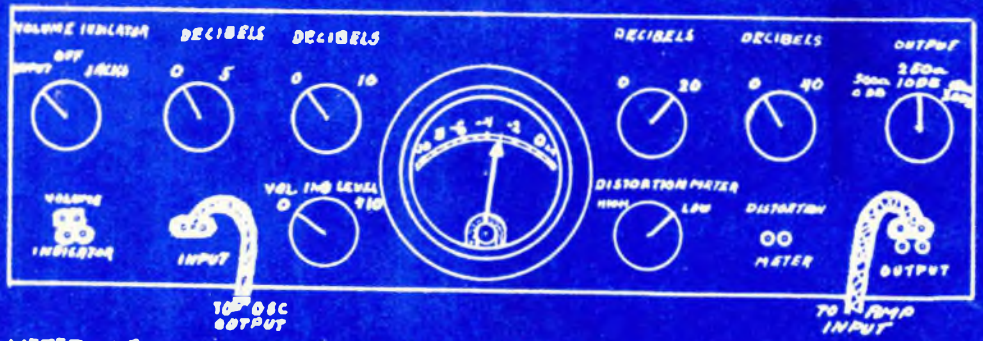

METER READING = -3.0 DB (0.025w) OR 0 DB (0.06w)  
INPUT LEVEL TO MIXER = -30.0 DB (0.06w REF)

3 IF NO 89A PANEL IS AVAILABLE USE INPUT CIRCUIT BELOW

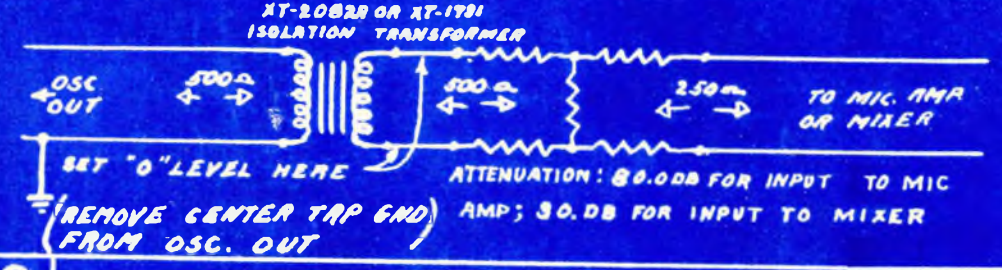

SET "0" LEVEL HERE  
(REMOVE CENTER TAP GND) FROM OSC. OUT  
ATTENUATION: 30.0DB FOR INPUT TO MIC AMP; 30.0DB FOR INPUT TO MIXER

- NOTE 1 - CHECK OSCILLATOR CALIBRATION BEFORE EACH CURVE
- NOTE 2 - VOLUME CONTROL SETTINGS SHOWN ARE STANDARD FOR RESPONSE MEASUREMENTS
- NOTE 3 - UNITS SHOWN DOTTED ARE CHANGED ACCORDING TO CURVE - SEE TABLE AT RIGHT
- NOTE 4 - STANDARD FREQUENCIES FOR ALL CURVES:-

|        |         |
|--------|---------|
| 30 ~   | 1500 ~  |
| 50 ~   | 2000 ~  |
| 80 ~   | 3000 ~  |
| 100 ~  | 4000 ~  |
| 150 ~  | 5000 ~  |
| 200 ~  | 6000 ~  |
| 300 ~  | 7000 ~  |
| 500 ~  | 8000 ~  |
| 800 ~  | 9000 ~  |
| 1000 ~ | 10000 ~ |
|        | 12000 ~ |

NOTE 5 - CHECK OSCILLATOR OUTPUT BALANCE BY REVERSING POLARITY OF OSC. OUTPUT (TURN OVER PATCH CORD) PLUG - WITH 10,000 ~ SIGNAL THE OUTPUT OF AMPLIFIER UNDER TEST SHOULD BE THE SAME FOR EITHER POLARITY.

ADJUSTMENTS OF UNITS SHOWN DOTTED - FOR STANDARD CURVES

| RESPONSE CURVE REFERENCE | INPUT TO | INPUT LEVEL | INPUT IMPED. | MIC AMP | MIC. AMP COMPENS. | 8500~ LO-PASS | MI-10206 | MI-10206 SETTING   | COMPENSATION | OUTPUT VI | EXT LOAD | OUTPUT LEVEL-1000~ |
|--------------------------|----------|-------------|--------------|---------|-------------------|---------------|----------|--------------------|--------------|-----------|----------|--------------------|
| S-851768                 | MIXER    | -30.        | 250Ω         | OUT     | NONE              | OUT           | OUT      | ---                | "NO COMP"    | I         | 500Ω     | +14.5              |
| S-851769                 | MIXER    | -30.        | 250Ω         | OUT     | NONE              | OUT           | OUT      | ---                | "NO COMP"    | II        | NONE     | +8.0               |
| S-851803                 | MIXER    | -30.        | 250Ω         | OUT     | NONE              | OUT           | OUT      | ---                | "NO COMP"    | III       | 500Ω     | +17.0              |
| S-851804                 | MIC. AMP | -80.        | 250Ω         | IN      | NONE              | IN            | IN       | POWER ON COMP. OFF | "LATERAL"    | I         | 500Ω     | +14.5              |
| S-851805                 | MIC. AMP | -80.        | 250Ω         | IN      | 18.0 @ 10000~     | IN            | IN       | POWER ON COMP. OFF | "NO COMP"    | I         | 500Ω     | +14.5              |
| S-851806                 | MIC. AMP | -80.        | 250Ω         | IN      | NONE              | OUT           | IN       | POWER ON COMP. OFF | "ORTHA."     | I         | 500Ω     | +14.5              |
| S-851807                 | MIXER    | -30.        | 250Ω         | OUT     | NONE              | OUT           | IN       | POWER ON COMP. OFF | "ORTHA"      | I         | 500Ω     | +14.5              |
| S-851808                 | MIXER    | -30.        | 250Ω         | OUT     | NONE              | IN            | IN       | POWER ON COMP. OFF | "LATERAL"    | I         | 500Ω     | +14.5              |

SEE ALSO LEVEL DIAGRAMS SEC XIV

| <p>Variations on Finished Dimensions unless otherwise marked</p> <table border="1"> <tr> <th>Basic Dimensions</th> <th>Fractional Dimensions</th> <th>Decimal Dimensions</th> </tr> <tr> <td>Up to 1/8"</td> <td>± 1/16"</td> <td>± .005</td> </tr> <tr> <td>Above 1/8" to 6"</td> <td>± 1/32"</td> <td>± .005</td> </tr> <tr> <td>Above 6" to 24"</td> <td>± 1/16"</td> <td>± .010</td> </tr> <tr> <td>Above 24"</td> <td>± 1/8"</td> <td>± .015</td> </tr> </table> <p>See Purch. Spec. for Stock Tolerances</p> |                       |                    | Basic Dimensions | Fractional Dimensions | Decimal Dimensions | Up to 1/8" | ± 1/16" | ± .005 | Above 1/8" to 6" | ± 1/32" | ± .005 | Above 6" to 24" | ± 1/16" | ± .010 | Above 24" | ± 1/8" | ± .015 | <p><b>FREQUENCY RESPONSE MEASUREMENTS</b><br/><b>STANDARD SETUP</b></p> <p>FIRST MADE FOR MASTER REFERENCE BOOK FOR DISC RECORDING</p> <p>BEGUN BY M. S. Klinedinst - 11-29-37</p> <p>FINISHED BY _____</p> <p>TRACED BY _____</p> <p>CHECKED BY _____</p> <p><b>RCA Manufacturing Co. Inc.</b><br/>RCA Victor Division</p> <p><b>MX-243536</b></p> |  |
|--|-----------------------|--------------------|------------------|-----------------------|--------------------|------------|---------|--------|------------------|---------|--------|-----------------|---------|--------|-----------|--------|--------|---|--|
| Basic Dimensions   | Fractional Dimensions | Decimal Dimensions |                  |                       |                    |            |         |        |                  |         |        |                 |         |        |           |        |        |   |  |
| Up to 1/8"   | ± 1/16"               | ± .005             |                  |                       |                    |            |         |        |                  |         |        |                 |         |        |           |        |        |   |  |
| Above 1/8" to 6"   | ± 1/32"               | ± .005             |                  |                       |                    |            |         |        |                  |         |        |                 |         |        |           |        |        |   |  |
| Above 6" to 24"  | ± 1/16"               | ± .010             |                  |                       |                    |            |         |        |                  |         |        |                 |         |        |           |        |        |   |  |
| Above 24"  | ± 1/8"                | ± .015             |                  |                       |                    |            |         |        |                  |         |        |                 |         |        |           |        |        |   |  |



Procedure For Making Frequency Response  
or "Christmas Tree" patterns of Wax Recorders

The setup for making regular (weekly) response patterns for the wax recorders is as follows:

1. Oscillator input to mixer adjusted to give normal recording level at the VI meter.
2. All amplifier volume controls to give normal recording volume.
3. Use the "No Comp." pad in the circuit.
4. Use NO other compensation either in mixer or amplifier rack.
5. Record a series of constant frequency bands from outside to inside as follows:-

| 1000 cycles | 15 seconds | 3000 cycles | 10 seconds                            |
|-------------|------------|-------------|---------------------------------------|
| 10000 "     | 10 "       | 2000 "      | 10 "                                  |
| 9000 "      | 10 "       | 1000 "      | 10 "                                  |
| 8000 "      | 10 "       | 500 "       | 10 "                                  |
| 7000 "      | 10 "       | 300 "       | 10 "                                  |
| 6000 "      | 10 "       | 100 "       | 10 "                                  |
| 5000 "      | 10 "       | 50 "        | 10 "                                  |
| 4000 "      | 10 "       | 1000 "      | 15 " ( <del>2 db higher level</del> ) |
|             |            | 1000 "      | 10 " ( <del>1 db higher level</del> ) |

6. Mark the waxes thus recorded - in the center - with the recorder number, the date and the initials of the person making the test.
7. Compare the waxes with the waxes for the same recorders made the previous week - or with the reference standard.
8. If the patterns are the same as those for the previous week, destroy the older ones.
9. If the patterns are not the same as those for the previous week and do not check with the reference standard - remove the recorder from service and recalibrate. If necessary return to Camden for repair.

Every month the latest set of wax patterns should be compared with a primary reference standard which is a frequency record supplied by the recording department. This will insure against the accumulation of small errors which might not be detected on the wax patterns.

It must be remembered that this test is only a comparative one and is not an absolute indication of the frequency response of the recorder under such conditions. The sharpness of the stylus, the angle and intensity of the light source and the angle of observation also affect the pattern.

Disc Recording Equipment  
WEEKLY TEST DATA

Studio 1, N.Y. Test Engineer J.J. Doe Date May 18 1940

REFER TO MASTER REF. BOOK, SEC. XIII -1.2 FOR FURTHER DETAILS.

A. RECTIFIERS: 1. Tubes <sup>OK</sup> (see Note); 2. Tungars OK; 3. Regulation OK

B. AMPLIFIERS:

Check each amplifier and note all changes and troubles on sheet 3 of this data.

|  | Mic. and Boost. Amps.     | Voltage & VI Amps. | "ERC" (Comp & Limit) | Driver Amps. | Monitor Amp. | Client's Rem. Mon. | Power Amp. No. 1 | Power amp. No. 2 |
|--|---------------------------|--------------------|----------------------|--------------|--------------|--------------------|------------------|------------------|
| 1. Tubes (Balance and Emission).....                 | OK                        | OK                 | OK                   | OK           | OK           | OK                 | ==               | ==               |
| 2. Filament Voltage.....                             | 6.1                       | 6.4                | 6.5                  | 6.3          | ==           | ==                 | ==               | ==               |
| 3. Plate Voltage.....                                | 180                       | 180                | 250                  | 180          | 285          | 290                | ==               | ==               |
| 4. Plate Currents.....                               | ==                        | OK                 | OK                   | OK           | OK           | OK                 | OK               | OK               |
| 5. Hum (Electrical).....                             | OK                        | OK                 | OK                   | OK           | OK           | OK                 | OK               | OK               |
| 6. Hum (Mechanical).....                             | ==                        | ==                 | ==                   | ==           | OK           | OK                 | OK               | OK               |
| 7. Noise.....  | <sup>see Note</sup><br>OK | OK                 | OK                   | OK           | OK           | OK                 | OK               | OK               |
| 8. Volume Controls.....                              | ==                        |                    | ==                   |              |              |                    | ==               | ==               |
| 9. Jacks-Rack and Console.....                       | <u>OK</u>                 |                    |                      |              |              |                    |                  |                  |
| 10. Patch Cord Plugs.....                            | <u>Cleaned</u>            |                    |                      |              |              |                    |                  |                  |
| 11. "ERC" Balance.....                               | <u>-64.0 db</u>           |                    |                      |              |              |                    |                  |                  |
| 12. (a) "ERC" Limiting Characteristic (Per S-851771) | <u>OK</u>                 |                    |                      |              |              |                    |                  |                  |
| (b) "ERC" Compressor Characteristic (Per S-851772)   | <u>OK</u>                 |                    |                      |              |              |                    |                  |                  |

C. MIXERS:

1. Mixer Controls - Noise ... OK; Attenuation... OK.  
2. Key Switches..... OK.

D. VOLUME INDICATOR METER:

1. Check accuracy of indication in 2 db steps..... OK.

E. GAIN AND FREQUENCY RESPONSE:

11. Gain:- (Overall System at 1000 cycles with "ERC" OUT)  
Note:- Check gain with (a) "Lateral Comp"; (b) "Orthacoustic Comp" and (c) "No Comp" pad - all three should show same gain within  $\pm$  0.5 db.

Input level to Microphone Amplifier..... -70.0 db  
Mixer Channel Control... Step 19 Mixer Overall Control... Step 30  
Driver Amplifier Volume Controls..... Step 16  
VI Meter Level..... "0" db (0.0125 watts) or 3.0 db (0.006 w)  
Output Level - Power Amplifier Number 1..... 14.5 db  
Output Level - Power Amplifier Number 2..... 14.2 db  
(All level values reference 0.006 watts except as noted)



E. GAIN AND FREQUENCY RESPONSE (Continued)

2. Frequency response data.

Note 1: Curves a to g inclusive measured with "Lateral Comp" IN, 8500 cycle lo-pass OUT, "ERC" unit OUT, no other compensation.

Note 2: Repeat curve f with 8500 cycle Lo-pass IN. (For curve h)

Note 3: Curve i measured with "Orthacoustic Comp" IN, 8500 cycle lo-pass OUT, "ERC" unit IN as a LIMITER, no other compensation.

Note 4: Curve j measured with "No Comp" pad IN, 8500 cycle lo-pass OUT, "ERC" unit IN as a COMPRESSER, no other compensation.

| Curve     | a                             | b                               | c                               | d                               | e                               | f                               | g                                | h                               | i                               | j                               |
|-----------|-------------------------------|---------------------------------|---------------------------------|---------------------------------|---------------------------------|---------------------------------|----------------------------------|---------------------------------|---------------------------------|---------------------------------|
| Frequency | Mic.Amp.1<br>In V.Amp.<br>Out | Mic.Amp.1<br>In P.Amp.<br>2 Out | Mic.Amp.1<br>In P.Amp.<br>1 Out | Mic.Amp.2<br>In P.Amp.<br>1 Out | Mic.Amp.3<br>In P.Amp.<br>1 Out | Mic.Amp.4<br>In P.Amp.<br>1 Out | Mic.Amp.4<br>In Mon.<br>Amp. Out | Mic.Amp.4<br>In P.Amp.<br>1 Out | Mic.Amp.4<br>In P.Amp.<br>1 Out | Mic.Amp.4<br>In P.Amp.<br>1 Out |
| 50        | +1.3                          | +10.0                           | +9.8                            | -                               | -                               | -                               | +7.5                             | -                               | +19.0                           | -1.0                            |
| 100       | +2.5                          | +12.2                           | +12.5                           | +12.0                           | +12.4                           | +12.0                           | +8.0                             | +12.0                           | +14.7                           | +2.5                            |
| 200       | +3.0                          | +12.5                           | +12.8                           | -                               | -                               | -                               | +8.2                             | -                               | +13.2                           | +3.0                            |
| 500       | -                             | +13.1                           | +13.6                           | +12.9                           | +13.4                           | +12.7                           | -                                | -                               | +13.4                           | +3.0                            |
| 1000      | +3.0                          | +14.3                           | +14.8                           | +14.1                           | +14.6                           | +14.0                           | +8.2                             | +14.0                           | +14.2                           | +3.0                            |
| 3000      | -                             | +18.8                           | +19.1                           | -                               | -                               | -                               | -                                | -                               | +18.7                           | +3.0                            |
| 5000      | +3.0                          | +21.7                           | +22.0                           | +21.5                           | +21.9                           | +21.4                           | -                                | +21.3                           | +22.0                           | +3.0                            |
| 7000      | -                             | +23.3                           | +23.4                           | -                               | -                               | +23.0                           | +8.2                             | +21.5                           | +24.1                           | +3.0                            |
| 8000      | +2.8                          | +23.4                           | +23.2                           | +23.2                           | +23.5                           | +23.4                           | +7.9                             | +21.0                           | +25.0                           | +2.5                            |
| 10000     | +2.0                          | +22.8                           | +22.2                           | -                               | -                               | +22.8                           | +6.7                             | -6.0                            | +26.7                           | +2.0                            |

(Curve sheet attached)

Note 5: Measure the following curves - j and k from Mixer input (-30.0 db, 0.006w) to Power Amplifier output with "No Comp" pad IN, 8500 cycle lo-pass OUT, "ERC" OUT and using only compensation under test.

Level reduced at mixer

k. Re-recording Compensator (Type MI-3119);  
Return controls of each section to "0" before testing next section.

|                    |       |              |       |       |       |              |       |
|--------------------|-------|--------------|-------|-------|-------|--------------|-------|
| Low-Freq. Control  | 0     | Lower 1      | 2     | 3     | 1     | Raise 2      | 3     |
| 100 cyc.           | +13.8 | +7.7         | +5.9  | +3.2  | +14.6 | +16.5        | +18.8 |
| Mid-Range Control  | 0     | Raise L.F. 1 | 2     | 3     | 1     | Raise K.F. 2 | 3     |
| 200 cyc.           | +14.0 | +15.1        | +17.0 | +2.0  | +14.0 | +14.0        | +19.8 |
| 3000 cyc.          | +14.0 | +14.0        | +14.0 | +14.4 | +15.0 | +17.0        | +14.3 |
| High Freq. Control | 0     | Lower 1      | 2     | 3     | 1     | Raise 2      | 3     |
| 10000 cyc.         | +13.3 | +7.5         | +2.4  | -1.3  | +13.6 | +17.9        | +21.4 |



WEEKLY TEST DATA (Continued)

E. GAIN AND FREQUENCY RESPONSE (Continued)

2. Mixer Compensators:

| Low Freq. Pos. 1. | Ch.1         | Ch.2         | Ch.3         | Ch.4         |
|-------------------|--------------|--------------|--------------|--------------|
| 1000 cyc.         | <u>+14.0</u> | <u>+14.1</u> | <u>+14.1</u> | <u>+14.0</u> |
| 100 cyc.          | <u>+9.5</u>  | <u>+9.5</u>  | <u>+9.7</u>  | <u>+9.3</u>  |
| Low Freq. Pos. 2  | Ch.1         | Ch.2         | Ch.3         | Ch.4         |
| 1000 cyc.         | <u>+13.5</u> | <u>+13.7</u> | <u>+13.6</u> | <u>+13.4</u> |
| 100 cyc.          | <u>+5.0</u>  | <u>+5.1</u>  | <u>+5.0</u>  | <u>+4.8</u>  |
| High Freq.        | Ch.1         | Ch.2         | Ch.3         | Ch.4         |
| 1000 cyc.         | <u>+14.0</u> | <u>+14.1</u> | <u>+14.1</u> | <u>+14.0</u> |
| 10000 cyc.        | <u>+5.2</u>  | <u>+4.8</u>  | <u>+5.3</u>  | <u>+5.0</u>  |

F. LOUDSPEAKERS:

|                    | Monitor Room      | Client's Room     |
|--------------------|-------------------|-------------------|
| 1. Field Voltage   | <u>112.0</u> v.DC | <u>108.0</u> v.DC |
| 2. Noise and Dist. | <u>OK</u>         | <u>OK</u>         |

G. MICROPHONES:

|                 | PB-144 | 144 | 144 | 144 | M-3025 | 3025 |
|-----------------|--------|-----|-----|-----|--------|------|
| 1. Type.....    | PB-144 | 144 | 144 | 144 | M-3025 | 3025 |
| 2. Serial.....  | 901    | 908 | 910 | 911 | 860    | 867  |
| 3. Quality..... | OK     | OK  | OK  | OK  | OK     | OK   |

H. RECORDING MACHINES:

|                 | Scully No. 1 | Scully No. 2  | No. 3 | No. 4 |
|-----------------|--------------|---------------|-------|-------|
| 1. Oiling.....  | OK           | OK            |       |       |
| 2. Cleaning.... | OK           | OK            |       |       |
| 3. Starting.... | OK           | OK            |       |       |
| 4. Gear Noise.. | OK           | OK            |       |       |
| 5. Speed(78)... | OK           | OK            |       |       |
| (33.3)          | OK           | OK            |       |       |
| 6. Air Lines... | OK           | OK            |       |       |
| 7. Rec.Saddle.. | OK           | OK (See Note) |       |       |

I. RECORDERS:

|                  | A 90 | A 85 | A 44 | A 45     | A 50 |
|------------------|------|------|------|----------|------|
| 1. Recorder No.  | A 90 | A 85 | A 44 | A 45     | A 50 |
| 2. Stylus.....   | OK   | OK   | OK   | OK       | OK   |
| 3. Advance Ball. | OK   | OK   | OK   | OK       | OK   |
| 4. Arm.Center..  | OK   | OK   | OK   | OK       | OK   |
| 5. Freq.Pattern  | OK   | OK   | OK   | SEE NOTE | OK   |



WEEKLY TEST DATA - Continued

J. TURNTABLES:

|                      | #1    | #2    | #3                               |  |  |
|----------------------|-------|-------|----------------------------------|--|--|
| 1. Serial No. ....   | 700   | 708   | 711                              |  |  |
| 2. Oiling.....       | OK    | OK    | OK                               |  |  |
| 3. Leveling.....     | OK    | OK    | OK                               |  |  |
| 4. Tone Arm.....     | OK    | OK    | OK <sup>SH</sup> <sub>Note</sub> |  |  |
| 5. Needle Point..... | OK    | OK    | OK                               |  |  |
| 6. Needle Press..... | 1.9oz | 2.0oz | 2.0oz                            |  |  |
| 7. Speed.....        | OK    | OK    | OK                               |  |  |
| 8. Quality.....      | OK    | OK    | OK                               |  |  |

REMARKS AND CHANGES: (Note here and on the back of this sheet all changes and corrections made during the test)

- A-1, '57 TUBE IN MI-3526 FOR "ERC" WAS BAD - CHANGED
- B-7, MIC. AMP. #1 HAD NOISY 1603 TUBE - REPLACED
- H-7, #2 REC. MACHINE SADDLE PIVOTS TIGHT - ADJUSTED
- I-5, RECORDER A-45 BAD AT HIGH FREQ - REPLACED WITH A50 - A45 RETURNED TO CAMDEN.
- J-4, TONE ARM PIVOTS WERE LOOSE ON #711 TT. ADJUSTED

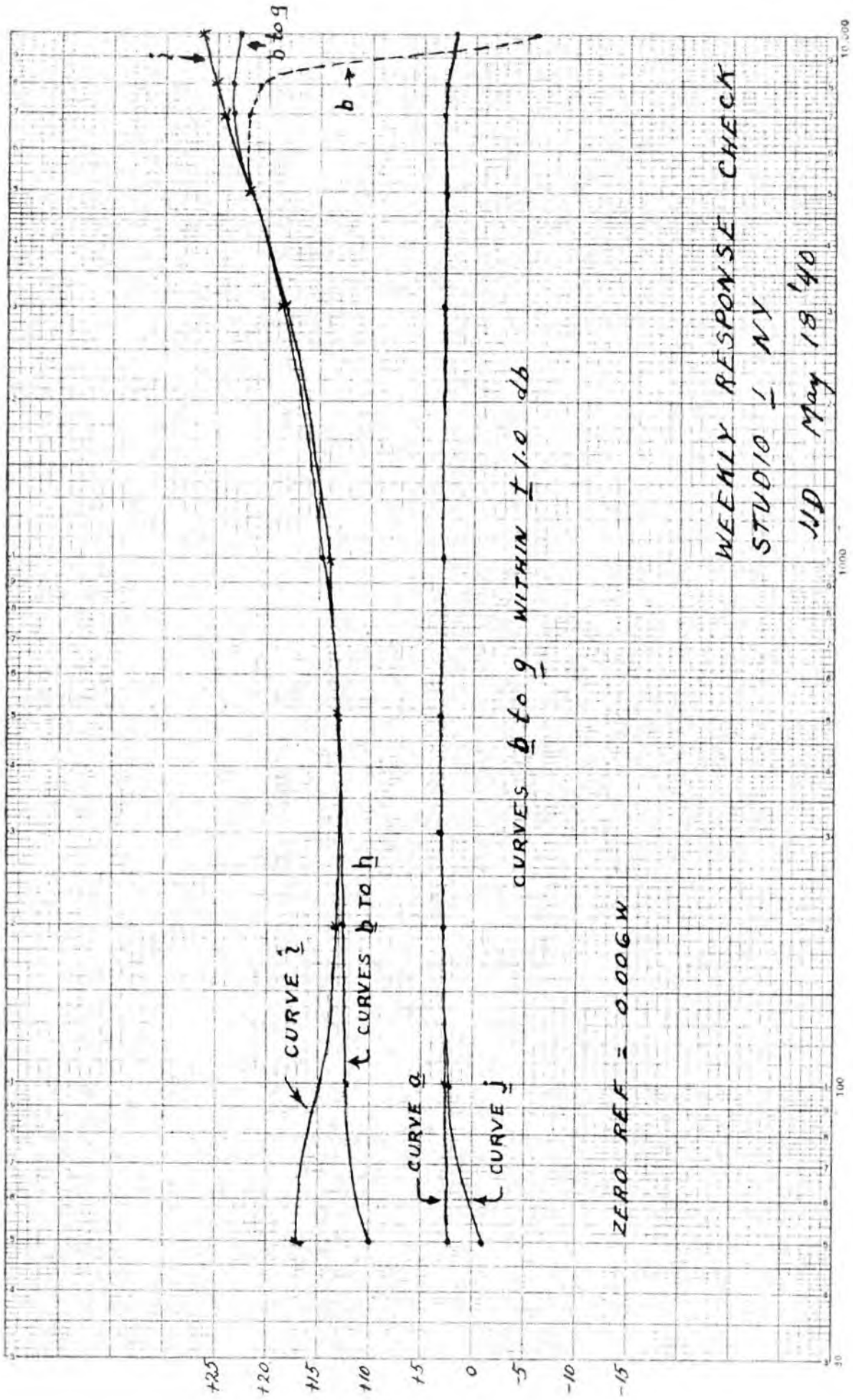

SAMPLE

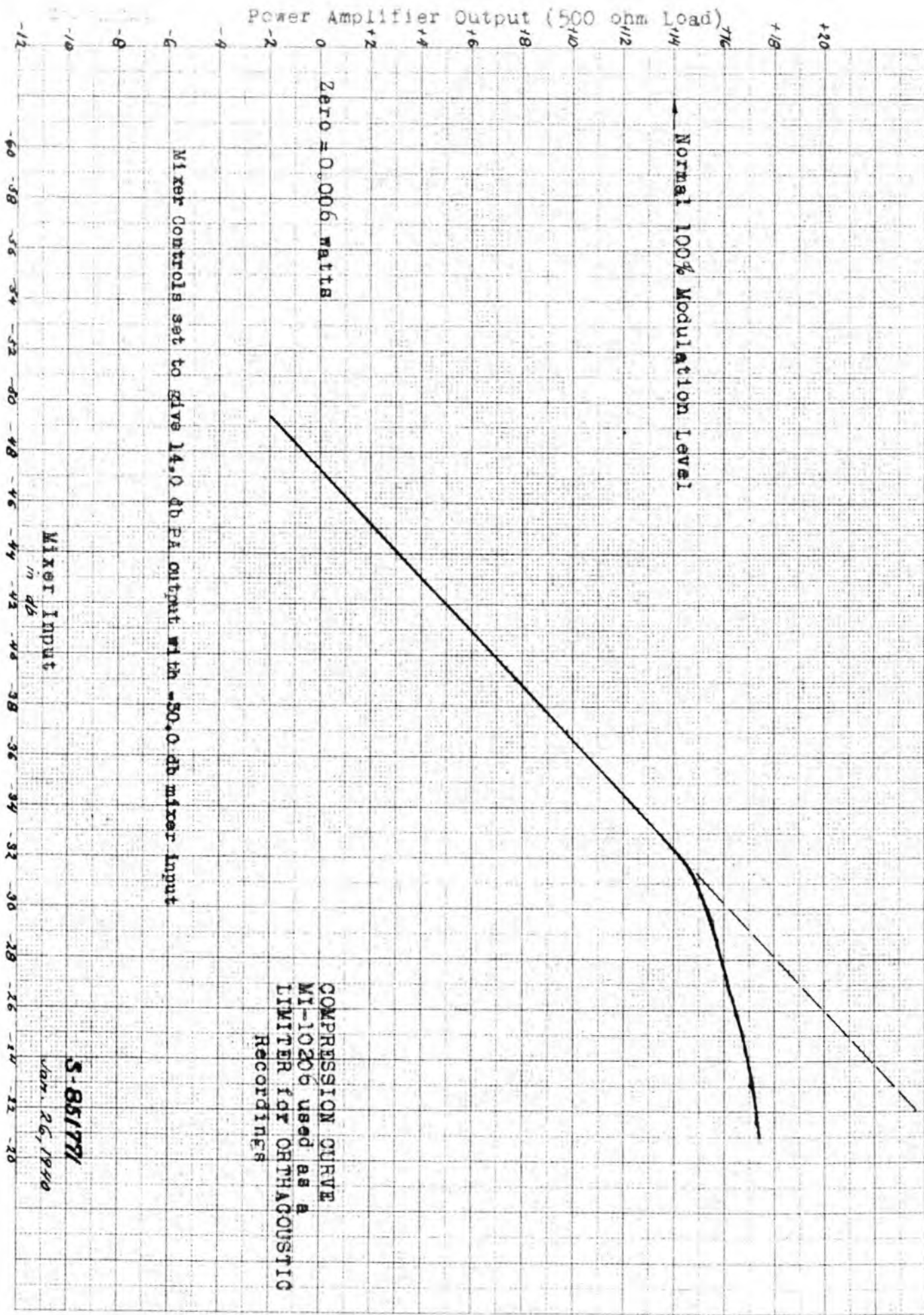

S-851771  
Jan. 26, 1940



COMPRESSION referred to 100% Recorder modulation.

| Driver Amp. | VO Step | VI Attenuator | Compression | is | into | (Normal Settings) |
|-------------|---------|---------------|-------------|----|------|-------------------|
| M           | 15      | M             | M           | 20 | 10   |                   |
| M           | 14      | M             | M           | 24 | 12   |                   |
| M           | 13      | M             | M           | 28 | 14   |                   |
| M           | 17      | M             | M           | 32 | 16   |                   |

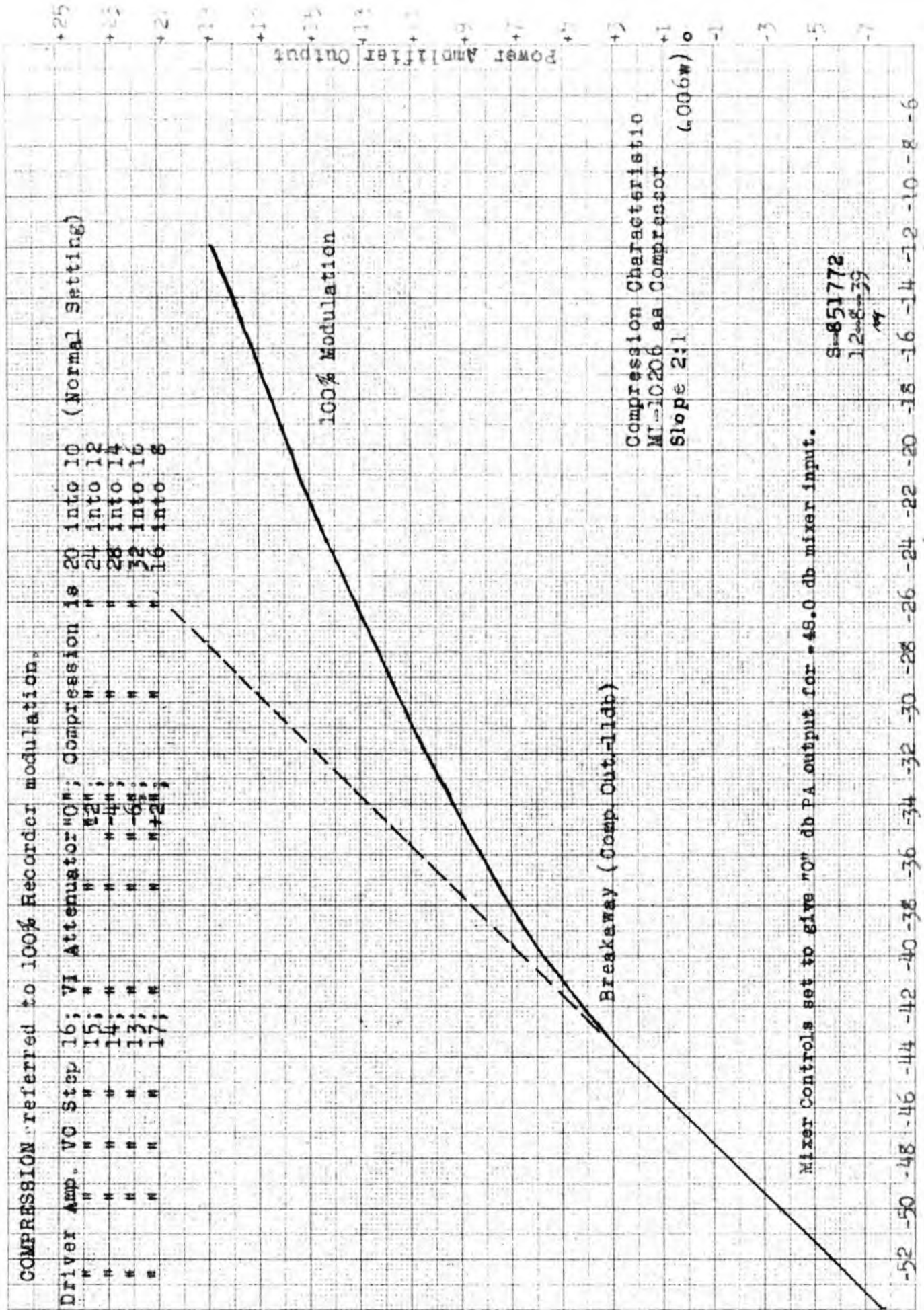



SECTION XIV

Operation Standards

Master Reference Book  
Disc Recording

# JACK BAY PATCHING FOR VARIOUS TYPES OF DISC RECORDINGS

MAIN AMPLIFIER RACK - TOP JACK BAY

No. XIV-1  
 Sheet 1 of 1 Sheets  
 Date 11-21-39

## A - STUDIO DOMESTIC - WITH COMPRESSION

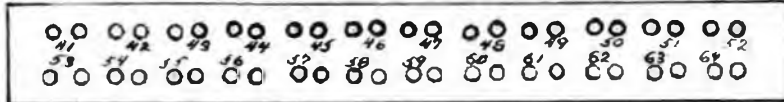

1. MI-10206 SET AS A COMPRESSOR
2. USE MIC. AMPLIFIERS FLAT
3. USE (NORMAL) 8500 CYCLE LO-PASS FILTER (CONSOLE)

## B - STUDIO DOMESTIC - NO COMPRESSION



1. USE MIC. AMPLIFIERS FLAT
2. USE (NORMAL) 8500 CYCLE LO-PASS FILTER (CONSOLE)

## C - STUDIO TRANSCRIPTION - ORTHACOUSTIC - WITH LIMITER

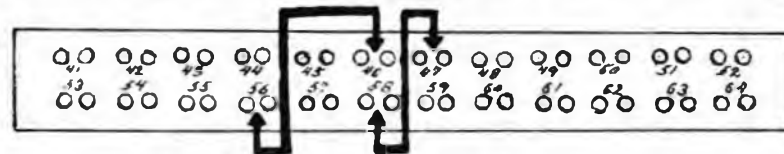

1. USE MI-10206 AS A LIMITER
2. USE FLAT MIC. AMPS.
3. REMOVE (PATCH OUT) 8500 CYCLE FILTER (CONSOLE)

## D - WIRE LINE TRANSCRIPTION - ORTHACOUSTIC - WITH LIMITER

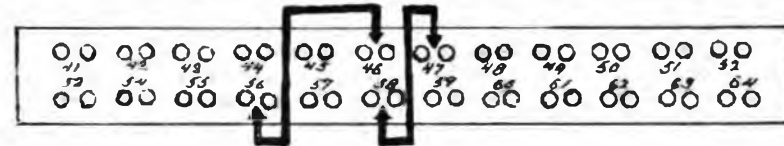

1. USE MI-10206 AS A LIMITER
2. REMOVE (PATCH OUT) 8500 CYCLE FILTER (CONSOLE)

## USE OF COMPENSATED MIC. AMPS. NOT STANDARD

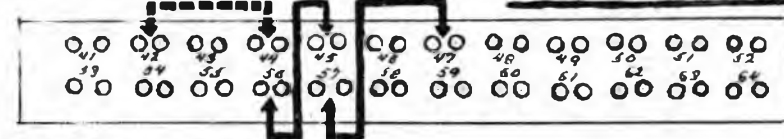

1. USE FOR "A" OR "B" ABOVE AND SEMI-ORTHACOUSTIC TRANSC.
  2. USE ONLY FOR SPECIAL SETUPS
- b. USE WITH OR WITHOUT LIMITER (DOTTED LINE)  
 c. USE WITH 8500 CYCLE LO-PASS (CONSOLE)

SEE ALSO TRANSMISSION DIA. T-613261 AND STANDARDS SHEETS XIV-2 AND XIV-3

M S Klinedinst

RECORDING STANDARDS SHEET FOR STUDIO  
DOMESTIC RECORDING - WITH COMPRESSION

|                     |
|---------------------|
| No. XIV-2           |
| Sheet 1 of 3 Sheets |
| Date 2-13-40        |

1. SOUND INPUT - Microphones
2. MICROPHONES USED - Velocity (Reference Standard) & Unidirectional
3. MICROPHONE AMPLIFIER - MI-3230B, Flat Response, ~~17~~ 41 db gain.  
Note: TEMPORARILY some of the studios are using mic. amps. with a response up ten db at 10,000 cycles (referred to 500 cycles). This will be discontinued as soon as the "Lateral" compensator is available to all studios.
4. MIXER - Use MI-3116A (Right hand unit on console), Approximate ~~2~~ 3/ loss at maximum level (see level diagram attached) ~~10~~ db; Use no compensation to reduce lows except on extremely boomy vocals; Do not use High Freq compensation.
5. VOICE FREQUENCY FILTER - Do Not Use
6. LO-PASS FILTER - Use 8500 cycle lo-pass (console jack bay)
7. VOLTAGE AMPLIFIER - MI-3232A; Flat Response; ~~30~~ 41 db gain.
8. MI-10206 ELECTRONIC RANGE CONTROL (Compressor) - Use with 2 to 1 slope with a breakaway of plus 4 db (power amplifier output)

|  |                    |
|--|--------------------|
| <u>Type Recording</u>  | <u>Compression</u> |
| (Until further tests indicate otherwise the compression ratio should always be 20 into 10) |                    |

Compression and breakaway are always referred to normal 100% modulation output of the power amplifier.  
For settings for different compression ratios, see S-851772, Section XIII-3b.

9. HI-PASS FILTER - 45 cycle hi-pass is integral electrically with the MI-10206 ERC.
10. COMPENSATION - "Lateral" Compensator per curve S-851767, Section II-1. For overall system see S-851804, Section XV-4.

Note: When using TEMPORARY setup of compensated mic. amps use "No Comp" pad instead of "Lateral" comp. Refer to S-851805, Section XV-5 for overall curve.

11. DRIVER AMPLIFIERS - (Are set according to recorder sensitivity-values shown are usual); MI-3233A  
Frequency response is flat.  
Number 1 driver volume control step 16; Gain 24 db  
Number 2 driver volume control step 15; Gain 22 db  
Number 2 driver should always be one VC step (2db) lower than number 1.  
For settings at different compression ratios see S-851772 (Sec. XIII-3b)

(continued from sheet 1)

No. XIV-2

Sheet 2 of 3 Sheets

Date 2-13-40

RECORDING STANDARDS SHEET FOR STUDIO  
DOMESTIC RECORDING - WITH COMPRESSION

12. VI AMPLIFIER - (driver for meter volume indicator and monitor amplifier) (MI-3233R)  
Volume control step 13; Gain 18db; Response flat.
13. METER VOLUME INDICATOR - New standard will be the VU meter. When used it should be set to read +11.0 vu at 100% modulation. To increase the useful scale range it should be set, however, to read zero meter scale at +5.0vu. The zero reference level for this meter is 0.0vu 0.001watt  
  
Studios still using the MI-3115 VI meter should set the meter attenuator at "0" and record for "0" maximum swing for 100% modulation. In this case "0" db equals 0.0125 watt  
  
For changes in VI AMPLIFIER settings for various degrees of compression see S-851772, Sec XIII-3b
14. MONITOR AMPLIFIER - MI-3223C; VC set on step 7; Gain 8 db ; Response flat.  
  
at 10,000~  
In the near future a 4 db boost will be inserted in this amplifier necessitating an increase in VC setting of 2 or 3 steps to give the same output.
15. RECORDERS - Response (optical) according to S-851770  
"Christmas Tree" Patterns identical; Sensitivity of all recorders used on a single recording must be the same within 0.5db
16. FREQUENCY RESPONSE - Overall not including recorders.  
With Flat Microphone Amplifiers See S-851804, Sec. XV-4  
With Boosted Mic. Amps. See S-851805, Sec. XV-5
17. WAX - Number 1 Machine - Use flowed wax only  
Number 2 machine - Use cast or flowed wax
18. RECORD PITCH - 88, 96, or 112 lines per inch. (Scully Mach.)<sup>104</sup>
19. RECORDED DIMENSIONS - (See also dwings P-76308 & P-718138, Sec. XVI)  
Groove Width:- 0.0065" to 0.007"  
Minimum Recorded Diameter:- 3.75"  
Minimum Recorder Cut:- Spiral ends at 3.625" Diam.
20. ADVANCE BALL - Use new type; trace not to exceed 0.0035" and trace to be cut out by recording sapphire except for several spirals inside the recorded diameter.
21. RECORDING SAPPHIRE - Face angle 88 degrees; Tip radius 0.00225"



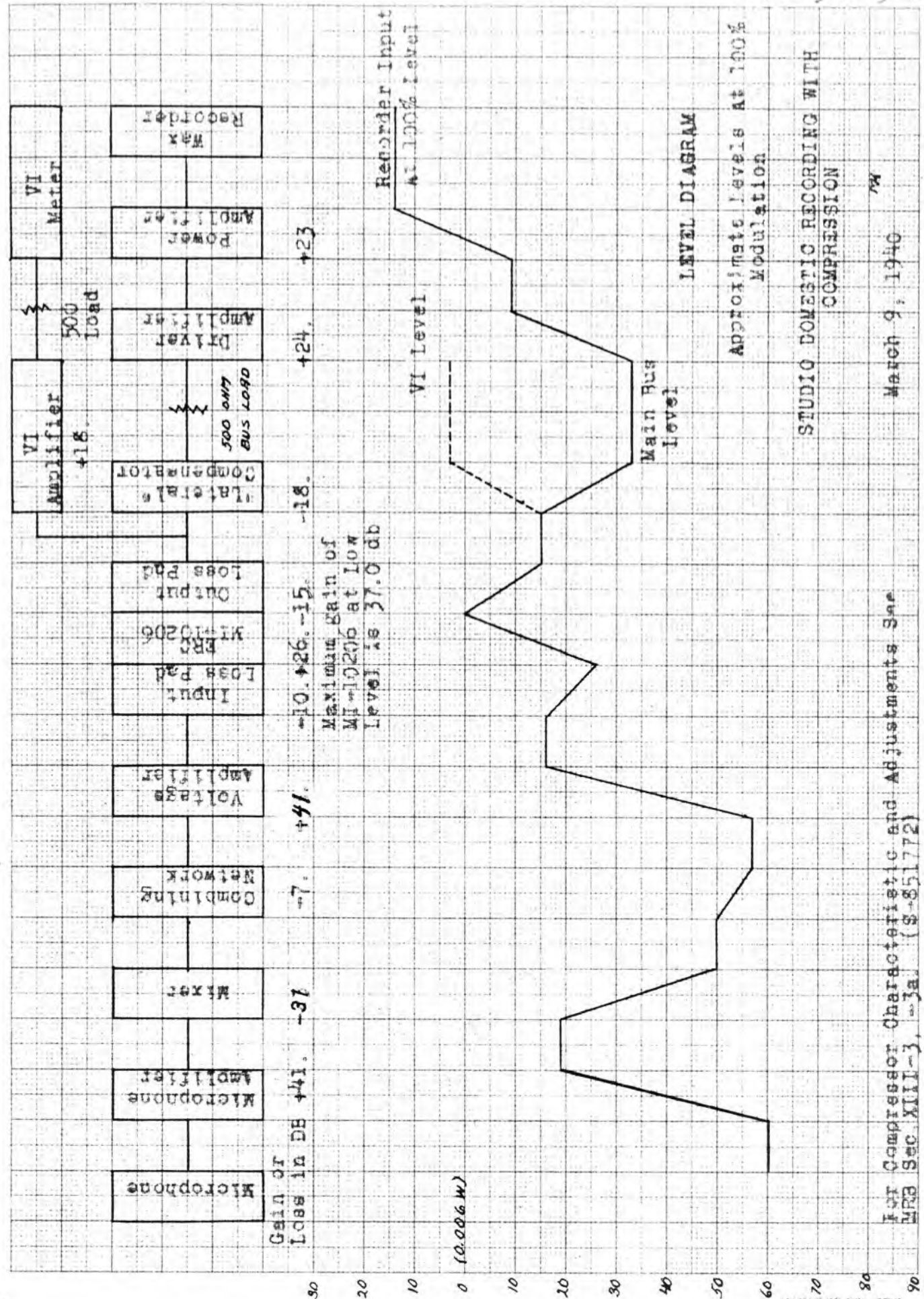

RECORDING STANDARDS SHEET FOR STUDIO  
DOMESTIC RECORDING - NO COMPRESSION

No. XIV-3  
Sheet 1 of 3 Sheets  
Date 2-13-40

1. SOUND INPUT - Microphones
2. MICROPHONES USED - Velocity (reference Standard) & Unidirectional
3. MICROPHONE AMPLIFIER - MI-3230B; Flat response; ~~40~~ 41 db gain  
Temporarily some studios are using compensated mic. amps. (see S-851805, Sec. XV-5). This is not standard and will be discontinued as soon as "lateral" compensators are available.
4. MIXER - Use MI-3116A Type (Right hand unit on console); Approximate loss at maximum level ~~30~~ db.; Use no Low Frequency Comp except on exceptionally boomy vocals; Do Not use high freq compensation.
5. VOICE FREQUENCY FILTER - Do Not Use
6. LO-PASS FILTER - Use 8500 cycle lo-pass normalled on console
7. VOLTAGE AMPLIFIER - MI-3232A; Gain ~~30~~ 41 db; Response flat.
8. MI-10206 ELECTRONIC RANGE CONTROL (COMPRESSOR) - Do Not Use
9. HI-PASS FILTER - Do Not Use (Integral with MI-10206)
10. COMPENSATION - "Lateral" Compensator per S-851757, Sec. II-1  
When using compensated mic. amps. temporarily use "No Comp" pad instead of "Lateral" comp. See S-851777 for connection.
11. DRIVER AMPLIFIERS - MI-3233A; Flat response  
Volume control settings depend partly on sensitivity of recorders used. Values below are normal.  
No.1 Driver Volume Control step 16; Gain 24 db.  
No.2 Driver Volume Control step 15; Gain 22 db.  
No.2 Driver VC should always be one step (2db) below No.1
12. VI AMPLIFIER - MI-3233R; VC step 13; Gain 18 db; Response Flat  
This amplifier drives the meter volume indicator and the Monitor amplifier.
13. METER VOLUME INDICATOR - Standard is the VU meter where zero VU (volume unit) equals 0.001 watt.  
Set scale sensitivity so that zero scale reading equals + 8.0 VU. Record for 100% modulation equal to + 11.0VU  
  
When using old style meter (MI-3115) set scale sensitivity so that zero scale reading equals "0" level or 0.0125 watt.  
Record with "0" level on the meter equal to 100% modulation.
14. MONITOR AMPLIFIER - MI-3223C; VC step 7; Gain 8.0db; Resp. Flat/  
This may be changed to give a 4 db boost at 10,000 cycles.

(continued from sheet 1)

RECORDING STANDARDS SHEET FOR STUDIO  
DOMESTIC RECORDING - NO COMPRESSION

|       |               |
|-------|---------------|
| No.   | XIV-3         |
| Sheet | 2 of 3 Sheets |
| Date  | 2-13-40       |

15. RECORDERS - Optical response to agree with S-851770; "Christmas tree" patterns to be identical; Sensitivity of all recorders used on same recording to be same within 0.5db.
16. FREQUENCY RESPONSE - Overall not including recorders.  
See S-851804 if using "Lateral" compensator. (Sec XV-4)  
See S-851805 if using compensated mic.amps. (Sec XV-5)
17. WAX - Number 1 Machine - Use Flowed Wax Only  
Number 2 Machine - Use Flowed or Cast Wax
18. RECORD PITCH - Use 88,96,104 or 112 lines per inch (Scully Mach.).  
or use 86,96,100 or 110 lines per inch (GC Mach.).
19. RECORDED DIMENSIONS - (See also Dwings P-76308 & P-718138, Sec. XVI)  
Groove width - 0.0065" to 0.007"  
Minimum Recorded Diameter (Last Music Groove) - 3.75"  
Minimum Recorder Cut (End of Lead-in Spiral) - 3.625"
20. ADVANCE BALL - Use new type. Trace not to exceed 0.0035" width  
and trace must be cut out by recording sapphire except for  
several spirals inside last recorded groove.
21. RECORDING SAPPHIRE - Face angle - 88 degrees; Tip Radius 0.00225"

See also level diagram, sheet 3

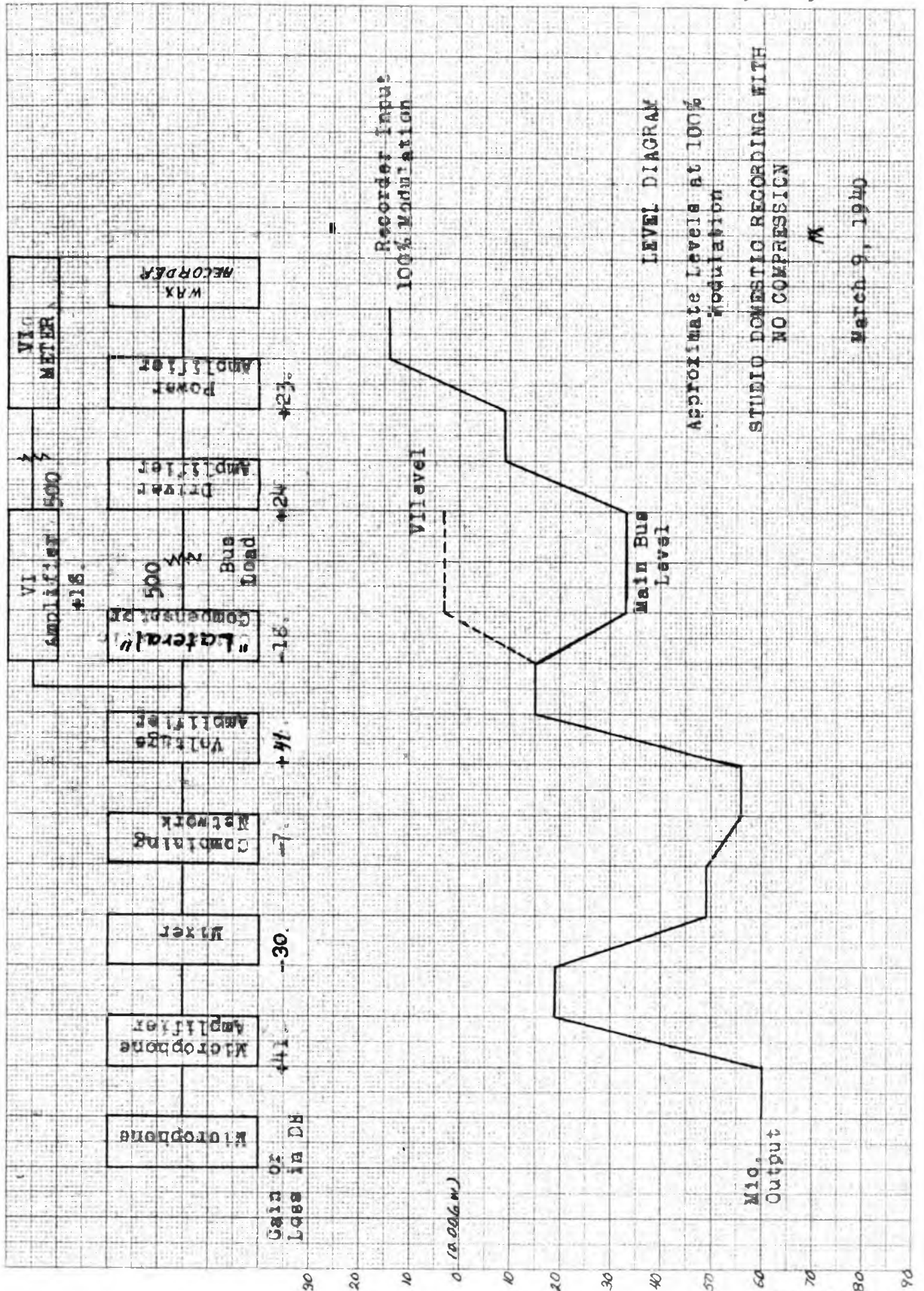



RECORDING STANDARDS SHEET FOR STUDIO  
ORTHACOUSTIC RECORDINGS

|                     |
|---------------------|
| No. XIV-4           |
| Sheet 1 of 3 Sheets |
| Date 2-13-40        |

1. SOUND INPUT - Microphones
2. MICROPHONES - Velocity (Reference standard) and Unidirectional
3. MICROPHONE AMPLIFIERS - MI-3230B; Response Flat; Gain ~~10~~ <sup>41</sup> db.
4. MIXER - Use MI-3116A Type (Right hand Unit on Console); Use No Mixer Compensation.
5. VOICE FREQUENCY FILTER - Do Not Use.
6. LO-PASS FILTER - Do Not Use.
7. VOLTAGE AMPLIFIER - MI-3232A; Response flat; Gain ~~16~~ <sup>41</sup> db.
8. MI-10206 ELECTRONIC RANGE CONTROL - Use as a limiter set up as on S-851771 and data XIII-3a
9. HI-PASS FILTER - Use (This unit is an integral part of the MI-10206)
10. COMPENSATION - Use "Orthacoustic" compensator per S-851766 (II-2)
11. DRIVER AMPLIFIERS - MI-3233A Response Flat; Gain depends partly on sensitivity of recorders used - following figures are normal:-  
No.1 Driver volume control setting step 16; Gain 24 db.  
No.2 Driver volume control setting step 15; Gain 22 db.  
No.2 driver is always one VC step (2db) less gain than No.1.
12. VI AMPLIFIER - MI-3233A Volume control step 13; Gain 18db; Response flat.
13. METER VOLUME INDICATOR - VU (Volume Unit) Meter is to be standard. Set the scale range so that the scale zero is equal to 8.0 VU. Record with 100% modulation level equal to 11.0 VU VI reading. Zero VU equals 0.001 watt.  
  
Using the old style VI (MI-3115) record with 100% modulation level equal to "0" db scale reading where "0" scale reading equals zero db or 0.0125 watt.
14. MONITOR AMPLIFIER - MI-3223C; Vol.cont.step 7; Gain 8.0 db; Response flat. ( This may be changed to a compensation of plus 4.0 db at 10,000 cycles)
15. RECORDERS - Optical calibration to agree with S-851770; "Christmas Tree" patterns to be identical; Sensitivity of all recorders on same recording to be the same within 0.5 db.

Continued on Page 2

(continued from page 1)

No. XIV-4

Sheet 2 of 3 Sheets

Date 2-13-40

RECORDING STANDARDS SHEET FOR STUDIO  
ORTHOACOUSTIC RECORDINGS

16. FREQUENCY RESPONSE - Overall not including recorders.  
See S-551806, Sec. XV-6
17. WAX - Number 1 Machine - Use Flowed Wax Only  
Number 2 Machine - Use Flowed or Cast Wax
18. RECORD PITCH - Use 120 lines per inch (Scully Machine)
19. RECORDED DIMENSIONS - (See also Dwing P-75331, Sec. XVI-3)  
Groove Width -  $0.005''$   
Minimum Recorded Diameter (Last Music Groove) -  
Diameter of inner concentric circle -
20. ADVANCE BALL - Use new type set to give a trace not larger than  
 $0.0035''$ . The recording sapphire should cut out this trace  
except for a few spirals inside the recorded diameter.
21. RECORDING SAPPHIRE - Face Angle 88 degrees; Tip Radius  $0.00225''$

See also level diagram sheet 3

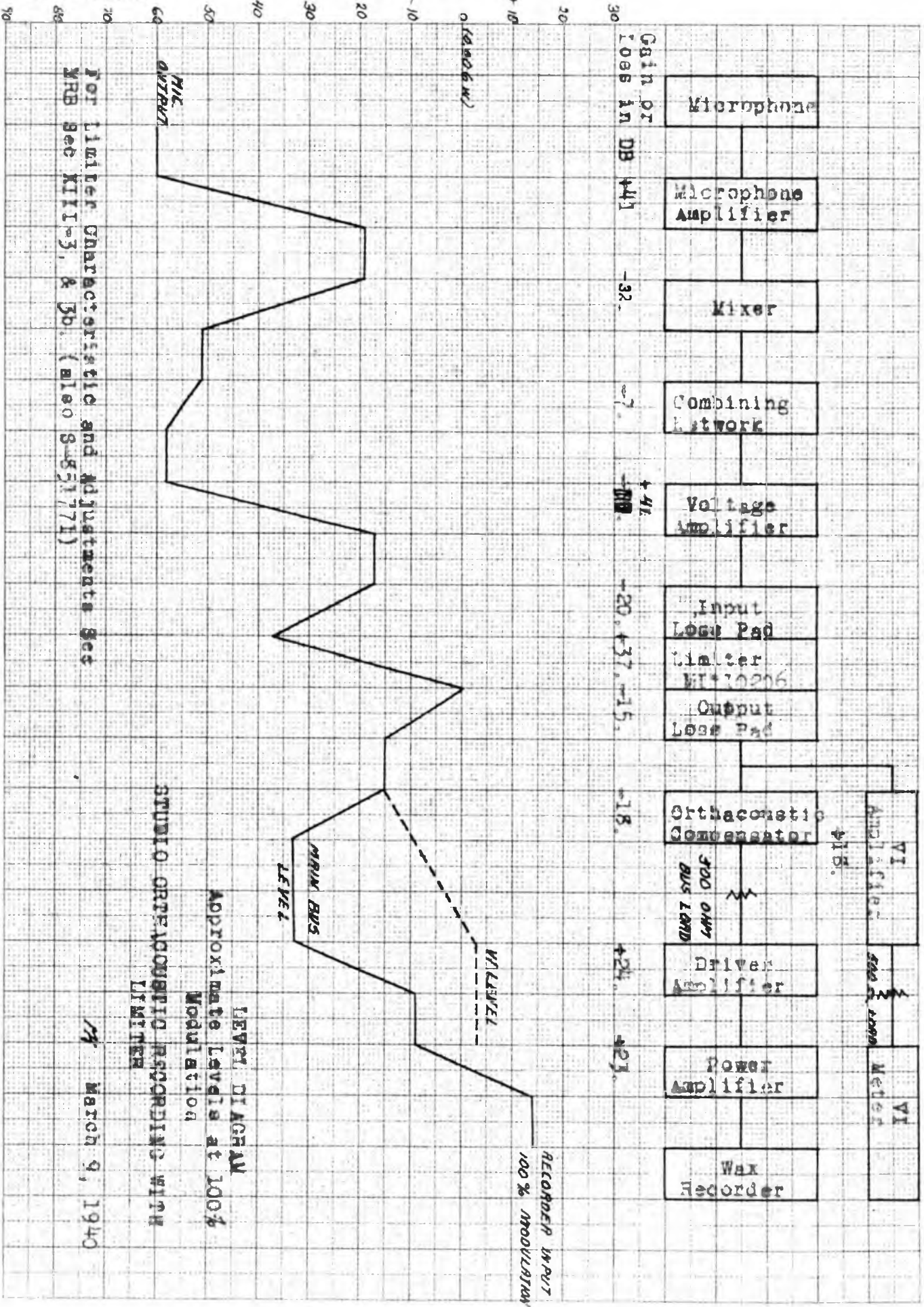

For Limiter Characteristic and Adjustments See  
 WRB Sec XIII-3, & 3b. (also 8-531771)

LEVEL DIAGRAM  
 APPROXIMATE LEVELS AT 100%  
 MODULATION  
 STUDIO ORTHOACOUSTIC RECORDING WITH  
 LIMITER

March 9, 1940

RECORDING STANDARDS SHEET FOR WIRE  
LINE ORTHACOUSTIC RECORDINGS

No. XIV-5

Sheet 1 of 1 Sheets

Date

1. SOUND SOURCE - Wire Line from Radio Broadcast Studio to Mixer Console in RCA Studio, through a Line Equalizer.
2. LINE EQUALIZER - Type 56 A (MI-4167) or equivalent. This equalizer should be adjusted so that the response from the station program bus to an equivalent resistance (250 ohms) substituted for the mixer input should be essentially flat.  
Limits:- 30 cycles to 100 cycle plus or minus 1.5 db from the 1000 cycle response.  
100 cycles to 8,000 cycles plus or minus 1.0 db from the 1000 cycle response.  
8000 cycles to 10,000 cycles, plus or minus 2.0 db from the 1000 cycle response.

NOTE:- From the Mixer Input throughout the remainder of the system the standard connections and usages of this setup are the same as for Orthacoustic Studio Recording, as outlined on Standards Sheet XIV-4.

The overall Frequency Response, less recorder, from mixer input to power amplifier output for Wire Line Orthacoustic Recording is shown on S-551807.



## RECORDING STANDARDS SHEET - RE-RECORDING FROM RECORDS

Definite standards have not been formally adopted for re-recording from records at this time. This operation represents such a diversity of problems and a wide variance of operating conditions that an extremely careful and detailed study will be made before "freezing" exact procedure standards.

Re-recording consists essentially of two kinds:

- a. Re-recording to correct mechanical defects such as over thin walls (from slight overrecording) or damage to the matrix. In this case it is desired to secure 100% quality transfer from the original recording.
- b. Re-recording to correct defects in frequency response or balance. Actually of course, it is impossible to completely "correct" such defects but it is usually possible to minimize them. Generally speaking, it is not possible to outline an exact procedure for this operation since every case is different. However, judicious use of the re-recording compensator provided will generally accomplish a maximum of correction.

The present temporary standards for re-recording from records for maximum quality transfer are outlined below.

1. TURNTABLE - Use 70 B type turntable with diamond point pickup.
2. TURNTABLE COMPENSATION:- Use base control Step 2 and treble control Step 3.
3. MIXER COMPENSATION:- None.
4. RE-RECORDING COMPENSATOR:- Do Not Use.
5. LO-PASS FILTER:- Use XT-2727C for extreme noise conditions  
or XT-2727A for quiet records.  
XT-2727C is a 6000 cycle lo-pass.  
XT-2727A is an 8000 cycle lo-pass.
6. RECORD:- Use a "Victrolac" pressing that has not been previously been played.

SECTION XV

Frequency Response and Performance Data

Master Reference Book  
Disc Recording

SEE TEST INSTRUCTIONS  
MX-243536



ZERO REFERENCE = ~~1140~~ 1140 DB (.006 w.)

12  
0  
-2  
DECIBELS

WAX RECORDING  
AMPLIFIER RESPONSE

MIXER INPUT TO POWER AMP OUT  
NO COMPRESSOR

NO MIXER COMPENSATION  
"NO COMPENSATION" PRD IN CIRCUIT

WAX RECORDING EQUIPMENT INSTRUCTIONS  
11-7-39

5-851768

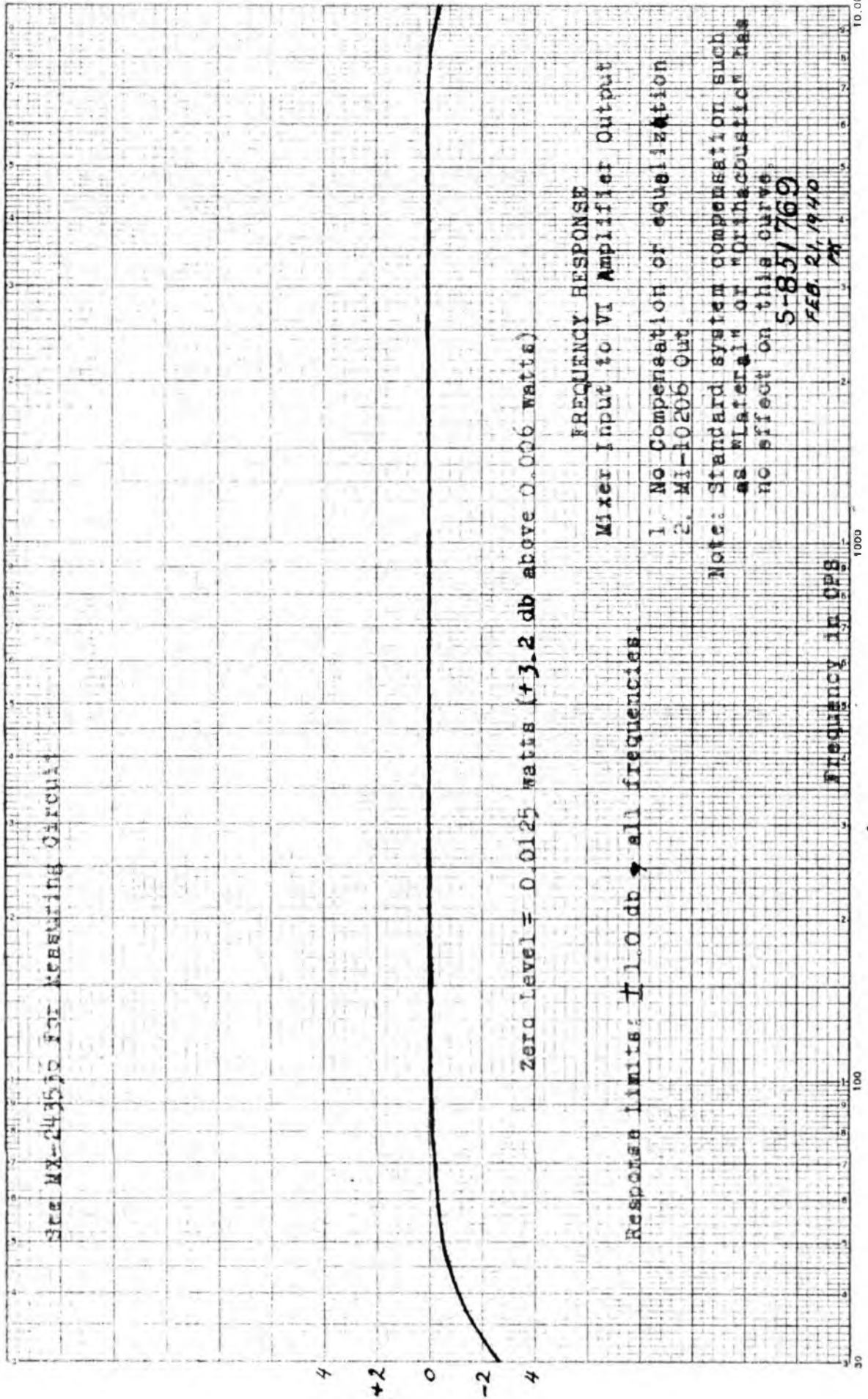



S 64 MX-24376 for MEASURING CIRCUIT

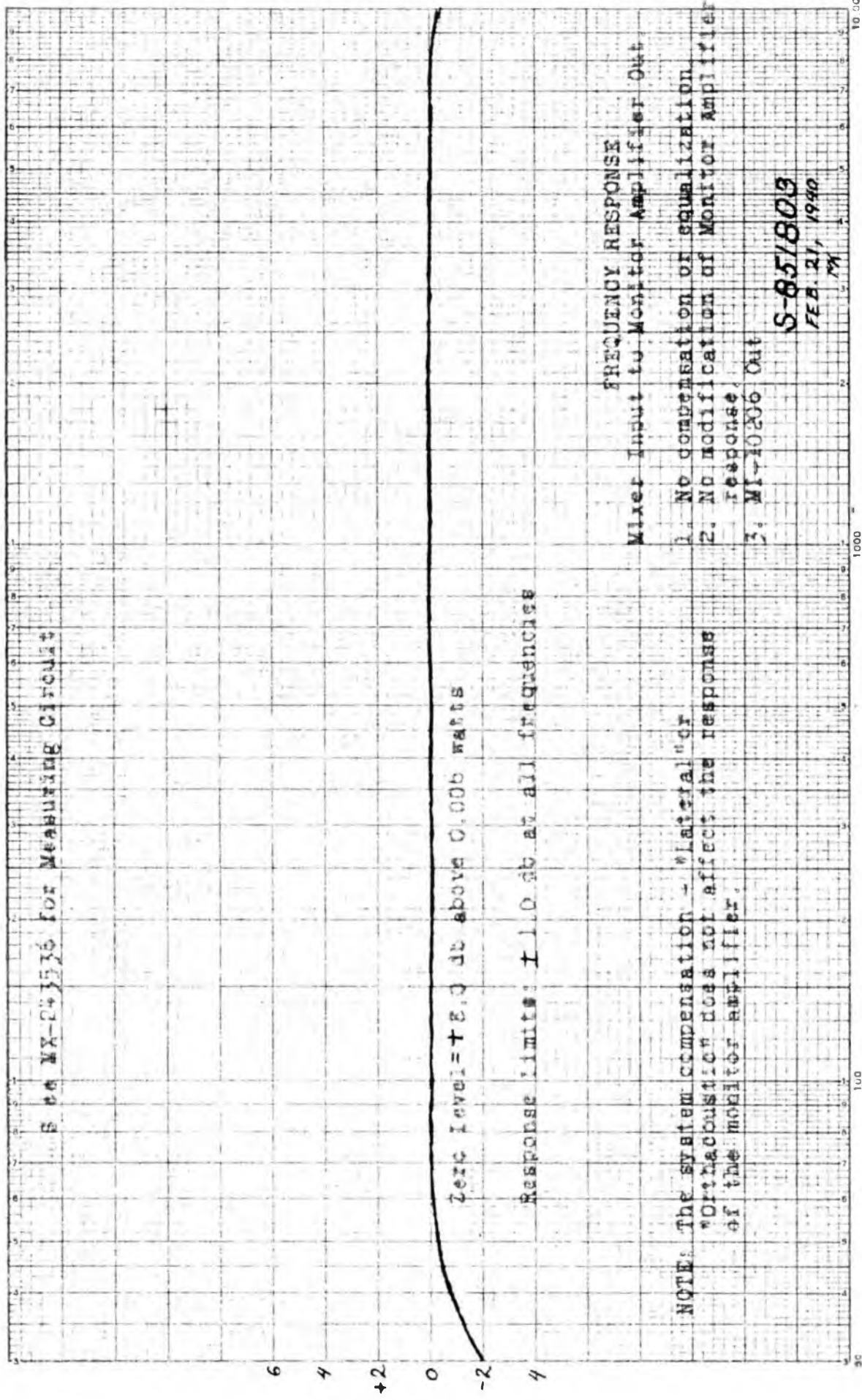

Zero level = +3.0 db above 0.006 watts

Response limits: ± 1.0 db at all frequencies

NOTE: The system compensation - "Lateral" or "Orthoacoustic" does not affect the response of the monitor amplifier.

FREQUENCY RESPONSE  
 Mixer Input to Monitor Amplifier Out

1. No compensation or equalization
2. No modification of Monitor Amplifier response
3. MI-10206 Out

S-85/803  
 FEB. 21, 1940  
 MM

See MX-243536 for measuring circuit

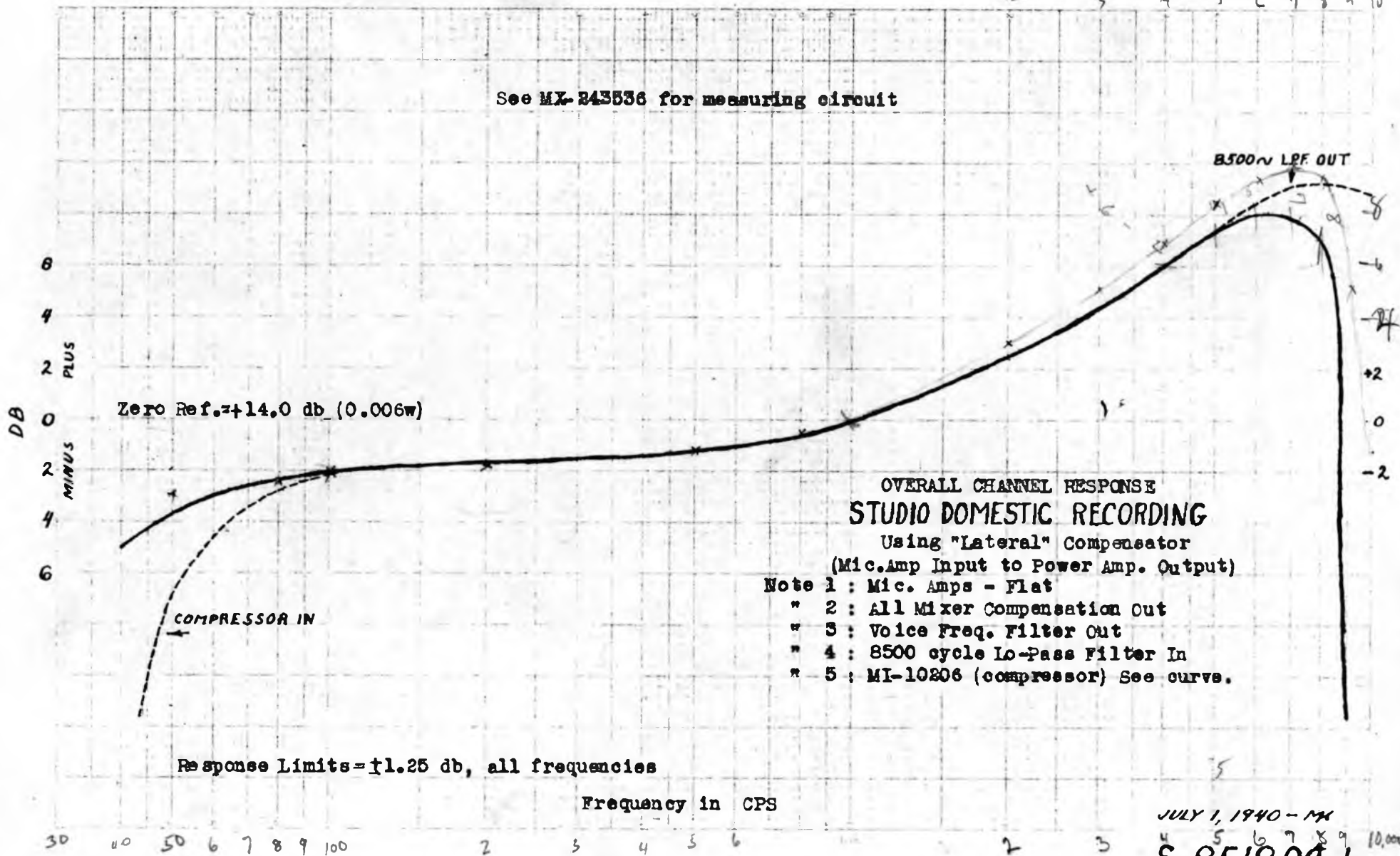

JULY 1, 1940 - MM  
S-851804-1 10,000

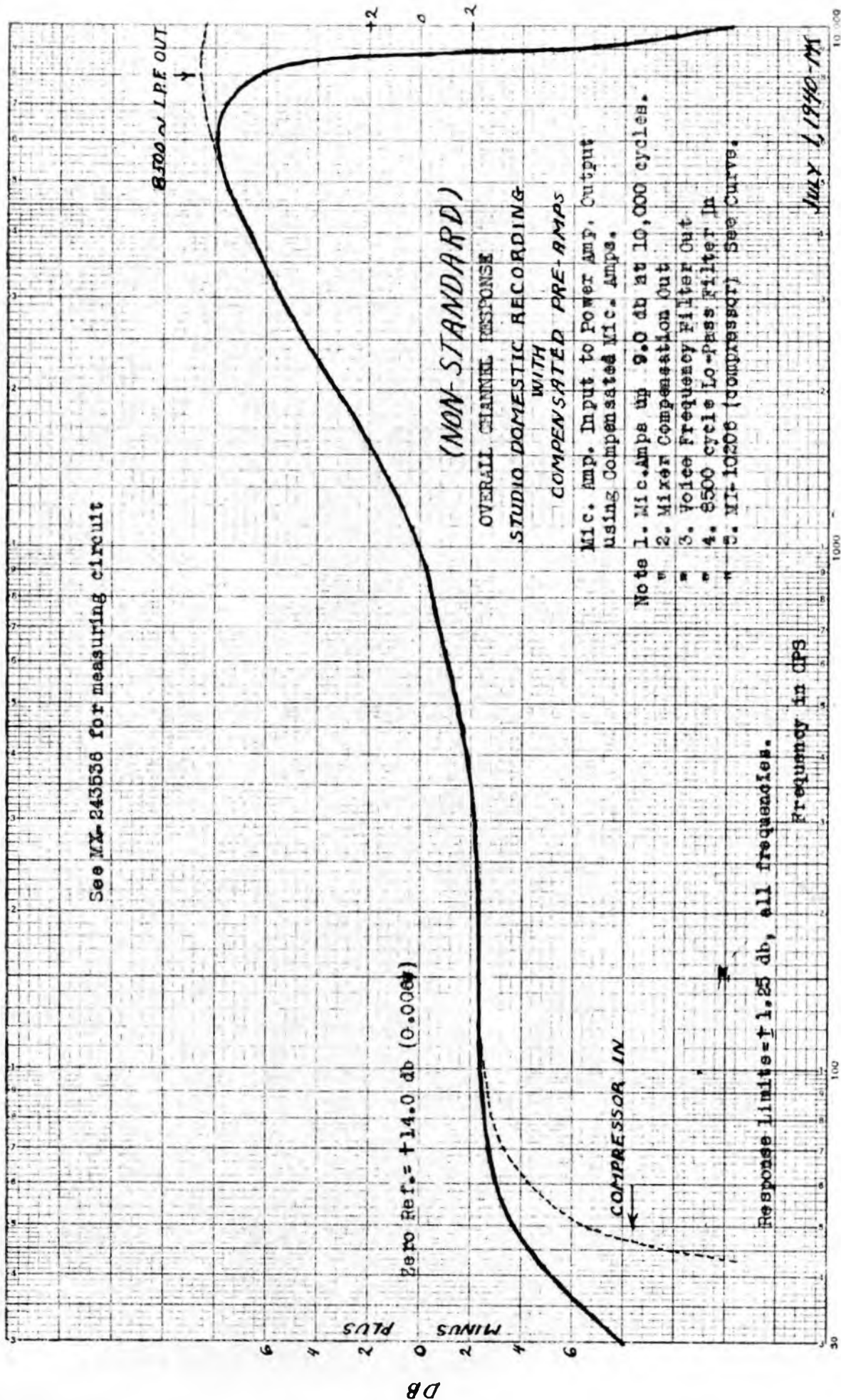

S-851805-1

See ML-243536 for measuring circuit.

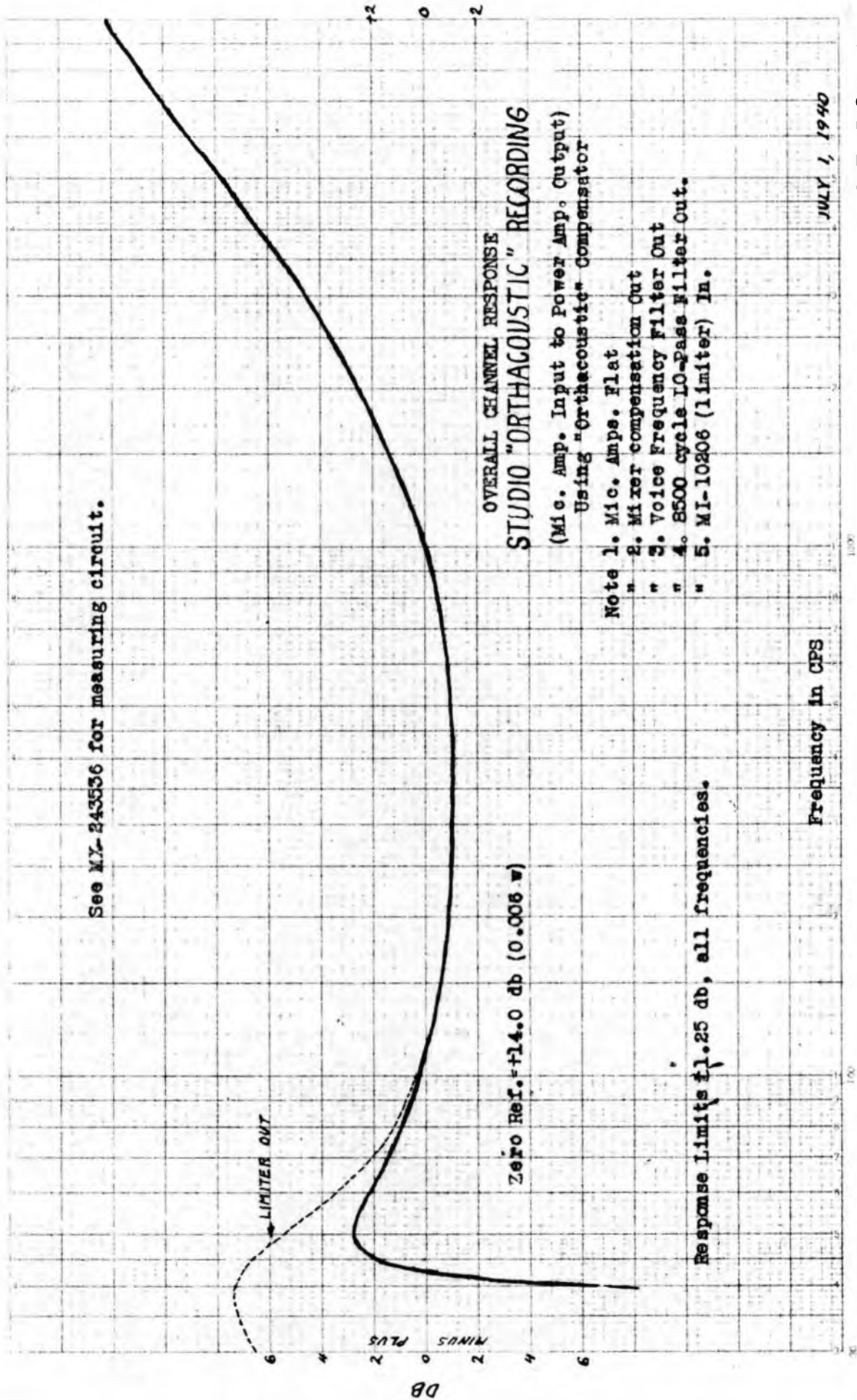

S-851806-1



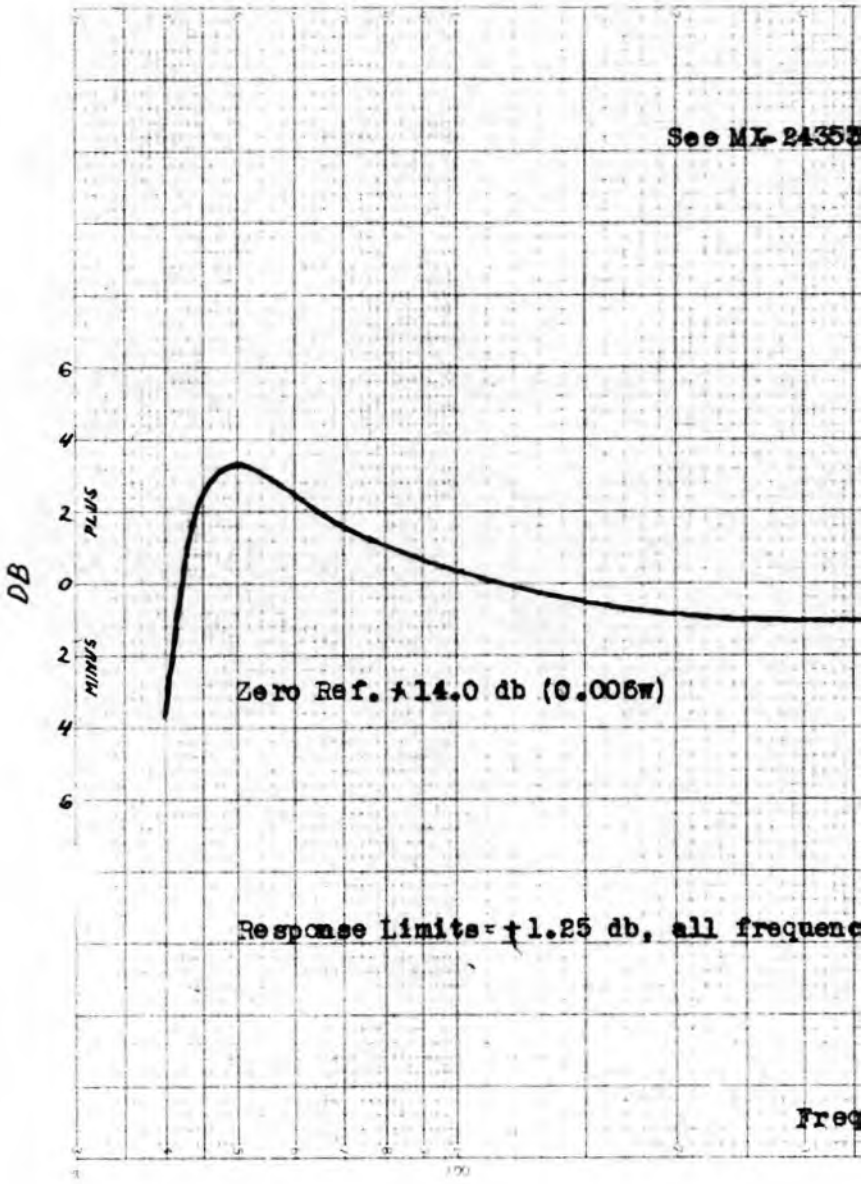

6 for measuring circuit.

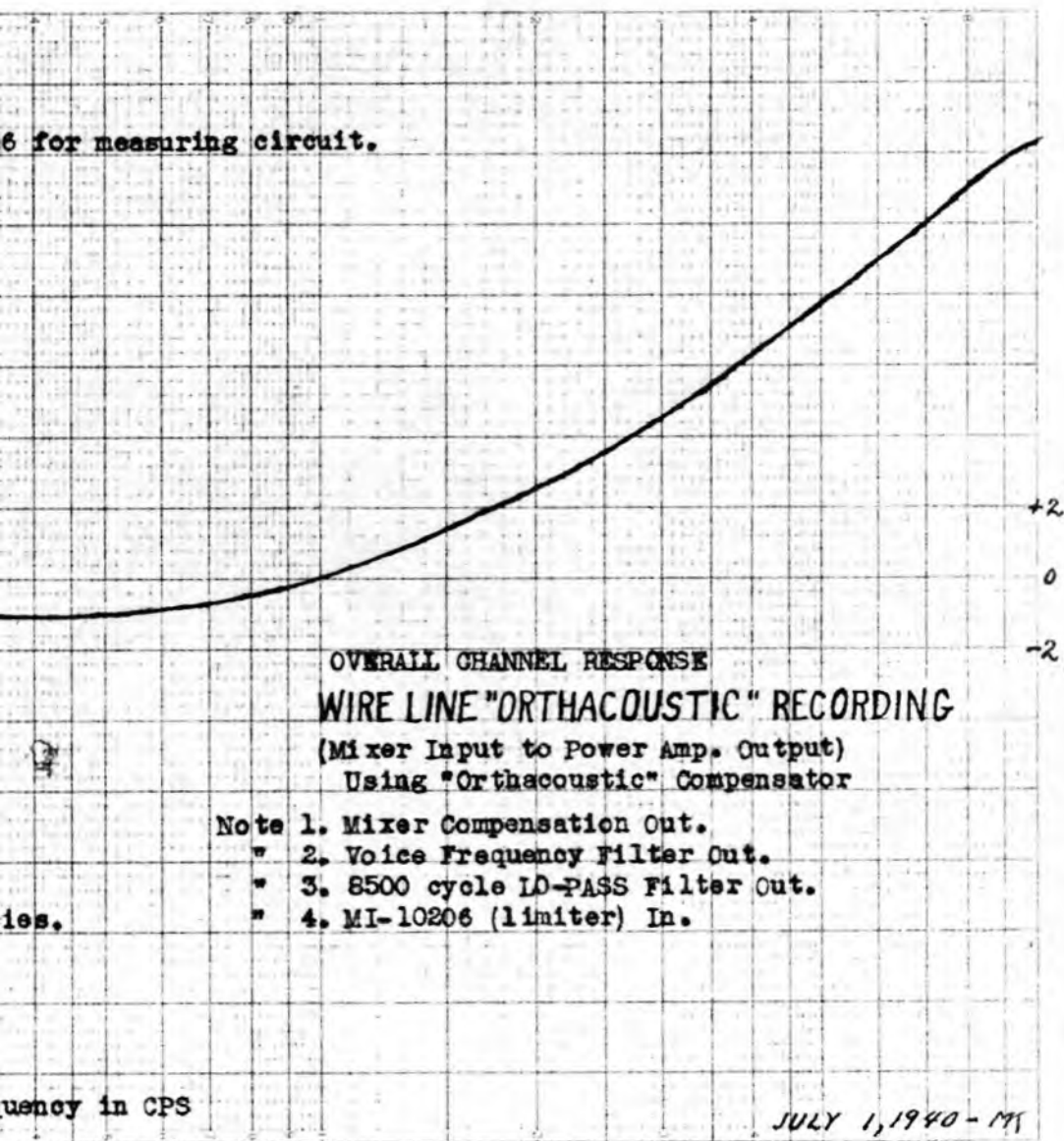

OVERALL CHANNEL RESPONSE

WIRE LINE "ORTHACOUSTIC" RECORDING

(Mixer Input to Power Amp. Output)  
Using "Orthacoustic" Compensator

- Note 1. Mixer Compensation Out.  
" 2. Voice Frequency Filter Out.  
" 3. 8500 cycle LO-PASS Filter Out.  
" 4. MI-10206 (limiter) In.

Frequency in CPS

JULY 1, 1940 - M/S

S-851807-1

See MX-243536 for Measuring Circuit

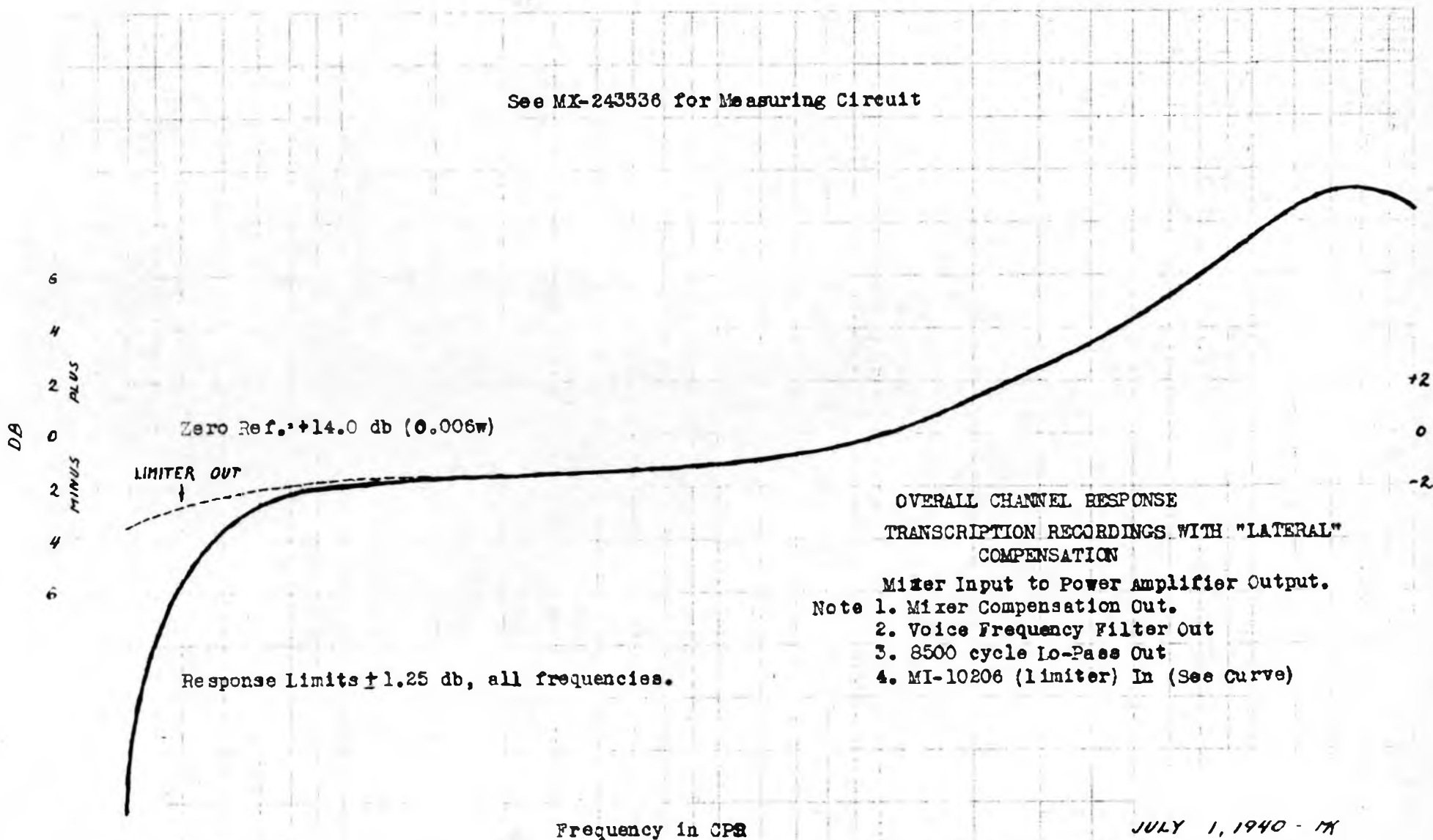

S-851808-1

SECTION XVI

Material and Dimensional Data on Recording Blanks and Records



NOTE: SEE DRAWINGS FOR CONFIRMATION OF DIMENSIONS

JAN 13 1933 (1) REVISED FEB. 26, 1934

| DRAWING NO.        | RECORD                        | THICKNESS OF RECORD | WEIGHT OF RECORD           | STOP OF GROOVE | DIRECTION OF SPIRAL | RADIUS OF START GROOVE | DIA OF LAST MUSIC GROOVE   | DIA OF ECCENTRIC CIRCLE | FINISH CIRCLE              | PITCH OF GROOVE PLAYING TIME       | GROOVE SIZE               | RECORD DIAMETER | REMARKS |
|--------------------|-------------------------------|---------------------|----------------------------|----------------|---------------------|------------------------|----------------------------|-------------------------|----------------------------|------------------------------------|---------------------------|-----------------|---------|
| F-76300<br>P-76308 | 10" COMMERCIAL SHELLAC        | .080±.005           | 6.533 MAX.<br>5.716 MIN.   | ECC.           | OUT TO IN           | 4 1/2                  | 3 1/2                      | 3 1/2                   |                            | 100 P. - 3.6 MIN.<br>96 - 3.5 -    | .0069-.0025               | 9 7/8 ±.01      |         |
| F-76303<br>P-76308 | 12" COMMERCIAL SHELLAC        | .087±.008           | 11.377 MAX.<br>10.087 MIN. | ECC.           | OUT TO IN           | 5 1/2                  | 3 1/2                      | 3 1/2                   |                            | 100 P. - 4.9 MIN.<br>96 - 4.7 -    | .0069-.0025               | 11 7/8 ±.01     |         |
| F-76309<br>P-76311 | 10" LONG PLAYING SHELLAC      | .080±.005           | 6.533 MAX.<br>5.716 MIN.   | ECC.           | OUT TO IN           | 4 1/2                  | 171 P. - 5<br>135 - 6 1/2  | TO SUIT RECORDING       |                            | 171 P. - 11.4 MIN.<br>135 - 5.5 -  | .004-.0011<br>.0055-.0018 | 9 7/8 ±.01      |         |
| F-76310<br>P-76311 | 12" LONG PLAYING VICTROLAC    | .040±.005           | 4.6 MAX.<br>3.6 MIN.       | ECC.           | OUT TO IN           | 5 1/2                  | 171 P. - 5<br>135 - 6 1/2  | TO SUIT RECORDING       |                            | 171 P. - 16.5 MIN.<br>135 - 9.6 -  | .004-.0011<br>.0055-.0018 | 11 7/8 ±.01     |         |
| F-76307<br>P-76312 | 16" MOTION PICTURE VICTROLAC  | .040±.005           | 4.6 MAX.<br>3.6 MIN.       | CON.           | IN TO OUT           | 3 1/2                  |                            |                         | 11 1/2                     | 128 P. - 7.5 MIN.                  | .006-.002                 | 11 7/8 ±.01     |         |
| F-76313<br>P-76314 | 10" HOME RECORDING VICTROLAC  | .040±.005           | 3.2 MAX.<br>2.5 MIN.       | ECC.           | OUT TO IN           | 4 1/2                  | 3 1/2                      | 3 1/2                   |                            | 100 P. - 2.6/3.6 MIN.              | .00425-.0019              | 9 7/8 ±.01      |         |
| M-76005<br>M-76008 | 6" HOME RECORDING VICTROLAC   | .025±.005           | 0.75 MAX.<br>0.50 MIN.     | ECC.           | OUT TO IN           | 2 1/2                  | 3 1/2                      | 3 1/2                   |                            | 100 P. - 3.0/4.2 MIN.              | .00425-.0019              | 5 1/2 ±.01      |         |
| F-76316<br>P-76312 | 16" MOTION PICTURE SHELLAC    | .125±.005           | 15.48 MAX.<br>12.52 MIN.   | CON.           | IN TO OUT           | 4 1/2                  |                            |                         | 15 1/2                     | 90 P. - 8.3 MIN.                   | .007-.0026                | 15 7/8 ±.01     |         |
| F-76330<br>P-76324 | 8" RECORD VICTROLAC-PAPER     | .035±.005           | 1.8 MAX.<br>1.4 MIN.       | CON.           | OUT TO IN           | 3 1/2                  | 2 1/2                      |                         | 2 1/4                      | 100 P. - 3 MIN.                    | .0069-.0025               | 7 7/8 ±.01      |         |
| F-76315<br>P-76311 | 10" LONG PLAYING VICTROLAC    | .085±.008           | 2.85 MAX.<br>2.15 MIN.     | ECC.           | OUT TO IN           | 4 1/2                  | 171 P. - 5<br>135 - 6 1/2  | TO SUIT RECORDING       |                            | 171 P. - 11.4 MIN.<br>135 - 5.5 -  | .004-.0011<br>.0055-.0018 | 9 7/8 ±.01      |         |
| M-76038<br>M-76014 | 7" RECORD VICTROLAC-PAPER     | .035±.005           | 1.4 MAX.<br>1.0 MIN.       | ECC.           | OUT TO IN           | 3 1/2                  | 3 1/2                      | 3 1/2                   |                            | 100 P. - 1.7 MIN.                  | .0069-.0025               | 6 7/8 ±.01      |         |
| M-76013<br>M-76014 | 7" CHILDREN'S VICTROLAC       | .035±.005           | 1.35 MAX.<br>1.00 MIN.     | ECC.           | OUT TO IN           | 3 1/2                  | 3 1/2                      | 3 1/2                   |                            | 100 P. - 1.7 MIN.                  | .0069-.0025               | 6 7/8 ±.01      |         |
| M-76017<br>M-76014 | 7" CHILDREN'S ACETATE-SHELLAC | .065±.005           | 2.75 MAX.<br>2.35 MIN.     | ECC.           | OUT TO IN           | 3 1/2                  | 3 1/2                      | 5 1/2                   |                            | 100 P. - 1.7 MIN.                  | .0069-.0025               | 6 7/8 ±.01      |         |
| F-76306<br>P-76327 | 14" BROADCAST VICTROLAC       | .050±.005           | 6.6 MAX.<br>5.4 MIN.       | CON.           | IN TO OUT           | 5 1/2                  |                            |                         | 15 1/2                     | 144 P. - 14.5 MIN.                 | .005-.0015                | 13 7/8 ±.01     |         |
| F-76306<br>P-76327 | 14" BROADCAST VICTROLAC       | .050±.005           | 6.6 MAX.<br>5.4 MIN.       | CON.           | OUT TO IN           | 6 1/2                  | 6 1/2                      |                         | 6 1/2                      | 144 P. - 14.5 MIN.                 | .005-.0015                | 13 7/8 ±.01     |         |
| F-76323<br>P-76324 | 8" RECORD SHELLAC             | .070±.005           | 3.735 MAX.<br>3.236 MIN.   | CON.           | OUT TO IN           | 3 1/2                  | 2 1/2                      |                         | 2 1/4                      | 100 P. - 3.0 MIN.                  | .0069-.0025               | 7 7/8 ±.01      |         |
| F-76300<br>P-76308 | 10" BLUEBIRD SHELLAC          | .080±.005           | 6.533 MAX.<br>5.716 MIN.   | ECC.           | OUT TO IN           | 4 1/2                  | 3 1/2                      | 3 1/2                   |                            | 100 P. - 3.6 MIN.<br>96 - 3.5 -    | .0069-.0025               | 9 7/8 ±.01      |         |
| F-76328<br>P-76329 | 16" HOME RECORDING VICTROLAC  | .040±.005           | 4.6 MAX.<br>3.6 MIN.       | ECC.           | OUT TO IN           | 5 1/2                  | 3 1/2                      | 3 1/2                   |                            | 100 P. - 11.4 MIN.                 | .00425-.0019              | 11 7/8 ±.01     |         |
| F-76306<br>P-76331 | 16" TRANSCRIPTION VICTROLAC   | .065±.005           | 12.3 MAX.<br>10.7 MIN.     | CON.           | OUT TO IN           | 7 1/2                  | 121 - 7 1/2<br>107 - 8 1/2 |                         | 121 - 6 1/2<br>107 - 7 1/2 | 121 P. - 14.8 MIN.<br>107 - 11.4 - | .006-.002                 | 15 7/8 ±.01     |         |
| F-76332<br>P-76308 | 16" RECORD ACETATE-SHELLAC    | .105±.005           | 11.317 MAX.<br>10.087 MIN. | ECC.           | OUT TO IN           | 5 1/2                  | 3 1/2                      | 3 1/2                   |                            | 100 P. - 4.9 MIN.<br>96 - 4.7 -    | .0069-.0025               | 11 7/8 ±.01     |         |
| F-76333<br>P-76308 | 10" RECORD ACETATE-PAPER      | .065±.005           | 3.5 MAX.<br>3.3 MIN.       | ECC.           | OUT TO IN           | 4 1/2                  | 3 1/2                      | 3 1/2                   |                            | 100 P. - 3.6 MIN.<br>96 - 3.5 -    | .0069-.0025               | 9 7/8 ±.01      |         |
| F-76334<br>P-76308 | 10" RECORD ACETATE-SHELLAC    | .080±.005           | 6.760 MAX.<br>5.739 MIN.   | ECC.           | OUT TO IN           | 4 1/2                  | 3 1/2                      | 5 1/2                   |                            | 100 P. - 3.6 MIN.<br>96 - 3.5 -    | .0069-.0025               | 9 7/8 ±.01      |         |
| F-76305<br>P-76308 | 10" COMMERCIAL VICTROLAC      | .035±.005           | 2.85 MAX.<br>2.15 MIN.     | ECC.           | OUT TO IN           | 4 1/2                  | 3 1/2                      | 3 1/2                   |                            | 100 P. - 3.6 MIN.<br>96 - 3.5 -    | .0069-.0025               | 9 7/8 ±.01      |         |
| F-76306<br>P-76308 | 12" COMMERCIAL VICTROLAC      | .040±.005           | 4.6 MAX.<br>3.6 MIN.       | ECC.           | OUT TO IN           | 5 1/2                  | 3 1/2                      | 3 1/2                   |                            | 100 P. - 4.9 MIN.<br>96 P. - 4.7 - | .0069-.0025               | 11 7/8 ±.01     |         |
| F-76330<br>P-76342 | 16" TRANSCRIPTION VICTROLAC   | .065±.005           | 12.3 MAX.<br>10.7 MIN.     | CON.           | IN TO OUT           | 4 1/2                  |                            |                         | 15 1/2                     | 107 P. - 10.6 MIN.                 | .006-.002                 | 15 7/8 ±.01     |         |
| F-76336<br>P-76347 | 10" TRANSCRIPTION VICTROLAC   | .055±.005           | 4.15 MAX.<br>3.43 MIN.     | CON.           | OUT TO IN           | 4 1/2                  | 135 - 6 1/2<br>107 - 8 1/2 |                         | 135 - 6 1/2<br>107 - 8 1/2 | 135 P. - 5.6 MIN.<br>107 - 1.2 -   | .0055-.0018<br>.006-.002  | 9 7/8 ±.01      |         |
| F-76335<br>P-76340 | 10" TRANSCRIPTION VICTROLAC   | .055±.005           | 4.15 MAX.<br>3.43 MIN.     | CON.           | OUT TO IN           | 4 1/2                  | 4 1/2                      |                         | 4 1/2                      | 100 P. - 3.3 MIN.                  | .006-.002                 | 9 7/8 ±.01      |         |
| F-76336<br>P-76341 | 12" TRANSCRIPTION VICTROLAC   | .055±.005           | 6.08 MAX.<br>4.97 MIN.     | CON.           | OUT TO IN           | 5 1/2                  | 135 - 6 1/2<br>107 - 8 1/2 |                         | 135 - 6 1/2<br>107 - 8 1/2 | 135 P. - 9.6 MIN.<br>107 - 4.4 -   | .0055-.0018<br>.006-.002  | 11 7/8 ±.01     |         |
| F-76336<br>P-76340 | 12" TRANSCRIPTION VICTROLAC   | .055±.005           | 6.00 MAX.<br>4.97 MIN.     | CON.           | OUT TO IN           | 5 1/2                  | 4 1/2                      |                         | 4 1/2                      | 100 P. - 4.5 MIN.                  | .006-.002                 | 11 7/8 ±.01     |         |
| F-76336<br>P-76342 | 12" TRANSCRIPTION VICTROLAC   | .055±.005           | 6.00 MAX.<br>4.97 MIN.     | CON.           | IN TO OUT           | 4 1/2                  |                            |                         | 11 1/2                     | 107 P. - 4.2 MIN.                  | .006-.002                 | 11 7/8 ±.01     |         |
| F-76336<br>P-76343 | 12" TRANSCRIPTION VICTROLAC   | .055±.005           | 6.00 MAX.<br>4.97 MIN.     | CON.           | IN TO OUT           | 2 1/2                  |                            |                         | 11 1/2                     | 100 P. - 4.3 MIN.                  | .006-.002                 | 11 7/8 ±.01     |         |
| F-76337<br>P-76308 | 12" RECORD VICTROLAC-PAPER    | .087±.008           | 6.7 MAX.<br>5.8 MIN.       | ECC.           | OUT TO IN           | 5 1/2                  | 3 1/2                      | 3 1/2                   |                            | 100 P. - 4.9 MIN.<br>96 - 4.7 -    | .0069-.0025               | 11 7/8 ±.01     |         |
| F-76338<br>P-76308 | 10" RECORD VICTROLAC PAPER    | .075±.005           | 4.7 MAX.<br>4.2 MIN.       | ECC.           | OUT TO IN           | 4 1/2                  | 3 1/2                      | 3 1/2                   |                            | 100 P. - 3.6 MIN.<br>96 - 3.5 -    | .0069-.0025               | 9 7/8 ±.01      |         |

T-60787



P-76308

| Part | Material | Quantity |
|------|----------|----------|
| 1    | 1        | 1        |
| 2    | 2        | 2        |
| 3    | 3        | 3        |
| 4    | 4        | 4        |

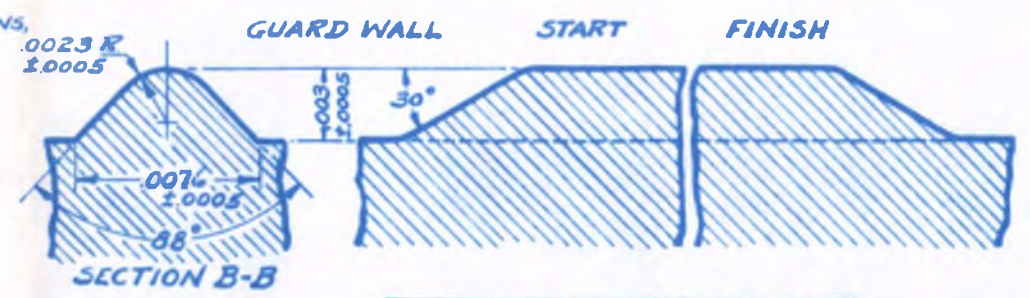
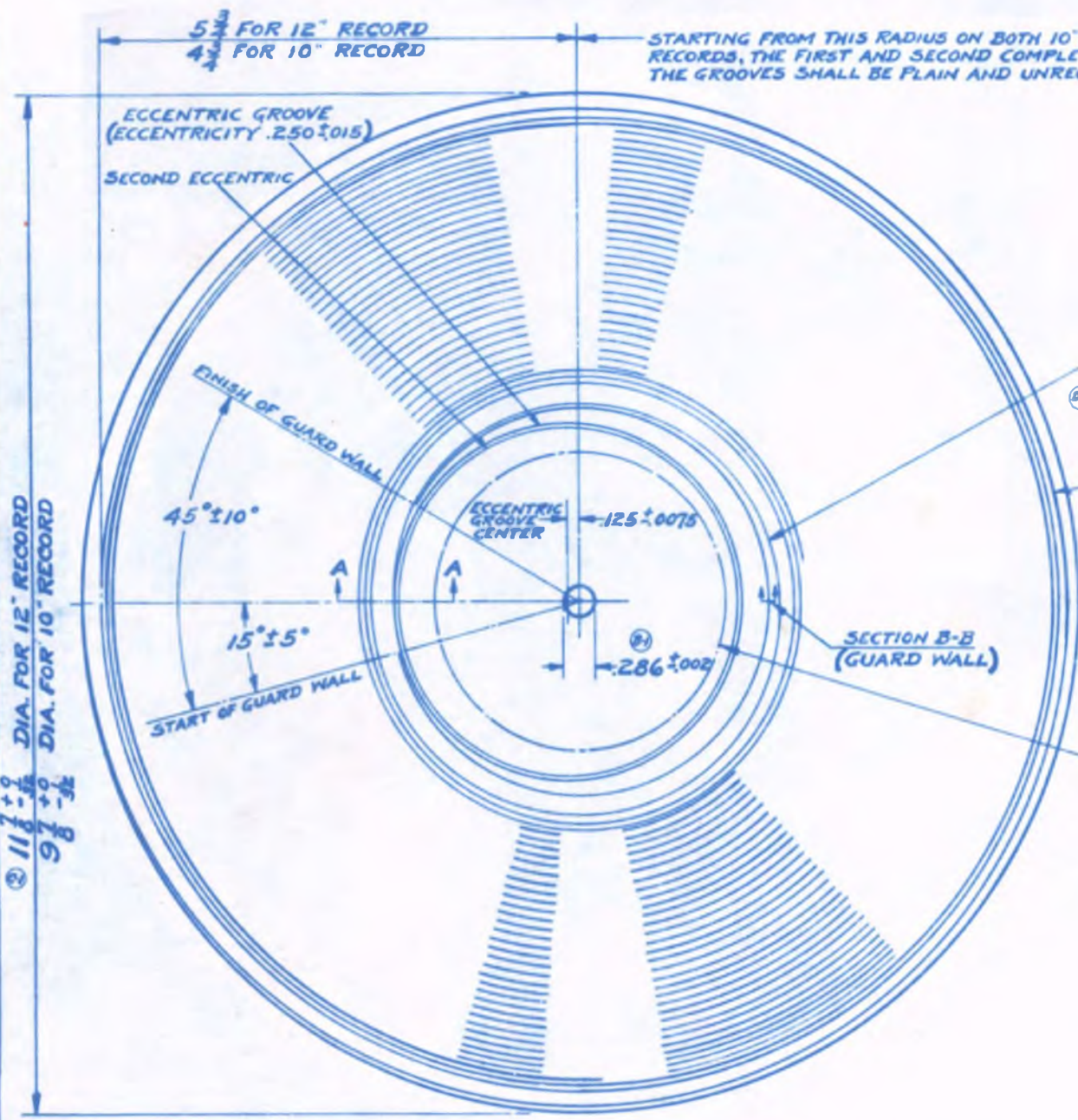
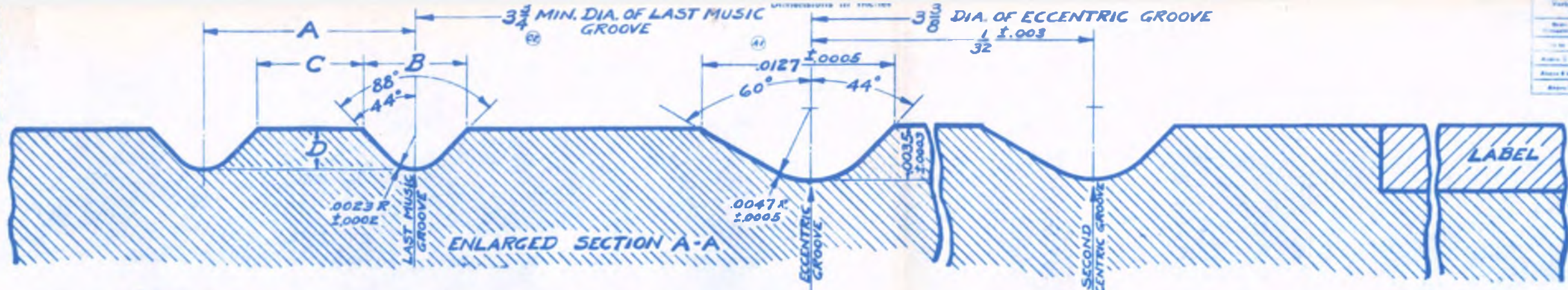

| A<br>PITCH OF<br>GROOVES<br>PER INCH | B<br>WIDTH<br>OF<br>GROOVES | C<br>LAND<br>BETWEEN<br>GROOVES | D<br>DEPTH<br>OF<br>GROOVE |
|--------------------------------------|-----------------------------|---------------------------------|----------------------------|
| 144                                  | .005                        | .0019                           | .0015                      |
| 135                                  | .0055                       | .0019                           | .0018                      |
| 128                                  | .006                        | .0018                           | .0020                      |
| 121                                  | .0065                       | .0018                           | .0023                      |
| 107                                  | .0069                       | .0024                           | .0025                      |
| 100                                  | .0069                       | .0031                           | .0025                      |
| 96                                   | .0069                       | .0035                           | .0025                      |
| 90                                   | .0069                       | .0042                           | .0025                      |
| 86                                   | .0069                       | .0047                           | .0025                      |
| 72                                   | .0069                       | .0068                           | .0025                      |

LEAD-IN GROOVE (1)  
CONTINUE FROM LAST MUSIC GROOVE WITH WIDTH INCREASED TO .0127 ±.0005 BUT CHANGING THE PITCH TO 4 GROOVES PER INCH AND ENDING AT 1 1/4" RADIUS FROM CENTER OF RECORD.

(2) OUTSIDE LEAD IN GROOVE SAME DEPTH AS RECORDED GROOVE STARTS ON 10" OR 12" DIA. OF WAX AND MOVED IN MANUALLY TO WHERE THE STANDARD MUSIC GROOVE STARTS IN ABOUT TWO REVOLUTIONS OF RECORD FROM THERE THE USUAL PITCH CONTINUES.

NOTE:  
LABEL (AS SPECIFIED BY SALES DEPT.)  
CLASS OF RECORD DETERMINES SELECTION OF LABEL.  
TOTAL THROW DUE TO ECCENTRICITY SHALL NOT EXCEED TOLERANCES ALLOWABLE FOR FOLLOWING CLASSES OF RECORDS.

|              |      |
|--------------|------|
| RED SEAL     | .010 |
| BLACK SEAL   | .012 |
| CROWN        | .015 |
| TIMELY TUNES | .015 |
| ELECTRADISC  | .015 |
| ACETATE      | .010 |

REV. 11-27-51  
AUG. 31 '51  
A-1, WAS .0012 ±.0005  
B-1, WAS .0012 ±.0005  
C-1, WAS 11 1/2 ±.002  
C-2, WAS 3 1/2  
C-3, ADDED  
D-1, WAS SAME SIZE AND SHAPE GROOVE.  
E-1, WAS .010  
E-2, ADDED  
F-1, WAS .010  
F-2, ADDED  
G-1, WAS .010  
G-2, ADDED  
H-1, WAS .010  
H-2, ADDED  
I-1, WAS .010  
I-2, ADDED  
J-1, WAS .010  
J-2, ADDED  
K-1, WAS .010  
K-2, ADDED  
L-1, WAS .010  
L-2, ADDED  
M-1, WAS .010  
M-2, ADDED  
N-1, WAS .010  
N-2, ADDED  
O-1, WAS .010  
O-2, ADDED  
P-1, WAS .010  
P-2, ADDED  
Q-1, WAS .010  
Q-2, ADDED  
R-1, WAS .010  
R-2, ADDED  
S-1, WAS .010  
S-2, ADDED  
T-1, WAS .010  
T-2, ADDED  
U-1, WAS .010  
U-2, ADDED  
V-1, WAS .010  
V-2, ADDED  
W-1, WAS .010  
W-2, ADDED  
X-1, WAS .010  
X-2, ADDED  
Y-1, WAS .010  
Y-2, ADDED  
Z-1, WAS .010  
Z-2, ADDED

| MATERIAL   | PART OR GROUP No. | REFERENCE PART             | DESCRIPTION    |
|--|-------------------|----------------------------|----------------|
| <b>GENERAL RECORD DIMENSIONS</b>                     |                   |                            |                |
| FIRST MADE FOR 10 & 12" COMMERCIAL 78 R.P.M. RECORDS |                   |                            |                |
| DESIGN BY: <i>M. C. ...</i>                          |                   | TRACE BY: <i>M. C. ...</i> |                |
| CHECKED BY: <i>M. C. ...</i>                         |                   | DATE: <i>1/1/51</i>        |                |
| RCA Victor Company, Inc.<br>Camden Works             |                   |                            | <b>P-76308</b> |



P-76331

Dimensions in Inches

| Feature | Feature | Feature |
|---------|---------|---------|
| No. 1   | No. 2   | No. 3   |
| No. 4   | No. 5   | No. 6   |
| No. 7   | No. 8   | No. 9   |
| No. 10  | No. 11  | No. 12  |

STARTING FROM THIS RADIUS THE FIRST COMPLETE REVOLUTION, THE GROOVE SHALL BE PLAIN.

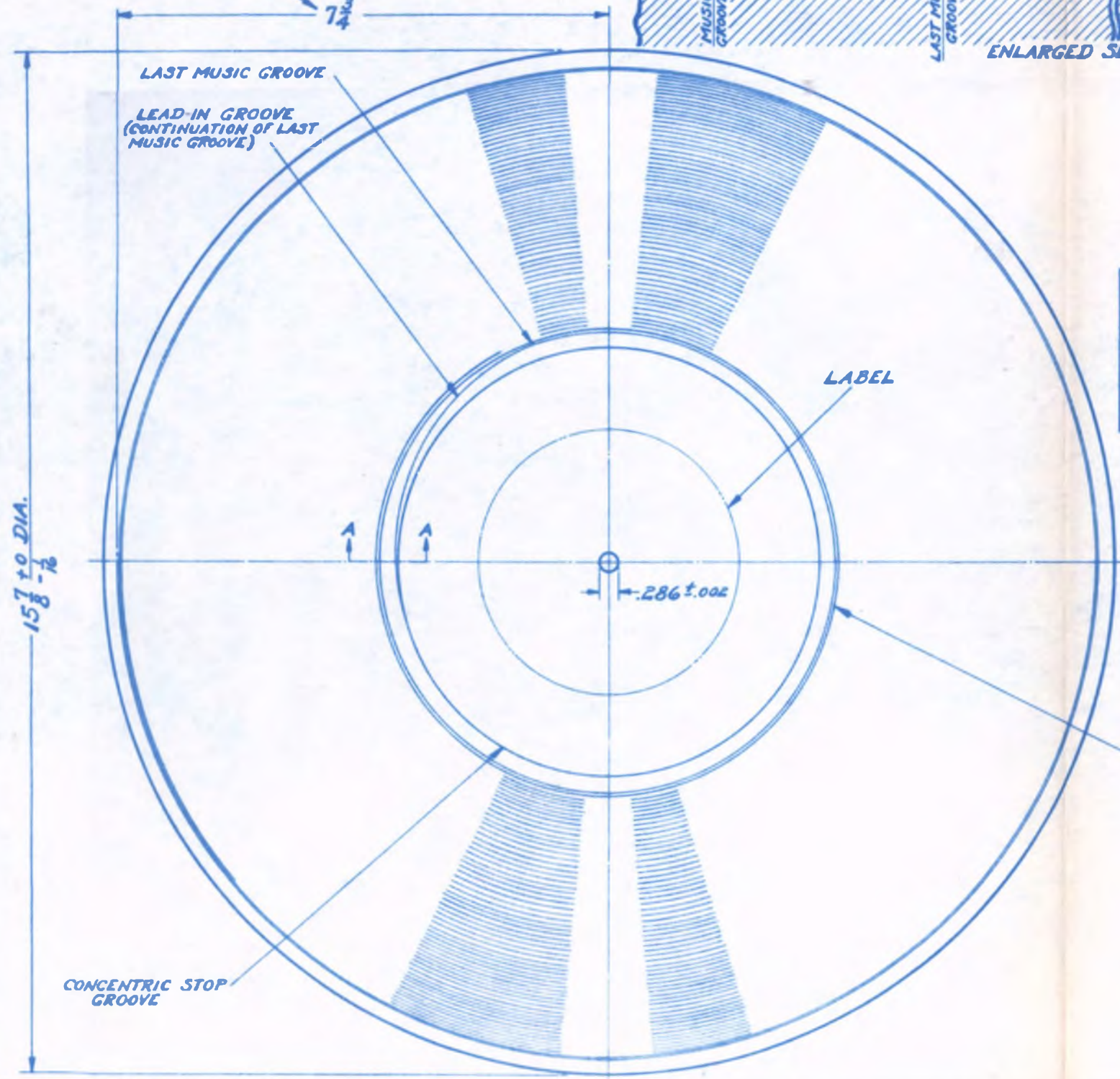
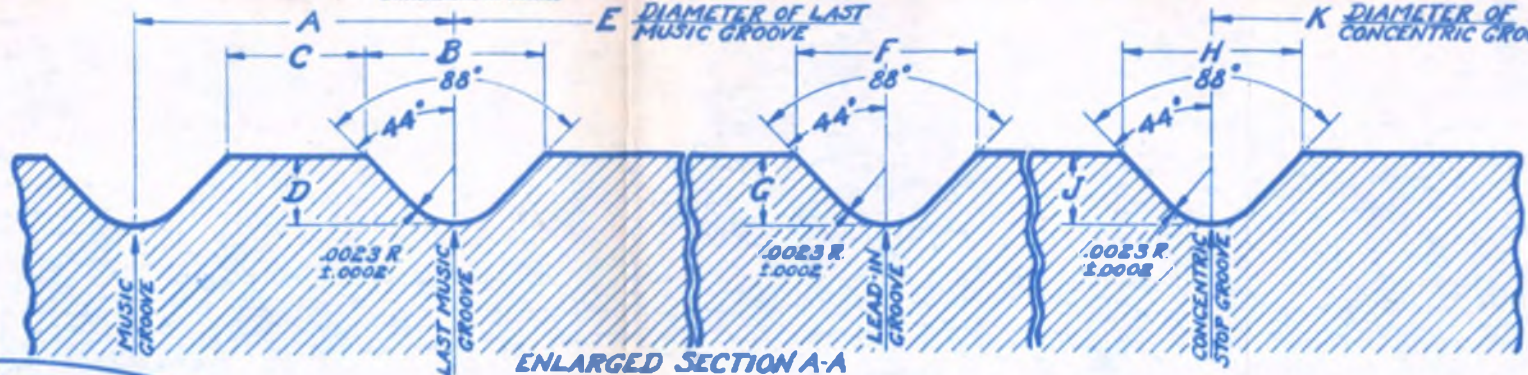

| A                         | B                | C                    | D                | E                        | F                       | G                       | H                               | J                               | K                              |
|---------------------------|------------------|----------------------|------------------|--------------------------|-------------------------|-------------------------|---------------------------------|---------------------------------|--------------------------------|
| PITCH OF GROOVES PER INCH | WIDTH OF GROOVES | LAND BETWEEN GROOVES | DEPTH OF GROOVES | DIA OF LAST MUSIC GROOVE | WIDTH OF LEAD-IN GROOVE | DEPTH OF LEAD-IN GROOVE | WIDTH OF CONCENTRIC STOP GROOVE | DEPTH OF CONCENTRIC STOP GROOVE | DIA. OF CONCENTRIC STOP GROOVE |
| 121                       | .006             | .0022                | .002             | 7 1/4 MIN.<br>7 1/4 MAX. | .006                    | .002                    | .006                            | .002                            | 6 1/2 MIN.<br>7 MAX.           |
| 107                       | .006             | .0033                | .002             | 8 1/4 MIN.<br>8 1/4 MAX. | .006                    | .002                    | .006                            | .002                            | 7 1/4 MIN.<br>8 1/4 MAX.       |

NOTE:  
TOTAL THROW DUE TO ECCENTRICITY SHALL NOT EXCEED .010

APPROVED  
DATE

| MATERIAL                                   | PART OR GROUP No. | REFERENCE  | PART | DESCRIPTION |
|--|-------------------|------------|------|-------------|
| <b>GENERAL RECORD DIMENSIONS</b>           |                   |            |      |             |
| <b>16 TRANSCRIPTION 33 1/3 RPM RECORDS</b> |                   |            |      |             |
| DESIGNED BY                                |                   | CHECKED BY |      |             |
| DRAWN BY                                   |                   | DATE       |      |             |
| RCA Victor Company, Inc. Camden Works      |                   |            |      |             |
| <b>P-76331</b>                             |                   |            |      |             |



P-716136

Dimensions in Inches

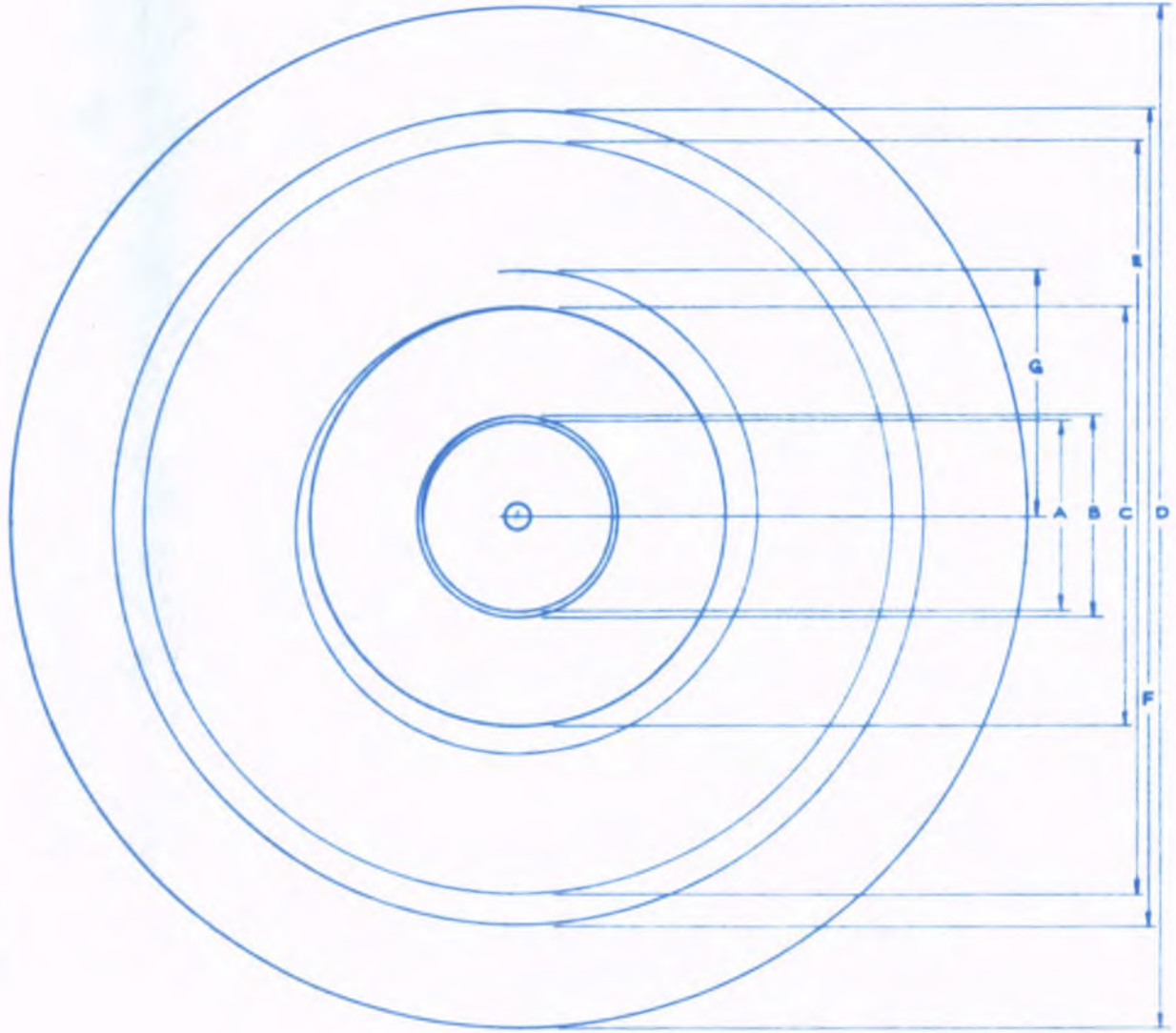

CENTER HOLE ON MATRIX NOT TO BE PLUGGED  
MUST BE LEFT SMOOTH

| DIA. | DIM.  | DESCRIPTION                              |
|------|-------|--|
| A    | 2 1/2 | CONCENTRIC CIRCLE                        |
| B    | 2 3/4 | DIA. OF LAST MUSIC GROOVE                |
| C    | 4 3/4 | DIA. OF FIRST MUSIC GROOVE               |
| D    |       | DIA. OF STANDARD 10" FLOWED WAX          |
| E    | 8     | MINIMUM INSIDE DIA. OF TEST CUT          |
| F    | 6 1/2 | MAX OUTSIDE DIAMETER OF TEST CUT         |
| G    | 6     | RADIUS OF START POINT FOR LEAD-IN GROOVE |

13.7  
2.32

NOTE:- TEST CUT (PLAIN GROOVE) TO BE MADE WITHIN DIMENSIONS E TO F CUT TO BE NOT LESS THAN 1/8 INCHES TO ENABLE FACTORY TO LOCATE CENTER HOLE PROPERLY

NOTE:- LEAD IN GROOVE TO START AT "G" DIMENSION MAKING AS NEAR AS POSSIBLE ONE COMPLETE REVOLUTION BEFORE GOING INTO REGULAR PITCH

NOTE:- 136 LINES PER INCH (MAX.) .0045 WIDTH GROOVE (AVERAGE)

NOTE:- USE STYLUS HAVING INCLUDED ANGLE OF 70 DEGREES .0025 RADIUS RADIUS

REVISIONS  
REVISED  
DATE

| REV. | DESCRIPTION | DATE |
|------|-------------|------|
| 1    | ...         | ...  |
| 2    | ...         | ...  |
| 3    | ...         | ...  |

**DIMENSIONS OF 4 1/2" RECORDING**

Printed at the  
RCA Manufacturing Co. Inc.  
RCA Victor Division  
P-716136  
TRADES BY  
CHECKED BY



Dimensions in Inches

**M-426080**

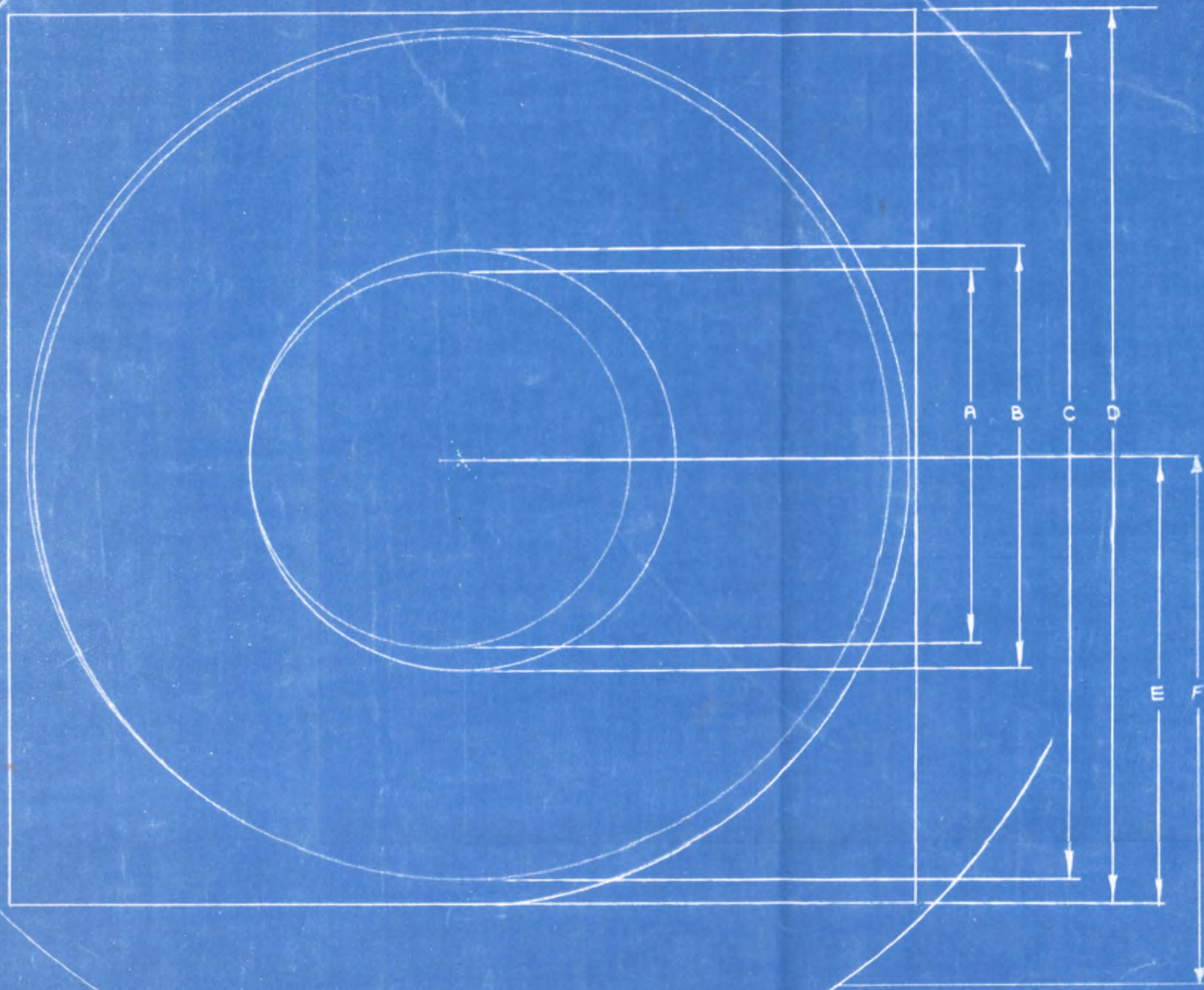

| DIA. | DIM.  | DESCRIPTION                             |
|------|-------|---|
| A    | 3 3/8 | STD. ECCENTRIC GROOVE See Note -7       |
| B    | 3 3/4 | MIN. DIA. LAST MUSIC GROOVE             |
| C    | 7 1/2 | DIA. FIRST MUSIC GROOVE                 |
| D    | 8     | DIM. OF FINISHED RECORD                 |
| E    | 4     | MIN. RADIUS OF START FOR LEAD IN GROOVE |
| F    | 6     | RADIUS OF CONCENTRIC CIRCLE             |

NOTES

- 1- USE STD. 12 INCH WAX FOR MAKING MASTER RECORDING
- 2- LEAD IN GROOVE TO MAKE AS NEARLY AS POSSIBLE ONE COMPLETE REVOLUTION BEFORE REACHING "C" DIM.
- 3- USE STYLUS HAVING INCLUDED ANGLE OF 70°. TIP RADIUS .0023"
- 4- 136 GROOVES PER INCH MAX. .0045 INCH WIDTH OF GROOVES
- 5- KEEP TEST CUT OUTSIDE OF 12.0 INCH DIMENSION
- 6- CONCENTRIC CIRCLE TO BE CUT AT 12 INCH DIM.
- 7- ECCENTRIC GROOVE DEPTH TO BE .0025 WIDTH .009 INCHES

AP. BY *[Signature]*  
 AP. MFG. *[Signature]*  
 WIG-7 All's out to 1  
 F-Dim. with 1-1/4" R  
 D.C. Kelly

Variations in Finished Dimensions unless otherwise marked

| Basic Dimensions | Fractional Dimensions | Decimal Dimensions |
|------------------|-----------------------|--------------------|
| Up to 1/4        | ± 1/128               | ± .005             |
| Above 1/4 to 6   | ± 1/64                | ± .005             |
| Above 6 to 24    | ± 1/32                | ± .010             |
| Above 24         | ± 1/16                | ± .015             |

See Purch. Spec. for Stock Tolerances

**8" COMMERCIAL RECORD**

FIRST MADE FOR \_\_\_\_\_

BEGUN BY *L. Haymer July 16, 1940* TRACED BY \_\_\_\_\_

FINISHED BY *L. Haymer July 16, 1940* CHECKED BY *July 16-40*

**RCA Manufacturing Co. Inc.**  
 RCA Victor Division

**M-426080**



## SECTION XVII

### Individual Studio Data

Note: This section is reserved for memoranda kept for the individual studio. For example, it is suggested that the overall performance curves of the studio's equipment be filed here as well as a record of the recorders used including dates when these recorders were last calibrated or tested.

This will make it possible to compare the data for the individual studio equipments with that of the average or standard as shown in this book and at the same time leave the other sections free for data as issued by the Recording Department.

SECTION XVIII

ACOUSTIC DATA

Master Reference Book

Disc Recording







## ADDENDA

**Note:** This space should be reserved for electrical, mechanical or chemical data not directly relating to the recording equipment or its operation.











## INDEX OF CONTENTS

### Master Reference Book For Disc Recording

|         |  |  |
|---------|--|--|
| Sec. #1 | "Microphones"                            |  |
| I       | S-851382                                 | Plane Wave Freq. Response Velocity Microphone for Disc Recording   |
|         | No Number                                | Correction in Pressure Response of Veloc. Mic. in Spherical Sound Wave   |
|         | 1B-2532                                  | MI-3027 Instruction Book   |
|         | 1B-2533-1                                | MI-4040B Type 77-A Uni-Directional Microphone  |
|         | S-859669                                 | 77-B Uni-Directional Mic. Freq. Response   |
|         | 1B-37022                                 | Aerodynamic Microphone Instruction Book  |
| Sec. #2 | "Filter and Compensation Units Data"     |  |
| II      | S-851767                                 | Lateral Compensation Freq. Response "Domestic Recording"<br>Note: This is equivalent to pre amp equalization.  |
|         | S-851766                                 | Orthoacoustic Compensation "Transcription Recording"   |
|         | S-851845                                 | 45 cycle Hi Pass (MI-10107) Freq. Response   |
|         | ⊗ S-851774                               | XI-2727A L.P. Filter "Home Recording"  |
|         | S-851773                                 | XI-2544 Telephone Effects Filter (Sound Effects)   |
|         | S-851802                                 | XI-914B Voice Freq. Filter Response 500 <sup>m</sup> circuit   |
|         | 2R6-5.2                                  | M3119 MI-10101 Re-recording Compt. Instruction Book  |
|         | 1B-25839                                 | 56A Line Equalizer "Schematic Diagram"   |
|         | No Number                                | 56A (MI-4167) Instruction Book   |
| Sec. #3 | "Microphone and Re-recording Mixer Data" |  |
| III     | III-1                                    | Instruction Sheet Disc Rec. Mixer Console<br>8500 c.p.s. L.P. Filter<br>Var. L.F. Atten. (Voice Freq. Filter) XI-914B<br>Volume Indicator to be WU Meter |
|         | W-308627                                 | Wiring for Console used in Disc Recording  |
|         | 2R6-8.1                                  | MI-3108-3108A Instructions re-Recording Mixer  |
|         | 2R6-2.1                                  | MI-3116 Input Mixing Panel Instructions  |
|         | 2R6-3.1                                  | MI-3120 Combining Network Instructions   |
| Sec. #4 | "Amplifier Data"                         |  |
| IV      | 1B-25837                                 | Bridging Amp. MI-3223 Instructions   |
|         | 2R1-3.1                                  | Bridging Amp. MI-3223C Addenda Sheet   |
|         | 1B-25991                                 | Mic. Amp. MI-3230 Instructions   |
|         | 2R1-6.2                                  | Mic. Amplifiers MI-3230A & B Addenda Sheet   |
|         | 2R1-4.1                                  | Booster Amp. Instructions  |
|         | 2R1-3.2                                  | DC Bridging Amp. MI-3233a Instructions   |
|         | 2R1-9.1                                  | Vol. Compressors MI-10201 MI-10206 Instructions  |
|         | 1V-7a                                    | Mod. of MI-10206 Range Control for Disc Recording.<br>Change from Compressor to Limiter.   |

Sec. #5  
V  
"Monitor Equipment— Meters, Loudspeakers, etc."  
2R05-1.1 Volume Indicator MI-3115 Instructions  
2R05-1.1A " " " Addenda  
S-85182 Var. Atten. for use with Weston VU 305 (301)  
V-5 Instruction Sheet Disc Rec. Monitor Speaker  
MI-3429 with MI-3404 Baffle

Sec. #6  
VI *check out*  
*Copy* → ⊗ S-851770 "Recorders, Pickups & Related Accessories"  
46286 Wax Calibration Freq. Response (Optical Calib.) Issue 2  
46285 Photo. Wax Recorder with advance ball mounted  
Photo. Wax Recorder Mounting Saddle

Sec. #7  
VII  
"Power Supplies"  
2R0-3.1 "B" Supply MI-3526  
IB-24196 " " " Addenda  
2R0-6.1 "A" Supply MI-3527  
IB-24196 " " MI-3527A Addenda

Sec. #8  
VIII  
"Recording Machines"  
VIII-1.1 Scully Recording Machine Instructions  
⊗ Lubrication & Oiling  
General Instructions  
Change of Recorded Pitch  
Recorded Dia. Scale & Indicator Lamp  
Carriage Feed  
Clutch Lever  
Screws & Lock Nut  
Microscope Scale  
Saddle Pivots  
⊗ Recording  
Power Switch  
⊗ Recorder Adjustment  
⊗ Advance Ball Adjustment  
46282 Photo. Scully Recording Machine  
46283 " " " " " Motor & Drive Unit  
W-300457 Wiring Diagram

Sec. #9  
IX  
"Turntables"  
IB-24181-1 70B Turntable Instructions  
S-839817 Freq. Response 70E Transcription Turntable  
IX-2 Proper Setting of 70B Eq. for Reproduction of  
RCA Recordings

Sec. #10  
X  
"Test Equipment"  
LB-32001 Type 68B Oscillator Instructions  
LB-23362-4 Type 69A Distortion Meter Instructions  
LB-23365 Type 89A Atten. Panel Instructions  
2RQ-2.3 MI-3222, MI-3222A Rec. Amp. Instructions  
X-6 Standard Test Records  
S-851899-2 Freq. Response of 78 and 33-1/3 Test Records



Sec. #11  
XI

"Transmission and Schematic Diagrams"

T-613261 Trans. Diagram Disc Rec. Equip. N.Y. & Chicago

Sec. #12  
XII

"Equipment Assembly and Inter-unit Wiring Dia."

W-302705 Typical Inter-unit Wiring N.Y. & Chicago

W-303171 Wiring Diagram N.Y. and Chicago "Studio Rack"

Sec. #13  
XIII

"Testing and Maintenance of Equipment"

XIII-1 Disc Recording Equipment  
Test and Maintenance Instructions

XIII-1.1 Daily Routine

XIII-1.2 Weekly Routine

XIII-1.3 Monthly Routine

XIII-1.4 Miscellaneous

XIII-1a Cleaning Attenuators & Amplifier Volume Controls

XIII-1b Checking RCA-845 Power Tubes

XIII-1c.1 Standards for Measuring Freq. Response Curves

XIII-1c.2 Chart MC-243536 Standard Setup for Making Freq. Response Curves

⊗ XIII-1d Procedure for Making Freq. Response or "Xmas Tree" Patterns of Wax Recorders

No Number Disc Recording Equipment Weekly Test Data (Sample Chart) (4 sheets)

No Number (Sample) Weekly Response Check Studio 1, N.Y.

S-851791 Compression Curve MI-10206 Used as Limiter

S-851772 Compression Curve MI-10206 Used as Compressor

*Review as to possible outline*

Sec. #14  
XIV

"Operation Standards"

XIV-1 "Jack Bay Patching" for Various Types of Disc Recordings

(XIV-2) Recording Standards Sheet for Studio Domestic Recording With Compression

(XIV-3) Recording Standards Sheet for Studio Domestic Recording - No Compression

(XIV-4) Recording Standards Sheet for Studio Orthoacoustic Recordings

(XIV-5) Recording Standards Sheet for Wire Line Orthoacoustic Recordings

(XIV-6) Recording Standards Re-recording from Records. Preliminary.

*Review as to standard setup so as to have some patching each time*

Sec. #15  
XV

"Frequency Response and Performance Data"

S-851769 Wax Recording Amp. Response Mixer-Input to Power Amp. Out

S-851769 Freq. Response Mixer-Input to UI Amp. Out

S-851803 Freq. Response Mixer-Input to Monitor Out

S-851804-1 Overall Channel Response Studio Domestic Recording Using "Lateral" Compensator

S-851805-1 Overall Channel Response Studio Domestic Recording Using Compensated Pre Amps (Non Standard)

S-851806-1 Overall Channel Response Studio Orthoacoustic Recording Mic. Amp. Input to Power Amp. Output

S-851807-1 Overall Channel Response Wire Line Orthoacoustic Recording Mixer Input to Power Amp. Out

S-851808-1 Overall Channel Response Transcription Recording with "Lateral" Compensation

Sec. #16 "Material and Dimensional Data on Recording Blanks and Records"  
XVI T-607517 Record Dimensions 1936  
P-76308 General Recording 10" & 12" 78 RPM Records  
P-76331 " " 16" 33-1/3 RPM Records  
P-718138 Dimensions of 4-1/2" Recording

Sec. #17 "Individual Studio Data"  
XVII

Sec. #18 "Acoustic Data"  
XVIII

Sec. #19 "Addenda"  
XLX

CLASS OF SERVICE

This is a full-rate Telegram or Cablegram unless its deferred character is indicated by a suitable symbol above or preceding the address.

# WESTERN UNION

1201

SYMBOLS

DL = Day Letter

NL = Night Letter

LC = Deferred Cable

NLT = Cable Night Letter

Ship Radiogram

A. N. WILLIAMS  
PRESIDENT

The filing time shown in the date line on telegrams and day letters is STANDARD TIME at point of origin. Time of receipt is STANDARD TIME at point of destination

SB2 24/22=NRH NEWYORK NY APR 13 1030A 1945

W W O'LE, RCA VICTOR DIVN=

REFER TO MASTER REFERENCE BOOK FOR DISC RECORDING SEE CURVES  
S-851804 AND S-851770 FOR RECORDING CHARACTERISTICS IN USE NEW  
YORK AND CHICAGO=

A A PULLEY.

S-851804 S-851770.814AM..

C-9601  
-2-1401