

**A Practical 26 MC. Remote Pickup  
Broadcast System**

**by William C. Grove  
General Manager and Technical Director  
KFBC, Cheyenne, Wyoming**

**July 1958**

**Attention: Engineering Department**

**Engineering Department  
National Association of Broadcasters  
1771 N Street, N.W., Washington 6, D.C.**



## A PRACTICAL 26MC REMOTE PICKUP BROADCAST SYSTEM

By William C. Grove

General Manager and Technical Director, KFBC, Cheyenne, Wyoming

Mr. Grove's original article which appeared in the 4th Edition of the NAB Engineering Handbook, and his paper delivered at the 12th Broadcast Engineering Conference, were combined into a single article by the NAB Engineering Department. We accept full responsibility for any errors or omissions.

### PART 1

The equipment described in this article consists basically of a one-way program shortwave system, operating in the 26 Mc. band, groups D through J, Part 4.401 of the FCC Rules, paragraph 2. The transmitter is intended for mobile use, operating from a standard 6-volt car battery. The major units, except the dynamotor, are component parts of SCR 508 (SCR 528 and SCR 538 also contain the same components), these are the BC 604 transmitter and the BC 603 receiver. The transmitter cost \$3.00, and the receiver cost \$5.95. The incidental components, such as plugs and receptacles, are also mostly available as war surplus. Such items as the transformers for the receiver power supply, microphone sockets, VI meter, will likely be new materials. Spray painting of the components is recommended. Masking of the front panel and name plates will be found quite simple. Duco Feather Grey #246-54909 or equivalent is recommended. Circuit drawings and diagrams are furnished only for the changes and additions, it being assumed the user will procure a copy of War Department Technical Manual TM 11-600 which contains complete circuit and adjustment information of the equipment as originally furnished for the armed services. TM 11-600 does not cover the Dynamotor PE 103. However, the circuit diagram of this unit, as well as changes, is included as Figure 7.

There is one disadvantage to the 26 Mc. band and that is potential diathermy interference. The equipment has one very handy feature to cope with this. The transmitter and receiver both are arranged for ten pre-set channels, inasmuch as the original design covered the band from 20 to 27.9 Mc. Actually, it is customary to apply to the FCC for use of only a single group of frequencies, groups D, E, F, G, and H, consisting of three specific frequencies, and groups I and J consisting of two frequencies. There are thus 19 specific frequencies available for this use in the range from 26.11 to 26.47 Mc. Most stations equip their transmitters with either two or three crystals, as the case may be, and pre-set their receiver push buttons correspondingly. If, during a transmission, diathermy interference occurs, a quick change to an alternate frequency usually eliminates the interference.

Crystals, in mounting FT 241 are readily available on the surplus market and carry the channel number and carrier frequency. The crystal frequency is multiplied 54 times to generate the carrier frequency. Crystals are readily available to produce carrier frequencies just under several of those specified





by the FCC for remote pickup service. They are as follows:

<u>Channel No.</u>	<u>Crystal Freq.</u>	<u>Carrier Freq.</u>	<u>FCC Channel</u>
61	483.333 kc	26.1 Mc.	26.11 Mc.
62	485.185 kc	26.2 Mc.	26.21 Mc.
63	487.037 kc	26.3 Mc.	26.31 Mc.
64	488.889 kc	26.4 Mc.	26.41 Mc.

These crystals are wire mounted, and silver plated. They vibrate in such a mode that the frequency is determined, for a given crystal, and within limits, by the large dimensions. Grinding one edge a very small amount will raise the frequency of the crystals listed above to exactly fit the corresponding FCC channel. It is also entirely feasible to grind somewhat more from the edge of the crystal, raising the frequency to one of the higher channels. The crystal mounting base is clamped in a vise and the crystal itself held by its edges by means of a pair of long nose pliers the prongs of which have been covered with either thin rubber tubing, rubber tape, or masking tape. A few light strokes of very fine sandpaper will take off sufficient material to raise the frequency measureably. Results are better if the sandpaper is wet. It is necessary in this case to wash and dry the crystal each time it is tested as to frequency.

The frequency of 26 Mc. lends itself to the use of a quarter wave whip type antenna suitable for mounting on a vehicle. The equipment described consists of a battery-operated transmitter and a 110 volt AC operated receiver. The transmitter was originally designed as a plug-in unit, and this feature has been preserved. As used by the Armed Services, the standard installation was one transmitter and two receivers, plug-in mounted upon a sturdy shock-mounted base, known as the FT 237 mount. As modified, the mount is shortened and re-wired.

The transmitter is frequency modulated, using a novel modulator, known as a Peterson Coil. This is a small toroid, using a permalloy ribbon core. The coil, which bears circuit designation L 104 in the schematic, carries RF current at crystal frequency, which is approximately 450 Kc., from the crystal amplifier stage V101. Also through the coil passes the audio modulating frequency from the second audio stage V106. The current magnitudes are so arranged that, superimposed, they saturate the core of the modulator coil. Relatively large inductive kicks or spikes are caused by the saturation, and the phase relation of these inductive kicks produces the phase or frequency modulation. The sharp spikes thus caused also make it entirely practical to pick off the ninth harmonic and amplify it in the following stage. A doubler and a tripler follow, then a power amplifier, and thus, with a minimum number of tubes, consequently low total battery drain, a carrier frequency which is 54 times crystal frequency, is reached. The principal advantage of this system of modulation is that there are no heavy audio transformers. Modulation occurs at a low audio



level, there being only two tubes used from microphone level to modulating level. There are only eight tubes used in the entire transmitter, 6 6V6GT, 1 6L6, 1 807. These replace the original complement of 7 Type 16L9 and 1 Type 1626, which are a two-volt direct filament type, used for quick heating, making a complete push-to-talk operation feasible, with no idling current drawn from the battery as far as the transmitter is concerned. It was found that the original tubes were unsuitable since car generator and other noises came through into the audio, hence the change to heater type tubes. A disadvantage of this type of modulator, and a very serious one, is the fact that the amount of phase shift, hence percentage of modulation, is proportional to audio frequency. While for the original purpose of voice communication, it proved quite satisfactory, the lack of bass response is objectionable in many applications for broadcast station use. The overall frequency response may be greatly improved by the addition of a simple circuit for bass frequency re-emphasis in the receiver. The network consists of the addition of two .01 condensers and one 12,000 ohm resistor and is illustrated in Fig. #1. A slight addition to the bass response in the audio circuits of the transmitter\*will bring the over-all audio response, transmitter microphone terminals through receiver audio output, to within plus or minus 3 db from 75 to 15,000 cycles. The circuit accomplishes negative feedback in the receiver at frequencies above 500 cycles, and, due to an unexpected assist from a very poor audio system ( poor from the standpoint of the broadcast engineer ), there is a phase reversal, or near reversal, at the low end with the combination over-all, and at 60 cycles there results actually a gain in the audio system from the addition of this negative feedback. The figure shows the basic audio system of the receiver and the heavy lines indicate the additions.

The volume control on the front of the receiver now becomes more of a tone control and should, under conditions for best audio response, be left full clockwise. Since it is now within a heavy feedback loop, rotation counter-clockwise for the first approximately 200 degrees of rotation, serves only to drop the audio response at both the high and low ends of the range, mostly at the low end, and reduces audio volume very little. In extreme cases of noise, when too great a range of transmission is being tried, and the received signal is filled with ignition and other noise, this can be of some use. However, over-all circuit noise out of the receiver will be at least 45 db down, and sometimes 50 db down. This does not take into account atmospheric noise, which is mainly a matter of propagation path and receiving antenna efficiency. Audio distortion will be less than 3% over the range 75 to 7500 cycles. It was discovered that a poor commutator in the dynamotor, especially in the low voltage side will at times contribute a surprising amount of low frequency noise.

The receiver, the BC 603, will almost always be used at a fixed location, such as the main studio. When the receiving location is also the location of the broadcast transmitter, additional problems are frequently encountered. These are not insurmountable. The first thing to take into consideration, is to select a group of frequencies that are not harmonically related to the broadcast frequency. This is examined before the remote pickup CP is applied for. Next, watch out for harmonics at the IF frequency, which is 2.65 Mc. Stations on frequencies around 880 and 1320 might expect trouble from this score with the

\* For further information regarding this modification, see Figures 10 a, b, c.





receiver located at the main transmitter. At KSID in Sidney, Nebraska, much difficulty was experienced when the receiver was located within 18 inches of the 250-watt broadcast transmitter. However, when it was moved to the basement, everything was fine. KSID operates on 1340, the second harmonic being 2680. The IF must be broad to prevent amplitude distortion of the frequency modulated signal. The original dynamotor is replaced by a 110-volt rectifier which is built on the dynamotor base, and plugs in just as the dynamotor did. No tube changes in the receiver are involved. The receiver is of moderate sensitivity, and is reasonably stable if warmed up a half hour or so. It has an effective squelch, which will cause audio distortion also some noise if left on during a program. A sensitive relay could easily be added so that a bell will ring upon a roving reporter calling in. For special applications, where it is desirable to work the receiver from a 6-volt source, a vibrator supply, constructed on the dynamotor base, to preserve the plug-in feature, was found much quieter than the original dynamotor, and the dynamotor is available only in the 12-volt or 24-volt rating.

Where the propagation path from the desired remote pickup point is too great for dependable operation, much use has been made in Cheyenne of locating the receiver at a remote point, its power being turned on and off by remote control, simplexed over the telephone line used to carry the audio from the receiver to the studio. For special events such as fires, disasters in nearby towns, the central telephone office in that town is a logical place, particularly if it is a small town. Actually, a telephone office is a prolific source of local interference, but if the program is only a short distance away, as it would be in a small town, the noise is taken care of by the limiter. It is convenient to have special toll facilities quickly available. Holding a telephone instrument up to the loudspeaker of the receiver is another expedient that has been used, in order to " get the show on ", taking advantage of the beep type service.

As originally manufactured, the transmitter was designed to work from a carbon microphone or telephone type microphone, or transmitter, as the phone people call it. This feature has been preserved. All that is necessary is to plug in the carbon microphone, such as a T-17 which is available on the surplus market. The transmitter can be easily installed in other vehicles than an automobile, such as a train, an airplane, or a boat. Several installations in trains and airplanes have been made in Cheyenne. In a plane, the background noise level is so high that results are practically worthless and unintelligible with the usual dynamic broadcast type microphone such as RCA 88. However, with the carbon microphone, the signal comes through loud and clear, the noises being discriminated against by the restricted audio range of the carbon microphone, and the fact that anybody just naturally talks much closer to this kind of microphone.

Remote Pickup Broadcast Stations may be used for:

1. Transmission of AM, FM or the aural portion of TV program material originating outside a regular studio. ( Normally, only mobile stations are used. )



2. Orders and related communications directly concerning such transmissions, but may not be used to provide private mobile telephone systems to station personnel. ( Both base and mobile stations may be so used. )
3. Emergency program or order circuits from studios in the event of failure of regular wire circuits, but may not be used for such purposes on a regular basis. (Both base and mobile stations may be so used. )
4. In Alaska, Hawaii, Puerto Rico and Virgin Islands for inter-city relays and STLs provided such transmissions are not intended to be received directly by the public. Such use is not authorized in the continental limits of the U. S. (Both base and mobile stations may be so used. )
5. Under STA for mobile communications in connection with adjustment and maintenance of antenna system, or in connection with field intensity surveys. ( Both base and mobile stations may be so used. )
6. Coordination of the activities of portable or mobile stations.
7. Two-way communication between the studio and transmitter of a broadcast station which has a radio STL. ( Base stations only. )

Wire lines may be used to complete remote pickup circuits, if necessary.

Remote pickup broadcast stations will not be granted exclusive frequency assignments, and the same frequency or frequencies may be assigned to other licensees in the same area.

Applicants may request information about the existing remote pickup assignments in a particular area, and apply for unassigned frequencies to the extent permitted by the FCC rules. The Commission is unable to supply information regarding existing assignments to the Industrial Radio Stations in the band shared by remote pickup stations with the service.

Where a frequency is shared by two or more remote pickup stations and simultaneous operation is contemplated, the transmission of actual program material has first priority, the transmission of cues and orders including preparatory communications has second priority, and the use of the remote pickup station for other authorized communication has the lowest priority.

The FCC has assigned exclusively to the remote pickup broadcast service the following 19 channels between 26.11 mc and 26.47 mc.

26.11 Mc.	26.17 Mc.	26.23 Mc.	26.29 Mc.	26.35 Mc.	26.41 Mc.
26.13 Mc.	26.19 Mc.	26.25 Mc.	26.31 Mc.	26.37 Mc.	26.43 Mc.
26.15 Mc.	26.21 Mc.	26.27 Mc.	26.33 Mc.	26.39 Mc.	26.45 Mc.
					26.47 Mc.



Under Part 4, Subpart D, of the FCC rules and regulations the above and other frequencies are authorized for remote pickup broadcast stations. The use of these frequencies is permissible regardless as to the availability of telephone lines. A license will be issued by FCC to an established broadcasting station and renewals may be made concurrently with the application for renewal of the regular station license. Application for construction permit is made using FCC Form 313 which is a short form and requires only a minimum of information. Application for construction permit and license may be submitted simultaneously following instructions on FCC Form 313.

1. Type of station ( remote pickup ).  
Station with which proposed station is to be used ( your call letters ).
2. Frequency ( one of those listed above ).  
Power ( 40 watts )  
Type of emission ( FM ).  
Communication bandwidth, kc.  $2(8.5 + .005\%$  of carrier frequency in kc)  
Example:  $2(8.5 + .00005 \times 26,410)$   
 $= 2(8.5 + 1.3205)$   
 $= 2(9.8205)$   
 $= 19.641$  kc
3. Location of transmitter ( vicinity of city in which standard station is located ).
4. Antenna system ( vehicle mounted whip 114 inches high ).
7. Transmitter manufacturer ( various )  
Type No. ( BC-604 modified )  
Maximum rated power output ( 40 watts )  
Oscillator, type of circuit ( crystal )  
Oscillator frequency ( carrier frequency divided by 54 )  
Oscillator tube type ( 6V6 GT ), make ( various ), number ( one )  
Last radio stage:  
Tubes, make ( various ), type ( 807 ), number ( one )  
Normal plate current ( 120 ma ), plate voltage ( 500 ),  
modulation ( not modulated )
8. Percentage of modulation or swing ( 8.5 kc )  
Frequency tolerance per cent ( .005% )  
Means for maintaining frequency tolerance ( temperature controlled CT cut crystal )  
External means employed to insure maintenance of assigned frequency within tolerance specified by FCC rules ( BC-221 frequency meter or crystal controlled multivibrator, checked against WWV ).

Rule 4.481 requires that a simple log be kept of each transmission. An operator holding a commercial license or permit is necessary at the remote pickup transmitter





UNITED STATES OF AMERICA  
FEDERAL COMMUNICATIONS COMMISSION

APPLICATION FOR AUTHORIZATION IN THE  
AUXILIARY RADIO BROADCAST SERVICES

INSTRUCTIONS

- A. This form is to be used for Remote Pick-up, Broadcast STL, Television Remote Pick-up, Television STL, or other stations coming under the Auxiliary Radio Broadcast Services (see Part 4 of the Rules). This form is to be used only by licensees or permittees of existing Standard (AM), FM, Television, and International Broadcast Stations.
- B. Complete all paragraphs if for a new station or for modification of construction permit or license; complete paragraphs 1, 2, 3, and 7 if for a license; complete paragraphs 1, 2, and 7 if for renewal of license.
- C. Prepare and file two copies (three for Television), and swear to one copy. File with the Federal Communications Commission, Washington 25, D. C.
- D. Number exhibits serially in the spaces provided in the body of the form and date each exhibit.
- E. The name of the applicant must be stated exactly as it appears in the authorization for the broadcast station with which the auxiliary station is to be used.
- F. This application must be executed by applicant if an individual; by one of the partners of applicant if a partnership; by an officer of applicant if a corporation or association; or by attorney of applicant only under conditions shown in Section 1.303, Rules Relating to Organization and Practice and Procedure, in which event satisfactory evidence of disability of applicant or his absence from the Continental United States and authority of attorney to act must be submitted with application.

FILE NO.

Name of applicant (See Instruction E)

Post-office address (Number, street, city, State)

1. Purpose of this application (Indicate below)

- (a) Type of station .....
- (b) Kind of authorization requested:  
 New Station     Modification of Existing Authorization  
(Construction Permit)  
 License         Renewal of License
- (c) Modification of existing authorization:  
 Call .....

  - Change frequency . . . . .
  - Replace equipment . . . . .
  - Change power . . . . .
  - Install different antenna system . . . . .
  - Other modification (explain below) . . . . .

- (d) Renewal of license:  
 Call .....

Have there been any changes since the date of the last authorization? . . . . . Yes  No

If so, indicate the changes in the appropriate paragraphs in this form.

- (e) Broadcast station or stations with which station is to be used:  
 Call .....

2. Facilities requested

FREQUENCIES	POWER <sup>1</sup>	TYPE OF EMISSION <sup>1</sup>	COMMUNICATION BAND WIDTH (KO) <sup>2</sup>

<sup>1</sup> For amplitude modulation television (A5), give maximum antenna input power during synchronizing pulses. If particulars are not fully described above, such as aural and visual carrier frequencies for television and type of emission, etc., supply this information below:

<sup>2</sup> Use emission symbols listed in Part 2 of Commission's Rules.  
<sup>3</sup> Communication band width is the actual band width of the emission plus twice the frequency tolerance. (See appropriate service rules for permissible band width.)

3. Location of proposed transmitter

(a) For stations with fixed location

STATE	COUNTY	CITY
STREET AND NUMBER (or other description of location)		
NORTH LATITUDE	"	WEST LONGITUDE

(b) Receiving point

STATE	COUNTY	CITY
STREET AND NUMBER (or other description of location)		

(c) For portable or mobile operation

Area in which station is to be used

---

4. Antenna system

(a) Description (including manufacturer and type number, if any)

Is a directional antenna system to be used? . . . . . Yes  No

If "Yes," specify antenna gain in the main lobe of radiation, preferably in terms of free-space field in millivolts per meter for 1 kilowatt at 1 mile.

Direction of radiation of the main lobe of the transmitting antenna in degrees, measured in a clockwise direction with true north as zero azimuth. (If more than one antenna is used, give direction for each.)



**4. Antenna system—Continued**

b. Supply the following for fixed installations only:

Over-all height above ground level in feet	Over-all height above mean sea level in feet
--	--

Description and height of supporting structure (Differentiate between structure now existent and that to be erected.)

Is supporting structure to be used in common for the antenna system of another class of station? Yes  No   
If the answer is "Yes," give—

Class of station(s)	Call letters
---------------------	--------------

If the over-all height above ground exceeds 150 feet, attach as Exhibit No. .... a sketch of vertical plan, showing heights of significant portions.

5. If cost involved exceeds \$1,000, submit as Exhibit No. .... a statement itemizing cost and a balance sheet of the applicant as at the close of a month within 90 days of the date of the application.

6. If this application is for a television remote pick-up or television STI, station incorporating an aural transmitter, the information requested in paragraphs 7 and 8 should also be supplied for the aural transmitter on an additional sheet.

**7. Transmitting apparatus proposed to be installed**

Manufacturer	Type No.	Maximum rated power output
--------------	----------	----------------------------

Oscillator:

Type of circuit	Frequency
-----------------	-----------

Tubes:

Make	Type	Number
------	------	--------

Last radio stage:

Tubes

Make	Type	Number
------	------	--------

Normal total plate current in last radio stage	Plate voltage	Method of modulation
--	---------------	----------------------

**8. Frequency and modulation**

For what percentage of modulation or swing is the transmitter designed?

What is the guaranteed frequency tolerance in percent?

Describe means incorporated in the transmitter for maintaining the frequency tolerance stated above.

What external means will be employed by the applicant to insure that the assigned frequency is maintained with the tolerance specified by the Commission's Rules?

The applicant waives any claim to the use of any particular frequency or of the ether as against the regulatory power of the United States because of the previous use of the same, whether by license or otherwise, and requests an authorization in accordance with this application. (See Section 304 of the Communications Act of 1934.)

The applicant represents that this application is not filed for the purpose of impeding, obstructing, or delaying determination on any other application with which it may be in conflict.

All the statements made in the application and attached exhibits are considered material representations, and all the exhibits are a material part hereof and are incorporated herein as if set out in full in the application.

The applicant, or the undersigned on the applicant's behalf, states that he has endeavored to supply full and correct information as to all matters which are relevant to this application and that he has done so as to all matters within his own knowledge.

Dated this ..... day of ....., 19..... (Name of applicant)

Subscribed and sworn to before By .....

me this ..... day of ....., 19..... (Title)

[SEAL] ..... Notary Public.

(Notary public's seal must be affixed where law of jurisdiction requires, otherwise state that law does not require seal.) My commission expires .....

**Exhibits furnished as required by this form:**

Exhibit No.	Para. No. of Form	Name of officer or employee (1) by whom or (2) under whose direction exhibit was prepared (show which)	Official title





The equipment described has been in use for over ten years, and hundreds of transmissions have been successfully relayed over KFBC. Many other stations have used identical equipment successfully. The range of reasonably quiet transmission is determined largely by the height and efficiency of the receiving antenna. Several stations report ranges of from ten to twenty-five miles. A good average figure is about four or five miles. In large metropolitan cities when working from locations surrounded by extremely tall steel buildings, particularly when the receiver is at some distance from the transmitter, deep fading effects may be experienced and it is likely that in these locations somewhat better results might be experienced with equipment operating on the higher frequency bands. Little difficulty has been experienced in towns of less than 100,000 population from these effects.

## PART 2

### MATERIALS NEEDED

#### Transmitter

1 BC 604 transmitter  
6 6V6GT tubes  
1 6L6 tube  
1 807 tube  
1 RCA K900849-501 microphone input transformer, or equivalent  
3 .001 300v mica condensers  
1 10 mmf 300 v mica condenser  
1 2200 ohm 1/2 watt carbon resistor  
1 510 ohm 1/2 watt carbon resistor  
1 16 to 20 mfd 450 volt tubular electrolytic condenser  
1 10 to 10 mfd 25 volt tubular electrolytic condenser  
1 40 mfd 25 volt tubular electrolytic condenser insulated tie points  
2 75 ohm 1/2 watt wire wound or carbon resistors  
7' shielded insulated stranded, single conductor hook up wire  
5' insulated stranded single conductor hook up wire  
18" varnished cambric tubing  
20' lacing cord  
1 3 ohm 2 watt wire wound resistor  
1 crystal, in FT 241 mounting  
1 100,000 ohm 1/3 watt carbon resistor

#### Receiver

1 BC 603 receiver  
1 1/2 watt 2500 ohm resistor  
1 small banana pin and socket  
1 miniature bayonet base lamp socket  
2 20 mfd 250 volt tubular electrolytic condensers  
1 .1 mfd 300 volt paper condenser



BC 603 Receiver Power Supply

- 1 base from dynamotor DM 34 or DM 36
- 1 Stancor plate transformer P-6134 or equivalent
- 1 Stancor filament transformer P-6010 or equivalent
- 2 500 ohm 10 watt resistors, wire wound
- 1 octal tube socket
- 1 110 volt power cord and convenience plug
- 1 5Y3GT tube
- 1 20 mfd 250 v condenser
- 1 75 mfd 250 v condenser

Transmitter Mounting

- 1 transmitter mounting FT 237D
- 1 socket SO-45
- 1 cannon receptacle, male P8-42
- 1 SPST toggle switch

Dynamotor

- 1 PE 103 dynamotor
- 1 20 ohm 1/2 watt wire wound resistor
- 1 16 mfd electrolytic tubular condenser, 600 v

Remote Control Unit

- 1 box, removed from dynamotor BD 77c or similar, or plain steel box, 9" long, by 5-1/2" wide, by 3" deep
- 1 no-insertion loss, T wire wound or carbon 250 ohm volume control (1800 ohm simple rheostat in shunt with mic will work quite well)
- 2 miniature bayonet-base pilot lamp mountings and 6 v lamps
- 1 V I meter, Weston Model 301, type 23, 5000 ohm resistance or equivalent
- 1 open circuit headphone jack ( two in parallel if desired )
- 1 hinged jack dust cover
- 1 six contact banana plug, male, receptacle, SO-45
- 2 microphone sockets, to match station's mike plugs
- 1 DPST toggle switch
- 1 DPDT toggle switch
- 1 5000 ohm 1/4 watt carbon resistor

Transmitting Antenna

- 1 commercial police type mobile antenna mounting swivel, spring, and insulator
- 1 mast section MS 49
- 1 mast section MS 50
- 1 mast section MS 51



### Cables

- 1 dynamotor cable shielded, CD 501A, with male plug, P8-24 on one end, and female connector P8-23 on the other end, 8 contact ( 7 contacts only used ). This fits the socket P8-41 on the PE 103 dynamotor and connects the dynamotor to the transmitter mounting.
- 1 15-foot length cordage CO 213. This is a seven-conductor rubber covered, shielded cable, with two of the conductors separately shielded within the overall shield. CO 213 is a component part of SCR 508.
- 2 plugs PL 106. These are six-contact female cord connectors and are attached to the ends of CO 213 and the cord thus constructed is used to connect the remote control box with the transmitter mounting, plugging into socket SO 45 on each end.

### PART 3

#### INSTALLATION

#### Receiver

Results as regarding distance covered without objectionable noise will depend largely upon the height and efficiency of the receiving antenna. A ground plane quarter wave antenna or co-axial half wave antenna located on top of the main transmitting tower will probably be the best, provided, the main transmitter is not too far removed from the area in which most of the relayed programs will originate. Next best is a similar antenna on top of a tall building in the center of the area in which programs will originate. Good results can be had over shorter distances with an antenna located in an open and quiet location on a 40 foot telephone pole. The receiving antenna is matched to a concentric transmission line such as RG 12U and the line connected to the receiver. The squelch control of the receiver should be OFF during program reception. The audio output is taken from the receiver at the phone jack. VOLUME is adjusted for +4 VU into 500 ohms. One side of output is grounded. The receiver should be peaked at carrier frequency by means of the RF trimmers. It is vital that the antenna trimmer be so peaked.

#### Transmitter

If a pleasure car is used, the transmitter is installed in the luggage compartment, on the left side. The mounting is screwed to the floor by means of heavy sheet metal screws or bolted down. It must be carefully grounded to the chassis of the car.





### Transmitting Antenna

Transmitting antenna is mounted on the left side of the body of the car at the rear, keeping the antenna lead as short as possible. Use three mast sections, a total of 11<sup>1</sup>/<sub>4</sub> inches. A commercial police type antenna mounting and insulator, which includes a spring to protect in case of driving under an obstacle, should be selected.

### Dynamotor

Mount the dynamotor permanently in the rear luggage compartment, next to the transmitter, on the right side of the car. Clamp the low voltage lead to the frame of the car. Cut a hole 1-1/4 inches diameter thru the floor. Pass the + low voltage lead thru the hole, and forward to the car battery. Clamp the lead directly to the hot terminal of the battery, splicing with similar cable if necessary. Clamp by means of pipe straps and tie snugly to the under side of the floor of the car to prevent chafing and shorting. By means of cable CD 501A connect dynamotor to transmitter mounting.

### Remote Control

Pass remote control cable around the back of the rear seat, forward to the driver's seat. Lay the remote control on the seat. Make the cord sufficiently long so that the operator may stand on the street with the remote control in hand, beside the car.

## PART 4

### OPERATION

Leave the filament switch of the transmitter on. Leave the high voltage and main overload switches of the dynamotor on. Turn the filaments on by means of turning on the filament overload of the dynamotor ( the switch nearest to the hinge of the door covering the overload control ). If left on continuously, this switch causes a small drain of about 15 milliamperes on the battery. Allowing the normal time for the filaments to warm, turn the DYNAMOTOR switch of the remote control to ON position. This applies high voltage to the transmitter, and places the carrier on the air. Microphones of an output level as great as that of the RCA 88 type must be used. Those of a low output level such as the RCA 44 type will not fully modulate the transmitter. Such microphones can be used, however, using a regular remote amplifier, the output of which is fed through the microphone terminal of the remote control, or directly into the transmitter through the MAGNETIC MIC socket. Once properly tuned up, the transmitter and transmitting antenna circuits will need little re-adjustment. These circuits will keep their adjustment even though the car is driven over hundreds of miles of rough roads. The equipment has been used for many years with any re-adjustment of any kind.



Since the equipment draws approximately 32 amperes from the 6 volt battery, it is well to run the car engine if transmissions are longer than 15 minutes.

For transmission from airplanes where the acoustic noise level is high, provision in the modification instructions is made for use of a carbon microphone. In such conditions, the carbon mic will give better overall results than a high quality broadcast type mic. The close-talking variety such as T-17 is most suited. The carbon mic is plugged into the " CARB MIC " jack. The volume control on the remote control is turned off during use of the carbon mic. No variable volume control for carbon mic is provided. However, the " TANK OTHER USE " switch is a high-low carbon mic volume control. The gain for a given carbon mic can be adjusted by shunting resistor R120 within the transmitter. The volume will be indicated on the V I meter. It should be anticipated that the announcer will use a high voice level under high noise conditions.

## PART 5

### TRANSMITTER NOTES

Since the type 1619 tubes have been replaced in the RF lineup with type 6V6GT, and since the 6V6GT has a different internal capacitance between the elements than the 1619, the trimmer condensers across the tuning coils will have to be changed to compensate. While this effect is very substantial, nevertheless, the condensers do not need to be rotated more than about 15 degrees, in order to bring the circuits into resonance. Some will be increased, some decreased. The tuneup procedure is to set the meter switch at position #3, Rectifier Grid Current, and rotate the main tuning shaft until a reading of 20 or 21, or maximum on the meter is had. Then set the meter switch to position #4, Doubler Grid Current, and adjust C153 and C157 for maximum meter indication. Next, set the meter switch to #1, Tripler Grid Current, and adjust C114 and C116 for maximum meter deflection. Next, set the meter switch to #5, Power Amplifier Grid Current, and adjust C120 for maximum deflection on the meter. Great care must be used to see that the 9th harmonic of the crystal frequency is selected in the plate circuit of the rectifier tube and not some other harmonic. One method, before modifying, is to connect the transmitter by means of using dynamotor DM-35 and a 12 volt source and a dummy antenna A162, and rotate the main tuning shaft with the tuning lock loosened until maximum output into the dummy antenna is had, all in accordance with instructions contained in the technical manual.

By using an absorption type wave meter, the proper harmonic can easily be selected and with such an instrument at hand, it should be not necessary to tune up the transmitter initially before making the modifications. There is the advantage, however, since surplus and not new equipment is being used, that if there may be any defect in the transmitter it can more easily be located and remedied if the transmitter is tested before modifications are undertaken.





Typical meter indications, after conversions outlined herein, are:

<u>Meter Position</u>	<u>Circuit Metered</u>	<u>Meter Reading</u>
2	RF Amp. grid	19
3	Rectifier grid	21
4	Doubler grid	20
1	Tripler grid	23
5	Power Amp grid	20
6	Total B supply current	60

The only value that is critical is the Rectifier Grid Current, meter position #3. The only requirement in the other grids is that sufficient grid excitation be had in each stage to drive the stage following and to secure stability of operation.

The SIDETONE control adjusts the voltage fed to the V I meter. With a meter as specified, the proper setting of this control will be about 15 degrees less than maximum clockwise position. Apply 1000 cycles of audio frequency to the microphone input, at such level as to cause 11.5 volts to appear at terminal 21 of FG 101 of the BC 604 transmitter, with V I meter and headphones of the remote control disconnected, measured with a vacuum tube voltmeter, with SIDETONE at maximum clockwise. This will produce a frequency swing of about 5 Kc. Modulation peaks will achieve the legal limit of 8.5 kc swing. Connect the V I meter, insert high impedance headphones, and adjust SIDETONE control to indicate +4 on the V I meter.

If the transmitter is adjusted so that a reading of other than 20 or 21 with meter selector on position 3 is obtained, the carrier swing, ( modulation percentage ) and distortion will not be optimum. This reading can be controlled by changing the screen grid voltage of the first RF amplifier, V101, by changing the value of R103.

The antenna current meter reads not only the antenna current, but the capacitance current of the small section of concentric line in the antenna circuit.

Frequently, large scale readings of antenna current can be had with the antenna entirely disconnected. Two antenna mast sections will produce a higher antenna current reading than three, but three will give considerably more radiation than two.

There is provision for operation on ten different frequencies, changed by means of pressing a single push button. For this application, the trimmers should be peaked at the single frequency, disregarding tracking over the whole band. Following the tuning instructions of Technical Manual TM 11-600 in every other respect.

The modifications make inoperative the RECEIVER-TUNE and RADIO-INTERPHONE switches. Tune the output stage and antenna coupling circuits for maximum antenna current, with three masts connected.



PART 6

BC 604 TRANSMITTER

Following is a step-by-step procedure for modifying the BC 604 transmitter. The essential modifications are; Change microphone input transformer to improve frequency response and reduce noise; change direct heated filament tubes to cathode type, to adapt filament supply to 6 volts and to reduce noise; change certain circuit elements to retain proper voltages on tube elements when plate supply is reduced to 500 volts; secure bias of audio stages from cathode resistors instead of filament drop. Figures 2, 3, and 4 pertain to these notes, and the numbers circled in Figures 2 and 3 refer to paragraphs 1 and 2 of these notes.

1. Unsolder heavy wires and smaller wire from contacts of dynamotor relay S102. Clip leads to coil of S102, at S102. Remove 4 screws holding relay S102, and remove relay. Remove 2 screws holding condenser C162. Clip strap connecting + end of C162 to tie point. Cut wire connecting - end of C162 to R133, at R133. Remove C162. Unsolder heavy wire that connected relay S102 at #1 and #3, PG 104, and discard. Splice heavy wire that formerly connected #1, PG101 to contact of S102 to smaller wire that formerly connected to same contact of S102, and slip piece of spaghetti over splice. This wire feeds battery to filaments. This operation removes the dynamotor relay and associated condenser since they are no longer needed, but preserves the filament feed.
2. Mount 16 mfd 450 v electrolytic lengthwise of transmitter in space formerly used in part by dynamotor relay S102. Connect positive end of this condenser to hot terminal of C145 ( or R147 ) with a wire about 6" long and negative end to that end of R130 that is connected to #4, PG103 ( -B ) or using a longer wire run direct to #4, PG103, if preferred.
3. Install RCA mike transformer K900849-501 in space formerly occupied by relay S101 and condenser C162.
4. Disconnect WH lead that connects D126 ( Tank-other use ) switch to #2 VS107, at #2 VS107, and ground D126 using same WH wire, shortened, connecting at solder lug close to D126. ( This is necessitated by other changes in filament circuits. ) Clip wire at #2, VS107. Don't try to unsolder it here.
5. Change lead connected to #2, VS101 from #7, VS106 to #2, VS106. Filament.
6. Ground #7, VS106 to ground lug, not to #8, VS106, because #8, VS106 will be lifted from ground later. Filament.
7. Disconnect lead connecting #2, VS106 from C139 at C139 end. Connect #2, VS106 to #2, VS105, using this wire that formerly connected to C139. Filament.
9. Disconnect lead from #7, VS105, which runs to R127, and pull from cable and discard. Also discard R127, unsoldering other lead to R127 at R127. Filament.



9. Ground #7, VS105.
10. Ground #7, VS101, using wire that formerly connected #7, VS101, to R127.
11. Cut strap connecting R113 to R140 and R141 at R140 and R141. Remove screw holding R113 and disconnect R113 from #7, VS102 at R113, and use wire formerly connected to R113 to connect #7, VS102 to R140 and R141 at former junction with R113. Cut yel wire that connects to lamp ES 101 from R113 and reconnect to R140 and R141 at former junction of R140 and R141 with R113. ( Cut wire from R113. Don't try to unsolder.) This connection is made to the accessible end of R141. Discard R113. Filament.
12. Connect #7, VS102 to #1, VS104, with a wire 13" long. Filament.
13. Change #7, VS108 from #7, VS103, to #7, VS102. Filament.
14. Ground #7, VS103. Filament.
15. Ground #2, VS108. Filament.
16. Ground #2, VS102. Filament.
17. Disconnect C110 from #2, VS102 and discard. There is no C110 in later units.
18. Install 510 ohm, 1/2 watt, resistor between #8, VS106 and ground removing ground from #8, VS106. Cathode bias resistor.
19. Install 10 mfd 25 or 50 v electrolytic condenser between #8 and ground, VS106, + to #8 ( cath. ). Cathode by-pass.
20. Install 2200 ohm, 1/2 watt, resistor between #8 and ground, VS105, removing ground from #8, VS105. Cathode bias resistor.
21. Install 10 mfd 25 v or 50 v electrolytic condenser between #8 and ground, VS106, + to #8. Cathode by-pass.
22. Disconnect BL-YL wire connecting #8 on PG103 (+HV) to F161 at F161, and tape end and tuck under cable, and use concentric line that connects C161 to #A2, PG101, for this + HV lead, making +B come through A2 on PG101 for using external dynamotor. Disconnect C161 from end of co-ax transmission line. Cut BL and GR wires from center contact of S101. Unsolder bus wire connecting L111 to S101 at L111 and discard bus. Unsolder short co-ax that connects "ANT" terminal to S101, at S101. Remove the four mounting screws of S101. Clip the BLK wire and the BL-OR wire connecting to the coil of S101. Cut the BLK-RD and RD wires from S101. Remove relay S101. Mount an insulated tie point in relay mounting screw hole near end of co-ax cable connecting to A2, PG101. Solder end of co-ax to tie point. Connect tie point to F101 by means of an insulated stranded wire 19" long, taking this wire through hole A.



Tie this wire to cable at top of transmitter, also at end removing plate at right end of transmitter to make cable accessible. See paragraphs 43, 44, and 45 for disposition of the rest of the wires that formerly connected to S101.

23. Disconnect transformer T101 primary from terminals C and D of J101 at J101, and install condensers from C and D to ground (.001) and connect shielded wires from C and D to #4 and #1 of RCA mike transformer K900849-501. Ground shields at jack J102 ( to solder lug installed under mounting screw ) and ground shields at transformer. Prepare and connect to transformer K900849-501 an additional shielded wire to each #1 and #4 and to #5 and #7 to be used later. Ground lug #6 of transformer K900849-501 to 6-32 screw adjacent, using soldering lug and small 6-32 nut. Run wire from this soldering lug to ground at C143. Slip spaghetti over ends of wires removed from C and D, J101.
24. Remove lead connecting #5, VS105 to #5, T101 and discard lead. If a small mica condenser is connected to #5, VS105, leave it connected to #5 but move other end from #2, VS105 to #8, VS105.
25. Run shielded lead from #7 transformer K900849-501 to #5, VS105. Ground shield at both ends. Audio grid lead.
26. Connect shielded wire from #5, transformer K900849-501 to #6, VS105, (used as tie point). Ground shield at both ends.
27. Disconnect wire that runs from junction of C137 and C138 to #4, T101 at T101 end, and connect junction of C137 and C138 to #6, VS105, (actually #5, transformer K900849-501). It may be advisable to replace the existing wire which is solid with a new wire about 3" long, which is stranded. Do not solder #6, VS105, until after next step is completed.
28. Connect 1/3 watt, 100,000 ohm resistor from #6, VS105, to #1, VS105, and a .001 postage stamp condenser from #6, VS105, to #8, VS106.
29. Disconnect BL-OR wire connecting C of C142.1 and C142.2 to C138 at C139 and move to #8, VS106 (it formerly went eventually to VS106, #2). Plate and grid isolation filters.
30. Disconnect R121 from C139.
31. Connect C139 (terminal formerly connected to R121) to #8, VS105. Screen grid by-pass, V105.
32. Solder the ground lug of an insulated tie point to the terminal of C138 nearest PG101, and connect the end of R121 that formerly connected to C139 to the tie point. Connect a 75 ohm 1/2 watt resistor from #2, VS106 to the tie point. Remove dust shield from trimmer con-





densers and S104. Disconnect C144 from radio-interphone relay S104, at S104, also at C144, and discard the wire. Connect a new wire 8" long from C144 to the tie point to which R121 is now connected, using hole E. Carbon mike button current feed and filter.

33. It is necessary to remove four mounting screws holding PG101, also spacers. Be sure spacers and grounding straps are restored after connections have been made. PG101 must be free to move. Connect #4, PG103 to #3, PG101, (-HV) with a wire 8" long. Connect #1, transformer K900849-501 to #4, PG101, using shielded wire and ground shield at transformer end. Connect #4, transformer K900849-501 to #5, PG101, using shielded wire and ground shield at transformer end. This operation disconnects mike circuit of T101 and substitutes transformer K900849-501 for T101 and connects -HV of dynamotor to R130. Disconnect present wires from #4, PG101 and #5, PG101 and slip spaghetti over ends and tuck under cable. Slip spaghetti over new wires to be connected to #3, #4, #5, of PG101 and slide same over terminals after soldering.
34. Disconnect at socket shielded wire from #5, VS106 which goes to #2, S104, thus removing R148 from the circuit and raising the gain of the audio amplifier. Some sets do not have R148 and have no connection to Sec. 2, S104, and Para. 34 can be disregarded in these cases. The purpose of R148 is to reduce the audio gain while transmitting and, in any event, this gain reduction circuit is not desired in this application. The easiest way may be to clip also the other shielded wire of this pair, at #6, VS106, (used as tie point), also the ground of the shield, so spaghetti can be slipped over end of entire cable and cable tucked away adjacent to relay S103. R148 may also be disconnected from #6, VS106, also at its other end, and discarded.
35. Connect A 10 mmf. condenser from #5, VS105, to #8, VS105, keeping leads not over 3/8" long. Some transmitters already have such a condenser connected from #5, VS105 to #2, VS105. If so, this condenser has been re-connected in Para. 24.
36. Lay a 40 MF, 25 V or 50 V, tubular electrolytic condenser in the space between the end of transmitter and PG103 and PG104, and connect the positive end of condenser to ground, using the ground lug at the corner of PG101, and the negative end to #4, PG103 (-B). Bias filter. If resistor R152 is in way, disconnect same and remove it. This resistor serves as a load on the interphone output and is not needed. It is connected from #20, PG101, to ground. Cut wire at #20, PG101, and at ground lug. The screw can be retained to tie the condenser to.
37. Connect #4, VS104, to ground (#5, VS104), grounding cathode of V104, Type 807.



38. Connect #2, PG103 to #7, PG104 and #5, PG104 to #8, PG104. Crystal heaters.
39. Connect #2 to #4 to #6, on PG104, shorting the 24 v dropping resistors R131 and R132, and R140 and R141.
40. Disconnect R115 from C138 and from T101 and discard R115.
41. Cut the BR wire at D122 that connects to R135, and cover out end with spaghetti and tuck under cable. This makes it impossible to close the battery circuit through the coils of antenna relay S101 and receiver disabling relay S103, which are not used, thereby saving battery current.
42. Cut the RD-BR wire at the tie point (near R132 and to which tie point + C162 was formerly connected) which connects S104 to D124. This cuts the feed of the DC filament battery to the coil of S104, radio-interphone relay, which is not used and which thereby saves a drain on the filament battery if radio-interphone switch should be inadvertently thrown to "interphone."
43. Mount a soldering lug in the hole which formerly held S101, near L110, and ground the GR and BL wires which were removed from the contact of S101 to the lug, thus maintaining a continuous short to ground of R129. R129 was used to quickly block all tubes when the press-to-talk switch is pressed. This feature is not needed since for this application the carrier is kept continuous.
44. Mount an insulated tie point with insulation suitable for RF near the end of short RF co-ax cable that connects to "ANT" post and solder free end of this co-ax to tie point. Connect the end of L111 formerly connected to S101 to the tie point by means of a piece of heavy tinned bus wire, taking care to form bus so it will not short to ground.
45. Mount a 3-point, vertical, insulated tie point strip in the remaining hole formerly used for mounting S101. To the lower tie point, connect BLK wire that formerly connected to coil S101. To the second point, connect BL-OR wire that formerly connected to coil, S101. To the top point connect the RD and BLK-RD wires that are in series with the HV to V4. The antenna relay S101 is not used.
46. Remove lamp E101, which is a 24 v lamp and replace with a 6 v to 8 v or a 12 v lamp. The 24 v lamp removed, is used in the receiver.
47. Shunt R120 (200 ohms) with a 75 ohm 1/2 watt resistor. The carbon mike current feed was designed to work from 12 v and having added 75 ohms in series with R121 already in Para. 32, it is now necessary to reduce the total resistance in the carbon button circuit so that the 6 v source will cause sufficient button current to flow. However, if the particular carbon mike used does not give sufficient output, this 75 ohm resistor should be replaced with one of 200 ohms. If mike level is too high, substitute 25 ohm resistor, which, while increasing the



current flow, will act as a voice frequency load, reducing the signal level.

48. Clip BL shielded wire from terminal #0 of L105 and clip RD-BL shielded wire from #2, T102, and clip the ground wire of this shielded twisted pair and slip spaghetti over the bared end of the cable and tuck away in space around relay S103. Unsolder bus wires from #1, L105 and temporarily remove L105. Short R156 by connecting #1, T102 to ground with a short bare tinned wire. Connect an insulated stranded wire 3" long to #2, T102, skin and tin the other end of wire. Connect a 3 ohm 2 watt wire wound resistor between #2, T102 and ground. Restore L105 to its original mounting. Connect #0, L105 to #2, T102 by means of wire already connected to #2, T102. Reconnect bare bus wires to #1, L105.
49. Rearrange screen grid dropping resistors R114 and R116, for V104, from series to parallel. Clip strap at #2, VS104 (screen grid) and solder clipped end to adjacent terminal of R114, thus connecting R114 and R116 in parallel. By means of an insulated wire 4" long, connect the original junction of R114 and R116 to #2, VS104.
50. Install tubes in transmitter as follows:

V101	6V6GT	V104	807
V102	6V6GT	V106	6L6
V103	6V6GT		
V105	6V6GT		
V107	6V6GT		
V108	6V6GT		

## PART 7

### TRANSMITTER MOUNTING

Mounting FT 237D is a component of SCR 508, SCR 528, SCR 538. FT 237D is designed to accommodate one BC 604 transmitter and two BC 603 receivers. The mounting is cut by means of a hack saw, so as to accommodate only a transmitter BC 604. It is necessary to dismount the right-hand shock mount from the discarded part, and remount the shock mount under the right-hand end of the receiver. All existing wiring of the FT 237D is discarded. Socket S045 and receptacle P8-42 are mounted on the left end of FT 238D, as is the SPST toggle switch. J 403 is retained. The mounting is wired in accordance with the diagram in Fig. 6. The mounting provides a plug-in shock mounting for the transmitter. No tools are needed to remove the transmitter for test or storage.





PART 8

PE 103 DYNAMOTOR

Most cars use a grounded negative battery. The PE 103 dynamotor is originally designed for use with a positive battery ground. The BC 604 transmitter is designed for a negative battery ground. ( The electrolytic condensers of the carbon mike circuit dictate a negative battery ground. ) The changes of the PE 103 dynamotor consist mainly of the following: Reverse the input polarity (this amounts to reversing the polarity of the high voltage brushes and interchanging the + and - signs at the ends of battery cables ). Raise the operating current value of the HV overload breaker. Raise the operating current value of the filament overload breaker. Bring the negative high voltage out through terminal #2 of the output connector, thus isolating the high voltage output from the dc input circuit. A high voltage filter condenser is also added. Following is a step-by-step procedure to accomplish these modifications. The following paragraphs refer to Fig. 7.

If it is desired to use the equipment with a positive ground, replace the carbon mike filter condensers in the transmitter with insulated tubular type, reversing the polarity of the connections. For positive battery ground, the only changes that will be needed in the original PE 103 are the addition of the HV condenser, raising the operating point of the two breakers, bringing out the negative high voltage through #2, 3K1, shorting 3R2.

1. Remove HV and bell (long brush cover, opposite end from battery cables). Loosen 4 knurled screws in the top plate and remove dynamotor from base.
2. Remove terminal bolt from old -HV brush. Isolate the two heavy wires formerly connected to old -HV brush, but connect them together by means of the screw and nut just removed. Slip piece of sleeving over junction or tape. Clear the heavy strip connected to old -HV brush by bending same toward outside.
3. Reconnect the green wire to the old -HV brush by means of a new bolt and nut, but clip green wire at lug and at condenser. Solder a new insulated wire 8" long to lug just bolted to old -HV brush, and connect other end of wire to condenser that is connected to old + HV brush (by means of green wire) and RF choke.
4. Clip green wire at condenser and RF choke to which old +HV brush was formerly connected; also clip same wire at old +HV brush. By means of an insulated wire 8" long, connect the old + HV brush to the condenser which formerly connected to the old -HV brush.
5. Disconnect 3 wires from breaker 3E3 and 3 wires from breaker 3E5. Remove 2 screws at the front of breaker 3E5 and one screw from rear of breaker 3E5 and remove breaker. Disassemble breaker 3E5 and divide coil into two approximately equal parts and reconnect two



halves in parallel, with current flowing around core in same direction in each half.

6. Before replacing 3E5 run an insulated wire 14" long through the hole in the base. Connect one end of wire to old +HV brush and the other end to the tie point that connects to condenser 3C8 and #2, 3K1. Clip wire at tie point that connects tie point to 3S1B, and slip sleeving over end of wire. Connect other end of wire to old +HV brush. This becomes the new -HV brush, and the -500v is thus isolated from the 6v circuit and is brought out separately through #2, 3K1.
7. Restore breaker 3E5 to original mounting position. Restore 3 wires to 3E3 and 3 wires to 3E5.
8. Connect a 10 ohm, 2 watt, wire wound resistor between the two coil terminals of breaker 3E3. These are the terminals to which are connected two black wires leading from inside the breaker. This raises the tripping point of the HV overload from the original .220 amp. to about .400 amp.
9. Drill a small hole through the bakelite strip mounting the insulated tie point which is connected to 3C8 and to #2, 3K1. Connect an insulated wire 5" long to a 16 mfd, 600 volt tubular electrolytic condenser, -end. Lay condenser parallel to breaker 3E3 in space between 3E3 and metal bracket supporting old +6v terminal, with -end of condenser nearest panel. Tie condenser in place with lacing cord. Connect +end of condenser to terminal of 3E3 farthest away from panel of dynamotor, and which terminal connects to +500v, #8, 3K1.
10. Short resistor 3R2 (6 ohm) which connects to #6, 3K1, by means of a heavy wire.
11. Restore Dynamotor to case. Restore HV end bell.
12. Change -tag to the battery cable now bearing the +tag, and move the + tag to the cable now bearing the -tag.

## PART 9

### BC 603 RECEIVER

Following is a step-by-step procedure for modifying the BC 603 receiver. The modification of the receiver proper consists mainly of adding plate supply filter condensers, reducing the audio level through the first audio stage, connecting the receiver ON switch into the 110 v ac supply to the rectifier, and the addition of a pilot lamp.



1. Remove front guard by removing four screws in corner. Remove dust cover by releasing shakeproof screw in rear.
2. Remove front panel by removing six 6-32 screws, including that holding EMERGENCY LOCK if receiver has this feature, and two 8-32 screws, one above and one below push buttons. Front panel is plug-in and by working back and forth the plug at bottom should readily disengage.
3. BC 604-DM only. (The 604-DM has 4 contacts on D5 ((is a make one-break-one switch))), whereas D5 on BC 604-D is a simple open and close switch. BC-604-DM has no R22, R32, R33.) Mount two 4700 ohm 1/2 watt resistors in parallel between the two tie points at the end of the bakelite terminal strip, removing the wire connected between these two points. This puts the new 2350 ohm resistance in series with T1, output transformer, and D2. Clip at both ends and remove from cable the wire connecting center terminal of P1 to D5. This wire is connected through #12, PG-3, then through #7, PG-1, and to the receiver disabling relay of the transmitter. Receiver disabling is not used in this application and since this wiring is in the grid circuit of the first audio amplifier, and is unshielded, it is best disconnected.
4. BC 604-D only connects a 1/2 watt, 2500 ohm resistor in parallel with R22, R32, R33.
5. Remove spare fuse mounting.
6. Mount a bayonet miniature lamp socket in the hole formerly used by spare fuse. It will probably be necessary to slightly enlarge the hole by reaming or filing.
7. Connect a small banana pin socket to the center terminal of the lamp mounting. Such a socket can be obtained by disassembling a plug and socket such as is used in the 247N command sets. Take care that the center pin of the lamp mounting is left free to move, slip a piece of spaghetti or rubber tubing over the banana socket for insulation.
8. Solder the shell terminal of the lamp socket to the frame of the mounting, grounding one side of the lamp.
9. Replace front panel on receiver. Replace front guard.
10. Place soldering lug under 6-32 screw at lower left hand corner of front panel, strip and tin the ends of an insulated wire 3" long, solder one end of the wire to the soldering lug, and insert the other end in the "G" binding post, thus grounding one side of the antenna input at the front panel, in addition to the ground at PG-1.
11. Connect by means of an insulated wire 19" long #8, PG-2, to #1, J-3. If #8, PG-2, is strapped to #11, PG-2, remove the strap. Run wire along main cable, and tie to same with lacing cord. This places REC ON switch, D1 also fuse F1, in series with 110 V AC supply to rectifier.



cord. This places REC ON switch, D1 also fuse F1, in series with 110 v ac supply to rectifier.

12. Lift cable from rear of receiver and place 20 mfd, 250 v, electrolytic tubular condenser in corner under PG-2, vertically, and connect + end to #13, PG-2, and -end to -terminal of C25 (lower terminal) or optionally to #7, PG-2. Plate supply filter.
13. Mount a 20 mfd, 250v, tubular electrolytic condenser in the space over condenser C20, and connect -end to -end of C25 and +end to + end of C25. Tie condenser in place with lacing cord. Plate supply filter.
14. Connect a .1 mfd condenser from #1 LCU4 (which is connected to #15, J3) to ground at the lug to which L1 is grounded.
15. Skin and tin the ends of a piece of insulated wire 13" long, and connect a banana plug, the mate to the banana jack of Para. 7, to one end of the wire, and connect the other end of the wire to #2, VS4. This connects the hot 12v filament to the pilot lamp. Slip a piece of spaghetti or rubber tubing over the banana pin to insulate same. Tie this wire with lacing cord to conduit carrying antenna wires.
16. Remove 250 M resistor, R10, which connects #4, V7 to C11 and remove meg resistor, R11, which connects between the junction of C11, C13, C26 and #2, V9. Return these resistors to the circuit, with their positions interchanged. In other words, change R10 from the original value of 250 M ohms to 1 meg ohm and change R11 from the original value of 1 meg ohm to 250 M ohms. This reduces the audio level at the grid of the first audio stage to prevent overloading.
17. Cut a piece of sheet metal of such size to cover the plug on the back of the receiver and drill two holes in the cover and two matching holes in the receiver at the ends of the plug and by means of self-tapping 6-32 screws, mount the cover. This is to protect the live contacts on the plug which now bear 110v ac.
18. Install negative feedback circuit as outlined by heavy lines in Fig. 1.

## PART 10

### POWER SUPPLY FOR RECEIVER

Since the receiver in most cases will be located at a place such as the studios or the main transmitter location, where 110 volt 60 cycle ac power supply





is available, it is modified to operate from such a power source, rather than from a dc source. The receiver requires 12 volts filament supply. If the components are carefully chosen, they can be mounted on the base of the originally furnished dynamotor DM 34 or DM 36. The socket for the rectifier tube is mounted flush with the dynamotor base. Two 500 ohm 10 watt resistors plus the addition of a 20 mfd and 75 mfd condenser are used as a filtering network and a voltage dropping device to drop the voltage from that provided by most stock transformers that will fit the base. The base suggested will plug into the receiver, thus making a convenient arrangement. The receiver requires 200 volts at about 60 ma. Figure 5 indicates suitable wiring of such a rectifier and strapping of the multiconnector socket on the base, to connect the front panel ON-OFF switch into the primary, and to connect the separate filament strings in parallel.

## PART 11

### REMOTE CONTROL

The function of the remote control is to provide a convenient means of controlling the audio level, and indicating when the filament is on, also to switch the plate supply dynamotor on and off. By frequent use of the DYN ON switch, much battery current is saved during test transmissions and cueing transmissions. Means is also provided for switching in a test microphone in place of the regular program mike. The remote control is usually placed on the seat beside the driver of the car. When not in use, it is removed from the connecting cord and placed in an out-of-the-way place.

If more than one mike at a time is needed, a regular 4 channel remote amplifier is connected in place of the program mike, by means of suitable level reducing pads and isolation coils. Since the volume indicator is fed from the output of the audio amplifier at about 0 level, through the same cable that the low level microphone is fed to the audio amplifier, it is absolutely necessary that the two microphone conductors be separately shielded, preferably within the overall shield of the cable. Such a cable is CORDAGE 213, a component of SCR 508. Figure 6 is a circuit diagram of the internal wiring of the remote control, also the manner in which the remote control is connected to the transmitter through the transmitter mounting and to the dynamotor. The lettering of the remote control shown in the photograph is engraved. An excellent job of lettering can be done with decals.



PART 12

DIFFICULTIES WHICH MAY BE ENCOUNTERED

Of the hundreds of installations that have been made, the most frequent causes of difficulty that have been encountered are discussed below:

1. Connection and matching of transmitter to antenna

There is about 18" of low impedance co-axial cable internally in the transmitter. If the output is taken from the antenna terminal on the front of the transmitter, this cable is still shunted across the antenna output. If the antenna output current is taken, as it will generally be if a plug-in mounting is used, through the co-ax connector at the end of the transmitter, then this internal co-ax is in series with the antenna. It has been found that only an open wire, not to exceed 18" in length, can be used to connect from the cannon plug to the base of the whip. A co-ax cable can be used--preferably RG 8U--for the connection to the whip, but this co-ax must be exactly one or more half waves long, electrically. <sup>1/</sup> When installed in a standard pullman car, a co-ax of 3 half waves in length was used. When an odd length of co-ax is used for this connection, the output tuning elements of the transmitter apparently cannot achieve resonance and a match. An antenna current meter is provided, but it is coupled to the antenna circuit in a rather unusual way, and when everything is right, it makes a very reliable antenna resonant indicator. It should be noted that under extreme conditions of non-resonance or mis-match, a large showing can still be obtained from this meter, with practically no radiation.

2. Receiver installation

Generally speaking, results will be governed very largely by the efficiency of the receiving antenna. The higher the receiving antenna, the better the results, assuming, of course, that there is an impedance match. The receiver apparently presents a fairly good match to RG-8U cable. A ground plane quarter wave antenna, omni-directional, matched to RG-8U cable, the antenna being mounted about 45 feet above ground in the clear, will give good results. Actually, satisfactory reception has been had over a distance of two or three miles with a fifteen foot piece of wire, hung out of a second story hotel window, provided the input of the receiver is carefully tuned.

<sup>1/</sup>Obviously, a matching network could be provided to feed any length of coax line with a low VSWR, but this assumes no additional circuits.



### 3. Receiver antenna tuning

On the left side of the receiver is the " Antenna Trimmer ". C 1.1 on the schematic diagram. This adjustment has the same effect that most antenna trimmers do, and its purpose is to bring the first tuned circuit in the receiver to resonance, regardless of the nature of the impedance that is connected across the antenna input terminals. Thus, for each particular antenna, there will likely be a certain best adjustment of this trimmer. It need not be adjusted when different channels are selected, within the allocated 26 Mc. band for this service, but should be checked from time to time to make up for any change in the antenna, or if the first tube is changed. This adjustment is best made with no transmitter carrier on, tuning for maximum noise, with the main tuning set to between 26 and 27 Mc. A good technique can be developed for this adjustment by using the " sensitivity " control in connection with the " squelch feeling " for the antenna trimmer adjustment that causes the noise to just operate the squelch, with the " sensitivity " the furthest counterclockwise that will still cause the squelch to operate as the trimmer is rocked.

## PART 13

### CUEING

A logical question which arises at this point relates to cueing. The reader may ask, " Why isn't two-way cueing utilized?". The answer is that there is a better way to do the " talk-back " job. The initial requirements are for a high quality, dependable, noise-free remote pickup circuit which is mobile and easily portable.

The transmitting equipment described draws about 32 amperes from the 6 volt battery. A new fully charged standard equipment car battery, with no other load on it, will operate this transmitter for over an hour. With the car engine running, it will operate for considerably longer. As other loads are added, first a receiver, then lights, perhaps a heater, etc., the margin grows more narrow. As a matter of fact, for complete freedom of worry from this source, many stations install the Leece-Neville alternator-rectifier type of generator in their mobile unit. This will put out up to 100 amperes continuously, with engine barely above idling speed. A condenser and coil filter is usually necessary to suppress ripple. The 32 amperes is about the feasible limit, and this transmitter uses about 40 watts input to the plate of the final stage. Input to the last tube of say, 250 <sup>2</sup>/<sub>2</sub> watts or more, would surely indicate some kind of gasoline generator, with all its cumbersome complications. Next, a mobile transmitting antenna is indicated. This means

2/ Not recommended for a single 807 tube!



that to get any efficiency, the antenna should be about a quarter wave long. At 26 Mc., the car body, with its large capacity to ground serves as a pretty good substitute for a ground, and a quarter wave whip is of a very convenient size. Thus, a good transmitting efficiency is achieved. And so, we find that for mobile use, this power range and this frequency is sort of a natural. Now examine the requirements for the circuit in the reverse direction or the " talk-back ". To begin with, the location of the talk-back transmitter, in the general case, will be fixed, and, in addition, it will mostly be at the same location as the main broadcast transmitter, which means that a near-perfect transmitting ground is available. There is nearly always, right close at hand, a tall structure ( the main transmitting tower ). Further the transmitter can and surely will be operated on an AC source, not a car battery. Thus, there is no rigid limitation on the number of watts available from the primary power source. And, probably the most important difference in the requirement between the talk-back and the mobile pickup equipment is the fact that the talk-back needs only to transmit intelligence. And finally, and very compelling, is the question of the receiver for the talk-back, which is of course located in the vehicle which carries the pickup transmitter. This vehicle will inevitably have a standard broadcast receiver as part of its original equipment. Group B of the FCC assignment specifies 1606 kc., in addition to other frequencies. Many standard BC car receivers will tune to 1606 as they come from the factory. Those that do not can be made to do so with a very slight adjustment of the oscillator trimmer, with no serious impairment to their operation across the broadcast band. Thus, the receiver part of the talk-back circuit is already provided in a most satisfactory manner. The talk-back transmitting antenna, using the regular ground, and a wire supported from the main transmitter tower, or part way up, insulated out far enough to prevent any de-tuning of the main radiator will prove highly efficient. Experiment has shown that this is quite feasible, using about 1/3 to 1/2 the available height, if the tower is located away from the building. In any event, a good ground is available. Since voice-only transmission is required, any of the many war surplus communication transmitters are adequate from this standpoint. A good example is the BC 191, which is available recently on the surplus market at \$29.90 complete with tuning unit TU 5. This is rated at 100 watts input to the last stage. It will have to be modified to crystal control. This is a very simple modification, the present oscillator is changed to an RF amplifier, and a 6L6 tri-tet crystal oscillator is constructed on a separate chassis, and fed by co-ax cable to the BC 191. In addition, a 1000 volt 350 ma power supply will be needed. Parts for this will cost no more than the transmitter. A push-to-talk relay is built into the transmitter, and a small dc rectifier will be needed for this. And so, for less than about \$100 worth of materials, plus our labor, we are in business with a talk-back that will surely communicate out as far as the remote pickup will transmit in. It will immediately be apparent that the first station in any community to apply for Group B assignment for its talk-back is the lucky one. Actually, however, it is fairly simple to make a converter so that most any of the lower authorized frequencies in Groups A, B, or C, will serve very nicely. The BC 375 transmitter is more readily located on the war surplus market, and will do about as well as the BC 191, but will require somewhat more extensive changes to operate from AC instead of the intended 28 volts DC.





PART 14

AVAILABILITY OF COMPONENT PARTS ON WAR SURPLUS MARKET  
(Listed for sale in advertisements in March 1958 RADIO & TV NEWS)

BC 604 Transmitter

R. W. Electronics 2430 South Michigan Avenue Chicago 16, Illinois	FOB Chicago or Sacramento	\$ 3.95
Fair Radio Sales Co. 132 South Main Street Lima, Ohio	New Used	19.95 14.95
Columbia Electronics 2251 West Washington Blvd. Los Angeles 18, Calif.	Used	3.95

BC 603 Receiver

C & H Sales Co. 2176 East Colorado St. Pasadena 8, Calif.	Used, good condition with tubes	6.95
Fair Radio Sales 132 South Main St. Lima, Ohio	New Used	19.95 14.95
Columbia Electronics 2251 West Washington Blvd. Los Angeles 18, Calif.	Like new	5.95

Miscellaneous

FT 237 Mount

Not advertised Fair Radio Sales 132 South Main St. Lima, Ohio	Used	9.95
--	------	------

BC 191 Transmitter

Not advertised Fair Radio Sales 132 South Main St. Lima, Ohio	New Used	34.95 24.95
--	-------------	----------------



TM 11-600  
Fair Radio Sales  
132 South Main Street  
Lima, Ohio 3.00

FT 241 Crystal  
Texas Crystals  
8538 West Grand Avenue  
River Grove, Illinois Each .50

<u>Channel</u>	<u>Frequency</u>	<u>Can be raised for use on:</u>
61	483.333 kc.	26.11 26.13 26.15 26.17 26.19
62	485.185	26.21 26.23 26.25 26.27 26.29
63	487.037	26.31 26.33 26.35 26.37 26.39
64	488.889	26.41 26.43 26.45 26.47

Phantom Antenna A-62  
Not advertised  
Fair Radio Sales 1.00  
132 South Main Street  
Lima, Ohio

Tuning Unit TU-5 ( For BC 191 Transmitter )  
Fair Radio Sales 5.95  
132 South Main Street  
Lima, Ohio

FT 241 Crystal ground to exact frequency  
Eidson Electronic Company  
.1902 North Third Street  
Temple, Texas



BC 442 Antenna: Relays ( For use in connection with parts from Phantom  
Antenna A-62 for making metered dummy antenna. )

G & G Radio Supply Company  
51 Vesey Street  
New York 7, New York

\$ 2.49



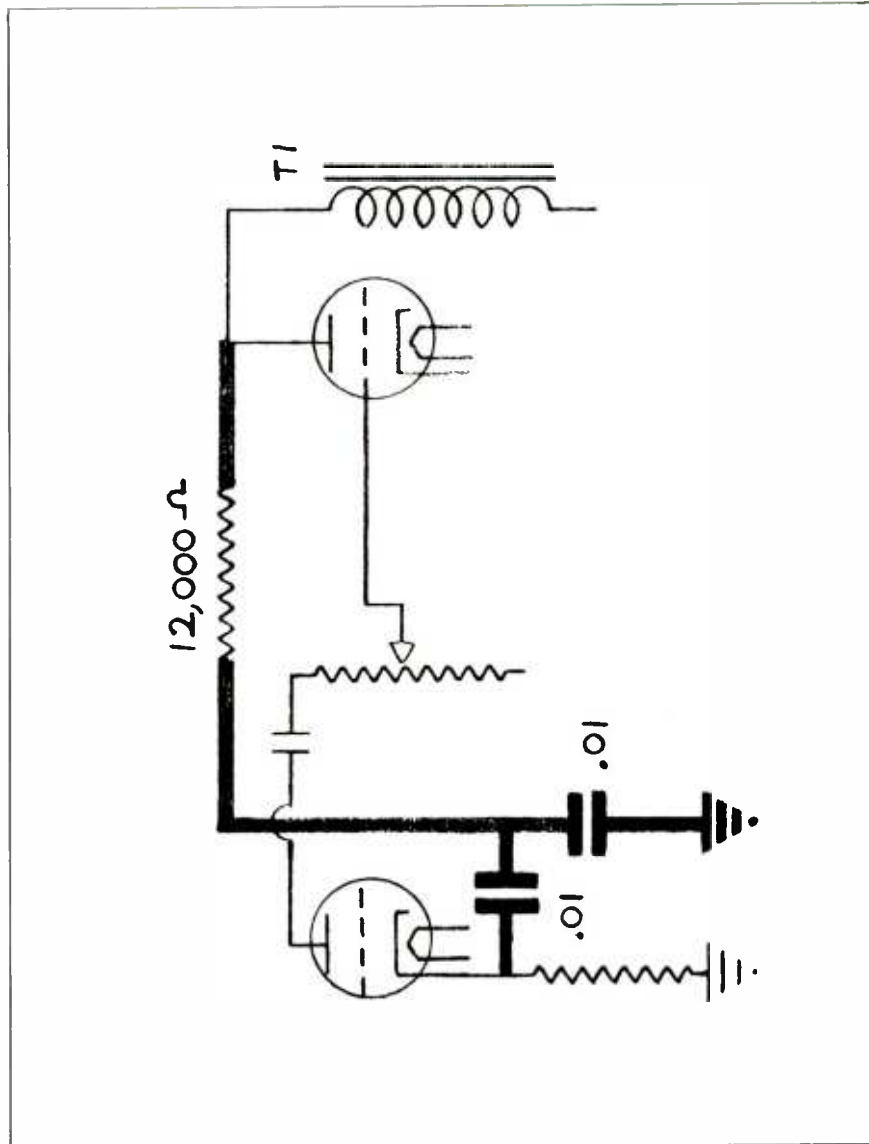

Fig. 1--Bass frequency re-emphasis circuit to be added to receiver.





Change V-106 from 6V6GT to a 6L6.

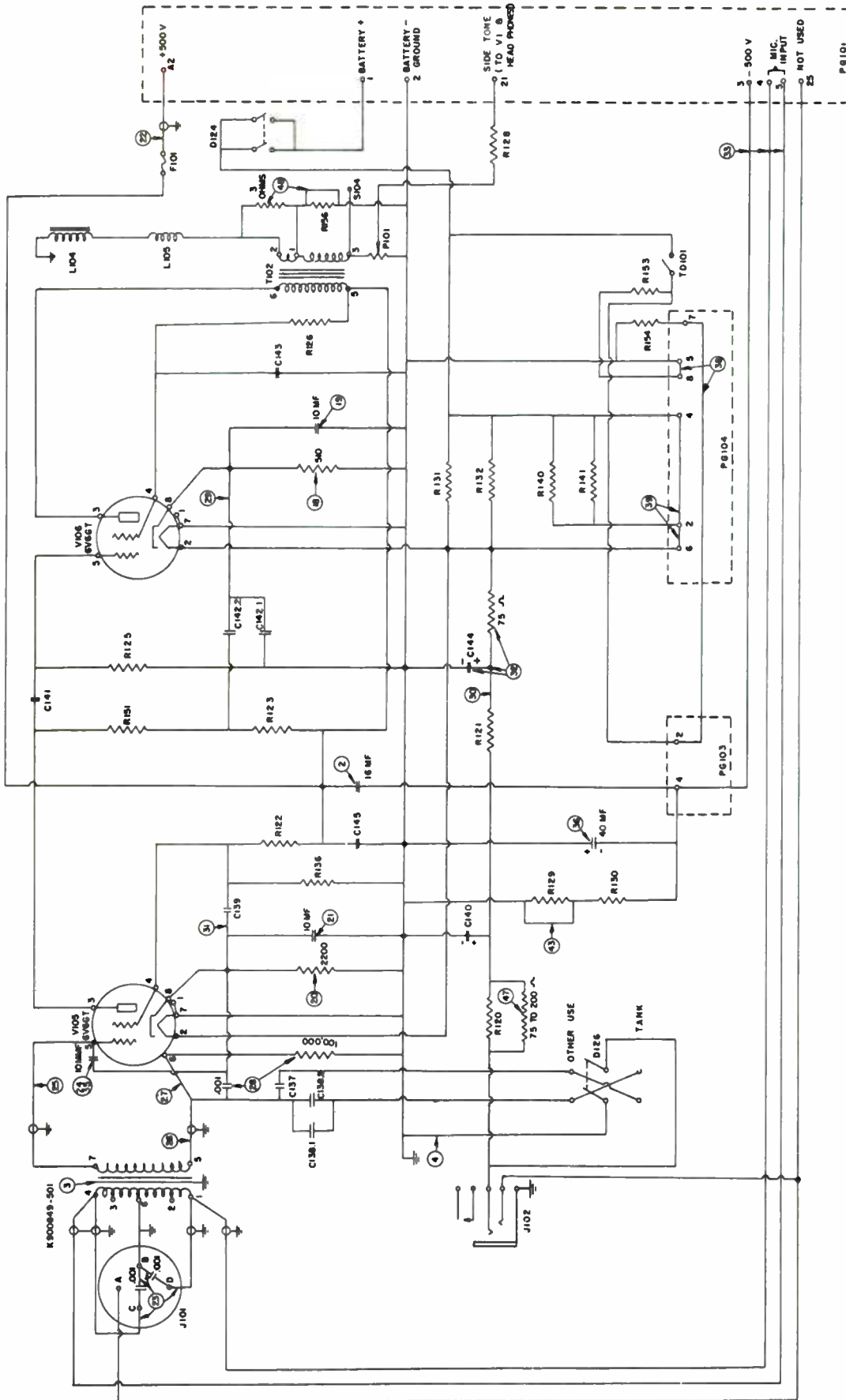
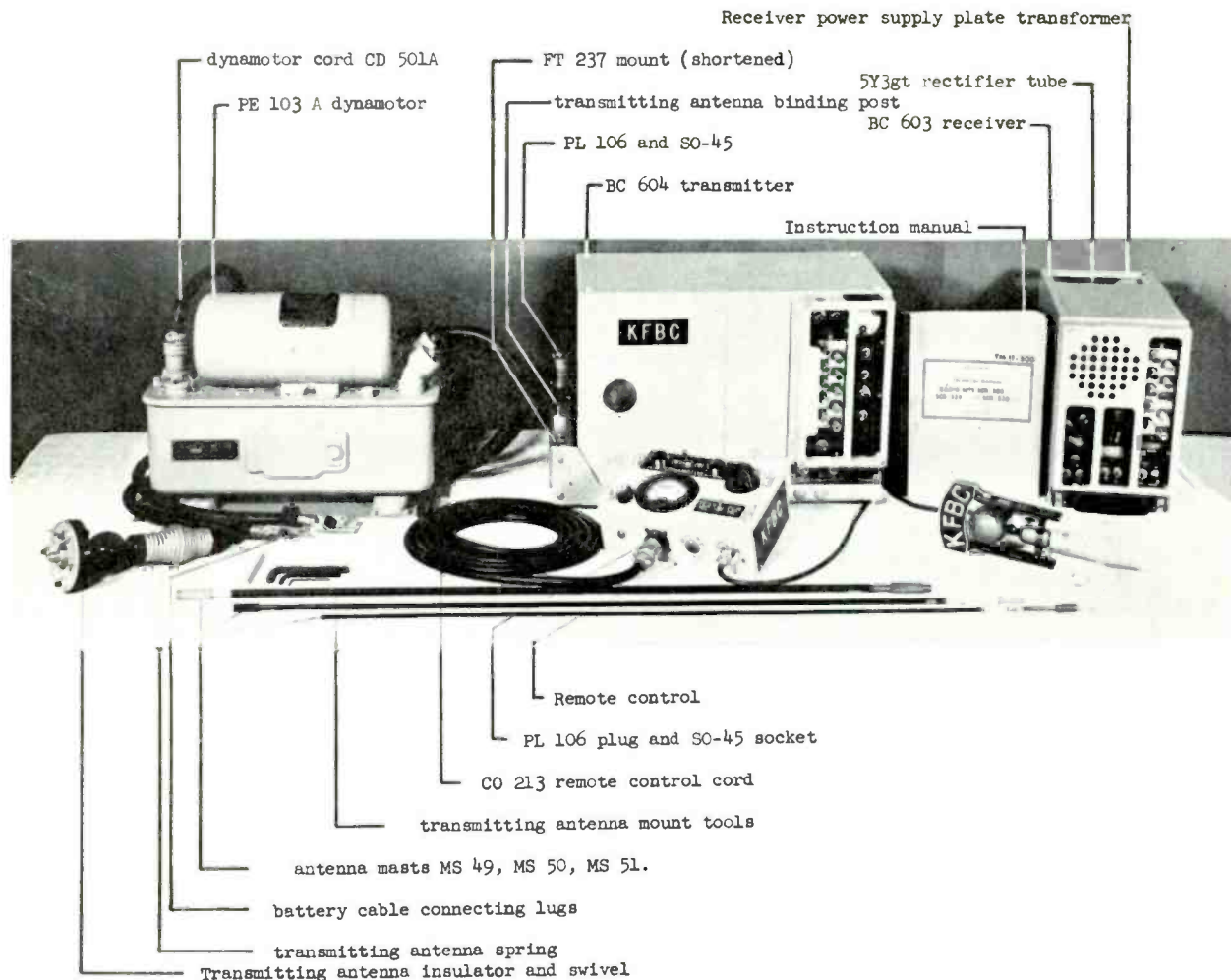
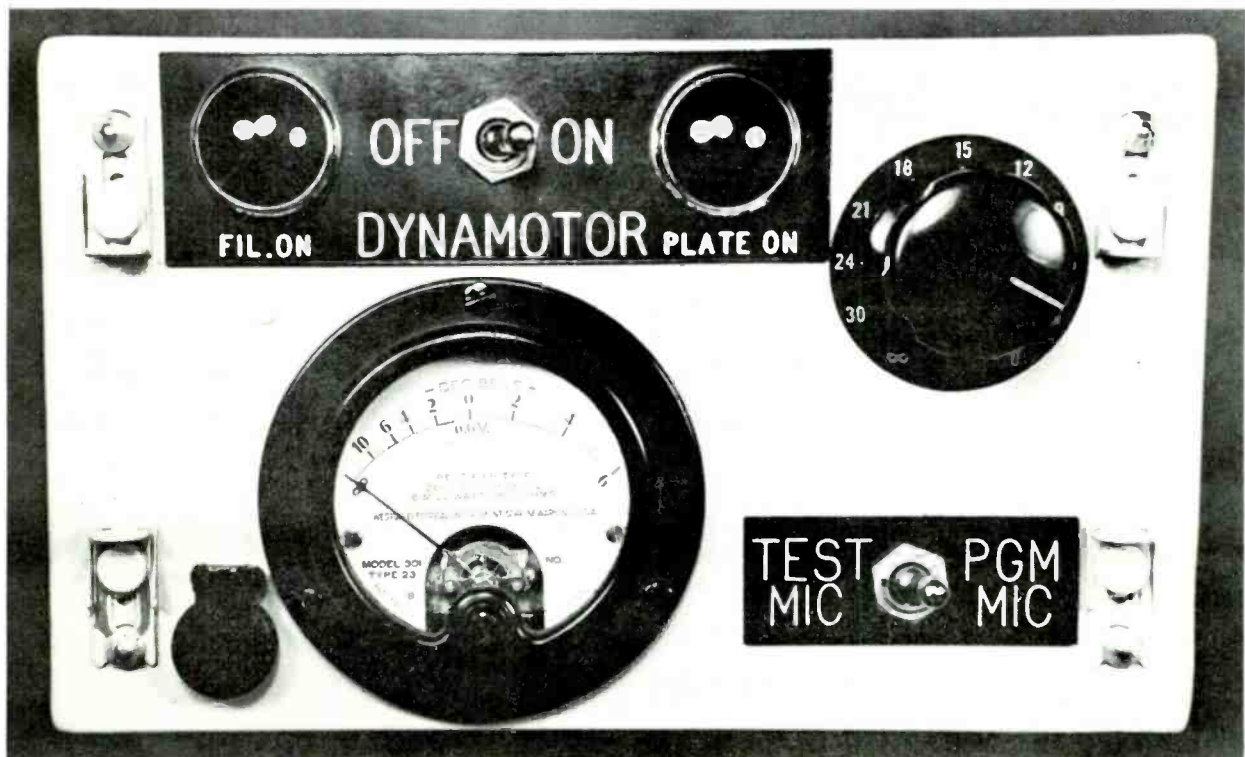

Fig. 2.--BC 604 Transmitter, audio circuits, converted. 31 indicates reference to paragraph 31, Part 6.





View of the Various Components of the System



Remote Control Unit



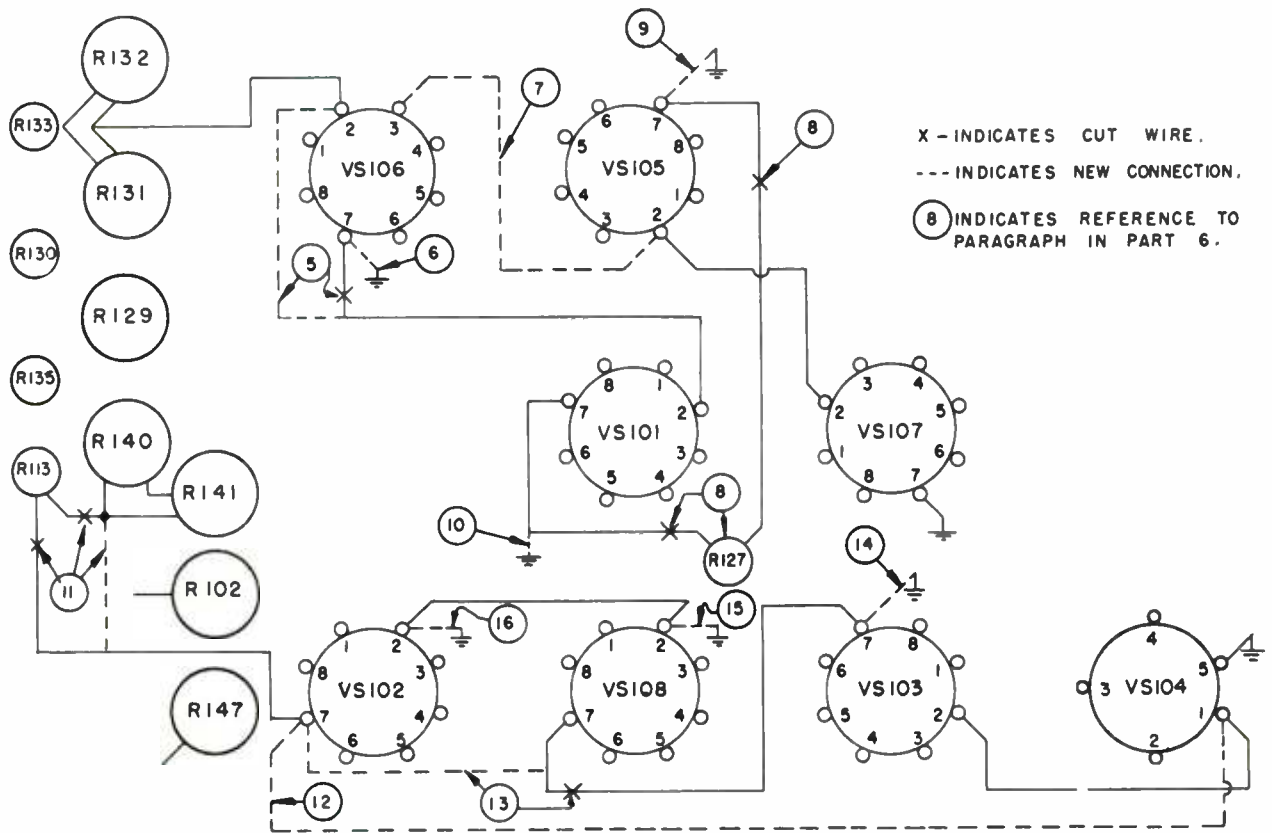

Fig. 3 -- BC 604 Transmitter, filament circuit wiring diagram, showing changes made in Part 6.

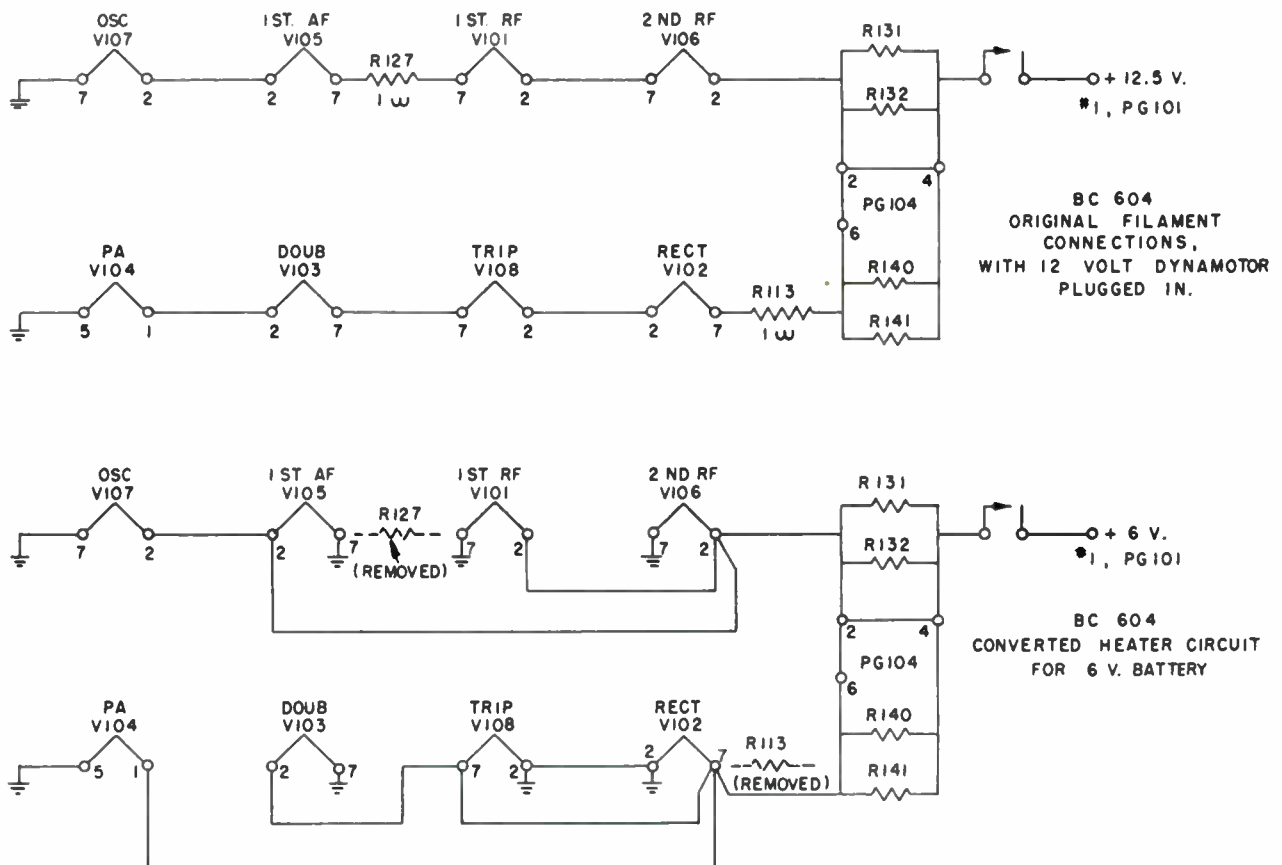
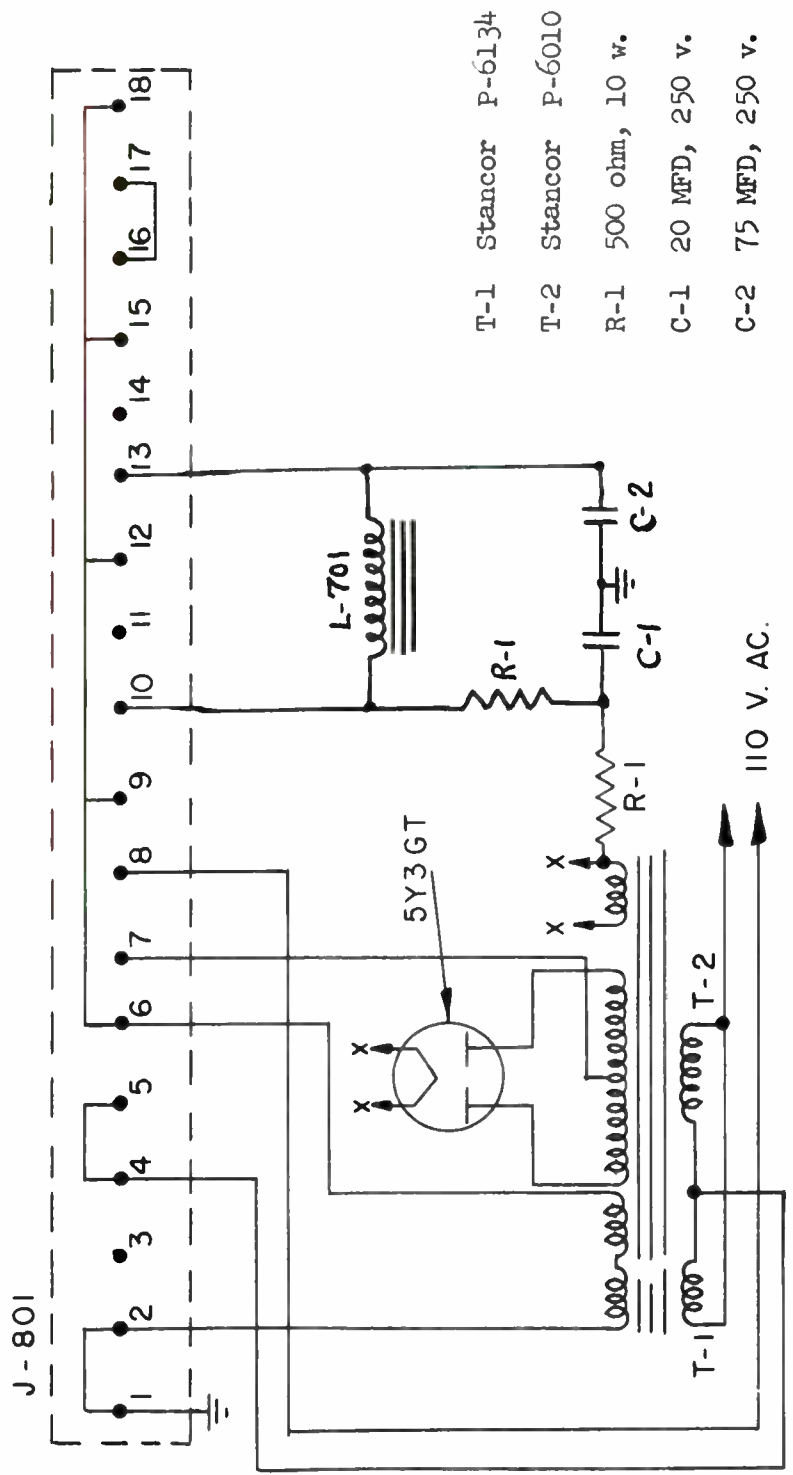

Fig. 4 -- BC 604 Transmitter, original filament schematic and converted heater schematic.





- T-1 Stancor P-6134
- T-2 Stancor P-6010
- R-1 500 ohm, 10 w.
- C-1 20 MFD, 250 v.
- C-2 75 MFD, 250 v.

Fig. 5--BC 603 Receiver, 110 V AC power supply





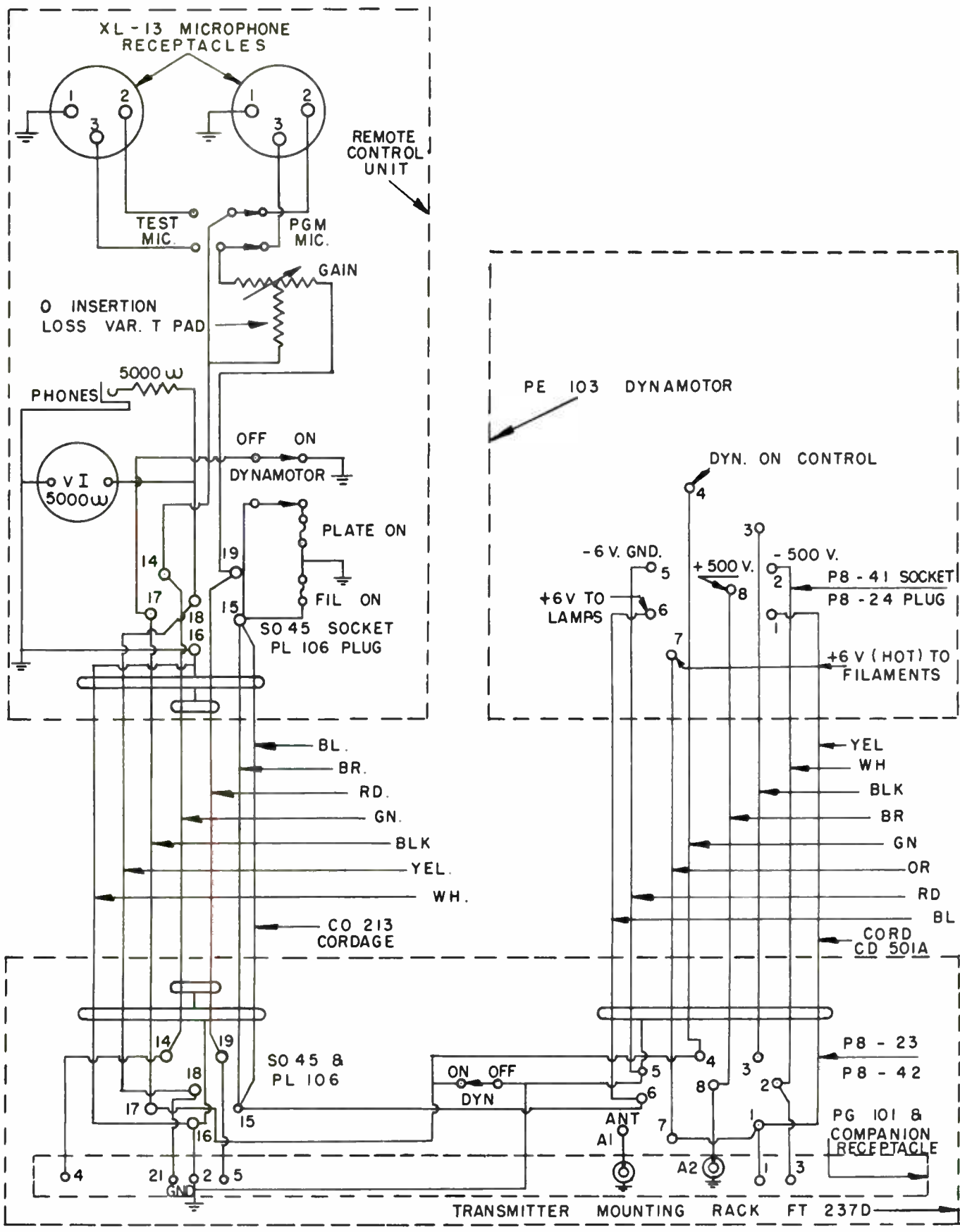
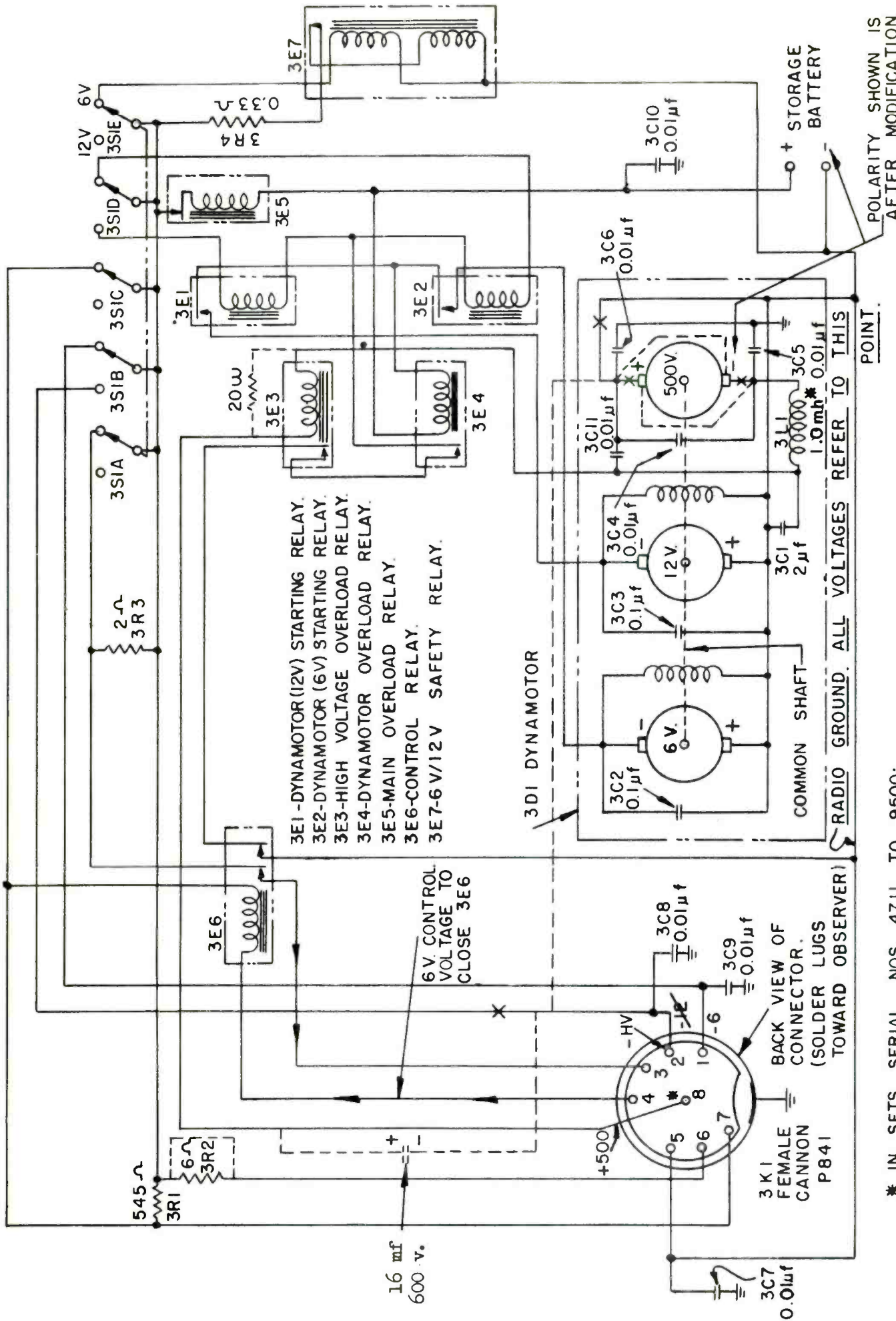

Fig. 6.--FT 237D Mounting, schematic as modified; remote control schematic; and connections for interconnecting cords, plugs, and sockets.





\* IN SETS SERIAL NOS. 4711 TO 9500:  
 CONNECTIONS TO PINS 3 AND 8  
 OF 3K1 ARE REVERSED.

VALUE OF 3L1 IS 2.5 mh.

X INDICATES CUT EXISTING WIRE.  
 --- INDICATES WIRE ADDED.

Fig. 7--PE 103 Dynamotor schematic, showing modifications.



Resistor and condenser, from Phantom Antenna, A-62.  
Thermocouple, meter, and case, from Ant. Relay, BC-442.  
Coil, 8-10 turns,  $\frac{1}{2}$ " dia. heavy wire.

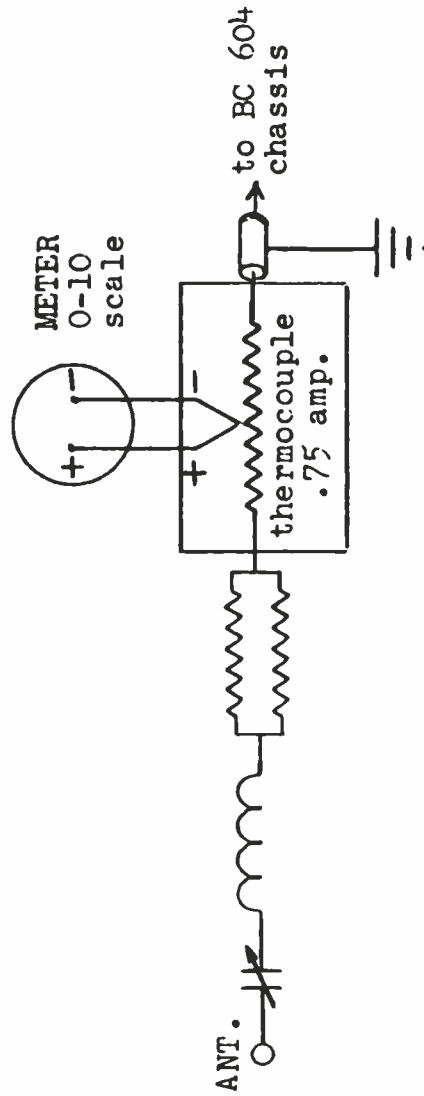

Fig. 8--Antenna output-tuning indicator



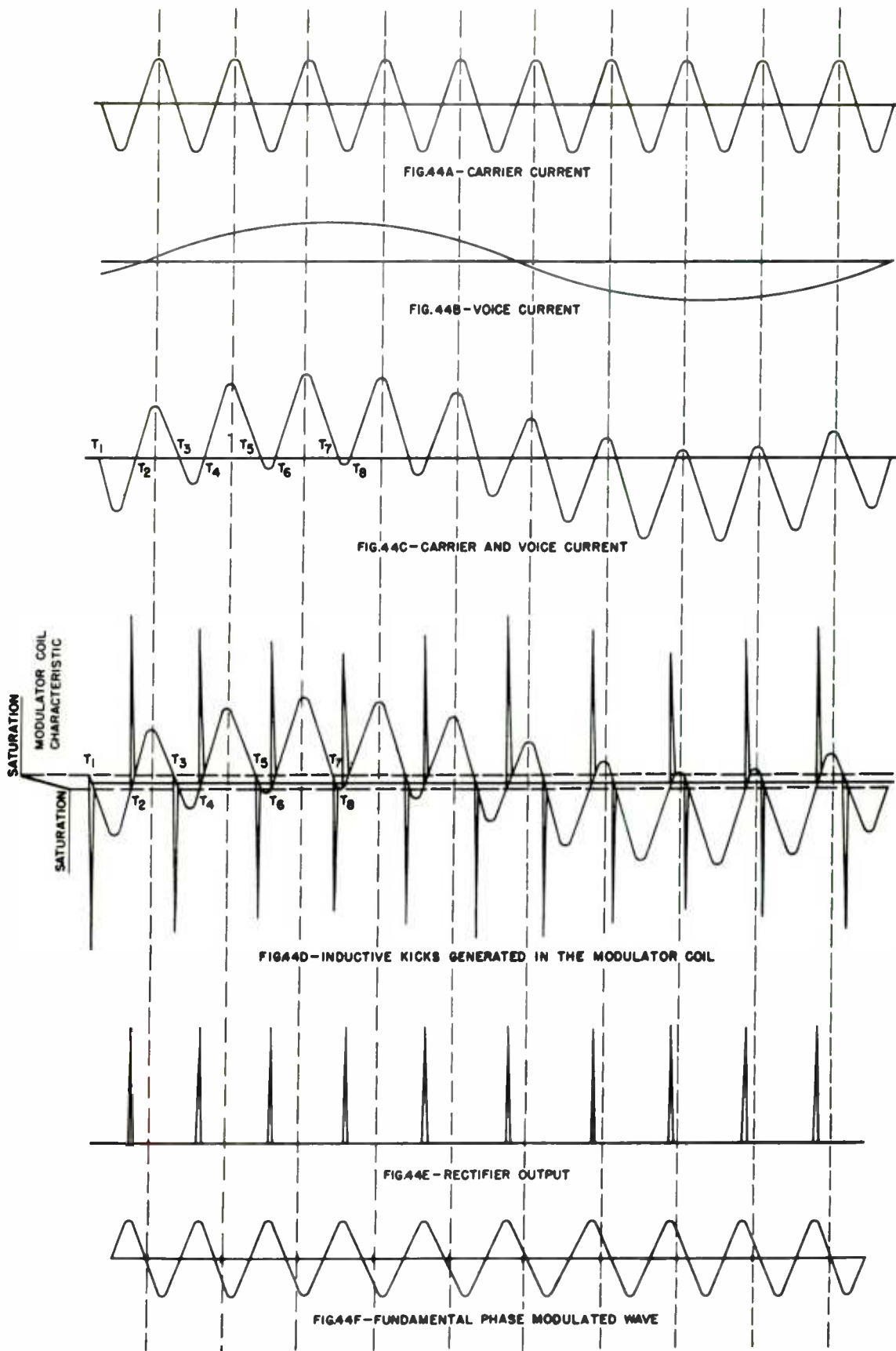

Fig. 9--Radio Transmitter BC-604, Method of Modulation





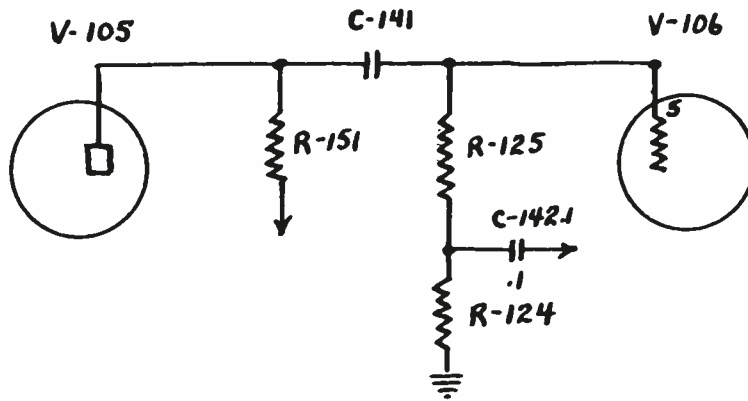

Figure 10 a - Partial diagram of BC-604 transmitter audio circuit as it appears in original diagram in Technical Manual TM 11-600.

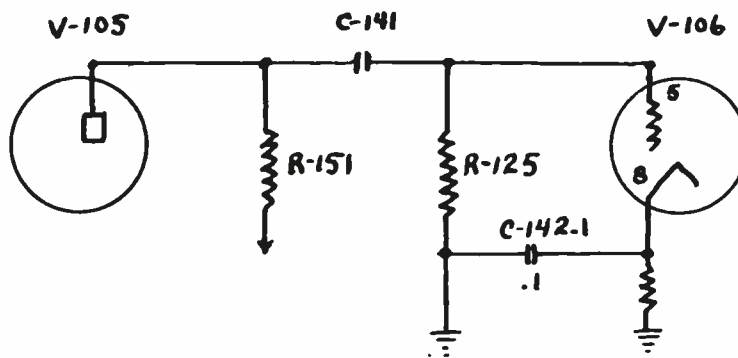

Figure 10 b - Partial diagram of BC-604 transmitter audio circuit as it appears in Figure 2.

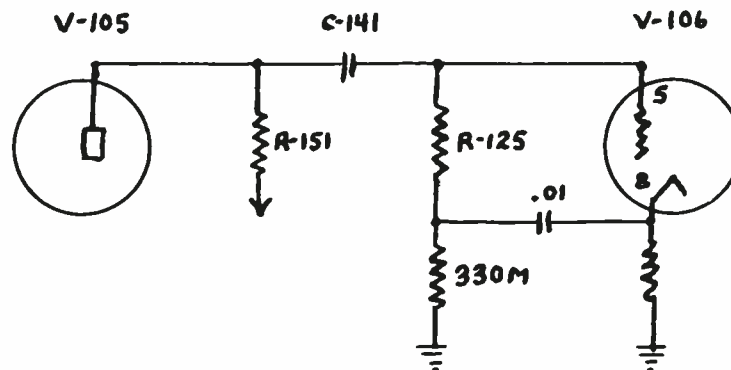

Figure 10 c - Partial diagram of BC-604 transmitter audio circuit including modification which should be made to increase frequency response. (This modification is not included in Figure 2.)





