

EXPERIMENTAL
WIRELESS
STATIONS

EDELMAN

EXPERIMENTAL WIRELESS STATIONS

Their Theory,
Design, Construction and Operation

INCLUDING
WIRELESS TELEPHONE, LABORATORY AND QUENCHED SPARK
SYSTEMS. A COMPLETE ELEMENTARY COURSE OF
INSTRUCTION IN AND AN ACCOUNT OF SHARPLY
TUNED MODERN WIRELESS INSTALLATIONS

LIBRARY

PHILIP E. EDELMAN, E.E.

Author of "Invention and Patent Experiments," Etc.



NEW 1922 EDITION

A NEW BOOK FROM COVER TO COVER WITH ENTIRELY NEW EN-
GRAVINGS. REVISED, ENLARGED AND RESET EDITION,
SHOWING ALL RECENT IMPROVEMENTS

FULLY ILLUSTRATED

NEW YORK
THE NORMAN W. HENLEY PUBLISHING COMPANY
2 WEST 45TH STREET
1922

COPYRIGHT, 1920 AND 1922 BY
THE NORMAN W. HENLEY PUBLISHING COMPANY

COPYRIGHT, 1912, 1914, BY
PHILIP E. EDELMAN

ALL RIGHTS RESERVED

PRINTED IN U. S. A.

All illustrations in this book have been specially made by the publishers, and their use without permission is strictly prohibited

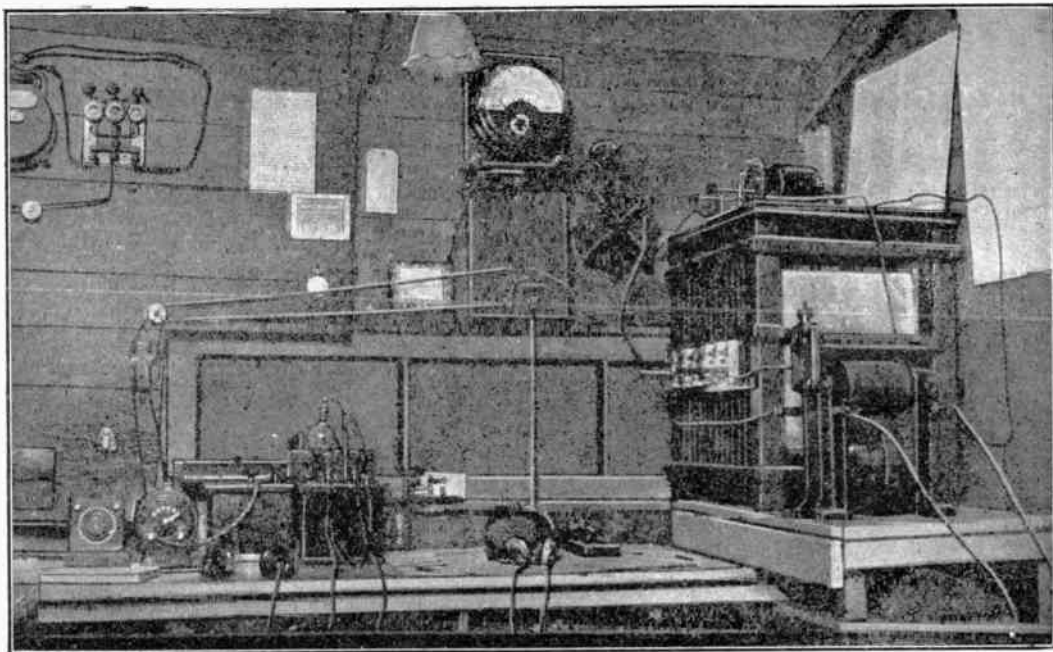

FRONTISPIECE.—An Amateur's Set Heard Over a 500-Mile Range. I. K. W. Station Built by Mr. Ralph Batcher, at Toledo, Iowa, with the Assistance of the 1916 Edition of this Book.

0814

PREFACE TO THE 1922 REVISED AND ENLARGED EDITION

During the recent World War, the earlier editions of this book were extensively used in the United States and Allied Training Camps, and were found to be readily understandable text for beginners in the art of Wireless Communication, who wished to start with the elements and continue thoroughly.

The readers of this book are assumed to have some knowledge of the fundamentals of electricity and mathematics. The knowledge of these branches need not be very extensive but when they have finished this book they will find themselves well advanced in the study of a fascinating subject. From the standpoint of operation, the best modern practice is presented in such simple language as to be well within the scope of the average reader. The basic principles of radio-communication, involving the theory and mathematics of the subject, are given in considerable detail, so that they can be followed consecutively by the reader. There is plenty of room in radio work for the exercise of individual ingenuity, and this book will enable the reader, while exercising such ingenuity, to reach results without depressing failure.

There is an army of wireless operators in all parts of this country, many of which figure as amateurs.

Many of them are so expert as to be ranked with professional operators. A standard design for so-called "Amateur Stations" will be found in this book, and this design is for a thoroughly practical working plant. Although many of the younger workers in this branch are still in the elementary stage, the study of such a work as the present one, combined with the practice they are daily receiving in their own laboratories and stations, will convert them rapidly into operators qualified for serious work in the commercial field.

The science of radio communication is developing with astonishing rapidity. One detector after another has gone out of use, as something better has been developed. The vacuum-tube rectifier has changed the whole aspect of the science and promises to have a permanent position. There are, however, any quantity of advances in details yet to be made, and the most recent of these in vacuum tube circuits, radio-telephony, mitigation of interference and general improvements are presented in this edition.

Radio communication played so important a part in the recent war that it puts the amateur operator in the position of a volunteer in training for patriotic service. There is so much to be done in the future that students of the art may feel that their life work is laid out for them in this fascinating study.

Suggestions from the readers will be most welcome.

THE AUTHOR.



March, 1922.

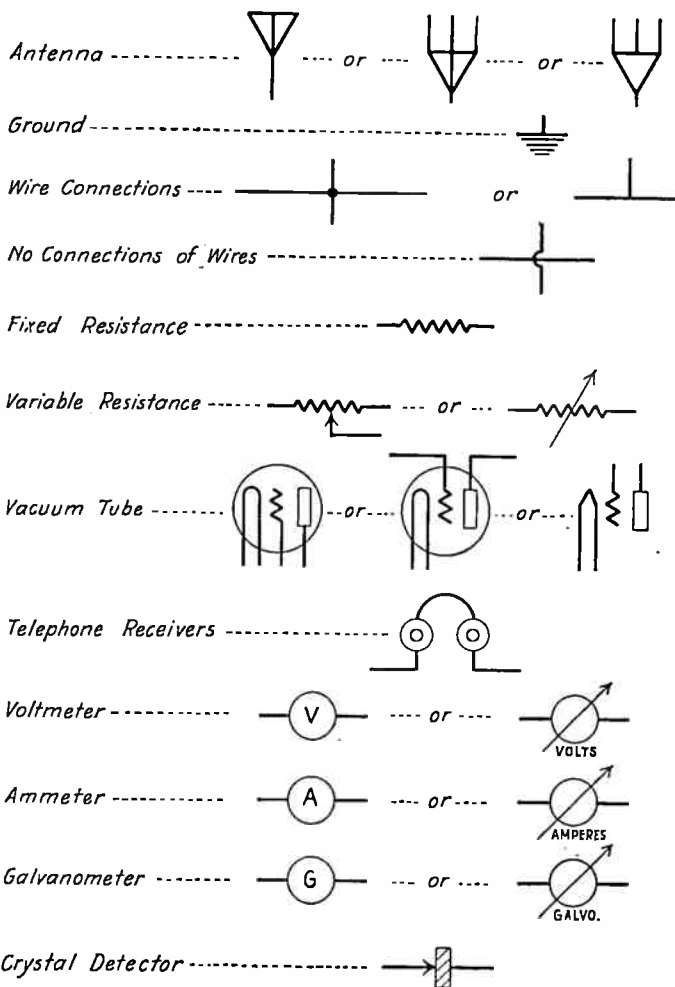

~ LIST OF SYMBOLS ~





~ LIST OF SYMBOLS ~

Battery ----- 

Direct Current Dynamo ---  or 

Alternating Current Generator } -----  or 

Fixed Capacitance (Condenser) -----  or 

Variable Capacitance (Var. Condenser) ----- 

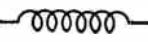
Fixed Inductance (Air Core Coil) ----- 

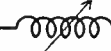
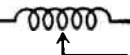
Variable Inductance (Air Core Coil) -----  or 

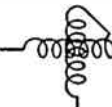
Variometer (Variable Inductance) --- 

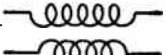
Fixed Coupling of Coils (Fixed Inductive Coupling) ----- 

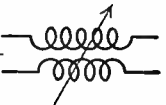
Variable Coupling of Coils ----- 

Transformer ----- 

Iron Core Inductance (or Reactance Coil) ----- 

CONTENTS

CHAPTER I

NATURE OF WIRELESS TRANSMISSION

	PAGE
Theory; Action of Radiant Waves; Interference; How Signals Are Sent; Wave Lengths Used	11

CHAPTER II

AERIALS

The Antenna; Dimensions; Supports; Height and Length; Various Types; 200 Meter Design; Table for Various Wave Lengths; Radiation Resistance; Capacity and Inductance; Insulation and Construction; Poles and Guy Wires	23
--	----

CHAPTER III

COIL AND SUB-SURFACE SYSTEMS

Multi-Turn Coil Receiver; Portable Receiving Long Distance Set; Principle of Coil Action; Directional Effects of Coils; Types and Construction; Radio Compass. Sub-Surface Radio; Antenna Buried Underground; Rogger's System; U. S. Navy Experiments	48
---	----

CHAPTER IV

GROUNDS AND LIGHTNING PROTECTION

Ground Connections; Various Types; Construction; Lightning Protectors; A Safe Radio Station; Underwriter's Rules	57
--	----

CHAPTER V

THE TRANSMITTER AND RESONANCE

- Transmitting Circuit; Principle of Oscillations; Action of Energy; Resonance; Period of Vibration; Adjustments; Harmonic Effects; Resistance; Beats; Typical Curves for Various Transmitters; Damping; Relation of Antenna Current and Voltage; Experiment Illustrating Coupling 65

CHAPTER VI

WAVE LENGTH, CAPACITY, AND OSCILLATION CIRCUITS

- Damped Wave Transmitter; Calculation of Wave Length, Capacity, and Circuits; Range of Transmission; Power; Frequency and Voltage; Table of Capacities; Formula for 200 Meter Calculations; Spark Gap; Antenna Circuit; Percentage of Coupling; Example of a Complete Spark Transmitter; Dimensions 90

CHAPTER VII

TRANSFORMERS AND SPARK COILS CONSTRUCTION DETAILS

- Principle of Induction Coil; Transformer Construction Data; Building a Transformer; Reactance Coil; Spark Coil; Table for Various Spark Coils with Dimensions 108

CHAPTER VIII

AUXILIARY APPARATUS

- Keys; Electrolytic Interrupter; Kickback Prevention; Aerial Switches; Automatic Antenna Switch; Storage Batteries 121

CHAPTER IX

CONDENSERS AND CAPACITIES

- Condenser Theory; Calculation of Capacities; Dielectric Table; Building Condensers; Dimensions and Materials 133

CHAPTER X

INDUCTANCES

- Calculation of Inductance; Construction of Helix and Oscillation Transformer; Simple Formulas for Definite Low Wave Length Sets 148

CHAPTER XI

SPARK GAPS

- Purpose of Gap; Materials Suitable; Series Gap; Rotary Gap; Construction of Rotary Gap; Rotary Quenched Gap; Rotary Gap Circuits; Chaffee Gap; Two Tone Gap 158

CHAPTER XII

RADIATION INDICATORS AND MEASUREMENTS

- Use of Radiation Indicators; Hot Wire Ammeter Construction; Wave Meter; Use of Hot Wire Ammeter; Shunt Resonator; Cost of Transmitter Complete; Frequency; Decrement; Logarithmic Decrement Illustrated; Electron Tubes for Measurements; Audion Connected to Wave Meter 170

CHAPTER XIII

ADVANCED SYSTEMS

- Continuous Waves; Wireless Telephone; Quenched Spark; High Frequency Alternators; Demonstration of Arc Radiotelephone; Poulsen Arc; Construction of Quenched Gap; Lepel Gap; Advantage of Quenched Gaps; Wireless Piano; Goldschmidt Alternator; Alexanderson Alternator; Magnetic Modulator; Static Transformer Frequency Multiplier; Onde Unique System; Vacuum Tube Methods; Duplex High Speed Operation; Wave Changing Systems 187

CHAPTER XIV

VACUUM VALVES AND CIRCUITS

- Vacuum Tubes; Amplifiers; Detectors; Oscillators; Modulators; Tube Radiotelephones; Experiments Showing

Fundamental Action; Two and Three Electrode Tubes; Curves of Operation; How the Circuits Work; Operation of Grid; Audion Circuits; Lieben Reisz Amplifier; Pliotron; Cascade Amplifier; Outside Grid Tube; Dynatron; Chart of Vacuum Tube Circuits for all Purposes; Ultra-audion Receiver; Damped and Undamped Wave Circuits; Audion Generator; Armstrong Circuit; Construction of Long Wave Length Oscillating Receiver; Adjustment of Oscillating Circuit; Short Wave Length Repeating Amplifying Receiver; Cascade Circuits; Advantages and Disadvantages of Audion; Combined Crystal Detector and Audion; Sensitizing Circuits; Special Vacuum Tube Circuits; Self-tuned Oscillation Generator; Self-Modulated Transmitter; New Tube Circuits	207
--	-----

CHAPTER XV

TUBE RADIOTELEPHONES

Modulation Systems; Portable Radiotelephone; Transcontinental Wireless Telephone; Connection of Tubes; U. S. Army Set; U. S. Navy Set; A Wireless Telephone Operated from Your Lamp Socket; Power Tube Radiotelephone; A Small Amateur Radiophone; Cost of a Telephone Set	238
--	-----

CHAPTER XVI

THE RECEIVING STATION

Operation of Receiver; Telephone Receivers; Purpose of Detector; Energy of Signal Received; Types of Detectors; Principles of Operation	251
---	-----

CHAPTER XVII

DETECTORS

Vacuum Tube Detectors; Solid Rectifiers; Crystals; Construction of Detectors; Crystal Mounting; Adjustments; Buzzer Test	257
--	-----

CHAPTER XVIII

SENSITIVE INDICATORS FOR RECEIVING SETS

Telephone Receivers; Continuous Wave Detectors; Einthoven Galvanometer; Construction of Indicators; Automatic Indicators; Hoxie Photographic Recorder;
--

Amplifiers; Microphone Amplifier; Baldwin Receiver; Adjustments; How Receiver Operates; Measuring Intensity of Received Signal; Audibility Meter . . . 269

CHAPTER XIX

TUNING AND INTERFERENCE PREVENTION

Principle of Resonance Used in Tuning; Interference; Mitigating Various Kinds of Interference; Tuning Methods; How to Tune a Receiving Set; Receiving Circuits; Loose Coupled, Bridge, and Interference Mitigating Circuits; How to Use a Loose Coupler; Balancing Out Power Line Hum 283

CHAPTER XX

SPECIAL RECEIVING SETS

Time Signal Receiver; Weagant's Stray Mitigator; Alexander Barrage Receiver; Heterodyne Receiver; Action of Heterodyne Circuit; Phase Modified Receivers; Balance Systems; Construction of Phase Rotator; Phase Shifting Explained; Multiple Unit Phase Shifting Receivers; Uni-Control and Automatic Receivers; Capacity Coupling; Universal Receiving Set for Long and Short Damped and Undamped Wave Signals; Autodyne Receiver; Magnetic Tube Sensitizer; Short Wave Oscillating Receiver; New Circuits 300

CHAPTER XXI

RECEIVING CONDENSERS

Construction of Fixed and Variable Condensers; Circuits for Condensers; Building a Condenser; Korda Air Condenser; Assembly of Plates; Geared Fine Adjustment Condenser 314

CHAPTER XXII

CONSTRUCTION OF RECEIVING INDUCTANCES

Tuners; Loose Couplers; Loading Coils; Sliders; Windings for Desired Wave Lengths; Variometer; Variometer Phase Rotator; Switching; Dead End Elimination; Tens and Units Connection; Multilayer Coils; Compact Long

Wave Length Coils; Couplers for Long Wave Lengths; Dimensions for Various Wave Lengths; Plural Receiving Sets	325
---	-----

CHAPTER XXIII

MAKING THE WIRELESS SET WORK

Trouble Finding; Principle Faults Found; How to Make Repairs; Reasons for Various Failures; Improving Poor Signals	346
--	-----

CHAPTER XXIV

MISCELLANEOUS APPLICATIONS

Railroad Wireless; Forest Fire Prevention; Automobile Wireless; Aeroplane Sets; Wireless Compass; Bellini Tosi Apparatus; Multiple and Ground Aerials; Balancing Aerials; Telemechanics	350
---	-----

CHAPTER XXV

TIME AND WEATHER SIGNALS

How Signals Are Transmitted and How to Receive Them; Naval Stations Sending Information; Codes Used; Example of Deciphered Code	357
---	-----

CHAPTER XXVI

RADIOCOMMUNICATION PATENTS

A List of Patents for System and Apparatus; Discussion of Some Patents	362
--	-----

CHAPTER XXVII

RIGHTS OF THE EXPERIMENTER

Information on Complete Sets; List of Radio Stations; The Law of 1912; How to Get Licenses; Radio Inspectors; Rules for Operating; Patents; Tendency of Art; Wireless Codes; Conclusion	373
---	-----

CHAPTER I

Nature of Wireless Transmission

Theory; Action of Radiant Waves; Interference; How signals are sent; Wave Lengths Used.

Before beginning the details of equipment, a brief outline of the essential theories which aid in understanding the art will be given. To begin with, it should be understood that many of the elementary theories have only been partially substantiated and that in any case they serve more for convenience than as scientific fact. It should also be remembered, that

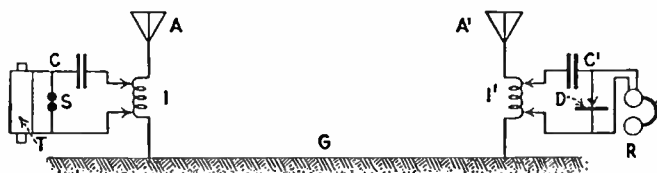

FIG. 1.—Example of a Radio System. A-A', Aerials. C-C', Condensers. T, Transformer Coil. D, Detector. I-I', Inductances. S, Spark Gap. G, Ground. R, Telephone Receiver.

while lines of force and similar terms are used as though the lines were visible and a matter of fact, they are merely imaginary and used for convenience.

In the practical wireless station with which we are concerned, electromagnetic waves are utilized to transmit intelligence without the use of a conductor or wire between the transmitting and receiving stations. It has been found that these electromagnetic waves closely resemble light waves and for this reason some knowledge of the physics of light will be useful and an aid in the mastery of the wireless art.

In Fig. 1 a simple diagram of the relations of the stations is shown as an example. Briefly, electromagnetic waves are generated by means of a discharge through a suitable gap which sets up oscillations in a shunt circuit of capacity and inductance and these oscillations are in turn radiated from the aerial in wave trains representing the dots and dashes of the code.

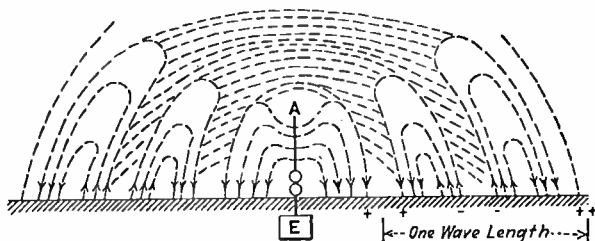

FIG. 2.—Illustrating Theory of Action of Radiating Waves.

By referring to the figure it will be observed that the sending and the receiving station are connected through the earth and that they have a second circuit through the space between their respective aerial capacities. It has not been established whether the

ground acts as the return circuit or whether the space serves for this purpose, but experiments have shown that a considerable part of the efficiency of transmission is dependent on having good ground connections through soil, which is a comparatively good conductor. In fact, the variable conductivity over different portions of the earth materially affects the range and clearness of transmission, ranging from maximum over water, to a minimum over dry uneven expanses of land. The earth is an imperfect and variable conductor in itself and it is for this reason that transmission over different portions of the earth's surface varies considerably. It has not been established

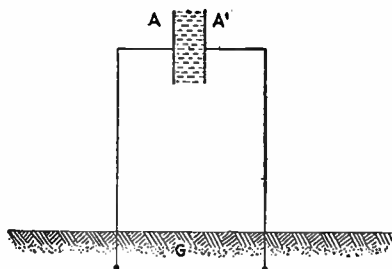

FIG. 3.—Illustrating Condenser Theory of Propagation.

whether or not the curvature of the earth materially affects transmission, but it is not likely that it does. Good earth connections then are essential to efficient wireless transmission. An exceptional case in which no ground is required is discussed in Chapter III.

Some experts consider that radio waves are principally propagated through the earth itself.

A commonly accepted theory of the action of wire-

less waves is illustrated in Fig. 2. The aerial (A) is represented by the upper part of a spark gap and the lower part terminates in a ground E. The aerial becomes charged and sets up a field of force, the area of which depends on the intensity of the charge and other natural conditions. The lines of electrical strain are represented by the dotted lines and should be understood as of spherical form, although shown as in a plane on the paper. Now after the charge accumulates to a certain point, a spark passes between the gap electrodes, making the gap a temporary conduc-

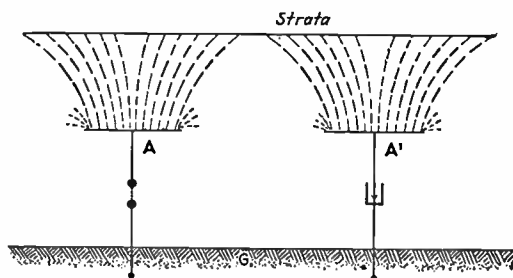

FIG. 4.—Heaviside Layer Theory.

tor. The aerial discharges at this point and as a result the strain in the electrostatic field is relieved. However, a new current is simultaneously produced which charges the aerial in substantially the opposite polarity to that of the first charge, and the process is repeated very rapidly a number of times. That is, the aerial is said to oscillate or vibrate. Now, each reversal of the polarity of the charge causes the direction of the strain to change so that the lines resulting

from the first charge are displaced by lines running in the opposite direction, thus forming partial loops. These loops form a circular series of ripples or waves about the aerial and travel away from it at the rate of 300,000,000 meters per second (186,000 miles per second), or the speed of light. In the figure, the arrows represent the direction of the lines of strain and a little study of this imaginary diagram will aid in the understanding of wireless phenomena. It is understood, of course, that the gap is charged by a suitable condenser and source of power, which are not shown.

Two complete oscillations are represented by the loops of Fig. 2, and the aerial is ready for a third discharge. These oscillations really occur at an exceedingly rapid rate.

A similar argument holds in the case of a vacuum tube transmitter. An ever-expanding volume wave of electromagnetic lines of force threaded at right angles thereto by electrostatic tubes of force is emitted from the transmitter and reaches the receiver where, in cutting conductors thereof, corresponding feeble currents of electricity are set up in the receiving circuits.

The function of the aerial capacities of the stations will be best understood, perhaps, when they are likened to a simple condenser. (See Fig. 3.) If this theory is accepted, a wireless circuit is practically a closed circuit in which one branch takes the form of a condenser. However, since the distance between the two aerials concerned is generally many miles, it is not unlikely that the effect is similar to that indicated by Fig. 4, since it has been established that the

upper strata of the atmosphere and the surrounding space form practically a perfect conductor. At any rate, the distance to which transmission may be carried out is less with relatively low aerials than with high ones, the other conditions remaining the same, and for this reason the higher the transmitting aerial can be supported, the better. The item of cost is the practical limit, however, since after a moderate height is reached the expense increases in a proportion many times greater than the corresponding increase in height. High antennas are unnecessary for receiving stations. In fact, the height of experimental aerials will naturally be limited for this reason and even in the few large commercial stations, the aerial supports form one of the largest items of expense. Large commercial and naval stations have supports for transmitting aerials 100 to 1,000 feet high above the earth's surface.

Now the transmitted wave impulses do not travel only in the desired direction to the receiving station, but spread out in all directions with practically equal force. The direction of transmission can be regulated to some extent, however, by means of directive aerials which tend to make the range of transmission greater in one desired direction than in other directions. Wireless transmission is perhaps best understood by a comparison to the waves which result when a small stone is thrown into a smooth body of water. It is suggested that the reader try the experiment when the opportunity is presented, if he has not already done so. The stone thrown into the water corresponds to

the wave generator at the transmitting station in wireless telegraphy, the water to the space or ether and the ripples to the electromagnetic waves. It should be observed that the ripples spread out continually in the form of a circle and that they gradually become feebler and feebler, until they are no longer visible. Wireless transmission presents a similar property and the electromagnetic waves become feebler so that the amplitude is approximately inversely proportional to the distance from the sending station.* Another factor which limits the transmitter's effective range is the item of absorption. Now, it has been found that the absorption varies in some cases with the wave length employed. In general, long wave lengths are subjected to *less absorption* than wave lengths which are relatively short. Inasmuch as the experimenter is expected to confine his experiments to the use of short wave lengths this is a matter of some importance. For example, waves having a length greater than 3,000 meters will even penetrate several feet below the surface of the earth. In transmission over water short wave lengths are nearly as good as the long ones, but over ordinary land, long wave lengths are a material advantage. However, in the case of land transmission over dry soil, neither long nor short wave lengths appear to have an advantage. It is understood that short waves mean those having a wave length of 200 meters or less, while long waves refer to waves having from 1,200 to 14,000 or more meters for their wave length. Wave lengths between 300 and 6,000 meters are gen-

* This is not a rigid rule or even exact.

erally recognized as the most advantageous for ordinary purposes.

Wave lengths as high as 30,000 meters have been used for transoceanic communication and 6,000 to 15,000 meters are commonly in use by several of the largest stations.

Other items which *affect* the *transmission* are *irregularities* in the composition of the earth such as mountains, minerals, etc., and daylight. It has been found that messages can be received over much greater distances at night than during the daytime. The difference is not marked or important over short distances and can be overcome to a considerable extent over long distances, by the use of long wave lengths. The reason why daylight affects the transmission is not really understood at the present time, although there are several theories. It is believed that the effect is due either to the ionization of the air or the upper strata or both, by the sun's light. When the theory that the aerial capacities of the stations form a condenser is used and it is remembered that the action of a condenser depends largely upon having a good dielectric material so that there will be little leakage, this theory seems plausible. Rain and damp weather have a similar effect on transmission because the dielectric is presumably rendered less conductive to the waves and more conductive to leakage. The humidity is related therewith in that stray disturbances increase when the humidity increases and vice-versa.

Now since the waves tend to spread out in every direction, it will be evident that all the receiving sta-

tions within the range of a transmitting station will be capable of receiving the same message equally well, other conditions remaining the same. This lack of secrecy is a considerable detriment to the advance of the art and efforts are constantly being made to overcome this lack of direct communication in a desired straight line. Instruments and apparatus have been developed which make it possible to either receive or not receive a given message with a certain degree of precision and directive methods have been developed to a certain degree as has already been mentioned. Another serious drawback to the advancement of the art is the matter of interference. This is an item which directly concerns the experimenter and although several arrangements to overcome this objectionable feature have been developed, there is considerable room for improvements.

Interference can be understood by reference to the experiment of throwing the stone into the water. If two stones instead of one are thrown into the water, and if one is considerably larger than the other, it will be noticed that the ripples or waves from the larger stone tend to absorb and superpose those of the smaller stone. A similar drowning out occurs in wireless transmission, and when several stations are sending simultaneously on approximately the same wave lengths it becomes practically impossible to select a desired message unless it is noticeably stronger or of different audible group frequency pitch than the remainder of the impulses. It frequently happens that six or more stations are sending simultaneously with

approximately the same wave length and with strong apparatus, making it nearly impossible to receive an intelligible message from a single one of them. Further, when a long distance message is being received, and another station sending at approximately the same wave length and situated in the neighborhood of the receiving station starts in, the result is obvious. To be sure, apparatus has been developed which makes the selection of desired signals, to the exclusion of others, certain within limits, but such cases as the one mentioned can usually not be entirely avoided, with the best of the present apparatus. This has recently been overcome by phase modifying means. When the stations are all sending at wave lengths which differ considerably from one another and are sharply tuned, the desired message can generally be received without much difficulty. However, if untuned or only loosely tuned signals are sent out from a moderately strong or neighboring station, it becomes ordinarily impossible to tune them out because they are received by forced oscillations. It is like trying to hear a phonograph a block away when a band is playing within a few feet of your ears.

When *tuned* or sharply tuned *waves* are spoken of, it means waves such as are transmitted from tuned transmitting stations so that it is necessary to tune within a very few per cent in order to receive them. When *untuned* or forced oscillations are spoken of, it means waves which may be received without sharp tuning or signals which have several wave lengths without any definite characteristics. This is the sort

which is so generally employed by beginners and even by commercial stations in some cases and can be received by all stations within range without any special effort. This property is certainly useful in case of emergencies at sea, but in ordinary transmission the stations with untuned wave transmission should be gotten rid of as soon as possible whenever they interfere with other stations. The matter of tuning will be more fully taken up later.

The only other natural condition of importance which affects wireless transmission is the matter of atmospheric disturbances. Ordinary strays resemble the disturbances caused by untuned waves and are practically impossible to entirely exclude, particularly when they are present in a large quantity. Certain localities have less trouble from stray interferences than others, but there are only a few localities in which static does not cause more or less trouble. In cases of local electrical storms, transmission or reception becomes impracticable and even dangerous. Apparatus recently developed, however, practically mitigates the effects of strays and makes reception possible even during thunderstorms.

The sending and the receiving stations of a wireless system are similar and the same aerial capacity may be used for both sending and receiving. The receiving apparatus of an up-to-date wireless system generally includes a detector to detect or rectify the incoming oscillations, sensitive recorders, which generally take the form of telephone receivers, to receive the intelligence, and various inductive and capacity apparatus

to tune the station to receive desired signals to the exclusion of undesired signals.

These points and the practical considerations which they involve will be discussed in detail in the following chapters.

The reader should always bear in mind that the radiant energy used for wireless work is as real as is the radiant energy of the sun. The length of the electric waves with which we are concerned can be controlled at will and while they may be made a fraction of an inch or several miles long by merely altering the oscillatory circuit as described in Chapter V, practical work is at present carried out within 150 to 16,000 meters.

One of the principal recent advances has been in the direction of stray mitigation. The reader can obtain some of the benefits thereof which are not too complicated for private use by employing a multiturn coil or underground receiver with special circuits as described in Chapter III.

The matter in this chapter is only a mere outline of the many conditions involved in wireless transmission, and the reader is referred to works by Pierce, Fleming, Eccles, Zenneck, Austin, Murray, and others, for further accounts of the history and theories of wireless transmission. The mathematical reader will find these volumes of particular interest.

CHAPTER II

Aerials

The Antenna; Dimensions; Supports; Height and Length; Various Types; 200 Meter Design; Table for Various Wave Lengths; Radiation Resistance; Capacity and Inductance; Insulation and Construction; Poles and Guy Wires.

The essential conditions for wireless transmission have been briefly outlined and we will now take up the matter of aerials. It will be remembered that short waves are more easily dissipated than long waves. This is particularly true during the summer months and when the transmitting station is in the vicinity of a large number of trees. Both the sunlight, and the foliage on the trees tend to absorb the shorter waves to a greater extent than the longer waves. Perhaps it is well to more fully define what is meant by wave length at this time.

Now the *electromagnetic* waves which are generated and radiated at the sending station are similar to light waves in that they have the same velocity (186,000 miles per second) in air of the same temperature and pressure, have the physical properties of re-

flection, refraction and polarization, but are *different* in that light waves have a relatively short length while the electrical oscillations have a relatively long wave length. It may be explained also, that the length of a wave means the distance between like points on any two consecutive waves. It will be remembered and noted that the transmitter of a wireless station sends out a series of waves at a very rapid rate, so that by the time one has left the aerial and another leaves, the first will have traveled a distance roughly equal to the wave length. Since these wave impulses occur at a very rapid rate (high frequency), a single transmitted dot may be made up of several wave impulses.

The aerial capacity or antenna consists of metallic conductors insulated from foreign objects and elevated in the air. It is generally made up of a number of similar wires, and its purpose is to radiate electromagnetic waves when used as the aerial for a transmitter, and to receive or regenerate intercepted waves when used with receiving apparatus. The aerial itself may take a number of shapes and since each has individual characteristics, different effects are obtainable from different combinations of conductors. In the early stages of the art solid metal or wire network aerials were adopted and the experimenters used chicken netting, bronze screen and similar materials for aerials, but it was soon found that plain conductors separated uniformly were better suited for this purpose.

Now the dimensions of the aerial determine the efficiency of the wireless station and also limit the efficient wave length of the transmitted impulses. In

accordance with good practice and in order to keep within the regulations embodied in wireless legislation,* the experimenter is expected and required to limit his experiments to wave lengths which are not over two hundred meters long. Now although low wave lengths are more readily absorbed and dissipated they are also more suited to low power apparatus than the long wave lengths.

In all ordinary conditions and particularly in cities having numbers of other stations, the *short wave length only* should be used. It should be remembered that the aerial itself is only one of the factors which determine the transmitted wave length and that for receiving purposes only the experimenter has a variable range of wave lengths at his service by employing tuning coils, variometers, or if very high wave lengths are desired he may use a loading coil.

Remarkable ranges have been accomplished with 200 meter transmission and less. Records of several hundred miles were obtained. The small aerial can be loaded successfully for long wave length reception.

The first item to consider, after obtaining permission to erect a station, is the exact location for the *aerial support*, and the height for the same. As has already been pointed out, the higher the transmitting aerial is placed above the surface of the earth, the

* The act of 1912 is still in effect and stipulates 200 meters with $\frac{1}{2}$ K. W. as maximum power. During the war private stations were closed and sealed up. A recently introduced bill H. R. 13159, Nov. 21, 1918, has been abandoned. The Navy Dept. has released amateurs from war-time restrictions.

better. When only occasional (and receiving) experiments are to be conducted, a tandem of kites, preferably box kites, will serve very well. The unsteady height resulting from the rising and falling motion is, however, not suited to delicate tuning, since the capacity of the aerial is thereby altered. There is no limit to the ingenuity which may be called to act in the selection of inexpensive aerial supports. A simple insulated wire dropped from the roof or an upper story of an apartment house, flat, water tower, or similar structure to a position some distance below (30 to 130 feet), will serve as a fair aerial. Insulated telephone cables may be impressed into service for receiving purposes alone. Two grounds may be used in place of an aerial, if no supports are available. Thus the water pipes may be used as an aerial while the gas pipes, or a cistern is used as the ground. Or the steel frame or tin roof of a building may be used for an aerial while another part of another building is used for a ground. Even leader pipes and gutters have been impressed into service in certain cases. Common wire netting suspended from trees or telephone poles may be utilized. It is always desirable to *insulate* even makeshift aerials and when two grounds are used, one should be connected through a condenser to the instruments. The author has even made use of a small aerial suspended in an attic, a brass bed in an upper story of a residence; and for very short distances such common things as dishpans, bed springs, and what not! may be utilized if nothing else is obtainable. During some experiments in Tripoli, Mr.

Marconi is reported to have laid both the aerial and a similar set of conductors to act as a ground directly on the sand, parallel to the direction in which the signals were to be sent. It is said that no aerial supports were necessary because the sand was perfectly dry and resembled glass in its conducting properties. These items are merely suggested as suitable make-shifts in case other and more business like arrangements are not practicable and good results may be obtained with them by exercising reasonable skill.

The supports should take the form of natural supports whenever possible as this will save considerable expense. Thus short extensions to trees, houses and building tops, and similar structures make excellent supports. Permission may often be obtained from the local telephone or light companies to place extensions on one or more of their poles so that they will not interfere with the regular service and some companies will even give aid if properly approached. The author has utilized such poles for his experiments for many years.

For receiving purposes only, no aerial, but the use of the multi-turn coil receiver is recommended. This is described in Chapter III and is superior to the aerial.

The erection of large poles from the ground up is a difficult task and one which had best be referred to the company which sells the pole or else to experienced erectors. They are not needed for receiving stations.

Good straight-grained 2x2 stock is suitable for small

poles up to 40 feet, and the size mentioned is preferably arranged into two or three lengths. Perhaps the best support for experimental stations, when natural supports are not available, is iron pipe. This form of support may also be used in addition to natural supports such as house-tops, etc. The height of the aerial should always be sufficient to clear objects between stations if possible. For experimental purposes a height of about 50 feet is a good average, though a higher one is preferable when possible.

After the height has been determined, the other dimension to be considered is the spread of the aerial. In many cases a low height can be compensated by a corresponding increase in the aerial spread. However, since an increase in the horizontal spread of an aerial also increases the minimum wave length of the transmitted impulses, this dimension must be limited so that the minimum wave length will be about 150 meters if the wave length is to be limited to 200 *meters* or less, the difference being left to the adjustment of the transmitting inductance. When possible it is a good plan to have a *duplex aerial*, which is nothing more or less than two separate aerials, one for receiving and sending in short wave lengths, and the other for receiving in the commercial wave lengths, but not for sending. While this means two separate aerials and should be regarded as such, much ingenuity may be used in utilizing the same supports for the two aerials. Thus one may be supported some distance below the other, and similar arrangements may be carried out in a variety of ways. The main objection to a duplex aerial is that part

of the transmitted energy is absorbed by the idle aerial. (See Fig. 5.) This can be overcome to an extent by placing the two aeri- als at right angles to each other or entirely eliminated by using the multi-turn coil described in Chapter III.

The large receiving aerial of a duplex system may have a length of from 100 to 1,000 feet depending on the individual conditions,—about 400 feet being a good length. The length means the *effective length* including the several parts. For the vertical, horizontal, or dipped aerial (straightaway) the length of one of the wires is the ef-

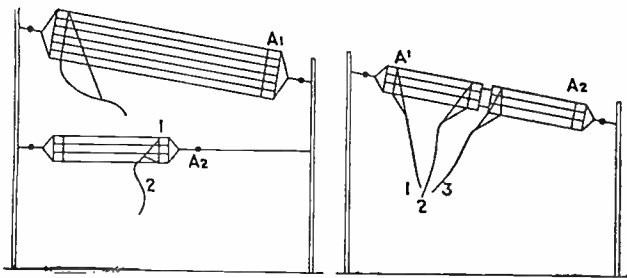

FIG. 5.—Examples of Duplex and Combination Antennas. A¹, Receiving Aerial. A², Sending Aerial.

fective length. (See the figures.) The effective length of the T aerial is the length of the vertical part plus one-half of the horizontal portion, while that of the reversed L aerial is the length of the horizontal part plus the length of the vertical portion. In a loop aerial the length is the sum of the lengths of the sides of the reversed U loop. With the ordinary umbrella aerial, the length is roughly equal to the length of one of the uniform aerial conductors, as is also the case in a directive aerial having

several independent and uniform conductors. In order to keep within the limits of the standard short wave length, an effective length of 120 or 125 feet should not be exceeded.* The transmitting aerial should, therefore, be made so that the effective length is within this limit. It is understood that the length of the lead-in is included in the effective length. The effective length is really the distance from the transmitting instruments to the aerial proper, plus the effective length of the aerial itself. In case a long ground lead is necessary to secure a ground to the instruments, its length must also be added to the effective length. In the latter case, the aerial itself must obviously be still further limited. It is suggested that the short length can be partially compensated for by making the *capacity* of the aerial correspondingly *larger*, but this must not be carried too far so that the capacity is too large for the wave length or for the charging capacity of the sending instruments. It is understood that the capacity of the aerial can be increased by adding more wires to it. A large electrostatic capacity in the aerial means greater energy and more power in the transmitted waves provided the transmitting instruments are able to charge it with a sufficient potential. The wires should always be arranged symmetrically and evenly spaced in order to decrease the effect of mutual induction between the adjacent wires as much as possible. An increase in the conductors of the aerial does not increase the capacity to a corresponding extent on account of this mutual induction. The distance between the respective conduc-

* This means that the length of the aerial proper should not exceed 75 feet, in order to allow for lead-ins.

tors of an ordinary aerial should not be less than .02 of their common length. Thus in an aerial 100 feet long, the wires should be spaced at least 2 feet apart, or even more if possible. In addition to increasing the capacity of the aerial, an increase in the number of conductors *decreases* the resistance. A minimum of three wires and a maximum of 8 or 10 is the range of the number of conductors suitable for the average experimental station and it is not desirable to exceed these limits. Some results may, of course, be had with even a single conductor, but for efficiency a plurality of conductors is desirable. The

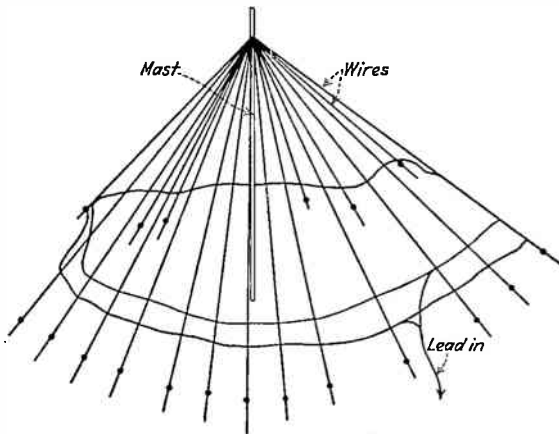

FIG. 6.—Umbrella Antenna.

single conductor serves very well for long wave length receiving purposes. A wire 1,000 feet or more long and 30 feet high may be used with suitable receiving inductances to obtain signals from the large stations operating on wave lengths as high as 15,000 meters.

The number of conductors used affects the *transmission* more than the reception of signals. It is desirable to use two conductors placed 6 feet apart instead of four wires only nine or twelve inches apart and the same rule may be applied for other dimensions, since much of the effect of the extra wires is lost by reason of their close proximity. When only two wires are used, they should, of course, have a correspondingly increased capacity. In any case, the size of the aerial conductors should not exceed No. 8, since larger sizes are wasteful

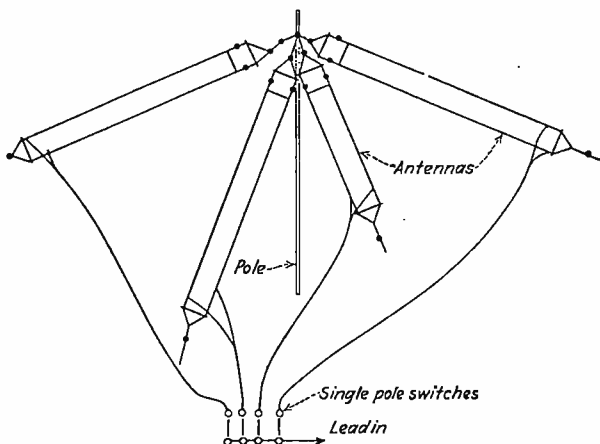
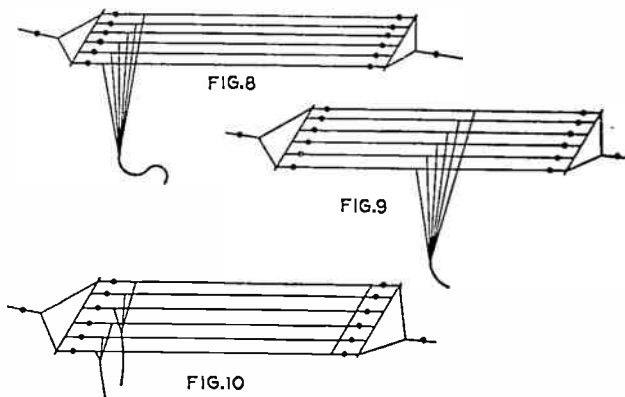

FIG. 7.—A Directive Aerial with Switch Selector.

and of prohibitive weight. No. 12 is a convenient size for experimental aerials. The constructional details will be more fully taken up a little later. Stranded wire is best, seven stranded phosphor bronze being a favorite kind.

For short wave lengths, the author considers that the *umbrella* aerial or perhaps a modified umbrella will

prove the most satisfactory for transmission because of the large capacity which is possible in a small space. A suitable form for this type of aerial is indicated in Fig. 6. This aerial is called the umbrella presumably by reason of its resemblance to the ribs of the umbrella. This arrangement may easily be converted into a *directive* aerial as shown in Fig. 7, in which form it will doubtless be the most useful to experimenters. The several conductors are preferably insulated from each other in this case, though they may be connected together at the top or



Figs. 8, 9, 10.—Arrangements for Flat-Top Antennas.

pole end. Each wire is separately connected to a single pole switch, preferably of the common porcelain base type. With this arrangement, one or more wires may be used independently from the remainder, or all may be used if considerable capacity for transmitting purposes is desired. This form of aerial is well adapted to experimental purposes and has the additional advantage of be-

ing mechanically strong and requiring only a single pole support. This type of aerial is particularly suited to house tops, the roofs of buildings, and similar places.

In congested places where the available space for the aerial is limited, as on ships, various types of horizontal or flat top aerials are used. Experimenters will find these types well adapted to their purposes. These aerials are also known by names which correspond to their respective shapes. The *reversed L* type is shown in Fig. 8, and is highly directive by reason of its shape. The maximum radiation is in a direction opposite to that in which its free end points and it also receives signals at the best from the same general direction. The leads are taken off from one end of the aerial, and if the two ends are of uneven length, the lead should be taken off from the lower end. In the latter case, the aerial is called an inclined aerial. When the leads are taken off in the form of a T as in Fig. 9, signals are sent and received the best in the plane of the aerial, but the directive effect is considerably less than with the L type. Instead of taking the leads off at right angles it is often necessary or convenient to take them at an angle to form an oblique lead. The several wires are preferably connected together at one end, although this is not essential.

By taking a double lead as illustrated in Fig. 10, either as a T or L type, a *looped aerial* is formed. This inverted U type is adapted to close tuning and eliminates humming caused by neighboring telephone and power lines. These types may of course be considerably varied, but a simple form is desirable in order to secure close, sharp tuning.

Having gained some idea of the several types and gen-

eral features of aerials, some of the constructional details will now be considered.

AERIALS RECOMMENDED FOR VARIOUS WAVE LENGTHS

The following dimensions are suitable for four-wire aerials of the "L" type with spacing between wires not less than 0.02 of the length. The length here means only the flat top length, as the lead-in length will vary with the location of the set. To find the amount of wire needed multiply the length of the aerial and lead-in by four, which gives the number of feet required. As regards range in miles which such an aerial can in each case cover, it should be understood that the size is no limit in this respect. The values given are the approximate natural wave lengths in meters and can be increased by loading with inductance or decreased by means of a condenser in series.

Meters.	Height above ground—feet.	Length in feet.
150	30	75
200	50	80
200	60	50
200	30	90
250	40	100
300	60	100
400	80	130
500	60	180
600	80	230

The second 200 meter aerial is recommended for amateur transmitting.

WAVE LENGTH OF ANY AERIAL

This is best found with a wave meter, but may be roughly calculated from—

$$W = \left(V + \frac{L}{4} \right) 4.2,$$

where W is the wave length in meters, V the height of the flat top in feet, and L the length of the four-wire aerial in feet.

RADIATION RESISTANCE

This term originated with J. S. Stone and means the equivalent resistance which would consume the same energy as that withdrawn from the sending antenna by radiation. It is often used and according to R. Ruedenberg is approximately equal to

$$\frac{1,600 (\text{height from earth to center of capacity of antenna})^2}{(\text{wave length})^2}$$

ohms, the meter being the unit of length.

Example; wave length 600 meters

mean effective height 40 meters.

$$\text{Radiation resistance} = \frac{1600 \times 40 \times 40}{600 \times 600} = 7.1 \text{ ohms.}$$

INSULATORS

It is important that the aerial be suspended so that it is thoroughly insulated. The insulation should be effective during all kinds of weather and faulty insulation should be avoided with considerable care if an efficient station is desired.

Hard rubber, fiber, and unglazed porcelain are not very desirable as aerial insulators. A material known by the trade name of Electrose is made into a number of suitable forms. This type of insulator is also mechanically strong, since metal rings are molded directly into the insulating material. Corrugations are provided to increase the distance over which a surface charge must pass and also serve to prevent the formation of a conducting film.

Aerials for transmitting purposes are necessarily better insulated than those used for receiving purposes only, but in any case the aerial conductors should not touch other partially conductive materials. Common two-wire glazed porcelain cleats make convenient insulators for small stations. These may be had for a few cents a piece. The holes are $1\frac{1}{2}$ inches apart, so that a single cleat is sufficient insulation for a receiving aerial and also for a transmitting station in which only 100 watts or a one-inch coil is used.

When more power or larger coils are to be used, several of these cleats may be arranged in tandem. The cleats may be joined, and used by passing wire through the two holes so that the wire to be insulated is separated by the insulator from the wire attached to the support. There are various other forms of porcelain and glass insulators which may be had at supply houses and since they are all used in much the same manner, no further comment seems necessary. Strain insulators are useful in breaking up the guy wires used in supporting the poles, so that the transmitted waves are not unduly absorbed. This form of insulator is also useful for the main aerial supports. The leads or lead-in wires should be insulated

with the same care as the aerial itself. The supports which hold the leads should have insulations of the same general nature as that provided for the aerial.

A problem is sometimes presented when it comes to bringing the wires into the building. A good way is to bore holes for the wires, in a glass window. Heavy porcelain tubes placed in holes in the woodwork are also suitable for small stations. A fairly good lead-in insu-

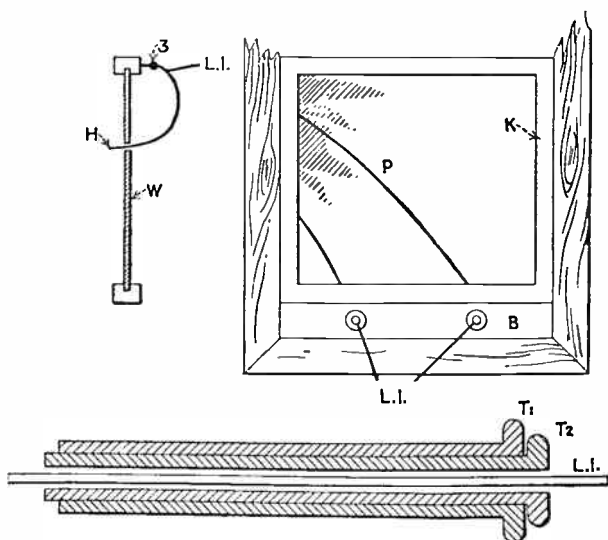

FIG. 11.—A Simple Lead-In. W, Window. H, Hole in Glass. 3, Insulator to Take Up Strain. L. I., Lead-In. P, Windowpane. K, Slide Casing. B, Board with Insulators. T¹, T², Porcelain Tubes.

lator can be made by using a nest of tubes, one over the other, starting with a half inch in outside diameter and ending in the largest convenient outside diameter. A number of special insulators may be had at supply houses.

See Fig. 11 for several details of construction for the lead-ins. The wires should be anchored by an insulator just before entering the building in order to take up the strain.

The general manner of suspending an aerial is illustrated in Fig. 12. The spreaders can be of wood or bamboo. Curtain poles are suitable for this purpose. Twisted wires, screw eyes, mast withes and similar or improvised hardware are useful in fastening the insulators and supports.

ASSEMBLING—CONDUCTORS

In assembling the aerial conductors and the spreaders, it is advisable to arrange everything on the ground first. The wires may be of copper, tinned copper, aluminum,

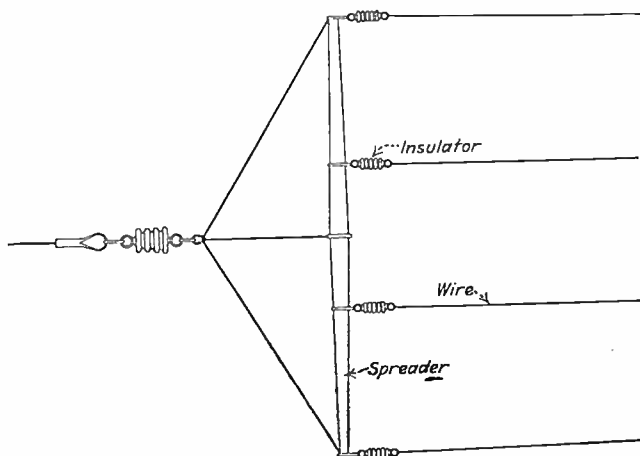

FIG. 12.—Antenna Spreader.

or phosphor bronze. Iron wire is not recommended, although it may be used. The phosphor bronze is the most desirable because it is strong, springy, and may be had in a standard strand of seven No. 22 B&S conductors. It is generally sold by the foot. Stranded conductors have a slight advantage over solid conductors.

Although copper has less than one-half the tensile strength of phosphor bronze, it is very easily obtained and quite suited to aerials. It has a good conductivity, is pliable, can be easily soldered, and may be had in strands if desired. Ordinary No. 12 telephone copper wire is suitable for experimental aerials. The wire used should never exceed No. 16 or its equivalent in fineness or No. 8 in coarseness.

Aluminum is not so good a conductor nor is it as strong as copper wire, but it is pliable and very cheap when compared foot by foot. The main difficulties with aluminum aerials are that the wires are easily broken by twisting and that a non-conductive coating soon forms which practically insulates the joints unless they have been well soldered.

In using aluminum wires, kinks, bends, and excessive strains should be avoided. This also applies to other wires. Aluminum is difficult to solder but special solders are obtainable which make the operation reasonably sure provided the joint is well cleaned to begin with. All joints in the aerial should be soldered and it is also advisable to cover them with a good quality of electrician's tape and rubber solution. Loose contacts in an aerial cut down the efficiency materially and also make the aerial weak mechanically. The high frequency currents must

have as *clear* and as good a *conducting* path as possible if the waves are to be radiated without considerable loss.

JOINTS

Fig. 13 shows a fairly good way to make a joint without solder. The wires should be *cleaned* and the *joint* made tight, after which wrap several layers of tinfoil about the joint and tape well. When the aerial is constructed with every concern for efficiency, the wires will be thoroughly insulated even at the points where they make contact with the metal connections of insulators.

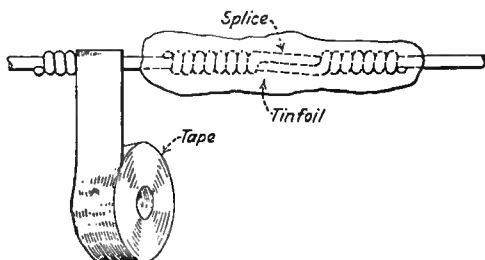
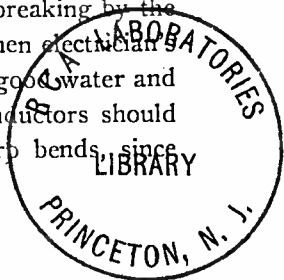

FIG. 13.—A Splice with Tin Foil Joint.

This may be done by tape, and the chief object is to prevent thermo-electric and galvanic action between the dissimilar metals. Fig. 14 illustrates a suitable joint for lead wires which prevents the wire from breaking by the swaying motion given it by the wind. When electrical tape and liquid insulation are used, a very good water and rust tight joint is insured. The wire conductors should be kept *free* from nicks, kinks, and sharp bends, since they are easily parted at such points.



WIRES—SIZE

Large spans require *larger sizes* of wires than short spans, since they are subject to greater strains. Numbers 8 to 10 are suitable for spans in excess of 200 feet, while numbers 11 to 15 are suitable for the shorter spans. In

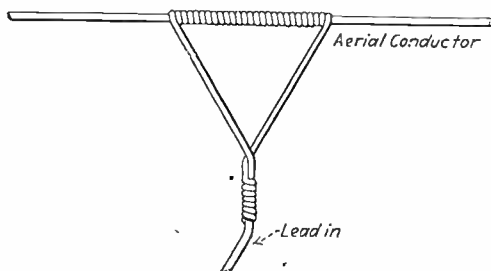

FIG. 14.—Lead-In.

planning the conductors larger sizes should be used when aluminum wire is used than for copper, larger for copper than for phosphor bronze, and larger sizes should also be used according to the increase in the span.

AERIAL SUPPORTS

It is always advisable to support the aerial by means of pulleys and ropes, so that it may be lowered for repairs when necessary. Good galvanized pulleys may be had at a low price at hardware and supply houses and ropes and flexible wires may also be had at these places. Flexible wire is preferable to rope, since the latter requires frequent renewals. The rope or wire should always be sufficient in size to take up all the strains as well

as a large overload. The working strain of manila rope may be found by dividing the square of the circumference in inches by 8 for the strain in tons. Thus, to find the size of rope required, estimate the weight, allowing for excess strains, and multiply the resulting weight in tons or fractions thereof by 8. Extract the square root to get the circumference in inches. The safe strain for wire rope is found by multiplying the square of the circumference in inches by .3 for *iron* and .8 for *steel* wire. For small aerals a good grade of clothes line or clothes wire is suitable. Put up an aerial only if you want to transmit and then make your supports strong so a heavy wind will not blow them down.

LEAD-IN WIRES

The lead-in wires should have a capacity equal to that of the aerial. Thus, if the aerial is composed of six No. 12 wires, the lead-ins should have a capacity equal to that of six No. 12 wires, and this is preferably obtained by twisting six No. 12 wires together. When the lead-ins have a smaller capacity than the aerial itself, they offer impedance to the high frequency oscillations and the radiation is accordingly reduced. The *lead-ins* should always be as *short* and *direct* as possible and should be connected to the lower end of the aerial. When long variously twisted lead-ins are used, sharp tuning is practically impossible. The lead-in wires are essentially *not intended* to radiate the energy but to conduct it up to the aerial, from which point it is most efficiently radiated. When this is not possible, the aerial itself should be ex-

tended directly to the vicinity of the transmitting instruments. The lead-in wires should have nearly a straightaway course, *i.e.*, without angles, bends, joints, or the like. If the term may be used,—high frequency currents abhor all joints, kinks, bends, and other defects in the conductor.

POLES

While a number of suitable aerial supports have already been suggested, a few notes on poles may be well taken. Many experimenters will find bamboo an excellent material for short poles as well as for aerial spreaders. Portable poles may be made from this material. Jointed wooden poles are not desirable for poles exceeding 40 feet in length, a wooden truss work being more suitable for larger poles. Experimenters have made poles from 100 to 150 ft. high on the truss plan without great difficulties. In this form of construction, the pole is built up in the form of a long, narrow pyramid with a base so that the builders can construct it piece by piece. See Figure 15.

Iron pipe makes a good material for aerial poles. The pipe can be had at any plumbers' or hardware supply house in nearly every locality. The stock should be what is known as "heavy." The pole may be made in sections, the lower section being the largest and the upper section the smallest of the progression. The sections are joined by reducing couplings, and the dealer should be consulted for suitable sizes and dimensions. It will be convenient to have the dealer cut and thread and fit the pipe unless

the reader has experience and tools for this purpose. The pole and the joints should be covered with a water-proof paint, such as a solution of asphalt. A hole to support a pulley should be drilled near the top, through which the rope to support the aerial is passed. It is desirable

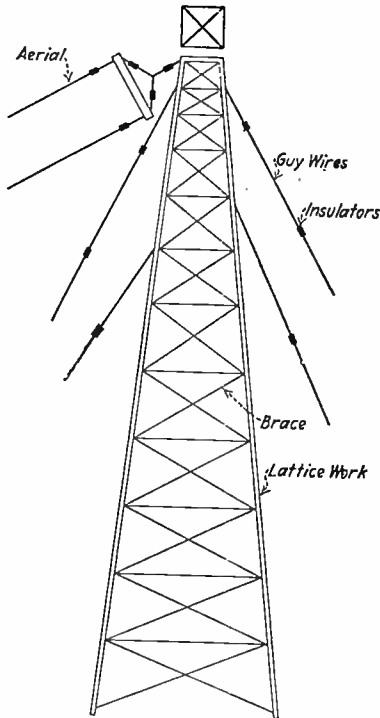

FIG. 15.—Lattice Tower for Antenna.

to insulate the pole at its base when such procedure is possible. Sockets for this purpose may be made from insulating material or purchased from supply houses.

The dimensions for a 40-foot iron pipe follow.

Sections—three.

1st. 15 foot length of 2-inch pipe.

2nd. 15 foot length of 1¼-inch pipe.

3rd. 10 foot length of ¾-inch pipe.

Reducers of malleable iron.

1st, between sections 1 and 2—2 by 1¼ inch reducer.

2nd, between sections 2 and 3—1¼ by ¾ inch reducer.

A top ornament or closure may also be provided.

Guy wires,—four wires at approximately a 30-degree angle from the top portion of each section. Size of wires, —No. 12 or 14 galvanized iron. The second and third sets are preferably broken by means of insulators.

GUY WIRES

The experimenter should take considerable care to make his aerial strong so that it will not need repairs after every little wind blow. The iron pole will not support itself without the aid of the guy wires. In the case of an umbrella aerial the conductors take the place of the top set of guy wires. Small aerials are easily erected and the guy wires may be tightened by hand. Turn-buckles should be provided for larger poles, however, in order to take up the slack. The insulators in the guy wires should be placed every ten or fifteen feet and may be of the type already described. Strain insulators are preferable for this purpose.

While the matter of aerials has now been considered in some detail, the minor details are left to the individual resources of the reader, since the conditions vary widely

in each case. The matter in this and other parts of the book is intended largely as suggestive rather than dictative, and various details may be modified, provided that the essential principles and dimensions are not violated. It is suggested that the umbrella, variable directive aerial, T aerial, and directive aerial will be most suited in the order mentioned, and that the duplex idea should be adopted if it is desirable to receive from the commercial stations without interfering with them.

CHAPTER III

Coil and Sub-Surface Systems

1. Multi-turn Coil Receiver; Portable Receiving Long Distance Set; Principle of Coil Action; Directional Effects of Coils; Types and Construction; Radio Compass.
2. Sub-surface Radio; Antenna Buried Underground; Roger's System; U. S. Navy Experiments.

THE MULTI-TURN COIL RECEIVER

The "coil" or loop, as it has sometimes been misnamed, is valuable as a substitute for the usual antenna circuit in radio receiving systems and may to an extent serve also for transmitting purposes.

It has the advantage of being highly directive, small in bulk, cheap, portable. It is less affected by strays than the antenna but retains the ability when used with oscillating vacuum tube circuits and amplifiers of reaching any range required.

A coil, for example, consisting of 200 turns of insulated wire on a frame but four feet in diameter, Fig. 1, serves very nicely, even inside of an office building, to receive good signals from the European and other dis-

tant stations. A signal audibility of 10,000 may be obtained from the amplifier with this arrangement from a sending source three thousand miles distant.

The shape of the coil does not appear to be material for squares, circles, ellipses, oblongs and other shape forms wound either in pancake or single layer form all suffice. A single turn pancake which might be expected to be more directional is about equalled by a single layer coil four inches wide in this respect.

The size of the coil is similarly not a critical factor and while a smaller coil requires the use of more amplification, one four feet in diameter functions to the same signals that another fourteen feet square will.

An explanation sometimes given for the directional effect of the coil or loop is that the front portion and the rear portion receive the signals out of phase when in alignment with the transmitting direction, but in phase such as to oppose and give zero when perpendicular to this direction as then both sides get the energy at the same time but deliver the result in opposition.

It seems that the electromagnetic component of the advancing electromagnetic waves has the principal if not sole effect upon the coil and this accounts for its directional qualities for the maximum currents will be induced therein only when the turns thereof are cut at right angles. This directional quality is so good that by moving a coil receiving, from one point to another in an automobile to afford a baseline gives the direction and to some accuracy the distance of the sending station, the latter depending upon the baseline used.

For transmitting purposes the coil seems limited to

relatively short distances and apparently a coil of relatively few turns is best therefor.

As the coil requires no ground terminal and in fact does not function well when connected with one terminal open for use as an antenna, it lends itself to shielding experiments because a cage or coil may be wound around it at right angles to the turns of the coil and grounded through a high resistance without shutting out the signals therefrom. Such a shield was found to not entirely eliminate strays from the coil receiver, but a metal lined box for the receiving apparatus was not employed in the test as desired.

That the coil receives fewer strays has been proven by recording the number and intensity of strays received by an antenna at the same time under similar conditions. The fact that the strays received by the coil are less intense is no criterion because the signals received are also at lower audibility.

If two coils are placed at right angles to each other and properly oriented, only one will receive the particular signals while both will be affected by strays. Unfortunately, though made alike, two such coils are not similarly affected by all strays except under unusual and occasional circumstances, some strays affecting both at intervals while more often one is affected while the other is not or more so.

The coil is most effective in the V plane and the received signals die down as it is tipped more and more toward the H plane, but all strays are not eliminated therefrom while resting in the H plane.

The size of the wire employed in the coil is not a

critical factor as long as the resistance thereof is kept within reasonable limits. A coil consisting of three hundred turns of No. 31 DSC wire closely wound functioned to the same signals but with much less intensity than one consisting of No. 16 wire, but as the dimensions of the latter were larger the size of the conductor does not wholly account for the difference. Smaller wire and lesser dimensions can, up to a working limit, be compensated for by increased amplification.

CONSTRUCTION

As shown in Fig. 16, wind 300 turns D.S.C. wire on a frame 6 feet square with slight spacing. The winding can be in one or more layers and either in pancake or layer form. The lead-in need not be over six feet long as a coil elevated to the roof of a building only receives the same signals that one inside of the same building will. Condenser (1) in series with coil (2) is adjusted until the proper wave length is attained. (2) may be a coil 8 inches in diameter and consisting of 300 turns of No. 26 S.C.C. wire. (3) may consist of a two-layer coil 8 inches in diameter and containing 500 turns adjustable in steps of 100 each. The terminal (7) is best connected to include about one-fifth of the turns of coil (3) which are in use. Condensers (1) and (4) are air variable plate types with maximum capacity up to .05 m.f. each. Consult Chapter VI to compute values for any desired wave length range. (5) is a vacuum tube with either an ordinary or an oxide coated filament (8). (9) is a one-half m.f. condenser which connects to a vacuum tube amplifier (6), preferably of the two-stage type later de-

scribed. The wave length of the circuit depends upon the inductance (3) and capacity (4) in use as the multi-turn coil circuit (1), (2), (10) can easily be brought to resonance therewith. When (2) is tightly coupled (close) to (3) a distinct "click" will be heard in the telephones (11) when (10), (1), (2) is in resonance with (3), (4) at the instant that the correct adjustment occurs, the tube (5) being, of course, lighted during this adjustment. Consult information given later on vacuum tube circuits. This is the ideal receiver for the amateur, the investigator, and the man who only wants to hear time signals and long-distance communications. It may also be used for short wave-length work by proper choice of inductance and capacity values.

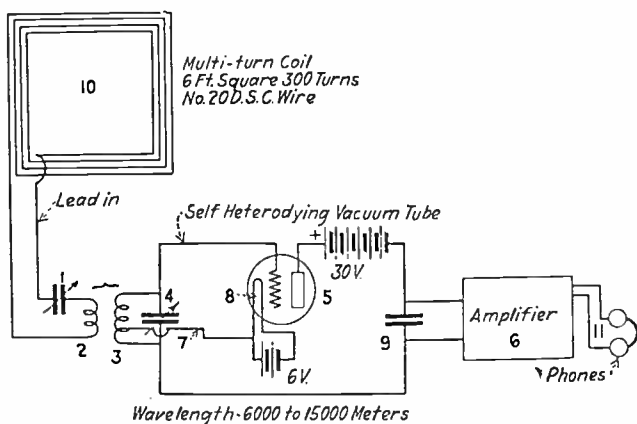

FIG. 16.—Multi-Turn Coil Directive Receiver.

There are many possible modifications. For instance, the coil (3) itself may be constructed like (10) is so that

the bulb (15) is directly connected to the multi-turn coil. This works nicely. Construct the multi-turn coil so that you can turn it about and point it towards the station you want to hear. When the signals are heard loudest you have the correct line of direction.

By using an open circuit loop inter-wound with the coil, the Navy has been able to reduce stray interference. (See paper by Dr. L. W. Austin, read at April, 1920, I. R. E. meeting.)

RADIO COMPASS

A radio compass can be had by mounting the coil so it can be turned. This may be done by suspending it from the ceiling of a room and marking the 360° N, S, E, W, on the floor. Amateurs can thereby do wireless detective work and find out where the new messages are coming from as well as locate unknown stations. Law violators are accordingly subject to certain detection.

SUB-SURFACE RADIO

For receiving purposes only the antenna (Fig. 17) may be underground or under water. Signals have been heard over a range of thousands of miles in this manner. Reception is safe even during a lightning storm with this type of antenna. For experimental purposes a single wire five hundred feet long and rubber covered with the free end insulated also may be inserted fifteen inches underground in a ditch dug for the purpose and later covered over. The wire should lie on a line with the sending station to be heard. Greater depths are less desirable owing to absorption—though signals have been

heard in a mine shaft more than 1,000 feet below the earth's surface. During the war a large portion of all trans-oceanic reception was done on sub-surface antennas. The ground terminal is used as is customary for an elevated aerial. Strays are not entirely eliminated by this arrangement but are mitigated considerably. A sensitive vacuum tube receiver with amplifier is required at the receiver.

ROGERS' UNDERGROUND ANTENNA

The U. S. Navy has developed sub-surface linear antennas demonstrated by J. H. Rogers, a former amateur reader of "Experimental Wireless Stations." Rubber covered or bare wire are run about one foot under the

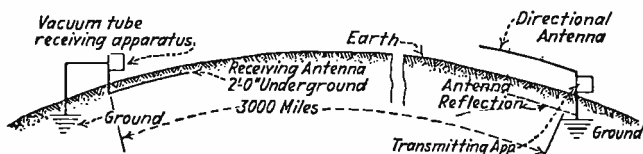

FIG. 17.—Underground Receiving Antenna. Messages Are Received from the Usual Transmitter with Elevated Antenna by Using an Insulated Wire Under Water or Underground at the Receiver as an Antenna Connected to the Usual Vacuum Tube Apparatus.

earth's surface in a trench or in short lengths of iron pipe interrupted by rubber hose connections, or in tiles. Such wires can be used in parallel, one serving as an antenna connection and the other as a ground connection to the usual receiving apparatus. Marked freedom from most strays is noticed but some are still received and have to be specially balanced out. Signals are received at low

audibilities so that an audion amplifying bulb receiver is a requisite for success.

The wire must be stretched in line with the transmitting station, as signals coming at right angles to the wire are substantially excluded, while those parallel to it are heard best. Signals can be heard safely even when a lightning storm rages in the immediate neighborhood of the receiver. For a given wave length a most efficient length of wire is found. For 600 meters this is about 240 feet for insulated No. 12 standard rubber-covered wire. Usually the grounded antenna is a periodic, that is, responds about equally well to many wave lengths, so that in fact several differently tuned receiving sets can be connected to the same sub-surface linear wires. The wires can be worked even in salt or fresh water and to considerable depths below the surface.

In transmission tests the Navy has been able to communicate 36 miles or more with 0.8 ampere in the underground wires, using the sub-surface antennas. Experimenters can easily verify the results by simply placing a single wire, bare or insulated, and three hundred feet or more long, one or more feet underground or under water in line with the transmitting station desired, and connecting a regenerative audion receiver of the usual type to this as an antenna, using the usual ground, or else a second similar wire as a ground. Mr. Rogers considers that currents through the earth affect this type of receiver while others, including Commander Taylor who did much scientific work on this system, do not consider that there is any separate current through the earth except such as results from the horizontal component of

the advancing electric waves of the type previously familiar. It is a remarkable fact that even submerged submarines carrying a single-turn loop may communicate over practicable ranges as well as receive long-distance messages.

CHAPTER IV

Grounds and Lighting Protection

Ground Connections; Various Types; Construction; Lightning Protectors; A Safe Radio Station; Underwriter's Rules.

Equally or more important than a good aerial is the item of a good ground. The quality of the ground connection materially affects the efficiency of a station and its operating range. Variations in the ground connection may cause a difference of failure or success. Except as noted in Chapter III, a good ground connection is essential to an efficient wireless station. The various means for obtaining grounds may be itemized and considered as follows:

GROUNDS IN WATER

This form consists of a mass of metal suspended in the ocean, a lake, a river, a well, or a cistern and forms a good connection. In fact, the grounding of ship stations through the hull affords a connection almost as good as metal. When connection is made to a pump or cistern

pipe, the iron should be thoroughly cleaned and the conductor soldered to it.

IMBEDDED GROUNDS

A good connection can generally be had by burying a large surface of sheet copper or zinc in damp earth, at least 12 feet below the surface and preferably more. A ground conductor should be *soldered* to the sheets which should be well connected to each other. The sheets may be in the form of old copper boilers which may be had from the scrap heap, and it is desirable to have a total surface equal to a single flat sheet, 10 feet x 10 feet. It is good practice to imbed the sheets in between layers of coke in order to insure a uniformly good contact during the different times of the year.

IMBEDDED GROUNDS—SPECIAL FORMS

There are several ready-made grounds to be had in the market, but since these are rarely intended for other than use for telephone lines and for lightning grounds, several of them connected together must be used for an effective wireless ground. They consist essentially of sheet copper formed so as to present a large surface to the ground and in some forms, a coke filling is used. *Chemical grounds* consist of the ordinary imbedded ground with layers of coke and calcium chloride, or calcium chloride alone around the metal. The calcium chloride is very cheap and insures a state of moisture about the plates at all times. About 50 pounds of coke and 25

pounds of calcium chloride will suffice in conjunction with 100 square feet of imbedded sheet metal to form a very good ground.

CONNECTION TO GAS AND WATER PIPES

In the cities, the gas and the water supply pipes are commonly used, preferably the latter. Special ground clamps may be had from supply houses for a very small sum which are adapted for making good connection with the pipes. When the pipes are used for a ground it is advisable to short circuit the meter by means of a heavy piece of wire. The wire from the instruments to the ground should be run as *straight* and direct as possible and all joints should be *soldered*. When several pipes, as water, drain, and gas, are in close proximity to each other, it is advisable to connect all of them.

For small stations and also as a separate lightning ground, an iron pipe or several iron pipes two or three inches in diameter and ten feet long may be buried into the ground just outside of the building in a convenient position. The lower end is preferably pointed by hammering the pipes into a V shape. (A blacksmith can do this for you.) The ground wire should be thoroughly soldered with care to this pipe and the joint covered with pitch or asphaltum. If possible this ground should be *located* over a drain pipe or otherwise provided with a supply of water.

INDIRECT GROUNDS

There are two general types of indirect grounds and neither is as desirable as a good direct ground. In one

form, a second aerial is constructed and suspended in a position close to but insulated from the ground. It thus forms a capacity or condenser with the ground. This type is adapted to close tuning and is convenient when a direct ground is impracticable for one reason or another, but is considerably less efficient. The other form of indirect ground is similar, except that a large meshwork of bare wires or a netting is spread over the surface in the immediate vicinity of the station without insulation, so that it makes both direct and indirect contact with the earth.* A very large area must be covered before this method is efficient, but it is sometimes used for portable outfits, in which case the network is spread out in grass or a similar moist surface in preference to other places. For experimental receiving purposes a fair ground may be had by driving a spike into a tree and making contact therewith. The steel frame of buildings may be used as a ground if nothing better is obtainable. In any case the ground wire should be run direct from the instruments and as short as is possible.

THE GROUND WIRE

It is not necessary to insulate the ground wire, although it is advisable to do so. When it is over 200 feet in length it should be well insulated to prevent loss from induced currents. The use of a ground wire no less than No. 4, B. & S. in diameter is advised and even larger sizes are desirable. Of course smaller sizes will serve for experimental purposes, but the larger size means a

* Some of the large stations use this form successfully.

better direct ground. Grounding *should not* be done by connecting to gas or electric fixtures, since these are often insulated from the ground and in any case afford poor connections.

PROTECTION FROM LIGHTNING

Wireless aerials do not attract lightning, as the term is generally understood, but they do accumulate undesirable static charges during the stormy part of the year. When well grounded OUTSIDE of the building, the aerial forms an EFFICIENT LIGHTNING ROD and actually protects the station and surrounding buildings.

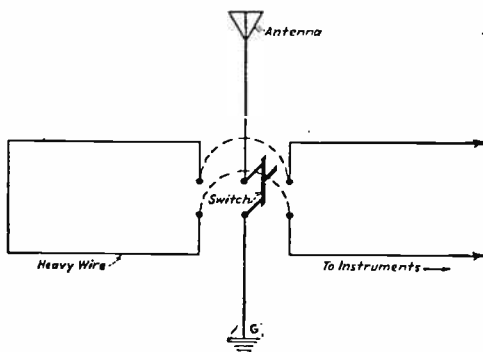

FIG. 18.—Ground Switch.

These facts have been ascertained by the author by numerous experiments and although his station has been struck several times, no damage has ever resulted. Experiments were carried out with a condenser and gap in the aerial during the electrical storms and large charges were accumulated and experimented with at such times.

Inasmuch as the experiment is attended with some danger, its repetition is not recommended. In the experiences of others with which the author is acquainted, several cases have presented warnings. In one case, the operator had his ears pierced while receiving (or trying to), from which it may be inferred that it is NOT ADVISABLE to operate during severe local storms.* In another case, the operator had his aerial, which was a high one, well grounded and no harm resulted to it or the immediate neighborhood, while a grocery a block away was completely demolished. It is always desirable to ground your aerial during storms and at all times when it is not in use. This is conveniently accomplished by means of a double throw switch on the *outside* of the building so that the aerial is grounded to an outside ground when not in use. The ground connection should be No. 4 B.&S. wire or even larger and very direct. (See Fig. 18.) The switch should have a carrying capacity of 25 or 30 amperes. Fifty or 100 ampere switches are the standard size.

AN EFFICIENT LIGHTNING PROTECTION

This arrangement takes advantage of the fact that the high frequency surges abhor impedance from a choke coil. The choke coils are, in fact, more advantageous than insulators would be. See Fig. 19 for the connections. The main switch, (4), should be able to carry 30 amperes and when the station is in use the choke coils

* i.e., unless the multi-turn coil receiver is substituted for the regular antenna circuit.

are short circuited by the auxiliary switches so that they will not impede the transmitted impulses. This arrangement prevents the charge from damaging the instruments or the building. The choke coils are made by winding 30 turns of No. 4 B.&S. wire on a large porcelain tube, two or three inches in diameter.

Lightning grounds should always be carried out to the outside of the building or station and if the regular ground does not meet this requirement, a separate ground must be used. Ordinary short gap lightning arresters are useless in wireless stations, because the transmitted

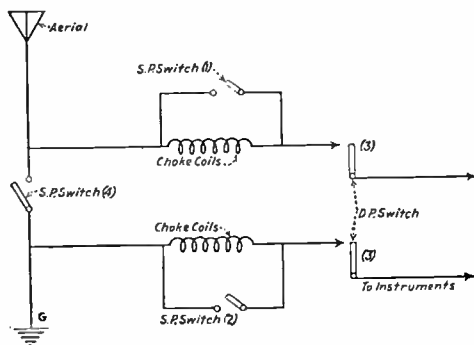

FIG. 19.—Lightning Protection Circuit. When Using Instruments Open (4), Close (1), (2) and (3). When Not Using Instruments, Open (3), (1), and (2). Close (4).

impulses jump the short gap the same as lightning does.

The lightning protection for a station does not cost a great deal and is well worth while. It is one of the first items which should receive attention, particularly in mountainous regions.

When the station is not to be used for a long time,

as during a vacation trip, it is desirable to lower the aerial conductors so that the liability to become blown down by winds or be struck by lightning is entirely removed.

It is not necessary to take the aerial down during stormy weather, however, or even desirable, provided that it is well grounded.

Attention is directed to the various underwriters' and local municipal rules affecting installation of the circuits of a radio station. Those who wish a safe workmanlike job should follow such regulations.

CHAPTER V

The Transmitter and Resonance

Transmitting Circuit; Principle of Oscillations; Action of Energy; Resonance; Period of Vibration; Adjustments; Harmonic Effects; Resistance; Beats; Typical Curves for Various Transmitters; Damping; Relation of Antenna Current and Voltage; Experiment Illustrating Coupling.

In the present chapter the general features of the transmitter together with a consideration of resonance will be considered, and it is suggested that this matter be understood before referring to the chapters on the several details.

To begin with, we are only to consider tuned transmitters, i.e., those which are coupled to the antenna circuit. There are two general types of coupled transmitters, the direct coupled and the indirect or inductively coupled. Each has certain characteristics which will be considered more fully. The exact circuits employed are, of course, somewhat varied, but since the general features are the same the circuit shown in Fig. 20 may be regarded as typical of the direct coupled type, while that shown in Fig. 21 may be regarded as typical for the inductively coupled type. For the present the circuits will be regarded as

excited only by means of ordinary spark caps. Other means for excitation which are within the limits of the average experimenter, will be considered in detail later.

The first point to be thoroughly understood is that the transmitting circuits are *oscillatory* in nature and that the transmitted impulses are radiated as waves having characteristic properties. In wireless transmitters, the essential characteristics of the circuits are that they may be caused to vibrate at a very high rate. The phenomenon is very much like other vibrations. For instance, in

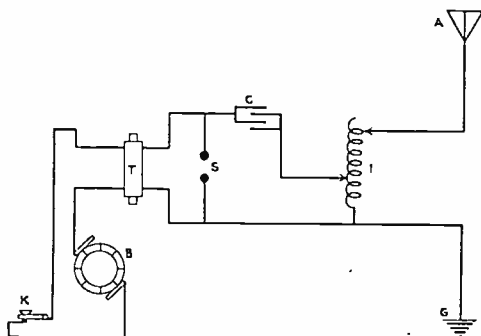

FIG. 20.—Typical Transmitting Circuit Diagram. K, Key. B, Current Supply. T, Transformer or Spark Coil. S, Spark Gap. C, Condenser. I, Inductance Coil. A, Aerial. G, Ground.

sound, if a bell is struck a sharp blow, it vibrates and the vibrations in turn cause sound waves to be radiated from the surface of the bell. The loudness of the sound will vary according to the dimensions of the bell and the force with which it is struck. The tone of the resulting sound will also vary according to the dimensions of the bell it-

self, i.e., its characteristic dimensions and vibratory period.

In a wireless transmitter, we have the same features. The current which causes a high potential to charge a condenser, corresponds to the force which strikes a bell. The condenser in turn sets up vibrations in the circuits so that waves are radiated from the antenna, in much the same manner as the vibrations of the bell cause sound waves to be radiated. In fact the difference in the waves radiated by the bell and a wireless transmitter lies in the characteristic properties (wave length, persistency, etc.), and in the medium through which the respective radiations are carried. (Air for sound and ether (space) for wireless waves.)

Now then, the circuits of the transmitter can be vibrated the same as a bell is vibrated and the character

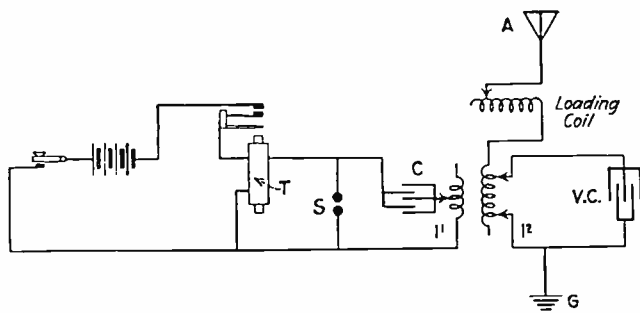

FIG. 21.—Inductively Coupled Transmitter.

of the radiations will vary according to the electrical dimensions of the circuits and the force with which they are set into vibration. This is the *keynote* to an under-

standing of the why of wireless transmission. We can vary the characteristics of the transmitted radiations by changing the electrical dimensions or vibratory period of the transmitting circuits. This is accomplished by adding or subtracting capacity or inductance or both, in much the same manner as a violinist varies the effective length of a given string to produce different tones. It is understood that even the *slightest* change in the capacity or inductance of a circuit changes its *electrical dimensions* and also changes the period or rate of vibration. The actual vibration in the circuits is caused by the surgings of the discharge from the condenser, or as is more often termed, the oscillatory discharge of the condenser.

By the referring to Fig. 20, in which A represents the aerial, G, the ground, I, the inductance which may be varied and which also couples the condenser and the antenna circuits, C, the condenser, S, the spark gap, T, a transformer or spark coil, B, a source of current and K, a circuit closing key, it will be obvious that when the key K is closed the transformer or coil T, which is wound to produce a high potential at the secondary terminals, will cause a spark at the gap S. In practice the gap and the condenser are adjusted so that the condenser is first charged and then discharged through the gap S. Now it has been definitely proven that although the coil T only produces a secondary current at its terminals with a frequency of say 120 cycles per second, this same current when used to charge the condenser C and subsequently discharged through the gap S, causes an oscillatory current to discharge in the gap S which may have a frequency enormously greater than the original frequency of

120 cycles per second. This high vibration may, in fact, be as much as 250,000 per second or even more. It is this high rate of *oscillation* in the condenser circuit which causes radiations to be sent out, as has already been explained. The condenser circuit through the gap S, and the inductance I (the oscillations do not pass through the secondary of T on account of the high resistance offered), is the actual part of the wireless transmitter which corresponds to the hammer of a bell. It differs from a simple comparison, however. It is found that the exact nature of the resulting vibrations depends on the dimensions of the several parts, S, C, and I. It will be obvious that the condenser in discharging through the circuit I, S, C, at a very high rate causes the turns of I through which it passes to vibrate at a corresponding rate. The oscillations are thus made useful for transmission purposes by forcing them to pass through a part of the inductance I. Now it is further found, that if the dimensions of circuit C, I, S, are changed, as by adding or subtracting capacity or inductance, that the characteristic properties of the resulting oscillations are varied, in much the same manner as the tone from a bell is varied if a lead weight is attached to its edge, or a violin string, if its effective dimensions are varied by the fingers of the violinist.

In further considering the circuit C, I, S, it should be understood that for the maximum effect, the several parts C, I, S, must be adjusted or varied so that they mutually contribute to produce the maximum effect. It is obvious that if there is too much capacity, the circuit will be unbalanced and consequently the coil T will not be able to fully charge it. Or if the gap S is too long the

condenser will not discharge through it, while if too short, the condenser will not be fully charged before it discharges. Or further, if the number of turns of I in the circuit is too many or too little, the circuit will also be unbalanced. In any case or combinations of any single cases, the result will be similar to that when an excessive weight is attached to the rim of a bell, that is, the circuit through C, I, and S, cannot vibrate properly. If the difference between the adjustment and the ideal adjustment is not great, the oscillatory effect will not be stopped, but the properties of the oscillations will be correspondingly varied. In practice it is generally found that there is a certain adjustment for the circuit which produces a maximum result. It is, of course, understood that any change in the dimensions of the parts of the circuits causes a change in the *natural wave length* of the circuit and the resulting oscillations, the same as changing the diameter of a bell produces a different tone. Changing either the inductance or capacity in even small amounts causes a noticeable change in the wave length and intensity of the resulting oscillations. The parts of the circuit have been arranged in definite mathematical formulas so that the proper dimensions for the several parts to produce a given result for a station can be worked out by a simple mathematical operation. This feature will be considered a little later.

Now, then, by referring to this same figure (20), it will be obvious that when an oscillatory current passes through some of the turns of I, that oscillations will also be set up in the antenna circuit A, I, G, by mutual induction between the portions of the turns of I included re-

spectively in the antenna and in the condenser circuit. The ratio and relation of the respective turns included in the antenna and the condenser circuits determine the degree of coupling between the two circuits. The oscillations in the inductance I are of very high frequency, as has already been explained, and the two portions of the inductance act as a transformer. The inductance I forms, in fact, an auto-transformer (step up). Now then, the voltage as well as the frequency through the part of I included in the condenser circuit is very high so that the frequency through the antenna circuit is of substantially the same frequency but a much higher potential, on account of the ratio between the turns included in the two respective circuits. The antenna circuit is thus supplied with a very high potential oscillatory charge, corresponding to the oscillatory discharge of the condenser C . The antenna circuit is consequently very powerfully vibrated and as a result radiations are transmitted from this circuit in much the same manner as sound waves are transmitted from the surface of a bell, except the sound waves are transmitted through air, while electromagnetic waves are transmitted through the ether and are caused by the intimate relation of the vibrating antenna circuit with the ether, which presumably disturbs the ether at a corresponding rate. It is understood that the term "*ether*" is the name for an all prevailing material which is assumed to exist and to carry this electrically generated vibratory motion in the same general way in which the air carries the sound waves.

Now the exact nature of the radiations is determined by the dimensions of the antenna and condenser circuits,

while their power is determined by the primary generating source as well.

INTERCHANGE OF ENERGY IN SPARK TRANSMITTER

Graph I, Fig. 22, shows how the oscillating energy repeats from the primary to the secondary or antenna circuit and *vice versa*. When the energy is a maximum

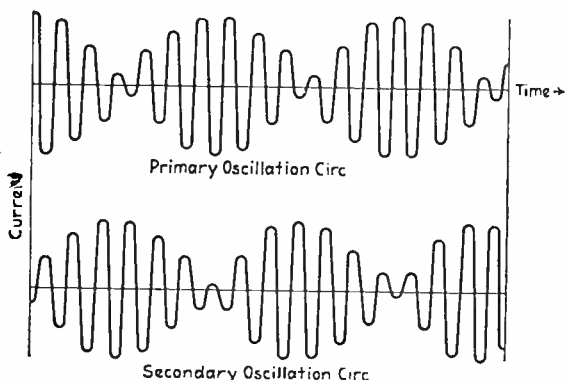

FIG. 22.—Graph. I. Energy Oscillations in Transmitting Circuits.

in one circuit it is a minimum in the other. This is an undesirable feature obviated by more modern transmitting equipment.

RESONANCE

Resonance in the transmitter means the attuned, or syntonic relations in and between the condenser and antenna circuits and is also further carried out between the

condenser and the transformer or coil T, when maximum results are desired. In Fig. 20, the condenser C, and transformer T are in resonance when the capacity of C is adjusted so that it is just enough and not too much to efficiently and economically receive a charge and discharge the same. This relation can be determined by a simple mathematical operation from a formula, which will be fully presented later. Now, then, with the condenser determined, its *capacity* must necessarily remain the same for a given coil T, so that if the circuit through C, I, and S, is to be brought into resonance, the respective parts must be *suited* to the given capacity. The gap, S, is of itself a minor item, the essential features being an ability to handle the full discharge currents without undue heating and to be of the proper length so that the condenser is properly charged and discharged. The main tuning, then, must be done by increasing or decreasing the *number* of turns of the inductance I, through which the condenser circuit must discharge. Now a wire or ribbon conductor, such as is used for constructing the inductance I, has both capacity and inductance, though the latter is in great excess so that the capacity is nearly negligible. In a like manner, the condenser of itself consists essentially of capacity. Even the connecting wires between the condenser and the inductance have *capacity* and *inductance*, also *resistance*, so that in order not to materially affect the resulting oscillations they must be made very short and of large size so as not to impede the high frequency oscillations.

Every conductor has a definite period of vibration for electromagnetic waves, just as every wire in a piano has

a definite vibratory period. Now the separate periods can be combined or superposed when a number of conductors or circuits are coupled or connected in much the same manner that two or more notes from a piano can be caused to produce a pleasing or displeasing tone. The condenser circuit, then, is made up of several parts which must have very little resistance and practically no *stray* inductance or capacity. Now, increasing the number of turns through which the condenser circuit passes also increases the time of the vibrations, causing a corresponding increase in the wave length. The wave length of the oscillations in the condenser can thus be *varied* by adding or subtracting the desired amount of inductance through which they pass, and the less the number of turns of inductance included in the circuit, the less will be the wave length.

Now then, consider the *resonant relations* in the *antenna* circuit. It is understood that the antenna itself,

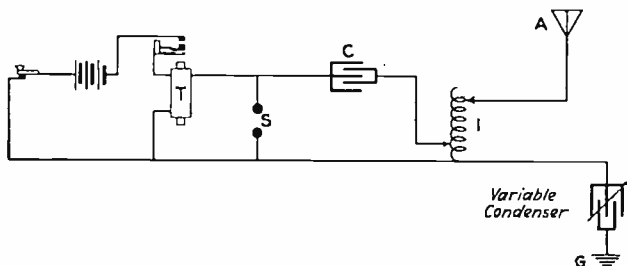

FIG. 23.—Transmitter; Direct Connected Through Inductance.

being made up of a plurality of spaced wires, consists essentially of capacity and also quite a little inductance. The antenna forms the capacity of the circuit in conjunc-

tion with the ground. The inductance of the circuit, then, will be the *variable factor* since the antenna is generally a fixed item. The wave length of the circuit A, I, and G, then, will be varied according to the variations in the amount of inductance or turns of I, included in the circuit, in the same manner as has already been explained for the condenser circuit.

That is, when the number of turns of I, through which the antenna circuit is included, is increased, the *wave length* of the circuit will be *increased*. It will be obvious that since A is a fixed quantity the natural wave length of the antenna circuit cannot be less than that of A and G without inductance,* in the circuit shown in Fig. 20, and that the variations must then be limited to increase the wave length of the antenna system. As in the case of the condenser C, when the maximum results are desired, the capacity of the antenna A must be made the proper amount to begin with. This can be accomplished by using the length and number of wires which will produce a capacity and inductance within the limits of the minimum wave length desired. It is possible to lower the wave length by means of circuit like that of Fig. 23, in which a condenser is connected in series with the ground circuit, but this method is not very desirable. In view of the limited wave lengths, to which experimenters are legally assigned, this method can be utilized in cases in which aerials already in use slightly exceed the maximum wave length. The disadvantage of this arrangement is that the transmission is less efficient.

But to return to Fig. 20. In order that the antenna

* See Fig. 23 for exception.

and condenser circuits should be in resonance with each other, it is necessary that the adjustments of the inductance I , be made so that the wave length of the condenser circuit is the same as that of the antenna circuit. The circuits will then be in a position to produce a maximum radiation. This condition is, however, difficult to obtain exactly and is further complicated by the phenomena of *beats*, that is, the oscillations in the two circuits superpose and interfere with each other so that two wave lengths are produced instead of one. This feature will be presently more fully discussed. Now if the circuits have been brought into resonance so that they are both attuned to, say, 300 meters wave length, and if it is de-

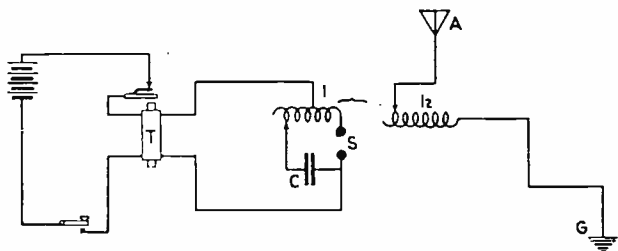

FIG. 24.—Loose Coupled Transmitter with Loading Coil.

sired to increase the transmitting wave length, both circuits must be increased accordingly. The wave length of the condenser circuit is increased by adding more turns of inductance and the maximum wave length for the condenser circuit will be reached when this circuit includes all of the inductance. Since the *wave length* depends on the product of the inductance and capacity of a circuit, the maximum wave length of the antenna circuit

will generally be reached before the maximum wave length of the condenser circuit is reached, so that after all of the turns of the inductance of the coil I, have been included in the *antenna* circuit, the wave length cannot be further increased. Increasing the inductance of the condenser circuit in this case will throw the circuit out of resonance. The wave length is thus *limited* by the dimensions of the antenna A and the inductance I. Since it is impractical to have the inductance I too large and since the antenna A is in practice a fixed quantity, the arrangement of Fig. 24 must be used if extra long wave lengths are desired. This method acts to increase the natural wave length of the antenna circuit. The shunt antenna condenser (v. c.) may be omitted if desired. The extra inductance is known as a loading coil and extremely long wave lengths may be obtained in this manner. As in the case of Fig. 23, however, the efficiency of transmission is considerably lowered, since there is generally a limited range of wave lengths at which a given station can economically operate. However, for experimental purposes, this arrangement can be used to attain very long wave lengths (those exceeding 1,500 or 2,000 meters in length), a field as yet open only to the experimenter who obtains a special license therefor.

There is one other case of resonance with which the experimenter is concerned. When spark coils or adjustable types of transformers are used in connection with adjustable condensers in the condenser circuit, there may be more than one adjustment of the condenser C, which will produce a maximum resonance effect with the in-

ductance of both the antenna and the condenser circuit in a fixed ratio. This is a peculiar *harmonic effect* * and it is remarkable that a maximum effect can be had with different adjustments of the capacity through essentially the same circuit. Now when the power used in the coil or transformer T is decreased (as when transmitting over a very short distance), the condenser C, and the other *adjustments* should also be *changed* if the maximum effect is to be carried out. To sum up:

The resonance relations and wave length of a transmitter depend on the relations of the circuits and the adjustments of the several parts. Since some of these parts are of fixed dimensions, the others must be adjusted to correspond with them and co-operate to produce resonant circuits. The order of tuning is practically,—

1. The transformer or coil being fixed, the condenser must be varied to resonate with it. If the power is changed, a corresponding change must be made in the condenser if the maximum effect is to be preserved.

2. With the condenser a fixed quantity, to produce a given wave length in the condenser circuit, the inductance must be varied to co-operate with the capacity, and although the wave length may be greatly increased, the addition of excessive inductance cuts down the transmitting efficiency.

3. The aerial being a fixed quantity, the antenna circuit can be adjusted for a desired wave length by the addition of inductance, but if too much inductance is used,

* The same effect is noticed at receiving stations. 12,000 meter signals can sometimes be advantageously received on a set adjusted to 6000 meters.

with or without a shunt capacity, the efficiency of transmission is reduced. A series capacity may be used to diminish the natural wave length.

4. The wave length of the two circuits should be very nearly the same, and if one is changed, the other must also be altered. In short, the several circuits and parts must be maintained in a nice balance in order to obtain the maximum results and resonance. This balance must be kept within the limits of the power employed in order to maintain the efficiency of transmission. This means that the small stations are naturally limited to small wave lengths, while large stations may be operated at longer wave lengths without appreciable loss, and often with gain.

The relations in the circuit of Fig. 21 are very similar to those of Fig. 20, and the adjustments are carried out in the same manner. In fact, the chief difference in the two circuits is in the matter of the coupling, as the effect is essentially the same in other respects.

In this arrangement the antenna and condenser circuits include the primary and secondary of a mutually inductive system which is not directly connected. The relative distances between the two coils is also made adjustable in practice, so that the coupling can be varied. The chief advantage of this arrangement is that it permits of sharper tuning, but it has a disadvantage in that this is accomplished at the expense of the intensity of the resulting radiations.

RESISTANCE

Resistance is an important item in a wireless system.

The high frequency oscillations travel over the surface of a conductor only and do not penetrate into the body of the conductor, as in the case of low frequency currents. Plenty of conducting surface must therefore be provided in both the condenser and the inductance coil as well as in all connecting wires or ribbons. Otherwise, a large amount of power is wasted in heat. Resistance also aids in preventing sharp tuning, so that there is an added reason for making all the parts of the transmitter of large and generous dimensions. A further desideratum is that all of the circuits as well as the several parts, including the antenna itself, should be as *uniform* as possible. That is, the several conductors should be as direct as possible, all joints electrically strong, the aerial well insulated, the ground good, the spark gap well cooled, and the several contacts always well made. Observance of these items together with reasonable skill in attuning the several circuits is sure to produce very satisfactory results. Some modern sets use braided copper wire for connections.

SHARP TUNING—BEATS

Reference has already been made to the phenomenon of beats in a wireless transmitter. Now it has been established, that when the condenser and antenna circuits are coupled by either the direct or inductive method, the primary or condenser circuit has two periods of oscillation instead of one, and that the secondary or antenna circuit has the same two periods of oscillation. This holds true with perhaps a few exceptions, in every case, including the ideal coupling of the two circuits adjusted to the same wave length. As a result, the transmitter emits two

distinct waves instead of one, thereby complicating the difficulty of selective receiving from a field of stations, still further. This is undoubtedly due to the fact that the primary and secondary circuits are alternately charged and discharged. The primary circuit starts out at a maximum, the secondary gradually building up while the primary decreases until the operation comes around to the beginning of the cycle, and is again repeated. The phenomenon of beats is caused in much the same manner as in sound waves and the reader is referred to an elementary text on Physics for a further understanding of the term. The analogy is complete, when the electromagnetic waves are regarded as having similar properties to those of sound waves.

The experimenter is directly concerned with this phenomenon, in that it materially concerns the matter of sharp tuning. Now when the transmitter is in resonance, the station is said to be tuned and if the resonance is very good, it is said to be *sharply tuned*. This is the desideratum of real scientific wireless work. On the other hand, when the circuits are not in resonance, the station is said to be untuned.

In this condition the station is only a very little better than a direct untuned station (see Fig. 25), and when in this condition a wide band of wave lengths are sent out which are difficult to tune out. Since this is the kind of waves which were formerly largely employed by amateurs, it has brought forth considerable criticism. Even commercial operators have wilfully or innocently used untuned waves or at least poorly tuned waves in the past. On account of the large number of stations in operation

at the present time, this form of "*pick me up wave*" is in disrepute because it causes unwarranted interference. At any rate it is not scientific or business-like and is soon to be stopped. In fact, it is equally or more important to have a sharply tuned station than to have one of limited wave length alone without sharp tuning. By reason of the limited wave length, tuning among experimenters themselves will become all the more difficult on account of the limited range, and the sooner all amateurs install and operate sharply tuned instru-

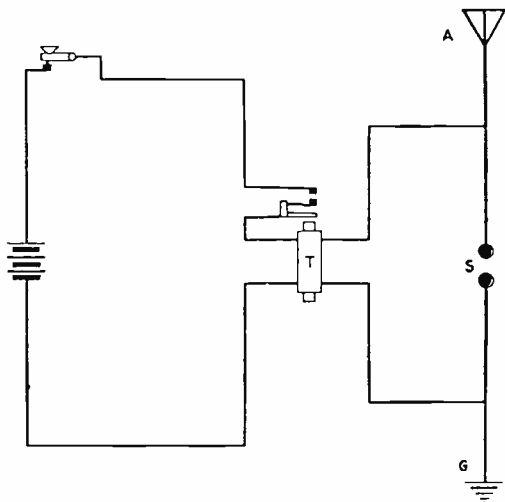

FIG. 25.—Untuned Direct Connected Transmitter.

ments, the better it will be for all concerned. To make this clear, some curves submitted to the radio communication committee of the House of Representatives by Mr. Kolster of the Bureau of Standards are reproduced here. (Figs. 26, 27, 28.)

These curves are plots to show the amount of energy received under different conditions. By referring to chart A the figures, 600, 700, 800, etc., at the bottom indicate wave lengths in meters. The numbers at the side of the sheet (95 to 140) represent the strength of the signal re-

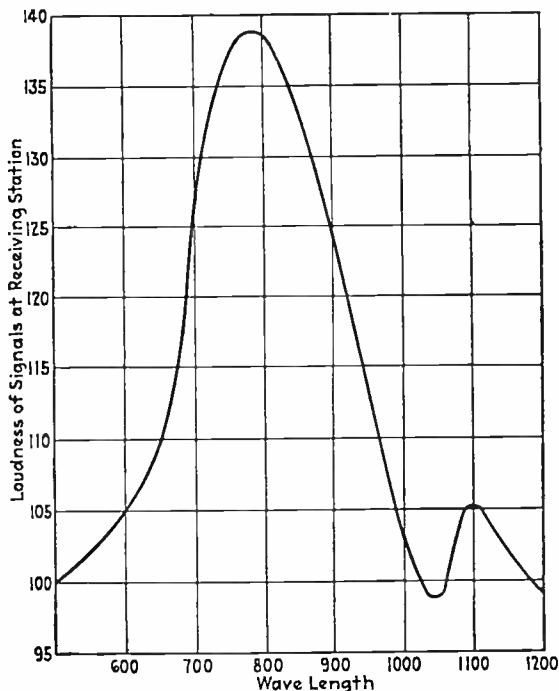

FIG. 26.—Chart A.

ceived at the receiving station. Thus at 600 meters, the strength of the received signal is 105. At 700, it is stronger, approximately 127, and so on. The curve thus indicates the wave length and the corresponding loudness

of the signal. The signals are the loudest between the wide range of 700 and 900 meters, and were taken from a ship station. The station is sending out a wide band of wave lengths (750-950 meters), so that it is sure to interfere with other stations. At a short distance, within, 1,100 meters the current makes another rise. That is, the

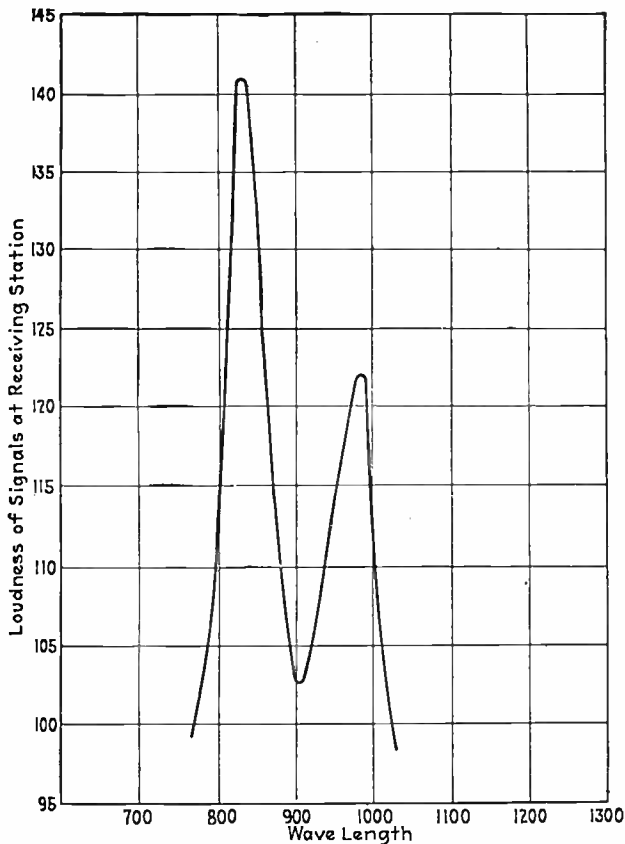

FIG. 27.—Chart B.

particular station under consideration sends out a second wave length defined at 1,100 meters as well as the broad band of 700-950 meters. This station is not sending out any definite wave length, so that it interferes with

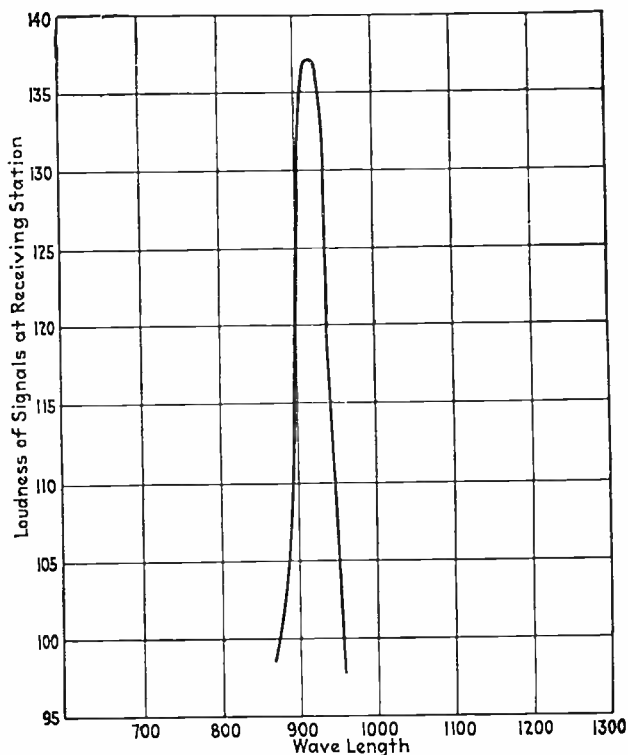

FIG. 28.—Chart C.

all other stations within a considerable range. Amateurs in the past have in some cases sent out wave bands of similar dimensions so that the meager efforts of commer-

cial operators to tune out interference with crude apparatus have been of little avail.

The chart 1 shows the double wave length from an ordinary spark excited commercial station, one wave being approximately 830 meters and the other 980 meters. The chart indicates that the station concerned was very badly tuned. As a contrast to this chart, the curve of chart 3 may be noted. This was made from a well tuned modern wireless set and the signals are sharply defined within a range of 75 meters.* This means that a difference of 75 meters would entirely cut out this station under good conditions.

While details of tuning will be again discussed, it is thought that every reader must realize the importance of sharp tuning, resonance, and definite wave lengths.

DAMPING

The damping of electromagnetic waves may be compared to sound waves as in the case of the other properties. That is, damped electromagnetic waves correspond to the sound which is emitted from a bell when a soft object such as the finger touches it, so that the vibrations are limited. This is a common experiment and when a similar property is understood for electromagnetic waves, the term should not be difficult to understand.

Undamped waves, then, are those which are free to vibrate while damped waves are those which are more or less hampered.† Now, absolutely undamped waves are

* Refers to a Quenched Spark Set.

† Perfectly undamped waves are not obtainable in practice but can be approximated by using arc or vacuum tube circuits. These are discussed later.

practically impossible, but the nearer the transmitted waves approach this point, the more efficient will be the transmission, just as the sound from a bell is greater and lasts longer if the bell is free to vibrate without impedance. When the transmitted waves meet considerable impedance, they are said to be damped or strongly damped and in this condition are not very efficient for wireless transmission. The damping is caused largely by the resistance which the circuits offer to the oscillations and generally speaking, the conditions for undamped waves require a minimum resistance.

The ordinary spark system with a close coupled circuit, similar to that of Fig. 20, emits waves which are more or less damped, depending upon the adjustment, while the arrangement of Fig. 21 emits waves which are less damped, the other conditions being practically the same. In the arrangement of Fig. 21 the coupling is free, so to speak, so that the vibration of the antenna circuit is not greatly impeded, while in the arrangement of Fig. 20, the antenna circuit has a close coupling with the condenser circuit so that its vibrations are hampered and limited to a considerable extent. Undamped waves or continuous waves are a desideratum in efficient long distance transmission, and it is for this reason that the untuned and even the close coupled circuits are being superseded by the inductively coupled circuits. This matter will be more fully discussed later on. In order to keep the damping to the smallest possible point, it is necessary to keep the resistance of the circuits down to a minimum, and when it is remembered that the resistance of a conductor to high frequencies is greater than to

currents of low frequencies, the need for large direct conductors should be all the more apparent.

ANTENNA CURRENT AND VOLTAGE

In chart D the current and voltage curves for the common flat top antenna are shown. At the ground (1) the current is maximum and voltage minimum, and *vice versa*

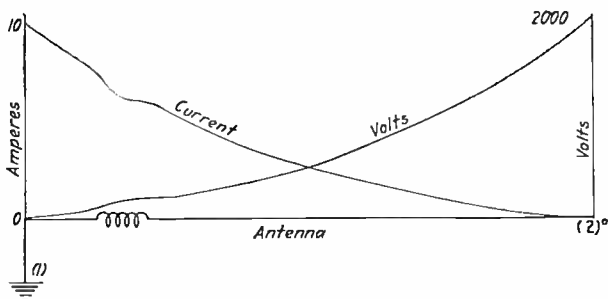

FIG. 29.—Chart D.

at the free end (2) the current is nearly zero while the voltage is at the highest value.

EXPERIMENT ILLUSTRATING COUPLING BEATS

In Fig. 30 a simple set to study the effect of coupling mechanically is shown. With (1) at rest, start (2) swinging and note result. By varying the length of string and distance between (1) and (2) all of the cases including resonance (when maximum swings are transmitted from one pendulum to the other which is coupled

to it) may be studied. Set it up on the backs of two chairs if you want a good idea of what happens when two

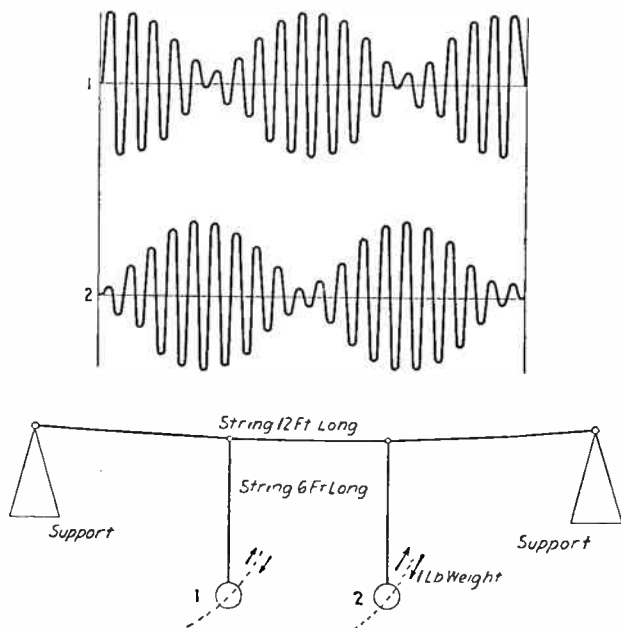

FIG. 30.—Experiment Illustrating Coupling Interaction Between Two Circuits.

electrical circuits corresponding to (1) and (2) are inductively coupled together.

CHAPTER VI

Wave Length, Capacity, and Oscillation Circuits

Damped Wave Transmitter; Calculation of Wave Length, Capacity, and Circuits; Range of Transmission; Power, Frequency and Voltage; Table of Capacities; Formula for 200 Meter Calculations; Spark Gap; Antenna Circuit; Percentage of Coupling; Example of a Complete Spark Transmitter; Dimensions.

In planning the transmitter, the main conditions which govern the design are the distance over which the transmission is desired, the number of stations and their location, to which it is desired to communicate, the local and intervening conditions, such as the condition of the soil, atmosphere, and other natural conditions, and the item of expense.

Perhaps the matter of expense is the main item and it is always desirable to keep within defined limits. The expense does not follow directly according to the transmission distance and will, in fact, vary considerably according to the conditions in each case. The actual amount depends on the price paid for raw materials, labor, transportation, and since all of these items are variable, the exact amount must be figured for each case.

Thus, if the raw materials may be obtained so that no transportation charges have to be paid, or if the apparatus can be had second hand, or if the labor is negligible, and so on, the cost will be materially reduced. Ordinary experimental stations do not entail a great deal of expense. While everything should be made as workmanlike and businesslike as possible, extraordinary finishes and polishes are not essential to success.

RANGE OF TRANSMISSION

While this cannot be accurately determined to begin with, it may be approximated to a sufficient extent. The experimenter generally has a few definite stations with which direct communication is desired and in all cases which permit the use of a *directive* aerial, this type should be adopted for the purpose specified. When communication is desired in all directions, the *umbrella* or *T type* aerial will be the best to adopt. The distance to which a given station can send is governed largely by *natural* conditions, such as character of the soil, foliage, mountains, minerals, height of aerial, and other similar items, as well as the per cent of efficiency which the apparatus is capable of, by itself. The variables are so great that while transmission has been carried out over a distance of 100 miles or more by the use of a one-inch spark coil at an expenditure of perhaps 100—200 watts, there are other extreme cases in which a 1 K. W. set has only been able to send a few miles. Again, the same set will be able to send to variable distances under other conditions and at different times. Thus, the transmission in winter is generally

better than during the summer. The transmission at night is generally nearly twice as good as during the day time. The transmission during favorable atmospheric conditions is from two to ten times greater than when carried out under unfavorable atmospheric conditions, and so on. In order to obtain data, the working distance under practical conditions and with efficient, well-adjusted sets is taken as a standard, and, of course, under favorable conditions, this limit is often greatly exceeded.

This *standard transmission* calls for a range of one mile for every ten watts of energy which is used at the transmitting station. Thus, a $\frac{1}{2}$ K. W. (500 watts) set is expected to cover 50 miles, a $\frac{1}{4}$ K. W. 25 miles, a 1 K. W. 100 miles, and so on. The range for spark coils will be similar and should be reckoned on the watts used instead of the spark length alone.

If the set is operated under very favorable conditions this limit will generally be exceeded, but, of course, if the adjustment or the instruments, or the natural conditions are poor, it is not likely that this limit can be attained. With this basis and the desired range known, the power required can be easily found.

With a vacuum tube transmitter large distances can be covered with very small power. One-tenth of a watt per mile may be allowed if a sensitive receiving set with vacuum tube amplifier is employed. Radio-telephony has been carried out over a range of one hundred miles using aeroplane vacuum tube stations of small power.

This done, the question is limited to the immediate selection of the type and size of transformer or spark coil to be used. Since a transformer requires a source

of alternating current such as a lighting circuit and since this method is simpler and more satisfactory for experimental purposes, it should be adopted whenever possible. Transformers may be had in the market at a figure which can scarcely be duplicated by the experimenter, even if his own time is not considered, and the same may be said of spark coils. The construction of such apparatus, of course, affords considerable education and satisfaction, but as regards the expense, little or no gain may be expected. Very often, good second-hand coils and transformers may be had for little or nothing. Discarded automobile spark coils are easily obtained at garages for a mere song and are satisfactory for short distances.

There are two general *types* of *transformers*, the open and closed core types. The former, while less efficient from the electrical standpoint is more efficient for wireless purposes than the ordinary closed core transformer. The latter type, to be of the greatest use for wireless purposes, must be specially designed. In wireless transmission the secondary of the transformer is largely on open circuit and the conditions are different than the ordinary transformer loads. For the maximum results, it is necessary to *apportion* the primary and secondary inductance and the mutual inductance properly, just as it is necessary to bring the condenser and antenna circuits into resonance. Almost any high tension transformer or spark coil will do, but special designs are necessary when efficiency is desired. In the ordinary transformer, the load on the secondary increases in practically a direct ratio with the current input, while in a wireless station the load is essentially a condenser. This condenser reaches a maxi-

mum charge only when the constants of the transformer bear a resonant relation to the capacity of the condenser. When the resulting discharge causes a spark, the secondary of the transformer becomes practically short circuited so that the ordinary transformer would draw a greatly increased amount of power and an arc would be formed in the spark gap. Now this arc is very undesirable since the condenser cannot be properly charged while it lasts and as a result an ordinary transformer cannot produce good oscillations.

The wireless transformer, then, must be designed to draw a comparatively small amount of power when the condenser discharges and short-circuits the secondary winding, so that the spark will extinguish just as soon as the condenser has been discharged.

In practice this may be attained by using an auxiliary adjustable resistance or *reactance* in the primary circuit of an ordinary transformer, or an adjustable inductance in series with the secondary of a closed core transformer, or else by combining this principle in the transformer itself. With the open core type of transformer, an adjustable *inductance* in the primary circuit becomes essential, and this method also allows of considerable flexibility in bringing the transformer into resonance with different capacities in the condenser circuit. Wireless transformers generally have several adjustments which allow the power input to be varied so that a corresponding change may be made in the condenser capacity without throwing the circuit out of resonance. In practice, it is common to rely upon the instinct of the operator to adjust the amount of capacity and power input to the right point as

indicated by the appearance of the resulting spark discharge. The main point is that the spark in the gap should not form an arc. With spark coils this method must be largely used since an accurate calculation of the required capacity is difficult. Spark coils should only be used when alternating current is not available. Either batteries or a D. C. generator may be used to operate spark coils and while they may be operated on 110 volts A. C. in connection with an electrolytic interrupter, this method is not very desirable. Data for wireless transformers and spark coils will be found in Chapter VII. The auxiliary primary apparatus such as keys, kickback preventers, and other items will also be considered later since their design depends largely on the amount of power used.

After the power and source of power to be used have been decided upon, the proper amount of *capacity* to be used should receive attention next. This item depends on several quantities, which may be listed as:

1. The power supplied to the condenser. (Watts.)
2. The frequency, or number of sparks per second.
3. The secondary discharge voltage.

In the case of an alternating current transformer, the transformer supplies an amount of power to the condenser which may be represented by P kilowatts. If the condenser and spark gap are arranged so that the condenser charges to a sparking potential once each half-cycle, or the natural spark rate (twice the natural frequency, i.e., 120 times per second if the primary frequency is 60 cycles),

$$P = \frac{nCV^2 \text{ Kilowatts}}{1,000}$$

in which P represents the power, n the frequency (as, for example, 60 cycles), C the capacity of the condenser in farads, and V the potential in volts to which the condenser is charged at the time the spark begins.

This formula may be simplified to the following form:

$$C = \frac{1,000 \times (\text{Power in K. W.})}{nV^2}$$

Now, when the power, the number of cycles, and the voltage to which the condenser is to be charged, are known, the required capacity can easily be calculated from this formula. It will be evident that the higher the frequency, the less will be the needed capacity, so that for the same output, a smaller capacity may be used for 60 cycles than for 25 cycles, and so on.

For example, suppose that the power source and power conform to the following data after the desired transmission range has been decided as approximately 25 miles.

Transformer, $\frac{1}{4}$ K. W., primary voltage 110, frequency 60 cycles, secondary voltage 20,000.* Substituting these values in the formula

$$C = \frac{1,000 \times \frac{1}{4}}{60 \times 20,000 \times 20,000} = \frac{1,000 \times .25}{60 \times 400,000,000} = \frac{.25}{25,000,000} = .0000000105 \text{ approximately.}$$

* This example serves more for an illustration than as a typical case.

On account of the large unit represented by a farad, wireless capacities are invariably calculated and carried out in microfarads, a microfarad being 1,000,000th of a farad. To change this result to microfarads then, the answer is multiplied by 1,000,000, giving a result of .0105 microfarads.

This calculation is simple and sufficiently accurate for all ordinary purposes. When the construction of condensers for transmitters is taken up, we shall see how the desired capacity can be worked out.

It will be obvious from the formula that when a low potential is used, the capacity must be relatively large, and that if a high potential is used, the capacity will be correspondingly small. In practice the transformer used generally has a potential of from 15,000 volts for $\frac{1}{4}$ and $\frac{1}{2}$ K. W. to perhaps 30,000 or more for the larger sizes. However, there is no material gain in the amount of necessary dielectric material for a given amount of power, whether or not a high or low voltage is used since the small capacity for a high voltage is compensated by the corresponding increase in thickness which is necessary to withstand the increased voltage without breaking down. If the capacity is not properly designed, it is liable to break down, as well as act to reduce the transmitting efficiency. An increase in the *frequency*, then, is the only factor which will materially decrease the actual bulk of the condenser. Generally speaking, a high voltage within limits is advantageous for transmitting purposes because of the resulting transmitting efficiency, but this item should always be kept within limits and particularly so,

when small and only moderately insulated aerials and instruments are used.

In estimating the voltage to substitute in the formula, 15,000 volts to the centimeter of spark length is generally allowed (1 inch being 2.54 centimeters), since this has been found the approximate value for a heated and ionized spark gap.

TABLE OF CAPACITIES REQUIRED FOR CONDENSER CIRCUIT WHEN SPARK COILS ARE USED

Length of spark in inches.	Capacity in microfarads.
$\frac{1}{4}$ inch.....	.001
$\frac{1}{2}$ inch.....	.002
1 inch.....	.004
2 inches.....	.008
3 inches.....	.012
4 inches.....	.016

These values are approximate, but will vary according to the particular coil used. Spark coils for wireless purposes should be rated in watts instead of spark lengths.

Now, with the condenser and transformer decided upon, the inductance for the primary or condenser circuit is the next item to work out. We have already seen how the wave length is varied by the amount of inductance and capacity in the circuit and since the capacity is preferably a fixed value (wireless manufacturers making transformers generally supply a fixed condenser of the proper dimensions to begin with), the amount of inductance will decide the wave length in most cases. Indeed, when

the condenser is properly calculated and constructed this method is the preferred standard. Before proceeding further, the method of determining the wave length must be understood. This involves only simple mathematics and can be easily mastered by every reader, if it is not already familiar. A careful reading together with the working of a few problems is all that is necessary.

CALCULATION OF WAVE LENGTHS

The argument here applies to other forms of transmitters and to receivers also.

The wave length is expressed in the metric system as a certain number of meters long. Now, feet can easily be changed into meters (sometimes written "Metres") by dividing the number of feet by 3.281 (1 meter being 39.37 inches).

The formula reads,

$$\text{Wave length } (\lambda) = v \times 2\pi \sqrt{L.C.}$$

(λ) being a symbol for wave length, v the velocity of light in meters = $3 \times 100,000,000$ in one second, L = the inductance in *henrys*, and C = the capacity in *farads*. $n = 3.1416$. (.000001 farad = 1 microfarad., .000001 henry = 1 microhenry).

This formula can then be simplified as follows:

Wave Length = $300,000,000 \times 2 \times 3.1416 \sqrt{L.C.} = 1,884,960,000$ times the square root of the product of L and C . or 1,884.96 times the square root of the product of L and C in microhenrys and microfarads respectively.

Now, for a given wave length, the product of L and C will be a *constant* quantity, so that if the capacity C is

large, L will be small, or if the inductance L is large, C will be small. The quantity (LC) varies as the square of the wave length, so that if the wave length is to be doubled (LC) must be made four times as great, or if a given wave length is to be tripled, (LC) must be made nine times its original value.

In arc transmitters and some vacuum tube sending sets the value of L, the inductance, is usually much larger than C, the capacity, while in spark sets, a larger condenser capacity can be used.

Now, in the formula there are three items to be filled in by mathematical quantities. If any two are known, the value for the other one may be readily found. Thus, if a wave length of 200 meters is desired with the use of the .0105 microfarad condenser already calculated for the case taken as an illustration, the necessary inductance can be readily found. In order to still further simplify the formula so that it will not be necessary to extract the square root of (LC) it may be expressed,

$$\left(\frac{\text{Wave length}}{1,884,960,000}\right)^2 = \sqrt{L \times C}, \text{ expressed in henrys and farads respectively.}$$

Using this formula, and expressing L and C in microhenrys and microfarads respectively for this example,

$$\left(\frac{200}{1,884,960,000}\right)^2 = L \times .0105$$

cancelling and dividing,

$$18.849,600\cancel{00} \ 2\cancel{00}. \text{ ist.}$$

$$9.4248 \quad) \ 1. \quad (.1061, \text{ quotient. . . . 2d.}$$

substituting this simplified value,

$(.1061)^2 = L \times C = L \times .0105$ for the example taken that is,

$$L = \frac{.011257}{C} = \frac{.011257}{.0105} = \underline{1.072 \text{ approximately.}}$$

Thus, to obtain a wave length of 200 meters when the inductance is an unknown quantity and the capacity is .0105 microfarads, the formula gives 1.072 microhenrys as the proper amount of inductance.

Now, this calculation is very simple, and may be used to find any of the values, wave length, capacity, or inductance, provided the other two are known. It applies to vacuum tube as well as other circuits.

It might be well to memorize or jot down this formula in a convenient place, and if desired it may be remembered in the following form which applies to all cases which may arise.

$$\left(\frac{\text{Wave length}}{1,884,960,000} \right)^2 = L \times C \quad \begin{array}{l} \text{Giving C in microfarads direct} \\ \text{Giving L in microhenrys direct} \end{array}$$

When the *wave length* is 200 this formula gives,

$L \times C = .011257$, so that any inductance and capacity which will give a product of .011257 when expressed in microfarads and microhenrys respectively, will satisfy the equation and give a wave length of 200 meters. Now, since the condenser is worked out to correspond to the transformer used in each case, the required inductance can be found from the following for any case, the wave length remaining at 200 meters.

$$L = \frac{.011257}{C} \quad \begin{array}{l} \text{(Giving L in microhenrys.)} \\ \text{(C being in microfarads.)} \end{array}$$

It is believed that this set of formulas places the calculation of wave lengths within the reach of all the readers.

When the construction of inductance is taken up, the matter of calculating the inductance so that the helixes and transformers are of the required design, will be taken up.

The reader should have a pretty good idea of the relations of the circuits to each other by now, so that it will be evident that to use a high wave length of 1,500 meters with a spark transmitter, the inductance must be nearly 50 times as great as for a wave length of 200 meters with the same condenser, and aside from the item of decreased efficiency, the dimensions of the necessary inductance make it impracticable. Small experimental stations should, therefore, limit the wave length to the smaller value. This could be done with a vacuum tube transmitter if desired with good efficiency.

SPARK GAP

Before considering the secondary or antenna circuit, a few notes on the general requirements of the spark gap will be given. The length of the spark gap is governed by the potential at the terminals, so that it must be *increased* as the potential at which the condenser is charged is increased, the other conditions being constant. The other dimensions, or the size of the faces of the spark electrodes, must be sufficient to conduct the energy without undue heating. These are the essential features of a gap and the exact size and shape admit of numerous

variations. Suitable constructions for various types of gaps will be taken up in detail later.

ANTENNA CIRCUIT

The proper dimensions for the antenna circuit are obtained in much the same manner as for the condenser circuit, and both of the said circuits must be adjusted to very nearly the same wave length for the maximum result. There is some difficulty in calculating the capacity and inductance of an antenna with any degree of accuracy, since there are many elusive quantities which make up the total.* When the primary or condenser circuit is accurately calculated and adjusted, the antenna or secondary circuit can probably be best adjusted to resonance with the primary circuit by means of a hot wire ammeter, wave meter, geissler tube, or miniature light bulb, and some of these methods will be taken up in detail later.

The capacity of the antenna wires increases with the height, but not directly. It is nevertheless desirable to have the transmitting aerial as high up as is possible. The capacity of stranded wire is only a very little greater than that of a solid conductor having the same outside circumference. The capacity of a number of wires in close proximity is considerably less than the sum of the individual capacities. Solid metallic structures in space have only a very little greater capacity than ordinary wires, and a few small wires uniformly spaced have prac-

* A ship's antenna capacity, for instance, is sometimes different when in port than at sea.

tically as great a capacity as a solid sheet or tube occupying a similar space. The use of sheets, netting, tubing, and the like is therefore not economical or desirable. Some battleships use twelve or more wires arranged in a circle as a cage conductor but this is done to decrease the resistance rather than to increase the capacity. The approximate inductance and capacity of aerial wires can be worked out by a complicated process, but since even this method admits of considerable error, these formulas are omitted.

Perhaps the most simple and satisfactory method of apportioning the antenna conductors for a given set is as follows: Take three-fourths of the wave length in meters to find the wave length to be embodied in the antenna conductors. That is, make the natural wave length of the antenna approximately three-fourths of the total wave length. To do this, it is necessary to make the effective length of the aerial approximately .6 of the total wave length in meters, in feet. This is calculated by a process which is simple and of no direct interest, and to illustrate,—

For a wave length of 200 meters, the effective length of the aerial should be .6 of 200 in feet, or 120 feet. (See Aerials.) This is only a rough approximation, however. For large wave lengths, this method is not recommended. When this rule is used, a margin of approximately one-fourth of the total wave length is left to the adjustment of the secondary portion of the oscillation transformer. In constructing the aerial itself, it is well to allow one No. 12 conductor or its equivalent in the antenna for every 100 watts of energy to be used, and to provide

a minimum of two conductors even if only 30 watts are to be used. Thus, a $\frac{1}{2}$ K. W. set should have five antenna conductors at least, and so on. In fact the limit is soon reached so that it is impracticable to use more than three-fourths or one K. W. with a wave length of 200 meters or less. For one K. W. and larger sets, a high wave length should be planned for. This will mean a considerable increase in the total expense, as everything is best enlarged accordingly. See Chapter XX for legal requirements.) A $\frac{1}{4}$ or $\frac{1}{2}$ K. W. outfit is ideal for experimental purposes.

We have now considered the main factors of the damped wave transmitting sets and station, and the details as well as the calculations which apply to any type of station are ready for attention. In choosing a site for a station, a quiet place is to be preferred and this matter is particularly true of the *operating* room. The latter should be provided with good ventilation, sound, tight walls, and should have a total floor space of about 125 square feet is possible, though less may be used. A corner of a workshop, laboratory, or similar place is suitable.

Note: It should be remarked that the estimated range of one mile for every ten watts cannot usually be expected over *long* distances with short aerials and wave lengths on account of the absorption of short waves.

PERCENTAGE OF COUPLING

By placing the wave meter in relation to the antenna circuit and observing the length of the two radiated waves emitted by the usual spark transmitter the percentage of

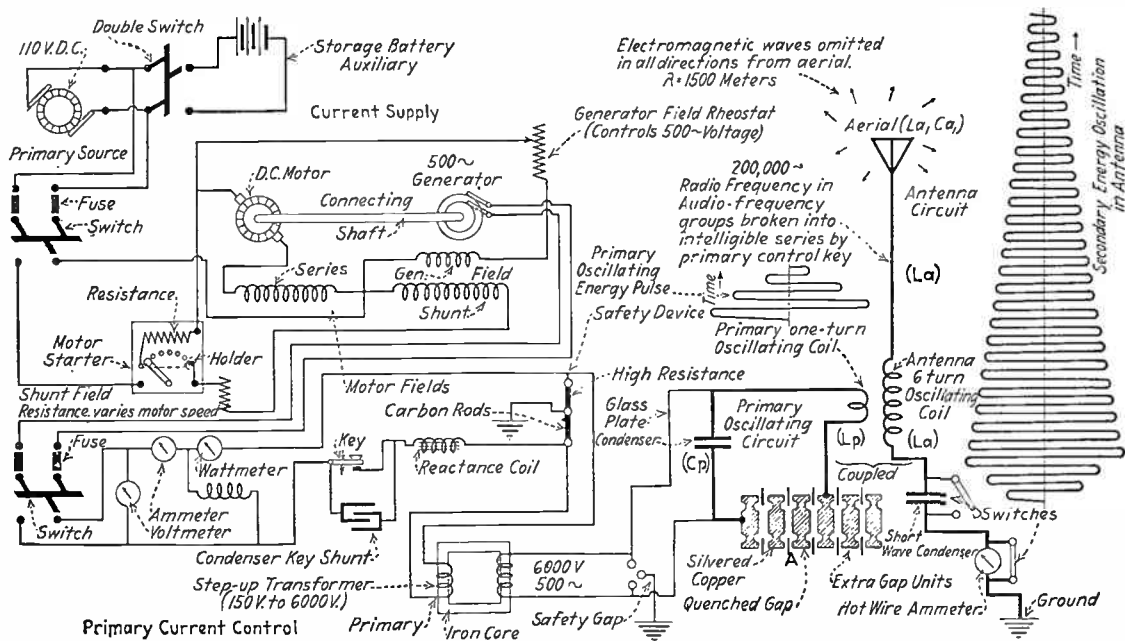

FIG. 31.—Example of a Complete Transmitter, Quenched Gap Type.

coupling between the primary and the antenna circuits can be determined from the relation,

$$\text{Percentage of coupling} = \frac{\lambda_2^2 - \lambda_1^2}{\lambda_2^2 + \lambda_1^2} \times 100.$$

λ_2 = longer wave

λ_1 = shorter wave

EXAMPLE OF A COMPLETE SPARK TRANSMITTER

In Figure 31 the complete circuits for a quenched gap spark transmitter are shown. Usually a private station does not have a separate generator for a primary source nor a complete set of indicating instruments. This illustration, however, is worthy of attention for study purposes because it shows the essential relations of the circuits.

CHAPTER VII

Transformers and Spark Coils Construction Details

Principle of Induction Coil; Transformer Construction Data;
Building a Transformer; Reactance Coil; Spark Coil;
Table for Various Spark Coils with Dimensions.

Transformers for wireless purposes are relatively inexpensive and quite efficient. They are rated according to the power, as $\frac{1}{4}$ K. W., $\frac{1}{2}$ K. W., and so on. They can only be used when an alternating current supply is available. For experimental purposes a transformer giving a secondary potential of 15,000 or 20,000 volts and of $\frac{1}{4}$ or $\frac{1}{2}$ K. W. is recommended, preferably the former. The reader is advised that it will probably cost as much to construct a suitable transformer as to buy it in the open market and that some skill is required in addition to the data here given if an efficient transformer is to be constructed.

In its simplest form, a transformer is nothing more than two independent coils of wire wound around a common iron core. An alternating current impressed upon one of the coils (the primary) causes a current to be generated in the other coil by mutual induction, although the two coils are insulated from each other and the core.

The second coil is called the *secondary* and is generally wound for wireless purposes so that it has a large number of turns. The voltage of the primary and the voltage of the secondary have a ratio corresponding to the relative number of turns. Thus, if the primary has 100 turns and is supplied with a voltage of 100 and current of 10 amperes, (1 K. W.), and the secondary has 50,000 turns of wire, the secondary voltage will be 50,000, but the amperage will only be one-fiftieth of an ampere.*

Now, there are many quantities to consider in designing a transformer, and a desired design can be nicely calculated. The matter in this chapter will be limited to the direct construction of designs which have already been worked out as suitable.

The core is generally arranged in the form of a rectangle and is made up of thin laminations of soft sheet iron, each lamination being coated on one side with varnish for insulation. This is to prevent eddy current loss and is essential. The arrangement of the coils admits of many variations, but for simplicity of construction it is preferable to place the primary winding on one leg of the core and the secondary on an opposite leg. The flux leakage is somewhat greater than when the primary and secondary are evenly divided on the two cores, but the construction and particularly the insulation is facilitated by this method. The foremost requirement of wireless transformers is good insulation, and this item should receive particular attention in the construction.

* This is taken without considering the core and copper losses. Good wireless transformers are about 90 per cent efficient.

TABLE OF TRANSFORMER DATA

Watts	100	250	500	750	1000	1500	2000
A	9	9½	9½	9½	11	12	11
B	6½	7	7	7½	10	10	15
C	1½	1¾	1¾	1¾	2	2½	2½
D	16	12	14	13	6	5	4
E	5	5½	5½	5½	6½	8¼	8¼
F	3/16	¼	¼	¼	¼	¼	¼
G	Empire Cloth						
H	16	16	14	14	12	10	8
	D.C.C.	D.C.C.	D.C.C.	D.C.C.	D.C.C.	D.C.C.	D.C.C.
J	3½	4	5½	6	7	10	14
K	8	9	9	10	18	22	23
L	34 Enamel		32 Enamel			30 En'l	
M	2½	2½	2½	2¾	5	5	9
N	⅜	⅜	⅜	⅜	¼	¼	¼
O	¼	¼	¼	¼	¼	¼	¼
P	7	7	7	8	10	10	16
Q	¼	¼	¼	¼	¼	¼	¼
R	Em Empire Cloth						

KEY TO TABLE

- A—Length of core (outside measurement).
 B—Width of core (outside measurement).
 C—Thickness of core.
 D—Number of primary layers.
 E—Width of secondary sections (each side).
 F—Thickness of insulation between core and primary.
 G—Kind of insulation between core and primary.
 H—Size (B and S) primary wire.
 J—Weight of primary wire.
 K—Approximate number of pounds secondary wire.
 L—Size (B and S) secondary wire.
 M—Length of windings.
 N—Thickness of separators for secondary sections.
 O—Thickness of sections in secondary.
 P—Number of sections in secondary.
 Q—Thickness of insulation between core and secondary.
 R—Kind of insulation between core and secondary.

The following data will be found useful in constructing suitable transformers (closed core type), with outputs which compare favorably with the inputs. The construction must be carefully carried out or the dimensions and sizes will not hold good. This data is for transformers operating on 60 cycles at a voltage of 100 to 120, which is the current most in use. The cores are arranged in the form of a rectangle and the primary is placed on one leg while the secondary is placed on the other. These legs are denoted by the letter B in the table. The letter C denotes one side of the core. The core proper is square, so that when the thickness is given as 2 inches, it means that the core is 2x2 inches. The separators (N) are of the proper size when fibre is used.

CONSTRUCTIONAL DETAILS

The core. Fig 32 shows the arrangement of a square core and details. The strips are best cut out by means

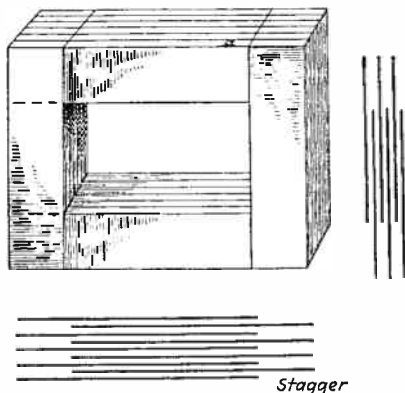

FIG. 32.—Iron Core Transformer. Arrangement of Core.

of square shears which may be found at any tinshop. When this type of core is used, it will be necessary to use an auxiliary primary inductance or reactance coil in order to compensate for the capacity and maintain a high power factor. This type of transformer lacks sufficient inductance after the windings are in place, so the arrangement of Fig. 33 should be adopted if possible.*

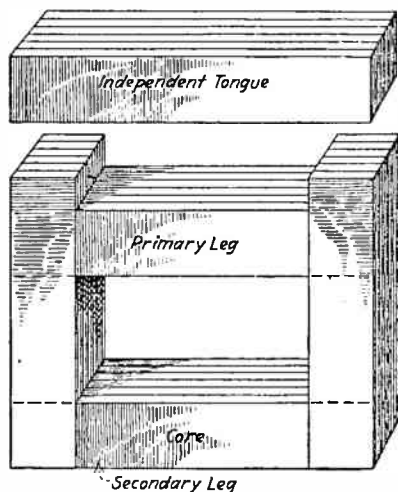

FIG. 33.—Transformer Core with Separate Tongue.

This form of core gives rise to considerable magnetic leakage, causing an increase in the primary inductance, and makes the use of auxiliary inductance unnecessary. When the primary has *insufficient* inductance the spark forms an undesirable arc at the gap, so that

* Extra iron must be allowed as the table is for plain cores.

this is an important item. In some types of wireless transformers, this extra portion or tongue is made so that the air gap is adjustable, giving a close control of the current. This extra portion does not materially alter the dimensions given in the table, but extra iron must be allowed and calculated if this arrangement is adopted. *Transformer iron* may be had from supply houses cut to size, or a good grade of stovepipe iron may be used. The legs should be wound with a few layers of empire cloth. The core can be squared up by tapping it with a hammer or mallet. The secondary leg should be further *insulated* by additional turns of empire cloth, the number of which should be ample to take care of the estimated secondary voltage and a 50 per cent overload. No. 6 is a convenient size for the empire cloth and has an average puncture voltage of 7,800. A good way to find the desired number of turns is to use as many times the number of turns used for the primary leg as the number of secondary turns is times the number of primary turns, that is, the insulation is best proportioned according to the relative turns of the two windings.

The Primary. Wind the primary evenly on the primary leg, leaving some 6 or 10 inches at the ends of the wire for leads. Taps may be taken out towards the end, if different inputs are desired, in which case the number of primary turns should be slightly increased over the number given in the table. The winding is best done by hand on account of the heavy wire and should never approach too near to the part of the core which forms a joint, or beyond the empire cloth, it being understood that the latter is kept within the limits of the leg proper.

The completed winding can be covered with a few turns of empire cloth or tape.

The Secondary. The sections are wound on a section former in a lathe or makeshift lathe. The arrangement of a section winder is shown in Fig. 34, and should be made in proportion to the size of the coil to be wound. This former should be made from iron, steel, or brass and not of wood, and is preferably made by a machinist so that the plates are *true*. The saw cuts (slots) are to allow threads to be passed around the completed section before it is removed. This round form is more con-

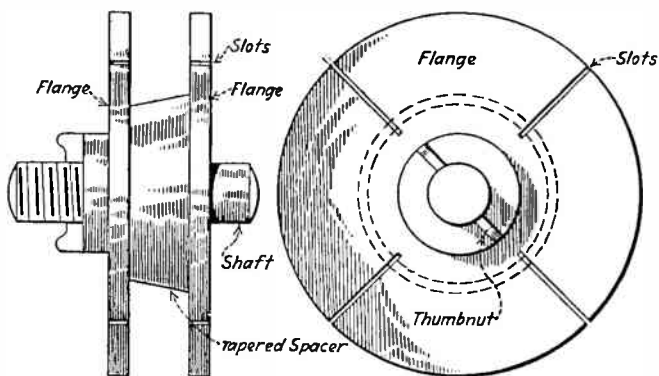

FIG. 34.—Section Winder for Making Spark Coil Secondaries.

venient than a square form, although the latter may be used. The resulting air space between the coil and core is no disadvantage since it acts as a cooling duct. The winding should be done slowly and evenly, avoiding kinks and breaks. A broken wire should be soldered.

With a little practice this winding will not be difficult,

and can be rapidly carried out. The section should be tightly wound and when completed, the threads should be passed around it and through the slots to keep it in shape. Leave several inches at the beginning and end of the winding for connections. After it is bound, the section should be removed with care and placed into a pot or pan containing melted paraffin or a mixture of paraffin and beeswax. The latter should not be too hot since its insulating value is less if it is at too high a temperature. Let the section soak in the wax for some time until air bubbles cease to rise, then lift it out by means of a string or spoon. Place the section on a porcelain plate and squeeze the excess wax out by pressing on the section from the top with another cold porcelain plate.* The other sections can be wound while the first few are being insulated, to save time. These sections can be taped with a strip cut from empire cloth if desired. The fibre separators can also be soaked in the wax mixture. Commercial coils are impregnated by the vacuum process.

Assembling. The sections should be connected in series so that they form a consecutive winding with the connections made alternately at the middle and at the outside. The joints should be soldered. Be sure that the sections are properly connected so that the direction of the winding is consecutive as otherwise one or more sections will buck up against the rest. The sections should then be arranged on the core with the separators between them, and melted wax may be used to fill up the intervening space so that they will be rigidly in place on the

* Glass may also be used.

core. It is good practice to divide the insulation between the sections into two parts so that the inner connection can be placed between two separators. The sections are best joined after they are arranged on the core. A number of separators should be placed at each end of the completed winding and if possible a thick head should be provided as a flange for each end of the coil.

The primary and secondary legs are now joined by the core pieces and squared up. The tongue of the tongue type is left alone for the present. In the tongue type, the primary core is placed at the tongue end. This tongue should be nicely bound by itself. The core is then clamped together and nicely squared up by means of strap or angle iron and bolts.

The transformer can now be mounted in any suitable manner and the terminals brought out to suitable binding posts. The tongue is left in an adjustable position close to the core but insulated therefrom, so that its relative distance can be adjusted according to the amount of condenser used across the secondary terminals. Tests should be made with a telephone receiver and battery for short circuits and breaks, and if any are found they must be located and repaired. It is well to cover the secondary with a number of layers of empire cloth. The other details are left to the reader.

REACTANCE COIL

A suitable reactance coil for use with the transformer when a plain core type is employed, may be constructed by making a hollow coil of wire and sliding an

iron core in or out of it according to the desired adjustment. The core should be of sheet iron and of dimensions corresponding to the size of the primary leg of the transformer core. That is, if the primary leg is 10 inches long and 2x2 inches, the core for the reactance should be this same size or a little larger. Now make a wooden or fibre frame about one-eighth or three-sixteenths of an inch thick with inside dimensions so that the iron core can slide freely in and out of it, and wind about two or three layers of wire on it. The wire should be a few sizes larger than the primary wire, if possible. Thus, if the primary wire is No. 12, No. 10 is suitable for the reactance coil. This reactance is connected in series with the primary winding and the adjustment is made by putting more or less of the iron core inside of the winding.

It is believed that the foregoing will be sufficient working directions to enable the reader to construct efficient transformers and reactances, providing that the work is carefully carried out. Many minor details have been omitted, and unless the reader has some experience, he will very likely find several little points which must be independently solved. The main requisite is again stated to be, INSULATION.

Inasmuch as open core transformers are less efficient than closed core types and little if any easier or cheaper to construct, designs for this type are omitted.

SPARK COILS

A spark coil is similar to a transformer except that it has an open core and operates by means of an inter-

TABLE FOR WIRELESS SPARK COILS

(Size.)	A.	B.	C.	D.	E.	F.	G.
¼ in.	5½	½	CT	1-16 in.	20	225	Em.
½ in.	5½	½	CT	1-16 in.	20	225	Em.
1 in.	5¾	½	Em	2	18	170	Em.
2 in.	7	5⁄8	Em	2	16	184	Em.
3 in.	8	¾	Em	2	16	208	Em.
4 in.	8¾	1	Em	3	16	232	Em.
5 in.	9½	1	Em	3	16	256	Em.
6 in.	10	1¼	Em	3	14	214	Mi.
8 in.	14	1½	Em	3	14	320	Mi.
10 in.	24	3	Em	4	12	400	Mi.
(Size.)	H.	I.	J.	K.	L.	M.	N.
¼ in.	4	38	3 oz.	1	1¾	4¼	250
½ in.	4	38	4 oz.	1	1¾	4¼	300
1 in.	6	38	¾ lb.	2	1¾	4½	800
2 in.	6	36*	1 lb.	2	2¼	5¾	1400
3 in.	8	36*	1½ lb.	2	3	6	2000
4 in.	8	36*	2 lb.	3	4	6	2500
5 in.	8	36*	3 lb.	3	4½	6	3800
6 in.	⅞ in.	36*	5 lb.	4	5	6½	6000
8 in.	⅞ in.	36*	8 lb.	8	8	7	8500
10 in.	⅞ in.	28*	12 lb.	16	11	12	10500

IN THIS TABLE,—

A—Length of Core in inches.

B—Diameter of Core in inches.

C—Insulation on Core—(C.T.—Carboard tube, E. M.—Em-Cloth.)

D—Thickness of insulation on core.

(In layers, except ¼ inch and ½-inch sizes.)

E—Size (B&S) Primary Wire (D. C. C.)

F—Number Turns Primary Wire.

G—Kind of insulating tube.

(Em—Empire Cloth) (Mi—Micanite.)

H—Thickness Insulating Tube. (Layers for Em. and inches for Mi.)

I—Size (B&S) Secondary Wire. (* means Enameled.)

J—No. Pounds Secondary Wire.

K—No. Sections in Secondary.

L—Approximate Diameter, Secondary. (In inches.)

M—Distance between coil heads. (In inches.)

N—Total No. Sq. In. of Foil in Condenser.

Note: These coils use a medium speed vibrator. To use table, find length of spark wanted (Size) and read across, as ¼ inch—5½—½—C. T., etc., ¼ inch—4—38—3 oz., etc.

rupted current. These coils are preferably purchased, since they may be had almost as cheap as the materials for construction. However, for those who may wish to construct coils and who have some idea of the details, the following data for wireless coils are given. Wireless coils require a different design than ordinary spark coils. The sections may be wound as has already been described for transformer sections. The core in this kind of coil is made up of a bundle of straight soft iron wires,

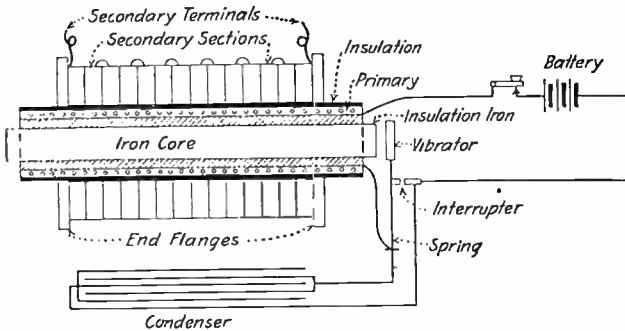

FIG. 35.—Induction Spark Coil.

which may be had cut to size from supply houses. The other requirements, such as insulation, etc., are similar to those for transformers, and with the aid of the diagram of the relations of the circuits shown in Fig. 35, it is not thought that there will be any difficulty in carrying out the construction. The vibrator is best purchased from a supply house, since it is as cheap or cheaper than making one. The construction of the condenser is similar to the

construction used in receiving condensers, and the reader is referred to this heading for further instructions.

A transformer is to be preferred and should be used whenever possible. The spark coil will operate satisfactorily on one or two six volt storage cells. A spark coil may also be used with an electrolytic interrupter on 110 volt A. C. or D. C. current. (See Chapter VIII.)

CHAPTER VIII

Auxiliary Apparatus

Keys; Electrolytic Interrupter; Kickback Prevention; Aerial Switches; Automatic Antenna Switch; Storage Batteries.

By using an electrolytic interrupter, a spark coil can be operated on 110 volts A. C. or D. C. The author finds

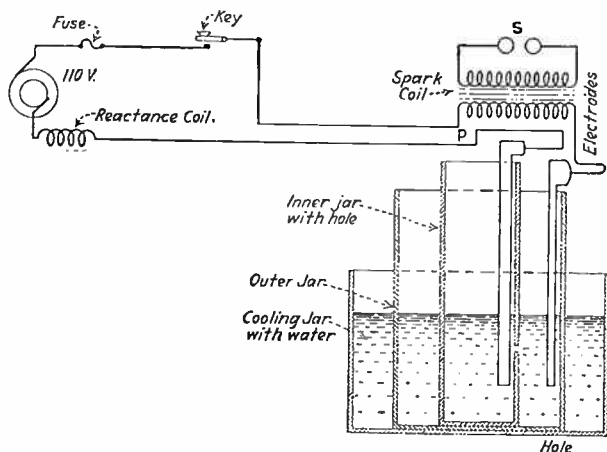

FIG. 36.—Electrolytic Interrupter.

that the interrupter shown in Fig. 36 is the most serviceable for experimental purposes. This interrupter is very

inexpensive and such common things as mason or other jars may be utilized. The electrodes are made of sheet lead. The electrolyte is made up by adding a little sulphuric acid to water, or else by adding some sal ammoniac to water. Other salts may also be used, but common table salt is not suitable. The proper amount is found by experiment. It is advisable to use the cooling jar as shown, as the interrupter heats rapidly when in use. The only difficulty in construction will probably be the hole in the glass or porcelain, or clay (glazed) jar. This may be readily bored with a new sharp twist drill, using turpentine as a lubricant. A glazed clay jar is the easiest to bore. The hole should not be too large, or too much current will pass. The following sizes for the holes are suitable.

1-32 inch for coils giving up to $\frac{1}{2}$ inch spark.

1-16 inch for coils giving up to 2 inch sparks.

3-32 inch for coils giving up to 3 inch sparks.

1-8 inch, largest size advised. This size allows from 5 to 8 amperes to pass.

In using the interrupter, the vibrator contacts of the coil must be screwed down tight as the vibrator is not needed. The interrupter is connected in series with the coil. (See Fig. 36.) The interruptions will be faster with the smaller size hole other conditions being the same, and they depend upon the fact that a gaseous insulating film is generated at the point of contact by the current which temporarily breaks the current. The interruptions or makes and breaks occur at a high rate of speed. The interruptions can be regulated to some extent by means of a variable inductance in series with it and the coil.

This may be constructed like the reactance coil described in Chapter VII.

KICKBACK PREVENTION

In using transformers or coils and interrupters connected to lighting circuits, the high tension currents often kick back into the line and cause considerable damage. The common effect of kickbacks are punctured meters, arcs in electric light fixtures, short circuits and blown

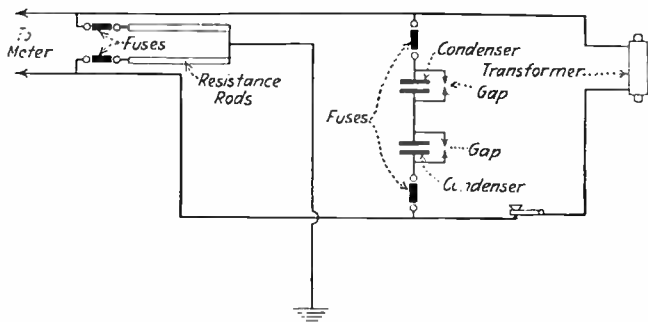

FIG. 37.—Protecting Device for Lighting Circuit.

fuses. In fact, whenever more than 200 watts are drawn from the line to operate a coil or transformer, steps should be taken to prevent kickbacks. An efficient triple preventer is shown in Fig. 37. The protection is three-fold, ground dissipators being provided in the form of condensers, high resistances, and minute gaps. These are all connected across the terminals of the line supplying current to the primary of the coil or transformer.

The gaps should be very carefully made so that they do not touch each other by a minute distance. The condenser should have a large capacity and may be of the following dimensions or their equivalent.

Each condenser has ten plates of 8x10 glass,* between which are sheets of tinfoil 6x8 inches alternately connected to form a capacity. This is constructed like any other condenser.

The high resistance is attained by using graphite rods, each having about 1,000 ohms resistance, and should be of large diameter to dissipate the heat which is accumulated after a time. These rods are also connected directly across the line. The ground may be the regular ground of the station or else the lighting ground may be conveniently used. This arrangement will take care of kickbacks and will save the remainder of the circuits from damage. The fuses shown are 6 amp. plug fuses, and should be promptly renewed if they blow. This protection may mean the difference between a serious fire and constant freedom from injury or trouble and should be adopted. The condenser cares for ordinary small charges, the gap for excessive charges, and the rods are an additional protection for the meter. The latter can be dispensed with if desired. Two incandescent lamps in series may be substituted for the rods and will serve as an efficient protection.

KEYS

The key used for breaking the current into dots and dashes must handle considerable currents in most cases

* Heavy paraffined paper can be used.

and ordinary telegraph keys are only suited when a few watts are used, as with small spark coils. The reader can easily construct a heavy key along the lines of a telegraph key, using large pieces of zinc or two silver

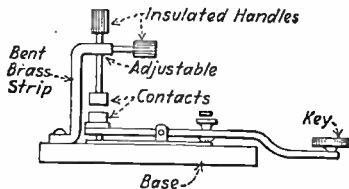

FIG. 38.—Ordinary Key Fitted with Large Contacts.

dimes for contacts. An attachment for an ordinary telegraph key which will handle large currents is shown in Fig. 38. The regular contacts are not used with this arrangement. A similar arrangement can easily be con-

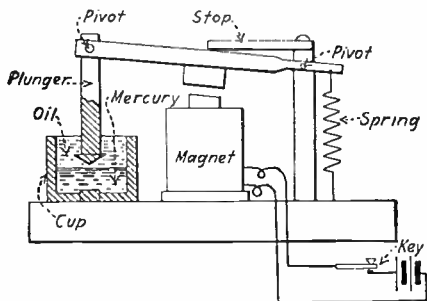

FIG. 39.—Magnetically Operated Key.

structed. The arrangement is so simple that further comment seems unnecessary. The contacts can be of zinc or silver and should be of large surface. The average telegraph key will have to be mounted on a separate

base to use this arrangement. A similar set of contacts can be magnetically operated as shown in Fig. 39, in which case an ordinary telegraph or strap key can be used to close the circuit. This arrangement is advisable when currents in excess of 10 amperes must be handled. Springy metal can be substituted for the mercury.

Another arrangement for handling large currents is shown in Fig. 40. Other arrangements for the same purpose are to connect a large condenser in shunt around the key contacts to absorb the spark, and to use oil about the contacts to prevent arcs from forming. The magnets

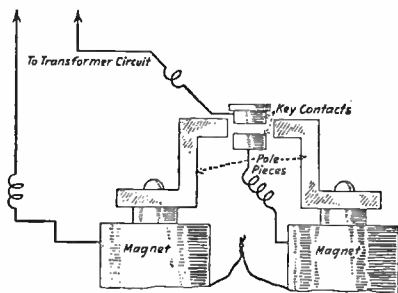

FIG. 40.—Magnetic Blow-Out to Prevent Key Arcs.

shown in the figure may be either single or double pole and of any suitable dimensions. The essential feature is that the poles should be extended to the locality of the contacts, so that they can act to blow out arcs which form before the latter become of unwieldy proportions. Note the connections. Strap iron is suitable for the pole extensions.

AERIAL SWITCHES

There are many forms of aerial switches, the object

of which is to change from the sending to the receiving instruments. For small stations, an ordinary double or triple pole double throw switch can be used and connected as shown in Fig. 41. For large stations, either a big double or triple pole double throw switch can be used. The aerial switch is conveniently located, preferably at the point where the aerial leads enter the operating

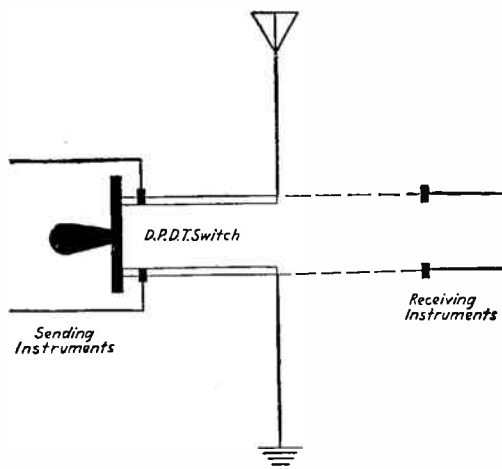

FIG. 41.—Change Over Switch; Sending to Receiving.

room. A switch which allows of rapid change from sending to receiving instruments and *vice versa* is a desideratum, one type of such key being shown in Fig. 42. The details of construction are left to the reader, the essentials being that the contacts and switch pieces should be well insulated from each other, it being desirable to use hard rubber throughout. On account of the leverage it is only necessary to move the handle a short distance

from the sending to the receiving position. The blades correspond to the radii of a circle in this type.

AUTOMATIC AERIAL SWITCH

This form is very much desired and used by experimenters. It automatically disconnects the receiving set the instant that the key is used to send and as soon as the

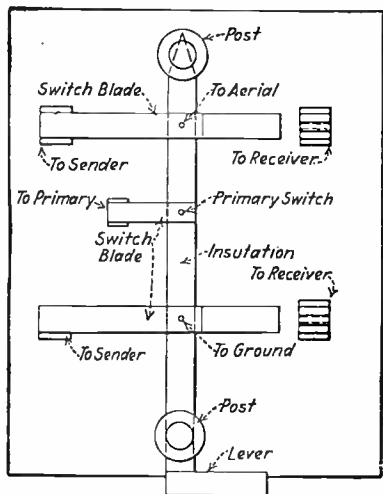
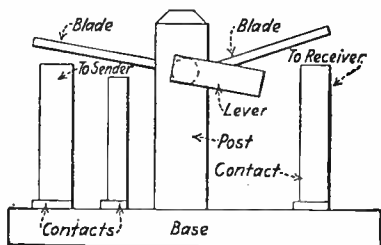

FIG. 42.—Antenna Switch; Rotary Type.

message is sent, the receiving set is again ready to receive. This particular embodiment is adapted to a closed circuit transmitter. The Figure 43 is self explanatory, and the reader will have little difficulty in making and attaching this arrangement to an ordinary key. German

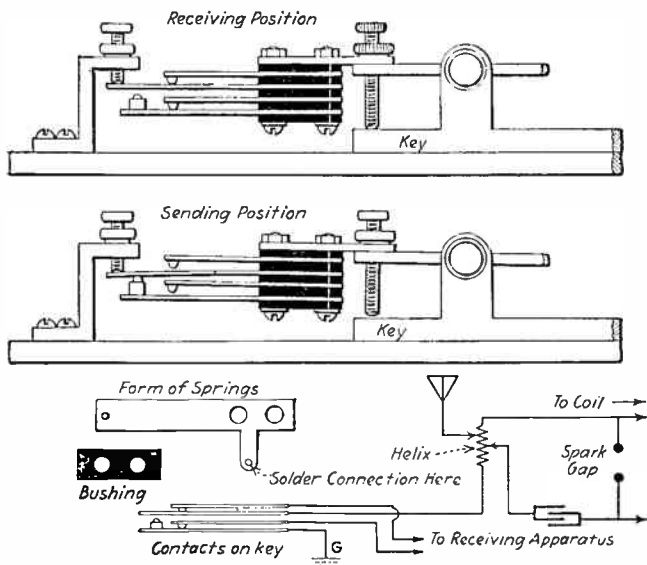

FIG. 43.—Break in Attachment Fitted to Key.

silver or brass may be used for the springs and platinum is desirable for the contacts. The spring strips are insulated by hard rubber or fibre bushings and rubber tubing, the whole being clamped together by two brass machine screws. A short brass strip is used to attach the device firmly to the back end of the key lever. The springs must be adjusted so that the first two and the

second two make contact when the key is up, and the second makes contact with the fourth when the key is down. This will be clear by referring to the diagram. Connections may be soldered to the lugs on the springs. Telephone switch parts may be used for a small power key only.

AUTOMATIC SWITCH FOR HEAVY CURRENTS

The foregoing switch is only suited to small stations. The one shown in Fig. 44 is adapted for heavy currents

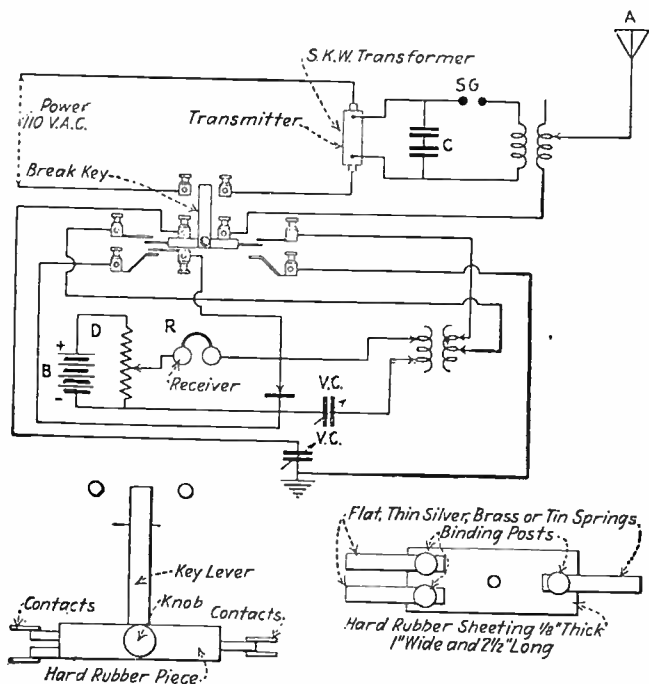

FIG. 44.—Automatic Antenna Switch.

and is also suitable for an inductively coupled transmitter. The key is not materially different from the foregoing and can be readily constructed from the diagram. The object of these keys is to protect the receiving detector from injury while sending and they operate through the sending inductance. This increases the wave length of the aerial for receiving to some extent, but is not harmful. This particular form is suited for both closed and inductively coupled transmitters or receivers. As in the other arrangement, the hard rubber sheet is arranged on the key, being placed between the button and the key lever in this case. It is also satisfactory to mount the contacts on the back of the key on the adjustment screw.

IN GENERAL

The wiring in a wireless station should be carried out in accordance with the code requirements. A copy thereof may be had gratis by addressing the National Board of Fire Underwriters at either New York, Chicago or Boston.

STORAGE BATTERIES

In radio work storage batteries are used as an emergency auxiliary source for transmitters, for filament lighting and plate circuit feeders in vacuum tube circuits, and similar work. Suitable forms of the lead-acid or iron-nickel-alkali type are supplied by reliable makers with full directions for care and use. For information

on batteries see any good electrical or battery handbook or manufacturers catalogues. The main thing is to keep the batteries always charged according to directions and to use only pure water to replenish or special electrolyte supplied by the maker to refill the cells.

CHAPTER IX

Condensers and Capacities

Condenser Theory; Calculation of Capacities; Dielectric Table; Building Condensers; Dimensions and Materials.

A *condenser* (see Figure 45) is a device which stores energy and in its simplest form it consists of two coatings of tinfoil separated by an insulating substance, such as air, paper, glass, or oil, which is called a dielectric. The two coatings are insulated from each other as far as metallic connections are concerned and if they are charged by means of an induction coil or transformer they will discharge with a brilliant crackling spark when connected through a suitable gap. Now this discharge occurs so rapidly that it appears to be a single discharge, but it is in fact made up of a number of rapidly oscillating discharges, first in one direction and then in another. During this process the polarity of the charge on the two coatings is rapidly reversed so that a given coating is first charged in one polarity and then in another at a high rate. The vibrations from the discharge are called oscillations and gradually die out with more or less rapidity according to the degree of damping. The spark gap

causes damping because it offers resistance to the oscillating current. The time taken by an ordinary discharge is generally a small part of a second, but during this small space of time there may be as many as 100,000 to 1,000,000 oscillations.

Now the nature and amount of this charge depends on the dielectric rather than the coatings employed. It has been definitely established that the charge of a condenser resides on the respective surfaces of the dielectric and not on the coatings or tinfoil. When a condenser is charged and the coatings removed, tests will show that they are not electrified to any appreciable extent, but if they are returned to position to form a complete condenser with the same dielectric, they will form a highly charged condenser again. The dielectric of a condenser actually undergoes a strain and as in the case of mechanical strains, this results in heat after a time.

The two coatings of a condenser are always charged oppositely, that is when one coat is charged positively, the other is charged negatively. These charges in oscillating back and forth travel at a speed of 300,000,000 meters per second or the speed of light. When a condenser is charged by a transformer, there are four stages as follows:

1. First quarter cycle, condenser coatings are charged to the potential of the impressed E. M. F.
2. E. M. F. decrease during the second quarter cycle so the charges on the coatings rush back to the transformer. (A discharge occurs in the spark gap at this point, resulting in oscillations as has just been described.)
3. Third quarter cycle. Same as the first quarter

cycle except that the direction and polarity of the charge is reversed.

4. Fourth quarter cycle; same as second quarter. A second discharge occurs in the gap.

There are two discharges at the least for each cycle, or if the frequency of the transformer is 60 cycles there will be at least 120 discharges per second.* The higher the frequency of the impressed E. M. F. is, the greater will be the power of the circuit including the capacity, because of the increased rate of change of flux. In wireless work, a capacity or condenser behaves in the following definite manner:

1. The apparent *conductivity* is directly proportional to the capacity and the frequency of the E. M. F.

2. The apparent *resistance* or capacity reactance is inversely proportional to the capacity and the frequency of the E. M. F.

We have already seen how the capacity in a transmitting circuit which is required for a given transformer may be found. All that remains then is to find the dimensions for a condenser which will give the required capacity.

CALCULATION OF CAPACITY

In order to standardize experimental apparatus, the *parallel plate* type of condenser is the best to adopt because its capacity or a desired capacity can be readily calculated. The formula is,

* A large number of discharges is obtained by interrupting the natural discharges with a rotary gap. See Chapter XI.

$$C = \frac{k A}{4 \pi d} \quad \text{c. g. s. electrostatic units.}$$

in which, C represents the capacity, k, the dielectric constant, air or other gas at atmospheric pressure being practically 1. Other values of k for different dielectrics will be found in the Table of Dielectrics. A represents the area of one of the plates overlapped by the other plate, and d is the distance apart of the plates in centimeters. This formula is accurate only when the distance between the two plates is relatively small in comparison with the length and breadth of the plates.

This may be expressed:

$$C = \frac{KA}{4 \pi D \times 9 \times 10^5} \text{ or } C 4 \pi D \times 9 \times 10^5 = KA$$

to express the capacity in microfarads.

To find the desired area, this may be arranged,

$$A = \frac{36. \pi DC \times 10^5}{K}$$

Now the quantity $36 \pi \times 100,000$ is the same in every case, so the formula may be simplified to

$A = \frac{DC \times 11309760}{K}$ and when glass is used for the dielectric, which has a constant of 8; this may be further simplified to

$$A = DC \times 1413720, \text{ because } \frac{11309760}{8} = 1413720.$$

So the calculation of the capacity and area for a given or desired condenser is really not difficult. The figures are in the metric system and to use in inches after the

area has been found in centimeters change in the following ratio:

1 inch = 2.54 centimeters. 1 centimeter = .3937 in.

1 square inch = 6.45 sq. cm. 1 sq. cm. = .1550 sq. in.

In order to illustrate the use of this formula,—suppose it is desired to find the necessary area for the tinfoil to make up a condenser of .002 microfarad, using glass .1 centimeter thick. Ordinary glass plates are .05 inch thick or approximately .125 centimeter thick. Using the simplified formula, we get

$$A = .1 \times .002 \times 1413720 = 282.74 \text{ sq. cm.}$$

DIELECTRIC TABLE

(K) Constants for,

Air, empty space, or gases at atmospheric pressure	1.	
Glass	6.	to 10
Light flint glass	6.5	
Dense flint glass	6.5	to 10
Hard crown glass	7.	
Mica	6.6	to 7.5
Hard rubber	2.7	
Kerosene oil	2.	
Castor oil	4.78	
Shellac	2.7	to 3.5
Ebonite	2.5	to 3.
Manilla paper	1.5	
Paraffin	1.75	to 2.3
Resin	1.77	to 2.5
Porcelain	4.38	
Water	80.	

Note, an average result is best to use in the formula. Glass should be taken as $7\frac{1}{2}$ or 8 when ordinary glass or old photographic plates are to be used. The emulsion should be cleaned off before using the latter.

Now this surface can be apportioned in almost any desired manner. For instance, three plates of glass of this size 12 by 14 centimeters and covered with tin foil on each side 9 by 10½ centimeters would be approximately right.

To take another example,—desired capacity .02 microfarad, using manilla paper .02 cm. thick,—what area of foil for A is required?

Use the simplified general formula,

$$A = \frac{DC \times 11309760}{K} \text{ substituting}$$

$$A = \frac{.02 \times .02 \times 11309760}{1.5} = \frac{4523.9}{1.5} = 3015.9 \text{ sq. cm.}$$

This can also be proportioned as desired, about 30 sheets of the dielectric being used.

Almost any desired capacity can be worked out to a close degree of accuracy in this manner. It will be noted from the formula that there are several factors which determine the capacity of a condenser, A, D, and K, so that if two are known, the third may be found.

Now in designing a condenser for transmission purposes, the thickness of the dielectric must be sufficient to withstand the impressed voltage and an overload without puncturing. For this reason one centimeter to every 40,000 volts should be allowed. Thus if the voltage is 10,000 the dielectric should be made .25 centimeters thick and so on. However, if glass cannot be had in this size or a large enough size, two or more capacities of the same dimensions can be connected together, in series. This

method makes the use of ordinary thickness of glass possible with high voltages, but since the capacity is thereby cut down, in approximately the same ratio, the capacity for each unit must be correspondingly larger. Thus if a single unit is used which has a capacity of .2 microfarad, and if two condensers must be used in series to secure this same capacity without breaking down under the impressed voltage, each must have a capacity of .4 microfarad. So that to *increase* the voltage which a condenser made up of a given size of plates may stand, by connecting units in series, to *twice* the voltage which a single unit can stand, each *unit* must have *twice* the capacity of a single unit if two are connected in series to give the *capacity* of the single unit. While we are on this subject, it is well to note that when condenser units are connected in parallel, the total capacity is the sum of the capacities of the condenser units, but the puncturing voltage which the parallel set can stand is limited to that of its weakest unit. For this reason the units used should be of identical dimensions whenever possible.

STRUCTURAL CONSIDERATIONS

The condenser is an important part of the wireless station and unless properly constructed, the transmission efficiency will be materially affected. The main requirements are,

1. The foil used should be a *good conductor* and of sufficient size to carry the charges without undue heating. Copper is preferably used and may be had in thin sheets for this purpose. Tin foil should be heavy if used at all.

The kind used by florists is generally suitable. The high frequency currents require a large surface and if this is not provided, the conductor is likely to burn up.

2. *Radiation* surface is necessary to dissipate the heat which is generated in the dielectric. When used in air, the condenser plates are generally spaced a short distance apart for this purpose, and when immersed in oil, the liquid acts as a cooling agent. Small condensers may be imbedded in paraffin or any good insulating compound.

3. Contacts should be *soldered* to the tin or copper sheets forming the coatings to make the best contact possible. The resistance of poor joints to high frequency currents is much greater than to low frequency currents. Stranded conductors make good leads to condensers. A common method of construction is to clamp projecting portions of the coatings tightly together to form a single conductor at the terminals.

4. Brush discharges, surface leakage, and other losses should be minimized. This is accomplished by using a good grade of *dielectric*, allowing a safe margin around the coatings, making the coatings *uniform* and even, making the coatings fit the dielectric tightly, and placing the complete condenser in an insulator such as boiled linseed oil.

5. Contacts should be as *large* as possible, to avoid undue resistance.

The items under (4) are perhaps the most important and require careful attention. Some commercial condensers have the coatings deposited directly on the glass dielectric. The first coat is silver and this is covered with electroplated copper. "Pyro" glass is used, as it stands

heating. Plate condensers offer the most satisfactory solution to the several problems and in addition have the advantage already mentioned of being *readily calculated* for a given purpose. Plate condensers separated in air are not as desirable as those imbedded in an insulator because they tend to blister and aid brush discharges under overloads. For these reasons the *standard type* to be adopted, is the *plate* condenser made into convenient or desired units and imbedded in an insulator.

DETAILS

The *glass* used may be had cut to size at any hardware or paint supply house and for voltages over 15,000 the use of double strength glass is advisable. Data regarding the sizes, thickness and so on may be had from the dealer and is useful in calculating capacity and estimating material. Old photographic plates make very good condenser dielectric material when the emulsion is removed and may be had very cheap. The author once purchased two hundred 5x7 glass plates at 25c per hundred, and while the larger sizes are valued higher because of their use in picture frames, they may be had for a nominal sum. In fact, many photographers will gladly donate old glass plates if properly approached and told that they are for wireless experimental purposes. The emulsion can be removed by soaking the plates overnight in a strong solution of lye in water. Glass containing much lead is not suited for condensers, and all of the plates used should be of the *same thickness* throughout.

Just before using, it is advisable to again clean the

plates with a rag dipped into alcohol, although warm water can be used if the plates are allowed to thoroughly dry afterwards. The glass should be thoroughly clean and dry before using.

MATERIAL FOR COATINGS

Thin *copper sheet* or *heavy tin foil* should be used for the coatings and should be cut to size. If tin foil is used, it should be about No. 35 gauge if possible, and in any case it must be smoothed, by means of a print roller such as photographers use. In making condensers which are so large that a single width of tin foil will not suffice, two or three strips overlapping each other can be used. The size of the coatings should be such that a margin of one inch is left on all sides relative to the edge of the glass plate for every ten thousand volts to be used in the charging, though less may be used after a limit of two or three inches is reached, or when the plates are immersed in oil.

ARRANGEMENT

The arrangement of the plates and coatings is shown in Fig. 45. The lugs for the coatings are preferably in *one piece* with the coatings, but they may be separate pieces if they make good contact *electrically* with the coatings and are *mechanically* strong. The latter method is less expensive as there is practically no waste of material.

In soldering tin foil, the foil to which a strip is to be

soldered must be laid upon a piece of copper or aluminum sheet of some thickness, in order to conduct the heat away, else the foil will melt or burn up. When the condenser is to be used on high voltage, two or three thicknesses of the glass can be used between each sheet of foil to secure a greater disruptive strength, but the

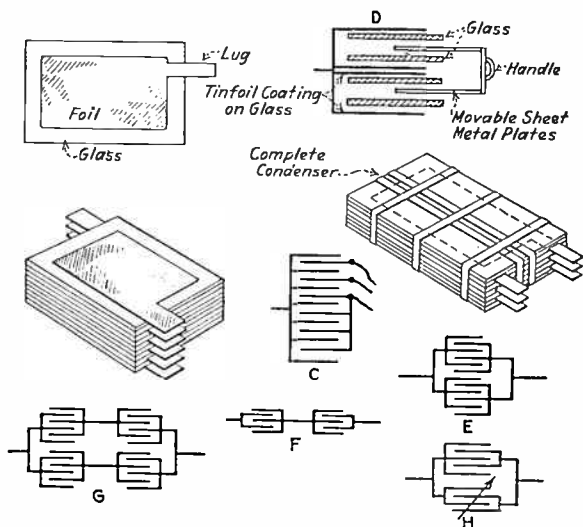

FIG. 45.—Condenser Details.

capacity is of course correspondingly less and the total thickness of the plates between the two coatings must be used to calculate the capacity.

The alternate lugs of the two coatings can be brought out on opposite sides of the plates or else suitably spaced on the same side. (See the figure.) It is a good plan to make the required condenser in several units, particularly if the capacity is large. Thus if twelve 8×10 plates

are to be used, two units each having six plates are preferable. This arrangement makes repairs from damages or punctures easier, since only one of the units is liable to be punctured at a time, while with a single unit, the whole condenser would be temporarily disabled. It is good practice to provide an extra unit or two if this method is adopted, in order to meet emergencies.

BUILDING THE CONDENSER

In building the condenser, lay a sheet of glass on a flat table, then place a sheet of foil with its lug on top of it, so that it lies flat and is evenly spaced from the edge of the plate. Now lay a second glass plate on top of this, and place a second sheet of foil on it, spaced as before, but arranged so that its lug comes either at the *opposite* side of the plate or suitably *spaced* from the first lug, as shown in the figure. Proceed as before, placing alternate sheets of glass and foil until all of the plates have been assembled. An extra plate should then be used to cover the top sheet of foil. When this **is** done, the condenser will be a unit, with two sets of insulated plates *alternately arranged*. The unit can then be bound together by large rubber bands, rubber tape or string, or any suitable form of clamp may be used provided too much pressure is not applied. If the plates are pressed together too tightly the glass will crack, ruining the condenser. The two respective sets of lugs should now be firmly clamped between brass or copper sheet, or soldered together and to a large lead. Test the unit for short circuits with a battery and telephone

receiver, (the faint response does not indicate a short circuit, but is caused by the capacity of the plates). A few of the lugs can be left disconnected as shown at (c) Fig. 45, and separate leads attached to them so that the capacity of the condenser can be varied a little. This method is useful particularly with spark coils since the exact capacity needed is difficult to predetermine.

The finished units should be placed in a suitable box or jar, (hard rubber or glass storage battery jars are excellent containers for this purpose), a hard rubber cover provided, connections brought to binding posts, and so on as desired. The jar or container should be liquid proof and should be filled with a good quality of transformer oil, boiled linseed oil, castor oil, vaseline, paraffin oil, or other non-explosive insulating oil. The condenser should be mounted or arranged in the jar so that it does not rattle and if the condenser is to be moved very much a thick insulator like vaseline should be used, so that the oil will not be continually running over and leaking. A good grade of lubricating oil can be used, the non-carbonizing oils used in automobiles being suitable and quite cheap. Oils which ignite easily or which carbonize or deteriorate quickly, as well as those which are poor insulators should not be used, since the function of the oil is to prevent leakage and brush discharges as well as to dissipate the heat caused by the hysteresis of the glass dielectric.

MAKESHIFT CONDENSERS

A condenser is really a very simple piece of apparatus, but too much care cannot be taken in constructing it if

efficiency is desired. For experimental purposes, old bottles, placed in a dishpan containing salt water, and filled two-thirds full with a solution of common salt and water can be impressed into service as a condenser, connections being made to the dishpan and to wires entering into the bottles respectively. A large capacity is possible by this makeshift arrangement, but the capacity can of course not be accurately determined. Two rubber covered wires twisted together but insulated at the ends will form a condenser when connected about the secondary terminals of a small coil. There are other suitable forms for condensers, but since the type described is equal or superior to them and serves for all experimental purposes, these will not be described.

By using copper, zinc, or even tin sheets (iron coated with tin), of some thickness between glass plates, a variable condenser may be made. The capacity can be varied by moving the plates forming one set of coatings in or out of the vicinity of the glass plates and the other set of coatings, thus increasing or diminishing the capacity. The construction of such an arrangement is very simple and the details need no further comment. The diagram of this arrangement is shown in Fig. 45 (d). It should be noted that this arrangement is just like an ordinary glass plate condenser except that rigid movable plates are substituted for the tin foil in one of the sets of coatings. In Fig. 45, (e) shows the manner of connecting condensers in *parallel* to *increase* the capacity, (f) shows the connections for *series* to *decrease* the capacity, and (g) shows a combination of the two, which *decreases* the capacity. Taking a single unit for

comparison, the units being of the same size (e) will give *double* the capacity, (f) *one-half* the capacity, and (g) an *equal* capacity, but using four units. The series and series multiple connections are used when the voltage impressed on a single unit is more than it can stand without puncturing. (h) Fig. 45 shows the method used to connect both a fixed and a variable condenser having the same form and size of dielectric in circuit. This method allows the exact capacity needed for a given transformer to be used. With this arrangement, the variable condenser need not have a very large capacity by itself since it is needed only to make up a small difference in most cases.

SANDWICH CONDENSER CAPACITY

For the condenser having N similar plates sandwiched in between dielectric sheets with alternate plates connected in parallel, the capacity is

$$C = \frac{.0885 \text{ K(N-1)S}}{d(1,000,000)} \text{ microfarad.}$$

K is the dielectric constant (1, for air).

S is the area of one plate in square centimeters.

d is the dielectric thickness in centimeters.

CHAPTER X

Inductances

Calculation of Inductance; Construction of Helix and Oscillation Transformer; Simple Formulas for Definite Low Wave Length Sets.

Like the calculation of wave length and capacity,* the calculation of inductance is quite simple provided the following formulas are used. The answer is of course only approximately correct, but this is quite accurate and may be used directly in supplying the proper inductance in the transmitting circuit. The calculation for self inductance takes into account the magnetic circuit of the coil and the number of turns of wire in the coil. Any change in the shape or size of a coil will alter the inductance and special shapes require special formulas. The following relation holds good, however, for cylindrical coils of one layer, as helixes or choke coils, and takes into account variable factors.

$$(1) \quad \frac{(5 \times D \times 7)^2}{M + 1/3 D} = \text{inductance in centimeters.}$$

In this formula,

* Bulletin No. 74 of the Bureau of Standards may be had for 60c from the Supt. of Documents, Wash., D. C., and contains excellent radio information for the advanced reader on measurements and calculations.

oscillation transformer and since it is easier to calculate and construct, it will be described first. The arrangement and details of the helix are shown in Fig. 46. The heads may be cut out of hardwood on a bandsaw or else turned out in a lathe, and should be eight inches in diameter and preferably $\frac{3}{4}$ of an inch thick. These heads are separated at a distance of 7 inches by four evenly spaced pieces, each $\frac{3}{4}$ of an inch thick by 1 inch

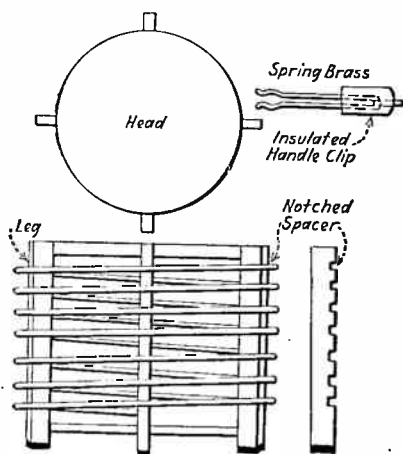

FIG. 46.—Helix or Transmitting Loading Coil.

wide by $9\frac{1}{4}$ inches long. These pieces should be smoothly finished. While the wire will stay on these pieces without artificial support, it is advisable to cut notches in these pieces to receive the wire. If possible, the outer surface of the pieces should be veneered with strips of hard rubber or fibre as extra insulation so that the wire does not make direct contact with the

wood. The separating strips are arranged as shown so that they form legs $\frac{3}{4}$ of an inch high at the bottom. The construction is quite simple, and if possible insulators should be substituted for the wood legs, in which case, the upright pieces will be made $\frac{3}{4}$ of an inch shorter. The frame may be fastened together by screws and glue and should set true. The wire used is No. 4 B&S brass, aluminum or copper, and should be purchased already coiled to approximately 9 inches in diameter or a little less. When wound, the wire will have a diameter of 10 inches and if of smaller diameter to begin with will stay tight. The wire is wound on the notches, so that the turns are spaced $\frac{3}{4}$ of an inch apart in an even winding. Seven complete turns are required so that about $19\frac{1}{2}$ feet of wire are necessary. This wire can be had at supply houses or hardware stores. The wire turns will start and end just a little less than one inch from each head, and the ends can be fastened down by large screw binding posts. The turns should be kept $\frac{3}{4}$ of an inch apart and 10 inches in diameter for the purpose of standardization. This arrangement will be most suited for the low wave lengths and will give fairly sharp tuning. If the turns are made larger in diameter, the tuning will be less definite, and if more turns are used the wave length is of course increased. However, if the inductance is made too large for the aerial, the *period* and the *radiation* are cut down. Small aerials must naturally have relatively *small helixes* to maintain the necessary balance. Flexible contacts or helix clips should be provided, as shown. Almost any desired size of inductance may be constructed along these same lines, and this standard

D is the diameter of the coil in *inches*.

T is the total number of turns of wire.

M is the length of the coil in inches.

The result is expressed in centimeters, which may be changed into microhenrys by dividing the result by 1,000.

To illustrate the use of this formula, find the inductance of a coil nine inches in diameter, 10 inches long and having 10 turns of wire.

$$\frac{(5 \times 9 \times 10)^2}{10 + \frac{1}{3} \text{ of } 9} = \frac{450^2}{13} = \frac{202,500}{13}$$

or 15,580 cm. approximately, or 15.580 microhenrys.

Another formula which may be used to find the inductance of a helix in C. G. S. units is,

$$(2) \text{ Inductance (L)} = 1 (3.1416 \text{ dn})^2 \text{ where}$$

l, is the length of the helix, d its diameter, and n the number of turns per unit length. Thus with this formula, a helix 5 cm. in diameter, 50 cm. long and having 2 turns to each cm., has an inductance of

$$50 (3.1416 \times 5 \times 2)^2 = 50,000 \text{ C. G. S.}$$

1 henry is equal to 1,000,000,000 C. G. S. electromagnetic units.

To calculate the inductance of flat or doughnut helices or coils (those having several layers wound over each other), the formula to use is,

(3)

$$\frac{(5 \times D \times T)^2}{1/3 D + 3/2 M + 5/4 N} = \text{inductance in cms.,}$$

in which

D is the average diameter of the coil in inches.

M is the length of the coil in inches.

N is the depth of the coil in inches.

T is the total number of turns of the coil.

To illustrate: Given a flat type of helix of the following dimensions, calculate the inductance. 6 turns of copper strip 1 in. apart, depth of winding 6 in. Width of strip is 1 in. and average diameter 12 inches. (Inside 6 in., outside 18 in.)

$$\frac{(5 \times 12 \times 6)^2}{4 + 1\frac{1}{2} + 7\frac{1}{2}} = \frac{(360)^2}{13} = \frac{129,600}{13} \text{ or } 9970 \text{ cm.}$$

or 9.97 microhenrys.

MUTUAL INDUCTANCE

In oscillation transformers, mutual induction must be considered. When the transformer is a long single layer coil having a lumped secondary wound about it, the formula is,

$$(4) \quad M = 4 \times 3.1416 \, nNA. \quad \text{C.G.S. units.}$$

M is the mutual inductance, n the number of turns per cm. on the primary coil, N the total number of turns on the secondary coil, and A represents the area of cross section included within the primary coil. The length is to be measured in centimeters.

1 henry is equal to 1,000,000,000 C. G. S. electromagnetic units.

1 microhenry is one millionth of a henry.

CONSTRUCTION OF A STANDARD HELIX

For small stations in locations not likely to cause interferences the helix is perhaps better suited than the

oscillation transformer and since it is easier to calculate and construct, it will be described first. The arrangement and details of the helix are shown in Fig. 46. The heads may be cut out of hardwood on a bandsaw or else turned out in a lathe, and should be eight inches in diameter and preferably $\frac{3}{4}$ of an inch thick. These heads are separated at a distance of 7 inches by four evenly spaced pieces, each $\frac{3}{4}$ of an inch thick by 1 inch

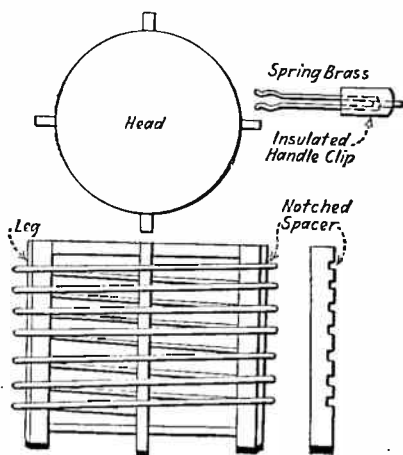

FIG. 46.—Helix or Transmitting Loading Coil.

wide by $9\frac{1}{4}$ inches long. These pieces should be smoothly finished. While the wire will stay on these pieces without artificial support, it is advisable to cut notches in these pieces to receive the wire. If possible, the outer surface of the pieces should be veneered with strips of hard rubber or fibre as extra insulation so that the wire does not make direct contact with the

wood. The separating strips are arranged as shown so that they form legs $\frac{3}{4}$ of an inch high at the bottom. The construction is quite simple, and if possible insulators should be substituted for the wood legs, in which case, the upright pieces will be made $\frac{3}{4}$ of an inch shorter. The frame may be fastened together by screws and glue and should set true. The wire used is No. 4 B&S brass, aluminum or copper, and should be purchased already coiled to approximately 9 inches in diameter or a little less. When wound, the wire will have a diameter of 10 inches and if of smaller diameter to begin with will stay tight. The wire is wound on the notches, so that the turns are spaced $\frac{3}{4}$ of an inch apart in an even winding. Seven complete turns are required so that about $19\frac{1}{2}$ feet of wire are necessary. This wire can be had at supply houses or hardware stores. The wire turns will start and end just a little less than one inch from each head, and the ends can be fastened down by large screw binding posts. The turns should be kept $\frac{3}{4}$ of an inch apart and 10 inches in diameter for the purpose of standardization. This arrangement will be most suited for the low wave lengths and will give fairly sharp tuning. If the turns are made larger in diameter, the tuning will be less definite, and if more turns are used the wave length is of course increased. However, if the inductance is made too large for the aerial, the *period* and the *radiation* are cut down. Small aerials must naturally have relatively *small helixes* to maintain the necessary balance. Flexible contacts or helix clips should be provided, as shown. Almost any desired size of inductance may be constructed along these same lines, and this standard

is recommended for stations up to 1 K. W. using the low standard wave length and located remotely from government stations.

This helix has a maximum inductance of approximately 14.28 microhenrys. One complete turn has an inductance of .291 microhenry. To find the inductance approximately for any number of turns, multiply .291 by the square of the number of turns. Thus for three turns, multiply .291 by 9, for $3\frac{1}{2}$ turns, by $12\frac{1}{4}$, and so on.

In practice, from one to three turns will be needed in the condenser circuit, according to the capacity of the condenser used, and while all of the seven turns may never be needed, the aerial circuit will generally include at least four or five turns, depending upon its dimensions.

Copper or brass ribbon or coiled strip is also suitable for helix construction.

STANDARD OSCILLATION TRANSFORMER

The type to be adopted is the flat *pancake* form. The mutual inductance is readily adjustable with this type, and every part of the inductances can be readily reached. This transformer allows of very sharp and accurate tuning and is recommended for all stations using over 100 watts of energy. It will also be useful to smaller stations. Brass ribbon $\frac{1}{2}$ inch wide is used in constructing both the primary and secondary and should be about 1-16 of an inch thick. This may be had at hardware stores. About 40 or 42 feet will be needed. Thinner ribbon may be used double or triple to make up the desired thickness.

Obtain four strips of rubber or fibre $\frac{3}{4} \times \frac{1}{2}$ by $14\frac{1}{2}$ inches long. These should be straight and smooth. Hard-

wood may be substituted. These should be joined as shown in Fig. 47, with half joints at the center to form two sets of crossed pieces. Before gluing the joints the pieces should be taken apart, marked and cut as shown. The slots are best cut with a hacksaw or band saw; each slot being 1-16 of an inch wide and 3-8 of an inch deep. The slots are placed exactly $\frac{1}{2}$ in. apart and begin $\frac{1}{4}$ of an inch from the end. Mark numbers 1 to 4 on the ends

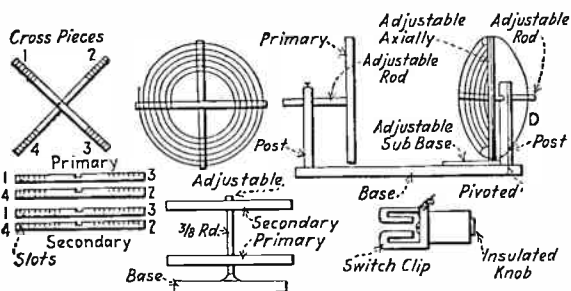

FIG. 47.—Oscillation Transformer.

of the strips as shown in the figure so that when the two pieces are put together again the outside ends will be in order.

The slots are laid off beginning from the outside so that each slot is one-eighth of an inch closer to the center than the one before, the slots thus forming a spiral when the pieces are placed together. Proceed the same for both sets of cross pieces, except that slots for five turns are provided for the set which is to support the primary while the other set is slotted for nine turns, thus coming nearer the center. After the slotting is done, fasten the pieces at the joints and bore a hole three-eighths of an

inch in diameter through each set exactly at the center.

Now fasten the two cross pieces down in a convenient place by means of one or two screws at the center hole and wind the ribbon in the slots. The ribbon should be either pressed or driven into the slots with a mallet. It is a good plan to begin at the inside to do this, taking care to make the curve of the spiral as uniform as possible. Both forms should be wound in this manner, the ends of the ribbon being cut and smoothed off. The projecting ends should be sent slightly away from the adjacent turn of the ribbon. The ribbon should fit snugly in the slots so that it will stay in place indefinitely. The curve of the ribbon should not be too sharp at the support points, but should form a gradual symmetrical spiral. The completed coils may be mounted in a number of ways, suitable supports being shown at (c) and (d) of the figure. In the latter case, the primary is movable axially as well as longitudinally with respect to the secondary, this radial effect being useful in tuning very sharply. The details of mounting may be varied to suit the individual case, a threaded metallic rod, three-eighths of an inch through which the cross arms may pass and be fastened at an adjustable distance being suitable. The clip shown in the figure is made from an old 10 or 15 ampere switch contact. An electrose or hard rubber handle is screwed on its base end. Four of these should be used, two each for the two coils. Similar pieces may be easily made for the clips if an old switch is not obtainable, almost any piece which will make good contact with the ribbon being suitable.

The inductance of the primary may be calculated ap-

proximately for each turn, beginning with the center by using formula (3), taking first one turn, then the first two, then the first three, as though they were independent coils. Or if the inductance of each turn beginning with the outside is desired, a similar method may be employed. The inductance for the several turns is not constant on account of the difference in diameter between each turn. The values for the turns, beginning with the outside turn, are approximately:

First turn, .868 microhenry.

Two turns, 3.96 microhenrys.

Three turns, 5.7 microhenrys.

Four turns, 10.245 microhenrys.

Five turns (maximum inductance), 13.5 microhenrys.

When the coils are mounted to form a radial transformer, the secondary should not be turned out of a parallel plane unless very *sharp* tuning is required. The tuning is sharper, within limits, the greater the distance between the two coils, but for ordinary purposes they should not be too far apart because the *intensity* of the transmitted signal is considerably less with a very loose coupling.

The secondary inductance may be similarly calculated, although this is not necessary, since after the primary or condenser circuit is tuned to a desired wave length, the antenna circuit can be brought into resonance with it by connecting a number of turns in the aerial circuit which experiment shows to be right.

A LOADING COIL

A loading coil for the purpose of securing a high wave

length for experimental purposes may be constructed like a helix and inserted in series with the aerial circuit, as has already been explained. This loading coil need not have quite as large wire as the sending helix, although this size is a desirable standard in order to avoid undue resistance. No. 8 is a common size for this purpose. The loading must not be carried out too far with a given aerial, for after the ohmic *resistance* exceeds the square root of four times the inductance in henries, divided by the capacity in microfarads, the *oscillations* cannot take place. Any resistance impedes the oscillations considerably. If the long wave lengths are desired, a large aerial capacity must therefore be provided to begin with, if efficiency is desired. A small aerial, however, may be loaded for experiments.

Almost any circular coil of wire can be made to serve as a helix or loading coil as a makeshift arrangement, but the reader is advised to adopt standardized instruments to make definite wave lengths, capacities, inductances, and adjustments possible. Sharp, scientific tuning can be attained in practically no other way. The best is not much harder to make than the other kinds and is well worth the time taken.

CHAPTER XI

Spark Gaps

Purpose of Gap; Materials Suitable; Series Gap; Rotary Gap; Construction of Rotary Gap; Rotary Quenched Gap; Rotary Gap Circuits; Chaffee Gap; Two Tone Gap.

A spark gap is inserted in the condenser circuit to allow the condenser to be discharged through it until the oscillations die out, and also to prevent the condenser from discharging until it is fully and properly charged. A spark gap, then, should be a good *insulator* while the condenser is charging and a good *conductor* while it is discharging. Now the resistance of the spark gap is one of the main factors which determine the damping of the oscillations, and unless properly constructed, considerable energy is wasted as heat in this part of the condenser circuit. The use of the proper amount of capacity in the condenser aids materially in keeping the length of the gap within efficient limits. Too long a gap causes an irregular stringy spark while too short a gap for the given condenser causes a wasteful arc to form in the gap. The gap should, therefore, be of adjustable length, able to conduct the energy without undue heating, and to make

and break as an insulator and conductor with rapidity. A poorly constructed or poorly adjusted gap can cut down the efficiency of transmission materially. Three types of gaps suitable for experiments are to be described, a common gap for small stations, a series gap for somewhat larger stations, and a rotary gap. The quenched spark system will be discussed in a later chapter.

A *simple gap* is shown in Fig. 48. The electrodes may be mounted in almost any suitable manner, care being taken to keep the two parts well insulated from each

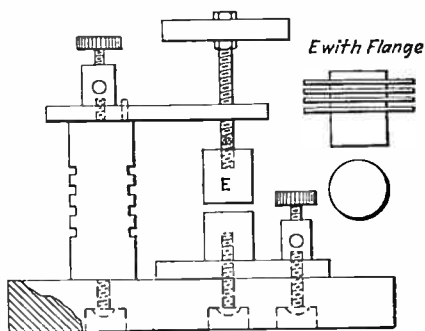

FIG. 48.—Spark Gap.

other and from other bodies. Either a vertical or horizontal mounting can be used and if desired, only one of the electrodes need be adjustable. The construction is quite simple and further comment seems unnecessary. The insulation used is preferably hard rubber throughout, though other materials may be substituted. The parts are preferably made of brass and the electrodes from

zinc or an alloy of zinc with 2 per cent aluminum.* These electrodes should be made removable, as they pit after a time, and should be perfectly true. It is well to purchase these parts or have them made by a machinist, if no lathe is available. The electrodes should have plenty of surface, a diameter of $\frac{1}{4}$ inch for every hundred watts being suitable. If this type of gap is used with large power, *metallic radiating flanges* should be provided to take care of the heat. The handle should be well insu-

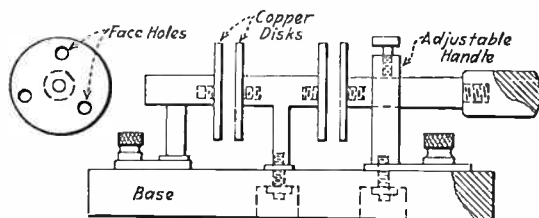

FIG. 49.—Series Gap.

lated so that the adjustment can be made while the coil or transformer is in operation. This form of gap can easily be muffled by placing a large glass jar over it, thus excluding the noise, or can be cooled by allowing a small fan to blow on to it, if desired.

A *series gap* is shown in Fig. 49, which gives a smooth spark with many desirable features. It can readily be constructed in a desired size by referring to the figure. Too much care cannot be taken to insulate the electrodes well, and to provide large, true surfaces on the gap electrodes. While only a single dead electrode is shown in the figure, two or more dead electrodes may be used if

* Tungsten metal can also be used if obtainable.

the sending coil or transformer is large. The electrode faces are made preferably of copper sheet, with *perforations* as shown to prevent uneven wear and made detachable as shown so that they can be cleaned or renewed. This type of gap has a large cooling surface and is to be commended for experimental use. The relative dis-

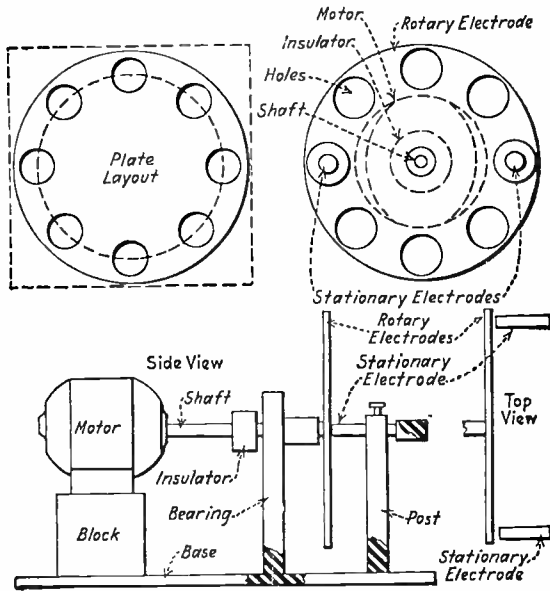

FIG. 50.—Rotary Gap.

tances of the electrodes should be adjustable, but each part of the gap should be of uniform length. The total length of all the gaps should be about the same as would be used in a single gap.

The *rotary spark gap* is perhaps the most desirable of all the open discharge gaps and should be adopted

whenever possible. Its advantages are many, among which may be mentioned its high spark frequency, (the discharge spark is broken up into a series of uniform sparks, which increase the effective transmission range), the well cooled electrodes and the uniform sparks. There are many types and constructions for rotary gaps and while some of these are quite complicated, the reader will have little difficulty in constructing an efficient inexpensive gap. A suitable construction is shown in Fig. 50. Other designs are also suitable. While numerous variations may be used, this form will prove satisfactory. The revolving electrode as well as the stationary electrodes should be thoroughly insulated from each other and foreign bodies. The revolving electrode should be insulated from the drive shaft or motor. This is best accomplished by using a three-eighths inch shaft and bearing for the revolving electrode and making connection with the motor shaft by an insulated coupling, such as is used in electric light fixtures. These couplings may be had for a few cents. Another simple method is to use quite a long belt between the motor and a pulley on the rotary electrode shaft. The motor used may be an ordinary small battery motor or a small synchronous motor, preferably the latter. Fan motors are desirable for this purpose and the power need not be large, since the rotary electrode offers very little if any greater resistance to the power than a small fan. The stationary electrodes need no further comment and may be constructed with perforated surfaces to make them wear out evenly, as has been described for the series gap. This perforated feature may also be embodied in the rotary electrode.

The rotary electrode is preferably made out of thick sheet aluminum, one fourth of an inch being a suitable thickness. The size of the rotary electrode can be from four to ten or more inches in diameter, depending on the power to be used. An eight inch rotary electrode is a convenient size and may be used for stations up to $\frac{3}{4}$ K. W. or more. To make this electrode, proceed as follows:

CONSTRUCTION OF A ROTARY PLATE

Find the center of a square sheet a trifle larger than the desired diameter and with it as a radius draw three circles. The outside circle will be for the finished diameter of the electrode, or eight inches in this case. The next circle will be a distance nearer the center, depending on the size of the electrode. In this case a circle with a three inch radius will be used. The inner circle will be the size of the shaft used, or three-eighths of an inch in this case. Now the circle on the three inch radius is divided into eight parts by means of dividers, and these points are prick punched. Eight holes, each $1\frac{1}{2}$ inch in diameter, are to be drilled at these points, either before or after the plate is turned down to the outside diameter. This size of hole leaves sufficient surface to care for power up to three-fourths of a kilowatt. The aluminum plate should be placed in a lathe and the shaft hole drilled out. The outside diameter should also be turned out. Aluminum should be worked slowly. Use plenty of kerosene oil. In drilling the holes, care should be taken to drill them true. It is advisable to trim the outer diam-

eter after the plate has been placed on a mandril. The simple bearings and mountings need no further comment. The stationary electrodes should have a face diameter of five-eighths of an inch each, and should be mounted so that they are at the center of the electrode holes when at that position. The electrode should be mounted so that its face runs without wobbling. If a lathe is not available, a machinist can be found to do the work for you, or a good saw and filing operation will suffice. The rotating electrode should be mounted in firm bearings to avoid undesirable vibration.

Note.—The drawing is not to scale. The extra bearing can be dispensed with and the rotary electrode connected direct to the motor shaft, using an insulated coupling as a connector. In the rotary gap the sparking distance is best when it is relatively short. If this is not maintained as a short space, it will be necessary to use *less* capacity in the transmitting condenser. This last is not desirable, since the capacity in small stations is seldom any too large. Rotary gaps have a further advantage in that they care for heavy discharges without heating. *Synchronous* gaps are those rotated by means of a synchronous motor or else attached directly to the generator shaft so that sparks occur in accordance with the alternations of the supply current. Pure tones are produced in this manner. This is not always possible when the gap is not driven synchronously. With small aerials, the rotary gap allows larger quantities of energy to charge the antenna circuit.

The rotating electrode should be revolved at a high rate of speed, that resulting from a direct connection

to a synchronous motor being suitable. The gap need only be rotated when in use, and may be stopped, while receiving, if desired.

A makeshift rotary gap can be made by driving evenly spaced brass headed tacks or screws into a wood disk mounted on a shaft and used as the gap just described. Just before the tacks are driven down, a twisted wire should be run between them for a continuous connection. This gap is not recommended for other than very small outfits, and then only as an experiment. The reader can doubtless make a more substantial modification along the same lines. A good rotary disk can be made by fitting silver plated round plugs into a hard rubber or Bakelite disk $\frac{1}{4}$ inch thick. This disk is then rotated between two stationary electrodes.

GAPS, IN GENERAL

The surface of the electrodes should always be kept clean and bright. Emery cloth is useful for this purpose, but after the faces have become worn and pitted, new electrodes should be used. Many makeshift gaps are easily arranged for emergency or experimental purposes. Thus ordinary nails, dry battery zincs, brass pipes, and other similar metallic pieces can be mounted and used. Common porcelain insulators may be used for insulating standards. However, the reader is advised to make a substantial efficient gap, whenever possible. Silver makes one of the best sparking surfaces.

It is interesting from the experimental standpoint to enclose a spark gap, preferably one of the series type, in

an air tight container provided with an ordinary bicycle valve. Compressed air from a tire pump or carbon dioxide from a Presto tube can then be used to increase the number of molecules present between the electrodes, and under certain conditions surprisingly good results may be obtained.

The reason why a high spark rate is desirable is that it can be distinguished and read better than the ordinary discharge, and that the individual discharges have an additive effect in the receiver, building up a charge which results in a good signal. An ordinary discharge does not have this building effect upon the receiver, because the initial impulse is the actuating force. The subsequent impulses resulting from the charge, die out rapidly without materially affecting the receiving signal. All the commercial spark stations have adopted a high spark rate in one form or another, the rotary gap being quite generally used. A rotary quenched gap consists of two aluminum disks, one rotated and the other stationary, both being segmented into evenly spaced series of electrodes by means of slots milled therein. They are used with a short gap and are enclosed in an airtight case.

ROTARY GAP CIRCUITS

Fig. 51 shows an ordinary double gap circuit, the motor is kept running during the sending only, but is not stopped between signals. Fig. 52 shows a rotary gap formed by rapidly bringing a series of insulated electrodes A between two gaps B and C as shown. This is a good series gap circuit.

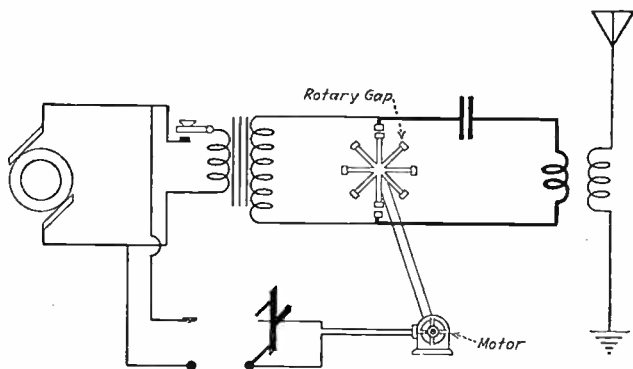

FIG. 51.—A Rotary Gap Transmitting Circuit.

THE CHAFFEE GAP

Fig. 53 illustrates the gap and circuit of a set which is quite successful for small power output. The gap is between copper and aluminum electrodes in an atmosphere of hydrogen or alcohol vapor. A direct current supply is best and the primary circuit should be tuned

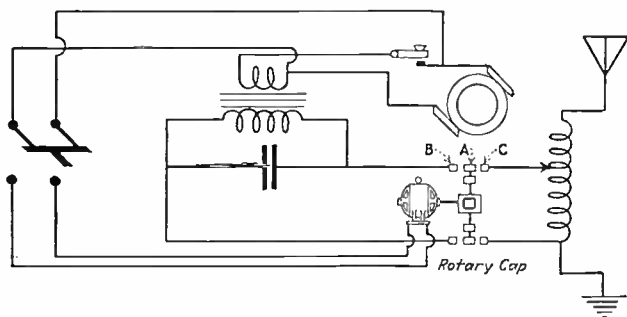

FIG. 52.—Another Rotary Gap Transmitter.

to a wave length 1.7 times the natural wave length of the antenna for maximum results. A tone circuit consisting of an iron core reactance coil in series with a condenser which is shunted by the transmitting key gives a musical note to the transmitted impulses. This type

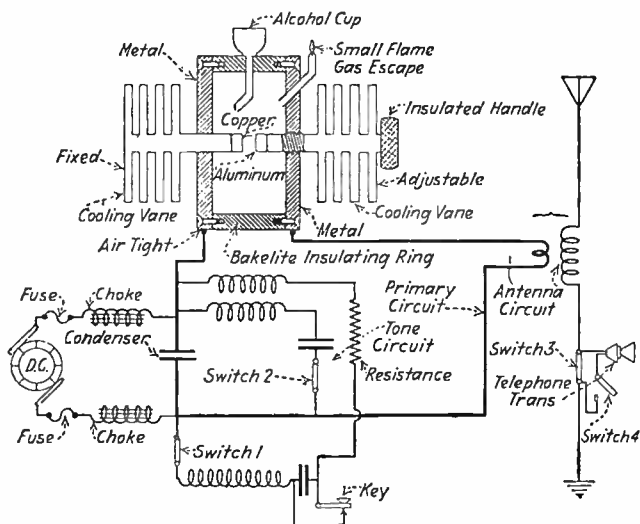

FIG. 53.—Chaffee Gap.

of gap can be used on alternating current supply also for experimental purposes. With direct current excitation the gap gives nearly continuous oscillations so that by opening tone circuit switches 1 and 2 and switch 3, the telephone transmitter can be switched in the antenna circuit by closing switch 4 to afford an experimental radio-telephone transmitter.

SIMULTANEOUS CHANGE OF WAVE LENGTH AND AUDIBLE GROUP FREQUENCY

Fig. 54 shows how a rotary quenched gap can be arranged with special circuit so that signals can be sent by dots entirely, one dot at a different wave length and

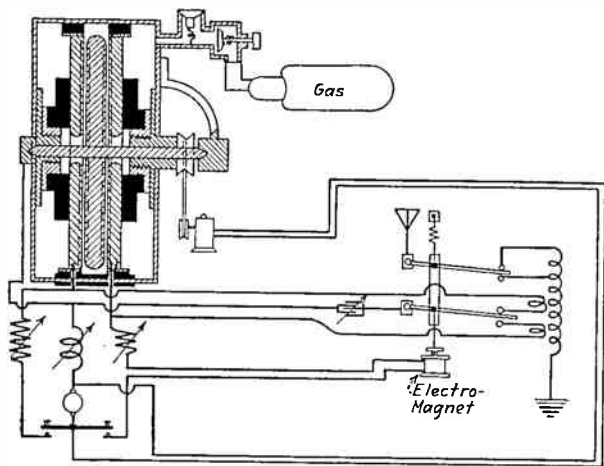

FIG. 54.—Edelman All Dot, Two Tone, Two Wave Transmitter.

tone than the other, taking place of the usual dash at a saving of time. This method is also valuable in working through interferences. U. S. Patent 1214022.

CHAPTER XII

Radiation Indicators and Measurements

Use of Radiation Indicators; Hot Wire Ammeter Construction; Wave Meter; Use of Hot Wire Ammeter; Shunt Resonator; Cost of Transmitter Complete; Frequency; Decrement; Logarithmic Decrement Illustrated; Electron Tubes for Measurements; Audion Connected to Wave Meter.

A radiation indicator is a device which indicates when the aerial is radiating the maximum amount of energy. It is essential to accurate effective wireless work, and is used to indicate when the circuits are in *resonance*. There are two types to be described here. The first, the *hot wire ammeter*, is recommended. The *shunt resonator* is perhaps a little easier to construct, but is less reliable to use. In addition to the methods described, there is an instrument called a *wave meter*, which, while readily constructed, (it is a simple condenser and inductance of known dimensions), is unsuited to experimental use unless accurately calibrated. While this can be approximated by calculations, this method is tedious and unreliable. However, if a calibrated wave meter can be had for comparison, the reader is advised to construct a wave

meter and calibrate it by comparison with the known standard, which is very simple. It may be remarked that almost any form of variable condenser can be used for the capacity and that a few turns of bell wire wound on a form about nine inches in diameter will do for the inductance. A telephone receiver and a detector serve to indicate well enough for experimental purposes.* In practice this instrument is placed so that the inductance is in a parallel plane to the sending helix or oscillation

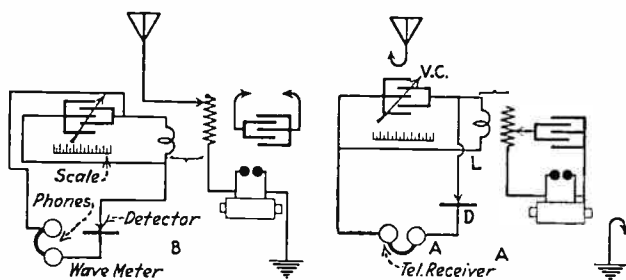

FIG. 55.—Illustrating Use of Wavemeter.

transformer. (See Fig. 55.) It should not be placed too near, however, a distance of a few feet being desirable. Now, to find the primary wave length with this device, the arrangement is as shown at (A) with the aerial and ground out of the circuit. The capacity of the wave meter is varied until the telephone receiver indicates a maximum point. The wave length of the circuit meas-

* A calibrated resistance (as described on p. 180) may be used about the telephone receiver of the wave meter, and will materially aid accurate work. A wave meter can be used to calibrate a receiving set also. For measurements see reference—Bulletin 74, U. S. Bureau of Standards.

ured is then very nearly the same as that indicated by the calibrated wave meter. The operation is essentially a comparison of a known wave length with an unknown one. The readings should be taken with different turns of the helix in the primary circuit until the wave length for the different amounts of inductance is ascertained. The wave length for the aerial circuit is obtained in the same way, the condenser being disconnected as shown at (B). The wave length using different amounts of inductance in the antenna circuit is then determined. In practice the two circuits are connected, so that both the aerial and condenser circuits are at the same wave length. Thus if the condenser circuit gives a wave length of 200 meters with one turn of the helix and the aerial circuit gives a wave length of 200 meters by itself when $4\frac{1}{2}$ turns are in circuit, the connections should be made in this ratio. If the primary wave length is increased or decreased, the secondary or antenna wave length must be changed accordingly. The reader is advised to purchase a wave meter for measurements. Directions for use should accompany the instrument.

In military and some commercial sets a mechanical switch makes the correct adjustments in the primary and secondary circuit for a calibrated set of wave lengths.

The *hot wire ammeter* is used in a somewhat different manner. The indicator of the meter is operated by the expansion and contraction of a fine wire according to the strength of the *oscillatory* current which passes through it, a maximum current causing a maximum deflection of the pointer. This meter is connected in the ground conductor directly in circuit with a shunt switch

(SW) which is opened when a reading is to be taken. After the adjustments have been made, it is preferably *short circuited* or removed as its *resistance* impedes the oscillations to some extent. The connections are shown in Fig. 56. Now, since with a standard experimental outfit, the primary or condenser circuit is to operate at a wave length of 200 meters, and the proper relations are found by calculation, the hot wire *meter will be used* to bring the secondary or antenna circuit into resonance

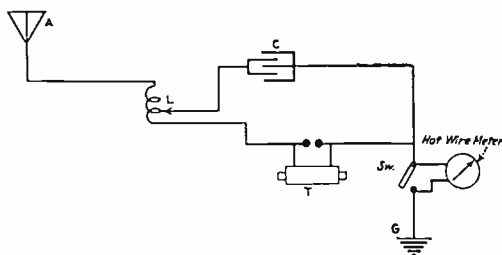

FIG. 56.—Hot Wire Meter.

with the primary circuit, and also to indicate the proper adjustment for the spark gap. To operate, connect the hot wire meter in the aerial or ground lead, and close the primary current. The condenser and inductance of the primary circuit are left so that they form a circuit having a wave length of 200 meters according to the calculations, and the aerial helix clip is placed at some arbitrary point on the helix. The deflection of the meter should be noted. Different amounts of the helix* are then con-

* If an oscillation transformer is used the operation is similar, both primary and secondary, also the coupling between them being adjusted.

nected in the aerial circuit until a maximum deflection is obtained, indicating that the circuits are in resonance or nearly so. For a wave length of two hundred meters, the contact points should always remain at this point and the capacity in the condenser circuit should not be changed. If the primary condenser is made larger or smaller, the whole tuning operation will have to be repeated again. Now leaving the rest of the circuits fixed, adjust the length of the spark gap until the meter indicates a maximum deflection. With this done, the station is reasonably sure to be well tuned. If there are no other troubles, such as leaks, short circuits, or brush discharges, the station is sure to radiate efficiently at the given wave length. Increased or decreased wave lengths may be obtained by changing the amount of the primary inductance, re-calculating the primary wave length with the new amount of inductance, and repeating the tuning operation with the wire meter until the secondary circuit is again in resonance. The spark gap need not be changed unless the capacity is varied, which is not recommended after the proper relations of the circuit are once found. Experiment will doubtless show that there is one wave length or range of wave lengths which will produce a greater deflection of the meter than the others at resonance and if this does not exceed 200 meters it may be used, though the adjustment which gives a wave length of 200 meters or very nearly 200 meters, with a maximum deflection at that point, is to be preferred. When a loading coil is used for long wave lengths a similar plan is used, the loading coil being regarded as an extension to the secondary inductance. When an oscillation

transformer is used, vary the distance between the coils to find the best coupling.

CONSTRUCTION OF A HOT WIRE AMMETER

A hot wire meter need not be a complicated piece of apparatus, since essentially it comprises a mechanical movement which will indicate the contraction and expansion of a fine wire through which the oscillatory current passes. The sensitive part, then, is the bearing and arrangement of the movement. The balance wheel of an old alarm clock is suitable for this purpose.

In taking the balance wheel and hair spring out of the old clock, leave enough of the framework to hold it together. This is all that is wanted from the clock and the remainder of the frame should be cut away with some heavy tin shears. It is well to clean and oil the bearing.

Mount the balance wheel with its bearings in a wooden frame, 8 inches long, 5 inches high and $2\frac{1}{2}$ inches deep as shown in the Figure 57. The frame should be neatly and strongly made. The balance wheel should be mounted at the center of the bottom piece.

Put the balance wheel spring into tension by rotating the wheel a few turns.

Obtain a short piece of silk thread (size A or O is suitable), and after fastening it to the balance wheel, wind it five times around the axle of the wheel. The winding should be arranged so that the pull of the spring under tension is checked by holding the thread. That is, the thread should be wound in a direction which will maintain the tension of the wound up spring.

The hot wire itself is made from a small piece of No. 36 B&S bare platinum, resistance, or copper wire, preferred in the order named. Nichrome or climax resistance wire serves very well for experimental purposes and copper wire will do. Stretch this wire between the two binding posts P and P', so that it is in a plane above the point where the silk thread is wound on the axle. This will be clear from the illustrations. Either P or P' should be made adjustable so that the tension of the wire

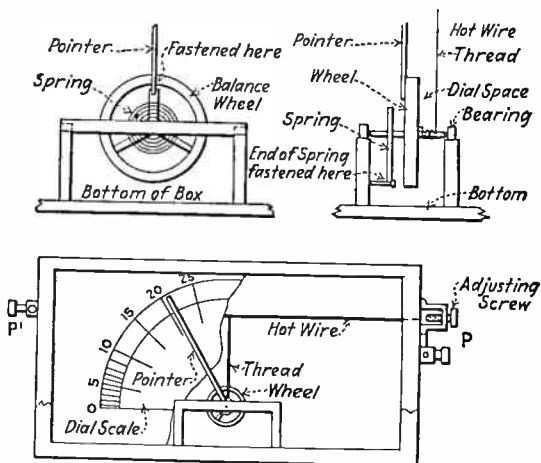

FIG. 57.—Construction of Hot Wire Meter.

can be adjusted. This adjustment is necessary to counteract the natural expansion or contraction of the wire under varying weather conditions.

The pointer can be made either from a thin piece of aluminum sheet or a small piece of wood. This pointer

should be made very light and is made $3\frac{1}{2}$ inches long. If this pointer is painted black the readings will be facilitated.

To fasten the pointer, pull the thread so that the spring is under tension and fasten one end of the pointer to one of the spokes of the balance wheel by means of a piece of No. 36 wire or of the silk thread left from the other parts. A drop of hot wax or glue will serve to make the joint rigid. When fastened, the pointer should be in line with the center of the wheel.

The dial can be made on a piece of stiff paper and should be placed close to the back of the pointer so that it does not interfere with its movement. The divisions on the scale may be any desired number and are used only for comparative readings. Commercial instruments are generally calibrated direct in amperes or parts of an ampere, but for ordinary experimental purposes, comparative readings are all that are necessary. The dial should be of a size which will co-operate with the pointer and should be placed so that its center point is directly above the center of the balance wheel.

In putting the parts together, place the scale in position first, and tie the silk thread to the No. 36 wire at its middle point so that the pointer is moved to the 0 point of the scale. A glass cover and a suitable back can then be provided, making a neat instrument. This meter will give comparatively large readings for small stations, and if large power is used the fine wire should be shunted with a coil of No. 26 or 28 copper wire. This coil can be wound on a pencil and the amount of wire needed must be found by experiment. If this shunt is not

provided, large coils or transformers will burn the fine wire out. A good plan is to start with only one or two turns in shunt and if the meter is not operated, add more turns until the proper amount is found. Part of the current goes through the shunt so that the fine wire is not overloaded.

When an oscillatory current passes from P to P₁ the fine wire is heated and in expanding it leaves a slack in the silk thread which is taken up by the tension of the spring.

This causes the axle to wind up so that the balance wheel and pointer move. On account of the small diameter of the axle and the large leverage of the pointer, a very small movement of the thread makes a large movement of the pointer. When the wire is cooled, it contracts again and draws the pointer back to zero. It will always return to zero when the wire cools again, and if it does not on account of weather conditions, the wire may be adjusted by either P or P₁ (made adjustable) so that it does.

The dimensions given need not necessarily be adhered to as long as the general principle is recognized and used. By using the balance wheel and hair spring of a watch with its delicate bearings, a much smaller and sensitive instrument can be made. In this case, a finer wire should be used, No. 40 being suitable for an ordinary watch spring. The remainder of the instrument should be correspondingly small, particular care being taken with the pointer.

The success of this instrument depends largely on the care taken in its construction, and though very simple,

it should be regarded as a delicate instrument. The casing may be made round or any other shape and can be of metal if the parts are well insulated from each other and the metal.

The hot wire ammeter is very desirable because it indicates the maximum radiation better than any other simple apparatus. While the wave meter does this to a certain extent, its use is limited to the actual measurement of wave lengths and is not very useful in determining the maximum radiation.

CONSTRUCTION OF A SHUNT RESONATOR

This arrangement acts as a *radiation indicator* and serves the same purpose as the hot wire meter except that it is less delicate and sensitive in its indications. It has the advantage of not interfering with the oscillations and can be left in circuit continually. The arrangement is shown in Fig. 58. The coil is constructed like a helix, about a dozen turns of No. 8 wire wound on a form three inches in diameter and spaced one-fourth inch apart, with a movable contact, being suitable. The lamp used is a small four or six volt carbon filament bulb, and may be had at any supply house. Whenever the transmitter is in operation the lamp lights up.

The coil is connected as shown in shunt around six or more feet of the ground wire, the proper amount to be determined by experiment. Only a part of the high frequency current is passed through the coil by this arrangement so that the resistance of the ground wire is not increased. It is really decreased to some extent. The

effect is probably due to the resonant relation of the coil and the section of the ground wire.

To find the maximum radiation at a desired wave length, place the slider of the indicator coil so that all the turns are in circuit and adjust the antenna circuit until the lamp lights up the brightest. Now decrease the number of turns on the indicator coil, thus decreasing the brilliancy of the lamp, and adjust the transmitting circuits again. Continue this process until the lamp lights up brilliantly with the least possible number of turns of the indicator coil connected in circuit. The transmitting

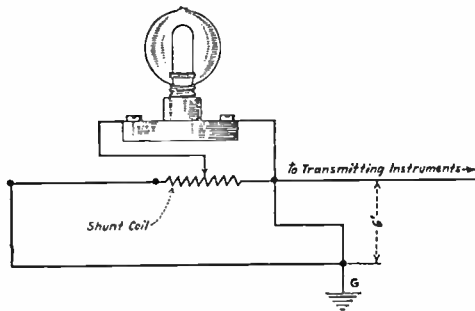

FIG. 58.—Shunt Resonator to Indicate Radiation.

station will then have a maximum radiation for a given wave length. A similar arrangement can doubtless be used by substituting a hot wire meter for the lamp, in which case, the radiation can be read directly. This is likely to be hard on the meter, however.

We have now considered the transmitter and its several details in some degree of thoroughness, paying particular attention to the resonant relations of the circuits

and the design of standardized instruments. It is well to again remind, that all of the circuits should be well connected, contact points clean and of even surface, spark gaps clean and properly adjusted, and everything arranged in as workmanlike a manner as possible.

A word as to *cost*. The cost of a station depends largely on the individual. Some experimenters are able to construct and operate efficient sets which cost only a few dollars, while other less experienced or less fortunate workers may spend many times as much without better or even as good results. A good 250 watt station to operate at a wave length of 200 meters can be constructed at an average cost of about \$30 for the transmitter, though the actual figures may be considerable more or less in each case, according to the circumstances involved. This figure does not consider the item of labor, transportation charges and many other variable factors, and indicates little more than the cost of the materials used. While larger stations (larger power) do not necessarily follow in the same ratio, the expense may be taken roughly as an additional \$20 for every 150 additional watts. This amount is not to be taken as fixed or even accurate, as there are so many variable factors concerned. As an example, the hot wire meter described in this chapter will be made by many readers at a total expense of less than 25c, while others will doubtless spend up to a few dollars in its construction. In general, then, it is well to make the several parts as substantial and neat as possible without an excessive expenditure. After all, the "Works are more important than the looks," though good appearance is also desirable.

Receiving stations can be made at a cost of perhaps 75c or up to as much as you wish. Designs for receiving apparatus will be found in later chapters.

The need of thorough *insulation* throughout is perhaps most important of all and all insulation should be quite *thick* in order to avoid the *dielectric* effect. In wireless transmission, a great deal of energy may pass through an insulator to a foreign body on account of the capacity which is formed. Thick insulation cuts down the capacity and consequently avoids this effect. With resonant, well adjusted circuits and a well insulated aerial, very good results may be expected. In fact with these precautions observed better results may often be had from a small outfit than from a much larger outfit in which the several points are not well carried out.

ACCURATE MEASUREMENTS—FREQUENCY

Although many who read this volume are not directly concerned with accurate measurements in radio work it seems well to mention that one can determine a wealth of facts by using the wavemeter, the hot wire ammeter, or both. Knowing the wave length for instance one can immediately determine the frequency of the oscillations in the aerial. Thus *frequency* equals 1,000 million divided by *wave-length in feet*. A wave length of 10,000 feet (nearly two miles) for example means that the frequency is only 100,000 and it is evident that lower wave-lengths mean, under like conditions, higher frequencies. Other quantities such for instance as the decrement can also be obtained with accuracy and facility. For com-

plete information on radio measurements see the Bureau of Standards Bulletin No. 74.

DECREMENT

Logarithmic decrement means the logarithm to the base 2.17828 of two successive maxima of the wave ampli-

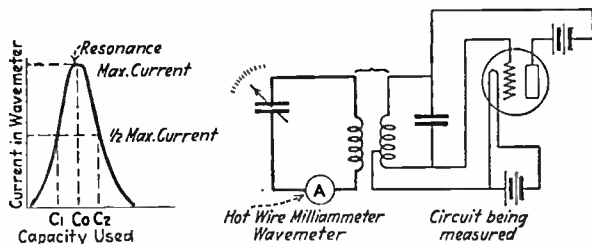

FIG. 59.—Measurement of Decrement.

tudes in a wave train taken in the same direction. Thus, Figure 60.

$$d = \log \frac{A}{B} \cdot *$$

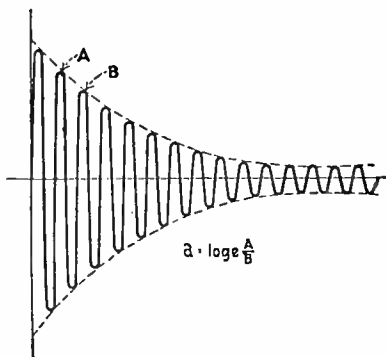

FIG. 60.—A Wave Train Illustrating Logarithmic Decrement.

* Standard American Practice.

Expressed in terms of resistance, inductance and capacity of the circuit concerned

$$d = \pi R \sqrt{\frac{C}{L}}.$$

In the case illustrated there will be 23 oscillations in the wave train before the amplitude dies down to one per cent of its starting value.

MEASUREMENT OF DECUREMENT

Decrement is best measured by a special decrometer but may be determined as follows: Figure 59 shows a resonance curve plotted by reading the current in the wave meter with a hot wire ammeter (or thermo-junction galvanometer method). When the wave meter is at the same frequency adjustment as the transmitter the resonance peak occurs. The decrements of the transmitting and of the wave meter circuits, d_1 , d_2 , determines the sharpness of this peak portion of the curve. The capacity of the wave meter condenser is noted at the point of resonance and called C_0 . The capacity is then both increased and decreased therefrom to get the two values C_1 , C_2 at which the wave meter responds with a current induced into it equal to one-half of the maximum current value. If the decrement d_1 of the wave meter itself is known, the decrement of the circuit being measured is, closely,

$$d_2 = \pi \left(\frac{C_0 - C_1}{C_0} \right) - d$$

or roughly, when d is very small

$$d_2 = \pi \left(\frac{C_0 - C_1}{C_0} \right)$$

The Kolster decrometer is a specially constructed wave meter, having logarithmic condenser plates, which reads this value directly. Its condenser is varied until I max. is ob-

tained, then varied to the value C . The gears of an auxiliary scale give d_1 and d_2 and are meshed to the condenser handle so that when a pointer is set at zero and the condenser is rotated to give the value C_2 , the decrement d_1 is indicated directly.

ELECTRON TUBES FOR MEASUREMENTS

Electron tube generators afford controllable constant intensity and frequency sources very valuable for measurement purposes. 5 to 500 watts output at 2 to 50,000,000 cycles per second can be had. Full information for such technical measurements may be found in Bulletin 74 of the Bureau of Standards.

SIMPLE MEASUREMENTS WITH AUDION GENERATOR CONNECTED TO WAVE METER

Fig. 61 shows a very convenient form of wave meter having its own tube oscillator. A detector bulb may be

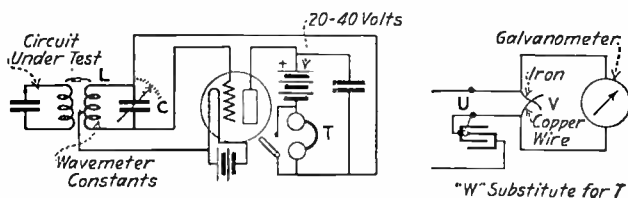

FIG. 61.—Self-Oscillating Wavemeter.

used. The circuit L, C gives the wave length and a scale on the variable condenser handle can be calibrated directly in meters. This device can be used as a buzzer

test, as the local oscillator in a heterodyne receiving circuit, or as the secondary of a complete autodyne (self heterodyne) receiving set. Two such wave meters can be readily calibrated against each other if one is already calibrated as beats there between when both are operated cease when the wave lengths are exactly equal. Also, as in the case shown, any unknown circuit of inductive capacity can be calibrated directly by closely coupling the wave meter inductance L to it. As the handle of C is moved a sharp transfer of energy between the two circuits occurs at resonance and this "burr-up-click" is heard in the telephones T so that it is easy to ascertain the wave length directly with sufficient accuracy for most purposes. The improvised thermo couple V consisting of two twisted iron and copper wires can be used with an inexpensive galvanometer of the torsion type in series with the condenser W to give quantitative indications of resonance. The high frequency oscillations heat the thermo-couple (or a crystal detector substituted therefore) and generate a direct current which operates the galvanometer. Close coupling produces a remarkable effect and, relatively, loose coupling is necessary for accurate resonance indications. The effect of coupling changes at Z can be studied in this manner.

CHAPTER XIII

Advanced Systems

Continuous Waves; Wireless Telephone; Quenched Spark; High Frequency Alternators; Demonstration of Arc Radiotelephone; Poulsen Arc; Construction of Quenched Gap; Lepel Gap; Advantage of Quenched Gaps; Wireless Piano; Goldschmidt Alternator; Alexanderson Alternator; Magnetic Modulator; Static Transformer Frequency Multiplier; Onde Unique System; Vacuum Tube Methods; Duplex High Speed Operation; Wave Changing Systems.

The more advanced methods of wireless communication utilize continuous waves, produced either by an arc, quenched spark, or direct high frequency generator. Inasmuch as these methods are quite likely to be developed into the ultimate perfected wireless system, some consideration of the theory together with experimental operation is worthy of attention.

A simple system that may be used for telegraphy or telephony is shown in Fig. 62. This arrangement will only operate on direct current of 220 volts or more. The power supply should be capable of furnishing a uniform current of 10 amperes. The arc light may be an ordinary arc, but the lower electrode is preferably made of brass

or copper and water cooled. This water cooled electrode may easily be made from a plumber's T connection, using a brass plug for the electrode end. Rubber tubing can be used to connect the T to a water supply. The arrows indicate the flow. The aerial, ground and oscillation transformer may be the same as for the spark system already described. The condenser should be variable, as the exact amount of capacity must be found by experiment. A hot wire meter in the aerial can be used to indicate the correct adjustment of the circuits. The impedance coil is made by forming an iron core $1\frac{1}{2}$ in.

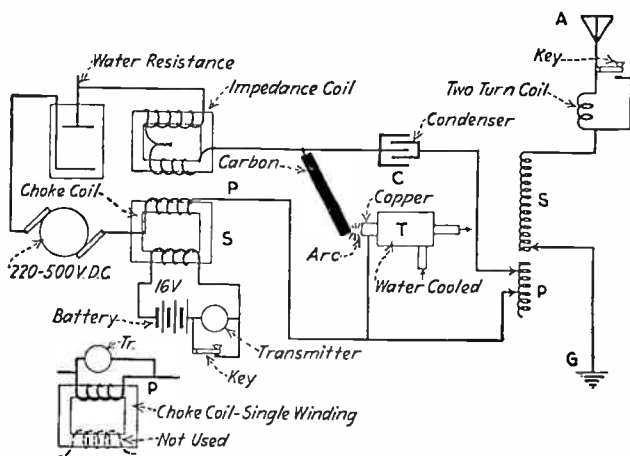

FIG. 62.—Demonstration Set for Arc Wireless Telephone.

square and 5x8 in. outside dimensions, as for a transformer, winding about four pounds of No. 12 D. C. C. wire on the long legs. The purpose of the impedance coil is to prevent the oscillations from surging back into

the generator. The choke coil is made similar to the impedance coil, except that only two pounds of wire are used and wound on one leg. If desired, a secondary can be wound on the other leg. (See chapter on transformers.) A resistance for the arc should also be provided. This may be made by placing two electrodes an adjustable distance apart in a solution of salt and water. A transmitter or a key can be shunted around the choke coil, according to the use to be made of the set, or the key or transmitter may be used to vary other parts of either the primary or aerial circuit. A current through the secondary winding of the choke coil may also be used when it is modified by a transmitter. Caution: 220 to 500 volts are dangerous, so be careful.

It is understood, of course, that the transmitter in Fig. 62 is used instead of a key when the circuit is used as a wireless telephone, or vice versa. That is, a key may be substituted for a transmitter to form an experimental arc telegraph. If the key or transmitter is used in the aerial, a duplicate in the main arc circuit is not needed. For telephone experiments the transmitter is best shunted around the choke coil as shown in the lower insert of Fig. 62. Only the choke coil and transmitter (Tr.) are shown in this insert, as the circuit is the same in other respects. In this case only one winding is used. If the two windings are used as shown, the transmitter is connected to the secondary winding through a battery. In this method the variations caused by the transmitter are superposed on the line current by induction and in turn cause variations in the arc circuit. In the shunt method the transmitter carries part of the cur-

rent directly, while in the inductive method it is only indirectly connected to the main circuit. Ordinary transmitters can be used. It is advisable to use two or three connected in parallel and grouped as a single unit. Larger currents can be cared for in this manner. The author has passed from 1 to 4 amperes through an ordinary transmitter with good results. The transmitter was heated by this treatment, however, and in some later trials, it was burned out. Indeed, the art was formerly hindered for want of a satisfactory transmitter, but this difficulty has largely been obviated by use of amplifying and vacuum tube methods.

It should be noted that the oscillatory circuit is formed by the condenser, oscillation transformer and arc. The circuit through the resistance, impedance coil, arc and choke coil is used to excite the arc.

In *operation*, the condenser is alternately charged and discharged at a very high rate, because the voltage between the arc terminals *decreases* with an *increase* of the current. The *condenser* takes current from the arc, causing an increase of the *voltage* between the terminals, and as a result more *current* flows into the condenser. Even after the condenser is charged to the same potential as that between the arc electrodes, the current in the condenser *continues* because of the *inductance* in series with it. The potential difference at the condenser thus becomes more than at the arc terminals, so that the condenser now begins to discharge through the arc. This immediately causes the voltage of the arc to drop, so that the discharge continues. Finally the condenser potential falls below that of the arc electrodes and the process

reverses again. The condenser continues to charge and discharge in this manner and the resulting oscillatory current is utilized in the transmission. The arc is varied by the transmitter or key and in the former case, causes the arc to reproduce the sounds spoken into the transmitter. The resulting oscillations are similarly varied so that the receiver gets a more or less exact reproduction of the transmitted sound waves which are sent as *electromagnetic waves*.

The frequency produced in an arc system is very high, being from 100,000 to 1,000,000 per second, and as it is not interrupted, cannot be heard by the receiver except when modified by a telephone transmitter or key with tone circuit such as shown for the Chaffee gap. Very close tuning is necessary to get results from this circuit, and the experimenter who is specially licensed therefor is quite safe in using any reasonable wave length with this arrangement. It is less efficient at low wave lengths. For best results the inductance, P , should be relatively large and the condenser, C , small.

A singing arc is made by connecting variable capacities in the shunt circuit of the arc. The pitch varies according to the capacity in this case, the highest pitch being obtained by the use of a very little capacity. If a telephone transmitter is also used the arrangement forms a *talking arc*. This is the same as the wireless telephone just described but without helix, aerial and ground. It is also possible to omit the condenser for this purpose. Words spoken into the transmitter are reproduced by the variations in the arc. The sound will be louder as the length of the arc is increased. (Do not look at the arc

too much, as it is very bad for the eyes.) It is best to enclose the arc in an insulated metal box.

An arc system allows very sharp tuning to be carried out, and as a result it does not interfere with other stations, as much as ordinary spark sets do. The persistent train of oscillations produced by this method is a decided advance in the wireless art. The received signal is an accumulated impulse resulting from a series of the oscillations. The arrangement described will only operate over short distances, however, as large power and specially designed arcs and apparatus are necessary for long distance work.

POULSEN ARC

The arrangement of a Poulsen arc is shown in Figure 63. The carbon electrode is slowly rotated with respect to a cooled copper electrode in the field of a strong elec-

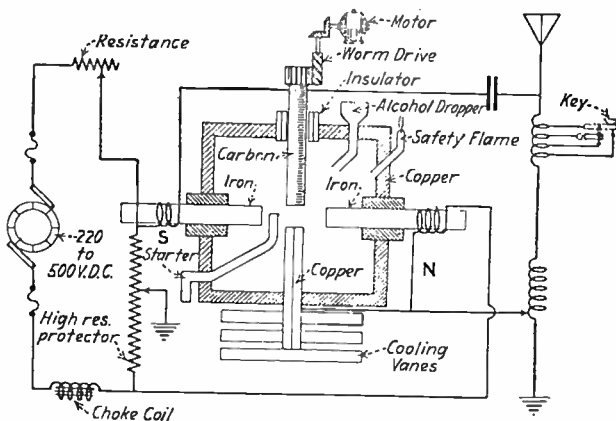

FIG. 63.—A Small Poulsen Arc.

tromagnet in a hydrocarbon vapor or gas as shown. In large stations several hundred kilowatts can be converted into radiant energy by the powerful water cooled arcs employed. The key merely alters the wave length of the emitted impulses by simultaneously closing several short-circuiting contacts every time it is depressed. The receiver hears two waves, the sending one containing intelligence and the compensating one which results in between signal elements when the key is raised. Often both can be plainly heard at the receiving station. Some of the largest stations now use this type of transmitter.

THE LEPEL ARC SYSTEM

This arrangement is a combination of the arc and quenched spark systems now little used in the United States. It operates on either direct or alternating current of 500 or 1,000 volts. This voltage may be obtained from an ordinary alternating current supply by

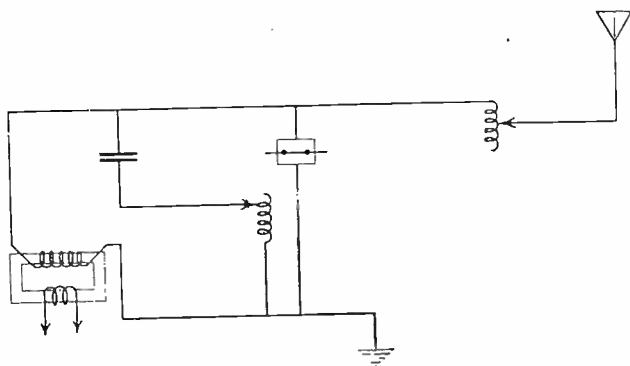

FIG. 64.—Lepel Transmitter.

means of a step up transformer. A five hundred watt step up transformer with a ratio of 1 to 5 will serve nicely on 110 volts A. C. for experimental purposes. The arrangement is simple and is shown in Fig. 64. The condenser used can be made of paraffined paper on ac-

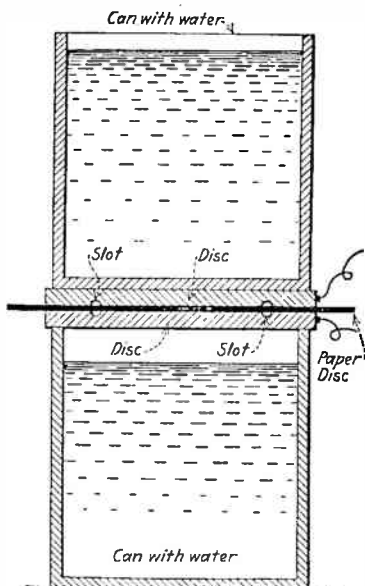

FIG. 65.—Detail of Lelel Gap.

count of the low voltage used, but glass is recommended. The remainder of the apparatus with the exception of the arc or gap itself is familiar and needs no further comment. A suitable construction for the gap for experimental purposes is illustrated in Figure 65. Ordinary tin cans can be utilized, but the electrode faces should be of copper turned smooth and having a groove as shown.

This groove serves to prevent the arc from reaching the outside of the gap. These copper disks should be from 3 to 5 inches in diameter, and can be arranged, after the cans are filled nearly full of water. The two electrodes are separated by a circular disk of paper, not more than .01 in. thick. A good bond paper will do. The disk should have a small hole at its center to afford a starting point for the arc.

WIRELESS PIANO

The circuit for direct current supply is shown in Figure 66. If the tone circuit is switched in, a musical note of any desired tone can be emitted. Indeed, it is possible

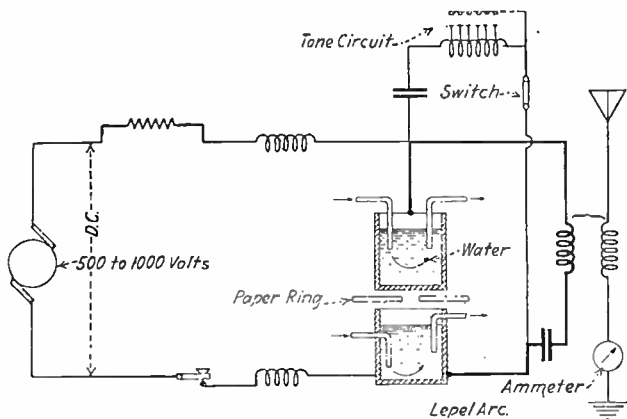

FIG. 66.—A Wireless Piano.

to arrange a keyboard as a "wireless piano" by placing contacts on the inductance I as shown. Without a tone circuit the emitted energy cannot be heard except at

stations equipped to receive substantially undamped waves.

In operation the arc starts at the center and gradually burns the paper away. As this burning occurs in an atmosphere lacking in oxygen, the paper does not burn all up until after a number of hours. It is essential to the arc, that the distance between the electrodes should be uniform and not over .01 inch, so that the arc occurs in an atmosphere lacking in oxygen. The products of combustion of the paper also aid the arc's efficiency.

The paper disk can be renewed after it is used up. This gap gives practically continuous oscillations and the circuits can be tuned by using a hot wire meter. This form of gap can be utilized for telephone purposes in much the same manner as described for the arc. Great care should be taken in handling the circuits as a shock from the line or secondary might easily prove fatal. Two or more of these gaps may be connected in series, this method being suitable for higher voltages.

TELEFUNKEN QUENCHED GAP

This is really a number of Lepel gaps connected in series. This arrangement can be substituted for the ordinary gap of a spark system. The disks are turned as shown from 3-16 or $\frac{1}{4}$ inch sheet brass to an outside diameter of $6\frac{1}{2}$ or 7 inches and grooved 1 or $1\frac{1}{2}$ inches in, so that the groove is about $\frac{3}{8}$ of an inch wide at the face. Each plate is grooved on one side in this manner. See Fig. 67.

The mica rings used may be had at supply houses and

should not extend further in than 1-8 inch beyond the outside diameter of the groove, so that the inside circumference of the mica comes within $\frac{1}{4}$ inch of the in-

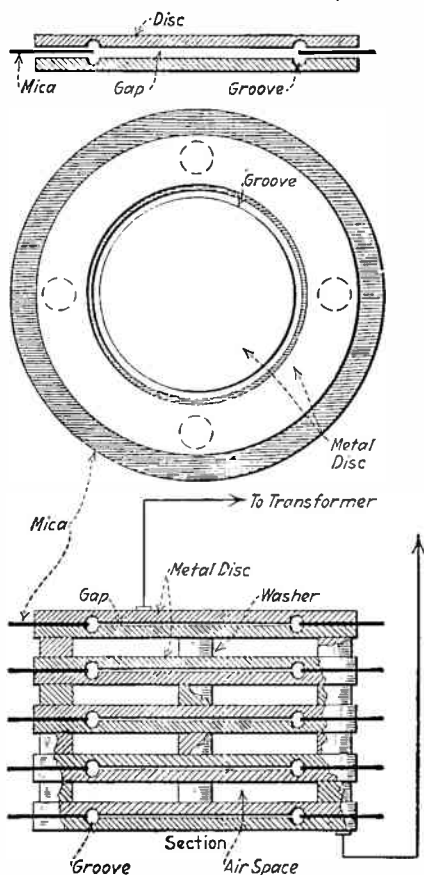

FIG. 67.—Quenched Gap.

side circumference of the groove. The groove is to prevent the spark from jumping to the mica as the latter

becomes a conductor when heated by a high frequency discharge. The mica rings should not be more than .01 inch thick. The disks are assembled in pairs so that the grooved faces are next to each other, and washers are placed between the pairs so that the pairs are separated by a distance equal to the thickness of one of the plates. Thus if $\frac{1}{4}$ inch plates are used, the washers used should be $\frac{1}{4}$ inch thick. The assembled gap may be suitably mounted by using insulated supports, a sufficient number of pairs being used so that the combined length of the gaps is somewhat less than the length of a single gap, ordinarily used. When large power is used with this gap, it is well to have a small fan blow upon it to dissipate the heat which is generated.

THEORY AND ADVANTAGES OF THE QUENCHED SPARK

The gaps described are not difficult to construct and operate and are recommended to the readers. The discharge is practically noiseless, almost 60 per cent more efficient than a common gap, and produces nearly undamped waves. A high pitch note, which increases the effective transmission range, can also be had.

The operation of the quenched gap depends upon the fact that the spark quenches itself out after it has made a few oscillations, allowing the secondary oscillations to continue freely. This was illustrated in Figure 31. The primary circuit is thus opened so that it does not interfere with the secondary or aerial oscillations. As a result the unwelcome beats common to open spark sys-

tems are avoided. Returning to the parallel case of a gong, the quenched spark may be compared to a padded hammer, which after striking the gong (comparable to the antenna circuit in this case), a forceful blow, allows it to continue by itself with a clear, powerful vibration. The *short spark gap* when well cooled prevents the primary from *oscillating* by itself after the secondary circuit has been excited. That is, the spark is *active only long enough* to allow the secondary oscillations to reach a maximum, and the secondary oscillations are a maximum after the primary oscillations are reduced to a minimum. The number of primary oscillations necessary for this ideal operation is governed by the degree of coupling between the primary and secondary. It is desirable to use a close degree of coupling with the quenched spark for this reason. The energy ordinarily lost as heat in an ordinary spark gap is thus conserved and the wear on the primary apparatus is reduced. One of the chief causes of heat in the condensers and wear of the gap with an ordinary open gap is the useless continuance of the energy after the useful oscillations have been generated. The *quenched gap*, then, *prevents* undesirable oscillations from being set up in the primary by the reaction of the secondary, and makes the resulting radiations have a single wave length, for receiving purposes.

In constructing the quenched gap, it is essential that the electrodes be pressed with some force against each other. In the Lepel form of gap described the weight of the upper electrode suffices, but in the form of Arco gap described, a clamp should be provided. A quenched gap in connection with a resonant outfit as described in pre-

vious chapters is an ideal set for the experimenter. These arrangements are also known as *shock excited* systems, and are rapidly coming into increased favor. Commercial quenched gaps use silver surfaced electrodes.

Note. If mica is not obtainable in the necessary size, rubber sheet of uniform thickness .01 inch may be used, though the mica is to be preferred. Stove repair companies carry mica in stock as do commutator concerns. The latter use a mica mixture which is much cheaper than mica and which is suitable. Smaller dimensions may be used for the electrodes for small stations, and for very small stations one or two sets of plates will suffice. By using soft rubber sheet instead of mica the length of the gaps can be varied by varying the pressure on the plates. Sheets of soft rubber can be had at dental supply houses. The quenched gap is of course used like a regular spark gap in an experimental set. Quenched gaps are made in both stationary and rotary forms, the latter having advantages similar to those of an ordinary rotary gap as well as those of the quenched gap.

HIGH FREQUENCY GENERATORS

While beyond the facilities of the average experimenter some description of certain other systems is of interest.

The Goldschmidt high frequency generator has been tried for long distance work. Its operation depends upon the fact that an armature mechanically rotated in a rotating magnetic field gives an initial frequency—say 10,000—which can be further stepped up by carrying the current back through the field to produce a more rapidly

rotating magnetic field; this new frequency current is again led back to still further increase the frequency, and so on until the desired frequency—say 40,000—is attained. The circuits must of course be nicely balanced electrically in order to obtain the necessary resonance, condensers being used for this purpose. To avoid eddy current losses, the armature is constructed of iron foil

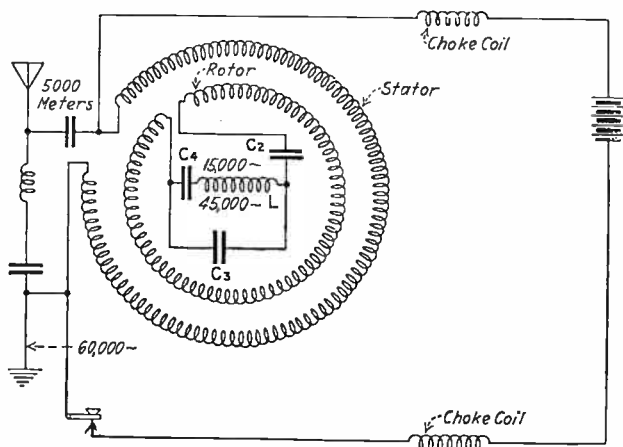

FIG. 68.—Goldschmidt Alternator.

only .002 inch thick, each sheet being insulated from the next one. Substantially undamped waves are emitted by the use of this machine and since the frequency is above audibility, the method of beats is employed to get the intelligence at the receiving station.

The arrangement is diagrammed in Figure 68. Here the initial 15,000 cycles is obtained initially by use of high speed and large number of poles. This causes an oppositely rotating field thereby set up to give 30,000

cycles which is in turn returned back to the rotor to give 45,000 cycles and again transferred to the antenna circuit which is tuned therefor at 60,000 cycles. The inductance and capacity in each circuit is chosen so as to select out the desired frequency.

ALEXANDERSON ALTERNATOR

The Alexanderson alternator as used successfully at one of the large U. S. Naval stations is diagrammed in Figure 69. A high speed (20,000 R.P.M.) rotor of the inductor type carrying a large number of teeth is inserted between the yoke on which are wound the field coil F and armature coils A, A. A special magnetic amplifier M controls the large output by direct absorp-

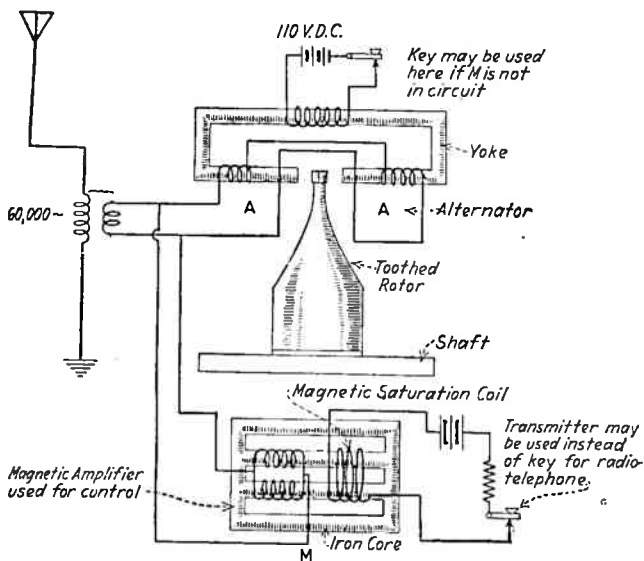

FIG. 69.—Alexanderson Alternator.

tion. When the key is depressed the core of M has its magnetization altered so that a maximum current is permitted to flow in the antenna circuit, and vice versa.

Still another method for producing sustained oscillations has been devised by Galletti. Direct current is used as the primary source and a plurality of oscillatory circuits are automatically excited in succession, a common condenser being coupled to these circuits.

An experimental alternator has also been constructed in which the primary frequency is multiplied by means of a polarized transformer.

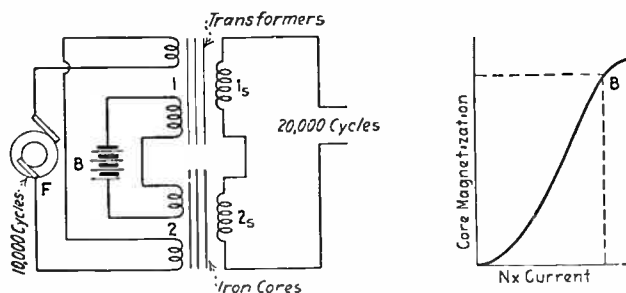

FIG. 70.—Static Transformer Frequency Multiplier.

The method of doubling the frequency with stationary transformers is illustrated in Figure 70. Each transformer 1 and 2 has two primary windings connected as shown, one to a battery B and the other to the alternator F. The secondaries 1_s , 2_s are tuned to double the primary frequency. As indicated by B of the appended magnetization curve each transformer has its core brought to the saturation point by the battery B.

The primary connections are such that the flux increases in transformer 1 while it decreases in transformer 2, so that in one half cycle a small increase in flux in 2 with a large decrease in 1 occurs. The opposite takes place in the next half cycle so that each half cycle is effective in causing a whole cycle to occur in the secondary windings.

It is possible to triple the initial frequency by adjusting the two transformers' magnetization so that one causes a peaked wave containing a strong third harmonic while the other sets up at 180° therefrom a flat topped wave containing the same harmonic so that the harmonic alone can be tuned for in the secondary circuit by difference. If an alternator gives 10,000 cycles this arrangement permits it to be changed up to 30,000 cycles which is equivalent to 10,000 meters wave length.

The French "Onde Unique" system is illustrated in Figure 71. An intermediate heavy turn circuit A is inserted between the usual transmitter B and antenna C. D shows the equivalent circuit. A single wave length impulse is emitted by the antenna with this arrangement.

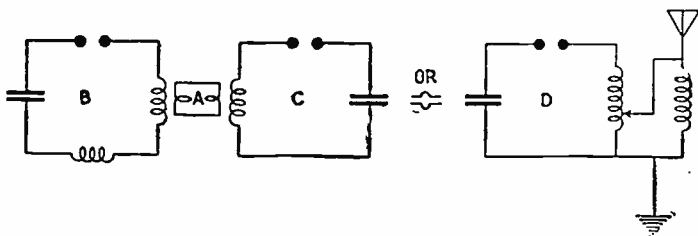

FIG. 71.—Onde Unique Circuit.

VACUUM TUBE METHODS

Vacuum tube transmitters have grown to an importance requiring special consideration and are discussed in the chapter covering this subject.

DUPLEX HIGH-SPEED OPERATION

Large radio stations are operated duplex, that is, messages can be received and sent at the same time by using two antenna systems, one for sending and one for receiving. The transmitter is then usually remotely controlled by electromagnet switches. All the large Navy Transatlantic Stations are controlled directly from

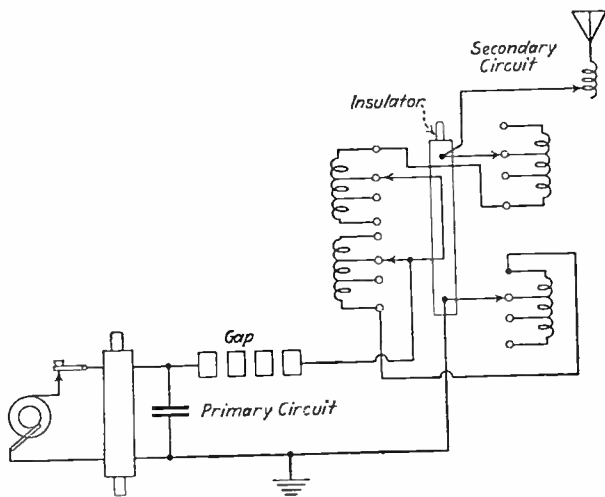

FIG. 72.—Lowenstein Wave Changing Switch.

Washington, D. C. This is done by means of magnetically operated relay switches.

High speed operation is accomplished by using automatic senders and recorders. The former are usually of the punched tape type and the latter are photographic or phonographic or telegraphonic. Radiotelephony can also be operated multiplex.

WAVE CHANGING

Nearly all military and naval transmitters are provided with special switching devices to permit rapid change of wave lengths. There are many ways in which this is done, some also being arranged to alter the resistance or reactance of the primary exciting circuit at the same time the wave length is changed; so as to maintain the most efficient circuit relations at all adjustments. A well-known example is shown in Fig. 72. Both the primary and secondary circuits are simultaneously altered.

CHAPTER XIV

Vacuum Valves and Circuits

Vacuum Tubes; Amplifiers; Detectors; Oscillators; Modulators; Tube Radiotelephones; Experiments Showing Fundamental Action; Two and Three Electrode Tubes; Curves of Operation; How the Circuits Work; Operation of Grid; Audion Circuits; Lieben Reisz Amplifier; Pliotron; Cascade Amplifier; Outside Grid Tube; Dynatron; Chart of Vacuum Tube Circuits for all Purposes; Ultra-audion Receiver; Damped and Undamped Wave Circuits; Audion Generator; Armstrong Circuit; Construction of Long Wave Length Oscillating Receiver; Adjustment of Oscillating Circuit; Short Wave Length Repeating Amplifying Receiver; Cascade Circuits; Advantages and Disadvantages of Audion; Combined Crystal Detector and Audion; Sensitizing Circuits; Special Vacuum Tube Circuits; Self-tuned Oscillation Generator; Self-Modulated Transmitter; New Tube Circuits.

The vacuum tubes which have come into universal use for detecting, amplifying, generating, modulating, and special work offer a good transition point from transmitting to receiving apparatus because used for both.

The beginner should now first read Chapter XVI on "Receiving Stations."

There are several types of these bulbs, but aside from

details of construction and modified mode of use, the general operating principles are the same.

EXPERIMENTS SHOWING FUNDAMENTAL ACTION

In the curve of Figure 73, a large change of the plate voltage (Battery B) causes but a small change of the plate current flowing through ammeter A in the region (1) and also (3) but near (2) a small change of B gives relatively a large change in A.

When the third electrode or grid is interposed be-

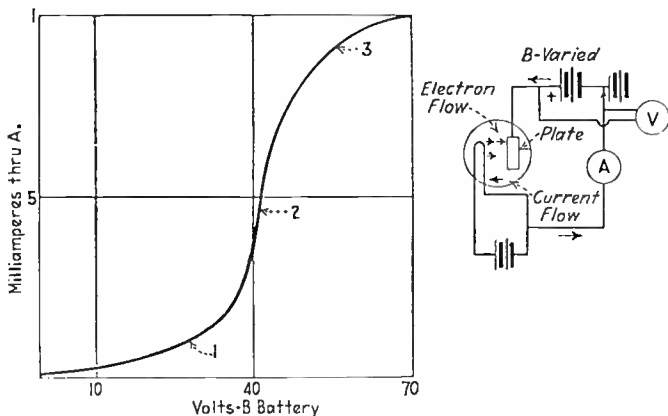

FIG. 73.—Two Electrode Vacuum Tube. Current Flow with Constant Filament Brightness and Varied Plate Voltage.

tween the filament and plate and its potential is varied with other conditions constant as shown in figure 74 a similar curve is obtained so that in the region (4) a small change of the grid potential causes a large change in the current flowing through A.

Current flows from the plate to the filament only when the grid is made less negative than the point which stops

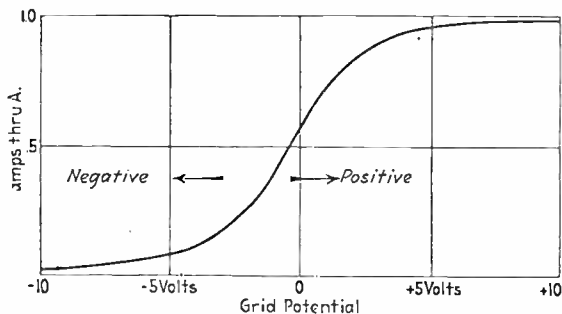
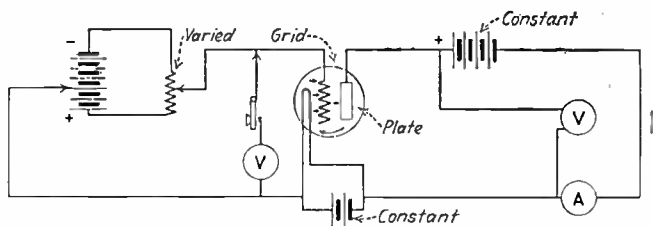

FIG. 74.—Three Electrode Tube. Flow of Plate Current at Various Grid Potentials.

the electron flow. Current flows readily, of course, if the grid is neutral or even positive.

DETECTOR ACTION SHOWN BY CURVES

In Figure 75 it will be seen how the incoming energy causes a telephone current corresponding to the audible group frequency to be set up. The grid potential is negative, the plate current positive, and the telephone current derived from the latter is smoothed out because of the inductance lag in the telephone receiver's windings.

A combined rectifier and amplifier results when the grid condenser is used because the incoming oscillations are rectified and stored in this condenser C_2 so that the

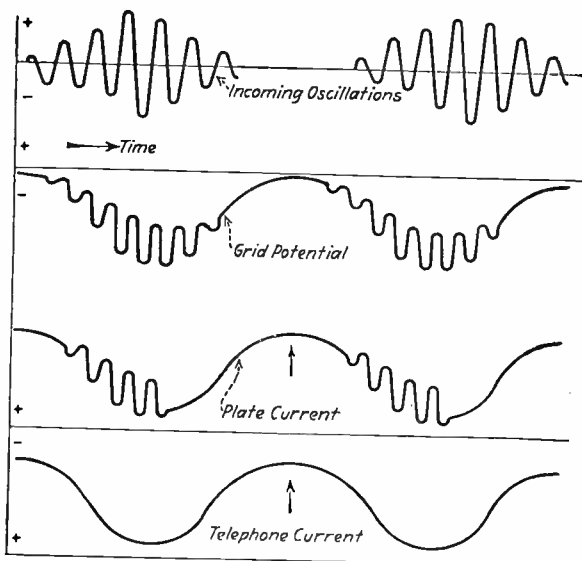

FIG. 75.—Detector Action Shown by Armstrong Curves.

charge and discharge thereof causes the telephone receivers to respond at audio frequency.

PRINCIPLE OF OPERATION

It should be remembered that there are two distinct actions of this class of valves, the one holding for bulbs containing appreciable gas so that ionization can occur by collision and the other taking place in bulbs so highly evacuated as to be almost free from gas so that a purely

electronic action occurs. The first class of bulbs may be recognized by the blue glow which occurs just beyond the sensitive and operating adjustment as in the audion. The Lieben-Reisz, Audio-tron and similar tubes are also of the first class. The second class embraces bulbs such as the plotron in which a pure electron discharge occurs from the heated cathode or filament. The second class does not rely upon residual gas as a conducting medium.

The hot filament in these devices emits electrons. In elementary static electricity it will be remembered that like charges repel and unlike attract; negative repels negative for instance. The electron may be considered as the smallest possible particle of electricity, the atom of electricity so to speak, and furthermore it is always negative. Hence if an electron comes near a negative charge or a piece of metal charged negatively by a battery the electron will be repelled, or on the other hand the same piece of metal if charged positively will attract the electron to it.

Now in a highly evacuated bulb containing filament, grid, and plate, the resistance between the filament and grid or plate when the filament is cold is very high, and a pressure of 100 volts for example can send no current across such a path. As soon as the filament is heated, however, electrons are emitted from the hot cathode and fill the surrounding space. As soon as the space is filled, however, additional electrons which are emitted by the filament cathode are repelled by the electrons already in the space and are absorbed again by the cathode. If now the grid, which is between the plate and the filament is negatively charged by a battery still more elec-

trons will be repelled and sent back to the filament, but on the other hand if this grid is positively charged the electrons will be attracted to it and a larger current will flow from the filament. This is the case for the pliotron.

When, however, there is gas present, as in the audion, the electrons in passing from the filament to the plate ionize the gas, that is split it up into elementary parts carrying electric charges so that the gas becomes a conductor. Now some of the charges of the ionized gas are positive and these partly neutralize the electrons which have been projected into the space by the filament. Also if a positive charge is applied to the grid the electrons from the filament will be attracted and pass more rapidly. In so doing they produce more ions in the gas and the action continues—more electrons pass the grid

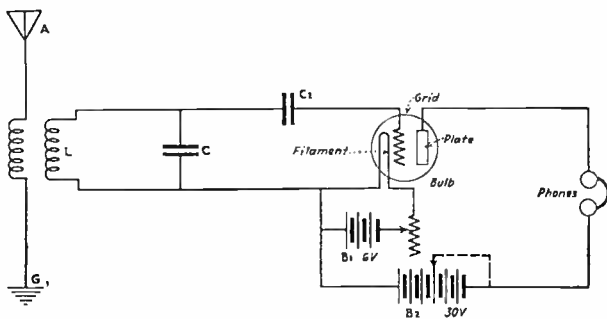

FIG. 76.—Audion Receiver.

and more ionization takes place. Now every time ionization occurs or increases the electrons in the space are reduced so that a much larger current can flow from the filament. Only a small amount of gas need be present for this purpose. In fact if too much gas is present

there will be too much ionization and too large a current will flow giving a blue glow and spoiling the relaying effect.

On such a basis we can understand what happens in the tube. Fig. 76 shows the ordinary audion circuit. Both detection as in a crystal rectifier and amplification of the received energy by trigger action occur. In use the filament is brought to incandescence and tuning adjustments are made until the desired signals are brought in. The incoming signals are embodied in oscillations and these are rectified between the filament and grid. One-half cycle passes, the other cannot because the hot filament—cold grid is uni-directional. If the grid condenser C_2 is omitted and the circuit at this point closed, a somewhat different action occurs. In the Fleming valve this is all, but in the audion under consideration amplification now occurs. The battery B^2 causes current to pass from the plate to the filament but by the action already explained the negatively charged grid decreases it. When this current decreases the change registers on the head phones and a loud response results which is much stronger than would result from the rectification alone. The potential on the grid caused by the incoming oscillations controls the larger current passing from the plate to the filament and through the phones to give the signal. A small increase of the potential on the grid means in practice a large change in the current passing between the grid and filament, and this in turn causes a corresponding change in the current passing through the phones by way of the plate to filament circuit.

The audion generally works best just below the point

which causes a blue glow to appear. The filament should not be lighted when the set is not in use because this results in a waste of current from the high voltage battery and deteriorates the filament. When the filament is lighted and the device is ready to use, the high voltage battery causes a continual flow of current through the bulb: the incoming oscillations merely cause this current to vary.

FLEMING VALVE

The Fleming valve, one of the first of these, consists simply of a miniature electric light bulb with a filament

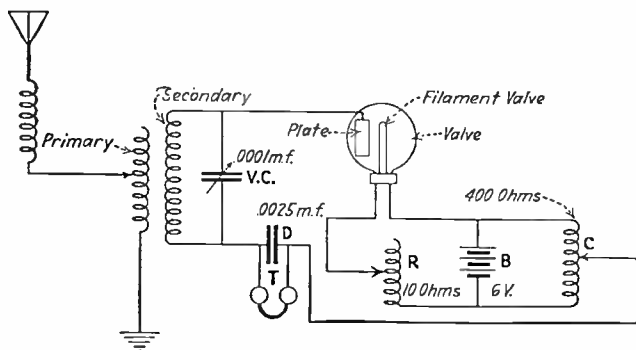

FIG. 77.—Fleming Valve.

and a metal plate near it as shown in Fig. 77. In use, current may pass from the filament to the plate but not reversely so that the device acts as a rectifier. It is not very sensitive and relatively few are in use now. The kenotron is a similar device which is evacuated so that less gas is left in the bulb. The kenotron is very highly

evacuated and built for larger current but is not used for wireless purposes at present. In these devices the resistance varies with the applied voltage differently than by Ohm's law.

AUDION

The audion (Fig. 76) is like the previously described device except that a grid, which is simply a piece of bent wire or metal screen or plate with holes, is placed between the filament and the metal plate or wing. The

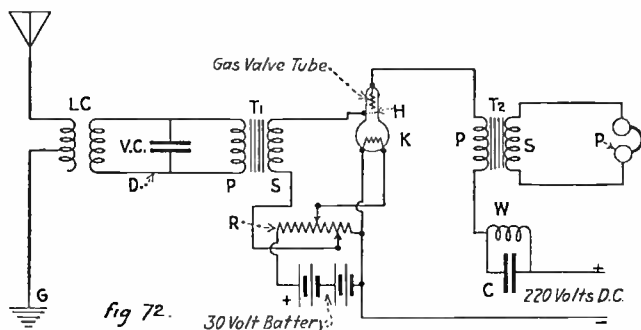

FIG. 78.—Lieben-Reisz Circuit.

audion usually has a double filament, only one filament of which is heated at a time, the other being saved for use when the first burns out. This filament is connected to a 6 volt storage battery through a small rheostat. Separated from the filament by about $\frac{1}{8}$ inch is the plate and between the two at the middle and insulated from both is the grid. The plate is about $\frac{1}{2}$ inch square and of sheet nickel in the size used as a detector. The whole

is sealed in a glass bulb and evacuated so that only a little gas is left. Various other forms have been made with two plates and grids, in larger sizes, with cylindrical plates, etc., but the principle of operation is the same in all types. The device called the plotron is

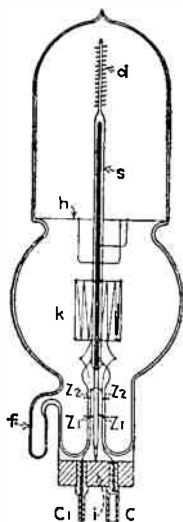

FIG. 79.—Lieben-Reisz Tube.

similar in all respects except that the bulb is very highly evacuated. Experimental bulbs have also been made in which mercury vapor is introduced into the bulb after it has been evacuated.

LIEBEN-REISZ AMPLIFIER

The Reisz gas tube as described in U. S. patent 1,142,625 is shown in Fig. 78. The circuit in which it is used is given in Fig. 79. T^1 and T^2 are iron core step

up transformers. The device is analogous to the audion which is better known and will be understood from discussions of the latter device.

PLIOTRON—CASCADE AMPLIFIER

This device has two plates, a grid of fine wire wrapped around a support F (Fig. 80) and a filament held in

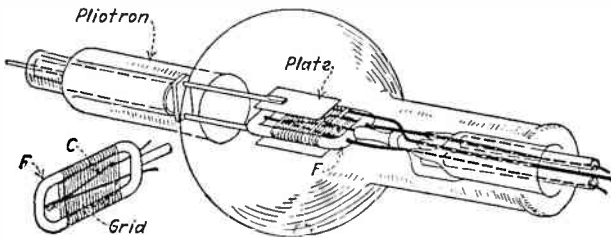

FIG. 80.—Pliotron Tube.

this support. It is very highly evacuated so that much higher voltages must be used with it than in the case of the audion. It can be built in larger sizes than the

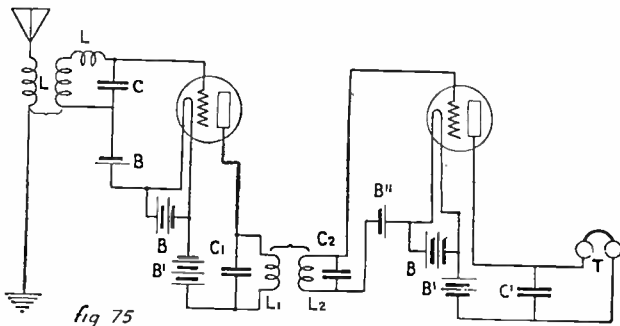

fig 75

FIG. 81.—Cascade Radio Frequency Amplifier.

audion for use as an undamped wave generator or relay and is more constant, so that whereas audions vary widely in characteristics, these more highly evacuated bulbs are nearly identical and many of them may be connected in parallel. Two such devices connected in cascade for receiving radio signals with an amplification as high as 1,000 times are shown in Fig. 81. L^1 and L^2 are the primary and secondary of an air core transformer. The first bulb detects and amplifies the incoming oscillations and the second bulb again amplifies the previously amplified oscillations. The battery B' must afford several hundred volts and the battery B'' is required to charge the grid. A similar circuit may be used with ordinary audion bulbs except that batteries B'' are not required.

OUTSIDE "GRID" TUBE

While less desirable a so-called "grid" can be wound on the outside of the tubes and connected as in Figure 82.

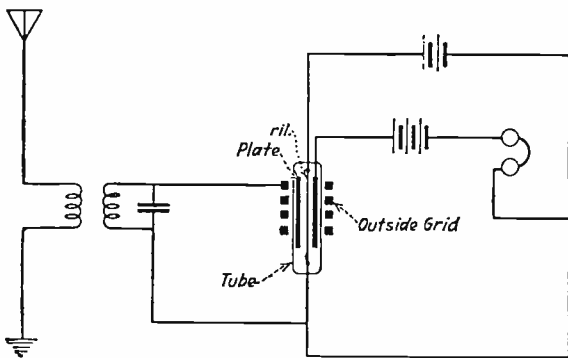

FIG. 82.—A Vacuum Tube with an Outside Grid.

DYNATRON

A form of tube called the Dynatron is shown in Figure 83. It has a rugged third electrode D with a special circuit such that at some adjustments the tube delivers back sufficient energy (derived from battery B) to off-

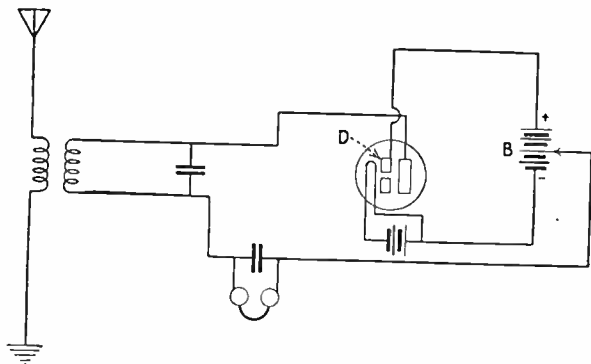

FIG. 83.—Dynatron Detector.

set or more than offset the resistance its circuits have. This is called "negative resistance" and can be attained with an ordinary audion bulb if desired.

VACUUM TUBE CIRCUITS

A number of useful vacuum tube circuits, including the most generally used ones, are shown in Figure 84.

I. shows the ordinary two element rectifier which conducts from plate to filament, but not reversely. Small arrows indicate electron flow from filament, while large arrow shows current flow from battery.

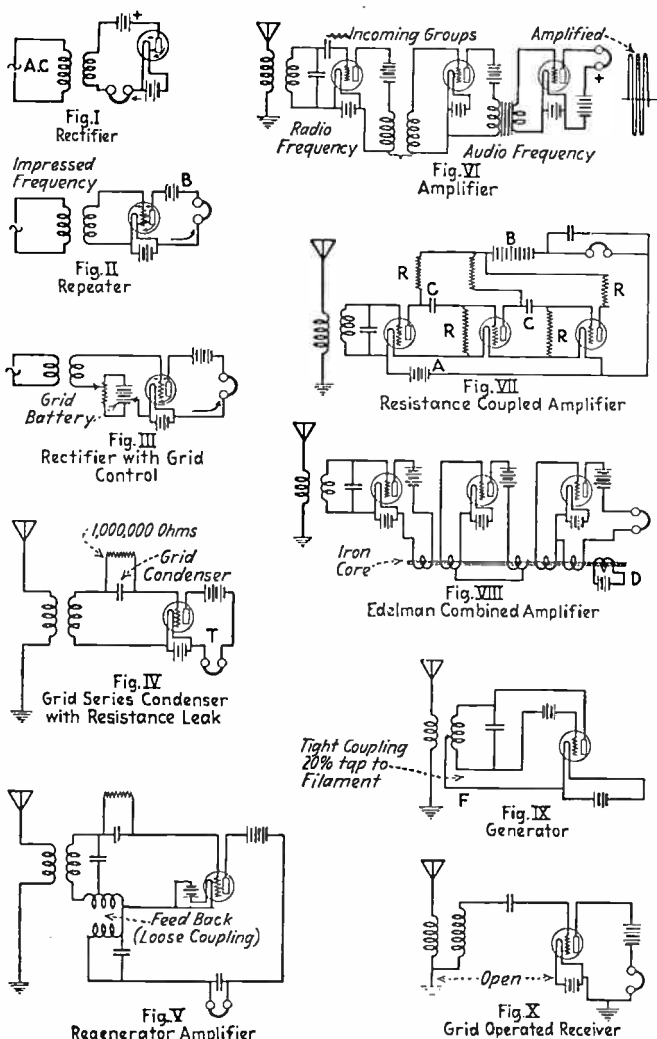

FIG. 84.—An Interesting Collection of Vacuum Tube Circuits.

II. shows a third element or grid added. This takes some of the electrons so that the current flow through T is reduced as long as the grid remains negative and stops altogether if the latter is sufficiently negative. But when the grid is neutral or positive, current flows freely from the plate to the filament from the battery B. The impressed positive half cycle increases this current flow while the negative half cycle decreases it, making the current through T rise and fall therewith, the amount of distortion, if any, depending upon the adjustments. As energy is taken from B, increased power is obtainable through T at the impressed frequency.

III. shows a grid control battery added to adjust the grid potential. Starting with a negatively charged grid the effect of a negative half cycle impressed is small but a positive half cycle causes a large increase in the plate current through T. If the grid is made positive to start with by reversing the grid battery the opposite result is obtained.

IV. shows the grid series condenser with high resistance leak. Radio frequency energy is rectified and a negative charge accumulates on the grid side of the small series condenser. This further reduces the plate current flowing through T until the shunt leak permits the charge to escape when the oscillations cease to arrive from the antenna circuit. The grid returns to normal potential then, and as this is repeated for each audible group of radio frequency oscillations the receivers T get a corresponding (and amplified) audio frequency excitation.

V. Figure 84 shows the feed back or repeating circuit

added so that enormous amplification up to the capacity of the tube results. If the coupling of the feed back coils is close the tube becomes a generator as shown in IX.

VI. shows cascaded radio and audio-frequency amplifiers. Seven stages can be used without "howling" trouble by proper grounding and shielding of the separate circuits and give enough amplification to permit the use of a relay in place of the telephones T. Amplification up to 2,000,000 times input audibility is possible though usually less than 1,000,000 times suffices.

VII. shows resistance coupled amplifier tubes which while less intense for the same number of bulbs in cascade requires less auxiliary apparatus and is free from "howl." The resistances R are high resistance units and a single battery suffices for all tubes up to 10.

VIII. shows a combined amplifier devised by the author which feeds back from the last to the first bulb and has the iron core magnetization adjusted for maximum results by exciter D.

IX. shows a simple single coil generating circuit.

X. shows an open circuit grid potential operated receiver claimed by Bucher.

EFFECT OF MAGNET ON AUDION

If a magnet, permanent or electromagnet, is brought near an audion in operation various effects may be produced. This may be accomplished by passing current through a coil of wire wound about the vacuum tube itself. Sometimes this merely causes the blue glow to

appear. In other cases the bulb starts to send pulsations through the phones at a rate which gives musical tones which may be made to run all the way up and down the scale by proper motion of the magnet. If, however, the magnet is brought in the proper plane the thermionic stream can be concentrated so that in very many cases the bulb will work better than ever and give an increased amplification. This may be quickly found by trial.

THE ULTRA-AUDION RECEIVER

De Forest's ultra-audion is a form of heterodyne circuit combined in one instrument. It is an ordinary

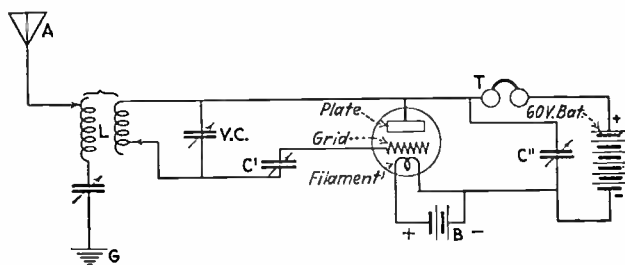

FIG. 85.—Ultra-Audion Receiver.

audion detector with a receiving circuit (Fig. 85) in which the inductance L is large (secondary of loose coupler wound with many turns of No. 30 to 36 wire) while the condenser C' is only about .0002 microfarad in capacity. The condenser VC is also made small. The electron flow in the audion used in this circuit is automatically unbalanced because of this system of inductance and capacity so that continuous oscillations are set

up. These oscillations are strengthened by the variable condenser *C*". Any audion bulb may be connected up in this manner to receive undamped wave signals. When the capacities are adjusted so that the audion sets up oscillations slightly differing in frequency from those received, beats result which are heard in the head receivers.

Often an ordinary audion in a common receiving set will oscillate in such manner if only the filament is burned slightly brighter than usual. One may ascertain

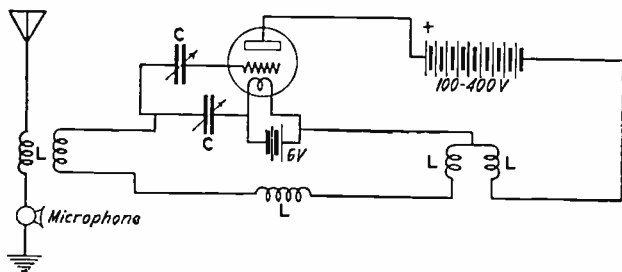

FIG. 86.—Armstrong Regenerative Circuit.

that the bulb is oscillating by touching any portion of the metallic circuit between *L* and *C*' whereupon a sound will be heard in the telephone receivers if the bulb is oscillating. For receiving from spark stations the bulb is often best when in the non-oscillating condition as when oscillating in the above manner the musical tone of the sending spark becomes ragged so that a louder but indistinct sound results. This is a sensitive arrangement for detection as it affords a combined detector and amplifier as well as a local oscillator.

This is best accomplished by means of a coupling coil built like a loose coupler. If this coil is made with an air core (no iron) the radio frequency oscillations will be amplified. Similarly by the use of an iron core induction coil the audio frequency current through the telephone will be amplified. It is possible to amplify either or both at the same time. In Fig. 87 the complete circuit for a long wave set using the oscillating and amplifying audion is given. Either spark or undamped wave sets can be heard with this arrangement. A less complicated circuit which will serve about as well is shown in Fig. 88. Compare with the ultra-audion, Fig. 85.

CONSTRUCTION—LONG WAVE UNDAMPED WAVE RECEPTOR—RANGE 14,000 METERS

Few of the readers have the facilities to construct the bulbs, but if one has a bulb the amplifying circuit may be readily made at small cost. When properly adjusted

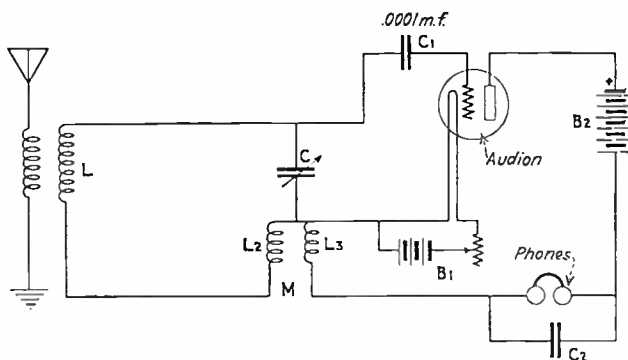

FIG. 88.—Simple Armstrong Circuit.

a single bulb amplifier of this type is as good or better than the usual two step amplifier employing two bulbs.

The values of the condenser capacities and maximum battery voltages are given in the diagram of Fig. 87. The inductances are made by winding a single layer of silk covered wire on paper tubes and for the various coils suitable dimensions follow.

L^1 ; core 6" diameter by 25" long wound with No. 24 S. C. C. wire, with taps taken at ten, five, and then every inch of length.

Loose coupler L^2 , L^3 . Primary L^2 ; 12" long by 6" diameter with No. 24 S. C. C. Secondary L^3 ; 12" long by 5½" diameter wound with No. 32 S. C. C.

L^4 and L^5 are each 5" in diameter and 30" long, and wound full of No. 32 S. C. C. Taps are taken every inch at the last 5 inches.

Loose coupler L^7 , L^6 . L^7 is 8" long by 5" diameter. L^6 is 7½" long by 4½" diameter. Both cores are wound full of No. 30 S. C. C. wire.

The condensers should be of the rotary plate type and C^2 which is used at very small values should have a streak of graphite rubbed between its binding posts to serve as a high resistance shunt which dissipates high voltage accumulations on the condenser from static disturbances.

ADJUSTMENT

Short circuit L^5 and place C^3 at its maximum capacity. Have L^2 , L^3 all in and vary L^4 and the other condensers, also L^1 until the signals are brought in best.

Now place L^5 in and adjust the number of turns used as well as C^3 until the loudest signal strength is obtained. Mark the adjustments for future reference and make any other necessary changes by means of L^1 , L^2 , L^3 , C^3 , and C^1 . When the bulb is replaced with a new one, the adjustments may have to be repeated as new values will be required. If siren effects bother, ground one terminal of battery B.

Fig. 87 will now be readily understood. The loose coupler L^2 , L^3 is made with variable coupling, L^2 is 5" in diameter by $4\frac{1}{2}$ " long. L^3 is $4\frac{1}{2}$ " in diameter by 5" long. Both cores are wound full of No. 28 S. C. C. B^2 should be adjustable up to 40 volts. The range will depend on the loose coupler used between the aerial and detecting circuit and is more suited to wave lengths under 6,000 meters.

SHORT WAVE REPEATING AMPLIFIER RECEIVER

With slight change the usual regenerative circuits will work nicely on 200 metres. See Fig. 89.

The antenna is 75 feet long and 50 feet high, two wires inverted "L" type, or if a multi-turn coil is substituted for indoor receiving, thirty turns of No. 20 D. C. C. wire are wound on a frame five feet square, no ground being used in the last case.

The condensers have the values shown in the diagram. A tubular audion operated on 6 volts is suitable.

As to the tuner; wind twenty-five turns No. 22 D. C. C. wire in a single layer on a tube three inches in diameter and one and one-half inches long, for the primary. Wind a similar tube for the secondary but two and three-fourths inches in diameter and with fifty turns of No. 26 D. C. C. wire.

Now wind a third coil on another tube about three inches in diameter and such that it will just slide over the end of the primary tube; this coil to have ten turns of No. 22 D. S. C. wire. Mount the three coils similar to a loose coupler so that the secondary and the third coil are adjustable with respect to the fixed primary coil.

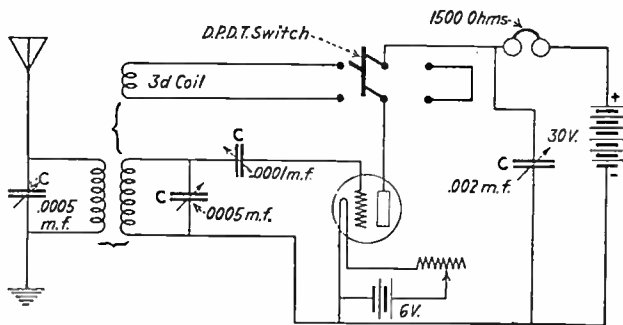

FIG. 89.—“Tickler” Oscillating Circuit.

Connect per diagram, and operate as usual. When the third coil is out ordinary signals can be heard. Then when the double pole switch is thrown to connect in the third coil, the repeating amplification starts. Also short wave beat reception becomes possible by suitable adjustment of the tuning condensers.

CASCADE CIRCUITS

Audions may also be used in cascade to amplify either the audio or radio frequency currents. Plotrons can also be used in a similar manner. There is a limit to the number of steps that can be used, however, as the amplified current soon causes distortion, so in practice not more than three bulbs in cascade have been found to be practicable. In the cascade circuits it will be noted

that the first step is the familiar circuit while the amplified current of this step (at audio frequency in the audion arrangement) operates the grid filament circuit of the next step through an iron core inductive coupling; then this is repeated in the next step in the same manner. The final current may be large enough to operate a loud

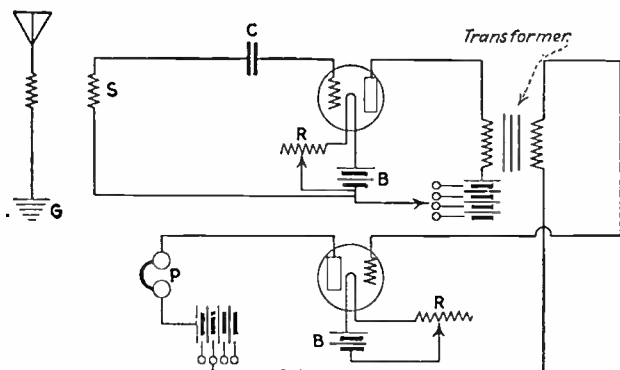

FIG. 90.—Cascade Audio Frequency Amplifier.

speaking telephone or even a relay or milliammeter. Often signals with any of the audion circuits have been so loud that they could be directly recorded on a wax cylinder phonograph by simply holding the telephone receiver against the recording diaphragm.

CASCADE CIRCUIT CONSTRUCTION

Fig. 90 shows how to connect two ordinary audion bulbs in cascade to amplify the audio frequency. Compare with Fig. 81 and note that these two figures could be combined to still further increase the magnification.

The transformer consists of a core 1" in diameter and 10" long made up of a bundle of soft iron wires wound with tape. The primary winding consists of one pound of No. 36 S. S. C. wire. Over this the secondary of one and one-half pounds No. 36 S. C. C. wire is wound. Amplification up to about 100 may be expected.

DISADVANTAGES OF AUDION—COMPARISON WITH CRYSTAL DETECTOR

The audion detector as now sold is bulky, fragile, and requires frequent care and renewal of batteries, bulb, etc. Many bulbs are not constant and some give annoying siren effects. In many cases there really is no need to employ any such device for a crystal detector will do as well or better. A crystal detector such as galena will even detect signals from arc and undamped wave sets under favorable conditions. The author has heard such signals when using such a detector in a receiving circuit containing a variometer coupler which caused the necessary reaction in the circuits. The tone, however, was not musical.

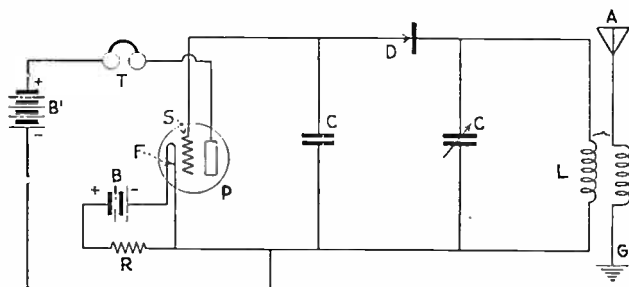

FIG. 91.—Crystal Detector Combined with Audion Circuit.

COMBINED AUDIO AND RADIO FREQUENCY FEED BACK

Figure 92 shows how both the radio and audio frequencies can be fed back to repeat again. The condensers 2 are of large size, for example, .2 m.f. each while the condensers, 1, are of the small air type. Iron core coils 3 form so called "tone circuits" with condensers 2, *i.e.*, these circuits have an electrical period corresponding to a low frequency or audible tone.

In the arrangement of Fig. 93 the grid potential is

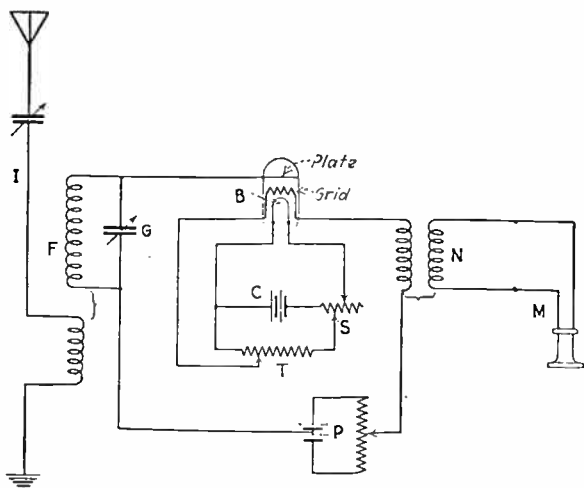

FIG. 93.—Receiver with Adjustable Grid Potential.

adjusted by shifting the potentiometer contact *t* and the plate voltage by potentiometer contact *p* so that the first adjustment limits the current which can flow while

the latter setting aims to secure the best response for this condition. In short, the tube is operated near the flat portion of its curve so that strong strays do not have nearly so much relative effect on the receiver as do the signals received.

RECEIVER WITH SENSITIZER

Fig. 94 shows an auxiliary sensitizing circuit which has been used by the U. S. Navy. It consists of a wave-meter coupled to the grid circuit and adjusted for maximum response in the telephones T.

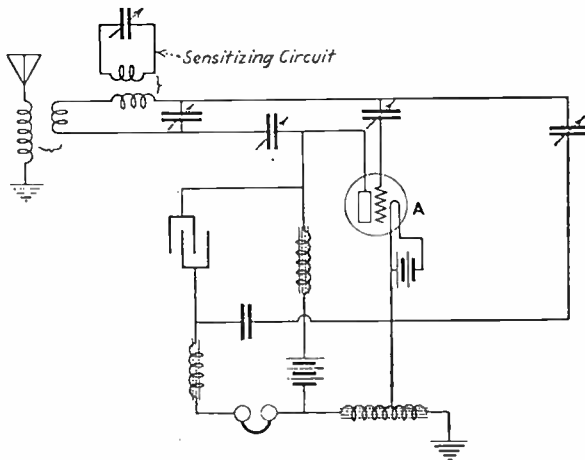

FIG. 94.—Sensitizing Circuit in Receiver.

Fig. 95 shows a tube combination circuit which has been used and known as "Meissner's receiver" though quite similar to others.

Fig. 96 shows another modified circuit which has been used by the Marconi Company.

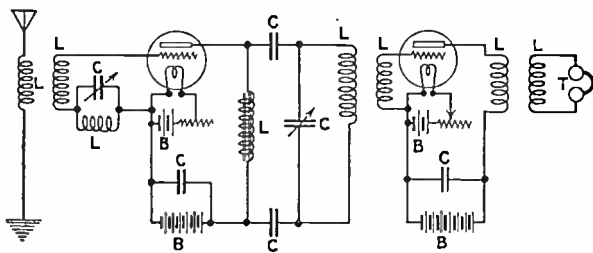

FIG. 95.—Meissner's Receiver.

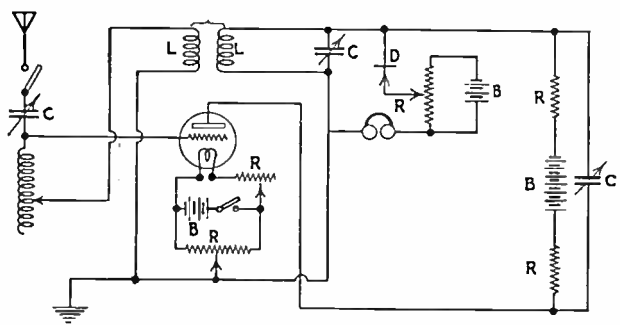

FIG. 96.—Marconi Receiving Circuit.

AUDION LABORATORY CIRCUITS

Fig. 97 shows suitable circuits proposed by White which can be used for laboratory or therapeutic purposes.

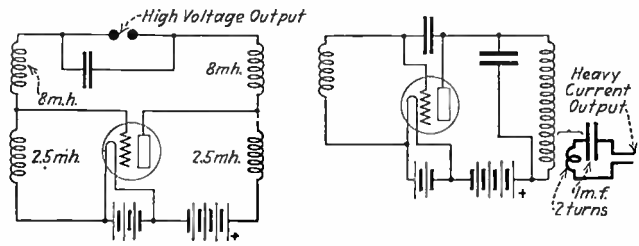

FIG. 97.—Audion Connections for Either High Voltage or Heavy Current for Laboratory Experiments.

A GENERATOR WHICH TUNES ITSELF

In Fig. 98 a very simple oscillating circuit is shown which may be used as a radio-phone transmitter or an autodyne (self heterodyne) receiver. The frequency is here determined by the constants of the separate oscil-

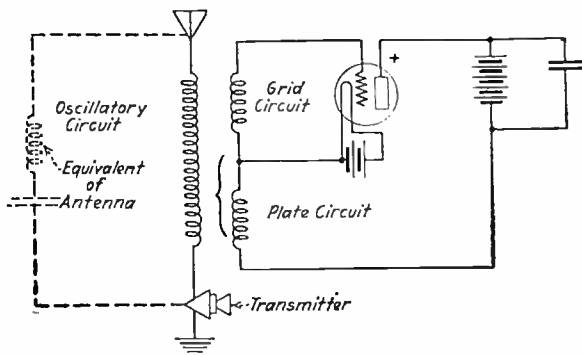

FIG. 98.—A Self-Tuned Oscillating Generator.

lating circuit (antenna-ground) coupled to the plate and the grid circuits so that the circuit is very well suited to the home experimenter's needs.

SELF-MODULATED AUDION TRANSMITTER

Fig. 99 shows how an audion generator can be used as a transmitter to give signals which may be received on an ordinary crystal detector set.

CONVERTED FREQUENCY AMPLIFIER

Recently a nine-step short wave length amplifier has been developed on the beat principle to convert the

short waves at high frequency to longer ones at less frequency. The latter are then amplified as usual with much greater efficiency than formerly. A diagram of such a circuit as constructed by an amateur is given in "The Wireless Age" for January, 1920, but is too complicated for use except by the advanced reader.

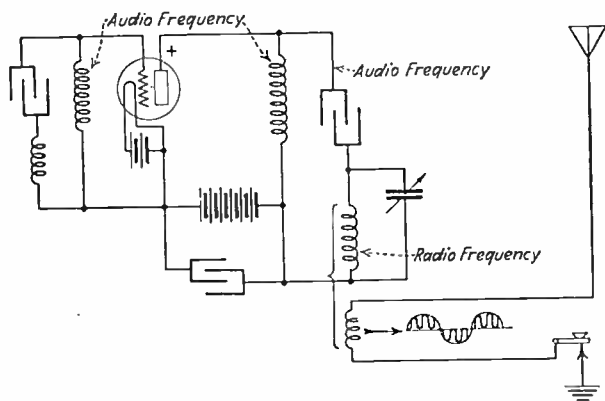

FIG. 99.—A Circuit for Self-Audio Frequency Modulated Groups of Sustained Radio Frequency.

CHAPTER XV

Tube Radiotelephones

Modulation Systems; Portable Radiotelephone; Transcontinental Wireless Telephone; Connection of Tubes; U. S. Army Set; U. S. Navy Set; A Wireless Telephone Operated from Your Lamp Socket; Power Tube Radiotelephone; A Small Amateur Radiophone; Cost of a Telephone Set.

COMBINED MODULATION

Starting with a telephone transmitter, this may be used to grid modulate one vacuum tube which in turn is cascaded to several others, the last of which repeats into an Alexanderson-Nixdorf magnetic amplifier, which latter controls directly the output of a large high frequency alternator. As much as 100 kilowatts can be modulated in this manner from an ordinary telephone transmitter.

Figs. 100, 101, 102, 103 show suitable circuits for radiophones with range up to about ten miles when a vacuum tube receiver is used. Larger ranges can be ob-

tained by increasing the power handling ability of the generating tubes used. The "grid modulation" shown is very effective and requires no large current capacity microphone transmitter, as is obvious, because the output is potentially controlled.

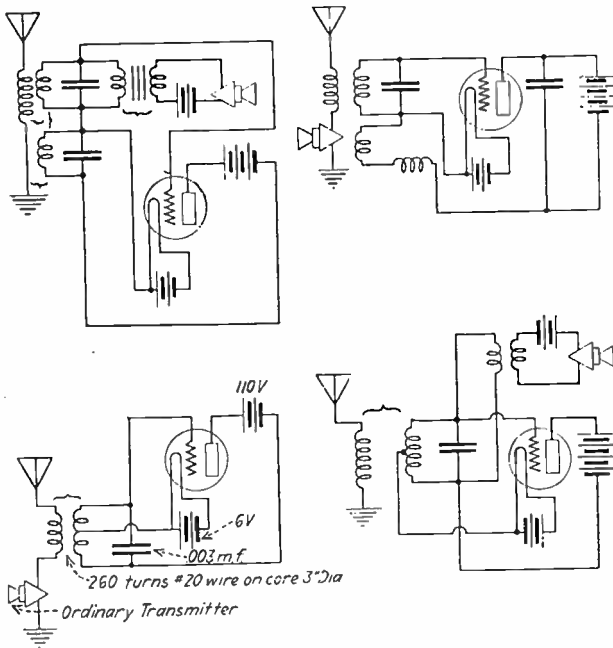

FIGS. 100, 101, 102, 103.—Radiophone Circuits.

Tubes are now built in sizes up to 1 K. W. each. The largest ones are made from "pyrex" heat resisting glass and have tungsten metal parts so that the plate can be run red hot.

COMBINED PORTABLE RADIOTELEPHONE AND TELEGRAPH SET

Fig. 104 shows a multi-turn coil combined radio telephone and telegraph transmitter and receiver devised by the author for short range work requiring no antenna.

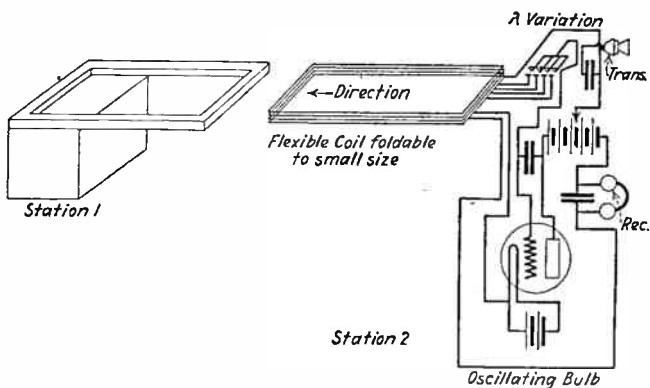

FIG. 104.—Portable Tube Radiophone and Telegraph Set.

This is an excellent set for demonstration as well as other obvious purposes.

TRANSCONTINENTAL WIRELESS TELEPHONE

In 1915 wireless telephone, one way communication was established from Arlington, Va., to Paris, France; Honolulu, Hawaii; Colon, Panama, and a few other places. On the basis of the author's own independent experiments, previous to the above mentioned tests, it is probable that the circuits employed were of the type

shown in Fig. 105. There are various modifications for the same result.*

In this figure the current from a telephone line is amplified through an audion bulb in the manner already set forth and this amplified current is used to actuate the grid-filament circuit of a large number of highly evacuated bulbs connected in parallel and arranged to generate undamped waves after the manner already set forth.

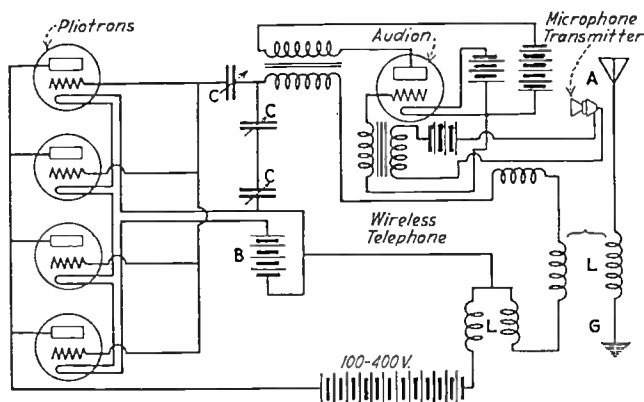

FIG. 105.—High Power Wireless Telephone.

An ordinary telephone transmitter may thus be used to vary the strength of the high frequency oscillations set up in several hundred bulbs and where one bulb is shown in the diagram it will be understood that any suitable number of bulbs may be substituted in a similar manner to secure higher power. Continuous radiation occurs in the aerial-ground circuit and this is modified in exact

* First complete publication was given as above in the 1916 edition of this book.

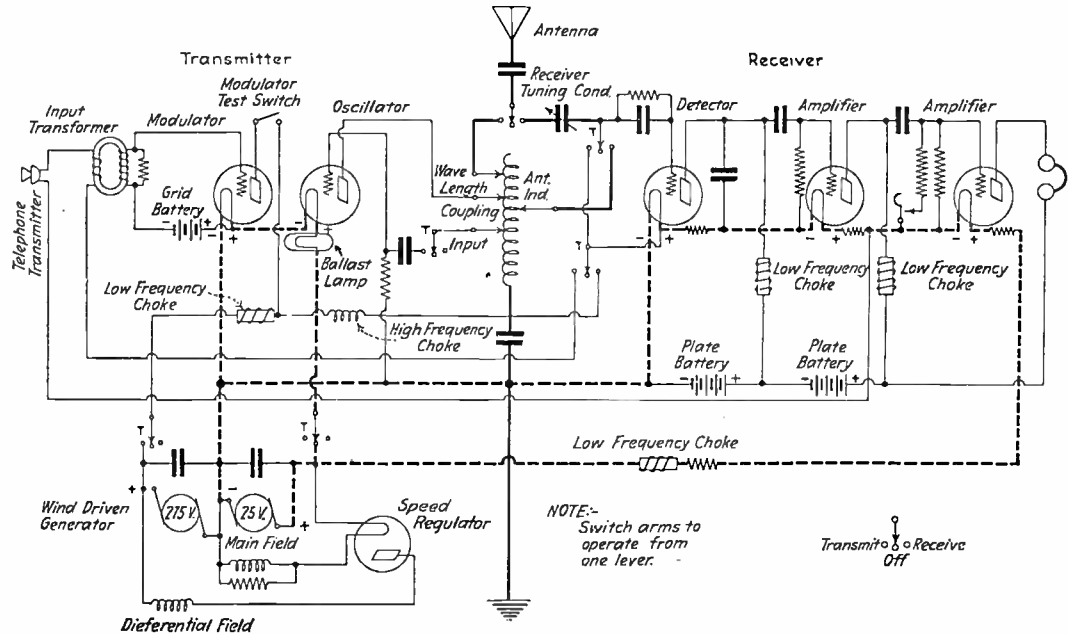

FIG. 106.—Aeroplane Radiotelephone Circuit.

accordance with the voice which causes the original variations of the electrical current which are amplified and made to control the larger current at radio-frequency. This will be readily understood by bearing in mind the previous discussions of the parts here combined. Any receiving station with a sensitive detector

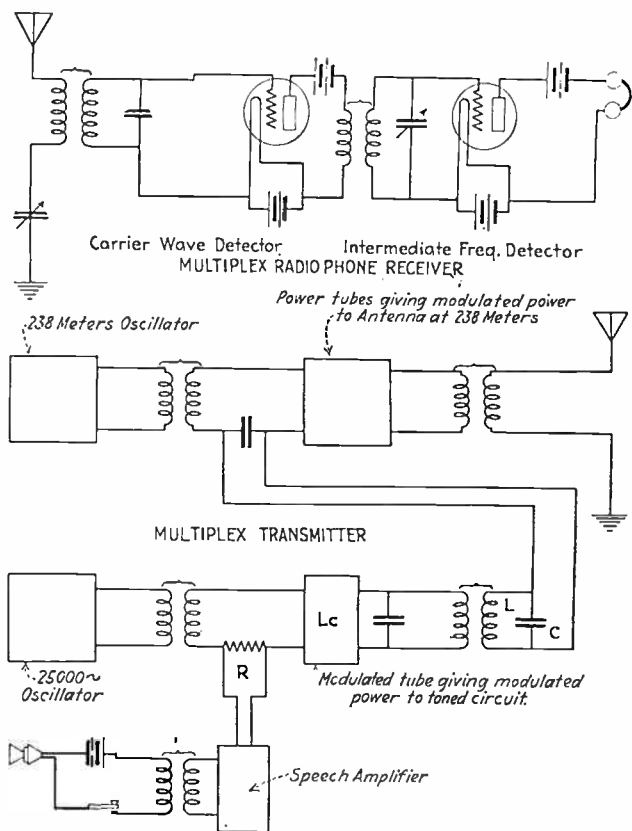

FIG. 107.—Multiplex Radiotelephone System.

such as an audion with amplifying circuit can receive from such a wireless telephone station and the voice reproduction will be even better than over land lines.

Transcontinental radio-telephony is an assured success in the immediate future for general commercial use.

ARMY AND NAVY SETS

Fig. 106 shows the aeroplane radiophone used by the U. S. Army. The vacuum voltage regulator keeps the generator voltage used to supply the transmitting bulbs constant at various speeds. See paper by Craft and Colpitts, A.I.E.E., Feb. 21, 1919, for further details.

Fig. 107 shows the principle of multiplex radio-telephony. The emitted waves are doubly modified, first at radio and then at voice wave frequency so that several

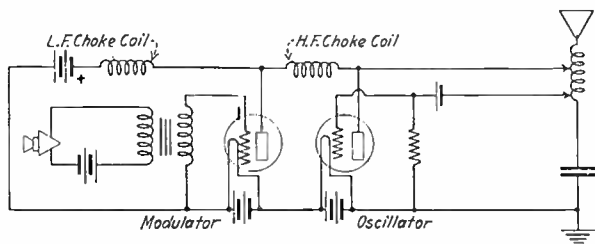

FIG. 108.—U. S. Army Radiotelephone Modulator.

voices can be carried by the same transmitter at one time. At the receiver there is a tuned circuit to select the radio frequency modified received wave which in turn is delivered to the proper detector. This principle is used also in multiplex line telephony.

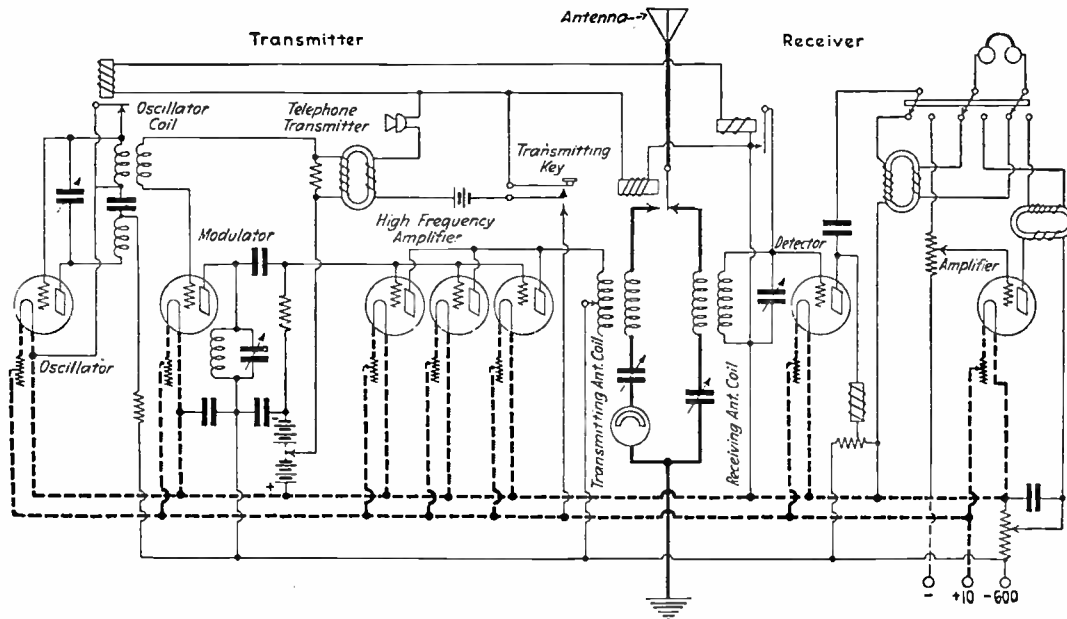

FIG. 109.—U. S. Navy Radiotelephone.

Fig. 108 shows the modulator used in army radiophone sets.

Fig. 109 shows the U. S. Navy radiophone. A small oscillator is grid modulated and repeated into several power tube amplifiers which supply the antenna circuit as shown. Circuits of this type can be arranged to give transmission over a range of 100 to 5,000 miles, depending upon the power used.

A WIRELESS TELEPHONE OPERATED ON YOUR LAMP SOCKET

Fig. 110 shows how three connections, A, B, C, will give a serviceable short range radio transmitter and receiver of fixed wave length requiring no further adjustments after initial installation. For receiving contact D

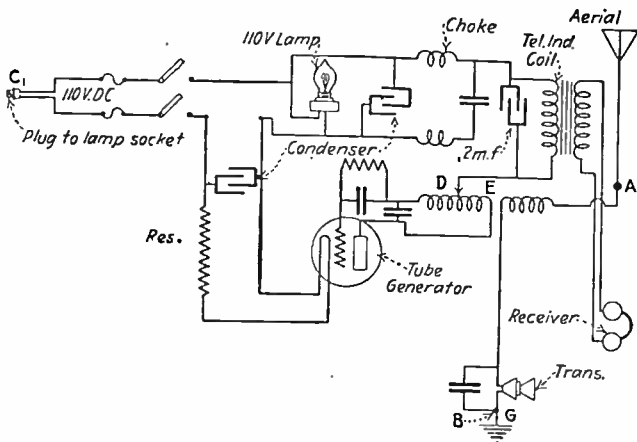

FIG. 110.—Wireless Telephone Operated from Lamp Socket.

is moved to end E instead of one-fifth from this end as for transmitting. A similar set has been developed for alternating current by using a rectifier.

POWER TUBE RADIO-PHONE

Fig. 111 shows an oscillating tube generator devised by the author to handle large power inputs. The ad-

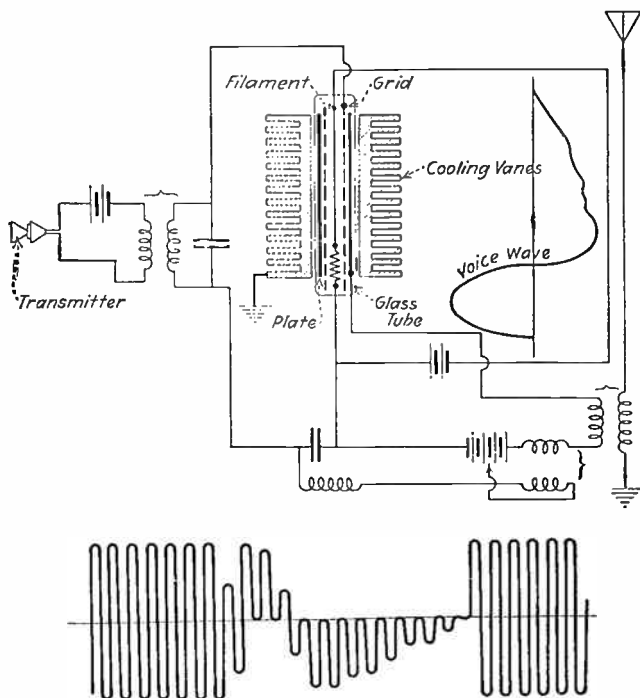

FIG. 111.—Edelman Air-Cooled Oscillating Tube.

vantages are obvious. The usual manner of voice modulating the continuous waves is employed as indicated.

AN AMATEUR'S RADIO-PHONE

The experimental set herein described uses from fifty to ninety volts of the large size tubular flashlight batteries or No. 6 dry cells.

The continuous wave generator in this outfit described by F. R. Pray (W. A., Mar., 1919), consists of two small, three element vacuum tubes such as tubular bulbs or electron relays with the members connected in parallel. Additional bulbs may be added to increase the range, which should be from two to six miles per bulb, depending on the tuning of the circuit and the efficiency of the antenna and ground.

Figure 113 gives the front and side view of the assembled outfit. The front panel should be made of some good insulating material such as Bakelite. The base and back may be of hard wood treated with asphaltum varnish or a mixture of lamp-black and shellac as they are touched by no current carrying connections. On each side of the panel, about 9 inches up from the base, two wooden strips 7 inches long should be placed between the back and front, to strengthen

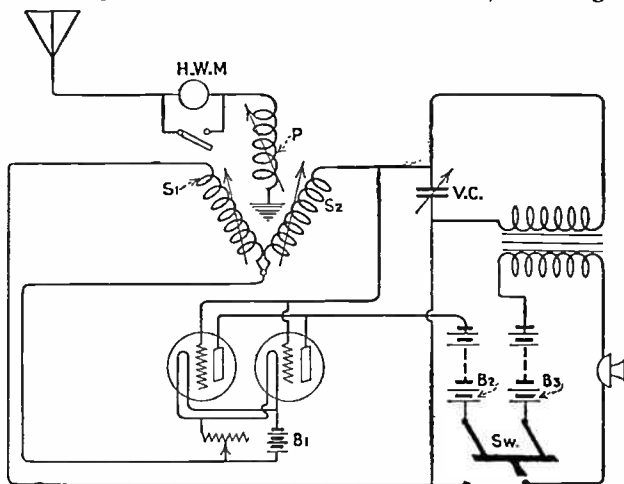

FIG. 112.—A Small Radiotelephone Set.

the construction. These are not shown in the side view as they would cover up the wooden, inch square strips which support the two secondaries. These hinge from the primary with these strips as axes. See diagram, Fig. 112.

Each of the two secondaries, S_1 and S_2 , is composed of five turns of edgewise wound copper strip spiral $7\frac{1}{2}$ inches in diameter, $\frac{1}{2}$ inch wide and $\frac{1}{16}$ inch thick. Each turn

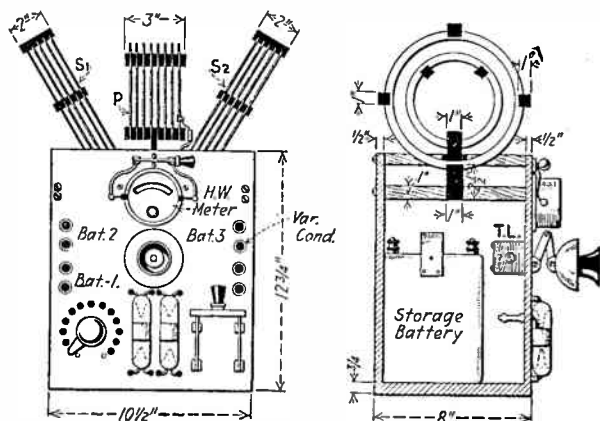

FIG. 113.—Arrangement of Small Radiotelephone Set.

is held $\frac{3}{8}$ inch apart from the adjoining turn by strips of Bakelite, 1 inch square and 2 inches long, except at the bottom. The coil is fastened to the axis upon which the secondary pivots by a piece of Bakelite shaped as in Figure 3-A. The primary, P, is composed of copper, spiral wound edgewise as the secondaries and is 5 inches in diameter, $\frac{5}{16}$ inch wide and $\frac{1}{16}$ inch thick. Each adjoining turn is held $\frac{3}{8}$ inch apart by Bakelite strips, $\frac{3}{4}$ inch square and 5 inches long, except at the bottom, where the primary is supported by a piece of Bakelite as in Figure 3-B. This piece is to be fastened to a strip of wood, held between the front and back panels by wood-screws as in the side view of Figure 2.

The copper strip for the "oscillation transformer" may be purchased from supply houses.

The transformer is considerably heavier than necessary for the current derived from the high voltage battery as suggested here, for the experimenter sooner or later may find himself in a position to use power bulbs and a commercial form of high voltage supply.

In most radiophone circuits a radiation indicator (such as a hot-wire ammeter) is essential, for successful operation depends mainly on careful tuning. The hot wire meter shown may be purchased for a few dollars or be made as described elsewhere in this book. Battery B_3 is comprised by six dry cells, ignitor type, or a storage battery. Coil I is a telephone transformer obtainable for a few cents from used apparatus dealers. Battery B_1 is a six-volt, ten-ampere hour storage battery. The rheostat switch in the lower left-hand corner is $1\frac{1}{2}$ inches in diameter and has twelve points of variation.

Any audion or equivalent bulbs costing around \$5.00 each may be used. Condenser VC should have about 36 plates with total capacity of .005 mfd and should be immersed in cylinder oil.

The range of the set is 175 to 350 meters with usual 200 meter type of aerial.

CHAPTER XVI

The Receiving Station

Operation of Receiver; Telephone Receivers; Purpose of Detector; Energy of Signal Received; Types of Detectors; Principles of Operation.

Having considered the transmitter and its details, as well as vacuum tubes, the *receiving* station details will now receive attention. The aerial and ground have already been discussed and since they are the same in most cases for both transmitter and receiver, they need no further attention.

We have seen that the transmitter emits *waves* of definite lengths and having definite characteristics, according to the adjustment of the transmitter and that these waves are spread out in all directions at the speed of light. Now at the receiver, all that is necessary is some apparatus which will *detect* the waves which strike the receiving aerial and translate them into an intelligible signal.

For this reason, the apparatus in its simplest form consists merely of a detector and a telephone receiver connected in the antenna circuit. This is shown in Fig. 114.

It will be understood that other sensitive recorders such as an Einthoven galvanometer can be used instead of the telephone receiver. The detector, however, is essential, because even the most sensitive telephone receiver or galvanometer cannot record signals without it.

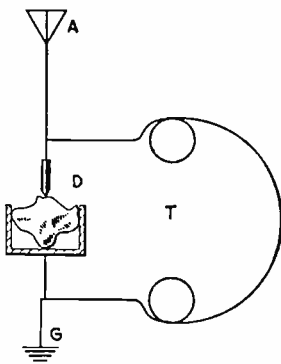

FIG. 114.—Simple Crystal Detector Receiver.

In early experiments, a relay was used for the recording instrument. In its most sensitive form, however, a relay will only operate with about .001 of a volt at its terminals. Further, its action is slow, so that it has been discontinued for signalling purposes. Its use is limited to the field of telemechanics, the art of controlling motors, boats, etc., by wireless through a local relay. Its co-operating detector, the coherer, has also become obsolete except for the purpose mentioned.

The *telephone receiver* is the instrument in universal use for wireless receivers. The receivers for radio purposes are made different than for ordinary purposes.

TELEPHONE RECEIVERS FOR WIRELESS RECEIVING

Receivers for wireless purposes should be very *sensitive*. It has been found by experiments that the degree of sensitiveness depends largely on the *frequency* at which the received signals are sent. Thus, messages from a 900 cycle transmitter will produce an audible sound in the receiver when only 0.6 millionths of a volt is used, while impulses received from a 60 cycle set will only produce an audible sound when 620 millionths of a volt are used. These figures are according to Dr. Austin, and while they are taken for a particular set of receivers, with the use of a laboratory arrangement, the general relation holds good. It is for this reason that the transmitters operating at 500 to 1,000 cycles are more effective than those operating at low frequencies. The sensitiveness of a given receiver depends on the frequency employed to operate it and also on the natural period of vibration of the diaphragm. It is for this reason that thin diaphragms are employed in wireless receivers.

WHY A DETECTOR IS ESSENTIAL

The detector (see Fig. 114), is not necessarily the most sensitive instrument at the receiving station, but is essential because the telephone receiver, while more sensitive, will not of itself respond to high frequency *oscillations* such as are received at a wireless station. The reason should be apparent, for the change first in one direction

and then in the other, of the oscillations is so rapid that the successive changes neutralize each other and produce no effect in the receiver. To operate on these oscillations a telephone diaphragm would have to move with frequency corresponding to approximately one-millionth of a second, which of course it cannot do. Again, we have seen that high frequency oscillations are greatly impeded by large inductance, so that the self inductance of the receiver would prevent any except minute currents from operating it. The detector, then, *translates* the received oscillations into a current which will operate the receiver.

The oscillations coming in on the aerial A, Fig. 114, are transformed by the detector into currents which operate the receiver.

THE RECEIVED SIGNAL

The received signal, then, is made up of wave trains which set up an oscillatory current in the receiving station which corresponds to that sent by the transmitter. When it is remembered that the transmitted energy is sent out in all directions it is remarkable that one point such as a receiving station receives as much energy as it does. According to Mr. Pickard, measurements of the maximum energy received from a high power transmitting station 90 miles away, showed this energy to be .03 ergs per dot. The "erg" is equivalent to one ten-millionth of a watt. Inasmuch as a sensitive telephone receiver will operate with an audible sound on as little as one-millionth of an erg this leaves a considerable margin. In any case, the received energy is many hundred times

the actual energy necessary to produce an audible sound in the receiver, but since the receiver will not of itself operate efficiently on the high frequency oscillations, the detector employed limits the efficiency of the receiving station to a large extent.

Like other transformers, the detector represents a source of loss. The modern detector, however, is quite sensitive.

Now the simple circuit shown in Fig. 114, comprises an untuned receiving set and is of little use without an auxiliary tuning apparatus if messages are to be received from modern transmitters.

TUNING

In order to receive signals from a transmitter, the receiver must be adjusted so that its circuits are in tune or resonance with those of the transmitter. Both the transmitter and receiving circuits must have the same time period of oscillation. Thus, if the receiver is to receive from a station sending out a 300 meter wave it must be adjusted so that its wave length is very nearly 300 meters. However, if the transmitter is poorly tuned or very close to the receiver, it is a common occurrence to receive the message without careful tuning, or even without any tuning. The apparatus for tuning a receiver consists, as at the transmitter, of adjustable circuits containing variable capacity and inductance.

The same receiving set may be used for either wireless telegraphy or telephony, since the conditions are identical in many respects. Indeed, both telephone and

telegraph messages can be heard at the same time in some localities.

The requisites for the receiver then are:

1. Sensitive detector.
2. Sensitive telephone receiver or recorder.
3. Accurate auxiliary adjustable circuits for tuning.
4. A good aerial and ground, as for the transmitter, or a coil as described in Chapter III.

The several items will receive attention presently, in some detail.

TABLE OF DETECTORS—SENSITIVENESS

Type of Detector.	Energy required to operate. in ergs. per dot.
Audion (regenerative)0001 †
Audion (rectifier without feedback)0003 †
Electrolytic003640—.000400 *
Silicon000430—.000450 *
Magnetic hysteresis detector01 §
Hot-wire barretter	0.08 §
Carborundum009000—.014000 *

* According to Pickard. † Author's estimate according to adjustment.
 § According to Fessenden.

CHAPTER XVII

Detectors

Vacuum Tube Detectors; Solid Rectifiers; Crystals; Construction of Detectors; Crystal Mounting; Adjustments; Buzzer Test.

Quite a number of different types of detectors have been discovered and developed and there are many forms for these.

Vacuum tube detectors are at present the most sensitive and popular. There are many forms but the general type is in universal use. It consists of a lighted filament placed near a sheet electrode or plate with another electrode or grid interposed there between, the whole being in an evacuated bulb. These devices will be separately discussed.

For experimental purposes, however, the types known as crystal or *solid rectifiers* are still valuable because of their sensitiveness, low cost, easy adjustment, portability and durability. Other forms which may be used are coherers, loose contacts, (almost any loose contact, as between a piece of carbon and a needle, being suitable), magnetic detectors, barretters or thermal detectors, electrolytic detectors, and gaseous detectors.

Solid rectifiers consist essentially of certain metallic compounds, such as oxides and sulphides, which have the property of *rectifying* the high frequency oscillations. That is, these metallic compounds when connected in a circuit, conduct the current better in one direction than in the other. This *unilateral* effect is quite marked, so that the detector acts as a valve, allowing the current to pass in one direction but *preventing* it from passing in the reverse direction. In addition it is necessary to have this rectifying effect carried on regularly so that the oscillations are rectified into a pulsating one way or direct current. The latter then serves to operate the telephone

Mineral Name.	Chemical Name.
Carborundum	Silicon Carbide
Fused Silicon	Silicon
Iron Pyrites	Iron Sulphides
Copper Pyrites	Copper Sulphide
Chalcopyrites	Copper Iron Sulphide
Hessite	Telluride of Silver and Gold
Zincite	Zinc Oxide
Octahedrite	Oxide of Titanium
Stibnite	Antimony Sulphide
Galena	Lead Sulphide
Molybdenite	Molybdenum Sulphide
Zirconium	Zirconium
Niccolite	Nickel Arsenide
Domeykite	Copper Arsenide.
Sphalerite	Sulphide of Zinc
Pyrrholite	Iron Sulphide
Corundum	Oxide of Aluminum and Iron
Hematite	Iron Oxide
Cassiterite	Oxide of Tin
Siderite	Iron Carbonate
Malachite	Copper Carbonate
Cerussite	Lead Carbonate

or other recorder. The metallic compounds used have this property also, so that a solid rectifier is a good detector for the wireless receiving circuit. It is interesting to note that while a part of this phenomena was noticed as early as 1874, these metallic compounds were not understood and used as detectors until about 1906. A partial list of the elements and compounds which may be used for this purpose follows:

With the exception of Carborundum these may all be used without a battery with good results. Usually a battery with potentiometer control is employed to adjust for the best portion of the detector's operating characteristic. When two different crystals are used together to form a pericon detector, the use of a battery is optional.

In use, a small piece of the compound which will be hereafter called a *crystal* for convenience, is mounted between two metallic contacts. The exact nature of these contacts depends upon the particular crystal employed, and in nearly every case, it is desirable to make the contacts adjustable, so that the most *sensitive* part of the crystal can be used with the contacts at the best pressure. In practically every case it is desirable to make one of the terminals or contacts with a *large* area so that it makes very good contact with the crystal. This is to prevent the other contact from forming an opposing and undesirable second rectifier, which would greatly reduce the effect. The crystal then, is mounted between a large and a small contact. *Silicon* is perhaps one of the most widely used solid rectifiers. The *iron pyrites* or pyron detector, the *galena* or lead sulphide detector, and the

molybdenite detector, in the order named, are the other single crystal rectifiers in most general favor. Each has certain advantages and disadvantages and the various factors which determine the utility of a detector are so variable that direct comparison without exact tests is not possible. In order to secure the necessary large contact for these detectors, the crystal is imbedded in a cup with a fusible alloy such as Woods' metal, while the small point consists of a rounded adjustable point of brass, gold, platinum, or else a wire of these metals. When two or more of these crystals, one of which is preferably zincite, are used, this small metallic point is replaced by a fragment from another crystal. A small piece of chalcopyrite is generally used for this purpose. This pericon detector is quite sensitive. Small metal points are most suitable for polished crystals such as iron pyrites and galena. These two detectors are particularly free from injury from mechanical shocks or foreign electrical impulses.

For experimental purposes it is well to provide what is known as a *universal* detector stand so that any or all of the materials as well as new ones as yet undiscovered may be tried. There are plenty of unfound materials which may be much better than those now in use and a search for some of these would furnish enough excitement for the average experimenter for some little time. It is well to remark, however, that a mere duplication of detectors no better than those already in use will not be of much importance or use. What is wanted is something better, more sensitive, having less resistance, and which is more reliable and permanent. Vacuum tubes

of course accomplish these results very closely but they have their own disadvantages and can be improved.

Even if a vacuum tube is to be used, a crystal detector is still a good auxiliary and can be relied on when the batteries of the tube circuits suddenly fail.

CONSTRUCTIONAL DETAILS

There are a great variety of constructions for solid rectifying detectors, almost every experimenter making a different kind or different form. Provided that the following general requirements are adhered to, the matter of size, adjustment (mechanical movement used), and form is of little consequence. The reader has unlimited latitude and opportunity to exercise his ingenuity. A few accepted forms which are similar to those in general use are shown as examples.

MATERIALS

The crystals in general use can be had from supply houses. Whenever possible tested crystals should be purchased, as this saves considerable time and trouble. For instance, it may happen that only a dozen or so suitable points will be obtained after trying out a pound of material, broken up into points. The silicon used should be *fused* silicon, the carborundum preferably *green* carborundum, and all of the others in the best grade obtainable. Cheap grades generally contain considerable foreign matter which is of course not desirable. Owing to the fact that the most commonly used crystals are

mentioned in the claims of patents held practically by one holding company, many dealers in minerals and crystals do not sell them for fear of infringement suits. The various cups, brass, screws, and other materials can also be had from supply houses.

Crystal mounting. Fig. 115 shows some suitable mountings for the crystals to form the large contact necessary. Two spring pieces fastened to a block of wood as at (a) will do. Perhaps the best mounting is that shown in the figure at (b), where the crystal is held in a cup containing a fusible alloy. This may be made by melt-

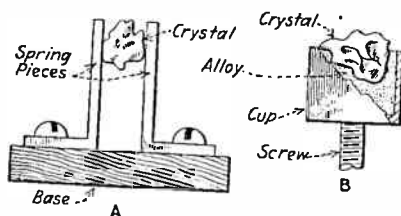

FIG. 115.—Mounting for Crystals.

ing four parts of bismuth, one part of cadmium, two parts of lead, and one part of tin together. Three parts of a good grade of solder may be used instead of the lead and tin. The melting point of this alloy is approximately 138 degrees F, and this mixture is used so that the resulting heat will not injure the crystal as ordinary solder would. The cup should be well cleaned before pouring the alloy in and around the crystal. The metal is preferably poured into the cup and then the crystal is placed into the metal, and held in place until the alloy cools. A substitute for this method is to pack the crystal

in the cup with tinfoil wads. This allows the crystal to be removed so that the sensitive part can be found. The cap from a round dry battery carbon can be used for a cup if it is well cleaned and polished. The tinfoil can be packed in so tight that the crystal will not fall out, and if the exposed part is found not to be sensitive, the crystal can be removed, turned over, and tried again, until a sensitive part is found. Many similar arrangements will suggest themselves to the reader. Almost any form of spring, clamp, or other contact which will make a large contact and hold the crystal in place is suitable.

The crystal used should be a small fragment as it will then work as well or better than a large piece. It must *not* be ground and should be left in its natural

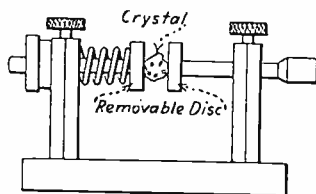

FIG. 116.—A Convenient Crystal Detector.

shape. Most of the materials are best used as small chunks. Molybdenite is best used as a thin sheet. The molybdenite may be easily copper plated so that connected wires can be directly soldered to it. When a pericon set is used, the zincite should have a larger surface than the other crystal. The latter may be a fragment of bornite or chalcopyrite, preferably with a definite point for contact.

In making a universal detector, it should be remem-

bered that three types of contacts will be needed to include suitable contacts for all materials. Crystals like silicon work best with a blunt point and light contact,

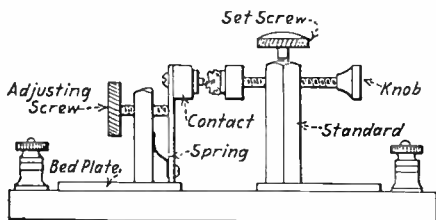

FIG. 117.—An Adjustable Crystal Detector Stand.

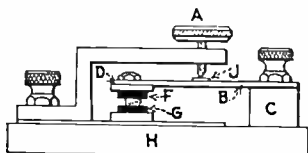

FIG. 118.—A Compact Crystal Detector.

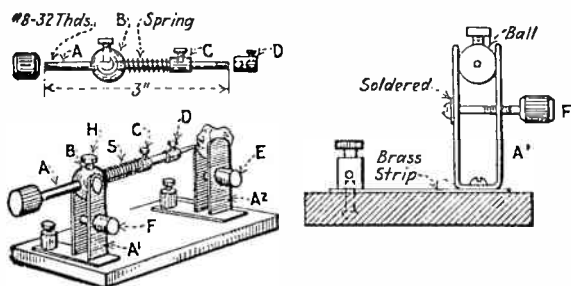

FIG. 119.—A Universal Detector.

molybdenite with a blunt point and comparatively heavy contact, those like galena and iron pyrites require a fine light point, and others like carborundum require two large contacts with a comparatively large pressure. An ar-

range which will provide for these variable conditions is, therefore, desirable. Some suitable mechanical arrangements are shown in Figs. 116, 117, 118. In the clamp type, the crystal can be removed and another one replaced, while in the multi-crystal type the several crystals are mounted so that any one may be used at a time. Where compactness is no object it is perhaps a better plan to have a plurality of separate detector stands for each crystal. A duplicate detector is also desirable, so that when one crystal becomes poorly adjusted, another sensitive detector can be immediately switched into circuit.

Referring to the figures, which were collected from various sources, Figs. 116, 117, 118 show suitable constructions for a simple universal detector and require no further comment. In Fig. 118, A represents an insulated thumbscrew, B a brass spring strip, C a metal standard of round or square brass, D, F, G, contacts which may be used for a variety of materials, H a base, I a brass strap, and J a notched cup.

Fig. 119 shows another universal detector. The shaft A slides into a ball B, which is in turn held by the strips A1 with a pressure adjustable by F. The spring S keeps A in position. C is a simple screw chuck holding another chuck D in which a point is in turn held. Different shaped points may be used in this manner. The crystal is held adjustably in a clamp A2. The arrangement is quite simple and allows almost any desired adjustment and use.

The multi-cup arrangement of Fig. 120 is taken from patent No. 1,027,238, and is quite simple. The post C

can be turned so that the contact G makes contact with any one of the cups arranged as a circle on the base. The contact G can be reversed so that the detector can be used as an electrolytic detector with one of the cups K. The spring I provides a mild, variable pressure, and the rough adjustment is made by the screw F clamping E to C after the proper length has been found. Fig. 121

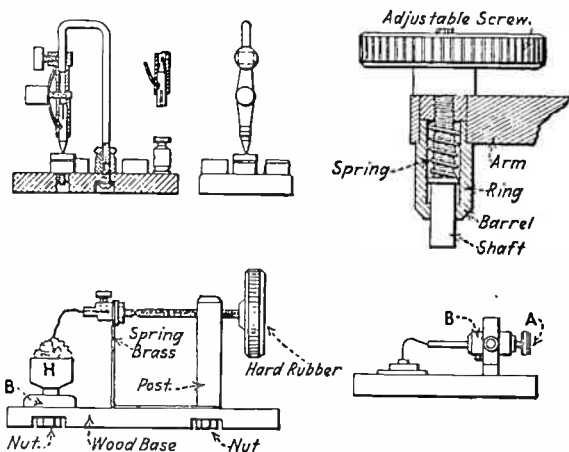

FIGS. 120, 121, 122, 123.—Crystal Rectifier Detector Details.

shows a simple arrangement suitable for galena, iron pyrites and silicon, and needs no further comment.

Fig. 122 shows a delicate adjustment suitable for the small movable point of a universal detector. Fig. 123 shows a novel scheme for adjusting the pressure of the small point on the crystal. The piece B is mounted on a pivot so that it balances nicely. The pressure on the small contact can then be varied by screwing the nut

A in or out, thus securing more or less weight on the fine point. Pericon crystals may be similarly mounted, the extra crystal replacing the fine point.

CARE AND ADJUSTMENT

Detectors should be regarded as sensitive and delicate instruments. They should be kept out of the sunlight, away from dust, dirt and acid fumes, and similar places.

The crystals become less sensitive after a time, but can often be renewed by cleaning with gasoline or carbon bisulphide, using an old tooth brush and taking great care to avoid a fire or even a burning light, because both materials and particularly the bisulphide are very explosive. Heat alone if applied rationally will often restore an old crystal to sensitiveness again.

BUZZER TEST

The actual *adjustment* is a matter which must be determined by experiment. A *buzzer test* is very valuable for this purpose and should be a part of every wireless receiving set. This is simply a common buzzer, such as may be had for about 25 cents, connected to a key and battery and to a short aerial wire as shown in Fig. 124. The wire need only be a few feet of number 18 bell wire. The connections can be arranged on the aerial switch so that when the switch is set for receiving, the transmitting key will operate the buzzer instead of the transformer. The noise of the buzzer should be deadened by covering it with old clothes or else by placing the buzzer outside of the building, since it is not de-

sirable to hear the buzzing sound. This buzzer sets up weak wireless waves and the detector is in adjustment when the said waves are received and heard the loudest. The short wire can also be directly connected to one terminal of the detector if desired but this is not recommended. Adjustment of the detector may also be carried out while receiving from another station, provided that the copying of the message is of secondary importance while the adjustment is being carried out. Another suitable circuit is readily made by connecting the condenser

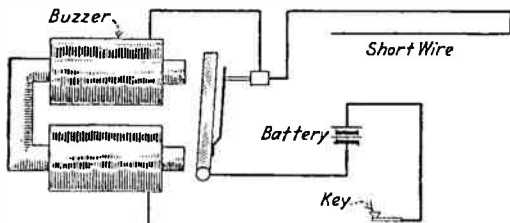

FIG. 124.—Arrangement of a Buzzer Test for Detectors.

terminals of a wave meter to the short wire and battery respectively. The turning on and off of an electric light socket can also be used as a buzzer test, the resulting arc supplying the necessary waves. While we are on this subject it may be noted that a lamp on a lighting circuit near the transmitting station can be made to light up when the station is sending. Turn the lamp on and then unscrew the bulb until it just goes out. The transmitter will then cause it to light, when the key is pressed. This experiment illustrates the coherer principle to a certain extent and will only work when the light is in close proximity to the transmitter.

CHAPTER XVIII

Sensitive Indicators for Receiving Sets

Telephone Receivers; Continuous Wave Detectors; Einthoven Galvanometer; Construction of Indicators; Automatic Indicators; Hoxie Photographic Recorder; Amplifiers; Microphone Amplifier; Baldwin Receiver; Adjustments; How Receiver Operates; Measuring Intensity of Received Signal; Audibility Meter.

In order to receive from a *continuous wave* transmitter such as a telegraph transmitter operated by an arc generator, which is not audibly altered at the transmitter, it is necessary to modify the received impulses audibly at the receiver. The human ear can only hear or recognize vibrations which do not exceed 35,000 or 40,000 per second, so that the waves sent out from an arc generator vibrating at many times this rate are inaudible. One form of indicator which will efficiently record such inaudible waves without modifying them at the receiver by a vibrator or chopper is the Einthoven galvanometer. While this is a delicate instrument, a brief account of it will be given so that it may be constructed by skilled workers.

EINTHOVEN GALVANOMETER

This instrument consists essentially of a fine wire stretched between the pole pieces of a powerful electromagnet. This wire may be of platinum, silver, aluminum, or copper, and should be very fine. No. 40 or 50 such as is used for telephone receivers can be used. The construction and arrangement is shown in Fig. 125. In the

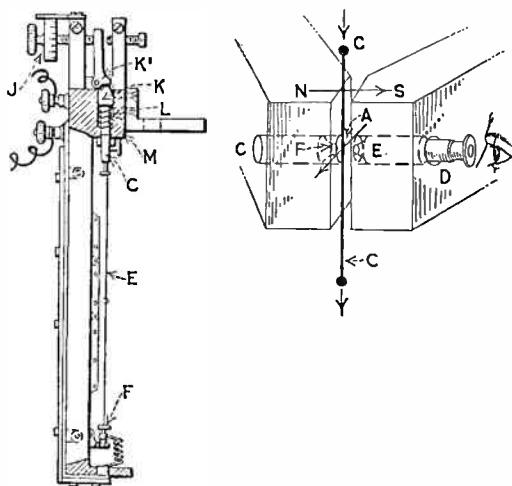

FIG. 125.—Einthoven Galvanometer Details.

most sensitive forms, a thin quartz or glass fibre which has been platinized is used and the reader is advised to purchase it from a supply house. The fine wire is mounted on T shaped set screws C and F, so that the tension can be delicately adjusted. As shown, this is accomplished by having C attached to a rod having a cam K on its upper end and held in place by a spring L.

When the lever KI presses down on the rod, a very fine adjustment is secured. KI is operated by a micrometer screw J , as shown. A more simple arrangement would also do, but the adjustment would then be less accurate, and more difficult to carry out.

The smaller part of the figure shows the position of the wire and magnets and one method for observing the displacement of the wire. The eye piece AE is inserted in a hole in one of the magnet poles.* Light is projected by the tube C and lens F . When the current flows in the direction of the arrows, the wire stretched between CC has a deflection indicated by the arrow a . This displacement can be magnified by projection upon a screen, in which case the eye piece is removed and a strong light applied at C . This recorder is very sensitive and can be used for long distance work as well as for experimental measurements. The amount of deflection indicates the strength of the received signal. In practice, a photographic record is taken by means of a moving film, so that a permanent record of the message as a defined line according to the dots and dashes, is the result. The experimenter may dispense with the photographic record. The skilled reader should not find it difficult to make a duplicate from this brief description. The magnet used should consume about 250 to 500 watts, and ready wound magnet coils may be pressed into service for experimental purposes. The success of the instrument depends on the fact that the fine wire has a rapid period. The instrument will not be of any use, however, unless delicately constructed.

* Old microscope parts can be used.

AUTOMATIC INDICATORS

Other sensitive recorders have been developed but require expert manufacturing facilities to produce. Signals received from stations several thousand miles away can be continuously recorded today by photographic or sound recording machines. The phonograph and telegraphone have been used successfully for short distance recording.

HOXIE PHOTOGRAPHIC RECORDER

A photographic recorder which can be connected in parallel to the telephone receivers in an ordinary amplified radio-receiver has been developed by C. A. Hoxie and it has been the author's privilege to make extensive pioneer use of this sensitive device.

A wee-bit of a mirror is mounted on knife edges and connected by a mechanical advantage whisker to a strip diaphragm similar to a telephone receiver diaphragm. This strip diaphragm is arranged so that its tension can be adjusted for response to different frequencies. Suitable magnet coils are arranged about the strip so that a slight movement is imparted thereto when audible group frequency flows in the coils from the detector-amplifier. This slight motion is mechanically amplified to vibrate the mirror. A spot of light from a tungsten bulb falls on this mirror and is thereby caused to move up and down on a strip of sensitized photographic paper which is driven by clockwork or an electric motor. The strip is automatically developed as it passes through suitable treating baths. Messages at as high a rate as 600 per minute can be recorded so that mechanical secrecy in communication is now feasible, it being impossible to get such intelligence with an ordinary receiver. The apparatus, while not as sensitive as a telephone receiver, works nicely on an audian amplifier so that long-distance signals are

readily recorded. The device is not simple enough for amateur duplication at present so construction details are not given here.

In order to receive unaltered continuous waves with an ordinary wireless telephone head receiver, the received impulses must be modified, interrupted or chopped. This can be done by the arrangement of Fig. 126, in which the relay shown is a 20 ohm or 75 ohm telegraph relay, having its magnet connected to an alternating current line through a lamp. The secondary platinum terminals are

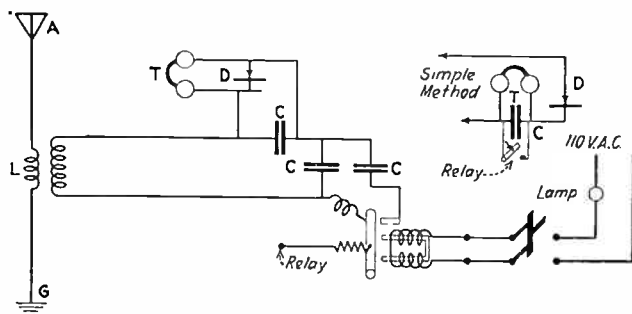

FIG. 126.—Poulsen "Tikker."

used to alternately connect and disconnect a large fixed condenser in the receiving circuit as shown, thus balancing and unbalancing the circuit at an audible frequency so that the received signals are rendered audible. This arrangement also effectually cuts out a great deal of other interference. When ordinary stations are to be heard the relay is merely disconnected from the line. The remainder of the circuit is familiar or will soon be and needs no further comment. The relay acts as an interrupter and may be used to throw either capacity or in-

ductance or both in and out of the circuit. The insert shows a simple method for the same purpose. In this case a single condenser is used in shunt about the telephone receivers. The remainder of the circuit is not shown as it is the same as before.

Either the Einthoven galvanometer or this chopper arrangement will be satisfactory to detect the continuous waves. With this arrangement, experimenters may receive from the Poulsen arc stations provided that the circuits are properly tuned. In connection with the apparatus described in Chapter XIII for telegraphy without modifying the continuous waves at an audible fre-

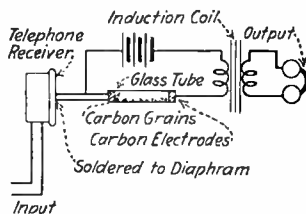

FIG. 127.—Microphone Amplifier.

quency at the transmitter, this form of detector forms an ideal one for the experimenter who does not wish to use vacuum tubes, but the latter are superior and more desirable. A somewhat similar arrangement is sometimes incorporated directly in the detector or condenser C (which latter is rotated by a motor), but since it is not much better, it will not be described here.

OTHER AMPLIFIERS

Brown's microphone relay has found slight use. It is connected in place of the phones and amplifies through a microphone contact which controls a local circuit. The telefunken amplifier is similar but employs a number of such telephone-transmitters of special reed type in cascade so that the amplified current of one circuit actuates the next, etc. A similar device employing a liquid microphone instead of a contact device has been brought out by L. Bishop and a few are in use. Microphonic ar-

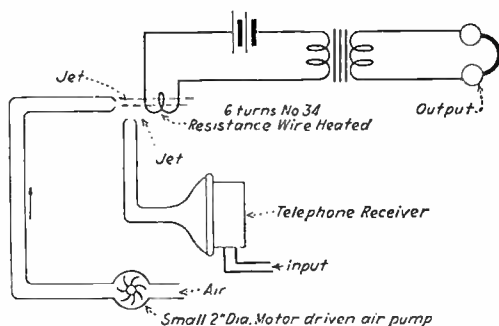

FIG. 128.—Hall Jet Amplifier.

rangements give amplifications of 20 upwards but are difficult to keep in adjustment and in general unreliable.

Various microphonic amplifiers have been used for experimental radio work. A readily constructed form is shown in Figure 127. A valuable air jet type amplifier is shown in Figure 128. A continuous current of air is passed through an enclosed electrically heated spiral of resistance wire. Another fine needle jet closely at right

angles thereto is acoustically connected to the receiving telephone and modifies the air jet and hence the resistance of the wire spiral, the changes of which are repeated as an amplified output. Some mechanical amplifiers have also been used experimentally. The electron tube amplifying circuits are best for most purposes.

TELEPHONE RECEIVERS

Fig. 129 shows telephone receivers used in radio work. The Baldwin type magnifies the motion. The monotelephone can be adjusted to respond best to a definite audible group frequency.

Ordinary telephone receivers may be used as recorders

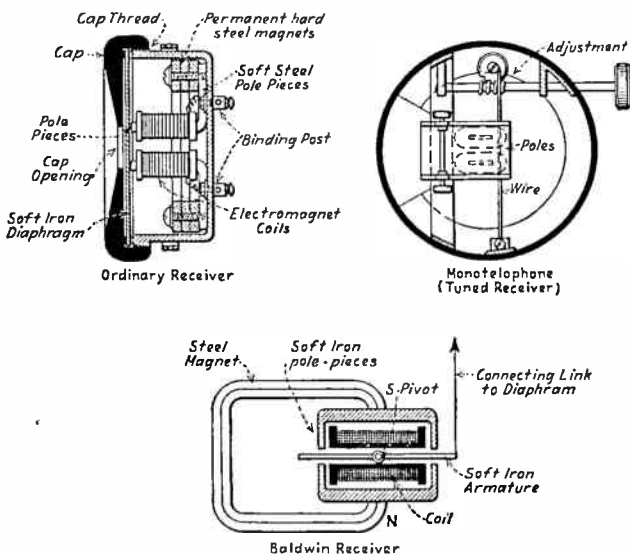

FIG. 129.—Telephone Receivers for Radio Service.

for experimental work over short distances, but specially constructed wireless receivers are necessary when long distance work is to be done. The receivers in general use are of the watch case type and either one or two receivers on a headband may be used. Since most people are able to hear much better with one ear than the other, it is an advantage to use only one receiver on the headband and to block off the other ear from foreign sounds by a rubber pad. This method is less expensive than when two receivers are used on a headband. However, if two receivers are used they must be identical in their dimensions and windings as otherwise the one having the least resistance or other unequal dimension will not work in accordance with the other one. Many manufacturers are now making reliable light weight receivers suitable for the most exacting wireless work, and while the latter are perhaps a little expensive, they are essential to efficient work, particularly over long distances. The reason why a low resistance telephone receiver such as is used for telephone work is not suited for delicate wireless work is that it is made to give a loud response with a comparatively large amount of applied energy but will not give any response with very minute currents, such as are produced by a detector receiving from a distant station. An ordinary receiver can be rewound, however, with No. 40 or 50 enameled wire so that its utility will be much greater. When this is done a new and thinner diaphragm should also be supplied, since the ordinary diaphragm is too thick for wireless purposes. These thin diaphragms may be had at supply houses and some are known as gold diaphragms because they are gold plated.

A wireless receiver is not intended to give a loud response, but rather to give an audible and working response with very feeble currents. The resistance, however, is not the real delicate part of the receiver, and the mere statement that a receiver is wound to 1,500 ohms means little or nothing. What is desired is a large number of ampere turns, and since this is best secured by using fine copper wire, No. 38 or 40 is generally employed. Receivers are rated according to their resistance largely because this is a convenient measure, but as far as workability is concerned, the number of ampere turns is the essential factor which determines the actual utility. In any case, a resistance of over 1,500 ohms is no advantage, and a resistance of less than 800 ohms is not desirable when the receivers are to be used with solid rectifying detectors. For vacuum tube detector circuits, 1,500 ohm receivers are suitable.

The author finds it advantageous to use a large telephone condenser in series with the telephone receiver so that much or all of the inductive impedance of the telephone receiver is neutralized by the capacity reactance of the condenser.

CARE AND ADJUSTMENT

While a receiver seldom requires attention after it has been adjusted, it should be kept clean, and free from dust and moisture. When rewound receivers are used it is sometimes necessary to adjust the distance of the diaphragm from the poles. This can be done by using a soft rubber cushion between the cap and the receiver

case, and screwing the cap on with more or less pressure, thus adjusting the distance between the diaphragm and the receiver's magnet pole. After long use, the permanent magnets should be tested and if the magnetic attraction is weak, the magnet should be strengthened by remagnetization. A common test is to judge by the distance between the receiver case and diaphragm, which is necessary just before the diaphragm (previously removed and laid on a table), is attracted to it.

Receivers are seldom burnt out. This may be the case after a station has been subjected to a heavy static or lightning discharge. This can be obviated by shunting the receiver or the whole receiving set with a pin gap or lightning arrester. The headband used should be comfortable and should keep the receiver tight against the ear. The receiver is very important and its sensitiveness together with the hearing ability of the operator is one of the largest factors which determine the receiving range of a station.

A word concerning *standard receivers* for wireless purposes. The magnets should be permanent and preferably of the consequent pole type, to prevent leakage about the pole pieces. The diaphragm should be thin and uniform, but of sufficient thickness to absorb sufficient magnetic flux. The poles, case, and diaphragm should be proportioned and made so that the maximum sensitiveness and least liability to injury and change is the result. Lightness and a good fit are important items as far as comfort is concerned, and if the receivers are to be used continually, this is a very important consideration. A suitable size for the wire used in the coils is No. 40 or

wire .0031 thick. A standard thickness for the diaphragm is .004 thick exclusive of the plate or varnish coat, which last is to prevent rust and corrosion.

HOW THE RECEIVER OPERATES

It is well known to the readers that the telephone receiver depends upon simple magnetic phenomena, so an account of the action will be dispensed with. It is well to understand the action in a wireless receiving set.

We have seen that the detector rectifies the oscillatory current into a pulsating direct current. Now, this direct current passes through the windings of the receiver and causes the diaphragm to be pulled according to the strength and changes in the current. While the current supplied to the telephone may have as much as a million pulsations in one second, the ear only hears a sound similar to that produced by a steady current on account of the regulation exerted by the *inductance* of the windings of the receiver. That is, each complete wave train after being rectified by the detector causes only one pull on the diaphragm, so that the operator hears one sound corresponding to each transmitted wave train. The argument is similar in the case of vacuum tube circuits. However, a complete signal, even a dot, generally comprises several successive wave trains so that the received signal is heard as a succession of clicks corresponding to the spark rate and speed at which the message is sent. The receiver gets the message almost the same moment that it is sent, since the waves travel at the rate of 186,000 miles per second, and the frequency

tone, wave length and other variable factors are practically the same as when the impulses leave the transmitting aerial.

MEASURING THE INTENSITY OF THE SIGNAL *

For experimental work it is often desirable to compare the *relative strengths* of the signals received either from two stations or from the same station using different instruments or circuits. A suitable simple arrangement for this purpose is shown in Figure 130, and consists simply of a calibrated shunt resistance about the phones. A non-inductive resistance box is suitable. The value of the received current in the telephone receiver

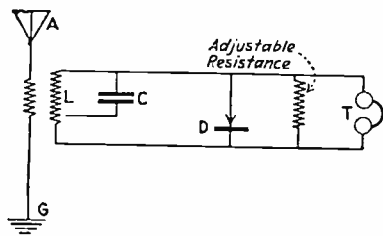

FIG. 130.—Shunt Audibility Meter.

is practically proportional to the energy of the incoming waves so that a rough table of values based on audibility is easily made. Thus a station which produces a sound just audible in the receivers when all the resistance is in

* This method can also be used to eliminate interference from weak stations, but is carried out at the expense of a decrease in the intensity of the received signal. It can, however, be utilized in connection with a wave meter.

circuit may be taken as a standard. If another station just produces an audible sound when one-half of the total resistance is in circuit, the new value can be compared with the standard. The calibration could just as well be the other way around so that the standard is audibility with no shunt resistance. The result is best expressed as a fraction of or so many times audibility, as the case may be.

Audibility is not an exact measurement because it depends upon human hearing ability which is variable.

$$\text{Audibility} = \frac{\text{Actual telephone current}}{\text{Least audible telephone current}} \\ = \frac{Z_1 + S}{S}$$

S = non-inductive shunt resistance

Z_1 = resistance of telephone receiver if X is neglected.

(Some audibility meters are corrected for X , the inductive reactance.)

CHAPTER XIX

Tuning and Interference Prevention

Principle of Resonance Used in Tuning; Interference; Mitigating Various Kinds of Interference; Tuning Methods; How to Tune a Receiving Set; Receiving Circuits; Loose Coupled, Bridge, and Interference Mitigating Circuits; How to Use a Loose Coupler; Balancing Out Power Line Hum.

If the reader will bear in mind the discussions given for resonant circuits at the transmitting station, the requirements for tuning at the receiving station will not be difficult to understand. The two circuits are in fact quite similar in some respects. The detector corresponds to the spark gap. As in the case of the spark gap the detector's *resistance damps* the oscillations and makes sharp tuning difficult. The resistance of the detector, then, prevents absolute tuning. As far as the rest of the apparatus and circuits are concerned, absolute tuning can be very nearly reached if desired. Now, the tuning apparatus and circuit to employ for experimental purposes will vary with the local conditions. In cities like New York, where the interference is considerable, very sharp

tuning is desirable at both the transmitter and receiver, while in localities where there are only a few scattered stations, simple circuits with rough tuning will suffice, so that the intensity of the signal is about all that needs attention. In most of the present tuning methods, fine tuning is carried out at the expense of the intensity of the received signal, but for practical purposes all that is needed is a distinct audible signal. Close tuning has one disadvantage in that a message can easily be missed if the apparatus is at the wrong adjustment. In arranging a receiving set it is well to bear in mind the use to which the apparatus is to be put and to provide for the design accordingly. An *ideal set*, in the author's opinion, is one which provides two standby points and a variable close tuning or non-interference arrangement. One of the standby adjustments is for the standard 200 meter experimental wave length and the other adjustment is for the standard longer wave lengths which one wishes to intercept for time signals or practice. After the message has started, any interference which may arise or be in progress can then be tuned out or dissipated by the sharp tuning adjustments. There are several arrangements which will give this ideal outfit and the parts will be described in some detail later. For the present, a close attention to the theory is of first importance.

In localities where there is little or no interference, elaborate short wave receiving apparatus is not necessary or even desirable. Aside from the extra expense, the complicated receiving circuits involve greater skill and require more experience to operate. Experimenters should spend much more time tuning the transmitter

than in tuning the receiver, in most cases, as the former is really more important and instructive.

INTERFERENCE

If there was no interference in wireless work, all that would be necessary at the receiving station is a simple inductance with which to alter the receiving wave length so that the receiver can be brought into resonance with the transmitter. As it happens, however, the average station must be designed to work through both natural and artificial interferences. It may be explained that the term "interference" includes all foreign disturbances which impede or interfere with the regular reception of a desired message.

NATURAL INTERFERENCE

Mechanical vibrations, waves received from street arc lights, induction from power and telephone lines, static and similar disturbances are natural causes of interference and can be overcome in nearly every case by the use of proper circuits. A looped aerial is best to adopt when these disturbances are particularly marked. With the exception of strong disturbances, these natural disturbances can be controlled and either dissipated or neutralized. Experimenters are advised to abandon the use of the aerial during local electrical storms. Although the use of short aerials of low height does not ordinarily mean a liability to much danger, it is well to be on the safe side. Mechanical vibrations can be taken up by

using cloth or rubber pads on the instruments. A small multi-turn indoor receiver is usually safe to use, even during a storm.

ARTIFICIAL INTERFERENCE

This is the form of interference resulting from regular wireless communication between several stations within the range of each other. The manner of overcoming this to a large extent, by the use of resonant transmitters having definite wave lengths, has already been pointed out in detail. If every station (this means both commercial and experimental) would use just enough power to transmit to the desired station, sharply tuned resonant circuits, a definite wave length and "wireless sense," the difficulty of the problem, even with simple instruments of the present design, would be much reduced. Phase tuning is also coming into some use, as described in Chapter XX.

In its average or worst form, artificial interference means working through from four to a dozen or more other stations, simultaneously sending at approximately the same band of wave lengths and same intensity. The operator who receives, however, cannot regulate the coupling or adjustments of the several transmitting stations and must accept conditions as they exist. The several items must be successfully met and the interference dissipated without losing the desired message. While this is not always possible, it can generally be approximated. The worst item to overcome is the matter of forced waves, or those which seem to come in at every wave

length on account of the proximity and heavy coupling of the transmitter. When the interference prevention methods to be described are employed, these forced wave disturbances can be practically eliminated in nearly every case. While the use of limited or restricted waves will prevent interference between commercial and experimental stations, the experimenters must still fight it out among themselves. In some respects short wave lengths are less immune from interference than the long wave lengths. If only undamped waves were universally used and vacuum tube beat receivers employed, several hundred stations could work close together without interference. However, the experimenter may receive from any and every station within range without difficulty, if the simple relations of a tuned receiving set are understood.

TUNING METHODS

It must be remembered that the ordinary station emits at least two defined wave lengths. The sharper the two are defined, the better as far as the receiving operator is concerned. See diagrams in Chapter V. With quenched spark or arc stations sharply tuned, practically a single sharp wave length is all that needs to be considered, but interference from other stations operating at the same wave length often complicates the matter. It may be stated right now that the number of possible connections for the receiving circuit is practically *unlimited*, but that many so called hook-ups are a mere duplication for old circuits and really accomplish noth-

ing. In building and arranging the apparatus for the receiving circuit, the actual factors concerned and the remedies should receive attention rather than a hit and miss elaboration of the circuits without conforming to the requirements. Bearing in mind that tuning the receiver means nothing more or less than altering the circuits by adjusting the amount of capacity and inductance used, (resistance is also a factor), the following summary will aid in designing a receiver.

FACTORS AND REQUIREMENTS FOR TUNING THE RECEIVER

1. *Close coupling* at the receiver should be used when the transmitter is close coupled and *vice versa*.
2. With the receiver tuned to the desired transmitter, a large amount of the disturbance can be eliminated by *reducing the coupling*, until the strength of the signals is just distinct.
3. A shunt resistance as described in Chapter XVII may be used as a substitute for or in addition to method 2.
4. The two wave lengths sent by a spark transmitter being designated as *short* and *long*, tuning for either the long or the short wave (detuning) to an extreme degree is often a marked advantage. Since the short wave is generally the least desirable, the aerial circuit of the receiver is best thrown out of tune on the short wave side as much as is possible.
5. When the desired message comes in quite loud, the insertion of some resistance directly in the aerial cir-

cuit will often cut out disturbances, but at the expense of the intensity of the signal.*

6. In tuning, remember, that an inductance in series with the aerial or a capacity in shunt with a series inductance in the aerial circuit, *increases* the receiving wave length. A series capacity in the aerial circuit on the other hand, *decreases* the receiving wave length.

7. A closed or looped aerial will eliminate many of the natural disturbances. (See Chapter III.)

8. The disturbing impulses can be made to oppose and neutralize each other, while the desired signal, (at a reduced intensity), is received. (Differential method). (Bridge method). This is a very desirable method, and if the waves are in a sufficiently long train, it is possible to discriminate between them and undesired impulses. If the undesired impulses are more rapidly *damped* than the desired impulses they can be avoided, even when they are of the same period as the desired waves, under favorable conditions.

We shall now discuss some examples of approved circuits embodying the above principles, starting with the more simple ones. See discussion of Vacuum Tube Circuits for more advanced examples. As has already been stated these may be varied almost at will, the essential forms being given wherever practicable. While a brief outline of the operation will be given, a close study of the diagrams will be necessary. The numbers which

* About 5000 ohms will usually prevent reception of any signals and very few strays. See British Pat. 101,540 for a proposed scheme based on this.

follow do not correspond with the numbers for the foregoing summary.

CRYSTAL DETECTOR CIRCUITS

1. Fig. 131. Simple tuned circuit with wave length varied by adding more or less inductance to the antenna. The particular inductance indicated is known as a single slide tuner. The condenser in shunt about the detector increases the intensity of the received signal. While desirable, it may be dispensed with for short distance receiving. The coupling is fixed in this arrangement and while it is useful to bring a station to approximate resonance with the transmitter, close tuning or prevention of interference is not possible. In this and other diagrams the letter A denotes the aerial, G the ground, D the detector, C a fixed condenser, T the receivers, and L represents the inductance.

2. Fig. 132. Same as before, except that a shunt variable condenser VC is provided. An increase of capacity of VC increases the wave length.

3. Fig. 133. Double slide tuner. Coupling of the circuit can be changed, but must be relatively close. Desirable where little interference is met with.

4. Fig. 134. Three slide tuner. Same as before, except that the coupling of the aerial and detector circuit can be varied to a larger extent. The position of the two circuits can be varied. Thus with the sliders including the detector circuit remaining a uniform distance apart, they can both be shifted up or down the turns of wire, while the ground slider remains fixed or also be-

comes changed. The relative positions of the aerial and detector circuits can thus be changed. The desired ad-

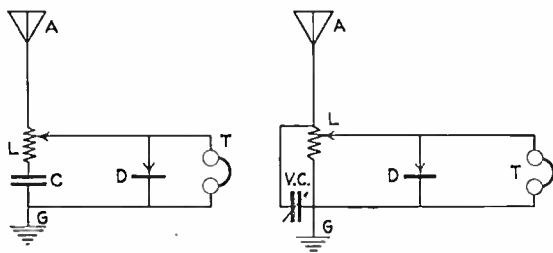

FIGS. 131, 132.—Detector Circuits.

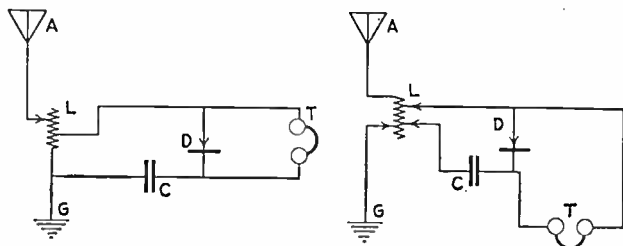

FIGS. 133, 134.—Crystal Detector Receiving Connections.

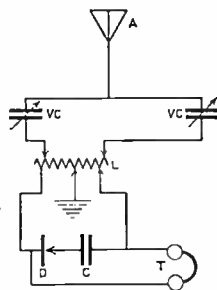

FIG. 135.—Bridge Receiving Circuit.

justment can only be found by trial and when once found should be noted before changes are made.

5. Fig. 135. Bridge. Three slide tuner with the detector circuit shunted around the terminals of the wire. Four or five slides would be better to use. When both branches of the divided circuit are maintained in a symmetrical condition the received impulses are *equally divided* so that they have no effect on the detector. The arrangement is like a Wheatstone bridge, the detector corresponding to the galvanometer. Now, to receive the desired signals, the ground contact is shifted to the right or left until the best position for the desired impulses is found. (See 8 of the foregoing summary.)

6. Fig. 136. Loose coupler, LC. Sharp tuning is possible because the coupling can be greatly varied. This is a very popular form of tuner, and while it derives its name from the fact that the secondary can be pulled away from the primary, the *heaviest coupling* is reached when the middle of the active primary turns is directly over the middle of the active secondary turns. When the sliding secondary is inserted farther in the primary after this point has been reached, the coupling again becomes loose. Since this form is best adopted as a standard because of its utility and comparative simplicity, its relations and peculiarities will be more fully described. The following summary by M. O. Andrews is of interest in this connection.

"1. Increasing the inductance of the primary increases the long wave length rapidly, but the short wave length is increased so slowly that it may be considered as remaining constant. The opposite is true when inductance is taken from the primary.

2. Increasing the inductance of the secondary increases both the long and the short wave lengths equally, or nearly so, and vice versa.

3. Loosening the coupling between the primary and secondary decreases the long wave length and increases the short wave length. Tightening the coupling increases the long and decreases the short wave lengths. In other words, its action is the same as the oscillation transformer of the transmitting set. As the coupling is loosened the two wave lengths approach the wave length to which each circuit is individually tuned, and as the coupling is closed the two wave lengths are driven farther from the natural wave length of the circuits.

4. Increasing the capacity in the primary circuit increases both wave lengths, and vice versa.

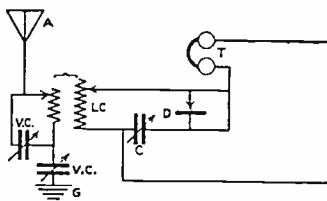

FIG. 136.—Loose Coupled Receiving Circuit.

5. The variable capacity in the secondary circuit is used principally to put the secondary in resonance with the primary, thereby allowing looser coupling than would otherwise be possible. This allows atmospheric disturbances to be cut out to some extent without decreasing the audibility of the signals.

We have already observed that it is possible to hear a station radiating a double wave at two places on our tuner. In one case, we are in tune with the long wave and in the other with the short wave. We may also be in tune with both the long and the short waves at the same time. This is a decided advantage, as we will then receive energy from both waves, and the signals will consequently be much louder than when tuned to only one of the waves.

How may the different types of interference be avoided?

Case 1. When in tune with the long wave length of the damped wave transmitting station, there are four principle types of interference that we must dodge.

1. Another station may commence sending, whose long wave is of the same length as the one which we are receiving, but whose short wave is either longer or shorter than the short wave of the station from which we are receiving. For instance, suppose we are receiving from a station radiating waves of 1,500 and 500 meters respectively. We are tuned to 1,500 and 400 meters, and another station commences sending using waves of 1,500 and 600 meters. By referring to the effects of coupling on double waves we find that this type of interference may be tuned out by simply loosening the coupling which lowers our long wave length perhaps to 1,300 meters and raises our short wave length to 500 meters. The desired signals will then come in not on the long wave, but on the short wave, where there is no interference. If the coupling is loosened too much our short wave length will be raised to 600 meters, where the undesired signals will again be picked up.

2. While we are still tuned to 1,500 and 400 meters, and are receiving from a station radiating waves of 1,500 and 500 meters, another station may begin sending, using a short wave of 400 meters and a long wave, either longer or shorter than 1,500 meters. It may be tuned out by adding capacity to the primary circuit, which increases both wave lengths to 1,700 and 600 meters, then by loosening the coupling our long wave length is again brought back to 1,500 meters and our short wave length driven still farther from the interference at 400 meters. The desired signals will again come in on the long wave, but our short wave length has been raised to 800 meters, where it is comparatively safe from interference, as there are fewer stations using wave lengths of from 600 to 900 meters.

3. Tuned as before to 1,500 and 400 meters and receiving from waves of 1,500 and 500 meters, we may get interference from waves 1,500 and 400 meters. In this case, we are in tune with both waves of the interference and the desired signals may be entirely drowned out. This may be overcome

by simply adding inductance in the secondary or capacity in the primary circuit, either of which raises both our wave lengths to 1,600 and 500 meters. We will then get our station on the short wave where there is no interference.

4. Under the same conditions as before, suppose a station begins sending, both waves of which are of exactly the same length as those of the station from which we are receiving. If there is no difference in the tone or intensity of the signals, we must wait our turn, as there is no simple way of getting around this type of interference. However, this is, fortunately, a very rare case and will not often be encountered. It may be overcome by means developed in 1918 but not yet available for publication.

Case 2. When in tune with the short wave length of the transmitting station, the types of interference are similar to those under Case 1, but the remedies are slightly different. One example will be given here, and the reader may work out the rest for himself.

1. We are tuned to 1,500 and 400 meters, and are receiv-

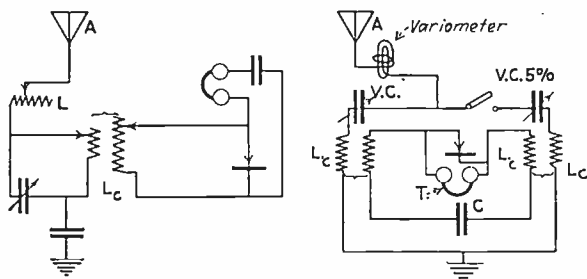

FIGS. 137, 138.—Selective Receiving Circuits.

ing from waves of 1,600 and 400 meters. Interference of 1,400 and 400 meters may be tuned out by adding inductance in the secondary circuit or capacity in the primary, either of which will raise our wave lengths to 1,600 and 500 meters. The desired signals will then come in on the 1,600 meter wave.

Questions now begin to come up. How can we tell to

which wave we are tuned? This sounds well on paper, but in practice how are we to determine whether we are tuned to the long, to the short, or to both waves? Nothing could be more simple. All we have to do is to add inductance to the primary and observe the result upon the intensity of the signals. If the signals are cut out altogether, we are in tune with the long wave, if the signals are not affected or are only slightly decreased in audibility, we are in tune with the short wave, and if they are not cut out entirely, but their

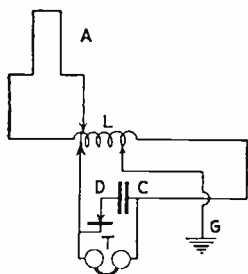

FIG. 139.—Loop Antenna Receiving Diagram.

audibility is considerably diminished, we are in tune with both waves.

Is it not possible to strengthen weak signals by these methods? It certainly is. For instance, suppose we are receiving from 1,500 and 500 meter waves and are tuned to 1,500 and 400 meters. If the signals are weak, they may be strengthened by first increasing the inductance in the secondary until we are tuned to 1,600 and 500 meters. The signals will then come in on the 500 meter waves. Then, by taking half as much inductance from the secondary as was added to it, and loosening the coupling, we become tuned to 1,500 and 500 meters and are getting energy from both waves and consequently stronger signals."

7. Fig. 137. Small stations will find it an advantage to use the series inductance in the primary circuit as

shown when receiving from stations using long wave lengths. This corresponds to the use of a loading coil at the transmitter.

8. Fig. 138. Differential (Fessenden) Method. Two identical loose couplers connected as shown are used. The variometer is a form of tuner which will be described later, and a single slide tuner may be used instead. In operation the switch "a" is opened and the set is tuned to the desired signals. A is then closed and the variometer or single slide tuner adjusted until the signals are received the loudest. The condenser marked 5% must be adjusted so that its capacity is nearly 5 per cent more than the other one. The interfering impulses are not in tune with either half of the circuit, so that they go through both sides very nearly equally. As in the bridge method, they become neutralized and do not affect the receiver.

9. Fig. 139. Simple loop aerial connection. Eliminates natural disturbances and short interfering waves. When a looped aerial is used it is used as an ordinary aerial for transmitting and a loop for receiving.

10. The intermediate coupling circuit shown in Chapter XIII for the "Onde Unique" system can be used in the receiving station also if desired.

BALANCING OUT POWER LINE HUM

A method sometimes effective in eliminating power line disturbance is shown in Figure 140. An insulated wire loop of several turns is stretched for about fifty feet on the ground near the power line and in a manner

which is not an obstruction. The current induced in this loop is opposed to the similar current picked up by the

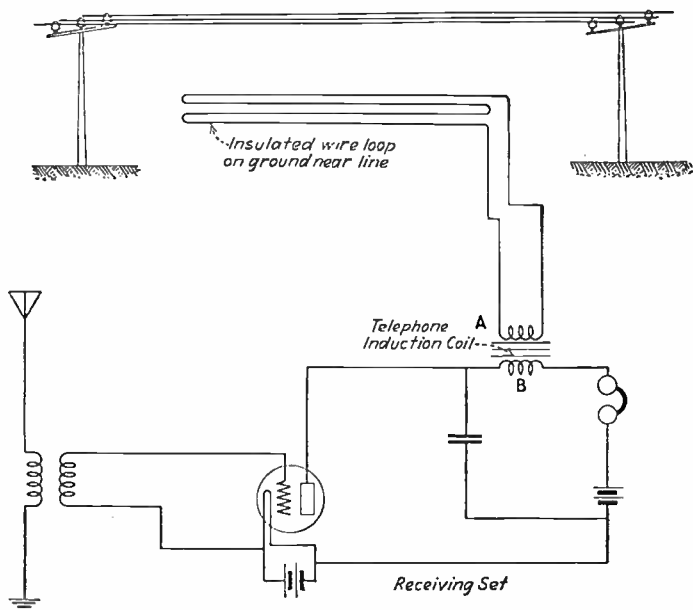

FIG. 140.—Balancing Out Disturbing Power Line Hum.

receiving set by adjusting the coupling of A and B suitably. Ordinarily such a circuit is not needed.

PROTECTING LOW TENSION SIGNAL CIRCUITS NEAR A RADIO-TRANSMITTER

Buzzer, telephone and similar circuits near large power radio transmitters are best placed in grounded metal conduits to avoid inductive disturbances and sometimes

special protective devices have to be used to avoid such troubles in unprotected lines.

SHIELDS

Many experiments have been made with shields to avoid disturbances. Antennas and coil receivers have been placed inside of cages which permit only electromagnetic waves to pass thereto but have not been generally found effective. Radio receiving circuits, especially vacuum tube outfits, are often wired with insulated conductors which are encased in a metal braid which is grounded. Sometimes electron tube amplifiers are wholly encased in a grounded metal shielding box insulated from the circuits thereof.

CHAPTER XX

Special Receiving Sets

Time Signal Receiver; Weagant's Stray Mitigator; Alexander Barrage Receiver; Heterodyne Receiver; Action of Heterodyne Circuit; Phase Modified Receivers; Balance Systems; Construction of Phase Rotator; Phase Shifting Explained; Multiple Unit Phase Shifting Receivers; Uni-Control and Automatic Receivers; Capacity Coupling; Universal Receiving Set for Long and Short Damped and Undamped Wave Signals; Autodyne Receiver; Magnetic Tube Sensitizer; Short Wave Oscillating Receiver; New Circuits.

TIME SIGNAL FIXED SET

It is possible to arrange a fixed adjustment set to receive from one certain station only, as in getting daily time signals. Figure 141 indicates a suitable arrangement. Coil I and II are pre-calibrated for the desired wave length in connection with the condenser IV and antenna V used. A variometer III of similar adjustment is provided to tune the antenna circuit to the calibrated receiving set so as to allow for use with antennas of slightly different constants due to the method of construction. A layman can be provided with such a set so

that no adjustment is necessary when the apparatus is once installed. Merely closing the filament lighting battery switch permits the time signals to be read.

WEAGANT'S STRAY MITIGATOR

While too complicated for general use Mr. R. A. Weagant has, March 7, 1919, described a stray mitigator suited to long distance land station work. Three single turn large loops are placed in alignment and $\frac{1}{4}$ wave length apart, and directed toward the sending station. The two outer loops, 1 and 2 (Figure 142), are one-half wave length apart and used to receive strays only because the signals received by one loop 1 balance out those received by the other 2, since when the current induced in 2 is a maximum in the positive direction it is a maximum in the negative direction in 1, as received at 4 because the signals reach 1 one-half wave length after they reach 2. Loops 1 and 2, however, both get strays, according to Weagant, at the same time, so 1 and 2 bring strays only to 4. Weagant states that strays known as "grinders" come from above or below from a source at a distance, so all three loops, 1, 2, 3, receive them at the same time.

The loop 3 is placed in the middle and receives both strays and signals. Now then, the strays remaining from 1 and 2 are used to balance against those in 3, so that at 4 presumably only signals are transferred to the receiving set. While not eliminating all strays, remarkably good results are claimed for this mitigator. The correct explanation is probably that since a loop receives

only strays to which it is oriented (whether these come from above or sideways too) all three loops get nearly the same strays so that they may be eliminated by differential balance. The signals from 1 and 2 only balance out because those received by 3 arrive at a different time (out of phase) so that they will not balance against those received by 1 and 2.

The Edelman Differential Wave System accomplishes a similar result in a different manner requiring no elabo-

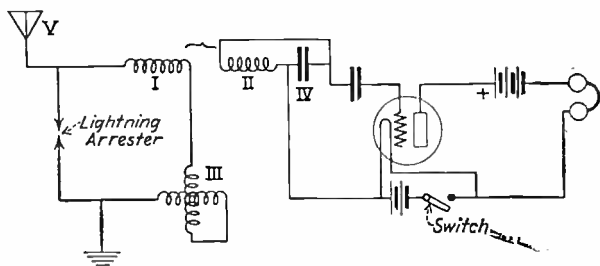

FIG. 141.—A Receiving Set for Time Signals.

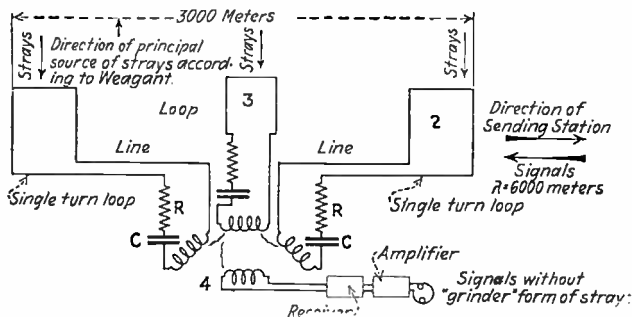

FIG. 142.—Weagant's Stray Mitigator.

rate extensive loop systems as in Weagant's plan, and operates regardless of the direction from which the strays

come. The latter mitigator, while of more general application, is not yet released for publication.

ALEXANDERSON BARRAGE RECEIVER

Special phase rotators and bridge balanced circuits have been developed by E. F. W. Alexanderson and others so that messages can now be simultaneously transmitted and received from the same station. The strong sending impulses are entirely balanced out while the distant signals are heard clearly. This is done by taking directly a portion of the transmitted energy and opposing it against the similar energy received from the local transmitter by the local receiver. This is exactly done by adjusting the intensity and phase correctly so that the

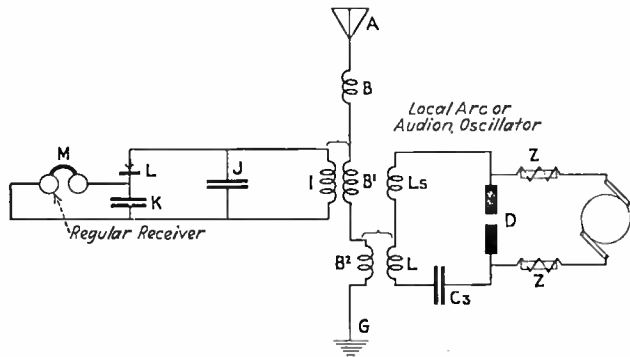

FIG. 143.—Heterodyne Receiving Circuit.

received energy meets the exactly similar and opposite portion of the transmitted energy thus electrically exposed to it. The apparatus is not yet sufficiently simplified for general amateur use but full information can

be had by those interested by obtaining a copy of the paper read April 2, 1919, to the Institute of Radio Engineers, New York.

HETERODYNE RECEIVER

This receiving method originated by R. Fessenden permits the tone of the received signals to be varied at will, thus aiding in overcoming interference, and also slightly increases the sensitiveness of the received signals. It consists (Fig. 143) essentially of an ordinary receiving set which is coupled with a local miniature sending set such as an arc or audion high frequency oscillator. If for example the incoming signals have a frequency of 300,000 and the local oscillator is adjusted to a frequency of 300,516 the interaction sets up beats by interference which give a musical tone of 516 frequency in the head receivers. This method is particularly useful for reception from undamped wave stations but may also be used with spark oscillations.

A short wave can be converted to a long one for amplification at higher efficiency on this principle, the beats being at radio (high) frequency instead of at audible (low) frequency. For example a 200 meter wave can be converted to a 3000 meter wave in the local audion receiving circuits, and the latter (long) wave then amplified.

HETERODYNE ACTION

The addition of two energy waves to form beats as in the heterodyne or autodyne receiver is shown in Figure

144. In the autodyne the local oscillator also serves as a detector for the incoming oscillations slightly detuned therefrom so that beats result.

It has been found that the 12,800 meter waves emitted

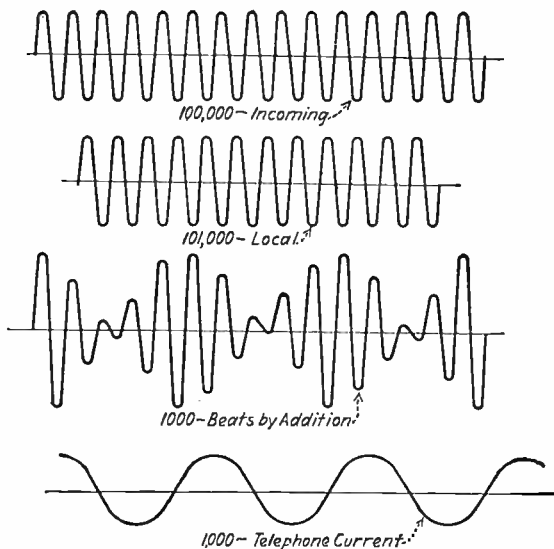

FIG. 144.—Principle of Heterodyne Action.

from Nauen in Germany add with those from the station in South San Francisco, California, to form beats when the two stations happen to work simultaneously.

PHASE MODIFIED RECEIVERS

Much work has been done by the author and others on phase modified receivers for elimination and mitigation of interference and strays. In such experiments either the radio frequency energy or the audio frequency

energy is slowed down by passing same through more or less loaded line, or by use of phase rotators as in Alexanderson's barrage receiver, so that any particular part of the wave energy can be brought in exact alignment with other similar energy for complete neutralization or even exact addition. That is essentially all that the Weagant balancer does as, other explanations notwithstanding, it so happens that the correct phase relations for neutralization were obtained thereby. Such work is not yet available for general use but soon may be.

The phase rotators* used are merely air core induction regulators such as are in general use in alternating current power work, whereby the time occurrence of the received impulses can be shifted 45, 90, or up to 180° as required so that proper balancing can be carried out. The same method can be used to exclude strong interference from one or more nearby stations, while distant feeble stations are still heard. Mr. Alexanderson tells me that he adopted the name "barrage" because of this ability to keep out other interfering stations.

PHASE SHIFTING EXPLAINED

Figure 145 shows how a portion of the effect of a signal wave acts when shifted against its effect on a

* The Bellini-Tosi radio-goniometer is a phase rotator also and was used by Weagant in his balancing work. Two loops were used, one connected to one stationary coil of the goniometer and the other loop to the other right-angle coil. The usual receiving set was then connected to the third and movable coil of the goniometer. As the angle is changed between the movable and the fixed coils the phase or time appearance of definite portions of the radiant energy in the receiver is altered.

nearby receiver. Enough of the local energy opposes the received energy from the same source at the same intensity and at the same time but in opposite polarity, so the result is zero. To get the opposing part to come

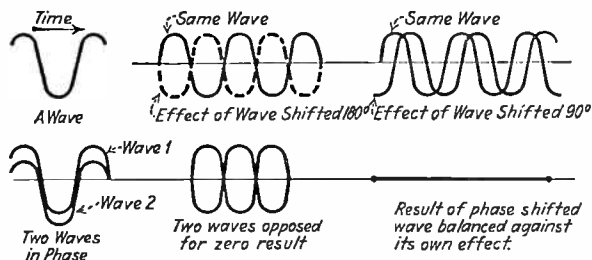

FIG. 145.—Illustrating Phase Tuning Methods.

opposite at the right time it is made to travel a little slower (by the phase modifier) so that the effect is shifted 180° to oppose the unretarded effect on the regular receiver.

MULTIPLE UNIT PHASE—MODIFIED STRAY AND INTERFERENCE ELIMINATING RECEIVERS

Highly developed multiple modified receivers remarkably free from stray and interference disturbances have been independently developed by the author but details are not available for present publication.

U. S. NAVY METHODS

A paper by Dr. Austin, read April 7, 1920, at the Institute of Radio Engineers, gives some valuable data on U. S. Navy methods of interference mitigation.

UNI-CONTROL RECEIVER

A continuously variable automatic receiver, motor driven so as to be always at an efficient adjustment at

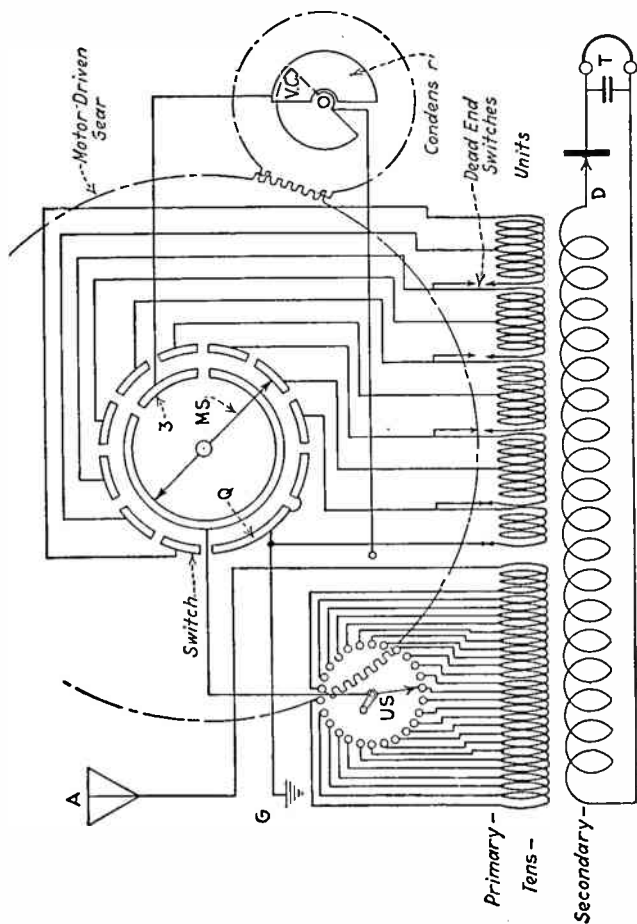

FIG. 146.—Thompson's Uni-Control Automatic Receiver.

300 to 3,000 meters within ten seconds' time, as described by Mr. R. Thompson to the Institute of Radio Engineers, February 5, 1919, is shown in Figure 146.

CAPACITY COUPLING

Fig. 147 shows a capacity coupled oscillating receiver.

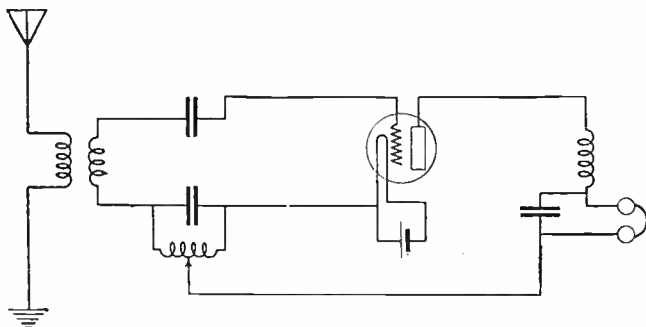

FIG. 147.—An Example of Capacity Coupling.

UNIVERSAL RECEIVER

A method of receiving either damped or sustained

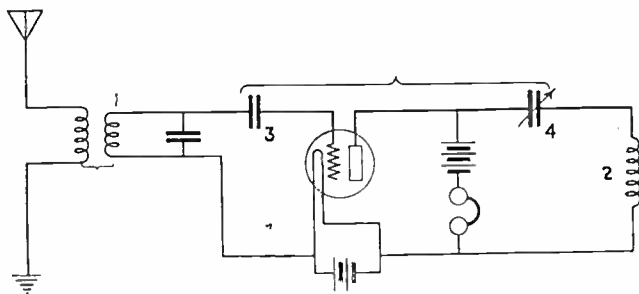

FIG. 148.—A Circuit for Either Damped or Undamped Wave Reception.

signals claimed by Weagant is shown in Figure 148. The coupling between 1 and 2 is merely sufficient to cause the circuit to act as an autodyne receiver when 4 and 2 are detuned from the incoming sustained signals. For ordinary damped signals 2 and 4 are not detuned.

RADIO FREQUENCY AMPLIFIER WITH CRYSTAL DETECTOR

Figure 149 shows how a vacuum tube 1 can be used

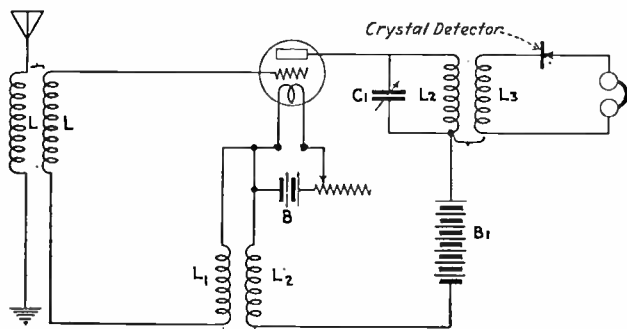

FIG. 149.—Crystal Detector Used with Radio Frequency Amplifier.

to simply amplify the incoming energy before it reaches the crystal or other audion detector circuit.

AUTODYNE RECEIVER

Figure 150 shows the use of a "tone" circuit L_2C in the plate circuit to afford an "autodyne" receiver for reception of sustained signal energy by the beat method.

MAGNETIC TUBE SENSITIZER

Figure 151 shows a solenoid A wound around the outside of tube C and connected in series with filament

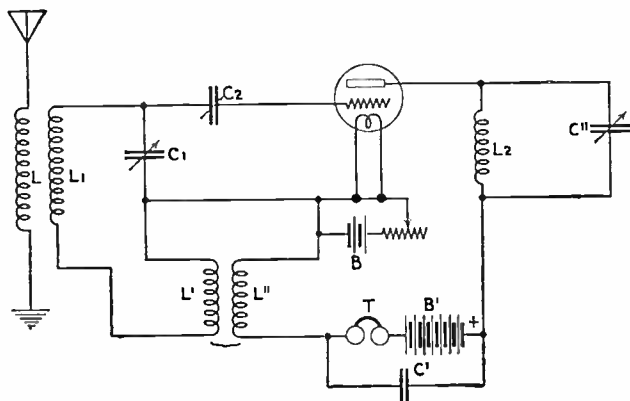

FIG. 150.—Autodyne Receiver.

D to use the effect of a magnet on the electron stream B. This can readily be added to any tube.

SHORT WAVE OSCILLATING RECEIVER

A form found most useful for radio receiving at wave lengths in the vicinity of 200 meters when sustained short wave transmitters such as have been described are employed is shown in Figure 152. The variometers are constructed exactly as has been set forth in this book as is also the case for the condensers. Flashlight batteries may be soldered together in series to give the necessary 30 volt plate battery. The circuit can be used with a multi-turn coil receiver instead of the antenna ground

shown by opening the circuit at A, B, and connecting a coil four feet in diameter containing 100 turns No. 22 of insulated wire thereto.

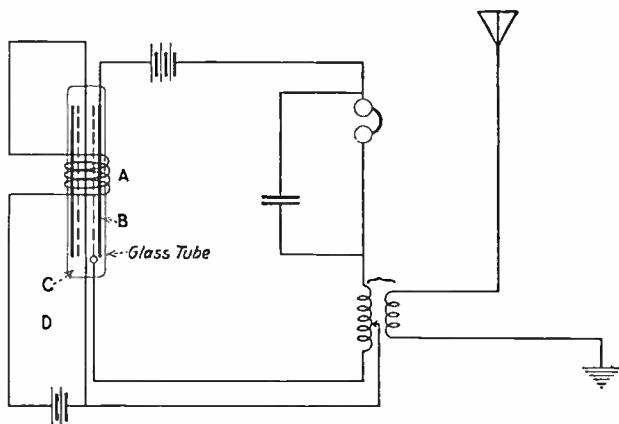

FIG. 151.—Magnetic Tube Sensitizer.

If the input circuit is tuned by the variometers to say 200 meters the output or plate variometer II is adjusted to slightly a different wave length so that local beats will

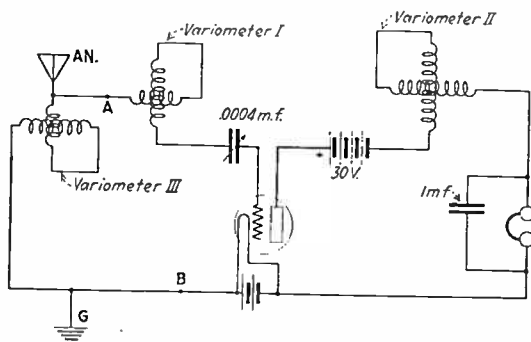

FIG. 152.—A Short Wave Oscillating Receiving Circuit.

result from the incoming energy and local oscillations set up in the circuit. Variometer I should be moved with respect to variometer II to get the desired result. A small difference of wave length in the vicinity of 200 meters makes a large change in the frequency. It is accordingly possible for a large number of stations using audion generators or other sustained wave transmitters and such a receiver as this to work in the same locality without causing interference with one another.

UNIVERSAL WAVE RECEIVER

As indicated in Figure 153 it is not difficult to arrange a receiving set which may be used for long or short damped or sustained wave heterodyne reception by ap-

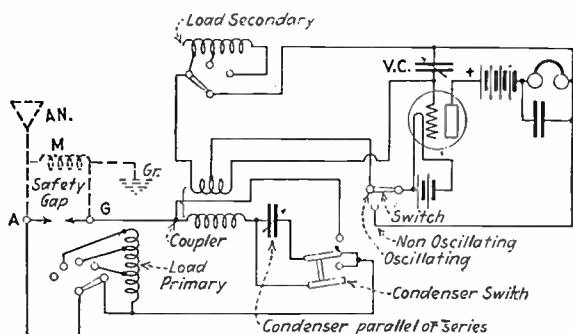

FIG. 153.—A Universal Set for Long or Short Sustained or Damped Wave Reception.

plying suitable switches. Such a set can be connected to AN-Gr or a multi-turn coil M, as indicated. The primary condenser is used in series for short, and in parallel for long, wave reception.

CHAPTER XXI

Receiving Condensers

Construction of Fixed and Variable Condensers; Circuits for Condensers; Building a Condenser; Korda Air Condenser; Assembly of Plates; Geared Fine Adjustment Condenser.

The discussion which has already been given for sending condensers applies, for the most part, to receiving condensers. The main difference is that the insulation for receiving condensers does not need to be so heavy because of the lower potential and currents used. The coatings of receiving condensers are, therefore, placed very close together so as to secure a large capacity in a small space. Air is used for variable condensers to a large extent because it provides a convenient dielectric which has no hysteresis losses. On account of the low dielectric constant, however, other dielectric materials, such as castor oil, mica, paraffin paper, and glass are used when large capacity is desired. The capacities necessary for the receiving circuits, however, are generally small. The laws for parallel and series connections as stated for transmitting condensers apply to receiving condensers as well. As has already been pointed out, a

fixed and variable condenser can be used in parallel, the fixed condenser to approximate the desired capacity and the variable condenser to make up the difference. This is perhaps the most satisfactory and economical arrangement as large variable capacities are then unnecessary. In making fixed condensers, the proper capacity must be approximated, and can be calculated by the formulas already given for transmitting condensers. It is well to make several units which may be connected in or out of the circuit to secure a variable step condenser.

The proper capacity necessary for each set must be determined experimentally, though the approximate amount can be found by calculation. This is essential because of the variable quantities concerned, such as the other apparatus employed, the size of the aerial, etc., which is a different problem than when the transmitting condenser is calculated for a definite size and kind of transformer. The use of too little capacity can generally be told by the *weakness* of the received signal. Capacity should be added until the maximum sound is received. If, however, an excess of capacity is used, the signals will become indistinct. The capacity should then be lessened until the ragged sound disappears and is clear.

There are many suitable constructions for both fixed and variable condensers, the designs here described being those most generally used.

FIXED CONDENSER

These are used as shunts around the detector or phones to increase the intensity of the received signal. When

tuning inductances having adjustable coils are used, the secondary or detector circuit condenser can be of the fixed step-by-step type. A continuously variable condenser is hardly necessary except in the primary or aerial circuit, and since it is more expensive, particularly in the large sizes, the step-by-step type is best to use in parallel with a small balancing variable condenser as has already been pointed out. Aside from intensifying the received signals, a condenser, if of the adjustable type, permits fine selective tuning.

A convenient condenser unit which may be connected together with duplicate units or variable capacity to secure almost any capacity is made as follows:

CONSTRUCTION OF A RECEIVING CONDENSER

This type is suitable for a shunt circuit around contacts of small spark coils and other purposes also.

Obtain a good grade of bond paper about .004 or .005 (measure with a micrometer), of an inch thick and soak several sheets in a pot of clean melted paraffin until the air bubbles are driven out. When air bubbles no longer rise, hang the sheets up to dry and cut them into pieces 2 inches by 3 inches.

The coatings are made from tin foil cut to pieces 1 5-8 of an inch by 3 inches long, and smoothed out by a roller as described for transmitting condensers. See Figure 45 of Chapter IX.

Lay a strip of tin foil upon a strip of paraffined paper so that 3-8 of an inch of one end of the foil projects

beyond one of the long ends of the paper. Now lay a sheet of paper on top of this and again place a sheet of the foil, but projecting the 3/8 of an inch on the other end of the paper. Repeat, until the desired number of sheets and foil have been alternately arranged, six or eight sheets being a desired number. The foil should be arranged evenly between the paper, so that the margin on three sides is nearly equal. When done, the condenser should consist of alternate layers of foil and paper with every other foil projection on an opposite end of the paper. Now place the assembled condenser between two temporary boards and a clamp. Squeeze together under the influence of heat. This may be accomplished over a hot air register or open oven which is just warm enough to soften the paraffin of the paper sheets. Tighten up the clamps and remove them after the wax cools. The two sets of connectors are then soldered or clamped to a conductor of stranded copper wire, and may be mounted in almost any desired manner. The condenser used as a detector shunt may be mounted in the base of the detector stand. Switches should be provided for connecting several of these units in series, parallel, or series multiple. About three of these units in parallel will be the right amount for the chopper condenser of the continuous wave receiving set, while a single unit will suffice for most of the secondary or detector circuits. *Test* as described for the transmitting condenser. The condenser should hold the battery charge for some little time and should be capable of discharging through the telephone receiver with an audible click several seconds after the battery terminals have been disconnected from it. It is seldom

that this kind of condenser is burnt out or injured, so that once made, it is practically permanent. The primary condenser for the spark coils already described is built in the same manner, except that the larger dimensions given are used. A shunt condenser around a telegraph key used for sending, should have a large capacity similar to that used around the vibrator contacts of a coil. Paraffined tissue paper such as is used to wrap eatables and instruments may be had ready paraffined and is desirable because of the uniform thickness. The condenser can also be assembled by applying the foil to the paper while the wax is still soft and warm, making the after-warming and pressure unnecessary.

KORDA AIR CONDENSER

This type of variable condenser is in general use for wireless receiving sets, wave meters, and is particularly desirable in the primary or aerial circuit for tuning purposes. Fine adjustment is possible and when properly made there is little or no loss in the condenser. The construction is somewhat difficult, however, but since the plates may be had already cut and smoothed, the main difficulty is limited to the arrangement of the plates. It is not necessary to use a large number of plates provided the arrangement with a parallel step by step condenser is adopted. Such a step by step condenser should not have more than one or two sheets of foil and dielectric to each unit or step and the switch contacts used should be good and well cleaned.

The plates used should be of brass or aluminum of

about No. 20 B&S gauge and since the cutting is difficult to do by hand, they are preferably purchased already stamped from supply houses or else turned out in a lathe by a machinist. It is essential that the plates be

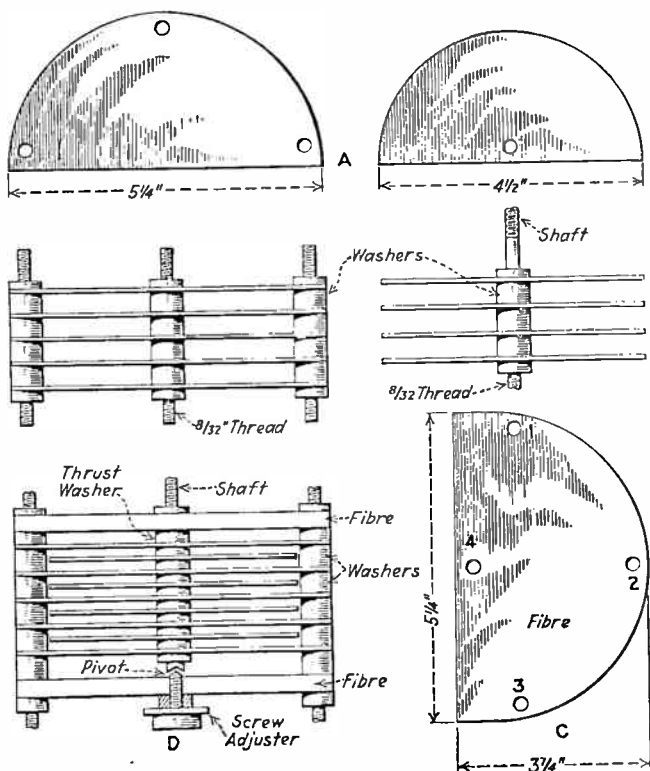

FIG. 154.—Variable Condenser Construction.

perfectly flat and even. The number of plates used need not be more than four or six if a fixed condenser in parallel is also used. If the condenser is to be used

alone, from twenty-four to twelve plates should be used. This is for the larger or stationary plates, one less being used for the rotary plates. Two plates suffice for a vacuum tube grid condenser for short wave sets. Five fixed and four rotary plates make it a convenient size for a variable unit.

The five fixed plates should be semi-circles $5\frac{1}{4}$ inches in diameter and the rotary plates of which four are needed should be $4\frac{1}{2}$ inches in diameter, as these are standard sizes. It will be understood that larger units may be made in the same manner, using more plates. The several details are shown in Fig. 154. The five large semicircles should be placed together and three $5\text{-}32$ in. holes drilled near the edge as shown at (A). The four small plates are placed in the same manner, except that only one $5\text{-}32$ inch hole is bored as shown.

Obtain brass or copper washers $5\text{-}32$ inch thick, $3\text{-}8$ of an inch in diameter and with a $5\text{-}32$ inch hole at the center. These may be had at a supply house or hardware store. Also obtain some $5\text{-}32$ inch brass rods.

ASSEMBLING THE ROTARY PLATES

The plates are assembled after the holes have been smoothed and burrs removed, by passing a piece of the $5\text{-}32$ inch rod alternately through a plate and then a washer. The ends of the rod should be threaded with an eight thirty-two die and the rod cut so that a short extension is left beyond the plates for a handle. The plates are held together on the rod by two threaded washers or nuts $\frac{1}{2}$ inch in diameter and $9\text{-}32$ of an inch thick. The

nuts should be turned tightly so that the plates cannot move after they are placed in alignment.

ASSEMBLING THE FIXED PLATES

A similar plan is used with the fixed plates, a rod being inserted in each of the three holes, and threaded 8-32 at the ends as before, care being taken to keep the plates in alignment. The washers between the plates are placed at all three positions. A longer extension should be left on these rods for fastening purposes. The appearance of the assembled plates is shown at (B) of the figure.

Obtain two pieces of fibre 3-16 of an inch thick and cut out two pieces with the shape and having holes as shown at (C). The holes 1, 2, 3 correspond to the holes of the large plates, and the hole 4 is bored so that when the shaft of the movable plates is in place in it and the fibre is assembled on the rods, the brass washers of the movable plates will not touch or make contact with the fixed plates. This is important, as otherwise a short circuit would result. About $\frac{1}{2}$ inch will be sufficient extension for this hole. The lower fibre piece is held in place on the rods by 8-32 nuts. It is preferably spaced a little distance from the lower plate by washers. The upper fibre piece is similarly placed after the plates have been located in position.

MOUNTING

The assembled plates must not rub or touch each other and must be brought into alignment, the adjustable

screw bearing at the bottom shown at (D) being a suitable means. The rotary plates can be raised or lowered by this arrangement. The condenser may be suitably mounted in a box or case, and the connections, one from a washer on the fixed plates and one from a brass strip or brush bearing on the rotary shaft near the top, may be brought to binding posts. The excess length of the rods can then be cut off, and a handle provided for the rotary shaft. A scale and pointer can also be arranged on the cover, to suit. Electrose or composition knobs such as are used for typewriter platens (obtainable at supply houses) make good handles for this purpose. The scale may be calibrated by comparison with a known standard, using a wave meter, or may be arbitrary, using equal divisions. A brass protractor such as is used by draughtsmen may be had for a few cents and makes a convenient scale. The pointer can be cut out of a strip of brass or aluminum. Two or more of these units may be mounted in a common case or box and switches provided for changing the connections. Moving washers are preferably provided at the upper bearing to take up the thrust, so that the condenser may be used in any position.*

MAKESHIFTS

It is often desired to have a simple makeshift variable condenser for experiments. Almost any two conductors in any shape separated by a dielectric, so that more

* A horizontal position for the axis is not desirable, as a counter-weight is necessary for balance. This type of condenser can be rotated by a motor to serve in a "tikker" circuit or indicating wave meter.

or less surface may be brought into relation to form capacity, are suitable. Such common things as tin cans may be utilized, the insulation being provided by using paper or even a coat of shellac or asphaltum. A can painted in this manner and suspended so that its height in a jar of salt water can be altered, connections being made to the can and to a plate inserted in the solution, is suitable, provided that every part of the exposed surface is covered by a thin coat of the insulating varnish. Sliding plates similar to those described for a variable sending condenser may also be used. Two tin cans having diameters so that one just slides into the other after a layer of paper has been shellaced on the inner or sliding one may be used. Similar arrangements will doubtless suggest themselves to the reader and if carried out carefully may serve quite well. The series capacity used in the aerial circuit should have a comparatively large capacity. This is best obtained by using a fixed and a variable capacity in parallel, in which case a makeshift arrangement carefully constructed will generally have sufficient capacity to make it of considerable use.

The Korda condenser described is desirable, however, and if immersed in a can of transformer or castor oil, preferably the latter, its capacity will be considerably increased. (See chapter on the calculation of capacity). The maximum capacity of such a condenser is readily calculated when the area is taken by using the formula.

Area of a circle = $3.1416 R^2$, taking the radius R for the rotary plates, and dividing by 2 to find the area of the half circle.

GEARED CONDENSER

For final small adjustment so desirable in electron tube work an extra geared knob can be added to the usual condenser knob as shown in Figure 155. The author has improved this by using a worm gear as the adjustment. It is not only finer but stays fixed once it is set because the wheel cannot turn against the worm as is the case with ordinary spur wheel gears. This fine adjustment is important in vacuum tube and phase adjustment work.

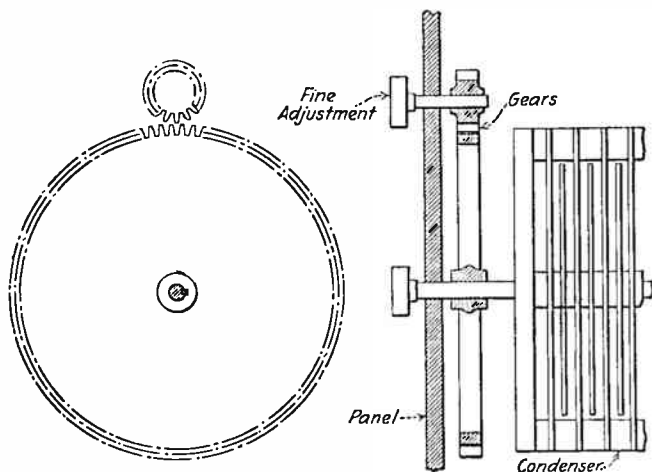

FIG. 155.—A Finely Adjusted Gear Operated Condenser.

CHAPTER XXII

Construction of Receiving Inductances

Tuners; Loose Couplers; Loading Coils; Sliders; Windings for Desired Wave Lengths; Variometer; Variometer Phase Rotator; Switching; Dead End Elimination; Taps and Units Connection; Multilayer Coils; Compact Long Wave Length Coils; Couplers for Long Wave Lengths; Dimensions for Various Wave Lengths; Plural Receiving Sets.

Whatever type of tuning is adopted, the inductances used should be *carefully* constructed with accurate and delicate adjustments. Every part should be nicely made and great care taken with the *insulation* and contacts. The cores and ends used are preferably made from hard rubber, fibre or molded composition, but wood and paper when dry and carefully shellaced may be substituted. The wire used should be uniform, and may either be bare or insulated. Bare wire is spaced by means of a thread or a groove cut into the core, while insulated wire is separated naturally. Contact is best made when bare wire is used. Enameled wire is neat and useful since a contact portion is readily scraped from the wire. Cotton and

silk insulations are difficult to scrape for contact with sliders, so that the job is neat and effective. The only objection to enameled wire seems to be that the turns are brought too close together, so that an undesirable electrostatic capacity is formed between the adjacent turns. Wood may be used for bases. All metallic parts including connecting wires should be carefully insulated from each other and even from wood, by using hard rubber sheeting and tubes. In receiving delicate and minute oscillations from distance stations, every detail counts for efficiency and too much care cannot be taken if the maximum results are desired. Holes are preferably filled up with tar or wax, and shields provided to prevent injury or leakage to or from the wires. In the following designs, descriptions will be given for inductances of standard design and merit. While there are varied forms for the detailed constructions, and much ingenuity can be exercised, the main dimensions and design should generally be adhered to, to secure efficient instruments. It should be remembered that a coil comprises principally inductance but also has some capacity. The windings are usually designed to reduce this capacity in the coil to as negligible a value as is possible. An example is the honeycomb or yarn warp wound coil.

TUNERS, SLIDE TYPE

This form is commonly employed for tuning, bridge, loading, and similar methods as has already been described. While only one slider is described, it will be understood that duplicate sliders can be provided on

other parts of the circumference of the core and wire. It is well to provide binding posts for the wire terminals in every case so that a variety of utility is the result. (See Fig. 156.)

Core. This may be turned out from hard wood, but since wood shrinks, a rubber, fibre, composition, or even a shellaced paper tube is much preferred. Suitable tubes may be had from supply houses. Paper or fibre tubes can be made by rolling up and gluing a sheet of the thin

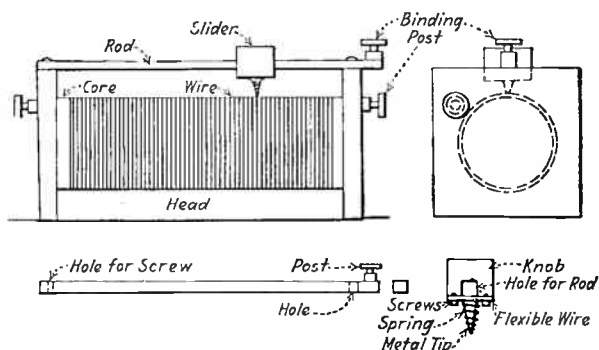

FIGS. 156, 157.—Tuner Construction.

fibre into the desired size. Hollow tubes have the additional advantage of light weight. The diameter of the tube may be any convenient size between $2\frac{1}{2}$ inches and 6 inches, the smaller diameters providing sharper adjustment. $3\frac{1}{2}$ inches is a desirable diameter. If bare wire is to be used on the fibre, rubber or composition tube, it is very desirable to turn or have a machinist turn a thread on the core. About 18 threads to the inch makes a suitable thread for use with No. 22 wire, which

is a common size in favor. The threads can be cut to within $\frac{1}{2}$ inch or so from each end. The length of the tube used may be from 3 inches to 12 inches or more as desired.

The winding. Use soft copper wire of not more than No. 24 in fineness, nor less than No. 18 in coarseness, No. 20 or 22 being preferred. The winding can be done by hand if care is taken, but a lathe or makeshift lathe is best to use. The wire should be wound tightly and evenly, avoiding kinks. When the core is threaded, this is easy. If bare wire is used without threading the core, the turns should be spaced by winding the wire with a turn of heavy linen thread, so that each turn is spaced by the thickness of the thread and the adjacent turns of wire do not touch each other. Enameled wire is wound without spacing. Cotton or silk insulation is not recommended for wire for tuners of this type. The bare wire is preferred. Then ends of the wire can be fastened by means of a small hole drilled at the end of the core or else by means of a small screw. If hard drawn copper wire, such as may be had at hardware stores, is available, it is preferred as it is more durable and easier to wind.

CORE ENDS—BASE

While the core ends must be of a size corresponding to the diameter of the tube used, which may vary from 2 in. to 6 in., a margin should be provided to allow for clearance from a base, sliders, and so on. The ends are preferably square and may be easily fastened to the cores in any desired manner. For solid wood cores, wood screws

may be used. Tubings are best fastened by turning a recess in the inner end of the core end which will fit over the tube snugly. Another method is to provide plug ends for the tube, which are then screwed on the core ends. When assembled, the tuner should set true. The use of a base is optional and is hardly necessary except for appearance and possibly convenience. The binding posts can be brought out on the core ends.

SLIDERS

(See Fig. 157.) These may be any suitable type which will make a step by step contact with the several turns of wire without undue friction. The slider rods are preferably of square or rectangular shape, as round rods must be used doubly to prevent undesired turning. The rod is cut as long as the length of the core plus the thickness of the core ends, which should not be over $\frac{3}{4}$ inch, plus a little extra for connections or a binding post. While only one form of slider is shown, to avoid unnecessary duplication, it will be understood that many other forms may be used. The essential feature of sliders is that they should make *good contact* with only *one turn* of wire at a time and without too much friction. If the slider touches two turns at once (which will happen if care is not taken), the turn is short circuited. This is not desirable as the intensity of the received signals is thus lessened. The spiral spring shown can be coiled from No. 22 spring brass, and a round piece of copper wire smoothed off to a round surface is soldered on the tip.

The length of the spiral should be enough to make contact with the wire after the slider is in place. A roller contact may also be used. While connection with the slider can be made through the rod by the sliding contact which results, this method is not desirable and a flexible insulated wire is best soldered directly to the slider. The knob is for convenience in handling, and can be made from hard rubber or purchased already molded. Sliders and rods may be had in the open market. The slider should slide on the rod without sticking. Loading coils may be made without sliders, by taking taps off from every ten or twenty turns and using multi-point switches. The wire when wound on smooth forms should be coated with two coats of shellac and allowed to dry. The portion for contact is then scraped clean for a distance along the length of the coil and under the slider, of about $\frac{1}{2}$ inch. This may be accomplished by using a knife or a small block of wood covered with emery cloth. The wire should be scraped until it shows clean and bright. Two wooden strips may be temporarily fastened on the core the desired distance apart to serve as a guide so that the scraped portion will be of uniform width. If several sliders are used, two may be taken from the top or one from each side, or all, as desired. The use of bare wire wound in a threaded tube core is best adopted for a standard, the diameter being 3 inches and length 10 inches, as this will give a serviceable instrument with a wide range of utility. Wires wound on smooth cores or wood cores, particularly enamelled wire, tend to loosen after a time, in which case it is best to either rewind the coil or make a new one.

VARIOMETER

A variometer is a form of tuner without any sliding or variable contacts and depends solely on the variable coupling between its two parts which are connected to-

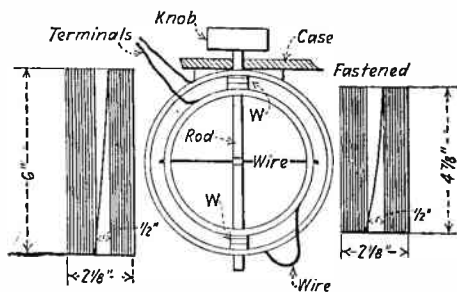

FIG. 158.—Variometer Construction.

gether. It is quite easily made and is very useful in connection with other apparatus, particularly as a loading coil. It may be used alone for short wave lengths.

VARIOMETER AS A PHASE ROTATOR

Phase modification experiments at radio frequency can be made by inserting a special variometer in series with the primary circuit of any radio receiver. Keep the terminals of the two coils separate and bring them out to extra binding posts. Add a third coil constructed like the stationary coil but placed at right angles thereto. Connect one circuit to be balanced to one stationary coil and the other circuit to be balanced against the first, to the other stationary coil. Connect the usual radio receiver to the movable coil. By adjusting the phase and separately adjusting the intensity of coupling some remarkable results are open to the advanced experimenter. See the 1919 and 1920 proceedings of the Institute of Engineers for details of some of such experiments.

A suitable construction is indicated in Fig. 158. The cores are of hollow fibre, rubber, composition or paper and may be made as has already been described. The stationary core is 6 in. in diameter and 2 1-8 inches wide. The inner and movable core is 4 7-8 inches in diameter and 2 1-8 inches wide. The larger core is wound with about forty feet of No. 22 insulated wire, so that a space of $\frac{1}{2}$ inch is left at the center. This will make about 24 turns on each side of the space. The small core is wound in the same way, except that 28 turns are wound on each side of the space. Both parts of each core should have the same number of turns.

One-quarter inch holes are now bored or punched, at opposite points of the two cores, in the center of the $\frac{1}{2}$ inch bare band, for a rod. This rod is a piece of $\frac{1}{4}$ inch round brass 7 $\frac{1}{2}$ inches long, and is passed through the holes as shown in the figure. Now take a piece of No. 18 bare wire about 5 $\frac{1}{2}$ inches long and fasten it as shown, soldering it at the center to the $\frac{1}{4}$ inch rod and bringing the ends through the small core. This is to make the inner coil fast to the rod so that it may be rotated. Rubber or fibre washers (W) should be placed as shown, so that the inner coil is free to rotate within the outer coil. The two coils are connected together as shown with a short length of flexible insulated wire. Additional layers of wire may be added for use with longer wave length circuits.

Mounting. This may be carried out as desired, a box 6 $\frac{1}{2}$ inches cube being suitable. Binding posts should be provided and connections made so that starting with the end of one coil, the wire continues until the opposite end

of the other coil is reached at the other binding post. A knob with a pointer and a scale may be provided as described for the variable condenser of Chapter XVIII. Use like a tuning or unloading coil. About 75 feet of the wire will be needed. The coils may be shellaced and the instrument finished as desired. In mounting the instrument, the outer coil is fastened rigidly to the case of cover so that only the inner coil is rotatable. When at right angles the two coils are neutral, while when concentric the closest coupling adjustment is reached. The inductance will be nearly uniformly variable as it has almost a straight line curve.

LOOSE COUPLER

The loose coupler is in general favor at the present time. With it and condensers, a wide variety of tuning and coupling is possible. The set can be tuned to either the long or short waves or both and when the maximum point is found the interfering stations can often be tuned out by making the coupling very small. (That is, pulling the primary far away from the secondary or *vice versa*.) The following design and data is for one of these instruments and two will be required if the Fessenden differential method is employed. (See Fig. 159.)

PRIMARY

Core. Insulating tube 3 inches in diameter and 4 5-8 long. The wall should not be more than 1-8 inch thick. Wind as directed for tuner, using either No. 20 or 22

B&S gauge bare or enameled wire, preferably the former, in threaded grooves. Start winding 9-16 of an inch from one end and wind until within 9-16 of the other end.

Heads for Primary. $\frac{1}{2}$ in. thick, $4 \times 4\frac{1}{2}$ in., smoothed on all sides. Find the center of each piece (two needed). These pieces are now centered in a chuck in a lathe so that the lathe center is $\frac{1}{4}$ inch below the marked center of the pieces. One piece is made with a hole 3 inches in

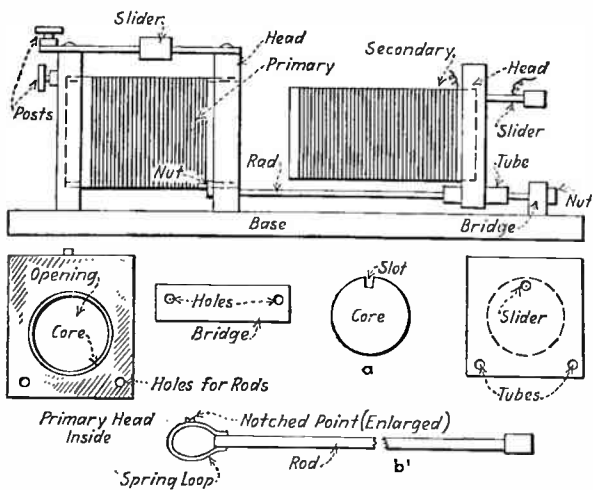

FIG. 159.—Loose Coupler Construction.

diameter through it, while the other piece is bored, with this same size, to have a depth of only 3-8 of an inch. When done, one piece will have a hole 3 inches in diameter through it while the other will have a smaller hole coming within 1-8 inch of the outer surface.

Base. Three-fourths of an inch thick, 6 inches wide

and 16 inches long. (Hardwood.) Mount the primary at one end so that it sets true and is nicely spaced, using screws driven from the bottom of the base into the heads, the screws being countersunk. A single slider may now be provided, as shown and as has been described for tuners. It is understood that the primary core with the winding, is mounted in the heads, using cement, so that the core and wire are held in the openings in the heads and so that the head with the hole all the way through it faces toward the long end of the base. (See figure.)

SECONDARY

Core. Hardwood cylinder turned from dry wood.* Diameter, $2\frac{1}{2}$ inches. Length, 5 inches. (See Fig. 159.) Have a machinist mill a slot 3-16 wide by 3-8 deep as shown at (a) the whole length of the core. This should be smooth when done. Inasmuch as bare wire is to be used, it would be well to have threads turned on the cylinder before the milling is done. These should be 20 to the inch, and very light. Wind with No. 26 B&S hard drawn copper wire. Threads may be used, spacing the turns with linen thread, if the machine threads cannot be cut. Use considerable pressure in winding, as the contact is to be made from below. The linen thread used should be about as thick as the wire used. Start $\frac{3}{4}$ inch from one end and wind to $\frac{3}{8}$ inch of the other.

* A hollow tube may be used if a frame is provided for the slot. Instead of using this slot with a slider it is satisfactory to bring the turns out in groups of tens and units to two switches which may be mounted on the movable head.

Head. One needed. $\frac{3}{4}$ inch stock, cut $3\frac{3}{4}$ inches square with a hole bored in center to a depth of $\frac{3}{8}$ of an inch. This hole is $2\frac{1}{2}$ inches in diameter and is turned as before.

Attach the head to the secondary core at the $\frac{3}{4}$ in. end by small screws started from the back of the head and screwed into the core. The secondary *slider* is made so that more or less wire is included in the circuit when the rod (See b) is moved in or out, and allows of adjustment after the secondary is within the primary coil. This slider is made from a piece of 5-32 inch brass rod, 7 inches long, to one end of which a small loop of thin spring brass 5-32 inch wide, is soldered, as shown. A rounded point is then soldered on the upper part of this spring to make contact with a single turn of wire at a time. Note the notch. This is made by a few strokes with a fine three-cornered file. A handle is provided at the other end of the rod. The slider is mounted in the milled slot and extends through the head through a small hole.

MOUNTINGS

The mountings are shown clearly in the figure. Binding posts should be provided and flexible insulated wires should be brought to the slider rods. The inner end of the secondary coil can be brought to the back by either boring a hole through the cylinder or else making a groove in one side of the milled slot so that the wire imbedded in it cannot possibly make contact with the slider. The ends of both primary and secondary should be

brought out to binding posts. The two pieces of tubing which act as bearings to support the secondary have an internal diameter of $\frac{1}{4}$ inch and are $1\frac{1}{2}$ inches long. They are forced into holes drilled in the secondary head. The rods on which the secondary slides are $10\frac{1}{2}$ inches long and are supported as shown, one end being fastened by passing through holes in the inner head of the primary and the other end being fastened to a small bridge fastened to the base. The latter is $1 \times 1 \times 4$ inches long. Small nuts serve to hold the rods in place. The coils should be mounted so that the secondary will slide freely into the primary. The remainder of the instrument is left to the individual worker and presents no difficulty. Provided that the general dimensions are preserved, any suitable mounting may be used. In using two of these with a Fessenden interference preventing circuit, the condenser marked 5 per cent must be calibrated so that it is about 5 per cent different in capacity than the other one. This may be accomplished by arranging the scale on this capacity so that when the pointer is on zero, the condenser will really be in mesh to approximately 5 per cent.

A receiving loose coupler can be made on the pancake plan using two flat spirals of wire, one of which is adjustable with respect to the other, as for the transmitting oscillation transformer. The spacing, however, is accomplished by using a thin insulated wire strip such as is used for transformer coils, and the turns can be close together on account of the low potentials used. Such an arrangement has very little if any advantage over the loose coupler described, particularly if a variometer is

also used, so the duplicated description will be omitted. The method of using the apparatus described has already been fully set forth.

The reader with limited tools can, of course, make a simpler arrangement. It is possible to make tuning instruments with little or no facilities and tools.

Fig. 160 shows another suitable manner of mounting the loose coupler in a box or on a panel. The tops of the

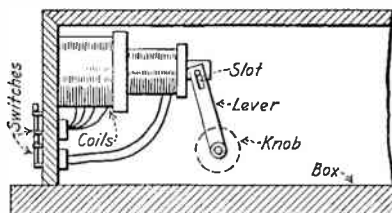

FIG. 160.—Mounting for Receiving Inductances.

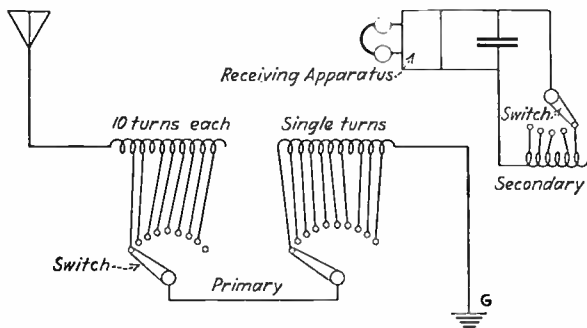

FIG. 161.—Method of Tens and Unit Switching.

windings are brought to the switches by means of a flexible cable. Units and tens are used so that nice adjustment is possible. Many prefer this type.

MULTI-LAYER COILS

For portable use coils for long wave length circuits can best be of the banked turn type shown in Figure 162. One turn is wound successively in each of the layers from one end to the other in the order shown by the

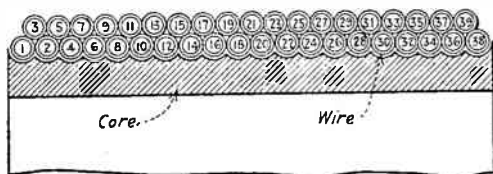

FIG. 162.—Method of Winding Banked Turn Multi-Layer Coils.

numbers. This reduces the capacity of the winding. Figure 163 shows how a coil of small bulk may be wound for both the primary and secondary of a loose coupler for long wave lengths. For 16,000 meters maximum with

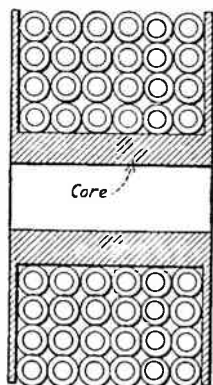

FIG. 163.—A Long Wave Length Coil Wound in Small Space.

a variable air condenser having eleven movable plates of four inch diameter the coil may consist of a fibre core $2\frac{1}{2}$ inches inside diameter, $3\frac{3}{4}$ inches outside diameter, and 5-16 inch wide wound full with number 31 S. S. C. wire with taps taken at 50, 20, 10, 5, 5, 5, 3, 2 per cent respectively of the total turns. While less efficient, long distance signals can be heard with such a coil.

LONG WAVE LENGTH STATIONS

There are only a few stations of very long wave length now in operation and a number of these are of the undamped wave type. Wave lengths of 6,000 to 16,000 meters may be employed, though 14,000 meters is the most recent limit for long distance work. It was considered quite a feat for an amateur to hear such stations. This may be easily done, however, either by constructing a long receiving aerial or by loading an ordinary multi-turn coil or aerial with inductance. A suitable long wave receiving aerial may consist of a single No. 14 wire supported about thirty feet from the ground and 1,000, 3,000 or even 5,000 feet long, preferably running in a straight line and insulated at the supports. Another method which may work if conditions are right is to simply connect the aerial terminal of the receiving set to one binding post of a small variable condenser, the other binding post of which is connected to one of the wires of a telephone line. When this is done no telephone conversation can be heard, but the telephone system is used as an aerial and brought to a suitable wave length by means of the series variable condenser. All the other connections and tuning are the same as usual.

LOOSE COUPLERS FOR LONG WAVE LENGTHS

Tuners for long wave lengths simply are made larger with more turns of wire and should be constructed with taps at intervals so that adjustments may be made. To say that a certain tuner has a certain wave length is misleading, as wave length depends upon the product of capacity and inductance as pointed out in the text whereas the tuner itself is only used to supply a portion of the inductance.

The accompanying table gives data which will serve as a guide in constructing loose couplers of correct dimensions. These were calculated by taking the average capacity of a large number of aerials from the smallest to the largest into account. The variable condenser to be used in the secondary circuit should have a maximum capacity of about .0009 Mfds. if a crystal detector is to be used and about one-third of this if an audion detector is to be employed. In practice only about three-tenths of the condenser capacity may be needed. More turns are used for the secondary in the case of audion detectors because they are potentially operated devices of high resistance and work best with large secondary inductance and small capacity. In any case it is desirable to add to the wave length by means of series inductance rather than shunt capacity as Dr. Austin has found that the efficiency is decreased by the parallel condenser. When considerable inductance is added in this manner the circuit is said to be "stiffened" and this is supposed to slightly reduce trouble from static.

Loading coils for long wave lengths coils may be constructed in the same way as the primary coils given in the table. In loading a small aerial to a long wave length both the primary and secondary circuits should be loaded as the ordinary secondary of the receiving loose coupler alone is not large enough. The loading coils in the two circuits may be coupled together like loose couplers or separated like straight tuners. The large cores may be made by wrapping many layers of paraffined paper around a cylinder and removing this tube when cold.

Wave lengths less than the maximum capacity may be had by taking out taps at intervals to a switch.

TABLE FOR LOOSE COUPLERS AND LOADING COILS

WAVE LENGTH 3,000 METERS

Primary: core $4\frac{1}{2}$ " long by 4" diameter, tightly wound with a single full layer of No. 26 S. S. C. wire.

Secondary: core $3\frac{1}{2}$ " diameter by 4" long, wound tightly with a single layer of No. 28 S. C. C. wire for use with crystal detector or with No. 34 for use with audion. See Figure 164.

WAVE LENGTH 6,000 METERS

Primary: core 8" long by 5" diameter wound with single layer of No. 24 S. C. C. wire.

Secondary: core $7\frac{1}{2}$ " long by $4\frac{1}{2}$ " diameter, wound

with a single layer of No. 30 S. C. C. wire for use with crystal detector or with No. 34 wire for use with audion.

WAVE LENGTH 14,000 METERS

Primary: core $7\frac{1}{2}$ " diameter by 12" long wound tightly with single layer of No. 24 S. C. C. wire.

Secondary: core $11\frac{1}{2}$ " long by 7" diameter wound with single tight layer of No. 30 S. C. C. wire for crystal detector use or with No. 34 wire for audion circuit.

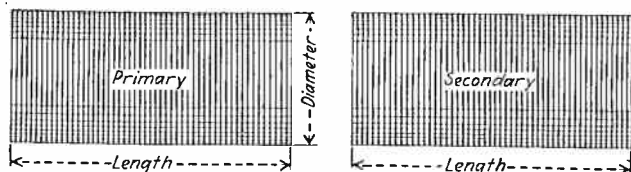

FIG. 164.—A Receiving Transformer for Long Wave Lengths.

With small aerials an additional primary loading coil of similar dimensions may be required in series with the primary coil. An aerial intended for only 200 meters has been successfully loaded to 8,000 meters and has received signals over 4,000 miles with the aid of an amplifying audion detector.

DEAD ENDS

The unused portion of a tuning coil or cover is said to be "dead" and may absorb some energy thus reducing the efficiency. This is almost eliminated by switching arrangements which entirely cut out the unused turns.

The principle is shown in Figure 165 which shows diagrammatically a form of switch constructed by the author for this purpose. Only the primary is here shown as the secondary winding may be arranged in the same way.

A wide range of wave lengths is thus possible in a single receiving set. The coil is divided into a number of insulating series of turns O, O, etc., which are connected to a switch built like a commutator so that contacts P, P, P, etc., may successively cause additional

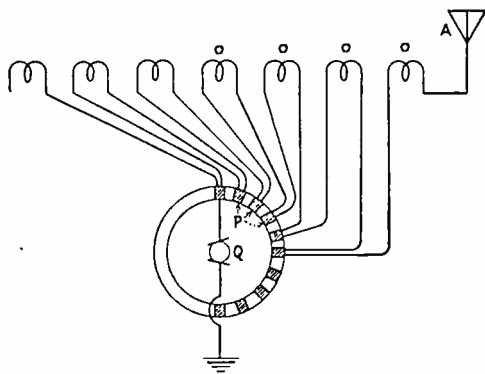

FIG. 165.—A Dead End Switch.

turns to be included in the circuit while at the same time unused turns at the other end of the coil are open circuited so that they cannot absorb the energy. Contact with the ground is made through slip ring Q which rotates with the switch. Each contact P, P, is of course insulated from the others and all are placed at equal intervals.

PLURAL RECEIVING SETS

Another plan is to make a number of separate and independent receiving sets or couplers, each exactly right to receive at a certain wave length or from a certain station. A switch is then made to put the desired set in and the others are not in use at such time.

CHAPTER XXIII

Making the Wireless Set Work

Trouble Finding; Principle Faults Found; How to Make Repairs; Reasons for Various Failures; Improving Poor Signals.

WHEN THE WIRELESS SET REFUSES TO WORK

Probably a majority of the difficulties arise from a misconception or ignorance of the fundamental principles involved; for example, (1) the use of a single wire for a lead-in from an aerial composed of six such wires, (2) the use of too small or too large a condenser for the transmitting circuit, (3) faulty insulation or design of instrument, such as using a helix or oscillation transformer for a $\frac{1}{2}$ kilowatt set which has No. 14 wire for its primary.

"I get a good spark, but cannot radiate any energy." Probably causes are a broken conductor in the aerial circuit, an overheated gap, too short or too long a gap, poor or practically no ground connection, enormous resistance due to loose contact, a broken wire, dry earth connection, a broken condenser plate, punctured insula-

tion, too much or too little primary or secondary inductance or both, causing a lack of resonance, a broken aerial insulator, grounded lead-in wire, coupling too loose, or again, the values of capacity, inductance, frequency, voltage or resistance may be such as to prevent free radiation. Occasionally an aerial will really radiate, the apparent failure being due to a burned out hot wire ammeter, which is used as an indicator. The proper relation of the values for capacity, inductance, resistance, voltage, amperage, frequency, and the coupling used are fundamental and any variation will cause some degree of loss or failure. Total failure is generally due to a definite leakage caused by a breakdown in the circuits.

"I am using one kilowatt of power, but cannot reach a friend fifteen miles away." The cause may be one already given, but in a case in mind the difficulty was due to the use of too small an aerial, a poor ground and very poor tuning.

"I cannot get a good spark discharge." This is often due to the use of too small electrodes, too much power for the size of the gap, lack of cooling, too short a gap, a leaking or broken condenser; or again, it may be due to the use of long connecting wires of small cross section, such as were found in one particular case where the connecting wires were heated hot.

"I cannot get my set down to 200 meters and radiate enough energy to affect my hot wire meter." A variety of causes may include the use of too large a condenser, an inductance consisting of a coil of too great diameter, a poor design of oscillation transformer, too long wires for connections, loose contacts of the clips, or connect-

ing wires of too small a cross section. In many cases, an inductance coil of the cylinder type will give better results with a smaller diameter, say six inches or less, and a large conductor, say No. 0 to 4, than is ordinarily used. The aim should be to use a condenser and inductance which will allow at least one complete turn of the inductance to be included in the primary 200 meter circuit. A pancake type of oscillation transformer embodying this principle of small diameter and large conducting surface is also suitable.

"I can hear NAX clearly, why cannot I get Arlington?" The usual reason for this is that a small station has insufficient wire in use to attain the necessary high wave length. It is a simple matter to construct a large loading coil, with taps, to bring a small set up to the longest wave length now in general use.

"A station 150 miles from here formerly came in very strong, but now I can hardly hear it." It was found that the station mentioned had changed its wave length, but the cause might have been poor contact of the sliders or coupler switches or a non-sensitive detector. Often, after some months, a conductor used in the circuits will become grounded or broken.

"My set tests out fine with a buzzer, but I cannot get even static." This failure is due to a poor ground or no ground, or a grounded aerial, or a broken lead-in, or a broken wire in the primary inductance (usually near the binding posts), or it may be merely a case requiring intelligent tuning.

"I am operating a ship station using a motor generator set, but I have to connect a battery across the fields to

get the generator started." This often happens with small generators because of a loss of magnetism due to a variety of causes, such as faulty connection, the iron used in construction, etc. A few dry cells are generally sufficient to supply the starting energizing current, after which the fields build up rapidly.

"My audion is noisy." The "B" battery has become leaky and polarized. Often dry batteries deteriorate so that they give a fluctuating current.

CHAPTER XXIV

Miscellaneous Applications

Railroad Wireless; Forest Fire Prevention; Automobile Wireless; Aeroplane Sets; Wireless Compass; Bellini Tosi Apparatus; Multiple and Ground Aerials; Balancing Aerials; Telemechanics.

RAILROAD WIRELESS

Railroad wireless telegraphy and telephony differs in no way from radiocommunication for other purposes except that the aerial consists of two or three wires suspended just a little above the train car while the ground is through the trucks to the rails. Couplings are provided for the aerial between cars. The Delaware and Lackawanna Railroad has had experimental success with such moving stations in conjunction with a few fixed land stations. Communication has been regularly established with the moving trains both ways, even when the train is passing through a tunnel.

FOREST FIRE PREVENTION

Radio apparatus is valuable as an aid in prompt reports on forest fires before conflagration can start. The author

was a pioneer in this beneficial application now adopted by several governments.

AUTOMOBILE WIRELESS

Successful communication may be established over several miles with a small wireless station on an automobile, using a small aerial suspended a few feet above or within the top and using the metal body of the car as a counterbalance in lieu of a ground. For army use, the automobile is merely used to transport and contain the apparatus and a portable aerial is rapidly erected when communication is to be established. A multi-turn coil receiver as described in Chapter III may be carried complete in an automobile.

AEROPLANE WIRELESS

Wireless communication is successfully used on aeroplanes to communicate to military bases from the air or enemy territory. The apparatus comprises a small sending and receiving station of light weight. Remarkable success has been attained over long ranges with radio telephone, telegraph, and direction finding equipment. The receivers are provided with sound protectors, but receiving is less successful than sending because of the propellor noise. This defect has been overcome to an extent by using sound insulated telephone head pieces. The aerial is generally mounted on the planes and a counterpoise or additional aerial is used instead of a ground. Hanging aeriels from reels, etc., though used in the recent war, are considered dangerous and obsolete. The total weight

of the equipment need not be over 50 pounds. Use of the wireless to direct gun fire and report troop movements has been very successful. The U. S. planes in France, except chasers, could be maneuvered via radio-telephone. They carried vacuum tube sets.

WIRELESS COMPASS

The Bellini and Tosi compass, of which a few are in use, utilizes an almost closed triangular oscillating antenna which radiates and also receives the strongest in its own plane and the least at right angles thereto. Two partially closed looped aerials are placed at right angles to each other and each is connected to a primary of a loose coupler having two primaries at right angles to each other and a single secondary winding which is rotatable therein. For any position of this secondary winding the received energy will be proportionately due to the two primaries so that by observing when the received signals are strongest the sending station can be located within two or three degrees. This is most useful in foggy weather. For sending the same arrangement is used with a transmitting oscillator connected to the two aerials in the same manner so that signals can be sent out strongest in a desired direction. International radio regulations require such stations to use small power and low wave lengths, this being necessary in order to avoid interference with other communications. This system has been largely replaced by the multi-turn coil receiver. A refinement of the latter is now used by the U. S. Navy.

The set uses no ground connection and is shown in Figure 166. The aeri-als A, B, respectively are connected to the primaries A', B' respectively of a loose coupler called a goniometer. The secondary S, wound on a spherical core connects to an ordinary detector circuit and is movable by means of handle R which carries a

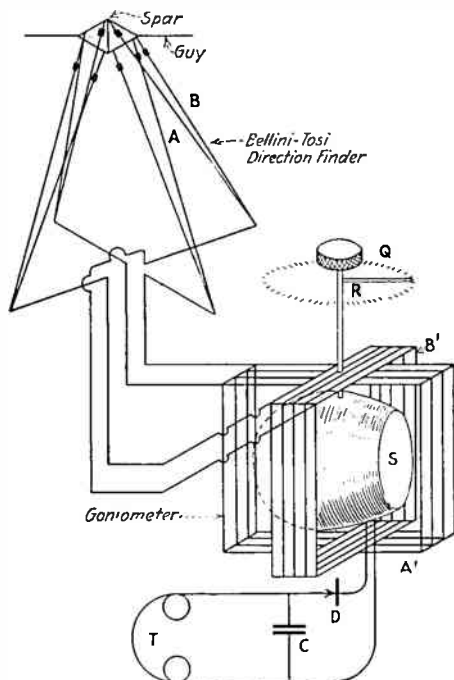

FIG. 166.—Bellini-Tosi Direction Finder.

pointer so that degrees may be read on a scale O. In practice a slightly elaborated arrangement is used. For purposes of demonstration it is not difficult to rig up an outfit of this kind.

With the Telefunken compass (now obsolete in the U. S. A.) an ordinary antenna on a ship may be used in conjunction with shore stations. Thirty-two separate aerials arranged in the form of an umbrella are used at the shore station for sending, a rotatable switch being provided so that each antenna may be separately and successively connected to the sending apparatus. Aboard the ship the direction is determined by comparing signal strengths. Various other arrangements have also been proposed. The multi-turn coil has proven successful on aeroplanes as a radio compass.

MULTIPLE TUNED ANTENNA

The radiation resistance of a large antenna is an important item. This has been reduced by a recent method called the multiple tuned antenna principle. The transmitting antenna is simply grounded at a number of points along its length, via tuning coil inductances. The arrangement for a large Trans-Atlantic station is described in a paper by E. Alexanderson, read at the October 1, 1919, meeting of the American Institute of Electrical Engineers.

LOW GROUND AERIALS

Experiments with grounded aerials show that signals may be received for distances of at least 3,000 miles with an ordinary receiving set by simply using a bare or insulated wire spread upon or supported a few feet either above or below the ground as an aerial with a

counterpoise. A single wire has been found to be the best especially if a Y is connected to its ends and such an antenna has also been found to be directive. The counterpoise is best made exactly like the aerial and arranged opposite it so that the receiving set is at the middle of a symmetrically placed conductor adjacent to the ground. For sending purposes such an arrangement has not been found effective except over a short distance.

BALANCING AERIALS

The Marconi duplex stations were designed to use a balancing aerial at the receiving station to overcome interference from the sending end of the station a number of miles away which is in simultaneous use. This is simply an aerial placed at right angles to the receiving aerial and of lesser height which is coupled to the main aerial through a loose coupler in such a way that the energy received by the one aerial is neutralized by that received by the other from the strong nearby station. The large aerial receives the long distance signals as usual but the balancing aerial being both lower and at right angles does not receive enough energy from the distant station to deter the reception of signals therefrom. A single horizontal wire suffices for the balancing aerial. This method has been superseded.

TELEMECHANICS

Wireless controlled torpedoes, boats, fog guns, etc., have been successfully experimented with so that ap-

plications may be expected to come into use soon. Most of this work has been done with the use of a coherer receptor and various mechanical switch and tuning arrangements. It is now possible, however, to use the more sensitive audion and amplified circuits already mentioned for this purpose. A simply made outfit for demonstrating the various possible applications is described in Chapter XIII of the book "Experiments" by the author which may be obtained for \$1.50.

Telemechanics is now a practical art. Large boats are exactly controllable by radio for naval purposes. Compressed air mechanisms governed by electrically operated valves included in audion amplifier and relay circuits with proper selection permit successful control. Details are not released for publication yet.

CHAPTER XXV

Time and Weather Signals

How Signals Are Transmitted and How to Receive Them; Naval Stations Sending Information; Codes Used; Example of Deciphered Code.

TRANSMISSION OF TIME SIGNALS BY NAVAL RADIO STATIONS

To receive time signals an aerial about 500 feet long is desirable though a much smaller one will do. A coil receiver as described in Chapter III is ideal for this purpose. Apparatus described in this book will bring in the signals with either a crystal or audion type of detector. The following advice is given by the U. S. Dept. of Commerce:

Time signals are now sent out on the Atlantic coast only through the radio stations at Arlington, Key West, and New Orleans. Signals from Arlington and Key West, which reach a zone formerly served by other coast stations, are sent out every day in the year twice a day, viz., from 11.55 a. m. to noon and from 9.55 to 10 p. m., seventy-fifth meridian time. Time signals from New

Orleans are sent out daily, including Sundays and holidays, commencing at 11.55 a. m., seventy-fifth meridian time, and ending at noon.

On the Pacific coast the time signals are sent broadcast to sea through the naval radio stations at Mare Island, Eureka, Point Arguello, and San Diego, Cal., and at North Head, Wash. The controlling clock for each station is in the naval observatory at the Mare Island Navy Yard. Signals from Mare Island are sent out every day from 11.55 to noon, and from 9.55 to 10 p. m., one hundred and twentieth meridian standard time. Those from North Head, Eureka, Point Arguello, and San Diego are sent out daily, excluding Sundays and holidays, from 11.55 to noon, one hundred and twentieth meridian standard time.

To get the maximum clearness of signals, the receiving circuit should be tuned to that of the sending station. Arlington and Mare Island send on a 2,500-meter wave length, North Head and San Diego on a 2,000-meter wave length, Eureka on a 1,400-meter wave length, Key West and New Orleans on a 1,000 meter wave length, and Point Arguello on a 750-meter wave length.

TRANSMISSION OF WEATHER REPORTS BY NAVAL RADIO STATIONS

Through co-operation with local offices of the United States Weather Bureau, weather forecasts are sent broadcast to sea through naval coast radio stations at certain times, varying with the locality. Storm warnings are sent whenever received and the daily weather bul-

letins are distributed by the naval radio stations at Arlington, Va., and Key West, Fla., a few minutes after the 10 p. m. time signal. These bulletins consist of two parts.

The first part contains code letters and figures which express the actual weather conditions at 8 p. m., seventy-fifth meridian time, on the day of distribution, at certain points along the eastern coast of North America, one point along the Gulf of Mexico, and one at Bermuda.

The second part of the bulletin contains a special forecast of the probable winds to be experienced a hundred miles or so off shore, made by the United States Weather Bureau, for distribution to shipmasters. The second part of the bulletin also contains warnings of severe storms along the coasts, as occasions for such warnings may arise.

Immediately following this bulletin, a weather bulletin for certain points along the Great Lakes is sent broadcast by the naval radio station at Arlington, Va., consisting of two parts. The first part contains code letters and figures which express the actual weather conditions at 8 p. m., seventy-fifth meridian time, on the day of distribution, at certain points along the lakes. The second part of the bulletin contains a special forecast of the probable winds to be experienced on the lakes, during the season of navigation—about April 15 to December 10.

The points for which weather reports are furnished are designated as follows: *For Atlantic coast and Gulf points.* S=Sydney, T=Nantucket, DB=Delaware Breakwater, H=Hatteras, C=Charleston, K=Key West, P=Pensacola, and B=Bermuda; *for points on*

the Great Lakes, Du=Duluth, M=Marquette, U=Sault Ste. Marie, G=Green Bay, Ch=Chicago, L=Alpena, D=Detroit, V=Cleveland, and F=Buffalo.

All bulletins begin with the letters U. S. W. B. (United States Weather Bureau) and the weather conditions follow. The first three figures of a report represent the barometric pressure in inches (002=30.02); the next figure, the fourth in sequence, represents the direction of the wind to the eight points of the compass: 1=north, 2=northeast, 3=east, 4=southeast, 5=south, 6=southwest, 7=west, 8=northwest, and 0=calm. The fifth figure represents the force of the wind on the Beaufort Scale, given on page 255.

BEAUFORT SCALE OF WIND FORCE

Number and designation.	Statute miles per hour.	Nautical miles per hour.
0 Calm	0 to 3	0 to 2.6
1 Light air	8	6.9
2 Light breeze	13	11.3
3 Gentle breeze	18	15.6
4 Moderate breeze	23	20.0
5 Fresh breeze	28	24.3
6 Strong breeze	34	29.5
7 Moderate gale	40	34.7
8 Fresh gale	48	41.6
9 Strong gale	56	48.6
10 Whole gale	65	56.4
11 Storm	75	65.1
	90	78.1
12 Hurricane	and over.	and over.

In order to simplify the code, no provision has been made for wind force greater than 9, strong gale, on the Beaufort Scale. Whenever winds of force greater than 9

GENERAL APPARATUS AND SYSTEMS, BOTH TRANSMITTING AND SENDING.

For any other apparatus or arrangement of circuits consult also this general list, as it includes patents treating of more than one related idea.

Patents numbered:

586,193	716,334	1,123,118*	1,120,054	711,266	711,184	717,773
717,769	717,771	717,772	711,183	711,182	749,584	748,597*
734,048	730,247*	743,999	749,370	749,131	737,170*	800,854
12,073	758,842	706,718	756,904	730,819*	756,719*	802,981
805,412	716,334	765,298	706,742*	710,355	710,354	733,842-
768,301*	710,122	706,746*	706,745	706,743	706,500	763,893
706,741*	671,406	711,132*	11,952	700,250*	671,407	680,001
757,559*	687,440	737,072	699,158	795,762	682,974	684,706
706,736*	684,467	758,005*	750,496	753,863*	720,568*	708,071
609,154*	711,130	708,072	12,168	703,712	706,737	706,740
707,064	717,766	743,056*	750,429*	671,732	696,715	685,742
741,622	763,772*	716,203	717,765	768,003*	674,846*	664,869
377,879	671,176	550,510	657,224	651,361	651,362	650,255
651,014	650,110*	650,109	647,009*	657,222	711,174*	644,497
627,650*	647,007*	647,008*	643,018	673,553	673,418	716,203
671,403	929,745	783,923*	781,823	716,000	962,014*	934,883
935,721	842,910	837,616	937,901*	841,386	889,790	889,792
884,109*	889,791	884,070	884,070	957,282*	884,108	884,106*
962,017	884,071	899,239	899,243	1,129,821	728,244	701,256
884,986*	729,797	768,778	1,006,786	1,128,210	730,246	897,278*
879,409	913,718	998,567*	908,816*	994,191	700,738	717,770
894,378	754,058	727,329	727,330	730,753	767,979*	767,983
927,641	770,668*	752,895	874,745	768,000	884,987*	802,430
763,992*	786,132*	770,229	759,216	767,984	759,825	711,444
760,463*	725,635	749,434	749,178	742,779	1,162,830	12,169

General Systems, Continued.

706,737	767,990*	767,985*	767,991*	725,634*	767,989*	767,988*
734,476	753,864	808,641*	768,003	818,236	771,818	767,978
923,963	764,093	974,762*	966,705*	764,094	1,111,777	929,145
926,936	879,532	997,515	1,059,666*	1,106,875	1,038,506	1,106,874
899,240	986,651	935,382*	916,301	827,524	884,107	858,569
1,020,032*	1,132,568*	1,019,236*	1,080,271*	1,018,555	813,914*	954,640*
979,276	808,594*	802,432*	1,074,423*	996,090	996,098	1,001,227
706,740	1,157,094	767,987*	767,980*	767,986	767,981	767,975
725,636	767,997*	767,976*	753,517	781,873	781,873	813,975
802,417	768,005	768,002	767,996*	929,349	1,018,555	759,826
768,004	884,989*	864,272	884,110	935,383	956,165	706,736*
798,650	913,528	793,652	1,014,002*	946,168	934,875	929,487
1,031,698	1,101,915*	824,003	899,242	889,289	822,936	937,281
1,010,669	924,560*	928,962	1,016,003	1,101,533*	1,015,881	1,003,375
1,006,635	1,006,636	1,012,456	753,527	761,450	802,418	739,287
1,020,032	797,514*	730,753*	742,800	1,002,049	958,006	749,372
824,676	767,995	768,001	767,997	767,992	767,993	767,993
829,787	908,742	901,649	992,042	711,131	785,803	711,445
962,018	624,516*	797,169*	1,128,210	1,045,781	1,132,569*	1,114,840
1,138,652	928,371*	956,489	946,166	851,821	854,813	869,714
899,241	714,648	1,050,728	1,074,456	1,059,625	1,082,221	1,035,334
716,334	730,819	1,123,119	1,139,226	14,012	806,966	756,720
788,477	843,733	776,337	782,181	787,780	755,846	771,819
792,528*	767,999*	767,994	943,969	935,386	946,167	965,060
1,002,051*	915,280	996,580	995,339	929,145	711,181	1,127,921*
1,101,914*	1,014,002*	802,431	802,421	802,420*	802,419*	444,678*
818,363	840,909	992,791	676,332*	680,002	716,000	713,000
758,004	714,246	960,304	850,917	1,021,132	1,045,782	1,080,554
1,050,441	1,022,540*	750,216	918,306	918,307	777,014	1,158,123

RECEIVING DEVICES, SYSTEMS, AND CIRCUITS.

Includes selective arrangements, interference compensators, beat receivers, audio-tuning, bridge circuits, apparatus arrangements, static shields, etc. See also related headings. Includes some detectors.

Patents numbered:						
1,895,342	1,138,147	1,144,968	1,116,183	1,116,588	1,019,236*	657,223
1,113,149*	997,516*	1,134,593	1,132,588*	1,139,632	1,143,799	1,123,910
1,127,368	727,327	762,829	767,971	801,118	796,800	787,922
761,258	712,764	806,052	962,417	668,315*	974,838	793,648*
921,531*	727,331*	995,312	936,258	12,115	982,016	665,957
780,842	802,613	897,779	962,015	962,016	845,316	836,531
883,437	936,258	962,015*	958,181*	974,986	974,538	921,531*
902,613	936,183	912,726	974,985	892,312	706,742	730,246
761,258	727,331	884,988	748,306	796,403	12,115	749,371*
727,328*	748,557*	745,463	737,271	744,936	756,219	755,586
773,171	773,340	774,922	775,050	782,422	793,648	780,842
783,712	961,645*	1,002,150	758,468	905,537	897,779*	924,827
888,191	959,510	982,312	896,139	877,451*	883,241	886,154
1,009,317	963,173	916,429*	918,618	974,927	1,012,496	952,403
784,762	931,586*	925,921	802,428*	824,682*	930,508	846,414
852,381*	853,929	839,029*	706,745	730,247	802,423*	802,422*
823,699*	857,375	994,426	858,668	846,081*	785,276	1,009,106
812,557	820,169	816,205	962,417	1,093,240	1,087,113*	1,104,256*
1,089,091	13,798	1,042,778	1,097,974	1,027,238	1,091,127	1,099,865
1,059,391*	1,022,539	1,044,837*	1,087,892	1,087,549*	1,132,568	916,429
897,278	752,894	752,895	1,018,155	1,012,496	716,135	167,970
1,156,677	1,163,839					

SELECTIVE SECRECY SYSTEMS.

(See also others.)

Patents numbered:						
1,102,442	1,091,768	714,384	715,203	717,978	714,756	795,840
750,894	727,326	12,149	714,831	12,141	1,123,119*	777,014
910,718	768,001*	1,091,768	1,214,022*			

DETECTORS.

Oscillation Responding Devices, Rectifiers, Electrolytic, Heat, Contact, Capillary Devices, etc.

(For circuit arrangements, etc., see Receiving Apparatus and Systems.)

OSCILLAPHONE.

Patents numbered: 769,005 819,779

MAGNETIC DETECTOR.

772,878	877,069	917,104	930,780	711,182	917,104	749,371
715,043						

ELECTRO-CAPILLARY DEVICES.

Patents numbered: 844,080 798,484 798,483 798,482 798,481 848,083

ELECTROLYTIC

Patents numbered:						
706,742	716,334	929,784	894,317*	875,105	902,569	795,312
894,317	875,105	962,014*	783,712	716,203	727,331	716,000
731,029	706,744	916,428	793,648	768,003		

HEAT DETECTOR.

Patents numbered: 800,856 767,996 767,997

BOLOMETER.

Patents numbered:
778,275 767,992 767,980 767,971 767,981 767,972

CRYSTAL AND MISCELLANEOUS—ALL TYPES.

Patents numbered:						
879,062	879,117	923,700	924,827	837,616	886,154	912,613
912,726	1,159,969	1,152,444	1,158,112	11162,765	1,080,681	1,052,355
1,096,142*	1,048,117	1,102,184	1,104,065	1,104,073*	867,876*	899,264
824,637*	824,638*	927,314	1,013,223	986,806	966,855	954,619
959,967	867,878	867,877	912,613	879,062	917,574	1,004,784
904,222	906,991	811,654	776,359	757,802	701,570	1,003,210
905,781	901,942	962,262	836,070*	836,071*	1,155,338	879,061
820,258	902,569	706,744	707,266	771,123	756,676	787,412
1,003,374	902,569	1,136,014	1,136,045	1,137,714	1,136,046	1,136,047
1,122,558	1,128,552	1,118,228	1,115,902	1,112,411	1,145,658	1,144,399*
1,008,977*	933,263	770,228	917,574	706,735	706,736	767,985
837,616	706,735					

MERCURY AUDION, VACUUM VALVES, AUDIONS, THERMIONIC RELAYS, AND DETECTORS.

Patents numbered:						
1,130,008	1,142,625	837,878	836,070	879,432	841,386	979,275
837,901	867,876	995,126	836,071	979,275*	802,689*	1,130,043*
1,127,371*	1,430,008	1,128,817	1,130,009	1,130,042*	1,128,280	1,137,275
1,145,735	1,144,596	1,159,307	1,138,652	1,113,149	841,397	1,156,625
943,969	824,637	824,638	867,071	915,280	824,637	803,684
837,901	841,387	867,877	867,878			

COHERERS.

(See Radio-Mechanical Control.)

Patents numbered:						
1,019,260	932,788*	700,703	691,815	993,024	886,983	794,459*
800,119*	908,504	985,854	775,113	742,298	763,894	759,835
968,007	670,711	703,070	755,840	722,139*	710,372	1,019,260
741,767	1,118,410	1,150,111				

WAVE METERS.

Patents numbered:						
804,189	1,064,325	1,018,769	804,190	932,819	846,675	918,256
892,311	993,316	1,152,632				

GALVANOSCOPE.

Patent numbered 798,152

SYNCHRONIZER.

Patent numbered 717,768

RANGE FINDER.

(See also Direction Finders.)

Patents numbered: 749,436* 1,135,604*

**SPARK GAPS, INCLUDING MUFFLED, COOLING AND TONE
TYPES.**

Patents numbered:							
1,073,371	1,051,744	1,075,075*	834,054	926,933	971,935*	1,132,589*	
1,117,681	750,180	750,005	1,163,586	792,014	706,741	768,000*	
1,148,521*	1,161,520	1,152,272	1,162,659				

WIRELESS TELEPHONY.

(See also Oscillation Producers, Transmitting and Sending Systems, etc.)

Patents numbered:							
1,118,004	1,125,496*	1,122,594	1,130,413	1,062,179*	1,086,530	1,107,985*	
1,044,798	1,052,849	1,088,686	803,199*	836,015*	814,942	836,072*	
803,513*	1,006,429	923,962	753,863	793,649	793,750	1,148,827	

**RADIO-MECHANICAL CONTROL. TORPEDOES, TYPEWRITERS,
ETC., CONTROLLED BY WIRELESS. COHERERS.**

(See also Detectors and Systems.)

Patent numbered:							
715,803	1,115,530*	1,097,871	1,072,152	1,987,966	625,823	1,029,573	
789,618	976,500	828,864	907,488	1,098,379*	957,001	663,400	
723,176	913,814	1,155,653	1,154,628	1,149,874			

RECEIVING RECORDER.

Patent numbered 766,743

RELAYS AND RELAY SYSTEMS.

Patent numbered:							
717,514*	786,696*	657,221*	718,535	717,513	717,509	717,570	
1,106,729	655,716						

AUTOMATIC TICKER.

(See also Receiving Devices.)

Patents numbered: 1,098,380 1,161,142

TUNING DEVICES AND COUPLINGS.

(See also Receiving Systems, Transmitting Systems, Wavemeters.)

Patent numbered:							
1,116,130	978,604	802,425	1,070,376	1,014,722	1,014,722*	1,083,085	
1,096,065	719,005	707,056	763,345*	717,511*	934,296	803,569	
956,936	996,082	717,512*	1,132,568	1,127,921	714,756	714,831	
1,151,098	1,148,279						

AMPLIFIERS FOR RECEIVING.

(See also Receiving Systems, and Audions.)

965,884	714,832	1,041,210	12,151	12,152	1,163,180	751,818	
714,833	1,165,454						

ALARM SYSTEM.

See Coherers, and Radio-Mechanical Control.)

Patent numbered 606,405

CONDITION AND EARTH SYSTEMS.

(See general system list.)

Patents numbered: 1,051,443* 690,151

**COMBINATION SETS. RECEIVING AND TRANSMITTING LINE
AND RADIO.**

Patents numbered: 996,089 1,104,712 1,092,294 918,483 972,721

PORTABLE STATIONS.

(See general list and Aerials.)

Patents numbered: 1,145,066 953,209

COMBINATION TRANSMITTING AND RECEIVING SETS.

(See also general list.)

Patent numbered:
 1,116,111 1,141,453 1,141,386 751,294 777,014 736,483 726,413
 840,908 979,144 916,985 876,281 794,334 798,158 810,150
 793,652

**TRANSFORMERS RESONANT WITH CAPACITY, FOR TRANS-
MITTING STATIONS.**

Patents numbered: 965,168* 835,023*

DIRECTION AND DISTANCE FINDERS.

Patent numbered:
 736,432 744,897 716,135 1,069,355 899,272 12,148 941,585
 943,960* 961,265 984,108 948,086* 945,440* 894,318 1,002,141
 833,034 716,134 758,517 1,149,123 1,149,122

**STATIONARY AND PORTABLE ANTENNA—AEROPLANE,
AERIALS.**

Patent numbered:
 1,141,387 918,255 919,115 930,746 898,197 945,475 972,004
 959,100 1,005,471* 793,718 793,651 948,068 860,051 1,106,945
 1,101,175 1,063,671 1,132,569 767,973 717,511 706,737 1,147,010
 770,229 749,436 719,131 748,697 771,819 707,746 706,738

Aerials, Continued.

706,739 716,136 899,272 1,153,124 717,512 793,718 753,864
 802,981 802,982 806,066 822,936 824,003 787,986 767,988
 767,988 767,999 716,177 1,163,412

BREAKING SYSTEMS AND KEYS—SENDING TO RECEIVING.

Patents numbered: 827,523 842,134 1,016,564* 1,073,624

**MASTS—AERIAL SUPPORTS, INCLUDING AEROPLANE AERIAL
DEVICES.**

Patents numbered: 1,116,059 857,152 1,034,760 1,099,861 768,005

AUTOMATIC CHANGE-OVER SWITCH—SENDING TO RECEIVING.

Patent numbered 1,074,057

CLEARING ICE FROM ANTENNAS.

Patent numbered 750,181

PROTECTING DEVICES.

Patents numbered: 771,820 978,607 1,035,958

CONDUCTOR FOR WIRELESS TELEGRAPHY.

Patent numbered 706,739

CURRENT INTERRUPTER.

(General interrupters not included.)

Patent numbered 1,039,011

KEYS, CIRCUIT CLOSERS AND CONTROLLERS.

917,749 792,020* 792,015 769,228 934,716 749,178 792,015

TRANSMISSION OF MUSIC.

(See Radiotelephony.)

Patent numbered 1,025,908

PUNCHED TAPE SYSTEMS.

Patent numbered:
725,634 725,635* 725,636 767,978 767,991 767,932 767,995

STATIC VALVE. STATIC PREVENTION.

Patents numbered: 823,402 825,402

METHOD OF UTILIZING ENERGY OF WAVES.

(See general list.)

Patent numbered 731,029

VISIBLE AND AUDIBLE SIGNAL.

(See Coherers, Radio-Mechanical Control, etc.)

Patent numbered 805,714

COMMUNICATION BY WAVE COMPONENTS.

(See also General Systems.)

Patent numbered 876,996

PRODUCTION OF TONE EFFECTS.

(See also Spark Gaps, General Systems, Transmitters.)

Patents numbered: 1,056,892* 1,056,893*

AUTOMATIC COMMUTATOR FOR WIRELESS TELEGRAPHY.

(See General Systems also for similar arrangements.)

Patent numbered 1,105,029

RELAYING HIGH FREQUENCY CURRENTS.

(See also Audions, Detectors, Oscillation Producers, etc.)

Patent numbered 1,042,069*

DETERMINATION OF FREQUENCY.

(See also Wavemeters.)

Patent numbered 1,022,584

SYSTEMS OF HIGH FREQUENCY DISTRIBUTION.

(See also general Systems, Transmitters, Oscillation Producers.)

Patent numbered:
 1,123,098* 1,122,027* 856,149* 856,150* 1,043,101* 1,043,766*

CONTROL OF SPARK PRODUCTION.

(See also Radiotelephony and General Systems.)

Patents numbered: 750,180 802,850

TELEPHONE RECEIVER.

(General telephone list not included.)

Patent numbered 936,684

DUPLEX, MULTIPLEX, SYSTEMS,

(See General Systems.)

716,136	772,829	802,429	802,426	717,767	767,970	924,168*
1,116,309*	1,076,312	1,042,205	749,434	720,568	716,134	772,879
767,980	716,134	793,652				

SUBMARINE SIGNALLING SYSTEMS, COLLISION PREVENTION, ETC.

711,386	1,126,095	1,073,088	749,694	802,020	914,483	913,910
526,609	1,090,998					

PHOTOPHONES.

(See General Systems.)

Patent numbered:
 235,120 680,614 796,254 766,355 241,909* 235,496* 235,190
 341,213

CONDENSERS, PAPER, GLASS, AIR, COMPOSITION, ETC.

(For complete list see general electrical classification omitted here.)

Patent numbered:
 1,127,513 793,647* 786,578 793,777 1,033,095 1,150,895 1,108,793
 1,063,105 1,094,178 1,116,013 1,111,289* 1,112,397 1,114,626, 1,139,976
 814,951 793,647 793,651 767,977 1,151,824

DIRECTIVE SYSTEMS.

Patent numbered:
 795,762 749,131 720,568 716,134 716,135 771,818 771,819

TRANSMISSION SYSTEMS AND APPARATUS.

(General list. See also detail lists, as they are not repeated here.)

See General Systems.)

1,145,239—Polyphase	974,169	1,119,952	247,127	255,305	11,913
586,193*	657,363	465,971	932,821	926,900	767,974*
749,435	685,953	685,954	685,957	785,956	754,737
755,132	775,416	776,876	876,165	792,014	787,056
935,381	950,258	932,820	921,293	1,005,338	986,405*
1,119,732	749,372	802,850	768,004	758,004	1,148,279
953,635	927,433	802,427*	851,336*	991,937	834,497
917,103	858,554	1,015,881*	921,013	1,136,411*	1,139,228
1,141,717	1,126,966*	723,188	685,958	685,955	714,832
714,837	767,990	767,975	767,976	767,984	767,989
767,979	1,153,717*				767,975

OSCILLATION PRODUCERS, ARC CONTROLS, PRODUCTION OF HIGH FREQUENCY CURRENTS AND ALL KNOWN TYPES OF WAVES.

(See Audions and General systems. This list includes mercury vapor devices applied to the art, except such as are listed elsewhere.)

Patent numbered:					
550,630	1,115,823	1,118,174	1,121,360	1,120,306	829,447
1,097,872	1,087,126	1,152,675	500,630	1,122,975	1,131,190
1,139,673	790,250	1,023,135	1,043,117	1,101,148	1,159,209
717,774	685,012	925,060	1,047,643	1,103,822	1,101,491
921,526	979,277	780,997	773,069	1,096,717	1,105,984
1,110,253	781,606	817,137	932,111	966,560	1,077,733
1,709,909	923,963	730,755	758,004	706,742	897,279
767,993					767,983

RELAY OF MESSAGE.

Patents numbered: 717,509 717,513 717,514 717,516

NOTES ON LIST.

As a guide to date of issue, the number of the first patent for a period is given herewith:

747,127-1881	691,176-1902	730,247-1903	749,131-1904	802,417-1905
808,641-1906	840,909-1907	876,165-1908	908,742-1909	945,440-1910
984,108-1911	1,014,002-1912	1,050,728-1913	1,083,667-1914	1,123,910-1915

Numbers of five figures, as 12,073, are for re-issued patents.

The author assumes no liability for the accuracy of the list. The general list of electrical patents which overlaps the radio list in many instances has not been included because it alone is far larger than the entire wireless list.

DISCUSSION OF SOME OF THE U. S. PATENTS LISTED

By way of pointing out indications of progress a few of the patents may be mentioned. Patents numbered 1,087,113 and 1,104,256 describe the tone wheel ticker receiving system of Rudolf Goldschmidt. Patents numbered 1,098,379, 1,154,628 and 1,115,530 describe the con-

trol system of J. H. Hammond, Jr. An improved audion circuit is given in patent 1,113,149 of E. H. Armstrong. An arc oscillator using an arc between cooled electrodes immersed in alcohol and said to have transmitted telephone communication 600 miles is set forth in Dwyer's patent No. 1,109,909. A multiphase transmitter is described in patent 1,114,840. A practical arrangement of an aerial on an aeroplane is given in patent numbered 1,116,059. The duplex system of Marconi using two aerials at right angles is explained in patent numbered 1,116,309. A receiving set which is selective and obviates the use of the loose coupler by a practical arrangement of inductance and capacity is described in Cohen's patent No. 1,123,098. A proposed secrecy system is described by De Forest in patent numbered 1,123,119.

A suitable system for radiotelephony over about fifteen miles is described by De Forest in patent 1,125,496. His arrangement uses a quenched spark gap oscillator. A balanced receiving circuit which attempts to prevent interference is described in patent 1,127,368. A good tuning circuit for receiving with both tight and loose coupling is described in Tronchon's patent 1,129,821. Weintraub furnishes much information on mercury vapor tubes as oscillation producers in patent numbered 1,131,190. Tape sending and phonographic recording is illustrated in Fessenden's patent 1,132,568. Marconi describes a plural circuit rotary gap method of generating continuous waves in patent 1,136,477. R. C. Galletti shows a system utilizing high frequency unidirectional impulses in patent 1,140,150. A novel aerial loaded with inductance and capacity to give a large wave-length

range in a small space is illustrated by Franklin in patent 1,141,387. A good exposition of the heterodyne system is given in patent 1,141,717. Patent 1,144,969 shows a method of using a crystal detector to receive from undamped wave stations. P. C. Hewitt describes his mercury vapor receiving system in detail in patent 1,144,596. Marconi explains his disk discharger in patent 1,148,521. An improved coherer is illustrated in patent 1,150,111 and a new manner of using it for radio control is shown in patent 1,155,653. Seibt describes a practical quenched spark transmitter in patent 1,153,717. Vreeland illustrates his mercury arc generator cooled by water in patent 1,152,675. An antimony and ferro-silicon detector is shown in patent 1,158,112. A secrecy method is shown in patent 1,401,2 of Nov. 16, 1915. The receiving ticker used by the Federal Telegraph Co. is shown in patent 1,161,142. Quenched spark gap construction is the subject of Pfund's patent 1,161,520. In patent 1,152,272 H. Boas makes the practical suggestion of using tungsten for spark gaps. One form of the plural receiving tuner mentioned on page 252 is described in patent 1,151,098. A practical quenched spark system is described in patent 1,162,830. Amplification by means of microphones in cascade is explained in patent 1,163,180. Patent 1,127,371 shows how an audion may be used in connection with a relay circuit for wireless control purposes. Patent 1,165,412 shows a practical installation of a wireless set on an aeroplane, but employs the objectionable hanging wire antenna. Patent 1,214,022 shows some interesting improvements by P. Edelman.

CHAPTER XXVII

Rights of the Experimenter

Information on Complete Sets; List of Radio Stations; The Law of 1912; How to Get Licenses; Radio Inspectors; Rules for Operating; Patents; Tendency of Art; Wireless Codes; Conclusion.

The completed receiver, of whatever type adopted, can all be mounted together if desired. In any case the connections used should be of stranded insulated conductors, kept free from each other, well insulated from wood and other matter, the switch contacts clean, and so on. The descriptions have been made as clear and concise as possible, though the details have been purposely left to the individual in many cases where the design is optional. Such items as cases, boxes or mountings are well within the limits of every reader, and even in the other apparatus and parts considerable ingenuity may be used. Duplication of apparatus has been avoided wherever possible, though in some cases all forms have been described. When one piece of apparatus will do the work of two, there is little use in using two. Every piece of apparatus should be made with care and should always be

understood. Learn to *know* your apparatus, master its peculiarities, note the good and bad adjustments, always be on the lookout for possible phenomena, and keep a record of your experiments. While the apparatus described is intended particularly for stations it can be easily made portable. Stations may be readily set up on small boats, in the field, camp, and so on. There is hardly a limit to the use to which a wireless set may be put.

The experimenter generally plans to receive over a much greater distance than he expects to send. Indeed, with the present network of high-powered stations, there are few readers who may not do long distance work with even simple apparatus. The Arlington station, "NAA," for instance, should be heard by every experimenter within 1,000 to 3,000 miles under favorable conditions. It is surprising to learn what can be done with even home-made apparatus. A list of wireless stations may be obtained for 15c by addressing the Superintendent of Documents, Washington, D. C.

If you have not already done so, join a local wireless club. Nearly every locality has one or is forming one and there is little or no expense attached. If you have not yet learned a code, start now. The continental code is in general favor and it is well to master it first. It is the one wireless code in universal use. There are so many messages which can be read with a simple receiving set, that the code can be mastered in a short time. In practice, it is well to start with the letters first, then with short words, and finally with simple sentences and paragraphs. The average person finds it much easier to

send than to receive. Acquire a free, easy and clear movement in making the dots and dashes. Speed is a secondary matter, as it will come with practice. It is worth while to keep a record of all messages in a small note book. It is unlawful to give out or publish intercepted messages.

THE EXPERIMENTER'S RIGHTS

All of the leading countries have laws regulating radiocommunication. The wireless law enacted on December 13, 1912, makes the following restrictions upon experimenters:

1. The law recognizes the experimenter, gives him rights, and licenses are to be given provided that,
2. The experimenter does not use a wave length over 200 meters long for transmission nor a greater power in either a coil or transformer than 1 K. W., if he is farther than 5 nautical miles away from a government station, or not more than $\frac{1}{2}$ K. W. if he is within 5 nautical miles of a government station.
3. Experimenters having apparatus which is not powerful enough to transmit farther than the boundaries of the state in which the station is situated, and which cannot interfere with the reception of signals from outside the state, need not take out a license unless they desire to do so. This means practically that if you live in the heart of say Texas, you may use large power without license provided stations in other states cannot hear you, but if you live near the border of another state you must use very weak power or else obtain a license.
4. It is not necessary to have a license for a receiving station only.
5. If the experimenter wishes to use a high wave length or high power, permission will be granted by the Secretary

of Commerce and Labor, upon proper application, provided the applicant shows cause why the additional power and wave length is desired.

6. The operator is required to preserve the secrecy of all messages sent or received upon the penalty of a fine and imprisonment.

7. The experimenters must use sharp and pure waves.

8. The penalty for sending a false message of any kind will be a fine up to \$1,000 or imprisonment up to two years or both. (Distress signal, \$2,500—5 years.)

9. The operation of wireless instruments for either sending or receiving except as before stated, without a license, will be punishable by a fine of not more than \$500 and the forfeiture of the apparatus. This does not apply to receiving apparatus only.

These are simple, boiled down accounts of the main requirements and provisions of the law as far as the experimenter is concerned. Information will be furnished by the Dept. of Commerce, Radio Inspection division without expense, upon your request.

The licensing is free and even advantageous to experimenters. The apparatus described in this book when used with reasonably loose coupling will enable the reader to comply with every feature of the law without difficulty, provided that the aerial used for transmitting purposes is not made longer than 70 feet by itself,* allowing for lead-ins to make up the remainder of the effective length. The plan of using a duplex aerial will be found particularly valuable in accordance with the law, so that long distance messages may be received. The two aerials should be placed at right angles to each other if possible in order to avoid unnecessary absorption of the transmitted energy. There is no cause for

* This allows a height of 50 to 70 feet for leads, etc.

alarm over the new laws proposed, as the act of 1912 still stands (1920) and the value of experimenters as well as amateurs is recognized. The Navy Dept. closed all stations with few exceptions during the war but the emergency authorizing this has now ended and pre-war conditions are again fully restored.

The Department of Commerce and Labor has formed certain rules and regulations which must be adhered to. Administration districts have been established, with offices at the custom-houses. Classifications have been made for the purpose of administration. Full particulars can be obtained gratis by addressing the Commissioner of Navigation. The first thing to do is to write for forms No. 756 and 757. Full instructions will be sent at the same time. There will not be any difficulties in obtaining a license, but it is imperative that you apply for the license at once before you operate. Radio Inspectors in government employ will even assist you when possible.

PATENTS

While most of the wireless apparatus is covered more or less completely by patents, the experimenter need have no concern. Although the experimenter is legally an infringer when he uses patented apparatus without permission from the patentee, it is generally recognized that experimenters may use patented articles for purely non-commercial purposes without liability. This educational idea seems to be so fixed that even manufacturers and dealers in patented experimental goods not made under license or permission of the patentee, are for the most part perfectly safe, since the patent rights are seldom pushed into this realm. The author certainly does not

advise the open and wilful infringement of patents, but also believes that for educational and experimental purposes where no commercial profits are realized from such use, the use of patented articles is recognized as legitimate in effect if not in the legal sense. The readers need have little concern on this point as long as they do not make or sell or rent the apparatus for commercial gain.

While there is a large field for improvement in the new art, the reader is not advised to take out or apply for patents unless he is sure that the device has merit, is a real improvement, and is needed, as otherwise failure in one form or another will generally result. There are at the present time something like 2,000 patents in full force which cover wireless apparatus and systems. While a part of these are useless and obsolete, it is not unlikely that the very improvement you have in mind is embodied in one or more of these, so that it is well to have a search made into the records before spending money for applications, models, etc. This is not intended to discourage but rather to encourage in the right direction.

In conclusion it seems well to remark that the present tendency in the art is toward the permanent establishment of large chains of powerful land stations employing directive aerials, the simplification of ship, train, and portable stations, the use of long wave lengths for large power radiation, the employment of high pitch musical tones for transmission, the transmission methods which make reception inaudible except when the principle of beats is employed at the receiving station, the use of amplifiers to increase the effective intensity of the received energy, the use of ground receiving antennas and multi-turn

receiving coils substituted for antennas, the extension of vacuum tube circuits, the use of automatic recorders, and a beginning toward early standardization. Among the new developments some brief mention of the Edelman Differential Wave System will doubtless be of interest. Experiments by the author have already shown that the common disturbances—undesired signals as well as atmospheric—do not interfere with this system. The promising experiments with pin point gaps, liquid transmitters, stepped-up-frequency-alternators, and low or even grounded aerials also deserve to be mentioned.

The reader will do well to continue with the study, as much interesting and useful material of an advanced nature is to be had.

And so, we come to the end of the book but, it is hoped,

Only the Beginning of a Study of the Wonderful New Art.

INDEX

A

- Absorption of short and long waves, 17.
- Adjustment of apparatus, 174.
- Advanced systems, 187.
- Aerial, assembly, 39.
- Aerial, conductors, 39.
- Aerial, dimensions of, 29, 30, 31.
- Aerial, duplex, 28.
- Aerial, effect of capacity, 29.
- Aerial, effect of dimensions on waves, 24.
- Aerial, effective length of, 29.
- Aerial, for 200 meters, 29.
- Aerial, function of, 15, 24.
- Aerial, joints for, 41.
- Aerial, lead-in, 38.
- Aerial, materials for, 40.
- Aerial, oscillation of, 14.
- Aerial, poles, 27, 28.
- Aerial, suited for 15,000 meter reception, 31.
- Aerial supports, kites, 26.
- Aerial switch, 126.
- Aerial, underground, 54.
- Aerials, 23.
- Aerials, balancing, 355.
- Aerials, for various wave lengths, 35.
- Aerials, height of, 16, 28.
- Aerials, low ground, 354.
- Aerials, makeshift, 26.
- Aerials, on ground, 26.
- Aerials, types of, 29.
- Aerials, wire for, 31.
- Acroplane, radiotelephone, 242.
- Acroplane wireless, 351.
- Air condenser, 318.
- Alcohol, use in spark gap, 168.
- Alexanderson alternator, 202.
- Alexanderson amplifier, 238.
- All dot system of transmission, 169.
- Alternator, 200.
- Amateur radiophone, 248.
- Amateur Station, typical, Frontispiece.
- Amplifier, 274, 275, 310.
- Amplifier, cascade, 217.
- Amplifier, combined audio and radio frequency, 233.
- Amplifier, converted frequency, 237.
- Amplifier, magnetic, 238.
- Amplifier, sensitive short wave, 237.
- Amplifiers, 220.
- Antenna circuit, 71, 103.
- Antenna circuit, tuning, 75.
- Antenna current and voltage, 88.
- Antenna, design, 103.

- Antennas, see aerials, 31, 33.
 Antenna, see aerial effective length of, 104.
 Antenna switch, 127.
 Apparatus, causes of failure, 347.
 Arcing, prevention of, 126.
 Arc set, small, 191.
 Arc transmitter, 188.
 Armstrong circuit, 224, 226.
 Army and Navy sets, 244.
 Atmospheric disturbances, 20, 22.
 Audibility meter, 281.
 Audibility of signal, formula, 282.
 Audio frequency amplifier, 229.
 Audion, action of, 209.
 Audion compared with crystal detector, 231.
 Audion, effect of magnet on, 222, 311.
 Audion generator, 220.
 Audion generator measurements, 185.
 Audion laboratory circuits, 235.
 Audion, noisy "B" battery, 349.
 Audion receiver, 212, 215.
 Audion, see Vacuum tube, 210.
 Audion with crystal detector, 231, 232.
 Autodyne receiver, 310.
 Automatic aerial switch, 127.
 Automatic indicator, 272.
 Automatic self tuned generator, 236.
 Automatic switch, 130.
 Automatic wave changing receiver, 308.
 Automobile wireless, 351.
 Auxiliary apparatus, 121.
- ### B
- "B" battery, 213.
 Balancing out power line hum, 297.
 Baldwin receiver, 276.
 Banked turn inductances, 339.
 Barrage receiver, 303.
 Beats, 80, 304.
 Beats, illustrated, 305.
 Beats, illustration of, 89.
 Beaufort scale, 360.
 Bellini-Tosi direction finder, 307, 353.
 Break-in system, 129.
 Bridge tuning method, 289.
 Broad wave production, 82, 83.
 Brush discharge, effect of, 140.
 Building a condenser, 318.
 Building detectors, 265.
 Building of condensers, 140, 146.
 Buzzer test, 266.
- ### C
- C, 99.
 Capacity, 133.
 Capacity and inductance, 69.
 Capacity coupling, 309.
 Capacity, formula, 136.
 Capacity for use with spark coils, 98.
 Capacity of aerial, 29.
 Carborundum, 258.
 Cascade amplifier, 217.
 Cascade circuits, 229.
 Centimeter, 137.

- Chaffee gap, 168.
Chalcopyrites, 258.
Change-over switch, 126.
Changing wave length, 289.
Circuit, wave length of, 70.
Circuits, measurement of, 171.
Circuits, rotary gap, 166.
Circuits, tests of, 186.
Codes in use, 380.
Coil receiver, 27, 49.
Coil receiver, at right angles to each other, 50.
Coil receiver, construction of, 51.
Coil receiver, principles of, 49.
Coil receiver, use of, 51.
Coils, inductance of, 148.
Complete sets, 374.
Condensers, 133, 315.
Condenser capacity, formula, 147.
Condenser construction, 134.
Condenser details, 146.
Condenser for fine adjustments, 324.
Condenser materials, 142.
Condensers, simple, 147.
Condenser, size of, 136.
Conflicting stations, 286.
Construction of condenser, 316.
Core, for transformer, separate tongue type, 111.
Core, transformer, 109.
Coupling, 288.
Coupling, capacity, 309.
Coupling of circuits, 106, 107.
Coupling of radio circuits, 89.
Crystal detector and audion, 231.
Crystal detector circuits, 290.
Crystal detector compared with audion, 231.
Crystal detectors, 252.
Crystal rectifiers, 258.
Cycles, action in transformer, 68.
Cycles, action on vacuum tube, 213.
- D
- Damped and undamped waves, 287.
Damping illustrated, 183.
Damping, see resistance, 86.
Dead ends, 343.
Dead end switch, 344.
Decrement, 183.
Decrement formula, 184.
Detector, 252.
Detector action of electron tube, 209.
Detector construction, 261-265.
Detector materials, 258.
Detector, purpose of, 253.
Detector, use of, 171.
Detectors, rank of, 256.
Detectors, see vacuum tubes, 257.
Diaphragm for telephone receiver, 279.
Dielectric table, 137.
Differential tuning, 289.
Differential wave system, 302.
Direct current transmitter, 192.
Direction finder, 49, 353.
Directional receiver, 51.
Distance of communication, 91.
Distributed capacity of coils, 339.

Double humped waves, 83.
 Duplex aerial, 28.
 Duplex high speed operation,
 205, 206.
 Dynatron, 219.

E

Earth, conductivity of, 13.
 Effective length of antenna,
 104.
 Efficiency of transformer, 109.
 Einthoven galvanometer, 270.
 Electrolytic interrupter, 121.
 Electron tube, see Vacuum
 tubes, 210.
 Electron tube, characteristic
 action of, 208.
 Energy, in spark transmitter,
 72.
 Energy, in wireless circuits, 73.
 Energy received, 254.
 Erg, 254.
 Experimenter's rights, 375.

F

Farad, 97.
 Flat top antennas, 31, 33.
 Fleming valve, 213, 214.
 Forest fire prevention, 350.
 Formula, capacity, 136.
 Formula for audibility, 282.
 Formula for condenser capac-
 ity, 147.
 Formula for coupling, 107.
 Formula for decrement, 184.
 Formula for inductance, 148,
 150.
 Formula for 200 meter cir-
 cuit, 100.

Formula for wave length, 99.
 Formula, transformer, 96.
 Frequency, 166.
 Frequency, conversion, 303.
 Frequency, effect of change, 97.
 Frequency, generator, 203.
 Frequency, measurement of,
 182.
 Frequency, spark rate, 95.

G

Galena, 258.
 Galvanometer, Einthoven, 270.
 Gaps, operated under pressure,
 166.
 Gaps, rotary, 163.
 Gaps, simple, 165.
 Gaps, spark, 159.
 Geared adjustable condenser,
 324.
 Geissler tube, use of, 103.
 Generator, vacuum tube, 237.
 Goldschmidt alternator, 201.
 Grid circuit, 209.
 Grid control, 220.
 Grid leak, 220.
 Grid operated receiver, 220,
 221.
 Grid potential, 209.
 Grounds, connections, 58, 59,
 60.
 Grounds, imbedded, 58.

H

Hall jet amplifier, 275.
 Head-sets, 253.
 Heaviside layer theory, 14.
 Helix, construction, 151.
 Helix, inductance of, 149.

Henry, 99.
 Heterodyne action, 304.
 Heterodyne receiver, 303.
 High frequency generator, 199,
 200.
 High frequency oscillations,
 185.
 High power station, 354.
 Home wireless set, 246.
 "Hook-ups," 287.
 Hot wire ammeter, 105, 108,
 172.
 Hot wire meter construction,
 175, 176, 177, 178.
 Hoxie recorder, 273.
 Humidity, effect on strays, 18.

I

Inductance, adjustable without
 sliders, 331.
 Inductance and capacity, 69.
 Inductance and capacity for
 arc generator, 190.
 Inductance formula, 148, 150.
 Inductance, transformer, 92,
 93.
 Inductances, 148.
 Inductances, receiving, 325.
 Inductances with minimum ca-
 pacity, 69.
 Inductively coupled receiver,
 293.
 Inductively coupled transmit-
 ter, 67.
 Insulation, aerial, 36, 37.
 Insulation, importance of, 182.
 Insulators, 137.
 Interference, 19.
 Interference from power line,
 297.

Interference prevention, 283.
 Interferences, types of, 285.
 Interrupter, electrolytic, 121.

J

Jeweller's receiving set, 300.

K

Keys, 124.
 Keys, magnetic operation, 125.
 Kickback prevention, 122, 123.
 Kites, as aerial supports, 26.
 Korda air condenser, 318.

L

L, 99.
 L aerial, 34.
 Laboratory oscillation pro-
 ducers, 235.
 Law of 1912, 375.
 Law, wireless, 376.
 Lead-in, aerial, 38, 43.
 Legal requirements, 375.
 Lepel arc, 195.
 Lieben-Reisz tube, 215.
 Lighting circuit, protector, 123.
 Lighting protection, 61.
 List of radio stations, 374.
 Loading coil, 76, 151, 157.
 Loading coil calibration, 174.
 Logarithmic decrement, 183.
 Long wave length receiver, 226.
 Long wave length stations, 340.
 Loop receiver, 49. See coil
 receiver, 51.
 Loose coupled transmitter, 76.
 Loose coupler, 292.

- Loose coupler construction, 334.
- Loose couplers for long waves, 342.
- M
- Magnetic blow off, 126.
- Magnetic tube sensitizer, 311.
- Making apparatus work, 346.
- Measurements of circuits, 171.
- Measurement of decrement, 183.
- Measurements with electron tubes, 185.
- Measuring signal intensity, 281.
- Messages, increasing number transmittable, 206.
- Meter, dimension of, 99.
- Meter, 200, formulas, 100.
- Meters, 200, legal requirements for, 25.
- Meters, 200, long distance work on, 25.
- Meters, 200, receiving set, 311.
- Meters, 12,000, on 6,000 meter adjustment, 78.
- Meter, 15,000, coil receiver, 53.
- Method of switching for tuners, 338.
- Micro-farad, 97.
- Micro-henry, 99.
- Microphone amplifier, 274.
- Miles, power to transmit given distance, 91.
- Modulation, 238.
- Molybdenum, 258.
- Monotelephone, 276.
- Motor-generator, 105, 108, 348.
- Multi-layer receiving coils, 339.
- Multiple tuned antenna, 354.
- Multiple unit phase tuning, 307.
- Multiplex radiophone, 243.
- Multiplex telephony, 244.
- Multiplier of generated frequency, 202.
- Multi-turn coil, 49.
- Multi-turn coil receiver, 27.
- Mutual inductance, 150.
- N
- Navy and Army radio apparatus, 244.
- Navy circuits, 307.
- Navy, loops used by, 52.
- Navy, under water antenna, 54.
- Navy wireless telephone, 245.
- Negative resistance, 219.
- O
- Onde unique system, 204.
- One-quarter kilowatt set, 96.
- Operating room, 106.
- Operating rules, 378.
- Operation of a receiver, 293.
- Oscillation transformer, 153.
- Oscillations, 15, 172.
- Oscillations, function of condenser, 135.
- Oscillations, graph of, 72.
- Oscillations in arc circuit, 190.
- Oscillations in quenched gap circuit, 105, 107.
- Oscillations, principles of, 182.
- Oscillations, production from audions, 235.
- Oscillations, production of, 68.
- Oscillations, production of various frequencies, 185.
- Outside grid tube, 218.

P

- Patent discussion, 362, 372, 377.
- Patents, list, 362, 377.
- Percentage of coupling, 106.
- Pericon detector, 259.
- Phase modified receivers, 305.
- Phase rotator, 331.
- Phase shifting explained, 306.
- Phase tuning, 303, 306.
- Photographic recorder, 272.
- Piano, radio, 195.
- Plate circuit, 210.
- Plate current, 209.
- Pliotron, 217.
- Plural receiving sets, 345.
- Poles, 44, 45.
- Portable radio set, 240.
- Poulsen arc, 192.
- Poulsen "tipper," 273.
- Power for transmission, 92.
- Power for transmitter, 95.
- Power required for transmitter, 96.
- Primary and secondary wave lengths, 172.
- Primary circuit, 71.
- Progress of art, 379.
- Protection from lightning, 61.
- Protection from radio circuits, 298.
- Protection of transmitting apparatus, 123.

Q

- Quenched gap, 196.
- Quenched gap transmitter, 105, 108.
- Quenched spark, advantages, 197, 198.

- Quenched spark set, 187, 198.
- Quenched spark set, chart of, 85.

R

- Radiant energy, 21.
- Radiation indicator, 170.
- Radiation, poor, 347.
- Radiation resistance, 36.
- Radio compass, 49, 52.
- Radio frequency amplifier, 217.
- Radio-Goniometer, 306.
- Radio information, advanced, 148.
- Radio inspectors, 375.
- Radio on trains, 350.
- Radio patents, 362.
- Radiophones, 239.
- Radio sets, 374.
- Radio station list, 374.
- Radiotelephone, home-made, 248.
- Radiotelephones, 238. See wireless telephone.
- Radiotelephone modulator, 244.
- Radiotelephone, simple, 189.
- Radiotelephone, portable, 240.
- Railroad wireless, 350.
- Range of sending station, 91.
- Reactance coil, 114.
- Reactance, transformer, 94.
- Received signal, 254.
- Received signals photographed, 272.
- Receiver, a combination set, 312.
- Receiver, automatic, 308.
- Receiver, for undamped waves, 223.

- Receiver, how it operates, 280.
 Receiver, ideal, 52.
 Receiver-recorder, 270.
 Receiver, sensitive recorder for signals, 273.
 Receiver, special circuits, 303.
 Receiver, telephone, 276.
 Receiver, testing a, 266, 268.
 Receiver, tuning of, 171.
 Receiver, with adjustable grid potential, 233.
 Receiver with sensitizer, 234.
 Receiving apparatus, 310, 314.
 Receiving apparatus for long waves, 340.
 Receiving circuits, 207, 252.
 Receiving condensers, 314.
 Receiving diagrams, 290.
 Receiving set, an ideal, 284.
 Receiving sets, plural, 345.
 Receiving station, 251.
 Receiving transformer, 332.
 Receiving transformer, improved, 344.
 Receiving tuners, 338.
 Receivers, phase modified, 305.
 Rectifier, 220, 252.
 Regenerative amplifier, 220.
 Repeater, 220.
 Resistance coupled amplifier, 220.
 Resistance coupling, 220.
 Resistance, effect of in radio circuits, 73.
 Resistance, effect of in receiver, 289.
 Resistance, in transmitter circuits, 79.
 Resistance leak for vacuum tube, 220.
 Resonance, 65.
 Resonance, circuit relations, 69.
 Resonance, harmonic effect, 77.
 Resonance, principles of, 72, 73.
 Roger's underground antenna, 54.
 Rotary gap, 161.
 Rotary gap circuits, 166.
 Rotary quenched gap, 166.
 Rotary quenched gas gap, 167.
 Rules for operating, 377.
- S
- Safety gap for transmitter, 105, 107.
 Secondaries, construction of, 114.
 Secondary wave length, 172.
 Section winder, 114.
 Selective receiving circuits, 294.
 Self modulated transmitter, 236.
 Sending-receiving switch, 126.
 Sending station, 67.
 Sensitive receiver, 234.
 Sensitivity of detectors, 256.
 Series gap, 159.
 Set, one-quarter kilowatt, 96.
 Sharp tuned transmitter, 85.
 Sharp tuning, 80.
 Shields, 299.
 Ship's antenna capacity varies, 103.
 Shock excitation, 168.
 Short wave oscillating receiver, 311.
 Short wave receiver, 228.
 Short wave repeating amplifier, 228.

- Shunt audibility meter, 281.
 Shunt resistance for measurements, 172.
 Shunt resonator construction, 179.
 Signal, measuring strength of, 281.
 Signals photographed, 273.
 Silicon, 258.
 Singing arc, 191.
 Simple wireless telephone, 246.
 Sliders, 329.
 Small local transmitter, 268.
 So-called "one wave" system, 205.
 Solid rectifiers, 257.
 Spark coil construction, 115, 117.
 Spark coils, condensers for, 98.
 Spark coils, tables for, 118.
 Spark gaps, 102, 105, 158.
 Spark rate, advantage of high, 166.
 Spark transmitter, 91.
 Special receiving sets, 300.
 Static frequency transformer, 203.
 Stations, cost of, 90.
 Storage battery, 131.
 Storage battery auxiliary, 105, 107.
 Stray mitigator, 301, 303.
 Strays, cut down by resistance, 289.
 Strays, effect of weather on, 18.
 Strays, mitigation of, 54, 307.
 Strays, phase tuning of, 303.
 Strays, reduced number on coil receiver, 49, 50.
 Sub-surface radio, 52.
 Supports, aerial, 41.
 Sustained wave apparatus, 203.
 Sustained waves, production of, 188.
 Switch, aerial, 126.
 Switch, ground, 62, 63.
- T
- T aerial, 34.
 Telemechanics, 355.
 Telephone head set, 276.
 Telephone receiver, 252.
 Telephone receiver, head set resistance, 279.
 Tens and units switching, 338.
 Tests of receiver, 266.
 Thermo-couple, use of, 186.
 "Tikler" oscillating circuit, 229.
 "Tikker," 273.
 Time and weather signals, 357.
 Time signal receiver, 300.
 Tone circuit, 168, 195.
 Tower, lattice, 45.
 Transcontinental wireless telephone, 241.
 Transformer, action of, 68.
 Transformer, adjustable, 111.
 Transformer, building a, 114.
 Transformer construction, 109.
 Transformer data, 110.
 Transformer, oscillation, construction, 153.
 Transformer preferred to spark coil, 119.
 Transformers, types, 92.
 Transmission, best at night, 18.
 Transmission, direction of, 16.

- Transmission, distance of, 16.
 Transmission, range of, 91.
 Transmission, theory, 12.
 Transmission via sustained waves, 188.
 Transmission, wireless, 11.
 Transmitter, 65.
 Transmitter, alternator for, 202.
 Transmitter, Edelman, 169.
 Transmitter, example of complete, 105, 108.
 Transmitter, inductively coupled, 67.
 Transmitter, principles of circuit, 78.
 Transmitter, rotary gap, 167.
 Transmitter, self modulated, 236.
 Transmitter, size for, 108.
 Transmitter, untuned, 82.
 Transmitting circuit, 66.
 Trouble finding, 346.
 Tube radio telephones, 238.
 See Vacuum tubes.
 Tuners, 326.
 Tuning, 20, 173, 255, 283.
 Tuning, automatic generator, 236.
 Tuning, effect of beats, 80, 81.
 Tuning, illustrated, 83.
 Tuning long and short waves, 293.
 Tuning methods, 284, 287.
 Tuning of a transmitter, 78.
 Tuning, phase changing method, 303.
 Tuning the receiver, 288.
 Tuning with a loose coupler, 292.
 Two-tone transmitter, 169.
 Two transmitted waves, 83.
 Two wave lengths emitted, 288.
- ### U
- Ultra-audion, 223.
 Undamped and damped waves, 287.
 Undamped wave generator, 225.
 Undamped wave sets, 203.
 Undamped wave transmitter, 188.
 Undamped waves, gap for, 168.
 Underground wireless, 52.
 Underwater radio, 52.
 Uni-control receiver, 308.
 Universal detector, 260.
 Universal wave receiver, 312.
 U. S. Patents, 362.
- ### V
- Vacuum tube, aeroplane set, 242.
 Vacuum tube circuit adjustments, 227.
 Vacuum tube circuits, 220.
 Vacuum tube, coil receiver, 53.
 Vacuum tube, curves of action, 210.
 Vacuum tube, filament, 211.
 Vacuum tube generator, 237.
 Vacuum tube, grid potential adjustment, 233.
 Vacuum tube, high power, 239, 247.
 Vacuum tube measurements, 185.

LATEST
REVISED
CATALOGUE

of the Best

Practical and Mechanical Books

Including Automobile and Aviation Books

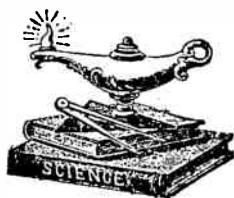

PRACTICAL BOOKS FOR PRACTICAL MEN

Each Book in this Catalogue is written by an
Expert and is written so you can understand it

PUBLISHED BY

THE NORMAN W. HENLEY PUBLISHING CO.

2 West 45th Street, New York, U. S. A.

Established 1890

 Any Book in this Catalogue sent prepaid on receipt of price

Manuscripts solicited on Practical Subjects

INDEX

	PAGE		PAGE
Abrasives and Abrasive Wheels.....	29	Lathe Work.....	23
Accidents.....	25	Link Motions.....	24
Air Brakes.....	24, 26	Liquid Air.....	24
Arithmetic.....	13, 27, 37	Locomotive Boilers.....	25
Automobile Books.....	3, 4, 5, 6	Locomotive Breakdowns.....	25
Automobile Charts.....	6, 7	Locomotive Engineering.....	24, 25, 26
Automobile Ignition Systems.....	7	Machinist Books.....	27, 28, 29
Automobile Lighting.....	4	Manual Training.....	30
Automobile Questions and Answers.....	5	Marine Engineering.....	30
Automobile Repairing.....	5	Marine Gasoline Engines.....	21
Automobile Starting Systems.....	4	Mechanical Drawing.....	13
Automobile Trouble Charts.....	6, 7	Mechanical Movements.....	12
Automobile Welding.....	6	Metal Work.....	28
Aviation.....	8	Model Making.....	29
Bells, Electric.....	14	Motor Boats.....	30
Bevel Gear.....	21	Motorcycles.....	7, 31
Boats, Motor.....	30	Motor Truck.....	3
Boiler Room Chart.....	9	Naval Engineering.....	30
Boilers, Marine.....	30	Patents.....	22
Brazing.....	9	Pattern Making.....	31
Cams.....	21	Perfumery.....	32
Carburetion Trouble Charts.....	7	Perspective.....	13
Carburetors.....	12	Plumbing.....	32, 33
Car Charts.....	9	Punches.....	4
Cements.....	12	Producer Gas.....	21
Change Gear.....	21	Questions and Answers on Automobile.....	5
Charts.....	6, 7, 9	Questions on Heating.....	38
Chemistry.....	10	Radio Time Signal Receiver.....	16, 17
Coal.....	24	Railroad Accidents.....	25
Combustion.....	19	Railroad Charts.....	9
Concrete.....	10, 11, 12	Recipe Book.....	34
Concrete for Farm Use.....	11	Refrigeration.....	22
Concrete for Shop Use.....	11	Repairing Automobiles.....	5
Cosmetics.....	32	Rope Work.....	23
Dictionary.....	12, 17	Rubber.....	35
Dies.....	12	Rubber Stamps.....	35
Drawing.....	13, 32	Saw Filing.....	35
Drawing for Plumbers.....	32	Saws, Management of.....	35
Dynamo Building.....	14	Screw Cutting.....	35
Electric Bells.....	14	Shipbuilders' Pocket Book.....	30
Electric Dictionary.....	17	Shop Construction.....	27
Electric Switchboards.....	15	Shop Management.....	27
Electric Toy Making.....	16	Shop Practice.....	27, 28, 29
Electric Wiring.....	15	Shop Tools.....	29
Electricity.....	13, 14, 15, 16, 17, 18	Sketching Paper.....	13
Electroplating.....	19	Slide Valve.....	24
Encyclopedia.....	29	Soldering.....	9
Engine, Aviation.....	8	Splices and Rope Work.....	23
E-T Air Brake.....	26	Steam Engineering.....	35, 36, 37
Factory Management.....	19	Steam Heating.....	37
Ford Automobile.....	4	Steel.....	38
Ford Tractor.....	4	Storage Batteries.....	18
Ford Trouble Chart.....	7	Submarine Chart.....	9
Formulas and Recipes.....	34	Switchboards.....	15
Fuel.....	19	Tapers.....	23
Gas Engines.....	20, 21	Telegraphy, Wireless.....	14, 16, 18
Gas Tractor.....	39	Telephone.....	18
Gearing and Cams.....	21	Thread-Cutting.....	27
Glossary Aviation Terms.....	8	Tool Making.....	27
Heating.....	37	Tool Steel.....	38
High Frequency Apparatus.....	15	Toy Making.....	16
Horse-Power Chart.....	36	Tractive Power Chart.....	9
Hot Water Heating.....	37	Tractor, Gas.....	39
House Wiring.....	17, 18	Train Rules.....	26
Hydraulics.....	22	Vacuum Heating.....	38
Ice.....	22	Valve Setting.....	24
Ignition Systems.....	4	Ventilation.....	37
Ignition Trouble Chart.....	7	Walschaert Valve Gear.....	26
India Rubber.....	35	Waterproofing.....	12
Interchangeable Manufacturing.....	27	Welding.....	6, 39
Inventions.....	22	Wireless Telegraphy.....	14, 16, 18
Kerosene Carburetors.....	4	Wiring.....	15, 17, 18
Knots.....	23	Wiring Diagrams.....	15

Any of these books promptly sent prepaid to any address in the world on receipt of price.

HOW TO REMIT.—By Postal Money Order, Express Money Order, Bank Draft or Registered Letter.

AUTOMOBILES

THE MODERN GASOLINE AUTOMOBILE—ITS DESIGN, CONSTRUCTION, MAINTENANCE AND REPAIR. By VICTOR W. PAGÉ, M.E.

The latest and most complete treatise on the Gasoline Automobile ever issued. Written in simple language by a recognized authority, familiar with every branch of the automobile industry. Free from technical terms. Everything is explained so simply that anyone of average intelligence may gain a comprehensive knowledge of the gasoline automobile. The information is up-to-date and includes, in addition to an exposition of principles of construction and description of all types of automobiles and their components, valuable money-saving hints on the care and operation of motor-cars propelled by internal combustion engines. Among some of the subjects treated might be mentioned: Torpedo and other symmetrical body forms designed to reduce air resistance; sleeve valve, rotary valve and other types of silent motors; increasing tendency to favor worm-gear power-transmission; universal application of magneto ignition; development of automobile electric-lighting systems; block motors; under-slung chassis; application of practical self-starters; long stroke and offset cylinder motors; latest automatic lubrication systems; silent chains for valve operation and change-speed gearing; the use of front wheel brakes and many other detail refinements. By a careful study of the pages of this book one can gain practical knowledge of automobile construction that will save time, money and worry. The book tells you just what to do, how and when to do it. Nothing has been omitted, no detail has been slighted. Every part of the automobile, its equipment, accessories, tools, supplies, spare parts necessary, etc., have been discussed comprehensively. If you are or intend to become a motorist, or are in any way interested in the modern Gasoline Automobile, this is a book you cannot afford to be without. 1032 pages—and more than 1,000 new and specially made detail illustrations, as well as many full-page and double-page plates, showing all parts of the automobile. Including 12 large folding plates. New Edition. Price \$4.00

WHAT IS SAID OF THIS BOOK:

"It is the best book on the Automobile seen up to date."—J. H. Pile, Associate Editor *Automobile Trade Journal*.

"Every Automobile Owner has use for a book of this character."—*The Tradesman*.

"This book is superior to any treatise horetofore published on the subject."—*The Inventive Age*.

"We know of no other volume that is so complete in all its departments, and in which the wide field of automobile construction with its mechanical intricacies is so plainly handled, both in the text and in the matter of illustrations."—*The Motorist*.

"The book is very thorough, a careful examination failing to disclose any point in connection with the automobile, its care and repair, to have been overlooked."—*Iron Age*.

"Mr. Pagé has done a great work, and benefit to the Automobile Field."—W. O. Hasford, Mgr. Y. M. C. A. Automobile School, Boston, Mass.

"It is just the kind of a book a motorist needs if he wants to understand his car."—*American Thresherman*.

THE MODERN MOTOR TRUCK, ITS DESIGN, CONSTRUCTION, OPERATION AND REPAIR. By VICTOR W. PAGÉ.

Just off the press and treats on all types of motor trucks and industrial tractors and trallers. It considers all types of trucks, gasoline and electric, and all varieties of truck bodies. This book is written in language everyone can understand and is not in any sense of the word a technical treatise. It is a practical volume that will make special appeal to the truck driver who seeks to better his position and to the mechanic charged with the repair and upkeep of trucks. The factory or business executive who wants to obtain a complete working knowledge of truck operation problems will find this book a reference work of great value. The truck salesman or automobile dealer will find that this work contains information that means money to them. All garage and service station men should have a copy of this book for reference because truck construction differs from passenger car design in many important respects. Anyone who reads this book is in touch with all the practical features that have been tested out in real service. 1921 Edition. Cloth, 6 x 9, 962 pages, 750 illustrations Price. \$5.00

CATALOGUE OF GOOD, PRACTICAL BOOKS

THE MODEL T FORD CAR, ITS CONSTRUCTION, OPERATION AND REPAIR, INCLUDING THE FORDSON FARM TRACTOR, F. A. LIGHTING AND STARTING SYSTEM, FORD MOTOR TRUCK. By VICTOR W. PAGÉ.

This is the most complete and practical instruction book ever published on the Ford car and Fordson tractor. All parts of the Ford Model T car and Fordson tractor are described and illustrated in a comprehensive manner. The construction is fully treated and operating principle made clear to everyone. Complete instructions for driving and repairing are given. To the New Revised Edition matter has been added on the Ford Truck and Tractor Conversion Sets and Genuine Fordson Tractor. All parts are described. All repair processes illustrated and fully explained. Written so all can understand—no theory, no guesswork. New revised and enlarged Edition just published. 153 illustrations, 410 pages, 2 large folding plates. Price . \$2.00

AUTOMOBILE STARTING, LIGHTING AND IGNITION SYSTEMS. By VICTOR W. PAGÉ, M.E.

This practical volume has been written with special reference to the requirements of the non-technical reader desiring easily understood, explanatory matter, relating to all types of automobile ignition, starting and lighting systems. It can be understood by anyone, even without electrical knowledge, because elementary electrical principles are considered before any attempt is made to discuss features of the various systems. These basic principles are clearly stated and illustrated with simple diagrams. *All the leading systems of starting, lighting and ignition have been described and illustrated with the co-operation of the experts employed by the manufacturers.* Wiring diagrams are shown in both technical and non-technical forms. All symbols are fully explained. It is a comprehensive review of modern starting and ignition system practice, and includes a complete exposition of storage battery construction, care and repair. All types of starting motors, generators, magnetos, and all ignition or lighting system units are fully explained. The systems of cars already in use as well as those that are to come are considered. *Every person in the automobile business needs this volume.* 5¼x7½. Cloth. 815 pages, 492 illustrations, 3 folding plates. New revised and enlarged edition. Price \$3.00

GASOLINE AND KEROSENE CARBURETORS, CONSTRUCTION, INSTALLATION AND ADJUSTMENT. By VICTOR W. PAGÉ. A new up-to-date Book on Modern Carburetion Practice.

This is a simple, comprehensive, and authoritative treatise for practical men explaining all basic principles pertaining to carburetion, showing how liquid fuels are vaporized and turned into gas for operating all types of internal combustion engines intended to operate on vapors of gasoline, kerosene, benzol, and alcohol. All leading types of carburetors are described in detail, special attention being given to the forms devised to use the cheaper fuels such as kerosene. Carburetion troubles, fuel system troubles, carburetor repairs and installation, electric primers and economizers, hot spot manifolds and all modern carburetor developments are considered in a thorough manner. Methods of adjusting all types of carburetors are fully discussed as well as suggestions for securing maximum fuel economy and obtaining highest engine power. This book is invaluable to repairmen, students, and motorists, as it includes the most complete exposition on kerosene carburetors ever published. The drawings showing carburetor construction are made from accurate engineering designs and show all parts of late types of carburetors. 213 pages. 89 illustrations. . \$2.00

HINTS AND TIPS FOR AUTOMOBILISTS. By VICTOR W. PAGÉ.

The book is ideal for the busy man or woman who wants to know about car operation and upkeep because of the economies possible when an automobile is intelligently operated. It contains many money-saving hints and a brief simple exposition of location and remedy of roadside troubles apt to occur under ordinary operating conditions. Price 75 cents

CATALOGUE OF GOOD, PRACTICAL BOOKS

AUTOMOBILE REPAIRING MADE EASY. By VICTOR W. PAGÉ, M.E.

A comprehensive, practical exposition of every phase of modern automobile repairing practice. Outlines every process incidental to motor car restoration. Gives plans for workshop construction, suggestions for equipment, power needed, machinery and tools necessary to carry on the business successfully. Tells how to overhaul and repair all parts of all automobiles. Everything is explained so simply that motorists and students can acquire a full working knowledge of automobile repairing. This work starts with the engine, then considers carburetion, ignition, cooling and lubrication systems. The clutch, change-speed gearing and transmission system are considered in detail. Contains instructions for repairing all types of axles, steering gears and other chassis parts. Many tables, short cuts in figuring and rules of practice are given for the mechanic. Explains fully, valve and magneto timing, "tuning" engines, systematic location of trouble, repair of ball and roller bearings, shop kinks, first aid to injured and a multitude of subjects of interest to all in the garage and repair business.

This book contains special instructions on electric starting, lighting and ignition systems, tire repairing and rebuilding, autogenous welding, brazing and soldering, heat treatment of steel, latest timing practice, eight and twelve-cylinder motors, etc. 5¼x8. Cloth. 1060 pages, 1,000 illustrations, 11 folding plates. Price. . . . \$4.00

WHAT IS SAID OF THIS BOOK:

"'Automobile Repairing Made Easy' is the best book on the subject I have ever seen and the only book I ever saw that is of any value in a garage."—Fred Jeffrey, Martinsburg, Neb.

"I wish to thank you for sending me a copy of 'Automobile Repairing Made Easy.' I do not think it could be excelled."—S. W. Gisriel, Director of Instruction, Y. M. C. A., Philadelphia, Pa.

QUESTIONS AND ANSWERS RELATING TO MODERN AUTOMOBILE CONSTRUCTION, DRIVING AND REPAIR. By VICTOR W. PAGÉ, M.E.

A practical self-instructor for students, mechanics and motorists, consisting of thirty-seven lessons in the form of questions and answers, written with special reference to the requirements of the non-technical reader desiring easily understood, explanatory matter relating to all branches of automobilism. The subject-matter is absolutely correct and explained in simple language. If you can't answer all of the following questions, you need this work. The answers to these and nearly 2000 more are to be found in its pages. Give the name of all important parts of an automobile and describe their functions? Describe action of latest types of kerosene carburetors? What is the difference between a "double" ignition system and a "dual" ignition system? Name parts of an induction coil? How are valves timed? What is an electric motor starter and how does it work? What are advantages of worm drive gearing? Name all important types of ball and roller bearings? What is a "three-quarter" floating axle? What is a two-speed axle? What is the Vulean electric gear shift? Name the causes of lost power in automobiles? Describe all noises due to deranged mechanism and give causes? How can you adjust a carburetor by the color of the exhaust gases? What causes "popping" in the carburetor? What tools and supplies are needed to equip a car? How do you drive various makes of cars? What is a differential lock and where is it used? Name different systems of wire wheel construction, etc., etc. A popular work at a popular price. 5¼x7½. Cloth. 701 pages, 387 illustrations, 3 folding plates. New revised edition. Price \$2.50

WHAT IS SAID OF THIS BOOK:

"If you own a car—get this book."—*The Glassworker*.

"Mr. Pagé has the faculty of making difficult subjects plain and understandable."—*Bristol Press*.

"We can name no writer better qualified to prepare a book of instruction on automobiles than Mr. Victor W. Pagé."—*Scientific American*.

"The best automobile catechism that has appeared."—*Automobile Topics*.

"There are few men, even with long experience, who will not find this book useful. Great pains have been taken to make it accurate. Special recommendation must be given to the illustrations, which have been made specially for the work. Such excellent books as this greatly assist in fully understanding your automobile."—*Engineering News*.

CATALOGUE OF GOOD, PRACTICAL BOOKS

HOW TO RUN AN AUTOMOBILE. By VICTOR W. PAGÉ.

This treatise gives concise instructions for starting and running all makes of gasoline automobiles, how to care for them, and gives distinctive features of control. Describes every step for shifting gears, controlling engine, etc. Among the chapters contained are: I. Automobile Parts and Their Functions. II. General Starting and Driving Instructions. III. Control Systems—Care of Automobiles. Thoroughly illustrated. 178 pages. 72 illustrations. Price \$1.50

THE AUTOMOBILIST'S POCKET COMPANION AND EXPENSE RECORD. By VICTOR W. PAGÉ.

This book is not only valuable as a convenient cost record, but contains much information of value to motorists. Includes a condensed digest of auto laws of all States, a lubrication schedule, hints for care of storage battery, and care of tires, location of road troubles, anti-freezing solutions, horse-power table, driving hints and many useful tables and recipes of interest to all motorists. Not a technical book in any sense of the word, just a collection of practical facts in simple language for the every-day motorist. Convenient pocket size. Price \$1.50

AUTOMOBILE WELDING WITH THE OXY-ACETYLENE FLAME. By M. KEITH DUNHAM.

Explains in a simple manner apparatus to be used, its care, and how to construct necessary shop equipment. Proceeds then to the actual welding of all automobile parts, in a manner understandable by everyone. Gives principles never to be forgotten. This book is of utmost value, since the perplexing problems arising when metal is heated to a melting point are fully explained and the proper methods to overcome them shown. 167 pages. Fully illustrated. Price. \$1.50

AUTOMOBILE, AVIATION AND MOTORCYCLE CHARTS

AVIATION CHART—LOCATION OF AIRPLANE POWER PLANT TROUBLES MADE EASY. By MAJOR VICTOR W. PAGÉ, A.S., S.C.U.S.R.

A large chart outlining all parts of a typical airplane power plant, showing the points where trouble is apt to occur and suggesting remedies for the common defects. Intended especially for aviators and aviation mechanics on school and field duty. Price 35 cents

CHART. GASOLINE ENGINE TROUBLES MADE EASY—A CHART SHOW- ING SECTIONAL VIEW OF GASOLINE ENGINE. Compiled by Victor W. PAGÉ, M.E.

It shows clearly all parts of a typical four-cylinder gasoline engine of the four-cycle type. It outlines distinctly all parts liable to give trouble and also details the derangements apt to interfere with smooth engine operation.

Valuable to students, motorists, mechanics, repairmen, garagemen, automobile salesmen, chauffeurs, motorboat owners, motor-truck and tractor drivers, aviators, motorcyclists, and all others who have to do with gasoline power plants.

It simplifies location of all engine troubles, and while it will prove invaluable to the novice, it can be used to advantage by the more expert. It should be on the walls of every public and private garage, automobile repair shop, club house or school. It can be carried in the automobile or pocket with ease, and will insure against loss of time when engine trouble manifests itself.

This sectional view of engine is a complete review of all motor troubles. It is prepared by a practical motorist for all who motor. More information for the money than ever before offered. No details omitted. Size 25x38 inches. Securely mailed on receipt of 35 cents

CATALOGUE OF GOOD, PRACTICAL BOOKS

CHART. LOCATION OF FORD ENGINE TROUBLES MADE EASY. Compiled by VICTOR W. PAGÉ, M.E.

This shows clear sectional views depicting all portions of the Ford power plant and auxiliary groups. It outlines clearly all parts of the engine, fuel supply system, ignition group and cooling system, that are apt to give trouble, detailing all derangements that are liable to make an engine lose power, start hard or work irregularly. This chart is valuable to students, owners, and drivers, as it simplifies location of all engine faults. Of great advantage as an instructor for the novice, it can be used equally well by the more expert as a work of reference and review. It can be carried in the toolbox or pocket with ease and will save its cost in labor eliminated the first time engine trouble manifests itself. Prepared with special reference to the average man's needs and is a practical review of all motor troubles because it is based on the actual experience of an automobile engineer-mechanic with the mechanism the chart describes. It enables the non-technical owner or operator of a Ford car to locate engine derangements by systematic search, guided by easily recognized symptoms instead of by guesswork. It makes the average owner independent of the roadside repair shop when touring. Must be seen to be appreciated. Size 25x38 inches. Printed on heavy bond paper. Price 35 cents

CHART. LUBRICATION OF THE MOTOR CAR CHASSIS. Compiled by VICTOR W. PAGÉ, M.E.

This chart presents the plan view of a typical six-cylinder chassis of standard design and all parts are clearly indicated that demand oil, also the frequency with which they must be lubricated and the kind of oil to use. A practical chart for all interested in motor-car maintenance. Size 24x38 inches. Price 35 cents

CHART. LOCATION OF CARBURETION TROUBLES MADE EASY. Compiled by VICTOR W. PAGÉ, M.E.

This chart shows all parts of a typical pressure feed fuel supply system and gives causes of trouble, how to locate defects and means of remedying them. Size 24x38 inches. Price 35 cents

CHART. LOCATION OF IGNITION SYSTEM TROUBLES MADE EASY. Compiled by VICTOR W. PAGÉ, M.E.

In this diagram all parts of a typical double ignition system using battery and magneto current are shown, and suggestions are given for readily finding ignition troubles and eliminating them when found. Size 24x38 inches. Price 35 cents

CHART. LOCATION OF COOLING AND LUBRICATION SYSTEM FAULTS. Compiled by VICTOR W. PAGÉ, M.E.

This composite diagram shows a typical automobile power plant using pump circulated water-cooling system and the most popular lubrication method. Gives suggestions for curing all overheating and loss of power faults due to faulty action of the oiling or cooling group. Size 24x38 inches. Price 35 cents

CHART. LOCATION OF STARTING AND LIGHTING SYSTEM FAULTS.

The most complete chart yet devised, showing all parts of the modern automobile starting, lighting and ignition systems, giving instructions for systematic location of all faults in wiring, lamps, motor or generator, switches and all other units. Invaluable to motorists, chauffeurs and repairmen. Size 24x38 inches. Price 35 cents

CHART. MOTORCYCLE TROUBLES MADE EASY. Compiled by VICTOR W. PAGÉ, M.E.

A chart showing sectional view of a single-cylinder gasoline engine. This chart simplifies location of all power-plant troubles. A single-cylinder motor is shown for simplicity. It outlines distinctly all parts liable to give trouble and also details the derangements apt to interfere with smooth engine operation. This chart will prove of value to all who have to do with the operation, repair or sale of motorcycles. No details omitted. Size 30x20 inches. Price 35 cents

CATALOGUE OF GOOD, PRACTICAL BOOKS

AVIATION

A B C OF AVIATION. By MAJOR VICTOR W. PAGÉ.

This book describes the basic principles of aviation, tells how a balloon or dirigible is made and why it floats in the air. Describes how an airplane flies. It shows in detail the different parts of an airplane, what they are and what they do. Describes all types of airplanes and how they differ in construction; as well as detailing the advantages and disadvantages of different types of aircraft. It includes a complete dictionary of aviation terms and clear drawings of leading airplanes. The reader will find simple instructions for unpacking, setting up, and rigging airplanes. A full description of airplane control principles is given and methods of flying are discussed at length.

This book answers every question one can ask about modern aircraft, their construction and operation. A self-educator on aviation without an equal. 274 pages. 130 specially made illustrations with 7 plates. Price \$2.50

AVIATION ENGINES—DESIGN; CONSTRUCTION; REPAIR. By MAJOR VICTOR W. PAGÉ, A.S., S.C.U.S.R.

This treatise, written by a recognized authority on all of the practical aspects of internal combustion engine construction, maintenance, and repair, fills the need as no other book does. The matter is logically arranged; all descriptive matter is simply expressed and copiously illustrated, so that anyone can understand airplane engine operation and repair even if without previous mechanical training. This work is invaluable for anyone desiring to become an aviator or aviation mechanic. The latest rotary types, such as the Gnome Monosoupape, and LeRhone, are fully explained, as well as the recently developed Vee and radial types. The subjects of carburetion, ignition, cooling, and lubrication also are covered in a thorough manner. The chapters on repair and maintenance are distinctive and found in no other book on this subject. Not a technical book, but a practical, easily understood work of reference for all interested in aeronautical science. 589 pages. 253 illustrations. Price, net \$3.00

GLOSSARY OF AVIATION TERMS—ENGLISH-FRENCH; FRENCH-ENGLISH. By MAJOR VICTOR W. PAGÉ, A.S., S.C.U.S.R., and LIEUT. PAUL MONTARIOL, of the French Flying Corps.

A complete glossary of practically all terms used in aviation, having lists in both French and English with equivalents in either language. Price, net . . . \$1.00

APPLIED AERODYNAMICS. By G. P. THOMPSON.

This is a scientific and mathematical treatise that has a special appeal to the student and engineer who are seeking exact information on the aerodynamics of heavier-than-air craft and data on airplane design testing. This book gives an up-to-date presentation of the existing state of Aeronautical Science. In addition to a very full discussion of the qualities which determine the speed and rate of climb of an aeroplane and the method by which they can be calculated, special attention is paid to stability—a problem now fairly well understood, and to controllability—our knowledge of which is at present in a much more elementary state. Attention is directed to the numerous directions in which further information is required, especially in the form of full-scale experiments. 312 pages (7 x 10). Illustrated with over 142 Diagrams and Graphic Charts. Price \$12.50

AVIATION CHART—LOCATION OF AIRPLANE POWER PLANT TROUBLES MADE EASY. By MAJOR VICTOR W. PAGÉ, A.S., S.C.U.S.R.

A large chart outlining all parts of a typical airplane power plant, showing the points where trouble is apt to occur and suggesting remedies for the common defects. Intended especially for aviators and aviation mechanics on school and field duty. Price 35 cents

CATALOGUE OF GOOD, PRACTICAL BOOKS

MOLDING CONCRETE BATHTUBS, AQUARIUMS AND NATATORIUMS. By A. A. HOUGHTON.

Simple molds and instruction are given for molding many styles of concrete bathtubs, swimming-pools, etc. These molds are easily built and permit rapid and successful work. (No. 7 of Series.) 75 cents

CONCRETE BRIDGES, CULVERTS AND SEWERS. By A. A. HOUGHTON.

A number of ornamental concrete bridges with illustrations of molds are given. A collapsible center or core for bridges, culverts and sewers is fully illustrated with detailed instructions for building. (No. 8 of Series.) 75 cents

CONSTRUCTING CONCRETE PORCHES. By A. A. HOUGHTON.

A number of designs with working drawings of molds are fully explained so anyone can easily construct different styles of ornamental concrete porches without the purchase of expensive molds. (No. 9 of Series.) 75 cents

MOLDING CONCRETE FLOWER-POTS, BOXES, JARDINIERS, ETC. By A. A. HOUGHTON.

The molds for producing many original designs of flower-pots, urns, flower-boxes, jardinieres, etc., are fully illustrated and explained, so the worker can easily construct and operate same. (No. 10 of Series.) 75 cents

MOLDING CONCRETE FOUNTAINS AND LAWN ORNAMENTS. By A. A. HOUGHTON.

The molding of a number of designs of lawn seats, curbing, hitching posts, pergolas, sun dials and other forms of ornamental concrete for the ornamentation of lawns and gardens, is fully illustrated and described. (No. 11 of Series) 75 cents

CONCRETE FROM SAND MOLDS. By A. A. HOUGHTON.

A Practical Work treating on a process which has heretofore been held as a trade secret by the few who possessed it, and which will successfully mold every and any class of ornamental concrete work. The process of molding concrete with sand molds is of the utmost practical value, possessing the manifold advantages of a low cost of molds, the ease and rapidity of operation, perfect details to all ornamental designs, density and increased strength of the concrete, perfect curing of the work without attention and the easy removal of the molds regardless of any undercutting the design may have. 192 pages. Fully illustrated. Price \$2.00

ORNAMENTAL CONCRETE WITHOUT MOLDS. By A. A. HOUGHTON.

The process for making ornamental concrete without molds has long been held as a secret, and now, for the first time, this process is given to the public. The book reveals the secret and is the only book published which explains a simple, practical method whereby the concrete worker is enabled, by employing wood and metal templates of different designs, to mold or model in concrete any Cornice, Archivolt, Column, Pedestal, Base Cap, Urn or Pier in a monolithic form—right upon the job. These may be molded in units or blocks, and then built up to suit the specifications demanded. This work is fully illustrated, with detailed engravings. Price . \$2.00

CONCRETE FOR THE FARM AND IN THE SHOP. By H. COLIN CAMPBELL, C.E., E.M.

A new book illustrating and describing in plain, simple language many of the numerous applications of concrete within the range of the home worker. Among the subjects treated are:

Principles of reinforcing; methods of protecting concrete so as to insure proper hardening; home-made mixers; mixing by hand and machine; form construction, described and illustrated by drawings and photographs; construction of concrete walls and fences; concrete fence posts; concrete gate posts; corner posts; clothes line posts; grape arbor posts; tanks; troughs; cisterns; hog wallows; feeding floors and barnyard pavements; foundations; well curbs and platforms; indoor floors; sidewalk; steps; concrete hotbeds and cold frames; concrete slab roofs; walls for buildings; repairing leaks in tanks and cisterns, etc., etc. A number of convenient and practical tables for estimating quantities, and some practical examples, are also given. (5 x 7). 149 pages, 51 illustrations. Price \$1.00

CATALOGUE OF GOOD, PRACTICAL BOOKS

POPULAR HANDBOOK FOR CEMENT AND CONCRETE USERS. By MYRON H. LEWIS.

This is a concise treatise of the principles and methods employed in the manufacture and use of cement in all classes of modern works. The author has brought together in this work all the salient matter of interest to the user of concrete and its many diversified products. The matter is presented in logical and systematic order, clearly written, fully illustrated and free from involved mathematics. Everything of value to the concrete user is given, including kinds of cement employed in construction, concrete architecture, inspection and testing, waterproofing, coloring and painting, rules, tables, working and cost data. The book comprises thirty-three chapters, 430 pages, 126 illustrations. Price \$3.00

WATERPROOFING CONCRETE. By MYRON H. LEWIS.

Modern Methods of Waterproofing Concrete and Other Structures. A condensed statement of the Principles, Rules, and Precautions to be Observed in Waterproofing and Dampproofing Structures and Structural Materials. Price 75 cents

DICTIONARIES

STANDARD ELECTRICAL DICTIONARY. By T. O'CONNOR SLOANE.

An indispensable work to all interested in electrical science. Suitable alike for the student and professional. A practical handbook of reference containing definitions in about 5000 distinct words, terms and phrases. The definitions are terse and concise and include every term used in electrical science. Recently issued. An entirely new edition. Should be in the possession of all who desire to keep abreast with the progress of this branch of science. Complete, concise and convenient. Nearly 800 pages. Nearly 600 illustrations. New Revised and Enlarged Edition. Price \$5.00

DIES—METAL WORK

DIES: THEIR CONSTRUCTION AND USE FOR THE MODERN WORKING OF SHEET METALS. By J. V. WOODWORTH.

A most useful book, and one which should be in the hands of all engaged in the press-working of metals; treating on the Designing, Constructing, and Use of Tools, Fixtures and Devices, together with the manner in which they should be used in the Power Press, for the cheap and rapid production of the great variety of sheet-metal articles now in use. It is designed as a guide to the production of sheet-metal parts at the minimum of cost with the maximum of output. The hardening and tempering of Press tools and the classes of work which may be produced to the best advantage by the use of dies in the power press are fully treated. Its 505 illustrations show dies, press fixtures and sheet-metal working devices, the descriptions of which are so clear and practical that all metal-working mechanics will be able to understand how to design, construct and use them. Many of the dies and press fixtures treated were either constructed by the author or under his supervision. Others were built by skillful mechanics and are in use in large sheet-metal establishments and machine shops. 6th Edition. 400 pages, 523 illustrations. Price \$3.50

PUNCHES, DIES AND TOOLS FOR MANUFACTURING IN PRESSES. By J. V. WOODWORTH.

This work is a companion volume to the author's elementary work entitled "Dies, Their Construction and Use." It does not go into the details of die-making to the extent of the author's previous book, but gives a comprehensive review of the field of operations carried on by presses. A large part of the information given has been drawn from the author's personal experience. It might well be termed an Encyclopedia of Die-Making, Punch-Making, Die-Sinking, Sheet-Metal Working, and Making of Special Tools. Sub-presses, Devices and Mechanical Combinations for Punching, Cutting, Bending, Forming, Piercing, Drawing, Compressing and Assembling Sheet-Metal Parts, and also Articles of other Materials in Machine Tools. 3rd Edition. 483 pages, 702 illustrations. Price \$4.50

CATALOGUE OF GOOD, PRACTICAL BOOKS

DRAWING—SKETCHING PAPER

PRACTICAL PERSPECTIVE. By RICHARDS and COLVIN.

Shows just how to make all kinds of mechanical drawings in the only practical perspective isometric. Makes everything plain so that any mechanic can understand a sketch or drawing in this way. Saves time in the drawing room, and mistakes in the shops. Contains practical examples of various classes of work. 4th Edition. 75 cents

LINEAR PERSPECTIVE SELF-TAUGHT. By HERMAN T. C. KRAUS.

This work gives the theory and practice of linear perspective, as used in architectural, engineering and mechanical drawings. Persons taking up the study of the subject by themselves will be able, by the use of the instruction given, to readily grasp the subject, and by reasonable practice become good perspective draftsmen. The arrangement of the book is good; the plate is on the left-hand, while the descriptive text follows on the opposite page, so as to be readily referred to. The drawings are on sufficiently large scale to show the work clearly and are plainly figured. There is included a self-explanatory chart which gives all information necessary for the thorough understanding of perspective. This chart alone is worth many times over the price of the book. 2d Revised and enlarged Edition. . . . \$3.00

SELF-TAUGHT MECHANICAL DRAWING AND ELEMENTARY MACHINE DESIGN. By F. L. SYLVESTER, M.E., Draftsman, with additions by ERIC OBERG, associate editor of "Machinery."

This is a practical treatise on Mechanical Drawing and Machine Design, comprising the first principles of geometric and mechanical drawing, workshop mathematics, mechanics, strength of materials and the calculations and design of machine details. The author's aim has been to adapt this treatise to the requirements of the practical mechanic and young draftsman and to present the matter in as clear and concise a manner as possible. To meet the demands of this class of students, practically all the important elements of machine design have been dealt with, and in addition algebraic formulas have been explained, and the elements of trigonometry treated in the manner best suited to the needs of the practical man. The book is divided into 20 chapters, and in arranging the material, mechanical drawing, pure and simple, has been taken up first, as a thorough understanding of the principles of representing objects facilitates the further study of mechanical subjects. This is followed by the mathematics necessary for the solution of the problems in machine design which are presented later, and a practical introduction to theoretical mechanics and the strength of materials. The various elements entering into machine design, such as cams, gears, sprocket-wheels, cone pulleys, bolts, screws, couplings, clutches, shafting and fly-wheels, have been treated in such a way as to make possible the use of the work as a text-book for a continuous course of study. 333 pages, 218 engravings. Price . . . \$2.50

A NEW SKETCHING PAPER.

A new specially ruled paper to enable you to make sketches or drawings in isometric perspective without any figuring or fussing. It is being used for shop details as well as for assembly drawings, as it makes one sketch do the work of three, and no workman can help seeing just what is wanted. Pads of 40 sheets, 6x9 inches, 40 cents. Pads of 40 sheets, 9x12 inches, 75 cents; 40 sheets, 12x18, Price . . . \$1.50

ELECTRICITY

ARITHMETIC OF ELECTRICITY. By Prof. T. O'CONNOR SLOANE.

A practical treatise on electrical calculations of all kinds reduced to a series of rules, all of the simplest forms, and involving only ordinary arithmetic; each rule illustrated by one or more practical problems, with detailed solution of each one. This book is classed among the most useful works published on the science of electricity, covering as it does the mathematics of electricity in a manner that will attract the attention of those who are not familiar with algebraical formulas. 22nd Edition. 196 pages. Price . . . \$1.50

CATALOGUE OF GOOD, PRACTICAL BOOKS

COMMUTATOR CONSTRUCTION. By Wm. BAXTER, JR.

The business end of any dynamo or motor of the direct current type is the commutator. This book goes into the designing, building, and maintenance of commutators, shows how to locate troubles and how to remedy them; everyone who fusses with dynamos needs this. 5th Edition 35 cents

CONSTRUCTION OF A TRANSATLANTIC WIRELESS RECEIVING SET. By L. G. PACENT and T. S. CURTIS.

A work for the Radio student who desires to construct and operate apparatus that will permit of the reception of messages from the large stations in Europe with an aerial of amateur proportions. 36 pages. 23 illustrations, cloth. Price . 35 cents

DYNAMO BUILDING FOR AMATEURS, OR HOW TO CONSTRUCT A FIFTY-WATT DYNAMO. By ARTHUR J. WEED, Member of N. Y. Electrical Society.

A practical treatise showing in detail the construction of a small dynamo or motor, the entire machine work of which can be done on a small foot lathe. Dimensioned working drawings are given for each piece of machine work, and each operation is clearly described. This machine, when used as a dynamo, has an output of fifty watts; when used as a motor it will drive a small drill press or lathe. It can be used to drive a sewing machine on any and all ordinary work. The book is illustrated with more than sixty original engravings showing the actual construction of the different parts. Among the contents are chapters on: 1. Fifty-Watt Dynamo. 2. Side Bearing Rods. 3. Field Punching. 4. Bearings. 5. Commutator. 6. Pulley. 7. Brush Holders. 8. Connection Board. 9. Armature Shaft. 10. Armature. 11. Armature Winding. 12. Field Winding. 13. Connecting and Starting. Price, cloth, \$1.00

DESIGN DATA FOR RADIO TRANSMITTERS AND RECEIVERS. By MILTON B. SLEEPER.

Far from being a collection of formulas, Design Data takes up in proper sequence the problems encountered in planning all types of receiving sets for short, medium and long wave work, and spark coil, transformer and vacuum tube transmitters operating on 200 meters. Tables have been worked out so that values can be found without the use of mathematics. Radio experimenters will find here information which will enable them to have the most modern and efficient equipment. Price . . . 75 cents

DYNAMOS AND ELECTRIC MOTORS AND ALL ABOUT THEM. By EDWARD TREVERT.

This volume gives practical directions for building a two H. P. Dynamo of the Edison type capable of lighting about fifty Mazda lamps of the 20-watt size. In addition, it gives directions for building two small electric motors suitable for running sewing machines. The concluding chapter describes the construction of a simple bichromate battery adapted for running electric motors. 96 pages. Fully illustrated with detail drawings. Cloth. Price \$1.00

ELECTRIC BELLS. By M. B. SLEEPER.

A complete treatise for the practical worker in installing, operating, and testing bell circuits, burglar alarms, thermostats, and other apparatus used with electric bells. Both the electrician and the experimenter will find in this book new material which is essential in their work. Tools, bells, batteries, unusual circuits, burglar alarms, annunciators, systems, thermostats, circuit breakers, time alarms, and other apparatus used in bell circuits are described from the standpoints of their application, construction, and repair. The detailed instructions for building the apparatus will appeal to the experimenter particularly. The practical worker will find the chapters on Wiring Calculation of Wire Sizes and Magnet Windings, Upkeep of Systems and the Location of Faults of the greatest value in their work. 124 pages. Fully illustrated. Price 75 cents

CATALOGUE OF GOOD, PRACTICAL BOOKS

EXPERIMENTAL HIGH FREQUENCY APPARATUS — HOW TO MAKE AND USE IT. By THOMAS STANLEY CURTIS.

This book tells you how to build simple high frequency coils for experimental purpose in the home, school laboratory, or on the small lecture platform. The book is really a supplement to the same author's "High Frequency Apparatus." The experimental side only is covered in this volume, which is intended for those who want to build small coils giving up to an eighteen-inch spark. The book contains valuable information for the physics or the manual training teacher who is on the lookout for interesting projects for his boys to build or experiment with. The apparatus is simple, cheap and perfectly safe, and with it some truly startling experiments may be performed. Among the contents are: Induction Coil Outfits Operated on Battery Current. Kicking Coil Apparatus. One-Half Kilowatt Transformer Outfit. Parts and Materials, etc., etc. 69 pages. Illustrated. Price 50 cents

HIGH FREQUENCY APPARATUS, ITS CONSTRUCTION AND PRACTICAL APPLICATION. By THOMAS STANLEY CURTIS.

The most comprehensive and thorough work on this interesting subject ever produced. The book is essentially practical in its treatment and it constitutes an accurate record of the researches of its author over a period of several years, during which time dozens of coils were built and experimented with. The work has been divided into six basic parts. The first two chapters tell the uninitiated reader what the high frequency current is, what it is used for, and how it is produced. The second section, comprising four chapters, describes in detail the principles of the transformer, condenser, spark gap, and oscillation transformer, and covers the main points in the design and construction of these devices as applied to the work in hand. The third section covers the construction of small high frequency outfits designed for experimental work in the home laboratory or in the classroom. The fourth section is devoted to electro-therapeutic and X-Ray apparatus. The fifth describes apparatus for the cultivation of plants and vegetables. The sixth section is devoted to a comprehensive discussion of apparatus of large size for use upon the stage in spectacular productions. The closing chapter, giving the current prices of the parts and materials required for the construction of the apparatus described, is included with a view to expediting the purchase of the necessary goods. The Second Edition includes much new matter along the line of home-made therapeutic outfits for physicians' use. The matter on electro plant culture has also been elaborated upon. Second Revised and Enlarged Edition. 266 pages. New second edition. Fully illustrated. Price . \$3.00

ELECTRIC WIRING, DIAGRAMS AND SWITCHBOARDS. By NEWTON HARRISON.

A thoroughly practical treatise covering the subject of Electric Wiring in all its branches, including explanations and diagrams which are thoroughly explicit and greatly simplify the subject. Practical, every-day problems in wiring are presented and the method of obtaining intelligent results clearly shown. Only arithmetic is used. Ohm's law is given a simple explanation with reference to wiring for direct and alternating currents. The fundamental principle of drop of potential in circuits is shown with its various applications. The simple circuit is developed with the position of mains, feeders and branches; their treatment as a part of a wiring plan and their employment in house wiring clearly illustrated. Some simple facts about testing are included in connection with the wiring. Molding and conduit work are given careful consideration; and switchboards are systematically treated, built up and illustrated, showing the purpose they serve, for connection with the circuits, and to shunt and compound wound machines. The simple principles of switchboard construction, the development of the switchboard, the connections of the various instruments, including the lightning arrester, are also plainly set forth.

Alternating current wiring is treated, with explanations of the power factor, conditions calling for various sizes of wire, and a simple way of obtaining the sizes for single-phase, two-phase and three-phase circuits. This is the only complete work issued showing and telling you what you should know about direct and alternating current wiring. It is a ready reference. The work is free from advanced technicalities and mathematics, arithmetic being used throughout. It is in every respect a handy, well-written, instructive, comprehensive volume on wiring for the wireman, foreman, contractor, or electrician. 3rd edition, revised and enlarged. 315 pages; 137 illustrations. Price \$2.50

CATALOGUE OF GOOD, PRACTICAL BOOKS

ELECTRIC TOY MAKING, DYNAMO BUILDING, AND ELECTRIC MOTOR CONSTRUCTION. By Prof. T. O'CONNOR SLOANE.

This work treats of the making at home of electrical toys, electrical apparatus, motors, dynamos and instruments in general, and is designed to bring within the reach of young and old the manufacture of genuine and useful electrical appliances. The work is especially designed for amateurs and young folks.

Thousands of our young people are daily experimenting, and busily engaged in making electrical toys and apparatus of various kinds. The present work is just what is wanted to give the much needed information in a plain, practical manner, with illustrations to make easy the carrying out of the work. 20th Edition. 210 pages, 77 illustrations. Price \$1.50

ELECTRICIANS' HANDY BOOK. By Prof. T. O'CONNOR SLOANE.

This work is intended for the practical electrician who has to make things go. The entire field of electricity is covered within its pages. Among some of the subjects treated are: The Theory of the Electric Current and Circuit, Electro-Chemistry, Primary Batteries, Storage Batteries, Generation and Utilization of Electric Powers, Alternating Current, Armature Winding, Dynamos and Motors, Motor Generators, Operation of the Central Station Switchboards, Safety Appliances, Distribution of Electric Light and Power, Street Mains, Transformers, Arc and Incandescent Lighting, Electric Measurements, Photometry, Electric Railways, Telephony, Bell-Wiring, Electric-Plating, Electric Heating, Wireless Telegraphy, etc. It contains no useless theory; everything is to the point. It teaches you just what you want to know about electricity. It is the standard work published on the subject. Forty-six chapters, 600 engravings. New 5th Edition, Revised and Enlarged. Price \$4.00

ELECTRICITY SIMPLIFIED. By Prof. T. O'CONNOR SLOANE.

The object of "Electricity Simplified" is to make the subject as plain as possible and to show what the modern conception of electricity is; to show how two plates of different metal, immersed in acid, can send a message around the globe; to explain how a bundle of copper wire rotated by a steam engine can be the agent in lighting our streets, to tell what the volt, ohm and ampere are, and what high and low tension mean; and to answer the questions that perpetually arise in the mind in this age of electricity. 15th Revised Edition. 218 pages. Illustrated. Price . . . \$1.50

EXPERIMENTAL WIRELESS STATIONS. By P. E. EDELMAN.

The theory, design, construction and operation is fully treated including Wireless Telephony, Vacuum Tube, and quenched spark systems. The new enlarged edition is just issued and is strictly up to date, correct and complete. This book tells how to make apparatus to not only hear all telephoned and telegraphed radio-messages, but also how to make simple equipment that works for transmission over reasonably long distances. Then there is a host of new information included. The first and only book to give you all the recent important radio improvements, some of which have never before been published. This volume anticipates every need of the reader who wants the gist of the art, its principles, simplified calculations, apparatus dimensions, and understandable directions for efficient operation.

Vacuum tube circuits; amplifiers; long-distance sets; loop, coil, and underground receivers; tables of wave-lengths, capacity, inductance; such are a few of the subjects presented in detail that satisfies. It is independent and one of the few that describe *all* modern systems.

Endorsed by foremost instructors for its clear accuracy, preferred by leading amateurs for its dependable designs. The new experimental Wireless Stations is sure to be most satisfactory for your purposes. 27 chapters, 392 pages. 167 illustrations. Price \$3.00

RADIO TIME SIGNAL RECEIVER. By AUSTIN C. LESCARBOURA.

This new book, "A Radio Time Signal Receiver," tells you how to build a simple outfit designed expressly for the beginner. You can build the outfits in your own workshop and install them for jewelers either on a one-payment or a rental basis. The apparatus is of such simple design that it may be made by the average amateur mechanic possessing a few ordinary tools. 42 pages, Paper, Price . . . 35 cents

CATALOGUE OF GOOD, PRACTICAL BOOKS

HOUSE WIRING. By THOMAS W. POPPE.

This work describes and illustrates the actual installation of Electric Light Wiring, the manner in which the work should be done, and the method of doing it. The book can be conveniently carried in the pocket. It is intended for the Electrician, Helper, and Apprentice. It solves all Wiring Problems and contains nothing that conflicts with the rulings of the National Board of Fire Underwriters. It gives just the information essential to the Successful Wiring of a Building. Among the subjects treated are Locating the Meter, Panel Boards, Switches, Plug Receptacles, Brackets, Ceiling Fixtures, The Meter Connections, The Feed Wires, The Steel Armored Cable System, The Flexible Steel Conduit System, The Rigid Conduit System. A digest of the National Board of Fire Underwriters' rules relating to metallic wiring systems. Various switching arrangements explained and diagrammed. The easiest method or testing the Three- and Four-way circuits explained. The grounding of all metallic wiring systems and the reason for doing so shown and explained. The insulation of the metal parts of lamp fixtures and the reason for the same described and illustrated. 208 pages. 4th Edition, revised and enlarged. 160 illustrations. Flexible cloth. Price \$1.00

HOW TO BECOME A SUCCESSFUL ELECTRICIAN. By Prof. T. O'CONNOR SLOANE.

Every young man who wishes to become a successful electrician should read this book. It tells in simple language the surest and easiest way to become a successful electrician. The studies to be followed, methods of work, field of operation and the requirement, of the successful electrician are pointed out and fully explained. Every young engineer will find this an excellent stepping stone to more advanced works on electricity which he must master before success can be attained. Many young men become discouraged at the very outstart by attempting to read and study books that are far beyond their comprehension. This book serves as the connecting link between the rudiments taught in the public schools and the real study of electricity. It is interesting from cover to cover. 10th Revised Edition, just issued. 205 pages. Illustrated. Price \$1.50

RADIO HOOK-UPS. By MILTON B. SLEEPER.

In this book the best circuits for different instruments and various purposes have been carefully selected and grouped together. All the best circuits for damped and undamped wave receiving sets, buzzer, spark coil and transformer sending equipment, as well as vacuum tube telegraph and telephone transmitters, wavemeters, vacuum tube measuring instruments, audibility meters, etc., are shown in this book. . 75 cents

STANDARD ELECTRICAL DICTIONARY. By T. O'CONNOR SLOANE.

An indispensable work to all interested in electrical science. Suitable alike for the student and professional. A practical handbook of reference containing definitions of about 5,000 distinct words, terms and phrases. The definitions are terse and concise and include every term used in electrical science. Recently issued. An entirely new edition. Should be in the possession of all who desire to keep abreast with the progress of this branch of science. In its arrangement and typography the book is very convenient. The word or term defined is printed in black-faced type which readily catches the eye, while the body of the page is in smaller but distinct type. The definitions are well worded, and so as to be understood by the non-technical reader. The general plan seems to be to give an exact, concise definition, and then amplify and explain in a more popular way. Synonyms are also given, and references to other words and phrases are made. A very complete and accurate index of fifty pages is at the end of the volume; and as this index contains all synonyms, and as all phrases are indexed in every reasonable combination of words, reference to the proper place in the body of the book is readily made. It is difficult to decide how far a book of this character is to keep the dictionary form, and to what extent it may assume the encyclopedia form. For some purposes, concise, exactly worded definitions are needed; for other purposes, more extended descriptions are required. This book seeks to satisfy both demands, and does it with considerable success. Complete, concise and convenient. 800 pages. Nearly 500 illustrations. Now Revised and Enlarged Edition. Price \$5.00

CATALOGUE OF GOOD, PRACTICAL BOOKS

STORAGE BATTERIES SIMPLIFIED. By VICTOR W. PAGÉ, M.S.A.E.

A complete treatise on storage battery operating principles, repairs and applications. The greatly increasing application of storage batteries in modern engineering and mechanical work has created a demand for a book that will consider this subject completely and exclusively. This is the most thorough and authoritative treatise ever published on this subject. It is written in easily understandable, non-technical language so that anyone may grasp the basic principles of storage battery action as well as their practical industrial applications. All electric and gasoline automobiles use storage batteries. Every automobile repairman, dealer or salesman should have a good knowledge of maintenance and repair of these important elements of the motor car mechanism. This book not only tells how to charge, care for and rebuild storage batteries but also outlines all the industrial uses. Learn how they run street cars, locomotives and factory trucks. Get an understanding of the important functions they perform in submarine boats, isolated lighting plants, railway switch and signal systems, marine applications, etc. This book tells how they are used in central station standby service, for starting automobile motors and in ignition systems. Every practical use of the modern storage battery is outlined in this treatise. 208 pages. Fully illustrated. Price \$2.00

TELEPHONE CONSTRUCTION, INSTALLATION, WIRING, OPERATION AND MAINTENANCE. By W. H. RADCLIFFE and H. C. CUSHING.

This book is intended for the amateur, the wireman, or the engineer who desires to establish a means of telephonic communication between the rooms of his home, office, or shop. It deals only with such things as may be of use to him rather than with theories.

Gives the principles of construction and operation of both the Bell and Independent instruments; approved methods of installing and wiring them; the means of protecting them from lightning and abnormal currents; their connection together for operation as series or bridging stations; and rules for their inspection and maintenance. Line wiring and the wiring and operation of special telephone systems are also treated.

Intricate mathematics are avoided, and all apparatus, circuits and systems are thoroughly described. The appendix contains definitions of units and terms used in the text. Selected wiring tables, which are very helpful, are also included. Among the subjects treated are Construction, Operation, and Installation of Telephone Instruments; Inspection and Maintenance of Telephone Instruments; Telephone Line Wiring; Testing Telephone Line Wires and Cables; Wiring and Operation of Special Telephone Systems, etc. 2nd Edition, revised and enlarged. 223 pages. 154 illustrations \$1.50

WIRELESS TELEGRAPHY AND TELEPHONY SIMPLY EXPLAINED. By ALFRED P. MORGAN.

This is undoubtedly one of the most complete and comprehensible treatises on the subject ever published, and a close study of its pages will enable one to master all the details of the wireless transmission of messages. The author has filled a long-felt want and has succeeded in furnishing a lucid, comprehensible explanation in simple language of the theory and practice of wireless telegraphy and telephony.

Among the contents are: Introductory; Wireless Transmission and Reception—The Aerial System, Earth Connections—The Transmitting Apparatus, Spark Coils and Transformers, Condensers, Helixes, Spark Gaps, Anchor Gaps, Aerial Switches—The Receiving Apparatus, Detectors, etc.—Tuning and Coupling, Tuning Coils, Loose Couplers, Variable Condensers, Directive Wave Systems—Miscellaneous Apparatus, Telephone Receivers, Range of Stations, Static Interference—Wireless Telephones, Sound and Sound Waves, The Vocal Cords and Ear—Wireless Telephone. How Sounds Are Changed into Electric Waves—Wireless Telephones, The Apparatus—Summary. 154 pages. 150 engravings. Price \$1.50

WIRING A HOUSE. By HERBERT PRATT.

Shows a house already built; tells just how to start about wiring it; where to begin; what wire to use; how to run it according to Insurance Rules; in fact, just the information you need. Directions apply equally to a shop. Fourth edition . . . 35 cents

ELECTROPLATING

THE MODERN ELECTROPLATER. By KENNETH M. COGGESHALL.

This is one of the most complete and practical books on electroplating and allied processes that has been published as a text for the student or professional plater. It is written in simple language and explains all details of electroplating in a concise yet complete manner. It starts at the beginning and gives an elementary outline of electricity and chemistry as relates to plating, then considers shop layout and equipment and gives all the necessary information to do reliable and profitable electroplating in a modern commercial manner. Full instructions are given for the preparation and finishing of the work and formulae and complete directions are included for making all kinds of plating solutions, many of these having been trade secrets until published in this instruction manual. Anyone interested in practical plating and metal finishing will find this book a valuable guide and complete manual of the art. Cloth. 142 illustrations. 276 pages. Price \$3.00

FACTORY MANAGEMENT, ETC.

MODERN MACHINE SHOP CONSTRUCTION, EQUIPMENT AND MANAGEMENT. By O. E. PERRIGO, M.E.

The only work published that describes the modern machine shop or manufacturing plant from the time the grass is growing on the site intended for it until the finished product is shipped. By a careful study of its thirty-six chapters the practical man may economically build, efficiently equip, and successfully manage the modern machine shop or manufacturing establishment. Just the book needed by those contemplating the erection of modern shop buildings, the rebuilding and reorganization of old ones, or the introduction of modern shop methods, time and cost systems. It is a book written and illustrated by a practical shop man for practical shop men who are too busy to read theories and want facts. It is the most complete all-around book of its kind ever published. It is a practical book for practical men, from the apprentice in the shop to the president in the office. It minutely describes and illustrates the most simple and yet the most efficient time and cost system yet devised. 384 pages, 219 illustrations. Price \$5.00

FUEL

COMBUSTION OF COAL AND THE PREVENTION OF SMOKE. By Wm. M. BARR.

This book has been prepared with special reference to the generation of heat by the combustion of the common fuels found in the United States, and deals particularly with the conditions necessary to the economic and smokeless combustion of bituminous coals in Stationary and Locomotive Steam Boilers.

The presentation of this important subject is systematic and progressive. The arrangement of the book is in a series of practical questions to which are appended accurate answers, which describe in language, free from technicalities, the several processes involved in the furnace combustion of American fuels; it clearly states the essential requisites for perfect combustion, and points out the best methods for furnace construction for obtaining the greatest quantity of heat from any given quality of coal. 5th Edition. Nearly 350 pages, fully illustrated. Price \$1.50

CATALOGUE OF GOOD, PRACTICAL BOOKS

GAS AND OIL ENGINES

THE GASOLINE ENGINE ON THE FARM: ITS OPERATION, REPAIR AND USES. By XENO W. PUTNAM.

This is a practical treatise on the Gasoline and Kerosene Engine intended for the man who wants to know just how to manage his engine and how to apply it to all kinds of farm work to the best advantage.

This book abounds with hints and helps for the farm and suggestions for the home and housewife. There is so much of value in this book that it is impossible to adequately describe it in such small space. Suffice to say that it is the kind of a book every farmer will appreciate and every farm home ought to have. Includes selecting the most suitable engine for farm work, its most convenient and efficient installation, with chapters on troubles, their remedies, and how to avoid them. The care and management of the farm tractor in plowing, harrowing, harvesting and road grading are fully covered; also plain directions are given for hauling the tractor on the road. Special attention is given to relieving farm life of its drudgery by applying power to the disagreeable small tasks which must otherwise be done by hand. Many home-made contrivances for cutting wood, supplying kitchen, garden, and barn with water, loading, hauling and unloading hay, delivering grain to the bins or the feed trough are included; also full directions for making the engine milk the cows, churn, wash, sweep the house and clean the windows, etc. Very fully illustrated with drawings of working parts and cuts showing Stationary, Portable and Tractor Engines doing all kinds of farm work. All money-making farms utilize power. Learn how to utilize power by reading the pages of this book. It is an aid to the result getter, invaluable to the up-to-date farmer, student, blacksmith, implement dealer and, in fact, all who can apply practical knowledge of stationary gasoline engines or gas tractors to advantage. 530 pages. Nearly 180 engravings. Price \$3.00

GASOLINE ENGINES: THEIR OPERATION, USE AND CARE. By A. HATT VERRILL.

The simplest, latest and most comprehensive popular work published on Gasoline Engines, describing what the Gasoline Engine is; its construction and operation; how to install it; how to select it; how to use it and how to remedy troubles encountered. Intended for Owners, Operators and Users of Gasoline Motors of all kinds. This work fully describes and illustrates the various types of Gasoline Engines used in Motor Boats, Motor Vehicles and Stationary Work. The parts, accessories and appliances are described, with chapters on ignition, fuel, lubrication, operation and engine troubles. Special attention is given to the care, operation and repair of motors, with useful hints and suggestions on emergency repairs and makeshifts. A complete glossary of technical terms and an alphabetically arranged table of troubles and their symptoms form most valuable and unique features of this manual. Nearly every illustration in the book is original, having been made by the author. Every page is full of interest and value. A book which you cannot afford to be without. 275 pages. 152 specially made engravings. Price \$2.00

GAS, GASOLINE, AND OIL ENGINES. By GARDNER D. HISCOX.

Just issued, 23d revised and enlarged edition. Every user of a gas engine needs this book. Simple, instructive, and right up-to-date. The only complete work on the subject. Tells all about the running and management of gas, gasoline and oil engines, as designed and manufactured in the United States. Explosive motors for stationary marine and vehicle power are fully treated, together with illustrations of their parts and tabulated sizes, also their care and running are included. Electric ignition by induction coil and jump spark are fully explained and illustrated, including valuable information on the testing for economy and power and the creation of power plants.

The rules and regulations of the Board of Fire Underwriters in regard to the installation and management of gasoline motors are given in full, suggesting the safe installation of explosive motor power. A list of United States Patents issued on gas, gasoline, and oil engines and their adjuncts from 1875 to date is included. 640 pages. 435 engravings. Folding plates. Price \$3.00

CATALOGUE OF GOOD, PRACTICAL BOOKS

GAS ENGINES AND PRODUCER-GAS PLANTS. By R. E. MATHOT, M.E.

This is a practical treatise, setting forth the principles of gas engine and producer design, the selection and installation of an engine, conditions of perfect operation, producer-gas engines and their possibilities; the care of gas engines and producer-gas plants, with a chapter on volatile hydrocarbon and oil engines. A practical guide for the gas engine designer, user and engineer in the construction, selection, purchase, installation, operation and maintenance of gas engines. *Every part of the gas engine is described in detail, tersely, clearly and with a thorough understanding of the requirements of the mechanic.* Recognizing the need of a volume that would assist the gas engine user in understanding the motor upon which he depends for power, the author has discussed the subject without the help of any mathematics. Helpful suggestions as to the purchase of an engine, its installation, care and operation, form a most valuable feature of the book. 6 x 9 inches. Cloth. 314 pages. 152 illustrations. Price. \$3.00

GAS ENGINE CONSTRUCTION, OR HOW TO BUILD A HALF-HORSE-POWER GAS ENGINE. By PARSELL and WEED.

A practical treatise of 300 pages describing the theory and principles of the action of Gas Engines of various types and the design and construction of a half-horse-power Gas Engine, with illustrations of the work in actual progress, together with the dimensioned working drawings, giving clearly the sizes of the various details; for the student, the scientific investigator, and the amateur mechanic. This book treats of the subject more from the standpoint of practice than that of theory. The principles of operation of Gas Engines are clearly and simply described, and then the actual construction of a half-horse-power engine is taken up, step by step, showing in detail the making of the Gas Engine. 3d Edition. 300 pages. Price \$3.00

HOW TO RUN AND INSTALL GASOLINE ENGINES. By C. VON CULIN.

Revised and enlarged edition just issued. The object of this little book is to furnish a pocket instructor for the beginner, the busy man who uses an engine for pleasure or profit, but who does not have the time or inclination for a technical book, but simply to thoroughly understand how to properly operate, install and care for his own engine. The index refers to each trouble, remedy, and subject alphabetically. Being a quick reference to find the cause, remedy and prevention for troubles, and to become an expert with his own engine. Pocket size. Paper binding. Price 25 cents

GEARING AND CAMS

BEVEL GEAR TABLES. By D. AG. ENGSTROM.

A book that will at once commend itself to mechanics and draftsmen. Does away with all the trigonometry and fancy figuring on bevel gears, and makes it easy for anyone to lay them out or make them just right. There are 36 full-page tables that show every necessary dimension for all sizes or combinations you're apt to need. No puzzling, figuring or guessing. Gives placing distance, all the angles (including cutting angles), and the correct cutter to use. A copy of this prepares you for anything in the bevel-gear line. 3d Edition. 66 pages. \$1.50

CHANGE GEAR DEVICES. By OSCAR E. PERRIGO.

A practical book for every designer, draftsman, and mechanic interested in the invention and development of the devices for feed changes on the different machines requiring such mechanism. All the necessary information on this subject is taken up, analyzed, classified, sifted, and concentrated for the use of busy men who have not the time to go through the masses of irrelevant matter with which such a subject is usually encumbered and select such information as will be useful to them.

It shows just what has been done, how it has been done, when it was done, and who did it. It saves time in hunting up patent records and re-inventing old ideas. 3rd Edition. 101 pages \$1.50

DRAFTING OF CAMS. By LOUIS ROUILLON.

The laying out of cams is a serious problem unless you know how to go at it right. This puts you on the right road for practically any kind of cam you are likely to run up against. 3d Edition. 35 cents

CATALOGUE OF GOOD, PRACTICAL BOOKS

HYDRAULICS

HYDRAULIC ENGINEERING. By GARDNER D. HISCOX.

A treatise on the properties, power, and resources of water for all purposes. Including the measurement of streams, the flow of water in pipes or conduits; the horse-power of falling water, turbine and impact water-wheels, wave motors, centrifugal, reciprocating and air-lift pumps. With 300 figures and diagrams and 36 practical tables. All who are interested in water-works development will find this book a useful one, because it is an entirely practical treatise upon a subject of present importance, and cannot fail in having a far-reaching influence, and for this reason should have a place in the working library of every engineer. Among the subjects treated are: Historical Hydraulics, Properties of Water, Measurement of the Flow of Streams; Flowing Water Surface Orifices and Nozzles; Flow of Water in Pipes; Siphons of Various Kinds; Dams and Great Storage Reservoirs; City and Town Water Supply; Wells and Their Reinforcement; Air Lift Methods of Raising Water; Artesian Wells, Irrigation of Arid Districts; Water Power; Water-Wheels; Pumps and Pumping Machinery; Reciprocating Pumps; Hydraulic Power Transmission; Hydraulic Mining; Canals; Dredges; Conduits and Pipe Lines; Marine Hydraulics; Tidal and Sea Wave Power, etc. 320 pages. Price \$4.50

ICE AND REFRIGERATION

POCKETBOOK OF REFRIGERATION AND ICE MAKING. By A. J. WALLIS-TAYLOR.

This is one of the latest and most comprehensive reference books published on the subject of refrigeration and cold storage. It explains the properties and refrigerating effect of the different fluids in use, the management of refrigerating machinery and the construction and insulation of cold rooms with their required pipe surface for different degrees of cold; freezing mixtures and non-freezing brines, temperatures of cold rooms for all kinds of provisions, cold storage charges for all classes of goods, ice making and storage of ice, data and memoranda for constant reference by refrigerating engineers, with nearly one hundred tables containing valuable references to every fact and condition required in the installment and operation of a refrigerating plant. New edition just published. Price \$2.00

INVENTIONS—PATENTS

INVENTORS' MANUAL, HOW TO MAKE A PATENT PAY.

This is a book designed as a guide to inventors in perfecting their inventions, taking out their patents and disposing of them. It is not in any sense a Patent Solicitor's Circular nor a Patent Broker's Advertisement. No advertisements of any description appear in the work. It is a book containing a quarter of a century's experience of a successful inventor, together with notes based upon the experience of many other inventors.

Among the subjects treated in this work are: How to Invent. How to Secure a Good Patent. Value of Good Invention. How to Exhibit an Invention. How to Invest Interest Capital. How to Estimate the Value of a Patent. Value of Design Patents. Value of Foreign Patents. Value of Small Inventions. Advice on Selling Patents. Advice on the Formation of Stock Companies. Advice on the Formation of Limited Liability Companies. Advice on Disposing of Old Patents. Advice as to Patent Attorneys. Advice as to Selling Agents. Forms of Assignments. License and Contracts. State Laws Concerning Patent Rights. 1900 Census of the United States by Counts of Over 10,000 Population. New revised and enlarged edition. 144 pages. Illustrated. Price \$1.50

CATALOGUE OF GOOD, PRACTICAL BOOKS

LOCOMOTIVE BOILER CONSTRUCTION. By FRANK A. KLEINHANS.

The construction of boilers in general is treated, and, following this, the locomotive boiler is taken up in the order in which its various parts go through the shop. Shows all types of boilers used; gives details of construction; practical facts, such as life of riveting, punches and dies; work done per day, allowance for bending and flanging sheets, and other data. Including the recent Locomotive Boiler Inspection Laws and Examination Questions with their answers for Government Inspectors. Contains chapters on Laying Out Work; Flanging and Forging; Punching; Shearing; Plate Planing; General Tables; Finishing Parts; Bending; Machinery Parts; Riveting; Boiler Details; Smoke Box Details; Assembling and Calking; Boiler Shop Machinery, etc., etc.

There isn't a man who has anything to do with boiler work, either new or repair work, who doesn't need this book. The manufacturer, superintendent, foreman, and boiler worker—all need it. No matter what the type of boiler, you'll find a mint of information that you wouldn't be without. 451 pages, 334 illustrations, five large folding plates. Price \$3.50

LOCOMOTIVE BREAKDOWNS AND THEIR REMEDIES. By GEO. L. FOWLER. Revised by WM. W. WOOD, Air-Brake Instructor. Just issued. Revised pocket edition.

It is out of the question to try and tell you about every subject that is covered in this pocket edition of Locomotive Breakdowns. Just imagine all the common troubles that an engineer may expect to happen some time, and then add all of the unexpected ones, troubles that could occur, but that you have never thought about, and you will find that they are all treated with the very best methods of repair. Walschaert Locomotive Valve Gear Troubles, Electric Headlight Troubles, as well as Questions and Answers on the Air Brake are all included. 293 pages. 8th Revised Edition. Fully illustrated. \$1.50

PRACTICAL INSTRUCTOR AND REFERENCE BOOK FOR LOCOMOTIVE FIREMEN AND ENGINEERS. By CHAS. F. LOCKHART.

An entirely new book on the Locomotive. It appeals to every railroad man, as it tells him how things are done and the right way to do them. Written by a man who has had years of practical experience in locomotive shops and on the road firing and running. The information given in this book cannot be found in any other similar treatise. Eight hundred and fifty-one questions with their answers are included, which will prove specially helpful to those preparing for examination. Practical information on: The Construction and Operation of Locomotives; Breakdowns and their Remedies; Air Brakes and Valve Gears. Rules and Signals are handled in a thorough manner. As a book of reference it cannot be excelled. The book is divided into six parts, as follows: 1. The Fireman's Duties. 2. General Description of the Locomotive. 3. Breakdowns and their Remedies. 4. Air Brakes. 5. Extracts from Standard Rules. 6. Questions for Examination. The 851 questions have been carefully selected and arranged. These cover the examinations required by the different railroads. 368 pages. 88 illustrations. Price \$2.50

PREVENTION OF RAILROAD ACCIDENTS, OR SAFETY IN RAILROADING. By GEORGE BRADSHAW.

This book is a heart-to-heart talk with Railroad Employees, dealing with facts, not theories, and showing the men in the ranks, from every-day experience, how accidents occur and how they may be avoided. The book is illustrated with seventy original photographs and drawings showing the safe and unsafe methods of work. No visionary schemes, no ideal pictures. Just plain facts and Practical Suggestions are given. Every railroad employee who reads the book is a better and safer man to have in railroad service. It gives just the information which will be the means of preventing many injuries and deaths. All railroad employees should procure a copy; read it, and do your part in preventing accidents. 169 pages. Pocket size. Fully illustrated. Price 50 cents

CATALOGUE OF GOOD, PRACTICAL BOOKS

TRAIN RULE EXAMINATIONS MADE EASY. By G. E. COLLINGWOOD.

This is the only practical work on train rules in print. Every detail is covered, and puzzling points are explained in simple, comprehensive language, making it a practical treatise for the Train Dispatcher, Engineman, Trainman, and all others who have to do with the movements of trains. Contains complete and reliable information of the Standard Code of Train Rules for single track. Shows Signals in Colors, as used on the different roads. Explains fully the practical application of train orders, giving a clear and definite understanding of all orders which may be used. The meaning and necessity for certain rules are explained in such a manner that the student may know beyond a doubt the rights conferred under any orders he may receive or the action required by certain rules. As nearly all roads require trainmen to pass regular examinations, a complete set of examination questions, with their answers, are included. These will enable the student to pass the required examinations with credit to himself and the road for which he works. Second Edition revised. 234 pages. Fully illustrated with Train Signals in Colors. Price \$1.50

THE WALSCHAERT AND OTHER MODERN RADIAL VALVE GEARS FOR LOCOMOTIVES. By Wm. W. Wood.

If you would thoroughly understand the Walschaert Valve Gear you should possess a copy of this book, as the author takes the plainest form of a steam engine—a stationary engine in the rough, that will only turn its crank in one direction—and from it builds up—with the reader's help—a modern locomotive equipped with the Walschaert Valve Gear, complete. The points discussed are clearly illustrated; two large folding plates that show the positions of the valves of both inside or outside admission type, as well as the links and other parts of the gear when the crank is at nine different points in its revolution, are especially valuable in making the movement clear. These employ sliding cardboard models which are contained in a pocket in the cover.

The book is divided into five general divisions, as follows: 1. Analysis of the gear. 2. Designing and erecting the gear. 3. Advantages of the gear. 4. Questions and answers relating to the Walschaert Valve Gear. 5. Setting valves with the Walschaert Valve Gear; the three primary types of locomotive valve motion; modern radial valve gears other than the Walschaert; the Hobart All-free Valve and Valve Gear, with questions and answers on breakdowns; the Baker-Pilliod Valve Gear; the Improved Baker-Pilliod Valve Gear, with questions and answers on breakdowns.

The questions with full answers given will be especially valuable to firemen and engineers in preparing for an examination for promotion. 245 pages. Fully illustrated. Third Revised New Edition. Price \$2.50

WESTINGHOUSE E-T AIR-BRAKE INSTRUCTION POCKET BOOK. By Wm. W. Wood, Air-Brake Instructor.

Here is a book for the railroad man, and the man who aims to be one. It is without doubt the only complete work published on the Westinghouse E-T Locomotive Brake Equipment. Written by an Air-Brake Instructor who knows just what is needed. It covers the subject thoroughly. Everything about the New Westinghouse Engine and Tender Brake Equipment, including the standard No. 5 and the Perfected No. 6 style of brake, is treated in detail. Written in plain English and profusely illustrated with Colored Plates, which enable one to trace the flow of pressures throughout the entire equipment. The best book ever published on the Air Brake. Equally good for the beginner and the advanced engineer. Will pass anyone through any examination. It informs and enlightens you on every point. Indispensable to every engineman and trainman.

Contains examination questions and answers on the E-T equipment. Covering what the E-T Brake is. How it should be operated. What to do when defective. Not a question can be asked of the engineman up for promotion, on either the No. 5 or the No. 6 E-T equipment, that is not asked and answered in the book. If you want to thoroughly understand the E-T equipment get a copy of this book. It covers every detail. Makes Air-Brake troubles and examinations easy. Second Revised and Enlarged Edition. Price \$2.50

MACHINE-SHOP PRACTICE

AMERICAN TOOL MAKING AND INTERCHANGEABLE MANUFACTURING. By J. V. WOODWORTH.

A "shoppy" book, containing no theorizing, no problematical or experimental devices, there are no badly proportioned and impossible diagrams, no catalogue cuts, but a valuable collection of drawings and descriptions of devices, the rich fruits of the author's own experience. In its 500-odd pages the one subject only, Tool Making, and whatever relates thereto, is dealt with. The work stands without a rival. It is a complete practical treatise on the art of American Tool Making and system of interchangeable manufacturing as carried on to-day in the United States. In it are described and illustrated all of the different types and classes of small tools, fixtures, devices, and special appliances which are in general use in all machine-manufacturing and metal-working establishments where economy, capacity, and interchangeability in the production of machined metal parts are imperative. The science of jig making is exhaustively discussed, and particular attention is paid to drill jigs, boring, profiling and milling fixtures and other devices in which the parts to be machined are located and fastened within the contrivances. All of the tools, fixtures, and devices illustrated and described have been or are used for the actual production of work, such as parts of drill presses, lathes, patented machinery, typewriters, electrical apparatus, mechanical appliances, brass goods, composition parts, mould products, sheet metal articles, drop-forgings, jewelry, watches, medals, coins, etc. 3rd Edition. 531 pages. Price \$4.50

MACHINE-SHOP ARITHMETIC. By COLVIN-CHENEY.

This is an arithmetic of the things you have to do with daily. It tells you plainly about: how to find areas in figures; how to find surface or volume of balls or spheres; handy ways for calculating; about compound gearing; cutting screw threads on any lathe; drilling for taps; speeds of drills; taps, emery wheels, grindstones, milling cutters, etc.; all about the Metric system with conversion tables; properties of metals; strength of bolts and nuts; decimal equivalent of an inch. All sorts of machine-shop figuring and 1,001 other things, any one of which ought to be worth more than the price of this book to you, and it saves you the trouble of bothering the boss. 7th edition. 131 pages. Price 75 cents

MODERN MACHINE-SHOP CONSTRUCTION, EQUIPMENT AND MANAGEMENT. By OSCAR E. PERRIGO.

The only work published that describes the Modern Shop or Manufacturing Plant from the time the grass is growing on the site intended for it until the finished product is shipped. Just the book needed by those contemplating the erection of modern shop buildings, the rebuilding and reorganization of old ones, or the introduction of Modern Shop Methods, time and cost systems. It is a book written and illustrated by a practical shop man for practical shop men who are too busy to read theories and want facts. It is the most complete all-round book of its kind ever published. . . . 384 pages. 219 original and specially-made illustrations. Revised and Enlarged Edition. Price \$5.00

"SHOP KINKS." By ROBERT GRIMSHAW.

A book of 400 pages and 222 illustrations, being entirely different from any other book on machine-shop practice. Departing from conventional style, the author avoids universal or common shop usage and limits his work to showing special ways of doing things better, more cheaply and more rapidly than usual. As a result the advanced methods of representative establishments of the world are placed at the disposal of the reader. This book shows the proprietor where large savings are possible, and how products may be improved. To the employee it holds out suggestions that, properly applied, will hasten his advancement. No shop can afford to be without it. It bristles with valuable wrinkles and helpful suggestions. It will benefit all, from apprentice to proprietor. 5th edition. Price \$3.00

THREADS AND THREAD-CUTTING. By COLVIN and STABEL.

This clears up many of the mysteries of thread-cutting, such as double and triple threads, internal threads, catching threads, use of hobs, etc. Contains a lot of useful hints and several tables. 4th edition. Price 36 cents

**THE WHOLE FIELD OF MECHANICAL MOVEMENTS
COVERED BY MR. HISCOX'S TWO BOOKS**

We publish two books by Gardner D. Hiscox that will keep you from "inventing" things that have been done before, and suggest ways of doing things that you have not thought of before. Many a man spends time and money, pondering over some mechanical problem, only to learn, after he has solved the problem, that the same thing has been accomplished and put in practice by others long before. Time and money spent in an effort to accomplish what has already been accomplished are time and money LOST. The whole field of mechanics, every known mechanical movement, and practically every device is covered by these two books. If the thing you want has been invented, it is illustrated in them. If it hasn't been invented, then you'll find in them the nearest things to what you want, some movements or devices that will apply in your case, perhaps; or which will give you a key from which to work. No book or set of books ever published is of more real value to the inventor, draftsman, or practical mechanic than the two volumes described below.

MECHANICAL MOVEMENTS, POWERS, AND DEVICES. By GARDNER D. Hiscox.

This is a collection of 1,890 engravings of different mechanical motions and appliances, accompanied by appropriate text, making it a book of great value to the inventor, the draftsman, and to all readers with mechanical tastes. The book is divided into eighteen sections or chapters, in which the subject-matter is classified under the following heads: Mechanical Powers; Transmission of Power; Measurement of Power; Steam Power; Air Power Appliances; Electric Power and Construction; Navigation and Roads; Gearing; Motion and Devices; Controlling Motion; Horological; Mining; Mill and Factory Appliances; Construction and Devices; Drafting Devices; Miscellaneous Devices, etc. 15th edition enlarged. 400 octavo pages. Price . \$4.00

MECHANICAL APPLIANCES, MECHANICAL MOVEMENTS AND NOVELTIES OF CONSTRUCTION. By GARDNER D. HISCOX.

This is a supplementary volume to the one upon mechanical movements. Unlike the first volume, which is more elementary in character, this volume contains illustrations and descriptions of many combinations of motions and of mechanical devices and appliances found in different lines of machinery, each device being shown by a line drawing with a description showing its working parts and the method of operation. From the multitude of devices described and illustrated might be mentioned, in passing, such items as conveyors and elevators, Prony brakes, thermometers, various types of boilers, solar engines, oil-fuel burners, condensers, evaporators, Corliss and other valve gears, governors, gas engines, water motors of various descriptions, airships, motors and dynamos, automobile and motor bicycles, railway lock signals, car couplers, link and gear motions, ball bearings, breech block mechanism for heavy guns, and a large accumulation of others of equal importance. 1,000 specially made engravings. 396 octavo pages. 4th Edition enlarged. Price \$4.00

SHOP PRACTICE FOR HOME MECHANICS. By RAYMOND FRANCIS YATES.

A thoroughly practical and helpful treatment prepared especially for those who have had little or no experience in shop work. The introduction is given over to an elementary explanation of the fundamentals of mechanical science. This is followed by several chapters on the use of small tools and mechanical measuring instruments. Elementary and more advanced lathe work is treated in detail and directions given for the construction of a number of useful shop appliances. Drilling and reaming, heat treatment of tool steel, special lathe operations, pattern making, grinding, and grinding operations, home foundry work, etc., make up the rest of the volume. The book omits nothing that will be of use to those who use tools or to those who wish to learn the use of tools. The great number of clear engravings (over 300) add tremendously to the text matter and to the value of the volume as a visual instructor. Octavo, 320 pages, 309 engravings. Price \$3.00

CATALOGUE OF GOOD, PRACTICAL BOOKS

MACHINE-SHOP TOOLS AND SHOP PRACTICE. By W. H. VANDERVOORT.

A work of 552 pages and 672 illustrations, describing in every detail the construction, operation, and manipulation of both hand and machine tools. Includes chapters on filing, fitting, and scraping surfaces; on drills, reamers, taps, and dies; the lathe and its tools; planers, shapers, and their tools; milling machines and cutters; gear cutters and gear cutting; drilling machines and drill work; grinding machines and their work; hardening and tempering; gearing, belting, and transmission machinery; useful data and tables. 7th Edition. 533 pages. 672 illustrations. Price \$4.50

COMPLETE PRACTICAL MACHINIST. By JOSHUA ROSE.

The new, twentieth revised and enlarged edition is now ready. This is one of the best-known books on machine-shop work, and written for the practical workman in the language of the workshop. It gives full, practical instructions on the use of all kinds of metal-working tools, both hand and machine, and tells how the work should be properly done. It covers lathe work, vise work, drills and drilling, taps and dies, hardening and tempering, the making and use of tools, tool grinding, marking out work, machine tools, etc. No machinist's library is complete without this volume. 20th Edition. 547 pages. 432 illustrations. Price \$3.00

HENLEY'S ENCYCLOPEDIA OF PRACTICAL ENGINEERING AND ALLIED TRADES. Edited by JOSEPH G. HORNER, A.M.I.Mech.E.

This book covers the entire practice of Civil and Mechanical Engineering. The best known experts in all branches of engineering have contributed to these volumes. The Cyclopaedia is admirably well adapted to the needs of the beginner and the self-taught practical man, as well as the mechanical engineer, designer, draftsman, shop superintendent, foreman and machinist.

It is a modern treatise in five volumes. Handsomely bound in half morocco, each volume containing nearly 500 pages, with thousands of illustrations, including diagrammatic and sectional drawings with full explanatory details. Five large volumes. Price \$30.00

MODEL MAKING Including Workshop Practice, Design and Construction of Models. Edited by RAYMOND F. YATES. Editor of "Everyday Engineering Magazine."

This book will help you to become a better mechanic. It is full of suggestions for those who like to make things, amateur and professional alike. It has been prepared especially for men with mechanical hobbies. Some may be engineers, machinists, jewelers, pattern makers, office clerks or bank presidents. Men from various walks of life have a peculiar interest in model engineering. MODEL MAKING will be a help and an inspiration to such men. It tells them "how-to-do" and "how-to-make" things in simple, understandable terms. Not only this, it is full of good, clear working drawings and photographs of the models and apparatus described. Each model has been constructed and actually works if it is made according to directions. 379 pages. 300 illustrations. Price \$3.00

ABRASIVES AND ABRASIVE WHEELS. By FRED B. JACOBS.

A new book for everyone interested in abrasives or grinding. A careful reading of the book will not only make mechanics better able to use abrasives intelligently, but it will also tell the shop superintendent of many short cuts and efficiency-increasing kinks. The economic advantages in using large grinding wheels are fully explained, together with many other things that will tend to give the superintendent or workman a keen insight into abrasive engineering. 340 pages. 174 illustrations. This is an indispensable book for every machinist. Price \$3.00

HOME MECHANIC'S WORKSHOP COMPANION. By ANDREW JACKSON, JR.

This treatise includes a compilation of useful suggestions that cannot fail to interest the handy man, and while it is not intended for mechanical experts or scientists, it will prove to be a veritable store of information for anyone who desires to rig up a small shop where odd jobs can be carried on. Price 75 cents

CATALOGUE OF GOOD, PRACTICAL BOOKS

MARINE ENGINEERING

THE NAVAL ARCHITECT'S AND SHIPBUILDER'S POCKETBOOK. Of Formulae, Rules, and Tables and Marine Engineer's and Surveyor's Handy Book of Reference. By CLEMENT MACKROW and LLOYD WOOLLARD.

The twelfth revised and enlarged edition of this most comprehensive work has just been issued. It is absolutely indispensable to all engaged in the Shipbuilding Industry, as it condenses into a compact form all data and formulae that are ordinarily required. The book is completely up to date, including among other subjects a section on Aeronautics. 760 pages, limp leather binding. Price \$6.00

MARINE ENGINES AND BOILERS—THEIR DESIGN AND CONSTRUCTION. THE STANDARD BOOK. By DR. G. BAUER, LESLIE S. ROBERTSON and S. BRYAN DONKIN.

In the words of Dr. Bauer, the present work owes its origin to an oft felt want of a condensed treatise embodying the theoretical and practical rules used in designing marine engines and boilers. The fact that the original German work was written by the chief engineer of the famous Vulcan Works, Stettin, is in itself a guarantee that this book is in all respects thoroughly up-to-date, and that it embodies all the information which is necessary for the design and construction of the highest types of marine engines and boilers. It may be said that the motive power which Dr. Bauer has placed in the fast German liners that have been turned out of late years from the Stettin Works represent the very best practice in marine engineering of the present day. The work is clearly written, thoroughly systematic, theoretically sound; while the character of the plans, drawings, tables, and statistics is without reproach. The illustrations are careful reproductions from actual working drawings, with some well-executed photographic views of completed engines and boilers. Fifth impression. 744 pages. 550 illustrations, and numerous tables. Cloth. Price \$10.00

MANUAL TRAINING

ECONOMICS OF MANUAL TRAINING. By LOUIS ROULLION.

The only book published that gives just the information needed by all interested in Manual Training, regarding Buildings, Equipment, and Supplies. Shows exactly what is needed for all grades of the work from the Kindergarten to the High and Normal School. Gives itemized lists of everything used in Manual Training Work and tells just what it ought to cost. Also shows where to buy supplies, etc. Contains 174 pages, and is fully illustrated. 2d edition. Price \$2.00

MOTOR BOATS

MOTOR BOATS AND BOAT MOTORS. By VICTOR W. PAGÉ AND A. C. LEITCH.

All who are interested in motor boats, either as owners, builders or repairmen, will find this latest work a most comprehensive treatise on the design, construction, operation and repair of motor boats and their power plants. It is really two complete books in one cover as it consists of two parts, each complete in itself. Part One deals with THE HULL AND ITS FITTINGS, Part Two considers THE POWER PLANT AND ITS AUXILIARIES. A valuable feature of this book is the complete set of dimensioned working drawings detailing the construction of five different types of boats ranging from a 16-foot shallow draft, tunnel stern general utility craft to a 25-foot cabin cruiser. These plans are by A. C. Leitch, a practical boat builder and expert naval architect, and are complete in every particular. Full instructions are given for the selection of a power plant and its installation in the hull. Valuable advice is included on boat and engine operation and latest designs of motors are described and illustrated. The instructions for overhauling boat and engine are worth many times the small cost of the book. It is a comprehensive work of reference for all interested in motor boating in any of its phases. Octavo. Cloth. 372 illustrations. 524 pages. Price \$4.00

MOTORCYCLES

MOTORCYCLES AND SIDE CARS, THEIR CONSTRUCTION, MANAGEMENT AND REPAIR. By Victor W. Pagé, M.E.

The only complete work published for the motorcyclist and repairman. Describes fully all leading types of machines, their design, construction, maintenance, operation and repair. This treatise outlines fully the operation of two- and four-cycle power plants and all ignition, carburetion and lubrication systems in detail. Describes all representative types of free engine clutches, variable speed gears and power transmission systems. Gives complete instructions for operating and repairing all types. Considers fully electric self-starting and lighting systems, all types of spring frames and spring forks and shows leading control methods. For those desiring technical information a complete series of tables and many formulae to assist in designing are included. The work tells how to figure power needed to climb grades, overcome air resistance and attain high speeds. It shows how to select gear ratios for various weights and powers, how to figure braking efficiency required, gives sizes of belts and chains to transmit power safely, and shows how to design sprockets, belt pulleys, etc. This work also includes complete formulae for figuring horse-power, shows how dynamometer tests are made, defines relative efficiency of air- and water-cooled engines, plain and anti-friction bearings and many other data of a practical, helpful, engineering nature. Remember that you get this information in addition to the practical description and instructions which alone are worth several times the price of the book. 2nd Edition Revised and Enlarged. 693 pages. 371 specially made illustrations. Cloth. Price \$3.00

WHAT IS SAID OF THIS BOOK:

"Here is a book that should be in the cycle repairer's kit."—*American Blacksmith*.
"The best way for any rider to thoroughly understand his machine, is to get a copy of this book; it is worth many times its price."—*Pacific Motorcyclist*.

PATTERN MAKING

PRACTICAL PATTERN MAKING. By F. W. BARROWS.

This book, now in its second edition, is a comprehensive and entirely practical treatise on the subject of pattern making, illustrating pattern work in both wood and metal, and with definite instructions on the use of plaster of Paris in the trade. It gives specific and detailed descriptions of the materials used by pattern makers and describes the tools, both those for the bench and the more interesting machine tools; having complete chapters on the Lath, the Circular Saw, and the Band Saw. It gives many examples of pattern work, each one fully illustrated and explained with much detail. These examples, in their great variety, offer much that will be found of interest to all pattern makers, and especially to the younger ones, who are seeking information on the more advanced branches of their trade.

In this second edition of the work will be found much that is new, even to those who have long practiced this exacting trade. In the description of patterns as adapted to the Moulding Machine many difficulties which have long prevented the rapid and economical production of castings are overcome; and this great, new branch of the trade is given much space. Stripping plate and stool plate work and the less expensive vibrator, or rapping plate work, are all explained in detail.

Plain, everyday rules for lessening the cost of patterns, with a complete system of cost keeping, a detailed method of marking, applicable to all branches of the trade, with complete information showing what the pattern is, its specific title, its cost, date of production, material of which it is made, the number of pieces and core-boxes, and its location in the pattern safe, all condensed into a most complete card record, with cross index.

The book closes with an original and practical method for the inventory and valuation of patterns. 2nd Edition. Containing nearly 350 pages and 170 illustrations. Price \$2.50

PERFUMERY

PERFUMES AND COSMETICS, THEIR PREPARATION AND MANUFACTURE. By G. W. ASKINSON, Perfumer.

A comprehensive treatise, in which there has been nothing omitted that could be of value to the perfumer or manufacturer of toilet preparations. Complete directions for making handkerchief perfumes, smelling-salts, sachets, fumigating pastilles; preparations for the care of the skin, the mouth, the hair, cosmetics, hair dyes and other toilet articles are given, also a detailed description of aromatic substances; their nature, tests of purity, and wholesale manufacture, including a chapter on synthetic products, with formulas for their use. A book of general, as well as professional interest, meeting the wants not only of the druggist and perfume manufacturer, but also of the general public. Fourth Edition much enlarged and brought up-to-date. Nearly 400 pages, illustrated. Price \$5.00

WHAT IS SAID OF THIS BOOK:

- “The most satisfactory work on the subject of Perfumery that we have ever seen.
- “We feel safe in saying that here is a book on Perfumery that will not disappoint you, for it has practical and excellent formulæ that are within your ability to prepare readily.
- “We recommend the volume as worthy of confidence, and say that no purchaser will be disappointed in securing from its pages good value for its cost, and a large dividend on the same, even if he should use but one per cent of its working formulæ. There is money in it for every user of its information.”—*Pharmaceutical Record.*

PLUMBING

MECHANICAL DRAWING FOR PLUMBERS. By R. M. STARBUCK.

A concise, comprehensive and practical treatise on the subject of mechanical drawing in its various modern applications to the work of all who are in any way connected with the plumbing trade. Nothing will so help the plumber in estimating and in explaining work to customers and workmen as a knowledge of drawing, and to the workman it is of inestimable value if he is to rise above his position to positions of greater responsibility. Among the chapters contained are: 1. Value to plumber of knowledge of drawing; tools required and their use; common views needed in mechanical drawing. 2. Perspective versus mechanical drawing in showing plumbing construction. 3. Correct and incorrect methods in plumbing drawing; plan and elevation explained. 4. Floor and cellar plans and elevation; scale drawings; use of triangles. 5. Use of triangles; drawing of fittings, traps, etc. 6. Drawing plumbing elevations and fittings. 7. Instructions in drawing plumbing elevations. 8. The drawing of plumbing fixtures; scale drawings. 9. Drawings of fixtures and fittings. 10. Inking of drawings. 11. Shading of drawings. 12. Shading of drawings. 13. Sectional drawings; drawing of threads. 14. Plumbing elevations from architect's plan. 15. Elevations of separate parts of the plumbing system. 16. Elevations from the architect's plans. 17. Drawings of detail plumbing connections. 18. Architect's plans and plumbing elevations of residence. 19. Plumbing elevations of residence (continued); plumbing plans for cottage. 20. Plumbing elevations; roof connections. 21. Plans and plumbing elevations for six-flat building. 22. Drawing of various parts of the plumbing system; use of scales. 23. Use of architect's scales. 24. Special features in the illustrations of country plumbing. 25. Drawing of wrought-iron piping, valves, radiators, coils, etc. 26. Drawing of piping to illustrate heating systems. 150 illustrations. Price \$2.00

CATALOGUE OF GOOD, PRACTICAL BOOKS

MODERN PLUMBING ILLUSTRATED. By R. M. STARBUCK.

This book represents the highest standard of plumbing work. It has been adopted and used as a reference book by the United States Government, in its sanitary work in Cuba, Porto Rico, and the Philippines, and by the principal Boards of Health of the United States and Canada.

It gives connections, sizes and working data for all fixtures and groups of fixtures. It is helpful to the master plumber in demonstrating to his customers and in figuring work. It gives the mechanic and student quick and easy access to the best modern plumbing practice. Suggestions for estimating plumbing construction are contained in its pages. This book represents, in a word, the latest and best up-to-date practice and should be in the hands of every architect, sanitary engineer and plumber who wishes to keep himself up to the minute on this important feature of construction. Contains following chapters, each illustrated with a full-page plate: Kitchen sink, laundry tubs, vegetable wash sink; lavatories, pantry sinks, contents of marble slabs; bath tub, foot and sitz bath, shower bath; water closets, venting of water closets; low-down water closets, water closets operated by flush valves, water closet range; slop sink, urinals, the bidet; hotel and restaurant sink, grease trap; refrigerators, safe wastes, laundry waste, lines of refrigerators, bar sinks, soda fountain sinks; horse stall, frost-proof water closets; connections for S traps, venting; connections for drum traps; soil pipe connections; supporting of soil pipe; main trap and fresh air inlet; floor drains and cellar drains, subsoil drainage; water closets and floor connections; local venting; connections for bath rooms; connections for bath rooms, continued; connections for bath rooms, continued; connections for bath rooms, continued; examples of poor practice; roughing work ready for test; testing of plumbing system; method of continuous venting; continuous venting for two-floor work; continuous venting for two lines of fixtures on three or more floors; continuous venting of water closets; plumbing for cottage house; construction for cellar piping; plumbing for residence, use of special fittings; plumbing for two-flat house; plumbing for apartment building, plumbing for double apartment building; plumbing for office building; plumbing for public toilet rooms; plumbing for public toilet rooms, continued; plumbing for bath establishment; plumbing for engine house, factory plumbing; automatic flushing for schools, factories, etc.; use of flushing valves; urinals for public toilet rooms; the Durham system, the destruction of pipes by electrolysis; construction of work without use of lead; automatic sewage lift; automatic sump tank; country plumbing; construction of cesspools; septic tank and automatic sewage siphon; country plumbing; water supply for country house; thawing of water mains and service by electricity; double boilers; hot water supply of large buildings; automatic control of hot water tank; suggestion for estimating plumbing construction. 407 octavo pages, fully illustrated by 58 full-page engravings. Third, revised and enlarged edition just issued. Price . \$5.00

STANDARD PRACTICAL PLUMBING. By R. M. STARBUCK.

A complete practical treatise of 450 pages covering the subject of Modern Plumbing in all its branches, a large amount of space being devoted to a very complete and practical treatment of the subject of Hot Water Supply and Circulation and Range Boiler Work. Its thirty chapters include about every phase of the subject one can think of, making it an indispensable work to the master plumber, the journeyman plumber, and the apprentice plumber, containing chapters on: the plumber's tools; wiping solder; composition and use; joint wiping; lead work; traps; siphonage of traps; venting; continuous venting; house sewer and sewer connections; house drain; soil piping, roughing; main trap and fresh air inlet; floor, yard, cellar drains, rain leaders, etc.; fixture wastes; water closets; ventilation; improved plumbing connections; residence plumbing; plumbing for hotels, schools, factories, stables, etc.; modern country plumbing; filtration of sewage and water supply; hot and cold supply; range boilers; circulation; circulating pipes; range boiler problems; hot water for large buildings; water lift and its use; multiple connections for hot water boilers; heating of radiation by supply system; theory for the plumber; drawing for the plumber. Fully illustrated by 347 engravings. Price \$3.50

CATALOGUE OF GOOD, PRACTICAL BOOKS

RECIPE BOOK

HENLEY'S TWENTIETH CENTURY BOOK OF RECIPES, FORMULAS AND PROCESSES. Edited by GARDNER D. HISCOX.

The most valuable Techno-chemical Formula Book published, including over 10,000 selected scientific, chemical, technological, and practical recipes and processes.

This is the most complete Book of Formulas ever published, giving thousands of recipes for the manufacture of valuable articles for everyday use. Hints, Helps, Practical Ideas, and Secret Processes are revealed within its pages. It covers every branch of the useful arts and tells thousands of ways of making money, and is just the book everyone should have at his command.

Modern in its treatment of every subject that properly falls within its scope, the book may truthfully be said to present the very latest formulas to be found in the arts and industries, and to retain those processes which long experience has proven worthy of a permanent record. To present here even a limited number of the subjects which find a place in this valuable work would be difficult. Suffice to say that in its pages will be found matter of intense interest and immeasurably practical value to the scientific amateur and to him who wishes to obtain a knowledge of the many processes used in the arts, trades and manufacture, a knowledge which will render his pursuits more instructive and remunerative. Serving as a reference book to the small and large manufacturer and supplying intelligent seekers with the information necessary to conduct a process, the work will be found of incalculable worth to the Metallurgist, the Photographer, the Perfumer, the Painter, the Manufacturer of Glues, Pastes, Cements, and Mucilages, the Compounder of Alloys, the Cook, the Physician, the Druggist, the Electrician, the Brewer, the Engineer, the Foundryman, the Machinist, the Potter, the Tanner, the Confectioner, the Chiropodist, the Manicuro, the Manufacturer of Chemical Novelties and Toilet Preparations, the Dyer, the Electroplater, the Enameler, the Engraver, the Provisioner, the Glass Worker, the Goldbeater, the Watchmaker, the Jeweler, the Hat Maker, the Ink Manufacturer, the Optician, the Farmer, the Dairyman, the Paper Maker, the Wood and Metal Worker, the Chandler and Soap Maker, the Veterinary Surgeon, and the Technologist in general.

A mine of information, and up-to-date in every respect. A book which will prove of value to EVERYONE, as it covers every branch of the Useful Arts. Every home needs this book; every office, every factory, every store, every public and private enterprise—EVERYWHERE—should have a copy. 800 pages. Cloth Bound.
Price \$4.00

WHAT IS SAID OF THIS BOOK:

"Your Twentieth Century Book of Recipes, Formulas, and Processes duly received. I am glad to have a copy of it, and if I could not replace it, money couldn't buy it. It is the best thing of the sort I ever saw." (Signed) M. E. TRUX, Sparta, Wis.

"There are few persons who would not be able to find in the book some single formula that would repay several times the cost of the book."—*Merchants' Record and Show Window.*

"I purchased your book 'Henley's Twentieth Century Book of Recipes, Formulas and Processes' about a year ago and it is worth its weight in gold."—WM. H. MURRAY, Bennington, Vt.

"THE BOOK WORTH THREE HUNDRED DOLLARS"

"On close examination of your 'Twentieth Century Receipt Book,' I find it to be a very valuable and useful book with the very best of practical information obtainable. The price of the book, \$4.00, is very small in comparison to the benefits which one can obtain from it. I consider the book worth fully three hundred dollars to anyone."
—DR. A. C. SPETTS, New York.

"ONE OF THE WORLD'S MOST USEFUL BOOKS"

"Some time ago, I got one of your 'Twentieth Century Books of Formulas' and have made my living from it ever since. I am alone since my husband's death with two small children to care for and am trying so hard to support them. I have customers who take from me Toilet Articles I put up, following directions given in the book, and I have found every one of them to be fine."—MRS. J. H. MCMACKEN, West Toledo, Ohio.

CATALOGUE OF GOOD, PRACTICAL BOOKS

RUBBER

RUBBER HAND STAMPS AND THE MANIPULATION OF INDIA RUBBER.

By T. O'CONNOR SLOANE.

This book gives full details on all points, treating in a concise and simple manner the elements of nearly everything it is necessary to understand for a commencement in any branch of the India Rubber Manufacture. The making of all kinds of Rubber Hand Stamps, Small Articles of India Rubber, U. S. Government Composition, Dating Hand Stamps, the Manipulation of Sheet Rubber, Toy Balloons, India Rubber Solutions, Coments, Blackings, Renovating Varnish, and Treatment for India Rubber Shoes, etc.; the Hektograph Stamp Inks, and Miscellaneous Notes, with a Short Account of the Discovery, Collection and Manufacture of India Rubber, are set forth in a manner designed to be readily understood, the explanations being plain and simple. Including a chapter on Rubber Tire Making and Vulcanizing; also a chapter on the uses of rubber in Surgery and Dentistry. Third revised and enlarged edition. 175 pages. Illustrated \$1.50

SAWS

SAW FILING AND MANAGEMENT OF SAWS. By ROBERT GRIMSHAW.

A practical hand-book on filing, gumming, swaging, hammering, and the brazing of hand saws, the speed, work, and power to run circular saws, etc. A handy book for those who have charge of saws, or for those mechanics who do their own filing, as it deals with the proper shape and pitches of saw teeth of all kinds and gives many useful hints and rules for gumming, setting, and filing, and is a practical aid to those who use saws for any purpose. Complete tables of proper shape, pitch, and saw teeth as well as sizes and number of teeth of various saws are included. Fourth edition, revised and enlarged. Illustrated. Price \$1.50

SCREW CUTTING

THREADS AND THREAD-CUTTING. By COLVIN and STABLE.

This clears up many of the mysteries of thread-cutting, such as double and triple threads, internal threads, catching threads, use of hobs, etc. Contains a lot of useful hints and several tables. Fourth Edition. Price 35 cents

STEAM ENGINEERING

MODERN STEAM ENGINEERING IN THEORY AND PRACTICE. By

GARDNER D. HISCOX.

This is a complete and practical work issued for Stationary Engineers and Firemen; dealing with the care and management of boilers, engines, pumps, superheated steam, refrigerating machinery, dynamos, motors, elevators, air compressors, and all other branches with which the modern engineer must be familiar. Nearly 200 questions with their answers on steam and electrical engineering, likely to be asked by the Examining Board, are included.

Among the chapters are: Historical; steam and its properties; appliances for the generation of steam; types of boilers; chimney and its work; heat economy of the feed water; steam pumps and their work; incrustation and its work; steam above atmospheric pressure; flow of steam from nozzles; superheated steam and its work; adiabatic expansion of steam; indicator and its work; steam engine proportions; slide valve engines and valve motion; Corliss engine and its valve gear; compound engine and its theory; triple and multiple expansion engine; steam turbine; refrigeration; elevators and their management; cost of power; steam engine troubles; electric power and electric plants. 487 pages. 405 engravings. 3d Edition. . . . \$3.50

CATALOGUE OF GOOD, PRACTICAL BOOKS

AMERICAN STATIONARY ENGINEERING. By W. E. CRANE.

This book begins at the boiler room and takes in the whole power plant. A plain talk on every-day work about engines, boilers, and their accessories. It is not intended to be scientific or mathematical. All formulas are in simple form so that anyone understanding plain arithmetic can readily understand any of them. The author has made this the most practical book in print; has given the results of his years of experience, and has included about all that has to do with an engine room or a power plant. You are not left to guess at a single point. You are shown clearly what to expect under the various conditions; how to secure the best results; ways of preventing "shut downs" and repairs; in short, all that goes to make up the requirements of a good engineer, capable of taking charge of a plant. It's plain enough for practical men and yet of value to those high in the profession.

A partial list of contents is: The boiler room, cleaning boilers, firing, feeding; pumps, inspection and repair; chimneys, sizes and cost; piping; mason work; foundations; testing cement; pile driving; engines, slow and high speed; valves; valve setting; Corliss engines, setting valves, single and double eccentric; air pumps and condensers; different types of condensers; water needed; lining up; pounds; pins not square in crosshead or crank; engineers' tools; pistons and piston rings; bearing metal; hardened copper; drip pipes from cylinder jackets; belts, how made, care of; oils; greases; testing lubricants; rules and tables, including steam tables; areas of segments; squares and square roots; cubes and cube root; areas and circumferences of circles. Notes on: Brick work; explosions; pumps; pump valves; heaters, economizers; safety valves; lap, lead, and clearance. Has a complete examination for a license, etc., etc. Third edition. 311 pages. 131 illustrations. Price . . . \$2.50

ENGINE RUNNER'S CATECHISM. By ROBERT GRIMSHAW.

A practical treatise for the stationary engineer, telling how to erect, adjust, and run the principal steam engines in use in the United States. Describing the principal features of various special and well-known makes of engines: Temper Cut-off, Shipping and Receiving Foundations, Erecting and Starting, Valve Setting, Care and Use, Emergencies, Erecting and Adjusting Special Engines.

The questions asked throughout the catechism are plain and to the point, and the answers are given in such simple language as to be readily understood by anyone. All the instructions given are complete and up-to-date; and they are written in a popular style, without any technicalities or mathematical formulae. The work is of a handy size for the pocket, clearly and well printed, nicely bound, and profusely illustrated.

To young engineers this catechism will be of great value, especially to those who may be preparing to go forward to be examined for certificates of competency; and to engineers generally it will be of no little service, as they will find in this volume more really practical and useful information than is to be found anywhere else within a like compass. 387 pages. Seventh edition. Price . . . \$2.00

HORSE-POWER CHART.

Shows the horse-power of any stationary engine without calculation. No matter what the cylinder diameter or stroke, the steam pressure of cut-off, the revolutions, or whether condensing or non-condensing, it's all there. Easy to use, accurate, and saves time and calculations. Especially useful to engineers and designers. 50 cents

STEAM ENGINE CATECHISM. By ROBERT GRIMSHAW.

This unique volume of 413 pages is not only a catechism on the question and answer principle, but it contains formulas and worked-out answers for all the Steam problems that appertain to the operation and management of the Steam Engine. Illustrations of various valves and valve gear with their principles of operation are given. Thirty-four Tables that are indispensable to every engineer and fireman that wishes to be progressive and is ambitious to become master of his calling are within its pages. It is a most valuable instructor in the service of Steam Engineering. Leading engineers have recommended it as a valuable educator for the beginner as well as a reference book for the engineer. It is thoroughly indexed for every detail. Every essential question on the Steam Engine with its answer is contained in this valuable work. Sixteenth edition. Price . . . \$2.00

CATALOGUE OF GOOD, PRACTICAL BOOKS

STEAM ENGINEER'S ARITHMETIC. By COLVIN-CHENEY.

A practical pocket-book for the steam engineer. Shows how to work the problems of the engine room and shows "why." Tells how to figure horse-power of engines and boilers; area of boilers; has tables of areas and circumferences; steam tables; has a dictionary of engineering terms. Puts you on to all of the little kinks in figuring whatever there is to figure around a power plant. Tells you about the heat unit; absolute zero; adiabatic expansion; duty of engines; factor of safety; and a thousand and one other things; and everything is plain and simple—not the hardest way to figure, but the easiest. Second Edition. 75 cents

STEAM ENGINE TROUBLES. By H. HAMKENS.

It is safe to say that no book has ever been published which gives the practical engineer such valuable and comprehensive information on steam engine design and troubles.

Not only does it describe the troubles the principal parts of steam engines are subject to; it contrasts good design with bad, points out the most suitable material for certain parts, and the most approved construction of the same; it gives directions for correcting existing evils by following which *breakdowns* and *costly accidents* can be avoided. Just look into the nature of the information this book gives on the following subjects. There are descriptions of cylinders, valves, pistons, frames, pillow blocks and other bearings, connecting rods, wristplates, dashpots, reachrods, valve gears, governors, piping, throttle and emergency valves, safety stops, fly-wheels, oilers, etc. If there is any trouble with these parts, the book gives you the reasons and tells how to remedy them.

The principal considerations in the building of foundations are given with the size, area and weight required for the same, also the setting of templets and lining up, and a complete account of the *erection* and "*breaking in*" of new engines in the language of the man on the job.

Contains special chapters on: I. Cylinders. II. Valves. III. Piping and Separators. IV. Throttle and Emergency Valves. V. Pistons. VI. Frames. VII. Bearings. VIII. Connecting Rods. IX. Hookrods. X. Dashpots. XI. Governors. XII. Releasing Gears. XIII. Wristplates and Valve Motions. XIV. Rodends and Bonnets. XV. Oilers. XVI. Receivers. XVII. Foundations. XVIII. Erection. XIX. Valve-Setting. XX. Operation. 284 pages. 276 illustrations. Price \$2.50

STEAM HEATING AND VENTILATION

PRACTICAL STEAM, HOT-WATER HEATING AND VENTILATION. By A. G. KING.

This book is the standard and latest work published on the subject and has been prepared for the use of all engaged in the business of steam, hot-water heating, and ventilation. It is an original and exhaustive work. Tells how to get heating contracts, how to install heating and ventilating apparatus, the best business methods to be used, with "Tricks of the Trade" for shop use. Rules and data for estimating radiation and cost and such tables and information as make it an indispensable work for everyone interested in steam, hot-water heating, and ventilation. It describes all the principal systems of steam, hot-water, vacuum, vapor, and vacuum-vapor heating, together with the new accelerated systems of hot-water circulation, including chapters on up-to-date methods of ventilation and the fan or blower system of heating and ventilation. Containing chapters on: I. Introduction. II. Heat. III. Evolution of artificial heating apparatus. IV. Boiler surface and settings. V. The chimney flue. VI. Pipe and fittings. VII. Valves, various kinds. VIII. Forms of radiating surfaces. IX. Locating of radiating surfaces. X. Estimating radiation. XI. Steam-heating apparatus. XII. Exhaust-steam heating. XIII. Hot-water heating. XIV. Pressure systems of hot-water work. XV. Hot-water appliances. XVI. Greenhouse heating. XVII. Vacuum vapor and vacuum exhaust heating. XVIII. Miscellaneous heating. XIX. Radiator and pipe connections. XX. Ventilation. XXI. Mechanical ventilation and hot-blast heating. XXII. Steam appliances. XXIII. District heating. XXIV. Pipe and boiler covering. XXV. Temperature regulation and heat control. XXVI. Business methods. XXVII. Miscellaneous. XXVIII. Rules, tables, and useful information. 402 pages. 300 detailed engravings. Third Edition—Revised. Price \$3.50

CATALOGUE OF GOOD, PRACTICAL BOOKS

500 PLAIN ANSWERS TO DIRECT QUESTIONS ON STEAM, HOT-WATER, VAPOR AND VACUUM HEATING PRACTICE. By ALFRED G. KING.

This work, just off the press, is arranged in question and answer form; it is intended as a guide and text-book for the younger, inexperienced fitter and as a reference book for all fitters. This book tells "how" and also tells "why." No work of its kind has ever been published. It answers all the questions regarding each method or system that would be asked by the steam fitter or heating contractor, and may be used as a text or reference book, and for examination questions by Trade Schools or Steam Fitters' Associations. Rules, data, tables and descriptive methods are given; together with much other detailed information of daily practical use to those engaged in or interested in the various methods of heating. Valuable to those preparing for examinations. Answers every question asked relating to modern Steam, Hot-Water, Vapor and Vacuum Heating. Among the contents are: The Theory and Laws of Heat. Methods of Heating. Chimneys and Flues. Boilers for Heating. Boiler Trimmings and Settings. Radiation. Steam Heating. Boiler, Radiator and Pipe Connections for Steam Heating. Hot Water Heating. The Two-Pipe Gravity System of Hot Water Heating. The Circuit System of Hot Water Heating. The Overhead System of Hot Water Heating. Boiler, Radiator and Pipe Connections for Gravity Systems of Hot Water Heating. Accelerated Hot Water Heating. Expansion Tank Connections. Domestic Hot Water Heating. Valves and Air Valves. Vacuum Vapor and Vacuo-Vapor Heating. Mechanical Systems of Vacuum Heating. Non-Mechanical Vacuum Systems. Vapor Systems. Atmospheric and Modulating Systems. Heating Greenhouses. Information, Rules and Tables. 214 pages, 127 illustrations. Octavo. Cloth. Price \$2.00

STEEL

STEEL: ITS SELECTION, ANNEALING, HARDENING, AND TEMPERING.

By E. R. MARKHAM.

This book tells how to select, and how to work, temper, harden, and anneal steel for everything on earth. It doesn't tell how to temper one class of tools and then leave the treatment of another kind of tool to your imagination and judgment, but it gives careful instructions for every detail of every tool, whether it be a tap, a reamer or just a screw-driver. It tells about the tempering of small watch springs, the hardening of cutlery, and the annealing of dies. In fact, there isn't a thing that a steel worker would want to know that isn't included. It is the standard book on selecting, hardening, and tempering all grades of steel. Among the chapter headings might be mentioned the following subjects: Introduction; the workman; steel; methods of heating; heating tool steel; forging; annealing; hardening baths; baths for hardening; hardening steel; drawing the temper after hardening; examples of hardening; pack hardening; case hardening; spring tempering; making tools of machine steel; special steels; steel for various tools, causes of trouble; high speed steels, etc. 400 pages. Very fully illustrated. Fourth Edition. Price \$3.00

HARDENING, TEMPERING, ANNEALING, AND FORGING OF STEEL. INCLUDING HEAT TREATMENT OF MODERN ALLOY STEELS. By

J. V. WOODWORTH.

A new work treating in a clear, concise manner all modern processes for the heating, annealing, forging, welding, hardening, and tempering of high and low grade steel, making it a book of great practical value to the metal-working mechanic in general, with special directions for the successful hardening and tempering of all steel tools used in the arts, including milling cutters, taps, thread dies, reamers, both solid and shell, hollow mills, punches and dies, and all kinds of sheet metal working tools, shear blades, saws, fine cutlery, and metal cutting tools of all description, as well as for all implements of steel both large and small. In this work the simplest and most satisfactory hardening and tempering processes are given.

The uses to which the leading brands of steel may be adapted are concisely presented, and their treatment for working under different conditions explained, also the special methods for the hardening and tempering of special brands.

A chapter devoted to the different processes for case-hardening is also included, and special reference made to the adaptation of machinery steel for tools of various kinds. 5th Edition, 321 pages, 201 illustrations. Price \$3.00

TRACTORS

MODERN GAS TRACTOR: ITS CONSTRUCTION, UTILITY, OPERATION AND REPAIR. By VICTOR W. PAGÉ.

An enlarged and revised edition that treats exclusively on the design and construction of farm tractors and tractor power plants, and gives complete instructions on their care, operation and repair. All types and sizes of gasoline, kerosene and oil tractors are described, and every phase of traction engineering practice fully covered. Invaluable to all desiring reliable information on gas motor propelled traction engines and their use. All new 1921 types of tractors are described and complete instructions are given for their use on the farm. The chapter on engine repairing has been greatly enlarged and complete and detailed instructions are now given for repairing well-known and widely used tractor power plants, numerous new forms of which are described. Valuable information compiled by Government experts on laying out fields for tractor plowing and numerous practical suggestions for hitches so all types of agricultural machinery can be operated by tractors, are outlined. The chapter on tractor construction and upkeep has been more than doubled in size. Over 100 new illustrations have been added and the book greatly enlarged. Full instructions are now given for using kerosene and distillate as fuel. The 1921 edition is 50 per cent larger than the second edition and is more than ever the acknowledged authority on farm tractors and their many uses. 5¼ x 7½ inches. Cloth, nearly 700 pages, and about 300 illustrations, 3 folding plates. Price \$3.00

WELDING

MODERN WELDING METHODS. By VICTOR W. PAGÉ.

One of the most instructive books on all methods of joining metals yet published for the mechanic and practical man. It considers in detail oxy-acetylene welding, the Thermit process and all classes of electric arc and resistance welding. It shows all the apparatus needed and how to use it. It considers the production of welding gases, construction and operation of welding and cutting torches of all kinds. It details the latest approved methods of preparing work for welding. All forms of gas and electric welding machines are described and complete instructions are given for installing electric spot and butt welders. Cost data are given and all methods of doing the work economically are described. It includes instructions for forge and dip brazing and manufacture of hard solders and spelters. It shows and explains soft soldering processes and tells how to make solders for any use. Complete instructions are given for soldering aluminum and authoritative formulas for aluminum solders are included. 292 pages. 200 illustrations. 1921 edition. Price . . . \$3.00

AUTOMOBILE WELDING WITH THE OXY-ACETYLENE FLAME. By M. KEITH DUNHAM.

Explains in a simple manner apparatus to be used, its care, and how to construct necessary shop equipment. Proceeds then to the actual welding of all automobile parts, in a manner understandable by everyone. Gives principles never to be forgotten. This book is of utmost value, since the perplexing problems arising when metal is heated to a melting point are fully explained and the proper methods to overcome them shown. 167 pages. Fully illustrated. Price \$1.50