

EVERYMAN'S GUIDE TO

# RADIO

RADIO ACCESSORIES, THE WONDERS OF  
RADIO TRANSMISSION, WIRING GRAMS  
FOR RECEIVERS AND TRANSMITTERS

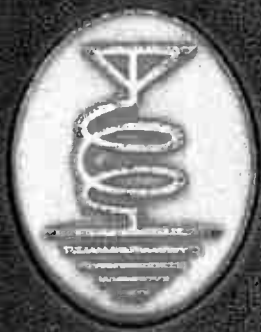

# EVERYMAN'S GUIDE TO RADIO

A PRACTICAL COURSE OF  
COMMON-SENSE INSTRUCTION IN  
THE WORLD'S MOST FASCINATING SCIENCE

VOLUME IV

RAYMOND FRANCIS YATES  
EDITOR-IN-CHIEF



CONTRIBUTORS TO THIS VOLUME:

G. MARCONI, Ph.D.  
DR. LEE DE FOREST  
PROF. J. H. MORECROFT

MAJ. GEN. GEORGE O. SQUIER  
DR. HENRY SMITH-WILLIAMS  
MR. P. RANGER

POPULAR RADIO, INCORPORATED  
NEW YORK, 1926

**COPYRIGHT, 1928  
POPULAR RADIO, INC.**

**PRESS OF WILLIAM GREEN, NEW YORK**

## Contents

### Volume IV

#### SECTION 16

*Important Radio Accessories.* Rheostats, potentiometers, meters, jacks, dials, switches, verniers, detectors, coil mountings, loudspeakers, etc. Specifications and description of all important radio accessories.

#### SECTION 17

*The Wonders of Radio Transmission.* How waves are generated with vacuum tubes. How the voice is impressed upon radio waves. How the different popular radio transmitting circuits function. Beam transmission. The use of very short waves. Arc transmitters. How radio waves are made to follow a wire in wired wireless. How pictures are transmitted by radio. How movies and colored pictures are transmitted by radio. Radio-dynamics; the control of distant mechanism by radio waves. How the vacuum tube makes the movies talk.

#### SECTION 18

*Wiring-Grams for Radio Receivers and Transmitters.* Diagrams and data for crystal, reflex, neutrodyne, superheterodyne, regenerative, and non-regenerative circuits. Diagrams and data for the various types of amateur transmitting circuits such as Colpitts, Hartley, etc. Diagrams and data for audio-frequency amplifiers of the impedance, resistance and push-pull types.

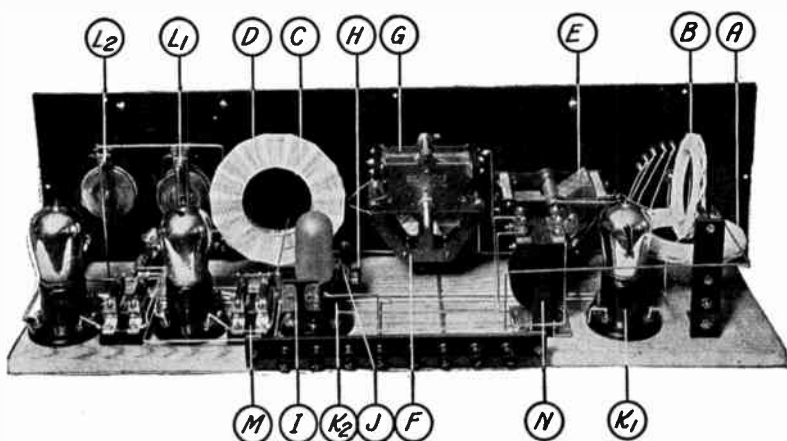

The Sections of the Everyman's Guide to Radio dealing with the various instruments keyed in this illustration may be quickly found by reference to the index below.

## ILLUSTRATED INDEX

- A-B—Loose couplers and variometers, Section 10.
- C—Coils, basket wound, D-Coils, honeycomb coils, etc., Section 10.
- D—Radio frequency transformers, all types, Section 8.
- E—Condensers, variable types, Section 9 and 2.
- F—Condensers, variable vernier, Section 9.
- G—Condensers, variable and multiple, Section 9.
- H—Fixed condensers, Section 9 and 2.
- I—Fixed condensers, adjustable, Section 9.
- J—Grid leaks, Section 6.
- K1—Amplifier vacuum tubes and sockets, Section 6 and 16.
- K2—Detector vacuum tubes, Section 6.
- L1—Rheostats, Section 6 and Section 16.
- L2—Potentiometers, Section 16.
- M—Resistance coupled audio amplifiers, Section 7.
- N—Audio-frequency transformers, Section 7.

## SECTION XVI

### Important Radio Accessories

**A**LTHOUGH more of an essential than an accessory, reproducing devices usually come under the latter classification. There are two different types of reproducers, the telephone receiver and the loud speaker. There is little electrical or mechanical difference between the telephone receiver and the loud speaker, and the distinction seems to be made largely on the basis of quantity of sound produced. If a conically shaped horn is attached to an ordinary telephone receiver so that the sound waves generated by the telephone receiver are guided through the horn, we have the effect of a loud speaker. Without the horn, which has the effect of amplifying the waves generated by the reproducer, it would be necessary to hold the device to the ear to render the sounds clearly audible.

In a later Section we shall have occasion to learn in detail how sound waves are impressed upon electric currents through the medium of a device called the telephone transmitter. It is the function of the telephone transmitter to convert sound waves into corresponding fluctuations of current. When a sound wave strikes the diaphragm of a telephone transmitter, the current flowing through the transmitter is made to "vibrate" in exact sympathy with the acoustic disturbances.

It is the sole function of a telephone

receiver or a loud speaker to convert these fluctuating, sound-carrying currents back into audible sounds. This, too, is done through the aid of a vibrating diaphragm, only the diaphragm is caused to vibrate by the fluctuating currents instead of by sounds as in the case of the transmitter. If we refer to Figure A we shall see a diagram of the simple mechanism involved in the conventional type of loud speakers and telephone receivers. The fluctuating currents, which we will recall are produced by the action of the telephone transmitter, are allowed to surge through the electromagnets illustrated. The diaphragm, which is mounted very close to the pole faces of the magnet, will be caused to take on a sympathetic vibration. In the case of radio, the vibration of the diaphragm of the loud speaker or telephone will be in exact sympathy (providing it is a good telephone or loud speaker) with the movement of the diaphragm in the microphone at the broadcasting station. The transmission of sound between the two points is practically instantaneous.

Let us return to Figure A. When the fluctuating sound-carrying current passes through the coils of the reproducing device, it naturally sets up a magnetic field which will be strongest at the ends of the coils. This magnetic field cannot be uniform so long as the current

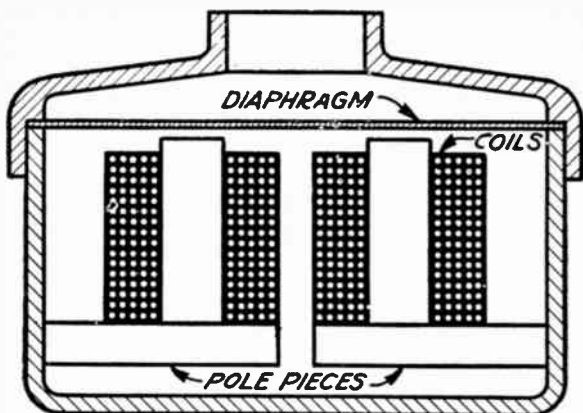

CONVENTIONAL LOUD SPEAKER CONSTRUCTION

Figure B: This loud speaker is really a form of telephone receiver with accommodations made for the attachment of a horn.

producing it is of a "vibratory" nature. If we had some means of seeing magnetic fields we should find that the field above an excited loud speaking element would be vibrating in sympathy with the distant transmitter whether of

the wire or wireless type. Since this highly agitated magnetic field acts on the iron diaphragm the iron will also get into step and make a brave effort to follow the rapid changes. Sometimes the diaphragm succeeds very well in

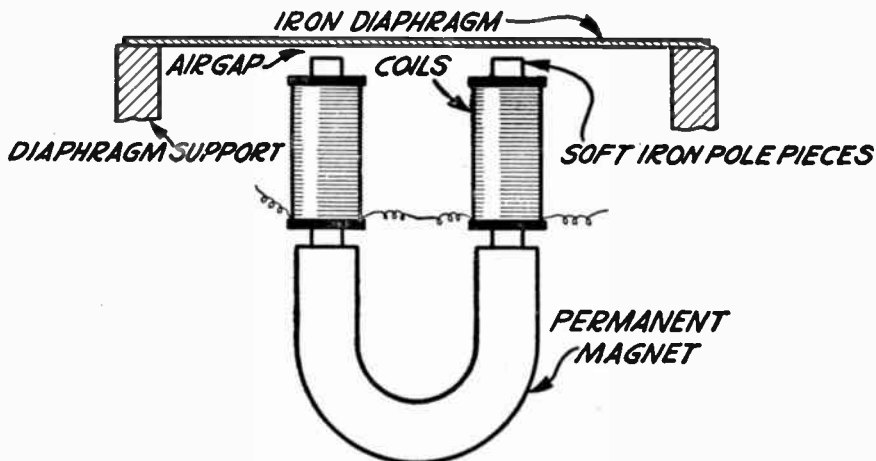

PLAN OF THE LOUD SPEAKER

Figure A: This shows the schematic arrangement of coils and diaphragm used in a loud speaker or telephones.

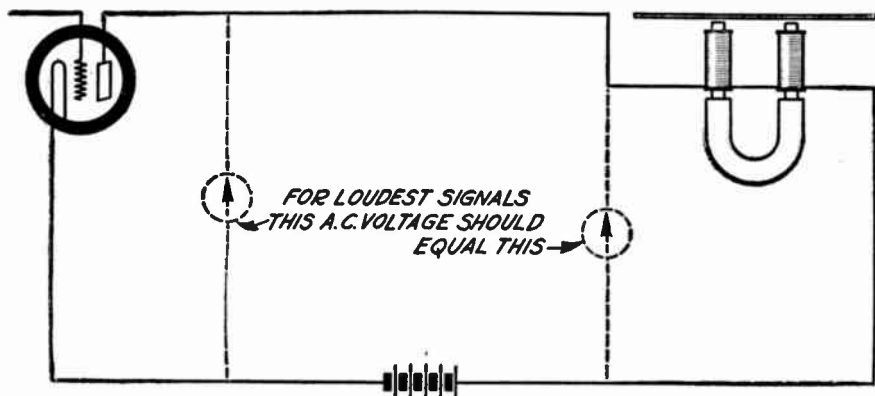

#### RELATION BETWEEN VACUUM TUBE AND LOUD SPEAKER

Figure C: According to electrical laws, for the most efficient operation the impedance or resistance of the last vacuum tube should match the impedance or resistance of the loud speaker. This is like saying that the alternating current voltage across each should be the same.

good loud speakers and other times it acts very badly as in poorly designed loud speakers.

In passing it will be seen that the diaphragm must be of thin sheet iron, otherwise it will not be sufficiently susceptible to the minute current changes. If the reader is observant he will notice that the coils of the speaking element in Figure A are wound upon the poles of a permanent magnet. He will further reason that the permanent magnet must exert a constant attraction for the diaphragm and that the diaphragm will tend to be pulled down toward the pole faces whether or not a current is passing through the coils. This is very true but this action facilitates rather than impairs the sympathetic vibration of the diaphragm.

All permanent magnets used in telephone receivers and loud speakers do not take the shape shown. Various systems are employed and the permanent magnet usually takes some compact form so that the unit is saved from being bulky and heavy.

The distance separating the poles of a permanent magnet from the diaphragm of a loud speaker is important, because upon this rests to a large extent the sensitivity of the device. In the interests of electrical efficiency it is evident that the pole faces should be as close to the diaphragm as possible so that the magnetic lines of force developed by the fluctuating current will have a minimum of air space through which to travel. Air, it will be remembered, is a most reluctant transmitting medium for magnetism and magnetic lines of force find it difficult to traverse any great distance without being very much the worse for it. Yet it will be seen that the movement of the diaphragm must be allowed for in setting the pole faces of the magnet. If the latter are set too close to the diaphragm, the diaphragm will strike them and this will have a dampening effect which will tend to destroy the quality of the transmitted music or voice. For this reason, some manufacturers have equipped their loud speakers with an adjusting screw which



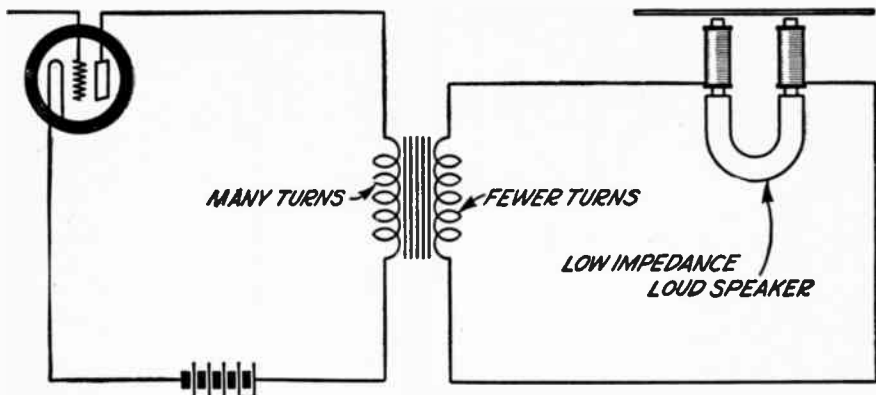

#### THE LOUD SPEAKER AND THE TELEPHONE TRANSFORMER

Figure D: The proper method of connecting an output transformer to a loud speaker is shown. The transformer illustrated in this case is a special one with a high resistance primary and low resistance secondary.

allows the user to regulate the distance between the pole faces and the diaphragm. This permits a loud speaker to carry extra large volume without rendering the device inoperative.

It may perhaps be helpful to add a few words concerning the exact function

of the diaphragm. We have seen how the diaphragm is made to vibration with the distant diaphragm. Air rests at the usual pressure upon both sides of the diaphragm and it is natural that any vibration of the diaphragm will be communicated to the air. This is exactly

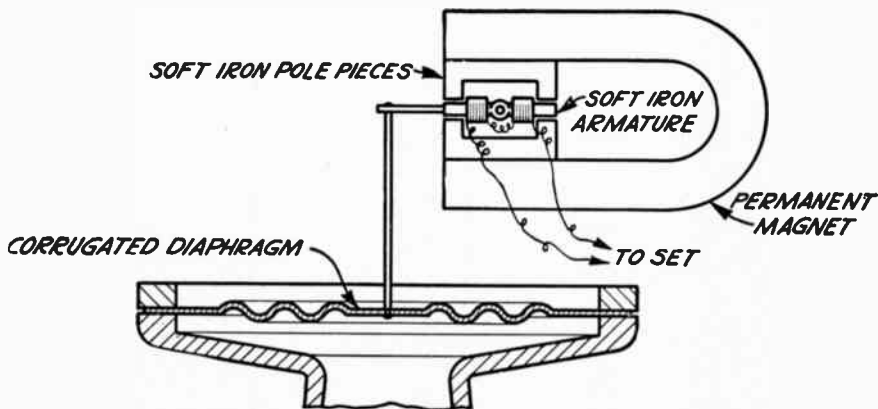

#### BALANCED ARMATURE LOUD SPEAKER

Figure E: This loud speaker was invented by Baldwin and its main feature is that there is no permanent strain on the diaphragm.

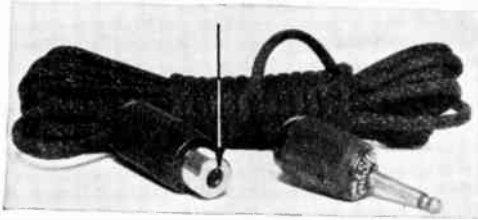

#### PLUG AND EXTENSION CORD

Figure F: This shows the conventional type of radio plug with an extension cord which permits the user to move the loud speaker about the room.

what happens and the air will be found to follow faithfully every minute movement of the diaphragm.

It is unfortunate that we cannot set the air into direct vibration without the use of some moving intermediary like the diaphragm of a loud speaker or telephone receiver. We can never hope to reproduce the complicated vibration of a symphony with absolute faithfulness while we depend upon a highly inefficient medium like a diaphragm. Those who have studied the physics of sound even superficially have been shown that

every body has a sound or frequency period of its own. For instance, a tuning fork may have a period of vibration of exactly 256. This is determined not only by the physical dimensions of the fork but also by its physical shape. Every body has its own sound frequency or the frequency to which it will respond most efficiently. A cigar box, a half dollar, a kitchen table, a telephone pole; all such things have their own frequency periods and a diaphragm is no exception. Every diaphragm used in a telephone or loud speaker has its own special sound

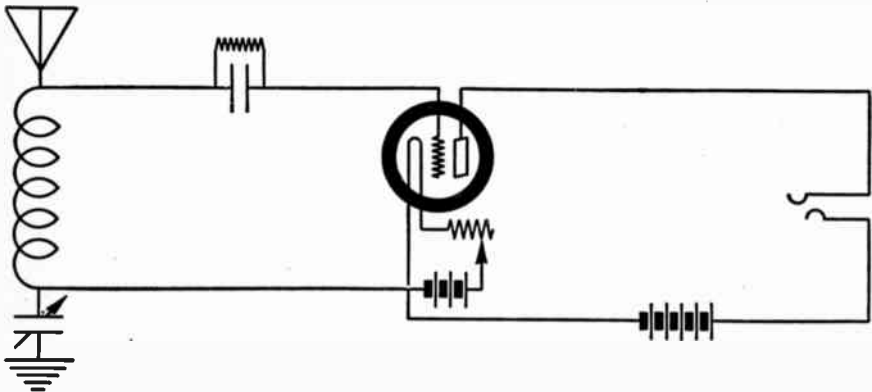

#### SIMPLE JACK CONNECTION

Figure H: How a two-pole jack is connected to a simple one tube radio receiver.

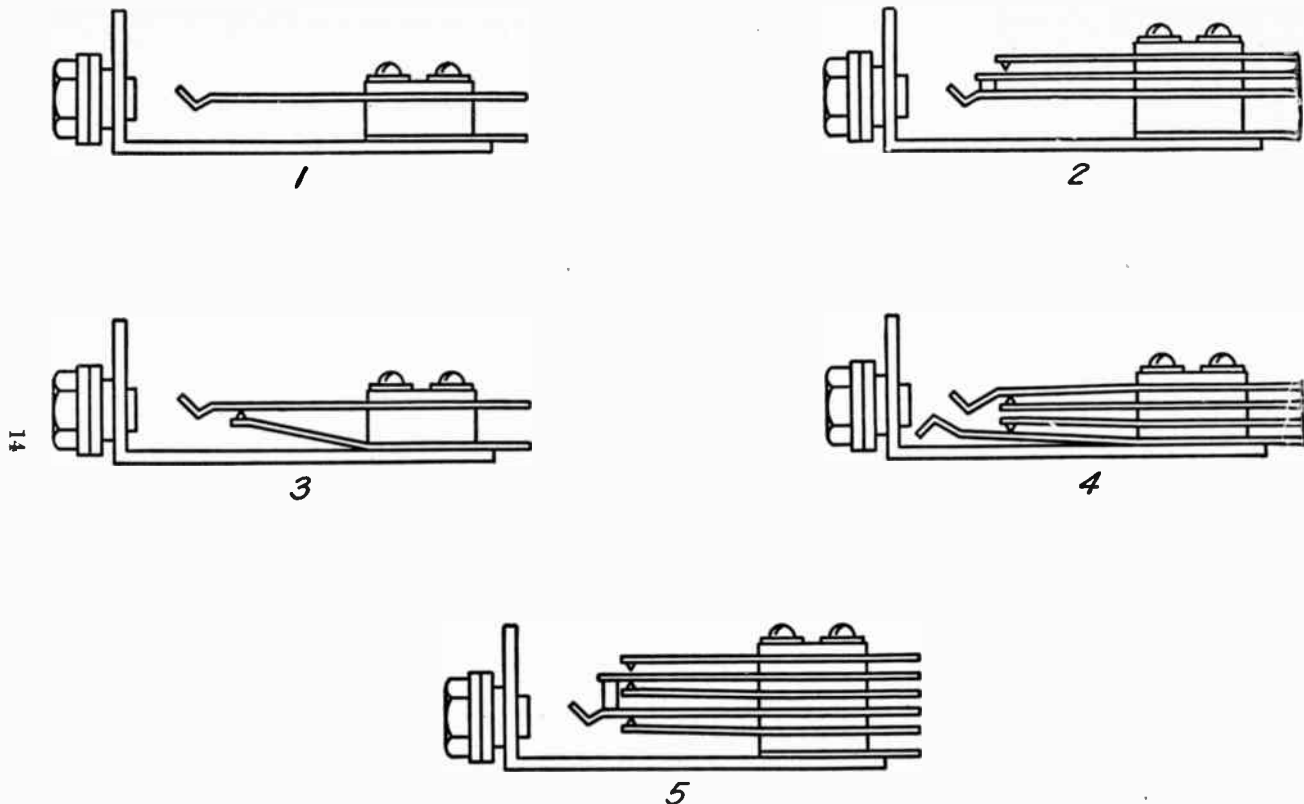

#### FIVE MEMBERS OF THE JACK FAMILY

Figure G: While there are many different types of jacks designed to bring about different connections, the five shown are most used in radio receivers. The purpose of each one is described in the diagrams and the text.

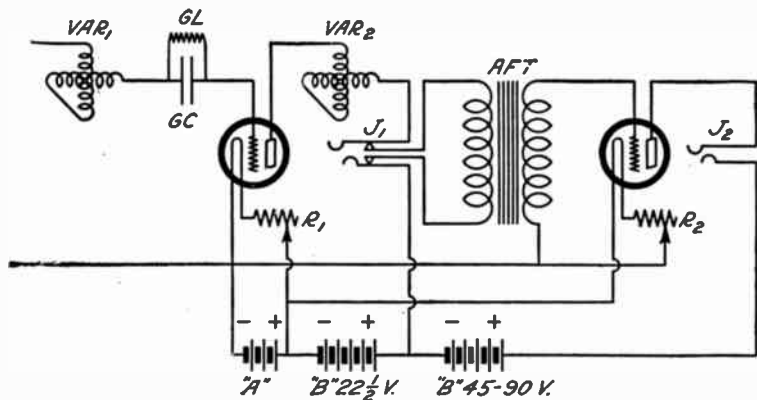

#### CONVENTIONAL USE OF JACKS

Figure I: By the use of the jacks shown the detector may be used alone or with one stage of amplification.

period which will depend upon (1) the thickness of the diaphragm (2) the diameter of the diaphragm and (3) the particular alloy or metal from which it is made.

There is always one particular frequency which will find the diaphragm most sympathetic and which will represent its highest point of efficiency. We do not mean in stating this that a diaphragm cannot be made to vibrate to sounds having a frequency above or below this natural *period*. However, it is physically impossible for the diaphragm to reproduce other frequencies with the same degree of faithfulness that it is able to reproduce a frequency near that of its own period. With these conditions holding we cannot expect a loud speaker to respond perfectly to the woodwinds, the bass viols, the kettle drums and brasses of a symphonic orchestra, nor can we expect such a diaphragm to respond with equal efficiency to the voices of baritones, tenors, contraltos and sopranos. Further

research in connection with loud speakers will have to do with the problem of either obviating entirely the diaphragm or finding some diaphragm that will handle a wide range of sound frequencies with fairly reasonable efficiency.

The conventional form taken by most loud speakers is shown in Figure B. The diaphragm is clamped solidly between the case holding the magnets and the cap or top which is screwed to the case. The aperture to which the horn is attached permits the sound waves to pass freely into the small end of the cone.

Trouble with loud speakers takes a number of different forms and perhaps the most prevalent one and the one least suspected by the average lay operator is that of overloading. By overloading we refer to the practice of permitting too heavy a current to flow through the magnets. The radio set with which the loud speaker is used is probably operated at its maximum and the heavy current surging through the magnet pulls the

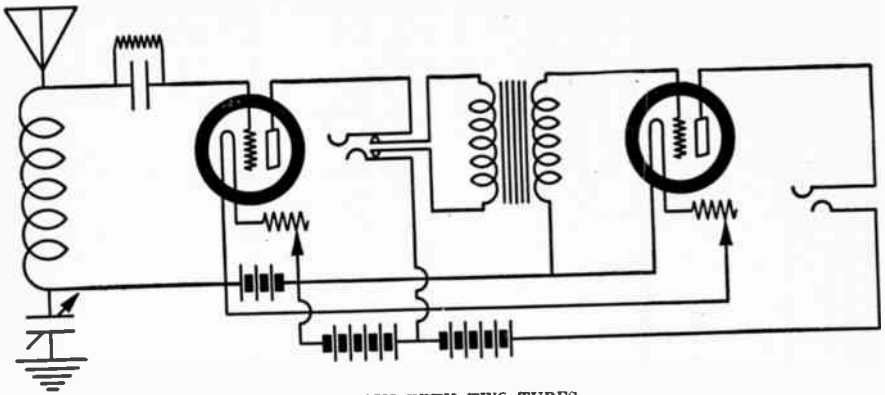

#### USING JACKS WITH TWO TUBES

Figure J: It is the function of the first jack to cut out the amplifying tube so that the detector may be used alone.

diaphragm down until it hits the pole faces. This results in a high pitched crackle, a sound that resembles metal touching metal. Of course the only remedy for a condition of this kind is that of reducing the current output of the set by retarding the filament current of the vacuum tubes. Nothing is gained by operating a set at high volume; indeed much is lost. The quality will be poor and there is imposed upon the

A and B batteries an unnecessary drain. It should be the rule of every set owner to operate his receiver at the lowest point consistent with good hearing. With the adjustable type of loud speaker the set may be operated at high volume without danger of striking if the adjusting screw is manipulated until the crackling sound is eliminated. However, the quality will be a disappointment to anyone who has a good ear for music.

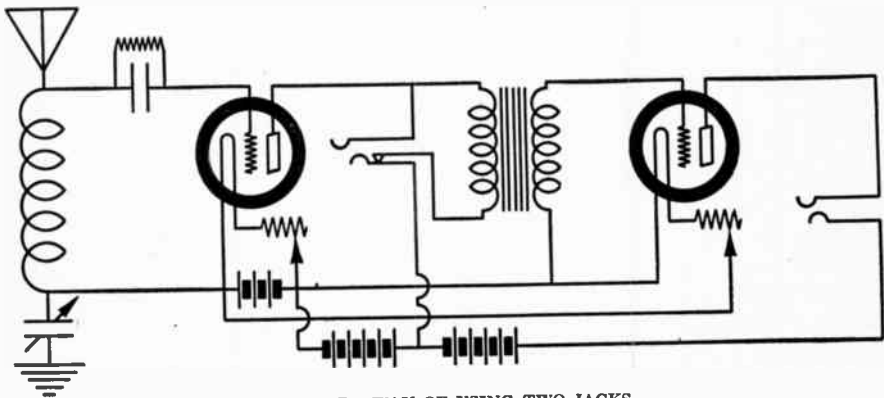

#### ANOTHER WAY OF USING TWO JACKS

Figure K: Here the action illustrated above is performed by a three-spring jack.

A loose diaphragm is another possible source of distortion and this is always remedied by the simple expedient of screwing down the cap of the speaking unit more tightly. Incidentally the owners of good loud speaking units are warned against the practice of removing the diaphragms for little or no reason or simply through insatiable curiosity. In being removed the diaphragm is very apt to be bent and if it is bent it becomes practically useless. Even the slightest indentation in the diaphragm can be responsible for bad behavior. If the diaphragm of a telephone or loud speaker must be removed it should not be lifted with the finger nails. Due to the constant pulling down of the permanent magnet any lifting done in this way may bend the diaphragm and destroy its efficiency. Diaphragms should be slid off their seat and slid back again. This preserves their flatness which is most essential to good reproduction.

Still another cause of not necessarily bad reproduction but weak reproduction is failing B batteries or A batteries. This is mentioned in connection with loud speakers because some new receiver operators may blame the loud speaker for weak reproduction when the blame should really rest with other parts of the radio set. Tubes that have been used for a long time can cause both poor and weak reproduction. The only way in which a loud speaker can cause weak reproduction is through the loss of magnetism in its permanent magnet. This, however, should not take place for several years, and any suspicion that the loud speaker has lost part of its magnetism can be confirmed or denied by the simple expedient of removing the diaphragm and conducting a simple experiment. The edge of the diaphragm is placed against the pole faces. If

there is enough magnetism left in the permanent magnet to hold the diaphragm on end, the trouble is undoubtedly located elsewhere. Although this is more or less of a rough and thoroughly unscientific test, it is of great value in locating trouble of this nature.

Before we go into the subject of other types of loud speakers it would perhaps be wise to say something about the resistance of both telephone and loud speaking devices. So many lay operators are confused to the point of believing that resistance is an indication of sensitivity. Ignorant or unscrupulous dealers have sold headphones on the strength of their being wound to a resistance of 4000 when a 2000 -ohm telephone of good manufacture would probably perform just as efficiently if not more so. All of this illicit traffic based solely on the gullibility of unwary purchasers could have been avoided by brief instruction in the meaning of resistance and its application to reproducing devices.

It is not the resistance of a reproducer magnet that counts so much as the number of ampere turns of wire that are carried by the magnets. To put it briefly, a magnet used for reproducing sound modulated currents through the medium of the vacuum tube should have as many turns of wire as possible in as small a space as possible. For this reason very small wire is used with very thin but highly efficient insulation. Such wire is usually enamelled with a current-resisting medium.

It is more scientific to calculate the resistance of telephone receivers and loud speakers with alternating current at from 500 to 800 cycles than it is to use direct current. A receiver measuring 2000 ohms with direct current may run as high as 20,000 ohms with alter-

nating current of 800 cycles. In such cases the resistance is usually referred to as impedance and instead of saying that a 'phone or loud speaker has an alternating current resistance of 20,000 ohms we say it has an impedance of 20,000 ohms. Impedance is always used with alternating current.

There is an old rule in electricity that states that maximum current from an electric cell will flow when the resistance of the external circuit will be equivalent to the internal resistance of the cell. This holds true with practically every electrical circuit and the vacuum tube and loud speaker are no exceptions. If the last vacuum tube has an impedance of 20,000 ohms between its filament and plate, the loud speaker to operate most efficiently should have the same impedance. Unfortunately, this matching of impedance cannot be brought about with extreme perfection because the voltage across the loud speaker terminals is found to vary with the sound frequencies carried by the modulated current whereas the voltage across the tube elements remains practically constant and is not influenced by the sound frequencies. Reference to Fig. C will help the reader to understand the condition that holds.

It has often been found convenient to produce loud speakers with a very low impedance, but in such cases it is advisable to insert between the loud speaker and the reproducing device an audio-frequency transformer with a secondary impedance that will match the impedance of the vacuum tube employed. The method of connecting such a combination is illustrated in Figure D. The battery shown in series with the plate and secondary of the transformer is the B battery.

In Figure E we have a loud speaker

which represents a severe departure from the conventional types that we have been investigating. We have here a loud speaker that is built on the Baldwin or balanced armature principle. It will be noticed that no electromagnet is brought in proximity to the corrugated diaphragm, but instead a small rod is fixed to the center of the diaphragm with the opposite end connected to an armature suspended on delicate bearings between the poles of a powerful permanent magnet. Since the pulling force of each pole of the magnet is equal and in opposite directions there will be no constant strain on the diaphragm as in the case of ordinary reproducers.

There is wound upon the soft iron armature a small coil and the current impulses from the radio set are permitted to flow through this coil. It is this fluctuating current that causes the armature to vibrate in the permanent field. This vibration is communicated to the small rod connecting the armature with the diaphragm and the diaphragm is thus made to keep step with the armature. Loud speakers of this type are remarkably sensitive and usually provide very good quality.

In the cone type of loud speaker, wherein the diaphragm takes the form of a large paper cone about 12 inches in diameter or more, units of this construction are generally employed. The unit is so mounted that the connecting rod between the armature and the diaphragm is attached to the apex of the cone.

Since jacks and plugs are so universally and abundantly employed in all types of radio receivers, and since they are used largely for the purpose of making connections with loud speaker horns and telephones, it will be advisable to take up their construction and intelligent employment at this time.

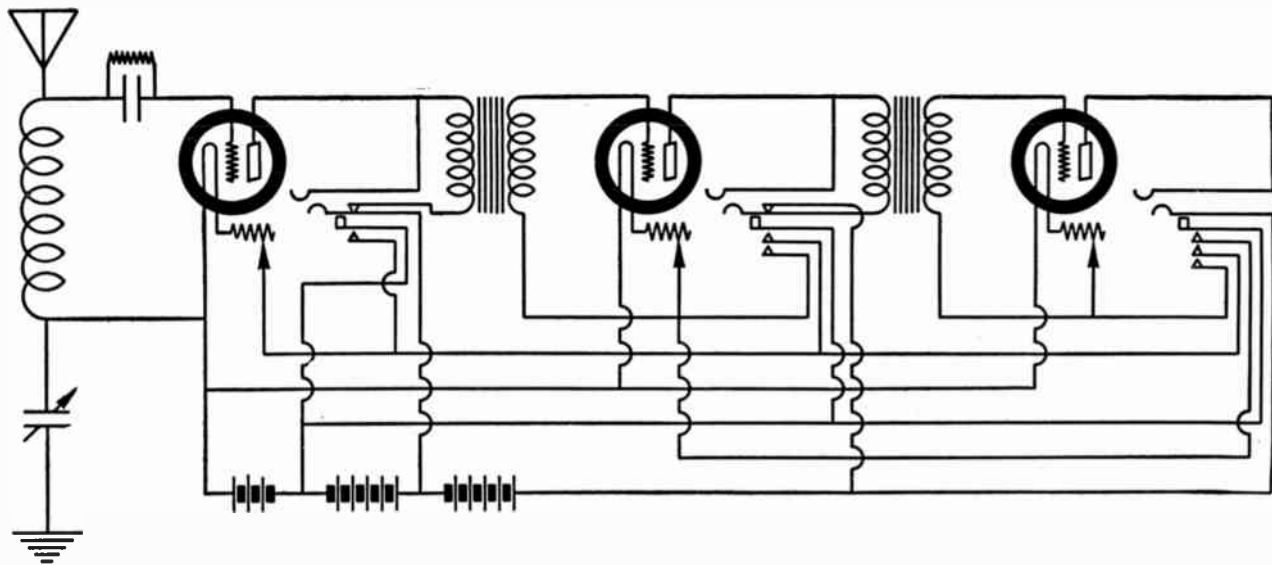

#### HOW THE MORE COMPLICATED JACKS ARE EMPLOYED

Figure L: By tracing the connections for these jacks the reader will note that they also control the filament current of the vacuum tubes not in use. For instance, when the detector alone is used the filament current of the two amplifying tubes is automatically cut off.



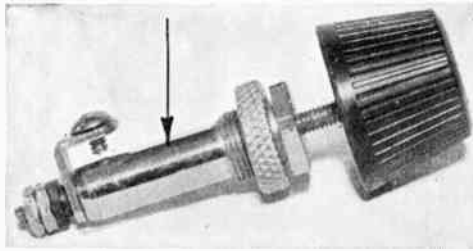

#### CARBON PILE RESISTOR

Figure O: This resistance unit is operated by varying the pressure on a pile of carbon disks. This varies the resistance.

In Figure F we will see the photograph of an ordinary plug which has been standardized for use in connection with all jacks. That is one fortunate thing that has happened in radio, the standardization of the dimensions of principal parts of all jacks and plugs. Although the various plugs and jacks mentioned each have their individual merits they are all interchangeable.

The plug in Figure F has an insulated covering so that the user may employ it without danger of grounding the set through his body or receiving a shock from a high-potential B battery. The

projecting part of the plug is made up of a sleeve with a rod fixed concentrically within it. The rod and the tube or sleeve are insulated from each other and one is connected to one tip of the telephone cord while the other is connected to the other tip. Various patented means have been devised for holding the tips of the cord to the plug and in some cases it is only necessary to insert the tips. They are held in position by a spring arrangement and the tip will be released only when a small lever or button is pressed. After all a plug is nothing more or less than two terminals

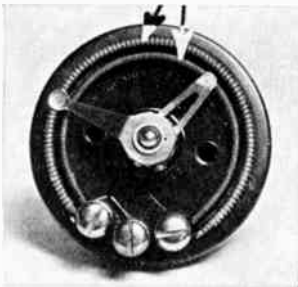

#### COMBINATION RHEOSTAT

Figure M: This rheostat is provided with two windings and two control handles. One winding serves as a potentiometer and the other as a filament resistance.

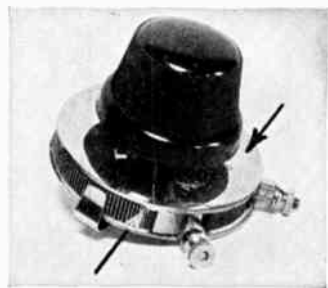

#### SIMPLE RHEOSTAT

Figure N: This shows another type of rheostat or variable resistance with but a single winding. The binding posts for connections are shown at the side.

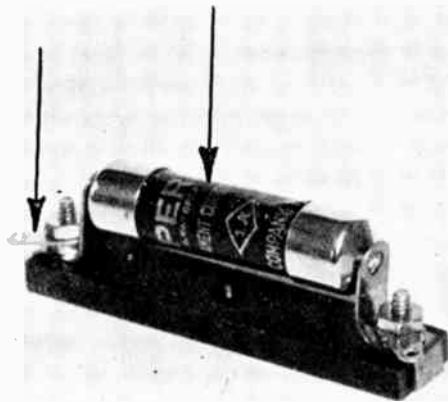

#### AUTOMATIC FILAMENT CONTROL

Figure R: This filament control is made up of a small piece of special alloy wire sealed in a glass tube. This automatically controls the filament current of the vacuum tube as will be explained in the text.

mounted on the end of a loud speaker cord. The jack is a device used to make connection with the peculiar kind of terminals used on a plug. The convenience sought in these two devices is a fast and reliable means of connecting and disconnecting.

In Figure G at 1 we will see a very simple type of jack. This is usually referred to as a single circuit jack

because connections may be changed in only one circuit at a time. The plug is inserted and the sleeve of the plug makes contact with the bushing through which it passes. Thus the bushing is grounded in the frame. The projecting prong, which is of spring brass or phosphor bronze, slips up onto the rounded end of the rod within the sleeve and thus we have established a double connection.



#### ANOTHER CARBON PILE RESISTOR

Figure P: Here is a potentiometer type of resistor built up on the carbon pile principle. Grid leaks are also made in this form.



#### ANOTHER RHEOSTAT

Figure Q: Here is another conventional rheostat of the wire type. It is made up in various resistances from 6 ohms to as high as 30 ohms.

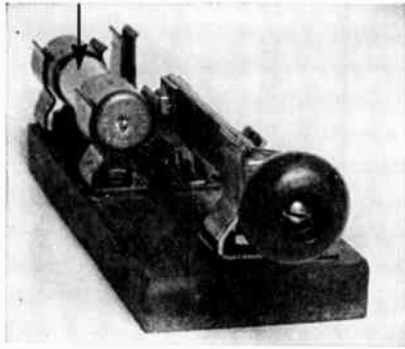

#### LIGHTNING ARRESTER COMBINATION

Figure T: On this block there is mounted a lightning arrester and a ground switch.

Of course the spring member is insulated from the frame of the jack by an insulating block. Connections are soldered, one to the frame and one to the flexible or spring member.

If we desire to use a jack of this nature in connection with an ordinary single tube radio set it will be employed in the manner shown in Figure H. Inserting the jack between the two contacts shown would establish a connection through the telephone receivers.

If the reader will study the various types of jacks shown in Figure G together with the diagrams I, J, K and L he will understand how many different functions may be performed with these devices. Jack No. 2 in Figure F not only connects the telephones but also lights the filaments of the vacuum tube, acting as an automatic switch. When the plug is taken out of the jack, the spring members return to their normal position and the filament current is

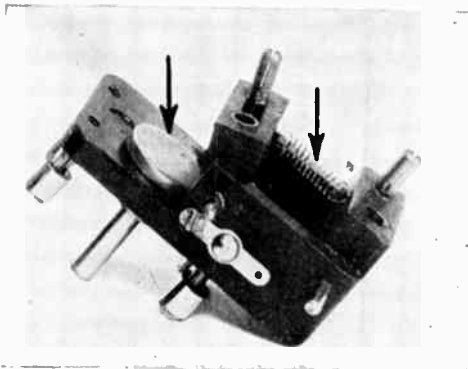

#### HONEYCOMB COIL MOUNTING

Figure S: This mounting is made to accommodate honeycomb coils with standard bases.

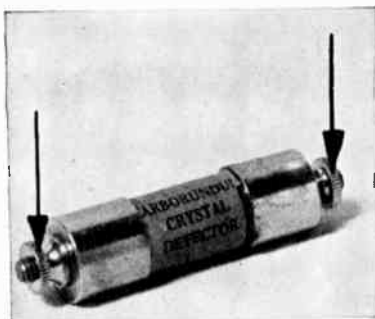

#### PERMANENT CRYSTAL DETECTOR

Figure U: By mounting a crystal in a very special way the adjustment may be kept permanent. This shows a sealed-in crystal of this type.

interrupted. When the plug is inserted in Jack No. 2, the lower spring member is forced up just enough to bring the two top spring members into contact thus lighting the filaments of the vacuum tubes. Jack No. 5 is a highly complicated one and when a plug is inserted in it it not only connects the telephones

but lights the filament and disconnects both terminals of the following audio-frequency transformer.

On many radio sets we find three or more jacks. The first jack permits the user to plug the 'phones in on the detector alone; the second one allows the use of the detector and one stage of

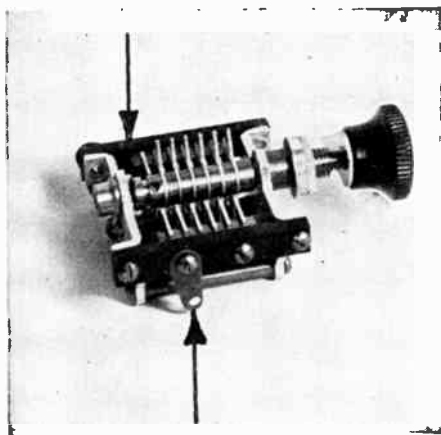

#### MIDGET CONDENSER

Figure V: By using this midget condenser in connection with a standard size, small changes in capacity may be brought about. This replaces the vernier dial.

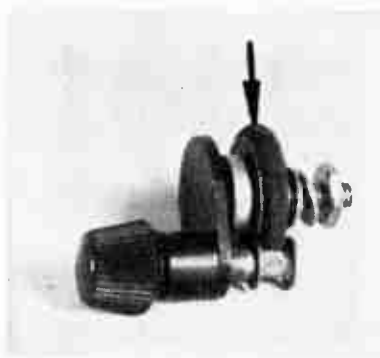

#### VERNIER ATTACHMENT

Fig. W: By permitting the periphery of the rubber wheel pointed out to come in contact with the edge of a condenser dial vernier tuning may be accomplished.

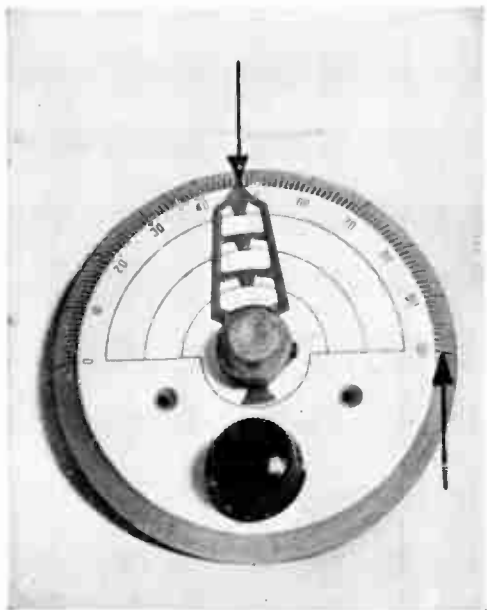

#### GEAR TYPE VERNIER

Figure X: This vernier operates with internal gears which permit the condenser shaft to turn very slowly through the high gear ratio.



#### ANOTHER VERNIER DIAL

Figure Y: This shows another type of dial used to make very small adjustments on variable condensers.

audio-frequency amplification while the third jack receives the total output of the set. References to Figure I will show how this is accomplished.

In Figure J we have a simple jack stationed at the detector which cuts the audio frequency out automatically when the 'phones are inserted. In Figure K we have a jack performing a similar function but the jack is of a different type having three spring members instead of four as in Figure J. In Figure L we have a highly complicated circuit in which the filaments of the vacuum tubes are controlled. The first jack controls one filament, the second jack two filaments and the third jack three filaments. By using the proper jacks automatic circuit control is brought about efficiently and quickly.

Rheostats and potentiometers (the latter are usually employed for fine

divisions of voltage) take on two distinct forms both of which are illustrated in Figures M and N. The one in Figure M has a double winding. Sometimes one winding is for the control of the filament current of the vacuum tube and the other winding is made to serve as a potentiometer for grid bias. Then, too, there are certain rheostats on the market with double windings, each one for the control of one vacuum tube. It is simply a method used to combine two rheostats in one for the purpose of simplifying construction. Rheostats of this particular design will be found to have two control knobs, one for each winding.

It is important that the proper rheostat be selected for the tube with which it is to be employed. The table given in Section 6 will help in the matching of rheostats with tubes. If the resistance

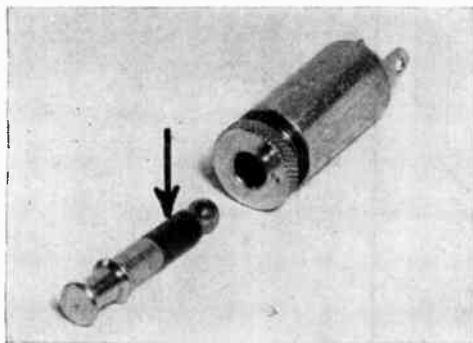

#### LOCK SWITCH

Figure Z: This shows a filament switch, the plug of which may be placed in the pocket. This is in event the owner does not care to have the set tampered with in his absence.

of a rheostat is too high for the filament of a tube, insufficient current will pass and the tube will fail to function at normal efficiency. If the current consumption of the tube is too great for the wire on the rheostat, the wire will heat up and burn the fibre strip upon which it is wound. This invariably destroys the rheostat and may set fire to the receiver.

Due to the constant sliding of the connecting arm of a rheostat over the wire, trouble is sometimes had with poor connections at this point. Such trouble can usually be corrected by a simple set screw which releases the slider arm and permits it to be adjusted to the shaft.

The type of rheostat and potentiometer shown in Figure O was brought out two years ago and has been found very practical. It embodies a pile of carbon discs and the resistance through the pile of discs will be lowered or increased by varying the pressure exerted upon the discs by the adjusting knob shown in the photograph. By carefully designing a device of this nature, it is possible to produce a regulator that will give a beautiful regulation of current. Rheostats, potentiometers and

grid leaks are made on this principle.

In Figure P we have another form of carbon pile rheostat for the regulation of filament current. This is included to show that current regulators of this nature can take different forms. In Figure Q we have still another type of wire wound rheostat constructed for use in connection with vacuum tubes. There is also on the market a device which automatically adjusts the filament current of vacuum tubes. This is illustrated in Figure R. It is made by sealing a wire of the proper resistance in a glass tube. If the vacuum tube is inclined to draw too much current, the wire becomes heated, its resistance increases and the current is automatically adjusted. The automatic filament controls have a low resistance at low temperatures but a high resistance at high temperature. In other words, the metal wire used has a high co-efficient of resistance. These filament controls are made for all standard tubes.

In Figure S we have a much used accessory which is more or less essential when honeycomb coils are used for wavelength adjustment. This is a double coil mounting with the standard



#### INDUCTANCE SWITCH

Figure AA: This inductance switch is so constructed that the connecting posts are back of the panel. This makes for neatness and practicability.

honeycomb plug so that the coils can be plugged in with a good electrical connection. With this particular type of mounting the shaft to which the arrow points

is equipped with a regular dial. The other arrow points to a spring member which permits the inductance between the coils to be varied when the dial is rotated. Honeycomb coil mountings



#### ELECTRICAL METER

Figure BB: Small panel meters of this type are used on the more complicated receiving sets to indicate filament voltage, B battery voltage, filament current, etc.



also come provided for three coils. These are usually used in regenerative circuits with one mounting provided for the tickler coil.

Lightning arresters take on a multitude of different forms. Some are of the vacuum type and others simply employ a small spark gap mounted in a glass cylinder. The arrester illustrated in Figure T is also equipped with a double-throw, single-pole switch which permits the user to ground his antenna when the receiving set is not in use during a heavy electrical storm. Some arresters are made for inside use and others for outside use.

In Figure U we have a conventional form of permanently fixed crystal detector. Detectors of this type are usually made in the form of a tube with the crystal sealed in in some very special manner so that no further adjustment is needed.

In Figure V we have a vernier variable condenser. This is really a midget condenser which is used in connection with larger condensers so that exceptionally small changes in capacity can be brought about. This permits sharper tuning and naturally eliminates some interference.

When vernier condensers are not employed, vernier attachments similar to that shown in Figure W may be used in their stead. Here we have a small wheel with a rubber periphery which is caused to make contact with the edge of the tuning dial. By turning this wheel through the agency of a small knob, the tuning dial is driven by friction and due to the great difference in size or to the ratio of the circumference of the dial to the rubber covered wheel,

a large movement of the latter will cause a small movement of the dial.

Figures X and Y show two other vernier attachments which operate on the gear principle. Reducing gears are housed behind the dials and a slow motion is imparted to the condenser shaft through this agency.

There are multitudes of switches for use in connection with radio sets, but the two principal types are shown in Figures Z and AA. In Figure Z we have a filament control switch which is used on receivers that are not provided with filament control jacks. Operating this switch either turns on all the tubes of the set or turns them all off. One of the features of the particular switch shown is that the plug may be placed in the socket so that the set cannot be operated without the owner's permission.

The switch shown in Figure AA is called an inductance switch and it is one of a great many types. The knob of this switch is mounted on the outside of the panel while the binding posts which are connected to the wires of the inductance which is to be varied protrude behind the panel. This is an improvement over the old method of mounting contact points on the outside of a set with a switch lever to play over them and make the connections.

In Figure BB we have an electric meter of the type used in radio. Both voltmeter and ammeter are employed and in the case of wavemeters, galvanometers or milliammeters of the same size are employed. Such meters are used to check up B battery voltage, measure the drop in filament voltage, measure filament current consumption, etc.

## LOUDSPEAKERS



### Acme Loudspeaker Specifications

Type; cone  
Material; wooden case, paper cone  
Finish; walnut  
Connectors; cord  
Size; 21 ins.  
Special features; double cone



### Atwater-Kent Loudspeaker Specifications

Type; plain magnetic  
Material; metal  
Finish; crystalline brown  
Connectors; cord  
Size; 22½ ins high  
Special features; none



### Atwater-Kent Loudspeaker Specifications

Type; plain magnetic  
Material; metal  
Finish; crystalline brown  
Connectors; cord  
Size; 19¼ ins. high  
Special features; none



### Atlas Loudspeaker

#### Specifications

Type; plain magnetic  
Material; wood  
Finish; mahogany  
Connectors; cord  
Size; 20 ins. long  
Special features; none



### Amplion Loudspeaker

#### Specifications

Type; special magnetic system  
Material; metal  
Finish; mahogany  
Connectors; cord  
Size; 20 ins. high  
Special features; floating diaphragm



### Apex Loudspeaker

#### Specifications

Type; plain magnetic system  
Material; wood cabinet, wood fibre horn  
Finish; walnut  
Connectors; cord  
Size; 16 x 9 x 9½ ins.  
Special features; none



### Apex Loudspeaker Specifications

Type; plain magnetic  
Material; wood  
Finish; black leatherette  
Connectors; cord  
Size; 21½ ins. high  
Special features; none



### Apollo Loudspeaker Specifications

Type; plain magnetic  
Material; metal  
Finish; crystalline black  
Connectors; cord  
Size; 21 ins.  
Special features; none



### Bosch Loudspeaker Specifications

Type; cone with special magnetic system  
Material; metal; wood veneer cone  
Finish; mahogany  
Connectors; cord  
Size; 15 ins. dia.  
Special features; wooden diaphragm



### Bosch Loudspeaker

#### Specifications

Type; special magnetic system, cone  
Material; metal and wood veneer  
Finish; mahogany  
Connectors; cord  
Size; 15 ins. dia.  
Special features; wooden cone



### Brandes Loudspeaker

#### Specifications

Type; plain magnetic system  
Material; composition horn  
Finish; brown  
Connectors; cord  
Size; 18 ins. high  
Special features; adjustable



### Brandes Loudspeaker

#### Specifications

Type; plain magnetic system  
Material; mahogany with composition horn  
Finish; mahogany  
Connectors; cord  
Size; 14 7/16 x 9 7/8 x 9 ins.  
Special features; adjustable



### Brandes Loudspeaker

#### Specifications

Type; plain magnetic for phonograph  
Material; pressed metal  
Finish; crystalline black  
Connectors; cord  
Size; 6 ins. high  
Special features; adjustable



### Brandes Loudspeaker

#### Specifications

Type; plain magnetic system  
Material; composition  
Finish; black  
Connectors; cord  
Size; 26¼ ins. high  
Special features; adjustable



### Bristol Loudspeaker

#### Specifications

Type; special magnetic system  
Material; mahogany  
Finish; mahogany  
Connectors; cord  
Size; 17 x 10 x 10¼ ins.  
Special features; adjustable



### Bristol Loudspeaker

#### Specifications

Type; special magnetic system  
Material; rubber composition  
Finish; velvet black  
Connectors; cord  
Size; 29½ ins. high  
Special features; adjustable



### Bristol Loudspeaker

#### Specifications

Type; special magnetic system  
Material; rubber composition  
Finish; bronze  
Connectors; cord  
Size; 26½ ins. high  
Special features; adjustable



### Bristol Loudspeaker

#### Specifications

Type; special magnetic system  
Material; hard rubber composition  
Finish; velvet black  
Connectors; cord  
Size; 24 ins. high  
Special features; adjustable



### Burns Loudspeaker

#### Specifications

Type; plain magnetic  
Material; pyralin and metal  
Finish; dark  
Connectors; cord  
Size; 20 ins. high  
Special features; adjustable



### Burns Loudspeaker

#### Specifications

Type; plain magnetic  
Material; metal and composition  
Finish; pyralin and metal  
Connectors; cord  
Size; 20 ins. high  
Special features; adjustable



### Crosley Loudspeaker

#### Specifications

Type; special magnetic system with cone  
Material; metal frame empire cloth cone  
Finish; brown  
Connectors; cord  
Size; 12 ins.  
Special features; adjustable



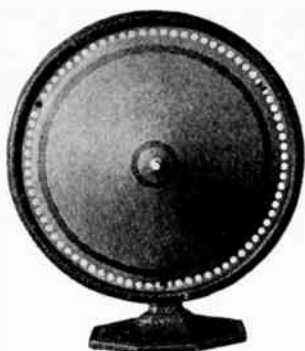

### DeForest Loudspeaker

#### Specifications

Type; special magnetic, cone type  
Material; metal frame  
Finish; dark brown  
Connectors; cord  
Size; 15 ins.  
Special features; special paper cone



### Day-Fan Loudspeaker

#### Specifications

Type; plain magnetic system  
Material; wood  
Finish; mahogany  
Connectors; cord  
Size; 12 ins.  
Special features; none



### Ferrand-Godley Loudspeaker

#### Specifications

Type; special magnetic system and cone  
Material; metal base, paper cone  
Finish; light brown  
Connectors; cord  
Size; 18 ins.  
Special features; adjustable



### Holtzer-Cabot Loudspeaker

#### Specifications

Type; plain magnetic  
Material; hard rubber horn  
Finish; black  
Connectors; cord  
Size; 20 ins.  
Special features; adjustable



### Holtzer-Cabot Loudspeaker

#### Specifications

Type; plain, magnetic  
Material; hard rubber horn  
Finish; brown  
Connectors; cord  
Size; 18 ins. high  
Special features; floating diaphragm



### Holtzer-Cabot Loudspeaker

#### Specifications

Type; phonograph attachment  
Material; metal  
Finish; nickle  
Connectors; cord  
Size; 4 ins. high  
Special features; none



## Jewett Loudspeaker

### Specifications

Type; plain magnetic system  
Material; composition  
Finish; crystalline brown  
Connectors; cord  
Size; 14 ins.  
Special features; covered with brown cloth



## Jewett Loudspeaker

### Specifications

Type; plain magnetic for phonographs  
Material; metal  
Finish; nickle  
Connectors; cord  
Size; 5 ins. high  
Special features; none



## Kellogg Loudspeaker

### Specifications

Type; plain magnetic for phonographs  
Material; metal  
Finish; black  
Connectors; cord  
Size; 20 ins. high  
Special features; none



### Kellogg Loudspeaker Specifications

Type; plain magnetic system  
Material; composition  
Finish; crystalline black  
Connectors; cord  
Size; 25 ins. high  
Special features; none



### Kodol Loudspeaker Specifications

Type; plain magnetic  
Material; pressed metal  
Finish; roman gold  
Connectors; cord  
Size; 8 ins. high  
Special features; coiled horn

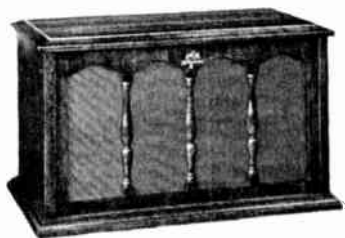

### Magnavox Loudspeaker Specifications

Type; special magnetic system  
Material; mahogany  
Finish; mahogany  
Connectors; cord  
Size; 16½ x 9½ x 9½ ins.  
Special features; none



## Magnavox Loudspeaker

### Specifications

Type; special magnetic system  
Material; metal  
Finish; brown crystal  
Connectors; cord and plug  
Size; 12 in. bell, 26½ in. high  
Special features; none



## Manhattan Loudspeaker

### Specifications

Type; plain magnetic, phonograph attach.  
Material; metal  
Finish; brown mahogany  
Connectors; cord  
Size; 5 ins. high  
Special features; none

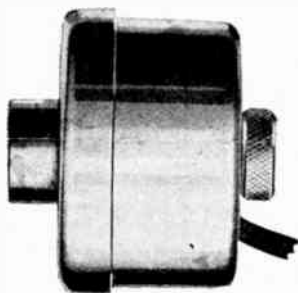

## Morrison Loudspeaker

### Specifications

Type; plain magnetic for phonograph  
Material; metal  
Finish; nickle  
Connectors; cord  
Size; 3½ ins.  
Special features; adjustable



### Multiple Loudspeaker Specifications

Type; plain magnetic  
Material; composition  
Finish; black  
Connectors; cord  
Size; 23 ins.  
Special features; adjustable



### Multiple Loudspeaker Specifications

Type; plain magnetic for phonograph  
Material; pressed metal  
Finish; nickle  
Connectors; cord  
Size; 3½ ins.  
Special features; adjustable



### Multiple Loudspeaker Specifications

Type; plain magnetic  
Material; composition  
Finish; black  
Connectors; cord  
Size; 25 ins.  
Special features; adjustable



## Music-Master Loudspeaker

### Specifications

Type; special magnetic system  
Material; wooden frame  
Finish; mahogany  
Connectors; cord  
Size; 15 ins. dia.  
Special features; cloth covered reproducer



## N and K Loudspeaker

### Specifications

Type; plain magnetic  
Material; metal  
Finish; crystalline black  
Connectors; cord  
Size; 9 x 6½ ins.  
Special features; non-directional



## Pathe Loudspeaker

### Specifications

Type; special magnetic system with cone  
Material; metal frame, paper cone  
Finish; gold  
Connectors; cord  
Size; 15 ins. diameter  
Special features; none



### Radio Corporation Loudspeaker Specifications

Type; special magnetic system with cone  
Material; metal frame  
Finish; bronze  
Connectors; cord  
Size; 18 ins.  
Special features; special cone



### Radio Corporation Loudspeaker Specifications

Type; special cone and special magnetic system  
Material; mahogany cabinet with amplifier and B eliminator  
Finish; mahogany  
Connectors; cable  
Size; 36 ins. high  
Special features; operates from 60-cycle lighting circuit



### Radio Corporation Loudspeaker Specifications

Type; special magnetic system with cone  
Material; metal frame, paper cone  
Finish; bronze  
Connectors; cord  
Size; 30 ins. high  
Special features; rectifier amplifier unit included





### Remo Loudspeaker Specifications

Type; plain magnetic  
Material; wood  
Finish; mahogany  
Connectors; cord  
Size; 21 x 12 ins.  
Special features; none



### Remo Loudspeaker Specifications

Type; plain magnetic  
Material; composition  
Finish; brown  
Connectors; cord  
Size; 14 ins.  
Special features; none



### Saal Loudspeaker Specifications

Type; special magnetic system  
Material; metal with bakelite bell  
Finish; black  
Connectors; cord  
Size; 21½ ins. high  
Special features; none



### Southern Toy Loudspeaker

#### Specifications

Type; plain magnetic  
Material; mahogany or walnut  
Finish; mahogany or walnut  
Connectors; cord and plug  
Size; 8½ x 9 x 8¼ ins.  
Special features; none



### Stromberg-Carlson Loudspeaker

#### Specifications

Type; plain magnetic  
Material; composition horn  
Finish; black  
Connectors; cord and plug  
Size; 24 ins. high  
Special features; adjustable

### Timbertone Loudspeaker

#### Specifications

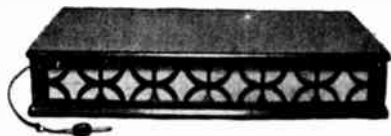

Type; plain magnetic  
Material; wood  
Finish; mahogany  
Connectors; cord  
Special features; to be placed beneath radio



### Timmons Loudspeaker

#### Specifications

Type; special magnetic system with cone  
Material; wood frame, paper cone  
Finish; brown cone, mahogany wood  
Connectors; cord  
Size; 18 ins.  
Special features; laminated wooden rim



### Trimm Loudspeaker

#### Specifications

Type; plain magnetic  
Material; vulcanite horn  
Finish; volax black  
Connectors; cord  
Size; 18 ins. high  
Special features; none



### Thorola Loudspeaker

#### Specifications

Type; plain magnetic  
Material; vulcanite horn  
Finish; black  
Connectors; cord  
Size; 22 ins. high  
Special features; mica diaphragm



### Thorola Loudspeaker Specifications

Type; special magnetic system, for phonographs  
Material; metal  
Finish; black  
Connectors; cord  
Size; 5 ins. high  
Special features; fits Victor, Silvertone and Sonora

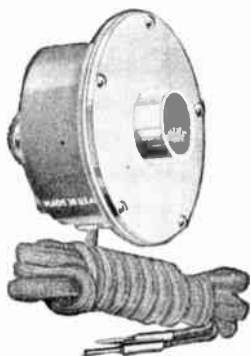

### Thorola Loudspeaker Specifications

Type; plain magnetic for phonographs  
Material; metal  
Finish; nickel  
Connectors; cord  
Size;  $2\frac{5}{8}$  ins. dia.  
Special features; adjustable

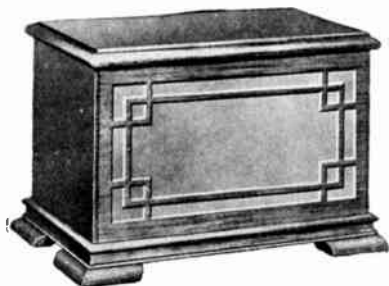

### Trimma Loudspeaker Specifications

Type; plain magnetic  
Material; walnut cabinet  
Finish; walnut  
Connectors; cord  
Size; 10 x 15 ins.  
Special features; volcanite horn



### Trimm Loudspeaker

#### Specifications

Type; plain magnetic  
Material; metal and composition  
Finish; black  
Connectors; cord  
Size; 22 ins. high  
Special features; adjustable



### Trimm Loudspeaker

#### Specifications

Type; plain magnetic  
Material; volcanite horn  
Finish; volax black  
Connectors; cord  
Size; 19½ ins. high  
Special features; none

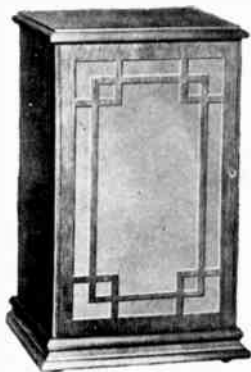

### Trimm Loudspeaker

#### Specifications

Type; plain magnetic  
Material; wooden cabinet  
Finish; mahogany  
Connectors; cord  
Size; 10 x 15 ins.  
Special features; volcanite horn



### Union Fabric Loudspeaker Specifications

Type; plain magnetic  
Material; metal  
Finish; nickle  
Connectors; cord  
Size; 5 ins. high  
Special features; none



### Victor Loudspeaker Specifications

Type; plain magnetic  
Material; metal  
Finish; black  
Connectors; cord  
Size; 27 ins.  
Special features; none



### Thorophone Loudspeaker Specifications

Type; special magnetic system  
Material; bakelite horn  
Finish; black  
Connectors; cord  
Size; 25 ins. high  
Special features; adjustable



### Western Electric Loudspeaker

#### Specifications

Type; balanced armature with cone  
Material; metal and paper cone  
Finish; brown and bronze  
Connectors; cord  
Size; 18 ins. dia., 21 ins. high  
Special features; adjustable



### Western Electric Loudspeaker

#### Specifications

Type; balanced armature with cone  
Material; metal frame, wood base, paper cone  
Finish; brown  
Connectors; cord  
Size; cone 36 ins. in diameter  
Special features; adjustable

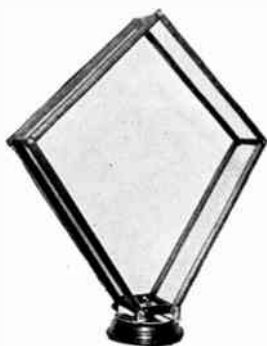

### LOOPS

#### Alco Loop

#### Specifications

Frame; wood  
Wire; stranded  
Connectors; binding posts  
Use; radio frequency receivers  
Special features; folding



### Amplex Loop

#### Specifications

Frame; wood, mahogany finish  
Wire; plain  
Connectors; binding posts  
Use; radio frequency reception  
Special features; folding, and tapped winding

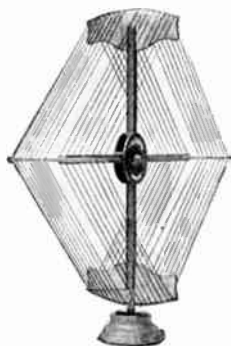

### Berling Loop

#### Specifications

Frame; wood  
Wire; stranded  
Connectors; binding posts  
Use; radio frequency reception  
Special features; calibrated

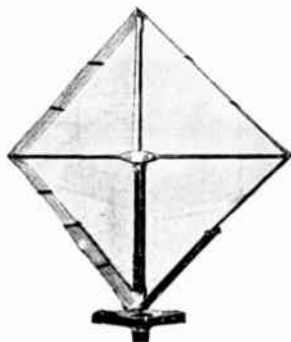

### Deutschmann Loop

#### Specifications

Frame; mahogany  
Wire; stranded  
Connectors; binding posts  
Use; radio frequency reception  
Special features; folding



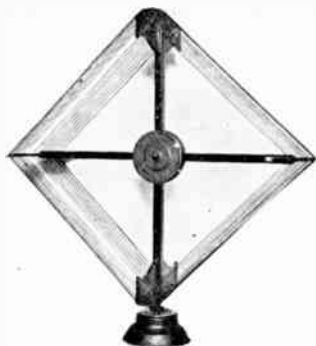

### Gowanda Loop Specifications

Frame; wood  
Wire; stranded  
Connectors; binding posts  
Use; radio frequency reception  
Special features; folding

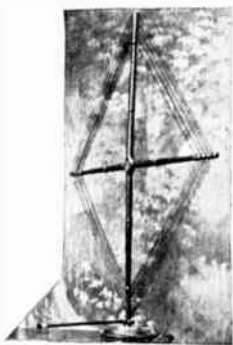

### Korach Loop Specifications

Frame; metal tubing  
Wire; special  
Connectors; binding posts  
Use; radio frequency reception  
Special features; compass and tapped winding

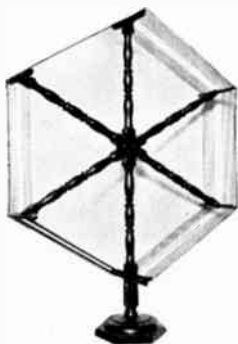

### Scribner Loop Specifications

Frame; mahogany  
Wire; stranded  
Connectors; binding posts  
Use; radio frequency reception  
Special features; folding

## VACUUM TUBE SOCKETS



### American Hard Rubber Socket Specifications

Material; metal and hard rubber  
Tube; universal  
Mounting; for base  
Connectors; binding bolts  
Special features; universal type



### Amsco Socket Specifications

Materials; brass and bakelite  
Tube; U V-201-A type  
Mounting; for base or panel  
Connectors; binding posts  
Special features; wiping contacts



### Amsco Socket Specifications

Materials; brass and bakelite  
Tube; U V-201-A type  
Mounting; for base  
Connectors; binding posts  
Special features; wiping contacts



### Camfield Socket Specifications

Material; bakelite  
Tube; UV-201-A type  
Mounting; for base  
Connectors; binding nuts  
Special features; none



### Cutler-Hammer Socket Specifications

Material; bakelite  
Tube; UV-201-A type  
Mounting; for base  
Connectors; binding nuts and lugs  
Special features; none



### Fleron Socket Specifications

Material; porcelain  
Tube, UV-201-A type  
Mounting; for base  
Connectors; binding nuts and lugs  
Special features, none



## Fleron Socket

### Specifications

Materials; porcelain  
Tube; 199 type  
Mounting; for base  
Connectors; binding nuts and lugs  
Special features; none

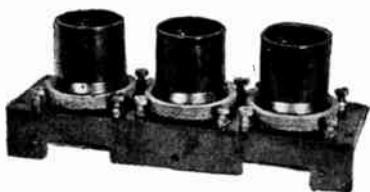

## Frost Sockets

### Specifications

Materials; bakelite  
Tube; UV-201-A type  
Mounting; for panel  
Connectors; binding posts  
Special features; rubber cushions



## Eby Socket

### Specifications

Material; bakelite  
Tube; UX-types  
Mounting; for base  
Connectors; binding screws and lugs  
Special features; none



### H and H Socket Specifications

Material; bakelite  
Tube; 199 type  
Mounting; for base  
Connectors; binding posts  
Special features; rubber feet



### Kellogg Socket Specifications

Material; bakelite  
Tube; UV-201-A type  
Mounting; for base  
Connectors; binding posts and lugs  
Special features; none



### Na-ald Socket Specifications

Materials; bakelite  
Tube; UV-201-A type  
Mounting; for base  
Connectors; binding posts  
Special features; none



### Pioneer Socket Specifications

Materials; bakelite  
Tube; UV-201-A type  
Mounting; for base  
Connectors; binding posts and lugs  
Special features; none

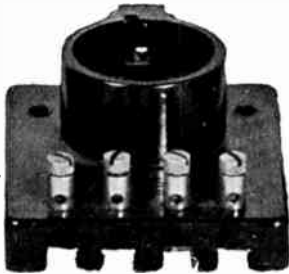

### Rembler Socket Specifications

Material; bakelite  
Tube; 199 type  
Mounting; for base  
Connectors; binding posts  
Special features; none

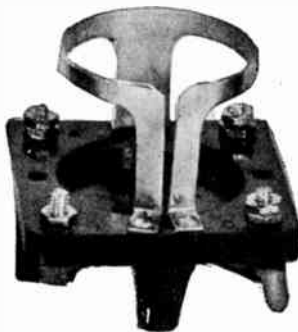

### Universal Socket Specifications

Material; bakelite and brass  
Tube; universal  
Mounting; for base  
Connectors; binding nuts  
Special features; none



### Walbert Socket

#### Specifications

Material; metal and bakelite  
Tube; UV-201-A type  
Mounting; for base  
Connectors; soldering lugs  
Special features; none

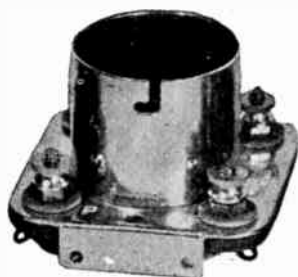

### Walnart Socket

#### Specifications

Materials; metal and bakelite  
Tube; UV-201-A type  
Mounting; for panel or base  
Connectors; binding posts  
Special features; none

## RHEOSTATS AND POTENTIOMETERS



### Amsco Rheostat

#### Specifications

Resistance element; wire  
Resistance; 6 ohms  
Body; bakelite  
Connectors; binding screws  
Mounting; for panel  
Special features; none

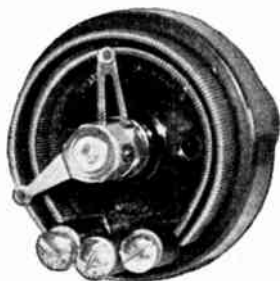

## Amsco Rheostat and Potentiometer

### Specifications

Resistance element; wire  
Resistance; 6 and 200 ohms  
Body; bakelite  
Connectors; binding screws  
Mounting; for panel  
Special features; none



## Allen-Bradley Potentiometer

### Specifications

Resistance element; carbon discs  
Resistance; 25,000 to 200,000 ohms  
Body; porcelain  
Connectors; binding screws  
Mounting; for panel or base  
Special features; none



## Brach Rheostat

### Specifications

Resistance element; special alloy  
Resistance; automatically adjusted  
Body; fibre tube  
Connectors; binding nuts and lugs  
Mounting; for base  
Special features; automatic in action





### **Carter Rheostat**

#### **Specifications**

Resistance element; wire  
Resistance; 30 ohms  
Body; composition  
Connectors; binding posts  
Mounting; for panel  
Special features; none



### **Cutler-Hammer Potentiometers**

#### **Specifications**

Resistance element; wire  
Resistance; various sizes  
Body; composition  
Connectors; binding posts  
Mounting; for panel  
Special features; none



### **Consolidated Instrument Rheostat**

#### **Specifications**

Resistance element; wire  
Resistance; 6 ohms  
Body; bakelite  
Connectors; binding posts  
Mounting; for panel  
Special features; none



### Central Labs. Potentiometer

#### Specifications

Resistance element; non-inductive  
Resistance; various sizes made  
Body; bakelite  
Connectors; binding posts  
Mounting; for panel  
Special features; none

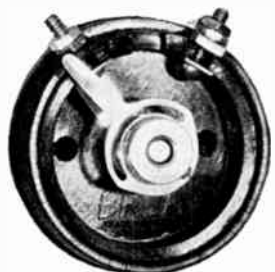

### Erla Rheostat

#### Specifications

Resistance element; wire  
Resistance; 30 ohms  
Body; bakelite  
Connectors; binding posts  
Mounting; for panel  
Special features; none



### Filko-Stat Rheostat

#### Specifications

Resistance element; carbon discs  
Resistance; for all tubes  
Body; insulated tubing  
Connectors; binding screws  
Mounting; for panel  
Special features; none



## Frost Rheostat

### Specifications

Resistance element; wire  
Resistance; 30 ohms  
Body; bakelite  
Connectors; binding posts  
Mounting; for panel  
Special features; none



## Frost Rheostat and Potentiometer

### Specifications

Resistance element; wire  
Resistance; 30 and 200 ohms  
Body; bakelite  
Connectors; binding posts  
Mounting; for panel  
Special features; none



## Frost Rheostat

### Specifications

Resistance element; wire  
Resistance; 30 ohms  
Body; metal  
Connectors; binding posts  
Mounting; for panel  
Special features; none

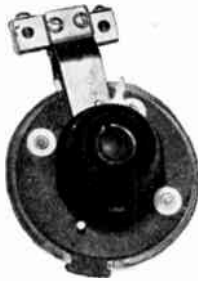

## Kellogg Rheostat

### Specifications

Resistance element; wire  
Resistance; all standard sizes  
Body; bakelite  
Connectors; binding screws  
Mounting; for panel  
Special features; none



## Kirsh-Kash Rheostat

### Specifications

Resistance element; wire  
Resistance; 6, 30 and 200 ohms  
Body; bakelite  
Connectors; binding screws  
Mounting; for panel  
Special features; double spring contact



## Jenkins Rheostat

### Specifications

Resistance element; wire  
Resistance; 6 and 30 ohm sizes  
Body; fibre  
Connectors; binding screws  
Mounting; for panel  
Special features; infinite adjustment



### Martin-Copeland Potentiometer

#### Specifications

Resistance element; wire  
Resistance; 200 and 400 ohms  
Body; metal  
Connectors; binding posts  
Mounting; for panel  
Special features; metal case



### Mirra Rheostat

#### Specifications

Resistance element; wire  
Resistance; 6 ohms  
Body; bakelite  
Connectors; binding screws  
Mounting; for panel  
Special features; none



### Yaxley Potentiometer

#### Specifications

Resistance element; wire  
Resistance; 200 ohms  
Body; bakelite  
Connectors; binding screws  
Mounting; for panel  
Special features; ventilated winding



### **Pacont Rheostat**

#### **Specifications**

Resistance element; wire  
Resistance; 6 and 30 ohms  
Body; porcelain  
Connectors; binding nuts  
Mounting; for panel  
Special features; dial



### **Polymet Rheostat**

#### **Specifications**

Resistance element; wire  
Resistance; 6 and 30 ohms  
Body; bakelite  
Connectors; binding posts  
Mounting; for panel  
Special features; none



### **Yaxley Rheostat**

#### **Specifications**

Resistance element; wire  
Resistance; 30 ohms  
Body; bakelite  
Connectors; binding screws  
Mounting; for panel  
Special features; none



## Wireless Products Rheostats

### Specifications

Resistance element; wire  
Resistance; 6 and 30 ohms  
Body; bakelite  
Connectors; binding screws  
Mounting; for panel  
Special features; none

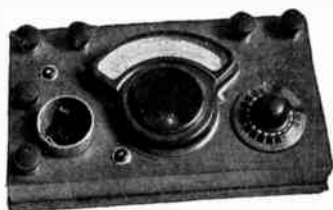

## Hoyt Tube Tester

### Specifications

Uses; for plotting plate current and grid voltage curves. Also for the measurement of filament emission. Hardwood case with socket, meter and rheostat. Rubber-covered binding posts.



## De Witt La France Tube Tester

### Specifications

Use; to measure filament current,  $\mu$ , plate resistance, amplification factor and mutual conductance of all standard vacuum tubes. Provided with all necessary meters for direct reading. Complete with carrying case and data table.



## Sterling Tube Tester

### Specifications

**Use;** to check the amplifying power of vacuum tubes. Made for types UV-201-A, C-301-A, C-300 and UV-200. Operates with receiver without disconnecting unit. Meter comes provided with chart allowing user to immediately determine condition of tubes.

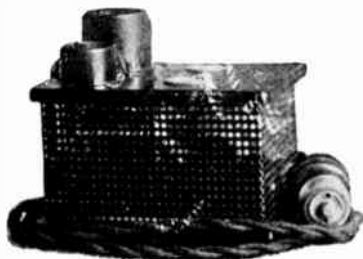

## Burton and Rogers Tube Re-activator

### Specifications

**Tubes;** UV-201-A and C-301-A and 199  
**Sockets;** two  
**Means of current reduction;** resistance  
**Case;** pressed metal  
**Equipped with cord and plug**



## Jefferson Tube Re-activator

### Specifications

**Tubes;** UV-201-A and C-301-A and 199 types  
**Sockets;** two  
**Means of current reduction;** resistance  
**Case;** pressed metal  
**Equipment;** provided with cord and plug





### Remo Tube Re-activator

Tubes; UV-201-A, C-301-A and 199 types  
Sockets; two  
Means of current reduction; resistance  
Case; pressed metal  
Equipment; card and plug



### Rhamstine Tube Re-activator

Tubes; UV-201-A, C-301-A and 199 types  
Sockets; two  
Means of current reduction; resistance  
Case; pressed metal nickled  
Equipment; cord and plug



### Sterling Tube Re-activator

Tubes; UV-201-A, C-301-A and 199 types  
Sockets; two  
Means of current reduction; resistance  
Case; pressed metal  
Equipment; card and plug

## SECTION XVII

### The Wonders of Radio Transmission

**I**N what follows we shall have the opportunity of gathering in some particularly interesting facts about the marvels of modern radio transmission as it is related to the control of distant mechanism (a science called radiodynamics), the transmission of moving and still pictures as well as transoceanic telephony and what has become known as "wired wireless."

Before launching into these absorbing topics it might be wise to first acquaint ourselves with the basic principles of vacuum tube transmitter operation for all of the modern accomplishments mentioned above are based upon this device and its functions. First, let us permit Mr. L. M. Cockaday to tell us how sound waves are converted into electric currents:

"Sound exists only in our brains. We ordinarily say that sound 'travels.' It does not. Indeed, it does not exist at all outside of our brain, for sound is merely a record on our brain produced by a sound 'wave.'

"If there were no human beings on earth, there would be no sounds on the earth—for there would be no brains upon which the sound waves could make a record. Sound waves might be created, but no sounds would be recorded.

"What, then, is a sound wave?

"First of all, we are sure that a sound wave is not a wave of sound, inasmuch

as sound does not exist outside of the living body. From its very name we learn that it is a wave—a wave that makes a record on our brain. But what kind of a wave? A wave in what? Here we have a clue.

"Sound waves are waves in air. We are sure of this because sound waves do not pass through a vacuum. They must have some sort of a medium (such as air) through which to travel.

"The earth is covered with a blanket of air which at any certain point has a fairly constant density; the molecules of air are fairly evenly spaced, in other words. When Milady sits at the opera on a warm evening, she languidly passes a beautifully feathered fan before her face. Little thought she gives to the fact that she is producing a 'wave in the air,' or in other words, an 'air wave.' But she is. In one sweep of the fan the molecules of air are crowded together in front of the fan and spread far apart in the region in back of the fan. A wave is produced; it strikes her face; she feels it.

"This wave is exactly like a sound wave, except that it is produced about once in every few seconds, whereas a sound wave is produced at the rate of from 16 to 20,000 times a second. Air waves which are produced at these frequencies (16 to 20,000 waves a second) then, are called 'sound waves.' We call them sound waves because the human

ear responds only to air waves of these frequencies. We say we cannot hear some sounds because they are too low or too high in pitch.

"A sound wave, therefore, is an air wave of a frequency that can be picked up by the ear and that will produce sound records on the brain.

"How do we hear sounds?"

"Science tells us, in the study of anatomy and physiology, that the ear consists of an outer sounding-board or reflector, which concentrates the sound waves and leads them into a tubular passageway to a thin stretched diaphragm called the ear-drum. This ear-drum vibrates in time with the sound wave impressed upon it and produces a nerve impulse (something like an electric current) which travels along the 'hearing' nerves up to the brain, where it is recorded directly on the brain. This brain record *is* sound. It will be seen that the sound wave does not travel to the brain, but it is converted into an impulse by the ear, which *does* travel to the brain.

"If we study the diagram in Figure A we will understand how the ear vibrates in time with the sound waves which pass by it.

"Here we have a picture of a man with his mouth open and producing one single air wave or sound wave. Before the man spoke the air density in his vicinity was even; the air molecules were undisturbed. This could be illustrated by drawing lines in front of him with equal spacing, showing an equal spacing of the air molecules. However, when he speaks and a sound wave issues from his mouth in ever-widening circles, the air molecules are displaced.

"If we could automatically stop a sound wave and make it visible so that we could examine it, it would look

something like that shown in the diagram. A human ear in the portion of the wave shown at 1, would be in a region of normal air density as shown by the curve A drawn on the diagram and therefore the ear-drum would be in a normal position, as shown, giving a normal impulse to the brain. In this position of the ear-drum we hear nothing, as the brain records only *variations* of the strength of nerve impulses.

"If the ear were in the position 2 (in relation to this stationary wave), it would be in a region of low air density or low pressure (see the curve A at this point), and the ear-drum would curve outward on account of the partial vacuum outside of the ear. This would produce a lesser nerve impulse to be transmitted to the brain.

"If the ear were in the position 3, it would be in a region of high air density or high pressure (see curve A at this point) and the ear-drum would curve inward on account of the pressure outside of the ear, and a greater nerve impulse would be transmitted to the brain. Thus 'sounds' or records of sound waves are produced in the brain which have the same frequency as the original air waves that pass the ear.

"The ear, then, changes sound waves into nerve impulses which have the same time and energy characteristics as the sound waves themselves.

"Someone may say: 'If science understands what the ear is, and how it works, why is it that it cannot devise an artificial ear that can record sound waves?'

"That is just what science has done. It has developed a device that changes sound waves into impulses in exactly the same general way as the ear does, except that the impulses are of an electrical quality and travel over wires

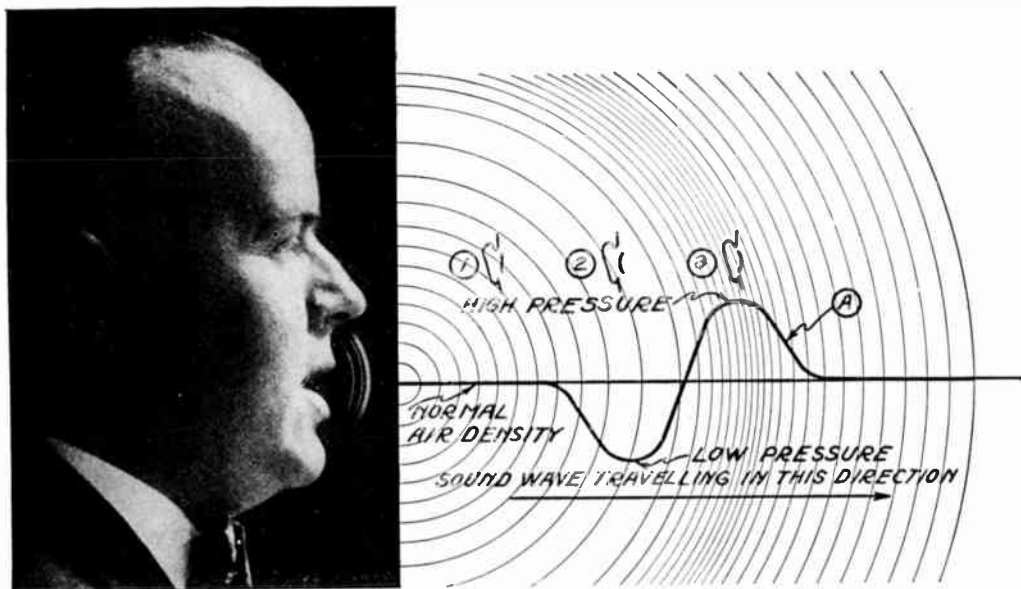

#### WHAT HAPPENS WHEN WE SPEAK

Figure A: A diagram that shows how sound waves spread when the vocal organs or any other source of sound is brought into play.

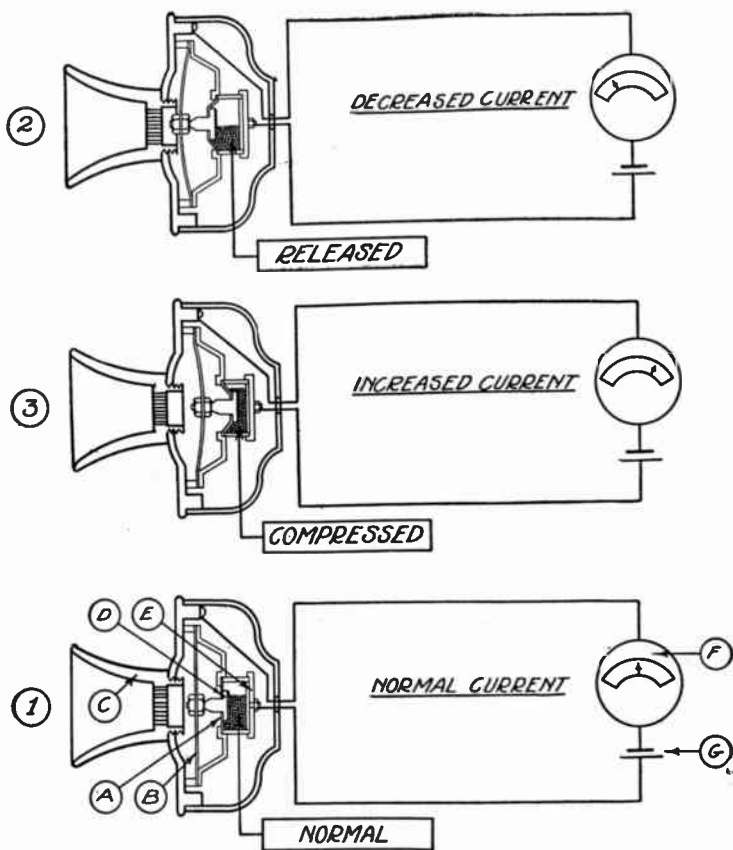

### HOW THE ELECTRIC CURRENT THAT FLOWS THROUGH A MICROPHONE VARIES WITH THE SOUND WAVES IMPRESSED ON THE DIAPHRAGM

Figure B: A microphone consists of a collector horn (C) and a diaphragm (B), to which is attached a plunger contact (D); this passes through a flexible insulating disc (A), which forms one end of a cylinder (E), which contains the carbon grains—all of which are shown in (1) above. A current from a battery (G) passes through the circuit, which includes the carbon grains; this current is registered on a meter (F). When the diaphragm is vibrated, first on one side and then on the other, by sound waves [as shown in (2) and (3)], the carbon grains are released and compressed, respectively, and a smaller or greater amount of current flows through the microphone. This variation of the strength of the current that flows through the microphone is directly in proportion to the strength of the sound waves which come from the voice or the musical instrument, and which are impinged against the diaphragm.

instead of being nerve impulses which travel over organic wires called 'nerves.'

"This brings us to our last question:

"How does this instrument, the microphone, change sound waves into electric currents?"

"This is really very simple, as we shall see. First of all, this artificial ear (the microphone) consists of an outer sounding board C (shown at 1, Figure B), which gathers up the sound waves and impresses them on the diaphragm B. On the back of this diaphragm, fastened to it and free to move with it, is a sort of plunger contact D. This plunger contact passes through a flexible insulator disc A, which forms one wall of a cylindrical box E, which is filled with carbon grains. The cylinder is connected in an electrical circuit in such a way that the electric current from a battery G has to pass through the carbon grains in its path around the circuit. The only way it can pass through the carbon grains is to pass from one grain to another as they make contact with one another. If they are pressed tightly together a large current will flow through them, and if they touch each other only lightly, a small current will flow through them. If, for experimental purposes, we connect a measuring meter F in series with the circuit, we will be able to read the value of current flowing. If no current flows through the meter, the pointer will be at zero at the left of the scale, and as the current increases the pointer will travel over the scale to the right, recording an increase of current in accordance with its deflection.

"Now if we place a microphone in position 1 (in Figure A), in place of the human ear, the diaphragm will be in a normal position and the pressure exerted on the carbon grains contained by the cylinder E will be normal, and therefore

a normal current will be measured by the meter F, flowing through the electrical circuit.

"The diagram in Figure C further illustrates the normal value of the current that flows through the microphone, by the straight line just above the outline of the microphone with the diaphragm in position 1.

"Now imagine the wave (Figure A) to be passing by the microphone until the microphone is in position 2. The diaphragm will now be curved outward. Referring again to Figure B, at 2, we see that when the diaphragm is curved outward it draws the plunger contact with it, and this lessens the pressure on the carbon grains. They are released and touch each other lightly and the current flowing through them is decreased. See how the current value falls off, for this condition, during the time when the diaphragm is in this position (2), Figure B.

"When the wave has advanced so that the microphone finds itself in the position 3 in Figure A, the surface of the diaphragm will be curved inward.

"Referring, once more, to the diagram (at 3) Figure B, we see that the diaphragm pushes the plunger contact into the cylinder, compressing the carbon grains tightly together so that the resistance is decreased and a large current flows through them, as indicated by the meter F. Now see how the current gains in strength during the time when the diaphragm is in this position (3) in Figure C.

"If you compare the shape of the curve of the sound wave, in Figure A, which is a measure of the air density, you will see that it corresponds exactly with the shape of the electric current wave in Figure C, which is a measure of the current density."

Now that we have an accurate idea

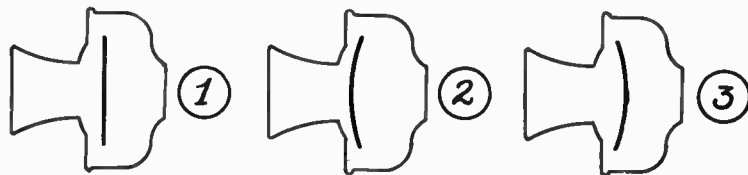
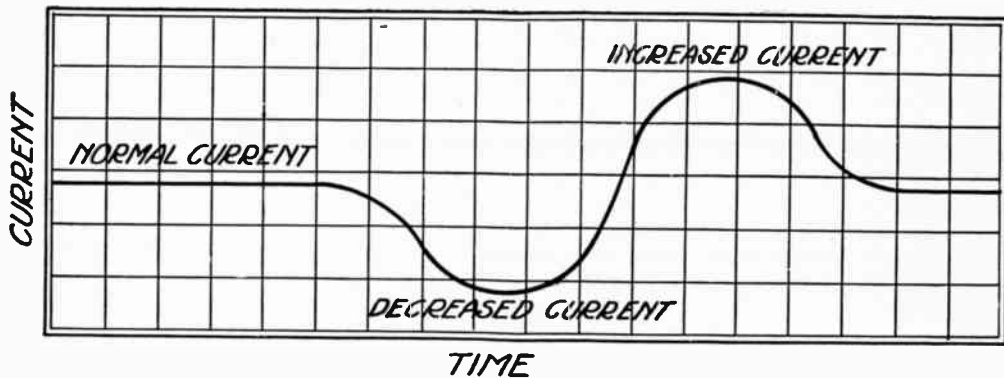

#### HOW DIAPHRAGMS SWING WITH SOUND WAVES

Fig. C: This diagram shows how the electric current that flows through a microphone varies with the strength of the sound waves. The currents for the three positions of the diaphragm shown in Figure B are indicated.

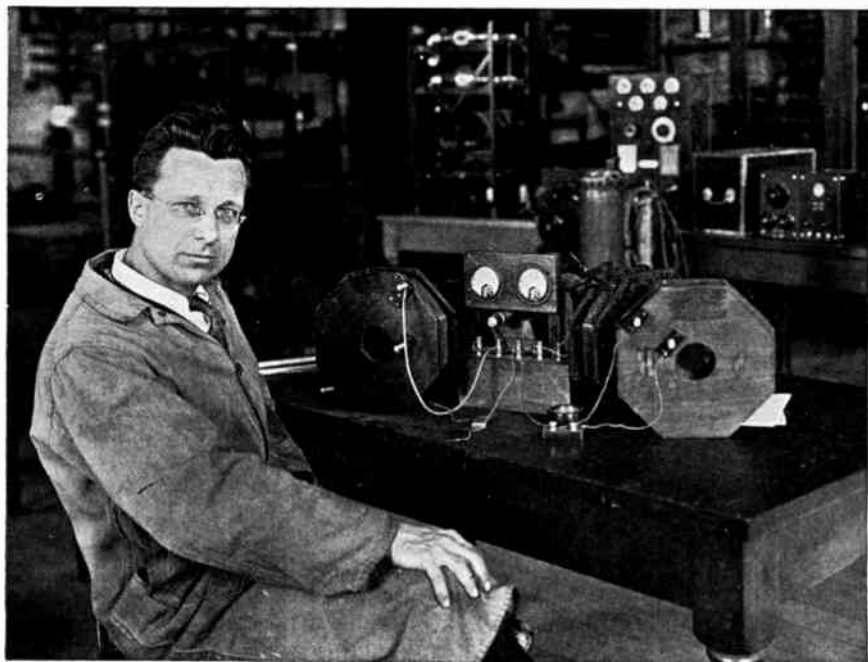

#### A MASTER OF ELECTRICAL THEORY

Prof. Morecroft of Columbia University who has made many valuable contributions to the literature of radio communication.

of the electro-mechanics involved in the transmission of sounds over wires by the aid of the simple telephone transmitter and receiver, let us see how the vacuum tube is arranged so that it will be able to create radio waves and impress these sounds upon them. Prof. Morecroft of Columbia University, is a master of vacuum tube operation and the following matter has been prepared by him:

“The vacuum tube is a device which, by a peculiar action, can take continuous (or direct) current power from a battery or generator and transform part of it into alternating current power. The frequency of the power generated

by the oscillating tube is determined entirely by the electrical constants of the circuit; the amount of power it is possible to generate is determined primarily by the size of the filament and plates of the tube, and secondarily by the adjustment of the circuits.

“To anyone at all familiar with the ordinary laws of the electrical circuit it will seem strange that a source of continuous power supply can, by means of such a device, be changed to an alternating current power supply. The ordinary laws of electrical circuits seem to prohibit just such an occurrence. If we have a generator that gives a continuous voltage and we connect a circuit of any kind



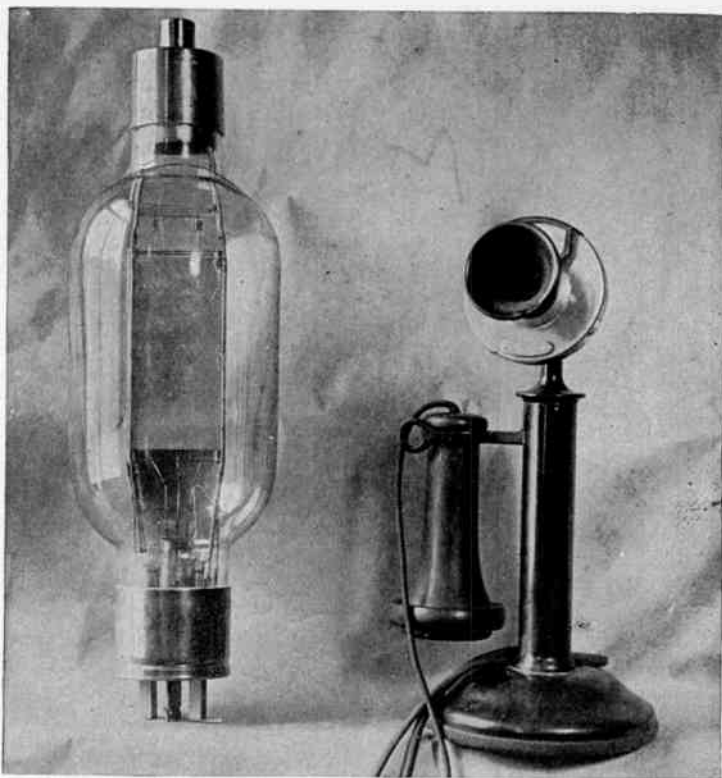

Paul Thompson

**A GIANT VACUUM TUBE, AS COMPARED IN SIZE  
TO A TELEPHONE INSTRUMENT**

Figure D: Tubes of this size ( $\frac{1}{2}$  kilowatt) are used for transmitting only. Of the various names applied to such tubes, ranging from "radio bottle" and "Aladdin's lamp" to audion, the term "triode" is coming into general use among scientists.

to the terminals of this generator we expect to get a flow of continuous current, and practically always we do so. How then is it that the vacuum tube, or triode, as it is gradually being re-named, can transform such a continuous energy flow into an alternating energy flow?

"It is first to be pointed out that there are many occurrences in our everyday life where just such phenomena are taking place, yet we scarcely notice them—occurrences in which a simple, straight-

forward push or pull makes something vibrate backwards and forwards. In fact, it seems likely than the present popular study of radio, including such things as the triode, will react to make us observe more closely many of the ordinary events that take place around us, which we do not understand and which have many points of similarity with radio. The oscillating triode certainly has a place in this category; an attempt to understand its action will

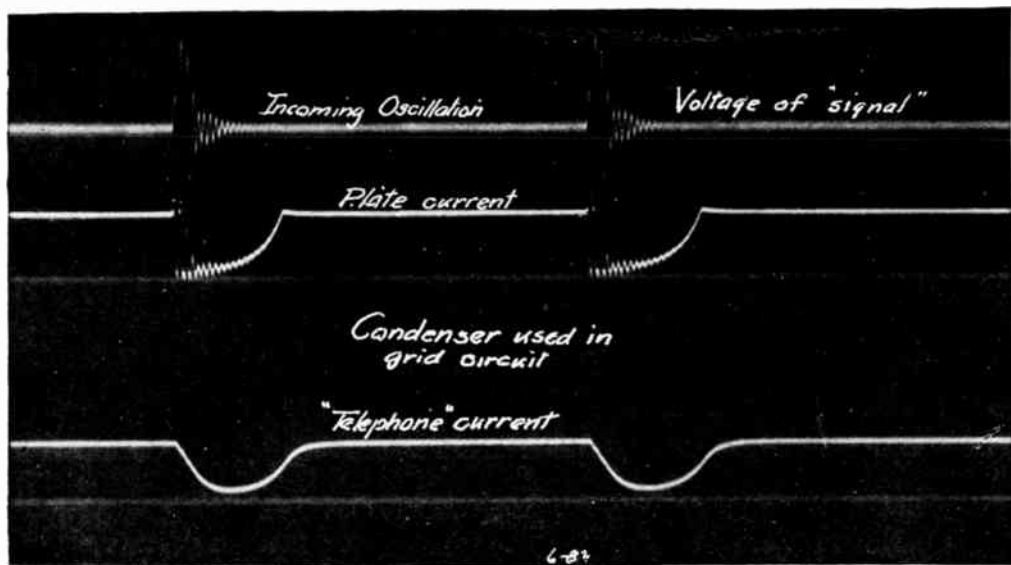

From a photograph loaned by Prof. J. H. Morecroft

#### A PHOTOGRAPH OF AN ELECTRICAL VIBRATION

Figure E: This picture is termed an "oscillogram." It shows in graphic form how a vacuum tube that is used with a condenser in series with the grid, detects a high frequency signal.

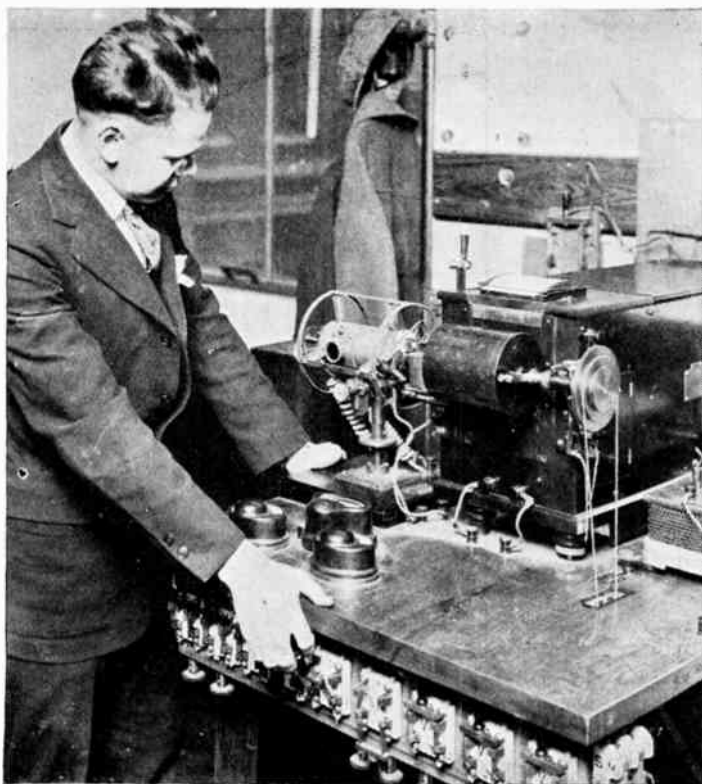

General Electric

#### THE OSCILLOGRAPH—A MACHINE THAT PHOTOGRAPHS ELECTRIC CURRENT

Figure F: The film end of an oscillograph box, showing the arc lamp in the spring tube at the left and control switches, vibrators, electric shutters and field magnets. The kind of picture that such a device produces is shown on page 77.

surely make us pay closer attention to many events taking place around us which we have never questioned, although we have understood them no better than we understand the triode.

“Everyone who has studied physics in high school knows that sound is a to-and-fro motion in the air, that it is a vibratory action in which energy flows past the ears at a non-uniform rate; the flow of energy goes from a maximum to

zero with a frequency depending upon the musical pitch of the note. Thus the sound from a violin string, giving the middle C, is really caused by a compression and rarefaction wave in the air which sends energy past our ears in the form of ‘pulses’ at a regular rate of 256 a second. The question should occur to anyone who hears such a sound: how can the man’s arm, which is evidently exerting a uniform pull on the violin bow,

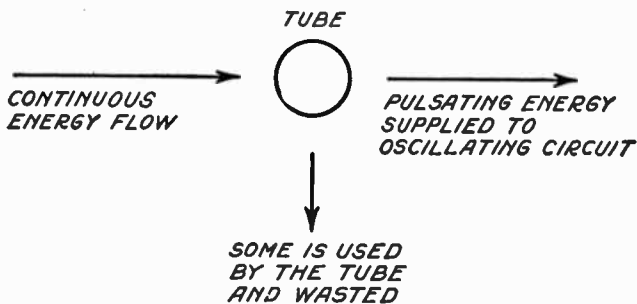

FIGURE G

The elements of an oscillating tube. This diagram illustrates in simple form the action that takes place within the oscillating vacuum tube.

send off energy at the rate of 256 pulses a second? Certainly the man's muscles are not causing that phenomenon directly.

"The answer to this question, although the phenomenon is a common one, is not simple; it can probably be accurately given by no one who reads this article. The question has probably not even occurred to any one of them, yet we frequently hear nowadays the question: 'What makes a triode oscillate?' It is a case of the unusual; the violin string is so simple that everyone thinks he knows how it works. But the vacuum tube seems much more complicated in its action. As a matter of fact it is easier to get an exact solution of the action of the triode than of the violin string.

"What makes the brakes of a train or automobile give off such a shrill squeal when they are suddenly applied? Does the driver actually vibrate the brake shoe thousands of times a second? Evidently not. What makes the balance wheel of a watch continually oscillate back and forth when the main spring is evidently trying always to push it in the

same direction? What makes the steam rush out of a whistle in pulses, giving off high-pitched musical notes when it could apparently flow through the hole through which it is escaping more easily if it came out uniformly—in which case no sound would be given off at all?

"Will a toy balloon, towed behind an automobile, proceed uniformly through the air or will it vibrate sideways, even though the towing string is exerting a uniform forward pull? Why does a flag flutter in the breeze?

"These cases could be multiplied without number; it seems in many instances that Nature would rather do things in an oscillatory fashion than in a straightforward fashion.

"We should not be surprised, therefore, in view of the actions just outlined, if the electrons in the triode, on their way from the filament over to the plate, may be made by certain circuit connections to proceed at a variable periodic rate rather than flow uniformly as the continuous current generator or battery in the plate circuit tends to make them do.

"The elements of an oscillating tube

circuit are as shown in Figure G. The plate circuit generator with its associated choke coil delivers a continuous flow of energy; this energy coming to the tube may be partly used up in the tube and partly flow on to the output circuit, which is the place where the high frequency power oscillations are started. The oscillating circuit may be made to act on the tube, so that the energy is supplied to the circuit in pulses, thus serving to keep it continually in oscillation. This action is much the same as in the escapement of a watch, which lets energy flow into the balance wheel in pulses—the pulses being so timed as to maintain the oscillatory motion of the wheel.

“The period, or frequency of oscillation of the balance wheel, is fixed by the effective mass of the wheel and the size of spring used; shortening the spring will increase the frequency and lengthening the spring will lower the frequency. This is what is accomplished by the ‘faster’ and ‘slower’ adjustment of your watch.

“As the electrical constants of the oscillating circuit determine the frequency of the alternating current that is generated, it might be presumed that any frequency could be generated at will. Such is nearly the case. With one of the ordinary tubes obtainable for small transmitters the writer has produced frequencies as low as one cycle a second by use of large inductances and condensers, whereas the same tube with the smallest inductances and condensers feasible has generated ten million cycles a second. These are not necessarily limits; it is possible for one who has large and efficient coils to go lower than one a second and by using proper care in the selection and arrangement of the apparatus the upper frequency can be pushed as high as three hundred million cycles a

second—a wide enough frequency range to suit almost everyone!

“The amount of power output of an oscillating tube is limited entirely by the amount supplied by the continuous current machine that furnishes the power to the plate circuit; only a certain fraction of this can be transformed into alternating current power. The power supplied by the continuous current machine is equal to the product of its voltage and current, hence to have a large output from a tube its plate circuit must be arranged to stand high voltage and its filament must be sufficiently large to liberate a great many electrons without operating the filament at such a high temperature that its life would be short. In the smaller tubes used for transmitting about 500 volts pressure is used in the plate circuit and a current of about 30 milliamperes is permissible, thus requiring from the plate circuit generator 15 watts of power. As an efficiency of 30 per cent is common in these tubes as generally used, the amount of alternating current power available is about 5 watts, which is the rating of the small transmitting tubes.

“For more power, larger filaments are required and the arrangement of connections in the tube must be such that high voltages may be applied between the plates and filament. Tubes are now being made for experimental purposes which permit an electron current from filament to plate of 60 amperes and which permit a voltage in the plate circuit of 15,000 volts. As the efficiency of these larger tubes can be made much higher than it is for the smaller tubes (just as is the case for any electrical machinery) we may figure on an efficiency of 80 per cent to 90 per cent, so that the output would be measured in the hundreds of kilowatts. Of course, these

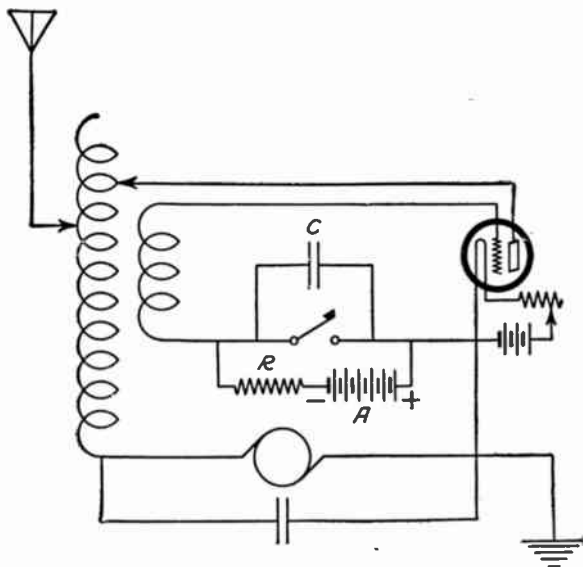

FIGURE H

A circuit that employs a small battery and a resistance to keep the grid negative while the sending key is "up." This prevents any current flow through the tube while the key is in this position.

powerful tubes cannot follow the same constructional lines as the smaller tubes; they are made of metal instead of glass, and all the parts of the tube must be arranged for cooling by circulating water through jackets properly built into the tube.

"For a given tube, well constructed and evacuated, there are two prime factors which serve to limit the safe output: the safe filament temperature and the safe plate temperature. Excess values of either will materially shorten the life of the tube.

"An oscillating power tube may be either separately excited or self-excited, the same as any continuous current generator. In case but one tube is being used it must evidently be self-excited, but if three or more are used better re-

sults will be obtained by using one of them (self-excited) to excite the grid circuits of the others. The writer has always found it possible to get more power out of three tubes by using one of them as an exciter and the other two as power amplifiers than if all of them were used to deliver power to the antenna. It is easier to control the various required adjustments for separately excited tubes than for those self-excited.

"It is especially advisable to use separately excited tubes for short wave telegraph transmission because of the greater constancy of the frequency generated; if self-excitation is used the frequency of oscillation is determined by the capacity of the antenna and any change in this capacity will affect the frequency sent out. If double frequency

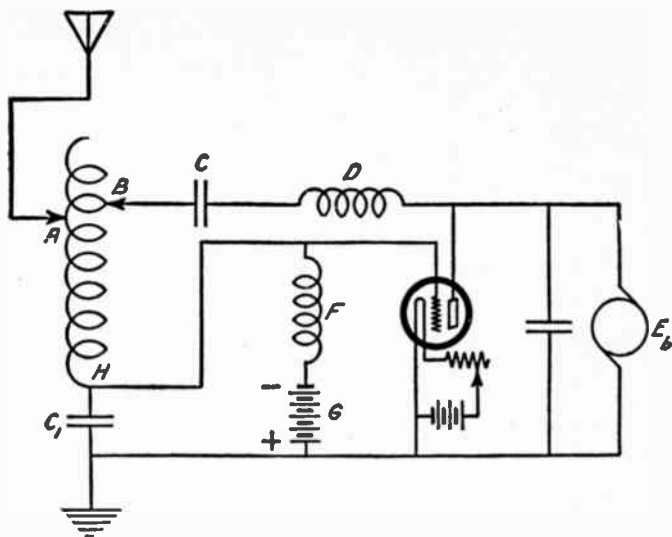

FIGURE I

An oscillating circuit that is adaptable for use by amateurs for transmitting. By insertion of the proper modulating apparatus this circuit may be used for telephony.

amplifiers (Armstrong's super-heterodyne) are used for receiving, the reception will be comparatively poor.

"The safe output of an ordinary tube is fixed by the heating of the plate. The largest tubes used by amateurs have a safe plate rating of 250 watts. If the tube is adjusted for 50 percent efficiency it is evident that the maximum safe output of the tube is 250 watts. Suppose that by a suitable adjustment the efficiency could be raised to 90 percent, what would be the safe output of the tube? Again the safe output would be fixed by the fact that there must be no more than 250 watts used on the plate, but with 90 percent efficiency, when the loss on the plates is 250 watts, the output of the tube will be 2250 watts; that is, the possible output has been increased something like ten times!

"It is easy to state the conditions

which must be obtained in a tube to get its maximum efficiency for any given filament current and plate voltage, but it is not quite so easy to furnish these conditions on an actual set. A comprehensive study of the question of triode efficiency was made by the writer, with the assistance of Mr. Trap Friis, and the results were published in the Proceedings of the A. I. E. E. for October, 1919. This seems to be the only work on record in English that shows the necessary conditions for maximum efficiency and how to obtain them.

"The grid potential and plate potential of the tube fluctuate as the tube generates alternating current power, generally following the form of a sine wave. For best conditions the plate voltage must fluctuate an amount nearly equal to the voltage of the machine in the plate circuit. For example, if a 500-

volt generator is used in the plate circuit the plate voltage should fluctuate from about 50 volts to 950 volts, the exact amount depending somewhat on the structure of the triode. The proper value of the lower limit (50 volts) is very important in determining the efficiency, but it can only be given accurately when the exact characteristics of the tube are known. The article cited above deals with this point in detail.

"The grid potential must fluctuate by an amount about equal to the fluctuation of plate voltage multiplied by the factor  $W_0/2$  where  $W_0$  is the theoretical voltage amplification factor of the tube, generally about five for the small power tubes sold for amateur use. The amount of grid bias voltage (always negative) should be so chosen that when the grid voltage has its maximum positive value it is nearly equal to the minimum plate voltage. This condition may be obtained either by the use of a C battery of small dry cells or by the use of a suitable grid condenser and grid leak. In either case a high frequency choke coil should be placed between the grid and ground (filament connection) to prevent the use of excessive power in exciting the grid.

"Not only must the proper magnitudes of grid and plate voltage fluctuations be obtained, as given above, but the relative phases of the two must be accurately adjusted. The phase of the two must be exactly 180 degrees apart, so that the maximum positive grid potential occurs simultaneously with the minimum value of plate voltage. This is an important point to observe if the maximum output of the tube is to be obtained, and is the most difficult condition to fulfill when the tube is using self-excitation.

"The fourth condition has to do with

the load circuit. In the case of separate excitation the natural frequency must be the same as the frequency of the exciter and for either separate or self-excitation, the effective resistance of the antenna circuit, between the two points where the tube supplies the alternating current power, must be equal to the alternating current resistance of the plate circuit of the tube. This is nearly equal to (but always somewhat less than) the voltage of the B machine divided by the continuous current furnished by this machine.

"It is possible, of course, to put the transmitting key directly in series with the antenna circuit if but little power is being generated, if opening the circuit at the point selected does not also interrupt the current from the B machine. It is generally better, however, to put the key in the grid circuit, thus cutting off the excitation of the tube when no signals are being sent out.

"Whenever possible the key should be so placed that when the key is 'up' no plate current flows from the B machine; in this case when no signals are being sent (all the time the key is up) the plates are being cooled off and also not so much power is used from the B generator. If this connection is properly made the safe output of the tube is nearly twice as much as if this precaution is not observed.

"Thus if a tube is rated at 12 watts safe power on the plate and the above condition is satisfied, the circuit may be adjusted so that when the key is down the power dissipated on the plates is 20 watts, and still the plates will not overheat.

"In the case of highly evacuated tungsten filament tubes this may be accomplished by leaving the grid 'free' or 'floating' when the key is up; with oxide



coated filament tubes this free grid is a dangerous condition and should never be tried. The free grid of a well evacuated tungsten tube will practically always be negative, thus cutting the plate current down to a very small value. The free grid of an oxide coated filament tube may suddenly go positive, in which case the plate current increases to a dangerous value and the tube is spoiled in a few seconds; in fact, they many times 'blow up,' breaking all the internal structure.

"For these oxide filament tubes it is best to have the key so inserted that when it is up the grid is forced to a proper negative value by a battery of small dry cells, as indicated in Figure H. With the key up the voltage of cells A forces the grid to become so negative that the plate current is brought to practically zero and when the key is down the cells are 'shorted' through the high resistance R, which is sufficiently high (say 50,000 ohms) so that the current which flows from the cells doesn't materially affect their life. A small condenser C across the switch points will eliminate whatever slight sparking might occur. Using this scheme it is possible for a small hand key to successfully control kilowatts of power in the antenna.

"When the conditions for best efficiency are obtained it often happens that the tube is sluggish in 'picking up' when the switch is closed, thus not permitting rapid sending; for this reason as well as for the others cited above, it is best to have the power tubes excited by a separate tube, which is continually left in the oscillating state.

"Of course, everyone finds his 'best' circuit by using that in which he gets most power out of his tubes. But any circuit which permits the fulfillment of

the conditions analyzed will be as efficient as any other.

"A circuit certainly as convenient as any is shown in Figure I. This is the one used most frequently by the writer. A coil H, A, B, is wound with sufficient inductance so that combined with the capacity of the antenna it will give frequencies considerably lower than any which it is desired to generate. It has about twelve taps, say every second turn is brought out for making connection to it by a clip. Condenser  $C_1$  is a mica condenser with four or five values, the minimum being about equal to the antenna capacity; a better but more expensive set-up uses a variable condenser in this place. F and D are high frequency chokes of about one millihenry each. C is an insulating (or blocking) condenser of say 0.1 microfarad. G is the biasing battery of a few small dry cells; for the ordinary 5-watt tube 20 cells will do.

"The wavelength sent out is controlled by the position of contact A. The grid excitation is controlled by the size of condenser  $C_1$ ; it should generally be about twice the capacity of the antenna. The position of contact B affects the wavelength slightly but its principal function is to make the effective resistance of the antenna, as measured between contact B and ground, equal to the plate circuit resistance of the tube. The amount of bias voltage in battery G affects the efficiency of the tube primarily; this, and the capacity of the condenser  $C_1$ , should be varied together in adjusting for maximum efficiency. For small power the sending key can be placed in the antenna circuit between condenser  $C_1$  and ground. If the maximum safe output is desired the grid should be excited through a condenser and the key arranged as shown in Figure H.

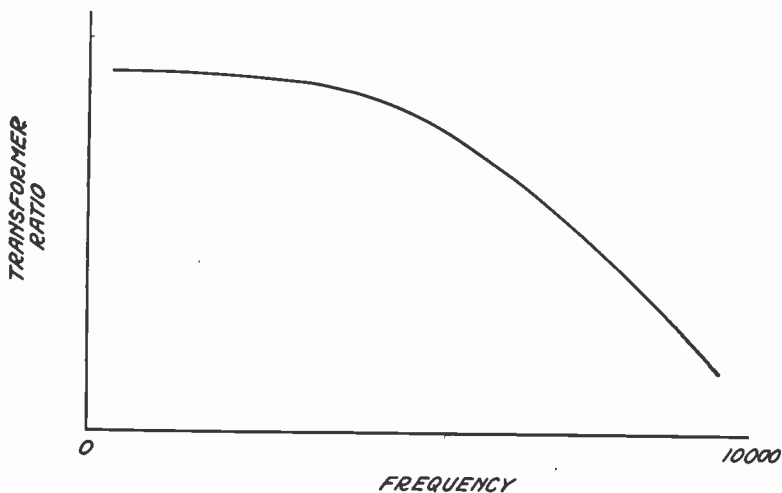

FIGURE K

Curve showing how the voltage transformation ratio, for a modulation transformer which has a great many secondary turns, decreases with an increase of frequency.

“For the single tube transmitter this circuit arrangement seems as good as any.

“When a vacuum tube is used to generate the high-frequency power sent off from the antenna by a radio telephone transmitter, the very rigid control which the grid potential exerts over the plate current offers a ready means for modulating the plate current—and the plate current controls the amount of power which the tube supplies to the antenna.

“An arrangement suitable for a small transmitter that uses one tube is shown in Figure J. When proper coupling is used between coils  $L_1$ ,  $L_2$ , and  $L_3$  the tube will oscillate and supply alternating current to the antenna, the frequency of which is approximately that fixed by the inductance and capacity of the antenna circuit.

“The amount of plate current which

the D.C. generator B supplies to the tube is determined by the potential of the grid of the tube, and this potential is controlled in turn by the voice currents set up by microphone M, acting on the grid through transformer A. The condenser  $C_1$ , is advisable as it facilitates the oscillation of the tube; it must not be more than about .001 microfarad, however, otherwise distortion of the speech will result.

“In some sets there is also connected across the secondary of transformer A, (called the ‘modulation transformer’) a resistance of about one megohm; it is supposed to improve the quality of the speech. The condenser  $C_2$ , is advisable, not only to facilitate the setting up of oscillations but also to protect the insulation of the armature of machine B, which is subjected to high-frequency dielectric losses if not shunted by this condenser.

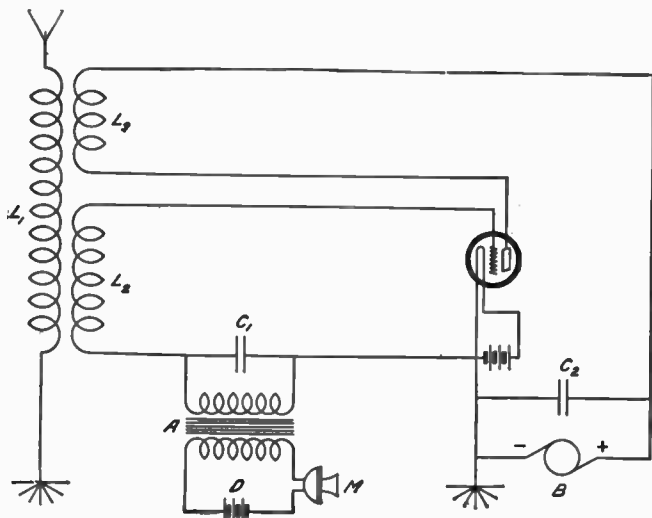

FIGURE J

The circuit diagram for a low power single-tube telephone transmitter that employs the grid method of modulation.

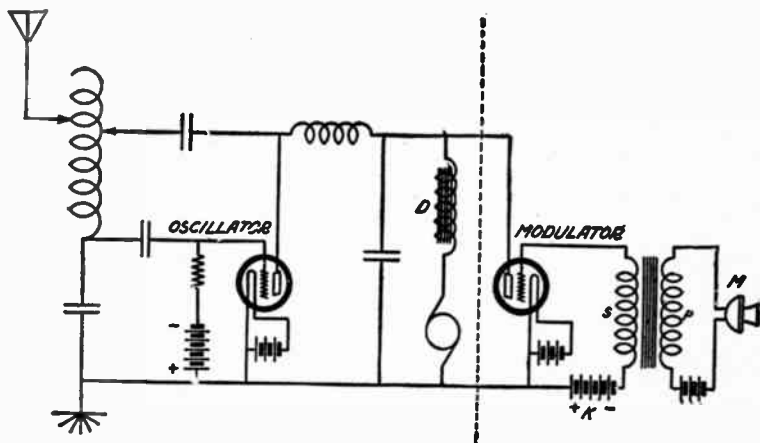

FIGURE M

This diagram shows how to wire up a set employing Heising modulation. All the apparatus shown at the left of the dotted line is in the oscillator circuit and the apparatus at the right of this line is connected in the modulation circuit. This is the scheme of modulation used at all the larger broadcasting stations.

"The modulation transformer A, must be especially designed for the microphone and tube with which it is to be used. It generally has a fairly high transformation ratio, sometimes as much as twenty-five to one.

"The primary coil, in series with the microphone, must be of low resistance, as low as that of the microphone itself

even with but little fluctuation in the primary current sufficient voltage will be induced in the secondary to properly modulate the antenna output. Such a high ratio would require a great many turns of fine wire in the secondary, however; this would be sure to bring about speech distortion as the consonants, the high-frequency waves of the voice,

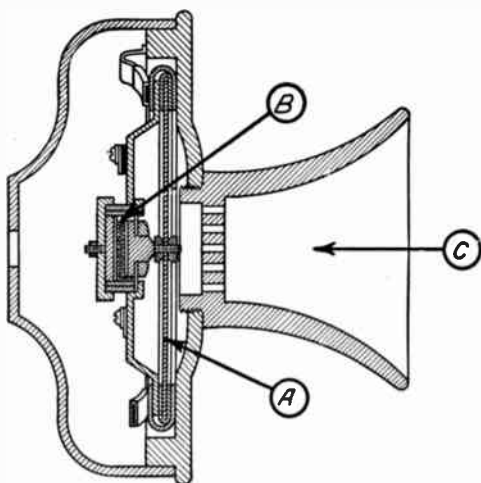

#### HOW SOUND WAVES ACT ON THE CARBON GRAIN MICROPHONE

Figure L: The sound waves enter the mouthpiece C, and vibrate the diaphragm A, which causes the carbon grains B, to be compressed and released, thus varying the current that flows through the microphone.

or lower; if not, the variation in microphone resistance, brought about by the voice waves, will not materially affect the current from battery D, and if this current does not fluctuate there will be no voltage induced in the secondary coil and so the tube output will not be controlled.

"It might seem advisable to wind the transformer with an extremely high ratio (say five hundred to one), so that

would not be repeated through the transformer.

"The voltage transformation ratio of a transformer is not the same for all frequencies; if the secondary has a great many turns this ratio decreases very rapidly for the higher voice frequencies.

"This effect is suggested in Figure K which gives the ratio of transformation for such a transformer; for the high voice frequencies the ratio is much less

than for the lower ones, so that the high-frequency consonants would not come through the transformer with their proper relative magnitude and the voltage affecting the grid potential would be deficient in consonant sounds. The power radiated from the antenna would thus be deficient in the high-frequency sounds of the voice and the speech received by the listener would be drummy and indistinct, no matter how good the receiving set might be.

"It is to be pointed out, however, that even if the quality of the speech sent out by the broadcast station is excellent, an improper adjustment of a regenerative receiving set will always make it seem poor. A transmitting station is frequently blamed for poor speech quality when actually the quality is spoiled right in the receiving set itself; we shall analyze this point later.

"The scheme given in Figure J, which we have just examined, called *grid modulation*, is not all that might be desired because even with the best adjustment it is impossible to obtain a high percentage of modulation (which causes wide variations in the antenna current) without getting poor quality.

"As long as we are content to change the amplitude of the antenna current by perhaps 25 percent (or in other words get 25 percent modulation) the quality of received speech is fair, but when it is pointed out that in radio telephone transmission *it is the change in amplitude of the antenna current brought about by the voice and not the actual antenna current*, which determines how far the signal will carry, it is evident that some scheme that will permit greater modulation is to be desired.

"Such a one is indicated in Figure M; in Europe it is called *plate modulation* or *choke-coil modulation*, but in the United

States it is styled the Heising scheme of modulation, because Heising was responsible for its development in this country.

"This Heising method of modulating the antenna current is almost universally used in the better class broadcasting stations of today; although it is expensive to install and maintain compared to the other schemes, the quality of speech obtained when it is properly adjusted makes it far superior to any other method so far devised.

"Many radio enthusiasts seem to object strenuously to this scheme because they have to 'waste' half their tubes; only half of them are oscillating to produce antenna power and their antenna current is much less than when they connect all their tubes in parallel to act as oscillators to supply power to the antenna, and modulate by the grid method.

"With all the tubes acting as oscillators the antenna current is about 50 percent greater than when connected for the Heising modulation scheme; hence it seems as though the Heising scheme must be inferior to the other. But we have to again emphasize the fact that such a judgment is based on a misconception as to what radio telephony really is; as stated before, the reading of the antenna ammeter is no criterion at all regarding the usefulness of a set to transmit telephone signals—it is the *variation of antenna current* produced by the voice that measures the station's efficiency and *not the antenna current itself*.

"One transmitting station that has two amperes of current in the antenna as read on the hot wire ammeter, using the Heising modulation scheme, should be able to telephone twice as far as is possible for another station that has a

much greater antenna current with a less perfect system of modulation.

"In some of the large stations used for broadcasting it has sometimes seemed advisable actually to use more tubes for modulators than were used for oscillators.

"The set shown in Figure M has only two tubes; in the average 500-watt broadcasting station two oscillators operate in parallel and either two or three tubes (of the same size as the oscillators) are connected in parallel with each other to act as modulators. The connection scheme shown in Figure M was used extensively during the war for Signal Corps sets and for the sets used on naval vessels. The circuit is divided by the dash line to indicate the two parts; all the apparatus to the left is used to make the oscillator function to furnish the high-frequency power to the antenna while that to the right is the required addition to the circuit to speech-modulate the antenna power.

"The two tubes, oscillator and modulator, both draw their plate current through the iron-core choke coil D; for the ordinary five-watt tubes this coil should have an inductance of about two henries. The grid biasing batteries and filament current of both tubes are so adjusted that the plate current of each is equal and equal to about half the total possible plate current, fixed by the amount of electron emission from the filaments.

"In Figure O (Page 91) is shown the static characteristics of the two tubes (supposedly the same for each); the grid of each tube is so adjusted in potential that the current taken by each is equal in amount to AC of Figure O, this equality of currents to be obtained when the oscillator tube is oscillating and no speech is acting on the microphone of

the modulator. This means that the grid battery K of the modulator must have the voltage OB and that the grid battery voltage of the oscillator, plus whatever resistance drop there is in the grid leak due to the grid current taken by the oscillator, is also equal to OB.

"As the amount of grid current flowing in the oscillator tube depends upon the adjustments of inductance, coupling, etc., the proper amount of grid battery for the oscillator cannot be obtained when the oscillator is not operating; an ammeter should be put in the plate circuits after the set starts to oscillate and the amount of grid battery adjusted to give equality of plate currents (the currents in the two plate circuits will not then be equal when the set ceases to oscillate). The amount of plate current in the oscillator, AC, corresponds to a certain definite amount of power in the antenna.

"If the grid of the modulator tube is now made to go up and down in potential, about the point B of Figure O, the plate current of this tube must go correspondingly up and down. As both tubes get their plate currents through coil D, however, and as this has sufficient choking action (the technician says it has sufficient *reactance*) to maintain the current through itself essentially constant, the plate current of the oscillator must go down and up by the same amount that the modulator current goes up and down. The sum of the two currents must continually be equal to twice the current AC.

"This means that if the modulator current decreases to the value AE, (Figure O), the oscillator plate current must rise to AG so that AE plus AG is equal to twice AC. As stated before, the power in the antenna depends directly upon the amount of plate current



### BUILDING A SET THAT EMPLOYS THE HEISING SCHEME OF MODULATION

Figure N: In this type of set one tube is used as an oscillator and another tube (of the same power) is used as a modulator. The circuit diagram for this set is shown in Figure M, which indicates how to connect the two tubes in the correct way.

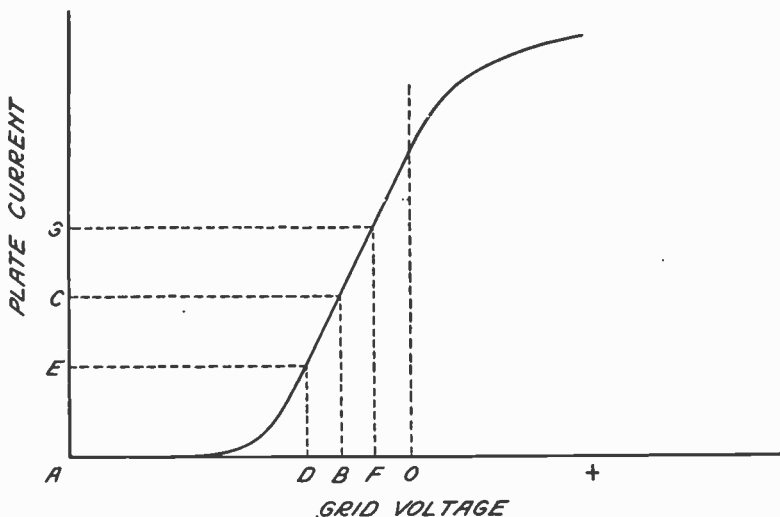

FIGURE O

The characteristic curve for the tube. This chart is shown in order to make clear the action of the modulator and oscillator tubes as explained by the author in the text. The curve actually shows the increase of plate current caused by an increase of voltage applied to the grid circuit.

supplied to the oscillator tube so that it is evident that the microphone M, controlling, through the modulation transformer S-P, the grid potential of the modulator tube, actually controls the amount of alternating current in the antenna. Moreover, the control exercised by this connection scheme is such that the fluctuation in amplitude of the antenna current represents the voice waves actuating the microphone M, more faithfully than is the case for any other modulation scheme so far tried.

"In the large broadcasting stations the microphone does not directly control the potential of the modulator tube grids, so it is necessary to use some intermediate tubes for amplifying. Thus the microphone into which the broadcaster talks works into an ordinary resistance-coupled, two- or three-tube speech-amplifier which controls the grid poten-

tial of a five-watt tube; this tube controls the grid potential of a fifty-watt tube, which, in turn, acts directly on the grids of the modulator.

"In this manner have the skilled researchers in this branch of radio communication developed that wonderful system of control by which the microwatts, sent out by the voice, control, accurately and instantaneously, the kilowatts of power necessary for communicating the hundreds and thousands of miles which are now easily covered by all of the best radio telephone stations."

We know that electric waves may be produced by the sparks of high-voltage transformers and by the oscillatory currents generated by vacuum tubes. It might surprise us to learn that arcs similar to those employed in street lighting are prolific producers of undamped radio waves when they are employed in



the proper circuits. Arc transmitters have proven so efficient since their introduction by Poulsen some years ago that they are used a great deal for high-power communication.

A brief reference to Figure Q will acquaint us with the general method used to connect all arc transmitters. It will be observed that a condenser is connected across the arc. It is the action of this condenser that sets up the high-frequency undamped currents. In a way, the action is similar to that occurring in a high voltage circuit of an

old fashioned spark transmitter save that continuous waves are generated.

In the following paragraphs we shall learn something of the modern application of the arc in the science of wireless communication.

The first arc transmitters designed for use on ships were cumbersome affairs, as every experienced marine radio operator knows. They occupied as much space as the first spark transmitters. The old arc chambers were designed on a generous scale, and with the auxiliary equipment just about filled the

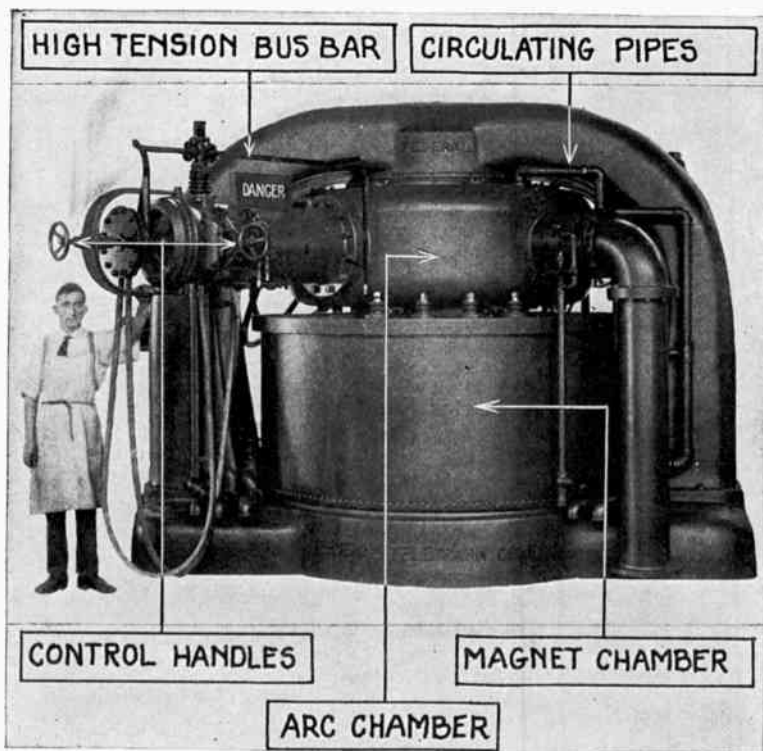

THE GRANDFATHER OF ARC TRANSMITTERS

Figure P: This huge arc converter has long been used in trans-Atlantic telegraphy. It employs 1,000 K.W. of power—ranging from 200 to 500 times as much as is used for the new type of transmitter described in this Part.

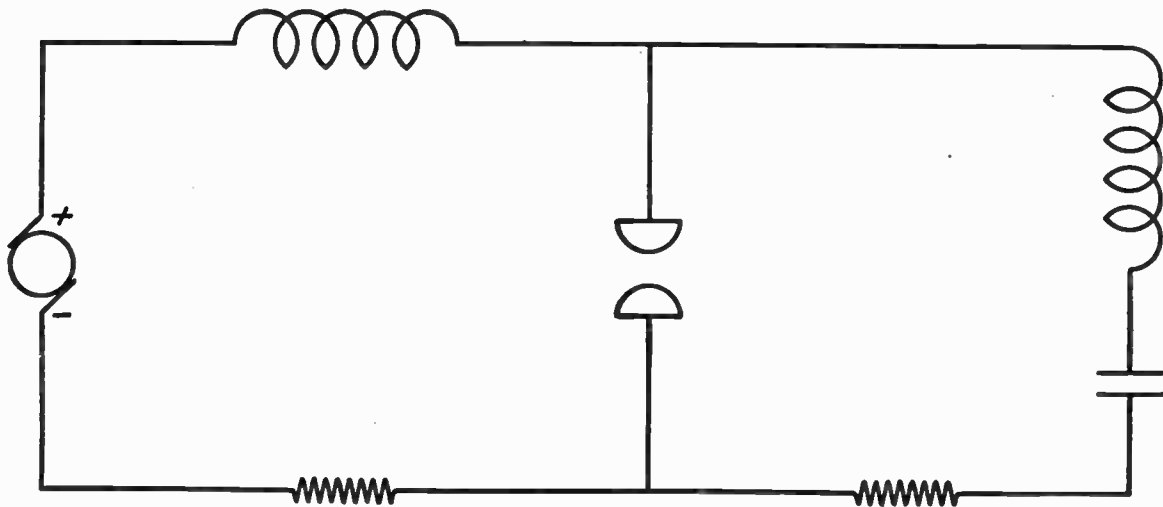

#### AN ARC THAT ACTS LIKE A VACUUM TUBE

Figure Q: When a condenser is placed across an electric arc in the manner illustrated, the arc immediately generates oscillations like a regenerative vacuum tube. Such a circuit properly connected to an aerial will create radio waves just as efficiently as vacuum tubes and with far greater efficiency than can be obtained with any spark or high voltage discharge method.

all too limited space of the vessel's radio cabin.

This unwieldy apparatus is now being replaced by a new and compact machine known as the panel transmitter, which can be included in a space 6 feet high on a floor space measuring only 24 by 20 inches for both the 2 K.W. and the 5 K.W. sizes.

This space may include the motor generator, but it does not provide for the water cooling tank or for the light-switch.

As the result of practical and persistent experiment, an apparatus has been developed that is automatic in its operation; to switch from sending to receiving is but a matter of pressing a button.

The auxiliaries and motor generator are designed for a 110-volt direct current supply, the usual source aboard ship, while the radio frequency portion is designed for an average ship antenna that has a capacity of approximately .002 mfd., with an average fundamental wavelength of 440 meters and a high frequency resistance of 6 ohms at 600 meters.

Four wavelengths can be used by adjusting one switch, the transmitters generally being adjusted to 600, 1800, 2100 and 2400 meters. However, the 2 K.W. units have one high wavelength less than the 5 K.W., and provision is made for a 300-meter instead of the 2400. This is required by law.

For receiving with non-oscillating equipment, a modulating device is used which allows damped wave transmission at 300 and at 600 meters.

As shown in Figure S, the upper panel is confined as far as possible to high frequency apparatus and leads. The open section in the center carries the arc chamber, the gas pressure regulator, the modulating device, the water pump and

the carbon rotative mechanism; the two latter mechanisms are driven by the same motor. The lower control panel contains all the low tension and high tension direct current devices and leads.

Figure S shows a complete mounting of the transmitter and its auxiliaries. The ship's mains are brought to the panel through the main fused switch.

After the set is wired, and with the Send-Receive switch turned to "send," operations may proceed as follows:

1. The motor generator is brought to full speed by the automatic starter, which is of the current relay type.
2. The generator field circuit is closed.
3. The main line (generator) circuit is closed.
4. The water circulating pump and the rotating carbon device are started.
5. The potential coil of the arc striking relay operates, closing its secondary contacts; this in turn closes the circuit to the arc striking solenoid.
6. Before the cathode (carbon) is drawn in to strike the anode, the starting resistor is connected in series with the arc and with the generator.
7. As soon as the arc is struck, the hydro-carbon magnetic needle valve automatically operates and the cathode slowly draws away from the anode, the proper action being regulated by an oil dash pot. At the same time the current coil of the arc striking relay predominates over the potential coil and the secondary contacts of the relay open again, allowing the cathode to withdraw from the anode. Again the starting resistor is shorted, and the arc is allowed to draw full power.

In the 110-volt leads an overload relay is provided; when the current in the circuit is abnormal it flows through the cur-

rent coil of the relay and this draws up an armature, breaking the circuit. The armature is held by a potential coil and cannot be released without disconnecting the ship's mains from the panel.

A relay similar to the overload relay is inserted in the generator leads, but in this case an overload opens the main line

contactor (solenoid type), and this opens the positive side of the generator line.

The normal full load voltage of the 5 K.W. unit is 375 volts, variable by a generator field rheostat, and the normal full load current ranges from 12 to 15 amperes. Meters are provided with readings in generator volts and amperes;

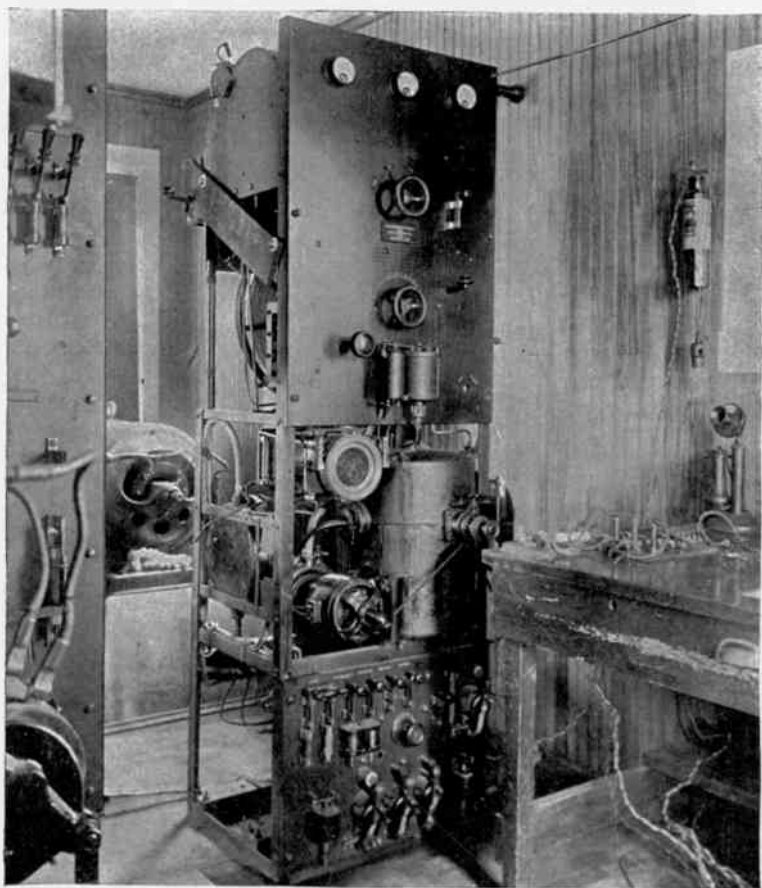

#### THE ORDINARY ARC TRANSMITTER INSTALLATION ON SHIPBOARD

Figure S: The apparatus in this case is a 2 K.W. arc transmitter on the U. S. S. Vulcan. The cabinet in the lower left corner contains the receiver; all the rest of the apparatus scattered about the cabin are the various parts of the arc equipment.

the product of these two readings gives the arc input in watts.

A radio frequency meter ranging from 0 to 30 amperes for the reading of antenna current is also provided. At 1800 meters a fair antenna current would be 18 amperes, assuming a 5-ohm high frequency resistance for the antenna. The antenna input would be of approximately 1620 watts, with an arc efficiency of approximately 30 percent.

The arc chamber is cast in two pieces. These are split about one-third of the way down, and in them are screwed the pole pieces. A water cooling duct of one complete turn is cast in the main chamber section.

The field coils are wound in four sections, one in the upper portion and three in the lower portion. They are wound with square cross-section asbestos-covered copper wire and are connected in series. Additional insulation in the form of empire cloth insulation is provided between coils and chamber.

Connected directly with the chamber, and at ground potential, is the cathode, its distance from the anode, or arc distance, regulated with a control handle. The cathode holder can be removed instantly from the chamber, and a new carbon may be inserted without tools.

The anode is, of course, insulated from the chamber. It consists of a solid copper tip held by a large copper tube. Within the large tube is a smaller one, also of copper. The water from the cooling system enters through the small tube, plays directly on the solid tip and returns through the large tube. Then it goes through the one-turn duct in the chamber back to the cooling tank and from there to the circulating pump. During a period of continued use, carbon will collect in the arc chamber; this may

be cleaned out when the anode is removed.

Hydro-carbon is supplied to the arc by vaporizing alcohol; when the alcohol drips on the hot electrodes it automatically vaporizes. The pressure of the gas in the chamber is kept constant automatically by a regulator that has a diaphragm similar to that in an ordinary gas meter, and poppet valves are provided to prevent dangerous explosions. It has been found that when this gas is supplied to the arc it tends to keep the oscillations stable and allows the arc to handle a greater amount of power.

Unlike the high-powered arc transmitter, this set does not emit a "compensating wave." Signalling is accomplished by switching the anode terminal from an absorbing circuit to the antenna circuit, and when the key switches the anode lead the anode must always be connected with either or both of these circuits in order to sustain the arc.

The absorbing circuit consists of a condenser, a resistor, and an iron plate resistor, the complete circuit having approximately the same characteristics as the average antenna.

The iron plate resistor is a variable unit; and it is possible to adjust the absorbing circuit so that it will draw exactly the same input as the antenna circuit. In other words, when signalling, the anode is first connected to the absorbing circuit and then to the antenna circuit; the arc input remains constant as indicated by the meters.

The transfer key is of the relay type and is remotely controlled by a single telegraph key at the operating table. An auxiliary handle protrudes through the panel so that the transfer key may be operated directly by hand in case of an emergency.

To change wavelengths with an arc



#### EXPERIMENTAL 'PHONE STATION

Figure U: From this radio telephone station at Deal Beach, N. J., the tests with ships at sea were conducted.

transmitter it is only necessary to vary the amount of inductance in series with the antenna, or to vary the antenna constants. In this case the desired change is reached by inserting the proper amount of inductance in series with the antenna. The main inductance consists of a large Bakelite-Dilecto tube, wound with a heavy Litzendraht wire nearly  $\frac{3}{8}$  inch in diameter. The inductance is wound in sections and the sections are bank wound. Taps are taken off at every section.

It is apparent that fine wavelength adjustment is not possible when the inductance is varied by taps in every section, so a compensating inductance is provided. This consists of one flat spiral of strip copper, which can be varied by a handle on the front of the panel.

There is in the wavechange switch a total of eight positions for the four wavelengths, the extra position for each wavelength cuts in the compensating inductance for fine adjustment.

For example, if the desired wavelength is 2,400 meters, the wavechange switch is turned to the right "half" por-

tion of 2,400 meters and the wavelength is measured and found to be 2,600 meters. Another section of inductance is cut out of the main inductance, increasing the frequency and the wavelength is then found to be 2,356 meters. Next, the compensating inductance is increased and the wavemeter read, the frequency decreasing until the wavelength is increased to exactly 2,400 meters. A permanent clip is then substituted for the variable contact and that contact is used again to adjust the other wavelengths.

To produce damped oscillations a modulator system is used. This consists of a few turns of heavy Litzendraht wire in inductive relation to the main inductance. These turns are periodically short-circuited by a special commutator which has a certain number of bars connected together. When current flows through the main inductance and these turns are shorted, the wavelength is decreased approximately  $7\frac{1}{2}$  percent. The speed of the commutator and the number of common bars were selected to give a 400-cycle note, while the re-

sulting decrement is just enough to provide sharp tuning and yet insure being heard when transmitting.

If the operator wishes to reduce his power when he nears land, he may insert a 10-ohm resistance in series with his antenna, or he may reduce his arc input.

The water cooling tank has a sight level glass and controlling valves, and is

usually mounted on the bulkhead with a casting provided for the purpose. Water connections are made with a special hot water hose, and in winter alcohol is mixed with the water to prevent freezing. Of course salt water can never be used as it would short-circuit the anode to the ground.

Excellent work has been done with

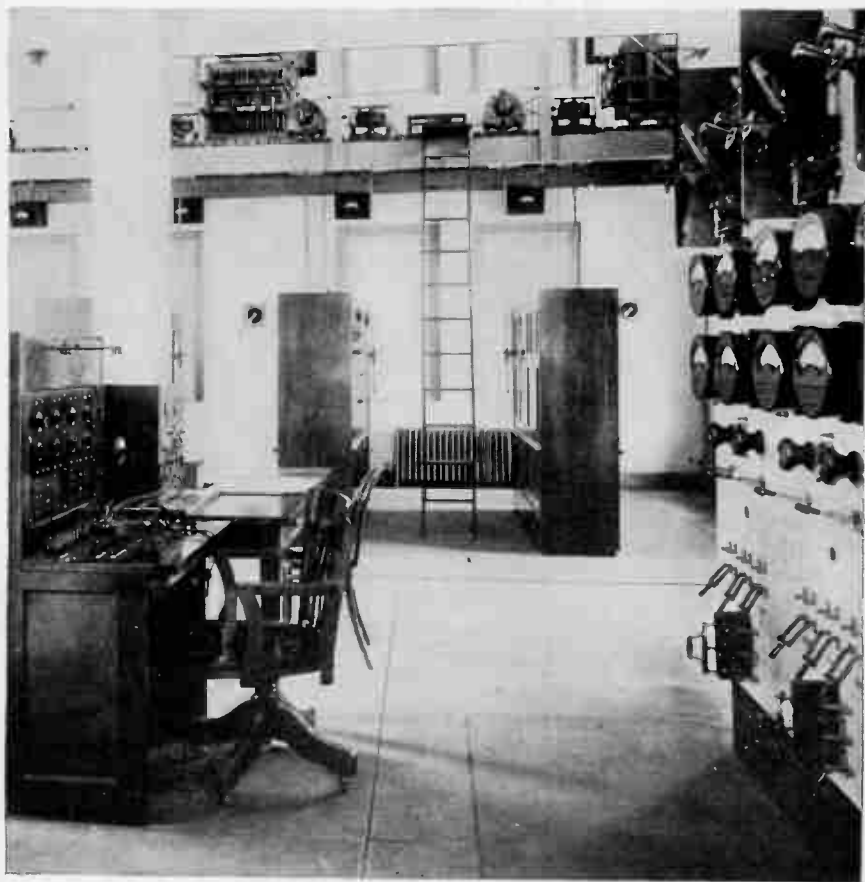

#### WHERE THE RADIO CALLS WERE RECEIVED

Figure V: At the desk in the foreground sat the operator in the Deal Beach Station when the two-way conversation with the "America" was carried on. The tube sets are in the background and the antennae connections are on the balcony

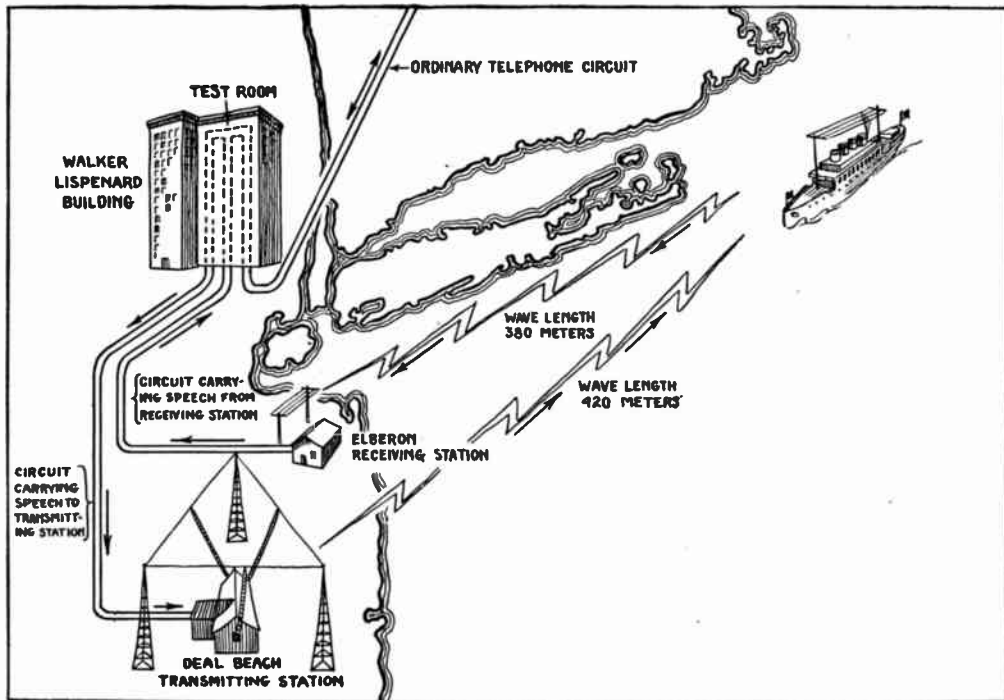

### RADIO WAVES HITCHED TO WIRES

Figure W: This diagram shows how the wireless impulses from the ship were transferred to the telephone circuit and carried into a country home in Connecticut.



these new transmitters. A 5 K.W. unit installed at Babylon, N. Y., when radiating only 8 amperes at 2,100 meters was reported by a tug stationed in the harbor at Hamilton, Bermuda. The tug had a standard Navy receiver with a two-stage amplifier and reported that the signals were readable ten feet from the phones.

Another unit installed on the S. S. *Minnekahda* has worked the Cuxhaven Station at distances approximating 2,000 miles. Cuxhaven uses a quenched spark gap.

Two-way talk by radio that enables a man at sea to talk over the land telephone lines is the latest achievement of the far-speaking art. The flawless performance which was given when the commander of the incoming ocean liner *America* talked when he was 360 miles at sea with H. B. Thayer, who was in his home at New Canaan, Connecticut, is a significant forecast of a new year. Mr. Thayer, then president of the American Telephone and Telegraph Company, was naturally interested in the development of the relations between the telephony of the air and that which follows the throbbing wire. The test in which he took part on the night of March 5, 1923, is only one of a series which was begun for the purpose of bringing people in the cities in touch with their friends on ocean-going vessels.

One of these days James Wilberforce Smith, or whatever his name may be, will sit in his stateroom in mid-ocean and call up Mrs. Smith to tell her what he had for dinner. He cannot go into too intimate detail, of course, for owners of radio-phones all over the world almost have a chance to listen in. They did just this the other night when Captain Rind and Mr. Thayer were talking of

the future of telephony. Radio fans all over the eastern part of the country knew all about the feat, as the conversation was naturally broadcast.

Experts may not consider it such a remarkable feat to join wire and vibrant air, but the communication of the *America* with the shore did much to make practical a whole lot of theory. That the change can be made satisfactorily was shown by the interesting tests made with the coastwise steamship *Gloucester*, from which speech was first sent by wireless to the shore, then transmitted across the Continent to the Pacific coast, and then relayed by radio once more to Catalina Island. When the World War was over, the company, as radio fans will remember, conducted long telephone communications between Arlington and the Eiffel Tower in Paris.

Many a radio amateur, in a spirit of experiment, has invited some friend who has no receiving set to listen to something choice which he has detected in the air. Merely by placing the receiver of the radiophone over the transmitter of the ordinary telephone, he can entertain an auditor with some entertaining selections. On the lines of this unauthorized practice, and, of course, with much greater precision, the company itself connected up the wireless with its own land wires. To do this it employed its wireless stations at Elberon and at Deal Beach, N. J., and such apparatus as it required in its big operating station in the skyscrapers at No. 24 Walker Street, New York City, where a group of company officials had gathered.

Owing to many factors with which every radio amateur is familiar by experience, there are obstacles to perfect communication which must be overcome in such experiments. The waves used in sending and receiving would have

burned each other up, so to speak, had the two stations not been separated by the mile and half of sands. The voice of the captain of the *America*, as is shown in the accompanying diagram Fig. W., was carried over the sea for one hundred and twenty leagues to the Elberon station. There it was so modified that its waves were made of such frequency as to make them audible over the land lines with which it was connected. When Mr. Thayer replied to Captain Rind his words followed the metal strands to the station at Deal Beach, and were then amplified and cast out into the air, where they were duly received on board the steamer. The two stations, on the New Jersey beach, although so widely separated, were doing fine team work. The two currents—the

going and the coming current—as far as the ship was concerned, passed through the plant in Walker Street, where greater power was imparted to them, for distribution to the telephone subscribers who cared to listen to this historic interchange of greetings.

By the use of various duplex devices the captain of the *America*, who did not have a mile and a half of beach for lee-way, was able to talk into the 'phone and to hear at the same time. His voice, going through the vacuum tubes, was easily spread in every direction and was caught up by the station at Elberon. Thus the two-way talk proceeded without interruption and Mr. Thayer and the captain conversed quite as easily as they might have done had they been in adjoining offices in the city. The in-

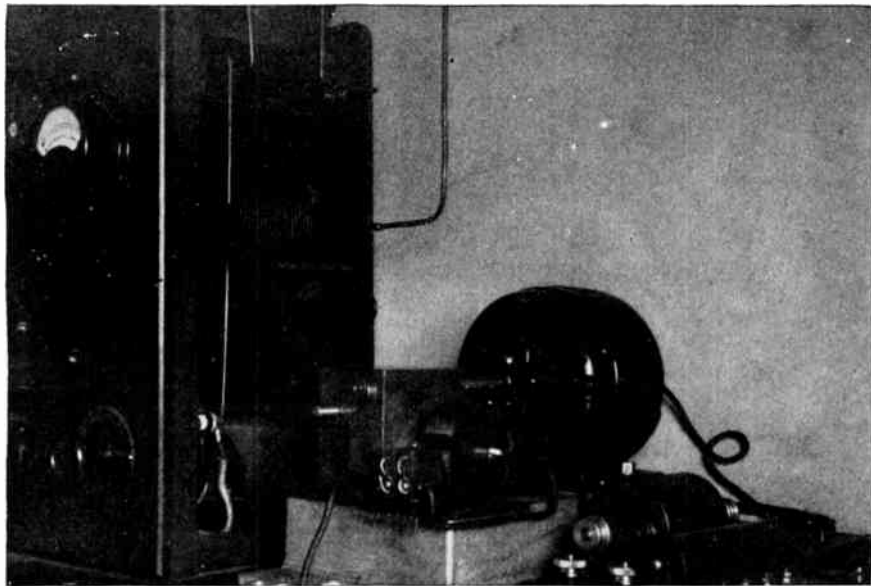

#### THE AUTOMATIC RADIO TRANSMITTER

Figure X: This is the type of apparatus that is installed aboard lightships and light stations. It is used for transmitting automatically in connection with the use of the radio compass.

stantaneous replies to questions and greetings was an admirable demonstration of the new method.

It is a bit early to predict just how far-reaching this innovation will prove to be. It certainly should become of great value for communications between captains of vessels and the agents or owners ashore. Instead of a long interchange of wireless telegrams, it would give the same direct and clear understanding of orders as might be obtained by those concerned had they sat facing each other across a flat top desk. The need of just such direct interchanges has often been apparent in emergencies.

While the functions of radio and wire transmissions are so radically different, yet they may be harmonized in many ways. The message which comes by wireless over many liquid leagues may in the first place be caught by the receiving sets of many alert fans. This was actually the case when the *America* was approaching. For the ordinary purpose of business, however, the network of land wires that reach all parts of the nation by telephone and telegraph are a powerful aid in the dispatching of information which is sent in throbbing from the realms of ether. The outcome of the latest liaison between wire and wireless will be followed closely by the disciples of radio.

Since we have just discussed the use of radio-telephony at sea, it may be interesting to tell of another very important use to which radio is put in making sea travel safe as well as more convenient. This device, which is also comparatively new and which has supplied a most valuable service since its introduction a few years ago, is known as the radio compass.

Blanketing banks of fog, obscuring curtains of snow and veils of pouring

rain all too frequently lower the visibility of navigational marks and beacons and arouse anxiety in the man upon the bridge when steering his vessel toward a dangerous coast.

More craft are wrecked or lost by reason of fog than through any other condition of the weather. Thousands of lives and millions of dollars' worth of property are thus sacrificed annually. Sudden temperature changes will turn the clear air above the water into an enshrouding mist, and the seafarer may find his objective shut out from view when the way ahead of him seemed plain sailing. A slight deviation from a prescribed course may make all the difference between safety and disaster.

Day or night, fog is ample reason for alarm, inasmuch as it is so easy for the navigator to make a mistake when groping onward toward his unseen haven. Lighthouses and lightships are no less essential as guides while the sun is above the horizon, and when these nautical mileposts, so to speak, are no longer visible, treacherous currents may swerve a vessel from the path of secure advance.

The radio compass is the outcome of radio phenomena which the man of science has turned to good account. Fully a decade back it was noticed that radio signals had a directive element; that is, they were heard loudest along a certain line when the receiving instruments were swung through an arc. Accordingly, during 1916 and 1917, arrangements were made by the U. S. Lighthouse Service and the Bureau of Standards for experimental tests between ship and shore stations for the purpose of devising some form of radio control. Those researches gave promising results, but the work was halted when the country entered the World War.

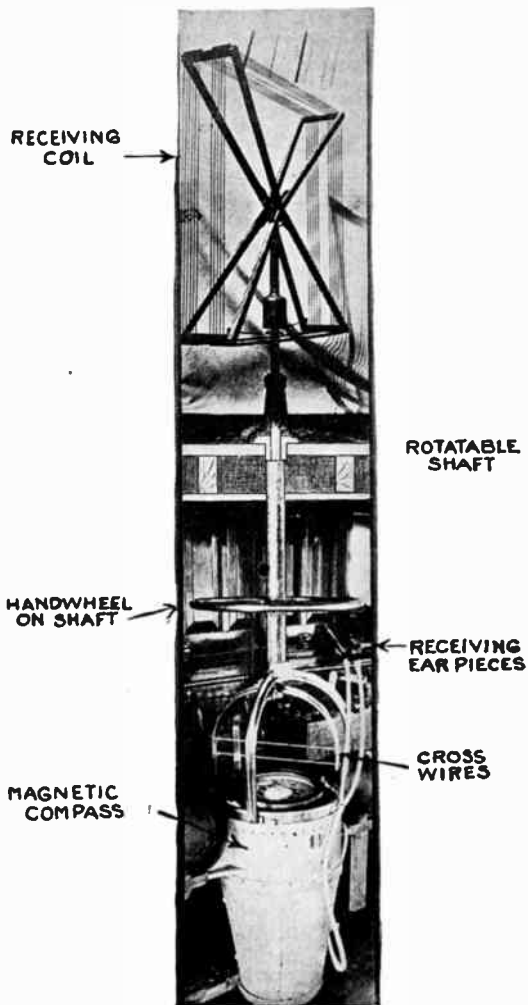

#### RADIO FOG COMPASS

Figure Y: A cross section through the chart house of a lighthouse tender equipped with a radio compass receiving outfit. The loop of the receiver is mounted outside on the deck of the ship while the control handle for turning it is inside the cabin.

During the period of conflict, the radio experts of the U. S. Navy evolved a type of radio compass, and they established a large number of shore stations to help such ships off the coast as were already provided with radio signalling equipment. The method consisted of an exchange of signals between the distant craft and one or more land stations, where, by radio cross-bearings, the vessel's position was determined and the information transmitted to her. To be effective, the inquiring ship had to have someone aboard who was capable of both sending and receiving radio code-signals. The system adopted by the Lighthouse Service operates differently, and the mariner himself ascertains the location of his boat; it is not needful for him to send a radio signal to do this.

As long ago as 1888, the German physicist Hertz made use of a coil for determining the source or direction of arriving radio waves, and the radio compass produced by F. A. Kolster of the Bureau of Standards is based upon a kindred sensitive or responsive element. His coil aerial is nothing more complex than ten turns of wire around a rectangular frame about four feet square. This frame is carried by a rotatable shaft. When the coil lies parallel with the path of the oncoming radio waves the signals received can be heard loudest, and when the coil is at right angles to the radio waves the signals are faintest. (This action was described in connection with loops back in Part V.) Therefore, all that the listener has to do is to swing the frame until the tell-tale dots or dashes are strongest and clearest. At that moment the pole of his coil is pointing directly at the sending station.

So far, so good, but this in itself is not enough to put the seafarer out of danger.

This is how the device works from this point:

Suppose the fog-bound ship is traveling due north and that the signals are sharpest when the coil is on an east-and-west line. How is the operator to tell whether the transmitting station is off to the right or to the left of him? This knowledge is essential to his safety; he must not steer toward the open sea when his objective is in the opposite direction. In its initial form, the Kolster radio compass was deficient in this particular, but it has been modified by the addition of what is termed a unidirectional feature. This simple attachment makes it practicable to pick up a signal's maximum intensity only when a marker is pointing right at the generating station.

Two parallel wires set one above the other and supported by a U-frame attached to the lower end of the rotatable shaft and suspended immediately above the magnetic compass, enable the man at the helm to compare the course of his vessel with the direction whence come the guiding radio signals. This information, however, while helpful, does not give him his distance from the sending station, and this he must have so that he may head his ship toward his unseen goal without fear of running upon intervening or submerged obstacles. Therefore, radio signals have to be picked up by the navigator from a *second* station, and its bearing also checked by the magnetic compass. When a line is drawn on the chart from each of the two stations, which agree with the magnetic-compass readings, the off-shore point of intersection of the two lines indicates the geographical position of the groping craft. This is made plain in the accompanying diagram, Fig. Z. It is a simple matter of triangulation-nautical surveying.

While the fundamental principle of the radio compass has been known for more than three decades, much study has been required to bring the apparatus

to its present dependability. Nearby wiring, rigging, smokestacks, ventilators and steel masts induce what is called "re-radiation." These "radio echoes" of

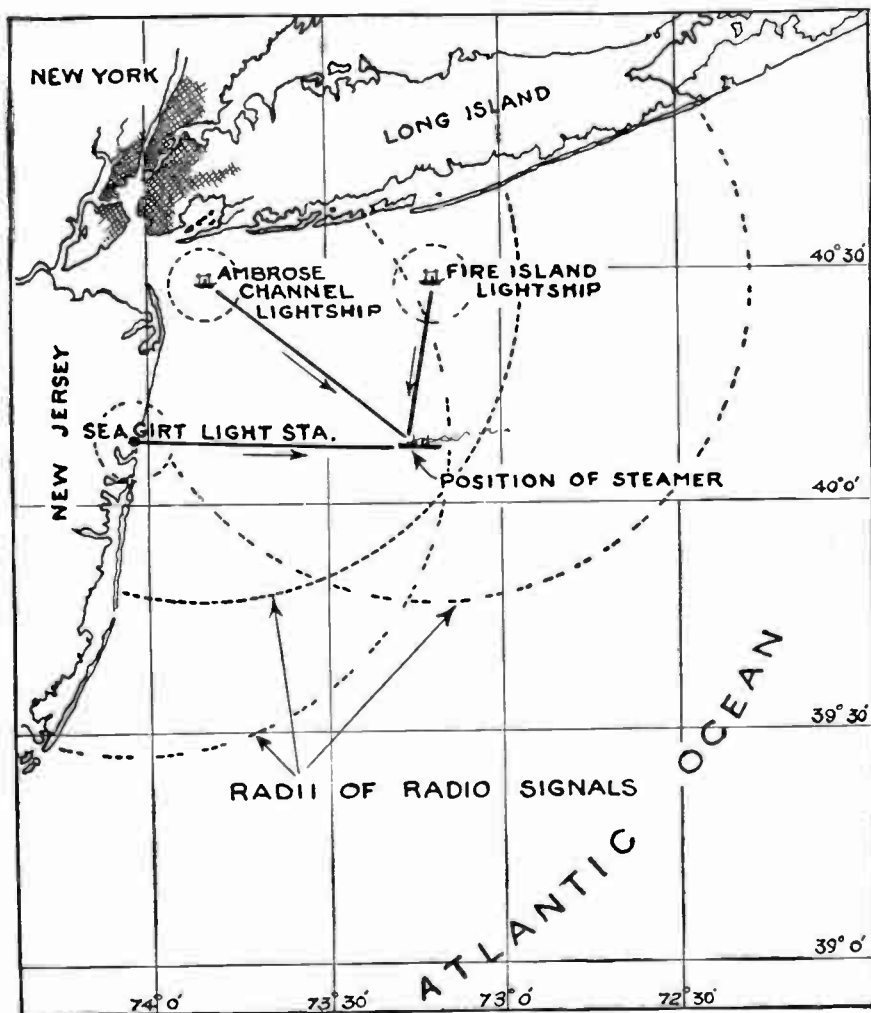

#### HOW RADIO SIGNALS DETERMINE A SHIP'S POSITION

Figure Z: This diagram shows the radio-compass stations at the approach to the port of New York. Each station sends out distinctive signals; by taking radio cross-bearings from two or more of the stations, a ship nearing the coast can determine her position even though the lightships and the lighthouse are invisible.

primary radio waves at first caused a good deal of confusion to the listener at the radio compass. Researches by the U. S. Bureau of Standards have shown how this source of error can be neutralized; and a radio compass can now be calibrated to offset these disturbances just as a magnetic compass can be compensated against the effects of neighboring masses of iron and steel.

The ordinary telephone receivers, if used by the operator of the direction finder, would be apt to deflect the needle of the magnetic compass if brought close to that instrument. To prevent this, a special radio receiver is located at a little distance from the magnetic compass, and the signal sounds are conveyed through rubber tubing to the ears of the man at the radio-compass.

The radio transmitting apparatus built for the U. S. Lighthouse Service is designed to operate automatically; each set propagates a series or a group of distinctive signals. This is indicated on the map drawing that illustrates the three radio-sending installations adjacent to the entrance to the port of New York, at Sea Girt, New Jersey, and also aboard the Ambrose Channel and the Fire Island lightships. In addition to the characteristic signal of each generating unit the tone of each signal is sufficiently individual to prevent confusion.

A number of lighthouse tenders now carry radio compasses, and their skipper have repeatedly demonstrated the value of these aids when traversing the waters in the vicinity of New York during the prevalence of a fog. On a run of about forty-three miles, for example, the tender *Tulip* was directed entirely by radio compass. While her commander was not very familiar with the use of the instrument he was able,

nevertheless, to bring his boat within 800 feet of Fire Island Light Vessel, which was his objective. He did this with but three readings of the radio compass, and the last of these was taken when the tender was fifteen miles away from the lightship.

The advantages of the new system of guidance have been summed up thus:

1. The navigator may obtain bearings himself, and is not dependent upon others for the accuracy of the results.
2. Any number of vessels may obtain bearings simultaneously and as frequently as they desire without interfering with one another.
3. No knowledge of radio telegraphy is necessary on the part of the radio-compass operator.
4. Transmitting stations, being automatic, may be supervised by the employees of existing lighthouses or light vessels. No additional personnel is needed.
5. The direction finder aboard a craft may be used for locating at sea other vessels that are transmitting signals, and this may be a means of preventing collisions in times of thick weather.

Experience up to date warrants the belief that the radio compass will do much to rob seafaring of some of its hazards and that it will go a long way toward reducing yearly the number of catastrophes due to low-visibility. The general adoption of the radio compass would appear to be inevitable.

It is known to all of us that every radio message is broadcast with equal intensity in all directions. For some years now, scientists have been trying to devise a means of directive communication. In such a system the waves, instead of being sent out in all directions and to all points of the compass, would

be concentrated into a beam and the beam would be directed to the station with which it was desired to communicate. It is believed that such a scheme would allow greater distances to be covered with less power and that less expense would be involved in the erection and operation of long-distance radio telegraph stations.

Senator Marconi has been working diligently with this problem for the past

nine years and his efforts have yielded some very startling results. It is fortunate that Senator Marconi contributes an explanation of his marvelous system in his own words:

"Twenty years ago I got the simple letter 'S' transmitted for the first time across the ocean from England to Newfoundland without the aid of cables or conductors. Those first feeble signals which I received proved once and for all

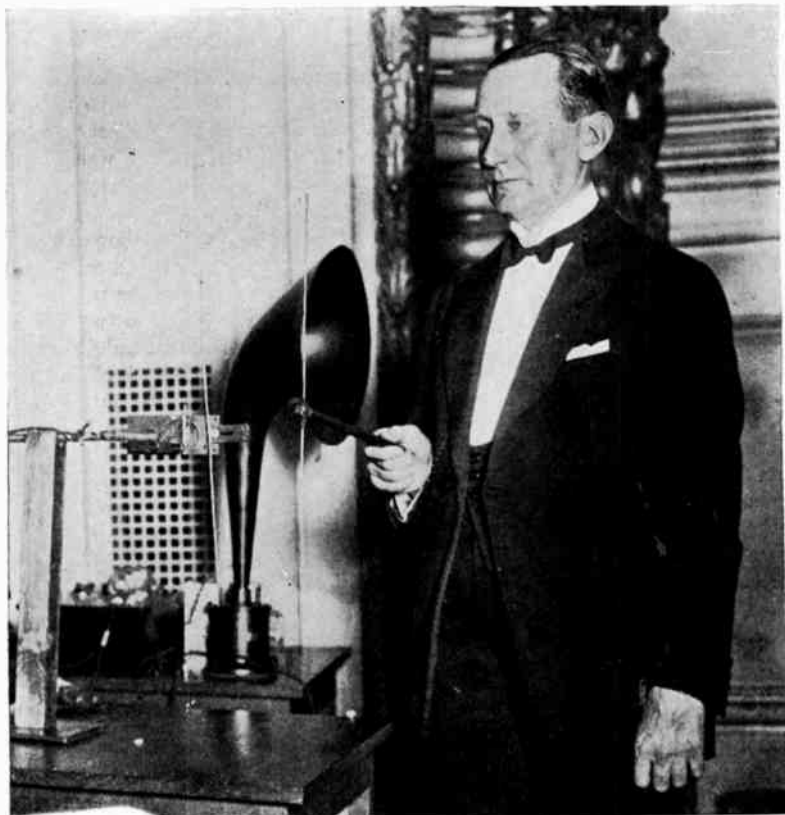

© Kadel & Herbert

#### THE MAGIC WAND OF THE MODERN MAGICIAN

Figure AA: With such marvelous accuracy may a beam of radio be directed by means of the "projector" which Senator Marconi is demonstrating, that it will actuate relays, one at a time, ring bells and operate receiving sets located at various points in a room as the beam is revolved.



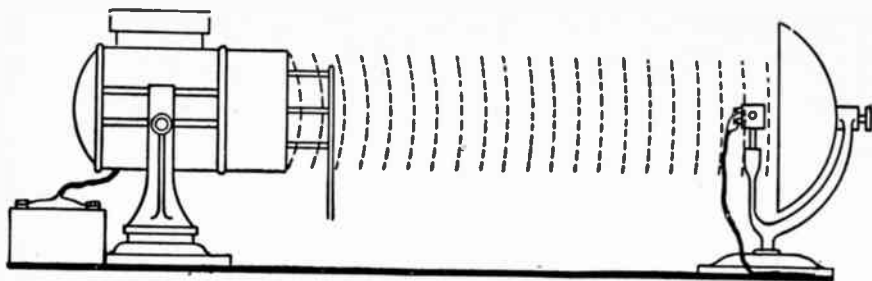

#### USE OF SKELETON REFLECTORS

Figure BB: Another new system for projecting a beam. Both the light and the radio beams are dependent on the same phenomena of electromagnetic wave motion. This system uses a radio beam which is invisible.

that electric waves could be transmitted and received across the ocean and that long distance radio telegraphy—about which so many doubts were then entertained—was really going to become an established fact.

“Radio has already done much for the safety of life at sea, and for commercial and military communication. From now on it is destined to bring new (and until recently even unforeseen) opportunities for recreation and instruction into the lives of millions of human beings. New designs and new uses of vacuum tubes are likely to work quite as many new wonders in the future as they have in the past.

“Great possibilities lie in the development of these tubes, especially in their connection with short wave transmission, a somewhat neglected branch of the art. Yet radio waves only a few inches long have many advantages over the waves now used, which range in length up to twelve miles. Such short waves can be more easily moulded to carry the human voice, and receiving sets tuned to them would be less disturbed by static and interference. Indeed, much of my time is now devoted to experiments with the short wave, particularly for use in the secret trans-

mission of messages. So free from interference is this short wave field that I am reminded of my earliest experiments, when the entire field was practically clear and the vast territory of radio was unexplored.

“As early as 1899 I showed how it was possible, by means of short waves and reflectors, to project the rays in a beam in one direction only, instead of allowing them to spread all around, in such a way that they could not affect any receiver which happened to be out of the angle of propagation of the beam. I also made tests in transmitting a beam of reflected waves across country over Salisbury Plain in England and pointed out the possible utility of such a system if applied to lighthouses and lightships, so as to enable vessels in foggy weather to locate dangerous points around the coasts. At that time I also showed that a reflected beam of waves could be projected across the lecture room to actuate a receiver and ring a bell only when the aperture of the sending reflector was directed toward the receiver.

“Again in 1916 I took up the investigation of the subject with the idea of utilizing very short waves combined with reflectors for certain war purposes; in this work I was assisted by Mr. C. S.

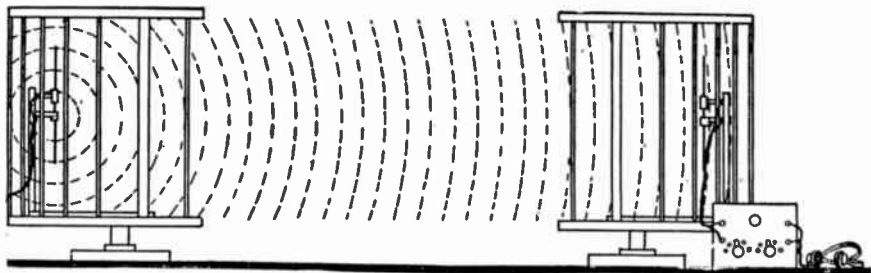

#### HOW BEAMS TRAVEL

Figure CC: A new system of communicating along a beam of light. A light wave is directed in a narrow path from a searchlight and picked up by a reflector which concentrates the waves on a light-sensitive cell which records the signals

Franklin. We used waves only two and three meters long. With these waves disturbances caused by static are almost non-existent; the only interference experienced came from the ignition apparatus of automobiles and motor boats. These machines apparently emit electric waves from 0 to about 40 meters in length; perhaps the day will come when they will be required to have their ignition system screened or to carry licenses for transmitting! During these experiments I observed that one of the short wave receivers acts as an excellent device for testing, even from a distance, whether or not one's ignition system is working right. Some motorists would have a shock if they realized how often their magnetos and spark plugs are working in a deplorably irregular manner.

"The transmitting reflector used to concentrate the waves into a ray or beam, in these experiments, was arranged so that it could be revolved and the effects were studied at a distance with receiving apparatus.

"Mr. Franklin has calculated the polar curve of radiation into space in the horizontal plane, which should be obtained from reflectors of various shapes, by assuming that the waves leave the

reflector as plane waves of uniform intensity, with a width equal to the aperture of the reflector. The calculated curves agree well with the observed results. Reflectors with apertures up to  $3\frac{1}{2}$  meters wavelength were tested and the measured polar curves agreed with the calculated values.

"At first the range of the signals was only six miles. Later, on a 15 meter wave generated by an electron tube at the Carnarvon station, we transmitted over a distance of seventy-eight miles to one of the mail boats on the Irish coast. The important fact noticed was that there was no rapid diminution of the strength of the signals after the ship had passed the horizon line from Carnarvon. It was easily proved later that clear speech could be exchanged at all times between Hendon (London) and Birmingham, a distance of ninety-seven miles, by using reflectors at both ends.

"For these tests, the power supplied to the tubes employed was usually 700 watts. The aerial was rather longer than half a wavelength and had a radiation resistance which was exceedingly high. The efficiency of the input to the tubes to aerial power was between 50 and 60 percent and about 300 watts could be actually radiated into space.

Speech heard with this arrangement is usually strong enough to be just audible with a shunt of from  $\frac{1}{4}$  to  $\frac{1}{2}$  ohm across a 60 ohm telephone.

“When both reflectors are disconnected and out of use, speech is only just audible with no shunt. Average measurements indicate that the value of the energy received when both reflectors are

used and the waves concentrated in a beam, is about 200 times that of the energy received without any reflectors. It would seem that here is one possible solution to secret radio communication, the use of directed beams of magnetic waves.

“During the continuous wave tests at Carnarvon, it was found that simul-

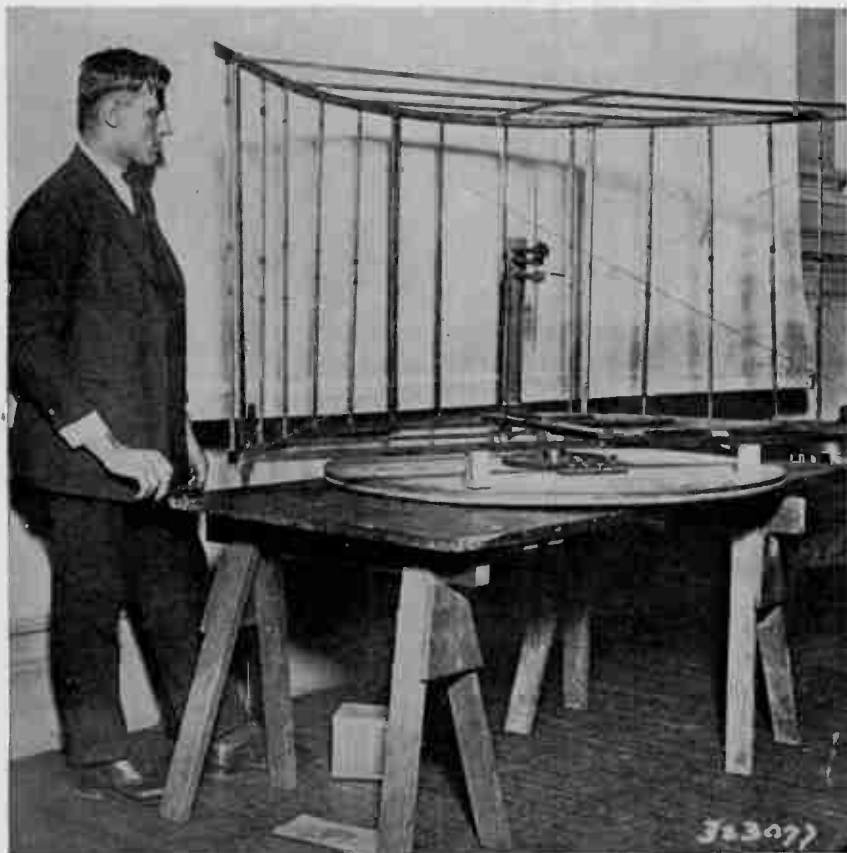

© Underwood & Underwood

#### A WORKING MODEL OF THE MARCONI REFLECTOR

Figure DD: This is the apparatus for concentrating the radio rays in one single beam. The small vertical object at the center of the reflector is the oscillator. The length of the waves propagated by this miniature antenna system is only about one or two meters

taneous transmission and reception was possible on the same aerial. This system is now being used successfully for duplexing, as it avoids all switching from transmitting to receiving.

"Besides giving directional working and economizing power, reflectors are showing another unexpected advantage, an advantage which is probably common to all sharply directional systems. It has been noted that practically no distortion of speech takes place, such as is often noticed with non-directional transmitters and receivers, even when using short waves.

"The results between Hendon and Birmingham easily constitute a record for radiotelephony in respect to the ratio of distance and wavelength, as Birmingham is 10,400 wavelengths from Hendon. We consider that these results represent only what could be obtained from a first attempt, and not what could now be done by utilizing the experience gained.

"A new wireless beacon has recently been developed at Inchkeith Island in the Firth of Forth, near Edinburgh. By means of a revolving directive beam of radiated energy which it produces, ships at sea can ascertain the position of the lighthouse in thick weather. With a 4 meter wave generated by a spark transmitter and a beam reflector, signals have been sent which were readily distinguishable on a ship seven miles away fitted with a single tube receiver. The reflector made a complete revolution every two minutes, and a distinct signal was sent at every half point of the compass. This enabled the ship to determine the bearing of the lighthouse accurately within a quarter point of the compass, or within 2.8 degrees.

"With the revolving beam the exact periods of maximum reception are not

easy to judge by ear, but the times of starting and vanishing are easy to determine, as the rate of rise and fall of the signals is extremely rapid.

"By means of a clockwork arrangement a distinctive letter is sent out every two points and short signs mark intermediate points and half points. This is done by contact segments arranged on the base of the revolving reflector.

"These short directional waves resembling a beam of light decrease in strength so gradually when traveling over water that the distance of the transmitting station may readily be estimated.

"Still another help to navigation may be found in the reflected beam wave. Hertz showed that electric waves can be completely reflected by sounding bodies. In some of my tests, I have noted the effects of reflection and deflection of these waves by metallic objects miles away.

"It seems to me that it should be possible to design apparatus by means of which a ship could radiate or project a divergent beam of these invisible rays in much the same manner as a searchlight, in any desired direction so that if they should meet another ship they would be reflected back to a receiver screened from the transmitter. This would reveal the presence and bearing of nearby ships in fog and heavy weather, even though such ships were not provided with radio equipment."

Now we come to the subject of "wired wireless" or the transmission of sounds over electric waves that are made to follow wires. Dr. Henry Smith-Williams has supplied a very intelligent explanation of this system in the following:

"If the textile workers of America had been able to braid silk a little faster (or, to be accurate, a good deal faster), there would probably be no such thing as 'wired wireless' known to radio science today.



From a photograph by Paul Godley

**"SECRET MESSAGES CAN BE SENT  
BY RADIO"**

So states Senator Marconi, whose recent experiments with short waves (some of them only a few inches in length) that can be focused like a beam of light is opening up a line of development in radio communications that has heretofore been regarded as closed. This picture of the Senator was snapped by Paul Godley during a visit to the Marconi yacht "Elektra," which is practically a floating radio laboratory.

"Of course you do not see the connection unless you happen to know the story. The application is simple, however; Major-General George O. Squier, known to everyone as the originator of the wired wireless method, explained it personally at the outset of the paper in which he made popular announcement of his discovery. This is how it happened:

"The 'key problem' in the procurement of essential Signal Corps supplies in the United States during the World War was the production of the necessary braiding machines for finishing insulated wire. The wire itself could be obtained; rubber insulation could be obtained; and there was no dearth of cotton thread for making the braid—but machinery for braiding the thread was inadequate, and could not be rapidly supplied.

"All the braiding machines in the United States in September, 1918, could produce the braided covering for only eight hundred miles of twisted pair insulated wire a month—and the American forces alone required forty thousand miles a month! And as if this was not bad enough, the allied council decided on October 1, 1918, that it would be necessary for the United States to furnish all of this type of wire used by the allied armies in the field, beginning March 1, 1919. The estimated minimum requirement was 100,000 miles a month, or more than twelve times the capacity output of all the American machinery in existence.

"Confronted with this situation, the United States Signal Corps, with General Squier at its head, not unnaturally realized the desirability of finding a substitute for braided cotton thread.

"The Signal Corps found it. Indeed, it found something not merely 'just as good,' but in many respects vastly bet-

ter. Confronted with the shortage of braiding machines, General Squier said, in effect: 'Let us try electron tubes instead.' Asked to supply 100,000 miles of braided cotton a month, he said: 'I will give you an unlimited quantity of electromagnetic waves instead.'

"Succinctly stated, what General Squier did was to run a bare wire of phosphor bronze (number 18, such as is used for Signal Corps field antennae) across the Washington channel of the Potomac River from the Army War College to the opposite shore in Potomac Park, letting it sink to the bottom and lie there absolutely unprotected. Not only was the wire not insulated, but pains had been taken to clean it entirely and free it from any grease or other material that could in the least protect it. A standard Signal Corps radio telephone and telegraph set was directly connected to each end of the wire; one set served as transmitter and the other as receiver. At the receiving end, the bare wire was directly connected to the grid terminal of an electron tube in the receiving set and the usual ground connection was left open. Tuning the wire to a frequency of about 600,000 cycles a second, excellent telegraphy and telephony were attained.

"'This experiment,' declared General Squier, 'demonstrated the possibility of transmitting electromagnetic waves along bare wires submerged in water, and the use of an electron tube as a potentially operated device on open wire for the reception of signals.'

"That statement shows the characteristic modesty of the true scientist. For the simple experiment had really resulted in a fundamental discovery, foreshadowing the opening up of an entirely new department of radio science of almost inexhaustible possibilities.



#### A DIVINING ROD FOR WIRELESS WAVES

Figure EE: This remarkable miniature coil antenna—a trifle larger than an ordinary walking stick—collects radio impulses when it is turned and pointed in the direction whence the impulses emanate.

"If, one of these days, you are able, sitting in your New York office, to take your telephone receiver off the hook and have a chat with a friend in London, it will be because General Squier was led (owing to the shortage of braiding machines) to find out whether he might not send a message along a bare wire under the Potomac.

"There are many interesting things to be told about General Squier's further experiments, which include successful tests of the bare wire as a carrier of messages when laid along the moist earth, and even buried under the soil; but before we come to these, let us consider the question as to how and why the electromagnetic waves follow the wire and are thus led to a definite goal, instead of radiating out into space and becoming rapidly attenuated as in ordinary radio transmission.

"This question, however, can be answered only provisionally. We have to do with an extremely puzzling phenomenon. Only a very bold or reckless theorizer would have predicted, with any measure of confidence, the results which were actually attained. Ninety-nine radio operators in a hundred would have dismissed the notion that a wireless message could be sent along a wire as absurd. The very phrasing seems self-contradictory. It is more than likely that General Squier himself was not over-confident about the success of his

experiment. But his imagination conceived the thing as possible; and presently his ears told him that the possibility had become a reality. 'Wired wireless' was an accomplished fact, whether or not a theory could be found to make it plausible.

"The discoverer himself was content for the moment to go on with his experiments, avowing no theory by way of explanation. Doubtless that was the part of wisdom. Certainly it is better not to hamper a practical discovery by harnessing it too closely with theory at the outset. Nevertheless, no one can thoughtfully consider the phenomenon without at least attempting to form a mental picture of things that are happening along the course of the strand of copper wire that is so magically holding the electromagnetic waves in leash.

"Of course it is not to be supposed that the electromagnetic waves travel in or even on the wire. By definition, these waves are undulations in the ether of space, which is supposed to be the universal medium, occupying the interstices between the electrons that are conceived as the ultimate particle of matter. According to one theory, the electron itself is only a whirl in the ether. In any event, the ether appears to ignore the very existence of matter, passing between the molecules of the most solid substance more freely than water passes through a sieve, inasmuch as there is no

friction. The electromagnetic waves with which ordinary radio deals are not altogether unaffected by material substances, but to an amazing degree they appear to ignore obstructions. As an illustration, we have just seen that the electromagnetic waves of General Squier's experiment followed the course of the wire laid along the bottom of the Potomac, apparently ignoring the presence of the water. Yet they obviously did not ignore the wire altogether—otherwise they would not have followed it.

“It was not the wire itself, in all probability, that enchaind the electromagnetic waves, but the electric field about the wire. An electric field, according to accredited theory is merely the condition (of ‘strain’ or what you will) that exists in the ether surrounding an electron or group of electrons. When electrons are in transitional motion, their transit is manifested in what we term a current of electricity, and the motion of the electric field about them establishes a condition that we term magnetism. The moving electric field is parent to the electromagnetic wave; so perhaps it is not strange that an electromagnetic wave in being should have affinity for the electric field surrounding a copper wire that chances to lead out from the source of its origin.

“At first thought it seems odd that the electromagnetic wave should follow a bend in the wire; but we must reflect that the electromagnetic waves of ordinary radio do not travel in a straight line, but follow the curve of the earth's surface. Possibly the electro-static conditions of the lower atmosphere have to do with the course of ordinary radio waves somewhat as the electric field about the wire has to do with the directed waves of General Squier's experi-

ment—the earth's surface itself representing, in this view, a magnified wire-surface. The familiar fact that radio messages are rapidly dissipated in the daytime, when the upper atmosphere is believed to be charged with electrons from the sun, possibly gives support to the analogy.

“All this is mere theory, however, which the reader may find more or less satisfactory according to the bent of his mind but which can neither add to nor detract from the force of observed facts, to which we now return. The traditional apple falling from the tree on the head of Sir Isaac Newton bruised the philosopher neither more nor less because of the theory of universal gravitation.

“The experiment of sending messages along the bare wire under the Potomac having thus succeeded beyond all reasonable expectation, a question naturally rose as to whether the experimenters might have drawn a false inference from their observations. Might it not be that the portions of wire out of water at either terminal had acted as antennae, and that the electromagnetic waves had passed directly through the air, as in ordinary radio transmission, or along the surface of the water?

“To answer that question, the simple procedure was adopted of cutting off the main portion of the wire, leaving only the short aerial portion at sending and receiving stations, and a few feet under water. But now messages were no longer transmitted; and this negative result was very properly interpreted as demonstrating that the messages previously sent and received had in reality been directed along the wire.

“Sundry other confirmatory experiments having been made with a submerged wire, attention was directed to



the possibility of conveying a directed message along a wire lying on the ground. A bare No. 16 wire was laid on the surface of the earth connecting the main laboratory of the Signal Corps and a small field station one and three-quarter miles distant. The radio telephone

instruments used were standard sets, utilizing an oscillating transmitter of the electron tube type. The transmitting current was about one hundred milliamperes, at any of the wavelengths available with these sets, ranging from about 200 to 550 meters. It was found

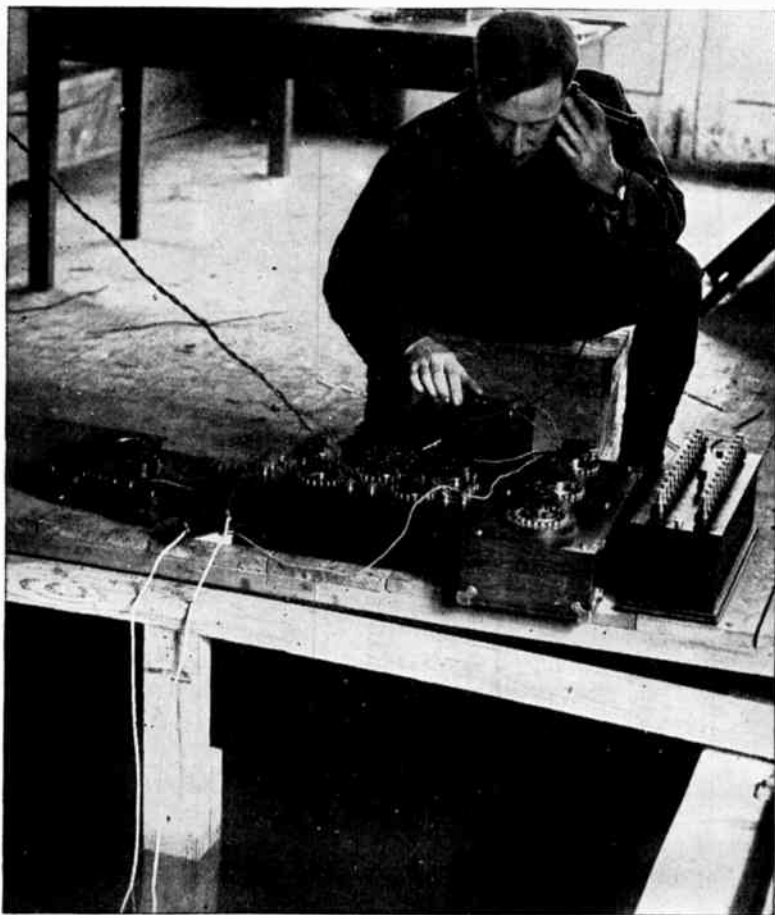

**MEASURING THE HIGH FREQUENCY RESISTANCE OF WIRE UNDER WATER**

Figure FF: An experimenter at work on the impedance bridge in the Signal Corps laboratory at the Bureau of Standards in Washington.

that good telephone communication could be made with this equipment.

"As the next important step in the series of experiments, the bare transmitting wire was buried in the earth to a depth of about eight inches. The bare No. 16 wire was laid in a plowed furrow and a second furrow was plowed alongside, completely covering the wire. The soil was moist, sandy loam, only a few feet above tide water.

"The wire thus buried conveyed the electromagnetic current as before, and satisfactory communication was established for the distance of about a mile.

"To make the experiment more definitive, tests were made with the buried wire not laid on a straight line, but turning at various angles. Were the

wire serving only as an ordinary antenna, it was reasoned, signals would be detected in the direction of a prolongation of a straight portion of wire; but in reality the test showed that signals could be detected best in close proximity to the wire itself in all its parts, proving that the electromagnetic waves turned the corners in order to follow the wire.

"Although the soil did not prevent the passage of the message-carrying waves, it did exercise a curious influence, screening them and in effect preventing their escape from the region of the wire. Proof of this was found by moving an exploring coil along the line of the buried wire. The detecting instrument, held just above the surface, failed to reveal a signal; but when a short length of the

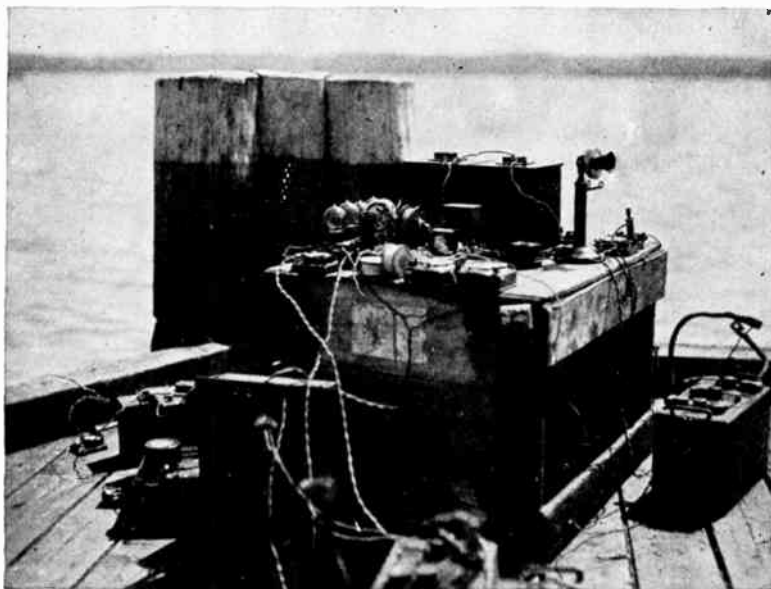

#### WHERE THE EARLY EXPERIMENTS WERE MADE

Figure GG: The original transmitter used in the submarine wireless experiments between Fort Hunt, Va., and Fort Washington, Md. The bare wire over which the signals were sent is shown going over the edge of the dock at the left.

wire was exposed by removing the earth, signals were at once appreciable, and these disappeared when the earth was put back over the wire.

"General Squier comments on the importance of this phenomenon from the standpoint of military usage. It is obvious that with a buried wire radio messages could be sent in secrecy, a desideratum well nigh impossible of attainment with aerial messages.

"The successful termination of the experiments above described may be said to have established the principle of 'wired wireless' beyond controversy. The importance of the discovery was so patent as to excite universal interest. Although the original tests had been made to meet war-time needs, it was clear that the new method would have abundant peace-time applications as well. The possibility of sending several messages along the same wire simultaneously at once suggested itself; and it was believed, with reason, that adaptation of the method will make feasible the transmission of messages to and from moving trains. Let it here suffice to note, however, that General Squier, whose earlier experiments in multiplex telegraphy are well known, stated in his early report that the applicability of the new method to multiplexing was self-evident. It is obvious to anyone familiar with the general principles of radio transmission that it should be possible, by using different wavelengths, to send several messages simultaneously in either direction along a single wire, each message indistinguishable except to the particular instrument tuned to receive it.

"Practical experiment was presently to demonstrate the validity of this assumption. In the meantime experiments designed to throw light on less patent features of the new method were

undertaken, particularly in the Signal Corps research laboratory at the Bureau of Standards. One object was to determine the electrical constants of bare wire submerged in water when subjected to high frequency currents.

"At the Bureau of Standards a tank was available 125 meters long, 2 meters deep, and 2 meters wide. Two wires placed in the tank served as a to-and-fro conductor, constituting a complete transmission line immersed in water. Using an electron tube oscillator as transmitter, measurements were made to determine the apparent impedance of the system with the remote end short-circuited and also open-circuited. Even at the preliminary stages, the observations as to capacity and leakage of the wire were found highly interesting.

"'It was seen,' says General Squier, 'that at low frequencies the capacity is extremely large, about 1,200 microfarads a kilometer, the equipment of an entire Atlantic cable, but the capacity diminishes very rapidly as the frequency is increased, and at a frequency of about 40,000 cycles a second, it practically vanishes. The leakage increases with the frequency up to about 5,000, and then begins to decrease slowly as the frequency is increased. The results were surprising, particularly the high capacity values at the low frequencies. The experiments apparently show that frequency of the current used has a marked influence on the behavior of water as a medium, and is entirely different from what it would be for direct or low frequency current.'

"Tests of this character, while of great theoretical importance (and that means always, potentially, of practical importance), have not the popular interest that attaches to the observations that were made by General Squire and

his associates at an early stage of the investigation with the aid of resonance wave coils of various dimensions. The use of the coil was originally resorted to in order to secure high potential points at the receiving end of the line without losing the advantage of tuning, the circuit being open, and the grid directly connected to the line. Adjustment was obtained either by moving along the coil the end of the wire connecting the grid, or by sliding along the coil a narrow metal ring connected to the grid, this constituting a capacity coupling between the grid terminal and the coil.

Coils were made up of wavelengths ranging from 250 meters to 1800 meters.

"One such coil, for example, was about four and a half inches (11.5 centimeters) in diameter and about twenty-three inches (58 centimeters) in length, with thirty-four turns of the wire per centimeter, and gave a fundamental wavelength of 1700 meters.

"This little instrument proved a veritable divining rod. Connected to an antenna or a bare wire in water or earth, as in General Squier's experiment, it can not only be used for tuning, but at the same time wave development on the

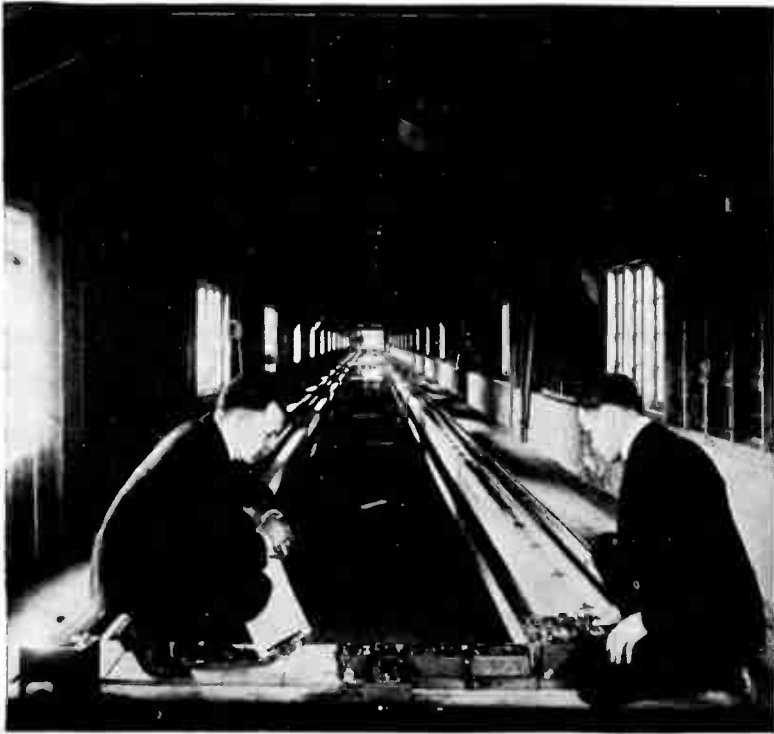

**WILL THE WAR OF THE FUTURE BE FOUGHT IN SUCH LABORATORIES?**

Figure HH: In this tank, 125 meters long, the radio experts of the United States government are carrying on their research work that has led to important changes in communication systems.

coil permits a test of the highest potential point, or point of greatest sensitiveness. More than that, the resonance wave-coil can be substituted for the ordinary antenna, itself constituting a complete antenna system. The coil may be grounded at one end or it may be entirely free. In either case it may be utilized to receive radio signals.

"It may be noted," says General Squier, "that in an antenna of this kind all the electrical constants, inductions, capacity and resistance and the electromotive force induced in it by the incoming signals are of a distributive character, which makes it in a sense an ideal wave-conductor."

"Even that does not tell the entire story of the little resonance coil. The discovery was presently made that it possesses also remarkable directive properties. If the coil is turned about, so that its position in relation to the direction of the electromagnetic waves of ordinary radio is modified, there is a constant change in the voltage and current distribution on the coil, and a corresponding shift in the position of the point of maximum potential. If the coil is held at right angles to the direction of the transmitting station from which the electromagnetic waves are coming, these waves beat evenly against it, as will be obvious, and so produce a condition of uniformly distributed electrical constants. There is a point of maximum potential, varying somewhat with the length of the coil, frequency, and terminal conditions. This maximum may be determined in moving the terminal of the grid of an electron tube along the coil. In practice a narrow metal ring that slides freely along the coil is used. But if now the coil is turned to point more or less in the direction of the transmitting station, so that

the electromagnetic waves come against it slantwise, the point of maximum potential shifts, owing to the difference in time at which the waves strike the oblique surface.

"Here, then, is a direction-finder comparable to the familiar looped antenna which can be so turned as to reveal the plane in which the electromagnetic waves are moving. But the resonance coil goes beyond this, for it was found that when it is moved about until its longitudinal axis is parallel to the direction of the electromagnetic waves (in other words, until it is pointed toward the transmitting station from which the waves emanate), the potential maximum loop, which has shifted along the shaft of the instrument, is duplicated by another loop of substantially the same amplitude at the opposite end of the coil. If now the pointing instrument is moved about a little, so that its axis is slightly out of parallel with the waves, it is observed that the potential loop at one end has greater amplitude, and that this is the end pointing toward the transmitting station—the north of the compass needle, so to speak.

"Evidently, then, manipulation of the little wire-wound divining rod (Page 114), held in the hand and tested with a sliding ring connected with the receiving grid, makes it possible to determine the direction of the transmitting station from which the signals proceed—a matter of tremendous significance as no one needs to be told. A looped antenna used, let us say, in Baltimore, does not tell whether the message comes from Philadelphia or from Washington. But the magic coil gives the answer."

Major-General George Squier, the inventor of the "wired wireless" system of radio communication, proposes the use of this system for the purpose of supply-

ing music and entertainment to the hundreds of thousands of American homes now wired for electric service. The plan is outlined in the words of the inventor of the system:

"Broadcasting was impossible without an audience. As soon as an audience was provided, broadcasting was possible, and it began. The audience

was provided by the boy amateurs—by the youthful tinkerers who for four or five years had been playing with coils and sparks and antennae—who had been trying, night after night, to get through a few dots and dashes to the other boy enthusiast in the next block. This amateur audience was ready and waiting for the broadcaster; its existence

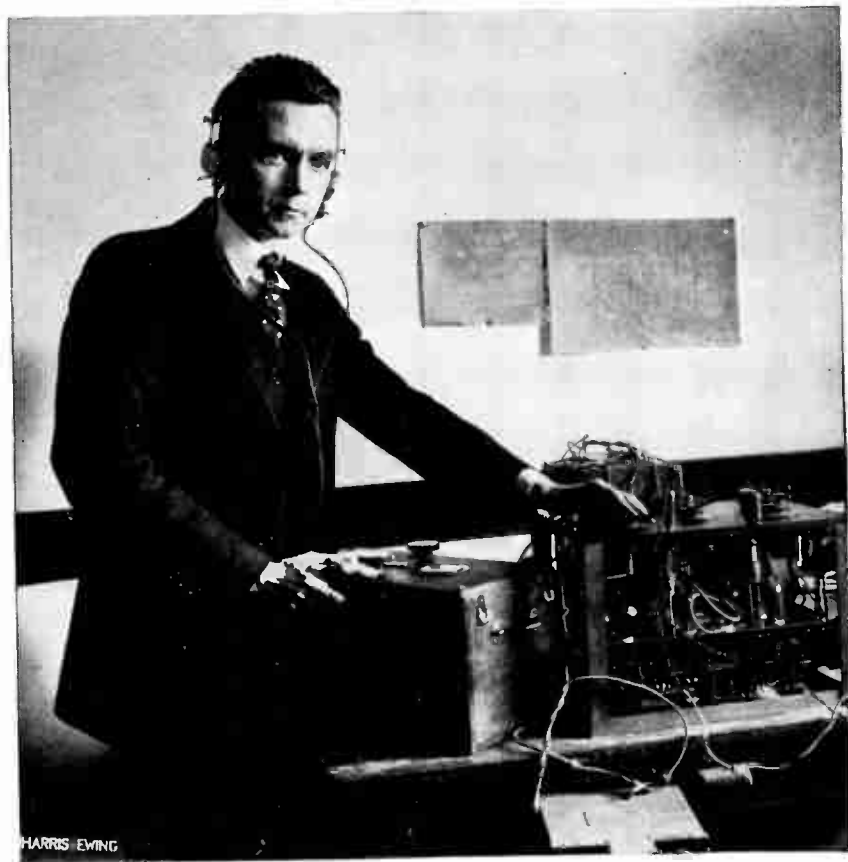

#### A RADIO RECEIVER THAT USES A TELEPHONE WIRE AS AN AERIAL

Figure II: The scheme for transmitting radio programs to subscribers only is brought within the realms of possibility by this super-phone, or "line radio duplex transmitter and receiver," developed by R. D. Duncan, Jr., head of the research laboratory of the Signal Corps. The device may be attached to the ordinary desk telephone.

is what made broadcasting such an instantaneous success.

"The present conditions in radio are training a larger audience. Father and mother have joined the boys around the radio set. It has been estimated that about five million people listen in every evening on the broadcast programs.

"What are we going to do with this audience?

"Amateur radio prepared the audience for broadcasting. Broadcasting is now preparing another audience, a larger one—for what?

"Some people seem to think that broadcasting is a fad; they believe that people will return for entertainment to the phonograph, to the motion picture and to the spoken drama. They believe, so they say, that the radiophone is a temporary craze.

"I do not think so. What happened to amateur radio? In one sense it passed, but it passed into a far bigger thing. It passed into radio broadcasting. Radio broadcasting as now conducted may pass in its turn. I imagine that it will. But it will pass into something else, into something bigger and better, something more useful to men and to society.

"The basis of a democracy is education. Unless we can properly educate our children and our immigrants, the American idea of government will fail. And no one can be educated solely in school. Far more important is the atmosphere at home; the background, good, bad or indifferent, against which the family life goes on. Is this a background of good books, good music, intelligent conversation? Or is it a background of crime news from the papers and of neighborhood gossip?

"Think of what radio can do to help this situation. Radio can go a long way

toward supplying whatever kind of home background the country needs its citizens to have. Inspiring music, the uplifting words of great teachers, the everlasting principles of our political fathers, can be poured every day and hour into the waiting ears of all our citizens—poured in to form the minds of children, to revive the courage of the common man, to instruct and set right the newcomer from foreign lands.

"The country can *make* us listen, all of us. It will be so easy to listen that we cannot escape. We will not want to escape. Comfortably, each one of us beside his own library table, in his favorite chair, without cost or exertion or the annoyance of dressing up, there will come to our ears at the turn of a little knob the best thought and the finest artistry of all the world.

"And to our children's ears no less. To our children radio will bring the intellectual background which only the very rich have been able to provide, a background of exquisite sound. The poorest nursery can have its interior decoration of music, its aural furnishing, as now we put bright pictures on its walls. For nurseries and for all the house we can replace mere noise with controlled harmony. Already the music of the Marine Band, which all of us help to support, is not confined to Washington; it is broadcast regularly. Already any little town in Maryland or Virginia can have its radio set and its loudspeakers—can gather in the evening at the band stand for its own concert by this world-famous organization. Yet this is only a beginning of the work of the radio engineer as an educator. Soon we will be measuring culture by watts.

"And as to the more permanent social influences of such daily aural backgrounds, what might be, for instance,

the influence on business morality if fifty people heard each day the simple and persuasive eloquence of the Sermon on the Mount?

"This is exactly what radio can do. The radio engineer will be, I firmly believe, the prophet and the architect of a new social era, the inventor of the first successful system for the education of all the people.

"For this to come about we need only two things:

"*First*: we must simplify the radio receiver, and

"*Second*: we must avoid, somehow, the present confusion of broadcast messages, the overcrowding of the ether.

"Both of these improvements can be made, and can be made easily.

"The Bureau of Standards has pro-



**YOU CAN "PLUG IN" THIS RECEIVING SET ON YOUR ELECTRIC LIGHT CIRCUIT**

Figure JJ: That the ordinary electric light wiring can serve as aerials for "wired wireless" reception has been demonstrated by this receiving set devised by the Bureau of Standards under General Squier's direction. It is possible that the electric light corporations of the future will furnish the broadcast service—to customers only.



duced a vacuum tube equipment which works on an ordinary electric lighting circuit. This may eliminate from the radio set the present type of battery. The principle of the resonance coil, developed in the laboratories of the U. S. Signal Corps, not only accomplishes the virtual elimination of static but reduces the laborious and uncertain tuning to a single operation, to the mere sliding of a contact arm along a coil. These two advances remove the main reasons why the present-day radio set is overcomplicated and is too hard to manage and adjust. The next step is get rid of the

aerial. This can be done easily by using the electric light wire or the telephone wire.

"Every house has two avenues through which the outside world comes into it, the electric light wire and the telephone wire. Already the massed network of these wiring systems is prodigious in extent. The United States is one vast grid of wire. If some jinn could dissolve away all the brick and iron and concrete of the buildings of lower New York, leaving only the electric light wires, the form of the buildings would be as visible as before. Each

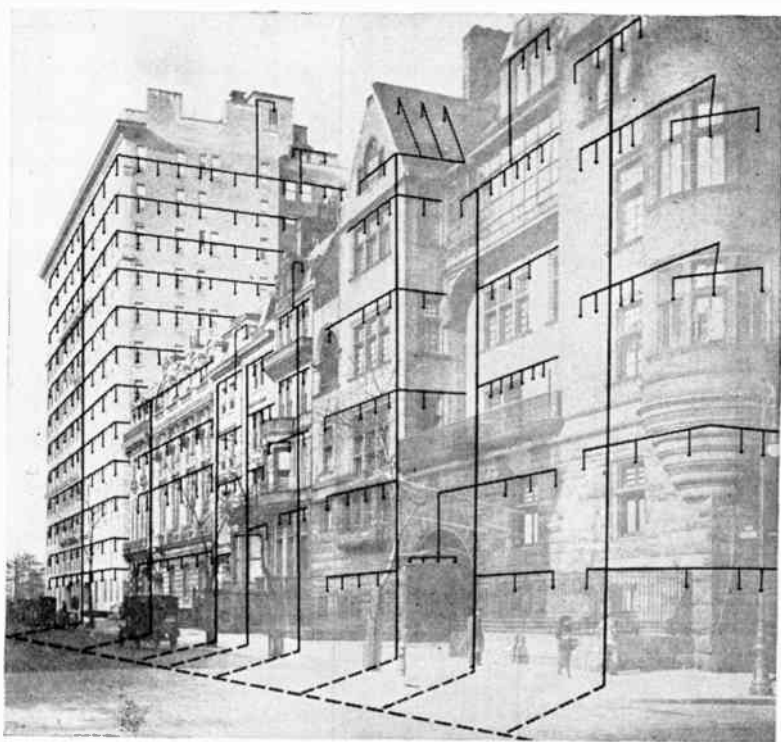

**THE WIRE SKELETON OF A CITY BLOCK**

Figure KK: The possibilities of bringing radio programs into buildings by way of the telephone and light circuits is illustrated by this diagram. If all the brick and iron of our city structures were dissolved away, the forms of the buildings would still be indicated by the wiring

floor, each wall, each room would be represented by a cage of intercrossing wires. The telephone wires make another system equally complete and complex, in fact, since the telephone system is continually changing its configuration as its calls are plugged in and out.

"Each of these vast networks of wire is really a cage aerial, a three-dimension antennæ system. The electric light wires and the telephone wires of New York pulsate every instant with all the potential changes due to every wireless message passing through the ether. Each Marconigram from Europe is recorded, pulse by pulse, on these two independent networks of wire.

"Both of these networks come into your house. Why not use them to get your radio signals? What is the use of spoiling your roof with troublesome and unsightly aerials, or filling up your parlor with complicated loops? The light and telephone wires are there. They have been laboriously and skillfully insulated from the ground and protected against lightning. Why do this all over again for a little private wire system of your own? Why not forget about your own private aerial and use those already available to you?

"With proper apparatus there is no danger to or from the wires, no interference with their use for light or telephone service. All the music and speech which is pulsating through the ether, all this wonderful potential background of education, comes into your house anyway through the two avenues, namely, the light wires and the telephone wires. The radio set of the future—I believe, of the very near future—will be some simple apparatus which you can plug into any light socket, or connect to any telephone. It will be something which you can buy in any drug store. It will be

something dependable and standard, which you do not have to 'set up' or 'install.'

"When we get this we can begin to count on developing an intelligent, well-meaning and broadminded public opinion.

"The difficulty of an overcrowded ether can be met with equal ease. The work of the Signal Corps on carrier current radio, or 'wired wireless,' is well known. By this system radio waves can be sent over ordinary wires. This is already in use for telephone service over power or telegraph wires and for superposing two or more telephone conversations on the same wire.

"By the use of this system anything could be broadcast over the electric light wires of a city. Items of local interest only need not be loaded on the ether for everybody to hear; the local wire systems will carry the load instead.

"For instance, department store advertising is of real interest to people who live near the store. It is not of interest to listeners a thousand miles away. It will be necessary to distinguish between local news and general news; between local civic matters and general governmental ones. The use of the local wire systems for broadcasting by radio permits one to make this distinction effective.

"Like the use of the electric light wires as aerials, this broadcasting over them will interfere in no way with their proper purpose of carrying current. Several power companies are understood to be experimenting already with the idea of furnishing their customers with broadcast entertainment just as they now furnish them with electric light.

"These, then, are the three developments in radio which I can see near at hand.



© Underwood and Underwood

#### A SMALL RADIO "TANK" WINDING ITS WAY THROUGH CROWDED TRAFFIC

Figure LL: A spectacular demonstration of a radio-controlled automobile—the forerunner of a radio-controlled tank—was given in the streets of Dayton, Ohio, on August 5, 1921, at an hour when the traffic was heaviest. This car was developed by Captain Raymond E. Vaughan, Chief of the Radio Branch of the Engineering Division of the Air Service, U. S. A., at McCook Field. The car was eight feet long, three feet high and two and a half feet wide. It was propelled by motor and storage batteries at a speed ranging from four to ten miles an hour, and was controlled entirely by wireless signals transmitted from an automobile that followed in its rear; Captain Vaughan states "the controls would be effective at a distance of 50 miles and could be operated from an aeroplane as well as from the ground." It was stopped, started, reversed, steered; made to blow a horn, ring a bell and fire a pistol by the pressure of buttons on an automatic transmitter that sent out various combinations of dots and dashes that caused certain controls in the car to function. The "brains" of Captain Vaughan's car is the selector—an apparatus about as large as a saucer which decodes the combinations of dots and dashes and puts the desired controls in operation within a quarter of a second. Any one of the twelve controls can be made operative in less than one second. The possibilities for operating war-machines on the same principle give these demonstrations a prophetic significance.

*"First:* the simplification and standardization of the receiving set.

*"Second:* the use of light wires and the telephone wires as aerials for everybody.

*"Third:* the use of local power systems for local broadcasting.

"Through these three developments there will come to every man's home a stream of the best things of the world—a stream to be tapped and enjoyed when he wishes, to be shut off by the simple turn of a switch when he does not; a stream out of which he may select what pleases his fancy or meets his changing needs.

"Thus will the radio engineer provide a new cultural background for humanity, a new and powerful agency for the advancement of mankind."

The control of distant mechanisms by radio waves has grown to be a very important development of the radio art and many astonishingly marvelous experiments have been made to prove the practicability of such remote operation. Here again Dr. Henry Smith-Williams has contributed a most enlightening manuscript on the subject and the reader is bound to find in it a pleasantly understandable outline of how such system functions:

"No radio apparatus exhibited recently that has attracted anything like the popular attention bestowed on Mr. E. P. Glavin's mystifying little automobile that is controlled by wireless.

"I use the word 'mystifying' advisedly, even though there is no secret as to the way in which Mr. Glavin accomplishes the wonder. A wonder it remains, however, even after the fullest explanation. The greater your knowledge of radio, in fact, the more fully you will agree to that.

"You see Mr. Glavin standing at the side of the room, a solid-figured man

with gray hair and strong, thoughtful face; you are at once struck with his resemblance to that other wizard in the field of electricity, Thomas A. Edison. The little automobile (Fig. NN), somewhat boatlike in shape and with a mast that heightens the resemblance, stands in the middle of the floor. It is indeed a prosaic looking vehicle; its metal covering might give the impression that it is a model of some new type of armored 'tank.' At a distance, your only clue to its real character is supplied by the coil of wire that ascends as a spiral about five or six inches in diameter that winds about the mast from bottom to top, where there is a little electric signal light. On closer inspection you might see within the open body of the vehicle a series of electric batteries and sundry mechanical devices, but even that glimpse would probably make you not much the wiser, even if you are a skillful mechanic. About the only obvious feature is a central wheel, the rim of which projects into the body of the little car, to which the propelling mechanism is attached. The single front wheel, it may also be noted, serves to guide the vehicle to left or right, just as a bicycle is guided. But there is no bicycle handle or other mechanism in sight by which the wheel might be turned.

"Mr. Glavin, standing perhaps twenty feet away from the car, raises his hand. You note that the signal light at the tip of the mast flashes, but nothing more tangible happens. Another slight motion of Mr. Glavin's hand. Now the car starts forward and begins its strange journey. It glides along at a moderate pace, like a tank leisurely charging the mass of spectators, but before it reaches them it circles to the left, and moves back toward the point from which it started.

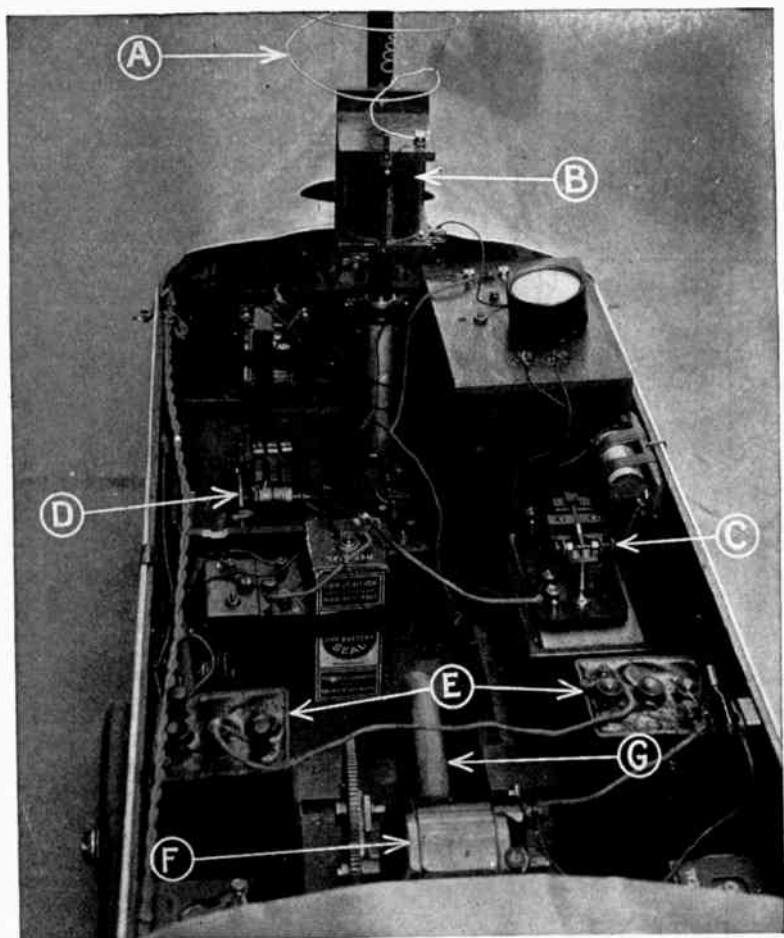

#### INSIDE INFORMATION ON THE CONTROLS OF THE RADIO CAR

Figure MM: The essential working parts, by means of which the vehicle is controlled, are as follows: A is the spiral antenna; B is the tuning coil; C is the sensitive relay operated by the feeble radio currents; D is the control switch which is set into action by the closing of the contacts of the relay; E are the storage batteries which furnish the electrical power to the motor F, and G is the propelling wheel.



**THE GLAVIN "MYSTERY MOTOR CAR"**

Figure NN: The motive power is furnished by a storage battery; electromagnetic waves from the aerial throw the current in and out of circuit. How this is done is the essence of the device.

"Mr. Glavin's face is impassive, but from time to time he lifts his hand with a little movement as of salutation; each time he does so you note that the car changes its course. It circles to right as well as left; it cuts a big figure eight; with seeming intelligence it turns its prow just in time to avoid collision with the spectators.

"I chanced to be standing beside Mr. Glavin on one of the occasions when the car was making such a journey.

"'Now I will have it come around and stop right in front of us,' he remarked quietly. A wave or two of the hand and the thing was done! It was hard to avoid the feeling that this weirdly responsive little vehicle, as it circled about and came toward us and stopped respectfully four or five feet away, was manifesting actual intelligence and consciously responding to the mandate of its master.

"There was a time when an exhibition like that would have been labeled 'wizardry,' and an interpretation would have been put upon the word that would have boded ill for the exhibitor. The word 'wizardry' still applies, but it now has scientific instead of superstitious implications. The medieval interpretation would have condemned the inventor for consorting with evil spirits, the modern interpretation explains that he is juggling with electromagnetic waves in the ether.

"There is, as I have said, no mystery about the method of operating Mr. Glavin's device. Every observer is aware that the little car makes its pilgrimage under radio control. Everyone knows that when the director lifts his hand he is merely signalling to the radio operator a short distance away. The operator touches a telegraph key connected with an ordinary transmitting

apparatus that operates in connection with a short two-wire aerial. Everyone knows that the electromagnetic waves sent out from the aerial are caught up by the receiving coil that is spiraled to the mast, thus constituting a receiving antenna, and that it is the impulse thus coming to the radio apparatus stored within the body of the little car that determines its movements.

"But this knowledge does not take away the mystery. To see that little vehicle, under no man's hand, start and move about in an intelligently directed path, stop, and start again and finally make its way to the stall that is its temporary home, and stop there—quite as a horse makes its way to its own stable—is to witness a scientific miracle that yields place to few others in genuine mystery. The builder of radio apparatus can tell how the thing is done in mechanical terms. The mathematician can calculate the energy involved. But no man can give what could properly be called a full explanation of the mystery.

"It is possible, of course, to go a little more into detail as to the precise steps of the series of processes by which a wave of the hand appears to be translated into the propulsion of a vehicle—not only appears to be, but really is so translated, if we accept words in their proper meaning.

"But what takes place within the mechanism of the vehicle when the wireless impulse is received from the transmitting aerial?

"At the outset it must be understood that the radio waves which determine the activities of the little car do not supply the energy of propulsion. By no possibility could they do that. The electromagnetic waves that come from the aerial could no more turn the driving wheel and propel the vehicle than could

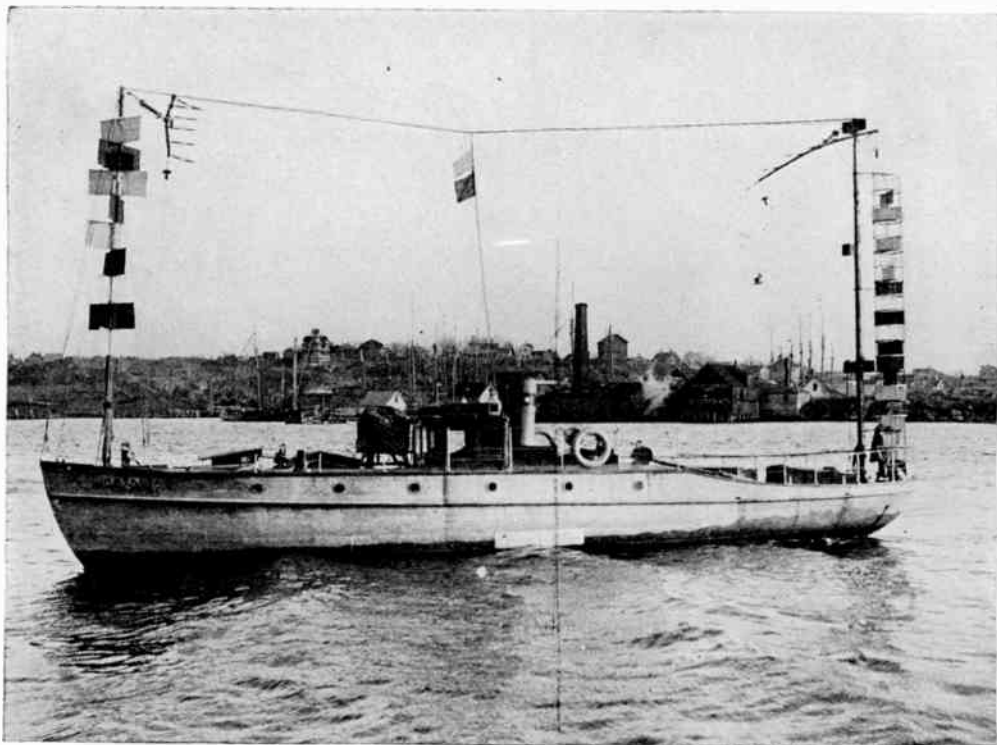

International

#### A FORERUNNER OF A RADIO-CONTROLLED NAVY

Figure 00: Several years ago the youthful "wizard" of Gloucester, Mass., John Hays Hammond, Jr., attracted world-wide attention by demonstrating how a yacht could be directed by radio impulses sent over a distance of several miles. These experiments were followed by the development of radio-controlled torpedoes.



the same feat be accomplished by those other electromagnetic waves termed rays of light which pass from Mr. Glavin's hand to the eye of the operator of the radio-telegraphic key. The radio waves convey more energy than the light waves, to be sure; but in no conceivable way could they convey enough energy to propel a vehicle weighing eight pounds, let alone eight hundred.

"Most of the observers are well aware of that. They understand that the actual propulsion of the wireless car is effected by a storage battery which is a part of the internal mechanism of the car itself. A little dynamo that differs in no essential from the dynamos that propel other electrically-driven vehicles—from automobiles to trolley cars—metamorphoses the energy of the storage battery to energy of molar motion—and turns the wheel. The electromagnetic waves from the aerial serve only the function of the motorman on the trolley car, they throw the electric current in or out of circuit.

"It is the way in which this is accomplished, however, that constitutes the essence of Mr. Glavin's invention.

"This statement does not do full justice to the problem. It is necessary not merely to throw on and shut off current, enabling the car to start and stop (which is all that the motorman on the trolley is called upon to do), but it is necessary also to provide for the lateral guidance of the car, a duty of which the motorman is relieved by the railway irons. The feat of Mr. Glavin's radio-automaton might better be likened to the task of the automobile driver who not only starts and stops his car but turns it to right and left.

"Mr. Glavin labored with this problem for nine years before he solved it to his satisfaction. The inventor himself

would probably qualify that phrase and say that he labored nine years before he got the car to operating as it now does, and that even now he feels that he has made only a tentative solution of the problem and is by no means satisfied with it as an ultimate achievement.

"But the present achievement is notable enough to satisfy most inventors and to excite the wonderment of all beholders. The mechanism involved, so Mr. Glavin assures us, is relatively simple; important mechanical devices almost always are simple when perfected. In this case, the mechanism that shunts the current from one circuit to another consists of a small drum actuated by an electromagnetic dog-and-ratchet arrangement. Released by one signal, the drum rotates enough to bring a brass collar in contact with poles of the battery, thus establishing a circuit that lights the electric lamp at the top of the mast head. A second signal releases the drum and permits it to turn into the next position, where another brass collar establishes the circuit that enables the dynamo to actuate the propelling wheel. The motorman has turned his lever and established the circuit, and the car is in motion.

"Now comes the third signal, and this (while leaving the propulsive current in circuit) permits another shift of the drum, bringing into action an electrically-driven power that turns the guiding wheel to the left. The car now circles to the left until the next signal brings the wheel back again; then it will go straight ahead again until the sequential signal turns it to the right.

"There are twelve signals in the entire series, and the successive shifts of the drum necessarily take place in an unvarying sequence. Straight ahead—turn to the left—straight ahead on a



#### HE LABORED NINE YEARS TO MAKE HIS RADIO CAR WORK

Not so many generations ago this inventor, E. P. Glavin, would have been condemned for consorting with the evil spirits that propelled and guided his miniature motor car. Modern science, however, knows that he is merely juggling with electromagnetic waves in the ether—until ultra-modern science disproves the existence of ether and proclaims another explanation of the phenomena of radio.

new tangent—turn to the right—straight ahead on a new tangent—turn to the left—and so on. There is no way of changing the succession of the signals.

“Nevertheless, the car can be made to take any desired course—as can the man-driven automobile. If Mr. Glavin wishes the car to make its first turn to the right instead of to the left, he merely gives three signals in rapid succession after the vehicle is under way. The

three signals can be given in less than a second's time with the result that the drum will shift so rapidly, that the left-turn circuit and the back-to-center circuit are passed before the wheel has fairly begun to respond and the turn-to-right circuit appears to have been directly established. In other words, the undesirable signals were ‘jammed’ and rendered inoperative.

“Such, then, are the essentials of Mr.

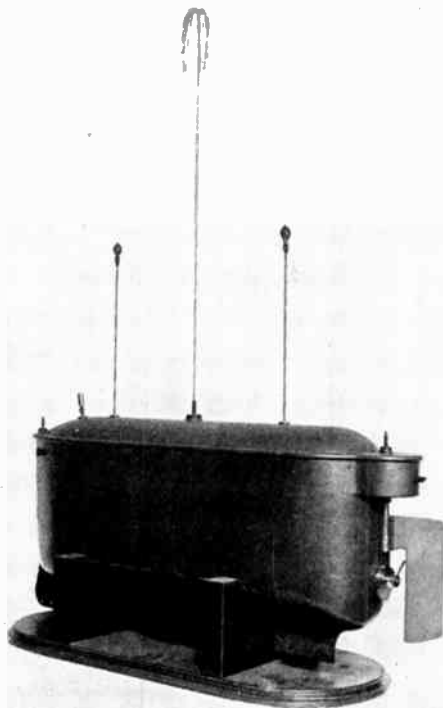

#### TESLA'S FAMOUS "TELAUMATON"

Figure PP: As far back as 1895 Nikola Tesla gave demonstrations in New York of this radio-controlled boat. It was eight feet long, and was operated in a large tank. The inventor made the boat go through many evolutions, turn lights on and off and fire miniature guns—to the consternation of the public to which radio was practically unknown.



**A PICTURE THAT CROSSED THE ATLANTIC IN 20 MINUTES**

Figure QQ: This is one of the photographs (of a street scene in London) that was sent from England in the radio photographic tests. These experiments prophesy the publication of pictures of important European events in the daily press of America as soon as in the newspapers abroad.

Glavin's invention. In a sense it is simple, yet of all radio marvels, few are more thought-provocative than this."

Perhaps the greatest marvel of radio transmission is the feat of translating a photographic print into a series of electrical impulses that may be reproduced at a distant receiving station as an intelligent replica of the original. While

we have many such systems, each with its own particular features and faults, the basic principles involved are practically the same and the description of two of the most widely divergent schemes will give the reader a fairly broad understanding of this growing branch of the radio art.

The Ranger system of photographic



A RADIO CAMERA WITH A 3,000 MILE FOCUS

Figure RR: The inventor is here comparing an original photograph with its transmitted duplicate.

transmission has been successful in trans-Atlantic work and it is perhaps the most simple scheme in use at the present time, a fact that makes it admirably suited for popular description. Mr. Ranger, the inventor, tells of the operation of his machine in his own words:

"Behind any development or invention there must be first the desire for its

particular accomplishment. This desire has long been behind the transmission of pictures by radio and it has finally culminated in the demonstration some time ago when picture after picture was successfully transmitted from the City of London to downtown New York by the Radio Corporation of America's high-powered transatlantic system.

"Set up in the laboratories were loud-

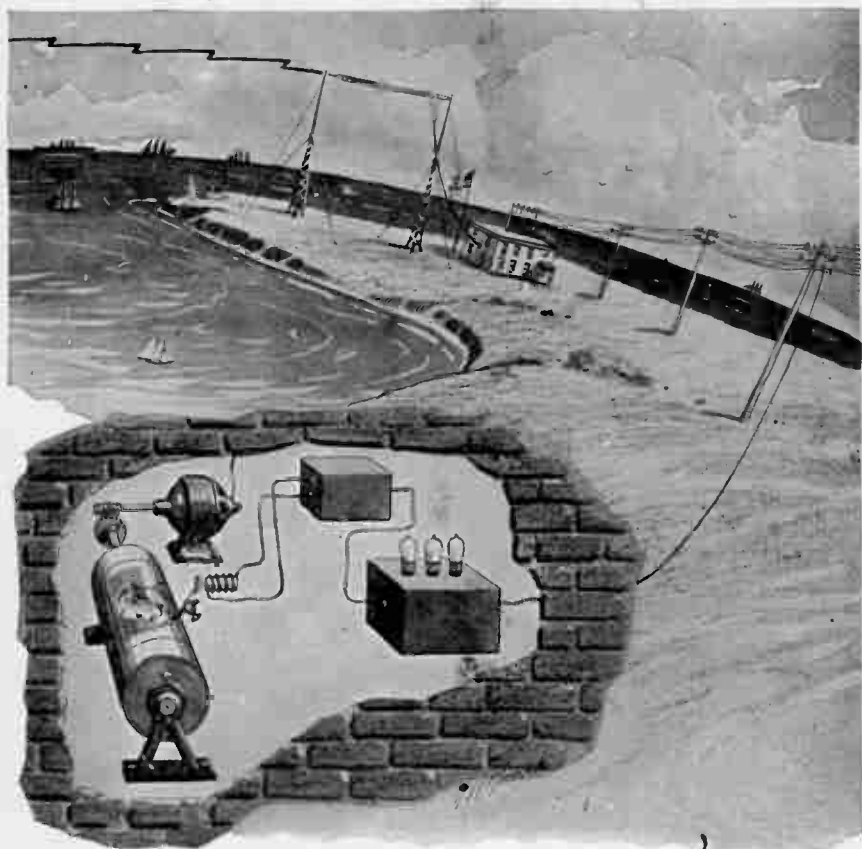

#### HOW THE PICTURES SPAN THE ATLANTIC.

Figure 55: The photographs and printed documents are sent from London by wire to a radio station. They are received by an American station as indicated on this page. From the radio station the electric impulses are relayed to New York and are recorded, as shown, on the cylinder by the special pen.

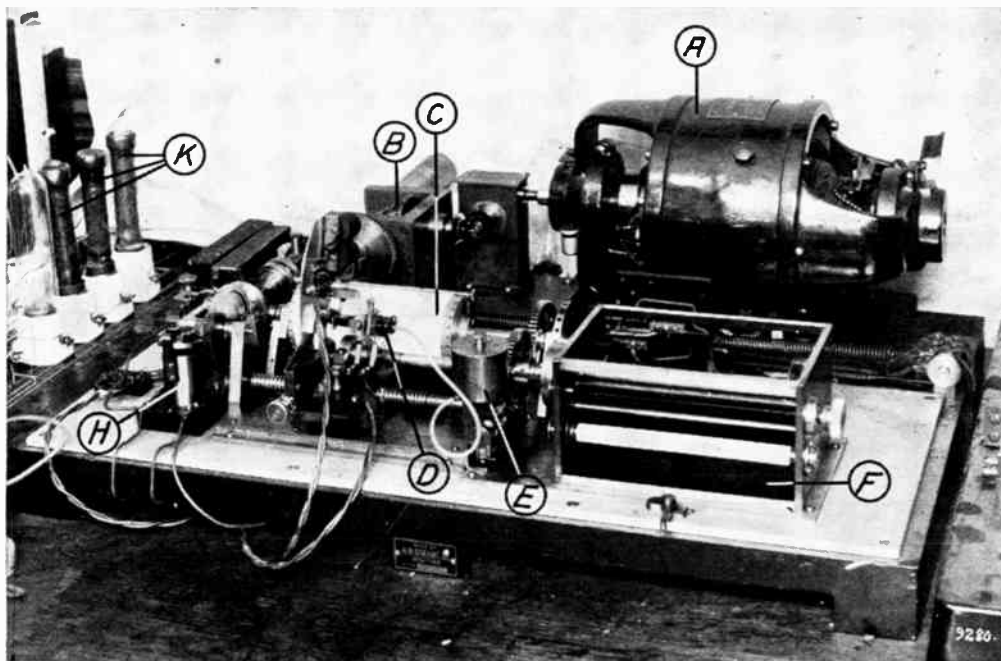

#### THE RECEIVING AND RECORDING APPARATUS

Figure TT: A in the picture above is the driving motor that runs exactly at the same speed as a similar motor at the sending end. B is the gear that runs the cylinder C on which the picture is recorded by the special pen D. At H is a magnet that shifts the pen like a typewriter carriage. K are resistances. E is an ink reservoir for the pen. While the pen makes a picture, a ray from an electric light makes a duplicate within the camera box F.

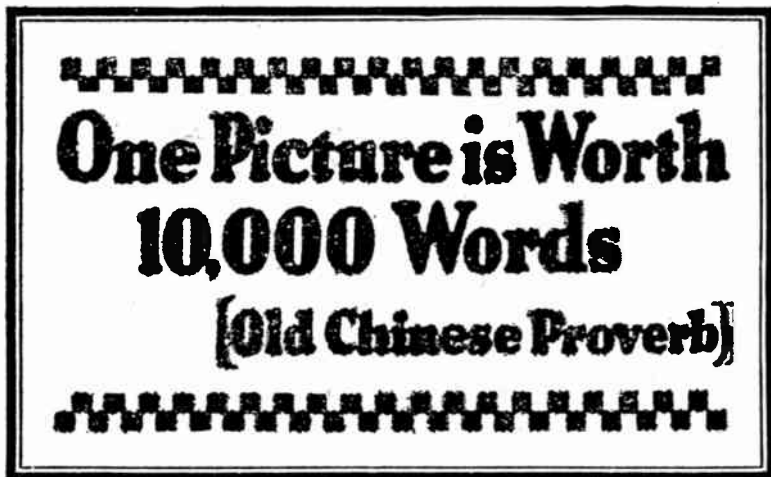

#### HOW PRINTED DOCUMENTS ARE RECEIVED BY RADIO

Figure UC: At a public demonstration of the Ranger apparatus a full-page advertisement, complete with reading matter and pictures, was transmitted from London within a few minutes, ready for reproduction in a New York newspaper.

speakers amplifying the signals coming in from England; but instead of the radio code signals with which most broadcast listeners are familiar, this picture talk seemed to be an incongruous collection of buzzing noises—not particularly rapid in succession and with more or less of a halting characteristic. Nevertheless, they were the shorthand indications which were accomplishing the registration in New York City of the photographic impulses that originated from Radio House, London.

"Mr. Donald G. Ward, an engineer, had gone across to London only three weeks before to set up a 'board' about 3 feet by 4 feet in size, on which was mounted a fair-sized motor which is used to rotate a glass cylinder. This motor revolves at an exact speed determined by a vibrating tuning fork which sees to it that, in spite of load or electric current variations, the mo-

tor will keep rigorously geared to time.

"The glass cylinder supports the photographic film to be transmitted. The film may be either a positive or negative, but from an operational point of view it is usually found convenient to use a positive print so that the operator can judge better of the values which should be brought out as the solid black and the pure white of the picture. Inside the glass cylinder is a powerful, although small, electric light which, with its appropriate lenses, sends a beam of light through the film at one point at a time as the drum rotates into a light proof box inside of which is a photo-electric cell

"This cell is the 'photoradiographic eye.' The electrical resistance of this cell changes in accordance with the amount of light which falls upon it and in this way takes care of the shading of the picture in transmission.



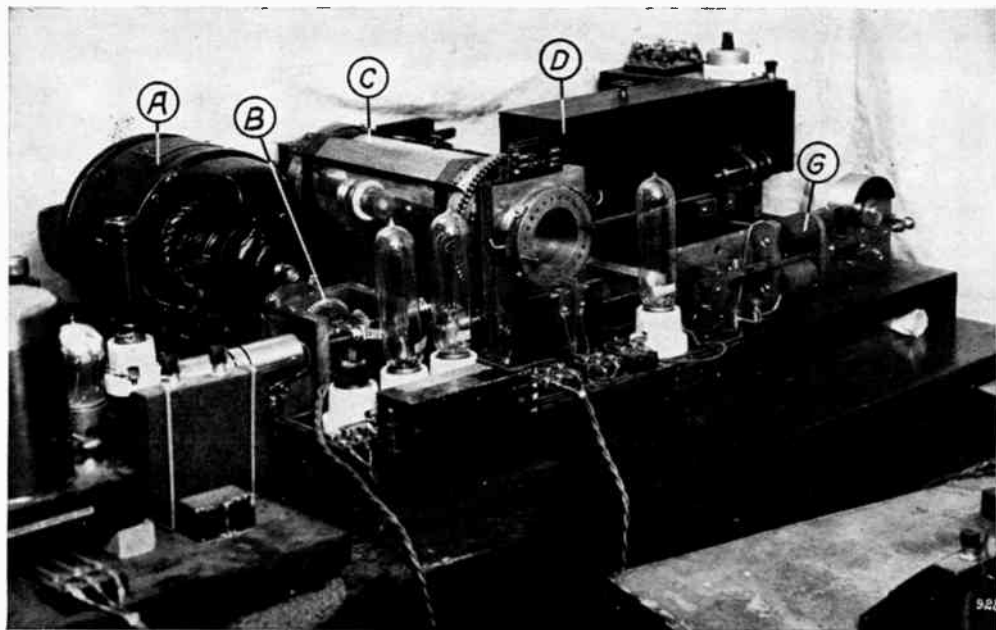

#### THE RADIO PHOTOGRAPHIC TRANSMITTER

Figure VV: A is the synchronous motor and B is a gear that connects it with the cylinder C on which the photograph to be sent is fastened. D is the camera box that is shifted by the magnets G while the varying lights and shades of the photograph are being converted into electric impulses

"The photo-electric cell functions practically without any lost motion. That is, the instant the slightest change in the amount of light reaches the cell, a corresponding change in the output current of the cell takes place. In this way the 'eye' of the transmitter is able to 'see' even the tiniest light variations; in fact the 'eye' sees and records electrically millions of different current impulses as the films sweep by the light beam from inside the cylinder.

"The photo-electric cell is, therefore, responsible for reproducing an infinite number of different electric current values which correspond with the light or dark areas of the pictures that are being transmitted.

"In order to cover all of the original film, the glass cylinder is rotated back and forth; in this way the entire surface is eventually exposed to the piercing light beam. The film rotates through an angle equal to the width of the picture, and the electric camera itself advances down the length of the picture one notch at a time. Thus, line upon line, the whole picture is covered.

"After the signal impulses or electric waves from the photo-electric cell pass through a series of vacuum-tube amplifiers, they are fed into a modulating device ready for transmission. The electrical interpretation of the picture is then transmitted over land wires from the London laboratory to the high-powered transmitting station of the Marconi Wireless Telegraph Company, Ltd., at Carnarvon, Wales. Here the electric impulses on the land wire operate small relays which turn on and off the high value currents that flow from the 200-kilowatt generator to the antenna system. This high power electrical energy leaving the antenna in interrupted impulses, similar to dots and

dashes of the telegraph code, creates the ether waves which carry the photograph 3,000 miles through space to the receiving station on this side of the Atlantic, located at Riverhead, Long Island.

"The development of the photoradiogram transmitter has purposely been carried on in connection with the established radio-transmitting stations, now engaged in sending radiograms daily between Europe and America. Thus the new device does not require the preparation of any special radio circuits for efficient operation.

"At Riverhead, Long Island, in the Radio Corporation's central receiving station, the operator tunes in to the Carnarvon station. He receives the picture just as he would receive a radiogram, but instead of dots and dashes which he can read he receives an undecipherable series of electrical impulses. These impulses pass through a bank of vacuum-tube amplifiers and are then sent by land wire to the laboratory of the corporation, located in the building in Broad Street, New York.

"Here this unintelligible code, carrying the photograph, is translated back into black and white, recording the original picture much in the style of a stippled engraving.

"An 'unscrambling' device in the laboratory then decodes the complex photo message and gives each individual electrical pulse of energy a definite task to perform in reassembling the picture.

"The picture is reproduced in duplicate at the receiver, both on a paper record and on a photographic film. The paper upon which the record is made is wrapped about a rotating cylinder, which, in size and appearance, much resembles the early type wax phonograph record. A specially constructed fountain pen bears against this just as the

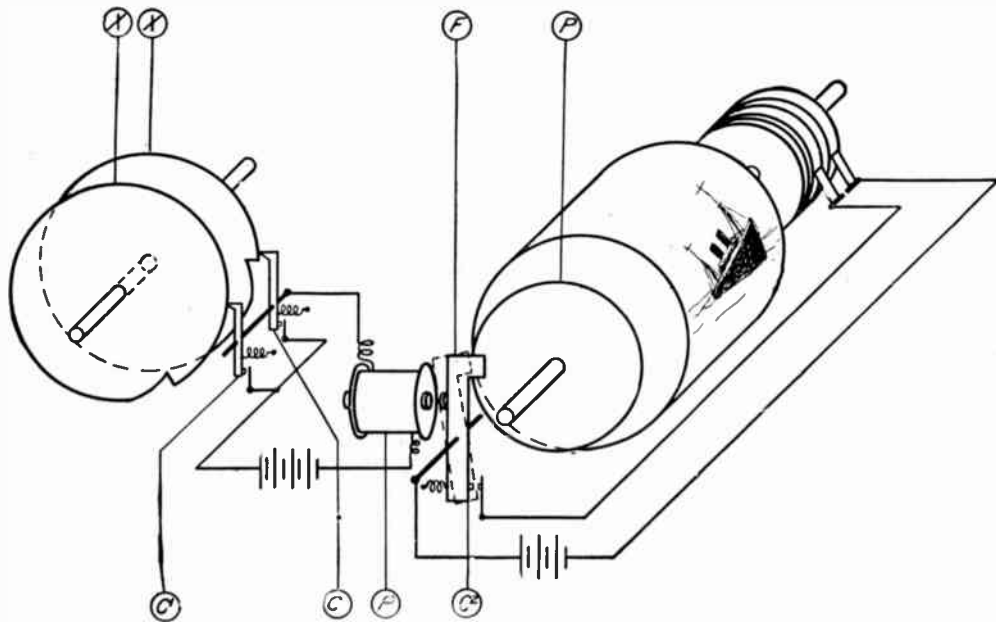

#### HOW THE PERIODS OF REST AND ACTION ARE CONTROLLED

Figure WW: This diagram illustrates how the two crypto discs XX control the periods of rest and revolution of the cylinder P by means of an electrical relay.

needle of the phonograph does on a record. The pen is attached to an electrically-controlled lever in such a way that every pulse of electrical current which passes through the magnet coils of the relay lever draws the pen to the surface of the paper, making a fine ink mark. A changing current fed through the magnet coils causes the pen to wiggle in step with the current impulses, thus giving the artistic stippling effect in the reproduced picture.

"One of the outstanding requirements in sending pictures by radio or wire is absolute synchronism of the sending apparatus with the receiving device; otherwise distortion will occur. If the receiving apparatus should lag the slightest particle of time behind the transmitting set, the received picture would be blurred and unrecognizable.

"This necessary synchronism is maintained by the use of special driving motors, one geared to the transmitting cylinder and the other geared to the receiving cylinder. These motors although separated by 3,000 miles maintain the same speed. This is accomplished by the aid of the tuning forks already mentioned.

"Chief of the features of this photoradiographic system may be mentioned the fact that the entire operation at transmitter and receiver is in broad daylight. This immediately removes the process from the laboratory stage, which necessitated dark rooms and many other special provisions and brings it into a category of usual commercial equipment.

"The building up of the received picture is a fascinating sight, even to those who have watched it as it became more perfect day by day. This is particularly true when it is realized that it is originating more than 3,000 miles away, and

that those particular dots are being formed nowhere else but right on the receiving cylinder in New York City. No human hand could hope to imitate the precision of the small special fountain pen which puts down, here and there, dots or dashes, then leaves an open space which gives the pleasing effects of the finished picture.

"If the same picture is transmitted twice, the dots do not occur in exactly the same spots on each picture; in other words, each and every transmission is individualistic, although the resultant pictures when held at a little distance are absolutely identical. In other words the dots come in seemingly, hit or miss, but it all depends upon the chance way in which the picture first starts, so that the succeeding dots will take up their proper places with mathematical exactness to give true tonal value to the picture.

"So it seems that this photoradiographic art will soon come to have a real place in communication; particularly as facilitated by the rapidity of radio waves."

One of the greatest obstacles in the transmission of pictures and documents, especially important documents, is that of secrecy. Anyone equipped with the necessary receiving apparatus may intercept the picture message by attuning their device to the transmitting station. Eduoard Belin, a capable French experimenter, has invented a method of sending pictures with what would seem to be positive secrecy. Mr. Belin tells how he does it in the following pages:

"The transmission of pictures and documents by radio is an accomplished fact. It has been done by many with more or less success, depending upon the method and apparatus that has been employed.

"One of the disadvantages of radio transmission is that someone may, with the proper apparatus, receive the message or document that is being sent, even though it is not addressed to him. This feature, of course, renders the apparatus almost valueless for commercial purposes, as no newspaper or police department would transmit under these circumstances any documents which should be kept inviolate.

"To overcome this objection and make any picture-sending method practical, I have devised a machine which

sends pictures by radio, but in such a manner as to make it impossible for the message to be received by anyone except the station to which it is addressed. After several years of experiments, I have succeeded in my endeavor and have produced an apparatus that I have called the 'radiocryptotelesterograph.'

"This apparatus (which is really a combination of two instruments) includes a transmitter and a receiver, almost identical to our telesterograph (Belin's picture transmitter), for the transmission of pictures over land

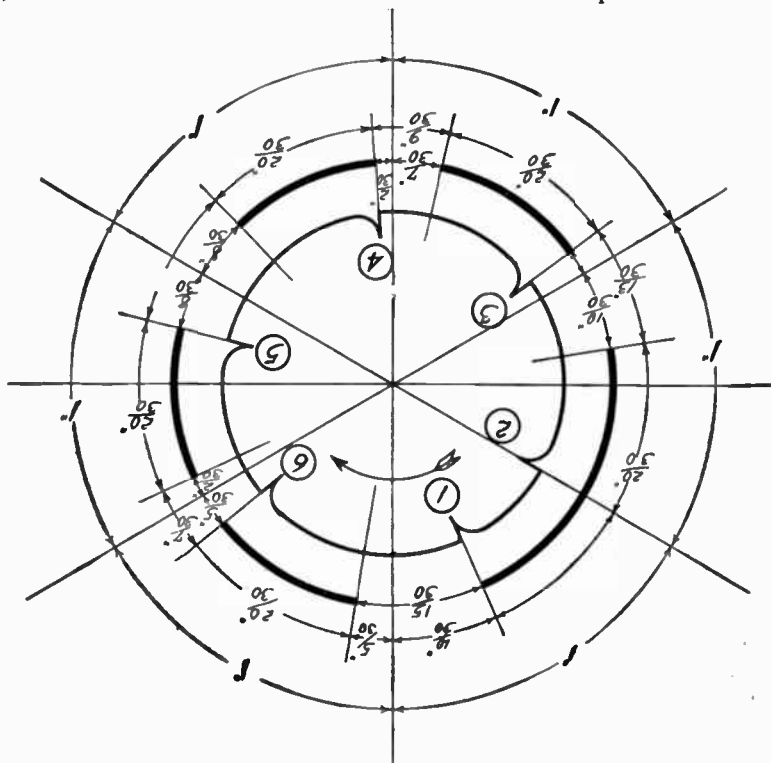

A "TIME CHART" OF THE CRYPTO MACHINE

Figure XX: This shows how the periods of rest and action are divided. The periods of rest are determined by the number combination in much the same manner as the combination on a safe; they are also disguised by sending out false signals which are similar to the transmitted signals which reproduce the picture.

wires, and a combination system somewhat similar to those used in safes, which may be adjusted to form 999,999 different combinations. There is, therefore, but one chance in a million for the message to be intercepted by a station even if it is equipped with the proper apparatus. As an added safety, however, during the interval when no part of the picture is being sent, a special device fixed on the machine sends false signals—a feature which makes it absolutely impossible to receive the documents unless the receiving operator knows the combination number and adjusts its apparatus so that it is exactly synchronized with the transmitter. I have named the apparatus that accom-

plishes this feat, the 'crypto,' from the Greek word *cryptos*.

"The crypto is composed of six discs that have cut on their circumference nine slots that are numbered from 1 to 9; these may be adjusted to form any desired combination of six figures. Once set at the proper place, a blade is set in the slots, thus making of the discs a unit which turns at the proper speed and that closes contacts in a certain order that depends upon the combination.

"Figure WW shows how at every turn the contact C, is closed, releasing by means of a relay R, the cylinder P, that bears the picture or message.

"The crypto discs make one-sixth of a turn every second while the cylinder P,

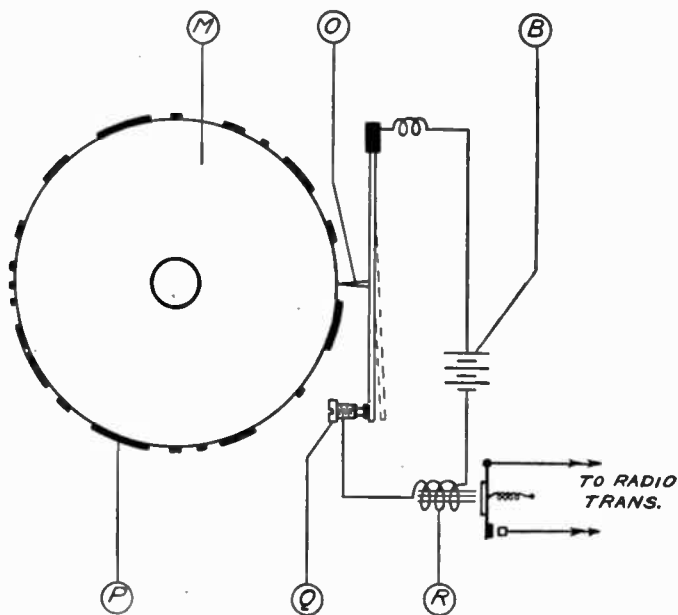

#### HOW THE CRYPTO DEVICE TRANSMITS THE CODE

Figure YY: On the disc M, the dot and dash characters P, are printed by raised portions which, by means of a needle O, close a switch Q and a relay R, thus sending a signal to the radio transmitter.

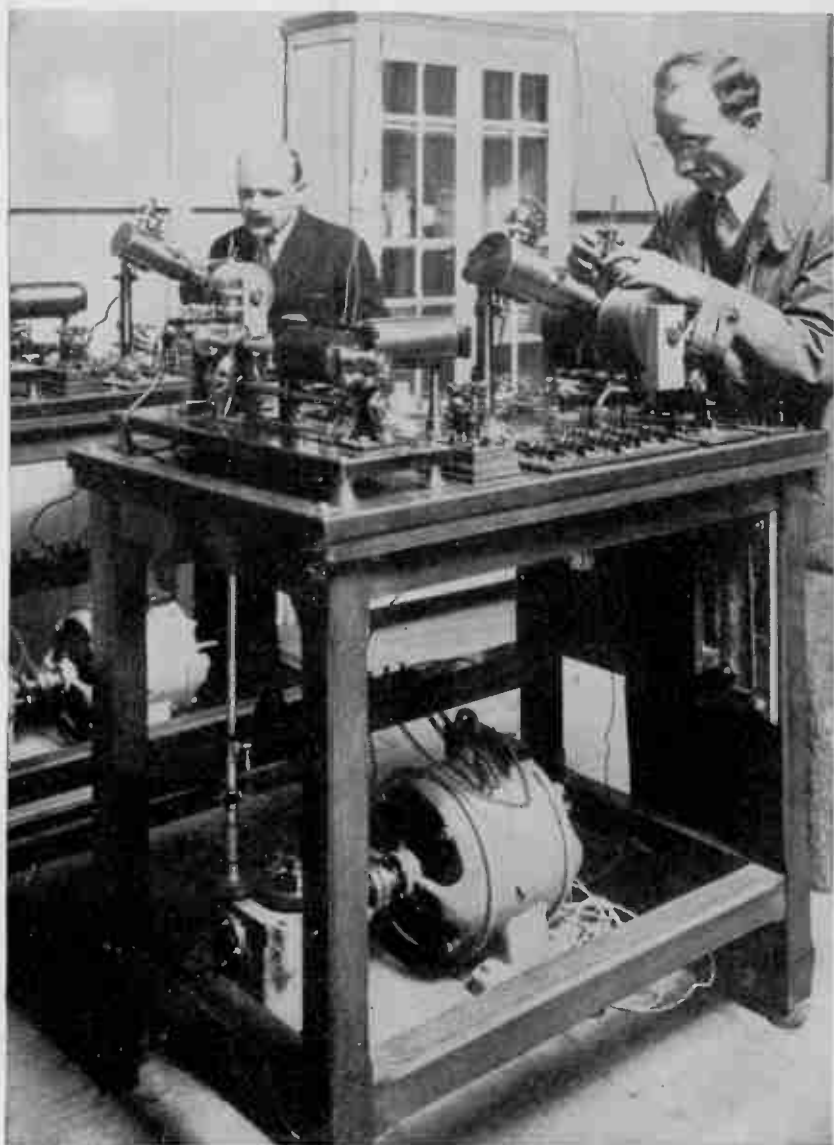

International

#### THE RADIOCRYPTOTELESTEREOGRAPH IN OPERATION

Figure ZZ: Here are shown the two complete machines, one for transmitting and one for receiving pictures by the Belin process. Both machines are run by synchronous electric motors, and the receiver is timed by a radio impulse sent out at regular intervals so that both the transmitter and the receiver will keep in time; otherwise the pictures would be deciphered incorrectly and would be reproduced merely as a meaningless jumble of light and shade.

accomplishes one revolution in two-thirds of a second; therefore, when the contact C, is closed, the relay R, attracts the finger F, locking the cylinder and at the same time closing the circuit of a magnetic clutch which couples the cylinder to the rotating shaft; these operations are made instantaneously.

"As the contact C, is only momentary the relay R, is energized for only a fraction of a second and the finger F, is attracted just long enough to release the cylinder, coming again in contact with the cylinder P, and sliding on its edge until it falls again in the slot, stopping it and opening the circuit of the clutch at C<sup>1</sup>. The same cycle of operations happens every time one of the contacts C or C<sup>2</sup> are closed. For the sake of clarity, only two contacts are shown in the sketch, but six contacts are used in the crypto, one for each disc.

"Figure XX illustrates clearly the method of operation, as it shows the periods of work and rest of the cylinder. The six breaks on the discs are numbered and are supposed to be set for the combination 913285.

"The efficient time of rotation of the cylinder upon which is fixed the picture that is being sent, is two-thirds of a second, and may be taken as twenty-thirtieths of a second. If the discs are adjusted to form the combination number 913285 (for example), there will be before the 1st turn of the cylinder, a rest period of ten-thirtieths; at the beginning of the 2nd second, the cylinder of one turn rotates in two-thirds of a second, and stops during thirteen-thirtieths of a second, before it starts for the 3rd turn, and so on; the inactive time is determined by the arrangement of the discs.

"As may be seen, therefore, the pic-

ture is sent at irregular intervals, which makes it necessary for the receiver to be exactly synchronized so as to start exactly at the same time as the transmitter. If but a single figure in the number is wrong, the lag at every turn would increase and put the whole system out of tune, and the results on the receiving cylinder would be unintelligible, as several spots would be reproduced at irregular intervals. The false signals disc, in other words, would produce some extra spots which would render the picture or message absolutely unreadable.

"All these operations are made at every turn and happen every second. The time required to send a picture or message being about  $4\frac{1}{2}$  minutes.

"The vital factor in my machine is the synchronism which insures the transmitter and receiver turning at the same speed. It includes a clock that has a contact system which closes a local circuit every second. By means of an adjustment at the receiver, the contact may be made exactly at the same time as at the transmitter. The operator at the receiving end listens to the tick of the transmitting clock which closes the circuit of the radio transmitter, and adjusts the contact so that the local circuit of the receiving clock is closed at the same instant. Once this is adjusted, both transmitter and receiver are started and the picture sent.

"The picture to be sent is photographed on a gelatin plate which is developed and stuck on a brass cylinder over which a needle contact slides in the same fashion as the needle of an old style phonograph or of a dictaphone. The motion is such that the needle covers at each turn one-hundred-and-twenty-fifth of an inch, which has been found sufficiently accurate to reproduce de-



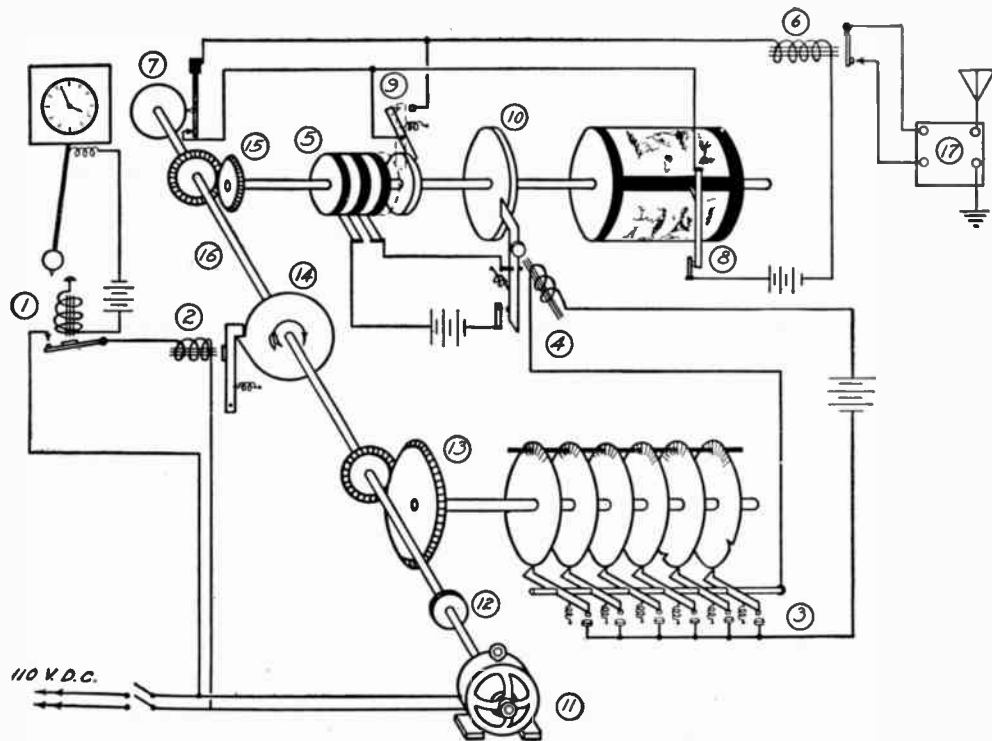

### THE COMPLETE TRANSMITTING APPARATUS

Figure A3: This schematic drawing shows how the apparatus insures the complete secrecy of the transmission. With this device there is less chance than one in a million that pictorial eavesdropping may be accomplished.

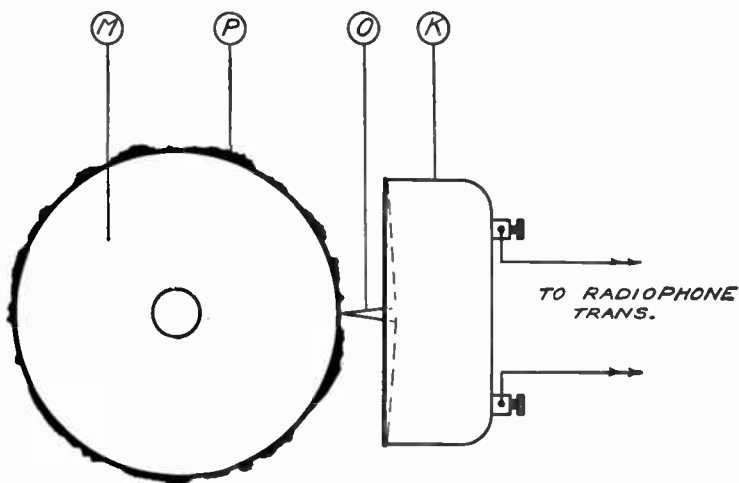

#### HOW PICTURES ARE TRANSMITTED

Figure B3: For transmitting photographs and other pictures that require half-tone effects this device is used instead of that pictured in Figure YY. The microphone follows all of the various shadings between white and black, whereas the switch device can only distinguish between pure white and deep black.

tails. Every time a black part of the picture passes under the needle it opens a local circuit, for these black parts are in relief; when the gelatin is developed, the white parts of the picture are eaten away by the developer and form a depression. (See Figure YY.) Every time the local circuit is opened, the current of the battery, B, is interrupted and the circuit of the radio transmitter, controlled by the relay, R, is closed, thus sending a signal.

"Figure A3 shows the complete transmitter with the crypto apparatus that insures complete secrecy of the transmission. The transmitter is operated by an electric motor upon the shaft of which are mounted a friction device, the necessary gears, the synchronizing disc and the small wheel that produces the false signals. Every second, when the clock makes a contact, the relay 1, is closed; the 110 volts that energize it

flows through the relay 2, releasing the synchronizing disc which is stopped at every turn when the tooth catches on the arm of the relay. The motion is therefore transmitted to the cylinder and the picture sent as explained previously.

"The purpose of the tooth on the synchronizing disc is to stop the cylinder at every revolution during a fraction of a second. The reason for this will be explained later. As the cylinder stops at every turn in the same position exactly where the picture ends, the contact 8, is closed, but at the same time, as the magnetic clutch 5, is released, the switch 9, is opened and is pushed back by the steel disc when released; this puts in circuit the 'static machine' 7, composed of a disc corrugated so as to imitate a picture. This disc, which turns all the time with the motor, sends artificial signals that operate the radio transmitter in the

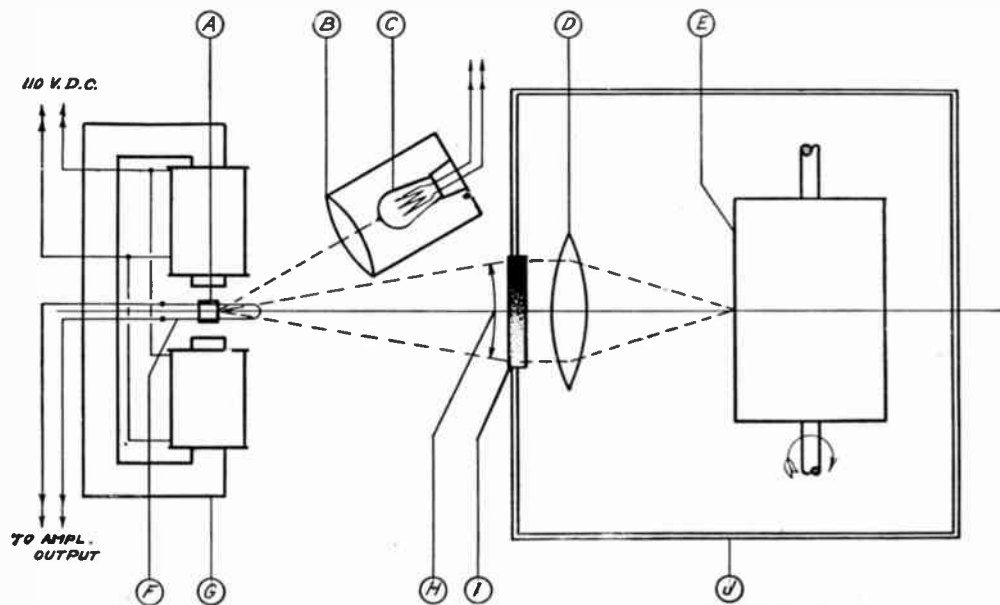

### THE COMPLETE RECEIVING APPARATUS FOR PHOTOGRAPHS

Figure C3: This includes the mirror A, which reflects a beam of light from the lamp C, passing through a lens B, through a shaded screen I, and a lens D, onto the drum E. The screen, lens, and drum are located in a darkened chamber, J. The moving coil F, causes the mirror to swing, thus causing the reflected beam of light to pass through the arc H, in accordance with the transmitted impulse. It is this swing which reproduces the picture by passing the beam through the clear portion or the opaque portion of the screen.

same manner as if the contacts were made by the picture. However, while the picture is being sent, the 'static disc' is short-circuited.

"The receiving apparatus is similar to the transmitter except that the cylinder upon which the sensitive film is stretched is enclosed in a light-proof box that has but one opening about the size of a pin-hole. The received current passes through the 'string' of an Einthoven galvanometer which normally obstructs a beam of light concentrated through a fine slot. When the needle passes over a black part of the picture at the transmitter, a signal is sent and causes the galvanometer string to deviate at the receiver, thus unobstructing the light beam which passes through the pin-hole, and thereby making an impression on the film.

"When the entire message or picture is sent the film is developed and prints are made in the usual way. Either a negative or a positive may be received at will by merely adjusting the galvanometer so that the string obstructs the light when a signal is sent. The reason why the cylinder that supports the pictures at both the transmitter and the receiver are stopped at each turn is that it has been found by experiment that the ordinary synchronizing systems are not reliable, and that it is almost impossible to keep the two cylinders turning at the same speed unless one uses a correcting system. In our apparatus, the correction is made at every turn by having the main shaft stopped by the tooth on the synchronizing disc. Every second both cylinders start at the same time, thereby preventing any great variation to be introduced while the machines are running, even in the cases of slight speed variations that are caused by the motors.

"This apparatus, which may be built in a compact form, has been used in experiments carried on aboard airplanes for sending sketches and messages from a plane to the ground. Very shortly I intend to transmit pictures from Europe to America.

"The process, as here described, permits only the transmission of pictures in black and white. This is on account of the equipment of the radio stations, which can send only dots and dashes. However, when a radio telephone station of sufficient power is available, the stylus that presses against the picture, fixed on the cylinder, may be replaced by a microphone that has a needle mounted in the center of the diaphragm. Half-tones may, therefore, be sent, as the microphone transmits all the variations of thickness of the gelatin, as shown in Figure B3.

"At the receiving end, a Blondel oscillograph is substituted for the Einthoven galvanometer, so as to permit the reproduction of all the values of gray in the picture.

"The oscillograph is composed of a strong electromagnet, in the field of which is an armature made of fine silver or gold wire in the shape of a long loop. Upon the wire is stuck a tiny mirror, that reflects a beam of light that is projected upon it. When the picture is being sent, the microphone modulates the radio waves in the same way as the voice does, and at the receiver the modulated current is sent through the armature of the oscillograph. This variable current, passing through the loop of fine wire, twists it more or less, and thus moves the mirror attached to it and deflects the beam of light—as shown in Figure C3.

"The beam of light passes through a screen that is shaded from black to

white, interposed between the galvanometer and the lens; this concentrates the beam upon the film. As the light is of variable intensity, a half-tone picture is received with all the details and shades of the original."

Is it possible to transmit radio pictures in color? This is a logical question for a layman to ask and the surprising part of it is that the question can be answered in the affirmative for this great technical feat has actually been performed. As a matter of fact, the sys-

tem used is amazingly simple when one stops to think of the miracle worked.

In order to understand all that is involved in transmitting a color photograph over a telephone line, it is necessary to outline the processes of making a color picture by the three-color process. The three-color process depends for its possibility on the fact that all colors may be copied with a high degree of fidelity by the mixture of three colors which are called primary colors. These colors are red, green and blue.

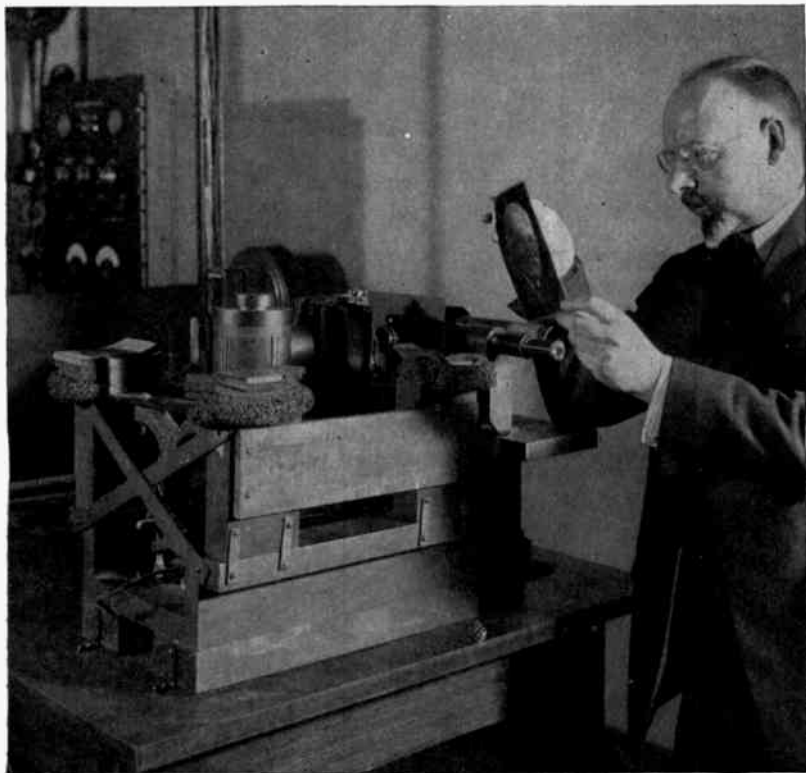

#### THE RECEIVING APPARATUS FOR COLOR PICTURE TRANSMISSION

Figure D8: The unexposed film is just below the hands of Dr. H. E. Ives, the illuminating engineer, who worked on this development. The lens to the left is the "light valve" that controls the light beams thrown on the film from the lamp house at the extreme left.

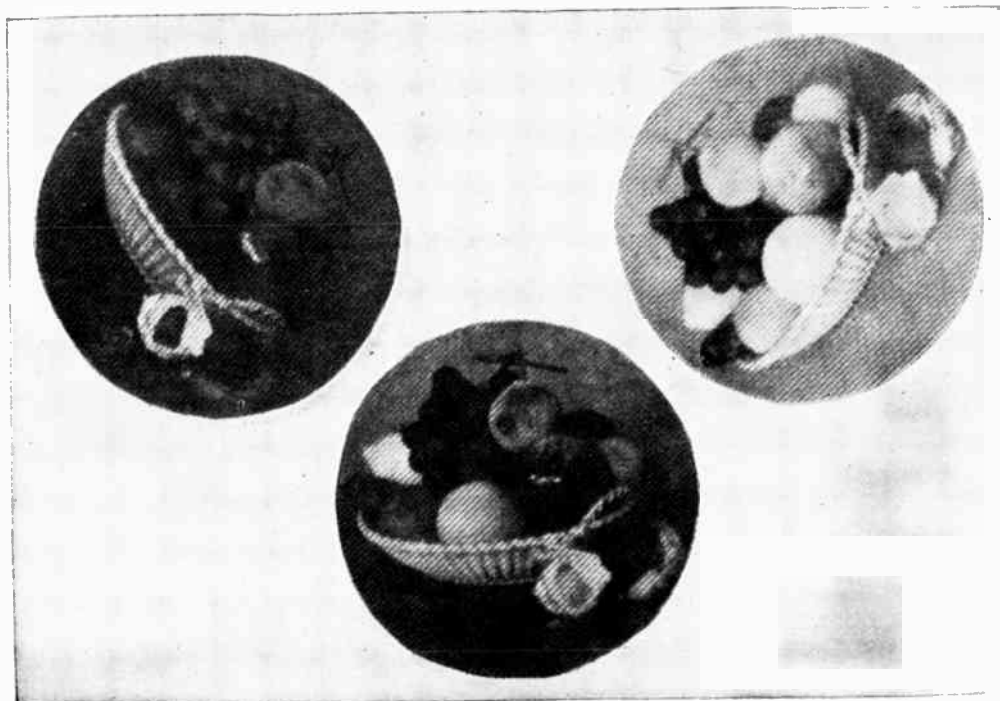

A. T. & T. Co.

**THE POSITIVES OF THE THREE KEY-NEGATIVES AS THEY ARE RECEIVED**

Figure E3: These negatives serve in the same way as engraved plates for printing in colors; each is a key to the primary colors, yellow, red and blue.

Mixing red, green and blue light, as for instance by means of three projection lanterns, each one furnished with a proper colored glass over its lens, enables us to make white light when the three colors are in a given proportion of intensity, and all other colors, including yellow, orange, violet, blue-green, and so on, when the proportion of the three primaries are altered.

The process of making a three-color photograph then consists in all cases of making three negatives of the original object each through a color filter, as it is called, which in combination with the color sensitiveness of the photographic plate makes a record of the amount of one of the primary colors which will be needed to mix with the others to reproduce the color of the original object. Thus the filter corresponding to the red projection lantern above considered must transmit light from a photographed object to the amount which red light is going to be used in order to copy the color of the original. An orange, for instance, will be recorded partly through the taking filter for green; since red and green light are to be mixed to produce the orange color.

When the three record negatives are obtained they may be used to make a color picture in any one of several different ways. Transparency prints from the negatives may be placed in three projection lanterns and projected on a white screen in red, green and blue light; the three images being accurately superposed one on the other. Or three transparent films may be prepared which are to be laid one over the other. In this case the colors to be used are not red, green and blue but the complementaries, that is, the colors which mixed with these make white; they are blue-green, crimson and yellow. The

object here is not to add lights to each other as was done with the lantern, but successively to absorb the primary colors from the white light. Accordingly the red record is printed in blue-green, so that where the red record is black, the transparency film will obstruct all the red light coming through; the green record is printed in crimson, the blue record in yellow.

It is now obvious that in order to send a three-color photograph over the wires, all that is necessary is to send three black and white record transparencies made from the original three-color negatives. One of the accompanying illustrations shows in black and white the three separate impressions of a single picture, which if they were printed in the proper colors and superimposed would give a colored reproduction. In making the positives for transmission, each one was turned at a different angle in order that the structure of fine lines which is introduced in the process of transmitting over the telephone wires would appear in each received picture at such an angle as to prevent geometrical patterns when the three were superposed. Also the differences in the photographic density of the three records is clearly shown, corresponding to differences in color in the original object. The actual transmission time of the three positives together was about 20 minutes, which included the time for changing and making adjustments of the apparatus between each picture.

Regarding the applications of telephone transmission of colored pictures, there may be an important field in the production of three-color transparency lantern slides of news subjects. Lantern slides can be made from the transmitted photographs in a very few min-

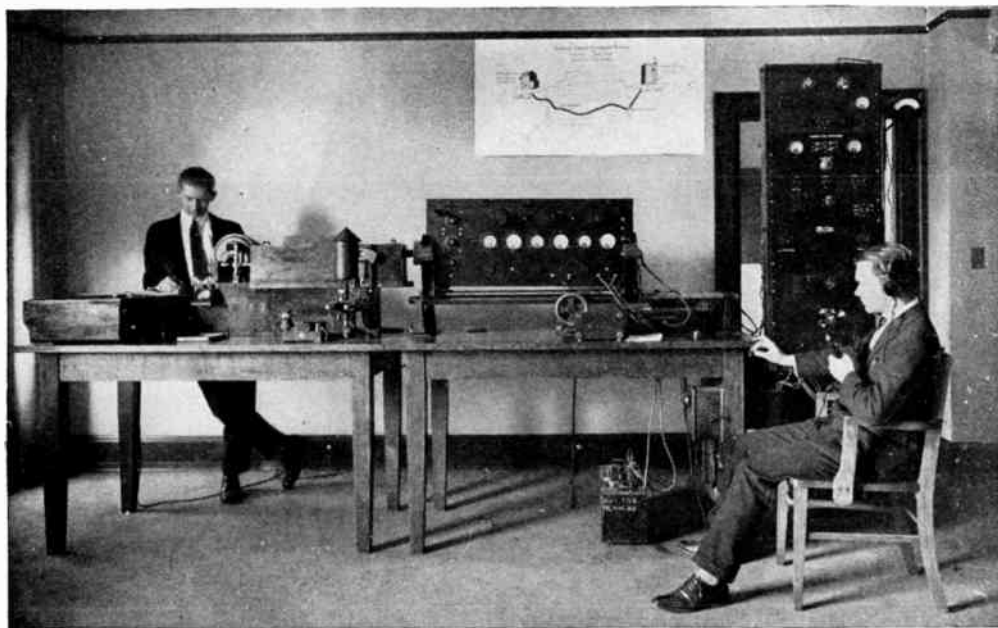

A. T. & T. CO.

### THE EYE AT THE SENDING END THAT PICKS OUT THE COLORS

Figure F3: On the extreme left is the synchronous motor for rotating the film which, with the photoelectric cell is under the dark cover just behind the lamp house. The large case with the dials contains the amplifier for enlarging the output of the photoelectric cell.



utes and could be shown to large audiences so quickly as to offer promise of their utilization in photo-news service in such places as moving picture houses. Lantern slides in color would give additional interest to such a service. For this purpose it is of course necessary to have available color cameras capable of making the original three-color negatives with such short exposures under practical lighting conditions as to be able to cover all kinds of subjects. Recent developments in photographic speeds, lenses and apparatus offer promise of the early availability of such three color negatives.

Having accomplished the transmission of still pictures, it is evident that the restless, inquisitive mind of man would go out in search of a system to transmit moving pictures. Those who understand the optical trick employed to give the illusion of motion in moving picture projecting machines perhaps know that the transmission of radio movies involves only the speeding up of still picture transmission. If it should become possible to transmit sixteen pictures in one second of time, the feat of moving pictures by radio would be accomplished.

C. Francis Jenkins, a Washington inventor, has come very close to making radio moving pictures a reality and with the great progress he has made it is only a matter of time before a polished system will be completed. Watson Davis, a well-known writer on technical subjects, describes a visit to the Jenkins laboratory:

"When I talked to C. Francis Jenkins over the telephone and he asked me to come up to his laboratory, I was not surprised and startled that he and I could talk over a copper wire. Telephoning is a common performance. Even the

nightly radio voices in the ether are no longer the marvel they were a mere two years ago.

"But, when Mr. Jenkins asked me to watch a screen in his laboratory which was shut off from the rest of the room and when I saw him wave his hand to me, although my back was turned to him, it was unusual.

*"I was seeing by radio!"*

"But Mr. Jenkins has done unusual and unprecedented things before. Every ordinary motion picture projector contains a vital principle invented by him. Readers of radio literature know also that he has within the last year made it possible to send diagrams, messages written in Chinese characters, and even photographs by wire and radio.

"Sending and receiving sets for transmitting still pictures by radio were in his laboratory, and it was plain that this apparatus for radio vision, a new assembly of disks, motors, lenses and lights, was related to the more finished and mature equipment that has been successful in sending pictures and diagrams through thin air.

"In reply to my hardly pronounced 'How?' Mr. Jenkins showed how he had made the movement of his fingers and hand visible by radio. The apparatus seemed extremely simple, certainly no more complex than the telephone when Bell first operated it. A magic lantern, the same as thousands in ordinary use, was projecting its shaft of light through a disk that revolved at high speed. The light fell on an opening in a rectangular box, supported, much like a small camera, on a heavy tripod placed half way across the room. From the black box on the tripod, wires ran to a radio transmitting set that was heavily screened to keep stray and troublesome electric currents from getting in the

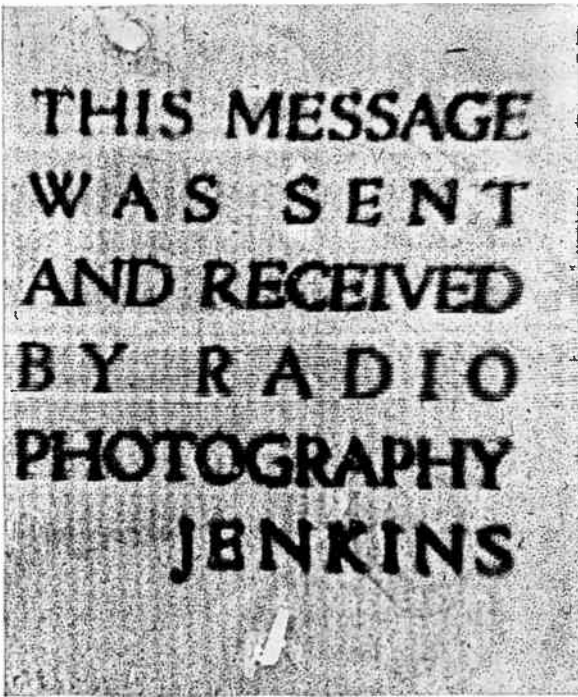

AN EXAMPLE OF FACSIMILE REPRODUCTION OF READING MATTER (OR PICTURE) BY THE JENKINS MACHINE

Figure G3: The transmission of a "still picture" by radio was the first step in the transmission of motion pictures—which are but a series of still pictures. Now the inventor is transmitting actual scenes directly from the moving objects.

way. When a wave of the hand was to be transmitted, Mr. Jenkins simply inserted his fingers into the space where the lantern slide holder of the ordinary stereopticon is placed.

"The object of the whirling disk and stereopticon, Mr. Jenkins told me, was to impress the shadow of the moving fingers and hand, portion by portion, upon the light-sensitive cell that was contained in the camera-like black box on the tripod. How this is done will be explained later. But the result is that the variations in light that this cell

receives are translated into variations in electric current, just as the variations in sound that enter the telephone transmitter exit upon the wires as variations in electric current. The shadow of the moving fingers, now in the form of varying electric current, was fed into the radio transmitting set and handled in exactly the same way as hundreds of jazz concerts are broadcast every night.

"The receiving antenna in the case of this demonstration was only a few feet away from the sending antenna on the

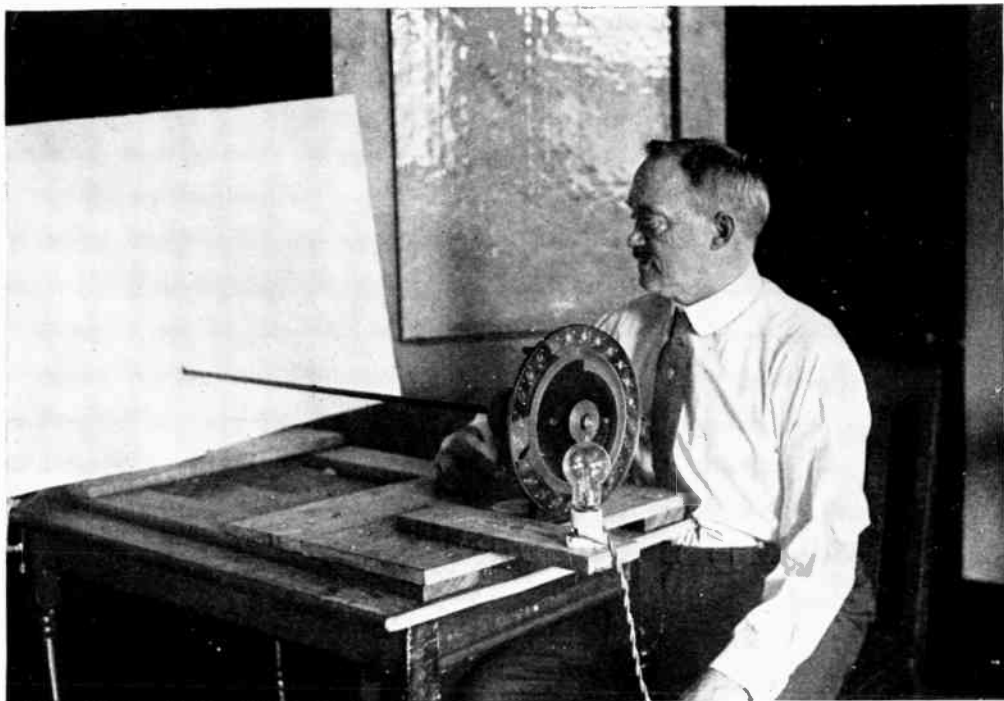

### THE ESSENTIALS OF THE RECEIVING SET FOR RADIO-VISION

Figure H3: The lamp shown in the picture receives a varying electric current and transforms it into variations in light, which are taken by the multiple lens disk and thrown onto the screen in the background in the form of a picture. The motor driving the disk is located behind the screen.

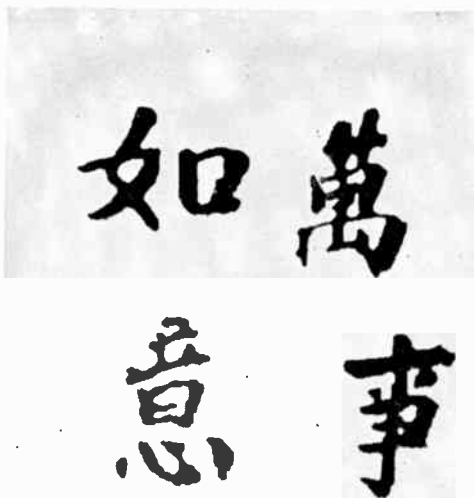

AS IT WAS SENT—

Figure 13: This is the original Chinese message that was handed to the radio operator for transmission at the sending station. Its Chinese significance is "Ten thousand joys on your journey."

roof of the Jenkins laboratory, but for a short distance that wave of a hand went through the ether in the form of radio waves. After being picked up by the receiving radio set, these impulses were changed back into an electric current and sent to the radio-vision receiving set.

"This receiving apparatus consisted of just four essentials: a lamp that changed electric-current variations into light variations, a whirling disk similar to the one in the transmitter, a lens, and a picture-receiving screen.

"Radio vision is as much a matter of optics as electricity, and since light and electricity are both members of the big family of ether waves, differing only in length, there is no reason why they should not work amicably.

"Yet there is no question but that the radio part of radio vision plays second fiddle to the whirling disk. These rings of lenses make radio-vision possible. They take the wave of the hand and impress it portion by portion on the light-sensitive cell; they take the rapidly fluctuating light and change it into a moving picture.

"The human eye is easily pleased and slurs over minute imperfections. All of the halftone illustrations in our newspapers are nothing but areas of coarse dots, sixty to the inch, that our eyes obligingly turn into pleasing pictures. That is a very useful optical trick and it is used by Mr. Jenkins in sending still pictures by radio and also in his process of radio vision.

"Again, speed can be used to fool the

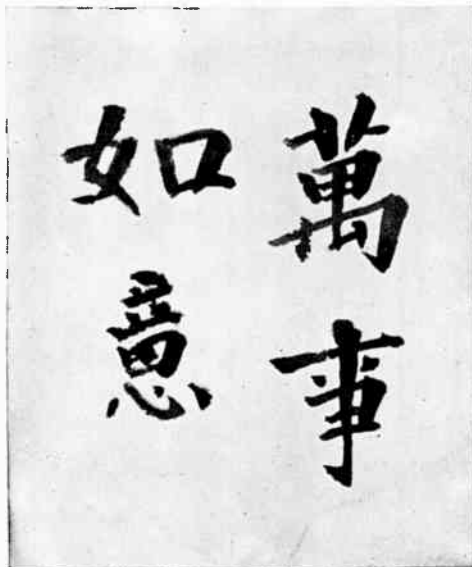

—AND AS IT WAS RECEIVED

Figure J3: This is the message as it was received by the radio operator and handed to its Chinese addressee: it is practically a perfect reproduction in somewhat grayer tone.

eye. Getting fooled is not always unpleasant, because it allows us to enjoy motion pictures. In the theaters, sixteen photographs appear on the screen each second, and that is speedy enough to make it seem to our eyes that the motion is in the objects in the pictures, not in the pictures themselves. And this optical illusion is used by Mr. Jenkins in radio-vision.

"Lines, not dots as in the halftone, very close together, are the structure of both pictures and vision by radio. These lines of light are swept across the progressing picture by the whirling disks. Light is the paint and the whirling disk is the brush in radio pictures and vision.

"In the Jenkins apparatus for transmitting still pictures, the whirling disk

has a prism curled around its circumference. Prismatic lenses, as almost all of us have observed, have a way of persuading light to deviate from its straight path. The disks used in transmitting still pictures by radio are made entirely of glass, and the prismatic lens is ground on the circumference. This is, however, the equivalent of many lenses since it is of varying thickness. And this causes a beam of light, projected through it while it revolves, to be swept from one side to the other or up and down.

"Two of these disks are used to project the photograph upon the transmitting light-sensitive cell in Jenkins' pictures by radio apparatus. One disk covers the picture in one direction while the other covers it at right angles to the first, and one of these disks operates

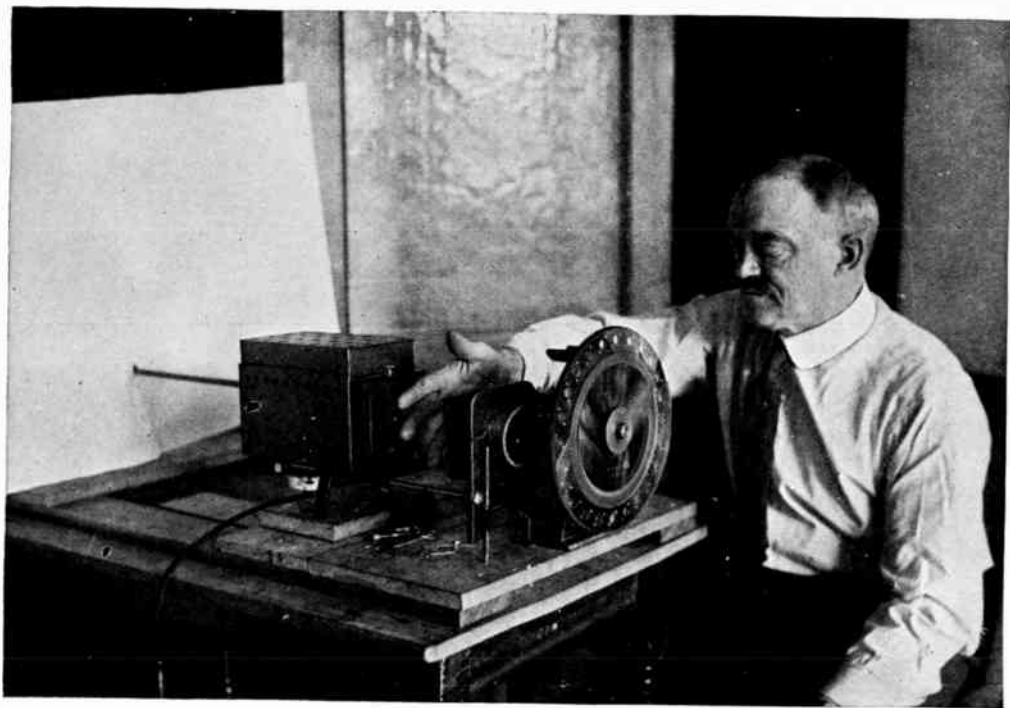

**THE SIMPLE APPARATUS THAT SENDS A WAVE OF THE HAND BY RADIO**

Figure K3: The inventor, C. Francis Jenkins, is placing his hand in the stereopticon which throws a beam of light on the multiple-lens disk. This disk impresses a picture of his hand upon the light-sensitive cell (which is across the room and not shown in the photograph) and this cell translates variations in light to variations in electricity.

many times faster than the other so that the effect, in both sending and receiving, is the drawing of lines across the picture very close to each other. In sending still pictures, this operation takes about a minute.

"To transmit motion, the sending must be speeded up so that at least sixteen pictures are transmitted each second instead of one picture in several minutes. Compared with this, ordinary motion pictures such as we see in theaters, are comparatively simple. At the movies whole photographs are projected on the screen all at once, and they are thrown on and taken off so rapidly that the eye cannot detect the separate projections but blends them together into continuous motion of the objects in the picture. In radio vision the picture is projected on the screen portion by portion, but to produce the effect of motion or actual vision a complete picture must be built up every sixteenth of a second. Prismatic disks that produce only one picture a minute are obviously too slow.

"So Mr. Jenkins has devised a new form or disk, that contains lenses that combine the function of covering the picture vertically and horizontally. In the apparatus that he demonstrated, the disk was so made as to produce one complete picture with each revolution. It contained forty-eight lenses in all. Each of these was, in effect, a combination of a rather flat convex lens and a prismatic lens. The lenses varied by having the prismatic part thick on one edge for the first lens and then gradually changing their angles until the thickness was on the other edge for the last or forty-eighth lens. For all lenses the convex portion was the same. Thus in this compound lens both horizontal and vertical motion of the light was obtained. The forty-eight lenses forming

a prism of varying angles shifted the scene once horizontally, while each convex lens by its vertical motion swept the scene over the light-sensitive cell in one-forty-eighth the time of the horizontal shift. Thus each scene was impressed on the cell as forty-eight horizontal lines spaced close together. The speed necessary for the production of continuous motion in the radio-vision receiving apparatus was sixteen revolutions a second or 960 r.p.m.

"Exactly the reverse process takes place in the radio-vision receiver. The dismembered scene enters the lamp of the receiver as a fluctuating current, strong where the light of the transmitted scene was strong, weak where it was weak. Faithfully the lamp reproduces light, and the whirling disk with its dual-purpose lenses sweeps the scene on the screen just as its twin in the transmitter swept it on the light-sensitive cell.

"It is a shadowy wave of the hand or movement of the fingers that is produced. A picture composed of only a few horizontal lines, varying in light intensity along their lengths, cannot be expected to be very distinct or detailed.

"But even shadowy motion such as was produced was a demonstration of the important possibilities that the method holds. Increase the number of lenses that produce each picture to several hundred and the detail will come.

"In another important way, the radio-vision apparatus differs from the radio-pictures outfit. The light source in the receiver must vary quickly with variations in the incoming current. The ordinary lamp that is speedy enough for still pictures by radio cannot make the pace necessary for radio vision. Mr. Jenkins is using a corona glow lamp, in

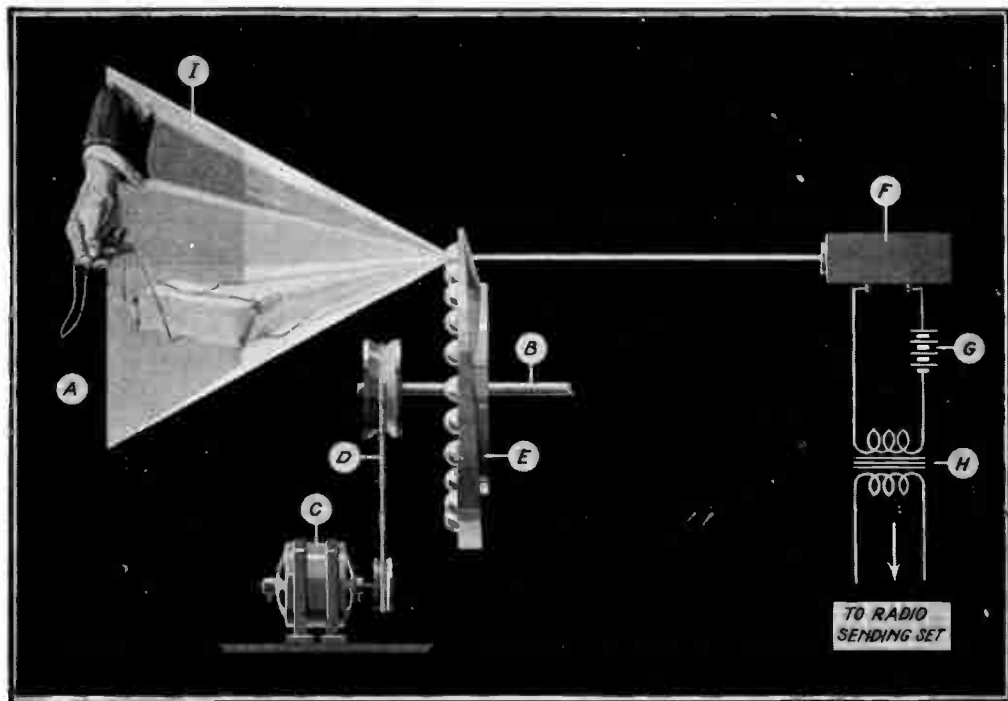

### THE RADIO TRANSMITTER FOR MOTION PICTURES

Figure 13: The light I, from an object A, is focused one strip at a time, through lenses on the rotating disk E, onto the light-sensitive cell F. Electric current from the battery G, is modulated by the light and sent out by radio in the usual way.



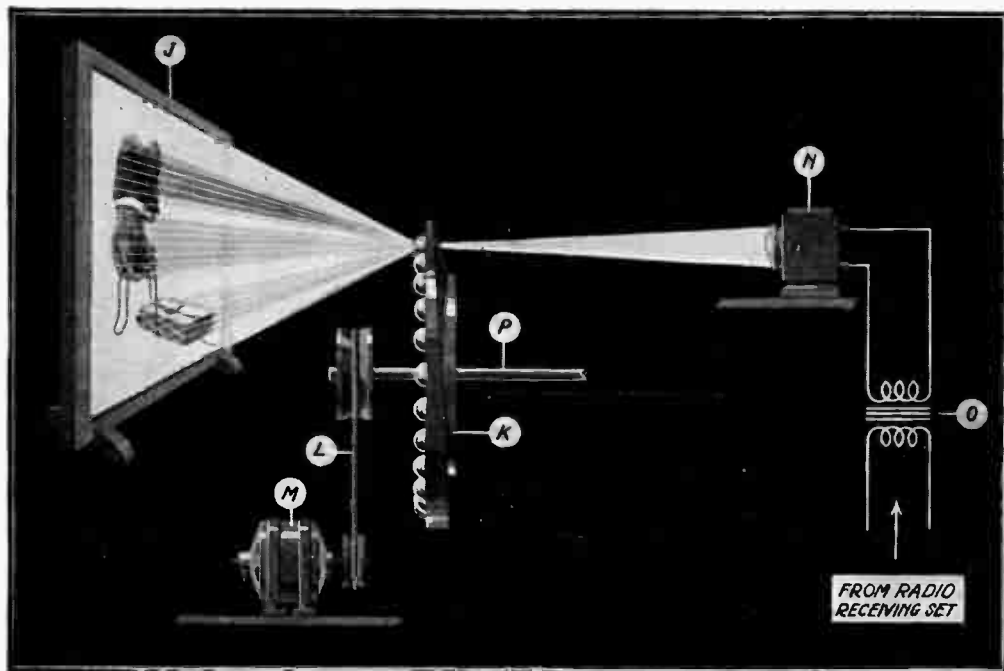

#### HOW THE RADIO MOVIES ARE RECEIVED

Figure M3: Radio impulses are communicated through the transformer O, to the device N, which reconverts them into pulses of light. These pulses, passing through the lenses on the rotating disk K, produce an image of the original object on the screen J.

which the gas around the internal electrodes gives off the light. The lamps are filled with neon, one of the rare inert gases. With this kind of lamp the lag is sufficiently small but the intensity of light is not great and efforts are being made to obtain lamps of the same principle that are more suitable.

"The question of synchronism, of keeping the disks of the transmitting and receiving sets running exactly together, Mr. Jenkins says, is a simpler problem in radio vision than in radio transmission of pictures. The pulleys used are conical and the speed of the disks can be regulated by sliding the belt slightly to such a degree that synchronism can be obtained more easily than the picture is framed in ordinary motion-picture projection today. In the experimental set that was demonstrated, disks of both the transmitting and receiving sets were driven from the same motor for the sake of simplicity in operation.

"The transmission of pantomime by radio has been accomplished. There is no reason why the receiver should not have been in New York rather than in Washington next to the radio-vision transmitting set.

"The perfection of the invention has not yet reached the point where actual scenes in all their lights and shadows can be reproduced or motion pictures distributed to the hearth and home. But the experimental apparatus devised by Mr. Jenkins gives promise eventually of our being able to see in New York at nine o'clock in the morning what 'will occur' the same afternoon at two o'clock in London.

"Mr. Jenkins simply moved his hand and fingers when he made his demonstration. With those moving shadows radioed on the screen, I could hardly re-

frain from hoping that he would form a shadowy rabbit or bird with a long neck or some other strange animal such as all of us have made or seen for the amusement of children. Tony Sarg and his marionettes might well produce pantomime by radio vision when the process is slightly perfected.

"In fact, it is a hope of Mr. Jenkins that he will be able to devise a low-priced piece of apparatus that will take pantomime entertainment into the home just as bedtime radio stories now are received with so much glee by eager childish ears."

Closely allied with the subject of radio movies is that of talking movies, for both these engineering feats are made possible with the aid of the little vacuum tube, a device that is accomplishing more marvels than the author of "Arabian Nights" could have dreamed of. The future will no doubt not only bring radio moving pictures alone but the added feature of talking will also be possible. Lee De Forest, whose active imagination and untiring efforts gave the world the vacuum tube, has applied it to talking moving picture and in the paragraphs that follow he describes his new system in his own way:

"Talking movies are an accomplished fact. Perfect synchronism of speech and action has been attained, and this success is another triumph for that wonder worker of radio, the audion amplifier. The talking movie depends upon the use of the tubes to amplify the minute electric currents with which it is necessary to work and it is no exaggeration to say that the vocalization of the motion picture would never have been accomplished at all were it not for the fact that the motion picture technicians had available to them the perfected inventions of the radio engineer.

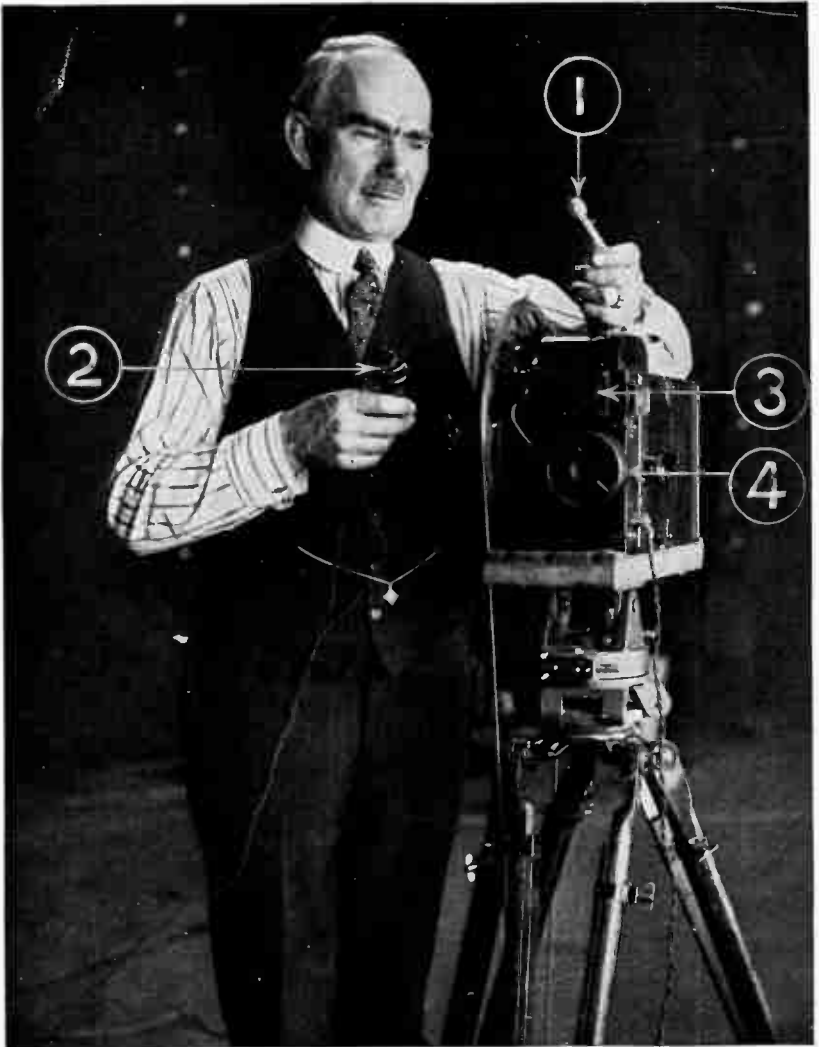

#### THE CAMERA THAT RECORDS BOTH ACTION AND SPEECH

Figure N3: Dr. Lee De Forest is here demonstrating his new and remarkable invention. He is inserting the "photon" (1) into its proper socket. This photon (coined from the words "photograph" and "audion," meaning literally an audion that takes photographs) is the secret of the phono-film machine. The microphone that receives the voice is shown at (2); the opening (3) leads into the chamber that contains the apparatus that converts sound into light waves. (4) is the regulation shutter equipment used on every motion-picture camera. The records of both motion and sound are thus recorded on the photographic film.

"The earlier attempts at talking movies, fiascoes which we all remember so well, depended upon schemes for connecting together an ordinary phonograph and an ordinary motion picture machine. The phonograph was supposed to repeat a certain sound at the exact instant that the appropriate action took place on the screen. To make the two machines run precisely at the same rate there were complicated arrangements of governors and regulators. In one of the processes, for instance, small holes were punched at intervals in the film. Compressed air escaped through these holes much as it does through the holes in the paper roll of a piano player and this escaping air was supposed to regulate the speed of the phonograph so that it would play its record at a rate exactly equal to the rate of progress of the film.

"None of these devices worked very well. Not only were there delicate mechanical or electrical adjustments which frequently got out of order, but there was another difficulty, one which would be entirely unforeseen, probably, by anyone not actually experienced in the motion picture business. This was the disturbance of the record caused by breakages of the film.

"Once in a while when you are watching the pictures in a motion picture theater you will see the picture suddenly disappear, leaving a blank white screen. This means that the film has torn in two. The young man in the projection room does a little fast work and presently the picture goes on again as though nothing had happened. But before that particular film can be used again its torn ends have to be trimmed off so that they are even and then stuck together again with film cement. This makes the film an inch or two shorter than it was before.

"So far as the picture is concerned, this shortening makes no great difference. There are sixteen separate snapshots to the foot of film and the loss of one or two of them is not even perceptible when the film is projected. But suppose that the film is one which has been carefully synchronized with a phonograph record. If you leave out an inch or two of film the sound record gets behind the action by just that much. After three or four breaks have been made and fixed you will hear the sound of a fall, for example, a second or two after it has really happened. It will sound like an echo.

"It is not possible to avoid occasional breakage of the film and this was the reason why experienced motion picture engineers were always rather skeptical of any scheme for mechanically synchronizing films with phonograph records. What was needed, they thought, was some way of recording the sound record on the film itself so that the sound record and the sight record would be synchronous and inseparable automatically.

"This is exactly what the new talking movies are. In my process, for instance, which I call the 'Phonofilm process,' the record of the sounds is registered in the form of a narrow strip of lighter and darker hairlike lines running crosswise, at the edge of the film, like the rungs of a tiny ladder. This record is produced at the same time that the pictures are taken, by a photographic process. When the film is run off these sounds are reproduced.

"The 'photographing of sounds' is new only in details. Scientists have been photographing sounds for many years and by half a dozen different processes. The beginning of the story takes us back to 1879 and to Dr. Alexander Graham Bell, the inventor of the telephone.

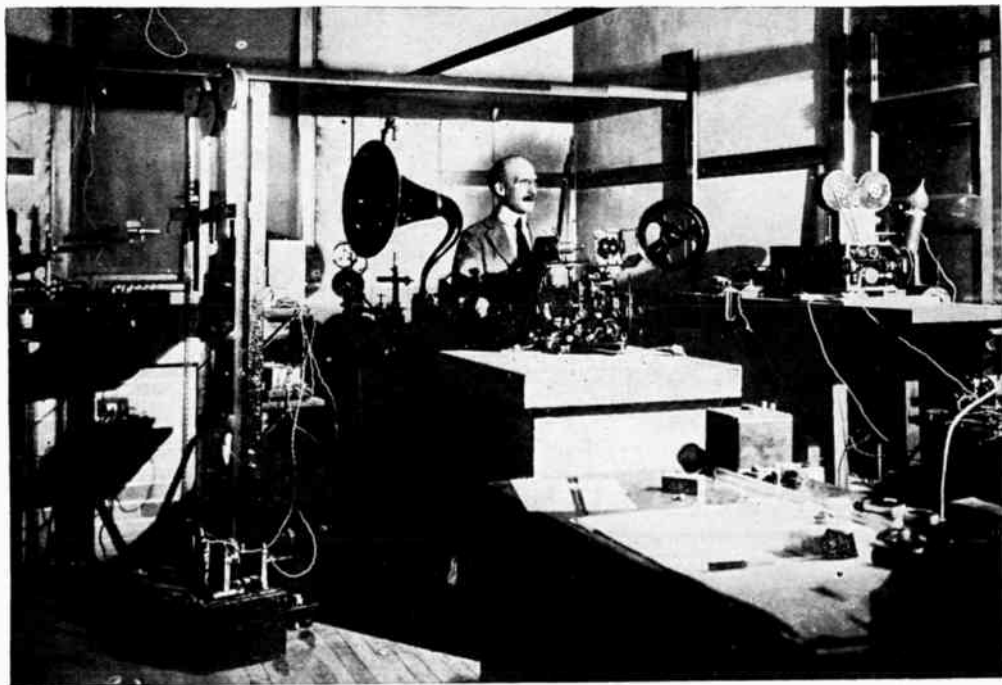

**THE LABORATORY OF A DOCTOR WHO IS A "VOCAL SPECIALIST" ON FILMS**

Figure 03: The workroom of Prof. J. T. Tykociner, of the University of Illinois, who has developed a talking motion picture film that uses a special shutter actuated by sound waves instead of the moving mirror or photon on which Dr. De Forest's invention depends

"When Dr. Bell was working out the telephone he gave a good deal of attention also to other ways of transmitting speech. Perhaps the telephone might turn out a failure and some different device might have to be substituted. Among other things he tried out a way of talking along a beam of light. One day in 1879 he stood in his garden and actually talked for over two hundred yards along a beam of sunlight reflected from a little mirror which he held in his hand.

"The secret was in the mirror. It was made out of very thin glass and it was not perfectly flat. Instead it had a slight spherical curvature as though it had been cut out of the side of a very large globe of glass. The beam of light was reflected from this curved surface.

"Back of the mirror was a mouth-piece into which Dr. Bell spoke so that the sound waves of his voice struck against the back of the mirror. These waves made the mirror vibrate just as the diaphragm of a telephone vibrates when you speak into it. And when the mirror vibrated its curvature changed, it became alternately a little flatter and a little more curved. This affected, of course, the amount of light reflected from its front surface. The beam of light fluctuated in strength and these fluctuations were found to correspond exactly to the sound waves, which were beating against the back of the mirror-diaphragm, just as the electric currents in a telephone transmitter correspond to the sound waves which strike against its diaphragm.

"Dr. Bell's device was really a telephone in which a mirror took the place of the usual transmitter and a ray of light took the place of the electric current in the wire.

"In 1879 there was no particular use

for such a device. The motion picture was still a dream. The electric telephone proved to be successful and the light-telephone—Dr. Bell called it a photophone—dropped out of sight. He did not attempt to photograph the sound waves.

"But might not such a device have its use in war? The Germans thought so and in 1890 they financed the investigation of one Ernst Walter Rühmer on this same problem.

"Rühmer did not use a mirror. He selected a totally different principle, the principle of the electric arc. He used an ordinary old-fashioned arc lamp, in the circuit of which was a microphone. When he spoke into the microphone, the sound waves affected it and it, in turn, affected the brightness of the arc; producing fluctuations which corresponded, as in Dr. Bell's device, to the pulses of the sound. This fluctuating light from the arc Rühmer sent out in a searchlight beam miles across the country to a receiving station where its pulses could be converted back again into audible sound.

"During the war the Germans revived and improved this old method of Rühmer's. An apparatus devised by Dr. H. Thirring is said to have been in use at times on the Western front. Many a searchlight beam watched incuriously by our scouts as of no importance may have been carrying light-borne words which our intelligence department would have enjoyed hearing. But Dr. Thirring's work was not known until after the armistice and the possibility that a photophone was being used went unsuspected.

"The British Admiralty, however, were working along similar lines, though for a different purpose. They were seeking a method of telephoning between



A STRIP OF TALKING FILM  
(Actual Size of Negative)

Figure P3: This negative was made by Dr. De Forest's new phonofilm process. The hairlike lines at the right of the strip of sprocket holes on the left is the record of sound. During projections, a beam of light passes through this record onto a photo-electric cell and converted first into an electric current, amplified by vacuum tube amplifiers and finally reconverted back into sound by means of a loudspeaker.



#### A SCIENTIST WHO UTTERS SPEECH THAT WE CAN SEE

Dr. De Forest—best known to radio fans as “the man who put the grid in the radio bottle,” or in more scientific terms, the inventor of the audion or three-element vacuum tube—is here revealed in his laboratory inspecting a motion picture film that records both the movements of his lips while speaking and also the sounds that issue from them. Long before the advent of the vacuum tube, however, Dr. De Forest was experimenting with “wireless” telephony; many old-timers among the radio amateurs of New York recall the thrilling experimental days when his squeaky and distorted voice-tones, transmitted by arc and high-frequency spark telephones, filled the ether with early promises of the marvels that were to come. The square box at the inventor’s elbow, with the small circular opening, contains the new type of microphone especially developed for the talking films.



ships at sea. Dr. A. O. Rankine, the distinguished physicist who conducted their investigations, did not use the arc method. He used a vibrating grating attached to a diaphragm, like that used years before by Dr. Bell and was so successful that he was able to talk for a distance of eight miles over a beam of sunlight only six inches in diameter. The familiar heliograph used in all armies and navies to exchange dot-and-dash signals by means of a beam of sunlight became capable of serving as a telephone as well.

"None of these things had any immediate application to the movies. Even in 1918 no one seemed to see that these new war inventions contained the answer to the old problem of how to make the movies speak.

"The first person to see this connection, or the first, at least, to actually make it effective, was Bergland in Sweden. Early in 1921, he exhibited to a group of scientific men a machine in which sound was recorded by means of a moving spot of light reflected from a tiny mirror. Sound waves were made to vibrate this mirror, and the mirror vibrated just as Dr. Bell's mirror did, but it was arranged so that the vibration took the form of back-and-forth swings instead of changes in curvature. These swings made the little spot of reflected light move back and forth across a moving photographic film, and the result was a wavy line photographed on the film. The waves in this line, the ups and downs of it, were found to correspond exactly to the pulses of the original sound. From this line the sound could be reproduced.

"According to the published descriptions of it, Bergland's original machine was merely a sound recorder. It produced a record of sound just as a phonograph does but it recorded this on a

strip of photographic film instead of a disk or cylinder of wax. In applying his invention to the making of a talking motion picture Bergland used two films side by side. One film received the picture just as it does in an ordinary motion picture camera. The other film received the wavy line which was the sound record. As the picture was taken the two films were moved forward by the same shaft. In this way, Bergland undertook to obtain exact synchronism between the two films.

"But it is reported that he did not. Motion picture film always shrinks and changes a little as time goes on. Separate pieces of it do not always shrink equally. Then the holes in the margin of it, into which fit the teeth of the sprocket arrangement which moves the film, sometimes wear a little larger, so that the motion of the film is not quite uniform. These difficulties and others like them, it is said, interfered with the perfect agreement of Bergland's two films. It was necessary, or highly desirable, to put the two records actually on the same single strip of film.

"Even while Bergland was working in Sweden this last step was being taken by another inventor in England. Only a few weeks after the Bergland tests Mr. Grindell Mathews announced the perfection of a camera which photographed the wavy line of the sound record and the successive pictures of the scenic record actually on the same film. The sound record was made in the same way as the Bergland camera, by means of a tiny mirror swung back and forth in correspondence with the waves of sound.

"This gave to the world for the first time a process in which the sound and the picture could not help being synchronous, since both of them were recorded on the same film strip.

"It might seem that not much could be added to this but in developing the phonofilm we have succeeded, I think, in improving in at least two particulars any of the previous processes for a

speaking film. The first of these improvements is what we believe to be a better way of photographing the sound. The second is an improvement in a part of the apparatus which I have said noth-



General Electric

#### HE PRODUCES SOUND BY MEANS OF A VIBRATING MIRROR

Figure Q3: What is in effect a motion picture photograph of the human voice, reproduces in the form of a graph that records vibrations, is the invention of Dr. Charles A. Hoxie. His machine is called the "Pallophotophone," and it not only "photographs" sound but reproduces it with most amazing clarity and power.

ing about so far, the part which translates the sound photograph back again into real sounds which we can hear.

"If you look inside the camera which we use in taking the phonofilm the only unusual thing you will see is a small glass tube about the size of your little finger. When the apparatus is operating, this tube glows with a brilliant violet light. It is the new invention, which we call the 'photion.' It is the thing which we use to photograph sound.

"The tube contains a special mixture of gases which it took me over three years of experiment to perfect. When an electric current is passed through the tube, this gas mixture becomes luminous. It is the gas which produces the violet glow.

"Perhaps you have seen lately some of the neon-filled glow lamps which are being used to attract attention in stores and shop windows. A tube of bent glass, often shaped into words or letters, contains a little of this neon gas, about one thousandth of one percent of which is contained in ordinary air. When a high frequency electric current is sent through this neon-filled tube, the gas glows with a soft reddish light which is pleasant and attractive. The photion works on much this same principle. Of course, the gas in it is not neon and the glow is violet, not red. But it, too, is a gas glow excited by an electric current.

"If you watch carefully the glow of a photion in operation you may be able to see that the light is not absolutely constant. It flickers a little. Pulses of greater brightness alternate with brief instants when the glow is a trifle dimmer. This means that the photion is translating sound into light. The rapid flickers and pulses which you see mean that you are literally seeing speech.

"The photion tube is excited by a

high frequency electric current, modulated by the voice in exactly the same way as in a small radio-telephone transmitter. This part of the apparatus is in fact identical with the radiophone transmitter.

"In the electric circuit which operates the photion and which causes it to glow we insert a highly special substitute for the microphone and one or more vacuum tubes as amplifiers. This ground receiver picks up sound waves and converts them into pulses of electricity. The electric pulses, after being amplified sufficiently, control the radiophone which is exciting the glowing photion and affect its light. The flickerings of this light, its rapid brightenings and dimmings, correspond exactly to the waves of sound which enter the microphone.

"This shows you how the phonofilm process transforms sounds into light; but how does it photograph them, how do we secure a permanent record of them on the motion picture film?

"This is how. The glowing photion is in a little chamber by itself inside the camera and this chamber is light-tight except for one tiny slit only one millimeter long and a fortieth of a millimeter wide. The moving film on which the motion picture is being taken runs past the photion chamber in such a position that the edge of the film passes just under this slit. The light from the photion streams through the slit and is photographed on the film, making the strip of tiny hairlike lines already described; a darker line for each instant when the photion is brighter, a less dense line when the light of the photion is a little more dim.

"This little ladder of lighter and darker lines is our photograph of sound, our answer to the problem of recording



#### THE FIRST MAN TO TRANSMIT SOUND ON BEAMS OF LIGHT

Back in 1880 Dr. Alexander Graham Bell invented the "photophone," by means of which speech was transmitted 200 yards on a ray of sunlight reflected from a curved mirror. In the picture above the good doctor is revealed as a diving Bell; it was snapped while he was emerging from the Williamson submarine tube in the West Indies, shortly before his death.

successfully both the sight and the sound. The width of the sound photographs is always the same. The *intensity* of the light, and that alone, is varied by the sound. This feature distinguishes the phonofilm from all other methods, and permits a more faithful reproduction of every light and shade of sound than is otherwise possible. And by this photion or phonofilm method, it is seen, there is complete absence of any mechanical moving parts, nothing in the entire system up to the final diaphragm of the loudspeaker which can introduce a natural period of vibration of its own, tending to distort the original sound, in recording or in reproduction. So far as the taking of the movie is concerned, this is the whole of the story.

"But how is one to get this back into real sound again? How is the sound record on the film to be reproduced when the motion picture is run off in the theatre?"

"Consider first what the problem is. The taking of the talking motion picture involved two successive conversions of one kind of vibration into another kind. First the waves of sound were converted into electric waves by the microphone. Next the electric waves were converted into light by the photion. Now we must do these same two things in reverse order. On the finished film is our little ladder of darker and lighter lines. A ray of light can be made to shine through this ladder and the strength of the light that gets through will correspond to the

lines on the ladder. As each dark line passes across, the light transmitted will be momentarily dimmer. This gives us, to start with, what we finished with when the movie was taken, namely, a light which flickers in exact correspondence with the waves of sound. The problem is to convert these flickers back again into real sound.

"Most of the previous investigators and inventors have made this light-sound conversion by means of the metal selenium, a metal which has the property of changing its electrical resistance when light rays fall on it. But no one was satisfied with selenium. It was too erratic and undependable, too slow in recovery.

"Years ago the same Dr. Hertz who discovered the waves now used in radio made another discovery. He discovered that plates of certain metals gave off electrons when they were illuminated. Every radio fan knows that the filament of a vacuum tube gives off electrons when it is hot. Dr. Hertz's metal plates did the same thing, only they did not have to be hot. All that was necessary was that light of some kind should be falling on them. This discovery was the beginning of the photoelectric cell.

"In modern forms of the cell, the metal plate which is to give off the electrons is in a vacuum inside a sealed glass bulb. It looks a good deal like a glass egg with two short glass tubes about the size of lead pencils sealed into it, one at each end. The light shines into this egg from one side. On the other side, facing the light, is the plate of the sensitive metal, usually of the rare metal potassium or the still rarer one, rubidium.

"When hit by the light the metal gives off electrons and the number given off a second changes with the strength of the light. The more light, the more elec-

trons. You see at once what the pulsating light which shines through the sound record on the film will do. It will cause the electron emission inside the photoelectric cell to pulsate also. More or fewer electrons will be given off in exact correspondence with the sound waves which were originally photographed on the film.

"This makes the first of the two conversions which we saw to be necessary, the conversion of the light pulses into electric ones. The next conversion, the one into real sound, is made in the usual fashion by amplifier tubes and a special telephone. The electron current in the photoelectric cell is feeble, but even one tube will amplify it until it will operate a telephone. Four or five tubes will make it strong enough to operate a loud-speaker and fill the largest motion picture theatre.

"This gives you the whole process. Suppose we are taking a motion picture in which, let us say, Buster Keaton falls downstairs. For each step there is a bump and the sound wave of each bump makes a little flicker in the glow of the photion. This flicker records itself on the little ladder of lines which is being photographed on the film. Wherever that film goes, whatever is done with it, there is the record of Mr. Keaton's bump side by side with the view showing just how he came to make it.

"Then some day the film is shown in a theatre. The light of the projection machine shines through one of the pictures and shows a visual image of Mr. Keaton's downfall. At the same instant another light shines through the sound record. This light sees, so to speak, the second image of Mr. Keaton's bump. It carries this image on to the photoelectric cell. The cell instantly transforms it into an electron image of the sound of

the bump and hands this on to the audi-on amplifier. The amplifier strengthens it into a greater sound and hands it on to the loudspeaker which lets out, in its turn, a loud bang and we who sit, watching and listening, hear the misfortunes of Mr. Keaton at the same instant that we see them.

"And at *exactly* the same instant! For all these changes and conversions happen with almost inconceivable rapidity, with the speed of electric currents which come close, most of them, to the 186,000 miles a second which is the speed of light.

"From the special viewpoint of the radio engineer there is one particularly interesting aspect of these various conversions of vibrations between light and sound and electricity. It is that they constitute a kind of modulation just like the modulation of continuous waves of radio telephony by sound waves.

"Light is, of course, an electromagnetic wave just like the radio waves except that its wavelength is very much shorter, or, in other words, its frequency is tremendously higher. Instead of the frequency of about 800,000 a second which characterizes the ordinary broadcasting wave, light has frequencies measurable only in quadrillions a second, wavelengths defined in millionths of a millimeter.

"Now in ordinary radio telephony the modulation consists merely in superimposing the low frequency waves of sound, which have from 20 to about

5000 vibrations a second, onto the moderately high frequency waves of the continuous wave radio. The sound wave goes out, one might say, as a passenger on the radio wave. Similarly, in the phonofilm, the function of the photon is to superimpose these same low frequency waves of sound first onto the higher frequency waves of the radio telephone and then onto the still higher frequency waves of light. The passenger is the same but is traveling on a different train, a train of much shorter cars. In ordinary radio modulation we speak of 'audio' frequency and 'radio' frequency. In these new light conversions we must speak of audio frequency in relation to what we may call 'photo' frequency, this being the tremendously high frequency of the waves of light.

"And just as there are various ways of producing the modulation of radio frequency by audio frequency, so there are various ways of superimposing sound waves on light. The photon is one of these ways. The mirror methods of Dr. Bell and of Dr. Rankine are others. The arc method of the Germans is still another. And two other methods, two newer ones, have been announced within the past year in the United States.\*

"And now what does this mean for the movies? Granted that a real talking movie can be produced about which there now seems little doubt, will this cause any serious change in the present methods of producing motion pictures and of presenting motion picture plays?

\*One of these methods is that of Professor J. T. Tykociner of the University of Illinois. This, too, has been applied to the making of talking movies. In place of the moving mirror or the photon, Professor Tykociner uses a special mercury arc lamp. The light of this lamp, modified in intensity by the vibrations of the sound, falls onto the moving film, where it is photographed to make a strip of shaded lines not unlike the record on the Phonofilm.

The other new method has been announced by Dr. Charles A. Hoxie of the Research Laboratory of the

General Electric Company. His device appears to depend on a moving mirror, which would make it an improved form of the method used by Bergland in Sweden and by Mathews in England.

In all of these methods, the curved mirror of Dr. Bell, the arc of Rühmer and Thirring and Tykociner, the shaking mirrors of Rankine and Bergland and Mathews and Hoxie, and in the photon, the result accomplished is the same. It is the superposition of an audio frequency signal on photo frequency waves of light.—Editor.

"The motion picture experts do not agree in their answers to these questions. Most of them seem skeptical. They do not expect, they say, any immediate public favor for a talking movie no matter how perfect it is. The reason they give is a psychological one.

"The essence of a successful motion picture, they say, is their ability to create an illusion. The images on the screen do not look exactly like the actors. They are just a jumble of black and white masses and lines and dots. Our favorite stars look lifelike to us because we have become used to this. We recognize the lights and shadows of the screen as symbols, much as the multitude of little black lines and dots and curves on this page are recognized by you as symbols of letters and words and thoughts. This page would not be so recognized by a savage who did not know the symbols of our alphabet.

"And without illusion of reality which the mind makes for itself out of the symbols on the screen, motion pictures would have, these experts believe, much

less interest and emotional appeal.

"Now suppose you combine these visual screen symbols with sounds. The sounds are symbols also. They too must create their illusion. Will they reinforce the eye symbols or will they interfere with them? Most likely, say the skeptics, the result will be interference, not reinforcement. It is easy, they think, to create one illusion at a time, either an eye illusion or an ear illusion. It is much less easy to create both at once and to have them fit into each other in the mind. And so, they think, the path of progress for the talking movie is not going to be altogether smooth.

"Perhaps not, but this is little likely to deter inventors from following it. We believe that we have already in the Phonofilm a device of great utility in scientific investigations and in the making of speech records side by side with pictorial ones, for instance in making records of important events. Whether the motion picture experts will adopt it for purposes of public entertainment we are content to leave to them—and to the future."

## END OF SECTION XVII

## SECTION XVIII

### Wiring-Grams for Receivers and Transmitters

*This collection of diagrams has been added to the course of instruction issued by the AMERICAN INSTITUTE for the Advancement of RADIO as a special service for those who wish to extend their studies into the milder engineering phases of receiver and transmitter construction. No effort has been made to include all of the circuits that have been designed in the last three years since very little original engineering work has been done and a complete collection of all of the closely allied types would do nothing more than confuse the reader.*

*In assembling this material, the editors have endeavored to include the circuits that represent basic improvements in the art, whether new or old. A cautious and careful study of these circuits will acquaint the student with the principles used in practically all of the radio receivers of the present time. Although several hundred types are available and the general press has presented innumerable descriptions of combinations that purport to be new, the illustrations that follow will be found to be remarkably complete in containing really workable and sensible receiver hook-ups based upon sound engineering principles. A large number of amplifier circuits showing methods of wiring push-pull, transformer and impedance-coupled and resistance-coupled instruments are included.*

*The transmitter circuits, while limited in number, include all of the best and latest systems that provide great power and good modulation.*



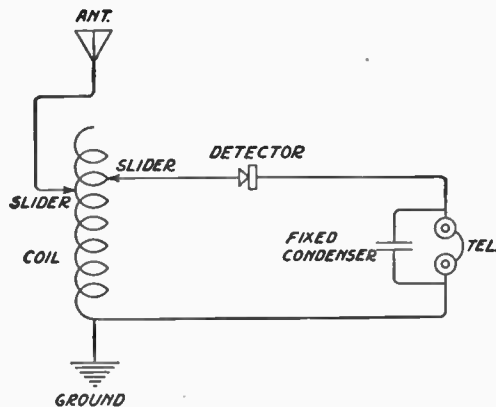

### THE CONDUCTIVELY-COUPLED CRYSTAL CIRCUIT

**Selectivity:** Fairly good.

**Operation:** Very simple. Only two controls are used; a primary and a secondary slider.

**Ease of construction:** No technical knowledge necessary.

**Approximate range:** 15 miles.

**Outstanding features:** This circuit is especially suitable for the beginner who wants to start out by building the simplest set that will give him clear reception of local signals at the smallest cost.

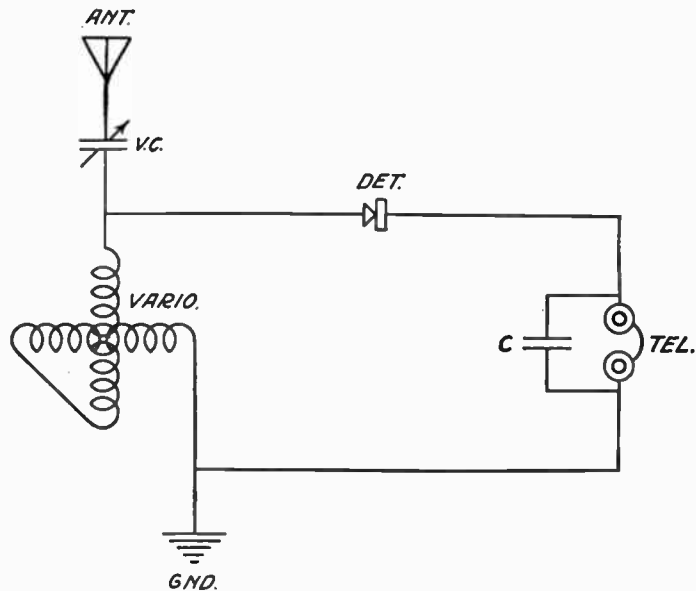

### SINGLE-CIRCUIT CRYSTAL SET

*Selectivity:* Fair.

*Operation:* Simple. The antenna circuit is tuned by both the condenser and the variometer. The closed circuit is controlled by the variometer.

*Construction:* Very simple to make.

*Approximate range:* 15 miles.

*Outstanding feature:* A good, inexpensive set for the city dweller who is content to listen to local programs with the headphones.

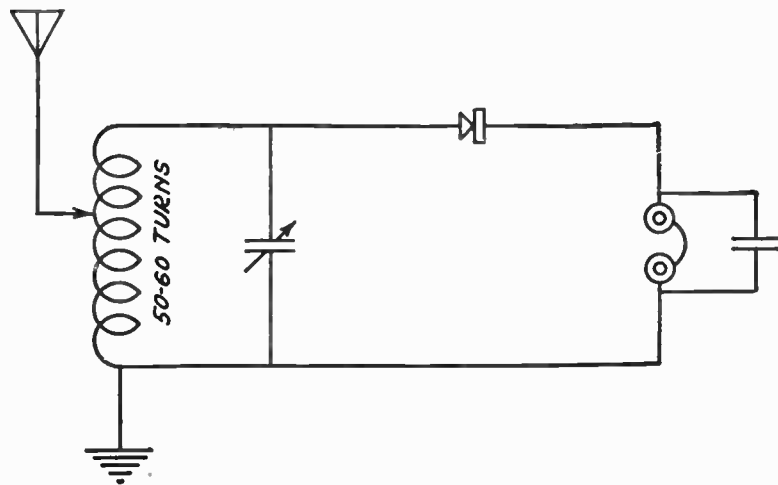

### THE CAPACITY-TUNED CRYSTAL CIRCUIT

**Selectivity:** Good.

**Operation:** Simple. Only two controls; a primary slider and a secondary variable condenser.

**Ease of construction:** Nothing complicated.

**Approximate range:** 15 miles.

**Outstanding features:** The circuit is more selective than the ordinary conductively-coupled tuner and the variable condenser gives smoother wavelength control.

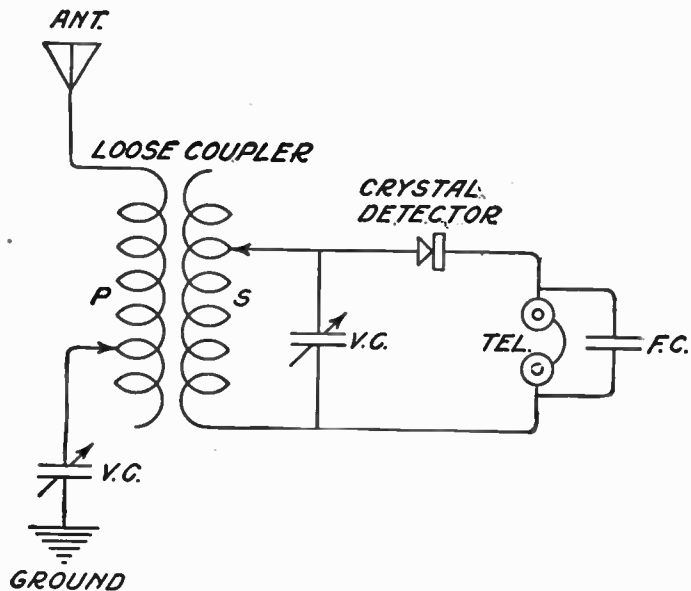

### INDUCTIVELY-COUPLED CRYSTAL RECEIVER

*Selectivity:* Good.

*Operation:* Fairly simple.

*Construction:* The whole set can be constructed on a board and wired up in an hour or two.

*Approximate range:* 15 miles.

*Outstanding feature:* The sharpest tuning crystal receiver that it is possible to make.

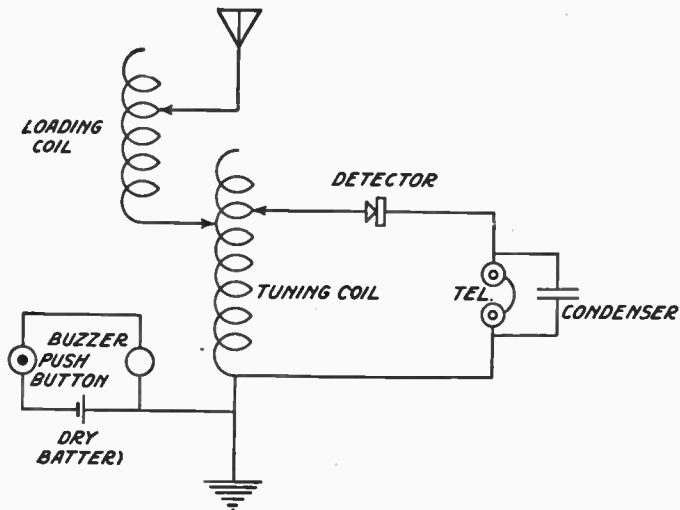

### CONDUCTIVELY-COUPLED CRYSTAL SET WITH LOADING COIL AND BUZZER TEST

*Selectivity:* Fair.

*Operation:* Simple. The buzzer test simplifies the adjustment of the crystal detector.

*Ease of construction:* Not difficult. The whole set can

be mounted on a board and wired up ready for use in an hour or so.

*Approximate range:* 15 miles.

*Outstanding feature:* A simple set for a young beginner to help him obtain his first knowledge of radio.

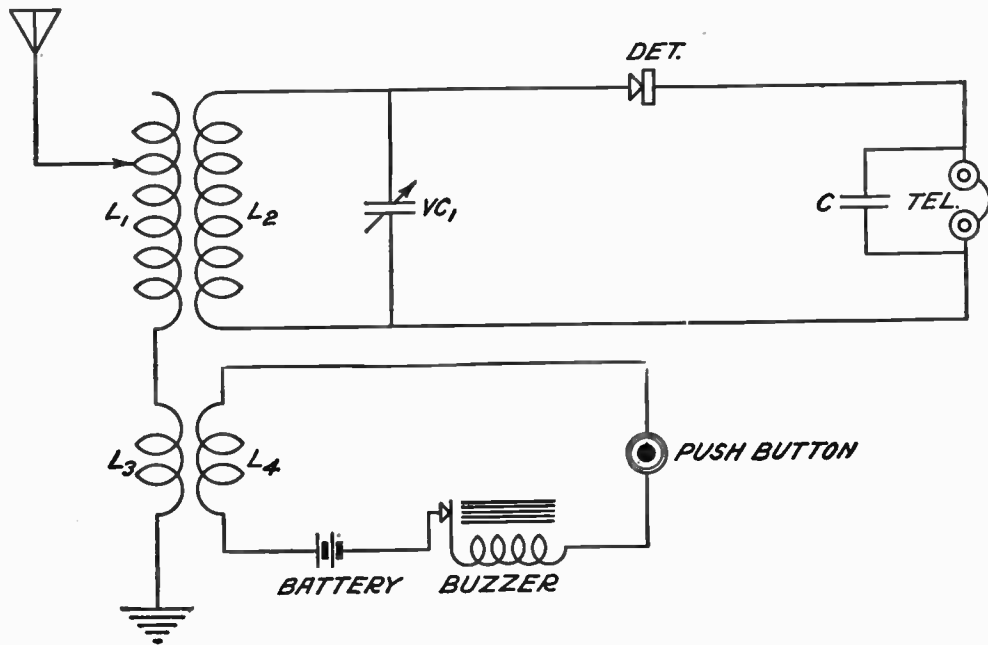

### CRYSTAL RECEIVER WITH INDUCTIVELY-COUPLED BUZZER TEST

*Selectivity:* Good.

*Operation:* Easy.

*Construction:* Very easy to make.

*Approximate range:* 15 miles.

*Outstanding feature:* A really good buzzer test for setting the crystal for maximum sensitivity.

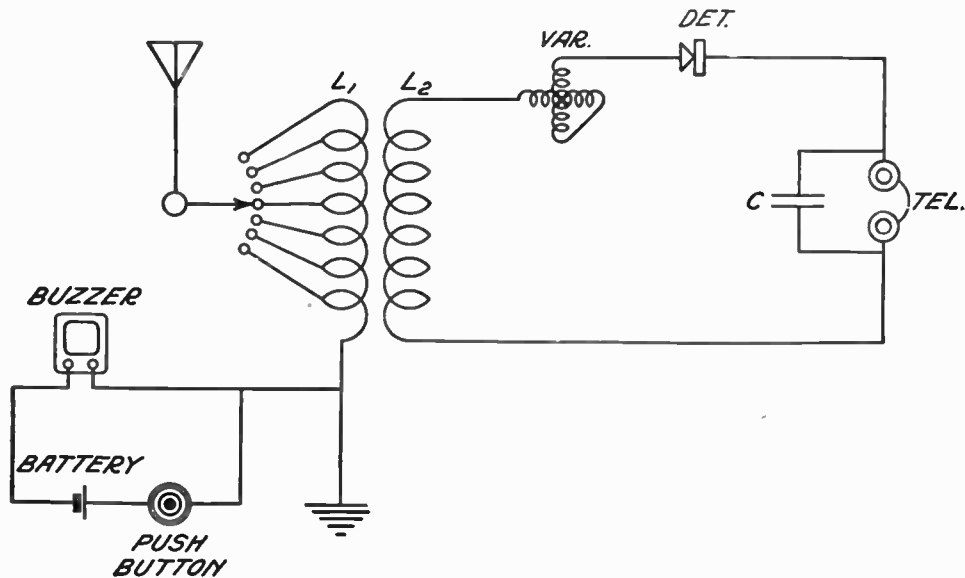

### THE INDUCTIVELY-TUNED CRYSTAL CIRCUIT

**Selectivity:** Good.

**Operation:** Fairly simple. The antenna circuit is tuned by a tapped switch, the secondary by a variometer and the coupling is varied by rotating the secondary coil of the variocoupler.

**Ease of construction:** Easy to build.

**Approximate range:** 15 miles.

**Outstanding features:** The set is sharp to tune on account of the loose coupling that can be employed, and it has a test buzzer which is a great help in setting the crystal in adjustment.

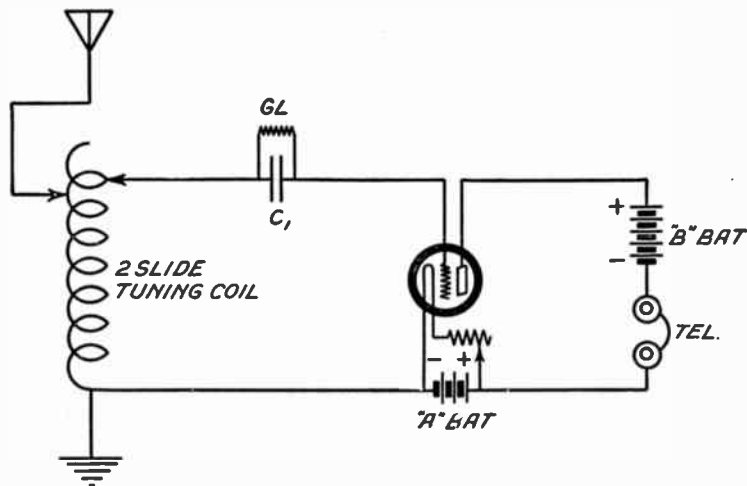

### THE TWO-SLIDE TUNER. NON-REGENERATIVE CIRCUIT

*Selectivity:* Fair.

*Operation:* An easy vacuum-tube circuit to tune.

There is one slider for the antenna circuit and one for the secondary circuit. The only adjustment for the detector is the rheostat, which controls the brilliancy of the filament.

*Ease of construction:* Extremely simple.

*Approximate range:* 100 miles.

*Outstanding features:* This is probably the next set for the beginner to build after he has experimented with the crystal receiver and found out how it works. This circuit will give good clear signals. It cannot re-radiate.



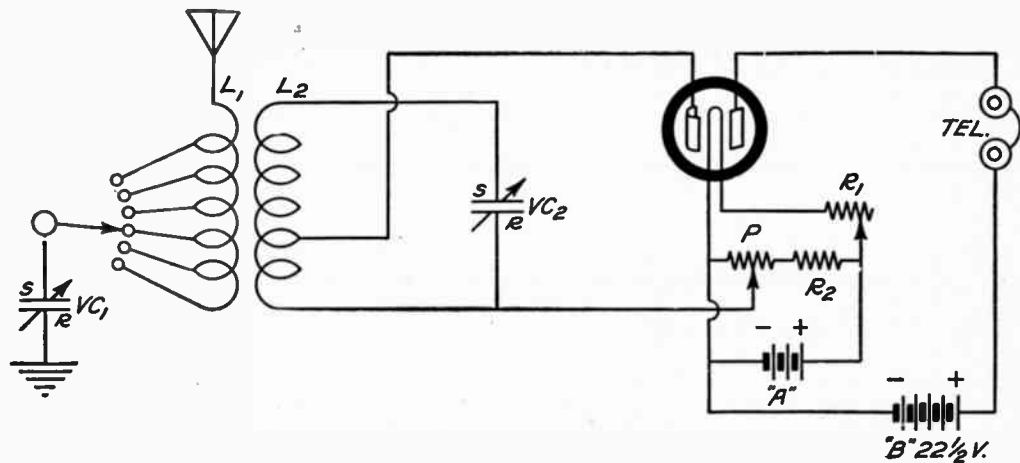

### NON-REGENERATIVE CIRCUIT FOR THE SODION TUBE

**Selectivity:** Good.

**Operation:** Fairly simple.

**Construction:** Simple to make.

**Approximate range:** 500 miles.

**Outstanding features:** Cannot radiate. Maximum sensitivity without regeneration. Good reproduction of voice and music.

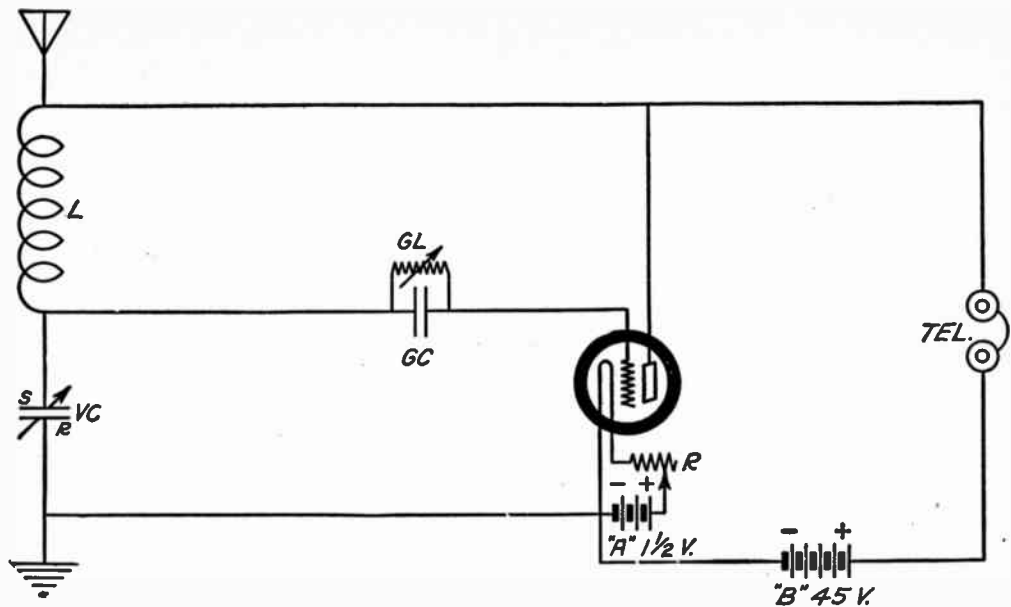

### MODIFIED COLPITTS CIRCUIT FOR RECEIVING

**Selectivity:** Fair.

**Operation:** Simple. The variable condenser changes the wavelength and the filament rheostat controls regeneration.

**Construction:** Easy to make.

**Approximate range:** 500 miles.

**Outstanding features:** Only a single, simple control for tuning. The filament rheostat should not be turned up too high or the set will radiate badly.

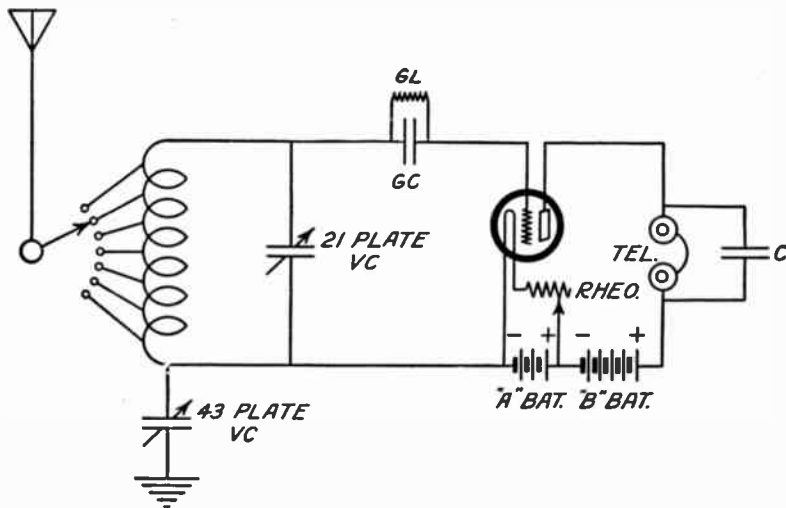

### CONDUCTIVELY-COUPLED, CONDENSER-TUNED, VACUUM-TUBE CIRCUIT

*Selectivity:* Fair.

*Operation:* Simple.

*Construction:* Easy to build, and a good circuit for the beginner to try.

*Approximate range:* 100 miles.

*Outstanding feature:* The best set for the beginner to learn the operating characteristics of the vacuum tube with.

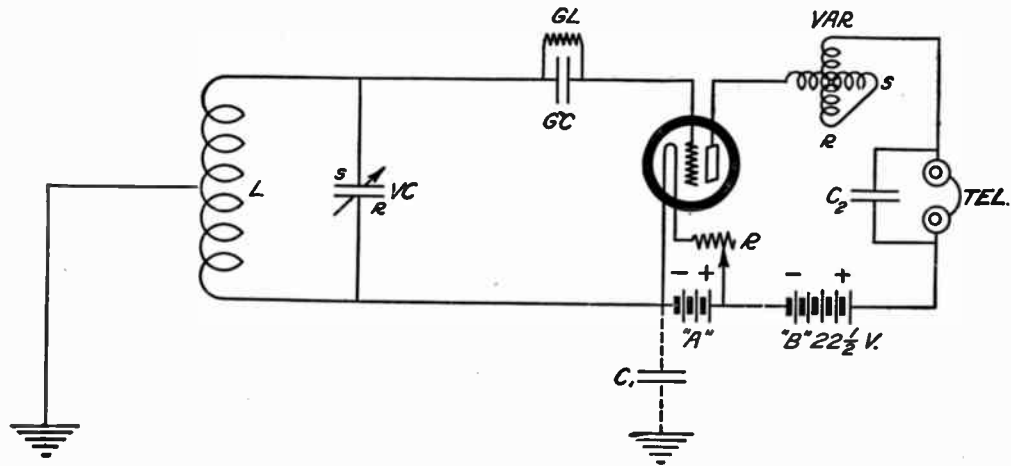

### ANTENNALESS REGENERATIVE CIRCUIT

*Selectivity:* Excellent.

*Operation:* Very simple. One control for wavelength and one for regeneration.

*Ease of construction:* Not difficult to make.

*Approximate range:* 20 miles.

*Outstanding features:* Works without an antenna.  
Reduction in static. Fine for local reception.

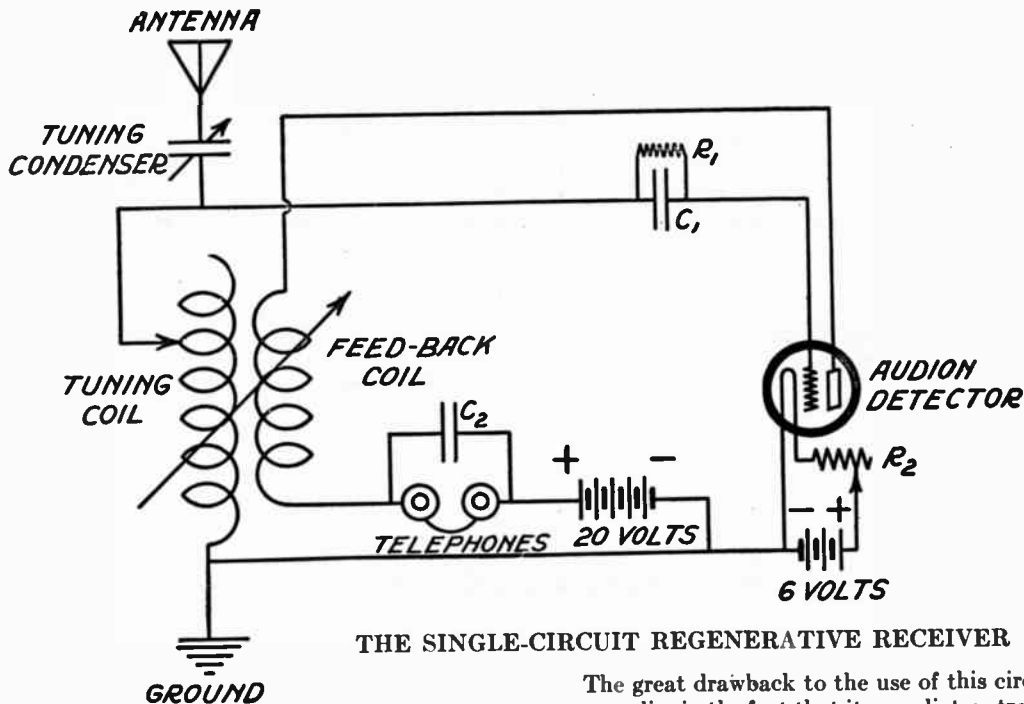

THE SINGLE-CIRCUIT REGENERATIVE RECEIVER

*Selectivity:* Poor.

*Operation:* Simple.

*Ease of construction:* Not complicated.

*Approximate range:* 500 miles.

*Outstanding features:* Easy to build and easy to operate; much simpler than most regenerative circuits.

The great drawback to the use of this circuit, however, lies in the fact that it re-radiates strongly. In other words, while it is being used for receiving, it generates radio-frequency currents in the antenna system which cause radio waves to be sent out to produce interference in other receiving sets in the neighborhood. In the hands of an expert operator this might not happen.

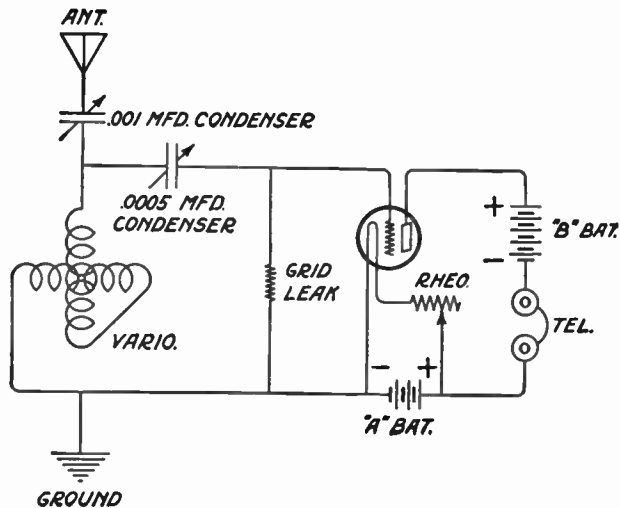

### SINGLE-CIRCUIT NON-REGENERATIVE SET

*Selectivity:* Only fair.

*Operation:* Simple. The variometer and one of the variable condensers tune the antenna, and the variometer and the other variable condenser control the grid-circuit tuning.

*Construction:* Not complicated.

*Approximate range:* 100 miles.

*Outstanding feature:* A non-re-radiating, single-circuit receiver for reception of local signals.



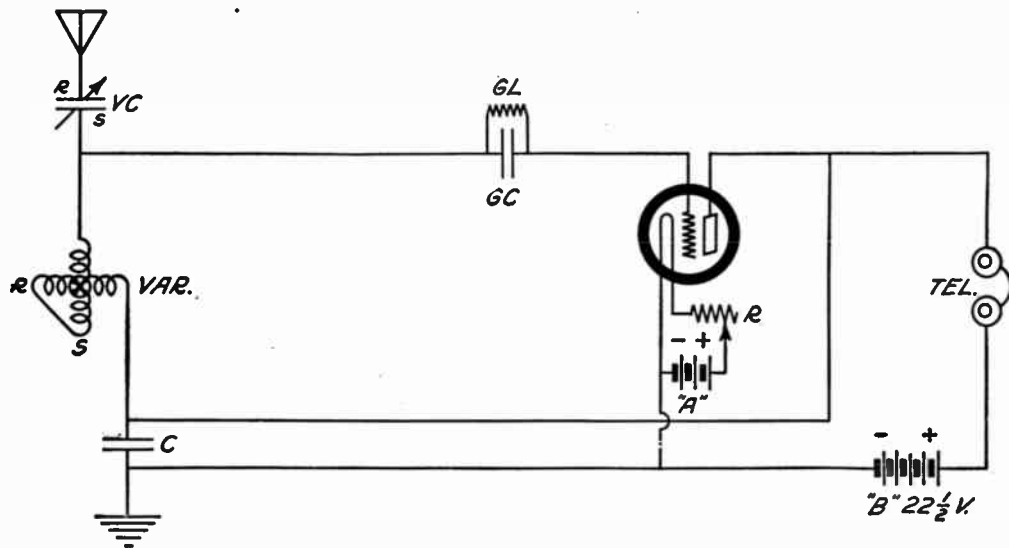

### SIMPLE ONE-TUBE REGENERATIVE RECEIVER

*Selectivity:* Fair.

*Operation:* Simple to tune. Wavelength is controlled by the variable condenser and the variometer.

Regeneration is controlled by the filament rheostat.

*Construction:* Extremely simple.

*Approximate range:* 500 miles.

*Outstanding features:* This is a simple set to build and operate. It will give good results in the hands of beginners. But the filament rheostat should not be turned up too high or the set will radiate badly.



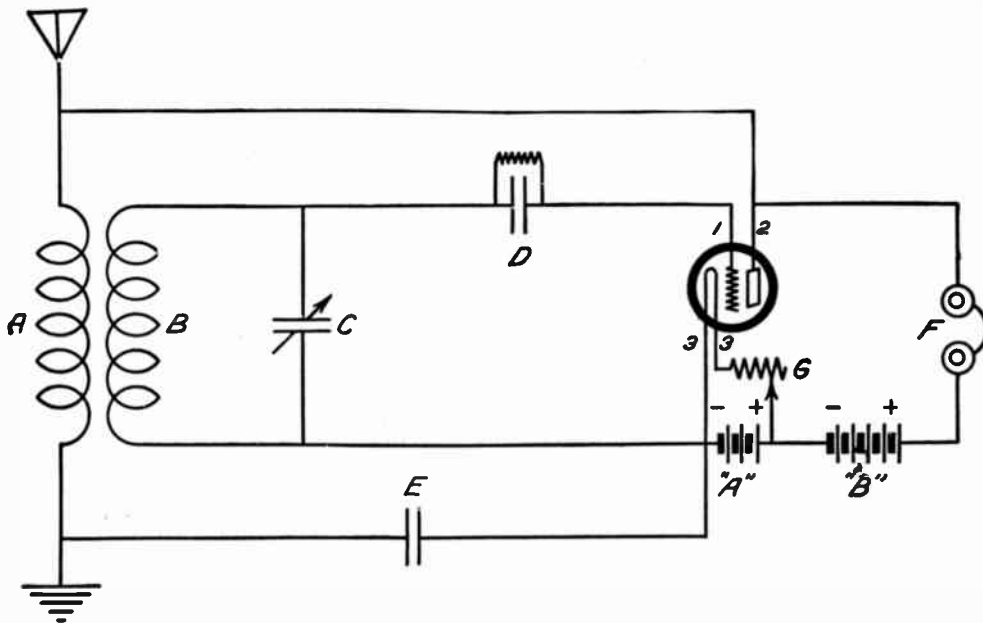

### THE MAN-DAY SINGLE-CONTROL REGENERATIVE CIRCUIT

*Selectivity:* Excellent.

*Operation:* Very easy. Only one control for wavelength. Regeneration is adjusted with the filament rheostat.

*Ease of construction:* Simple.

*Approximate range:* 500 miles.

*Outstanding features:* This is the simplest regenerative circuit to tune. It is very selective and costs but little.

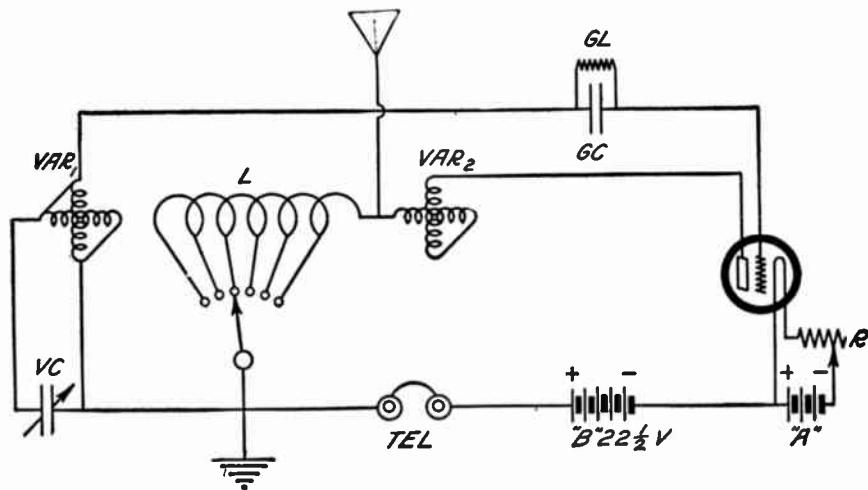

### NOVEL VARIOMETER HOOK-UP

*Selectivity:* Fair.

*Operation:* Rather complicated.

*Construction:* Just an ordinary acquaintance with tools and some experience in wiring up the circuit is necessary.

*Approximate range:* 800 miles.

*Outstanding features:* Strong signals from one tube.

The set will readily radiate, unless carefully handled. For this reason it is a menace to a neighbor's reception, when in the hands of a novice.

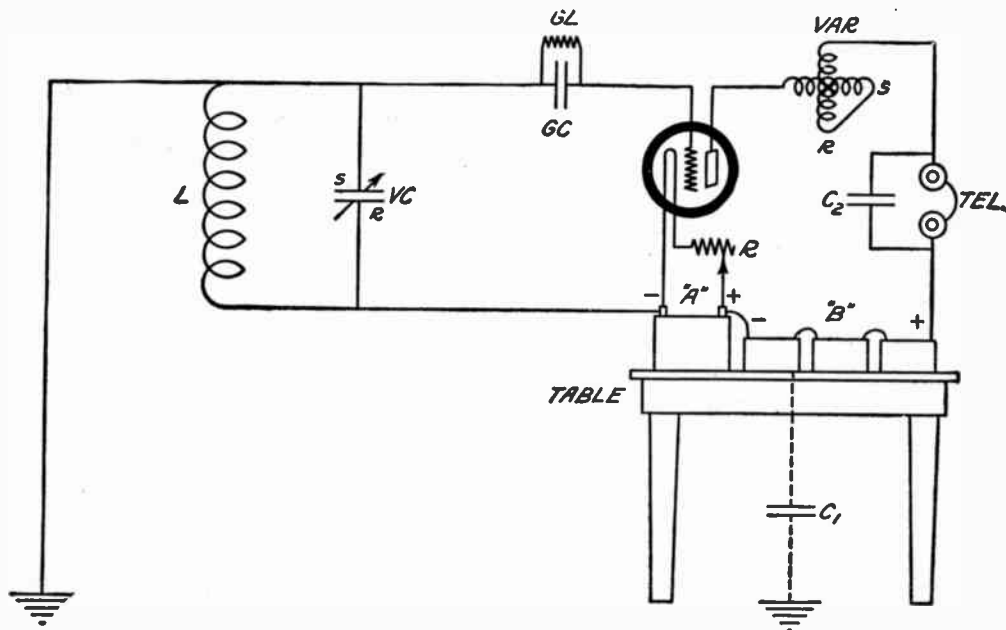

### A REGENERATIVE SET FOR RECEPTION WITH A GROUND ONLY

*Selectivity:* Excellent.

*Operation:* Easy to tune. There are only two controls, the variable condenser for wavelength, and the variometer for regeneration.

*Construction:* Very simple to make.

*Approximate range:* 25 miles.

*Outstanding feature:* This is a good type of receiver for local reception where the conditions make impossible the erection of an outside antenna.

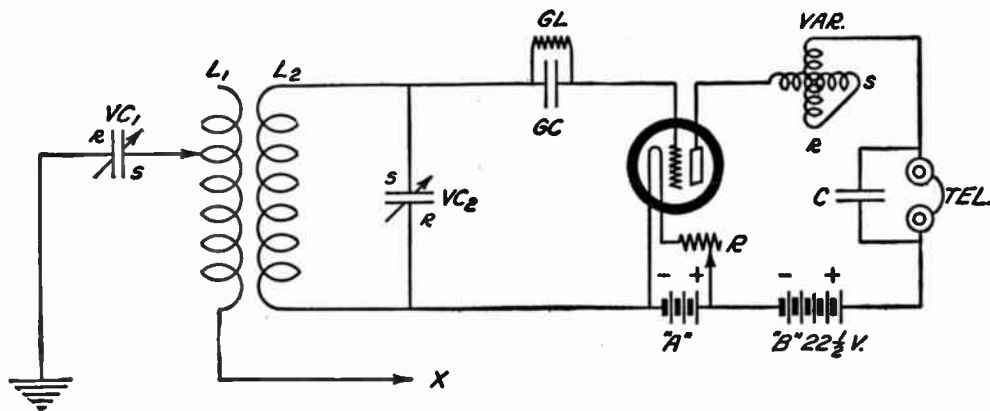

### A SIMPLE REGENERATIVE RECEIVER FOR USE WITH TWO GROUNDS

*Selectivity:* Excellent.

*Operation:* Not especially complicated. The ground circuit is tuned by means of a variable condenser; likewise the secondary circuit. The plate circuit of the detector tube is tuned by means of a variometer and this controls regeneration.

*Construction:* Not complicated.

*Approximate range:* Local.

*Outstanding feature:* No antenna is necessary. Just use two grounds; one may be the water pipe and the other the radiator system or the gas pipes.

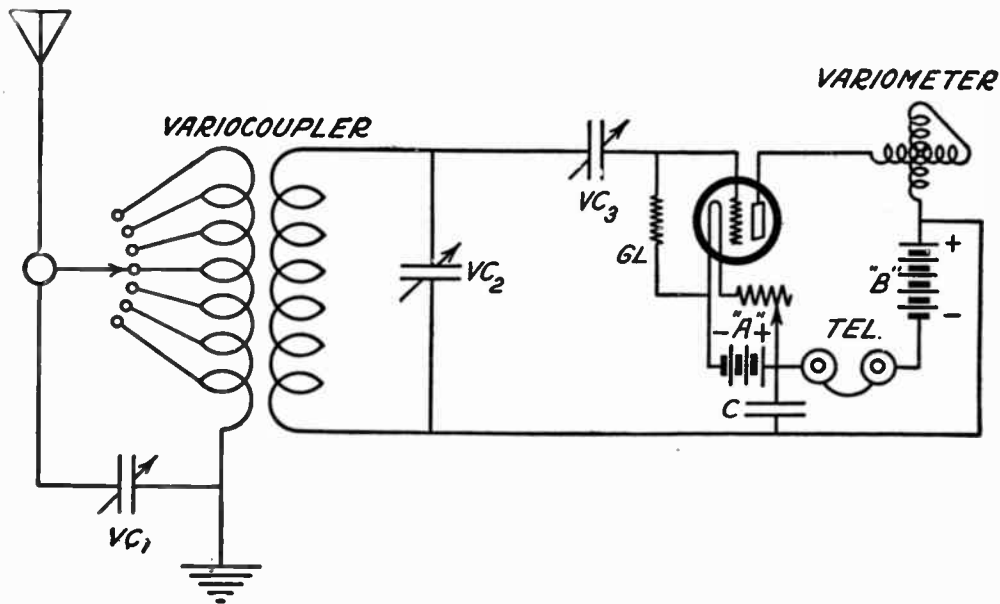

### TUNED-PLATE ULTRA-AUDION CIRCUIT WITH FINER CONTROLS

*Selectivity:* Excellent.

*Operation:* Fairly simple. This adaptation of this circuit contains variable tuning elements such as a variable grid-condenser, variable grid-leak, and a variable condenser in the antenna circuit which will enable the more experienced operator to get maximum results out of the receiver.

*Ease of construction:* Just an ordinary acquaintance with tools and some ability in wiring up the circuit are necessary.

*Approximate range:* 1,000 miles.

*Outstanding features:* A real set for the advanced man who wants selectivity and sensitivity at reasonable cost.

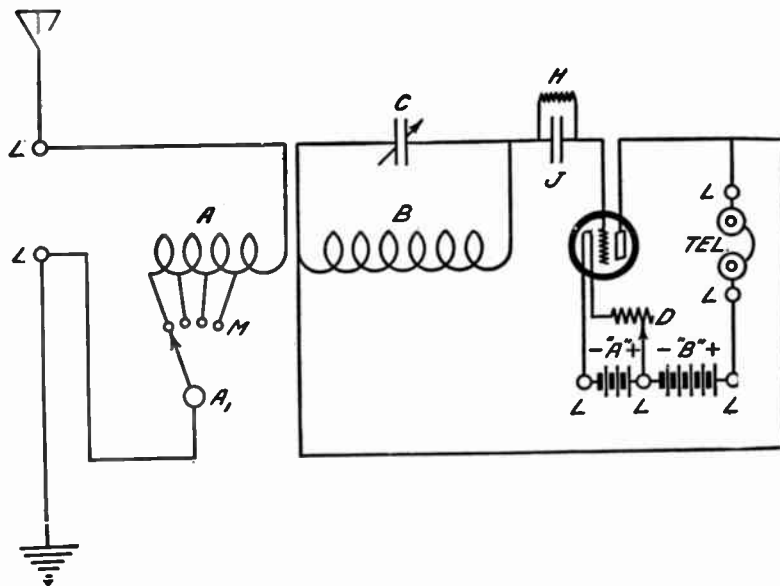

### SPECIAL ULTRA-AUDION CIRCUIT

**Selectivity:** Excellent.

**Operation:** Very easy. When the switchpoint A1 is adjusted for the antenna, there is only one control for wavelength. The regeneration is controlled by the filament rheostat.

**Ease of construction:** Simple.

**Approximate range:** 500 miles.

**Outstanding features:** This circuit shares first place with the Man-Day circuit in simplicity of operation. It is very selective, and costs but little.

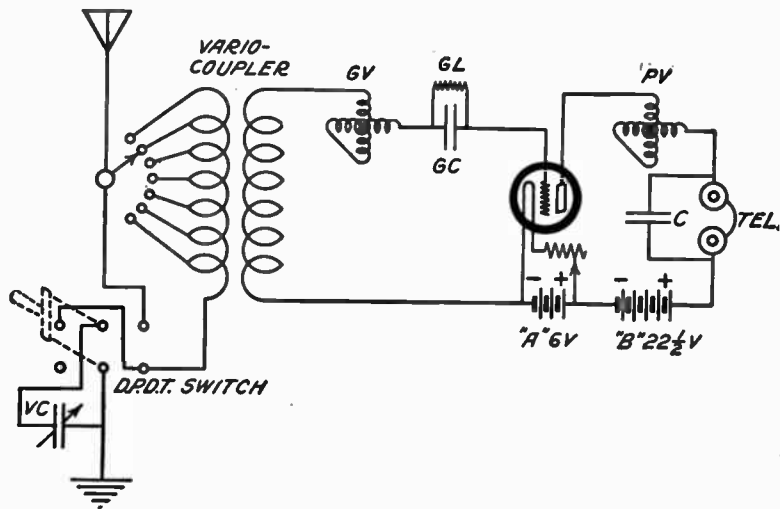

### THE TWIN-VARIOMETER-VARIOCOUPLER CIRCUIT

*Selectivity:* Good.

*Operation:* Requires considerable skill which can be acquired in a couple of months of experimenting with the tuning.

*Ease of construction:* Just an ordinary acquaintance with tools but some electrical ability in wiring up

the circuit is necessary.

*Approximate range:* 500 miles.

*Outstanding features:* This was the first well-known short-wave regenerative receiver and it has been found reliable and probably has been more used than any other type of receiver in the past.

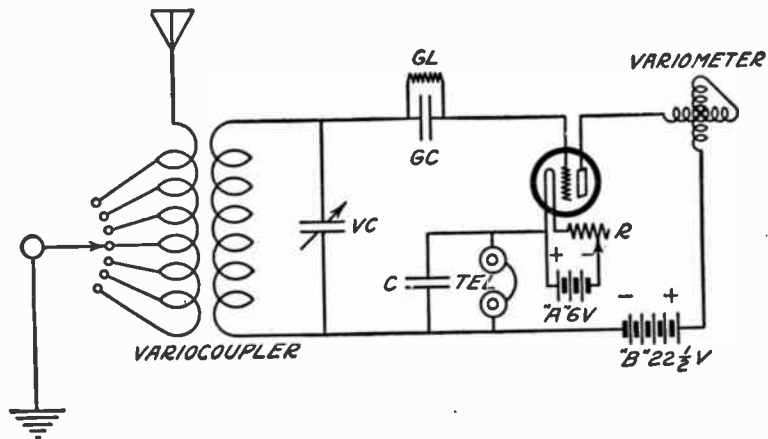

### THE COMBINATION TUNED-PLATE ULTRA-AUDION CIRCUIT

*Selectivity:* Excellent.

*Operation:* Requires considerable skill which can be acquired in a couple of months of experimenting with the tuning.

*Ease of construction:* Just an ordinary acquaintance

with tools but some electrical ability in wiring up the circuit is necessary.

*Approximate range:* 500 miles.

*Outstanding features:* Exceptionally suitable for DX amateur work on CW. Tuning is very sharp and easy when it is learned correctly.



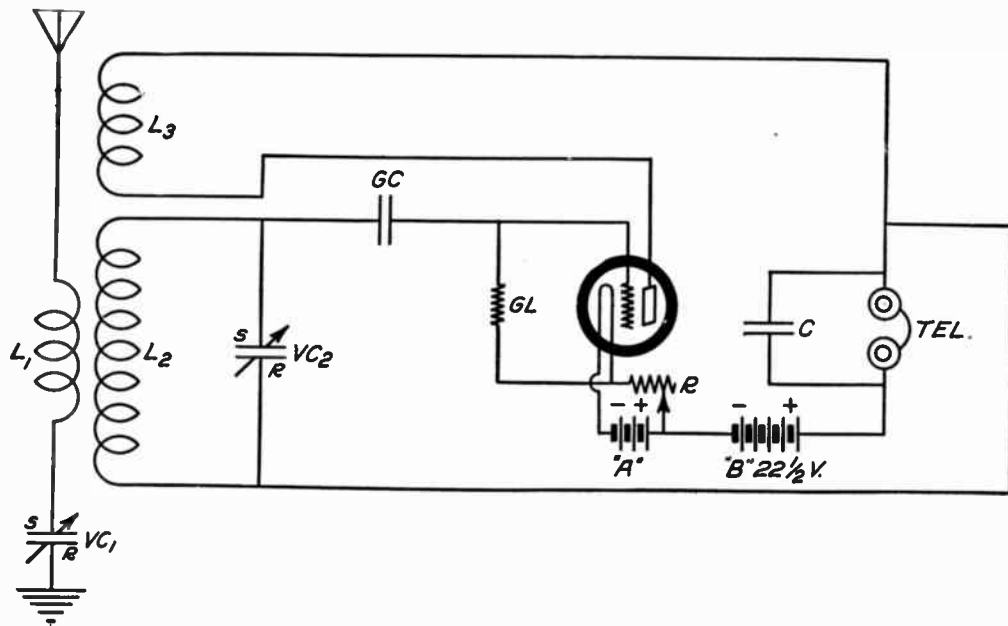

### THREE-CIRCUIT TUNER FOR SHORT-WAVE RECEPTION

*Selectivity:* Very good.

*Operation:* Not very hard to tune when the operator has worked with the set for a week or so.

*Construction:* Not difficult to make.

*Approximate range:* 500 miles for telephony; 1,000 miles for CW reception.

*Outstanding features:* For work below 200 meters. For short-wave broadcast reception and amateur CW reception.

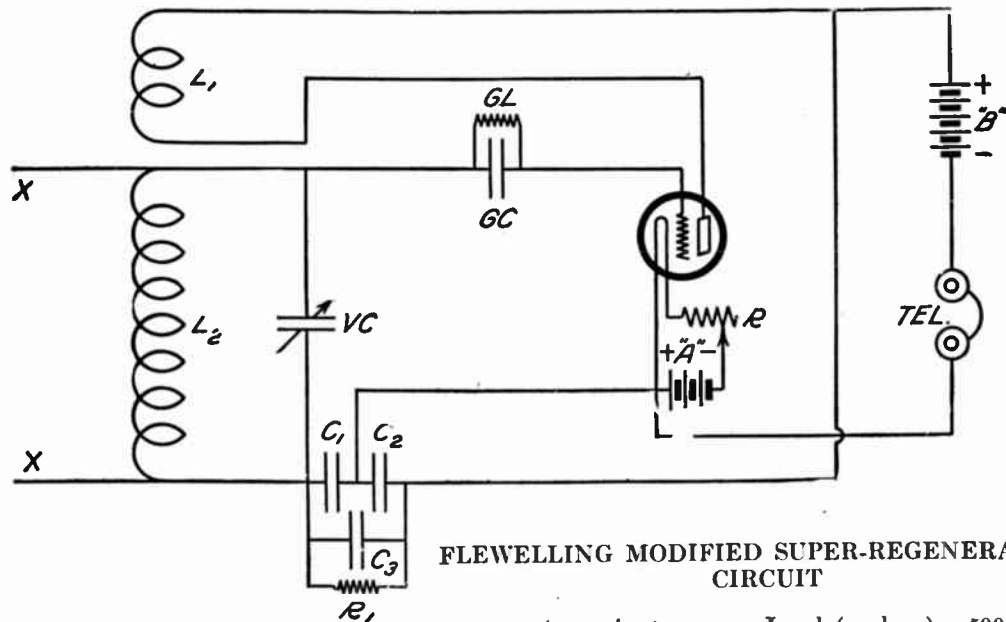

**Selectivity:** Fair (on outdoor antenna). Good (on loop).

**Operation:** Not hard to operate when the circuit has once been adjusted properly. When used on an outdoor antenna, however, it is liable to produce bad interference to neighbors, due to re-radiation.

**Ease of construction:** Easy to make but not easy to get adjusted right.

**Approximate range:** Local (on loop). 500 miles (on an outdoor antenna).

**Outstanding features:** Simplest super-regenerative circuit. Can be made to operate a loudspeaker on one tube. This is only true when all conditions are satisfied. Actually, many experimenters do not get very good results on account of some mistakes they have made and have failed to locate. Reception is accompanied with a high-pitched whistle.

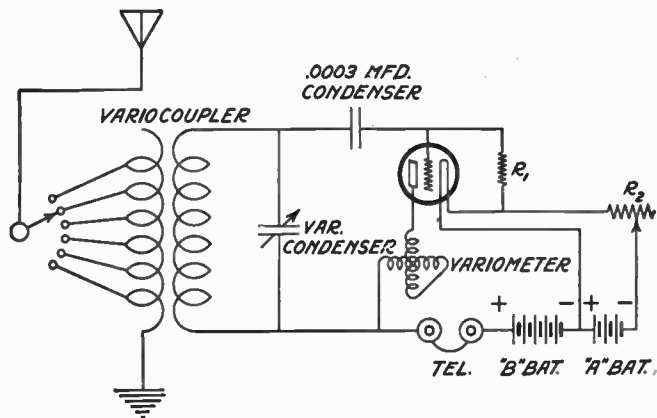

### TUNED-PLATE ULTRA-AUDION CIRCUIT

**Selectivity:** Excellent.

**Operation:** Fairly simple.

**Ease of construction:** Not complicated.

**Approximate range:** 1,000 miles.

**Outstanding features:** Noted for DX, amateur and broadcast reception and for its exceptionally sharp tuning.

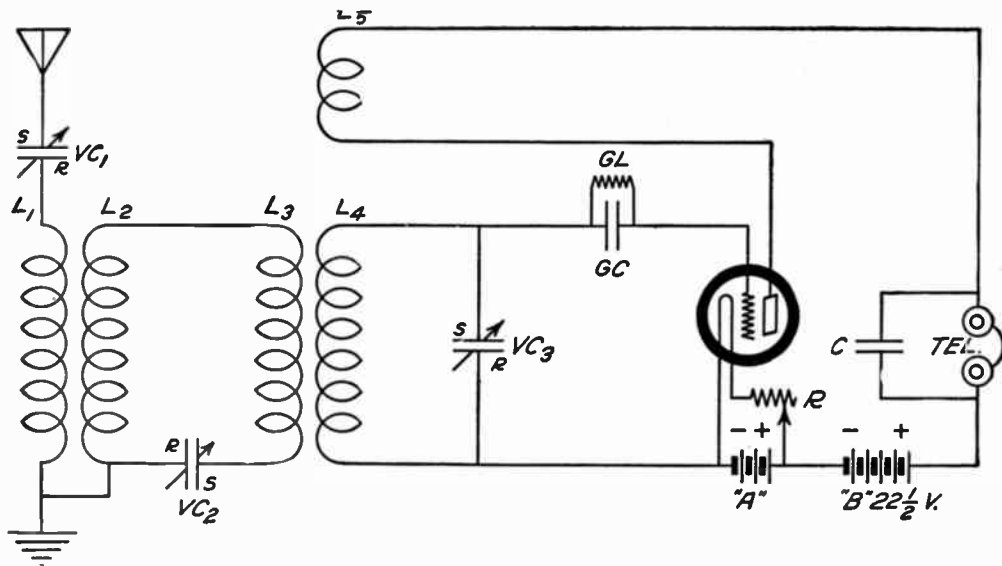

### A REGENERATIVE RECEIVER WITH AN INTERMEDIATE CIRCUIT TO REDUCE RADIATION

*Selectivity:* Very good.

*Operation:* Rather complicated.

*Construction:* Just an ordinary acquaintance with tools and some ability in wiring up the electrical circuit are necessary.

*Approximate range:* 500 to 1,000 miles.

*Outstanding features:* The receiving system used here makes use of an intermediate, resonant circuit for loosening the coupling between the antenna circuit and the grid circuit so that radiation will be prevented.

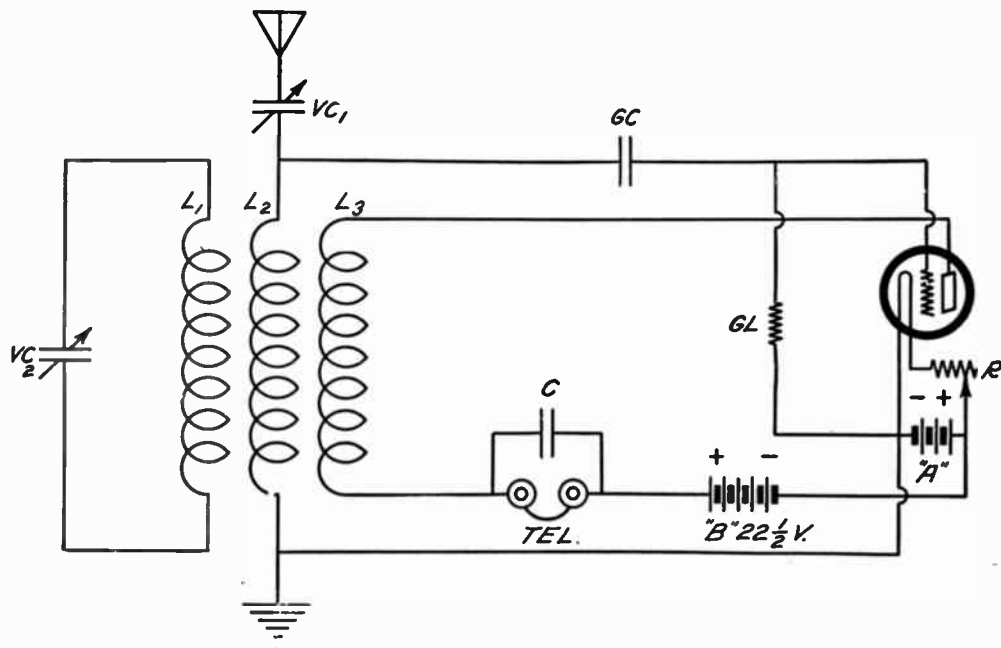

### THE 4-CIRCUIT PRINCIPLE ADDED TO THE SINGLE-CIRCUIT SET

*Selectivity:* Fair.

*Operation:* The extra circuit, comprising the condenser VC2 and the coil L1, gives a much better control of regeneration than in the conventional circuit.

*Construction:* Just an ordinary acquaintance with tools and some ability in wiring up the circuit are necessary.

*Approximate range:* 500 miles.

*Outstanding feature:* The added circuit will give stability to the control of regeneration so that the circuit will not burst into oscillation and cause a violent disturbance in neighbors' receivers.

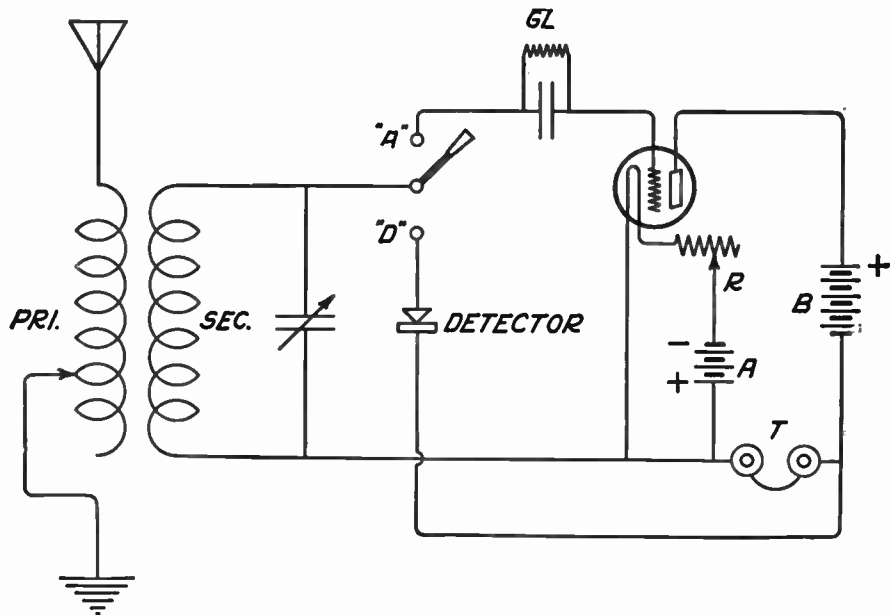

### COMBINATION CRYSTAL AND VACUUM-TUBE SET

*Selectivity:* Fairly good.

*Operation:* Very simple.

*Ease of construction:* Simple to make.

*Approximate range:* 15 miles on the crystal detector.

100 miles on the vacuum-tube detector.

*Outstanding features:* Here is the circuit for the man

who already has a crystal receiver and wishes to find out what the vacuum-tube detector will do for him in the way of increased signals. The crystal may be used for strong local stations and the vacuum tube may be used for the more distant and weaker ones.

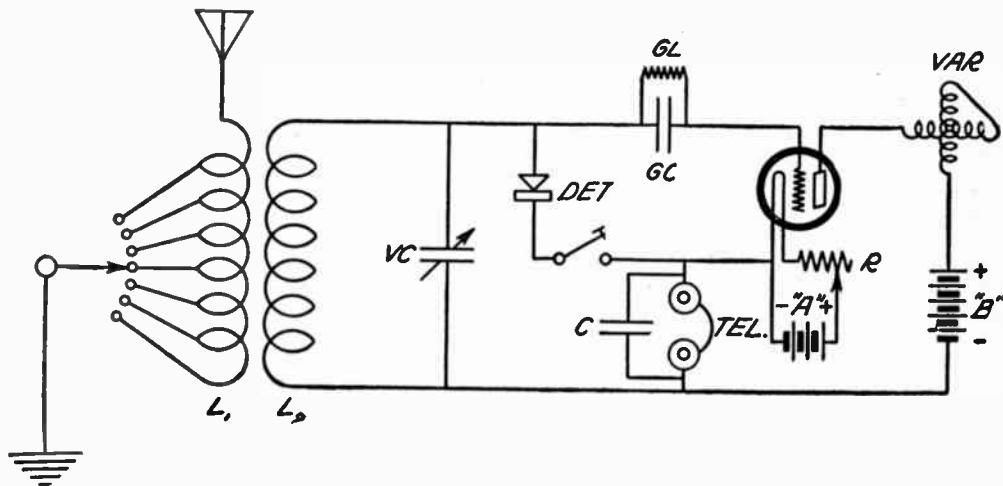

### COMBINATION CRYSTAL AND REGENERATIVE VACUUM-TUBE RECEIVER

**Selectivity:** Good (with crystal). Excellent (with vacuum tube).

**Operation:** Simple.

**Construction:** Not complicated.

**Approximate range:** 15 miles (with crystal); 500 miles

(with vacuum tube).

**Outstanding feature:** By simply throwing a switch, the operator can listen in with a crystal detector for local reception, or can use the vacuum tube for distant stations.

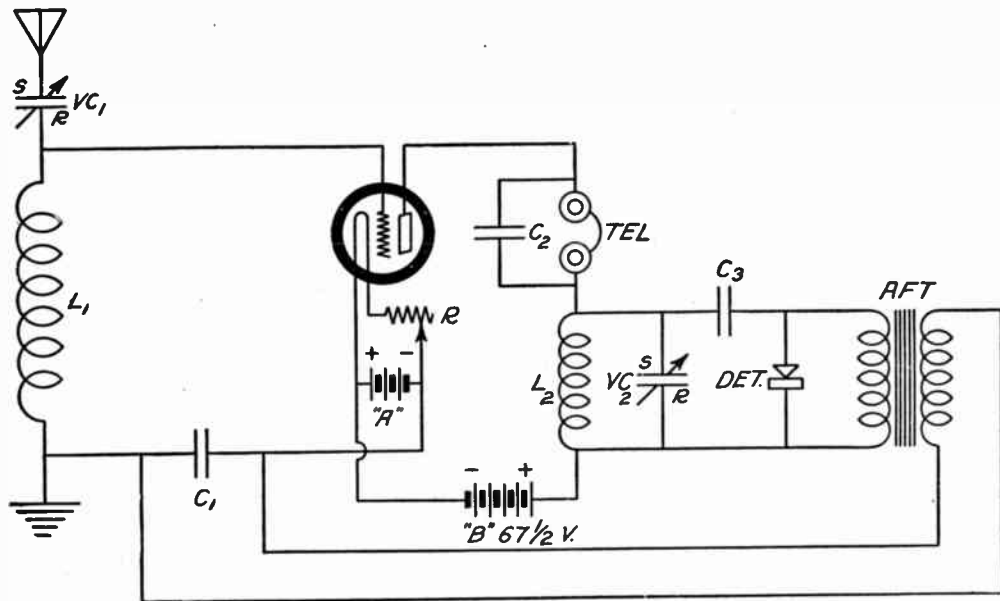

### SINGLE-TUBE REFLEX WITH TUNED-PLATE CIRCUIT AND A CRYSTAL DETECTOR

*Selectivity:* Good.

*Operation:* Easy to tune. The variable condenser in the antenna circuit tunes the input circuit to the tube and the variable condenser in the plate circuit tunes that circuit.

*Construction:* Just an ordinary acquaintance with tools and some ability in wiring.

*Approximate range:* 500 miles.

*Outstanding features:* A good set for the experimenter who wishes to learn the principles of radio-frequency amplification and of the reflex.



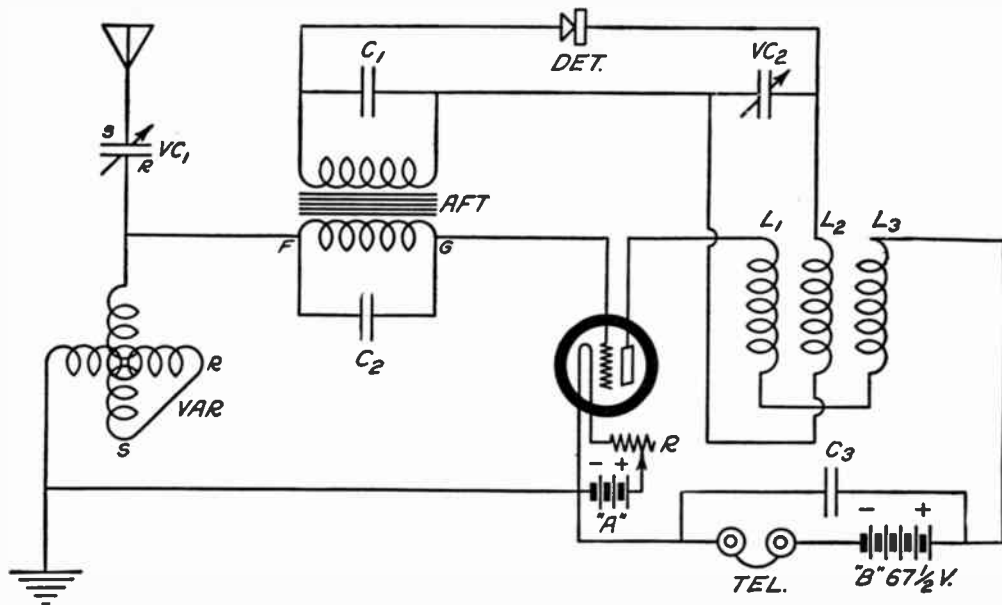

### SIMPLIFIED REFLEX WITH HONEYCOMB-COIL, RADIO-FREQUENCY COUPLING

**Selectivity:** Fair.

**Operation:** Rather difficult.

**Construction:** Some experience in making sets should be had before trying this one.

**Approximate range:** 1,000 miles.

**Outstanding features:** Will operate a loudspeaker on local stations. Incorporates one stage of radio-frequency amplification and one of audio with only one tube.

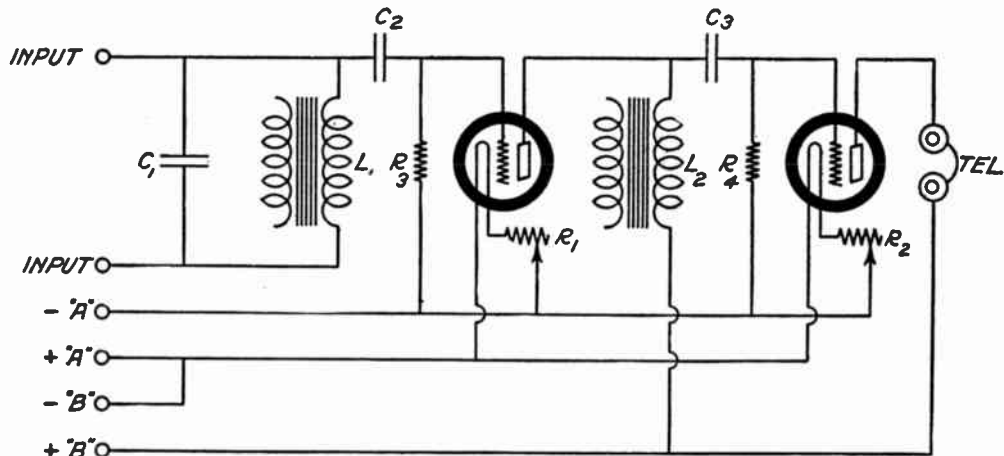

### TWO-STAGE, IMPEDANCE-COUPLED AMPLIFIER MADE FROM FORD SPARK COILS

**Usage:** With headphones or loudspeaker.

**Signal strength:** Fairly good.

**Quality of reproduction:** Fairly good.

**Construction:** Simple.

**Outstanding features:** Simple to make and operate, and of low cost, especially if you have some old Ford coils on hand.

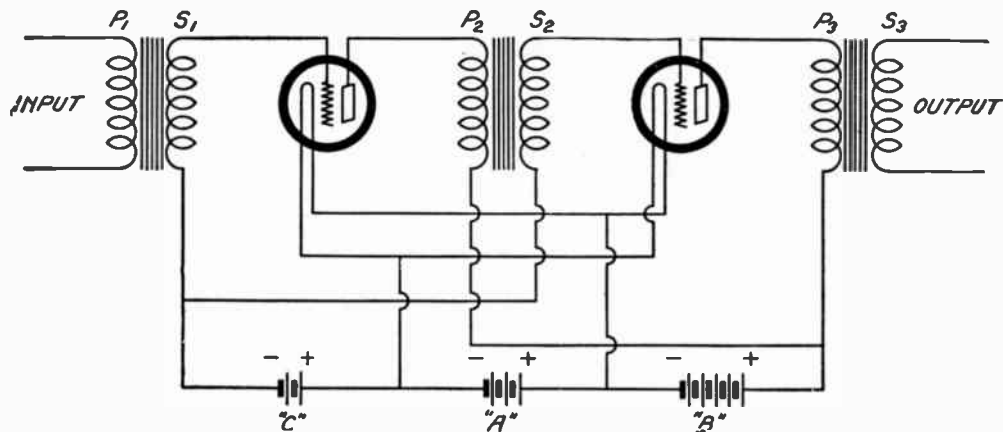

### TWO-STAGE, TRANSFORMER-COUPLED, POWER AMPLIFIER FOR USE WITH 5-WATT TUBES

*Usage:* With loudspeaker.

*Signal strength:* Excellent, when added to a two-tube receiver.

*Quality of reproduction:* Good, if good transformers are used.

*Construction:* Not complicated.

*Outstanding features:* No rheostats need be used with these tubes (Western Electric 216-a) on 6 volts. The plate circuit of the last tube includes a step-down transformer across the secondary of which is connected the loudspeaker.

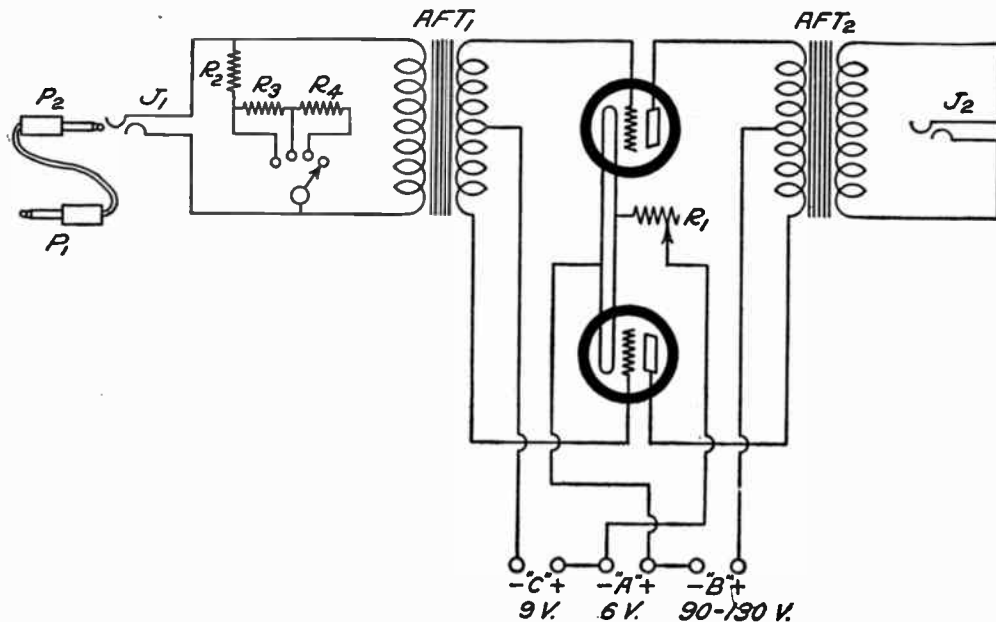

### ONE STAGE OF PUSH-AND-PULL POWER AMPLIFICATION

*Usage:* With loudspeaker.

*Signal strength:* Very good when used with a single-stage of transformer-coupled amplification.

*Quality of reproduction:* Very good, if good transformers are used.

*Construction:* Just an ordinary acquaintance with

tools and some ability in wiring up a circuit are necessary.

*Outstanding feature:* This form of amplification takes advantage of both sides of the amplified alternating current that makes up audible voice signals.

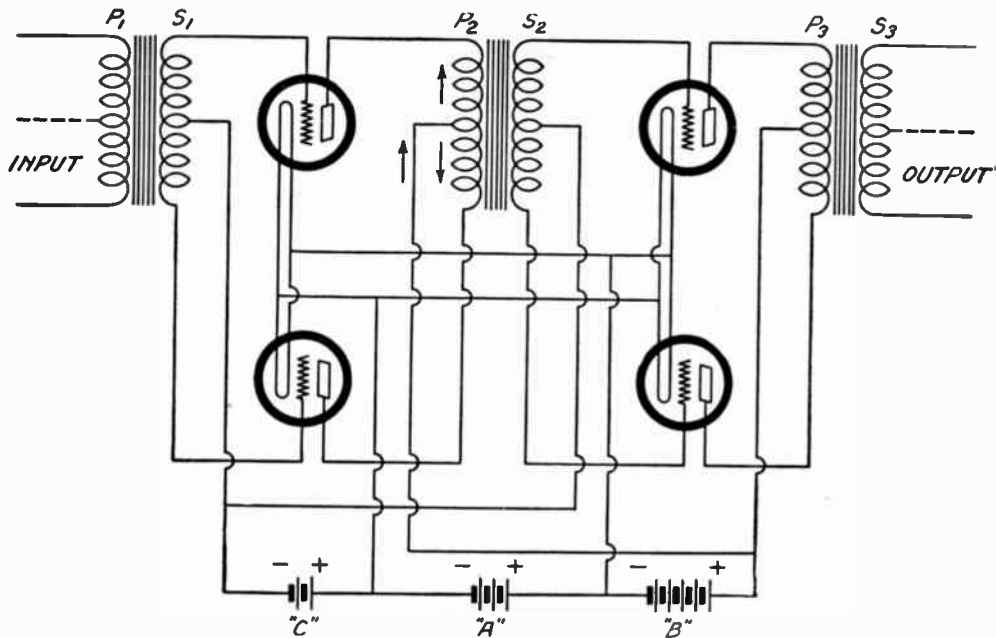

### TWO STAGES OF PUSH-AND-PULL AMPLIFICATION

**Usage:** With loudspeaker.

**Signal strength:** Excellent, when used as a power amplifier.

**Quality of reproduction:** Very good—if the transformers are good.

**Construction:** Rather complicated.

**Outstanding feature:** Excellent for use as a power amplifier where great volume and good clarity is required.

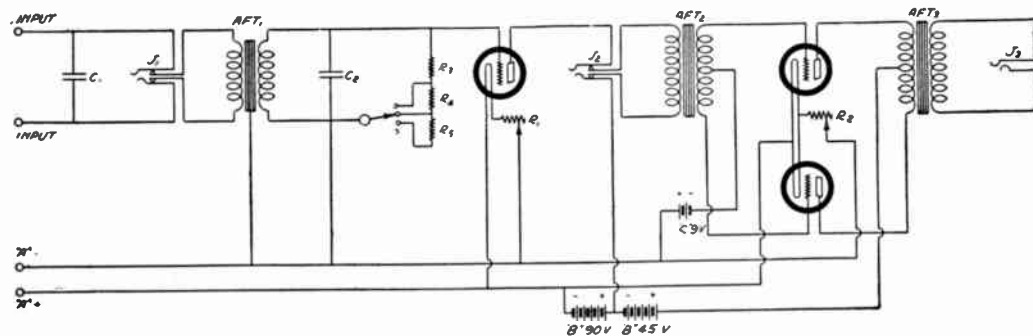

### ONE STAGE OF TRANSFORMER-COUPLED, AND ONE STAGE OF PUSH-AND-PULL AMPLIFICATION

**Usage:** With headphones or with loudspeaker.

**Signal strength:** Excellent.

**Quality of reproduction:** Very good, if good transformers are used.

**Construction:** Not very difficult to make.

**Outstanding feature:** Large volume and good reproduction through a loudspeaker.

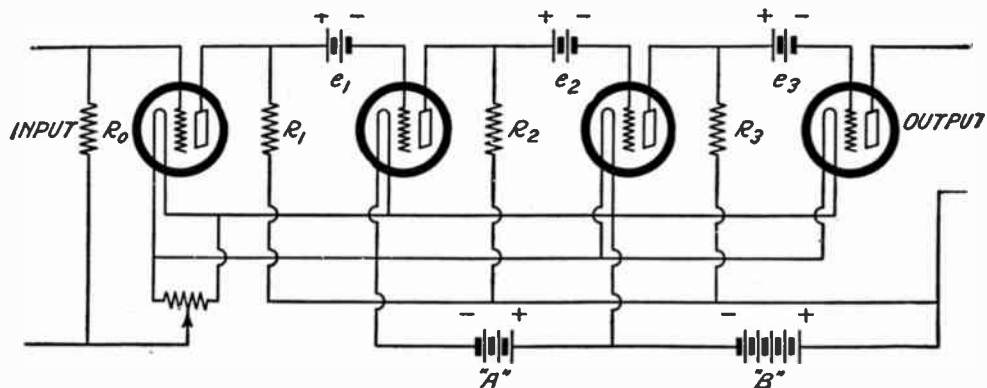

### APERIODIC RESISTANCE-COUPLED AMPLIFIER

*Usage:* With headphones or with loudspeaker

*Signal strength:* Good.

*Quality of reproduction:* Excellent.

*Construction:* Simple.

*Outstanding features:* Perfect reproduction, if properly adjusted. Simplicity of construction. Low cost.

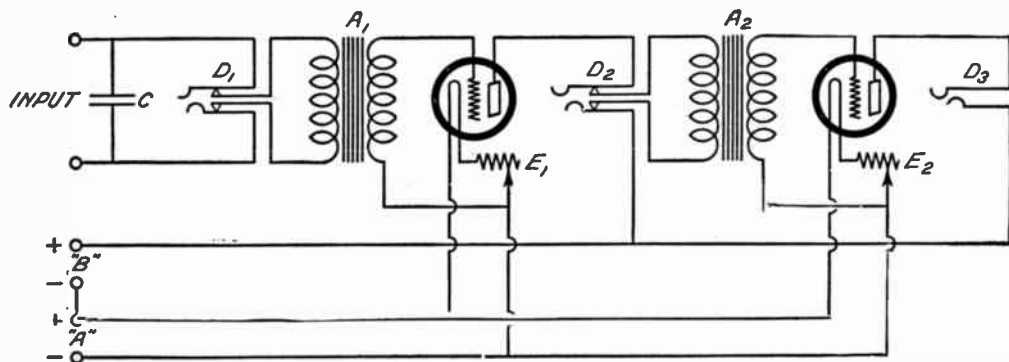

### TWO STAGES OF TRANSFORMER-COUPLED AMPLIFICATION

*Usage:* With headphones or with loudspeaker.

*Signal strength:* Good.

*Quality of reproduction:* Good, if good transformers are used.

*Construction:* There is nothing really difficult in putting together and wiring up such an amplifier.

*Outstanding feature:* A simple circuit for getting consistent loudspeaker reception with a small number of tubes.



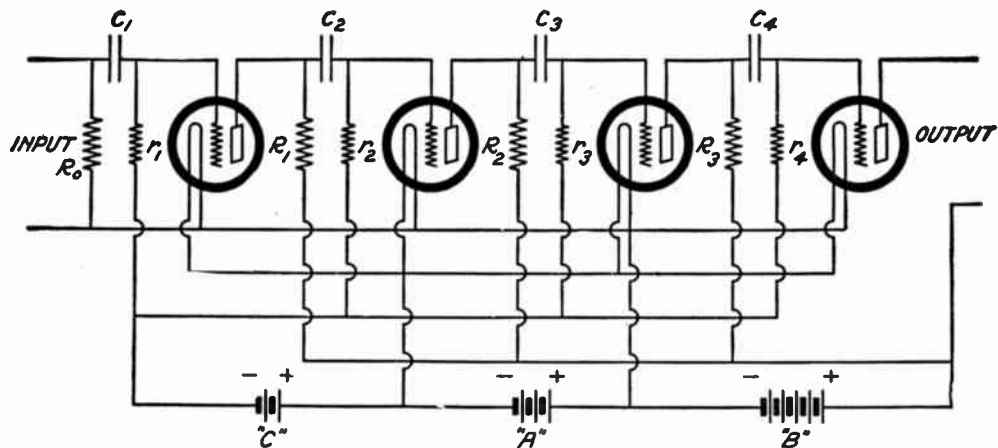

### RESISTANCE AND CONDENSER-COUPLED AMPLIFIER

*Usage:* With phones or with loudspeaker.  
*Signal strength:* Good.  
*Quality of reproduction:* Excellent.

*Construction:* Fairly simple.  
*Outstanding features:* Truthfulness of reproduction and simplicity and low cost.

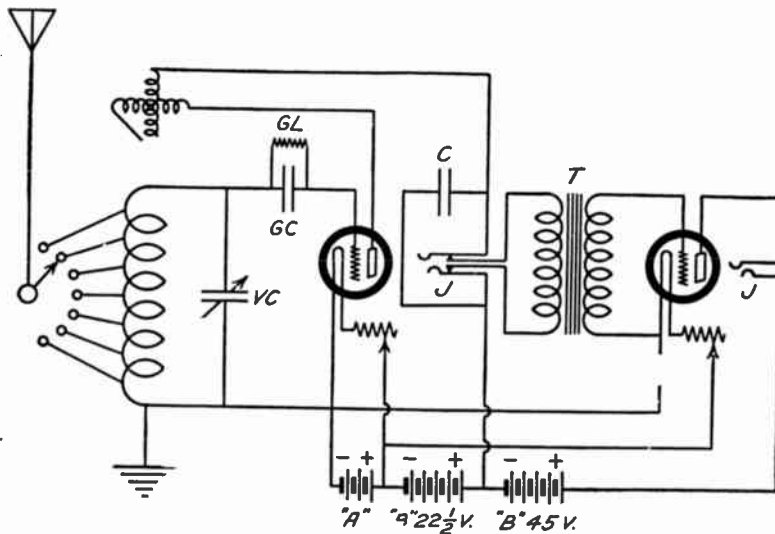

### THE CONDUCTIVELY-COUPLED, TUNED-PLATE REGENERATIVE CIRCUIT WITH ONE STAGE OF AUDIO-FREQUENCY AMPLIFICATION

*Selectivity:* Fair.

*Operation:* Not very complicated. The antenna is tuned by means of a tapped switch, the secondary by means of a variable condenser and the regeneration is controlled by the variometer.

*Ease of construction:* Just an ordinary acquaintance

with tools and some ability in wiring up the circuit are necessary.

*Approximate range:* 800 to 1,000 miles.

*Outstanding features:* Easy to operate and will bring in distance with good volume on a pair of telephones. Good for amateur CW reception.

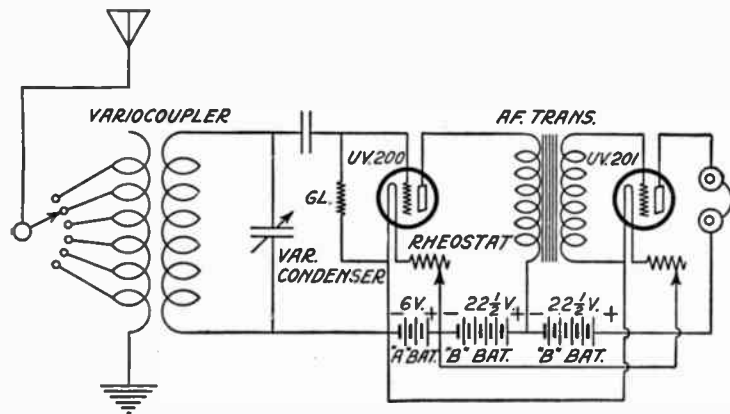

### INDUCTIVELY-COUPLED, VACUUM-TUBE RECEIVER WITH ONE STAGE OF AUDIO-FREQUENCY AMPLIFICATION

*Selectivity:* Fairly good.

*Operation:* Simple.

*Construction:* Easy to make.

*Approximate range:* About 100 miles.

*Outstanding features:* The added stage of amplification increases the operating range considerably and makes the local programs more enjoyable for use with a number of headphones.

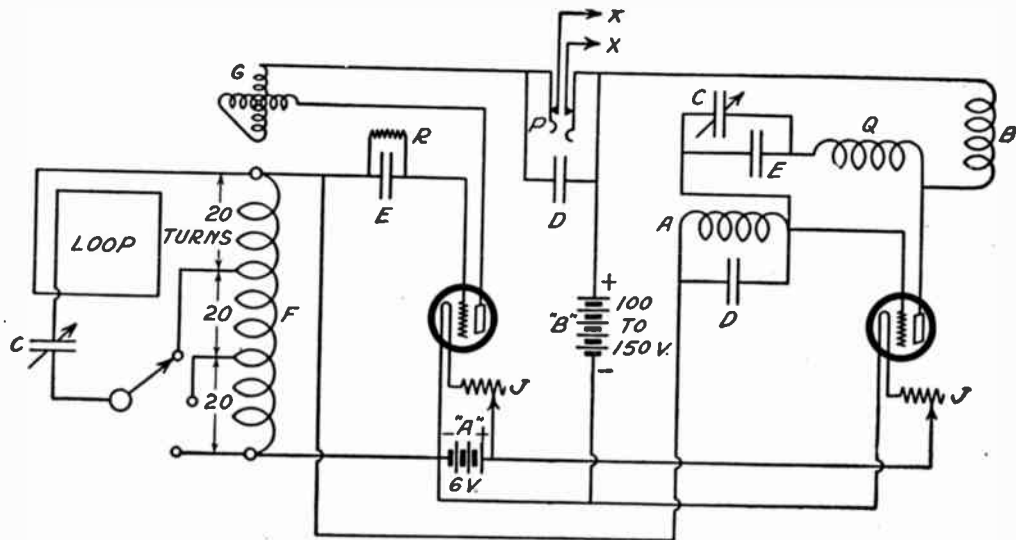

TWO-TUBE SUPER-REGENERATIVE CIRCUIT

*Selectivity:* Good.

*Operation:* Difficult. It is a real engineering feat to get the oscillator circuit to function with the correct frequency and amplitude to cause the proper "super" action and at the same time filter out the high-pitched whistle in the detector circuit.

*Ease of construction:* Difficult. Every part of the circuit must be just right before the set will function

as it should.

*Approximate range:* Variable; from local reception on the higher broadcasting wavelengths up to 1,000 miles on lower wavelengths (with a loop).

*Outstanding features:* The best method for unlimited amplification at the extremely short wavelengths. Especially suitable for local reception with great volume for a minimum number of tubes.

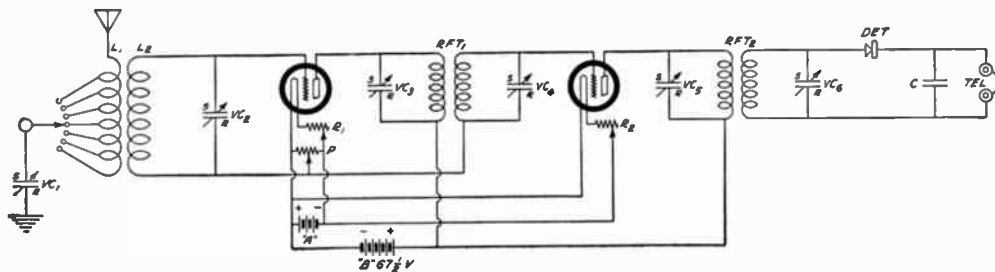

### CIRCUIT EMPLOYING TWO STAGES OF TUNED-RADIO-FREQUENCY AMPLIFICATION, WITH A CRYSTAL DETECTOR

*Selectivity:* Excellent.

*Operation:* Rather critical in operation.

*Construction:* Not very hard to make. Be sure that the best parts are obtained and the results will exceed expectations. Poor parts will render the

circuit useless.

*Approximate range:* 1,500 miles.

*Outstanding features:* A set for the man who wants distance, but who is willing to depend on the headphones instead of trying to use a loudspeaker.

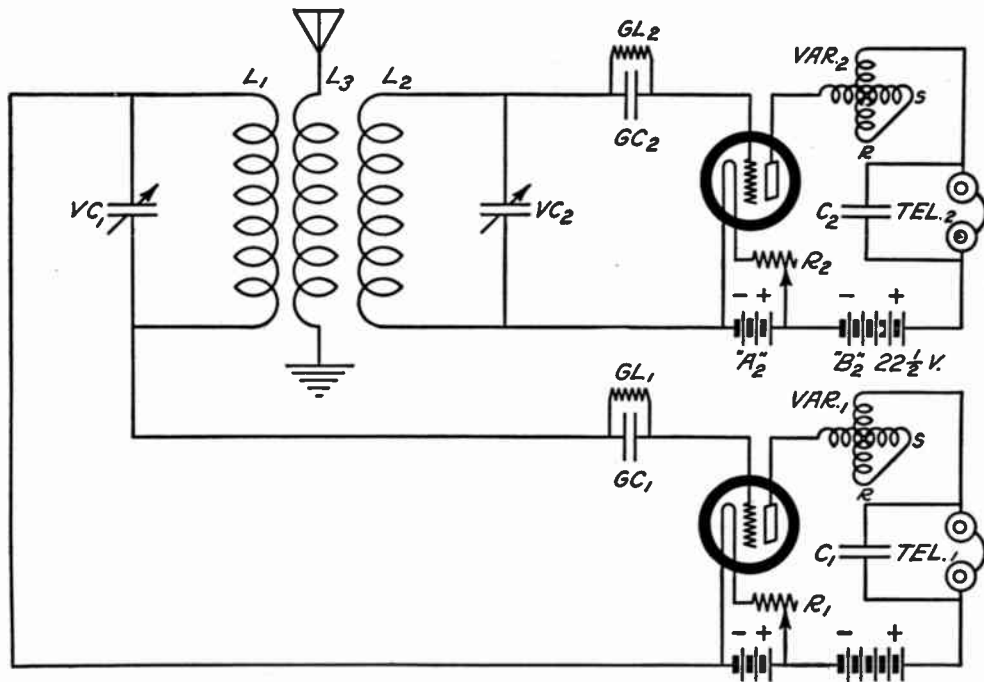

A DUPLEX REGENERATIVE RECEIVER

**Selectivity:** Very good.

**Operation:** A few weeks' practice will suffice to enable efficient tuning of both parts of the set.

**Construction:** Just an ordinary acquaintance with tools and some ability in wiring up the circuit are necessary.

**Approximate range:** 500 miles.

**Outstanding features:** Sharp tuning, and the fact that the set will bring in two programs (on different wavelengths) at the same time on two pairs of telephones.

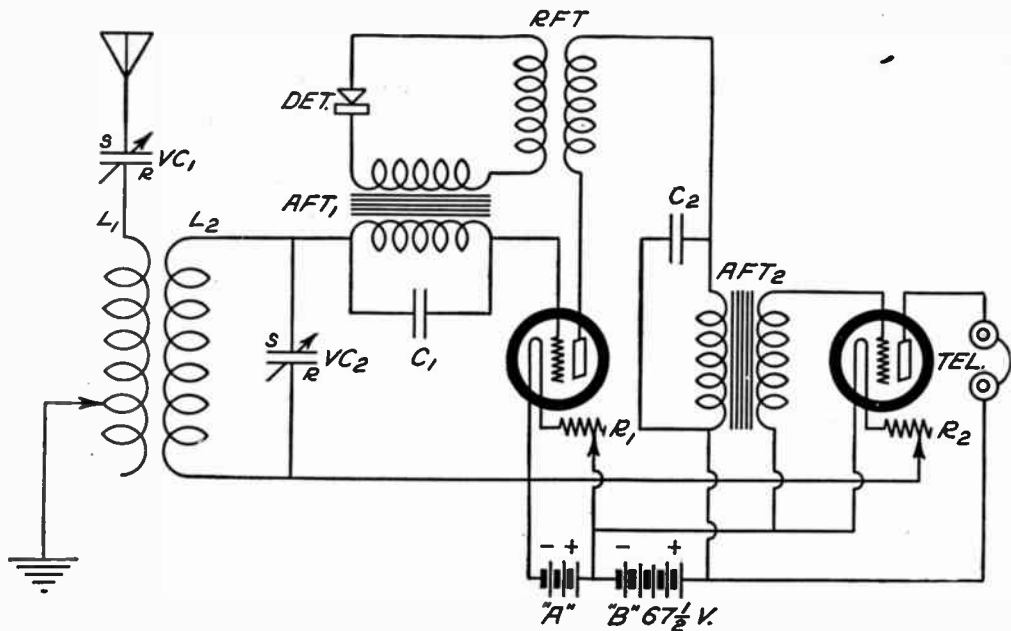

### TWO-TUBE CRYSTAL-DETECTOR REFLEX

**Selectivity:** Very good.

**Operation:** Fairly simple.

**Construction:** Not easy to make. Care must be used in mounting the transformers in the proper position with respect to each other.

**Approximate range:** 1,000 miles.

**Outstanding features:** Loudspeaker operation is possible with only two tubes. The circuit has the advantage, also, of being workable with a short antenna.

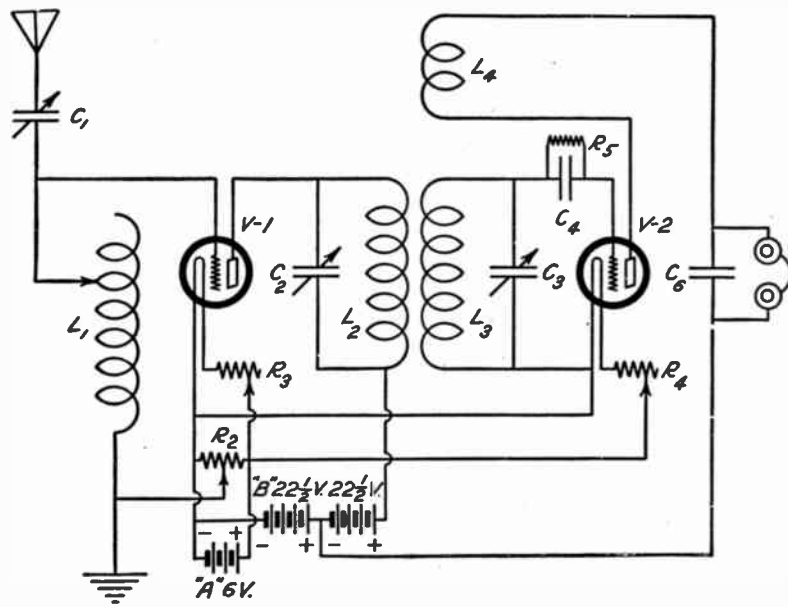

TUNED RADIO-FREQUENCY CIRCUIT

**Selectivity:** Good.

**Operation:** Rather complicated for a beginner.

**Ease of construction:** Easy.

**Approximate range:** 500 miles.

**Outstanding features:** May be used with short indoor

antenna. It may be made from a single-circuit, honeycomb set to stop re-radiation, and may be used to give the builder a good idea of radio-frequency amplification before he tries out the more complicated circuits.



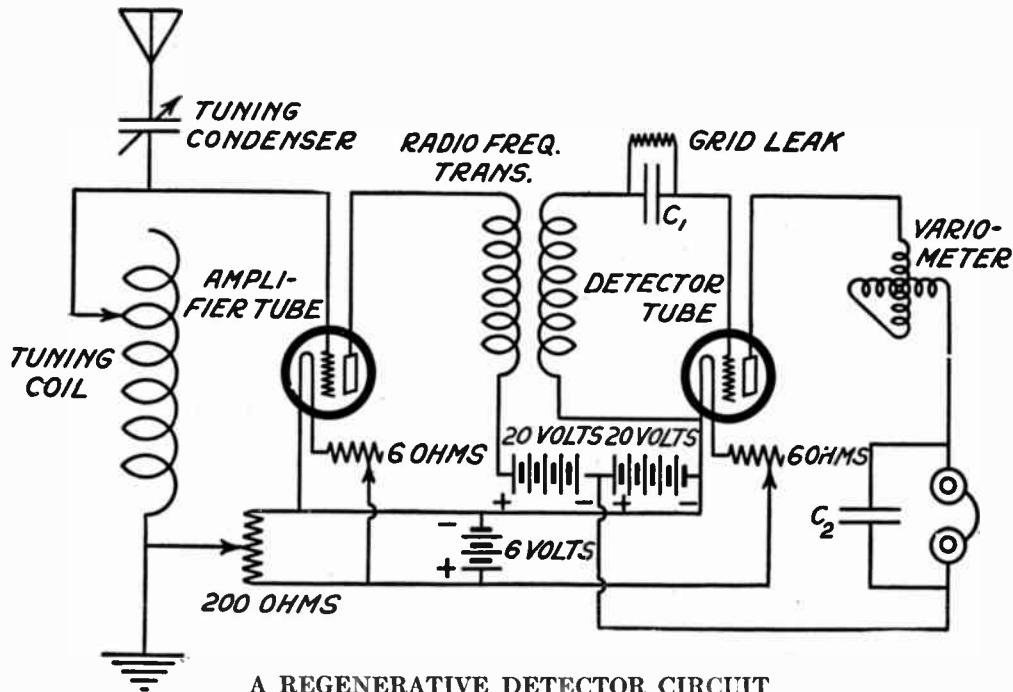

A REGENERATIVE DETECTOR CIRCUIT

*Selectivity:* Good.

*Operation:* Fairly simple. The antenna tuning is done with a variable condenser and a tapped coil.

*Ease of construction:* Just an ordinary acquaintance

with tools and some ability in wiring up a circuit are necessary.

*Approximate range:* 800 to 1,000 miles.

*Outstanding features:* Radio-frequency amplification gives clear reception even from distant stations.

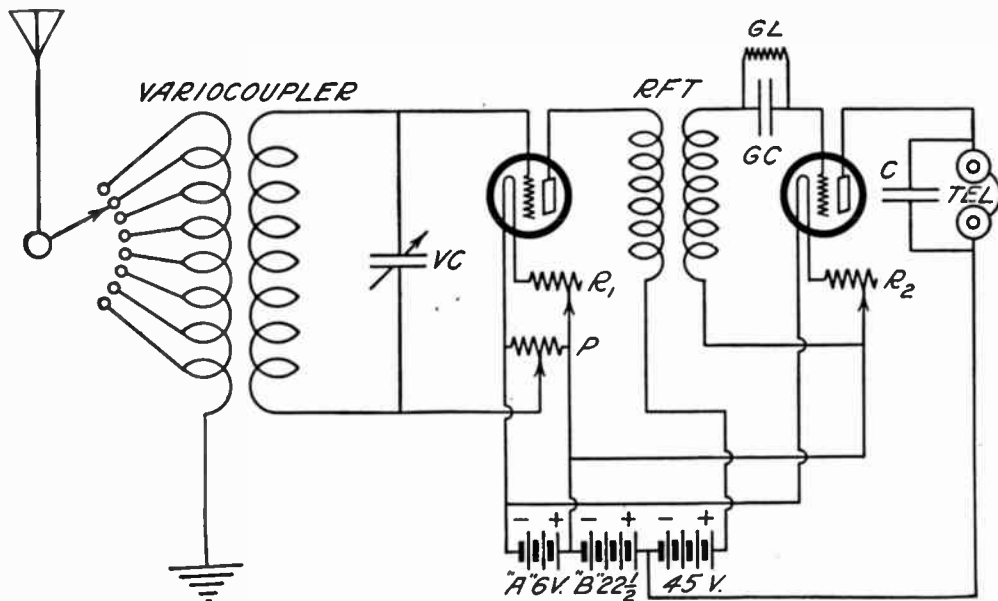

### ONE STAGE OF RADIO-FREQUENCY AMPLIFICATION

**Selectivity:** Good.

**Operation:** Not difficult.

**Construction:** Nothing especially complicated.

**Approximate range:** 500 miles.

**Outstanding feature:** A good circuit for the man who has a simple vacuum-tube circuit and wishes to make it more sensitive.

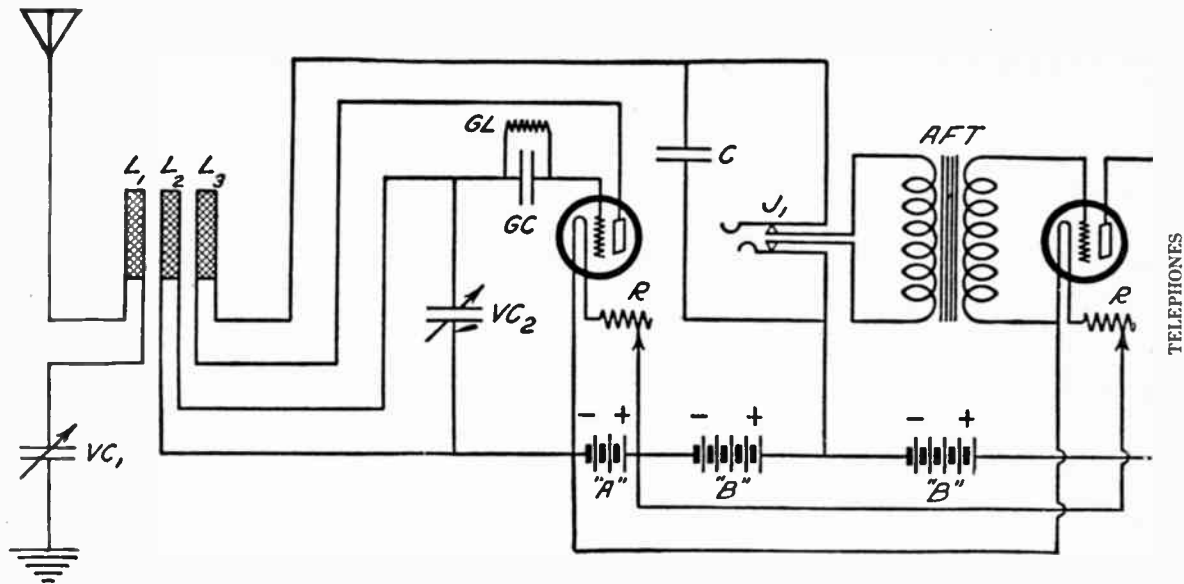

### THE TRIPLE-COIL HONEYCOMB REGENERATIVE RECEIVER WITH ONE STAGE OF AUDIO-FREQUENCY AMPLIFICATION

*Selectivity:* Very good.

*Operation:* Rather complicated for a beginner.

*Ease of construction:* Fairly simple.

*Approximate range:* 800 miles.

*Outstanding features:* Can be used on any wavelength.

By merely changing the three coils, using large or small, for the long or short waves, the set can be used for commercial reception, broadcast reception or amateur reception.

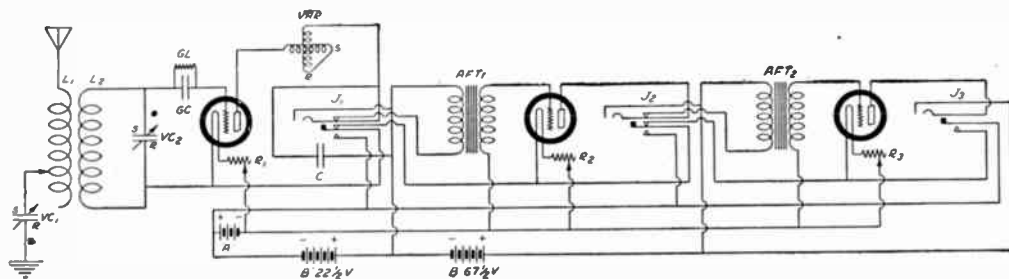

### REGENERATIVE RECEIVER WITH TWO STAGES OF AUDIO-FREQUENCY AMPLIFICATION, EQUIPPED WITH AUTOMATIC FILAMENT-LIGHTING JACKS

*Selectivity:* Excellent.

*Operation:* Simple. The primary and secondary condensers control tuning, with the variocoupler for coupling control and the plate variometer for effecting regeneration. By merely inserting the telephone plug into the stage desired the filaments used

are automatically turned on and off.

*Construction:* Some care is necessary in laying out the circuit and in wiring up the filament circuit.

*Approximate range:* 1,200 to 1,500 miles.

*Outstanding features:* Selectivity. Automatic filament control.

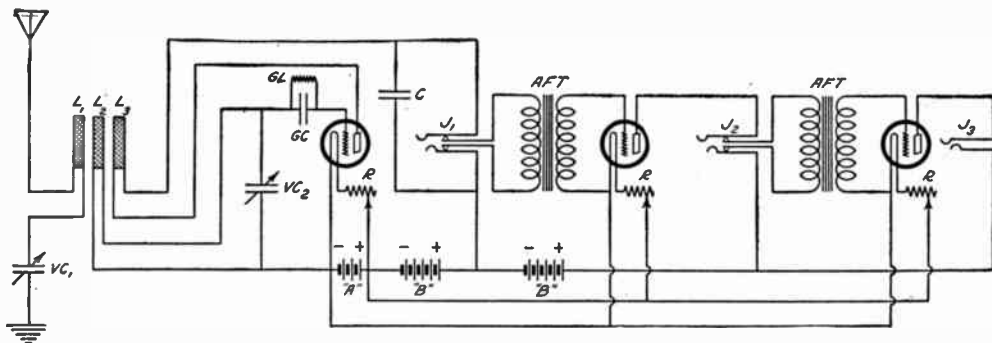

### TRIPLE-COIL HONEYCOMB REGENERATIVE RECEIVER WITH TWO STAGES OF AUDIO-FREQUENCY AMPLIFICATION

*Selectivity:* Good.

*Operation:* Rather difficult to tune.

*Ease of construction:* The building of such a set is more difficult than the single-circuit tuner but better results in tuning will be worth the extra trouble,

and the amplifier will make the set suitable for loud-speaker reception.

*Approximate range:* 1,200 miles.

*Outstanding feature:* The set can be used for reception on any wavelength range by merely changing the size of coils.

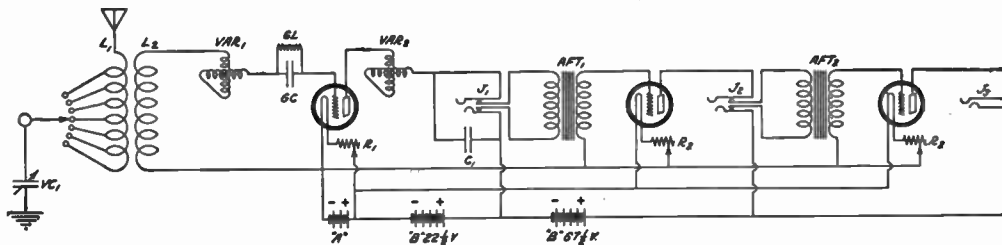

### TWIN-VARIOMETER, VARIOCOUPLER REGENERATIVE CIRCUIT WITH TWO STAGES OF AUDIO-FREQUENCY AMPLIFICATION

*Selectivity:* Good.

*Operation:* Difficult.

*Ease of construction:* Just an ordinary acquaintance with tools and some ability in wiring up the circuit is necessary.

*Approximate range:* 1,200 miles.

*Outstanding features:* All the tuning is inductive and this makes for louder signals, at a slight loss of selectivity. Both tuning and regeneration are controlled by variometers.

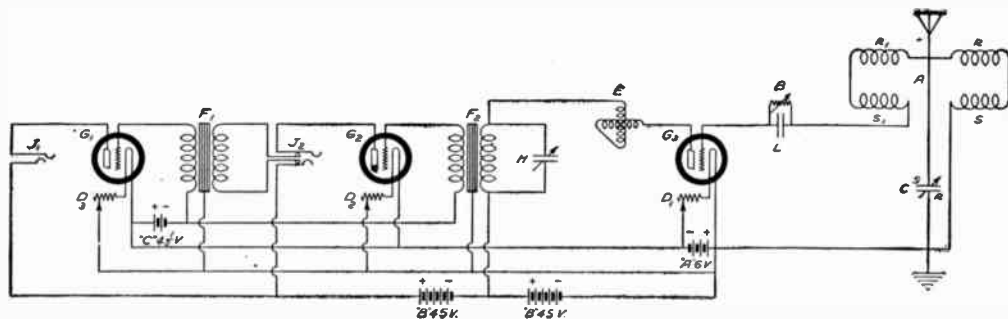

### THE TOBIAS CIRCUIT FOR RECEPTION WITH AN INDOOR ANTENNA

**Selectivity:** Excellent, if used on a short antenna.

**Operation:** Not hard to tune, once the mode of adjustment has been thoroughly learned.

**Construction:** No more complicated than other types of regenerative circuits.

**Approximate range:** 1,200 miles.

**Outstanding feature:** Operates on a short indoor antenna with results about equal to the ordinary regenerative receiver used on an outdoor one.

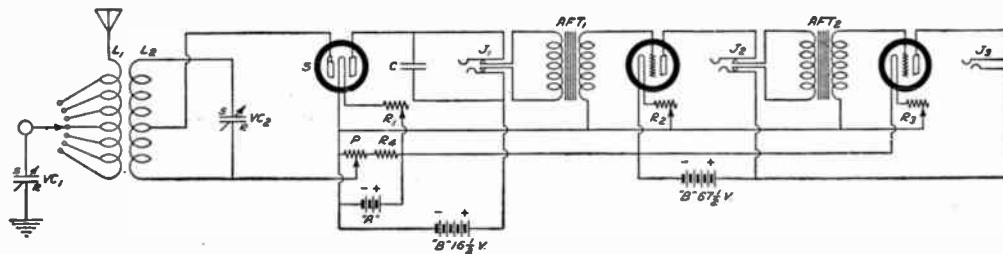

### DONLE DETECTOR CIRCUIT WITH TWO STAGES OF AUDIO-FREQUENCY AMPLIFICATION

*Selectivity:* Fair.

*Operation:* Very simple.

*Construction:* Not hard to put together.

*Approximate range:* 1,000 miles.

*Outstanding feature:* This circuit uses the sodium tube which is extremely sensitive but which cannot oscillate or radiate.



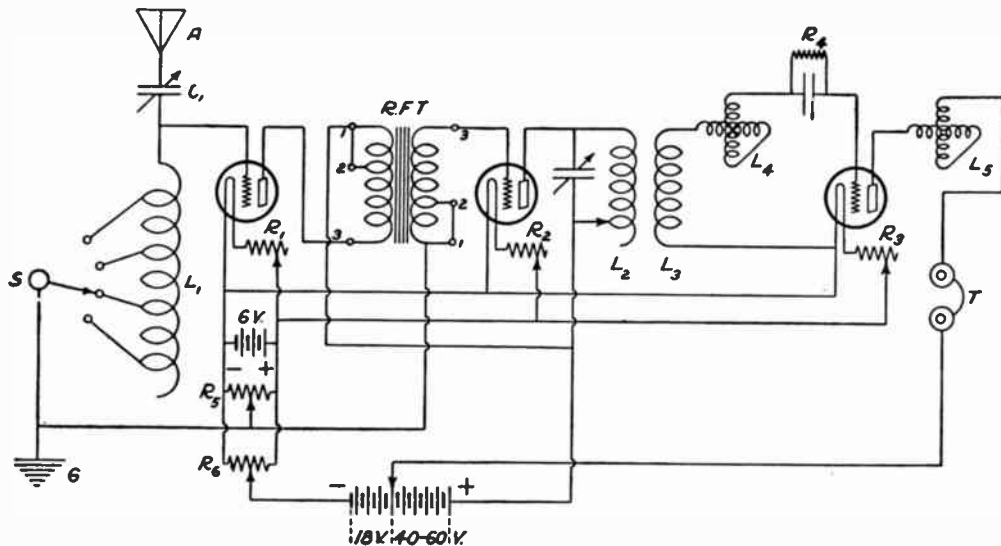

## TWO STAGES OF TRANSFORMER-COUPLED, RADIO-FREQUENCY AMPLIFICATION ADDED TO THE TWIN-VARIOMETER, VARIOCOUPLER, REGENERATIVE CIRCUIT

**Selectivity:** Good.

**Operation:** Complicated. The antenna must be tuned with the tapped switch and the variable condenser. There are two potentiometer adjustments, one for the stabilizer for the radio-frequency tubes, and one for adjusting the plate potential of the detector tube. Then the output circuit of the second radio-frequency tube must be tuned with the variable

condenser, and the regular tuning of the variometers in the grid and plate circuits of the detector must be done before the signal is tuned in properly.

**Ease of construction:** Fairly complicated.

**Approximate range:** 1,500 miles.

**Outstanding features:** Is reliable for distance reception without the audio-frequency amplification that is usually used with this detector circuit.



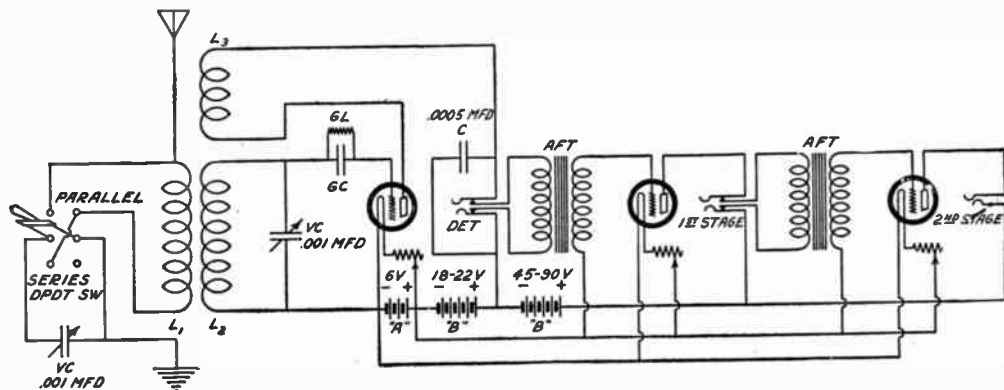

### TRIPLE-COIL, HONEYCOMB REGENERATIVE CIRCUIT WITH TWO STAGES OF AMPLIFICATION

*Selectivity:* Good.

*Operation:* Rather complicated.

*Ease of construction:* Not hard to make.

*Approximate range:* 1,000 miles on the low broadcasting and amateur wavelengths and 3,000 miles on the extreme high wavelengths.

*Outstanding features:* It may be made to cover all wavelengths by interchanging coils. The coils may be plugged into sockets at will, thus making the set into a high or low wave receptor which is regenerative.



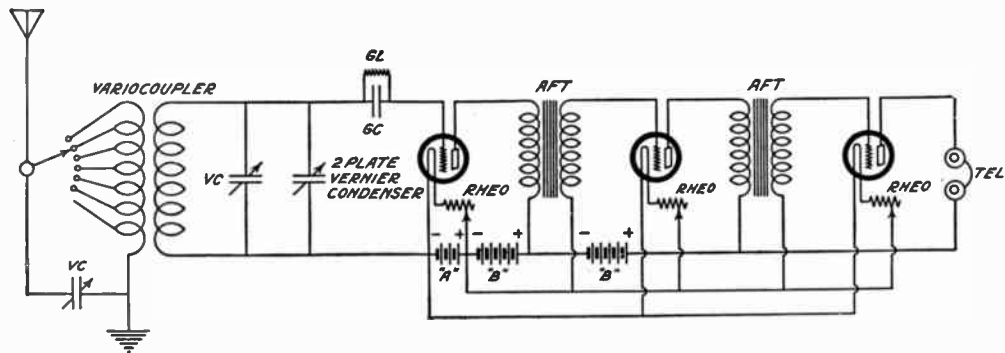

### A SIMPLE AUDION CIRCUIT WITH TWO STAGES OF AUDIO-FREQUENCY AMPLIFICATION

*Selectivity:* Fairly good.

*Operation:* Easy to operate.

*Construction:* Simple.

*Approximate range:* 300 miles.

*Outstanding feature:* The set will bring in any signals, with great clarity, as long as they are strong enough to operate the detector.

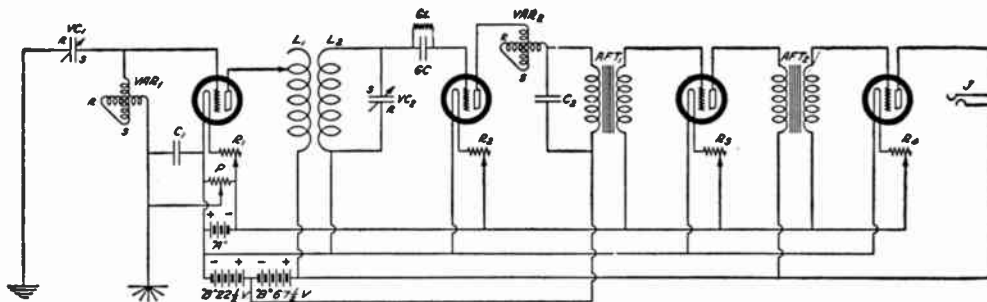

ONE STAGE OF TUNED-RADIO-FREQUENCY AMPLIFICATION, WITH A VACUUM-TUBE DETECTOR AND TWO STAGES OF AUDIO-FREQUENCY AMPLIFICATION

*Selectivity:* Excellent.

*Operation:* Not hard to tune. Some experience will have to be gotten, however, before the operator will be able to get the most out of the set.

*Construction:* Rather complicated. The layout of the set should be carefully studied before it is finally decided upon.

*Approximate range:* 500 miles.

*Outstanding features:* The set will operate without an antenna and employs two grounds or a ground and a short piece of wire acting as a counterpoise. It tunes extremely sharp, and will operate a loud-speaker.

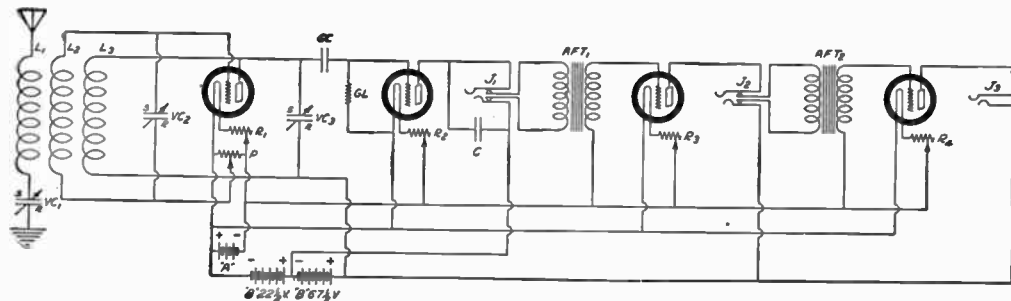

**ONE STAGE OF TUNED-RADIO-FREQUENCY AMPLIFICATION, VACUUM TUBE DETECTOR AND TWO STAGES OF AUDIO-FREQUENCY AMPLIFICATION EMPLOYING HONEYCOMB COILS FOR TUNING**

*Selectivity:* Good.

*Operation:* Fairly complicated.

*Construction:* Not easy to build.

*Approximate range:* 2,400 miles.

*Outstanding features:* With few additions, this set can be made from the standard triple-coil hook-up. It is good on distance reception.

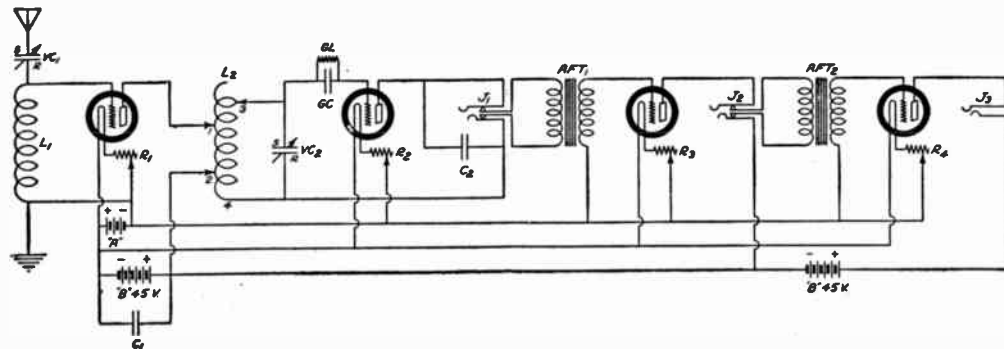

**ABELE CIRCUIT COMPRISING ONE STAGE OF TUNED-RADIO-FREQUENCY AMPLIFICATION  
VACUUM-TUBE DETECTOR AND TWO STAGES OF AUDIO-FREQUENCY AMPLIFICATION**

*Selectivity:* Very good.

*Operation:* Fairly complicated.

*Construction:* Rather difficult to make.

*Approximate range:* 2,000 miles.

*Outstanding features:* Tuned-radio-frequency ampli-

fication is employed with a novel means for coupling the plate circuits of the radio-frequency amplifier tube and the detector tube together, to obtain regeneration.



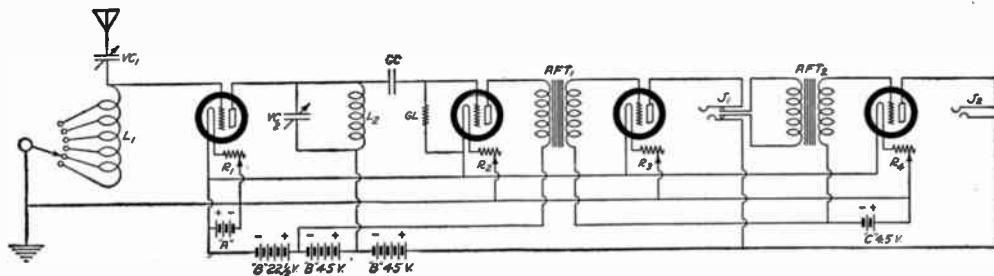

### ONE STAGE OF TUNED-RADIO-FREQUENCY, DETECTOR AND TWO STAGES OF AUDIO-FREQUENCY AMPLIFICATION

*Selectivity:* Good.

*Operation:* Not difficult to tune.

*Construction:* Not any more complicated than the ordinary 3-tube regenerative receiver.

*Approximate range:* 2,000 miles.

*Outstanding features:* Good on DX reception. No potentiometer used. Truthful reproduction.

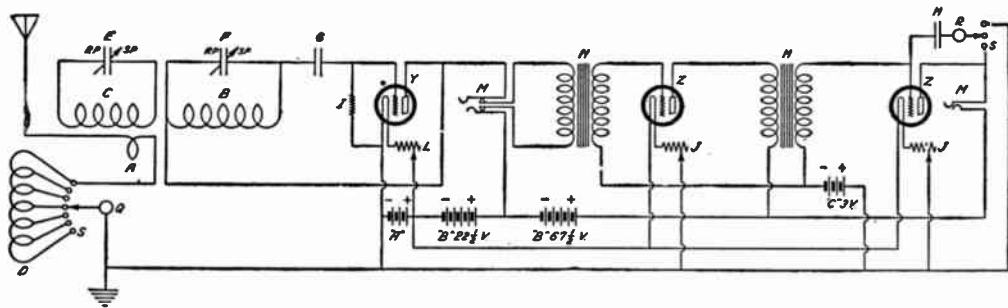

### THE THREE-TUBE, 4-CIRCUIT TUNER

**Selectivity:** Excellent.

**Operation:** Very simple. There is one dial which controls the wavelength and one dial which controls regeneration. This dial can be set for the whole band of wavelengths over which regeneration will be constant.

**Ease of construction:** Not complicated. Be sure that

the best parts are obtained, and the results will exceed expectations. Poor parts will render the circuit useless.

**Approximate range:** 2,400 miles.

**Outstanding features:** Loudspeaker reception from distant broadcasting. Regeneration is independent of wavelength. Best sensitivity and selectivity.

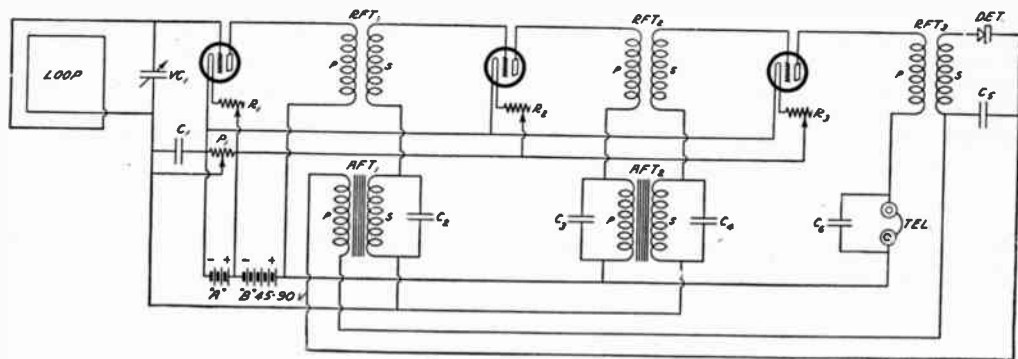

### THE SQUIRE REFLEX CIRCUIT

**Selectivity:** Excellent.

**Operation:** Very simple. One control for wavelength and one control for regeneration; the only other adjustment that must be made is the setting of the crystal detector.

**Ease of construction:** More or less complicated. There

are a number of precautions that must be taken to get the circuit to operate at highest efficiency.

**Approximate range:** 500 miles (with the loop antenna).

**Outstanding features:** No outdoor antenna is needed for DX reception. Simplicity of tuning.

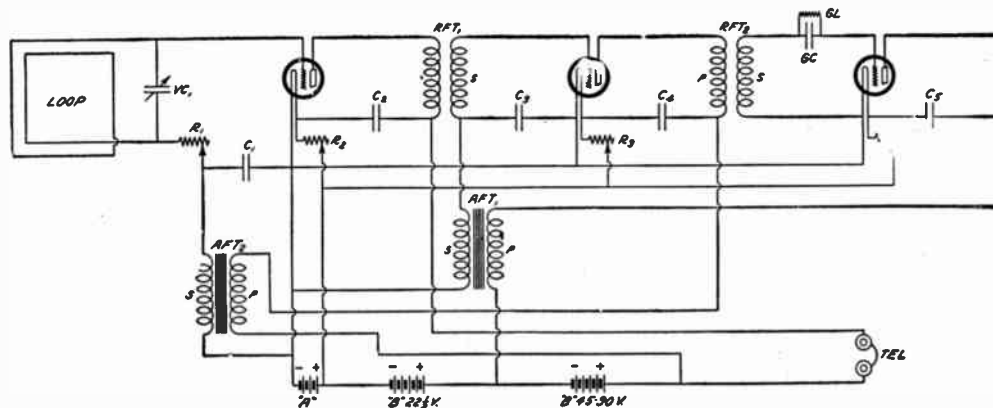

### THE GRIMES REFLEX CIRCUIT

**Selectivity:** Excellent.

**Operation:** Extremely simple. Only one control for wavelength needed and one control for regeneration.

**Ease of construction:** This is a quite complicated circuit to follow out and to get in operation. There are a number of details that will give the beginner trouble when he first tries to make this set, but they can be

overcome with some practical experimentation.

**Approximate range:** 500 miles (with loop antenna).

**Outstanding features:** No outdoor antenna is needed for DX reception. Simplicity of tuning. No crystal detector to bother with. The audio-frequency amplification is fed back to the next preceding tube in each stage.

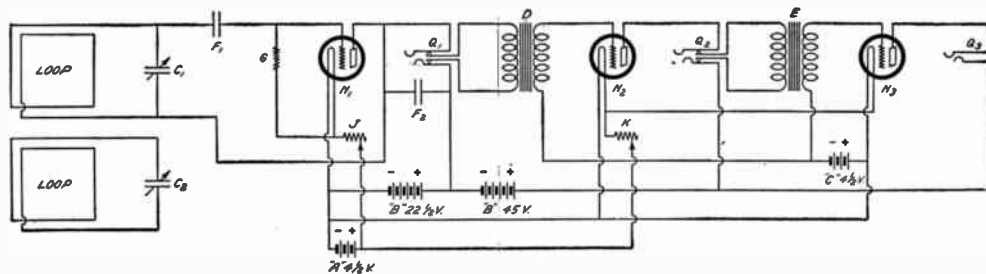

### FOUR-CIRCUIT PORTABLE RECEIVER

*Selectivity:* Excellent.

*Operation:* Simple.

*Construction:* Not difficult.

*Approximate range:* Local.

*Outstanding feature:* All parts mounted in a cabinet, including loops, batteries and tubes.

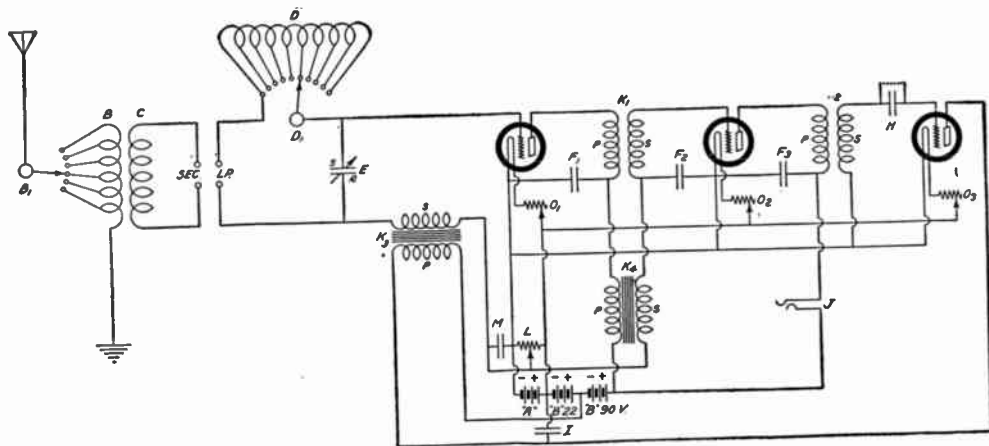

### THE REMY REFLEX

*Selectivity:* Very good.

*Operation:* Simple.

*Construction:* Not very difficult to make.

*Approximate range:* 1,000 miles.

*Outstanding features:* Simplicity of control and economical from a tube standpoint.

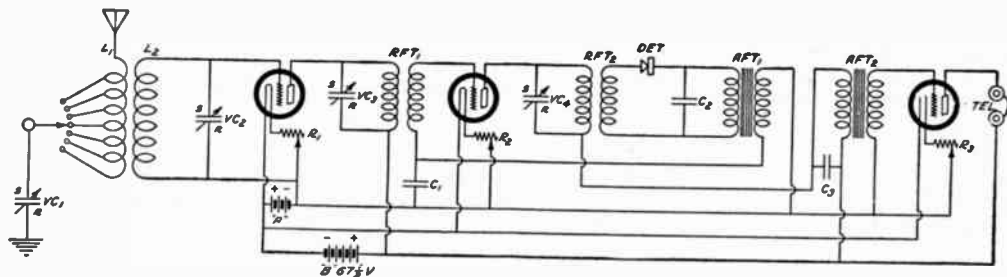

## TWO STAGES OF TUNED-RADIO-FREQUENCY AMPLIFICATION, CRYSTAL DETECTOR AND TWO STAGES OF AUDIO-FREQUENCY AMPLIFICATION

**Selectivity:** Very good. Tuning is accomplished entirely by means of variable condensers.

**Operation:** Rather complicated. The tuning should be done by logging the settings for the various wavelengths.

**Construction:** Not a simple set to make. Some ex-

perience in making sets should be had before attempting construction.

**Approximate range:** 2,500 miles.

**Outstanding features:** Only three tubes are used. One stage of audio-frequency amplification is reflexed.

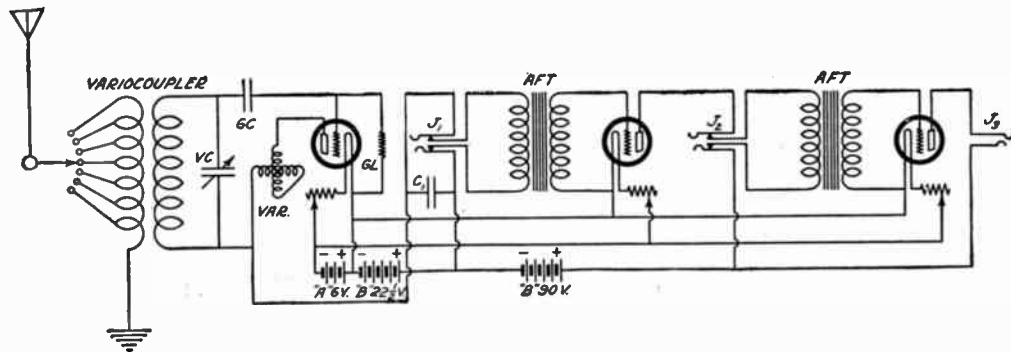

### MODIFIED DX THREE-CIRCUIT REGENERATIVE RECEIVER, WITH TWO STAGES OF AUDIO-FREQUENCY AMPLIFICATION

*Selectivity:* Excellent.

*Operation:* Fairly simple.

*Ease of construction:* Fairly easy to build.

*Approximate range:* 1,500 miles.

*Outstanding features:* Noted for DX amateur and broadcast reception and for its exceptionally sharp tuning.



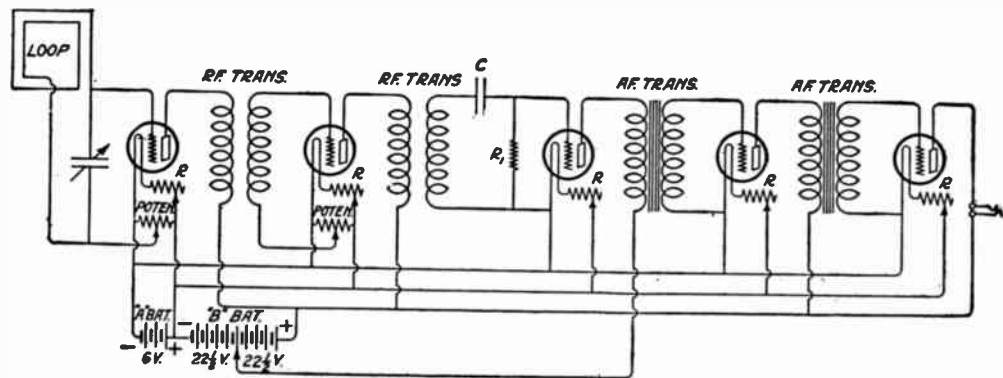

### TWO STAGES OF RADIO, DETECTOR, AND TWO STAGES OF AUDIO-FREQUENCY AMPLIFICATION

**Selectivity:** Good.

**Operation:** Simple. Only one control for tuning the variable condenser. The two potentiometers are used as stabilizers for the control of regeneration in the radio-frequency stages.

**Ease of construction:** More or less complicated.

There are a number of precautions that must be taken to get the circuit to function properly.

**Approximate range:** 500 miles (on a loop antenna).

**Outstanding features:** No outdoor antenna necessary and simplicity of tuning.

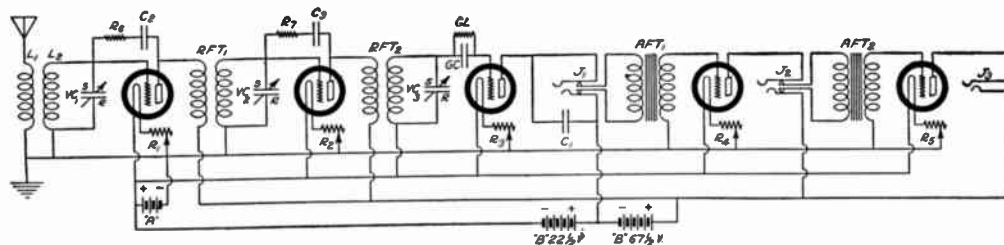

### THE PLIODYNE PRINCIPLE INCORPORATED INTO A RADIO-FREQUENCY CIRCUIT WITH VACUUM TUBE DETECTOR AND TWO-STAGE AUDIO-FREQUENCY AMPLIFIER

*Selectivity:* Very good.

*Operation:* Not very difficult to tune. Three variable condensers, which are set at practically the same settings, control the tuning.

*Construction:* Complicated.

*Approximate range:* 2,400 miles.

*Outstanding features:* Oscillation and regeneration are prevented by means of "phasing out." The set will not radiate.

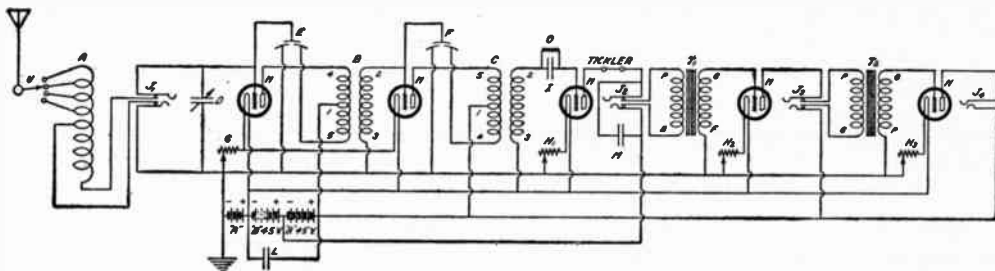

### MODIFIED ACME DYNE CIRCUIT WITH TWO STAGES OF COMPENSATED RADIO-FREQUENCY AMPLIFICATION AND TWO STAGES OF AUDIO-FREQUENCY AMPLIFICATION

*Selectivity:* Wonderful.

*Operation:* Rather complicated for the beginner, but the correct method can be acquired in a month's practice in tuning.

*Ease of construction:* This, of course, is a complicated circuit to follow out and to get going properly, but it can be done and the set is well worth while.

*Approximate range:* 2,500 miles.

*Outstanding features:* Extremely sharp tuning, DX

reception and clarity of signals. The trouble encountered in most radio-frequency amplification circuits, that of properly controlling or eliminating oscillation, is definitely taken out of this circuit by an ingenious device called a compensating condenser which has three plates attached respectively to the grid, filament, and plate circuits of the vacuum tubes.

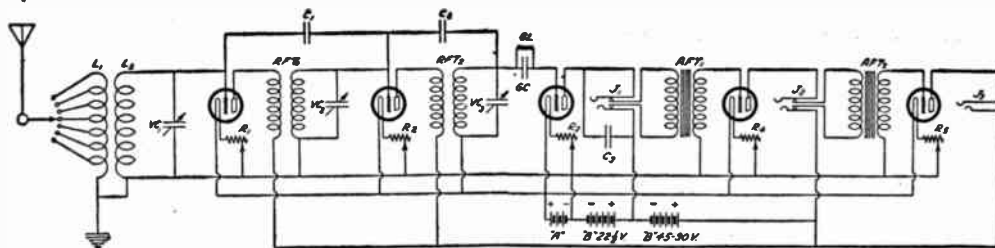

### FIVE-TUBE NEUTRODYNE

**Selectivity:** Very good. There are three controls for wavelength.

**Operation:** Simple, if the set is tuned by means of a chart. In fact, this is the only way to tune this receiver successfully.

**Ease of construction:** More or less complicated. There are a number of precautions that must be taken to get the circuit to function properly, especially in the matter of eliminating feedback. The set will

operate more efficiently when the neutralizing condensers are upset slightly so that the set will regenerate without readily bursting into uncontrolled oscillation.

**Approximate range:** 2,400 miles.

**Outstanding features:** The wavelength can be calibrated. The set will not re-radiate. Anyone can operate the set by means of the tuning chart.

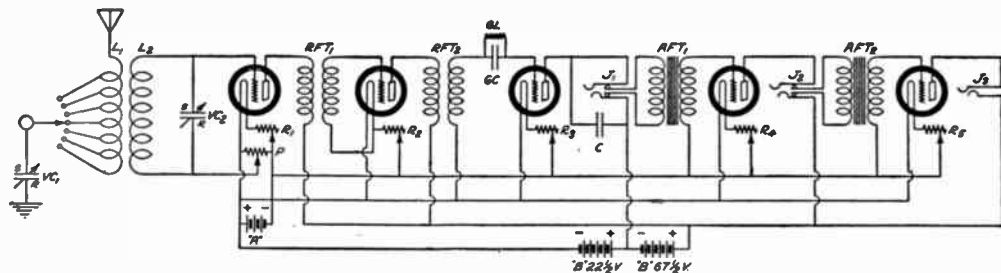

## TWO STAGES OF TRANSFORMER-COUPLED RADIO-FREQUENCY AMPLIFICATION WITH VACUUM-TUBE DETECTOR AND TWO STAGES OF AUDIO-FREQUENCY AMPLIFICATION

**Selectivity:** Good.

**Operation:** Easy to tune. The two variable condensers control tuning. Coupling is varied by means of the variocoupler, and regeneration in the first stage is controlled with the potentiometer.

**Construction:** More or less complicated. There are a number of precautions that should be taken to

get the circuit to function properly.

**Approximate range:** 1,500 miles.

**Outstanding features:** Only two dials for changes of wavelength. The coupling can be set for the desired degree of selectivity and then all other tuning can be accomplished with the two condensers.

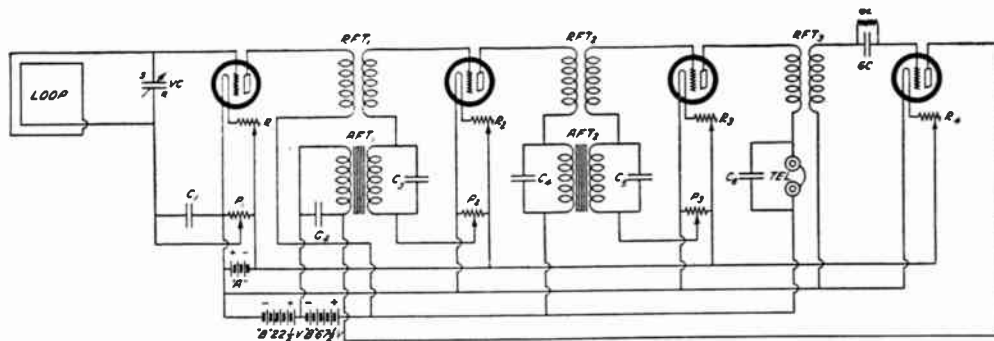

### FOUR-TUBE REFLEX WITH THREE STAGES OF RADIO-FREQUENCY AMPLIFICATION, VACUUM-TUBE DETECTOR AND TWO STAGES OF AUDIO-FREQUENCY AMPLIFICATION

*Selectivity:* Excellent.

*Operation:* Very simple. Just one control for tuning—a variable condenser connected in shunt to the loop. Regeneration is controlled in the radio-frequency circuits by means of potentiometers.

*Ease of construction:* More or less complicated. There

are a number of precautions that must be taken to get the circuit to function properly.

*Approximate range:* 1,000 miles (on a loop antenna).

*Outstanding features:* No outdoor antenna needed for DX reception. Simplicity of tuning. No crystal detector to bother with.

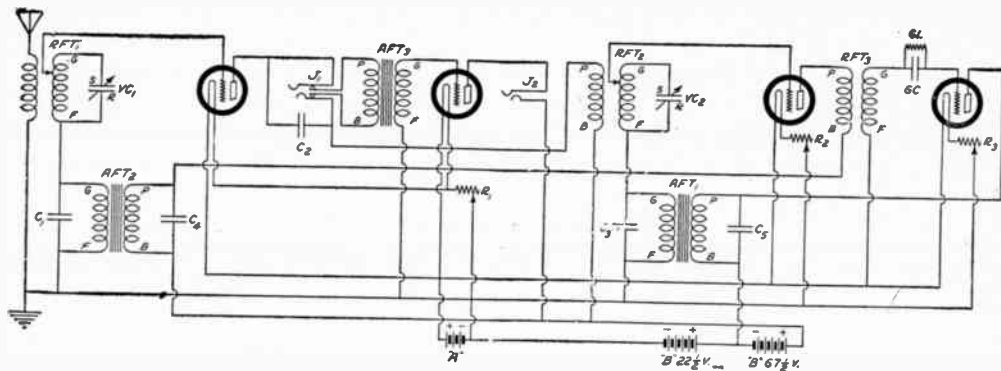

### GRIMES INVERSE-REFLEX

Using two stages of tuned-radio-frequency amplification, one stage of transformer-coupled radio-frequency amplification, vacuum-tube detector, and two stages of audio-frequency amplification.

*Selectivity:* Very good.

*Operation:* Not complicated. Two controls.

*Construction:* More or less complicated. There are a

number of precautions that must be taken to get the circuit to function properly.

*Approximate range:* 2,000 miles.

*Outstanding features:* Simplicity of control, and sensitivity to weak signals, as well as being economical from a tube standpoint.





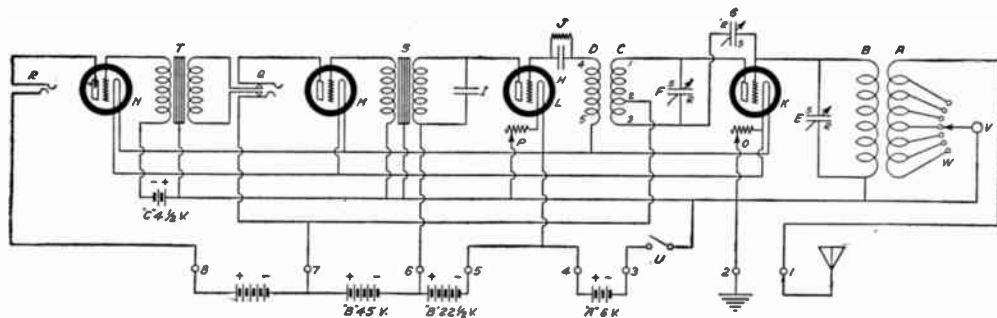

### THE CRAIG CIRCUIT, EMPLOYING THE PRINCIPLE OF TUBE-CAPACITY NEUTRALIZATION

**Selectivity:** Excellent.

**Operation:** Easy to tune. Two dials on the variable condensers tune the input and the output circuits of the radio-frequency tube.

**Construction:** Not hard to build.

**Approximate range:** Up to 3,000 miles.

**Outstanding features:** Exceptional volume. DX reception and clarity of reception. Does not radiate.

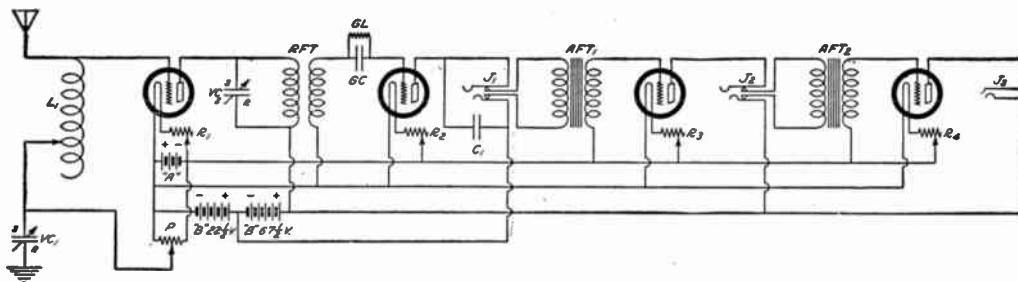

### SINGLE-STAGE RADIO-FREQUENCY AMPLIFIER WITH TUNED-PLATE CIRCUIT, DETECTOR, AND TWO-STAGE AUDIO-FREQUENCY AMPLIFIER

*Selectivity:* Very good.

*Operation:* Simple.

*Ease of construction:* Not any more complicated than the regular regenerative 3-tube circuit.

*Approximate range:* 2,000 miles.

*Outstanding features:* Particularly good for DX reception of broadcasting. Simple to handle and truthful in reproduction of musical programs.

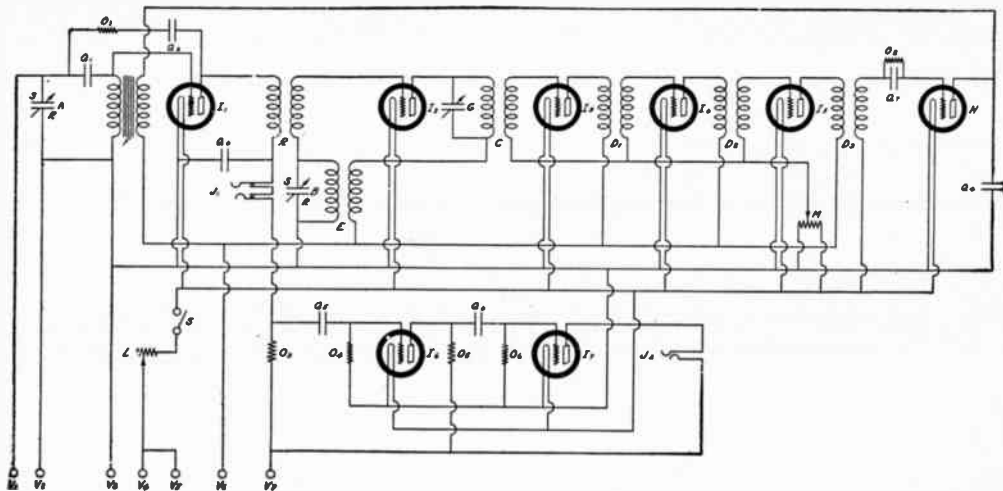

### 8-TUBE SUPERHETERODYNE REFLEX CIRCUIT

*Selectivity:* Excellent.

*Operation:* Rather simple.

*Construction:* A complicated circuit to put together and to get into proper operation.

*Approximate range:* 3,500 miles.

*Outstanding features:* This receiver has an exceptional

range on a loop. Its tone quality is good and the directional effect of loop tuning helps to cut out a large percentage of interference that could not be eliminated through ordinary tuning means. Needs no outdoor antenna.

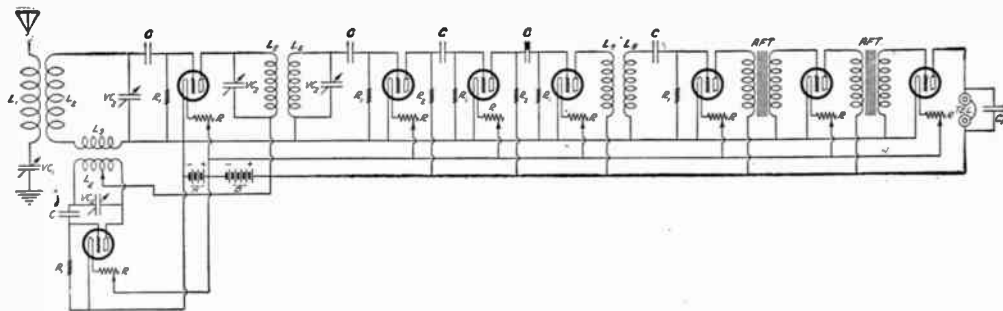

### A RESISTANCE-COUPLED SUPERHETERODYNE WITH TWO STAGES OF AUDIO-FREQUENCY AMPLIFICATION

*Selectivity:* Excellent.

*Operation:* Difficult.

*Construction:* A very complicated circuit to master.

*Approximate range:* 3,000 miles.

*Outstanding feature:* This set combines sensitivity with great selectivity.

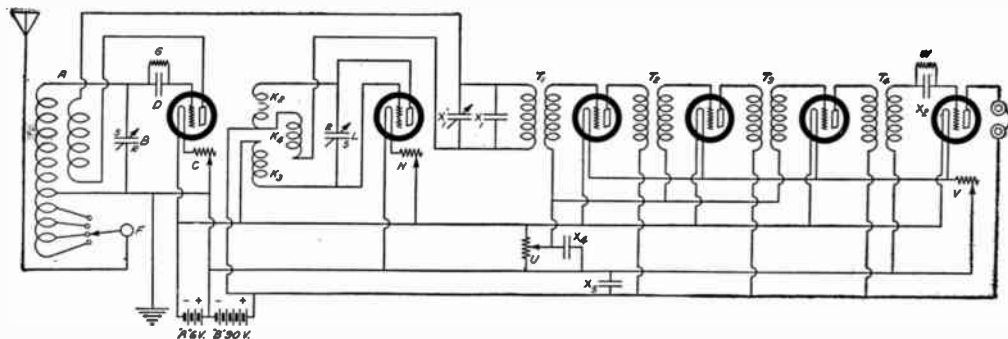

### A SUPERHETERODYNE CIRCUIT FOR AIR-CORE INTERMEDIATE-WAVE TRANSFORMERS

*Selectivity:* Very good.

*Operation:* Not difficult to tune, when the mode of operation is learned.

*Construction:* Rather complicated.

*Approximate range:* 3,400 miles.

*Outstanding features:* Easier to tune than most complicated circuits. Good distance and selectivity.

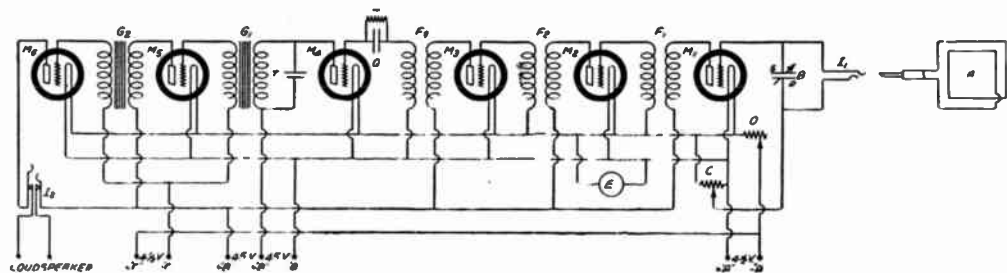

### SIX-TUBE PORTABLE

*Selectivity:* Good.

*Operation:* Extremely simple. All tuning is done with the variable condenser, and regeneration in the first tube circuit is controlled by the potentiometer.

*Construction:* Not difficult, but there is a lot of work

necessary.

*Approximate range:* Up to 1,500 miles.

*Outstanding features:* Portability. All batteries and tubes and loudspeaker contained in carrying case; Simplicity of operation.



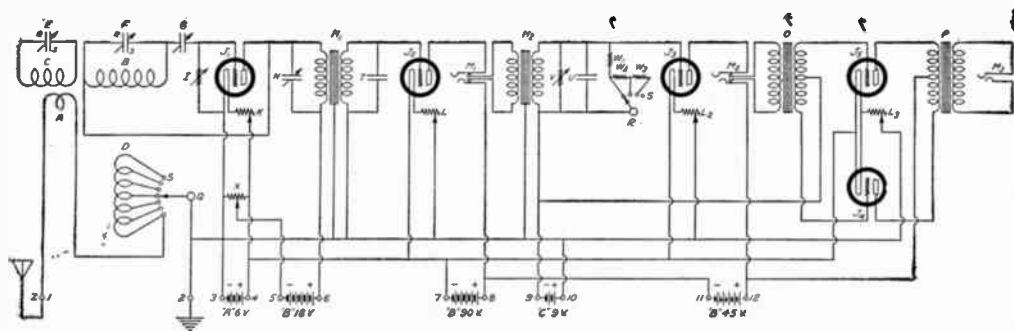

### THE FOUR-CIRCUIT TUNER WITH TWO STAGES OF STRAIGHT TRANSFORMER-COUPLED AMPLIFICATION, AND ONE STAGE OF PUSH-PULL AMPLIFICATION

*Selectivity:* Excellent.

*Operation:* Simple to tune.

*Construction:* Some experience in wiring up the circuit is necessary.

*Approximate range:* 3,400 miles.

*Outstanding features:* Selectivity. Ease of tuning.  
Good reproduction.



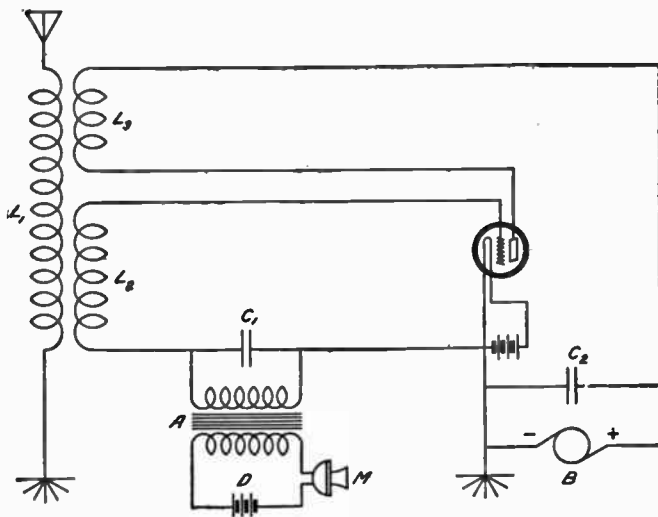

### THE MEISSNER CIRCUIT FOR TELEPHONY, WITH GRID MODULATION

*Emitted wave:* Fairly sharp.

*Operation:* It is quite difficult to get a large percentage of modulation and still keep the transmitted speech clear.

*Construction:* The most important parts in this circuit are the coils; they should be wound on high-grade composition tubing with no shellac on the windings.

A regular modulation transformer should be used at A.

*Approximate range:* 50 to 100 miles (on telephony).

*Outstanding features:* This is a good single-tube telephony outfit for the amateur. It will give him a lot of information and allow him to try a lot of experimenting to get better modulation.

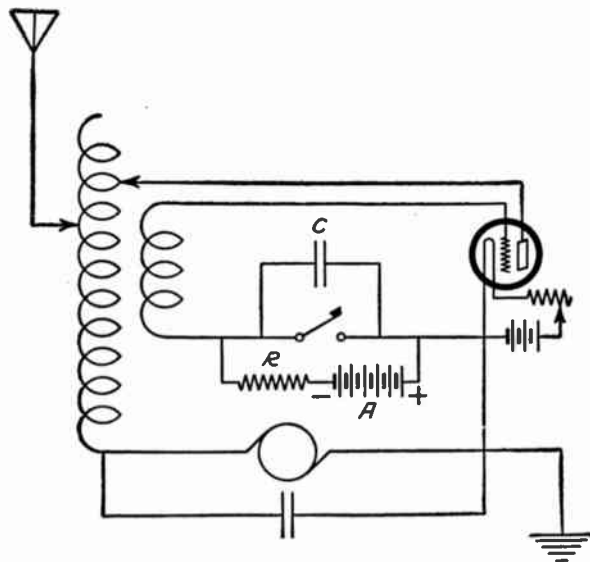

### GRID-TICKLER CIRCUIT FOR PURE CW TELEPHONY

*Emitted wave:* Extremely sharp.

*Operation:* Not difficult.

*Construction:* Nothing especially complicated in the arrangement of this set, but the builder should have had some experience in putting together receiving

sets, wiring, soldering and the like before he attempts to make a transmitter.

*Approximate range:* 1,000 miles.

*Outstanding features:* A sharp wave, and a pure "whistle" note for telegraphy.

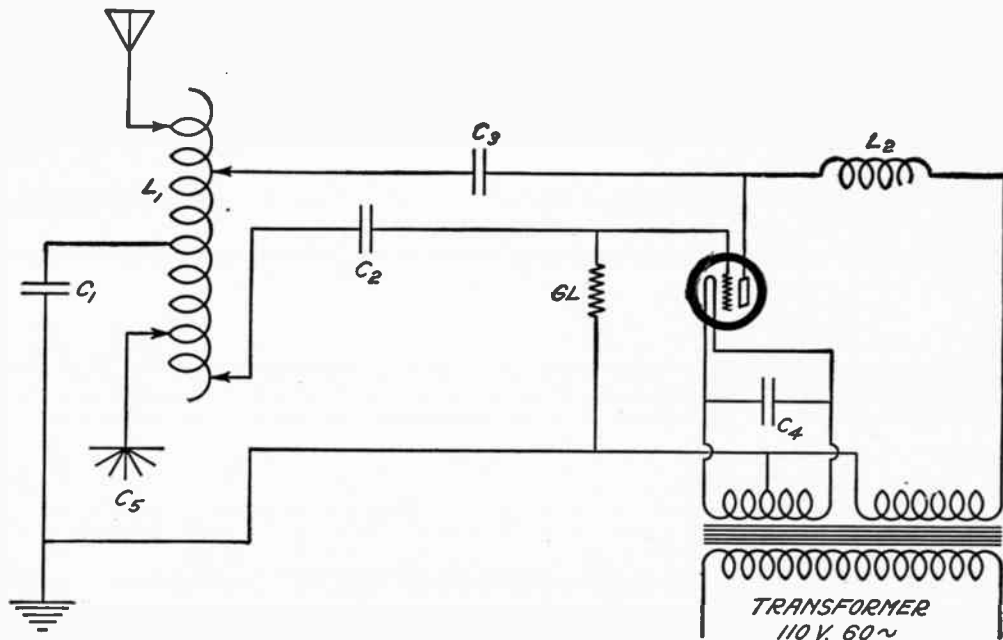

### MODIFIED COLPITTS CIRCUIT WITH AC POWER SUPPLY

*Emitted wave:* Fairly broad. (This is due to the AC power supply and not to the type of circuit used.)

*Operation:* Simple to get into successful operation (if a counterpoise is used).

*Construction:* Not complicated.

*Approximate range:* 500 miles.

*Outstanding features:* A persistent oscillator and efficient. This set employs no batteries of any kind. It is run wholly from the 110-volt, 60-cycle, AC lighting mains.

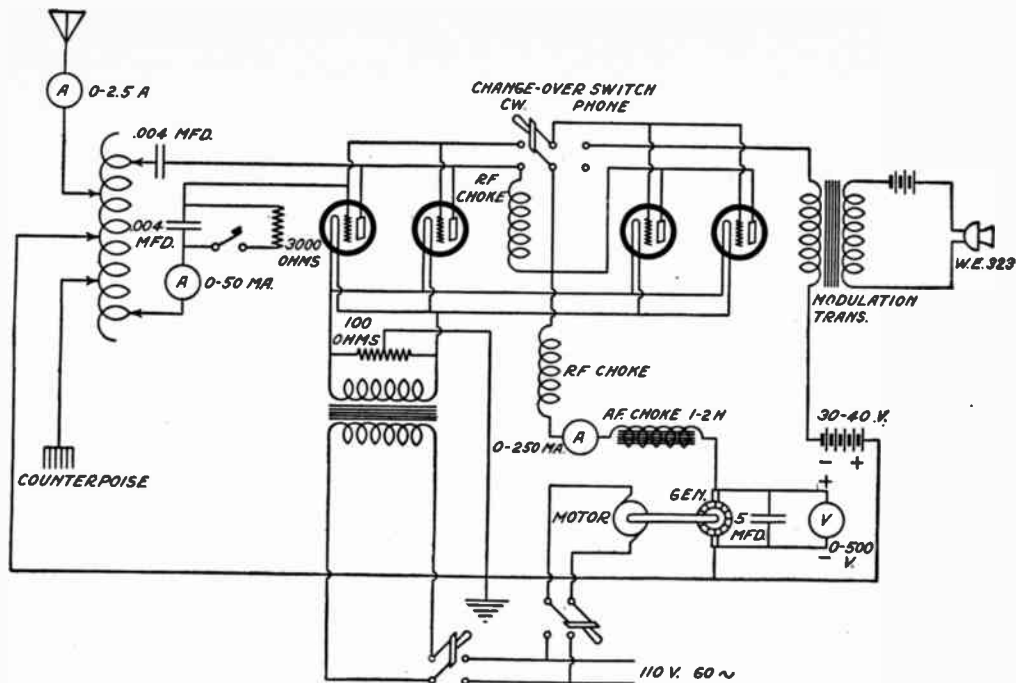

### THE HARTLEY CIRCUIT USING HEISING MODULATION FOR TELEPHONY

*Emitted wave:* Extremely sharp for CW and good on telephony.

*Operation:* Complicated. A thorough understanding of the principles of modulation is necessary to get the set operating efficiently on telephony.

*Construction:* Difficult.

*Approximate range:* 2,500 miles (on CW), and 1,000 miles (on telephony).

*Outstanding features:* This circuit is noted for its efficiency and perfection of modulation. This type of modulation is used at most of the broadcasting stations.

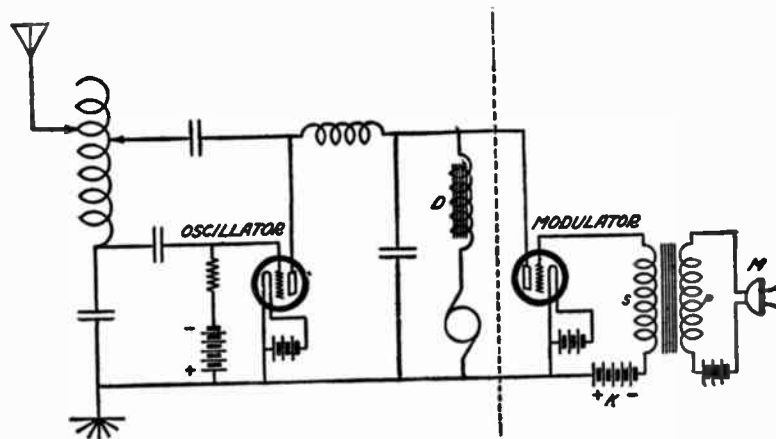

### THE COLPITTS CIRCUIT WITH HEISING MODULATION

*Emitted wave:* Fairly sharp. The modulation is (if the set is properly adjusted) of a very high order and also of a high percentage. This may cause the wave to be broadened out so that the set may interfere locally.

*Operation:* Simple and efficient.

*Construction:* Rather complicated.

*Approximate range:* 500 to 1,000 miles (on telephony).

*Outstanding features:* The best modulating system and the one most used for broadcasting.

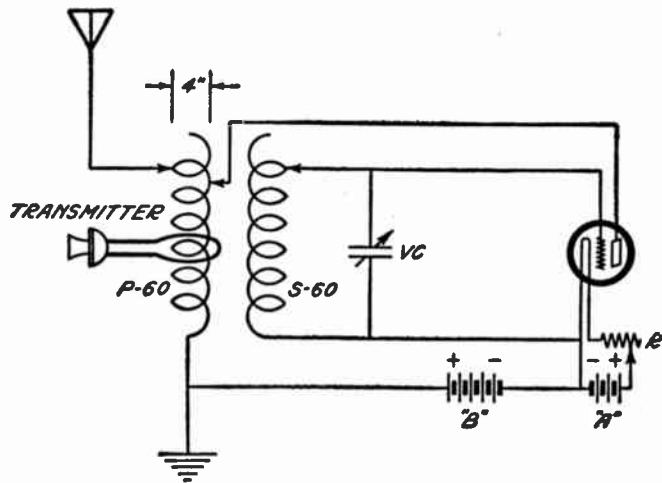

### SHORT-RANGE TELEPHONIC TRANSMITTER WITH BATTERY POWER SUPPLY

*Emitted wave:* Fairly sharp. The percentage of modulation is quite low and the wave does not spread much in frequency.

*Operation:* Just as simple as a single-circuit receiving set. The UV-201-a tube may be used with about

100 volts of "B" battery for the plate supply.

*Construction:* Simplicity itself.

*Approximate transmitting range:* 5 miles.

*Outstanding features:* Simple to make and operate.

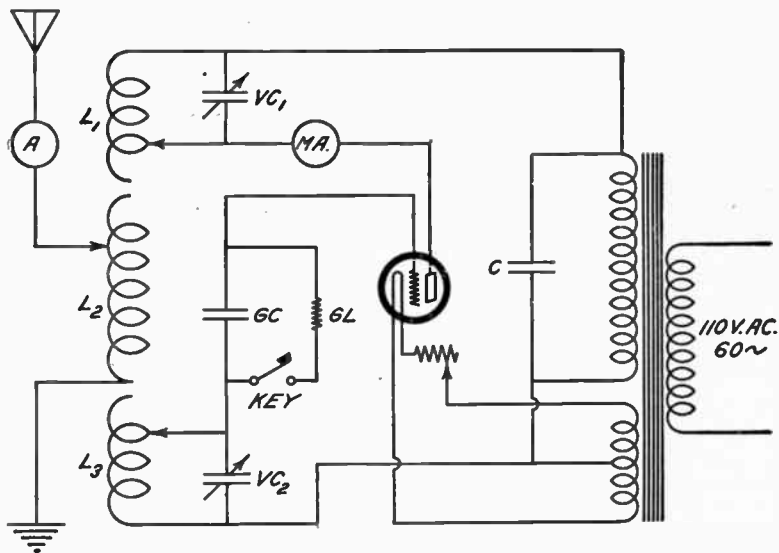

### MODIFIED MEISSNER CIRCUIT WITH AC POWER SUPPLY

*Emitted wave:* Fairly broad. Using straight AC on the plate of the oscillator tube causes a 30-cycle note to be transmitted (as the modulator frequency) which spreads out the frequency to a band instead of a single pure wave. This will cause interference in nearby receivers which do not tune sharply.

*Operation:* Easy to get working and inexpensive to keep up. The first cost is the last cost except for tube replacements. It will work on any type of antenna.

*Construction:* Nothing difficult about making this set, probably as simple as a single-tube receiving set.

*Approximate transmitting range:* 500 miles.

*Outstanding features:* Simple to make and get into operation. Set functions without any moving parts to wear out, is applicable to a large band of wavelengths with any type of antenna, and requires no batteries.

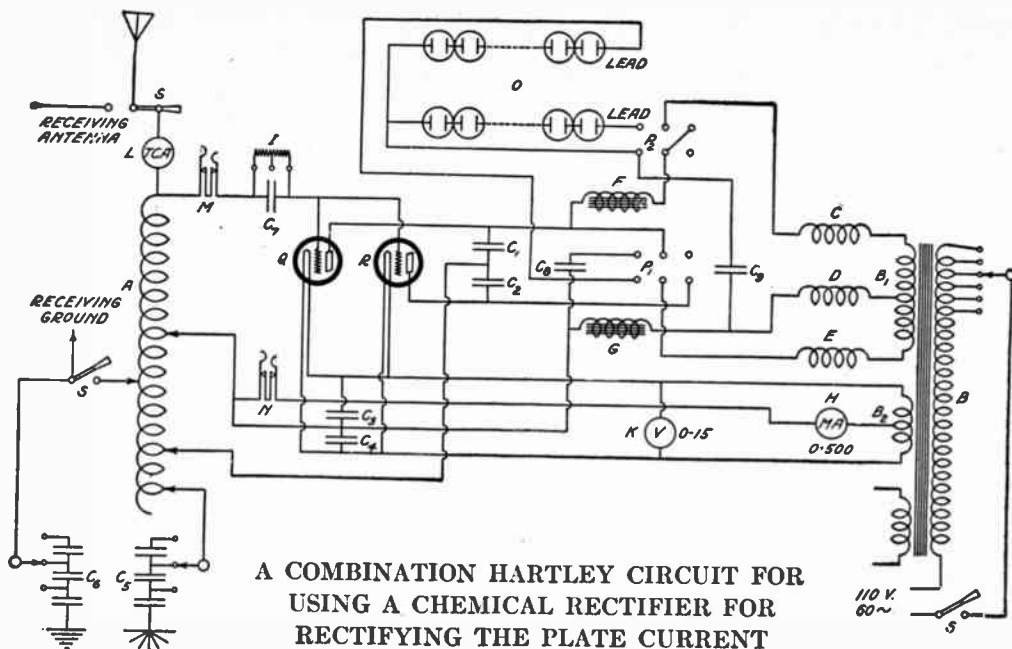

*Emitted wave:* Broad (with self-rectified AC). Somewhat sharper (with chemically-rectified AC. It depends upon how good the filter is).

*Operation:* Complicated.

*Construction:* None but the experienced amateur had

better try to build this set alone.

*Approximate range:* 2,500 to 3,000 miles (on telephony).

*Outstanding feature:* A powerful set which can be used without batteries for CW telegraphy.



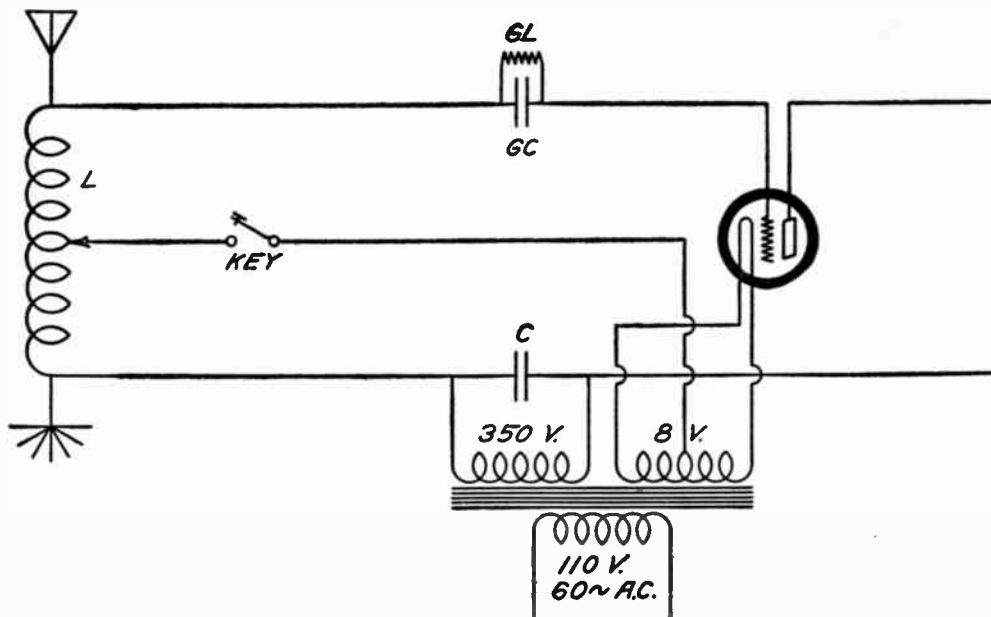

### THE HARTLEY CIRCUIT FOR AC CW

**Emitted wave:** Fairly broad.

**Operation:** Easy to get working and very inexpensive.

It will work on any type of antenna. A counterpoise is advisable.

**Construction:** Simplicity itself.

**Approximate range:** 500 miles.

**Outstanding features:** Simple to make and easy to get into operation. It is also most economical to set up.

