

**AUDIO CONTROL
HANDBOOK**

**AUDIO CONTROL
HANDBOOK**

Revised Edition

AUDIO CONTROL HANDBOOK

FOR RADIO AND TELEVISION BROADCASTING
Revised Edition

BY ROBERT S. ORINGEL

**BROADCAST ENGINEER,
VOICE OF AMERICA**

HASTINGS HOUSE, PUBLISHERS, NEW YORK

COMMUNICATION ARTS BOOKS

Copyright, © 1963, 1956, by Robert S. Oringel

All rights reserved. This book, or parts thereof, may not be reproduced in any form without permission of the publishers.

Library of Congress Catalog Card Number: 56-7002

Published simultaneously in Canada by
S. J. Reginald Saunders, Publishers, Toronto 1

Printed in the United States of America

To Beverly, Susan, and Patti

PREFACE to Revised Edition

The advancing state of the broadcasting art has required certain revisions in this book. Since its first publication, important changes have been made in new control equipment and in microphones that are manufactured for use in broadcast stations. This edition reflects those changes.

We wish to express thanks to these additional manufacturers who permitted use of photographs of their equipment in this revised edition.

Gotham Audio Corporation of New York; Aerovox Corporation, Cinema Engineering Division; Electro-Voice Company.

Washington, D.C.
August, 1963

PREFACE

Radio and television broadcasting art has reached the point where personnel without technical training are employed in studio operation. These functions were formerly performed almost exclusively by broadcast engineers. One such task is that of the operator of the audio equipment in a radio or television control room and studio.

The audio operator must be adequately trained for this creative job, however. He must have a thorough knowledge of all operating features of the equipment under his control, even though he may not have the technical background necessary to understand the electronic operation of audio equipment.

To the achievement of that end, this text is dedicated.

Despite the adage that "one picture conveys more information than a thousand words," good quality audio is considered by many authorities to be fully as important as good picture quality on a television program. The listening and viewing public is becoming increasingly interested in high fidelity sound or Hi-Fi, as it is called. The manufacturers of television receivers are incorporating Hi-Fi sound systems into their sets, and the television broadcaster must respond with equally good sound quality.

Thus the audio operator in the television control room must be as well versed in the art of sound reproduction and control as his counterpart in the radio control room.

This is not a technical book. It is rather, a "how to" manual. Little space is devoted to the purely technical factors of the design,

PREFACE

the construction, or the maintenance of the audio equipment mentioned here. Instead we have concentrated on the *operating* features of audio equipment, and *operating procedures*.

The author, bearing in mind that this manual will be used in the main by students or beginners having little or no technical electronics background, has attempted to describe and explain broadcast audio operations in non-technical language wherever possible, without omitting the trade terms or language of the industry.

The author wishes to thank the many people whose time and efforts helped to contribute to the writing of this book.

Thanks go to colleagues on the Studio Engineering staff of the Voice of America, and the faculty of the Cambridge School of Radio & Television Broadcasting, who inspired it, to Mr. H. Arthur Gilbert, Engineering Supervisor, who photographed the section on Hand Signals and gave valuable aid in editing the manuscript, to Mr. Robert J. Kent, of the VOA and Cambridge staffs, who posed for the hand signal pictures as well as lending his talents and suggestions to the manuscript, to Mr. Daniel J. Scherer, Assistant Chief of the VOA English Service, who edited the author's sometimes faulty grammar.

We wish also to acknowledge the help given by the following organizations in permitting the use of drawings and photographs of their equipment and products in illustration of the text.

Altec Lansing Corporation	General Electric Company
American Telephone and Telegraph Co.	Johns Manville Company
Ampex Electric Corporation	Magnecord Incorporated
Broadcast Equipment Specialties Corporation	Minnesota Mining & Manufacturing Company
Cannon Electric Company	Mole-Richardson Company
Capitol Records Corporation	Par-Metal Products
Collins Radio Company	Radio Corporation of America
Columbia Broadcasting System	Rason Manufacturing Company
Fairchild Recording Equipment Company	Stancil Hoffman Corporation
Gates Radio Company	Tech Laboratories Incorporated
General Control Company	Weston Electrical Instrument Corporation

Lastly, but by no means the least of the author's thanks go to a patient wife who, in addition to her household chores, undertook to do most of the typing of this book.

Washington, D.C.

CONTENTS

<i>PREFACE</i>		vii
<i>FOREWORD</i> by J. R. Poppele		xi
1		
<i>Introduction to Audio Control</i>	1	Cuts—Microgroove or Long Playing Records— Handling Records and Transcriptions—Tape Re- cordings—Tape Editing—Leader Tape.
2		
<i>Control Board Equipment</i>	3	
Control Board and its Functions—Basic “One Microphone Channel” Console—“Four Channel” Console—Cueing, Audition and Talkback Sys- tem—The Volume Unit Meter—Commercial Con- trol Boards—Sub-Mixers—Collins 212G-1 Con- sole—RCA BC-3C Consolette—Gates Amba- sador Console—Gates Executive Console— General Electric BC-31-B Console. RCA BC-7 Consolette.		
3		
<i>Auxiliary Console Input Facilities</i>	18	
Dynamic Microphones—Velocity Microphones— Cardioid Microphones—Turntables—Tape Play- back—Magnetic Tape Recorders—Ampex Tape Recorders—Field Tape Inputs—Stancil- Hoffman M9 Minitape—Ampex 602 Series—RCA Cartridge Tape Recorder—Incoming Lines— Echo and Reverberation Effects.		
4		
<i>Console Output Facilities</i>	35	
Lines Out—Lines to the Transmitter—Telephone Company Lines—Lines to Loudspeakers and Monitor Bus—Lines to the Network—Lines to Recording Rooms—Lines to Master Control Room —Lines to Warning Lights.		
5		
<i>Records, Tape and Tape Editing</i>	39	
Disc Recordings — Transcriptions — Lateral and Vertical Cut Records—Outside-In and Inside-Out		
6		
<i>Patching</i>		57
7		
<i>LEVELS, Balance and Operating Techniques</i>		61
Levels—Balance—Operating Techniques.		
8		
<i>Cueing, Turntable and Tape Playback Techniques</i>		65
Cueing—Record Cue up and Play Procedures— Fades—Cross-Fades—Segue—Dead Pot—Tape Cue Up and Play Procedure.		
9		
<i>Microphone Use Techniques</i>		70
Microphone Types and Patterns—Dynamic Micro- phones—Velocity Microphones—Cardioid-Com- bination Microphones—Special Purpose Micro- phones—Television Microphone Usage—Es- thetic Considerations in Microphone Use—On- Mike and Off-Mike—Presence—Into vs Across the Mike—Microphones vs Talent—Microphone Clipping—Care of Microphones and Microphone Cords—Microphone Stands.		
10		
<i>Studio Microphone Setups</i>		81
Talks: One and Two Speakers—Groups of Voices —Dramatic Programs and “Soap Operas”—Mu-		

CONTENTS

- sic Programs—Solo Instruments—Small Studio Band—Large Studio Orchestra—Studio Audience Reaction and Public Address.
- 11**
The Program—As the Audio Operator Sees It 90
Newscast — Sportscast — Disc Jockey Show — Live Music Program — Dramatic Program.
- 12**
Studio-Control Room Communication 103
Hand Signals—Microphone, Turntable and General Information Hand Signals—Intercom for Television.
- 13**
Remote Broadcasts 112
Nemo Equipment—Inputs to the Remote Amplifier—Remote Amplifier Output—Remote Broadcast Procedure—Public Address System “Bridge” Pickups—Taped Remote Broadcasts—Short Wave Remote Broadcasts—Microphone Setups.
- 14**
Studio Design and Construction Practices 123
Aural Quality Factors — Radio Studios — Live-End and Dead-End Studios—Television Studios.
- 15**
Rules and Regulations of the Federal Communications Commission that Pertain to Audio Control Operators 128
- 16**
The Other Members of the Broadcast Team 131
General Manager — Commercial Manager — Program Director — News Department — Production-Direction Department—Continuity Department—Music Library—Traffic Department—Chief Engineer—Television Operating Crew—Switchers, Boom Operators, Dolly Pushers, Cable Pullers, Floor Manager, Stage Electricians and Stagehands.
- Glossary of Broadcast Terminology* 135
- Index* 143

FOREWORD

Since the day in 1920 when KDKA went on the air with the first commercially licensed radio station, the need for trained audio operators has been ever increasing. The tremendous expansion in the broadcasting industry in the last ten years has highlighted the need for trained audio personnel.

The part the audio operator plays in a broadcast is often underestimated. His voice is not heard on the air. He writes no copy nor does he sell advertising time. He is the silent partner. He puts the program on the air and is the one around whom the quality of the broadcast revolves. He is expected to be ready for all emergencies. In short, he is an invaluable member of a staff which turns personality, sales ability and technical know-how into valuable saleable time.

New horizons are offered to the audio operator in the fields of television, motion pictures and high-fidelity recording. The profession is becoming more and more important.

It is indeed encouraging to note the increasing recognition given by schools and universities to the need for including within curriculums more and more courses in the broadcasting art and in audio subjects. *Audio Control Handbook* gives to the newcomer the hard-won knowledge, skills and techniques of an especially well qualified author by virtue of his experience in large and small broadcast stations both in the Government and in private industry. The author has recognized the need for a thorough text to assist the audio operator in his responsibilities in the studio and in the field.

A text of this type has been long overdue and it is most welcome in the broadcast field. I wish Mr. Oringel, the author, well with it.

J. R. Poppele
Formerly Assistant Director for Radio and
Television, U. S. Information Agency

**AUDIO CONTROL
HANDBOOK**

Revised Edition



Figure 1-1
An Audio Control Console
Courtesy Columbia Broadcasting System

Audio control is the operation of all of the various types of sound equipment that are found in the studios, and the control rooms associated with those studios, of a radio or television broadcasting station.

The audio operator is the person who performs the audio control operations. Most of his work is done in the control room, operating the audio control board, or control console.

The job of the audio control operator is to insure that the proper amount of amplification is given to each sound that is received by the control board, and to see to it that the correct blend of sounds is sent out of the control board, to the listener.

It is readily acknowledged by the author that "sound", upon entering a microphone, becomes electrical energy and remains in the form of electrical energy until it is emitted by a loudspeaker. For the sake of clarity and understanding, however, we will throughout this text refer to "sound" as traveling through a microphone or amplifier, rather than the aforementioned electrical energy. For this variation from scientific fact, we beg the indulgence of our fellow broadcast engineers, into whose hands this volume may fall.

To begin, let us follow the path of a word, from the time that it leaves the mouth of a performer standing in front of a microphone at a broadcast station, until it enters the ears of the listener sitting near his receiver at home.

INTRODUCTION TO AUDIO CONTROL

As the performer speaks, sound waves are created and are picked up by a microphone. From the microphone, the sound travels to a control board. There, it is amplified or enlarged, and sent to a transmitter. The function of the transmitter is to superimpose the sound waves onto higher frequency radio waves. These radio waves are then sent by the transmitter to the antenna, from where they are radiated into the air.

Figure 1-2
The Radio Sound Path

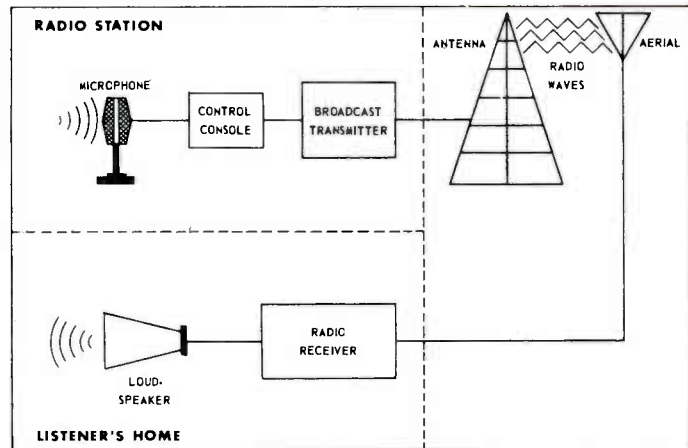

The aerial at the listener's home captures the radio waves and sends them to a receiver. In the receiver, the sound is separated from the radio waves. It is amplified and then it activates the loudspeaker. The listener at home then hears the identical words that were uttered by the performer at the broadcast station.

It might be well at this point to define sound. Sound is a disturbance, movement, or vibration, in a wavelike motion, of the air. It is caused or produced by an emitting source such as an announcer's mouth, the movement of a violin string, or a hammer striking an anvil. A sound wave is composed of two elements, the pressure component or strength of the wave, and the velocity component or speed of the wave.

CHAPTER 1 REVIEW QUESTIONS

1. Trace the path of a broadcast sound in its passage from an announcer's mouth to the listener's ears.
2. Define "sound".
3. What are the two components of a sound wave?

All of the control boards that are found in the control rooms of broadcast stations have basic similarities. If one board is learned thoroughly, and if that one console can be operated, you will be able to understand and operate any and all control consoles with but a small amount of additional information and explanation.

Control Board and its Functions.

A control board or console is an electronic instrument that has two primary functions:

1. To amplify sound. That is, to take the minute amounts of sound that are picked up by the microphones and turntables, and to enlarge these to greater amounts without any distortion of the quality of the sound.
2. To control and route the amplified sound to the various points within the broadcast station where a need for it exists.

A power supply, or source of electric current and voltage is necessary to operate the vacuum tubes which comprise a control console. You can expect to find a power ON-OFF switch and a fuse box for the console, located on or near the console — the switch, to turn the console on or off, and the fuse box in case of a power failure in the console. The operator should ascertain the exact location of the power switch and the fuse box, as his first assignment in a control room. He will be guided on most equipment by a pilot light, which will indicate whether the power is *on* or *off*.

Basic "One Microphone Channel" Console

Let us first consider the features of a hypothetical console which has the sole function of amplifying and controlling the output of one microphone.

You should commit to memory, the names of the individual components

CONTROL BOARD EQUIPMENT

of this console, and the order in which they are combined as well. Later we will observe that all, even the most complicated-appearing consoles, are merely extensions of this basic "one microphone channel" console.

Figure 2-1

Block Diagram Of A "One Microphone Channel" Control Board

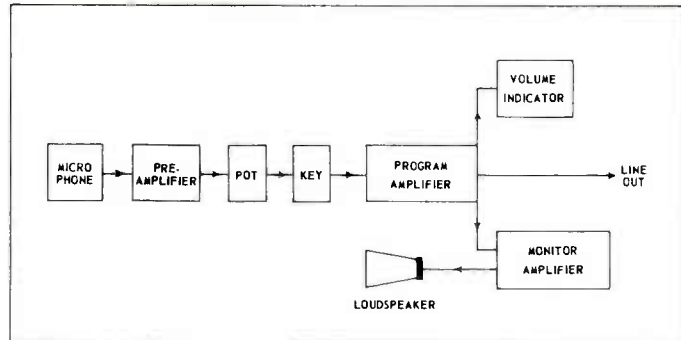

In the accompanying block diagram, note the progression of components within the console (except for the microphone) that the sound encounters from the time it enters, until it leaves the console:

The sound goes from the microphone, or "mike", to the preamplifier, or "pre-amp", which enlarges the sound from the microphone to useable proportions; to the pot, or volume control which varies the volume of sound coming from the microphone just as you vary the loudness of your home radio receiver; to the key—a switch which turns the microphone on and off, much like the light switch on the living room wall; to the program amplifier which again enlarges the sound, this time to sufficient proportions so that it may be sent via telephone lines to the transmitter.

A portion of the sound is sent to the monitor amplifier which activates the loudspeaker in the control room. This enables the audio operator to hear the sound emanating from the studio. At the same time, there is a meter or indicator connected to the program amplifier, so that the operator will see, as well as hear, the degree of volume of the sound that is leaving the control console.

"Four Channel" Console

Now, having shown the features of a basic console, we will expand the hypothetical "one microphone channel" console to include the inputs of another microphone, and in addition two turntables, to make it a "four channel" control board.

Note that in Figure 2-2, the topmost microphone channel is identical to the basic console already studied. All that has been added are the three additional inputs, or channels: the master pot, the monitor pot and another loudspeaker, for the studio.

All of the microphone and turntable pre-amplifiers feed into the *one* program amplifier, through the master potentiometer, or master pot. The master pot is the volume control that varies the volume of the program amplifier.

CONTROL BOARD EQUIPMENT

Thus it ultimately controls the overall sound volume output of the entire console, and in turn, the individual volumes of all of the microphones and turntables that are operating through the console.

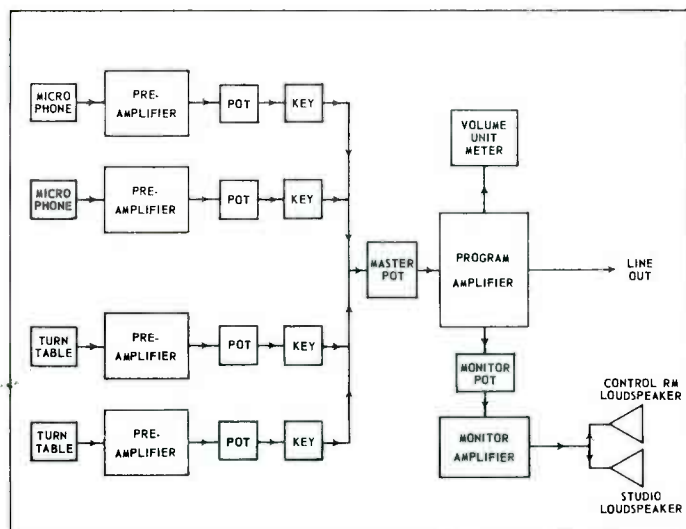

Figure 2-2
Block Diagram Of A Four
Channel Control Console

The monitor amplifier has its volume controlled or varied by the monitor pot. Thus, the monitor pot varies the sound volume of the loudspeakers in both the control room and its associated studio.

You will have noted by this time that the operator of a console exerts his control through the manipulation of keys and pots on the console. The pot, or potentiometer, is also known in the industry by several other names: mixer, fader, attenuator, and pad.

Returning to Figure 2-2, we find the volume unit meter or VU meter connected to the output of the program amplifier. This meter is sometimes referred to as the VI, or volume indicator. The operator observes this meter as he adjusts the pots which control the microphone and turntable volumes. The volume unit meter is used in conjunction with the master pot as well, as the operator controls the sound volume of the entire console.

The operator may utilize either or both of the microphones, by throwing their keys to the *on* or *program* position, and by "riding gain" on their pots. Riding gain consists of turning the pots (opening or closing them like the water faucets in a bathtub), until the desired degree of volume appears on the VU meter.

Similarly, the operator may use the turntables by throwing either or both of their keys to the program position, and riding gain on their pots.

Before operating either microphones or turntables the master pot must be opened so that the program amplifier may be used, and the overall sound volume of the console may be varied. The monitor pot must similarly be opened to enable the operator to hear the results of his turning on microphones or turntables.

CONTROL BOARD EQUIPMENT

Cueing, Audition, and Talkback System

When a microphone or turntable key is in the on or program position, anything uttered into that microphone or emanating from that turntable will go out "on the air".

To enable the announcer, or other talent in the studio to talk to the operator or anyone else in the control room, while a record is being played, *without* their conversation going out on the air, there is an opposite position provided on the microphone keys. This position is called the audition, or cue position.

We therefore find that each key has three positions: *Program, Off, and Audition*. The keys are mounted on the front panel of the console, to operate either vertically or horizontally, depending upon the design of the console.

Figure 2-3
Microphone and
Turntable Keys
Courtesy General
Control Co.

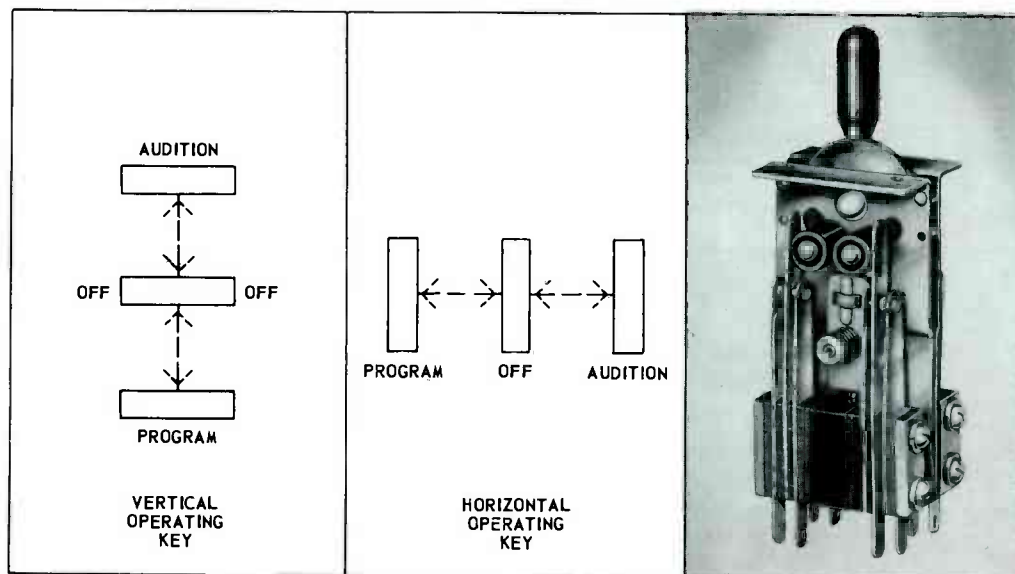

If the operator in the control room wishes to speak to anyone in the studio, without his leaving the control room, he is able to do so. At a radio station that is equipped for combination announcer/operator ("combo man") operation, one that has an "air-able" microphone in the control room, the operator throws the key for that microphone to the audition position and speaks into the microphone. He is heard then, only in the studio. If any of the microphones in the studio are on the air, or *live*, however, the operator faces the possibility of his words being picked up by that microphone and aired, with the program. Some stations therefore make provision for having the control room microphone disabled in the audition position, or the studio loudspeaker disabled or automatically disconnected when a studio microphone is live.

At stations that are not set up for combo operation, that is, large radio and all television stations, a microphone is located in the control room near the console, to be used by the operator for "talkback", to the studio. This is then called the "talkback microphone". Since the talkback microphone

CONTROL BOARD EQUIPMENT

is not to be used on the air, and the quality of its sound reproduction is not important, an inexpensive microphone is generally used.

The talkback microphone is turned on by a key or push-button located on the console. This key or push-button is usually of the spring-back type—one that springs back to its original off position as soon as the operator removes his finger from it, when he has finished speaking.

The turntable keys too, have three positions as previously indicated for the microphone keys. The audition position on a turntable key is used for listening to a record in the control room, *without* sending the record out on the air. The audition position is also used for “cueing up” a record, which will be discussed in detail in a later chapter.

In order that auditioning or cueing should not conflict with the operator's listening to the program as it goes out on the air, there is generally an additional amplifier known as a cue amplifier, or audition amplifier, located either within the console or somewhere in the control room near the console. This amplifier activates, or feeds, a separate loudspeaker called the cue speaker. At some stations, a pair of earphones (called “cans”) are used instead of the cue speaker. Thus the operator can listen to a program going out on the air, on the monitor loudspeaker, and he can listen to a record that he may be cueing or auditioning, on the cue speaker, both at the same time.

Two notes of caution should be mentioned at this time:

1. If one microphone is “on the air” in the studio, the operator may not allow anyone to speak on the audition position of another microphone in that same studio. This is because anything that is voiced into the microphone on audition, will be picked up to some extent by the live microphone as well.
2. Whenever a microphone is live in a room then the monitor loudspeaker in that room, be it control room or studio, is automatically disconnected or disabled. This is done with an electrically operated switch called a relay.

Consider what would happen if the loudspeaker remained on while the microphone was also on. An announcer utters a sound which is picked up by the microphone. The sound goes through the console, is amplified and emitted by the monitor loudspeaker. This amplified sound is then picked up by the microphone, goes through the console, is reamplified, comes out of the monitor loudspeaker, is picked up again by the microphone..., and so on ad infinitum.

Each time that the sound goes through the console, it is re-amplified, and becomes louder and louder until it becomes a violent squeal or howl. Actually, this howl takes place immediately, since the sound travels at the speed of light, 186,000 miles per second, through the console.

This howling phenomenon is called *feedback*. When an operator hears feedback, he can be certain that the monitor loudspeaker-muting-relay is not working, or is not operating correctly. The operator must counteract the feedback by quickly turning the monitor pot off, preventing the sound from emanating from the loudspeaker. He thus prevents the feedback howl from

CONTROL BOARD EQUIPMENT

going out on the air. The audio operator then calls for the chief engineer or the maintenance technician to repair the ailing relay.

The Volume Unit Meter

The volume unit meter, or volume indicator, is located centrally on the front panel of the control board. It consists of a dual graduated scale, a moving needle or pointer, and a light bulb to illuminate the scale, all mounted in a plastic case with a protective glass cover on the front. The meter is constructed so that the pointer swings back and forth across the scale, following the degree of sound loudness that it is measuring.

Figure 2-4
The Volume Unit Meter
Courtesy Weston Corp.

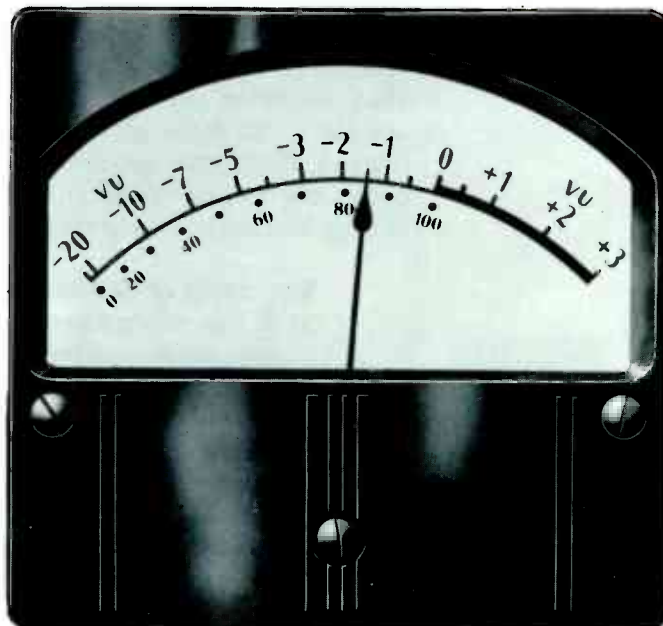

As the sound becomes louder, the needle swings to the right, or towards the high end of the scale. When the needle passes the 100, or zero VU mark on the scale, we say we're operating or peaking "in the red", or we're "spilling over".

When the sound intensity is very low, or between the zero and the 20 mark at the left hand or low end of the scale, we say we're "riding in the mud". Riding, refers to the amount of sound volume that the needle is measuring. Riding gain with a VU meter then, consists of watching the moving needle, while adjusting the pot which is controlling the sound.

Commercial Control Boards

The discussion until this point has covered a hypothetical, but nevertheless operable control board. Figure 2-5 shows what that console might look like if it were to be constructed.

CONTROL BOARD EQUIPMENT

The console as pictured, is rather skimpy in its operating features and its adaptability. There are several additions and refinements that should be included to make a control board more flexible in its use.

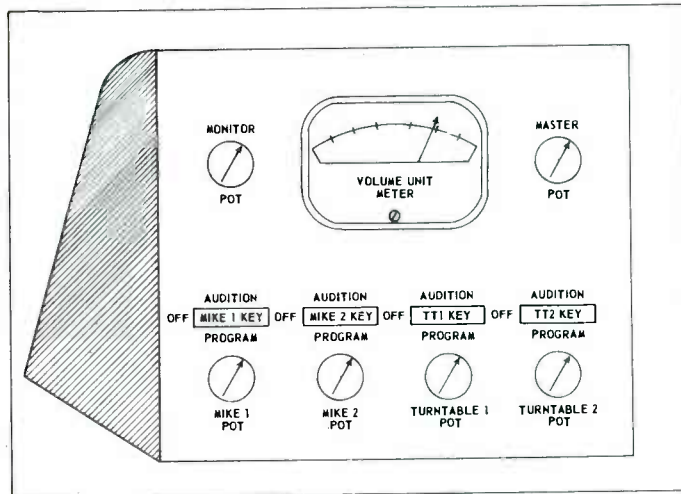

Figure 2-5

A Basic Four Input Control Console
Two Microphones, Two Turntables

The audio operator requires more than two microphones available to him in the studio for large or complicated programs. He should be able to route network programs through the console, as well as be able to play back tape recorded program material in addition to the live shows originating in the studio.

These, and other features are available with commercially manufactured control board equipment, so let us examine closely a few of the more popular commercial control boards that are found at radio and television broadcasting stations, and which are illustrated in Figures 2-6 to 2-11 inclusive.

Although each of the consoles described has some features not found in the others, all are basically the same. They each have a key, a pot, and a pre-amplifier for every microphone and turntable. Every console has a program amplifier and a monitor amplifier. Finally, they all have auditioning and talkback facilities.

They differ only in physical size, the direction in which the keys operate, and the number of additional features such as auxiliary inputs and outputs that are required by the broadcast stations at which they are found.

Sub-Mixers

The usual commercially built control board has an average of but four microphone inputs. On programs which require more microphones than there are inputs on the usual control board, a sub-mixer may be employed in addition, to handle the extra microphones.

As an example of a program needing extra microphones there might be one with a large orchestra, requiring 10 microphones for the orchestra alone. In addition, microphones are required for the master of ceremonies, the soloists, and for the commercial announcer.

CONTROL BOARD EQUIPMENT

The sub-mixer is an auxiliary control panel having a number of additionally available microphone inputs. It has a pot and key for each input, but no master gain control, no VU meter, and no auditioning or monitor facilities.

The sub-mixer is constructed so that its sound output feeds into either a sub-mixer master pot on the regular console, or into one of that console's microphone inputs. Thus, the console microphone input pot becomes the master gain control for the sub-mixer. The console's VU meter and its auditioning and monitoring facilities handle those functions for the sub-mixer.

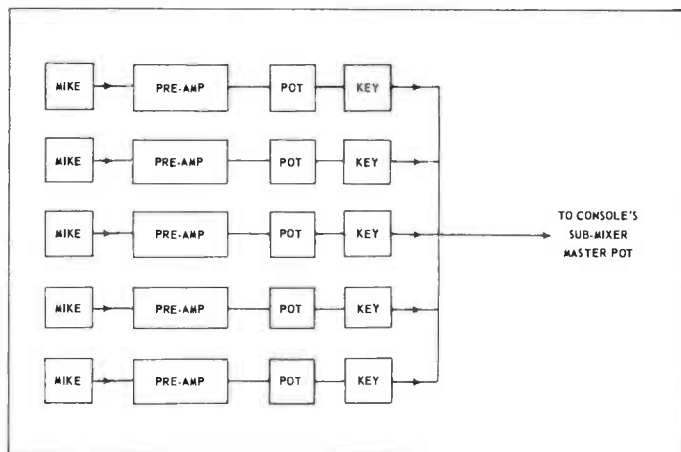

Figure 2-6
Block Diagram of a Five
Microphone Input Sub-mixer

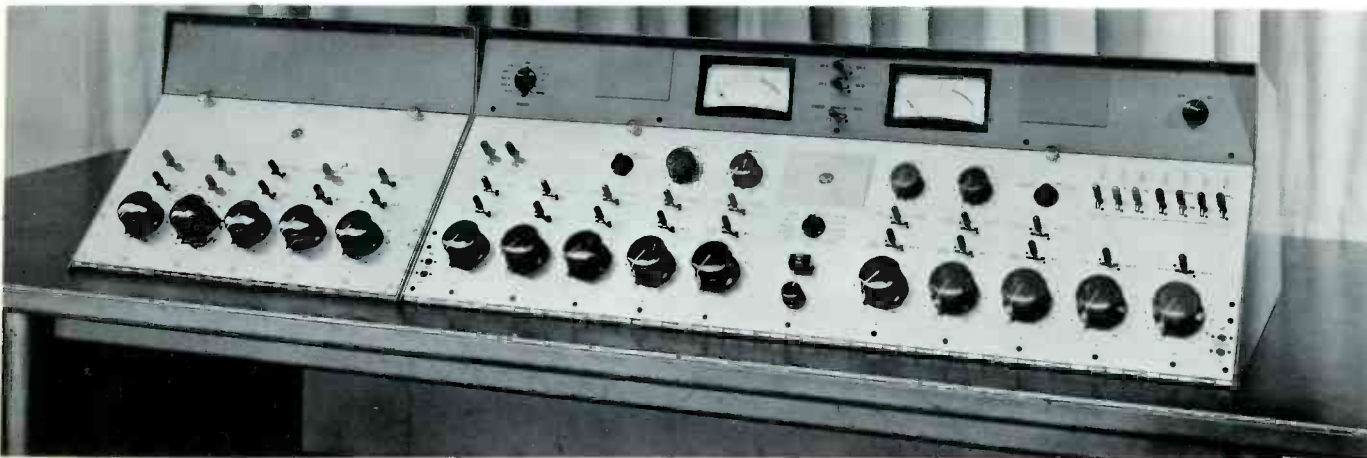

Figure 2-7—RCA Sub-Mixer with BC-7 Consolette
Courtesy Radio Corp. of America

CONTROL BOARD EQUIPMENT

Two developments of recent date have brought about changes in some consoles. One, the substitution of transistors for tubes in the electronic circuitry of some manufacturers. This change does not affect the operation of the console, but does permit the control board to be made smaller in overall size, or a greater number of channels to be incorporated in a cabinet of like size.

The second development is the advancement of stereophonic radio, brought about by Federal Communications Commission's approval of "multiplexing"—the superimposing of *two separated* sound channels on a single radio wave. This development has necessitated re-design of control consoles to accept inputs of stereo pairs of microphones when a station broadcasts in stereo. The stereo pairs of microphones in turn necessitate pairs of pre-amplifiers and all of the other components in the mixing channels of a console. Thus, on a stereo broadcast the job of the control operator becomes more complex, although the basic principles remain the same.

A stereo console uses two VU meters, one for each "side" of the stereo sound, left and right. When the console is operated monaurally, the meters can usually be switched to operate so that either one is off. Both are on the single output channel or, if the functions of the console may be "split," as is often the case to handle two studios, then the meters are switched so each monitors a separate studio.



Figure 2-8
The Collins model 212G-1 Console
Courtesy Collins Radio Co.

This Collins Console has nine mixing channels—a mixing channel being the combination of one pot, one key, and one pre-amplifier. Mixers #1 and #2 each handle two studio microphones with the additional aid of mixer keys 1 and 2 on the upper left of the board. Mixer #3 handles the control room microphone. Mixer #4 is an auxilliary—to be connected as the individual station finds necessary. Mixers #5 and #6 are turntable pots. Mixers #7 and #8 are tape input pots. Mixer #9, in conjunction with the key on the upper right of the board, handles the network input and/or the incoming remote lines, using the remote pots to the right of the VU meter. Also

CONTROL BOARD EQUIPMENT

to the right of the meter is a meter function rotary switch, an unmarked auxilliary key, and the program line out key. To the left of the VU meter, in addition to the microphone mixer keys, is another unmarked spare or auxilliary key, the monitor amplifier pot, the monitor function rotary switch, and the cue amplifier pot. Below the VU meter are earphone jacks for network, program, and remote line listening.

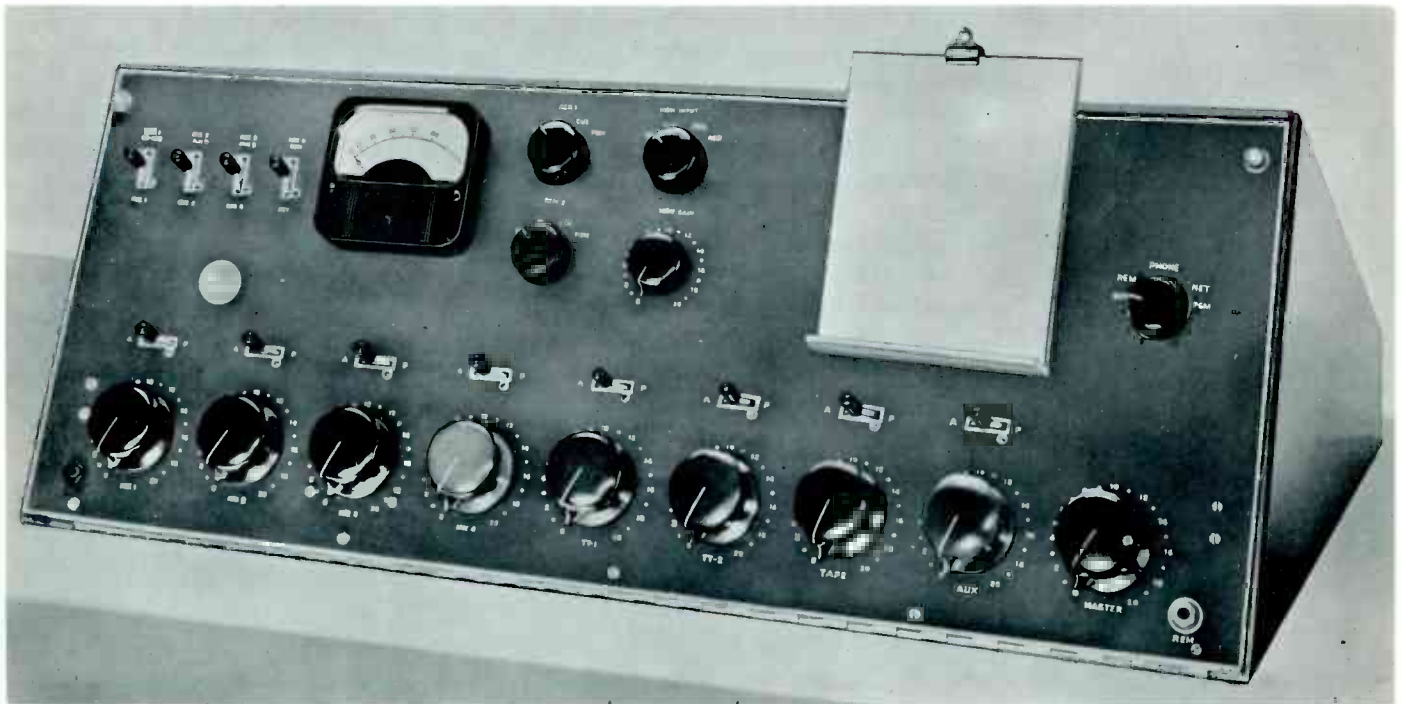

Figure 2-9

The RCA BC-3C Consolette

Courtesy Radio Corp. of America

This console has eight mixing channels. The first three are microphone mixers with selector keys in the upper left corner permitting the use of up to six microphones. Channel 4 is the network/remote mixer. This mixer, operating in conjunction with the selector key above, chooses either the network or remote line input. The two rotary switches to the right of the VU meter determine which of two remote lines are fed into channel 4. Channels 5 and 6 are straightforward turntable mixers. Channel 7 is a tape recorder input, channel 8 is an auxilliary or spare, and the master pot is the last in the line. An earphones jack in the lower right of the console is fed from a rotary selector above. To the left of this selector is a script clipboard and the monitor input selector rotary switch and gain control.

CONTROL BOARD EQUIPMENT

The Gates Ambassador is a 5-mixer channel audio control console. Channels 1 and 2 are microphone channels with a selector above each permitting the employment of four microphones. Three utility keys are located between the microphone selectors, to be wired as the individual station requires. Channel 3 may be used as shown, as a remote line input, with the selector key above choosing either of two remote lines. This channel may also be converted by a plug-in pre-amplifier so that it can be used with its associated selector key as an additional two-microphone mixer instead of a line input mixer. To the left of the channel 3 selector key is the master pot and line output key.



Figure 2-10
The Gates Ambassador Console
Courtesy Gates Radio Co.

Mixer channels 4 and 5 employ between them two 12-position pushbutton banks. These pushbuttons are used to select for either mixer 4 or 5, one of 11 turntable, tape recorder, tape cartridge, or film projector sound inputs, and the network and four remote lines from the 12th position. Selector switch keys for network and remote lines are located above the pushbutton banks. To the left of these keys is the recessed talkback microphone, the cue-talkback rotary selector, the cue-talkback gain control and the talkback key. On the upper right corner is the monitor gain control and key, and a headset function key which feeds either program, network or cue to the earphones jack on the right of mixer 5.

Note that this console has a mobile VU meter. It may be placed as pictured, or clamped to the top of the console or, in fact, placed anywhere convenient to the sight of the operator.

CONTROL BOARD EQUIPMENT

The Gates Executive utilizes ten mixing channels in a completely transistorized console. Channels 1, 2 and 3 are microphone channels. Immediately above each microphone key are two transfer switch keys. These permit the use of two sets of stereo microphones into each of the three mixing channels. This console then can be employed at stations which specialize in stereo broadcasting. Channels 4 and 5 have switching facilities to accommodate up to four turntables into either channel, in any sequence. A cue position at the closed end of the pot on each of these two channels permits cueing in the channel not in use. Channels 6 and 7 have switching facilities to accommodate four tape machines playing into either channel in any sequence. There is a cue position on each of these two channels. Four incoming remote lines may be individually switched into channel 8. Channel 9 is the network input channel. Channel 10 is an auxiliary or spare input channel. The cue switch on channels 4 through 10, located at the closed end of the pot, permits the operator to smoothly fade from cue to program.



Figure 2-11
The Gates Executive Console
Courtesy Gates Radio Co.

The Gates Executive console has two VU meters. Below each are their function switches. Between and below the meters is the built-in talkback microphone, and below this the intercom, monitor and earphone controls, and the talkback pushbutton. The upper right corner of the console, above channels 9 and 10, contains the master pots and output function control switches. These determine whether the output is stereo or the more usual monaural.

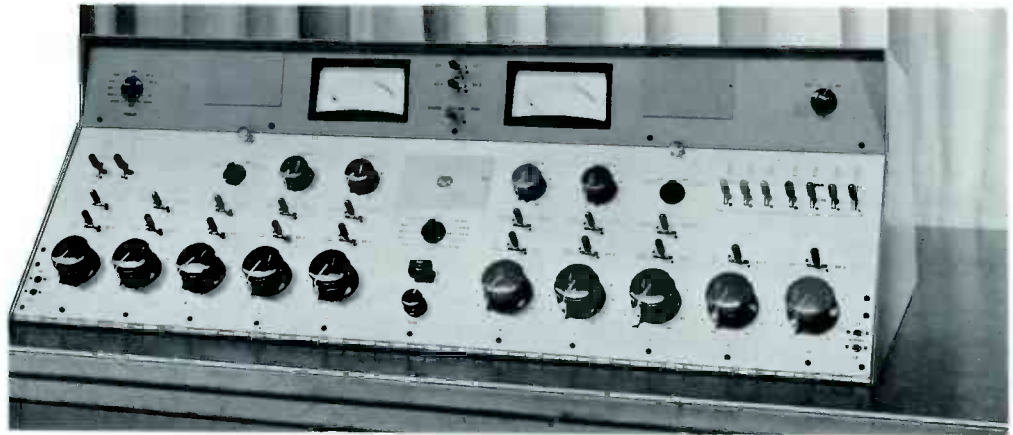

Figure 2-12
 The RCA BC-7 Consolette
 Courtesy Radio Corp. of America

This model may be used as either a dual output channel, or as a stereo console. The first five mixers are microphone channels. Above each is a three-microphone selector key for a total of 15 microphone facilities. The center of the console has a recessed talkback microphone and below it the cue-intercom rotary selector, large rectangular push-to-talk button and gain control. Mixing channels 6, 7 and 8 are for turntable, tape or film projector sound. Each has a three-input selector key above the mixer. Mixer 9 is the network input. Mixer 10 handles incoming remote lines in conjunction with the selector keys above.

To the left of the talkback microphone (beneath the RCA emblem) are the output channel 1 master pot, monitor pot and monitor function selector. To the right are the output channel 2 master pot, monitor pot and monitor function selector. The upper panel features an earphones rotary selector on the left, VU meters for the two output channels, and an on-off switch. Between the VU meters are two keys which feed output channels 1 and 2 to either or both of two lines out. Below these is the console mode key which determines whether the console operates monaurally or in stereo. Four earphone jacks are located on the lower corners of the board—two on each corner.

CONTROL BOARD EQUIPMENT



Figure 2-13

The General Electric BC-31-B Console
Courtesy General Electric Co.

This General Electric control board is designed for either stereo or monaural applications. It is quite versatile in that all of the mixing channels are "plug-ins." The station purchasing this equipment can therefore specify how many—up to 12 microphone channels—it requires, or how many—up to 21 tape input, turntable, or incoming line channels—it requires. The correct type of plug-in mixing channels—up to 12 in all—are then supplied to meet the station's needs.

The first six mixing channels in the console pictured here are microphone channels. Above each is a microphone selector key. The middle panel contains six intercom selector buttons—three to remote lines, two to studios, and one to an announce booth—also the cue and talkback level control, press-to-talk pushbutton, earphone jacks for both output channels, and the remote line override switch.

The six mixing channels pictured to the right are for incoming lines, tape recorder inputs, or turntables. The first of these channels has a selector key above, for two incoming sources. The next four mixers each have a four-input selector switch pushbutton bank above, and the last mixing channel has above it three keys for monaural remote line or network input selection. All six mixing channels shown on the right side of the board have cue switches at the closed position of their pots.

On the upper panel, to the left are the monitor pots and monitor function selectors for each of the two output channels, the meter function key for the left VU meter, the hidden talkback microphone between the meters, the right VU meter and its function switch; and on the far right are the master pots for each of the two output channels; also the mixer bus switch which permits two output monaural operation or stereo operation, and two line out keys. Finally this General Electric console is fully transistorized.

CHAPTER 2 REVIEW QUESTIONS

1. What is a control board?
2. What are the two primary functions of a control board?
3. By what other names do we refer to a control board?
4. List in their proper sequence, the components of a "one microphone channel" control board.
5. What is a pre-amplifier?, A key?, A program amplifier?, A pot?, A monitor amplifier?
6. What is the function of the master pot?
7. By what other names are pots known?
8. Define "riding gain".
9. What are the purposes of the audition system of a control board?
10. What is the function of a talkback system in a control board?
11. Define "feedback".
12. What is a VU meter and for what purpose is it used?
13. What are the functions of a dual output console?
14. What is a sub-mixer?
15. When is a sub-mixer used?

The discussion thus far has covered mainly the control board, as the primary instrument used by the audio control operator. Mention has been made, however, of such things as microphones, turntables, and tape machines which are also found in the studios and control rooms of a broadcast station. It will now be seen how these auxiliary items work, and how their operation is controlled through the console by its operator.

All of the items that are considered in this chapter are referred to as *inputs* to the console. An input is a unit that feeds into the console for the purpose of having its sound amplified and routed to the output of the console. The console outputs will be considered in the next chapter.

Microphones

Three types of microphones are found in wide use at broadcast stations. They are:

1. *The Dynamic Microphone.* It uses either a diaphragm or a condenser element, which is actuated by the pressure of the sound wave. Dynamic microphones have a non-directional or omnidirectional (all directions) pickup pattern.
2. *The Velocity Microphone.* It utilizes a wash-board shaped aluminum ribbon element. It is actuated by the velocity of the sound wave. Velocity microphones have a bi-directional or two-direction pickup pattern.
3. *The Cardioid Microphone.* It is a combination of both the dynamic and velocity types, built into one microphone. The cardioid microphone is activated by both the pressure and the velocity of the sound wave. Cardioid microphones have a uni-directional, or one-direction pattern.

In addition to the three above types, a combination cardioid microphone is made for studio use. The combination cardioid has an adjustable switch on the back of the unit which enables the operator to select the dynamic ele-

AUXILIARY CONSOLE INPUT FACILITIES

ment alone, the velocity element alone, or to use both elements combined to form the cardioid microphone.

Let us now take a look at some of these microphones so that they will be familiar when they are observed in a studio. Any or all of the microphone types shown may be found at a broadcast station. Located in the studios, they are connected to the control board by rubber covered microphone cables or cords which terminate in Cannon plugs (see Fig. 3-7).



Figure 3-1
RCA "Commentator" Microphone
Courtesy Radio Corp. of America

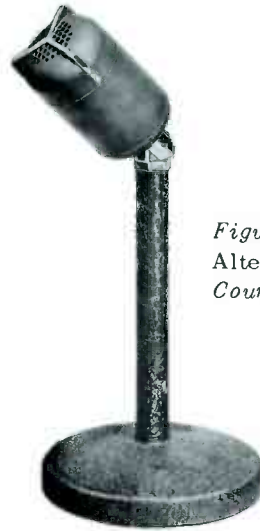

Figure 3-2
Altec 633 Dynamic
Courtesy Altec Lansing Corp.



Figure 3-3
Altec 21B Condenser
Courtesy Altec Lansing Corp.



Figure 3-4
RCA Senior Velocity Microphone
Courtesy Radio Corp. of America



Figure 3-5
RCA 77 Cardioid Microphone
Courtesy Radio Corp. of America



Figure 3-6
Altec 639
Cardioid Microphone
Courtesy Altec Lansing Corp.

AUXILIARY CONSOLE INPUT FACILITIES



Figure 3-7



Figure 3-9



Figure 3-8

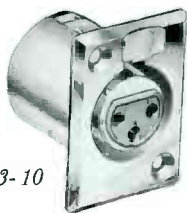

Figure 3-10

Cannon Plugs & Receptacles
Courtesy Cannon Electric Co.



Figure 3-11



Figure 3-12

Neumann Model U-47 & U-67 Microphones
Courtesy Gotham Audio Corp.

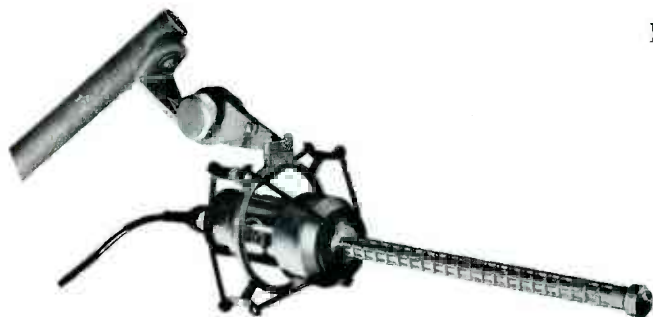

Figure 3-13
EV Model 642 Microphone
Courtesy Electro-Voice

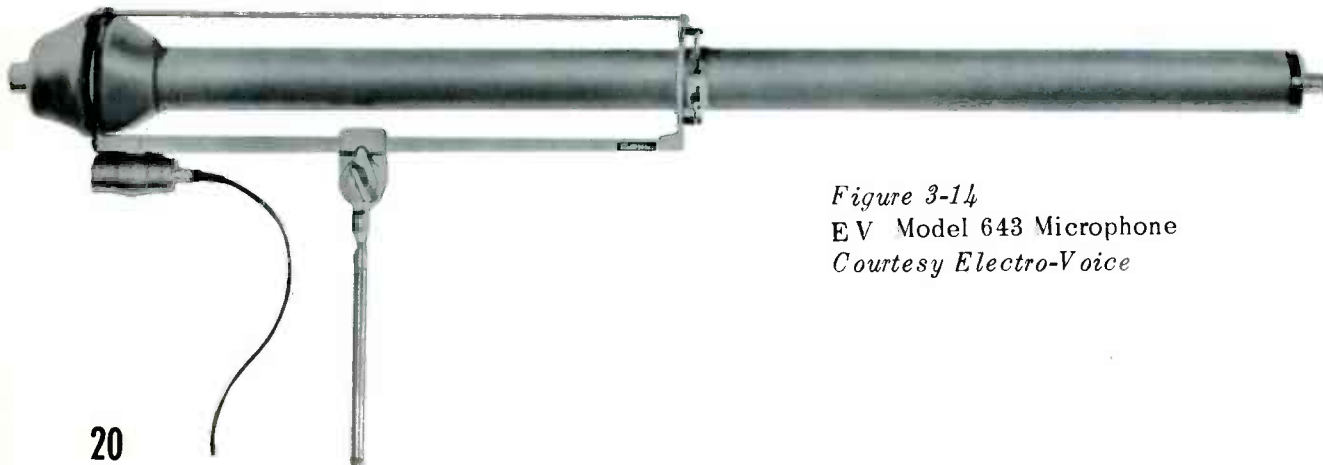

Figure 3-14
EV Model 643 Microphone
Courtesy Electro-Voice

AUXILIARY CONSOLE INPUT FACILITIES

The Cannon plugs are connected to the console through Cannon receptacles (sockets) which are located conveniently on the baseboards of the studio walls (see Fig. 3-8).

At small radio stations, one microphone is located in the control room, mounted directly over the console for the use of the combo-man. The combo-man is a combination announcer/operator. He does his programs entirely by himself in the control room.

Turntables

A turntable, as used at a broadcast station, is a high quality record player. A station will have two or three turntables in each control room to permit uninterrupted playing of records. Usually they will be placed so that there is one on either side of the control board, within easy reach of the operator as he sits in a swivel chair in front of the control board.

Turntables are used to play phonograph records and electrical transcriptions, which are played at one of three speeds for broadcast use. These speeds are 78 revolutions per minute, 45 revolutions per minute, and $33\frac{1}{2}$ revolutions per minute (rpm). Therefore, the turntables or "playback machines", must be able to operate at each of these three speeds, at a simple adjustment by the operator. Some older turntables operate only at 78 and $33\frac{1}{2}$ rpm.

A broadcast turntable consists of a large, heavy, flat metal revolving plate, felt or rubber covered, and mounted on top of a cabinet. The revolving plate is rotated by an electric motor. The motor, and the speed changing mechanism are located within the cabinet.

Beside the revolving plate, a pickup arm which houses the stylus (needle), is mounted on the cabinet top. Also found on top of the cabinet are a support for the pickup arm, and a filter switch. The filter switch provides the operator with several record and transcription filters and equalizers, the uses of which will be described later.

The switch that is used to activate the turntable motor, and the turntable speed-change lever may be located either on top or on one side of the cabinet.

The layout of the above mentioned items on the turntable cabinet varies with the manufacturer. We will examine turntables made by RCA and by Fairchild, two of the most popular turntables used at broadcast stations (see Figs 3-9 to 3-11).

The pickup arm is a metal rod or tube, between 12 and 18 inches in length. It houses the reproducing cartridge containing the stylus at one end, and carries the sound from the record or transcription to the console. The weight of the arm and cartridge are counterbalanced at the mounted end of the arm by a weight, or a spring, to prevent excessive wear on the records over which the stylus travels. The mounted end of the arm is a swivel arrangement that allows the entire arm to move up and down, and from side to side across a record.

The reproducing cartridge receives the vibrations picked up from the



Figure 3-9
RCA BQ70 Turntable Front View
Courtesy Radio Corp. of America



Figure 3-10
RCA BQ70 Turntable Top View
Courtesy Radio Corp. of America



Figure 3-11
Fairchild 530 Turntable
Courtesy Fairchild Recording Equipment Co.

AUXILIARY CONSOLE INPUT FACILITIES

record by the stylus (needle). It acts similarly to the element in a microphone, and sends the sound from the record to the console. The magnetic type of cartridge is the most widely used in broadcast stations.

High quality styli (needles) are used for broadcast purposes and are made with either diamond or sapphire tips. It is the jeweled tip of the stylus that rides in the grooves of a record and picks up the sound captured there.

There are two schools of thought as to whether the diamond or the sapphire tipped stylus should be used. The diamond tip is the harder, more durable of the two substances, and this makes for long stylus life. However, the very hardness of the diamond causes the records to wear out more quickly. The sapphire tip is not as hard a substance as diamond, and therefore it wears out faster, but it is gentler in its treatment of the record grooves.

Figure 3-12
Reproducing Cartridge & Stylus
*Courtesy Fairchild Recording
Equipment Co.*



As the stylus is used, "flats" are worn on its curved surface. These flat areas then scrape against the record groove walls, and distort the quality of the sound. When the stylus becomes worn or broken, the entire cartridge is removed and replaced. The defective unit is sent back to the manufacturer for repair and reconditioning.

Figure 3-13
RCA Reproducing
Group
*Courtesy Radio Corp.
of America*

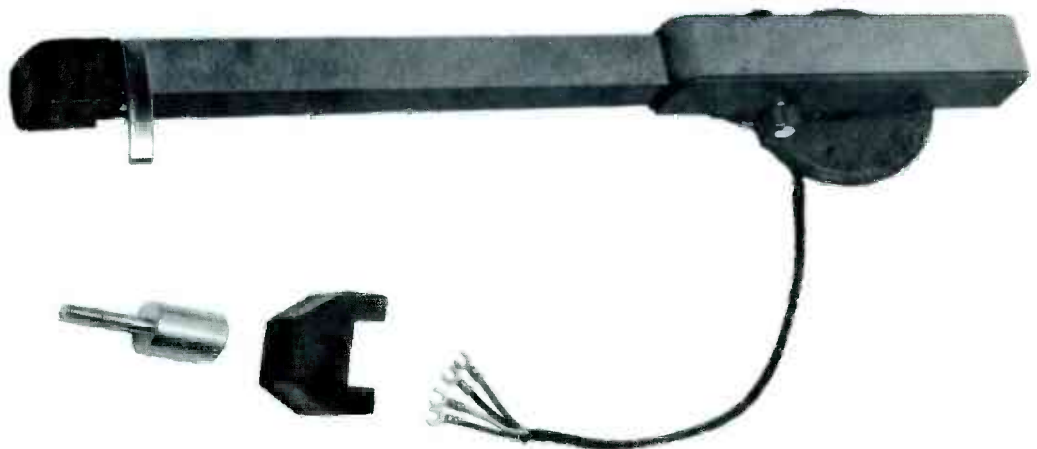

AUXILIARY CONSOLE INPUT FACILITIES

A filter/equalizer is standard equipment on broadcast turntables. The operator, when playing a record or transcription, chooses the filter or equalizer which makes the recording sound best to his ears, by means of a multi-position switch on top of the turntable cabinet.

Filters and equalizers are necessary because of the nature of the material of which the record is made—usually a vinyl plastic or a shellac. They are necessary as well, because of inherent vibrations of the metal in the stylus and pickup arm, and dirt particles deposited in the record grooves—all of which prohibit a true and accurate reproduction of the sound frequencies that originally entered a microphone at a recording session.

The human ear, on the other hand, is a highly sensitive aural or hearing device. It becomes keenly aware of the difference between actual sounds, and their recorded reproduction.

The operator must compensate for the sound frequencies that are lost or distorted, due to the mechanical inability of the record and the pickup arm to reproduce them. He uses record equalizers which replace, as far as the ear can tell, the high and low frequencies which otherwise would be lost to the listener.

Records tend to become noisy and scratchy sounding from repeated use, and the adherence of dirt particles to the groove surface. The operator uses filters to alleviate this noisy condition before the records are sent "out on the air".

Noisy music records are a near guarantee that the listener will search his dial for another station or channel that is presenting music without the distraction of noise.



Figure 3-14
Fairchild Filter Outside View
Courtesy Fairchild Recording Equipment Co.

AUXILIARY CONSOLE INPUT FACILITIES

Tape Playback

In recent years, tape recorders have become *must* equipment in the up-to-date control room. While they serve a similar purpose to turntables, they are infinitely more flexible in their operation and use.

Entire network shows may be tape recorded in advance for later playback. Sports programs, special events, and on-the-spot news items may be recorded for later insertion into the stations program schedule. Talks by inexperienced speakers may be tape recorded and later "edited," to remove those embarrassing long pauses, and the hemming and hawing that goes with inexperience in front of a microphone.

All of these abilities, and particularly the ability to "erase" the tape when no longer of use, and the re-use of it for other tape recording, make tape recorders a requirement of good broadcast station operation.

A tape recorder consists of:

1. A tape transfer mechanism which moves the tape from a feed reel, past the tape heads to a takeup reel, *at a constant speed*. The constant speed is maintained by a capstan, a pair of tangent wheels or rollers through which the tape must pass.
2. A speed changing switch, and a start switch. The start switch can usually be positioned to Record, Play, Fast Forward, or Reverse.
3. From one to three tape heads, which either record, erase, or playback the tape as required, as the tape passes across their sensitive surface areas.
4. A recording amplifier to impress the sound onto the tape through the record head.
5. A playback amplifier to feed the sound that is impressed on previously recorded tape, to the control board. The sound on the tape activates the playback head which sends it to the playback amplifier.
6. An erase oscillator to clean unwanted, previously recorded sound from the tape. The erase oscillator operates the erase head, which in turn erases the tape.

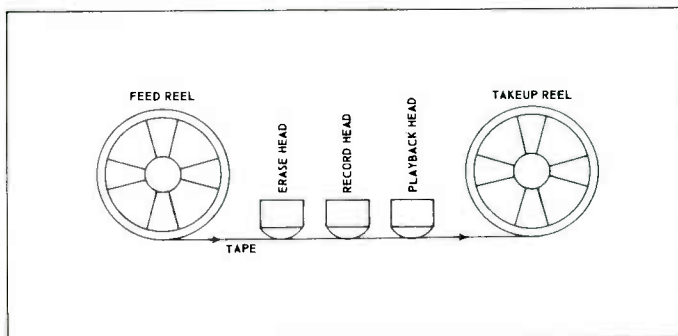

Figure 3-15
Tape Transfer Mechanism & Tape Heads

AUXILIARY CONSOLE INPUT FACILITIES

The tape heads are arranged in a line near the tape transfer mechanism. They are usually aligned in this order: erase head, recording head, playback head.

In the less expensive home-recorder tape machines, the functions of the tape heads are carried out by two heads or sometimes by one combination head with, of course, a subsequent loss of reproduction quality.

The exact placement of the tape machine in the control room varies from station to station, the important thing being that it is within easy reach of the control operator.

Tape recorders for broadcast use are operated at either 7.5 inches per second (ips), or at 15 inches per second. The standard operating speed set by the NARTB (the National Association of Radio and Television Broadcasters) is 15 ips, with a sub-standard of 7.5 ips. Some home tape recorders operate at $3\frac{3}{4}$ ips, for economy of tape, but with a subsequent loss in reproductive quality, others operate at 7.5 ips, and a very few at $1\frac{1}{4}$ ips. The phonograph recording industry uses some machines that operate at 30 ips for maximum ease in editing, and maximum quality of reproduction.

Two examples of the most widely used tape machines in the nation's broadcast stations are the Ampex and the Magnecorder. The Magnecorder is familiarly known to broadcast men as the "Maggie".

Magnecorder Operating Instructions

1. Turn the power switch ON.
2. Place an empty reel on the takeup spindle which is located on the right side of the machine. Fasten the retaining spring to hold the reel on the spindle.
3. Place a reel of tape on the feed spindle which is located on the left side of the machine. Fasten the retaining spring to hold the reel of tape on the spindle.
4. Run the loose end of the tape from the feed reel over the top idler wheel, around and under the bottom idler wheel, across the tape heads, through the constant speed capstan rollers, and attach it to the takeup reel.
5. To record on the Magnecorder, turn the selector switch to the record position. Turn the motor start switch to the forward position, and proceed to ride gain on the program being recorded.
6. To play back on the Magnecorder, turn the selector switch to the playback position. Turn the motor start switch to the forward position.
7. To rewind the tape, lift it from the tape heads and the idler wheels. Turn the motor start switch to the rewind position.

Ampex Operating Instructions

1. Turn the power switch ON.
2. Place an empty reel on the takeup spindle which is located on the right side of the machine.



Figure 3-16
Magnecorder Tape Recorders
Courtesy Magnecord Incorporated

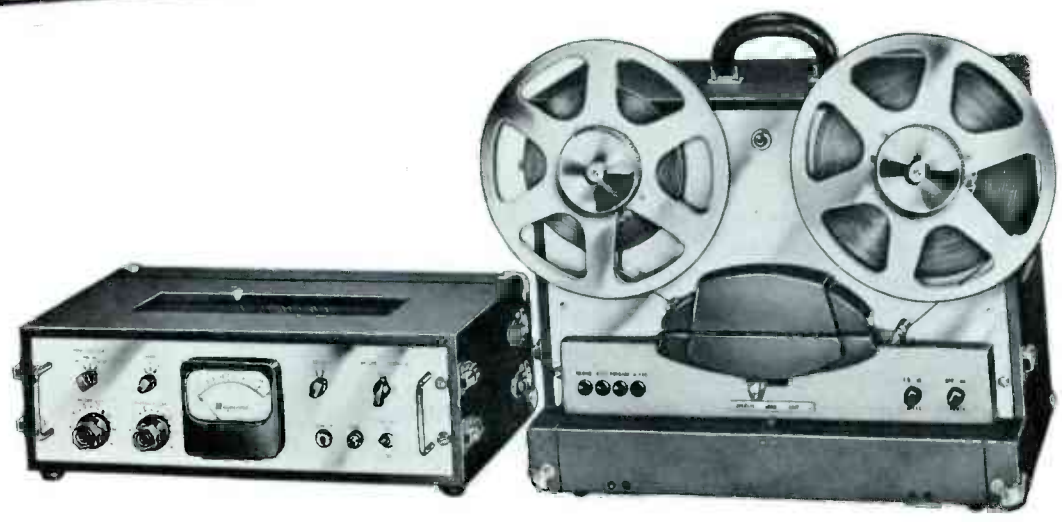
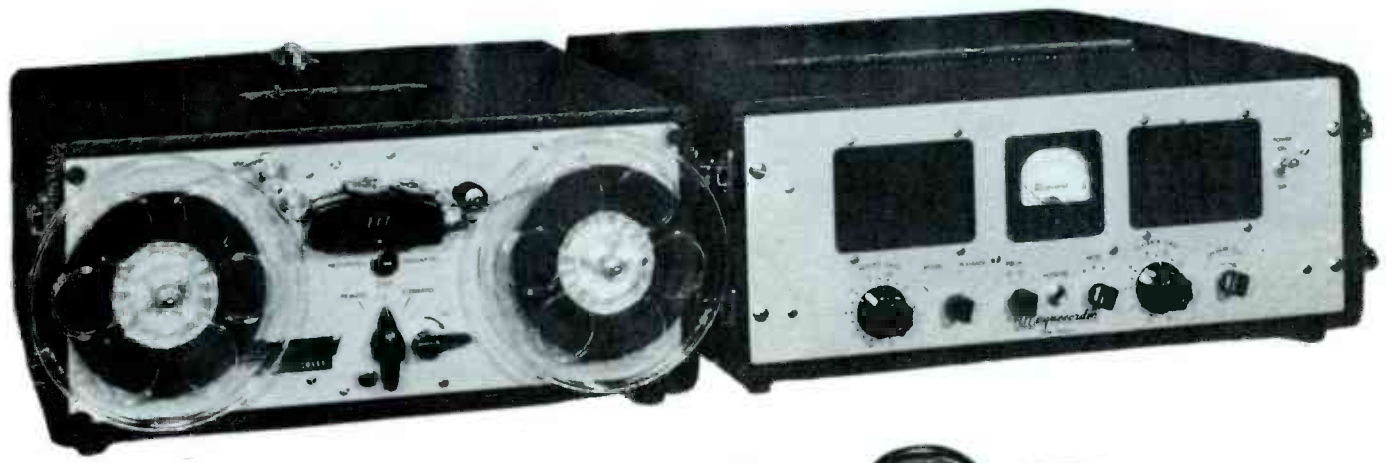

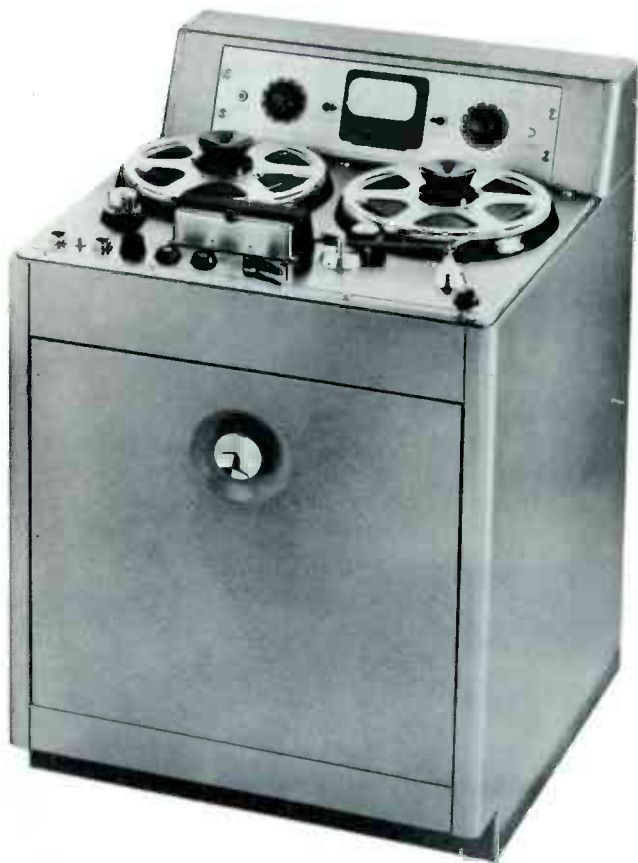

Figure 3-17
Ampex Tape Recorders
Courtesy Ampex Electric Corp.



3. Place a reel of tape on the feed spindle which is located on the left side of the machine.
4. Set the speed-change switch for either 7.5 or 15 IPS as desired.
5. Set the tension switch for either large or small reels.
6. Open the gate which covers the tape heads by pulling its handle forward, towards the front of the machine.
7. Run the loose end of the tape from the feed reel through the feed reel idler, between the gate and the tape heads, through the constant speed capstan rollers, through the takeup tension arm, and attach it to the takeup reel.

AUXILIARY CONSOLE INPUT FACILITIES

8. Close the tape head gate.
9. To record on the Ampex, turn the selector switch to the play position. Depress the start pushbutton, wait a few seconds, then depress the record pushbutton and procede to ride gain on the program being recorded.
10. To play back on the Ampex, turn the selector switch to the play position. Depress the start pushbutton.
11. To rewind the tape, open the tape head gate, turn the selector switch to the rewind position, and depress the start pushbutton.

Field Tape Inputs

In addition to the Magnecorders and the relatively large studio-type Ampex recorders, there are professional tape machines of a more portable nature which are used in "field," or away-from-station work. Two of the more popular recorders of this type are the Stancil-Hoffman M9 Minitape and the Ampex 600 series, the latest of which is the 602.



Figure 3-18
The M9 Minitape
Courtesy Stancil-Hoffman Corp.

AUXILIARY CONSOLE INPUT FACILITIES

The M9 Minitape

A small recorder weighing 13 pounds, battery operated and completely transistorized. The batteries are the nickel-cadmium rechargable type which will permit four to five hours of recording before recharging is necessary. The M9 has automatic gain control, adjustable through the setting of a high-gain, normal-gain switch on the right side of the tape deck. The recorder will accept up to 5-inch reels, permitting 15 minutes of recording at 7½ inches per second. The tape is threaded from the feed reel on the left, past a tape guide, through the head assembly slot, between the capstan and pressure roller, around the outside of the right guide and onto the takeup reel. Spring clip hold-downs retain the reels in place with the recorder held in any position. To the left of the head assembly is the mode switch which places the machine in Rewind, Off, Play, or Record—with the safety interlock button depressed.

On the outside of the case, adjacent to the handle, are the Battery Charger-Earphone connector, the Stop-Start switch which operates the recorder in all modes, the slide type selector switch which permits monitoring of either the input sound or the reproduced output sound while recording, and the Microphone connector.

The M9 is employed primarily under conditions where there is no power (AC) available for the more conventional recorder, or where the recording is to be made in a mobile situation.

The Ampex 600 Series

These recorders, the latest of which is the 602 (pictured here), have become the workhorses of the field recordist in recent years—an extremely rugged machine weighing 28 pounds. The seven-inch (1200 ft.) feed reel is placed on the left spindle of the tape deck and the rubber hold-down is pressed onto the spindle tip. The tape is threaded through a roller tape guide, through the head assembly, between the capstan and pressure roller, outside of the right guide post and onto the takeup reel.

To the right of the capstan are two mode switches. The first is the Play-Record switch, with a safety interlock button which lights up when depressed to Record. The second switch provides Fast Forward or Fast Rewind. These switches are mechanically interlocked so that only one may be engaged at one time.

On the panel below the tape deck is a standard VU meter. Below the meter are the microphone level control, the monitor selector switch enabling listening to either the input sound or that which has been recorded on the tape, the line level control, the microphone connector, and the power switch and earphone jack. Connections for AC power, line input and line output are made through an open window in the right side of the carrying case. This recorder may be used as a remote line amplifier as well as a recorder.

AUXILIARY CONSOLE INPUT FACILITIES



Figure 3-19
The Ampex 602
Courtesy Ampex Corp.

Figure 3-20
Cartridge Tape Recorder
Courtesy Radio Corp. of America



Incoming Lines

Many broadcast stations are network affiliates. A network is a broadcasting company that provides local stations with many programs each day. These programs originate in the network's studios, or at large metropolitan stations called key stations of the network. The "net" programs are sent to the local station via telephone lines. These special telephone company or "telco" lines are run in what are called "loops", throughout the United States. Program feeds to the local station are provided on a fee basis from these loops.

AUXILIARY CONSOLE INPUT FACILITIES

Another service of the telephone company used by broadcast stations is its remote line service. When a broadcast station does a remote broadcast or *nemo* from a movie theater, sports arena or banquet hall, the telephone company sets up lines between the remote point and the station.

Two pairs of lines are sometimes ordered for a remote broadcast. One pair is used as the radio or audio line, the line on which the program is fed from the remote point to the studios. The other pair is called the "order wire". It is used as an emergency line in case of failure of the radio or audio line, and also as a private telephone line between the operator at the "remote", and the operator in the station's control room.

In the event of a failure of the radio or audio line, the operator at the studio calls his associate at the remote site quickly on the order wire. He explains the situation and they reverse lines so that program is fed to the studio on the order wire, with a minimum of lost air time.

Several classes of audio line service are available to the broadcast station at a fee commensurate with the line quality:

Class AAA Line—Ordered for continuous use, having a frequency range of from 50 to 15,000 cycles per second.

Class AA Line—same usage, with a frequency range of from 50 to 8000 cycles per second.

Class A Line—same usage, with a frequency range of from 100 to 5000 cycles per second.

Classes BBB, BB, and B Lines—Ordered for *occasional* useage with the same frequency characteristics as the comparable A lines.

Class C Line—Ordered for continuous use with a frequency range of from 200 to 3500 cycles per second.

Class D Line—Ordered for occasional use with the frequency characteristics of the class C line.

Class E Line—Ordered for occasional use, with a frequency range of from 300 to 2500 cycles per second.

Thus, a broadcast station would order its lines dependent upon the quality needed and whether full time or occasional use is the deciding factor.

Echo and Reverberation Effects

Echo and reverberation are often used for special or trick effects, or to lend additional aural perspective to a broadcast.

If a dramatic sequence portrays a mountain climber who has fallen into a crevasse, then reverberation may be added to his cries for help, to add needed aural depth to a studio "crevasse". If the same mountain climber, now rescued, yodels his song of gratitude from the top of a hill, then echo might be added to his song, to make up for the lack of actual hills in the studio.

Echo and reverberation are both conditions which result from the delay

AUXILIARY CONSOLE INPUT FACILITIES

and subsequent reflection of sound waves. If the time delay between the original sound and its reflection is short, reverberation, or sound overlapping, is the result. If the time delay is great enough so that the original sound has disappeared before its reflection is heard, then the condition is called echo.

Echo and reverberation occur naturally in large open spaces with reflective backgrounds, but they may be created and controlled artificially at a broadcast station. An electronic instrument called a reverberation unit can be used, which introduces an adjustable time delay to sound that is fed into it. One such device is manufactured by the Audio Instruments Company.

The audio operator connects the microphone which will require the introduction of echo or reverberation, so that its pre-amplifier can feed into either the program amplifier as it usually does, or so that it can feed into the input of the reverberation device. The instrument is then set for the required time delay.

The operator throws an auxiliary key on the console to switch the microphone in question from its normal feed to the program amplifier, to a feed to the reverberation device. The delayed sound is then returned to the console and appears on another auxiliary pot and key. Thus, the operator can change the sound that is picked up by this one microphone from no-echo to echo, and back to no-echo, at will. He can ride gain on both the sound that is entering the reverberation device, and the delayed and reverberated sound that is emanating from it.

Still another method that is used to obtain echo and reverberation effects at a broadcast station, is the use of an echo chamber. A large, highly reflective room, usually an empty cellar, or an empty elevator shaft is employed at the larger stations. Smaller stations sometimes use a large wooden box, constructed as a maze, with hard, polished inside surfaces. If a microphone and several loudspeakers are mounted in this room, shaft, or box, we have an echo chamber.

The loudspeakers are mounted so that each is a distance further away from the microphone than the one preceding it, thus permitting the operator to feed the sound from the studio microphone to any one of the loudspeakers. The operator chooses the loudspeaker which will give him the required degree of reverberation. He then feeds the sound to that loudspeaker. It is reverberated in the chamber, and picked up by the microphone in that same chamber. The reverberated and delayed sound is then returned to the console and appears on an auxiliary pot and key. The operator can then choose either echo or no-echo for the microphone, and ride gain on both.

AUXILIARY CONSOLE INPUT FACILITIES

CHAPTER 3 REVIEW QUESTIONS

1. Define an input to the console.
2. Name four inputs to a console.
3. How many types of microphones are used in broadcasting? Name them.
4. Explain the directional characteristics of each microphone type.
5. In what manner are microphones connected physically to a console?
6. What is a turntable? For what purposes are they used at a broadcast station?
7. At what speeds are records played?
8. What is a stylus? Of what materials are styli made?
9. What is the purpose of a filter? An equalizer?
10. Give the advantages of tape recordings over disc recordings.
11. What are tape "heads"? Describe their uses.
12. What is a tape transfer mechanism? Describe its operation.
13. What are the standard tape speeds approved for use in the broadcast industry?
14. Name the various types of incoming lines to a console.
15. Name and explain the classes of line service available to a broadcast station.
16. What is an echo chamber?
17. For what purposes are reverberation and echo used on a broadcast?

We have until now considered some of the equipment which feeds into the audio control console, to be amplified and routed. At this point we will begin to discuss the uses that are made of sound when it leaves the output of the console.

Lines Out

The amplified sound is sent out of the console on lines, or wire circuits. There are two categories into which these lines fall:

1. Telephone lines to outside points.
2. Internal lines to points within the broadcast station.

Lines to the Transmitter.

The most important lines out of the console are the lines that go to the transmitter. The transmitter, you will recall, is the device that sends the sound through the airwaves to the listener at home. There are always two lines to the transmitter: the normal program line and the emergency, standby line, which is switched in when the program line fails for any reason.

In some small broadcast stations, the transmitter is located within the same building as the studios. The lines to the transmitter would then be internal lines. If, on the other hand, the transmitter is located some distance away, the sound is sent to the transmitter via telephone company lines. Class A lines are used, to maintain a high sound reproduction quality.

The sound quality of the program will suffer from distortion, and indeed the modulator tubes of a broadcast transmitter may be blown by sudden heavy surges of high sound volume from the control console. The control operator, no matter how alert, will occasionally be occupied elsewhere when the sound volume rises abruptly. He will be unable to adjust the pot quickly enough to prevent the sudden volume rise from leaving the console for the transmitter.

CONSOLE OUTPUT FACILITIES

To protect the transmitter tubes from damage, and to prevent sound distortion, a limiter unit is employed. The limiter is installed near the transmitter and the program line from the control console feeds through the limiter and then to the transmitter. The function of the limiter is to automatically lower abnormally high peaks of sound volume to normal levels before they reach the transmitter.

Lines to Loudspeakers, Monitor Bus.

Mention has already been made of the part that loudspeakers play in the control room and studio. The operator must be able to hear the program that is emanating from the studio. The talent in the studio should be able to hear those portions of the program coming from the control room, on records or on tape.

In addition to the control room and the studio, there are other locations at a broadcast station where outgoing programs must be heard; some of these locations are:

- Station manager's office.
- Program director's office.
- Chief engineer's office.
- Announcer's lounge or standby room.
- Sponsor's auditioning room.
- Station's reception room.

All of these locations and possibly more, depending upon the size of the of the station, have loudspeaker installations. These loudspeakers are connected by lines to the monitor amplifier of the console in the control room of the originating studio.

This system of lines which runs to many rooms and offices throughout the broadcast station building is called the monitor bus.

Lines to the Network.

If the broadcast station is a large one in a metropolitan area, it may be a key station in its network and originate programs for its network. Individual programs, but not its entire daily program schedule, are fed to the network from the control board of the originating studio via telephone company lines.

Lines to Recording Rooms.

Some broadcast stations, particularly the larger ones, have a special room where their recording is done on tape, on disc, or both. In this room are large tape recorders and massive disc recorders. The program material to be recorded is sent via internal lines from the recording studio's control room, to the recording room. At small stations, recording is done on equipment located in the control room.

CONSOLE OUTPUT FACILITIES

Lines to Master Control Room.

Broadcast stations having a large number of studios employ a master control room for routing programs. Instead of having lines to the transmitter, network, monitor bus, and recording room from *each* studio, the studios each have *one* line to master control. In the master control room, the programs are routed to their various destinations by the master control operator. This system saves duplication of lines from the studios, and provides a single point of control of the quality and sound volume of all programs emanating from the broadcast station.

Figure 4-1

CBS Master Control Room

Courtesy Columbia Broadcasting System

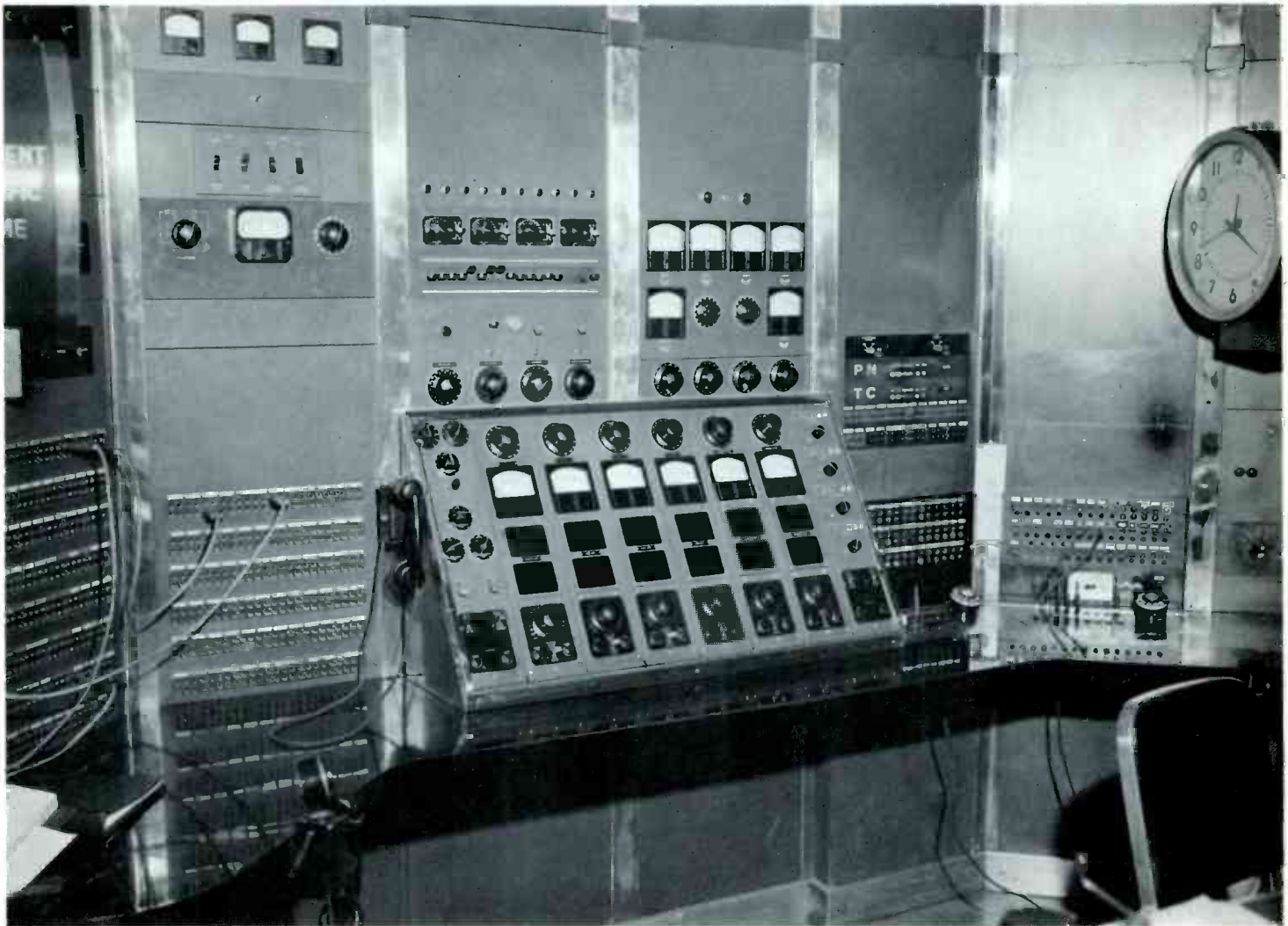

CONSOLE OUTPUT FACILITIES

Lines to Warning Lights.

To discourage unauthorized persons from entering a studio while it is on the air or during a recording session, and possibly disturbing the actors and announcers, an easily-visible sign is mounted above each studio door. The sign usually reads, "On The Air", or "Recording-Keep Out".

When a studio is in use, either on the air or during a recording session, a relay (electrically operated switch) within the control console automatically illuminates the warning sign. The illumination is usually a bright red light so that there will be no doubt of its meaning.

Another warning system employing a red light is found in most studios and control rooms. In this system, whenever a microphone is turned on, a red bulb is illuminated in that room to warn the announcer or other talent that a microphone is live.

While neither of the above warning systems is technically an output of the console in the same sense that program lines are, they are included here because they operate from the control console in conjunction with the sound output, and because they are necessary to unhampered studio operation.

CHAPTER 4 REVIEW QUESTIONS

1. What is meant by a console output?
2. Name the lines out of a console.
3. What is a monitor bus? Where does it go?
4. What is a master control? What is its purpose?
5. What is the purpose of "On The Air" lights?

While records and tape by themselves are not part of a control room's equipment, they are a vital part of most programs. The audio control operator is responsible for airing the records or tape on a show. He should therefore have some knowledge of how recordings are made, and how to handle them.

Disc Recordings

Disc recordings, or "platters", as they are called, are found in two general types:

1. The "instantaneous" type, which can be played back immediately after recording. This type of platter consists of a flat aluminum plate, either 12 or 16 inches in diameter, that has been coated with an acetate or lacquer compound. In the recording process, the platter is placed on the turntable of a disc recording machine or "lathe", and the sound is impressed in a spiralled groove that is cut into the acetate by the lathe.
2. "Pressings", which are made by a more complex manufacturing process. Here is how pressings are made by the Capitol Records company.

RECORDS, TAPE, AND TAPE EDITING



Figure 5-1 Recording Session
A singer and small orchestra perform before the high-fidelity microphones of Capitol's Hollywood studios.

RECORDS, TAPE, AND TAPE EDITING

Figure 5-2 In The Control Room

Producer and engineer supervise the session from a sound-proofed control room. Magnetic tape machine in the foreground is the most modern of recording equipment.



RECORDS, TAPE, AND TAPE EDITING



Figure 5-3 Tape Recording

The record is first made on magnetic tape, which permits editing by cutting and splicing (just as motion picture film is edited) before the music is transferred to discs.

Figure 5-4 Cutting The Master Disc

A lacquer (acetate) "master" disc is cut on a lathe whose high precision assures perfect reproduction. The sound is fed to the lathe from the tape machine in an adjoining room.





Figure 5-5 Checking Reproduction Quality
Sensitive electronic equipment permits accurate checking of the master disc before it ever leaves the studio.

Figure 5-6

Factory Operations

The approved lacquer master disc now enters the factory for processing. Here the operator sprays the disc with a silver concentrate. From these silver-coated discs, metal master discs are next made.



Figure 5-7 From Master To Mother To Stamper

By this electrochemical process, duplicates called "mothers" are made from the metal masters. From the mothers are made the "stampers", which are used to press the final records.



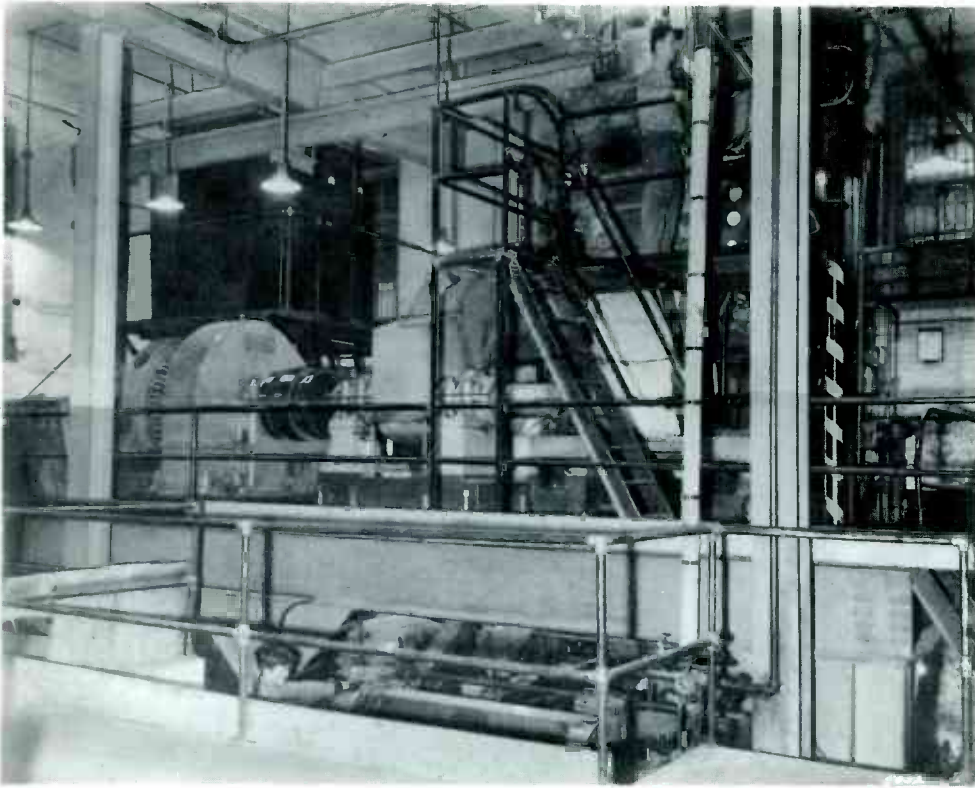

Figure 5-8 Preparing The Record Compound

This huge machine mixes raw materials according to exacting specifications. It produces the plastic compound from which are cut the carefully measured "biscuits" that become records.



Figure 5-9
Pressing A Record

A pre-heated biscuit is inserted between the stampers and dies of a hydraulic press. Compression-molding forms it into a nearly finished record, complete with labels and center hole.



Figure 5-10

Inspection And Packing
Finished records receive their final inspection before being placed into their individual sleeves or album containers, ready to be shipped to distributors.

All photos courtesy Capitol Records Corp.

Transcriptions.

A transcription is a disc recording that has been manufactured for use at broadcast stations only.

Lateral and Vertical Cut Records.

When a record is made, the sound captured on it is cut or engraved into grooves made on the record. One method of cutting, engraves the sound into the walls of the groove. This is termed "lateral" recording. Another method which engraves the sound on the floor of the groove, is called "vertical", or hill-and-dale recording. In bygone days vertical recording was used extensively for transcriptions. In recent years however, virtually all of the recording companies have adopted the lateral cutting method.

One company, World Transcriptions, still makes vertical recordings, but all records that are made for home use and most of the records and transcriptions made for broadcast use, are recorded laterally.

This information is of more than just passing interest to the control operator. If he is given a vertical recording to be played on a program, he must be certain that he chooses a vertical filter on the turntable. Conversely, when the operator receives an everyday lateral recording to play, he should check to see that a lateral filter is being employed. The use of a vertical filter for a lateral recording, or a lateral filter for a vertical recording, will result in a thin, tinny, distorted sound.

RECORDS, TAPE, AND TAPE EDITING

Information regarding the type of recording will be found on the record label. If no information is given, the record may be assumed to be a lateral cut, or the operator may check by auditioning the record.

Outside-In and Inside-Out Cuts

The familiar music record that is made for home use, is cut "outside-in". That is, the music starts in one of the grooves near the outside, or outer edge of the record and continues as the groove winds its way toward the center of the record.

Records and transcriptions may also be cut "inside-out". That is, the sound begins in one of the grooves near the center of the record and continues as the groove winds its way towards the outside edge of the record.

The operator may determine whether a record has been cut outside-in, or inside-out, by reading the information given on the record label. If no information is given, the record can be presumed to be an outside-in cut. The operator may further assure himself of the type of cut by auditioning the record.

Microgroove or Long Playing (LP) Records.

To increase the playing time available on a record LP's, or microgroove records were devised. LP's are recorded at speeds of either 45 or 33 $\frac{1}{3}$ revolutions per minute. The object in devising the LP record was to be able to put a greater number of grooves per inch on the record, and thus be able to put a longer musical selection on one record than was heretofore possible. Microgroove, or LP records are cut so that they contain from 160 to 350 lines (or grooves) to the inch.

The standard 78 rpm home-use music record is cut at a rate of 80 to 96 lines (grooves) per inch. The standard 33 $\frac{1}{3}$ rpm records and transcriptions are cut at a rate of from 120 to 144 lines (grooves) to the inch.

Handling Records and Transcriptions.

A few precautions should be observed by the operator in handling records. If a record is held so that the operator's fingers touch the recorded grooves, some of the oil that is excreted by human fingers will adhere to the groove surfaces. This oil attracts and holds gritty dust particles found in the air. When the record is played, these particles will impart noise to the sound of the record.

An operator who takes pride in the quality of the records he plays, will not touch the records on their grooved surfaces. He will hold them instead by the outside edges, or by the label area in the center of the records.

The operator should be careful not to scratch the groove surface, or place a record on anything which would cut into the grooves. This is particularly true of instantaneous acetate recordings, since the acetate surface is necessarily soft, and easily damaged.

Records should be kept in jackets when not being played. They should be stored in a dust-free room to avoid their picking up gritty dust particles which distort their quality. They should be stacked on end, in bins or racks,

RECORDS, TAPE, AND TAPE EDITING

never lying down on the groove surface area. If records are stored in a flat position, they will warp and become difficult or impossible to play.

Tape Recordings

In recording sound on tape, a cellulose or polyester plastic ribbon is used. This ribbon has been coated with a finely powdered magnetic iron oxide. The coating, due to its iron content, permits the tape to be easily magnetized.

The recording amplifier in the tape recorder changes sound to magnetism and imparts it to the tape. The tape stores the sound in the form of magnetism on its iron oxide coating.

Upon examination a tape will be found to have a dull side and a glossy



Figure 5-11

*Magnetic Recording Tape
Courtesy Minnesota Mining
& Mfg. Co.*

side. The dull side of the tape is the side which is coated with the iron oxide compound. It is the dull, coated side which must always face towards the tape heads, and be in contact with them during either recording or playback.

When playback of the sound is desired, the magnetism on the tape, passing over the playback head, activates the playback amplifier, which sends the sound to the console. A reel of recorded tape may be played back any number of times without any ill effect to the sound stored on the tape, provided that the tape is not stretched or its edges frayed.

When the recording on a reel of tape is no longer wanted, the tape may be erased. As a matter of fact, when the operator records on a reel of tape, the tape is automatically pre-erased by the erase head before it reaches the recording head. Tape erasing is accomplished by the erase oscillator of the recorder, which impresses on the tape a high frequency alternating magnetic field by way of the erase head. This high frequency field disrupts the magnetic alignment on the tape, and the sound is effectively removed. Noises sometimes remain on the tape after erasure due to a phenomenon called re-

RECORDS, TAPE, AND TAPE EDITING

residual magnetism. The noises caused by residual magnetism can be removed from the tape by using a special bulk tape eraser unit. Bulk tape erasers are also used to erase entire reels of recorded tape rapidly, without re-recording.



Figure 5-12
Bulk Tape Eraser
Courtesy Cinema Engineering Division

Bulk tape erasers like the one pictured contain a powerful electromagnet which disrupts the orientation of the magnetic particles, and thus removes the sound stored in those particles, from a reel of tape. The reel of tape need not even be removed from its cardboard container to be erased.

To bulk erase a reel of tape:

1. Place reel of tape on phenolic surface of eraser, using locating spindle if tape is not boxed.
2. Turn power switch ON
3. Rotate reel three or more turns in same direction, slowly.
4. Slide reel off of eraser, out and away from magnetic field, continuing to rotate reel slowly until at least 3 feet away.
5. Turn power switch off.

Care should be exercised in the handling and storage of reels of cellulose ribbon tape. They should be kept in a cool, somewhat moist atmosphere

(about 50% relative humidity), to prevent the plastic ribbon from becoming hard and brittle. An improperly stored tape will have a tendency to snap apart during playback.

A condition known as "cross-talk" sometimes occurs if a reel of recorded tape is stored for long periods of time without being played. Cross-talk is the leaking over of the magnetically stored sound from one layer of tape to an adjacent layer, either above or below it on the reel. This condition occurs because of the tightness of the tape layers on the reel as it is rewound onto the feed reel at high speed.

It has been found that if the tape is stored on the takeup reel, that is, backwards, cross-talk is much less likely to occur. The operator should then remember to label the tape "Rewind Before Playing", or he will find himself playing it backwards the next time that it is used.

Recording tape is sold by footage, in several reel sizes. The two most popular sizes used at broadcast stations are the seven inch reel and the ten inch reel. The seven inch reel holds 1,250 feet of tape and runs for a half hour at 7.5 ips, or for fifteen minutes at 15 ips. The ten inch reel holds 2,500 feet of tape and runs for one hour at 7.5 ips, or for a half hour at 15 ips.

Tape Editing

A tremendous advantage of tape recording over disc recording is the ability to edit the tape. An ordinary scissors may be used to cut out a word, a phrase, or a pause, from a recorded tape. A special type of gummed adhesive tape is then employed to put the two severed ends together again.

For increased speed and ease in editing tape, a number of tape editing devices exist. Basically, they each consist of a slotted metal bar which holds the severed tape ends while they are cut diagonally across with a razor blade. The diagonal cut is made to provide a greater joining surface for the splicing tape which is used to re-connect the severed tape ends. At the same time, the diagonal cut prevents a noticeable "Bloop" from being heard at the splice when the tape is played.

Two tape editing devices on the market are the Jiffy Tape Editor (Fig. 5-17) and the Editall (Fig. 5-18).

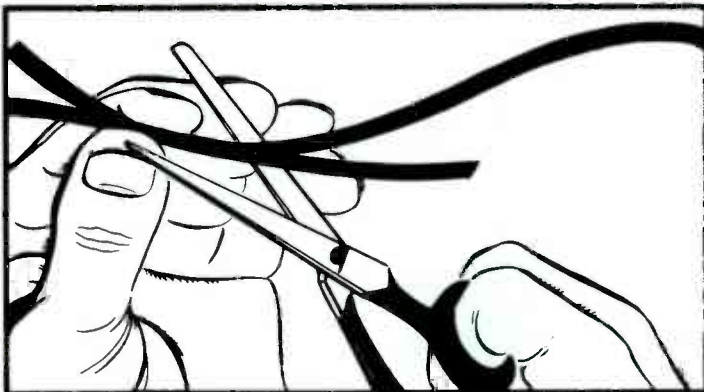

Figure 5-13

Cutting the Tape

Courtesy Minnesota Mining & Mfg. Co.

RECORDS, TAPE, AND TAPE EDITING

Figure 5-14
Aligning the Ends
Courtesy Minnesota Mining & Mfg. Co.

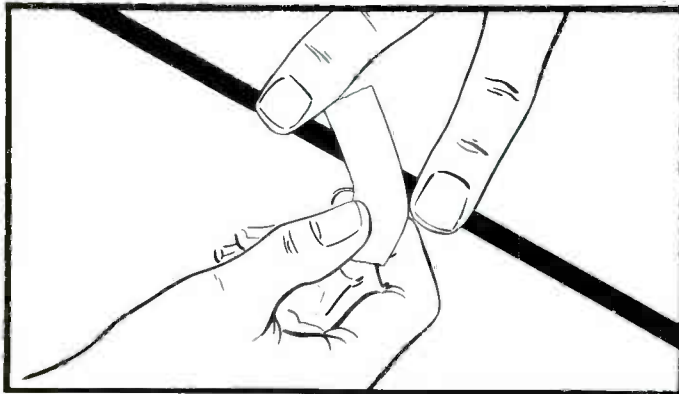
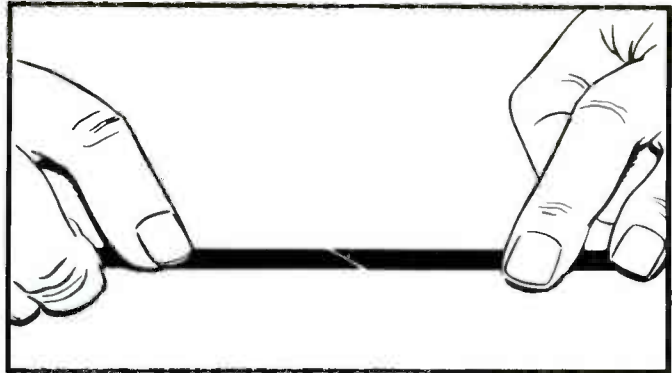

Figure 5-15
Applying the Splicing Tape
Courtesy Minnesota Mining & Mfg. Co.

Figure 5-16
Trimming the Finished Splice
Courtesy Minnesota Mining & Mfg. Co.

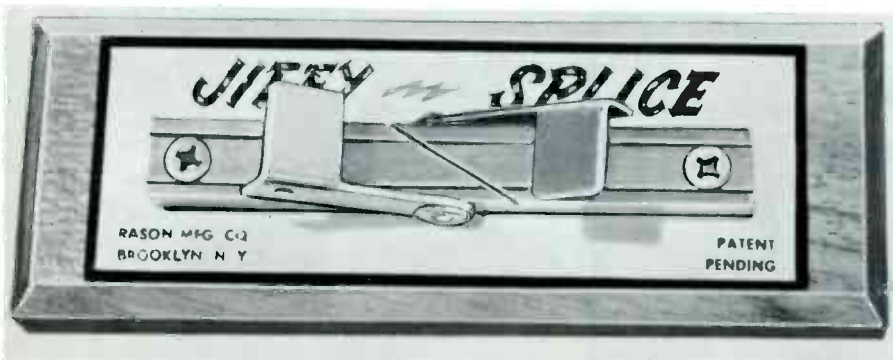
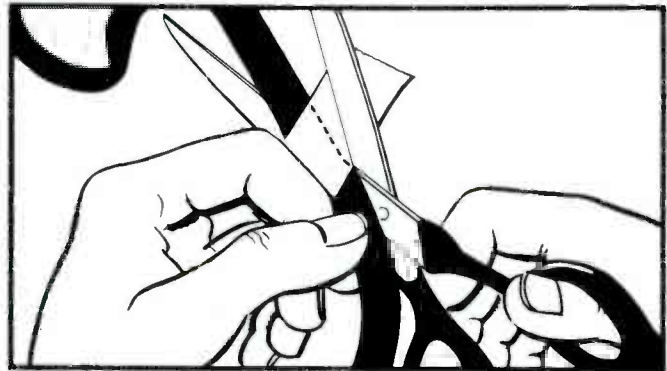

Figure 5-17
Jiffy Tape Editor
Courtesy Rason Mfg. Co.

Instructions for using the Jiffy Tape Editor

1. Raise the retaining arms of the editor.
2. Place the ends of the tapes to be spliced, shiny side up, into the editor, overlapping them at the diagonal cutting groove.
3. Lower the retaining arms to hold both of the tapes in the editor.
4. Make a diagonal cut through the tapes by running a razor blade through the cutting groove.
5. Remove the top scrap of excess tape.
6. Place a piece of splicing tape over the joint so that it covers both tape ends evenly.
7. Run the razor blade through the side grooves of the editor to remove any splicing tape which overlaps the edges of the recorded tape.
8. Lift the retaining arms of the editor and remove the spliced tape.



Figure 5-18
Editall Tape Editor
Courtesy Tech
Laboratories Inc.

Instructions for using the Editall Tape Editor

1. Place the ends of the tapes to be spliced into the lipped depression of the Editall, shiny side up, overlapping them at the diagonal cutting groove.
2. Make a diagonal cut through the tapes by running a razor blade through the cutting groove.
3. Remove the top scrap of excess tape.
4. Place a piece of $\frac{1}{32}$ inch splicing tape over the joint so that it covers both tape ends evenly and does not overlap the edges of the recorded tape.
5. Remove the spliced tape from the Editall by gently pulling it upwards from both sides of the editor simultaneously.

Leader Tape.

Leader tape consists of a plastic or paper ribbon which is the same width as recording tape. It is usually marked with alternately spaced plaid-colored and blank, white areas (Scotch Brand).

RECORDS, TAPE, AND TAPE EDITING

Two or three feet of leader tape should be spliced to a recorded tape, at each end of the reel. When two or more programs or selections have been recorded on the same reel of tape, a short piece of leader tape should be inserted between each two selections.

Leader tape serves four important purposes when it is attached to a reel of recorded tape:

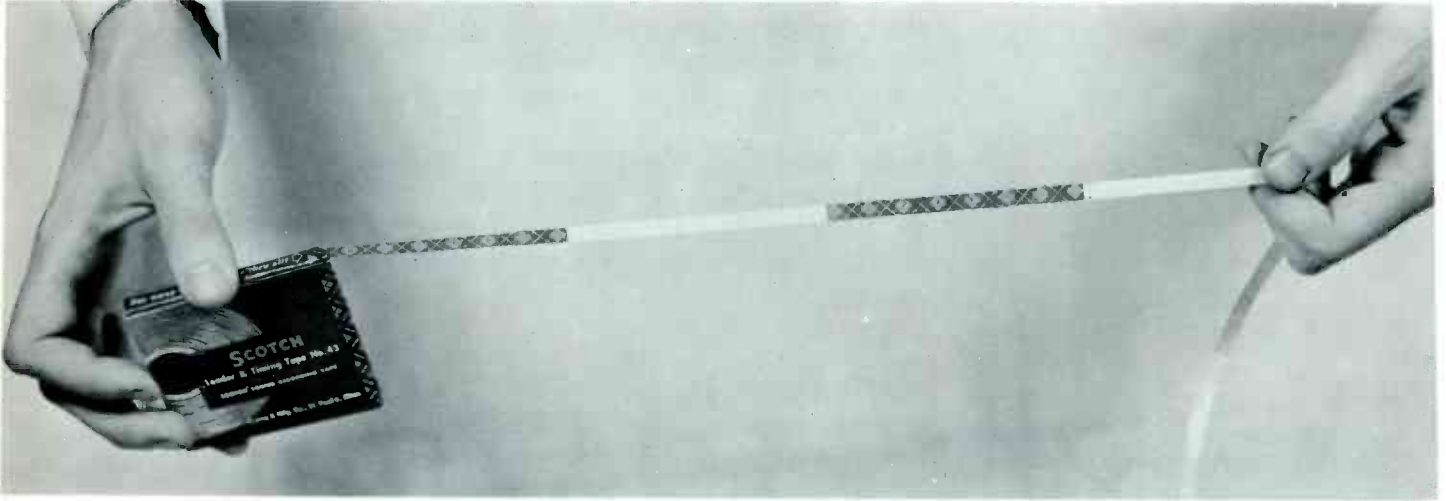

1. It saves valuable recorded material from being torn from the tape when the end of a tape is whipped from a fast moving, emptying feed reel. When the tape is being rewound, leader tape will save the beginning of the recorded tape from being torn off. The leader tape will be torn instead, but since it is easily replaceable, no damage will have been done.
2. If the leader is joined to the recorded tape within a few inches of the recorded material, then the operator playing back the tape can "cue by eye". He threads the tape into the tape machine until the joined end of the leader is at the playback head. The tape is then effectively cued by eye, that is, without the use of the console's auditioning system.
3. The names of *individual selections* can be written on the leader tape preceding each selection, or the name of the *program* can be written on the leader tape at the beginning of the reel.
4. If a pause of specific duration is desired between selections on a recorded tape, this can easily be accomplished by the use of leader tape. Each plaid segment, and each white segment of the Scotch Brand leader is exactly $3\frac{3}{4}$ inches long. One plaid *or* one white segment runs one second at a tape speed of $3\frac{3}{4}$ inches per second. One plaid *and* one white segment runs one second at 7.5 ips playing speed. One second of playing speed at 15 ips is indicated by two plaid and two white segments, or between two sets of arrows which are printed after every four segments of leader tape.

Figure 5-19
Leader Tape Segments
Courtesy Minnesota
Mining & Mfg. Co.

RECORDS, TAPE, AND TAPE EDITING

Thus, if we wished to have a five second pause between two selections on a tape that was recorded at 7.5 ips, we would insert a piece of leader between the selections, consisting of exactly five plaid segments and five white segments. If the same five second pause was desired between selections on a tape that was recorded at 15 ips, we would insert a piece of leader that consisted of ten plaid and ten white segments, or four sets of arrows and one white and one plaid segment.

Figure 5-20
Attaching Leader
to Recorded Tape
Courtesy Minnesota
Mining & Mfg. Co.



Figure 5-21
Trimming Off Excess
Splicing Tape
Courtesy Minnesota
Mining & Mfg. Co.



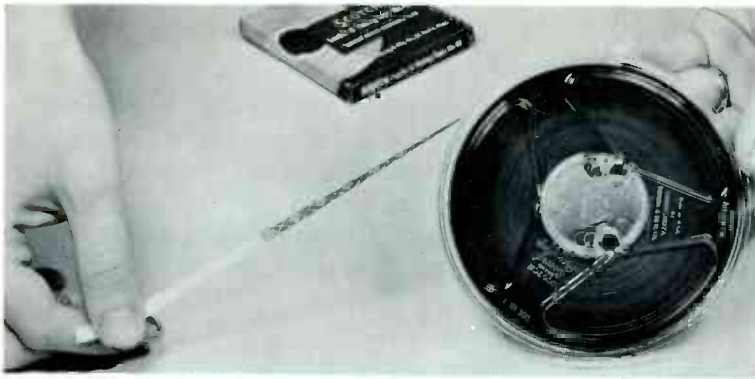
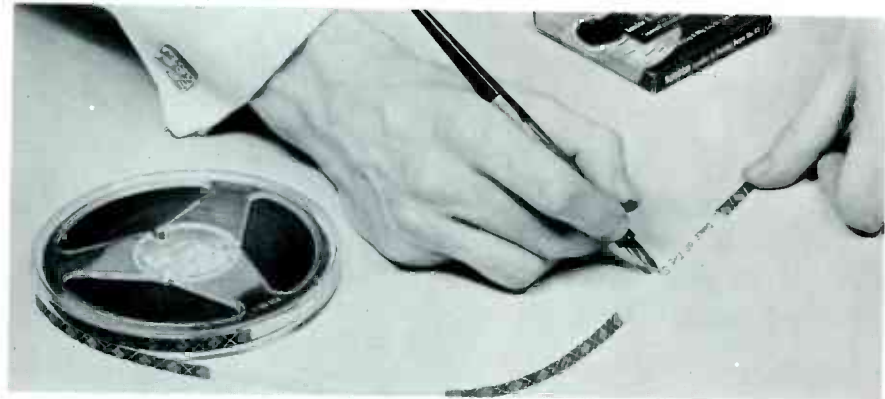

Figure 5-22
Recorded Tape with
Leader Attached

Figure 5-23
Marking Recording
Information on Leader
*Courtesy Minnesota
Mining & Mfg. Co.*



CHAPTER 5 REVIEW QUESTIONS

1. Describe the two methods or types of disc recording.
2. Explain briefly how "pressings" are made.
3. Define a transcription.
4. Explain the difference between lateral cut and vertical cut records.
5. Explain outside-in, and inside-out, starting records.
6. What is a microgroove recording? Why were they devised?
7. What pertinent information can be found on a record label?
8. Briefly explain the proper handling of a record by a control board operator.
9. In what manner should individual records be stored? Describe the proper conditions for a record library.
10. Recording tape is made of what two materials?
11. In what form is sound impressed on tape?
12. How many times may a reel of tape be played before it becomes distorted?
13. How is tape erased?
14. Explain the proper method of tape storage.
15. What is tape cross-talk? How may it be avoided?
16. Describe the various methods of editing tape.
17. What is leader tape?
18. Describe the four purposes of leader tape.

One might well ask, "What happens if, during a broadcast, an amplifier, a key, or another item of equipment breaks down? Do we go off the air? Do we stop the program and repair the faulty item? Do we have spare items of equipment to replace the faulty ones?" The answers to all those questions are found in a system of by-passing and replacing items of equipment called patching.

In a control room which has a patch panel (also called patch bay, jack bay, or patch board) every item in that control room may be connected to its preceding unit, and its following unit, *through* the patch panel. This is termed normal-through connection.

The patch panel allows the operator to dispense with or replace a faulty item quickly, with a minimum loss of airtime. He may also use the patch panel to add additional pieces of equipment to his operating facilities if he deems it necessary.

To illustrate patching, let us go back to the basic, one microphone channel console. Instead of a direct connection between the microphone, pre-amp, pot, key, program amplifier and line, as originally shown, the items are connected in the same sequence, but this time they are patch connected (see Fig. 6-1). This means that the operator can break the connection, if necessary, between any two or more items in the sequence. When the chain of items remains unbroken it is termed a normal-through connection, that is, the normal connection of item to item through the patch panel.

Assume now, that the pre-amplifier burns out during a program. What could the operator do to keep the microphone in operation during the show? We know, of course, that the microphone must operate through a pre-amplifier.

Briefly, what the operator does is replace the burned out pre-amplifier with a spare pre-amplifier that is connected to the patch panel (Fig. 6-3). To do this, he uses a patch cord which is a piece of electric wire with an

PATCHING

identical plug at each end. The patch cord plugs fit into the "jack pairs", or socket holes in the patch panel (see Fig. 6-2).

The operator replaces the burned out pre-amplifier in the following manner:

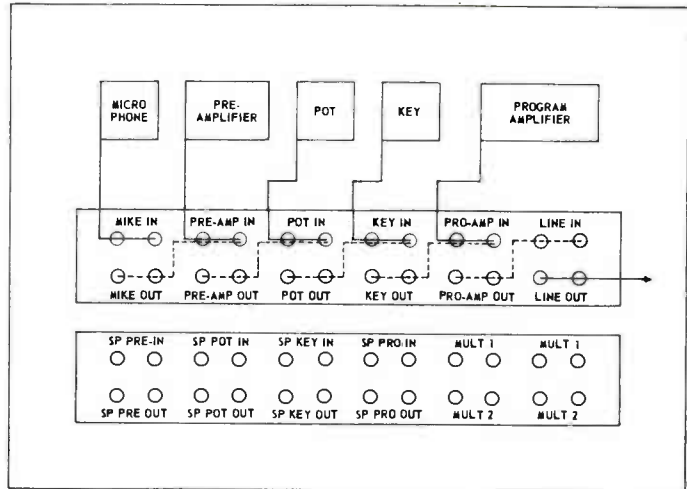
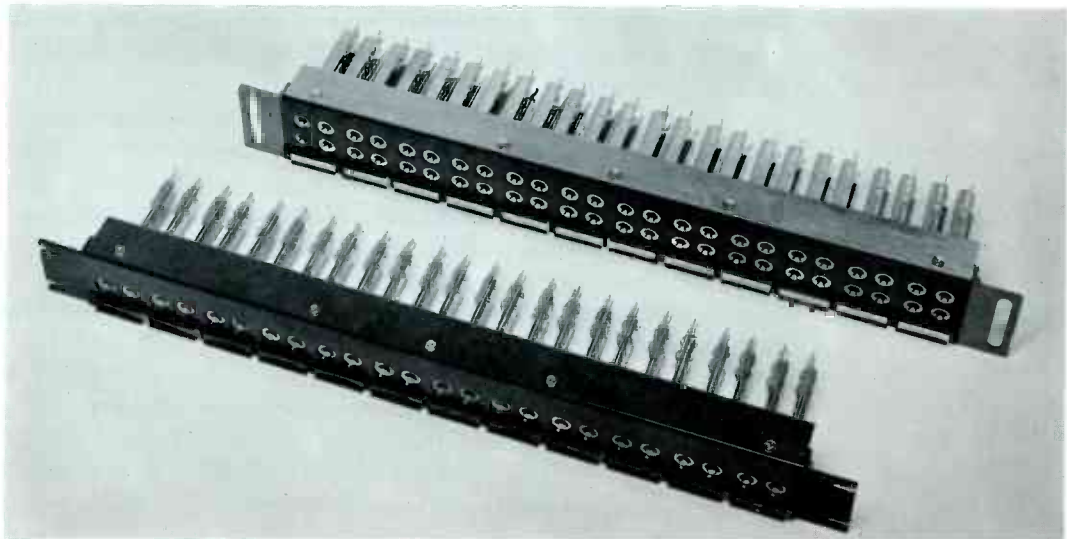

Figure 6-1
One Microphone Channel
Patch Connected



Figure 6-2
Patch Cord

Figure 6-3
Patch Panel
Courtesy Radio Corp. of America



PATCHING

1. He takes a patch cord from a supply of cords hanging near the patch panel.
2. He plugs one end of the cord into the jacks marked "pot in". The connection between the pot and the defective pre-amplifier is now broken.
3. He plugs the other end of the patch cord into the jacks marked "spare pre-amp out". The pot is now connected to the spare pre-amplifier.
4. The operator takes another patch cord from the supply of cords.
5. He plugs one end of this patch cord into the jacks marked "spare pre-amp in".
6. He plugs the other end of this second cord into the jacks marked "mike out". This breaks the connection between the defective pre-amplifier and the microphone, and connects the spare pre-amplifier to the microphone.

The burned out pre-amplifier has now been replaced with the spare. The entire procedure, despite the lengthy explanation of it, takes no more than ten seconds to accomplish, and the microphone is back in operation.

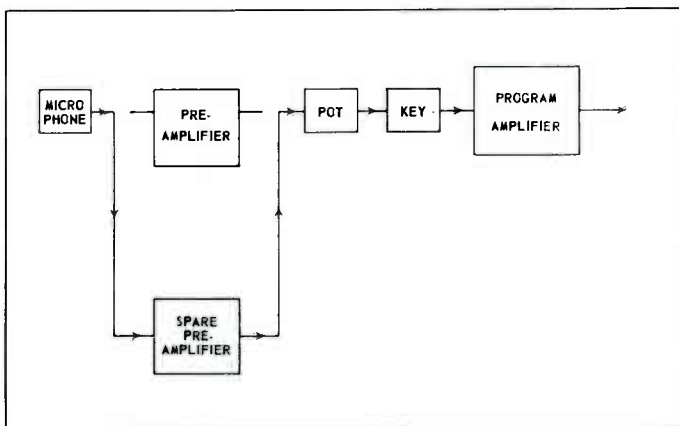

Figure 6-4

Defective Pre-Amp Replaced With Spare

In the illustration, Figure 6-4, the pre-amplifier plays the part of the defective member of the microphone channel. In actuality any item, the pot or the key, etc., could become defective and be replaced by patching around it, and patching in a spare unit to take its place.

The patch panels are located in racks situated in the control room. These racks also contain the spare amplifiers and other miscellaneous pieces of equipment. In some cases, as many as four or five racks, each about six feet high and two feet wide, will be found in a control room.

It may happen that a spare unit which the operator wishes to patch in, appears on a section of patch panel located six or eight feet away. The patch cords, on the other hand, are each about three feet in length and not elastic. How can the patch be made?

To provide for such a situation, the last couple of jack pairs on each

PATCHING

patch panel section are used as multiples. A multiple consists of two or more pairs of jacks that are internally connected to each other. If two patch cords are plugged into the same multiple set, then in effect they become one patch cord, twice the length of either cord alone.

If then, the operator wishes to patch from a pre-amp out, jack pair on one section of patch panel, to a spare program-amp in, jack pair on another patch panel section located six feet away, he would employ the following sequence:

1. Plug one end of a patch cord into the pre-amp out, jack pair.
2. Plug the other end of that patch cord into a multiple.
3. Plug one end of another patch cord into another multiple of the same set of multiples.
4. Plug the other end of this patch cord into the spare program-amp in, jack pair.

There are other uses for patching such as bridging and termination, but these fall within the realm of the broadcast engineer or technician.

Figure 6-5
Equipment Rack
Courtesy Par Metal Products

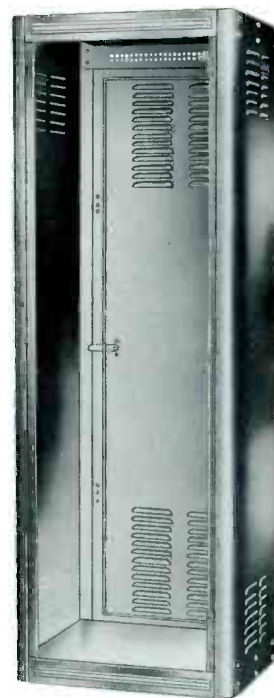

CHAPTER 6 REVIEW QUESTIONS

1. What is a patch?
2. Why do we patch?
3. What is a patch cord? A patch panel?
4. Explain the procedure for patching around a defective item of control room equipment.
5. What is a multiple? Explain why multiples are used.

The audio control operator is faced daily with many situations that require the application of esthetic values. It is within his domain to decide how to tastefully blend music and speech. His sense of precise timing and feeling for aural quality can be the difference between an excellent program and a merely adequate one.

The operator's actions must be accurate and he must be willing to stake his reputation on those actions every time he "fades in" a musical selection or opens a microphone. Did the music come "blasting" in? Did the announcer sound "bigger" than the one hundred piece symphony orchestra he introduced? Was the microphone opened too late to catch the announcer's opening words? Was the music "clipped" out instead of "faded" out?

These are some of the pitfalls that await the unwary operator. He must develop within himself a strong sense of what will, and what will not, "sound good" on a radio or a television program. To aid the operator in this development, we will include here some of the principles of good operating practice that are accepted in the broadcasting industry, and some of the operating techniques used by the author in his own audio control operating work.

Levels

Levels, refer to the degree of sound loudness that is read on the volume unit meter by the audio control operator. Levels are important in that they determine whether the listener at home hears clear or distorted sound, whether he must strain his ears to hear or is blasted out of his chair by high volumes of sound.

Surveys indicate that no matter how loud or how softly the individual operates his receiver, he still wants to hear music and speech at the same relative sound levels. Further, listeners prefer an even level regardless of whether they are hearing drama, variety, commentary or plain music. Although the listener's ear will tolerate a reasonable change in levels, he becomes annoyed if large volume level changes occur abruptly.

Abrupt changes in volume level may occur in the following situations:

LEVELS, BALANCE AND OPERATING TECHNIQUES

1. Between one speaker and another.
2. Between the end of a speech and the following music.
3. Between the loud musical opening of a program and subsequent quiet speech.
4. Between one music passage and another.
5. Between the end of one program and the beginning of the next program.
6. Sudden loud sound effects, screams, etc.
7. Sudden loud applause or loud audience laughter.

Changes in volume level should be made gradually by the operator. He should anticipate loud passages, noises and sudden drops in level, having heard them previously during rehearsal of the program, or from his past experience with similar programs.

The correct volume levels, as read on the volume unit meter of the console, should be:

STANDARD VOLUME UNIT METER READINGS

Speech and Popular Music	A reading of not higher than 100 nor lower than 40
Audience Reaction (Applause)	Not higher than 70
Symphonic Music	Not higher than 100 on normal passages. On very low passages the VU meter needle must always be moving.

The control operator adjusts the volume levels by turning the pots on the control board. This is termed "riding gain" on a program. Before going on the air, the operator "takes a level" on the talent in the studio. That is, he opens their microphones and adjusts the pots while they speak, until the level is about that required in the table of Standard VU Meter Readings. Then he occasionally varies the pots as the volume levels change, as the sound volumes become higher or lower, to stay within the prescribed meter readings.

Balance

Balance refers to the difference in sound loudness between any two or more components of a program.

The operator sees two announcers in the studio. One announcer has a very loud, strong voice, and the other, a quiet, weak voice. To make both voices sound relatively alike in volume, is a balance problem.

A thirty piece orchestra sets up its instruments in the studio. The tympani, or the brass must not drown out the other instruments. The reed in-

LEVELS, BALANCE AND OPERATING TECHNIQUES

struments must be heard in their proper proportion to the tympani and the brass. This, too, is a problem in balance.

In order to achieve good balance, the operator cannot rely on his VU meter alone. He must have or must develop a sensitive ear to the sometimes delicate shadings of volume which make the difference between good and poor balance.

In the first case cited above, concerning the two announcers, the balance problem is a relatively simple one. The operator first "takes a level" on each announcer individually. He makes a mental note of the relative strength of each announcer's voice. Then he adjusts the positions of the announcers before the microphones so that they sound relatively even in volume. He then takes a final level check to assure himself that his adjustments were correct. During the program, the operator occasionally adjusts the master pot slightly to compensate for level changes, while keeping the balance the same. Adjustment of the master pot, it will be recalled, varies the *total* sound volume output of the console, rather than that of an individual microphone.

In the case of the thirty piece orchestra, the operator first takes a level on each section: the piano, the tympani, the reeds, and the brass, each in turn. Then the operator asks the conductor to have the orchestra run through a musical selection. He listens carefully to the music, slightly readjusting the pots so that each section of the orchestra appears to be in the right proportion musically, to each other section.

If the operator is not well versed in music, he might enlist the aid of the orchestra leader at this point. The leader or conductor will be glad to assist, since a good balance will present the orchestra in its most favorable light. After proper balance is assured, to the satisfaction of both the control operator and the conductor, the operator controls the overall orchestra level by adjusting the master pot. Any further adjustment of an individual pot, controlling the level of a section of the orchestra, will throw the entire orchestra out of balance. The individual pots thus remain untouched until the conclusion of the program.

Operating Techniques

Levels and balance are of course two most important segments of operating technique. There is yet another segment, however, that requires discussion. It may be summed up in a statement to the operator: *Don't make technical operations apparent.*

What is a technical operation? How may it be made apparent, and to whom? Any operation that is performed in the control room or studio, that affects the program going out on the air, can be considered by the operator to be a technical operation.

When the operator "fades in" a record, when he throws a microphone key to the program position and makes that microphone *live*, a technical operation has been performed.

If the record starts out by "blasting in", or if it comes in at the wrong turntable speed, or if it slowly picks up speed until it finally sounds normal,

LEVELS, BALANCE AND OPERATING TECHNIQUES

then a technical operation has been made apparent.

If the operator opens a microphone after an announcer has started speaking, thus losing the first few words and perhaps the entire sense of what he is saying, if the operator "clips" the microphone key before the announcer has finished speaking, perhaps even in the middle of a word, a technical operation has been made very apparent.

To whom are all these things apparent? To the final judge of a program, *the listener*. When technical operations are not apparent to the listener, he enjoys the program material and receives a sense of fulfillment from it. He visualizes the program as an enjoyable, continuous progression. If he becomes aware of the technical operations that are necessary to air a program, he begins to lose the trend of continuity of that program, and his interest in it wanes.

There is one important exception to what has been said above. When a program is aired which uses a broadcast station as part of its plot, then, to lend authenticity and flavor to the story, the operator tastefully makes some of his technical operations apparent to the listener.

CHAPTER 7 REVIEW QUESTIONS

1. What is a level? Why are levels important?
2. What are the proper levels as read on the volume unit meter for:
(a) speech and popular music (b) audience reaction (c) symphonic music?
3. How are levels varied or adjusted on a console?
4. What is meant by "taking a level"?
5. What do we mean by balance?
6. Describe how balance between voices is achieved.
7. Define a technical operation.
8. How is a technical operation made apparent?

The use of records, transcriptions and tape, as program material has already been established. A procedure must be followed for inserting this recorded material into a program.

Cueing

In its largest sense, a "cue" is a "go ahead" signal in broadcasting. Relating this to recorded material, cueing a record or a tape means preparing the record or tape on its playback machine so that it is ready to play at the demand of the operator. If it plays then, without undue long pauses before it, or lost openings at the beginning of it, the recording is said to have been "cued up".

Record Cue Up and Play Procedure

1. The operator first ascertains the speed of the record from the information given on the record label.
2. He then adjusts the turntable so that it will play (or rotate) at the indicated speed.
3. He places the record on the turntable and sets the stylus (needle) in the record's first groove.
4. The operator then throws the turntable key on the console which is associated with that turntable to the audition (or cue) position.
5. He rests one hand lightly on the edge of the record, retaining it, and turns the turntable power switch *on*. The turntable will then rotate, but the record, held by the operator's hand, will remain stationary.
6. The operator then gently releases the record and allows it to rotate through the two, three, or four "dead" grooves, or until it reaches the beginning of the sound on the record.
7. Hearing the beginning of the sound on the audition or cue loudspeaker, the operator quickly, but gently, stops the record's rota-

CUEING, TURNTABLE AND TAPE PLAYBACK TECHNIQUE

tion by lowering his hand back onto its edge. He then turns the turntable power switch *off*.

8. When the turntable ceases its rotation, the operator moves the record back and forth on the turntable, and stops it at the exact point where the sound begins.
9. The operator then "backs up" the record or rotates it back, counter clockwise. The extent of counter clockwise rotation depends upon the speed at which the record is to be played. One full revolution for 78 RPM records, and between a quarter and a half revolution for 33½ and 45 RPM records.

The record is now cued.

Another method of record cueing that is preferred by some operators is as follows:

- a. The record is placed on the turntable and the needle set in the first groove.
- b. The turntable key associated with that turntable is placed in the audition or cue position.
- c. The operator notes a spot or point on the record label, and keeps his eye on that spot.
- d. The power switch is turned *on* and the record is allowed to rotate on the turntable. Watching the spot that he has picked out, the operator counts how many times it passes the needle, or how many revolutions and part revolutions it takes, until the sound is first heard.
- e. He then lifts the needle from the record, and holding the record he replaces the needle in the first groove, opposite the counting spot or point.
- f. He again releases the record, counting the revolutions until a full turn before sound is reached for 78 RPM records, or a quarter to a half revolution before sound is reached for 33½ and 45 RPM records. At this point he gently stops the record's rotation by lowering his hand onto its edge. He then turns the turntable power switch *off*. The record is cued.

Before playing a record, the operator must know whether it begins with a voice speaking, as in a transcribed commercial announcement, or whether it begins with music. He must have this information because the playing procedure is different for each type.

To play a record starting with music, or consisting wholly of music, the operator first cues it up.

1. Then he returns the turntable key to the program position and checks to see that the turntable pot is closed.
2. He places one hand on the outside edge of the record, and with the other hand turns the turntable power switch on. The hand that is not holding the record then grasps the turntable pot.
3. Finally, to play the record, the operator gently releases it, and

CUEING, TURNTABLE AND TAPE PLAYBACK TECHNIQUE

smoothly whips open the pot. This brisk, but smooth opening of the pot is called "potting in" a record.

If the record has been cued too tightly, that is, if it wasn't "backed up" sufficiently, it will "wow-in" when played. A wow-in is a record that is aired before it has reached normal playing speed.

To play a record that begins with speech, the procedure is somewhat altered. The operator first "takes a level" on the record.

1. He places the stylus in the grooves and plays the record until he has adjusted the turntable pot for the proper level on the VU meter, all previous to putting it on the air.
2. Then he replaces the stylus in the first groove on the record and cues it up.
3. He returns the turntable key to the *off* or neutral center position. He does not touch the turntable pot, which he adjusted while taking a level on the record.
4. The operator then places one hand on the record, holding it, and with the other hand turns the turntable power switch *on*.
5. The hand that is not holding the record then grasps the turntable key.
6. To play the record, the operator gently releases it, and at the same time throws the turntable key to the program position. The same precaution is observed as with music records, to prevent a wow-in.

This is termed "keying in" a record. When the record starts with speech it is keyed in to prevent the illusion that the speaker on the record is running toward the microphone from the other end of the studio as he begins to speak.

Fades.

A "fade", is a potting operation that is accomplished gradually. A record might be "faded in" to "sneak" a music background under an announcer's voice. The fade in is performed so that the listener is not immediately aware that the music has started. When the announcer finishes speaking, the music might be "brought up full", or up to normal music level.

To fade in a record, the operator follows the procedure for playing a music record, except that in the final step, instead of whipping the pot open, the pot is opened very slowly.

A "fade out", is simply the reverse of a fade in. If a music record must be terminated before it has been played through to its end, the pot is slowly closed until the record is no longer heard.

When fading out a music record containing both vocal and instrumental choruses, it is considered better taste to fade it out during an instrumental chorus, or at the end of a vocal chorus, rather than during the vocal chorus.

CUEING, TURNTABLE AND TAPE PLAYBACK TECHNIQUE

Cross-Fades.

When a music record must be terminated before being played through to its end, and another music record must be started immediately, with no live announcement in between, the operator performs a "cross-fade". The cross-fade is a combination of a fade in, and a fade out. It is done as follows:

As one record is playing, the operator slowly fades in a second record and fades out the first one. At the midway point, where both records are heard equally, he quickly finishes the fade out of the first record, and brings the second one up to full, normal level.

Cross-fades are done only with music records, never with speech records.

Segue

A segue (pronounced *seg-way*) is a continuous uninterrupted playing of two or more records with no live announcement in between. When one record finishes playing, another record is immediately played by the operator.

A segue differs from a cross-fade in that the first record is played to its conclusion before the operator plays the second record.

Dead Pot.

A "dead pot" is a closed pot. A dead potted record is sometimes used as a closing theme for a program. Its playing time is first ascertained by the operator. Assume for example, that the playing time of a particular theme record is three minutes duration. Then, three minutes before the end of a program, the record is begun on a closed or dead pot. That is, the operator releases the record but does not immediately open the pot. As the program is concluding, the theme is sneaked, or faded in, under the announcer's closing words. When the announcer is finished, the theme is brought up to full level.

The theme record, accurately timed, ends exactly at the time the program is to close. This assures the program a logical and complete ending. Such an ending has an air of finality about it which cannot be attained if an uncompleted record is faded out to close the program.

Tape Cue Up and Play Procedure

The cueing and playback procedure for tape is somewhat simpler than for records.

To cue up a tape:

1. The operator places a reel of recorded tape on the feed reel spindle, and an empty reel on the takeup spindle, of the tape machine.
2. He throws the tape input key on the console to the audition or cue position.

CUEING, TURNTABLE AND TAPE PLAYBACK TECHNIQUE

3. He threads the recorded tape past the tape heads and starts it onto the takeup reel, dull side toward the heads.
4. The operator then starts the tape machine on the play position of its starting switch.
5. When the beginning of the sound is heard on the audition loudspeaker, he stops the machine. He then manually rocks the reels back and forth until the exact beginning of the sound on the tape is found.
6. The operator then manually reels the tape back onto the feed reel a few inches to prevent wow-in, and the tape is cued up.

To play the tape, its input pot and key are arranged in a similar manner to record playback. The operator starts the tape machine with its starting switch on the play position. He "pots it in", if it starts with music, and he "keys it in", if it starts with speech.

CHAPTER 8 REVIEW QUESTIONS

1. Define the word "cue".
2. Explain the cue up and play procedure for (a) a music record (b) a speech record.
3. What is a "wow"?
4. What is a fade in, a fade out?
5. When do we cross-fade?
6. Explain a segue.
7. For what purpose is a dead pot used?
8. Explain the cue up procedure for a tape.
9. Why do we back up the tape after cueing?

Broadcast microphones, like cameras, do not lie. But like a camera, a distorted sound picture may result if a microphone is incorrectly used.

The audio control operator is limited to the adjustment of volume alone, on the control board, once a microphone is *live* or on the air. Additional adjustments affecting the quality of the microphone pickup must be done by the performer, by changing his position before the microphone.

The performer, however, has no idea of how his voice sounds in the control room. He relies on the operator for directions on how to position himself in front of the microphone for optimum pickup.

The operator then, must know when to tell the performer to alter his microphone position, in any given situation, and with any type of microphone. Therefore, the operator must be aware of the characteristics, the abilities, and the peculiarities of all of the microphone types that are liable to be found in a broadcast studio.

This chapter will be devoted to the study of the pickup patterns, and the other operating characteristics of the microphones previously discussed in Chapter 3.

Microphone Types and Patterns

The Dynamic Microphone.

The most rugged in construction of all of the broadcast microphones, the dynamic, is the microphone that is used for most sports, or other outdoor remote broadcasts, as well as in studios. When used out of doors, it is not as subject to "wind pickup" noise, the noise caused by wind blowing across the microphone as the other types are.

The dynamic microphone tends to favor high frequency sounds over low frequency sounds. It is sometimes used in the studio to aid a speaker with a deep or bass voice, to attain a somewhat higher pitch. Because of its sensitivity to high frequencies, it tends to accentuate sibilance in a performer's voice. Sibilance is defined as a "hissing" sound, made in the pronunciation of the letter "S".

If a dynamic microphone is mounted, face upward, its pickup pattern or area is a complete 360 degree circle around the microphone (omni-directional).

The performer may speak *across* a Dynamic microphone from any direction for an identical pickup. A group of performers may form a circle around a dynamic microphone, and each may use it in turn, or in concert.

Three of the most popular dynamic microphones are: The RCA Commentator, The Altec Lansing Saltshaker, and The Altec Lansing Condenser, as shown in Chapter 3 (Figs. 3-1, 3-2, and 3-3).

The Velocity Microphone.

Probably the most widely used studio microphone, the velocity microphone is usually called the "ribbon" microphone because of its pickup element. Constructed for studio use, its delicate ribbon element prohibits extensive application as a remote microphone because of the danger of rough handling in moving it about, and because of its sensitivity to wind noise when used out of doors.

The velocity microphone is the most favorable one to use for performers who have a tendency to "pop". Popping is defined as a performer's tendency to stress the explosive consonants, "B", "P", and "T". The explosive quality of these letters causes a very sharp, momentary increase in the pressure component of the sound wave, which sounds to the listener as though a small firecracker was detonated in front of the microphone. Since the ribbon microphone is activated by the velocity component of the sound wave, it is less apt to be affected by a performer's explosive popping.

The velocity microphone tends to favor low frequency sounds over high frequency sounds. It may be used then, to deepen or lend authority to a voice which is too high in pitch. Further, the closer that a performer works to a velocity microphone, the deeper his voice will sound.

Used in its normally mounted position, the Velocity microphone has two live sides and two dead sides. Its pickup pattern is bi-directional, or two-directional, resembling a figure eight. A performer may work into either of the live sides of the microphone or two performers may use both live sides alternately, as in a discussion or interview type of program.

The most popular ribbon-velocity microphone at broadcast stations is the RCA 44 Senior Velocity, shown in Chapter 3 (Fig. 3-4).

The Cardioid—Combination Microphone.

The most versatile of all the broadcast microphones, since it can be used as either a dynamic microphone, a velocity microphone, or a combination of both, is a Cardioid microphone. The designation "cardioid", is applied to this microphone because of its heart-shaped pickup pattern. It is a uni-directional, or one direction microphone, in its normally mounted position.

The cardioid finds wide use in studios where extraneous noises would be picked up by a microphone with a more extensive pattern area. It is of particular use in television studios. Using a cardioid microphone, only those sounds that are created directly in front of, or slightly to either side of the live side of the microphone are picked up.

The cardioid is rarely used for remote broadcasts as it contains a ribbon

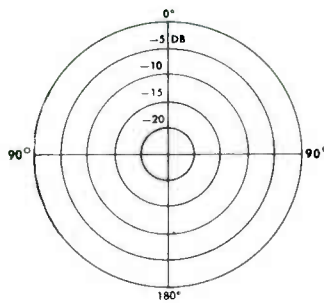

Figure 9-1
Dynamic Microphone
Pattern

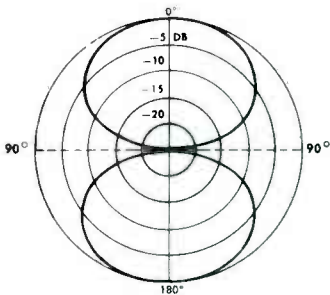

Figure 9-2
Velocity Microphone
Pattern

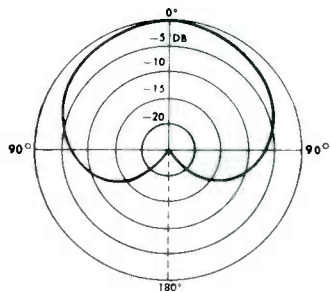

Figure 9-3
Cardioid Microphone
Pattern

MICROPHONE USE TECHNIQUES

element. However, where the remote broadcast entails a music pickup, in a theater or auditorium, cardioid microphones are sometimes used.

The operator adjusts the combination cardioid microphone for the desired pickup pattern, either dynamic, velocity, or cardioid, by means of a recessed slotted switch on the back of the microphone casing. The switch adjustment is made with either a small screwdriver, or a ten cent piece.

Special Purpose Microphones

The Condenser Microphone—Already mentioned as a dynamic microphone, it has been refined in recent years to provide all three polar patterns: the omnidirectional, the figure eight, and the cardioid, as in the Neumann U 67. The condenser microphone will faithfully reproduce sound reaching its axis to a greater degree than virtually any other microphone made. The U 67 or its earlier counterparts, the Neumann and Telefunken U 47's, can be found in almost every major music recording studio.

The Cardiline Microphone—Developed by Electro-Voice to narrow the field of acceptance of sound. This permits spot aiming of the microphone, such as the model 642 which is around 18 inches in length, from a boom in a TV studio at a much greater distance from the performer than would be possible with a conventional microphone. It allows the model 643, which is 7 feet 2 inches long, to be used to pick up with "on mike" quality questions at a press conference asked at a distance of better than 50 feet from the microphone. The cardiline microphones combine the best characteristics of dynamic and cardioid microphones with the principles of "distributed front opening" designs. Simply stated this design feature requires a long tube, slit along its axis mounted in front of the microphone element. This tube has the effect of cancelling to a large degree sound emanating from the sides or rear of the microphone and thus enhancing sound which arrives directly on the axis of the microphone.

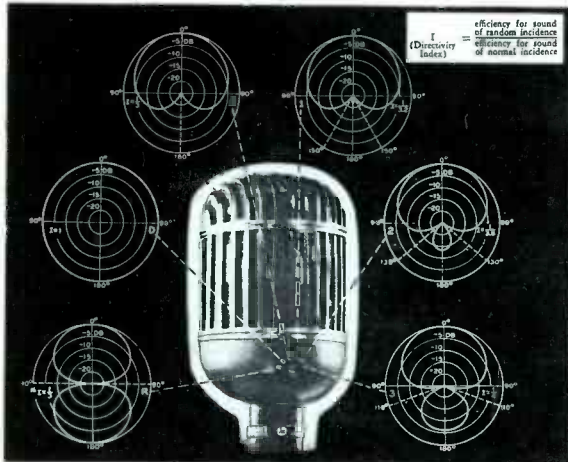

Figure 9-5
Altec 639 Cardioid Microphone—REAR VIEW
Courtesy Altec Lansing Corp.



Figure 9-4
RCA 77 Cardioid Microphone—REAR VIEW
Courtesy Radio Corp. of America

MICROPHONE USE TECHNIQUES

Television Microphone Usage

Regarding microphone use, there are two types of program situations existing in television. Either the microphones on the program may be visible to the viewer, or they may not be seen at all.

If microphones are permissible in the picture then the practice is to use the least obtrusive microphones possible, desk or floor stand mounted, or even hand held. Examples of this type of microphone are the RCA Starmaker and the Altec Lansing Condenser Microphone, both of which are omnidirectional in their pickup patterns.

On some types of program, however, visible microphones would spoil the illusion that the program is trying to create. Such a show might be a dramatic program with an 18th century setting, for example. The audio operator could hide microphones amid the scenery, and in a limited manner this is sometimes done, but so many microphones would be necessary that the control problem could easily get out of hand. The operator cannot do a "re-take" on a television show if he should forget to open one of the microphones at the proper time, and leaving all microphones open would create an insurmountable sound problem.

The usual method of microphone pickup on this type of program is to employ two manually operated booms. The booms are arranged so that one is picking up the sound of the action in progress, while the other one is standing by for the next scene or point of action, at another place in the studio. The audio operator in the control room positions the booms by directing the movements of the boom operators in the studio.

Since a boom suspended microphone is necessarily six to eight feet away from, and above the head of the performer, its use technique differs from a stand mounted microphone.

The performer speaks in normal voice, facing either the television camera or an opposite player. The microphone, through the manipulations of the boom operator, follows the performer, turning when he turns and moving when he moves, so that the live face of the microphone is always aimed at the performers mouth, keeping him within its pickup pattern. The operator in the control room compensates for the increased microphone distance by keeping that microphone's pot open to a greater degree than would be necessary for a stand-mounted microphone.

A cardioid microphone is employed for boom work since any other pattern would cover too much area and pick up unwanted, stray sounds.

Esthetic Considerations in Microphone Use

We now consider the element of microphone use that has to do with the quality, or aural beauty of the pickup.

On-Mike—Off-Mike.

A performer should be "on-mike" for normal voice reproduction by the micro-

MICROPHONE USE TECHNIQUES

phone. On-mike, is defined as being within the area covered by the pickup pattern.

The areas not within the pickup pattern, and the areas on the so-called "dead" sides of the microphone are referred to as "off-mike" areas. There is *some* pickup in these areas. Dead sides are not totally dead to sound, in actual use. However, any sound that is picked up will have a far-away, "down-in-a-barrel" quality. The off-mike effect is sometimes deliberately used to simulate aural distance between two performers, with one performer on-mike, and the other off-mike.

For a non-dramatic program like a newscast or a music presentation, the announcer should always be on-mike. The operator should feel that it is his prerogative to inform the announcer or other talent to change position at the microphone for a better pickup.

Presence.

A performer's microphone presence may be defined as his being on-mike, at *his* proper distance from the microphone. Merely to say that a performer is on-mike is not sufficient. It only indicates that he is within the microphone's pickup pattern area.

If he is too close to the microphone, lip smacking, teeth clicking (particularly false ones), tongue slapping, and gasp-like breathing noises will be heard. The performer is said to have "too much presence". If, on the other hand, the performer is too far away from the microphone, his voice will have a roomy, hollow, lusterless quality. He is then said to have "no presence".

The performer then, should be *his* proper distance from the microphone for optimum presence.

The average performer-to-microphone distance for an optimum presence pickup is from 8 to 12 inches for announcers, from 1½ to 3 feet for vocalists, and from 12 to 24 inches for masters-of-ceremonies.

These are average distances and it should be borne in mind that they will vary greatly from performer to performer, and from microphone to microphone. As a matter of fact, individual microphones of the same type and manufacture will differ slightly in their characteristics. The operator must know the peculiarities of all of the microphones under his control. He must not hesitate to experiment with the adjustment of the position of a performer at the microphone for optimum quality pickup at any time, when he feels that it will improve the quality of the program.

Into vs Across the Mike.

Much is said, in discussion between operators and announcers, as to whether it is preferable to speak directly into a microphone, or to speak "across it" for best quality pickup.

As a rule, a microphone should be used in the manner for which it was designed, that is, one speaks *across* a dynamic microphone, and *into* a velocity or cardioid microphone. The results, however, are more important

MICROPHONE USE TECHNIQUES

than the method used, and the operator should use his own judgment for best results with individual performers. Any question on this point may be resolved by trying both methods.

Microphones vs Talent.

The operator will find, in dealing with performers, that he must exercise a great deal of tact and patience. Some artists feel that they will sound better on a certain type or a certain color of microphone, regardless of the facts. This is sometimes due to poor advice or perhaps a previous bad experience.

The operator should attempt to pacify such performers by adjusting the situation however it may require to preserve harmony, and yet remain consistent with good aural quality.

Microphone Clipping.

"Clipping a mike" is a term used to denote the rapid removal of a console key from the program position, which cuts off its associated microphone abruptly.

The operator always clips a microphone when the talent is finished with its use, or to prevent extraneous mumbling and throat clearing from being aired.

During a commentary or newscast program where one person speaks for lengthy periods, the speaker often gets a "frog" in his throat. He finds it necessary to cough, and clear his throat. On a signal from the speaker, the operator clips his microphone, and the speaker quickly clears his throat. He then signals the operator to re-open the microphone so that he may continue.

A newscaster, working alone in the studio will sometimes find that he does not have sufficient news copy to fill his remaining airtime. At the end of a news item, or during a natural pause, he signals the operator for a clip, at which time he asks for more news copy.

In both of the above cases, the operator clips the microphone key and in the same motion throws the key to the audition position—in the first instance, to hear the end of the cough, so he will not inadvertently re-open the microphone while the speaker is still clearing his throat; in the second instance, to hear the newscaster's hurried call for some more news copy.

Care of Microphones and Microphone Cords

Regarding the care of microphones, it will merely be stated that they are delicate, sensitive instruments, costing hundreds of dollars in some cases, and should be cared for with that in mind.

Performers should be cautioned against coughing directly into a microphone. Velocity microphones are particularly vulnerable; the ribbon element may be bent or broken by the direct blast of a cough into the microphone.

Too, performers should be cautioned not to use spare microphones in the studio for hat or coat racks.

MICROPHONE USE TECHNIQUES

Microphone cords should be neatly coiled and hung on hooks provided on the microphone stands, when those microphones are not in use. An abused cord will invariably break internally during an airshow, possibly causing the loss of program material during a crucial moment in the performance.

The operator should form the habit of making a visual check of the mi-

Figure 9-6
Microphone Cord Hook
Courtesy Radio Corp. of America



crophones and cords upon entering a studio. In this way, he may notice some obvious damage that could cause trouble later on during the program. He should also check to see that all of the microphones to be used on that program have been properly plugged into their receptacles on the studio wall.

Microphone Stands

Microphone stands, or supports, are available at a broadcast station in various sizes and shapes. When the operator sets up microphones for a broadcast, he chooses the types of stands most suitable for that broadcast.

1. Studio floor stand—a metal tube, adjustable in height, attached to a heavy base plate, usually made of cast iron. The microphone is attached to a screw type fitting on top of the adjustable tube.
2. Portable floor stand—the floor stand that is used for remote broadcasts. It consists of an adjustable tubular rod, attached to a folding tripod base, made of a lightweight metal such as aluminum for ease in carrying.
3. Boom stand—of which there are two general types. One, as pictured in Figure 9-9, which the boom operator pushes and manipulates by himself, and the other, as pictured in Figure 9-10, which requires another man as a boom pusher.

The Hollywood boom was borrowed from the motion picture industry and is used in broadcasting, on television shows where the microphone must move fast and reach into otherwise inaccessible places on a studio set.

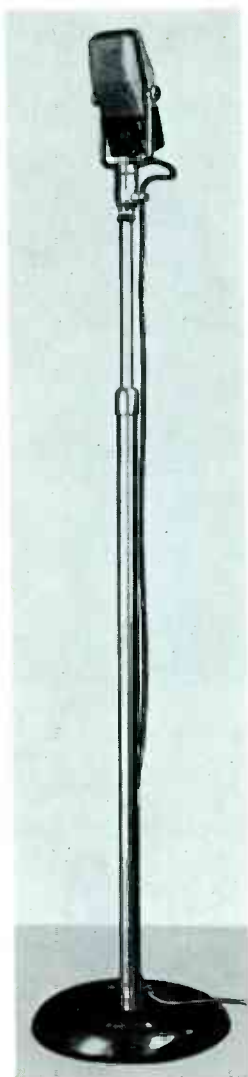

Figure 9-7
Studio Floor Stand
Courtesy Radio Corp. of America

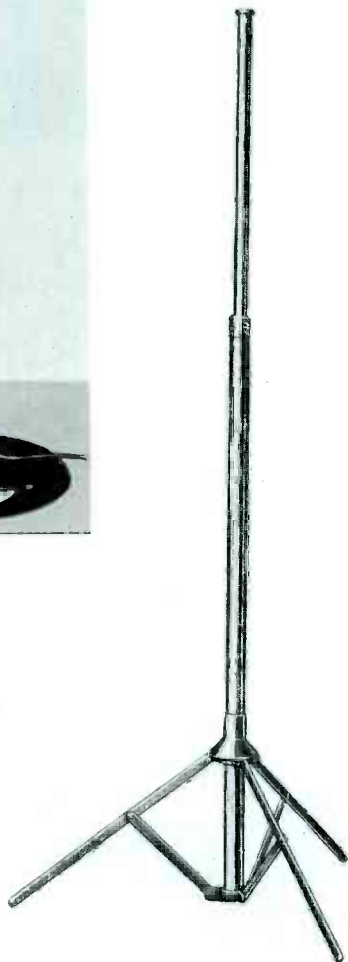

Figure 9-8
Portable Floor Stand
Courtesy Radio Corp. of America



Figure 9-9
Boom Stand
Courtesy Radio Corp. of America

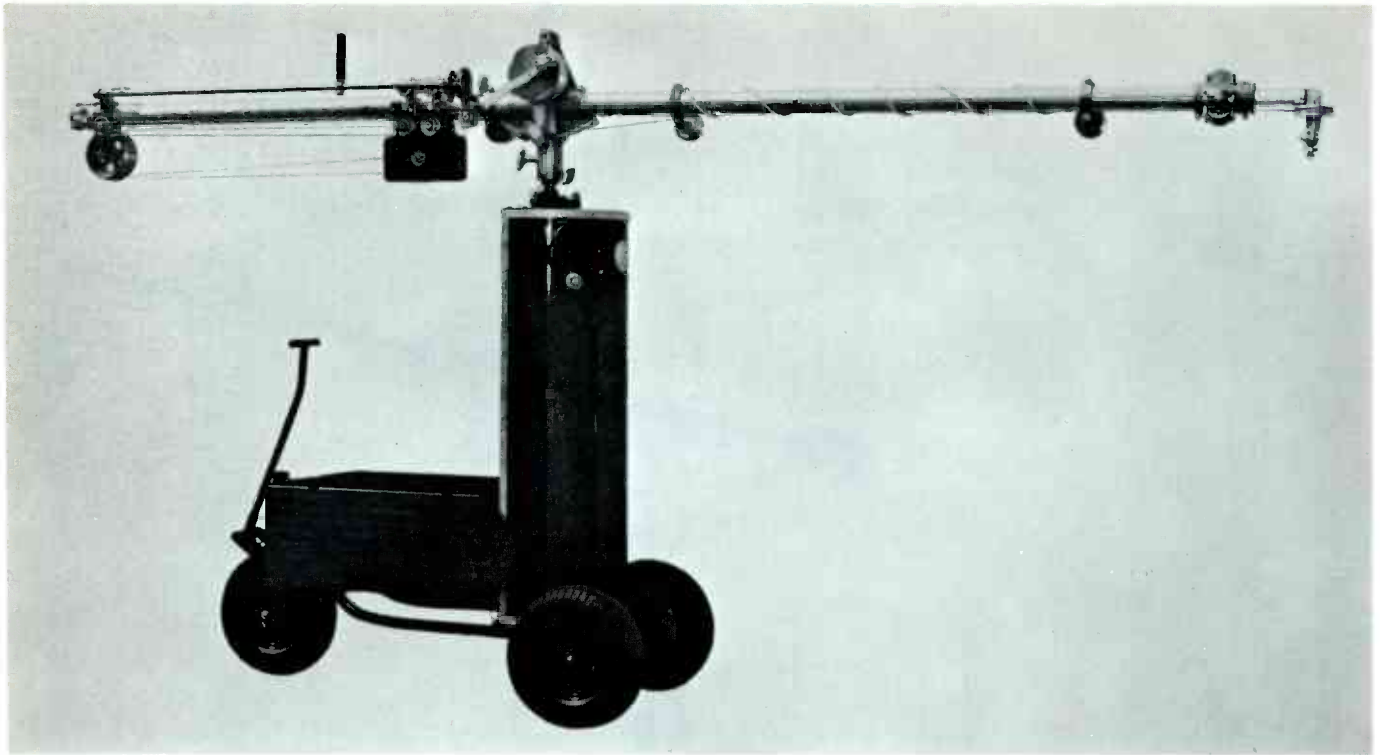

Figure 9-10
Hollywood Microphone Boom
Courtesy Mole-Richardson Co.



Figure 9-11
Desk Stand
Courtesy Radio Corp. of America

Figure 9-12
Banquet Stand
Courtesy Radio Corp. of America



MICROPHONE USE TECHNIQUES

4. Desk stand—a three to six inch tubular rod on a base plate, weighing three or four pounds.
5. Banquet stand—a six to twelve inch adjustable metal tube on a base plate weighing five or six pounds.
6. Clamp stand—sometimes called a “sky hook”. It is used mainly on remote broadcasts, where other types of stand would be inaccessible. It consists of a short tubular rod mounted on a screw-type, wood clamp. When there is no space available for a regular desk stand, as on a small speaker’s lectern in a hall or auditorium, the clamp is attached to the edge or sill of the lectern and the microphone mounted upon it.

A clamp stand may be easily constructed at a station if one is not presently available. A short length of pipe is threaded at one end to fit the microphones, and the other end is welded to a three inch “C” clamp which may be purchased at any hardware supplier.

CHAPTER 9 REVIEW QUESTIONS

1. Which type of microphone should be used for out of doors pickups? Why?
2. Define sibilance.
3. For what type of voice is the dynamic microphone best suited?
4. Describe the pickup pattern of a dynamic microphone.
5. What portion of the sound wave activates a dynamic microphone?
6. Define popping.
7. Where does the velocity microphone find its primary use?
8. What portion of the sound wave activates a ribbon microphone?
9. Describe the pickup element of a velocity microphone.
10. For what type of voice is the velocity microphone best suited?
11. Describe the directional characteristics of a velocity microphone.
12. Why do we call the cardioid microphone a combination microphone?
13. Describe the cardioid microphone pickup pattern.
14. How do we adjust or vary the pickup pattern of a combination cardioid microphone?
15. Define “on-mike”; “off-mike”.
16. Define presence.
17. What is meant by microphone “clipping”?
18. Describe the various types of microphone stands.
19. For what purpose is a boom used?
20. When do we use a clamp stand?



Figure 10-1
A Studio Microphone Setup
Courtesy Johns Manville Co.

This chapter discusses the arrangement of microphones in a studio for the various types of programs that it might originate.

A rule-of-thumb for the operator, in setting up microphones for a program might be stated as follows. Never use two (or more) microphones on a program where one microphone will do the job. In other words, keep it simple!

The fewer microphones used, consistent with the requirements of the program, the less likelihood there is for interaction between microphones. Microphone interaction will result in an echo effect. Two open (live) microphones pick up the same sound. One, directly and the other, after the sound has reflected from a studio wall or other obstruction. The time delay, or difference in pickup time between one microphone and the other, causes the echo.

Too, the fewer microphones used on a program, the less likelihood there is of an operator inadvertently opening the wrong microphone during the program.

Several program possibilities, involving microphone placement will therefore be discussed with suggestions for best microphone arrangement.

Talks—One Speaker

Let us first consider the factors involved in a program consisting of a single speaker.

The operator determines whether the speaker desires to sit or stand during the program. If the speaker has no preference, the operator arranges for a table microphone. The non-professional speaker, particularly, is usually less nervous when seated and his notes or script are much more easily handled.

The table or stand microphone may be placed anywhere in the studio where it can be seen from the control room. However, it should not be placed too close to the window between the studio and control room as the window, being a hard highly reflective surface, will create an echo effect at close quarters.

The operator, keeping in mind the pickup pattern of the type of microphone being used, asks the speaker to read from his prepared text. A level

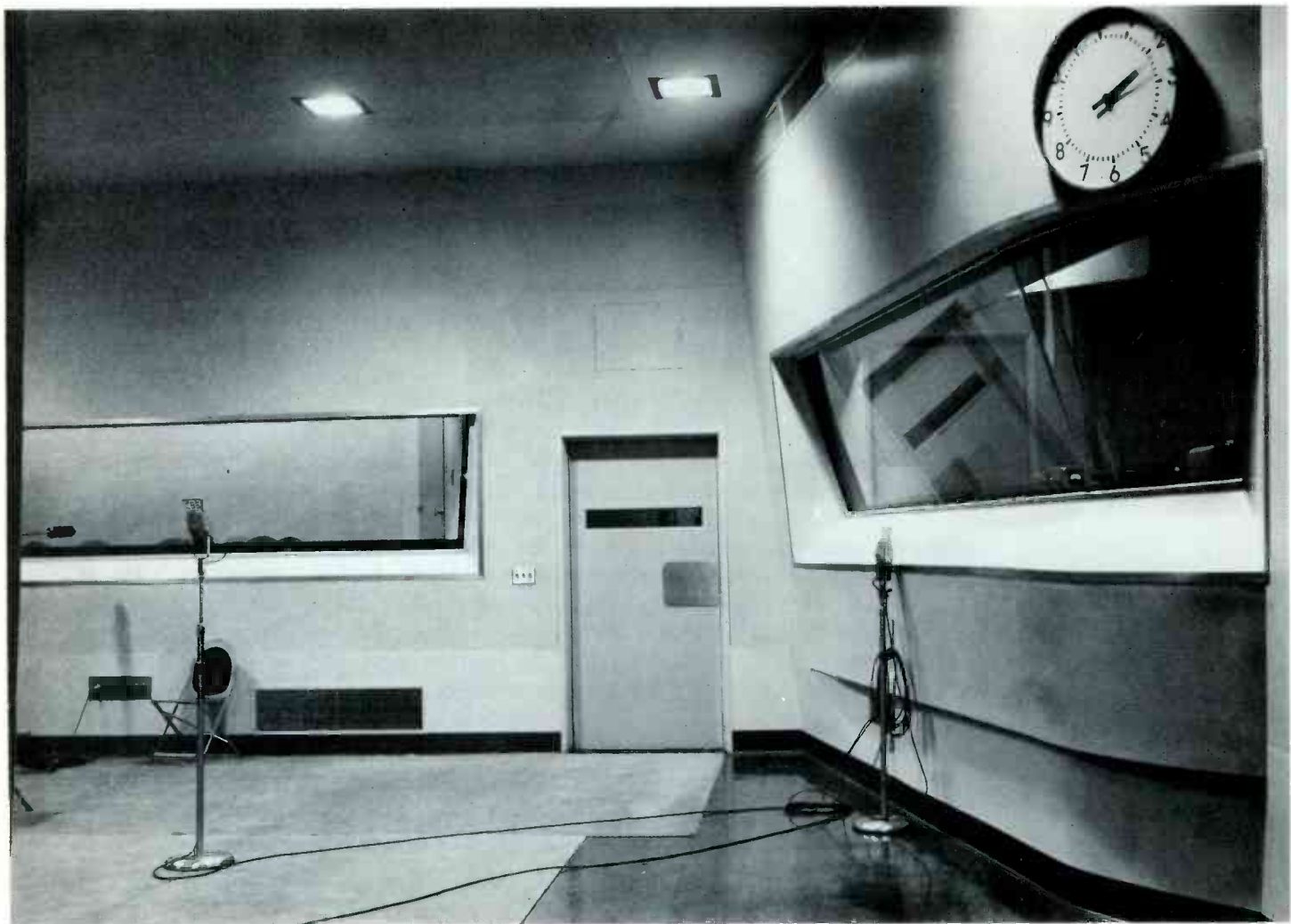

Figure 10-2
Studio-Control Room Window
Courtesy Columbia Broadcasting System

is taken on the speaker, and the operator asks him to position himself so that he is on-mike, and has the proper degree of presence.

If he is a non-professional speaker, he is:

1. Instructed to signal the operator if he desires to cough or clear his throat.
2. Warned against rattling the pages of his script.
3. Advised to remove paper clips or staples from the script.
4. Asked not to move his head off-mike.
5. Asked not to make extraneous noises like foot tapping, or elbow thumping on the table.
6. Asked to watch for a signal to start speaking.
7. Asked to signal the control room when he is finished with his talk.

STUDIO MICROPHONE SETUPS

Two Speakers

Two speakers may be arranged one on each side of a bi-directional microphone, either sitting at a table or at a stand microphone. The speakers are positioned by the operator so that the one with the weakest voice is closest to the microphone, and the one with the more powerful voice is farther away from it.

By placing one person on each side of the microphone, they do not interfere with each other, and their respective sound volume levels may be adjusted by varying the ratio of their distances to the microphone. A one microphone setup of this sort can only be used if the speakers are going to talk alternately, however.



Figure 10-3

Two Speakers at One Bi-Directional Microphone
Courtesy Gilbert Photo



Figure 10-4

Two Speakers at Two Microphones
Courtesy Gilbert Photo

If, for instance, the two voices were to be heard in a dual recitation or if they were to sing, they would each feel very uncomfortable working right into another's face, on the opposite side of the microphone. In this application, both voices should be positioned on the same side of the microphone, standing or sitting, side by side.

Try to avoid the use of more than one microphone. If, however, one of the speakers carries the bulk of a program, he is usually assigned a separate microphone. Such is the case with a newscaster or commentator who has an announcer to open and close his program. The announcer is given a separate microphone, which the operator promptly clips when the introduction to the program is finished. The operator does not open the announcer's microphone again except for commercial inserts, or until it is time to close the program.

STUDIO MICROPHONE SETUPS

If both persons speak alternately, and two microphones are used, as in an interview, then both microphones must remain open during the program. To prevent microphone interaction, cardioids are used, if available. They are placed back to back, or dead-end to dead-end so that their pickup patterns do not overlap. If cardioids are not available, then ribbon microphones should be used and they should be arranged to face on the base angles of a hypothetical triangle drawn in the studio, as in Figure 10-5.

Figure 10-5
Two Ribbon Microphones Both Open

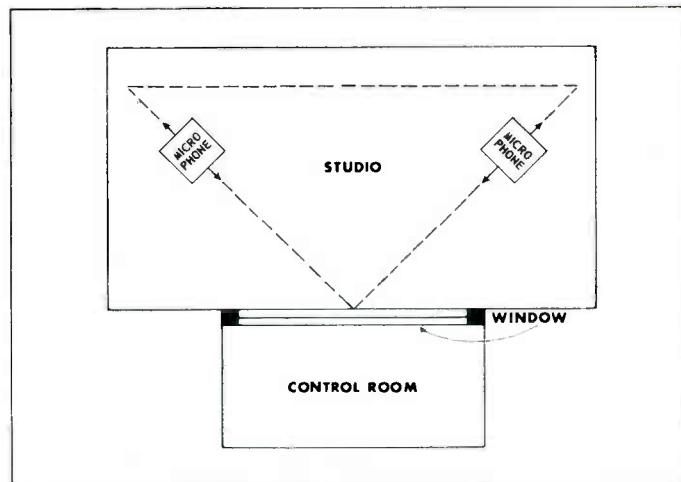

Groups of Voices

Round table discussions, panel programs and quiz programs, are all examples of shows involving groups of voices. These programs generally have a leader, called the moderator or the master of ceremonies (MC).

The MC speaks with the other members of the group singly, or all together. He is allotted a separate microphone for himself, generally a cardioid. The remainder of the group, if there are no more than three or four people, may be handled on both live sides of a ribbon microphone, or they may be grouped around a dynamic microphone. Groups of more than four persons can only be handled by a dynamic microphone.

If the group is large, and seated, more than one microphone may have to be used. If the cast uses a stand microphone, a very large group may be handled on one omni-directional microphone. Each performer must leave his position when he is finished, to make room for another member of the group.

Dramatic Programs and "Soap Operas"

For dramatic shows, and the serialized daily dramas called "soap operas", the following microphone setup is used:

1. A ribbon or a dynamic "cast" microphone which is used by all members of the dramatic cast.

STUDIO MICROPHONE SETUPS

2. A cardioid microphone for the commercial announcer.
3. A ribbon microphone for the sound effects technician, if one is used on the show. Sound effects are often found on records, and in such cases are inserted into the program by the audio control operator.
4. Music microphones as required, if live music is used on the show.

Music Programs

The audio control operator who has a knowledge of music will find this knowledge an asset in setting up microphones for a music program. Musical training, however, is not absolutely necessary. The operator may confer with the leader or conductor of a musical group, and follow his advice as to the way the music should sound, setting up the microphones accordingly.

Solo Instruments

In a solo instrument pickup, one microphone is used. If the instrument produces a large volume of sound, such as a trumpet or other brass instrument, the microphone is placed several feet away. To pick up the low volume of a violin or other string instrument, the microphone is placed close to the instrument. A ribbon microphone is generally used for a one-instrument pickup.

If the instrument is held high (most of the horns are), a stand mounted microphone is used. For low instruments like the cello, a desk-stand mounted microphone is sometimes placed on the floor near the instrument.

Small Studio Band

The problem to be faced in setting up microphones for a small studio band is primarily one of musical balance. The piano, the horns, the drums and the reeds, if any, must each be heard in proper proportion to the overall sound of the band.

The band members are usually seated in the studio so that the reeds are in front, facing the control room. The brass instruments are seated behind them and the drums are in the rear, behind the brass. The piano is usually situated to one side of the band, so that the pianist can see the other band members.

A ribbon microphone on a floor stand is set up in front of, and a few feet away from, the reeds. From here on, it becomes a trial and error task for the operator. He goes back and forth from the control room to the studio, listening to the musical balance in the control room, and then back to the studio to re-position the microphone. Perhaps the brass sounds too strong, or the reeds are drowned out by the drums. The microphone is moved back and forth in front of the band, raised or lowered on its stand, tilted and angled, until the operator arrives at the best possible balance.

With a small studio band which generally plays stock musical arrangements, the piano is often the lead instrument, that is, the piano carries the melody. The piano, then, should have a separate microphone.

STUDIO MICROPHONE SETUPS

If an upright piano is used, the piano microphone should be placed on a floor stand, a few inches from the sounding board, behind the piano. On a grand piano, the sounding board is underneath the piano. The microphone is then hung, spiderlike, from the three legs of the piano by lengths of twine, so that it is centered under the piano with the live side of the microphone facing up at the sounding board.

If the pianist sings, while playing, a different approach is used. A floor stand mounted microphone is placed near him. If possible, it is placed so that it is on a line, perpendicular to the hammerline of the piano. The trial and error method is then used for a balance between the piano and the pianist's voice.

Figure 10-6
Pianist-Vocalist
Microphone Setup

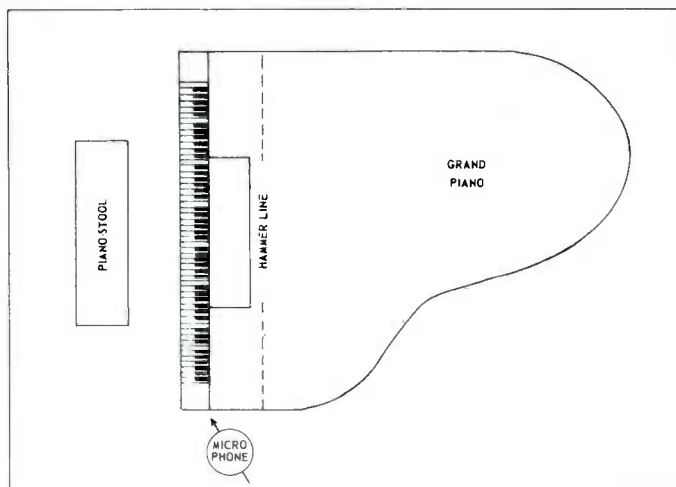

When the small studio band is working in a wide but shallow studio, the band sets up its instruments so that the brass is on one side of the reeds, and the drums are on the other side. In this setup, two or even three microphones may have to be utilized to encompass the entire group. The operator still has the trial and error task, but with a more complex balance problem.

Almost every band has at least one soloist, either vocal or instrumental. The operator provides, for the soloist, a separate cardioid microphone which is placed from six to eight feet away from, and in front of, the band. The solo microphone is placed live side facing the band, and generally is only opened during the soloist's portion of the program. This microphone may also be used by the announcer who introduces the program.

Large Studio Orchestra

The large studio orchestra is merely an expansion of the previously discussed studio band, as far as the control operator is concerned.

The main difference between them is that instead of the group consisting of one or two of each type of instrument, there is a *section* of each type. A section may consist of from four to eight instruments, depending upon the size of the orchestra and the desires of the conductor. In addition to the

STUDIO MICROPHONE SETUPS

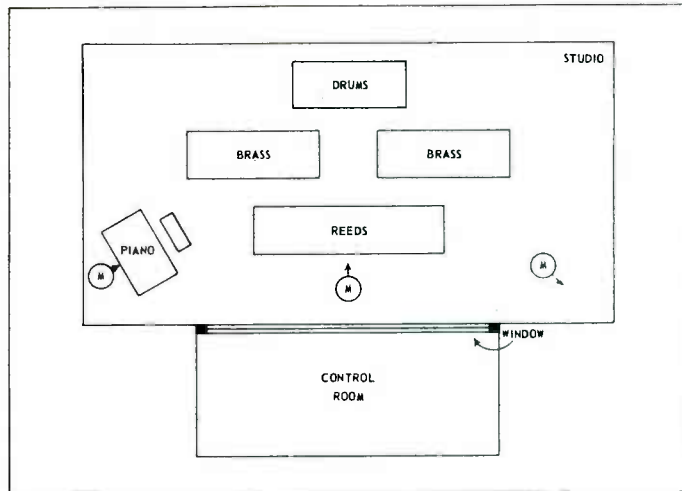

Figure 10-7
Small Band Setup
Normal Studio

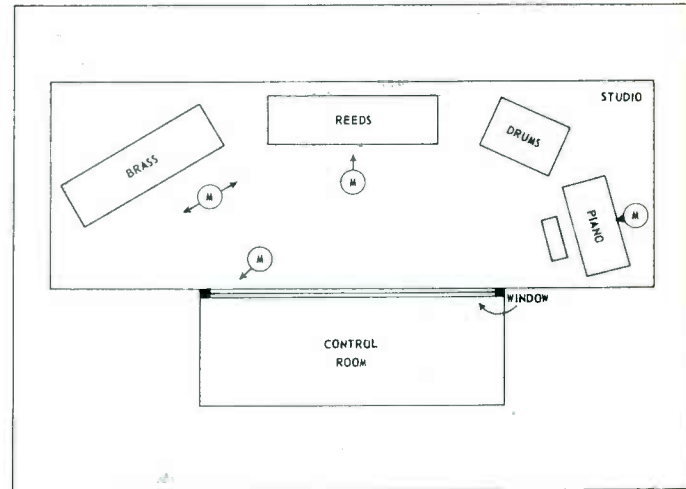

Figure 10-8
Small Band Setup
Shallow Studio

usual band instruments—the piano, drums, trumpets, trombones, saxaphones and clarinets—the large orchestra may have strings, bassoon, oboe, harp, flutes, and other instruments.

When a large audience-type studio or auditorium is employed for a music broadcast, one microphone can be used for the entire orchestral pickup, regardless of the size of the orchestra. The microphone, a cardioid type, should be hung from the ceiling of the auditorium. Its placement should be on a line with the dead center of the stage, twelve to fifteen rows into the audience, and about fifteen feet above the heads of the orchestra. A soloist-announcer microphone, floor stand mounted, is placed on one side of the stage.

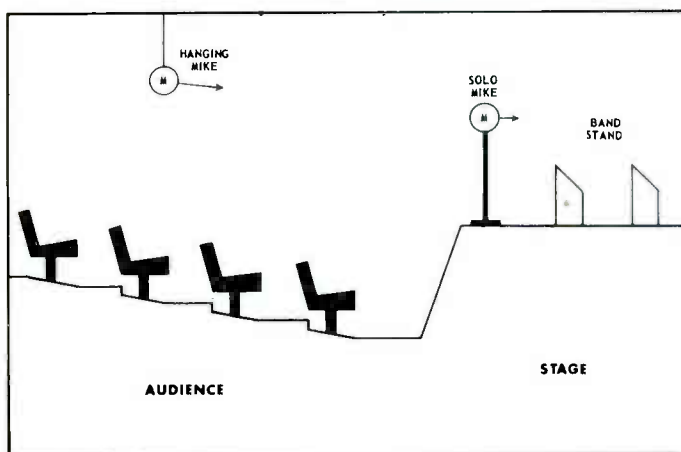

Figure 10-9
Live Audience Studio

Where the performance of a large orchestra takes place in a non-audience studio, the control operator's microphone placement problem is somewhat different. Since a single pickup microphone cannot generally be placed far

STUDIO MICROPHONE SETUPS

enough away from the orchestra to pick up the entire orchestral effect, several microphones must be utilized. The problem then becomes one of "section presence".

Section presence infers that each section of the orchestra must be as prominent as each other section, in their respective musical places within the combined orchestra. To achieve section presence, a separate microphone is allotted to practically every section of the orchestra. When it is found that one microphone can adequately serve more than one section, some of the microphones may be discarded. The microphones for such a program can be set up so that all of those being used for the orchestra are connected to the console through a sub-mixer.

The operator takes a level on each section, and then he proceeds with the trial and error method of positioning the microphones, until a balance is achieved that satisfies both himself and the conductor of the orchestra. The orchestra is balanced by adjusting the sub-mixer pots, after which these pots are not handled again. The overall volume of the orchestra is controlled by the sub-mixer's master pot. This, you will recall, is either a special sub-mixer master gain control on the console or, if none is provided, it may be one of the console's regular microphone input pots.

An additional microphone is provided for the announcer and the soloists, to insure adequate coverage for solo numbers and to prevent the solo from being lost amid the music of the rest of the orchestra. The solo microphone is connected directly to the console, *not* through the sub-mixer. Thus, the operator may lower the orchestral volume without lowering the volume of the soloist.

Figure 10-10
Large Orchestra Studio Setup

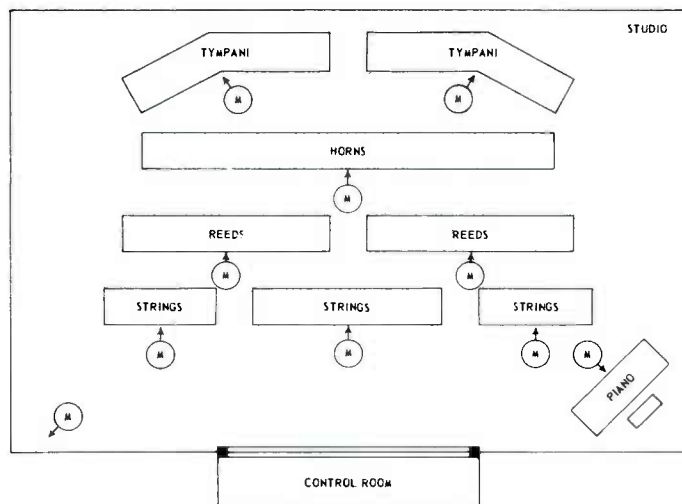

It should be apparent by the foregoing that a high quality music program cannot be properly aired without extensive rehearsal, not only of the musicians involved but of the audio operator as well. Many hours of studio preparation must go into a program of this kind. An operator cannot simply "walk in on" a music program fifteen minutes before airtime and expect to do a

STUDIO MICROPHONE SETUPS

good show, regardless of the number of times he has previously done the same or similar programs.

Studio Audience Reaction and Public Address

It is often desirable to include the reactions to a program of a studio audience, as a part of that program. The reactions referred to are applause and laughter.

The comedian times his quips by the laughter of his studio audience, and the winners of many "new talent" programs are chosen by the applause of the audience in the studio. The reaction of the studio audience at a broadcast of this type must therefore be picked up by microphones, and controlled by the audio operator.

The pickup is usually accomplished by stringing a number of dynamic microphones across, and few feet above, the heads of the audience. The number of microphones used depends upon the size of the audience seating area. Regardless of the number of microphones, however, they all feed into one amplifier and their total pickup volume may be controlled by the audio operator with an auxiliary pot on the console.

The audience in a theater-studio must be able to hear the program that they are observing, as it is aired. To enable the program to be heard in a large theater-studio a public address system, or PA, is used. Loudspeakers are mounted on the studio walls, facing away from the stage microphones, and toward the audience. Careful control of the sound volume emanating from these loudspeakers must be maintained by the operator. The sound must be loud enough to be heard by the audience, but not loud enough to be picked up by the microphones on stage, which are on the air, or feedback will result.

CHAPTER 10 REVIEW QUESTIONS

1. When making microphone setups, what is meant by "keep it simple"?
2. Describe the microphone setup for one speaker in a studio.
3. Describe the setup for two speakers, using one microphone. Using two microphones.
4. Describe the microphone setup for a panel program. For a dramatic show.
5. Describe the studio pickup of a solo musical instrument.
6. What is meant by musical balance in the pickup of a studio band or orchestra?
7. How does the musical balance problem differ between a small studio band and a large studio orchestra?
8. What is meant by audience reaction? How is it used on a broadcast?
9. What is the purpose of a studio PA?

Now that we are familiar with the individual operations that are performed by the audio control operator, let us integrate those operations to form a program—as the audio operator sees it from behind the control board.

We will take the formats, or skeletons, of a few of the routine types of broadcasts and indicate what the audio operator should be considering, and what his operations should be in each case.

The Newscast

The usual newscast might be a two microphone show, employing the services of a newscaster and a commercial announcer. The format of such a newscast would look something like this:

Opening Announcement
 Opening Commercial
 Introduction To News
 News
 Middle Commercial
 News
 Closing Commercial
 Weather Report
 Closing Announcement

The audio operator's job on this type of program is to alternately open and close two microphones. He follows a script of the program, and maintains good audio levels.

Now, we will repeat the same format, showing each operation in its turn, as performed by the audio operator: Previous to airtime the operator, the announcer and the newscaster meet in the studio. The operator is given a script of the show. He goes into the control room and takes levels on the announcer and newscaster at their individual microphones.

Opening Announcement

At airtime the operator opens the announcer's microphone by throwing its key to the program position. The announcer opens the program.

THE PROGRAM—AS THE AUDIO OPERATOR SEES IT

<i>Opening Commercial</i>	He reads the opening commercial announcement.
<i>Introduction To News</i>	The announcer introduces the newscaster. The operator then opens the newscaster's microphone and at the same time cuts the announcer's microphone.
<i>News</i>	The newscaster reads news copy. During the newscast, as indicated in the script, the operator opens the announcer's microphone and closes the newscaster's.
<i>Middle Commercial</i>	The announcer reads the middle commercial and re-introduces the newscaster. The operator opens the newscaster's microphone and closes the announcer's.
<i>News</i>	The newscaster reads news copy. At the conclusion of the news, the operator opens the announcer's microphone and closes the newscaster's.
<i>Closing Commercial</i>	The announcer reads the closing commercial. The operator opens the newscaster's microphone and closes the announcer's.
<i>Weather Report</i>	The newscaster reads the weather report. The operator opens the announcer's microphone and closes the newscaster's.
<i>Closing Announcement</i>	The announcer closes the program. The operator closes the announcer's microphone. The program is ended.

The Sportscast

A sportscast is essentially a news program—the news, of course, being about the latest happenings in the sports world. Our sportscast example differs from the usual news program in that themes and fanfares are used in an attempt to capture the excitement of the sporting events.

Here, then, is a typical sportscast format:

Theme
Opening Announcement
Theme
Sports News
Transcribed Commercial
Live Tag
Fanfare
Sports Features

THE PROGRAM—AS THE AUDIO OPERATOR SEES IT

Transcribed Commercial
Closing Announcement
Theme

Now, the same format as the audio operator sees it: Previous to the broadcast, the sportscaster and the operator meet in the studio. The operator is given a copy of the program script and the recorded themes, commercials and fanfares, in the order that they are to be played on the program.

The operator returns to the control room and takes a level on the sportscaster, at the microphone which he will use on the show. The operator then cues up the opening theme record on one turntable, and the first transcribed commercial announcement on another.

Theme

At airtime, the operator plays the theme for 20 to 30 seconds to establish it, and then he fades it down and opens the sportscaster's microphone.

Opening Announcement

With the theme in the background, the sportscaster makes a brief opening announcement.

Theme

The operator then closes the microphone and brings the theme up to full level. At the conclusion of the theme, the operator closes its turntable's pot and, at the same time, opens the sportscaster's microphone.

Sports News

The sportscaster reads sports news copy. The operator now removes the theme record from its turntable and cues up the fanfare record on that turntable. He then continues to follow the program script.

Transcribed Commercial

At the conclusion of the sports news he plays the first transcribed commercial announcement.

When the commercial ends, the operator rapidly opens the sportscaster's microphone for the live tag to the commercial and clips the transcription's turntable key. He then stands by on the fanfare which is on the other turntable.

Live Tag

The sportscaster reads the tag to the commercial.

Fanfare

At the conclusion of the tag, the operator plays the fanfare and closes the sportscaster's microphone.

When the fanfare ends, he closes its pot and opens the sportscaster's microphone at the same time.

THE PROGRAM—AS THE AUDIO OPERATOR SEES IT

Sports Features

The sportscaster reads the sports feature copy. The operator now cues up the second transcribed commercial announcement and the closing theme, after first removing the fanfare and first commercial transcription from their turntables.

Transcribed Commercial

At the conclusion of the sports features, the operator plays the second transcribed commercial and closes the sportscaster's microphone.

Closing Announcement

When the commercial ends, the operator clips its turntable key and opens the sportscaster's microphone. He then "dead pots" the theme. The sportscaster reads the program's closing announcement.

Theme

As the sportscaster reaches the last few sentences of the closing, the operator sneaks the theme music into the background. When the closing announcement is finished, the operator brings the music up to full level, and closes the sportscaster's microphone. When the theme concludes, the program is over.

The Disc Jockey Show

The disc jockey show, from the audio operator's viewpoint, consists of his alternately playing records and opening a microphone for live introductions to the records and commercial announcements.

Let us look at a typical 15 minute disc jockey program format:

Theme
Opening Announcement
Theme
Introduction To 1st Record
1st Record
Lead Out 1st Record
Live Commercial
Lead In 2nd Record
2nd Record
Transcribed Commercial
Lead In 3rd Record
Sneak 3rd Record
Lead Out 3rd Record
Live Commercial
Closing Announcement
Theme

THE PROGRAM—AS THE AUDIO OPERATOR SEES IT

The audio operator views the DJ show this way: Before the program, the operator and the DJ meet in the studio. The operator is given the records and transcriptions which are to be used on the show, stacked in the order that they are to appear on the program. He also receives a list of the records, in that same order.

The operator returns to the control room and takes a level on the DJ. He then cues up the theme record on one turntable and the show's 1st record on the other. As airtime approaches, he stands by with the theme. That is, he holds the record on an already spinning turntable with one hand while the other hand rests on the turntable pot.

Theme

At airtime, the operator releases the theme record and whips open the pot so that the music comes in at full level. After 15 or 20 seconds, when the theme has been established, he fades the music down by partially closing the pot, and at the same time he opens the DJ's microphone by throwing its key to the program position.

Opening Announcement

The DJ, in a few short sentences, opens the show with the theme music in the background.

Theme

When the DJ has finished his brief opening, the operator closes the microphone and in the same motion he brings the theme music back up to full level.

At the conclusion of the theme, the operator closes the turntable pot and opens the microphone.

Introduction 1st Record

The DJ introduces the first record on the program. The operator stands by on that record and brings it in full, on the DJ's cue.

1st Record

He then closes the DJ's microphone. The operator then removes the theme record from its turntable. He places the program's 2nd record on that turntable and cues it up. He then gives all of his attention to riding gain on the first record.

Lead Out 1st Record

When the first record ends, the operator closes its pot and opens the DJ's microphone. The DJ leads out the first record, reads the commercial announcement, and then he introduces the program's second record.

Commercial Announcement

THE PROGRAM—AS THE AUDIO OPERATOR SEES IT

Lead In 2nd Record

The operator stands by on the second record as it is being introduced, and brings it in on the DJ's cue.

2nd Record

He then closes the DJ's microphone, removes the first record from the turntable, places the transcribed announcement on the vacated turntable, and cues it up. He stands by on the transcribed commercial announcement.

Transcribed Commercial

When the second record ends, the operator segues to the transcription.

He then quickly removes the second record from the turntable. Rapidly, he cues up and stands by on the third record.

The transcription ends. The operator opens the DJ's microphone and clips the transcription's turntable key with the same hand, in that order. His other hand is holding the third record.

Lead In 3rd Record

As the DJ begins to lead in the third record, the audio operator releases that record and slowly sneaks its pot open so that the music comes in under the DJ's voice.

3rd Record

When the introduction is finished, at the DJ's cue, the operator brings the music up to full level. He then removes the transcribed commercial from its turntable, replaces it with the theme record, and cues up the theme. At the conclusion of the third record, the operator closes its pot and opens the DJ's microphone. He then "dead pots" the theme record.

Lead Out 3rd Record

The DJ leads out the third and final record on the program.

Commercial Announcement

He reads the closing commercial announcement and begins to close the program.

Closing Announcement

The audio operator sneaks the previously dead potted theme music under the last few sentences of the closing.

Theme

When the closing is finished, he brings the theme music up to full level. The theme plays itself out at the exact time that the program is to end.

THE PROGRAM—AS THE AUDIO OPERATOR SEES IT

The Live Music Program

A program which is made up of live music, that is, music emanating from a live orchestra rather than on records, is very similar to the disc jockey type of program in its format. The two main differences that the operator will observe are the use of a master of ceremonies to introduce the music and the fact that it is an all microphone show, the turntables remaining silent.

The microphone setups for a studio music program are covered in detail in the preceding chapter, so for purposes of examining program formats here that portion of the pre-airtime preparations will be glossed over lightly. Too, in the interests of explanation, we will assume that all of the orchestra's microphones operate through a sub-mixer, whose master gain control appears as one of the inputs on the control console. This, then, enables the audio operator to control the entire volume of the orchestra through the manipulation of this one pot.

Here is the format of our typical live music program:

Theme
Opening Announcement
Theme
Commercial Announcement
Introduction to the MC
MC's Introduction, 1st Music
1st Music (Orchestral)
MC's Lead Out 1st Music
MC's Introduction to 2nd Music
2nd Music (Vocal Solo)
MC's Lead Out 2nd Music
MC's Intro to Announcer
2nd Commercial Announcement
MC's Introduction to 3rd Music
3rd Music (Instrumental Solo)
3rd Commercial Announcement
MC's Closing Announcement
Theme

And again, the same live music show format as seen by the audio operator: One or two hours before airtime, the operator, the announcer, the MC and the musicians, assemble in the studio for rehearsal. The operator is given a script of the show which he scans, to see what equipment, microphones, etc., will be required for the program. The musicians seat themselves and the operator sets up their microphones. In addition, he sets up a solo microphone, and one for the announcer and MC. The operator returns to the control room where he takes levels and checks the balance of the orchestra, the soloists, the announcer and the MC.

The orchestra then rehearses its individual selections. The operator follows this rehearsal, and makes notations in his script of the places in the

THE PROGRAM—AS THE AUDIO OPERATOR SEES IT

music where he will have to quickly adjust the orchestra pot to avoid excessively high or very low sound levels.

<i>Theme</i>	<p>At airtime, the operator opens the orchestra pot to the point that was determined during rehearsal. The orchestra plays the theme for 20 to 30 seconds at full level to establish it, and then diminishes its own volume to background.</p> <p>The operator throws the announcer's microphone key to the program position.</p>
<i>Opening Announcement</i>	<p>The announcer reads the opening announcement with the theme music in the background. At the conclusion of the announcement, the orchestra increases its volume back up to full volume level.</p>
<i>Theme</i>	<p>The operator closes the announcer's microphone. When the theme is finished, the operator closes the orchestra pot and opens the announcer's microphone.</p>
<i>Commercial Announcement</i>	<p>The announcer reads the commercial announcement.</p>
<i>Intro To MC</i>	<p>He then introduces the Master of Ceremonies at the same microphone. The announcer then leaves the microphone.</p>
<i>MC's Intro 1st Music</i>	<p>The MC introduces the first musical selection. The operator opens the orchestra pot to the point that was determined for that selection during rehearsal, and he closes the MC's microphone.</p>
<i>1st Music</i>	<p>The orchestra plays the first musical selection.</p> <p>At the conclusion of the music, the operator closes the orchestra pot and opens the MC's microphone.</p>
<i>MC's Lead Out 1st Music</i>	<p>The MC leads out the first selection.</p>
<i>MC's Intro 2nd Music</i>	<p>He then introduces the second selection, noting that it will be in part a vocal solo.</p> <p>The operator, at the conclusion of the announcement, opens both the orchestra pot and the solo microphone pot to their predetermined points for this selection, and he closes the MC's microphone. The or-</p>

THE PROGRAM—AS THE AUDIO OPERATOR SEES IT

<i>2nd Music</i>	chestra plays and the soloist sings the second musical selection. When the second selection has concluded, the operator opens the MC's microphone, and closes the orchestra and solo microphone pots.
<i>MC's Lead Out 2nd Music</i>	The MC leads out the second selection.
<i>MC Intros Announcer</i>	He then re-introduces the announcer, at the same microphone.
<i>2nd Commercial Announcement</i>	The announcer reads the second commercial announcement.
<i>MC's Intro 3rd Music</i>	The MC returns to the microphone and introduces the third music, which includes an instrumental solo. The operator opens the orchestra pot to the point that was determined during the show's rehearsal, and closes the MC's microphone.
<i>3rd Music</i>	The orchestra begins to play the third music. At a point in the music, the soloist walks to the solo microphone. Then the operator opens the solo microphone pot to its pre-determined point, and the soloist plays to orchestral accompaniment. When the third selection has ended, the operator opens the announcer/MC microphone, and closes the orchestra and solo microphone pots.
<i>3rd Commercial Announcement</i>	The announcer reads the third and final commercial announcement.
<i>MC's Closing Announcement</i>	The MC then closes the program, at the same microphone.
<i>Theme</i>	During the closing announcement, the operator opens the orchestra microphone pot, and the orchestra begins to softly play the theme. When the MC has concluded the closing announcement, the orchestra returns its volume up to full level. The operator closes the MC's microphone. The orchestra plays theme music until the time that the program is scheduled to end. The operator then closes the orchestra microphone pot.

THE PROGRAM—AS THE AUDIO OPERATOR SEES IT

The Dramatic Program

Despite the great variety of types of dramatic programs, their formats are somewhat similar. This is typical of what one dramatic format might look like:

Theme
Opening Announcement
Theme
Opening Commercial
Lead In To Narrator
Narrator
Mood Music
Cast (1st Act)
Bridge Music
Middle Commercial
Bridge Music
Cast (2nd Act)
Curtain Music
Narrator
Closing Commercial
Theme
Closing Announcement
Theme

The complexity of a dramatic program requires the audio operator to use his talents and know-how to the utmost. The variety of situations with which he may be faced on a dramatic show, make it necessary for him to think fast and act faster. Good taste in the mixing and blending of sound, and an accurate sense of timing are essential to the operator who handles dramatic programs.

Here are the considerations and actions of an operator on a dramatic show:

Some hours before airtime, the audio operator, the announcer, the narrator and the cast meet in the studio. The operator is given a script of the program and the recorded themes, music bridges, mood music, curtain music and any recorded sound effects that are to be used on the show, all in the order in which they are to be used. He is also given a listing of these recordings, in the same order.

The operator scans the script to determine what equipment will be needed on the show. If an echo chamber is required, for instance, he makes necessary arrangements. He then sets up microphones, one for the dramatic cast, one for the narrator and one for the announcer. The operator then returns to the control room, where he takes levels on the announcer and narrator, and marks the level settings of their pots in his script.

The cast then rehearses the dramatic portions of the program, with the operator following the script and marking the places where hushed whispers,

THE PROGRAM—AS THE AUDIO OPERATOR SEES IT

shouts and required sounds occur in the script. The operator will then know in advance how to adjust the cast microphone pot when those situations occur during the airshow. As a part of the rehearsal, the operator inserts all of the recorded material, in its proper sequence. He gets the "feel" of the timing necessary for each recorded insert. He also determines, and marks in his script, the levels of all background music.

Finally, the operator cues up the opening theme record and the mood music record, and he is ready to go on the air.

Theme

At airtime, the operator plays the theme, keeping it at full level for 15 to 20 seconds, to establish it.

He then fades it to background and opens the announcer's microphone.

Opening Announcement

The announcer makes the opening announcement of the program with the theme music in the background.

Theme

At the conclusion of the announcement, the operator closes the microphone and brings the theme back up to full level.

When the theme ends, the operator closes its pot and opens the announcer's microphone.

Opening Commercial

The announcer reads the opening commercial announcement.

Lead In To Narrator

He then introduces the narrator.

Narrator

The operator opens the narrator's microphone and closes the announcer's.

The narrator sets the scene of the dramatization.

Mood Music

During the narration, the operator sneaks the mood music in under the narrator's voice, and holds it in the background. At the end of the narration, the operator brings the music up to full level for 5 or 10 seconds and then fades it to background and out, as he opens the cast microphone.

Cast—1st Act

The actors in the cast perform the first act of the dramatization.

The operator removes both the theme and mood music records from their turntables. He cues up the sound effect records for the first act if there are any. If the first act employs no recorded sound effects, the op-

THE PROGRAM—AS THE AUDIO OPERATOR SEES IT

<i>Bridge Music</i>	<p>erator cues up the mid-program bridge music record. He also cues up the first of any sound effect records to be used in the second act of the play.</p> <p>As the first act is ending, the operator sneaks the bridge music in under the final sentences. He then closes the cast microphone and brings the bridge music up to full level. After 10 or 15 seconds of music, he opens the announcer's microphone and fades the bridge music out.</p>
<i>Middle Commercial</i>	<p>The announcer reads the middle commercial.</p>
<i>Bridge Music</i>	<p>At the conclusion of the commercial, the operator fades the bridge music back in, and up to full level. He closes the announcer's microphone.</p> <p>After 10 or 15 seconds of music the operator fades the bridge to background, and out as he opens the cast microphone.</p>
<i>Cast—2nd Act</i>	<p>The actors in the cast perform the second act of the drama.</p> <p>The operator removes the bridge music record from the turntable and cues up any recorded sound effects. If there are none, he cues up the curtain music and the closing theme.</p>
<i>Curtain Music</i>	<p>As the second act is concluding, the operator sneaks the curtain music in under the final actor's voice. When the act ends, the operator closes the cast microphone and brings the curtain music up to full level. The curtain music plays to its conclusion. The operator closes its pot. Then he opens the narrator's microphone.</p>
<i>Narrator</i>	<p>The narrator "wraps up" the dramatization. The operator then opens the announcer's microphone and closes the narrator's.</p>
<i>Closing Commercial</i>	<p>The announcer reads the closing commercial.</p>
<i>Theme</i>	<p>At the conclusion of the commercial, the operator closes the announcer's microphone and brings the theme music in at full level. After 15 or 20 seconds of theme music, the operator fades it to background and opens the announcer's microphone.</p>

THE PROGRAM—AS THE AUDIO OPERATOR SEES IT

Closing Announcement

The announcer reads the program's closing announcement.

Theme

The audio operator then brings the theme back up to full level. He closes the announcer's microphone. The theme plays to the conclusion of program time, at which time the operator closes its pot.

CHAPTER 11 REVIEW QUESTIONS

1. Briefly describe the duties of the audio operator on a newscast.
2. How does the sportscast differ from the newscast, as far as the operator is concerned?
3. Describe the function of the operator on a DJ Show.
4. Why are music records sometimes "sneaked"?
5. How does a live music show differ from a DJ show?
6. Why is it necessary for an operator to be present during rehearsal of a music program or dramatic presentation?

It became apparent during the study of control console operation that the people in the control room and the people in the studio could talk to each other via the console's audition and talkback systems, either before airtime or while a recording was being played.

What, then, of the need for studio-control room communication while a program is in progress, on the air? Two systems of communication were developed to fill that need:

1. Hand signals—for radio use.
2. An intercom system, using earphones—for television use.

Hand Signals

Hand signals were developed for use in radio broadcasting, where the people in the control room and in the studio can see each other during a program.

The announcer wants to tell the operator to "stand by" or get ready, to play a record. The operator wants to tell the announcer that he is too close to the microphone. This information may be conveyed to the person involved, by hand signals.

The signals described and pictured here are not universally used by every radio station. Many stations have developed their own signals, to cover situations that are peculiar to those stations. These signals, however, are representative of those used at many stations and are, in the author's opinion, those enjoying the widest use.

For study purposes, the hand signals have been grouped into three broad categories:

1. Microphone hand signals
2. Turntable hand signals
3. General information hand signals—relating to the program in progress.



MICROPHONE HAND SIGNAL

Figure 12-1 Hand Signal

1. *ATTENTION*—Made by raising one hand, palm forward, above the head, and waving it back and forth. It is given in the controlroom to attract the the attention of a performer, or in the studio to attract the attention of the operator.



Figure 12-2 Attention ◀

Figure 12-3 Stand By ▶

2. *STAND BY*—Made by raising the hand, palm forward, above the head, and holding it there. It is used as a preliminary signal, to indicate that something additional is about to be signalled. It is given either from the control room or from the studio.



MICROPHONE HAND SIGNALS



Figure 12-4 Watch Me

3. *WATCH ME*—Made by pointing to one's eye with one finger, indicating either a lack of attention by the person to whom it is given, or that another signal will follow rapidly.



Figure 12-5 You're On

4. *YOU'RE ON*—The cue given to the person at the microphone to begin speaking, or the cue given to the operator to perform a technical operation. It is preceded by the stand by signal and then the hand moves down and forward, one finger pointing at the person being signalled.



Figure 12-6 Audition My Microphone

5. *AUDITION MY MICROPHONE*—The performer at the microphone forms the letter "A", with the thumbs and index fingers of both hands, to indicate to the operator that he wishes to speak to the control room, but not on the air.

Figure 12-7 Open My Microphone

6. *OPEN MY MICROPHONE (ON THE AIR)*—It is given by the performer at the microphone, who rapidly points at the microphone with one finger, three or four times.





Figure 12-8 Clip My Microphone

7. **CLIP MY MICROPHONE**—Given by the performer at the microphone, to the control operator. It is made by moving one hand horizontally across one's throat, as though cutting the throat. It is usually preceded by a stand by signal.



Figure 12-9 Cut

8. **CUT**—This signal is given to indicate termination of whatever is in progress. A general purpose signal given to a performer to indicate cutting an optional paragraph, cutting an entire speech, etc. It is made in the same manner as #7 above, by drawing one hand horizontally across one's throat.



Figure 12-10 Move Closer To The Microphone

9. **MOVE CLOSER TO THE MICROPHONE**—Made with both hands raised at eye level, palms facing each other, hands moving toward, but not touching each other. It may also be made with one hand, moving toward, but not touching, the face.



Figure 12-11 Move Back From The Microphone

10. **MOVE BACK FROM THE MICROPHONE**—Made with both hands raised at eye level, palms facing away from each other, the hands moving away from each other. It may also be made with one hand, moving away from the face.



Figure 12-12 Speedup

11. **SPEEDUP**—Increase your reading page. It is made by raising one hand, index finger outstretched and pointing at the performer. The wrist is then rotated, rapidly and in a large circle, for a large increase in pace, or slowly and in a small circle, for a small increase in pace.

Figure 12-13 Stretch

12. **STRETCH**—Slow down your reading pace. Both hands are raised, and are drawn apart as though there were a rubber band held between the hands, grasped by the fingers. The hands are drawn wide apart for a great decrease, or they are drawn an inch or two apart for a small decrease in pace.



TURNTABLE HAND SIGNALS

All turntable hand signals are given by the announcer or performer in the studio, to the operator in the control room.



Figure 12-14 Wrap It Up

13. **WRAP IT UP**—Close the program. It is given to the final performer or announcer on a program. Both hands are raised to eye level, palms inward, and the hands are rapidly rotated about each other.

Figure 12-15 Record—Stand By—Play

1. **RECORD—STAND BY—PLAY IT**—The hand is first raised to the stand by position. Then the wrist bends over, the index finger pointing down and describing a slow, lazy circle. At the moment that the music is wanted, the hand moves to the you're on signal.



TURNTABLE HAND SIGNALS



Figure 12-16 Spot—
◀ Stand By—Play

2. *TRANSCRIBED "SPOT" COMMERCIAL—STAND BY PLAY IT*—The hand is raised to the stand by position, with the third finger bent into the palm of the hand. At the moment that the "spot" commercial is wanted, the hand moves to the you're on position.



Figure 12-17 Segue ▶

3. *SEGUE*—The hand is raised to eye level, and the index and second fingers are crossed or intertwined, pointing upwards.



Figure 12-18 Cross-Fade

4. *CROSS-FADE*—Both hands are raised to eye level, palms down, and are then lowered on an arc so that they cross each other at chest level.



Figure 12-19 Fade In ▶

5. *FADE MUSIC IN (OR UP)*—The hand is slowly raised, palm upwards, describing a slow arc, and stops when the desired music volume is heard.



Figure 12-20 Sustain Music

6. **SUSTAIN MUSIC**—Keep the music volume where it is. Preceded by the fade in signal. The hand describes a slow circle, palm upwards.



Figure 12-21 Fade Out

7. **FADE MUSIC OUT (OR DOWN)**—Preceded by the sustain music signal, the palm of the hand is slowly turned over, and palm facing down, the hand is slowly brought down, describing a slow arc.

GENERAL INFORMATION HAND SIGNALS *Always relating to the program in progress.*

Figure 12-22 Theme

8. **THEME—STAND BY—PLAY IT**—Both hands are raised to eye level. The index fingers form the letter "T". Then the stand by signal is given. When the theme is wanted, one hand moves to the you're on signal.



Figure 12-23 Thirty Seconds

1. **THIRTY SECONDS**—To the end of the program. Both hands are raised to eye level. The index fingers form a plus sign (+). Caution: do not confuse this signal with the theme signal.

GENERAL INFORMATION HAND SIGNALS



Figure 12-24 Fifteen Seconds
◀

2. **FIFTEEN SECONDS**—To the end of the program. One hand is raised in a clenched fist. Note: this same signal is used at the networks to indicate, "Give the network system cue", and it is given by band leaders to their bands to indicate, "Hit the sock chorus".

Figure 12-25 Station Break
▶

3. **STATION BREAK**—Give the station's call letters. Both hands are raised above the head, and the motion of breaking a twig is made with clenched fists.



Figure 12-26 On The Nose
◀

4. **ON THE NOSE**—The program is exactly on its predetermined time schedule. It is made by tapping one's nose lightly with one finger.

Figure 12-27 Headlines ▶

5. **READ THE HEADLINES (NEWSCAST)**—It is made by tapping the top of one's head lightly with one finger.



All hand signals should be made with wide, exaggerated motions, to emphasize their meanings.

All hand signal photographs courtesy: Gilbert Photo.

STUDIO—CONTROL ROOM COMMUNICATION

Intercom For Television

During a television program the control room is kept in semi-darkness. This is necessary so that the video control operators and the director of the program may critically view their television picture monitors. The problem thus created so far as communication is concerned, is that the talent in the studio cannot see into the control room to receive hand signal cues. In addition to the talent, the operating crew in the television studio, the cameramen, and the microphone boom operators must also be periodically cued from the control room.

To enable cues from the control room to be given to the people in the studio, an intercom system is used.

An intercom system is, in its simplest terms, a closed circuit telephone system. The director and his aides in the control room each wear a headset consisting of one earphone and a telephone type microphone—like those worn by telephone switchboard operators. In the studio, similar headsets are worn by the cameramen and by the floor manager. The latter is the director's representative in the studio; he receives the cues from the director on his intercom and, in turn, cues the talent by using hand signals. The director and the cameramen communicate with each other during the program directly through their intercom headsets.

The audio operator must be able to cue the boom operators during the program as well. For this purpose the audio operator is provided with a talk-back microphone. The boom operators each wear a headset consisting of two earphones, but no microphone. One of the two earphones is connected to the intercom system so that the boom operator may be cued by either the director or by the audio operator. The other earphone is connected to the console's monitor amplifier, so that the boom operator can hear program and thus determine for himself how to best position the microphone on the boom he is operating.

CHAPTER 12 REVIEW QUESTIONS

1. Why are hand signals used?
2. Who gives hand signals? To whom are they given?
3. Give the hand signal for "Attention", for "Stand By", for "You're On".
4. When is the "Clip My Mike" signal given? How does it differ from the "Cut" signal?
5. Give and explain the various types of speedup signals.
6. Give and explain the various types of stretch signals.
7. Why do we use different signals for record and for transcription?
8. Explain the difference between the signal for "Theme" and the signal for "thirty seconds".
9. Why are hand signals not given directly from a television control room?
10. How are hand signals used in a television studio?
11. How does the control room communicate with the studio during a television program?

A remote broadcast or *Nemo*, as it is familiarly termed, is a broadcast that originates anywhere except at the studios of a broadcasting station or from its network. Some of a station's studios may be located elsewhere than in the same building as the rest of the station. These other studios may even be equipped with remote-type portable audio equipment, but since they are usually semi-permanently wired up, and the equipment is not dismantled after each broadcast, they will not be referred to as remotes.

As far as the audio control operator is concerned, the prime difference between the *Nemo* and the studio broadcast is that all of the equipment used for the *Nemo* is portable. It must be transported to the *Nemo* site and there, set up for operation.

***Nemo* Equipment**

1. Microphones—A sufficient number of microphones, usually dynamics, to do the job on any particular *Nemo*. If only one microphone is needed, two are carried, one of them as a spare.
2. Microphone stands—A sufficient number of stands to do the job, both portable floor stands and table stands.
3. Microphone extension cables, AC power extension cords, telephone termination wire.
4. A pair of earphones.
5. A flashlight.
6. Screwdriver, pliers, knife.
7. A roll of friction tape.
8. A set of spare tubes and fuses.
9. A telephone talkback unit, if the station uses one.
10. A suitcase large enough to carry all of items #1 to #9, except the microphone floor stands.
11. A remote amplifier.

These are the items generally found necessary on a remote broadcast. Most of the items have either been discussed previously, or are everyday things

that require little explanation. One item however, does require further examination—the remote amplifier.

The remote amplifier is a small, portable, special-purpose control board. It contains some of the features of a studio type audio console, but being portable, all of the input and output connections to it are made by the operator at the site of the remote broadcast.

Inputs to the Remote Amplifier.

Most remote amplifiers have input facilities for from one to four microphones, but generally no turntable inputs. The microphones plug into receptacles that are located either on the back, or on one side of the remote amplifier case.

On the front of the remote amplifier, the operator will find a pot to control each microphone input, and a master pot to control the volume output of the entire remote amplifier. A volume unit meter is located on the front panel of the amplifier.

Most remote amplifiers have no microphone keys. When a pot is opened, its associated microphone is live. There are no auditioning facilities, nor is there a monitoring system included in remote amplifiers. The remote operator listens to the program that he is sending back to the broadcast station on earphones, or "cans", as they are called.

Remote Amplifier Output.

The output of the remote amplifier is connected to two pairs of terminals, or binding posts, which are mounted either on the front panel or on the back of the remote amplifier case. These terminals must be connected by the Nemo operator at the remote site to telephone lines, which carry the program back to the broadcast station.

Some of the other necessary items that the remote operator can expect to find on either the front panel or the back of the remote amplifier case are: A jack (receptacle) for the earphone plug, an AC power cord, a power on-off switch, and a pilot light to indicate that the amplifier is either on or off.

Let us now examine a block diagram (Fig. 13-1) of a typical remote amplifier to see how it compares with the larger studio control board.

The similarity of the remote amplifier diagram to that of the studio audio control console will be noted. The primary differences are the lack of microphone keys, monitor amplifier, monitor pot, and loudspeaker.

Now we shall examine some of the popular types of remote amplifier found at many broadcast stations.

The RCA Remote Amplifier has four microphone inputs, with microphone #3 or #4 being used at any one time. Note the binding posts on the right side of the front panel, where the lines are connected, and the microphone receptacles on the back of the amplifier case.

The Collins Remote Amplifier has four microphone inputs. The line terminals, microphone receptacles and the AC power line socket are all located on the back of the amplifier case. A separate power cord is plugged into the power line socket.

REMOTE BROADCASTS

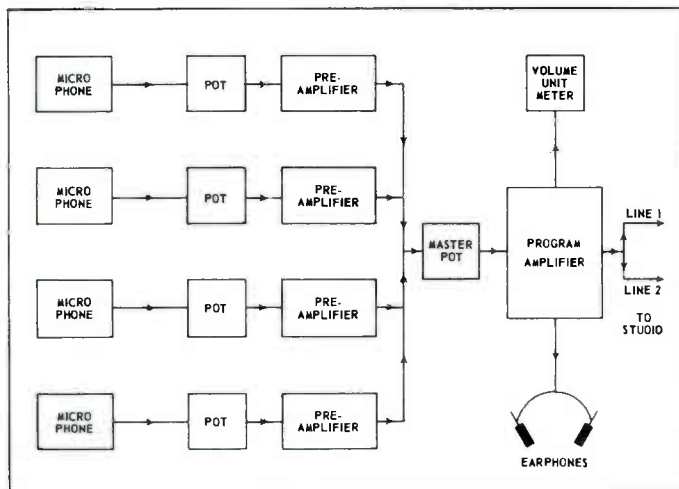

Figure 13-1
Remote Amplifier Block Diagram

Figure 13-2
RCA Remote Amplifier Front View
Courtesy Radio Corp. of America

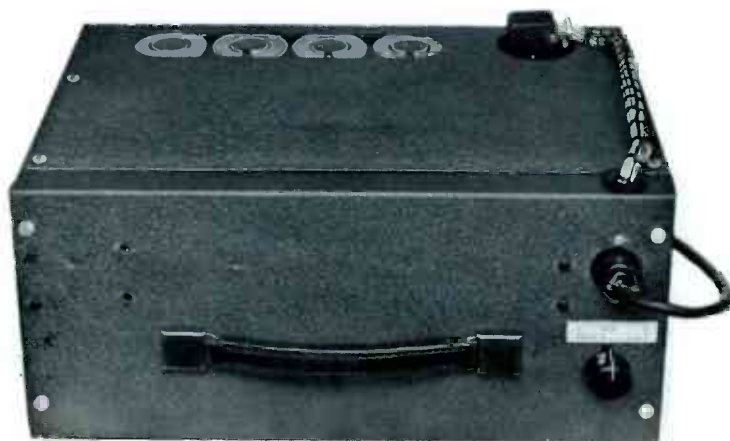

Figure 13-3
RCA Remote Amplifier Back View
Courtesy Radio Corp. of America

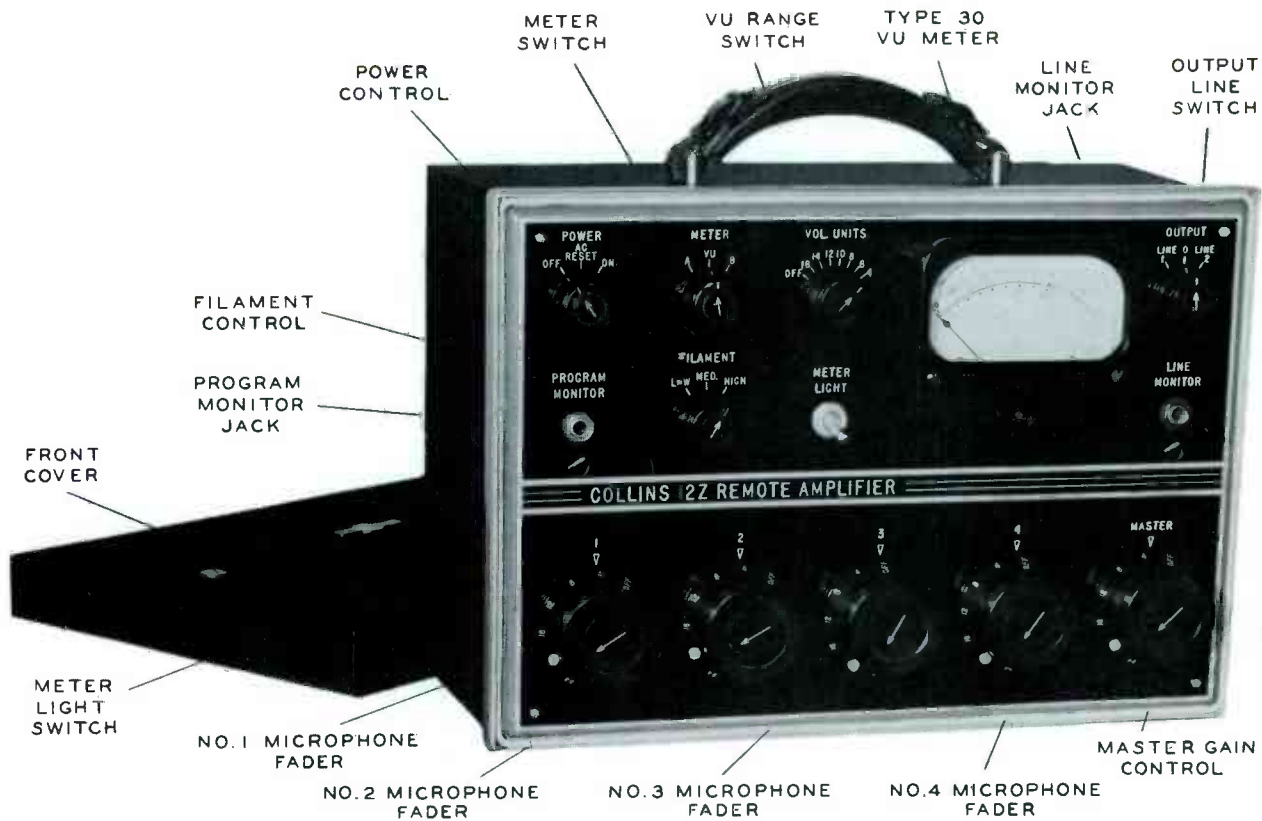

Figure 13-4
 Collins Remote Amplifier
 Front View
 Courtesy Collins Radio Co.



Figure 13-5
 Collins Remote Amplifier Back View
 Courtesy Collins Radio Co.



Figure 13-6
 General Electric Remote Amplifier
 Courtesy General Electric Co.

REMOTE BROADCASTS

The GE Remote Amplifier has four microphone inputs. Its AC power cord is on the front panel. The microphone receptacles are found on the left side of the case and the line binding posts are on the right side.

It has self-contained batteries, as does the RCA and Collins amplifiers. These are used as an emergency power supply for the amplifier, in the event of a power failure of the regular AC at the remote site.

The GE remote amplifier has a built-in source of "test-tone", which is found useful by the remote operator. Its use will be described under remote broadcast procedure.

All of the remote amplifiers mentioned in this chapter are light weight, easily carried equipment. They measure about 15 by 20 by 8 inches in size and weigh approximately 30 pounds each.

Remote Broadcast Procedure

The following procedure is followed, upon the decision of a broadcast station to do a remote broadcast of a particular event at a given location.

1. The chief engineer or technician-in-charge at the station calls the telephone company and orders the audio remote lines, as far in advance of the broadcast as possible.
2. The phone company runs the required lines, and terminates them at the Nemo site in a terminal block.

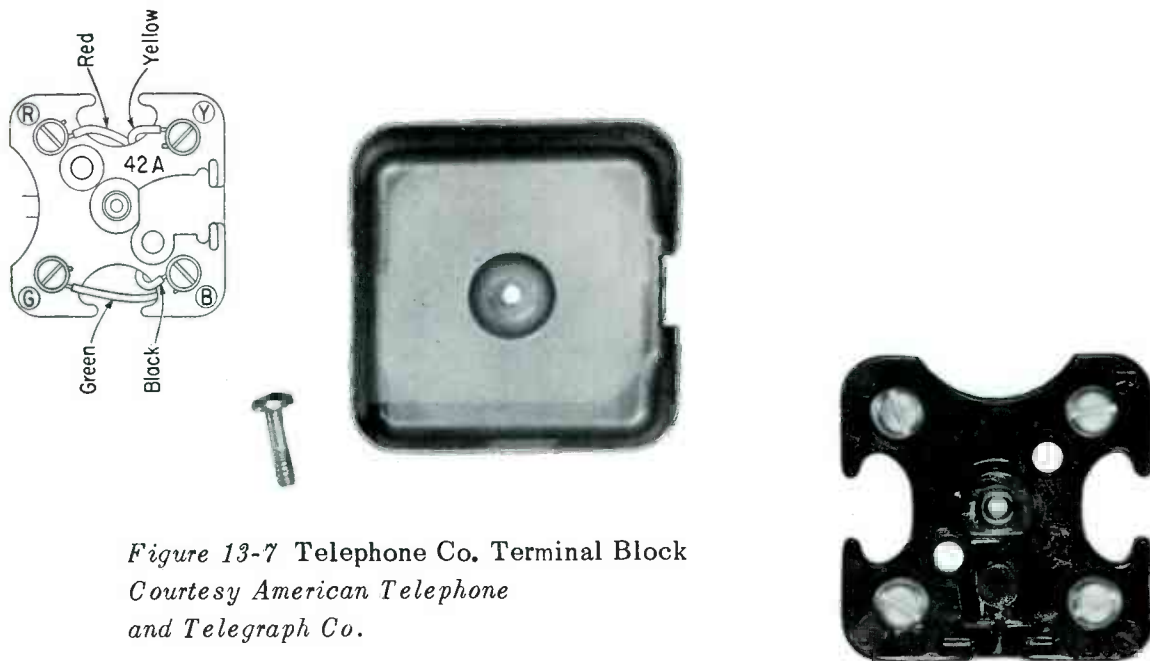

*Figure 13-7 Telephone Co. Terminal Block
Courtesy American Telephone
and Telegraph Co.*

REMOTE BROADCASTS

The terminal block is a small plastic square, two inches by two inches, with a metal cover that is screw-mounted to the center of the block. The block itself has four terminals, one in each corner. Two of these terminals are connected to the remote line going to the broadcast station, by the telephone company installer, for each pair of lines ordered.

It will be recalled that generally two pairs of lines are ordered. One, for the program line and the other as an emergency spare line. The installer hangs a tag marked "Radio" on the terminals to which he has connected the program line.

The terminal block has two mounting holes as well, so that it can be fastened to a wall or other convenient mounting, by the installer.

3. An operator is sent from the station to "scout" the location at which the broadcast will originate. He is usually sent out on the same day as the remote broadcast, but at least several hours before airtime.

He looks particularly for the source of AC power to be used for the remote amplifier. He looks for the terminal block and he notes the distance between the block and the power source, both to each other, and to where the remote amplifier must be set up. He attempts to secure locally, a table and a chair to be used during the actual broadcast.

4. Before leaving the station for the remote broadcast, the Nemo operator checks out all of the equipment he will use, particularly the remote amplifier, to see that everything is in perfect working order.

The operator removes the protective front cover from the amplifier, plugs the power cord into an AC outlet and turns the power switch on. He plugs in the earphones and connects one microphone to the amplifier.

Talking into the microphone, the operator watches the VU meter, and listens to himself on the earphones. If the equipment appears to be in working order, he disconnects the microphone and connects, one by one, each of the other microphones to be used on the remote broadcast.

5. Having determined that all equipment is in operating condition, the operator unplugs all connections to the amplifier, replaces its protective front cover and proceeds to pack the rest of the equipment into the suitcase.

Each of the microphones is wrapped or cushioned in a heavy cloth padding, or in foam rubber. The amount of microphone extension cable, AC power cord and terminal wire that was found to be necessary on the "scouting" trip and the earphones, the flashlight, tools, friction tape, spare tubes and fuses, all go into the suitcase.

6. The Nemo operator checks his wrist or pocket watch against the

REMOTE BROADCASTS

control room clock, which is kept timed accurately by a pulse from the U.S. Naval Observatory. He makes certain that his watch is in synchronization with this accurate clock.

7. He leaves for the remote site in time to get there at least one hour before airtime, taking all of the remote equipment with him.
8. When the operator arrives at the site of the remote broadcast, he sets up his equipment.

A table is placed so that all microphones will be within sight. The remote amplifier is placed on the table and its front cover removed. The amplifier's power cord is connected to the AC power source, directly if it is close, or through extension cords if necessary. If extensions are used, the cords are knotted or taped together at each connection to prevent their being pulled apart during the broadcast.

A piece of terminal wire of the required length is connected to the line terminals on the remote amplifier. The other end of this wire is connected, with the screwdriver, to the terminals on the telephone company terminal block marked "Radio Line". This operation may also require the use of a knife, to clean the wires, and the pliers to make the connections.

If two pairs of lines were ordered by the station, the talkback telephone is connected to the other two terminal screws on the terminal block.

The microphones are then mounted on their stands, and their cables are plugged into the receptacles on the remote amplifier. If the microphones are to be located far enough away to require extension cables, then the cables are knotted or taped together at each junction to prevent their being pulled apart during the broadcast.

The earphones are plugged into the amplifier's earphone jack, and the remote amplifier's power switch is turned on.

9. The remote operator now puts the earphones on his head, and opens the amplifier's master pot and one microphone pot.

Holding the microphone near him, he calls, "Remote calling studio, remote calling studio. Hello studio, do you hear me?"

The operator in the control room of the broadcast station is listening for the call of the remote operator on the audition loudspeaker. He previously threw the remote line key on the console to the audition position as soon as the remote operator left for the Nemo. Upon hearing the call, the operator in the control room throws the remote talkback key on and answers, "Hello remote, hello remote, I hear you loud and clear. Please woof me some peaks".

The remote operator then proceeds to "woof peaks". This is done as follows: The remote operator says, "woooof", into the microphone and immediately thereafter calls out the peak, or highest reading of the needle on the VU meter, for that woof.

REMOTE BROADCASTS

He repeats this procedure several times. The operator in the control room, meanwhile, adjusts the remote pot on the console for a coinciding reading on the console's VU meter. When the remote pot has been adequately adjusted, both VU meters should read the same for each peak called. As soon as the operator in the station's control room is satisfied that the readings are substantially the same, he advises the remote operator that enough peaks have been called.

If the remote amplifier has a built-in source of test-tone, such as the GE amplifier, the entire peak woofing procedure may be eliminated. As soon as the remote operator has called in, and received an answer from the station's control room, he turns on the amplifier's test-tone and adjusts it so that he is feeding zero VU, or 100 on the meter scale, to the station. The operator in the control room adjusts the remote pot until the VU meter on the console reads a corresponding zero VU, or 100 on the scale.

When volume levels have been synchronized between remote and control room, the remote operator asks for a time check and accurately re-adjusts his watch if necessary. He then notifies the operator in the control room that he will call back for a final check, five minutes before airtime.

10. The Nemo operator then puts the microphones into position for the broadcast. If the talent is available, he takes levels. The remaining time is spent checking over his cabled connections and other equipment in preparation for the broadcast.
11. Five minutes before airtime, the Nemo operator again calls the studio. He receives another time check, and is instructed as to the cue that will be given to start the remote broadcast. Either a voiced cue will be given from the studio such as, "Come in, Palace Theater", or the remote will start "by the clock" at a pre-arranged time. An "out-cue", or signal to return to studio, is also arranged between the remote and the studio at this time.
12. The operator in the station's control room then feeds the program then in progress to the Nemo. The remote operator listens for the signal to start the remote broadcast on his earphones, or when the previous program ends, he consults his watch and at the proper time he signals to the talent to begin the show.
13. The remote broadcast is *On The Air*.

Public Address System "Bridge" Pickups.

The remote operator may have occasion to do a remote broadcast at an auditorium or a stadium which has its own public address system. At such a broadcast, particularly if it is a music concert, the Nemo operator will find that the technician employed by the auditorium or stadium has already set up microphones for the best pickup at that location. Rather than duplicate that microphone setup, and possibly create a confusion of microphones and ca-

REMOTE BROADCASTS

bles, the Nemo operator should secure permission to take a "bridge feed" from the public address amplifier to his remote amplifier.

To take a bridge feed, a bridging transformer is carried to the remote site along with the rest of the Nemo equipment. The bridging transformer will have two pairs of leads. The operator connects one pair to the output of the public address amplifier and the other pair to a microphone receptacle on the remote amplifier.

The Nemo operator's task during the broadcast is then greatly simplified. He has only to ride gain on one microphone pot, the bridged input, and perhaps one other pot, controlling the microphone used by the station's announcer at the broadcast. Bear in mind however, that the quality of a bridge feed will only be as good as the quality of the equipment and operator providing the feed.

Taped Remote Broadcasts.

Some remote broadcasts will be recorded on tape, at the remote site, rather than sent back to the station over telephone lines. Taped remotes have several advantages over line remotes:

1. The taped program can be inserted into the station's broadcast schedule at a time that is convenient to the station. This time is not necessarily the same time that the event or program occurs originally.
2. There are no lines used, with a consequent saving of line fees to the station.
3. Any errors or "fluffs" that occur during the program can be edited out before the program is aired.
4. The taped program can be cut to conform to an allotted time.

The control operator who does a tape remote carries all of the previously mentioned equipment with him, with one notable exception. Instead of the remote amplifier, he carries a portable tape recorder. Probably the most widely used recorder for tape remote broadcasts is the Magnecorder.

Short Wave Remote Broadcasts.

A broadcast station often desires to do a remote broadcast at a place where the telephone company is not able to supply remote line service. A Nemo of this type might be done with a tape recorder as described earlier, or if the broadcast must be aired at the same time that the event takes place, a portable short wave transmitter can be used in addition to the regular Nemo equipment.

The remote amplifier is connected to the short wave transmitter, which broadcasts the program back to the station. There, it is picked up on a short wave receiver which feeds the program to one of the remote inputs of the console. An operator handling this type of remote broadcast, and operating the short wave transmitter, must be the holder of a F.C.C. license in addition to his other qualifications.

A short wave Nemo can best be described by an example of such a program:

The remote equipment, including a short wave transmitter, is assembled in a delivery truck belonging to the sponsor of the program. This truck cruises in a particular neighborhood of the city while the program is on the air. Back at the studio, a disc jockey show is in progress. Between the musical selections, the announcer gives the approximate locations of the truck to the listening audience, and announces that the truck will stop in front of a house on a certain street.

At that point the remote portion of the broadcast begins. Another announcer, who is in the truck with the remote operator, listening to the program from the studio on an ordinary radio, leaves the truck carrying a microphone on a long extension cable with him. He goes up to a house and knocks on the door. If the person who opens the door has been listening to the program, he will have in his hand one of the sponsor's products. If so, he is given a prize and, in any event, is interviewed about the product.

To accomplish this type of program the Nemo portion must be aired at the same time as the studio part; thus, it cannot be pre-recorded. Because of the necessary mobility of the operation, telephone lines cannot be used and this necessitates the use of a short wave transmitter.

Remote Broadcast Microphone Setups

Unless the remote broadcast is one requiring high fidelity, such as a music program, dynamic microphones are used.

For a music Nemo, cardioid, ribbon, or the newer condenser microphones are used but special care is taken in packing them and transporting them to the Nemo.

On a sports remote two microphones are used, one by the announcer and one by the sportscaster. The microphones, mounted on desk stands, are placed on a table which overlooks the sports arena or event.

Political speeches or banquet broadcasts generally require two microphones. One is placed on the speaker's dais or rostrum and the other, for the announcer, is placed in a quiet corner of the room where it will be least affected by crowd noise. A press conference might employ the highly directional cardiline microphone to pick up questions from the far corners of the room with "on mike" presence.

The dance band or orchestra remote broadcast should have three or four available microphones.

The remote operator should attempt to follow the setup of microphones suggested for studios, but since he can do nothing to adjust the acoustics of the room, or the positioning of the musicians, on a remote broadcast, he must be prepared with enough microphones so that he can experiment before airtime for the best possible pickup.

When the remote broadcast has ended the operator disconnects all microphones, cables and cords, and repacks all of the equipment. He then returns to the station, taking the equipment with him.

REMOTE BROADCASTS

CHAPTER 13 REVIEW QUESTIONS

1. What is a Nemo?
2. How does a Nemo differ from a studio program?
3. Enumerate the equipment that should be carried to a remote broadcast.
4. What is a remote amplifier?
5. Why are there no provisions normally made for turntable inputs to a remote amplifier?
6. What does the remote operator look for when he is scouting a Nemo site?
7. Explain the procedure for checking remote equipment before leaving the station for a Nemo.
8. Explain how the Nemo equipment is set up at the remote site.
9. What is meant by "woofing peaks"?
10. What is a bridging transformer used for?
11. How does a tape remote differ from a line remote?
12. How many microphones should be carried on a remote broadcast where there will be only one speaker?
13. For what reasons might a short wave transmitter be used on a remote broadcast?

Among the major factors affecting the sound quality of a radio or television program are microphone placement in the studio, and the physical design and construction of the studio. Having previously considered the problems of proper microphone placement, we now go on to develop the factors involved in the aural quality of a studio. It should be noted, in this connection, that even the best microphone setup for a program would serve little purpose unless the studio itself was designed properly.

First, it should be remembered that when sound strikes a surface such as a wall, a ceiling or a floor, it is either reflected by, transmitted through, or absorbed by that surface.

Reflection occurs when the sound hits a hard, shiny surface and "bounces" off that surface. *Transmission* takes place by the vibration of the surface itself, caused by the sound, and continues until the sound has passed through the material comprising that surface. *Absorption* occurs when the sound hits a very soft, pliable surface and is lost in dissipation through that surface.

The Radio Studio

What, then, are the factors affecting the aural quality of a studio?

1. The studio should be sound-proof. Sound that originates outside the studio must not be allowed to leak through the walls, the floor, the air conditioning ducts, or the ceiling of a studio and affect the program. At the same time, sound should not leak out of the studio and affect programs in adjoining studios. Sound-proofing of a studio may be accomplished in one of two ways:
 - (a.) By constructing the studio walls of heavy, solid, sound-absorbing materials such as cement or cinder blocks, and covering the walls, floor and ceiling of the studio with sound-absorbing materials such as Celotex tiles, cork, heavy rugs and heavy draperies. This method is used mainly in small stations, or at stations where the cost of studio construction is a major factor.

STUDIO DESIGN AND CONSTRUCTION PRACTICES

- (b.) By constructing the studio as a "room within a room". In this method, the inner-built room does not touch the outer room but instead is supported on specially built springs which will not transmit sound. This is a rather costly method of sound-proofing a studio and is therefore used primarily by the larger stations.
2. Reverberation within the studio must be carefully controlled. Reverberation is the "bounce", or lack of it, of sound on the surfaces that comprise a studio.

It is referred to in terms of *reverberation time*, the time which elapses between the cessation of the original sound and the decay of that sound to one millionth of its original value. It is also referred to in terms of *reverberation path*, the direction that sound will follow after having bounced off a surface of the studio.

The reverberation time of a studio depends upon the ability of the studio surfaces—the walls, floor and ceiling—to absorb sound. The proper reverberation time for any given studio depends upon the size of that studio, measured in cubic feet, and the use to which the studio will be put.

The reverberation time for any given radio studio might run anywhere from three tenths of a second, for a 1,500 cubic foot studio that is to be used only for talks, to one and three quarters seconds for a 125,000 cubic foot studio that is used primarily for orchestras and dance bands. The average general purpose radio studio might be designed so that its reverberation time would be about half way between the above extremes, and thus it would be usable for all types of programs.

Some of the materials that are used to control the reverberation time of a studio (by controlling the sound absorption of the studio surfaces) are: acoustical tiles, draperies or cork on the studio walls; rugs or cork tiles on the floors; and Celotex tiles or acoustical plaster on the studio ceilings.

The reverberation paths of a radio studio, or the directions in which sound will bounce from its wall surfaces, may be controlled by adjusting the the relationship of the wall surfaces to each other. The length of the reverberation paths, together with the reverberation time, determine the degree of liveness of a given studio.

Reverberation paths in a studio may be altered by employing tiltable vertical panels made of plywood, attached to the studio walls, or by mounting vertical plywood half-cylinders on the walls, or by the use of mobile gobo boards. Gobo boards are sound-absorbing screens. The principle is that no two wall surfaces in a studio should be parallel, for a minimum of studio liveness. The degree of liveness of a studio, then, can be altered by the arrangement of the tilting panels and the placement of the gobo boards. It follows that a given sound could be made to bounce around a studio dozens of times, losing most of its strength, and materially shortening its reverberation time before it again returned to the same place. A microphone located at that place would not be affected by sound reflections.



Figure 14-1 Vertical Tiltable Panels, and Poly-Cylinders on a Radio Studio Wall

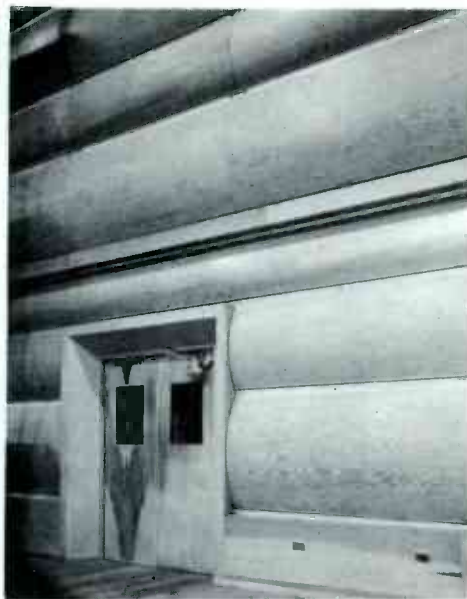

Figure 14-2 Horizontal Poly-Cylinders

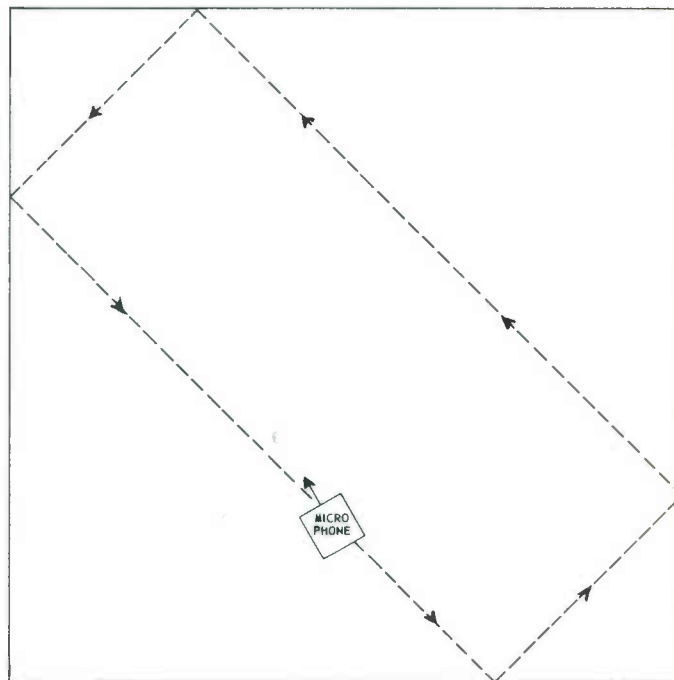

Figure 14-3 Vertical Poly-Cylinders. Note the control room window at the lower left of the picture.



Figure 14-4 Audience Type Radio Studio. Observe how the walls and ceiling are treated to eliminate parallel surfaces. Note too, the control room window at the right, with a clock and loudspeaker above it, and the microphone receptacles located both below the window, and across the stage from it.

Figure 14-5 Sound Reflection
Sound reflection in a studio with parallel wall surfaces. Note that one trip around the studio brings the sound back to its starting point, the microphone.



STUDIO DESIGN AND CONSTRUCTION PRACTICES

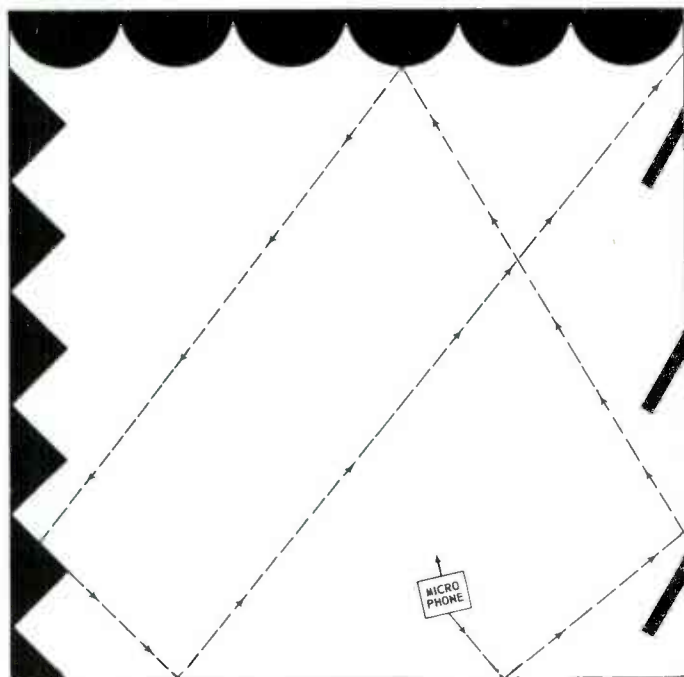
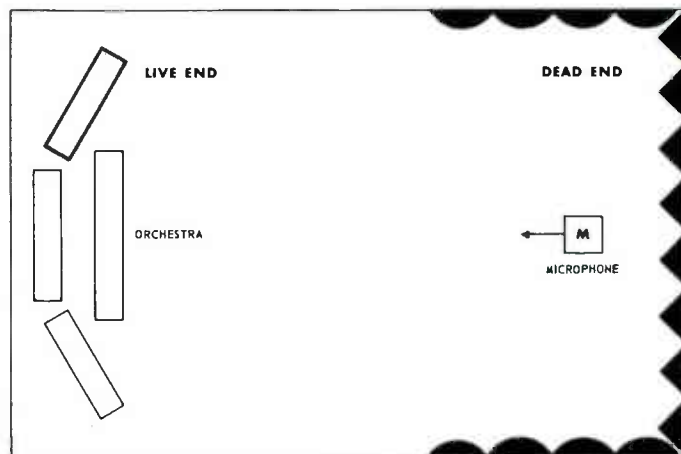

Figure 14-6 Sound Diffusion
Sound diffusion in a studio with non-parallel wall surfaces. Notice the comparative reverberation paths that the sound must travel, before returning to the microphone.

Figure 14-7
Live End—Dead End Studio



The Live-End—Dead-End Studio

The operator may encounter a live-end—dead-end studio at some radio stations. This is a studio that was designed to take advantage of the merits of both a live studio and one that has been deadened to sound reflection.

A live studio is excellent for music fidelity. The greater reverberation time enhances the brilliance, and the overtones of the music. The microphone pickup suffers in a live studio from the sound reflection but this is the very thing that enhances the music.

In a dead studio, one with long reverberation paths and short reverberation time, music would sound lifeless but the microphone pickup would be excellent.

A live-end—dead-end studio combines the better features of both the live studio and the dead studio. It is constructed as a live studio but about 10 feet of one end of the studio is thoroughly deadened. An orchestra sets

STUDIO DESIGN AND CONSTRUCTION PRACTICES

up its instruments in the live end, and microphone is placed in the dead end. Thus all of the brilliance of the music is picked up by the microphone without the unwanted reflection, or over-liveness.

The Television Studio

Television studios are, in most cases, larger than radio studios. This is necessitated by the addition of scenery, sets, props and other large bulky items which are used to build the visual illusion on a television program. There must be room for the cameras and microphone booms as well; these must be moved around the studio during the broadcast to pick up the different scenes.

A television studio scene must be well lighted for good picture quality. This requires extensive overhead lighting equipment, which in turn calls for a high studio ceiling. In some cases, the ceiling is two stories high.

A large, high-ceilinged studio as just described presents added problems to the audio control operator. Reverberation paths are more difficult to control, and a hollow, echo-like, roomy sound quality is the likely result. For this reason the walls and ceiling of a television studio are treated to make them as sound-absorbent as possible. Design considerations are focused toward creating a "dead" studio. In addition, as previously noted, cardioid pattern microphones are used to narrow the pickup area of the microphones as much as possible.

CHAPTER 14 REVIEW QUESTIONS

1. How may a studio be soundproofed?
2. Describe the materials used to soundproof a studio.
3. What is a floating studio?
4. Define sound reflection.
5. Define sound transmission.
6. Define sound absorption.
7. Define sound reverberation.
8. What two factors comprise sound reverberation?
9. What materials are used to control reverberation?
10. What is a live-end—dead-end studio?

RULES AND REGULATIONS OF THE
FEDERAL COMMUNICATIONS COMMISSION
THAT PERTAIN
TO AUDIO CONTROL OPERATORS

Standard radio and television broadcasting stations and the operators employed therein are governed by the Federal Communications Commission through its rules, regulations, laws and standards.

These are contained mainly in the following four F.C.C. publications:

- a. The Rules Governing Standard Broadcast Stations, and the Standards of Good Engineering Practice.
- b. The F.C.C. General Substantive Rules.
- c. The Communications Act of 1934.
- d. The Rules Governing Commercial Radio Operators.

The audio control operator should be familiar with those portions of the F.C.C. rules and regulations which pertain to his occupation, his safety, and his desire to keep himself and his employer within the confines of lawful broadcast operation. Following is a summary of some of these rules:

1. Any person who willfully and knowingly violates any rule, regulation, restriction, or condition made or imposed by the F.C.C. under authority of the Communications Act, or any rule, regulation, restriction or condition made or imposed by any international radio or wire communications treaty, or convention or regulations annexed thereto, to which the United States is or may hereafter become a party, shall in addition to any other penalties provided by law, be punished, upon conviction thereof, by a fine of not more than \$500 for each and every day during which such offense occurs.
2. No person within the jurisdiction of the United States shall knowingly utter or transmit, or cause to be uttered or transmitted, any false or fraudulent signal of distress or communication relating thereto.
3. Whoever utters any obscene, indecent, or profane language by means of radio communication, shall be fined not more than \$10,000, or imprisoned not more than two years, or both.
4. Any person receiving official notice of violation of the terms of the Communications Act of 1934 as amended, or treaty, or rules and regulations of the F.C.C., must answer such notice within three days after receipt.

RULES AND REGULATIONS OF THE FCC

5. The licensee of each broadcast station shall maintain program logs, and shall require entries to be made as follows:
 - (a) Time of the beginning and end of each program.
 - (b) An entry of the time each station identification (call letters and location) is made.
 - (c) Time that each commercial or sustaining announcement is made.
 - (d) An entry briefly describing each program that is broadcast, such as "music", "drama", "speech", etc., together with the name or title thereof, and the sponsor's name, with the time of the beginning and ending. If a mechanical record is used, the entry shall show the exact nature thereof, such as "record", "transcription", etc., together with the name or title of each, and the time that it is announced as a mechanical record. If a speech is made by a political candidate, the name and political affiliation of such speaker shall be given.

On commercial programs, an entry confirming that commercial credit has been given shall be made.
 - (e) An entry showing that each sponsored broadcast has been announced as sponsored, paid for, or furnished by the sponsor.
6. Logs of standard broadcast stations shall be retained by the licensee for a period of 1 year, provided however that the logs involving communications incident to a disaster, or which include communications incident to, or involved in an investigation by the F.C.C. and concerning which the licensee has been notified, shall be retained by the licensee until he has been specifically authorized in writing by the F.C.C. to destroy them; provided further, that logs incident to or involved in any claim or complaint of which the licensee has notice, shall be retained by the licensee until such claim or complaint has been fully satisfied, or until the same has been barred by statute limiting the time for the filing of suits upon such claims.
7. No log or portion thereof shall be erased, obliterated, or willfully destroyed within the period of retention provided by the rules. Any necessary correction may be made only by the person originating the entry, who shall strike out the erroneous portion, initial the correction made, and indicate the date of correction.
8. Rough logs may be kept, transcribed into condensed form, but in such case, the original log or memoranda, and all portions thereof shall be preserved and made a part of the complete log.
9. Logs shall be made available for inspection upon request by an authorized representative of the F.C.C.
10. Each log shall be kept by the person or persons competent to do so, having actual knowledge of the facts required, who shall sign the log when starting duty, and again when going off duty.
11. Station Identification.
 - (a) A licensee of a standard broadcast station shall make a station identification announcement (call letters and location) at the be-

RULES AND REGULATIONS OF THE FCC

- ginning and ending of each time of operation and during operation, on the hour and half hour as provided below.
- (b) Such identification announcement during operation need not be made, when to make such announcement would interrupt a single consecutive speech, play, religious service, symphony concert, or operatic production of longer duration than 30 minutes. In such cases, the identification announcement shall be made at the first interruption of the entertainment continuity, and at the conclusion of such program.
 - (c) In the case of variety-show programs, baseball game broadcasts, or similar programs of longer duration than 30 minutes, the identification announcement shall be made within 5 minutes of the hour and half hour.
 - (d) In the case of all other programs, except as provided in paragraphs (b) and (c), the identification announcement shall be made within 2 minutes of the hour and half hour.
 - (e) In making the identification announcement, the call letters shall be given only on the channel of the station identified thereby.
12. The following procedure should be followed by an operator if he sees a person come in contact with a high voltage circuit:
- (a) All power should immediately be switched off on that circuit, provided that the switch is quickly accessible.
 - (b) Pry the victim loose from the contact with a dry board, dry wooden stool, or chair. Avoid bodily contact with the victim.
 - (c) Call a doctor.
 - (d) Give first aid to the victim until the doctor arrives.

CHAPTER 15 REVIEW QUESTIONS

1. Why should the audio operator be familiar with the rules and regulations of the F.C.C.?
2. What is the fine and penalty for violation of any rule or regulation of the F.C.C.?
3. What is the fine and penalty for uttering obscene, indecent, or profane language on the air?
4. What information must a program log contain?
5. How long must a log be normally retained by a broadcast station? Under what circumstances must they be retained longer?
6. How may corrections be made in a log?
7. How frequently must broadcast stations identify themselves on the air?
8. What information must a station identification contain?

Throughout this text, the audio control operator has been discussed almost to the exclusion of everyone else who is employed in the operation of a broadcast station. This was done as a calculated effort to specifically point up the job of the audio control operator.

In all justice, however, we must indicate at this point that there are other important people employed at a broadcast station. The audio control operator is in daily contact with many of these people and often their jobs overlap his, so it behooves him to know who they are and of what their jobs consist.

The General Manager.

Every broadcast station regardless of its size has a general manager, whether by that title or by some other. In small stations he may perform other duties as well as those of managing the station, and in large stations he may have a staff of assistants to perform the one managerial function. His primary job is to formulate the overall policies by which the station is operated, and to provide supervisory people for its various departments who are capable of carrying out those policies.

He coordinates the activities of the various departments of the station, to see that they work together with cooperation and in harmony. In short, he is the Boss.

The Commercial Manager.

Sometimes known as the sales manager, he coordinates the activities of the broadcast time salesmen employed by the station.

A broadcast station must earn money to stay in business, and the commercial manager's job is to see that a goodly portion of the station's air time is sponsored. Sponsorship of programs is the means by which money is acquired to pay salaries and other station expenses. A sponsor is a business man who pays to have a message concerning his business or products inserted into, or made a part of, a radio or television program.

In a small station, the commercial manager may be the entire sales staff of the station. At a large station, he might have several broadcast time salesmen working under his supervision.

The Program Director.

The program director's job is to schedule the shows that emanate from the station. He sees to it that the proper kind of program is on the air at the

THE OTHER MEMBERS OF THE BROADCAST TEAM

right time of day. In carrying out that function, he hires the announcers and other talent used at the broadcast station.

His jurisdiction includes the News Department, the Production-Direction Department, the Script or Continuity Department, the Music Library, the Traffic Department and, of course, the announcers and other talent. The program director may himself supervise all of these departments and individuals in a small station or he may delegate this authority to department heads in a large radio or television station.

The program director schedules the work shifts of the staff announcers, or delegates that authority to a chief announcer. The other talent, and the musicians employed on a part time basis at the station, are also scheduled for their shows by the program director.

To understand the complexity of the program director's job, let us examine a few of the departments that he oversees.

News Department.

All of the international, national, and local news is compiled and edited by the News Department, and made into newscasts. The station receives its international and national news by subscribing to the facilities of any or all of the three wire news services; The Associated Press, The United Press and The International News Service. News is supplied to the broadcast station by these news service companies via teletype printer. Local news is acquired either from the local newspapers, or by the employment of local news reporters. The station may also employ one or more news editors and newscasters.

Production-Direction Department.

This is the department with which the audio operator will have the closest contact. At small radio stations, particularly those employing combo-men, the operator/announcer will be a member of the Production-Direction Department since he will produce and direct his own shows.

At the large broadcast stations where the bigger, more complicated programs are aired, production and direction become highly specialized arts. There, Production consists of assembling a program by securing the script, hiring the talent and obtaining clearance for all of the material to be used on the program. Then the director takes over. He rehearses the cast, times the program, edits and interprets the material used, and directs the program when it is being aired.

Continuity Department.

The members of the Continuity Department assemble all script material. They write any special copy necessary. They write, or check, all commercial copy submitted by the sponsors. All continuity and commercial copy that is read on the air is filed by the Continuity Department for future reference.

THE OTHER MEMBERS OF THE BROADCAST TEAM

Music Library.

The Music Library buys, or acquires free, records from the recording companies. In addition to records they rent transcribed music from program library services, such as Thesaurus, Capitol, Sesac, World, etc.

The Music Library stores the records and transcriptions thus acquired, cross-index files them and makes them available for the station's programs. They obtain clearance for the use of the music from the music writers associations, ASCAP and BMI, which collect royalties for the authors of the music.

A staff of several people, it can be seen, would be necessary to carry out these functions at a large station, while at a small station one person, usually an announcer, is the total staff of the Music Library.

Traffic Department.

The Traffic Department receives program information from the program director, and they furnish the commercial manager with all the information regarding unsold airtime. They begin and terminate all contracts for air time with the sponsors. This function includes keeping all commercial copy up to date. Traffic gets the commercial copy from the Continuity Department.

The Traffic Department types up the daily program schedule. They check the schedule to determine that there are no similar adjacent programs, or no adjacent similar spot announcements with different sponsors. Traffic checks the completed program log to see that performance agrees with their billing, as per the sponsor's contract. They make up the sworn statements that commercials were given at the time paid for. These statements are then signed by the announcers. The Traffic Department schedules the individual studios for programs, rehearsals, auditions and recording sessions.

The Chief Engineer.

The chief engineer is in charge of all of the technicians employed at the broadcast station. He is responsible for the care, maintenance, and installation of all technical equipment owned by the station.

At small radio stations, the engineering staff may consist of a chief and two or three transmitter Engineers. If the station employs combo-men, they are under the joint jurisdiction of the program director and the chief engineer. At non-combo stations, large or small, the chief engineer supervises the audio control operators, the transmitter engineers and, at television stations, the video control operators and cameramen as well.

The chief engineer schedules the work shifts of the technicians, and he makes recommendations for the purchase of new or replacement technical equipment.

The Television Operating Crew.

On a television program the audio operator is joined by several other operators, both in the control room and in the studio, to form an operating crew. The other operators are:

The cameramen—Usually from one to three cameramen on a TV broadcast. They operate the studio cameras, focusing, composing and taking the

THE OTHER MEMBERS OF THE BROADCAST TEAM

pictures that are sent by the cameras to the video control board.

The Video Control Operators—There is usually one video control operator for every two cameras. His job parallels that of the audio control operator. The video operator rides gain on, and controls the shading of, the picture going out on the air, on his video control board.

The Switcher—He is generally the coordinator of the TV crew. On a program, he fades or switches from camera to camera, on cues from the director of the program.

The Boom Operators—Two boom operators are usually employed on a TV operating crew. They position the microphones, keeping the performers always on-mike. The boom operators are cued from one position to another in the studio by the audio control operator.

The Dolly Pushers and Cable Pullers—They push the microphone booms and the large camera dollies from place to place, wherever they are needed in the studio, and they lay out and move the microphone and camera cables on the studio floor so that they are not crossed by the wheels of the heavy booms and dollies.

The Floor Manager.

He is the director's aide in the studio. The director remains in the control room during the program, coordinating the actions of the talent and the operations of the crew. The floor manager in the studio receives the cues for the talent from the director and he relays those cues to the talent.

The Stage Electricians.

They set up and arrange the lighting of the sets previous to airtime, and they alter the lighting conditions during the broadcast upon instructions from the director.

The Stagehands.

They set up and arrange the sets, walls, backdrops, curtains and props, in fact all of the physical properties that are used to create the picture illusions on a television program.

CHAPTER 16 REVIEW QUESTIONS

1. What are the duties of the general manager?
2. What are the duties of the commercial manager?
3. What are the duties of the chief engineer?
4. What are the duties of the program director?
5. Describe the functions of the News Department.
6. Describe the functions of the Production-Direction Department.
7. Describe the functions of the Continuity Department.
8. Describe the functions of the Music Library.
9. Describe the functions of the Traffic Department.
10. Name the members of the TV operating crew.
11. What are the duties of a floor manager?

One who enters the broadcasting industry with a good "talking" knowledge of his occupation will not appear to be a novice. Included here, therefore, is some of the every-day terminology of the industry.

A

- Acetate An instantaneous cut record; the soft plastic material on which an instantaneous record can be cut.
- Acoustic Pertaining to the sense of hearing, or the science of sound; treatment of room surfaces for desired sound reflection.
- Aerial The wire that is attached to a home radio receiver, which picks up the radio waves.
- Ampex The trade name of a high quality broadcast tape recorder.
- Amplifier An electronic unit which is used to enlarge an audio or radio wave.
- Audition Amplifier—The amplifier which is used to activate the control room auditioning loudspeaker.
- Cue Amplifier—Another name for audition amplifier.
- Monitor Amplifier—The amplifier which activates the monitor loudspeakers in the control room and its associated studio.
- Pre-Amplifier—An amplifier which is used to enlarge minute microphone or turntable output energy so that it may be used by the program amplifier.
- Program Amplifier—The master amplifier of a control console; the amplifier that feeds program out of a control room.
- Announcer A person who is employed by a broadcast station to speak or read on the air.
- Antenna A transmitting radiator; a metal structure which is used to either radiate or receive radio waves.
- Attenuator See Pot.
- Audio That which can be heard; the equipment for handling sound.
- Audition A tryout of a record, tape, or live voice, without putting same on the air; see audition amplifier.

B

- Background Music or sound that is kept underneath a speaker's voice.
- Bi-Directional
Microphone A microphone that has two live sides.
- Blast-in Sound volume that is too high, and out of propor-

GLOSSARY OF BROADCASTING TERMINOLOGY

Board	tion to the sound that immediately preceded it. See Control Console.
Boom	A mobile microphone stand.
Bridge	A musical transition between scenes.
C	
Call Letters	The identifying letters, preceded in the United States by the letter W or K, assigned to a broadcast station by the Federal Communications Commission.
Cans	Earphones.
Cardioid Microphone	A microphone which has one live side.
Cartridge	The element of a turntable pickup which translates the record's groove inscription to sound.
Channel, mixing	A chain consisting of a pre-amplifier, pot and key. This input channel may accept a single input, or a number of inputs determined by an associated selector switch.
Channel, output	The program amplifier or amplifiers of a control console. Where there are two, they may each carry the output of a separate studio, or they can carry the stereo output of a single studio.
Clearance	Permission obtained from authors or publishers to use their material on a broadcast.
Clip	To cut off sharply.
Commercial	That portion of a program in which the sponsors products or services are described.
Control Console	An electronic unit which blends, mixes, amplifies, and routes sound.
Continuity	Written script material.
Control Room	The room overlooking a studio where the program is controlled.
Cord	Patch cord, see Patching.
Cross Talk	A spillover of sound from a line to an adjacent line; a spillover of sound on a reel of recorded tape, from one layer to an adjacent layer.
Cue	A signal to start.
Cue Amplifier—	see Audition Amplifier.
Cue Speaker—	see Loudspeaker, Audition.
Cueing	Pre-setting a record, transcription, or a tape on its playback machine, for immediate starting.
D	
Dead	Highly sound-absorbent, referring to studios.
Distortion	The undesirable alteration of sound
Dolly	A mobile television camera stand.
Dynamic Microphone	A microphone which is Live all around its face.
E	
Echo Chamber	A highly reflective room, especially prepared for sound reverberation.

GLOSSARY OF BROADCASTING TERMINOLOGY

Equalizer A device to compensate for losses in frequency response, in a mechanical playback machine.

F

Fade The operation of a pot on the console, to vary the volume of an incoming or outgoing music record, in graduated steps.

Fader See Pot.

F.C.C. Federal Communications Commission.

Feed The transfer of sound by lines, from one place to another.

Feed Reel see Tape.

Feedback A squeal or howl usually caused by faulty loud-speaker muting relays. Could also be caused by open control room-to-studio door.

Filter A device which eliminates from a record those frequencies at which scratch is heard.

Fluff An error in speech or music made by an announcer, actor or musician, on the air.

Frequency In sound, the tone or pitch.

Frequency Response The degree to which audio equipment handles the entire range of audible sound, without distortion.

G

Gain Amplification of sound. Riding gain is the varying of sound amplification in the control console, by the operator.

Gobo Board A movable sound-absorbing screen.

H

High Fidelity The accurate reproduction of music by a recording process; the equipment used to reproduce that music.

I

Indicator, Volume See Volume Unit Meter.

Input That part of an item of electronic equipment *into* which sound is fed.

J

Jack A socket or plug receptacle.

Jack Panel or Bay—see Patch Panel.

K

Key A switch on a control console.

Key Station A broadcast station which originates programs for its network.

GLOSSARY OF BROADCASTING TERMINOLOGY

L

- Label** The center portion of a record, containing all of of the information pertaining to that record.
- Level** The degree of sound loudness.
- Limiter** An electronic device which protects a broadcast transmitter from sound volume surges.
- Line** A pair of wires used for carrying program.
Network Line—The line on which programs travel to or from a network.
Remote Line—The line on which program travels from a remote broadcast to the broadcast station.
- Live** A live microphone is one that is turned on. A live program is one that employs live talent, rather than recordings.
- Log** A listing of various items comprising a broadcast, as required by the F.C.C.
- Loudspeaker** A device which changes electrical energy into sound.
Audition or Cue Loudspeaker—The loudspeaker in the control room that is used for listening to console outputs which are not being sent out on the air.
Monitor Loudspeaker—The loudspeakers in both the control room and studio, which are used for listening to console outputs that are going out on the air.

M

- Magnecorder** The trade name of a good quality broadcast tape recorder.
- Master Control** The central control point at a large broadcast station which routes outgoing and incoming programs.
- Master Pot** See Pot, Master.
- M C** Master Of Ceremonies.
- Microphone** A device for changing sound into electrical energy.
- Microphone, talkback** A low quality microphone employed in the intercom system between the control room and the studio.
- Mike** Abbreviation for microphone.
- Mixer** See Pot.
- Monaural sound** Single output channel sound.
- Monitor** To listen to program going out on the air.
Monitor Amplifier—see Amplifier.
Monitor Loudspeaker—see Loudspeaker.
Monitor Pot—see Pot.
- Multiplexing** Employing two separated sound channels carried by a single radio wave.

N

- Nemo** Remote broadcast.
Nemo Line—see Line, Remote.
- Network** A company which supplies complex programs to the local broadcast station via telephone lines.

GLOSSARY OF BROADCASTING TERMINOLOGY

O

Off Mike	Not within the pickup pattern of the microphone.
Omni-directional Microphone	A microphone that is live, 360 degrees around its face.
On Mike	Within the microphone's pickup pattern.
On The Air	The time when a program is being broadcast.
Operator	A person employed by a broadcast station to operate the program controlling equipment.
Output	The terminal point of a unit of electronic equipment, from which sound is taken.

P

Pad	See Pot.
Patching	Connecting units of electronic equipment for the purpose of routing sound, by means of patch cords which plug into patch panels or patch bays.
Pattern, Microphone—	The area near the live sides of a microphone, in which the microphone is effective in capturing sound.
Pickup	The ability of a microphone or a turntable cartridge to respond to sound; a phonograph arm.
Platter	A disc recording.
Playback	The reproduction of the sound on a record or on a tape; a sound reproducing machine.
Pot	A control knob on a console which varies the sound volume of an input to the console. "Pot" is an abbreviation of the word potentiometer. Pots are also known as mixers, faders, pads, attenuators, and gain controls.
Master Pot—	The control knob which varies the sound volume output of the entire control console.
Monitor Pot—	The control knob which varies the sound volume emanating from the monitor loudspeakers.
Popping	An explosive sound caused by excess stress in the pronunciation of the letters "B", "P" and "T".
Pre-Amplifier	See Amplifier.
Presence	The quality of being on mike, at the proper individual distance from the microphone.
Pressing	A manufactured disc recording.
Pressure Microphone	See Dynamic Microphone.
Program	A complete broadcast presentation, usually of five or more minutes in duration.
Program Amplifier	See Amplifier, Program.

R

Receiver	An electronic device employed for the reception of radio waves which carry sound or picture.
----------	--

GLOSSARY OF BROADCASTING TERMINOLOGY

Record	To impress sound on disc or tape; a disc on which phonographic sounds have been impressed.
Recording Room	A room where instantaneous records are cut and/or tape recordings are made.
Reel	A metal or plastic wheel-shaped container used for holding recording tape.
Relay	An electrically operated switch.
Remote Broadcast	A broadcast which takes place anywhere except at the studios of a radio or television station, or its network.
Reverberation	A reflection of sound, after the sound has impinged on a surface.
Ribbon Microphone	See Bi-Directional Microphone.
Ride Gain	To control sound volume by means of the pots on a control console.

S

Segue	(pronounced seg-way). A continuous uninterrupted playing of two or more records with no live announcement in between
Sibilance	A hissing sound made in the pronunciation of the letter "S".
Sound	A disturbance of the air particles, causing an audible vibration of those particles.
Spillover	A loud sound volume causing the VU meter needle to go above the 100 mark on the scale; the leakage of sound from one line to an adjacent line; the leakage of sound from one layer of recorded tape, to an adjacent layer.
Sponsor	One who pays the costs of a broadcast for the purpose of having a message concerning his products or services made a part of that broadcast.
Stereophonic radio	A system whereby sound is picked up, amplified and routed through two separate input channels. It is carried unmixed through two separate output channels and transmitted by a multiplex system. Stereo provides the listener with an additional spacial effect which approximates to some degree a live performance.
Studio	A room which is designed to be used for recording sessions or the production and airing of radio or television programs.
Stylus	The pickup needle on a turntable arm.

T

Talent	Anyone who appears for pay on a broadcast, other than the announcer.
--------	--

GLOSSARY OF BROADCASTING TERMINOLOGY

- Talkback** Conversation between control room and studio that does not go out on the air.
- Tape** A plastic ribbon coated with an iron oxide, that is used for recording sound magnetically.
- Tape Machine**—A device for the recording and playback of tape.
- Tape Feed Reel**—The reel from which the tape travels, on a tape machine.
- Tape Takeup Reel**—The reel to which the tape travels, on a tape machine.
- Telco** The Telephone Company.
- Transcription** A record which is manufactured solely for broadcast purposes.
- Turntable** A playback machine for records and transcriptions.

U

- Uni-Directional Microphone** See Cardioid Microphone.

V

- Velocity Microphone** See Bi-Directional Microphone.
- Volume** The amount or fullness of sound.
- Volume Unit Meter** A meter or instrument which measures the degree of sound loudness. It is sometimes called a volume indicator.

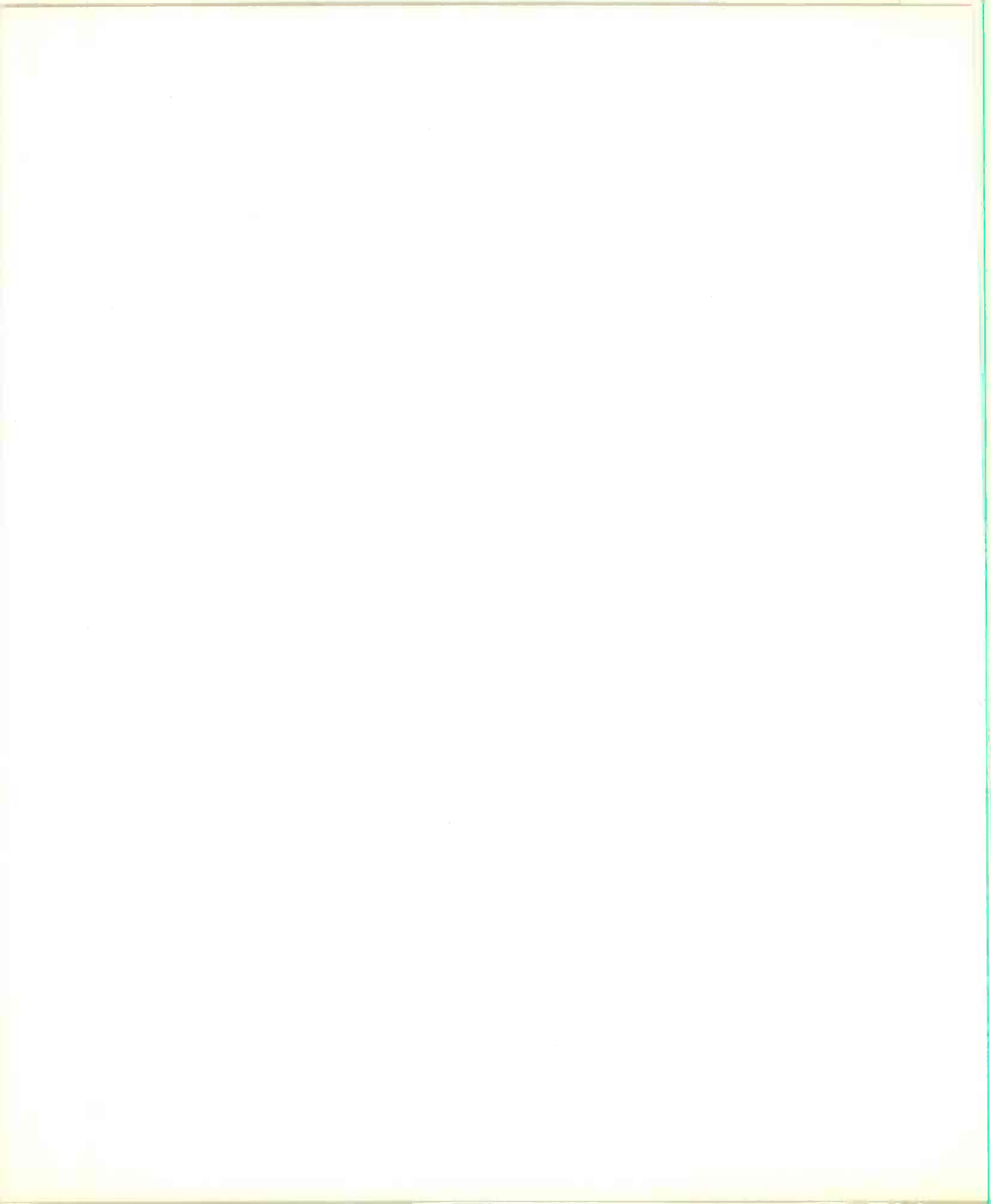

INDEX

-A-

Aerial, 2
 Amplifier, monitor, 4
 Amplifier, pre-, 4
 Amplifier, program, 4
 Amplifier, remote, 112
 block diagram of, 114
 Collins, 115
 General Electric, 115
 inputs to, 113
 weight of, 116
 RCA, 114
 Amplifier, tape playback, 25
 Amplifier, tape recording, 25
 Antenna, 2
 ASCAP, 133
 Attenuator, 5
 Audience reaction, 89
 Audio control, 1
 Auditioning, 7
 Audition, key position, 6

-B-

Balance, definition of, 62
 music, 63
 Blasting, microphone, 61
 BMI, 133
 Broadcast, remote, 112
 location scouting, 117
 microphone setups, 121
 PA bridge pickup, 119
 procedure of, 116
 short wave, 120
 tape recorded, 120
 Broadcast schedule, 120
 Broadcast station, 1
 Broadcast time salesman, 131

-C-

Capstan, 25
 Cartridge, record reproducing, 21
 Chamber, echo, 33
 Chief Engineer, 133
 Channel, mixing, 11-16
 Channel, output, 11
 Combo man, 6
 Commercial announcer, 90

Connection, normal through, 57
 Connector, Cannon, 20, 21
 Console, Collins 212G-1, features of,
 11-16
 four channel, block diagram of, 5
 functions of, 3
 Gates Ambassador, features of, 11-16
 Gates Executive, features of, 11-16
 General Electric BC-31-B, features of,
 11-16
 one microphone channel, 4
 one microphone channel, block diagram
 of, 4
 RCA BC-3-C, features of, 11-16
 RCA BC-7, features of, 11-16
 Control board, 2
 functions of, 3
 Control operation, 1
 Control room, 1, 6
 Control, volume, 4
 Cord, patch, 58
 Cross-fade, 68
 Cueing, definition of, 65
 Cue, key position, 6

-D-

Dead pot, 68
 Director, program, 132
 Disc jockey, 94

-E-

Earphones, 7
 intercom, 111
 Echo, 32, 33
 Electrician, TV stage, 134
 Energy, electrical, 1
 Equalizer, record, 24
 Equipment, nemo, 112

-F-

Fade, 67
 Fader, 5
 F.C.C., license, 120
 rules and regulations of, 128
 Feedback, 7
 Feed, bridge, 120
 Filter, Fairchild, 24

INDEX

Filter, lateral, 47
 record, 24
 vertical, 47
Floor manager, TV, 134
Format, program, 90

-G-

Gain, riding, 5, 62, 120
Gobo board, 124
Groove, 47

-H-

Hand signal, types of, 103
 uses for, 103
Heads, tape, 25, 26

-I-

Input, console, 18
Intercom, TV, 111

-J-

Jack, earphone, 12

-K-

Key, 4
 microphone, 6
 operating, 5
 override, 10
 talkback, 6

-L-

Lathe, recording, 39
Level, changes of, 62
 definition of, 61
 taking a, 62
Library, music, 133
Limiter, 36
Lines, audio service classes, 32
 incoming, 31
 transmitter, 35
Loops, 31
Loudspeaker, 2, 4
 location of, 36
 studio, 6, 89

-M-

Magnetism, residual, 50
Master control, CBS, 37
 lines to, 37
Master of ceremonies, 84, 98
Meter, volume unit, 5
 description of, 8
 readings of, 62
Microphone, 2, 4
 Altec 639 cardioid, 20
 Altec 633 dynamic, 19
 band setups, 85
 cardioid, 18
 cardioid combination, 71
 care of, 75
 clipping of, 75
 combination, 18
 condenser, 19
 control room, 6

Microphone, cord, 75
 cord hook, 76
 dynamic, 18, 70
 Electro-Voice 642 cardiline, 20, 72, 121
 Electro-Voice 643 cardiline, 20, 72, 121
 interaction of, 81
 large orchestra pickup, 86
 music pickup, 85, 87, 88
 Neumann U-47 (Telefunken) condenser,
 20, 72, 121
 Neumann U-67 condenser, 20, 72, 121
 number per program, 81
 patterns, adjustment of, 72
 piano pickup, 86
 pickup, quality of, 73
 presence, 74
 RCA 77 cardioid, 20
 RCA Commentator, 19
 Senior Velocity, 20
 setup, one speaker, 81, 82
 setup, two speakers, 83
 setup, voice groups, 84
 stands, 76, 77, 78, 79
 stand placement, 81
 talkback, 6, 10-16
 television usage of, 73
 use of, 74
 velocity, 18, 71
 vs talent, 75

Mixer, 5
Monaural, 10-16
Multiplexing, 11
Music, program, 96

-N-

Nemo, 32, 112
Network, 31
 lines to, 36
Newscast, 90
Newscaster, 91

-O-

Off-mike, 74
Operating crew, TV, 133
Operations, technical, 63
Operator, 1
 microphone boom, 111, 134
 nemo, 119
 video control, 111, 134
Oscillator, tape erase, 25
Output, console, 35

-P-

Pad, 5
Patch, panel, 57
 procedure of, 59, 60
Peaks, woofing, 118
Performer, 2
Pickup, arm, turntable, 21
Platter, 30
Plug, Cannon, 20, 21
Popping, microphone, 71
Pot, 4
 auxilliary, 33
 master, 4

INDEX

Pot, master, use of, 5
 monitor, 4, 5
 Power supply, 3
 Pre-amplifier, 4
 Presence, section, 88
 Production, 132
 Program, disc jockey, 93
 dramatic, 99
 key position, 6
 Public Address system, studio, 89
 Pushbutton, talkback, 7

- R -

Rack, equipment, 59
 Record, cueing procedure for, 65
 keying in, 67
 listening to, 7
 playing of, 66, 67
 potting in, 67
 Recorder, tape, 25
 tape cartridge, 31
 Recording, master, 43
 pressing, 46
 process of, Capitol Records, 40, 41,
 42, 43, 44, 45, 46, 47
 room, lines to, 36
 Recordings, disc, 39
 instantaneous, 39
 pressings, 39
 Records, handling of, 48
 jackets for, 48
 lateral and vertical cut, 47
 lines per inch, 48
 microgroove and LP, 48
 order of play, 94
 cuts, outside in, inside-out, 48
 Reel, feed, 26
 takeup, 26
 Relay, 38
 loudspeaker muting, 7
 Remote broadcast, 32
 Reverberation, 32, 33
 control, materials to, 124
 path, 124
 time, 124

- S -

Screens, sound absorbing, 124
 Script, 96, 99, 132
 Segue, 68
 Sibilance, 70
 Sound, 1
 absorption of, 123
 definition of, 2
 diffusion of, 126
 proofing, 123
 reflection of, 33, 123, 125
 transmission of, 123
 Sportscast, 91
 Stagehands, television, 134
 Station, commercial manager of, 131
 departments of, 132
 manager of, 131

Station, program director of, 131
 Stereophonic sound, 10-16
 Studio, 4
 design of, 123
 live end - dead end, 126
 quality of, 123
 television, 127
 Stylus, 21, 23
 Sub-mixer, 9, 10
 block diagram of, 16
 RCA, 16
 use of, 88

- T -

Talkback unit, telephone, 112
 Tape, bulk eraser, 50
 coating of, 49
 crosstalk, 51
 cue up and play procedure, 68, 69
 Editall editor, 53
 editing of, 51, 52, 53
 erasing, 49
 Jiffy Editor, 51, 52
 leader, purposes of, 53, 54
 plastic base, 49
 playback, 49
 recorder, Ampex, 28
 recorder, Magnecord, 27
 operating instructions, Ampex, 26, 27
 operating instructions, Magnecorder,
 26
 recording on, 49
 reel size and footage, 51
 speed of, 26
 storage of, 50, 51
 timing with leader tape, 54
 types of, 49
 Telco, 31
 Telephone company, 32
 Terminal block, telco, 116
 Theme, 91
 Traffic department, 133
 Transcription, definition of, 47
 Transfer mechanism, tape, 25
 Transistor, 11
 Transmitter, 2, 35
 Turntable, 4
 description of, 21
 Fairchild, 22
 RCA, 22
 TV cameraman, 133
 switcher, 134

- V -

Vacuum tube, 3
 Volume indicator, 4
 Volume unit meter, remote amplifier use,
 117, 118, 119

- W -

Warning signal lights, lines to, 38