

BBC ENGINEERING TRAINING MANUAL

TELEVISION ENGINEERING

Principles and Practice

VOLUME THREE

WAVEFORM GENERATION

S. W. AMOS, B.Sc.(Hons.), A.M.I.E.E. and D. C. BIRKINSHAW, M.B.E., M.A., M.I.E.E.

A 'WIRELESS WORLD' PUBLICATION



Abacs or Nomograms

By A. Giet. Translated from the French by H. D. Phippen and J. W. Head. This book not only demonstrates the many and varied applications of the Abac or Nomogram, but shows how even those without highly specialised mathematical knowledge may construct their own charts. Specially adapted for English readers, this edition will prove of the greatest practical value to engineers and physicists, and many others who require time-saving methods for repetitive and complicated calculations.

35s. net. By post 35s. 10d.

Laplace Transforms for Electrical Engineers

By B. J. Starkey, Dipl. Ing., A.M.I.E.E. A presentation of the theory of the Laplace transformation in which a physical vocabulary rather than a purely mathematical one is used as far as possible. This method of analysis has become of increasing importance to electrical engineers in many fields during recent years, and the work is designed to provide a thorough treatment of the subject in a language with which they will be familiar.

30s. net. By post 31s.

The Oscilloscope at Work

By A. Haas and R. W. Hallows, M.A.(Canrab.), M.I.E.E. An up-to-date handbook explaining the characteristics of the cathode-ray oscilloscope and its many uses in servicing radio receivers, amplifiers and television equipment. Special attention is given to the correct interpretation of oscillograms, and the work is profusely illustrated by practical examples of oscillograms and circuits.

15s. net. By post 15s. 10d.

Second Thoughts on Radio Theory

By Cathode Ray of "Wireless World". Forty-four articles reprinted from popular *Wireless World* series, in which the author examines various aspects of elementary radio science, explains them clearly, and shows that there may be more behind them than is apparent from the usual textbook. An entertaining and helpful textbook for the student, refresher course for the engineer, and reference book for all, combined.

25s. net. By post 26s. 2d.

Television Receiving Equipment

4th Edition. By W. T. Cocking, M.I.E.E. This is one of the most important books on television and the fourth edition has been very largely re-written in order to bring into account the vast strides in technical development of the subject since the publication of the previous edition. The circuits of the television receiver are split into a number of sections and a separate chapter is devoted to each. Other chapters deal with general principles, the signal, special circuits, the aerial, interference and Band III converters.

25s. net.

ILIFFE & SONS LTD, DORSET HOUSE, STAMFORD ST, LONDON S.E.1

About this Book

THE third volume of a textbook on television engineering written by members of the BBC Engineering Division, primarily for the instruction of the Corporation's own staff. The work is intended to provide a comprehensive survey of modern television principles and practice.

This volume gives the application in television of sinusoidal, rectangular, saw-tooth and parabolic waves and shows the mathematical relationship between them. The main body of the text is devoted to the fundamental principles of the circuits commonly used to generate such signals, the treatment being largely descriptive in nature and therefore less mathematical than that of the previous volume.

Volume I deals with fundamental television principles, camera tubes, television optics and electron optics. Volume II describes the fundamental principles of video-frequency amplifiers and examines the factors which limit their performance at the extremes of the pass-band, and also includes a section dealing with the special problems of camera-head amplifiers. Volume IV, which is in preparation, will deal with a wide range of circuit techniques. This volume will complete the series.

226 pages.

132 illustrations

30s. net

Indispensable to technicians

Britain's leading technical journal in the field of radio, television and electronics, **WIRELESS WORLD** covers every phase of radio and allied technical practice, with news of the wider aspects of international radio. New techniques, design data and circuits for every application are dealt with by recognised experts.

Wireless World

MONTHLY 2s. ANNUAL SUBSCRIPTION £1 12s. 6d.

Design, Application, Production

ELECTRONIC & RADIO ENGINEER is the leading source of information for all concerned with the design, development, production and industrial application of electronic and radio apparatus. Contributions by eminent physicists, engineers and an editorial staff of experts keep the reader in constant touch with progress. Each issue contains valuable abstracts and references compiled from the world's technical press.

**ELECTRONIC &
RADIO ENGINEER**

MONTHLY 3s. 6d. ANNUAL SUBSCRIPTION £2 9s. 0d.

HILL & SONS LTD., DORSET HOUSE, STAMFORD ST.,
LONDON, S.E.1.

BBC ENGINEERING TRAINING MANUALS

TELEVISION ENGINEERING
Principles and Practice

VOLUME THREE
WAVEFORM GENERATION

By
S. W. AMOS, B.Sc. (Hons.), A.M.I.E.E.
and
D. C. BIRKINSHAW, M.B.E., M.A., M.I.E.E.

LONDON : ILIFFE & SONS, LTD.
NEW YORK : PHILOSOPHICAL LIBRARY

First published in this series, 1957

*Published, by arrangement with the BBC, for "Wireless World" by
Iiffe & Sons, Ltd., Dorset House, Stamford Street, London, S.E.1*

*Published in the U.S.A. by Philosophical Library, Inc., 15, East
40th Street, New York 16, N.Y.*

Made and printed in England at The Chapel River Press, Andover, Hants

BK8 2649

CONTENTS

<i>Chapter</i>	<i>Page</i>
PREFACE	9
<i>PART I: FUNDAMENTAL CONSIDERATIONS</i>	
1 WAVEFORMS USED IN TELEVISION EQUIPMENT	11
Introduction—Applications of Rectangular Waves—Applications of Sawtooth Waves—Applications of Parabolic Waves—Properties of Waveforms—Relationship between Rectangular, Sawtooth and Parabolic Waveforms—Simple Differentiating Circuit—Simple Integrating Circuit	
2 APPLICATION OF WAVEFORMS IN A CAMERA CHANNEL	21
Introduction—Simplified Schematic of Waveform-generating Equipment—Relative Timing of Waveforms	
<i>PART II. GENERATION OF SINE WAVES</i>	
3 HARTLEY AND COLPITTS OSCILLATOR CIRCUITS	27
Introduction—Basic Principles of LC Sine-wave Oscillators—Hartley Oscillator—Colpitts Oscillator—Appendix A: Input Impedance of a Valve with one Reactance between Grid and Cathode and another between Anode and Cathode	
4 GRID CURRENT BIAS IN OSCILLATORS	36
Introduction—Graphical Representation of Operating Conditions—Grid Time Constant—Spurious Modes of Oscillation	
<i>PART III: GENERATION OF RECTANGULAR WAVES</i>	
5 PROPERTIES OF RECTANGULAR WAVES	42
Introduction — Pulse Repetition Frequency — Mark-space Ratio — Spectrum of a Rectangular Wave	
6 GENERATION OF RECTANGULAR WAVES BY DIODE LIMITING CIRCUITS	46
Introduction—Simple Diode Limiting Circuits—Biased-diode Limiting Circuits—Circuit Employing Two Diodes	

CONTENTS

<i>Chapter</i>	<i>Page</i>
7 GENERATION OF RECTANGULAR WAVES IN AMPLIFYING LIMITERS	54
Introduction—Triode Limiting Amplifier—Cathode-follower Limiting Circuit—Two-valve Cathode-coupled Limiter—Pentode Limiting Amplifier—Typical Application of Limiting Amplifiers	
8 BI-STABLE, MONOSTABLE AND ASTABLE GENERATORS	63
Introduction—Stable and Unstable States—Bi-stable Circuits—Monostable Circuits—Astable Circuits	
9 ANODE-COUPLED BI-STABLE MULTIVIBRATOR	66
Introduction—Basic Features of the Circuit—Choice of Component Values and Static Voltages—Method of Triggering—Operation of the Circuit—Effect of Valve Capacitances on Output Waveform—Speed-up Capacitors—Production of Overshoot by Speed-up Capacitors	
10 CATHODE-COUPLED BI-STABLE MULTIVIBRATOR	78
Introduction—Fundamental Features of the Circuit—Static Conditions—Operation of the Circuit	
11 ANODE-COUPLED MONOSTABLE MULTIVIBRATOR	82
Introduction—Fundamental Features of the Circuit—Operation of the Circuit—Duration of Unstable State—Use of Positive Bias to Control Duration of Unstable State—Appendix B: Time of Exponential Rises and Falls	
12 CATHODE-COUPLED MONOSTABLE MULTIVIBRATORS	94
Introduction—Multivibrator with Timing Components in the Grid Circuit—Multivibrator with Timing Components in the Cathode Circuit	
13 ANODE-COUPLED ASTABLE MULTIVIBRATOR	101
Introduction—Operation of the Circuit—Duration of States of Multivibrator—Effect of Charge Time Constant on Output Waveform	
14 CATHODE-COUPLED ASTABLE MULTIVIBRATOR	110
Introduction—Operation of the Circuit	
15 THE TRIGGERING AND SYNCHRONISING OF MULTIVIBRATORS	114
Introduction—Use of a Hold-off Resistor—Use of a Hold-off Capacitor—Use of a Diode—Use of Two Diodes—Use of a Buffer Stage—Synchronisation of Astable Multivibrators	

CONTENTS

<i>Chapter</i>	<i>Page</i>
16 USE OF PENTODES IN MULTIVIBRATORS Introduction — Anode D.C. Resistance of Triodes and Pentodes—Typical Multivibrator Circuit Employing Pentodes	125
17 BI-STABLE TRANSITRON CIRCUITS Basic Principles of Transitron Circuits—Screen-coupled Bi-stable Transitron Circuit—Cathode-coupled Bi-stable Transitron—Suppressor-grid Emission—Limited Application of Bi-stable Transitron Circuits	128
18 MONOSTABLE TRANSITRON CIRCUITS (PHANASTRONS) Introduction — Screen-coupled Phantastron — Cathode-coupled Phantastron—Applications of Phantastrons	137
19 SCREEN-COUPLED ASTABLE TRANSITRON (MILLER-TRANSITRON) CIRCUIT Introduction — Fundamental Circuit — Operation of the Circuit	152
<i>PART IV: GENERATION OF SAWTOOTH WAVES</i>	
20 FUNDAMENTAL PROPERTIES OF SAWTOOTH WAVES Introduction—Spectrum of Ideal Sawtooth Wave—Effects of Non-linearity of Forward Stroke—Linearity Requirements—Flyback-period Requirements	155
21 FUNDAMENTAL PRINCIPLES OF SAWTOOTH GENERATORS Introduction—Fundamental Properties of Constant-voltage Sawtooth Generator—Relationship between Sawtooth and Rectangular Wave Generators—Properties of Free-running Sawtooth Generator—Properties of Driven or Synchronised Sawtooth Generator—Methods of Linearising the Output of a Simple RC Sawtooth Generator—Use of a Pentode as a Constant-current Source—Equivalent Circuit of a Pentode—Appendix C: Use of the Initial Part of an Exponential Curve as an Approximation to a Linear Characteristic	160
22 SAWTOOTH GENERATORS USING SIMPLE VALVE DISCHARGERS Introduction—Gas Diode Sawtooth Generator—Gas Triode Sawtooth Generator—Vacuum Triode Sawtooth Generator	175

CONTENTS

<i>Chapter</i>	<i>Page</i>
23 BLOCKING-OSCILLATOR SAWTOOTH GENERATORS	186
Introduction—Operation of the Circuit—Methods of Controlling Frequency and Output Amplitude—Methods of Synchronising Blocking Oscillators—Design of a Blocking-oscillator Sawtooth Generator	
24 MULTIVIBRATOR SAWTOOTH GENERATORS	197
Introduction—Driven Cathode-coupled Multivibrator Sawtooth Generator—Free-running Anode-coupled Multivibrator Sawtooth Generator—Alternative Circuit for Free-running Anode-coupled Multivibrator Sawtooth Generator—Design of Multivibrator Sawtooth Generator	
25 MILLER-INTEGRATOR SAWTOOTH GENERATORS	204
Introduction—Basic Features of Miller-integrator Circuit—Basic Features of Bootstrap Circuit—Operation of Miller-integrator and Bootstrap Circuits—Equivalent Circuit of Miller-integrator—Driven Miller-integrator Circuits—Free-running Miller-integrator Circuits	
<i>PART V: GENERATION OF PARABOLIC WAVES</i>	
26 PARABOLIC-WAVE GENERATORS	218
Introduction — Parabolic Wave Generator with Sawtooth Input—Parabolic Wave Generator with Rectangular Wave Input—Shading Mixers	
BIBLIOGRAPHY	223
INDEX	225

PREFACE

THIS is the third volume of a textbook on television engineering written principally for the engineering staff of the British Broadcasting Corporation and intended to provide a comprehensive survey of modern television principles.

This volume gives the applications in television of sinusoidal, rectangular, sawtooth and parabolic waves and shows the mathematical relationship between them. The main body of the text is devoted to the fundamental principles of the circuits commonly used to generate such signals, the treatment being largely descriptive in nature and therefore less mathematical than that of the previous volume.

The terminology used in this volume is in agreement with the most recent recommendations of the British Standards Institution and the terms now used for certain fundamental television concepts differ from those used in the first editions of Volumes 1 and 2; the principal changes in nomenclature are the use of *field* for *frame*, *blanking* for *suppression*, *front porch* for *pre-sync line suppression period* and *back porch* for *post-sync line suppression period*.

The text of the present volume was written by S. W. Amos, B.Sc., A.M.I.E.E., of the Engineering Training Department, in collaboration with D. C. Birkinshaw, M.B.E., M.A., M.I.E.E., Superintendent Engineer, Television, and is based on an internal BBC manual written by the same authors in collaboration with J. L. Bliss, A.M.I.E.E., of the Designs Department. This volume was edited by L. F. Ostler, Assoc.I.E.E., of the Engineering Training Department.

PART I : FUNDAMENTAL CONSIDERATIONS

CHAPTER I

WAVEFORMS USED IN TELEVISION EQUIPMENT

1.1 INTRODUCTION

To produce a video signal, a television camera tube and its associated equipment require a number of controlling voltages or currents of particular waveform. Some of these, such as the rectangular pulses constituting the sync signals, are part of the video waveform itself, but others, such as the sawtooth scanning current required by camera tubes, do not appear in the video waveform. Thus the waveforms required in a television system are more numerous than an examination of the video waveform would suggest and a large proportion of

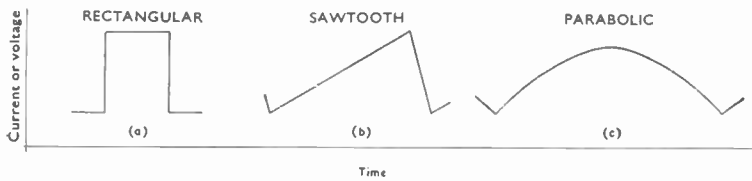

Fig. 1—Sawtooth, rectangular and parabolic waveforms

the camera channel is devoted to their generation. In this volume we shall describe the principles employed in waveform generators.

The major part of the waveform-generating equipment is generally used to produce rectangular or sawtooth waveforms (Figs. 1 (a) and (b)) but parabolic waveforms (Fig. 1 (c)) are sometimes used and the master oscillator in a complete television equipment is often a sine-wave generator. The principal applications of these waveforms are summarised below.

1.2 APPLICATIONS OF RECTANGULAR WAVES

- (a) As constituent parts of synchronising signals. The line-sync signal and the broad pulses constituting the field-sync signal are both of rectangular form.

- (b) As gating pulses. Such pulses are used to switch a valve on or off thus permitting other pulses or signals either to pass through the valve or not. Two examples of gating pulses are:—
- (i) Blackout pulses. These are used to extinguish the scanning beam in a camera or picture tube during line- and field-flyback periods.
 - (ii) Blanking pulses. These are used for gating picture signals to prepare a period of blanking level prior to the insertion of sync pulses.
- (c) As keying pulses for clamp circuits. This application is described more fully in Volume 4.
- (d) As triggering pulses for other generators. For example, rectangular pulses at line frequency may be used to trigger a sawtooth generator supplying line-scan current to a camera tube.
- (e) As constituent parts of the video signal corresponding to an artificial picture such as a black cross on a white ground used for testing television equipment. Another form of test signal sometimes used is a rectangular pulse of 2-microsecond duration and at line frequency.

1.3 APPLICATIONS OF SAWTOOTH WAVES

- (a) For deflecting electron beams in camera tubes, viewfinder tubes and monitor tubes; for horizontal deflection the sawtooth must be at line frequency and for vertical deflection at field frequency. If the camera tube has oblique scanning, both line and field sawtooth waveforms must be distorted according to a certain law to produce a rectangular scanned area.
- (b) As shading signals to reduce the effects of unwanted spurious signals present in the output of iconoscope, image-iconoscope and image-orthicon camera tubes.
- (c) For test purposes such as horizontal deflection in oscilloscopes. Sawtooth waveforms are sometimes fed into a picture chain in measurements of contrast law.

1.4 APPLICATIONS OF PARABOLIC WAVES

The chief applications of parabolic waveforms in television equipment are as shading signals at line and field frequencies used to

reduce the effects of unwanted spurious signals produced by certain types of camera tube.

1.5 PROPERTIES OF WAVEFORMS

So far the various waveforms have been identified by their *shape*, but this is only one of a number of properties of a waveform. In a complete specification it is necessary to state (in addition to the shape) the *polarity* (or *sense*), *amplitude*, *frequency*, *duration* and *timing*. In waveforms intended for certain television applications, the values of some of these properties must be maintained within very close tolerances. These properties will now be discussed in greater detail.

1.5.1 *Polarity (or Sense)*

A waveform can be inverted by use of a transformer but it is more usual in television equipment to employ valve amplifiers for this purpose, the stage gain being made unity if no change in amplitude is required. A number of waveform-generating circuits, however, have two possible output points giving signals in antiphase and a signal of the required polarity can be obtained by correct choice of output point.

1.5.2 *Amplitude*

The amplitude of a waveform can be made almost any desired value by amplification but the harmonics of the waveform may extend over a wide frequency range and for distortionless amplification of the waveform the frequency and phase response of the amplifier must be good throughout the spectrum of the waveform. Methods of designing suitable amplifiers are described in Volume 2.

1.5.3 *Frequency*

The frequencies of the waveforms used in a television system are identical with the field frequency, the line frequency and, in a twin-interlaced system, twice line frequency. The ratios between these frequencies must be maintained with precision and this is generally achieved by deriving all three frequencies from a master oscillator, usually a sine-wave generator operating at twice line frequency. The line frequency is obtained by dividing the master frequency by two and the field frequency by dividing the master frequency by the number of lines per picture.

1.5.4 Duration and Timing

These two properties of the waveforms used in the production of a video signal are so closely related that examples of both are given together in the following few paragraphs.

The video waveform contains a number of intervals such as the line-sync pulses and the front and back porches of which the duration must be maintained with accuracy. There are, in general, two ways in which such intervals can be obtained. The first and obvious method is to use a generator which produces pulses of the required duration; line-sync pulses are usually generated in this manner. The duration of a pulse is a function of the design and adjustment of the generator and can be given any desired value within limits. The second method of producing a required interval is by superimposition of two pulses; the front and back porches can be produced in this way, as shown in Fig. 2, by mixing line-sync pulses with line-

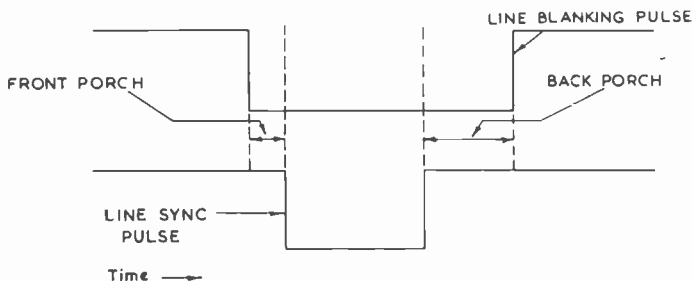

Fig. 2—Production of front and back porch periods by superimposition of line-sync and line-blanking pulses

blanking pulses. The required duration of front porch is obtained by arranging for the leading edge of the line-blanking pulse to precede that of the line-sync pulse by the correct interval; in other words the required interval is obtained by correct *timing* of the two pulses.

Provided the front-porch duration is accurately maintained, the duration of the back porch is dependent on the duration of the line-sync and line-blanking pulses; this required interval is thus obtained by correct choice of *duration* of the two pulses and the constancy of the back porch is dependent on the constancy of duration of the line-sync and line-blanking pulse generators.

To keep the duration of the front porch constant, the relative timing of the line-blanking and line-sync pulse generators must be

accurately controlled. There is thus a need for some means whereby the leading edge of one pulse can be delayed to a controllable extent after the leading edge of another pulse. In general there are two methods by which this can be achieved. One is by the use of delay lines, i.e. *passive networks*. The second method uses monostable valve circuits similar to pulse generators of which the best-known example is the *phantastron*. The leading edge of the line-blanking pulse is used to trigger the phantastron and the trailing edge of the phantastron output pulse is used to trigger the line-sync pulse generator. By this means a controllable delay equal to the duration of the phantastron output pulse is obtained. The valve circuit may be described as an *active delay network* or *delay generator* and examples are given later.

1.6 RELATIONSHIP BETWEEN RECTANGULAR, SAWTOOTH AND PARABOLIC WAVEFORMS

There is a significant relationship between these three waveforms which has an important bearing on the types of circuit used to generate them. This relationship can be approached in the following way.

A parabola is the curve obtained when one quantity is plotted against another proportional to its square. The form of the curve is illustrated in Fig. 3 which shows a parabola lying wholly to one side of the y -axis. The equation to such a curve is generally given in the form

$$y^2 = 4ax$$

where a is a constant.

In television engineering the parabolas are relationships between a voltage or current (represented by y) and time (t) and they lie wholly to one side of the t -axis. The general equation to such a parabola is

$$t^2 = 4by$$

b being a constant. This may alternatively be expressed

$$y = kt^2$$

where k is another constant.

We shall now illustrate the relationship between parabolic, sawtooth and rectangular waves by reference to the waveform shown at Fig. 4 (a). This is a repetitive waveform composed entirely of parabolas, one being concave upwards (AD) and the other convex upwards (JA and DK).

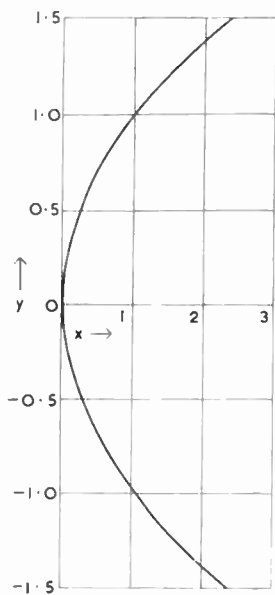

Fig. 3—General form of the parabola $y^2 = 4ax$

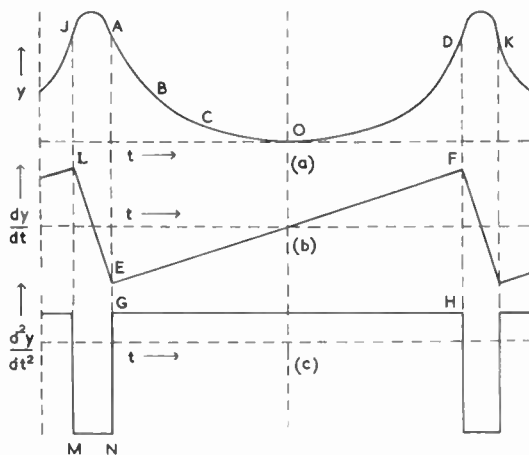

Fig. 4—Illustrating the relationship between parabolic, sawtooth and rectangular waves

The curve AD obeys the equation $y = kt^2$. At point A the gradient of curve AD has a high negative value; at B the gradient is less negative, at C it is yet smaller and at O it is zero. Farther along the curve the gradient increases positively reaching a maximum at D. If this gradient is plotted against t , the curve obtained has the form of the straight line EF in Fig. 4 (b). If now the gradient of EF is plotted against t , the resulting curve has the form of a straight line GH, parallel to the time axis as shown in Fig. 4 (c). This relationship can easily be shown mathematically as follows:

The equation to curve AOD is

$$y = kt^2$$

where k is a constant. Differentiating

$$\frac{dy}{dt} = 2kt$$

which is the equation to the straight line EF in Fig. 4 (b).

Further differentiation gives

$$\frac{d^2y}{dt^2} = 2k$$

the equation to the straight line GH in Fig. 4 (c).

If a similar process is applied to the parabola JA, we find on plotting the gradient that a straight line LE is obtained and on plotting its gradient the horizontal line MN is obtained. It will now be clear that the curve of Fig. 4 (b) is of sawtooth form, EF being the forward stroke and LE the return stroke. Fig. 4 (c) has the form of a rectangular wave.

Thus we have shown that a sawtooth wave can be obtained by differentiating a parabolic wave and that a rectangular wave can be obtained by differentiating a sawtooth wave. It follows that a rectangular wave can be obtained by twice differentiating a parabolic wave.

Conversely a sawtooth wave such as (b) in Fig. 4 can be obtained by integrating the rectangular wave (c) with respect to time. Rectangular waves are easy to generate and this integration forms the basis of many circuits used to produce sawtooth waves.

Parabolic waves (Fig. 4 (a)) can be obtained by integrating sawtooth waves once or rectangular waves twice; this, too, forms the basis of methods used to produce a parabolic wave.

1.7 SIMPLE DIFFERENTIATING CIRCUIT

There is a simple electrical circuit which gives a good approximation to the time differential of the input applied to it. It consists of an RC combination arranged as in Fig. 5 (a) the input

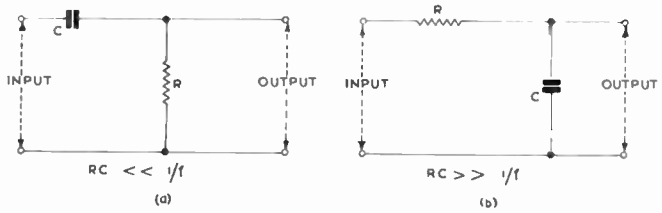

Fig. 5—(a) A simple differentiating network and (b) a simple integrating network

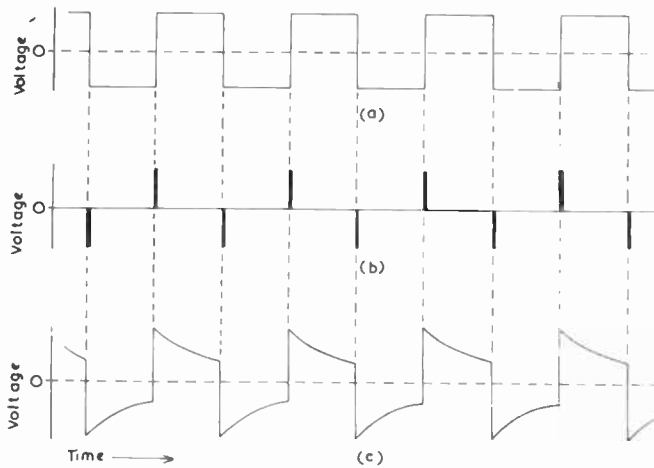

Fig. 6—A rectangular wave (a) applied to a network of the form of Fig. 5 (a) gives an output of the form shown in (b) when the time constant is short and as in (c) when it is longer

being applied to R and C in series, and the output being taken from across R . It is essential that the time constant RC should be very small compared with the period ($1/f$) of the input signal. Then if a parabolic wave is applied to the input terminals, a sawtooth is obtained at the output and if a sawtooth is applied to the input the output is of rectangular form. If a rectangular wave is applied to the input terminals, the output waveform is a series of spikes of alternate polarity as shown in Fig. 6 (b). This is the waveform obtained when the time constant is short compared with the period of the input signal. If the time constant is not short, the output has the form shown in Fig. 6 (c), i.e., it has appreciable sag. The extent of the sag is a matter of some concern in the design of video amplifiers where the aim is to reproduce the original signal as faithfully as possible and is discussed in Volume 2. The spikes may be regarded as the limiting case of sag which occurs when the time constant is made very short.

1.8 SIMPLE INTEGRATING CIRCUIT

There is also a simple electrical circuit which gives a good approximation to the time integral of the input voltage applied to it. It consists of an RC combination arranged as in Fig. 5 (b), the input being applied to R and C in series and the output being taken across C . The time constant RC must be large compared with the period ($1/f$) of the input signal.

Fundamentally the capacitor performs the integration; it is a storage device generating a voltage V_{out} dependent on the quantity of electricity Q put into the plates, the relationship being

$$V_{out} = \frac{Q}{C} \quad \dots \quad (1)$$

Q , in turn, depends on the magnitude of the current i and the time for which it flows, as shown in the expression

$$Q = \int i \cdot dt \quad \dots \quad (2)$$

which is true in general for it applies to a current which varies with time. Combining (1) and (2) we have

$$V_{out} = \frac{1}{C} \int i \cdot dt \quad \dots \quad (3)$$

which shows that the voltage generated across the capacitor is proportional to the integral of the *current* waveform applied to it.

The current depends on R , the reactance of C and the input signal

V_{in} but if R is large compared with the reactance of C at the frequency of applied signals, the current is given approximately by

$$i = \frac{V_{in}}{R} \quad \dots \quad \dots \quad (4)$$

Substituting for i in (3)

$$V_{out} = \frac{1}{RC} \int V_{in}.dt \quad \dots \quad \dots \quad (5)$$

Showing that the output voltage is proportional to the time integral of the input *voltage*. This is true only if R is large compared with $1/\omega C$, i.e. when RC is large compared with $1/\omega$ and therefore with $1/f$.

CHAPTER 2

APPLICATION OF WAVEFORMS IN A CAMERA CHANNEL

2.1 INTRODUCTION

BEFORE discussing the methods employed to generate the various waveforms used in television equipment we shall examine their use in a camera channel in greater detail. Fig. 7 is a simplified schematic diagram illustrating one possible arrangement of waveform-generating equipment and signal chain in a television channel. It shows the connections to one camera only and omits the connections to view-finder tube, picture monitor and waveform monitor.

2.2 SIMPLIFIED SCHEMATIC OF WAVEFORM-GENERATING EQUIPMENT

The master oscillator is represented by a block on the left-hand side and its output is fed to two frequency dividers, one of which gives an output at line frequency and the other at field frequency. The output of the field divider is used to synchronise scanning, blackout, blanking and other generators required to work at field frequency. The output of the line divider feeds a delay line, tappings on which are connected to scanning, blackout, blanking and other generators working at line frequency. The sync generator has an input from both dividers but in addition is connected to the master oscillator via a further delay line. This third input is necessary because the field-sync signal consists of broad pulses at twice line frequency.

The right-hand side of Fig. 7 illustrates in very simplified form one possible chain of equipment which could be used to generate a video signal.

The camera is fed with line and field sawtooths which are applied to the respective scanning coils of the tube. In addition, negative-going blackout pulses at line and field frequencies are supplied to the control grid of the camera-tube electron gun to suppress the electron beam during line- and field-flyback periods. The tube produces a picture-signal output containing intervals which coincide with the blackout pulses. In practice the picture signal is often marred by spurious signals; in addition there are unwanted signals in the flyback interval caused by induction from the rapid change in current in the line-scanning coils. Different methods are used to eliminate

these two types of unwanted signal; the spurious signals superimposed on the picture signal are reduced in amplitude in a mixer stage termed the shading mixer in Fig. 7 where sawtooth and parabolic waveforms at line and field frequencies (and correctly timed with respect to other generators the outputs of which are later added to the signal) are mixed with the picture signal in the amplitude necessary to minimise unwanted shading effects. The unwanted signals during the flyback period are eliminated by adding to the picture signal a pulse at line frequency known as a *pseudo-suppression pulse* which lifts the spurious signals well above white level. The

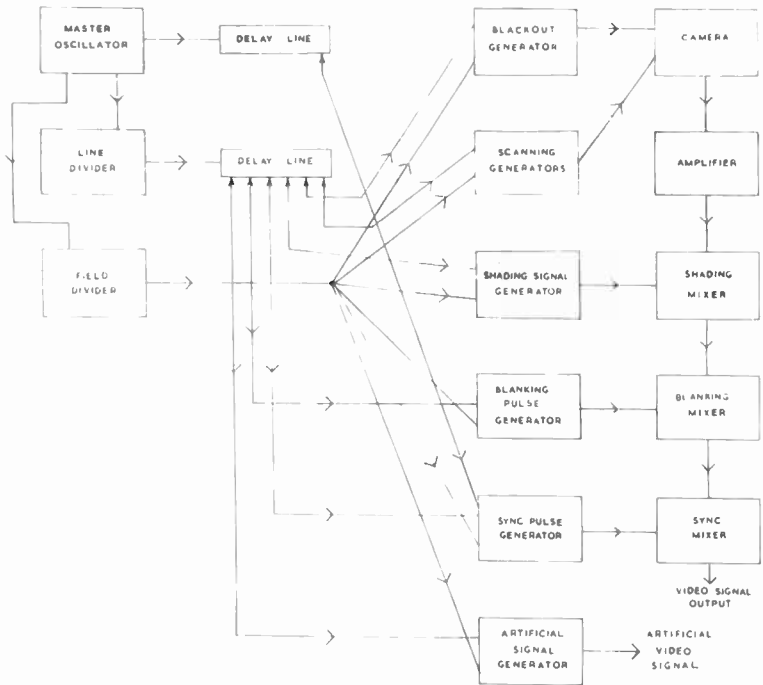

Fig. 7—One possible arrangement of the interconnections between master oscillator, frequency dividers and pulse generators in a television channel

picture signal is then passed through a limiter which cuts off the spurious signals but leaves the picture signal unaffected. The output of the shading mixer is fed to the blanking mixer; here the periods of black level required for line and field blanking are ensured.

The signal is next fed to a sync mixer where the sync pulses are inserted in the periods of blanking level created in the previous mixer. The sync-mixer output constitutes the required video signal.

2.3 RELATIVE TIMING OF WAVEFORMS

To illustrate the relative timing of the various waveforms necessary to produce a video signal the pulses and sawtooths required by the camera tube, viewfinder tube and the earlier stages of the signal chain are illustrated, in a somewhat different way, in Fig. 8. This does not represent any particular equipment and shows an ideal camera tube requiring no keystone correction of scanning signals and giving no spurious output signals. This diagram has been reduced to its essentials by the omission of all amplifiers; moreover it does not indicate connections to other cameras, to picture or waveform monitors or to artificial-signal generators.

The line and field sawtooths are applied to the deflection coils of the camera tube and may also be applied to those of the viewfinder tube. The line- and field-blackout pulses are applied to the control grids of the electron guns in the camera tube and viewfinder tube. The pulses must be correctly timed with respect to the scanning waveforms because flyback must occur within the blackout period. The relative timing is indicated in Fig. 9.

In an ideal camera tube of the type in which the output is taken from a signal plate, the output voltage during flyback periods accurately represents black. The value of this voltage depends on the amount of light entering the camera during the flyback period and the black-level voltage therefore varies with the average scene brightness as explained in Volume 1. It is essential for the proper operation of the equipment in the camera chain that the voltage representing black should be constant. To achieve this without distorting the picture signal, the camera output voltage during flyback periods must be artificially changed to a predetermined value. There are a number of circuits which can be used to do this and the establishment of this voltage can be carried out as frequently as once per line period if necessary.

Two circuits which can be used for this purpose are the *d.c. restorer* and the *d.c. clamp*. These are described in Volume 4 where it is shown that the latter circuit requires pulses (known as *clamping* or *keying* pulses) for its operation. If establishment of the black-level voltage is required once per line period, the clamping pulses must be at line frequency; this is assumed in Figs. 8 and 9. The timing and duration of the clamping pulses are such that the pulses fall within the line-flyback period.

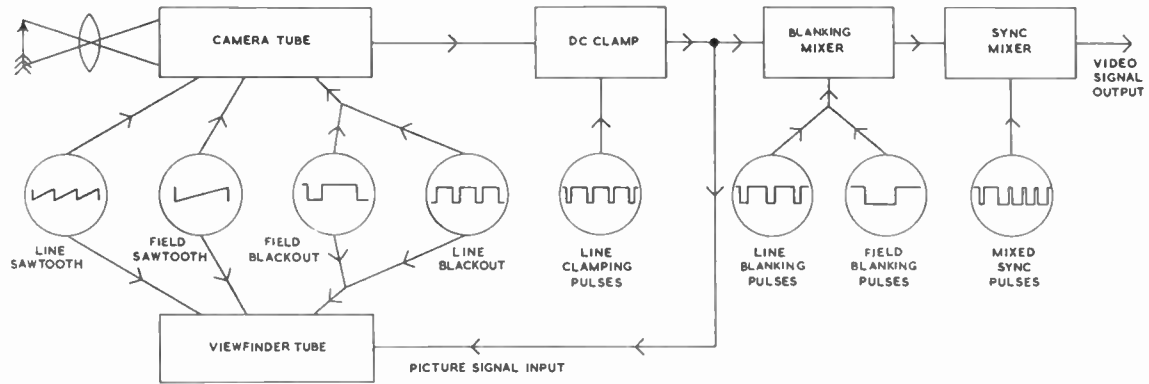

Fig. 8—Application of pulses in a camera channel

APPLICATION OF WAVEFORMS IN A CAMERA CHANNEL

The picture-signal output from the clamp has a constant-voltage black level; this signal is fed to the viewfinder tube to give a picture representing the field of view of the camera and is also fed to the blanking mixer, in which it is mixed with line- and field-blanking pulses of correct duration and appropriately timed with respect to the scanning and blackout pulses used earlier in the chain (Fig. 9). The blanking pulses have the effect of preparing a period of blanking

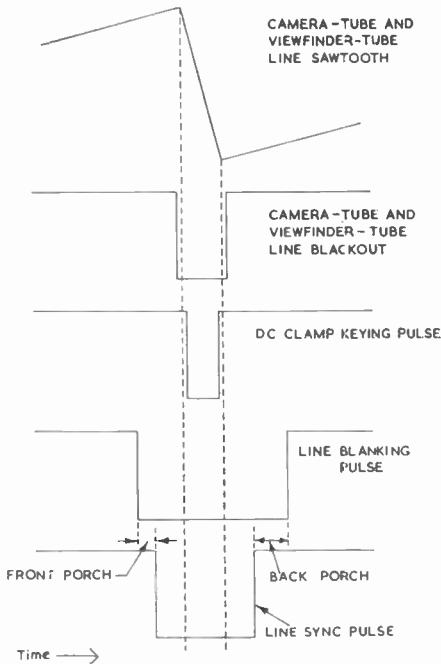

Fig. 9—Relative timing of line pulses in a camera channel

level during each line and field period, within which the respective sync signals are later inserted.

By making the blackout pulses shorter than the corresponding blanking pulses and symmetrical in time with respect to them (as shown in Fig. 9) the field of view of the viewfinder tube can be made slightly greater than that of the final picture.

It will be clear from the above account of the use of the various waveforms that successful results can only be obtained by precise control over the duration of the waveforms and by introducing them

at the exact instant required. The necessary accuracy in timing is achieved in the system represented in Fig. 7 by use of two delay lines, one connected to the output of the master oscillator and the other to the output of the line divider. By connecting the inputs of the various generators to appropriate tapplings on the delay lines the required timing can be obtained.

The extent to which the start of a certain pulse should be delayed is often dependent upon factors additional to those mentioned in the previous paragraphs. For example, the required delay must frequently take account of the finite time occupied by picture signals and waveforms in travelling through cables and amplifiers.

If a camera is situated at a considerable distance (say a thousand feet) from its associated generators, the scanning and blackout waveforms take an appreciable time to travel along the cable to the camera; the picture signal from the camera also takes an approximately-equal time to travel through the head amplifier and along the cable back to the equipment. Thus any pulse added to the picture signal at the end of the cable remote from the camera must be delayed by an interval which allows for the double journey along the cable and the delay in the head amplifier.

Practical camera equipment is usually more complex than Fig. 8 suggests and requires waveforms additional to those shown. For example, if the camera tube employs oblique scanning, allowance must be made in the sawtooth waveforms for the keystone effect; the scanning waveforms are thus not true sawtooths and cannot be used in the viewfinder tube.

PART II : GENERATION OF SINE WAVES

CHAPTER 3

HARTLEY AND COLPITTS OSCILLATOR CIRCUITS

3.1 INTRODUCTION

THE prime mover in television-camera waveform-generating equipment is, in general, a sine-wave oscillator usually termed the master oscillator. The frequency of the master oscillator determines the line and field frequencies of the system and it might be thought the oscillator should have extreme frequency stability. In such circumstances, however, if the mains frequency varied there would be phase variations between it and the master frequency and these can cause difficulties in television-receiver design. It is common practice, therefore, in conventional black and white television systems to make the master oscillator of variable frequency and so to design the circuit that the master frequency is always a certain multiple (405 in the British television system) of the mains frequency.

Although sine waves can be generated in a network of resistance and capacitance, the oscillators used in television waveform generators commonly use networks of inductance and capacitance and we shall first discuss the basic principles of LC oscillators.

3.2 BASIC PRINCIPLES OF LC SINE-WAVE OSCILLATORS

When a voltage is momentarily induced into a closed circuit of inductance, capacitance and resistance, an oscillatory current flows and its amplitude dies away exponentially, as shown in Fig. 10, due to loss of power in the resistance of the circuit. Most of the resistance in a normal LC circuit is usually associated with the inductor and if this has a high Q value corresponding to a low value of resistance, the current takes a comparatively long time to die away. In a low Q circuit the resistance is larger and the delay more rapid. To produce continuous oscillation the power lost must be replaced in some way. Perhaps the most obvious way of doing this is to connect the LC circuit to an amplifier, the output of which is returned to the LC circuit as shown in Fig. 11, in which the LC circuit

is represented in the most general way as a frequency-discriminating network. Many of the common types of oscillators may be regarded as such a combination of LC circuit and amplifier. Thus the oscillator consists essentially of two parts:—

- (a) An LC circuit the component values of which decide the frequency of the oscillator output; this is the *frequency-determining network*.
- (b) An amplifier supplying the power necessary to maintain the oscillation amplitude; this is known as the *maintaining system*. The maintaining system has the property of effectively neutralising the a.c. resistance of the frequency-determining network and can be regarded as a source of negative a.c. resistance.

The connection from amplifier output to the LC circuit in Fig. 11 is an example of positive feedback; thus the oscillator circuit may

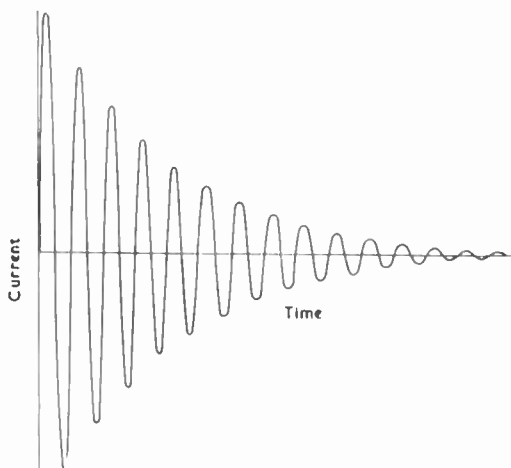

Fig. 10—Exponential decay of current in an LC circuit

alternatively be regarded as a tuned amplifier capable of supplying its own input.

There are many ways in which a valve may be connected to an LC circuit to maintain oscillation and thus there are many types of oscillator, the most familiar of which are the tuned-grid, tuned-anode, Hartley, Colpitts, dynatron, transitron and Franklin. Of these, the Hartley and Colpitts are the most widely used in television waveform-generating equipment and will be described. These two

HARTLEY AND COLPITTS OSCILLATOR CIRCUITS

oscillators have much in common and both belong to the general type illustrated in Fig. 12 in which X_a , X_b and X_c are reactances. For simplicity the h.t. feed to the valve is omitted. The dotted line

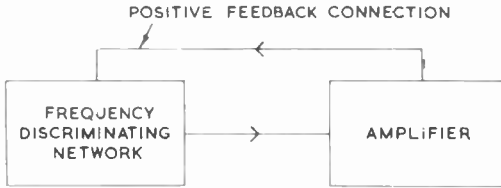

Fig. 11—Schematic diagram for many common types of oscillator

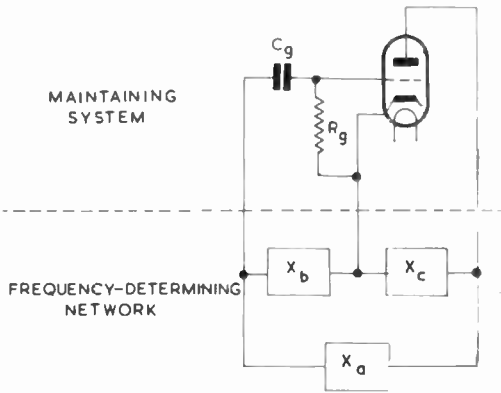

Fig. 12—General form of 3-terminal negative-resistance oscillator

separates the frequency-determining network from the maintaining system and shows the three essential connections between them.

If X_a is disconnected, the impedance Z measured between grid and anode of the valve is given by

$$Z = j(X_b + X_c) - g_m X_b X_c \quad \dots \quad (6)$$

which is deduced in Appendix A. This shows that the input impedance has a reactive component equal to $(X_b + X_c)$ and a resistive component equal to $-g_m X_b X_c$.

X_b and X_c must both be of the same sign, i.e. both inductive or both capacitive, in order that the resistive component may be negative, which, as already shown, is the condition required in an oscillator. The sign of X_a must clearly be opposite to that of

X_b and X_c in order that the composite circuit shall have a natural frequency of oscillation. If X_b and X_c are both inductive, and X_a is disconnected, the input impedance will be inductive; if X_a is made capacitive and is reconnected to the circuit, provided the negative

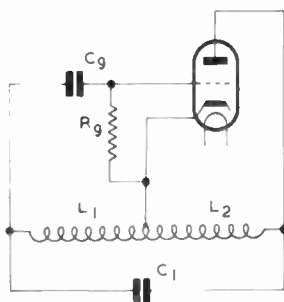

Fig. 13—Basic circuit of Hartley oscillator

resistance is sufficient to overcome the losses in the circuit, oscillation will result at approximately the frequency for which the inductive ($X_b + X_c$) and capacitive (X_a) reactances are equal. The circuit now has the form of a Hartley oscillator (Fig. 13).

If X_b and X_c are both capacitive and X_a is disconnected, the input impedance will be capacitive. If X_a is made inductive and is

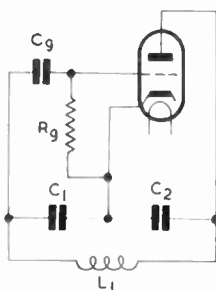

Fig. 14—Basic circuit of Colpitts oscillator

reconnected to the circuit, provided the negative resistance is adequate, oscillation will result at approximately the frequency for which the capacitive ($X_b + X_c$) and inductive (X_a) reactances are equal. This circuit (Fig. 14) has the form of the Colpitts oscillator.

HARTLEY AND COLPITTS OSCILLATOR CIRCUITS

For most efficient operation of a 3-terminal negative-resistance oscillator, the negative resistance should be as great as possible. For a given value of reactive component ($X_b + X_c$) of the input impedance, this condition is secured when $X_b = X_c$. Thus Hartley oscillators usually contain a centre-tapped inductor and Colpitts oscillators have two equal capacitors for X_b and X_c .

3.3 HARTLEY OSCILLATOR

The Hartley oscillator (Fig. 13) has the advantage over tuned-grid and tuned-anode oscillators that only one inductor is required, though this must, of course, be tapped.

The frequency of oscillation is approximately given by

$$f = \frac{1}{2\pi\sqrt{(L_1 + L_2 + 2M)C}}$$

where L_1 and L_2 are the inductances of the two parts of the coil and M is the mutual inductance between them, assumed to be aiding. This can be more simply written

$$f = \frac{1}{2\pi\sqrt{LC}}$$

where L is the inductance in parallel with C .

Fig. 13 is a theoretical circuit from which d.c. feeds are omitted; practical Hartley circuits may have a variety of forms depending on whether the LC circuit is series-fed or shunt-fed from the valve and what point on the circuit is chosen to be earthed. Fig. 15 shows seven possible circuits.

3.4 COLPITTS OSCILLATOR

The basic circuit for the Colpitts oscillator is given in Fig. 14. The frequency of oscillation is approximately that for which the reactance of L_1 equals that of C_1 and C_2 in series and is thus given by

$$f = \frac{1}{2\pi\sqrt{L_1 C_1 C_2 / (C_1 + C_2)}}$$

The oscillation frequency is usually varied by simultaneous adjustment of C_1 and C_2 , which can be conveniently ganged since their common connection may be earthed. Use of a two-gang capacitor has the advantage of maintaining equality of C_1 and C_2 , the condition necessary for most efficient operation.

The Colpitts circuit has the advantage that it requires no coupling coil (as in the tuned-grid or tuned-anode circuit) and no tapping

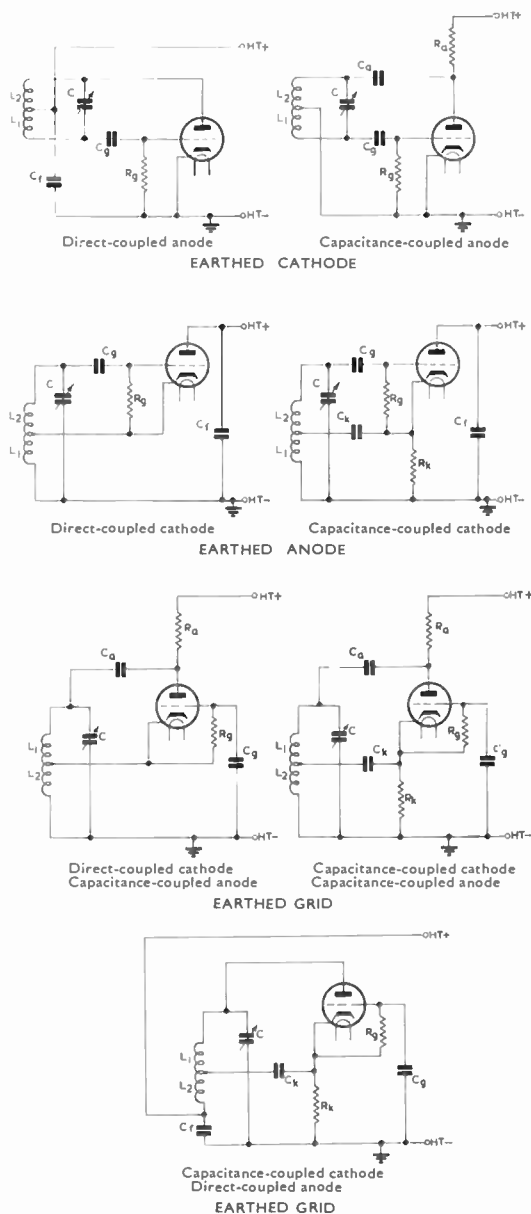

Fig. 15—Seven circuits for a Hartley oscillator

HARTLEY AND COLPITTS OSCILLATOR CIRCUITS

point on the inductor (as in the Hartley circuit). Thus the circuit is particularly suitable when it is inconvenient or impossible to tap the inductor or to couple another coil to it.

Practical Colpitts oscillators may have various circuits depending

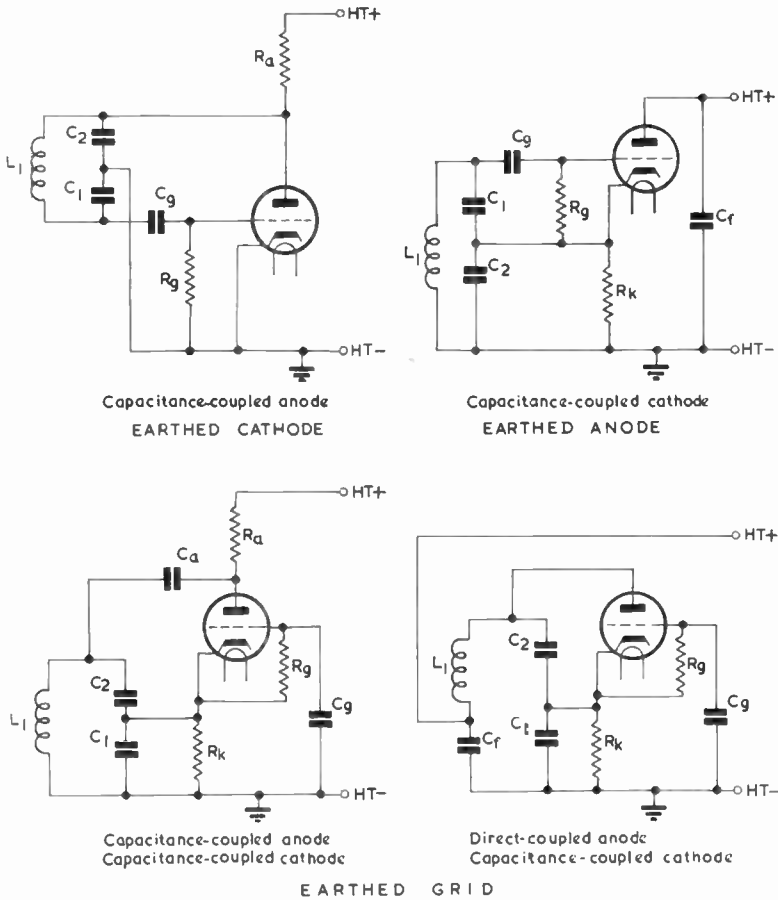

Fig. 16—Four circuits for a Colpitts oscillator

whether the LC circuit is series- or shunt-fed and whether the grid, cathode or anode of the maintaining valve is earthed. Fig. 16 gives four possible arrangements.

APPENDIX A

INPUT IMPEDANCE OF A VALVE WITH ONE REACTANCE BETWEEN GRID AND CATHODE AND ANOTHER BETWEEN ANODE AND CATHODE

THE valve in a 3-terminal negative-resistance oscillator has a reactance X_b connected between grid and cathode and another X_c between anode and cathode as shown in Fig. 17. It is the purpose of this appendix to deduce a general expression for the impedance

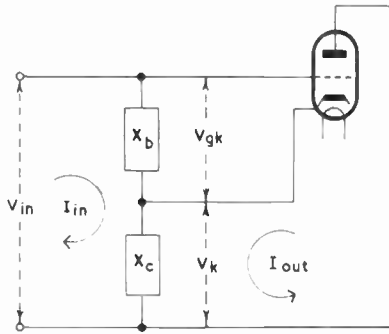

Fig. 17—Essential features of 3-terminal negative-resistance oscillator

(measured between grid and anode) of such a circuit. The input impedance of the valve is given by

$$Z_{in} = \frac{V_{in}}{I_{in}} \quad \dots \quad \dots \quad \dots \quad \dots \quad \dots \quad (1)$$

V_{in} is equal to the sum of V_{gk} and V_k . Thus

$$Z_{in} = \frac{V_{gk} + V_k}{I_{in}} \quad \dots \quad \dots \quad \dots \quad \dots \quad \dots \quad (2)$$

V_{gk} is the voltage set up across X_b by the current I_{in} flowing through it.

$$\therefore V_{gk} = jX_b I_{in} \quad \dots \quad \dots \quad \dots \quad \dots \quad \dots \quad (3)$$

APPENDIX A

and V_k is the voltage set up across X_c by the two currents I_{in} and I_{out} flowing through it.

$$\therefore V_k = jX_c(I_{in} + I_{out})$$

Substituting for V_{gk} and V_k in (2)

$$\begin{aligned} Z_{in} &= \frac{jX_b I_{in} + jX_c(I_{in} + I_{out})}{I_{in}} \\ &= j(X_b + X_c) + \frac{jX_c I_{out}}{I_{in}} \quad \dots \quad \dots \quad \dots \quad (4) \end{aligned}$$

I_{out} is the alternating component of the valve anode current and is given by $g_m V_{gk}$ which, from (3), is equal to $jX_b g_m I_{in}$.

Substituting for I_{out} in (4)

$$Z_{in} = j(X_b + X_c) - g_m X_b X_c$$

The impedance thus has a reactive component equal to $(X_b + X_c)$ and a resistive component equal to $-g_m X_b X_c$. If X_b and X_c are of the same sign, i.e. both inductive or both capacitive, this resistive component is negative which is the condition required in an oscillator.

CHAPTER 4

GRID CURRENT BIAS IN OSCILLATORS

4.1 INTRODUCTION

IN many oscillators the maintaining system has the form of an amplifier and grid bias can be obtained, as is usual in amplifiers, from an RC combination in the cathode circuit. This method of obtaining bias is sometimes used in oscillators, particularly when the maintaining amplifier is required to operate in Class A conditions to give a very pure waveform. In general, however, the grid bias for an oscillator is obtained from an RC combination in the grid circuit. Such a bias circuit was shown in all the oscillator circuits given in the previous chapter, the bias components being labelled $R_g C_g$. Bias obtained by this means has the advantages over cathode bias circuits that oscillation starts more readily and that the output amplitude is more independent of variations in h.t. or l.t. supply voltage or in output load.

The circuit operates in the following way:—On the positive excursions of the oscillatory signal between grid and cathode the valve takes grid current. This current flows into C_g and charges it, the polarity of the charge being such as to bias the grid negatively. When the signal at the grid falls sufficiently for grid current to cease, capacitor C_g begins to discharge through R_g , but provided the time constant $R_g C_g$ is large enough, the charge across C_g falls by only a small percentage when the next cycle of oscillation occurs and C_g is again charged by grid current. The process of charging and discharging C_g continues in a manner similar to that occurring in a diode detector. The charge on the plates of the capacitor C_g does not greatly vary during the oscillation cycle and the voltage across C_g may be regarded as approximately constant. This capacitor is the source of bias for the valve since one plate is connected to the grid and the other (through a part of the frequency-determining network which must have continuity) to the cathode. Thus the valve has approximately-constant negative bias from this source. The bias so obtained normally exceeds the grid base of the valve which operates in Class C conditions, taking bursts of grid and anode current once during each oscillation cycle.

The negative voltage developed across C_g is approximately equal

GRID CURRENT BIAS IN OSCILLATORS

to the peak value of the oscillatory signal between the grid and cathode. Thus this bias circuit can be regarded as providing automatic gain control; if, for any reason, the oscillation amplitude tends to fall, the resulting reduction in negative bias causes the effective mutual conductance of the valve to increase and this tends to increase oscillation amplitude. The result is that the oscillation amplitude settles down to a new value which is smaller than before but not so small as when fixed bias is employed.

The reason for the good starting of oscillation in circuits with grid-current bias can now be appreciated; when the valve is switched on there is no grid bias until oscillation begins. Initially, therefore, the mutual conductance considerably exceeds the value which applies

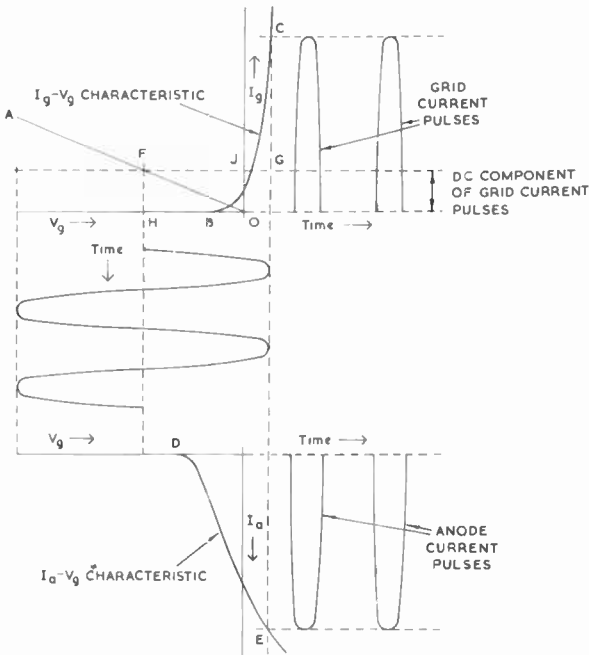

Fig. 18—Graphical representation of conditions in a grid-current-biased oscillator

in the presence of oscillation. In such conditions oscillation begins immediately the valve receives a signal; it is not normally necessary to apply a signal because thermal-agitation or shot-noise voltages usually start oscillation immediately the mutual conductance is large enough to maintain it.

4.2 GRAPHICAL REPRESENTATION OF OPERATING CONDITIONS

The mechanism of the biasing process can be represented graphically as in Fig. 18. The upper half of this diagram shows the I_g-V_g characteristic BC of the valve; the slope of this curve is equal to $1/r_g$ where r_g is the grid a.c. resistance. OA is the load line for the grid resistor R_g , i.e., the line has a slope of $-1/R_g$.

The sinusoidal curves at the centre of the diagram represent the oscillations developed by the valve between grid and cathode. On positive peaks the valve is driven into grid current and the pulses of grid current are shown at the top right-hand corner. The approximately-steady voltage developed across C_g and R_g by this pulsating current is equal to the product of the average grid current and the grid resistor. The average value of the grid current is determined by the ratio of the time constant $R_g C_g$ to the period of the oscillation and is commonly of the order of 1/5th the peak value. In Fig. 18 the average value is represented by OJ and the horizontal through J meets OA at F. The vertical through F meets the V_g axis at H which represents the grid bias value.

The I_a-V_g characteristic of the valve shown in the lower part of the diagram indicates that the valve is biased beyond cut-off and the anode current thus consists of a series of pulses as shown.

In practice the grid resistor R_g is normally great compared with the grid a.c. resistance r_g of the valve. For the sake of clarity the difference in slope of the two characteristics OA and BC is much reduced in Fig. 18. BC should be much steeper and point G, which represents the most positive value reached by the grid during the oscillation cycle, is only slightly positive with respect to the origin. Thus the grid bias value OH is very nearly equal to the amplitude of oscillation. This is a useful result enabling a micro-ammeter connected in series with the grid resistor R_g (at its earthy end for convenience) to be used for approximate indications of oscillation amplitude; the steady meter reading should be multiplied by the grid resistor value. For example, if the reading is $32 \mu\text{A}$ and the grid resistor is $470 \text{ k}\Omega$ the oscillation amplitude is $32 \times 10^{-6} \times 470 \times 10^3$ approximately 15 volts.

4.3 GRID TIME CONSTANT

The time constant $R_g C_g$ should preferably have a value such that the potential across the capacitor decays by a small amount (for example 5 per cent) in the period of one oscillation. The potential on a capacitor decays according to the equation

$$V_t = V_0 e^{-t/R_g C_g} \quad \dots \quad \dots \quad \dots \quad (7)$$

GRID CURRENT BIAS IN OSCILLATORS

where V_o is the initial potential and V_t is the potential after a time t . This expression is derived in Appendix B of Volume 2.

Differentiating (7) we have

$$\begin{aligned} \frac{dV_t}{dt} &= - \frac{V_o e^{-t/R_g C_g}}{R_g C_g} \\ &= - \frac{V_t}{R_g C_g} \quad \dots \quad \dots \quad \dots \quad (8) \end{aligned}$$

At the beginning of the discharge $V_t = V_o$ and the rate of fall of potential is given by

$$\frac{dV_t}{dt} = - \frac{V_o}{R_g C_g} \quad \dots \quad \dots \quad \dots \quad (9)$$

The rate of fall of potential decreases as t increases, as shown by (8), but for small values of t we can assume that the rate of fall remains constant at the value given by (9). The fall in potential ΔV which occurs in a time interval Δt is, from (9), given by

$$\frac{\Delta V}{V_o} = \frac{\Delta t}{R_g C_g} \quad \dots \quad \dots \quad \dots \quad (10)$$

The negative sign is ignored here because we are concerned only with the magnitude of ΔV .

If we decide that the permissible fall in potential per cycle of oscillation is 5 per cent, we have, substituting $1/20$ for $\Delta V/V_o$ in (10)

$$\frac{\Delta t}{R_g C_g} = \frac{1}{20}$$

giving $R_g C_g = 20 \Delta t$

Δt is the period of one cycle and equals $1/f$

$$\therefore R_g C_g = \frac{20}{f} \quad \dots \quad \dots \quad \dots \quad (11)$$

As an example, in an oscillator to work at 20 kc/s,

$$\begin{aligned} R_g C_g &= \frac{20}{20 \times 10^3} \text{ sec.} \\ &= 1 \text{ millisecc} \end{aligned}$$

If $R_g = 470 \text{ k}\Omega$, C_g is given by

$$\begin{aligned} C_g &= \frac{10^{-3}}{R_g} \\ &= \frac{10^{-3}}{470 \times 10^3} \text{ F} \\ &= 0.002 \mu\text{F approximately} \end{aligned}$$

There is, of course, an infinite number of RC combinations having a time constant of a given value but the choice of values for R_g and C_g is limited by two considerations:—

- (a) If R_g is too small it will impose serious damping on the frequency-determining network and may so reduce the internal gain that oscillation is impossible. The precise minimum value of R_g depends on the gain of the valve, the Q of the inductor and the coupling between anode and grid circuits, but is not usually less than $10 \text{ k}\Omega$.
- (b) C_g must not be made too small otherwise the attenuation introduced by the potential divider formed by the grid capacitor C_g and the grid-cathode capacitance c_{gk} so reduces the internal gain that oscillation is impossible. To avoid this possibility C_g should be large compared with c_{gk} . In practice c_{gk} is commonly about 5 pF and values of C_g are not usually less than 30 pF .

4.4 SPURIOUS MODES OF OSCILLATION

If the time constant $R_g C_g$ is strictly maintained at 20 times the period of oscillation, the choice of values for R_g and C_g may be difficult at frequencies much higher than 50 Mc/s . Usually, however, the time constant can be increased beyond $20/f$ without serious ill-effects, permitting the use of larger values of R_g and/or C_g . If, however, the time constant is increased in an oscillator with considerable internal gain, spurious oscillation may result. When the valve begins to oscillate, it may generate such a large amplitude that the first few bursts of grid current charge capacitor C_g to a very high potential, biasing the valve so negatively that it does not conduct on the positive peaks of ensuing oscillations. Because of anode-current cut-off the LC circuit no longer receives the periodic pulses of energy necessary to maintain the amplitude of oscillation and oscillation dies away at a rate dependent on the Q value of the inductor. At the same time the negative bias of the valve also dies away as C_g discharges through R_g . When the bias reaches the

GRID CURRENT BIAS IN OSCILLATORS

cut-off value and anode current begins to flow again, the circuit bursts into oscillation and the process just described begins again.

The output of the valve consists of damped trains of oscillations recurrent at a frequency dependent on the time constant $R_g C_g$. The valve is then said to be *squegging* and the output waveform has the appearance shown in Fig. 19. If the internal gain of the oscillator is high it is possible for the valve to bias itself beyond cut-off in the

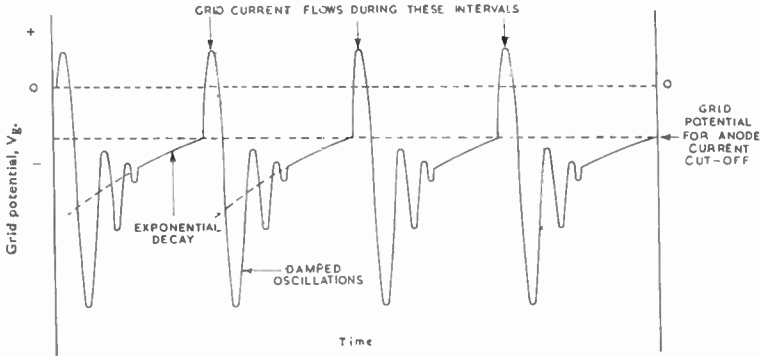

Fig. 19—Waveform of output from a squegging oscillator

first half-cycle of oscillation (as shown in Fig. 19); if, in addition, the LC circuit is very heavily damped so that oscillations die within half a cycle, the output of the oscillation is of approximately saw-tooth form. This is the basis of the *blocking oscillator* described in detail later in this Volume.

PART III : GENERATION OF RECTANGULAR WAVES

CHAPTER 5

PROPERTIES OF RECTANGULAR WAVES

5.1 INTRODUCTION

THE general form of a rectangular wave is illustrated in Fig. 20. It may be described as that of a voltage which alternates rapidly between two levels which are designated V_1 and V_2 in the diagram. The rectangular wave is described as *positive-going* when changing to the more positive level V_2 and *negative-going* when changing to the more negative level V_1 . The wave illustrated has vertical edges and thus changes instantaneously from one level to the other; such a

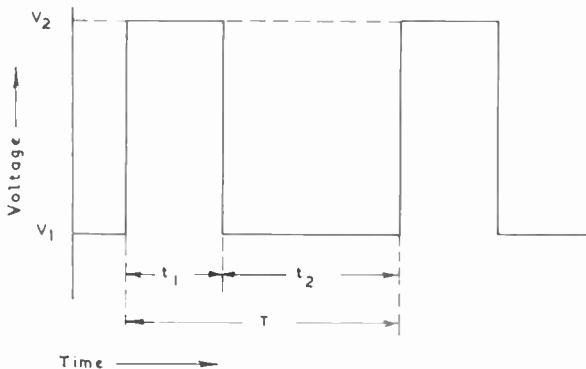

Fig. 20—An ideal rectangular wave

wave is ideal and has infinitely short rise and fall times. Practical rectangular waves necessarily have finite rise and fall times, these being related to the passband of the equipment which generates or transmits them as explained in Chapter 1 of Volume 2.

It is a significant feature of the rectangular wave that for most of the time the voltage is not changing but is stationary at the value

PROPERTIES OF RECTANGULAR WAVES

V_1 or V_2 . For this reason the rectangular wave is usually generated in a circuit which alternates between two possible quiescent states.

5.2 PULSE-REPETITION FREQUENCY

In the rectangular wave of Fig. 20 the voltage remains at the more positive level for periods of duration t_1 and at the more negative level for periods of duration t_2 . The sum of t_1 and t_2 is equal to T (Fig. 20), the time occupied by a complete cycle of the waveform. T is the *period* of the wave and the number of periods in one second is the *pulse-repetition frequency* (p.r.f.) of the wave, often abbreviated simply to frequency.

5.3 MARK-SPACE RATIO

In a series of pulses the positive-going (or negative-going) excursion is usually required to perform some operation, such as holding a valve conductive (or non-conductive) and the waveform is

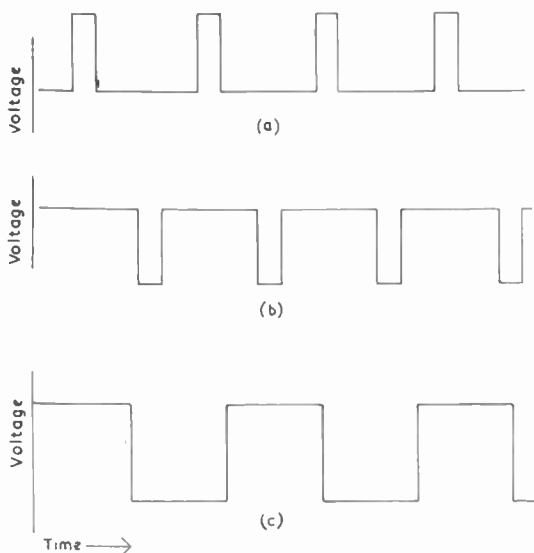

Fig. 21—A series of rectangular pulses: (a) positive-going, (b) negative-going and (c) square

commonly described by quoting the ratio of the duration of this useful pulse to the duration of the interval between successive useful pulses, this being known as the *mark-space* ratio. If, in

Fig. 20, the significant feature is the positive-going pulse, this waveform can be described as having a mark-space ratio of $t_1 : t_2$, i.e. 1 : 2; if, however, the negative-going pulse is the useful feature, the waveform could alternatively be described as having a mark-space ratio $t_2 : t_1$, i.e. 2 : 1.

Alternatively a series of pulses may be described in terms of their *duty ratio*, this being the ratio of the useful pulse duration to the period of the wave. If in Fig. 20 it is the positive-going pulse which is of interest, this wave could be described as having a duty ratio of $t_1 : T$, i.e. 1 : 3. If the negative-going pulse is the significant feature, the duty ratio is $t_2 : T$, i.e. 2 : 3.

Frequently the duration of the useful pulses is small compared with the intervals between them. Two trains of such pulses are illustrated in Fig. 21, diagram (a) representing positive-going and (b) negative-going pulses.

Another pulse waveform which is commonly encountered is that in which the duration of the useful pulses is equal to the interval

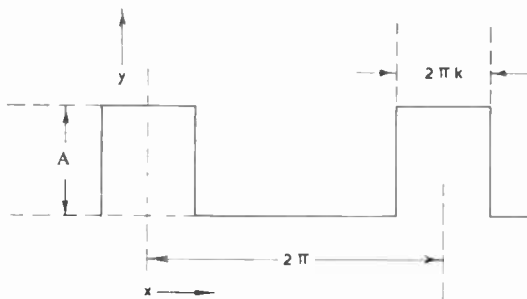

Fig. 22—A series of positive-going pulses

between successive useful pulses. Such a wave may be described as having a mark-space ratio of unity or a duty ratio of 1 : 2; it is commonly referred to as a *square wave* and is illustrated in Fig. 21 (c).

5.4 SPECTRUM OF A RECTANGULAR WAVE

The equation for a succession of short positive-going rectangular pulses (Fig. 22) is:—

$$y = A \left[k + \frac{2}{\pi} (\sin k\pi \cos x + \frac{1}{2} \sin 2k\pi \cos 2x + \frac{1}{3} \sin 3k\pi \cos 3x + \frac{1}{n} \sin nk\pi \cos nx + \dots) \right] \dots \dots \dots (12)$$

PROPERTIES OF RECTANGULAR WAVES

where A is the peak-to-peak amplitude and k is the duty ratio (ratio of the pulse duration to the period). The spectrum contains an average or d.c. component of kA and a series of harmonics spaced at intervals equal to the repetition frequency of the pulse and extending to infinity. The amplitude of any given harmonic is inversely proportional to its order and thus they become progressively less important as the order increases. The 50th harmonic, for example, has an amplitude only 2 per cent that of the fundamental and higher order components are still smaller. Thus it is possible to suppress all the harmonics above a certain order without greatly affecting the shape of the waveform. In fact, as pointed out in Volume 1, the effect of suppressing all the components above a certain frequency is to introduce rise and fall times t which are related to the cut-off frequency f by the simple expression

$$t = \frac{1}{2f}$$

The corresponding expression for a square wave can be obtained from (12) by putting the duty ratio $k = 0.5$. We then have:

$$y = \frac{A}{2} + \frac{2A}{\pi} (\cos x - \frac{1}{3} \cos 3x + \frac{1}{5} \cos 5x - \frac{1}{7} \cos 7x - \dots) \dots \quad (13)$$

As would be expected for a symmetrical wave, the d.c. component is equal to half the peak-to-peak amplitude of the wave. Only odd-order harmonics are now present, however, and an interesting point is that the fundamental component has an amplitude ($2A/\pi$) which is greater than the single peak amplitude ($A/2$) of the square wave.

CHAPTER 6

GENERATION OF RECTANGULAR WAVES BY DIODE LIMITING CIRCUITS

6.1 INTRODUCTION

ONE of the simplest ways of producing a rectangular wave is by applying an input such as a sine wave to a device with a non-linear characteristic of the type shown in Fig. 23 which has horizontal sections at both extremes. The output signal from such a device is proportional to the input provided the latter lies within the limits of

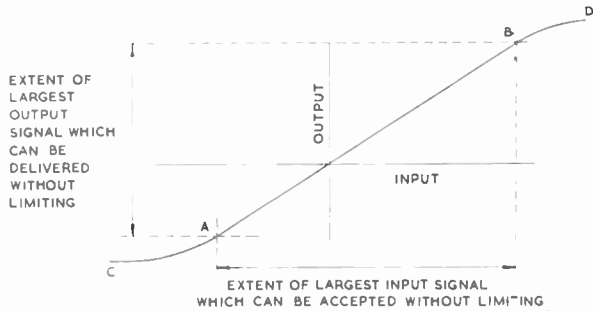

Fig. 23—Shape of non-linear output-input characteristic which gives limiting

the linear section AB of the characteristic. If the input amplitude is increased beyond these limits, the output fails to increase in proportion but oscillates between the voltages corresponding to C and D, remaining constant at these voltages for considerable fractions of each cycle. The output wave thus has horizontal sections and is approximately rectangular in form.

A device with a characteristic of this shape (Fig. 23) is said to cause *limiting* and the critical input or output voltages at which non-linearity of the characteristic begins are referred to as *limiting levels*. The operation of a limiting device is illustrated in Fig. 24 which shows a sinusoidal input signal ABCDEFGHJ applied to a characteristic of the form shown in Fig. 23. If the characteristic were linear the output signal would also be sinusoidal as indicated

GENERATION OF RECTANGULAR WAVES BY DIODE LIMITING CIRCUITS

by the dotted curve (abcdefghj) but, because of limiting, the peaks of the input wave are not reproduced and the output has the approximately-rectangular form (abdefh). The input signal need not necessarily be of sinusoidal form to produce an output of this shape. Any form of input signal can be used provided its amplitude is large compared with the extent of the linear part of the input-output

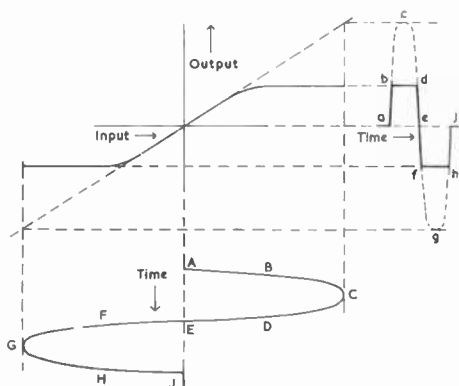

Fig. 24—Production of a rectangular wave by amplitude limitation of a sine wave

characteristic. For a given characteristic, the larger the input amplitude is made the shorter is the rise time of the output signal.

In Fig. 24 the input signal oscillates about the mid-point of the linear portion of the characteristic, producing an output signal with a mark-space ratio of unity, i.e., a square wave. This happens because the datum line of the input signal falls symmetrically between the limiting levels. The mark-space ratio can be varied within limits by suitably biasing the sine wave with respect to the limiting levels. This is illustrated in Fig. 25 in which the datum line of the input sine wave is negative with respect to both limiting levels; the output has a mark-space ratio of approximately 2 : 1. By biasing the sine wave positively it is possible to produce an output in which the mark-space ratio is less than unity.

6.2 SIMPLE DIODE LIMITING CIRCUITS

A diode valve provides a simple means of achieving amplitude limitation and a basic circuit providing one limiting level consists of a resistor R_a connected in series with the diode V1 as shown in Fig. 26. The resistor value should be large compared with the

forward resistance of the diode but small compared with its reverse impedance. The forward resistance is commonly as low as $1,000 \Omega$ but the reverse impedance of a diode has a capacitive component and falls with increasing frequency; or at the frequencies with which we are concerned it is at least several megohms and satisfactory limiting is obtained when R_a is $47 \text{ k}\Omega$.

When a sinusoidal signal is applied to the input of the circuit, the diode conducts on positive half-cycles and, because of its low

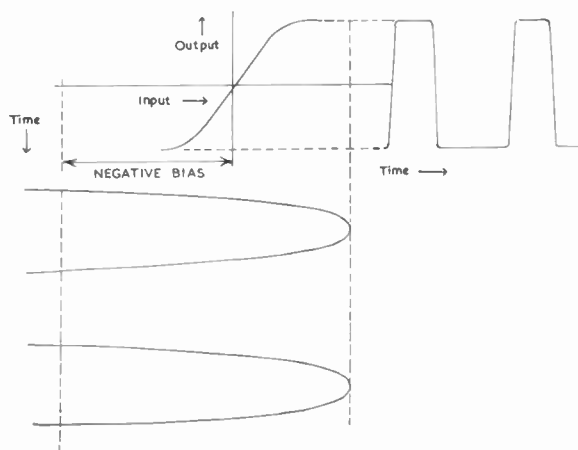

Fig. 25—Alteration of mark-space ratio by adjustment of sine-wave bias

forward resistance, the circuit behaves as a potential divider with a large step-down ratio. Thus for positive half-cycles only a very small signal is developed across the diode. On the negative half-cycles the diode is non-conductive and its impedance is high; the potential divider has a step-down ratio only slightly less than unity and the signal developed across the diode is practically equal to the input signal, as shown in Fig. 27. This circuit gives positive-peak limitation and the limiting level is zero volts, since it is at this input voltage (or slightly less in practice) that the diode begins to conduct.

The signal developed across the diode, together with that across the resistor, equals the applied signal. If the signal across the diode is large, that across the resistor must be small. Thus if the output of the circuit of Fig. 26 is taken from the resistor, the circuit gives

GENERATION OF RECTANGULAR WAVES BY DIODE LIMITING CIRCUITS

negative-peak limitation, the limiting level being again approximately zero volts.

Two additional limiting circuits can be obtained by reversing the diode in Fig. 26 and taking the output from the diode or the resistor, making a total of four possible arrangements. The performance of

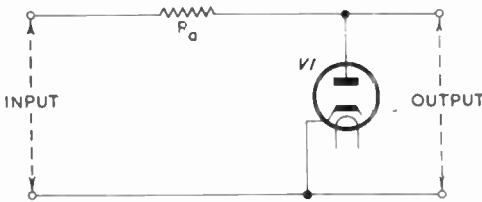

Fig. 26—Diode circuit giving limitation of positive peaks

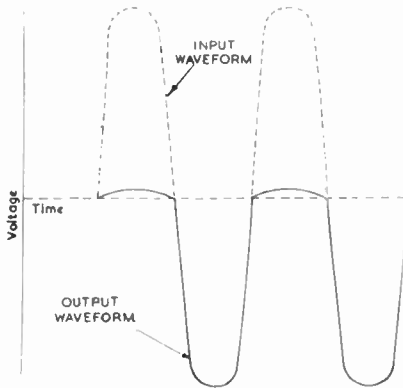

Fig. 27—Input and output signal waveforms for the circuit of Fig. 26

these circuits is illustrated in Fig. 28, which shows the shape of the output waveform (for sinusoidal input signal) for each circuit.

6.3 BIASED-DIODE LIMITING CIRCUITS

All the diode circuits illustrated in Fig. 28 have a single limiting level of zero volts. To give limitation at a voltage other than zero, the diode may be biased as shown in Fig. 29, which is similar to Fig. 26

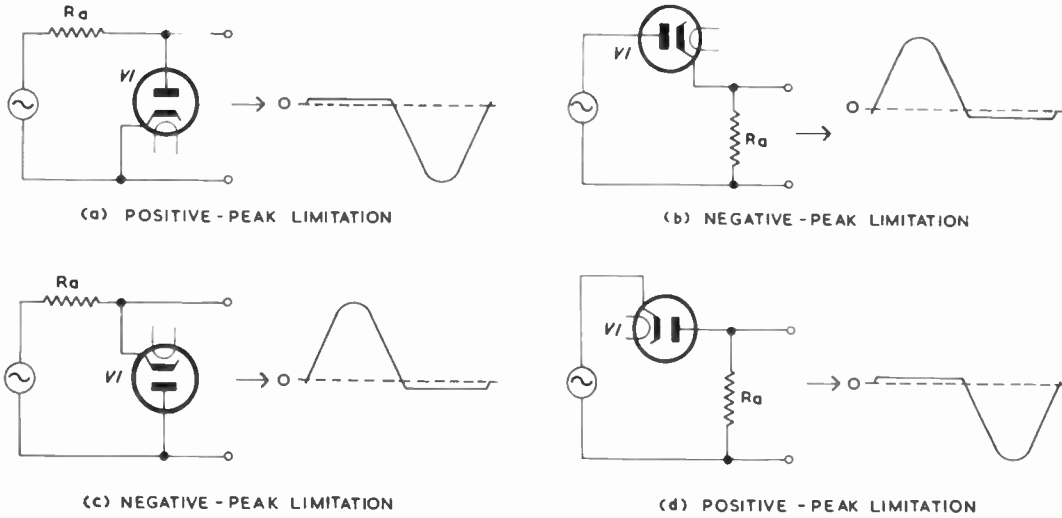

Fig. 28—Illustrating the performance of four simple diode limiting circuits

GENERATION OF RECTANGULAR WAVES BY DIODE LIMITING CIRCUITS

except for the positive bias applied to the diode cathode. The diode will not now conduct until the signal input exceeds V_k , the cathode bias potential; thus the output voltage has the form shown in Fig. 30. The limiting level V_k is given approximately by the

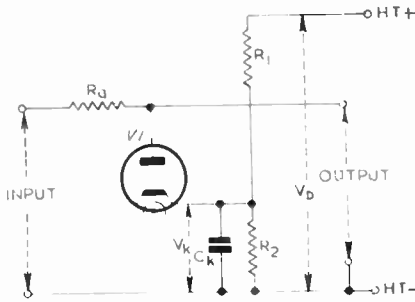

Fig. 29—Diode circuit giving positive-peak limitation with provision for adjusting the limiting level

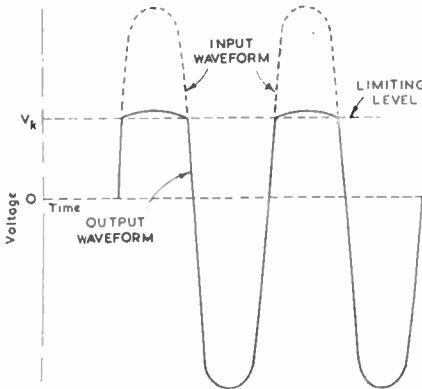

Fig. 30—Input and output waveforms for the circuit of Fig. 29

following expression:

$$V_k = \frac{R_2}{R_1 + R_2} \cdot V_b$$

in which V_b is the h.t. voltage. C_k is a capacitor the value of which is not critical provided its reactance is small compared with the forward resistance of the diode at the frequency of the input signal.

6.4 CIRCUIT EMPLOYING TWO DIODES

By using two diodes, positive- and negative-peak limitation can be obtained and one possible circuit is shown in Fig. 31.

Consider first the conditions in the circuit when no signal is applied to the input terminals. The anode of V2 is returned to a point on the potential divider R_3R_4 across the h.t. supply and its

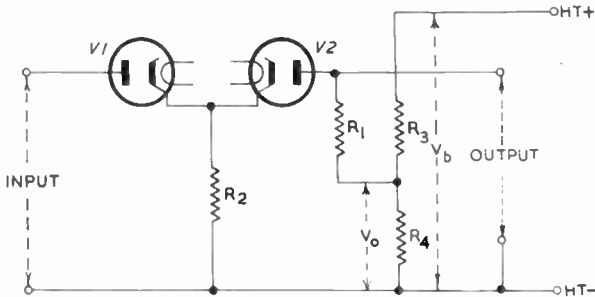

Fig. 31—Diode circuit giving positive- and negative-peak limiting

cathode is connected via R_2 to h.t. negative. Thus diode V2 is conductive since its anode is biased positively with respect to its cathode from the h.t. supply. Its resistance is low and if this is neglected in comparison with R_1 and R_2 we can say that the steady voltage V_k developed across R_2 and appearing across the output terminals is given by

$$V_k = \frac{R_2}{R_1 + R_2} \cdot V_o \quad \dots \quad (14)$$

where V_o is the steady potential across R_1 . Provided the sum of R_1 and R_2 is large compared with R_4 , V_o is given by

$$V_o = \frac{R_4}{R_3 + R_4} \cdot V_b \quad \dots \quad (15)$$

V_b being the h.t. voltage. From (14) and (15)

$$V_k = \frac{R_2}{R_1 + R_2} \cdot \frac{R_4}{R_3 + R_4} \cdot V_b \quad \dots \quad (16)$$

and this is the cathode bias for V1.

Now consider the behaviour of the circuit when a sinusoidal input signal is applied to the input terminals. For positive-going input signals with an amplitude less than V_k , V1 does not conduct and

GENERATION OF RECTANGULAR WAVES BY DIODE LIMITING CIRCUITS

the voltage at the output terminals is still V_k . When the positive input signal exceeds V_k the voltage across R_2 rises as a result of V1 diode current flowing in it. This rise in voltage across R_2 appears at the output terminals because diode V2 has a low resistance, being maintained in a conducting state by the positive bias applied to its anode from the h.t. supply. When, however, the input signal rises to a higher positive value such that the voltage across R_2 equals the steady voltage V_o across R_4 , V2 ceases to conduct and for this and higher values of input signal the output terminals are effectively isolated from R_2 .

Thus there is no output from the circuit if the input signal has an amplitude less than V_k (equation 16) or greater than V_o (equation 15) and if a large-amplitude sinusoidal signal is applied to the input terminals the output is approximately rectangular in form as shown in Fig. 32. The output here has a mark-space ratio of less than unity

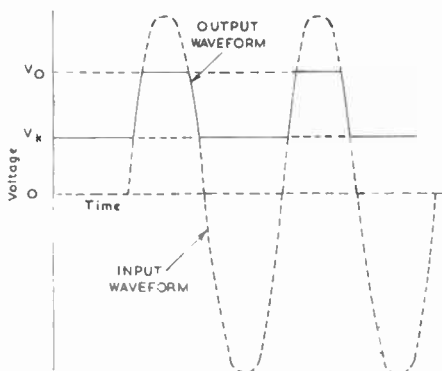

Fig. 32—Output waveform of the circuit shown in Fig. 31

but other ratios can be obtained by suitable choice of values for R_1 , R_2 , R_3 and R_4 .

This is an example of the type of circuit discussed in the introduction to this chapter in which some variation of the mark-space ratio of the output waveform is possible by suitably biasing the input sine wave with respect to the limiting levels. The relationship between the sine-wave datum level and one limiting level is controlled by the ratio of R_1 to R_2 and between the datum level and the other limiting level by the ratio of R_3 to R_4 .

CHAPTER 7

GENERATION OF RECTANGULAR WAVES IN AMPLIFYING LIMITERS

7.1 INTRODUCTION

IN diode limiting circuits a resistor forms a potential divider with the (much smaller) diode forward resistance and greatly attenuates input signals which are of the right polarity and magnitude to cause the diode to conduct. Such simple circuits have only a single limiting level and two diodes must be used (as shown in Fig. 31) to give the two limiting levels necessary for the production of a rectangular wave.

Possibly a simpler method of generating a rectangular wave by limiting is to use an amplifying stage. Positive-peak limitation can be achieved by use of a series grid resistor (the control grid and cathode behaving as the electrodes of a diode) and negative-peak limitation occurs naturally through anode-current cut-off. For successful limiting a very large input signal is necessary and the amplifier operates under conditions which in linear amplification would be described as constituting gross overloading.

In this chapter the basic principles of limiting amplifiers are described and it is shown that a pentode can give positive-peak limitation without the necessity for a series grid resistor, the I_a-V_a characteristics performing this function provided the value of anode-load resistor is correctly chosen.

7.2 TRIODE LIMITING AMPLIFIER

The circuit of a simple triode limiting amplifier is given in Fig. 33. The valve has an anode resistor R_a and cathode bias is provided by the potential divider $R_k R_1$ connected across the h.t. supply. To minimise any fluctuations in cathode bias due to the alternating component of valve anode current a low-reactance capacitor C_k is shunted across R_k . The input is applied via a series grid resistor R_g which has the effect of limiting positive input peaks at a grid voltage approximately equal to the cathode bias V_k of the valve.

Negative-peak limitation occurs at the cut-off bias which, for a triode, is given approximately by V_b/μ (where V_b is the h.t. supply voltage and μ is the amplification factor). The bias can thus be

GENERATION OF RECTANGULAR WAVES IN AMPLIFYING LIMITERS

varied by adjustment of h.t. voltage and by choice of amplification factor. The cathode bias of the valve is V_k and the negative input limiting level is given by $(V_b/\mu - V_k)$.

The performance of a limiting amplifier of this type is illustrated in Fig. 34 which shows the dynamic $I_a - V_g$ characteristic for a triode,

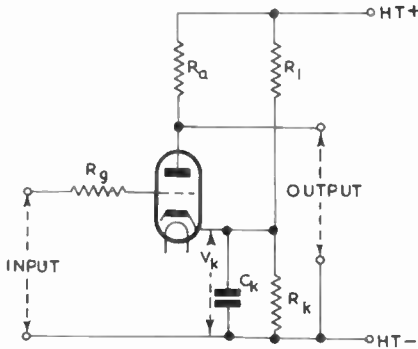

Fig. 33—Circuit of a triode limiting amplifier

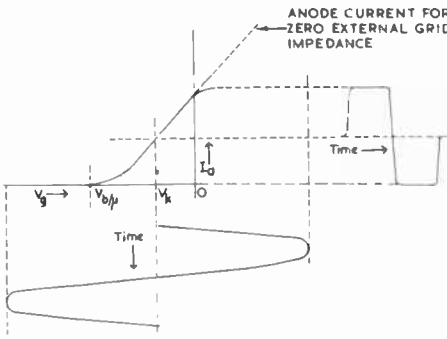

Fig. 34—Illustrating the operation of a triode limiting amplifier

an input signal (sinusoidal for convenience) and the approximately rectangular output.

To obtain a square-wave output the positive and negative input limiting levels must be equal: in other words the valve must be so biased that the datum line for the sine-wave input is at the mid-point of the linear part of the characteristic shown solid in Fig. 34. These

are the conditions of a Class A amplifier; thus it is possible to omit R_1 and to make R_k the normal value for automatic cathode bias. The amplifier is, of course, overloaded when used for limiting.

The rise and fall times of the rectangular waves produced by a limiting amplifier depend on the time constants in the grid and anode circuits as discussed in Volume 2 and it may be necessary to limit the values of R_g and R_a to obtain low values of rise times. In fact R_g can sometimes be omitted, the resistance of the source of input signal performing the function.

7.3 CATHODE-FOLLOWER LIMITING CIRCUIT

Limiting may be achieved by a simple cathode-follower circuit such as that shown in Fig. 35. As in the limiting amplifiers, positive-peak limiting is produced by grid current in the signal-source resistance and negative-peak limiting by anode-current cut-off. To avoid undue extension of the valve grid base (which would necessitate

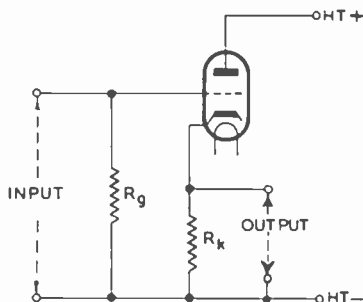

Fig. 35—Simple cathode-follower limiter

large input signals for effective limiting) R_k is made low and is often approximately $1/g_m$, i.e., $200\ \Omega$ for a valve with $g_m = 5\ \text{mA/V}$. Such small values of R_k also tend to give low rise and fall times in the output pulses.

A disadvantage of this type of limiter is that the output fall time is greater than the rise time. These times are determined by the time constant in the cathode circuit, i.e., the product of the capacitance C (chiefly cathode-heater and output-load capacitance) and the associated resistance. When the valve is cut off by negative-going signals on the grid, the cathode potential falls exponentially with a time constant of $R_k C$, where R_k is the external cathode-circuit

GENERATION OF RECTANGULAR WAVES IN AMPLIFYING LIMITERS

resistance. On positive-going grid signals the valve supplies anode (and grid) current to the output capacitance and the effective charging resistance is considerably less than R_k , being approximately R_k in parallel with r_k , the internal cathode resistance ($1/g_m$). Thus the cathode potential rises more rapidly than it falls and the difference in the rate of change becomes more marked as R_k is increased relative to r_k . Conversely by making R_k small compared with r_k the rise and fall times can be made approximately equal but the output amplitude is then very small. For example, if R_k is 20 Ω and the valve has an anode current of 10 mA, the single amplitude peak output is only $20 \times 10 \times 10^{-3} = 0.2$ volt. This may require an input signal of perhaps 10 volts amplitude; thus although the circuit is an effective limiter it can introduce great attenuation.

7.4 TWO-VALVE CATHODE-COUPLED LIMITER

7.4.1 Basic Circuit

A better performance is obtainable from the two-valve cathode-coupled circuit, the basic form of which is illustrated in Fig. 36. A significant feature of this circuit is that limiting may occur without

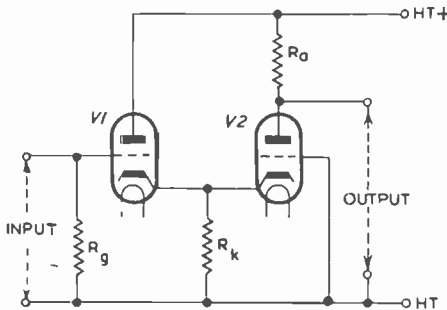

Fig. 36—Basic form of two-valve cathode-coupled limiter

grid current flow. The circuit may be regarded as a combination of a cathode follower and a grounded-grid stage, the two cathodes being bonded and connected to h.t. negative via a resistor R_k which is of a high value such as 10 k Ω .

In the static condition, i.e., with no input signal, both valves take anode current and the combined current flows in R_k to give both valves the same value of grid bias. However, the anode voltage of V2 is lower than that of V1 (due to the voltage drop across R_a) and the anode current of V2 is, therefore, less than that of V1.

For small signals at V1 grid, the two valves operate in Class A

conditions, the alternating components of the anode currents being in antiphase and, if V1 is given an anode-load resistor, a push-pull output can be obtained from the two anodes.

When the circuit is used for limiting, much larger input signals are required. When positive-going signals are applied to V1 grid they appear at practically full amplitude at V1 cathode and cut V2 off, causing V2 anode potential to rise, the time constant being deter-

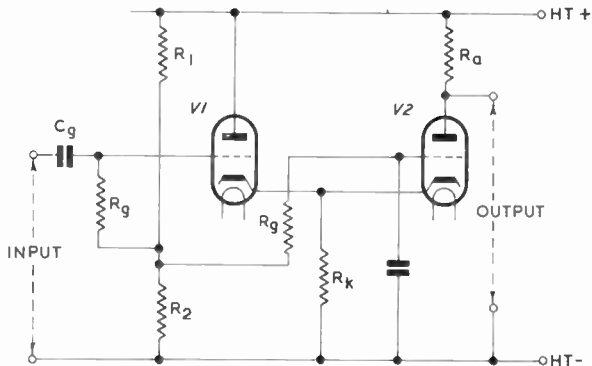

Fig. 37—Practical circuit diagram for cathode-coupled limiter

mined by the product of R_a and the shunt capacitance at the anode. When negative-going signals are received at V1 grid, V1 is cut off, removing the positive bias from V2 cathode. Anode current starts again in V2 and the anode potential falls, the time constant being substantially the same as before. During this fall of anode potential R_a is not appreciably shunted by the anode a.c. resistance of V2 because, in effect, this is very large, due to current feedback in R_k .

Thus during large-amplitude positive-going input signals on V1 grid, V2 is cut off and its anode potential is steady at h.t. value. During large-amplitude negative-going signals on V1 grid, V1 is cut off and V2 takes a steady anode current chiefly determined by the value of R_k ; V2 anode potential is thus steady again but at a value lower than the h.t. supply voltage by the voltage drop across R_a . Hence a rectangular output is generated at V2 anode at a frequency equal to that of the input signal.

One advantage of this circuit over the simple cathode-follower limiter is that the output rise and fall times are substantially equal. Moreover, provided V1 input signal has not too large an amplitude or too short a rise time, V1 does not take grid current and no loading

is imposed on the input-signal source. The factors affecting the overloading characteristics of stages of this type are discussed in Chapter 17 of Volume 2.

7.4.2 Practical Circuit

A practical circuit diagram is given in Fig. 37. Grid bias for both valves is provided by the potential divider R_1R_2 and the grid resistors labelled R_g . With an h.t. supply of 250 volts if R_1 is 200 k Ω and R_2 is 47 k Ω , the grid potential is approximately 50 volts.

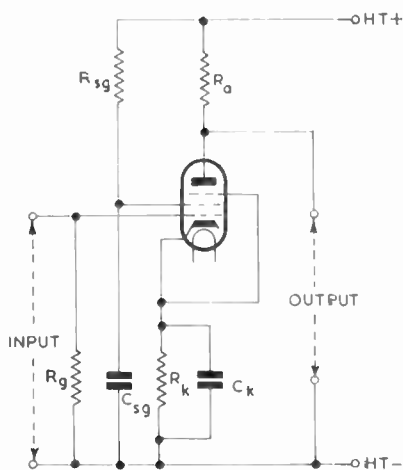

Fig. 38—Circuit of pentode limiting amplifier

Under static conditions each valve will take approximately 2.5 mA anode current, giving 5 mA in the cathode resistor (assumed 10 k Ω) and 50 volts common cathode potential. Under driven conditions one valve is always cut off and the other conductive; the conductive valve takes 5 mA approximately.

7.5 PENTODE LIMITING AMPLIFIER

A pentode is frequently used as a limiting amplifier and it has a number of advantages over a triode. For example, by use of a low screen-grid potential it has a very short grid-base. One possible circuit for a pentode limiting amplifier is shown in Fig. 38. The value of R_{sg} should be chosen to give the desired screen-grid voltage and C_{sg} should have a reactance which at the operating frequency is

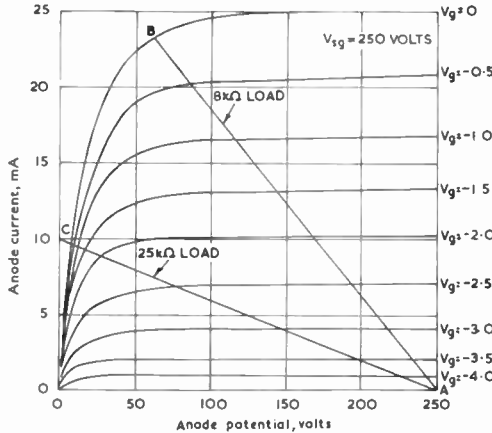

Fig. 39—Typical I_a-V_a characteristics for a pentode with load lines drawn for anode resistors of $8\text{ k}\Omega$ and $25\text{ k}\Omega$

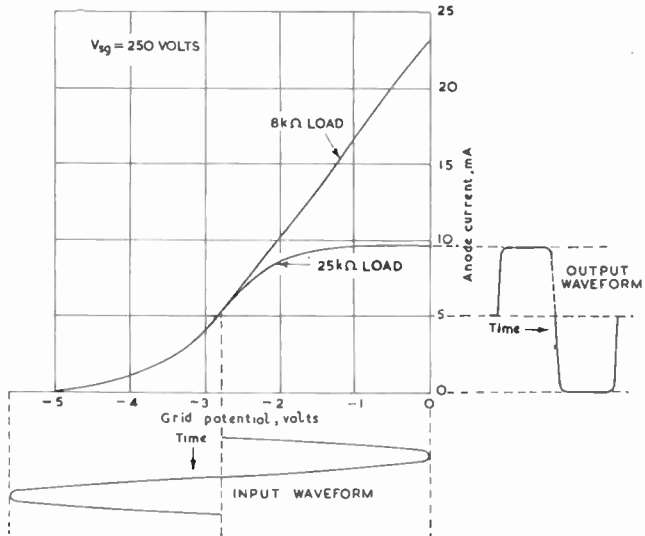

Fig. 40—Dynamic $I_a-V_{g_1}$ characteristics for a pentode showing limiting effect of a high-value anode load

small compared with the internal screen resistance r_{sg} and the external screen resistor R_{sg} in parallel.

There is, however, another and in some respects a more effective circuit for a pentode limiting amplifier. Because of the knee in pentode $I_a - V_a$ characteristics, it is possible to choose an anode load which will give limiting on positive peaks without need for a grid resistor. The required performance is obtained by using an anode-load resistor of higher value than would be used in Class A amplification. Thus in the absence of an input signal the anode potential is very low, say 20 or 30 volts only, and on receipt of a positive-going input signal the anode voltage first falls to zero—after which limiting occurs. On negative-going input signals the anode current is cut off and the anode potential rises to h.t. value; this is a large voltage change but the conditions of operation of the valve give high voltage gain and only a comparatively small negative change in control-grid voltage is required to cut the valve off, after which limiting occurs again. The circuit thus acts as an effective limiter but is capable of a large signal output which is in fact almost equal to the h.t. supply voltage.

The performance of a limiting amplifier of this type is illustrated in Figs. 39 and 40. The screen voltage is assumed to be 250 volts and load lines are drawn for 8 k Ω , which is suitable for Class A operation, and 25 k Ω , which gives limiting; Fig. 39 shows that limiting occurs at grid voltages more positive than -1 volt and more negative than -5 volts approximately; for this change of 4 volts the anode potential swings between 20 and 250 volts, representing a gain of nearly 60. An input of, say, 50 volts (d.a.p.) amplitude would give very effective limiting and an output of 230 volts amplitude (d.a.p.).

7.6 TYPICAL APPLICATION OF LIMITING AMPLIFIERS

In the above diagrams illustrating the action of limiting amplifiers, the input signal was shown, for convenience, as sinusoidal, but in practice the shape is often very different. For example, limiting amplifiers are commonly fed from the output of multivibrators which is of rectangular waveform. This is done for two reasons:

- (a) If the multivibrator output is sufficiently large the use of the limiting amplifier brings about an improvement in rise time; that is to say, the output of the limiting amplifier has a smaller rise time than that of the multivibrator. As an illustration, suppose the multivibrator output has an amplitude of 50 volts and that the input limiting level of the following amplifier is 5 volts. The output of the limiting amplifier rises to its maximum value during the first 5 volts excursion of the input

signal and remains constant during the time taken by the input signal to rise from 5 to its maximum of 50 volts amplitude. Thus the rise time of the limiting amplifier is only 1/10th that of the multivibrator output. It is assumed here, of course, that the rise time is not degraded in the limiting amplifier itself, for example, by the time constant of the anode circuit.

- (b) The rectangular waves from a multivibrator usually have overshoots but if these correspond to voltages in excess of the limiting levels the limiting amplifier will not respond to them and the output of the limiting amplifier is a better approximation to a rectangular wave than the output of the multivibrator.

CHAPTER 8

BI-STABLE, MONOSTABLE AND ASTABLE GENERATORS

8.1 INTRODUCTION

IN the limiting amplifiers described above, approximately rectangular waveforms are derived from an input signal by a circuit designed to give an output signal only when the instantaneous input signal lies between two chosen limits. We shall now describe the circuits which can generate rectangular waves without need for input signals.

In general these circuits belong to a class of generator termed *relaxation oscillators*; these are oscillators in which the frequency-determining network is composed of resistance and capacitance, the frequency of the generated wave being determined by the time constants of the RC combinations. One of the most useful properties of such oscillators is that they can readily be synchronised at the frequency of an externally-applied signal.

Before the oscillators are described in detail, certain principles of valve operation commonly used in such circuits will be mentioned because they differ markedly from those employed in amplifying circuits. These principles can be illustrated by reference to the previous sections on sinusoidal oscillators and limiting amplifiers; in both, valves are operated with input signals which greatly exceed the grid base. In a Class A amplifier such conditions would be described as constituting a gross overload. For an appreciable fraction of each cycle of input signal, the valve is cut off, i.e., non-conductive; similarly for another relatively long period during each cycle the anode current is steady at a maximum value, i.e., the valve is in a state of conduction. In the circuits about to be described the periods of non-conduction and conduction are very long compared with the transition periods and to a first degree of approximation the valve can be described as being at all times in one or other of these two states. Thus the shape of the characteristic relating anode current with control-grid potential, which is very important in linear amplification, is of little significance in waveform-generating circuits. The valves are, in fact, used as switches and are turned on and off by signals applied to the control grid.

8.2 STABLE AND UNSTABLE STATES

In some circuits a valve remains permanently in a state of conduction, or of non-conduction, unless compelled to leave it by a signal applied to the circuit from an external source; such a state is referred to as *stable*. In other circuits a valve remains only temporarily in either of the two states, and voluntarily changes to the other state as a result of automatic changes in voltage occurring in the circuit itself, no external signals being necessary to initiate the change of state. States of this type are known as *unstable*. This distinction between stable and unstable states can be used as the basis of a method of classifying the various types of waveform generator, which can be grouped into the three main types described below.

8.3 BI-STABLE CIRCUITS

A bi-stable circuit has two stable states and remains permanently in either unless compelled to leave it by external signals. Triggering signals from an external source are essential for the operation of a bi-stable circuit and, in general, the first triggering signal switches the circuit from one state to the other and the next switches it back to the first state again. If a bi-stable circuit is in a particular state, two triggering signals are necessary to change this state and restore the original; two triggering signals thus produce one alternation in the output of the circuit. Such circuits can thus be made the basis of a *frequency divider* or *counter*.

8.4 MONOSTABLE CIRCUITS

Monostable circuits have one stable and one unstable state. The circuit remains permanently in the stable state unless it is compelled to leave it by an externally-applied signal. Under such stimulus the circuit enters the unstable state in which it remains for an interval after which it returns automatically to the stable state. It is characteristic of circuits of this type that an external signal is necessary to bring about the transition from the stable to the unstable state but that the transition from the unstable to the stable state occurs automatically after a time interval which, by appropriate design, can be made almost any desired value within wide limits. Circuits of this type are known as *relay* or *monostable circuits*; they are often used when a switching action is required at a given time interval after a triggering signal.

8.5 ASTABLE CIRCUITS

In astable circuits both states are unstable and the circuit alternates between the two states at a frequency which can be controlled within wide limits by choice of circuit constants. The sinusoidal oscillators described at the beginning of this section may be regarded as belonging to this type. Such oscillators are termed *free-running* or *astable*. Although no external signals are necessary to initiate the changes of state, astable oscillators can readily be synchronised at the frequency of such a signal.

The classification of relaxation oscillators can be summarised thus:

- (a) *Bi-stable circuits*, i.e. circuits with two stable states. These require triggering signals and are mostly used for counting or frequency division.
- (b) *Monostable circuits*, i.e. circuits with one stable and one unstable state. These require a triggering signal and are mostly used to produce accurately-timed delays.
- (c) *Astable circuits*, i.e. circuits with two unstable states. These are inherently self-running but can be synchronised with an external signal.

CHAPTER 9

ANODE-COUPLED BI-STABLE MULTIVIBRATOR

9.1 INTRODUCTION

ONE of the circuits extensively used for the generation of rectangular waves is the multivibrator, a two-valve circuit so designed that the input of each valve is obtained from the output of the other. In one type of multivibrator the anode of each valve is coupled to the grid of the other; such a circuit is referred to as *anode-coupled*. Other types of multivibrator employ a cathode-to-cathode link, either in addition to the anode couplings or in place of one of the anode couplings; these are known as *cathode-coupled* multivibrators.

Each of these two basic types of multivibrator can be bi-stable, monostable, or astable depending on the nature of the inter-valve couplings and on the choice of operating conditions; thus the total number of basic circuits is very large. This chapter deals only with the *anode-coupled* bi-stable multivibrator.

9.2 BASIC FEATURES OF THE CIRCUIT

As shown in Fig. 41 the anode-coupled bi-stable multivibrator comprises two triodes V1 and V2 with resistive anode loads R_a and R_a' , the anode of each valve being d.c. coupled to the grid of the other through resistive potential dividers $R_r R_g$ and $R_r' R_g'$, returned to a source of negative bias.

The component values and operating conditions are so chosen that if V1 is conductive, its low anode potential causes V2 grid to be negative and beyond cut-off, holding V2 in a non-conductive condition. This is one of the states of the circuit: V1 conductive and V2 non-conductive. If, however, V1 is made non-conductive, its high anode potential keeps V2 grid positive, holding this valve in a conductive state. This is the second state of the circuit: V1 non-conductive and V2 conductive. When placed in either of these states the circuit will remain in it indefinitely, that is to say both states are stable.

If the circuit is changed from one state to the other (e.g. by applying a negative voltage to the grid of the conductive valve) the change of state takes place with great rapidity, generating very steep voltage steps at the two anodes. This rapid change-over is charac-

ANODE-COUPLED BI-STABLE MULTIVIBRATOR

teristic of all multivibrators and is due to positive feedback inherent in the circuit. Examination of Fig. 41 shows that the circuit can be regarded as that of a two-stage d.c.-coupled amplifier with the output returned, with very little attenuation, to the input; these are the connections for a considerable degree of regeneration or positive feedback.

If, by use of a succession of external signals, the circuit is made to change its state repeatedly the anode current of each valve alternates

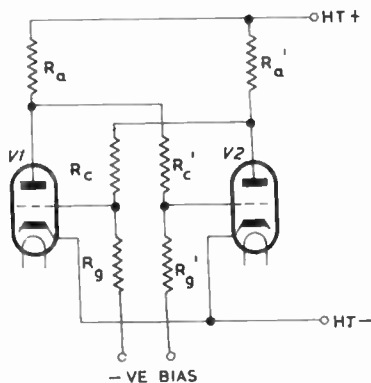

Fig. 41—Basic circuit of bi-stable multivibrator

between a maximum and zero, the signals generated at the control grids being large enough to cause grid current or anode-current cut-off. These are, of course, the conditions existing in a limiting amplifier and the circuit may thus be regarded as a combination of two triode limiting amplifiers, each giving rectangular wave outputs at the anode.

9.3 CHOICE OF COMPONENT VALUES AND STATIC VOLTAGES

Suppose the h.t. supply is 240 volts and the bias supply -100 volts. The valves will be assumed to cut off at a control grid-cathode potential of -5 volts and to have a maximum anode current of 10 mA. The anode loads are assumed to be 10 k Ω and the potential dividers are such that $R_c = 2R_g$ and $R_c' = 2R_g'$.

When V1 is conducting, the voltage across the anode load is 10 mA \times 10 k Ω = 100 volts, and the anode-cathode potential is therefore $240 - 100 = 140$ volts. Since $R_c = 2R_g$ and R_g is returned to a point 100 volts negative with respect to h.t. negative,

the grid-cathode potential for V2 is given by

$$\begin{aligned} -100 + \frac{1}{3}(240) &= -100 + 80 \\ &= -20 \text{ volts} \end{aligned}$$

more than sufficient to keep the valve cut off. The anode current of V2 is zero and its anode-cathode potential is 240 volts. The potential divider $R_c R_g$ thus gives rise to a grid-cathode potential for V1 of

$$\begin{aligned} -100 + \frac{1}{3}(340) &= -100 + 113.3 \\ &= +13 \text{ volts approximately} \end{aligned}$$

sufficient to keep V1 conductive;* these conditions represent one stable state. The second stable state exists with V1 non-conductive and V2 conductive, the potentials in the circuit being as follows:—

- grid-cathode potential of V1 = -20 volts,
- anode-cathode potential of V1 = 240 volts,
- grid-cathode potential of V2 = +13 volts.*
- anode-cathode potential of V2 = 140 volts.

9.4 METHOD OF TRIGGERING

To achieve a change of state in the circuit, the non-conductive valve must be made conductive. This can be brought about by applying a positive-going triggering signal to the grid of the non-conducting valve, but a signal of considerable magnitude may be necessary to overcome the static negative bias on this grid (13 volts in the above example). An alternative method which produces the same result is to apply a negative-going signal to the grid of the conducting valve: this is amplified by the valve and appears as a positive-going signal at the grid of the non-conducting valve. As the grid-cathode potential of the conducting valve does not normally differ very greatly from zero, there is no large positive voltage to overcome and a comparatively small negative voltage applied to this grid is sufficient to produce a positive-going signal of the required magnitude at the grid of the other valve. For example, if the stage gain of the conducting valve, including the attenuation in the coupling circuit to the next stage, is 15, a negative-going triggering signal of just less than -1 volt amplitude is sufficient to give a

* In practice the valve will take grid current through the resistor R_i (or R_i') connecting the grid to h.t. positive and the grid-cathode potential will fall to approximately zero.

positive-going signal of 13 volts at the grid of the non-conducting valve. In practice, therefore, multivibrators are triggered by negative-going signals applied to the grid of the conducting valve.

9.5 OPERATION OF THE CIRCUIT

We will now trace the sequence of events which occur when a negative-going signal, such as the leading edge of a negative pulse, is momentarily applied to the grid of V1, assumed to be the conducting valve. The signal causes a reduction in V1 anode current and an increase in anode potential which is transferred to the grid of V2 by R_c' and R_g' . Provided the signal at V2 is large enough, it starts anode current in V2 and causes a fall in V2 anode potential which is transferred to V1 grid by R_c and R_g . The amplitude of the signal returned to V1 grid from V2 anode is determined by the gains of the two valves and the attenuation of the inter-valve coupling circuits, but provided V2 is made sufficiently conductive for it to have an appreciable g_m , the gains exceed the losses and the amplitude of the signal returned to V1 grid exceeds that of the original externally-applied signal.

The amplified signal received from V2 anode causes a further decrease in V1 anode current and an increase in V2 anode current, with the result that the signal amplitude at V2 anode increases still further. This is a process of positive feedback or regeneration and it continues until checked by the anode current of V2 reaching a maximum value or the anode current of V1 reaching zero. The process is, of course, very rapid and the effect of applying the external signal to V1 grid is to switch V1 almost instantaneously to non-conduction and V2 to conduction.

To achieve this change of state the loop gain of the circuit, e.g. the gain from grid through V2 and back to V1 grid, must exceed unity. To give such a gain the g_m of V2 must exceed a certain minimum value and the amplitude of the triggering signal must be such as to produce sufficient anode current in V2 to give this minimum value of g_m .

The application of the triggering signal to the grid of V1 effectively interchanges the states of the two valves and the circuit now remains in the state in which V1 is non-conductive and V2 conductive unless it is triggered by a further negative signal which should now be applied to V2 grid. If the circuit is to be triggered by a series of signals, these must be applied alternately to the valve grids. A number of circuits can be used for this purpose and those most commonly used are described later.

The waveforms generated in a bi-stable multivibrator in which

triggering signals are applied alternately to the valve grids are as illustrated in Fig. 42; the multivibrator generates rectangular waves, in antiphase at the two anodes, at a frequency equal to half the frequency of the triggering signals. This illustrates the use of the bi-stable multivibrator as a frequency divider.

The grid bias for the two valves of a multivibrator can be obtained by use of a common cathode resistor R_k as shown in Fig. 43; to minimise coupling between the cathode circuits R_k is shunted by a capacitor C_k with a reactance small compared with $1/g_m$ at the

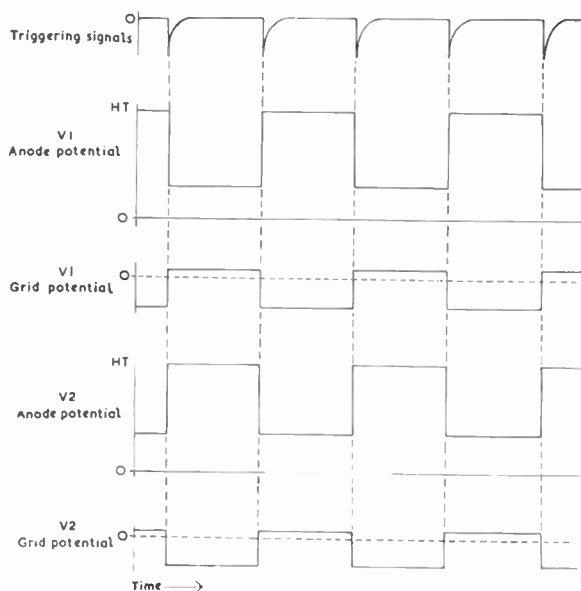

Fig. 42—Grid and anode waveforms in a triggered bi-stable multivibrator

lowest operating frequency. This automatic bias circuit has the effect of making the multivibrator performance less susceptible to changes in h.t. supply voltage than in the basic circuit of Fig. 41.

In some multivibrator circuits V1 and V2 are similar and the values of R_a , R_g , etc., are equal. Such a circuit is termed *symmetrical* and has the property that the mean current taken from the h.t. supply does not vary at a change of state. In such a circuit there is no need for C_k but the capacitor is usually included to minimise any interval cathode coupling which may occur if, for any reason, such as one valve ageing more rapidly than the other, the anode currents become unequal.

ANODE-COUPLED BI-STABLE MULTIVIBRATOR

9.6 EFFECT OF VALVE CAPACITANCES ON OUTPUT WAVEFORM

9.6.1 Output Capacitance

In Fig. 42 the grid and anode potentials are shown as changing instantaneously during multivibrator operation but in practice the grid and anode circuits contain shunt capacitance which must be

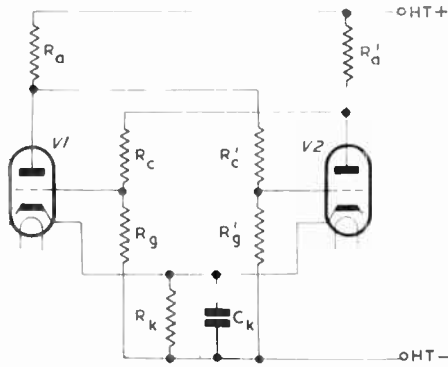

Fig. 43—Bi-stable multivibrator with bias obtained from a common cathode resistor

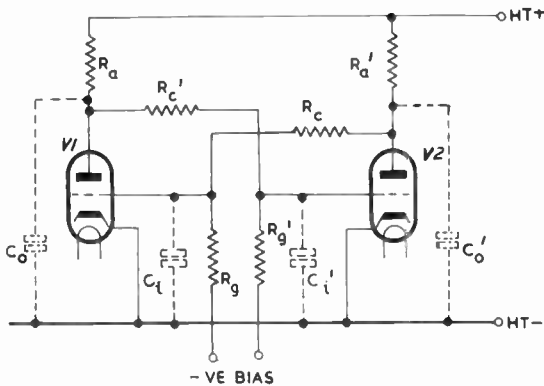

Fig. 44—Basic bi-stable multivibrator with valve input and output capacitances shown in dotted lines

charged or discharged whenever the potential alters. It takes time to alter the voltage across a capacitor and shunt capacitance degrades

the output waveform by lengthening rise and fall times. The effect of shunt capacitance is measured by the time constant it has with the associated resistance and, as shown in Volume 2, the rise (or fall) time is given approximately by $2.2 RC$ where C is the shunt capacitance and R the associated resistance.

Fig. 44 illustrates the chief sources of shunt capacitance in a bi-stable multivibrator, C_o and C_o' representing the valve output capacitances, and C_i and C_i' the valve input capacitances.

We will consider first the effect of the output capacitance C_o . When VI is conductive there is a steady voltage across C_o but if the anode current of VI is suddenly cut off by a negative potential applied to the grid, the voltage across C_o and the valve tends to rise. It cannot rise instantaneously, however, but does so exponentially as C_o charges through R_a . If we ignore any effect due to coupling components to the other valve, the rise time of the potential step at the valve anode is given approximately by

$$t = 2.2 R_a C_o \quad \dots \quad \dots \quad \dots \quad \dots \quad \dots \quad (17)$$

If $C_o = 10 \text{ pF}$ and $R_a = 10 \text{ k}\Omega$,

$$\begin{aligned} t &= 2.2 \times 10 \times 10^{-12} \times 10 \times 10^3 \text{ sec} \\ &= 2.2 \times 10^{-11} \times 10^4 \text{ sec} \\ &= 2.2 \times 10^{-7} \text{ sec} \\ &= 0.22 \text{ }\mu\text{sec} \end{aligned}$$

a value slightly greater than the maximum allowable value of rise time for line-sync pulses in any modern television system.

When the anode current is suddenly restored by a positive potential applied to the grid, the anode potential falls exponentially as C_o discharges. The circuit into which C_o effectively discharges consists of the anode-load resistor R_a and the anode d.c. resistance of the valve r_{dc} in parallel. If we ignore any effects due to the coupling components to the other valve, the fall time of the potential step at the valve anode is given approximately by

$$t = \frac{2.2 C_o R_a r_{dc}}{R_a + r_{dc}} \quad \dots \quad \dots \quad \dots \quad \dots \quad \dots \quad (18)$$

If $C_o = 10 \text{ pF}$, $R_a = 10 \text{ k}\Omega$ and $r_{dc} = 20 \text{ k}\Omega$

$$\begin{aligned} t &= \frac{2.2 \times 10^{-11} \times 10^4 \times 2 \times 10^4}{3 \times 10^4} \text{ sec} \\ &= 0.15 \text{ }\mu\text{sec approximately} \end{aligned}$$

9.6.2 Input Capacitance

The rise and fall times calculated above are those of the pulses which would be generated at the valve anode if its anode current were instantaneously cut off and restored. In practice, however, the grid potential of the valve cannot be changed rapidly because of the series resistance R_c and the shunt capacitance C_i associated with this electrode. The rapidity with which the grid potential can be changed is determined by the time constant formed by C_i with the resistance of R_c and R_g in parallel and is given by

$$t = \frac{2 \cdot 2 C_i R_c R_g}{R_c + R_g}$$

This can be many times greater than that due to C_o . As a practical example let $C_i = 20$ pF, $R_c = 47$ k Ω and $R_g = 27$ k Ω . The rise time is given by

$$\begin{aligned} t &= \frac{2 \cdot 2 \times 20 \times 10^{-12} \times 47 \times 10^3 \times 27 \times 10^3}{74 \times 10^3} \text{ sec} \\ &= 0 \cdot 76 \mu\text{sec} \end{aligned}$$

a value nearly four times the maximum permitted in the line-sync pulses in a modern television system. This is the value of rise time which applies when the grid of the following valve is driven negative; when it is driven positive the rise time due to C_i may be much lower. For if the valve is driven into grid current, R_g is effectively short-circuited by the low value of valve input resistance and the rise time is correspondingly shortened.

The foregoing calculations show that the output of a multivibrator with a circuit diagram such as that illustrated in Fig. 43 is likely to have markedly different rise and fall times and that in practice the greater of the two may be of the order of 1 microsecond.

9.7 SPEED-UP CAPACITORS

Steep waveforms (i.e. waves with short rise times) are required for test pulses which must necessarily have rise times which are small compared with those of the circuits they are used to test. For generating such pulses in bi-stable multivibrators some method is required of reducing the effects of shunt capacitances. As illustrated in the calculations performed above, the degradation of performance is due primarily to the valve input capacitance (C_i) which shunts the lower arm (R_g) of the potential divider $R_c R_g$. The combination of R_c and C_i gives a falling high-frequency response which is responsible for the rise time. This effect of C_i can be eliminated by connecting

a capacitor (C_s) across the upper arm (R_c) of the potential divider as shown in Fig. 45. Provided the correct capacitance is used, this eliminates the high-frequency loss, making the voltage transfer from

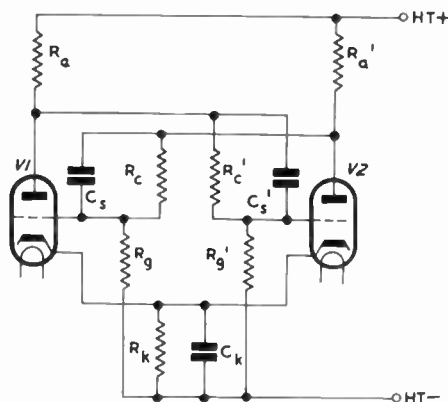

Fig. 45—Bi-stable multivibrator with speed-up capacitors, C_s and C_s'

one anode to the other grid independent of frequency. The circuit connecting anode to grid is, in fact, made aperiodic by the correct value of C_s and the condition to be satisfied by the speed-up capacitor is that

$$R_c C_s = R_g C_i$$

This condition can be derived by considering the expression for the voltage transfer of the coupling circuit comprising $R_c C_s R_g$ and C_i . The lower arm of the potential divider is composed of R_g in parallel with C_i and has an impedance given by $R_g / (1 + j\omega C_i R_g)$. The upper arm of the potentiometer is composed of C_s in parallel with R_c and has an impedance $R_c / (1 + j\omega C_s R_c)$. Thus the voltage transfer is given by

$$\frac{R_g / (1 + j\omega C_i R_g)}{R_g / (1 + j\omega C_i R_g) + R_c / (1 + j\omega C_s R_c)} \quad \dots \quad (19)$$

This becomes independent of frequency and equal to $R_g / (R_g + R_c)$ if $C_i R_g = C_s R_c$.

ANODE-COUPLED BI-STABLE MULTIVIBRATOR

This gives a simple expression for determining the value of C_s , namely

$$C_s = \frac{R_g C_i}{R_c} \quad \dots \quad \dots \quad \dots \quad (20)$$

As a numerical example, if $C_i = 20$ pF, $R_g = 47$ k Ω and $R_c = 27$ k Ω , the value of C_s is given by

$$\frac{47 \times 10^3}{27 \times 10^3} \times 20 = 35 \text{ pF}$$

In practice somewhat larger values than this are often employed and expression (20) may be taken as giving a minimum value for the speed-up capacitor. The use of speed-up capacitors eliminates the grid-circuit time constant (the effects of which are calculated immediately above) but increases the anode-circuit time constant because the capacitance of C_s and C_i in series is now added in parallel with C_o . The effect of this on the rise and fall times of the output pulses can be assessed quite simply as follows. If $C_i = 20$ pF, $C_o = 10$ pF and $C_s = 35$ pF, the effective capacitance in parallel with R_a is given by

$$10 + \frac{20 \times 35}{20 + 35} = 23 \text{ pF approximately}$$

As pointed out in the earlier calculations the resistance of the anode circuit is simply R_a (say 10 k Ω) when the valve is cut off but is equal to R_a in parallel with r_{dc} which amounts to 6.7 k Ω if $r_{dc} = 20$ k Ω when the valve is turned on. Thus the rise time of the output pulses is given by

$$\begin{aligned} 2.2 RC &= 2.2 \times 10 \times 10^3 \times 23 \times 10^{-12} \text{ sec} \\ &= 0.51 \mu\text{sec} \end{aligned}$$

and the fall time by

$$\begin{aligned} 2.2 RC &= 2.2 \times 6.7 \times 10^3 \times 23 \times 10^{-12} \text{ sec} \\ &= 0.34 \mu\text{sec} \end{aligned}$$

These values represent an improvement over the performance of the multivibrator without speed-up capacitors for which the rise and fall times were of the order of 1 microsecond.

9.8 PRODUCTION OF OVERSHOOT BY SPEED-UP CAPACITORS

The use of speed-up capacitors improves the performance of a multivibrator by reducing rise and fall times of the output pulses but

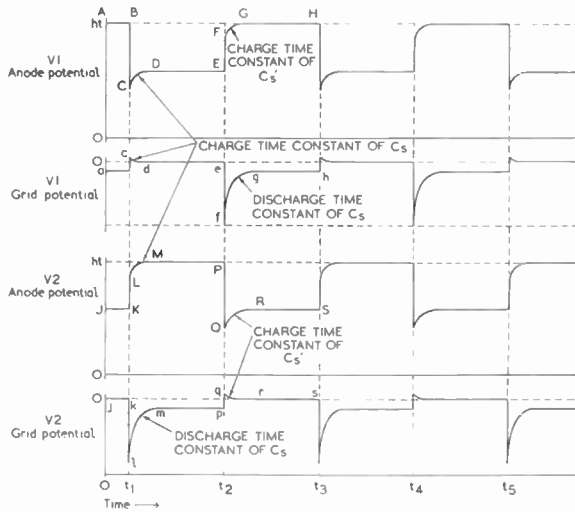

Fig. 46—Waveforms for bi-stable multivibrator with speed-up capacitors

it introduces a number of overshoots as shown in the waveforms of Fig. 46. These are caused by charging and discharging of the speed-up capacitors as explained below.

9.8.1 *During Charging*

Consider the conditions in the circuit immediately before the instant $t = t_1$. V2 is conducting and its anode potential is low (point K in Fig. 46); V1 is cut off, the grid potential being beyond cut-off (b). When a triggering pulse is applied to the grid of V2, the anode potential of V2 rises rapidly to the value (L). This potential step is transferred by C_s to the grid of V1 and the immediate tendency is for the grid of V1 to make an equal positive rise in potential. But as soon as the grid potential of V1 reaches its cathode potential, V1 starts to take grid current, the effect of which is to place a low-value resistance r_g in parallel with R_g . This low resistance tends to

ANODE-COUPLED BI-STABLE MULTIVIBRATOR

stabilise the grid potential of V1 near earth potential and the positive pulse at V1 grid (bc) is of smaller amplitude than the pulse (KM) at V2 anode. When V2 anode potential begins its excursion, C_s charges and the charging current instantly assumes its maximum value, subsequently decaying exponentially. This current, in flowing through r_g , produces a corresponding voltage waveform at V1 grid, the chief characteristic of this waveform being the sharp initial blip (bcd). This causes a similarly-shaped blip (BCD) in the anode-potential waveform for V1.

The onset of grid current in V1 affects the waveform at V2 anode; when V2 is cut off by the triggering signal its anode current abruptly ceases. Current from the h.t. source continues to flow through R_a' but goes wholly into C_s which at the moment of cut-off is not fully charged. Thus the positive pulse at V2 anode has an appreciable rise time and the exponential curve (KLM) corresponds to the same time constant as curves (bcd) and (BCD).

9.8.2 *During Discharging*

Before the instant $t = t_1$ the anode potential of V1 is equal to the h.t. supply voltage (B) and the grid of V2 is at earth potential (k); the voltage across C_s' is therefore equal to the h.t. supply voltage. At $t = t_1$ the anode potential of V1 falls very rapidly to a low value (C). Immediately C_s' begins to discharge through R_c' and R_g' ; the discharge current rises instantaneously to a maximum value, which in flowing through R_g' produces a correspondingly large negative potential (kl) on V2 grid equal to the fall in anode potential (BC). As the discharge current decays exponentially, V2 grid potential rises to the value (m). The extent of the immediate grid potential fall (kl) is approximately equal to that of V1 anode potential fall (BC); as shown on page 67 the ultimate extent of the fall (the vertical distance between k and m) depends on the extent of the anode potential fall (BC), the step-down ratio $R_g'/(R_g' + R_c')$ of the potential divider forming the inter-valve circuit, and the value of bias to which R_g' is returned.

CHAPTER 10

CATHODE-COUPLED BI-STABLE MULTIVIBRATOR

10.1 INTRODUCTION

In the basic bi-stable multivibrator circuit of Fig. 41 each anode is d.c. coupled to the grid of the other valve. Coupling of this type ensures that an increase (or decrease) of current in one valve brings about a decrease (or increase) of current in the other, this reversal of phase being necessary to obtain regeneration during changes of state.

It is possible to replace one of the anode-to-grid couplings by a cathode-to-cathode connection. This does not fundamentally alter the mode of operation of the circuit because it is still true that an increase in current in one of the valves raises its own cathode potential and hence the cathode potential of the other, this in turn reducing the current in the other valve. It is thus possible to have a multivibrator circuit in which one inter-valve coupling consists of an anode-to-grid connection and the other a cathode-to-cathode connection; such a circuit is known as a cathode-coupled multivibrator.

One of the advantages of the cathode-coupled multivibrator is that the anode circuit of one valve is free, i.e. does not require a resistor in order to make the circuit operate. This anode can be used to provide an output and the load resistor used here has virtually no effect on multivibrator performance. Thus to obtain *fast* waveforms, i.e. waveforms with small rise and fall times, the anode-load resistor can be given a low value, of the order of hundreds of ohms, which has a small time constant with the shunt capacitance at the anode.

10.2 FUNDAMENTAL FEATURES OF THE CIRCUIT

The basic circuit of a cathode-coupled bi-stable multivibrator is given in Fig. 47. The coupling from V1 to V2 is by a resistive potential divider $R_c'R_g'$ as in the anode-coupled circuit, the speed-up capacitor C_s' being added in parallel with R_c' to improve the output waveform. The cathode-to-cathode coupling is achieved very simply by bonding the two cathodes and connecting them to h.t. negative via a common resistor R_k . To provide a reasonable degree of coupling R_k must have a value somewhat higher than that

CATHODE-COUPLED BI-STABLE MULTIVIBRATOR

of an automatic bias component and to enable V1 to take a normal value of anode current with a high value of cathode resistor, the

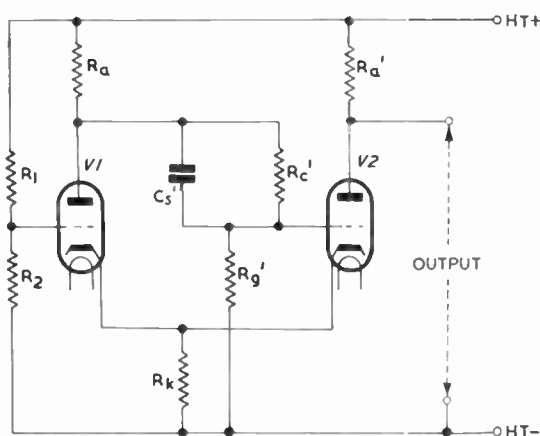

Fig. 47—Cathode-coupled bi-stable multivibrator

grid is returned to the junction of a fixed potential divider R_1R_2 across the h.t. supply.

10.3 STATIC CONDITIONS

The two stable states of the multivibrator are as follows:

- (a) V1 is conductive, its anode potential being low. The step-down ratio of the potential divider $R_c'R_g'$ is such that the potential applied to V2 grid is sufficiently negative with respect to the common cathode potential to keep V2 non-conductive.
- (b) V2 is conductive and its anode current, in flowing through R_k , sets up a voltage which makes the cathode of V1 sufficiently positive with respect to V1 grid potential to keep V1 cut off. V1 anode potential is thus at h.t. potential and that fraction of it which is applied to the grid of V2 through the coupling network keeps V2 conductive.

For this circuit to operate correctly, the anode current of V2 (when conductive) must exceed that of V1 (when conductive). This can be shown in the following way. When V1 is conductive the common cathode potential is approximately equal to the voltage across R_2 ; in this state the cathode potential is given by I_aR_k where I_a is the anode current of V1. When V2 is conductive the common cathode

potential must be greater than the voltage across R_2 by an extent which exceeds the grid base of V1 to keep V1 non-conductive; in this state the cathode potential is given by $I_a' R_k$ where I_a' is the anode current of V2. Thus when a common cathode resistor is used, as in Fig. 47, the anode current of V2 must exceed that of V1 for the circuit to work.

This point is illustrated in the following numerical example. Let V1 and V2 be similar valves taking 10 mA maximum current and cutting off at a grid-cathode potential of -5 volts. The h.t. supply will be assumed to be 240 volts and R_c' is taken to equal R_g' . When V1 is non-conductive, its anode-earth potential is $+240$ volts and the grid-earth potential of V2 is $240/2 = +120$ volts. V2 behaves as a cathode follower and its cathode potential will also be approximately $+120$ volts. If V2 anode current is 10 mA and the cathode potential is $+120$ volts, R_k must be $12 \text{ k}\Omega$. The cathode potential of V1 will also be $+120$ volts, and, to keep V1 non-conductive, the grid potential must not exceed $+120$ volts and, to give a margin, will be taken as $+100$ volts. This is determined by the ratio of R_1 and R_2 , the individual values of these resistors being of incidental importance.

When V1 is conductive the grid-cathode potential will be zero and the cathode-earth potential will also be $+100$ volts. The current in the valve is thus $100/(12 \times 10^3) = 0.0083 \text{ A} = 8.3 \text{ mA}$. The cathode-earth potential of V2 is also $+100$ volts and, to keep V2 cut off, its grid-earth potential should not exceed 95 volts and should preferably be less. If we assume the value 80 volts, the anode-earth potential of V1 is $+160$ volts and the voltage across the anode load is 80 volts. At an anode current in V1 of 8.3 mA, this requires an anode-load resistance of approximately $10 \text{ k}\Omega$.

10.4 OPERATION OF THE CIRCUIT

The regenerative changes of state occur in the following manner. Suppose V2 is conductive, V1 non-conductive and a momentary negative sync pulse is applied to the grid of V2. The subsequent changes which occur in the circuit can be tabulated in the following manner though they are, in fact, simultaneous:

- (a) V2 anode current falls.
- (b) The common cathode potential falls.
- (c) V1 anode current rises.
- (d) V1 anode potential falls.
- (e) V2 grid potential falls, and, because of the amplification of V1, this effect more than offsets the fall in common cathode

CATHODE-COUPLED BI-STABLE MULTIVIBRATOR

potential with the result that V2 anode current falls still farther.

Thus a state of regeneration exists and it results in V2 being switched quickly to non-conduction and V1 to conduction.

Suppose now a negative pulse is applied to the grid of V1. The subsequent events are as follows:

- (a) V1 anode current falls.
- (b) V1 anode potential rises.
- (c) V2 grid potential rises.
- (d) The common cathode potential rises.
- (e) V1 anode current falls.

Again a state of regeneration exists and it results in V1 being switched quickly to non-conduction and V2 to conduction.

CHAPTER 11

ANODE-COUPLED MONOSTABLE MULTIVIBRATOR

11.1 INTRODUCTION

IN bi-stable multivibrators the inter-valve couplings, no matter whether anode-to-grid or cathode-to-cathode, are capable of transferring steady potentials from one valve to the other. The valves are, in fact, d.c.-coupled and, in the absence of triggering signals, the positive bias on one valve grid and the negative bias on the grid of the other valve persist indefinitely, the valves remaining permanently in their established states of conduction or non-conduction.

If one of the inter-valve coupling circuits is made to respond to alternating signals only, for example by connecting the anode of one valve to the grid of the other by means of a capacitor (as in conventional RC coupling), the multivibrator circuit so obtained behaves in a different manner in that it now has only one stable state. Due to the presence of the coupling capacitor, the grid potential of the capacitance-coupled valve will, in time, always revert to the potential of the point to which its grid resistor is connected, there being no means whereby the grid potential can be maintained permanently at a different value. In this, the stable state, the grid potential of the capacitance-coupled valve is equal to that of the bias source and the valve can be conductive or non-conductive depending on the value of the bias. If the grid resistor is returned directly to the cathode, grid bias is zero and the stable state is that in which the capacitance-coupled valve is conductive (the other valve being necessarily non-conductive). Alternatively if the grid resistor is returned to a point considerably negative relative to cathode potential, the stable state is that in which the capacitance-coupled valve is non-conductive and the other valve conductive.

These states of conduction and non-conduction can temporarily be reversed by applying an appropriate triggering signal to the circuit. The resulting state is unstable for the reasons given above and the circuit returns automatically to the stable state; this behaviour is characteristic of monostable circuits.

The time taken for the circuit to revert to the stable state after receipt of a triggering signal, i.e. the duration of the unstable state, is governed by the time constant of the coupling capacitor-grid

ANODE-COUPLED MONOSTABLE MULTIVIBRATOR

resistor combination and this is therefore an important parameter of a monostable multivibrator.

11.2 FUNDAMENTAL FEATURES OF THE CIRCUIT

Fig. 48 gives the basic circuit of one form of anode-coupled monostable multivibrator. The capacitance coupling is from V1 anode to V2 grid via the components C_g' and R_g' ; the coupling from

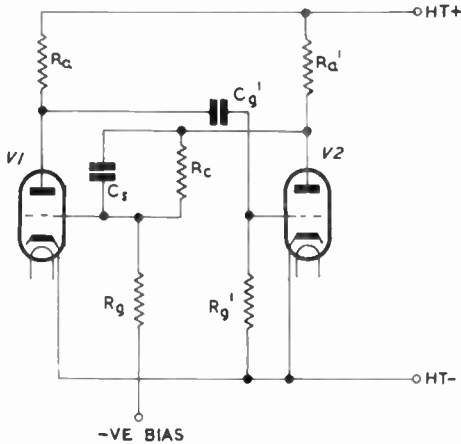

Fig. 48 —Basic circuit of one form of monostable multivibrator

V2 anode to V1 grid is of d.c. type consisting of a resistive potential divider $R_r R_g$ of which the upper arm is shunted by a speed-up capacitor C_s .

The grid resistor R_g' is connected directly between grid and cathode of V2; thus the stable state of this circuit is with V2 conductive and the design is such that the effective grid potential of V1 produced by the step-down ratio of the divider $R_r R_g$, the negative bias supply and the low anode potential of V2, keeps V1 non-conductive. Thus in the stable state, V1 is non-conductive and V2 conductive; in the unstable state V1 is conductive and V2 non-conductive.

11.3 OPERATION OF THE CIRCUIT

Fig. 49 represents a practical circuit of a monostable multivibrator. The negative bias for V1 is obtained by use of a common

exponentially. This current in flowing through r_g' produces a corresponding waveform at V2 grid the chief characteristic of which is the sharp initial blip (qrs). This causes a similarly-shaped blip (QRS) in the anode-voltage waveform of V2.

The onset of grid current in V2 affects the waveform at V1 anode. The anode potential does not instantaneously rise to h.t. value when the valve is cut off because it can only rise by charging C_g' and thus the anode waveform shows an exponential rise (EFG) towards h.t. and the time constant has the same value as for (qrs) and (QRS).

The blips (pqr) and (PQR) are produced by an action similar to that by which the overshoots (pqr and PQS in Fig. 46) are generated by speed-up capacitors (see page 76); these features are characteristic of multivibrator waveforms and will appear in subsequent diagrams but the process by which they are produced will not be described again.

The effective resistance of the circuit from which C_g' charges is equal to R_a in series with the parallel connection of R_g' and r_g' (the internal resistance of V2 grid circuit). Thus

$$\text{charge time constant for } C_g' = C_g' \left(R_a + \frac{R_g' r_g'}{R_g' + r_g'} \right) \quad \dots \quad (21)$$

When grid current flows r_g' is small compared with R_g' and the parallel resistance of r_g' and R_g' is approximately equal to r_g' . Thus the following approximate expression can be used to calculate the charge time constant without introducing appreciable error:

$$\text{charge constant for } C_g' = C_g' (R_a + r_g') \quad \dots \quad (22)$$

Moreover, r_g' is often small compared with R_a and expression (22) can be further simplified to

$$\text{charge time constant for } C_g' = R_a C_g' \quad \dots \quad (23)$$

11.4 DURATION OF UNSTABLE STATE

The duration of the unstable period depends on the discharge time constant of C_g' , which may be evaluated as follows. If we ignore R_k , which is usually small compared with the other resistances, the circuit into which C_g' discharges consists of the grid resistor R_g' in series with the parallel connection of the anode load R_a and the anode d.c. resistance r_{dc} of V1 (which is conductive in this period). The discharge time constant of C_g' is thus given by

$$\text{discharge time constant of } C_g' = C_g' \left(R_g' + \frac{R_a r_{dc}}{R_a + r_{dc}} \right) \quad \dots \quad (24)$$

ANODE-COUPLED MONOSTABLE MULTIVIBRATOR

In many circuits the parallel resistance of R_a and r_{dc} is small compared with R_g' and the discharge time constant can be taken as $C_g'R_g'$ with very little error. Thus

$$\text{discharge time constant of } C_g' = R_g'C_g' \quad \dots \quad (25)$$

The duration of the unstable period is thus determined by the product $R_g'C_g'$; for this reason R_g' and C_g' are often referred to as *timing components*.

The duration of the unstable period is equal to the time taken for the voltage across C_g' to fall from one value to a lower. These values can be determined by considering the discharging process in detail. In the stable state V1 is non-conductive and V2 conductive. V1 anode is thus at h.t. potential and V2 grid at approximately h.t. negative potential. The voltage across C_g' is substantially equal to the h.t. supply voltage V_b , say 250 volts. When the circuit enters the unstable state the anode potential of V1 drops abruptly by, say, 100 volts, but the voltage across C_g' persists and the grid of V2 is driven to -100 volts (V_m'). At this instant the potential on the left-hand plate of C_g' is $+150$ volts and on the right-hand plate -100 volts. V2 grid is connected to its cathode by the resistor R_g' and there is thus instantaneously a voltage of 100 volts across R_g' at the commencement of the discharge current of C_g' through R_g' . This current decays exponentially and as it does so V2 grid potential rises towards zero volts; but at a particular value V_c' , say -5 volts, V2 has sufficient anode current to give a loop gain greater than unity and the circuit reverts to its stable state. The voltage driving discharge current through the circuit immediately before this change is 5 volts. The voltage across R_g' is 100 volts at the beginning of the unstable state and 5 volts at the end of it; the duration of the state is thus the time of an exponential decay from 100 volts (V_m') to 5 volts (V_c'), the time constant being $R_g'C_g'$. This is independent of the h.t. supply voltage V_b (250 volts in this example). The duration of an exponential discharge is deduced in Appendix B. In general it is given by

$$T = RC \log_e V_o/V_t$$

in which V_o is the initial voltage and V_t the final voltage. Substituting V_m' for V_o and V_c' for V_t we have the duration of the unstable state of the monostable multivibrator given by

$$T = R_g'C_g' \log_e V_m'/V_c' \quad \dots \quad (26)$$

It is significant that the capacitor C_g' almost completes its discharge before the change of state occurs. Thus the rate of change of V2 grid potential is relatively small when the critical value of V2

anode current is reached and the duration of the unstable state is not as constant as could be wished. Moreover, if the I_a-V_g characteristic of V2 varies for any reason (due, for example, to a change in h.t. voltage or an ageing valve) or if V2 is exchanged for another valve with slightly different characteristics, there will also be changes in the duration of the unstable state.

As a numerical example, suppose 10- μ sec positive-going pulses are required from the anode of V2; this implies that the unstable state is required to last 10 μ sec. We will assume that $V_m' = -100$ volts and $V_c' = -5$ volts, typical practical values. Re-arranging (26) we have

$$\begin{aligned} R_g' C_g' &= \frac{T}{\log_e V_m' / V_c'} \\ &= \frac{10}{\log_e 20} \mu\text{sec} \\ &= 3.33 \mu\text{sec} \end{aligned}$$

There is, of course, an unlimited number of possible combinations of resistance and capacitance with this value of time constant but R_g' should preferably be large compared with R_a , and one suitable combination is 33 pF and 100 k Ω .

A number of assumptions were made in deducing these component values which should be regarded as approximate indications of the values to use. Some of the possible sources of inaccuracy inherent in the calculations are as follows:

- Neglect of $R_a r_{ac} / (R_a + r_{ac})$ in comparison with R_g' in deducing expression (26).
- Assumption that V_m' is -100 volts. It is difficult to design a circuit to have a particular value of V_m' .
- Assumption that V_c' is -5 volts. The unstable period does not end when the voltage across R_g' equals the cut-off potential for V2, but when V2 has sufficient anode current to give a loop gain of unity. It is difficult to assess this value of anode current and therefore the grid-cathode potential which gives it. A small error in this potential results in a comparatively large error in timing because when the voltage across R_g' is small, C_g' is almost completely discharged and the voltage across R_g' is changing very slowly.

11.5 USE OF POSITIVE BIAS TO CONTROL DURATION OF UNSTABLE STATE

The duration of the unstable state can be shortened by reducing C_g' or R_g' but a better method is to return R_g' to a source of positive

ANODE-COUPLED MONOSTABLE MULTIVIBRATOR

potential, as shown in Fig. 51, keeping the values of $R_{g'}$ and $C_{g'}$ unaltered. The use of positive bias also improves the output waveform because it brings about a more abrupt start to the conduction period of V2. This is illustrated in the following account of the modified discharging process of $C_{g'}$: the description should be

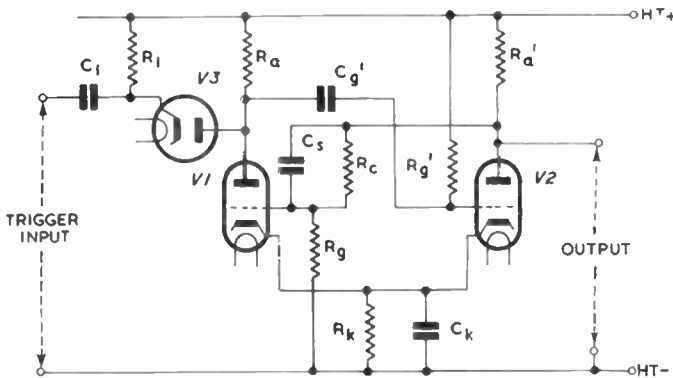

Fig. 51—Monostable multivibrator with positive bias

compared with that which applies when the grid resistor is returned to V2 cathode.

During the stable state, V2 takes grid current through $R_{g'}$ but if this is a high-value resistor the current is small and the V2 grid potential is only slightly above cathode potential. During this state, therefore, the potentials in this circuit are very similar to those in the circuit of Fig. 49, and the voltage across $C_{g'}$ is again 250 volts. During the change to the unstable state the anode potential of V1 falls by 100 volts and the grid potential of V2 becomes instantaneously -100 volts as before. The voltage across $R_{g'}$ is now 350 volts, made up of -100 volts at V2 grid and $+250$ volts at the h.t. line. The discharge current for $C_{g'}$ is thus $350/R_{g'}$, 3.5 times that when $R_{g'}$ is returned to V2 cathode. As $C_{g'}$ discharges, the grid potential of V2 rises exponentially from -100 volts towards $+250$ volts as shown in Fig. 52. Only the initial part of the discharge is realised, however, because V2 starts to take anode current at a grid potential of V_c' (negative with respect to zero volts) and the circuit then returns to its stable state. If $V_c' = -5$ volts, the voltage across $R_{g'}$ at the end of the unstable period is 255 volts made

up of + 250 volts from the h.t. supply and - 5 volts on V2 grid. The duration of the unstable period is equal to the time of an exponential fall from 350 to 255 volts, the time constant being

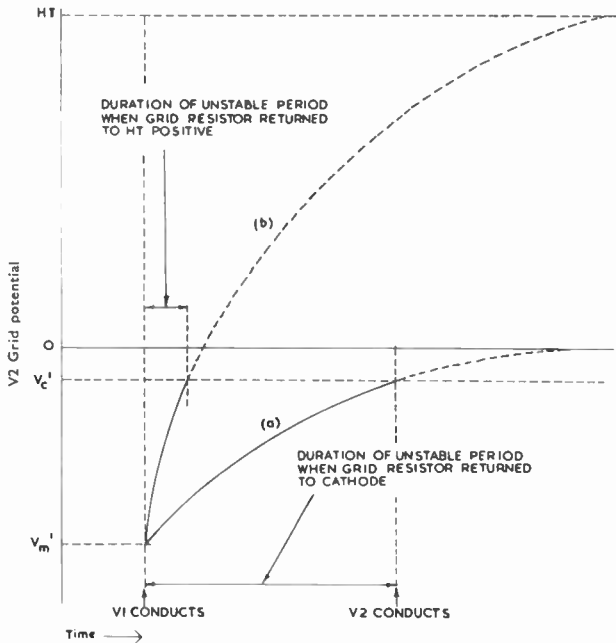

Fig. 52—Changes in V2 grid potential in a monostable multivibrator (a) without and (b) with positive bias

$R_g' C_g'$. In general terms the fall is from $(V_b - V_m')$ to $(V_b - V_c')$, in which V_m' and V_c' are negative, and the time is obtained by substituting $(V_b - V_m')$ for V_o and $(V_b - V_c')$ for V_t in the general expression deduced in Appendix B. We have

$$T = R_g' C_g' \log_e (V_b - V_m') / (V_b - V_c')$$

which gives the duration of the unstable period of a monostable multivibrator when the grid resistor is returned to h.t. positive.

In Fig. 52 curve (b) has a steeper slope than curve (a) at the points where the curves cut the horizontal through V_c' . This shows that a given change in the value of V_c' has a smaller effect on the duration of the unstable state when the grid resistor is returned to h.t. positive. Both curves in Fig. 50 apply to a circuit with the same time constant

but the duration of the unstable state with positive bias is less than with zero bias. If the grid resistor is returned to the slider of a potentiometer connected across the h.t. supply, the potentiometer can be used to control the duration of the unstable state over a wide range.

As a numerical example we will again calculate values of R_g' and C_g' suitable for generating positive-going pulses of 10 μ sec duration at V2 anode, but this time we will assume R_g' to be returned to h.t. positive. We will take the h.t. supply as 250 volts, V_m' as -100 volts and V_c' as -5 volts.

From the above expression we have

$$R_g' C_g' = \frac{T}{\log_e (V_b - V_m') / (V_b - V_c')}$$

Substituting for $T=10 \mu$ sec, $V_b=250$ volts, $V_m' = -100$ volts and $V_c' = -5$ volts.

$$\begin{aligned} R_g' C_g' &= \frac{10}{\log_e (250 + 100) / (250 + 5)} \mu\text{sec} \\ &= \frac{10}{\log_e (350/255)} \mu\text{sec} \\ &= \frac{10}{\log_e 1.373} \mu\text{sec} \\ &= \frac{10}{0.317} \mu\text{sec} \\ &= 31.55 \mu\text{sec} \end{aligned}$$

This is approximately 10 times the time constant required to give pulses of the same duration with zero bias on V2 grid. Suitable component values for this circuit are 30 pF and 1 M Ω but, of course, these values are approximate because of the assumptions implicit in the calculation as mentioned on page 88.

APPENDIX B

TIME OF EXPONENTIAL RISES AND FALLS

IN a number of circuits the action is controlled by a capacitor which charges from an h.t. supply via a resistor or discharges through a resistor. In some applications, particularly in multivibrator problems, it is useful to know how long a capacitor will take to charge or discharge from one voltage to another: in other applications, e.g. in sawtooth-generator problems, we may need to know by how much the capacitor voltage changes when it is allowed to charge or discharge for a particular period. In this appendix we deduce the relationship between the voltage change, the time, and the circuit constants.

In a circuit in which a capacitor is charging, let the voltage rise from V_1 to V_2 in a time t , the h.t. voltage being V_b . From Appendix B in Volume 2 we have

$$V_1 = V_b(1 - e^{-t_1/RC}) \quad \dots \quad \dots \quad \dots \quad (1)$$

and

$$V_2 = V_b(1 - e^{-t_2/RC}) \quad \dots \quad \dots \quad \dots \quad (2)$$

where t_1 is the time taken for the voltage to rise to V_1 and t_2 is the time taken for it to equal V_2 . The interval t is given by $(t_2 - t_1)$. Rewriting (1)

$$e^{-t_1/RC} = 1 - V_1/V_b = (V_b - V_1)/V_b$$

$$\therefore e^{t_1/RC} = V_b/(V_b - V_1)$$

Writing this in logarithmic form

$$\log_e V_b/(V_b - V_1) = t_1/RC$$

$$\therefore t_1 = RC \log_e V_b/(V_b - V_1)$$

Similarly from equation (2) we can show

$$t_2 = RC \log_e V_b/(V_b - V_2)$$

$$\text{Thus } t = t_2 - t_1 = RC \log_e V_b/(V_b - V_2) - \log_e V_b/(V_b - V_1)$$

$$= RC \log_e [(V_b - V_1)/(V_b - V_2)]$$

The duration of the states of a relaxation oscillator is equal to the time taken for the voltage across a capacitor to decay from one particular value to another lower value when discharging through a

APPENDIX B

resistor. The duration can be expressed in terms of the initial and final voltages and the time constant of the RC circuit as follows.

In general when a capacitor C has an initial voltage V_0 and discharges into a resistance R , the voltage V_t after a time t is given by

$$V_t = V_0 e^{-t/RC}$$

which is also derived in Appendix B of Volume 2. This may be written

$$e^{-t/RC} = V_t/V_0$$

or

$$e^{t/RC} = V_0/V_t$$

Thus

$$\log_e V_0/V_t = t/RC$$

from which

$$t = RC \log_e V_0/V_t$$

CHAPTER 12

CATHODE-COUPLED MONOSTABLE MULTIVIBRATORS

12.1 INTRODUCTION

By replacing one of the inter-valve coupling circuits of a cathode-coupled bi-stable multivibrator by a capacitance coupling, a cathode-coupled monostable multivibrator can be obtained. Such a circuit has an unstable state with a duration determined by the value of the capacitor and the associated resistor, these components constituting the so-called "timing circuit". Two basic forms of cathode-coupled monostable multivibrator exist, one in which the timing components form part of the anode-to-grid coupling and the other in which they are embodied in the cathode-to-cathode coupling. Both circuits have the property of the bi-stable prototype that the anode of one triode is free and may be loaded with a low-value resistor to give output pulses with short rise times.

12.2 MULTIVIBRATOR WITH TIMING COMPONENTS IN THE GRID CIRCUIT

12.2.1 *Introduction*

One circuit of a multivibrator of this type is given in Fig. 53; d.c. coupling between the cathodes is provided by the common resistor R_k and the a.c. coupling from V1 anode to V2 grid is via R_g' and C_g' . For R_g' and C_g' to operate as timing components V2 must have zero or a positive bias and R_g' is returned to cathode in Fig. 53.

12.2.2 *Operation of the Circuit*

Since V2 grid resistor is returned to V2 cathode the stable state is with V2 conducting and V1 non-conducting, the design being such that the anode current of V2, in flowing through R_k , produces a positive bias on the cathode of V1 which exceeds the positive bias on the grid of V1 derived from the potential divider R_1R_2 by a margin sufficient to maintain V1 in a non-conducting state.

Negative triggering signals are applied to the grid of V2 (often via a series diode connected to the anode of V1 as in Fig. 49) and initiate a change of state, hastened by the regeneration characteristic of multivibrators, V1 being switched to conduction. The negative

CATHODE-COUPLED MONOSTABLE MULTIVIBRATORS

potential step developed at V1 anode drives the grid of V2 beyond cut-off. There is now a period of relaxation whilst $C_{g'}$ discharges, an unstable state which is abruptly terminated when the potential at V2 grid (produced by the discharge current of $C_{g'}$) has risen to the point at which V2 takes anode current. This causes another regenerative change of state as described for the bi-stable circuit and the multivibrator reverts to its original stable condition. The waveforms for this multivibrator are given in Fig. 54.

12.2.3 Duration of Unstable State

The duration of the unstable state depends on the time constant $R_{g'}C_{g'}$ and also on the steady voltage across R_2 (V1 grid potential). When V1 is conductive, its cathode potential is approximately equal

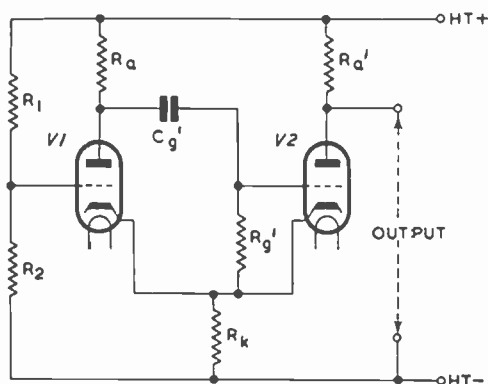

Fig. 53—Basic circuit of cathode-coupled monostable multivibrator with timing components in the grid circuit

to its grid potential and thus, for a given value of R_k , the anode current of V1 is almost linearly related to its grid potential, i.e. the voltage across R_2 . The amplitude of the negative potential step developed across R_a when V1 is switched to conduction is proportional to the anode current and hence to V1 grid potential. The time taken for the grid potential of V2 to rise to the cut-off voltage, after V1 has become conductive, depends on the amplitude of the potential step at V1 anode; thus, finally, the duration of the unstable state is approximately linearly related to the voltage across R_2 . If R_1 and R_2 are replaced by a potentiometer across the h.t. supply, this may be used to control the duration of the unstable state (i.e. the

duration of the positive rectangular pulses at V2 anode) within wide limits; this is a useful property of the circuit.

The dependence of the duration of the output pulses on V1 grid potential is illustrated in the waveforms of Fig. 54. The waveforms in (a) apply when V1 grid potential has the value OA and in (b) when

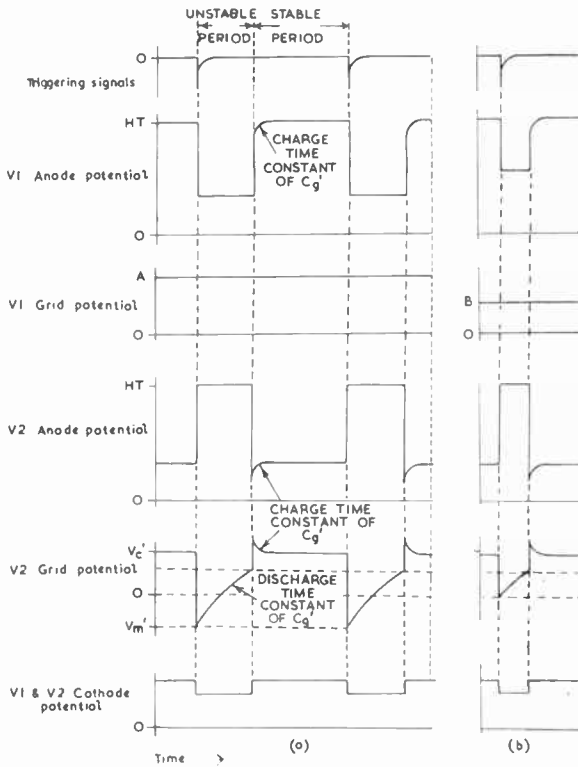

Fig. 54—Anode, grid and cathode waveforms for the monostable multivibrator of Fig. 53

V1 grid potential has approximately half this value (OB). As shown, the duration of the output pulses at V2 anode is approximately halved by this reduction in V1 grid potential.

A useful feature of this form of multivibrator is that the cathode circuit can be used as a source of negative-going output pulses (the

CATHODE-COUPLED MONOSTABLE MULTIVIBRATORS

pulses at V2 anode being, of course, positive-going). The output resistance of the cathode circuit is very low, being approximately $1/g_m$ during the unstable state and $1/g_m'$ during the stable state, g_m and g_m' being the working mutual conductances of V1 and V2 respectively. In practice the output impedance may be as low as 200 Ω , implying that a relatively large capacitive load can be connected across the output terminals without seriously impairing the shape of the output pulses.

12.3 MULTIVIBRATOR WITH TIMING COMPONENTS IN THE CATHODE CIRCUIT

12.3.1 Introduction

One circuit for a multivibrator of this type is given in Fig. 55. The capacitor responsible for timing the duration of the unstable

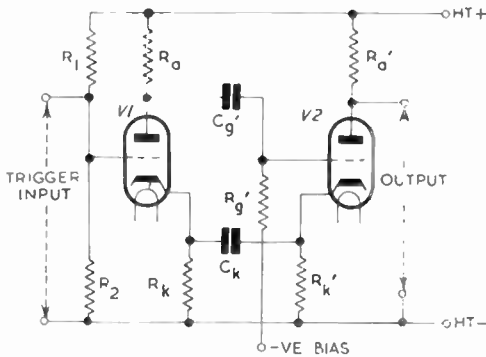

Fig. 55—Basic circuit of cathode-coupled monostable multivibrator with timing components in the cathode circuit

state is C_k connected between the two cathodes, and this capacitor can act as a timing component only if V2 is non-conductive in the stable state (cf. the multivibrator of Fig. 53): thus V2 grid resistor is returned to a source of negative bias as illustrated. The coupling from V1 anode to V2 grid could be a d.c. type (as in Fig. 47) but the capacitance coupling via $R_{g'}$ and $C_{g'}$ illustrated is also satisfactory. $R_{g'}$ and $C_{g'}$ do not perform as timing components in this circuit because the bias value for V2 is unsuitable. When, as in the circuit of Fig. 53, $R_{g'}$ and $C_{g'}$ are required to time the duration of an unstable state, $R_{g'}$ must be returned to a source of zero or positive bias. A negative-going voltage applied to $C_{g'}$ will then cut V2 off

and it will remain cut off whilst C_g' discharges through R_g' , becoming conductive again when the grid potential has risen sufficiently. This mode of operation cannot occur if R_g' is returned to a source of bias which keeps V2 cut off in the stable state.

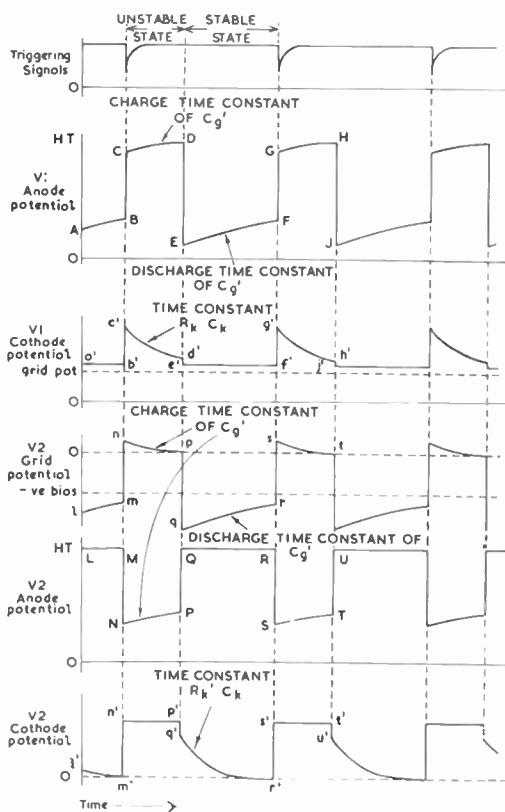

Fig. 56—Anode, grid and cathode waveforms for the monostable cathode-coupled multivibrator of Fig. 55

Negative-going triggering signals are applied to V1 grid, this valve being conductive in the stable state.

12.3.2 Operation of the Circuit

The operation of this circuit is more complex than that of the multivibrators previously described because the anode current of

CATHODE-COUPLED MONOSTABLE MULTIVIBRATORS

each valve is determined by the potentials on its anode, its control grid and its cathode, all of which potentials vary simultaneously.

The stable state is with V2 non-conductive and V1 conductive; thus the cathode potential of V1 is high (point a' in Fig. 56), and that of V2 is low (l'). C_k is charged to the cathode-earth potential of V1, the left-hand plate being positive with respect to the right-hand one.

When a negative triggering pulse is applied to V1 grid there is a change of state, accelerated by regeneration, resulting in V1 being switched to non-conduction and V2 to conduction. This action occurs in a manner similar to that described earlier for the bi-stable cathode-coupled multivibrator and can be summarised thus:

- (a) V1 anode current falls.
- (b) V1 anode potential rises.
- (c) V2 grid potential rises.
- (d) V2 cathode potential rises.
- (e) V1 cathode potential rises, causing a further reduction in V1 anode current.

The rapid start of V2 anode current due to this change of state causes a positive potential step (m'n') in V2 cathode potential. This is transferred by C_k to V1 causing an equal step (b'c') in V1 cathode potential. This rise in cathode potential cuts V1 off by rising above its grid potential. At the same time, V2 takes a burst of grid current as a result of the positive potential step (BC) at V1 anode and, as described for some of the preceding multivibrators, the decay of this current (which is governed by the charge time constant of C_g') causes the exponential form of the curves (np), (n'p') and (NP).

There is now a period of relaxation during which C_k discharges through the series circuit comprising R_k and R_k' . R_k' is, however, shunted by the internal cathode resistance ($1/g_m'$) of V2 (now conducting) which is normally small compared with R_k' and thus the discharge time constant is approximately $R_k C_k$. The cathode potential of V1 falls exponentially (c'd') until the cut-off bias of V1 is reached. This initiates another regenerative change of state and the circuit reverts to its original condition; the action occurs in a manner similar to that described for the bi-stable cathode-coupled circuit and may be summarised thus:

- (a) V1 takes anode current.
- (b) V1 anode potential falls.
- (c) V2 grid potential falls.
- (d) V2 cathode potential falls.
- (e) V1 cathode potential falls, accelerating the growth of V1 anode current.

The negative step (DE) in V1 anode potential is transferred by C_g' to V2 grid (pq) and cuts the valve off, the grid potential afterwards rising exponentially (qr) towards the negative bias value, the curve being governed by the discharge time constant of C_g' . The discharge current flows in the anode-load circuit of V1, causing the exponential curvature (EF). When V2 is cut off, the anode current ceases abruptly but the cathode potential remains momentarily (q) at its previous positive value, being maintained by the charge on C_k which takes time to leak away.

There is now another period of relaxation as C_k discharges (the current being now in the opposite direction to that which flowed from C_k during the previous period of relaxation) through the series circuit comprising R_k and R_k' . R_k is shunted by the internal cathode resistance ($1/g_m$) of V1 (now conductive) which is normally small compared with R_k and thus the discharge time constant is approximately $R_k' C_k$. In the absence of further triggering pulses the cathode potential of V2 falls to zero (q'r') and the grid potential of V2 rises to the negative bias value (qr), the circuit remaining in this, the stable state, indefinitely.

Multivibrators of this type are suitable for generating short-duration pulses with rapid rise times because the timing resistors R_k and R_k' , being in the cathode circuit, can have relatively low values, such as 1 k Ω (compared with values of the order of 100 k Ω or more when the timing resistor is in the grid circuit).

CHAPTER 13

ANODE-COUPLED ASTABLE MULTIVIBRATOR

13.1 INTRODUCTION

IF both valves in a bi-stable multivibrator are given capacitance couplings and zero or positive grid bias, the resulting circuit has two unstable states, that is to say it is astable. It cannot remain indefinitely in either state but oscillates automatically and continuously between the two without need for triggering signals from an external source. Such multivibrators can, however, readily be synchronised at the frequency of any external signals applied to the circuit. Astable multivibrators have, in general, two sets of timing

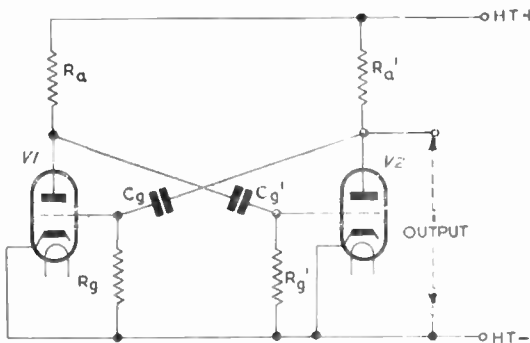

Fig. 57—Basic circuit of astable multivibrator with timing components in the grid circuits

components and these may be included in the grid circuits, in the cathode circuits, or in both, making possible a number of different designs.

One basic circuit of a multivibrator with timing components in the grid circuits is given in Fig. 57; it comprises two triodes with resistive anode loads, each anode being capacitance coupled to the other grid. Fig. 57 shows the grid resistors returned to h.t. negative

(equivalent to zero grid bias) but they could alternatively be returned to h.t. positive.

13.2 OPERATION OF THE CIRCUIT

When the circuit is first switched on there is a short period during which both valves conduct but after this the multivibrator settles down to its normal mode of operation, developing rectangular

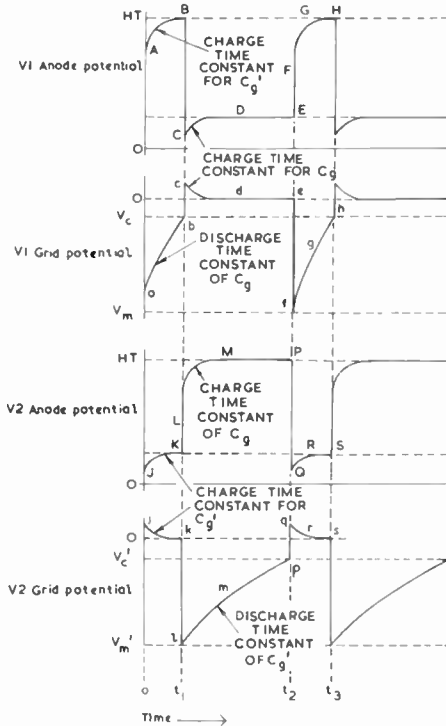

Fig. 58—Anode and grid waveforms for the astable multivibrator of Fig. 57

current waveforms at a frequency determined by the component values. The signals generated at the grids and anodes have the waveforms shown in Fig. 58.

Let us suppose that at a particular instant V1 is non-conducting (point A) and V2 conducting (J). The grid of V1 is negative (a) and

ANODE-COUPLED ASTABLE MULTIVIBRATOR

beyond cut-off, but the potential is rising towards zero. As soon as V1 grid potential reaches the value V_c there is a change of state speeded by regeneration, V1 being switched to conduction and V2 to non-conduction. The negative step developed at V1 anode biases V2 beyond cut-off and there follows a period of relaxation whilst C_g' discharges (Imp). This period ends when V2 grid potential reaches the value V_c' (p). There is now another regenerative change of state, ending with V1 being switched to non-conduction and V2 to conduction. The negative potential step at V2 anode biases V1 beyond cut-off and there follows another period of relaxation whilst C_g discharges (fgh). This period ends when the grid potential of V1 reaches V_c again, initiating a further change of state. So the process continues as long as the circuit is switched on.

13.3 DURATION OF STATES OF ASTABLE MULTIVIBRATOR

The duration of the positive-going pulse at V1 anode is determined by the discharge time constant of C_g given approximately by

$$\text{discharge time constant of } C_g = R_g C_g \dots \dots \dots (27)$$

which can be deduced by analogy from equation (25). If the minimum potential of V1 grid (V_m) and the cut-off bias (V_c) are known, the duration of the pulse can be calculated from expression (26), i.e.,

$$\text{duration of positive pulse at V1 anode} = R_g C_g \log_e V_m / V_c \quad (28)$$

which applies when R_g is returned to V1 cathode. If, however, R_g is returned to h.t. positive, the duration is given by

$$\text{duration of positive pulse at V1 anode} = R_g C_g \log_e (V_b - V_m) / (V_b - V_c)$$

Similarly, the duration of the positive-going pulse at V2 anode is determined by the discharge time constant of C_g' given approximately by expression (25)

$$\text{discharge time constant for } C_g' = R_g' C_g'$$

From this we have

$$\text{duration of positive pulse at V2 anode} = R_g' C_g' \log_e V_m' / V_c' \dots (29)$$

By adding (28) and (29) we can obtain an approximate expression for the period of the free-running astable multivibrator thus

$$\text{period of oscillation} = R_g C_g \log_e V_m / V_c + R_g' C_g' \log_e V_m' / V_c' \dots (30)$$

If $V_m = V_m'$ and $V_c = V_c'$, this simplifies to

$$\text{period of oscillation} = (R_g C_g + R_g' C_g') \log_e V_m / V_c \dots \dots (31)$$

and if the multivibrator is symmetrical, having $R_g = R_g'$ and

$C_g = C_g'$, the output is of square waveform with a period of oscillation given by

$$\text{period of oscillation} = 2R_g C_g \log_e V_m/V_c \dots \dots \dots (32)$$

The oscillation frequency is, of course, given by the reciprocals of expressions (30) to (32).

The ratio of (28) to (29) gives the mark-space ratio of the output pulses.

$$\text{Mark-space ratio} = \frac{R_g C_g \log_e V_m/V_c}{R_g' C_g' \log_e V_m'/V_c'} \dots \dots (33)$$

If $V_m = V_m'$ and $V_c = V_c'$

$$\text{mark-space ratio} = \frac{R_g C_g}{R_g' C_g'} \dots \dots (34)$$

13.4 EFFECT OF CHARGE TIME CONSTANT ON OUTPUT WAVEFORM

The rate at which V1 anode potential rises when the grid circuit is cut off (EFG in Fig. 58) depends primarily on the time taken for the capacitor C_g' to charge by grid current flow in V2. It thus depends on C_g' charge time constant, given approximately by expression (21), namely

$$\text{charge time constant for } C_g' = R_a C_g'$$

The duration of the positive-going pulse at V1 anode depends on the discharge time constant of C_g , given approximately by expression (27), thus

$$\text{discharge time constant for } C_g = R_g C_g$$

If this is large compared with the charge time constant of C_g' , C_g' becomes fully charged in a small fraction of the waveform period and the waveform is approximately rectangular in form as shown in Fig. 58. If the discharge and charge time constants are of the same order, the rise time of the waveform is comparable with the duration and the waveform is a poor approximation to a rectangular form. If the discharge time constant is small compared with the charge time constant, C_g' becomes only partially charged during the period of the anode-potential waveform, which thus has the form of the initial part of an exponential curve. This is approximately linear in form and the anode waveform is approximately triangular in shape. The change in shape of the anode-potential waveform as the charge time constant is increased relative to the discharge time constant is illustrated in Fig. 59. We can thus say that the shape of the anode-potential waveform is determined by the ratio

ANODE-COUPLED ASTABLE MULTIVIBRATOR

$$\begin{array}{l} \text{charge time constant of } C_g' \\ \text{discharge time constant of } C_g \end{array} \quad \dots \quad (35)$$

From (21) and (27) we have approximately

$$\begin{array}{l} \text{charge time constant of } C_g' \\ \text{discharge time constant of } C_g \end{array} = \frac{R_a C_g'}{R_g C_g} \quad \dots \quad (36)$$

and if the multivibrator is symmetrical, $C_g = C_g'$, giving

$$\begin{array}{l} \text{charge time constant of } C_g' \\ \text{discharge time constant of } C_g \end{array} = \frac{R_a}{R_g} \quad \dots \quad (37)$$

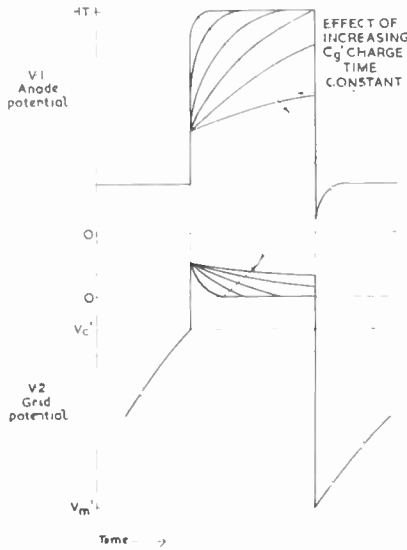

Fig. 59—Effect of increasing C_g' charge time constant on anode-potential waveform for V1 and grid-potential waveform for V2

Similarly the shape of the anode-potential waveform for V2 is determined by the ratio

$$\begin{array}{l} \text{charge time constant of } C_g \\ \text{discharge time constant of } C_g' \end{array} \simeq \frac{R_a' C_g}{R_g' C_g'} \quad \dots \quad (38)$$

which, for a symmetrical multivibrator, again reduces to R_a'/R_g' , agreeing with (37). In general, we may say that the shape of the

positive-going pulse at the anode of either valve in an astable multivibrator is determined by the ratio of the charge time constant for its anode capacitor to the discharge time constant for its grid capacitor. If this ratio is small compared with unity, the shape is approximately rectangular, whereas if it is large compared with unity the shape is approximately triangular. To obtain good rectangular waves the ratio should not be allowed to exceed 0.1; to obtain triangular waves it should not be less than 10.

A multivibrator is generally regarded as a generator with an output *voltage* of rectangular form but, as just illustrated, if R_a is made small compared with R_g , the output is of sawtooth form. In fact, the multivibrator vibrator is fundamentally a generator of *rectangular current waves* and when R_a is small compared with R_g these are supplied to a load which is predominantly capacitive in nature. The circuit thus approximates to an integrating circuit of the type shown in Fig. 5 (b) in which R is the anode d.c. resistance of the valve and C is the capacitance. Thus the voltage generated across C is of integrated-rectangle, i.e. sawtooth, form. More details of multivibrator sawtooth generators are given later.

Numerical Example

As an example of the design of a multivibrator, we will assume that square waves are required at 50 c/s and that the multivibrator is to be synchronised by pulses at that frequency. We need to determine the values of all components and to make an estimate of the rise time likely to be achieved using valves rated for a maximum steady anode current of 10 mA.

We will assume the h.t. supply is 250 volts and that the minimum grid potential is -100 volts. For the particular valve type and h.t. supply the cut-off bias is taken as -5 volts. From (32) we have

$$R_g C_g = \frac{\text{period of oscillation}}{2 \log_e V_m / V_c}$$

in which the period of oscillation is $1/50$ th second. If R_g is returned to h.t. negative the necessary time constant $R_g C_g$ is given by

$$\begin{aligned} R_g C_g &= 2 \times 50 \times \frac{1}{\log_e 20} \text{ sec} \\ &= \frac{1}{100 \times 2.99} \text{ sec} \\ &= 0.0033 \text{ sec} \end{aligned}$$

ANODE-COUPLED ASTABLE MULTIVIBRATOR

As the multivibrator is to be synchronised, its natural frequency must be lower than 50 c/s and the time constant must exceed this value. Let $R_g C_g = 0.005$ second. Any combination of resistance and capacitance of this value will give the required frequency but the rise time is determined by the charge time constant $R_a C_g$ and thus C_g should be as small as possible to minimise the rise time. To give the minimum value of C_g , R_g should be the largest value which can be used with the chosen valve. The maximum permissible value of R_g is commonly 1 M Ω ; with this we have

$$\begin{aligned} C_g &= \frac{0.005}{R_g} \\ &= \frac{0.005}{10^6} \text{ F} \\ &= 0.005 \mu\text{F} \end{aligned}$$

Since $V_m = -100$, the pulses generated at the valve anodes are assumed to be of 100 volts amplitude. To obtain such a value, with a valve rated at 10 mA maximum current, requires anode loads of 10 k Ω . The rise time is given approximately by $2.2 R_a C_g$, i.e.

$$\begin{aligned} t &= 2.2 \times 0.005 \times 10^{-6} \times 10^4 \text{ sec} \\ &= 110 \mu\text{sec}. \end{aligned}$$

Smaller rise times could be obtained by using larger-current valves because smaller anode resistors can then be used whilst still giving the required anode potential swing. Alternatively the rise time could be reduced, using the same valves, by reducing the anode loads. This would reduce the anode potential swing, and, as shown in (32), a larger value of C_g would be needed to give the same natural frequency. But the factor by which C_g must be increased is smaller than that by which R_a is reduced and the net effect is a reduction in rise time. In practice a better rise time could be obtained by passing the output pulses (100 volts in amplitude) into a limiting amplifier with a small limiting level such as 5 volts. The output of the limiting amplifier could have 1/20th the rise time, i.e. approximately 5 μsec .

Numerical Example

As a second numerical example, suppose a multivibrator is required to give rectangular pulses 10 μsec in duration at the rate of 10,000 per second. The rise time of the 10 μsec pulses must not exceed 0.2 μsec . The multivibrator is to be synchronised by pulses

at 10 kc/s. Find suitable values for $R_{a'}$, R_g , $R_{g'}$, C_g and $C_{g'}$. Such a multivibrator might form part of the line-sync generator in television waveform-generating equipment.

The period of oscillation is 100 μ sec and the mark-space ratio is therefore 9 : 1. From (34)

$$R_g C_g = 9 R_{g'} C_{g'}$$

From (31)

$$R_g C_g + R_{g'} C_{g'} = \frac{\text{period}}{\log_e V_m/V_c}$$

We shall assume that the grid resistors are returned to h.t. negative, that $V_m = V_m' = -100$ volts and that $V_c = V_c' = -5$ volts. Substituting for the period (100 μ sec), V_m and V_c in the above expression we have

$$\begin{aligned} R_g C_g + R_{g'} C_{g'} &= \frac{100}{\log_e 20} \mu\text{sec} \\ &= \frac{100}{3} \mu\text{sec} \\ &= 33 \mu\text{sec} \end{aligned}$$

Substituting for $R_g C_g$

$$10 R_{g'} C_{g'} = 33 \mu\text{sec}$$

$$\therefore R_{g'} C_{g'} = 3.3 \mu\text{sec}$$

giving

$$\begin{aligned} R_g C_g &= 9 \times 3.3 \mu\text{sec} \\ &= 29.7 \mu\text{sec} \end{aligned}$$

As the multivibrator is to be synchronised, values slightly in excess of these should be used; we will take $R_g C_g$ as 35 μ sec and $R_{g'} C_{g'}$ as 5 μ sec. The rise time of the 10- μ sec pulses is controlled by the time constant $R_a' C_g$ and C_g should therefore be small. Thus R_g should be large and will be taken as 1 M Ω , giving C_g as 35 pF.

The rise time is given approximately by $2.2 R_a' C_g$. Equating this to 0.2 μ sec gives

$$\begin{aligned} R_a' &= \frac{0.2 \times 10^{-6}}{2.2 C_g} \Omega \\ &= \frac{0.2 \times 10^{-6}}{2.2 \times 35 \times 10^{-12}} \Omega \\ &= 2.5 \text{ k}\Omega \text{ approximately} \end{aligned}$$

ANODE-COUPLED ASTABLE MULTIVIBRATOR

With such a value of anode load, an anode current of 40 mA is necessary to develop potential steps of 100 volts at the anodes. It is possible to use a smaller-current valve by assuming a smaller potential step at the anodes. For example, if V_m is taken as $5V_c$ (i.e. the potential steps are assumed to be 25 volts) we find that the time constants $R_g C_g$ and $R_g' C_g'$ must be approximately doubled to give the same natural frequency. This implies that R_a' must be halved, to 1.25 k Ω , to maintain the rise time. The current needed to develop 25 volts across 1.25 k Ω is 20 mA, half the value previously calculated. In practice, however, the required rise time would probably be obtained by the use of a limiting amplifier fed from the multivibrator output.

CHAPTER 14

CATHODE-COUPLED ASTABLE MULTIVIBRATOR

14.1 INTRODUCTION

A CATHODE-COUPLED multivibrator such as that illustrated in Fig. 55 can be made monostable or astable by appropriate choice of bias value for the second valve. If the bias is made sufficiently negative, as suggested in Fig. 55, V2 grid components cannot function as a timing network and the circuit has only one unstable state, the duration of which is timed by the cathode components; a monostable multivibrator of this type was described in Chapter 12. If V2 bias is made zero, as in Fig. 60, or positive, R_g' and C_g' behave as timing components and play a part in determining the duration of

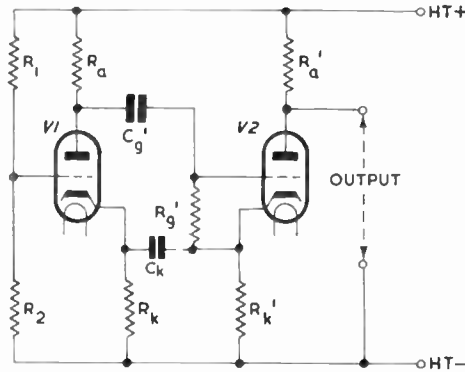

Fig. 60—Basic circuit of one type of cathode-coupled astable multivibrator

one unstable state whilst the cathode components time the duration of the other unstable state. This chapter describes the mode of operation of such an astable multivibrator.

14.2 OPERATION OF THE CIRCUIT

The operation of the circuit has much in common with that of Fig. 55 and reference should be made to the description of the 110

CATHODE-COUPLED ASTABLE MULTIVIBRATOR

monostable circuit for details. When V1 is non-conductive, its cathode potential, initially high, falls exponentially (c'd' in Fig. 61) with a time constant equal to $R_k C_k$ and, when the potential reaches a certain value (d'), V1 starts to take anode current. This causes a change of state, accelerated by regeneration, resulting in V1 being

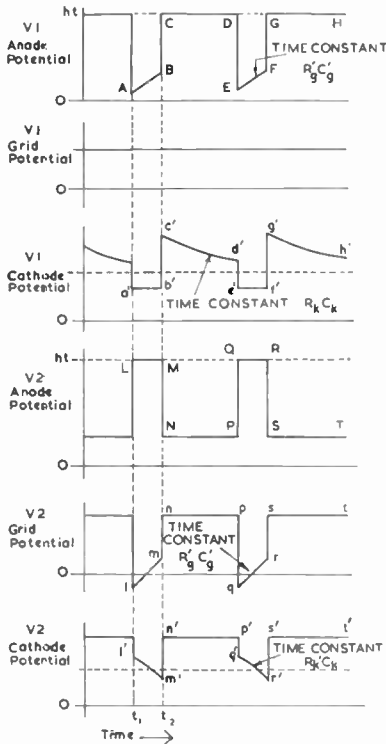

Fig. 61—Anode-, grid- and cathode- potential waveforms for the cathode-coupled astable multivibrator of Fig. 60

switched rapidly to conduction, the negative potential step (DE) developed at its anode biasing V2 beyond cut-off (pq).

During the period of relaxation which follows, the grid potential of V2 rises exponentially (qr) towards zero bias value with a time constant approximately equal to $R_g' C_g'$. At the same time the cathode potential of V2, which was high in the preceding period because of the steady current then in V2, falls abruptly (p'q')

subsequently ($q'r'$) with a time constant equal approximately to $R_k'C_k$. Both these changes in potential tend to cause conduction in V2, and, after a certain interval, the grid-cathode potential reaches the value at which V2 starts to take anode current. This behaviour contrasts with that of the monostable multivibrator of Fig. 55 in which the grid potential falls to zero and V2 does not become conductive, the circuit remaining with V1 conductive and V2 non-conductive, this being the stable state.

The start of conduction in V2 initiates a second change of state (aided by the regeneration characteristic of multivibrators) which arises in the following way:

- (a) V2 takes anode current.
- (b) V2 cathode potential rises.
- (c) V1 cathode potential rises.
- (d) V1 anode current falls.
- (e) V1 anode potential rises.
- (f) V2 grid potential rises.
- (g) V2 anode current rises further.

Thus V2 is switched rapidly to conduction, causing a sharp fall in V2 anode potential (RS). At the same time the cathode potential of V2 makes a rapid rise ($r's'$) which is transferred to V1 cathode, causing this potential also to rise ($f'g'$), and cutting V1 off.

Since V1 is cut off, its cathode potential begins to fall and the cycle of events described above begins again.

The period of relaxation during which V1 is non-conductive depends on the time constant R_kC_k as in the monostable multivibrator. The period during which V2 is non-conductive depends on the two time constants $R_g'C_g'$ and $R_k'C_k$. If, however, $R_g'C_g'$ is made large compared with $R_k'C_k$, V1 grid potential changes very slowly compared with V1 cathode potential and this period depends almost entirely on $R_k'C_k$.

The exponential curves AB, CD, $c'd'$, $q'r'$, etc., in Fig. 63 appear approximately linear because only a small part of the possible potential range is, in fact, utilised. For example, when V1 is cut off, its cathode potential may be, say, 100 volts, and begins to fall exponentially towards zero. If the grid potential is 75 volts and the valve grid base 5 volts, V1 begins to conduct again when the cathode potential has fallen to 80 volts. Thus only 20 volts out of a possible 100 volts fall are used in practice.

In this type of multivibrator the capacitor C_k is used to time both of the astable periods and if R_k is made equal to R_k' , a square-wave output is obtained. The performance of the multivibrator can be improved at the expense of losing the "free" anode of V2 by

CATHODE-COUPLED ASTABLE MULTIVIBRATOR

including a coupling network $R_g C_g$ between the anode of V2 and the grid of V1, R_g being returned to a point positive with respect to h.t. negative. The time constant $R_g C_g$ should be large compared with $R_k C_k$ which determines the period during which V1 is non-conductive.

CHAPTER 15

THE TRIGGERING AND SYNCHRONISING OF MULTIVIBRATORS

15.1 INTRODUCTION

BI-STABLE and monostable circuits cannot operate without triggering signals and astable circuits, though inherently free-running, are also generally synchronised by signals applied from an external source. Thus, nearly all forms of waveform-generating circuits are controlled by external signals and some means is required of injecting such signals. In general, waveform generators produce a substantial output voltage at their input terminals and it is undesirable for the output of the generator to be fed back into the source of trigger or sync signals. The coupling between generator and source is usually designed to reduce such feedback to a minimum. The following describes a number of circuits which can be used for this purpose.

15.2 USE OF A HOLD-OFF RESISTOR

A simple method of injecting triggering or synchronising signals is that illustrated in Fig. 62. This shows a trigger- or sync-signal source coupled to a generator by a resistor R . The output impedance of the source is represented by R_{out} and the input impedance of the generator by R_{in} . If V_1 represents the trigger- or sync-signal amplitude at the output terminals, its amplitude V_2 at the input terminals is given by

$$V_2 = V_1 \cdot \frac{R_{in}}{R_{in} + R}$$

V_2 should preferably not be much less than V_1 ; thus R should be small compared with R_{in} .

If V_3 represents the output of the waveform generator at its *input* terminals, the amplitude V_4 at the output terminals of the trigger- or sync-signal source is given by

$$V_4 = V_3 \cdot \frac{R_{out}}{R_{out} + R}$$

V_4 should be as small as possible; this requires that R should be large compared with R_{out} . Thus R should be small compared with R_{in}

TRIGGERING AND SYNCHRONISING OF MULTIVIBRATORS

but large compared with R_{out} . In practice the emphasis in design is usually on minimising the feedback of energy to the sync-signal source and since a small loss in sync-signal amplitude can usually be tolerated, R is frequently made approximately equal to R_{in} . For example, if R_{out} is 100 Ω and R_{in} 10,000 Ω , R could be 10,000 Ω .

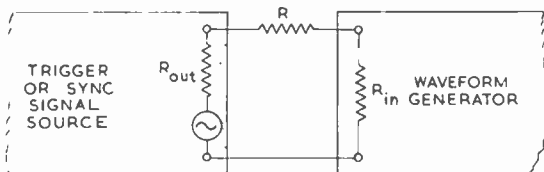

Fig. 62—A trigger- or sync-signal source coupled to a waveform generator by a hold-off resistor R

This gives half the trigger amplitude at the waveform generator input terminals whilst signals fed back to the trigger source are reduced to 1/100th of their initial amplitude.

15.3 USE OF HOLD-OFF CAPACITOR

An alternative method of applying sync or triggering signals is to use a series capacitor C in place of the series resistor R shown in Fig. 62. Providing R_{out} is small compared with R_{in} , the capacitance C can be so chosen that there is little attenuation of the signal input to the waveform generator but considerable attenuation of signals fed back from the generator to the input-signal source. When this condition is obtained it is possible that the time constant $R_{in}C$ may be small compared with the period of the sync or trigger signals. $R_{in}C$ then behave as a differentiating circuit and only the steep positive- or negative-going edges in the input signals are transferred by the network to the generator. As it is such edges which perform the switching action, this effect of the small time constant is no disadvantage; it is in fact common practice to apply sync and triggering signals to generators via differentiating networks. Further examples of such circuits are given later and the effect of differentiation is illustrated graphically.

15.4 USE OF A DIODE

An alternative circuit for the injection of triggering or synchronising signals is shown in Fig. 63: this may be used when the previous

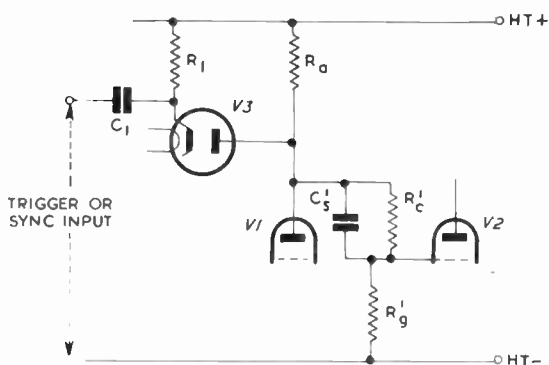

Fig. 63—Use of a diode to couple a trigger- or sync-signal source to a multivibrator

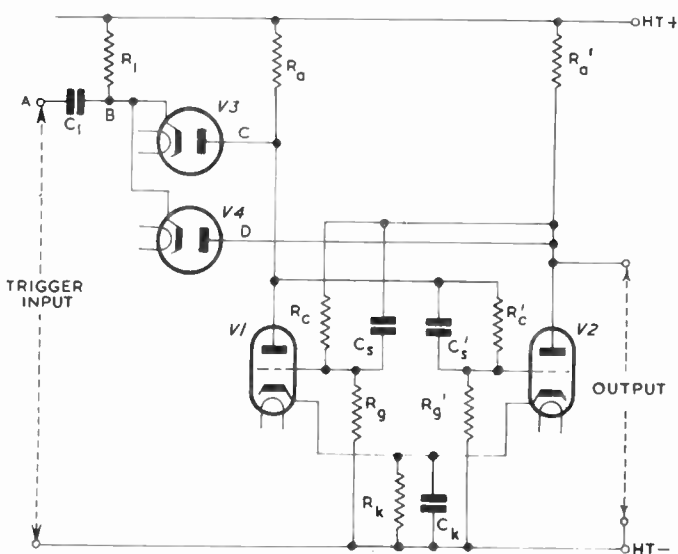

Fig. 64—Use of two diodes to trigger a bi-stable multivibrator

method is impracticable because R_{out} is not small compared with R_{in} . The input signals are applied to the grid of V2 through the series-connected diode V3 and the capacitors C_1 and C_s' .

Suppose the multivibrator is in the state in which V1 is non-conductive and V2 conductive. V1 anode potential is at h.t. value, say 250 volts, and this is also the potential of V3 anode. V3 cathode is returned to h.t. positive through R_1 and thus the anode and cathode of V3 are both at the same potential. Negative-going trigger or sync signals applied to the cathode of V3 cause V3 to conduct and the signals are transmitted to V1 anode and via C_s' to V2 grid, causing V2 to be switched to non-conduction.

This, in turn, causes V1 to be switched to conduction and the anode potential of V1, and therefore that of V3, falls to, say, 150 volts. V3 anode is thus at -100 volts with respect to its cathode, and is not likely to become conductive even during the application of triggering or sync signals unless these exceed 100 volts in amplitude. The diode thus has the effect of ensuring that negative-going sync signals are received at V2 grid only when V2 is conductive.

The diode also isolates the trigger- or sync-signal source from the multivibrator output. The circuit generates rectangular waves of, say, 100-volts amplitude at V1 and hence V3 anode but these are negative-going with respect to V3 cathode and are not conducted to the source of trigger or sync signals.

15.5 USE OF TWO DIODES

If the multivibrator of Fig. 63 is monostable or astable, after V2 has been made non-conductive by a trigger or sync signal, the circuit will in time revert to the original state and V2 will again become sensitive to the triggering or synchronising signals. If, however, the multivibrator is bi-stable it will remain indefinitely in the state in which V2 is non-conductive unless compelled to leave that state by a negative signal applied to V1 grid. To provide such a signal a second diode can be used as shown in Fig. 64. This circuit makes a change of state for each negative-going triggering signal applied to C_1 , the diodes automatically switching the signals to the grid of the conductive valve, whether it be V1 or V2. If V1 is non-conductive its anode potential (and also that of V4) is at h.t. value. V4 can therefore conduct negative-going signals to the grid of V1. If a succession of negative-going signals is applied to C_1 they are conducted alternately to the grids of V1 and V2; if the signals are regularly occurring the circuit generates rectangular waves as pictured in Fig. 42.

The waveform labelled *triggering signals* in Fig. 42 is that obtained at V3 and V4 cathodes (Fig. 64) when rectangular pulses are fed to C_1 and when the time constant R_1C_1 is made small to differentiate the input pulses. The horizontal sections of the waveform across R_1 are distorted but this is of little consequence because the triggering action is performed by the vertical edges and these are not distorted during differentiation. The waveform applied to C_1 is shown at

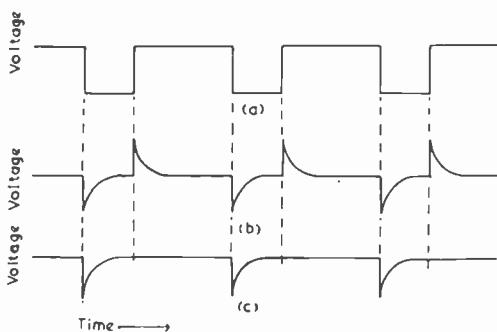

Fig. 65—If a rectangular wave (a) is applied to point A in the circuit of Fig. 64, the signals at B and C have the waveforms shown at (b) and (c) respectively

(Note: The multivibrator output generated at point C is not included in this diagram)

(a) in Fig. 65 and the waveform across R_1 is at (b). The diodes are non-conductive to positive-going signals and thus the signal at the diode cathodes has the form shown in Figs. 42 and 65 (c).

In practice, the waveform at points C and D differs from that shown in Fig. 65 because these points are also the anode connections of V1 and V2 at which the circuits generate rectangular waves. The waveforms at these points are thus compounded of spikes as shown in Fig. 65 (c) and rectangles as shown in the second and fourth curves of Fig. 42. We can assume, however, that Fig. 65 shows the waveform obtained at points C and D when V1 and V2 are removed from circuit.

15.6 USE OF A BUFFER STAGE

Another method of injecting synchronising signals uses a valve, commonly a pentode, to couple the trigger- or sync-signal source to the waveform generator. One possible circuit is shown in Fig. 66, in which the generator is a multivibrator. The pentode behaves as a buffer stage but in practical circuits it may perform additional

TRIGGERING AND SYNCHRONISING OF MULTIVIBRATORS

functions such as the amplification or phase-inversion of trigger or sync signals or the separation of sync from picture signals.

15.7 SYNCHRONISATION OF ASTABLE MULTIVIBRATORS

The astable multivibrators of Chapters 13 and 14 were described as free-running oscillators but one of their most useful properties is the ease with which they can be synchronised with any regularly occurring signal applied to them. The circuits are synchronised by positive-going signals applied to the control grids (or negative-going signals applied to the cathodes) which have the effect of terminating the unstable periods earlier than would occur naturally; thus for successful synchronising the natural frequency of the multivibrator must be lower than the frequency of the synchronising signals. If

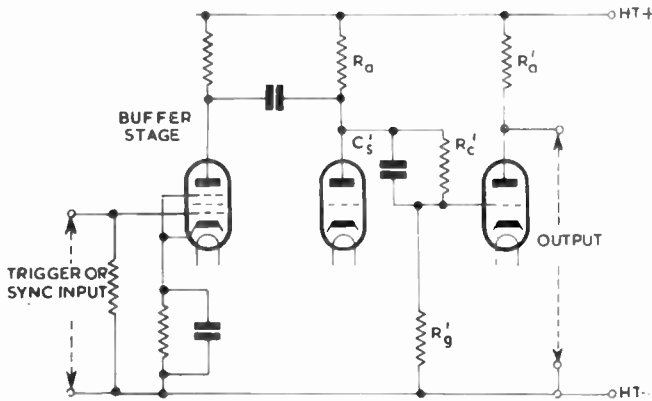

Fig. 66—Use of pentode as buffer between trigger- or sync-signal source and a multivibrator

the natural frequency is slightly less than that of the sync signals, the multivibrator frequency increases to that of the sync signals when the latter are applied. This may be termed direct or simple synchronisation and this is the means whereby the line and field sawtooth generators in a television receiver are locked by the negative sync signals. In fact the *line-hold* and *field-hold* controls are used to adjust the natural frequencies of the generators to a value just below that of the sync signals.

If the natural frequency of a multivibrator is considerably below that of the sync signals, when the latter are applied the multivibrator

frequency may increase to a value which is a simple ratio of integers (such as $2/3$, $3/4$, $4/5$, etc.) of that of the synchronising signal. When operating in this manner the multivibrator may be regarded as a frequency divider with a fractional division ratio, e.g. $1.66 : 1$, $1.5 : 1$, etc. The particular ratio obtained depends on the ratio of the natural to the sync frequencies and on the amplitude of the sync signal.

If the natural frequency of a multivibrator is a small fraction of that of the sync signals, when the latter are applied the multivibrator frequency increases to an exact sub-multiple, e.g. $1/8$, $1/7$, $1/6$, etc., that of the sync frequency. When operating in this mode the multivibrator may be regarded as a frequency divider with an integral division ratio, e.g. $8 : 1$, $7 : 1$, etc. The particular ratio obtained depends on the ratio of the natural to the sync frequencies, the amplitude of the sync signal and on the circuit used to inject the sync signals. As the amplitude of the sync signal or the natural frequency of the multivibrator is progressively increased, the synchronised frequency increases in steps until it ultimately becomes equal to the sync frequency. If the synchronising signals are applied in push-pull to the two grids (i.e. positive-going signals on one grid coinciding with negative-going signals on the other grid) the multivibrator tends to operate at odd sub-multiples ($1/7$, $1/5$, $1/3$, etc.) of the sync-signal frequency. If the synchronising signals are applied in the same sense (i.e. positive-going pulses on both grids simultaneously) the circuit favours even sub-multiples ($1/8$, $1/6$, $1/4$, etc.) of the sync-signal frequency. If the synchronising signals are applied to one grid only, there is no discrimination between even and odd sub-multiples and the multivibrator will operate at any sub-multiple (i.e. $1/7$, $1/6$, $1/5$, $1/4$, etc.).

The behaviour of the multivibrator when synchronised thus depends to a large extent on the ratio of natural frequency to sync-signal frequency and three modes of operation were distinguished above, these giving synchronised frequencies equal to, slightly below, and considerably below the sync-signal frequency. We shall now examine in greater detail the process of synchronisation for all three modes of operation.

15.7.1 *Synchronised Frequency equal to Sync Frequency*

Fig. 67 shows at (a) a series of rectangular waves used here for synchronising; five complete cycles are illustrated. At (b) is the grid waveform of a free-running multivibrator; four complete cycles are illustrated. These occupy the same period as the five synchronising waves and thus the natural frequency is slightly below

TRIGGERING AND SYNCHRONISING OF MULTIVIBRATORS

(80 per cent of) the sync frequency. Waveform (c) is the result of adding (a) and (b), i.e. it represents the grid waveform when the sync signals are injected. It is assumed here that the amplitude of the sync signals is too small to affect the operation of the multivibrator. Now suppose the amplitude of the sync signals is increased until they cause the voltage at the grid to reach the critical value V_c prematurely. The waveform now obtained is shown at (d) and

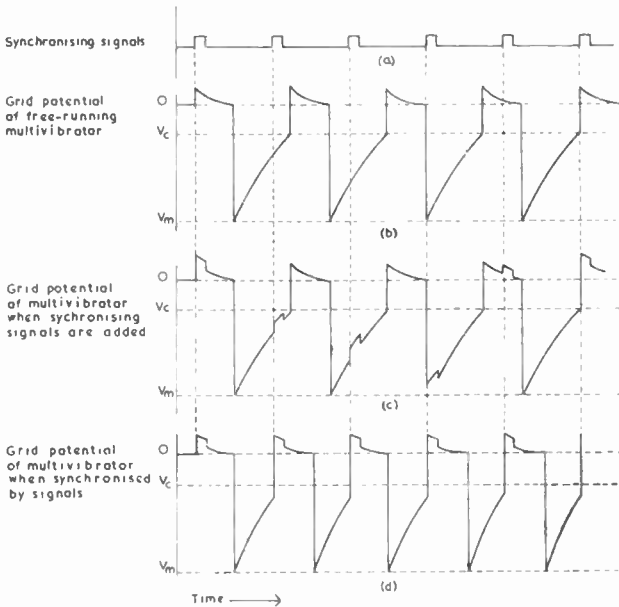

Fig. 67—Synchronisation of an astable multivibrator to give a synchronised frequency equal to the sync frequency

indicates that we now have five complete cycles of multivibrator action for five cycles of sync signal. The frequency of the multivibrator is now locked to that of the sync signals.

15.7.2 Synchronised Frequency Slightly below Sync Frequency

The process of synchronising a multivibrator to obtain a non-integral ratio of synchronising-signal frequency to multivibrator frequency is illustrated in Fig. 68. When the synchronising pulses illustrated at (a) are applied to the multivibrator grid the waveform obtained at the grid is as shown at (b), in which the sync-pulse

amplitude is too small to affect the operation of the multivibrator. However, a slight increase in synchronising-signal amplitude will cause the leading edges of synchronising pulses 2 and 5 to reach V_c and initiate the switch from non-conduction to conduction. It is

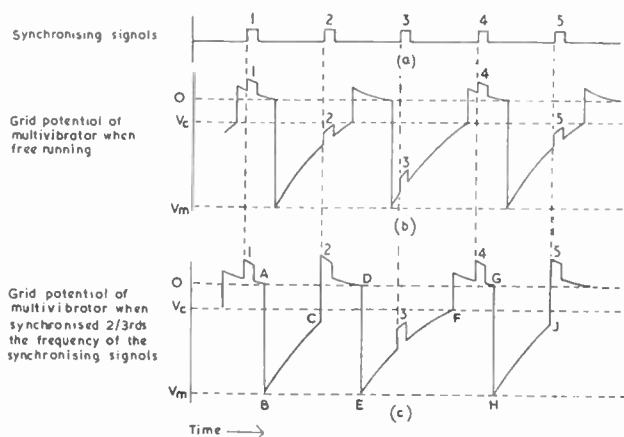

Fig. 68—Synchronisation of a multivibrator to give a synchronised frequency slightly below the sync frequency

clear from this diagram that the switching action now occurs at every third pulse and the grid waveform of the synchronised multivibrator is as shown at (c). In this, two cycles of multivibrator action occupy the same time as three synchronising pulses; in other words the multivibrator frequency is 2/3rds that of the synchronising pulses. Fig. 68 (c) shows that the grid waveform of the synchronised multivibrator has a cycle irregularity, namely that the duration of the discharge periods ABC and GHJ, which are terminated by the synchronising pulses, is shorter than the duration of those such as DEF, which are terminated by natural action of the multivibrator.

15.7.3 Synchronised Frequency Small Compared with the Sync Frequency

Fig. 69 illustrates at (a) a series of rectangular synchronising pulses which are applied to one grid of a multivibrator the natural frequency of which as shown at (b) is exactly 1/6th that of the synchronising pulses; diagram (c) shows the grid waveform when

TRIGGERING AND SYNCHRONISING OF MULTIVIBRATORS

the synchronising pulses are injected. It can be seen that the leading edges of pulses 5, 11, 17, etc., coincide with the instant at which the grid potential reaches the potential V_c at which the change of state occurs, i.e. every sixth synchronising pulse coincides with this instant in the free-running multivibrator cycle.

Now suppose the amplitude of the synchronising pulses is increased sufficiently for the leading edge of pulse 4 (diagram (c)) to reach the value V_c . The valve will now switch from non-conduction to conduction on the leading edges of pulses 4, 9, 14, etc., i.e. at every fifth synchronising pulse as shown at (d). The increase in synchronising-pulse amplitude has caused the multivibrator frequency

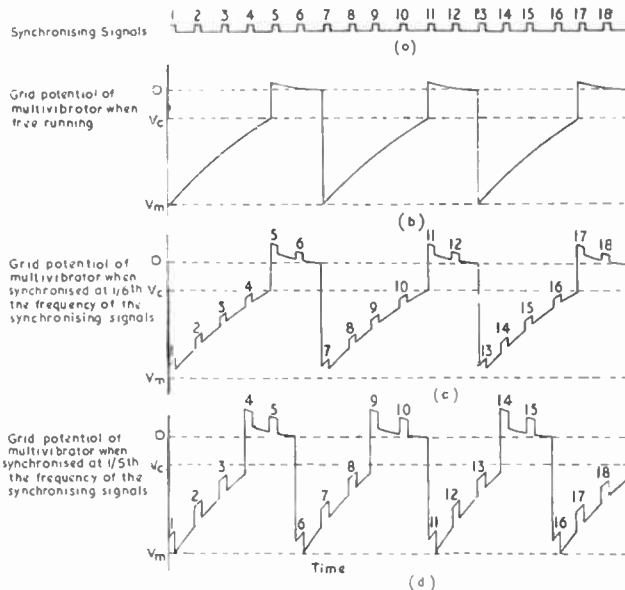

Fig. 69—Synchronisation of a multivibrator to give a synchronised frequency small compared with the sync frequency

to jump from $1/6$ th to $1/5$ th of the synchronising-pulse frequency. If the synchronising-pulse amplitude is further increased, the change from non-conduction to conduction can be made to occur at the leading edges of pulses 3, 7, 11, 15, i.e. at every fourth pulse, causing the multivibrator frequency to jump to $1/4$ th the pulse frequency.

Thus it can be seen that an increase in synchronising-pulse amplitude causes the multivibrator frequency to increase in steps.

Multivibrators synchronised in this way can provide pulses at a fraction of the frequency of the synchronising signal and may thus be used as frequency dividers. Provided care is taken to keep the amplitude of the synchronising pulses constant, division ratios of 50 : 1 can be obtained but 10 : 1 is perhaps the highest ratio used in practice.

More details of the synchronisation of multivibrators is given in Volume 4 under the heading of Frequency Dividers.

CHAPTER 16

USE OF PENTODES IN MULTIVIBRATORS

16.1 INTRODUCTION

IN the multivibrators described earlier, the valves are shown, for simplicity, as triodes, but in practice pentodes are sometimes used. These have certain advantages over triodes; for example, for a given emission a pentode can have an appreciably lower anode d.c. resistance than a triode, implying that the coupling capacitors can be charged more quickly to a given potential (or to a higher potential in a given interval) in a multivibrator using pentodes than in one using triodes.

A second advantage of using a pentode in a multivibrator is that triggering or synchronising can be achieved by injecting signals into the screen-grid or suppressor-grid circuits. The screen-grid circuit usually has a low internal resistance and some power is necessary to bring about appreciable changes in screen potential. Suppressor-grid injection avoids this difficulty but unless the valve is specially designed to have a short suppressor-grid base, a large amplitude signal may be necessary to give effective triggering.

16.2 ANODE D.C. RESISTANCE OF TRIODES AND PENTODES

The anode d.c. resistance of a valve is given by the quotient of the anode-cathode potential and the anode current; for example, a valve consuming 5 mA at an anode potential of 100 volts has an anode d.c. resistance of $100/(5 \times 10^{-3}) = 20 \text{ k}\Omega$. Because of the knee in the $I_a - V_a$ characteristics, a pentode can take a larger anode current at a low anode-cathode potential than a triode. This is illustrated in Fig. 70 which gives a set of $I_a - V_a$ curves for a triode at (a) and a pentode at (b), both valves having approximately the same maximum emission. At $V_{gk} = 0$ and $V_{sgk} = 250$ volts the pentode takes 20 mA at an anode potential of 30 volts, corresponding to an anode d.c. resistance of $1.5 \text{ k}\Omega$; at $V_{gk} = 0$ the triode needs an anode potential of 180 volts to give the same anode current, giving an anode d.c. resistance of $9 \text{ k}\Omega$, six times that of the pentode.

At anode potentials greater than that corresponding to the knee, the anode current of a pentode tends to be independent of the anode potential and thus the anode d.c. resistance is approximately

proportional to the anode potential, falling as the potential approaches that of the knee. For lower anode potentials, the anode d.c. resistance tends to become constant, at a minimum value, because the curves tend to coalesce into a straight line passing through the origin.

To obtain the minimum anode d.c. resistance, therefore, the electrode potentials should be so chosen that the operating point corresponding to the conductive state lies on the coalescent characteristic. In general this means that for a given screen-grid potential the anode-load resistance should be higher than would be used in a

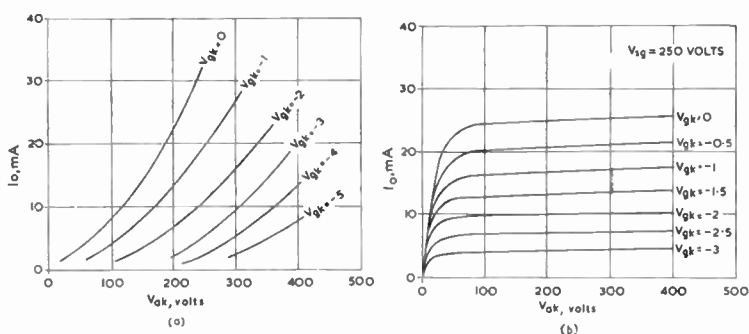

Fig. 70— I_a - V_a characteristics for (a) a triode and (b) a pentode

Class A amplifier. The conditions are, in fact, those required in a pentode limiting amplifier and it is possible to arrange for the valve to limit at a negative value of grid-cathode potential. The blips due to charging of the coupling capacitors by grid current are not then reproduced in the anode-potential waveform, which is therefore better than would be obtained with a triode.

16.3 TYPICAL MULTIVIBRATOR CIRCUIT EMPLOYING PENTODES

Fig. 71 gives a circuit diagram for an anode-coupled astable multivibrator employing two pentodes. The two screen grids are both fed from a potential divider R_1R_2 across the h.t. supply and are decoupled by the capacitor C_3 . It is assumed that the screen-grid potential is chosen in conjunction with the anode-load resistors R_a and R_a' to give operation on the coalescent characteristic as suggested above. The sync input is applied to the suppressor grid

USE OF PENTODES IN MULTIVIBRATORS

of V1 and to prevent this grid being driven positive with respect to cathode (which would cause damping of the sync-signal source) the

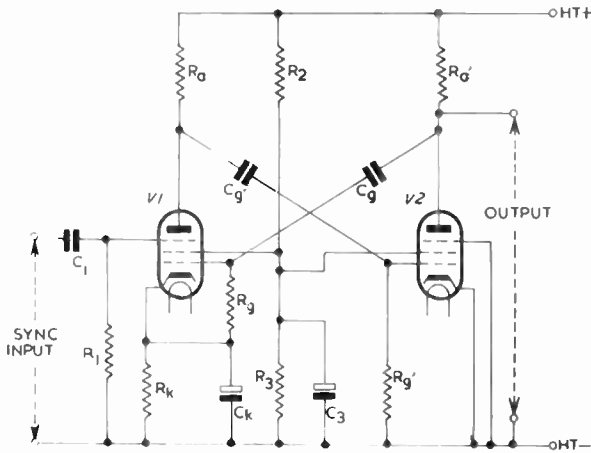

Fig. 71—An anode-coupled multivibrator circuit employing pentodes

automatic bias components R_k and C_k are introduced. By returning R_1 to h.t. negative, as illustrated, the suppressor grid is given a negative bias equal to the voltage across R_k . No negative bias is required on the control grid, however, and the grid resistor R_g is therefore returned directly to cathode.

CHAPTER 17

BI-STABLE TRANSITRON CIRCUITS

17.1 BASIC PRINCIPLES OF TRANSITRON CIRCUITS

17.1.1 Introduction

It is possible to obtain a performance similar to that given by some double-triode multivibrator circuits from a single pentode operating with a high screen-cathode and low suppressor-cathode potential. Electrons accelerated from the cathode are retarded by the field between the screen grid and suppressor grid and collect in large numbers, i.e. form a space charge between these electrodes. Electrons from this space charge are attracted to the anode if the latter has a positive potential and the number reaching the anode can be controlled by variation of the suppressor-grid potential. The space charge thus acts as a virtual cathode and the pentode anode, suppressor grid

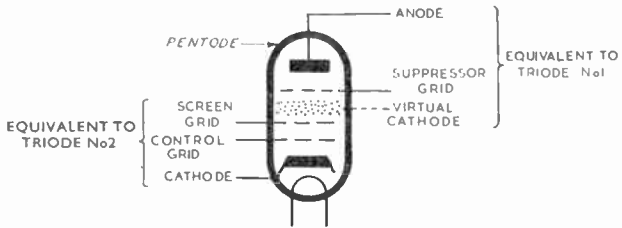

Fig. 72—A pentode with space charge between the screen grid and suppressor grid can be regarded as two triodes

and space charge behave as the three electrodes of a triode. The pentode screen grid, control grid and cathode also constitute the electrodes of a second triode and the pentode can thus be regarded as the equivalent of two triodes, as shown in Fig. 72. If the electrodes of a pentode with a virtual cathode are connected to circuits similar to those of the double-triode multivibrators described above, the circuit so obtained is termed a transitron circuit.

17.1.2 *Conditions in the Two States of a Transitron*

The transitron is similar to the multivibrator in that it has two states. In one of these states the first equivalent triode is conductive and the second is non-conductive; in the second state the first triode is non-conductive and the second conductive. The anode of the first equivalent triode is, in fact, the screen grid and thus the conditions in the two states are as follows:—

1st state: Screen current at a minimum; anode current at a maximum.

2nd state: Screen current at a maximum; anode current zero.

In the first state the screen current has a finite value; it cannot be made zero without at the same time reducing the anode current to zero. This is one of a number of respects in which the two-triode analogy falls short of perfection; another example is that the

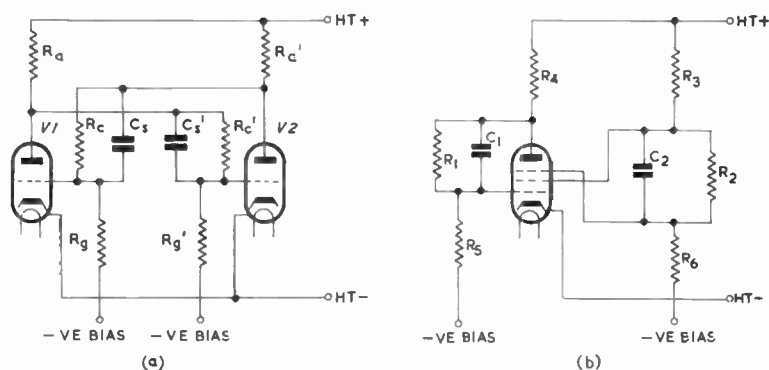

Fig. 73—The circuit of an anode-coupled bi-stable multivibrator is shown at (a) and the equivalent bi-stable transitron at (b)

potential on the control grid determines the anode current of both equivalent triodes. A third example is that the suppressor-grid potential controls the anode current of both equivalent triodes; in fact, a positive change in suppressor-grid potential increases pentode anode current but decreases screen-grid current.

As in multivibrators either of the states of a transitron circuit can be stable or unstable and thus there are three basic types of transitron, namely bi-stable (in which both states are stable), monostable (in which one state is stable and the other unstable) and astable (in which both states are unstable).

17.2 SCREEN-COUPLED BI-STABLE TRANSITRON CIRCUIT

17.2.1 Introduction

Fig. 73 is the circuit of an anode-coupled bi-stable multivibrator and the equivalent bi-stable transitron circuit is shown at (b). This is derived from (a) by assuming that the cathode, control grid and screen grid of the pentode are equivalent to V2 in (a) and that the remaining electrodes of the pentode, together with the virtual cathode, are equivalent to V1. The transitron components are labelled with odd suffixes (R_1, R_3, R_5) belonging to one of the equivalent triode sections of the pentode and even suffixes (R_2, R_4, R_6) to the other.

To facilitate comparison of the two circuits the coding of equivalent components is given in the table below:

<i>Multivibrator Circuit</i>		<i>Transitron Circuit</i>	
<i>Component</i>	<i>Code</i>	<i>Component</i>	<i>Code</i>
V2 grid coupling resistor	R_1'	Anode-control grid resistor	R_1
V2 speed-up capacitor	C_1'	Anode-control grid capacitor	C_1
V2 anode-load resistor	R_2'	Screen grid-load resistor	R_3
V2 grid resistor	R_3'	Control-grid resistor	R_5
V1 grid-coupling resistor	R_4'	Screen-grid suppressor-grid resistor	R_2
V1 speed-up capacitor	C_2	Screen-grid suppressor-grid capacitor	C_2
V1 anode-load resistor	R_5'	Anode-load resistor	R_4
V1 grid resistor	R_6'	Suppressor-grid resistor	R_6

17.2.2 Static Conditions

The potentials present on the electrodes in the two stable states of the transitron circuit can be assessed by reference to the equivalent double-triode circuits but details are given below.

The two states are best identified by the value of the screen-grid current, which is low in one state and high in the other.

(a) *Screen-grid current low*

The voltage developed across R_3 by the screen-grid current is small and the screen potential is high. The suppressor-grid potential is determined by the screen potential, the ratio of the potential divider R_2R_6 , and the negative bias voltage. The two latter factors are so chosen that the suppressor grid-cathode potential is zero or slightly positive when, as now, the screen-grid potential is at the higher of its two permissible values. With a

BI-STABLE TRANSITRON CIRCUITS

suppressor-grid potential of this value, the anode current is of the order of 3 or 4 times the screen current and the anode potential is therefore low as a result of the voltage developed across R_4 . The control-grid potential is determined by the anode potential, the ratio of the potential divider R_1R_5 , and the negative bias voltage. The two latter factors are so chosen that the control grid-cathode potential is appreciably negative when, as in this state, the anode potential is low. A certain amount of automatic readjustment of anode and control-grid potentials will occur because the anode potential is dependent on the anode current which is, in turn, dependent on the control-grid potential.

(b) *Screen-grid current high*

The voltage developed across R_3 is large and the screen potential is low. The suppressor-grid potential is also low and the design is such that in this state the suppressor-cathode voltage is sufficiently negative to cut off the anode current completely, the whole of the current leaving the cathode being collected by the screen grid. The anode is at h.t. potential and the control-grid potential will be more positive than in the previous state. The control grid may tend to go positive with respect to the cathode and will then stabilise itself at approximately the cathode potential by taking grid current.

In this state the screen-grid current is many times greater than is normal in valve amplifiers and care must be taken not to exceed the maximum safe screen dissipation.

The conditions in the pentode during the two possible states are summarised in the table below.

<i>Voltage or Current</i>	<i>State (a)</i>	<i>State (b)</i>
Screen-grid current	low	high
Screen-grid potential	high	low
Control-grid potential	low	high
Space current	low	high
Suppressor-grid potential	high	low
Anode current	maximum	zero
Anode potential	minimum	maximum

To illustrate the magnitude of the electrode currents in the two states, the following values are typical of those obtained with a small receiving-type pentode rated for a maximum cathode current of 10 mA.

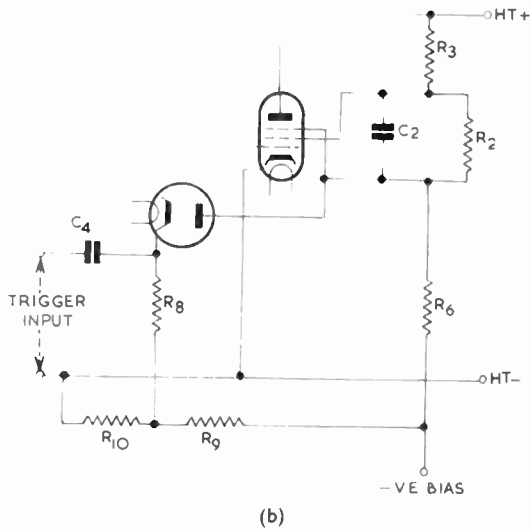
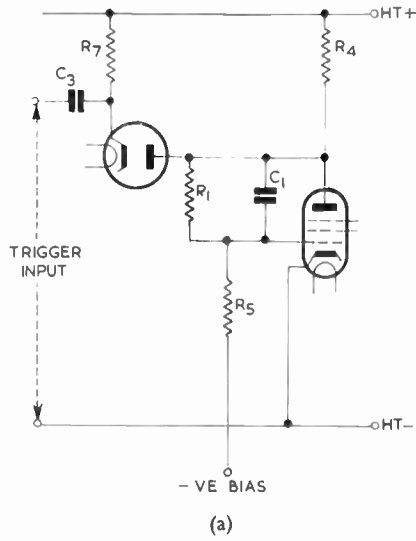

Fig. 74 (a) and (b)—Use of diodes to trigger a bi-stable transistron circuit

BI-STABLE TRANSITRON CIRCUITS

<i>Current</i>	<i>State (a)</i>	<i>State (b)</i>
Anode	3 mA	0
Screen	1 mA	8 mA
Cathode	4 mA	8 mA

Although the anode current is a maximum in state (a), its value is less than that of the screen current in state (b). This is due to the effect of the control-grid potential which is more negative in state (a) than in state (b).

The above accounts of the electrode potentials during the two states of a transitron circuit show that anode current is a maximum when control-grid potential is low and is zero when control-grid potential is high. This, of course, contrasts with the normal behaviour of a pentode amplifier; the difference is due to the coupling between the screen grid and the suppressor grid in the transitron circuit.

If in a transitron circuit in which anode current is at maximum and control-grid potential low the control-grid bias is made more negative, the space current falls, the virtual cathode disappears and transitron action ceases. The anode current steadily falls to zero as the control-grid bias approaches cut-off value, this being typical of normal amplifier action. Thus transitron action is possible only over a limited range of control-grid potential.

17.2.3 Method of Triggering a Transitron Circuit

The circuit may be triggered by negative-going pulses applied to the control grid or the suppressor grid. The pulses can be applied to the control grid by the circuit shown in Fig. 74 (a), which is similar to that used for triggering bi-stable multivibrators (see, for example, Fig. 63). The operation of the circuit is described on page 115; briefly R_7C_3 acts as a differentiating circuit and the diode as a switch operated by the anode potential, the negative-going edges reaching the grid via C_1 . When anode potential is at h.t. value the diode conducts negative-going edges to the grid; these initiate a change of state causing the anode potential to fall and biasing the diode anode negatively with respect to its cathode. The circuit is now unresponsive to triggering signals applied to C_3 .

It will however respond to negative-going pulses applied to the suppressor grid and Fig. 74 (b) illustrates a circuit which can be used to inject such pulses. Due to the finite value of the minimum screen current the maximum value of the screen potential is not equal to h.t. value but appreciably lower. Thus the resistor R_8 is returned to a source of potential approximately equal to the higher of the

two possible suppressor-grid potentials. The diode then performs in a manner similar to that in (a); that is to say it will conduct negative triggering signals to the suppressor grid but, after the change of state, the diode anode is biased negatively with respect to its cathode, thus isolating the transitron circuit from the source of triggering signals. Both diode circuits are necessary, of course, to give continuous changes of state.

17.3 CATHODE-COUPLED BI-STABLE TRANSITRON CIRCUIT

17.3.1 Introduction

There is a transitron circuit equivalent to the cathode-coupled bi-stable multivibrator and it is given in Fig. 75 (b), the multivibrator circuit being given at (a). The component notation used in Fig. 75 (b) is in agreement with the table of page 130 with the addition of R_7 (equivalent to R_k) and of R_8 and R_9 (equivalent to R_1 and R_2 respectively).

17.3.2 Static Conditions

The transitron circuit has two stable states similar in general principles to those of the bi-stable multivibrator; as in the previous transitron circuit these are best identified by the value of screen-grid current.

(a) Screen-grid current low

The voltage developed across R_7 by the cathode current is small and the cathode potential is approximately equal to the suppressor-grid potential obtained via the potential divider R_8R_9 . The anode current is thus 3 or 4 times the screen-grid current and the anode potential is low, giving a low control-grid potential.

(b) Screen-grid current high

The voltage developed across R_7 by the cathode current (now equal to the screen-grid current) is large and the cathode potential is higher than the suppressor-grid potential, cutting-off anode current and causing the whole of the cathode emission to flow to the screen grid. The anode potential is at h.t. value and the control-grid potential is higher, giving a greater cathode current than in the previous state.

17.3.3 Method of Triggering

The circuit may be triggered by positive- or negative-going voltages applied to the control grid or to the suppressor grid and the approxi-

BI-STABLE TRANSITRON CIRCUITS

mately-rectangular output can be taken from the screen grid (which is free) or, in opposite polarity, from the cathode circuit.

17.4 SUPPRESSOR-GRID EMISSION

In bi-stable as in all transitron circuits there is a possibility, if screen grid and suppressor grid become sufficiently positive with respect to the cathode, that electrons may strike the suppressor grid with sufficient velocity to cause secondary emission. If this happens when the external suppressor-grid-cathode circuit is of high resistance, the suppressor grid may lose more secondary electrons than it gains from cathode emission, with the result that the suppressor-grid potential becomes more positive and may ultimately reach the

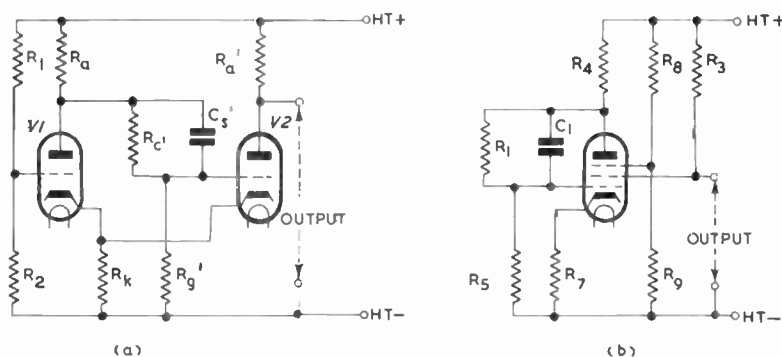

Fig. 75—The circuit of a cathode-coupled bi-stable multivibrator is shown at (a) and the equivalent bi-stable transitron circuit at (b)

anode potential. The process is similar to that of second-anode and cathode-potential stabilisation in camera tubes, described in Volume I. This can be prevented by reducing the value of the external suppressor-grid resistors (R_x and R_y in Fig. 75), but this results in increased h.t. drain and a better method is to connect a diode anode to the suppressor grid, the diode cathode being returned to the pentode cathode. This makes the external suppressor-grid circuit of low resistance if the suppressor-grid potential tends to go positive. A number of short suppressor-base pentodes developed for use in transitron circuits have such a diode inside the bulb and connected internally to the suppressor grid and cathode.

17.5 LIMITED APPLICATION OF BI-STABLE TRANSITRON CIRCUITS

To obtain a satisfactory performance from bi-stable transitron circuits, a valve with a short suppressor-grid base should be used and the operating potentials must be carefully chosen to avoid excessive screen-grid dissipation when the circuit is in the state of maximum screen current. These transitron circuits are susceptible to changes in supply voltages and the operating potentials may need slight re-adjustment to maintain a good performance if the valve is replaced by another of slightly different characteristics.

CHAPTER 18

MONOSTABLE TRANSITRON CIRCUITS (PHANTASTRONS)

18.1 INTRODUCTION

A BI-STABLE transitron circuit can be made monostable by replacing one of the d.c. couplings by an a.c. coupling and by appropriate choice of bias conditions. The transitron circuits so produced are termed *phantastrons* and they have a close analogy with monostable double-triode multivibrators; thus there is a *screen-coupled phantastron* equivalent to the monostable anode-coupled multivibrator and a *cathode-coupled phantastron* equivalent to the monostable cathode-coupled multivibrator. The a.c. coupling in such circuits is between the anode and the control grid and these circuits belong to a type known as "Miller integrators"; they are circuits in which

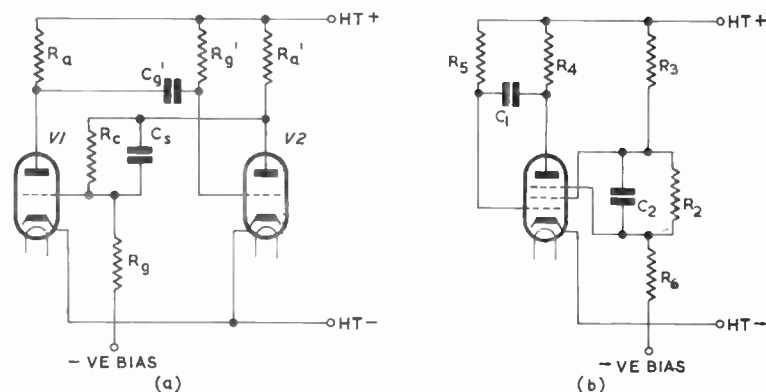

Fig. 76—The circuit of an anode-coupled monostable multivibrator is shown at (a) and the equivalent transitron circuit (a screen-coupled phantastron) is shown at (b)

a capacitor is connected between the anode and grid of a high-gain amplifier in order deliberately to create a prominent Miller effect, and their most outstanding property is the almost linear fall in anode potential when the Miller capacitance charges or discharges. The linear fall in anode potential has the advantage of permitting

accurate timing of the duration of the pulses generated at the screen grid and the phantastron is chiefly used in applications such as delay generators where this property is utilised. Phantastrons may be regarded as Miller integrators with a transitron switching action and can be used as sawtooth generators by taking an output from the anode circuit.

18.2 SCREEN-COUPLED PHANTASTRON

18.2.1 *Introduction*

Fig. 76 gives the circuit of an anode-coupled monostable multivibrator at (a) and the analogous phantastron circuit at (b); the nomenclature used in these diagrams is in agreement with the table given on page 130.

18.2.2 *Conditions in the Two States*

The conditions in the two states of the circuit are as described for the bi-stable transitron circuit and are briefly summarised below:

- State 1. Screen-grid current low; screen-grid potential high.
 Suppressor-grid potential high.
 Anode current maximum; anode potential low.
 Control-grid potential low.
- State 2. Screen-grid current high; screen-grid potential low.
 Suppressor-grid potential low.
 Anode current zero; anode potential at h.t. value.
 Control-grid potential high.

The bias conditions of the capacitance-coupled electrode determine which of these two states is stable. The capacitance-coupled electrode is the control grid and the grid resistor is returned to h.t. positive; thus the circuit will always revert to the state in which the control grid takes grid current via R_5 from the h.t. supply. If R_5 is a high-value resistor, such as $1\text{ M}\Omega$, the grid current is limited (it cannot exceed 0.25 mA if the h.t. supply is 250 volts) and the grid potential differs only slightly from cathode potential. Thus state 2, above, is the stable state; it is characterised by zero anode current and a maximum screen-grid current.

18.2.3 *Methods of Triggering*

The circuit can be triggered into the unstable state by applying a negative pulse to the control grid or a positive pulse to the suppressor grid. Either form of triggering signal will start anode current. A positive pulse applied to the suppressor grid starts anode current by allowing electrons from the space charge to cross to the anode

MONOSTABLE TRANSITRON CIRCUITS (PHANASTRONS)

under the attraction of its positive charge. A negative pulse applied to the control grid achieves the same end by the following indirect method. The negative pulse reduces space current and the fall in screen-grid current causes an increase in screen-grid potential which is transferred by C_2 to the suppressor grid, starting anode current as before.

As in the multivibrator circuits, the start of anode current is hastened by regeneration which, in this circuit, occurs in the following manner.

- (a) The anode current increases.
- (b) The anode potential falls.
- (c) The control-grid potential falls (because of C_1).
- (d) The screen-grid current falls.
- (e) The screen-grid potential rises.
- (f) The suppressor-grid potential rises (because of C_2).
- (g) The anode current rises still further.

18.2.4 *Initiation of Unstable State*

Consider a screen-coupled phantastron in its stable state and let us trace the sequence of events when it is triggered into the unstable state. Conditions in the stable state are represented by the curves of Fig. 77 at $t = t_0$. The control grid is at approximately zero potential and the anode is at h.t. potential; thus the capacitor C_1 is charged to the full h.t. voltage.

At $t = t_1$, a negative-going edge is applied to the control grid, causing anode current to start as described above.

18.2.5 *Limitation of Initial Anode-potential Fall*

If the potentials on the screen grid and suppressor grid were the only ones which determined the anode current, the latter would rise very sharply to a considerable value causing an abrupt and large fall in anode potential as in double-triode multivibrator circuits. In the transitron circuit, however, there is an additional factor, not present in two-valve circuits, which seriously limits the extent of the anode-potential fall. This factor is the mutual conductance relating control-grid potential and anode current; potentials on the control grid cause an alteration not only in the screen-grid current but also in the anode current.

The control-grid potential thus affects the anode current in two ways: indirectly via the screen-grid current and suppressor-grid potential and directly as in a normal amplifier. The direct effect opposes the other and, when the control-grid potential falls low enough to eliminate the virtual cathode, becomes the only effect.

As the anode potential falls, the change is communicated to the control grid and the action is inherently self-limiting, the fall in anode potential being limited to a value which almost causes anode current cut-off. The limiting value of anode current is, in fact, given by V_c/R_1 where V_c is the cut-off bias for the pentode and R_1 is the anode-load resistor.

Thus the effect of applying the triggering signal is to cause anode and grid potentials to fall sharply by an equal though small amount as shown at $t = t_1$ in Fig. 77. The sharp fall in control-grid potential causes space current to decrease; thus the screen-grid and suppressor-grid potentials make positive steps, the amplitude at the suppressor grid being less than that at the screen grid because of the potential division in R_2R_6 . The circuit is now in its unstable state.

18.2.6 Mechanism of Approximately-linear Anode-potential Fall

The capacitor C_1 now begins to discharge and the voltage between its plates falls. This voltage is the potential between the anode and the control grid of the pentode; as it falls the control-grid potential rises and the anode potential falls, the ratio of the change in anode potential to the change in grid potential being the stage gain of the valve. As C_1 discharges, the anode potential falls from its initial value nearly equal to the h.t. supply voltage to approximately zero and the grid potential rises very slightly, the stage gain of the pentode being very high because of the high-value anode-load resistance. The grid-cathode potential change is very small and, to a first degree of approximation, can be taken as zero. R_3 is connected between control grid and h.t. positive and the voltage across it is approximately equal to the h.t. voltage and remains substantially constant as the anode potential falls. The current in R_3 is thus approximately constant throughout the discharging process. This current is the discharge current of C_1 and the voltage across the capacitor therefore falls approximately linearly with time as shown in Fig. 77. It is an interesting feature of this circuit that the small change in control-grid potential is sufficient to apply a linearising factor to the fall in anode potential which, but for this correction, would be exponential in form.

18.2.7 Termination of Unstable Period

When the anode potential reaches a certain value below that of the screen grid, the retarding field between screen grid and anode tends to return electrons penetrating the screen-grid mesh back to the screen grid, thus reducing the rate of increase of anode current and tending to increase screen-grid current. When the anode

MONOSTABLE TRANSITRON CIRCUITS (PHANTASTRONS)

potential falls below this value, the retarding field increases in strength and becomes the predominating influence, overcoming the effect of the control grid. This initiates a new mode of behaviour which terminates the unstable period in the following way. An increase in screen-grid current causes a fall in screen-grid potential and in suppressor-grid potential. The latter change tends to decrease the anode current and to increase screen-grid current still further. Moreover, the rising anode potential brings about an

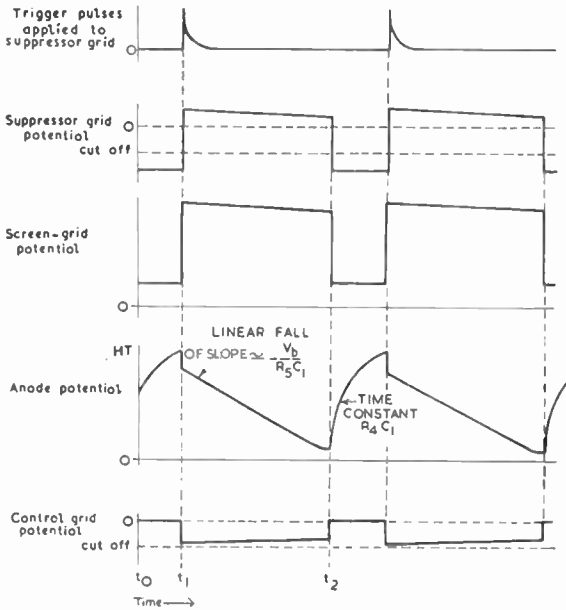

Fig. 77—Waveforms at the electrodes of a screen-coupled phantatron

increase in control-grid potential and an increase in space current. Thus regeneration occurs, resulting in anode current falling to zero and screen-grid current rising to a maximum. The control-grid potential rises to approximately cathode potential and is stabilised at or near this value by grid current in R_3 shown in Fig. 77 ($t = t_2$). The increase in control-grid potential increases space current, causing both screen-grid and suppressor-grid potentials to fall to their original values.

Although the anode current is cut off very quickly, the anode potential cannot immediately rise to h.t. value because of C_1 which is almost completely discharged and is connected between anode and cathode, via the internal control grid-cathode resistance (which is very low because the grid is positive with respect to the cathode). Thus the anode potential rises exponentially, the curve corresponding to a time constant $C_1 R_4$. When charging is complete the circuit is back in its original stable state.

18.2.8 Linearity of Anode-potential Fall

The shape of the anode-potential waveform marks the chief difference between the phantastron and equivalent multivibrator circuits. In the latter the timing waveform is exponential because the discharge current is proportional to the voltage across the capacitor and decreases as the capacitor charge decays. In the phantastron, however, the discharge current is approximately constant and the capacitor voltage falls linearly with time.

Let the charge on the capacitor C_1 be q_0 initially and q_t after a time t . We then have

$$V_0 = \frac{q_0}{C_1}$$

and

$$V_t = \frac{q_t}{C_1}$$

where V_0 is the initial voltage across the capacitor and V_t is the voltage after a time t . The rate of fall of voltage is thus given by

$$\begin{aligned} \text{rate of fall of voltage} &= \frac{V_0 - V_t}{t} \\ &= \frac{1}{C_1} \cdot \frac{q_0 - q_t}{t} \end{aligned}$$

$(q_0 - q_t)/t$ is the discharge current i given approximately by V_1/R_5 where V_1 is the voltage across R_5 . Thus

$$\begin{aligned} \text{rate of fall of voltage} &= \frac{i}{C_1} \\ &= \frac{V_1}{R_5 C_1} \text{ volts per second} \dots (39) \end{aligned}$$

The rate of fall of potential is thus directly proportional to V_1 and inversely proportional to C_1 and R_5 . If the total voltage through which the anode potential falls is V_a , the time occupied by the fall,

MONOSTABLE TRANSITRON CIRCUITS (PHANASTRONS)

i.e. the duration of the output pulses, is given by

$$\text{duration of output pulses} = \frac{V_a R_5 C_1}{V_1} \text{ seconds} \quad \dots \quad (40)$$

In some circuits, such as that shown in Fig. 78, V_a is approximately equal to V_1 (and to the h.t. voltage) and the duration of the pulses is then approximately $R_5 C_1$ seconds. In general, however, this

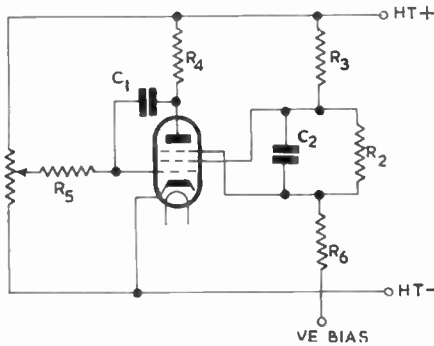

Fig. 78—One circuit for controlling the output pulse duration by varying the slope of the anode-potential fall

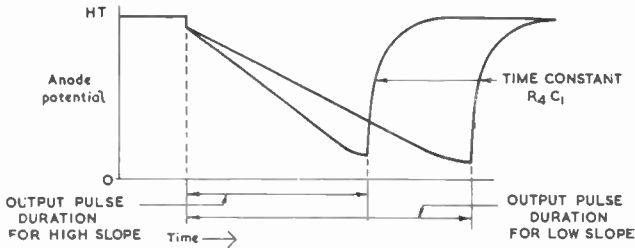

Fig. 79—Illustrating the effect of varying the slope of the anode-potential fall

equality is not obeyed and the pulse duration is directly proportional to C_1 , R_5 and V_a but inversely proportional to V_1 . Although the pulse duration can be controlled by variation of any of these four quantities, it is most usual to vary V_a or V_1 . Examples of both types of control will be given.

18.2.9 Control of Pulse Duration by Varying the Slope of the Anode-potential Fall

V_1 may be varied by returning R_5 to a potentiometer connected across the h.t. supply as shown in Fig. 78. As the potentiometer slider is moved downwards towards h.t. negative V_1 is reduced and, if we assume that the grid end of R_5 is maintained at cathode potential, the current in R_5 is reduced in the same proportion. C_1 discharge current is reduced and the discharge takes longer, increasing the duration of the output pulses as shown in Fig. 79.

18.2.10 Control of Pulse Duration by Varying the Extent of the Anode-potential Fall

Fig. 80 illustrates a circuit which can be used to vary the pulse duration by controlling the extent of the anode-potential fall. The pentode anode is connected to the anode of a diode, the cathode of which is returned to a low-impedance source of controllable potential shown, for simplicity, as a potentiometer connected across the h.t.

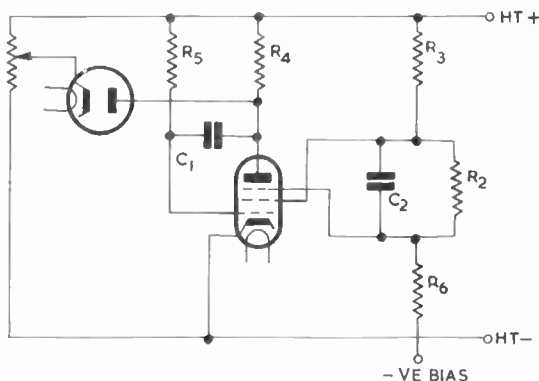

Fig. 80—One circuit for controlling the duration of the output pulses by varying the extent of the anode-potential fall

supply. The effect of the diode is to prevent the anode potential rising appreciably above the diode cathode potential, though it has no effect on the circuit when the anode is at lower potentials. Thus, in the stable state, when anode current is cut off, the anode potential rises as C_1 charges, until it reaches the diode cathode potential. At this potential the diode conducts and effectively connects the anode plate of C_1 to the slider of the potentiometer. No further rise in

MONOSTABLE TRANSISTRON CIRCUITS (PHANTASTRONS)

anode potential can occur and in the stable state of the circuit C_1 is charged to the voltage between the potentiometer slider and the pentode cathode. The fall in anode potential is thus from the value

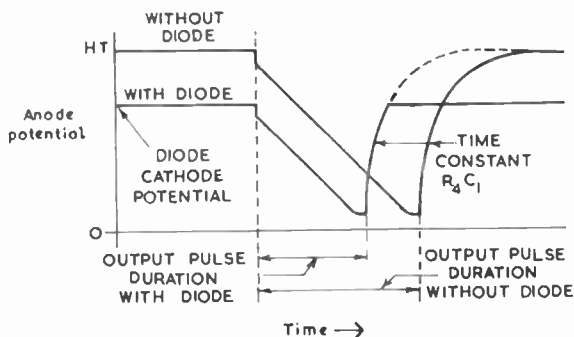

Fig. 81—Illustrating the effect of varying the extent of the anode-potential fall

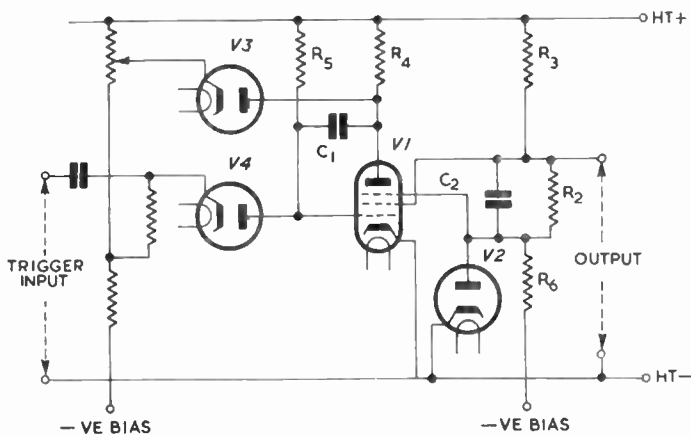

Fig. 82—Practical screen-coupled phantastron circuit

at the potentiometer slider to approximately zero and, as suggested in expression (40), the time occupied by the fall increases as the slider is moved towards h.t. positive. The effect on the anode-potential waveform is illustrated in Fig. 81.

18.2.11 *Practical Screen-coupled Phantastron Circuit*

Fig. 82 gives the complete circuit of a practical screen-coupled phantastron pulse generator. It includes diodes for the following purposes:

- (a) V2 is included to prevent the development of appreciable positive suppressor-cathode potentials.
- (b) V3 controls the duration of the output pulses.
- (c) V4 has a dual function; in common with other series-connected diodes described earlier it is used as a means of introducing negative triggering pulses into the control-grid circuit and at the same time it prevents pulses generated at the control grid by the phantastron from entering the source of triggering signals; secondly it also serves to prevent the control-grid potential rising beyond the value at which the cathode current exceeds the maximum safe value, or at which the screen-grid dissipation in the stable state becomes excessive. Without this diode the control grid-cathode potential may become positive in the stable state resulting in very large cathode emission. By including the diode and making its cathode negative with respect to the pentode cathode, the pentode control grid-cathode potential can be kept negative even in the stable state, so that emission and screen dissipation have safe values.

18.3 CATHODE-COUPLED PHANTASTRON

18.3.1 *Introduction*

Fig. 83 gives the circuit of a cathode-coupled monostable multivibrator at (a) and the equivalent transitron circuit, the cathode-coupled phantastron, at (b). The latter has a performance similar to that of the screen-coupled phantastron (Fig. 76), but, in general, is to be preferred to it for the following reasons:

- (a) The screen-grid circuit is free and is a convenient point from which to take a rectangular-wave output. The resistor in the screen circuit can be given a low value to give good rise and fall times.
- (b) If required, a rectangular-wave output of opposite phase can be taken from the cathode circuit which is inherently of low internal resistance.
- (c) No negative bias supply is required.

On the other hand the linearity of the anode-potential fall is inferior to that of the screen-coupled phantastron as explained below.

MONSTABLE TRANSITRON CIRCUITS (PHANASTRONS)

18.3.2 *Conditions in the Two States*

The two states of this circuit are as described for the cathode-coupled bi-stable transitron circuit and are briefly summarised below:

- State 1. Screen-grid current low; screen-grid potential high.
Anode current maximum; anode potential low.
Control-grid potential low.
Cathode current low; cathode potential low, giving suppressor-cathode potential of approximately zero.
- State 2. Screen-grid current high; screen-grid potential low.
Anode current zero; anode potential high.
Control-grid potential high.
Cathode current high; cathode potential high, giving a suppressor-cathode potential sufficiently negative to cut off anode current.

The bias value for the a.c.-coupled electrode determines which of these two states is stable. The a.c.-coupled electrode is the control

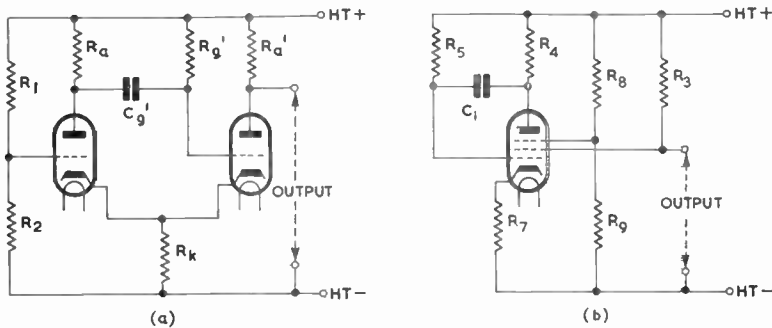

Fig. 83—Cathode-coupled monostable multivibrator circuit (a) and its transitron equivalent (b)

grid and the grid resistor is returned to h.t. positive; thus the circuit always reverts to the state in which the control grid takes grid current via R_5 from the h.t. supply. As in the screen-coupled circuit the grid potential differs only slightly from the cathode potential. The space current is high and the cathode-h.t. negative potential exceeds the suppressor grid-h.t. negative potential (determined by R_8R_9), giving a suppressor-cathode potential sufficiently negative to cut off anode current. These are the conditions in state 2 above and this is thus the stable state.

18.3.3 *Method of Triggering*

The circuit can be triggered into the unstable state by negative signals on the control grid or positive signals on the suppressor grid. The effect of both forms of triggering signal is to start anode current. Positive pulses on the suppressor grid start anode current by allowing electrons from the virtual cathode to cross to the anode.

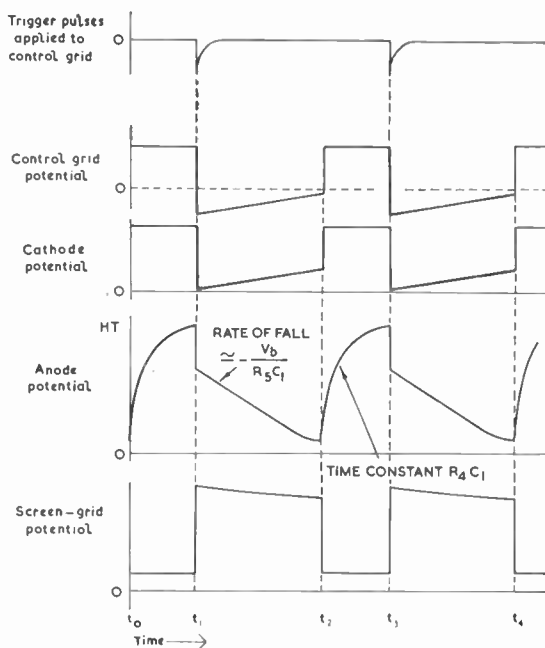

Fig. 84—Waveforms at the electrodes of a cathode-coupled phantastron

Negative pulses on the control grid achieve the same end by the following indirect method. When the pulse is received, the cathode voltage drops by normal cathode-follower action, and, since the suppressor-earth potential is fixed by the divider $R_8 R_9$, the suppressor-cathode potential increases, permitting anode current to start as before. As soon as anode current starts, the anode potential falls, and the negative potential step is transferred via C_1 to the control grid, causing its potential to fall equally, this in turn bringing about a further drop in cathode potential. Thus the changes

initiated by the triggering signals are regenerative and the start of anode current is very abrupt.

18.3.4 Operation of the Circuit

The operation of the circuit is illustrated by the waveforms of Fig. 84. Between $t = t_0$ and $t = t_1$ the circuit is in the stable state; control-grid and cathode potentials are high, giving a high space current which goes wholly to the screen grid. Thus anode potential is at h.t. value and screen-grid potential is low.

At $t = t_1$ a negative-going edge is applied to the control grid; this initiates a number of changes in circuit conditions as explained above. Anode current is abruptly started and screen-grid current sharply reduced, causing a negative step in anode potential and a positive step in screen-grid potential. As in the screen-coupled phantastron the fall in anode potential is limited and is followed by an approximately-linear run-down of slope $-V_b/R_5C_1$, this being checked at $t = t_2$ when the anode potential reaches a certain minimum value. At this instant the unstable state is abruptly terminated, the mechanism being similar to that occurring in the screen-coupled circuit. During the unstable state the grid-cathode potential executes a very small change as in the screen-coupled circuit, but the change in grid-earth potential may be much greater because of the extension of the grid base due to the cathode resistor R_7 .

At the end of the unstable state the anode current is cut off very abruptly but the anode potential rises exponentially to h.t. value, the curve corresponding to time constant C_1R_4 as explained for the screen-coupled phantastron. When the anode potential reaches the h.t. value the circuit is back in its original stable state.

The linearity of the anode-potential fall in the cathode-coupled phantastron is inferior to that of the screen-coupled type. The reason for this can be seen from the waveforms (Fig. 84 and Fig. 77); due to the use of a cathode resistor in the cathode-coupled circuit the control-grid potential varies appreciably during the anode-potential fall. It may vary, say, 40 volts compared with 5 volts in the screen-coupled circuit. Thus the voltage across R_5 (which determines the discharge current) varies by 40 volts in, say, 200 volts for the cathode-coupled circuit compared with 5 volts in 200 volts for the screen-coupled circuit. The percentage variations in discharge current are thus 20 per cent and 2.5 per cent and these may be regarded as approximate estimates of the departure from linearity for the two circuits.

18.3.5 *Practical Cathode-coupled Phantastron Circuit*

The duration of the output pulses generated during the unstable state (positive-going at the screen grid and negative-going at the cathode) can be controlled by methods similar to those described for the screen-coupled phantastron. One of these methods in which the extent of the anode-potential fall is controlled is employed in the practical cathode-coupled phantastron illustrated in Fig. 85. In this the potentiometer R_{10} controls the duration of the output

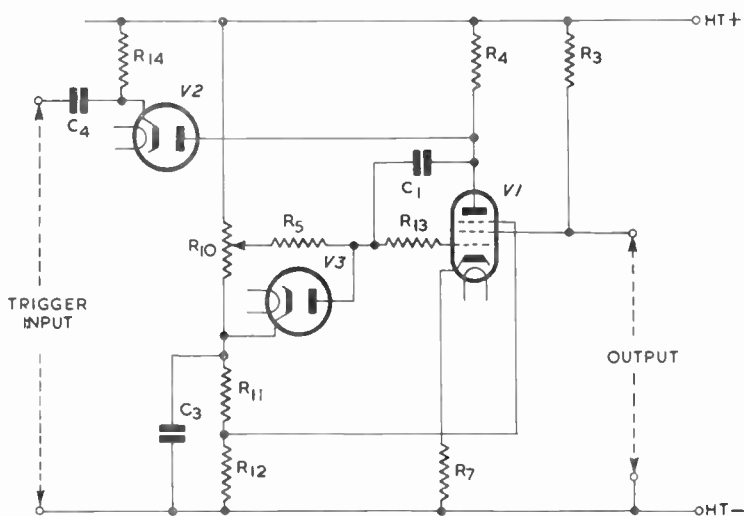

Fig. 85—Practical circuit of a cathode-coupled phantastron

pulses, which is directly proportional to the voltage between the potentiometer slider and V1 cathode. The diode V2 is used to conduct negative-triggering signals to the control grid (and also isolates the triggering source from the phantastron), the other (V3) being used to limit the cathode emission of the valve in the stable state. The potential divider $R_{10}R_{11}R_{12}$ serves to provide the necessary potential for the cathode of V3 (this is slightly negative with respect to V1 cathode potential in the stable state) and for the suppressor grid of V1. C_3 is a decoupling component and R_3 is a low-value resistor included to prevent any tendency for V1 to generate parasitic oscillations.

18.4 APPLICATIONS OF PHANTASTRONS

Positive-going pulses of approximately-rectangular waveform are generated at the screen grid of phantastrons, the leading edges of which coincide with the trigger pulses, the duration being controllable within fine limits as described earlier. The chief use of phantatron circuits is the generation of pulses where precise control over duration is necessary; in particular such circuits are used as "delay generators", i.e. in applications where a triggering action is required at an interval after reference pulses. The reference pulses are used to trigger the phantatron and the trailing edges of the phantatron output pulses are used to trigger the apparatus in which delayed action is required. Phantastrons are sometimes used in frequency-dividing equipment where such delayed action is required.

CHAPTER 19

SCREEN-COUPLED ASTABLE TRANSITRON (MILLER-TRANSITRON) CIRCUIT

19.1 INTRODUCTION

By replacing both of the d.c. couplings in a bi-stable circuit by capacitance couplings, an astable transitron can be produced; this is, in many respects, analogous in performance to the astable double-triode multivibrator. Provided the bias conditions are suitable, such a circuit will oscillate continuously between its two

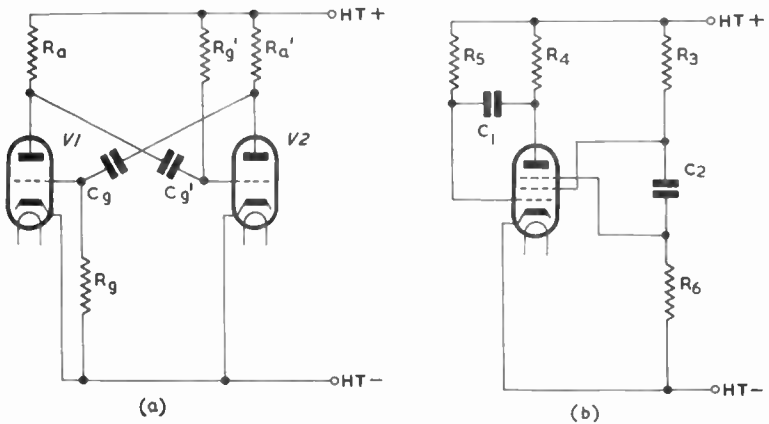

Fig. 86—The circuit of an astable anode-coupled multivibrator is shown at (a) and the equivalent transitron circuit at (b)

states, generating sawtooth waves at the anode and rectangular waves at the screen grid. Although the circuit oscillates freely without need for external triggering signals, it can readily be synchronised at the frequency of any regularly-occurring signal applied to it. The astable transitron is generally known as a Miller-transitron circuit and its chief application is as a single-valve time-base generator for oscilloscopes.

SCREEN-COUPLED ASTABLE TRANSISTRON CIRCUIT

19.2 FUNDAMENTAL CIRCUITS

The circuit for the astable transistor can be derived from that of the bi-stable transistor circuit by replacing the d.c. by a.c. couplings or can be obtained by comparison with the astable double-triode multivibrator. Thus the circuit of the astable screen-coupled transistor (Fig. 86 (b)) can be derived from the bi-stable transistor (Fig. 73(b)) simply by omitting R_1 and R_2 or can be obtained from the circuit of the anode-coupled multivibrator of Fig. 86 (a). It is not possible to obtain a connection to the virtual cathode and thus

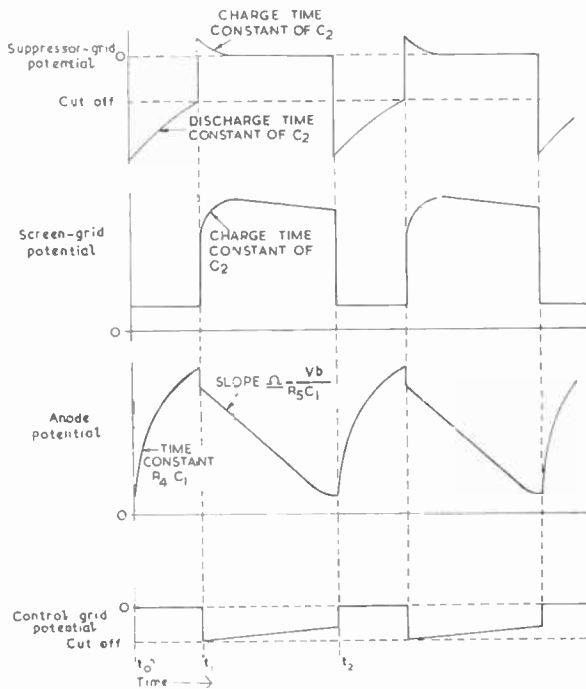

Fig. 87—Waveforms at the electrodes of a Miller-transistron circuit

there is no transistor circuit equivalent to the cathode-coupled astable multivibrator of Fig. 60.

19.3 OPERATION OF THE CIRCUIT

The circuit has the two possible states characteristic of transistrons, one identified by a minimum value of screen-grid current and the

other by a maximum value. The changes of state occur in a manner similar to those described earlier for multivibrators and transitrons and are very briefly outlined below.

We shall assume that the anode potential has just fallen to its minimum value and that the screen-grid current has just risen to its maximum value ($t = t_0$ in Fig. 87). The screen-grid potential has abruptly fallen, causing the suppressor-grid potential to fall equally. In the ensuing interval the suppressor-grid potential rises exponentially towards zero and the anode potential rises exponentially towards h.t. value. The interval is terminated ($t = t_1$) when the suppressor grid reaches cut-off value and anode current starts. This causes a change of state in which the screen-grid current abruptly falls, causing a sharp rise in screen-grid potential communicated to the suppressor grid via C_2 . In the following interval the anode potential performs its linear run-down, preceded by the initial sharp drop characteristic of Miller circuits. At the end of the run-down ($t = t_2$) the circuit reverts to the state assumed initially.

The derivation of expressions for the time constants are similar to those already given in the sections on the multivibrator and transitron circuits.

As shown in Fig. 87, the duration of the positive-going pulse at the screen grid is timed by the linear fall in anode potential (as in the phantastron circuits) and the duration of the succeeding negative-going pulse at the screen grid is timed by the exponential rise in suppressor-grid potential as in multivibrator circuits. The duration of the negative-going pulse could, of course, be reduced by returning the suppressor-grid resistor R_6 to h.t. positive, to reduce the flyback period, but it would then be necessary to connect a diode in parallel with the suppressor-cathode connections to ensure that the suppressor grid does not become sufficiently positive to cause secondary emission.

More details of this circuit are given in the section on sawtooth generators.

PART V : GENERATION OF SAWTOOTH WAVES

CHAPTER 20

FUNDAMENTAL PROPERTIES OF SAWTOOTH WAVES

20.1 INTRODUCTION

THE uses of sawtooth waves in television were enumerated in the first two chapters of this book; the chief application is in deflecting electron beams in camera tubes, flying-spot scanners and picture tubes. In magnetic deflection, sawtooth currents are passed through deflecting coils clamped to the outside of the tube neck and in electrostatic deflection sawtooth voltages are applied to deflecting plates inside the tube neck. Both types of deflection system require an amplifier with a sawtooth voltage input and thus the fundamental problem is that of providing a generator of sawtooth voltage. To produce the required scanning pattern two sets of deflection coils

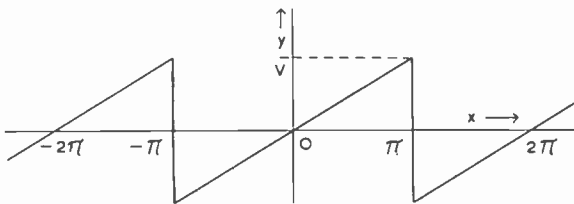

Fig. 88—Ideal sawtooth waveform

or plates are necessary, one supplied with a sawtooth at line frequency (for horizontal deflection) and the other with a sawtooth at field frequency (for vertical deflection). To avoid geometric distortion of reproduced pictures, both scans should be linear, i.e. the horizontal deflection should be such that the electron beam moves across the target or screen at a uniform velocity whilst, as a result of the vertical deflection, it also moves downwards at a (much smaller) uniform velocity. This implies that the working strokes of the line and field scanning waveforms should be linear. Ideally the flybacks

should be as rapid as possible because time occupied by this could be more usefully employed in transmitting pictures. Theoretically, therefore, the ideal scanning waveform has the sawtooth shape of Fig. 88. In practice, as we shall see, some deviations from this shape are not only tolerable but desirable. Before discussing these points, however, we will consider the properties of the ideal wave.

20.2 SPECTRUM OF IDEAL SAWTOOTH WAVE

The equation to the wave illustrated in Fig. 88 is

$$y = \frac{2V}{\pi} \left(\sin x - \frac{1}{2} \sin 2x + \frac{1}{3} \sin 3x - \frac{1}{4} \sin 4x + \dots \right) \dots (41)$$

This shows that the spectrum contains even and odd harmonics up to an infinite frequency but the coefficients of the terms decrease as frequency is raised. For example, the 20th harmonic has only 5 per cent of the amplitude of the fundamental component. It is possible, therefore, to attenuate some of the higher harmonics without causing undue departure from linearity in the forward stroke. Some attenuation (and associated phase-shift) is inevitable in practical circuits, due to their limited passband, and such circuits

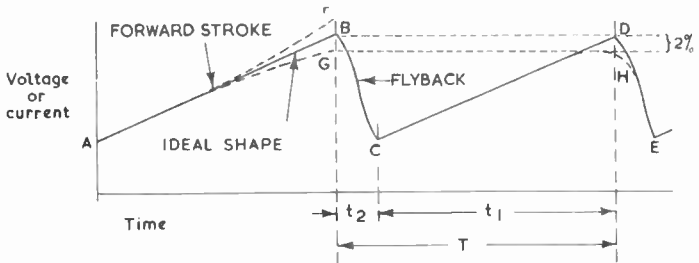

Fig. 89—Ideal sawtooth waveform (AB) and some non-linear approximations (AF, AG and CH)

cannot, therefore, produce perfect sawtooth outputs. Provided the response to harmonics up to, say, the 50th is satisfactory, the departure from linearity in the forward stroke may be tolerable. A limited passband also has an effect on the flyback which in practice will have an appreciable fall time and will therefore occupy a significant fraction of the sawtooth period. Thus the output of a sawtooth generator may have the forms shown in Fig. 89 in which the straight lines AB and CD represent the ideal, the dotted lines AF, AG and CH representing typical practical approximations to it.

20.3 EFFECTS OF NON-LINEARITY OF FORWARD STROKE

20.3.1 *Geometric Distortion*

One effect of non-linearity in the sawtooth wave is to cause geometric distortion of the reproduced picture: this is because the speed at which the spot flies across the scanned area either at the transmitting or receiving end is directly related to the change of scanning current or voltage with time. For example, if the slope of the line sawtooth current fed to a camera tube increases with time as shown by curve AF in Fig. 89, the spot velocity increases towards the end of each scanning line and scans, say, the right-hand side of the image more quickly than it should; if at the same time scanning is linear in the picture tube, the reproduced picture is crowded on the right-hand side. Conversely, if scanning is linear at the transmitting end but of the form shown by curve AF at the receiving end, the reproduced picture is "opened out" on the right-hand side.

If a scanning waveform at the transmitter has the shape AG (Fig. 89), the spot slows up as it traverses the right-hand side. If scanning is linear in the picture tube, the right-hand side is "opened out". If scanning is linear at the transmitter but of the form shown by AG at the receiving end, the picture is crowded on the right-hand side.

Similarly, non-linearity in field scanning causes crowding or "opening-out" at the bottom or top of the reproduced image.

20.3.2 *Shading*

Non-linearity in scanning waveforms can also bring about undesirable variations in the illumination of a receiving-tube screen although these are, in general, less objectionable than the geometric distortion. The light emitted from a cathode-ray tube screen is directly proportional to the intensity of the electron beam striking it and inversely proportional to the velocity with which the scanning spot moves across the screen. If the beam is of constant intensity but variable velocity, the screen is brighter where the velocity is low; it is for this reason that the trace observed on an oscilloscope screen during flyback periods is very faint compared with that produced on forward strokes. If the forward line scanning stroke in a picture tube is non-linear the trace is brighter at some parts of the line than at others and the screen is shaded from left to right. These variations in brightness are, of course, superimposed on the picture. This unwanted shading effect is sometimes described as "velocity modulation" because it is due to lack of constancy in scanning-spot velocity.

20.4 LINEARITY REQUIREMENTS

The degree of linearity of a sawtooth waveform may be expressed by quoting the maximum extent of the departure of the curve from the ideal straight line, expressing the departure as a percentage of the picture height or width. Pictures can be acceptable, and without obvious geometric distortion, even though the departure from linearity is as much as 5 per cent, provided that the deviation from linearity is gradual and occupies a considerable portion of the picture height or width as in curves AF and AG, but smaller degrees of non-linearity cause obvious distortion if the non-linearity is confined to a small fraction of the forward stroke, as in CH (Fig. 89). It is generally accepted that departures from the ideal are not troublesome provided they do not exceed ± 2 per cent of the picture width or height and provided they are spread over at least one-third of the picture width or height.

20.5 FLYBACK PERIOD REQUIREMENTS

As explained in Volume 1, an essential practical requirement of a television system is that there should be sync and blanking periods between consecutive strokes of the line- and field-scanning generators and there is little point in attempting to reduce the flyback time to less than that of these periods, which are commonly of the order of 10 per cent of the working stroke.

Moreover, a very short flyback period has a definite disadvantage in sawtooth waves for certain applications. The voltage developed across an inductor such as a scanning coil is directly proportional to the rate of change of current in it. A quick flyback is brought about by a rapid change in current, and a current which changes quickly in an inductor generates a large voltage across it. To withstand high voltages, the scanning coils must be well insulated and the provision of the necessary insulation places an economic limit on the extent to which it is desirable to shorten the flyback time. A rapid collapse of current also causes voltages to be induced in nearby conductors where their presence may be undesirable; for example, some of these voltages are radio-frequency harmonics of the sawtooth frequency and can cause interference with radio reception on nearby receivers. If the sawtooth generator is part of a television receiver, such voltages may also cause interference with reception on this receiver.

The presence of a large flyback voltage is, however, sometimes put to useful account by rectifying it to provide the e.h.t. supply for the final anode of the cathode-ray tube. This technique has the advantage of limiting the amplitude of the flyback voltage by damp-

FUNDAMENTAL PROPERTIES OF SAWTOOTH WAVES

ing it, i.e. by taking from the scanning coil some of the power which would otherwise go to building up the flyback voltage even further.

The shape of the waveform during the retrace or flyback periods (BC in Fig. 89) is usually of little consequence and in practical circuits this interval sometimes contains damped oscillations.

CHAPTER 21

FUNDAMENTAL PRINCIPLES OF SAWTOOTH GENERATORS

21.1 INTRODUCTION

IN most sawtooth generators the output voltage is generated across a capacitor by passing a current of suitable waveform through it. As shown in Chapter 1, to obtain a linear rise of output voltage for the working stroke the current should be constant. The input current can be of rectangular waveform, the horizontal sections of the wave coinciding in time with the linear rise of output voltage. Thus one type of sawtooth generator comprises a current source of rectangular waveform such as a multivibrator with a capacitive load; some sawtooth generators of this type are described later.

If no source of constant current is available an approximation to it may be obtained from a *constant-voltage* supply by connecting this to the capacitor by way of a series resistor. This simple circuit gives only an approximation to a linear output voltage because the current falls as the capacitor voltage rises; the capacitor voltage may be regarded as a *back e.m.f.* which opposes the steady voltage, reducing the voltage across the resistor and hence the current through it as charging proceeds. As a result of the gradually-diminishing current the voltage across the capacitor rises exponentially with time. Provided the voltage excursion is limited to the initial part of this exponential curve, the departure from linearity is not serious and sawtooth generators with an output thus restricted are suitable for many applications.

21.2 FUNDAMENTAL PROPERTIES OF CONSTANT-VOLTAGE SAWTOOTH GENERATOR

In the fundamental circuit shown in Fig. 90 the capacitor C charges from the h.t. supply through the resistor R_1 and discharges through R_2 when the switch S is operated. If R_2 is small compared with R_1 , the capacitor discharges more rapidly than it charges; thus the charging current provides the forward or working stroke and the discharging current provides the flyback voltage.

An alternative arrangement of the circuit is illustrated in Fig. 91, in which R_1 is left permanently in circuit and R_2 is brought into

FUNDAMENTAL PRINCIPLES OF SAWTOOTH GENERATORS

circuit by operation of the switch S . Provided R_1 is large compared with R_2 this circuit gives substantially the same performance as that of Fig. 90.

In the third possible arrangement of Fig. 92, when the switch S is closed, C is connected across the h.t. supply via the low-value

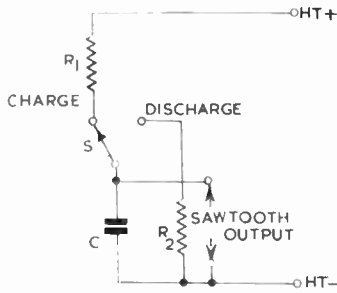

Fig. 90—Fundamental circuit for one type of sawtooth generator

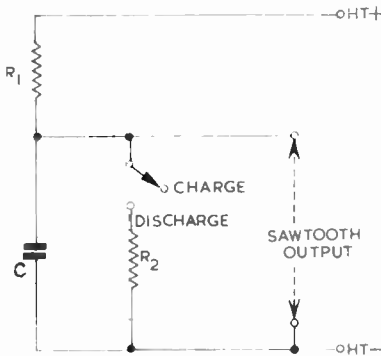

Fig. 91—Alternative circuit of sawtooth generator giving substantially the same performance as that of Fig. 90

resistor R_2 and charges rapidly to give the flyback voltage. When S is opened C discharges relatively slowly through the high-value resistor R_1 to give the approximately-linear working stroke. Here the working stroke coincides with *discharge* of C whereas in the previous two circuits it coincides with the *charge*: nevertheless for given values of R_1 and R_2 all three circuits produce similar

waveforms. This is true because the capacitor either charges or discharges through the greater of the two resistors to give the working stroke.

To simplify the following text all the circuits are drawn in the form of Figs. 90 or 91, the charge resistor being represented by R_c and the discharge resistor by R_d . It should be remembered, however, that the alternative connections of Fig. 92 are possible.

In a practical circuit R_c or R_d may be linear resistors or the electrode d.c. resistances of valves. The latter are often non-linear but

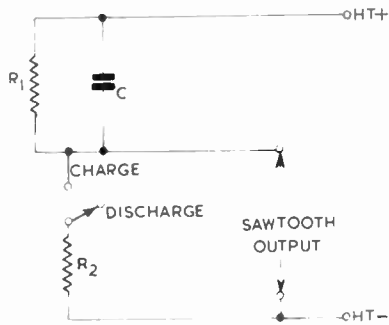

Fig. 92—Another alternative circuit for a sawtooth generator which gives substantially the same performance as that of Fig. 90

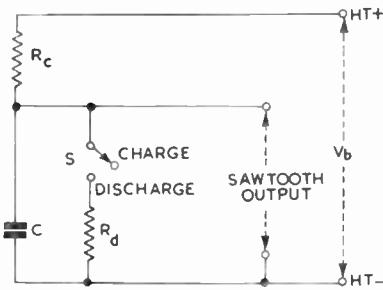

Fig. 93—Basic form of sawtooth generator circuit

the non-linearity can sometimes be put to good effect by arranging for it to oppose the curvature of the capacitor output voltage and give a better approximation to the required sawtooth form. Initially, however, we will assume that both charge and discharge resistors are linear and the basic circuit of the generator has the form shown in Fig. 93.

FUNDAMENTAL PRINCIPLES OF SAWTOOTH GENERATORS

If the capacitor is initially uncharged and the circuit is connected up with the switch S in the *charge* position as indicated, the voltage

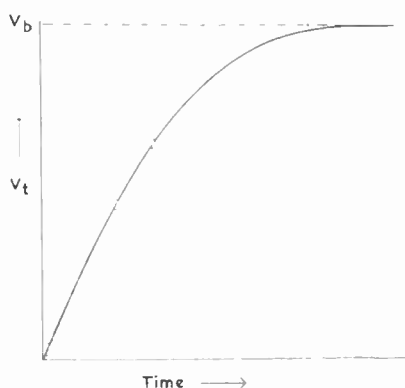

Fig. 94—Rise of voltage across capacitor C (Fig. 93) when the switch S is in the charge position

across C rises exponentially towards the value V_b as shown in Fig. 94, the curve obeying the equation

$$V_t = V_b(1 - e^{-t/R_c C}) \quad \dots \quad (42)$$

in which V_t is the voltage across C at an interval t after switch-on. This equation is deduced in Appendix B of Volume 2. The rate of rise of voltage is governed by the product $R_c C$, the *charge time constant* of the circuit.

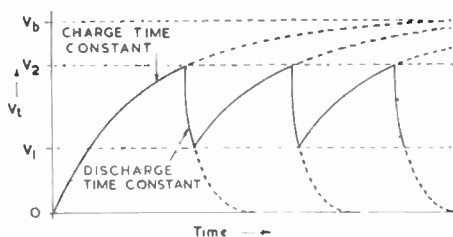

Fig. 95—Voltage across capacitor C (Fig. 93) when the switch S is alternately operated from the charge to the discharge positions

Suppose the switch S is operated to the *discharge* position at the instant when the voltage across C is equal to V_2 (Fig. 95). The

capacitor discharges into R_d and the voltage across C falls exponentially as shown, the curve obeying the equation:

$$V_t = V_2 e^{-t/R_d C} \quad \dots \quad \dots \quad \dots \quad (43)$$

(also deduced in Appendix B of Volume 2). The fall of voltage is determined by the product $R_d C$, known as the *discharge time constant*.

If when the voltage across C has fallen to the value V_1 , the switch S is again operated to the *charge* position, the discharge of C ceases and it begins to charge again according to equation (42). By operating the switch S to the *charge* position whenever the voltage across C rises to V_2 and to the *discharge* position whenever the voltage falls to V_1 , the voltage across C varies as shown in Fig. 95. This is a series of exponential rises and falls which approximates to the required sawtooth.

21.3 RELATIONSHIP BETWEEN SAWTOOTH AND RECTANGULAR-WAVE GENERATORS

The switch S (Fig. 93) has the function of reversing the direction of the current through the capacitor at the required instants. Its place could be taken by a multivibrator or any other source of rectangular-current waveform. This also follows from the fundamental considerations in Chapter 1 where it was shown that the waveform of the voltage across a capacitor approximates to the integral of the current waveform applied to it. If the current is of rectangular waveform the voltage is of sawtooth form. Thus a sawtooth-generator output can be obtained from a rectangular-current generator by giving it a capacitive load.

The parent rectangular-current generator can, of course, be bi-stable, monostable or astable and it is instructive to consider how the sawtooth output depends on the nature of the parent generator. If the parent generator is astable, the output is a continuous sawtooth and there is no need for signals from an external source. Such a generator can, however, readily be synchronised at the frequency of an externally-applied signal. Sawtooth generators of this type are termed *free-running*.

If the parent generator is monostable, it cannot generate continuous sawtooths without triggering signals from an external source. In effect, the signals operate the switch S in one direction (thus initiating, say, the working stroke) but the generator itself operates the switch in the reverse direction (to initiate the flyback stroke). Alternatively, of course, the external signal can start the flyback and the internal signal the forward stroke. In either case, one external signal is necessary to produce one complete cycle of

sawtooth output, i.e. one forward stroke followed or preceded by a flyback stroke. External signals are essential for this type of sawtooth generator which is therefore termed a *driven* type.

If the parent generator is bi-stable, external triggering signals are necessary to initiate both the forward and the return strokes: that is to say, two external signals are required to produce one cycle of sawtooth output. Sawtooth generators of this type are also termed *driven* but they are less frequently encountered than the monostable type.

The preceding classification applies to circuits such as multi-vibrators which are fundamentally generators of rectangular-current waves and which can be used to generate sawtooths by the addition of a capacitive load. There are, however, a number of generators which, without an additional capacitor, produce a sawtooth output at one point and a rectangular output at another. An example is the Miller-transitron circuit which generates a sawtooth output at the anode and a rectangular output at the screen grid. If the circuit is used as a source of rectangular waves, the sawtooth output acts as a timing waveform. The main aim in design is then to obtain a small rise time and negligible sag in the rectangular output, the shape of the sawtooth output being of little concern provided the timing is precise. Alternatively if the circuit is used as a source of sawtooth waves, attention in design is directed towards obtaining good linearity, the shape of the rectangular output being of little interest. Due to these differences in aim, the circuit of a Miller-transitron for producing rectangular waves may differ from that used for generating sawtooths.

21.4 PROPERTIES OF FREE-RUNNING SAWTOOTH GENERATOR

From Fig. 95 it is possible to predict some of the properties of the simple RC sawtooth generator in which the switch S automatically operates when the output voltage reaches the critical values V_1 and V_2 . For example, if the time constant $R_c C$ is increased by increasing R_c or C , charging proceeds more slowly and the voltage across C takes a longer time to rise from the lower critical voltage V_1 to the higher critical voltage V_2 , as illustrated in Fig. 96, in which, for simplicity, ideal sawtooth waveforms are shown. The effect of *increasing* the time constant is to *decrease* the frequency of the sawtooth waveform, the output amplitude remaining constant. The variable resistor or capacitor could hence be labelled as a *frequency control*.

Now consider the effect of increasing V_2 , the upper critical voltage to which the capacitor charges. Increasing V_2 brings about an

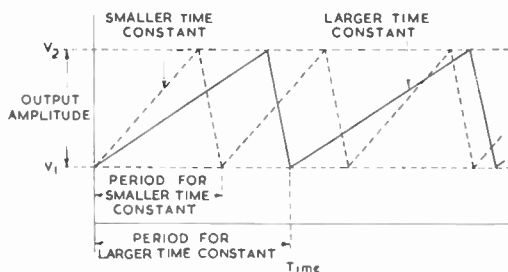

Fig. 96—Effect of increasing the time constant in a free-running simple RC sawtooth generator

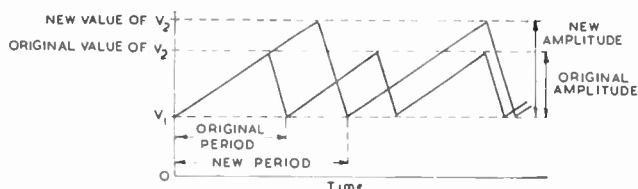

Fig. 97—Effect of increasing upper critical voltage in a free-running simple RC sawtooth generator

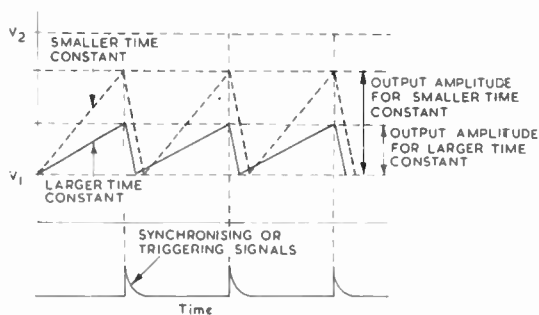

Fig. 98—Effect of increasing the time constant in a synchronised or triggered simple RC sawtooth generator

FUNDAMENTAL PRINCIPLES OF SAWTOOTH GENERATORS

increase in output amplitude and a decrease in frequency because, for a given time constant, the voltage across C takes longer to reach the new value of V_2 , as illustrated in Fig. 97.

21.5 PROPERTIES OF DRIVEN OR SYNCHRONISED SAWTOOTH GENERATORS

If the generator is synchronised or triggered, the behaviour of the circuit is quite different. The switch S is now controlled by the external signal and the frequency of the sawtooth cannot vary. When R_cC is increased, the rate of rise of voltage across C is decreased and the change in voltage which is accomplished during the period of the forward stroke is reduced, as illustrated in Fig. 98. The variable resistor or capacitor does not now control the *frequency* but the *amplitude* of the output.

The value of V_2 has no significance in a synchronised or triggered circuit, because the forward stroke is terminated by the external signal: thus alteration in the value of V_2 has no effect either on the amplitude or the frequency of such a circuit. The conclusions of the last few paragraphs are summarised in the following table:—

<i>Adjustment</i>	<i>Circuit Type</i>	<i>Effect</i>
Increase R_c or C	Free running	Decrease output frequency
	Synchronised or triggered	Decrease output amplitude
Increase V_2	Free-running	Increase output amplitude and decrease output frequency
	Synchronised or triggered	None

21.6 METHODS OF LINEARISING THE OUTPUT OF A SIMPLE RC SAWTOOTH GENERATOR

The output of a simple RC sawtooth generator is exponential, but if the voltage excursion is limited to the initial part of the curve the output is very nearly directly proportional to time. In fact, by suitably limiting the output voltage, the departure from linearity can be reduced to an acceptable value and a simple RC circuit suffices for a number of practical applications. It is shown in Appendix C on page 172 that if the voltage excursion is limited to 10 per cent of the h.t. voltage, the departure from linearity is within ± 2.5 per cent and if it is limited to 4 per cent of the h.t. supply, the departure is within ± 1 per cent. If the h.t. supply is 250 volts, therefore, a 10-volt output can be obtained for an error of less than 1 per cent; such an output is sufficient to drive the valve feeding

the scanning coils of a picture tube and simple RC sawtooth generators are extensively used in television receivers.

Because the output voltage must be limited to a small fraction of the h.t. voltage to give good linearity, a large sawtooth voltage, if generated directly in a simple RC circuit, necessitates a high h.t. voltage. There are three methods of linearising the output of the simple circuit thereby enabling a large linear output to be obtained with a normal value of h.t. voltage.

- (a) By including an inductor in series with the resistor R_c (Fig. 93). It is a property of an inductor that a varying current in it induces a voltage across it which tends to oppose the changes in current. Thus by including the inductor the variations in charging current are reduced and the linearity of the output is correspondingly improved. There is no optimum value for the inductor; the larger it is made the more nearly does the output approach the ideal sawtooth form.
- (b) By use of a feedback circuit which ensures that the capacitor is fed with a substantially-constant current during the working stroke. Two examples of such circuits are the Miller integrator and the Bootstrap, both described later.
- (c) By use of a non-linear resistor for R_c which varies with the voltage across it in such a way that the current supplied to the capacitor during the working stroke is substantially constant. A non-linear resistance of this type is the anode d.c. resistance of a pentode valve and a number of sawtooth generators employ such a valve. The use of the pentode for such a purpose is described in the next few paragraphs.

21.7 USE OF A PENTODE AS A CONSTANT-CURRENT SOURCE

The anode current of a pentode is determined primarily by its control-grid and screen-grid potentials and is almost independent of the anode potential unless this is within 10 or 20 volts of the cathode potential. If, therefore, the control-grid and screen potentials are fixed and the pentode has a capacitor as an anode load as shown in Fig. 99, the capacitor will acquire charge by current supplied from the h.t. supply via the pentode valve. This current will be constant and the voltage across the capacitor will rise linearly with time.

To generate a sawtooth output from such a circuit it is necessary to connect across the capacitor a device which discharges it to produce a flyback voltage. Such a device is illustrated in generalised form in Fig. 99. The rate of change of the linear rise of voltage across C depends on the pentode anode current and can be controlled

FUNDAMENTAL PRINCIPLES OF SAWTOOTH GENERATORS

by adjustment of the control-grid, screen-grid or suppressor-grid potential; such a control may be termed a *speed* or *velocity* control.

The superiority of a circuit using a pentode over one using a linear resistor can be assessed by evaluating the constants of a

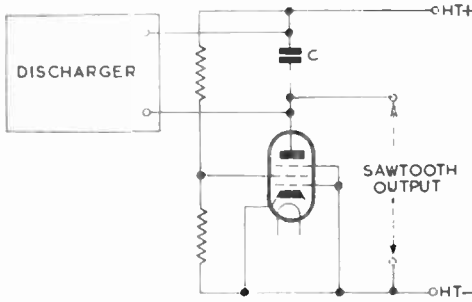

Fig. 99—Essential features of a sawtooth generator using a pentode as constant-current source

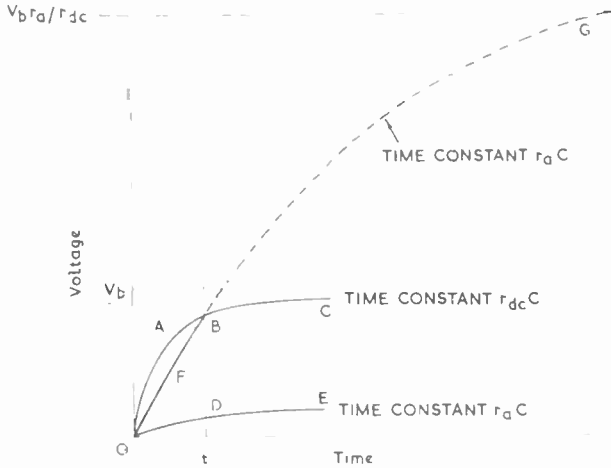

Fig. 100—Performance of sawtooth generator using a pentode compared with that using linear resistors

simple linear RC circuit giving the same performance as the pentode.

First consider a linear circuit which gives a voltage output equal to that of the pentode with the same value of h.t. supply. The

value of linear resistor required to give such a performance is equal to the average value of the *anode d.c. resistance* r_{ac} of the pentode and the output voltage from the linear circuit has the form illustrated by curve OABC in Fig. 100.

The pentode is, however, non-linear and although the rate of change of voltage across C is determined by its anode current,

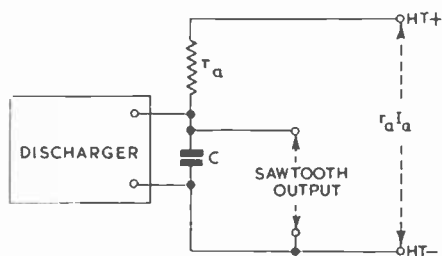

Fig. 101—Linear circuit equivalent to a pentode

changes in voltage across the capacitor produce very small changes in current. The ratio of V_a to I_a is, in fact, the *anode a.c. resistance* r_a of the pentode and is large compared with r_{ac} . The *linearity* of the voltage developed across C is thus equivalent to that of a circuit with a time constant of $r_a C$. Curve ODE illustrates the performance of a *linear* circuit with this value of time constant. Between the ordinates at O and t this curve is a better approximation to the ideal straight line than curve OABC, but the extent of the change in voltage, i.e. the voltage output, is much reduced.

Curve OFB illustrates the performance of the pentode. This is part of the exponential curve OFBG which has the same form and corresponds to the same time constant as curve ODE, but the ordinates are multiplied by r_a/r_{ac} . Curve OFBG thus corresponds to an h.t. supply of $V_b r_a/r_{ac} = I_a r_a$ but only the initial part shown solid, and corresponding to a voltage swing of less than V_b , can be realised in practice; the remainder of the curve (shown dotted) is of theoretical interest only.

21.8 EQUIVALENT CIRCUIT OF PENTODE

The equivalent circuit of the pentode is thus as shown in Fig. 101. It has a linear resistor r_a equal to the anode a.c. resistance of the pentode and an h.t. supply equal to $r_a I_a$.

As an example a pentode consuming 5 mA from an h.t. supply of 250 volts and having an r_a of 1 megohm gives the same performance

in respect of voltage output and linearity as a simple linear circuit including a resistor of 1 megohm and an h.t. supply given by

$$\begin{aligned} I_a r_a &= 5 \times 10^{-3} \times 10^6 \text{ volts} \\ &= 5,000 \text{ volts} \end{aligned}$$

The sawtooth output voltage must necessarily be less than the h.t. voltage but could nevertheless be as much as 200 volts. This is only 4 per cent of the 5,000 volts h.t. required by the equivalent linear RC generator and, as we have already seen, the departure from linearity is unlikely to exceed ± 1 per cent.

A pentode charging circuit can alternatively be regarded as one in which a capacitor charges via a d.c. resistance which varies in such a way as to produce a linear rise in voltage. The anode current of a pentode is substantially independent of the anode potential and the anode d.c. resistance of the valve is therefore directly proportional to its anode potential. A capacitor connected in series with a pentode charges via a d.c. resistance which falls at the same rate as the voltage across the pentode, thus maintaining a constant charging current. The higher the anode a.c. resistance of the pentode, the less dependent is the anode current on anode potential and the more constant is the charging current in the circuit. Thus the performance of a pentode as a constant-current source can be improved by including an undecoupled resistor in the cathode circuit. This gives current negative feedback which increases the effective anode a.c. resistance. To obtain maximum benefit from such a feedback resistor the screen grid must be decoupled to the cathode of the valve.

APPENDIX C

USE OF THE INITIAL PART OF AN EXPONENTIAL CURVE AS AN APPROXIMATION TO A LINEAR CHARACTERISTIC

WHEN a capacitor C is charged from a constant-voltage supply of voltage V_b via a resistor R , the voltage across C at a time t after the first application of the voltage is given by

$$\frac{V_t}{V_b} = 1 - e^{-t/RC} \quad \dots \quad (1)$$

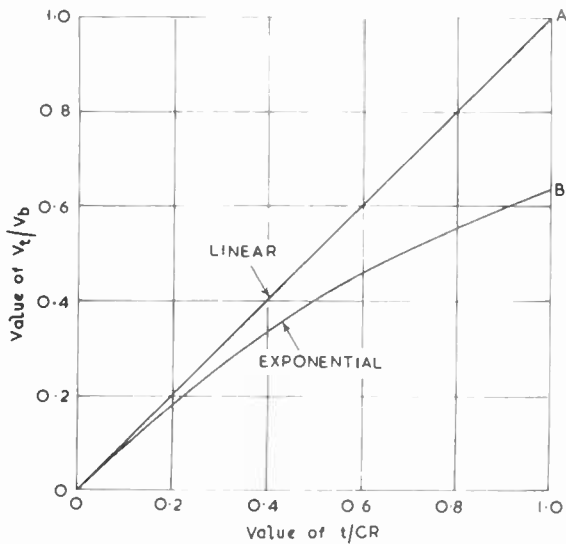

Fig. 102—The straight line OA has the same slope as the exponential OB at the origin

an equation derived in Appendix B of Volume 2. The curve of this equation is OB in Fig. 102. The slope of the curve at any point

APPENDIX C

is obtained by differentiating $V_t(1)$ thus

$$\frac{dV_t}{dt} = \frac{V_b}{RC} e^{-t/RC} \quad \dots \quad \dots \quad \dots \quad (2)$$

The slope of the curve at the origin is given by putting $t = 0$ in (2) giving

$$\frac{dV_t}{dt} = \frac{V_b}{RC} \quad \dots \quad \dots \quad \dots \quad \dots \quad (3)$$

OA is the straight line passing through the origin with this value of slope: its equation is

$$\frac{V_t}{V_b} = \frac{t}{RC} \quad \dots \quad \dots \quad \dots \quad \dots \quad (4)$$

The exponential curve coincides with the straight line at $t = 0$ and approximates to it at small values of t , departing from it as t increases. The difference between the two characteristics for various values of

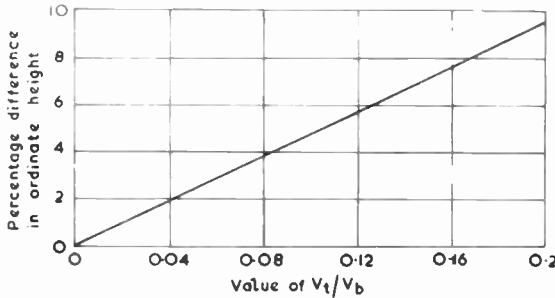

Fig. 103—Percentage departure of the initial part of an exponential curve from linearity

t/RC can be obtained from equations (1) and (4) or can be obtained approximately by interpolation from Fig. 102. As an example of such a determination let $t/RC = 0.1$. From (4)

$$\frac{V_t}{V_b} = \frac{t}{RC} = 0.1$$

From (1)

$$\begin{aligned}
 \frac{V_t}{V_b} &= 1 - e^{-t/RC} \\
 &= 1 - e^{-0.1} \\
 &= 1 - 0.905 \\
 &= 0.095
 \end{aligned}$$

Thus when $t/RC = 0.1$ the ordinate to the exponential curve is 5 per cent less than that to the linear characteristic. This is true for $V_t/V_b = 0.1$, i.e. when the voltage excursion is 10 per cent of the h.t. voltage. This calculation can be repeated for various values of t/RC and the results are exhibited in Fig. 103 which shows the percentage difference between the two curves as a function of V_t/V_b .

CHAPTER 22

SAWTOOTH GENERATORS USING SIMPLE VALVE DISCHARGERS

22.1 INTRODUCTION

MANY sawtooth generators consist fundamentally of a capacitor which is charged relatively slowly to produce a rise of voltage for the working stroke and is discharged rapidly to produce a quick fall for the return or flyback stroke. A generalised circuit for this type of generator is given in Fig. 104. We have considered in the previous

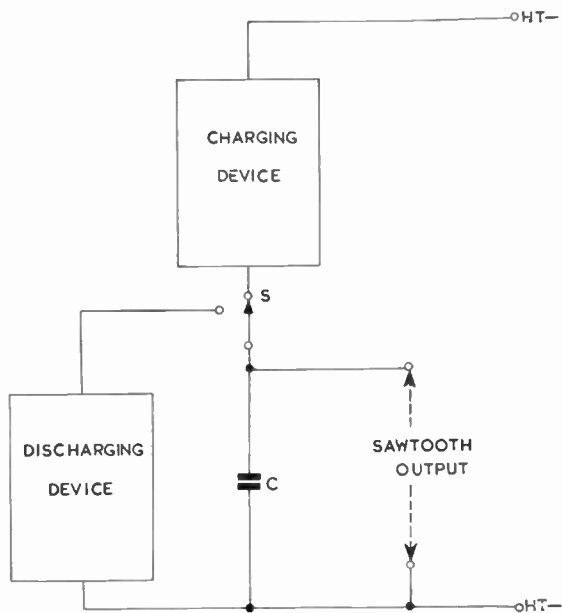

Fig. 104—Fundamental circuit of sawtooth generator

chapter some of the devices which can be used to supply the constant charging current which is essential to give a linear change of voltage for the working stroke. In this chapter we shall describe some of

the simple devices which are used to discharge the capacitor, and we shall describe a number of complete sawtooth generators using simple chargers and dischargers.

The discharger may consist of a passive device such as a low value of resistance, for example, the anode-cathode resistance of a gas or vacuum valve, or it may take the form of an active network such as a multivibrator or a blocking oscillator.

By using various combinations of charger and discharger a large number of different types of sawtooth generator can be produced;

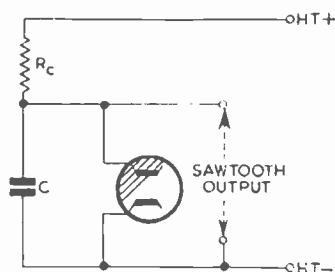

Fig. 105—Simple sawtooth generator using a gas-diode discharger

for example, one type of line sawtooth generator commonly used in television receivers consists of a linear resistor as charger and a blocking oscillator as discharger. In the Puckle time base a pentode is used as charger and a multivibrator as discharger. The remainder of this chapter is devoted to some of the most commonly encountered forms of sawtooth generator.

22.2 GAS-DIODE SAWTOOTH GENERATOR

Fig. 105 gives the circuit of a very simple type of sawtooth generator in which the charging device is a linear resistor R_c and the discharging device is a gas diode. The diode also carries out the function of the switch S in Fig. 93. V_1 and V_2 in Fig. 95 being the extinguishing and striking potentials respectively of the gas. This circuit was used many years ago as a time-base generator but is now only of theoretical interest.

When the circuit is connected up, the voltage across C builds up until it reaches the striking voltage of the gas diode, say 130 volts. During the time the voltage is below this critical value the diode takes negligible current and can be regarded as an open circuit. When the diode strikes, however, the gas ionises and becomes a low

SAWTOOTH GENERATORS USING SIMPLE VALVE DISCHARGERS

resistance which begins to discharge the capacitor rapidly. The voltage across the capacitor now falls to the value at which it is incapable of maintaining the gas in an ionised, i.e. conductive, state. At this, the extinguishing voltage (say 100 volts), the gas ceases to conduct and the capacitor begins again to acquire charge from the h.t. supply. So the cycle continues, the circuit operating as a free-running sawtooth generator. The striking voltage is the upper critical voltage, mentioned in the previous chapter, and the extinguishing voltage is the lower critical voltage.

The frequency of the sawtooth can be altered by varying the value of R_c or C as explained earlier but, due to the finite time taken by the gas ions to recombine when the extinguishing potential is reached, must be less than approximately 50 kc/s. The output amplitude is independent of the frequency, being equal to the difference between the striking and extinguishing potentials for the gas diode, i.e. 30 volts if $V_1 = 100$ volts and $V_2 = 130$ volts as suggested above.

22.3 GAS-TRIODE SAWTOOTH GENERATOR

22.3.1 Free-running Circuit

Fig. 106 gives the circuit of a sawtooth generator in which the charging device is a linear resistor R_c and the discharging device is

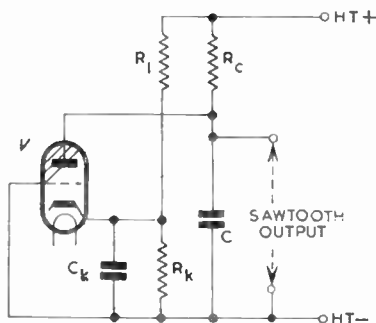

Fig. 106—Sawtooth generator using a gas-triode discharger

a gas triode V : the circuit may be regarded as a more versatile version of the previous type. Circuits similar to this are sometimes used as the line or field sawtooth generators of television receivers.

Before discussing the operation of the circuit we shall briefly describe the chief properties of the thyatron (gas triode).

When the valve conducts, the grid potential has no effect on the

anode current and the valve can be made non-conductive only by reducing the anode potential almost to zero. If, with zero anode current and a negative grid-bias potential, the anode potential is raised, the anode current remains at zero until a certain anode potential is reached when full conduction occurs. The value of this anode potential depends on the grid potential; the more negative the grid is, the higher must be the anode potential to give conduction. If the anode potential is set to a value just below that necessary for conduction, the valve conducts if the grid is made slightly more positive. The ratio of the change in anode potential to the change in grid potential necessary to promote conduction is known as the *control ratio* and is commonly between 20 and 40.

Thus the thyatron may be regarded as a gas diode in which the lower critical voltage is nearly zero and the upper critical voltage may be varied by adjustment of grid bias; moreover the thyatron can be made conductive by positive pulses applied to the grid.

In Fig. 106 grid bias is applied to the valve by the potential divider R_1R_k connected across h.t. supply and the bias can be varied by adjustment of R_k . Provided the h.t. supply voltage exceeds the upper critical voltage for the setting of R_k , this circuit will operate as a free-running sawtooth generator, the mechanism being similar to that for the gas diode. If the valve is initially non-conductive and the anode potential zero, the capacitor C charges from the h.t. supply and the voltage across the capacitor rises exponentially. When the voltage reaches the upper critical value the valve conducts and the capacitor begins to discharge through the valve. This discharge continues until the voltage across C reaches the lower critical value when the valve becomes non-conductive again. The cycle then recommences.

As shown in Fig. 96, the frequency of the output waveform can be varied by adjustment of R_c or C , alteration in either component value altering the speed with which the anode potential approaches the upper critical value. Moreover, the upper critical potential can be varied by adjustment of R_k ; thus the value of R_k also has an effect on the free-running frequency as shown in Fig. 97. The amplitude of the output is the difference between the two critical voltages and can be varied by adjustment of the cathode bias resistor R_k ; this is also illustrated in Fig. 97.

22.3.2 Synchronised Circuit

The circuit can be synchronised by regularly occurring positive pulses applied to the grid circuit, as shown in Fig. 107. This effects the mechanism of operation in the following way. Assume that

SAWTOOTH GENERATORS USING SIMPLE VALVE DISCHARGERS

the valve is initially non-conductive. The capacitor C begins to charge from the h.t. supply and the adjustment is such that a sync pulse is received and initiates conduction before the anode potential reaches the striking potential. The capacitor is now rapidly discharged and the voltage across it falls to the lower critical value at which the valve ceases to conduct. C now begins to charge again and so the process repeats itself. Since the valve is rendered conductive by each sync pulse before it would become so automatically if unsynchronised, the amplitude of the output is smaller and the frequency higher than in the absence of sync pulses.

The effect of varying R_r and C when the thyatron is synchronised differs from that described for the free-running generator. The output frequency is, of course, determined by the sync signals and

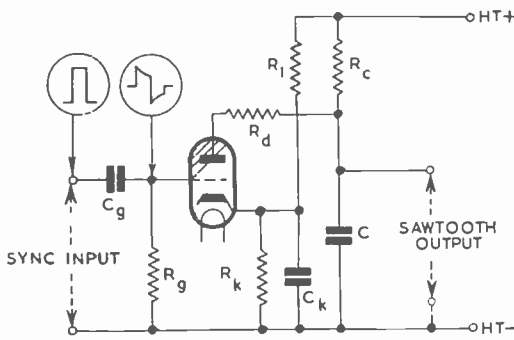

Fig. 107—A gas-triode sawtooth generator with provision for application of sync signals

adjustment of R_r or C controls the amplitude of the output as shown in Fig. 98. Alteration in the value of R_k affects the sensitivity of the circuit to the synchronising signals, but if R_k is increased beyond a certain value the circuit ceases to be free-running in the absence of sync signals.

Unless precautions are taken, gas triodes can take extremely large anode currents and the bombardment of the cathode by heavy positive ions released during conduction can seriously reduce the useful life of the valve. The resistor R_d in the valve anode lead in Fig. 107 is included to limit the anode current to a reasonable value and is commonly of the order of 1,000 ohms. Since C discharges into R_d and the gas triode in series, R_d also controls the

179

The performance of this circuit is greatly dependent on the duration of the trigger pulses; in this respect the circuit differs markedly from that using a gas triode in which the performance is

183

22.4 VACUUM-TRIODE SAWTOOTH GENERATOR

22.4.1 Introduction

It is possible to replace the gas triode of the sawtooth generator described above by a vacuum triode. Although the anode d.c.

CHAPTER 23

BLOCKING-OSCILLATOR SAWTOOTH GENERATORS

23.1 INTRODUCTION

THE vacuum-triode sawtooth generator as described in the previous chapter is essentially a driven type because an external signal is required to switch the valve from non-conduction to conduction at the required instants. However, such a generator can be made free-running by including additional components which ensure recurrent periods of conduction. This can be done by coupling the anode and grid circuits to form a blocking oscillator, a development of the squegging oscillator described on page 41. Such an

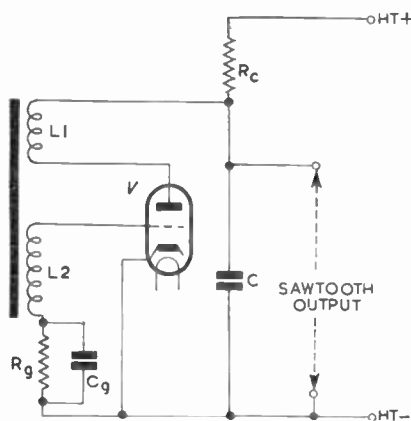

Fig. 110—Basic circuit of sawtooth generator using a blocking-oscillator discharge

oscillator is well suited for use in a sawtooth generator because the interval between the bursts of conduction can be very simply varied over a wide range and the oscillator can readily be synchronised at the frequency of any applied signal.

23.2 OPERATION OF THE CIRCUIT

The circuit of a simple type of blocking oscillator is given in Fig. 110. R_c and C are the fundamental components and the

BLOCKING-OSCILLATOR SAWTOOTH GENERATORS

additional components introduced to make the circuit free-running include the transformer and $R_g C_g$, the time constant controlling the interval between bursts of conduction.

The mechanism of operation of a blocking oscillator is complex and the following description is simplified. We shall assume that C_g is charged to a negative potential high enough to bias the valve beyond cut-off. C_g discharges through R_g and the voltage across the combination falls exponentially, causing the grid potential of the valve V to become less negative. At the same time, C charges through R_c from the h.t. supply and the voltage across C rises exponentially, causing the valve anode potential to rise. The voltage across C is the output of the sawtooth generator and the conditions described are those existing during the forward stroke.

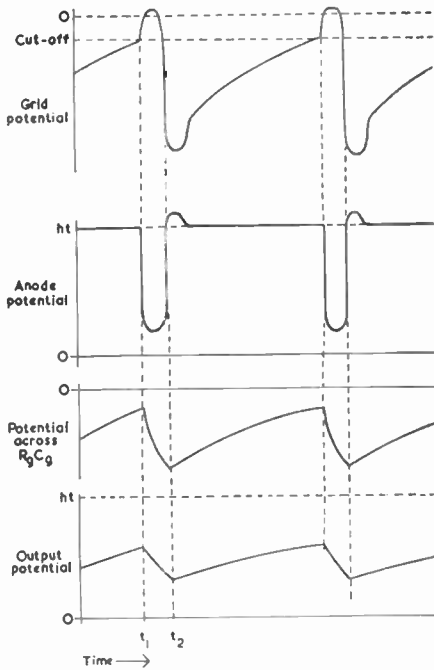

Fig. 111—Waveforms in blocking-oscillator sawtooth generator

The positive-going grid and anode potentials tend to cause conduction and, after an interval, anode current starts at the instant t in Fig. 111. This marks the beginning of the flyback period.

The start of anode current in L_1 induces a voltage in L_2 which is so connected that the induced voltage tends to drive the grid positive, still further increasing the anode current. Thus the growth of anode current is speeded by regeneration and the current rapidly assumes a large value which quickly discharges C to produce the flyback voltage. At the same time the voltage across L_2 rises very rapidly to a positive value which can be a large fraction of the h.t. voltage. This causes grid current which flows into C_g , charging it to a negative voltage approximately equal to that across L_2 . (This compares with the behaviour of a diode detector in which the voltage developed across the load circuit is nearly equal to the peak applied voltage.) Since the negative voltage across C_g opposes the positive voltage across L_2 , the net grid-cathode voltage does not rise appreciably above zero and the anode current rises to the value corresponding to zero grid potential.

At the same time as the grid voltage increases (tending to increase anode current) the anode potential falls (as C discharges), this tending to decrease anode current. The effect of the falling anode voltage is to retard the growth of anode current and, after a time, the current becomes momentarily stationary, at a maximum value, at an instant between t_1 and t_2 . At this instant, the rate of change of anode current is zero and the induced voltage in L_2 is also zero, leaving the negative voltage across C_g as the only input signal for the valve. This causes the anode current to fall, a process which is hastened by regeneration since a falling current in L_1 induces a voltage in L_2 which drives the grid negative, accelerating the collapse of anode current. Thus the anode current falls rapidly to zero and the grid potential assumes a large negative value due to the sum of the negative voltage generated across L_2 and that stored in the capacitor C_g . These are the conditions in the circuit at the instant t_2 and they mark the end of the flyback period.

The anode current is now zero and C begins to charge from the h.t. supply to start another forward stroke. As the rate of change of anode current is also zero, the voltage induced in L_2 falls to zero and the grid potential is that due to C_g , a large negative voltage which keeps the valve cut off. The circuit is now back in the state assumed initially. So the cycle continues, the valve having recurrent bursts of conduction at a rate dependent on the time constant $R_g C_g$.

As shown in Fig. 111, the voltage generated across $R_g C_g$ is a poor approximation to a sawtooth waveform but where such a departure from linearity can be tolerated, this voltage can be used for deflection purposes, the components R_c and C being omitted. The linearity is poor because the capacitor C_g discharges almost completely

BLOCKING-OSCILLATOR SAWTOOTH GENERATORS

before each conduction period and the voltage across C_g thus consists of an almost complete exponential curve.

23.2.1 Conditions for Satisfactory Operation

The blocking oscillator may be regarded as a squegging oscillator in which the oscillation preceding each exponential fall in the grid waveform is limited to a single cycle. To achieve this limitation the following conditions must be observed:

- The coupling between the anode and grid coils must be very tight to give great regeneration and cause a rapid build-up of positive voltage across L_2 once anode current starts.
- The damping of the resonant circuit formed by L_2 and its self and stray capacitances must be so heavy that only one cycle of oscillation occurs each time anode current is restored.
- The valve must have a high mutual conductance and high emission to enable it to deliver a large current into C_g the moment regeneration occurs.

The first two conditions are usually met by winding L_1 and L_2 as a transformer, generally of unity turns ratio, on a laminated iron

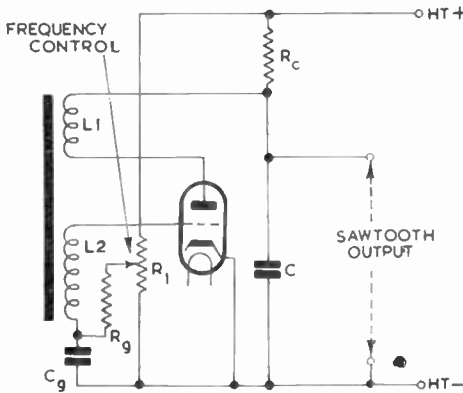

Fig. 112—One method of controlling the frequency of a blocking-oscillator discharger

core. This can give a coupling coefficient approaching unity and, if the resonance frequency of the winding L_2 is high (50 — 100 kc/s is a common value for a line-sawtooth generator), the hysteresis losses of the core provide the required damping.

23.3 METHODS OF CONTROLLING FREQUENCY AND OUTPUT AMPLITUDE

The frequency of the anode current pulses can be altered by variation of R_g or C_g ; alternatively, R_g and C_g may be fixed and R_g returned to the slider of a potentiometer R_1 across the h.t. supply as shown in Fig. 112 in which R_1 acts as frequency control. The latter method of controlling frequency has much in common with that used in multivibrators and described on page 88. It has the advantage that the potentiometer carries d.c. only and may be

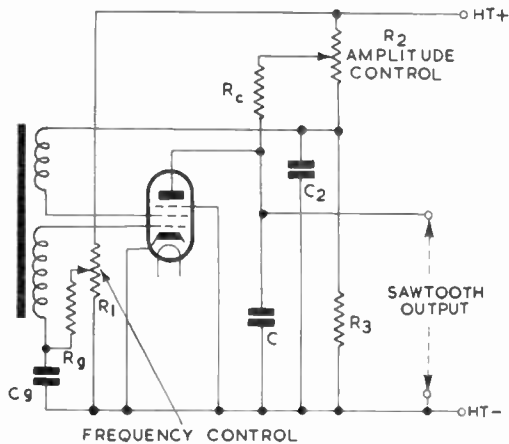

Fig. 113—Method of controlling the frequency and output amplitude of a blocking-oscillator discharger by means of potentiometers

situated at some distance from the blocking oscillator, the length of the leads having virtually no effect on the performance of the oscillator.

The amplitude of the output can be varied by adjustment of R_c , as explained earlier. The technique of using a potentiometer across the h.t. supply can be used to control the amplitude as in the circuit shown in Fig. 113. A circuit of this type enables both frequency and amplitude controls to be situated at some distance from the generator.

The circuit of Fig. 113 uses a pentode of which the cathode, control grid and screen grid are connected as the blocking-oscillator discharger, the time constant circuit R_cC being connected in the

BLOCKING-OSCILLATOR SAWTOOTH GENERATORS

anode circuit. R_2 functions as amplitude control and it also forms, with R_3 , a fixed potential divider for feeding the screen grid. C_2 is a decoupling capacitor which ensures that the h.t. supply for the screen grid is free from any sawtooth potentials developed across the upper part of R_2 by the main time constant circuit $R_c C$ and from any fluctuations due to short pulses from the screen circuit itself.

23.4 METHODS OF SYNCHRONISING BLOCKING OSCILLATORS

A blocking oscillator may be synchronised by positive-going signals applied to the control grid or negative-going signals applied to the anode; the latter are, of course, phase-inverted by the transformer and become in effect positive-going signals at the grid. To give precision in synchronising, the signals should preferably have a very steep leading edge. Such signals terminate the forward stroke by switching the valve to conduction earlier than would

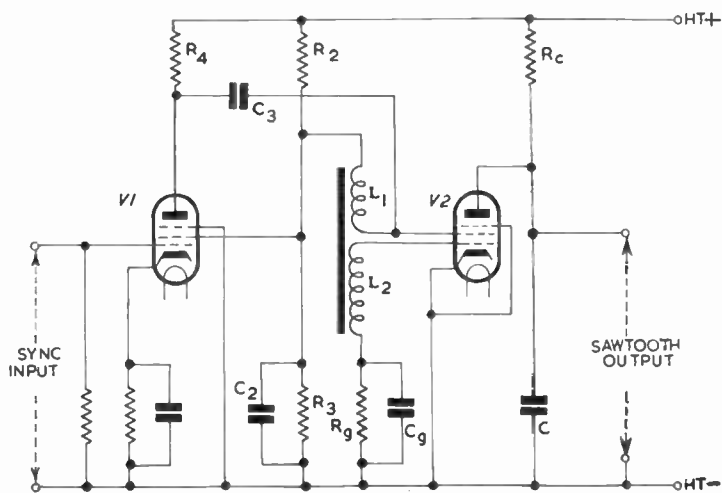

Fig. 114—A buffer stage used to inject synchronising pulses into a blocking-oscillator sawtooth generator

occur naturally. Thus the synchronised oscillator operates at a frequency above its natural frequency; moreover, the sawtooth amplitude is less than under free-running conditions. Any of the circuits described on page 114 for synchronising multivibrators can be used for blocking-oscillator dischargers and a typical example of a circuit using a buffer stage is given in Fig. 114.

23.5 DESIGN OF A BLOCKING-OSCILLATOR SAWTOOTH GENERATOR

23.5.1 Introduction

As a practical example we will consider the design of a blocking-oscillator sawtooth generator of the type shown in Fig. 112 for generating sawtooths at a frequency of 10 kc/s, flyback occupying 10 per cent of the total period. The discharger is to be synchronised and hence must be designed to have a natural frequency lower than 10 kc/s; the natural frequency can, of course, be varied over a wide range by adjustment of R_1 and we will assume that the natural frequency is 8 kc/s with R_1 at its mid-position. Other assumptions made in the following calculations are that the h.t. supply is 250 volts, that the maximum positive voltage developed across L_2 is 50 volts and that the valve cathode is rated for a maximum steady emission of 10 mA. The problem is to calculate values of R_g , C_g , R_c and C suitable for delivering a sawtooth of 50 volts amplitude.

The period is $1/(8 \times 10^{-3})$ sec = 125 μ sec

The forward stroke thus occupies $125 \times 10/11 = 114 \mu$ sec

and the flyback period = $125 \times 1/11 = 11 \mu$ sec

23.5.2 Values of Grid-circuit Components

The time constant $R_g C_g$ can be obtained from the equation derived in Appendix B which may be written

$$R_g C_g = \frac{T}{\log_e (V_1 - V_m)/(V_1 - V_c)} \quad \dots \quad (48)$$

where T is the duration of the forward stroke, V_m is the maximum negative potential reached by the non-earthly plate of C_g (i.e. -50 volts), V_c is the negative grid potential at which the valve begins to conduct, and V_1 is the potential at the slider of R_1 . T is 114 μ sec and the potential of the slider is 125 volts when R_1 is at its mid-position. We will assume that the grid potential of the valve for anode-current cut-off is -5 volts, i.e. $V_c = -5$ volts.

Substituting in (48) we have:

$$\begin{aligned} R_g C_g &= \frac{114}{\log_e (125 + 50)/(125 + 5)} \mu\text{sec} \\ &= \frac{114}{\log_e 1.346} \mu\text{sec} \\ &= \frac{114}{0.2971} \mu\text{sec} \\ &= 400 \mu\text{sec approximately} \end{aligned}$$

BLOCKING-OSCILLATOR SAWTOOTH GENERATORS

Such a value of time constant can be obtained from an unlimited number of combinations of resistance and capacitance but there is an upper limit to the value of C_g which can be used.

At the end of each forward stroke, the capacitor C_g must be charged in order to restore the potential of the non-earthly plate from -5 volts to -50 volts and this must be accomplished within the flyback period of $11 \mu\text{sec}$. The peak grid current available for charging can be as much as 10 times the value normally quoted for maximum grid current without overheating the grid. Such high currents are possible because the current is in the form of widely-spaced pulses; the current is, in fact, taken from the space charge surrounding the cathode, which acts as a reservoir and is replenished from cathode emission during the intervals between pulses. If we use a valve with a maximum cathode emission of 10 mA we can assume the maximum mean grid current to be, say, 1 mA and the maximum peak current to be 10 mA .

From the general relationship $Q = it = CV$ we have

$$C_g = \frac{it}{V}$$

Substituting 10 mA for i , $11 \mu\text{sec}$ for t and 45 volts for V

$$\begin{aligned} C_g &= \frac{10 \times 10^{-3} \times 11 \times 10^{-6}}{45} \text{ F} \\ &= 2.44 \times 10^{-9} \text{ F} \\ &= 0.0024 \mu\text{F} \end{aligned}$$

This is the greatest capacitance which can be charged to 45 volts in 11 microseconds by a current of 10 mA and in practice a smaller capacitance is preferable. Such a capacitor may be charged to a greater potential than 45 volts , thus increasing the duration of the forward stroke, but this can be offset by adjustment of R_g . This does emphasise, however, that the results of this calculation are approximate.

If we assume C_g to be $0.002 \mu\text{F}$, the value of R_g can be determined from the time constant of 400 microseconds thus:

$$\begin{aligned} R_g &= \frac{\text{time constant}}{C_g} \\ &= \frac{400 \times 10^{-6}}{0.002 \times 10^{-6}} \Omega \\ &= 200 \text{ k}\Omega \text{ approximately} \end{aligned}$$

23.5.3 *Values of Anode Circuit Components*

The determination of suitable values for R_c and C is carried out as for the vacuum-valve discharger (page 184). First the limiting values V_1 and V_2 of the anode potential are decided and the necessary time constant is evaluated from expression (47)

$$R_c C = \frac{T}{\log_e(V - V_1)/(V - V_2)}$$

in which V is the potential at the slider of R_2 . This expression is deduced in Appendix B. Let $V_1 = 50$ volts, $V_2 = 100$ volts and $V = 150$ volts. Then

$$\begin{aligned} R_c C &= \frac{114}{\log_e(150 - 50)/(150 - 100)} \mu\text{sec} \\ &= \frac{114}{\log_e 2} \mu\text{sec} \\ &= \frac{114}{0.6931} \mu\text{sec} \\ &= 164.5 \mu\text{sec} \end{aligned}$$

The value of C must be such that the voltage across it can be changed by 50 volts when a current of 10 mA flows from it for 11 microseconds (flyback period).

The maximum value of C is thus given by

$$\begin{aligned} C &= \frac{it}{V} \\ &= \frac{10 \times 10^{-3} \times 11 \times 10^{-6}}{50} \text{ F} \\ &= 0.0022 \mu\text{F} \end{aligned}$$

and a suitable value to use is $0.001 \mu\text{F}$. The value of R_c is given by

$$\begin{aligned} R_c &= \frac{\text{time constant}}{C} \\ &= \frac{164.5 \times 10^{-6}}{0.001 \times 10^{-6}} \Omega \\ &= 160 \text{ k}\Omega \text{ approximately} \end{aligned}$$

23.5.4 *Range of Free-running Frequency Control*

Knowing the value of the time constant $R_c C$ is 400 microseconds,

BLOCKING-OSCILLATOR SAWTOOTH GENERATORS

we can estimate the range of free-running frequency obtainable by adjustment of R_1 . The frequency is given by the expression:

$$f \simeq \frac{1}{\log_e(V - V_m)/(V - V_c)}$$

in which $V_m = -50$ volts, $V_c = -5$ volts and V is the potential at R_1 slider. When the slider is at the top of its travel it has the h.t. potential of 250 volts and the frequency is given by

$$\begin{aligned} f &\simeq \frac{1}{R_g C_g \log_e (250 + 50)/(250 + 5)} \\ &= \frac{1}{R_g C_g \log_e 300/255} \\ &= \frac{1}{400 \times 10^{-6} \times 0.1625} \text{ c/s} \\ &= 16 \text{ kc/s} \end{aligned}$$

When the slider of R_1 is at the opposite end of its travel $V = 0$ and we have

$$\begin{aligned} f &\simeq \frac{1}{R_g C_g \log_e 50/5} \\ &= \frac{1}{400 \times 10^{-6} \times 2.3026} \text{ c/s} \\ &= 1.1 \text{ kc/s approximately} \end{aligned}$$

Thus variation of R_1 gives an approximate 15 : 1 change in natural frequency. This is a greater range than is normally necessary and in practical equipment is usually restricted by connecting a fixed resistor in series with each end of R_1 .

23.5.5 Range of Amplitude Control

We know from the determination of R_c and C above, that the output voltage rises from 50 to 100 (corresponding to an output amplitude of 50 volts d.a.p.) when the slider of R_2 is set to 150 volts and when the period of the output is related to the time constant according to the expression

$$\frac{T}{R_c C} = 0.6931$$

Now let us assume that R_2 is set to the top of its travel to give $V = 250$ volts. Such an adjustment will alter the values of V_1 and

V_2 , making the determination of the new output amplitude difficult. We can, however, obtain an approximate indication of the changed output by assuming that V_1 remains at 50 volts and calculating the new value of V_2 . The relationship between R_c , C , T , V , V_1 and V_2 is given by expression (47)

$$R_c C = \frac{T}{\log_e(V - V_1)/(V - V_2)}$$

in which all quantities are known except V_2 . Re-arranging this as an expression for V_2 we have:

$$\log_e(V - V_1)/(V - V_2) = T/R_c C$$

from which $(V - V_1)/(V - V_2) = e^{T/R_c C}$

$$\therefore (V - V_2)/(V - V_1) = e^{-T/R_c C}$$

$$\therefore V_2 = V + (V_1 - V)e^{-T/R_c C}$$

Substituting $V = 250$, $V_1 = 50$, $T/R_c C = 0.6931$

$$V_2 = 250 - 150e^{-0.6931}$$

$$= 250 - 150/2$$

$$= 175$$

The difference between V_1 and V_2 is now 125 volts, showing that the output amplitude has increased from 50 to this value. It must be emphasised that this and other calculations on relaxation oscillators give very approximate results and can be used only as guides to the order of component values to use. Accurate determination of component values is possible only by experiment.

CHAPTER 24

MULTIVIBRATOR SAWTOOTH GENERATORS

24.1 INTRODUCTION

MULTIVIBRATORS can be used for sawtooth generation in two distinct ways:

- (a) The multivibrator can be used simply as a discharger, charging occurring via a linear resistor. For this type of generator the cathode-coupled multivibrators are particularly suitable because the anode of the final valve is free, permitting R_c and C to be connected to it without affecting operation of the multivibrator.
- (b) The multivibrator can be used as a source of rectangular-current waves which are fed to a capacitor to give a sawtooth voltage across it. This may be regarded as a special example of (a) in which the multivibrator acts as charger and discharger. There is no need to introduce an additional capacitor into the circuit to act as integrator; one of the coupling capacitors can be used to perform this function as described below.

24.2 DRIVEN CATHODE-COUPLED MULTIVIBRATOR SAWTOOTH GENERATOR

A circuit of a multivibrator sawtooth generator of type (a) above is given in Fig. 115; it consists of a cathode-coupled multivibrator of the type illustrated in Fig. 53 to which the components R_c and C have been added. C charges from the h.t. supply via R_c when V2 is non-conductive and discharges through V2 when the latter is conductive. The particular multivibrator illustrated is monostable and thus this sawtooth generator is a driven type.

24.3 FREE-RUNNING ANODE-COUPLED MULTIVIBRATOR SAWTOOTH GENERATOR

Fig. 116 gives the circuit of an astable anode-coupled multivibrator in which the components R_c and C have been added to obtain a sawtooth output. R_c and C cannot be connected directly in V2 anode circuit as in Fig. 115 because this would prevent normal operation of the multivibrator circuit which requires very rapid

changes in anode potential during the changes of state. Thus the anode resistor R_a' must be retained in the circuit; its value should, however, be as small as will give satisfactory operation because the

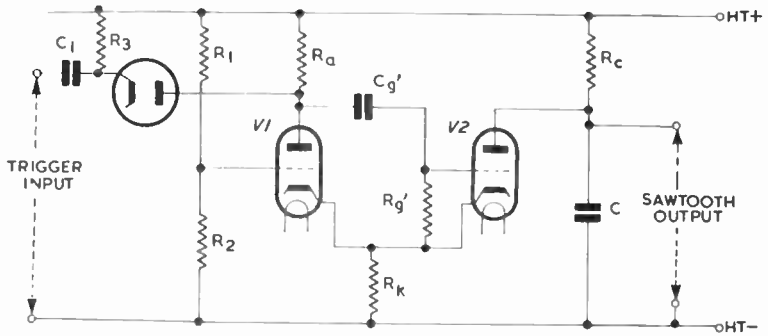

Fig. 115—Driven cathode-coupled multivibrator sawtooth generator

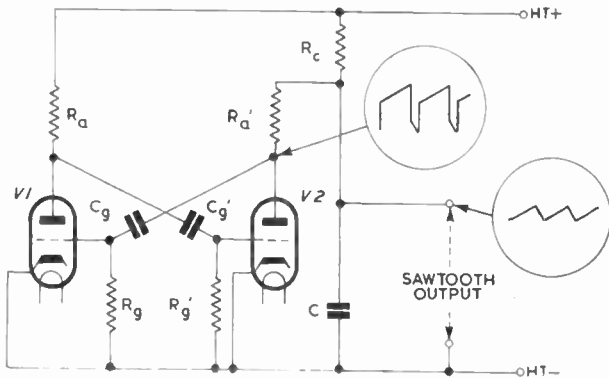

Fig. 116—Free-running anode-coupled multivibrator sawtooth generator

resistance through which C discharges during flyback is made up of R_a' and r_{dc} in series and should be as small as possible to achieve rapid flyback. Since the parent multivibrator circuit is astable this is a free-running sawtooth generator.

MULTIVIBRATOR SAWTOOTH GENERATORS

An alternative circuit giving a similar performance is illustrated in Fig. 117 in which components are similarly coded; for both circuits, the waveforms generated across C and at $V2$ anode are

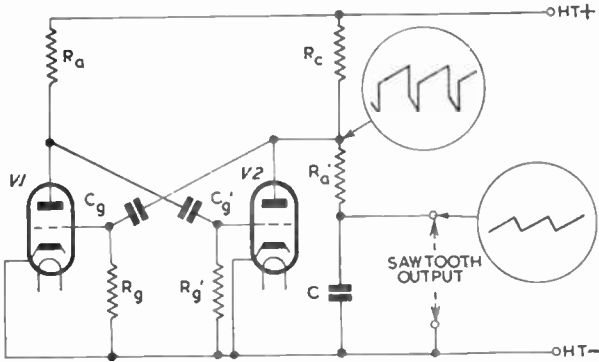

Fig. 117—An alternative multivibrator sawtooth generator circuit giving a performance similar to that of Fig. 116

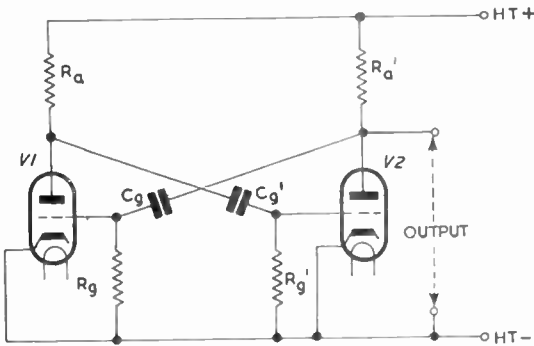

Fig. 118—The conventional multivibrator circuit can also be used to generate sawtooth waves by suitable choice of time constants

shown. The waveforms at $V2$ anode are combinations of the sawtooth generated across C and the rectangular waveforms generated across R_a' by the multivibrator.

24.4 ALTERNATIVE CIRCUIT FOR FREE-RUNNING ANODE-COUPLED MULTIVIBRATOR SAWTOOTH GENERATOR

We shall now discuss the type of sawtooth generator classified under (b) in the introduction and Fig. 118 gives the circuit of a conventional anode-coupled multivibrator which by suitable choice

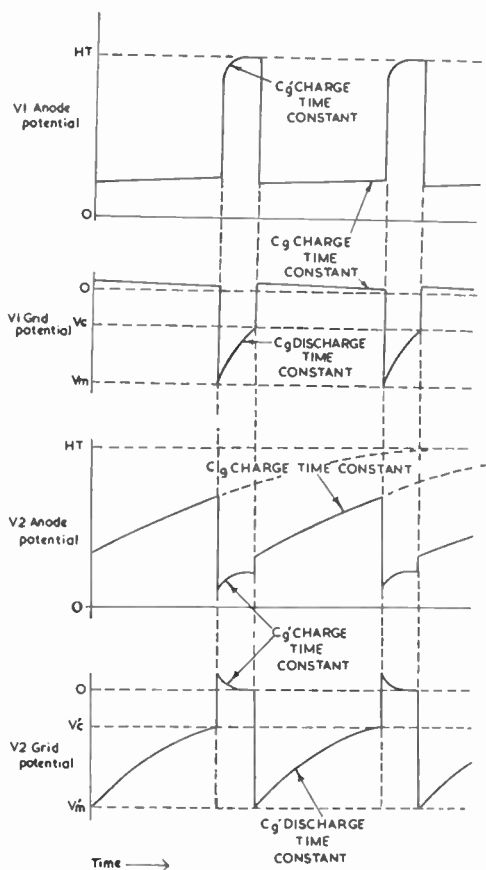

Fig. 119—Waveforms for the multivibrator of Fig. 118 when designed for a sawtooth output

of component values can be made to deliver a rectangular or a sawtooth output. The condition for sawtooth-wave generation at a particular valve anode is that the load at this point should be 200

MULTIVIBRATOR SAWTOOTH GENERATORS

predominantly capacitive. As shown on page 104 this condition is obtained by making the time constant of its anode circuit large compared with that of its grid circuit. Thus to obtain a sawtooth output from V2 anode the condition is that $R_a'C_g$ should be large compared with $R_g'C_g'$. The waveforms then obtained are as indicated in Fig. 119 which should be compared with those of Fig. 58 which apply when the output is rectangular.

During the period in which C_g' discharges through R_g' , the voltage across R_g' keeps V2 non-conductive for a time dependent on the time constant $R_g'C_g'$. During this period C_g charges from the h.t. supply through R_a' , V2 anode potential rising as it does so. If, however, the time constant $R_a'C_g$ is large compared with $R_g'C_g'$, V2 begins to conduct before its anode potential has reached the h.t. value and the rise in anode potential is only the initial part of an exponential curve. By suitable design it can be arranged that the fraction of the exponential curve actually realised is very small; the rise in V2 anode potential is then a good approximation to a sawtooth waveform.

24.5 DESIGN OF MULTIVIBRATOR SAWTOOTH GENERATOR

The value of the time constant $R_g'C_g'$ is chosen to give the required free-running frequency and, as shown on page 108, a suitable value for a generator to operate at 10 kc/s is 35 microseconds. R_g' could be 470 k Ω and C_g' 70 pF. The time constant $R_a'C_g$ determines the sawtooth amplitude at the anode of V2. Suppose 20 volts amplitude is required. If the anode potential of V2, when conductive, is 50 volts and the h.t. supply is 250 volts, the exponential rise at the anode when V2 is cut off is from 50 to 70 volts, a change of 20 volts compared with a possible total change of 200 volts. Thus the fraction of the exponential curve which occurs is very small, the condition for producing an output of approximately sawtooth form. This rise of 20 volts must be accomplished during the period of the forward stroke (approximately 90 microseconds). From (46) we have

$$R_a'C_g = \frac{t}{\log_e V_o/(V_o - V_t)}$$

where V_o is the voltage initially across the circuit and therefore available to drive changing current through the resistor. In this circuit V_o is $(250 - 50) = 200$ volts, V_t is 20 volts and $t = 90 \times 10^{-6}$ second. Substituting in (46) we have

$$\begin{aligned}
 R_a' C_g &= \frac{90 \times 10^{-6}}{\log_e 200/180} \\
 &= \frac{90 \times 10^{-6}}{0.1053} \text{ second} \\
 &= 1 \text{ millisecond approximately}
 \end{aligned}$$

The individual values of R_a' and C_g can be determined as follows. During the flyback period C_g discharges through a circuit consisting primarily of the anode d.c. resistance r_{dc}' of V2 and R_g in series. The relative values of C_g , r_{dc}' and R_g must be such that the voltage across C_g can decay from 70 volts to 50 volts within 10 microseconds and the discharge current must not exceed the value which V2 can safely supply. Let $r_{dc}' + R_g = R$. Then the discharge obeys the equation

$$\frac{V_t}{V_o} = e^{-t/RC_g}$$

$$\text{From this } RC_g = \frac{t}{\log_e V_o/V_t}$$

Putting $t = 10 \times 10^{-6}$ seconds, $V_o = 70$ volts and $V_t = 50$ volts, we have

$$\begin{aligned}
 RC_g &= \frac{10 \times 10^{-6}}{\log_e 1.4} \\
 &= 30 \times 10^{-6} \text{ seconds approximately}
 \end{aligned}$$

The discharge current has a maximum value equal to V/R at the beginning of the discharge where V is the voltage initially across the capacitor and equal to 70 volts in this example. If we decide that this initial current is 10 mA we have

$$\begin{aligned}
 R &= \frac{V}{I} \\
 &= \frac{70}{10 \times 10^{-3}} \Omega \\
 &= 7 \text{ k}\Omega
 \end{aligned}$$

Of this the valve d.c. resistance will probably contribute one half and R_g is thus 3.5 k Ω .

Dividing the charge time constant by the discharge time constant for C_g we have

MULTIVIBRATOR SAWTOOTH GENERATORS

$$\begin{aligned}
 \frac{R_a' C_g}{R C_g} &= \frac{R_a}{R} \\
 &= \frac{1000 \times 10^{-6}}{30 \times 10^{-6}} \\
 &= 33 \\
 \therefore R_a' &= 33R \\
 &= 33 \times 7 \times 10^3 \Omega \\
 &= 230 \text{ k}\Omega \text{ approximately}
 \end{aligned}$$

Finally, substituting for R_a' in the expression for the charge time constant

$$\begin{aligned}
 C_g &= \frac{1000 \times 10^{-6}}{R_a'} \\
 &= \frac{1000 \times 10^{-6}}{230 \times 10^3} \text{ F} \\
 &= 0.005 \mu\text{F approximately}
 \end{aligned}$$

Lastly we must determine the value of R_a . This can be evaluated from the amplitude of the signal which must be generated at V1 anode to cut V2 off for the required duration. The value of 35 microseconds for the time constant $R_g' C_g'$ was evaluated (on page 108) by assuming that the grid of V2 is biased to -100 volts when V1 becomes conductive. To give such a bias the amplitude of the negative step generated at V1 must be of the order of 100 volts and if we assume that V1 has a maximum anode current of 10 mA, the value of R_a is given by

$$\begin{aligned}
 R_a &= \frac{V}{I} \\
 &= \frac{100}{10 \times 10^{-3}} \Omega \\
 &= 10 \text{ k}\Omega
 \end{aligned}$$

Thus the component values required to produce the desired sawtooth are as follows:

$$\begin{aligned}
 R_a &= 10 \text{ k}\Omega \\
 R_g &= 3.3 \text{ k}\Omega \\
 C_g &= 0.005 \mu\text{F} \\
 R_a' &= 230 \text{ k}\Omega \\
 R_g' &= 470 \text{ k}\Omega \\
 C_g' &= 70 \text{ pF}
 \end{aligned}$$

CHAPTER 25

MILLER-INTEGRATOR SAWTOOTH GENERATORS

25.1 INTRODUCTION

ONE of the methods quoted on page 168 for linearising the output of a simple RC sawtooth generator is by the use of feedback. This can be used to reduce variations in the current which flows through the capacitor during the working stroke. One way of applying such feedback is to introduce, in series with the fundamental RC combination, an additional voltage which varies during the cycle so

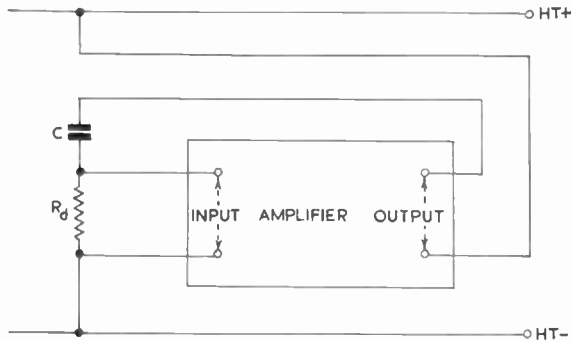

Fig. 120—Fundamental circuit of a sawtooth generator employing feedback to ensure linearity of working stroke

as to keep the current constant. In feedback generators of this type the additional voltage is obtained from the output of an amplifier the input to which is the voltage across the charge or discharge resistor as indicated in Fig. 120. This method of linearisation is the basis of a number of practical sawtooth generators, two examples of which, namely the Miller-integrator and the Bootstrap circuits, will now be described.

25.2 BASIC FEATURES OF MILLER-INTEGRATOR CIRCUIT

The basic form of the Miller-integrator circuit is illustrated in Fig. 121 (a). It may be regarded as that of a valve amplifier with

an anode-load resistor R_a and a grid resistor R_d with a capacitor C connected between anode and grid. This capacitor greatly augments the internal (Miller) anode-grid capacitance of the valve and this accounts for the name of this circuit. During operation of the circuit R_d behaves as a discharge resistor and during the working stroke C discharges through R_d , the voltage across R_d being applied to the amplifier V . Magnified voltages generated across R_a are included in series with C and R_d to give the required feedback. The feedback keeps the voltage across R_d substantially constant during the working stroke and the valve grid potential does not differ greatly from earth potential; thus the sawtooth output may be taken from the junction of R_a and C as indicated. In practical circuits the valve is usually a pentode and R_d is returned to h.t. positive, but neither change makes any significant difference to the principle of operation. The use of a pentode has the advantage that the capacitor can be charged or discharged by applying voltages to the suppressor grid to cut off or start anode current. Thus the circuit is a complete sawtooth generator in itself and requires only the application of a rectangular triggering signal to the suppressor grid to give a sawtooth output. An interesting feature of the circuit is that it makes use of the anode-grid capacitance of the valve, a capacitance which is usually a nuisance in the design of electronic equipment.

25.3 BASIC FEATURES OF BOOTSTRAP CIRCUIT

The basic form of the Bootstrap circuit is illustrated in Fig. 121 (b). In spite of the different appearance of this circuit, it is, in fact, another version of the Miller-integrator circuit with the h.t. supply applied to different points. The anode in the Bootstrap circuit is at zero alternating potential and thus the capacitor C is effectively between anode and grid, as in the Miller-integrator circuit. The Bootstrap circuit has two additional components R_1C_1 but these are used to couple the cathode to the "top end" of R_c without causing d.c. continuity. They play no fundamental part in the operation of the circuit and the time constant R_1C_1 is large compared with the period of the generated sawtooth, making the voltage across R_1 an undistorted copy of that across R_k . During the working stroke C charges through R_c and the voltage across R_c is applied via C_1 between grid and cathode of the valve. Magnified voltages generated across R_k are transferred by R_1C_1 to appear in series with C and R_c giving the required feedback.

The valve in the Bootstrap circuit can alternatively be regarded as a cathode follower connected across C and generating across R_k

a signal equal to that across C , this signal being impressed on the h.t. supply by the coupling components R_1C_1 . As C charges, each increment in voltage across C produces a corresponding increase in the voltage at the junction of R_c and R_1 ; thus the circuit may be

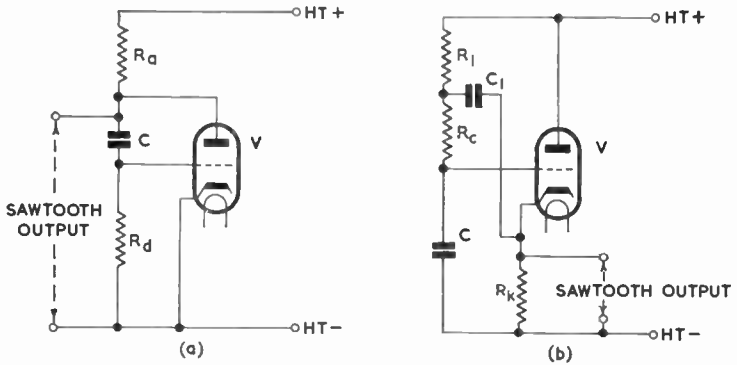

Fig. 121—Basic forms of (a) Miller-integrator and (b) Bootstrap circuit

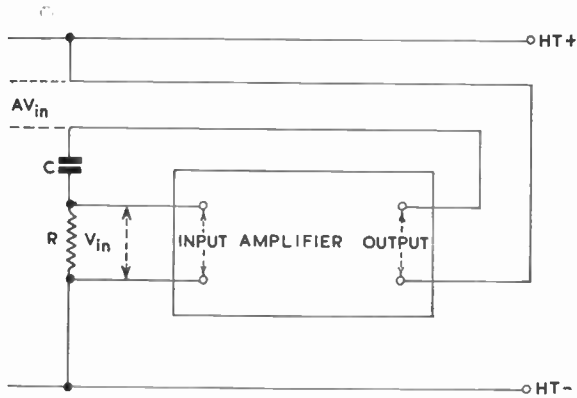

Fig. 122—Basic features of Miller-integrator and Bootstrap circuits

described as “pulling itself up by hauling on its own bootstrap”. This is the origin of the name of the circuit.

This interpretation of the circuit shows that the sawtooth output can be taken from the cathode at which point the circuit has a low output impedance.

MILLER-INTEGRATOR SAWTOOTH GENERATORS

Unlike the Miller-integrator circuit, the Bootstrap is not a complete sawtooth generator; it includes the charging resistor R_c and capacitor C but a separate discharger must be connected across the capacitor to complete the generator.

25.4 OPERATION OF MILLER-INTEGRATOR AND BOOTSTRAP CIRCUITS

The way in which the feedback in these circuits linearises the output of a simple RC sawtooth generator can be illustrated by means of the circuit of Fig. 122, in which the resistor R represents the discharge resistor of the Miller-integrator circuit or the charge resistor of the Bootstrap circuit.

Let the voltage across C at any instant t be V . This voltage is made up of the amplifier input and output voltages. Thus

$$V_{in} + V_{out} = V$$

But $V_{out} = AV_{in}$ where A is the gain of the amplifier. Substituting for V_{out} we have

$$V_{in} = \frac{V}{A + 1}$$

Suppose at a time $(t + \delta t)$ the voltage across C has changed to $(V + \delta V)$. The corresponding change in amplifier input voltage is $\delta V/(A + 1)$ and this is also the change in voltage across R . In a simple RC discharger the change in voltage across the resistor is equal to that across the capacitor, i.e. δV . Thus the effect of the amplifier is to reduce the change in discharge current in the ratio $(A + 1) : 1$. Since a constant discharge current is the ideal aimed at in all sawtooth generators, this reduction in the change of discharge current represents an improvement in the linearity of the sawtooth output.

25.5 EQUIVALENT CIRCUIT OF A MILLER INTEGRATOR

The reduction in the change of discharge current in R_d in the Miller-integrator circuit or of charge current in R_c in the Bootstrap circuit is equivalent to an increase in the effective resistance and thus of the effective time constant. This is illustrated in the following description which applies to the Miller-integrator circuit although the result deduced applies equally to the Bootstrap circuit.

The feedback in the Miller-integrator circuit increases the effective value of the discharge resistor to $(A + 1)R_d$ and the performance of a Miller-integrator circuit containing a capacitance C and a resistance R_d is therefore similar in some respects to that of a simple series circuit of capacitance C and resistance $(A + 1)R_d$. Such a

This can be written in the form

$$t = \frac{VCR_d}{V_b} \dots \dots \dots (50)$$

which agrees with equation (40) on page 143 because $V = V_a$, $C = C_1$, $R_d = R_5$ and $V_b = V_1$.

Equation (50) shows that the output voltage V of a driven generator (for which the period t of discharge is fixed by the triggering signals)

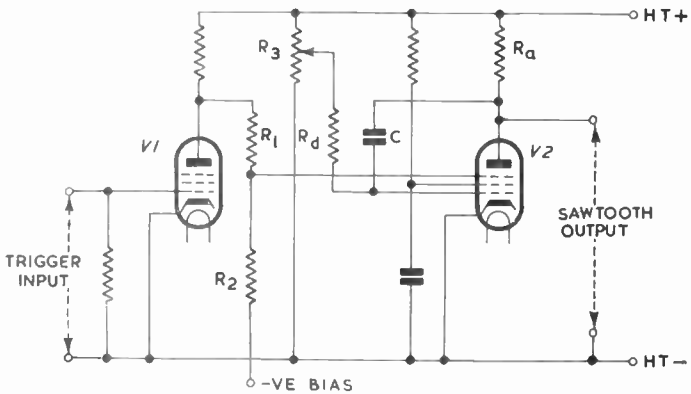

Fig. 125—Driven Miller-integrator sawtooth generator

can be controlled by adjustment of V_b , R_d or C , but the first two alternatives are generally preferred. Examples of both types of control are given in the following descriptions of practical generators.

25.6 DRIVEN MILLER-INTEGRATOR CIRCUITS

Practical Miller-integrator circuits generally employ a pentode as the feedback amplifier. Although a pentode may be expected to give better linearity than a triode because of its greater gain, it is used in these circuits because it can be controlled by triggering signals applied to the suppressor grid.

In the circuit of Fig. 125 V2 is the Miller-integrator discharger stage and V1 is a control stage which applies triggering voltages to V2 suppressor grid. In the absence of triggering signals, V1 conducts and its anode potential is low. This potential, together with the negative bias voltage and the values of R_1 and R_2 , are so chosen that V2 suppressor grid is negative with respect to V2

MILLER-INTEGRATOR SAWTOOTH GENERATORS

cathode and there is no anode current in V2. Cathode current is considerable in V2 but it is all collected by the screen grid. The anode potential is at h.t. value, V2 grid is near cathode potential and C is charged to the h.t. voltage.

Now consider the operation of the circuit in the presence of rectangular triggering signals. When a negative pulse is received at V1 grid, V1 anode current is cut off and the anode potential rises to h.t. voltage. V2 suppressor-grid potential rises allowing V2 to take anode current and initiating the almost-linear run-down of anode potential. The fall in potential continues until terminated by the end of the negative pulse on V1 grid, at which instant V1 conducts again and V2 suppressor grid is biased negatively, cutting-off V2 anode current. C now charges from the h.t. supply via R_a

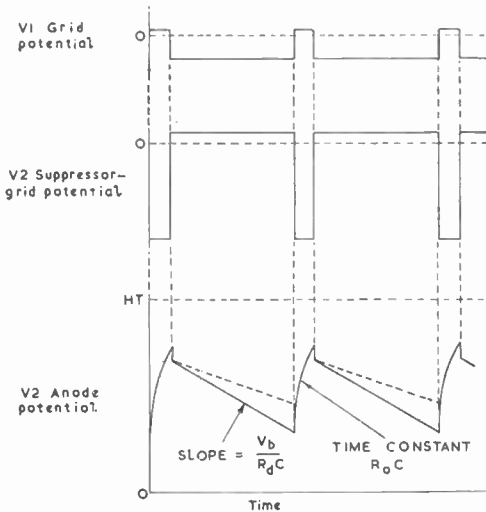

Fig. 126—Waveforms for the circuit of Fig. 125

and the anode current rises exponentially towards h.t. positive. The circuit is now in the state assumed initially.

The waveforms for the circuit are similar to those of Fig. 77 and are reproduced in Fig. 126. This circuit is an example of one in which the output amplitude is controlled by adjustment of the h.t. voltage applied to R_a , and the dotted curve shows the effect of moving the slider of R_3 downwards. Normally R_3 is set at a value which does not allow the anode potential of V2 to fall to low values; at such potentials the run-down ceases to be linear. The screen

grid of V2 is decoupled by a capacitor which is assumed large enough to keep the screen-grid potential constant during operation of the circuit.

As a numerical example, suppose a Miller-integrator discharger of this type is required to give 100 volts output amplitude and is triggered by negative-going pulses of 9 : 1 mark-space ratio and at a frequency of 10 kc/s. We will assume that the potential at the slider of the amplitude control (R_a) can be varied from 100 to 250 volts and that the required output is obtained when the slider is at its centre position, giving a potential of 175 volts. From (48)

$$R_d C = \frac{V_b t}{V}$$

in which $V_b = 175$ volts and $V = 100$ volts. t is the time of the forward stroke and is equal to $0.9 \times 10^{-4} = 90 \mu\text{sec}$. Substituting these values

$$\begin{aligned} R_d C &= \frac{175 \times 90 \times 10^{-6}}{100} \text{ sec} \\ &= 157.5 \mu\text{sec} \end{aligned}$$

As in the other sawtooth generators discussed, the precise values of R_d and C are determined by flyback considerations. During flyback C charges through R_a and the voltage across C must change by 100 volts in the 10 $\mu\text{seconds}$ occupied by this period. The initial and final anode potentials need not necessarily be 150 volts and 250 volts; in fact better linearity can be achieved when the potentials are lower, say 50 to 150 volts. These potentials are related to the h.t. potential, R_a and C by expression (47)

$$R_a C = \log_e \frac{t}{(V - V_1)/(V - V_2)}$$

Substituting $t = 10 \mu\text{seconds}$, $V = 250$ volts, $V_1 = 50$ volts and $V_2 = 150$ volts, we have

$$\begin{aligned} R_a C &= \frac{10 \times 10^{-6}}{\log_e 200/100} \\ &= \frac{10^{-5}}{0.6931} \text{ sec} \\ &= 14.43 \mu\text{sec} \end{aligned}$$

MILLER-INTEGRATOR SAWTOOTH GENERATORS

Dividing the discharge by the charge time constant

$$\begin{aligned} \frac{R_d C}{R_a C} &= \frac{R_d}{R_a} \\ &= 157.5 \\ &= 14.43 \\ &= 11 \text{ approximately} \end{aligned}$$

R_a should be reasonably high because it is the anode load of V2 and high gain is necessary to achieve good linearity. A commonly-used value is 100 k Ω and for such a value R_d is 1.1 M Ω . The capacitance value is given by

$$\begin{aligned} C &= \frac{\text{discharge time constant}}{R_d} \\ &= \frac{157.5 \times 10^{-6}}{1.1 \times 10^6} \text{ F} \\ &= 140 \text{ pF approximately} \end{aligned}$$

Another type of Miller-integrator circuit is illustrated in Fig. 127. This differs from the circuit of Fig. 125 in the method of triggering

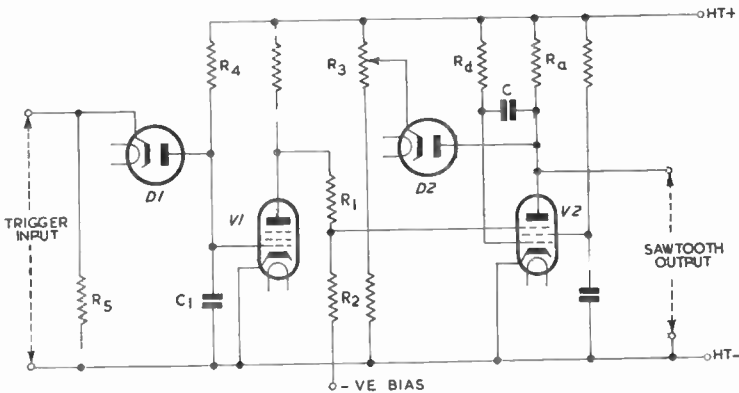

Fig. 127—Another circuit for a driven Miller-integrator sawtooth generator

and in the method employed to control the output amplitude.

First consider the conditions in the circuit in the absence of triggering pulses. V1 grid takes up a potential of approximately

zero (relative to cathode potential), taking grid current from h.t. positive via the high-value resistor R_1 . There is thus zero or very little voltage across C_1 , and D1 anode has approximately the same potential as its cathode. D1 is therefore ready to conduct negative-going signals to V1 grid.

Now consider the behaviour of the circuit when triggering pulses are applied. D1 conducts negative-going triggering voltages and C_1 is charged up to the potential of the pulse, cutting V1 off and allowing V2 to start the linear fall in anode potential. After the trailing edge of the triggering signal, C_1 is left charged but begins to discharge through R_1 , and V1 grid potential rises towards zero as in a multivibrator circuit. When V1 grid potential reaches the cut-off bias, V1 starts to conduct and V2 anode current is cut off, terminating the linear potential fall at V2 anode. The duration of the run-down is thus determined by the values of C_1 , the h.t. voltage and the amplitude of the triggering signals; the method of calculating component values to give a required duration is shown in the multivibrator section. To give a constant run-down period, the amplitude of the triggering signals must be kept constant.

The duration of the run-down is so chosen that V2 anode does not reach low voltages; in this way the fall in potential is kept linear.

The method of controlling the amplitude of the output is by means of a diode connected between the anode of V2 and a potentiometer R_3 across the h.t. supply. The diode D2 is so connected that it becomes conductive when the anode current is cut off. The diode anode current flows through R_a and, if this is large compared with the diode forward resistance, the diode anode potential takes up a value slightly greater than that at the diode cathode. Thus the effect of the diode D2 is to prevent the pentode anode potential rising appreciably above that at the diode cathode. By varying the diode cathode potential, therefore, it is possible to control the output amplitude.

25.7 FREE-RUNNING MILLER-INTEGRATOR CIRCUITS

25.7.1 Introduction

In a pentode the suppressor grid controls the ratio in which the current leaving the cathode is shared between the anode and the screen grid. A positive suppressor-grid potential increases anode current and decreases screen-grid current; a negative suppressor-grid potential decreases anode current and increases screen-grid current. When a series of rectangular pulses is applied to the suppressor grid, as in a Miller-integrator circuit, a current of similar waveform flows in the screen-grid circuit and, if a resistor is included

MILLER-INTEGRATOR SAWTOOTH GENERATORS

in this circuit, a rectangular voltage is generated at the screen grid. This voltage is in phase with the suppressor-grid voltage and provided the resistor is large enough, is a magnified version of it. Because of this phase relationship, regeneration can be obtained by coupling the screen grid to the suppressor grid by a simple RC circuit. If such a coupling is employed in a Miller-integrator circuit, the generator does not require external triggering signals but operates freely on its own at a frequency governed by the constants of the screen grid-suppressor grid coupling components. The circuit thus developed is, of course, the Miller transitron described in Chapter 20, but the circuit was then deduced by analogy with the free-running multivibrator; we now see that these circuits can be used as free-running sawtooth generators.

25.7.2 Miller-transitron Sawtooth Generator

The basic circuit of the Miller transitron is given in Fig. 128; the operation of the circuit is described on page 153 and the waveforms at the electrodes are illustrated in Fig. 87. In the absence of synchronising signals, variation of R_d or adjustment of the h.t.

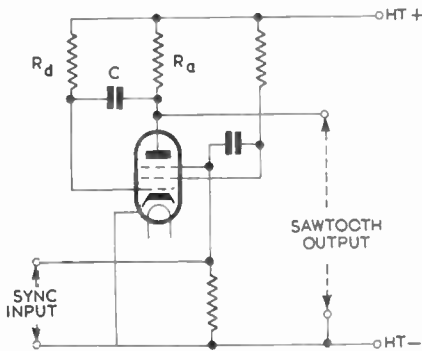

Fig. 128—Basic circuit of Miller-transitron sawtooth generator

voltage to which R_d is returned alters the frequency of the output sawtooth but does not affect the amplitude. Normally, however, the circuit is synchronised and these adjustments then control the output amplitude, the frequency being fixed by the sync signals. The circuit is synchronised by negative-going signals applied to the suppressor grid and if there is an appreciable difference between the natural and synchronised frequencies, the anode current is cut off by the sync signals before low anode voltages are reached, thus

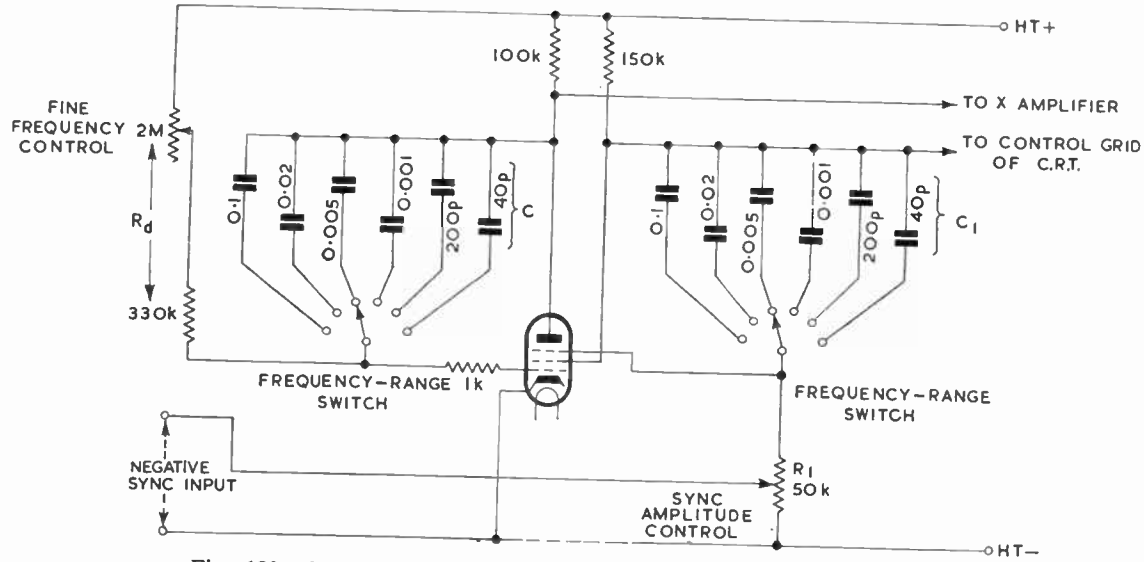

Fig. 129—Complete circuit of a Miller-transitron time-base generator

avoiding the non-linearity which occurs in a Miller-integrator circuit at such low voltages.

A Miller-transitron circuit is often used as a time-base generator for oscilloscopes, where it provides the linear sawtooth required for horizontal (X) deflection of the electron beam.

An oscilloscope time-base generator should be capable of providing a wide variation in sawtooth frequency, say from 10 c/s to 1 Mc/s. Such a wide range can be obtained from a Miller-transitron circuit by varying the capacitance C in steps to provide a *coarse frequency control* or *range switch* and by varying R_d to give a *fine frequency control*. As an illustration, Fig. 129 gives a complete circuit of a Miller-transitron time-base generator.

The flyback period is primarily determined by the product $R_1 C_1$ and it is desirable to vary C_1 in the same ratio as C to maintain a constant ratio of working to flyback period when the frequency range is changed. This ratio necessarily changes, however, when the fine frequency control is varied.

As an alternative fine frequency control, R_d could be fixed in value and returned to the slider of a potentiometer connected across the h.t. supply.

The waveform at the screen grid consists of approximately-rectangular pulses which are negative-going during the flyback period: these pulses can be applied to the control grid of an oscilloscope cathode-ray tube to suppress the beam during flyback periods.

PART V: GENERATION OF PARABOLIC WAVES

CHAPTER 26

PARABOLIC-WAVE GENERATORS

26.1 INTRODUCTION

PARABOLIC waves at line and field frequencies are used in camera channels to reduce the amplitude of spurious signals generated by camera tubes. As pointed out in Chapter 1, a parabolic wave can be generated by integrating a sawtooth wave, and thus a parabolic-wave generator may consist essentially of an RC network of the type shown in Fig. 130 to which a sawtooth input is applied. However, a complete sawtooth generator employing a hard-valve discharger may also be regarded as an integrator because from an

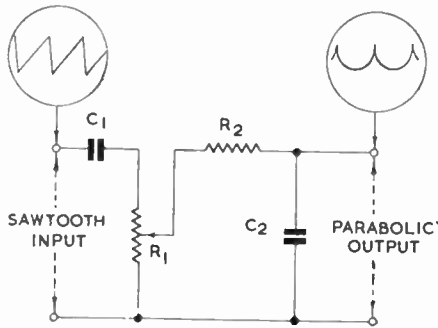

Fig. 130—Integrating circuit with provision for adjusting the amplitude of the output

input of rectangular form it delivers a sawtooth output. It follows that if such a generator is given an input of sawtooth form, the output will be of parabolic form. If the only input available is of rectangular form, two stages of integration are necessary, the first to generate a sawtooth from the rectangular input and the second to generate a parabolic from a sawtooth input.

26.2 PARABOLIC-WAVE GENERATOR WITH SAWTOOTH INPUT

Fig. 130 gives the circuit diagram of a parabolic-wave generator containing a simple integrating circuit R_2C_2 . This is preceded by potentiometer R_1 which plays no part in the integration and is used to control the amplitude of the parabolic-wave output.

To avoid distortion, the time constants R_1C_1 and R_2C_2 must both be large compared with the period of the sawtooth input. Moreover, R_2C_2 must not be an appreciable shunt on R_1 ; thus R_2 should be large compared with R_1 .

26.3 PARABOLIC-WAVE GENERATOR WITH RECTANGULAR-WAVE INPUT

Fig. 131 shows a circuit for generating parabolic waves from rectangular waves. V1 is the first integrator, R_2 and C_2 being the

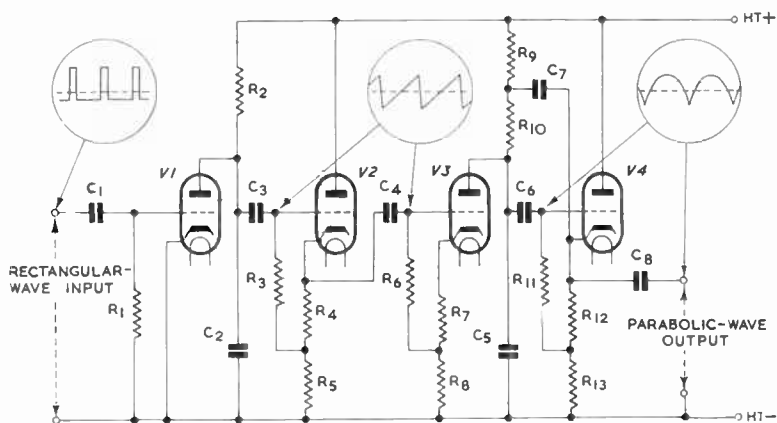

Fig. 131— Circuit for generating parabolic waves from rectangular waves

fundamental components. The sawtooth waves produced at V1 anode are applied to a cathode follower V2 the output of which feeds V3. This is the second integrator and generates parabolic waves at its anode. V4 is a Bootstrap circuit which applies feedback to V3 and in addition acts as a cathode-follower output stage.

The operation of the circuit may be described in the following way:

The circuit operates by virtue of the changes in anode d.c. resistance of V3 brought about by the sawtooth signal at the grid. At the beginning of each sawtooth the grid potential of V3 is instantaneously negative and its d.c. resistance is high; C_5 thus charges rapidly from the h.t. supply and the voltage across it rises quickly. As the grid

potential of V3 is driven more positive by the sawtooth signal, the d.c. resistance becomes smaller and the rate at which C_5 acquires charge is reduced. Near the mid-point of the linear rise in V3 grid potential the d.c. resistance of V3 is low enough to halt the charging of C_5 ; further increase in V3 grid potential causes C_5 to begin to discharge through V3 and the voltage across C_5 begins to fall. The rate of fall progressively increases to a maximum as the grid of V3 reaches its most positive value at the end of the linear rise. During the sawtooth flyback period the grid potential of V3 falls to a negative value again and C_5 recommences to charge. Thus a

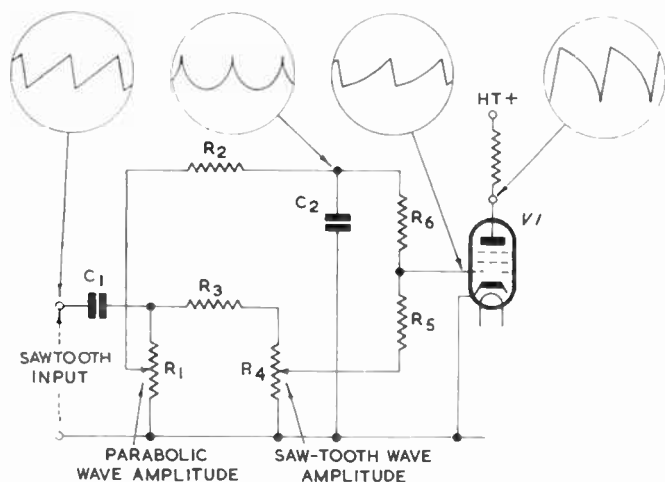

Fig. 132— Circuit for generating parabolic waves and mixing them with sawtooth waves in any proportion

parabolic voltage is generated across C_5 . For this waveform to be accurately parabolic, the anode d.c. resistance of V3 must respond linearly to the sawtooth voltage at the grid; anode current must not be cut off at the negative extreme nor must grid current flow on the other. To enable the valve to accept the sawtooth input without distortion, the resistors R_7 and R_8 are included in the cathode circuit. These give current feedback and their values are chosen to extend the grid base to the required degree.

26.4 SHADING MIXERS

In camera equipment the spurious signals generated in the camera tube are minimised by adding to them in correct phase a mixture

PARABOLIC-WAVE GENERATORS

of sawtooth and parabolic signals. Provision is required for varying the proportion of these signals and Fig. 132 is one example of a circuit which generates parabolic waves and permits such variation.

A sawtooth waveform is applied to the input terminals; this appears undistorted across R_1 , the time constant of R_1C_1 being large compared with the period of the input signal. The signal across R_1 is attenuated by R_3 and R_4 (of which R_4 is a potentiometer) and is then applied to the grid of the valve V1 via the series resistor R_5 . R_4 thus controls the amplitude of the sawtooth input to V1.

R_1 is also a potentiometer and the sawtooth output from the slider is applied to the integrating network R_2C_2 as in Fig. 130. Thus a parabolic waveform is generated across C_2 , the amplitude of which is controlled by the setting of R_1 . The signal across C_2 is applied to the grid of V1 via the series resistor R_6 . R_4 and R_6 are isolating resistors and are necessary to hold off the two signal sources from the grid so that alterations in component values in one source (caused, for example, by potentiometer adjustments) do not affect the amplitude of the signal received at the grid from the other source. The signal at the anode of V1 is an amplified and inverted copy of the combined parabolic and sawtooth input at the grid. In a camera channel the anode of V1 may be directly connected to the anode of a second valve amplifying the picture signal requiring correction; mixing then occurs in the common anode load.

BIBLIOGRAPHY

ARTICLES

1. R. Benjamin: "Blocking Oscillators," *Journal I.E.E.*, Part IIIA, March–May 1946.
2. R. Feinberg: "Symmetrical Multivibrators," *Wireless Engineer*, May 1949.
3. B. C. Fleming-Williams: "Single-Valve Time-base Circuit," *Wireless Engineer*, April 1940.
4. G. G. Gouriet: "High-stability Oscillator," *Wireless Engineer*, April 1950.
5. F. C. Williams: "Ranging Circuits, Linear Time-base Generators and Associated Circuits," *Journal I.E.E.*, Part IIIA, March–May 1946.

TEXTBOOKS

1. P. A. Neeteson: "Flywheel Synchronisation of Sawtooth Generators," Monograph No. 2 of *Television Receiver Design*. Philip's Technical Library.
2. O. S. Puckle: "Time Bases." Chapman and Hall.
3. Britton Chance (Editor): "Waveforms," Volume 19 of *M.I.T. Radiation Laboratory Series*. McGraw-Hill.

INDEX

- ANODE-COUPLED ASTABLE MULTI-VIBRATOR, 101-108
Anode-coupled Bi-stable Multi-vibrator, 66-77
Anode-coupled Monostable Multi-vibrator, 82-91
Anode-coupled Multivibrator Sawtooth Generator, 197, 200
- BACK PORCH, 14
Blackout Pulses, 12, 21, 23, 25
Blanking Mixer, 22, 25
Blanking Pulses, 12, 14, 21, 25
Blocking Oscillator, 41, 176, 186
Bootstrap Circuit, 168, 204-207, 219
Buffer Stage, 118, 191, 205
- CATHODE-COUPLED ASTABLE MULTIVIBRATOR, 110-113
Cathode-coupled Bi-stable Multi-vibrator, 78-81
Cathode-coupled Bi-stable Transistor, 134-136
Cathode-coupled Limiter, 57
Cathode-coupled Monostable Multivibrator:
 With Timing Components in Cathode Circuit, 97-100
 With Timing Components in Grid Circuit, 94-97
Cathode-coupled Multivibrator Sawtooth Generator, 197
Cathode-coupled Phantastron, 146-151
Cathode Follower, 56, 57, 80, 148, 205, 219
Clamping Pulses, 23
Coalescent Characteristic, 126
Colpitts Oscillator, 28, 30, 31, 33
Control Ratio, 178
Counter Circuit, 64
Current Feedback, 58, 171, 220
- D.C. CLAMP, 12, 23
D.C. Restorer, 23
Delay Generator, 15, 151
Delay Line, 15, 21, 26
Differentiating Circuit, 17, 115, 118, 133
Driven Sawtooth Generator, 165, 167, 182, 186, 197, 210
Duty Ratio, 44, 45
- FALL TIME, 42, 45, 56, 58, 72, 73, 75, 78, 146, 156
Field Frequency, 12, 13, 21, 22, 155, 184
Field Sync, 11, 12
Free-running Sawtooth Generator, 164, 177, 179, 186, 191, 198-200, 214
Frequency-determining Network, 28, 29, 36, 40
Frequency Divider, 64, 70, 124, 151
Front Porch, 14
- GEOMETRIC DISTORTION, 157
- HARTLEY OSCILLATOR, 28, 30-32
Hold-off Capacitor, 115
Hold-off Resistor, 114
- INTEGRATING CIRCUIT, 18, 19, 106, 218, 219, 221
- KEYING PULSES, 12, 23

INDEX

- LIMITING AMPLIFIERS, 54, 67, 109, 126
 Limiting Level, 46-49, 51, 53-55, 61, 107
 Line Frequency, 12, 13, 21, 22, 155
 Line Sync, 11, 14, 72, 73, 108
- MAINTAINING NETWORK, 28, 29
 Mark-space Ratio, 43, 44, 47, 53, 104, 108, 212
 Master Oscillator, 11, 21, 27
 Miller Integrator, 137, 168, 204-208, 210, 212-214, 217
 Miller Transitron, 152, 165, 215, 217
- OVERSHOOT, 62, 76, 86
- PERIOD, 43, 103, 106
 Positive Feedback, 28, 67, 69
 Pseudo-suppression Pulse, 22
 Pulse Repetition Frequency, 43, 45
- RELAXATION OSCILLATOR, 63
 Relay Circuit, 64
 Rise Time, 42, 45, 47, 56, 58, 61, 62, 72, 73, 75-78, 94, 100, 104, 107-109, 146, 165
- SAG, 19, 165
 Screen-coupled Astable Transitron, 152-154
 Screen-coupled Bi-stable Transitron, 130-134
 Screen-coupled Phartastron, 138-146
 Shading Mixer, 22, 220
 Shading Signals, 12, 22, 220
 Spectrum:
 Series of Short Pulses, 44
 Sawtooth Wave, 156
 Square Wave, 45
 Speed-up Capacitor, 73-76, 78, 83, 130
 Spurious Oscillation, 40
 Spurious Signals, 12, 21, 22
 Square Wave, 44, 104, 112
 Squegging Oscillator, 44, 186, 189
 Sync Mixer, 23
- THYRATRON, 177, 181
 Timing Components, 87, 94, 97, 100, 101, 110
 Transitron, 28
- VELOCITY MODULATION, 157
 Video Amplifiers, 19