

MANUAL OF SIMPLIFIED RADIO SERVICING

BY
MAJOR J. G. TUSTISON
U. S. ARMY SIGNAL CORPS

ALLIED RADIO CORPORATION
CHICAGO

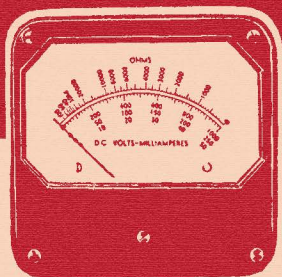

MANUAL OF SIMPLIFIED RADIO SERVICING

A Condensed Summary of Practical Short-Cut Methods for
Locating Trouble in Radio and Electronic Devices

★

by J. G. TUSTISON

Major, U. S. Army Signal Corps. Formerly Electronics Engineer with Electrical Research
Products, Inc. (Erpi), and Altec Service Corporation

★

Supplementary Data Supplied by the Technical Staff of ALLIED RADIO CORPORATION

★

Published By

Allied Radio Corporation, Chicago, Illinois, U. S. A.

Printed in U. S. A. Copyright 1943 by Allied Radio Corp.

TABLE OF CONTENTS

Foreword	3
General Servicing Hints	4
Voltage Readings	9
Current Readings	16
Impedance Measurement	18
Inductance and Capacity	25
Transmitters	28
Signal Tracing	30
Radio Color Codes	32
Resistor Color Codes	33
Condenser Color Codes	34
Power Transformer Leads	35
I.F. Transformer Leads	35
Speaker Leads and Plug Connections	36
Audio Transformer Leads	38
Battery Cable Leads	38
Fractional Inches to Decimal and Millimeter Equivalents	39

FOREWORD

The object of this manual is to describe, briefly, useful practical and simple methods for locating troubles and making adjustments in vacuum tube (electronic) equipment. The equipment and methods used are not the most ideal but were selected to show that a minimum of test equipment can be used to a great extent and with very satisfactory results.

The success of a repairman, forced to operate under adverse conditions, depends largely upon his imagination and resourcefulness. The suggestions presented in this booklet are the result of information that has been gained and found of value by the author during his early radio training days in the school of hard experience. Consider this as a REPAIRMAN'S REMINDER when it is "UP TO YOU" to repair and keep equipment operating.

Whenever possible, of course, the repairman should utilize all available modern test equipment, either specialized or general. Signal generators, oscillators, oscilloscopes, bridges, analyzers, signal tracers, etc., are highly desirable and are an invaluable aid in achieving optimum results. However, only too often the man in the field does not have access to laboratory instruments and is forced to maintain equipment in constant operating condition with what few instruments he has available.

WASHINGTON, D.C.,
January, 1943.

J. G. TUSTISON.

GENERAL SERVICING HINTS

A careful visual inspection and thorough cleaning of the equipment should be the first thing to do. By the time this inspection and cleaning have been completed, you will probably not need a test meter to locate the trouble.

Next, test all vacuum tubes in a tube tester; or if a tube tester is not available, replace each tube, one at a time, with a known good tube, trying the equipment for normal operation after every exchange. Now, turn on the equipment, and check each tube to see that the filaments are operating, either by looking at the filament glow in glass tubes, or by feeling metal tubes to see if they are warm.

In AC-operated sets, if a fuse blows when the equipment is turned on, remove the rectifier tube from its socket to kill the high-voltage power supply. Now, turn the equipment on again. If removing the rectifier tube has cleared the trouble, it is a good indication

of an overload in the high-voltage power supply. Frequently this trouble is caused by a shorted filter condenser. In AC-DC sets, where tube filaments are connected in series, it will be necessary to make a point-by-point check of the circuit in order to find the cause of the overload.

When equipment can be turned on and no fuse blows, check all tubes for normal plate and filament voltages. Then check through the set by placing a signal on the input and trace the signal through each circuit by means of a headphone having a condenser in series with one lead of the headphone.

A second method of signal tracing is to start at the output end of an amplifier or receiver and, using either a low-voltage AC supply or a high-frequency buzzer as a signal generator, put a signal across the final output leads. Verify the presence of the signal by listening to it in the speaker or by means of headphones or an output meter

connected across the same output leads. Now proceed, stage by stage, toward the input of the equipment, putting the signal into each tube at the plate and grid, and at each coupling transformer or condenser, until the point is reached where the signal is lost or appreciably reduced. Remember that each stage of amplification will add to the signal strength at the output. When the point where the signal is lost or reduced has been reached, it is a relatively simple matter to test each component of that particular stage and thereby locate the trouble.

If a receiver or amplifier is noisy or scratchy, it usually indicates a defective tube or a bad connection. To locate a noisy tube, turn the set on and tap each tube lightly with your finger or a pencil. To locate a bad connection, use a small dry stick or piece of fiber rod several inches long as an "insulated finger" and test each connection throughout the equipment by pressing on it while the set is in opera-

tion. Do not use your bare finger or a piece of metal to poke around in equipment which is turned on. Speaker noises may be caused by a ruptured diaphragm, a voice coil dragging on the pole piece, or metal filings and dirt in the air gap.

Use a headphone in series with a condenser to check noises in power supplies and audio circuits of a set. The same method can be used to check a commercial power line to determine whether it carries AC or DC.

A small door-bell transformer may be used for a variety of purposes, such as a substitute for a filter choke, a signal generator for driving audio circuits, a multiplier for AC voltmeters, a booster for reading low noise levels on a meter, etc.

To check proper operation of an oscillator stage, connect a voltmeter from plate of tube to ground. Shorting the tuning condenser should change the meter reading. If it does not, check the circuit

further for shorts, opens, bad connections, etc.

When lining up the IF stages in a receiver that has AVC, keep the test signal near the threshold of sensitivity in order to give the effect of a weak signal. This will prevent alignment errors due to action of the AVC circuit. A piece of dry hard-wood sharpened into a screwdriver point makes a good alignment tool.

A condenser not in service may be charged and is dangerous; discharge it before handling. For replacements, two condensers with a breakdown voltage lower than the required voltage may be connected in series. This doubles the voltage rating, but halves the capacity.

Be careful when making tests; you are dealing with high voltages. Mark your test leads, and always use the same lead for probing. It is customary to use the black test lead for negative or common, and the red lead for the positive or hot side. Be careful about applying

too high a voltage and kicking a meter against the pin. This will bend the needle and destroy the calibration of the meter.

When replacing resistors check the wattage of the circuit before installing the resistor. Be sure that the replacement resistor is of sufficient wattage to dissipate the heat. Formulas I^2R , $\frac{E^2}{R}$, or IE will apply.

An IF signal taken from the IF stage of an operating receiver will often provide the necessary signal for peaking another set.

VOLTAGE READINGS

Be sure to use the highest meter scale available when checking an unknown voltage; after which you can change to a more appropriate scale for most accurate reading.

The calibration of a volt meter may be checked by connecting it, in parallel with another meter of known accuracy, across a conveni-

ent voltage source. (See Figure 1.) The readings of both can then be compared. Small inaccuracies can be corrected by moving the pivot adjustment on the face of the meter being calibrated.

To measure voltages beyond the scale of any voltmeter, place a series of resistors across the voltage to be measured, being careful that the combined resistors have sufficient resistance value so that they do not appreciably load the circuit, draw too much current, and thus lower the overall voltage. Now take readings across each resistor in turn. (See Figure 2.) The total of these individual readings is equal to the voltage across the line or load being measured.

Resistance Multipliers. Place a resistor in series with the voltmeter, choosing a value that will keep the needle on scale. Then, using a voltage within the normal meter range, take a reading with the voltmeter alone (reading A), and a second reading on the same voltage with the selected resistor in series with the meter (reading

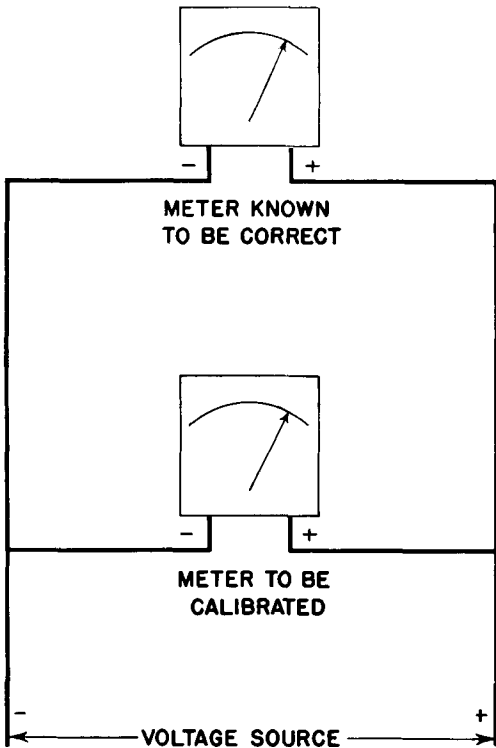

Fig. 1

B). (See Figure 3.) Now divide reading (A) by reading (B) to obtain the constant (K) of your multiplier resistor. Then, using the voltmeter with the multiplier resistor in series, make readings and multiply all of the readings thus made by the (K) to obtain true voltage. The resistor so calibrated and tagged with the (K) value can be used with the same voltmeter again without recalibration. It is desirable, but not necessary, to select a resistor that will make the (K) value an even number.

Transformer Multipliers. On AC voltmeters only a transformer may be used as a voltmeter multiplier. To obtain the constant (K) for such a multiplier, read a voltage with and without the transformer multiplier in circuit. Divide the reading taken without the multiplier transformer in use by the reading with the multiplier transformer in use to obtain the (K). (See Figure 4.) To obtain the true voltage when using the multiplier with this same voltmeter, multiply

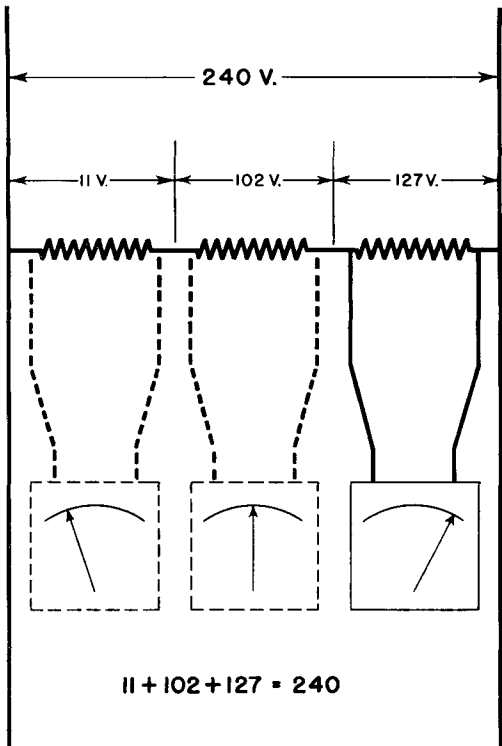

Fig. 2

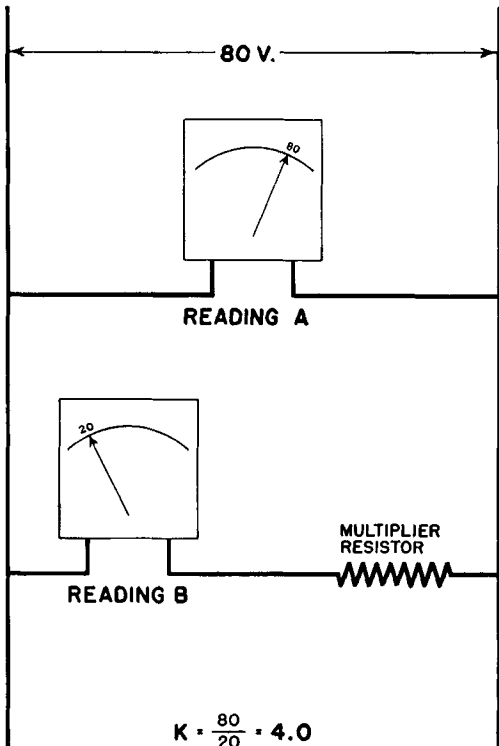
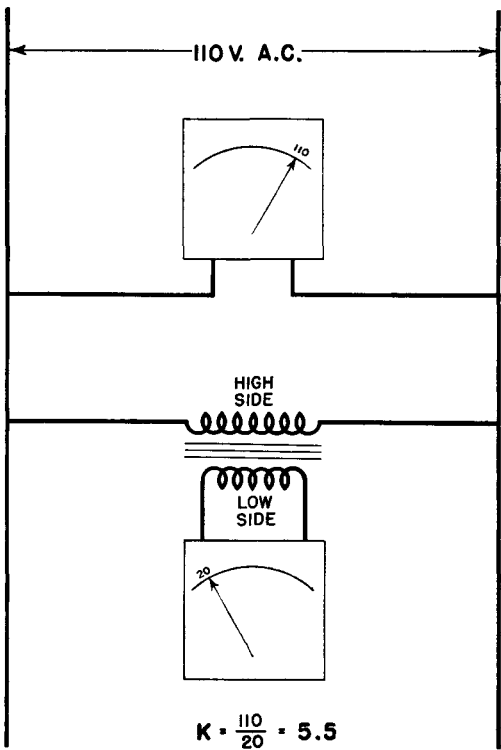

Fig. 3



$$K = \frac{110}{20} = 5.5$$

Fig. 4

all scale readings by (K). Be sure to connect the low voltage side of the transformer to the meter.

CURRENT READINGS

Always use the highest current scale available when first checking an unknown circuit. Then change to a more appropriate scale for accurate reading.

Ammeters may be checked for calibration by placing the meter to be checked in series with a meter of known accuracy, correcting any small irregularities by means of the pivot adjustment on the face of the meter being calibrated. (See Figure 5.)

To measure current beyond the scale of an ammeter place a shunt or low-value resistor of sufficient power rating to carry the excess current across the terminals of the ammeter. To find a (K) for this shunt take a reading of a given current within the range of the meter

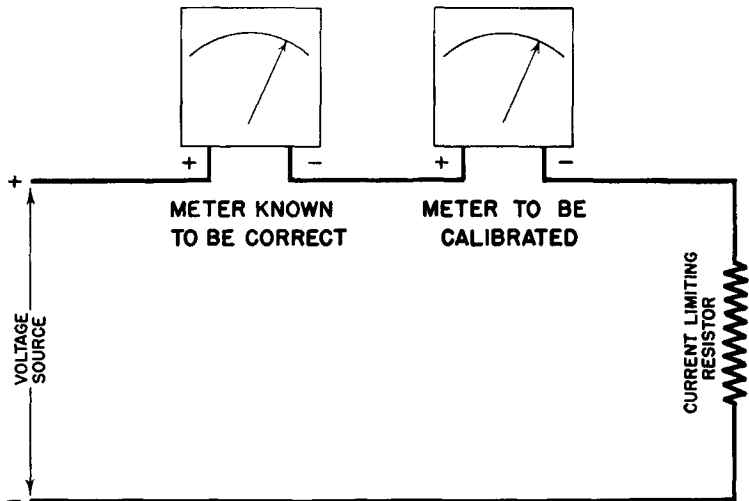

Fig. 5

without the shunt and another reading with the shunt in place. (See Figure 6.) Divide the reading taken without the shunt by the reading taken with the shunt to obtain the (K) value. When the shunt is used, multiply all scale readings on the meter by this (K) to obtain the true current.

IMPEDANCE MEASUREMENTS

Method one—substitution. An unknown impedance may be determined by first measuring the AC voltage drop across it, then across a non-inductive resistor, adjusting the value of the resistor until the same voltage drop is obtained across both loads. The DC resistance of the resistor may now be measured by means of an ohmmeter or a Wheatstone bridge. The value of the unknown impedance in ohms is equal to the value of the resistance in ohms. Since impedance changes with frequency, the measurement thus made indicates the

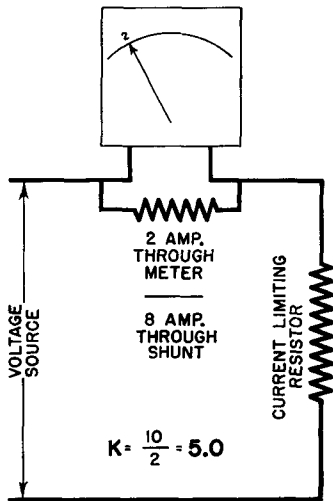
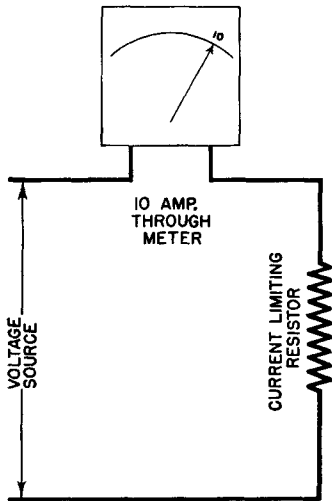

Fig. 6

impedance of this inductive or capacitive load only at the frequency under which the test was made. (See Figure 7.)

Method two—voltmeter readings and computation. Place a resistor R in series with the unknown impedance Z . Then make a voltage reading across the resistor R , calling this (E_r) and also across the unknown impedance Z^* , calling this (E_z). (See Figure 8.)

Now, by computation,

using formulas $Z = \frac{E_z}{I}$, and $I = \frac{E_r}{R}$,

and substituting for
 I in the first equation, $Z = \frac{E_z}{\left(\frac{E_r}{R}\right)} = \frac{E_z R}{E_r}$.

**The unknown impedance may be either inductive or capacitive.*

Z MAY BE INDUCTIVE - OR - CAPACITIVE
Fig. 7

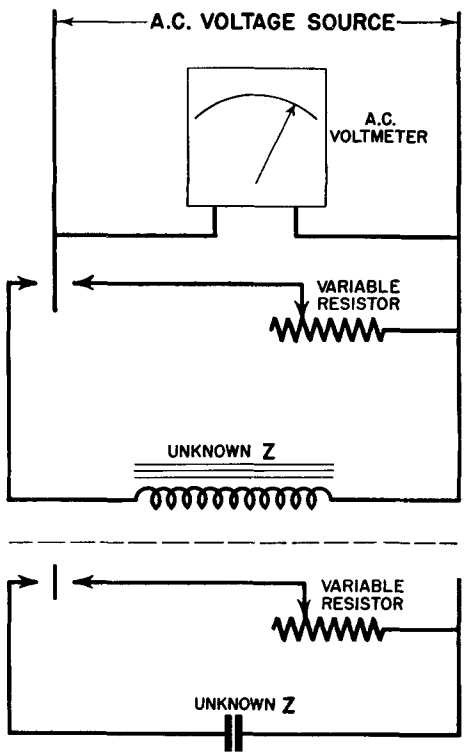

To measure the effective impedance of an output transformer in an amplifier, for load matching purposes only, connect an output meter across the unloaded secondary of the transformer and make a reading in decibels (db). Then place a non-inductive load (resistor) across the output and vary its value until the output reading obtained, is 6 db lower than the unloaded reading. (See Figure 9.) The DC resistance of this resistor, measured with an ohmmeter, equals the effective impedance of the transformer.

Matching impedance. A speaker or output load should have an impedance or resistance equal to or higher than the effective impedance of the transformer which drives it. Good practice is a matching ratio of 1:2 to 1:5.

To provide a signal to drive an amplifier for testing purposes, a bell-ringing transformer is suitable if no audio oscillator is available. Connect the bell-ringing transformer so as to provide an AC voltage

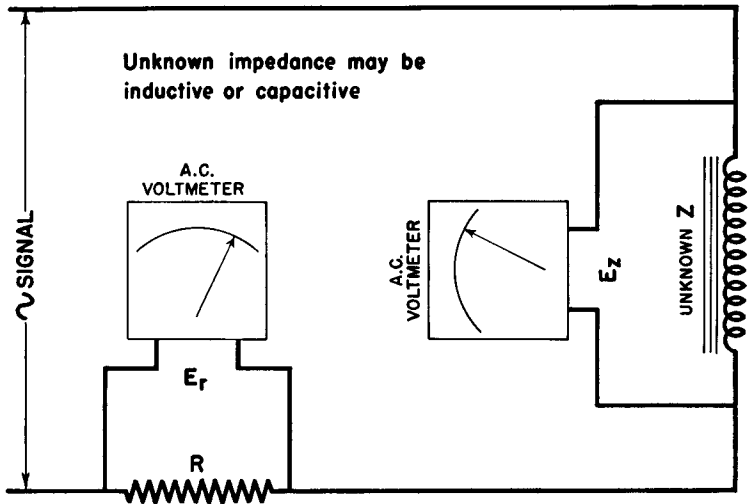

Fig. 8

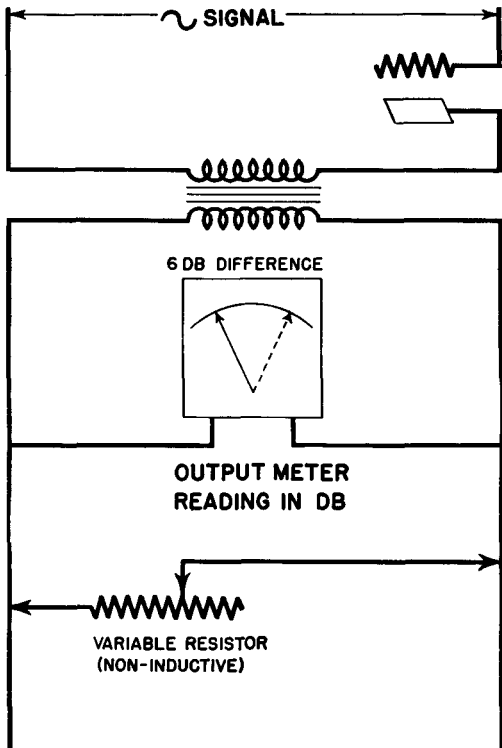

Fig. 9

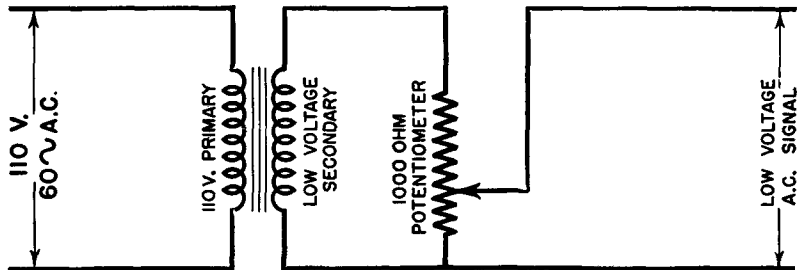

Fig. 10

of approximately 10 volts on the low side and a 1,000-ohm potentiometer across the 10 volts to permit attenuation of this signal so as to feed the amplifier without overloading. (See Figure 10.)

INDUCTANCE AND CAPACITY

The methods outlined on the preceding pages for the determination

of impedance may also be used as a basis of computing the value of an inductance in henrys, and of a capacity in farads. The following formulas will serve:

$$L = \frac{X_L}{2\pi f}, \text{ and } C = \frac{1}{2\pi f X_c},$$

where $2\pi = 6.28$
 f = frequency in cycles per second.
 L = inductance in henrys.
 C = capacity in farads.

If resistance is considered negligible and need not be taken into account, impedance Z in the formula on page 20, may be used as the inductive reactance X_L or the capacitive reactance X_c , in the formulas above.

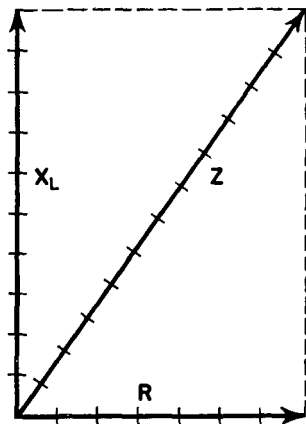

**INDUCTANCE AND
RESISTANCE**

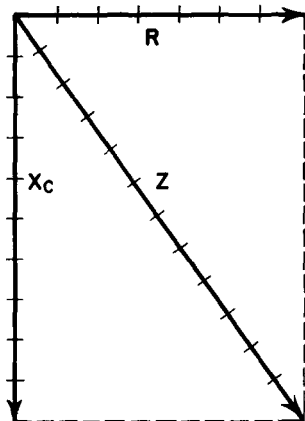

**CAPACITY AND
RESISTANCE**

Fig. 11

When resistance is not negligible and must be taken into account, square the value of the impedance Z , and subtract the square of the resistance R . The figure thus obtained is equal to the square of the reactance. Therefore, extract the square root of this figure to find the value of reactance X_L or X_C for use in the formulas on page 26. These values may also be found graphically by laying R and Z out to scale, completing the rectangle, and measuring the linear value of X_L or X_C . (See Figure 11.)

TRANSMITTERS

In testing transmitters, make a pickup coil approximately two inches in diameter and consisting of one or two turns of copper wire connected to a flashlight bulb. Holding this loop in the field of the tank or tuning circuits will cause the bulb to light if the circuit is oscillating. A small loop connected to the input of a receiver will

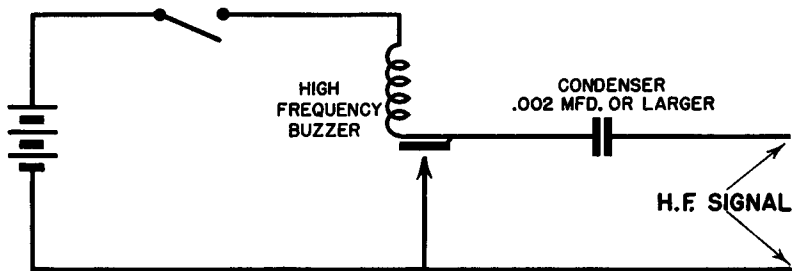

Fig. 12

provide an exploring coil for use on the oscillator stage. The receiver should be tuned to the frequency or a harmonic of the frequency of the stage under test. Do not, however, use the exploring

coil and receiver on the higher power stages. It is understood that before making tests with an exploring coil, all filament and plate voltages have been checked and have been found normal.

SIGNAL TRACING

Signal generator for tracing a signal. A high-frequency buzzer, operated by a battery, makes an effective signal generator for tracing through a receiver or amplifier. (See Figures 12 and 13.)

To use the signal tracer start at the output of the receiver or amplifier, and place a signal on the output (speech or signal) leads. The signal may be observed by means of a speaker, headphones or an output meter connected to the output leads of the set. With the set operating, follow the signal circuit progressively back through the various stages of the set, placing the signal on the output and then the input of each coupling transformer, coupling condenser,

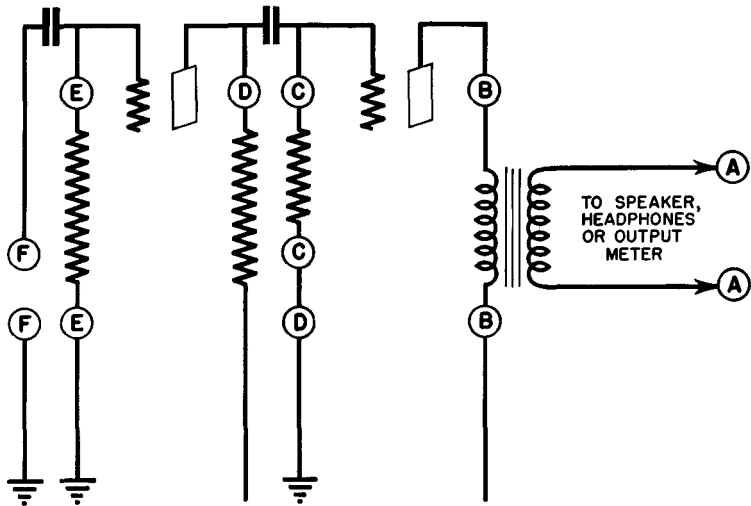

Fig. 13

and on the plate and grid of each tube until the point is found where the signal is impeded or fails to come through. When this point is determined, check each component of that stage until the defect is located. Remember that each stage of amplification will increase the signal level at the output. (See Figure 13.) Lettered circles indicate progressive points in the circuit across which the signal is introduced.

RADIO COLOR CODES

The color codes which follow are used by most radio and instrument manufacturers in the wiring of their products, and by parts manufacturers for identifying lead placement or resistor and condenser values, ratings, and tolerances. These have been included for whatever help they may provide in identifying parts and leads when shooting trouble.

RESISTOR COLOR CODES (Values in Ohms)

Body		Heavy Woven Thread		Light Woven Thread		← Flexible type resistors. All others below are carbon	
Body		End		Dot or Band		End	
1st Band or Dot		2nd Band or Dot		3rd Band or Dot		End Band	
Color	Value	Color	Value	Color	Value	Color	Tolerance
Black	0	Black	0	Black	None	Gold	± 5%
Brown	1	Brown	1	Brown	0	Silver	± 10%
Red	2	Red	2	Red	00	None	± 20%
Orange	3	Orange	3	Orange	000		
Yellow	4	Yellow	4	Yellow	0000		
Green	5	Green	5	Green	00000		
Blue	6	Blue	6	Blue	000000		
Violet	7	Violet	7				
Grey	8	Grey	8				
White	9	White	9				

CONDENSER COLOR CODES *(Values in Micromicrofarads)*

1st Dot		2nd Dot		3rd Dot		4th Dot		Used on paper condensers only	
Color	Value	Color	Value	Color	Value	Color	% Tolerance	Color	DC Working Volts
Black	0	Black	0	Black	None	White	±2.5	Brown	100
Brown	1	Brown	1	Brown	0	Green	± 5	Red	200
Red	2	Red	2	Red	00	Blue	±10	Orange	300
Orange	3	Orange	3	Orange	000	Yellow	±15	Yellow	400
Yellow	4	Yellow	4	Yellow	0000	Red	±20	Green	500
Green	5	Green	5	Green	00000	None	Over 20	Blue	600
Blue	6	Blue	6	Blue	000000			Violet	700
Violet	7	Violet	7	Violet	0000000			Gray	800
Grey	8	Grey	8					White	900
White	9	White	9					Gold	1,000
								Copper	1,600
								Silver	2,000

POWER TRANSFORMER LEADS

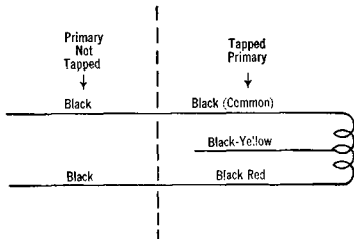

I F TRANSFORMER LEADS

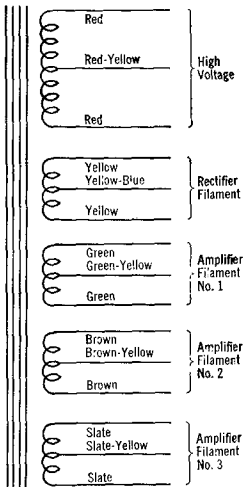
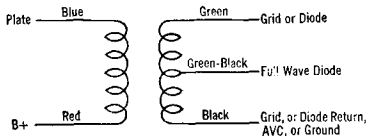

SPEAKER LEADS AND PLUG CONNECTIONS

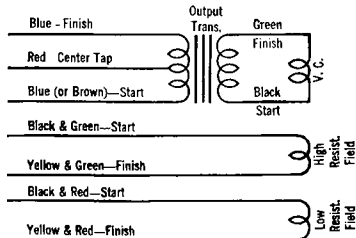
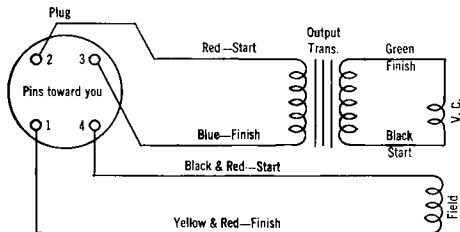
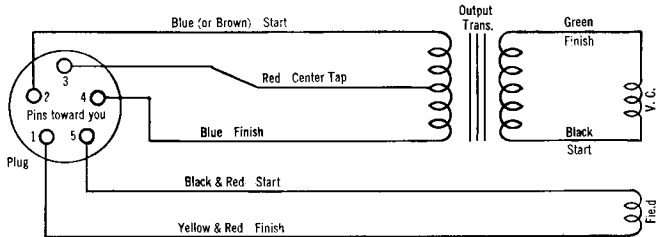

Speaker Leads and Plug Connections—continued

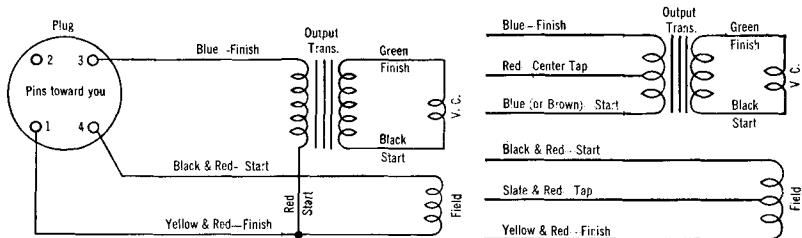
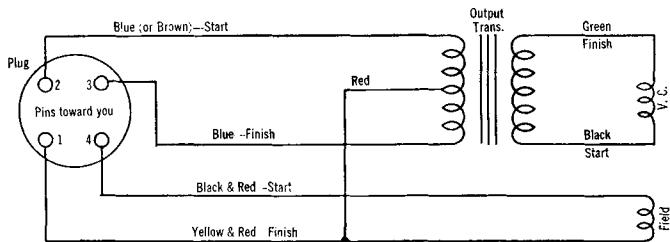

AUDIO TRANSFORMER LEADS

(Input, Interstage, Output)

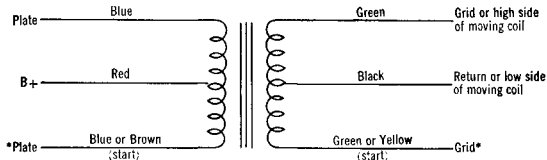

*Found only on push-pull primary or secondary windings.

BATTERY CABLE LEADS

Red	A +	White	B + Intermediate
Black	A -	Brown	C +
Blue	B +	Orange	C - Intermediate
Yellow	B -	Green	C -

FRACTIONAL INCHES TO DECIMAL AND MILLIMETER EQUIVALENTS

Inches \times 2.540 = Centimeters

Inches \times 8.33×10^{-2} = Feet

Inches \times 1.578×10^{-5} = Miles

Inches \times 10^3 = Mils

Inches \times 2.778×10^{-2} = Yards

Inches		Decimal Equivalent	Millimeter Equivalent
1/64	1/32	.0156	0.397
		.0313	0.794
3/64		.0469	1.191
		1/16	.0625
5/64	3/32	.0781	1.985
			.0938
7/64		.1094	2.778
		1/8	.1250
9/64	5/32	.1406	3.572
			.1563
11/64		.1719	4.366
		3/16	.1875
13/64	7/32	.2031	5.159
			.2188
15/64		.2344	5.953
		1/4	.2500
17/64	9/32	.2656	6.747
			.2813
19/64		.2969	7.541
		5/16	.3125
21/64	11/32	.3281	8.334
			.3438
23/64		.3594	9.128
		3/8	.3750
25/64	13/32	.3906	9.922
			.4063

(Continued on page 40)

(Continued from page 39)

Inches		Decimal Equivalent	Millimeter Equivalent
27/64		.4219 .4375	10.716 11.112
29/64	15/32	.4531 .4688	11.509 11.906
31/64		.4844 .5000	12.303 12.700
33/64	17/32	.5156 .5313	13.097 13.494
35/64		.5469 .5625	13.891 14.287
37/64	19/32	.5781 .5938	14.684 15.081
39/64		.6094 .6250	15.478 15.875
41/64	21/32	.6406 .6563	16.272 16.669
43/64		.6719 .6875	17.067 17.463
45/64	23/32	.7031 .7188	17.860 18.238
47/64		.7344 .7500	18.635 19.049
49/64	25/32	.7656 .7813	19.446 19.842
51/64		.7969 .8125	20.239 20.636
53/64	27/32	.8281 .8438	21.033 21.430
55/64		.8594 .8750	21.827 22.224
57/64	29/32	.8906 .9063	22.621 23.018
59/64		.9219 .9375	23.415 23.812
61/64	31/32	.9531 .9688	24.209 24.606
63/64		.9844 1.0000	25.004 25.400