

# THE SUPERHET MANUAL

---

F. J. Camm

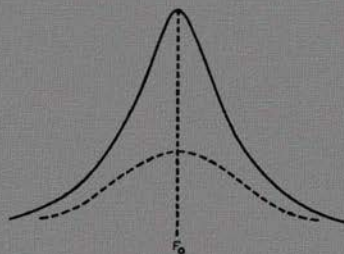

# THE SUPERHET MANUAL

A Handbook dealing with Principles, Design  
and Servicing, and Including Chapters on  
Aerials, Tone Control and Variable Selectivity

EDITED BY

F. J. CAMM

Editor of

*"Practical Wireless," "Practical Engineering,"  
and "Practical Mechanics"*

FULLY ILLUSTRATED



1942

First American Edition

CHEMICAL PUBLISHING COMPANY, INC.

Brooklyn, N. Y.

U. S. A.

*Manufactured in the United States of America*  
DORAY PRESS  
New York, N. Y.

## PREFACE

By far the greater proportion of modern receivers function on the superheterodyne principle, an unwieldy word now abbreviated to superhet. The present volume is entirely devoted to various aspects of superhet design, operation, and servicing. In the belief that before the superhet can be understood a knowledge of the underlying principles of radio is essential, the first chapter deals with the fundamental principles, and leads up to the problems of selectivity which it is the special function of the superhet to solve. Other chapters deal with valve fundamentals; the principle of the superhet; the general design; aerial design; variable selectivity and the superhet; noise suppression and A.V.E.; tone control; and servicing with the Cathode Ray Tube.

*Practical Wireless*, now published monthly, regularly deals with superhet problems.

F. J. CAMM

## CONTENTS

| CHAPTER  | PAGE |
|--|------|
| I. FUNDAMENTAL PRINCIPLES OF RADIO . . . . .         | 9    |
| II. PROBLEMS OF SELECTIVITY . . . . .                | 26   |
| III. VALVE FUNDAMENTALS . . . . .                    | 50   |
| IV. THE PRINCIPLE OF THE SUPERHET . . . . .          | 78   |
| V. GENERAL DESIGN . . . . .                          | 91   |
| VI. AERIAL DESIGN . . . . .                          | 96   |
| VII. VARIABLE SELECTIVITY AND THE SUPERHET . . . . . | 100  |
| VIII. NOISE SUPPRESSION AND A.V.E. . . . .           | 106  |
| IX. TONE CONTROL . . . . .                           | 110  |
| X. SERVICING WITH THE CATHODE RAY TUBE . . . . .     | 116  |
| INDEX . . . . .                                      | 133  |

# THE SUPERHET MANUAL

## CHAPTER I

### FUNDAMENTAL PRINCIPLES OF RADIO

IN order that we may clearly understand the principles of the superhet receiver, it is necessary first of all to have a thorough understanding of the technicalities of ordinary radio—that is, a full knowledge of the character of the “signal” voltage developed in the receiving aerial by a broadcast transmission, and its behaviour in passing through a receiver. In addition, the working data of valves and other components must also be understood clearly. By starting with a consideration of the aerial signal voltage a considerable insight may be gained into the requirements of broadcast reception, and also some indication of the major problems which arise will be obtained.

**The Broadcast “Signal” Unmodulated.**—First, we will consider what happens during a pause in the broadcast programme, *i.e.* while the microphones are idle. The transmitter is still actively radiating, and the voltage produced in the receiving aerial has the comparatively simple character shown graphically in Fig. 1. The oscillations are of “unmodulated continuous wave” type, and have a frequency which represents the “carrier frequency” of the transmitter. Note the constant amplitude of the oscillations.

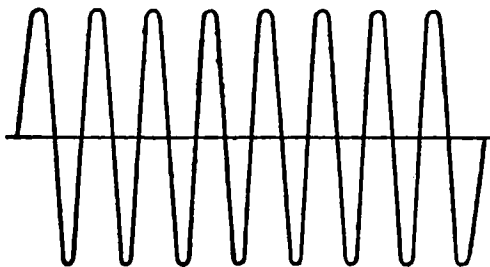

FIG. 1.—The simple waveform of an unmodulated carrier wave.

The fact that different transmitters are allocated, different carrier frequencies shows at once the necessity for variable receiver "tuning," and also indicates where lies the possibility of avoiding interference between different transmissions. The selectivity problem is not a simple one, however, as we shall see.

**Kilocycles, Megacycles, and Metres.**—The allocation of carrier frequencies is a supremely important matter from the listeners' point of view, and is a nightmare of a problem for those who have to decide upon such allocation.

If a list of medium-wave European broadcast stations, arranged in order of carrier frequencies, is examined it will be noticed that 9 kilocycles per second occurs frequently as the difference between the frequencies of stations adjacent in the list. The allocation of frequencies has, as a matter of fact, been planned to give 9 kc/sec. separation as far as possible.

To make 9 kc/sec. separation constant throughout has been impossible, for the simple reason that there are too many stations to be packed into the band of available frequencies. The situation is eased a little by the fact that low-power transmitters widely separated geographically can work close to each other's carrier frequencies with small risk of either interfering with reception in the service area of the other; also, synchronisation of stations radiating the same programmes has proved helpful. The problem of frequency allocation remains a serious one, however, and, cutting across the whole issue is the fact that 9 kc/sec. is, in any case, insufficient from the point of view of the requirements of high-quality reception.

What about wavelengths? It is unfortunate that so many of us have got into the habit of thinking about, and referring to, broadcast transmissions in terms of wavelengths and a pity, too, that receiver manufacturers consider it necessary to pander to us by preserving wavelength calibrations on tuning scales.

Corresponding to every carrier frequency there is a particular wavelength, easily calculated from the following:

$$\text{Wavelength} = \frac{300,000}{\text{Frequency}} \text{ metres}$$

the frequency being expressed in kilocycles per second.

Any information dependent upon carrier frequency values can, of course, be derived from the corresponding wavelengths, but to take wavelengths at their face values (without converting to frequencies) can sometimes be misleading. As an example, round about a carrier frequency of 565 kc/sec. a frequency difference of 9 kc/sec. is represented by a wavelength difference of  $8\frac{1}{2}$  metres, approximately, whereas, near a carrier frequency of 1122 kc/sec. a frequency difference of 9 kc/sec. is represented by a wavelength difference of 2 metres, approximately.

Since consideration of frequencies is so important in respect of station allocation, and also with regard to the work of the receiver designer, it behoves the earnest amateur to make himself accustomed to thinking of

TABLE I

| Wavelength.   | Frequency.  | Wavelength.        | Frequency.         |
|---------------|-------------|--------------------|--------------------|
| Metres.       | Kilocycles. | Metres.            | Kilocycles.        |
| <b>LONG</b>   |             | <b>200</b>         | <b>1034.5</b>      |
| 2000          | 150         | 200                | 1071.4             |
| 1750          | 171.4       | 270                | 1111.1             |
| 1500          | 200         | 200                | 1163.8             |
| 1250          | 240         | 250                | 1200               |
| 1000          | 300         | 240                | 1250               |
|               |             | 230                | 1304.3             |
| <b>MEDIUM</b> |             | 220                | 1363.6             |
| 500           | 534.7       | 210                | 1422.6             |
| 540           | 555.6       | 200                | 1500               |
| 520           | 576.9       |                    |                    |
| 500           | 600         | <b>SHORT</b>       | <b>Megacycles.</b> |
| 490           | 612.2       | 100                | 3                  |
| 480           | 625         | 90                 | 3.33               |
| 470           | 638.3       | 80                 | 3.75               |
| 460           | 652.2       | 70                 | 4.29               |
| 450           | 667         | 60                 | 5                  |
| 440           | 681.8       | 50                 | 6                  |
| 430           | 697.7       | 49                 | 6.12               |
| 420           | 714.3       | 40                 | 7.5                |
| 410           | 731.7       | 31                 | 9.68               |
| 400           | 750         | 25                 | 12                 |
| 390           | 769.2       | 20                 | 15                 |
| 380           | 789.5       | 19                 | 15.79              |
| 370           | 810.8       | 17                 | 17.65              |
| 360           | 833.3       | 15                 | 20                 |
| 350           | 857.1       | 13                 | 23.08              |
| 340           | 882.4       | 11                 | 27.27              |
| 330           | 909.1       |                    |                    |
| 320           | 937.5       | <b>ULTRA-SHORT</b> |                    |
| 310           | 967.7       | 7.23               | 41.5               |
| 300           | 1000        | 6.26               | 45                 |



broadcast transmissions in terms of their carrier frequencies. Table I. is given as an aid in this respect. The frequencies of the short waves are of such very high values that they are more conveniently expressed in megacycles per second than in kilocycles per second. (N.B.—Kilo=1000, mega=1,000,000.)

If the carrier frequency corresponding to any particular wavelength not shown in the table is required it can be calculated, as follows :

$$\text{Frequency} = \frac{300,000}{\text{Wavelength}} \text{ kilocycles per second}$$

the wavelength being expressed in metres.

**The Broadcast "Signal" Modulated.**—As soon as the transmitter starts transmitting programme material

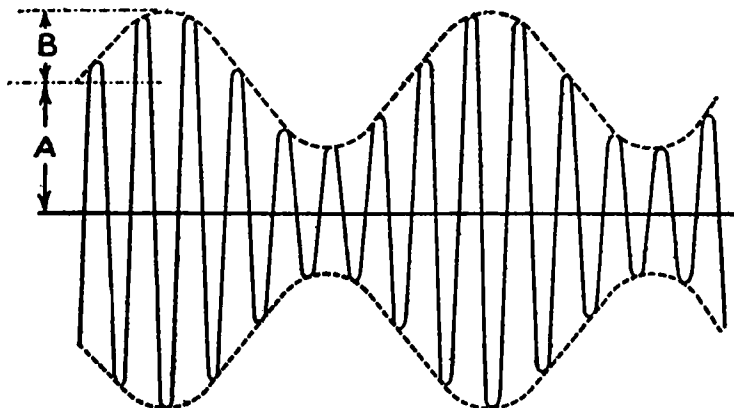

FIG. 2.—The effect of a modulated carrier, showing the "modulation envelope."

the oscillations at the receiver take on a very complicated character. The oscillations now carry the characteristics of the broadcasted sounds and carries them in the form of an amplitude variation. This amplitude variation is, normally, continually changing and is, at any instant, of complex form.

Fig. 2 shows, graphically, a case of modulated H.F. oscillations which is comparatively simple, but is useful for illustrative purposes. It will be seen that the amplitude variation follows a simple sine wave curve and this would be the kind of modulation produced if the sound

controlling the transmitting microphone was a (single frequency) "pure tone."

The dotted curves of Fig. 2 constitute what is known as the "modulation envelope." Simple modulation of this kind can be fully described, first, in terms of the frequency of the modulation, and, secondly, of the "depth of modulation." If, in Fig. 2, A represents the amplitude of the carrier oscillations when unmodulated, then the depth of modulation is given by the ratio  $B/A$  or, as is more usual, by the percentage

$$B/A \times 100.$$

If the unmodulated voltage amplitude in one of the receiver circuits were 1 volt, then, with 50 per cent. modulation, the amplitude would rise and fall at modulation frequency between the extremes of 1.5 volts and 0.5 volt, while, at 100 per cent. modulation, the extremes would be 2 volts and zero. Obviously, 100 per cent. represents a limit, but, as we shall see later, there are reasons why the modulation shall not be allowed to reach such a limit.

**Sideband Frequencies.**—Referring to Fig. 2 again, suppose the carrier frequency is  $F$  cycles per second and the modulation frequency  $M$  cycles per second. A process of analysis applied to modulated oscillations of this kind reveals that they must not be regarded as the resultant of the two components,  $F$  cycles per second unmodulated, and  $M$  cycles per second unmodulated, which is what one might at first suppose. The analysis shows that three unmodulated components together make up a resultant of the character shown in Fig. 2. These three components are all of high frequency, and the frequency values are, respectively,

$$\begin{aligned} &F \\ &F+M \\ &F-M \text{ cycles per second.} \end{aligned}$$

Whether we refer to the oscillations in terms of the graphical interpretation of Fig. 2, or whether we substitute the idea of the three unmodulated component oscillations, we are actually dealing with the same thing, but the analysis above makes it easier to understand many important practical facts.

Before leaving this single modulation frequency case it is well to bear in mind that the ratio of the amplitude of the  $F+M$  (and also of the  $F-M$ ) component, to that of the  $F$  component, is one-half of the modulation ratio  $B/A$ .

With modulation of the normal broadcast kind there is not just a single modulation frequency to consider but a range of modulation frequencies. Extending our ideas from the simple case of Fig. 2, we have to regard a normal broadcast transmission as amounting to the radiation of unmodulated oscillations of the carrier frequency  $F$ , and two *ranges* of unmodulated oscillations of the "sideband" frequency ranges of

$$F+M \text{ to } F+m$$

and

$$F-M \text{ to } F-m$$

where  $M$  is the highest modulation frequency used, and  $m$  is the lowest modulation frequency used.

This means, in effect, that the radiation of a broadcast transmitter "spreads" over a band of frequencies stretching from  $F+M$  to  $F-M$ . That this greatly complicates the requirements for satisfactory broadcast reception is surely obvious. We shall return to this matter later.

**Tuning : Series Resonance.**—Considering the characteristics of different broadcast transmissions it must be understood that the essential factor which must be utilised in reception to enable one particular transmission to be received is the carrier frequency value. This raises the subject of "tuning," for the receiver must contain one or more (normally, more) "tuned" circuits.

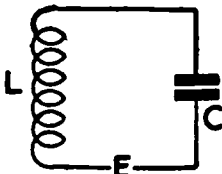

FIG. 3.—A tuned circuit in which  $L$  represents inductance,  $C$  represents capacity, and  $E$  the electro-motive force operating in the circuit.

Fig. 3 represents a circuit containing an inductance coil  $L$  and a condenser  $C$ , both in series. It is to be understood that a high-frequency electro-motive force  $E$  is operating in the circuit. The circuit must not be regarded as broken as the diagram might suggest. The diagram has been drawn that way to emphasise the fact that the e.m.f. is operating *internally* in the circuit.

A given value of  $E$  will produce a high-frequency current in the circuit, and the current value will be dependent upon the impedance of the circuit.

$$I = \frac{E}{\sqrt{R^2 + (\omega L \sim \frac{1}{\omega C})^2}}$$

where  $I$  = current

$E$  = e.m.f.

$R$  = H.F. resistance of the circuit

$L$  = inductance

$C$  = capacity

$\omega$  =  $6.28 \times$  frequency.

The square root expression represents the impedance of the circuit.

As regards units, the current will be in amps. if the e.m.f. is in volts, resistance in ohms, inductance in henrys, capacity in farads, and frequency in cycles per second.

The current will be of peak value if the e.m.f. is of peak value, and the current will be of virtual (R.M.S.) value if the e.m.f. is of virtual value.

The bracketed expression ( $\omega L \sim 1/\omega C$ ) is all-important. It represents the difference between the inductive reactance,  $\omega L$ , and the capacitive reactance,  $1/\omega C$ , and it can be called the net reactance of the circuit. It is to be noted that the smaller of the individual reactances is to be subtracted from the larger. That is why the  $\sim$  sign is used instead of a minus sign in the above equation. Thus, sometimes we have ( $\omega L - 1/\omega C$ ) and sometimes ( $1/\omega C - \omega L$ ).

$\omega = 6.28 \times$  frequency, so the net reactance is obviously a value that is dependent upon frequency. As a result the impedance of the circuit will vary with change of frequency.

Inspection of the impedance formula shows at a glance that there is a special possibility simply asking for comment. This is the possibility of  $\omega L$  being exactly equal to  $1/\omega C$ . In this case the net reactance will obviously become zero, and the impedance expression will simplify down to  $R$  (the resistance). Therefore

$$I = \frac{E}{R}.$$

This is the case of "resonance," and when the frequency of E is such as to produce the condition of resonance the impedance is lower than at any other frequency (being R, merely), and the current in the circuit is greater than at any other frequency. In making this statement we are assuming that R holds constant for different frequencies. There are, however, complications looming ahead in this connection.

Here, then, we have a circuit which behaves differently to one particular frequency than to any other—the very sort of thing that we need to enable a receiver to select a broadcast transmission of a certain carrier frequency from a number of transmissions of different carrier frequencies.

The question that arises now is, What governs the particular frequency value at which the circuit will be in the resonant condition?

The resonant frequency is that frequency which makes

$$\omega L = 1/\omega C$$

and is equal to

$$\frac{1}{6.28\sqrt{LC}} \text{ cycles per second}$$

where L=inductance (henrys)  
C=capacity (farads).

To say that a circuit, such as that of Fig. 3, is "tuned to a frequency F," implies that F is the resonant frequency corresponding to the values of L and C in the circuit.

In case there may be some reader who, while he can appreciate from the equations given above the effect of the frequency reaching the resonant value, yet cannot quite "see" what is happening in the circuit, we give the following explanation:

Referring to Fig. 3, the presence of L is responsible for a reactive voltage being developed in the circuit. This voltage is induced by the fluctuations of the magnetic field of L, and it is very important to note that this particular reactive voltage is lagging in phase behind the current by 90°. C is responsible for another reactive voltage. This is dependent upon the fluctuations of electric charge in the condenser, and is a voltage which, as regards phase, leads ahead of the current by 90°. Obviously

these two reactive voltages will be  $180^\circ$  out of phase with each other, *i.e.* in direct opposition.

Individually, each of the two reactive voltages tends to bring about an increase in the circuit impedance but as, in the circuit of Fig. 3, they oppose each other, it is the difference between their two values which actually counts as regards the effect of L and C upon the circuit opposition, and the corresponding current value.

In the case of resonance, the two reactive voltages become equal and therefore balance each other out (considering the circuit as a whole). That is why the circuit impedance reduces down to R only.

**Two Particular Advantages of Resonance.**—There are two special features of the resonant condition which must be noted.

First, there is the fact that has already been pointed out, namely, for constant e.m.f., the current is maximum at the resonant frequency.

Secondly, it must be noted that although the two reactive voltages balance each other out as regards the circuit *as a whole*, they nevertheless are in active existence and, under favourable circumstances, will be considerably greater in value than the applied e.m.f., E. Across the half of the circuit which contains L (but not C) there can, therefore, actually be a voltage drop greater than the applied e.m.f. The same remark applies to the half of the circuit which contains C (but not L). Either of these voltage drops can be considered as offering considerable possibilities where radio reception is concerned, but we will defer a more detailed consideration until we come to the subject of circuit magnification.

**Variable Tuning.**—We have seen that the resonant frequency is inversely proportional to  $\sqrt{LC}$ ; correspondingly, the wavelength appropriate to the resonant frequency is directly proportional to  $\sqrt{LC}$ . It follows that if the resonant frequency value is to be adjustable, either L or C (or both) must be variable.

The normal practice, in H.F. receiving circuits, is for the tuning control to operate a variable condenser.

**Tuning Range.**—For a given inductance value the circuit will be tuned to the lowest frequency (longest wavelength) when the condenser is at its maximum

capacity setting. The highest frequency (shortest wavelength) that can be tuned to will now depend upon the value of residual capacity that still remains when the condenser is adjusted to its so-called zero setting. The residual ("stray") capacity of the circuit is therefore a factor of considerable importance when it comes to a question of what tuning range will be obtained.

We are assuming constant inductance. Upon this assumption it can be said that the variation of resonant frequency will depend upon the variation of  $\sqrt{C}$ . Thus, the ratio of the maximum to the minimum frequency will be equal to the square root of the ratio of the maximum to the minimum capacity.

The residual capacity is made up of a number of contributory factors: the minimum capacity of the variable condenser, the self-capacity of the tuning coil, the stray capacity of the wiring, and, in usual circumstances, there will be additional capacity imposed on the circuit by components connected across the circuit (*e.g.* the input capacity of a valve, valve-holder capacity, etc.). In addition, there may be capacity "reflected" into the circuit by some other circuit coupled to it.

The minimum capacity of a variable condenser is not zero for, even with no overlap between the plates, there is still an electric field between the plate edges; moreover, there is always a certain permanent small capacity residing in the insulating plate mountings.

**Self-capacity.**—The self-capacity of an inductance coil can sometimes have far-reaching results. It must be noted by the reader that it is impossible to wind a coil to have inductance *only*. It is easy to appreciate that it must inevitably have resistance, but not so easy perhaps to understand that it is equally inevitable that it should have capacity. This self-capacity is actually distributed throughout the coil. Between adjacent turns of the coil there is insulation—silk, cotton, etc., or perhaps air. The potential difference that exists between the turns sets up an electric field in the insulation. In other words, and taking an elementary viewpoint, the two turns of wire, and the insulation between them, act like two plates and dielectric of a condenser. It is, of course, one of the principles of good coil design that the self-capacity shall

be made as small as possible. Spacing of turns, method of winding, type of insulation, nature of coil former, are all factors that have a bearing upon the value of the self-capacity.

In considering L and C as separate items of a circuit, we have seen that to the value of LC there is appropriate a certain resonant frequency. Could this same idea apply to the inductance of a coil and its self-capacity? It does so apply, and it is a fact that any inductance coil can exhibit resonance effects quite on its own. We shall have to take this fact into account later in connection with certain special problems, but at the moment we are more concerned with the matter of tuning range.

**Resonant Frequency.**—In the typical H.F. circuit consisting of a coil with a variable condenser across it, the resonant frequency of the coil itself represents a frequency above which the circuit cannot be tuned by the variable condenser. Actually, the stray capacities which are additional to the self-capacity of the coil will prevent even this frequency being reached.

To get an idea of tuning range limitations imposed by residual circuit capacity, let us work out an example. Suppose a coil of 157 microhenrys inductance is tuned by a variable condenser and that the maximum capacity (inclusive of all factors) is .00057 microfarads.

The frequency to which the circuit will be tuned by this capacity can be found by the formula :

$$\frac{1000}{6.28\sqrt{LC}} \text{ kilocycles per second}$$

where L = microhenrys

C = microfarads.

Substituting 157 and .00057 for L and C respectively, the frequency works out to 532 kc/sec. approximately.

The corresponding wavelength may either be calculated direct from the frequency value or by the formula :

$$1885\sqrt{LC} \text{ metres,}$$

L and C being in microhenrys and microfarads.

The wavelength works out to 564 metres approximately.

Now let us suppose that the minimum capacity obtainable is .00006 microfarad (*i.e.* 60 micromicrofarads).



The frequency and wavelength to which the circuit will be tuned with the variable condenser at its "zero" setting will be 1640 kc/sec. and 183 metres.

As a consequence of the tuning range limitation with any one coil it becomes necessary to split the tuning of the normal receiver into a number of "wave ranges," a different value of inductance being used for each range. Hence the familiar "wave switch."

It will be understood that the use of a trimming condenser in any one of a set of ganged circuits raises the residual capacity of the circuit and that no more capacity than is absolutely necessary should be used.

**Spreading the Stations over the Dial.**—The ratio of maximum to minimum capacity is not the only point of particular interest in connection with variable condenser tuning. The manner in which the capacity varies as the condenser control is turned is a factor of importance because it will determine how the tuning points for the various transmissions will be distributed over the tuning dial.

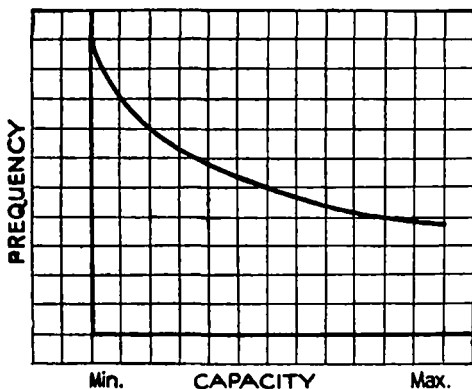

FIG. 4.—This graph shows the effects of reaction at various frequencies.

For normal reception purposes it is not desirable that the capacity shall increase by equal increments for each degree of rotation from minimum. If the capacity did vary directly with the rotation the resonant frequency of the circuit would not change uniformly but in the manner indicated graphically in Fig. 4. Obviously the station tuning points would be much more congested at one end of the tuning scale than at the other.

In the early days of radio, variable condensers normally had vanes of semi-circular shape, giving more or less uniform change of capacity with rotation. Condensers of

this simple plate shape still have their uses in certain work, but those now used for reception have plates of special shape designed to give more uniform *tuning* control.

From what has been stated previously, the reader will see that for linear frequency variation the value of  $I/\sqrt{C}$  must change uniformly with rotation of the condenser.

**The Possibility of Ganging.**—If a number of circuits have their tuning condensers ganged to the one control they will obviously keep to the same tuning frequency as one another if the product  $LC$  keeps of equal value in all the circuits. Coil manufacturers turn out coils which are sufficiently closely matched to make ganging possible as far as  $L$  is concerned. Condenser manufacturers, too, provide us with ganged condensers with close matching between the individual sections at all tuning settings.

A practical difficulty where ganging is concerned is that the circuits tuned by the variable condenser sections will not have the same values of residual capacity normally.

For ganging to be possible there is only one thing that can conveniently be done to overcome this difficulty and that is to use small capacity "trimming" condensers connected across the circuits and to adjust these trimmers to make the residual capacities equal.

**Circuit Magnification.**—The reactive voltage developed by  $L$  and that developed by  $C$  will, in the case of resonance between  $L$  and  $C$ , be normally considerably greater than the e.m.f. operating internally in the circuit. The ratio of the reactive voltage of  $L$  to the e.m.f. is equal to

$$\omega L/R$$

(Remember that  $\omega = 6.28 \times \text{frequency}$ ).

Correspondingly, the ratio of the reactive voltage of  $C$  to the e.m.f. is equal to

$$\frac{I/\omega C}{R} \text{ which simplifies to } \frac{I}{\omega CR}.$$

Either of these expressions can be referred to as the voltage magnification of the circuit.  $\omega L/R$  is the one that is the more frequently used.

We see that three factors—frequency, inductance, and resistance—control the value of the magnification. From the circuit design point of view,  $R$  is the factor of im-

portance for the frequency is frequently an independent value, while  $L$  is determined largely by considerations of convenient tuning arrangements, and any particular effort made to raise the magnification of a circuit is generally a matter of attacking the H.F. resistance. Intermediate frequency circuits of superhets represent the cases where the designer has got the most opportunities of fixing the magnification to a high and predetermined value.

$\omega L/R$  is often designated by the symbol  $Q$ .

**H.F. Resistance.**—The earnest amateur who is keen to "get down" to the technicalities of radio will find that H.F. circuit resistance is rather a bogey. Where D.C. circuits are concerned, the calculation of resistance is a comparatively simple matter and, apart from considerations of temperature rise (which, again can be allowed for without much difficulty), there are no complications due to resistance changing with circuit operating conditions.

The effective resistance of an H.F. radio circuit, however, is a value that does not lend itself at all readily to accurate calculation. As a matter of fact, it is usually better to rely upon measurement. The value of the resistance is dependent upon quite a large number of contributory factors, and is one that varies with changes of frequency.

Among the factors that make up the total effective H.F. resistance are: (1) resistance of the conductors; (2) dielectric losses, including those arising in coils; (3) eddy current losses (in coil cans, H.F. iron cores, chassis plates, etc.); (4) losses introduced by energy absorption of another (coupled) circuit, if any; (5) losses caused by the "shunt damping" of components connected across the circuit; and (6) in open oscillatory circuits there will also be radiation losses.

The resistance of the conductors (wire resistance) will be greater for H.F. currents than for D.C., due to the fact that whereas D.C. distributes itself uniformly through the cross-section of the conductor, an H.F. current tends to concentrate on the outer surface of the wire, the depth of penetration decreasing with increase of frequency. In the case of stranded wire with parallel strands, the current will tend to concentrate on the outer strands. This peculiarity of H.F. currents is taken into special account when "Litz" wire is used. This is a stranded wire with

individually insulated strands and the latter are interwoven in such a way that no one strand is entirely outside or inside.

The resistance of the conductors, the dielectric losses, and the eddy current losses increase with increase of frequency. The energy absorption of a coupled circuit offers a complex problem as the tuning in this circuit may greatly affect the issue.

On the whole, however, it can be anticipated that under normal conditions the H.F. resistance value of any receiver circuit will go up with increase of frequency.

**Parallel Resonance.**—In the case of resonance that we have previously dealt with the e.m.f. operates internally in the circuit, and as far as this e.m.f. is concerned, L and C are in series.

Fig. 5 illustrates a case where the e.m.f., E, is applied externally and one in which, as far as E is concerned, L and C are in parallel. To avoid confusion we will refer to either of the wires that run from E to the LC combination as "feed line."

The first technical point to note is that the feed line current will split into two parts at the junction of L and C, one part taking the L path and the other the C path.

The current in the C branch will be practically  $90^\circ$  ahead of E in phase. If the value of  $\omega L$  is large compared to the resistance of the coil (the circumstance we are most interested in), the current in the L branch will lag behind E by an angle not very far off  $90^\circ$ . The phasing conditions complicate the issue somewhat, but in the type of case with which we are concerned the two component currents into which the feed current splits will be very nearly  $180^\circ$  out of phase with each other. If the frequency of E is close to the resonant frequency of the LC combination the branch component currents will be considerably greater in value than the feed line current. This idea of a current "splitting" into components larger than itself is not ridiculous, providing that certain phase conditions

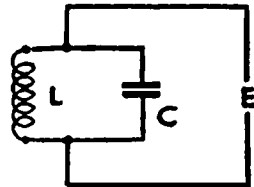

FIG. 5.—An external voltage applied to a tuned circuit as met with in standard radio circuits.

apply. Actually, the feed line current value will be nearly equal to the difference between the values of the L and C branch currents.

Let us concentrate now upon the case where the frequency of E is equal to the resonant frequency of the LC combination.

$\omega L$  will be equal to  $1/\omega C$ , as we know.

If it were not for complications introduced by the fact that the resistances in the L and C branches respectively are not normally equal it would be safe to say that in the resonant condition the two branch currents would be equal. However, in the usual practical radio case, the two branch currents will be very nearly equal, and also very nearly  $180^\circ$  out of phase with each other. The feed current will be a minimum, and because E is able to force only a very small current along the feed lines this can mean only one thing—the LC combination must be putting up a very high opposition, acting effectively in series with E.

This opposition is equivalent to a resistance of

$$\frac{L}{CR} \text{ ohms approximately.}$$

This is usually called "dynamic resistance."

From the fact of  $\omega L$  being equal to  $1/\omega C$  it can be shown that

$$\frac{L}{CR} = \frac{\omega^2 L^2}{R}$$

and the alternative formula will be frequently met. Incidentally, the obvious close connection of  $\omega^2 L^2/R$  with circuit magnification ( $\omega L/R$ ) is worth noting.

Any difficulty in understanding just how the dynamic resistance is set up will probably be eased by consideration of the following points:

(1) Internally in the closed LC circuit the two reactive voltages balance out just as in the ordinary series resonant case. As a consequence, current *circulating inside* the LC circuit can be comparatively large.

(2) As far as E is affected, the reactive voltages of L and C respectively are voltages operating in parallel.

(3) The two reactive voltages (acting in parallel) are very nearly  $180^\circ$  out of phase with E, *i.e.* practically in dead opposition to E, and therefore severely limiting the

value of current that can be developed in the feed lines by the applied voltage.

If the applied frequency is raised above the resonant frequency the current component in C will increase, and that in L will decrease. The LC combination now behaves effectively as a capacity.

If the applied frequency is reduced below the resonant frequency the LC combination will, in effect, be equivalent to an inductance.

Thus we have the interesting fact that if the applied frequency were to start below resonance, and were increased to a value above resonance, the LC combination will start as an effective inductance, become equivalent to a high resistance (at resonance), and will finish up as an effective capacity.

**Practical Applications of Parallel Resonance.**—**THE REJECTOR.**—The simplest form of "aerial rejector wave trap" consists of a coil and condenser in parallel, the LC combination being placed in series with the aerial circuit. The rejector circuit is tuned to resonance at the frequency of a particular interfering signal, and the high dynamic resistance that it introduces into the aerial circuit at this frequency will tend to reduce the amplitude of the interfering oscillations.

**TUNED ANODE.**—In this case the dynamic resistance of a tuned LC combination is utilised to form the "load" resistance of an HF valve amplifier circuit.

**CHOKE RESONANCE.**—There is the possibility that an experimenter will meet examples of undesirable parallel resonance effects. Suppose that he is using an inductance coil as a high frequency choke, perhaps in the anode circuit of a valve. The requirements are not only that the impedance of the choke shall be high at all the frequency values that have to be handled, but also that abrupt changes of impedance, with change of frequency, shall not occur to any marked degree. The choke has inductance and self-capacity and must, therefore, have a resonant frequency (perhaps several, with section winding). If the resonant frequency happens to come within the range of operating frequencies then what we have learned about L and C in parallel indicates that there will be erratic behaviour of the choke over at least a small part of the frequency range.

## CHAPTER II

### PROBLEMS OF SELECTIVITY

**Single H.F. Tuned Circuit.**—We will commence our consideration of the important subject of selectivity by dealing with the case of a single H.F. tuned circuit. Towards an internally injected high frequency e.m.f. the circuit presents an impedance which is minimum at the resonant frequency, and which rises in value as the applied frequency is taken further from resonance, either up or down. Assuming that the circuit is tuned to the carrier frequency of a wanted signal, and knowing that unwanted signals will have different carrier frequencies, it is clear from the foregoing that the circuit exercises some discrimination between the wanted and an unwanted signal. The characteristics of the circuit as regards this signal "selection" property is termed its "selectivity."

For the present we will look at the matter of selectivity only from the point of view of the prevention of interference by unwanted signals; other considerations will follow later. The first obvious practical complication that comes to mind is the possibility of an unwanted signal, e.m.f., having very much greater amplitude than that of the wanted signal. In such a case there is the risk that although the unwanted signal meets the greater circuit opposition it may produce stronger oscillations in the circuit than those of the wanted signal. This is enough to suggest that the characteristics of the circuit should be such that the impedance rises very rapidly, with departure of frequency from resonance. As will be appreciated later, complications come in here.

The selectivity characteristics of a circuit can be detailed in various ways, but undoubtedly a graphical diagram gives the information in a form that can be most readily appreciated. Fig. 6 is an example of one kind of graph.

(Ignore the dotted curve at present.) It is to be assumed that the H.F. circuit is kept tuned to a constant frequency and that an e.m.f. of constant amplitude, but of variable frequency, is injected into it. The voltage built up across the circuit by the oscillations at various frequency values is measured, and these voltage values are plotted against frequency. As we are interested only in a fairly limited range of frequencies centred on the resonant value, it is convenient to make the frequency scale show kilocycles off resonance (with a centre zero point for the resonant frequency itself).

In Fig. 6 let  $F_0$  and  $F_1$  correspond to the frequencies of the wanted signal and an unwanted signal respectively. For equal e.m.f.'s, A will represent the output from the wanted signal, and B the output from the unwanted signal. The ratio  $A/B$  is of great importance. Incidentally, this ratio gives the number by which the output voltage at resonance must be divided to give the output voltage of the unwanted signal, and "so many times down at so many kc/s off tune" is a useful method of indicating the selec-

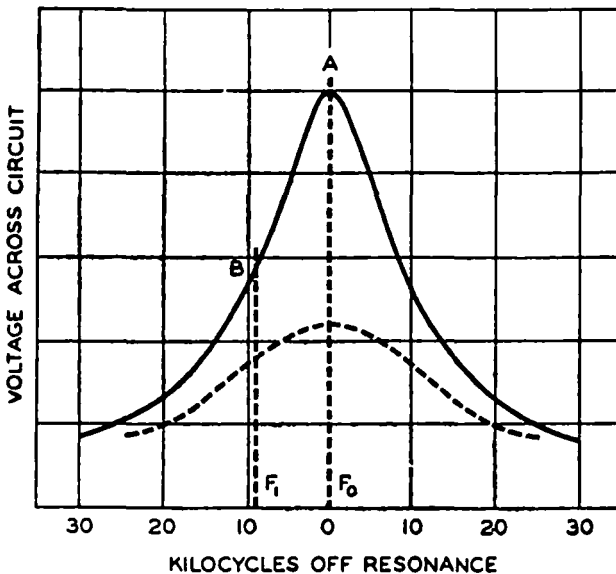

FIG. 6.—A graphical diagram representing the selectivity characteristics of a circuit.



tive properties of a circuit. It will be understood, however, that a number of different frequency points must be specified if a clear idea of the circuit's selectivity is to be obtained. That is why a graph is so convenient.

The narrower the graphical curve (*i.e.* the more "peaky" it is), the greater is the selectivity indicated.

**Factors controlling Selectivity.**—Of close interest to the amateur experimenter is the question as to what governs the selectivity. The whole matter hinges upon the variation of the impedance

$$\sqrt{R^2 + (\omega L - I/\omega C)^2}$$

with changes of frequency.

The reactive component ( $\omega L - I/\omega C$ ) of the impedance is obviously a function of frequency and, as a few simple calculations would show, the greater the ratio  $L/C$ , the greater will be the variation of ( $\omega L - I/\omega C$ ) with frequency changes. So, one factor governing selectivity will be the ratio of the inductance to the capacity. This leaves the resistance to be allowed for.

H.F. resistance normally increases with increase of frequency, as already stated, but over the range of frequency variation that is associated with such a curve as that of Fig. 6 we can regard any change of resistance as being small. It is to be understood, however, that it will not be permissible to neglect resistance changes unless the tuning of the circuit remains constant.

If we regard  $R$  as being approximately constant, then we can see that it must have a steadying influence upon impedance variations (with frequency). Therefore, the greater the value of  $R$  the less will be the selectivity. Furthermore, the greater the value of  $R$  the smaller will be the output voltages at all frequencies, including that of resonance. Again, an increase of  $R$  (say by deliberately adding resistance to the circuit) would reduce the output at resonance to a greater extent than that at some frequency off resonance.

In Fig. 6 the dotted curve corresponds to a case where the  $L/C$  ratio is the same as for the full-line curve, but  $R$  is greater.

Selectivity is greater the greater the ratio  $L/C$ , and the smaller the value of  $R$ , *i.e.* the greater the value of

$I/R$ . This indicates a very close connection between the selectivity of a circuit and its magnification at resonance.

$$\begin{aligned} \text{Magnification} &= \omega L/R. \\ \text{At resonance } \omega &= I/\sqrt{LC}. \end{aligned}$$

Substituting  $I/\sqrt{LC}$  for  $\omega$  in the magnification formula gives us

$$\frac{\omega L}{R} = \frac{I}{R} \sqrt{\frac{L}{C}}$$

Still confining our attention to the single H.F. tuned circuit, let us consider what is involved when it comes to a question of how to get the maximum selectivity. It may appear that it is merely a matter of making  $L$  high,  $C$  low, and  $R$  low, and in many respects this is so, but there are practical complications. First of all, assuming variable condenser tuning, the importance of tuning range must not be ignored, and this will impose practical limitations upon the range of values from which both  $L$  and  $C$  can be chosen. Again,  $R$  tends to increase with increase of  $L$ , and may do so disproportionately, so the choice of suitable value for  $L$  is normally quite a narrow one.

$R$  is, of course, the effective H.F. resistance of the circuit and, without taking shunt damping into account at the moment it can be said that the tuning coil generally contains the major part of the total H.F. resistance. As a consequence, coil design is very much wrapped up in the matter of selectivity. As far as the coil alone is concerned,

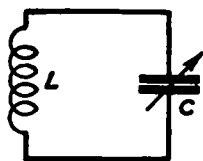

FIGS. 7 AND 8.—Simple H.F. tuned circuits.

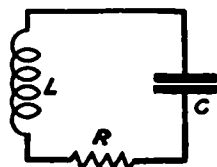

high selectivity demands a high  $Q$  value ( $Q = \omega L/r$ , where  $r$  is the coil's H.F. resistance).

**Shunt Damping.**—We have been considering a single H.F. tuned circuit, such as that of Fig. 7. This circuit inevitably has resistance, and Fig. 8 is a theoretical equivalent diagram drawn to emphasise the existence of the

resistance.  $R$  in Fig. 8 represents, theoretically, the total H.F. resistance of the circuit.

In the usual practical case the H.F. circuit will not be an isolated one, but will be connected to other apparatus, and we generally have to allow for some value of resistance, or impedance, which is in shunt with the H.F. circuit. The plain resistance case is illustrated in Fig. 9.  $R_1$ , the external shunt resistance across the LC circuit, will definitely cut down both the magnification and the selectivity of the latter. In fact, the effect of  $R_1$  will be exactly as though the internal resistance of the LC circuit, had been increased. Fig. 10 is theoretically equivalent to Fig. 9,  $r$  representing the additional resistance which is effectively "thrown" into the LC circuit by the external shunt

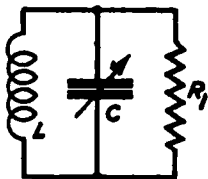

FIGS. 9 AND 10.—Tuned circuits incorporating shunt and additional resistances.

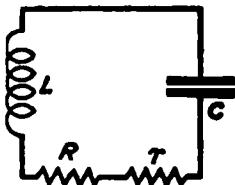

resistance  $R_1$ , while  $R$  represents the resistance of the LC circuit itself.

It should be noted that at the resonant frequency,

$$r = \frac{L}{CR_1}$$

In a more complex shunt impedance case we would find that the reactive component of the impedance affects the tuning of the HF circuit, while the resistive component effectively increases the resistance of the latter.

Generally, the effect of resistance shunted across an H.F. tuned circuit is to be regarded as undesirable, even though it may be unavoidable, but should it so happen that it is necessary to cut down the magnification and selectivity of a tuned circuit, then a resistance shunt can prove to be very helpful.

**Using Several Tuned Circuits.**—Still keeping to the sole idea of preventing interference between stations, we must now face up to the fact that the best selectivity

obtainable from a receiver with only one HF tuned circuit is actually not very good.

Shunt damping and other effects, due to causes external to this one tuned circuit, will inevitably keep the selectivity to a low order. In any case, the maximum coil  $L/r$  ratio has its practical limitations.

It is necessary to keep in mind that when it comes to a matter of distant reception the requirements for the prevention of interference are rendered all the more stringent by the fact that it is necessary to allow for the possibility of the wanted signal (at the aerial) being of much less amplitude than some unwanted signal of "adjacent channel" frequency.

A great improvement in selectivity will be obtained if the signals are made to pass through several tuned circuits before reaching the detector. If one tuned circuit cuts down an unwanted signal relative to the wanted signal, then it is obvious that if the output of this circuit is caused to energise a second tuned circuit the latter will still further increase the ratio of wanted to unwanted signal. We are not necessarily referring to the case of coupled circuits. Strictly speaking, "coupling" involves some form of impedance common to two circuits, but such cases have a special story of their own, which will be discussed later.

If two tuned circuits are so arranged that the output of one can excite the other, without common impedance being involved, the two circuits are said to be "in cascade," and this is the case in which we are interested at the moment. The outstanding practical example is that of a tuned-grid circuit and a tuned-anode circuit associated with an H.F. amplifying valve. There is the complication that the inter-electrode capacity of the valve will actually couple the two circuits, but such coupling is incidental and, in any case, can be reduced to very small proportions with suitable arrangements.

To add tuned circuits in cascade is one method of gaining selectivity that is open to the experimenter. If they are all variably tuned circuits, however, the handling of them may prove to be difficult, except where the number is restricted to two, or perhaps three.

If two tuned circuits have exactly similar characteristics,

and if they are truly in cascade, then an unwanted signal output, at the first circuit of, say, "two times down at 5 kc/s off tune" will become "four times down" as regards the output of the second circuit. A third circuit would make it "eight times down."

**Selectivity over a Wave-range.**—With variable condenser tuning, every change of tuning adjustment alters the L/C ratio. This suggests that in tuning over a wave-range the selectivity will change, becoming greater at the higher frequency end of the range. The changing of the effective H.F. resistance complicates the issue, however.

In considering selectivity at one tuning setting we permitted ourselves to ignore such changes of H.F. resistance as would occur over the limited range of frequencies involved, but we cannot ignore resistance changes when it comes to a matter of shifting from one part of a wave-range to another. The H.F. resistance of a tuned circuit will be very appreciably different at the two extremes of, say, the medium wave-range. Since H.F. resistance increases with frequency, there is the implication here that the selectivity will become less as the tuning is adjusted towards the higher frequency end of the range. In view of the L/C ratio change having the opposite tendency, what can we anticipate as being the effect likely to be found in practice? In normal circumstances the H.F. resistance changes have the predominating influence, so we can expect that the selectivity will actually decrease as the variable condenser is reduced in setting.

Out of all this emerges the obvious fact that a selectivity curve gives correct information only for a particular tuning setting, and it is customary for the resonant frequency to be specified against such a curve.

**Selectivity and Quality.**—The question of selectivity involves another consideration apart from that of the prevention of interference.

The analysis of a modulated signal into carrier and sideband components shows that if the selectivity is so great that the H.F. response drops rapidly from the resonant frequency, then the sideband components of the wanted signal are going to suffer from attenuation. Now, if the amplitudes of the sidebands are cut down (and to different

degrees) then the modulation envelope of the oscillations applied to the detector will not be a replica of the original modulation; in other words, there will be distortion. This sideband "cutting" will have the tendency to decrease the intensity of the high notes reproduced in relation to the low notes.

To make the response curve (assuming that it is single peaked) so flat over the range of frequencies centred on resonance that the sidebands are not appreciably attenuated, would be all very well from the point of view of quality of reproduction, but for any degree of distant reception the results would be hopeless. The spread of the H.F. response would be sufficient to lead to bad interference between stations.

We have a problem here. Still keeping to the idea of a selectivity characteristic of the kind shown in Fig. 6, it looks as though freedom from interference demands a sharp "peaky" curve, while very good quality reproduction demands a wide curve with no suggestion of a pronounced peak.

The ways in which this problem can be tackled depend upon the particular standard of reception that it is required to work to. If it is the case that considerable high-note "cutting" can be tolerated, the problem becomes simpler because the way is open for a compromise. The selectivity can be made just sufficient to prevent bad interference between stations, the response curve not being so sharp at the peak that the sideband attenuation makes the reproduction intolerable. If there is to be no attempt at distant reception the selectivity problem becomes very simple because for local station (and local station only) reception, there is little need to worry about the adjacent channel stations. The low sensitivity which is permissible in such a case will, in itself, act as a safeguard against interference from distant stations.

But are we bound to link up this problem entirely with selectivity curves of the single peaked type? The fact that the answer is in the negative opens up a most interesting story—the story of coupled circuits.

For the H.F. response to keep sensibly level on either side of resonance, so as to prevent bad sideband cutting, and yet for the response to be well down at the frequency

of the carrier of an adjacent channel station is a condition that would be realised if the response curve was flat-topped (perhaps slight double peaking), with a very rapid fall-away on either side of the flat top. So a flat-topped, steep-sided response curve represents an ideal where the selectivity versus quality problem is concerned, and such can be obtained under certain conditions with coupled tuned circuits. Even so, the present frequency allocation of broadcast transmissions makes matters very difficult when both high fidelity reproduction and freedom from interference is desired.

After we have looked into the matter of coupled circuits we will briefly, but more definitely, deal with standards of reproduction in relation to H.F. response.

**H.F. Coupled Circuits.**—Even the simplest of receivers normally incorporate at least one example of H.F. coupling, while in more elaborate assemblies not only may there be a number of H.F. couplings, but the performance of the receivers concerned will be very dependent upon the design and adjustment of these.

As already stated, the coupling of two circuits involves some form of impedance common to the two circuits. Fig. 11 illustrates a case where two circuits,  $L_1 L C_1$  and  $L_2 C_2 L$  have the inductance coil  $L$  in common. This form of coupling is known variously as "direct" coupling or "auto-inductive" coupling. In Fig. 11 and the succeeding diagrams,  $E$  represents the source of e.m.f., so the left-hand circuit must be regarded as primary circuits, and the right-hand ones as secondary circuits.

In Fig. 12 the common coupling impedance is formed by the condenser  $C$ , which is obviously part and parcel of the two circuits. This is a case of capacity coupling.

Fig. 13 illustrates a case where the diagram itself actually shows nothing that is common to the two circuits, but if the coils  $L_a$  and  $L_b$  are so disposed in relation to each other, that current in one produces a magnetic field which threads through the turns of *both* the coils, then this magnetic field provides the coupling. It will, as a matter of fact, be a case of mutual inductance coupling (sometimes referred to under the simple title of "inductive" coupling).

Figs. 11, 12, and 13 cover very commonly used forms of

coupling, although they must not be looked upon as being a complete survey of all possible cases.

The three examples given merit very careful consideration. First, we must have a clear understanding as to how the primary circuit excites the secondary. With auto-inductive coupling (Fig. 11) the primary current passing through  $L$  sets up a voltage across the latter which, ignoring resistance, is equal to  $\omega L I$  volts

where  $\omega = 6.28 \times$  frequency (in cycles per second)

$I =$  primary current (amps)

$L =$  inductance of coupling coil (henrys).

As far as the primary circuit is concerned  $\omega L I$  volts represents the inductive reactive voltage in  $L$ . To the secondary circuit, however, this voltage acts as the injected e.m.f., and will set up a secondary current, the value of which will be dependent upon the values of the voltage and of the effective secondary impedance.

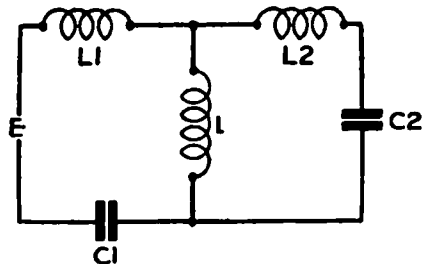

FIG. 11.—Two coupled circuits with a common inductance.

With capacity coupling (Fig. 12) the secondary e.m.f. is the voltage established across  $C$  by the primary current and is equal to  $I/\omega C \times I$ , or  $I/\omega C$  volts ( $C$  being in farads).

In the case of mutual inductance coupling (Fig. 13),

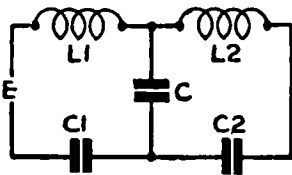

FIG. 12.—Two circuits with common coupling impedance.

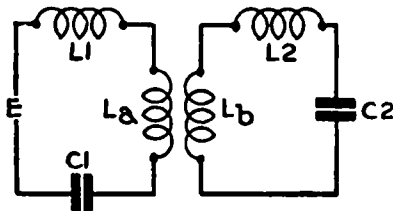

FIG. 13.—Two circuits having magnetic coupling.

the secondary e.m.f. is the voltage electro-magnetically induced into the secondary by the primary current and is equal to  $\omega M I$  volts, where  $M$  is the mutual inductance in henrys, and  $I$  is, as before, the primary current.



At this stage it is advisable for us to look into the matter of degree of coupling. Suppose there were two separate coupling cases, both involving a similar kind of coupling, but that in one case a small value of primary current produces (comparatively speaking) a large secondary output, while in the other case a large primary current produces only a small secondary output, then although the couplings are of similar type there is obviously a difference of degree. How can the degree of coupling be expressed? The matter is not quite so simple as first ideas might suggest, for, actually, it is not only the value of the coupling impedance that must be taken into account, but also the values of the impedances (of the same kind as that forming the coupling) which are present in the circuits but which do not happen to be common to the two circuits. In the case of Fig. 11, for instance, the degree of coupling depends not only upon the common impedance,  $\omega L$ , but also upon the values of  $\omega L_1$  and  $\omega L_2$ . (Note: resistance is neglected here.)

It is customary to express the degree of coupling as a ratio.

For Fig. 11

$$k = \frac{L}{\sqrt{(L_1 + L)(L_2 + L)}}$$

For Fig. 12

$$k = \frac{\sqrt{C_a C_b}}{C}$$

where  $C_a$  = joint capacity of  $C_1$  and  $C$  in series  
and  $C_b$  = " " " "  $C_2$  "  $C$  " "

For Fig. 13

$$k = \frac{M}{\sqrt{(L_1 + L_a)(L_2 + L_b)}}$$

$k$  is known as "coupling coefficient," or "coupling factor." Sometimes it is given in percentage form (simply multiply  $k$  by 100).

The larger the value of  $k$  the "tighter" is said to be the coupling; the smaller the value of  $k$  the "looser" is the coupling.

Certain similarities of form will be noticed in the three cases, but the common capacity case  $\sqrt{C_a C_b}/C$  has an upside-down character about it compared to the other two. This arises quite simply as a consequence of the fact that, with common capacity coupling, the larger the value of the coupling condenser the *smaller* is its reactance  $1/\omega C$  and, therefore, the looser is the coupling.

**The Tuned Secondary H.F. Transformer (Intervalve).**—We will start with the case of the H.F. intervalve transformer (see Fig. 14). The untuned primary circuit

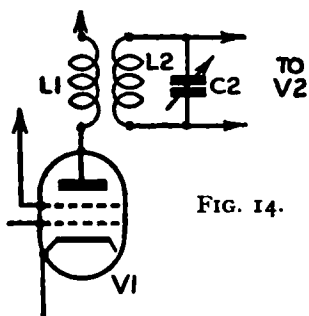

FIG. 14.

somewhat simplifies this case, and it will be a good example to start with.

Fig. 15 is the theoretical equivalent of Fig. 14.  $R_a$  represents the anode A.C. resistance of the valve  $V_1$ .  $M$  indicates that there is mutual inductance between the two circuits.

As neither diagram directly shows any inductance in the two circuits, apart from the two

coupling coils, it may appear at first that there is 100 per cent. coupling. This will not be the case, however, because there will necessarily be magnetic leakages, *i.e.* there will be a certain number of magnetic lines of force which will not thread through all the turns of both the coils. To move the coils further apart, so as to increase the magnetic leakage, is, of course, one way of loosening the coupling.

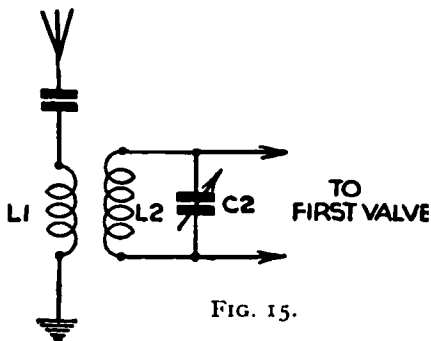

FIG. 15.

As a matter of interest, it should be noted that if the coupling were to be 100 per cent. then  $M$  would equal  $\sqrt{L_1 L_2}$  (ref. Fig. 14).

We now come to a very important fact about coupled

circuits. When two circuits are coupled together each one affects the other as regards tuning and impedance so that neither behaves exactly as it would if it were isolated. In connection with Fig. 14, and as regards the influence of the secondary circuit upon the primary, we need only consider the case in which  $L_2 C_2$  is tuned to resonate at the frequency of the e.m.f. which is induced into it by the primary. This would be the normal circumstance, in reception.

The primary current sets up a secondary e.m.f. equal to  $\omega M I_1$  volts (where  $I_1$  is primary current). As the secondary is in resonance, its impedance will simply be  $R_2$  ( $R_2$  representing the H.F. resistance of the secondary circuit) so the secondary current will be  $\omega M I_1 / R_2$  amps.

There is nothing to stop this secondary current utilising the coupling to induce a voltage back into the primary, and it does do so, this voltage being  $\omega M I_2$  (where  $I_2$  is secondary current). This "new" voltage operating in the primary has the direct result of putting up the primary circuit opposition. Actually, the effect is just as though the secondary circuit had thrown an extra value of resistance into the primary. This resistance (sometimes called the "reflected" secondary resistance) is equal to  $(\omega M)^2 / R_2$  ohms and, with a low loss secondary circuit, can very greatly modify the conditions in the primary.

Since Fig. 14 represents an H.F. amplifying stage there are two factors in which we need to be particularly interested, in view of their practical importance. The first is the value of the voltage that is developed across  $C_2$ . This is the voltage that will be applied as input to the succeeding valve. The second is the selectivity of  $L_2 C_2$ .

It will need little thought to appreciate that the greater the amplitude of the oscillations in  $L_2 C_2$  the greater will be the voltage built up across  $C_2$ . This implies that the greater the H.F. power that can be introduced into  $L_2 C_2$  the greater will be the output voltage of the stage. Coming back a step, the greater the H.F. power in the primary the greater will be that in the secondary. The transformer primary represents a power consuming load on the valve  $V_1$ , so it becomes obvious that the matter of anode circuit power efficiency is important.

Before investigating the optimum conditions from this

point of view, it may perhaps be advisable to emphasise that all this talk about power is not contradictory to the idea of the stage illustrated by Fig. 14 being an H.F. *voltage* amplifying stage.

As regards the primary circuit, there is the anode A.C. resistance ( $R_a$ ) of the valve  $V_1$ , and also the effective load resistance set up by the H.F. transformer primary. This load resistance is made up of the H.F. resistance of the primary itself plus the reflected secondary resistance. The reflected secondary resistance is so very much greater than the H.F. resistance of the primary itself that the latter can be neglected in comparison. So we have an internal valve resistance of  $R_a$  ohms, and an external load resistance of  $(\omega M)^2/R_2$  ohms approximately. Under what conditions will there be maximum H.F. power developed in the load and, consequently, the maximum H.F. voltage developed across the secondary? The optimum condition is that the internal and load resistances should be equal, *i.e.* that  $(\omega M)^2/R_2$  should equal  $R_a$ .

Since the reflected secondary resistance, which we are taking as approximately representing the load resistance, is very dependent upon the closeness of coupling, it follows that there is an optimum degree of coupling for maximum stage amplification.

The question of selectivity, however, introduces a complication. The selectivity of the tuned secondary is lessened by the presence of the primary circuit and, as far as selectivity is concerned, the primary circuit must be regarded as a damping load upon the secondary. To be more exact, the primary circuit reduces the selectivity of the secondary circuit to the extent that would be caused by an extra H.F. resistance of  $(\omega M)^2/R_a$  thrown into the secondary. This brings to light two interesting facts: (1) The resistance ( $R_a$ ) of the valve has a considerable bearing upon the selectivity, and (2) selectivity as well as amplification is dependent upon the coupling. Selectivity, however, progressively, improves with loosening of the coupling.

It has, perhaps, rather maliciously, been said that radio is "the art of compromise." Be that as it may, a compromise is certainly called for with an H.F. transformer of the Fig. 14 type. If the coupling were to be designed

for maximum amplification the selectivity would almost certainly be too low, and it is customary for the coupling to be made rather looser than the amplification optimum.

**Aerial Coupling.**—We can see from the foregoing that the main object of using a tuned secondary H.F. intervalve transformer is to obtain satisfactory selectivity and, at the same time, as near to maximum signal amplitude as it is possible to get, consistent with the selectivity requirements.

The familiar aerial coupling system of Fig. 15 has much the same ideas about it. The H.F. resistance of an aerial circuit is necessarily rather high. Quite apart from the possibility of their being, in some cases, heavy losses due to inefficient rigs, the aerial circuit is of the open oscillatory type and must therefore have radiation losses.

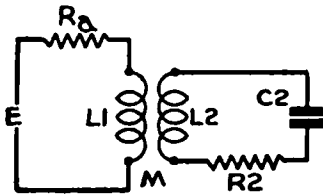

FIG. 16.

By using  $L_2 C_2$  (Fig. 15) we gain the selectivity of this closed circuit, lessened, however, by the H.F. resistance of the aerial circuit in so far as it is "reflected" into the secondary. The value of this reflected resistance will decrease the looser the coupling. There is here, too, an optimum coupling value from the signal strength point of view, but it is normal to use looser coupling than this in the interests of selectivity.

The case of Fig. 15 is actually somewhat more complicated than that of Fig. 14. In the H.F. transformer case that we considered we had an untuned primary. This primary must, of course, possess a resonant frequency, but this will normally be very much removed from any of the signal frequencies. This fact, allied with that of the presence of the very high valve resistance in series with the primary, enabled us to ignore any influence of the primary upon the secondary tuning.

In the aerial coupling case the secondary circuit is variably tuned. The aerial circuit is not variably tuned. Its natural frequency will be partly dependent upon the inductance value of  $L_1$ , but in the most common cases the natural frequency of the aerial circuit will be higher

than any of the signal frequencies. The fact that the aerial circuit's natural frequency is not very far off signal frequencies has the result that the tuning of the secondary circuit is somewhat affected by the aerial circuit.

In a case where the signal frequency is "below resonance" in the aerial circuit the capacity reactance will exceed the inductive reactance and, as a consequence, the aerial circuit will have an essentially capacitive character. The effect upon the secondary circuit will now be as though a little extra capacity had been "reflected" into it. Unfortunately, the magnitude of this effect varies with frequency. This does not matter at all if the secondary circuit is individually tuned, but it complicates matters when the circuit is ganged tuned with others. It is to be noted that the influence of the aerial circuit upon the secondary tuning will decrease with loosening of coupling.

**Band-pass Couplings.**—The H.F. transformer of Fig. 17 has both secondary and primary tuned, and the circuit arrangements are, by the way, typical of an intermediate frequency stage of a superhet receiver. We will deal with the details of superhet practice later, but since the intermediate frequency remains fixed in value, the condensers  $C_1$  and  $C_2$  will be of the pre-set trimmer type.

We will assume that both  $L_1$   $C_1$  and  $L_2$   $C_2$  are tuned to the same frequency. This assumption not only agrees with the normal practice but, incidentally, greatly simplifies the technical consideration of H.F. transformers of the Fig. 17 type. Call the individual resonant frequency of each of the two circuits  $F$ . As both circuits are tuned to  $F$  it may appear at first thought that the two circuits in combination will exhibit resonance at  $F$ .

If the coupling between the primary and secondary circuits is loose this will, for all practical purposes, be the case, but if the coupling is tight some very special conditions arise.

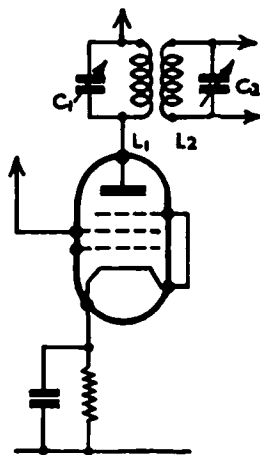

FIG. 17.—Standard I.F. (H.F.) transformer connections.

It will be obvious that if both primary and secondary are low-loss circuits, and both individually tuned to the same frequency then, with tight coupling, the interaction between them will be considerable, and it is to be anticipated that the behaviour of either circuit will be greatly influenced by the presence of the other. The matter is a complicated one, and the mathematical equations associated with Fig. 17, simple though the circuit arrangements appear, are quite formidable. Fortunately, the practical effects produced can be stated quite definitely, and they are certainly of the greatest practical importance.

**Interaction.**—In brief, the interaction between the two circuits is such that, with tight coupling, resonance shows up at two different frequencies, neither of which is equal to  $F$ , the frequency to which each circuit is individually tuned. One of the resonant frequencies is higher than  $F$  and the other is lower than  $F$ .

With the system of Fig. 17 the higher resonant frequency will be  $F/\sqrt{1-k}$  and the lower resonant frequency will be  $F/\sqrt{1+k}$ , where  $k$  is the coefficient of coupling. From this statement it will be seen that the tighter the coupling the greater will be the difference between the two resonant frequencies.

If the coupling is sufficiently tight to give a pronounced difference between the two resonant frequencies, and if the frequency applied to the primary were progressively increased from a value below the lower resonant frequency, it would be found that the output voltage of the secondary circuit would rise up to a peak value as the lower resonant frequency is reached, fall away as this frequency is passed, rise to another peak as the higher resonant frequency is reached, and then fall away without further rise as this frequency is passed. If both circuits are low loss, the response curve will be markedly double-peaked, as shown in Fig. 18.

An increase of H.F. resistance would have a levelling effect upon the "trough" between the two peaks. By suitable circuit design and coupling adjustment it is possible to get a response curve of the nature of that shown in Fig. 19. This curve is a steep-sided and very nearly flat-topped curve. Here we have something of importance, because we have already seen that a characteristic of this

kind will prove to be of value in tackling the difficulties practically associated with the selectivity versus quality problem.

A coupling system designed to give a response curve of the character of Fig. 19 is said to have a "band-pass" characteristic, this term implying that a band of high frequencies is handled with negligible attenuation; outside this band there is, of course, fairly sharp cut-off. In connection with band-pass system it must be remembered

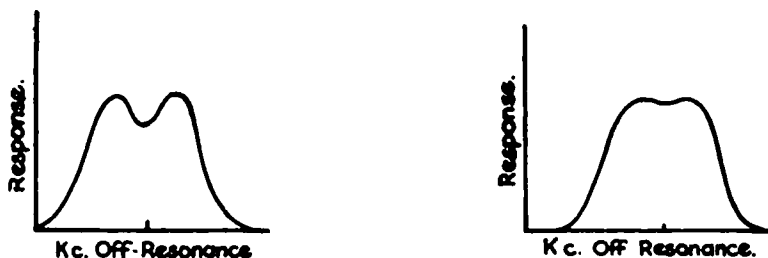

FIG. 18 (left).—A double-humped response curve.  
 FIG. 19 (right).—A "square-peak" response curve.

that the degree of coupling determines the "band-width" (*i.e.* frequency difference between the peaks), while the  $Q$  of the coils has a great deal to do with the extent of the troughing between the peaks.

It is to be strongly emphasised that a circuit diagram like that of Fig. 17 does not necessarily indicate a system with band-pass characteristics. Everything depends upon the degree of coupling, and the circuit diagram gives no indication of the value of this.

To appreciate the point at issue, imagine that the coupling between  $L_1 C_1$  and  $L_2 C_2$  of Fig. 17 is at first sufficiently tight to give a band-pass effect, and that the coupling is then progressively loosened.

The first change in the characteristic will be that the two resonant frequencies will come closer together (Fig. 19) and the top of the curve will shorten. If the coupling is loosened still further there will come a point when the two resonant frequencies are practically indistinguishable from each other. The response curve will now have lost its band-pass characteristic, and will be sensibly single-peaked. A certain value of coupling must be regarded as



a critical value. As the critical coupling the curve is single-peaked but is, so to speak, on the verge of becoming double-humped.

If the coupling is made looser than this critical value the response curve will remain single-peaked, but will become sharper and sharper with reduction of coupling. The output voltage will decrease, too, this being maximum at the critical coupling. From the point of view of voltage amplitude the critical coupling is often regarded as the optimum coupling.

In any practical case, and assuming fixed coupling, an H.F. transformer of the type shown in Fig. 17 may, according to the purposes of the designer, have optimum coupling, for maximum voltage gain; over-optimum coupling, for band-pass characteristics, or, sub-optimum coupling, for high selectivity.

**Band-pass Aerial Coupling.**—Band-pass coupling is not restricted to intervalve H.F. transformers. Fig. 20 shows the basic arrangement of a very commonly used type of receiver input band-pass coupling. Capacity coupling is employed. As the secondary tuned circuit will normally form the tuned grid circuit of the first valve it may be necessary to take steps to prevent the coupling

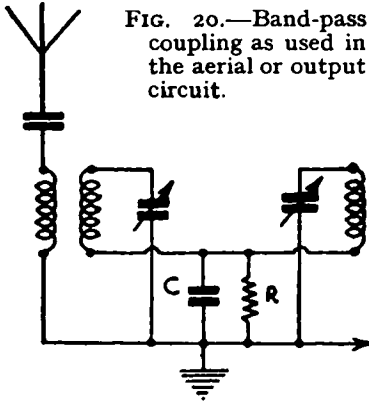

FIG. 20.—Band-pass coupling as used in the aerial or output circuit.

condenser C forming a D.C. break in the grid circuit. A resistance connected across the condenser, as shown in Fig. 20, will effectively close the grid circuit as far as D.C. is concerned.

Sometimes mixed couplings are used. One of the practical difficulties associated with the use of variably tuned coupled circuits is that the coupling characteristics change with frequency. With the circuits of Fig. 20, for

example, a given value of primary current will produce a greater e.m.f. in the secondary the lower the frequency. Mixed couplings are used when it is desired to make the combined characteristic of the coupled circuits as con-

stant as possible from one end of a wave-range to the other.

Fig. 21 shows a case of mixed capacity coupling. This diagram is a modification of Fig. 20 and shows the addition of a "top end" coupling condenser  $C_1$ , connected between the high potential ends of the two tuned circuits.  $C$  tends to be more effective at the lower frequency end of the range, but  $C_1$  evens up matters by being responsible for greater secondary e.m.f. at the upper end of the frequency range. Very small capacity values are used for top end coupling condensers.

**Receiver Over-all Selectivity.**—As far as any one receiver is concerned, the selectivity of one of the H.F. tuned circuits, or of one of the pairs of coupled circuits, is important from the design point of view, but only in so far as it has a bearing upon the selectivity of the receiver as a whole.

Receiver selectivity is usually specified in graphical form. A graph is drawn showing "selectivity ratio" plotted against kc/s off resonance. The selectivity ratio at any given frequency off resonance is the ratio of the signal input voltage required at this frequency to produce a certain receiver power output to the signal voltage required at the resonant frequency for the *same* receiver power output.

Fig. 22 is an example of such a graph. There is one particular feature about it which catches the eye, and that is the manner in which the voltage ratio scale is divided up. This merits explanation and brings us to decibel notation.

**Decibels.**—In radio we are very much concerned with ratios expressing gains or losses, or involving gains or losses, of power.

The decibel is a unit that represents a gain or loss of power in a manner that has a very particular significance.

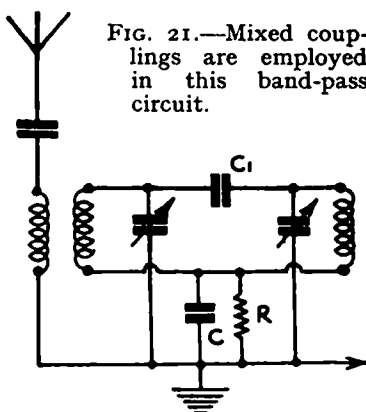

FIG. 21.—Mixed couplings are employed in this band-pass circuit.

To understand this, imagine yourself to be listening to the sound from a loud-speaker. Naturally, the greater the audio power in the speaker the greater will be the loudness of the sound. Would doubling the audio power double the loudness, as appreciated by your ear? The answer is, no. Actually, the power would have to be about ten times greater than before to give the impression of double the loudness. To double the loudness yet again the power would have to go up to about one hundred times the original value.

Take the numbers 1, 10, 100, 1000, etc.; the common logarithms of these numbers are: 0, 1, 2, 3, etc. It becomes clear, then, that where changes of sound power are concerned, the logarithms of the ratios involved give a much better idea of the effectiveness of the power changes

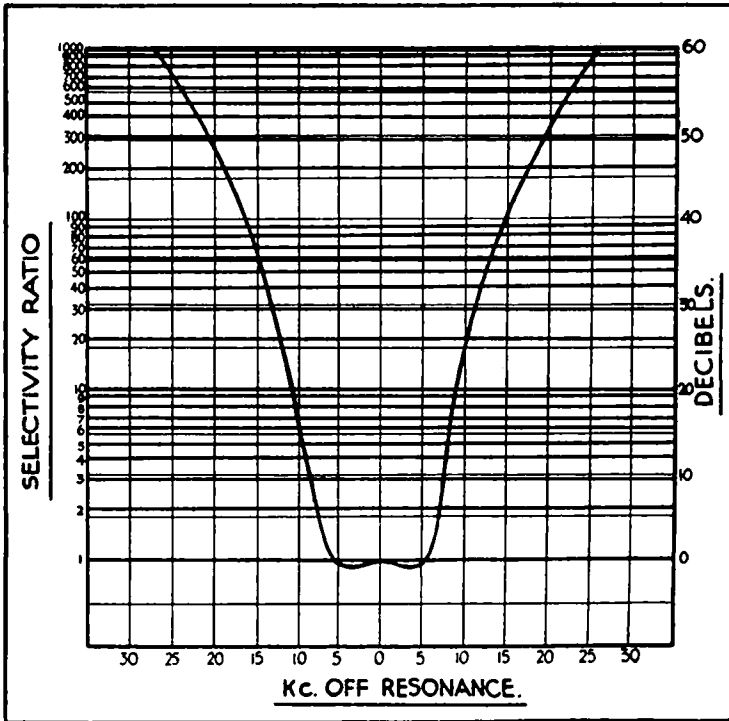

FIG. 22.—Graph showing the selectivity quality of a receiver.

than do the actual power ratios themselves. The common logarithm of the power ratio is, therefore, a very useful unit for expressing gain or loss. The name of this unit is the Bel.

For radio purposes it is more convenient if we consider the Bel to be divided up into ten equal parts and take one of these parts to be our standard unit. This is the decibel.

Thus,

$$\text{Decibels} = 10 \times \text{logarithm of power ratio.}$$

It is most important to appreciate that since the decibel is a unit of gain or loss there must always be some datum level specified.

Although the decibel is primarily a unit of power gain or loss we can bring decibel notation into voltage or current gain or loss problems by, first, working in terms of the power change involved and, secondly, remembering that, for constant impedance, power is directly proportional to the square of the voltage or current.

Thus,

$$\text{Decibels} = 10 \times \text{logarithm of (voltage ratio)}^2.$$

This is the same as saying that

$$\text{Decibels} = 20 \times \text{logarithm of voltage ratio.}$$

Although it is very easy to convert ratios to decibel notation with the aid of a book of logarithms, the accompanying table may be found useful for rough and ready purposes.

**CONVERSION TABLE OF POWER AND VOLTAGE RATIOS TO DECIBELS**

| Power Ratio. | Decibels. | Voltage Ratio. | Decibels. |
|--------------|-----------|----------------|-----------|
| 1            | 0         | 1              | 0         |
| 2            | 3         | 2              | 6         |
| 3            | 4.8       | 3              | 9.5       |
| 4            | 6         | 4              | 12        |
| 5            | 7         | 5              | 14        |
| 6            | 7.8       | 6              | 15.6      |
| 7            | 8.4       | 7              | 16.9      |
| 8            | 9         | 8              | 18        |
| 9            | 9.5       | 9              | 19.1      |
| 10           | 10        | 10             | 20        |
| 100          | 20        | 100            | 40        |
| 1,000        | 30        | 1,000          | 60        |
| 10,000       | 40        | 10,000         | 80        |

Referring again to Fig. 22, the vertical scale is evenly divided in decibel units, and that is why the voltage ratios themselves come out at such unequal spacing. Actually, this method of plotting gives a much better idea of the selectivity performance of the receiver than that given by a graph plotted with the voltage ratios on a linear scale.

**Reception Standards.**—We have already seen that selectivity and fidelity of reproduction are not independent, and that the whole matter is in the nature of a problem, rendered difficult by the present allocation of broadcast carrier frequencies.

Hard and fast rules cannot be laid down, but it is advisable for all technically minded amateurs to have some ideas of standards.

Let us consider real "high fidelity" first. For truly "life-like" reproduction on a good transmission the receiver would have to deal with audio frequencies ranging from 30 cycles per second up to something like 15,000 cycles per second, with no more than about 3 decibels variation up or down. As far as the high frequency section of the receiver is concerned, this is going to mean handling sideband frequencies extending to 15 kc/s above and below the carrier frequency. A little consideration of the present allocation of carrier frequencies will show that real high-fidelity reproduction, without interference, is going to be impossible except under very favourable circumstances. There is the possibility, however, with a local transmission if the receiver's sensitivity can be kept down sufficiently to give no audible response to the adjacent channel transmissions.

Turning now from real high fidelity to more average reproduction, we know that, even if a radio receiver falls far short of high fidelity, it can still be very pleasant to listen to.

Taking the average mains receiver, giving what we normally regard as "good quality," what would be the frequency range involved? Generally, something of the order of 60 or 70 cycles per second up to about 7000 cycles per second, within about 5 decibels up or down. Even this range, however, is sufficiently wide to give interference trouble in some cases.

It should now be apparent that for very long range reception, considerable sacrifice of high note response will have to be made if freedom from interference is to be secured.

**Variable Selectivity.**—Very obviously the maximum of satisfaction will be obtained from a sensitive, general purpose receiver only if the selectivity can be varied at will, enabling the listener to adjust according to the particular circumstances of each reception case.

It is especially useful, from the listener's point of view, if the over-all selectivity characteristic of the receiver can be varied between the limits of a fairly wide bandpass response on the one hand to a single peak characteristic on the other.

This suggests variable H.F. coupling, and there is an important point to be noted. If the coupling between two tuned H.F. circuits is of the mutual inductance type, and the two circuits are correctly adjusted as regards tuning, then variation of the coupling will cause the response curve to change *symmetrically* about the carrier frequency point. This is not true of all types of coupling. Variation of capacity coupling, for instance, will cause the response curve to change, but it will not keep symmetrical about the carrier frequency. It will therefore be appreciated that mutual inductance coupling is particularly suitable for variable selectivity circuits.

## CHAPTER III

### VALVE FUNDAMENTALS

**Electronic Emission.**—The emission of electrons from a heated cathode forms the basic action of all valves of normal types. In the case of a directly heated valve the electronic emission takes place from a special coating on the filament itself, the latter forming the cathode element of the valve. In an indirectly-heated valve, however, the emission takes place from a coated metal cylinder which is indirectly heated by a filament placed inside, but insulated from, it. In this case the metal cylinder referred to, and not the filament, is the cathode.

The addition of a metal anode in proximity to the cathode gives us the electrode assembly of the two-electrode valve.

Electrons are negative. Electrons repel one another, and are attracted by any electrode of positive potential. These facts are widely enough known, but they are mentioned here for the sake of emphasis. Valve action depends very much upon them.

**The Two-Electrode Valve.**—If the cathode of the valve is brought up to sufficient temperature to emit electrons, but the anode is not connected externally, the latter will acquire a negative charge due to some of the electrons which are expelled from the cathode collecting on the surface of the anode. This anode charge will not grow indefinitely because the repulsion set up by the charge will very soon prevent further electrons reaching the anode. When this state is reached the conditions inside the valve are that in the space between the cathode and the anode there is a dense (although invisible) "cloud" of electrons which can be referred to as the "space charge." A state of equilibrium is very quickly reached when the

space charge keeps constant in intensity, despite the fact that the cathode is continuously shooting more electrons into it. The point is that just as fast as electrons are leaving the cathode and joining the space charge group, others are returning from the space charge to the cathode. In the latter connection it must be appreciated that the loss of electrons, due to emission, leaves the cathode electrostatically positive with reference to the space charge, so that there is actually an electrostatic attraction tending to pull electrons back to the cathode.

By making the anode of the valve positive in potential with reference to the cathode we can cause the anode to attract electrons from the space charge, and if the anode is held constantly at a positive potential then the movement of electrons to the anode will be a continuous movement. It is possible to make electrons move from cathode to anode as fast as they are emitted by the latter (no space charge forming at all), but this must be regarded as an exceptional condition, permitted only under special circumstances. Under more usual conditions, there will still be a certain number of electrons moving from cathode to space charge and back to the cathode again, despite the high positive potential of the anode. Why should this be? The reason is due to the shielding action of the outer layers of the space charge which, in effect, shield the electrons which are nearer to the cathode from the electric field of the anode. There is thus a "space charge limitation" on the number of electrons reaching the anode in any given time.

The greater the anode potential the greater will be the number of electrons attracted to it in given time. Finally, if the anode potential were to be made high enough, the anode would gather up the electrons sufficiently fast to prevent the formation of any space charge. The limiting factor is now the rate of emission of the cathode. This is the exceptional condition referred to above, and when the condition exists the valve is said to be "saturated."

In Fig. 23 is a diagrammatic sketch

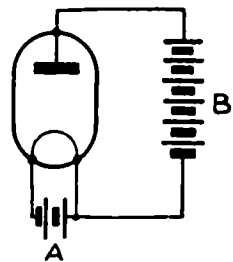

FIG. 23. — Typical diode or half-wave rectifier circuit.



of a directly heated two-electrode valve. There are two batteries—A, to supply the heating current to the filament and, B, to make the anode positive with reference to the filament and to maintain it so. Electrons reaching the

anode will displace others in the external circuit containing B. There will, in fact, be a current in the anode circuit, the direction of electronic movement being from cathode to anode inside the valve, and anode to cathode outside the valve.

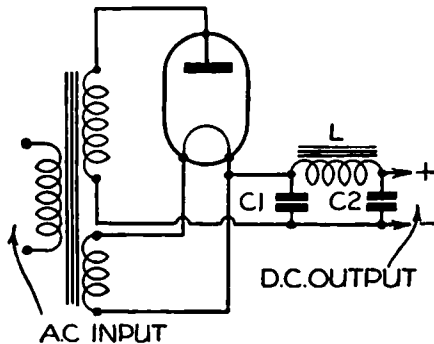

FIG. 24.—A half-wave rectifier as met with in a mains unit.

**Rectification.** — We have only to think of what would happen if battery B were reversed

(negative to anode, positive to cathode) to arrive quickly at the secret of the valve action when acting as a rectifier of A.C. With a reversed H.T. battery making the anode potential negative with reference to cathode there will be no attraction of electrons to anode; instead, the anode will set up repulsion and drive the space charge closer to cathode. Under this condition the valve forms a non-conductive "barrier" in the circuit formed by the valve and the H.T. battery.

It becomes obvious that if the H.T. battery were replaced by a source of alternating voltage the current passing from the latter through the valve cannot possibly be of alternating character; actually, it will be intermittent D.C., one pulse of current passing through the valve for each voltage alternation that makes the anode positive, and no current for each voltage alternation that makes the anode negative.

For H.T. supply to a radio receiver, operating from A.C. mains, it will be necessary to have not only rectification but also "smoothing," for a continuous D.C. supply with the minimum of fluctuation is required.

Fig. 24 illustrates half-wave rectification. Note that the H.T. secondary of the transformer, the valve and whatever may be connected across the D.C. output points form a series circuit. C1 is the "reservoir" condenser.

This condenser is charged by the intermittent pulses of current that are passed by the valve, and the output load circuit must be regarded as drawing current from C1. Essentially C1 charges up intermittently but discharges continuously. The charging pulses are of briefer duration than the actual voltage alternations because no current can pass through the valve, even when it is conductive until the voltage has risen up to that across the reservoir condenser terminals.

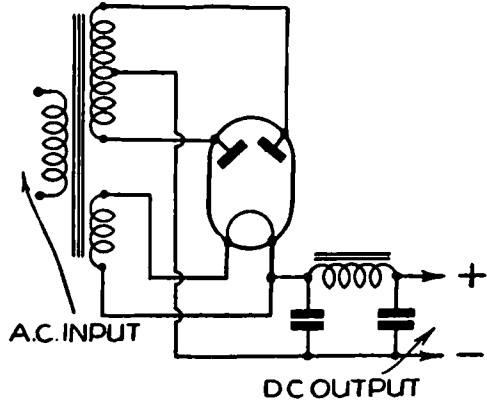

FIG. 25.—A full-wave rectifying circuit.

To minimise fluctuation at the D.C. output terminal points the filter consisting of the "smoothing" choke L and the "smoothing" condenser C2 is provided.

The problem of obtaining an adequately smoothed supply is rendered much easier if full-wave rectification is used. This entails either the use of two two-electrode valves or, what amounts to the same thing, a double anode rectifier, as shown in Fig. 25. With full-wave rectification both alternations of each A.C. cycle in the secondary of the mains transformer are made use of. For one alternation one anode becomes positive, and current flows via one-half of the H.T. secondary and this particular anode. For the next alternation the other anode becomes positive and the current flows via the other half of the H.T. secondary and this anode. It follows, of course, that while one anode is positive and one-half of the secondary is carrying current the other anode is negative and the other half secondary is out of action. Whichever half of the rectifier is conductive the direction of current flow to the reservoir condenser will always be the same, and the cathode of the rectifier will always be positive with reference to the centre tap of the H.T. secondary, and this centre tap is the point

from which the negative side of the D.C. output is taken.

**The Diode Detector.**—As we are dealing with two-electrode valves it is a logical step to proceed to the diode detector. Up to this point in this chapter we have not dealt with the matter of detection at all, but the necessity for it, in radio reception, is not at all difficult to appreciate.

In an earlier chapter it was shown that the H.F. oscillations carry the characteristics of the broadcasted sounds in the form of amplitude modulation fluctuations. For the operation of a loud-speaker (or headphones, for that matter) we require either audio-frequency A.C. or D.C. having an audio-frequency fluctuation. The waveform of the A.C. (or of the D.C. fluctuation) must conform to the waveform of the H.F. modulation. High-frequency oscillations, even though they may be modulated at audio-frequency, are unsuitable for the direct operation of sound reproducing apparatus, and the necessary conversion from modulated H.F. to pure audio-frequency is carried out by the "detector" and its associated components.

A small two-electrode valve, usually called a "diode," is frequently used as a detector. Such a valve is essentially a rectifier, which suggests that there must be some close connection between the process of detection and that of rectification.

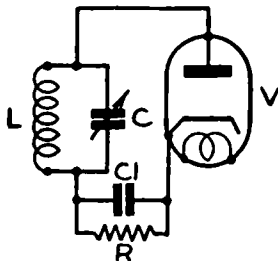

FIG. 26.—Diode circuit with load resistance and by-pass condenser.

In Fig. 26 let LC represent the last tuned H.F. circuit of a radio receiver. Across this circuit are connected a diode valve V and a resistance R. R and V are in series with each other.

Suppose unmodulated H.F. oscillations are set up in LC. As the diode is a rectifier the H.F. voltage developed across LC will not be able to force an H.F. alternating current through V and R. The valve is a "one-way traffic" device, and will pass current only for the alternations that make the anode positive with reference to cathode. For the reverse alternations the valve current will cut off, and it is assumed that the H.F. voltage is not of exceptionally small amplitude.

If there were absolutely no capacity associated with R we could imagine the current in R to be of intermittent D.C. character, the pulses occurring at high frequency. There must, however, inevitably be capacity associated with R, even if it is only stray capacity, and in practice we would use a condenser, C<sub>I</sub> (Fig. 26). The presence of capacity across R has important effects. The pulses of current passing through the valve will build up a charge in C<sub>I</sub>. At the same time a discharge current will flow from the condenser through R. With an unmodulated applied H.F. voltage (having, of course, a constant amplitude), the current through R will be of *steady* D.C. character.

We now have an arrangement whereby H.F. of constant amplitude gives rise to D.C. of constant value, and it needs little imagination to see that if the H.F. were to change to greater amplitude the D.C. in R would rise to a higher value. Correspondingly, if there were a reduction in the H.F. amplitude there would be a drop in the value of D.C. in R. It is only a small step now to appreciate that if the H.F. were to have a fluctuating amplitude, then the D.C. in R would also fluctuate, and this is just what is desired. In broadcast reception the H.F. amplitude certainly will be fluctuating; more than that, the amplitude fluctuations will have the wave-form of the sounds that we wish to reproduce. In R we have, in effect, eliminated the H.F. alternating fluctuation but retained the audio-frequency amplitude fluctuation. It now becomes a straightforward matter to follow up with L.F. amplification and sound reproduction.

The condenser C<sub>I</sub> (Fig. 26) is normally of the order of .0001 mfd. Apart from its action in connection with the actual detection process, as outlined above, it can be regarded as an H.F. by-pass across R.

As for the present we are dealing solely with the basis of valve action, we will not at this stage go into any question regarding distortion in the detector circuit.

**The Triode.**—The triode, or three-electrode, valve contains the anode and cathode features of the two-electrode valve plus an additional electrode. This additional electrode is of grid construction, and is placed between the cathode and anode.

It is quite obvious that electrons which reach the anode of a triode valve must necessarily have found their way through the spaces of the grid. It should be apparent, too, that the grid is going to have some influence upon the number of electrons that reach the anode, and therefore upon the value of the anode current. That the potential of the grid exercises a very profound influence on the anode current is worthy of explanation.

Let us start with the case of the grid being at zero potential (see Fig. 27). Convention has it that the cathode potential, if the cathode is indirectly heated, or the negative end of the cathode if it is directly heated, shall be taken as the zero of reference for valve potentials.

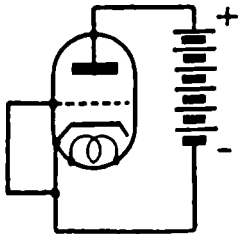

FIG. 27 (left).—A triode connected to act as a diode.

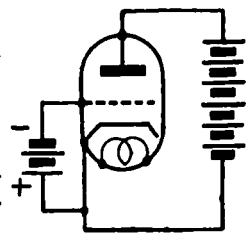

FIG. 28 (right).—Negative bias applied to a triode.

As the grid of the valve of Fig. 27 is at cathode potential it will neither attract nor repel electrons. Some electrons will, more or less accidentally, drive on to the grid wires, and there will therefore be a small grid current, but it will be exceedingly small. The majority of the electrons that are pulled away from the space charge by the anode attraction will pass through the grid spaces and go to the anode.

Suppose, now, that the grid is given a potential which is negative to the cathode. Fig. 28 illustrates the circumstances, using battery bias. It will be noted that a battery has been inserted into the grid circuit with negative to grid and positive to cathode. The grid, being at negative potential, will repel electrons, and this fact suggests at once that the anode current will be reduced. The negative repulsion of the grid will force the space charge closer to cathode, and lessen the number of electrons that will experience the direct pull of the anode. Also, some of

the lines of force which previously acted from anode to space charge will now act between anode and the grid wires, and the grid, remember, is a non-emitting electrode.

From the practical point of view the fact of supreme importance is that a comparatively small negative potential on the grid will affect the anode current to a considerable degree. If the grid is made sufficiently negative the anode current can be "shut off" altogether—no electrons reaching the anode. To bring about this condition it is not necessary to make the grid/cathode p.d. (grid negative) anything like the anode/cathode p.d. (anode positive). In other words, a negative grid potential that is small compared to the positive anode potentials can completely annul the effect of the latter.

Arising out of this is the fact that, as far as anode circuit conditions are concerned, the valve is very sensitive to changes of grid potential.

To finish off this discussion we must consider the effect of making the grid positive with reference to cathode (see Fig. 29).

A positive grid will attract electrons, and some electrons will move from space charge to grid under this attraction. The value of grid current will rise with increase of positive grid potential. It will normally, however, always be much smaller than the anode current.

The fact that the grid is now doing some electron collecting on its own account may possibly suggest that the anode current will become smaller in value. Actually, a positive grid increases the anode current, despite the diversion of electrons to the grid. One effect of the positive pull of the grid will be to draw the space charge further away from cathode, and more electrons will come under the attractive influence of the anode. There is another viewpoint. We have already mentioned the space charge limitation effect. The space charge is negative and the positive potential of the grid will act directly counter to the negative potential of the space

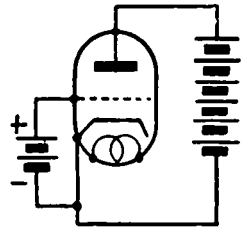

FIG. 29. — Positive bias applied to a triode.

charge, and have the effect of lessening the space charge limitation of anode current.

Under conditions of radio reception it becomes important in many cases to prevent the grid from running into positive grid potential values, but we will consider such cases when we come to them.

We will now deal with valve constants.

**Mutual Conductance.**—If the anode potential is held constant a change of grid potential will cause the anode current to change. The change of anode current caused by one volt change of grid potential is called the mutual conductance of the valve and is usually expressed in milliamps per volt. The mutual conductance is sometimes called the "slope." This is because the greater the mutual conductance the steeper will be the anode current/grid volts characteristic curve of the valve.

**Anode Impedance.**—This is sometimes referred to as the "A.C. resistance" of the valve. If the grid potential is held constant a change of anode potential will cause a change of anode current. The change of anode potential divided by the corresponding change of anode current gives the value of anode impedance. Note particularly that we do not merely divide anode voltage by anode current. This would give a value that is not of much practical interest. It must be emphasized that we divide a *change* of voltage by a *change* of current.

**Amplification Factor.**—In the last two paragraphs we have mentioned two different ways of producing a change of anode current. In one case the anode voltage was held constant and the grid volts were changed; in the other case the grid potential was held constant, and the anode volts were changed. Suppose the actual anode current change was the same in the two cases. Then we could say that a certain grid voltage change was equivalent to a certain anode voltage change (as far as effects on anode current were concerned). The ratio of the anode voltage change to the equivalent grid voltage is called the amplification factor.

The heading of this section refers to mutual conductance, anode impedance, and amplification factor as "constants." Actually, where any one valve is concerned they are not constant but depend upon operating conditions.

For any one valve, and for given operating conditions, the three values are related, as follows :

$$M = \frac{1000 A}{R}$$

where M=mutual conductance, in milliamps per volt

A=amplification factor

R=anode impedance, in ohms.

**The Triode as H.F. Amplifier.**—A change of grid potential will cause a change of anode current, and if an H.F. voltage is set up between grid and cathode there will be an H.F. variation of anode current, *i.e.* the anode current will rise above and fall below its mean value at high frequency.

We have previously emphasised the fact that the anode current value is very dependent upon the grid potential, but this in itself does not indicate the possibility of obtaining H.F. voltage amplification. Essentially, H.F. amplification in a radio receiver implies that a small H.F. voltage operating in the grid circuit causes a much greater H.F. voltage to become available in the anode circuit. The action of the grid potential in causing an anode current variation is only part of the story, even though it may be an important part. It is necessary for H.F. voltage amplification that the anode circuit shall contain some form of H.F. impedance. Then such changes of anode current as do occur will give rise to an H.F. potential difference across this "load" impedance, and the H.F. voltage established across the "load" will, if conditions are suitably arranged, be greater than the H.F. grid voltage. The H.F. load may take the form of a tuned anode circuit, an H.F. transformer, or perhaps merely an H.F. choke.

The triode has gone out of popularity for H.F. amplification for the reason that much better results can be obtained from screen-grid and H.F. pentode valves. It is rather important to know why the triode does not show up too well as an H.F. amplifier, because the information can be useful in other connections.

The anode and grid electrodes have electrostatic capacity between them ; they act, in fact, as a condenser. This capacity although it can be considered as small, from some



points of view, is actually large enough to be of serious consequence when the valve is amplifying H.F. Due to the anode/grid inter-electrode capacity an H.F. potential variation at the anode will induce an H.F. potential variation back on to the grid. In the grid circuit, therefore, there will be two H.F. voltages—the original signal voltage and the voltage “fed back” from the anode circuit. As to what effects the latter will cause will depend upon the phase relationship it bears to the signal voltage. If the feed-back voltage happens to be  $90^\circ$  out of phase with the signal voltage it will not be of much account. If, however, it is in phase with the signal voltage it will boost up the oscillations in the grid circuit. This may seem at first sight to be rather a useful effect, but in practice, and if the design of the stage has been on low-loss lines, the boosting-up process will generally be overdone, and the valve will run into continuous oscillation. If the feed-back voltage is  $180^\circ$  out of phase with the signal voltage it will cut down the amplitude of the oscillations in the grid circuit, and the amplification will be reduced.

Three possibilities have been mentioned. Is any particular one to be anticipated as the most likely? As a matter of fact, it all depends upon the character of the anode load. If this is behaving effectively as a resistance the feed-back voltage will be  $90^\circ$  out of phase with the signal voltage. If it is essentially capacitive in character there will be a large component of the feed-back voltage producing phase opposition in the grid circuit. If the load effective impedance is inductive in character then the in-phase condition will apply in the grid circuit.

Fig. 30 illustrates the tuned-grid tuned-anode arrangement, and if the stage has anything like low-loss design it will almost certainly be troublesome to operate. All of the three possibilities mentioned can occur, according to the setting of the anode tuning condenser. If the anode circuit LC is tuned to resonance it will, as we know, behave as a resistance. If LC is tuned above the signal frequency it becomes equivalent to an inductance, while if it is tuned below the signal frequency it becomes equivalent to a capacity. Thus, small tuning changes about the resonant point may give drastic changes in the action of the H.F. stage. A jump from low amplification to fierce and un-

controllable oscillation can be caused by a fractional change of the anode tuning.

**The Triode as Grid Detector.**—Although diodes (in the larger receivers) and H.F. pentodes (in the smaller receivers) represent the most commonly used detector types to-day, nevertheless the triode has by no means completely gone out, and it is advisable to know something of its action as a grid detector.

Fig. 31 illustrates a basic form of grid detector circuit.

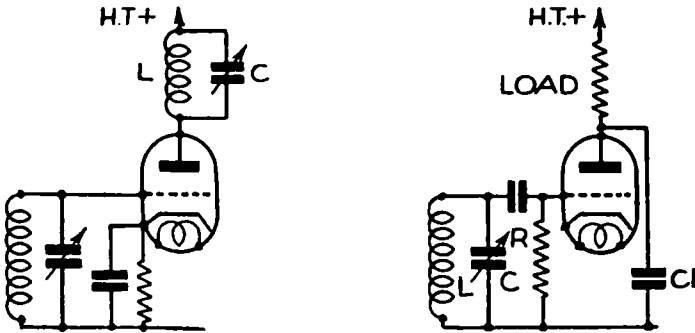

FIG. 30 (left).—The tuned-grid tuned-anode arrangement.

FIG. 31 (right).—A standard leaky-grid detector circuit.

The grid and the cathode can be regarded, from the detection point of view, as forming a diode valve, the grid leak  $R$ , functioning as the load resistance. The rectified voltage developed across  $R$  will act between grid and cathode, and therefore affect the value of anode current. An increase of amplitude of the H.F. in the tuned circuit  $LC$  will cause the grid to become more negative, and reduce the anode current, while a decrease of H.F. amplitude will cause the grid to become less negative, and increase the anode current. If the anode circuit contains something which will form an anode "load" at low frequency, such as a resistance, L.F. choke or L.F. transformer primary, then, since the grid potential fluctuation contains a component corresponding to the H.F. amplitude modulation, it follows that the anode current fluctuations will produce across the anode load a voltage at modulation frequency.

Thus a modulated H.F. input will give rise to a modulation frequency output voltage.

It must be understood that the actual detection process takes place in the grid circuit, and that the grid to anode action is one of L.F. amplification. The subject of valve characteristic curves has already been thoroughly dealt

FIG. 32.—The anode current-grid volts characteristic.

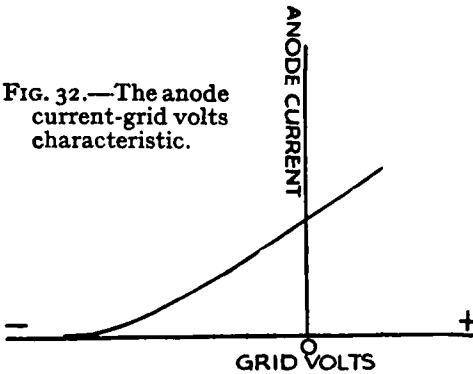

with elsewhere, but Fig. 32 is given to make clear one or two points that we wish to emphasise in connection with the valve-operating conditions for grid detection. The curve of Fig. 32 is an anode current-grid volts characteristic curve, and is to be regarded as a dynamic curve (due

allowance being made for the presence of the anode load). The no-signal grid potential will be very near zero, perhaps slightly positive, and it will be observed that the point on the curve itself corresponding to no-signal conditions will be a point on the straightest part of the curve. It will also be understood, from what has been written above, that the part of the curve over which the operating point can be considered as running during reception lies to the left of the vertical zero grid volts line. (Remember that rectification produces a negative grid voltage, and a fall of anode current if unmodulated H.F. oscillations are applied.) If we inspect the section of the curve to the left of the zero grid volts line we can see clearly that any semblance of a linear relation between changes of grid potential, and the consequent changes of anode current will be lost if the excursions of the operating point trespass on the lower bend, where the slope of the curve varies so rapidly. Trouble will occur in this connection if the valve is given too large a signal input so the signal handling capabilities of the grid detector are limited—very limited, as a matter of fact, with low H.T. By using higher H.T. the anode

current-grid volts curve is made longer and straighter, and a greater signal input can be accepted before input overloading takes place.

Although the main purpose for using the triode grid detector is concerned with the production of the audio-frequency output voltage in the anode circuit, yet it so happens that there is, in addition, an H.F. component in the anode current fluctuations, and it is inevitable that this should be so, since there is an H.F. voltage acting on the input side of the valve. Apart from the possibility of making use of the H.F. anode current component for reaction purposes (see later), its presence in the anode circuit tends to have undesirable effects in so far as it may make the anode *potential* fluctuate at high frequency. We have already dealt with H.F. feed back between anode and grid circuits through the inter-electrode capacity of the valve. We were considering then a triode H.F. amplifier, but the feed back can occur just as readily with the triode grid detector. With the detector, however, the feed-back voltage in the grid circuit will be of the "opposing" variety because the anode load impedance will be essentially capacitive for high frequency. The reason for this is that the anode load is designed for L.F. work, and if the load component is an L.F. choke or an L.F. transformer primary the H.F. will be so very far above the natural resonant frequency that the effective impedance at H.F. must necessarily be capacitive in character. The case of a resistance load might, at first thought, seem to be an exception, but here, too, the effective impedance at H.F. is capacitive owing to the presence of stray capacities, acting across the resistance.

If the inter-electrode capacity feed back of the detector is allowed to occur without some kind of check, the valve will produce a very heavy damping effect in the input circuit but, fortunately, there is a simple means of minimising the trouble. Fig. 31 shows a condenser  $C_1$ , connected between anode and cathode. This condenser will reduce the impedance to H.F. between anode and cathode and, in so doing, will reduce the amplitude of the H.F. potential fluctuations at the anode, and therefore lessen the feed back. Although the aim is to "tie down" the anode potential, as regards H.F. variation, we obviously

do not want to reduce the L.F. variation, and it is therefore necessary to adopt a compromise for the value of  $C_1$ . It must certainly not be so large that it leads to loss of the higher audio-frequencies in the output of the detector stage. Values used in practice vary with the design of the receiver, but  $\cdot 0001$  mfd. to  $\cdot 0005$  mfd. covers the commonly used values.

**The Triode as L.F. Amplifier.**—The triode is still well in the limelight as an L.F. voltage amplifier, although

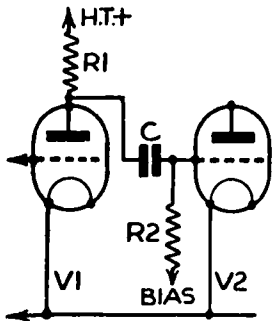
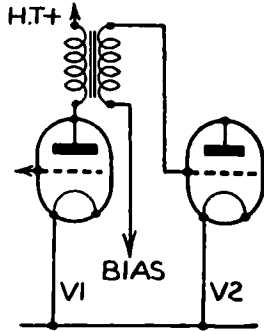

FIG. 33 (left).—Standard resistance - capacity coupling.

FIG. 34 (right).—Standard L.F. transformer coupling.



we very frequently find it in use now as part of a multiple valve (double diode triode).

For L.F. voltage amplification the anode circuit must contain some form of L.F. "load." Then L.F. voltages applied between grid and cathode will cause the anode current to fluctuate at low frequency, and the anode current fluctuations will develop across the anode load an amplified output voltage. Freedom from distortion demands as linear a relation as possible between input and output voltages. This implies, among other things, that grid current must not be permitted, because once grid current pulses are set up, the consequent rectification effect in the grid circuit will prevent changes of anode current being in proper proportion to the changes of input voltage. Prevention of grid current can only be secured by negative biasing of the grid potential.

Fig. 33 illustrates resistance-capacity coupling.  $R_1$  is the load resistance for the valve  $V_1$  and the voltage, at L.F., set up across  $R_1$  is applied across  $C_1$  in series. The L.F. voltage across  $R_2$  forms the input voltage for the next valve ( $V_2$ ).

Fig. 34 shows simple transformer coupling. Here the amplified voltage developed across the transformer primary by the valve V1 is stepped up by the transformer, and applied directly to the next valve.

Fig. 35 shows "parallel-fed" transformer coupling, which is to be particularly advised if the transformer is of the midget type, with high permeability core. This coupling is really a combination of resistance-capacity and transformer couplings, and confers benefits by virtue of the fact that D.C. is kept out of the transformer primary.

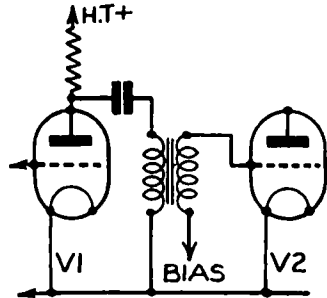

FIG. 35.—A parallel-fed transformer coupled circuit.

**The Triode as Power Amplifier.**—The output stage of a receiver differs in its purpose from any of the preceding stages, including L.F. voltage amplifying stages. The output

valve, like the preceding ones, has an anode "load," but the "load" this time is essentially a power-consuming one, for it is the loud-speaker. Consistent with the rather considerable demands of minimum distortion, the object here is not so much that the L.F. input voltage shall give rise to an amplified L.F. output voltage, as that it shall lead to the maximum production of audio-frequency power in the loud-speaker. The requirements of maximum audio-frequency power on the one hand and minimum distortion on the other are, to some extent, conflicting and call for some care in regard to the relation between the anode load and the valve's anode impedance. (Where a triode output stage is concerned, the dynamic resistance set up by the speaker should be of the order of two or three times the valve's anode impedance.)

There is much to be said in favour of the triode as an output valve, and there is no doubt that it would be seen in more frequent use if it were not that output pentodes and tetrodes have gained popularity on the score of their greater sensitivity.

**The Screen-grid Valve.**—With the electrode assembly of the screen-grid valve the valve manufacturer shows us

a direct attack upon the problem of reducing the internal capacity existing between anode and grid. Comparing the triode assembly with the S.G. assembly we can say that the S.G. valve contains one additional electrode. This is an electrode of grid construction, known as the screening grid, and is placed between the control grid and the anode. Fig. 36 shows a diagrammatic sketch of the electrode assembly of an indirectly heated S.G. valve.

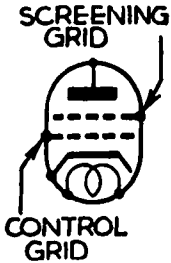

FIG. 36. — Diagram of an S.G. valve, naming the electrodes.

The capacity between anode and control grid would be completely removed if an unearthed metal sheet were placed between anode and grid. Obviously, it would be ridiculous to attempt to employ such a screen, because then there could not possibly be any movement of electrons from cathode to anode. The screen must, therefore, be of wire grid construction, which implies that the screening cannot be perfect from the electrostatic point of view. To earth the screening grid will also be out of the question because a zero potential electrode right in front of the anode would greatly lessen the positive attraction tending to pull electrons away from the cathode region. However, it is not so important that the screening grid shall be at zero potential, as that it shall be at *constant* potential (at least as far as H.F. is concerned). In practice the screening grid is given a positive potential (about two-thirds of the anode potential), and its potential is suitably "tied down" to a constant value by the use of a condenser between screen and cathode, this condenser sometimes being associated with a decoupling resistance. The residual anode/grid capacity which remains in the screen-grid valve is very greatly reduced below that of the triode and, as a result, the screen-grid valve can give a very satisfactory account of itself as an H.F. amplifier. The story of the screen-grid valve does not end with the matter of reduction of inter-electrode capacity for, still comparing the triode with the S.G. valve, it is to be anticipated that the presence of the screening grid is bound to have considerable influence upon the characteristics of the valve.

As the screen is at a positive potential, some of the electrons passing through the control grid will be diverted to the screening grid, away from the anode, yet it will be appreciated that the actual controlling action of the control grid will not be greatly influenced by the presence of the screen. That being so, it follows that the mutual conductance of the S.G. valve will not be markedly different to that of a triode (ignore the output triode). Comparison, in any valve list, of the mutual conductances of triodes and S.G. valves, although it will disclose certain differences between individual valve types, will show on the whole that the values are of much the same order for the two groups.

It was stated at the beginning of this chapter that the anode impedance of a valve is equal to the ratio of a small change of anode potential to the corresponding change of anode current. To get some idea of what order of anode impedance can be expected with the S.G. valve, we have only to consider what sort of effect upon anode current will be caused by a small change of anode potential. When we remember that immediately in front of the anode is the screening grid, at a positive potential which is high with reference to cathode, it needs little imagination to appreciate that a small change of anode potential will affect the anode current only to a very small extent (much less than in the case of the triode). The conclusion, therefore, is that the anode impedance of the S.G. valve will be very much greater than that of the triode.

It was also stated on previous pages that the amplification factor of a valve is the ratio of the change in anode potential to the change of grid potential which would produce the same change of anode current. From what has been written above it is easy to see that this ratio will be comparatively high for the S.G. valve. The amplification factor of the S.G. valve is very much greater than that of the triode.

It is to be mentioned that the S.G. valve is very "touchy" on the matter of screen volts, and considerable changes of characteristic values will be caused by a change of screen potential.

The high anode impedance of the S.G. valve leads to the result that, for H.F. amplification, the dynamic



resistance of the anode "load" can be very much higher than could be used with the triode. It was with the introduction of the screen-grid valve that rapid improvements of efficiency of H.F. coupling systems began.

Considerations of selectivity place a limit upon the maximum dynamic load resistance that should be used; also, the existence of the small residual anode/grid capacity

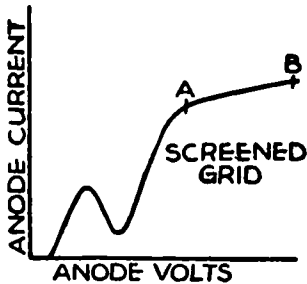

FIG. 37.—The kink in the S.G. valve anode current-anode volts curve.

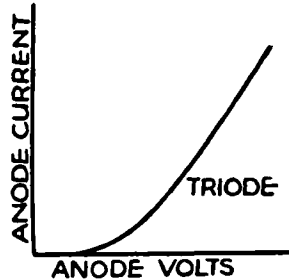

FIG. 38.—The "straight" curve of a triode valve.

should not be overlooked for it can still cause trouble if the dynamic load resistance is put up too much. If the dynamic load resistance is much lower than the anode impedance of the valve, the amplification of an S.G., H.F. stage is proportional to the mutual conductance of the valve, and to the dynamic load resistance.

**The S.G. Valve's "Kink."**—The screen-grid valve has a peculiarity of characteristic which, in many respects, must be regarded as undesirable, although advantage can be taken of it in certain special applications of the valve.

To understand this peculiarity we must refer to an anode current-anode volts characteristic curve of an S.G. valve. A typical curve is given in Fig. 37. (A triode curve is given in Fig. 38 for purposes of comparison.) The S.G. peculiarity referred to is indicated by the very obvious kink in the curve which, of course, represents the variation of anode current with anode voltage, the screening grid and control grid potentials being held constant.

If the anode voltage is increased from the value at which the anode current starts, the latter will, at first,

increase as the voltage rises. It is important to remember that, to begin with, the anode potential will be below that of the screening grid. As the anode voltage is increased, the intensity of the electron bombardment of the anode increases, and at the anode voltage appropriate to the point where the kink of the curve commences (see Fig. 37) secondary emission starts at the anode. This means that the high velocity electrons which bombard the anode cause others to be driven off the anode. The screening grid is still at a higher potential than the anode and will attract these "secondary" electrons. Thus there are cathode to anode and anode to screen electron movements, and the actual anode current will depend upon the difference between the number of electrons received from the cathode and the number lost by secondary emission. As the anode voltage is increased above the value at which the secondary emission just starts the secondary emission increases so rapidly that the anode current actually falls with increasing anode voltage. It may even happen that "secondary" electrons will, over a small range of anode voltage, exceed in number those reaching the anode from the cathode, in which case the anode current will show a small reversed value. (See Fig. 37. This would mean that the kink would actually dip below the horizontal axis.)

Still assuming a steady increase of anode voltage, the latter will presently approach close to the screening-grid voltage value, and the secondary emission will fall off because the anode will, by now, be getting sufficiently positive to start pulling back some of the "secondary" electrons. As the anode voltage is still further increased, the electron movement from anode to screen will rapidly get less, with consequent increase of anode current, until, just as the anode potential rises above the screen potential, the anode current will get up to normal value and there will be no further drop of current with increasing voltage.

Comparison of the S.G. curve with the triode curve of Fig. 38 shows that there is a striking difference quite apart from the matter of the S.G. curve's kink. After the S.G. anode potential has been raised above the screen volts, and the kink conditions no longer apply, the increase of anode current with increase of anode potential is very slow indeed. With the triode, however, the rise of anode current

with volts is comparatively rapid after the lower bend conditions are departed from. Admittedly the triode characteristic would bend over at the top if the anode volts were increased enough, but this saturation condition would not normally be permitted. The very marked difference in the slopes of the upper parts of the two curves is an indication of the great difference that exists between the anode impedances of the two valves.

As a matter of practical interest it is to be mentioned that the S.G. valve is very touchy as regards screen volts, and that both the anode impedance value and the amplification factor are very dependent upon the adjustment of screen voltage.

For normal H.F. amplification the S.G. valve must work under conditions which do not involve the kink in any way. This means that the useful part of the curve of Fig. 37 is the section marked AB.

**The H.F. Pentode.**—If the kink could be removed out of the characteristic curve, an obvious improvement in the effectiveness of the valve would be indicated. This brings us to the subject of the H.F. pentode, because such a condition applies to it. The H.F. pentode contains an electrode, additional to the number in the S.G. valve, in the form of yet another grid placed, this time between anode and screening-grid. This additional electrode is called the suppressor grid. The suppressor grid is kept at low potential (very frequently it is directly connected to cathode), and, as its name suggests, has the effect of suppressing the secondary emission, and therefore of removing the kink out of the

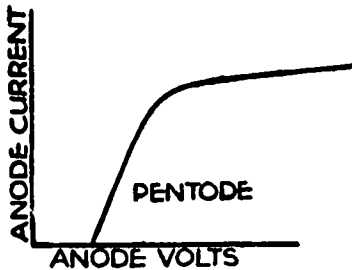

FIG. 39.—The pentode anode current-anode volts curve.

anode current - anode volts characteristic. Since the suppressor grid prevents movement of "secondary" electrons from anode to screening-grid it follows that the general shape of the pentode's anode current - anode volts characteristic curve will be that of the S.G. valve, *less the kink*.

Fig. 39 is an example, and it is obvious that the useful

part of the curve is more extended than is the case with the S.G. valve.

The presence of the suppressor grid is bound to affect the anode impedance value for it lessens the control that changes, of anode potential have upon anode current ; in other words, it puts up the impedance value, compared to that of the S.G. valve (but see later note regarding suppressor biasing).

We can regard the H.F. pentode as a valve of very high anode impedance, and capable of handling a larger anode voltage "swing" than the corresponding S.G. valve. It is more tolerant than the S.G. valve to an anode load of high D.C. resistance value, such as may be used in a detector circuit, and it can also work with higher dynamic H.F. loads.

H.F. pentodes of the 4-pin and 5-pin types have their suppressor grids internally connected to the cathode. With 7-pin valves, however, it is standard practice for the suppressor connection to be brought out to a separate pin, and with this type of valve the suppressor grid must be externally connected to the cathode, or to some other selected point. The fact that advantage is taken of the 7-pin base by the valve manufacturer, to give the suppressor its own pin, suggests that occasions must arise when it is desired to put a bias voltage on to the suppressor grid (with reference to cathode). Negative bias on the suppressor grid does, as a matter of fact, lower the anode impedance of the valve, and the impedance control exercised by suppressor biasing will sometimes be found useful.

**Variable- $\mu$ .**—Increasing negative grid potential with either an S.G. or an H.F. pentode valve will reduce the anode current, and in the case of an ordinary (non-variable- $\mu$ ) valve the anode current-grid volts characteristic curve has a fairly sharp lower bend, and the anode current reaches zero at a comparatively small negative grid potential. The valve obviously will not handle much in the way of an input grid voltage "swing" without the pronounced lower bend curvature leading to the two halves of an input voltage cycle receiving disproportionate treatment (the increase of anode current for the positive half-cycle being greater than the decrease of anode current for the negative half-cycle).

This is, in effect, a "detection" process, and is certainly not to be desired in an H.F. amplifying stage. It tends to give rise to a particularly exasperating form of interference, referred to as cross-modulation interference. Suppose a receiver containing non-variable- $\mu$  H.F. valves is tuned to a distant station but it so happens that there are still, despite the mistuning involved, oscillations from a local station in the H.F. input circuit. As far as the ordinary problem of selectivity goes, one could hope that the H.F. circuits following the first H.F. valve would deal with the unwanted signal and cut it out. If, however, the unwanted signals experience, at the first valve, the "detection" process mentioned above, what will happen is that the modulation of the unwanted signal will become impressed on the carrier of the wanted signal. Then all the H.F. circuit selectivity possible, acting after the first valve, will not get rid of the interfering signal, for it will come right through, cheerfully sitting on top of the carrier that the receiver is actually tuned to.

H.F. volume control is an awkward problem with the ordinary S.G. or H.F. pentode valve, and control by variation of screen-voltage has the disadvantage that lowering screen volts increases the curvature of the characteristic.

Control of volume by grid bias will not affect the curvature of the characteristic itself, but increasing the negative grid potential will bring the input signal voltage "swing" more on to the sharply curved portion of the characteristic and increase cross modulation tendencies. This also rules out A.V.C.

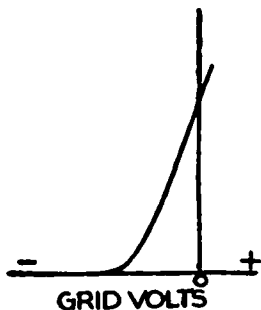

FIG. 40.—This and the curve on the opposite page show the differences between an ordinary and a variable- $\mu$  valve.

The variable- $\mu$  valve has a modified grid construction, the spacing of the grid wires being such as to make the anode current tail off very gradually with increasing negative grid potential.

Figs. 40 and 41 make clear the essential difference between the anode current - grid volts characteristic of an ordinary (Fig. 40) and a variable- $\mu$  (Fig. 41) valve.

The very gradual change of slope at the lower section of the variable- $\mu$  characteristic indicates that cross-modulation tendencies will be negligible, and that control of volume by H.F. grid biasing will be a practical proposition, with the consequent fact that A.V.C. can be successfully employed. These are important points where H.F. amplification is concerned, but we must remind the reader that a very popular type of valve for grid detection is the non-variable- $\mu$  H.F. pentode.

**The Output Pentode.**—The type of pentode valve suitable for use in the output stage of a receiver does not have such close screening as the H.F. pentode and is designed, not for high amplification of voltage, but for high anode power efficiency (ratio of AC/DC power in the anode circuit).

The general shape of its anode current - anode volts characteristic resembles that of the H.F. pentode, and it is a valve of relatively high impedance. As far as avoidance of distortion is concerned, it is rather exacting in its requirements in respect of correct anode load value. It is generally necessary, too, to employ a tone compensating shunt across the anode load in order to prevent accentuation of the higher audio-frequencies.

**The Output Tetrode.**—The S.G. valve that we have already considered in this chapter is a "tetrode," since cathode, control-grid, screening-grid, and anode make up a total of four electrodes. The output tetrode valve must, however, be considered more in relation to the output pentode than to the S.G. valve. We must remind the reader that the pentode contains a suppressor-grid which, in effect, "irons out" the characteristic kink typical of the S.G. valve. This reminder makes the output tetrode decidedly interesting because this valve has an anode current - anode volts characteristic of the same shape as that of a pentode, yet the valve does not contain a suppressor grid. The output tetrode was brought out much

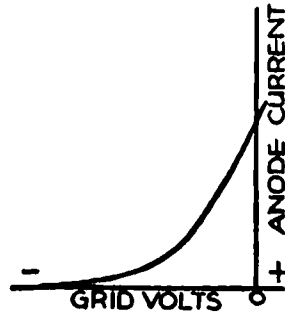

FIG. 41.—Compare this curve with that on the opposite page.

later than the pentode, of course, and came into existence when it was found that secondary emission could be prevented, without the aid of a suppressor, by employing certain particular dimensions and spacing for the tetrode electrodes. The inter-electrode capacity from anode to the other electrodes is less in the case of the output tetrode than with the corresponding pentode.

**Reaction.**—The idea of feed back of radio frequency energy from anode circuit to grid circuit arose in a previous article in connection with the inter-electrode capacity. The possibility of conditions arising under which the oscillations in the grid input circuit would be increased in amplitude by the feed back voltage was discussed, but it was made clear that the feed-back could only be regarded as undesirable in view of the fact that it was not under independent control, and was liable to give varied effects ranging from instability to a degenerative influence.

Controllable feed back from anode circuit to grid circuit of the correct phase to give "regenerative" amplification of the input oscillations is, however, something that can be usefully employed, and it is customary to use inductive coupling between anode and grid circuits for the purpose. The coupling coil associated with the anode circuit is called the "reaction" coil, and the actual feed-back process is usually called "reaction."

Apart from self-oscillating valve circuits (which will be dealt with later), reaction is generally used with the grid detector, in the case where the receiver would have insufficient H.F. amplification for all the reception requirements that the receiver is intended to meet.

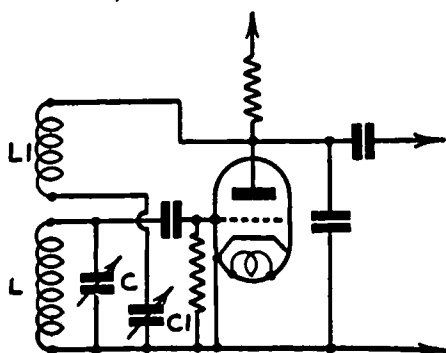

FIG. 42.—A typical standard reaction circuit.

Fig. 42 shows a typical circuit arrangement.  $L_1$  is the reaction coil and is coupled with the tuning coil,  $L$ , of the grid circuit. As to whether the H.F. voltage induced by  $L_1$  back into  $L$  will assist or

assist or

oppose the oscillations in the circuit LC will depend upon the sense of the winding and of the connections of  $L_I$ . A reversal of the connections of  $L_I$  would give the change from the one condition to the other. Naturally, it is arranged in practice that the feed-back voltage shall assist the oscillations in LC.

There are various ways in which the degree of the reaction can be controlled. Variation of the coupling between  $L_I$  and  $L$  is a possibility, but is, these days, considered to be inconvenient. Most readers will probably remember the "swinging coil" reaction of the early days, however. Reaction condenser control is the most commonly used method, and Fig. 42 shows an example of its use. It will be observed that the reaction coil,  $L_I$ , and the reaction control condenser,  $C_I$ , form a series circuit which is in shunt with the main anode circuit. The  $L_I C_I$  circuit is of comparatively low impedance to the H.F. component of the anode current, but the actual value of the impedance is very dependent upon the adjustment of  $C_I$ . Greater or less capacity at  $C_I$  will cause greater or less H.F. current to flow in the reaction coil so that adjustment of  $C_I$  exercises the required control upon the degree of the reaction effect.

Fig. 43 is given, first, to illustrate how it is possible to use a single tapped winding to provide both tuning and reaction and, secondly, to give the clue as to the correct "sense" of the windings and connections for regenerative results. It is easy to see from Fig. 43 that if one were to trace round the tuned winding from grid to cathode, the direction of circulation would be opposite to that obtained if one were to trace round the reaction winding from anode to cathode.

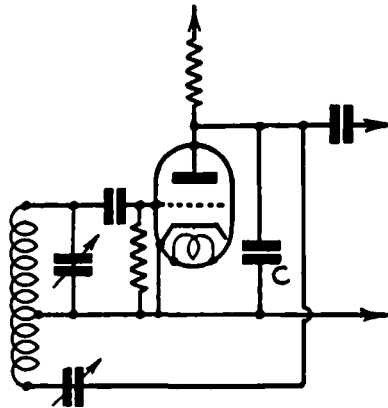
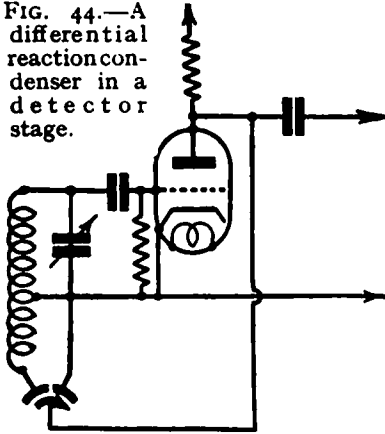

FIG. 43.—Circuit showing the use of a single-tapped winding for tuning and reaction.



condenser marked C is the usual anode by-pass condenser. At low capacity settings of the reaction control condenser the by-passing action of C is very necessary, but it will be appreciated that for higher capacity settings of the reaction control condenser the reaction circuit will itself

FIG. 44.—A differential reaction condenser in a detector stage.



provide satisfactory H.F. by-passing. By using a "differential" reaction control condenser the reaction control capacity can be made to increase, and the by-pass condenser capacity made to decrease at the same time (and vice versa). A differential reaction condenser contains two sets of fixed plates, and one set of moving plates and its action will be understood by reference to Fig. 44.

To deal with the general effects of reaction it must

be understood that if the reaction control condenser capacity is increased from minimum value, a greater feed-back voltage is induced into the grid circuit, and the amplitude of the oscillations correspondingly increases. This regenerative amplification cannot be raised without limit, and the limit is marked by the valve jumping into continuous oscillation.

Reaction necessarily involves a feeding back of H.F. energy from the anode circuit to the grid circuit. Energy is dissipated in the grid circuit in various H.F. losses, and the latter, as we know, have a close and important connection with selectivity. If the grid circuit receives a supply of energy from the anode circuit it stands to reason that the effects of the grid circuit losses will be less pronounced, and this implies that the selectivity will be raised. When interference between stations is being experienced with the simpler type of "straight" receiver, employing reaction, it will often be found that a little careful juggling with the volume and reaction controls will improve matters.

So much for the good points about the use of reaction. The fact that every receiver does not have regenerative amplification is a sufficient indication that there must be some snag about it. We have mentioned the raising of selectivity as one of the effects of reaction, but it will be understood that the selectivity is raised in a very artificial way, and with a considerable degree of reaction, such as would be used for maximum amplification, the tuned grid circuit takes on a very "peaky" H.F. response characteristic, and this gives such drastic sideband cutting that the quality of reproduction is affected, a bad loss of high notes being caused.

As to whether reaction should, or should not, be incorporated in a receiver design depends entirely upon the kind of receiver that is contemplated. If it is to be a small job, as regards number of valves, and the maximum of sensitivity is required, it will be practically necessary to take advantage of reaction in order to gain the required sensitivity. On the other hand, if the receiver will contain sufficient H.F. stages to give adequate H.F. amplification, and particularly if the receiver is being designed with any pretensions to high quality reproduction, then reaction should certainly not be used.

The fact, already mentioned, that increasing reaction above a certain point causes the valve to go into continuous oscillation brings us to a consideration of the valve oscillator. In view, however, of the very important part played by the valve oscillator in the superheterodyne system of reception we will deal with it in the next chapter, which gives the story of the superhet.

## CHAPTER IV

### THE PRINCIPLE OF THE SUPERHET

**Complicated System of Reception.**—In the ordinary tuned radio-frequency ("straight") receiver each tuned H.F. circuit works at the carrier frequency of the signal being received. If, for example, a 300 metre, or 1000 kc/s signal is operating in the aerial circuit, the oscillations will remain at 1000 kc/s in every circuit right up to the detector.

It will, of course, be necessary for every H.F. circuit in the receiver to be variably tuned, to allow for the reception of signals of various different carrier frequencies. In the superhet receiver, however, only a certain number of the tuned H.F. circuits are variably tuned and work at the carrier frequency of the signal, and these circuits (there may be only one, however) come first, counting from the aerial. The remaining H.F. circuits are *fixed*-tuned to a particular frequency which is independent of the signal carrier frequency, and is known as the "intermediate" frequency.

It is pointed out that whatever adjacent channel selectivity, and H.F. amplification a superhet may show is mainly to be attributed to its intermediate-frequency stages.

As there are two high-frequency values, the signal carrier and the intermediate frequencies, involved in superhet reception it follows that a frequency conversion process must be an essential feature of the system. In brief, the signal comes at its carrier frequency, and carrying its modulation, through one or more H.F. circuits. Then a change of frequency is made, and the signal comes through the rest of the H.F. circuits with the carrier frequency changed to the intermediate value, although the modulation frequencies are unaffected.

Before considering how all this is brought about we will first look into the question as to what advantages are to

be gained by employing such an apparently complicated system of reception.

**Matching.**—The fact that the intermediate-frequency circuits are fixed-tuned gives more than a clue as to the position. First of all, it implies that the number of sections of the ganged condenser will not need to equal the number of tuned circuits. A typical superhet receiver containing eight tuned H.F. circuits, excluding the oscillator circuit, has only three sections in the ganged condenser, and one of these belongs to the oscillator circuit. A little thought given to the idea of making a "straight" receiver with eight tuned circuits, and employing a ganged condenser with eight sections, should soon convince anybody that there is something to be said for the superhet. Quite apart from the formidable character of an eight-section ganged condenser, there is the problem of getting accurate matching between eight circuits to be considered and remember, too, that each of the eight circuits will need wave-range switching.

The foregoing, important though it may appear to be, does not by any means exhaust the argument in favour of the superhet. The fact that the intermediate frequency does not vary with changes of signal carrier frequency greatly simplifies the problems of the designer when it comes to a matter of making one or more H.F. stages have amplification and selectivity characteristics that will remain constant, and not vary with the tuning of the receiver. In earlier chapters of this book we considered complications that arise with a variably-tuned circuit that has to be adjustable over a wide range of frequencies, and how changes of L/C ratio and H.F. resistance affect the dynamic resistance and magnification of the circuit. It was also pointed out that it is very difficult to work to some specified band-pass characteristic, and to get the circuits concerned, if variably tuned, to hold closely to this characteristic over a range of frequencies.

In the case of an intermediate-frequency stage in a superhet receiver there is only the one (converted) carrier frequency to be catered for, and the typical tuned primary, tuned secondary, I.F. transformer can be designed and adjusted for some particular selectivity characteristic, and to give some particular dynamic load, with the com-

portable knowledge that the frequency upon which the design is based will be the frequency of operation.

So far we have been taking the frequency conversion process rather for granted, but as it necessitates the generation of local oscillations in the receiver we will first deal briefly with the valve as an oscillator.

**The Valve Oscillator.**—In connection with regenerative amplification it was stated that a limit to the amplification is reached as soon as the reaction is advanced to the point that any further increase will cause the valve to “jump into oscillation.”

It has been emphasised that reaction causes a feed back of energy from the anode circuit to the grid circuit, and by increasing the reaction sufficiently it becomes possible to supply the grid circuit with energy at just the same rate as the various circuit losses dissipate it. Under this circumstance the obvious happens—the oscillations will carry on indefinitely, even if the applied signal ceases. The valve has, in other words, become a *generator* of oscillations.

The fact that we have stepped from the idea of regenerative amplification to that of the generation of oscillations may, however, tend to make the reader think that an applied signal is necessary, to provide the initial start. This is not so.

Fig. 45 represents a simple basic oscillator circuit, and it is to be particularly noted that there is no question of there being any applied signal, for the circuit is self-contained. If the reaction is arranged in the correct sense, and is tight enough, then the mere act of switching on the valve will be sufficient to start the generation of oscillations in LC. The frequency of the oscillations will depend upon the tuning of LC.

The question as to how the oscillations start in the first place is simply answered. We have had no previous occasion in this book to mention the self-oscillatory properties of a tuned H.F. circuit, but the fact is that a circuit containing inductance and capacity will (provided that the H.F. resistance is not too high) oscillate

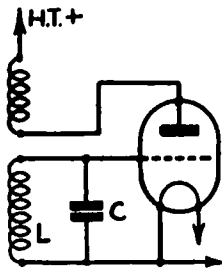

FIG. 45.—The basic oscillator circuit.

at its natural frequency when excited by any voltage impulse, even though the latter may be only a momentary "kick." In this connection there is a good and simple analogy in the pendulum. A pendulum needs only a tap to start it swinging at its natural frequency. In each of these cases (the electrical and the mechanical) a single impulse will set up oscillations that are of the "damped" variety, *i.e.* the oscillations commence with a certain maximum amplitude, but the peaks decrease with each successive alternation until zero is reached.

In the electrical case the actual process of oscillation involves a transfer and re-transfer of energy between the inductance and capacity of the circuit.

Referring to Fig. 45, suppose an initial impulse puts a charge in C. This will discharge through L, and the current will create a magnetic field around L. The magnetic field will then collapse on the coil setting up an e.m.f. of self-induction which will recharge the condenser. The latter will then discharge again (reverse direction of current), and so on.

Once oscillations do start in LC, they will not be damped out, for the reaction will take charge and maintain the oscillations at constant amplitude. The necessary initial impulse need be only very slight, and is bound to occur when the valve is switched on and starts emitting.

Fig. 45 illustrates a case where the oscillating circuit is on the grid side of the valve. Fig. 46 shows another basic oscillator diagram, and in this case the oscillating circuit is on the anode side of the valve.

Where the circuit of Fig. 46 is concerned it would be incorrect to suppose that the oscillations in LC are maintained by energy fed into LC by the grid circuit, for the latter contains no source of energy. It is to be understood that for both the Fig. 45 and the Fig. 46 circuits the H.T. supply represents the source of the energy that is consumed in the oscillating circuit. In the case of the arrangement of Fig. 46 the oscillations in LC will be main-

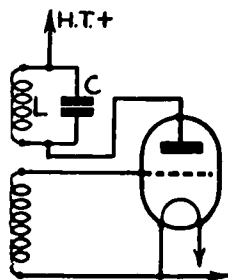

FIG. 46.—In this circuit the oscillatory circuit is on the anode side of the valve.

tained if an oscillating "feed current" component can be produced in the anode circuit. This requirement will be met if the anode current can be made to rise and fall at the correct frequency, and with the correct phase. This brings the matter to one directly concerning the reaction, for if the latter is of the correct sense and degree, the initial oscillations in LC will produce an H.F. voltage in the grid coil and this, in turn, will make the anode current rise and fall. The anode current fluctuation will now contain the oscillating component necessary to feed energy into LC, and to maintain the oscillations.

**Superhet Frequency Changing.**—The frequency changing process involves the "mixing" of the signal oscillations and locally generated oscillations, so we must first consider the effects produced by combining together two continuous oscillations of different frequencies.

Suppose that there are applied to the circuit LC of Fig. 47 two continuous H.F. e.m.f.'s of frequencies  $F_1$  and  $F_2$  respectively,  $F_1$  being the higher frequency. What is going to happen in LC? As the two e.m.f.'s operating in LC have different frequency values, no simple statement can be made that they are in phase, or that they are out of phase. Actually the phase relationship between them will vary. The two e.m.f.'s will drift into phase, drift out of phase (to  $180^\circ$ ), come into phase again, and so on, and this will occur in a certain regular manner. The definite fact is that the two e.m.f.'s will come into phase at a rate exactly equal to the difference between the two frequencies. As far as the resultant of the two e.m.f.'s is concerned this will reach maximum peak value every time the two component e.m.f.'s get into phase, and will drop to minimum value every time they get  $180^\circ$  out of phase. It can be said that the resultant of the two component e.m.f.'s is "beating" at the frequency  $F_1 - F_2$ .

If we could get this  $F_1 - F_2$  frequency filtered out from the two component frequencies we would have a definite case of "frequency changing," but as the arrangements of

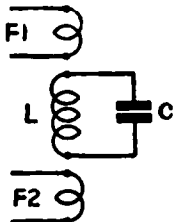

FIG. 47.—Illustrating the application of two different e.m.f.'s to a closed circuit.

Fig. 47 stand, there would be no hope of doing so. It must be remembered that the  $F_1$ - $F_2$  frequency is no more than the amplitude variation of the resultant of the two component e.m.f.'s, and that the latter are actively present. It would be quite impossible, assuming that the "beat" frequency is the one we were after, to pick it out by a coupled tuned filter.

It becomes a different story, however, if we apply the resultant voltage developed across LC to a detector. Then the output of the detector will contain an  $F_1$ - $F_2$  component that can easily be filtered out from other components of the detection process. That the output current of the detector should contain an  $F_1$ - $F_2$  component can be deduced from quite elementary considerations. The resultant input voltage is rising and falling in amplitude at the frequency of  $F_1$ - $F_2$ , so it could be assumed, just from that fact alone, that the detector output current would have a fluctuation at  $F_1$ - $F_2$ .

The application of the above to superhet practice is as follows: of the two frequencies,  $F_1$  and  $F_2$ , one is that of the incoming signal oscillations, while the other is that of oscillations generated in the receiver itself by a valve oscillator. By suitable adjustment of the local oscillation frequency the value of  $F_1$ - $F_2$ , can be made exactly equal to the intermediate frequency. As to whether the local oscillation frequency is the higher, or the lower, of the two component values is immaterial from the theory point of view, although it is almost invariable practice to make the local oscillation frequency the higher one. Thus the frequency conversion from signal carrier to intermediate frequency is a conversion from  $F_2$  to  $F_1$ - $F_2$ .

In working out the basic theory we have taken no account of modulation. Actually any L.F. modulation carried by the signal oscillations will appear as modulation of the "converted" oscillations, and there will be no trouble on this score, provided that the  $F_1$ - $F_2$  frequency is very considerable above the highest audio-frequency. That the intermediate frequency is well above audibility is emphasised by the full title of the system which is "supersonic heterodyne."

**The "First Detector."**—To employ detection as part of the frequency changing process is not so essential as the



foregoing may suggest, for there happens to be an alternative (and a better one), but we will deal with the latter presently.

When a detector is used for frequency changing it is referred to as the "first detector." Obviously, there will have to be another detector (the second detector) to do the normal detection work necessary (in any type of receiver) to obtain the audio-frequency, corresponding to the signal modulation, and necessary for the output stage of the receiver. It should be clear that the I.F. section of the receiver begins and ends with the output circuit of the first detector and the input circuit of the second detector respectively.

Until the arrival of the modern frequency changer valve the use of detection in frequency changing led to almost innumerable circuit designs, and no good purpose would be served now by going into close details of some of these. Dealing with the matter briefly, there are two main systems: (1) those employing an oscillating first detector which itself generates the local oscillations, and (2) those using a separate oscillator valve, coupled in some manner to the grid circuit of the first detector.

Fig. 48 shows an example of a first detector circuit using

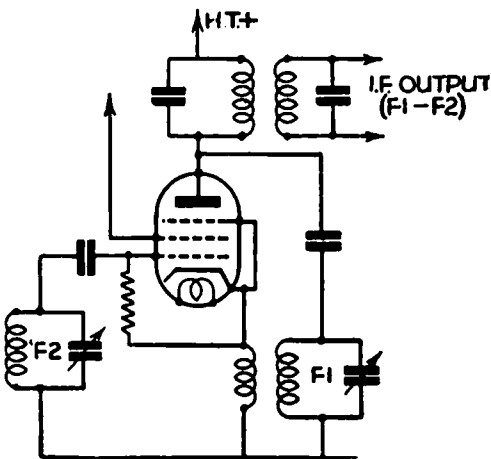

FIG. 48.—The first detector circuit, in which an H.F. pentode is employed.

an H.F. pentode for both detection and the generation of oscillations.

**Frequency Changer Valves: the Heptode.**—The mathematical analysis of the action of a detector to which are applied two H.F. e.m.f.'s of different frequencies is interesting but rather beyond the scope of this book. However, there is one point that emerges from such analysis

which is of particular importance and worthy of mention. It can be shown that the output current of the detector contains a term which is proportional to the product of the two applied e.m.f.'s. In

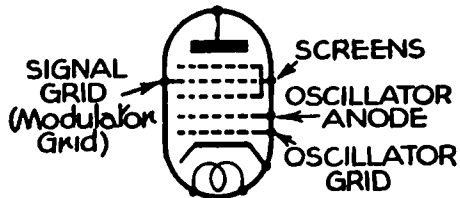

FIG. 49.—Diagrammatic representation of the pentagrid.

the circuit LC of Fig. 47 there is no actual frequency conversion, and the resultant e.m.f. is something that depends upon the vectorial *addition* of the two component e.m.f.'s. There is the implication here that the indirect *multiplication* produced by the detector is intimately concerned with the frequency changing that the detector makes possible. This is actually the case; so much so that if the signal and locally generated e.m.f.'s are applied to any device, other than a detector, which will give an output dependent upon the *product* of the two e.m.f.'s, then this device will make frequency changing possible.

The modern frequency changer valves are examples. They are "frequency changers" without being detectors and give a number of advantages over the earlier "first detectors." Among these advantages are greater sensitivity to very weak signals, less trouble from cross-modulation, and more stable working. A.V.C. control is possible, too.

Fig. 49 diagrammatically indicates the electrode assembly of the heptode type of frequency changer (indirectly heated mains variety). There are five electrodes of grid construction, two of these being bonded together. Counting up from the cathode the first and second grid constructed electrodes form the grid and anode, respectively, of a triode oscillator, and Fig. 50 shows appropriate external connections for the generation of local oscillations. Each of the two electrodes which are bonded together acts as a screen. The remaining grid electrode (the one between the two screens) is the one to which the signal oscillations are applied, while the outer anode is the one that is connected to the first I.F. transformer.

As will be clear from Fig. 50, signal oscillating potentials,

and locally generated oscillating potentials, are acting on two separate grids of the same valve, and it stands to reason that both these grids will have a control on the current at the outer anode. Actually, the effective mutual conductance of the signal amplifying section of the valve varies in sympathy with the oscillating potential on the grid of the oscillator section. The result of main interest, from our present point of view, is that the fluctuating current in the outer anode circuit is dependent upon the *product* of the signal and oscillator e.m.f.'s. This, in turn, means that there will be a component fluctuation having a frequency equal to the difference between the signal and oscillator frequencies. This "difference" frequency will, of course, be adjusted to the required intermediate frequency value, and the I.F. transformer in the outer anode circuit (Fig. 50) will respond to this particular frequency.

It is to be emphasised again that the signal section of the valve is not adjusted for detection. Incidentally, that is one reason why it is possible to apply A.V.C. to the signal grid.

There is a certain optimum amplitude for the local oscillations which implies that the oscillator (external) circuit should be designed accordingly. It is, of course,

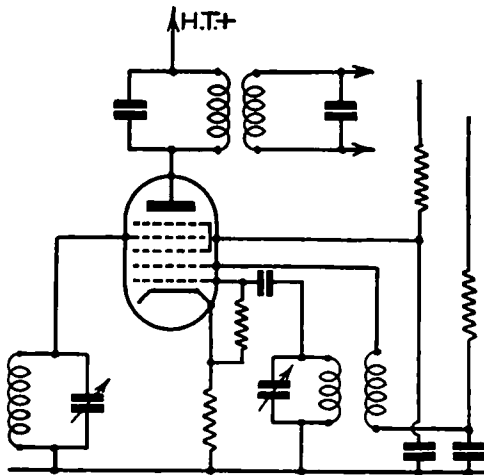

FIG. 50.—A pentagrid frequency-changing stage.

correspondingly desirable that the local oscillations should keep reasonably constant in amplitude, and the presence of the grid condenser and grid resistance in the circuit of Fig. 50 is concerned with this requirement.

**The Octode.**—The octode frequency changer is a valve containing one electrode additional to the number contained in the

pentagrid. This additional electrode is a suppressor grid which is mounted directly in front of the outer anode, and is internally connected to the cathode. The presence of the suppressor grid has the effect of making the signal amplifying (or "modulator") section of the valve have the characteristics of an H.F. pentode.

The triode-hexode frequency changer can be regarded as consisting of two valves, with a common cathode. Essentially, the triode-hexode consists of a triode oscillator and a hexode "mixer." The electrode assembly is represented diagrammatically in Fig. 51. Note that the grid of the triode section is internally linked across to an "injector" grid in the hexode assembly.

The oscillator tuned circuit is connected between the triode grid and the cathode, and the oscillating potentials set up on the triode grid are directly applied to the injector grid of the hexode. Electrons passing from the cathode to the hexode anode must necessarily pass, through both the signal grid (carrying the input signal potentials) and the injector grid (carrying the local oscillation potentials). The current fluctuations in the hexode anode circuit are, therefore, dependent upon both the signal and the local oscillation potentials and, as in the case of the pentagrid, will be proportional to the product of these potentials. As a result, the first I.F. transformer will be supplied with a component having the usual "difference" frequency.

The triode-hexode offers an appreciable advantage over the pentagrid, and the octode, where short-wave reception is concerned. This is due to the fact that the virtual separation of the oscillator of the triode-hexode renders interaction negligible between the oscil-

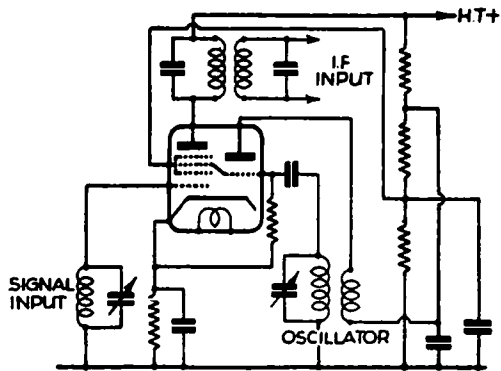

FIG. 51.—A triode-hexode frequency-changing stage.

lator anode and the signal grid. Such interaction is appreciable with the pentagrid and the octode, particularly on short-wave signals, and has the effect of lowering the conversion efficiency.

**A.V.C.**—Automatic volume control is the term applied to the automatic control of the effective high frequency amplification of a receiver, in such a manner as to bring about a decrease of amplification with an increase of signal carrier amplitude, and an increase of amplification with a decrease of carrier amplitude. The primary objects of incorporating A.V.C. in a receiver are : (i) to prevent strong signals overloading the output stage, (ii) to minimise the effects of signal fading.

The control upon the H.F. amplification is exercised by means of grid biasing, and this implies that the controlled valves must be of variable- $\mu$  types. The question that is raised now is, How can a direct voltage, dependent upon the signal carrier amplitude, be obtained for application as bias to the grids of the controlled valves ?

The problem brings us to a further consideration of the diode detector. In Chapter III of this series it was shown that if unmodulated H.F. oscillations are applied to a diode detector circuit the rectified current in the load resistance will be of steady D.C. character. Under modulation conditions the current in the load resistance will, of course, fluctuate at audio-frequency, and in that chapter we were chiefly concerned with utilising the corresponding audio-frequency voltage developed across the load resistance.

In connection with our present interest it becomes a very useful idea to regard the current in the load resistance as consisting of two components: a D.C. component dependent upon the carrier amplitude and an A.C. component dependent upon the modulation of the signal. Corresponding to these two current components there will be two voltage components set up across the load resistance. For A.V.C. purposes it is the direct voltage component that matters.

It must be emphasised that, under conditions of negligible detector distortion, this direct voltage is independent of the modulation, but is directly dependent upon the carrier amplitude so that the value of the voltage will rise with

an increase of the incoming *signal strength*. The practical problem resolves itself into that of picking up this direct voltage and applying it to the grids of the H.F. valves. The direct and alternating voltage components are both

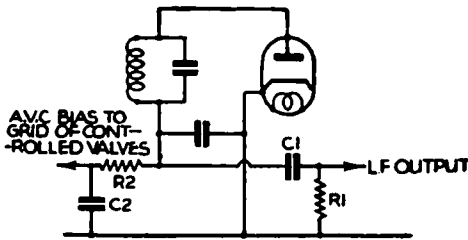

FIG. 52.—A simple A.V.C. circuit.

A.V.C. detector, and Fig. 52 shows a basic circuit,  $C_1$  and  $R_1$  respectively are the grid condenser and leak of the succeeding valve.  $C_1$  will block D.C. so that the alternating component of voltage only will act on the L.F. valve.  $R_2$  and  $C_2$  provide the filtering for the A.V.C. feed line. The alternating component of voltage acts across  $R_2$   $C_2$  in series. The impedance of  $C_2$  can be made sufficiently low in comparison to the resistance of  $R$  that only a negligible fraction of the alternating voltage remains across  $C_2$ , and the voltage acting on the controlled valves becomes sensibly direct in character.

There is some disadvantage in making the one diode act as both signal and A.V.C. detector. Such an arrangement will give a certain amount of A.V.C. biasing, even on very weak signals, which means that the receiver will not be able to attain its maximum sensitivity under the circumstances when it is most desirable that it should be able to do so.

present at the diode load resistance, but separation is easily effected by quite simple filtering arrangements.

It is possible to make a single diode detector perform the double function of signal detector and

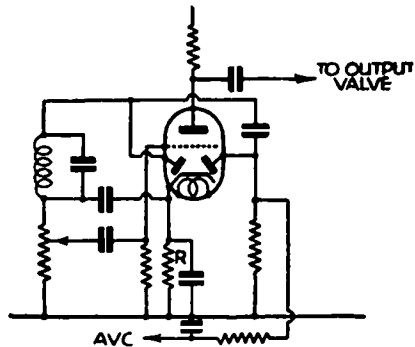

FIG. 53.—A double-diode-triode circuit providing detection, delayed A.V.C. and L.F. amplification.

It is more satisfactory to have a delay on the A.V.C. action, such that the controlled valves receive no A.V.C. bias unless the input signal amplitude is above a certain, predetermined level. With delayed A.V.C. the receiver will provide its maximum H.F. amplification on all signals below this particular amplitude.

For delayed A.V.C. a diode separate to the signal detector is used as A.V.C. detector, and the required delay is brought about by negatively biasing the anode of the A.V.C. diode. The A.V.C. diode will now remain out of action unless the peak amplitude of the H.F. oscillations applied to it exceeds the value of the delay bias.

Convenience in construction of circuits involving two diodes has been well catered for by the valve manufacturers, and commonly used multiple valves include the double diode (detector and A.V.C.), the double-diode triode (detector, A.V.C. and L.F.), and the double-diode output pentode (detector, A.V.C. and output).

Fig. 53 shows a typical circuit arrangement using a double-diode triode for signal detection, delayed A.V.C., and L.F. amplification. It will be observed that the resistance  $R$  in the cathode circuit provides the bias for the triode and also the delay bias for the A.V.C. diode.

## CHAPTER V

### GENERAL DESIGN

WHY did the superhet lose popularity amongst some amateurs? There are two reasons. Firstly, the use of terms such as frequency changer, intermediate-frequency amplifier, separate oscillator, and similar names frightened the non-technical and gave the circuit an apparent air of mysterious complications. It made the ordinary amateur think that the receiving circuit bearing the name superheterodyne was only for the advanced technician, and consequently he did not trouble to examine it. Secondly, many experts openly proclaimed that the quality of the superhet was inferior. Good loud-speaker results could not be obtained, they said. Therefore, the superhet was relegated to the background because manufacturers could not sell the necessary coils, etc., and very few amateurs were interested in it. In spite of this, however, it was definitely employed in many research laboratories, and even by the B.B.C. for certain relay purposes. The improvement in valves and coil design has led to a revival of the circuit, and it can now be quite definitely stated that the quality of a superhet can be equal, even if not better than the majority of ordinary circuits, and it is even simpler to handle than many two-valve sets. This latter feature is due to the fact that a superhet can be "one-knob tuning," and a volume control is the only other fixture apart from the necessary on-off and wave-change switches. Actually there is nothing out of the ordinary in the circuit, and it is proposed to show just how the superhet follows standard practice, and how the mysterious terms which are given to its different functions are really no more complicated than the circuit arrangement. It is certainly the circuit of the future, as it is the only one which will give perfect separation to stations working with the allotted wavelength separation

**The Circuit.**—To commence with we will take a com-



plete superhet circuit, and not one wherein one valve is employed for dual purposes. This will make the working clearer and avoid complicated terms. In Fig. 54 is a diagrammatic representation of a seven-valve superheterodyne, with each separate stage represented by a box. The first point is that some of these boxes carry names familiar in ordinary receivers, namely, H.F. amplifier, detector, L.F. amplifier, and output stage. These are exactly the same as are used in any ordinary receiver and consequently need no explaining. They do not differ in the slightest

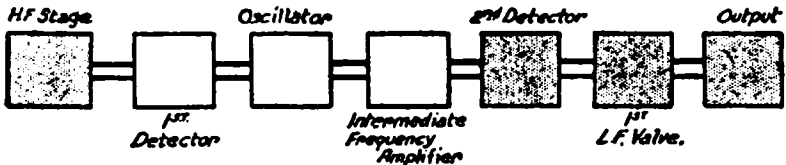

FIG. 54.—Diagrammatic representation of a complete superhet circuit.

degree, either in construction or the manner in which they function. These stages are shaded in the sketch, and it will be seen that there are only three stages left. Before going on with the explanation it should once again be stressed that the shaded portions may be taken from any circuit of normal design and would be replaceable in the superheterodyne. Thus, the H.F. stage is employed as an amplifier for very weak or distant signals; the second detector operates on the normal grid leak or anode-bend arrangement, and the L.F. stage is used to enable a sufficiently loud signal to be passed to the output stage for the satisfactory operation of the loud-speaker. There is thus left the I.F. stage and the first detector and oscillator. Let us take the I.F. stage first.

**The Intermediate-Frequency Amplifier.**—Its name should enable its function to be understood, but for the non-technical it may be described simply as a standard H.F. amplifier, the tuned circuits of which are adjusted to work at one wavelength only (Fig. 55). There are no tuning condensers to be manipulated, and the H.F. transformer which is included in its grid circuit is designed to work at

a wavelength of usually just over 2000 metres (or 110 to 125 kc/s). Now, as we wish to receive stations working on all sorts of different wavelengths, how can we use such a fixed amplifier? Obviously, we shall have to make all our stations equivalent to 2000 metres or so, and this is where the first part of the superhet circuit comes in. To

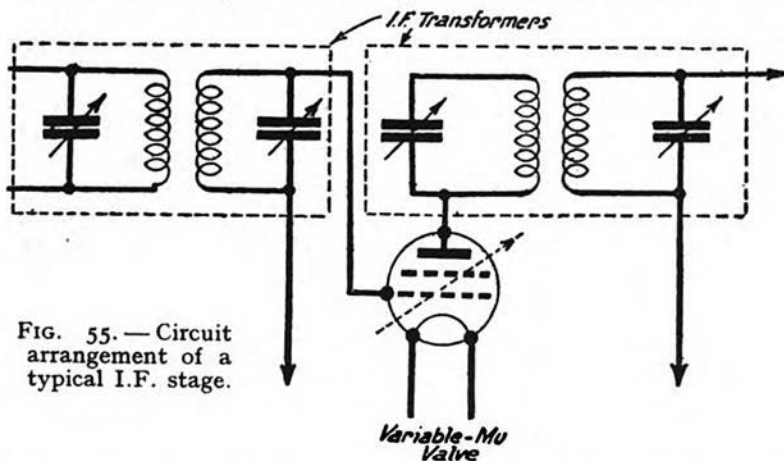

FIG. 55.— Circuit arrangement of a typical I.F. stage.

enable us fully to understand the principle, it is essential to work in kilocycles (or frequency) in place of the customary wavelengths (in metres), and the reason for this will be seen as we go along. Assume a station working on a wavelength of 356 metres, which is a frequency of 843 kc/s. Now, as we must turn this to 110 or 125 kc/s to enable our I.F. stage to work on it, we must obviously change the frequency to that figure. This is the function of the first detector and oscillator, and the combination is known as the "frequency changer."

The question of frequencies and wavelengths is a very vexed one, and although it is customary for us in this country to refer to wavelengths when dealing with various subjects, this is a rather troublesome thing. The I.F. stage is, we have decided, to work on a frequency of 110 kc/s. This is a wavelength of 2727.2 metres. Now the changing of our signal into the intermediate frequency is carried out by having one valve (as already explained) to rectify the beat produced by the signal and a voltage set

up by a second valve which is arranged to oscillate continuously. The coils in this oscillator are tuned to a frequency which differs from our signal by the frequency of the I.F. stage. This may sound a little complicated, but will be better understood if we take an actual example. Suppose there is a station working on a frequency of 500 kc/s, and we wish to hear this on our superhet circuit. As the I.F. stage works with a frequency of 110 kc/s we must tune our oscillator so that the difference (or beat note) produced by the mixing of the signal and the oscillator has a value of 110 kc/s, which means to say that the oscillator must be tuned to 610 kc/s or 390 kc/s. In other words, we tune the oscillator to a frequency 110 kc/s above or below the signal frequency. If this example is expressed in metres, we would have a most confusing array of figures. We should say that we wish to hear a station working on a wavelength of 600 metres, and we adjust our oscillator to 491.8 metres or 769.2 metres, thus producing a beat note of 2727.2 metres. You see now the advantage of the kilocycle working? (Wavelengths in metres are converted to frequencies in kilocycles by dividing 300,000 by the number of metres.) Well, to get back to our superhet circuit, we have found that we have to tune the oscillator coil so that we produce in that circuit a frequency which differs from the frequency of our required signal by the frequency of the I.F. stage. The first point which will occur to the thinking reader is that there should thus be a possibility of hearing a station working on the wavelength to which the oscillator is tuned.

**Second Channel Interference.**—Furthermore, a station which is working 110 kc/s above our oscillator frequency should also be heard. That is to say, if we adjust our oscillator to 610 kc/s in order to hear a station on 500 kc/s, a station working on 610 kc/s might leak through the receiver, whilst it is practically certain that a station on 730 kc/s would beat with our oscillator in the same manner as our required station. This actually does happen in the superhet and is known as Second Channel Interference. Furthermore, harmonics may cause whistles in the following manner. If our local station is very close, and we are tuned to a station which is 55 kc/s lower than the local (55 is, of course, half of 110), the local may be

received sufficiently strongly by the first detector for beats to be set up which will cause interference. This can happen at practically every harmonic of 110 kc/s. There is, however, no need to think from this that the superheterodyne will only tune in a station with whistles all round the dial, as it is quite easy to ensure that not even one whistle can be heard when the control is turned from zero to maximum.

**Single Valve Frequency Changers.**—We have referred so far to a separate detector valve and separate oscillator valve, but it is easily possible to combine these two valves and so carry out the process of frequency changing in one single stage. With mains operated receivers a screen-grid valve may be used with the cathode employed as part of the tuning circuits. There are certain reasons why this is not an ideal arrangement, but we will not complicate matters by discussing these now. A pentode valve may be employed in a similar manner, one of the grids playing an important part. More recently, the pentagrid (or heptode) has been developed to fulfil the same purpose, and with this reduction in the number of valves certain improvements have been effected in the circuit, but the principle remains exactly the same.

**Aligning the Oscillator.**—A most interesting point which arises when considering the modern superhet (which employs a ganged condenser for tuning all the circuits) is the alignment of the oscillator, or, in other words, the correct tracking of the section of the variable condenser which tunes the oscillator coil. It may not be apparent at first sight, but a little thought will reveal the fact that this tuned circuit will not have the same variation (when tuning through the broadcast band) as the aerial circuit, or the first detector input circuit. For instance, the normal or medium broadcast band is from 1500 to 500 kc/s (200 to 600 metres). Our oscillator circuit will have to cover, therefore, from 1610 to 610 kc/s. The ratio of our signal-tuning circuit is 3 to 1 (1500 over 500), whilst the oscillator ratio is 2.65 to 1 (1610 over 610). In order, therefore, that a ganged condenser may be used to tune both oscillator and input circuits it is necessary to "pad" the oscillator circuit in order to bring it up to the same ratio as the other circuits.

## CHAPTER VI

### AERIAL DESIGN

IF a superhet has any shortcomings, the greatest of them is undoubtedly background noise, and it is probably not exaggerating to say that 50 per cent. of superhet trouble with background noise could be cured, or at least very much improved, by the use of a suitable aerial. There appears to be a misunderstanding regarding the proper way to handle a receiver of this type. Development has brought about more sensitive, and still more sensitive, circuits, which have made owners and those responsible for the arranging of aerials somewhat careless. One is apt to feel when buying a superhet having, perhaps, a gain fifty times greater than strictly necessary, that a piece of disused clothes-line (metaphorically speaking) is unnecessarily generous aerial equipment. Those people who must get China will automatically realise the necessity of putting up a really good aerial, but those who buy a receiver "guaranteed to get China" and are content with a couple of dozen European stations, feel that expenditure on aerial equipment would be a wicked waste.

When the bogey of background noise appears, one's friend or dealer, or anybody else who may be interested, suggests the use of some sort of screened anti-interference aerial. This is undoubtedly very sound advice, but it is not everybody who can afford, say, £2 for an aerial outfit, plus the cost of erecting it, when there is no guarantee forthcoming that the interference is of such nature that it may be cured in this manner. The idea that a large aerial will bring in more background noise than a small one is one of the greatest fallacies of radio, which is saying a good deal, and it is very definitely time that some clear thinking on the subject be made available to users of superhets.

**Signal-to-Noise Ratio.**—Consider first of all what happens with a modern superhet working with an indoor aerial, say 20 ft. in length. Firstly, the signal input being small, the signal-to-noise ratio of the receiver will be very

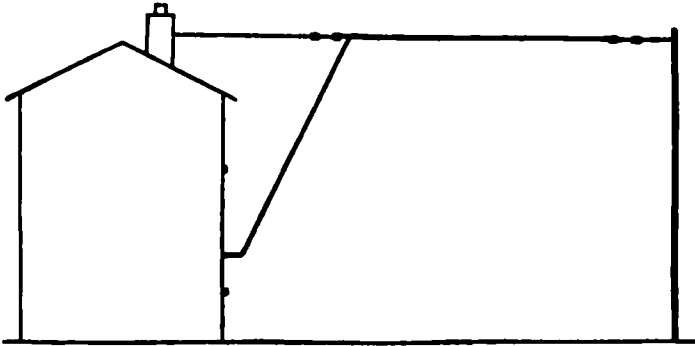

FIG. 56.—The conventional type of outdoor aerial.

poor. Secondly, the aerial will almost always be in close proximity to electric-light wires, water pipes, gas mains, and possibly a telephone, all of which are carriers of background noise interference, and as the superhet will be in a

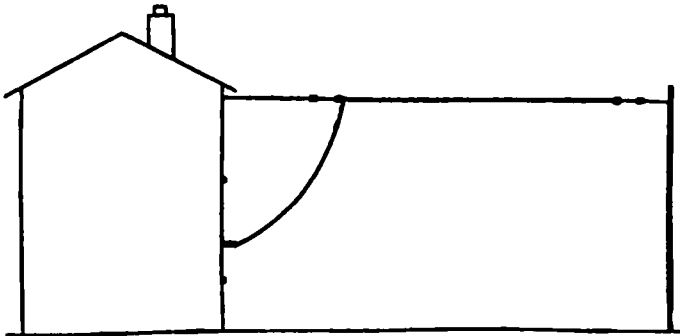

FIG. 57.—A long, low aerial which has advantages when used under certain conditions.

sensitive condition by virtue of the small signal in the aerial, it will be well able to pick up a large amount of interference from these sources. Thirdly, if the receiver has a band-pass pre-selector, it is highly probable that the use of an aerial of a size quite remote from that which the designer

would expect to be used will very probably result in upsetting the ganging of the pre-selector circuit. This will impair both sensitivity and quality, and result in the automatic or manual volume control being set at a greater degree of sensitivity, with further increase in background noise.

The only justification for a short aerial must surely be when a straight receiver is used, which would be unselective with a large aerial, but the selectivity of a superhet is for all practical purposes sensibly constant, irrespective of the length of the aerial, providing only that the latter does not differ so widely from the normal standard that ganging is thrown out. Bearing in mind, then, that the use of a large aerial will not impair selectivity, it will be useless to consider the working of the receiver under this condition and compare it with the alternative condition outlined above. Assuming that the aerial is of the conventional type, as shown at Fig. 56, it is obvious that a very large signal will be picked up, which will result, firstly, in the best signal-to-noise ratio possible; secondly, low pick-up from house wiring, pipes, telephone, etc., as the large signal will operate the automatic volume control and reduce the sensitivity of the set, and, thirdly, the aerial being of normal proportions it will not impair ganging.

**Indoor Aerials.**—It is apparent, therefore, that a highly efficient aerial will increase sensitivity, decrease background noise, and affect selectivity. It is also evident that for maximum performance it is just as important to use an efficient aerial with a modern superhet as it was when using a crystal detector in the early days, although the reasons may not be the same. For convenience, the writer has cited a small indoor aerial, and compared it with a large outdoor aerial, but it should be clearly understood that efficiency rather than size is the ruling factor. Generally speaking, an indoor aerial cannot be classed as efficient, but certain cases will arise where quite a good aerial can be placed in the loft, which will be found quite satisfactory, particularly in houses without electric light and situated well away from sources of interference. Such cases cannot be generalised, so attention may be directed entirely to outside aerials.

It is not intended to give a general treatise on aerial

erection, but for the purpose of suiting the requirements of the type of receiver under discussion, attention is drawn to the aerial shown at Fig. 57. The aerial pictured is low and long, and has its down-lead end at a considerable distance from the house. Assuming that the wire is strung along a garden, this arrangement has certain advantages. Being below the level of the house, it is to some extent screened from interference, particularly if the garden backs on to other gardens in the conventional way, so that the aerial might be considered to be between two rows of houses, and reasonably remote from either. Since for the very distant reception the sky wave has to be relied upon, the screening effect of the houses will not be serious; in fact, it may be quite negligible, and by keeping the down-lead end away from the house, the aerial can be led in so that it is a compromise between appearance and the avoidance of pick-up from house wiring, etc. In our own opinion, the best possible aerial for a superhet is that illustrated in Fig. 57, but using the screened down lead with the necessary impedance-matching transformers each end; where this expense cannot be countenanced, it will be found worth while to use screened wire for the last six feet of the down lead, not using the transformers. For this purpose the screened wire should be one of the several types available, which have a minimum amount of insulating material between core and shield.

In conclusion, a warning will not be out of place on the subject of impedance-matching transformers. Many manufacturers have produced aerial coils in their latest sets which are really extraordinarily efficient, and rely for the overall performance of their set very largely on the excellence of this component. We have in mind one moderately priced superhet which has the excellent figure of 18 for the magnification of the aerial tuning coil. If an impedance-matching transformer is used in conjunction with such a set, the efficiency of the aerial coil will be reduced to a very much lower figure. The moral is obvious.



## CHAPTER VII

### VARIABLE SELECTIVITY AND THE SUPERHET

SINCE the superheterodyne receiver depends for its selectivity on the use of fixed I.F. circuits tuned to a given frequency, it is obvious that any attempt to improve the high-note response of such a receiver is most easily and best carried out in the I.F. circuits themselves.

It is, of course, obvious that by the use of tight coupling between the primary and secondary coils of an I.F. transformer, the frequency response will be good and the selectivity poor. With loose coupling the reverse occurs, and we have high selectivity and an attendant loss of high notes.

What is wanted, therefore, is an I.F. circuit which is adjustable for both high quality from the local station and, at the same time, possesses the ability to receive a very distant station, even though it may be on a waveband adjacent to the local, to the exclusion of all other stations.

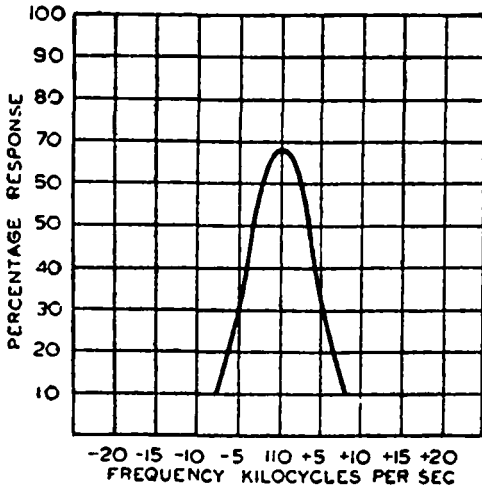

FIG. 58.—Single peak giving high selectivity and severe cut-off.

This is most easily achieved by varying the coupling between the two coils of the I.F. transformer.

**Resonance Curves.**—By the use of band-pass filters in the I.F. amplifier circuits and variable coupling, either electrical or mechanical, both high quality and selectivity can be obtained. In Fig. 58 is shown the response curve of

an I.F. amplifier with the coupling at minimum. It will be noted that the resonance curve has a single peak, corresponding to a high degree of selectivity. Fig. 58 is not an actual resonance curve obtained by measurements, but is arbitrary, and intended to show only the selectivity of a loosely-coupled I.F. transformer. The height of the curve is an indication of signal strength, and it will be noted that on either side of the resonant point there is a falling-off of amplification of the frequencies. Since the signal received consists not only of the carrier-wave frequency, but of the carrier wave and sideband frequencies of approximately plus and minus 10,000 cycles above and below the frequency of the carrier, it is apparent that this selective circuit will respond only to the carrier wave and frequencies one or two thousand above and below it, resulting in a severe loss of the higher notes.

As the coupling between the two coils is increased, two peaks occur with a trough between them, as shown in Fig. 59, and further increase in coupling causes the peaks to move farther apart. The resonant curve now has a broad peak at the top and steeply sloping sides, the centre of the trough corresponds to the resonant point of the original single peak, and the two peaks are equally spaced on either side of the original resonant point. The circuit will now respond to frequencies 5000 cycles above and below the original resonant point, while other frequencies will produce little or no result. This gives very much improved high-note response but has not lowered the selectivity to the extent of introducing sidebands from adjacent unwanted stations.

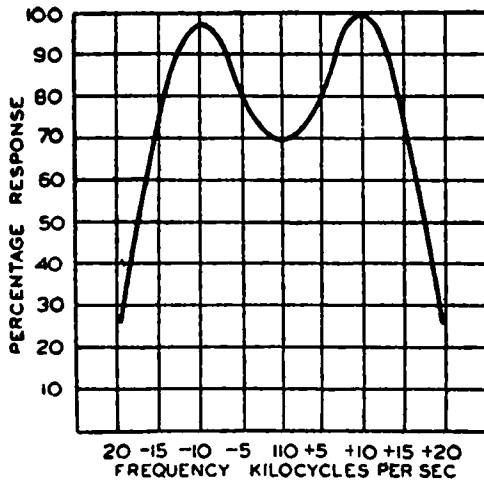

FIG. 59.—Band-pass effect giving improved frequency response.

If the two peaks are made excessively sharp with a large dip in between them, the ideal aimed at will not be achieved, but the result will be shrill and distorted reproduction.

**External Control.**—The variation of coupling may be achieved either electrically or mechanically, and one obvious method is to adjust the distance between the two coils mechanically by means of an external control. The closer the coils are together, the tighter the coupling and the better the quality of reproduction.

An easier method, however, than varying the distance between the primary and secondary windings of an I.F. transformer is to fix one winding and rotate the other. This system is similar to the old "variometer" type of aperiodic aerial coupling, in which the aerial coupling coil was mounted with the tuning coil and rotated on its axis to give the required degree of selectivity. When the coupling coil was at right angles to the tuning coil the coupling was at minimum and selectivity at its greatest.

In the case of the I.F. transformer, the two windings are mounted one above the other with their horizontal axes at right angles to the side of the screen. The external controlling rod rotates the lower coil about its vertical axis, and thus varies the coupling between the two windings, and controls the degree of selectivity and high-note response. This method has the advantage of producing symmetrical double-peaked curves with little change in the single peak resonant frequency. A typical variable-selectivity I.F. transformer of this type is shown in Fig. 60.

Another method, which is carried out electrically, consists of mounting the two coils comprising the band-pass arrangement for the I.F. transformer the correct distance apart so as to give a single-peaked resonance curve, and to control their coupling by means of a small variable condenser across the high potential ends, as shown in Fig. 61. The currents in the primary winding pass through this coupling condenser and will energise the secondary winding. The larger the capacity of the coupling condenser, the weaker will be the potentials established across it, and therefore the coupling effect will be reduced. This is equivalent to moving the coils

farther apart, and gives maximum selectivity. On the other hand, if the coupling condenser is reduced in value, the potentials established across it will be greater at all frequencies, and the coupling will be increased giving greater and wider frequency response. The coupling condenser is usually of the pre-set variety, and when screwed right up gives a peak separation of about 6 kc/s. This method has the advantage that the coils are fixed relative to the screen, and their inductance and tuning are not, therefore, affected by adjustment of the coupling. The obvious disadvantage is the method of controlling the pre-set condenser externally, as neither plate is "earthed," and the addition of a long controlling rod will add unwanted capacity.

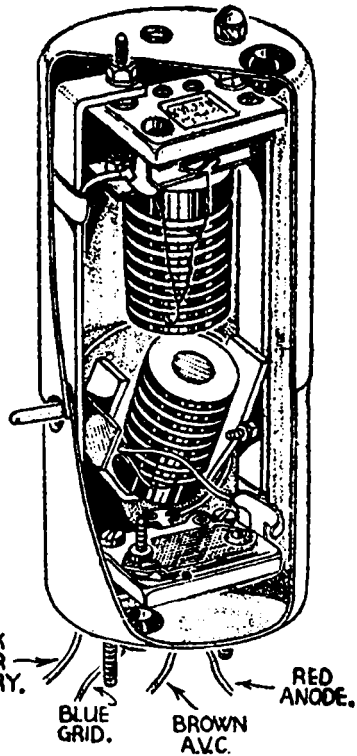

FIG. 60.—A variable-selectivity I.F. transformer having mechanical control of the coupling.

**Tertiary Winding.**—There is another electrical method of controlling coupling, which is now being more widely used. This consists of a third or tertiary winding acting as a coupling between the two coils comprising the I.F. transformer. This tertiary winding is shunted with a variable resistance, as shown in Fig. 62. The degree of coupling depends on the inductance of the third winding and its associated resistance, which helps to communicate the potentials established across the primary winding to the secondary winding. The degree of coupling depends

upon the value of the resistance. The greater the value of the latter, the less will be the coupling and the more selective the circuit. As the value of the resistance is

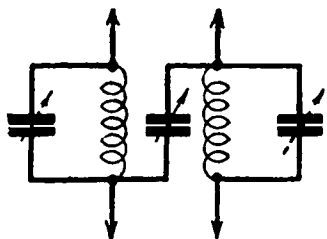

FIG. 61.—A variable condenser to control selectivity is used in this circuit.

decreased, so the inductance of the circuit is increased, and the coupling between the windings becomes tighter.

A modification of this arrangement is to dispense with the variable resistance and allow the auxiliary coupling winding to be controlled for single-peak selectivity or double-peaked quality by means of a

single - pole double - throw switch.

These are the methods of controlling I.F. selectivity in general use to-day, but there are two or three methods which, while not being very popular, are at least worth consideration.

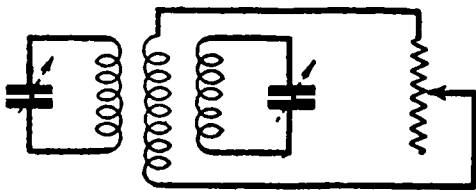

FIG. 62.—A tertiary winding shunted by a variable resistance may be used to control selectivity.

**Alternative Methods.**—The first is a modification of Fig. 61, in which an external condenser is added to a normal I.F. transformer, and controlled by a low-capacity switch, as shown in Fig. 63. The disadvantages of this arrangement are the capacity of the switch and its external control, hand-capacity effects, and the fact that a condenser of very low value is necessary. The exact value of the condenser is a matter of trial and error, and is the cause of much experiment on the part of a constructor. However, quite good results may be obtained by using a .0001 mfd. fixed condenser.

When both windings of an I.F. transformer are accurately tuned to the frequency of the local oscillator, high selectivity results. Two methods of "damping" the windings and thus broadening the tuning are resistances

in series or in parallel, as shown in Figs. 64 and 65. In each case the gain is reduced, and the high-note response improved. When the series method is used, resistances with a value of 500-1000 ohms will generally be found suitable, while shunts of 50,000 ohms will usually give good results. In either case, the resistance of the coil

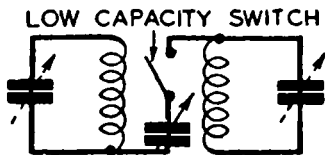

FIG. 63.—Method of adding variable selectivity to an ordinary I.F. transformer.

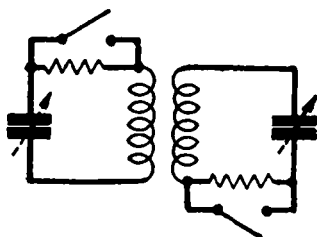

FIG. 64.—Damping resistances added in series to broaden tuning.

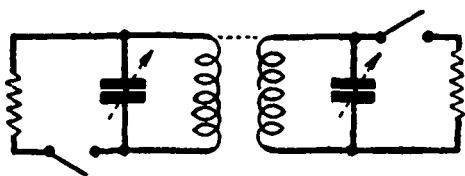

FIG. 65.—Damping resistances added in parallel to broaden tuning.

windings, the I.F. frequency, etc., have to be taken into consideration, but the values given made a good starting-point for experimental work.

The resonant frequency of an oscillatory circuit depends, among other things, upon the capacity in the circuit. Providing the remaining components making up the circuit remain constant, it follows that any alteration in the capacity will affect the resonant frequency to a given degree. The smaller the ratio of the capacity to the inductance in the circuit, the sharper will be the resonance curve. It follows, therefore, that by increasing the capacity across the windings of an I.F. transformer, we shall extend the frequency response. This method has been tried out, but has been found to give unsymmetrical peaks and to introduce distortion, unless the values of the condensers are accurately adjusted for value and equality.

## CHAPTER VIII

### NOISE SUPPRESSION AND A.V.E.

A REFINEMENT which has not met with approval in this country is the automatic volume expander. A general opinion is that the circuit is not worth while. There are several reasons for this. Firstly, in this country it would appear that the B.B.C. control engineers do not exercise the same control over the outgoing broadcast as is adopted in the U.S.A., and thus although a circuit may work in that country it does not prove satisfactory over here. It is quite true that it works, and in fact it is because it works in the manner designed that it proves of little value. It may briefly be stated that the idea underlying the arrangement is to restore to the broadcast some of the balance which is claimed to be lost in the broadcast. Theoretically, when a loud passage is reached in a symphony broadcast, in order to avoid overloading the transmitter, the signal is reduced in intensity, and when a very quiet passage is reached the control engineer turns up the volume control to enable the signal to provide sufficient modulation to render the passage audible above the carrier and other noise background. The result, when an expander is in use is very good on some items, but when the announcer speaks one has to rush to the volume control to avoid being deafened, and if the normal speaking voice is turned to a suitable level the contrasts in the music are altogether unnatural.

**Noise Suppression.**—On gramophone records it is possible to arrive at values which will give a much better balance of contrast than are obtainable with ordinary reproducing means, probably because the records are more consistently recorded, and a circuit has been adopted which is good with such reproduction. There is, however, another use for this type of circuit and that is in the suppression of noise due to atmospherics and similar electrical disturbances which may be met with in receiving

weak telephony stations, and the normal A.V.E. circuit can be modified for use in such arrangements. The experimenter may, therefore, desire to carry out a few tests with this type of arrangement, and the following notes will prove interesting. In principle the circuit operates by taking the L.F. signal at some point in the L.F. circuits and rectifying it. The rectified circuit is applied to a variable-mu valve which acts purely as a volume control and thus regulates the outgoing signal. A schematic diagram is given in Fig. 66 where  $V_1$  is the L.F. stage. A portion of the signal is taken to the output, and a portion is tapped off and fed to  $V_2$  which acts merely as an amplifier to provide sufficient signal impulse to be further dealt with. This is rectified in  $V_3$ , amplified again at  $V_4$ , and fed back to the variable-mu valve  $V_2$ , which thus adds to the signal passing out of  $V_1$ . It will be seen from this that it will be possible to introduce a delay to the signal in its passage through these three stages so that various interesting effects may be introduced.

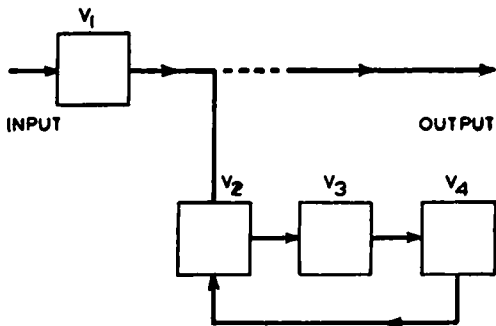

FIG. 66.—Diagrammatic illustration of the sequence of A.V.E.

**Time Filters.**—A simple time filter will enable the necessary delay to be introduced, and by so choosing the coupling components it will be possible to delay background noises due to atmospherics so that they are more or less inaudible against a strong signal. It is, of course, only necessary to suppress the noises when the signal fades or on weak passages as it is then that the noises are most apparent. A very interesting circuit which may appeal to the keen experimenter is given in Fig. 67, and this was developed by the chief engineer of the McMurdo Silver Corporation of America. It makes use of two dual valves, although separate valves could be employed for the purpose. The actual types specified are two 6F8G's. The



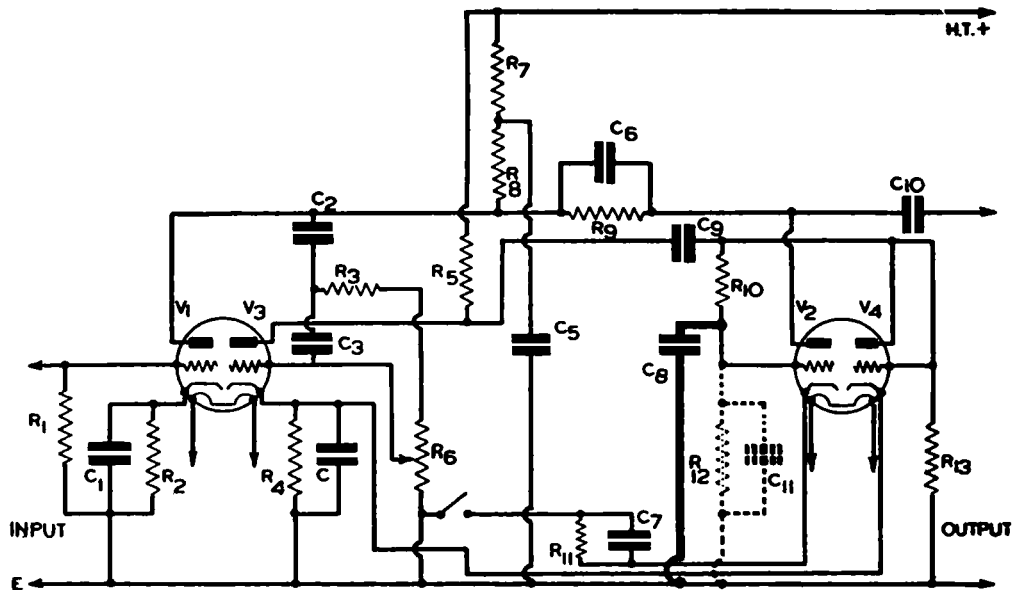

FIG. 67.—Experimental circuit for use in A.V.E. and noise suppression.

Values are as follows :

|                    |                   |                  |                   |               |
|--------------------|-------------------|------------------|-------------------|---------------|
| R1 .5 to 1 megohm. | R6 1 megohm.      | R11 2,000 ohms.  | C4 25 mfd. elect. | C8 See text.  |
| R2 2,500 ohms.     | R7 15,000 ohms.   | R12 See text.    | C5 0.1 mfd.       | C9 0.1 mfd.   |
| R3 300,000 ohms.   | R8 30,000 ohms.   | C1 5 mfd. elect. | C6 0.0005 mfd.    | C10 0.1 mfd.  |
| R4 5,000 ohms.     | R9 300,000 ohms.  | C2 0.1 mfd.      | C7 0.25 mfd.      | C11 See text. |
| R5 30,000 ohms.    | R10 500,000 ohms. | C3 0.0001 mfd.   |                   |               |

order in which these separate valve sections operate should be particularly noted, the first dual acting as V1 and V3, and the second as V2 and V4. The essential time delaying condenser is shown in heavy lines, and the designer also recommends that a resistor shunted by a condenser may also be included as shown in broken lines. Values for the time control condenser are from .001 up to .5 mfd., and for the resistance-capacity shunt from 1000 to 3000 ohms and .001 up to .5 mfd. may also be tried.

On some broadcast some interesting effects may be produced by the interchange of component values, but tests show that on B.B.C. broadcasting the effects are totally different from those experienced on certain continental broadcasts. On records the effects are very marked and very pleasing, but at times it becomes difficult to discern whether the circuit is actually functioning. The additional gain which the circuit gives may result in a slight difficulty from overloading, and it is therefore recommended that the circuit be included in such a position that a normal L.F. volume control can be employed before the output stage, and this will enable the volume level to be kept within bounds. The degree of expansion or contrast is, of course, controlled by the potentiometer, but if separate valves are employed quite a wide range of effects may be obtained merely by exchanging the types of valve used in position V2.

## CHAPTER IX

### TONE CONTROL

THE average receiver when first built up fails to give the type of reproduction desired. As a result, practically every modern receiver contains a tone control, and apart from the value of this device to modify the balance of reproduction, it often proves of use in removing background noises when a long-distance station is being received. The pentode output valve, the Class B stage, and the Q.P.P. arrangement all need some form of tone correction in order to give a pleasing tone to the reproduction, and many criticisms of these circuits are due to the fact that the tone control is omitted. Dealing first with the pentode, it may be stated that this gives over-emphasis to the higher notes with the result that the tone sounds too shrill. Consequently, we need a high-note cut-off to balance the reproduction, but as certain types of orchestral music need more cut-off than speech, for instance, the control should

be variable so that it may be adjusted according to the item being received. The usual tone control for this type of valve is shown in Fig. 68, and it will be seen to consist merely of a fixed condenser in series with a variable resistance, both being joined across the output circuit. In this connection it should be remembered that the H.T. positive side of the speaker or output transformer is at earth potential in relation to the anode, and accordingly it is quite in order to join the tone control components between the anode and earth as shown in Fig. 69.

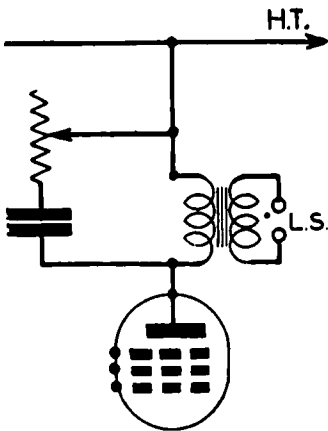

FIG. 68.—Standard tone-control as used with pentode or tetrode valves.

**Q.P.P. Stages.**—The Q.P.P. arrangement utilises either a double pentode or two separate pentodes in a push-pull circuit, and accordingly a similar type of tone

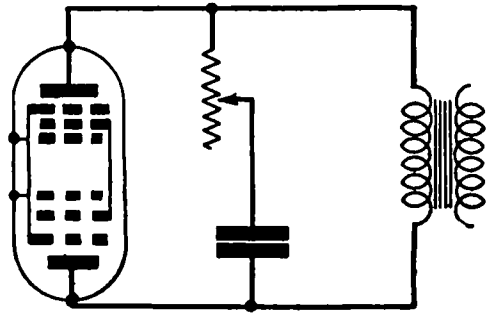
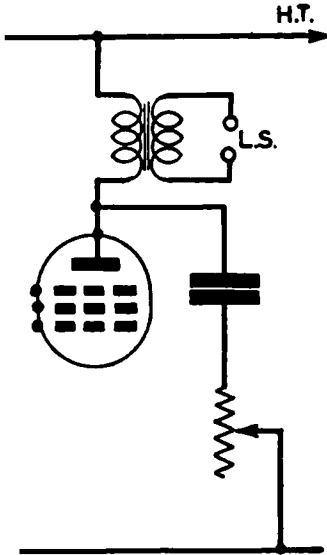

FIG. 69 (left).—An alternative method of using the Fig. 68 scheme.

FIG. 70 (above).—A Q.P.P. or double pentode stage needs a similar tone-control. Condenser valves are up to  $\cdot 05$  mfd. and resistances up to 100,000 ohms.

corrector may be employed. This should be joined across the two anodes, which is, of course, across the output circuit, as shown in Fig. 70. The resistor may be fixed or

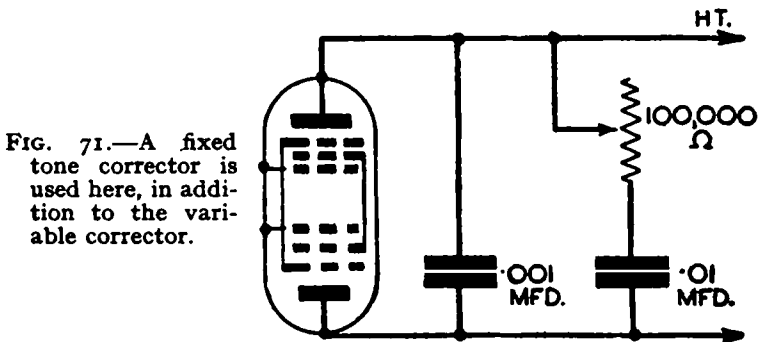

FIG. 71.—A fixed tone corrector is used here, in addition to the variable corrector.

variable. In some cases it may be found that it is desirable to connect a fixed condenser permanently across this type of output stage and use the tone control arrangement

already referred to as an addition. This arrangement is shown in Fig. 71, and values suitable for the pentode tone corrector may be stated to be as follows. For the fixed condenser some value between .001 and .05 mfd. is gener-

FIG. 72. - The Class B tone-control arrangement in its simplest form.

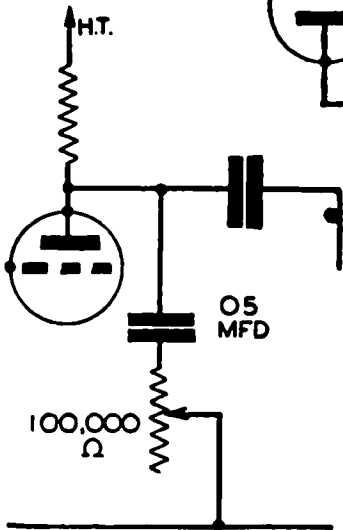
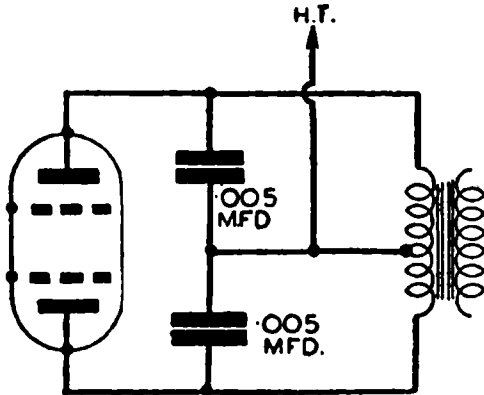

FIG. 73.—Tone control may be effected in an L.F. stage by connecting the components between anode and earth as shown here.

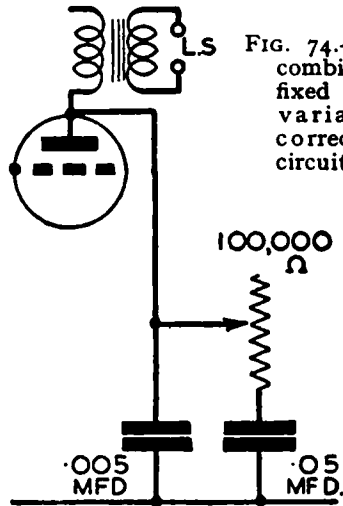

FIG. 74.—A combined fixed and variable corrector circuit.

ally suitable, and for the resistor from 20,000 to 100,000 ohms. The shunt condenser in Fig. 71 should not generally be greater than .001 mfd.

**Class B Stage.**—In the Class B circuit such a comprehensive tone control is not needed, and generally the tone is

sufficiently well balanced if a fixed condenser shunts each anode. A value of  $\cdot 001$  mfd. up to  $\cdot 005$  mfd. will generally be found satisfactory and they should be placed as shown in Fig. 72. The use of resistors on the input side is sometimes recommended with the Class B arrangement, but generally speaking if the L.F. circuits are properly designed the condenser filter alone is adequate.

**Control in L.F. Stages.**—An argument is often put forward that tone control should be effected before maximum amplification has taken place, and many modern receivers are accordingly being provided with a tone control across the first L.F. stage. This usually takes the form of a condenser and resistance arrangement (similar to that used in the pentode circuit), joined between the anode of the L.F. valve and earth. The general principle is shown in Fig. 73 where it is used in conjunction with the standard resistance-capacity circuit. Suitable

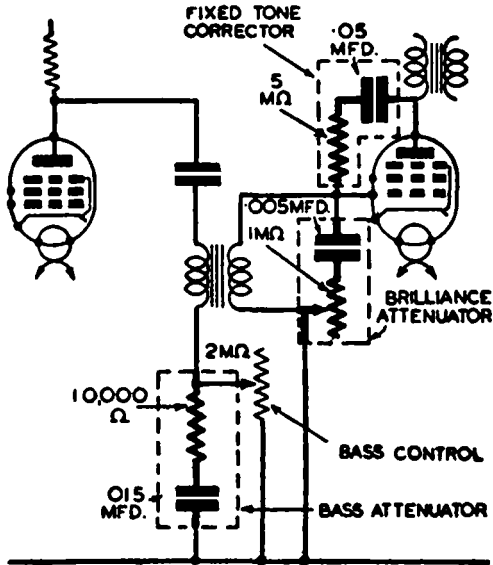

FIG. 75.—A comprehensive bass and treble tone correcting circuit as used in a well-known commercial receiver.

values will depend upon the valve and the R.C. components, and again up to  $\cdot 05$  mfd. and up to 100,000 ohms are generally suitable. A more comprehensive arrangement for use in this stage is seen in Fig. 74, where, in addition to the usual resistance and condenser a fixed condenser is permanently joined between anode and earth. This follows on the lines of Fig. 71, and a suitable value for the additional condenser is  $\cdot 005$  mfd.

**Bass Control.**—All of the circuits so far described

merely control the high notes or, in other words, the brilliance, but a circuit of great interest is seen in Fig. 75, which is the arrangement employed in a popular commercial receiver.

In this provision is made for bass attenuation, brilliance attenuation, and in addition a fixed tone corrector is employed. As will be seen, the bass attenuator consists of a fixed resistor and condenser in series between the anode of the penultimate stage and earth, and shunted across these two components is a variable resistor. This is a

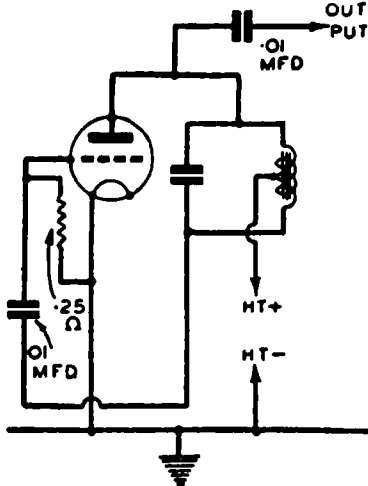

FIG. 76.—The Bulgín tone-control choke in a suitable circuit.

bass control and, as its name implies, it controls the degree of bass attenuation. The brilliance attenuation is effected by a fixed condenser and resistor across the grid circuit of the output valve, and the resistor is of the variable type to effect the degree of brilliance attenuation desired.

The fixed tone corrector in this circuit is a fixed condenser and resistor coupled between the grid and anode of the output valve. The separate circuits are indicated by varying line thickness in Fig. 75, and the values used by the makers are given.

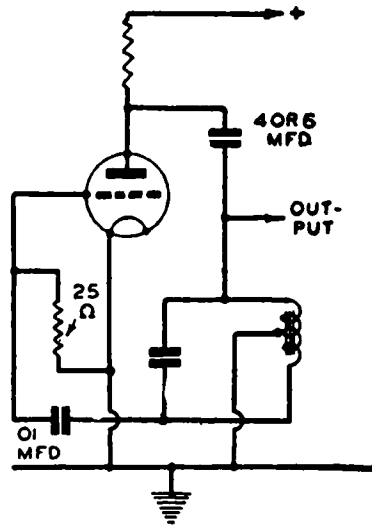

FIG. 77.—In this arrangement the Bulgín choke is paralleled to maintain a high inductance value.

**Tone Control Components.**—In addition to the usual arrangements shown, it is possible to employ chokes and other components in special circuits, and in this connection it should be remembered that in the Bulgin range of components is a special tone-control choke consisting of a tapped winding with a total inductance of 3 henrys. This inductance naturally varies according to the current flowing through it, and to preserve the maximum value it should be so arranged in circuit that no D.C. flows. This may easily be arranged by using the normal filter circuit arrangement. In this choke, tappings have been provided to give inductance values of 0.5, 1, 1.5, 2 and 2.15 henrys, and the resonant frequency of the choke with various values of condenser are shown in the following table :

| Capacity. | Frequency. | Capacity. | Frequency. |
|-----------|------------|-----------|------------|
| Mfd.      | Cycles.    | Mfd.      | Cycles.    |
| 0.1       | 500        | 0.0043    | 2000       |
| 0.07      | 600        | 0.0041    | 2500       |
| 0.052     | 700        | 0.0028    | 3000       |
| 0.04      | 800        | 0.0021    | 3500       |
| 0.031     | 900        | 0.0016    | 4000       |
| 0.025     | 1000       | 0.00125   | 4500       |
| 0.011     | 1500       | 0.001     | 5000       |

Suitable circuit arrangements are shown in Figs. 76 and 77, and it should be noted that when the condenser is in parallel with the choke the circuit is of the rejector type, and when it is in series with the choke the circuit is of the acceptor type. For the benefit of those to whom these terms are not clear it may be explained that a rejector circuit provides maximum voltage at the resonant frequency, whilst the acceptor gives minimum voltage at the resonant frequency. Thus, to eliminate needle scratch, for instance, an acceptor circuit would be needed, and 4000 cycles is generally regarded as the frequency of needle and surface noise, which means that an acceptor circuit made up from the complete choke winding and a .0016 mfd. condenser would be needed.



## CHAPTER X

### SERVICING WITH THE CATHODE-RAY TUBE

FOR service bench testing the cathode-ray oscillograph is rapidly coming into its own. Many service establishments have cathode-ray apparatus, but there are still many which have yet to take up cathode-ray testing technique. It can be prophesied, however, that in the natural course of the evolution which is going on it will only be a matter of time before the cathode-ray oscillograph becomes as commonplace as any other of the testing instruments which are now regarded as essential for speedy and efficient servicing.

Of all the indicating instruments that human ingenuity has devised, the cathode-ray oscillograph is probably the most versatile, although many of its applications necessitate the use of apparatus additional to the oscillograph itself. In some cases elaborate set-ups are required.

There must be many who are interested in the radio servicing possibilities of the oscillograph when used, at the most, with an oscillator of suitable type.

**Electron Beam-Deflection.**—Various types of CR tubes are employed in servicing oscillographs; some are of the gas-focused type, others of the high-vacuum, electron-lens focused type. There are differences of screen sizes, differences in the visual and photograph properties of the screen traces, etc., but a feature that they have in common is the provision of two sets of deflector plates (in the simplest case, two pairs of plates) mutually at right angles and so arranged that the beam of electrons shot from the gun (anode) on to the fluorescent screen passes through both sets of plates. The electric field produced by the application of a potential difference to one set of plates deflects the electron beam in a direction perpendicular to the surfaces of these plates and to an extent proportional to the value of the applied voltage. Certain oscillographs also contain coils external to the

tube assembly but capable of causing deflection of the beam by the magnetic field set up by currents in the coils.

It is normally arranged that the deflecting force of one set of plates tends to move the light spot horizontally across the screen, and these particular plates are invariably referred to as the X plates. The other set of plates tend to move the light spot vertically and are called the Y plates (see Fig. 78).

If deflecting voltages are applied to both sets of plates simultaneously the light spot will be moved in a direction somewhere between the horizontal and vertical, dependent upon the vector resultant of the two deflecting forces.

If constant deflection voltages are applied, the light spot will take up a position dependent upon the deflection resultant, but will thereafter remain steady as long as the plate potential keep constant. If there is any variation of voltage at

the deflecting plates, the light spot will move in sympathy and a very slow variation of voltage will be shown by a slowly moving spot (definitely visible as a spot). Fast voltage variations, however, will, owing to the persistence of vision, cause the movement of the light spot to show up as a line trace.

**X-Deflection as a Function of Time.**—In radio we are particularly interested in voltage waveforms. This is another way of saying that we are particularly interested in the exact manner in which the voltage varies with respect to time. If we wish a "picture" of a voltage waveform to be visible on the screen, it will be of no use applying the voltage either to the X-plates alone, or to

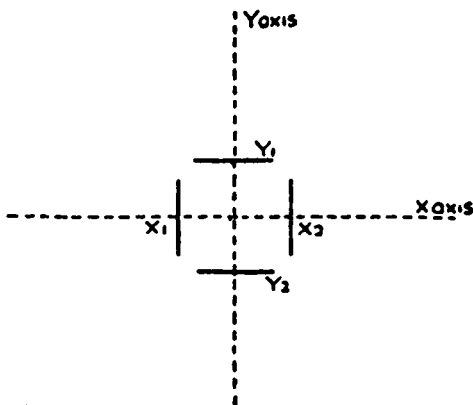

FIG. 78.—Plan view of the deflector plate arrangement to give horizontal, vertical, or resultant-deflection.

the Y-plates alone, or to both together, for that matter. Suppose we did apply an alternating voltage to the X-plates. The light spot will certainly move in strict accordance with the voltage variations, but as it will run backwards and forwards along a straight line the trace of this line will be the only visible result. (See Fig. 79.)

What is required is that the X-deflection shall cause movement of the light spot across the screen independently of any variation of the voltage under test; preferably the movement of the spot with reference to the X-axis should be at uniform speed, in which case the position of the spot with reference to the X-axis should be at uniform speed, in which case the position of the spot with reference to the X-axis will be a function of time. Then, if the voltage under test is applied to the Y-plates, the position of the spot with reference to the Y-axis will be a function of this voltage. In brief, horizontal movement represents TIME, vertical movement represents voltage variation, and the excursion of the spot over the screen will actually "graph" the waveform of the voltage. As to how many cycles will show up will depend upon the ratio of the voltage frequency to the X-sweep frequency, but we will return to this point presently.

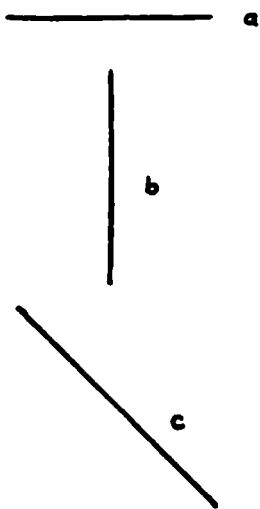

FIG. 79.—Showing the effect of applying periodic deflecting voltages, without time base :—

- (a) Trace obtained when the voltage is applied to the X plates only.
- (b) Trace obtained when the voltage is applied to the Y plates.
- (c) Trace obtained when the voltage is applied to both X and Y plates simultaneously.

In radio service testing we are not normally concerned with transient waveforms and, therefore, do not want the X-deflection to give just a single sweep across the screen. What is desirable is that a horizontal traverse shall occur at a uniform speed (usually from left to right) that the spot shall then fly back rapidly to the starting-point, and immediately start another left to right traverse at the same speed as before, and so on.

Remembering that X-deflection depends upon the voltage applied to the X-plates we can now see what kind of deflecting voltage is required. For the left to right traverse a voltage increasing in a linear manner will be necessary, and for the rapid right to left fly-back a sudden drop of this voltage to the starting value will be required. In other words, we want an X-deflecting voltage of saw-tooth waveform, as shown graphically in Fig. 80, and a "time base" circuit to produce such a voltage will be an essential part of the oscillograph.

Quite a lot can be written about time-base systems, but we will content ourselves here with the basic principle. Fig. 81 is a simplified time-base circuit, and will serve to illustrate the principle. A condenser,  $C$ , is connected in series with a resistance,  $R$ , across an H.T.-D.C. source.

Upon first switching on, the condenser will charge up, and the voltage across it will rise at a rate governed by the values of both  $C$  and  $R$ . If it were not for the presence,

across  $C$ , of the gas-filled triode  $V$ , condenser would charge up to the voltage of the D.C. supply, and further action would cease. As matters stand, however, the condenser will charge up to the break-down voltage of  $V$  (the voltage at which the gas ionises). The valve becomes conductive, and the condenser will discharge through it, the condenser voltage dropping very rapidly to the extinguishing voltage of  $V$ . Then  $C$  will



FIG. 80.—Saw-tooth waveform of voltage for X deflection as a function of time.

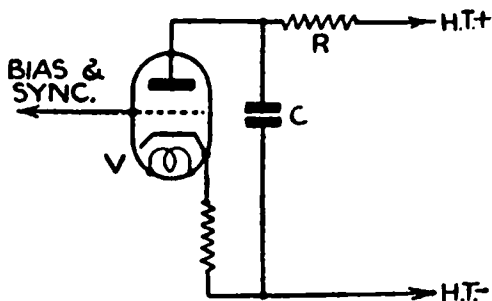

FIG. 81.—Simple circuit illustrating the principle of the time base.

charge up again until the triode once more permits discharge, and so on.

There is a natural tendency with the simple arrangement of Fig. 81 for the condenser voltage, during the charging period, to rise exponentially, but it is very desirable that the voltage rise shall be linear. If the striking voltage of the triode is kept well below the H.T. voltage, the voltage rise will then be approximately linear, but another way of tackling the problem is to charge the condenser through a valve, generally a diode or a pentode, worked at saturation point. With suitable operating conditions the condenser voltage variation can be made to be a close approximation to the saw-tooth waveform, and can be utilised to give us the particular X-deflection just discussed.

Flexibility of control is an important requirement with a C.R.O., and it is very desirable that the speed of the left to right traverse shall be adjustable, according to needs of any particular test that is being made. With the simple arrangement of Fig. 81, variation of C or R will give speed control. As the light spot keeps repeating its left to right traverse we can speak of the "sweep frequency." Obviously, the speed of the traverse and the sweep frequency are closely related.

It is to be understood that the fly-back (right to left) sweep of the spot should be so fast as to render the return stroke invisible (or only faintly discernible). It is to be mentioned, however, that certain oscillographs have arrangements for modulating out the beam during the fly-back sweeps.

**A Waveform "Picture."**—Any one handling C.R.O. testing gear for the first time will be well advised to make some tests on an A.C. voltage derived from the mains (suitably stepped down). Such tests form useful preliminary practice in handling the apparatus and getting to know the scope of the controls of the oscillograph.

Suppose the time-base voltage is in operation on the X-plates at a frequency of 25 sweeps per second, and that the A.C. test voltage is applied to the Y-plates at a frequency of 50 cycles per second. During each visible traverse of the spot it will be moved from left to right by the X-deflection and will also be moved up and down by the voltage on the Y-plates, the vertical deflection being in

strict accordance with the Y-voltage. The net result will be that the line trace, made by the spot, will mark out the waveform of the voltage on the Y-plates and with the frequency values specified above two cycles will show up on the screen (see Fig. 82). If the time base is speeded up to 50 sweeps per second one cycle only will appear (see Fig. 84).

In both these cases the ratio of the "work" frequency (as we will now call the frequency of the voltage under test) to the sweep frequency is a whole number. The ratio of work to sweep frequency is  $2/1$  for Fig. 82, and  $1/1$  for Fig. 84. It is interesting to consider what will happen for work/sweep frequency ratios which are not whole numbers. If, starting with the conditions appropriate to Fig. 82, the time base is slowly speeded up it will be found that before the simple, single cycle "picture" of Fig. 84 appears the trace on the screen will pass through a succession of interlace patterns. An interlace pattern will appear whenever

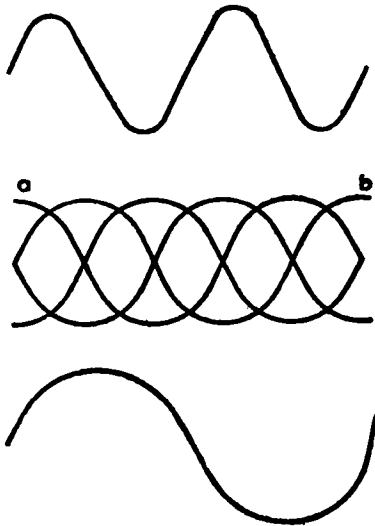

Figs. 82, 83 and 84.—Screen traces of an alternating voltage waveform for different ratios of A.C. frequency to the time base "sweep" frequency. The traces are appropriate to ratios of  $2/1$ ,  $5/4$  and  $1/1$  respectively.

conditions are such that the light spot finishes the end of one sweep at a different point in the A.C. cycle to that at which it started the sweep. Then, naturally, it will trace out, during the next sweep, a curve which appears on the screen in out-of-phase relationship to the first curve.

An example is shown in Fig. 83. Such an interlace pattern is not as crazy as it might appear at first sight. As a matter of fact, the ratio of work to sweep frequency can

be accurately determined by inspection of the pattern. The rule for determining the work/sweep frequency is simple. The ratio of work to sweep frequency is equal to the ratio of the number of peak amplitude points to the number of curves. In Fig. 83 there are five peak amplitude points (a and b together count as one) and four curves. Hence the ratio of work to sweep frequency is  $5/4$ .

**Frequency Calibration.**—From the foregoing it is easy to see that if the work frequency is known, the sweep frequency can be very readily ascertained. Conversely, if the sweep frequency is known, the work frequency can be determined. With the C.R.O., therefore, it becomes a simple matter to determine the frequency of any L.F. voltage applied to the Y-plates.

In normal radio fault tracing, or ganging work, the need to do this is not likely to arise, but since most service workshops contain audio-oscillators (even if they are only rough and ready "howlers"), it is worth noting that the C.R.O. provides a delightfully simple means of calibrating an audio-oscillator in terms of cycles per second.

If the audio-oscillator's output is made to operate on the Y-plates, and the ratio of work to sweep frequency determined, as described above, then, provided that the sweep frequency is known, and known accurately, presents no difficulty, because this can be ascertained beforehand with the aid of the A.C. mains.

**Locking the "Picture."**—Any irregularities, or drift, in the operation of the time base are most undesirable in frequency calibration work, or when a waveform is being closely examined, and it is, therefore, important to have provision for synchronising.

In the case of a gas-filled triode the voltage at which the discharge occurs is very dependent upon the grid potential, and by applying an alternating voltage to the grid it becomes possible to synchronise the time base and this A.C. voltage. It is customary, with servicing oscillographs to have switching, or terminal connections, enabling the time base to be synchronised either with the mains voltage or with any particular test voltage that is operating on the Y-plates.

When the time base and the voltage on the Y-plates are synchronised, it is possible to lock the screen trace

so that it does not wander, and thus a steady "picture" is obtained.

In frequency calibration work, the time base should, of course, be kept synchronised with the A.C. mains throughout the tests since the mains frequency is the frequency standard upon which the calibration is based.

#### **Obtaining H.F. Response Curves "Wobulation."**

—For radio service testing it is absolutely essential to have, in addition to the oscillograph itself, an accurately calibrated oscillator providing not only the normal amplitude modulated H.F. output but also, when required, an H.F. output that is "wobbled" by the time base of the oscillograph. The expressive word "wobulation" has been created to describe a variation of the oscillator frequency over a band of frequency values and in the manner described below.

For an H.F. response curve to be shown on the screen of the C.R.O. we want, first, the frequency of the testing oscillator to vary in a linear manner during each sweep of the light spot. With the light spot at the commencement of a sweep, the oscillator frequency must be so many kc/s (according to the band-width covered) below the frequency corresponding to the tuning setting of the oscillator. Then, as the light spot moves across the screen, the oscillator frequency must come up to the tuning setting value, rise above it and, at the end of the sweep, be as many kc/s above the tuning setting value as it was below at the commencement of the sweep. The next sweep must give a repetition of the foregoing, and so on.

Since the X-deflecting voltage, from the time base, controls the horizontal traverse of the light spot, it should be obvious that, in some way, the X-deflecting voltage must be made to bring about the required frequency variation (wobbling) of the oscillator. There are various ways in which this can be brought about. One commonly used method takes advantage of the fact that the input capacity of a triode is dependent upon the working amplification factor of the valve, this effect occurring as a result of the anode to grid feed-back through the inter-electrode capacity. It is a simple matter to arrange that the input capacity of a triode shall form part of the capacity of the oscillator's tuned circuit. For "wobulation" of the



oscillator output the input capacity of the triode must vary with the sweep of the oscillograph. The input capacity changes with the effective amplification of the valve, and this amplification depends upon grid bias, so it should be obvious that some connection between voltage and tuning can be secured. Very careful design is, of course, necessary to secure the particular kind of frequency variation that is required, but as far as we are concerned at the moment it will be sufficient for us to appreciate that the "wobbling" of the oscillator H.F. output can be brought about by feeding the grid of the triode (or other type of valve connected as a triode) from the time-base circuit.

**Constant Amplitude.**—The ordinary amplitude modulation of the oscillator is cut out of action while the oscillator is being "wobbled," and with a good outfit the output of the oscillator will be constant in amplitude but varying in frequency in the manner described.

It is important to understand that the X-deflection of the oscillograph must now be looked upon not so much as being a function of time as a function of frequency. The X-axis of the screen must, in other words, be regarded as a frequency base.

For obtaining the "picture" of an H.F. response curve it will be necessary that a direct voltage acts on the Y-plates and that this voltage shall vary with the amplitude of oscillations in the circuits under test. As regards receiver testing, the receiver itself contains the necessary item for the production of the direct voltage. We refer to the receiver's detector. In radio service testing, therefore, the Y-deflection is operated by the rectified output of the detector. The trace on the screen will be a graph of the detector output volts against frequency, over the range of H.F. values covered by the "wobulation."

The horizontal and vertical scales are to be regarded as linear scales by the way—not logarithmic.

Fig. 85 shows a possible result that would be obtained from one or more H.F. circuits, plus the detector, in the case where the receiver has no band-pass couplings. Sometimes the curve will be inverted, as in Fig. 86. As to which way the curve will extend, up or down, on the screen will depend first upon the type of detector and the

point from which the Y-voltage is taken, *e.g.* a Y-input taken from a grid detector anode will give inversion with respect to the trace obtained if the Y-input is taken from a diode anode. The question of inversion will also depend upon the use, or otherwise, of any stages of R.C.C. amplification between the receiver's detector and the Y-plates, and upon the number of stages, if an amplifier is in use.

The service engineer is not so much concerned with absolute measurements as he is with comparative measurements. It is true that where such values as valve voltages and currents, component resistances, etc., are concerned,



Figs. 85 and 86.—H.F. response curve inversion.

straight measurements form an ordinary testing procedure, but where such factors as receiver sensitivity, selectivity, and quality of reproduction are concerned, the service engineer works in an atmosphere of comparisons.

C.R.O. apparatus enables the service engineer to see instability and exactly what happens as a result of many possible component changes or adjustments, and removes a great deal of the uncertainty that inevitably overhangs the work of anybody who has to service receivers without the aid of the cathode ray. The very considerable removal of uncertainty is the outstanding feature of cathode-ray testing technique, and labels the C.R.O. as essentially a time-saver. To appreciate this time-saving element of cathode-ray testing, one has only to consider that very common example of a service engineer trying to improve the selectivity of a receiver. Whatever adjustment or component repair that he may make, it is necessary for him to check up to find the extent of the improvement, if any. How will he do this? Suppose we say, by a reception test. This may seem a very proper way to make a check, but it is going to take time, even if it is only a matter of minutes. Minutes are precious in service work, and it may well happen that a succession of such reception checks are required, in which case the time involved will mount up considerably. With C.R.O. apparatus, how-

ever, an H.F. response curve check will give all the information that is wanted, and the occurrence of any change in selectivity will be instantly apparent, and without the least uncertainty.

C.R.O. apparatus for service testing consists essentially of two instruments—the oscillograph and the oscillator, the latter being of the special type previously referred to. The oscillograph will contain a time base and one, or perhaps two, R.C.C. amplifiers, the latter being designed for linear amplification over a wide range of frequencies. For normal service test requirements one amplifier will usually be found to be sufficient, this being used to amplify the Y-deflecting voltage in the cases where insufficient deflection would be obtained without amplification.

As regards the controls on the oscillograph that are to be considered as most usual, these are :

Sweep frequency control (general coarse and fine adjustments are provided).

Amplifier gain control.

Synchronising control.

Focusing control.

Sweep amplitude control.

Shift control (it is very convenient to have means of shifting the screen "picture" up or down, particularly when H.F. response curves are being obtained).

It is to be understood, of course, that the time base can be switched in or out, as required.

Most receiver servicing tests are carried out with the time base in action, the Y-deflection being controlled by signals picked up at various alternative points in the receiver. It is to be mentioned that one side of both the X- and the Y-deflecting systems are normally "tied down" in potential, and that the deflecting voltages are applied between the "free" X-plate and E, or the "free" Y-plate and E. Thus, with the time base switched on for X-deflection, the Y-deflecting voltage can be picked up from the receiver with the aid of one test prod. The amount of information that can be gathered by a run round with this

one test prod is usually a source of surprise to people not previously familiar with cathode-ray testing technique.

**The C.R.O. as Output Meter.**—When straightforward peak signal trimming adjustments are being made, the oscillator can be used on amplitude modulation, and the C.R.O. employed as an output meter.

Assuming that receiver, oscillator, and C.R.O. are all earthed, all that will be necessary will be to take the Y-lead to the anode of the output valve. With push-pull, or class B output, the Y-lead can be taken to either of the two anodes. It will usually be desirable to have the C.R.O.'s amplifier in use between receiver and Y, and the gain should be adjusted to give maximum sensitivity of indication (consistent with the trace not running off the screen vertically).

If the time base is switched on, the trace will be that of an A.C. waveform (due to the audio-frequency modulation of the oscillator), the Y-deflection being controlled by the potential variations at the output valve anode. Trimming adjustments will have the effect of causing the screen "picture" to expand or contract vertically, and a peak adjustment is indicated by maximum vertical distance between positive and negative peaks. Alternatively, the time base could be switched out, in which case the Y-deflection will produce a simple vertical straight line trace, and trimming may be adjusted to give the maximum length of line.

**Ganging.**—As an aid towards the reganging of receivers in general, and of modern type, the C.R.O. and associated oscillator must be regarded as virtually a necessity if speed with certainty is to characterise the work.

In the simple case of a receiver having no pretensions to band-pass characteristics, and where all trimmer settings will be of the peak type, the C.R.O. may usefully be employed as an output meter, as described above. Perhaps in connection with such a simple case, one could say that simpler gear than C.R.O. apparatus would be quite satisfactory, but it must be remembered that the C.R.O. provides the means of checking up on H.F. response curves. This is a valuable attribute, even where a "straight three" receiver is concerned.

It is with the receiver containing band-pass couplings

that the C.R.O. really shines as a trouble remover and a time-saver.

In such a case a considerable amount of the adjusting will be done with reference to H.F. response curves. The procedure is easy to follow, and such precautions as are necessary are not at all complicated. We will deal with the latter first.

The A.V.C. should be kept cut out while all the trimming is being done. (Disconnect A.V.C. feed lines from A.V.C. detector and earth them to chassis.) It is important to realise that the action of A.V.C. can lead to false response curves appearing on the screen. The reason for this is that although the trace on the screen represents a graph of detector-output volts against frequency, the conditions

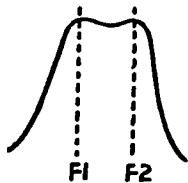

FIG. 87.—Illustrating the effect of A.V.C. on the tube.

under which any particular response curve is produced are artificial, and differ in one important respect from the conditions of actual radio reception. In actual radio reception carrier and sideband frequencies are present simultaneously, but with a "wobbled" H.F. input the frequencies covered by the base of the response curves are passed through by the oscillator in succession, and at a certain rate. Referring to Fig. 87 the oscillator will attain the frequency  $F_1$  before it reaches the frequency  $F_2$ . If the rise of H.F. amplitude exceeds the A.V.C. delay voltage, the A.V.C. diode will commence to rectify. The A.V.C. feed line to the controlled valves has, however, a certain time constant, and in view of the consequent "sluggishness" of the A.V.C. bias variation, it should be easy to appreciate that although the H.F. response of the receiver under reception conditions might correspond to a symmetrical curve, such as that of Fig. 84, yet, under "wobulation" conditions, the trace shown on the screen could be rendered lop-sided by the effect of A.V.C.

The idea of keeping the test signal well down in amplitude, so that the delay voltage keeps the A.V.C. out of action, may suggest itself to the reader as an alternative to cutting out the A.V.C. by circuit modification, but while this is satisfactory enough for quick check test purposes, it

is not to be advised when actual ganging work is being done. When making trimmer adjustments with an H.F. response curve as guide, it is desirable to have a reasonably big "picture" on the screen, and this makes a very low amplitude of input unsuitable. At the same time care must be taken that valve overloading is not permitted as this, again, would give distortion of the trace. Using the C.R.O. amplifier in front of the Y-plate with the gain well up will make it easier to get a good size of trace without overloading of the receiver valves.

Another precaution concerns the frequency at which the time base is run while H.F. response curves are being taken. This should not be too high, and, as a general rule, 25 sweeps per second can be considered as satisfactory.

The procedure for ganging follows the usual practice as regards the sequence of the adjustments. With a superhet, for instance, the I.F. trimming should be done first.

When adjusting band-pass I.F. stages for satisfactory response the Y-amplifier lead should be taken from the detector. If this is a diode the high potential end of the diode load resistance will be the proper test point.

Where grid detectors are concerned one most frequently finds a resistance anode load in modern receivers, but should the case be met where L.F. transformer coupling is used between the detector and the succeeding valve, the anode circuit should be temporarily modified to have a resistance load while an H.F. response curve is being taken; otherwise the reactance component of the primary impedance will tend to produce a false shape of curve. Use the detector anode as a test point.

If a receiver contains three I.F. transformers, the I.F. test signal ("wobbled") should be applied to the grid of the first I.F. valve, and the combined response curve of Nos. 2 and 3 transformers got right first. Then the test oscillator input can be shifted back to the frequency-changer grid, and No. 1 transformer adjusted to give satisfactory response of the I.F. section of the receiver as a whole. During I.F. aligning work, the receiver's oscillator should, of course, be kept out of action.

When band-pass circuit adjustments are tackled with the aid of an output-meter indication only, it is particularly

easy to land up with a pseudo band-pass response that is, in reality, a double-peaked curve obtained by mis-tuning. There is little risk of doing this with a C.R.O. response-curve indication if a careful eye is kept on the changes of response-curve shape with each trimmer adjustment. The C.R.O. user scores heavily over his less fortunate technical brethren in the respect that the former is able to see instantly what effect any particular band-pass trimmer adjustment is having.

After the I.F. stages of a superhet have been correctly aligned the oscillator trimming and padding can be attended to, using the C.R.O. as output meter. Then the signal-frequency circuits should be aligned, and if there are any band-pass couplings involved, the adjustment should be done against a receiver overall H.F. response curve, using a "wobbled" test signal. In any case, a final check should be made of the overall H.F. response curve.

The fact that H.F. response traces can be obtained makes the C.R.O. an extremely useful device as an aid to the location of faults. As many readers will be able to testify, the locating of a fault frequently takes far more time than the actual rectifying of the fault once it has been found. Particularly is this liable to be the case when the fault is associated with an H.F. circuit and affects the selectivity or sensitivity of the receiver.

Considering the H.F. section of a receiver, it will be appreciated that no fault can develop affecting selectivity, or sensitivity, without in some way "making its mark" on the H.F. response curve.

Figs. 88 and 89 illustrate a case in point. A superhet gave weak reception.



FIGS. 88 and 89.—On the left is seen the effect of heavy damping on an I.F. transformer, and on the right the result of removing the damping.

Results were so poor on all wavebands that it became a matter of immediate interest to find out what the I.F. stages had to say for themselves. A response-curve check on the I.F. section of the receiver gave the

result of Fig. 88. This curve showed definitely that there was trouble in the I.F. section ; moreover, its shape and size suggested the presence of excessive H.F. damping. Fig. 89 shows the effect of clearing the fault (a resistance leak through an I.F. trimmer).

Time in locating intermittent H.F. faults can very often be saved by obtaining an H.F. response curve and watching to see exactly what happens to it when the fault occurs. To quote an example : A superhet developed an intermittent signal fluctuation on one waveband. A "wobbled" test signal was applied and a watch kept upon the overall H.F. response curve. It was observed that when the signal fluctuation occurred it was associated with a sideways jump of the response curve. A sideways movement of an H.F. response curve indicates one of two possible happenings ; either a change of applied signal tuning, or a change of receiver oscillator frequency. In the case under consideration the first possibility could be ruled out, so it became obvious that the fault, whatever it might be, was causing the receiver oscillator frequency to shift. This information made the tracing of the fault a comparatively simple matter, and a certain padding condenser was very soon on the scrap-heap.



# INDEX

## A

- Aerial coupling, 40.
- —, band-pass, 44.
- Aerials, indoor, 98.
- Aligning the oscillator, 95.
- Alternative methods, 104.
- Amplification factor of variable selectivity, 58.
- Amplifier, the intermediate-frequency, 92.
- the triode as H.F., 59.
- — as L.F., 64.
- — as power, 65.
- Amplitude, constant, 124.
- Anode impedance, 58.
- Applications of parallel resonance, 25.
- Automatic volume control, 88.

## B

- Band-pass aerial coupling, 44.
- couplings, 41.
- Bass control, 113.
- Beam deflection, electron, 116.
- Broadcast "signal," modulated, 12.
- — unmodulated, 9.

## C

- C.R.O. as output meter, 127.
- Calibration, frequency, 122.
- Channel interference, second, 94.
- Circuit magnification, 21.
- single H.F. tuned, 26.
- , superhet, 91.
- Circuits, H.F. coupled, 34.
- using several tuned, 30.
- Class B stage, 112.
- Components, tone control, 115.

- Conductance, mutual, 58.
- Constant amplitude, 124.
- Control, automatic volume, 88.
- bass, 113.
- external, 102.
- components, tone, 115.
- in L.F. stages, 113.
- Coupled circuits, H.F., 34.
- Coupling, aerial, 40.
- band-pass aerial, 44.
- Couplings, band-pass, 41.
- Curves, resonance, 100.
- wobblelation, obtaining H.F. response, 123.

## D

- Damping, shunt, 29.
- Decibels, 45.
- Deflection, electron beam, 116.
- Detector, the diode, 54.
- the first, 83.
- the triode as grid, 61.
- Dial, spreading the stations over, 20.
- Diode detector, the, 54.

## E

- Electron beam deflection, 116.
- Electronic emission, 50.
- Emission, electronic, 50.
- External control, 102.

## F

- Factor, amplification, 58.
- Factors controlling selectivity, 28.
- Filters, time, 107.
- Frequencies, sideband, 13.
- Frequency calibration, 122.
- changer valves, 84.

Frequency changers, single valve,  
95.  
— changing, superhet, 82.  
— resonant, 19.  
Function of time, X-deflection  
as a, 117.  
Fundamental principles, 9.

## G

Ganging, 127.  
— the possibilities of, 21.  
Grid detector, the triode as, 61.

## H

H.F. amplifier, the triode as, 59.  
— coupled circuits, 34.  
— pentode, the, 70.  
— resistance, 22.  
— response curves wobble, obtaining, 123.  
— transformer, the tuned secondary, 37.  
— tuned circuit, single, 26.  
Heptode, the, 84.

## I

Impedance, anode, 58.  
Indoor aerials, 98.  
Interaction, 42.  
Interference, second channel, 94.  
Intermediate-frequency amplifier, the, 92.

## K

Kilocycles, megacycles, and  
metres, 10.  
Kink, the S.G. valve's, 68.

## L

L.F. amplifier, the triode as, 64.  
— stages, control in, 113.  
Locking the picture, 122.

## M

Magnification, circuit, 21.  
Matching, 79.

Megacycles, and metres, kilo-  
cycles, 10.  
Meter, the C.R.O. as output, 127.  
Metres, kilocycles, megacycles,  
and, 10.  
Mutual conductance, 58.

## N

Noise suppression, 106.

## O

Octode, the, 86.  
Oscillator, aligning the, 95.  
— the valve, 80.  
Output meter, the C.R.O. as,  
127.  
— pentode, the, 73.  
— tetrode, the, 73.  
Over-all selectivity, receiver, 45.

## P

Parallel resonance, 23.  
— — practical applications of,  
25.  
Pentode, the H.F., 70.  
— the output, 73.  
Picture, waveform, 120.  
— locking the, 122.  
Power amplifier, the triode as,  
65.  
Practical applications of parallel  
resonance, 25.  
Principles, fundamental, 9.

## Q

Q.P.P. stages, 111.  
Quality, selectivity and, 32.

## R

Range, tuning, 17.  
Ratio, signal-to-noise, 97.  
Reaction, 74.  
Receiver over-all selectivity, 45.  
Reception, complicated system  
of, 78.  
— standards, 48.  
Resistance, H. F., 22.

Resonance curves, 100.  
 — parallel, 23.  
 — practical applications of parallel, 25.  
 — series, 14.  
 — two advantages of, 17.  
 Resonant frequency, 19.  
 Response curve obtaining H. F., 123.

## S

S.G. valve's kink, 68.  
 Screen-grid valve, 65.  
 Second channel interference, 94.  
 Secondary H.F. transformer, the tuned, 37.  
 Selectivity and quality, 32.  
 — factors controlling, 28.  
 — over a wave-range, 32.  
 — receiver over-all, 45.  
 — variable, 49.  
 Self-capacity, 18.  
 Series resonance, 14.  
 Shunt damping, 29.  
 Sideband frequencies, 13.  
 Signal-to-noise ratio, 97.  
 — unmodulated, the broadcast, 9.  
 Single H.F. tuned circuit, 26.  
 — valve frequency changers, 95.  
 Spreading the stations over the dial, 20.  
 Stage, class B, 112.  
 Stages, control in I.F., 113.  
 — Q.P.P., 111.  
 Standards, reception, 48.  
 Stations over the dial, spreading, 20.  
 Superhet frequency changing, 82.  
 Suppression, noise, 106.

## T

Tertiary winding, 103.  
 Tetrode, the output, 73.  
 Time filters, 107.  
 —, X-deflection as a function of 117.

Tone control components, 115.  
 Transformer, the tuned secondary H.F., 37.  
 Triode, 55.  
 — as grid detector, 61.  
 — as H.F. amplifier, 59.  
 — as L.F. amplifier, 64.  
 — as power amplifier, 65.  
 Tuned circuit, single H.F., 26.  
 — circuits, using several, 30.  
 — secondary H.F. transformer, the, 37.  
 Tuning range, 17.  
 — -series resonance, 14.  
 — variable, 17.  
 Two-electrode valve, the, 50.

## U

Unmodulated broadcast signal, 9.

## V

Valve frequency changers, single, 95.  
 — oscillator, 80.  
 — the screen-grid, 65.  
 — the two-electrode, 50.  
 Valve's kink, the S.G., 68.  
 Valves, frequency changer, 84.  
 Variable selectivity, 40.  
 — tuning, 17.  
 — -mu, 71.  
 Volume control, automatic, 88.

## W

Waveform picture, a, 120.  
 — -range, selectivity over a, 32.  
 Winding, Tertiary, 103.

## X

X-deflection as a function of time, 117.