

# DUNLAP'S RADIO MANUAL

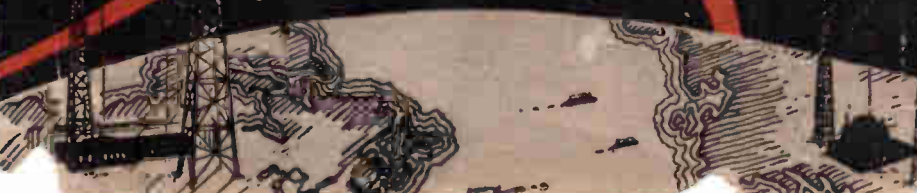

# DUNLAP'S RADIO MANUAL



How vacuum tubes operate

Which way to point the antenna?

Where to take the lead-in off the antenna?

How to balance a neutrodyne?

How to tune?

How to take care of the batteries?

How a reflex circuit operates?

What "dead spots" are?

How to install a set?

How to tell time by radio?

The advantages of a loop antenna?

How to erect an indoor antenna?

What type of coils to use?

How to...  
and circuit

Why certain...  
in your locality?

Where static comes from?

What makes a good ground contact?

The latest developments in broadcasting?

The best system of radio frequency amplification?

How to locate trouble in your set?

How to install a buzzer test?

Dunlap's Radio Manual will give you the answers to these and hundreds of other questions. Complete, practical, up-to-date, easy to read; the most comprehensive book ever published in this field. From his experience as radio editor of *The New York Times*, the author, Orrin E. Dunlap, Jr., knows just what the public wants to know about radio. In this book he tells it in non-technical language that any one can understand. Read it and your radio problems are solved.

# THE RADIO MANUAL

BY  
ORRIN E. DUNLAP, JR., B.S.

RADIO EDITOR OF THE NEW YORK TIMES  
SENIOR MARCONI OPERATOR; U.S. NAVY OPERATOR

WITH DIAGRAMS BY THE AUTHOR  
AND OTHER ILLUSTRATIONS



BOSTON AND NEW YORK  
HOUGHTON MIFFLIN COMPANY  
*The Riverside Press Cambridge*

1924

**COPYRIGHT, 1924, BY ORRIN E. DUNLAP, JR.**

**ALL RIGHTS RESERVED**

**The Riverside Press**

**CAMBRIDGE · MASSACHUSETTS**

**PRINTED IN THE U.S.A.**



**PRESIDENT COOLIDGE AND THE MICROPHONE**

Speaking at the thirty-eighth annual dinner of the National Republican Club at the Waldorf-Astoria, New York, on Lincoln's birthday, 1924.



TO  
MY MOTHER AND FATHER





## BY WAY OF EXPLANATION

THIS book is elementary — it tells what the great host of radio followers want to know about their receiving sets and the invisible waves which carry entertainment to them.

You will find radio explained here as I wished for some one to tell me about wireless in 1910, in non-technical terms. Radio in this book is stripped of technicalities and the story is told so that everybody can understand and enjoy it.

During the past two years I have answered thousands of questions pertaining to radio, asked by radio enthusiasts in every State in the Union, Hawaii, the Virgin Islands, Cuba, Porto Rico, Mexico, Canada, England, Spain, Czecho-Slovakia, and Germany. All combined, the multitude of questions blend into one, "What is radio?"

Keeping in mind what all of these people want to learn, I wrote this book as the answer to the universal question. It is intended to add to your pleasures of listening-in.

If you are unfamiliar with radio, you may meet some new words in this story, or old words used in a new way to explain radio clearly. For example, the word "frequency," used in speaking about an electric current, may seem technical, but it, like many other old words, has merely been employed in a new sense to explain radio, and is

simpler than the forbidding aspect of the word suggests. The frequency of anything that occurs over and over again is the number of times it happens in a given period of time. The frequency of an electric current is the number of times it reverses in direction at regular intervals, or the number of cycles of vibration. A twenty-five-cycle current is one which has twenty-five complete reversals per second, or a frequency of twenty-five cycles. Such a current reverses its direction of flow twenty-five times per second, and is called an "alternating current." Alternating currents of extremely high frequency are called "electrical oscillations."

All frequencies above 10,000 cycles per second are inaudible to the human ear and are called radio frequencies. All frequencies below 10,000 cycles, normally audible to the human ear, are known as "audio frequencies." A radio frequency transformer is one which deals with radio frequency currents. An audio amplifying transformer amplifies audio frequency currents. A transformer is a device used in a radio or other electrical work to transfer energy from one circuit to another, with or without a change of voltage. All transformers have a primary and a secondary winding. The primary receives the current and passes it on to the secondary, either with the same voltage, higher voltage, or lower voltage, depending upon the ratio of the primary and secondary windings in relation to each other.

The term "vario" used as part of the name of a radio coil, means that the amount of wire can be varied either by taps taken off to a multiple point switch, or the inductance can be varied by arranging the primary and secondary coils in relation to each other, so that they will add to or oppose each other's magnetic field. "Inductance" is the electrical term given to the magnetic energy-storing property of coils of wire. "Capacity" is the property of a condenser to store up an electrical charge.

"Reflex" is not a technical radio term. It means to "turn or direct back," and that is what is done in a reflex circuit. The current after passing through the circuit and vacuum tubes is directed back for further amplification.

"Antenna" is defined as "feeler or horn of an insect." Used in radio it is a wire in the air which "feels" for passing ether waves.

Thus you see radio can be written without the use of technical words. To understand it is to be familiar with new meanings for old words.

O. E. D., JR.

NEW YORK, *February*, 1924



## CONTENTS

- I. THE BIRTH OF RADIO I
- Coherer was the First Detector — Radio Reports Marine Accident — Marconi's Early Experiments — Wireless Spans the English Channel — Atlantic Spanned by Wireless — History of Distress Calls — Titanic Used "SOS" — Meaning of SOS and CQD.
- II. ETHER WAVES AND WAVE MOTION 17
- How Ether Waves are Created — Wave Length Explained — Measuring Waves — How to Calibrate a Set — Amperes and Volts Determine Range — Inductance Increases Wave Length — Series Condenser Lowers Wave Length — How to Calculate Wave Length — Meaning of Kilocycle — Why Kilocycles are Used — Beat Notes — Harmonics — Theories of the Ether — Strong Signals at Antipodes — Seven Trips around the World Instantaneous — Absorption Lowers Range — Fading — Why Radio Travels Farther over Water — Sun Weakens Radio — Effect of Weather on Radio Waves — Darkness Aids Radio Transmission — Why Waves are Called Damped and Undamped — Vacuum Tube to Replace Alternator — Undamped Waves Superior — Pure Wave Defined — The Human Ear can Hear 300,000 Sounds — Partially Deaf can Hear Radio — "Dead Spots" in the Ether — Tests Reveal "Dead Spots" — Mountains Deflect Waves — Trees Absorb Energy — Say Cables Absorb Energy — Static Electricity — Sources of Static — Strays Forecast Storms — Static with Snowstorms.
- III. ANTENNÆ 58
- Antenna has Fundamental Wave Length — Proper Size for Antenna — Capacity Antenna Most Popular — Antenna Insulation — Care of Antenna — Directional Effects — Types of Antennæ — Loop Antenna Data — Counterpoise — Wave Antenna — Indoor Antenna Methods — Indoor Antenna Construction — Light Socket Aerial — Reduce Antenna Resistance — Antenna cannot Serve Two Stations — Antenna Protective Device — Ground Wire.

IV. DETECTORS	75
<p>Buzzer Test — Electrons — Vacuum Tube Detectors — Function of the Plate — Action of the Grid — Rectifying Action of the Tube — Interesting Facts about Vacuum Tubes — Putting the Vacuum in the Tube — “Clean-up” Phenomenon — How Dry-Cell Tubes are Made — Differences in Tubes — How to Select a Vacuum Tube — The UV-199 — Tube Characteristics — Transmitting Tubes — Ten Tubes Develop 200 Kilowatts.</p>	
V. METHODS OF AMPLIFICATION	106
<p>Radio Frequency Methods — How Transformers Differ — Audio Frequency Amplification — Transformer Ratio Explained — Transformer Construction — How to Test a Transformer — Hysteresis — Amplifying Crystal Detectors — Reflex Circuits — Advantages of the Reflex — “Push-Pull” Amplifier — Super-Heterodyne — The Neutrodyne Principle — Precautions to Observe — Loud-Speakers — Selecting a Loud-Speaker — Long Necks to Disappear.</p>	
VI. COILS AND CONDENSERS	136
<p>Types of Coils — Honeycomb Coils — Distributed Capacity — Vario-Coupler — Variometer — Condensers — Action of Series Condenser — Vernier Condenser — Avoid Loose Contacts — Construction of Fixed Condenser — Grid Condenser — Bridging Condenser — Action of a Condenser — Transmitting Condensers — Condenser Connections.</p>	
VII. TUNING	152
<p>Selectivity — Coupling — Types of Coupling — Capacity Coupling — Types of Circuits — Wave Trap or Filter — Reinartz Tuner — Operating Hints — Vibration Causes Interference — Chief Metals of Radio — Insulating Materials — Conventional Symbols.</p>	
VIII. HEAD PHONES AND BATTERIES	176
<p>Radio Energy Weak — Telephone Jacks — The “A” Battery — Hydrometer — Correct Wiring — Grid Leak — When to Use Dry Cells — The “B” Battery — How to Charge a Battery — The “C” Battery.</p>	

## CONTENTS

xiii

<b>IX. HOW WORDS ENTER THE ETHER</b>	<b>194</b>
Modulation — "Glow Discharge" Microphone — Methods of Modulation — Modulation Meter — Location of Microphone — Remote Control — Radio Relay Method — The Radio Studio — Stage Fright Common — Radio Drama.	
<b>X. RADIO POSITION-FINDERS AND BEACONS</b>	<b>213</b>
Radio Beacons — Guidance by Radio.	
<b>XI. TIME SIGNALS: WEATHER REPORTS: RADIO LAWS</b>	<b>222</b>
The Master Clock of the United States — Transmitting Clocks — Weather Reports — Government Regulations — International Abbreviations — Call Books — Canadian Regulations — Radio's Place in Communication.	
<b>RADIO DICTIONARY</b>	<b>243</b>
<b>INDEX</b>	<b>259</b>





## ILLUSTRATIONS

PRESIDENT COOLIDGE AND THE MICROPHONE	
	<i>Frontispiece</i>
GUGLIELMO MARCONI	
RADIO CENTRAL AT ROCKY POINT, LONG ISLAND	12
AERIALS OF RADIO CENTRAL	20
THE HEAVISIDE LAYER THEORY	30
A TWO-HUNDRED-KILOWATT RADIO FREQUENCY ALTERNATOR AT ROCKY POINT, LONG ISLAND	42
ONE WAY "DEAD SPOTS" ARE CREATED IN THE ETHER	46
DISTRIBUTION OF RADIO WAVES THROUGH THE METROPOLITAN AREA OF NEW YORK	50
AERIALS OF BROADCAST CENTRAL ON THE ROOF OF ÆOLIAN HALL, NEW YORK	60
LOOP ANTENNA	66
CRYSTAL DETECTOR	66
VACUUM TUBES	94
THE REGENOFLEX	94
TRANSMITTING EQUIPMENT IN THE FORM OF A FOUR-KILOWATT VACUUM-TUBE SET AND CONTROL PANEL	98

THE HEART OF WJZ	194
SHIP TRANSMITTER	198
A MICROPHONE OF STATION WJZ CONCEALED WITHIN A MINIATURE WORLD OF THIN GAUZE	202
BROADCASTING STUDIO OF STATION WEAf, NEW YORK	206
RADIO POSITION-FINDER ON BOARD S.S. PRESI- DENT MCKINLEY, ADMIRAL ORIENTAL LINE	214
RADIO DIRECTION-FINDER AND GYRO-COMPASS	216
THE GYRO-COMPASS USED IN CONNECTION WITH A RADIO POSITION-FINDER	216
SANDY HOOK RADIO COMPASS STATION	220
OPERATING ROOM OF SANDY HOOK RADIO COM- PASS STATION	220
THE MASTER CLOCK OF THE NATION	224
THE TRANSMITTING CLOCK	224

### Diagrams

CRYSTAL DETECTOR SET AND BUZZER TEST	76
ARMSTRONG REGENERATIVE CIRCUIT	85
ONE STAGE OF TUNED RADIO FREQUENCY AMPLIFICATION	107
TUNED RADIO FREQUENCY AMPLIFIER, DE- TECTOR, AND AUDIO AMPLIFIER	111
DETECTOR AND TWO STAGE AUDIO AMPLIFIER	112
CRYSTAL DETECTOR CIRCUIT AND AUDIO AM- PLIFIER	119

## ILLUSTRATIONS xvii

SINGLE TUBE SUPER-REFLEX	120
REFLEX AND TUNED RADIO FREQUENCY AMPLIFIER	121
PUSH-PULL AMPLIFIER	125
AUDIO FREQUENCY AMPLIFIER UNIT	133
THREE TYPES OF COUPLING	157
ULTRA-AUDION SINGLE CIRCUIT RECEIVER	159
WAVE TRAPS	162
SINGLE CIRCUIT SET EMPLOYING A TUNER KNOWN AS THE REINARTZ COIL	163
ONE STAGE RADIO FREQUENCY AMPLIFIER, DETECTOR, AND TWO STAGES OF AUDIO FREQUENCY AMPLIFICATION	177
CONVENTIONAL RADIO SYMBOLS	244

The author acknowledges the courtesy of the following in supplying the photographs used in illustrating this volume: the American Telephone and Telegraph Company, the Radio Corporation of America, the United States Navy Department, Popular Radio, Inc., the Sperry Gyroscope Company, the Kolster Company, the International Newsreel Corporation, and the Admiral Oriental Line.

The principles of the receiving circuits printed in this book are patented. They are published here with descriptions for the benefit of radio followers for their own use and for experimental purposes only.



# THE RADIO MANUAL



## CHAPTER I

### THE BIRTH OF RADIO

RADIO could not be invented until man discovered that a medium existed, such as the ether, which could be set in wave motion by the action of an electric circuit. Professor James Clerk Maxwell, of the University of Edinburgh, in 1867 outlined theoretically and predicted the action of ether waves as used in radio to-day.

Heinrich Hertz, of Karlsruhe, Germany, confirmed Maxwell's theory in 1886, by creating and detecting the electro-magnetic waves, and for this reason they are sometimes called Hertzian waves. Elihu Thomson, of Lynn, Massachusetts, proposed to use the invisible waves for signaling, in 1889. A number of scientists, including Sir Oliver Lodge, of London; Professor Augusto Righi, of Bologna, Italy; and Professor Edouard Branly, of Paris, began experiments for transmission and reception of the Hertzian waves. Guglielmo Marconi was a pupil of Righi.

Marconi was practical, and the idea that electro-magnetic waves could be employed for signaling inspired him to solve many of the problems which confronted theoretical experimenters. He made a set of transmitting and receiving instru-

ments in 1894 after he had studied and recognized defects in the laboratory equipment of others. He built a device which would send and receive messages in the dots and dashes of the Morse code, and with this equipment, in 1896 he went to England to demonstrate wireless at Salisbury Plain, where he sent and received a message over a distance of two miles.

By the end of 1897, Marconi had "wirelessed" from ships at sea over a distance of ten miles and between shore stations at Salisbury and Bath in England, about twenty-four miles apart. Marconi used an electric spark to set-up the waves in the ether. Spark sets are still in use, but are destined to become obsolete within a few years because of the vacuum tubes, which are far superior as a means of generating electrical oscillations.

Professor R. A. Fessenden, of the University of Pittsburgh, inspired by the inefficiency of spark apparatus, in 1906 invented a radio-frequency alternator, which would produce a continuous wave, making possible a continuous radiation of energy, instead of energy in short groups, as in the case of the spark sets. In 1917, Dr. E. F. W. Alexanderson designed and produced 200-kilo-watt alternators, which made world-wide wireless possible.

The Poulsen arc, invented in 1908 by Valdemar Poulsen, of Denmark, was a competitor of the high-frequency alternator. Poulsen was the first to apply the arc as a generator of continuous waves for practical use in radio. Elihu Thomson,



**GUGLIELMO MARCONI**  
The inventor of wireless.





in 1892, and William Duddell, in 1900, also experimented with the electric arc as a means of propagating electro-magnetic waves.

A new radio generator in the form of high-power vacuum tubes will undoubtedly supplant the huge and cumbersome alternators and arc sets. Dr. J. A. Fleming, of England, invented the Fleming valve and applied it to wireless reception in 1904. Dr. Lee De Forest improved the Fleming valve in 1906, by adding a third electrode called the "grid," making the tube practical for transmission and improving its receiving efficiency.

#### COHERER WAS THE FIRST DETECTOR

The coherer was the first form of detector. It was developed by Professor Branly. In 1902, Marconi introduced the magnetic detector and Fessenden patented a thermal receiver of about equal sensitiveness.

Then came the electrolytic detector and crystal detectors such as galena, silicon, carborundum, and several other minerals. Crystals superseded the liquid detectors, such as the electrolytic, because of their simplicity of adjustment. The troublesome acid, necessary in the electrolytic detector, was also eliminated by the use of a crystal.

When De Forest introduced the improved vacuum tube in 1906, he called it the "audion." Structural improvements made it stable and increased its dependability, and in 1912, it was ac-

cepted by some commercial stations and by hundreds of amateur experimenters. Edwin H. Armstrong, in 1913, improved the wiring circuit in which the audion was used. He made the circuit regenerative, greatly increasing the range of the detector and the volume of signal strength. Armstrong showed that the audion was not only a sensitive detector, but also a good amplifier. The audion is now known as the vacuum tube and is in universal use as a detector and amplifier. It was the vacuum tube as a transmitter and receiving element that made possible radio telephony.

#### RADIO REPORTS MARINE ACCIDENT

Marconi's experiments in 1896 and 1897 encouraged the installation of wireless equipment on board ships. The first marine accident to be reported by radio was on April 28, 1899, when the steamer R. F. Mathews collided with the East Goodwin Sands Light Ship. Help came from shore twelve miles away before the ship sank.

British naval vessels sent messages over eighty-five miles, and the international yacht races between the Shamrock and the Columbia were reported to the press by radio that year. A wireless station on the Isle of Wight talked with the S.S. Lizard in 1901, when the ship was about two hundred miles distant. A big station was erected at Poldhu, England, in 1900, and it was from the aerial of this station that the first signal was flashed across the Atlantic.

## MARCONI'S EARLY EXPERIMENTS

Marconi began his experiments at telegraphing without wires, in 1895, in the fields of his father's estate at Bologna, Italy. He was then twenty years old. In 1896, Marconi went to London to conduct tests in Sir William Preece's laboratory. Then came the signal at Salisbury Plain, which proved that neither house, stone walls, rocks, nor earth could stop the Hertzian waves.

Balloons covered with tinfoil were used in March, 1897, to hold aloft the antenna, but the strong winds blew them to bits and the wire dropped to the earth. Six-foot calico kites, covered with tinfoil, were substituted for the balloons, and Marconi succeeded in flashing messages between points eight miles apart.

In November, 1897, Marconi and his assistants rigged up a transmitting station and mast 120 feet high at Needles on the Isle of Wight. He then put out to sea in a tugboat, taking along a receiving set connected to an antenna hung from a sixty-foot mast. The object was to determine how far the Needles' spark would carry a message. Tests continued for several months, and finally signals were sent across to the mainland. A permanent station was erected at Bournemouth, fourteen miles from Needles, but was later removed to Poole, eighteen miles away.

Then came the Kingston regatta in July, 1898. "The Express," of Dublin arranged to have the races observed from the steamer, The Flying

Huntress, and the reports sent to shore by wireless. A receiving station was installed at Kingston and the dispatches copied there were telephoned to Dublin enabling the paper to print full accounts about the yachts almost before the races were over and while the crafts were still out of range of telescopes. It is reported that over seven hundred of these messages were transmitted during the regatta.

A few days later, Marconi was called upon to establish communication between Osborne House, on the Isle of Wight, and the royal yacht anchored off Cowes Bay, with the Prince of Wales on board. During sixteen days, 150 private messages were sent by wireless giving the Queen frequent bulletins regarding the Prince's injured knee.

At that time Marconi was asked if he thought it would be possible some day for Paris to talk with New York, without ocean cables, and he said, "I see no reason to doubt it. What are a few thousand miles to this wonderful ether which brings us light every day for millions of miles?"

So apparent were the advantages of wireless that in May, 1898, Lloyds arranged to have instruments installed at the various Lloyd stations. Preliminary trials were made between Ballycastle and Rathlin Island in the North of Ireland. The distance was seven and a half miles and the results of many tests were more than satisfactory.

### WIRELESS SPANS THE ENGLISH CHANNEL

Wireless was put to its most severe test, up to that time, in the end of March, 1899, when the French Government asked Marconi to attempt sending messages across the English Channel between Dover and Boulogne. At five o'clock on the afternoon of March 27th, Marconi pressed the key which released the first electric sparks that set the ether in vibration across the Channel. Anxious eyes gazed out upon the sea, across Napoleon's old fort abandoned in the foreground, wondering if listeners in England would hear the dots and dashes. Thirty-two miles seemed a long way. Marconi stopped transmitting and tuned the receiving set, hoping to hear the news that his signals had been heard in England, and at the same time pick up the first wireless message sent from England to the Continent. Clearly he heard the English signals, which told that the English Channel had been crossed and recrossed by Hert-zian waves.

### ATLANTIC SPANNED BY WIRELESS

Marconi landed at St. John's, Newfoundland, December 6, 1901, accompanied by two assistants. Wireless equipment was installed in the old barracks of Signal Hill, which stood at the mouth of the harbor, a mile and a half from St. John's. Little publicity was given Marconi's arrival in America and it was reported that he would attempt to communicate with transatlan-

tic ships as they passed about three hundred miles off the Grand Banks. On December 10th, four days after his arrival, Marconi sent up a nine-foot hexagonal kite of bamboo and silk. The wind snapped the wire and the kite blew out to sea. A fourteen-foot hydrogen balloon was then sent aloft, but the antenna wire again broke away and fell to the ground, as the balloon disappeared in the fog.

Then came December 12, 1901, important in the annals of wireless. Marconi sent up a kite to about four hundred feet elevation. It held the wire firmly, and Marconi prepared to tune the set for radio waves radiated in England. Before leaving the British Isles he had given instructions to operators at Poldhu, Cornwall, on the southwest tip of England, to send the letter "S" at a fixed time each day, beginning as soon as word was received that St. John's was ready to listen. He cabled for the tests to begin at 11.30 A.M. and continue until 2.30 P.M., St. John's time.

Marconi and one of his assistants began tuning for Poldhu's wave length about noon. They were the only two persons present. Marconi thought he heard a signal and he handed the phones to his companion to verify it. Distinctly and unmistakably came the three dots forming the letter "S." At 1.10 P.M., more signals were heard, and at 2.20 P.M., Marconi again picked up Poldhu's spark, still sending "S." The Atlantic had been spanned by radio.

On the following Friday he heard Poldhu

again, but on Saturday no impulses actuated the detector, chiefly because of adverse atmospheric conditions, fluctuations of the kite's elevation, and the delicacy of the receiving set. Marconi hesitated to announce his achievement to the world, and it was not until two days later that he gave a statement to the press. Many disbelieved that messages could be sent through space for 2000 miles without the use of cables or wires.

It was on April 25, 1874, that Marconi was born. His father was Joseph Marconi and his mother Anna Jameson, from whom it is said he inherited Irish persistence, initiative, and alertness, and from his Italian father, power of invention and conception. He was a conservative scientist. He never made an announcement to the public until he was absolutely sure. Marconi never had to withdraw a statement as to his progress. He never made a claim of being the first wireless experimenter, but was prompt to acknowledge the work of others and his assistants. Marconi perfected the work of others and made wireless of practical use. Many scientists aided in forming the foundation of Marconi's triumph; among them were Professor Samuel F. B. Morse, inventor of the telegraph; Dr. Oliver Lodge and Sir William Preece, of England; Professor Dolbear and Professor Trowbridge, of America; Thomas A. Edison and Tesla; Clerk Maxwell and Hertz. Marconi used Branly's coherer, the oscillator of Righi, and the discovery of Hertz; but, as one writer has stated, "Marconi's creation, like that



of the poet who puts words of men in perfect lyric, was none the less brilliant and original."

On board the S.S. Philadelphia in February, 1902, Marconi copied Poldhu, 1551 miles away, and this won him many supporters who had doubted his transatlantic achievement. In January, 1903, a transatlantic wireless message was sent by President Roosevelt to King Edward VII by way of Cape Cod and Poldhu, England. It is not known whether this message was relayed by ships on the Atlantic or whether Poldhu received directly from the Massachusetts station.

Construction was started on a more powerful station than Poldhu at Clifden, Ireland, in 1905, and in 1907 this plant was opened for a limited commercial service with a twin station at Glace Bay, Nova Scotia.

January 23, 1909, was the date of the collision between the steamship Florida and the Republic. A "CQD," the distress call at that time, was flashed by Jack Binns, operator of the Republic, and neighboring ships equipped with radio went to the assistance of the ships in collision, rescuing all passengers and crew of the Republic before she sank.

In 1910, messages from Clifden, Ireland, were intercepted by the S.S. Principessa Mafalda, when over 6500 miles away. On the morning of April 14, 1912, the S.S. Titanic struck an iceberg and sank. Over seven hundred persons were saved by the Carpathia and other ships which responded to the "CQD" and "SOS" calls.

Wireless tests were made on board the Delaware, Lackawanna and Western Railroad trains running between Hoboken, New Jersey, and Buffalo, New York, in 1913. In 1914, commercial service was established between San Francisco and Honolulu. Direct communication was also made between Sayville, Long Island, using the call WSL, and Nauen, Germany, known as POZ. A station was later opened at Tuckerton, New Jersey, for communication with OUI at Hannover, Germany. Further development of international radio circuits was prevented by the World War. In May, 1919, the NC- transatlantic seaplanes used both wireless telegraphy, radio telephony, and radio direction finders, enabling the navigators to communicate with each other and with the land over a distance of 1800 miles. Station NBD, Otter Cliffs, Bar Harbor, Maine, was in communication with the flying boats soon after they left Rockaway, and could hear the signals from the planes until they were nearly to the Azores.

In 1920 and 1921 high-power stations were built along the Atlantic coast for communication with Europe, and in 1922 a powerful station called "Radio Central" was opened at Port Jefferson, Long Island. Ship service was greatly improved, and now many of the large transatlantic liners are equipped with sufficient power to communicate with either side of the Atlantic throughout the entire voyage.

On November 2, 1920, wireless dots and dashes

blended into music. Station KDKA, Pittsburgh, Pennsylvania, began public broadcasting on that date, opening up an entirely new field and making radio of interest and a pleasure to all people of the earth. The word "radio" was substituted for "wireless." This was done because "wireless" referred more to the idea of using radiated energy, which was practically shaking energy free from the transmitting aerial to travel in all directions, in contrast with conduction through the earth's surface or to magnetic induction.

#### HISTORY OF DISTRESS CALLS

Since the invention of wireless telegraphy, two distress calls, "CQD" and "SOS" have been used to call for assistance. These three-letter combinations have pierced the ether with thrills and anxiety more than any other radio vibrations. They have summoned help across horizons of oceans to burning ships, torpedoed vessels, liners torn by icebergs, and to others tossing helplessly in stormy seas.

Forced to change their course to respond to calls of distress, the captains of rescue ships have broadcasted short but reassuring messages to ill-fated crafts. The *Volturno* battered by a raging sea was on fire. Its decks were so hot that the feet of the crew were blistered. They waited anxiously to catch sight of a tramp oil steamer which answered the distress call, and which had oil enough on board to calm the waves. As a reply to the call for help the captain of the oil tramp



### RADIO CENTRAL AT ROCKY POINT, LONG ISLAND

All trees and buildings are cleared away so that energy will not be absorbed by near-by objects. The apparatus is controlled by operators in New York City by means of long-distance wires.



flashed, "I'll be up with the milk in the morning."

"CQD," the first distress call used, was erroneously translated by many to mean, "Come Quick — Danger." This group of letters became the distress call through a process of evolution. Wireless in its youth adopted a number of rules from the land telegraph and cables, which through their higher state of development were governed by regulations established by an international convention. Among the rules was a group of double-letter symbols used by operators to abbreviate and rush traffic. The letter "Q," because it is one of the least used in the alphabet, and in the wireless code is distinctive and can quickly be recognized. The call "CQ" on a land telegraph line means the operator sending it wants every one along the line to listen to his message. "CQ" as a wireless signal also means to stop sending and listen. Alone it is important, but not a cause for alarm. It is a general thing, when listening to commercial and amateur stations to-day, to hear the letters "CQ" in dots and dashes. But in the early days of wireless when "CQ" was followed by "D," the signal of danger and distress, it became a message of general alarm.

Most telegraph and cable abbreviations were adopted by the Marconi Company in 1902, when commercial wireless traffic began at sea. "CQ" was one signal especially fitted to wireless because a ship's operator hearing it would imme-

diately stop and listen, or try to communicate with the ship broadcasting the call. Several minor emergency calls showed that "CQ" did not sufficiently express the urgency required for distress purposes. As a result the Marconi Company issued a general order, "Circular No. 57," on January 7, 1904, establishing "CQD" as the distress call on and after February 1, 1904.

"CQD" was superseded, in July, 1908, by "SOS," selected as a distress signal by the International Radio Telegraphic Convention held at Berlin. The acts of the convention were not ratified by all nations until about a year later, so "CQD" remained in force long enough to prove the value of wireless at the wreck of the S.S. Republic in 1909.

#### TITANIC USED "SOS"

The "CQD" blended into "SOS" when the Titanic sank, April 14, 1912. When Captain Smith ordered operator Philips to send the distress call, he flashed, "Come at once. We've struck a berg. It's a CQD, OM." Junior operator Bride suggested, "Send SOS. It's a new signal and it may be your last chance to send it." So Philips interspersed his "CQD" with the "SOS." "CQD, SOS, from MGY. We have struck iceberg. Sinking fast. Come to our assistance. Position Lat. 41.46 N., Long. 50.14 W. MGY."

## MEANING OF SOS

"SOS" has been erroneously interpreted to mean, "Save Our Ship," and "Save Our Souls." The call consists of three dots, three dashes, and three more dots, forming an unusual combination which makes it easily recognized among all other calls and messages.

During the early part of the World War, enemy submarines and raiders broadcasted false "SOS" calls, and when ships responded, they were attacked. This necessitated the adoption of a secret "SOS" in code, unknown to the Germans. Operators of the Allied nations, familiar with the code, could tell the nature of the cause of distress, so unarmed ships would not go to the rescue in a sea where torpedoes and mines lurked.

The French decree of 1923 registered one important advance over all previous wireless legislation involving the consideration of safety of life at sea. The obligation to render assistance in case of disaster is one of the oldest traditions of the sea. It is expressed definitely in Article II of the Brussels International Convention of December, 1910, on "Assistance and Salvage at Sea," which reads: "Every master is bound, so far as he can do so without danger to his vessel, her crew, and passengers, to render assistance to everybody, even though an enemy, found at sea in danger of being lost. The owner of a vessel incurs no liability by reason of the contravention of the foregoing provision."



This convention was ratified by all maritime nations and its provisions were incorporated in their statutes before the outbreak of the World War in 1914. The Safety at Sea Convention of 1914 extended this obligation so as to bring within it all ships in the range of radio communication, if equipped with wireless. It prescribed that "Every master of a vessel who receives a call for assistance from a vessel in distress is bound to proceed to the assistance of the persons in distress."

## CHAPTER II

### ETHER WAVES AND WAVE MOTION

ETHER, an invisible, odorless, tasteless substance, occupying all space, is the medium through which light and radio waves travel. The electro-magnetic waves cannot be seen; neither can they be heard until transformed into sound at the receiving set.

All types of waves, including heat, light, water, sound, and radio, are produced in mediums which will vibrate or oscillate when disturbed. Waves are vibratory motion. When a stone is cast into a body of water, the surface of the water is disturbed and waves are set in motion. When the vocal cords of a person vibrate, the air is disturbed and sound waves are created.

Water waves help to explain the action and formation of radio waves. Picture a pond of smooth water as the ether of space. When a stone is thrown into the water, it starts a series of ripples or waves, which spread in all directions, but at a speed sufficient to cover only a few inches a second. If there are any little pieces of wood floating within range of the waves, they bob up and down as the waves strike them. These bits of floating material may be contrasted to radio receiving sets because both intercept the waves and are affected by the wave motion. If the floating particles go up and down ten times in

a minute, their frequency would be ten cycles a minute and the frequency of the waves would be the same.

Radio waves, as well as waves of light, heat, and sound, travel in ever-increasing circles. Incidentally that is why the seats in a theater are generally arranged in a semicircle. Heat from a fire radiates in all directions from its source. The farther one moves from the fire the less intense is the heat. Waves of heat, light, water, sound, and radio become weaker with distance.

#### HOW ETHER WAVES ARE CREATED

To produce radio waves it is necessary to have an electrical circuit carrying a vibrating, or, to use the electrical term, an alternating, current, which sets the ether in motion. The condenser, two or more sheets of metal, separated by an insulating material called the "dielectric," serves as the basis for radio transmission. One of the metallic plates acquires a positive charge of electricity and the other plate a negative charge. They are connected through a conducting wire, and a discharge takes place, giving rise to radio frequency currents or ether waves.

The aerial and ground form an enormous condenser. The aerial acts as one metallic plate, the ground as the other plate, with the air between serving as the insulating material or dielectric. In connection with the transmitting apparatus this big condenser receives an electric charge which it then discharges, setting the ether in vibration,

similar to the effect created by a stone dropped in a pond of water.

The microphone in the radio studio picks up music and sends it in the form of an electric current over the wires to the apparatus room, where voice amplifier tubes give it increased strength; modulator tubes vary the current in accordance with the sound vibrations, and power tubes give it impetus which sends radio frequency currents into the aerial system. The waves spread out from the aerial in all directions, similar to water waves, but at the speed of sunlight, 186,000 miles a second, sufficient velocity to encircle the earth seven and one half times in a second.

#### WAVE LENGTH EXPLAINED

Radio waves maintain a certain distance between each other. The distance from the crest of one wave to the crest of the wave ahead or preceding is called a wave length. If the distance from crest to crest is 400 meters, then the station is said to operate or broadcast on a wave length of 400 meters. A meter is equal to 39.37 inches.

The distance a wave travels does not depend upon the length of the wave; that is a wave 600 meters long will not necessarily travel farther than a 400-meter wave signal. Wave length has no more to do with the distance a set will cover than the distance from the crest of a wave in New York Harbor to that of a preceding wave has to do with the distance across the Atlantic. The power of the transmitter and the sensitiveness of

the receiving apparatus govern to a great degree the distance the signals may be heard, and atmospheric conditions also play an extremely important part. A short wave may travel thousands of miles, but it is not capable of carrying high power, and, therefore, the message carried on a low wave length weakens as it gets farther from the origin.

Long wave lengths are used for long-distance work because low frequency currents carry far better than high frequency currents, which make up the shorter waves. When the instruments are tuned to receive a certain wave length, they merely pick up sounds of a definite number of vibrations. Enemy submarines during the war used as low as 75 meters for transmission, and the powerful station at Nauen, Germany, used a wave of 12,600 meters.

The Lafayette station near Bordeaux, France, uses the longest wave of any radio station in the world at the present time. It is 23,000 meters, about fourteen miles in length. Second place belongs to Radio Central on Long Island — 19,000 meters. This is approximately twelve miles from crest to crest for a wave leaving the Long Island station's aerial. The distance a message travels from New York to Germany is about 4000 miles. Thus, there are a trifle more than 333 complete dips or troughs between Radio Central's wires and the antenna in Germany.

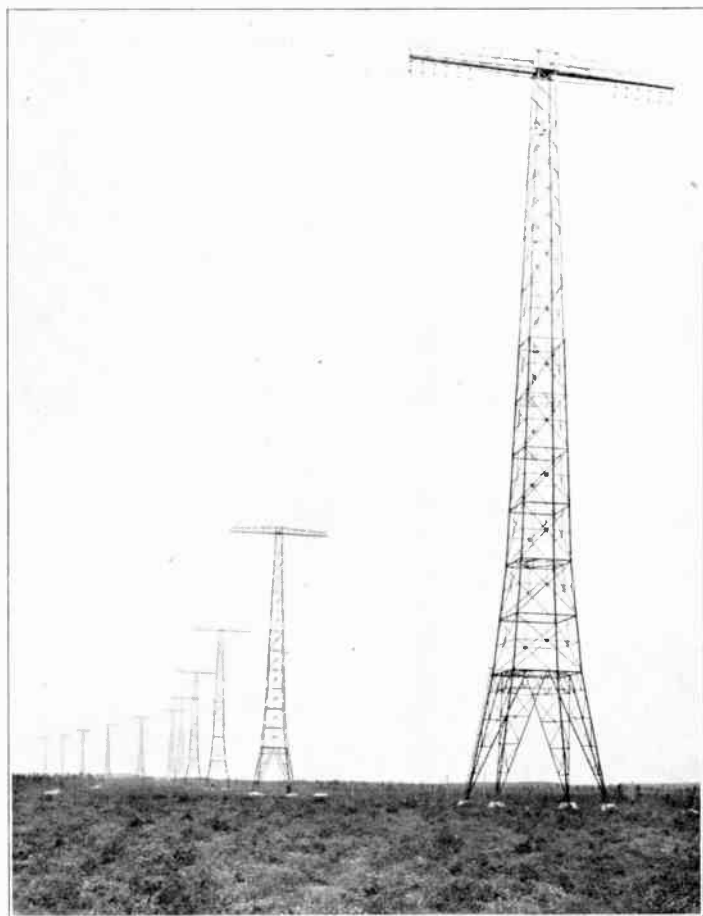

### AERIALS OF RADIO CENTRAL ON LONG ISLAND

They are held aloft by great steel towers, making possible communication with any country on the face of the earth. This is the most powerful station on the globe and the center of world-wide wireless.



## MEASURING WAVES

To measure the length of an ocean wave — that is, the distance from the crest of one wave to that of the next wave, or from trough to trough — would not be a difficult task. But, when the layman in radio thinks of taking the measurement of an ether wave, which is invisible and intangible, the job takes on a complex aspect. Suppose you were in a boat anchored in a pond and you counted the waves that passed, noting by a watch how many crests passed in a second. If five crests passed in a second, it could be said that the frequency of the waves was five a second. After the speed of the waves is known, the distance from crest to crest can be calculated. If the speed is ten feet a second, then the length of the wave is ten divided by five, giving as the result two feet. The speed of radio waves is known to be 300,000,000 meters a second. If the frequency with which the waves strike the antenna is also known, the distance from crest to crest can be calculated.

One of the characteristic features of sound is its frequency. Low frequency currents pass through cycles, while high frequency currents pass through oscillations. The number of waves taking place per second is known as the "wave frequency."

The coils and condensers, called the "inductance" and "capacity," of a transmitter are variable; that is, they can be tuned just like a receiv-



ing set; thus frequency or wave length can be varied at will. The coils and condensers are generally calibrated so the operator has only to move a handle or pointer over a scale to change the wave length of the transmitter. Then the receiving operator must adjust the coils and condensers of the receiving set to be in tune with the wave length of the transmitter, if he wishes to hear the signals. Otherwise the receiving set would be out of tune with that particular wave length. A receiving set may also be calibrated so that immediate and accurate adjustment can be obtained whenever a change in wave length is quickly desired.

#### HOW TO CALIBRATE A SET

The instrument used to measure wave length, thus making it possible to calibrate and adjust a transmitting or receiving set, is called a "wave meter." This instrument is merely a little transmitter and a little receiving set which always registers the wave length it sends or receives.

The wave meter generally employed for calibrating a receiving set consists of an ordinary buzzer, a small coil, and a variable condenser, the scale of which indicates the various wave lengths.

To determine the wave length of an incoming signal, the wave meter is placed near the ground wire of the receiving set. The receiving instruments are then tuned to the point where the signals of a transmitting station are loudest in the

phones. The wave meter is then made to send out all manner of wave lengths by patrolling the pointer over the condenser scale until the wave meter's buzzer is heard most loudly in the phones. The reading of the wave meter scale at that point indicates the wave length of the transmitter.

To adjust and calibrate a receiving set to some particular wave length, adjust the wave meter by means of the pointer and scale. When the buzzer is started, that definite wave length to which the wave meter is set will be radiated. Tuning adjustments are then made with the receiving set until the sound in the phones is loudest. Mark or make a note of the receiving set's adjustment. Thereafter all one has to do to listen-in on a particular wave length is to adjust according to the marks on the dials. To calibrate a set to 360 meters, the wave meter scale should be set at 360 meters. Start the buzzer and tune the receiving set to the point where the sound is loudest.

#### AMPERES AND VOLTS DETERMINE RANGE

The larger a stone and the greater the force with which it strikes the surface of a pond of water, the larger will be the waves. In radio, wave length has nothing to do with the power of the transmitter. The more amperes in the aerial circuit and the greater the pressure in volts between the aerial and ground, the more powerful will be the radio waves and the longer the distance over which they will spread.

When a Hertzian wave strikes an antenna in

tune with its particular wave length, a current similar to the transmitter current, but of decreased intensity, is induced in the wire. The receiving instruments place the operator in tune with the incoming waves; that is, by varying the amount of wire in the coils and the capacity of the condensers, the wave length or frequency of the receiver is made most responsive to the wave length of a particular broadcasting station. The stations are then said to be in resonance or in tune. The human ear cannot hear all frequencies. Frequencies below 10,000 cycles are known as "audio frequencies" because they are normally audible to the ear. All frequencies above 10,000 cycles are termed "radio frequencies" and are not audible to the unaided ear. It is the duty of the detector to convert the incoming high frequency wave to a frequency low enough to actuate the phones and produce sound audible to the human ear.

#### INDUCTANCE INCREASES WAVE LENGTH

When wire or inductance, as it is termed, is added to a radio receiving or transmitting circuit, the wave length is increased. For example, if your set is capable of tuning to 1500 meters and you wish to hear the Arlington, Virginia, time signals on a wave length of twenty-six hundred meters, a loading coil can be placed in series with the antenna lead-in. This has the same effect as increasing the length of the antenna. A loading coil is generally made variable, by taps taken off

to a multiple-point switch, so that the amount of wire can be varied and different wave lengths received. After the antenna is erected, it cannot be varied at will by the movement of a switch arm over an arrangement of contacts, and for that reason the loading coil is employed.

### SERIES CONDENSER LOWERS WAVE LENGTH

If the natural wave length of the antenna itself is 500 meters, it will be difficult if not impossible to pick up signals on 400 meters. A condenser can be placed in series with the antenna or ground to reduce the natural period or fundamental wave length of the antenna, but it does not tend for efficiency such as may be had from an antenna of the proper size and construction.

### HOW TO CALCULATE WAVE LENGTH

Wave length may be calculated to an approximate degree by adding the length of the antenna, length of the lead-in, and length of the ground wire, then multiplying the total length of all three by one and one half. For example, the antenna is 100 feet long, lead-in thirty feet, and ground wire twenty feet, making a total of 150 feet. Multiplying the 150 feet by one and one half, the result is 225, the natural period or fundamental wave length of the antenna.

### MEANING OF KILOCYCLE

The word "kilocycle" has been adopted to describe and identify radio waves, so that stations

may not only be referred to by wave length in meters, but also by frequency in kilocycles. The unit kilometer equals 1000 meters, or 39,370 inches, or 3280 feet, or about five eighths of a mile. The word "kilometer" is formed by combining "kilo" which means 1000, and "meter," which is the basic unit of length in the metric system. In the same manner the word "kilocycles" is formed by combining "kilo," or 1000, with "cycles," and therefore a kilocycle means 1000 cycles, generally per second. Thus, 511 kilocycles means 511,000 cycles a second.

Many may ask the question, "What is a cycle?" And further they wonder what is meant when it is said that a station radiates a wave of 511 kilocycles frequency. The frequency of anything is the number of times that it occurs over and over again in a given period of time. A good illustration is a clock pendulum swinging back and forth thirty times a minute. A complete swing from one side to the other and back is called one cycle of vibration, and it may be said that the pendulum swings or vibrates at a frequency of thirty cycles a minute. A small clock with a pendulum only one sixth as long will have a pendulum vibratory frequency six times as great.

Vibrations can be increased until it is no longer possible to see them. One radio expert who broadcast a talk relative to the use of kilocycles pointed out that the individual pictures that make up a moving picture appear at the rate of about sixteen a second. Eyes are not quick

enough to see each picture separately and so the motion picture is produced. We can hear a vibration of sixteen cycles a second, and that is the lowest note of a large church organ. The last key of the piano, which is C, has a frequency of 4096 cycles. Persons with normal hearing can hear two octaves higher than the highest note of the piano, or up to about 16,000 cycles. In order to get rid of the useless ciphers, sixteen kilocycles can be used instead of 16,000 cycles. A frequency of about eight kilocycles from the piccolo is about the highest a person can hear.

Some one has said that every broadcasting station, like every key on the piano, has its own characteristic wave frequency. The electric current at the radio phone station, its radiated waves, and the electric current that those waves produce in the receiving set, all have the characteristic frequency of the station. Consequently, frequency stated in kilocycles is a useful and accurate measurement of a radio wave. "Wave length" applies only to the waves in space. Frequency in kilocycles is universal throughout the transmitter, the waves, and the receiving set, and it tells the relations of interference between the waves.

#### WHY KILOCYCLES ARE USED

The Second National Radio Conference, which met in March, 1923, introduced the kilocycle method of designating radio waves. It has been pointed out by the Bureau of Standards that the

idea of kilocycles is simpler than the sound of the word suggests. The number of kilocycles indicates the number of thousands of times that the rapidly alternating current repeats its flow in either direction of the antenna in one second. The smaller the wave length in meters, the larger is the frequency in kilocycles.

The reason that kilocycles were adopted to replace meters is that the necessary separation of the frequency of transmitting stations to prevent interference is the same, no matter what the frequency may be. This necessary separation is variable and misleading when expressed in meters. Thus the number of radio messages transmitted simultaneously without interference can be correctly judged from kilocycles but not from meters.

### BEAT NOTES

A regular waxing and waning of intensity, sometimes in the form of a whistle, is produced by the interaction of two similar waves, having a slight difference in frequency. The difference between the interacting frequencies is called the "beat frequency." A 1000-pitch beat note will be audible when two waves having frequencies of 860,000 and 861,000 cycles interact upon the detector.

### HARMONICS

When a receiving station is tuned so that reception of a transmitter can be heard at two en-

tirely different points on the dials of the tuner, it is because of harmonics. When waves carry extra peaks and depressions riding on the main wave, they are said to have harmonics or overtones. Harmonics are incidental waves mostly noticeable in undamped or continuous waves. Harmonics differ in frequency and length to the true wave of the transmitter. If you tune your set to hear amateur transmitters or radiophone stations, and happen to hear a high-power long wave signal, although the set is adjusted for short wave reception, it is because of the harmonics of the big station.

#### THEORIES OF THE ETHER

Radio puzzled one of its followers to the extent that he asked, "If wireless waves travel around the world seven and one half times a second, why do we not hear the music more than once? What finally becomes of the waves and what is the ether?"

Marconi in one of his lectures said, "The question as to whether it would or would not be possible to send radio signals around the earth as far as the antipodes has always fascinated me." He explained that he thought signals from great distances do not always retain their direction in one great circle, but reach the receiving station from various ways around the earth. He called attention to the fact that observations made by means of loop antennæ or direction finders near the antipodes indicate that wireless waves from Eng-



land and Germany seem to arrive from all directions. Similar tests made in New Zealand showed that the messages from POZ, Nauen, Germany, appeared to travel by way of the South Pole, while signals radiated from the aerials of Hannover, Germany, seemed to arrive by way of the North Pole.

### STRONG SIGNALS AT ANTIPODES

A French experimenter cruising about the ocean near Australia made observations relative to the strength of European wireless signals and reported that the signals from Lyons, France, were much stronger when the receiver was exactly opposite Lyons. The same was true of signals from Nantes, France, when the receiving station was exactly at the antipodes of Nantes.

It is thought that the waves curve around the earth in all directions from the transmitting aerial, so the French signals reaching Australia come across the American continent and also over Europe. At the antipode they meet and reinforce each other, making signals stronger at that point.

Some believe there is a "wireless screen" around the earth formed by solar dust far up in the earth's atmosphere. This is based on the theory of Sir Oliver Heaviside. The theory has suggested the idea that this stratum confines the radio waves to the surface of the earth, preventing them from going on into the infinite. Dr. J. A. Fleming stated in one of his lectures that he believed long-distance radio communication

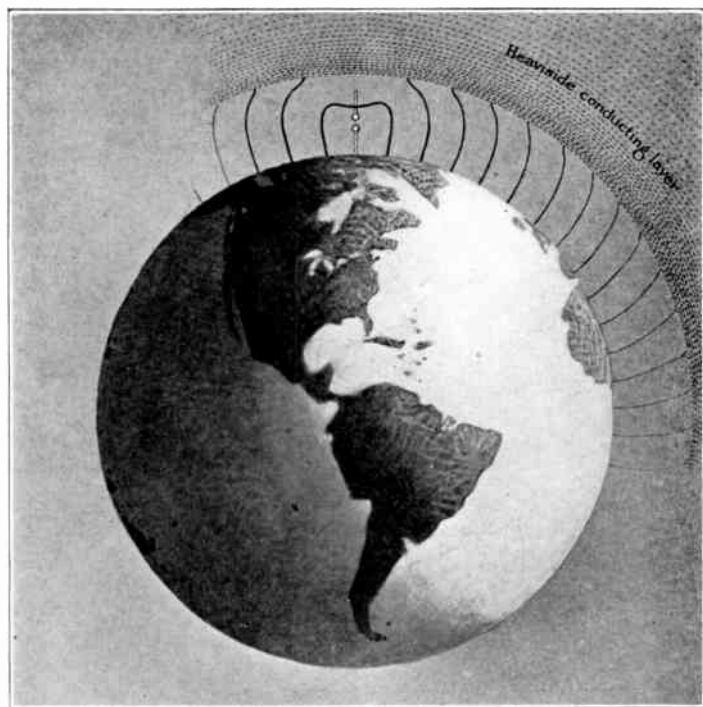

### THE HEAVISIDE LAYER THEORY

Some scientists assume that a hypothetical Heaviside layer, impenetrable to radio waves, bends the waves around the surface of the earth.



would be impossible but for some such force as the "wireless screen," forcing Hertzian waves to follow the curvature of the earth. Other scientists express the opinion that no such "Heaviside" layer exists.

Some who have studied the subject advance a "gliding wave" theory, according to which radio waves are guided by the earth's surface and therefore follow the curvature of the globe because of ground conduction, similar to the way a fly would crawl around the surface of a baseball. To prove this theory one scientist points out that, when the land surface between two stations is damp because of rain, improved transmission results, but is again decreased when evaporation dries the land. The fact that transmission is far better over the sea than over land also indicates that the surface of the globe must play an important part in guiding the ether waves and that a "Heaviside" layer has little to do with it.

Dr. Charles P. Steinmetz declared, "There are no ether waves." He believed light and radio waves to be merely properties of an alternating electro-magnetic field of force extending around the earth.

Einstein, in a lecture on the ether and the theory of relativity, delivered at the University of Leyden, stated that according to the general theory of relativity space is endowed with physical qualities, and that in such a sense the ether exists, because without it propagation of light would be impossible.

Sir Oliver Lodge thinks there is such a medium as the ether, and he gives a good conclusion for such a discussion by stating that the theory of the ether has not yet been worked out, that its properties are largely unknown and remain to be discovered.

#### SEVEN TRIPS AROUND THE WORLD INSTANTANEOUS

If a radio signal could go around the world seven and one half times in the twinkle of an eye, each time with the same intensity, the human ear would detect only one signal, for the trips around the globe would be practically instantaneous. A musical tone or word carried by radio is like the seconds of time ticked from the master clock of the nation at the Naval Observatory, Washington, D.C., and broadcasted by station NAA, at Arlington, Virginia. Radio time ticks like those direct from the clock never return, but are lost in space forever. A group of musical notes are a lost chord after they once leave the aerial and encircle the earth.

#### ABSORPTION LOWERS RANGE

The ideal medium for radio waves would be a perfect insulator in which no absorption would take place. However, as the Hertzian waves move across the earth's surface they encounter conditions both favorable and unfavorable to their propagation. Moisture and dust in the air and sunlight help to absorb energy from the

waves. If the conductivity of the earth is low, the ether waves surrender power in overcoming the resistance. That is one reason why signals travel much greater distances over bodies of water. On land, large conducting objects, such as skyscrapers, steel bridges, wires, trees, and mountains containing metallic substances, take energy from the passing waves.

If the objects are good insulators, the waves have little difficulty in passing through, but when they encounter great steel buildings such as stand aloft on Manhattan Island a short-circuiting effect takes place. A gap is left in the wave front, but as the rest of the wave continues in its flight, the gap is closed up, although some of the energy at that point is reduced. A similar effect takes place when the wave strikes an antenna, but in such a case only a minute fraction of the power is intercepted. A good illustration of this effect is a bather in the surf. After striking the person in the surf, the wave rolls on toward the beach and the little gap is closed up by the rest of the wave.

#### FADING

A waxing and waning, or periodical dying out of signals is known as "fading." The best explanation of fading is theoretical. Two years' study of fading, conducted by the Bureau of Standards, in conjunction with members of the American Radio Relay League, throughout the United States, resulted in the following conclusions concerning this phenomenon: The chief cause of fad-

ing is absorption by conducting surfaces, such as the earth and ionized atmosphere. The causes of fading are intimately associated with conditions at the "Heaviside" surface of the atmosphere, which is a conducting surface about sixty miles above the earth. Fading occurs more pronouncedly on short wave lengths and is strongest at about 250 meters. A changing barometer or clouds at the transmitting station do not have an effect on signal strength. Clouds in the vicinity of the receiving station are conducive to strong signals, but are likely to be accompanied by static. The presence of near-by land wires has no effect on fading. Waves transmitted at night are free from the more uniform absorption encountered in the daylight. These conclusions are the result of 5684 observations, participated in by ten transmitting and about one hundred receiving stations. It is thought that daytime transmission is largely carried on by means of waves moving along the ground, and night transmission is by means of waves transmitted along the "Heaviside" surface. Thus signals transmitted at night, especially over great distances and on short waves, are free from the uniform absorption encountered in the daytime, but are subject to great variations caused by irregularities of ionized air at or near the "Heaviside" layer. The boundary of the "Heaviside" layer is constantly shifting, resulting in varying intensity of the signals.

Fading and swinging of radio signals may be caused by a permanently ionized region above

the "Heaviside" surface, which as a good conductor is impenetrable by the waves. However, this theory cannot be absolutely established, although at the present time no experimental fact reverses the theory. From the electrical standpoint the atmosphere is not a perfect dielectric or insulator, for the gases constituting it are ionized by the influence of cathodic rays from the sun, bombardment by cosmic dusts, ultra-violet rays, and radio-active substances constituting the terrestrial crust.

#### WHY RADIO TRAVELS FARTHER OVER WATER

Radio waves travel farther over water than over land, owing to the absence of obstructions at sea which tend to absorb the strength of signals. Trees and many other objects on land take energy from the Hertzian waves. Trees, especially in the summer, when full of sap, absorb considerable radio energy from the surrounding ether.

Radio apparatus on board ship is so arranged that the hull of the vessel serves the purpose of the ground on shore. This connection in the salt water affords an excellent "ground" and in most cases surpasses the ground contact of a shore station. This good ground is a great help to long-distance transmission and reception.

#### SUN WEAKENS RADIO

Many radio enthusiasts, especially those located more than a hundred miles from a broadcasting station, begin to think there is something



wrong with their receiving instruments or batteries in the Spring because the music and voices in the ether lose their volume and distant stations disappear. But the instruments are not at fault.

The weakened signals are caused by Old Sol's summer trip toward the north. It is estimated that the sun's rays decrease the strength of radio signals about seventy per cent. Many times a ship's spark signal can be heard with great intensity throughout the night hours of darkness; then suddenly its strength fades, or, to use the wireless term, the signals "swing." It is a condition which indicates that dawn is sapping the strength of the distant ship's messages. Then the radio man on shore transmits "QRX" — stand-by. As soon as evening envelops the ocean again, the signals come back even stronger than the previous night, if the vessel has been moving nearer to the shore receiving station throughout the hours of daylight.

With the last few days of August, radio begins to regain its full strength as the sun moves south taking with it the great tormentor of the ether-static, or atmospheric electricity. At times, especially during winter nights, ordinarily feeble signals from far-distant stations can be heard with a great increase in volume. This is called freak transmission, a condition under which many an amateur has established the range record for his station. Winter's atmosphere, with its freak conditions of the air, often makes possible a clearer signal from a far-away station than from

a near-by transmitter. An operator in Maine might be talking with a ship a few miles off the coast only to be interfered with by freak signals from Miami, Florida, with such clearness as to make it impossible to hear the messages from the vessel despite its power and proximity. Peculiar layers of winter atmosphere seem to carry the messages without much loss in transmission, and thus amazing results are accomplished.

#### EFFECT OF WEATHER ON RADIO WAVES

Radio followers in the days when radio was known as wireless were practically all in the schoolboy class. From their schoolroom windows they kept a watchful eye on the weather in an effort to determine just what kind of a "wireless night" would arrive under the cover of darkness. Now radio listeners are everywhere, in schools, offices, and homes. Many grown-up persons watch the Weather Man's forecasts to learn if the weather of the approaching night will be favorable for long-distance radio reception. The weather, to a great extent, determines whether a receiver in New York will pick up voices with Bostonian accent, one from "Out Where the West Begins," or the Southern drawl telling the world that "This is Atlanta, Georgia." What radio forecast accompanies clouds and fog? What is the effect of moonlight and of the aurora borealis on the electro-magnetic waves of radio?

### DARKNESS AIDS RADIO TRANSMISSION

Observations made during the winter months show that good radio transmission across overland distances at night is preceded the day before by cloudy conditions in the region across which the message is to be sent. Particular experiments, conducted by radio experts, have shown that out of sixty cases of good transmission forty-four have followed a generally cloudy sky over the area in which the experiments were carried on. Of the remaining sixteen cases, the majority fell during the shortest days of the year when the hours of sunlight were few. Signals broadcast just at dusk, during cloudy conditions, have covered a radius of three hundred miles, and less than an hour later, after darkness had set in, signals from the same transmitter were clearly heard for one thousand miles. The barometric pressure was low on the days preceding twenty-four of the sixty cases of transmission, and in areas of low barometer the sky is usually cloudy. In only two of the twenty-four cases was there a record of bad transmission.

Scientists believe that the aurora borealis is produced in a rarefied atmosphere, where electrons traveling at a high speed create a luminous phenomenon. Such being the case, the aurora takes place in extremely high regions where it is believed electro-magnetic waves are not likely to reach. Reports from radio operators support the theory advanced by scientific observers that the

aurora borealis has only a slight if any effect upon radio transmission and reception. Displays of aurora borealis greatly affect land telegraph lines and transoceanic cables, often making it impossible to operate them. During a spectacular display of "Northern Lights" in the spring of 1919, land lines throughout New England and Canada were completely crippled, but the radio of ships and shore stations from Boston to Halifax experienced no ill effects.

Moonlight has no appreciable effect upon radio transmission or reception in the northern section of this country, but operators who have sailed through the tropics say that the moon has a tendency to weaken signals in the southern climes. The effect is more noticeable in connection with spark signals.

Fog generally weakens the strength of radio in that the air and objects enveloped by fog are damp. Dampness makes them better conductors of electricity and causes them to absorb the Hertzian impulses or lead them astray to the ground. The ideal night to establish long-distance radio records is the one having the cold, clear atmosphere of winter, just after a storm, with its low-hanging clouds, has cleared away.

#### WHY WAVES ARE CALLED DAMPED AND UN-DAMPED

There are two distinct types of radio waves, namely, damped and undamped. The first wireless telegraph waves were produced by an electric

spark jumping across an air gap between two electrodes, known as the "spark gap." A spark transmitter produces damped waves. The name "damped" is given to the spark impulses because they dampen or die quickly, not continuing with the same strength indefinitely. It was a spark set which vibrated the ether with distress calls from the S.S. Titanic.

Undamped waves have almost the same force throughout their entire length and therefore are used for long-distance communication. Many of the transatlantic liners are now equipped with undamped wave transmitters enabling them to keep in constant communication with land throughout the voyage.

There are three methods of producing undamped waves suitable for radio work: first, by an electric arc; second, by means of a high-frequency alternator; the third and latest method, by means of high power vacuum tubes.

Soon after Marconi first spanned the ocean with spark waves it was realized that the spark system was not efficient or reliable for long-distance communication, so the necessity for a better method developed the electric arc transmitter. In 1906, the Telefunken arc succeeded in covering a distance of twenty-five miles. Professor Poulsen perfected another arc transmitter in 1908, and the initial test sent a message over 150 miles. In 1917, the Alexanderson high-frequency alternator made its appearance with ability to develop two hundred kilowatts.

This system made trans-ocean radio service reliable.

#### VACUUM TUBE TO REPLACE ALTERNATOR

Great stations were built worth millions of dollars only to find several years later that there was still a superior method — the high-power vacuum tube. A twenty-kilowatt tube, many times the diameter and length of the ordinary radio-tron, has been invented and is destined to replace the large and expensive alternators. A bank of ten such tubes is capable of generating two hundred kilowatts, furnishing sufficient power to easily bridge the ocean and encircle the globe. On January 14, 1923, these water-cooled tubes installed at Rocky Point, Long Island, made possible a three-hour conversation with Southgate, England, where Marconi among others listened to the words coming through 3400 miles of space. The words were just as distinct across the sea as if sent over a few miles of telephone line.

The vacuum tube transmitter has a tremendous advantage over the cumbersome alternator in that it can be built in compact form. When the current is passed through the tubes, oscillating currents are set up in the circuit and are radiated from the aerial wires in every direction, similar to the spark, arc, and alternator installations. The undamped wave method has many advantages over the damped or spark system of transmission.

### UNDAMPED WAVES SUPERIOR

Undamped waves are superior to damped waves because of the extreme sharpness of the radiated wave, allowing selective tuning and a minimum of interference at receiving stations. Another advantage is that higher transmitting speed can be attained by the use of undamped waves. Some stations have apparatus capable of sending one hundred words a minute under favorable atmospheric conditions.

Absorption of the energy by the sun's rays is responsible for the greatest losses affecting radio transmission. Loss from absorption in the case of undamped waves is much less than with the damped or spark signals. That is one reason a ship equipped with a continuous wave transmitter can work with either American or European shore stations at any time during the trip across the sea. The average spark set on board ship cannot reach shore after the vessel is out three days.

Radio telephony would not be possible without undamped waves. In their continuous form such ether waves serve as a path through the air along which the voice and music can travel as over telephone wires.

### PURE WAVE DEFINED

Government regulations require transmitters to emit a "pure" wave; that is, one having at least ten times the energy of any other wave which

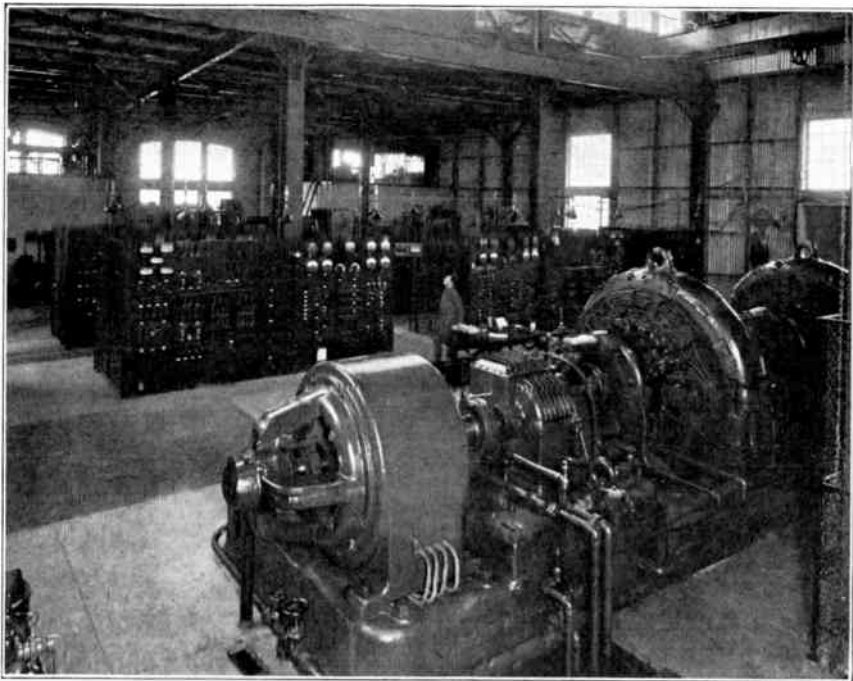

**A TWO-HUNDRED-KILOWATT RADIO FREQUENCY ALTERNATOR**  
Alternator and switchboards of Broadcast Central, Rocky Point, Long Island, developing sufficient power to flash a message around the world seven and a half times in a second.





may be radiated from the circuit. A pure wave necessitates fine tuning at the receiving station so that just a slight adjustment of the instruments will tune the signals in or out. This tends to minimize interference when two or more stations are transmitting at the same time. Still another class of Hertzian wave is the broad wave, which is not sharply defined and can be heard on a number of different wave lengths. A broad wave is generally used in times of distress, for it is more likely to be picked up than a sharp wave, because all operators listening-in may not have their receiving sets tuned sharply. The factor which determines whether a wave is sharp or broad is the tuning adjustment of the coils and condensers in the transmitting circuit.

#### THE HUMAN EAR CAN HEAR 300,000 SOUNDS

The pitch of high-power transatlantic wireless signals, unlike music from broadcasting stations and code from spark transmitters, can be raised or lowered at receiving stations by varying the coils and condensers. This enables the operator to adjust the signal to a low tone or high whistle, whichever is most pleasing to his ear.

It frequently happens that two operators listening-in with the same set find it difficult to adjust the signal's pitch so both can copy the messages with the same ease. A good illustration of this occurred in a naval receiving station on the Atlantic coast. Two operators were on the POZ, Nauen, Germany, watch. The operator tuning in

the signals suddenly began to copy, but the other operator could not hear a sound. It was found that the operator tuning in the dots and dashes adjusted them at a pitch pleasing to his own ears, but entirely out of range of the other operator's hearing.

It is known that all ears are not equally sensitive to all pitches. Those who have studied sound and hearing calculate there are 300,000 sounds audible to the human ear. By measuring the hearing of a number of normal ears there has been established a standard for normal hearing. This is accomplished by finding the total number of "pure tones" audible to a group of persons with normal hearing. A pure tone is one in which there is no mixture of other tones. It is specified by its pitch and loudness. Pitch is determined by the rate of vibration and loudness by the intensity of the vibration. An instrument called the "audiometer" makes possible accurate measurement of the hearing.

#### PARTIALLY DEAF CAN HEAR RADIO

Many cases have been reported where people partially deaf, unable to hear sounds spoken in their presence, could hear radio music when phones covered their ears. This is thought to be due to a concentration of sound which, unlike sound spoken in a room, is not dispersed through the air.

### "DEAD SPOTS" IN THE ETHER

The Bureau of Standards and many experimenters have tried to determine the cause of "dead spots" in the ether, which seem to form an almost impenetrable barrier for radio between a number of cities in the United States and Canada. Montreal hears Philadelphia concerts clearly, but sections of New York State, which lie between, have difficulty in hearing the Quaker City music with any volume. Philadelphians report trouble in hearing Newark and New York stations, as loud as KDKA at Pittsburgh. A pronounced "dead spot" is said to exist in the ether tract between Baltimore and Washington, D.C. "Dead spots" are thought to be caused by partial absorption of the ether waves.

Ship stations in Long Island Sound find it difficult to establish communication with shore stations on the Atlantic side of the island, although the widest point across the island is only forty miles. When ships are close to the Jersey coast, much trouble is experienced in establishing radio contact with New York if the distance is over sixty miles. Listeners in Atlantic City report trouble in picking up loud signals from Philadelphia and New York. It is thought that this may be caused by the sandy nature of the soil, containing metallic particles, which have a tendency to absorb the electro-magnetic waves. It is a well-known fact that sand dunes have a shielding effect.

### TESTS REVEAL "DEAD SPOTS"

Radio auditors receiving from local stations have observed that two equally powerful stations equally distant from the receiving antenna, but in different directions, do not necessarily give equal signal strength in the receiver, and again a friend in a different section of the city may get quite different results. These variations in many cases are chargeable to the use of different receiving equipment, but, after these factors have been canceled, it is found that variations in reception over short distances are caused by inequalities of distribution which depend on the physical character of the landscape.

Engineers of the American Telephone and Telegraph Company have made a study of irregularities in transmission over short distances. Results of this study in the urban and suburban districts of New York and Washington, D.C., were revealed in a paper presented before the Institute of Radio Engineers.

It was pointed out that energy radiated from a radio aerial spreads out in all directions, diminishing rapidly at first and then more gradually, until finally at considerable distance it becomes too unstable to be discernible. Characteristics of the earth's surface which affect radio transmission have been classified as follows:

(1) Areas of different electrical constants, such as fresh water, salt water, dry land, wet land, rock, and snow. (2) Differences in elevation,

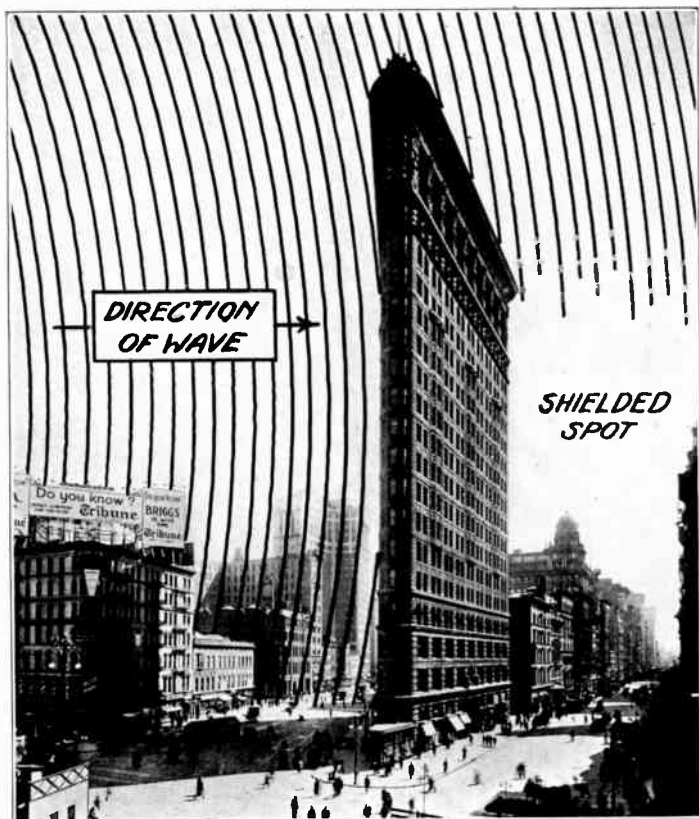

ONE WAY "DEAD SPOTS" ARE CREATED IN THE ETHER  
A wall, especially in the form of a building that is largely of metal construction, if located between a receiving set and a transmitting station, will obstruct and deflect radio waves, creating a "dead spot."



such as hills, valleys, and mountains. (3) Absorbing structures, including buildings, towers, and other structures, many of which have resonance characteristics producing selective absorption.

Engineers of the American Telephone and Telegraph Company used a short-wave measuring set to obtain the data presented to the Institute of Radio Engineers. In order to cover the ground rapidly, the outfit was mounted in an automobile. The data contained in the paper represented the results of about two months of field work during which the automobile carrying the radio measuring apparatus traveled three thousand miles.

The first measurements were made around Washington in the summer of 1923. Station WCAP, operating on 469 meters, was used as the transmitting station in the tests. Observations made over alternating steep and flat portions of the land brought out clearly the effect of different electrical characteristics of the land and brackish water over which the radio waves passed. At the foothills of the Blue Ridge Mountains the rate of falling-off of signal strength increased until a low point registered in the shadow of the mountain range.

This was explained as follows: "If the ground is considered to be a fairly good conductor, penetration of the waves will not be great, and there will be but little transmission directly through the mountain. As the waves pass the crest, the



bottom of the wave front is stretched and the strength reduced. Simultaneously the wave front is given a forward tilt. Since the flow of energy is perpendicular to the wave front, this means that energy is being fed-down from above. The effect of feeding-down of energy gradually erases the 'shadow' after the mountain has been well passed. What occurs is thought to be similar to the diffraction of light."

Observations made near the Blue Ridge Mountains gave a general indication that land elevations cause "shadows" in the ether. Wide variations in the attenuations caused by different surface conditions were shown by a simple calculation which disclosed that, at a distance of sixty-two miles from a 400-meter transmitting station, the salt water factor gives a received field strength about seventy times as great as that given by the dry land sand factor.

The situation is much the same in cities as over open country except that large steel buildings make the effects more intense. Station WEAJ, operating on 492 meters, was used in the New York tests. The measurements were taken in the fall of 1923. Measurements were taken on the Hudson River, where a clear line to the station was obtainable; at City Hall Park, and on a boat just off the Battery. A heavy "shadow" was found to exist between City Hall Park and the Battery. This shadow is explained by the same reasoning as was used to explain the "dead spot" behind the Blue Ridge Mountains. The research

engineers called attention to the fact that the skyscraper area is not only a great hill of steel lattices, but that this hill is divided by deep criss-crossing cuts of the streets into a group of lattice pillars. These pillars have natural electrical oscillation frequencies near the frequency of transmission, and so are excellent absorbers of radio waves. It is thought that this greatly contributes to the sharpness and depth of the "shadows." These "shadows" expose the puny size of landscape features, including the skyscrapers, in comparison with the vast overhead space through which the Hertzian waves are propagated. The wave fronts, rising to great heights, proceed forward for hundreds of wave lengths, with an irresistible sweep. At their feet the objects on the surface of the earth tend to drag them downward and cast obstacles in their path, but the gaps are quickly healed as the greater store of energy above is partially directed downward.

Tests made on board a boat in the East River showed that Queensboro Bridge caused a "dead spot" in the ether. The fact that signal strength over the river is much larger than over the adjacent city causes a continual feeding-in of energy from the river to the land. This is closely analogous to the refraction of light.

It was found that radio waves traveling over New York are reflected, refracted, diffracted, and re-radiated. Heavy local distortion of the waves was noticed near buildings, which themselves were in resonance or in tune with the transmit-

ting frequency used. On the west side of the city, feeding-in from the unobstructed ether over the Hudson River is present, as on the east side. Central Park, surrounded by the city on all sides, has a big "dead spot."

Except for the effect created by the city of Newark, it was found that the Hertzian waves spread widely apart in response to good transmission over the New Jersey meadows.

### MOUNTAINS DEFLECT WAVES

Signals from Pittsburgh are said to be feeble when they reach Cleveland, Ohio, and a similar condition exists between Boston and the western section of Massachusetts. It is the opinion of some who have studied this particular "dead spot" that the iron deposits in the Monson district serve as a shield and prevent the Boston signals from reaching the other end of the State with much strength. Since the early days of wireless it has been thought that hills and mountains absorb and deflect the Hertzian waves. The naval radio station at Otter Cliffs, Bar Harbor, Maine, is located in a sort of horseshoe-shaped pocket formed by two mountains with the opening toward the east. This station is noted for reliable reception from European stations and from ships at sea. Distress calls originating nine hundred miles east of Bermuda have been picked up at Otter Cliffs when no other station along the Atlantic seaboard seemed to hear the "SOS." Experts advance the theory that ore deposits in the

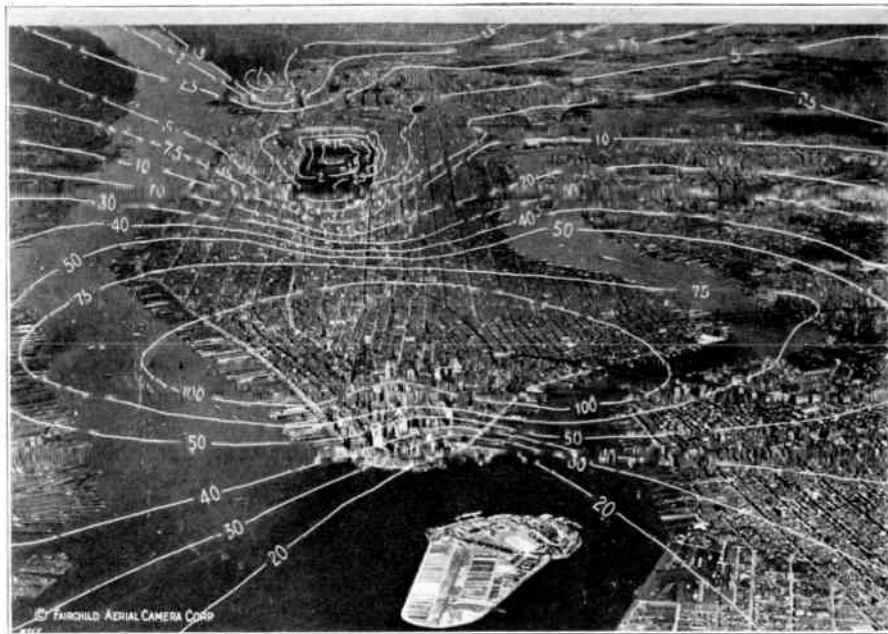

**DISTRIBUTION OF RADIO WAVES THROUGH THE METROPOLITAN AREA  
OF NEW YORK, SHOWING HOW IT IS INFLUENCED BY SKYSCRAPERS**

The numbers indicate ether field strengths in millivolts per meter. Note that the tall buildings at the tip of Manhattan Island cause a radio "shadow," so that the intensity observed in the neighborhood of South Ferry is only one fifth of the value in the neighborhood of the Woolworth Building. The region of Central Park is a very noticeable "shadow."



mountains act as a "back stop" for the waves, deflecting them to the antennæ in the valley.

#### TREES ABSORB ENERGY

Signals in transit across forests have lost much of their power, especially in the spring and early summer when the sap and foliage make the trees better conductors of electricity. Radio waves passing through the trees give up energy just as in striking a skyscraper. If a short length of wire serving as an antenna can intercept sufficient power from a passing wave to create a sound which can be heard several hundred feet away from the "loud-speaker," one can realize how much energy must be intercepted by trees, steel buildings with electric wires and pipes connected directly to the ground. Such absorption is more noticeable when short wave lengths are used.

When a wave length is eight to fourteen miles long, "dead spots" seem to cause little interference. Such a wave is comparatively long compared to the Woolworth Building and other skyscrapers, and for this reason it is thought that they do not obstruct the wave's path to such a great extent.

#### SAY CABLES ABSORB ENERGY

One theory given to account for "dead spots," chiefly the one supposed to exist between Washington and Baltimore, is that numerous high-tension cables and conduits absorb the radio impulses. Yet, despite the great network of high-

tension lines radiating from Niagara Falls, listeners in that locality find it ideal for reception of radio concerts played on the Atlantic and Pacific coasts and all other directions.

The most plausible theory to explain "dead spots" seems to be the presence of mineral deposits in the hills and mountains. However, the direction in which the transmitting aerial and receiving antenna point has a great deal to do with the strength of signals from different directions. Ships have been known to receive strong signals from distant stations when suddenly a shift in the course would point the antenna in a different direction and signals would become faint. If the antenna extends east and west with the lead-in taken off the western end, it will favor reception from the west. Imagination coupled with directional effects of the antenna has helped many radio listeners to have visions of "dead spots," in the ether surrounding their homes.

#### STATIC ELECTRICITY

Dr. Charles P. Steinmetz hurled artificial lightning about his laboratory in Schenectady, and in the Spring of 1923, Giuseppe Faccioli tossed 2,000,000-volt thunderbolts about the General Electric laboratory at Pittsfield, Massachusetts, destroying miniature churches, trees, and houses.

Through such study and research something may be learned of lightning that will open a pathway for the discovery of a means to eliminate in-

ference created in radio receiving sets by Nature's thunderbolts. Men marvel as they hear the powerful crack of artificial lightning controlled at will by one human being, yet the little scratches in radio phones caused by disturbances in the sky remain a puzzle and are uncontrolled.

Atmospheric disturbances known as "static" or "strays" are the greatest obstacles to perfect radio reception. Such interference is strongest in the northern section of the world during the summer. Observations show that at least three kinds of atmospheric disturbances exist, all of which arise from different causes.

The most common type produces a frying or grinding noise in the phones and is called "grinder" static. The second type, caused by lightning flashes, renders a sharp click in the phones. The third type creates a hissing noise and frequently occurs during a heavy snowstorm. Lightning clicks and hissing static produce little interference with communication because they are generally local and last only a few hours.

#### SOURCES OF STATIC

Grinding static is the most troublesome. It is thought to originate in the upper atmosphere. During a trip Marconi made across the Atlantic in 1922, he observed static, and reported that up to about halfway across the ocean disturbances appeared to be coming mainly from the African coast. At more than halfway across, the strays seemed to have their origin over the American



continent. This was taken to indicate in a general way that the sources of static were chiefly over the land.

Observations made by radio engineers show that up to very high wave lengths the increase in static intensity is proportional to wave length. One experimenter has estimated that static is about twenty times as strong on 17,000 meters as at 3000 meters. Other observations show that above 25,000 meters there is a marked decrease in static intensity.

Some believe static to be entirely aperiodic. Others disagree. It is thought that static consists of a multitude of distinct disturbances coming from various sources and all on different wave lengths, so that to whatever wave length the receiving set is tuned a corresponding static wave length is found.

Observations made at a number of stations along the Atlantic coast indicate that heavy static in the afternoon and night originates in the southwest. The morning disturbances and those of the cooler months seem evenly distributed in regard to source of direction.

#### STRAYS FORECAST STORMS

Static is generally at a minimum about 1.30 A.M., and just after dawn. Its maximum strength is reached from 10 P.M., to midnight. Receiving operators often find static heavy about noon, 7 P.M., and 3 A.M., but the greatest disturbances prevail during the last two hours of the day.

If static is noisy in the phones from about 6 A.M. to 10 A.M., it can generally be considered as a forecast for an electric storm, not far distant.

A study of atmospherics reveals that the intensity varies greatly from year to year. A research showed the average static during August, 1917, to be about three times as strong as that of August, 1918, and August, 1919.

Up to the present time no successful method has been discovered to eliminate static entirely. Special efforts were directed toward the production of a static eliminator during the World War because the disturbances were generally strongest at the time of day when the European signals were weakest at receiving stations in the United States, due to the weakening effect created by the sun's rays. Several methods were devised by the use of closed loops and underground or underwater antennæ. These were all unidirectional and such a feature explains why static could be minimized. The antennæ were directed to pick up signals from the east, and since the most troublesome static came from the southwest its interference was reduced. These methods were operated on long wave lengths and required large outdoor loops and wires extending underground or under water for over 1000 feet.

Practically nothing has been accomplished to eliminate static from short wave lengths as used by the broadcasting stations. It is probable that when a means of elimination is discovered, it will be adaptable to all wave lengths. Static presents

no danger to the radio set properly installed and equipped with a lightning arrester or lightning switch. Danger is not the reason radio engineers are trying to eliminate static from the receiving set. The incentive for an eliminator is interference. Static must be filtered out of receiving sets before radio communication can be perfect and absolutely dependable.

### STATIC WITH SNOWSTORMS

Static is more troublesome in the summer than in the winter. It is always heavy in the tropics. However, many will be surprised to know that static does prevail at times during the cold weather, so strong as to make reception impossible.

Heavy static often accompanies heavy, wet snowstorms, and blizzards. One of the finest receiving stations in the country during the World War was at Otter Cliffs, Bar Harbor, Maine. Little receiving shacks in which signals from European stations were received stood several hundred feet from the spark receiving station. One February afternoon a blizzard blew across the Maine coast. Static increased as the storm progressed, but it did not bother the receiving sets tuned to high wave lengths and operating in connection with large rectangular loop antennæ. But at the spark receiving set, in tune with 600 meters, the static raised havoc with the detector, jumped the micrometer safety gap, and across the variable condenser plates, causing the receiv-

ing circuit to act as a little transmitter. Operators listening on high wave lengths complained of interference, sounding like a series of clicks. It was traced to the spark receiving set. The lightning switch was thrown, grounding the antenna of the spark set, and all "QRN," interference, stopped. "QRN" is the international abbreviation which to all wireless operators means "static."

The strength of radio current at the receiving set has been estimated to be one millionth of an ampere. Thus we see why the heavy atmospheric electricity such as lightning registers in a loud, crackling noise in the phones and reigns supreme as interference. The only means the feeble wireless wave has to combat the static at present is to use a high-pitch, whistle-like note, which tends to pierce through the atmospheric disturbances.

## CHAPTER III

### ANTENNÆ

THE antenna is one or more wires suspended above the ground and insulated from it and used to intercept energy in the form of electro-magnetic waves, as produced by a transmitting set. When used for transmitting purposes the correct name is aerial. A well-constructed antenna is essential for radio receiving.

Several kinds of wire may be used for the antenna. No. 14 hard-drawn copper wire serves well for the average receiving station. Stranded wire, especially phosphor bronze, has great durability and therefore will withstand heavy strains should the elements of the weather such as wind, ice, and snow demand an extra strong antenna. A second advantage of stranded wire is that it offers a larger surface over which the high frequency radio currents can travel with greater ease, because they skim over the surface of a conductor and not through it.

#### ANTENNA HAS FUNDAMENTAL WAVE LENGTH

Many are of the opinion that the more wire in the antenna, the greater will be the distance covered and the louder the signals. This is not true. Much of the code interference broadcast listeners have trouble with comes from 600 meter commercial stations, and the reason the code

cannot be tuned out is because the natural wave length of the antenna is too large. The fundamental or natural period of an antenna is the wave length the antenna will radiate or pick up because of its own inductance and capacity. The antenna wire itself is inductance, because a magnetic field may be produced around the wire. The capacity of the antenna is determined by its relation to the ground; that is, the height and area over which it spreads. If too much wire is used in the antenna, the natural wave length will be so great that low wave lengths cannot be tuned in. It is practically the same as employing too large a tuner. The antenna should be so constructed that the operator can tune in signals transmitted on a wave length shorter than the fundamental. As pointed out previously, code interference on 600 meters can generally be completely eliminated from the average set by using a variable condenser in series with the antenna or ground. Such a condenser is called a "series condenser." If connected in the antenna, the lead-in wire will go to one binding post of the condenser and the other terminal will connect with the antenna binding post on the set. The smaller the capacity, the greater will be the cut in wave length.

#### PROPER SIZE FOR ANTENNA

To pick up efficiently, concerts passing through the ether on wave lengths ranging from 200 to 550 meters, the ideal antenna is a single copper

wire antenna about 150 feet in length, including the length of the lead-in wire. The antenna should be as high above the ground as possible and clear of all objects such as trees, electric wires, steel structures, and telephone lines. If the antenna must be erected in the vicinity of electric or telephone wires, it should run at right angles to them. The height of the antenna is measured at the middle point. If the antenna slants, the middle point is lowered. The length of the lead-in and ground wire should be as short as possible. Length added to these wires increases the wave length.

#### CAPACITY ANTENNA MOST POPULAR

Antennæ are divided into two distinct classes — the capacity antenna and the magnetic or loop antenna. One wire or group of wires elevated in the air between two supports or masts form a capacity type antenna, so named because in its relation to the ground it forms a big condenser. The wires and the earth, both conductors of electricity, serve as the plates of this large condenser and the air between as the dielectric or insulating material.

#### ANTENNA INSULATION

An important consideration in the erection of an antenna is good insulation in order to prevent leakage or loss of energy through antenna supports to the ground. The tendency for leakage is more pronounced in damp weather, a condi-



**AERIALS OF BROADCAST CENTRAL ON THE ROOF OF  
ÆOLIAN HALL, NEW YORK**

Two transmitters are used, one by Station WJZ and the other by WJY, and programmes are broadcast simultaneously on different wave lengths, 455 and 405 meters.





tion which makes wood and other substances better conductors of electricity. At each end of the antenna wire should be placed a composition antenna insulator. Porcelain cleats, as used in electric wiring, may be used to insulate the antenna, but these insulators are likely to crack when subject to strain. Moulded insulators have rings embedded into the insulating substance, thus providing suitable means for attaching the wires and at the same time adding to the ability of the insulator to stand up under strain. Most antenna insulators of the composition type are provided with corrugations or grooves which lengthen the surface of the insulator, making the path of leakage longer.

The lead-in wire — that is, the wire leading from the antenna proper to the instruments — should be thoroughly insulated from all objects with which it may come in contact. The lead-in should be at least one foot from the side of a building. The antenna wire does not need an insulated covering. There is no difference in the results obtained from bare and insulated wire. Bare wire is less expensive and its lighter weight recommends it for use as the antenna.

The entrance of the lead-in through the walls of a building to the radio set presents a problem which is easily solved. Cut a board the same width as the window frame and fit it below the window similar to a window screen. Then the window can be dropped, thus keeping out the cold blasts of winter, rain or snow. A hole should

be cut in the board large enough to hold a porcelain tube insulator through which the lead-in can be passed.

#### CARE OF ANTENNA

There is no necessity for a joint in a single wire antenna. The wire forming the antenna proper should be purchased long enough to extend to the receiving set without a break. A joint in the wire, although it may be soldered, is likely to cause some resistance. If the wire needs to be spliced, it should be scraped clean, twisted and soldered, and then covered with tinfoil and insulating tape to protect it from the weather and dirt. Pulleys can be used to raise and lower the antenna from the masts. If rope is used to hold the antenna to the supports, it should be replaced about every six months so that the rope will not give way when extra strain is encountered.

#### DIRECTIONAL EFFECTS

When erecting an antenna some thought should be given to the broadcasting stations from which reception is most desired. Antennæ are directional. If a single wire points east and west and the lead-in is taken off the western end of the antenna, signals will be received better from the west. If a person in Buffalo, New York, desires to hear southern stations, just as efficiently as possible, the antenna should point north and south with the lead-in off the southern end.

## TYPES OF ANTENNÆ

There are several types of antennæ, among them the inverted "L," the "T" type, umbrella, vertical, fan, cage, and loop.

The inverted "L" is used by the majority of broadcast listeners because of its efficiency, convenience of installation, and simplicity. It consists of one or several parallel wires stretched horizontal to the ground with the lead-in connected at one of the ends. After such an antenna is erected, the main wires of the system and the lead-in resemble the letter "L" turned upside down, and thus its position and shape in the air gives it the name inverted "L." It receives most efficiently from the direction off which the lead-in is taken.

The "T" antenna is built the same as the inverted "L," the only difference being the position of the lead-in, which is taken from the center of the antenna instead of from one end. This form of antenna is not as good for receiving as the inverted "L," although it serves well for transmission. It is directional from both ends.

The umbrella type antenna is more popular for transmission than for reception and is of advantage where space will not permit an antenna to be stretched out. To construct an umbrella antenna, a pole is erected for the center support and a number of wires radiate downward from the top similar to the ribs of an umbrella; hence the name, "umbrella antenna."

The wires are insulated from the mast and ground. The lower ends of the wires should be at least twenty to thirty feet from the base of the supporting mast. The lead-in wire is formed by extending the wires of the antenna proper from the top. These, wound together, run down the center as one wire to the receiving apparatus. The umbrella antenna receives equally well from all directions.

An antenna built like the inverted "L," except that the wires at one end spread out in the shape of an open fan, is known as a "fan antenna." The lead-in of this antenna is taken off the point of the fan where all wires come together. This antenna does not show preference to direction. The fan can be used for both transmission and reception.

The vertical antenna is formed by a wire or several wires extending vertically from a stake driven in the ground to the top of a mast or some means of support. This antenna receives well, but is not suited for transmission. It is not directional.

The cage antenna consists of a number of wires, usually four or six, fastened to rings or hoops, which serve the same purpose as spreaders at both ends, thus forming a tubular cage. If the cage is very long an extra hoop should be employed in the middle of the antenna in order to maintain proper spacing between the wires and prevent them from twisting together. The cage because of its capacity effects is excellent for

transmission and it is also a good antenna for receiving. The wires extended at one end form the lead-in.

### LOOP ANTENNA DATA

The magnetic type antenna or, as it is better known, "the loop," consists of an insulated frame on which is wound a number of turns of wire. The amount of wire used depends upon the wave lengths to be received. For low wave lengths fewer wires are necessary and a smaller frame may be employed. The frame is mounted so the loop can be revolved, making it possible to swing it in any direction. The main characteristic of a loop is its ability to receive from a definite direction. If several stations are sending on the same wave length, at the same time, and they are located in different directions from the receiving antenna, any one can be picked up without interference from the others, by pointing the loop toward the desired station. When a loop points directly toward a transmitting station, it will pick up the signals with maximum intensity, but, if the side of the loop is facing the incoming waves, very little or no energy will be intercepted. This is the principle on which the radio compass or direction-finder is based.

The use of a loop in connection with a crystal receiving set is not practical because the energy absorbed by the loop is too weak to actuate the detector unless the broadcasting station is very near. Several stages of amplification are neces-

sary for the successful operation of a loop. The loop antenna minimizes the effects of atmospheric disturbances and is easily made portable. Its small size makes it well adapted for use on small boats and automobiles.

The loop serves as an inductance. The incoming waves induce a current to flow in the circuit. It possesses distributed capacity and has a wave length or natural period of its own similar to the regular outdoor antennæ. Litzendraht wire is far superior to solid wire for loop windings, because the resistance offered to the high frequency radio currents is much lower when stranded wire is used. The greater the number of turns of wire, the greater will be the area and, therefore, the inductance increases. Increase in resistance due to the number of turns is not compensated for by the increased number of turns. This is because resistance of radio frequency currents depends upon wave length, and increases rapidly as the latter approaches the natural wave length of the antenna. Spacing between the wires should be about one fourth of an inch. A three-foot loop with eight turns spaced a quarter of an inch will have a natural wave length of approximately 185 meters. A variable condenser, generally about seven plates, is always necessary across the terminals of a loop for tuning. No ground connection is required when the loop is used. One end of the loop connects with the antenna binding post on the set and the other end of the loop goes to the ground binding post.

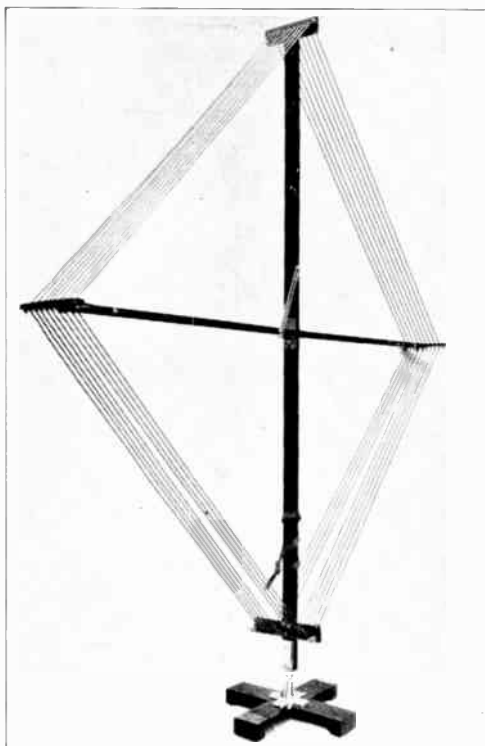

LOOP ANTENNA

Used for indoor reception and for radio compass work. When the loop points directly toward a transmitting station, the signals are loudest; when the plane of the loop is at right angles to the incoming waves, signals are at a minimum intensity, if not inaudible.

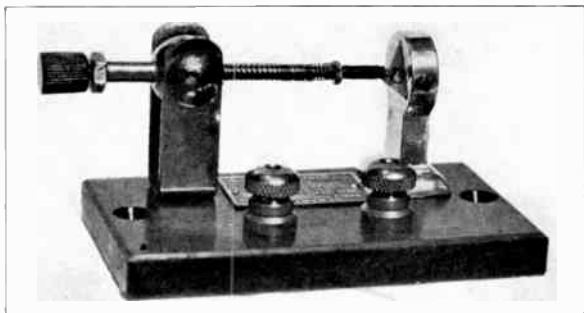

CRYSTAL DETECTOR

A fine wire called the cat-whisker at the end of the rod touches the surface of the mineral in the metal cup. This detector, though not so sensitive as the vacuum tube, is still popular with many broadcast listeners.





### COUNTERPOISE

Many summer camping resorts are situated where a radio ground connection is impossible. Especially is this true in rocky country so characteristic of many localities in Maine, where only a thin layer of moss or soil covers the solid rock. The counterpoise type of ground is valuable in such cases. The counterpoise is like an antenna constructed directly underneath the antenna and about three feet above the rock surface. The wires of the counterpoise should be connected to stakes insulating them similar to the antenna in relation to its supports. The shape of the counterpoise need not be too particularly arranged. In 1917 a counterpoise was built for the radio station at Duluth, Minnesota, and excellent results were obtained. The Duluth section is solid rock, so the counterpoise had an ideal opportunity to prove its worth.

It is evident that a direct ground connection is not possible for an airplane in flight, and for that reason the counterpoise is employed. Guy wires and other metal parts of the machine generally serve as the counterpoise and a wire trailing from the machine as the aerial.

### WAVE ANTENNA

It is a source of wonder to many radio followers who have been bothered by interference from atmospheric electricity, or from transmitting stations, how the great commercial receiving sta-

tions are able to pick up reliable signals from Europe during the summer when static disturbances are at a maximum. Much of this interference is solved by the Beverage or wave antenna. One of the busiest receiving stations in the world is Riverhead, Long Island, and its efficiency is attributed in a marked degree to the wave antenna system. A remarkable feature is its ability to tune out powerful impulses from the giant stations on the American coast especially New Brunswick, New Jersey, and Marion, Massachusetts, and at the same time copy messages from European transmitters. It is estimated by radio engineers that the wave antenna eliminates about ninety per cent of interference created by static electricity. By employing the wave antenna at Cape Cod receiving stations, ocean liners are able to establish direct communication as soon as they clear English ports.

If a new transmitting station in Europe begins operation, the only work necessary at Riverhead for reception of the new signals is to install a new receiving set on a shelf, which stands ready for increased business. An indefinite number of signals can be received at the same time over the one wave antenna. The Riverhead station receives practically from all European stations including Bordeaux and Saint-Assise, France; Carnarvon, Wales; Stavanger, Norway; Nauen, Germany, and Poland. The wave lengths of these stations range from 12,000 meters to 23,000 meters. The average wave is about nine miles long. There-

fore an antenna nine miles long is used, for the wave antenna theory requires a wire equal to one full wave length. The Riverhead antenna is supported by poles thirty feet high. One end of the antenna is grounded through a non-inductive resistance and the other through a variable inductance. This antenna receives daily from seven different European stations, simultaneously, and without the slightest interference.

### INDOOR ANTENNA METHODS

One of the greatest mysteries of radio, in the minds of many people, is that ether waves can be intercepted by a wire located inside a building, without even a window open. However, results obtained with an indoor antenna are never as satisfactory as when the wire is outdoors. Signals are at least five times louder and greater distances are covered with an outdoor antenna. Nevertheless, with two or three stages of amplification, especially radio frequency amplification, remarkably clear signals may be heard with an indoor antenna.

Little do we realize as we sit in our homes reading the papers that the latest news of the world is passed before us, in fact, right through our bodies, at the speed of 186,000 miles a second. Every minute of the day and night invisible radio waves rush through our homes and offices carrying the melodious strains of bands and orchestras; voices of speakers far away; dots and dashes of ships at sea and high-power trans-Atlantic sig-

nals from foreign countries. Wireless messages of the world are ever present just like the medium which transports them — the ether.

Ether is found everywhere, even in the most perfect vacuum, and in the greatest mountains. Therefore, anything traveling with such a substance as a medium of transportation goes through all objects. Radio shows no preference to the wealthy. It leaves more energy at the peasant's home because it has no great steel girders to obstruct its flight and absorb the energy. A simple receiving set connected to a wire inside the house will prove that there is more truth than poetry in the lines of the old song, "There is Music in the Air."

#### INDOOR ANTENNA CONSTRUCTION

Those living in apartments generally find it inconvenient to stretch an outdoor antenna. Where circumstances prevent the use of outdoor wires, there are three schemes left, including the loop. The other two methods are: a wire run around the picture moulding of a room, or an aerial plug which fits into the electric-light socket.

A convenient way to install a simple indoor antenna is to extend about 150 feet of cotton-covered wire, about size No. 20, along the top or behind the picture moulding, and any effect which might detract from the appearance of the room is prevented. With this type of antenna a ground connection is required, and can be obtained by connecting a wire from the ground

terminal of the set to the cold-water pipe or radiator. This wire can be run along the base-board or through a crack in the floor so that it will not be in the way. The part of the radiator or pipe where the contact is made should be filed clean, affording a firm electrical connection. All paint or aluminum covering must be scraped off to make a good connection.

#### LIGHT SOCKET AERIAL

One of the latest indoor antenna methods is to use a condenser plug which fits into the light socket similar to a lamp. This enables the radio listener to use the house lighting wires as the antenna, without trouble of installation or expense. In some apartments the plugs work well, but success depends upon local conditions, such as the manner in which the electric wires are strung. If the wires are shielded by metal ceilings or conduit, the signals will not be as loud as if the wiring was open. If the building in which the plug is used is surrounded by steel structures, the signal's volume will be reduced.

Experiments indicate that the aerial plugs function best on the second and third floors, and especially in frame or brick buildings unobstructed by high steel structures. A single-tube set used in New York in connection with a condenser plug has picked up music from as far west as Davenport, Iowa, and Chicago.

The antenna plug is a condenser or number of condensers encased, which serve to prevent the

current of the electric wires from surging through the radio instruments. If the plug is properly constructed, there is no danger of electric light current flowing into the set. The function of the plug is to afford a coupling, similar to a condenser, in the circuit allowing the high-frequency radio currents picked up by the house wiring to reach the receiving set, but not the electric currents of the lighting system. High-frequency currents will pass around a condenser, but the low-frequency currents are held back. Aerial plugs should contain condensers of sufficient dielectric to withstand any voltage which might prevail in the line. Paper should never be used as the condenser plug dielectric.

A crystal detector set will not function satisfactorily in connection with indoor wires. The vacuum tube must be employed.

### REDUCE ANTENNA RESISTANCE

It is estimated by engineers that the current picked up by the antenna is about three trillionths of the energy broadcast from the transmitting station's aerial. Conservation of the feeble impulses is extremely important for long-distance reception and loud signals. So weak are many of the impulses reaching the antenna that a few unnecessary ohms of resistance in the wires make it impossible for the music to get to the receiving set. Too much resistance in the antenna is like an obstruction in a water pipe — the flow is stopped or greatly reduced.

### ANTENNA CANNOT SERVE TWO STATIONS

One antenna will not serve two receiving sets, owing to the different characteristics of the receiving circuits, and the difference in wave lengths to which they are tuned. Two or more antennæ can be erected on the same roof, but in such a case the wires should extend at right angles to each other and about twenty feet apart. Characteristics of some receiving circuits, especially the regenerative hook-up, cause them to act as small transmitting sets and the result is that a near-by antenna will pick up interference radiated when the set is tuned.

### ANTENNA PROTECTIVE DEVICE

Each lead-in should be provided with an approved protective device properly connected and located, inside or outside the building, as near as practicable to the point where the wire enters the building. The protector should not be placed in the immediate vicinity of easily ignitable stuff, or where exposed to inflammable gases or combustible materials. In accordance with the Fire Underwriters' regulations the protective device should be an approved lightning arrester which will operate at a potential of five hundred volts or less. The use of an antenna ground switch is desirable, but does not obviate the necessity for the approved lightning arrester. The antenna ground switch, if installed, should, in its closed position, form a shunt around the protective device.



### GROUND WIRE

The wire leading from the protective device to the ground should be copper or approved copper-clad wire. If copper, the ground wire should not be smaller than No. 14 B. & S. gauge, and if copper-clad not smaller than No. 17. The ground wire should run as straight as possible to a good permanent ground. Preference is given cold-water pipes. Gas-pipes should never be used for grounding protective devices because electric sparks are likely to ignite the gas. Other permissible grounds are grounded steel frames of buildings, or other grounded metallic work in the building, and other artificial grounds such as buried metallic plates or pipes. A clamp can be secured from most radio stores to connect the wire firmly to the pipe.

The most generally used ground for the receiving set itself is a cold-water pipe or radiator.

A radio antenna will not attract lightning any more than a telephone wire, lightning rod, gutter pipe, or tin roof. The antenna, if correctly installed, is much less likely to be struck by lightning than any other object in the neighborhood. It serves as a medium through which atmospheric electricity can pass from the air to the earth, just the same as a lightning rod. There is no risk involved if the antenna is properly installed and equipped with an approved lightning arrester.

## CHAPTER IV

### DETECTORS

A DETECTOR is any instrument which transforms the oscillations received by the antenna into the form of current which will operate a sensitive telephone receiver or other recording device.

The simplest form of detector is the crystal. Crystals are inexpensive and give clear reproduction of sound which is almost distortionless. A crystal detector is capable of receiving music and speech over a distance of twenty-five miles under normal conditions of the atmosphere, and wireless telegraph signals over much greater distances.

The most widely used materials for the crystal detector are galena, silicon, carborundum, zincite, and chalcopyrite. The crystal is generally mounted in a small metal cup and held firmly in the cup by a set screw or by a substance called Wood's metal, which melts at a low temperature. Most crystals are used in connection with a small metal point, usually the terminus of a small wire or spiral, so that delicate pressure can be applied to the surface of the mineral. Crystals employing the fine wire on their surface are called "cat-whiskers," because of the nature of the wire. Carborundum and silicon require heavy pressure, which may be obtained by pressing a piece of carbon against the surface of the carborundum and a steel needle against the silicon. In the case

of a Perikon detector, zincite and chalcopyrite are brought in contact with each other.

The "cat-whisker" wire is generally connected to a small rod mounted in a chuck, constructed so the wire can be moved about the surface of the

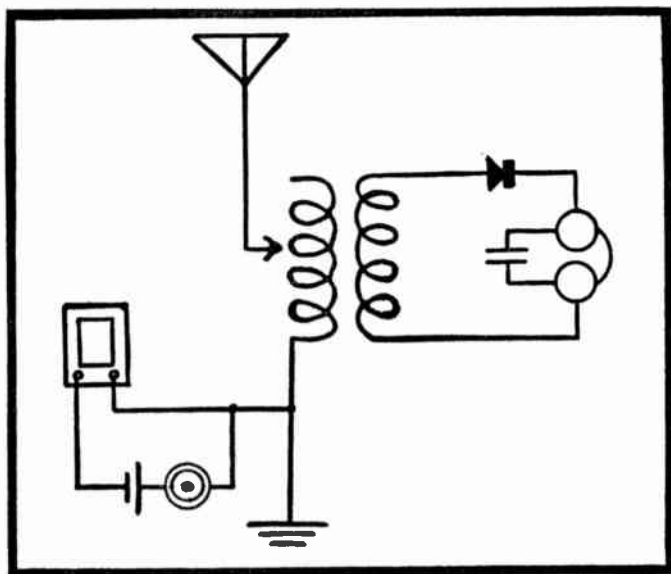

CRYSTAL DETECTOR SET AND BUZZER TEST

The tuner is a vario-coupler; fixed condenser .001 mfd. capacity; push button and battery connections are shown in the buzzer circuit.

mineral in search of a sensitive spot. Some parts of the crystal are "dead," and do not respond to radio impulses, and for that reason the "cat-whisker" must be moved about until an appropriate spot is found. The big disadvantage of the crystal is that a slight jar will knock the wire off the sensitive spot. Carborundum, because of the

heavy pressure applied to its surface, holds its adjustment better, and for that reason it was popular on board ships before the vacuum tube was invented. When galena is used on board ship, the vibration and rolling of the vessel soon destroy the adjustment. Galena, however, is about the most sensitive of crystals. Since broadcasting began, synthetic crystals have been made by a number of concerns. Carborundum requires a potentiometer which allows a small current to pass through the crystal.

There are a number of ways in which a crystal detector can be placed in the circuit. The simplest is by placing it in series with the antenna and ground with the phones shunted across it. Such an arrangement forms the simplest radio receiving circuit, but it is not satisfactory because it does not permit the operator to tune out any undesired signals, and therefore interference is at a maximum. Two other methods of utilizing the crystal are in a single or double circuit. The latter is most satisfactory, for it permits more selective tuning.

It is the duty of the crystal to rectify incoming high frequency radio currents to low frequencies to which the receivers can respond and produce sound audible to the human ear. A mineral used as a crystal detector has the property of permitting an electric current to flow through it in only one direction, completely checking the flow in the opposite direction. The crystal acts in the radio circuit as a valve does in a water pipe per-

mitting water to flow freely in one direction, but if there should be a back-flow the valve would close and stop the water from going any farther.

The crystal literally chops high frequency radio currents in two, and only half are allowed to flow through the phones. This causes a pulsating instead of an alternating current to flow in only one direction.

Crystal detectors have received wireless telegraph signals for several thousand miles and this leads many broadcast listeners to ask why a crystal set will not pick up music over the same distance. The current sending out dots and dashes is of constant amplitude — that is, the pitch or tone never varies — but, when dealing with radio music and voice, the currents are of varying amplitudes and some of the inflections are loud and others soft.

### BUZZER TEST

To use a crystal receiving set the first operation is to adjust the detector; that is, find the most sensitive spot. After the select spot is located, the detector is ready to perform its duty. If a buzzer test is not employed, the operator must discover the sensitive spot by moving the wire across the mineral until the music is heard loudest, and by so doing part of the concert is lost. A buzzer test serves to have the detector adjusted to its maximum degree of sensibility when the concert begins. An operator might sit for hours listening-in with the idea that the detector was

finely adjusted and believe that no music or signals were in the air, just because the wire was off a sensitive spot. When a buzzer test is used, the operator can close a switch or press a button, which completes the buzzer circuit, and he is assured that the detector is or is not adjusted. The buzzer merely sets up vibrations in the receiving circuit, which are used as a substitute for radio signals.

The buzzer should be placed away from the radio set so that sound from it will not be heard in the room so loud that the external noise interferes with hearing it in the phones. Another method is to place the buzzer in a box and stuff it with cotton, making it sound-proof.

The buzzer circuit consists of an electric buzzer, dry battery, and switch or push button. A wire from each binding post on the buzzer connects to the terminals of the battery. One of the wires is broken by placing the switch or push button in series. A wire soldered to the vibrating point of the buzzer — that is, the small point against which the arm vibrates — connects to the ground wire of the set. To test the crystal, the switch is closed, and while the buzzer is in action the "cat-whisker" wire is moved over the surface of the mineral. The loudest sound in the phones indicates the most sensitive spot.

If a push button is used, it may be placed on the floor, making it possible to operate the test by foot, leaving the hands free to adjust the crystal and tune the set. An ordinary buzzer

works satisfactorily, but if no buzzer is handy an electric doorbell with the gong removed will serve the purpose. It may be necessary to adjust the armature of the buzzer so that a clear, high-pitch note similar to radio signals can be heard. This may be done by bending the arm or by placing a paper wedge between the arm and lower part of the magnets. One dry cell is sufficient to operate the buzzer. If too much current is used, it will throw the crystal out of adjustment as fast as it is regulated, and will also injure the crystal's receiving properties.

It should be remembered that the effective range of a set depends to a great degree upon the sensitivity of the crystal. Some crystals are protected by a glass case because action of the air oxidizes their surface and lowers their efficiency. Never touch a crystal with the fingers, because such contact will cover the sensitive spots with a thin coating of grease or oil. Sensitive spots can sometimes be restored by scraping the surface of the crystal with a penknife.

## ELECTRONS

It is necessary to know something about electrons to understand the operation of a vacuum tube detector. Electrons are tiny specks of electricity, so small that even the most powerful microscope cannot detect them. These little particles of electricity have been pictured by one scientist who states that if a drop of water, which includes a great number of electrons, because of

the hydrogen and oxygen within it, were magnified to the size of the earth, each electron magnified in proportion would be about as large as a grain of sand. Electrons are to the receiving set as blood to the human system.

All materials are composed of atoms, defined as the smallest particle into which a substance may be divided and still preserve its identity. It was thought for a long time that the atom was indivisible, but it has been discovered that the atom is composed of a number of units. All atoms consist of a nucleus called the "proton," which is a positive charge of electricity. Surrounding the nucleus are a number of electrons or negative charges of electricity. According to the electron theory, the structure of the atom is like the solar system with the proton or nucleus acting as the sun and the electrons like planets revolving about it.

Some substances have more electrons than others. Under normal conditions the atom is in a state of electrical equilibrium. When a body has more electrons than the proper number necessary to maintain its equilibrium, it is said to be negatively charged. If it has fewer electrons than the proper number, it is positively charged. When a material has its proper number of electrons, no electrical effect is noticeable, and that is why a piece of copper wire disconnected from a complete electrical circuit seems unelectrical. If a piece of wire receives more electrons than its share, it is said to be electrified. Electrons try to pass from a



place they are not wanted to a place where they are wanted, and such a flow of these tiny specks of electricity constitutes an electric current.

When copper wire connects several batteries and forms a complete electrical circuit, a current flows. A battery has the ability to pump or push electrons out at the negative terminal and attract them back at the positive terminal. When a spark leaps an air gap, it is due to the efforts of the electrons to surge back and forth, to distribute themselves evenly on both sides of the gap. When both sides have the same number of electrons, sparking stops.

There are a number of electrons which move back and forth in materials they occupy at high speeds. These are called "free electrons." Materials which are good conductors of electricity, such as silver and copper, contain a comparatively large number of free electrons. Insulators, such as porcelain, glass, and rubber, have few free electrons compared to a copper wire.

As the temperature of material is increased, the speed of the electrons is increased, and if the temperature is made high enough, the electrons will jump off the surface of the material into space. This is what happens when the filament of a vacuum tube is heated. The electrons leap from the filament to the positively charged plate with tremendous velocity. It has been calculated that electrons leaving the filament of a vacuum tube move approximately 50,000 miles a second.

A vacuum is employed within the tube to

prevent atoms of air from hindering the flow of electrons. Atoms and molecules of air are much larger than electrons and can easily stop them. Edison discovered this phenomenon when experimenting with the electric incandescent light. He placed a metallic plate within the lamp near the filament. When the current was turned on, the filament became hot, the needle of a galvanometer or current indicator was deflected, although the filament and plate were not connected. This demonstrated that electricity was flowing across the gap between the filament and plate to complete the circuit. It was called the "Edison effect."

A statement of the modern conception of the atom as a miniature solar system, with electrons whirling around a nucleus, with velocities as high as 93,000 miles a second, was made by Sir Ernest Rutherford in an address delivered in Liverpool, England.

He spoke of the discovery of radium and the emanation of Alpha, Beta, and Gamma rays, and declared, "The use of Alpha particles as projectiles with which to explore the interior of the atom has definitely exhibited its nuclear structure and has led to the artificial disintegration of certain light atoms and promises to yield more information yet as to the actual structure of the nucleus itself."

"The nucleus of a heavy atom," Sir Ernest said, "is undoubtedly a very complicated system, and, in a sense, a world of its own, influenced

little, if at all, by the ordinary and physical agencies at our command."

### VACUUM TUBE DETECTORS

The vacuum tube was invented by Dr. J. A. Fleming, of England, who took out patents in 1904. It was known as the "Fleming valve" and consisted of a filament and plate. Dr. Lee De Forest, in 1907, took out patents, improving the Fleming valve by adding a grid, and in the new form called it the "audion."

The vacuum tube consists of three elements, namely, filament, plate and grid. The filament is usually made of tungsten, but in some tubes platinum ribbon coated with an oxide is employed. The purpose of the filament is to emit electrons from its surface when heated. An oxide coating increases the electronic flow at much lower temperatures. Electrons in the filament are in a constant state of motion and their degree of activity depends upon the temperature of the filament. The higher the temperature, the more active are the electrons.

If the filament is heated to a sufficient degree, the activity of the electrons becomes so great that some of them fly off into space with great velocity. This action is called "thermonic emission."

When electrons are free to move, they will naturally move toward a point where there is a scarcity of electrons, just as water seeks its level. Since the electrons are negative charges of elec-

tricity, the space in the tube soon becomes negatively charged and is made a conductor for an electric current. This is known as a "space

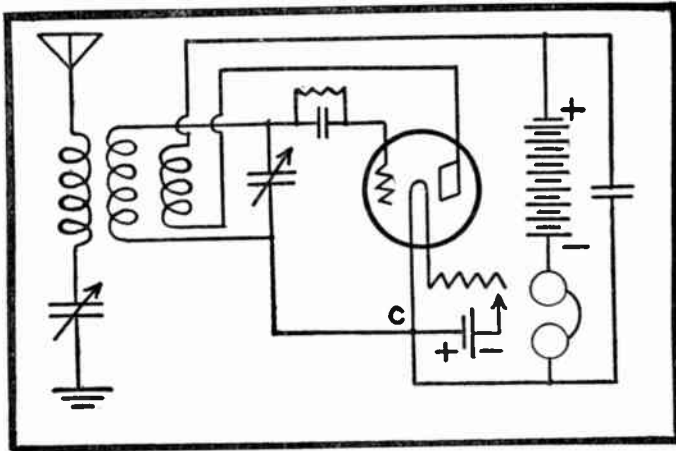

ARMSTRONG REGENERATIVE CIRCUIT

Honeycomb coils are used for tuning; reading from left to right the coils are No. 75, No. 50, No. 35; variable condensers .0005 mfd.; fixed condenser .002 mfd.; grid leak 1 megohm; grid condenser .00025 mfd.; "B" battery 22½ volts; "C" denotes the "common center." If correctly constructed and installed under favorable atmospheric conditions this receiver is capable of reception from 100 to 1000 miles.

charge." The presence of a near-by positively charged body will attract the electrons and thus speed up their flow. A negatively charged body will repel them and retard the flow.

The vacuum tube holding the filament, grid, and plate is airtight. The filament is heated by the "A" battery current. Some tubes require a six-volt storage battery and others operate with 1½ volts supplied by an ordinary dry cell or flashlight battery. The temperature of the filament depends upon the strength of the cur-

rent. The current is regulated by a rheostat. When the filament is heated to incandescence to such an extent that the space within the bulb becomes densely charged negatively, no more electrons can escape from the filament.

### FUNCTION OF THE PLATE

In order that electrons can continue to flow in a continuous stream, a small rectangular or circular plate within the tube is connected to the positive terminal of a high voltage battery, in radio parlance the "B" battery. The duty of the "B" battery is to keep a positive charge on the plate. Since opposite electrical charges attract each other, the negative electrons from the filament are attracted by the positive charge on the plate, forming a continuous flow between the filament and plate. This makes the intervening space a conductor of electricity. Current can then flow in the plate circuit as if a wire bridged the gap between the filament and plate instead of electrons. Leaving the positive terminal of the "B" battery, the current flows from the plate to the filament returning to the negative terminal of the "B" battery. The current in the plate circuit travels in the opposite direction to that in which the electrons travel in the tube. The strength of the current flowing in the plate circuit depends upon the temperature of the filament and the voltage of the "B" battery.

There is a certain filament temperature and plate voltage at which the detector action of the

tube is most efficient. At this "critical point" the variations in the grid potential will cause maximum changes in the plate current. A slight increase in the grid potential may mean an increase of five to ten times in the strength of the direct current flowing over the path afforded by the electrons from the plate to the grid. To burn the filament past the "critical point" decreases the life and efficiency of the tube. The filament and plate current differ with every tube, so no set rule can be given relative to the proper amount of current to be used.

The vacuum tube acts not only as a detector or rectifier of alternating current oscillations, but also as an amplifier or relay. The tube is sometimes called an "electron relay," because the electrons emitted from the filament cause the electrical oscillations to be "relayed" from the grid to the plate. During this relay the oscillations are both rectified and amplified.

#### ACTION OF THE GRID

The grid is a form of network, mesh, or zigzag wire placed between the filament and plate. The grid acts as a valve or regulator for the current flowing in the plate circuit. When the grid is positively charged, it assists the plate and increases the flow of electrons and thus the flow of plate current. If the grid is negatively charged, it will repel some of the electrons, thereby opposing the plate action and decreasing the plate current flow. Under normal conditions the grid is nega-

tive. The grid is generally connected to the secondary of the tuner and is therefore affected by the incoming radio waves.

Ether waves intercepted by the antenna induce in it electrical oscillations of the same nature and frequency as were originally set up in the transmitting aerial. In order that the induced oscillations may be of maximum intensity, the antenna receiving circuit must be in tune with the incoming waves. This is accomplished by the primary coil of the tuner.

Electro-magnetic induction causes similar oscillations to be set up in the secondary coil of the tuner. In order to obtain maximum results a variable condenser is shunted around the secondary coil to establish more efficiently resonance in the closed or secondary circuit. This causes maximum voltage regulations to be set up across the condenser terminals and these pulsations are then impressed upon the grid and filament of the detector tube.

The circuit between the grid and filament is called the "input circuit" or "control circuit" of the tube, since the action in this circuit regulates the entire operation of the tube. As long as the filament is cold and no electrons are emitted, the space between the plate and filament is an insulator and no current can flow in the plate or output circuit. For this reason the "B" battery can be left connected to the circuit when the set is not in use, without discharging.

As soon as the "A" battery current is turned

on, the electrons start to fly off the filament and the presence of the positively charged plate attracts them. This closes the plate circuit and allows the "B" battery to send a current through the phones. However, as long as this current is steady no sound is produced by the receivers. A variable or pulsating current only can induce the phones to produce sound.

At this point the grid begins its work. Electrons passing from the filament must first encounter the grid, and their action can be retarded or increased according to the electrical condition of the grid. The electrical status of the grid, in turn, is influenced by the presence of a small fixed condenser in series with the grid circuit and therefore called a "grid condenser." This is shunted by a high resistance known as the "grid leak."

High-frequency oscillations set up across the secondary or tuning condenser, and impressed across the grid and filament, occur in groups. As one of the groups or wave trains moves toward the grid, it meets the grid condenser, generally of about .00025 mfd. capacity. Through the action of this little condenser, each individual wave or group causes a negative charge to collect on the grid. This charge accumulates during the occurrence of one wave train. As soon as a wave train ceases, there is nothing to hold this negative charge, and hence it leaks off again through the grid leak. The action of the grid condenser is to allow a negative charge to collect on the grid, while



the grid leak allows the charges to escape between successive wave trains. The grid leak always maintains the grid at zero potential as long as new wave trains are being received.

### RECTIFYING ACTION OF THE TUBE

As long as a negative charge is on the grid, the electron flow is hindered or reduced, and therefore the flow of current in the plate circuit is decreased. Between wave trains, retarding action of the negatively charged grid stops, and plate circuit current increases to its normal value.

When the filament temperature and plate pressure are the right value — that is, at the critical point — a given negative charge on the grid will cause a greater increase in the plate current. Therefore current in the plate circuit becomes pulsating direct current with decreases greater than increases. The decreases in plate current correspond exactly to the trains of waves that were originally in the grid circuit.

Since audio frequency pulsations are thus created in the plate circuit, the phones will be affected and produce sounds corresponding to the nature of the electrical pulsations supplied. Since these electrical oscillations are identical with those broadcast by the transmitting station, the sounds heard in the phones are identical with those that actuated the microphone in the transmitting circuit.

## INTERESTING FACTS ABOUT VACUUM TUBES

Vacuum tubes do not contain a perfect vacuum. The ordinary detector is calculated to contain about thirteen trillion molecules of air. An absolutely perfect vacuum has never been produced. In the highest vacuum so far attained, less than one ten billionth of the air originally present in the bulb remained after the exhausting pump had done its best work. This most "perfect" vacuum made by man is estimated to contain enough molecules of air so that every person on earth could have eighty of the tiny air particles before the tube would be entirely empty.

One engineer has visualized it in a different way by showing that the molecules in a cubic inch of air, if enlarged to the size of a grain of sand, would make a beach one thousand feet wide and ten feet deep, to extend from New York to San Francisco. After exhaustion to the highest degree possible, with present-day apparatus, it is estimated there would still be enough molecules of air per cubic inch to form a double line of sand grains across the United States.

Edison first discovered that a glowing filament in a partial vacuum within a glass bulb not only shed light, but also electrons. Further development of the X-rays and a twenty-year study of radio-activity has led scientists to conclude that everything in the universe is composed of electrons. These tiny particles of electricity determine to a great degree whether a receiving set

will pick up music from local or foreign stations.

If there was too much air or gas in the glass tube the filament would burn up at high temperatures. The molecules of air would also interfere with the electronic flow. Molecules of air have a tendency to attach themselves to the surface of the filament and prevent the electrons from getting away. Although there are millions of air molecules left in the tube after exhaustion, they are not sufficient in number to interfere with the operation of the tube. Millions of electrons can collect on the point of a pin. In comparison to a few million molecules the filament is broad; however, the less air in the tube the better it will function.

#### PUTTING THE VACUUM IN THE TUBE

There are three common methods of denoting air and gas pressures. One is the equivalent mercury column, such as the ordinary barometer. The second method is pounds per square inch, and the third is in "atmospheres." One atmosphere is normal pressure at sea level, which is 14.5 pounds per square inch. The record vacuum equals a trifle less than one ten billionth of one atmosphere, or approximately .000,000,014 pound per square inch. This record vacuum has been made possible by the Langmuir condensation pump. In exhausting the air from the glass tube, the pump works similar to the way in which water running out of a bathtub sucks air down through the outlet.

Instead of a stream of water the Langmuir pump uses a blast of gaseous mercury or vapor from boiling quicksilver. As the blast of mercury vapor blows through the tube, it takes the air molecules with it. The part of a tube which connects the bulb to be evacuated with the pump is cooled with liquid air at a temperature of about  $290^{\circ}$  Fahrenheit below zero. This prevents mercury vapor from getting back into the bulb and producing in it a mercury gas.

One great obstacle in obtaining a perfect vacuum is caused by gas given off from the glass bulb itself. It has been found that air will penetrate into solid glass, and it is known as "absorbed gas." Gradually this gas is given up as the tube is evacuated, but there is always some left and that is what lowers the degree of vacuum. Sometimes the entire bulb is heated in a furnace up to a degree where the glass is not softened, and then, while hot, the exhaust pump is put to work. This operation is repeated a number of times.

#### "CLEAN-UP" PHENOMENON

What is known as the "clean-up" phenomenon is a little aid Nature gives to man in making a vacuum more perfect. It has been discovered that after certain metallic filaments burn for a while a portion of air left in the tube disappears. It is thought that some of the air molecules combine chemically with the metal of the filament or with materials in the glass walls. Another theory

is that the air molecules collide with the electrons flying at the rate of 60,000 miles a second, penetrate the glass, and stick there, or else shoot right through the glass walls of the tube.

### HOW DRY-CELL TUBES ARE MADE

The first commercial dry-cell tube was called the WD-11 and was produced by the Westinghouse Electric and Manufacturing Company, in March, 1921. This tube required thirteen steps or processes of assembly. A test is made after each assembly and still further tests after the tube is complete. The filament used in the WD-11 is a platinum-iridium alloy, coated with oxides of barium and strontium. This alloy is used because platinum alone is not strong. An oil pump and mercury vapor pump are used to exhaust the tube to the required vacuum. Before the pumps are turned on, a covering which serves as an oven is pulled down over them and they are subjected to a temperature of 400° Centigrade to drive gases from the glass walls and metal parts.

Vacuum tubes used for radio purposes are exhausted to a much higher point than the electric lamp. In making the WD-11, a coil of wire surrounds the tube when it is placed in the exhausting machine and by means of a high-tension spark the vacuum is tested. Next the plate of the tube is heated red-hot by a high frequency oscillating current generated from two 250-watt tubes, to remove gas from the glass and metal supports. The filament is then heated to obtain proper

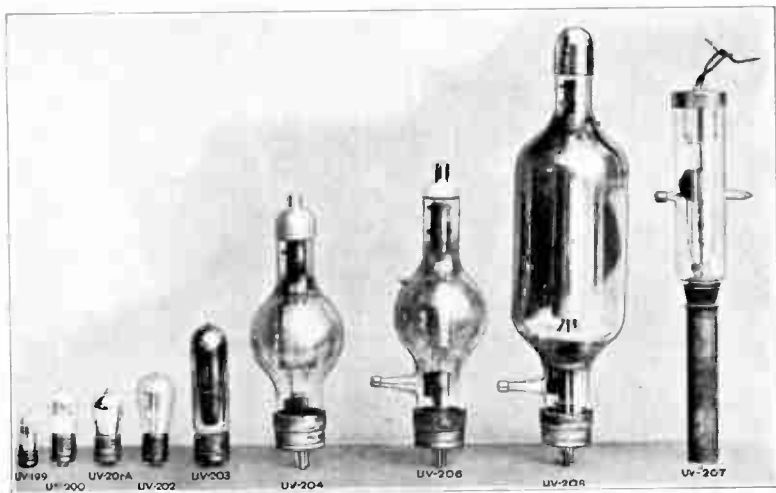

### VACUUM TUBES

Ranging from the small dry-cell tubes through the storage-battery type to the big water-cooled transmitting tubes which make radio telephony possible.

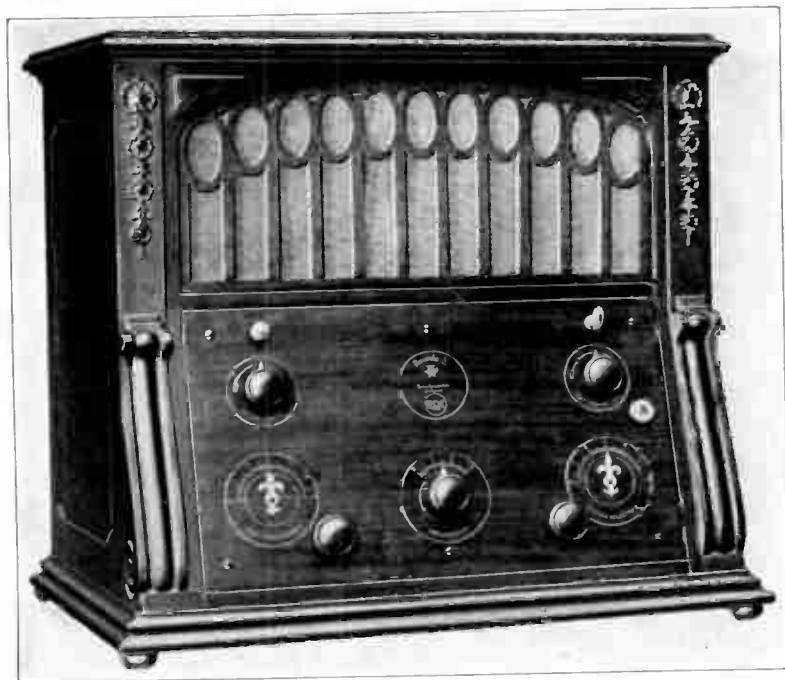

THE REGENOFLEX



chemical reaction on the filament oxide and thus increase the possible electron emission. Exhausting pumps are then turned off and a gas flame run around the bottom of the glass tube until it melts off forming the tip of the vacuum tube. The base is then baked on and the tube tested for short circuits. The tubes are then subjected to a current slightly stronger than they are given in actual use. They remain under this test for an hour to see if any faults develop. The tubes are then stored for three weeks to see if any leaks develop. If they pass the final tests, they are then ready for use in receiving sets.

#### DIFFERENCES IN TUBES

Some vacuum tubes are called "soft" and others "hard." A "soft" tube, the type recommended for use as a detector, does not have a high vacuum as it contains some gas or gases. The "hard" tube used as an amplifier contains a higher vacuum and requires a higher "B" battery voltage for successful operation. The X-ray developed the terms "soft" and "hard" as descriptive of vacuum tubes. It has been explained by X-ray specialists that a "soft" X-ray tube contains gases and produces feeble rays. A "hard" X-ray tube contains a higher vacuum and requires a higher plate voltage for its operation. The rays of such a tube are very penetrative and are known as "hard" rays. The "soft" detector generally requires  $22\frac{1}{2}$  volts on the plate, and the "hard" or amplifying tubes, 45 to 90 volts, "B" battery.



### HOW TO SELECT A VACUUM TUBE

The selection of a vacuum tube becomes more puzzling as the variety continues to increase. Two governing factors in the selection of a vacuum tube are, whether it is to be used as a detector or amplifier, and whether it is to be used with a storage battery or dry cells. Tests show that the UV-199 can be depended upon as an excellent detector and radio frequency amplifier. It also ranks high as an audio amplifier. When this tube is used as an amplifier, it is extremely important that the filament rheostat should be connected in the negative filament lead and that the return lead from the grid be connected to the negative side of the "A" battery, and not to the negative side of the filament. Such connections place the proper negative bias on the grids. When the UV-199 is used as a detector, it is preferable to connect the grid return to the positive terminal of the "A" battery.

The WD-11 and WD-12 are more satisfactory detectors than amplifiers, although they work well as audio amplifiers. The electrical characteristics of these tubes are the same; the only difference is in the bases. The WD-11 requires an adapter to fit the standard socket. The WD-12 is equipped with a standard base. The UV-199, WD-11, and WD-12 can be operated from ordinary dry cells.

The following data will answer many questions which arise relative to the WD-11 vacuum tube.

The "A" battery used with it is an ordinary dry cell. The average life of the tube is 1000 hours. As a detector it operates best with a "B" battery of  $22\frac{1}{2}$  volts. The grid condenser in a WD-11 circuit should be .00025 mfd. capacity and the grid leak two megohms. It is not critical in filament or plate voltage adjustments. It will withstand eighty volts on the plate. A plate voltage upward to 200 volts may be used without damage to the tube. However, such high voltages should not be used because the majority of audio transformers will burn out if 90 volts are applied to the plate. A blue glow in the WD-11 when high voltages are applied does not indicate a leak or ionized gas in the tube, neither does the glow interfere with the operation of the tube. This blue glow is generally caused by phosphorescence given off by salts used to coat the filament. When more than one WD-11 tube is used, an additional  $1\frac{1}{2}$  volt battery should be employed for each tube. Connect the batteries in parallel. The average life of a dry battery used with a WD-11 is sixty to ninety hours.

### THE UV-199

Two dry cells connected in series can be used as the "A" battery with a UV-199, but, as the voltage drop in these cells is rapid, three cells should be employed. Three ordinary dry cells in series will operate a UV-199 an hour a day for a year. The maximum plate voltage is 80 volts. If one tube is used, the "A" battery rheostat

should be 30 ohms; twenty ohms for two tubes; and if three UV-199s are operated in parallel a ten-ohm rheostat can be used. The filament of this tube like all others should be operated at the lowest current which will give the best results. If excessive filament current or plate voltage is applied to this tube, it may cease to function. Ordinarily proper operation may be restored by lighting the filament at a rated voltage for ten or twenty minutes with the plate voltage off. The UV-199 and all other vacuum tubes used for receiving should be mounted in a vertical position. Critical plate voltage is not required by the UV-199, but it works best as a detector at about forty volts. When used as an amplifier, it is important that the rheostat be connected in the negative filament lead and that the return lead from the grid be connected to the negative terminal of the "A" battery and not to the negative side of the filament. This is also true for the UV-201-A. As an amplifier the UV-199 requires from 40 to 80 volts on the plate. It requires an adapter to fit the standard sockets.

#### TUBE CHARACTERISTICS

Tube requirements and their ability to perform as detectors and amplifiers are as follows: UV-199 and C-299 can be operated by dry cells supplying three volts to light the filament. These tubes require a 30-ohm rheostat. They are good detectors; fair audio amplifiers and excellent radio frequency amplifiers. When used as

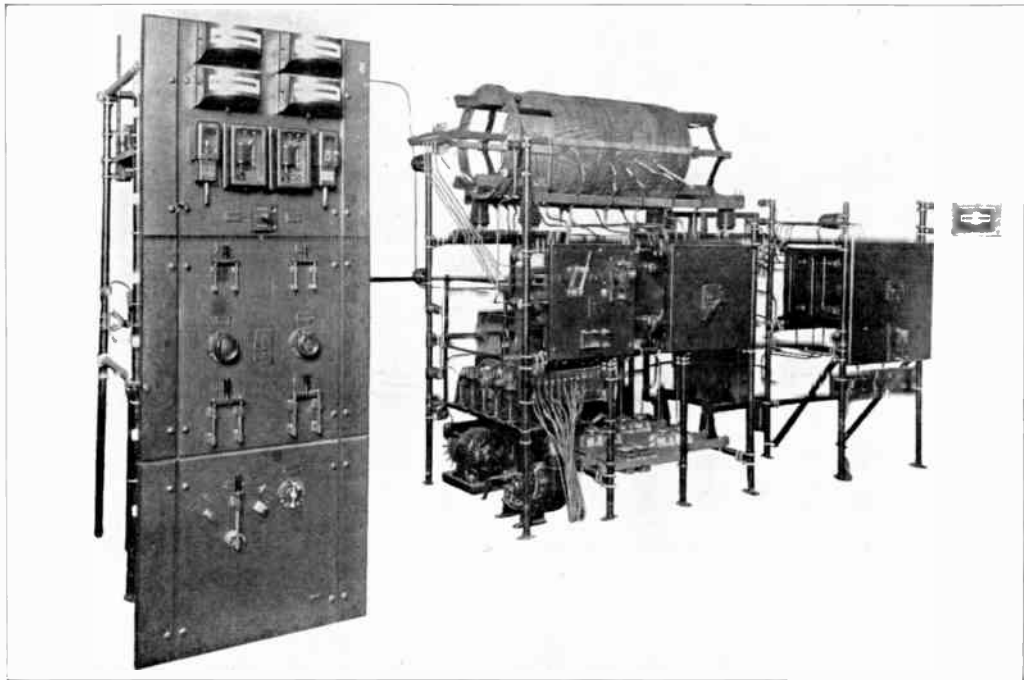

**TRANSMITTING EQUIPMENT IN THE FORM OF A FOUR-KILOWATT VACUUM-TUBE  
SET AND CONTROL PANEL**

The helix on top of the set is used to alter the wave length or tune, just as a vario-coupler serves in a receiving circuit.



detector they require from 20 to 45 volts "B" battery and as amplifier, 40 to 80 volts. The grid condenser should be .00025 mfd. capacity.

The WD-11 and WD-12 operate with a dry cell which supplies  $1\frac{1}{2}$  volts to the filament. The "A" battery is regulated by a six-ohm rheostat. As a detector they need 20 to 45 volts "B" battery and as amplifiers 45 to 90 volts. They are excellent detectors and good audio amplifiers, but do not rate high as radio frequency amplifiers. A grid condenser of .00025 mfd. capacity is necessary, with the WD-11 and WD-12.

The UV-200 and C-300 require a 6-volt storage battery controlled by a 6-ohm rheostat. They are good detectors, and operate with a "B" battery ranging from 15 to 24 volts. A grid condenser of .00025 to .0005 mfd. capacity is necessary.

The filaments of the UV-201 and C-301 tubes are lighted by a 6-volt storage battery regulated by a 6-ohm rheostat. As detectors they require a  $22\frac{1}{2}$ -volt "B" battery, and as amplifiers from 45 to 100 volts. They are good audio amplifiers, but are not desirable as detectors. Both are poor radio frequency amplifiers. The grid condenser used with these tubes should be .0005 mfd. capacity.

The UV-201-A and C-301-A tubes use a six-volt storage battery and a 16 to 30-ohm rheostat. As detectors they require 18 to 45 volts "B" battery and as amplifiers 40 to 120 volts. They are good detectors, excellent audio amplifiers, and good radio frequency amplifiers.

The VT-1 or "J" tube requires a 6-volt storage battery with vernier rheostat of 6 to 15 ohms. When the VT-1 is used as a detector, the "B" battery should range between 12 and  $22\frac{1}{2}$  volts, and as an amplifier from  $22\frac{1}{2}$  to 45 volts. It is an excellent detector and good amplifier. The grid condenser should be .00025 mfd. to .0005 mfd. capacity.

The UV-202 and C-302 are transmission tubes rated at 5 watts. They require 350 volts on the plate and a 10-volt battery supplying 7.5 volts to the filament. They can be used as detector or amplifiers in connection with a 6-volt storage battery. When used as detector the "B" battery should range from  $22\frac{1}{2}$  to 45 volts, and as amplifiers they require up to 200 volts for maximum volume.

The VT-2 or "E" tube is an excellent audio amplifier which requires an "A" battery of 7 volts, but works well with a 6-volt storage battery regulated by a 6-ohm rheostat. The "B" battery may range as high as 350 volts.

The 216-A employs a 6-volt storage battery controlled by a 6- to 15-ohm rheostat. The "B" battery should be 120 volts. It is an excellent audio amplifier especially adapted for a power amplifier circuit.

The 215-A uses a dry battery to light the filament. A 6-ohm rheostat is employed to regulate the "A" battery. When used as a detector the "B" battery should be about 45 volts. As an amplifier it needs 45 to 60 volts on the plate. It is a good detector and fair amplifier.

The UV-203 and C-303 are transmission tubes with a rated output of 50 watts. A 10-volt "A" battery is necessary. As oscillators they require 1000 volts on the plate.

The DV-1 requires 3 volts to light the filament, and this can be furnished by two dry batteries in connection with a 30-ohm rheostat. When employed as a detector, it needs  $22\frac{1}{2}$  to 45 volts on the plate, and as an amplifier 50 to 80 volts. It is a good detector, fair audio amplifier, and excellent radio frequency amplifier.

The DV-2 is a power amplifier corresponding to the 216-A. The filament is lighted by a 6-volt storage battery regulated by a 6-ohm rheostat. As a detector it requires a "B" battery of  $22\frac{1}{2}$  to 60 volts, and as an amplifier 45 to 150 volts. It is a poor detector, but good audio amplifier.

The DV-6-A is fair as a detector and amplifier. It operates with a 6-volt storage battery controlled by a 6-ohm rheostat. When used as a detector, the plate requires  $22\frac{1}{2}$  to 45 volts and as an amplifier from 45 to 100 volts.

The 209-A is an excellent amplifier requiring a 6-volt storage battery, which can be regulated by a 30-ohm rheostat. The "B" battery should be 120 volts.

The Diode tube is a small reproduction of the old Fleming valve and does not contain a grid. It is a trifle more sensitive than a crystal detector. It operates on dry cells, but does not require a "B" battery. Such tubes will not amplify and cannot be used in regenerative circuits.



The French tube is a good detector and a good audio and radio frequency amplifier. It uses a 6-volt storage battery which can be regulated by a 15-ohm rheostat. The "B" battery can range as high as 200 volts.

The Melotron DC-12-A is a detector which can be operated by an ordinary dry battery. The "B" battery should have a range from 20 to 80 volts.

The Mullard valve is a tube used in England and Canada. It is a good detector and audio amplifier and an excellent radio frequency amplifier.

The Margo tube is similar to the Fleming valve and operates in connection with dry cells. It is a little better than a crystal for range of reception and volume, but not as clear. It does not require a "B" battery and will not amplify. It cannot be used in a regenerative circuit.

The Alpha tube is a fair detector and audio amplifier which operates with two dry cells. When used as a detector, the "B" battery should be 45 volts, and as an amplifier 45 to 60 volts. It is not a good radio frequency amplifier.

The Welsh WT-501 is a detector operated by a 6-volt storage battery. A "B" battery ranging from 16 to 22½ volts is necessary.

In connection with all vacuum tubes mentioned above, a variable grid leak should be used across the grid condenser. Different tubes require grid leaks of different resistances.

The Sodian S-13 tube is a good detector, but

will not amplify and cannot oscillate. It is entirely different from other tubes and will not work in a regenerative circuit. Since it does not oscillate, it does not produce regenerative "howls." It is a three-element tube. The filament and plate are somewhat similar to those of amplifying tubes, but the grid is replaced by a collector trough, placed close to the filament on the opposite side of the plate. The filament lies in the axis of the trough. Operation of the Sodian tube depends upon alkali vapor. Sodium, the alkali used, is placed in the tube after it is thoroughly evacuated. The lead from one end of the filament is wrapped around the outside to serve as a heater coil. This keeps the tube warm and creates the sodium vapor. The filament including the heater requires a quarter of an ampere at 3.8 volts. The "B" battery is  $22\frac{1}{2}$  volts. The collector potential is kept negative with respect to the filament.

### TRANSMITTING TUBES

Big vacuum tubes containing exactly the same three elements — filament, plate, and grid — as the small tubes used in receiving sets are employed for transmission. The elements are much larger and are in proportion with the size of the tube, which is about 20 inches long. In place of  $22\frac{1}{2}$  or 45-volt "B" battery, the big tubes require about 2200 volts on the plates. This voltage is not supplied by "B" batteries, but by a motor generator operated off the lighting mains.

The majority of broadcasting stations have this apparatus in duplicate in case one of the generators breaks down. The filaments are lighted from the same source. Storage batteries are not generally used to heat the filaments because of the rapid consumption of current.

A 20-kilowatt tube has a very large rugged filament, many times the diameter and length of the ordinary radiotron used for reception. The grid is cylindrical in form and surrounds the filament. The plate is a metallic cylinder about  $1\frac{1}{2}$  inches in diameter and 8 inches long. The plate, instead of being inside the tube, as in receiving tubes, forms an outside wall of the tube. In order to dissipate the large amount of energy liberated in the plate, the plate is water-cooled.

#### TEN TUBES DEVELOP 200 KILOWATTS

A bank of 10 tubes of this kind operated in parallel is capable of generating 200 kilowatts of power, about all that is required for trans-oceanic communication. Engineers predict that it will undoubtedly be possible, when the necessary development work has been completed, to construct tubes of many hundreds or even thousands of kilowatts. Such devices will not only play an important part in radio communication, but also in the electrification of railroads and the transmission of power to long distances by means of direct current.

A 1000-kilowatt vacuum tube, called the "magnetron," has been developed by the Gen-

eral Electric Company. It weighs 60 pounds and will supply energy equivalent to that required to light 40,000 25-watt incandescent lamps or supply the electrical energy required by 1500 average homes. The tungsten filament, if drawn into a filament of the size used in the ordinary incandescent lights, would supply filaments for 175,000 such lamps. The filament in the tube is four tenths of an inch in diameter and 22 inches long. This is large compared to the filament of the UV-199, which has a filament diameter four times smaller than an ordinary hair.

Six big water-cooled tubes were used in place of the Alexanderson high-frequency alternator at one of the powerful transmitting stations in the United States, and the signals were received at Nauen, Germany, with such clearness that the receiving operators did not know any change had been made in the sending apparatus.

The name "kenotron" was originated in 1913 to cover all types of vacuum tubes. The word is derived from two Greek words, "keno" and "tron," the former meaning space or vacuum and the latter meaning an object or thing, the word "kenotron" implying a vacuum device. The term has not taken the place intended for it, and as used at present refers only to the two-element rectifying tube, the term "pliotron" being used for the three-element tube. The kenotron has no grid.

## CHAPTER V

### METHODS OF AMPLIFICATION

THERE are two methods of amplifying incoming radio signals at the receiving set: first, radio frequency amplification, so named because it amplifies the impulses at the original or radio frequency, before they reach the detector. Thus they have more power to actuate the detector and can be further amplified by audio or low frequency amplifiers. Herein lies the principal advantage of radio frequency amplification. It makes audible impulses originally too weak to cause the detector to function. Radio frequency amplification increases the range of a set and gives increased volume to feeble signals, but only slightly affects the strength of near-by stations. The second system of amplification is known as audio frequency amplification. To say a set has a stage or step of amplification means it is equipped with one amplifying tube in connection with the detector. A two-stage amplifier employs two amplifying tubes.

Radio frequency amplifiers are placed in the circuit ahead of the detector. Audio amplifiers follow the detector. Radio frequency amplification is well adapted for use with loop antennæ, or indoor antennæ which, because of their shielded location, intercept only a small amount of energy from the passing waves. Another feature of radio

frequency amplification is its ability to make tuning sharp, because under this method the signals of the transmitting station are inaudible until the receiver is tuned to the exact frequency of the incoming waves. Such action reduces interference

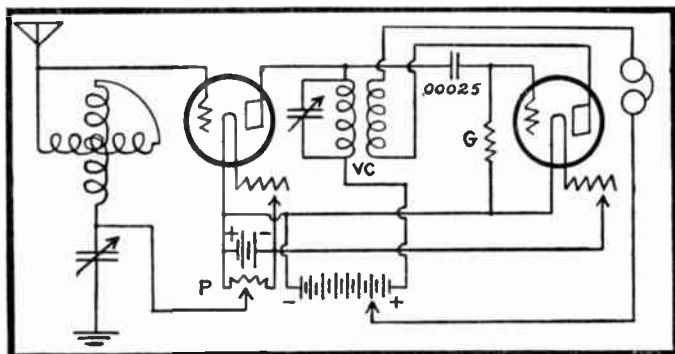

ONE STAGE OF TUNED RADIO FREQUENCY  
AMPLIFICATION

A variometer is used for tuning; variable condensers .0005 mfd., "VC" is a variocoupler with a variable condenser across the stator; "P" is a 400 ohm potentiometer; "G," one megohm; "B" battery 80 volts. This set used in New York has received music from Cuba.

when the frequencies of stations differ, and the effect is more noticeable when a loop is employed, because of its directional characteristics. Another advantage of radio frequency amplification is the elimination of disturbing noises such as produced by variations in the battery voltage, vibration of the elements in the tubes, and by induction. These sounds are not intensified to any appreciable extent because radio frequency amplifying transformers are unaffected by low frequency, which is common to such noises.

A potentiometer, which is a resistor serving as

a variable voltage supply device, is required across the "A" battery in a radio frequency circuit to bias the grids of the amplifying tubes and stabilize the circuit. That is, it regulates the negative charge of electricity which accumulates on the grids, thereby increasing the signal strength. Every wire in a radio frequency set must be as short as possible, especially the grid and plate wires. Switches to alter the number of stages in the radio frequency unit should be avoided, as should telephone jacks, which are likely to cause capacity effect; that is, they act like small condensers.

### RADIO FREQUENCY METHODS

There are four main methods for obtaining radio frequency amplification, depending upon the types of intercoupling used between the tubes. The vacuum tubes can be intercoupled by radio frequency transformers; choke coils having an iron core; a resistance; a variometer or some form of tuned inductance, such as a coil shunted by a variable condenser.

Transformer coupled radio frequency amplification has one big disadvantage in that radio frequency transformers have a fixed ratio; that is, they do not receive all wave lengths equally well. Some manufacturers use iron cores to broaden the useful range of radio frequency transformers. However, in all radio frequency transformers there is a peak with a narrow band on each side which favors stations operating on certain wave

lengths. On either side of this band the efficiency is greatly reduced. If a transformer is designed to work on 360 meters, the 400 and 300 meter wave signals will be received less efficiently. The wide wave-length band of broadcasting stations from 222 to 545 meters makes it impossible to build a radio frequency transformer which will do justice to all wave lengths.

### HOW TRANSFORMERS DIFFER

Radio frequency transformers differ from audio frequency amplifying transformers, in that both the primary and secondary windings have much smaller values of inductance. The secondary inductance is generally of such a value that the tube capacity between the grid and the filament is sufficient to place the secondary circuit in tune with a definite wave length. This develops the disadvantage of transformer-coupled radio frequency amplification, because good results are obtained only on the wave length to which the secondary is tuned. For this reason a number of manufacturers have discontinued the production of radio frequency amplifying transformers and are turning their attention to other methods of amplification, chiefly, tuned radio frequency.

The question of wave-length range of radio frequency transformers seems to puzzle many radio followers, because no statement is made limiting audio amplifying transformers to certain wave lengths. The question is often asked why a radio frequency transformer is restricted to certain



wave lengths and an audio frequency transformer is free of such restriction.

An understanding of the two forms of amplification will help to explain the reason why radio frequency transformers are limited. The frequency involved in the different wave lengths depends upon the length of the wave and the speed with which it travels. A transformer to work efficiently on all wave lengths must be designed to meet the electrical requirements of all frequencies. The same condition does not exist in the case of audio amplifying transformers. They do not deal with high-frequency currents. By virtue of their position after the detector only currents rectified to low frequency reach the audio amplifying transformers. If an audio amplifying transformer is designed to handle frequencies within the audible band, roughly from 200 to 5000 vibrations a second, it will work well with any set no matter how high or low the wave length and the original frequency of the signal.

Radio frequency amplification by means of a choke coil is obtained by placing a choke coil of thirty to forty henries in the plate circuit. This method does not work well on all wave lengths. It produces best results above 300 meters.

Resistance coupled radio frequency amplifiers are used extensively by European experimenters. The chief disadvantage of this method is low amplification obtained by each amplifier tube, and it therefore necessitates five or six tubes for successful operation. Distortion is at a minimum with

this type of coupling because there is no inductive capacity effects due to coils as employed in amplifying transformers.

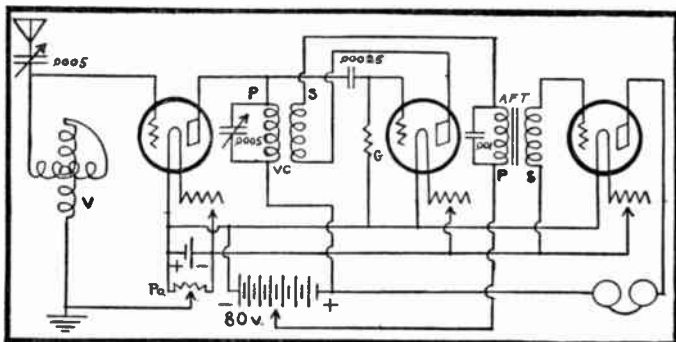

TUNED RADIO FREQUENCY AMPLIFIER, DETECTOR  
AND AUDIO AMPLIFIER

"V" is a variometer and "VC" a vario-coupler; "P" denotes primary and "S" secondary windings; "G", one megohm; "AFT," audio frequency amplifying transformer 5 to 1 ratio; "Po" potentiometer 400 ohms. This circuit used in New York is capable of reception from Cuba.

The fourth method of obtaining radio frequency amplification is derived by inserting a variometer or tuned inductance in the plate circuit to serve as the intercoupling between the tubes. Each plate circuit must be tuned to the incoming wave by the variometer in this system. The main disadvantage is the trouble required to tune each plate circuit.

There are limits to the value of radio frequency amplification because, when the signal's strength is built up to a certain point, it is of no avail to increase the number of tubes or stages of amplification. This explains why it is possible with radio frequency amplifiers to build up the strength of

distant stations without intensifying local stations.

### AUDIO FREQUENCY AMPLIFICATION

Audio frequency amplifiers strengthen the signals after they have passed through the detector and have been rectified to low frequencies. Thus it can be understood that radio signals, too weak to influence the detector, cannot be amplified by the audio frequency system. Audio amplifiers are not determining factors in the distance a set will cover. The range of a set employing only audio frequency amplifiers depends chiefly upon the

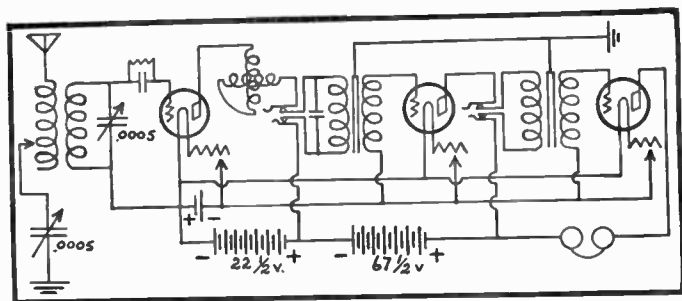

DETECTOR AND TWO STAGE AUDIO AMPLIFIER

A vario-coupler or honeycomb coils can be used as the tuner, and a variometer in the plate circuit produces regeneration; amplifying transformers are 5 or  $3\frac{1}{2}$  to 1 ratio; cores of transformers connect to ground binding post; telephone jacks are used so either the detector or one stage amplifier can be employed; fixed condenser .001 mfd. This set can be used successfully with a loud-speaker.

sensitiveness of the detector. Theoretically any number of stages of audio frequency amplifiers can be used, but practically two stages are the limit, because all extraneous noises and circuit "howls" are amplified by this method, and if car-

ried too far will produce interference and distorted signals.

The most serious criticism of audio amplifying transformers is their inability to reproduce accurately notes below middle C of the piano. This fault decreases the accurate reproduction of the violincello, bass saxophone, bass baritone, bass of organs and pianos, trombone, and drums. Tinny music is not always caused by the loud-speaker. It is traceable in numerous cases to poorly designed amplifying transformers.

It is a puzzle to many builders of receiving sets whether to use a high-ratio transformer on the first stage and a low-ratio on the second stage or low-ratio transformers on both stages. Some manufacturers recommend a high-ratio transformer on the first stage and a low-ratio transformer on the second step. They explain that the voltage on the first stage is low enough to warrant the use of high-ratio transformers without distortion. A high-ratio transformer, such as 9 or 10 to 1, is not recommended for the second stage because it so greatly intensifies the voltage that distortion results.

There is another group which advocates the use of low-ratio transformers on all stages of the audio frequency amplifying unit. They claim that if distortion results from the use of a high-ratio transformer on the first stage the distortion as well as the signal will be intensified by the second amplifier.

### TRANSFORMER RATIO EXPLAINED

When it is said that an audio amplifying transformer has a 5 to 1 ratio, the meaning is that the number of turns of wire on the secondary is five times as great as the number of turns of wire on the primary. This causes a step-up voltage which increases the variations in the grid potential. The grid voltage must not be increased too much, because, after a certain voltage is applied to the grid, the tube reaches a saturation point. If a high-ratio transformer is employed, which increases the grid voltage past the saturation point, the music will be distorted.

The majority of audio amplifying transformers on the market to-day operate most efficiently on one particular frequency. A musical instrument produces many different frequencies of sound; that is, the sound varies from low vibrations to high-pitched tones. Therefore, if an audio amplifying transformer is particularly adapted to build up the electrical current representing a particular frequency, and is opposed to other frequencies, it will reproduce music in a distorted way. This misrepresentation makes little difference in the case of jazz because it adds to the syncopated effect.

Few transformers are made with an effective amplification greater than four; that is, the voltage applied to the primary will be increased in strength four times after passing through the secondary winding of the transformer. Most trans-

formers rated with amplification factors seven or eight are capable of such amplification only at a particular frequency. Few transformers, even of the same manufacturer, in tests by engineers prove capable of equal performance.

As pointed out previously, audio amplifiers depend upon the detector to reproduce a signal which can be amplified. If one tube is capable of amplifying a signal 20 times, two tubes would be capable of intensifying it 400 times and three tubes 800 times.

#### TRANSFORMER CONSTRUCTION

Elaborate workmanship is necessary to make an audio amplifying transformer. One transformer on the market is reported to have 3800 turns of No. 40 enamel wire, about the diameter of a hair, for the primary winding. The secondary consists of 13,300 turns of No. 40 enamel wire, and is separated from the primary by three thicknesses of .005 inch moleskin paper. The primary and secondary leads are 16 strands of No. 38 bare copper wire stranded together and covered with a wrapping of green silk. The coil is impregnated under a vacuum process in a compound of beeswax and rosin and then covered with a black cloth.

A transformer which will reproduce frequencies ranging from 100 to 4000 cycles with little distortion is ideal for audio frequency amplification. However, it is difficult to obtain such a device, although a few transformers on the market to-

day will operate well on frequencies ranging from 300 to 4000 cycles. If a loud-speaker is used, it is always well to have the transformer favor the higher frequencies. Transformers having a ratio from 5 or  $3\frac{1}{2}$  to 1, have proved successful for general use.

The type of vacuum tube employed has considerable to do with the success of the amplifying transformer. If the tube has a high plate resistance, it will have a tendency to distort at high and low frequencies. If an audio amplifying transformer is designed to operate with a particular tube, and it is used with another type of tube, it will not produce satisfactory results.

When connecting audio amplifying transformers in the circuit, care should be taken to establish proper connections. The leads are usually marked so the correct connections can be made to the grid, plate, and filaments. If the wrong secondary terminal of the transformer is connected to the grid, howling is likely to result. An .001 mfd fixed condenser is usually an asset across the primary of the first audio amplifying transformer, as it aids regeneration and minimizes squeals. Connecting the cores of audio amplifying transformers to the ground binding post also reduces disturbing noises, especially howls. Another system which is often helpful in securing quiet operation of the amplifier unit is to connect a fixed condenser of .001 or .002 mfd capacity between the grid of the last amplifier tube and the ground or plate circuit.

When a high-plate voltage is required on amplifier tubes, a "C" battery should be used to give a negative grid bias, which tends to render undistorted amplification. There is practically no current taken from the "C" battery, so a few small flashlight cells may be used with fine results. The "C" battery generally ranges from three to seven volts.

### HOW TO TEST A TRANSFORMER

To test an audio frequency amplifying transformer, connect one terminal of a weak dry cell to one binding post of the transformer primary and fasten the two tips of the phones between the other battery terminal and the remaining binding post of the transformer primary. If the primary winding is all right, a sharp click will be heard in the phones. If no sound, or just a slight click, is heard, the transformer primary winding is broken. The secondary need not be tested, because if the primary is destroyed the transformer is useless. Seldom does the secondary winding give trouble. It is the primary that must be protected from overloads of current. The wire on audio transformers is finer than hair, so the instrument should never be dropped, because a slight pressure will easily break the wire.

### HYSTERESIS

When a mass of iron, such as the core of an audio transformer, is being magnetized by a fluctuating or reversing current, more energy is used in



magnetizing the iron than is given up by the iron when it is demagnetized. The flux in the iron always lags behind the magnetizing force. This lag or heating effect is known as "hysteresis." The hysteresis loss varies with different irons and is less with soft iron. That is why soft iron is used as the cores of audio amplifying transformers.

### AMPLIFYING CRYSTAL DETECTORS

Audio frequency or radio frequency amplifiers may be used in connection with a crystal detector. One stage of radio frequency amplification ahead of a crystal detector operates most efficiently, but if more stages are added there is likely to be a reduction in signal strength. A crystal set used with a radio frequency amplifier is much more selective than when the amplifier is not employed. It has been found more satisfactory to use carborundum, silicon, or iron pyrites, instead of galena, in such a circuit, because such detectors are not easily jarred out of adjustment. Reproduction of music from a crystal and one stage of radio frequency amplification is extremely clear, chiefly, because there are no noises caused by the operation of a crystal detector.

Audio frequency amplification may be used in conjunction with a crystal set or with a crystal and a radio frequency amplifier. It is not practical to use more than two audio amplifiers with a crystal detector. The audio amplifier unit is added to the crystal set by connecting the primary of the first amplifying transformer where the

phones are used in the crystal circuit. The audio amplifiers will give volume to the signals, but will not increase the range of the crystal detector.

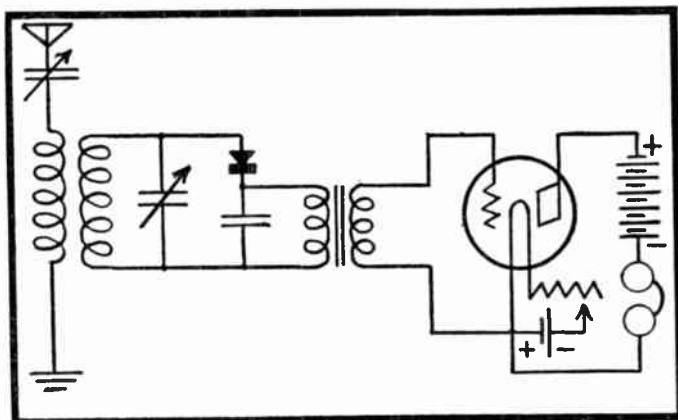

**CRYSTAL DETECTOR CIRCUIT AND AUDIO AMPLIFIER**

Honeycomb coils or a vario-coupler can be used as the tuner; variable condensers .0005 mfd., fixed condenser .001 mfd., audio transformer 5 to 1 ratio; "B" battery 45 volts.

Radio frequency amplification will increase the crystal's range.

### REFLEX CIRCUITS

A reflex circuit is a combination of radio frequency and audio frequency amplification. Reflex means "to turn back upon itself or in the direction whence it came." In a reflex circuit electrical currents of different frequencies are superimposed upon each other without interference. The vacuum tube or tubes in a reflex circuit serve as detector and amplifiers of both radio and audio frequency currents. Energy intercepted by



service from batteries. A properly built reflex circuit tunes sharp and therefore little trouble is caused by interference.

Small fixed condensers are required across the primary and secondary of the audio amplifying transformers because the windings act as choke coils to the radio frequency currents. Condensers serve as a path for high-frequency currents. If the transformers have a low impedance in their

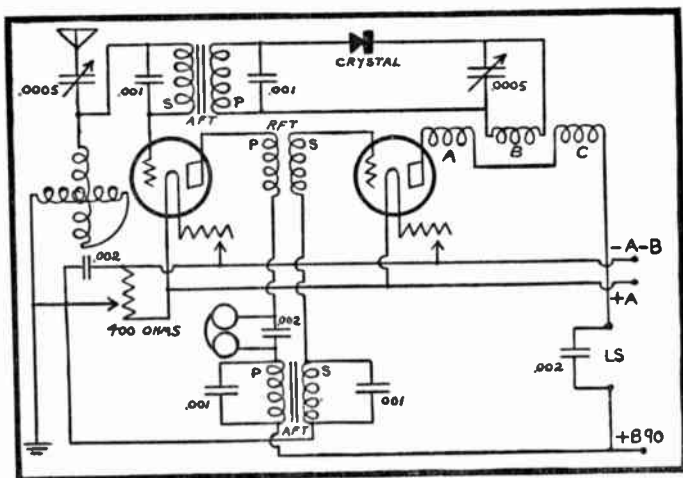

### REFLEX AND TUNED RADIO FREQUENCY AMPLIFIER

A variometer is used as the tuner; "AFT" is an audio frequency amplifying transformer 5 to 1 ratio; "RFT" is a radio frequency amplifying transformer 275 to 600 meter range; "P" denotes primary and "S" secondary; double circuit jacks are used for the phones and loudspeaker, indicated by "LS"; "A" and "C" are the stator windings of a split variometer and "B" is the rotor. This is an excellent long-distance receiver and can be used with a loop or indoor antenna.

secondary windings the by-pass condensers can be omitted. The phones and loud-speaker also act as a choke and must be shunted by condensers. It is extremely important that all wires in

a reflex hook-up be as short as possible. They should not run close or parallel. A five-tube reflex forms the limit, because the accumulative effect of more than two stages of audio frequency amplification is so great that it paralyzes the tubes, and the potential on the grids is so great that a feeble radio frequency wave has little effect.

### “PUSH-PULL” AMPLIFIER

Why are audio amplifier units built in only two stages and not in three or four?

When three stages of audio amplification are connected between a detector and loud-speaker, the music and voice received are distorted. Furthermore, circuit noises, such as battery disturbances caused by variations in the current, are greatly amplified along with the music, when more than two audio amplifiers are employed. If the third stage of amplification is eliminated, an improvement in quality is obtained, but the volume is reduced considerably. The difficulty is that the ordinary vacuum tube used for receiving cannot handle so much power. When too much energy is fed into the grid, the tube becomes partially paralyzed. Some experimenters endeavor to overcome this trouble by placing a leak across the secondary of the last audio amplifying transformer so some of the energy can be by-passed. This method wastes energy, as it merely throws away part of the power from the second stage because the last tube cannot handle it all.

Several systems have been developed to handle the energy so that it is available to operate a loud-speaker with good volume. One way is to use a large tube in the last stage, but this is not practical for the average broadcast listener. It is expensive and requires a high "B" battery voltage for successful operation.

Another method is to divide the last stage into two sections so that one tube on each side of the circuit can use half the power. This permits the tubes to work satisfactorily within their capacity. The ordinary audio amplifying transformers cannot be used efficiently to couple the tubes used in a "push-pull" circuit. The two tubes in the last stage are connected in parallel and are coupled by special transformers known as "push-pull transformers."

A "push-pull" system employs two vacuum tubes connected together in one stage of audio amplification so that one tube operates while the other is inoperative. The action is analogous to a two-cylinder engine in which the flywheel receives a push from the second cylinder at the moment the first cylinder is not in a position to be effective.

In a "push-pull" amplifier the two grids are connected to the secondary of a "push-pull" transformer. This method of wiring makes the grids oppose each other, so when one grid is positive the other will be negative. One grid assists the flow of electrons to the plate of the tube in which it is located and the other grid impedes the

electron flow. Therefore, constant tube action causes less distortion and a well-balanced output under complete control.

A "push-pull" transformer has a primary exactly the same as a standard audio amplifying transformer. The secondary, however, has twice the number of turns as the secondary of an audio transformer, and is tapped at the center. It is practically two audio transformer secondary windings joined in series. The center tap connects to the filament, generally through a biasing "C" battery ranging from  $1\frac{1}{2}$  to 7 volts. Flashlight cells are used as the "C" battery. Each end connection of the transformers is led to the grid of one of the two tubes. With this arrangement a positive impulse in the primary will make one of the grids positive and the other negative with respect to the center tap. Voltages applied to the two grids are opposite in phase. This balances out distortion.

The plates of the tubes are connected to the loud-speaker by a special transformer in which the primary has more windings than the ordinary audio transformer. It is tapped at the center. The positive "B" battery terminal connects to the center tap and one plate to each end of the primary. The secondary connects to the loud-speaker.

"Push-pull" transmitters were originally developed for telephone use and later for loud-speaking systems. When this form of amplification was first used in radio transmitting equip-

ment, the transmitter had a button on each side of its diaphragm. The plate of one tube connected to one button and the plate of the other

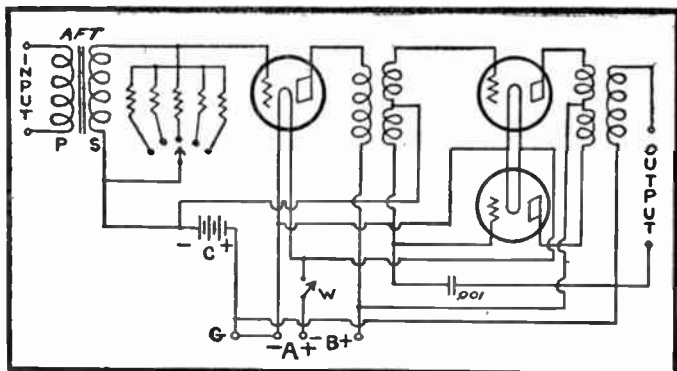

PUSH-PULL AMPLIFIER

The group of resistances are grid leaks ranging from 1 to 5 megohms starting from left to right; a multiple point switch is used in connection with the grid leaks; "C" battery is 12 volts; "W" is a battery switch. Two push-pull transformers and one audio amplifying transformer are used; if a loop is employed the connection between "G" and the 6 volt battery is not required, but a wire should run from "G" direct to the ground; "B" battery 120 volts.

tube to the second button. When the diaphragm vibrated to produce sound, it pushed one button and at the same time pulled the other. Thus it was called the "push-pull" system.

The volume of amplification produced by a "push-pull" unit is about equal to one stage of audio frequency amplification. The extra tube is employed to obtain quality of sound rather than quantity.

### SUPER-HETERODYNE

There are five fundamental methods used for obtaining louder radio signals: (1) regeneration;



(2) super-regeneration; (3) radio frequency amplification; (4) audio frequency amplification; (5) super-heterodyne.

The drawbacks of each system are as follows: (1) Regenerative circuits, when permitted to oscillate, act as small transmitters and create interference for near-by receiving sets. (2) Super-regeneration is not selective and it is difficult to control. (3) Untuned radio frequency amplification by means of transformer coupling does not do justice to all wave lengths and tuned radio frequency amplification requires too many adjustments to tune the various circuits. (4) Audio frequency amplification is limited practically to two stages. (5) The super-heterodyne is free of the limitations possessed by the other methods of amplifying, but it has a drawback to many because of its complex construction and expense of building. The super-heterodyne is sensitive to weak impulses and is extremely selective. It is a sharp tuner, but not too critical. It is easy to manipulate, having only two controls.

A super-heterodyne consists mainly of two divisions, a frequency changer and a long wave receiving set. It is based on this reasoning: a radio frequency amplifier will operate easily on long wave lengths, but not on short wave lengths. It was imperative during the World War to devise a method capable of intercepting feeble short-wave signals used by the Germans in trench, submarine, and other communication systems. Thus the super-heterodyne was invented by Major E. H.

Armstrong while in France. He studied the problem and decided to receive the short waves and then change them to long waves, making it possible to employ efficient long-wave radio frequency amplifiers.

The wave changer can be built as an entirely separate unit and be as distinct from the ordinary receiving set as an audio amplifier unit. A wave changer consists of a detector tube having two frequencies applied to it; the frequency of the incoming signal picked up by the antenna, and, second, a frequency furnished by a vacuum tube oscillator, called the "heterodyne," which feeds the detector by means of a suitable coupling. The output of the frequency changer has a frequency equal to the difference between the signal frequency and the heterodyne oscillator. This frequency can be varied by adjusting the heterodyne frequency.

For example, if an incoming signal has a wave length of 400 meters or 750 kilocycles, and the heterodyne tube is adjusted to oscillate at 850 kilocycles, the difference between the two frequencies will be 100 kilocycles. The heterodyne could be adjusted to oscillate at 650 kilocycles and the difference would still be 100 kilocycles. It makes little difference which way it is adjusted. The difference in the two frequencies is impressed upon the intermediate frequency amplifier.

Since there are only two points where the same frequency difference exists with every wave length, the super-heterodyne is most selective.

The question is often asked relative to the best frequency to amplify, and experts, who have studied the super-heterodyne say 100,000 cycles, which corresponds to the 3000-meter wave length. This frequency is not too high for efficient amplification, but still it is much above audible frequencies, so it does not interfere with the audio frequency division of the set.

Each stage of amplification must be shielded, preferably in a metal compartment. This prevents feed-back of energy into other parts of the circuit. It is not necessary to have a top on the compartment. All grid leads must be as short as possible.

The super-heterodyne is designed to overcome all difficulties of radio frequency amplification at short wave lengths. It converts the frequency of the incoming signal to a value that can be amplified without difficulty.

To operate a super-heterodyne the signal is tuned-in just as with an ordinary receiving set. The incoming signal is then mixed with a signal coming from the oscillator tube or heterodyne. The result is a signal of much lower frequency equivalent to a high wave-length signal. This low-frequency signal is passed through an intermediate frequency amplifier, designed especially for long-wave amplification. The signal is then passed on to an audio amplifier unit, loud-speaker or phones. Generally one stage of audio amplification is sufficient in connection with a super-heterodyne.

### THE NEUTRODYNE PRINCIPLE

The neutrodyne circuit is a system of radio frequency amplification which completely eliminates regeneration. It produces a power amplification of one hundred million for two stages. The system was invented by Professor L. A. Hazeltine, of Stevens Institute of Technology.

It achieves a step-up ratio in the oscillation transformers in the radio frequency stages. Regeneration can be used, but re-radiation is impossible. The basic principle of the system is to prevent regeneration by means of specially designed balancing condensers, which neutralize the effect of capacity coupling between the grids and plates of vacuum tubes. These condensers are of extremely small capacity measuring as low as 0.1 micro-micro farads. They are called "neutrodons."

These small condensers, the secret of the system, must be adjusted for the particular type of vacuum tube used in the circuit. Describing this adjustment before the Radio Club of America, Professor Hazeltine said: "The adjustment of each neutralizing capacity is made experimentally by tuning in some strong signal and then turning out the filament of the tube whose capacity is to be adjusted, but leaving the tube in the socket. If the neutralizing capacity is not correct, the circuits on each side of the tube will have capacity coupling which will transmit the signal. The neutralizing capacity is then adjusted until the signal disappears."

This method of adjustment clearly illustrates that the neutrodyne circuit operates to eliminate capacity coupling and is not a method for counteracting the effects of regeneration, because the adjustment is made with the filament cold and, therefore, under conditions when the tube can have no regenerative action.

Adjustments of the neutralizing capacities are made when the set is tested by the manufacturer. Tubes of the same type may be substituted without upsetting the balance, and even tubes of different types, providing the capacity of the tubes does not differ greatly.

The transformers for radio frequencies in the neutrodyne circuit are of special design and must be mounted in a special manner in order to prevent interaction between their magnetic fields. They are called "neutroformers." The primary and secondary are each wound on tubes of insulated material four inches in length. The primary is placed inside the secondary tube. The primary should have a diameter of two and three quarters inches; the secondary is three inches in diameter. The primary consists of eleven to fifteen turns of No. 22 D.S.C. wire wound on the middle of the tube, while the secondary has from fifty-five to sixty turns of the same size wire. When the windings are completed, the small tube is fixed inside the larger one and the completed transformer mounted and set at an angle of 54.7 degrees. Three such transformers are necessary for two stages of ra-

dio frequency amplification and each must be mounted in the same plane.

The first of these transformers precedes the first tube and the other two follow the tubes in succession, so that the last precedes the detector. The secondary of each transformer is tuned by an .0005 mfd., high quality, variable condenser. All wires must be short.

The whole trick of the neutrodyne lies in the little neutrodon condensers and in mounting the neutroformers at the proper angle. Neutrodons are simple in construction. A piece of brass tubing about an inch and a half long, with an internal diameter large enough to take a No. 14 B. & S. gauge wire, will serve as the outer plate of this condenser. Two pieces of No. 16 wire with an insulated covering can be used to form the inner plates. These two covered wires are inserted inside the brass tube, one from each end of the tube, in such a manner that their ends are about a quarter of an inch apart. The two wires will then be connected to the grids of vacuum tubes. The capacity of the little condenser can be adjusted by pushing the wires farther into the brass tube or pulling them farther apart. They must not touch each other or the brass sleeve placed around them. The insulation will protect them from making contact with the sleeve. The best method to adjust them is to tune in the incoming signal and then regulate the little condensers until all extraneous noises, squeals, howls, and hisses are eliminated.

### PRECAUTIONS TO OBSERVE

The transformers must be mounted at an angle, so as to eliminate electro-magnetic coupling between them, and each transformer should be about six inches apart. If the coils are mounted on the variable condensers used to tune them, the coils should be at right angles to the condenser plates, so that eddy currents will not reduce the efficiency of the coils. The coil windings must not be reversed to each other; that is, in connecting the transformers to the grids and plates of the respective tubes with which they are used, the correct polarity must be maintained. A reversal of the connections will soon show which is the proper connection.

### LOUD-SPEAKERS

There are four tests which may be applied to a loud-speaker to determine its efficiency. Does it produce clear sound at different pitches? Is there equal loudness of sound at different pitches? In complicated sound do the individual pitches get through in the same proportion as they have in the original sound? Is the natural sound of the loud-speaker minimized as much as possible?

One can easily distinguish between clear sound of a definite pitch, such as that of a flute or organ, and complicated sound, such as the voice, which is the blending of a number of pitches. A loud-speaker to be perfect must be capable of re-

producing all musical tones and various pitches of the voice, without any of its own characteristic sounds. A loud-speaker having a horn, diaphragm, or vibrating reed is sure to have its own characteristic sounds; that is, it will vibrate itself at certain frequencies and cause distorted

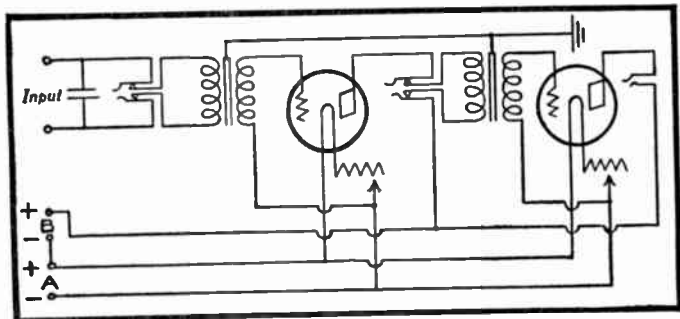

AUDIO FREQUENCY AMPLIFIER UNIT

This amplifier can be constructed in a separate cabinet and connected to any detector set by connecting "input" in place of the phones in the detector circuit; audio amplifying transformers are 5 or  $3\frac{1}{2}$  to 1 ratio, and the cores are connected to the ground binding post; fixed condenser is .001 mfd., all wires must be short and transformers mounted at right angles to each other.

sound. When the tin horn vibrates, it is said to be "tinny." The natural sound of a loud-speaker is dependent to a great extent on the horn. A comparatively long horn gives a lower and more pleasing pitch.

A poorly adjusted amplifier will make the best loud-speaker sound badly. The most successful results are obtained by accentuating low notes and suppressing high ones. For this reason it is sometimes difficult to reproduce a distant station clearly through a loud-speaker. A loud-speaker cannot be used successfully with a crystal detec-



tor set or with a single vacuum tube detector unless the transmitter is very near. At least two stages of audio frequency amplification are necessary for good results. However, a power amplifier or the "push-pull" is much preferable. Unless two or three stages of radio frequency amplification are employed, the loud-speaker will not function in connection with an indoor antenna.

### SELECTING A LOUD-SPEAKER

Engineers have pointed out that the best way to select a loud-speaker is to listen for a pure sound, such as that from an organ. If this is not available, the "howl" of the radio set itself may be used to test the quality of the loud-speaker. If the loud-speaker sends out the various pitches of the howl without a rattle and with fairly even volume, it will generally give good reproduction of voice or music without much distortion. Piano music picked up by a radio set and sent through a loud-speaker also serves as a good test. If some notes are abrupt, blast through, and sound "tinny," it is an indication that the loud-speaker is not of good quality.

The voice is complicated sound and affords a good test for a loud-speaker's ability. Sometimes twenty to thirty pitches are necessary to produce the quality and inflection of the voice. If a person hears a familiar voice through a loud-speaker and can recognize the naturalness of the voice, it is a good indication that the loud-speaker is of superior quality. If the listener is not familiar with

the voice of the speaker, the best criterion is to stand away from the loud-speaker and try to understand the voice.

#### LONG NECKS TO DISAPPEAR

As radio develops, the long-necked loud-speaker, resembling the ventilators of an ocean liner, will become obsolete just as the phonograph horn became unnecessary after the early stages of development were passed. It has been pointed out that a nightingale can be heard when over a mile away and a person speaking does not require a horn to disperse sound. Then why should a radio set?

## CHAPTER VI

### COILS AND CONDENSERS

EFFICIENT operation of a radio-receiving or transmitting set depends upon the proper adjustments of the coils and condensers — to use the electrical terms, the inductance and capacity. The wave length of a circuit depends upon the product of its inductance by its capacity. By regulating the amount of inductance and capacity in the circuit, the set can be tuned to receive the wave length of a particular transmitting station, without interference from other stations using different wave lengths.

Various results are obtained by placing a coil of wire at different points in the circuit. An inductance inserted in series with the antenna and tuner primary increases the wave length. Such a coil is called a "loading inductance." The effect is similar to increasing the length of the antenna. Condensers cannot be substituted for coils. Condensers furnish capacity for the circuit and sustain the oscillations, and thereby aid in tuning. The effective voltage across a coil of wire for a given impressed voltage is higher than the effective voltage across a condenser. It is voltage rather than current which causes the detector to function; therefore the higher the voltage the louder will be the signals.

## TYPES OF COILS

There are various types of coils, each depending upon the manner in which the wire is wound. The most widely used coils are the single layer, honeycomb, duolateral, bank-wound, stagger-wound, and spider-web. Each type has a variety of uses and can be adapted to serve in different parts of the circuit. The solenoid coil consists of a single layer of wire wound on a cardboard or composition cylindrical tube. The disadvantage of this type is its size, especially if built to receive high wave lengths. Distributed capacity is generally large in single-layer coils. The necessity for compact coils with little distributed capacity brought forth the honeycomb, and other forms of compact coils.

## HONEYCOMB COILS

Honeycomb coils, so named because the windings of the wire resemble honeycomb, are used for tuning, but differ from tuners generally employed, in that they have a fixed value. Instead of having switches, taps, or sliders to vary the amount of wire in the circuit, honeycomb coils are provided with prongs which fit into a receptacle placing the total inductance or wire in the circuit. Condensers are used in series or parallel with honeycomb coils to accomplish accurate tuning.

If an operator desires to receive higher wave lengths, larger coils must be substituted. The

size of honeycomb coils to be used depends upon the natural wave length of the antenna. The average set used for broadcast reception works well with a No. 75 coil as primary, No. 50 as secondary, and No. 35 as tickler.

Honeycomb or duolateral coils are the most flexible forms of inductance designed for radio-receiving circuits. They eliminate the necessity of taps and switches, because the coils are designed to receive efficiently different wave lengths, and the correct size coils can be quickly inserted in the mounting. There are no losses from unused turns; thus "dead-end" switches are not required. The tuning is done by variable condensers used in conjunction with the coils. Small condensers should be employed, because the greatest efficiency of a receiving set is obtained with a maximum inductance and a minimum capacity for a given wave length.

#### DISTRIBUTED CAPACITY

Honeycomb and duolateral coils are the result of efforts that have been made by radio engineers to minimize capacity effect as much as possible in coils of wire. In each turn of wire wound in the form of a coil, with insulation between the windings, there is an electrical quality called "distributed capacity." If there are a great number of parallel turns of wire, the capacity will be increased. Two electrical conductors which are at different potentials have capacity between them. Electrical energy is stored up in the di-

electric or insulating material between the turns of wire. The turns act similarly to plates of small condensers. The result is a series of small capacities distributed along the length of the coil, and these capacities added up make the total or "distributed capacity" of a coil. A coil, therefore, is not a pure inductance, for it has capacity across the terminals equal to the distributed capacity of the windings. In calculating the wave length a coil will reach, not only the amount of wire, or inductance, must be considered, but also the resistance and distributed capacity.

When the effect of distributed capacity was first observed, many experimenters endeavored to build coils that would reduce the capacity effect to a minimum. Honeycomb coils were the result. The turns of wire are in zigzag form and subsequent turns overlap the layer underneath. There is considerable air space between the layers and the windings are arranged so the space is filled with other turns extended at right angles to each parallel layer. It was found that the honeycomb coil had a slight capacity, and the duolateral coil was designed to overcome the capacity effect that still existed. The duolateral coil differs from the honeycomb coil, in that the parallel coils, instead of being directly over the layer beneath, are a little to one side of it, and, therefore, are not exactly parallel. This method further reduces the capacity effect of the coil.

No varnish or shellac is used to hold the wire in place, for such coverings add to the capacity and

greatly reduce the coil's efficiency at high frequencies. It is also important in the use of honeycomb or duolateral coils to employ only those mountings which have a minimum capacity in their metal parts, but yet give good electrical contact. The mounting should also be equipped with locking devices, so that after the correct degree of coupling has been obtained the coils can be locked in position so no vibration or jar will alter the degree of coupling. The prongs should be made to slide easily into the socket of the mounting, but at the same time the contact must be firm, because loose connections will cause disturbing noises in the phones. In selecting the coils the size designed for the desired wave length must be used. No greater size should be used than is necessary. The coil should not be too small, although a condenser can be used to obtain sharp tuning. The results will be much more satisfactory if dependence is placed upon the coil rather than upon the condenser.

#### VARIO-COUPLER

A vario-coupler is a variable inductance consisting of a primary coil or stator and a secondary coil called the "rotor." It is an inductively coupled tuner; that is, the coils are not connected, but energy is transferred from the primary to the secondary by induction. High-frequency alternating currents of incoming waves pass through the primary in an oscillating state and are induced in the secondary.

The primary or stator is tapped to a multiple-point switch and the rotating secondary makes the instrument a variable inductance so it can be placed in tune with incoming waves. The variable relationship between the primary and secondary coils causes a variation in the induction taking place between the coils.

In an oscillating circuit such as the secondary, capacity is necessary, and for that reason a variable condenser, with a maximum capacity of .0005 mfd., should be shunted across the secondary coil. The secondary of a vario-coupler is not variable by taps, or slider, as is true in some other types of tuners. A vario-coupler is more efficient than a loose coupler, because the coupling can be varied without drawing the secondary coil out of the primary's magnetic field.

The primary coil of a vario-coupler is stationary and the secondary coil mounted on an axis rotates within the primary, so its windings may be at any angle from a parallel to perpendicular position to the windings of the primary coil. This regulates the amount of current induced in the secondary. When the secondary is turned so its plane coincides with the plane of the primary, the currents circle through both windings in the same direction. Their magnetic fields add to each other and self-induction is at a maximum. When the windings of the two coils run in opposite directions, the magnetic fields oppose and the self-induction is at the minimum.

A vario-coupler suitable for reception of



broadcasting stations with wave lengths from 200 to 600 meters should have about eighty turns of No. 22 wire on a primary,  $3\frac{1}{2}$  inches in diameter. The rotor, of sufficient size to rotate within the primary, should have about fifty turns of No. 24 wire. A vario-coupler should not have a large surplus of wire. It should be constructed to receive efficiently a limited band of wave lengths such as 200 to 600 meters. It is not advisable to have a tuner cover from 200 to 3000 meters, because in such an instrument losses occur due to "dead ends" — unnecessary wire.

The primary winding should be tapped each turn for the first eight and connections made to a multiple-point switch. The other turns should be tapped in groups of eight and joined to contact points of a switch. A vario-coupler can be used in a single circuit receiver by employing the secondary as the tickler or feed-back.

### VARIOMETER

A variometer is built of two spherical coils; one, called the "rotor," revolves, and the stator remains stationary similar to the vario-coupler. The difference between a vario-coupler and a variometer is that no taps are taken from the variometer coils, and one end of the primary coil is connected directly to one end of the secondary coil. Tuning is accomplished by the variometer by rotary motion of the rotor within the stator. The elimination of a multiple-point switch and sliders permits the variation in the inductance

without any break in the circuit or poor electrical contact. This feature especially adapts the variometer for vacuum-tube circuits, since multiple-point switches are likely to leave a break in the circuit when the set is being tuned, and often an interruption in the continuity of the wiring paralyzes the tubes.

The two coils forming the variometer are so arranged that they will either add or oppose each other's magnetic field, thus permitting a variation in the inductance. The rotor and stator are connected in series; that is, the end of the stator winding is joined with the beginning of the rotor winding. The wire should be continuous and be wound in the same direction on both coils. When the rotor is in a position so its plane coincides with the plane of the primary winding, the current will pass through both coils in the same direction and their magnetic fields add to each other, giving a maximum inductance. When the magnetic fields of the coils oppose each other, there will be practically zero inductance. The extent of inductance is determined by turning the rotor.

A variometer whose rotor is shaped like a ball is known as the "ball" type. Another type, which is a great favorite among radio fans, because of its simplicity of construction, is the variometer consisting of two cylindrical tubes, one which rotates within the other. This cylindrical form does not have a minimum or as high a maximum inductance as the ball type. Still an-

other type is the basket-weave variometer, so named because the windings of both coils are woven like wicker baskets. A good variometer has a minimum clearance between the rotor and stator and both coils have the same inductance. A popular use of the variometer is in series with the plate circuit as a means of feed-back to produce regeneration.

### CONDENSERS

A condenser is a system of alternate conducting and insulating materials used to store up electrical energy. Condensers are employed in both transmitting and receiving circuits. Like coils, they can be placed at different points in the hook-up to secure various results. The farad, which is the unit of capacity, is too large a measurement to be used in practical radio work. Consequently there is a smaller division called the "microfarad," or one millionth of a farad, the abbreviation of which is "mfd." Capacity of a condenser depends upon size and area of the plates and upon the thickness and nature of the dielectric medium.

Condensers are one of the most important parts of a radio receiver, and are employed in two distinct forms, fixed and variable. Fixed condensers have a definite capacity and are used in parts of the circuit involving radio frequency currents, and those corresponding to audible tones, where variations in capacity are not necessary. The capacity of a variable condenser may

be changed at will by turning a dial or handle. It is used in that part of the circuit which deals with high-frequency currents. The variable type condenser is constructed in various forms, such as sliding plates, rotary, and sliding tubular. The rotary form is by far the most popular. Such a condenser consists of fixed and movable plates generally made of aluminum. The stationary plates are mounted with a spacing of about one fourth inch between each plate. The movable plates are mounted on a shaft and each plate is separated by about one fourth inch, so the movable plates can be rotated between the stationary plates without touching. When the movable plates are all inside the fixed group, the full capacity of the condenser is in effect. The minimum capacity is obtained by turning the variable plates, so they are completely outside the fixed plates. By changing the position of the movable plates in relation to the fixed plates, the capacity is increased or decreased. Air between the plates serves as the dielectric.

Sir Oliver Lodge formed the first tuned radio circuit when he connected a condenser to an inductance, and this step helped wireless advance from the laboratory to commercial service.

Korda, a German, patented the first rotary variable condenser in 1893, but this type of condenser did not make its *début* in the wireless field until 1902. The first type consisted of two concentric cylinders, one of which was movable. The sliding plate condenser came next, and was

the popular type, in 1910. Then came the rotating plate condensers, which are used extensively at the present time. In the early type rotary condenser trouble was experienced in "dielectric losses"; that is, the insulation material between the fixed and movable plates absorbed some of the radio energy, causing leakage. The Bureau of Standards in 1915 developed a practically resistanceless condenser by using quartz supports. This low resistance increased the signal strength and made finer tuning possible.

When purchasing a variable condenser, the mechanical construction should be considered. Are the contacts good? Are the bearings smooth-running? Are the plates accurately spaced and strongly clamped? Is a counterweight provided for the panel mounting types? Is the dial well calibrated? Are the rotary plates locked together and firmly secured to the shaft?

Good insulating material is essential. Quartz, porcelain, hard rubber are good. Bakelite is fair, and fiber poor. A good condenser does not have small insulation bushings between metal parts, which are at different potentials, such as the stationary and movable plates, and where a vernier plate is insulated from the main shaft. A condenser having an .001 mfd. capacity is generally used in tuning low-resistance circuits, such as a loop receiving circuit, in a wave meter or wave trap. The .0005 mfd., or 23-plate condenser, works well as the antenna series condenser and also across the secondary of the tuner.

### ACTION OF SERIES CONDENSER

A condenser in series with the antenna decreases the wave length, and the smaller the capacity, the greater will be the reduction in wave length. If a 600-meter code station interferes with reception of a broadcasting station operating on a lower wave length, a series condenser will help to eliminate the dots and dashes if the antenna is not too large. A condenser shunted around an inductance increases the wave length.

### VERNIER CONDENSER

A small vernier condenser is generally mounted on the same shaft as the variable condenser and is used to obtain delicate tuning. The vernier is controlled by an independent knob. The plate or plates of a vernier should not be as large as those of the ordinary variable condenser. The larger the plates, the greater will be the capacity. Selective tuning cannot be secured if the capacity of the vernier is too great.

### AVOID LOOSE CONTACTS

Many variable condensers are designed so there is a friction contact to the movable plates; that is, the contact is made by the shaft touching a piece of metal. This is a cheap and easy way to make a contact, but it will develop into a loose connection and dust collecting between the shaft, and the contact point decreases the efficiency of

the entire set. Good firm connections, usually made in the form of pig-tails, by wire fastened to the shaft or bearing, form a far superior contact. Scratching and grinding noises in the phones are often traced to a friction contact in a variable condenser. It should be remembered that sliding and friction contacts are always loose connections and a source of trouble. It has been pointed out that most of the energy radiated by the transmitting aerial is lost in space. Only the smallest part of the power reaches the receiving set. A loose connection places resistance in the path of a feeble current, and it may be prevented from making an impression upon the detector. Using three stages of radio frequency amplification, detector, and two stages of audio frequency amplification, all connections clean and firm, in New York signals have been picked up from Leafields, England, with sufficient strength to deflect a voltmeter.

#### CONSTRUCTION OF FIXED CONDENSER

The fixed condenser is the simplest form and can be made by laying sheets of copperfoil or tin-foil between sheets of mica or waxed paper. The edges of the metallic foil must be well within the margins of the paper and accurately centered over each other. Copperfoil is more satisfactory than tin-foil, because it does not tear so easily and will withstand hot solder when a connection is made. Each sheet of foil should extend over one edge of the insulating material forming a lug to

which the wires can be connected. One half of the lugs protrude at one end of the condenser and the other half at the other end.

A fixed-variable condenser is one provided with taps taken off the plates so different values of capacity can be obtained by moving a fan-shaped switch over an arrangement of contacts. Such a condenser serves well as a phone condenser.

#### GRID CONDENSER

A grid condenser is generally a small fixed condenser of .00025 mfd. capacity. This condenser insulates the grid from the filament except for such leakage as may take place through the condenser or about the vacuum tube. A high-resistance grid leak should be placed around a grid condenser, allowing the negative charges to leak off the grid, thus improving the efficiency of the tube. Such a condenser is sometimes called a "stopping" condenser, because it prevents voltage from reaching a certain point.

#### BRIDGING CONDENSER

A condenser placed around a high resistance, such as a grid leak, primary of an audio transformer, phones and "B" battery, is known as a "bridging" or "by-pass" condenser. It serves as a path of low impedance for high-frequency radio currents. Audio currents, being of a much lower frequency, find it difficult to go through a small capacity condenser and are forced through the transformer windings, which afford less im-



pedance to low-frequency currents than to high frequencies.

### ACTION OF A CONDENSER

A condenser in operation is first charged and then discharged. When the current is sent through the circuit, the condenser stores up the electrical charge on its dielectric to the maximum of its capacity. If the current is alternating, the condenser offers a free path for its passage, as the condenser will first bear a positive charge and then reverse the charge with each alternation. When a direct current is sent through the circuit, the current flows up to the time the condenser is charged, after which there is no further passage of the current. The ability of a current to pass through a condenser depends upon its frequency. The higher the frequency, the more easily it can pass. The condenser in a radio circuit assists the passage of the current which alters its direction or flow, such as an alternating current.

### TRANSMITTING CONDENSERS

Condensers used in transmitting or high voltage circuits are of the same general type as those of the receiving circuit, but are built of materials which will withstand the strain of high potential. Therefore, the dielectric medium must be puncture-proof and capable of resisting leakage. The dielectric of such condensers is generally air, glass, mica, or a composition of insulating materials. The maximum charge of a condenser de-

depends upon its insulation and the ability of the dielectric to resist puncture. High-tension condensers are usually made of brass plates with a composition dielectric. A condenser in a transmitting circuit acts as a storage reservoir for electricity. The electrical pressure between the plates becomes so great that the condenser discharges the accumulated energy back through the circuit and across a spark gap. The spark does not jump the gap only once, as is apparent to the eye, but discharges first in one direction, then in the opposite. It recharges the condenser, but with a weaker charge than the original. The charging and discharging continue until the charge becomes exhausted. The condenser discharges in the form of an oscillating current set up in the aerial.

### CONDENSER CONNECTIONS

Several condensers connected in parallel are equal to one large condenser, having a capacity equal to the sum of the capacities of all the condensers. The breakdown voltage is that of the weakest condenser in the parallel. When condensers are connected in series, they act as a single condenser, and the breakdown voltage is the sum of the breakdown voltages of all the condensers in the series. The total capacity of a series connection is always less than the capacity of the weakest condenser in the series.

## CHAPTER VII

### TUNING

SUCCESSFUL radio reception does not depend on the set alone, but requires a certain skill and technique in the tuning and handling of the instruments, similar to the technique necessary to play a violin or any other musical instrument. Poor results in radio receiving, such as feeble signals, short-distance range, and maximum interference, can be attributed in many cases to faulty manipulation of the apparatus.

Two sets may be identical in appearance, but differ greatly in efficiency. Seldom are two vacuum tubes alike, so there is one point where sets will differ and require different adjustments. Perhaps one operator burns the vacuum tube filament at the proper brilliancy, so the tube is just below the oscillating point, the ideal condition for efficient operation. The filament should not be lighted to maximum brightness as is the opinion of many owners of radio sets. Filament control is afforded by the "A" battery rheostat. Careful and delicate adjustment of the filament current is necessary for successful reception. Some manufacturers of radio sets, realizing the importance of accurate filament control, provide a vernier rheostat in series with the main rheostat. The vernier has about one ohm resistance and fewer turns of wire, permitting finer adjust-

ment. It will be well to note in this connection that refined and steadier control may be accomplished by a 400- or 500-ohm potentiometer placed across the terminals of the "A" battery. The addition of a potentiometer to the majority of vacuum tube sets produces more selective tuning and elimination of interference.

Skillful adjustment of tuning coils and condensers can be attained only through practice. Each little hum, squeal, and circuit noise is a symptom for something wrong, and after the operator becomes familiar with the cause and effect, he will find he is no longer troubled with disturbances originating in the set. Loud signals and long-distance reception depend upon the operator's skill in tuning just as the music from a violin depends as much upon the musician as it does upon the quality of the instrument.

There are a multitude of details which play important parts in successful radio receiving. Among the essential factors are soldered connections, neatness, cleanliness, protection of the set from accumulations of dust and dampness, proper length of the antenna, a good ground contact, and correct values of "A" and "B" battery voltage. In soldering joints, too much flux should not be used, because grease used in the flux spreads between the wires when heated and produces a high resistance, causing howls or no signals. Never oil the arm of a rheostat. Trouble, which develops in the best of sets, may generally be traced to lack of attention to little things. Every

slight improvement in the circuit will help to produce louder and clearer signals and at the same time increase the receiving range.

Two sets may be identical, right from the antenna through the apparatus to the ground, but results will vary according to the consideration given to details and the technique of tuning.

### SELECTIVITY

If all radio transmitting or broadcasting stations in the United States were operating on the same wave length, at the same time, there would naturally be a maximum of interference, making it impossible to distinguish one from the other, although spark signals can be distinguished by difference in pitch. Adjustment of the coils and condensers in the circuit makes it possible to place the receiving set in tune or resonance with a definite wave length. The effectiveness to which a set responds to a definite wave length, or its ability to exclude other wave lengths, is called "selectivity."

A great number of radio listeners complain of one broadcasting station continually causing interference with some favorite station. The elimination of interference nine times out of ten rests with the receiving operator, who if skilled in the technique of tuning could without any difficulty exclude all undesired stations.

## COUPLING

Practically all radio receiving sets are of the two-circuit type; that is, they consist of a primary and secondary circuit, in both of which is a coil of wire known as the "primary" and "secondary" of a tuner. These coils have no direct connection with each other. It is the distance which separates the coils that determines to a great degree the amount of energy transferred from the primary to the secondary circuit. Regulation of the distance between the coils, or the variation of angles at which the coils are placed in relation to each other, is known as "coupling." In the case of a loose coupler, tuning is controlled by sliding the secondary in and out of the primary coil. The coupling of the vario-coupler is regulated by rotating the secondary within the primary. When spider-web or honeycomb coils are employed, the coupling is regulated by moving one coil nearer or farther from the other, or by placing them at different angles to each other.

When an operator speaks of the degree of coupling, he means how far apart or at what angles the primary and secondary coils are placed in relation to each other. There are two kinds of coupling, close and loose. The coupling is said to be close when the two coils are as close together as possible. Close coupling affords a larger transfer of energy from the primary or open circuit to the secondary or closed circuit, although the two circuits are not necessarily in resonance. Close

coupling is used to listen-in on a broad range of wave lengths at the same time, without readjustment to any particular wave. It can be easily understood that close or tight coupling produces maximum interference, because a number of stations not on the same wave length can be heard simultaneously. For that reason operators on board ship, just listening-in, use close coupling in order to more easily pick up distress calls or any other messages which may be directed to them.

When loose coupling is used, the coils are separated and there is a small transfer of energy from the primary to the secondary circuit, except at the wave length to which the set is tuned. The circuits must be in exact resonance; that is, the wave length of the primary circuit and the secondary circuit are equal — in other words, the frequency or number of vibrations of radio impulses a second is the same in both circuits. Loose coupling is used for sharp, accurate tuning to eliminate interference between stations.

#### TYPES OF COUPLING

Coupling between the coils may be direct, inductive, or capacitative. Direct coupling is obtained when the primary and secondary circuits are connected directly together. The ordinary two-slide tuner serves to illustrate direct coupling. When inductive coupling is employed, energy is transferred from the primary to the secondary circuit by means of a magnetic field.

This is called "induction." The loose coupler, vario-coupler, and honeycomb coils are examples of inductive coupling.

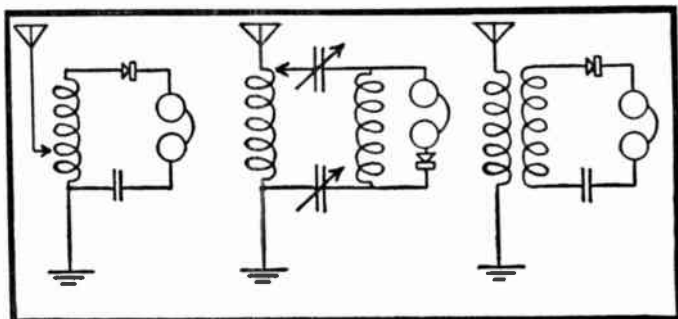

THREE TYPES OF COUPLING

Reading from left to right the circuits illustrate direct coupling, capacity coupling, and inductive coupling.

This question is often asked, "When a vario-coupler, or two-circuit tuner, is used, how can the current in the primary coil get to the secondary coil when there is no connection between them?"

The incoming radio signals pass from the antenna down the lead-in wire to the primary of the vario-coupler. A conductor through which a variable or alternating electric current flows is surrounded by a magnetic field, and when a magnetic field is established around a conductor, there is a current generated within the conductor. The magnetic field or lines of force rising and falling expand outward around the primary coil and cut the turns of wire on the secondary, causing a similar but entirely separate current to flow within that coil. The voltage set up in the sec-



ondary coil is called "induced voltage," and the current set up in the secondary circuit, which includes the detector, is termed "induced current." The word "induce" means to "influence." It is the result of the influence of the vario-coupler primary that a current is set up in the secondary coil. This method of setting up an induced current is known as "induction," and the two coils are said to be in "inductive relation" or "inductively coupled." When the secondary windings of a vario-coupler are parallel with the primary windings, close coupling is in effect, and when the stator and rotor windings are at right angles to each other, the coupling is loose.

#### CAPACITY COUPLING

A set is said to be capacitatively coupled when the primary and secondary circuits are coupled or joined by condensers, generally of the variable type. The coupling is varied by adjusting the condensers. Small capacity represents loose coupling, and an increase in capacity is equivalent to close coupling.

#### TYPES OF CIRCUITS

The question is frequently asked, "Which of the following three circuits is best for long-distance reception: a single-circuit receiver, a triple-circuit receiver, or a radio frequency amplifier set?" The answer is, first, the radio frequency amplifier circuit; second, a single circuit; third, a triple circuit.

As previously pointed out, radio frequency amplification strengthens the radio frequency or carrier wave of the broadcasting station before it reaches the detector. In this way weak signals from distant cities are built up and given power enough to operate the detector. Three stages of radio frequency amplifiers form a practical limit for this type of circuit.

The single circuit has a direct coupling between the antenna circuit and the input circuit of the

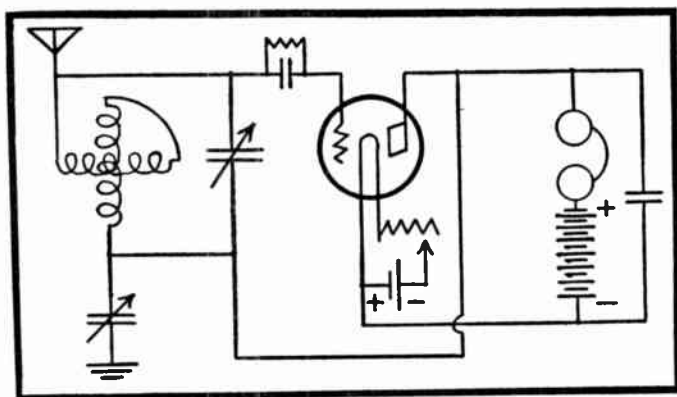

ULTRA-AUDION SINGLE CIRCUIT RECEIVER

The tuner is a variometer; variable condensers .0005 mfd.; grid condenser .00025; grid leak variable; "B" battery 22½ volts; mica fixed condenser .002 mfd. This is a good circuit for long distance reception, but is not as selective as a double-circuit set.

vacuum tube, and that is why it is an excellent set for distance work. In a double or triple circuit an effort is made to gain maximum selectivity, and in order to accomplish this the two circuits are placed in inductive relation to each other, so the original energy picked up by the

antenna must be transferred from one circuit to the other by induction before it reaches the detector. Sacrifice of energy is made for selectivity. It is a good idea to bear in mind that the simpler a circuit is, the better will be the results. Simple circuits are easy to operate and control and there is less likelihood that errors will be made in construction.

#### WAVE TRAP OR FILTER

A wave trap, or filter, as a means of reducing interference, is a coil shunted by a condenser, inserted in series with the antenna lead-in, or ground wire, of the receiving set. By tuning the wave trap to the wave length of an interfering station, the undesired signals can generally be eliminated. Similar combinations of coils may be used in series with each other to cut out more than one station, but when the combined wave length of the wave traps and receiving set exceeds that of the desired station, the limit of utility is reached. A wave trap offers high impedance to the wave of an undesired station, and at the same time offers normal impedance to a station the operator wishes to hear.

With a good wave trap it is often possible to obtain satisfactory reception through conditions of interference which are beyond the ability of the receiver to prevent. A wave trap can easily be built and is a useful adjunct to any receiving set. The wave trap is sometimes called an "acceptor-rejector" circuit.

To understand the operation of the wave trap, first, consider the primary circuit of the receiving set in which a primary coil and condenser are employed for tuning. When the coil and condenser are connected in series, the circuit responds to only one wave length, determined by the size of the coil, condenser, and antenna. Each adjustment of the condenser makes the circuit responsive to only one wave length. There is a minimum impedance to the current of the frequency to which it is tuned. When it is in exact resonance, or in tune, resistance is the only factor which limits the magnitude of the current. An impedance is offered to all other frequencies, which is greater than the resistance, that is, the station the operator desires to hear will produce the greatest signal current and all stations on other wave lengths will produce a weaker current, because the circuit is not in tune with them.

A wave trap tends to make tuning extremely sharp, and this is not always desirable, because some of the higher and lower frequencies of the modulated wave are not passed through the trap and the signals will not be clear.

A good wave trap for use on wave lengths ranging from 225 to 550 meters can be made by using a honeycomb coil No. 75 and a 23-plate variable condenser with vernier attachment. If interference is caused by a station using a higher wave length, a larger honeycomb coil should be substituted and bridge the variable condenser with an .00025 mfd. fixed condenser. To operate

a wave trap, tune in the desired signal with the set and then adjust the variable condenser in the wave trap. When it is in tune with the interfering

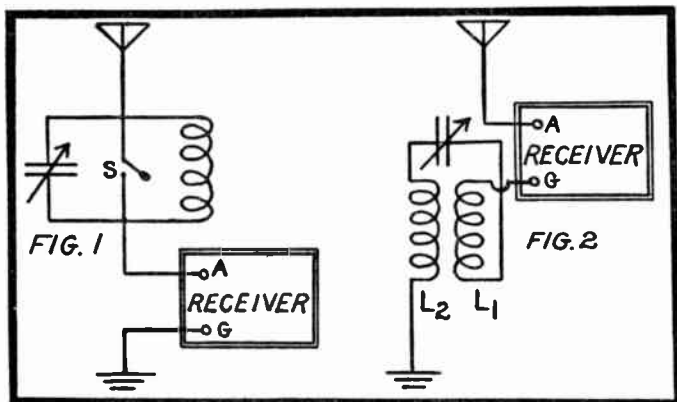

### WAVE TRAPS

Fig. 1. consists of a honeycomb coil and .0005 mfd. variable condenser; when switch "S" is closed the wave trap is out of the circuit. Wave trap in Fig. 2 consists of two coupled coils and a .0005 mfd. variable condenser; L1 is 2½ inches in diameter wound with 30 turns of No. 22 copper magnet wire; L2 is 3 inches in diameter wound with 30 turns of No. 22 wire; L1 is placed inside L2; wave-length range 200 to 500 meters. To eliminate 600-meter code, shunt a .00025 mfd. fixed condenser around the variable condenser.

wave, the trap will absorb energy from the disturbing signal and prevent it from causing interference. When the trap is tuned to the interfering signal, it should be left alone.

### REINARTZ TUNER

The Reinartz coil is a single-circuit tuner. It is more selective than the ordinary tuner used in a single-circuit regenerative set. Critical tuning in the antenna circuit is avoided, because the antenna circuit is tuned to a much shorter wave

length than that which is received. Close coupling between the antenna circuit and grid circuit of the vacuum tube enables the antenna to transfer energy at longer wave lengths to the grid circuit. Acting as a collector circuit only, the

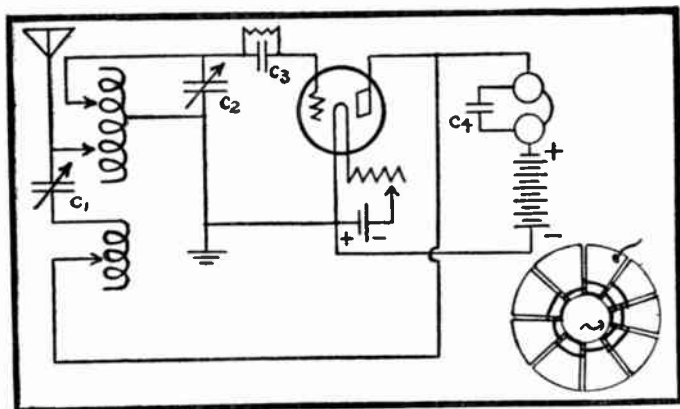

SINGLE CIRCUIT SET EMPLOYING A TUNER KNOWN AS THE REINARTZ COIL

$C_1$ , 23 plate variable condenser;  $C_2$ , 13 plates;  $C_3$ , .00025 mfd.;  $C_4$ , .002 mfd.; grid leak variable; "B" battery  $22\frac{1}{2}$  to 45 volts; insert shows form of winding. This is a favorite circuit among amateurs for long-distance reception.

antenna circuit does not require fine tuning adjustments. Regeneration is obtained and accurately controlled by a combination tickler and coupling condenser. The tickler winding is tapped at several points, and together with the condenser an accurate amount of regeneration is obtained between the various taps.

The tuning coil is built in spider-web form, but is not a continuous winding. The coil can be home-made or purchased at radio stores. No. 24

or No. 26, copper magnet wire serves well as the windings. Forty-five turns are wound and taps taken off at the fifteenth, thirtieth, and forty-fifth turns. A break is made in the circuit at the end of the forty-fifth turn. This constitutes the plate coil.

The winding is then continued in the same direction, but must not make any electrical contact with the plate coil. On this second coil taps are taken off each of the first five turns, the seventh and ninth. Each tap is joined to a multiple-point switch. This section forms the antenna tuning coil. No break is made in the windings at this point, but the wire is continued until twenty-five more turns have been added and a tap is made at the twenty-fifth turn. The thirty-second turn is the next tap, then the thirty-ninth and forty-sixth. This section of the winding makes up the secondary or grid coil.

The Reinartz coil is wound on a circular disc about six inches in diameter. The form can be cut from heavy cardboard. Nine slits are cut in the disc, radiating from the center with a diameter of two inches. The windings must be very close together. The most critical tuning is done by the grid condenser. The switch points can generally be left in a fixed position after the operator becomes familiar with the set.

Audio amplifiers can be added to this circuit in the usual way by connecting the first audio amplifying transformer where the phones are connected in the detector circuit.

## OPERATING HINTS

All radio enthusiasts, no matter how elaborate their apparatus, have two goals constantly in mind — louder signals and increased receiving range. The greatest lure in the realm of radio is distance. The first scheme thought of to accomplish this is stages of amplification or a loudspeaker; but in practically every station, no matter how simple or complex, there are many little details of construction, installation, and operation which, if given proper attention, would increase the efficiency of the instruments to a marked degree.

Neatness and cleanliness, although not electrical terms, are two essentials which afford an easier path for the feeble radio currents. Dust should not be allowed to gather on the instruments, for it causes leakage. Dust between the plates of a variable condenser develops short circuits, and collections of dust and soot on the antenna insulators make it easy for radio currents to leak away to the ground before they have a chance to reach the receiving set.

One operator noticed the signals gradually growing weaker. He overhauled the entire set, carefully inspecting all connections, but failed to locate the trouble. He began to lose faith in radio. One morning, while dusting, his wife happened to brush the dust off the spider-web coils, mounted on top of the cabinet. That night the set worked to perfection, as it did when first installed.



A Mississippi radio follower discovered local concerts gradually losing their intensity and music of distant stations disappeared. He did everything he and his friends could think of to remedy the trouble. Determined to locate the fault, he tried a friend's set connected to his antenna and ground, thereby tracing the trouble directly to the set. He bought a complete set of new parts and mounted them on the hard-rubber panel in place of the old ones. The music was just as faint. The idea occurred to him to clean the panel before discarding it, because he felt possibly some acid from the soldering flux had crept into the panel, making it a conductor instead of an insulator. He soaked a cloth in ether and as he rubbed it across the panel the cloth turned black. The problem was solved. Soot from a near-by cotton mill had deposited a coating on the panel, causing a path of leakage for radio impulses. Neighbors in that locality were having the same trouble, and they too discovered that the cotton-mill soot was leading their radio waves astray.

There are very few sets which cannot be improved in some way. Little things may seem unimportant, but experience in radio will prove in time that little improvements join with each other to produce louder signals and increased range, forming an efficient foundation for successful operation of amplifiers. Nine times out of ten trouble in a radio receiving set is caused by some little thing, so small that it escapes notice and consideration.

Here are a few suggestions which will test the weak spots of the receiving system and help to eliminate trouble. Inspect all antenna and ground connections frequently. Joints should be firm and clean. Solder every connection to insure good electrical contact. Remember, a "soft" vacuum tube is always more sensitive as a detector than a "hard" amplifier tube. If a loud signal chokes the set, a lower resistance grid leak should be used. Use a .001 mfd. mica fixed condenser across the primary of the first amplifying transformer, and a .002 mfd. condenser across the phones and "B" battery. Connect the cores of the amplifying transformers to the ground binding post. Place amplifying transformers at right angles to each other and about four inches apart. The last few suggestions will minimize howls.

A soft noise like rushing water indicates the set is regenerating. If the set will not oscillate, it is not capable of regeneration. Verify if the tube is a detector or an amplifier. An amplifier tube will not oscillate as easily as a detector tube. Try reversing the plate variometer or tickler connections. The simplest way to determine whether a set is regenerating is to short-circuit the grid condenser, and a click will be heard in the phones when a finger touches the grid terminal of the socket, and a similar click when the finger is removed, if the set is regenerating. An increase in "B" battery voltage will help some tubes to oscillate.

Do not connect the antenna or ground wire to the end of a loose coupler farthest from the secondary. With such a connection it is impossible to obtain maximum coupling. Do not shellac or paraffin the windings of coils. Do not handle with the fingers galena or any other mineral used as a detector, because the surface will become coated with a thin covering of grease which impairs the efficiency of the crystal. It is more satisfactory to obtain a new crystal than to try to clean an old one.

A continuous hum indicates a break in the circuit. Trace through the wiring for a broken connection. A good place to look for poor contacts is in the tube sockets, where the prongs are likely to become bent and form a loose connection. Contacts of the telephone jacks often work into loose connections. Sometimes a break develops in the head-set cord or in the cord tips. The best remedy is a new cord. Never oil or grease switches or rheostats, for oil is a poor conductor of electricity.

If the plates in an antenna series condenser fall out of line and touch, the effect will be similar to eliminating the capacity from that part of the circuit, but if the short circuit takes place in the secondary condenser, the secondary coil will be cut out of the circuit and no signals will be heard. Sliding contacts on tuning coils are inefficient. The fewer movable contacts on a radio set, the more successful will be results.

Some sockets have the positive and negative

signs marked incorrectly, so, to verify the proper connections for the "A" battery, connections should be reversed. Be careful not to increase the "B" battery over eighty volts, because some transformers will burn out if a higher voltage is applied. When soldering use as little flux as possible, because too much will make a thin coating of insulation over the wires. Remember, fixed condensers that give way under light pressure of the fingers are not dependable, as their capacity varies. See that no wires in the hook-up run close together or parallel. Make every wire as short as possible, especially the wires leading to the plates and grids. Try reversing the connections of the antenna or ground series condenser to eliminate the effect of body capacity. The terminal of the rotor plates and shaft should be connected to the wire leading direct to the ground.

The end of a condenser shaft covered by a knob of poor insulating material will cause leakage, and is also likely to serve as a small condenser producing an annoying effect similar to body capacity. Duolateral or honeycomb coils are more efficient in a radio frequency amplifier set than spider-web coils. To protect coils from absorbing moisture, paint or dip them in collodion. Insert insulators in guy wires.

When purchasing a panel, be sure it is a good insulating material. It frequently happens that a composition panel is not a good insulator. If leakage occurs through the panel, signal strength is greatly reduced and tuning is not sharp. This

is especially true when radio frequency amplifiers are employed. If the lay-out for mounting instruments is made on the panel in pencil, make sure that all pencil lines are completely removed after their purpose is served. Pencil marks are conductors of electricity and serve as pathways of escape for radio currents.

Keep storage battery acid away from the phone cords. A drop of acid is likely to eat through the insulated covering and create a short circuit. If trouble develops inside the case of the receivers, the phones should be returned to the manufacturer for repair.

Vacuum tubes are not all perfect and are sometimes a source of trouble. A tube that lights is not necessarily good. The grid and plate touching is a defect in some tubes and in such an instance a tube is worthless. Always mount vacuum tubes in a vertical position. If they are placed horizontally, the heated filament will have a tendency to sag and come in contact with the grid, making the tube useless.

Radio antennæ installed near high voltage lines have brought sorrow into a number of American homes. It is reported that twelve radio enthusiasts, mostly boys, met death in 1922, as a result of touching exposed live wires while installing radio antennæ. In several cases the antennæ fell across a high-tension wire and death resulted when the owner tried to lift the antenna off the electric wire. Install the antenna so there is no possibility of its falling or coming in

contact with electric light or power lines, during the course of erection or afterwards.

#### VIBRATION CAUSES INTERFERENCE

When some sets are in operation a ringing sound is heard in the phones if the least jar affects the cabinet or table on which the set stands. The ringing continues for some time after the table has been jarred. Such a noise makes tuning impossible, especially when the signals are faint.

These microphonic noises, as they are called, are caused by mechanical vibrations, which vibrate the elements of the tube, especially the grid. The practical way to eliminate this ringing annoyance is to cushion the tube socket and mountings on strips of sponge rubber, heavy felt, or light springs, so mechanical shocks will be absorbed and not be transmitted to the tube. Never mount the tubes directly on the bottom of the cabinet. Some tubes give more trouble from microphonic noises than others, depending upon the support given to the grid, plate, and filament. The effect is more noticeable in dry-cell tubes.

The cushioning effect will be lost if rigid wire is used to connect the tube sockets. Flexible wire should be employed, because it will not transmit vibrations like a solid conductor. Many of the dry-cell tubes are very susceptible to mechanical vibrations, and in some cases even a pencil dropped on the table will start the ringing noise.

### CHIEF METALS OF RADIO

Practically every instrument in a radio receiving set or transmitting equipment makes use of copper, bronze, aluminum, brass, or iron in its construction. The high electrical conductivity of copper renders it essential for switches and parts employing wire to convey the feeble electrical currents. Brass, because of the ease with which it can be machined and its excellent conductivity, is used for binding posts, plugs, and sockets in the receiving set, and also finds numerous uses in transmitting outfits. Where unusual strength is required, phosphor bronze or silicon bronze find wide application. Aluminum, because of its light weight, serves admirably for variable condenser plates. Sheet copper and brass are also used in condenser construction, but more so for transmitting condensers than for the receiving type.

Undoubtedly copper plays its greatest part as the antenna. To perform such duty it must resist corrosion caused by the elements of the weather and changing climatic conditions. The wire must have sufficient strength to withstand wind-storms and heavy coatings of ice, as well as its own weight, when stretched in long spans. Experiments conducted by the Bureau of Standards led to the conclusion that No. 14 or No. 16 bare copper wire is most satisfactory for short-span antennæ as used for receiving music from broadcasting stations. Phosphor bronze stranded wire gives most satisfactory service for long an-

tennæ. A good size is No. 20 or No. 22, which furnishes a large surface over which the radio energy can travel more easily. The stranded construction tends to absorb considerable stress before the metal begins to stretch.

A copper sheet or copper boiler buried several feet in moist earth provides an ideal ground connection for a radio set. In magnetic circuits iron or steel alone, or the air itself, in some cases, provides a path for the flux. The vario-coupler and other tuners in the receiving set and the helix in the transmitting circuit serve as examples of the air path. Audio amplifying transformers and choke coils afford examples of the iron pathway. Where the amount of magnetic flux which the material will retain makes little difference, steel can be used. Norway iron serves well for a core, when it is not necessary to hold the magnetism. The core of a telegraph relay and cores of spark coils are examples of this type.

### INSULATING MATERIALS

It is imperative that a radio system be properly insulated to produce highest efficiency. Materials which do not conduct electricity are insulators. Glass is a poor conductor of electricity, and for that reason glass, which does not contain metallic veins, is often used as an insulator. Air is generally a good insulator.

The ability of a material to resist the stress impressed upon it by high voltages is called its "dielectric strength." Electricity like water



will attempt to escape from its confines unless properly guided. Radio currents are of high frequency and good insulating materials must be employed to prevent leaks and short circuits. The dielectric strength varies with different materials, and for that reason insulating material should be chosen with respect to the use to which it is to be put.

The insulating, or conducting, quality of a substance is determined by the number of electrons in the substance which are available to move about. Cheap insulation is generally detrimental. Materials which will absorb moisture are not good insulators. Some grades of fiber fall into this class. Any material which is likely to melt under warm conditions will become sticky and pick up dust, making it a poor insulator. Porcelain is brittle and often breaks. Hard rubber is good, but discolors with age, especially if subjected to bright sunlight. Phenolic resin is good and is without many of the disadvantages of other materials.

Paraffin is good for treating wooden parts, such as rotors, stators, tuning-coil cylinders, and tubes. Paraffin repels moisture. When a piece of wood is dropped in hot paraffin, above the boiling point of water, bubbles will rise to the surface. These bubbles are atomic particles of water leaving the wood in the form of steam. If this treatment is not given wooden parts designed to hold coil windings, they will shrink in time and the wire will loosen, necessitating rewinding.

Marble is often used as electrical switchboards, but for such purposes it must be carefully selected, because it is likely to contain metallic veins. Slate is a poor insulator and should not be used as a switchboard in connection with a radio transmitter, or as a panel in the receiving set. If the receiving set is placed on a table with an oilcloth covering, the set should be insulated from the oil cloth, which generally conducts electricity.

#### CONVENTIONAL SYMBOLS

It is evident that a large percentage of radio followers are unable to understand or interpret the conventional electric-circuit diagram. Many unable to read the diagrams made up of electric symbols ask for a "picture hook-up." The picture method is inferior, and it will be far more satisfactory in the end to learn and master the regular circuit diagram. The first step to do this is to learn the conventional symbols used in all hook-ups.

## CHAPTER VIII

### HEAD PHONES AND BATTERIES

PHONES, or receivers, used in radio to produce sound are of the watch-case type, and are usually connected by a head-band. When a head-set is marked "3200" ohms, the meaning is that each receiver has a resistance of 1600 ohms. A permanent horseshoe magnet is located in the bottom of each case. Good permanent magnets are important. Hard steel is not as satisfactory as alloys of tungsten, chromium, or cobalt, or some combination of these metals.

A permanent magnet must be seasoned before it will produce good results. The seasoning can be done artificially by tapping and by exposure to heat and cold at ordinary temperatures. This insures permanency of the magnetic force of the magnet.

To the ends of the magnets are attached soft iron pole pieces and around each pole piece is wound a coil of fine insulated copper wire. The windings are usually connected in series, so that the current passes through both windings. In some receivers the wire is as fine as a hair and the two coils contain thousands of turns. The larger the number of turns, the greater is the magnetic effect in the receivers.

Placed above the pole pieces, and very close to them, is a very thin circular disc called a "dia-

phragm." In standard instruments the distance between the pole pieces and the diaphragm is about .003 of an inch. The variations of the current in the windings correspond to the sound vibrations of the voice, or music, picked up by the microphone connected to the broadcasting apparatus. The current variations produce corresponding variations in the magnetic field of the pole pieces and the diaphragm moves accordingly, reproducing the voice or music.

There is a special type of phones on the market which have a mica diaphragm instead of steel. In this diaphragm the variations are created by a small iron vane which is affected by the permanent magnet. Current flowing through the coils causes a twisting of the vane and by means of very light levers this vibration is conveyed to the

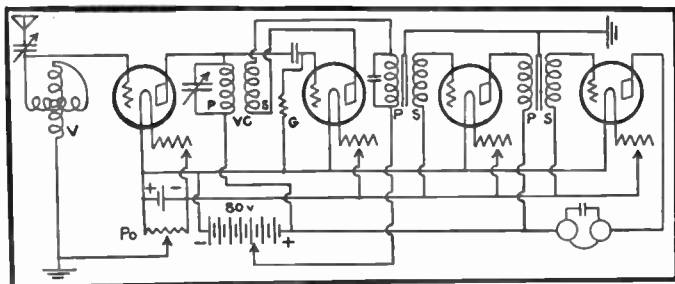

ONE STAGE RADIO FREQUENCY AMPLIFIER,  
DETECTOR AND TWO STAGES OF AUDIO FREQUENCY  
AMPLIFICATION

"V" is a variometer and "VC" a standard vario-coupler; "G" one megohm; audio transformers 5 or  $3\frac{1}{2}$  to 1 ratio; cores of transformers are connected to ground binding post; variable condenser .0005 mfd.; grid condenser .00025 mfd.; "Po" is a potentiometer 400 ohms; phone condenser .002 mfd.; fixed condenser across audio transformer primary .001 mfd.; "P" indicates primary and "S" secondary. This circuit is capable of transatlantic and transcontinental reception.

mica diaphragm. In such a phone the diaphragm is under no constant tension and therefore strong permanent magnets can be employed. The mica diaphragm receivers are excellent where the volume of sound produced by amplifiers is great, because there is less distortion with such a receiver.

The resistance of a good pair of phones suitable for radio reception may be as low as 2000 or 1500 ohms. Resistance is not wanted, but cannot be avoided. A few turns of German silver wire would produce 2000 ohms resistance, but no magnetic effect. Phones have permanent magnets for two reasons — to keep the diaphragm under strain and to prevent hysteresis losses.

If an operator desires to use several pairs of phones, they should be connected in series, not in parallel, unless the resistance of all receivers is the same. When a series connection is used, there will be a slight decrease in signal strength in comparison with a single pair of phones in the circuit. The ear-drum and phones' diaphragm function normally, responding faithfully when the phones are not pressed too tightly against the ears. A certain amount of air space is necessary for resonance. If it is found that signals are louder when the hands touch the metallic cases of the phones, the same effect can be secured by placing a .002 mfd. fixed condenser in shunt around the phones.

Ordinary telephone receivers will not work successfully in connection with a radio set. Telephone receivers have a resistance of seventy-five

ohms. The average radio head-sets range from 2000 to 3200 ohms. The ohm is the standard unit of resistance, just as a yard represents a certain fixed distance. The principles of operation in both receivers are the same, but the radio phones are much more delicate. Receivers should not be subjected to heavy jars. It is a good idea to have a hook near the receiving set, so the phones can be hung up when not in use. If they are laid on a table they are jarred, and are often dropped on the floor. Such treatment demagnetizes the permanent magnets and also develops loose connections or broken wires within the cords or within the metallic tips of the cords.

#### RADIO ENERGY WEAK

Dr. Charles P. Steinmetz estimated that the energy in a pound of coal is more than enough to operate a radio receiving set continuously at an audible signal over one thousand years, so feeble are the radio impulses which the antenna intercepts from the ether.

The energy in the flame of a match burning for two seconds is calculated to be enough to create audible sound in a sensitive radio head-set for ten thousand years. It is estimated that less than one one thousandth of the electrical energy is transformed into sound. The force of air waves produced by the voice on the microphone is calculated to be more than ten thousand times that received from the diaphragm of the phones. Such illustrations show the feebleness of radio currents

in the receiving circuit. All connections should be firm to afford good electrical connections and an easier path for the minute impulses to reach the detector and operate the phones.

### TELEPHONE JACKS

There are five different styles of telephone jacks used in radio receiving circuits. The double-circuit jack is most commonly used. It is placed between the successive steps of audio frequency amplifiers, so when the phone plug is removed from the jack the next tube is automatically placed in the circuit. A double-circuit jack has four springs, all insulated from each other and from the frame of the jack. When no phone plug is in the jack, the tips of the inner springs press against the outer ones. When the phone plug is inserted, the inner and outer springs are disengaged, and the end of the plug makes a connection with the lower outer spring, while the sleeve touches the outer upper spring.

The single closed circuit jack has only one inner and one outer spring. The end of the plug touches the tip of the long spring and the sleeve contact is made directly on the frame. A single open-circuit jack is similar.

Automatic filament jacks have extra sets of springs to control the battery circuit of the tubes. If properly wired, all the tubes will be out of the circuit when the plug is out of all jacks, although the rheostats may be turned on. When the phone plug is inserted, only the tubes up to that jack

are supplied with current. When the plug is removed, the entire set is out of operation. The wiring of automatic filament jacks is somewhat complicated, but they are convenient as a means to stop the battery from supplying current to the tubes as soon as the operator has finished listening-in. There are two types of automatic filament jacks, single and double-circuit. The double one is similar to the regular single closed-circuit jack, and the single circuit is like the single open-circuit standard model. The conventional symbols for jacks are practically pictures of them so they can easily be followed in wiring.

#### THE "A" BATTERY

The duty of the "A" battery is to light the filament of a vacuum tube. There are three types of "A" batteries and the selection of any one depends upon the type of vacuum tube employed. Some tubes operate with ordinary dry cells; others with flashlight cells or a storage battery. The latter requires more care and attention than other "A" batteries, if it is to produce efficiently over a reasonable period of years. Radio homechargers enable owners of storage batteries to charge them at home off the house-lighting lines.

Violent discharging and excess overcharging shortens the life of a storage battery, causing injury to the plates by warping or buckling. The liquid inside the battery, known as the "electrolyte," is a definite mixture of chemically pure sulphuric acid and water. The electrolyte should



never be permitted to fall below the tops of the plates. Exposure of the plate tops induces sulphation, a chalky deposit, which is a nonconductor of electricity, thus causing internal resistance. Distilled water should be added to maintain the proper level of the electrolyte — about one quarter of an inch — above the tops of the plates. Never use water which has been in contact with metal. Handle the water only in glass, hard rubber, or glazed earthenware vessels. During the summer it is well to add water once a week, as evaporation is more rapid in warm weather. Never add too much water, because the solution will spill over and cause a short circuit on the exterior of the battery. The electrolyte will also eat the case and sulphate the terminals. Sulphation of the terminals may be stopped by wiping them off with a vaseline rag. Always keep the top of the battery case dry and clean. Idleness is bad for batteries. If a battery is to be inoperative for several months, it should be left in care of a service station, where it will be given proper care.

#### HYDROMETER

The state of charge and discharge of a lead-plate-and-acid storage battery can be determined by an instrument called a "hydrometer," which, if inserted in the electrolyte within the battery, will give the specific gravity. Specific gravity of a liquid is a comparison of its weight to the weight of the same quantity of water. Sulphuric acid used in a storage battery is heavier

than water. A tube such as the hydrometer, weighted to float in sulphuric acid, will sink in a glass of water.

As a storage battery discharges, the plates absorb sulphuric acid leaving the remaining electrolyte lighter in weight. When a battery is recharged, acid is forced from the plates back into the solution, which, on full charge, regains its original strength. Thus, by measuring the specific gravity of the electrolyte the amount of acid absorbed by the plates can be determined. This indicates the state of charge.

To test the specific gravity of a storage battery cell, remove the vent, insert the tube, at the bottom of the hydrometer syringe, into the electrolyte. Squeeze the rubber bulb, then remove the pressure from the bulb. The electrolyte will rise in the glass barrel. Read the figures on the graduated scale reached by the surface of the electrolyte. The figure 1.285 is the "full charge" for battery specific gravity. The figure 1.270 indicates one quarter discharge. The reading 1.255 shows the battery is half discharged, and 1.225 warns that the battery should be charged.

After the reading is noted, squeeze the bulb to expel the liquid from the tube, and always restore the electrolyte to the cell from which it is taken — never to another. Always take the hydrometer reading either before adding water, or after there has been an hour or two of use, to insure thorough mixing. Water mixes slowly with the electrolyte since the acid is heavier.

### CORRECT WIRING

The "A" battery terminals wrongly connected in a receiving set are the cause in many cases for weak signals and short receiving range. Many are of the opinion that the "A" battery is properly placed in the circuit if the vacuum tube is brilliant. This is not true, for it is extremely important that the positive and negative terminals be joined to definite points in the circuit if maximum efficiency is to be obtained. There are several hundred radio receiving circuits, but all are based on a few fundamental principles which must be adhered to in wiring the apparatus. Vacuum tube circuits have one point in the wiring known as the "common lead" or "common center." At this point three different circuits join, and it is essential that the connections at the junction point be correct.

A single tube detector set consists of three different sections or circuits: the filament circuit, grid circuit, and plate circuit. The filament circuit extends from the positive side of the "A" battery through the filament and "A" battery rheostat, back to the negative terminal of the "A" battery. This is the circuit which lights the filament. The grid circuit consists of the secondary of the tuner, one side of which connects to the grid and the other to a side of the filament. The grid circuit acts as the control of the tube. The plate circuit runs from the plate in the tube through the tickler or means of feed-back, and

through the "B" battery and phones to the filament. It will be observed that the grid and plate circuits are completed within the tube. At one point in the wiring all three circuits come together at a common point, which is the nerve center of the receiving circuit — the "common lead."

In the case of a detector, the wire extending from the positive terminal of the "A" battery should run to the common center. When such circuits are in operation, there is a constant accumulation of negative electrons on the grid, which, if permitted to remain there, would interfere with the successful operation of the detector. It is the function of the grid leak to serve as a path for the negative charge to leak off the grid.

### GRID LEAK

The grid leak is a high resistance of 1,000,000 ohms, known in radio parlance as "one megohm." One end of the grid leak is connected to the grid and the other end leads through the secondary of the tuner to the "common center," which is connected to the positive side of the "A" battery. It is one of the laws of electricity, that unlike charges attract each other. The positive side of the "A" battery attracts the negative charges off the grid through the grid leak. One of the duties of the grid condenser is to allow the high frequency radio currents to pass around the high resistance of the grid leak unimpeded.

When stages of audio frequency amplification are used, the wire leading from the "common center" should always connect to the positive terminal of the "A" battery, as in the case of the detector, when used without amplifiers. However, the grid returns through the audio amplifying transformers should always connect to the negative side of the "A" battery.

If the grid is positive in an audio frequency amplifier tube, there is likely to be distortion and an excess flow of "B" battery voltage. The wiring must be made so the grid of amplifier tubes will not become positive. A simple way to prevent this is to connect the grid return wire direct to the negative terminal of the "A" battery, and the filament rheostat is placed in the negative side of the filament circuit.

Radio frequency amplification, unlike the single tube detector, requires a negative charge on the grid of all radio frequency amplifier tubes. A potentiometer, of about 400 ohms, is used in the first stage of radio frequency across the terminals of the "A" battery, to regulate the negative potential on the grid. The center contact or arm of the potentiometer is generally connected to the secondary of the tuner, forming a path from the filament through the secondary winding to the grid. It is important that the wire leading from the "common center" of the wiring, in this case, should connect with the negative terminal of the "A" battery.

It would be well for all owners of vacuum tube

sets to check up the "A" battery connections. Reverse the connections and note which method of connection produces the best results.

#### WHEN TO USE DRY CELLS

Detector and amplifier tubes requiring more than one half ampere at five volts or more should be used with a storage battery. Tubes requiring less current or less voltage can be used successfully with dry cells.

The smaller the current taken from any battery, the longer will be its life, but if the current taken from the battery is too small, its period of usefulness will be reduced because of natural depreciation which takes place in batteries. When current is drained from cells for two or three hours continuously, the current drawn from each cell should not exceed one quarter ampere. If currents of over one quarter ampere are required, the drain on each cell can be minimized by connecting a sufficient number of cells in multiple, thus dividing the total drain among the cells. The drain on each cell can be reduced to one eighth ampere by using eight dry cells in multiple instead of four. The amount of service will be more than double that of four cells.

If the current is reduced too low, the time required to exhaust the battery is great enough to allow natural depreciation to shorten the life of the dry cell. It has been pointed out that natural depreciation of dry cells is similar to evaporation of a water tank. If the tank is allowed to stand

long enough, the water will evaporate and none of it will be left for useful purposes. If water is drawn off occasionally in small amounts, less will be available for use, because evaporation takes place continually and more time is allowed for evaporation under these conditions. If the tank is exposed to heat, evaporation is more rapid. A dry cell exposed to heat loses electrical energy.

### THE "B" BATTERY

If the wiring of a radio receiving set is traced through, it will be found that there is a break in the circuit inside the vacuum tube, because there is no connection between the filament and plate. It is the duty of the "B" battery to "pump" electrons or electricity across this gap between the filament and plate, completing the circuit. In order to do this, the "B" battery keeps a positive charge of electricity on the plate, attracting negative charges emitted by the lighted filament.

A single tube detector set generally requires a "B" battery of  $22\frac{1}{2}$  volts; amplifier tubes, about 45 volts each; reflex and radio frequency amplifying circuits, about 80 volts. "B" batteries can be obtained in sections of  $22\frac{1}{2}$  volts, 45 volts, and 90 volts. They are usually variable by taps, so the voltage can be roughly regulated. It is not necessary to have the "B" battery voltage finely regulated.

This question is often asked, "How can the noise of a 'B' battery be eliminated?" Disturb-

ing noises caused by the "B" battery sound like static, and are generally the result of irregular fluctuations of a weakening "B" battery voltage. Falling-off of the "B" battery voltage is caused by work done by the battery, whereby chemicals in the cells are gradually exhausted, and, secondly, by natural deterioration of the cells when the battery is idle. The best batteries are the ones in which the grade and proportion of the chemicals are most efficiently combined to prevent slow deterioration.

All noises in the set cannot be blamed on the "B" battery. Anything in the circuit capable of creating irregular fluctuations in the voltage is a source of noise and not the battery itself. When the "B" battery voltage is nearly exhausted, a scratchy noise is the symptom which tells the operator a new "B" battery is needed. Such noises stop as soon as a fresh battery restores the voltage to normal. A combination of low "B" battery voltage and a "soft" detector tube will develop more noise than a "hard" tube. A "B" battery which becomes noisy in connection with a "soft" tube can in many cases be used with an amplifier tube without creating any noise, providing a fresh battery is applied to the detector. Such factors as loose battery connections, either internal or external, or improper position in the hook-up, or too much voltage, will cause "B" battery noises.

"How long will a 'B' battery last?" is another popular question relative to the high-voltage bat-



tery. Factors governing the life of a "B" battery are as follows: the number and type of vacuum tubes used; length of time the set is operated; size of cells in the battery, and care given the battery.

The more tubes used, the greater will be the drain on the battery, and its life will be shortened. Ordinary detector and amplifier tubes draw comparatively small currents. Power tubes, for example, draw heavily from the "B" battery. There are two common sizes of "B" batteries; the midget type of  $22\frac{1}{2}$  volts weighing less than a pound and the standard size  $22\frac{1}{2}$ -volt battery weighing about  $3\frac{1}{2}$  pounds. Tests have shown that under average conditions, operating the ordinary three-tube set one or two hours a day, the midget battery will last two or three months. Under the same conditions the standard size battery will last at least eight months. The advantage of the midget battery is for use in portable outfits.

Keep the battery with the top up and not on its side. If a battery is left standing on its side the electrolyte will ooze out and make contact with the cells causing a short circuit. All the cells so affected will become rapidly discharged. The battery should not be placed where it will be overheated or affected by moisture; neither should it be dropped. Never short-circuit a battery even momentarily to test it by the size of the spark. A voltmeter having a resistance of at least 50 ohms per volt should be used to test the "B" battery.

Never use an ammeter to test a "B" battery. "B" batteries are also made in the form of small storage batteries and can be charged just as any storage battery.

#### HOW TO CHARGE A BATTERY

Charging is injecting electrical energy into a battery. The standard measure of energy put into or taken out of a battery is in terms of ampere-hours. A flow of ten amperes, maintained for eight hours, amounts to eighty ampere-hours. A battery is so connected in the charging circuit that during charge current will flow from the positive terminal of the generator to the positive terminal of the battery. Since the generator develops higher voltage than the battery, it is able to overcome the pressure of the latter and force current to flow in the direction opposite to that in which the battery pressure would direct it. Electric current always flows from higher potential, or pressure, to lower, just as water flows from a higher to a lower level.

A battery is not fully charged until the acid is out of the plates and into the solution, which means that further charging cannot raise the specific gravity of the electrolyte. The vent caps should be removed and left off while the battery is being charged.

If the battery refuses, on a continued charge, to come up to the required specific gravity, but gases freely, there is probably insufficient acid in the electrolyte. The battery should be taken to

a service station, because this job requires the attention of a battery expert. Seldom is it necessary to add acid unless the electrolyte has been spilled. Gases evolved during charging carry only a minute portion of acid out of the cells. This loss is so small that it is of practically no consequence during the battery's life.

### THE "C" BATTERY

When a high-plate voltage is used on some audio amplifier tubes distortion often occurs. A "C" or grid battery will relieve this trouble. A "C" battery is a small dry battery, generally flashlight cells, giving about  $4\frac{1}{2}$  volts, whose negative terminal is connected to one side of the audio transformer secondary. The other terminal of the transformer connects directly with the grid, and the positive side of the "C" battery connects with the negative terminal of the "A" battery. If over 120 volts are used on the plate, the "C" battery should be from 6 to 9 volts.

The "C" battery is also known as the "grid bias" battery. The current capacity of such a battery is very low, and the drain upon it is infinitesimal. A good "C" battery properly installed will function from eight months to a year. The use of a "C" battery is not dependent upon the type of receiver or upon the method of tuning, because it is employed in the audio frequency unit. It may be used in connection with any type of vacuum tube regardless of type.

The chief duty of a "C" battery is to clarify the signal and minimize distortion. However, the "C" battery cannot overcome distortion caused by a poor audio frequency amplifying transformer or by excessive regeneration. Distortion created by overloading the amplifying tubes cannot be clarified by a "C" battery.

It has been observed by operators of audio frequency amplifying units that the amplifier works to perfection on weak signals, but distorts strong signals. By reducing the brilliancy of the filament the strong signals are clarified, but some of the intensity is lost. A "C" battery clears up the strong signal and does not decrease the intensity.

## CHAPTER IX

### HOW WORDS ENTER THE ETHER

LONG before most Americans were born and before any one dreamed of radio telephony, Ezra Meeker, ninety-four years old in 1924, was clearing a large acreage of timber land in the West and helping to blaze the Oregon Trail. The nonagenarian made his *début* before the radio microphone in 1923.

A number of persons expressed belief that ninety-three years had made his voice too weak to set the ether in vibration. To the surprise of many, the microphone treats all sound alike. It reproduces with entire fidelity all sounds from the cry of a baby to the feeble voice of an old man. The individual characteristics are always preserved, even more so than over the ordinary telephone. Just the tick of a watch, a sigh, a cough, or deep breath, before a microphone in New York, is sufficient to set the ether in vibration across the continent.

A speaker at a New York station once placed his watch on the pedestal beside the microphone to time his talk. Ticks of the watch were so loud that they mixed with the words in a disturbing manner. Telephone calls from near-by listeners and telegraph messages from listeners hundreds of miles away informed the announcer, and



### THE HEART OF WJZ

The control equipment located in the transmitting room on the roof. The operator can talk by radio telephony, dot-dash telegraphy, or ordinary telephone, which provides communication with any part of the world.



the watch was quickly removed. During initial radiophone tests conducted across the Atlantic in January, 1923, a man coughed near the New York microphone and it was heard in England.

Seventy-one years after a trip across the continent in a covered wagon, Ezra Meeker told the story by radio, and his voice was taxed less than if he had described the journey in the living-room of his home. It took him five months, traveling by ox team at the rate of two miles an hour, to cross the country. More than threescore and ten years later the story of the Oregon Trail, Indians, prairie schooners, and the epidemic of cholera which struck the column as it advanced through the Platte River Valley, was broadcast over the country at the speed of sunlight and with less effort than required to speak to a friend present in the radio studio.

The actual power of a singer's or speaker's voice is astonishingly small. It has been calculated that it would require thirty million cornetists blowing their loudest to produce just one horse-power of sound. When the average voice strikes the microphone it delivers only one one-hundred millionth of a watt. One horse-power is just short of 750 watts.

President Harding was the first President of the United States to broadcast a speech by radio. It was calculated by engineers in charge of the radio installations that President Harding's voice was amplified about three thousand billion times in its trip from the microphone over the wires



leading to the broadcasting apparatus of station WEAJ, New York. Mr. Harding spoke before a microphone in St. Louis.

If the strength of the average man could be amplified to such a degree, he could move the largest yearly haul of freight traffic in the history of the United States and replace all the locomotives in freight service. He would find the task as easy as moving a four-ounce weight.

Speaking by radio is done without effort. The voice is not raised higher than in ordinary conversation; in fact, not as loud as over the ordinary telephone. The speaker stands or sits a foot or more from the microphone, depending upon the strength and quality of the voice. The microphone serves the same purpose as the telephone transmitter. It is designed to pick up sound waves and convert them into electrical energy. Sound waves carry the words to the diaphragm of the microphone causing it to vibrate, and this vibration causes corresponding changes in the current flowing in the circuit. After speech is impressed upon the electrical circuit, it is forwarded over wires to the station's control room where low-power amplifiers increase the power to about one watt. High-power amplifiers then increase the energy to about twenty watts, thus preparing the voice currents to control the radiophone transmitter, with its power of 500 watts or more. The current is then passed through vacuum tubes known as "modulators." Their duty is to mould the continuous wave into the form of the voice.

Big transmitting tubes make possible radiation of energy and the ether is set in motion.

As the waves go through space to the receiving stations, they lose their power continuously, ending with a very small fraction of a watt. Engineers estimate in this connection that a single 500-watt transmitter supplies enough power to feed about 50,000,000 receiving sets, more than is likely to be in the world for some time to come.

Vacuum tubes at the receiving station take the feeble incoming impulses and strengthen them about 100,000 times until there is available about one hundredth of a watt for the loud-speaker, and again the original sound vibrates the air.

Words spoken into a microphone have a checkered career. First, their power is increased 50,000,000,000 times. Then the waves lose, during actual transmission to the receiving set, all but one five-hundred-millionth of their strength. The capabilities of the detector and amplifying tubes at the receiving station bring the power up again 100,000 times and reproduce the original sound.

## MODULATION

Moulding of the current in a radio high frequency circuit so radio impulses will take the form of music, voice, or any other sound by affecting the diaphragm of a transmitter or microphone, is called "modulation."

The regular telephone transmitter, such as used in telephone work, heats up if too strong a

current is applied; therefore, that type of transmitter is unsuited for radio broadcasting where heavy currents are employed. The telephone transmitter is one of the simplest forms, and an understanding of it will help to make clear the principles of the microphone used in a radio broadcasting station, although they differ in construction. A transmitter, or microphone, is a device which converts sound waves into electrical currents. It consists of a cup-shaped container one half of which is movable. The other half is fixed. The center of a thin metal diaphragm is fastened to the movable section of the cup. This cup, or container, holds a mass of small carbon granules, which serve as a conductor of electricity. When the transmitter is placed in series with an electrical circuit, one connection is made to the movable part of the container and the other connection with the stationary division.

As the sound waves, in the form of music, or voice, cause the diaphragm to vibrate, naturally that section of the container fastened to the diaphragm moves back and forth, pressing against the carbon grains, which fill the stationary part of the cup. A battery is connected in series with the transmitter so the resistance of the carbon mass varies with the sound vibrations, since the carbon granules when compressed form a good electrical connection, and when released render an imperfect contact. This causes the current to flow through the transmitter in accordance with the sound waves meeting the diaphragm,

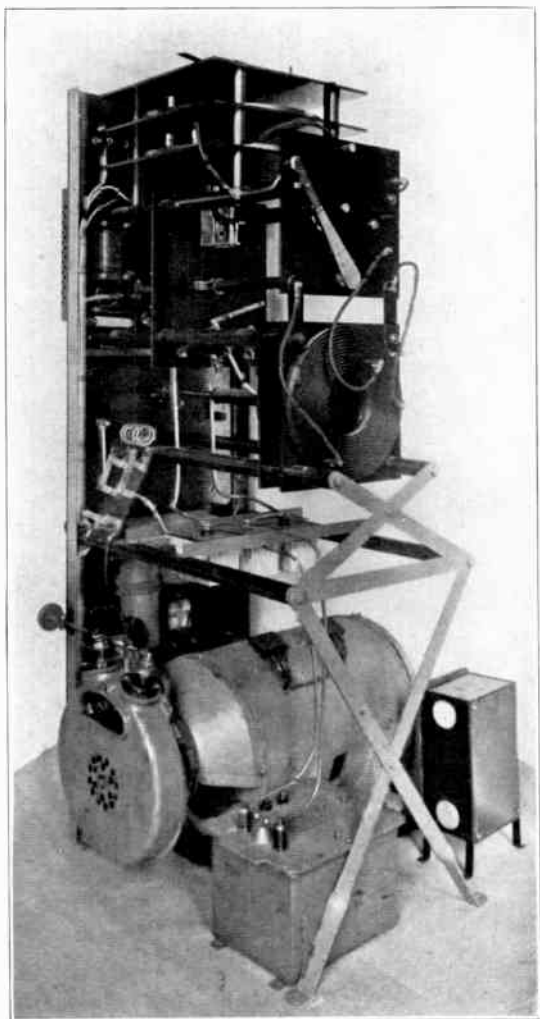

### SHIP TRANSMITTER

As installed on many vessels at sea and on the Great Lakes. The wave length of this set is determined chiefly by adjustment of the spiral on the back. Controls are provided on the front of the panel.



and thus the melodies of an orchestra or the voices of singers or speakers are transformed into an electrical current.

When large currents are used, it becomes necessary to substitute a microphone for the transmitter. The microphone is the most important electrical mechanism in the studio. It does not employ carbon grains, because, when they are subjected to heat produced by heavy currents, they coagulate into a solid mass.

The microphone, as used in the majority of broadcasting stations to-day, is similar to a condenser, and is therefore called a "condenser microphone." Sound waves are impinged on one of the plates causing it to vibrate. It is a well-known fact that the capacity of a condenser is partly determined by the distance separating the plates. Therefore, as the vibrating plate varies the distance between the plates, a change in capacity is produced. The microphone is connected in a part of the transmitting circuit which is extremely sensitive to capacity changes, and in that way the sound waves impinged on the microphone vary the current strength flowing in the circuit.

#### "GLOW DISCHARGE" MICROPHONE

Dr. Philips Thomas perfected an electric microphone in 1923 which records sounds too faint for perception by the human ear. It records sounds made by insects apparently mute. It does for the human ear what the microscope has

done for the human eye, and it is expected not only to be of valuable service in radio broadcasting, but also as a means of studying physical and biological phenomena.

The instrument consists of two small electrodes placed diametrically opposite each other in a ring of insulating material. A high voltage applied to the electrodes forms a "glow discharge" between them, which can be affected by sound waves causing changes exactly corresponding to the sound waves in the flow of current to the electrodes. The glow discharge will respond to the uttermost limit of sound vibrations, and thus will permit the identification and study of all sounds in the ultra-audible region.

#### METHODS OF MODULATION

There are several methods of modulation, chief among them grid modulation, magnetic modulation, and constant current modulation. In the grid method a modulation transformer is employed, which consists of a primary low-voltage winding and a high-voltage secondary winding, both wound on a soft iron core. This step-up transformer modulates high-frequency currents by applying the voltage to the grid of a vacuum tube. The disadvantage of the grid system of modulation is the critical adjustment necessary for its success.

The magnetic method of modulation employs a transformer, which consists of a low-resistance winding and a secondary winding connected to a

microphone. The transformer is placed in the antenna circuit. Sound waves striking the diaphragm of the microphone vary the resistance of the primary winding.

The constant-current method of modulation is the best in use at the present time, as it is capable of handling a large amount of power and also renders very clear reproduction of sound. Two sets of vacuum tubes, equal in number, are put in use, one group known as the "oscillators," the other as the "modulators." A coil which keeps constant the combined current flowing to the two tube sets, is placed in the wire leading to the plates of the tubes.

#### MODULATION METER

Modulation is measured by an instrument known as a "modulation meter." Although this piece of apparatus only indicates the average volume of sound, it serves as a convenient way to determine the correct distance a speaker or singer should be from the microphone.

#### LOCATION OF MICROPHONE

It is a source of wonder to many persons where the microphone is placed when an opera, theatrical performance, or church service is broadcast. To those assembled in an auditorium, theater, or church there is generally no indication that radio listeners are in tune with the entertainment or service. The microphone which many look for and expect to see is usually hidden from view.



In the case of broadcasting an opera, knowledge of the stage acoustics and of the opera itself is necessary before the microphones can be properly placed to pick up all sound vibrations. The sound must not be too weak or too strong as the actors move about the stage and change their distance from the microphone. When opera has been radiated from New York stages, three microphones have been used and judiciously located so as to pick up every sound made either by the orchestra, soloists, or choruses.

One microphone is generally placed under the stage, in front of the prompter's box facing the orchestra and audience. The second and third microphones are usually placed to the right and left of the prompter's box. At some theatrical performances two microphones are placed in the wings, or in some other more advantageous location on the stage. Sometimes special "pick-up" horns are fitted to microphones, to pick up solos or subdued music. All microphones, including the announcers, are connected to a control box, and by means of switches either one or all may be connected into the circuit. This permits picking up sounds on any part of the stage as the actors move about. This feature of the control box is often exhibited at football games, when the announcer switches different microphones into the circuit, so listeners can hear the cheering louder. For example, one microphone may be placed suitably to pick up Harvard cheers on one side of the stadium, and another micro-



A MICROPHONE OF STATION WJZ

Concealed within a miniature world made of thin gauze



phone in the Yale cheering section to forward the Eli's yells to the ether.

From the control box the impulses are sent through a speech amplifier, generally placed underneath the stage. The output from this amplifier is fed into long-distance telephone or telegraph lines which connect directly with the broadcasting station. At the apparatus room the currents are amplified again by a voice amplifier and the intermediate modulator tube so the original impulses picked up in a theater or on a gridiron can be supplied to the five powerful vacuum tubes. The modulated energy goes to the oscillator tubes, and then the energy is sent directly to the radiating system and broadcast in all directions.

When station WJZ, New York, broadcasts the St. Thomas Episcopal Church service, eight microphones are employed. The pulpit is equipped with one microphone to pick up the sermon, another is placed in the lectern, one on the altar, and another on the altar rail; two are used near the choir, one near the organ, and one in the recessional.

#### REMOTE CONTROL

Many of the big events of radio, such as the broadcasting of President Harding's speeches in St. Louis and Kansas City through station WEA, New York; President Wilson's Armistice address of 1918; President Coolidge's addresses to Congress; theatrical performances; prize fights,

baseball and football games, band concerts and opera, are made possible by remote control.

Broadcast Central at Æolian Hall, New York, has three main arteries of remote control wires extending through Manhattan Island. They are suspended under the elevated railway structures on Sixth, Ninth, and Third Avenues. The Sixth Avenue lines lead from the elevated structure underground to the control room at Æolian Hall. The Ninth and Third Avenue wires run to the Western Union terminal at Walker Street, where they connect with Sixth Avenue lines leading to the Æolian Building on Forty-Second Street.

When band concerts are radiated from the Mall in Central Park, the wires leading from the bandstand microphone run through the trees and connect with the Ninth Avenue wires. When music is broadcast from hotels, the microphone is generally suspended amidst the orchestra, and it is visible to diners and dancers. One or two operators and an announcer are always hidden in the near background.

### RADIO RELAY METHOD

When wires are used to connect a stage or concert hall with a broadcasting station, it is called "remote control broadcasting." When low wave lengths are substituted for wires to forward the entertainment to the main station, it is known as "relay broadcasting." A portable radio transmitter working on about one hundred meters is placed in the concert hall, and it forwards the

music to the mother station. The average broadcast listener cannot tune-in extremely short wave lengths, but the main station picks up the low wave lengths on a special receiving set, amplifies the impulses, and re-broadcasts on full power on the regular wave length used for broadcasting from that station.

Stations in England and at Hastings, Nebraska, pick up concerts from KDKA, Pittsburgh, Pennsylvania, radiated on ninety-four meters. The signals are amplified at these relay points and re-radiated on higher wave lengths. This allows radio auditors in the British Isles and in the West, using simple, inexpensive crystal sets, to enjoy the Pittsburgh concerts with the same intensity as listeners in the vicinity of Pittsburgh.

### THE RADIO STUDIO

A radio studio is a sound-proof room resembling the parlor of a richly furnished home. It is the place where speakers, instrumentalists, and singers perform before the microphone. When one enters a radio studio he is immediately conscious of the intense stillness, the absence of external noises. The voice of any one speaking in the studio sounds "dead" and unnatural, because of draperies and sound-proof materials on the walls and ceiling and heavy carpets on the floor.

Comfortable furniture, a piano, phonograph, palms and flowers do not give the impression of a radio station, where one might rightfully expect

to be greeted by generators and vacuum tubes, meters, switches, and wires. The microphone stands on a mahogany pedestal.

At one end of the studio or on a switchboard are three signal lights flashing — white, green, and red. There is also a listening booth where there is a telephone connection with the operators in the transmitting room and controls in the radio power room. Illumination of the white light tells the announcer that the operators on the roof wish to speak to him through the telephone in the booth. The green light signifies the apparatus is ready and the carrier wave is on the air. A carrier wave is a high-frequency current through the ether on which the words and music travel. It serves the same purpose through the air as a telephone line. Red-letter signs flash in the studio warning every one to be "Silent," and the microphone is switched into the circuit by the announcer. The little red signal then lights up as an indication that the microphone is in the circuit and that the entire system is in operation, and every sound in the studio will be picked up and sent through space.

The announcer then introduces the speaker, and if he has been familiar with wireless of the past, the microphone is a source of wonder to him. Does it really send the messages into the air as the wireless key did so nobly before the radio-telephone came into existence? In old wireless days there was a little arc between the electrodes of the key, and the crack of a spark told that the set



BROADCASTING STUDIO OF STATION WEAf, NEW YORK  
The microphone stands on a mahogany pedestal.





was functioning. Now the tongue forms the words, and not the metal key with its dots and dashes. There is no arc or sputtering spark to show that the message is getting into the ether lanes. It seems as if the person speaking before the microphone was singing or playing for himself.

### STAGE FRIGHT COMMON

After the graduation exercises the boy who delivered the declamation generally tells his chums in the school yard just how it felt to go to the front near the teacher's desk and speak. The speaker making his radio *début* often gets stage fright. He can put his hands in his pockets, and need not wonder if his tie is straight or his hair combed. Appearance counts for nothing. The success of the radio speaker depends upon what he says and how he says it.

The radio orator need not worry about facing his audience or directing his voice to all parts of the hall. Radio broadcasts sound in all directions to an invisible audience.

The nervous radio speaker can rely on no prompter, because the microphone picks up the faintest whisper. A whisper in the studio is a whisper in the ether.

After the radio speaker is introduced, he must begin immediately. If he falters or coughs nervously, impatient listeners will tune to another station. The attention of the unseen audience is held by sound alone. Deprived of elocutionary

gestures and tricks, radio speakers must depend upon their speech. There are no friendly smiles or applause to indicate success, not even the shuffle of restless feet moving about to tell of failure.

The radio speaker is likely to be embarrassed as his last words impinge on the microphone. Silence reigns in the studio. When he turns away and sees the announcer near by, he feels like a person caught talking to himself.

The studio is a place of suspense. The broadcasting novice feels like running away after he finishes his first talk. In the reception room adjoining the studio he sees others scheduled for the programme awaiting their turn. The scene reminds one of a doctor's anteroom, because a general tension and silence prevail. The atmosphere is of nervous portent. After a restive walk around the hall, curiosity may prompt the man who has just finished broadcasting to visit the roof, where the transmitting apparatus is located.

Aerial towers silhouetted against the sky are like sentinels. The air is quiet and there is no sputtering of a spark or no purr of an arc to indicate that a band is playing in the studio below and that thousands hear it at a distance. His confidence is somewhat restored when the engineer in the control room tells him that his words slipped off the wires perfectly.

With this reassurance he returns to the reception room, where he receives telephone and telegraph reports sent in by listeners relative to his

talk. He finds that one listener wanted to argue over the telephone on some point of his talk; another man had a name similar to his, and wondered if a relationship existed; two women had tuned in his voice and were betting on his age, and wanted him to render the decision by telephone or mail. Such calls give courage, for they are radio's applause.

### RADIO DRAMA

Production of radio drama has convinced programme directors that there is a public demand for this type of entertainment and that the peculiar requirements of radio drama as compared with stage and moving-picture productions will in time result in a new form of dramatic art. The screen has evolved a distinct type of drama dependent solely on the eye for its appreciation. Radio drama must be so written that the ear and imagination unaided by the eye will be satisfied.

The author of radio drama must place himself in the position of writing for a blind person. The lines of the characters must convey a picture of the scene in which the action takes place. The chase, long a popular feature of moving pictures, may be brought into the radio play by means of speech. Radio drama requires no scenery. No careful search need be made for locations. Spoken words build the scenery. Rain, thunder, surf, roar of locomotives, pistol shots, telegraph keys, airplanes, galloping horses, and automobile engines may all be reproduced by sound-

making devices to impart atmosphere and realism.

A radio drama may be tuned-in by a million listeners, forming an audience equivalent to the attendance at a five hundred night run of a stage production in a theater seating two thousand persons. Radio has modified Shakespeare's words that "all the world's a stage." Broadcasting of drama through the ether is making all the world the audience and the radio studio the stage. Radio's theater is not limited by seating capacity. The sign, "Standing Room Only," is never displayed.

The only stage property one company carried to a studio was a cocktail shaker. Since ice could not be seen by the radio audience, a couple of coins were placed in the empty shaker. The noise of the coins, deadened by the hand of the actor, produced a sound which gave the illusion of creating a cocktail. It is reported that operators in the apparatus room on the roof heard the sudden shaking and thought it was a sudden burst of static forecasting a fast-approaching electric storm.

Authors realize that the radio play must be written so that it not only can be heard, but so that the imagination of the listener can easily picture the scenes. There must be some way of letting the invisible audience know when the actors enter and exit. One impresario signalizes the entry of an actor by ringing a doorbell followed by the closing of a door.

The actors in a radio drama are grouped about the microphone, the women generally being closer to it than the men, because their voices are not as strong. The parts are not memorized, but are read; thus there are no delays and prompting is not required. Each actor studies his part in advance of the presentation, because he must depend upon the voice alone to convey the expression. Clear enunciation, quality of voice, careful articulation, and skill in declamation take the place of actual acting. Plays are carefully rehearsed before they are sent into the air. The paper on which the parts are written is usually of such quality that rustling is eliminated, and no sound except that made by the players as part of the show can be heard.

The director or stage manager has his ears covered with a pair of receivers, covered externally so no outside sound can directly reach his ears. His head-set is connected to a receiving set permitting him to hear the play just as the audience miles away. In this manner he can signal to the actor to speak louder or softer, or direct him to stand at different positions in relation to the microphone. Some directors have printed cards which direct the players to talk "louder," or whatever the occasion demands.

It has been pointed out that one advantage the radio drama has over the moving picture and legitimate stage is that elaborate scenery and expensive accommodations for the audience are not necessary. After the radio drama is presented

once, it can be filmed by the Pallophotophone, which makes a permanent record, and it can be broadcast at any time, and at any station.

The story is told how a policeman in Pittsfield, Massachusetts, heard shrieks from the window of a house along his beat. He ran into the house to investigate, and found the screams were coming from Schenectady, where station WGY was broadcasting "The Wolf."

## CHAPTER X

### RADIO POSITION-FINDERS AND BEACONS

A HEAVY fog hung over the New England coast and its duration forced many ships out of their course. One British vessel, in more serious plight, used its radio to say, "Hurry, hurry, QTE, QTE [international abbreviation requesting a bearing], we are nearly aground."

Naval operators at Otter Cliffs, Bar Harbor, Maine, and others at Boston, Massachusetts, picked up the urgent call. Radio compass stations or direction-finders in Boston Harbor and Otter Cliffs took bearings. The Boston reckoning was sent by direct telegraph line to the Maine station, from whence the bearings taken by both direction-finders were flashed to the ship. In less than three minutes, navigators of the vessel in danger knew its exact position and the land operators specified the direction to navigate without danger. Operators at Otter Cliffs, by plotting the bearings on the map, saw that the Britisher was on George's Shoals, over a section of the sea denoted by light blue on the marine map.

The loop antenna is used as the position-finder. It consists of a coil of wire wound on a frame of insulating material, about four or six feet square, and constructed in such a way as to revolve on a vertical axis. The loop is generally installed in a room or compartment above the



wireless cabin or on the deck, and the axis on which the loop revolves extends through the ceiling to a table where the receiving apparatus is located. A stationary scale marked off in 360 degrees is arranged at the lower end of the axis. This serves as the face of the direction-finder. When the loop revolves, a pointer attached to the axis moves around the scale, indicating the direction of the transmitting station.

As the loop is turned, by means of a wheel or handle attached to the axis, the strength of the signals heard in the phones becomes stronger or weaker, depending upon the direction in which the loop points in relation to the transmitting station. When the direction-finder points directly toward a transmitting station, the signals are loudest. When the plane of the loop is at right angles to the incoming waves, the signal strength is at minimum intensity if not inaudible.

Radio compass stations are equipped with a map on which a scale or calibration chart, exactly the same as that of the direction-finder's face, is marked off in 360 degrees. The point on the map where the radio compass station is located is made the center of the circular scale.

When a ship calls for a position report, or bearing, the operator turns the loop until the signals are inaudible or reach a minimum intensity. The reading of the compass face is noted, and, by referring to the chart and map, the bearing can be plotted. Some maps have a string attached to the location of the compass station on the map so

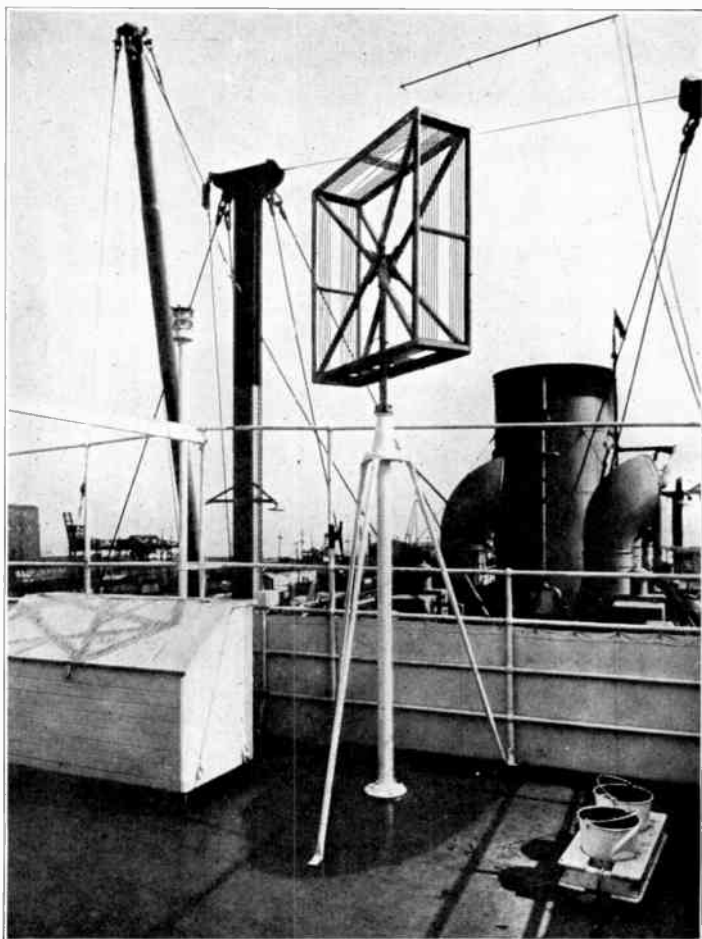

**RADIO POSITION-FINDER ON BOARD S.S. PRESIDENT  
MCKINLEY, ADMIRAL ORIENTAL LINE**

The wires of the loop antenna are wound on a wooden frame mounted on a shaft which is revolved by the operator in the radio room below the deck.



that the operator can extend the string through the scale on the map in accordance with the reading of the pointer on the compass face. For example, if the pointer on the axis points to 139 degrees on the compass face, the string radiating from the location of the compass station on the map will be extended through 139 degrees on the scale laid off on the map. The ship will be somewhere along that line as indicated by the string.

Radio compass stations on land are in many cases connected by telegraph wires, so that bearings taken along the coast can be sent to a central wireless station and forwarded to the ship. The point where bearings of two or more direction-finders intersect is the exact position of the vessel. Accuracy of bearings of a well-installed and carefully calibrated compass station vary between one and two per cent.

Direction-finders also serve airplanes and render valuable service to a plane flying in thick weather. Both a ship or airplane, if their navigators know the geographical location of a wireless transmitting station, or beacon, may determine their position or direction. For example, if a ship is lost in a fog the radio compass operator on board can determine his latitude and longitude by taking bearings on the transmitters along the shore. An aviator flying from New York to Boston can set his radio compass to the position on the scale which indicates a direct line to Boston, and fly in that direction. By the strength of the Boston signals the aircraft operator can determine

throughout the flight whether or not he is on or off the direct course.

Great care must be exercised when calibrating a radio compass in order to have it accurate. If the loop is inside a building there is certain to be error, because of metal structures and objects in the building, such as radiators, stoves, pipes, and wires, which pick up radio waves and re-radiate them. This causes the loop to show a false direction. A typewriter placed in a radio compass room after the set has been calibrated has been known to cause a variation in reading from five to ten degrees. The entire room in which some radio compass stations are located is copper-screened on the ceiling, walls, and floor.

Some of the latest position-finders, including that of the S.S. Leviathan, have a gyro-compass repeater located at the base of the loop's axis in the place of a calibrated 360-degree scale. A radio position-finder combined with a gyro-compass makes it possible for the operator to obtain a true and accurate location of the ship. With such a radio-bearing indicator installed in the chart room, a navigator can put on the phones, tune for the Nantucket radio beacon, and then turn the wheel which revolves the loop until the Nantucket signals are inaudible or at minimum intensity. This indicates that the plane of the loop is facing Nantucket, and by reading the pointer on the repeater compass dial he can read directly and accurately the bearing of Nantucket. He may then tune for one or two other



### RADIO DIRECTION-FINDER AND GYRO-COMPASS

They join to give a true location of a ship by radio. When the loop antenna is turned so that signals are of minimum strength, the operator can note the reading of the pointer on the repeater compass dial and read directly and accurately the bearings.

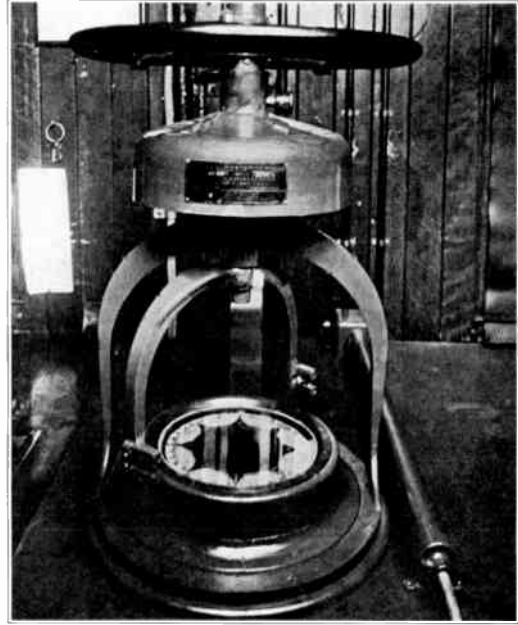

### THE GYRO-COMPASS USED IN CONNECTION WITH A RADIO POSITION-FINDER

It points to true north instead of magnetic north and hence eliminates errors of variation. It is not affected by the iron or steel of the ship.



radio beacons and determine their bearings in a similar way. Then by plotting the three bearings from the three known points he can locate the point of intersection of the three bearings and get the ship's true position.

The three most important advantages of the gyro-compass over the magnetic compass are: first, it points true north instead of magnetic north, and therefore eliminates errors of variation; secondly, it is not affected by the iron or steel of the ship, and hence is free from errors of deviation; thirdly, it can be used as a master compass and the service compasses are repeaters of the master.

Millions of dollars have been spent for fog-horns, but they are all subject to error because of variations in the intensity of the atmosphere, which hinders sound waves from traveling in a definite direction, and because of refraction there are some areas where no sound can be heard. It was pointed out at the Twenty-ninth Annual Convention of the American Institute of Electrical Engineers in Boston, June 27, 1912, that from 1893 to 1902, about one thousand ships were wrecked by aberrations of sound or by following a false echo. No less than five hundred lives were lost and \$57,500,000 in property.

Radio waves pierce the thickest fogs when fog-horns and powerful lights fail. During the year ending June 30, 1923, radio compass stations on the Atlantic and Pacific coasts gave positions to 57,836 ships, involving 120,523 bearings. The



average time required to give a bearing was three minutes and one second.

The branch of radio which deals with radio compasses is known as "Radio Goniometry."

### RADIO BEACONS

Navesink, at Highlands, New Jersey, the most powerful light in the vicinity of New York Harbor, flashes several hundred thousand candlepower, but in thick fogs this great beam of light is visible for only a few yards off the shore. Navesink Light has power enough to be seen for 140 miles, but owing to the earth's curvature sailors do not "pick it up" until they come within a distance of 22 miles. The S.S. Leviathan carries a radio compass which enables its navigators to know the exact position in foggy weather after the ship is within 150 miles of Nantucket Light.

Radio has developed a new type of "lighthouse," and New York Harbor has three of them, broadcasting invisible signals which guide ships safely along their course, no matter how impenetrable the fog. Curvature of the earth does not limit the range of a radio beacon and it can be placed in a small building eliminating the lighthouse keeper.

Four radio beacons are used to guide ships in from the Atlantic to New York Harbor and to keep coastwise steamers in their courses. One of these radio fog signals is established on the Nantucket Light Station, Nantucket Shoals, Massachusetts. The other three are at Fire Island

Lightship, Ambrose Lightship, and Sea Girt Light Station. The radio apparatus of each beacon sends out a characteristic signal at definite intervals, enabling a radio compass operator on board ship to take bearings and determine his position.

To eliminate interference, time schedules have been arranged for each beacon. The Sea Girt beacon sends groups of three dashes, for sixty seconds; silent, six seconds. Fire Island sends a series of two dashes for twenty-five seconds and is silent twenty-five seconds. Ambrose Channel Light Vessel broadcasts a series of one dash for twenty seconds and remains silent for twenty-five seconds before sending the next series of dashes. The signals are repeated rapidly so a ship's operator can quickly obtain bearings.

All radio beacons transmit on the 1000-meter wave length and have a power rating of approximately one kilowatt. An automatic motor-driven timing switch is provided to produce the desired signal at regular intervals. The beacons operate continuously during foggy weather, and in clear weather daily from 9 to 9.30 A.M. and from 3 to 3.30 P.M.

When a ship's operator wants to get a position, he points the loop toward the beacon and revolves it until the signals are weakest or inaudible. He can then refer to the radio compass scale or chart which will tell him the bearing. By taking bearings on more than one beacon and noting where the bearings intersect, the exact

position can be determined. Ships not equipped with radio compass installations can call the shore compass stations for bearings by flashing the international abbreviation "QTE." If a position is wanted, the signal is "QTF." The 600-meter wave length is used to call for bearings or positions. In such circumstances the ship transmits similar to the beacons enabling the land compass operators to make the calculations.

New York Harbor has four radio compass stations in addition to the three beacons. All New York compass stations are controlled from the Naval Radio Station at South and Whitehall Streets, New York. These stations have been known to give forty-five ships positions within eight hours, when all other means of reckoning had failed because of severe storms of several days' duration.

Other beacons are located at Cape Henry Light Station, Virginia, which flashes groups of two dots, followed by one dash, for twenty seconds and is then silent fifteen seconds. Diamond Shoals Light Vessel, North Carolina, groups of two dashes for thirty seconds; silent, thirty seconds. San Francisco Light Vessel, groups of two dashes for thirty seconds; silent, thirty seconds. Blunt's Reef Light Vessel, single dashes for thirty seconds; silent, thirty seconds. Heath Point Lightship, off Heath Point, Gulf of St. Lawrence, groups of four dashes broadcast for sixty seconds, followed by a silent interval of four minutes. The elapsed time from the begin-



**SANDY HOOK RADIO COMPASS STATION**  
Showing the loop antenna above the operating room.

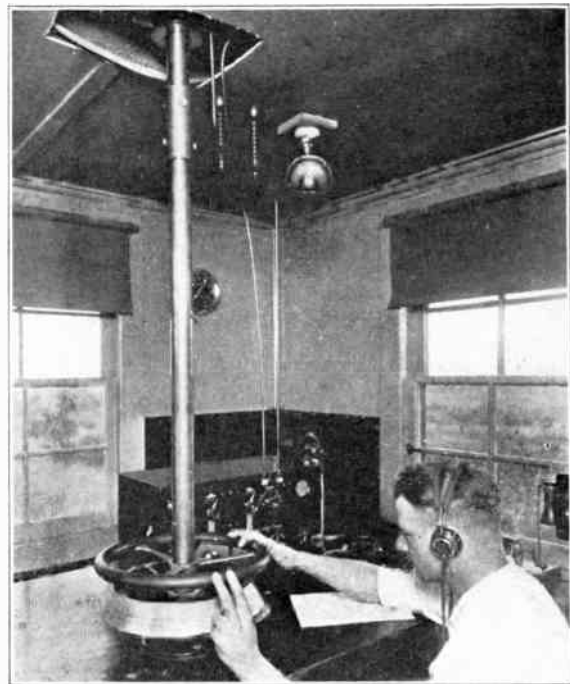

**OPERATING ROOM OF SANDY HOOK RADIO  
COMPASS STATION**

When the loop in the room above is turned until the signals are at minimum intensity or inaudible, the operator notes the reading on the scale and by referring to a chart or map can tell the location of the transmitting station.



ning of one group of dashes to the beginning of the next group is four seconds.

#### GUIDANCE BY RADIO

When Alcock, the Englishman, was about ready to hop off from the Grand Banks of Newfoundland in June, 1919, for what proved to be the first successful non-stop transatlantic airplane flight, the question was asked where he expected to land on the other side of the sea. His reply was, "Clifden, Ireland." The aircraft disappeared in cloud-banks over the sea and the world waited anxiously for news. Throughout the flight no word came back from the ether over the Atlantic, as had been planned and expected. The radio was listening instead of talking, keeping its radio compass pointed in the direction of powerful wireless signals sent out from Clifden, on the Irish coast. So true was the guiding influence of radio that in sixteen hours and twenty minutes after the machine lifted from Canadian soil it flew directly over the lofty wireless towers at Clifden. The Atlantic had been crossed for the first time by a non-stop airplane, guided through clouds, fog, and darkness by radio.

## CHAPTER XI

### TIME SIGNALS: WEATHER REPORTS: RADIO LAWS

TIME is regulated by the travels of Old Sol. Therefore, a watch in Boston is not correct for Cambridge, Massachusetts. Differences in time are quite noticeable even in places close together. Some one has figured that at noon in City Hall in New York it is 12h. 00m. 21s. at the Brooklyn Navy Yard, and 11h. 59m. 39s. at Newark, New Jersey. The sun rises at New Haven, Connecticut, 4 minutes, 11½ seconds, before it appears above the horizon of New York. There is a difference of seven seconds between New York time and that of Sandy Hook.

When watches made their appearance, it became necessary to establish a uniform system of time. Consequently, various cities adopted a certain standard of time. Later, countries adopted a standard of time, and in most cases the capital or most important city was chosen. English clocks were set to conform with Greenwich time and those of France with Paris. Difficulties were encountered when this system was applied to America and other countries of vast extent. The distance is so great across the United States that, when the whistles blow noon in Maine, it is just about eight o'clock in the morning in Oregon.

Sir Sanford Fleming, a Canadian, evolved the plan of time zones. Canada first adopted his idea and the United States followed. He divided the entire continent into zones running north and south, in each of which the time used is that of its central meridian. Each zone is fifteen degrees wide, and in each the time is one hour in advance of that in the next zone to the west of it, and one hour behind the zone adjoining on the east.

Professor Charles Nordmann, a French astronomer, likened the globe to a melon with twenty-four sections or twenty-four zones, fifteen degrees in width, running from pole to pole, because the sun circuits the world once in twenty-four hours. In each zone the time is that of its central meridian. Reckoning begins in the zone, which is bisected by the meridian of Greenwich, from which longitude is counted east and west. Each country for many years figured longitude from an arbitrary meridian of its own. Then came international commerce, fast ocean liners, cables, telegraph and radio, which brought the countries of the earth nearer together, and it became necessary to establish a common meridian. France led the way by setting her clocks to Greenwich time.

#### THE MASTER CLOCK OF THE UNITED STATES

There are millions of clocks in the world which denote each passing second of time. To keep all of them accurate a master clock, regulated by the observations of astronomers, is necessary,



since all people cannot calculate time and set their clocks by studying the solar system. The advent of the telegraph in 1844 made it possible to keep more accurate check on time. Following the telegraph came the wireless, which, with its speed of 186,000 miles a second, can almost keep pace with time's flight, making possible accurate time for ships in mid-ocean, for caravans on great deserts, and for explorers in the Arctic, or in tropical jungles, just as though they were in the Naval Observatory in Washington, D.C. There stands the master of all clocks, the regal timepiece of the United States, the Nation's time-keeper. This standard master clock is mounted on a concrete base in a subterranean vault. Its delicate mechanism performs in a partial vacuum and at a temperature which is constant, in order to prevent expansion and contraction of the metallic parts. The pendulum is made of invar, an alloy of nickel and steel, which is practically free from expansion in heat or cold. The big clock is wound every thirty seconds by electricity.

#### TRANSMITTING CLOCKS

On the first floor of the Naval Observatory there are two transmitting clocks. Only one is used, but the other stands ready in the event the one in operation gets out of order. Eastern Standard Time, or 75th meridian time, is taken from the master clock in the vault below and by means of the transmitting clock, connected by

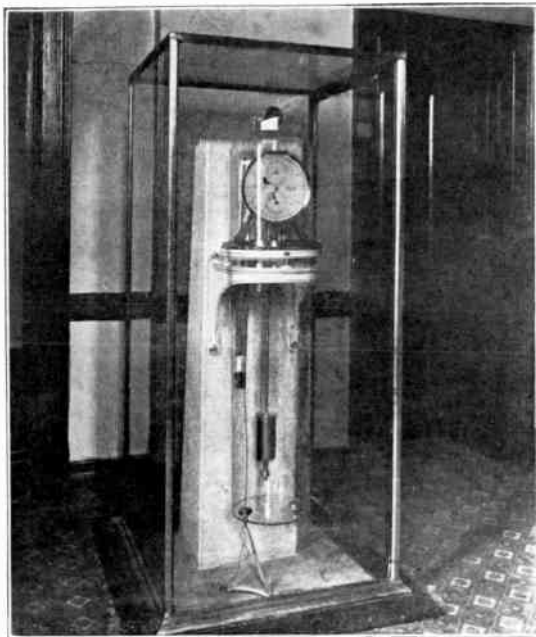

**THE MASTER CLOCK OF THE NATION**

Three of these standard clocks are kept in the Naval Observatory at Washington, in a vault at a constant temperature of 84 degrees. Each clock is sealed in a glass jar with the air partially exhausted and kept constant. The clocks wind themselves. The error of each clock is determined astronomically by observing transits of stars with a meridian circle.

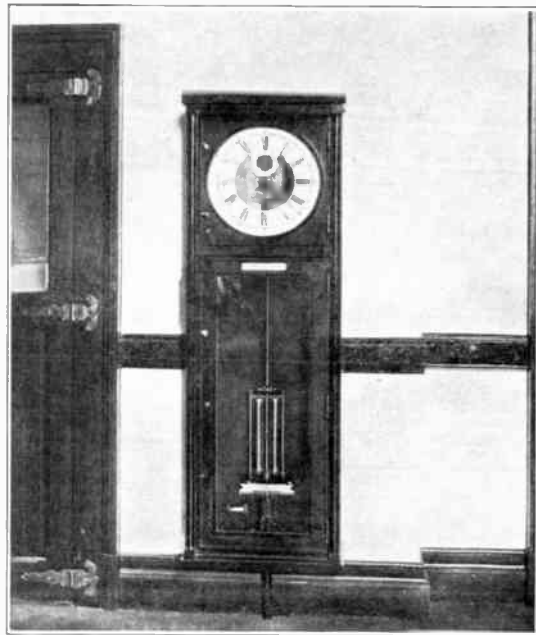

**THE TRANSMITTING CLOCK**

This clock is set to correct time by slowing or accelerating the pendulum by an electromagnet. It is set by chronograph comparison with the standard clock in the vault below. It actuates by wire connection the sending apparatus of the Naval radio stations at Arlington and Annapolis, making the ticks of the clock audible half way around the world.



wires with the Naval radio station at Arlington, Virginia, time is broadcast into the ether. Each tick of the clock completes the electrical circuit and a radio dot is sent simultaneously into space on the 2650-meter wave length.

Despite its great speed, radio cannot supply absolutely correct time, because of what is known as the "rate" of the clock, together with a mere fraction of a second which is lost in the relay. These very minute losses simply show that Father Time does not wait for even the quickest of mechanical parts to operate.

The Naval radio station at Key West was formerly connected with Arlington by land wires so it too could send out time signals. The Florida signals lagged about twenty-eight hundredths of a second behind those of Arlington. The fraction of a second was lost in the operation of several relays which connect the southern station with Washington. Key West transmitted time on 2000 meters, so that on a winter night, when atmospheric conditions were well suited for radio, northern receiving stations could be tuned to hear both Arlington and Key West time signals, the dot from the far south lagging a trifle behind that from Virginia. Key West now receives time signals from Annapolis by radio, amplifies the impulses, and re-broadcasts them.

All navigators must have accurate time in order to know their longitude and latitude at sea. Longitude is the determination of the difference

between local time and time of another locality. Local time is calculated by sextant observation of the sun, a star, or planet. The difference between local time and the world's standard time, at the zero meridian in Greenwich, England, is the longitude at sea. If the ship's chronometer, a timepiece of the highest attainable precision, is inaccurate, the navigator will find it difficult to determine the ship's position.

Time signals twice daily from the Arlington station render a great service to mariners, because the best chronometers become inaccurate through the changes of temperature and barometric pressure, as well as from the vibration and tossing of the ship. A vessel three thousand miles off the eastern coast of the United States can intercept Arlington time signals with a variation of less than one two-hundredths of a second.

Arlington broadcasts time signals from 11.55 to noon, and from 9.55 to 10 P.M., Eastern Standard time. Each second's tick from the Washington clock forms a dot on the radio, which produces in the phones at receiving stations a clear, tick-like sound of a clock. The twenty-ninth second of each minute is omitted to make clear the passing of the half-minutes. The last five seconds of the first four minutes are also omitted to make more noticeable the passing of each minute. The last ten seconds of the fifth minute are dropped leaving ten seconds of silence, which is broken by a dash exactly at noon and at ten o'clock. By following the ticks an

operator can check his watch and set it to the exact second.

Operators on board ships in the Pacific have been able to catch the midnight time signal from Honolulu and by a quick-tuning adjustment pick up the noon time tick from station POZ, Nauen, Germany. Eiffel Tower's (Paris) midnight signal is broadcast at 6.49 P.M., Eastern Standard Time, and Pearl Harbor's (Hawaii) noon signal at 7.00 P.M., Eastern Standard Time. The time difference between the two stations is twelve hours and the distance about eight thousand miles. By quick tuning, a long-wave receiving set in the United States can hear both signals.

Many of the radiophone broadcasting stations intercept Arlington time signals, amplify them, and then re-broadcast them on lower wave lengths, so they are within reach of low wave-length receivers, designed to pick up only the broadcasting stations.

## WEATHER REPORTS

Directly after the time signals at 10 P.M., Eastern Standard Time, each day, Arlington, Virginia, broadcasts complete weather reports on the 2650-meter wave length. These reports contain the barometer reading, direction and velocity of the wind in accordance with conditions existing at 8 P.M. The broadcasts are made in dots and dashes of the Continental code and are in abbreviated form, making it possible to com-

plete the schedule in much less time than if each symbol was transmitted in complete form.

The following explanation will serve as a key to the Arlington weather reports, which are for the eastern section of the United States and Great Lakes region. Observations are taken from seventeen centers, and in broadcasting each locality is denoted by an abbreviation as follows:

S. Sydney, N.S.	M. Marquette, Mich.
T. Nantucket, R.I.	U. Ste.-Marie, Mich.
DB. Delaware Breakwater.	G. Green Bay, Wis.
H. Cape Hatteras, N.C.	CH. Chicago, Ill.
C. Charleston, S.C.	L. Alpena, Mich.
P. Pensacola, Fla.	D. Detroit, Mich.
B. Bermuda.	V. Cleveland, O.
K. Key West.	F. Buffalo, N.Y.
DU. Duluth, Minn.	

The Beauford wind intensity scale is used to indicate the wind velocity.

*Miles per hour*

0 Calm.....	0-3
1 Light Air.....	8
2 Light Breezes.....	13
3 Gentle Breezes.....	18
4 Moderate Breezes.....	23
5 Fresh Breezes.....	28
6 Strong Breezes.....	34
7 Moderate Gale.....	40
8 Fresh Gale.....	48
9 Strong Gale.....	56
10 Whole Gale.....	65
11 Storm.....	75
12 Hurricane.....	90

Eight different wind directions are denoted by

the points of the compass, such as N, S, E, and W, etc. These are transmitted as numbers: North, 1; Northeast, 2; East, 3; Southeast, 4; South, 5; Southwest, 6; West, 7; Northwest, 8.

After the time signals are finished NAA begins to transmit a series of letters and figures as follows: "QST de NAA, USWB, So2082, To1260; DB92571; Ho1734; Co2260; Ko0541; Po1341."

In the above transmission "QST" is the international call for all stations to listen; "de" is the Latin word for "from"; "NAA" are the Arlington call letters; "USWB" stand for "United States Weather Bureau"; "S" accompanying the first group of figures is the symbol for Sydney, Nova Scotia. The first three figures following the letter "S" indicate the barometer reading. If the first figure is zero the barometer reading begins with 30. In this case the reading is "30.20." The fourth figure indicates wind direction, which in the case of "S" is northwest. The fifth figure is the velocity of the wind, and at "S" in the above example it is a light breeze, or thirteen miles an hour. If the first figure is nine, then the barometer reading will begin with "29." For example, "DB" in the above message has a barometer reading of 29.25.

#### GOVERNMENT REGULATIONS

The owner of a radio receiving set does not have to obtain a license to operate the set, and there are no fees or taxes levied on the receiving set as in many of the foreign countries.



The owner of an amateur radio transmitting station must obtain a station license before it can be operated if the signals radiated therefrom can be heard in another State; and also if such a station is of sufficient power to cause interference with neighboring licensed stations in receipt of signals from transmitting stations outside the State. These regulations cover the operation of radio-telephone stations as well as radio-telegraph stations.

Transmitting stations must be operated under the supervision of a person holding an operator's license, and the party in whose name the station is licensed is responsible for its activities.

Station licenses can be issued only to citizens of the United States, its territories and dependencies.

Licenses are issued by the Department of Commerce. Examinations for licenses may be taken at the offices of the Department of Commerce Radio Supervisors, located at the following places: Custom House, Boston, Massachusetts; Custom House, Baltimore, Maryland; Custom House, New Orleans; L. C. Smith Building, Seattle, Washington; Custom House, New York; Federal Building, Atlanta, Georgia; Custom House, San Francisco; Federal Building, Detroit, Michigan; and Federal Building, Chicago, Illinois.

### INTERNATIONAL ABBREVIATIONS

Wireless telegraphy has an international language of its own. By this common radio language American operators can talk to operators of Spanish, Japanese, French, or Italian stations without knowing their native tongues.

There are about seventy-five combinations of letters which form the international language of the ether. If an American operator wants to know the time from a Norwegian operator, he flashes the international signal "QSD" — which means, "What is your time?" "QRT" means, "Stop transmitting"; "QRW" means, "Are you busy?" "QRD" asks the question, "Where are you bound?" "QST" is the general call for all stations to listen. "QRM" signifies interference, and "QRN" means interference caused by static.

This common language of dots and dashes has been successful, making possible communication between ships and shore stations of all nations.

### CALL BOOKS

The Department of Commerce publishes annually a list of licensed radio stations, including broadcasting stations, classified by locations and call letters, also the wave length used, type of service furnished, ownership and schedule of operation. All licensed amateur transmitting stations are listed in a separate call book. Both books can be obtained from the Government

# DEPARTMENT OF COMMERCE

## BUREAU OF NAVIGATION

### RADIO SERVICE

#### INTERNATIONAL RADIOTELEGRAPHIC CONVENTION

#### LIST OF ABBREVIATIONS TO BE USED IN RADIO COMMUNICATION

ABBREVIATION	QUESTION	ANSWER OR NOTICE
PRB	Do you wish to communicate by means of the International Signal Code?	I wish to communicate by means of the International Signal Code.
QRA	What ship or coast station is that? .....	This is .....
ORB	What is your distance? .....	My distance is .....
ORC	What is your true bearing? .....	My true bearing is ..... degrees.
ORD	Where are you bound for? .....	I am bound for .....
ORF	Where are you bound from? .....	I am bound from .....
ORG	What line do you belong to? .....	I belong to the ..... Line.
QRH	What is your wave length in meters? .....	My wave length is ..... meters.
QRJ	How many words have you to send? .....	I have ..... words to send.
QRK	How do you receive me? .....	I am receiving well.
QRL	Are you receiving badly? Shall I send 20? .....	I am receiving badly. Please send 20.
	<p style="text-align: center;">•••••</p> for adjustment? .....	I am receiving badly. Please send 20.
	<p style="text-align: center;">•••••</p> for adjustment? .....	I am receiving badly. Please send 20.
QRM	Are you being interfered with? .....	I am being interfered with.
QRN	Are the atmospherics strong? .....	Atmospherics are very strong.
QRO	Shall I increase power? .....	Increase power.
QRP	Shall I decrease power? .....	Decrease power.
QRQ	Shall I send faster? .....	Send faster.
QRS	Shall I send slower? .....	Send slower.
QRT	Shall I stop sending? .....	Stop sending.

ORU	Have you anything for me? .....	I have nothing for you.*
ORV	Are you ready? .....	I am ready. All right now.
ORW	Are you busy? .....	I am busy (or: I am busy with.....). Please do not interfere.
QRX	Shall I stand by? .....	Stand by. I will call you when required.
QRY	When will be my turn? .....	Your turn will be No. ....
QRZ	Are my signals weak? .....	Your signals are weak.
QSA	Are my signals strong? .....	Your signals are strong.
QSB	{ Is my tone bad? .....	The tone is bad.
	{ Is my spark bad? .....	The spark is bad.
QSC	Is my spacing bad? .....	Your spacing is bad.
QSD	What is your time? .....	My time is .....
QSF	Is transmission to be in alternate order or in series? .....	Transmission will be in alternate order.
QSG	.....	Transmission will be in series of 5 messages.
QSH	.....	Transmission will be in series of 10 messages.
QSI	What rate shall I collect for .....	Collect .....
QSK	Is the last radiogram canceled? .....	The last radiogram is canceled.
QSL	Did you get my receipt? .....	Please acknowledge.
QSM	What is your true course? .....	My true course is .....
QSN	Are you in communication with land? .....	I am not in communication with land.
QSO	Are you in communication with any ship or station (or: with.....)? .....	I am in communication with..... (through.....).
QSP	Shall I inform..... that you are calling him? .....	Inform..... that I am calling him.
QSQ	Is..... calling me? .....	You are being called by.....
QSR	Will you forward the radiogram? .....	I will forward the radiogram.
QST	Have you received the general call? .....	General call to all stations.
QSU	Please call me when you have finished (or: at..... o'clock)? .....	Will call when I have finished.
*QSV	Is public correspondence being handled? .....	Public correspondence is being handled. Please do not interfere.
QSW	Shall I increase my spark frequency? .....	Increase your spark frequency.
QSX	Shall I decrease my spark frequency? .....	Decrease your spark frequency.
QSY	Shall I send on a wave length of..... meters? .....	Let us change to the wave length of..... meters.
QSZ	.....	Send each word twice. I have difficulty in receiving you.
QTA	.....	Repeat the last radiogram.
QTE	What is my true bearing? .....	Your true bearing is.....degrees from.....
QTF	What is my position? .....	Your position is.....latitude.....longitude.

\* Public correspondence is any radio work, official or private, handled on commercial wave lengths.  
When an abbreviation is followed by a mark of interrogation, it refers to the question indicated for that abbreviation.

# DEPARTMENT OF COMMERCE

## BUREAU OF NAVIGATION

### RADIO SERVICE

# INTERNATIONAL MORSE CODE AND CONVENTIONAL SIGNALS

## TO BE USED FOR ALL GENERAL PUBLIC SERVICE RADIO COMMUNICATION

1. A dash is equal to three dots.
2. The space between parts of the same letter is equal to one dot.
3. The space between two letters is equal to three dots.
4. The space between two words is equal to five dots.

A · · -  
B - · · ·  
C - · · - ·  
D - · · ·  
E ·  
F · · - ·  
G - - - ·  
H · · · ·  
I · ·  
J · - - - -  
K - · - -  
L · - · ·  
M - -  
N - ·  
O - - -  
P · - - ·

Period..... · · · ·  
Semicolon..... - · - - -  
Comma..... · - - -  
Colon..... - - - ·  
Interrogation..... · · - ·  
Exclamation point ..... - - · - -  
Apostrophe ..... · - - - -  
Hyphen..... - · · · -  
Bar indicating fraction..... - · · - ·  
Parenthesis..... - · - - -

Q ---.-  
 R .-.  
 S ...  
 T -  
 U ..-  
 V ...-  
 W .-.-  
 X -.-.  
 Y -.-.-  
 Z -.-..

Ä (German) .-.-  
 Å or Ǻ (Spanish-Scandinavian) .-.-.-  
 CH (German-Spanish) -.-.-  
 Ê (French) .-.-.-  
 Ñ (Spanish) -.-.-  
 Ö (German) -.-.-  
 Ů (German) .-.-.-

1 .-.-.-  
 2 .-.-.-  
 3 .-.-.-  
 4 .-.-.-  
 5 .-.-.-  
 6 -.-.-.  
 7 -.-.-.  
 8 -.-.-.  
 9 -.-.-.  
 0 -.-.-.-

Inverted commas .....-.-.-  
 Underline.....-.-.-  
 Double dash.....-.-.-  
 Distress call.....-.-.-.  
 Attention call to precede every transmission.....-.-.-  
 General inquiry call.....-.-.-  
 From (de).....-.-.-  
 Invitation to transmit (go ahead) .....-.-.-  
 Warning — high power.....-.-.-  
 Question (please repeat after ..... ) — interrupting long messages.....-.-.-  
 Wait.....-.-.-  
 Break (Bk.) (double dash).....-.-.-  
 Understand.....-.-.-  
 Error.....-.-.-.  
 Received (O.K.).....-.-.-  
 Position report (to precede all position messages).....-.-.-  
 End of each message (cross).....-.-.-  
 Transmission finished (end of work) (conclusion of correspondence).....-.-.-

Printing Office, Washington, D.C. A radio Service Bulletin is issued monthly by the Bureau of Navigation, and is obtainable from the Government Printing Office. The Bulletin contains changes in radio laws and regulations, new licenses issued and those cancelled; also a list of references to radio in current periodicals.

### CANADIAN REGULATIONS

Administration and control of the use of radio in Canada is vested in the Minister of the Department of Marine and Fisheries. All transmitting and receiving stations are required to be licensed. The penalty on summary conviction for operating an unlicensed station is a fine not exceeding fifty dollars, and on conviction on indictment, a fine not exceeding five hundred dollars, with imprisonment not exceeding twelve months in addition to a forfeiture of all unlicensed apparatus. A license fee of one dollar is required from all private receiving stations. Licenses are valid for one year, commencing April 1st, and expiring on March 31st of the following year.

Copies of the "Radio-telegraph Act, Statutes 1913, and regulations issued thereunder," may be obtained from the Department of Marine and Fisheries for ten cents each.

### RADIO'S PLACE IN COMMUNICATION

A question which has often been asked is whether or not radio will become a public utility more important than the telephone, telegraph or

cable. A glance at the history of communication as well as that of transportation shows that each new system has supplemented methods already in existence, affording and providing a greater range of facilities to meet new up-to-date conditions and to render more efficient public service.

Radio waves linked Japan with the rest of the world after seismic waves had caused catastrophe and destroyed all other means of communication in September, 1923. Cable relay stations were carried away, telephone exchanges swamped, inland telegraph and telephone lines destroyed, and many operators killed. The earthquake spared the 660-foot tower of Japan's most powerful radio station, which answers to the call JAA. Stations along the Pacific coast of the United States maintained constant communication over the transpacific circuit in the ether lanes through Honolulu, and showed how admirably radio could supplement other means of communication.

During the month of August, 1922, Irish Irregulars took possession of seventeen cable lines linking Europe with the American continent causing accumulation of piles of messages. The great radio circuits leading from England, one to Norway, one to Germany, and another to France were soon handling the diverted traffic which was scheduled to travel beneath the Atlantic as cablegrams, but instead arrived in the United States at the speed of sunlight via the ether. Radio facilities, both transmitting and receiving,



proved adequate for the heavy traffic entrusted to it. Delays were kept down to a minimum and the Hertzian waves demonstrated their ability to supplement the cables.

When the subway and elevated lines were opened in the large cities of the country, many were of the opinion that the surface cars would no longer be of use. But time has attested that the surface car is adapted for use where an elevated or subway line cannot be operated efficiently or economically. An incidental relation exists between the telephone, telegraph, cables, and radio. As systems of communication each method aids the other, since their individual characteristics enable them to accomplish and overcome conditions adverse to any one method of communication. The telephone cannot reach every one; neither can the telegraph, the cables, or radio; but with all four working together it is possible to reach any spot on the face of the earth by the telephone transmitter, microphone of radio, or key of the telegraph. The steamship, the railroad, the airplane, and automobile all supplement each other, and so it will be with the telephone, telegraph, cable, and radio — "One for all, all for one."

The applications of commercial radio telegraph and radio telephony are particularly adapted for mobile vehicles, such as trains and automobiles, ship to ship, and ship to shore, and between airplanes and airplanes to the ground. Radio is undoubtedly the first line of communication

across large expanses of water and deserts. As a medium for the dissemination of entertainment and news, radio is also of great importance.

Two of the excellent features of radio, not possessed by either the telephone, telegraph, or cables, are its great speed of 186,000 miles a second, a velocity which carries a radiogram around the earth in the twinkle of an eye; in less time than a telephone receiver can be lifted from the hook to attract the attention of the operator. The second salient feature of radio is its ability to reach instantaneously an audience numbering millions. It is calculated that, on a basis of one radiophone station adequately serving the whole area within a radius of thirty miles of its aerial, eight stations in the British Isles are capable of entertaining 30,000,000 people, approximately sixty-five per cent of the population, even though crystal sets are employed for receiving.

Broadcasting of President Harding's speeches, Lloyd George's addresses made in America, the Armistice speech of President Wilson on Armistice Day, 1923, President Coolidge's addresses to Congress and his eulogy of President Harding, and the funeral services of Woodrow Wilson showed radio extremely valuable as a medium to carry a vital message to the people.

The feasibility of transoceanic and transcontinental radio has been clearly demonstrated in tests conducted across the Atlantic and from New York to California. Interesting and successful experiments have been performed be-

tween ships and shore. Such tests tend to portray a picture when in the future a person on board a ship will be able to talk directly to his home in San Francisco, Chicago, New Orleans, or New York. These events also serve to show how radio will supplement the telephone and thus render more extensive service throughout the world.

Conditions which developed from the World War were such that the manufacture of cable would have involved a long delay in supplying service between Los Angeles, California, and Avalon, on Catalina Island. Radio provided an interconnecting link for three years. If a person in Boston, or any other city in the United States, wished to talk with a person in Avalon, the long-distance call was made in the usual way through the Los Angeles exchange of the telephone system. The voice from Boston continued over the wires from Los Angeles to the radio station at Long Beach, and from that point it leaped thirty-one and a half miles of water to the receiving station at Pebbly Beach where the voice was plucked from the air and put back on the regular telephone wires which led to Avalon, without the slightest intimation to the parties talking that radio played a part in the circuit. This celebrated "talk bridge" was discontinued in June, 1923, and was replaced by two submarine cables. It was a case of the ether supplementing the cables.

Although radio has encountered more ob-

stacles in radiophone service on moving trains than it has on board ship, it is safe to say that the day will come before many years pass when an individual can successfully talk from an express train, speeding between New York and Chicago, to his home in any city or town in the United States or to a friend on a vessel far out on the Atlantic or Pacific.

The two chief characteristics of radio which prevent it from direct competition with the telephone are its nature to travel in all directions so every one listening in can hear the conversation; the second drawback is the limitation of wave lengths which permit the handling of only a certain amount of traffic. The telephone can handle thousands of messages each hour. Each day more than 60,000,000 telephone calls are sent over the wires in the United States. In New York City, 4,000,000 telephone calls are handled daily, and 100,000 calls a minute during the busy hours of the day. Facilities of the ether lanes, within any practical range, are so limited that at the present time only a fractional part of such a tremendous amount of traffic could be sent by radio. The cost of radio equipment and its operation in universal service would be too great to warrant its use. The investment of the Bell system in the United States to-day is less than two hundred dollars for each subscriber station, including both local and long-distance lines, comprising all the poles, wires, cable, conduit, equipment, land and buildings and accessories of the

entire system. It is difficult, with the present theoretical and practical knowledge of radio, to conceive, at any cost, of a radio equipment which would furnish the same universal telephone service in a more economical fashion.

The best applications of commercial radio telephone are over large stretches of water; in moving vehicles; in some forms of broadcasting where it is desired to direct the same communication simultaneously to a large number of persons and in remote places where it is impractical to stretch wires for telegraph or telephone. It should be remembered that radio telephony is limited in scope by natural conditions, but the same is true of the telephone and telegraph. Each system of communication is endowed with advantages not possessed by the others, but all cooperating and working together they supplement and make possible a wider and more efficient communication system; the telephone and telegraph forming a web of copper over the land; the cable secluded in the depths of the sea; and radio with its tall steel towers silhouetted against the sky.

THE END

RADIO DICTIONARY

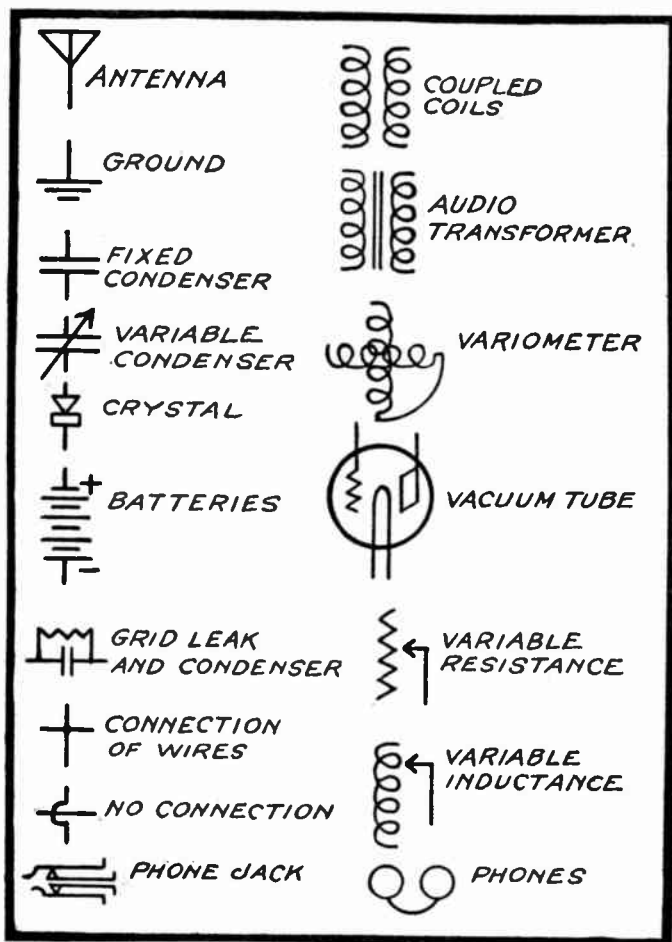

CONVENTIONAL RADIO SYMBOLS

## RADIO DICTIONARY

**Alternating current.** An electrical current flowing through a wire which has the direction of its flow periodically changed. Thus a 25-cycle current is one that completely reverses its direction of flow twenty-five times per second.

**Ammeter.** An instrument for measuring in amperes the current which flows in an electric circuit. An ammeter is always connected in series with the circuit.

**Ampere.** The standard electrical unit of current flow. An ampere will flow through one ohm when one volt is applied. The analogy of this is as follows: One gallon of water will flow through a one-inch pipe when one pound of pressure is applied.

**Ampere-hour.** That quantity of electricity which flows in one hour through a circuit carrying a steady current of one ampere. The capacity of storage batteries is rated in ampere-hours.

**Amplifier.** A device which magnifies the waves or sound in a receiving set. This term is used in referring to either an amplifier tube or to an amplifier unit consisting of several tubes.

**Amplitude.** The highest point reached by a wave or oscillation; i.e., the crest of each wave. A wave may, therefore, have a high or low amplitude depending upon the initial energy which created it. Amplitude is one indication of the strength of a radio wave.

**Anode.** A positively charged electrode.

**Antenna.** One or more wires insulated from and suspended at a certain height above the ground, and used to absorb or radiate energy in the form of ether waves. When used for receiving purposes, the correct name is "antenna," and for transmission the term "aerial" is used.

**Aperiodic circuit.** A circuit having no definite time period. A circuit having no tuning condenser or tuning coil. It is an



untuned circuit or one having sufficient high resistance to prevent natural oscillations.

**Arc.** An electric discharge through gas separating two electrodes and largely depending for its continued passage upon the heat it produces at one or both electrodes.

**Armature.** An iron member located in the field of a magnet.

**Atmospherics.** Natural electrical discharges occurring in the ether. Also known as "static," "strays," and "X's."

**Audibility.** The loudness of radio signals reproduced in a telephone receiver.

**Audio Frequencies.** Frequencies corresponding to vibrations, normally audible to the human ear. All frequencies below ten thousand cycles per second are termed audio frequencies.

**Audion.** A vacuum tube consisting of three elements, a filament, grid, and metal plate.

**Auto-transformer.** A transformer in which the same winding acts as part of both primary and secondary coils.

**Bank winding.** A coil of wire wound in layers one on top of the other. The layers are not symmetrical, but are wound above one another in staggered form. An example of bank winding is as follows: Turn No. 1 is wound on the tube; turn No. 2 is wound next to No. 1; turn No. 3 is wound on top of turns No. 1 and No. 2; and so on until the required number of turns is obtained.

**"B" Battery.** A battery for the plate or anode circuit of a vacuum tube. "B" batteries may be obtained in two forms, wet or dry.

**Beats.** Regular waxing and waning of intensity in radio signals produced by the interaction of two similar wave motions having slightly different frequency.

**Bias.** A means of influencing the grid of a vacuum tube. A small flashlight battery is sometimes connected in the circuit so that a negative voltage is applied to the grid.

**Binding Post.** A mechanical means of connecting wires to the instruments of a radio set.

- Blocking condenser.** A condenser generally of small capacity inserted in a circuit in order to separate it from another part of the circuit. It is sometimes called a "stopping condenser," and may be used to allow an alternating current to flow in a circuit, but block any direct current.
- Bus wire.** A single bar or wire which serves as a connector between instruments.
- Buzzer.** An electro-magnetic circuit interrupter having a vibrating armature.
- By-Pass Condenser.** A condenser of sufficient capacity to offer low impedance to radio frequency currents, but much higher impedance to audio frequency currents than does the instrument across which it is connected.
- Cage Antenna.** An antenna in which the wires are arranged to outline a cylinder.
- Calibration.** The act of determining the wave length, dial adjustment, or frequency of a radio receiver or transmitter.
- Capacity.** Capacity is the property of a device to store energy in electro-static form. Capacity, as well as inductance, governs the frequency or wave length of a circuit.
- Cascade Amplification.** High amplification of received radio signals where several vacuum tubes are employed in cascade fashion.
- Catacomb.** A receiver unit enclosed in a metal box filled with wax.
- Cathode.** A negatively charged electrode.
- Charger.** A device constructed to permit a definite quantity of electricity to flow in order that a storage battery may be recharged. Battery chargers are made in three forms, motor-generator, valve, and vibrating.
- Choke coil.** A coil wound to have great self-induction or choking effect when in the path of an alternating current.
- Circuit.** In electrical work and in radio, the path in which an electric current flows from the source and returns to it is called a circuit.

**Close coupling.** A tuner or transformer is said to be close-coupled when the primary and the secondary are very close together, thereby causing greater transfer of energy.

**Condenser.** Two or more sheets of metal separated by an insulator called the "dielectric." A condenser is used in radio for storing electrical energy and for bringing circuits into tune or resonance.

**Conductor.** A material through which electricity passes freely. Silver and copper are good conductors.

**Continuous Wave.** A form of electro-magnetic wave having a constant amplitude and no damping, as distinguished from the discontinuous highly damped wave produced by a spark transmitter. The abbreviation is C.W.

**Core.** The center or innermost part of an electro-magnet. The core of a transformer consists of iron wire or strips placed inside the primary and secondary windings.

**Corrosion.** The action of eating or wearing away slowly. Chemical elements in the atmosphere corrode the antenna.

**Counterpoise.** An artificial ground system consisting of one or more wires stretched immediately above the earth, but insulated from it. It is placed directly beneath the regular antenna and can be used in transmission and reception instead of a connection with the ground.

**Coupler.** A linking apparatus used to transfer electrical energy between two circuits.

**Crystal Detector.** Certain metallic crystals when used in a radio receiving circuit have the property of rectifying the incoming oscillations so that the resultant intermittent direct current will operate the receivers.

**Damped Waves.** Waves whose intensity, at any given point in space, gradually dies away. A spark transmitter creates damped waves.

**Damping.** The dying-away of the intensity of a damped wave. If the intensity falls off rapidly, the damping is said to be high.

- Decrement.** A measure of damping based upon the ratio of amplitude of successive oscillations.
- Detector.** An instrument which rectifies incoming radio impulses so that they will operate a telephone receiver or other recording device producing sound audible to the human ear.
- Dial.** A graduated disc mounted on the shaft of rotating parts so that the position of adjustment may be observed.
- Diaphragm.** A thin disc, generally iron or mica, in a telephone receiver which sets up audible sound waves from the vibrations caused by the periodic attractions of the telephone magnets.
- Dielectric.** The insulator between the plates of a condenser. Any insulating material is a dielectric.
- Dielectric constant.** A measure of the effectiveness of a dielectric in storing energy.
- Dielectric strength.** A measure of the ability of a dielectric to withstand high potentials without breaking down.
- Diode.** A vacuum tube containing two elements, a filament and grid. Diode means two electrodes.
- Direct current.** An electric current flowing continuously in one direction. Direct current always flows from the positive source to the negative. The abbreviation is D.C.
- Directional Antenna.** An antenna which receives from a certain direction more favorably than from other directions.
- Down-lead.** The approximately vertical part of an antenna, leading from the antenna proper to the instruments. Such a wire is called a "down-lead" in England, and a "lead-in" in the United States.
- Edison Cell.** A storage battery having positive plates made of nickel hydroxide and flake nickel pressed in alternate layers into tubes formed by helical coils of stripped nickel. The negative plates are made of iron oxide and mercury held in perforated steel pockets. The electrolyte is a solution of caustic potash.
- Electrode.** Terminals used for passing an electric current through any desired substance.

**Electrolysis.** The decomposition of a compound into its component elements by passing an electric current through it. Electrolysis occurs in wire rheostats, but not in carbon pile rheostats.

**Electrolyte.** A conductive liquid such as the sulphuric acid solution in a storage cell. It is a chemical compound which can be decomposed by an electric current.

**Electromotive force.** The electric force that tends to produce a flow of electric current in a circuit. This force is also called "voltage," "electric pressure," and "potential difference."

**Electron.** The smallest negative electric discharge. Electrons proceed from the negative to the positive parts of a circuit and this constitutes a flow of electric current.

**Emission.** The throwing-off of electrons. The filament of a vacuum tube emits electrons.

**Ether.** A medium supposed to pervade all space as well as the interior of solid bodies. It is the medium through which radio, heat, and light waves are transmitted.

**Fading.** The fluctuation of the strength of a radio signal, generally caused by atmospheric phenomena.

**Farad.** The unit of capacity.

**Filament.** A fine thread of carbon or fine metallic wire, which glows when an electric current passing through it causes sufficient heat. The main function of a vacuum tube filament is to emit electrons and not to produce light or heat.

**Filter.** A system of coils, condensers, and resistors, or some of them, offering low impedance to certain frequencies, but higher impedance to other frequencies.

**Frequency.** In alternating current, the number of complete periods per second. Frequency is always expressed in cycles or kilocycles.

**Frequency Changer.** A device that converts alternating current of one frequency into an alternating current of another frequency.

- Grid.** The controlling element of a vacuum tube. It is a frame of wire gauze or perforated metal placed between and insulated from the plate and filament of a vacuum tube. The framework holding the paste on the plates of a storage battery is also known as the "grid."
- Grid Leak.** A high non-inductive resistance used to permit excessive electrical charges to leak off the grid of a vacuum tube, thus furnishing stable control under all operating conditions. The detector is a rectifier and uses only one half of the radio wave. The other half is waste, and the grid leak serves as a path to lead the waste energy away from the tube.
- Ground.** The return circuit of a radio signal. The term "ground" is used in any connection with the earth, river, or sea.
- Hard Tube.** A vacuum tube highly exhausted of gas. Such a tube is usually employed as an amplifier.
- Harmonic.** Incidental waves differing in length and frequency from the natural wave of the transmitting station. A wave length harmonic is found below the rated wave length of the transmitter and a frequency harmonic is found above the natural frequency of the sending station.
- Henry.** The unit of inductance.
- Hertzian Waves.** Ether or electro-magnetic waves were named after their discoverer, Professor Heinrich Hertz, in 1887.
- Heterodyne.** A receiving system utilizing beats produced by the interaction of two radio frequency forces.
- Honeycomb Coils.** Insulated copper wire bank-wound in a form that resembles honeycomb. It has the advantage of low distributed capacity.
- Hook-Up.** A diagram showing the relative positions of the instruments in a circuit and their respective connections.
- Hot Wire Ammeter.** An instrument which measures current in amperes by means of a wire expanding in proportion to the heat generated by the passing current.
- Hydrometer.** An instrument used for measuring the specific gravity or density of a liquid by flotation. A reading of 1250

on a hydrometer indicates full charge. The reading that indicates discharge varies with the type of battery.

**Impedance.** The quality that tends to hold back the flow of current produced by an alternating voltage. A condenser, resistance, and inductance may offer impedance to an electric current.

**Inductance.** The magnetic energy-storing property exhibited by coils of wire. Inductance tends to prevent any change in the value of current flowing through it. It governs the frequency and therefore the wave length.

**Induction.** The transfer of energy from one circuit to another by means of electro-magnetism. The interaction of magnetic lines of force upon one another produce electric currents.

**Inductive reactance.** The opposition that inductance produces to the passage of an alternating current.

**Inductor.** A conductor, usually a coil of low resistance.

**Input circuit.** The circuit through which power is led to a device.

**Insulation.** A non-conductor of electricity.

**Insulator.** A non-conductive material through which electricity will not pass.

**Interference.** A radio signal or noise that interrupts the signal to which the set is tuned.

**Ion.** An atom or molecule having an electric charge either positive or negative.

**Ionization.** The process of producing ions.

**Jack.** A spring contact receptacle into which a plug may be inserted to complete one or more circuits.

**Kilocycle.** One thousand cycles.

**Kilowatt.** One thousand watts.

**Lead-in.** The wire leading from the antenna proper to the instruments.

**Lightning Arrester.** A device designed to lead high-voltage discharges, such as static, to the earth. Under normal conditions it will allow a radio signal to pass through to the receiver, but if a heavy charge strikes the antenna it will be passed on to the earth, thus protecting the set.

**Loading Coil.** A coil of wire placed in series with the antenna to place the circuit in tune with higher wave lengths.

**Loop Antenna.** An insulated frame around which are wound several turns of wire. The ends of the loop connect to the antenna and ground terminals of the set. It gives marked directional effects.

**Loose Coupler.** A tuner consisting of a primary and secondary winding. The secondary slides in and out of the primary.

**Loud-speaker.** A receiving device designed to reproduce signals loud enough to be heard without the individual use of head-phones.

**Magnetism.** That property which can be induced into any magnetizable substance by virtue of which that substance has the power to attract other magnetizable substances. When freely suspended in a horizontal position in the air such a substance will point toward the north and south magnetic poles.

**Megohm.** One million ohms.

**Microampere.** One millionth of an ampere.

**Microfarad.** One millionth of a farad.

**Microhenry.** One millionth of a henry.

**Microphone.** An instrument used to vary the current in a circuit by means of sound.

**Milliampere.** One thousandth of an ampere.

**Millihenry.** One thousandth of a henry, or one thousand microhenrys.

**Modulation.** The process of impressing an audio frequency variation, such as sound, upon a radio frequency carrier wave.



**Muffler Tube.** A vacuum tube used in a special circuit to eliminate radiation from a receiving set.

**Natural frequency.** The frequency of a circuit due to its own inductance and capacity.

**Natural Wave Length.** The wave length to which an oscillatory circuit is tuned.

**Neutrodyne circuit.** Essentially a tuned radio frequency amplifier with the capacity couplings between the tubes neutralized by small condensers called "neutrodons." Neutrodyne is derived from the Greek word "neutro," meaning neutral, and "dynamic," meaning force. Therefore neutrodyne means neutralizing force.

**Ohm.** The unit of electrical resistance.

**Ohms law.** Current in amperes flowing through a circuit is equal to the pressure in volts divided by the resistance in ohms.

**Oscillating circuit.** A circuit containing inductance and capacity and of sufficiently low resistance to oscillate when acted upon by a voltage impulse.

**Oscillations.** Alternating currents of high frequencies are called "electrical oscillations."

**Oscillator.** A device capable of generating oscillations.

**Oscillograph.** An instrument designed to trace visibly the wave forms of alternating current or potentials.

**Output Circuit.** A circuit into which a device delivers energy.

**Panel.** An insulating compound such as hard rubber, bakelite, or formica on which radio instruments are mounted.

**Parallel connection.** Battery cells having all the negative cell terminals connected together and all the positive cell terminals connected together.

**Period.** The length of time required to complete one cycle of oscillation.

**Plate.** The anode or output anode of a vacuum tube.

**Plug.** A connecting device used in conjunction with a jack for rapid alteration of circuits or transfer of instruments.

**Potential.** Voltage or electrical pressure.

**Potentiometer.** A resistor used for convenient alteration of voltage applied to a circuit. It consists of a variable resistance of high value.

**Power Amplifier.** A system of connecting two vacuum tubes in one stage so that a balancing effect is secured between them making it possible to get more energy out of each tube with minimum distortion. It is also known as a "push-pull" circuit.

**Primary.** The input coil of a transformer or circuit.

**Radiation.** The transmission of energy through space in the form of electro-magnetic waves.

**Radio Beacon.** A radio transmitter kept in continuous operation for use in direction-finding.

**Radio Compass.** A directional receiver calibrated to indicate by means of a loop antenna, the direction from which waves are received.

**Radio Frequency.** Frequency of vibration above the range of the human ear, usually considered as between 16,000 and 300,000,000 cycles a second.

**Radiotron.** A trade name for vacuum tubes.

**Ratio.** The proportion of two quantities. When it is said that the ratio of an audio amplifying transformer is 5 to 1, the meaning is that the secondary has five times as many turns of wire as the primary.

**Reactance.** Opposition offered to the flow of a varying current by a condenser (capacity reactance) or by a coil of wire (inductive reactance).

**Rectifier.** An apparatus which converts alternating current into direct current.

**Reflex Circuit.** Reflex means, "to turn back upon itself or in the direction whence it came." In a reflex circuit currents of different frequencies are superimposed upon each other with-

out interference. The two currents are of different frequency, and therefore do not lose their identity.

**Regenerative Circuit.** A radio circuit comprising a vacuum tube so connected that, after detection, the signal introduced in the plate circuit is led back to or caused to react upon the grid circuit, thereby increasing the original energy of the signal received by the grid and greatly amplifying the response to weak signals.

**Regenoflex.** A non-radiating regenerative receiver having one tube which amplifies at both radio and audio frequency.

**Relay.** A device by means of which electric power in one circuit controls electric power in another circuit.

**Resistance.** Opposition to the flow of an electric current through a conducting medium.

**Resistor.** A unit in which resistance is prominent.

**Resonance.** Harmony in frequency. Resonance is said to exist in a given circuit when its natural frequency has the same value as the frequency of the alternating electro-motive force induced in it.

**Resonance Curve.** A chart showing the change in voltage, current, or power in a resonant system as the condition or resonance is approached and reached.

**Resonant Circuit.** An oscillatory circuit.

**Rheostat.** A variable resistance usually employed to control or regulate the flow of current.

**Rotor.** The revolving part of any piece of radio apparatus.

**Secondary.** The output coil of a transformer or circuit.

**Second Harmonic Super-Heterodyne.** A circuit in which an oscillating detector oscillates at approximately one half the frequency of the incoming radio waves, instead of at the whole incoming frequency as is the case in other types of super-heterodyne sets.

**Selectivity.** The ability of a radio receiving set to select any particular wave length to the exclusion of others.

**Self-Inductance.** The part of the inductance of a circuit produced by a magnetic field of the current in the circuit.

**Series Connection.** Battery cells having the positive of one cell connected to the negative of the next throughout the battery.

**Sharp Tuning.** Where a slight change of a tuner or tuning system will produce a marked effect in the strength of signals.

**Shield.** A metal plate or casing, usually connected to the ground, for preventing changes in capacity.

**Soft Tube.** A vacuum tube not thoroughly exhausted of air and gases.

**Spark Frequency.** The number of groups of waves radiated per second as produced by a spark discharge.

**Spark Gap.** A discharger across which current flow disrupts air or other gas filling the gap.

**Static.** *See Atmospheric.*

**Stator.** The part of a radio instrument that does not move, such as the primary of a vario-coupler.

**Stopping Condenser.** A by-pass condenser used to block the passage of a direct current in a circuit.

**Storage Battery.** A number of cells capable of being charged or discharged through the same circuit.

**Superdyne Circuit.** A receiving circuit which contains a combination of regeneration and magnetic neutralization. It is a case of tuned radio frequency amplification.

**Tickler.** A coil used to feed-back power from the plate to the grid circuit of a vacuum tube.

**Transformer.** Any device used in electrical and radio work for the transference of energy from one circuit to another, with or without change in voltage, as desired.

**Triode.** A three-electrode vacuum tube.

**Tuner.** The portion of a radio set which is used in adjusting to resonance or to place the receiving circuit in tune.

**Tuning.** The act of altering capacity or inductive values in a

radio circuit so as to bring the circuit into resonance with an external source of similar character.

**Undamped Waves.** A train of high frequency oscillations of constant amplitude such as continuous waves.

**Vacuum Tube** in radio applies to a glass bulb exhausted of air and containing a filament for the creation of electrons; a plate positively charged and to which the electrons are attracted; and a grid, inserted between the filament and plate for controlling the electronic flow. A vacuum tube can be used for detection, amplification, and generation of high frequency electro-magnetic waves.

**Vario-Coupler.** An inductive coupler of variable mutual inductance, usually having the primary coil in a stationary position and a secondary coil that may be rotated. The primary is called the "stator," and the secondary, the "rotor."

**Variometer.** A variable inductor consisting of two coils whose mutual inductance may be changed. The coils are connected in series. One coil is fixed in position and the other rotates.

**Velocity of waves.** Radio waves travel at the speed of light, 186,000 miles a second.

**Volt.** The unit of electric pressure.

**Voltmeter.** An instrument for measuring the voltage across an electric circuit.

**Watt.** The unit of electric power. Power in watts is found by multiplying voltage by amperage.

**Wave Changer.** A switching device used to change the electrical constants of one or more resonant circuits in a radio transmitter so as to alter the wave length radiated.

**Wave Length.** The distance traveled by a radio wave after leaving an aerial before the next wave generated leaves the aerial. It is the distance from the crest of one wave to the crest of the preceding or succeeding wave.

**Wave Meter.** A device calibrated to indicate wave length corresponding to radio frequency currents applied to it. It measures frequency.

**Wave Train.** The continuous succession of radio waves.

## INDEX



## INDEX

- "A" battery. *See* Battery.
- Abbreviations, use of international, 231; list of, 234, 235.
- Aerial, function of, 18; definition of, 58. *See* Antenna.
- Alexanderson, E. F. W., designs 200 KW high frequency alternator, 2.
- Alternator, development of, 2; disadvantage of, 41.
- Amplification, methods of, 106-15; 125-26; applied to crystal detectors, 118-19; reflex method of, 119-22; push-pull method of, 122-25; drawbacks in various systems of, 125-28; super-heterodyne method of, 124-28; neutrodyne system of, 129-32.
- Antenna, action of, 23-24, 33; definition of, 58; constructional details of, 58-62, 172; fundamental or natural period of, 59; classification of, 60; insulation of, 60, 61; installation of, 62, 170-71; directional effects of, 62; types of and advantages of each, 63-69; types used indoors, 69-71; resistance of, 72; energy intercepted by, 72; characteristics of, 73; protection from lightning, 73-74.
- Arc transmitter, invention of, 2; tests of, 40.
- Arlington, Virginia, wave length of, 227; time signals of, 223-27; weather reports of, 227-29.
- Armstrong, Edwin H., invents regenerative circuit, 4; develops super-heterodyne, 124.
- Atmospherics. *See* Static.
- Audio frequency, definition of, 24; stages of, 106; amplification of, 112-16; transformers used for, 109-17; limitations of, 122-23; use in super-heterodyne, 127-28; push-pull amplification of, 121-25.
- Audiometer, function of, 44.
- Audion, invention of, 3, 84. *See* Vacuum Tube.
- Battery, "A" battery, function of, 85-90, 181; types of, 85-86, 181; required with different tubes, 96-103; care and charging of, 181-83, 191-92; use of hydrometer with, 182-83; correct wiring of, 184-85; when to use dry cells, 187-88.
- "B" battery, function of, 86-87, 188; connections of, 86; care of, 88, 190-91; required with different tubes, 96-103; use in transmitting, 103; characteristics of, 188-91; factors governing life of, 190; types of, 190.
- "C" battery, use of, 117, 192-93; use in push-pull circuit, 124; size of, 192.
- Beacons, principles and characteristics of, 218-21; location of, 218-21; schedule of, 219-21.
- Beat notes, creation of, 28.
- Beauford, wind intensity scale, 228.
- Beverage antenna, description of, 68-69.
- Branly, E., wireless experiments of, 1; develops coherer, 3.
- Broadcasting, started, 11-12; use



- of undamped waves in, 42; interesting facts about, 194-97; remote control, 203-04; relay method, 204-05; how accomplished, 205-09; drama, 209-12; time signals, 222-27; weather reports, 227-29.
- Broad wave, advantages and disadvantages of, 43.
- Buzzer, purpose in wave meter, 23; test with crystal detector, 78; installation of, 78-80.
- Cage antenna, construction of, 64.
- Call book, contents, 231; publication of, 231-32.
- Capacity, function of, 21, 22; neutralization of, 129-31; action of, 136; distributed in coils, 137-40; factors governing, 144; measurement of, 144; elimination of body, 169.
- "C" battery. *See* Battery.
- Circuits, crystal and buzzer, 76-80; vacuum tube, 88-90; radio and audio frequency amplifying, 106-17; reflex, 119-22; push-pull, 122-25; superheterodyne, 125-28; neutrodyne, 129-31; types and advantages of, 158-60; description of Reinartz, 162-64; divisions of, 184-85; connection of batteries in, 184-87.
- Clifden, Ireland, station opened, 10.
- Coherer, first detector, 3.
- Coils, function in transmitting set, 21-22; function in receiving set, 24, 136; types of, 137-44; coupling of, 155-158; construction of Reinartz, 162-64.
- Condenser, definition of, 18; purpose in transmitting circuit, 18, 150-51; function in receiving set, 24, 136, 150; action in series with antenna, 25, 59, 147; grid, 89-90, 149; purpose in secondary circuit, 88; by-pass, 116, 149-50; function in reflex circuit, 121; neutrodon, 129-31; types of, 144-51; characteristics of fixed and variable, 144-46; development of variable condenser, 145-46; function of vernier, 147; connection of, 147-48, 151; construction of fixed, 148-49; characteristics of transmitting, 150-51; metals used in, 172.
- Continuous wave, apparatus used for production of, 2; use in radio telephony, 42.
- Counterpoise, construction and function of, 67.
- Coupling, explanation of, 155, 156; types of, 155-58.
- CQD, first use of, 10; used by Steamer Titanic, 10; history and meaning of, 12-16.
- Crystal detectors, supersede electrolytic detectors, 3; action with indoor antenna, 72; types of, 75-78; function of, 77, 78; adjustments of, 78-80; care of, 80; application of, 118-19.
- Cycle, definition of, 26.
- Damped waves, creation of, 39-40; disadvantages of, 42.
- Dead spots, location and cause of, 45; tests and observations of, 46, 47; over New York, 48-50.
- DeForest, Lee, invents audion, 3, 84.
- Detector, function of, 24; definition of, 75; crystals, 75-80; vacuum tubes, 80-103; amplification of vacuum tube detectors, 106-15; amplifying crystals, 118-19.
- Dictionary, 245-58.
- Direction-finder. *See* Position-finder.

- Distress calls, history and meaning of, 12-16.
- Drama, broadcasting of, 209-12.
- Duddell, W., experiments with arc transmitter, 3.
- Duolateral coils, construction and advantages of, 138-40.
- DV-tubes, types and characteristics of, 101.
- Edison effect, discovery and action of, 83, 91.
- Electrolyte, mixture of, 181; use of, 181-83; specific gravity of, 183.
- Electrolytic detector, 3.
- Electrons, definition of, 80; theory of, 81; action of, 80-84; action in vacuum tube, 84-94; facts about, 91-94.
- Ether, theoretically outlined, 1; definition of, 17; how set in motion, 18; Einstein's theory of, 31; theories of, 29-32. *See* Radio waves.
- Fading, explanation of, 33-35.
- Fessenden, R. A., invents alternator, 2; patents thermal receiver, 3.
- Filament, function and characteristics of, 84; action of, 84-94.
- Fire Underwriters' Regulations, regarding radio, 73-74.
- Fleming, J. A., invents valve detector, 3, 84; theory of long-distance transmission, 30-31.
- Frequency, of waves, 18, 21; control of, 21, 22; types of, 24; explanation of, 26; relation to wave length, 27.
- Fundamental wave length, factors governing, 58-59.
- Gliding wave theory, explanation of, 31.
- Grid, added to vacuum tube, 3, 84; action and function of, 87-90; construction of, 87.
- Grid condenser, size of, 89; function of, 89-90, 149.
- Grid leak, function of, 89-90, 185-87; purpose of, 186.
- Ground, purpose of, 18; ship's connection to, 35; counterpoise, 67; connection for lightning arrester, 74; types and size of, 74.
- Harmonics, creation of, 28, 29.
- Hazeltine, L. A., invents neutrodyne, 129; describes adjustment of neutrodyne, 129.
- Heaviside, Sir O., theory of, 30, 31; effect of Heaviside layer on waves, 34, 35.
- Hertz, H., creates and detects radio waves, 1.
- Hertzian waves. *See* Radio waves.
- Honeycomb coils, construction and advantages of, 137-40; capacity of, 139; coupling of, 155-56.
- Hydrometer, function of, 182-83; operation of, 183.
- Hysteresis, explanation of, 117, 118.
- Indoor antenna, 69-71.
- Inductance, function in transmitting circuit, 21, 22, 136; purpose in receiving circuit, 24, 136.
- Insulation, antenna, 60; condenser, 146; materials used for, 173-75.
- Insulators, types of, 61, 173-75.
- Intermediate frequency, use of, 127-28.
- Jacks, types and advantages of, 180-81; use in radio frequency circuits, 108.

- KDKA, station opened, 12; relay broadcasting by, 205.
- Kenotron, derivation of, 105.
- Kilocycles, why used, 25-28; meaning of, 25-27.
- Laws, pertaining to receiving, 229; pertaining to transmitting, 230; Canadian, 232.
- Lead-in, arrangement of, 61, 62.
- License, granting of, 230; issued at, 230.
- Lightning arrester, installation of, 73, 74.
- Lightning switch, installation of, 73, 74.
- Light socket antenna, function of, 71; principle of, 71, 72.
- Litzendraht wire, use and advantages of, 66.
- Loading coil, function of, 24, 136; location in circuit, 136.
- Lodge, Sir O., experiments with wireless, 1; his theory of the ether, 32; forms first tuned radio circuit, 145.
- Loop antenna, principle and construction of, 65, 66; use as direction-finder, 213-18.
- Loud-speaker, determining efficiency of, 132; characteristics of, 132-35; selection of, 134-35.
- Magnetic detector, invention of, 3.
- Marconi, G., early experiments of, 1-5; predicts transatlantic radio, 6; sends and receives message across English Channel, 7; lands in Newfoundland, 7; tests at St. Johns, 7-8; detects first transatlantic wireless signal, 8; date of birth, 9; explains reception at the antipodes, 29; observes static, 53-54.
- Maxwell, J. C., predicts action of ether waves, 1.
- Metals, used in radio, 172-73.
- Microphone, function of, 19; types and construction of, 197-200; location of, 201-03.
- Modulation, definition of, 197; methods of, 200-01; measurement of, 201.
- Modulation meter, function of, 201.
- Morse Code, use in early wireless, 2.
- Natural period, factors governing, 58-59.
- Nauen, Germany, station POZ opened, 11; wave length of, 20; peculiarities in reception of, 30.
- NC-boats, use radio, 11.
- Neutrotons, description of, 129; construction and adjustment of, 130, 131.
- Neutrodyne, principle of, 129; adjustment of, 129-32.
- Neutroformers, construction and function of, 130-32.
- Otter Cliffs, station serves transatlantic seaplanes, 11; success of reception attributed to mountains, 50, 51; effect of static on reception at, 56, 57; direction-finder at, 213.
- Pallophotophone, drama filmed by, 212.
- Phones, sound produced by, 90; construction and characteristics of, 176-79; mica diaphragm, 177-78; connections of, 178; use of jacks with, 180-81.
- Plate, function of, 86-87.
- Poldu, England, spark station erected, 4; flashes first transatlantic wireless signal, 8.
- Position-finder, principle and use of, 213-18; value of, 217; use with airplanes, 221.

- Potentiometer, use of, 107-08; function with carborundum detector, 77; use with radio frequency amplifier, 186.
- Poulsen, V., invents arc transmitter, 2.
- Protective device, for antenna, 73-74.
- Pure wave, definition and advantages of, 42, 43.
- Push-pull amplifier, 122-25; hookup of, 125.
- Radio, reports first marine accident, 4; reports international yacht races for press, 4; spans English Channel, 7; spans Atlantic, 8; first tests on trains, 11; transocean service, started, 11; partially deaf hear, 44; place in communication, 232-33, 238-42; applications of, 242.
- Radio Central, station opened, 11.
- Radio compass. *See* Position-finder.
- Radio frequency, definition of, 24; amplification of, 106-12; amplifying transformers, 108-12; tuned amplification of, 109-11.
- Radio laws. *See* Laws.
- Radio waves, types of, 17, 39-43; wave motion, 17; illustrations of, 17; characteristics of, 17; how created, 18; action of, 19; velocity of, 19; measurement of, 21; what determines size of, 23; reception at the antipodes, 30; effect of Heaviside layer on, 30, 34, 35; effect of land and sea on, 31, 33, 35; Steinmetz theory of, 31; ideal medium for, 32; effect of sun, moisture, and dust on, 32, 35, 36, 42; absorption of, 35, 51; effect of moon, clouds, fog, aurora and darkness on, 37, 38, 39; deflected by mountains, 50; carrier, 206.
- Receiving set, calibration of, 22, 23; strength of current at, 57, 179-80; care of, 152-54; selectivity of, 154; operation of, 165-71.
- Reflex circuit, action of, 119, 120; advantages of, 120-21; construction of, 121-22.
- Regeneration, determination of, 167.
- Regenerative circuit, invented, 4; action of, 84-90; nature of, 73; disadvantages of, 126.
- Remote control, use of, 203-04.
- Rheostat, requirements with different tubes, 96-103.
- Righi, A., conducts experiments, 1; inventor of oscillator, 9.
- Rocky Point, L.I., radiophone tests, 41.
- Rutherford, Sir E., reference to atoms by, 83, 84.
- Salisbury Plain, demonstration of wireless at, 2, 5.
- Selectivity, factors governing, 154.
- Sodion tube, construction and characteristics of, 102-03.
- SOS, used by steamship Titanic operator, 10; history and meaning of, 12-16.
- Spark transmission, early use of, 2; type of waves used in, 39, 40; inefficiency of, 40, 42; effect of moonlight on, 39.
- Static electricity, types and sources of, 53, 54; methods used to minimize static interference, 55, 57; occurrence of, 55-57; protection of receiver from, 73-74.
- Steinmetz, C. P., theory of radio waves, 31; estimates strength of energy in receiving sets, 179-80.
- Storage battery, care and charging

- of, 181-83, 191-92; when to use, 187-88.
- Studio, equipment of, 205-09.
- Super-heterodyne, description and principle of operation of, 125-28.
- Switch, function of multiple point, 25.
- Symbols, advantages of conventional, 175; drawing of, 244.
- Thomas, Dr. Philips, invention of "glow discharge" microphone, 199-200.
- Thomson, E., proposes to use radio waves for signaling, 1; experiments with arc transmitter, 2, 3.
- Time signals, reckoning of, 222-23; master clock used for, 223-24; transmitting clocks used for, 224-27; transmission of Arlington and Key West, 224-27; broadcasting of, 226-27; schedule of, 226-27; rebroadcasting of, 227.
- Titanic, steamship, distress messages of, 14.
- Transatlantic radio, first message, 8; commercial service started, 11; methods used, 40; tests with vacuum tube transmitter, 41; wave lengths used for, 68.
- Transformers, radio frequency amplifying, 108-12; audio frequency amplifying, 112-17; construction of, 109-17; tests of, 117; correct ratio of, 113-15; push-pull, 123-25; neutrodyne, 130-32.
- Tuning, how accomplished, 24; technique of, 152-54; hints on, 165-71.
- Undamped waves, creation of, 39, 40; advantages of, 42.
- UV-tubes, types and characteristics of, 96-103.
- Vacuum tube, superior to spark for transmission, 2; invention of, 3, 84; replace alternators, 41; advantages for transmission, 41; action of electrons in, 80-84; elements of, 84; action within and operation of, 84-94; facts about, 91-94; putting the vacuum in, 92-94; manufacturing process of, 94-95; differences in, 95; selection of, 96-97; characteristics and various types of, 96-103; characteristics of transmitting, 103-05; possibilities in transmission, 104-05; function in reflex circuits, 119-20; eliminating microphonic noises from, 171.
- Vario-coupler, function and construction of, 140-42; action of, 157-58.
- Variometer, function and construction of, 142-43; types of, 143-44.
- Voltage, effect on detector, 136; effect in transmission, 23-24; effect across coil and condenser, 136.
- Wave antenna, description of, 68, 69.
- Wave changer, principle and function of, 127-28.
- Wave length, definition and explanation of, 19, 20; how measured, 21; how determined, 22; how increased, 24; method of reducing, 25, 147; calculation of, 25; relation to frequency, 27; fundamental or natural period, 59; transatlantic stations', 68; factors governing, 136.
- Wavemeter, definition and action of, 22; construction and operation of, 22, 23.

- Waves. *See* Radio waves.
- Wave trap, construction and installation of, 160-62.
- WD-tubes, manufacture of, 94-95; characteristics of, 96, 97, 99.
- Weather reports, broadcasting of, 227-29; abbreviations used for, 228-29; how to read, 229.
- Wire, stranded, advantages of, 58.
- Wireless, name changed to radio, 12.
- Wireless screen. *See* Heaviside.

