

basic
TRANSISTOR
course

by **Paul Rodger Kenian**

Diodes
Characteristics
Audio amplifiers
Detectors
Semiconductor lattice structure
Semiconductor materials
Transistor construction
Circuit analysis
Agc and i.f. amplifiers
Mixers
Transistor types
Oscillators
Choppers, inverters, multivibrators
and switches

Basic Transistor Course

Paul Rodger Kenian

TAB **TAB BOOKS Inc.**
BLUE RIDGE SUMMIT, PA. 17214

FIRST EDITION

ELEVENTH PRINTING

Copyright © 1962 by Paul R. Kenian

Printed in the United States of America

Reproduction or publication of the content in any manner, without express permission of the publisher, is prohibited. No liability is assumed with respect to the use of the information herein.

Library of Congress Catalog Card No. 62—21783

ISBN 0-8306-1111-8 (pbk.)

contents

CHAPTER

page

1

The World of the Atom 7

Elements. Compounds and mixtures. Union of elements. Atoms. Mass of the atom. The magnetic field of the electron. Orbital electrons. Shells. Multiple orbits. Shared electrons. Atomic structure. Atoms and molecules. Electrons in motion. Conductors. Insulators. Semiconductors. Germanium. Valence electrons. Valence bond. Electron behavior. Doping or adding impurities. Lattice structure. The donors — antimony, arsenic, phosphorus and bismuth. The acceptors — boron, aluminum, gallium, indium and thallium. Diffusion. Holes. P-type and n-type germanium. Current flow. Gallium arsenide and the tunnel diode.

2

The Diode 37

N-type and p-type germanium. Recombination and movement. Net charge of atoms. Donors and acceptors join to make a diode. The p-n junction. Movement of charges. The electric field barrier. Lines of force. Ionization. The measurable junction voltage. The p-n barrier. Interface potential. Bias and the potential barrier. Positive and negative ions. Ionization and de-ionization. Hole and electron movement. Forward and reverse bias. Forward or reverse current. The diode. Graphs. Avalanche multiplication and breakdown. Zener diode. Controlling resistance.

3

Enter the Triode 57

P-n and n-p diodes. Emitter, base and collector. The transistor. Biasing the transistor. Addition of signal and bias voltages. Resistance, reactance and impedance. Values of signal and bias voltages. Impedance reference. Collector bias. Input and output circuits. The transistor symbols. Formation of p-n-p and n-p-n transistors. P-n-p and n-p-n circuitry. Adding components. How the transistor works. Electron flow in the n-p-n transistor. Amplification. Current amplification — alpha. Current amplification — beta. Collector current vs emitter current. Transistor as an oscillator. Feedback.

4

Transistor Characteristics 79

Biasing methods and requirements. Biasing with one or two batteries. Fixed bias. Making the bias self-adjusting. Self bias. Bias voltage divider. Collector voltage vs collector current. Static testing. Collector characteristic curve. Tube vs transistor biasing. Collector characteristic family. Collector load. How to determine the load line. Other values of load. Distortion. Transfer characteristic curves. Mutual or transfer characteristics. Stabilization. Effects of temperature. Current feedback. Voltage feedback. Input resistance. Measuring input resistance. Output resistance.

5

Audio Amplifiers 103

Basic transistor amplifier circuit. Amplifier arrangements. The common-emitter circuit. Complementary symmetry. Biasing the amplifier. Classes of amplifiers. Base bias line. Class A vs Class B. Voltage and power amplifiers. Class A, single-ended, power amplifier. Capacitor polarity. Resistance and transformer coupling. Stability of operation. Temperature coefficients. Thermistors. Preventing thermal runaway. Heat sink. Efficiency - Class A. The pushpull amplifier. Efficiency - Class B and AB. Power output. Adjusting the bias. Driver stage. Emitter follower (grounded collector). Direct-coupled drive. Diode compensation.

6

Detectors, AGC, IF Amplifiers and Front Ends 137

Transistor detectors. Unbiased base operation. Detection and amplification. Decoupling. 2-transistor receivers. Automatic gain control. Diode detection and agc. Development of agc. Decoupling. Auxiliary agc. Shunted diode agc. Weak and strong signals. Impedance matching. Tapped collector winding. Base and collector matching. Negative feedback and neutralization. Basic neutralizing circuits. Feedback variations. Problem of selectivity. Ferrite antennas. Frequency conversion. Converters. Autodyne converter. Local oscillator. Operating frequency. Transformers and autotransformers. Mixer and rf amplifier.

7

Transistor Types 165

Transit time. Capacitance of a diode. Alpha cutoff frequency. Tetrode transistor. Surface-barrier transistor. Diffused transistor. Microalloy transistor. Junction transistors. Intrinsic transistors. Hook transistors. Field-effect transistor. Gate electrode. Source and the drain. Point-contact transistor. Multi-headed transistors. Tandem transistors. Germanium and silicon. Evaporation-fused transistors. Transistor dimensions. Manufacturing transistors. Crystalline formation. Power transistors. Alloy-junction transistors. Number of leads. Techniques of mounting transistors. Circuit packaging. Other transistor types. Inverters, flip-flops, choppers and amplifiers.

8

Circuit Analysis 195

The basic circuit. Meter amplifier. Increasing meter sensitivity. Transistor relay amplifier. Preamplifier circuit. Using a solar cell. Methods of connecting electrolytic capacitors. Signal tracer. Rearranging the circuit. Transformer-coupled audio amplifier. A transistor receiver with minimum parts. Transistors as a voltage divider. Common-collector amplifier. Advantage of redrawing the circuit. Oscillators. The multivibrator. Crystal-controlled transistor oscillators. The transistor as a switch.

Index 219

introduction

COLUMBUS is popularly known as a hardy and venturesome explorer who tested his beliefs in a very practical manner, but long before Christopher, other lesser known adventurers probed the American coastline. And, in the same way, while John Bardeen and Walter H. Brattain of Bell Telephone Laboratories are deservedly credited with the invention of the transistor, many others, some long before these two, poked, probed, tested the very curious and intriguing properties of crystalline materials.

As far back as 1855, and that is really reaching into the far recesses of the beginnings of electronics, some of the basic properties of semiconductors had been investigated. Even before then in 1835, an enterprising researcher by the name of Munk Af Rosenschöld had been doing experiments on electrical conduction in solids. And still earlier, in 1833, Michael Faraday was learning about temperature coefficients of solids.

These tidbits of knowledge kept adding to a growing mass of information about solids, yet they remained unrelated, waiting for the beginnings of electronics communications. Although wireless communication did start to stir during the latter portion of the 19th century, it wasn't until the end of World War I that the direct ancestor of the transistor made its appearance as the cat's-whisker crystal. This was a true semiconductor but its function was solely that of a rectifier. It is amusing to wonder whether, if the triode vacuum tube had not appeared to replace the crystal detector, some enterprising soul might not have found practical ways of making crystals amplify and oscillate. A few loyal investigators were sufficiently impressed with semiconductors to continue their work. Gabel V. Lossev in 1924 described the possibilities of the crystal as a generator and amplifier. And, in 1928,

R. S. Ohl obtained a patent for a multi-electrode crystal that would amplify and oscillate. He was also the discoverer, in 1941, of the p-n junction, basically the heart of the modern transistor.

But we must assign the formal birthdate of the transistor to June 1948, when Bell Telephone Laboratories first announced it. This transistor, a type not now used, was called the point contact and basically was a germanium diode, but with two cat's-whiskers instead of the one associated with the old-time crystal detector. Containing three leads, known as the emitter, collector and base, the device could be used to amplify and oscillate.

Of course this was just the beginning but, if the transistor was somewhat slow in getting started (compared to vacuum tubes), this tiny device has made gigantic strides. And, that brings us to the purpose of this book . . . to explain what the transistor is, how it works and just how it behaves in the presence of such well known companions as resistors, coils and batteries. The treatment here is nonmathematical, with many of the explanations by analogy—a dangerous procedure if rigorous exactness is demanded. This book will, however, give you a good general understanding of transistors, and, if that whets your appetite for a more definitive knowledge, so much the better.

New York, N.Y.

PAUL R. KENIAN

chapter 1

the world of the atom

WE know you expect us to tell you all about transistors (and we will) but let us start by taking a slight detour and talking about nails. What is a nail? Just a bit of iron, shaped in a special way and intended for a special purpose.

But when we say a nail is iron, we're indulging in what is known as a half-truth. Iron is a very sociable sort of metal and very rarely will you find it all by itself. For the most part, it likes to associate with oxygen, and when it does, we call the partnership iron oxide (rust).

This union of iron and oxygen is a very strange one. By itself, oxygen (at our usual temperatures) is a gas. We take in a lungful every time we inhale. And it is highly unlikely that you have ever seen pure iron, or that you would recognize it as iron, if you did. Pure iron is as white as silver, malleable and ductile. All this means is that it is so soft you wouldn't dream of using it to help build a house. But join iron and oxygen, add a pinch of carbon, and what a difference you get. You now have a strong, dark metal with which you can build houses or bridges.

Elements

What man hath joined together, man can put asunder. We can take iron oxide, separate the two partners, and have our pure iron (soft and silvery) and our oxygen (a gas) once again. Iron and oxygen belong to a family of substances called elements. Elements form a very exclusive society, since there are only about a hundred of them, but their importance is far out of proportion to their numbers, because they form the building blocks of the universe. Everything you wear, eat or drink, everything you see, including yourself and the people around you, is made of elements.

Some you know very well or, at least, their names are familiar. You know arsenic and aluminum, calcium, chlorine and carbon, helium, hydrogen and iron, but there are some that, until recently, were not so publicity-conscious. But we are going to stir up these very shy ones—germanium, selenium and silicon, indium, boron and gallium—and give them the sense of importance they deserve.

Compounds and mixtures

Elements, like people, have very distinctive characteristics. And, like people, they may change these characteristics when they get into a group or they may remain as individualistic as they ever were. Iron and oxygen unite to form iron oxide, a substance that is as different in its characteristics from iron and oxygen as it could possibly be. Sodium, a soft, silvery-white, waxlike metal, joins enthusiastically with chlorine (a nasty gas) to form sodium chloride. We know it much better as ordinary salt and we need it as part of our diet. Carbon, hydrogen and oxygen, having rid themselves of their inhibitions, group together to form alcohol (Fig. 101). Add some coloring matter, invite a few congenial people,

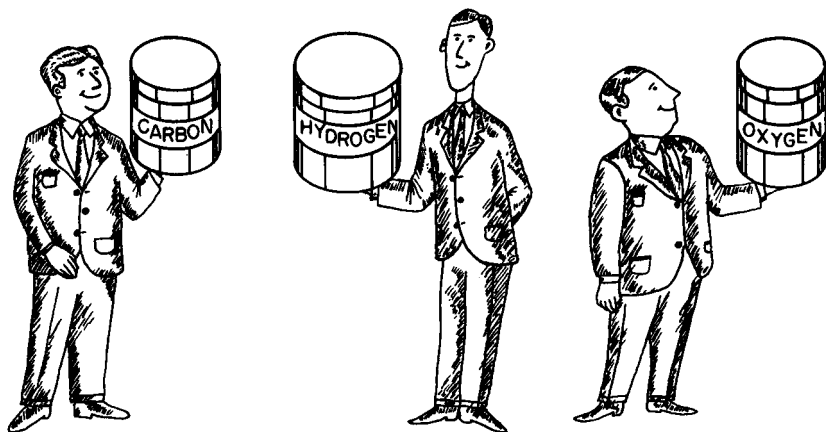

Fig. 101. *Alcohol is just one of the many thousands of compounds that can be formed from carbon, hydrogen and oxygen.*

and we have ourselves a party. But how different carbon (think of coal or diamonds), hydrogen and oxygen (both gases) are from alcohol.

This grouping, or combination, of elements to form something completely new, something with entirely different characteristics, is called a compound. Water is a compound, made of hydrogen and oxygen. Salt is a compound. And so is iron oxide.

Does this mean that the penalty for being sociable is loss of identity? Not always. We can take one compound, such as salt, shake it together thoroughly with another compound, such as pepper, but neither compound, pepper or salt, will change its characteristics. The pepper remains sharp or tangy and the salt remains salty. A loose union of this sort in which the substances retain their individualities is called a mixture.

Atoms

Now that we've moved somewhat in one direction, the joining of elements, let's make an about face and start marching off in the other. What happens when we start slicing elements apart, finer and finer and finer. . . ? The end product is an extremely tiny particle of the element, known as an atom. We say end product because, if we tamper with the atom in any way, it loses its

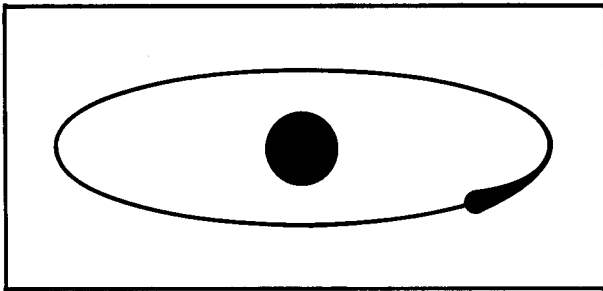

Fig. 102. *The lonely world of the hydrogen atom. The nucleus has just a single orbital electron to keep it company.*

identity. An atom of pure iron behaves in the same way as any other atom of pure iron, but start taking one of them apart and it is no longer an atom, and it is no longer iron.

Actually, though, the atom is as far as we are going to go. Taking the atom apart is the role of the atomic physicist. We are going to dally in that very pleasant and instructive playground barely long enough to get some basic information about transistors.

Just about the simplest of all the atoms we could start with is the atom of the element hydrogen. Fig. 102 is a drawing of what we think an atom might look like. Note that this atom has only two parts—a central body called the nucleus and a single, solitary electron revolving around it. This electron, in its motion around the nucleus, follows a definite orbit.

An atom is matter—mighty small, but it is matter, and as such

it has mass. This applies both to the central part of the atom, the nucleus, and to its restless associate, the electron. Oddly enough, although the nucleus of the hydrogen atom has a mass that is about 1,845 times that of the electron,¹ it is the electron that we are interested in. It is the diminutive member of this duo, the electron, that lets us have radio and television, that is responsible for modern communications.

There are a few things we know about the electron and there are quite a few things about the electron that have us guessing. We know it has a negative charge², and has a magnetic field around

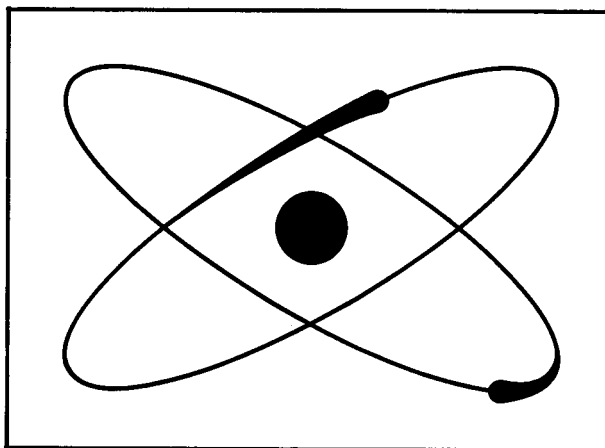

Fig. 103. *The helium atom is content with its two orbital electrons. The helium atom is stable.*

it. It is possible that the electron has angular momentum—that is, it spins or rotates around an axis. This knowledge of the vital statistics of the electron is singularly useful because it enables us to persuade the electron to leave its nice, comfortable orbit and to go traveling for our benefit. Specifically, we have transistors because we are able to make electrons do our bidding.

In the matter of electrons, hydrogen is the poorest element, since it has but one. The next element, helium, has two orbital electrons (Fig. 103). But now comes a sad story—a story of envy, desire and greed, the story of the haves and the have-nots. An atom with two orbital electrons (and helium is an example) is a

¹ The electron has a mass of 9.107×10^{-28} gram. The diameter of an electron is believed to be 2×10^{-12} centimeter. All electrons are identical, whether free or part of an atom.

² Each electron has a charge of 4.80×10^{-10} C.G.S. electrostatic units.

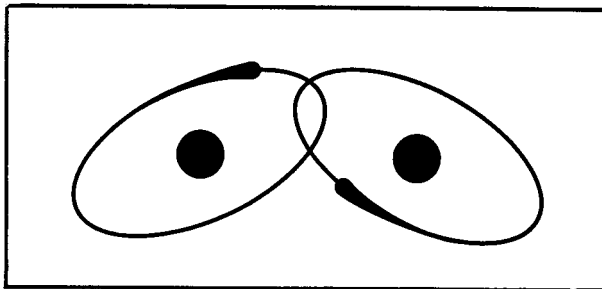

Fig. 104. *Two hydrogen atoms can satisfy their yearning for stability by sharing electrons.*

satisfied, contented atom. It has no ambition. It has no desire to acquire more electrons and, even if offered some, will reject them.

But what about hydrogen, poverty-stricken hydrogen, with its single electron? It schemes day and night to form a stable, happy family group, so reminiscent of helium. But, electrons are not easily come by, and so the hydrogen atom shrewdly does the next best thing—it joins forces with other hydrogen atoms, just as shown in Fig. 104. Each hydrogen atom shares its electron with its neighbor, and so, in that sense, we can say that the hydrogen atom has finally satisfied its yearning to have two electrons. But what about atoms (see Fig. 105) that have more than just one or two electrons?

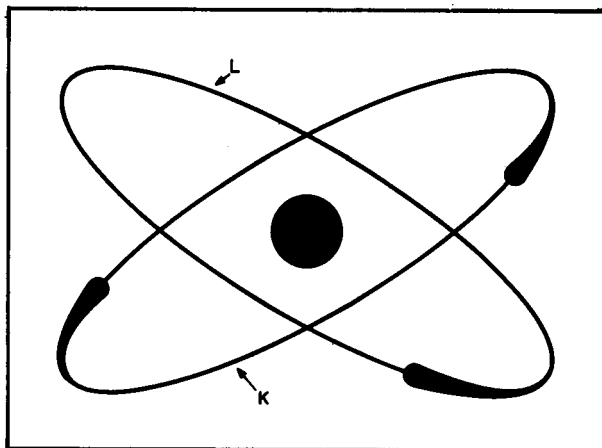

Fig. 105. *The lithium atom has three electrons in two orbits. The two innermost electrons form an orbit or ring of their own. This is known as the K ring. The remaining electron has a separate orbit called the L ring. The single electron is much further removed from the large, centrally located nucleus, than the two electrons in the K ring.*

We don't know why two electrons revolving around a nucleus makes the atom satisfied, but it does. One hint lies in the fact that the next atom, lithium, has three electrons. Two of lithium's electrons play in an orbit of their own which we have marked with the letter K in Fig. 105. But what about the third electron? It must revolve in an orbit all by itself. We have marked this orbit with the letter L.

Is there anything about the lithium atom that seems familiar? Doesn't it seem to you that there is some resemblance to our smug, self-satisfied helium atom (two electrons), and also to the

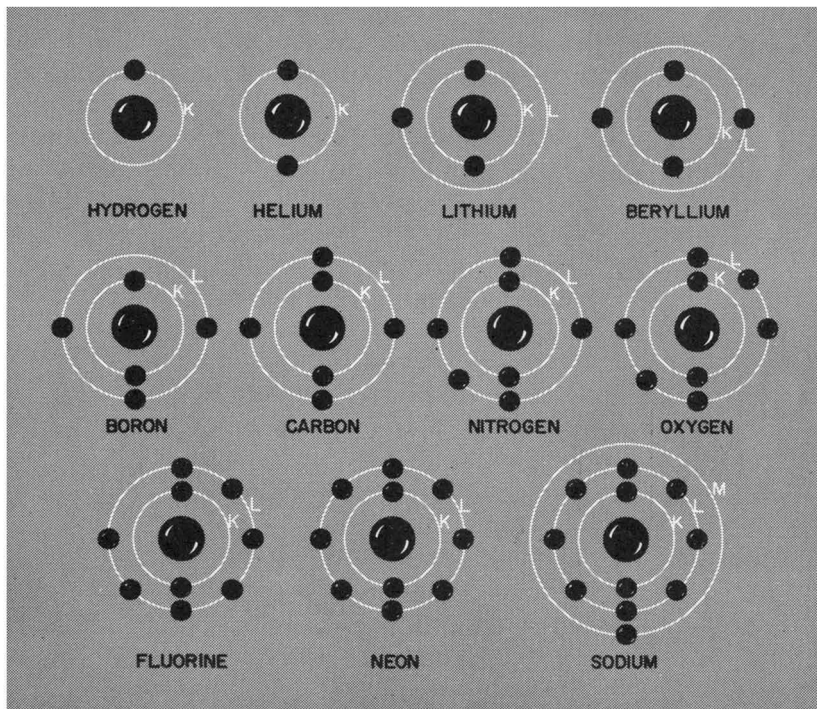

Fig. 106. One of the differences between atoms is the addition of electrons in the various rings. Hydrogen has one electron, helium has two, lithium three, etc.

dissatisfied hydrogen atom (with just one electron)? Actually, such is the case. The electrons in the K group are complete but, give it half a chance, and the lithium atom will associate with some other atom just so that its outermost electron (the single electron in the L ring) will have a playmate.

Other Elements

There are far too many elements for us to describe each one in detail, but Fig. 106 gives some indication of what is happening. As you can see, one big difference between atoms is that each succeeding element has one more electron.

There is something even more important that Fig. 106 is trying to tell us. The electrons seem to want to arrange themselves into definite orbits. We call them shells, because they surround the nucleus or kernel. The first, or K, shell has 2 electrons. The next, or L, shell is filled when it has 8 electrons. The next shell (M) calls for 18 electrons and when we move along to the N shell it wants 32 electrons.

But what if an atom does not have 2, 8, 18 or 32 electrons? What does it do? It follows the pattern set up by the hydrogen atom and shares electrons, or, as we shall see, it will surrender electrons, provided we can supply the atom with some sort of guarantee that it will get other electrons in return.

Please pass the electron

As you have probably noticed by now, we're spending quite a bit of time talking about electrons. This is exactly as it should be, since electrons are our stock in trade. We're not really interested in all electrons, just those we can persuade to leave home and travel. Like people, some electrons can be influenced to do what we want; others cannot. And since this is so, let's separate those who will from those who won't.

If a shell, or ring, of electrons is complete—that is, if the ring contains 2, 8, 18 or 32 electrons, don't even bother trying to talk them into leaving. These are the home bodies. We have a few of them in Fig. 106. Helium is one of this group. It has one ring (K) of 2 electrons, is a stand-patter, and that's that. The next one is neon with a total of 10 electrons. No chance of borrowing any electrons here, since the K ring is complete with 2 electrons and the L ring is filled with its quota of 8.

Some electrons move — some electrons won't

Now you can begin to appreciate why we started our study of semiconductors with atoms and why we did not plunge immediately into an explanation of transistors. We're interested in getting electrons to move when we tell them to. A small knowledge of atomic structure is helpful because we know in advance what elements will be cooperative and which elements will be stubborn.

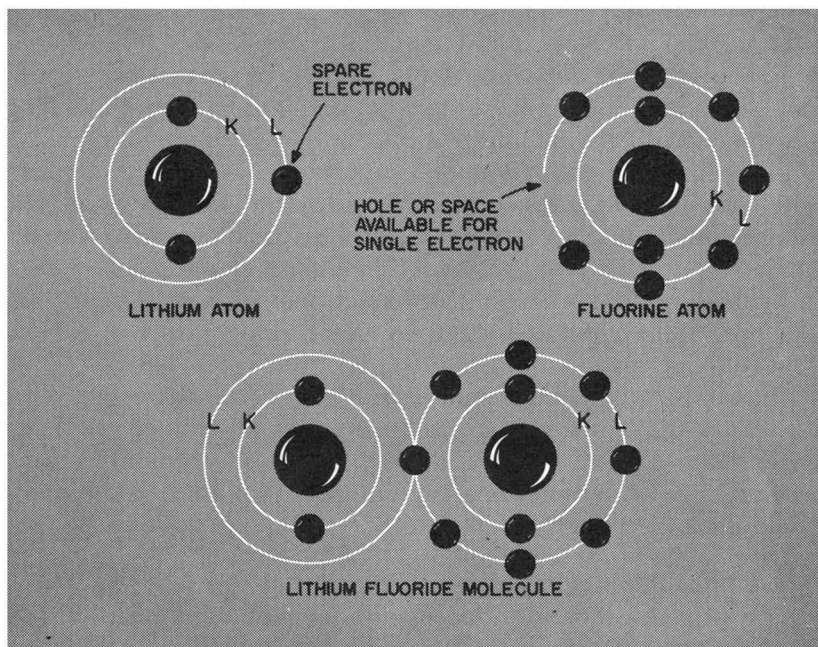

Fig. 107. Lithium has an electron it can spare. Fluorine has a vacant space into which this electron can fit. The two atoms, lithium and fluorine, form a molecule of lithium fluoride. This is a chemical combination. The molecule of lithium fluoride is a compound that has its own characteristics, completely different from that of either lithium or fluorine.

Fortunately for us, very few atoms are as complete as helium or neon. Most of them have electrons that jump about almost as fast as women at a bargain hunt at a charity bazaar. Let's examine two of them, shown in Fig. 107. Here we have lithium and fluorine. Lithium's inner ring is 2 electrons, so we don't bother with it. But that outer electron has an itch to travel. Adjacent to the lithium atom, we have one of fluorine. Fluorine also has an inner ring of 2 electrons, but its outer ring has a juicy total of 7.

How do lithium and fluorine compare? Lithium is "electron poor." It has just 1 electron in its outer ring and not much opportunity to reach a grand total of 8. But what about fluorine? Its outer ring has almost made its quota. Just one more little electron and the L ring of fluorine is complete.

Now if we bring lithium and fluorine near each other, just what do you think will happen? Fig. 107 gives us the result. The single, solitary, out-in-space electron of lithium moves over to fluorine.

This union of lithium and fluorine gives us a molecule⁸ which we call lithium fluoride.

We're not interested in teaching you chemistry—that is quite incidental to this book. The important thing to learn from Fig. 107 is that we now have one way of making an electron move. We don't say it is the best way (for us), but it does show us that electrons do get about.

Of even greater importance, Fig. 107 illustrates *which* electron moves. It is the electron in the outermost ring or orbit. And because it is so important, so fundamental to our work in transistors, let us examine this union of atoms with another example.

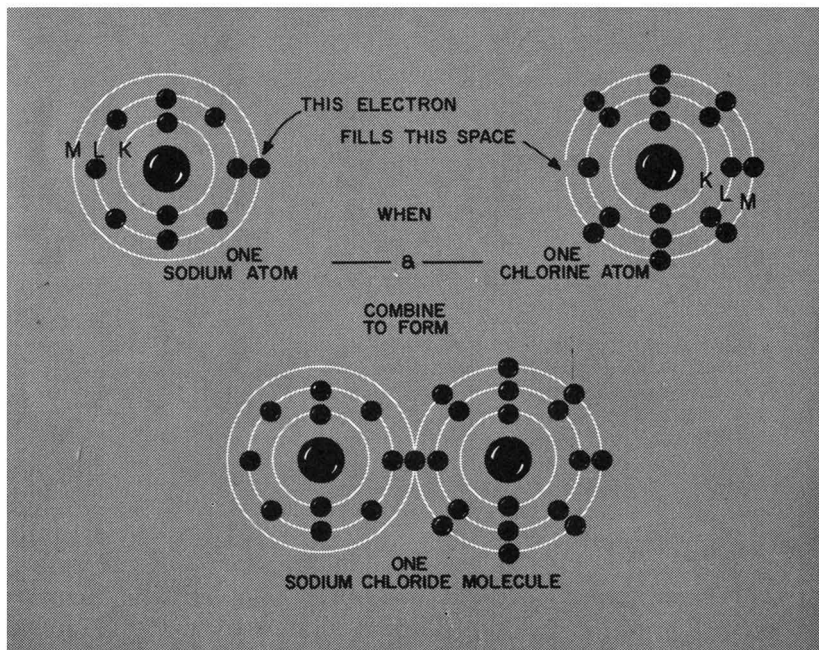

Fig. 108. The sodium atom has an electron it can spare in its outermost ring (M) while the chlorine atom has room for one more electron in its outermost ring (M). The union of these two atoms produces a molecule of sodium chloride.

Fig. 108 is a drawing of a sodium atom. This atom has three rings, two of which we cannot touch. The first, or K ring has the usual 2 electrons, the next or L has a complete and very satisfying full quota of 8. But orbiting out in the space around the nucleus we have a single electron in the M shell.

⁸A molecule is the union of 2 or more atoms, forming a compound.

In the same drawing we have pictured the chlorine atom. This also has three rings, two of which are filled. The M ring, though, has 7 electrons. And, as in the case of lithium and fluorine, the one electron in the outermost shell moves over. The result of this very fortuitous joining of sodium and chlorine is sodium chloride.

Other combinations

We selected lithium and fluorine, sodium and chlorine, because they lent themselves so nicely to the idea of a moving electron. But other atoms join in just the same way. In each case, though, the only electrons we are interested in are those that can (and do) move, and these are *always* the electrons in the outermost orbit.

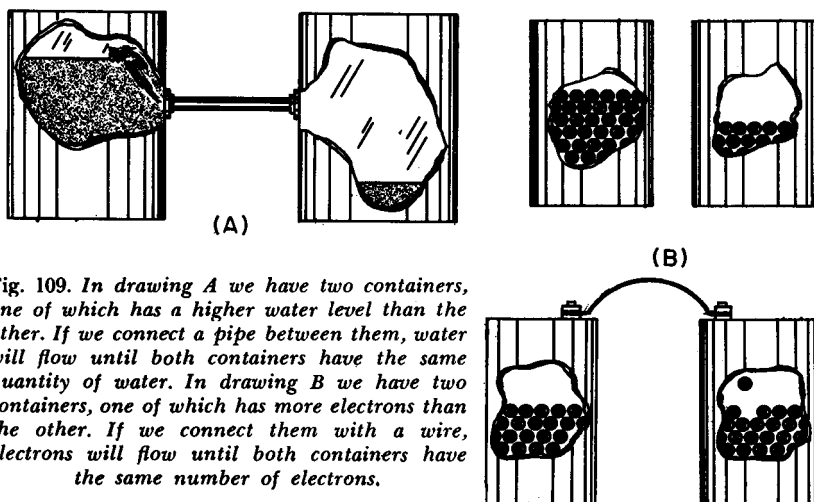

Fig. 109. In drawing A we have two containers, one of which has a higher water level than the other. If we connect a pipe between them, water will flow until both containers have the same quantity of water. In drawing B we have two containers, one of which has more electrons than the other. If we connect them with a wire, electrons will flow until both containers have the same number of electrons.

This is true whether the atom has two shells or more than two. And because of this, we can simplify matters for ourselves in talking about other atoms by forgetting all electrons except the outermost ones.

Electrons in motion

Getting electrons to move is easy. To get the picture, we can compare their motion to the flow of water, but we must bear in mind that this is not a really correct description. In Fig. 109-A we have two cans of water, one of which has a higher water level than the other. Connect the two with a pipe and water will flow until both cans have the same water level. Now let's try idea with electrons. In Fig. 109-B we have a container and let

us just imagine that we have somehow managed to fill it with electrons. Standing nearby is another container with far fewer electrons. And connecting the two is not a pipe, but a copper wire. Although we have no way of seeing directly what is going on, electrons will move from the electron-rich container to the one having not so many, until both have the same amount.

Now you might argue that it isn't possible to have two containers, one with, and the other without, electrons. But any battery presents almost that situation. A battery is a chemical factory, the end product of which is the condition whereby one electrode is loaded with electrons while the other has a terrible shortage of them. And if you wonder how it is possible for such a situation to come about, just remember that a battery is a very convenient arrangement for robbing some atoms of their outermost electrons. Some atoms are constantly losing electrons, some are always gaining them, and some (as in the case of neon or argon) never swap.

Conductors

The copper wire we connected between our two containers of electrons, or the terminals of our battery, is called a conductor because it supplied a passageway for electrons. Copper is another one of those elements whose atoms have very unsatisfied outer rings. Copper has four rings, 2, 8, 18 and 1 electron. This last ring, or shell, is so empty that it accepts all contributions with gratitude.

Now suppose we connect our copper wire to the negative terminal of a battery. Can't you just see the very first atom of copper saying to the electrons, "Come over and join my outermost ring"? And so they do. But the copper atom adjacent to the first one is also unsatisfied, so it demands, and gets, the electrons. This leaves the first atom shy of electrons again, but why worry? There are more available. And so the electrons are handed along, from atom to atom, much like buckets of water passed down the line by a 17th century fire brigade.

Now let's move over to the very last atom of copper, the one nearest the positive terminal of the battery. Do you think the last atom on the line is going to be allowed to hold on to its precious hoard of newly acquired electrons? Hardly! The positive terminal of the battery has even fewer electrons than this atom, and so it demands, and gets, its share.

When will this sort of thing cease? When the positive terminal of the battery has as many electrons as the negative terminal. Of

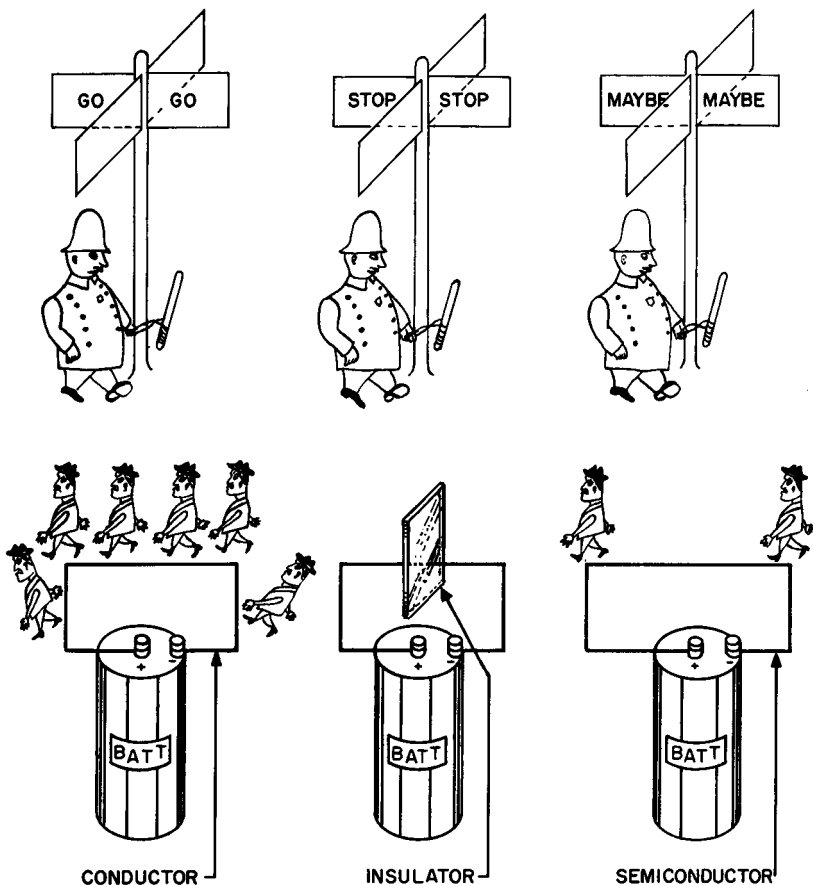

Fig. 110. A conductor permits the passage of electrons; an insulator does not. A semiconductor comes somewhere between these two extremes.

course, at that time, there will no longer be such a thing as positive or negative terminals, since both will have the same number of electrons. And what about our copper wire? Will it have been permitted to keep any of the electrons it was so busy passing along? Sorry. The battery gives electrons and the battery takes them away.

Our copper wire, willing and gullible, ready to work without electron compensation for any slick battery that comes along, is called a conductor. A conductor permits the easy passage of electrons through it (Fig. 110).

Insulators

Once a compound has acquired all the electrons it will ever need, any attempt we make to supply it with some will be rebuffed. Generally these are compounds whose outer rings have joined and so wouldn't know what to do with extra electrons if offered on a silver platter. Glass is one such compound. It has all the electrons it needs, thank you, so connecting a battery across it is a nice gesture, but a useless one.

Semiconductors

Substances that are very good conductors or very good insulators are unique and represent a minority group. They belong to the all-or-nothing-at-all groups. We can take certain insulators, modify them somewhat to form a let's-straddle-the-fence-group, which we call semiconductors. It is from this group that we are going to build our transistors.

The trouble with oversimplification (which is what we tried to do in the paragraph above) is that it can lead you down the garden path to some incorrect thinking. An ideal insulator could be represented by an open circuit, or an infinite amount of resistance. An ideal conductor could be considered as a short circuit, or zero resistance. Between these two limits we have a tremendous number of resistors which are able to pass current to a greater or lesser degree. We can call them resistors or we can call them conductors, just as we prefer. They do *not*, however, include semiconductors. A semiconductor is not something that is halfway between an open circuit and a short circuit. As we mentioned in the preceding paragraph, a semiconductor starts out in life as an insulator and is then modified to give it certain characteristics.

Back to the electron

Germanium, a grayish-white, brittle sort of metal is among the more important semiconductors. In some ways it is like carbon or silicon and, in others, like tin. Germanium is a mineral and, like almost all other minerals, has a crystalline structure. Salt is also crystalline. Look at it under a magnifying glass sometime and you will see how each face of this mineral has a definite geometric pattern. This doesn't mean that salt and germanium look alike, any more than two hats. Each mineral has its own definite structure.

Germanium has four electron shells, 2, 8, 18 and 4. It is the outer

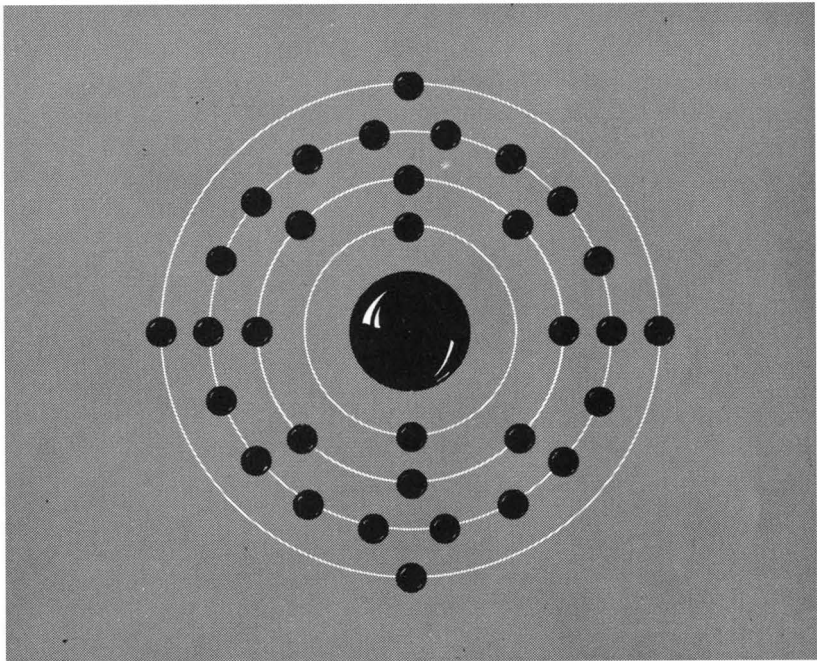

Fig. 111. *The germanium atom has 4 electrons in its outermost ring.*

ring that fascinates us, since it is responsible for some rather unusual behavior. Actually, having four electrons in the outermost ring is what helps make germanium unique. It really doesn't fit in with those other atoms, like lithium, which loses electrons readily, or like fluorine, which obtains electrons so easily. Germanium is a sort of halfway point between atoms that surrender electrons and those that take them in. We have a drawing of a germanium atom in Fig. 111 and as you can see, the atom is sort of at loose ends with its incomplete outer shell.

But what will happen if we introduce our germanium atom, not to some stranger, but to some other germanium atom, also beset with the same problem. Which of the two will surrender its electrons? Which of the two will be the more demanding, and get electrons? What we have is a tug-of-war between equally matched contestants. Neither side wins and neither side loses.

Valence

Up to now we have really been talking about two kinds of electron behavior. We have the stay-at-home, stick-in-the-mud

types that form the ultraconservative complete rings or shells. And we have the let's-go-traveling-and-see-what-other-atoms-are-up-to types. But even here we must make some sort of distinction, since not all of the electrons in the outer incomplete rings are truly and equally venturesome. Let's go back to the case of lithium and fluorine. Lithium has 1 electron in its outermost orbit and fluorine has 7. Should they all get equal credit for having some git up and

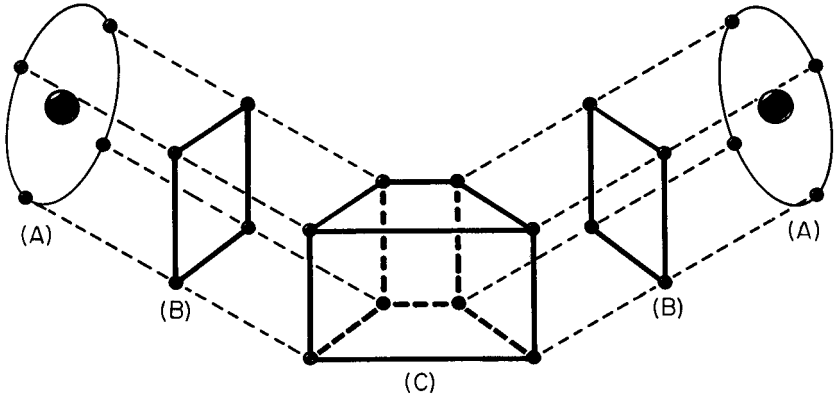

Fig. 112. In A we have a pair of germanium atoms. Just the outermost ring of electrons is shown. We can imagine these removed from the atoms, as in B. In C we have the 8 valence electrons, 4 from each germanium atom, forming a bond. This is atomic union, not chemical, as in the case of sodium and chlorine.

go? Not likely! There is just one electron that does any moving, so we should distinguish it in some way. We can, by giving it a new name. We can call it a valence electron.

But having endowed the lithium electron with this verbal croix de guerre, what shall we do about germanium? Fig. 112 shows what happens. The electrons don't move from one germanium atom to the next, but they do sort of link hands. Technically speaking, each germanium atom now has a complete outer ring of 8 electrons. True, it gets this way by a sharing process, but the ring is still complete and that is just what the atom wants. While the electrons didn't move, they do deserve some sort of special recognition, so let us say that they have formed a valence bond.

Back to conductors

A little earlier we connected a copper wire across a battery and saw how we could get an electron movement, or drift, through the wire. We were aided by the fact that the outermost rings of

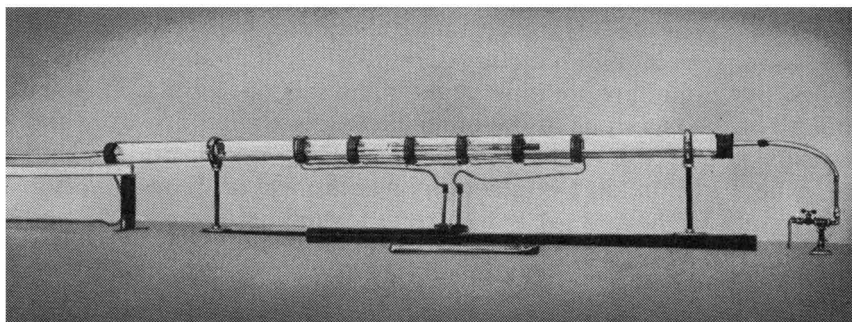

Fig. 113. *Technique for refining germanium. This uses a method known as zone refining. The coils produce heated zones in succession, the impurities being pulled to one end of the tube. If the refining is repeated often enough, the amount of impurities remaining will be less than 1 part in 1 billion. (Bell Telephone Laboratories, Inc.)*

all the copper atoms were incomplete and were happy to get electrons from the battery, even if only on a highly temporary loan basis.

Now let us repeat our experiment, but this time let us make our wire out of germanium. We connect our wire to the battery and stand back expectantly, but nothing happens. Why? Our battery is fresh, its negative terminal is practically crawling with electrons and its positive terminal is suffering from an electron famine. Conditions are just ripe for the passage of electrons through the germanium wire—or are they? Why should the germanium wire pass electrons? What have the germanium atoms to gain? Absolutely nothing. Linked arm in arm by mutually shared electrons—by valence bonds—they are self-sufficient, and have no need of electrons. No current will flow and we have no choice but to classify germanium among the insulators. A rather odd situation, since germanium is a metal.

Down with the valence bonds

Possibly you find the idea of germanium as an insulator slightly irritating. But if so, what can be done about it? One method (and we do not offer it as a practical technique) is to heat the germanium. As the temperature rises, some of the valence bonds weaken. Some of the outer rings assume an attitude of haughty aloofness. In this condition they have only 4 electrons and will welcome electrons from the battery. Later we will learn that this tidbit of knowledge is useful in protecting the transistor and keeping it, lemming-like, from attempted suicide.

Add a pinch of this or that and stir thoroughly

The germanium we have been talking about so far is absolutely pure. You might argue that an absolutely pure element does not exist, but in the case of germanium at least, methods are known and used which make germanium 99.99999 (add a few more nines of your own) percent pure (Fig. 113).

But now, into this undefiled mass of germanium atoms, let us drop a tiny impurity. Did you ever see a kitchen floor that was absolutely spic and span, but with one tiny, muddy footstep? What did you notice—the whole expanse of clean floor, or the

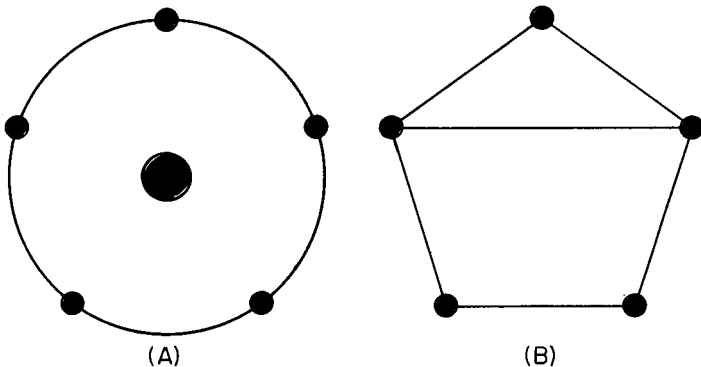

Fig. 114. The atom of antimony has 5 electrons in its outermost ring, as in A. The inner rings have been omitted to simplify the drawing. We can connect the electrons as shown in B. Antimony has 1 electron more in its outer ring than germanium.

small spot of mud? We're not going to use mud for our germanium but we can add a different element to it, and because this element is different, we can call it an impurity. (The process of adding the impurity is known as doping.)

In Fig. 114 we have a drawing of the element we are going to use. This element, antimony, has no less than 5 rings, or shells, of electrons. The innermost has the usual 2 electrons, the next has 8, followed by two complete rings of 18 electrons each. And in the outermost shell we have 5 electrons.

As far as the outer shells are concerned, how does antimony compare with germanium? Germanium has 4. Antimony has 5. Do you remember our description of germanium. Antimony sounds almost like a twin, since it is tin-white in color, and is a hard, brittle metal having a crystalline structure.

Lattice structure

Before we stir up a witches' broth by adding antimony to germanium, let's go back for just a moment to germanium itself and consider an important fact about the construction of that element. Did you ever see a beehive? A marvel of geometric construction, isn't it? And if you could see the way germanium is put together, you would marvel at it too. Germanium has a lattice structure. Whenever we have a definite arrangement of atoms in a geometric pattern, we have a lattice. This is why germanium is crystalline. The most beautiful example of crystalline structure is the diamond. The surfaces of a diamond are arranged symmetrically, but the surfaces are just an indication of the extremely orderly arrangement of the atoms inside.

Atoms, like people, can come in clumps or bunches without any sort of order or plan. Think of people walking back and forth, and cross-wise along a pavement. Or, people can form orderly groups, as in a well organized parade.

Adding the antimony

Now antimony is a crystalline substance too and so, when we put a tiny speck of it in with the germanium, we are adding one element with a lattice structure to another with a similar lattice structure. All well and good, but there's an electron in the ointment (Fig. 115).

If antimony had only four outermost electrons instead of five, all would be fine. Four electrons—yes, but that fifth electron is about as necessary as an extra guest when all the chairs are filled. But that extra electron, that orphan, should not be overlooked, for now it can serve a useful function. Now you might think that the antimony would want to keep its number 5 electron, but such is not the case. Its lattice structure fits right in with the germanium. It can form valence bonds with four of its outer electrons. What is the antimony doing? It has gone native, hasn't it? It no longer needs or wants its surplus electron and is quite willing to release it and let it go elsewhere.

Now we can try our experiment once again, but this time let us use a wire made of germanium to which we have added a tiny amount of an impurity—antimony. We connect this wire across our battery. This time the electrons on the negative terminal push over onto the wire. The extra electrons of the antimony atoms, unwanted, are repelled by the electrons from the battery, and edge their way over to the positive terminal. But as soon as an

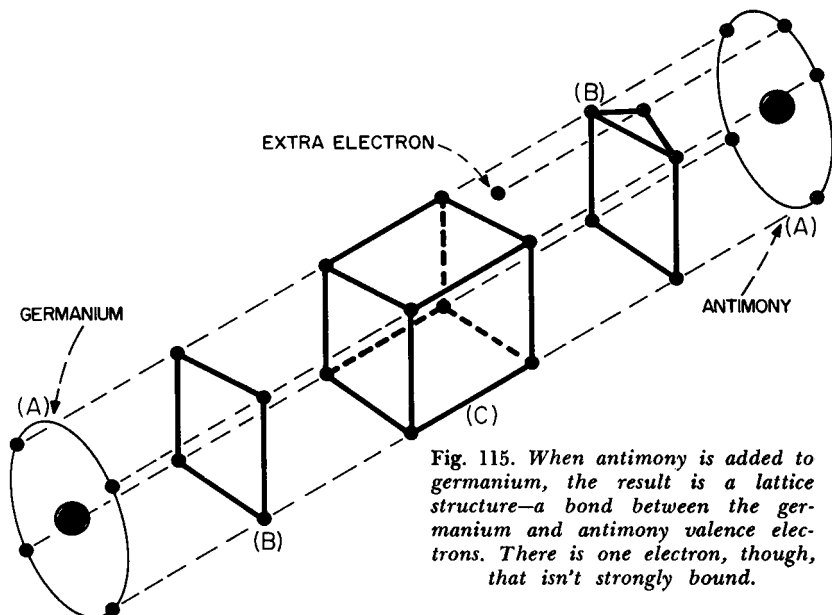

Fig. 115. When antimony is added to germanium, the result is a lattice structure—a bond between the germanium and antimony valence electrons. There is one electron, though, that isn't strongly bound.

electron leaves the outer ring another one hops in to take its place, only to be displaced by another electron moving forward toward it. But where have we heard this story before? Isn't this somewhat like the movement of electrons along the copper wire?

Our germanium is now no longer in the insulator class. At the same time, we really can't claim that it belongs with the good conductor group of which copper is such a prominent member. Since it is in a sort of limbo between the two, we call germanium, doped with an impurity such as antimony, a semiconductor.

Other impurities

The person who tracked up our nice clean kitchen floor a few paragraphs ago could also have brought in other impurities. Similarly, we need not depend on antimony alone. We could also use phosphorus or arsenic. Phosphorus has only three electron rings, but the outermost one has 5 electrons. Arsenic has four electron rings, but once again the outermost shell has 5 electrons. Unfortunately, we don't have an unlimited supply of elements with 5 electrons in the outer shell. Bismuth is the only other one. It has no less than six rings, but it still meets our requirements.

The donors

These elements we have been talking about, antimony, arsenic, phosphorus and bismuth, always come bearing gifts. The gifts are

the extra electrons so essential if we are to make germanium into a partial conductor. We call these elements donors, since they really do come equipped with a present of an electron. And since electrons are negative, we really should call them negative donors. Of course, the germanium, recipient of extra electrons, should be called negative germanium to distinguish it from germanium that has retained its essential purity. And negative germanium it is, abbreviated as n-type germanium.

The union of germanium and a donor element such as antimony or arsenic isn't at all like the joining of lithium and fluorine we talked about earlier. Lithium and fluorine combine chemically to form a completely new compound. An example with which you are more familiar is the formation of salt (sodium chloride) from sodium and chlorine. The salt doesn't look at all like its forbears, doesn't act like them, and is the true chemical union called a compound. But let's get back to germanium and the antimony. We add some antimony to the germanium but no new compound is formed. The germanium remains what it is and so does the antimony. The intermingling of the two is on an atomic basis. The nearest analogous situation we have in practice is putting butter on hot pancakes. The butter melts and mixes with the pancake until every tiny available space is filled with it. But the pancake remains a pancake and the butter is still butter.

The acceptors

Did you ever see the number 4 written as 4 ± 1 ? What this means is that we can have 4 plus 1 (to give us 5) or 4 minus 1 (resulting in 3). What has this to do with us? We've been talking about germanium atoms with 4 outer shell electrons and about donor elements all of which have 5 outer shell electrons. In other words, 4 plus 1. This gives us a clue to the idea that we might intermingle another type of element with our germanium. This element would have only 3 electrons in its outer shell.

What elements could these be? Boron is one of them. Boron has just two shells, a complete K shell having the usual 2 electrons, and an outside shell of 3 electrons. Aluminum is another one but has three rings; 2 electrons for the first, 8 electrons for the second and 3 outermost electrons. We have to travel down a long list of elements to come to the next one—gallium, with four electron rings: 2, 8, 18 and 3. The next is indium with five rings: 2, 8, 18, 18 and 3. Then we have thallium with six rings—2, 8, 18, 32, 18 and 3. And that is all. There are no more elements with 3 electrons in the

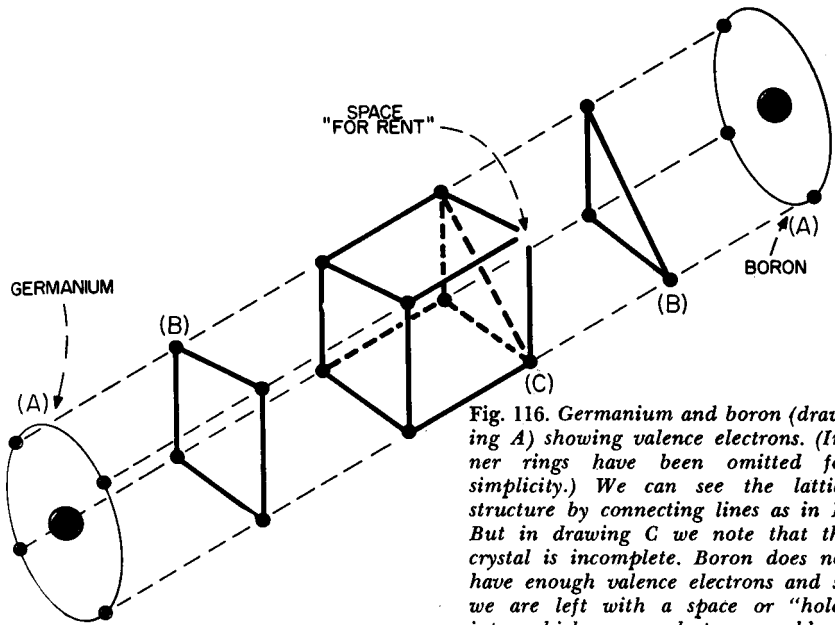

Fig. 116. Germanium and boron (drawing A) showing valence electrons. (Inner rings have been omitted for simplicity.) We can see the lattice structure by connecting lines as in B. But in drawing C we note that the crystal is incomplete. Boron does not have enough valence electrons and so we are left with a space or "hole" into which some electron could fit very nicely.

outside shell, but we have enough now, and any one of those we have mentioned is suitable for our purpose.

Now let us *diffuse* some boron into pure germanium. Did you notice that we italicized a word? We did so deliberately because the process of getting some boron into the germanium isn't just an ordinary mixing operation. The effect is shown in Fig. 116.

Of course, the boron atom, being part of a minority group, would like to do anything and everything to make people think that it is not a boron, but a germanium atom. But to be able to carry out this deception it needs just one electron, which it promptly borrows from its nearest neighboring germanium atom. But this germanium atom, having lost an outer electron to the predatory boron atom, promptly borrows an electron from the nearest adjacent germanium atom. And so it goes. Not a single atom wants to be short that single electron in its outer ring, and so we have a sort of aimless wandering of electrons from one atom to the next.

Positive and negative charges

Back on page 10 we mentioned that electrons are not only particles of matter (but extremely tiny) but that they also carry

a negative charge. Of course, the more electrons you manage to collect into one spot, the more negative that spot is. Suppose we do have such a location and that four electrons are sitting there, just as nice and comfortable as you please. And now, while we are using our imagination, let us also suppose that one of the electrons gets into a huff and departs. Our location now has fewer electrons. But precisely because it has fewer electrons, it is not as negative as it was before. And because it is less negative, we can say that it is more positive. It's just like saying that if a person becomes less rich he also becomes more poor. We know you may think this is just a play on words, but it is important for us to realize that we can say one thing in two different ways and to have both of them mean the same.

Holes

Let us now consider the case of the unfortunate germanium atom that finds an eager-beaver boron atom located right next to it. Before the germanium atom realizes what has happened, it loses one of its four outer-shell electrons to the boron atom. We know that the germanium is going to steal an electron from its neighbor, in turn, but before it gets a chance to do so, let us "freeze" the picture, so that we can examine the germanium atom as it exists during the time of its loss.

The germanium atom has lost an electron and, since electrons are negative, the germanium atom is now less negative than it was before. But let's define a little more clearly just what we mean by less negative. If your shoe is too tight, it may be just one toe that hurts. You don't ache all over. And when a germanium atom loses an electron, it doesn't become positive all over. We're concerned only with the outer ring, and even there, not with the entire ring. Consider the region vacated by the electron. It is now positive due to the departure of the electron. The loss of the electron has left a space. We call that space a hole, and to add further to what you must surely think is a state of confusion, some people refer to it as a positive hole.⁴

Do you remember our description of a germanium atom? One of its characteristics is that it has 4 — not 3 — not 2 — not 5 — electrons in its outermost ring. For a germanium atom to really be a germanium atom, it must have its particular structure, and no other. Remove any part of the germanium atom, such as an electron, and you have made a change, an important change. It is

⁴This is a redundancy. A hole is positive.

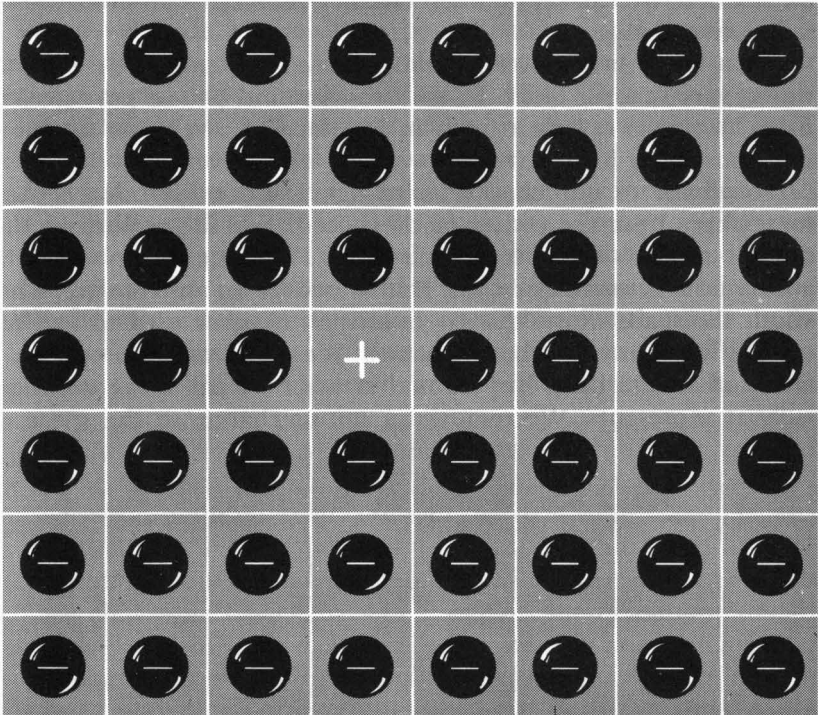

Fig. 117. All we need is a single vacant space on the checkerboard, and every electron on the board can be made to move. We can visualize this movement in two ways. We can think of the electrons moving about on the board, or, equally important, we can think of the space or "hole" taking different positions on the board.

no longer really and truly a germanium atom, since its architecture has now been made different. It is an atom with a positive charge.

But now let us take pity on our electron-deprived germanium atom and supply it with an electron—a negative charge. Where do you think that electron will go? There is only one place it can fit and that is in the "hole" created by the departure of an electron. If you want, we can say that the hole and the electron *recombine*.

A strange game of checkers

We want you to imagine that we have a checkerboard in front of us and that we have covered every available space on the board with checkers. This is extremely unusual, but so are transistors, so we'll make up our own rules as we go along. We also want you to imagine that each checker has a big, bold minus sign painted right

on it where we can see it. Each checker represents an electron, or a negative charge.

What is our first move? Actually, there is no move we can make since every space is filled. Doesn't this remind you of pure germanium, where every electron is in its place? There's just no room or opportunity for electron movement whatsoever.

Now back to our checkerboard again. Let's lift one checker, somewhere near the center of the board. For the most part this doesn't seem to help very much (Fig. 117) but we do have the ability now to move electrons. But before we do any moving, what about the space where the single solitary checker used to be? We could give it any number of names. We could call it a space, an enclosed area, a hole. But no matter what we call it we do know what it represents. We removed a minus charge, so the space or hole, or whatever we want to call it, is positive.⁵

Now let's start moving checkers. If we're patient about it we can make that hole or space move anywhere on the board we want. We can chase the hole progressively from one end of the board to the other. But as we do a very peculiar circumstance emerges. As the hole moves in one direction, electrons move in exactly the opposite direction. We can call the movement of the hole a movement of positive charge or hole flow. Or, if this represents too great a strain on our imagination, we can still think of electron flow.

We've been away from our germanium for quite a while now, so let's go back to it. Into a bit of pure germanium let's diffuse some boron. There's going to be a bit of an electron scramble as the germanium and boron atoms start their mad interchange of electrons. But, as in our strange checker game, there's always going to be a positive hole somewhere. Actually, we are going to have a tremendous number of holes because just a speck of boron provides millions of atoms. This is going to be a checker game on a really grand scale. We are going to have numerous positive charges, so it's perfectly proper and permissible to call this type of germanium, positive germanium. Let's do some abbreviating and call it p-type germanium.

We now have two types: n-type germanium and p-type. Which we get depends entirely on the element we add to our pure germanium.

⁵ The electron not only has a charge, but mass as well. It can exist independently of the atom. A hole, though, is a charge only. It depends for its existence on the existence of the atom. Holes, or positive charges, do not have a life apart from the atom.

Current flow

When we made a wire of n-type germanium and connected it across a battery, we had a trickle of current flowing, but there was nothing particularly unusual about it. But what about p-type germanium? What will happen when we make a wire of such germanium and connect it across a battery?

As usual, the negative terminal of our battery is crowded with untold millions of electrons all of whom are casting longing eyes at the wide open spaces on the positive terminal, so near and yet so far away. When we connect our p-type germanium wire, the electrons on the negative terminal can see but one thing . . . holes — positive charges — just willing and waiting to be filled by electrons. And so the electrons go hopping through the wire,

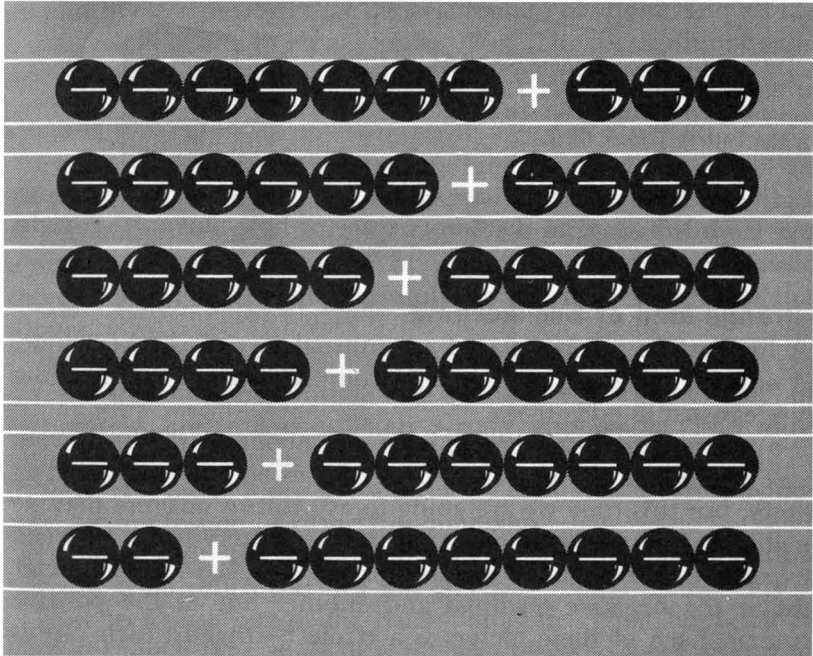

Fig. 118. As the electrons (negative charges) move to the right, the hole (absence of electron, or positive charge) moves to the left.

moving along from atom to atom. And while the electrons move through the wire in one direction, we get the effect of the positive holes moving in exactly the opposite direction. If you have any trouble visualizing this, just look at Fig. 118 where we have a

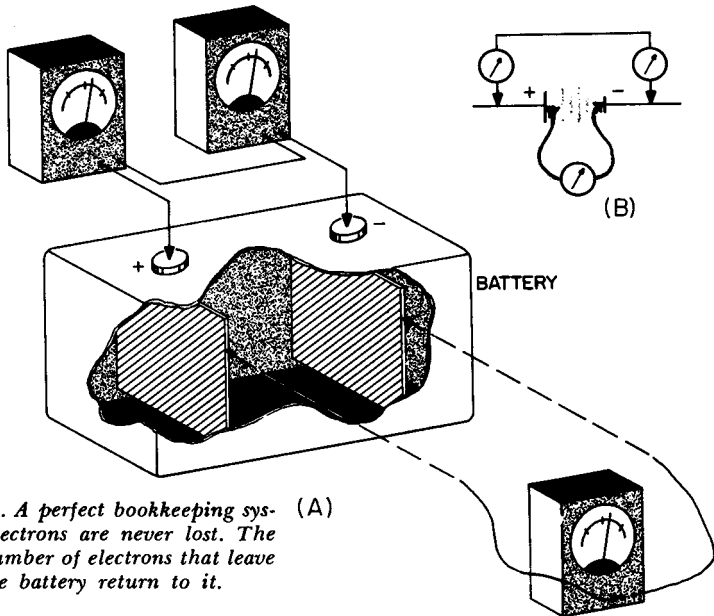

Fig. 119. *A perfect bookkeeping system! Electrons are never lost. The same number of electrons that leave the battery return to it.* (A)

simplification of what is happening in our wire. As electrons move from left to right, the empty space or hole moves from right to left.

A strange kind of bookkeeping

A little while ago we played an unusual sort of checker game, and now we are going to have an accounting system that is going to appear just as odd.

To understand just what it is we are about to thrust at you, please take a look at Fig. 119. We are still using our long-suffering battery, but this time we are going to ask you to imagine that we are able to insert an ammeter right in the battery itself, between the positive and negative electrodes. We also have an ammeter right at the negative terminal and another one at the positive terminal. Each of these meters is a triplet*—that is, each one is absolutely identical. With our wire connected, each meter will read exactly the same.

Is this so surprising? Hardly! We have a series circuit and so the current must be the same in each and every section of that circuit. We are sure this isn't front-page news as far as you are concerned, but there is a moral and a lesson to be learned here. For every

* With apologies to Triplett Electrical Instrument Co.

electron that leaves the negative terminal of the battery an electron must enter the positive terminal. And because of this, our copper wire never changes. When we disconnect it, after electrons have passed through it from the battery, it is precisely the same as it was when we first connected it. The books are balanced. There has been no loss of electrons, nor has there been any gain.

Doesn't this apply to our germanium as well? Obviously a series circuit is a series circuit no matter what components we use, and equally obviously, the battery isn't going to change the way it operates just because we hang some germanium wire across its terminals. Again, what does this really mean to us? Simply this: p- or n-type germanium, like any other conductor, will let electrons enter from a battery, but the total number coming in will equal the same number going out. The germanium is not left with a surplus of electrons. All that the germanium has done, and all that it can possibly do, is to act as a passageway. The germanium doesn't care which element we use as an impurity either.

Current movement

There are just a few miscellaneous facts we should discuss before we go into the next chapter. We've been talking about wire made of germanium simply to convey an idea. It is doubtful if there is such a commodity and, if by some very strange coincidence there should be, it would certainly be lots more expensive than copper.

We've also been talking about the flow of current through copper and through germanium. The words *flow of current* may, unfortunately, create a completely wrong impression. The movement of current through a copper wire is not a mad dash. Far from it. It is much more like a leisurely drift, but it certainly does give the impression of being instantaneous.

Consider a circular tube filled with metal balls, just like a ball bearing, from which the idea was taken.

Now let's push one of the balls — any one. What happens? All the balls move. The effect of your push seems to have been transmitted almost without loss of time, from the first ball to the last. Actually, though, the ball you pushed traveled a very small distance only and so did the ball next to it, and the ball next to that one.

The movement of current through a semiconductor is at an even slower pace than through a conductor, such as copper. In the case of p-type germanium we assumed that the holes would form an

absolutely straight line so that the electrons could go hopping, also in a straight line, from one end of the germanium wire to the other. No such thing happens and we have no right to make such an assumption. The current might actually spread out and take a rather devious route. We've also enthused about the beauty of the orderly lattice structure of germanium. But nature isn't perfect by any means, and so some germanium crystals may not be as well constructed as others. Bluntly, there may be imperfections and because of these imperfections the movement of the electrons may not be the smooth passage we imagine. Our meter in our series circuit won't reveal this to us, since it indicates just the average flow.

Other semiconductors

We've been talking so steadily about germanium that we have perhaps created the false impression that this is the only semiconductor. The requirement is simple and any element that meets the requirement is eligible for joining the semiconductor club. There aren't very many, however. Next to germanium, and quite possibly just as important, is silicon. Silicon has three electron rings (compared to four for germanium). The inner ring is the usual 2-electron orbit, the next ring has 8 electrons and the outer ring (the one that interests us) has 4.

Oddly enough, we have a somewhat unexpected member of the semiconductor family—lead. The ore of lead is lead sulphide or galena, and in the early days before vacuum tubes it was used as a semiconductor in crystal sets. We called them crystal sets since the galena looked like — and was — and is a crystalline substance. And so, if you think semiconductors are new, the answer is that they have been with us since the very early days of radio.

Lead has no less than six electron rings: 2, 8, 18, 32, 18, 4. If you can think of all these electrons whirling in orbit around the lead nucleus, your imagination is in fine working order.

Gallium arsenide is another semiconductor material. Like lead sulphide, it is a compound. Gallium arsenide is being used in the manufacture of tunnel diodes. Although we call it a diode (Fig. 120), it can work as an oscillator, it can amplify, and is very useful as an electronic switch.

Gallium arsenide uses materials we have come to regard as acceptor and donor impurities. Gallium has 3 electrons in its outermost orbit; arsenic has 5. A semiconductor made of these elements is known as a III-V compound. Another type of semiconductor

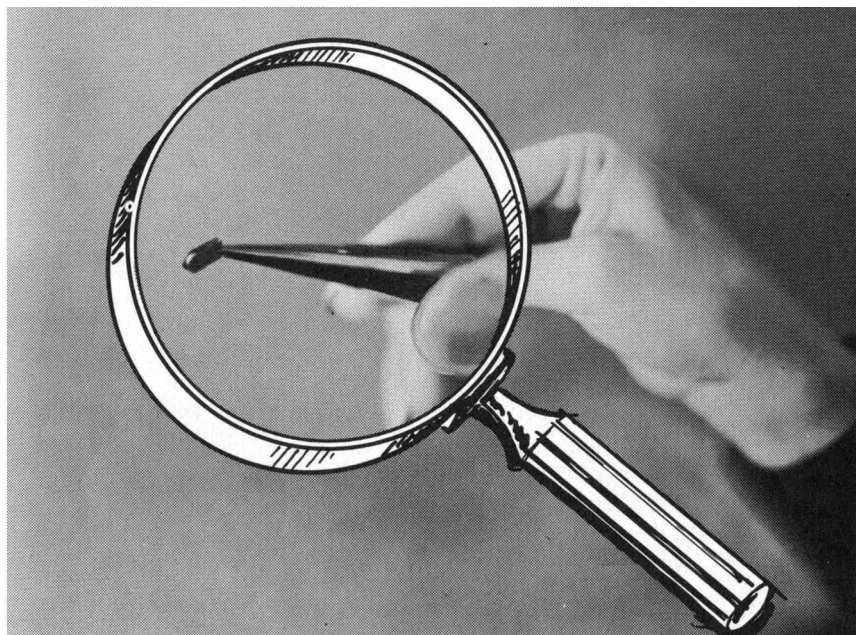

Fig. 120. Tunnel diode is so small that tweezers are helpful in handling it.

along these lines is gallium phosphide. This is also a III-V crystalline compound semiconductor. Unlike germanium, some of these semiconductors will operate continuously at temperatures as high as 930°F. Thus, diodes produced from this material show promise for high-temperature operation, and as electroluminescent structures. The semiconductor itself is optically transparent. This makes it very useful in the basic study of semiconductors in general. For instance, it may actually be possible to see the differences caused by various degrees of doping and also the effects of various voltages.

The last of our semiconductors is tin, also rather surprising. But surprising or not, tin meets all the requirements. Tin is a sort of blue-white crystalline metal having five electron rings: 2, 8, 18, 18 and 4.

Looking Forward

The man who first realized that a slice of ham and a few slices of bread had unsuspected possibilities was a genius, for he invented the ham sandwich. He's in the same class with those who looked at p-type germanium, at n-type germanium and then com-

bined the two, for this led directly to the invention of the transistor. How this was done and what happens when we make this sort of electronic sandwich will give us mental food for thought in the next chapter.

QUESTIONS

1. What is an electron shell? How many electrons make a complete K shell?
2. Describe what is meant by n-type germanium.
3. What is a donor element? Name two and describe the effect of their diffusion into pure germanium.
4. What is meant by p-type germanium?
5. What is a lattice?
6. Can a copper wire or a bit of germanium accumulate electrons when connected to a source of voltage? Explain your answer.
7. Describe a conductor. An insulator. A semiconductor.
8. How does the movement of electrons through germanium compare to the movement of electrons through copper? Is there a difference?
9. Describe the formation of positive charges in germanium.
10. What is the direction of hole movement compared to electron movement?
11. What is a valence electron? How does it differ from other electrons?
12. What is a valence bond?
13. What is an acceptor element? Name two.
14. What difference, if any, exists between donor and acceptor elements?
15. What name or names do we use for the central portion of an atom?

chapter 2

the diode

BEFORE an automobile can be built, all the materials for its manufacture must be assembled. Since the same sort of thinking applies to the transistor, you now have one more clue to the purpose of the preceding chapter. We were getting the transistor's component parts all ready. These consist of n-type germanium and p-type germanium. And, just so that we can identify these

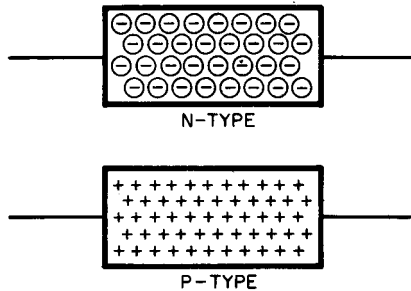

Fig. 201. We can represent n-type germanium (or any other semiconductor) by a rectangle filled with minus signs. These indicate an excess of electrons. For p-type germanium (or any other semiconductor) we can show a shortage of electrons by plus signs.

items readily, we have drawings of n-type and p-type germanium in Fig. 201. These drawings, in their own exaggerated way, emphasize what we have already learned — that p-type germanium contains numerous atoms that suffer from electron shortages. Because of this, p-type germanium is shown as a rectangle with numerous plus signs scattered throughout. The atoms in the n-type germanium suffer from an embarrassment of richness — they have a surfeit of electrons and so we show this by numerous minus signs inside the little rectangle. More often, though, a semiconductor is shown in block form, as in Fig. 202.

Now you might very well object to the drawing in Fig. 201,

since it may be difficult for you to regard the absence of an electron as a positive charge. But if you feel this way, consider a storage battery. One terminal is positive, while the other is negative. They are even stamped this way or have some other sort of identifying mark. But what is the true difference between the two terminals? The only real difference is that one terminal (the negative terminal) has far more electrons than the other terminal (the positive terminal). Note precisely what it is we are saying here. The terms negative and positive are relative. We do not say the positive terminal has no electrons; just that it has fewer electrons than the negative terminal.

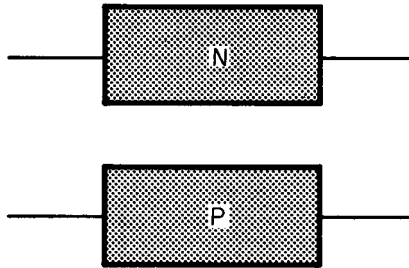

Fig. 202. A common method of representing n-type and p-type semiconductors in block form. These are not electronic symbols.

Recombination and movement

Have you ever been in a train that was packed so tightly with people that no one could move? We hope you have, because the inconvenience you suffered will now help you one step forward in understanding transistors.

Imagine a train, with no seats at all. The train is absolutely jammed with people, packed so tightly that no one can possibly move. The train pulls into a station and just one person gets off. This creates a vacancy (or hole) into which a person could move. And so now we have a condition in which some movement inside the train is possible. Thus, one person adjacent to the vacant space could move into it; but in so doing, he would also create a vacant space into which the next person could move. The important thing to notice here is that movement is possible.

Now suppose that by this time the train pulls into the next station and one person gets on. This person occupies the only available space, and so movement stops entirely.

What sort of conclusion does this bring us to? Simply that if a person is to move, there must be a space for him (or her) to move into. This isn't a revolutionary idea, but what happens to our thinking if we apply it to an electron? An electron has mass and it occupies space. But here the analogy between people and electrons breaks down. An electron has a charge. When an atom loses an electron—or gains one—the net charge of the atom increases or decreases (Fig. 203). The atom becomes more negative if it gains an electron, more positive if it loses one. And if an atom reverts to its status quo, it is neutral once again.

Grand union

The ancient Chinese had a belief that the world was made of opposites, and these they called ying and yang. Many are immedi-

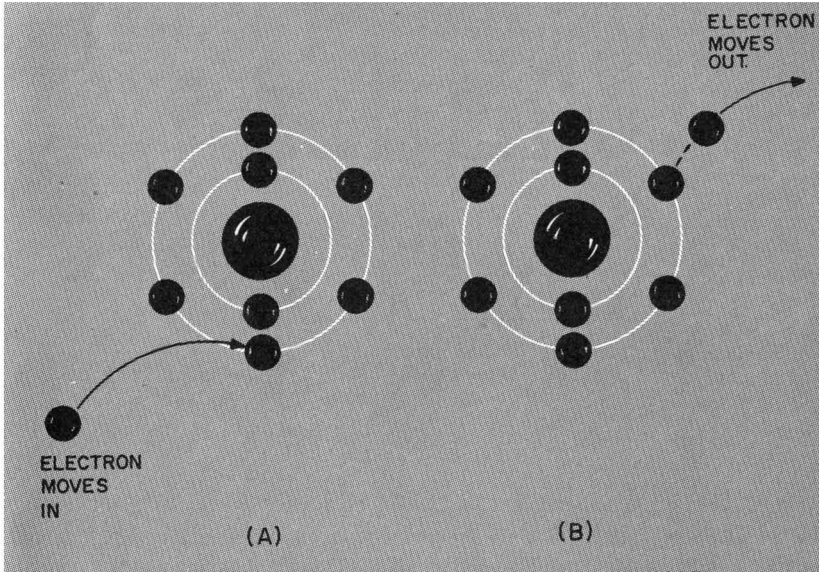

Fig. 203. An atom that has its regular quota of electrons is electrically neutral. It becomes an ion if it loses or gains an electron. If it gains an electron, it becomes a negative ion, as in drawing A. If it loses an electron (as in B), it becomes a positive ion.

ately apparent — black and white, hot and cold, up and down, male and female, rich and poor. So it wouldn't surprise our friends of the far east if we came up with n-type and p-type germanium. And because opposites have a habit of wanting to cling to each other, let's join our two types of germanium and examine the

results. Before we do though, suppose we consider our two germanium types just a bit further.

Our n-type germanium is called that because it is electron rich. Unfortunately, though, this sort of language may create a wrong impression. Fig. 204 illustrates the problem. Here we have a block of n-type germanium and a block of p-type. We have a voltmeter connected across the two, but the voltmeter reads zero. Why should this be so? Isn't the situation here exactly the same as a battery? Don't we have more electrons on one side than the other? To get the answer, think back to the way in which we made n-type germanium. We added donor atoms. In trying to adapt its own structure to the lattice structure of the germanium, the donor atom creates a condition in which an electron has been released so that it can travel. That is all that has been done. The net charge of the slab of the n-type germanium is zero. Similarly with the

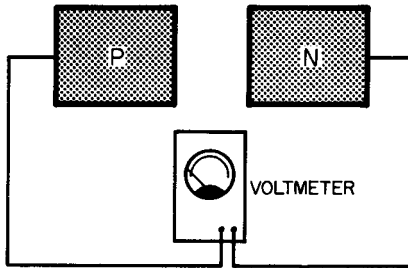

Fig. 204. The situation here is not the same as a battery. There is no movement of electrons from n-type to p-type germanium.

p-type. We have added an acceptor element with the result that the p-type germanium is in a position to allow the passage of electrons. That is all we have done and the net charge of the p-type germanium is also zero.

But now let's put our two blocks of germanium in as intimate contact as we can get them. In doing so we create a very pleasant situation for the germanium. The single-valence electrons of the donors in the n-type germanium will now move because there is good reason for them to do so. Not too far away from them is an area of p-type germanium with holes just waiting and receptive for any stray electrons. And so we get a recombination of electrons and holes.

Farewell to neutrality

The events that just took place did so at the junction of the two blocks of germanium (Fig. 205). Our first thought might be that all of the spare electrons in the n-type germanium and all the holes in the p-type would combine, but they are prevented from doing so. Let's consider the atoms at the junction. What has happened to the atoms of p-type germanium? The holes of these atoms (at the junction) have disappeared. They've been filled with electrons. But because of this these atoms are no longer neutral. The atoms have acquired an electron and so are negative. Similarly the atoms of the n-type germanium (at the junction) have lost electrons and so are positive. These charged atoms at

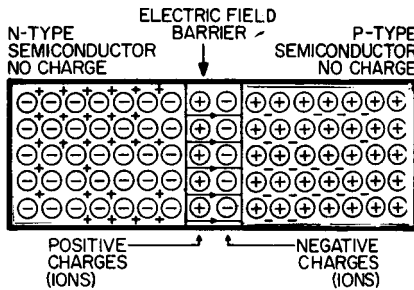

Fig. 205. The area at which n-type and p-type germanium (or any other semiconductor) meet is known as a junction. In this area we get a diffusion of electrons and holes. The result is a buildup of positive and negative charges which stops any further diffusion. The charges form an electric field, or barrier, which prevents any additional movement of charges.

the junction form a barrier. This barrier is an electric field—or voltage, since we have had an electron movement.

Now we can see why all of the atoms in the p- and n-germanium do not swap charges. They can't. The barrier, or electric field, prevents the rest of the holes in the p-type germanium and the remainder of the electrons in the n-type germanium from getting together.

The electric field

We cannot dismiss the condition existing at the junction of n- and p-type germanium blocks so summarily. The reason we may not is that transistors work the way they do because of the barrier that exists. The barrier is the heart of the transistor.

Suppose, as shown in Fig. 206, we have a pair of metal plates connected to a battery. A force exists between the two plates. We cannot see this force any more than we can magnetic lines of force, but it exists just the same. And just as we can draw imaginary lines to represent a magnetic field, so too can we draw lines between the two plates. We can call these lines an electric field.

If we were able to pick up an electron and deposit it in this electric field, the electron (carrying a negative charge) would

Fig. 206. This drawing shows a pair of plates connected to the positive and negative terminals of a battery. Electric lines of force exist between the plates.

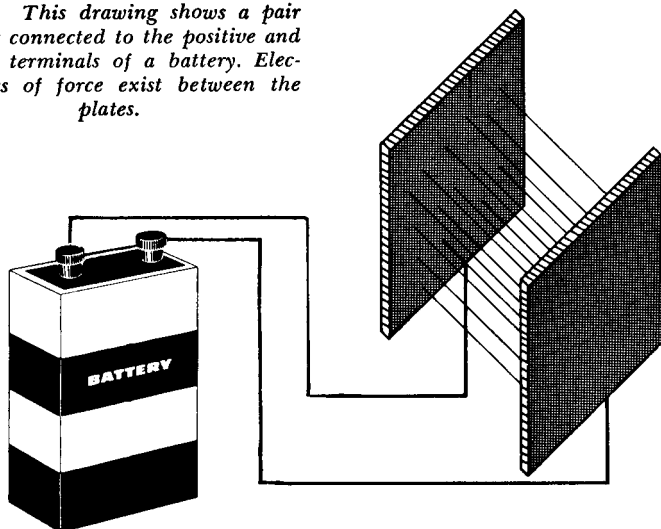

promptly accelerate over to the positive plate. And if you could, without overstraining your imagination, pick up a positive charge and put it in the region of this electric field, it would just as promptly move to the negative plate.

But let's be contrary for a while. Suppose we did put an electron into the electric field and decided that we wanted it to go to the negative plate. The electron would oppose our efforts. For the electron the negatively charged plate is a force in opposition — a sort of barrier. And we would have exactly the same results if we tried to push a positive charge toward the positive plate. Again we would get that same frustrated feeling of opposition — a barrier.

Ionization

It is very easy to see, in Fig. 206, how we get our electric field. It is supplied by the battery. A battery is something tangible. We

can buy it, we can touch it, we can connect it. But how do we get an electric field at the interfaces (the junction) of our two blocks of germanium?

To get the answer to this question we must think about our atoms once again. Suppose we deprive an atom of an electron. An electron, remember, carries a negative charge. So our atom, having lost a negative charge, is now considered positive — and quite rightly so. All we are really saying is that the atom isn't quite so negative as it was before the robbery took place. If our atom manages to acquire an extra electron we think of it as being negative.

Back in Chapter 1 we told you that atoms that gain or lose electrons are no longer the same. They have changed, and because they are different than they were originally, we call them ions. An

Fig. 207. A small, but measurable, voltage exists at the junction of the n- and p-type semiconductors.

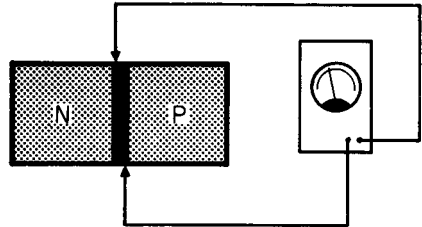

ion is an atom that has gained or lost an electron. An ion is a charged atom and can be either positive or negative. An atom is neutral, but when it becomes an ion, that fence-straddling neutrality is gone.

Back to the barrier

Armed with this information, let us see how an electric field is set up at the junction. Electrons migrate from the n-type germanium. They are attracted to those beautiful open spaces which are really positive charges. But the departure of an electron from an atom changes it from an atom to an ion. All along the interface of the n-type germanium we have ions. But what sort of ions? Since these atoms have lost electrons they must be positive, or plus, ions. What a strange thing to have happened. Our n-type germanium now has one side or face filled with positive charges.

What about the p-type germanium? The atoms along its face are gaining electrons. But if they are, they are no longer really atoms. They are ions — and negative ions at that!

And so, facing each other (Fig. 205) we have positive and

negative ions — or, more simply, positive and negative charges. But how different is this from the charged plates in Fig. 206? If, in Fig. 206, we put a voltmeter across the charged plates, we would read a voltage. But isn't the situation the same in Fig. 207? In the case of Fig. 207, though, we did not need to depend on a battery to supply an electric field. Because of the ionization that takes place at the junction of the n- and p-type germanium, we have a measurable voltage. The effect is just as though we had somehow managed to insert a tiny cell between the two germanium blocks.

Going back to Fig. 205, we have a drawing which sums up what we have done thus far. We have two blocks of germanium — p and n — closely joined. Where they join, we have the formation of ions. On the p-side, the ions are negative. On the n-side, the ions are positive.

What about the electrons in the n-type germanium? How do they feel about all this? They would like to get across to the p-type germanium, but they are unable to get past the positive ions. We have the same sad situation in the p-type germanium. Here the atoms would like nothing better than to play host to some electrons, but the negatively charged ions on their side stand in the way.

We now have an impasse. We have a potential, or voltage, across the interfaces of the two types of germanium. This is our barrier potential. The electrons in the n-type germanium need some help at this point since, on their own, they just do not have enough energy to overcome the potential barrier. At this stage of the game, we have a p-n junction. This junction has its own electric field which keeps electrons on the n-side and holes on the p-side from getting together.

A matter of potential

We now have a rather odd situation. Here are two blocks of germanium — one n- and the other p-type. Each is electrically neutral. Yet some of the extra electrons in the n-type have moved across into the p-type. At the interface, the n-type, having lost electrons is now *positive*. And the p-type, having gained electrons, is now *negative*. This difference of potential, though, just exists at the interface.

Away with the status quo

We have been talking quite a bit about the potential barrier because it is so important to our story, but compared to the total number of available electrons in the n-type germanium, the

amount that actually move are trifling. If we want to transfer any substantial amount of electrons, we're going to need to supply the electrons with energy. We could do it with heat, but there is a more practical method available.

Fig. 208 shows the technique we are going to use. Here we have connected a battery so that the positive terminal is attached to the p-type germanium and the negative terminal to the n-type germanium. Electrons will now move from the negative terminal of the battery into the n-type. What is this motion? It isn't a calm or leisurely affair. The battery must overcome opposition, actually force or inject electrons into the n-type germanium. It's like getting a shot for the flu. However cooperative the patient, and however sharp the needle, some amount of force is needed to accomplish the injection. In the case of germanium, the battery supplies

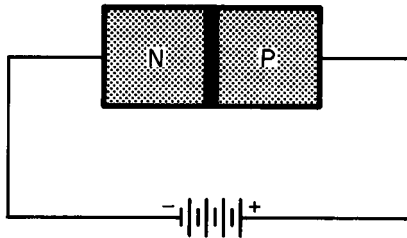

Fig. 208. We can use a battery to force current through the semiconductor.

the force, and the higher the voltage, the more force we have available.

What have we accomplished? We've injected electrons into the n-type germanium. But isn't this the germanium that, just a short time ago, lost some electrons at its interface? We even said that this region had become positive because of this loss. Now, we have re-supplied electrons to make up for that loss, so the number of positive ions at the n-side of the interface decreases. If we reduce the number of ions, though, what happens to our potential barrier? Since the potential barrier exists because of ionization, a reduction in the number of ions lowers the potential barrier. Wasn't it the potential barrier that kept more than a limited number of electrons from moving across the interface? With the lowering of the barrier, electrons can now move across from the n- to the p-type germanium.

What's going on here?

When we first joined n- and p-type germanium, ionization, caused by movement of holes and electrons, could not exist until the two blocks of germanium were physically joined. When we finally did unite the germanium we obtained ionization on both sides. The voltage across the barrier — the barrier potential — soon put a stop to further movement of any charges. But if we lower the barrier potential, we lower the hindrance.

Does this mean that we eliminate the barrier completely? Not at all. We have lowered the potential difference across the interface but we haven't done away with it completely, since we will have ions constantly being formed. The situation has changed

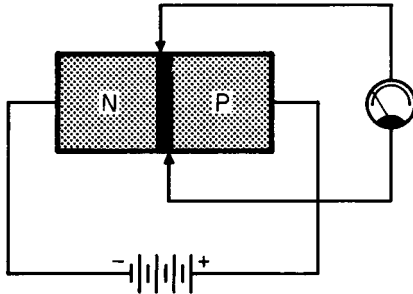

Fig. 209. The application of a voltage to the n- and p-type semiconductor reduces the potential barrier.

because we are now able, with the help of the battery, to de-ionize many of the ions being formed. Most — not all — of the atoms that lose electrons (hence become positive ions) will receive electrons because of that electron storehouse — the battery (Fig. 209).

Up to now, though, we have been neglecting the positive terminal of the battery and the bit of p-type germanium to which we have connected it. The positive terminal of the battery is characterized by a very important feature. It does have electrons — but far, far fewer than the negative terminal of the battery. What effect will this have on the p-type germanium? Actually, we should have been speaking about the ions at the interface. What sort of ions are these at the p-type interface? In this case we are dealing with negative ions — atoms that have one electron more than in their neutral state.

These negative ions now have a wonderful chance to become

neutral once again. Their extra electrons, heeding the siren call of the positive terminal of the battery, soon start to move in that direction. Again we have de-ionization, only this time it is the negative ions that become neutral.

Let's recapitulate what happens when we connect our battery. The positive ions at the n-type interface acquire electrons and so de-ionize. The negative ions at the p-type interface lose electrons and so de-ionize. With de-ionization taking place on both sides, the potential barrier is lowered.

What happens to the electrons from an overall point of view? They move from the negative terminal of the battery, through the n-type germanium, across the lowered barrier, through the

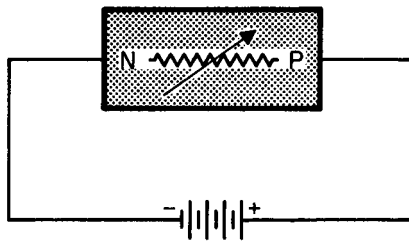

Fig. 210. The potential barrier acts like a variable resistor. Its value at any moment depends on the battery and the diffusion taking place at the interfaces of the n- and p-type semiconductors.

p-type germanium over to the positive terminal of the battery.

How many electrons will flow? That depends on the potential barrier. If it is low, more current will flow. If it is high, less current. We can, if you like, regard the barrier as a resistance (Fig. 210). With a comparatively large potential barrier, we'll get small current flow. A large potential barrier would correspond to a high value of resistance.

Hole movement and electron movement

How shall we regard the movement of charges in our diode? We have three choices. We can consider it from the viewpoint of electron flow. Or we can think of it as hole flow. Actually, it is both, but there is a practical aspect we must consider. As long as we confine our attention to the germanium, and to the germanium only, the true action is a movement of electrons and holes, and in opposite directions. But the transistor is simply a

means to an end. It will be used, just as a vacuum tube is used, to control current (electron) flow. Thus, in all circuits external to the transistor, in the wiring and the various components we are going to connect to the transistor, we are only going to consider electron flow, for that is all that will take place. Recombination — the re-union of holes and electrons, hole and electron movement combined, takes place only in the transistor. Outside the transistor we have only electron movement.

Why, why, why?

It might seem that what we have accomplished thus far is not too important, but consider what has been done. We took germanium, which in its pure state is an insulator, and made a conductor out of it. But to do this required that we trick the germanium in some way. We did this by making one block of it so that it had an electron surplus, and another block so that it had an electron deficiency. When we joined the two blocks we did get a small amount of current drift, and if electron movement had not been blocked by ionization, we would have had a gradual diffusion, a gradual equalization of electrons on both sides. That equalization is never reached, since, when we connected a battery to the germanium, electrons were coaxed into entering the positive terminal of the battery as fast as electrons departed from the negative terminal.

Forward bias

We have so many different sizes, shapes, styles and chemical arrangements in batteries, that the word battery, used by itself, is somewhat meaningless. If we say flashlight battery, auto battery or filament battery, then the modifying word adds some sense; it paints a picture. The battery that we used in Fig. 209 also needs a name. It is a bias battery. And because this battery helps overcome the potential barrier, because it makes numerous electrons march where relatively few moved, we call it forward bias. Note well that in forward bias the negative terminal of the battery connects to the n-block of the semiconductor; the positive terminal to the p-block.

Reverse bias

The opposition to the flow of current, that is, to hole movement and electron movement, that exists as a result of the potential barrier can be lowered by using forward bias. But the control of current flow is not really complete if all we can do is to increase it.

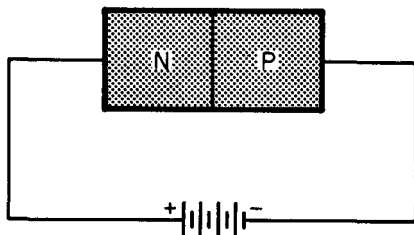

Fig. 211. Reverse biasing of a semiconductor diode.

To see how we can raise the opposition to current flow, look at Fig. 211. We are still using our two blocks of p- and n-type germanium. They are still in very intimate contact. The only change we seem to have made is to transpose the battery. But this reversal of polarity produces important changes at the junction of the two germanium blocks.

The drawing in Fig. 212 shows that the number of ions on both

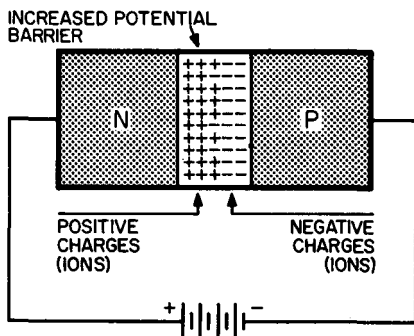

Fig. 212. Reverse biasing increases the potential barrier.

sides of the junction has increased. We have more negative ions and we have an equal amount of positive ions. But the formation of ions on both sides results in a potential difference. This potential difference, or voltage, is our barrier, but now our barrier is stronger than it ever was.

What has produced this condition? The positive terminal of the battery, connected to the n-type germanium, has provided a haven for electrons. Some of these move into the positive terminal

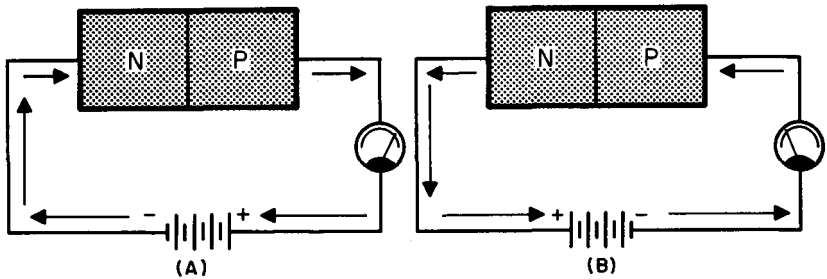

Fig. 213. The drawing in A shows forward biasing; the one in B is reverse biasing. Although current flows through the diodes in opposite directions its movement is still from minus to plus.

of the battery. At the same time an equal amount of electrons move way from the negative terminal of the battery into the p-type germanium.

In Fig. 213 we have a drawing in which we can compare the two ways in which we connected a battery to the semiconductor. In both cases the electron current flows away from the negative terminal of the battery, toward its positive terminal. And yet, as you can see by the arrows, the currents flow in opposite directions through the transistor. To emphasize the opposite flow of current, a semiconductor diode that has a reverse (or opposite) flow of current is said to be reverse biased.

A matter of degree

We can get forward current or reverse current, depending entirely on how we connect our battery to the semiconductor diode. But there is an implication of equality here that is not true. Reverse current is small, generally measured in terms of microamperes. Forward current is large and is usually milliamperes or amperes. But you can no more consider current by itself than you can operate a seesaw alone. High current connotes low resistance. Similarly, low current means that its opposite, resistance, is way up in the air. Forward biasing is just another way of saying low potential barrier or low resistance at the junction. Reverse biasing goes hand in hand with high resistance at the junction or a high potential barrier.

The diode

It may seem to you a little late in this chapter for us to give a name to our two blocks of germanium. It is known as a diode,

a rather lazy selection, since the name was borrowed directly from its vacuum-tube counterpart. The dictionary definition is certainly not applicable. The prefix is di (from the Greek *dis*, meaning two) while the suffix is ode (from the Greek *hodos*, meaning a way or path). Thus, a diode has two paths, and if we think of the forward and reverse flows of current, then perhaps the name diode isn't too poor a selection after all.

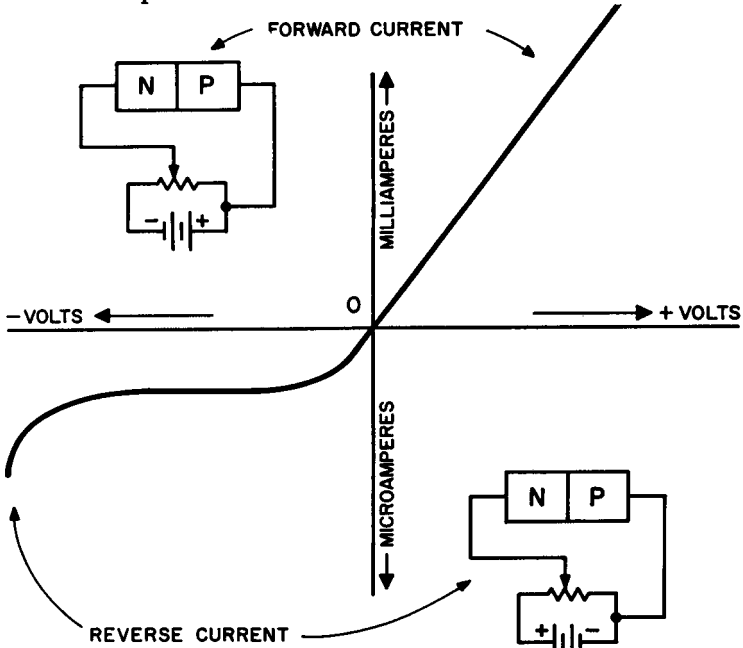

Fig. 214. Forward and reverse currents of a semiconductor diode.

Graphs

Now you might wonder why we have spent so much time on the diode, since our basic interest is the transistor. There are a number of good reasons for this. The transistor (as we shall learn in our next chapter) is developed directly from the diode. To understand how the transistor works you must first know what happens in the diode. Actually (again, as we shall learn later) the transistor can be considered as a pair of diodes, back to back, so you are really studying transistors, possibly without realizing it. Finally, transistors can be used as diodes.

In Fig. 214 we have the graph of the forward and reverse currents of a semiconductor diode. Let's examine the graph to see

what information we can extract from it. First, consider the situation in which the diode is forward biased. As the voltage is gradually increased the forward current increases. Now consider the case when the battery is transposed. As the voltage is increased, we get a very small rise in reverse current. Note, in the instance of reverse bias, that the reverse current remains fairly uniform for a large part of the curve.

It is also very important for you to see that the forward current is plotted in milliamperes and the reverse current in microamperes. Technically, both curves should have been plotted in the same units but even here you can see that relatively, the forward current is far more substantial than the reverse current.

While the graph of Fig. 214 is useful as a comparison between forward and reverse currents, it does not supply an adequate

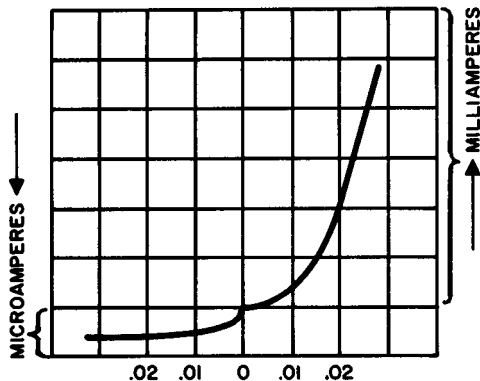

Fig. 215. *Forward and reverse currents of a semiconductor diode. As the forward bias is increased, the current increases gradually (at first) but a point is soon reached where the current takes a sharp rise. The reverse current is much smaller than the forward current, is measured in microamperes. In this diode the forward current is in milliamperes. The difference is much more marked than would seem offhand since it takes a thousand microamperes to make up one milliampere.*

picture in the region near zero voltage. It is close to this point that the potential barrier exists and, graphically, we are interested in seeing what happens to it. Fig. 215 is an enlargement of the graph close to the zero point. As we increase our forward voltage,

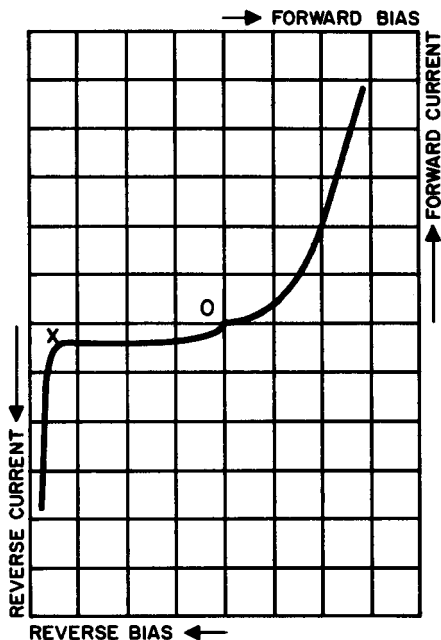

Fig. 216. If the reverse bias is increased, a value is reached at which the reverse current increases drastically. This is at point X in the graph.

from zero to .01, there is a bare increase in current. This tells us that we have not yet overcome the potential barrier. But look what happens to the curve as we reach .01 volt. The current rises dramatically. Since this occurs at approximately the .01-volt point, we can assume that this was the value of the potential barrier.

Now let's examine the reverse current in the same way — near the zero-volt point. Here there is a small, but steady, increase in reverse current, as we go from zero to .01 volt. But beyond this point the current levels off.

How high is high?

With the p-n diode, as with everything else, a limit exists somewhere. Fig. 216 illustrates this very nicely. As we increase the reverse bias, the reverse current remains quite uniform. But when we hit a certain voltage point we get an extremely abrupt increase in current. Increasing the voltage beyond this point has no effect,

since the maximum reverse current is now going through the diode.

To understand what has happened we must go back to our potential barrier. With the application of reverse bias, the potential barrier increases. But this barrier is a voltage, and so there is an electrostatic stress between the two ionized regions — one in the p-type germanium and the other in the n-type. This stress — or field — is a strong force. Electrons that would normally be quite content to remain in the outer orbit of their atoms, are pulled away. Of course, in moving out of position, they leave holes thus creating quite an opportunity for other electrons to get moving. Still more electrons are added to the general stampede through collision — electrons being knocked out of orbit, just as a pedestrian could get bowled over by a mad rush of people.

What we get now is a flood, an avalanche of electrons — and the graph in Fig. 216 shows this very well. The whole chain of events we have described is called avalanche multiplication. The critical point at which this multiplication of electrons in motion starts, producing a current that is independent of voltage, is called avalanche breakdown. Point X on the graph is the avalanche breakdown point.

The Zener diode

Earlier, in Fig. 212, we showed you a magnified view of the interface region in the n-p diode. Where the battery voltage is below the critical point we get a small current. Above the critical point, the current through the interface is large, the voltage across the interface is constant.

Now you might think (and quite correctly, as far as transistors are concerned) that we don't want this avalanche effect. For certain applications, though, this sudden transition from small to large current is very useful. Some diodes are manufactured especially to take advantage of this characteristic. They are known as Zener diodes.

Our interest in the Zener diode stems from the fact that we are going to use them in conjunction with transistors. Also, any transistor with sufficient reverse voltage will suffer the avalanche effect.

Resistance characteristic

We've been talking about voltage and current, but whenever we do, you can be sure that you will find resistance lurking somewhere about. Fig. 217 is the graph of the resistance characteristic

of a semiconductor diode. But while we refer to it as a resistance characteristic, it is really a measure of the effectiveness of the potential barrier. Examine the curve in the region of zero volts. Put your finger at the zero mark and then move up on the vertical line until you reach the curve. The value here is somewhere between kilohms and megohms. From here we can move down on the curve in the direction of forward bias. As the forward bias overcomes the potential barrier, we get a decreased opposition to current flow. This is just as though we had reduced the resistance at the junction.

Moving in the other direction, you can see that the resistance

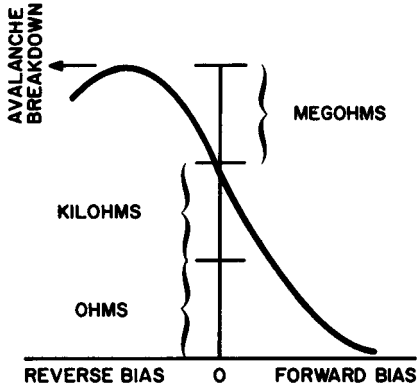

Fig. 217. Diode characteristics can be interpreted in terms of resistance. An increase in forward bias results in a decrease in resistance. An increase in reverse bias raises the resistance.

curve rises to a peak. This peak is really a plateau, for the resistance remains high, remains uniform. But as we move further to the left we are moving in the direction of higher reverse bias. At some voltage we will reach the breakdown point, and, of course, the resistance will take a precipitous drop.

A few implications

A graph is more than just a pretty picture and there is a lot more significance to the curve in Fig. 217 than its resemblance to a scenic railway. What we are really saying is that we can control *resistance* by means of voltage. Now this might not seem like a startling innovation until we remember that we ordinarily think of *current* as being controlled by voltage. Ohm's law emphasizes this for us in no uncertain terms. But in Fig. 217 we have

managed to adjust the resistance of our diode in two ways. The first depends on polarity — that is, whether we are forward- or reverse-biasing our diode. And the second is predicated on the amount of bias voltage used.

In the meantime, you may have noted that, while we discussed the effects of an excessive reverse voltage, no mention has been made of excessive forward voltage. This bit of information is being reserved for the discussion on transistors.

The transistor cometh

Since the very first page of this book there has been implied a promise to talk about transistors, and it would seem as though that promise has not been kept. And yet, as you will see in your next chapter, we are going to need every bit of information we have gathered so far to understand and use transistors.

QUESTIONS

1. What is reverse bias? Forward bias?
2. What is a negative ion? A positive ion?
3. Describe ionization at the p-n junction.
4. What is the potential barrier? How can we increase it?
How can we decrease it?
5. What is electron injection?
6. What is avalanche voltage? Avalanche current? What conditions produce avalanche current?
7. What is the name of the battery connected to the p-n diode?
8. In terms of quantity, what is the difference between forward and reverse current?
9. What is the relationship between the resistance of a p-n junction and the potential barrier?
10. What type of field is set up between blocks of p- and n-type germanium in close contact?

chapter 3

enter the triode

WE are now in the happy position of a contractor who arrives on the scene and finds all his building materials on hand. We can start the labors of this chapter with the two diodes shown in Fig. 301. Here we have a pair of p-n diodes (we could call them n-p

FIRST P-N DIODE

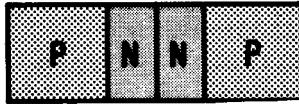

SECOND P-N DIODE

Fig. 301. Our first step toward the transistor is to use a pair of p-n diodes back to back.

diodes just as correctly) and we have placed them so that the two n-sections are in close contact.

Our two n-sections, though, are fairly identical, so there is no reason why we cannot have one single block of n-type germanium instead of separate pieces. Fig. 302 shows our new arrangement.

FIRST P-N DIODE

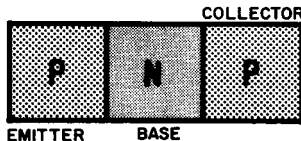

SECOND P-N DIODE

Fig. 302. We still have a pair of p-n diodes but we have now joined the two n-sections into a single unit.

Other than the unification of the n-section (and that was no radical move) we have made no changes whatsoever.

What do we have now? Just three blocks of germanium—some-what giving rise to the idea of a sandwich, but rather more difficult to manufacture. However, two of our blocks are still identical, so

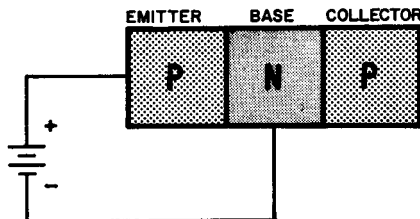

Fig. 303. With the positive terminal of the battery connected to p-type semiconductor and the negative terminal to n-type, we have forward-biased the diode.

to keep from compounding confusion, let's give them names. The one at the left is called the emitter, the one at the right the collector, and separating the two is the base. This is a transistor, and just as we informed you earlier, it can be regarded as a pair of diodes placed back to back.

Biasing the transistor

As long as diodes are separate entities they have a sort of independence. Consider the transistor in Fig. 302, though. How do we bias it? We can connect a battery between the base and the emitter. We can immediately recognize this (in Fig. 303) as forward biasing, since the plus terminal of the battery connects to the emitter (p-type germanium) and the minus terminal to the

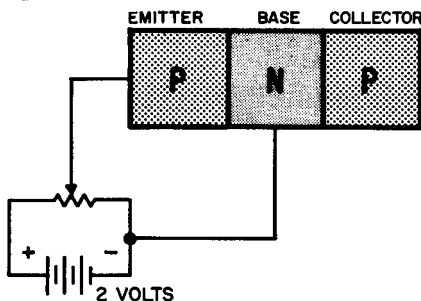

Fig. 304. In this case, the forward biasing can be varied from zero to a maximum of 2 volts.

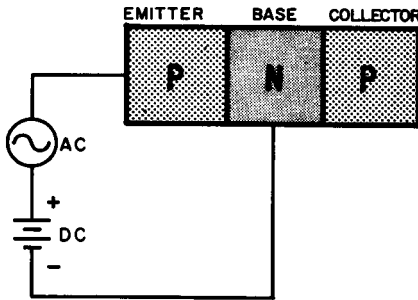

Fig. 305. Instead of using a potentiometer to change the amount of forward biasing, we can use a signal voltage, represented here by the symbol for an ac generator.

base (n-type germanium). Disregarding the collector for the moment, we have a single forward-biased diode.

Changing the bias

Our forward bias battery is connected between the base and the emitter. Changing the bias is no great problem, since we can follow exactly the same techniques described earlier in Chapter 2. The idea is repeated in Fig. 304. Adjusting the moving arm of the potentiometer gives us any value of bias we want, within

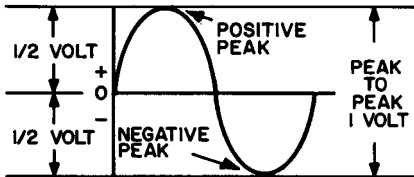

Fig. 306. Both the positive and negative halves of an ac input have an effect on the forward biasing.

the voltage limits of our battery. In the drawing of Fig. 304 we are assuming a battery voltage of 2.

We have another technique for varying the bias, although it may not be so readily apparent. The technique is illustrated in Fig. 305. Here we have an ac voltage source in series with the battery. What is this voltage? It could be supplied by a transformer, a signal generator, or it could be a broadcast signal. But regardless of how we obtain it, suppose we assume that the voltage has a peak-to-peak value of 1. This means that the maximum

positive peak is one-half volt. Similarly for the maximum negative peak, as shown in Fig. 306.

What effect will this have? It is just as though we kept varying the potentiometer arm in Fig. 304 at a frequency rate equal to that of the input signal. When the signal reaches its positive peak, the two voltages ac and dc, will add, and the total bias will be the two volts contributed by the battery and the half volt supplied by the ac source. The two voltages, ac and dc, at this time, are series aiding. As the ac voltage climbs down from its maximum positive peak and moves toward the zero line, we get a reduction from the maximum bias of 2.5 volts. When the ac voltage is zero it is as though it had been effectively removed from the circuit, and the only bias is that contributed by the battery—2 volts. But once the ac voltage crosses its zero line, it moves in a negative direction, and now, instead of aiding the battery, it opposes it.

At its maximum negative peak, we have one-half volt ac. This voltage, whose polarity at the moment is contrary to that of the bias battery, has the effect of subtracting from it. And so our bias now drops to 1.5 volts. The total value of forward bias swings from 1.5 to 2.5 volts. At all times, though, our p-n section is forward-biased, to a greater or lesser degree, depending, at any instant, on the algebraic sum of battery and ac voltages.

What effect will this changing bias have? The barrier potential of our p-n junction — the junction between the sections we now call the emitter and the base — will vary. The greater the bias, the lower the barrier potential, and the greater the amount of current flow.

Signal voltage and battery voltage

There is a very interesting point to note here. Compare the values of the signal and bias voltages. At no time is the signal voltage greater than the voltage supplied by the battery. This means that current flows at all times in what we can now regard as our base-emitter circuit. Our constantly forward-biased base-emitter circuit consists of n-type germanium (the base), p-type germanium (the emitter) and all components and voltages connected in series between these two.

Impedance

If we were to have a purely resistive circuit, such as a battery shunted by a resistor, the opposition to the current flow would be simple and well-defined. It would consist of the value of resistance

in the circuit (assuming that wire resistance, resistance of soldering joints, resistance of the battery, etc. would be negligible). But, add some coils or capacitors, and change that dc to ac, or put a generator (or other ac voltage source) in series with the battery, and the total opposition to current flow becomes a little more complicated. The frequency of the ac and the coils and capacitors in the circuit, all contribute to an opposition effect we call reactance. Combined vectorially with resistance we get the total opposition to the flow of current. We call it impedance. Like the reactance and resistance of which it is formed, impedance is measured in ohms.

When impedance is specified in actual ohms, there is no doubt as to what is meant (if the frequency is mentioned along with the impedance). But quite often terms such as low impedance and high impedance are used. These words are meaningless unless we have some reference.

This might seem strange until we compare dc and ac. For resistance we specify the value in ohms since we know it isn't going to change, whether we use dc or ac. But impedance, also in ohms, doesn't have such fixed habits. Its value fluctuates with frequency, while for dc, it has no meaning at all.

Impedance reference

Consider the vacuum-tube output circuit of an ordinary radio receiver. The plate is referred to as a high impedance point. But the control grid has an even higher impedance. And the voice coil circuit is called low impedance. In these three circuits—grid, plate and voice coil, what determines impedance? It is the amount of *relative* current flow. Thus, the control grid circuit has little or no current flow. But small current means high opposition or impedance. The plate circuit has much more current flowing in it (compared to the control grid) hence has a lower impedance. And the voice coil circuit, thanks to the assistance of the stepdown transformer, has more current flowing in it than either the plate or control grid, hence has the lowest impedance of the three. We always associate low impedance with current flow — high impedance with very small or no current flow.

Getting back to our forward-bias base-emitter circuit, we can temporarily call it a low-impedance circuit — temporarily, because we have established no other operating circuit as yet to which we can compare it. Also, in Fig. 305, we have not as yet inserted reactive components (such as coils or capacitors) in our base-emitter circuit, hence practically all of the opposition to the forward-biased current is resistive.

And still more bias

Up to now we have been working with just one part of our transistor — the emitter–base circuit. We can add another battery, as shown in Fig. 307. This battery is connected between the collector and the base. But just how did we get our collector and base? The base is n-type germanium and the collector is p-type.

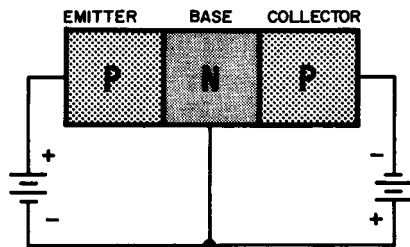

Fig. 307. Our forward-biasing technique remains the same, but note that we have added another battery and that this battery forms a reverse-biased connection between base and collector.

This, as we learned earlier, is one of the diodes we used to make our transistor. But note how this part of the transistor is biased. The negative terminal of the battery is connected to the collector (p-type germanium) while the positive terminal goes to the base

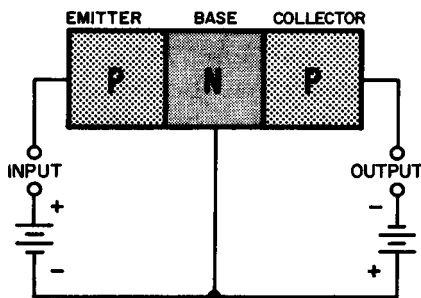

Fig. 308. We can break open the circuit of Fig. 307 for input and output, as shown here.

(n-type). What we have here is reverse biasing. And, just as in the case of the base–emitter circuit, we can vary the amount of reverse biasing by using a potentiometer, or by putting an ac voltage in series with the reverse-biasing battery.

Input and output

With the help of Fig. 308 we can take another forward step. The base-emitter circuit now has another name — input. And the base-collector circuit can also be identified in another way — output. Fig. 308 is interesting in that it emphasizes the fact that the base is common to both input and output circuits. But, unlike

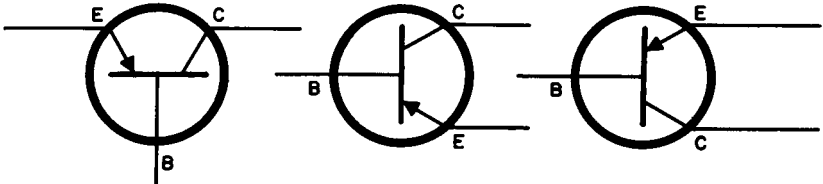

Fig. 309. Here is the symbol for the p-n-p transistor. The symbol can be put in any position and we can transpose the emitter and collector leads for our convenience in circuit diagrams.

the elements in a tube, separated by space, our three transistor elements, emitter, base and collector, are in very close contact.

The transistor symbol

Just as a child in early school grades gradually puts away his blocks and takes to the use of more convenient numbers and letters, so too can we dispense with our block-diagram arrangement of the p-n-p transistor and use its electronic symbol. This is shown in Fig. 309. The base is marked with the letter B, the

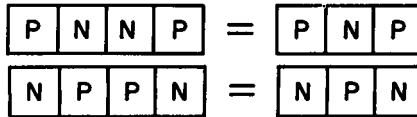

Fig. 310. Formation of the p-n-p and n-p-n transistors follows the same technique in both cases.

emitter with E, and the collector with C. The emitter and collector are always drawn at angles to the base. The emitter always has an arrowhead. For a p-n-p transistor, the first letter (p) always represents the emitter, the second letter (n) is the base and the third letter (p) is the collector.

The n-p-n transistor

In constructing our transistor we started with a pair of p-n diodes. We joined the two n-sections and so the terminal point of this activity was a p-n-p transistor. But Fig. 310 shows that we

selected just one of two possible ways of joining the diodes. We could have butted the two p-sections, and thus, as the illustration indicates, could have produced an n-p-n unit.

Biasing for the n-p-n transistor follows the same sort of arrangement we used for the p-n-p — that is, the input is forward-biased (as shown in Fig. 311) while the output is reverse-biased. Be careful, though. To make the n-p-n transistor, we transposed our pair

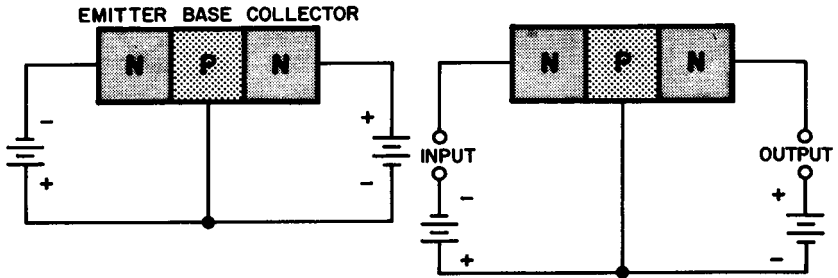

Fig. 311. The formation of the n-p-n circuit follows the same approach we used for the p-n-p in Fig. 308.

of diodes, so now we must also transpose our bias batteries. Other than that, there is no difference between the two types of transistors.

Electronic symbols

We have the electronic symbol for the n-p-n transistor in Fig. 312. We have also repeated the symbol for the p-n-p so that you

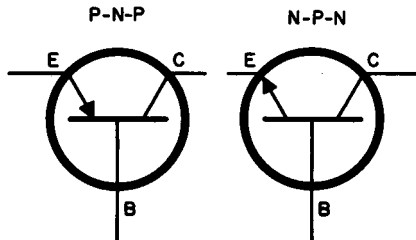

Fig. 312. Symbols for the p-n-p and n-p-n transistors. They are almost identical. The only difference is in the emitter element. For the p-n-p the arrow points inward to the transistor; for the n-p-n it points outward.

can compare the two. The only difference is in the arrowhead. In the p-n-p unit it points inward, while in the n-p-n it points outward.

No standard symbol has as yet been accepted for the transistor but, as you can see in Fig. 312, the differences are fairly slight. Various letters are often used to represent transistors, but here, as in the case of symbols, there is no uniformity. The letter T (for transistor) is often used. (This is somewhat confusing since T is also used for transformer). An attempt has been made to popularize the letter Q, presumably because the letter does not represent any other component. In this book we will use the letter V (for valve) since the action of the transistor (like the tube) is valve-like in its behavior.

Adding components

We now have our transistor, but, to add a few final touches to the picture, suppose we add a pair of resistors (as in Fig. 313). And so, with these few components, for both types of transistors

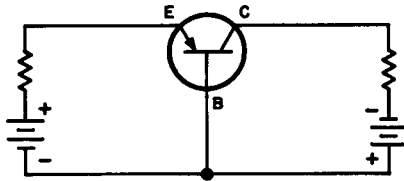

Fig. 313. With the addition of a few resistors, our elementary transistor circuit begins to take shape.

(n-p-n and p-n-p) we are ready to learn how the transistor works and, having learned that, find out how we can put the transistor in key spots in a variety of jobs.

How the transistor works

Up to now our block diagrams of the transistor created the impression that each of the blocks — emitter, base and collector — contained equal volumes of material. To have our two diodes work together as a transistor, let's modify our diodes and our thinking at the same time. We now want you to think of the base as an extremely thin section, compared to the emitter and the collector.

Continuing with our analysis of the transistor as an arrangement of diodes, look at Fig. 314. What we have here is a p-n-p transistor but we are using diode symbols. If we disconnect the lead going to the base, you can see quite readily that the two diodes and their biasing batteries form a series circuit. And since we have a series circuit, the current will be the same in all parts

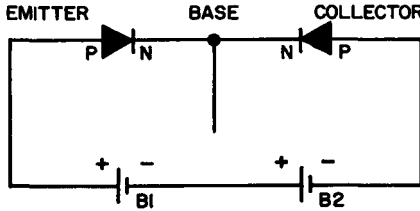

Fig. 314. The diodes and their biasing batteries form a series circuit.

of the circuit. Also, take a good look at the batteries. They are connected in series aiding.

Just so that we won't be accused of showing a preference for the p-n-p type, we also have an n-p-n unit in Fig. 315. It is exactly the same as Fig. 314, except, of course, the diodes have been turned around, and so have the batteries. But the two diodes are still in series and the batteries still form a series-aiding pair.

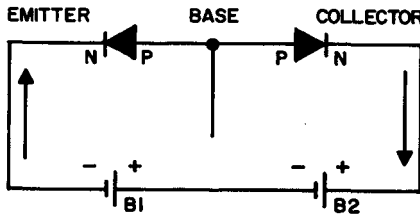

Fig. 315. This circuit is similar to that of Fig. 314 except that both batteries and diodes have been transposed.

What about current flow in the circuit of Fig. 315? Assuming current flow to mean electron flow, we can start at the negative terminal of B1. The current will move through the block of germanium marked n (the emitter), through the two combined (but very thin) p-regions (the base), into the n-region (the collector),

and then from that region through B2 and B1 back to the starting point again.

Although we started this explanation by assuming that current first moved out of the negative terminal of B1, remember that this was just a matter of convenience. The current in a series circuit is a bit like a merry-go-round. Which part starts first?

Unfair! Unfair!

The circuits of Figs. 314 and 315 aren't really playing the game and we're violating some of our own rules. We've talked at great length about the diodes being forward- and reverse-biased, but the disconnected base lead in Fig. 315 isn't cricket. So, as shown in Fig. 316, let's connect the base lead to the junction of the two batteries.

Now you must admit that everything is quite proper. We have our two diodes — one forward-biased, the other reverse-biased. What effect will this have on the current?

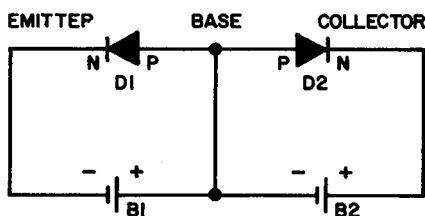

Fig. 316. With the connection of the base lead we provide a current path between the base and battery B1.

Offhand, you might argue that the two diodes could be represented by two resistors. Diode D1 in Fig. 316 is forward-biased, the current should be comparatively large, hence we could say it is equivalent to a small resistance. Diode D2 is reverse-biased, the current should be much smaller than through diode D1, hence its resistance is much higher. But D1 and D2 are in series. If we have a small resistor (say of 1 ohm) in series with one having a large value (say, 1,000 ohms) we can practically forget about the 1-ohm resistor as far as the total series resistance is concerned. But D1 and D2 are not resistors. They're a pair of diode elements constructed in a very special way.

Since we cannot consider D1 as a low-value resistor only and D2 as a high value resistor only, let's see just how they do differ. Let's analyze them from the viewpoint of an electron current. In

Fig. 316, D1 is forward-biased. To trace the path of electron current flow, suppose we start at the negative terminal of B1, since that is just as convenient a starting point as any. The electrons move along to the first diode, D1. Because this diode is forward-biased, its potential barrier is pleasantly low, and so the electrons move easily enough into the base.

Our electrons are now faced with the necessity for making a decision. They can either travel down the wire to the positive terminal of B1 or they can make an effort to flow through D2 to the positive terminal of B2. Now everything we have told you up to now would make you think that there really is no choice. Going back to the plate of B1 we have a nice solid wire — an easy path for electrons. And, to clinch the argument in favor of such a path, D2 is reverse-biased and we know that it has a high potential barrier that opposes the passage of electrons. Yet, despite

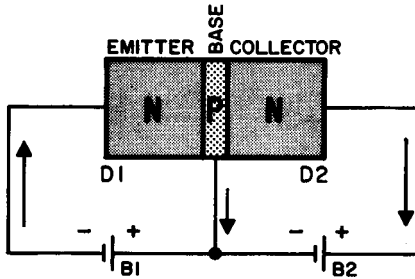

Fig. 317. Paths of current (electron) flow in the n-p-n transistor circuit.

both of these factors, most of the electrons move through the second diode (D2) and from there through B2 and then back to battery B1. Since this is so contrary to the way the circuit would behave if we had a low-value resistor in place of D1 and a large resistor in place of D2, let's investigate a bit further.

We can do this by moving on to Fig. 317. We still have our two diodes, but now the base region is extremely thin. Furthermore, the base is common to both diodes. It is shared by D1 and D2. As before, when the electrons get into the base region, they have a choice of going down the solid conductor to the positive terminal of B1 or, seemingly, struggling through the collector n-region.

To understand what is happening, let's go back to Fig. 315 for a moment. B1 and B2 are in series. The total voltage of these two batteries (because of the series connection) now exists between the n-type collector and the n-type emitter. And, as we saw way

back in Chapter 1, an electron likes nothing better than to move along the lines of force of an electric field. This is the same reason why electrons will move through a vacuum from a hot cathode (and sometimes a cold one) to a positive plate. As soon as the electrons find themselves in the base region, they feel the pull of the positive terminal of B1. But the voltage of B2 adds to the voltage of B1 to provide a strong electric field. So the potential barrier is overcome.

However, the base is still a dividing point for the electron current. Most of the current, though, proceeds through diode D2, with a much smaller amount flowing back to battery B1.

Our discussion of Fig. 317 centered around the n-p-n transistor. What happens in the case of the p-n-p type? Exactly the same thing, except that the electron current flows in the opposite di-

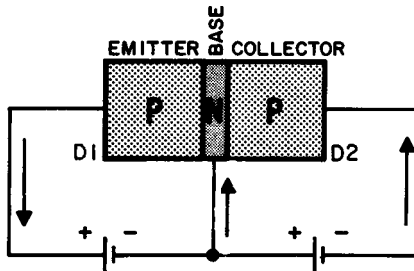

Fig. 318. Paths of current (electron) flow in the p-n-p transistor circuit.

rection. Fig. 318 illustrates this. The arrows, representing the paths of electron flow, are opposite in Figs. 317 and 318.

Naming names

Not too long after the triode vacuum tube became popular, engineers found many reasons for giving the three elements added company. Grids were inserted, resulting in tetrodes, pentodes, and pentagrids. Probably the most widely-used receiving tube today is the pentode.

Like the tube, the transistor came into being as a three-element device. The transistor, though, is following its own evolution and since it is an entity in its own right, we have no reason for thinking that the transistor will follow the path trod earlier by the tube. At this time, the most widely used transistor is a triode, although other types are available. The triode (tri, the prefix, means three) is a three-element device.

We have a name for each element in our transistor — emitter,

base and collector. The word emitter would seem to indicate that electrons are boiled out, much as in the case of a hot cathode. This isn't true, of course, since no heat is used. All we can say of the emitter (in the case of Fig. 317) is that it is electron-rich. The collector (a good name) is so called (in Fig. 317) because it collects electrons. In a tube, the equivalent would be the plate. We can consider the base in the manner of a control grid.

It would seem, in Fig. 318, that these names are now meaningless (except for the base) since the roles of collector and emitter are reversed. But this is only so because we have been considering

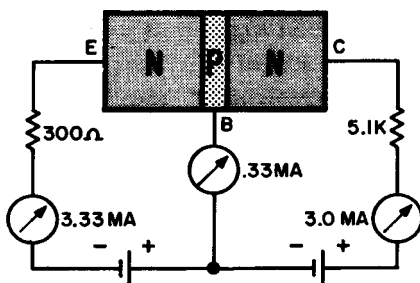

Fig. 319. Most of the current passes from the emitter to the collector. The remainder flows from the base to the forward-biasing battery.

current flow as electron flow. If, in Fig. 318, we think of the movement of holes, or positive charges, then the emitter is rich in positive charges and the collector is on the receiving end.

Amplification

In the circuit of Fig. 317 we managed to transfer most of the current flowing in a low-resistance circuit (the emitter-base circuit) to a much higher one. Thinking of this from a resistance viewpoint, we transferred (changed) a low-resistance circuit to a high-resistance one. But from *transfer* and *resistor* we manage to get transistor. Think of the transistor as being somewhat in the nature of a special type of step-up transformer. In this special transformer a variation of resistance in the primary will produce a variation of resistance in the secondary. It is this characteristic that enables us to use the transistor as an amplifier and an oscillator. Let's see how we can go about getting amplification. We can do this by examining the circuit in Fig. 319.

In Fig. 319 we have an n-p-n transistor, a pair of bias batteries, a 300-ohm resistor in the emitter-base circuit (our input circuit)

and a 5,100-ohm resistor in the collector-base circuit (our output circuit). Let us assume that we have a current of 3.33 ma beginning to flow. This current, in passing through the 300-ohm resistor, will produce a drop of almost 1 full volt across it. Most of the current (3 ma in this case) will pass through the base, over to the collector. A small amount of current (.33 ma) will go through the base to the input bias battery.

We now have 3 ma of collector current flowing through our 5,100-ohm collector resistor. This will result in a drop of 15.3 volts across it.

So far we have nothing that could be called spectacular. The two resistors, plus the transistor, are acting as a dc voltage divider across the two series batteries. But suppose, as in Fig. 320, we put an ac signal source in series with the emitter-base input. This ac source is going to supply an emf that is 1 volt peak-to-peak. At its maximum negative peak point, the ac voltage will add one-half volt to the input battery voltage. At its maximum positive peak, it will subtract one-half volt. Consider what happens when one-half volt is added. Our forward-biased section becomes even

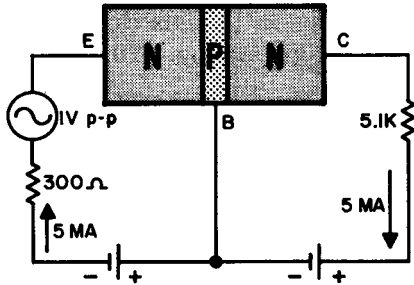

Fig. 320. A signal voltage (represented by the symbol for an ac generator) varies the amount of forward biasing, thus varying the current flowing to the collector.

more so. Since we have added a voltage in series aiding with our other batteries, more current will flow. In Fig. 320 the current will rise to 5 ma.

To make our arithmetic a bit easier, imagine that all of this current will go over to the collector. With 5 ma flowing through the 5,100-ohm resistor, the drop across it will now become 25.5 volts. But since we had 15.3 volts to begin with, we have an increase of 10.2 volts in our output circuit. What about the input?

That went up by only one-half volt. Thus, we have a voltage gain in the ratio of 10.2 to 0.5, or 20.4 to 1.

When the signal voltage changes, it will be in opposition to the battery voltage. This will decrease the forward bias (or increase the input resistance), lowering the current. If we get a proportionate decrease in current, the ratio of output voltage to input voltage will still be 20.4 to 1.

We could have obtained exactly the same results by using a p-n-p transistor instead of the n-p-n we used in Fig. 319. The batteries would be transposed. And while the voltage drops across the input and output resistors would still show us a ratio of 20.4 to 1, the polarities of these voltage drops would be exactly opposite to those of the n-p-n circuit.

We know you are going to agree that the n-p-n circuit of Fig. 320 can immediately be classified as a rather simple type. It certainly has few enough components! However, Fig. 320 is a sort of hybrid diagram, since we are using circuit elements for the components and a block-diagram style for the transistor. All we need do now is take just one small step forward, use the symbol we learned earlier for the transistor, and end up with a complete schematic as shown in Fig. 321. This diagram, of course, represents the same action we got in Fig. 320.

Current amplification — alpha

If, for some reason, we did not have the services of the forward-biased portion of the transistor (it could be shorted), collector current would be a function of the emitter-collector bias battery. Because of the reverse-biasing action, collector current would be very low indeed. However, if we allow our forward-biasing section to work properly, collector current rises considerably. In this sense, then, the transistor is a current-operated device.

Not all the electrons that enter the emitter make the full transit through the transistor. Percentage-wise, somewhere between 95 and 99 percent do manage to make the complete trip, but a few percent do get sidetracked through the base, back to the forward-biasing battery. If we manage to increase the emitter current (as we did before) the collector current will also increase (but not to the same extent). This ratio between a change in collector current and a change in emitter current is known as the current amplification factor. The Greek letter alpha (α) is used to indicate this characteristic of the transistor.

It may seem very strange that we talk about current amplifica-

tion, especially since collector current is invariably lower than emitter current, but remember how this extraordinary situation came about. If it were not for the forward-biased emitter–base circuit, the current in the collector–base circuit would be a very small fraction of the current. Since alpha is less than unity, we generally discuss it in terms of percentage. Typical values of alpha are 95 to 99%.

Current amplification – beta

When we change the amount of emitter current, not only does the collector current change, but the base current as well. The ratio of the change in collector current to the change in base current can also be used as a measure of the amplification of the transistor. It is represented by the Greek letter beta (β). Since collector current is so much larger than base current, beta is in

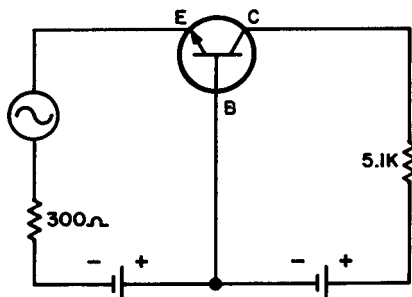

Fig. 321. Elementary transistor amplifier circuit.

terms of whole numbers. Thus the beta of a transistor might be 20, or 30 or 40, etc. A transistor with a beta of 40 means that 40 times more current flows in the collector than in the base circuit.

Quite naturally, the more current we have in our collector circuit the more current will flow through the resistor connected to the collector and the greater will be the voltage drop across it. Since our output is taken from across this resistor, we naturally want as much current through it as we can get. This means, in terms of alpha, that we would like to have alpha as high a percentage as possible — that is, as close to 100 percent as we can get. In terms of beta, we would want the number to be as large as possible. A transistor with a beta of 100 has more amplification than a transistor with a beta of only 20.

Alpha and beta

Obviously, we cannot change alpha without affecting beta. The relationship between the two can be put into a very simple formula so that we can calculate the value of alpha (if we know beta) or the value of beta (if we know alpha). This is the formula:

$$\beta = \alpha / (1 - \alpha)$$

We can make our work much easier if we use letters:

$$\beta = \alpha / (1 - \alpha)$$

Example 1: A transistor has an alpha of 95%. What is the value of beta?

$$\beta = \alpha / (1 - \alpha)$$

since 95% is the same as .95

$$\beta = .95 / (1 - .95)$$

$$\beta = .95 / .05 = 19$$

Example 2: A transistor has a beta of 45. What is the value of alpha?

$$\beta = \alpha / (1 - \alpha)$$

$$45 = \alpha / (1 - \alpha)$$

If we multiply both sides of this equation by $1 - \alpha$ we will get:

$$45(1 - \alpha) = \alpha$$

$$45 - 45\alpha = \alpha$$

We can now transpose the -45α to the right-hand side:

$$45 = 45\alpha + \alpha \text{ or } 45 = 46\alpha$$

Dividing both sides of the equation by 46, we get:

$$45/46 = \alpha \text{ or } \alpha = .978 \text{ or } 97.8\%$$

Voltage amplification

Ultimately, in dealing with an amplifier such as the transistor, we must come back to the idea of voltage amplification. We start with a signal voltage and this signal voltage changes the current flowing through the transistor. But this flow of current must be translated into a form we can use. In passing through the output resistor, the resistor connected in series between the collector and its bias battery, we get a voltage. To the extent that this varying voltage is greater than the signal voltage, we get amplification. The waveform of the voltage across the output resistor should be the same as that across the input resistor since the change in current is being produced by the input voltage. The technique is just the same as that used by a vacuum tube amplifier where the signal voltage, inserted between grid and cathode, modifies the tube's bias. It might seem strange to talk about voltage amplification since the collector current is less than the emitter current,

even though by just a small amount. It is the great difference between the output or load resistance and the input resistance that helps produce voltage gain. The difference between emitter and collector current might be small, but there is a deliberately large difference between input and output resistances.

The transistor as an oscillator

Basically, an oscillator is a dc to ac converter. We take the voltage and current supplied by the battery (or batteries) and change

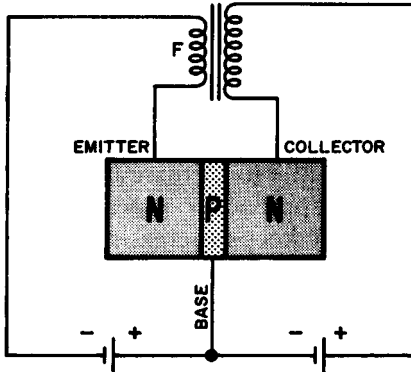

Fig. 322. Elementary transistor oscillator circuit.

this dc voltage and current (with the help of the oscillator) into ac form. The most commonly used technique is to take some of the energy of the output circuit and feed it back, in phase, to the input. But before you decide that what we have here is a perpetual motion machine, remember that the energy is supplied by the battery, and that the ac power we get out of the oscillator is never quite as much as the dc power we put in. In oscillators, as in so many other things, you get nothing for nothing.

Fig. 322 shows a simple oscillator arrangement. Oscillator circuits will be covered in greater detail in Chapter 6. What we have in Fig. 322 is a stripped-down version for purposes of explanation.

The only change of interest is the addition of the transformer which couples the output (collector) circuit back to the input (emitter). If you will trace the path of current flow, you will see that each transformer winding is in series with the transistor and the bias batteries.

The feedback winding, F, has very few turns. The resistance of the winding is very low and so its ohmic resistance has very little effect on the current. The winding soldered to the collector

lead has many more turns. And while the current flowing through that winding is dc, yet the moment the circuit is closed, there is a rapidly growing magnetic field around the winding. A voltage is induced across winding F. But this voltage is in series with the emitter-base biasing voltage. If the induced voltage is phased so that it adds to the forward bias, the flow of current to the emitter will be increased. This increased current (most of it) will also flow through the collector and the collector winding. The growing magnetic field around the collector winding induces more voltage across winding F, which, in turn causes more current to flow.

But all good things must come to an end. The induced voltage across F depends on the rate of change of the magnetic flux. The combination of induced voltage plus battery bias is no guarantee that the current will continue to increase indefinitely. The current gradually slopes off and approaches a steady state value. All this means is that the current keeps increasing, but more and more slowly.

However, the change in the magnetic field around the collector winding depends on how rapidly the current through it changes. If the rate of current increase diminishes, so will the variation of the magnetic field around the collector winding. But this means less voltage will be induced across winding F. Less voltage, across F, though, means a smaller amount of current going to the emitter.

We now have a condition of a decreasing current through the collector winding. As a consequence, the polarity of the induced voltage changes, and now, the induced voltage, instead of aiding the forward bias battery, opposes it. With this sort of situation, the current rapidly drops to almost zero. This means that the magnetic field around the transformer is also so small as to be ineffectual. The forward bias battery now takes over again, because the opposition voltage across winding F has disappeared. This is where we came in, since the entire cycle of events repeats itself.

We have taken some liberties with this description of oscillator action since certain important components were omitted and since we have had no discussion as yet of transistor current curves. The description is of use since the behavior of a transistor as an oscillator is similar to that of its vacuum tube counterpart.

Transistor manufacture

You will note that at no point in these first three chapters have we supplied any information on how transistors are manufactured. This is a highly specialized technique and there would be no point

to our engaging in such discussion. However, there are numerous transistor types — so many that they deserve a chapter all to themselves. But even in the chapter on transistors (other than the triode) it would be impossible to describe all the new ones. Not only is there a large and growing variety, but developments now include semiconductors that behave somewhat like transistors, but which cannot be named as such. Fortunately, the basic theory presented earlier will help you reach a more ready understanding of the way in which they work.

So we come to the end of another chapter. We know you may be impatient to come to grips with practical circuits, but our introduction to the transistor has barely been completed. Before we concern ourselves with circuitry, we need to know more about the transistor, its special characteristics, its likes and dislikes, and its needs and its efficiency.

QUESTIONS

1. What is beta?
2. What is alpha?
3. A transistor has a beta of 65. What is the value of alpha?
4. A transistor has an alpha of 98%. What is the value of beta?
5. How do the values of emitter, base and collector currents compare?
6. How is the emitter–base circuit biased? The collector–base circuit?
7. How does the volume of the base compare with that of the emitter or collector?
8. What is the technique used for varying the forward bias of a transistor?
9. How was the word transistor obtained?
10. What is the difference between high impedance and low impedance?
11. What is the difference between impedance and resistance?
12. What is reactance? What is the difference between reactance and resistance?
13. In a p-n-p transistor, which element is represented by the letter p? Which by the letter n? And which by the final letter p?
14. What is the difference in electron current flow in a p-n-p transistor compared to an n-p-n type?
15. How does the input impedance of a transistor compare to the output impedance?

transistor characteristics

OUR introduction to the transistor in the last chapter was a bit formal, but now that the strangeness has worn off, we see that the transistor is just the application of some well-tested ideas but using a new technique. We have input and output circuits, just as with tubes. Our input is the base-emitter circuit, with the emitter (for the n-p-n transistor) analogous to a cathode, and the base to a control grid. And, just as in the case of a tube, the input signal varies the bias. The output is the collector-emitter circuit, with the collector (again, for the n-p-n type) reminiscent of the plate in a tube. (See Fig. 401-A,B.)

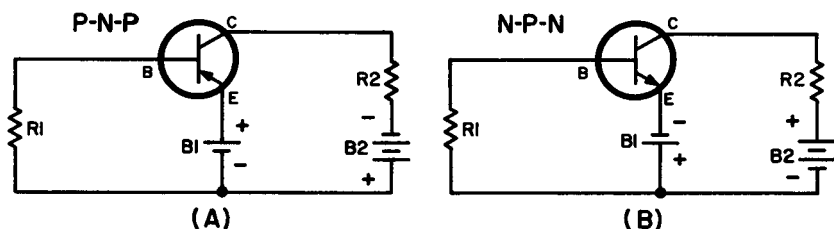

Fig. 401. The voltage between emitter and collector is the sum of the battery voltages of both p-n-p and n-p-n circuits shown here. Although the circuits have been drawn somewhat differently than those in Chapter 3, if you will examine the circuits you will see that all biasing requirements have been met.

Because you may be much more familiar with tubes than you are with transistors, the temptation to make comparisons between them will always be with you. In a way this will be unavoidable since many of our old, familiar tube circuits have been picked up, lock, stock and resistor, and simply put to use with transistors . . .

with some component changes. However, we just cannot pull a tube out of a circuit with the idea of substituting a transistor — and then sit back and hope for the best. If we do, the best will never arrive. A transistor has characteristics of its own.

Biasing methods

Transistors are much simpler than tubes in their voltage requirements. All that the triode transistor needs is a forward bias for its base-emitter circuit and reverse bias for its collector-emitter circuit.

Fig. 401 shows one possible arrangement for bias for a p-n-p and an n-p-n transistor. The voltage between collector and emitter is the sum of the voltages of B1 and B2 just as it was in the circuits you saw in the last chapter. In the new arrangement of Fig. 401, though, both the input and output circuits share the voltage of B1. We can re-arrange the batteries as shown in Fig. 402 so that each circuit — input and output — has its own bias supply.

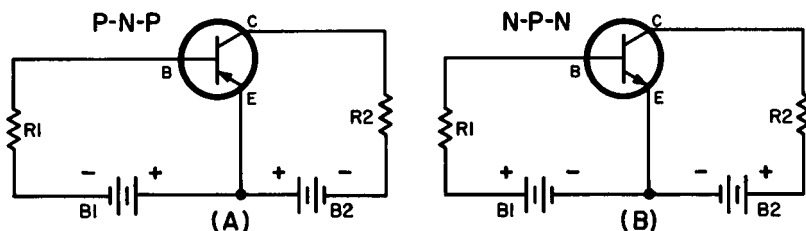

Fig. 402. In these circuit arrangements, the bias voltages are independent of each other, but now battery B1 does not add to the voltage between emitter and collector.

However, in Fig. 402, the voltage between collector and emitter is now reduced by the amount of B1. We can overcome this by increasing the value of B2. The disadvantage of the circuit of Fig. 401 is that we cannot change the forward bias without, at the same time, changing the reverse bias. The arrangement in Fig. 402 eliminates this difficulty, but we do lose the advantage of the added voltage supplied by the series connection of Fig. 401.

Single battery operation

We can eliminate one of the batteries altogether, as shown in Fig. 403. Note that in this n-p-n circuit, the collector is still positive with respect to the emitter, while the base is also positive. Thus, we meet the conditions for biasing this transistor. Now it

might seem odd that we can do this, since the input and output circuits require different amounts of biasing voltage. But you will note that R_1 is in series with the battery in the base-emitter circuit while R_2 is in series with the same battery in the collector-emitter circuit. By selecting the right values for R_1 and R_2 , we can still have the voltages we want. This might seem to give us the flexibility of the circuit of Fig. 402 – and so it does – but remember that we pay for it by having voltage drops across R_1 and R_2 .

Fixed bias

Although the circuits of Fig. 401, 402 and 403 are different, they do have one item in common. The *forward bias* has a *fixed* value, the amount of bias being determined by the voltage of the forward biasing battery (B_1) and the value of R_1 . In these circuits, to change the forward bias we would generally use a differ-

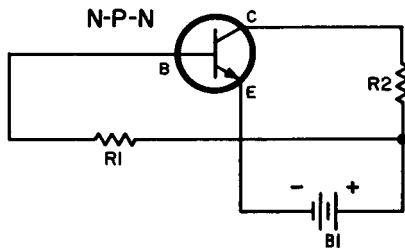

Fig. 403. A single battery, B_1 , supplies both forward and reverse bias. The correct amounts of bias can be obtained by selecting the proper values for R_1 and R_2 .

ent battery. For a particular value of base bias, the bias current remains constant. Fixed bias has the serious disadvantage that it is best for one particular operating point or set of conditions only. There are two factors that make life difficult for fixed bias. Transistors are temperature-sensitive. This means that the operating characteristics of a transistor will change with temperature. Also, there is quite a bit of variation, even between transistors of the same type number, so that if you replace a transistor (in a circuit having fixed bias) you cannot be sure that the bias is correct. To make it correct, you would need to experiment with B_1 , or R_1 , or both.

Self bias

We can make the bias self-adjusting (which is why we call it self bias) as shown in Fig. 404. The circuit is exactly the same as that shown in Fig. 403, with but one change. In both cases, one end of R1 is connected to the base. The other end of R1, though, (in Fig. 404) is wired to the top end of R2. Now let's see how this changes the circuit from fixed to self bias. First, using Fig. 403 as our guide, let's trace the path of the base-emitter circuit. Starting at the emitter, we go through the transistor to the base, from there through R1, then through battery B1, and so back to the emitter. But if we try to follow the same path in Fig. 404, we now find that we must include the collector load resistor R2, in our path. What difference can this possibly make?

In Fig. 404 we have an arrow immediately next to R2. This arrow shows the direction of current flow and the polarity of the voltage drop, across R2, due to collector current. This voltage is in opposition to the battery voltage. But the voltage between the

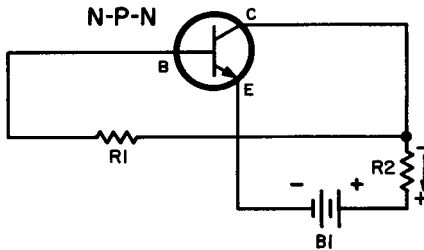

Fig. 404. In this circuit, forward biasing depends on the amount of collector current flowing through R2.

base and the emitter (our forward bias) depends almost entirely on the arithmetic sum of these two voltages — the battery voltage and the drop across R2. If collector current is large, so is the voltage across R2. A large voltage across R2, though, means less forward bias. If forward bias decreases, less current passes through the transistor and so collector current decreases. This reduces the drop across R2. Less voltage across R2 means more forward bias.

Sometimes the act of drawing a circuit hides the information it is supposed to convey. Generally, most circuits are prepared so that there is an orderly progression of signal, from left to right. This means that we start with a weak signal at the input, moving through circuit after circuit, toward a strong signal at the output.

In a way this makes sense since we then try to “read” the circuit just as though we were trying to read a line. Its disadvantage is that the circuit becomes less clear electronically.

To understand what this is all about, take another look at Fig. 404. To understand what is happening in the way of forward biasing, you would need to trace the entire circuit between the input elements — the base and the emitter in this case. While this might be fairly easy to do in the case of Fig. 404, remember that what we are dealing with here is a very simple circuit. It might not be so simple when associated with a half-dozen or more transistors and assorted parts.

To see just what is happening in the way of bias, examine Fig. 405. Here we have redrawn Fig. 404 in a somewhat unorthodox manner so that you can see what is happening quite clearly. Let’s

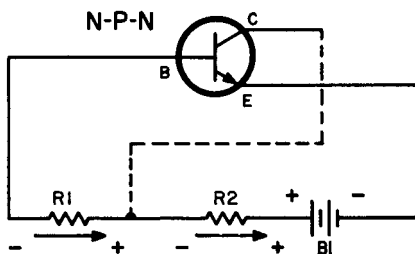

Fig. 405. This is not the way in which we usually draw a transistor circuit, but it does show forward biasing very clearly.

trace the paths of current flow, beginning at the negative terminal of B1. From here we move into the transistor, through the emitter and base, through R1 and R2, and back to the battery once again.

The arrows across R1 and R2 show the direction of electron flow and because we know this direction, we know the polarity of the voltage drops across R1 and R2. These voltage drops are in opposition to the battery voltage. And what is the voltage between emitter and base — in other words, what is the amount of forward bias? It is equal to the voltage supplied by battery B1 *minus* the voltage drops across the two resistors — R1 and R2.

Now let’s consider R1 and R2. Because we have drawn them with equal physical dimensions, we might succumb to the temptation to regard them as having equal voltage drops. There are several reasons why this is most definitely not so. First, consider

the relative resistances of R1 and R2. R1 has a very small value, much smaller than that of R2. But there is another important consideration. Examine the dashed line we have drawn from the collector to the junction of the two resistors. This represents another path of current flow — a path that does *not* include R1. Furthermore, just to make the evidence more compelling, this current is many times greater than the current flowing through R1. All in all, the voltage drop across R2 is much greater than that across R1 and for this reason is the determining factor in the forward biasing of the transistor.

One other fact emerges from a study of Fig. 405. We can transpose R2 and B1 without affecting the circuit. When we do this the amount of current flow through R1 and R2 is not changed. If you will examine Fig. 406 you will see that the status of the components and their behavior has not been altered. But if you will now move along to Fig. 407, you might very well imagine that we have a completely new circuit. Actually, it is not new in the slightest. It is identical with that of Fig. 404. The difference (as

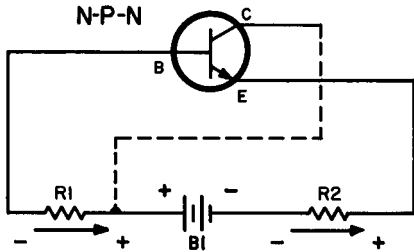

Fig. 406. Although B1 and R2 have been transposed (see Fig. 405), circuit operation remains exactly the same.

in the case of Figs. 405 and 406) is in the transposition of B1 and R2, a change that does not affect operation of the circuit.

We've had a rather steady diet of resistors in the output, so suppose we insert a coil, L1, as shown in Fig. 408. But because we want variety, we have given ourselves a problem. We had depended on the resistance of the load to give us a voltage drop. Our coil, though, isn't so obliging. We can solve this difficulty quite easily by inserting a resistor, R2, in the emitter circuit.

This resistor performs exactly in the same way (as far as forward bias is concerned) as load resistor R2 in Fig. 404. The arrow alongside R2 gives us the direction of electron current flow and

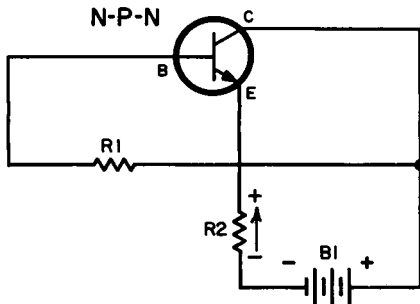

Fig. 407. This circuit is identical with that of Fig. 404. Transposition of B1 and R2 has not changed circuit operation.

also the polarity of the voltage drop across R2. Again, this voltage is in opposition to the battery voltage. If you will take a walk, starting at the emitter, through the transistor to the base, you will

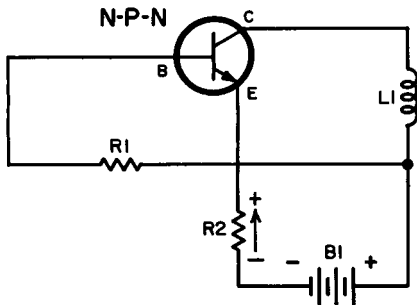

Fig. 408. In this circuit, coil L1 is used instead of a load resistor. This coil could be the primary of a transformer.

see that we can continue through R1, the battery, and then R2. The position of the resistor hasn't changed the fact that we still have self bias.

Collector voltage vs collector current

To learn the condition of a patient, a doctor pokes, probes, listens with his stethoscope, and finally gets a picture of the patient's general state of health. We follow a similar routine with

transistors, except that our equipment consists of a microammeter (to measure base current) and a milliammeter (to measure collector current) as shown in Fig. 409. While this setup is for an n-p-n transistor, the same arrangement (with transposed batteries) would do for a p-n-p.

Collector characteristic curve

With the test circuit of Fig. 409 we can obtain a relationship between collector voltage and collector current. This is a static test. All that this means is that we are going to apply dc voltages only. You might think that this isn't quite fair, since our transistor is ultimately going to work with a signal input, yet the collector characteristic is important. We've been talking about putting bias voltages on our transistor, and have examined several circuits. The collector characteristic is going to help us come to a decision

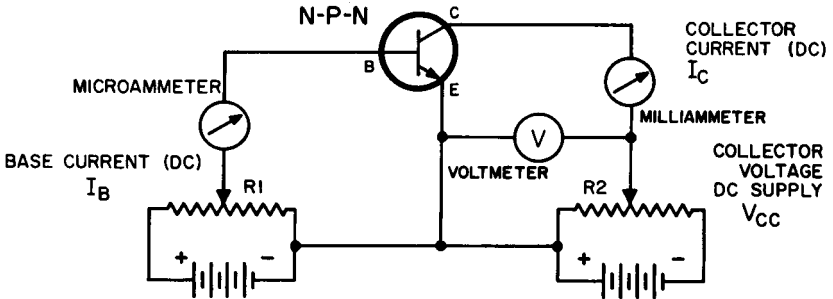

Fig. 409. Setup for determining the relationship between collector voltage and collector current.

on just what values of bias we should use and what sort of a resistor we should have as our collector load.

Fig. 410 shows the results of one test using the circuit of Fig. 409. R_2 was set for different values of collector voltage. R_1 was adjusted to keep the base current at a constant 40 microamperes.

Now examine the curve between the points at which we have 2 volts on the collector, and 6 volts. At 2 volts, the collector current is slightly less than 5 ma. At 6 volts it is slightly above 5 ma. This is quite a range of collector voltage change, and yet the collector current has remained substantially constant, with a constant amount of base current.

If we were testing a tube, we would be measuring plate voltage vs plate current, for a particular value of grid bias and in this way

we would obtain a plate characteristic curve. In Fig. 409 we measured collector voltage vs collector current for a fixed amount of bias current, and obtained a collector characteristic curve. Thus, base current in the transistor performs the same function as grid bias voltage in a tube.

Tube vs transistor biasing

There is, of course, a mental hazard in equating vacuum-tube grid bias and the technique we use for forward-biasing a transistor. In the vacuum tube, an increase in bias means that we are making the control grid more negative with respect to the cathode. As far as bias is concerned, we are moving in a negative direction and the result is a decrease in plate current. In the case of the transistor, the base is biased either negative or positive with respect to the emitter, depending on whether we are using a p-n-p or n-p-n type. Furthermore, an increase in bias, regardless of the transistor type, means an increase in collector current, an action quite opposite to the plate current decrease resulting from raising the bias in a vacuum tube.

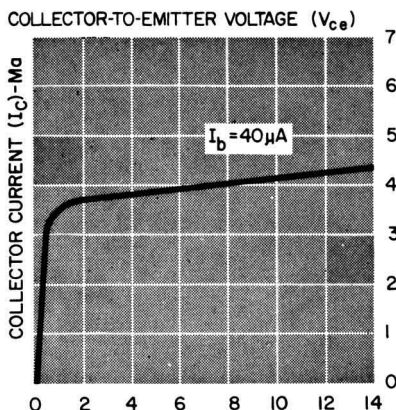

Fig. 410. Collector characteristic curve. Note how little the collector current changes with collector voltage for a given value of base current.

Collector characteristic family

A single collector characteristic, such as that shown in Fig. 410, supplies limited information. To learn more about the transistor,

we can have a whole family of collector characteristics, as in Fig. 411. The procedure for obtaining these curves is exactly the same as that outlined earlier. In this we get a whole family of curves, all the way from zero base current, in steps of 10 microamperes, up to 60 microamperes. Note how similar the collector characteristic curves are to the plate characteristics for a 6AK6 pentode, shown in Fig 412. The curves are similar, yet the transistor we have been testing is a triode. The straight line portion of the curve, (whether tube or transistor) is the useful part. In the transistor, we get to the straight line portion quite rapidly. In Fig. 411, all we need is about one quarter to one half volt. For the tube, we need about 75 volts on the plate before we get the same results.

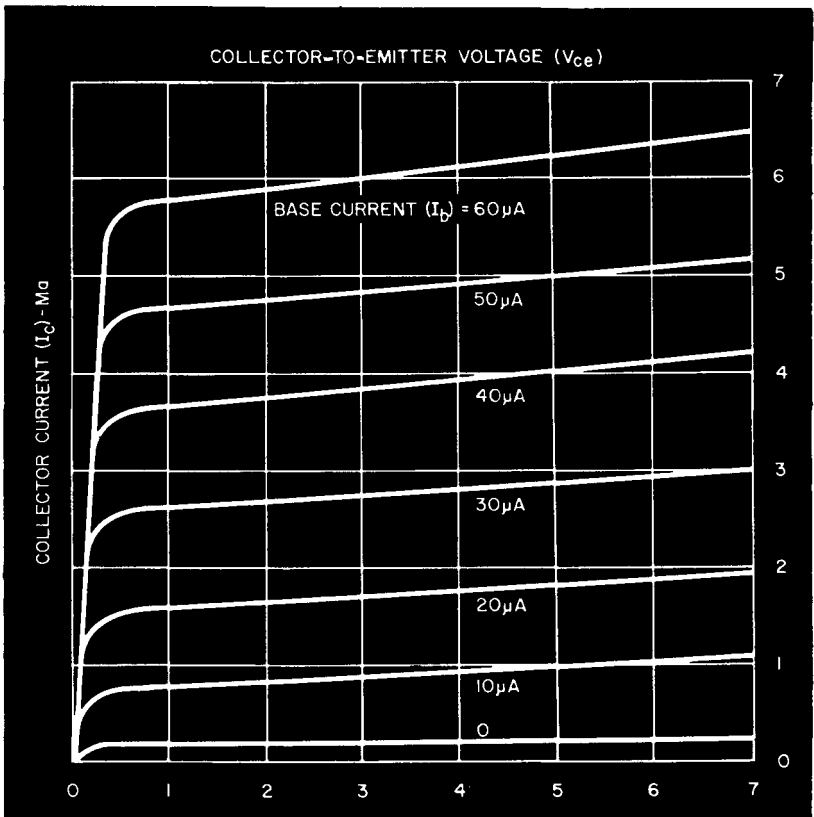

Fig. 411. Family of characteristic curves for a transistor.

This gives us another clue to transistor vs tube behavior. Transistors not only work with smaller voltages than tubes, but respond to much smaller *variations* in voltage. If you're accustomed to tube potentials, revise your thinking downward for transistors.

The collector load

In a transistor circuit (as in a tube circuit) the components must work together as a team. It takes just one wrong part or value to make the circuit act sluggishly, or not at all. This doesn't

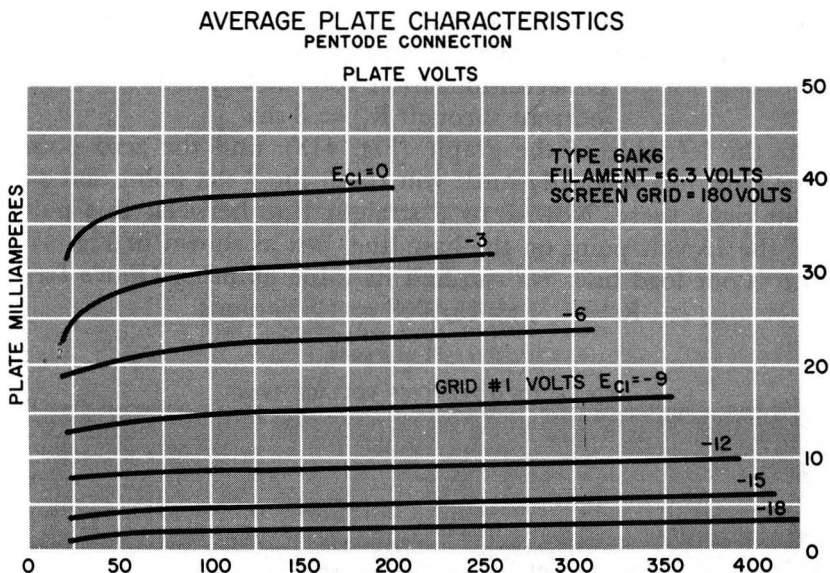

Fig. 412. Pentode characteristic curves. These are similar to characteristic curves for a transistor. The transistor, though, is a triode while the curves shown here are for a pentode tube.

mean that there is only one right combination of parts and values — there are many. The whole idea is to select the one right group out of the many available.

At first thought this might seem like an impossible suggestion, since the number of variables involved would give us a very large number of component combinations. That is why characteristic curves of transistors — and of tubes — are so important. They give us some idea about the behavior of these components and enable us to make a selection of associated parts in a more intelligent manner.

To see how this concept works, start with Fig. 413 which gives the collector characteristics for a transistor. Since the collector-to-emitter voltage ranges from zero to 20, let's start with a battery of 15 volts, using the circuit shown in Fig. 414. Why 15 volts? It is just a starting point, and possibly not the best one either.

Using the circuit of Fig. 414, suppose we connect a wire between the collector and emitter. Since this is a short across these two elements of the transistor, the collector to emitter voltage becomes zero. The full voltage of the battery is now across the load resistor, R_L . The amount of current will now depend only on the battery voltage and the value of R_L . Suppose this current is 8 milliamperes. We now have a condition of:

$$\begin{aligned} \text{collector-to-emitter volts} &= 0 \\ \text{current through } R_L &= 8 \text{ ma} \end{aligned}$$

At the left side of the graph (Fig. 413) find the zero point. Now move up vertically until you reach the 8 ma point and put a dot right there. Now draw a straight line between this point and the 15 volt point on the base line, just as shown in Fig. 413. This is our load line. We can find its value by using Ohm's Law:

$$R = E/I = 15/.008 = 1,875 \text{ ohms}$$

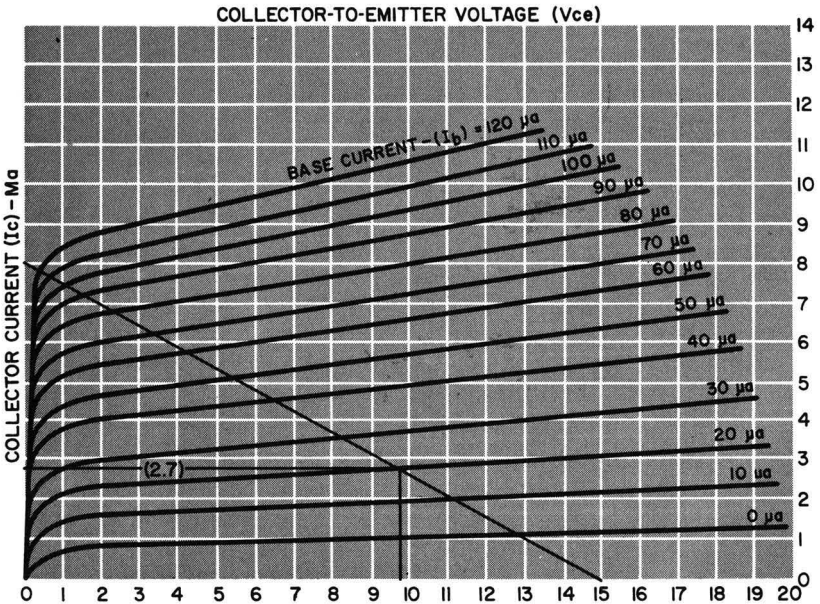

Fig. 413. Family of collector characteristics.

We cannot dismiss the graph in Fig. 413 now because it contains information we need. Let's move along, first, to the 15-volt point on the base line. What is this 15 volts? We know it is our full battery voltage, but there is more to it than just that. The description on our base line tells us that we are working with collector-to-emitter voltage — that is, the voltage existing between

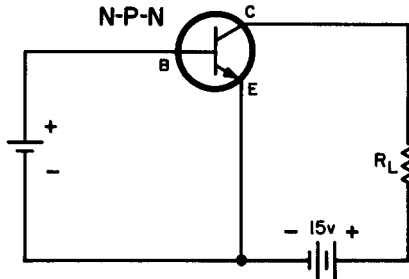

Fig. 414. Simple circuit used for measuring collector characteristics. The value of forward bias can be changed to obtain the base current values shown in Fig. 413.

the collector and the emitter. But for a full 15 volts to exist between collector and emitter, we cannot afford any voltage drop across R_L . We can eliminate the drop across R_L in two ways. We can assume the transistor is at cutoff — that is, no collector current flowing, or else we can put a shorting wire right across R_L . Whichever method we use, the voltage between collector and emitter would be the full battery voltage.

However, we did put the load resistor in the circuit for a purpose — to develop an output signal across it, so now let us remove the short from across R_L or else take the transistor out of cutoff. If collector current flows at this time, it will also pass through R_L , producing a voltage drop across it. This means we will now have less voltage between collector and emitter. Thus, if we have a 5-volt drop across R_L we will have:

$$15 - 5 = 10 \text{ volts between collector and emitter}$$

At this time, how much current is flowing in the output circuit? Move your finger along the base line until you reach the 10-volt point. Now move straight up until you reach the load line. Then move across horizontally, toward the left, until you reach the vertical current line. The intercept is at 2.7 milliamperes.

What do we learn from this? As the voltage between collector and emitter becomes smaller, current in the output circuit gets larger. Carrying this to its logical conclusion, our graph shows us that when the voltage between collector and emitter becomes zero, we have a maximum current of 8 ma flowing through the load.

We need only two points to determine the load line. We used two extreme conditions: — 1) a condition of maximum current (8 ma) and zero collector-to-emitter voltage and 2) a condition of maximum voltage (15 volts) and zero current in the output circuit.

A little earlier we found the value of the load line by using

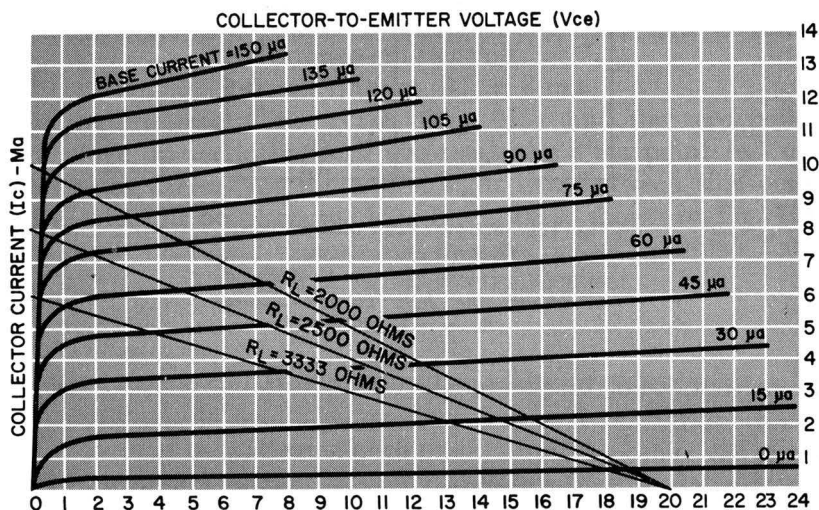

Fig. 415. When the load line intersects base-current curves that are equally spaced, distortion produced by the transistor will be at a minimum.

maximum values, but this value is confirmed even when current is flowing through both transistor and its load. In Fig. 413 we see that for a 5-volt drop across the load, we have 10 volts remaining between collector and emitter. For this value of voltage, we get a current of 2.7 ma. The load value then is:

$$R_L = \frac{5 \text{ volts}}{.0027 \text{ ampere}} = 1,852 \text{ ohms}$$

Obviously, the value of the load is equal to the voltage across it divided by the current through it. The graph in Fig. 413 gives us this information. The voltage across the load is equal to the battery voltage minus the drop between collector and emitter.

Other values of load

The slope of our load line depends on the battery voltage and the current that flows in the circuit with the collector-emitter shorted. The slope becomes steeper for different values of load as shown in Fig. 415.

We can use load lines to see which one will give us the least amount of distortion. Suppose we assume that we are going to start with a base current of 45 microamperes. We will then decrease our forward bias, dropping the base current to 30 microamperes, and then increase it to 60 microamperes; that is, we will decrease and increase our base current by 15 microamperes. When we do, and tabulate our results, this is what we will get:

When $R_L = 3,333$ ohms

base current	collector current	difference
30 μ a	3.6 ma	1.2 ma
45 μ a	4.8 ma	
60 μ a	5.8 ma	1.0 ma

When $R_L = 2,500$ ohms

30 μ a	3.9 ma	1.1 ma
45 μ a	5.0 ma	
60 μ a	6.2 ma	1.2 ma

When $R_L = 2,000$ ohms.

base current	collector current	difference
30 μ a	3.9 ma	1.2 ma
45 μ a	5.1 ma	
60 μ a	6.4 ma	1.3 ma

Since we get almost equal swings of collector current for equal changes of base current, distortion in the output will be small. Note that our operating point (sometimes called the quiescent or Q point) is at the intersection of the load line and the base current curve.

How do we know that we won't get distortion? Look at the base current curves. They are fairly equally spaced. This means that an increase or decrease of base current will produce fairly equal changes in collector current. If the base current lines were not equally spaced, we would not get equal changes in collector current for equal changes in base current. You can see an example of this sad situation in Fig. 416. Our operating point is at the intersection of the load line with the curve for a base current of 200 microamperes. Our input signal has a peak-to-peak value of 200 microamperes — that is, it has a positive component of 100 microamperes and a negative component of the same amount. Our base current, then, is going to swing 100 microamperes either

way. Note the uneven spacing of the base current curves. The distance from our starting point to the 300 microampere curve is much smaller than the distance from the starting point to the 100 microampere curve. This means that our collector current variation is not going to be symmetrical. Our input signal current, though, is symmetrical. What the graph is trying to tell us is that our transistor is going to distort the signal.

How serious is the situation in Fig. 416? The collector current waveform doesn't look too different than the signal current waveform. The answer here is that the amplitudes of the two waveforms mean little until we consider that the signal current is in

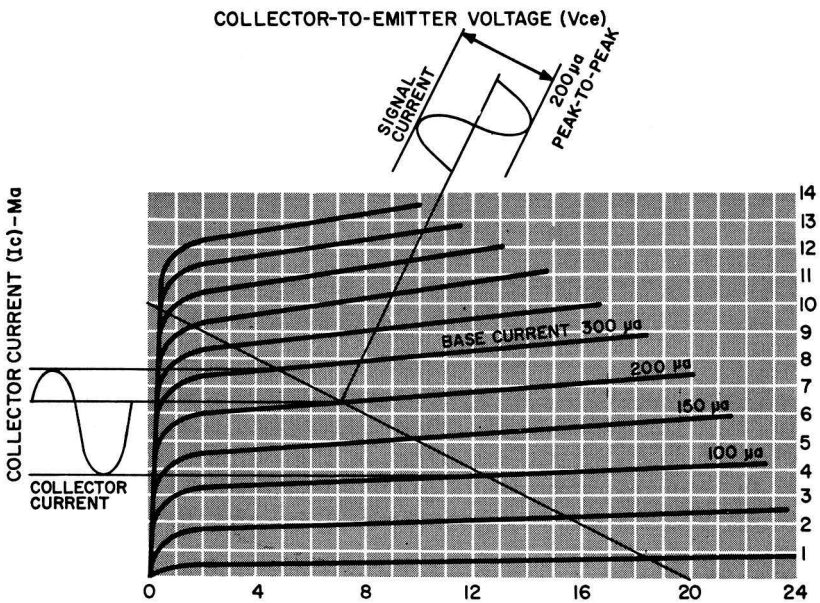

Fig. 416. Distortion will result because of the unequal spacing of the base-current curves above and below the quiescent point.

microamperes and the output or collector current is in milliamperes. A milliampere is a thousand microamperes. Viewed in this light, if we consider the signal current as "same size", then the collector current waveform is a thousand times larger. Does this mean that the gain of our transistor is a thousand? Hardly! The variation in output voltage is still the product of the collector current multiplied by the value of the resistance through which it flows.

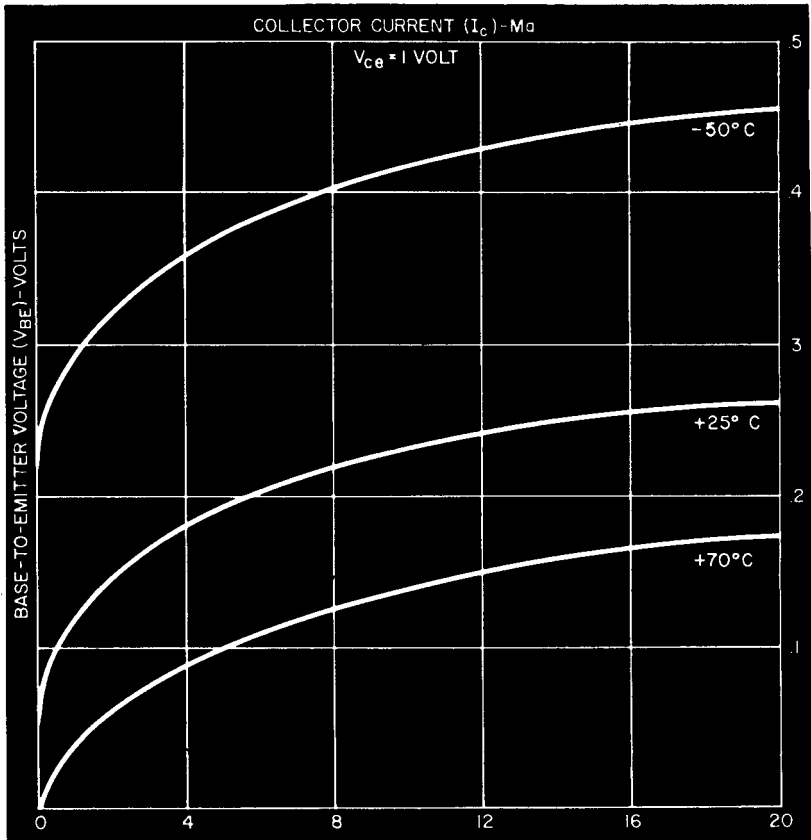

Fig. 417. Transfer characteristic curves. These graphs show the effect of temperature on collector current.

Mutual or transfer characteristics

The graph in Fig. 416 is a bit of scientific fortune-telling. With its help, we can begin to predict just how the transistor will behave and what we can expect from it. But you can't expect a transistor to reveal all in just one picture, so, just to be able to say that we are more than just nodding acquaintances, let's work with a new graph of transistor characteristics — the one shown in Fig. 417.

In Fig. 417 we have plotted (sounds sinister, but it isn't) base-to-emitter voltage vs collector current. But what is base-to-emitter voltage? Just our old friend, forward bias. And, as the curves show, as our forward bias goes up, so does our collector current.

There are a few exciting facts we can gather here. Take a look

at the lowest curve — the one marked 70°C. When the forward bias is zero, so is the collector current. But as we increase the forward bias — not by volts, mind you — but by tiny fractions of a volt — whoosh, away goes the collector current.

There's still another item that's just as important. As the temperature changes, so does the collector current. Actually, we should have had just one curve. Having the temperature affect the collector current isn't at all desirable. In Fig. 417 we have only three curves because the temperature changed only three times. But what if the temperature kept going up and down. Which curve would be the right one? You can be sure we're going to do something about that, in just a few moments.

In the meantime, why should we consider a graph of the type in Fig. 417 so important? This graph gives us an insight into the amplifying properties of the transistor. We can see (we don't have to imagine) the effect of forward bias on the output or collector current. Curves of this sort are known as transfer or mutual characteristic curves.

Stabilization

Most tubes (there are some exceptions) operate at respectably high temperatures. Try removing a power tube (after it has been on for a few minutes) with your bare fingers, and you'll have a dramatic example of what we mean. Even low-voltage miniatures have a temperature much higher than that of the surrounding air. This means that tubes aren't affected by room temperature — they have their own, warm operating region.

But transistors don't have heated filaments or cathodes. They don't have plates that must dissipate heat. It doesn't take much of a rise in temperature to set the electrons in a bit of n-type germanium to thinking about traveling over to those very attractive positive charges just on the other side of the potential barrier. But in a transistor (or in a tube) it is we who must control the current, and not temperature, or any other nonsense of that sort.

You might think that we're making a big fuss over a small matter, but in Fig. 417 we went to the trouble to draw graphs of transistor behavior for you. Temperature changes mean that these curves vary all over the place. And if these curves change, then so will the current gain change, and naturally, right along with it, the output impedance will vary. This is definitely not a good situation.

We can "immunize" the transistor, protect it against the seduc-

tive effects of temperature by stabilizing it. One technique we can use, known as current feedback, is shown in Fig. 418. The circuit is similar to one we talked about earlier — Fig. 407, on page 85. However, let's consider R2 from a new point of view.

R2 is in a rather unique position. Trace the output circuit and you will see that it is part of it. But you can do the same with the input circuit. R2, then, is common to both, and holding on to this tidbit of information in our hot little hands, we can learn of two ways in which R2 overcomes the effects of temperature.

Let us say that the temperature does change and in such a way that the collector current increases. What other change could have produced the same result? We could have increased the collector

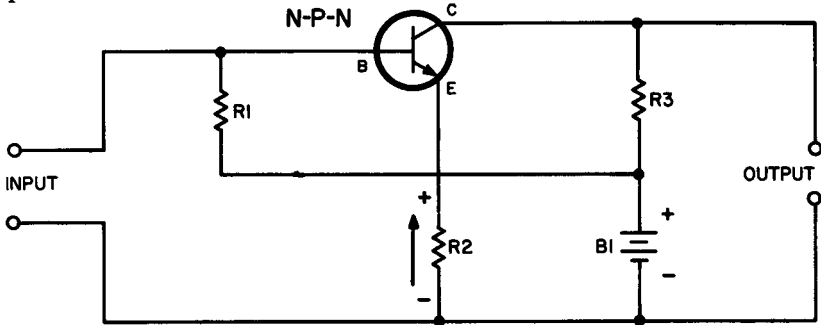

Fig. 418. R2, common to both input and output circuits, is a stabilizing resistor.

voltage or we could have increased the forward bias, or we could have done a little bit of both. But, as far as we know in this case, none of these things happened.

With an increase in temperature, our collector current starts to rise. The collector current not only flows through R3, but through R2 as well. Note the direction of current flow through R2. This produces a voltage drop across R2 whose polarity is such that the top end of R2 (the end connected to the emitter) is plus and the bottom end (the end connected to the base through the signal input) is minus. Since our transistor is an n-p-n type, our forward bias works by putting a negative voltage on the emitter and a positive voltage on the base. The voltage across R2, though, acts as a reverse bias for the base-emitter circuit. Or, we could say that the forward bias is being opposed by the voltage across R2. Since, in effect, the forward bias is being reduced, the collector current decreases.

This isn't the only action that takes place. Collector current

depends on the voltage existing between collector and emitter. This voltage is supplied by the battery. The actual voltage between collector and emitter, though, isn't the full amount of battery voltage for we must subtract the amount of voltage dropped across load resistor R3. In addition, in the case of the circuit of Fig. 418, we must also subtract the voltage drop across R2.

Thus, R2 acts in two ways to counteract the increase in collector current caused by a rise in temperature. It reduces forward bias and it also reduces the collector-emitter voltage.

Current feedback

Components in some circuits often perform a dual function, but the name given to the component is often a concession to the more important function. Thus, a coupling capacitor is so called because it couples one stage to the next, but, at the same time, it is a blocking capacitor, preventing the dc voltage of a previous stage from moving over into the following one.

In Fig. 418, R2 is a stabilizing resistor, but it does more than just that. Let us imagine that we now have an incoming signal. If the signal (at a particular moment) increases the forward bias, collector current will increase. But this increase in collector current will produce more voltage across R2, which, of course, has a certain amount of opposition to the increase in forward bias. Since the voltage across R2 will vary at the same rate as the input signal, but will oppose it, we can see that we have an out-of-phase condition, or, a form of negative feedback. And, since negative feedback reduces the gain of the stage, that is exactly the sort of result we can expect from R2. This type of negative feedback is called current feedback.

Negative feedback is a sensible way in which to stabilize a transistor against increases in current due to temperature rises. It's just like having too much water pouring out of a faucet. We don't telephone back to the reservoir and tell them to cut down on the pressure. All we do is turn the valve a bit.

Since negative feedback is the solution to our temperature problem, we can use any form of out-of-phase feedback (negative feedback) we want. Fig. 419 is an example of what we mean. Here we have an n-p-n transistor. As we make the base more positive (a positive-going signal can do that for us), collector current increases. This produces a voltage drop across R3. The arrow shows us that the top end of R3 is negative-going (it is becoming more negative with respect to its other end). All we need do now, is

connect the negative-going end, through R4, to our positive-going base. This is a form of negative feedback, since the voltage R4 steals from R3 is out of phase with the input signal. We call this voltage feedback.

If you've examined the circuit of Fig. 419 carefully, you've probably observed that we still have R2 in the circuit. Shunted across R2 is an electrolytic capacitor. We could remove this capacitor, and then we would have both voltage feedback (supplied by R4) and current feedback (supplied by R2). Feedback of this sort not only keeps temperature changes at arm's length, but also improves the performance of the circuit. We're not going to discuss it further at this point, since we would be encroaching on the material in chapter 5.

Input resistance

Whenever we have voltage *and* current, we always have resistance. We may not even have a physical resistor in the circuit, but the fact that we can divide the voltage across a pair of points

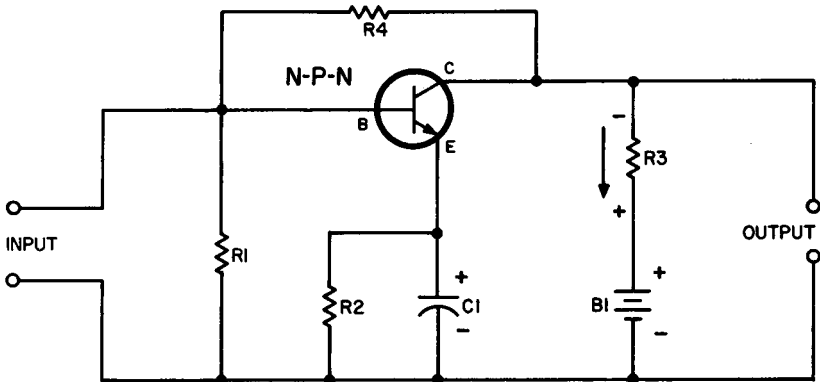

Fig. 419. We can immunize the transistor against the effects of temperature by using voltage and current feedback.

by the current flowing between those points, means that we must have resistance. And the movement of current is one of those facts of life we must always associate with the transistor. Whether or not we have a signal, we always have current flowing in both input and output circuits.

Resistance can be measured directly or indirectly. We can put the leads of an ohmmeter right across a resistor, and there you are — the value of resistance can be read directly from a scale on the meter. But if we have current flowing (whether or not we

have an actual resistor in the circuit) we must put our ohmmeter away and measure resistance indirectly.

Fig. 420 shows how easy this is to do. Here we have a dc microammeter connected between base and emitter. This will measure our base current. And, shunted across the base and the emitter we have a high-impedance vacuum-tube voltmeter to measure our voltage. Divide the voltage reading by the current reading and we have the input resistance.

In Fig. 420 the collector floats — that is, we have no provision for reverse bias. The collector-emitter is open circuited. Remember — a transistor is different from a tube in that there is no isolation between the elements. The emitter, base and collector

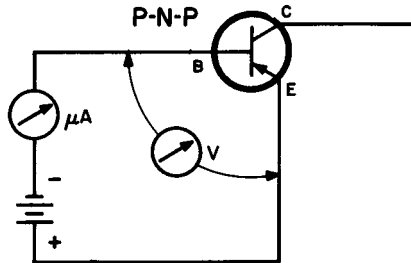

Fig. 420. Setup for measuring input resistance.

are in close contact. Thus, in measuring the input resistance we want nothing in the collector circuit to affect our test.

What value of voltage shall we use in Fig. 420? We use the amount of forward bias voltage determined by the location of our operating point on the load line. This value is used since this is the value at which the transistor will operate.

Output resistance

In measuring output resistance, our input will now be open circuited, but the transistor will have its operating reverse bias applied, as shown in Fig. 421. And, while we are on the subject of input and output resistance, keep in mind that we can run the same tests on n-p-n units just as easily (Figs. 420 and 421 show p-n-p's). All we do is transpose everything — the leads to our test meters and the leads to our battery.

Small and large power

In a vacuum tube circuit, events move along very smoothly until we reach the speaker. Most speakers are current-operated devices. This means that the tube — or transistor — preceding the speaker must be a power type. All tubes preceding the output tube can be voltage amplifiers. Voltage amplification is their primary concern. But the output tube (because of the demands of the speaker) is interested in power — the product of volts and current.

Transistors are not excused from these requirements just because they are transistors. Unlike tubes, transistors are current operated devices — that is, current flows in both the input and

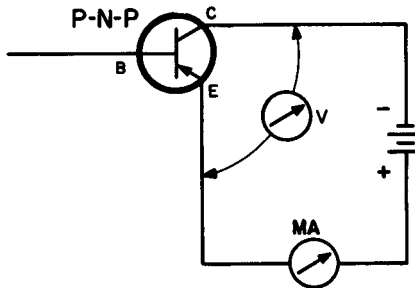

Fig. 421. Setup for measuring output resistance.

output circuits of a transistor at all times. But how much current? For transistors preceding the output transistor, currents are measured in microamperes and milliamperes. The output transistor, though, like its tube counterpart, must be a power type. In its output circuit we will have current in the order of milliamperes or amperes.

Our transistor menu

One of the nicest parts about dining out is that you can get a menu and plan your own dinner. For your transistor menu we are going to serve transistor audio amplifiers in your next chapter. Following that, we are going to move back, stage by stage (in the succeeding chapters) until we have covered an entire receiver. And then, for your electronic dessert we will serve you with information on different transistor types and miscellaneous applications. We hope your appetite for knowledge will keep up with what we are going to put before you.

QUESTIONS

1. What is meant by fixed bias?
2. What is self-bias? How does it differ from fixed bias?
3. Describe the circuit arrangement for determining the relationship between collector voltage and collector current.
4. What is a static test?
5. Explain the method for determining the load line for a transistor.
6. How can load lines be used to determine possible distortion?
7. What is the quiescent point?
8. What is a mutual characteristic?
9. What is stabilization? Why is it needed? What is a stabilizing resistor?
10. What is current feedback? What are its effects on a circuit?
11. In general, what is the relationship of input and output resistance in an amplifier circuit?
12. Transistors are current-operated devices. What does this statement mean?

chapter 5

audio amplifiers

A TRANSISTOR is to a signal what a lens is to light — a magnifier. But what is this bit of magic whereby a few minerals are able to take a varying current and amplify it?

Let's start our investigation with Fig. 501. We're going to put a signal voltage right across R1. This varying voltage will modify the forward bias supplied by B1. The result of all this will be a varying current through the transistor and also through R2. Where, then, does amplification come in?

To understand this, there are a few items we must first con-

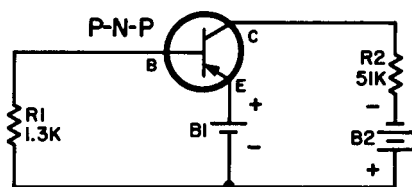

Fig. 501. This is an elementary amplifier circuit. An input voltage appearing across R1 will vary the forward bias. This will change the current through the transistor, developing a changing voltage across R2.

sider. Our input circuit consists of the emitter and base of the transistor, battery B1 and resistor R1. The current that flows in this circuit is small — usually a matter of microamperes. How does this compare with the current in the output circuit? Here the current is much larger and is measured in milliamperes in this particular case. The output circuit consists of the emitter and collector, R2 and both batteries — B1 and B2.

This, then, is the first part of the answer to our question — why amplification? We have a much larger current in the output than in the input. But what more do we know about the currents? Both are varying at a rate determined by the input signal, for it is the input (ac) signal that modulates or changes the forward bias (dc).

Now examine the two resistors, R1 and R2 in Fig. 501. The resistor (R1) in the input circuit is much smaller than the resistor (R2) in the output circuit. We get signal voltages developed across both of these resistors. What about the magnitude of these two voltages, both changing at the same rate? At the input, we have a small current going through a small value resistor compared with a large current going through a large resistor, at the output. And, since voltage is the product of current and resistance, we can see that the output voltage is going to be much larger than the input. In a representative transistor, the voltage across R2 will be several hundred times that across R1.

This reasoning on why a transistor amplifies may seem a bit too smug and too pat, so let's examine the problem somewhat further. To do so, suppose we ask a question: "Just what is the collector current?" Theoretically, if we had no base current, the current flowing to the collector in an n-p-n transistor would be the emitter current. But we do lose some current, however small, to the base, and so the collector current is less than the emitter current by that amount. Offhand it might seem that, since the collector current is smaller than the emitter current, we could not possibly obtain amplification. The answer here lies in a comparison between the input and output resistances. We are not dealing with currents alone, but with voltages as well, since our currents are going to be made to flow through resistive or inductive components. Thus our varying voltage drop in the output is going to be much larger than that same varying voltage in the input simply because our output or load is much larger in value than the input resistance.

The fact that collector current is smaller than emitter current might seem contrary to what we have learned in tube theory, but if you will think about it for a moment or two, you will see it is identical. Consider a pentode. Is the plate current equal to the cathode current? If there is no secondary emission to worry about and if the screen draws current, the plate current will be less than the cathode current but the tube doesn't know this and goes right on amplifying.

Does a transistor amplify? Not really. Not any more than a tube does. All that a transistor (or tube) can do is to control or vary the current supplied by a battery or power supply. A transistor or tube is just a link, permitting a small voltage (usually the signal) to control or manipulate or modulate the current furnished by a voltage source.

What is it that we have really accomplished? All we have done is to take a battery and a resistor and have managed to secure control of its current. You can invent an amplifying device of your own, if you wish. Fig. 502 shows the basic problem. We have a resistor R_1 connected across an ac source. This ac source could represent the signal supplied by a receiving antenna. A varying current will flow through R_1 . Nearby, we have R_2 connected

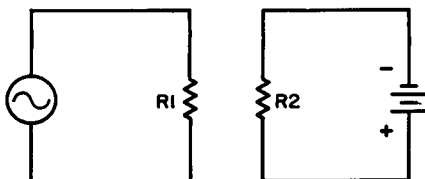

Fig. 502. Want to invent an amplifying device such as a tube or transistor? Solve the basic problem shown here and you are on your way to fame and fortune. All you need do is to make the varying current through R_1 control the current through R_2 .

across a battery. Flowing through R_2 is a direct current. Because R_2 is much larger than R_1 and because the current supplied by the battery is also much greater than that supplied by the signal, the voltage across R_2 is several hundred times that across R_1 . Now all you have to do is to manage, in some way, to get the direct current through R_2 to vary exactly in step with the current through R_1 and you will have an amplifier.

Amplifier arrangements

In all the circuits we have examined so far we have used one special type. You may have noticed that in each case we always specified one element — the emitter — as common to both the input and output circuits. For this reason it is called the common emitter circuit. Since ground is often a widely used reference point, the circuit is sometimes referred to as a grounded emitter.

Because the transistor has three elements — emitter, base and collector — we can use any of the three as the common element.

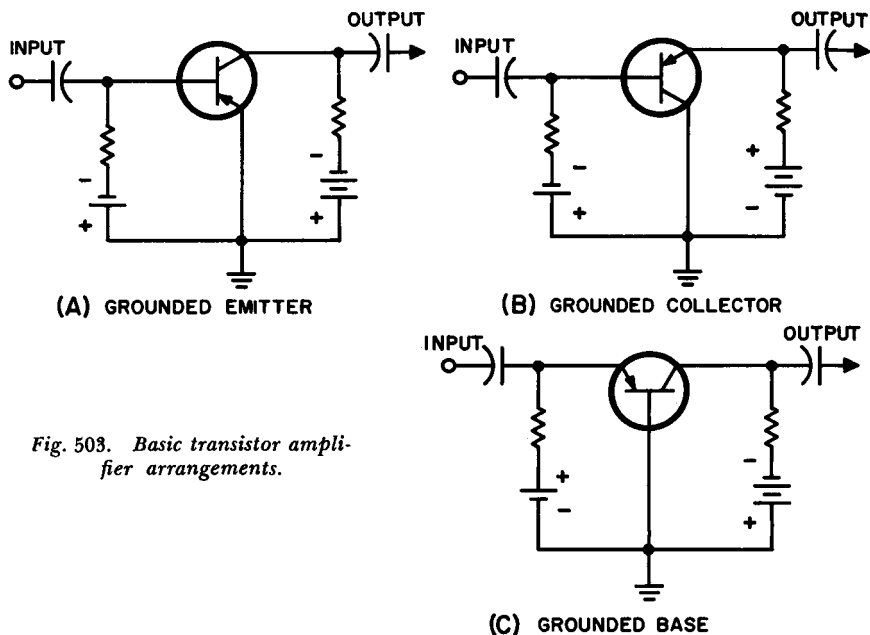

Fig. 503. Basic transistor amplifier arrangements.

Fig. 503 shows the three possible circuit arrangements. Each of the circuits has its own characteristics. However, the common or grounded emitter circuit is the most widely used.

The three basic circuits have certain similarities. The common emitter and common collector arrangements are identical except for the transposition of the output elements. Thus, you could easily change a common emitter circuit into the form we call common collector just by transposing a few leads. Similarly, the common emitter and common base could be changed, one to the other.

Phase

The word phase is used so often in electronics that we must understand just what it is trying to tell us. Phase is used to describe the relationship existing between a pair of currents, a pair of voltages, or a current and a voltage. Sometimes a voltage is compared to what it was when it started or what it will be at some time other than this moment.

Now that we have managed to confuse you, let's unravel this tangled web of words. The classic description of phase is to compare it with a seesaw. If you sit on one end and we on the other there is no possible way in which we can both rise or fall at the same time. When you go up, we go down. The two ends of the

seesaw are in opposite phase, or out of phase — call it what you like. If I climb up when you march down — we are out of phase. If you save while we spend — we are out of phase. If you charge a battery while we discharge a battery — the battery voltages will be out of phase. One will be increasing, the other decreasing.

We can also have in-phase conditions too. If we both go up in an elevator, we are in phase. We are rising at the same time. If we applaud a show at exactly the same time, we are in phase.

Suppose we have two ac voltages of identical frequency, and let us imagine that they both start from zero at the same time. If

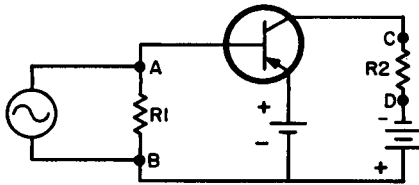

Fig. 504. A slight case of phase inversion. When point A becomes more positive [is positive-going], point C will become more negative [is negative-going].

they both move in a positive direction, they are in phase. If one voltage becomes more positive while the other becomes more negative, they are out of phase.

Examine the common emitter circuit shown in Fig. 504. When a varying signal appears across R1, we will have a varying signal across R2 as well. Suppose point A (resistor R1) becomes more positive with respect to point B. When this happens, point C (resistor R2) will become more negative with respect to point D. But we have the input voltage across R1 and the output voltage across R2. Thus, the two voltages are out of step or out of phase. But since the voltage across R2 is a magnified replica of that across R1, we can say that the common emitter circuit in Fig. 504 has given us not only amplification, but phase inversion as well.

Now suppose we were to take the common emitter circuit of Fig. 504 and just transpose the leads to the emitter and base. We would then have a common base circuit. But what happens to the current through R1 when we do that? It just flows in the opposite direction. As a result we have changed the polarity of the voltage across R1 so that it is now in step or in phase with the voltage across R2. We can understand this a bit more easily if you will remember that in going from the common emitter to the

common base circuit, we made no change in the collector or its load resistor or in the output battery.

Now what about the common collector circuit? It has no phase reversal either. And the reasoning is exactly the same as that used for the common base arrangement. To get a common collector, we take the common emitter and transpose emitter and collector leads. The effect of this is to transpose the collector load resistor. But if we do this, we also transpose the polarity of the voltage across the collector load. This puts it in phase with the input voltage.

The complementary symmetry principle

The three basic amplifier arrangements — common emitter, common base and common collector — were shown in Fig. 503 as p-n-p units. We could have used n-p-n transistors just as well, once more keeping in mind that n-p-n's and p-n-p's may require the

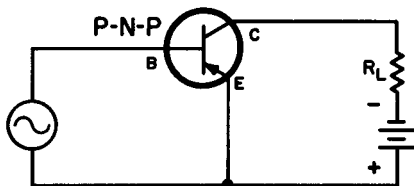

Fig. 505. The input circuit is not properly biased since the ac input will supply, alternately, forward and reverse bias.

same voltages but opposite polarities. And because the polarities are transposed, so are the currents. We might even say that the two types are mirror images or complementary. We are going to build circuits around this knowledge. The idea of complementary units is unique to transistors since we have nothing like it in vacuum tubes. Tubes require a positive voltage on the plate — transistors can have either positive or negative voltage on the collector depending on whether we use a p-n-p or n-p-n type.

Biasing the amplifier

In radio tube circuits we will sometimes come across a tube designed to operate with zero bias. This is a condition you will not find with transistor audio amplifiers since bias is an essential part of their operating conditions. Let us see why this is so.

In Fig. 505 we have a circuit that is normal in every respect, except that we have no battery for forward bias. If the input

signal is symmetrical (such as a sine wave) then, during half the input cycle the base-emitter circuit will be forward biased, but during the other half of the cycle it will be reverse biased. During forward biasing we will get current flow through R_L , the collector load resistor. But during reverse biasing of the input by the signal, only an extremely tiny current will flow through the collector load. Since the output signal does not resemble the input, we have a severe case of distortion. Actually, the circuit in Fig. 505 behaves more like a rectifier, although there is amplification for part of the cycle. (In Chapter 6 this action is used for detection.)

What should the relationship be between forward bias and signal voltage? Since the input signal alternately adds to and subtracts from the forward bias, we must make sure that the bias voltage is always large enough to give the signal something to

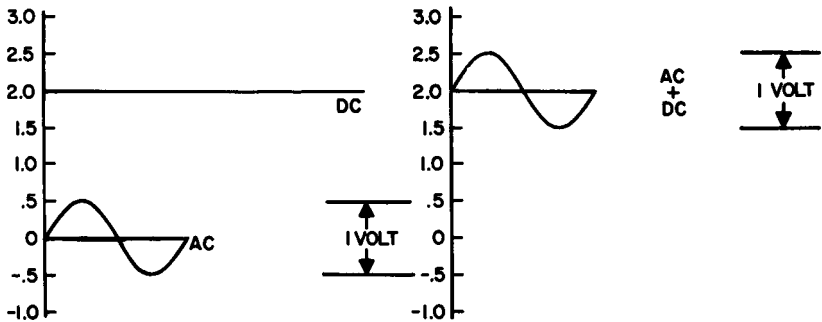
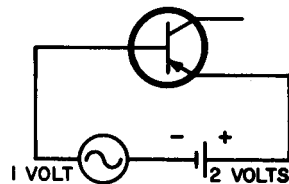

Fig. 506. For proper biasing, the signal voltage must be less than the forward biasing voltage. Note that the dc bias is far above the zero reference line. The signal voltage varies above and below the reference. In the graph you can see that the combination of dc bias and ac signal does not permit the resultant voltage to drop below zero.



work with. Since you may be snowed under by this torrent of words, let's consider several possible situations. Suppose the bias is 2 volts and we have an input signal of 1 volt, peak-to-peak. Assuming the same sort of waveform we had earlier, the net result of combining the ac signal plus the dc bias would mean (as shown in Fig. 506) that half the time our forward bias would be:

$$2 + .5 = 2.5 \text{ volts}$$

$$2 - .5 = 1.5 \text{ volts}$$

Our forward bias now ranges between 1.5 and 2.5 volts. Because our bias battery is larger than the input signal voltage, we always

meet the condition of having forward bias in the circuit.

But what if the opposite took place? What if we had a bias of just 1 volt dc, but a signal voltage of 3 volts, peak-to-peak. What has happened in our input circuit? We now have:

$$1 + 1.5 = 2.5 \text{ volts}$$

$$1 - 1.5 = -0.5 \text{ volt}$$

Fig. 507 shows graphically, the result of such operation. So, we always want to make sure that our bias will be larger than the highest peak-to-peak signal voltage we are going to have.

Now that we have convinced you that an improperly biased transistor results in a distorted or a rectified output signal, it is our sad duty to inform you that what appears to be a vice can, if we so wish, be virtue triumphant. And, if you are about to

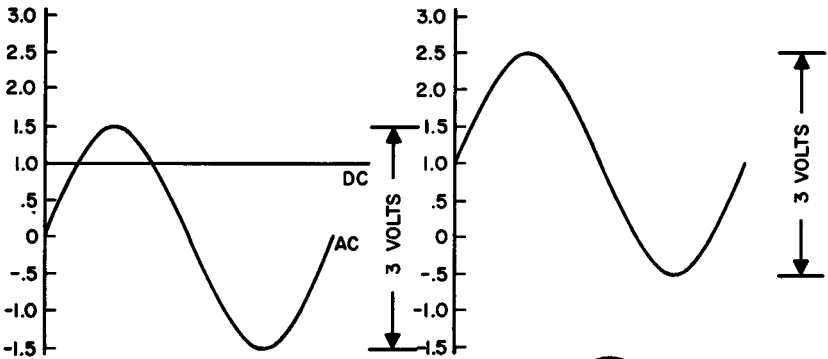
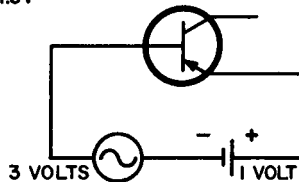

Fig. 507. When the signal is larger than the bias voltage, the transistor input will be both forward and reverse biased.



leap forward to the conclusion that what we have in mind is some sort of rectifier or detector, control your reflexes, for this is a chapter on audio amplifiers. But, while you are still tantalized about this forthcoming tidbit of information, let's take a small sidepath. Don't fret about this detour, since it is really just a shortcut to the main highway.

Classes of amplifiers

There are many ways of classifying audio amplifiers. We can talk about voltage and power amplifiers, driver and output amplifiers, push-pull and single-ended. One other way is to arrange them in accordance with their bias requirements. For transistors,

where we seldom stray far from the word “bias”, this is a very attractive thought, indeed. And, with a strong penchant for original thinking, we reach right over into vacuum-tube theory, and borrow a classification, lock, stock and element.

A favorite vacuum-tube type of classification is to call amplifiers class A, B or C. This doesn't mean that A is better than B, or that B is slightly superior to C. In vacuum tube theory, a class A am-

Fig. 508. The class of amplifier operation is set by the operating point Q on the load line. Changing the base bias will move this point, resulting in a different class of operation.

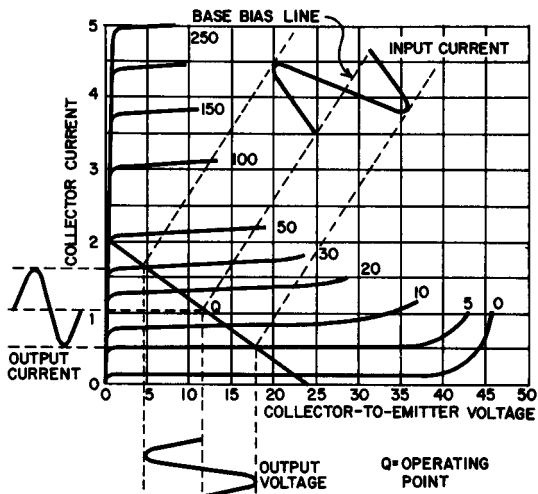

plifier is one so biased that plate current flows no matter which part of the input cycle is tickling the grid at the moment. Thus, whether the input signal is crossing its zero axis, is at maximum positive or maximum negative, we always get more or less current flowing to the plate. A class B amplifier has plate current flowing for only fifty percent of the input cycle, while for class C, plate current exists for only a small fraction of the input cycle.

But how do we arrive at that happy condition in which we can make the plate current do our bidding? How can we take a single tube and make it work as class A, or class B, or class C, just as we wish? The clue to this — no, the whole answer to this — lies in the bias. Very high bias and you will probably have class C. Very low bias, class A. And class B somewhere in between.

If, from your studies of vacuum tube theory you know all this, be of good cheer for you also know it for transistors, and without effort on your part. In tubes, we talk about bias controlling plate current. In transistors, it is the amount of forward bias that determines collector current.

In Fig. 508 we have a drawing which demonstrates this for

you graphically. What is the class of operation? All you need do is to select the correct amount of forward bias for the input circuit. However, we have been a little crafty about this since we haven't really told you the whole story. We start with what we fondly believe to be the correct amount of bias for the class of operation we want, and then (this is the sneaky part) we make sure that our input signal is never large enough to distort the output waveform. Take the case of class-A operation in Fig. 508. We very carefully chose an amount of forward bias that put us as close to the center of the collector current curve as possible.

Now work along with us with the graph in Fig. 508. Locate the dashed line marked "base bias line". What is this line and just what does it represent? This line is our forward bias. If you will go back to Fig. 506 you will see that we have a straight line marked "dc". We have a similar line in Fig. 507. This is the type of line we are using in Fig. 508.

Now suppose that to the dc represented by the base bias line we add an ac voltage. The result will be a variation around the base bias. To get the appearance of the output current and the output voltage, we can project to the left and also downward. If you will look at the dashed lines in the drawing, you will see that they center equally around the base bias line. Also note that we are working along the straight portion of the collector current curves. As a result, our output waveform is a rather decent replica of our input waveform.

But what if we change our forward bias? We can either increase the bias or decrease it from the condition shown in Fig. 508. As a start, let us say that we increase the forward bias. The effect of this will be to move the base bias line down the slope of the load line. To see what will happen, just imagine the letter Q (our operating point) sliding down the load line and coming to rest somewhere near the bottom. We could still project our input current waveform onto the load line, but a projection of the output current and output voltage waveforms would show severe distortion. Similarly, if we decreased the forward bias, the base bias line would move up on the slope of the load line, once again producing a distorted output waveform — even though the input might be undistorted.

Now here is where the subtle part comes in. Note that in Fig. 508 our modulating wave never takes us into the saturation or cutoff regions of collector current. How do we know this? Look at the vertical dashed lines moving up from the output voltage

waveform and note where they touch the collector current curve. These two lines come close to the beginning and the end of the curve. But if our input signal were too large, our output waveform would be clipped top and bottom. And, since the output would no longer be an enlarged replica of the input, we would have distortion.

How do we get the other classes of operation — classes other than A? Simply move the operating point Q up or down on the load line. Class B works at the cutoff point — class C beyond that. We also have one more class — AB — with an operating point on the collector current curve halfway between that of A and B.

Class A vs class B

There is just one class of operation that does not result in distortion. This is class A. All the others — AB, B and C — give us an output waveform that is an amplified, but amputated version, of the input. But before we rejoice about class A, before we decide that that's for us, consider its limitation. Make the input signal too strong and we will get an output waveform that will be clipped top and bottom — a distorted wave. This is the disadvantage. With class A we actually cut the useful length of our collector current curve in half. We start our bias at its center point. It's just as though we had a street in which to practice running, but, instead of starting at one end and running the full length, we started at the center, with the option of running to either end.

How can we get around this seemingly dead-end situation? We can run our audio amplifier class B. But since class B gives us what is tantamount to rectifier operation, one transistor with half a waveform output won't be enough. We get right past this problem just as neatly as you please by using two transistors in class B pushpull. One transistor supplies the lower half of the output wave; the other supplies the upper half. But please don't get the idea that just class B works in pushpull. We have every class, A, AB, B and C using push-pull. Unfortunately, class C produces so much distortion that we can't use it for audio work, but it does nicely for rf.

Voltage amplifiers and power amplifiers

Practically every circuit in a transistor radio receiver is an amplifier, starting at the antenna and going right on out to the speaker. And, if the detector is a transistor, we can make the statement a unanimous one.

In any radio set, the objective is quite simple. The problem is to take the signal off the antenna or loopstick and amplify it —

and to keep right on amplifying it. Granted that various changes do take place. We get frequency conversion up at the front end and signal rectification somewhere along the middle of the chain of events. But as we move, stage by stage, in the direction of the speaker, we amplify the signal. The reason for this is that we must have a signal strong enough to dominate the activities of the output transistor.

With this idea in mind, we can roughly classify amplifiers as voltage or power types. Note the word "roughly", used deliberately, for this separation of amplifiers into voltage and power types is a crude designation, but a handy one, nevertheless. (In the case of transistors, it might be more accurate to call them current, rather than voltage amplifiers.) In the sense, though, that our signal is a voltage, and that our transistors are intended to augment this voltage, we have voltage amplifiers. And, because our audio output transistor must furnish the energy to move the voice coil, it is a power amplifier. The separation between voltage and power amplifiers is not sharp and clear-cut. Voltage amplifiers supply some power gain and our power amplifiers do deliver some voltage gain.

There are many ways in which we can classify amplifiers. We can pigeon-hole them quite neatly by bias (Class A, B, etc.) or by whether they are primarily voltage or power amplifiers. We can describe them as single-ended or pushpull. A single-ended amplifier uses a lone transistor to deliver power to the speaker. Pushpull uses a pair. Or we can talk about amplifiers in terms of their functions — an output amplifier or a driver amplifier. And, just as some people need four or five names to achieve complete identity, so too do we sometimes take all of these designations, and come up with a mouthful such as: class A, single-ended, power amplifier.

Class A, single-ended, power amplifier

This may seem like a rather elaborate name to hang on the inoffensive little circuit shown in Fig. 509, but we can extract a lot of information from that name. Class A gives us a clue about the forward bias and our location on the collector current characteristic. Single-ended tells us not to look for more than one transistor. Power amplifier is our clue to look for a speaker or output transformer as the load.

Let's examine the circuit of Fig. 509 to get acquainted just a little better. Our component parts are simple enough and few

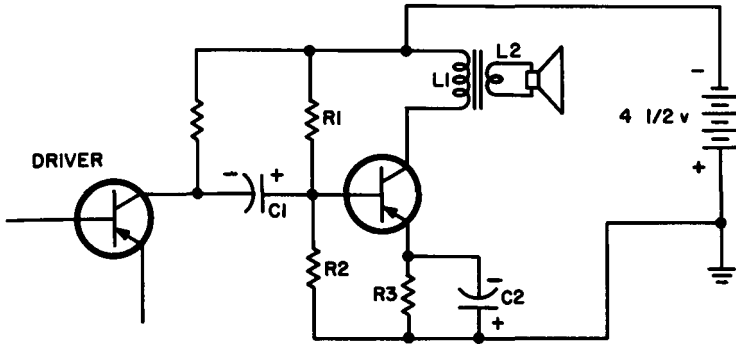

Fig. 509. Single-ended class-A power amplifier R-C-coupled to the preceding stage.

enough. A small assortment of resistors, capacitors, a transistor, transformer and a battery, and that is all there is to it. Starting with the capacitors we see that we have two of them. Both are electrolytics. C1 is a coupling capacitor from the collector of the preceding (driver) stage. C2 is the emitter bypass. With electrolytics we always have the problem of polarity. We've marked C1 and C2 carefully, but the question still remains as to why they are positioned in this way.

Let's start with C1. One side of the capacitor connects to the collector of the p-n-p driver. But this collector is wired to the negative terminal of the battery. The plus side of C1 is soldered to the junction of R1 and R2. This is a plus point with respect to the top end of R1.

Now what about C2? Current flows through R3 from the emitter toward ground. Because of this direction of current flow, the top end of R3 is minus, the bottom end plus.

If you will look carefully, you will see that R1 and R2 are in series, but that this series combination is connected directly across the 4½ volt battery. It is true that the base is tied right on to a plus point on the voltage divider, but because of the voltage drop across R2, the base is less positive than ground. Ground is the maximum plus point since it is attached to the positive terminal of the battery.

How does the transistor get its forward bias? In two ways. Our voltage divider, R1 and R2, supplies fixed bias. R3, the emitter resistor, takes care of self bias. The values of R1 and R2 are chosen so as to put the operating point of the transistor at the center

point of the collector current curve (with the help of R3). This gives us our class A operation.

The collector is transformer coupled to the speaker through an output transformer. The transformer is a stepdown type. L1 has a primary impedance of several hundred ohms. L2 is just a few ohms.

What other information can we get out of Fig. 509? The transistor is a p-n-p type. If we were to use an n-p-n we could still work with the same components, but rearranged. We would need to

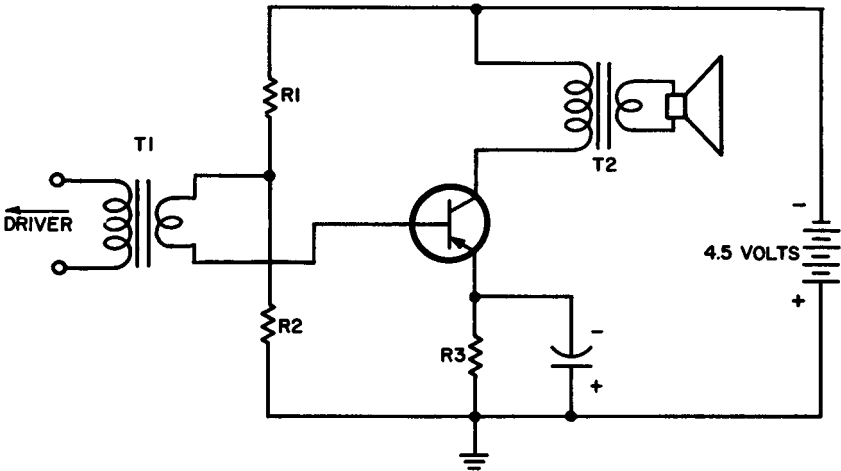

Fig. 510. Single-ended class-A power amplifier transformer-coupled to the preceding stage.

transpose the two electrolytics, and the battery. We probably would need to alter the values of R1 and R2 to meet the bias conditions of the new transistor.

Resistance coupling and transformer coupling

The circuit of Fig. 509 is resistance-capacitance (R-C) coupled to the preceding driver stage, but a transformer could have served just as nicely. We see this new arrangement in Fig. 510. As you see, it is almost the same as the R-C stage. We've removed coupling capacitor C1 and put in transformer T1.

The change is an interesting one. T1 is a stepdown type since the collector of the preceding driver stage is a much higher impedance circuit than the base-emitter circuit of the power amplifier. As before, R1 and R2 form a voltage divider shunted directly across the battery. In series between the dc voltage sup-

plied at the junction of R1 and R2 we now have the ac signal voltage delivered by the secondary of T1. This is no great development since we know that the purpose of the signal is to modulate or change the forward bias.

In vacuum-tube receivers, R-C coupling to the output stage is so customary that an occasional transformer coupled job causes some eyebrow lifting. In transistor receivers, though, transformer coupling is common.

Stability of operation

You would think that having gone to the trouble of determining the correct amount of forward bias to put on our transistor (thereby establishing the operating point on the collector current characteristic) this operating point would remain as fixed as a dab of glue. The transistor, though, is temperature sensitive. This means that as temperature goes up, so does collector current. Back in Chapter 4, on page 96, we told you about feedback techniques for stabilizing the transistor. But there are other methods. One technique is to use a thermistor. This is a semiconductor which functions as a temperature-sensitive resistor having a negative temperature coefficient. Translated, this means a thermistor is a component whose resistance goes down when the temperature goes up, and vice versa.

How much change?

This doesn't tell the whole story. Metals have a positive temperature coefficient, meaning, of course, that their resistance tags along after temperature, rising when temperature goes up, decreasing when temperature goes down. But the amount of resistance change is small. Thermistors, however, have a large temperature coefficient, just another way of saying that they are very sensitive to temperature changes. To give you an example, in the range from zero to 200 degrees, a platinum wire would have an increase in resistance amounting to a fraction of an ohm. A similar volume of thermistor material, for the same temperature increase, would change from about 8,000 ohms down to about 11 ohms.

Thermistors are made in the shape of discs, washers and rods, of manganese, nickel and cobalt oxides. As in the case of resistors, suitable binder material is added, and then the combination of chemical and binder is extruded, pressed or molded into the desired shape.

Now let's see how the thermistor does its job. In Fig. 511 we have a thermistor, quite properly shown as a variable resistor, shunted across R_2 . R_1 and R_2 , as we know, supply forward bias to the base-emitter input circuit. And, because we have a p-n-p transistor, we want our emitter to be positive with respect to the base. The bottom end of R_2 is our most positive point since it is connected directly to the plus terminal of the battery. As we move up on R_2 we become less positive, since, if we continue long

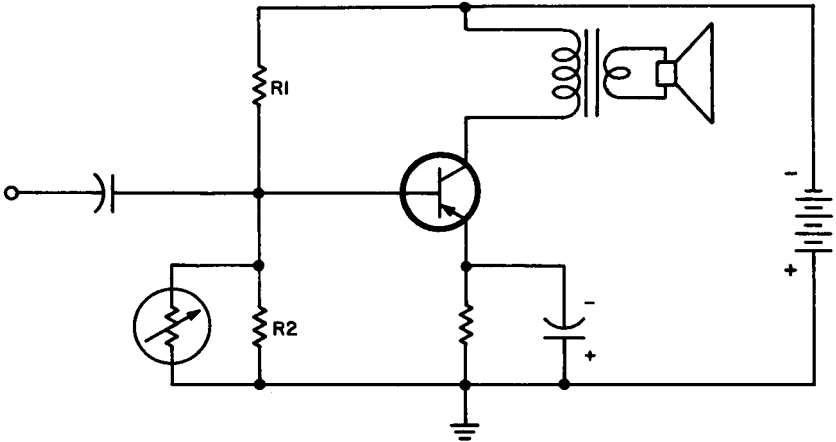

Fig. 511. Thermistor shunted across R_2 prevents thermal runaway. Electrically, the thermistor is in parallel with R_2 . Physically, it is placed near the power transistor and is thus immediately affected by any temperature rise of this component.

enough, we will go right on through R_1 to the negative terminal of the battery.

Collector current, though, depends upon the proper forward biasing of the base-emitter circuit. If the forward bias should decrease, so would the collector current. The thermistor in Fig. 511 is quite able to go from a value of almost zero ohms to a value much higher than that of R_2 . As long as collector current is normal (by normal we mean the correct amount of collector current), the resistance of the thermistor will be so high that its paralleling effect on R_2 will be negligible. Or, if not, then the combination value of thermistor and R_2 can be selected so that the two in parallel supply the correct amount of resistance.

Now suppose that an increase in temperature causes the collector current to increase. This same temperature rise decreases the resistance of the thermistor — fast and substantially. Because of this, the total resistance between base and ground (R_2 in

parallel with the thermistor) becomes smaller. But this has the effect of lowering the amount of forward bias since the base now approaches ground. But ground is positive and the base needs to be negative. The reduction of forward bias cuts the collector current down to a smaller value.

Heat sink

Since what we have said has given you the impression that heat and transistors had best be kept apart, it may not be surprising to learn that output transistors can get hot and do get hot. Power transistors, though, often have collector current ratings measured in amperes, and where we have amperes, plus resistance, we have heat. To dissipate the heat we do something that heating engineers

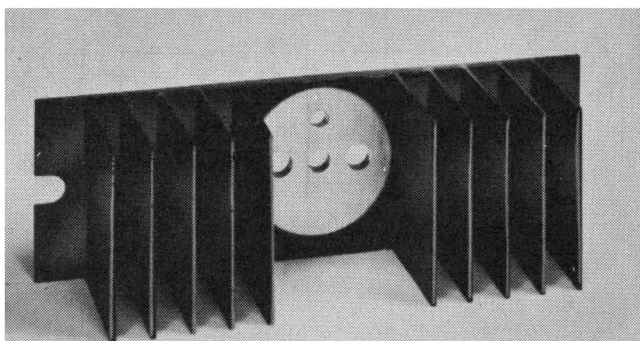

Fig. 512. The purpose of the heat sink is to dispose of heat as quickly and as effectively as possible. Heat sinks are often made in a corrugated or ribbed style to provide as much surface area as possible. A metal chassis is also used as a heat sink. (Delco Radio Div., General Motors)

and automobile engineers have been doing for a long time. We use a large metal surface to radiate the heat, and the more surface area, the better. Sometimes the chassis is used to conduct heat away from the transistor. In some cases the power transistor is mounted on what seems to be a series of metal fins. A unit of this sort is shown in Fig. 512.

Efficiency — Class A

The power to operate a transistor radio comes from its battery. The ac power or the signal power used to drive the voice coil of the speaker is derived from that battery. Basically, what happens in a transistor radio is that the power supplied by the battery is

modified or altered by the signal, in cooperation with the transistors. But here, as in everything else, we must pay a price. Our battery delivers dc watts. Our speaker needs ac watts. In the conversion, the transistor will exact its little toll. The ratio of these two values, the output power divided by the input power, is always less than one. In the case of the single-ended class A power amplifier, the maximum efficiency is 0.5 or one half. Thus, if our battery supplies 6 dc watts, and our audio power at the output is 3 watts, then $3/6$ equals 0.5. We convert this to a percentage by multiplying our answer by 100. The maximum efficiency of our single-ended class A power amplifier is 50 percent, but usually

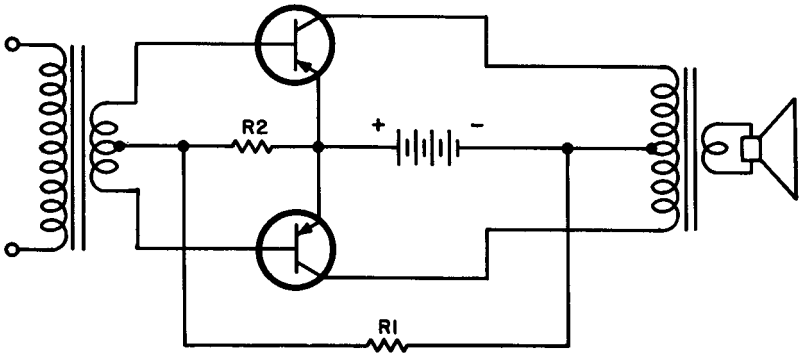

Fig. 513. Pushpull amplifier. Class of operation is determined by the values of R1 and R2. Because of the way the circuit is drawn, it is difficult to see that R1 and R2 act as a voltage divider across the battery, to supply forward bias to the two transistors.

less. And if you think this is a low value, some steam locomotives and machines clock in at 12 percent efficiencies. However, if efficiency is a consideration (and there are others) we can move on to pushpull amplifiers.

The pushpull amplifier

Our single-ended amplifier works class A because this is the only way in which it can work. We can't operate it class AB, B or C without running into some waveform distortion. However, this limitation does not cause trouble in some rf amplifiers.

The circuit of a class-B power amplifier is shown in Fig. 513. We've drawn this circuit for you in a rather neat way, but unfortunately its very neatness hides the fact that the pushpull amplifier is nothing more than our single-ended job multiplied by two. To see that this is really so, we have separated the biasing

system into two sections, as shown in Fig. 514. Since we have p-n-p units, we want our emitter to be maximum positive, the collector maximum negative, and the base somewhere in between. But isn't this the same arrangement we had for the single-ended amplifier? We've omitted the emitter resistor, but all you need do is to break open the line between the common emitter connection and the plus terminal of the battery and insert it. And, if we need to or want to, we can also add a thermistor.

We haven't told you what class of operation we've been using in the pushpull circuit of Fig. 514. Actually, you can't tell without a score card. The class will depend on the relationship of R_1 to R_2 . To understand this, imagine R_1 and R_2 as a single resistor

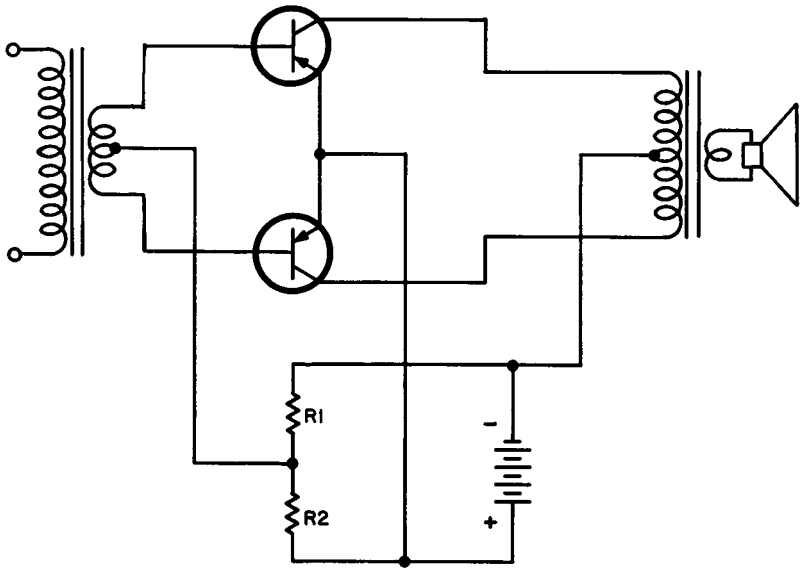

Fig. 514. The circuit of Fig. 513 has been redrawn to show the voltage-divider action of R_1 and R_2 . The emitter is maximum positive. The voltage divider makes the base less positive than the emitter. Collector is maximum negative.

(but with the value of R_1 and R_2 in series) and the fixed connecting point as a sliding arm on that single resistor. As we move the slide down toward the bottom end (the end connected to the plus terminal of the battery) we keep reducing the forward bias. This drives the transistor collector current down toward the cutoff point. If we move the slide arm up toward the top end of the resistor, we increase the forward bias, so that the collector current

goes to saturation. But what are we really doing? We've actually been sliding up the operating point Q (see Fig. 508 once again) from its point at cutoff to its point at saturation.

But if we can determine our operating point in this way, what we are really doing is establishing the class of operation we will use. Incidentally — we didn't have to go as far as we did. If we started at cutoff, and moved up to the center point of the collector current characteristic, that would have been far enough.

Efficiency — Class B and AB

Class B efficiencies run up to a little more than 75 percent while class AB comes somewhere between class A and class B. Class C is the most efficient, but as we told you earlier, it isn't used for audio work, because of the distortion it produces at audio frequencies.

In class B, when one transistor is hovering around the cutoff point, the other transistor is doing an honest day's work. No criticism here, though, since each transistor takes its turn in delivering collector current to the primary of the output transformer.

Aside from the greater efficiency of class B pushpull contrasted with class A single-ended, the pushpull arrangement has other attractive features. The core of the output transformer for pushpull can be smaller than the core of a similar transformer for single-ended. The reason for this lies in the effect direct current has on the core of a transformer. All currents, whether ac or dc, carry a magnetic field along with them. But in a transformer, only a varying magnetic field (such as that supplied by ac) is of any use in the transfer of energy from primary to secondary. The steady magnetic field of dc not only does not transfer energy, but it actually pre-empts some of the iron core for itself. Thus, if we have both ac and dc flowing through the primary of a transformer, we can get a greater transfer of energy if we simply remove the dc. In pushpull, we have two direct currents flowing, one from each collector (or toward each collector). But these two currents have magnetic fields which oppose each other. This leaves the core free to take care of the ac component — that is, the varying current due to the signal.

Power output

The power we can get out of a transistor depends on its class of operation, but this isn't the whole story. Power output is

determined by the amount of heat the transistor can dissipate. In turn, this depends on the cooperation we give the transistor in the way of a heat sink. And, to compound the confusion, not all heat sinks have the same thermal efficiency. In other words, some heat sinks get rid of heat better than others. If the chassis is used as the heat sink a heat-conducting insulating washer is inserted between the chassis and the power transistor. The washer is made of mica, anodized aluminum, teflon, mylar or fibreglas. To improve heat conductivity, each side of the washer should be coated with a thin film of silicone lubricant. If we didn't use a lubricant, the space between the base of the transistor and the chassis might become a dead air region, and an air pocket of this sort could effectively block the transfer of heat to the chassis. When you replace power transistors, coat the washer with silicone on both sides.

Unlike transistors used in stages preceding the audio output, power transistors usually have but two leads — base and emitter. The collector is connected to the case of the transistor to help conduct heat away from the junction. There are some power transistors made with three leads, but these are not as common as the two-lead variety. Sockets can be used with power transistors but, when currents are measured in amperes, it doesn't take too much contact resistance to produce an unwanted (and, frequently, unexpected) voltage drop. In some cases it may be more practical to weld or to solder connections directly to the leads of the power transistor or to use machine screws and lugs.

Other pushpull arrangements

The pushpull circuits we've examined are common-emitter types. Common-base and common-collector arrangements could be used, but you will find the common emitter most often.

As in the case of tubes, transformers represent a natural application in transistor pushpull circuits. Transformers are not only highly convenient for impedance matching but also supply phase inversion. But, no sooner do we get a component to do a good job, than all sorts of schemes get underway for eliminating that component. Transistors lend themselves very nicely to this bit of skullduggery if we take advantage of the fact that in n-p-n and p-n-p transistors, currents move in opposite directions.

The pushpull circuit, known as complementary symmetry, is

The pushpull circuit, known as complementary symmetry, is shown in Fig. 515. A careful look shows that the two transistors are really connected in parallel.

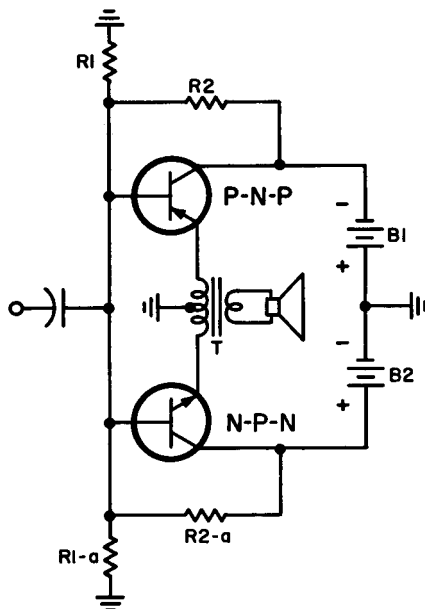

Fig. 515. Complementary symmetry arrangement takes advantage of opposite current flows in n-p-n and p-n-p transistors, manages to eliminate the input pushpull transformer.

To understand how this circuit works, consider an input signal. Depending on its polarity at the moment, it will either increase or decrease the forward bias. But if that signal is applied to the base-emitter input of two different transistor types, such as an n-p-n and a p-n-p, it will increase the forward bias of one and decrease the forward bias of the other during one half of the cycle and produce exactly the opposite effect during the other half of the cycle. But this is exactly what a transformer will do for us.

In the circuit of Fig. 515, our output is taken from the common emitter, joined by the primary of the output transformer. If you will trace R1 and R2 (for both transistors) you will see that once again we have our usual voltage dividers, R1 and R2 for the p-n-p being shunted across B1, while R1-a and R2-a for the n-p-n are in parallel with B2.

Adjusting the bias

It doesn't take much of a change in forward bias to push us up or down on the load line. And, even using the bias voltage recommended by the manufacturer doesn't always ensure that we will get the class of operation we want. We can get out of this difficulty by making one of the biasing voltage divider resistors variable. Unfortunately, this makes biasing rather critical.

A better setup is shown in Fig. 516. Here we have our voltage divider, R1 and R2, furnishing forward bias to both p-n-p tran-

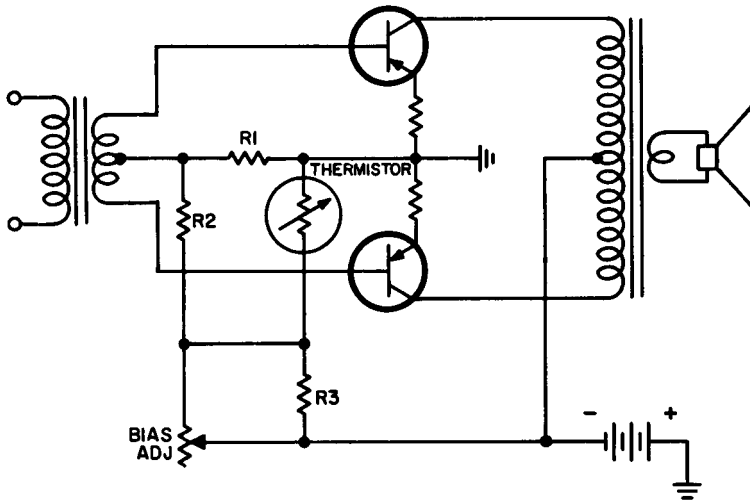

Fig. 516. Bias-adjust potentiometer permits small change in the forward bias of the push-pull transistors.

sistors. In series with R1 and R2, we have a third resistor R3. The value of this resistor can range from practically zero, to almost full value, depending on the setting of the arm of the bias adjustment potentiometer. Note that the bias adjust pot is shunted across R3. With one position of the arm of the bias adjust pot, R3 is shorted. At the opposite position, R3 is almost full value, since the resistance of the bias adjust pot is so much greater than R3.

The driver stage

Feeding the power output, whether this is single-ended or pushpull, is an audio amplifier known as a driver. Driver amplifiers are invariably class A since a single transistor is used. A

driver circuit is shown in Fig. 517. The input is resistance-capacitance coupled to the preceding stage. In a transistor receiver this could be the detector. R1 and R2 form the usual voltage divider to supply forward bias. The interstage transformer, T, can be used to drive a pair of pushpull transistors.

Circuitwise, how new or different is the driver compared to single-ended power output? Compare the two circuits, Figs. 509 and 517 and you will see the remarkable resemblance.

Control positions

There are three types of controls you will find associated with audio amplifiers. One of these, the bias control has already

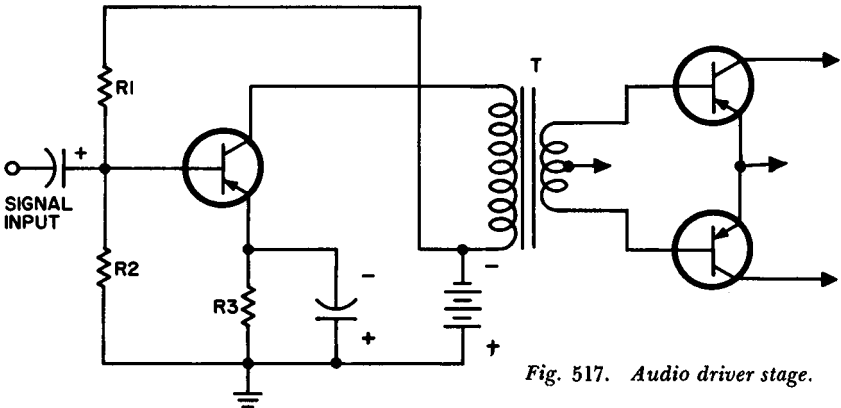

Fig. 517. Audio driver stage.

been mentioned, and is found in connection with power amplifiers. The other two, tone and volume (or gain) controls are part of driver circuitry or output stages.

Two tone control circuits are shown in Fig. 518. They both work in exactly the same way. They supply bass and treble boost, although actually, neither of the two circuits does anything of the sort. Both work because they bypass higher audio frequencies to ground, the amount of "highs" being shunted in this way depending on the position of the potentiometer in Fig. 518-A, or the setting of the rotary switch in Fig. 518-B. As more highs are bypassed, there is a seeming boost of the lower frequencies. The tone control consists of a capacitor in series with a resistor. The higher the value of resistance, the more "treble" in the sound since fewer higher audio frequencies are bypassed. The maximum bass "boost" is obtained when all, or almost all, the resistance is out of the circuit. In the case of Fig. 518-A, this would be when the slide arm of the potentiometer is at one of

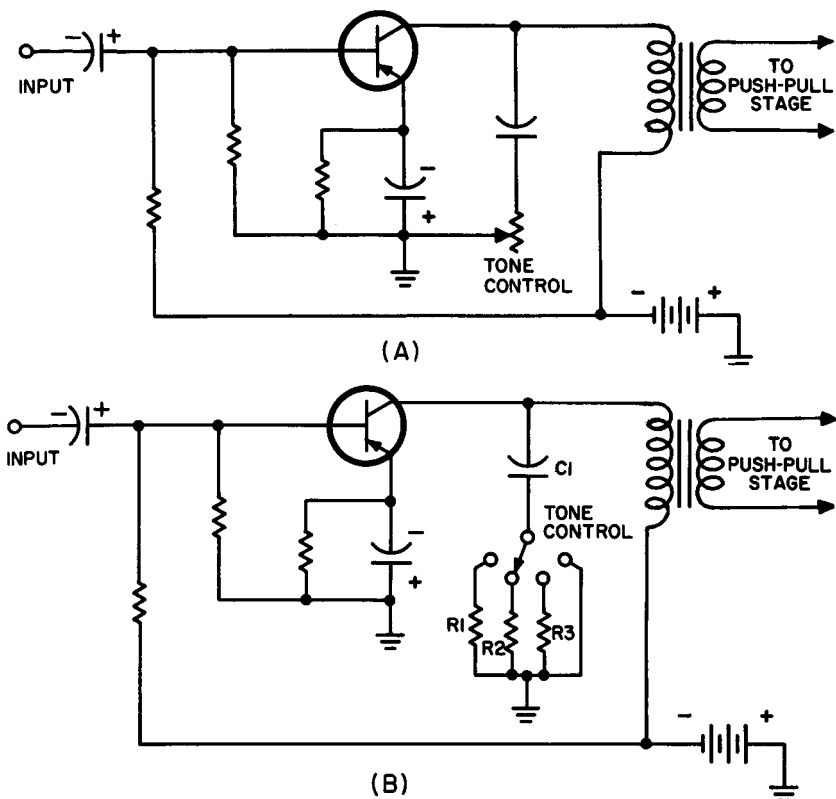

Fig. 518. Two types of tone control circuits.

its end positions. In the case of Fig. 518-B, this same situation would prevail when the tone capacitor is connected directly to ground — when the switch is at the wire connection, rather than at R_1 , R_2 or R_3 .

An alternate arrangement to the circuit shown in Fig. 518-B above would be to have fixed capacitors of various values in place of R_1 , R_2 and R_3 . A variable resistor would then be used instead of capacitor C_1 .

Sometimes, just as in the case of vacuum-tube ac-dc sets, you will find a capacitor hanging across the primary of the output transformer. This is a tone control of sorts but tone-compensation capacitor might be more nearly correct. Its function is to cut down the highs, thus diminishing the somewhat tinny sound produced by the speaker.

Fig. 519 shows a gain control circuit. The secondary of the interstage transformer, T1, is shunted by a potentiometer. This picks off the amount of audio signal that will be used to modulate the dc bias supplied by R1 and R2. Note C1, connected to the collector. This is a form of tone "control" but the word control here must be used tongue-in-cheek. C1 bypasses high tones to ground or chassis, giving apparent emphasis to lower-frequency tones.

The emitter follower (grounded collector)

In most audio amplifiers, the signal output is taken from the collector circuit. However, it is sometimes advantageous to take

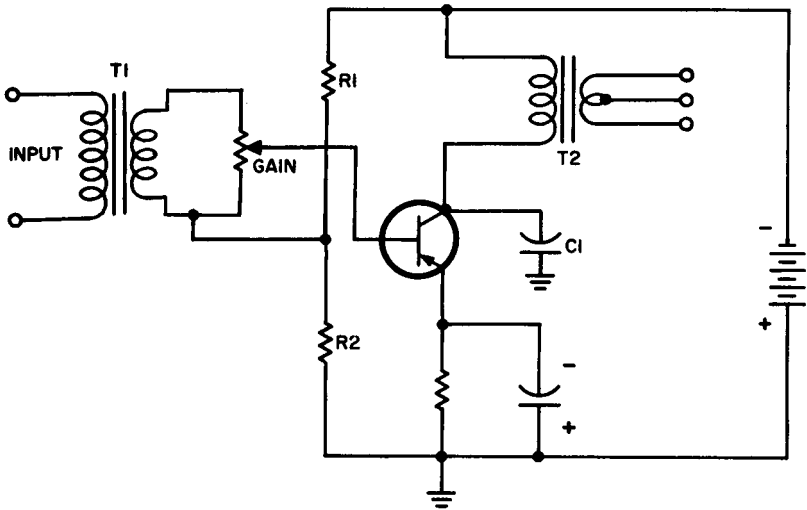

Fig. 519. One possible position for the gain control is at the input to the driver stage.

the output from a different element, such as the emitter. Such a circuit is known as an emitter follower or grounded collector. The emitter follower has a high input resistance, a low output resistance, and no phase reversal. Because of these characteristics, the emitter follower is useful in coupling to low impedance loads. The load can be another transistor, producing a rather nice circuit for us known as the direct-coupled amplifier. A circuit of this sort is shown in Fig. 520. Let's start with the collectors. The collector of the output transistor, V2, is transformer coupled to the speaker. The primary resistance of the output transformer

is fairly low, so the collector of V2 gets almost the full negative voltage. The collector of V1 looks as though it has a load resistor, R3, but this resistor has such a very small value that practically no signal develops across it. If it did, we could always bypass it with a capacitor shunted right in parallel with R3.

We can see that R1 and R2 act as voltage divider for V1, but

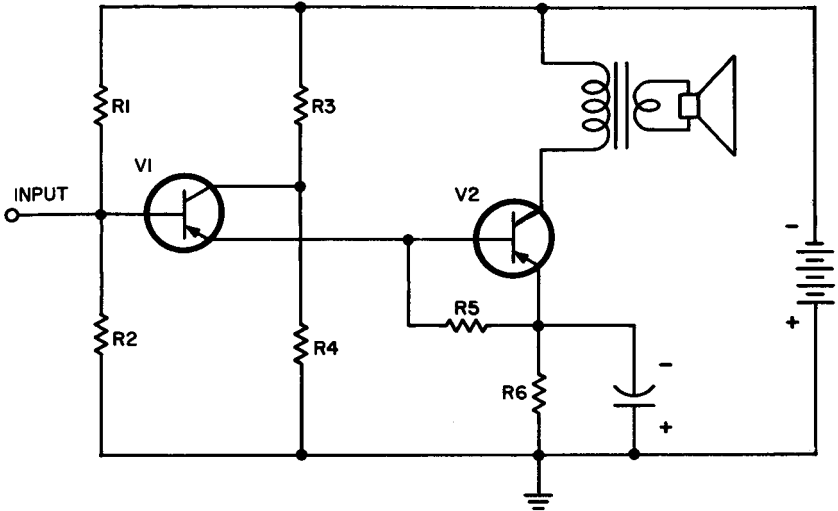

Fig. 520. The emitter-follower circuit in this arrangement is used as a driver. V1 is direct-coupled to V2. V2 and its circuitry acts as the load on V1.

this isn't quite so clearly shown for V2. If you will examine V2 you will see that it forms the emitter load for V1. Thus, R1 and R2 really supply bias for both transistors.

How does current flow in a circuit of this sort? If you will start at the negative terminal of the battery, you will be able to move over to R3, through V1 and then back to the positive terminal of the battery through the base of V1 and R2. This base current is very small, so let's get back on to the main path. We can now go from the collector of V1, over to the emitter of V1. From here, following along with the emitter current, we can go through R5 and R6 or through the base-emitter circuit of V2. But the emitter current of V1 is our amplified signal current.

Now let's get back to the negative terminal of the battery once more. This time, suppose we move down through the primary of the output transformer, through V2, and through R6 to ground (or the plus terminal of the battery). Is this the only current

flowing through V2? Not at all, since we just described the passage of V1's emitter current through V2. We now have two currents going through V2. One is the steady direct current supplied by the battery. The other is the amplified signal current out of the emitter of V1. This signal current will modulate the steady current of V2. R6 is not only the stabilizing resistor for V2, but R6, together with R5, form the emitter return path to ground for V1.

What about the input to the direct-coupled stage? There is nothing unusual here. It could be resistance-capacitance coupled to the preceding circuit or transformer coupling can be used.

Complementary symmetry in direct coupling

Transistors have one (some would claim more) great advantage over tubes. We got a glimpse of this advantage when we examined the complementary-symmetry pushpull amplifier. Complementary symmetry is just another way of saying that p-n-p and n-p-n transistors work with opposite polarities and opposite directions of current flow. We've put this principle to work for us again, in the direct-coupled amplifier circuit shown in Fig. 521. The funda-

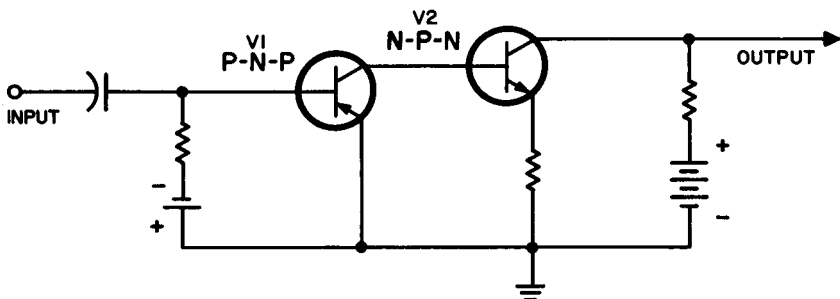

Fig. 521. Direct-coupled amplifier uses complementary-symmetry principle.

mental idea is the same, though, as in the earlier direct-coupled circuit we described. The difference is that this time V2 forms the transistor load for V1. The advantage here is that loading the collector produces more gain than the emitter follower. And it isn't necessary for the p-n-p transistor to act as the driver for the n-p-n. The transistors can be transposed, but when we do, we must also remember to transpose the batteries.

A few thoughts

What is it that we are trying to do when we couple one transistor stage to the next? All we want is to vary the forward bias

so that it goes up and down exactly in step with every little wiggle and movement of the signal. If you will look back at the single-ended stage shown in Fig. 510, and if you could change R1 into a potentiometer that you could operate rapidly enough, you would get audio output. This gives us a clue to how we can

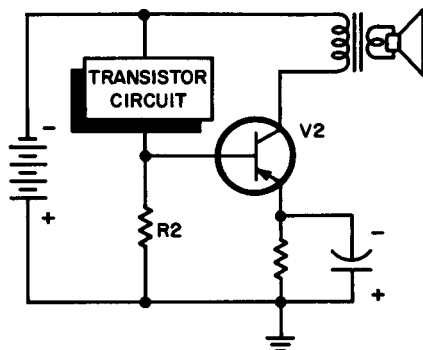

Fig. 522. A transistor circuit can be substituted for one of the forward-biasing voltage-divider resistors.

operate an audio stage, as shown in Fig. 522. Instead of having R1 and R2 as a voltage divider to supply forward bias, we have R2 and some kind of a transistor circuit substituted for R1. But is this so surprising? Earlier, in Fig. 519, didn't we put the secondary winding of an interstage transformer in series with R1 and R2? What we have in Fig. 522, then, is just another way of varying the forward bias.

What would a circuit of this sort look like? We've already had several, but may not have recognized them as such. As an example, let's go back to Fig. 520 in which we show an emitter-follower circuit used as a driver. If you will examine the base circuit of V2, you will see that we have R5 and R6 in series. One end of R6 connects to the plus terminal of the battery. And one end of R5 goes to the base of V2. These two series resistors, then, correspond to R2 in Fig. 522. Now what about the block marked "transistor circuit"? Still working with the emitter follower of Fig. 520, we know that we must work our way up from the base to the other end (the minus end) of the battery. To do this we must go through the collector-emitter circuit of V1 and R3. But the collector-emitter circuit of V1 and R3 just represent a substitute for R1. And since this substitute supplies a varying audio signal, we will get audio modulation of the base circuit of V2.

Diode compensation or stabilization

All along we've been using a pair of series resistors, which we have marked R_1 and R_2 , to supply forward bias for our transistors. But there is an assumption here that we haven't told you about. We have taken for granted that we will have a constant voltage drop across the resistors. Was this reasonable on our part?

To answer this question we need to ask another one. What could possibly cause the voltage across R_1 and across R_2 to change? Presumably a weak battery could be one cause of this trouble, but we can't take this too seriously. If the battery is weak, its regulation will be poor, the forward bias will be incorrect and we will get distortion. The end result of this is that what we hear out of the speaker will be a constant reminder to get a fresh

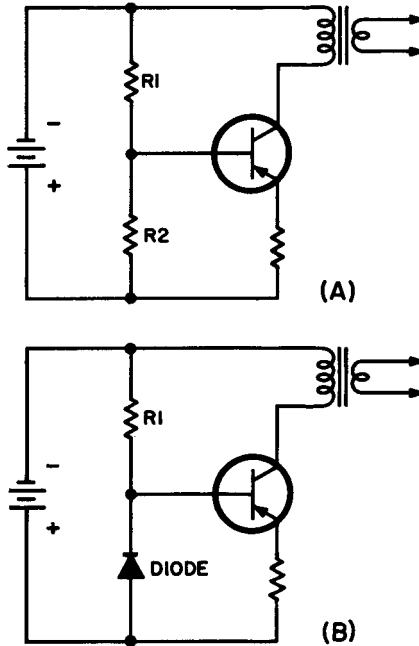

Fig. 523. The circuit shown in [A] uses R_1 and R_2 as a voltage divider for forward bias. In [B] we have substituted a diode for R_2 .

battery. Now assuming that we have a fresh battery, what other difficulties could we have? What about our resistors, R_1 and R_2 ? As resistors, they have a positive temperature coefficient. But isn't this the opposite of what the transistor has? If you will

examine Fig. 528-A you will see that we have R2 in shunt with the base-emitter circuit of the transistor. This is like compounding a felony, since R2 and the base-emitter circuit have opposite temperature coefficients.

To get around this unhappy situation, we can substitute a diode for R2, as shown in Fig. 523-B. The theory here is that the diode has a negative temperature coefficient. But what about the base-emitter part of our transistor? That's a diode, too.

Suppose temperature increases. The resistance between base and emitter decreases, causing an increased current flow between

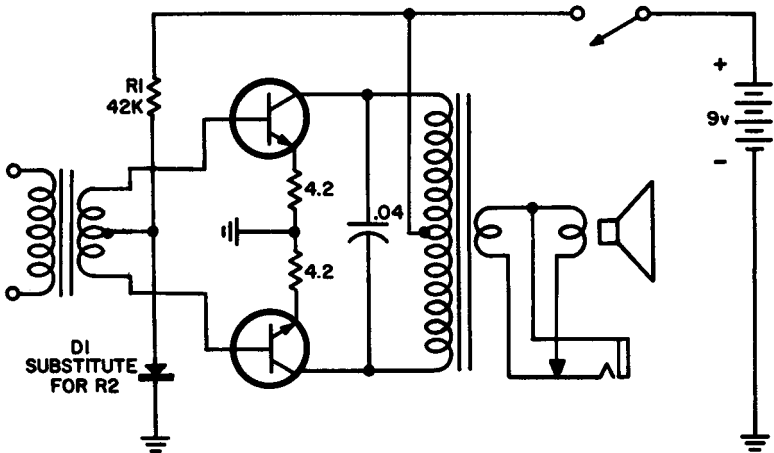
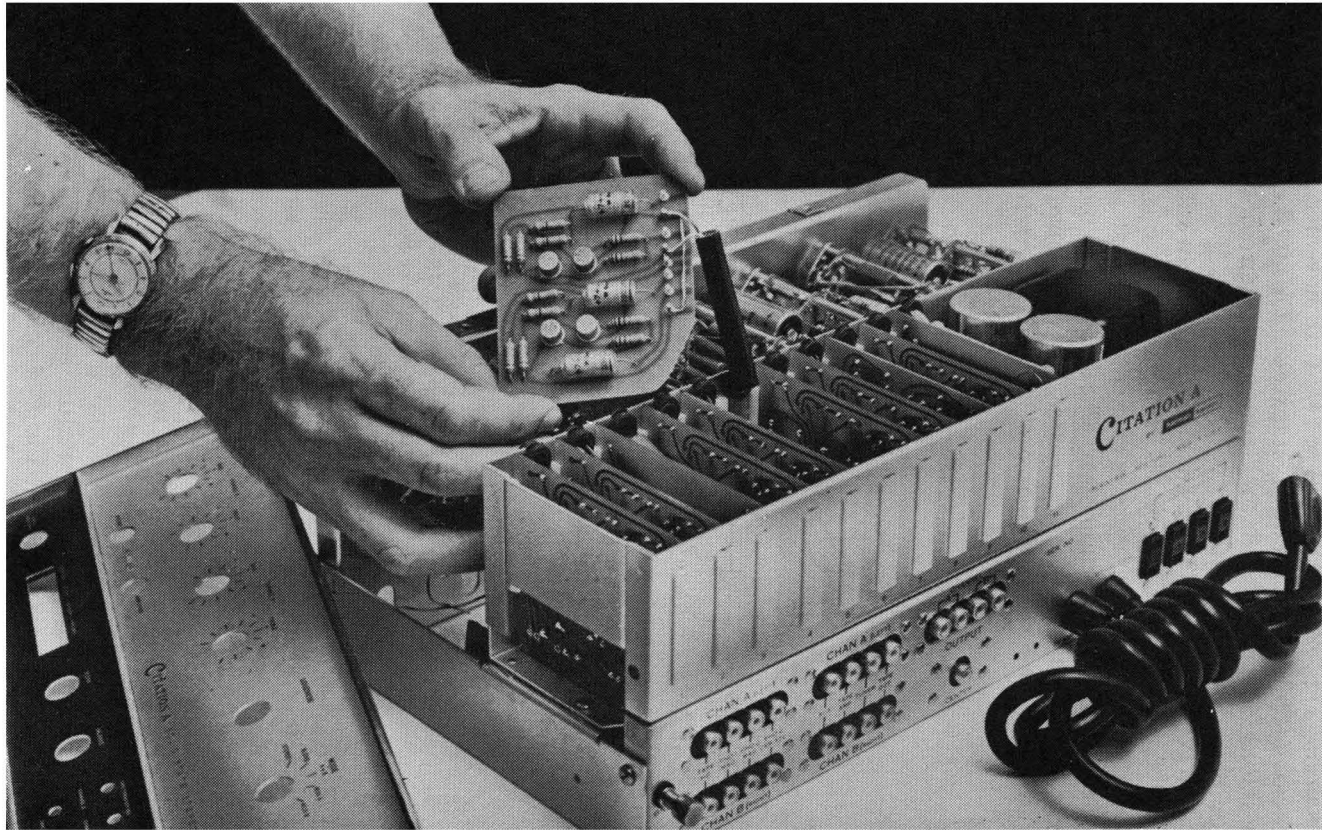

Fig. 524. Diode D1, substituted for voltage-divider resistor R2, has the advantage of acting as a temperature-compensating device. Note that the diode is forward-biased. Its forward-biased resistance is the correct value so that the bases of both transistors are properly biased.

these two elements. At the same time, though, the resistance of the diode (substituting for R2) also decreases. Because the diode is in shunt with the base-emitter circuit, we have a bypass path for additional current.

Now what if we had a temperature increase and had R2 in place of the diode? With a rise in temperature, the resistance of R2 goes up and so this very action forces even more current to flow between base and emitter.

Diode compensation or stabilization is generally found with power output stages since it is in such stages that temperature has a chance to do its dirty work. In Fig. 524 we have a circuit using



This all transistor stereo preamplifier features computer-like plug-in modules. A transformerless circuit gives a 1 cycle to 1 megacycle frequency response.
(Harman-Kardon Inc.)

a diode in this way. Note also the capacitor connected from collector to collector. This bypass is a bass-boost unit. The higher the capacitance, the higher the boost. A typical value would be .04 μ f.

The circuit of Fig. 524 uses n-p-n transistors. P-n-p's could also have been used, but in this case both the diode, DI, and the 9-volt battery would need to be transposed.

A final word

Amplifiers, like people, come in all sizes and shapes. A popular indoor sport among engineers is to try to see just how many different variations of audio amplifiers they can dream up—and, considering the choice of audio transistor circuitry we now have, they haven't just been wool-gathering. We have pushpull drivers feeding pushpull output; amplifiers in which all transformers (interstage and output) are eliminated; new arrangements of bias supplies; various feedback arrangements; temperature compensation, etc. This is like a huge plate of spaghetti. Dig around with sufficient seriousness, and you're bound to find yourself a few meatballs. The same is true of any audio circuit. Keep in mind just what it is the transistor is supposed to do, rearrange the circuit so that the biasing becomes obvious, and you'll be able to brush aside the clutter of extra components with ease, so that the basic amplifier circuits just shine through at you.

This doesn't mean we're finished with amplifiers. Those we've examined cover audio frequencies. We now have to climb the frequency range up to if and rf. We start our ascent in the next chapter.

QUESTIONS

1. What is base current? Emitter current? Collector current?
2. What is a common-emitter circuit? Common-collector? Common-base?
3. What is meant by in phase? Out of phase?
4. What is phase inversion?
5. Describe biasing of a transistor amplifier. What is the effect of forward biasing? Reverse biasing?
6. Describe class-A,-AB,-B and -C amplifier operation.
7. What are the differences between voltage and power amplifiers?
8. How does a single-ended amplifier differ from a pushpull amplifier?
9. What are the advantages and disadvantages of R-C coupling?
10. What are the advantages and disadvantages of transformer coupling?
11. What is meant by temperature coefficient?
12. What is positive temperature coefficient of resistance? Negative temperature coefficient? Zero temperature coefficient?
13. What is a thermistor? How is it used?
14. How does temperature affect a transistor?
15. What is a heat sink? How is it used?

chapter 6

detectors, agc, if amplifiers and front ends

IF you like the “whodunit” type of novel, you know that the trick is to supply as many clues as possible and yet spring a surprise ending on the reader. In an electronics book of this sort we also supply as many clues as possible. The big surprise will come when you realize that basically, transistor circuitry is fairly simple and repetitive.

The audio amplifiers we studied in Chapter 5 live on a diet of dc and ac. The dc is supplied by one or more batteries. The ac is the signal, and the closer we get to the speaker, the hungrier the transistor gets for hefty input. To build the signal to a value large enough to satisfy the audio driver we generally need several if stages. Note that we did not include the detector, although this stage follows the if's as a matter of course. The reason for this is that in almost all transistor radio receivers the detector is a diode, and as such, supplies no gain.

Transistor detectors

A transistor can be used as a detector and it does this job very nicely and easily, as we can see in Fig. 601. The circuit has

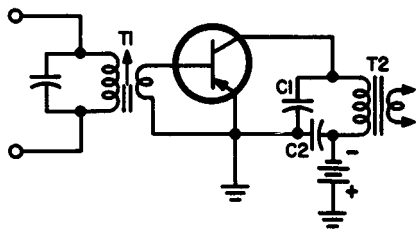

Fig. 601. Transistor detector works class B. In absence of a signal, the transistor is cut off. A signal of proper polarity supplies forward bias. The transistor rectifies, and supplies gain.

several points of considerable interest, so let's take a good look at it. We can start with transformers T1 and T2. T1 is an if transformer and couples the transistor detector to the preceding stage. T2 is the audio-output transformer and is our connecting link to the following audio stage. T1, as shown by the short lines separating the primary and secondary, has a ferrite core or slug. The arrowhead on top does not indicate the proximity of Indians, but rather that the core is tunable. Since we have a single arrowhead we know that this core will tune either the input or output side of T1, depending on its position. Sometimes you will see a double dashed line (each with its own arrowhead). This means that both primary and secondary are tunable. T2, the audio transformer, has a laminated iron core, and, of course, this is fixed.

We've been talking about if at T1 and audio at T2 and so, as you have probably gathered, something takes place in between these two transformers to effect this conversion. The change from if to audio is done for us by the transistor, working as a detector or signal rectifier.

The case of the missing bias

What is so unusual about this transistor, though? We've seen transistors before. If you'll look carefully, you'll see that while we have the collector-emitter circuit properly biased by the battery, we have made no provision for biasing the base-emitter or input circuit. It is true that the emitter is tied to the plus terminal of the battery, but as far as the base is concerned, it is way up in the air.

The low resistance of the secondary winding of if transformer T1 might easily lead us to believe that the base is practically shorted to ground (or to the emitter). It is if we consider it only from the viewpoint of dc. But the impedance of the secondary is adequate for the signal.

Effect of the signal

Since we have no forward bias on the transistor, very little collector current flows. Suppose, though, that transformer T1 receives a signal voltage from the preceding stage, and let us also suppose that the polarity of this signal is such that the top end of the secondary is plus and the bottom end is minus.

What has the signal done? Because the secondary of the if transformer is connected between the base and the emitter, we now have a signal voltage between those two elements. The signal

has made the base positive and the emitter negative. But this is reverse bias! Its effect is to drive the transistor collector current down toward the cutoff point. As a result we get no signal output and transformer T2 just sits idly by, waiting for something to happen. This won't take too long since the polarity of our input signal changes. The top end of the secondary of T1 now becomes negative and its bottom end positive. This is just what the base-emitter circuit has been waiting for, since this is forward bias. The collector current now climbs, its value depending on the strength and duration of the incoming signal.

Detection and amplification

What has our transistor done? Two things! It has rectified the signal, since only half of the input waveform has any effect on the output. It has also amplified that half that did get through.

But what is the if? Isn't it just a sort of carrier with the audio superimposed on it? All we want for the audio amplifier is audio signal, though, the carrier being valueless at the output of the transistor detector. For this reason we put an if bypass (C1) between collector and emitter. Like all other capacitors, its reactance varies inversely with frequency. Since the if will probably be 455 kc, while the audio might have a top range of 10 kc (if that high), you can readily appreciate that C1 will do its best to bypass the if but will offer considerably more opposition to the audio signal. The audio signal passes through the primary of T2, and promptly gets transferred, by electromagnetic induction, to the next stage.

Decoupling

This sounds so neat and pat that it may be hard to believe — and you would be right to be skeptical. Some audio does sneak through C1, thus getting back to the emitter, and never has a part in ultimately moving the voice coil of the speaker. And some if and audio does get through the primary of T2, down to the battery. To keep these currents from circulating through the battery, we protect ourselves with another bypass, C2. Since the battery we show in Fig. 601 is used by all stages, we can't have the battery working as a coupling device. When C2 is fresh, it just goes along for the ride. But batteries get older and as they do they are very much inclined to act as coupling devices in addition to their primary function of supplying a voltage.

Transistor detectors are used where the gain of the detector is essential. This is not the case in the average 6 (or more) -transistor radio, but it is sometimes used in inexpensive two-transistor receivers. We have the circuit in Fig. 602.

With two-transistor receivers we need every bit of gain, and so these are often made with a collapsible rod antenna. The tuned circuit is L1-C1. C1 is a single-section variable capacitor having a maximum capacitance value of 365 $\mu\mu\text{f}$. R1, the volume control, is a 5-megohm potentiometer shunted across the primary of audio transformer, T1. V1 works in the same manner as described for the detector circuit in Fig. 601. It would be helpful to have an rf bypass capacitor connected to the collector of V1, but since sets of this sort sell for a very low price, this component is often omitted. V1 gets its forward bias from the signal, and its collector-emitter bias from a 3-volt battery.

After detection and amplification by V1, the signal is transferred by an audio step-down transformer to the base-emitter

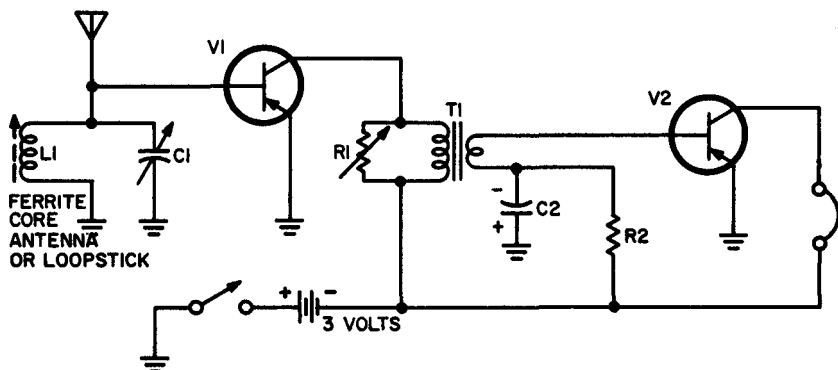

Fig. 602. Two-transistor receiver. V1 is the amplifying detector; V2 the audio amplifier.

input circuit of audio-amplifier transistor V2. This transformer could have a primary impedance of one hundred thousand ohms or more and a secondary impedance of about a thousand ohms.

Forward bias for V2 is supplied by a single resistor, a 100,000-ohm unit, R2. This may seem a little strange, since we've become accustomed to a series-resistor voltage divider arrangement shunted across the battery for forward bias. We can examine the biasing arrangement by taking a closer look at the components involved, in Fig. 603. Instead of having the bias resistors in

parallel with the battery, we have just a single resistor, and it is series connected. Again, the idea behind an arrangement of this kind is economy. Since we are working with a p-n-p unit, we want the base negative with respect to the emitter, but certainly not as negative as the collector must be. The arrow shows the direction of base-emitter current. This current passes through R2, but the voltage developed across R2 is in opposition to the battery voltage. The base-emitter voltage is equal to the battery voltage, minus the drop across R2. The signal voltage, appearing across the secondary of T1, modulates the current moving in this circuit, and as a result we get a similar (but amplified) variation in the output.

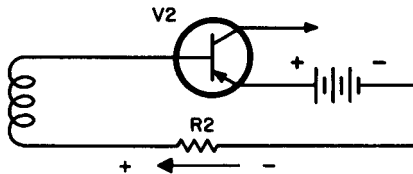

Fig. 603. Forward-biasing system for V_2 depends on a single series resistor.

Getting back to Fig. 602, we have a capacitor (C_2) rated at 3 working volts dc and $10\ \mu\text{f}$ functioning as a bypass at the bottom end of the secondary of T1. The purpose here is to keep any audio frequency currents out of R2. We depend on R2 to furnish bias and we would like to keep the voltage across R2 as steady as we can.

Automatic gain control

Since transistors have been designed to supply gain, we can't get too exasperated when they amplify weak signals and strong signals with equal enthusiasm. It would be much better if the transistor showed a little judgment here, but that would be expecting too much . . . or would it? What do we want the transistor to do? We would like it to use its full gain for very weak signals, less gain for stronger signals; and for very strong signals not to flex its muscles at all. We force the transistor to do this with the help of a very simple circuit with not such a simple name. We call it automatic gain control, which we promptly abbreviate as agc. Sometimes the same circuit is called automatic volume control, or avc.

To understand agc, consider how the transistor works. As we

increase forward bias, collector current increases. A strong signal will give us a much greater rise in forward bias than a weak signal. If we could increase the forward bias for a weak signal and reduce it for a strong signal, we might be able to rid ourselves of the annoyance of sound blasting from the speaker as we go from station to station. Agc isn't a cure-all, but it does help alleviate the problem somewhat.

Our first step toward getting agc is shown in the stripped-down circuit of Fig. 604. T1 is an if transformer and is responsible for delivering the if signal to the diode detector. As you can see, our diode detector is just a half-wave rectifier. R1, our volume control, is our diode load. When the signal across the secondary of T1 has the correct polarity (diode cathode negative) current

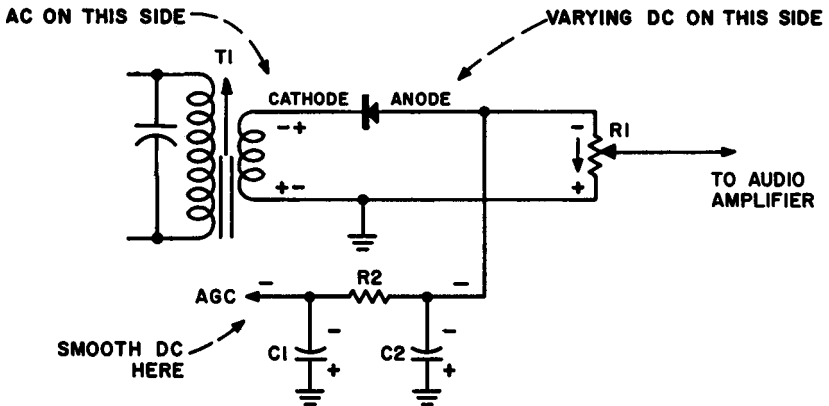

Fig. 604. Diode detector and agc circuit. R1 is the diode-load volume control. The voltage developed across R1 is also used for agc.

will flow through R1 in the direction of the arrow. This makes the top end of R1 negative with respect to ground. It is true that the voltage across R1 is a varying audio signal, but it flows in one direction only, hence is a changing dc. We can take this dc voltage, and send it through a filter consisting of C1, C2 and R2 and by the time we get to the arrow marked agc, we have a nice, steady dc voltage.

But can we really boast about the steadiness of this dc voltage? If we get a strong signal, we will get a greater voltage drop across R1. This means more voltage for our filter. A weak signal means less voltage. We now have available a negative voltage (with

respect to ground) whose strength is determined by the signal.

Let's see what we can do with this negative voltage. In Fig. 605 we have a transistor if stage and a diode detector. The top end of the diode load is positive and the bottom end negative (for part of the time) when a signal is received. We have inserted this resistor right in series with our two voltage divider resistors that normally supply forward bias for the transistor. If you will examine the diode load, you will see that the voltage developed across it is in opposition to the voltage across R1 and R2. But how great is this opposition and on what does it depend? A strong signal will develop a stronger voltage across the diode load. But this stronger voltage will oppose the forward biasing arrangement of R1 and R2. As a consequence, the gain of the transistor in the

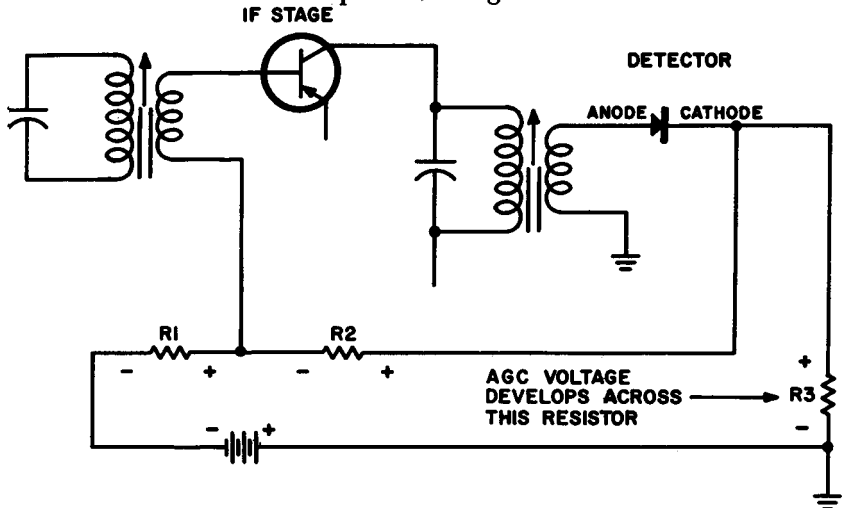

Fig. 605. Steps in the development of an agc system. The diode load is in series with R1 and R2. In the absence of a signal, forward bias for the if transistor is supplied by R1 and R2 in series with the diode load resistor. Resistors R1, R2 and R3 are shunted across the battery. Signal current, though, flows only through R3. The voltage developed across R3 is in opposition to the voltage produced across R3 by the battery current.

last if stage (in Fig. 605) will not be as great as it would be without this opposition. A weak signal, of course, will produce much less voltage than a strong one, and so the transistor will be allowed to work with greater gain.

Now you might think this is a wonderful idea and just jim-dandy, but look hard enough and you will find a price tag cached away somewhere. And where is the serpent in the agc Garden of Eden? The gain is reduced for all signals. We can tolerate this

for strong signals, but for some weak signals it is tantamount to signal suicide.

As a matter of common practice, agc is often tapped from the top of the volume control (which acts as the diode load) and is fed back as a control voltage to the transistor in the first if stage. We have this arrangement in Fig. 606. The series arrangement, R1, R2 and the volume control, R3, act as the voltage divider for the first if transistor. Capacitors C1 and C2 are agc filters, bypassing any signal variations to ground or to the emitter of the first if. C4 looks as though it might be part of the agc network, but its function is that of an rf bypass, to keep the if out of the volume control, hence out of the audio system which follows. Similarly, C3 in the first if stage is also an rf bypass.

Decoupling

All of the stages in a transistor radio receiver, no matter what we may ask them to do, have a common denominator. The one

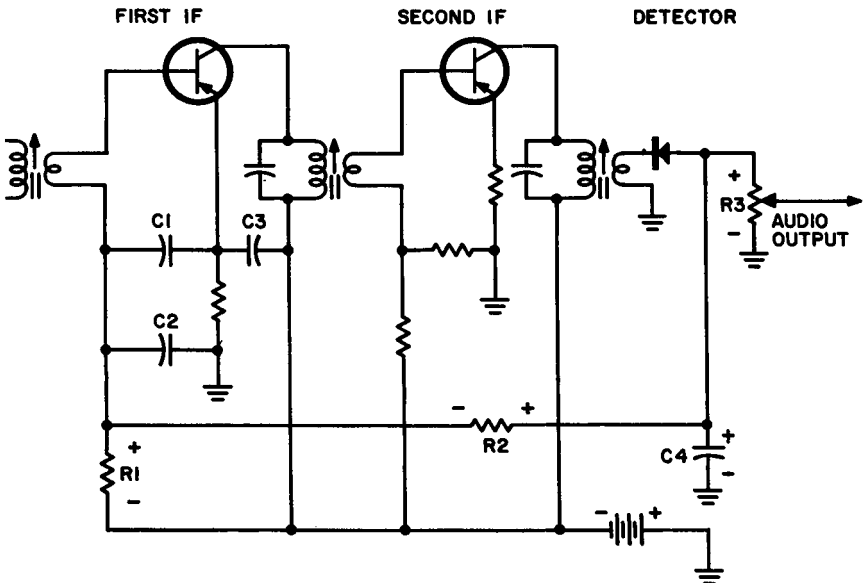

Fig. 606. Capacitors C1 and C2 and volume control R3 form the essential elements of the agc system.

component through which all the transistors are related is the battery. Transistors, though, have signal currents as their stock in trade. And these signal currents do not regard a battery with

the same uncritical eye as a transistor-radio fan. To a signal current a battery is an impedance. When the battery is fresh, it has such a low impedance that the signals just go scooting right through it as fast as a junior scout on a greased pole. But as a battery gets used, or if it just sits around waiting to be used, its impedance rises just as surely and inevitably as your yearly taxes. When the impedance gets high enough the signal has a field day, since it can develop a signal voltage across the battery.

The battery, though, is common to all stages, and when in a somewhat discharged condition, acts as a coupling element. The sum and substance of all this is that there is nothing the signal currents would rather do than go wandering through the battery and then through the various receiver stages. Now we cannot

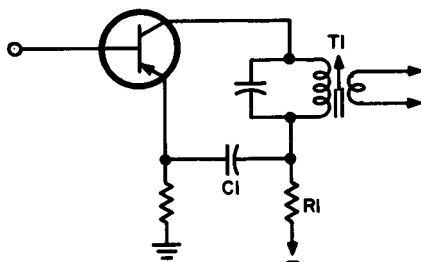

Fig. 607. R_1 and C_1 are the decoupling components.

have this since it is a form of signal anarchy. Once we lose control of the signal anything can happen, with the result usually evidenced as a series of weird noises out of the speaker.

We can avoid this unhappy state of affairs by shunting the battery with an electrolytic capacitor or by decoupling the collectors of the transistors. All that is needed are some series resistors and capacitors. A typical circuit is shown in Fig. 607. C_1 is the bypass and R_1 is the series resistor. R_1 can have a value of several hundred ohms up to about 1K. A value of $.05 \mu\text{f}$ for C_1 is common. In this circuit, T_1 is an if transformer.

Auxiliary agc

Nothing delights the heart of a design engineer more than his ability to make one component do two jobs. An emitter resistor, for example, not only supplies the correct voltage for the emitter, but (when its shunting capacitor is omitted) some negative feedback as well. In Fig. 607, decoupling resistor R_1 can be made to

do an interesting variety of chores. It works, as we have mentioned, as a decoupling resistor. It drops the battery voltage so that the correct amount is placed on the collector. And it contributes its little mite to the circuit shown in Fig. 608, and known as an auxiliary agc.

Problems, problems

Now you might have thought that we were finished with agc. We are, except for a problem we have when operating a transistor radio in strong signal areas. Transistor receivers can produce an inspiring amount of gain and if we begin with a strong signal, it is entirely possible that the agc system couldn't cope with this combination. To help matters, we use the circuit shown in Fig. 608. The heart of this auxiliary system is the diode which we have connected from the collector circuit of one if stage to the collector circuit of the next. The two if stages are identical, except for one

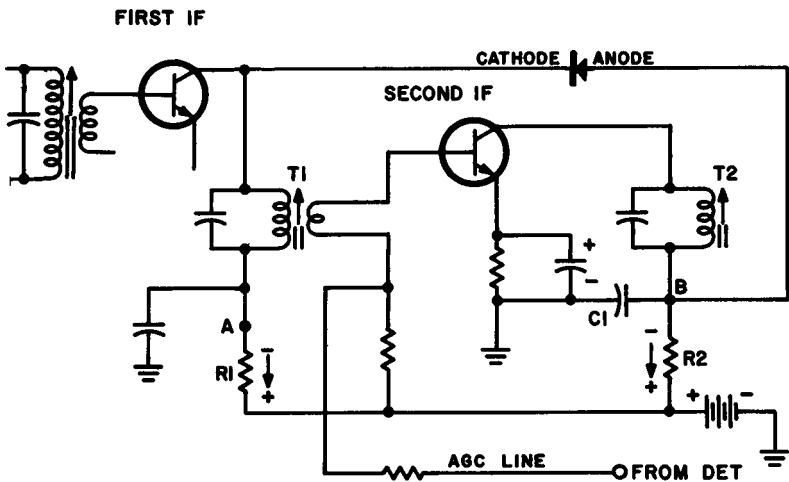

Fig. 608. This auxiliary agc system uses a diode shunted across an if stage.

very important difference. The first if is not agc controlled; the second if is. Suppose, now, that no signal is being received. Without signal, the collector currents of the two stages will be the same (assuming identical transistors and components). If R1 and R2 are resistors of the same value, the voltage drops across these resistors will be the same. This means that the voltage at point A in Fig. 608 will be the same as the voltage at point B. For-

getting the resistances of the if transformer windings for the moment, this means that the cathode of the diode and its anode are both at the same potential. Under this condition, the diode might just as well not be in the circuit. However, we do have a little bit of a voltage drop across the primary of T1, and so we have a potential impressed across the diode. The polarity of this potential, though, is such that the diode is reverse biased. We need this touch of reverse biasing, since the diode, hanging on to the collector of our first if, is in a fine position to sabotage the signal. Reverse biasing, hence increased resistance, prevents this.

Signals — weak and strong

Now suppose we receive a weak signal or one that is just moderate. The effect of this is to reduce the forward bias of the second if. But if we do this, the collector current of the second if is also reduced. The collector current, though, flows through R2. This reduced current means less voltage across R2, with the result that point B becomes more positive. For weak or moderate signals, the increase of positive voltage at point B isn't too significant. But what if we get a signal that is strong? The drop across R2 will become much less. It will be just as though we had moved point B right down to the plus terminal of the battery. But this is connected to the anode terminal of the diode. The diode becomes forward biased.

From here on events take place rapidly. A forward biased diode acts very much like a resistor of very low value. When the signal arrives at the top of T1 it finds to its surprise that a short cut awaits — an easy path to ground through the diode over to point B and from point B through the bypass capacitor (C1) to ground. Of course not all of the signal is killed, enough of it getting through T1 and the second if to produce a respectable amount of volume out of the speaker. But no blasting and no mad dash to get at the volume control.

Impedance matching

Every if transformer has two requirements, but unfortunately these demands can be in conflict — and usually are. One essential of an if winding is that it should have enough turns so that it can be tuned to the intermediate frequency. To be able to do this, it must have a certain number of turns. But as the number of turns is increased, so is the overall impedance of the winding. But we want the impedance to match the base-emitter input or the collector-emitter output.

Although this idea is fairly evident when we work with resistors, it isn't quite so obvious with inductors. To make sure we understand it, let's move on to Fig. 609. In Fig. 609-A we have a pair of 500-ohm resistors in series, for a total of 1,000 ohms. The resistance from point A to ground is 1,000 ohms, but if we move the ground point up, as in Fig. 609-B, the resistance from point A to ground is only 500 ohms. This is true even though we still

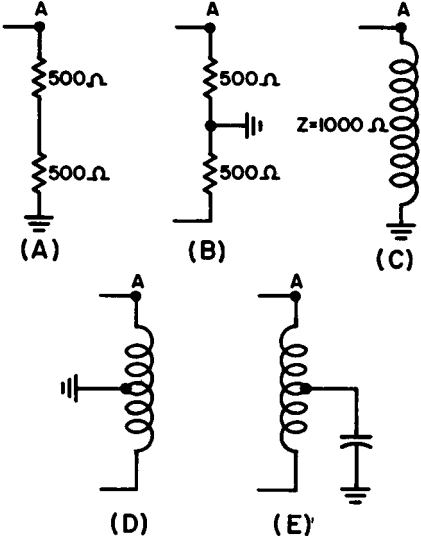

Fig. 609. Out of the total impedance supplied by a coil, we can select as little as we need for our transistor circuit.

have 1,000 ohms connected into our circuit. Now move over to Fig. 609-C where we have a coil having an impedance of 1,000 ohms from point A to ground. If we put the tap at the *electrical* center of the coil (this is not the same as the physical center), then the impedance from point A to ground (Fig. 609-D) is only 500 ohms. We do not need to connect a direct ground, for in Fig. 609-E we see that we have a capacitor wired into our electrical centertap. This puts the center at ac ground potential and so the impedance from A to the point of connection for the capacitor is only 500 ohms. However, the entire coil might still be connected into our circuit.

All of this has a very practical bearing on our transistor cir-

uits. We can take advantage of the techniques shown in Fig. 609 so that we get a good match between the transistor and the if transformers. If you will look at Fig. 610 you will see that we have the final if stage of a transistor receiver. The total impedance of the primary of the if transformer is measured between points A

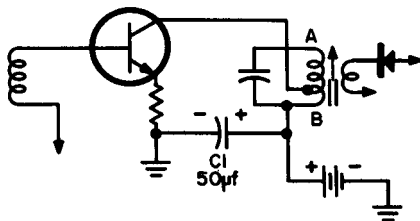

Fig. 610. The collector of the transistor is tapped down on the primary of the if transformer to obtain an impedance match. Capacitor C1 acts as an ac short to ground. Maximum impedance would be at point A on the coil winding. The impedance gets less and less as we move toward point B.

and B. Point B, though, is connected to C1, a 50- μ f capacitor. One side of this capacitor is grounded and so, as far as any signal voltage is concerned, point B is at ac or signal ground potential. The collector is connected to a tap on the primary. The total impedance presented by the primary winding to the transistor is the impedance of the coil between the collector tapping point and point B. If we were to move the tap further up on the coil, we would get more and more impedance into the collector circuit. The maximum would be if we connected the tap to point A.

The impedance divider

Impedance division, such as that obtained through the use of a tapped coil, is no different from using a resistor as a voltage divider. Actually, a tapped coil used as an impedance divider could also be called an ac voltage divider, a somewhat better name since this is a constant reminder that the impedance or voltage division is effective for ac only.

Looking at Fig. 610 again, you might get the impression that since the collector is tapped so far down, there is a large loss of signal voltage. The tap, though, has the effect of converting the primary into an autotransformer, supplying both a voltage stepup and a very nice example of having our cake and being able to munch on it as well.

Tapped coils can be used in the transistor input, the transistor output, or both, as shown in Fig. 611. It is applicable to both types of transistors — p-n-p and n-p-n. And although we have indicated impedance matching by having the collector tapped down on the if transformer, we could connect the collector to the top of the coil and tap up with the emitter. This is shown in Fig. 612.

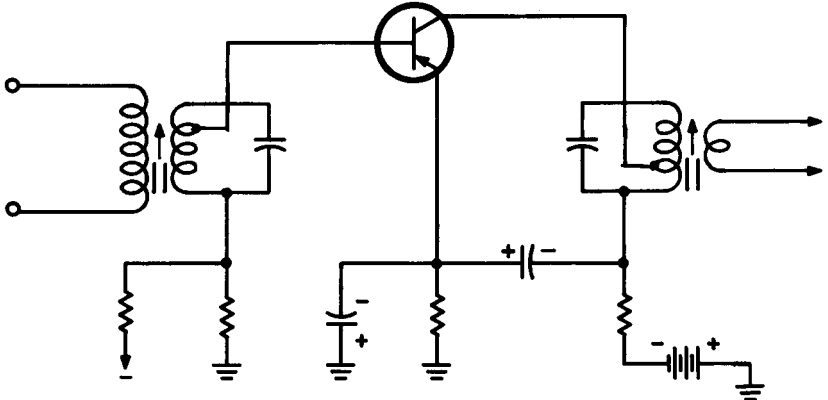

Fig. 611. Both the base and the collector are tapped down on their respective if transformers for impedance matching.

The tap on the coil is at signal ground. The impedance presented to the collector is between the tap and the top end of the coil. Not only is the tap important for impedance matching purposes, but its position also helps control the amount of negative feedback, when this is used.

Negative feedback or neutralization

If the transistor is behaving itself, the signal in the collector circuit is much more substantial than the signal in the input of the same transistor. Do you remember the story of Lot's wife? As told in the Bible, she looked back and was turned into a pillar of salt. Now this won't happen to our output signal but we want it to look forward, not backward. We don't even want a small fraction of it to go backward, because if it does, it may cause miscellaneous troubles such as oscillation and narrowing of the bandpass. We're particularly worried about the if stage since it so happens that its design is just ideal for signal feedback. Our transistors are triodes and our input and output circuits are tuned to the same frequency. Triodes love to oscillate and do so with carefree ease, especially with if transformers. Now the very strange thing about all this is that for oscillation to take place,

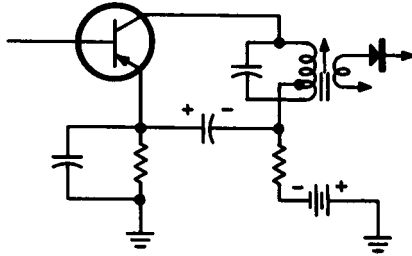

Fig. 612. For impedance matching, we can have the collector tap down (as in Fig. 611) or the emitter tap up on the if winding. The result is the same.

the fed back signal (the output signal) should have the same phase as the input. But in the common emitter circuit, the output is out of phase with the input. However, between the stray capacitance in the circuit, and the inductance of the if transformer,

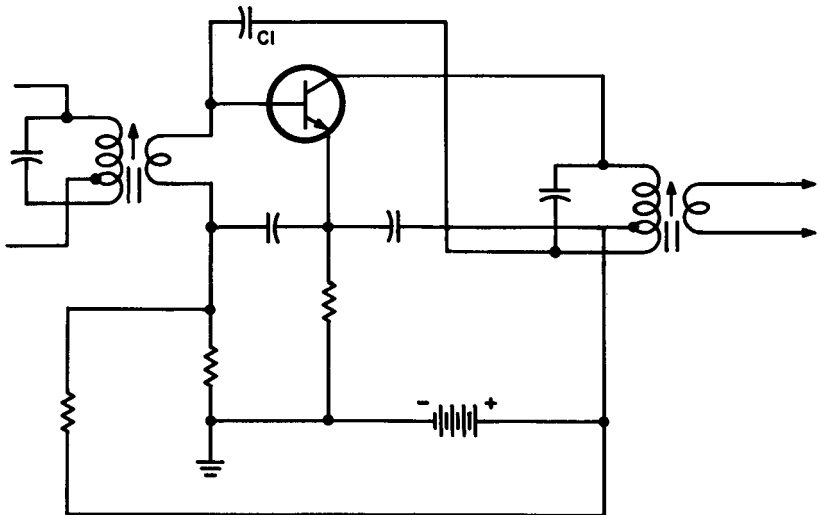

Fig. 613. C_1 is the neutralizing capacitor. The amount of negative feedback depends on the value of C_1 and the position of the tap on the primary winding of the if transformer.

we can get enough of a phase shift so that the output signal drifting back to the input is sufficiently in phase with it so that it creates mischief.

The answer to this problem (see Fig. 613) is to feed back,

deliberately, enough of the output signal to the input, to cancel the signal leaking back accidentally. We connect a feedback capacitor, C1, between the output and the input. Note that C1 is really attached to the bottom end of the coil while the collector bias

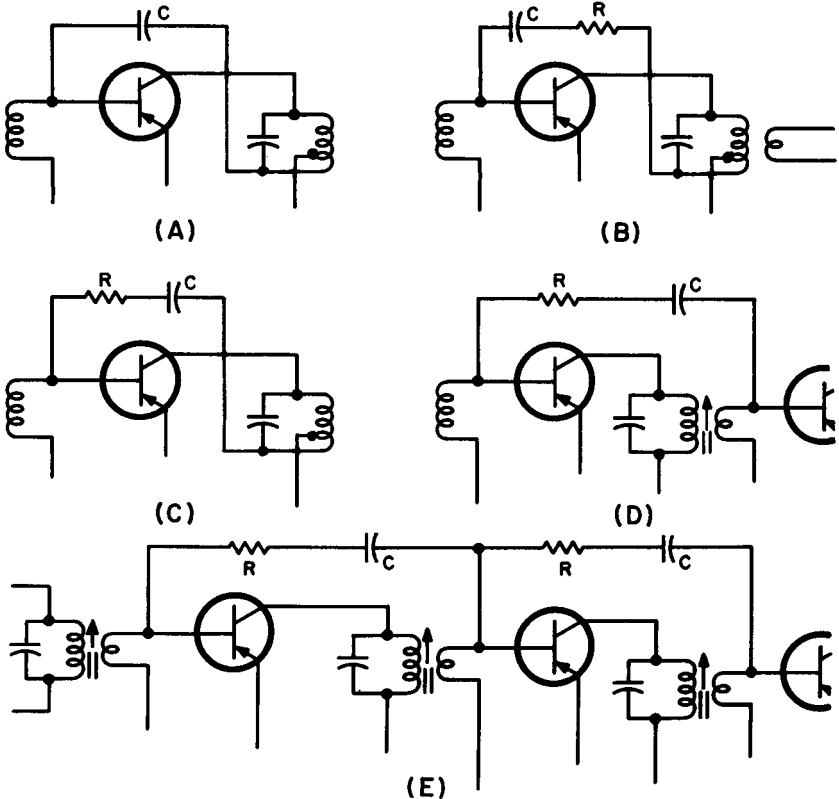

Fig. 614 Some negative feedback circuits for neutralization of if amplifiers. The simplest method (A) uses a fixed capacitor and a tapped transformer. A series resistor can be inserted as in B to help control the feedback. The positioning of the resistor (R) and the capacitor (C) in B and C does not affect the results of the feedback. Sometimes the negative feedback is arranged from the base of the following stage (as in D) to the base of the preceding stage. The amount of feedback is controlled by R and C. Feedback is usually needed in more than one stage and is connected as in E when tapped transformers are not used.

is attached to the tap on the if transformer. This provides an out-of-phase signal to cancel the collector-to-base feedback in the transistor. We can adjust the amount of neutralization feedback by moving the tap, but remember, when we do so, we are also changing the impedance of the transformer and this is also the

collector load. Changing the value of C1 will also change the amount of feedback to the base circuit. Putting resistance in series with the capacitor will reduce the feedback. The best way to control this is with a variable capacitor that can be adjusted so that we get just the amount of feedback that is needed. This is the most expensive technique.

Feedback variations

There are other ways in which we can neutralize a triode transistor so that it does not oscillate. A few of these techniques are shown in Fig. 614. In Fig. 614-A we have a capacitor connected as in Fig. 613. The capacitor can have a very small value, a few micromicrofarads being sufficient. We can also cut down on the amount of feedback by putting a resistor in series with the feedback capacitor as in Fig. 614-B. It makes no difference whether the resistor comes before or after the capacitor (Fig. 614-C). We can also make our feedback connection directly to the input of the following stage, as in Fig. 614-D. When neutralization is continued stage to stage the circuit in 614-E is used.

The problem of selectivity

Every receiver — whether transistor or tube — has at least one variable tuned circuit and a number of fixed tuned circuits. We want tuned circuits in a receiver because we need them to be able to separate one station from the next. Variable tuned circuits are those that are continuously adjustable by either a moving ferrite slug or a variable capacitor. A fixed tuned circuit, as its name implies, is tuned to a particular frequency and remains that way. Theoretically, variable tuned circuits are just dandy, but in practice having more than one tuned circuit presents a host of practical problems, particularly the very serious one of having all of the tuned circuits remain in step throughout the whole tuning range. This was the difficulty faced by early radio receivers which invariably were of the trf (tuned radio frequency) type. At first each circuit was tuned separately. This meant a separate tuning dial for each circuit and it was not uncommon to see radio sets with three dials, each one of which had to be adjusted whenever a different station was to be tuned in. As you can imagine, tuning from one station to the next was not the most popular indoor sport. Then some bright-eyed lad had the brilliant inspiration of putting all the tuning capacitors on a single shaft. This worked fairly well, but in general it limited the trf to about three tuned circuits.

The superheterodyne changed this, for each tube-type if stage could supply two tuned circuits. If a receiver had three if's, this meant a total of six tuned circuits, thus supplying at once twice as many tuned circuits as the old trf's.

Frequency conversion

Briefly, a superheterodyne works on the principle of frequency conversion. The receiver has a variable tuned circuit capable of selecting any frequency on the broadcast band. In the receiver, a circuit known as a local oscillator also produces a signal. We now have two signals, one supplied by the broadcast station and the other, locally, by the receiver. When these two signals are mixed, the result is a third signal which we call the intermediate frequency. The receiver oscillator (or local oscillator) is continuously adjustable, so that the difference between its frequency, and that of the radio station, is always constant. Thus, if you tune a radio set to a station at 1400 kilocycles, the local oscillator will

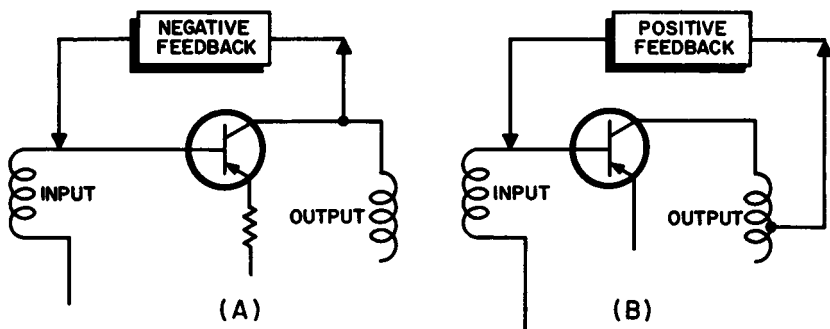

Fig. 615. We have two types of feedback: negative (also known as degenerative, inverse, or out-of-phase) for neutralization, and positive (also known as regenerative or in-phase). Positive feedback is used to produce oscillation; negative feedback to prevent it.

be set by that same tuning action to 1855 kilocycles. When these two frequencies, 1400 kc and 1855 kc, are mixed, one of the resulting frequencies will be the difference between the two, or 455 kc. This is our intermediate frequency or if. If we tune our set to 800 kc, our local oscillator will be at 1255 kc. Once again, the difference between the two frequencies will be 455 kc. Thus, the whole idea — the basic idea — of a superheterodyne receiver

is to change any frequency on the broadcast band to a single fixed frequency. Because of this action, we can have many tuned if stages — actually fixed tuned because they remain tuned to but one frequency.

Converters

The job of changing the broadcast signal to an intermediate frequency (if) signal can be done by a pair of transistors or by a single unit. If two transistors are used, one is known as the mixer and the other is called the local oscillator. In practically all transistor receivers, however, just a single transistor is used to work both as a mixer and local oscillator. This transistor is called a frequency converter, or, more simply, a converter. If a separate transistor is used as the local oscillator, and a separate transistor as the mixer, we refer to the combined operation as a heterodyne action. If a single transistor combines both functions, we call the operation autodyne. Actually, the behavior is the same whether we use one transistor or two.

The autodyne converter

The converter transistor circuit receives the signal from the antenna at its input; delivers an if signal at its output. The trouble with this statement is that it is notable for the information it does not give us. The converter is a triple header. It:

1. amplifies the incoming or rf signal
2. mixes or heterodynes the rf signal with the locally produced oscillator signal
3. amplifies the if signal

This is quite a multiplicity of jobs for just one transistor, so let us separate these transistor functions and examine them separately.

The local oscillator

An oscillator, as used in a radio receiver, is a radio or high frequency ac generator. Typically, the oscillator works because we take a portion of the amplified signal developed in its output and feed it back to the input. Now this sounds very much like the neutralization techniques we described earlier, and so it is, with one basic difference. Neutralization uses feedback that is out of phase with the input; oscillation uses feedback that is in phase. These differences are shown in Fig. 615.

The Hartley oscillator

In Fig. 616 we have a very popular oscillator; the Hartley. The battery, resistors and capacitors have been omitted for the moment. In this circuit current will flow from the collector to the emitter. The emitter is grounded and so is a tap on the coil. The current will flow through this common connection, up through the coil, back to the collector, thus completing its rounds. But the current, in passing through that part of the coil we call L1, built up a magnetic field around L1. This magnetic field induces a voltage across L2. If you will trace the connections to L2 you will see that it is in the base-emitter or input circuit.

Now let us suppose that the voltage across L2 has a polarity such that it supplies forward bias for the input. The result of this will be an increase in collector current. But if we get an increase in collector current, we will get a stronger growing mag-

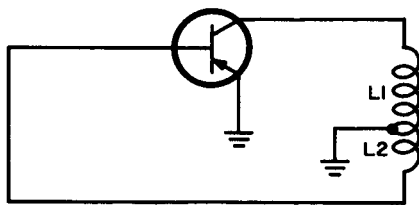

Fig. 616. Basic elements of a Hartley oscillator.

netic field around L1, and this, in turn, will induce even more voltage across L2. This increases the forward bias, which, once again, produces more collector current.

Of course there is a limit. The output circuit cannot increase its current output indefinitely, and soon the collector reaches saturation, or maximum current level. As it approaches saturation, the rate of change of increase in current becomes less and less. But to get an induced voltage we need a *changing* magnetic field — our induced voltage across L2 depends on it for its existence. Consequently, we get a smaller and smaller induced voltage across L2, until finally, when the collector current is at saturation, we get no induced voltage at all. At this point we have maximum current through L1 and a maximum magnetic field around it. But this magnetic field is a steady one and as such, is incapable of inducing a voltage. What has happened to our forward bias? Since it consists of the voltage across L2, it has disappeared. But with no forward bias, the collector current starts to decrease. This decreasing current once again produces a changing magnetic field

around L1 and once again we get a voltage induced across L2. But the polarity of this voltage is exactly the opposite of what it was before. Now the voltage across L2 reverse biases the input. This drives the collector current down to cutoff. But at cutoff, there is no current through L1. There is no magnetic field around L1 and we have nothing with which to induce a voltage across L2.

But isn't this where we came in? When the reverse bias is removed from across L2, a small amount of collector current begins to flow. This produces a growing magnetic field across L1, inducing a forward-biasing voltage across L2 — and so the entire action repeats.

Operating frequency

In this circuit, the collector current runs the gamut from cutoff to saturation. The frequency with which it does this is determined by the value of L1. If we put a capacitor in shunt with L1 or in series with it, the frequency will be determined by the value of both components — the coil and the capacitor, the combination often being referred to as a tank circuit. L2 is sometimes called the tickler or feedback coil.

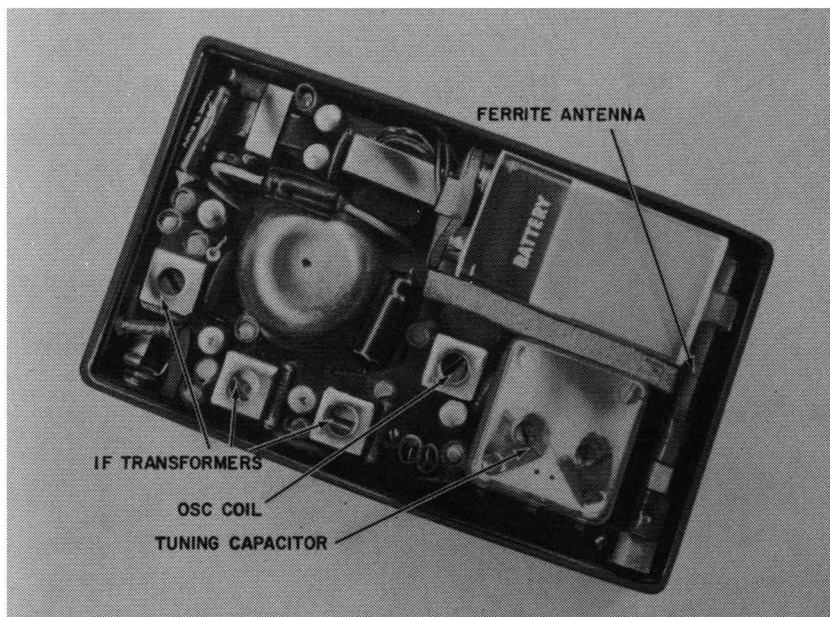

Typical transistor portable has three fixed tuned circuits in the if transformers and the tuning capacitor controls the resonant frequency of the ferrite antenna and oscillator.

The Armstrong oscillator

Although they may not seem so, coils L1 and L2 in Fig. 616 form a transformer. This isn't immediately apparent since most of us are accustomed to thinking of transformers as units having separate primaries and secondaries. Transformers with a tapped winding, as in the case of the Hartley oscillator, are called autotransformers. In Fig. 617 we have two examples of such transformers. Fig. 617-A is a step-up unit; that in Fig. 617-B is a step-down. Corresponding to these autotransformers we have those with separate primaries and secondaries, as in Figs. 617-C and D.

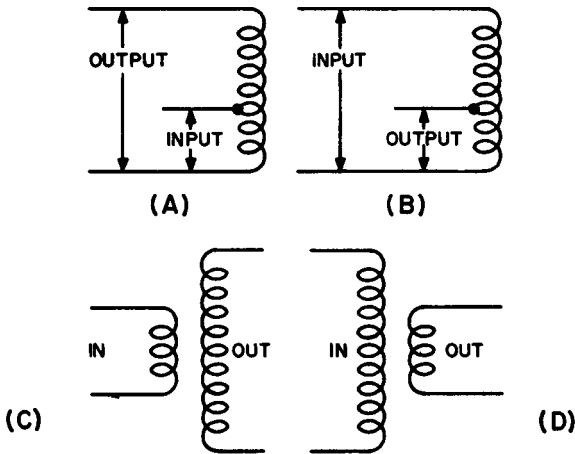

Fig. 617. Autotransformers and transformers with separate windings. In A we have a stepup autotransformer; its counterpart is shown in C. B is a stepdown autotransformer; its counterpart is shown in D.

The Armstrong oscillator uses a transformer having individual primary and secondary windings. See Fig. 618. The circuit works in exactly the same way as the Hartley. As far as any current variation is concerned, the two coils L1 and L2, are really connected. The bottom end of L2 is grounded. The bottom end of L1 is grounded through capacitor C1. This means that L1 and L2 are connected electrically, although not physically, as in Fig. 616.

The complete oscillator

What we have shown you so far are the basic essentials of an oscillator. The local oscillator, though, must have a variable tuning circuit so that its operating frequency can be continuously

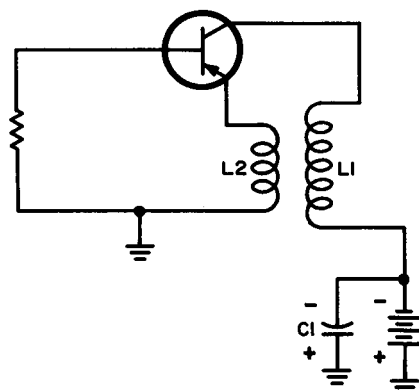

Fig. 618. Basic elements of an Armstrong oscillator.

adjusted when selecting a station. In Fig. 619 we have a variable tuning capacitor, C2, shunted across L2. This capacitor is mounted on the same shaft as the rf tuning capacitor (not shown in Fig. 619). Thus, when the rf tuning capacitor is turned to select the station desired, C2 is also turned at the same time. The local oscillator frequency is determined by the values of L2 and C2, and this frequency, as we mentioned earlier, is 455 kilocycles higher than the frequency of the broadcast signal.

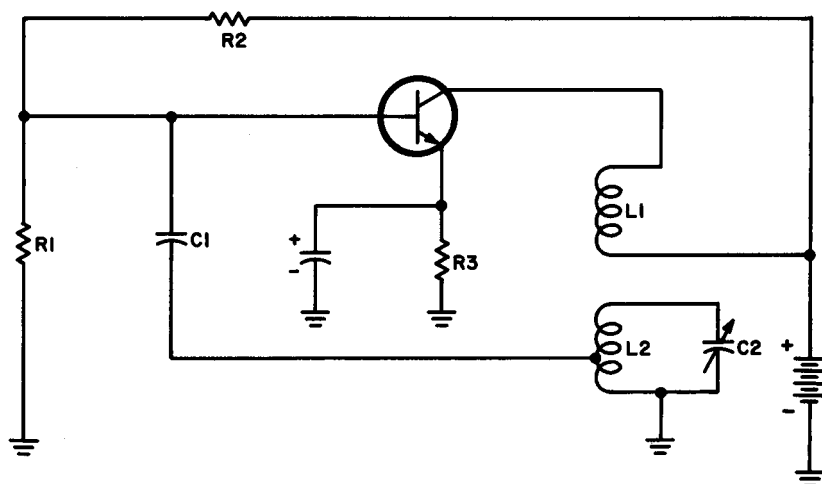

Fig. 619. Local oscillator circuit. L1 is the tickler or feedback coil.

Fig. 619 has a few other items of interest. Note our old friends, R1 and R2, once more in the act. In this case, we choose a value of bias so that our transistor works in the low-current region. This is the part of the collector characteristic that is curved or non-linear. We must operate this way to get the local oscillator and rf (or broadcast) signals to beat or mix with each other.

R1 and R2 put a dc voltage on the base. But the base is connected to a tap on L2, one end of which is connected to ground. To keep L2 from shorting R1, we include a capacitor C1.

The mixer

Now that we have our local oscillator, let's remove the transistor and see how it also works as a mixer. We're going to use

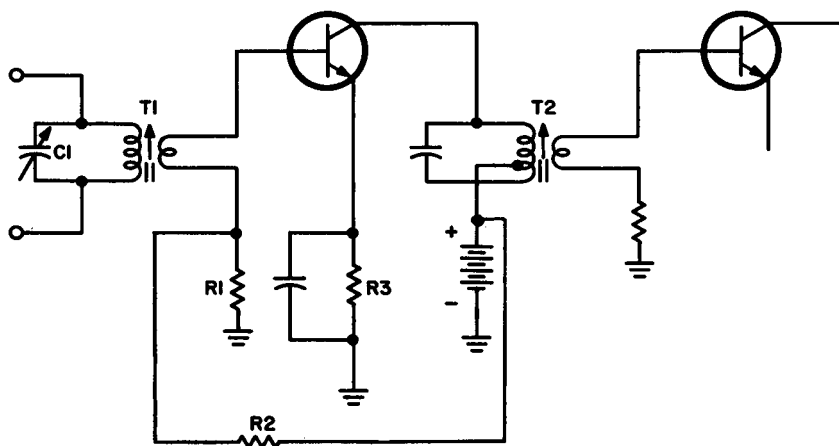

Fig. 620. Mixer circuit. The local oscillator has not been connected to it.

the same transistor since it is going to operate both as a mixer and local oscillator. The circuit is shown in Fig. 620.

As you can see, the arrangement looks just like a straightforward amplifier. The rf signal is tuned by C1, shunted across the primary of T1. The rf tuning capacitor is mounted on the same shaft as C2 in Fig. 619. The signal is delivered to the base-emitter input circuit by T1. R1 and R2 are the same forward-biasing components we used in Fig. 619. R3 is also the same. In the collector circuit, though, we now have T2, our first if transformer. T2 delivers the if signal to the base of the following stage.

When the signal is received by T1 it is rf. T1 is a ferrite-rod antenna and picks up the signal. The signal that is delivered by

T2 is if, and so, somewhere between T1 and T2, we must have some sort of frequency conversion, to change the signals of all stations on the broadcast band, to the single frequency required by the if stages.

Our final step to the complete mixer is to combine the circuits of Fig. 619 and Fig. 620, the local oscillator and the mixer, into just one circuit. We have this in Fig. 621, and if you will examine it carefully, you will see just how this was done.

Most of our components remain the same. C1 is ganged to C2, as shown by the dashed line connecting them. The oscillator transformer consists of L1 and L2. The primary of the if transformer,

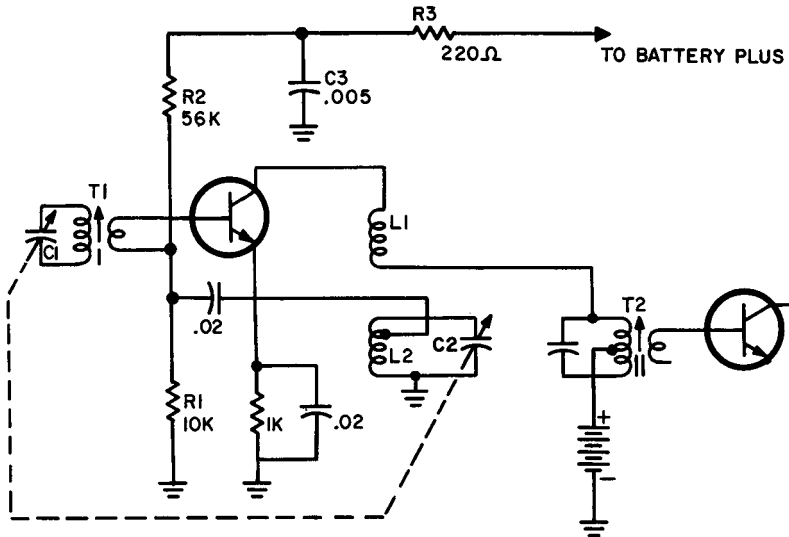

Fig. 621. Complete mixer circuit.

T2, is in series with L1 of the oscillator section. We've added some new components — C3 and R3. These form a decoupling filter to isolate the mixer from the other stages in the receiver.

How it all works

Our ride from the back end of a receiver to the front end is just about completed. At this time, though, let's think back over our whole trip to see if we can connect our ideas into one neat, little package.

The ferrite antenna in the receiver is capable of picking up any signal in the broadcast band. The desired signal, though, is selected by a variable capacitor shunted across the ferrite antenna.

The broadcast signal, consisting of a radio frequency carrier modulated by an audio signal, is brought into the input of a mixer transistor. Here the signal is mixed or heterodyned with a locally produced signal. The result of this mixing process is a signal which represents the difference between the rf and local oscillator signals. This is a frequency conversion process and produces the intermediate frequency or if signal. All that has really happened is that our radio frequency has been lowered in frequency. It is still carrying with it, the audio signal from the broadcast station. The if is amplified by one or more if stages. Finally, when the if signal is strong enough, it is fed into a detector circuit. In the detector, the audio signal is rectified by means of a diode or a transistor. Immediately after rectification, the remaining if is

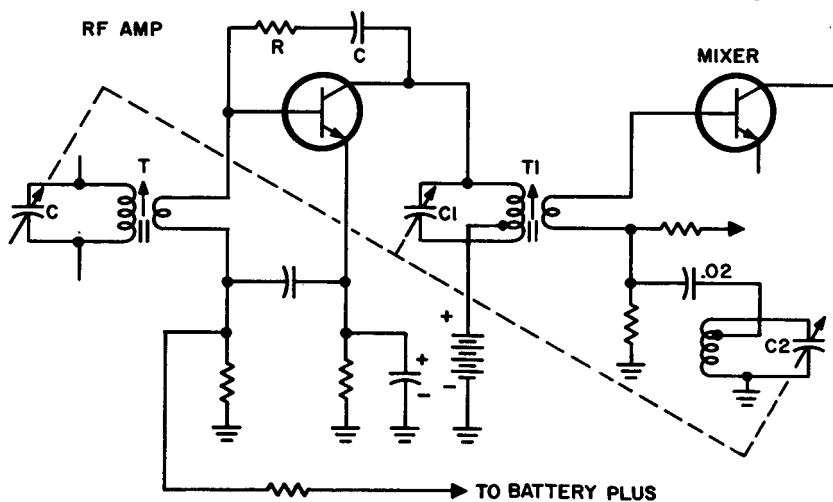

Fig. 622. Rf amplifier circuit. It can be connected to the mixer shown in Fig. 621.

shunted away or bypassed by means of a capacitor. The audio is fed into a driver stage, and then into a single-ended or pushpull audio amplifier, and finally to the speaker. Meanwhile, back at the detector, the rectified audio signal is also filtered and sent back to one or more earlier stages as an agc voltage.

Although each transistor stage does a slightly different job, you can see that they are similar in many respects. If you know how any transistor amplifier works, you are well on your way to understanding them all.

For this reason, the transistor rf amplifier shown in Fig. 622, will come as no great surprise. In this circuit, T1 now becomes

an rf transformer coupling the rf stage to the mixer. The rf amplifier supplies the receiver with certain advantages. There is greater gain because of the amplification supplied by the rf transistor. There is also some added selectivity, since we now have three variable tuned circuits. This calls for a three-gang tuning capacitor on which we have mounted C, C1 and C2. Transformer T now becomes our ferrite rod antenna. The rf amplifier is neutralized by resistor R and capacitor C.

And still more circuits

The circuits we studied in this chapter simply prove that transistors can perform the same functions as tubes in a receiver. But transistors aren't limited to receivers only. In our last chapter we are going to have a chance to become acquainted with other transistor abilities.

QUESTIONS

1. What is the function of a detector?
2. What are the advantages of using a diode as a detector?
3. What are the advantages of using a triode transistor as a detector?
4. How must a transistor be operated to make it work as a detector?
5. What is automatic gain control. How does it improve reception?
6. How does an automatic gain control circuit work?
7. What is the difference between ordinary agc and auxiliary agc?
8. What is decoupling? Why is it needed? How is it obtained?
9. What is meant by impedance matching? How is it done? Why is it necessary?
10. How is a transistor if stage neutralized? Why is neutralization used?
11. What is negative feedback? Positive feedback? When and why are they used?
12. What is a converter? Why is it needed? How does it work?
13. Describe a typical local oscillator and explain its operation.
14. Draw the basic diagram for a Hartley oscillator and for an Armstrong oscillator.
15. Compare mixers and converters and explain how they differ.
16. How does an rf amplifier improve reception?

chapter 7

transistor types

THE transistors we have been discussing thus far have all been lumped into two very broad and general categories. They have been either p-n-p or n-p-n units, but other than the fact that we have designated them as triodes, we have said nothing to you so far to give you a hint that there might be some very strong differences in transistors. The electronic symbols for an audio power transistor and a converter transistor will look exactly alike, and yet the operating requirements for these transistors are opposites. The output transistor must handle power at comparatively low frequencies. The mixer is much less concerned with power but works at considerably higher frequencies. Obviously, since their functions are so dissimilar, there must be considerable differences in the way they are fabricated and packaged.

Transit time

Although we may be inclined to look on the electron as a speedy little cuss, yet electrons can be slowed when they encounter obstacles and barriers, just like people. Consider the electron in a vacuum tube. If we have a triode, nothing (with the exception of the control grid) stands in the way of a rapid passage from the cathode to the plate. And even here we make the grid as much of an open mesh as possible so as not to interfere with electron travel.

But what do we have in the transistor? Instead of open space, we have a crystal lattice structure, and so we are, in effect, forcing the electron to hop from one atom to the next. But the frequency

at which we can operate is determined by how fast we can get the electron from the emitter to the collector or from the collector to the emitter. And, quite unlike the tube, we always have a barrier between these two electrodes. This barrier is the base, and while we can make the base extremely thin, the fact remains that the base exists between the collector and emitter. (A typical value of base thinness would be .001 inch or less.)

There are other factors which tend to limit the frequency range – that is, the upper limit of frequency at which the transistor will operate. One of these is the capacitance existing between the transistor electrodes. In Fig. 701-A we see how we can come to regard the transistor as a capacitor. Here we have the p-n section and, as you will observe, the diode is reverse biased. Current flows initially, but ceases shortly thereafter, because of the build-up of opposing charges at the junction between the two blocks of

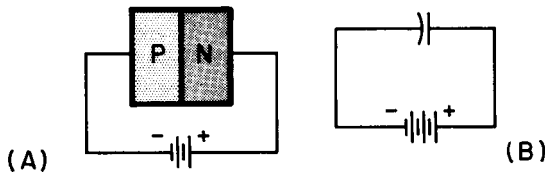

Fig. 701. The diode has some resemblance to a capacitor.

semiconductor material. But isn't this action very reminiscent of the way a capacitor charges. When we connect a capacitor to a battery as in Fig. 701-B, there is a momentary rush to charge the capacitor. The current flowing in the circuit rapidly drops as opposing charges collect on the plates. In the transistor, the effect is just as though we had a capacitor in shunt with the elements of the transistor. But as we go up in frequency, the reactance of this shunting capacitor becomes less and less, and, if the frequency is high enough, acts like a virtual short across the transistor.

There is still another factor with which we must contend when considering transit time and that is the material of which the base is made. We will get swifter movement of electrons through certain semiconductor materials than through others.

Alpha cutoff frequency

As we increase the frequency of a signal to be amplified by a transistor, there will come a point at which we will simply be wasting our time, for there will be no amplification. The transi-

tion from a condition of gain to one of no-gain isn't an abrupt change. As a basis for comparison among all transistors, we can establish the gain of a transistor at 1 kc as standard. We can consider the practical operating limit to exist when the gain drops to .707 of the gain at 1 kc (as we increase the frequency). This is known as the alpha cutoff frequency.

The tetrode transistor

We have now revealed the base as one of the chief culprits in limiting alpha cutoff frequency. This means that if we want to increase the operating frequency of a transistor we must force the

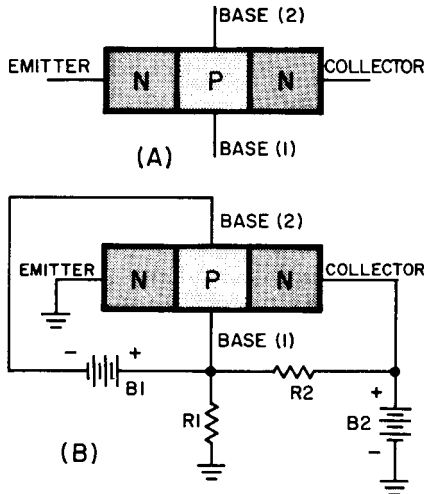

Fig. 702. The tetrode transistor gets the effect of a reduced base area by applying an additional bias to it.

base to yield to some sort of treatment. There are various pleasant ways of doing this, one of which results in a unit known as a tetrode transistor.

At this point you have probably jumped headlong to a wrong conclusion, based on your experience with vacuum tubes. In the tube we make a tetrode by adding a fourth element known as a screen grid. The name tetrode means four elements, so applying it to the transistor is somewhat misleading.

In Fig. 702 we have a block diagram of a tetrode transistor. All we have really done, though, is to add another lead to the existing base. Basically, what we have is a transistor, with the added lead

biased negatively with respect to the base. The transistor can be either a p-n-p or an n-p-n type, but, as you can see, the one in Fig. 702 is an n-p-n. Since we now have two base leads, one is identified as base 1 and the other as base 2. The transistor is forward and reverse biased in the usual way. R1 and R2 are the

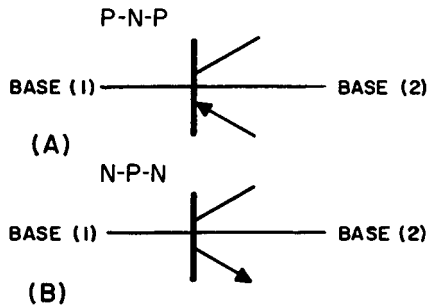

Fig. 703. Electronic symbols for p-n-p and n-p-n tetrode transistors.

biasing resistors for the base-emitter input circuit. A single battery, B2, supplies both forward and reverse bias for the transistor. However, we have an additional battery, B1, connected between base leads 1 and 2.

Now examine the lead going to base 2. It is connected to the negative terminal of B1, and so, apparently, we have made the base negative with respect to the emitter. But this isn't entirely correct, since the other base lead (#1) is connected tapped up on voltage divider R1-R2. But how do we want the base biased? Since we have an n-p-n unit, we want the base to be positive with respect to the emitter. The effect of B1, then, is to reduce the amount of area of the base that is really positive with respect to the emitter. But reducing the area gives us the same effect as reducing the volume of the base. Since the alpha cutoff frequency depends on the thickness of the base we have increased our available operating frequency. Actually, the situation is a little better than we expect, since the alpha cutoff frequency varies as the square of the thickness of the base. Thus, if we manage to cut the thickness in half, we raise the alpha cutoff frequency by a factor of four. If we cut the thickness to one-third of the original, we increase the alpha cutoff frequency by nine. As you can see, the rewards are great for this effort.

Just as we have symbols for n-p-n and p-n-p triodes, so too do

we have symbols for n-p-n and p-n-p tetrode transistors. These are shown in Fig. 703.

The surface-barrier transistor

Since our objective (at the moment) is to get a high-frequency transistor and since we can do this by making the base thin, why not shave the base down as much as possible? This may sound terribly difficult, since the thickness of the base is often fractions of a thousandth of an inch, but it can be done. When we do this, we solve one problem only to be faced with another. How do we fasten a lead to something that must be be so thin? A pleasant and practical solution to this problem is achieved by the surface-barrier transistor. We have a sliced-through section of one of these in Fig. 704.

Most of the base remains just as it is in an ordinary transistor. However, in the region between the emitter and the collector, the base material has been etched away, and as a result the emitter and the collector may be separated by as little as ten thousandths of an inch. Since the remainder of the base is as thick as it was

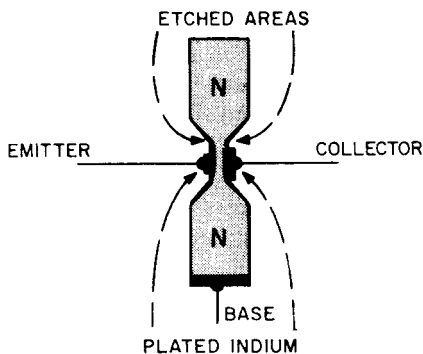

Fig. 704. The surface-barrier transistor uses a single section of n-type germanium. The effect is that of a p-n-p transistor.

before, there is no additional problem of fastening the base lead.

We now have two techniques for reducing base thickness. One is electrically, as in the tetrode transistor, and the other is physically, as in the surface-barrier. In both cases we must pay a price to get what we want, and the price is a reduction in power handling capabilities. An electric strain exists between emitter and collector due to the battery. By reducing the thickness of the base, we have really brought the negative and positive terminals of the battery much closer (electrically) to each other.

The surface-barrier transistor, though, is not quite the same as all the other transistors we have studied. The base is a single crystal or wafer of n-type germanium, and that is all — no p-type germanium is used. The emitter and collector electrodes are made of a metal called indium. These metals are plated onto the etched out part of the n-type germanium wafer. The metal does not melt or diffuse into the germanium, simply forming a plated electrode. We do have a barrier, though, just as in any ordinary transistor. This barrier exists between the plated electrodes (emitter and collector) and the base, and as a result we get the equivalent of transistor action.

The symbol for the surface-barrier transistor is the same as for a p-n-p unit, and is treated as such with respect to bias. That is, the emitter is made positive, the base less so, while the collector is negative with respect to the emitter.

The element, indium, selected for the emitter and collector of the surface-barrier transistor, belongs to the acceptor group, gallium, boron and aluminum, mentioned in an earlier chapter. Since it has but three electrons in its outermost ring, indium is short an electron, hence the p-type designation. For this reason, all surface-barrier transistors using indium for emitter and collector, and n-type germanium for the base must be of the p-n-p type.

There is a very important difference between the surface-barrier transistor and all the others we have studied so far. In the usual transistor, the semiconductor material is doped with an impurity — either donor or acceptor type — to form n-type or p-type semiconductor material. In the surface barrier transistor, however, just one element is so treated — and that element is the base, made of n-type germanium. The other electrodes, the emitter and the collector, consist of a small plated area of a metal — indium.

The diffused transistor

There is still another type, the diffused transistor, which seems to resemble the surface-barrier transistor, yet possesses a very significant difference. The diffused transistor appears in Fig. 705. In this transistor, as in the surface barrier transistor, we start with a section of n-type germanium. This is our base. A small amount of indium is melted into the base on each side, forming the emitter and collector. The melting process is continued until the emitter and collector almost touch each other, resulting in a very narrow

base region between them. This is just what we want, of course, to permit a high alpha cutoff frequency.

When the indium melts into the germanium, we get the effect of doping the immediate region around the indium. And since indium, as we mentioned earlier, is an acceptor impurity, the result is that we get the formation of p-type germanium in the region of the impurity.

Note the difference between the surface barrier and diffused p-n-p transistors. In the surface-barrier transistor, the indium is just a plated electrode. There is no physical penetration into the n-type base. The surface-barrier transistor depends on an etching process to reduce the base thickness. The diffused transistor de-

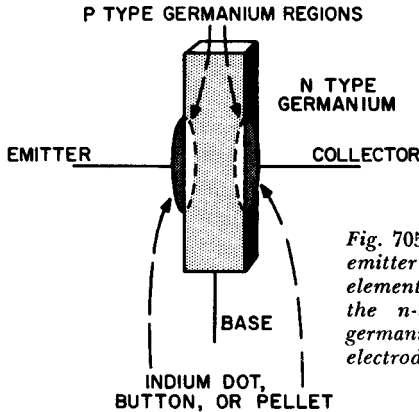

Fig. 705. The diffused transistor has an emitter and collector made of an acceptor element, indium. The indium, melted into the n-type germanium, creates p-type germanium in the immediate region of the electrodes. This results in a p-n-p transistor.

depends on the melting of the indium to narrow the base. For both types of transistors, the symbol is identical — and is that of a p-n-p transistor.

Micro-alloy transistor

There are different methods used in putting the emitter and collector electrodes onto a surface-barrier type transistor. They can be plated on or they can be alloyed as a very thin film of metal on the n-type germanium base. This produces a unit known as a micro-alloy transistor. An alloy consists of two substances that are melted or diffused into each other and so, in this respect, the micro-alloy transistor is more closely related to the diffused transistor.

In working with transistors you will come across many rather

descriptive names, perhaps giving you the idea that these transistors must be radically different in many respects. As you can see from our description of the diffused transistor, the surface-barrier, and the micro-alloy transistor, one of the biggest differences is in the way the particular transistor is manufactured. The micro-alloy transistor, as an example, is sometimes referred to as a MADT — a micro-alloy diffused-base transistor. And, to compound the growing confusion, this same transistor is often called just an alloy-diffused transistor, or an alloy transistor. The alloy material, indium, is termed a dot or button, because of its shape on the surface of the n-type germanium base.

Manufacturers of transistors often use names of their own to describe transistors, sometimes creating the impression that there must be many different types of transistors. Thus, what we have called a diffused transistor is also called a diffused junction transistor, a fused transistor, a fused junction transistor, a diffused emitter-collector transistor, a diffused E-C transistor, graded diffused, or (quite strangely) drift transistors. The tetrode transistor, described earlier, is also known as a double-base junction transistor. These are not all, because there is no doubt that we must have missed a few, or somewhere there must be a manufacturer concocting still another name. If you come across a transistor whose name seems unusual (and you will) stop and reflect for a moment. It may be just the name that is new — not the transistor type.

Junction transistors

These are the workhorses in transistor radios and are the units we used in describing our audio, if and rf amplifiers. And, as we have emphasized so often, they come in two basic types — n-p-n and p-n-p. A receiver may use n-p-n's, p-n-p's, or both, in a single set. P-n-p's seem to be more popular for radio receivers.

Before you rejoice over the fact that the name for this very widely-used transistor type is so simple and easy to remember, it is our sad duty to inform you that like almost all other transistors it is available under a variety of names, the choice depending upon the semantic ability of the manufacturer's engineering department. Thus you may find the junction unit listed as a fusion alloy junction transistor or alloyed junction transistor. Either germanium or silicon can be used as the semimetal, and so this information is often included in the name. We will then get names such as silicon fusion alloy junction transistor or germanium fusion alloy junction transistor.

Intrinsic transistors

These are also known as intrinsic-region transistors, p-n-i-p transistors, n-p-i-n transistors. Unlike the surface-barrier and diffused transistors in which we try to make the base as thin as possible, the intrinsic transistor may actually increase the base thickness and yet have an extremely high alpha cutoff frequency.

This may seem to contradict what we said earlier so let us examine Fig. 706 to see if we can come to some sort of reconciliation.

As you can see, in Fig. 706-A, we have what appears to be an ordinary p-n-p transistor, but sandwiched in between the base and the collector, we have a block of material marked with the letter I. This letter I is the first letter of the word, intrinsic. The intrinsic region consists of a semiconductor that is free of any doping impurity. This means that the semiconductor has an

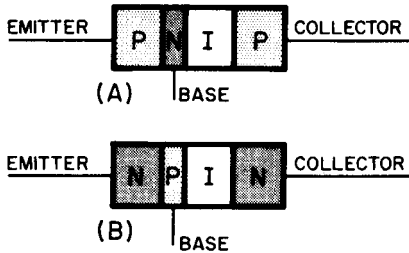

Fig. 706. An intrinsic transistor raises the alpha cutoff frequency by reducing capacitance between collector and base.

equal number of holes and electrons, hence is neither n-type or p-type. Since its facilities for current flow are very poor, it has a high resistance.

The virtue of the intrinsic region is that it separates the collector and the base. This is like moving the plates of a capacitor further apart. When we do this, we reduce the capacitance. Earlier we mentioned that one of the hurdles a transistor must overcome is capacitance between electrodes. In an ordinary junction transistor, the base (input) and the collector (output) are in intimate contact. This makes the capacitance large enough to lower the alpha cutoff frequency considerably.

There is probably one statement that is now worrying you and that is the high resistance of the intrinsic region. If it is, think of the resistance that appears between cathode and plate of the ordinary vacuum tube. In power tubes or power transistors, where we

work with high values of current, resistance between elements is important and we want it to be as low as possible. But for rf work, where the current in a transistor (or in a tube, for that matter) is so very small, high resistance does not seem to be detrimental.

The intrinsic transistor comes in two types, as shown in Fig. 706-A and 706-B.

Hook transistors

Every cook has a specialty, and those that feature soup, come up with some surprising (and often tasty) combinations. The true culinary artist will put anything and everything into the soup (at least once) just to see what will happen. So too in electronics do we have engineers who will try anything once. The more success-

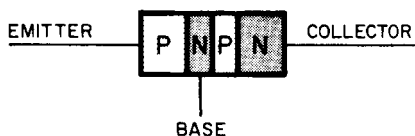

Fig. 707. Hook transistor resembles combined p-n-p and n-p-n transistors.

ful of these artists graduate to transistor design, where we can recognize their deft hands in the manufacture of unusual transistor combinations. One such is known as the hook transistor, or four-layer triode.

We have an example of this transistor in Fig 707. At first glance it looks as though we have a pair of p-n diodes, but we can wipe our glasses and look again. Now you can see that what we really have (reading from left to right) is a p-n-p transistor or (starting at the base) an n-p-n transistor. If this shocks you, consider a cascode circuit in which we go from the cathode to the plate of one tube, and then immediately into the cathode of the next.

Getting back to the hook transistor, the chief difference is in the way the collector is constructed. It has a slice of p-type germanium sandwiched in between itself and the base. With this sort of an arrangement, the hook transistor is most unusual in that it has an alpha greater than 1. No other transistor has such a characteristic except the point contact, the original transistor to be developed and which is now obsolete. Unlike the usual grounded emitter transistor arrangement, the hook transistor has an output which is in phase with its input.

Now let's consider the n-p-n side of this unusual combination. Starting at the extreme right we have n-type germanium and we have marked this as collector for the entire hook transistor, but right now let's think of it as the emitter for the n-p-n. From here we pass to a base which has no connection, and then to the n-germanium marked base but which is really the collector for our n-p-n transistor. Since this is all very confusing, suppose we separate the n-p-n section as in Fig. 708. In a typical n-p-n transistor we would have a negative voltage at the emitter and a positive voltage at the collector. But this is exactly what we have, since the collector in Fig. 708 is the base of the hook transistor and so really has a positive voltage on it. We haven't put any voltage on the p-section. This acts as the base of our n-p-n unit, but it isn't biased in the usual manner. Because of the thinness of the base, electrons have no problem in flowing from the emitter to the collector. Note the direction of current movement for the n-p-n transistor. As you know, in an n-p-n transistor, current moves from

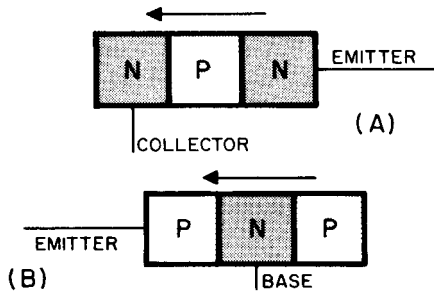

Fig. 708. The hook transistor can be separated into an n-p-n, as in A, and a p-n-p, as in B.

emitter toward collector, and so the drawing in Fig. 708-A fulfills this requirement.

Right below Fig. 708-A, in Fig. 708-B, we have the remainder of the hook transistor. This is the p-n-p section and, as usual in this type of transistor, current flows toward the emitter. Now if we recombine our two transistors into the single unit of Fig. 707, we have two currents, and the output coming out of the emitter is the sum of the two.

Field-effect transistor

Before we begin with the next transistor, let's list its other name. It is also known as a unipolar transistor. We can start our

construction of the unit with a single block of n-type germanium, as in Fig. 709. We can regard the germanium in this case just as we would a resistor. We will call the germanium the "body", the connection at the left side the "source" and the exit point for the electrons, the "drain". The electrons flow through the entire body,

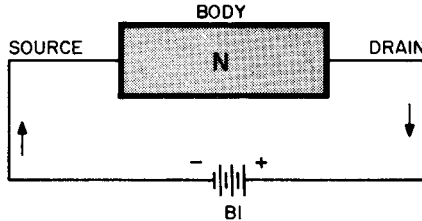

Fig. 709. We start our field-effect transistor with a core of n-type germanium, connected to a battery.

utilizing the full volume of the body for passage from the left of the unit to the right.

Our next step is to put a jacket of p-type material around the body, as shown in Fig. 710-A. It may be a little difficult to visualize this from a cross-sectional view, but Fig. 710-B will give you a better idea of the construction. The jacket of p-type material is entitled to a name of its own, and so we will call it a gate. We have added another battery (B2) in the drawings in Fig. 710 and have arranged the battery so the gate is biased negatively with respect to the body.

We now have a negatively charged semiconductor surrounding another semiconductor through which electrons are bravely moving along from source to drain. But our new addition hasn't added to their ease or comfort. Electrons don't like negative charges and so now, instead of using the full volume of the body, they all try to get as far away from the gate as possible, constricting their passage to the central portion of the body. What is the effect of all this? It is just as though we had removed a portion of the volume of the body. If we did this, though, we would be increasing the resistance of the body. And, raising the resistance reduces the current.

Of course, since we have p-type germanium (the gate) in contact with n-type germanium (the body) we have a p-n junction, and if we reverse bias this junction (just as in Fig. 710-B) we will get very little current (few electrons) passing between the gate and the body.

What we are interested in, though, is control of the current going from the source to the drain. As we increase the reverse biasing between gate and body, current flow from source to drain also decreases, until finally it levels off to a steady value.

Never content to let a condition of status quo exist, suppose we turn our attention once again to the voltage between source and drain, shown as B1 in Fig. 710-B. As we increase this voltage you would expect two things to happen: a) faster current flow and b) more current flow. Electron speed is accelerated, but beyond a certain value of gate voltage, known as the pinch-off voltage, we do not get an increased flow of current through the body

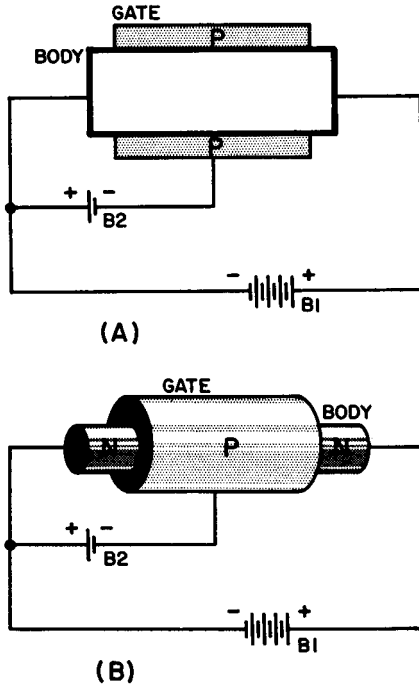

Fig. 710. The field-effect transistor. A cross-section is shown in A. In B we see how the gate, made of p-type germanium, fits snugly as a jacket around the n-type germanium.

from source to drain. This might seem strange until we consider that the gate has surrounded the body with a strong electric field which repels electrons.

The field-effect transistor, complete with input and output, is shown in Fig. 711. The input resistance, because of the reverse biasing supplied by battery B2, is extremely high and is in the

order of megohms. This was to be expected, because, as we mentioned earlier, the current flow between gate and body is negligible. The output is a lower impedance, since, even though we have restricted the amount of current flow through the body from source to drain, it is still much greater than between gate and body.

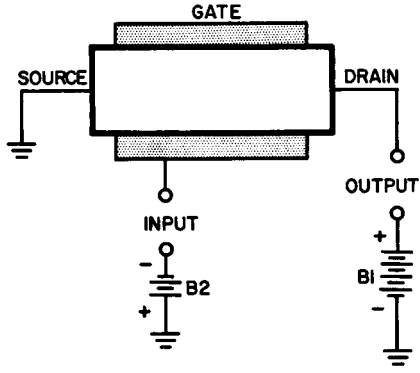

Fig. 711. The field-effect transistor has a high-impedance input, a lower-impedance output.

The field-effect transistor works more like a tube than any other transistor. We can consider the source as the cathode, the drain as the plate and the gate as the control grid. The input and output impedances are like those of a tube. But, while the field-effect unit is a triode transistor, its characteristic curve is somewhat like that of a pentode vacuum tube.

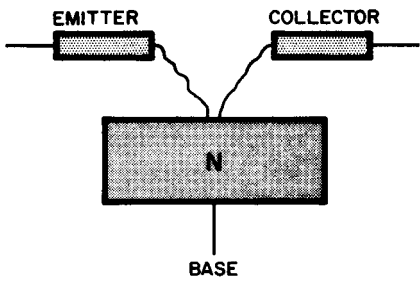

Fig. 712. Point-contact transistor is the forerunner of the junction type.

The point-contact transistor

Now that we have covered a few (and we mean just a few) of the possible transistor types, it is our sad duty to tell you that

we have thus far completely ignored and neglected the honorable ancestor of all transistors — the point-contact. Its glory dimmed by its illustrious offspring, the point-contact may yet come back into its own since it has some remarkable characteristics. It has an alpha greater than 1, and it is adept where a transistor is needed for rapid switching purposes.

We have a drawing of the point-contact transistor in Fig. 712 and a photo in Fig. 713. As you can see, we've started with a slice of n-type germanium and have placed two springy metallic points on it. One of these is called the emitter, the other the collector, while the n-type section is the base. A voltage is placed across the emitter and collector leads momentarily, so that a current passes between them. This is believed to form p-type germanium regions in the immediate area around the contacts, thus supplying us with a p-n-p type transistor. In use, the point-contact is biased in the same way as a p-n-p junction type transistor.

It is quite some time since we talked about alpha. Briefly, it is

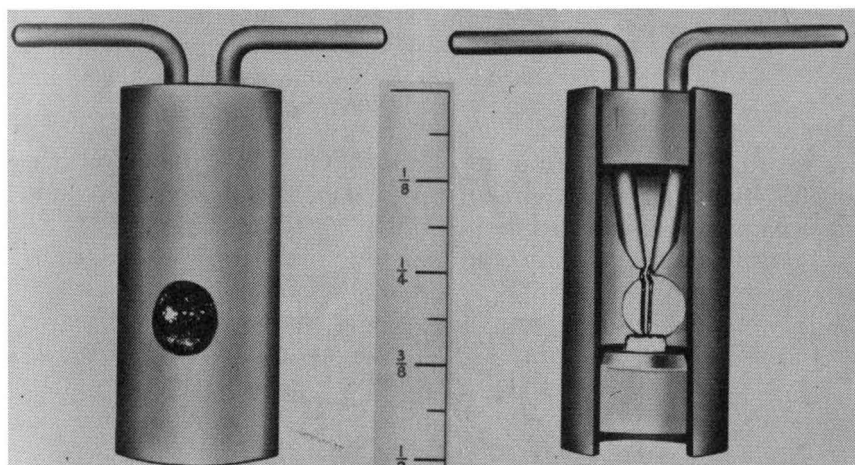

Fig. 713. Exterior and interior views of a point-contact transistor. (Bell Telephone Laboratories, Inc.)

the ratio of collector current to emitter current and for transistors (except the hook transistor and the point contact) is less than 1. In other words, collector current is always less than emitter current. In the point contact transistor, collector current is sometimes as much as twice the emitter current. This might seem a great advantage, but it leads us into a trap. Current flowing through a transistor (uncontrolled) tends to produce more cur-

rent. This is current runaway and can destroy a transistor faster than you can reach for a switch to turn off the current.

Multi-headed transistors

Ever pack a suitcase? With a little ingenuity, planning and some brute force to close the cover, the amount of clothing you can get into a small space is amazing. A similar technique is used

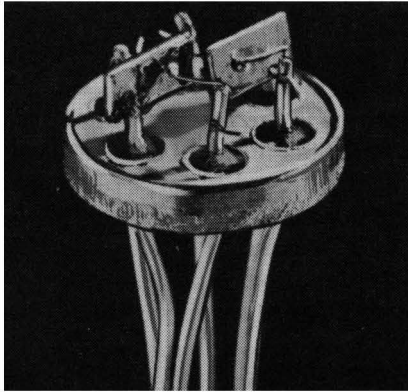

Fig. 714. Interior view of a multi-headed transistor. (Electronic Transistors Corp.)

in vacuum tubes, ranging all the way from duo-diodes, diode triodes, triode-triodes, right on up to the Compactron — a multiplicity of tubes all within the single glass envelope.

Transistors aren't to be outdone by this. Multi-headed tran-

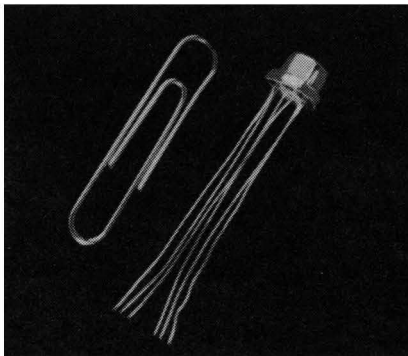

Fig. 715. Multi-headed transistor, shown in actual size. This unit contains two transistors in one package. (Electronic Transistors Corp.)

sistors can be had in any desired combination. We have an inside view of one of these in Fig. 714. This unit contains two transistors in one package. The two transistors are completely independent of each other, can be used singly or in combination. Each multi-headed unit has six leads. You can get an idea of the size of the unit in Fig. 715.

Tandem transistors

In some vacuum tubes certain elements are internally connected; in others, each element is independent. Thus, we can have

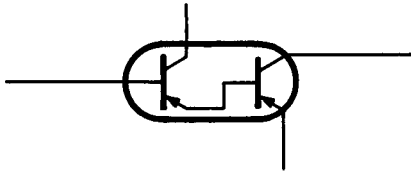

Fig. 716. *The tandem transistor is connected internally.*

a suppressor grid internally connected to the cathode, or wired to a pin in the base so we can make any use we want of the suppressor.

The multi-headed transistor is designed for external wiring, but as shown in Fig. 716, we can also have transistors connected internally. The unit in Fig. 716 has the emitter lead of the first transistor wired to the base of the following one. In some tandem units, the collector is the tied-in element, wired to the base of the following transistor. All sorts of combinations are possible but aside from the saving in space, there is no particular advantage in using a tandem transistor instead of two separate units.

Germanium and silicon

In an earlier chapter (page 20) we brought in a little bit of chemistry for you to examine. At that time we became particularly interested in those elements which had four electrons in their outermost orbit. We have a nice collection of these — carbon, silicon, germanium, tin and lead. Now the order in which we have listed these elements isn't accidental. Carbon has two electron rings, silicon has three, germanium has four, tin has five and lead has six. Thus we started with the lightest element and moved along to the heaviest. Although all of these elements are related in that

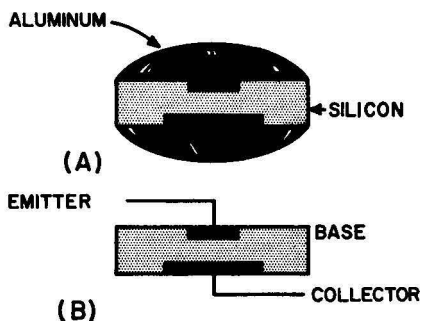

Fig. 717. The evaporation-fused transistor uses aluminum, fused into the silicon, for the emitter and collector connections.

they have similar outermost electron rings, they do have very definite differences. Consider the two heaviest — tin and lead. These are metals, nor do you have any doubt that they are. Silicon and germanium, though, aren't really metals, but semimetals. And when we get to carbon we arrive at an element that does not have metallic properties.

Germanium is the most widely used semimetal or semicon-

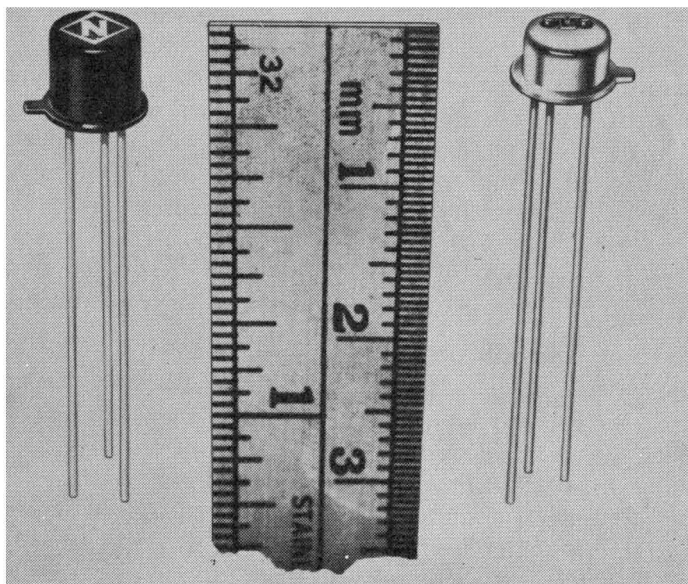

Fig. 718. These silicon mesa transistors are about $3/16$ inch long (National Semiconductor Corp.)

ductor. Silicon transistors, though, do have certain characteristics that may make them more desirable. They do not suffer as much from high temperatures as germanium transistors. Also, they have lower leakage currents. Silicon is a much more abundant semi-metal than germanium, but it is much more difficult to purify.¹

As in the case of germanium, silicon must be purified and then "doped" with controlled impurities so that we get either p-type or n-type silicon. One type of silicon transistor, known as the silicon alloy or evaporation-fused transistor, is shown in Fig. 717.

In the manufacture of the silicon-alloy transistor, cavities are cut into the silicon wafer. Aluminum is evaporated and allowed to alloy into the surface of the silicon. The result of this process is shown in Fig. 717-A. The excess aluminum is then removed. The aluminum that remains in the upper and lower cavities forms the emitter and the collector, illustrated in Fig. 717-B.

Transistor dimensions

Transistors, other than those used for work as power amplifiers, are well-known for their smallness. Typical units are shown in the photograph, Fig. 718. But small as they are, even tinier units

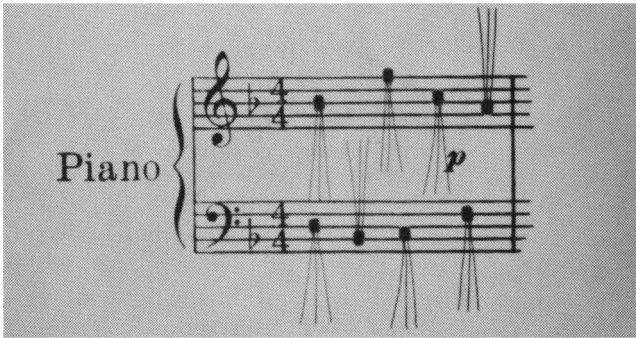

Fig. 719. The transistors shown here in actual size are smaller than the musical notes they represent. (Raytheon Co.)

are needed for special applications where all space is at a very high premium. This could include missile units or computers using tremendous numbers of transistors, or in hearing aids. Fig. 719 shows some of these, representing the notes on a musical staff.

¹ The nonmetal carbon, and the semimetal silicon, as elements or as compounds form all living material. Practically all of the earth's minerals are accounted for by just these two elements.

Actually, these subminiature transistors, intended for hearing-aid use, are smaller than the musical notes they will amplify.

At this point we must be careful not to fall into the trap of thinking that reduction in size means an increase in the alpha cutoff frequency. With vacuum tubes, one way of raising the operating frequency was to bring the cathode closer to the plate, and since the tube envelope accommodated this space shrinkage, the

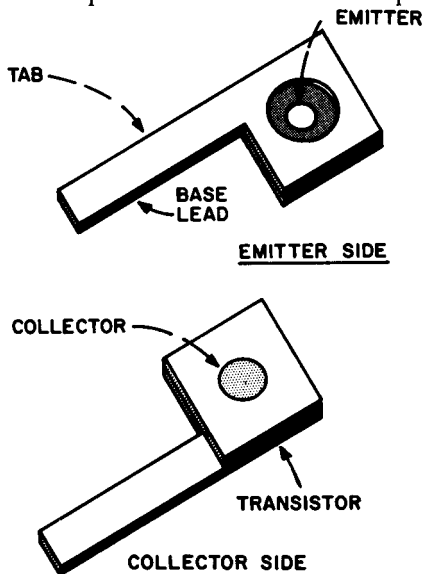

Fig. 720. The transistor is mounted on a tab which forms the lead for the base.

result was a smaller tube. This situation is not analogous in the case of transistors. In some cases, subminiature transistors have a *lower* alpha cutoff frequency than their bigger brothers.

A representative subminiature might have a height of 0.160 inch compared to 0.260 inch for the more common type. This is a difference of only a tenth of an inch, but think of it in terms of percentage and you will see that the decrease in size is quite astonishing. But this doesn't mean that the end has been reached. The hearing-aid transistors in Fig. 719 are less than 0.1 inch in height, while some are down to 0.05.

Transistor manufacture

The first step, and probably the most important in the manufacture of transistors of all types, is refining the semiconductor material. The refining process is carried to the point where the

semiconductor is almost 100 percent pure. The silicon or germanium is then melted. While the semiconductor is in this molten state, either donor or acceptor impurities are added. The type of impurity will determine whether we will have n-type or p-type semiconductor.

At this time, a small bit of crystalline material known as the seed is dipped into the melt and is then withdrawn slowly. The effect of the seed is to trigger the crystalline formation of the

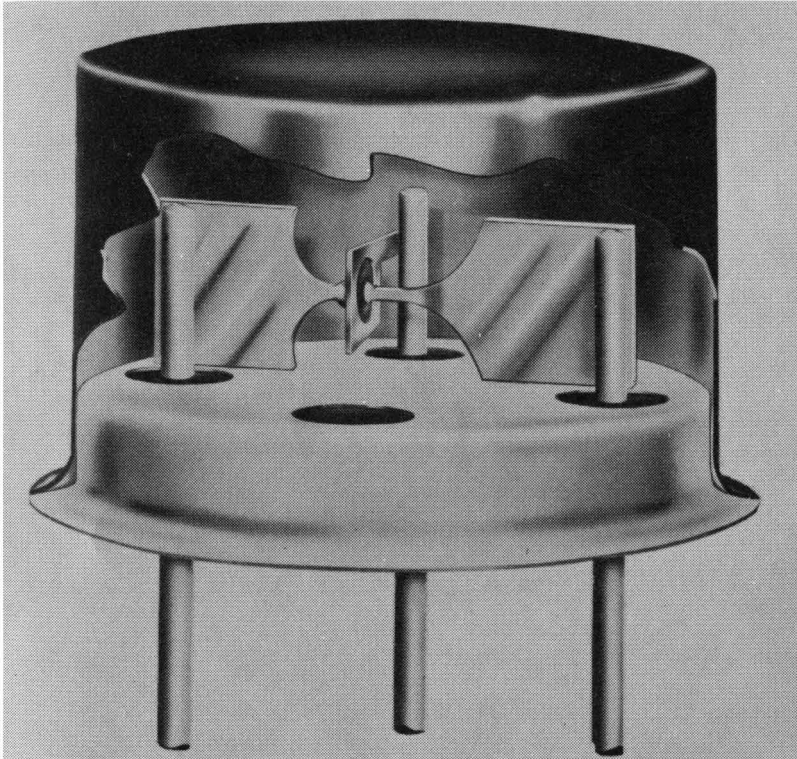

Fig. 721. Interior view of an alloyed-junction transistor. A pair of "bow ties" connects the emitter and collector to their external leads. The center, or base lead, is connected to the body of the transistor by a tab. (Raytheon Co.)

semiconductor. This crystalline formation, though, is not in the direction of millions of tiny crystals, but rather more like that of a single, large crystal.

Did you ever watch a salami being sliced by a machine? That's our next step, but the cutting of the semiconductor crystal is

carried on in sanitary surroundings that no delicatessen could duplicate. Each thin semiconductor wafer is then cut into tiny chips. These tiny bits of semiconductor crystal are our transistors. In the manufacture of the most common type of transistor, the junction transistor, tiny dots of indium, aluminum or antimony are alloyed to the surfaces of the semiconductor.

Our transistor is now completed, but we must somehow make connections to the emitter, collector and base. As a start, we mount the transistor on a metal tab, as shown in Fig. 720. This tab now forms our connection to the base of the transistor. As you can see in the drawing, a hole is cut in the tab to permit access to the dots of indium. The unit is now mounted in its housing or package and is ready for testing.

In Fig 721 we have a cutaway photo of an alloyed-junction transistor. As you can see, this resembles the drawing in Fig. 722. However, various manufacturers all have their own techniques.

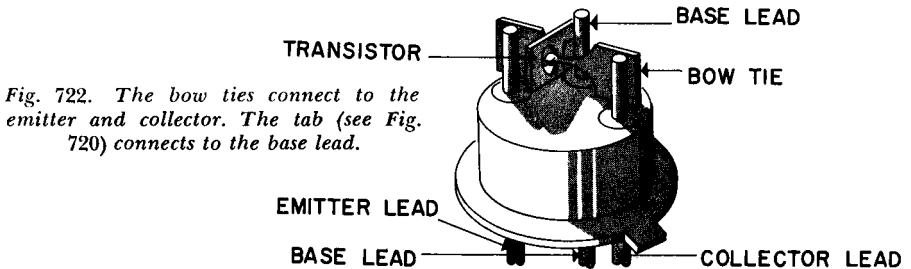

Fig. 722. The bow ties connect to the emitter and collector. The tab (see Fig. 720) connects to the base lead.

Thus, a similar transistor in Fig. 723 shows wires connected to the indium dots. These wires help support the transistor and also make connections to the external emitter and collector leads. No tab is used in this particular construction with the exception of a small rectangular block from the body of the semiconductor to the base lead.

Power transistors

Power transistors, as their name implies, represent the final link between the load and the signal. In the case of a radio receiver the load is the speaker and since the voice-coil type of speaker is a current-operated device, it must be driven by a tran-

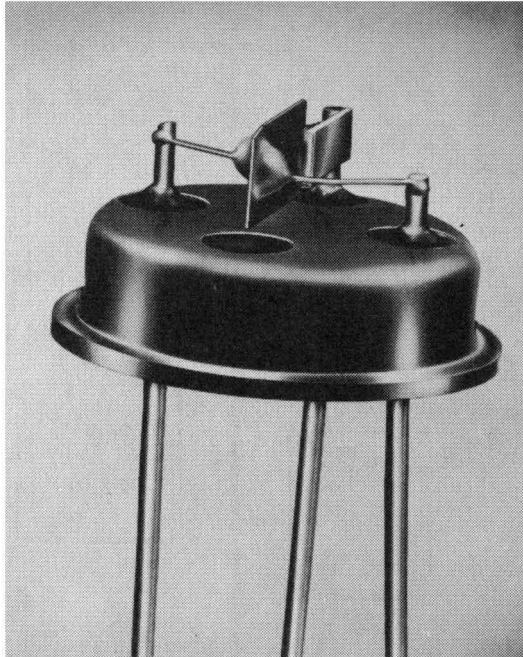

Fig. 723. In this alloyed-junction transistor, a pair of wires is used to help support the transistor and to connect to the emitter and collector. Note the circular holes cut in the "package" to permit the external leads to come through to the emitter, base and collector. (Raytheon Co.)

sistor capable of delivering audio power. Power transistors are no different than ordinary transistors, except they are specially designed to handle large values of current. Thus, in the case of ordinary amplifying transistors we are accustomed to currents in microamperes and milliamperes; for power units we can have dc collector currents of 10, 20 amperes or more. These large currents raise immediate problems, for where we have a high current there is always the pressing question of an IR drop. When currents are measured in amperes, just a small amount of resistance causes a voltage loss. Of equal concern is the fact large amounts of heat result from I^2R losses. Since the power to be dissipated (in the form of heat) varies as the square of the current, heat sinks must invariably accompany power transistors. Thus, if we consider the movement of a moderate amount of current such as 10 amperes through a 1-ohm resistor, we would have (based on the formula: $W = I^2R$) $10 \times 10 \times 1$ or 100 watts. Now this may not sound

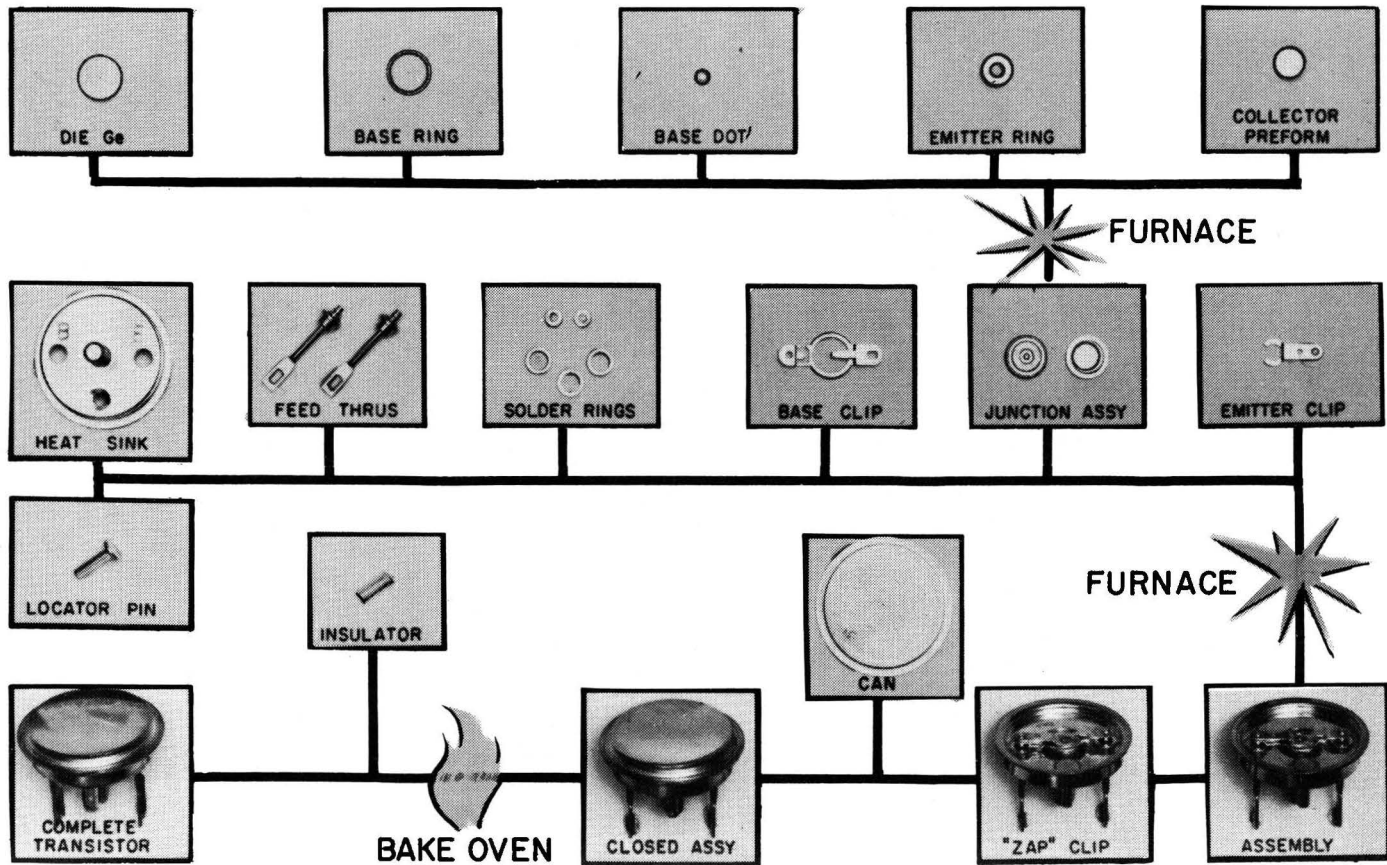

Fig. 724. Steps in the construction of a power transistor (Motorola, Inc.)

like much, but try touching a 100-watt electric-light bulb after it has been on for a few minutes and you will get the skin-blistering idea.

Number of leads

In Fig 724 on the facing page we have the step-by-step processes used in the manufacture of power transistors. The heat sink is an integral part of the transistor assembly, but in itself this is often inadequate. The metal chassis on which the transistor is mounted helps dissipate the heat, or specially-designed separate heat sinks are provided. These are often corrugated or ribbed to supply the maximum amount of radiating surface.

Not only are power transistors much heavier and larger than ordinary amplifying transistors, but instead of having three connecting leads most have just two. These leads are for the base and the emitter. The collector of the power transistor is mechanically and electrically connected to the metal shell of the unit. Incidentally, as you might expect, while the majority of amplifying transistors (other than power transistors) have three leads, there are some that have four. A transistor of this type is the post-alloy diffusion transistor (abbreviated as PADT) which has an extra lead connected to the case.

Mounting transistors

Since transistors (other than power types) are so extremely small and light, mounting them is no more of a problem than mounting a quarter-watt resistor. Just keep in mind that transistors aren't too partial to the heat of a soldering iron and there should be some sort of thermal shunt on the transistor lead, between the tip of the soldering iron and the transistor proper, to bypass the heat of the iron. You can avoid the need for a thermal shunt by using a clean, well-tinned iron and soldering with the correct melting point solder. Transistors are not affected by the rather substantial magnetic field surrounding a soldering gun or the smaller field around the usual soldering iron.

Sockets

Sockets are sometimes used for transistors, but since the life expectancy of a transistor is equal to or better than most other components, the transistors can be soldered directly into place. Unlike tubes, transistors can be soldered in any position. They can be mounted vertically, horizontally, below, above or between

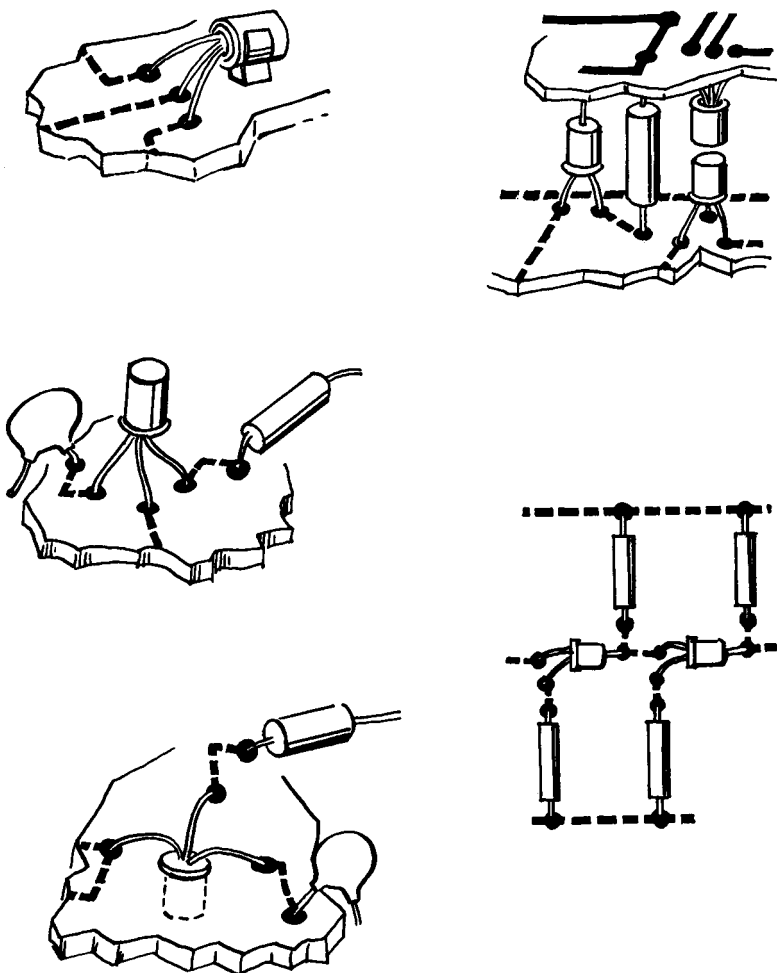

*Fig. 725. These are some transistor mounting techniques. Transistors can be placed in any position.
(Raytheon Co.)*

printed boards, as shown in Fig. 725. Transistors can be connected so that they sit on their leads, or hang from them.

Circuit packaging

When you service a radio or television receiver you do so with

the idea of finding the one component that is defective. Granted that sometimes the trouble is caused by more than one defective part, the fact remains that servicing consists first in localizing the difficulty and then in isolating the troublemaker.

For equipment used in industry and in military applications this approach is time-consuming. It can also be expensive, since the down time of a machine such as a computer can cost far more than any amount of servicing. For this reason a circuit that does not work properly is completely replaced. Granted that a half-dozen or so good parts might surround one weak component, this is still faster and far more economical than to institute a search for and replacement of an individual resistor, capacitor, transistor, etc.

On page 193 we have a number of packaged circuits. These can be used in original design applications or as replacements. A complete electronic device can be built of these blocks and can be repaired by simple substitution. The components are connected and are then encapsulated and potted into a variety of packages — tubular, rectangular, bathtub shape, etc. Connecting leads are brought out to a 9-pin standard plug-in base, octal and subminia-

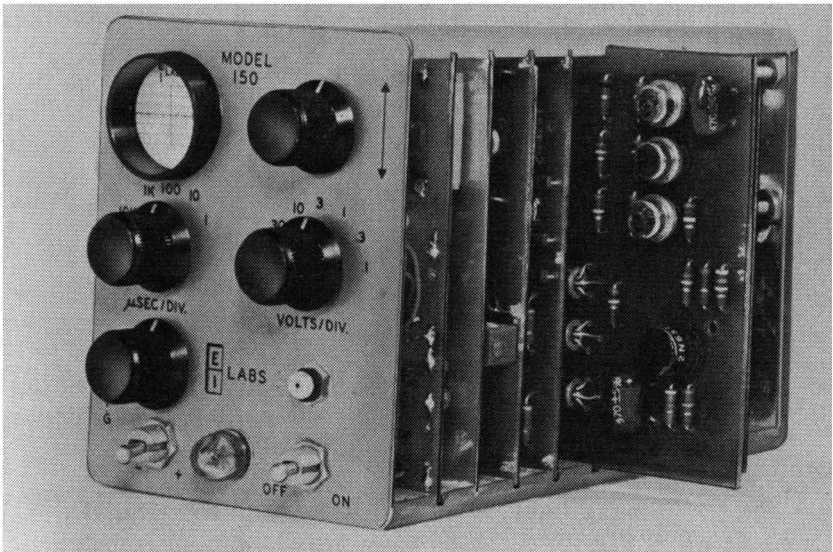

Plug-in modules often contain complete stages. It is a form of construction that supplies a very high component packaging density. In the instrument shown above, components are mounted on boards which slide into grooves. Connections are made through special connectors on the inside edge of each of the boards. [EI Labs]

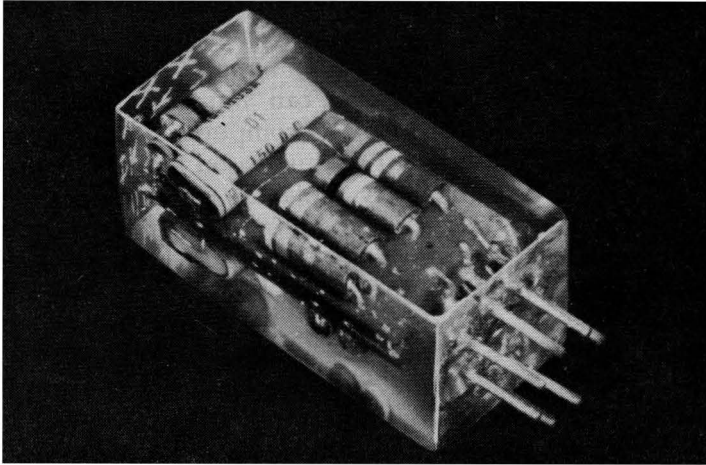

Fig. 726. *Packaged transistor circuit.* (Bell Telephone Laboratories, Inc.)

ture in-line base, a 7-pin standard base, or with pig-tail leads or pin terminals. Replacement is as simple and as easy as replacing a tube. Fig. 726 shows an experimental model of a transistor amplifier for telephone switching circuits. All components of this miniature plug-in type device, including the beaded-junction transistors, are compactly embedded in lucite. The model is about $1\frac{5}{8}$ -inches long.

Other transistor types

The transistors we told you about earlier in this chapter are just a few of the many different types. There are so many of them now, and so many constantly being developed, that a book could be written just describing them. And each new type that is produced may have as many as a half-dozen different names depending on the manufacturing techniques being used. Little purpose would be served in listing them all here, for the list would be out of date on publication.

There is one more item we should discuss and that is that transistors represent just one branch on the semiconductor tree. There are many types of semiconductor devices. Among the best known of these are the diodes. Transistors are the most glamorous, have been the most publicized, and are the only types of semiconductors described in this book.

Inverters are well named since they are used to do just that to an electrical signal. Basically amplifiers, they have no gain. The output has the same amplitude but opposite polarity of the input.

Flip-flops, equally well named, come in many varieties. Some are used for counting, others for pulse shaping or pulse generating.

Amplifiers need no further explanation as to their application. They may be used before, after or between any of the modules.

In the chopper, the three-winding transformer, indicated by the dotted line, feeds a pulse to the transistor bases. The polarity of the pulse causes one or the other of each transistor pair to conduct. These modules are plugged in to connection boards for rapid setup of complex control systems or small computers.

Modules are taking the place of much electronic wiring. Some modules are no bigger than a transistor alone. Computers and data control equipment may consist of a dozen module types repeated several hundred times. One group of modules is logic circuits which have multiple inputs. A signal or the lack of a signal at one or more of these inputs will cause or prevent an output signal to the next stage which may be another logic module, an inverter, a flip-flop or one of many varieties or a relay or readout device.

INVERTERS

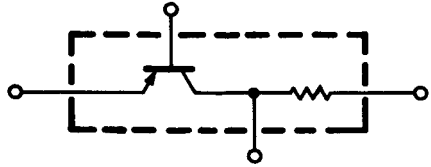

FLIP-FLOPS

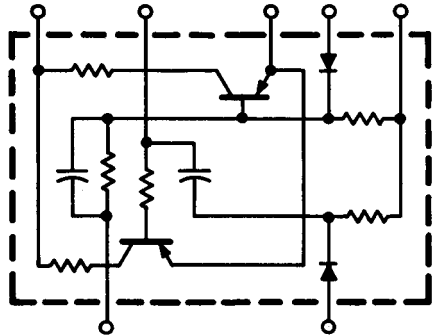

AMPLIFIERS

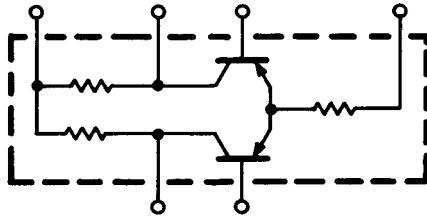

CHOPPERS

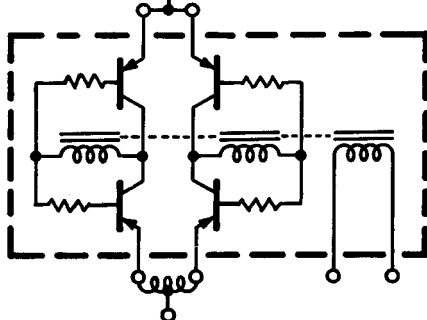

Transistors are probably best known to you through their use in radio receivers. But the radio receiver circuits we covered in earlier chapters represent just the beginning, not the end of the tremendous number of ways in which transistors can be used in circuits. In our next chapter we are going to examine some of them.

QUESTIONS

1. What is transit time? How does it affect transistor operation?
2. What is alpha cutoff frequency?
3. How does the tetrode transistor differ from the triode transistor?
4. How does a surface-barrier transistor overcome the problem of transit time?
5. What are the differences between a microalloy transistor and a MADT type?
6. Describe the major characteristics of germanium and silicon as a semiconductor.
7. What characteristic does the hook transistor have in common with the point contact transistor?
8. What are modules?

circuit analysis

IT may seem very odd that we should have a chapter entitled Circuit Analysis. And we wouldn't be at all surprised if you were to demand, "And what have we been doing up to now? Studying medicine? Law? Business? True! Quite true! Take a single component such as a resistor, connect another component or a battery, and we have a circuit. We've been doing that almost from the very beginning of the book. But what sort of circuits have you and we gone through together? Wouldn't you say that they've been the common-garden variety, the sort of stuff you would logically expect? We've had audio and rf amplifiers, converters, mixers and oscillators. And before that we had a generalized conglomeration, just so that we would get the idea of how transistors behave in the polite society of resistors, capacitors and batteries.

If we were to stop right there you would have every right to say, "So what? Is that all transistors can do?" Quite correctly you expect more, so let's examine some other transistor accomplishments. Before we do, though, we are sure you know by now that a transistor isn't just a vacuum-tube substitute. We can't take a vacuum-tube circuit (remove Dr. de Forest's brainchild), put in a transistor, and then say, "There, that's that." Hardly! Transistors have their own ideas as to the components that should accompany them. Does this mean, then, that you are going to need to learn a whole line of new circuits and that your knowledge of vacuum-tube circuits has gone down the drain? No — for you will see that the basic circuit idea has remained the same and in many cases

you will be able to identify the circuit from earlier experience and knowledge. So let's start in an easy way and see what we can do together. However, please remember that this is *not* a construction chapter. The purpose here is to learn more about how transistor circuits work through theory analysis.

Meter amplifier

Of all dc milliammeters ever manufactured, the one having a full-scale deflection of one milliampere (sensitivity, 1000 ohms-per-volt) was probably the most common. At one time this meter was a workhorse but with improvements in magnets and manufacturing techniques, much more sensitive meters are being used. The great big hitch here, of course, is that the more sensitive the meter, the more it costs. The circuit shown in Fig. 801 will give a meter an apparent ten-time increase in sensitivity, but by the

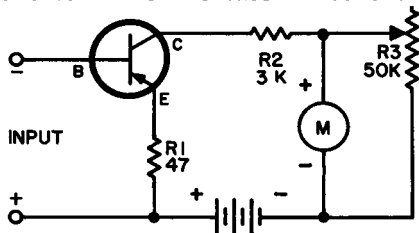

Fig. 801. Insensitive meter can be used to measure currents in the order of microamperes with the help of a transistor amplifier.

time you get through paying for the parts, you may not have made any savings at all. But at least its nice to know that you have a choice.

To understand the circuit of Fig. 801, think of the current amplification capability of a transistor. In an earlier chapter we called this beta. It is the ratio of the change in collector current to a change in base current. For a representative transistor, beta could have a value, say, of 50. Thus, if we had 20 microamperes of base current, we would have 1,000 microamperes (or a milliampere) of collector current. And if the base current changes, we get 50 times as much change in the collector current.

Now suppose that in the circuit of Fig. 801 we had a dc milliammeter in the base circuit of the transistor. We would need a very sensitive meter indeed to give us a full-scale deflection of 20 microamperes. But if we had a dc meter in the collector circuit, we could easily use a 1 milliampere movement. We could calibrate

this meter in microamperes and when it would read full scale we would be measuring a current of only 20 microamperes.

Is the circuit new? Not actually, since it is a very ordinary, very simple transistor amplifier. What we have here is a dc amplifier with but one new component. This is potentiometer R3, a calibration adjustment that is varied until the meter reads full-scale.

It is important to understand just what it is that the meter in the collector circuit does. It just reads collector current. But this collector current is the same as the base current multiplied by the beta of the transistor. Thus we can take advantage of the amplifying action of the transistor to measure small currents. Remember, though, that these small currents are not measured directly, but indirectly.

Relay amplifier

Just as the circuit in Fig. 801 permits us to use a less sensitive meter (and therefore a less expensive meter) so too can we use

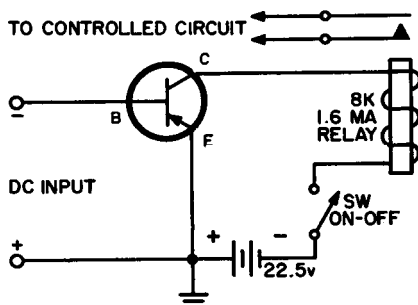

Fig. 802. Simple transistor amplifier can be used to operate a relay.

this circuit, or some variation of it, to give us an apparent increase in the sensitivity of other components. A relay is one such item. Relays, like meters, are assessed in terms of their sensitivities.

Fig. 802 shows the relay circuit. The relay might require a current of one or more milliamperes to attract the armature of the relay toward its core. In the circuit of Fig. 802 a current of about 50 microamperes in the input will increase the collector current to the amount required to close the relay. Assuming this current to be 2 milliamperes (or 2,000 microamperes), the gain in our circuit is 40 ($40 \times 50 = 2,000$). In this circuit the relay is the load.

In the circuits of Figs. 801 and 802, what would be our input? It could be some sort of signal which would give us the necessary

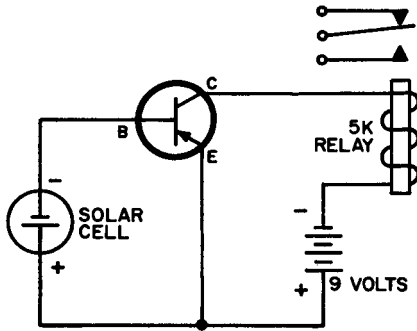

Fig. 803. Relay circuit will operate when solar cell receives light.

amount of forward bias to activate the collector circuit. The input current could also be produced by a solar cell, as shown in Fig. 803. Now take a few moments out to note the considerable similarity these circuits have.

Preamplifier circuit

At first glance, the circuit in Fig. 804 looks far more complicated than any of those we have shown so far in this chapter. For this reason we have drawn a dashed line down the center of the circuit so that you can see for yourself that all we have here is just a pair of audio amplifiers, with the first amplifier driving the second.

We have analyzed the components in circuits similar to this one in earlier chapters, but let's take out a few brief moments to do it

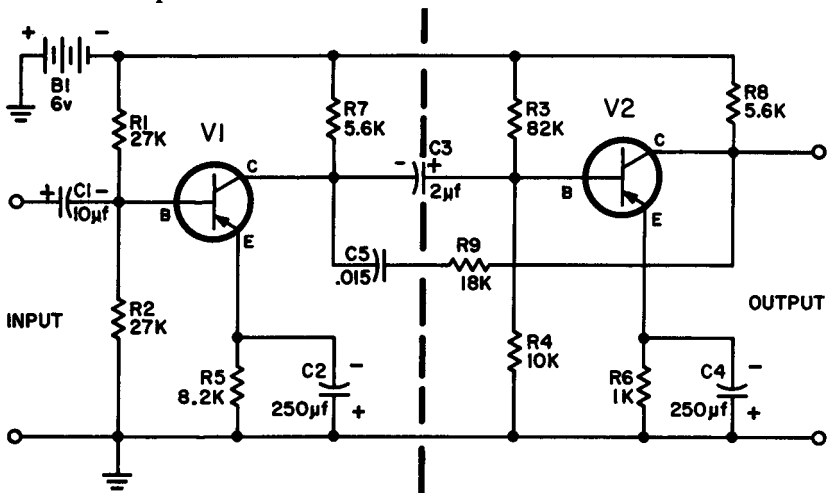

Fig. 804. Resistance-coupled audio amplifier consists of a pair of amplifiers, one driving the other.

again, just by way of review. If you will examine R1 and R2 you will see at once that these two resistors are in series. If you will trace their connections to battery B1 you will see that they are connected directly across it. These two resistors supply the correct amount of forward bias for V1. Now what about R3 and R4? Exactly the same as R1 and R2! They supply bias for V2.

Note that R1 and R2 do not have the same values as R3 and R4. If V1 and V2 are different you would expect their forward-biasing requirements to be different also. The two transistors also use emitter bias. The emitter resistors, R5 and R6 are shunted by large values of capacitance — 250 μ f. These capacitors have a rating of 6 volts. While we're on the subject of capacitors, examine C1 and C3. These are also fairly large capacitance units (compared to the types used in vacuum-tube amplifiers) and are 25-volt electrolytics. We must watch our polarity in the case of electrolytics.

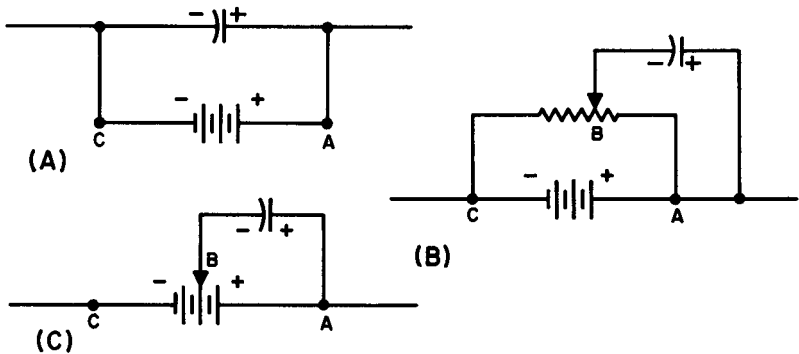

Fig. 805. Methods of connecting an electrolytic capacitor.

When considering the emitter bypass capacitors, remember that for p-n-p transistors the current flows from the emitter down to ground. This makes the top end of the emitter resistor minus and the bottom end plus. C2 and C4 are connected to observe this polarity.

In the case of C2 and C4 the matter of polarity is quite clear cut, but what do we do about coupling capacitors C1 and C3? It is entirely possible for a coupling unit to be connected to two positive voltage points, yet we must still be careful about polarity.

To see how we can come to a decision about this, please look at Fig. 805. In Fig. 805-A we have an electrolytic directly across a battery. There is no problem here since the plus terminal of the

electrolytic goes directly to the plus terminal of the battery. Similarly, the negative lead of the electrolytic is wired to the negative end of the battery. The electrolytic receives the full voltage of the battery and must be able to withstand it.

In Fig. 805-B, we are still observing polarity properly since the negative end of the electrolytic is connected to the arm of the potentiometer. But isn't point B a positive point? Yes, it is, but it is less positive than point A.

To simplify matters even further, we have eliminated the potentiometer in Fig. 805-C. Now you can see that we have connected the negative terminal of the capacitor to one of the positive terminals of the battery. This is point B. But so is point A. However, while point B is positive, it is less positive than point A. Another way of saying exactly the same thing is to say that point B is negative with respect to point A.

Now getting back to Fig. 804, how do we know that we have connected C1 and C3 correctly, so that polarity is observed? In the case of C1 we don't know. We have not been told just what it is that C1 connects to. It is possible that in connecting C1 to its input we would find it necessary to turn C1 around.

We have no such doubts about C3. The collector of V1 to which this capacitor is connected is more negative than the base of V2, to which the capacitor is also connected.

R7 and R8 are easy to identify. These are our collector load resistors. What is left? Just a series combination of C5 and R9. This is our negative feedback circuit. It improves the stability of the amplifier and gives the amplifier a somewhat better frequency response.

We have gone through this amplifier rather hurriedly, since audio amplifiers were covered in an earlier chapter. A simple resistance-capacitance coupled amplifier of this sort could be used as an audio preamplifier.

Signal tracer

A signal tracer is just an audio amplifier plus a detector. The detector is generally a crystal diode as shown in Fig. 806. For the amplifier portion we could have used the circuit of Fig. 804, but we have added the one in Fig. 806 just to emphasize the fact that not all audio amplifiers are exactly alike. As an example, locate C3 (Fig. 806). If you will trace its connections you will see that it is shunted directly across the battery. The purpose of this capacitor is to maintain a low-impedance path around the battery.

As long as the battery is fresh, or at least not too used, its impedance will be fairly low. But with time and use the internal resistance of the battery will rise, and long before a decision is

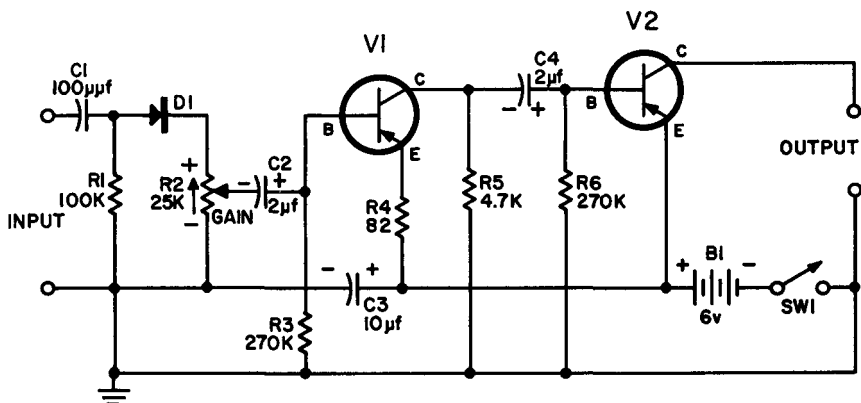

Fig. 806. The diode permits use of the audio amplifier as a signal tracer.

made to discard it, will act as a common impedance or coupling device between stages. This can result in feedback between stages, producing amplifier instability. An electrolytic across the battery ensures a low-impedance path around it regardless of the condition of the battery. But before we decide that this is a wonderful cure-all, remember that electrolytics also get old and that they have their own ills—including an increase in their own internal impedance.

Now examine the coupling capacitors in Figs. 804 and 806. How do they compare as far as capacitance and polarity are concerned? C3 in Fig. 804 has the same capacitance and the same positioning as coupling capacitors C2 and C4 in Fig. 806. But what about the input capacitors (C1 in Fig. 804 and C2 in Fig. 806)? Quite a difference here in several respects. Note the arrow in Fig. 806 showing the direction of current flow through the diode load resistor R2. When the slide arm is at the bottom end of the resistor the negative end of C2 is connected to the negative end of the battery. But suppose the slide arm is at the top end of the potentiometer. The lead of C2 is now at some plus point depending on the amount of current being rectified by the diode and the value of the gain control. This might be as much as 1 or 2 volts. Now what about the other side of C2? This side of the capacitor

is connected to the base of V1. From the base we have two ways of approaching the battery. One path is through a fairly high value of resistance ($R3 = 270,000$ ohms) to the negative terminal of the battery. The other path is through the transistor to the emitter, through 82-ohm emitter resistor $R4$ to the plus terminal of the battery. This latter path is so very much lower in resistance than $R3$ that the base (hence capacitor $C2$) is not too far removed (in terms of voltage) from the plus terminal of the battery.

Since this may not be too clear from an examination of the circuit, we have re-drawn it for you in Fig. 807. Consider the emitter and base of the transistor as a resistor of low-value in series with $R4$ and $R3$. These three components act as a voltage

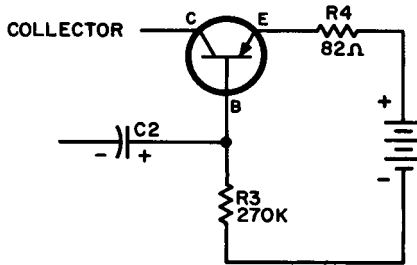

Fig. 807. Rearrangement of part of the circuit of Fig. 806 to show voltage-divider action.

divider across the battery. But because of the very large value of $R3$, the plus connection of $C2$ is much closer, from a voltage viewpoint, to the plus terminal of the battery.

While we are making comparisons between the two amplifiers, is there anything else we should notice? Yes — there are several items we should spot. $V2$ in Fig. 806 has no emitter resistor. The emitter resistor for $V1$ isn't bypassed. Also, the two transistors, $V1$ and $V2$ act as part of a voltage dividing network. In Fig. 804, however, we had an actual resistive voltage divider network ($R1$ and $R2$; $R3$ and $R4$) for forward bias. This arrangement is better than compelling the transistor to work in a resistive function. Also, in Fig. 806 we have no feedback network. From all this you might conclude that Fig. 804 is the better circuit, and so it is. But before we toss out Fig. 806, consider the uses of the two circuits. One is an audio preamplifier where we have some interest in stability and sound quality. The other is intended as a rather

ordinary audio amplifier to be used as part of a test instrument.

It is possible that the difference between these two circuits may have been immediately apparent to you. Carry this sort of analysis along to transistor radio receivers and you will at least have learned a few of the reasons why there is a price differential among them.

Another audio amplifier

As long as we're examining audio amplifiers, let's take a look at the one shown in Fig. 808. This is a transformer-coupled unit,

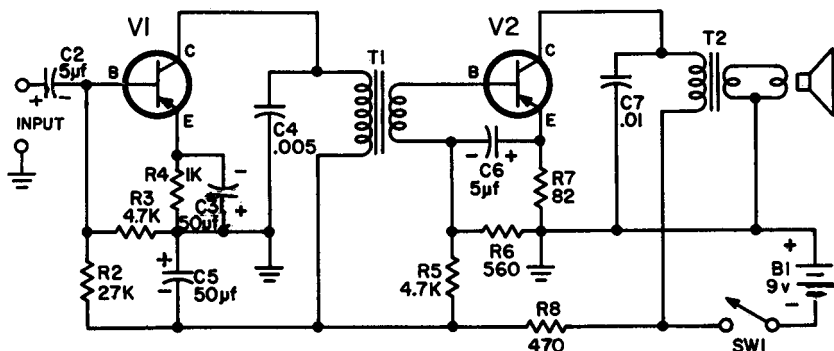

Fig. 808. Sometimes radio components are drawn so that their function isn't too obvious. When this happens start tracing the circuit and all the parts will fall into their proper places.

but a first glance seems to show some component arrangements worth investigating. The emitter circuit for VI looks a bit odd until we examine it more closely and see that some of the components have been drawn in such a way as to make the circuit look peculiar. R4 and C3 we can recognize immediately as the emitter resistor and bypass capacitor. But what about R2, R3 and C5. We can't do much about these until we grope around a bit and locate R8. Look just a bit more carefully and you will see that R2, R3 and R8 are all in series and that this series network is connected directly across the battery. What is this network? It supplies forward bias for VI. Similarly, R5, R6 and R8 have the job of forward biasing V2.

What other information can we extract from this circuit? C4 in the output circuit of VI might require a bit of thinking. The small value of C4 indicates that it is an rf bypass, somewhat unusual to find in an audio amplifier. However, if the input is supplied through a diode detector, we might find C4 necessary.

It is possible, however, that the diode detector might have an rf bypass in its own output circuit, so C4 might be an unnecessary luxury. C7, in the output of V2 is a fixed tone-control capacitor.

Look Ma — no parts!

The circuits we have examined so far in this chapter are certainly modest enough in their demands for parts, yet you could have a complete transistor receiver with still fewer components.

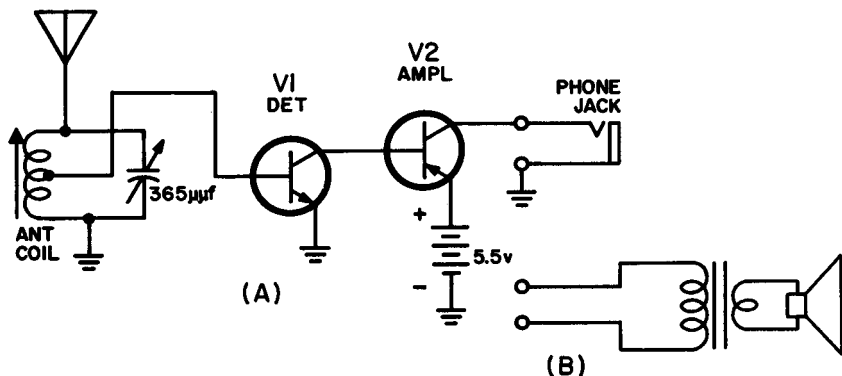

Fig. 809. Transistor radio receiver with a minimum number of parts.

We have the circuit in Fig. 809. And just in case you think that this is good for earphone reception only, we have included provision for a speaker.

A receiver of this sort will not have the sensitivity or selectivity of a six-transistor set, nor is there any claim of this sort being made. What we are interested in here is not in running a contest between receivers but in learning more about the functioning of transistor circuits.

With this caution in mind, what is there about Fig. 809 that can add to our storehouse of knowledge? You might think that the obvious absence of parts might clarify the situation.

The first item we might notice is that V1 is being used as a detector. The fact that it is marked detector is a sure-fire giveaway. How could we know, then, that it is a detector without the help of the label? There are several clues that demand attention.

V1 is located between a transistor (V2) being used as an audio amplifier and a tuning coil. Even if V2 were not marked, we see that it is connected to a phone jack. Consequently we can draw the conclusion that the input to V2 must be audio. And since the

input is a tuned rf circuit (it would have to be with a $365 \mu\mu\text{f}$ tuning capacitor) then the only function left to V1 would be detection.

Suppose, though, we assume this isn't enough evidence. What more information do we have? What about the forward bias for V1? Actually, there is no forward bias other than that supplied by the input signal. And since this is the case, we may assume that the operating point on the characteristic curve must be in the vicinity of the cutoff point. In this circuit we depend on one-half of the input signal to supply enough forward bias to take the transistor out of cutoff. The other half of the signal will drive it further into the cutoff region. This is rectification, or, to give it its other name, detection.

What about V2? Is it biased at all? Is it properly biased? Since we have a p-n-p transistor we want our emitter to be positive with respect to the base. We can see quite readily that the emitter con-

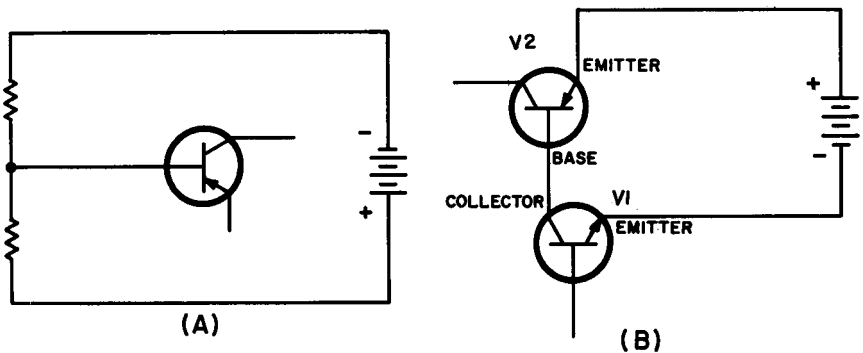

Fig. 810. A pair of transistors can be used as a voltage divider.

nects to the plus terminal of the battery, but what about the base. The return path to the minus terminal of the battery is through the emitter-collector circuit of V1. Before we decide this is not for us, consider the emitter-collector of V1 as a resistive path and you'll have no trouble getting back to the negative terminal of the battery.

Working with crystalline materials, as we are, does not necessarily imply that all our explanations are going to be crystal clear. Earlier in this chapter we mentioned that a circuit diagram will often obscure an understanding of the theory. For this reason let us consider the biasing of V2 once again, but this time from the vantage point of Figs. 810-A and -B. In drawing A the biasing

arrangement for the transistor is the same circuit arrangement we have used so often in earlier chapters. But what about drawing B? We don't have to connect the base of V2 into the divider since V2 and V1 in series act very much like the resistive pair shown in Fig. 810-A.

Common-collector amplifier

We guarantee one thing. Once you get accustomed to the idea of circuit analysis, you will not be satisfied to look at a circuit without really seeing it as it is. Circuit analysis is guaranteed to keep your mental gear-box turning, and that is as it should be.

So, flexing our gray-matter muscles, we come across Fig. 811, which does not deceive us for a moment because of its simplicity. We recognize it immediately as a grounded-collector amplifier, but classifying the circuit is just a small step. There aren't many components, so we can dispose of them fairly rapidly. C1 is a coupling

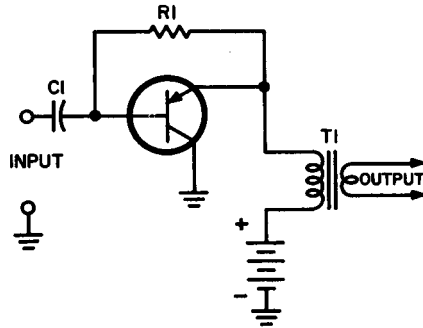

Fig. 811. Grounded-collector amplifier. The true relationship of R1 to the transistor isn't clear until the circuit is redrawn.

capacitor connecting the circuit to a preceding stage or some signal source. Ditto for T1 except that it couples the output to the next stage.

Since R1 is the only component remaining, we might become sort of complacent and think that we have analyzed the circuit. But have we? How is the circuit biased? And just what is R1 up to anyway? Since R1 is obviously involved in the biasing, answering one question will probably give us the solution to both.

Since this is a p-n-p transistor, we want a positive emitter and that is exactly what we do have. The emitter is connected to the positive terminal of the battery through the primary of T1. For

this type of transistor we want the collector negative, and since both the collector and the minus terminal of the battery are grounded, that requirement is filled.

R_1 is still dangling in mid-air and so is the question of how we get our forward biasing. The way the circuit of Fig. 811 is arranged isn't too much help in supplying an answer, so let us re-arrange the circuit as shown in Fig. 812. Once again we have a voltage

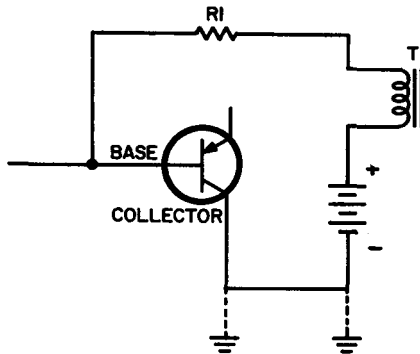

Fig. 812. The base and collector of the transistor of Fig. 811 are considered here as part of a voltage divider.

divider, but this time it consists of the primary of the output transformer in series with R_1 and the base-collector circuit of the transistor. Think of the transformer primary winding as a resistor and the base-collector circuit of the transistor in the same light and you will see the voltage divider for what it really is. And here, just as in Fig. 810-A, the base is connected directly into the voltage divider for proper forward biasing.

What do we need for circuit analysis? Our first and most obvious need is to toss out complacency and for it substitute the realization that a circuit diagram is a convenience and as such it can often obscure as much as it explains. The second and not such obvious need is to re-draw that portion of the circuit diagram that is not absolutely clear so that its operation and function become evident. This isn't an operation that will appeal to lazy people, so, if you wish, you can use it as a measure of character analysis.

Oscillators

Many people like to classify their ideas and their thoughts, and by putting them into compartments in their mind are able to keep

all their facts nice and orderly. If we go along with this sort of thinking, a logical step would be to put all transistor circuits into two categories – amplifiers and oscillators. What we have talked about in this chapter are amplifiers, but it isn't such a big jump to oscillators as you might think. Some amplifiers will oscillate at the slightest opportunity and frequently we must take steps to make sure that they will not do so

The very close relationship between a multivibrator type of oscillator and amplifier circuitry is very nicely illustrated by the drawing in Fig. 813. A quick look might convince you that what we have here is an ordinary resistance-coupled amplifier, but a single component, C2, changes all that. The output at the collector of V2 is in phase with the base-emitter circuit of V1. This is the sort of thing positive feedback is made of, a condition that leads to oscillation. Now you might insist that there is no input to V1, consequently there can be no signal feedback. It is true we have no external signal, something we would need if C2 were not present, but consider how unlikely it is that both V1 and V2 will conduct exactly the same amount of current at exactly identical moments. Any small voltage change at the collector of V1 will be sent along to the base input of V2, through C1. This small voltage change will be amplified by V2 and fed back to V1, through C2. What could have caused the current in V1's collector circuit to change? This could have been the amplified effect of a very tiny change in the forward biasing of V1.

It may seem odd to talk about a change in the forward biasing of V1 since what we have here is a dc circuit. This change, though could consist of a very slight variation in the amount of current flowing between base and emitter. In what direction would this variation be – that is, would the change be such that the base-emitter current increased? Or would it be a decreasing current? It makes no difference. We're not interested right at this point in knowing what the base-emitter current is up to. The important fact is that a change does take place. Please keep in mind, too, that the variation in base-emitter current is practically microscopic – if we can use such a word in connection with current.

That the change is tiny does not bother us either. For this minute change is amplified by V1, further amplified by V2 and is then fed back to V1 (via C2) in such a way that the extremely tiny change receives considerable support. Add the two – the small change and its highly amplified counterpart – and we now have the equivalent of an input signal.

The operation of a multivibrator is simple. Its explanation is quite complex. Briefly, what happens is that each transistor, V1 and V2, runs the gamut from cutoff to saturation. The output of this oscillator, when compared to the symmetrical sine waves produced by coil-type oscillators of the Hartley and Colpitts varieties, is highly distorted.

Crystal oscillators

The silicon and germanium semiconductors we have covered in this book form the very famous and highly-publicized duo of a rather large family of crystalline substances. Other crystals – such as quartz, and tourmaline – have their own, very legitimate claim

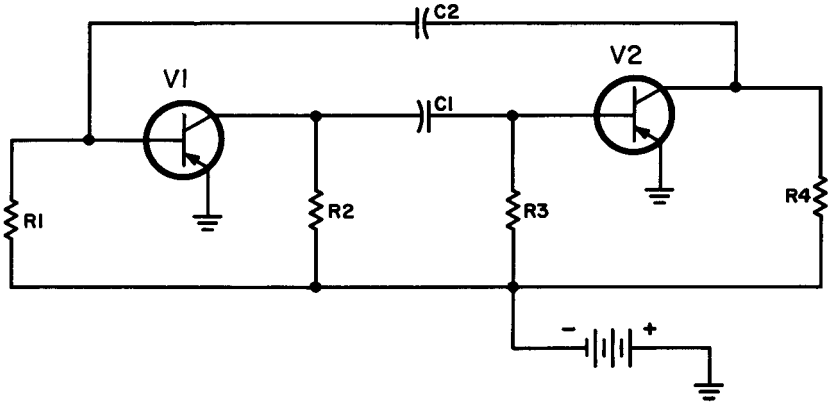

Fig. 813. The addition of a feedback capacitor, C2, changes the circuit from a resistance-coupled amplifier to a multivibrator oscillator.

to fame. These crystals act as true transducers¹ and can change a mechanical strain to a voltage.

The crystal is ordinarily placed between a pair of metal plates. When the plates are connected to a voltage source, the crystal will distort. When the crystal is permitted to resume its natural shape once again, its action produces a voltage or electrical charge across the two metal plates which hem it in. But a crystal can no more resume its exact shape immediately, than a compressed spring can when released. What we will get will be a series of charges on the metal plates, each one smaller than the preceding. Again we can

¹A transducer is a substance or device which can change a force, such as torque, pressure, velocity, strain, shear, sound, heat or light, into a voltage, or conversely, can take a voltage and change it into sound, pressure, etc. A microphone is a transducer. So is a speaker.

compare this to a spring whose expansions and contractions keep getting smaller and smaller. But we can keep the spring bouncing and we can keep the crystal in action by applying properly timed voltages. In this respect the crystal behaves very much like a coil in series with or in parallel with a capacitor. The coil-capacitor combination will resonate at a particular frequency, depending on its physical dimensions. So will the crystal.

With these facts safely tucked away, let's proceed to an examination of the crystal oscillator circuit of Fig. 814. We can recognize some old friends immediately, such as the emitter resistor R1 and its bypass capacitor C1. We have also come across R4, the collector load, in other circuits. There are a few other components whose appearance or function may seem to be new. Start with the crystal. It is represented by a pair of parallel lines used to indicate the metal plates sandwiching the crystal, shown as a rectangle. Shunted across the plates of the crystal is a radio-frequency choke coil, marked rfc. Neglecting the choke coil and the crystal for a moment, what about R2 and R3? These two resistors are in series but, as you can see, they are shunted directly across the battery. The base of the transistor is connected to the junction of these two resistors through the choke coil. The function of the two resistors now becomes evident. Since we have a p-n-p transistor, we want the base at a slightly lower positive voltage than the emitter and this is just what these two resistors do. Now we can also see the necessity for the radio-frequency choke coil. The dc resistance of this coil is very low, possibly less than 1 ohm, and so the base quite properly considers itself directly connected to the junction of R2 and R3.

The choke coil raises some technical questions in our thinking processes, and if it doesn't, it should. A little earlier we mentioned the action of the crystal in charging the metal plates which hold it. But with a choke coil of just 1 ohm resistance, don't we have what amounts to a short across the plates? Yes, for dc. But the varying charge on the crystal plates is ac and so for this type of voltage the choke coil could have an impedance of thousands of ohms.

How can we regard this circuit? Ignoring the base and the crystal for the moment, current will flow from the negative terminal of the battery, through R4, through the transistor from collector to emitter, through R1 to ground or the positive terminal of the battery. This is a direct current flow and we have done nothing to change it. But with our natural born penchant for disturbing the existing order you know by now that things are going to change.

Connected to the base we have a crystal which will act very much like a tuned circuit. But this tuned circuit, connected as it is between base and emitter, will vary the forward bias. This same crystal is not only in the base-emitter circuit, it is also located in

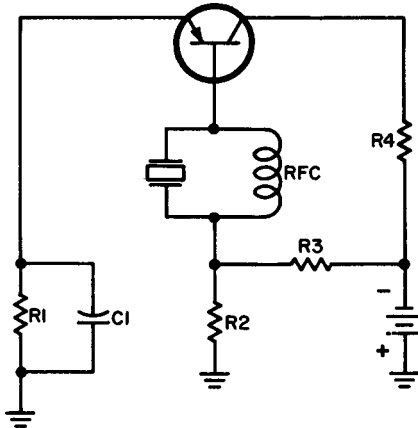

Fig. 814. Crystal-controlled transistor oscillator.

the base-collector circuit. A small part of the energy of the output circuit is fed back to the input, overcoming its losses, and permitting continued oscillation.

More about the crystal

An oscillating crystal is a nice challenge to our mental processes because when we get right down to it, the crystal (and its holder) are mechanical. The challenge arises out of the fact that we had better think of it as electrical, if our crystal oscillator circuit is to make any sense. The crystal, though, doesn't hold any monopoly on mechanical devices which can be interpreted electrically or electronically. A stretched spring, released and then allowed to come back to a resting point after its wild back and forth gyrations have subsided, can be represented by a damped wave. The rotating armature of a generator results in a sine wave of constant amplitude.

Fig. 815 shows the equivalent circuit of the crystal. There is a certain amount of capacitance between the metal plates and, because this shunts the crystal, that is exactly the way in which we show it. The crystal itself behaves like a series-tuned circuit and since every tuned circuit has a certain amount of resistance associated with it, it isn't too surprising to find R in series with

L and C. Unfortunately, in a generalized circuit of this form, values of R are not given, and since one unmarked resistor looks very much like another, we have no way of knowing whether R is large or small. In the case of the crystal, more so than in the case of actual tuned coil and capacitor arrangements, R is very low. R, though, influences Q directly, and so the crystal, because of the very low amount of R, has a very high Q.

With this information on hand, circuit analysis of Fig. 814 resolves itself very nicely as we see in Fig. 816. R, in series with L and C (in Fig. 815), has been omitted since there is less need for its inclusion than in an actual coil-capacitor circuit. Since C and L form a series circuit, it will have its minimum impedance

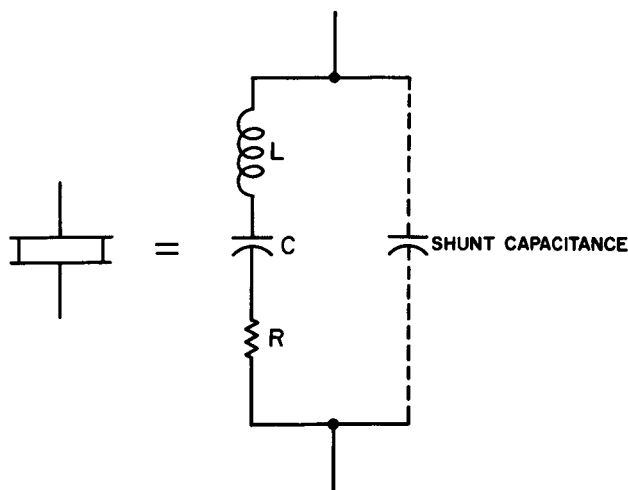

Fig. 815. A crystal and its equivalent electrical circuit. The shunt capacitance and the series resistance are small and can often be disregarded.

at its resonant frequency. At any other frequency than the resonant one, the impedance of L and C rises quite dramatically. The net effect of this electronic behavior is to give us an oscillator that works at a single frequency, so much so that crystal oscillators are often used as frequency control circuits or where single frequency stability is the prime consideration.

Now what about the choke coil, RFC, in Fig. 816? We still need it, for the substitution of the electrical equivalent of the crystal just serves to emphasize that without the choke we would have no dc return from the base of the transistor to ground—that is, to the plus terminal of the battery.

If you can't lick 'em — join 'em.

The most positive cure for a headache is decapitation. This is quite a drastic cure for what may be a very minor illness. Similarly, the shunting capacitance existing between the metal plates of a crystal is usually nothing more than just a slight annoyance, particularly since the overall shunting effect of the circuit itself may be so much greater.

Somewhat unexpectedly, we sometimes shunt capacitance directly across the crystal plates. Offhand, it would seem as though

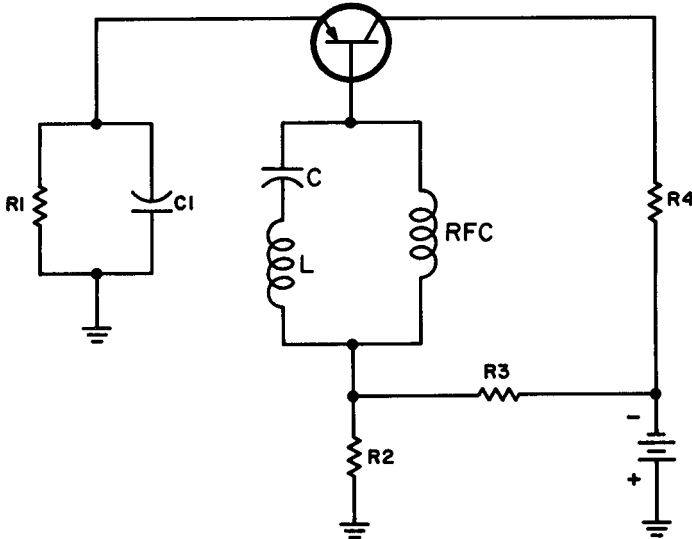

Fig. 816. The crystal-oscillator circuit becomes somewhat more understandable when the electrical equivalent of the crystal is substituted for it.

additional capacitance would be extremely undesirable, yet it can be made to work in a very beneficial way. We can use it to tune the crystal within small limits. Or, we can use this capacitance as an ac voltage divider. Or both. Fig. 817 shows how.

A circuit analysis of this illustration shows how few new parts demand our attention. R3 and C1 are old-timers we've discussed in connection with other circuits. R1 and R2 are immediately recognizable as a voltage divider for forward biasing. R4 is the collector load. Other than the battery and the transistor, all that we have left in the way of components to study is the crystal and a pair of capacitors, C2 and C3. C2 and C3 are in series, and this series combination is shunted directly across the plates of the crystal holder.

Now join us in a bit of mental transposition. In place of the crystal, visualize the electrical equivalent as shown earlier in Fig. 815. We can disregard the shunt capacitance since it will simply add to the equivalent capacitance of the series combination of

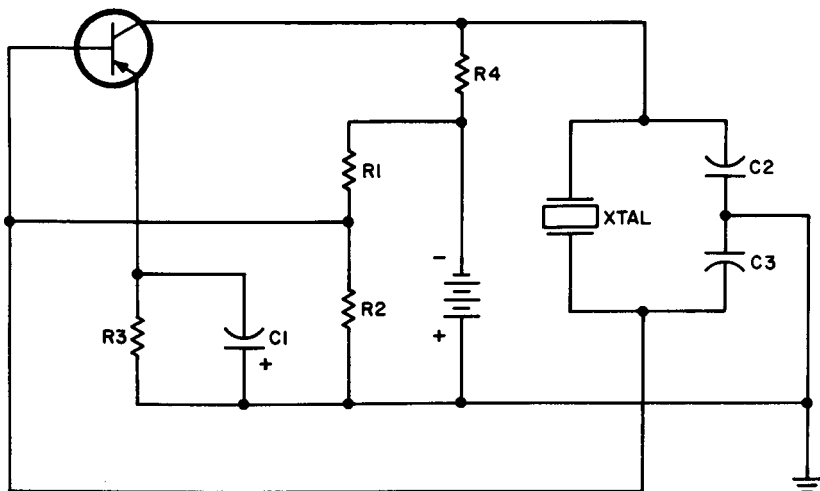

Fig. 817. This crystal oscillator circuit uses a capacitive voltage divider. Feedback is through C3 to the base-emitter circuit.

C2 and C3. Similarly, we can forget about resistor R of Fig. 815. What is left? Just a series-connected inductor and capacitor in place of the crystal.

With the crystal in oscillation, an ac voltage at the resonant frequency will appear across the plates of the crystal holder. C2 and C3 are shunted across this voltage and will promptly divide it between them. Equally? Only if C2 and C3 are equal. If they are not of equal capacitance, the unit with the smaller capacitance will get the larger amount of voltage. Thus, we can control the division of voltage through proper selection of the relative capacitances of C2 and C3.

If you will trace the circuit you will see that the base is connected directly to the bottom end of C3 while the top end of C3 goes to the emitter. Offhand, this might seem incorrect, since, if you will move along from the top of C3 (on your way to the emitter), you will promptly run into C1. But the capacitance of C1 is so much greater than C3, that we can disregard it completely. Thus, if C1 is 1 μf and C3 is 100 $\mu\mu\text{f}$, the ratio is 10,000 to 1.

The voltage produced across C3 is fed back to the input since it is quite clearly connected in the base-emitter circuit. But the crystal and C2 and C3 are part of the collector circuit. In this way, a selected amount of output voltage, depending on the ratio of C3 to C2, is fed back to the input. And if we also arrange for proper phasing, we have met all the conditions necessary for sustained oscillation.

Oscillators and amplifiers

It is very nice to be able to put things into mental compartments. Designating a transistor circuit as an oscillator or as an amplifier falls into this category, but while it is convenient, it is also misleading. It tends to give us the impression that a wide chasm exists between oscillators and amplifiers. But is the separation as wide as we might think? If we have an amplifier we can feed back part of the output, in phase, to the input. Would we then have an oscillator? Not necessarily. We would have a regenerative amplifier but it would not oscillate until the feedback reached a certain amount. Thus, the transition from amplifier to oscillator is not as clear and as sharply defined as we might have expected.

And now that we have managed to bring about an apparently closer relationship between oscillator and amplifier, let's separate them again. What is the difference? With an amplifier we select a particular operating point on the characteristic curve and that point determines our class of operation. An oscillator of the L-C type, though, runs the gamut from cutoff to saturation and back again. For an understanding of just what it is that a transistor does, then, we must always go to its characteristic curve.

Transistor as a switch

We can use selected portions of the transistor characteristic curve or all of it for amplifiers and oscillators, but if we wish we can also use the beginning of the characteristic (cutoff) and the end (saturation). Cutoff means no current while saturation is maximum current. This all-or-nothing-at-all state of affairs is what we get every time we use a switch.

Fig. 818-A shows our first step toward using the transistor in this function. When the arm of the potentiometer is at the top, the transistor is heavily forward-biased and we get maximum, or saturation, current. When the arm is at the opposite end, the base-emitter circuit is heavily reverse-biased and we are at cutoff. To get a faster transition from cutoff to saturation, we could substitute a single-pole double-throw switch for the potentiometer.

We want to use the transistor as a switch since it will be faster and much more dependable than manual switching. That is why the circuit of Fig. 818-B, using a switch to control the bias, is self-

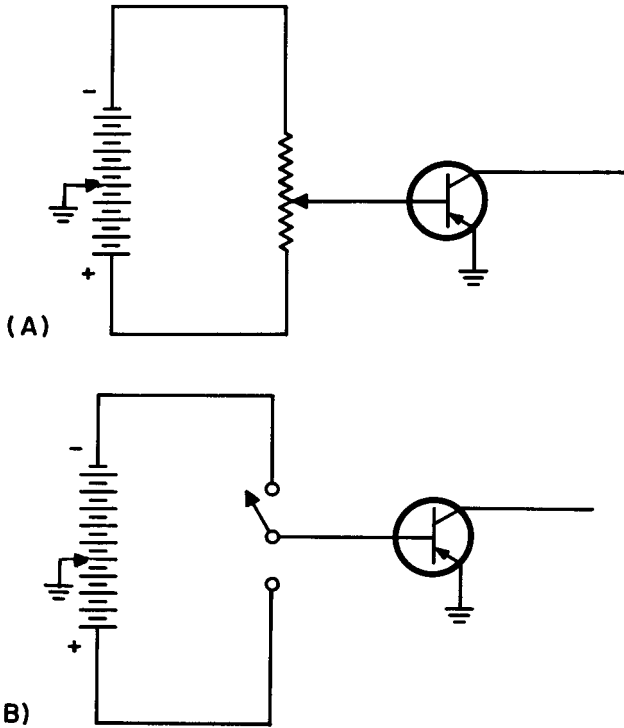

Fig. 818-A,-B. In this arrangement, the transistor input is forward- or reverse-biased, depending on the position of the potentiometer arm or the switch.

defeating. But instead of a switch, we can control the biasing electronically, as shown in Fig. 819.

Let's analyze the circuit and see what we have. Since we have a p-n-p transistor we must have the emitter positive, the base and the collector negative with respect to the emitter. Tracing the circuit shows that it meets these requirements, within limits. With the help of potentiometer R2 we can vary the amount of bias to the base-emitter circuit. When the arm is at the top, we get the maximum amount of forward biasing. Let us say that the voltage of the battery is sufficient to produce maximum transistor current—that is, saturation. This condition is comparable to having a closed switch.

Finale!

And so we come to the end of our story—but not yours. What you have had in this book is to transistors what an appetizer is to a heavy ten-course dinner. Just the beginning. But if you have managed to follow the text then you are well-equipped to move on to a more detailed study of transistors.

If you will examine R1 and R2, you will see that they are in series, but these two series-connected components are shunted across the pulse input. If we inject a strong positive-going pulse,

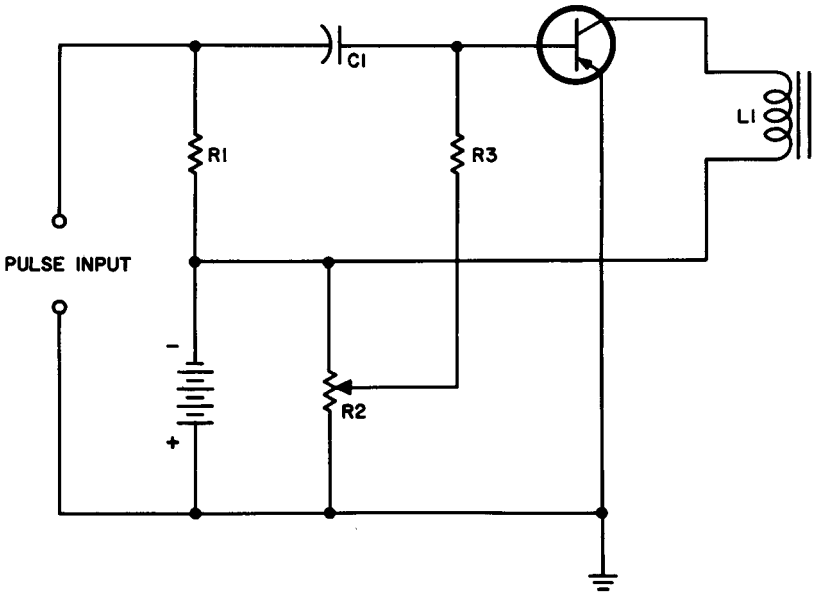

Fig. 819. Transistor switching circuit. The transistor has two operating points—saturation and cutoff.

the resulting current flow through R1 and R2 will produce a voltage that will be in opposition to the battery voltage. If this voltage is strong enough, it will reverse-bias the input and drive the transistor down into cutoff. Through proper selection of pulse amplitude and frequency we can work our transistor just as you would an ordinary light switch you have in your home—but much faster. Transistor switches are used in computers and in equipment that is pulse-operated, such as radar units and television receivers.

QUESTIONS

1. Describe the operation of a meter amplifier. What would be the advantage of using such a circuit?
2. Draw the circuit of a simple transistor-operated relay amplifier and explain how it works.
3. Describe several methods of connecting an electrolytic capacitor in a circuit. What problems are involved in making the connections?
4. What is a signal tracer?
5. If a circuit diagram is drawn so that you cannot immediately understand the functioning of some of the components, what can you do to overcome this difficulty?
6. Explain how transistors can be used as voltage dividers.
7. Draw a common-collector amplifier circuit and explain how it works.
8. Draw a multivibrator circuit and explain its operation.
9. What is a transducer? Give three examples.
10. Draw the circuit diagram of a crystal-controlled transistor oscillator.
11. What is the purpose of the shunting capacitor across a battery?
12. What are typical values of coupling capacitance used in transistor audio amplifiers?
13. Are the transformers used in transistor audio amplifiers step-up or stepdown types. Explain the reason for your answer.
14. What is meant by circuit analysis? What is the advantage of being able to do a circuit analysis?

index

A

Ac and Dc Voltages, Combining	109
Ac Voltage Divider	149
Acceptors	26
Adjusting Bias	125
Agc:	
Auxiliary	145
Filtering	142
Simple	141
System, Steps in Development of	137, 141
Alloy-Diffused Transistor	172
Alloy Transistor	172
Alpha:	
Cutoff Frequency	166
Cutoff Frequency vs Amplification	166
Explanation of	72
To Beta, Converting	74
Vs Beta	74
Aluminum	26
Amplification:	
and Detection	139
By the Transistor	104
Current	70, 72, 73
Voltage	74
Vs Alpha Cutoff Frequency	166
Amplifier:	
Arrangements	105
Biasing the	108
Class-A	111
Class A, Single-Ended Power	114
Class-AB	113
Class B	111
Class C	111
Common-Collector	206
Direct-Coupled	128
Efficiency, Class B	122
Grounded-Collector	206
Meter	196
Pushpull	120
Relay	197
Transformer Coupled	116
Amplifier Circuit:	
Analysis	115
Class-B Power	120
Direct-Coupled	130
Elementary	103
Power	118
Transistor	73
Amplifiers:	
Audio	103
Classes of	110
If	137
Intermediate Frequency	137
Neutralization of If	152
Voltage and Power	113
Analysis	
Amplifier Circuit	115
Bias	83
Circuit	195
Antimony	23
Armstrong Oscillator	158
Arsenic	25
Atom:	
Germanium	20
Hydrogen	9
Lithium	11
Mass of the	10
Sodium	15
World of the	7
Atomic:	
Rings	11

Shells	11
Union	26
Atoms:	
Charged	43
Neutral	39
Attenuation of Treble	126
Audio:	
Amplifier	103, 203
Driver Stage	126
Autodyne Converter	155
Automatic Gain Control	137, 141
Auxiliary	145
Steps in Development of	143
Automatic Volume Control	137, 141
Autotransformers	158
Auxiliary Age	145
Avalanche:	
Breakdown	54
Multiplication	54
Avc	137, 141

B

Barrier:	
Increasing the Potential	49
Junction	43
Potential	41
Reducing the Potential	46
Value of Potential	47
Voltage	44
Base:	
Circuit, Common	106
Circuit, Grounded	106
Description of	58, 70
Emitter Circuit	60
Region	68
Volume of	166
Base Current:	
Curves, Spacing of	94
Path	67
Vs Collector Current	73
Basic Transistor Circuits	106
Base Boost	126
Battery Operation, Single	80
Battery Voltage	60
Beta	73
Beta to Alpha, Converting	74
Beta vs Alpha	74
Bias:	
Adjust Potentiometer	125
Adjusting the	125
Analysis of	83
Changing the	59
Critical	54
Effect of Amount of	111
Effect of Collector Current on	82
Fixed	81
Forward	48
Increasing Reverse	53
Missing	138
Reverse	48
Self	82
Self-Adjusting	82
Signal	108
Voltages, Independent	80
Vs Class of operation	111
Vs Signal voltage	110
Zero	108
Biasing:	
Diodes	66
Methods	80
Pushpull Transistors	125
Reverse	62

Single Battery	81	Efficiency	119
The Amplifier	108	Single-Ended Power Amplifier	114
The Transistor	58	Vs Class B	113
Tube vs Transistor	87	Class-AB Amplifier	113
Bismuth	25	Efficiency	122
Body	176, 177	Class B:	
Bond, Valence	21	Amplifier	111
Boost, Bass	126	Efficiency	122
Boron	26	Power Amplifier Circuit	120
Breakdown, Avalanche	54	Pushpull	113
		Vs Class	113
C		Class-C Amplifier	111
Capacitance of the Diode	166	Class of Operation vs Bias	111
Capacitor, Output	127	Classes of Amplifiers	110
Tone-Compensation	127	Coefficient, Negative Temperature	117
Charges, Negative	27	Positive Temperature	117
Positive	27	Collector:	
Capacitors, How to Connect		and Emitter, Coupling Between	75
Electrolytic	199	and Emitter, Voltage Between	79
Changing the Bias	59	Characteristic Curve	86
Characteristic:		Characteristic Family	87
Curve, Collector	86	Characteristics, Circuit for	
Curve, Diode	55	Measuring	91
Family, Collector	87	Circuit, Common	106, 128
Resistance	54, 55	Circuit, Grounded	106, 128
Characteristics:		Description of	58, 70
Circuit for Measuring Collector	91	Load	86, 89
Mutual	95	Output	128
Transfer	95	Voltage vs Collector Current	85
Transistor	79	Collector Current:	
Tube vs Transistor	89	Effect of on Biasing	82
Charge of Electron	10	To Emitter Current, Ratio of	72
Charged Atoms	43	Vs Base Current	73
Chlorine	15	Vs Collector Voltage	85
Chopper	193	Vs Temperature	95
Circuit:		Waveform vs Signal Current	
Analysis	115, 195	Waveform	94
Audio Amplifier	203	Combining AC and DC Voltages	109
Audio Driver	128	Common:	
Base-Emitter	60	Base Circuit	106
Basic Transistor	106	Collector Amplifier	206
Class-B Power Amplifier	120	Collector Circuit	106, 128
Collector Characteristic	86	Element	105
Common Base	106	Emitter	105
Common Collector	106, 128	Emitter Circuit	106
Common Emitter	106	Compensation, Diode	132
Complementary Symmetry	124	Complementary Symmetry:	
Crystal-Controlled Oscillator	209	Circuit	124
Current Flow in N-P-N		In Direct Coupling	130
Transistor	68	Principle	108
Current Flow in P-N-P		Components:	
Transistor	69	Adding	65
Diode Detector and Agc	142	Decoupling	145
Direct-Coupled Amplifier	130	Dual Function of	98
Elementary Amplifier	103	Transposition of	84
Elementary Transistor Amplifier		Compounds	8, 26
for Measuring Collector	73	Conductors	17, 19
Characteristics	91	Control:	
for Measuring Input Resistance	100	Automatic Gain	137, 141
for Measuring Output Resistance ..	101	Automatic Volume	137, 141
Grounded Base	106	Gain	126
Grounded Collector	106, 128	Positions	126
Grounded Emitter	106	Steps in Development of	
Input	62	Automatic Gain	143
Local Oscillator	159	Tone	126
Mixer	160	Volume	126
Negative Feedback	152	Conversion, Frequency	154
Oscillator	75	Converter, Autodyne	155
Output	62	Converters	155
Packaging	190	Converting	
Power Amplifier	118	Alpha to Beta	74
Preamplifier	198	Beta to Alpha	74
Pushpull	120	Copper	17
Rf Amplifier	162	Coupling:	
Simplified Radio Receiver	204	Between Collector and Emitter	75
Single-Ended Class-A Power		Complementary Symmetry in	
Amplifier	115	Direct	130
Temperature Compensated	133	R-C	115
Thermistor	118	Resistance	116
Tone Control	127	To Low Impedance Loads	128
Transformer-Coupled Amplifier	116	Transformer	116
Two-Transistor Receiver	140	Critical Bias	54
Class-A:		Crystal Oscillators	209
Amplifier	111	Crystalline Structure	19, 24
		Current:	
		Amplification	72, 73

Collector	71	Drain	176
Curves, Spacing of Base	94	Driver Stage	125
Feedback	97, 98		
Forward	52		
Injection	45		
Movement	33		
N-P Diode	67		
of a Semiconductor Diode,			
Forward	51		
of a Semiconductor Diode,			
Reverse	51		
Paths, Diode	67		
P-N Diode	67		
Ratio of Base to Collector	73		
Ratio of Emitter to Collector	72		
Reverse	52		
Temperature vs Collector	95		
Transistor Signal	71		
Vs Voltage, Collector	85		
Current Flow:			
Description of	31		
Direction of Through Diodes	50		
in N-P-N Transistor Circuit	68		
in P-N-P Transistor Circuit	69		
Relative	61		
Curve:			
Collector Characteristic	86		
Diode Characteristic	55		
Curves, Transfer Characteristic	95		
Cutoff Frequency, Alpha	166		
D			
Dc and Ac Voltages, Combining	109		
Decoupling	139		
Components	145		
De-Ionization	47		
Detection and Amplification	139		
Detector and Agc Circuit, Diode	142		
Detector Circuit, Transistor	137		
Detectors	137		
Determination of the Load Line	92		
Diameter of Electron	10		
Diffused Transistor	170, 172		
Diffusion	27		
Diode:			
as a Temperature-Compensating			
Device	133		
as a Voltage Divider	132		
Capacitance of the	166		
Characteristic Curve	55		
Compensation	132		
Current Paths	67		
Currents	67		
Detector and Agc Circuit	142		
Elements	67		
Forward Current of a			
Semiconductor	51		
in If Stage	146		
Load Volume Control	142		
Reverse Biasing of Semiconductor	49		
Reverse Current of a			
Semiconductor	51		
Stabilization	132		
Substitution for Resistor	132		
Zener	54		
Diodes:			
Biasing	66		
Direction of Current Flow			
Through	50		
in Series	66		
P-N	57		
Tunnel	34		
Direct-Coupled Amplifier	128, 130		
Direct Coupling, Complementary			
Symmetry in	130		
Dissipation of Heat	119		
Distortion	92		
Load Lines	93		
Divider, Impedance	149		
Donors	25, 26		
Negative	26		
Doping	23		
Double-Base Junction Transistor	172		
E			
Efficiency:			
Class-A	119		
Class-AB	122		
Class-B	122		
Electric Field	41		
Electrolytic Capacitors, How to			
Connect	199		
Electron:			
Charge	10		
Diameter of	10		
Flow in N-P-N Transistor			
Circuit	68		
Flow in P-N-P Transistor			
Circuit	69		
Movement	47		
Orbit	9		
Shells of Germanium	19		
Valence	21		
Electronic Symbols	64		
for Tetrode Transistors	168		
Electrons:			
in Motion	16		
Movement of in Copper	17		
Orbital	10		
Sharing	11		
Element, Common	105		
Indium Acceptor	171		
Elements	7		
Diode	67		
of the Agc System	144		
Transistor	69		
Emitter:			
and Collector, Coupling Between	75		
and Collector, Voltage Between	79		
Circuit, Common	106		
Circuit, Grounded	106		
Common	105		
Current vs Collector Current	72		
Description of	58, 69		
Follower	128		
Grounded	105		
Output	128		
Etched Transistor	169		
Evaporation-Fused Transistor	182		
F			
Family of Collector Characteristics	87		
Feedback:			
Current	97, 98		
Description of	75		
Negative	98, 150		
Variations	153		
Voltage	99		
Winding	75		
Field:			
Barrier	41		
Effect Transistor	175		
Electric	41		
Filtering, Agc	142		
Fixed Bias	81		
Flip-flop	193		
Flow, Current	31		
Fluorine	14		
Follower, Emitter	128		
Formation of Holes	28		
Forward:			
Bias	48		
Biasing Transistors	58		
Biasing, Varying	58		
Biasing With Single Resistor	141		
Current	52		
Current of a Semiconductor			
Diode	51		
Frequency:			
Alpha Cutoff	166		
Conversion	154		
Converter	155		
Operating	157		

Front Ends	137
Function of Components, Dual	98
Fused Transistor	172
G	
Gain:	
Control	126
Control, Automatic	137, 141
Control, Auxiliary Automatic	145
Voltage	72
Galena	34
Gallium	26
Arsenide	34
Gate	176, 177
Germanium:	
Description of	19, 181
Electron Shells of	19
N-Type	26, 30, 37
P-Type	30, 37
Refining	22
Graphs	51
Grounded:	
Base Circuit	106
Collector Amplifier	206
Collector Circuit	106, 128
Emitter	105
Emitter Circuit	106
H	
Hartley Oscillator	156
Heat:	
Dissipation	119
Sink	119
Helium	10
Heterodyne Action	155
High-Frequency Transistor	169
Hole:	
Formation	28
Movement	30, 47, 70
Holes	28
Hook Transistors	174
Hydrogen Atom	9
I	
If:	
Amplifiers	137
Amplifiers, Neutralization of	152
Stage, Diode in	146
Impedance:	
Description of	60
Divider	149
High	61
Low	61
Matching	147
Matching Methods	148
Reference	61
Impurity, Adding an	23
Indium	26
Acceptor Element	171
Inductive Load	85
Injection, Current	45
Input:	
and Output of Transistor Circuit ..	79
Circuit	62
Resistance	99
Resistance, Measuring	100
Insulators	19
Interface Potential	44
Intermediate-Frequency Amplifiers ..	137
Intrinsic-Region Transistors	173
Intrinsic Transistors	173
Inversion, Phase	107
Inverters	193
Ionization	39, 42
Ions	39, 43
Iron	7
J	
Junction:	
Transistors	172
Barrier	43

L	
Large Power	101
Lattice Structure	24
Lead:	
Sulphide	34
Leads:	
Number of	189
Transistor	123
Line, Load	91
Lithium	14
Atom	11
Load:	
Collector	86, 89
Inductive	85
Line	91
Line, Determination of the	92
Line, Slope of the	93
Lines and Distortion	93
Value of the	92
Local Oscillator	155
Circuit	159
Low Impedance Loads, Coupling to ..	128
Lubricant, Silicone	123
M	
Manufacture of Transistors	76
Mass	10
of Atom	10
Matching, Impedance	147
Measurement of Resistance	99
Metals, Temperature Coefficient of ..	117
Meter Amplifier	196
Methods, Biasing	80
Micro-Alloy:	
Diffused-Base Transistor	172
Transistor	171
Minerals	19
Missing Bias	138
Mixer	155, 160
Circuit	160
Mixtures	8
Modules	193
Molecule	15
Mounting Transistors	189
Movement:	
and Recombination	38
of Electrons	47
of Electrons in Copper	17
of Holes	30, 47
Multi-Headed Transistors	180
Multiplication, Avalanche	54
Mutual Characteristics	95
N	
Negative:	
Charges	27
Donors	26
Feedback	98, 150
Feedback Circuits	152
Feedback, Control of	151
Germanium	26
Going Voltage	107
Ions	39
Temperature Coefficient	117
Neutral Atoms	39
Neutralization	150
of If Amplifiers	152
N-P Diode Current	67
N-P-N Transistor	63
N-P-N Transistor Circuit, Current ..	68
Flow in	26, 30, 37
N-Type Germanium	9
Nucleus	9
Number of Leads	189
O	
Ohms	61
Operating:	
Frequency	157
Point	111

Operation, Stability of	117	R-C Coupling	115
Orbit, Electron	9	Reactance	61
Orbital Electrons	10	Receiver, Two-Transistor	140
Oscillator:		Recombination	29, 48
Action	75	and Movement	38
Armstrong	158	Reducing the Potential Barrier	46
Circuit, Transistor	75	Region, Base	68
Hartley	156	Relative Current Flow	61
How it Works	75	Relay Amplifier	197
Local	155	Resistance:	
Transistor as an	75	Characteristic	54, 55
Oscillators	207	Control of	55
Crystal	209	Coupling	116
Output:		Input	99
and Input of Transistor Circuit	79	Measurement of	99
Capacitor	127	Measuring Input	100
Circuit	62, 63	Measuring Output	100
Power	122	Output	100
Resistance	100	Transfer	70
Resistance, Measuring	100	Resistor:	
Waveform	74	Diode Substitution For	132
		Forward Biasing With Single	141
P		Stabilizing	97
Packaging, Circuit	190	Transistor Substituted For	131
Phase	106	Reverse:	
Phosphorus	25	Bias	48
P-N Diode Current	67	Bias, Increasing	53
P-N-P Transistor	63	Biasing	62
P-N-P Transistor Circuit, Current		Current	52
Flow in	69	Current of a Semiconductor	
Point:		Diode	51
Contact Transistor	178	Rf Amplifier Circuit	162
Operating	111	Rings of Electrons	11
Q	93	Runaway, Thermal	118
Quiescent	93		
Positions, Control	126	S	
Positive:		Selectivity, Problem of	153
Charges	27	Self-Adjusting Bias	82
Going Voltage	107	Self Bias	82
Ions	39	Semiconductor Diode, Reverse	
Temperature Coefficient	117	Biasing of	49
Potential:		Semiconductors	19, 34
at the Interface	44	Semimetals	172
Barrier	41	Sensitivity, Temperature	117
Barrier, Increasing the	49	Series Diodes	66
Barrier, Reducing the	46	Signal:	
Barrier, Value of	47	Bias	108
Potentiometer, Bias-Adjust	125	Current, Transistor	71
Power:		Current Waveform vs Collector	
Large	101	Current Waveform	94
Output	122	Effect of the	138
Small	101	Rectifier, Transistor as a	137
Speaker	119	Tracer	200
Transistors	186	Voltage	60
Power Amplifier:		Vs Bias Voltage	110
and Voltage Amplifier	113	Signals — Weak and Strong	147
Circuit	118	Silicon	34, 181
Circuit, Class-B	120	Fusion Alloy Junction	
Class-A, Single-Ended	114	Transistor	172
Preamplifier Circuit	198	Mesa Transistor	182
P-Type Germanium	30, 37	Silicone Lubricant	123
Pushpull:		Single Battery:	
Advantages	122	Biasing	81
Amplifier	120	Operation	80
by Complementary Symmetry	124	Single-Ended Power Amplifier,	
Circuit	120	Class A	114
Class-B	113	Sink, Heat	119
Transistors, Biasing	125	Slope of the Load Line	93
		Small Power	101
Q		Sockets, Transistor	123, 189
Q Point	93	Sodium	15
Quiescent Point	93	Atom	15
		Chloride	16
R		Source	176
Radio Receiver Circuit	204	Spacing of Base Current Curves	94
Ratio of Base Current to Collector		Speaker Power	119
Current	73	Stability of Operation	117
Ratio of Collector Current to Emitter		Stabilization	96
Current	72	Diode	132
		Stabilizing Resistor	97
		Stage:	
		Audio Driver	126
		Driver	125
		Static Test	86

Stepdown Transformer	116	Output Power	122
Strong and Weak Signals	147	P-N-P	63
Superheterodyne, Principles of the	154	Point-Contact	178
Surface-Barrier Transistor	169	Power	186
Symbols:		Signal Current	71
Electronic	64	Silicon Fusion Alloy Junction	172
for Tetrode Transistors,		Silicon Mesa	182
Electronic	168	Sockets	123
Symbols, Transistor	63, 64	Substituted For Resistor	131
Symmetry Principle, Complementary ..	108	Surface-Barrier	169
		Symbols	63, 64
T		Tandem	181
Tandem Transistors	181	Tetrode	167
Temperature:		Three-Element	69
Compensated Circuit	133	Triode	69
Compensation by Diodes	133	Types	165
Sensitivity	117	Vs Tube Biasing	87
Sensitivity of Transistors	81	Vs Tube Characteristics	89
Stabilization	96	Transistor Circuit:	
Vs Collector Current	95	Current Flow in N-P-N	68
Temperature Coefficient:		Current Flow in P-N-P	69
Negative	117	Elementary	65
of Metals	117	Transistors As Voltage Dividers	205
of Thermistors	117	Transistors:	
Positive	117	Forward Biasing	58
Test, Static	86	Temperature Sensitivity of	81
Tetrode Transistor	167	Transit Time	165
Tetrode Transistors, Electronic		Transposition of Components	84
Symbols For	168	Treble	126
Thallium	26	Triode Transistor	69
Thermal Runaway	118	Triodes	57
Thermistor:		Tube vs Transistor:	
Circuit	118	Biasing	87
Description of the	117	Characteristics	89
Positioning of	118	Tunnel Diodes	34
Shapes	117	Two-Transistor Receiver	140
Temperature Coefficient of	117		
Three-Element Transistor	69	V	
Time, Transit	165	Valence	20
Tin	35	Valence Bond	21
Tone-Compensation Capacitor	127	Valence Bonds, Weakening	22
Tone Control	126	Value of the Load	92
Circuits	127	Voltage:	
Tracer, Signal	200	Amplification	74
Transfer Characteristics	95	Amplifiers and Power Amplifiers ..	113
Transfer of Resistance	70	Barrier	44
Transformer Coupled Amplifier	116	Battery	60
Transformer-Coupling	116	Between Emitter and Collector	79
Transformer, Stepdown	116	Bias vs Signal	110
Transistor:		Divider, Ac	149
Alloy	172	Divider, Diode as a	132
Alloy-Diffused	172	Dividers, Two Transistors as	205
Amplifier Circuit	73	Feedback	99
as an Oscillator	75	Gain	72
as Signal Rectifier	137	Negative Going	107
as Voltage Divider	202	Positive Going	107
Biasing The	53	Signal	60
Characteristics	79	Transistor Signal	71
Derivation of	70	Vs Current, Collector	85
Detector Circuit	137	Voltages, Combining Ac and Dc	109
Diffusions	172	Independent Bias	80
Dimensions	183	Volume Control	126
Double-Base Junction	172	Automatic	137, 141
Elements	69	Diode-Load	142
Etched	169	of Base	166
Evaporation-Fused	182		
Field-Effect	175		
Fused	172		
High-Frequency	169		
Hook	174		
How It Amplifies	104		
How It Works	65	W	
Intrinsic	173	Waveform, Output	74
Intrinsic Region	173	Waveforms, Comparison of Collector	
Junction	172	and Signal Current	94
Leads	123	Weak and Strong Signals	147
Manufacture	76, 184	Winding, Feedback	75
Micro-Alloy	171		
Micro-Alloy Diffused-Base	172		
Mounting	184		
Multi-Headed	180		
N-P-N	63	Z	
Oscillator Circuit	75	Zener Diode	54
		Zero Bias	108