

# RADIO

## TROUBLE SHOOTING GUIDEBOOK

by

JOHN F. RIDER  
J. RICHARD JOHNSON



A RIDER  
publication

volume 1.



\$2.40

**RADIO**

**TROUBLESHOOTING**

**GUIDEBOOK**

**Vol. 1**

*by*

**John F. Rider and J. Richard Johnson**



**JOHN F. RIDER PUBLISHER, INC.**  
116 W. 14th Street • New York 11, N. Y.

*Copyright 1954 by*

**JOHN F. RIDER PUBLISHER, INC.**

*All rights reserved. This book or parts thereof may not be reproduced in any form or in any language without permission of the publisher.*

**FIRST EDITION**

*Library of Congress Catalog No. 53-12613*

**Printed in the United States of America**

# CONTENTS

<i>Chapter</i>	<i>Page</i>
<b>PART I</b>	
<b>SUPERHETERODYNE RECEIVERS</b>	
1. A-M Superheterodynes .....	3
2. F-M Superheterodynes .....	37
<b>PART II</b>	
<b>FUNDAMENTAL TROUBLESHOOTING</b>	
3. Fundamental Troubleshooting Systems .....	67
<b>PART III</b>	
<b>COMMON SYMPTOMS AND REMEDIES</b>	
4. Undesired Signals .....	93
5. Weak Signals .....	117
6. Distortion .....	130
7. Noise .....	141
8. Dead Receiver .....	147
INDEX .....	154

## INTRODUCTION

*T*roubleshooting is the *detective work* of servicing. By itself it involves no physical action of final repair or adjustment of the receiver, yet it is the most important step in the servicing procedure. In the majority of cases, troubleshooting takes many times as much time and effort as the actual part replacement or adjustment to which it leads. Troubleshooting is thus the process in which the service technician has the greatest opportunity to increase profit and reduce time and effort through squeezing out the last drop of efficiency.

What is troubleshooting? In this book we define it as all those procedures necessary to determine the particular cause of trouble and its exact location and nature.

*Symptoms* of trouble are characteristic of the operation of the receiver as a *whole*. On the other hand, *sources* of trouble involve only one (or sometimes several) of the many components in the receiver. For example, the owner of a receiver with a shorted filter capacitor is just as handicapped by the failure of that one component as he would be if all the components in the receiver were defective—at least as far as performance is concerned. Troubleshooting consists in efficiently distinguishing between the component or components that are defective or mis-adjusted and the remainder which are in good operating condition.

Radio servicing in general can be divided into the following operations:

1. Determining the symptoms by which the trouble exhibits itself and obtaining all possible information about them.
2. Locating the stage of the receiver in which the trouble exists.
3. Tracking down the defective or misadjusted component or components in that stage.
4. Making the necessary replacement, adjustment, or repair.
5. Testing the receiver before returning it to the owner.

These steps cover the whole process of servicing. Troubleshooting comprises operations (1), (2), and (3), and it is about these steps with which we are concerned in this book.

It will be seen that the fundamentals of troubleshooting are applicable to all types of receivers, even though the details may have to be adjusted to suit the case. The technician who is well versed in the information given in this volume should have no difficulty in tackling any of the complex receivers now encountered in radio service work.

**PART I**  
**SUPERHETERODYNE RECEIVERS**





## CHAPTER 1

### A-M SUPERHETERODYNES

#### 1-1. Troubleshooting and the Receiver Function

Basically, every radio receiver has the function of intercepting radio-frequency (r-f) energy, amplifying it, and transforming it into sound for information and entertainment.

When some defect interferes with this function, the service technician must find the defect as quickly and easily as possible. In order to do this, he must be familiar with the manner in which the receiver functions.

Although this book assumes that the reader is well grounded in the fundamentals of radio, nevertheless it is important to review the types of receivers from the standpoint of *troubleshooting* procedures. In other words, we shall talk more about the agencies available to us for getting at the trouble and less about abstract theory of operation.

In this chapter we shall consider types of a-m receivers and their functional parts; in Chapter 2 we shall do the same thing for f-m receivers. Except for certain special precautions, use of different frequencies, etc., it will become clear that the basic troubleshooting approach is the same for all types. We shall then follow with a chapter-by-chapter discussion of important trouble symptoms, treating each individually and objectively.

#### 1-2. Comparison of T-R-F and Superheterodyne Receivers

*Why We Discuss Only the Superheterodyne.* While the t-r-f (tuned-radio-frequency) receiver is almost obsolete and supplanted by the superheterodyne, the technician may occasionally encounter one. For this reason, let us consider this type, compare it with the superheterodyne, and show why it is necessary to discuss only the superheterodyne to include all the principles necessary for t-r-f servicing.

As we said before, each receiver has the basic function of transforming modulated r-f energy into useful sound at the loudspeaker. The way in which the t-r-f receiver does this is somewhat simpler in *principle*, but in practice, receivers of the same weight, total number of parts, etc. are not much different. In both types, energy radiated at different fre-

## SUPERHETERODYNE RECEIVERS

quencies from nearby transmitters is intercepted by the antenna and applied to the input circuit of the receiver. The tuned circuits of the receiver select only the desired frequency and allow that signal to pass on to the remaining stages.

*The T-R-F Receiver.* In the t-r-f receiver, this signal voltage is fed to the first of the radio-frequency amplifying stages. The exact number of radio-frequency amplifying stages used in the receiver is not of great moment. As the modulated carrier passes from one radio-frequency amplifying stage to the next, the only change in the signal, with respect to the original signal received from the broadcasting station, is one of amplitude of the voltage representing the signal. As the signal passes from one amplifying stage to the next, it is always strengthened. Each radio-frequency amplifying tube passes on to the next an amplified version of the signal fed into that stage. The original carrier frequency and the modulation characteristics are retained during the passage of the signal through the radio-frequency amplifier.

If the broadcast station carrier is a 1000-cycle modulated 890-kc wave, and the radio frequency amplifier is functioning in normal fashion, the signal voltage, (which is passed out of the last radio-frequency stage into the detector, or demodulator) is a greatly strengthened 1000-cycle modulated 890-kc signal. In the detector, or demodulator stage, the modulation component, the 1000-cycle signal, is separated from the 890-kc carrier and passed into the audio-frequency amplifying system and then into the speaker.

For the purpose of comparison with the superheterodyne receiver, we wish to stress one significant point related to the t-r-f receiver: namely, that the *demodulation action takes place upon the amplified version of the originally received broadcast carrier*. Whatever selectivity is achieved in the t-r-f receiver is dependent solely upon the design and efficiency factor of the respective tuned-radio-frequency stages and circuits.

*The Superheterodyne Receiver.* In the superheterodyne receiver, received broadcast carrier may be passed through an r-f section just as in the t-r-f receiver, but after passing through this section, it *mixes* with a locally generated unmodulated carrier so as to produce a new carrier. This new carrier bears the modulation characteristics of the originally received broadcast carrier, but it differs from the received broadcast carrier in frequency. In direct contrast to the t-r-f receiver, the demodulation action in the superheterodyne receiver *takes place upon the modulated carrier newly created in the receiver*. The locally generated signal, which is *heterodyned* (mixed), with the received signal, is produced by a *local oscillator*. The local oscillator is an integral part of the re-

## A-M SUPERHETERODYNES

ceiver, and the frequency of its output is variable and depends on the setting of the tuning control.

*The Intermediate Frequency.* The newly generated carrier produced in the receiver is called the *intermediate frequency*. The intermediate frequency (i-f) carrier is amplified in a section called the *i-f amplifier*. Because the intermediate frequency is considerably lower than the carrier frequency of the received signal,<sup>1</sup> the superheterodyne receiver has the following important advantages over the t-r-f receiver:

1. There is less tendency toward instability and oscillation in the i-f amplifier, where most of the amplification is obtained; hence, the receiver can be designed to receive higher frequency signals than the t-r-f receiver and still remain stable.
2. The over-all selectivity of the receiver is controlled by the i-f amplifier and can be made much better than in t-r-f receivers because tuned circuits of the same quality provide a smaller pass-band at lower frequencies and because the i-f amplifier circuits are fixed-tuned.
3. Selectivity and gain remain more uniform over the tuning range, since the intermediate frequency, at which these are controlled, remains fixed.
4. Each stage in the i-f amplifier is simpler, since the frequency is lower and the tuning is fixed.

These and other reasons have led to the complete discard of the t-r-f circuit in home radio receivers in this country, in favor of the more efficient superheterodyne.

It is interesting to note, however, that the t-r-f receiver is simply a part of a superheterodyne. Note in Fig. 1-1 that if the converter (mixer-oscillator) section and i-f amplifier section of the superheterodyne are removed and the second detector connected to the r-f amplifier, the basic setup is exactly the same as that of a t-r-f receiver tuned to the intermediate frequency. It is thus apparent that the t-r-f receiver contains nothing that the superheterodyne receiver does not also contain. Accordingly, a full discussion of the superheterodyne receiver also covers the important factors involved in the t-r-f type. The service technician who learns his superheterodyne troubleshooting thoroughly is qualified to troubleshoot t-r-f receivers also.

For this reason, we discuss in this book only the superheterodyne, not only because it is in universal use, but also because the same information can be easily applied to the rare t-r-f receivers encountered.

<sup>1</sup>Occasionally, in special types of receivers, the intermediate frequency is higher than the received signal frequency. However, this condition never exists in home receivers and will not be considered in this book.

## SUPERHETERODYNE RECEIVERS

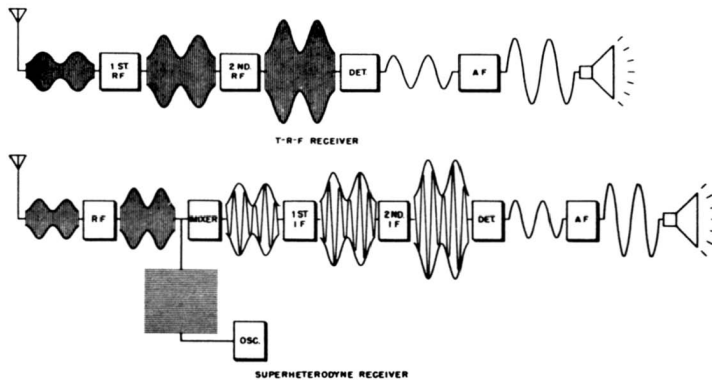

Fig. 1-1. Comparison between t-r-f and superheterodyne receivers. Note that if the oscillator, mixer, and i-f amplifier are removed from the superheterodyne, and the r-f output connected to the detector, the resulting set-up will be, in principle, the same as that of the t-r-f-receiver.

### 1-3. Functional Receiver Sections

No matter how simple or elaborate the superheterodyne receiver, it can be divided into five functional sections. Each section is different from the others because of the type of signal it handles, and what it does with that signal. These five sections are:

1. R-f section
2. Conversion (mixer plus oscillator)
3. I-f section
4. Demodulator (detector)
5. A-f section, including loudspeaker

We might also mention "special features," which would include such things as AVC, AFC, and the like. However, these are not basic sections; instead they are usually directly connected with one or more of the basic sections and are merely supplementary. Also necessary to the proper functioning of the basic sections is a power supply, another important factor in troubleshooting.

First, let us consider some of the various types of a-m superheterodyne receivers we will be encountering in service work, and see how the sections mentioned above include them.

### 1-4. Typical A-M Superheterodyne Arrangements

The simplest superheterodyne circuit is illustrated in block form in Fig. 1-2. Such an arrangement is seldom found, although it is quite feasible and could be useful for headphone reception wherever reasonably

## A-M SUPERHETERODYNES

strong signals are available. Two tubes, or one tube and a germanium detector, are all that is required for this setup. (Of course, we are considering a converter, functioning as both oscillator and mixer in one envelope, as a single tube.)

Now notice that this receiver, although the ultimate in simplicity for a superheterodyne, contains all the basic sections listed above. Although it provides little or no r-f amplification, it contains an r-f section, which is the tuned circuit between the antenna and the grid of the mixer (converter). The mixer and oscillator are combined in the converter tube circuit, as they are in many more elaborate receivers. The r-f tuned circuits and the oscillator tuned circuits are ganged for single control. The i-f section consists of the tuned output (plate) circuit of the converter and the tuned input circuit of the detector. The output circuit of the detector and the headphones constitute the a-f section in this receiver.

The block diagram in Fig. 1-3 illustrates the arrangement most frequently found in small a-m broadcast receivers. Notice that the only difference between the arrangement here and that in Fig. 1-2 is that the i-f section and the a-f section have each been built up by the addition of an amplifier stage. Most midget receivers are in this class. A typical tube lineup, such as 12SA7, 12SK7, 12SQ7, 50L6, and 35Z5, has become very familiar to all experienced radio service men. It will be noted that the main sections listed in par. 1-3 still apply to the receiver in Fig. 1-3.

Some a-m broadcast receivers employ an r-f amplifier stage, as shown in Fig. 1-4. This stage improves reception not only of broadcast receivers,

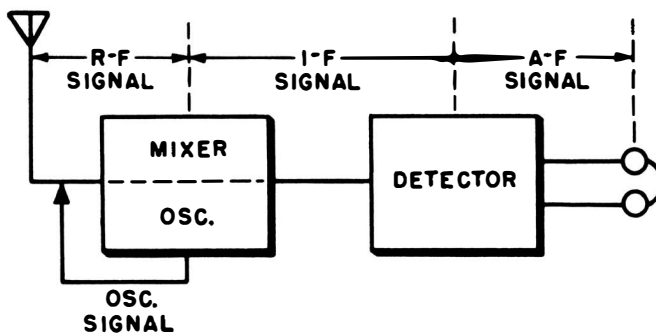

Fig. 1-2. Simplest practical superheterodyne circuit.

## SUPERHETERODYNE RECEIVERS

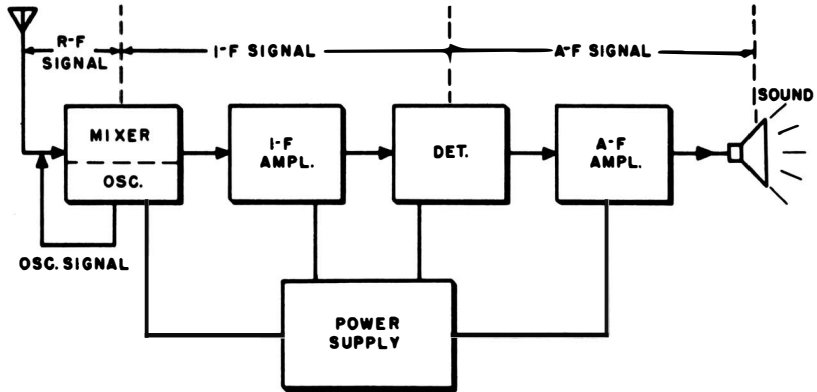

Fig. 1-3. Most popular arrangement for small a-m broadcast receivers.

but also of all-wave receivers, in which preselection (r-f amplification) is desirable for good signal-to-noise ratio. This arrangement differs from that of Fig. 1-3 only in that r-f amplification has been increased by the addition of an amplifier stage.

Now consider a more elaborate circuit, such as might be used for a communications receiver. Such a layout is shown in Fig. 1-5. Here we have a stage of r-f amplification, a separate oscillator tube, two stages of i-f amplification, and a two-stage a-f amplifier with push-pull output. Also shown in this diagram is the AVC circuit, which we list as a special feature and not as a basic section. It should be emphasized that AVC is used in practically all a-m receivers; but, to keep them simple, it was not shown on the block diagrams in Figs. 1-2, 1-3, and 1-4.

In this expanded arrangement, we have again included no more basic sections than we had in the simple receivers; we have simply built up some of the sections.

We have not, by any means, included in the block diagram survey all possible types and arrangements of a-m receivers. But no matter what variation concerns us, we shall always find that we are treating the same basic sections.

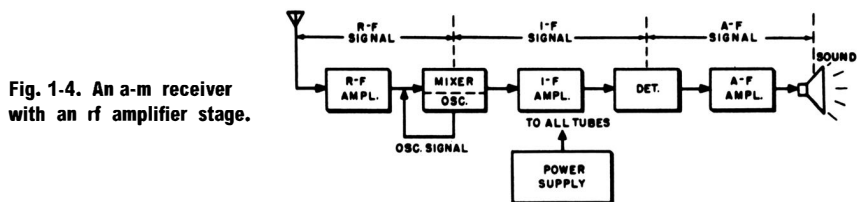

Fig. 1-4. An a-m receiver with an rf amplifier stage.

## A-M SUPERHETERODYNES

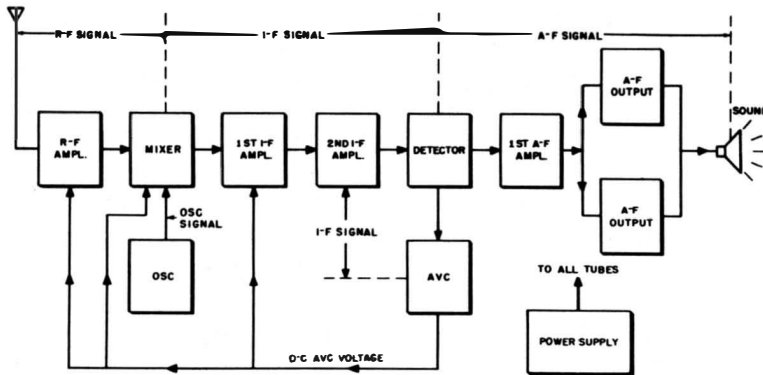

Fig. 1-5. Elaborate type of a-m superheterodyne, using an r-f stage, two i-f stages, and push-pull a-f output. Used in virtually all receivers, avc is shown here, but was omitted from preceding diagrams for the sake of simplicity.

### 1-5. Importance of Basic Sections

The reason why we have so emphasized the general and universal nature of basic sections for all superheterodyne receivers is that rapid troubleshooting is accomplished in two parts: (1) trouble is localized to a single section, then (2) is isolated to a single component. By recognizing the presence and function of each basic section, the trouble indications it can give, and how it reacts to certain tests, we develop skill in rapidly determining the offending section.

In later chapters, we shall consider troubles according to the symptoms they exhibit. For each symptom, we shall demonstrate how it may be linked to a particular section of the receiver.

We shall now consider typical circuit details for each of the sections in a-m receivers, with emphasis on the troubleshooting problems of each.

### 1-6. R-F Section

As we have previously stated, the r-f section is that portion of the receiver between the antenna and the mixer. In many modern receivers, it consists merely of an antenna transformer whose secondary winding is tuned, as shown in Fig. 1-6. In more elaborate receivers, an amplifier circuit is employed so that the r-f signal is amplified to a greater intensity before it is applied to the mixer. This latter arrangement is exemplified by the generalized r-f amplifier circuit of Fig. 1-7.

In either case, the function of the r-f section is to transfer to the mixer grid a suitable r-f signal for mixing with the r-f signal. If there is trouble in the r-f section, the mixer will receive no signal, an ex-

## SUPERHETERODYNE RECEIVERS

cessively weak signal, or a noisy or distorted signal, depending on the type of trouble.

What are the main possibilities for trouble? Of course, if a tube is used (as in Fig. 1-7), it is the first thing to check. A defective tube can cause complete loss of signal at the mixer, weakening of the signal, or instability and noise. The supply voltages for heater, screen, and plate, and the AVC or other bias source are also important factors. Tuned circuits can drift out of alignment. Transformers, resistors, capacitors, and coils can develop opens and shorts. All these possibilities must be considered.

When r-f amplification is used, instability and oscillation are always strong possibilities. These troubles can result from improper shielding, a defective tube, or a poor ground connection on grounded components.

In some cases, deterioration of the tuned circuits due to moisture, corroded connections, or radical changes in loading resistance values may cause abnormally poor selectivity. In the r-f section, poor selectivity may result in image interference; but it does *not* ordinarily

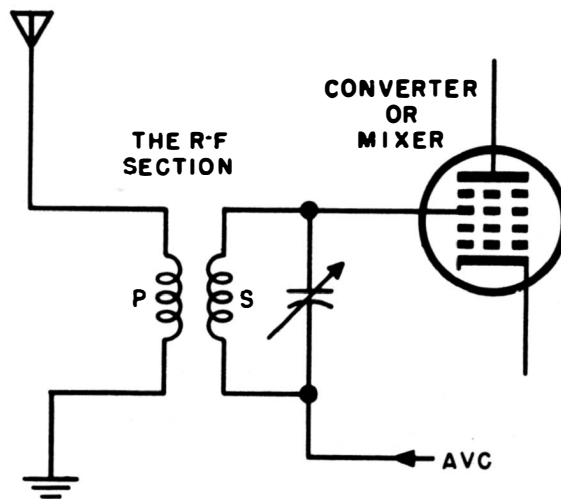

Fig. 1-6. In the simpler superheterodyne receivers, which start with the converter, the r-f section is just the r-f transformer and tuned circuit, as shown here.



## A-M SUPERHETERODYNES

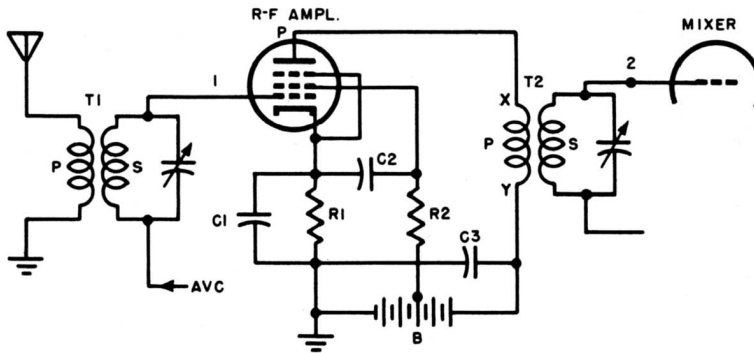

Fig. 1-7. Typical r-f section in which one stage of r-f amplification is used.

affect adjacent channel selectivity, since the latter is almost completely controlled in the i-f amplifier.

It should be noted that the proper AVC voltage is essential to the function of the r-f section. If the AVC voltage is too great or too small, distortion, weak signals, tube blocking, and overloading can result.

In all-wave, multiband, and communications receivers, the r-f section is also related to band-switching and selector systems, which share their operation with the r-f section and the oscillator and mixer circuits. Further details of these circuits are discussed in a later chapter.

### 1-7. Conversion Section

The conversion section takes the r-f signal from the r-f section and converts it to another, *intermediate*, frequency having the same modulation but a different carrier frequency. This conversion is accomplished by beating (heterodyning) the signal from the local oscillator with the received r-f signal. This heterodyning must take place in a circuit which is *nonlinear*. In other words, the output current is not proportional to the input voltage. This nonlinearity permits heterodyning between the oscillator and the received r-f signals in the manner described in par. 1-8.

The output signal of the mixer contains many frequencies. It is composed of the sum and difference frequencies of the local oscillator signal and the received r-f. In addition, a variety of frequencies stemming from harmonic relationships exist. Most important of these fre-

## SUPERHETERODYNE RECEIVERS

quencies is the one equal to the *difference* of the oscillator and r-f signal frequencies. It is, of course, this difference heterodyne which is universally used in a-m receivers. This is the i-f signal, and it carries the same modulation as the original received signal.

Note that the converter is the junction between three of our main troubleshooting sections: the oscillator, the r-f section, and the i-f section.

An important distinction should be made between the words *mixer* and *converter*. A converter *converts* an r-f signal to an i-f signal and must therefore include the oscillator circuit. A mixer *mixes* the oscillator and r-f signals and is therefore only part of the conversion section. Of course, the end product is the same—the output i-f signal.

### 1-8. Pentagrid Converters

Pentagrid converters are the most widely used of all types in most modern receivers. Of these, the 6A7 (or its equivalent, the 6A8) is one example, and a typical circuit for this converter is shown in Fig. 1-8. This type of tube has five grids, whence the name *pentagrid* is derived. The first grid, nearest the cathode, acts as the oscillator grid, while the second serves as the oscillator anode. The third grid forms a screen around the fourth, or signal, grid to minimize interaction between the oscillator and r-f signal sections of the tube. The fifth grid serves as a screen grid and provides a high plate resistance so that a high plate load may be efficiently utilized. The third and fifth grids are connected to each other within the tube.

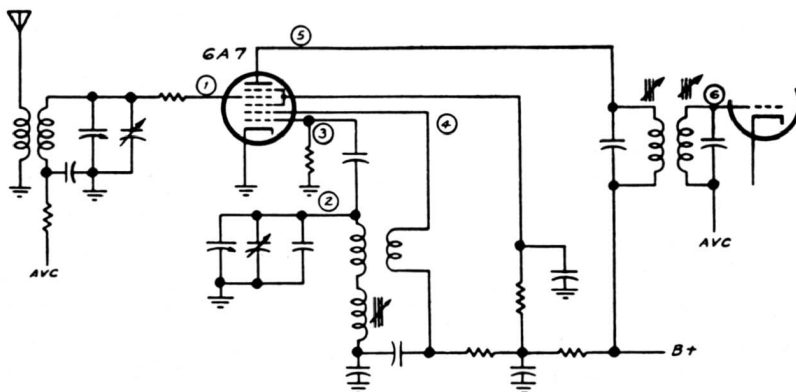

Fig. 1-8. A typical pentagrid converter circuit. The incoming signal is applied to the fourth grid and the oscillator frequency is controlled by tuning the circuit connected to the second grid.

## A-M SUPERHETERODYNES

In operation, oscillation in the section of the tube composed of the cathode and the first two grids causes the electron flow to the plate to vary at the oscillator frequency. Since the electrons must flow through all five grids, they will be affected by signal voltages which happen to vary any of these grid voltages. The incoming r-f signal is applied to the fourth grid, and the varying potentials resulting from the r-f signal voltages on this grid modulate the electron flow which is already varying at the oscillator frequency. This causes the plate current to vary not only at the oscillator and signal frequencies, but also at the difference frequency, which is the required intermediate frequency when the circuits are properly adjusted.

The ratio of the desired i-f signal voltage at the pentagrid plate and the r-f signal voltage at the input signal grid is the *conversion gain*, which, in broadcast receivers, varies from about 10 to 40, when the AVC system is inoperative. When AVC action is present, the conversion gain is reduced to about one-fifth of these figures. Exact gain measurements are seldom necessary in servicing procedure; usually the mere fact that there is a conversion gain, rather than a loss, in the converter tube is sufficient to eliminate this portion of the receiver as a cause of poor operation.

The pentagrid converter circuit shown in Fig. 1-8 is used in several commercially available home receivers; it is representative of a large number of designs. The r-f signal appears at point 1; the oscillator signal at points 2, 3, 4, or 5; and the i-f signal at points 5 and 6. The rectified oscillator voltage, which acts as a grid bias; appears at point 3 as a negative d-c voltage. This voltage varies widely in different receivers, usually ranging from  $-30$  to  $-20$  volts with respect to ground. If the oscillator section is inoperative, this voltage will be zero or some positive value, depending on the circuit used. However, regardless of the circuit, a measurement of the rectified d-c voltage across the oscillator grid leak will tell the story. The grid always will be negative when the oscillator is functioning.

The circuit of Fig. 1-8 employs a 6A7 tube. Also designed for, and used in, the same circuit are the 6A8 (metal version of the glass 6A7), 12A8GT for a-c/d-c receivers, 7B8, 1LA6, 6D8G, and battery types 1A6, 1C6, 1C7G, and 1D7G. These tubes all operate on the same principle, but differ in filament ratings, basing, envelopes, and other minor physical characteristics.

More recent a-m broadcast receivers make use of an improved version of the pentagrid converter exemplified by the 6SA7, 12SA7, 7Q7, 14Q7,

## SUPERHETERODYNE RECEIVERS

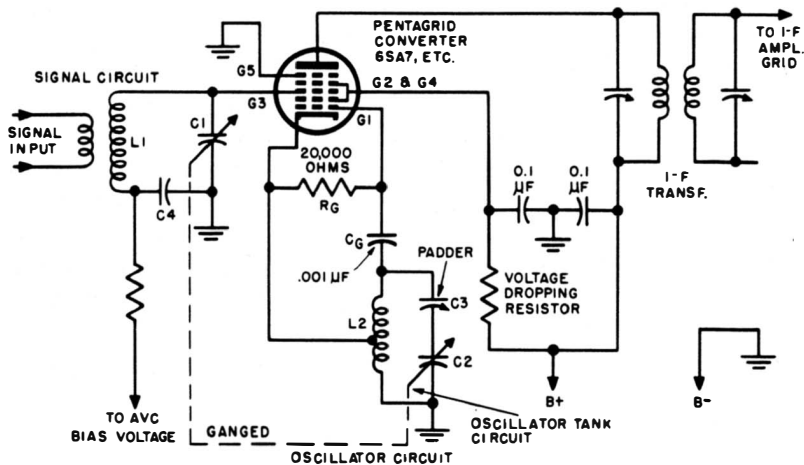

Fig. 1-9. Improved pentagrid converter circuit.

and 1R5. A typical circuit arrangement is shown in Fig. 1-9. Several important differences exist between this and the 6A7 tube and circuit. First, notice that the oscillator anode (G2) is not a separate isolated element, but is connected inside the tube to the mixer screen grid (G4). Second, a suppressor grid (G5) is added. This grid gives the mixer section pentode characteristics, increasing conversion gain. Third, *collector plates* (not shown in schematics), fastened to G2, reduce the space charge around the cathode and reduce the effect of the signal grid (G3) upon the oscillator. Otherwise, the converter circuit is substantially the same as that of Fig. 1-8.

Later versions of the 6SA7 are exemplified by the 6SB7Y and the 6BE6. These tubes incorporate certain physical modifications in the elements that make for more efficient operation at higher frequencies. In fact, these converter tubes were designed for use particularly in f-m and in combination a-m/f-m receivers. They are further discussed in Chapter 2.

### 1-9. Triode-Heptode and Triode-Hexode Converters

These converters consist of a triode oscillator and a six- or seven-element mixer contained in the same envelope. Both the oscillator and mixer sections share the same cathode. The triode elements are located above the mixer elements in the triode-heptode, and on the opposite side of the envelope in the triode-hexode. Examples of the triode-heptode are the 6J8G, 7J7, 7S7, and the 14J7. The 6K8G, 6K8GT, and 12K8 are triode-hexodes.

## A-M SUPERHETERODYNES

A typical triode-hexode circuit is illustrated in Fig. 1-10. The plates of the oscillator and mixer sections are entirely separate. The oscillator grid and the injection grid (G1) of the mixer are connected inside the envelope so that the oscillator signal is automatically applied to the mixer grid.

Some of the advantages of separate oscillator tube operation are realized in the triode-heptode and triode-hexode arrangements. Although their conversion transconductance at a-m broadcast frequencies is a little lower than that for pentagrid converters, their low input loading and low noise level make them desirable for short-wave and communications receivers.

### 1-10. Critical Nature of Converter Oscillator Sections

One important troubleshooting factor should be mentioned before we leave our discussion of converter circuits. This factor involves the oscillator section. Frequently, the oscillator section will stop oscillating, while the mixer section continues to operate. A change in the value of the oscillator grid leak resistor, a defective tube, a poor ground connection, or an open or shorted circuit element can cause this trouble. The feedback circuit is especially important. Sometimes, small variations

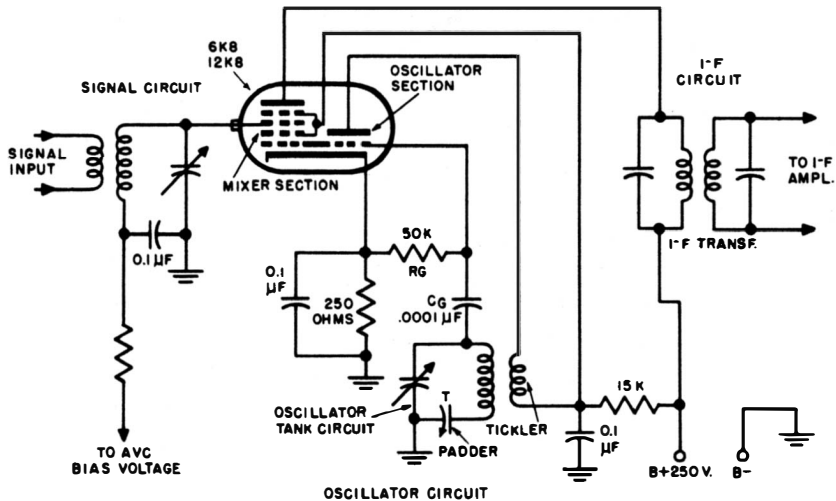

Fig. 1-10. Typical triode-hexode converter circuit.

## SUPERHETERODYNE RECEIVERS

in the tube constants can cause this trouble—especially at high frequencies. Often the defect will not show up on a tube tester. For this reason, it is good practice to substitute a tube known to be good to be sure whether a cessation of oscillation is due to a tube defect.

Then again, the fact that a tube is oscillating does not ensure satisfactory over-all results. Perhaps it is oscillating weakly, or too strongly. Both conditions can result in faulty operation. Check the operating voltages of the oscillator to guard against these defects.

### **1-11. Separate Oscillator-Tube Arrangements**

A few a-m broadcast receivers employ a separate tube for the oscillator. Most separate-oscillator circuits presently being used are in f-m (and t-v) receivers. Accordingly, discussion of these circuits is reserved for Chapter 2.

### **1-12. Intermediate Frequencies**

After the oscillator and r-f signals have been heterodyned in the mixer, the resulting i-f signal is fed from the plate circuit of the converter to the i-f amplifier section, where it is amplified to a level high enough for proper demodulation by the second detector. (The mixer, as we shall see later, is considered as the first detector.) The i-f section is very important to the performance of the receiver, since it determines the over-all gain and the selectivity. In this connection, it is well that we consider the intermediate frequencies commonly used and the reasons certain values have been adopted by receiver manufacturers.

As far as the design of the mixer-oscillator circuit is concerned, almost any intermediate frequency up to about 500 kc for a-m broadcast receivers could be used. In other receivers, any value up to the low-frequency end of the receiver's tuning range could be utilized. However, other considerations limit the manufacturer's choice of intermediate frequency. Because the technician must be prepared to align and adjust i-f amplifiers, and also be able to determine intermediate frequencies when data on them are not available, he must have full knowledge of the various intermediate frequencies used in the different types of receivers.

In early superheterodyne receivers, relatively low intermediate frequencies were used, 175 kc being common. Very low frequencies were necessary because high-frequency techniques and high-frequency pentodes had not been sufficiently developed. Only on such low frequencies could the old low- $\mu$  triodes give a good gain and stability without resorting to critical neutralizing methods.

## A-M SUPERHETERODYNES

Although stability, gain, and selectivity at low intermediate frequencies like 175 kc are excellent, there is one definite disadvantage at these frequencies: namely, *image interference*.

Image interference can be caused by a signal whose frequency is equal to the desired station frequency (to which the receiver is tuned) plus (or minus) twice the intermediate frequency. For example, if a receiver with an i-f of 175 kc is tuned to a station of 600 kc, image interference can be caused by another station operating on 600 plus ( $2 \times 175$ ), or 950 kc. If such a signal is very strong, the r-f selectivity may not be good enough to reject it, or it may find its way into the mixer input circuit by direct pickup by the mixer stage. R-f selectivity and shielding around the mixer stage are the only agencies which can reduce or eliminate image interference, once the intermediate frequency is fixed. However, the higher the intermediate frequency, the less the chance of image interference, because the separation between the desired station frequency and the interfering station frequency is greater.

The advent of modern high-transconductance pentodes made satisfactory gain, selectivity, and stability easy to obtain at much higher frequencies. Hence, for home receivers, a standard value of 455 kc has been employed by most receiver manufacturers. By using this value, image interference is greatly minimized, but can occur if the local broadcasting stations happen to be of correct frequencies and radiate exceptionally strong signals. In all-wave and communications receivers employing this frequency, image interference is kept reasonably low well up into the short-wave bands. Of course, in communications receivers, one or two high-gain r-f amplifier stages before conversion help considerably in keeping image interference down during reception of the higher short-wave frequencies. Double detection circuits used in communications receivers also help to relieve the image interference problem. These types of receivers are dealt with later.

The higher the frequency of the station to be received, the higher must be the intermediate frequency to provide the same amount of image suppression, because r-f selectivity is on a *percentage* basis. For example, assume that a tuned circuit provides 10-kc selectivity at 1000 kc. At 10,000 kc a circuit of the same quality would provide selectivity of 100 kc; at 100,000 kc (100 mc) a selectivity of 1000 kc; and so on. Thus, at high frequencies the intermediate frequency must be high enough to throw the image-interference frequency far enough away from the desired-station frequency so that r-f selectivity can prevent interference.

For this reason, vhf and uhf receivers usually employ intermediate frequencies above 5 mc. For example f-m broadcast receivers, which must

## SUPERHETERODYNE RECEIVERS

tune from 88 to 108 mc, ordinarily employ a standard 10.7-mc intermediate frequency. TV receivers use intermediate frequencies as high as 45 mc.

It is important that you, the technician, keep in mind the various intermediate frequencies that are likely to be encountered. For your convenience in this respect, the most common intermediate frequencies and frequency ranges are listed in the table on this page, with information about the types of receivers in which they are employed.

Occasionally, you may be called upon to determine the intermediate frequency of a receiver for which no information is available. The required procedure to be followed in that event is discussed in Chapter 4.

<i>Service</i>	<i>Intermediate Frequency</i>	<i>Where Used</i>
A-m broadcast	175 kc	Older receivers and some modern automo- bile types
	262 kc	
	370 kc	Present home receivers and communications receivers
	455-456 kc	
F-m broadcast	465 kc	Older home receivers
	4.3 mc	Older (pre-World War II) models
Low-frequency communica- tions (100–500 kc)	10.7 mc	Most modern models
	30-150 kc	Ship-to-shore, etc.
High-frequency communica- tions (2–30 mc)	0.40-5 mc	Short-wave receivers
V-h-f communications (30–300 mc)	5-50 mc	Short-wave receivers
Television (audio)	20-45 mc	Split-sound models
	4.5 mc	Intercarrier models
Television (video)	20-45 mc	
Television (uhf)	50-88 mc	Uhf converters

### 1-13. I-F Amplifier Section

In most a-m receivers, the i-f section consists of but one amplifier stage, using a high-transconductance r-f pentode such as the 6SK7, 6SG7, 6BA6, 6SS7, etc. In more elaborate receivers—and in communications receivers—two, three, or four i-f amplifier stages are used.

A typical i-f amplifier section for the ordinary a-m broadcast receiver is shown in Fig. 1-11. The i-f amplifier is nothing more than an r-f amplifier designed to operate at the intermediate frequency. It is thus very similar to the r-f amplifier of the receiver. The important difference is that the r-f amplifier has to provide adjustment to any frequency in



## A-M SUPERHETERODYNES

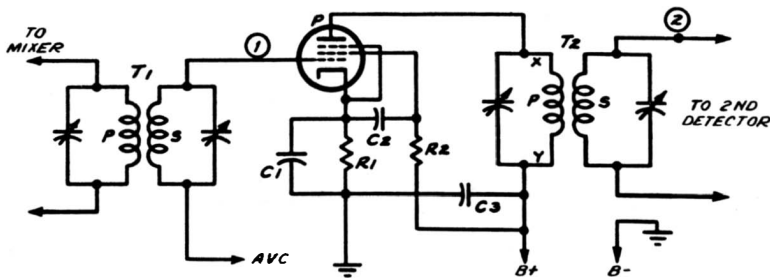

Fig. 1-11. Typical i-f amplifier circuit.

the tuning range, whereas the i-f amplifier tuning remains fixed at the intermediate frequency, or is variable in frequency over a relatively narrow band. Because of this, it is feasible to provide tuned circuits in both the primary and secondary circuits of the i-f transformers, thus obtaining greater gain and selectivity from each amplifier stage.

Generally, the troubleshooting factors are about the same as for r-f amplifiers except for the signal frequencies involved. In signal tracing there is an advantage over the r-f amplifier in that signal levels are much higher, since r-f amplification (if any) and conversion gain have already operated on the signal. For signal-injection methods of troubleshooting, higher-level signals are required for i-f amplifiers than in r-f amplifiers.

As in other sections, heater or filament, screen, and plate voltages must be present for proper operation and should be checked. I-f transformers are often subject to shorts, opens, and damage to trimmers, slugs, and connections.

One of the factors important in troubleshooting i-f amplifiers is *alignment*. Since the selectivity of these stages is quite sharp, the adjustments must be close to their optimum point for satisfactory operation. For a-m receivers (the smaller, midget types particularly), alignment is quite simple; but for communications and f-m broadcast receivers, it can become quite involved.

### 1-14. Second Detectors, or Demodulators

The process of separating the intelligence contained in the received modulated signal from the modulated carrier is known as *demodulation*, or *detection*. Although only one true detector is used in a superheterodyne receiver, it has become common practice to call the mixer the *first detector* and the stage which demodulates the i-f signal the *second detector*.

## SUPERHETERODYNE RECEIVERS

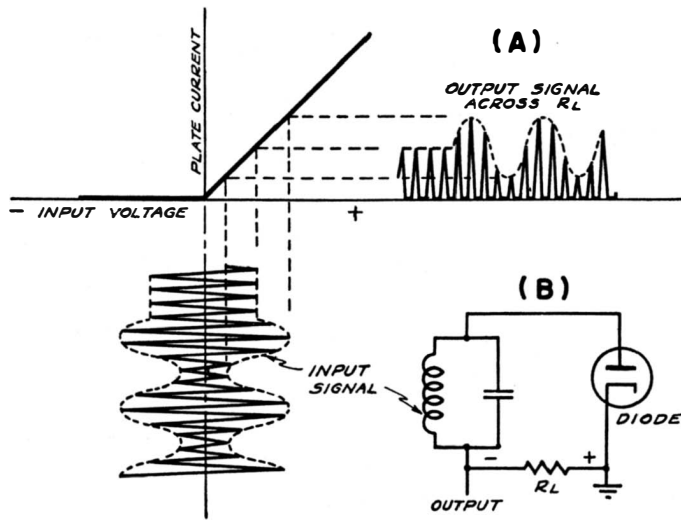

Fig. 1-12. A basic diode circuit is shown at (a). When a modulated signal is applied to the diode input, rectification of the signal takes place as shown at (b).

The second detector demodulates the signal from the i-f amplifier—that is, it removes the a-f modulation from the carrier. Its action is very similar to that of the converter. The converter maintains the modulation but changes the carrier frequency from r-f to i-f. The second detector changes the carrier from i-f to *zero*, leaving the useful a-f modulation available.

The second detector of a superheterodyne receiver is provided with a high-level input i-f signal, so it is not necessary that a sensitive detector be used. However, it is important that the detector be one which can handle a wide range of strong signals with minimum distortion. The *diode* detector fulfills this requirement admirably, and in addition, makes it easy to provide automatic volume control (AVC) voltage for the receiver.

Basically, the second detector in Fig. 1-12 (a) is similar to that used in commercial receivers, but in order to simplify the discussion, we have omitted a number of relatively unimportant features. The signal voltage, which might be the output of the last i-f amplifier, is connected in series with the diode plate and with the diode load  $R_L$ .

To illustrate the action that takes place when a signal is applied to the diode, Fig. 1-12 (b) shows the diode characteristic as a straight line, which is permissible if the load resistance is quite high. On the

## A-M SUPERHETERODYNES

negative half-cycles of the input signal, electrons are repelled from the plate and no current flows through the circuit. On the other hand, the positive half-cycles cause corresponding pulses of current through  $R_L$ . Thus the negative halves of the signal are removed, and only the positive halves of the signal voltage are effective in causing current to flow through  $R_L$ .

The purpose of a detector is to produce an audio signal which faithfully follows the envelope of the modulated carrier. The action explained above produces an output the average value of which varies in accordance with the modulated wave. However, together with this a-f signal, we also have the i-f variations in the plate current. These variations are present across  $R_L$  because no effort has been made in this simple detector circuit to eliminate them.

To eliminate the i-f pulsations from the output of diode detectors, it is common practice to by-pass the diode load with a capacitor. As we show in Fig. 1-13, this capacitor  $C$  offers a low-reactance path to the intermediate frequency, so that practically no i-f voltage is developed across the load. Unlike the previous case where no capacitor was used, the current in the diode circuit does not return to zero during each cycle, but instead, the capacitor charges up to a value slightly less than the peak value of the i-f signal. As Fig. 1-13 shows, when the carrier is unmodulated so that its amplitude does not vary, the plate end of the load resistor is maintained at a fairly constant negative voltage with respect to ground. When the carrier amplitude varies, as it does when the signal is modulated, the pulsating output follows the modulation in the manner indicated in Fig. 1-13 (b). In this way, an audio output is produced which has the same waveform as the envelope of the modulated i-f signal.

No doubt you have noticed the ripple in the voltage present across  $R_L$  in Fig. 1-13 (b). The ripple indicates that the capacitor  $C$  does not

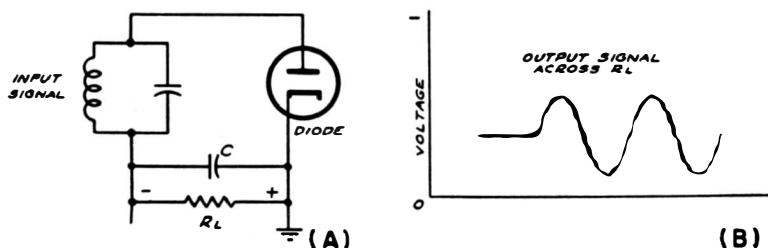

Fig. 1-13. A typical detector circuit using a capacitor across the load is shown at (a). The rectified output at (b) shows that this capacitor removes practically all the carrier signal.

## SUPERHETERODYNE RECEIVERS

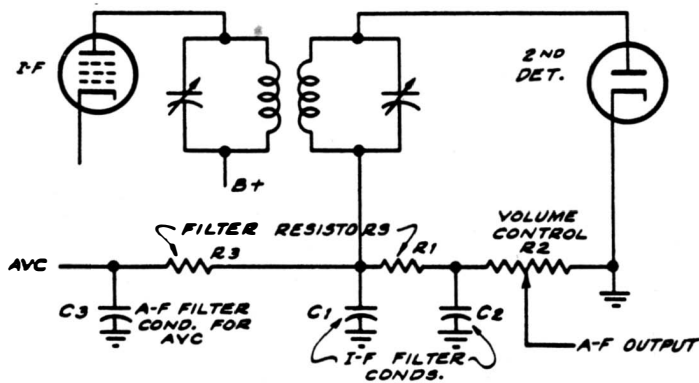

Fig. 1-14. A typical diode detector showing the a-f and avc output circuit.

remove all the i-f signal from the diode load, but that a small amount of the carrier is still left. This slight ripple results because the diode draws a charging current into the capacitor only for short intervals during the positive half-cycles. During the remaining parts of the positive half-cycles, the steady negative voltage across  $R_L$  makes the diode plate negative with respect to the cathode and thus prevents the diode plate from drawing current.

We are now in a position to examine a typical diode detector circuit and to look into the distribution of signals throughout the circuit. The circuit shown in Fig. 1-14 is, in general, similar to the preceding circuit, but appears more complicated because of several additional components. However, the action taking place in the two circuits is basically the same. You will note that volume control  $R_2$  is the d-c diode load and that the amount of audio signal which is picked off and fed to the a-f amplifier is controlled by the setting of  $R_2$ . At all times, regardless of the setting of the volume control, the full value of a-f signal voltage is developed across  $R_2$ . An additional filter has been added in series with the diode load. This consists of resistor  $R_1$  and capacitors  $C_1$  and  $C_2$ . The purpose of this filter is to remove the i-f components of the signal more effectively so that only a comparatively small i-f signal will be present across the volume control. In addition to improving the filtering of the i-f signal, this filter combination also helps to improve the fidelity of the detector for signals having a high percentage of modulation.

In contrast to these half-wave detector circuits, we show in Fig. 1-15 a full-wave detector circuit which has been used rather widely in receivers. If you examine this circuit closely, you will observe that it is

## A-M SUPERHETERODYNES

similar to the type of full-wave rectifier circuit used in practically all receiver power supplies, with the filter choke omitted and  $R_1$  serving as the load circuit.

From the viewpoint of signal voltage at different places in the circuit, the full-wave detector circuit has several interesting characteristics. Both halves of the input signal are rectified, since each of the diodes draws current on alternate halves of the cycle. On that half of the cycle where  $V_{IA}$  is positive, this diode draws current and contributes a pulse of current through the diode circuit. During this interval,  $V_{IB}$  is, of course, not drawing current, because the other half of the center-tapped input winding is negative. During the next half of the cycle, the plate of  $V_{IB}$  is positive with respect to its cathode; thus it contributes a pulse of current through the load in the same direction as the current passed by the first diode on the preceding half cycle. In this way, both halves of the input signal are rectified, each of the diodes functioning exactly as in the case of the preceding half-wave detectors. The resultant output is thus similar to the wave shown in Fig. 1-13 (b), with the exception that the frequency of the carrier ripple is twice as great because of the full-wave action.

Because of the balanced nature of this circuit, there is no i-f signal voltage at the center tap of the secondary winding of the input circuit. However, harmonics of the i-f or carrier frequency are present across the diode load. But these are not important, and their presence is ordinarily of no consequence. Actually, it is not possible to achieve perfect balance,

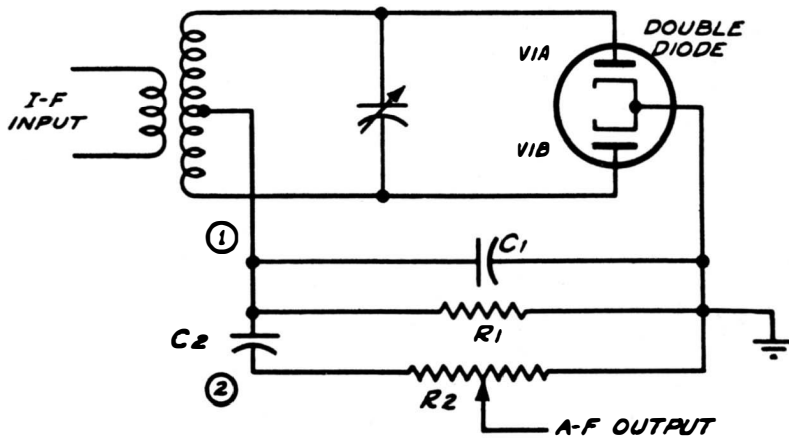

Fig. 1-15. A full-wave circuit using a double diode such as 6H6. The distribution of signal voltage is described in text.

## SUPERHETERODYNE RECEIVERS

so that in commercial receiver circuits a small by-pass capacitor will generally be found across the diode load. Even where the circuits are perfectly balanced, this capacitor is useful because it serves the purpose of by-passing the harmonics of the carrier frequency which are always present across the diode load.

The full-wave circuit shown in Fig. 1-15 shows an interesting variation in that the volume control is located so that the d-c component of the diode current is blocked from the volume control by means of the capacitor C2. In practice, C2 is large enough so that the audio frequencies developed at point 1 will be fed to point 2 and develop essentially the same value of audio voltage at point 2. A tendency toward longer volume control life and greater freedom from noise has been found to be characteristic of this type of circuit in which the d-c component of the diode current does not flow through the audio volume control.

The fact that there is no plate voltage present is important in troubleshooting diode detector circuits. Except for the heater supply, the detector tube obtains all its power for operation from the output of the last i-f amplifier. For this reason, the detector circuit is best analyzed by dynamic methods—that is, by signal tracing or signal injection. Once a signal has been applied *ahead* of the detector circuit, operation can be checked by measurement of both a-c and d-c voltages across the load resistor. Signal injection requires a very high input signal to the diode input transformer.

Although a simple type of vacuum tube is used for the detector, it is not free from troubles. The condition of the tube itself is always important. Tube substitution is a rapid check, although tests on a tube checker are conclusive. Among these should be a test for leakage between cathode and heater as a possible source of hum in the rectified signal. Distortion in the rectified signal is attributable more to the diode load circuit components than to the tube itself.

In the preceding discussion, we have considered the detector diode as separate and alone. In practice, however, it is usually combined in the same envelope with a voltage amplifier triode, such as the 6SQ7, 6SR7, etc. Thus, such tube troubles as low emission, shorted cathode, and the like may give trouble symptoms in both the detector and first a-f amplifier stage.

### **1-15. A-F Amplifier Section**

In the vast majority of a-m broadcast receivers, the a-f amplifier section consists of but two stages: a voltage amplifier, and a power

## A-M SUPERHETERODYNES

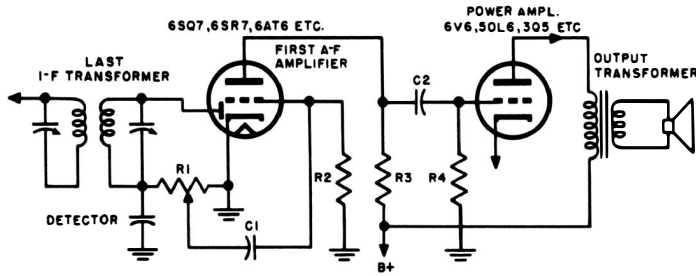

Fig. 1-16. Typical a-f amplifier section for a-m broadcast receiver.

amplifier. The loudspeaker follows these stages and we shall consider its electrical system as part of the a-f amplifier section.

A typical a-f amplifier section, with the detector preceding it, is illustrated in the circuit of Fig. 1-16. Note that the detector and first a-f amplifier stage are combined in the same tube envelope, while the power amplifier is a separate tube.

Because in the combination detector-amplifier circuit the tube ordinarily has one common cathode which must be grounded, bias is obtained by means of grid leak resistor R2. This resistor has a very high resistance—5 to 10 megohms. Note that, if coupling capacitor C1 is leaky, the bias on the grid of the first a-f amplifier will be reduced and distortion will result.

The modulated i-f signal is applied to the diode from the i-f transformer. The signal is rectified and the demodulated a-f signal (plus some d-c) appears across load resistor R1, but only the a-f component is fed to the a-f amplifier for amplification. Thus it is apparent that the load resistor R1 is really the dividing point between the i-f amplifier section and the a-f amplifier section of the receiver. From that point to the loudspeaker, we are dealing only with a-f signal.

Note that, except for the loudspeaker, resistance coupling is used in this circuit, a condition that holds true for practically all modern receivers. Because of the high value of most of the resistors used, a vacuum-tube voltmeter or a 20,000-ohms-per-volt voltmeter is a practical necessity for troubleshooting. A meter with a low impedance will give false readings for plate, screen, and grid voltages.

In higher-price receivers, in which low distortion is important, push-pull a-f power amplifiers are used. This circuit introduces the necessity for *phase inversion*, since the grids of the push-pull tubes must be fed with signals which are 180 degrees out of phase.

## SUPERHETERODYNE RECEIVERS

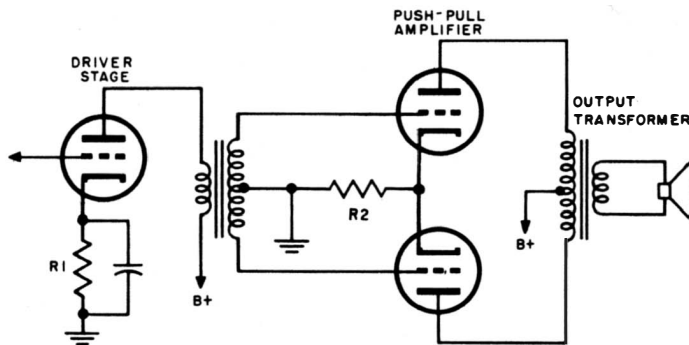

Fig. 1-17. A-f amplifier section with transformer-coupled push-pull output stage.

The easiest way to obtain this phase inversion is to use an input transformer to the power amplifier tubes. The primary winding is the output load of a single-ended amplifier, while the secondary winding is center-tapped, with the two halves of the secondary providing the signal voltages for the push-pull grids. A circuit of this kind is shown in Fig. 1-17.

However, transformers are not often used for phase inversion because a transformer suitable for the purpose and designed to give good response and low distortion is quite expensive, and there are other ways of accomplishing the same purpose.

One way is by using a tube as a simple resistance-coupled voltage amplifier. The output voltage of such an amplifier is 180 degrees out of phase with the input voltage. The input circuit of the inverter is connected to the grid circuit of one of the push-pull tubes. The output circuit of the inverter is then connected to the other push-pull grid, and thus supplies it with signal 180 degrees out of phase with the first push-pull grid. Such a circuit is shown in Fig. 1-18. V1 is the first a-f amplifier stage; its output signal is applied to the grid of V3 through C1. This grid voltage appears across series resistors R1 and R2. That portion of it across R2 is coupled through C2 to the grid of phase inverter V2. The output signal of the inverter, now shifted 180 degrees in phase, is coupled through C3 to the grid of V4; the grids of V3 and V4 are thus supplied with signals 180 degrees out of phase.

Push-pull amplifiers in a-m receivers are ordinarily Class A or AB<sub>1</sub>. In a few models, Class AB<sub>2</sub> or Class B amplifiers are used. For these, an appreciable amount of power must be supplied to the grids of the push-pull stage, and resistance-coupled phase inverters are not practical. There-



## A-M SUPERHETERODYNES

fore, the stage preceding the power output amplifier must be a power stage. It is known as the *driver* and supplies power to the push-pull output grids through what is known as the *driver transformer*. The circuit is essentially the same as that in Fig. 1-17, but the bias of the output stage is nearer cut-off than for a Class A amplifier; and the drive power is great enough so that the grids swing through a greater voltage range, drawing grid current on peaks. This grid current causes an effective grid impedance lower than for Class A amplifiers. The driver transformer is designed somewhat differently than an inter-stage transformer for a Class A amplifier.

These factors should be kept in mind when signal tracing. For instance, the voltage-gain of the voltage-amplifier circuit is much greater than the voltage-gain of the power amplifier, since the latter feeds into a relatively low impedance in most cases. Another factor, important in push-pull amplifiers when distortion is present, is *balance*. Whenever the two out-of-phase signals are of different values, harmonic distortion is introduced. This unbalance may be due to a poor phase-inverter tube or circuit, amplifier tubes of different characteristics in the output stage, and so on.

### 1-16. Automatic Volume Control (AVC)

Automatic volume control, generally called AVC, has become an integral part of practically all commercial radio receivers. The few modern receivers which are not so equipped are mainly small t-r-f sets, employing not more than three or four tubes.

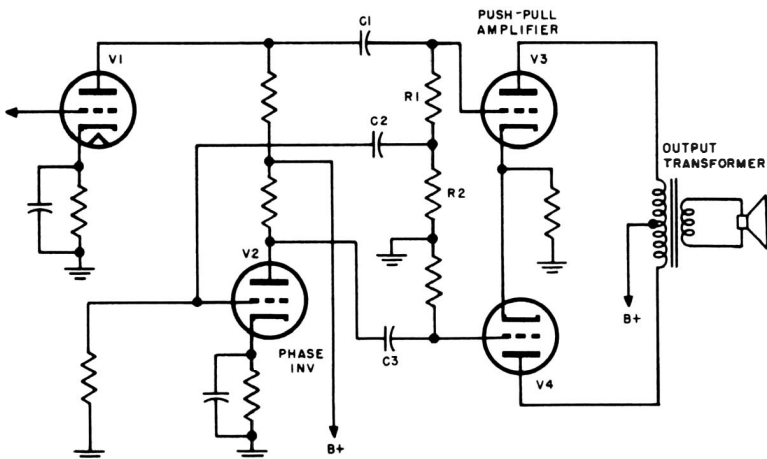

Fig. 1-18. Push-pull a-f output stage fed by resistance-coupled phase inverter.

## SUPERHETERODYNE RECEIVERS

It is easy to see why AVC has been so universally adopted. The signal strength of broadcast programs in any one radio receiver installation may vary over an extremely wide range in a ratio as great as one million to one. A nearby powerful station may provide a signal as strong as .25 volt across the antenna, while another station, weaker and remote from the receiver, may supply a signal of only two or three microvolts. Even strong signals sometimes fade, due to changes in the transmitting medium between the transmitter and the receiver, so that the received signal fluctuates. These various influences, up to the time AVC was introduced, represented some of the objectionable characteristics of broadcast reception.

AVC controls sensitivity by making the gain of the receiver lower for strong signals than for weak ones. This is done automatically and, in a perfect AVC system, only as much reduction in gain takes place as is required to provide a uniformly strong signal to the detector in the receiver.

If we tune the receiver from one station to another which is ten times as strong, the sensitivity of the receiver is automatically reduced to about one-tenth of what it was for the first station. Therefore, the signal which reaches the detector is of substantially the same strength for both stations. If there were no AVC in the receiver, the stronger signal would produce a much louder sound from the speaker or, if the speaker were already working at full volume, one or more of the tubes in the receiver would become overloaded and reception would be weak and distorted. Through the use of AVC, such troubles are avoided. One can tune from one station to another which is weaker or stronger, without bothering to readjust the volume control to give the desired sound volume. And the possibility of "blasting" when passing from a weak station to a stronger one is eliminated.

AVC also increases the sensitivity of the receiver when the set is tuned from a strong signal to a weaker one. Thus, it is possible to rotate the tuning dial over its range without continually readjusting the volume control to avoid passing a desired weak station which otherwise might not be heard. This increase in sensitivity, under these conditions, does not mean that additional amplification is put into the receiver; it means that more of the amplification of which the receiver is capable is being utilized. Receivers employing AVC usually operate at the maximum possible sensitivity of which they are capable when no signal at all is being received. Then, as soon as any signal which the receiver is able to detect is received, the AVC starts to function.

## A-M SUPERHETERODYNES

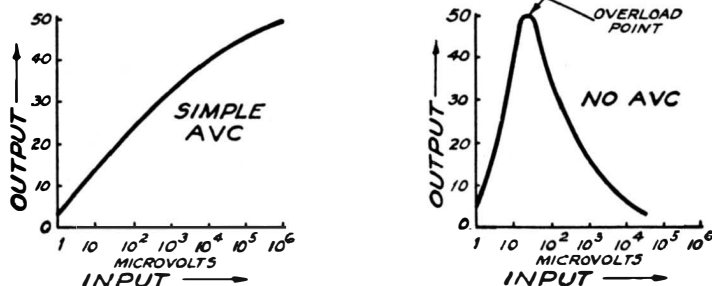

Fig. 1-19 (left) and Figure 1-20 (right). The variation in output of a receiver without AVC for different values of input signal is shown at the right. When AVC is used, no overloading takes place on strong signals.

No AVC system is perfect. If it were, then every signal within the sensitivity range of the receiver would be of precisely the same strength at the detector. However, a very substantial degree of uniformity of signal strength is realized through its use. With even a simple AVC system, a change in input signal from 10 microvolts to 1 volt changes the receiver output from 10 units to only 50 units. In other words, a change of 100,000 to one in the input signal level changes the output signal level in the ratio of only 5 to 1.

The actions of a simple AVC system and a non-AVC system are shown graphically in Figs. 1-19 and 1-20. Note that the curve in Fig. 1-19 climbs uniformly and gradually tapers off. Comparing Fig. 1-19 with Fig. 1-20, it is significant to note that Fig. 1-19 shows no overload point. While the receiver without AVC, shown in Fig. 1-20, overloads considerably with an input signal of less than 100 microvolts, the receiver equipped with simple AVC does not overload even when the input signal is as much as 1 volt.

In AVC systems, varying control-grid bias is used as a means of varying the mutual conductance, and consequently, the amplifying properties of tubes in the r-f and i-f amplifiers. The sensitivity of the receiver is dependent on the amount of gain or amplification in the r-f and i-f amplifying stages, and therefore, by varying the mutual conductance of the tubes in these stages, AVC controls the sensitivity of a receiver.

The manner in which the control-grid voltage changes the plate current and gain in any tube depends on a number of different factors, primarily the design of the tube. However, regardless of design, one condition exists in general—an increase of the negative bias applied to the control grid reduces the plate current and likewise reduces the gain or amplification of the stage. If we express this condition in relation to the

## SUPERHETERODYNE RECEIVERS

Fig. 1-21. The variation in the mutual conductance of sharp cut-off and remote cut-off tubes: The gradual cut-off shown in curve B makes the remote cut-off pentode suitable for use in receivers equipped with AVC.

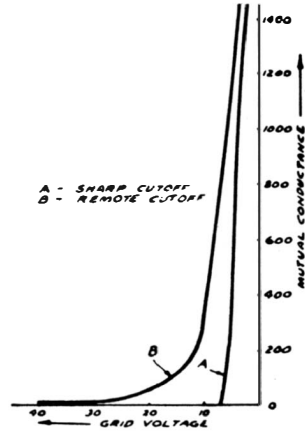

sensitivity of the receiver, rather than in terms of gain or amplification, it means that an increase in the negative control-grid bias applied to the r-f and i-f tubes in a receiver reduces the sensitivity of the complete system and vice versa.

It will be noted that, in receivers employing AVC, the amplifier tubes in the controlled r-f and i-f stages are always of the *remote cut-off* types, such as 6K7, 6SG7, and 6SS7—never of the *sharp cut-off* types exemplified by 6J7, 6SJ7, 6AC7, 6AU6, etc. The reason for this is that the variation between mutual conductance (transconductance), which determines gain, and grid voltage is not smooth in the sharp cut-off types. Figure 1-21 illustrates the difference between this relation for sharp cut-

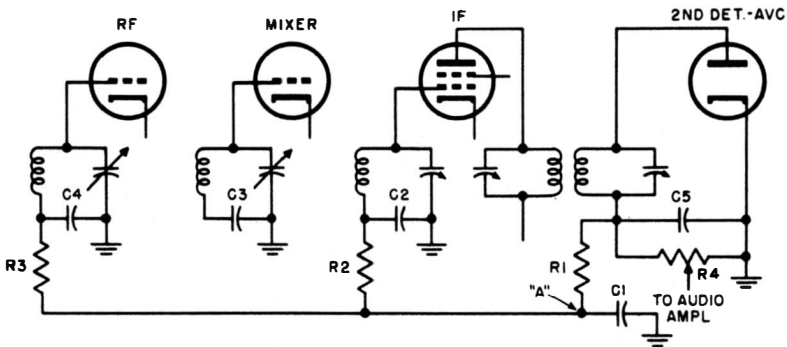

Fig. 1-22. In this circuit the second detector diode provides the AVC voltage, which is distributed to the two controlled tubes through the individual R-C filters.

## A-M SUPERHETERODYNES

off tubes and for remote cut-off tubes. If the sharp cut-off type is employed (curve A), partial or complete rectification takes place as soon as the AVC raises the bias to about  $-8$  volts, with distortion resulting because operation is near, or at, the cut-off point.

On the other hand, with the remote-cut-off type (curve B), the mutual conductance variation is smooth and gradual, and such distortion and interference effects are minimized.

A typical AVC system is shown in Fig. 1-22. The sensitivity control voltage is the d-c voltage developed across the diode load resistor R4. From the ungrounded end of this resistor (which is negative relative to ground), the control voltage is fed through filter R1-C1, which prevents the a-f fluctuations from getting to the controlled grids. R1 is ordinarily from 2 to 5 megohms, while C1 is almost invariably a  $0.05\text{-}\mu\text{f}$  capacitor. It is not always deemed necessary by the receiver designer to control all stages; sometimes only the i-f amplifier is controlled, with other bias methods used elsewhere.

Many receivers use a refinement of the basic AVC circuit called *delayed* AVC or *DAVC*. In the basic circuit, the AVC is operative regardless of the strength of the input signal. This condition is undesirable since it prevents the full amplification potential of the receiver from being developed on very weak signals. To overcome this objection, a fixed bias optimum for maximum gain is applied to the controlled stages. No AVC is fed back until the incoming signal is strong enough to overcome this fixed bias. Hence the AVC cannot act, or is *delayed*, until the signal strength reaches a predetermined level.

### 1-17. Automatic Frequency Control (AFC)

Some pre-World War II broadcast receivers used automatic frequency control (AFC) to offset the undesired consequences of carelessness in tuning by the operator. AFC is a means for correcting such errors in tuning. This correction is accomplished automatically by special circuits designed to shift the frequency of the local oscillator so that the proper i-f signal results even when the oscillator is appreciably mistuned.

To understand how AFC functions, let us first consider the properties of an inductance. If a given inductance has a certain reactance at one frequency, it will have a higher reactance to a slightly higher frequency and a lower reactance to a slightly lower frequency. Now, if we can make a vacuum tube vary in impedance with frequency in the same manner as an inductance, the vacuum tube can be used in a circuit in place of a variable inductance. This is accomplished in AFC circuits by varying the grid bias on a tube which is arranged to act as an apparent

## SUPERHETERODYNE RECEIVERS

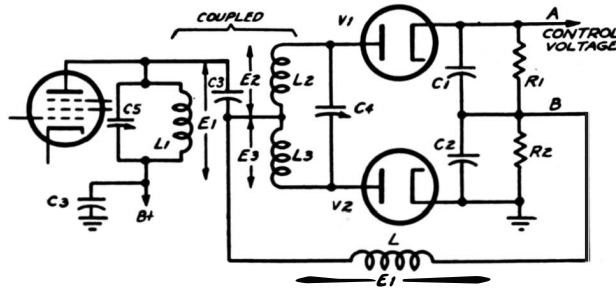

Fig. 1-23. A basic discriminator circuit used in AFC systems to provide the voltage required for controlling the oscillator frequency.

inductance that varies automatically in accordance with changes in frequency above or below the desired point so that the tube impedance varies with frequency.

The tube which is thus transformed into an apparent inductance is called the *oscillator control* or *reactance tube*. The tube that causes the oscillator control tube to perform in this manner is termed the *discriminator*. The proper functioning of any AFC circuit is based upon proper performance of these circuits, so let us see how they operate.

A typical discriminator circuit is shown in Fig. 1-23. Inductance  $L_1$  is tuned by  $C_4$  to the intermediate frequency used in the receiver and is inductively coupled to the secondary coils  $L_2$  and  $L_3$ . The secondary is likewise tuned to resonance with the intermediate frequency. When an i-f signal is present, a rectified d-c voltage in the secondary circuit is developed across  $R_1$  and  $R_2$ . The signal voltages applied to the two diodes are equal and opposite when the i-f signal is of the proper frequency, because the secondary of the discriminator transformer is center-tapped and an equal voltage is developed across each half. Since  $R_1$  and  $R_2$  are likewise equal, the resulting d-c voltages across  $R_1$  and  $R_2$  are equal but of opposite polarity. Hence the voltage at point  $A$  relative to ground is zero.

A portion of the i-f signal voltage is also fed to the secondary of the discriminator transformer through capacitor  $C_3$ . The phase relationship of this signal voltage  $E_1$ , with respect to  $E_2$  and  $E_3$ , changes with frequency so that the control voltage, at point  $A$ , changes in a positive or negative direction as the i-f signal varies above or below the proper frequency. This d-c control voltage is applied to the control grid of the reactance tube, causing its impedance to vary in accordance with the changes in the applied control voltage. Since the reactance tube circuit is shunted

## A-M SUPERHETERODYNES

across the local oscillator, these changes in impedance serve to vary the oscillator frequency. When properly adjusted, the AFC circuit will compensate for errors in the oscillator frequency due to mistuning by automatically changing the oscillator frequency to the value required to produce the desired intermediate frequency.

Figure 1-24 shows the reactance tube and oscillator circuit of a typical AFC system. The AFC control voltage is applied to the grid of the reactance tube through filter network R5-C5 and R4-C4, which perform the same functions as similar filters in AVC systems. The apparent inductance of the reactance tube is controlled by the magnitude of the AFC control voltage from the discriminator tube. When the bias voltage changes in a positive direction, the plate current of the reactance tube is increased and its apparent inductance is decreased. When the control voltage becomes more negative, the plate current is decreased and the apparent inductance of the tube is increased. Thus, the reactance tube acts as a variable inductance shunted across the tuned circuit of the local oscillator.

Since the resonant frequency of a tuned circuit is controlled by the amount of inductance in the circuit, the variable inductance of the reactance tube serves to vary the resonant frequency of the tuned circuit. When the inductance of the reactance tube decreases, the resonant frequency of the tuned circuit increases; and when the inductance increases, the resonant frequency decreases. When all circuits are properly adjusted, the local oscillator should produce the proper beat with the r-f signal to give the desired intermediate frequency. Then, should the oscillator deviate from this frequency, the resulting intermediate frequency will change by the same amount. This brings the AFC control voltage into action, changing the bias on the grid of the reactance tube in either a

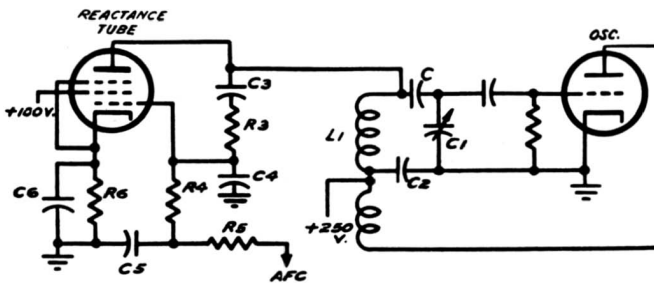

Fig. 1-24. A basic reactance tube circuit showing the connection to the oscillator circuit.

## SUPERHETERODYNE RECEIVERS

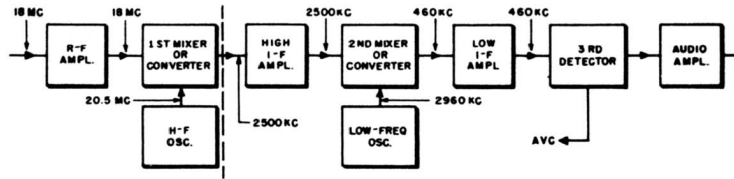

Fig. 1-25. A typical double-superheterodyne receiver in which the two oscillators produce intermediate frequencies of 2500 kc and 460 kc.

positive or negative direction, as required to increase or decrease the effective inductance of the circuit and thereby restore the proper oscillator frequency.

### 1-18. Double-Conversion Superheterodynes

A number of receivers, especially communications receivers, use the superheterodyne principle twice in succession. These receivers are known as double-conversion superheterodynes. In addition, any superheterodyne (such as one originally intended for use on the broadcast band) which is used in conjunction with a short-wave converter for short-wave reception, is another example of a double superheterodyne or a double-conversion system. The primary difference between these two types of double-conversion systems is that the former is a single unit embracing all of the elements, whereas the latter consists of two distinct units: namely, the converter and the receiver.

The block diagram in Fig. 1-25 is an example of the general double-conversion receiver. To illustrate the operation of the receiver, the path of an 18-mc signal is traced through the receiver. At the same time, this will illustrate the frequency at which the circuits should be aligned. Of course, it is possible that other alignment frequencies may be specified, but the values given will serve as suitable examples.

The received 18-mc signal is impressed on the r-f amplifier and, after being amplified, is fed to the first mixer, or converter. In some cases, the r-f amplifier is not present, so that the received high-frequency signal is fed directly into the first mixer. The high-frequency oscillator generates a 20.5-mc signal, assuming that the first intermediate frequency produced 2500 kc. As a result of the operation of the mixer tube, the difference frequency of 2500 kc is produced and fed into the high-frequency intermediate amplifier; this 2500-kc signal constitutes the high intermediate-frequency signal. This completes the first frequency conversion.

After due amplification, the high intermediate-frequency signal is fed into the second mixer. The design of this receiver is assumed to be



## A-M SUPERHETERODYNES

such that the low intermediate frequency in the broadcast section is 460 kc. In order that this signal be developed, the low-frequency oscillator generates a voltage which is 460 kc higher than the signal fed into the broadcast mixer. This means that the oscillator frequency is 2960 kc. As a result of the operation of the broadcast mixer, the 460-kc intermediate-frequency signal is developed and fed into the low intermediate-frequency amplifier and, in the usual manner, reaches the demodulator, or third detector (counting each of the mixers as a detector), wherein the signal is demodulated and the audio voltage is fed into the audio amplifier.

It is significant to note that, in a receiver of this type, only the r-f high-frequency mixer and high-frequency oscillator are variable-tuned. The high-frequency intermediate amplifier, the low-frequency mixer, and the low-frequency oscillator are fixed-tuned to frequencies that are independent of the signal being received. This becomes evident upon analysis of the circuit, since the frequency relation between the received signal and the high-frequency oscillator is always such that the difference frequency of 2500 kc is developed. Since the input to the high-frequency intermediate amplifier is a fixed frequency, the input to the 1000-frequency mixer is likewise a fixed frequency, regardless of the frequency of the original signal received; the low-frequency oscillator also can be fixed-tuned.

Double conversion has two advantages. First: with two intermediate frequencies available, one intermediate frequency can be high enough to eliminate image interference while the second intermediate frequency can be low enough to provide the desired selectivity. Of course, to minimize images, the high intermediate frequency must follow the *first* conversion, with the low intermediate frequency following the *second* conversion. The second advantage of the double-superheterodyne principle is that the first conversion can be accomplished in a separate converter unit, the output of which can be applied to any receiver that tunes to the converter's output intermediate frequency.

Double conversion is seldom encountered in modern a-m broadcast receivers, although often found in communications receivers and converters. Its use is now becoming extensive for television reception wherein a uhf converter is connected ahead of a conventional vhf television receiver.

A variation of the double conversion arrangement now becoming quite popular in communications receivers is one that employs *crystal* control for the first oscillator. Tuning is accomplished by varying the resonant frequencies of both the r-f amplifier and the i-f amplifier at the same time. The first, crystal-controlled, oscillator remains fixed in fre-

## SUPERHETERODYNE RECEIVERS

quency. Consequently, the first oscillator is very stable for even relatively high frequencies, and only the comparatively low-frequency second oscillator needs to be variable. The latter is varied in frequency simultaneously with the r-f and high i-f circuits.

### 1-19. Crystal Filters

In communications receivers, it is often desirable to have extreme selectivity, to combat interference from stations on closely adjacent channels. One way to provide this is with a crystal filter.

Figure 1-26 shows the basic circuit of the crystal filter. The crystal has the electrical properties of a very selective tuned circuit (extremely high  $Q$ ). It is connected in series with the lead to the grid of one of the i-f amplifier tubes (usually the first). The crystal acts as a series-resonant circuit, passing only signals at, and very close to, the resonant frequency.

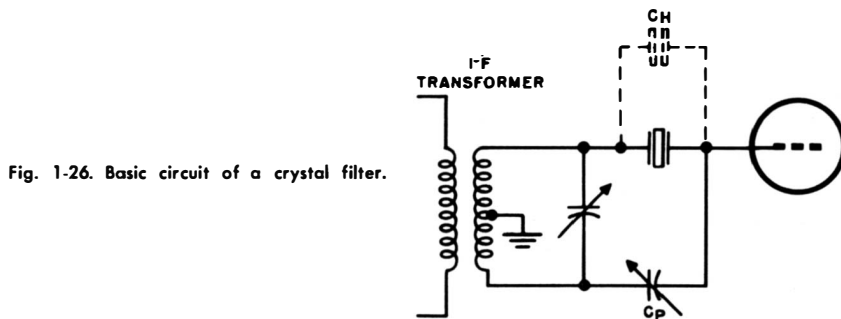

Fig. 1-26. Basic circuit of a crystal filter.

The crystal is mounted between two plates of metal to which external connections are made, the whole assembly being called a *holder*. In practice, the capacitance between the plates of the holder is sufficient to interfere with operation by shunting r-f of other frequencies around the crystal. To overcome this, a *phasing* arrangement is employed. The secondary winding of the i-f transformer is center-tapped, with the center-tap grounded. The voltage at the bottom end is 180 degrees out of phase with that applied to the top end. This out of phase voltage is fed through  $C_p$  to the grid.  $C_p$  is known as the *phasing adjustment*, and is adjusted so that the effect of the holder capacitance is just compensated.

Different degrees of selectivity can be obtained by varying the phasing adjustment; in some receivers, different resistors can be switched into the crystal circuit to lower its  $Q$  and provide variable selectivity.

## CHAPTER 2

### F-M SUPERHETERODYNES

#### 2-1. Universal Use of Superheterodyne for F-M Reception

In Chapter 1, we outlined the types of a-m superheterodyne receivers being used, and some of the troubleshooting factors involved. The a-m receiver evolved gradually from the t-r-f circuit to the superheterodyne, through years of development. On the other hand, the receivers used in this country for f-m reception have always been superheterodynes.

The superheterodyne circuit is especially well adapted to reception of f-m signals. Satisfactory reception of f-m signals dictates that the selectivity characteristic of the receiver must meet certain special requirements; the superheterodyne allows meeting these requirements by design in the i-f section, which maintains these selectivity characteristics throughout the tuning range. The special demodulation and limiting processes necessary in f-m reception are easily handled in the i-f amplifier section, where the signal is at a relatively high level and the signal-to-noise ratio has already been determined. In a t-r-f receiver, such operations would have to be accomplished at received-signal frequency.

Since f-m receivers are superheterodynes, their general principle of operation is the same as that for the a-m superheterodynes discussed in Chapter 1. Therefore, all the material in Chapter 1 which applies to superheterodyne characteristics in general, applies equally well to f-m receivers. Accordingly, in this chapter, we shall confine our discussion to those functional details and troubleshooting factors in which the f-m superheterodyne differs from the a-m superheterodyne.

#### 2-2. Types of F-M Receivers

Three fundamental superheterodyne receivers are illustrated in the block diagrams of Fig. 2-1. In Fig. 2-1 (a) the block diagram of the conventional a-m receiver is shown, while in Fig. 2-1 (b) and (c) appear block diagrams for the two basic f-m receivers in use today. As far as the function of these receivers is concerned, the only difference lies in their demodulator circuits. The a-m receiver employs a conventional demodulator, or detector, wherein the envelope of the modulated signal

## SUPERHETERODYNE RECEIVERS

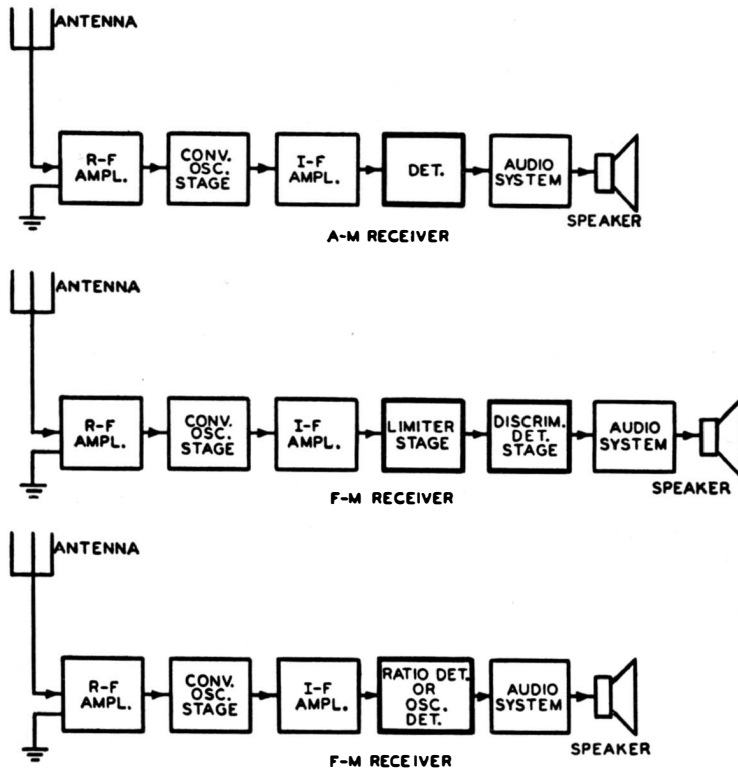

Fig. 2-1. Block diagram of conventional o-m and f-m superheterodyne receivers. Note that the difference occurs only after the i-f amplifier stages.

is detected. In Fig. 2-1 (b), a limiter stage is used in conjunction with a discriminator detector stage. This circuit was the only one commercially used from the beginning of f-m broadcasting until 1946. In 1946, two new detector circuits found their way into f-m sets. The block diagram of the f-m receiver employing these two detectors appears in Fig. 2-1 (c).

This latter f-m receiver does not employ a limiter stage because the limiting action is accomplished within the detector itself. Of these single-stage detectors, one type is known as the *ratio detector*; the other type, using the principles of the locked-in oscillator, is known as the *oscillator detector*. The former is used more often than the latter.

Except for the detector circuits, not much difference can be noted between the a-m and f-m receivers in the block diagrams of Fig. 2-1. However, the r-f, oscillator, and i-f circuits differ as far as their actual

## F-M SUPERHETERODYNES

physical designs are concerned. For example, the r-f coils in the f-m receiver may have only one turn of wire as compared to a large number of turns in the r-f coils of an a-m receiver. The i-f coils, too, have correspondingly few turns. The importance of f-m design, as far as wiring and other physical factors are concerned, becomes immediately apparent, because the added inductance of long leads and the stray capacitance of undressed wiring may detune the set or produce unwanted oscillations.

The primary functions of the r-f, oscillator, and i-f stages are the same for both the a-m and the f-m receivers. This is amply evidenced by the fact that many combination receivers use the same r-f, oscillator, mixer, and i-f tubes for both a-m and f-m reception. The associated circuits, however, are different for each type of modulation. The selection of the tuned circuits is made by special switching arrangements within the receiver.

One great difference between an a-m and an f-m receiver is the effect of interference. Due to the type of modulation involved, and to the circuits employed, the signal-to-noise ratio of an f-m receiver can be as poor as 2 to 1; an a-m receiver may require a ratio of 100 to 1. This means that, with frequency modulation, the strength of the desired signal need only be twice as strong as the interfering or noise signal; whereas, with amplitude modulation, the strength of the desired signal must be 100 times as great as that of the interfering or noise signal in order to eliminate the effects of interference.

The great majority of home f-m receivers are combination a-m/f-m receivers. The technician, accordingly, will be called upon to service far more combination sets than those designed for f-m reception only. We shall therefore devote most of our discussion of f-m receivers to the combination type. However, it is well for us to first consider the exclusively f-m type, and then to consider its requirements alone; after this, we shall proceed to a consideration of a-m/f-m combinations.

As in Chapter 1, we shall not attempt to discuss all the theory of each section, but rather to point out such factors as are of special importance in troubleshooting.

### **2-3. R-F Section**

Although the schematic diagram of the r-f section of an f-m broadcast receiver looks about the same as that for an a-m receiver, the difference in the frequencies of the received signals makes the design of coils, capacitors, wiring methods, etc. different. The main problems in the design of the r-f stage, as well as of other f-m stages, result from the frequencies of operation and the bandwidth involved. In the a-m broadcast

## SUPERHETERODYNE RECEIVERS

band, the frequencies involved are between 550 and 1600 kc as compared to the frequencies of 88 to 108 mc for the f-m broadcast band. Based on these frequency differences alone, the problem of circuit design for f-m reception becomes very critical, because the introduction of small amounts of lead inductances and stray capacitances, which under normal circumstances will not affect the a-m band, will affect tuning at such high frequencies.

In addition, the r-f amplifier must have a broad response characteristic for f-m reception, at least as far as *kilocycles* of bandwidth are concerned. Actually, the relative selectivity, which governs the design of the tuned circuits, is *sharper* for f-m broadcast receivers than for a-m broadcast receivers. For example, a bandwidth of 15 kc is 1.5 percent of a frequency of 1000 kc in the a-m broadcast band; a bandwidth of 300 kc at 100 mc in the f-m broadcast band is only 0.3 percent.

However, the nature of f-m reception is such that the top of the response curve should be as flat as possible. The r-f section is thus made quite broad, but selective enough to minimize image interference. Adjacent channel selectivity is then provided by the i-f amplifier.

For the maximum amount of signal energy to be transferred from the transmission line to the grid of the first r-f stage, the input transformer must match the high impedance of the grid to the relatively low impedance (generally 300 ohms) of the transmission line. Figure 2-2 illustrates how the input transformer couples the signal energy from the low-impedance primary circuit to the relatively high-impedance secondary circuit. The impedance  $Z_1$  looking into the secondary of the input transformer should be equal to  $Z_2$ , the input impedance of the r-f tube.

While most f-m home receivers employ a standard grounded-cathode circuit in the r-f section (similar to those used in a-m receivers, as shown

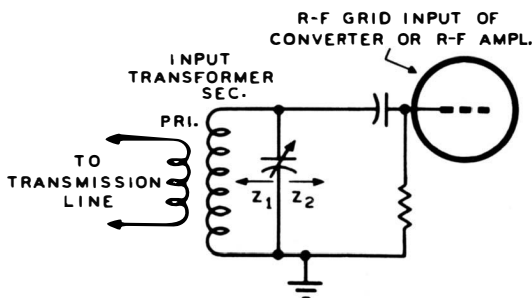

Fig. 2-2. Input circuit to the grid of the first r-f amplifier section. The input transformer provides an impedance match between the low impedance of the transmission line and the high impedance of the grid circuit.

## F-M SUPERHETERODYNES

in Fig. 1-7), certain high-fidelity tuners use special circuits. Two examples of these are illustrated in Fig. 2-3.

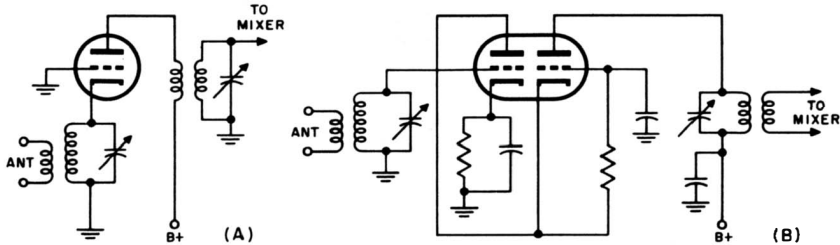

Fig. 2-3. Special r-f amplifiers used in high-fidelity tuners and other applications in which low noise level is important. The grounded-grid type is shown in (a) and the cascode amplifier type in (b).

Both these circuits use triodes. The advantage of triodes in an r-f amplifier is that the noise level is much lower than for tetrodes and pentodes. Ordinarily, a triode in an r-f amplifier at these frequencies would tend to oscillate if not neutralized. However, in the two circuits of Fig. 2-3, the triodes are so connected that the phase relations between input and output signals are not conducive to positive feedback. In other words, the grid is grounded and signal is fed to the cathode; the grounded grid acts as a shield between the cathode and the plate. The cathode signal is *in phase* with the plate signal, and thus the 180-degree phase shift necessary for oscillation or instability is not present.

The circuit in Fig. 2-3 (a) is called the *grounded-grid amplifier*. It has a lower absolute gain than the standard grounded-cathode amplifier, but its noise level is very low, thus providing a better signal-to-noise ratio.

The circuit in Fig. 2-3 (b) is known as the *cascode amplifier* and is noted for its low noise level in the vhf range. Note that the first stage is a grounded-cathode amplifier, but that its plate is connected directly to the cathode of the second stage, which is a grounded-grid amplifier with its grid grounded to r-f through a by-pass capacitor. Since the plate is directly connected to the cathode of the next stage, the two tubes are connected in series as far as the plate power supply is concerned, with the same plate current passing through both tubes.

### 2-4. Conversion Section

The mixer-oscillator and converter circuits found in f-m sets are similar to those used in a-m receivers. The purpose of heterodyning to produce an intermediate frequency is the same in frequency modulation as in amplitude modulation. However, again due to the frequencies used

## SUPERHETERODYNE RECEIVERS

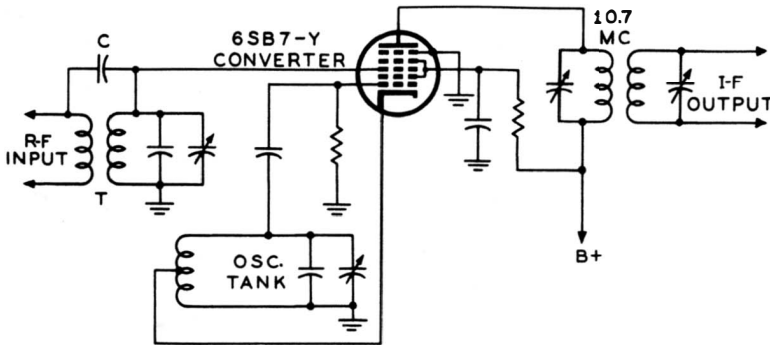

Fig. 2-4. A converter circuit that is used in several f-m receivers. The 6SB7-Y tube was especially designed as an h-f oscillator and mixer.

in frequency modulation, certain circuit modifications must be made to produce the proper i-f signal.

Present-day f-m receivers employ two types of frequency conversion systems; one type using a single tube, a converter, to perform the complete function of frequency conversion and the other type using separate oscillator and mixer tubes. The use of a single-tube converter is quite acceptable at the frequencies in the a-m broadcast band, but increased frequencies present a greater chance for interaction between the oscillator and mixer sections of the converter tube. Some of these difficulties were found with converter systems that operated on the old f-m band of 42 to 50 mc. As the frequency increases beyond these values, interaction of the system and instability of the oscillator section becomes more pronounced. To reduce the effects of these conditions, one of two things is done: separate tubes are used for the mixer and oscillator, or the converter tube employs some means of neutralizing the effect of interaction. Specially designed converter tubes for high frequencies sometimes handle frequency conversion quite adequately. In the majority of cases, however, a separate oscillator tube is used.

A typical converter system is illustrated in Fig. 2-4. The type 6SB7-Y tube employed is specially designed for high-frequency work and is used in a number of the f-m receivers on the market today. The circuit is more or less the same as that of an a-m converter system. For instance, the first grid is used as the oscillator grid in a Hartley oscillator circuit. The third grid is the r-f signal input grid, and the r-f signal input is either fed directly from the antenna circuit or from a separate r-f stage. There are, however, certain circuit changes or additions made in these circuits which stem from the high frequencies involved. As already mentioned,



## F-M SUPERHETERODYNES

the coils contain fewer windings because of the need for smaller values of inductance, but other changes are also noticeable.

In wiring any part of the front end of an f-m receiver, special care should be taken to make the lead wires no longer than necessary because of the added inductive effect greater length has on the circuit. Such special care should be taken in wiring the cathode of the r-f tube to ground. If the inductance presented by the cathode lead is appreciable at the frequencies involved, a feedback voltage will develop across this inductance, which will lower the input resistance of the tube. If the input resistance of the tube changes, the impedance match existing between the receiver input and the antenna will be upset.

Interaction between the oscillator and signal grid circuits exists in most pentagrid converter tubes, causing undesired coupling between the two circuits. This interaction is caused by an *effective* capacitance existing between the r-f signal grid and the oscillator grid. This effective tube capacitance consists of two parts. One is the interelectrode signal-grid-to-oscillator-grid capacitance, which is not too great for most converter tubes but definitely has an effect at high frequencies. The other part is due to *space-charge coupling* between these two grids. This space-charge effect is very important, because it occurs in most converter tubes.

Most of the defects found in the use of converter tubes are eliminated by the use of separate oscillator and mixer tubes as illustrated in Fig. 2-5. This type of circuit is also used in many a-m receivers employing a

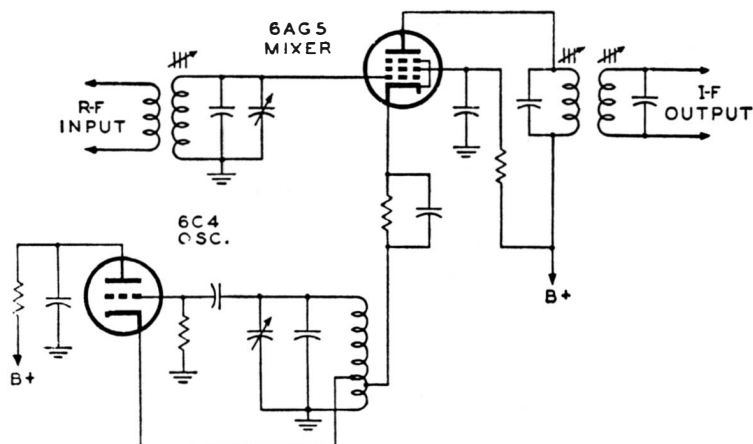

Fig. 2-5. The tubes used in this mixer and oscillator circuit are of the miniature type and were designed for use at high frequencies. The use of separate mixer and oscillator tubes eliminates many troubles that are inherent in a circuit in which a converter tube is used.

## SUPERHETERODYNE RECEIVERS

separate oscillator tube, but for high frequencies it is definitely recommended. The 6AG5 mixer tube and 6C4 oscillator are miniature tubes designed especially for high-frequency work. Their input, output, and interelectrode capacitances are smaller than those of regular-size tubes, making them readily adaptable to high-frequency work. The separate oscillator is a conventional Hartley circuit in which the cathode is tapped to the coil. The 6AG5 mixer tube is a pentode, with the control grid used for the r-f voltage input and the cathode circuit for the injection of the oscillator voltage.

The method used to inject the oscillator voltage into the mixer tube is readily noticed in Fig. 2-5. Some of the oscillator voltage is tapped off part of the oscillator tank coil and fed directly into the cathode circuit of the 6AG5 mixer tube through the cathode's resistor-capacitor bias combination. Within this 6AG5 tube, the r-f signal and oscillator signal are mixed and the intermediate frequency is selected by the i-f tuned-transformer output circuit.

In using a separate oscillator and mixer tube, the oscillator is coupled as loosely as possible to the mixer stage to avoid any interaction between the circuits. In Fig. 2-6 (a), (b), and (c) are illustrated three other types of oscillator-mixer combinations found in receivers. In Fig. 2-6 (a), a simple Hartley oscillator is employed, wherein the oscillator voltage is coupled to the signal grid of a pentode mixer tube through a "gimmick." The effect of the gimmick is such that a small amount of capacitance exists between the turns of the gimmick and the grid circuit wiring. This capacitance couples the oscillator grid voltage to the mixer tube. The degree of coupling can be varied by physically changing the number of turns in the gimmick or by changing the distance between the mixer grid and the gimmick.

The mixer in Fig. 2-6 (b) is a pentagrid tube in which the first and third grids are used as the oscillator injection grid and r-f signal grid respectively. The oscillator is of the tuned-grid tickler-coil type where the oscillator voltage is taken off the grid circuit and capacitively coupled through capacitance  $C$  to the oscillator injection grid of the mixer tube. The tickler coil in this oscillator is in the cathode circuit of the tube. The proper choice of the value of  $C$  will determine the closeness of coupling between the oscillator and signal circuits.

In Fig. 2-6 (c), the frequency conversion system uses a pentode mixer tube in conjunction with a tuned-grid tickler coil oscillator. The tickler coil is so situated in the plate circuit of the oscillator tube that coupling exists between it and the r-f signal input coil to the mixer tube and, also, the oscillator tank coil. In either case, the coupling occurs through the

## F-M SUPERHETERODYNES

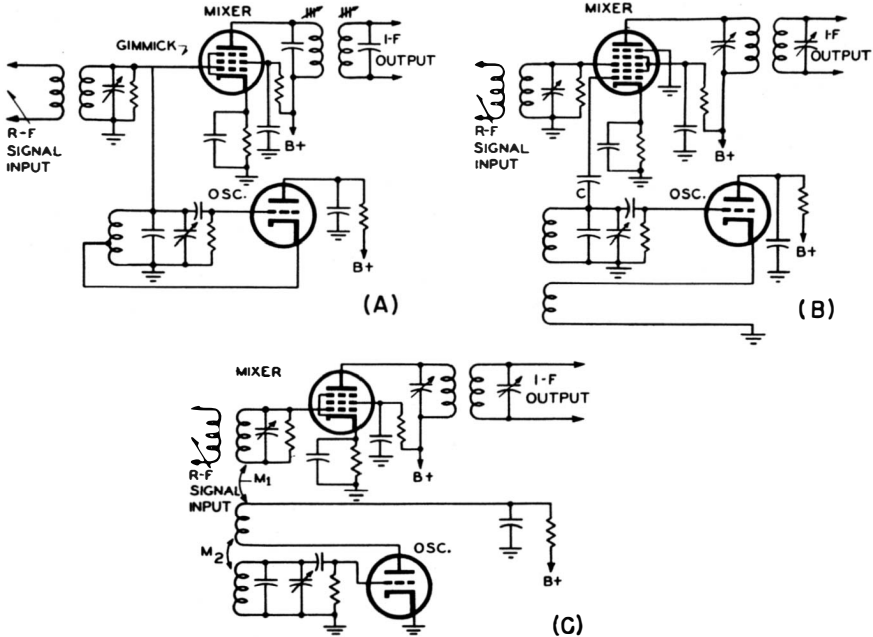

Fig. 2-6. Three types of oscillator-mixer circuits, which employ different means of coupling the oscillator signal to the mixer tube.

medium of transformer action, since a mutual inductance  $M_1$  exists between the tickler coil and the r-f coil, and a mutual inductance  $M_2$  exists between the tickler coil and the oscillator tank coil. The distance the tickler coil is placed from the r-f input coil of the mixer determines the amount of mutual inductance  $M_1$  and, hence, the degree of coupling between these two circuits. To avoid interaction between the two circuits, the coupling between these coils should be made as loose as possible, consistent with the maintenance of proper mixer operation. This means that the magnitude of  $M_1$  should be as small as possible.

### 2-5. I-F Amplifier Section

We now come to that portion of the f-m receiver in which the i-f output from the converter system is selected and amplified prior to detection. This part of the receiver is similar in circuitry and function to the corresponding section of an a-m set. However, as mentioned previously, differences do exist, primarily because of the frequency and bandwidth involved. The purpose of the i-f transformers and amplifiers, besides being essential parts of all superheterodyne receivers, is to provide a large part of the r-f gain and most of the necessary selectivity. For, al-

## SUPERHETERODYNE RECEIVERS

though the receiver may contain an r-f stage in which a certain amount of selectivity and gain is obtained, the i-f system usually is the determining factor in completing the required gain and selectivity.

In most f-m receiver designs, the bandwidth of the i-f transformer and amplifier arrangement is such that the minimum bandwidth is at least equal to the maximum deviation of 150 kc for 100 percent modulation of the transmitter. Therefore, the i-f transformers must have a broad selectivity to pass this range of frequencies. It should be remembered that this 150-kc pass-band is a minimum requirement, and if possible, the bandwidth should be 200 kc or more, in order that the 150-kc center band be as flat in response as possible.

The 2.1-mc intermediate frequency of the first commercial f-m receivers was low compared with that in use today. Though a low intermediate frequency improves the gain per stage, the bad image interference that occurred with this early value made a change in the intermediate frequency necessary. (This original work was in the old f-m band of 42 to 50 mc, and the new intermediate frequency became 4.3 mc.) Since image frequency response on the same band can occur only when twice the value of the intermediate frequency does *not* exceed the band of frequencies between the assigned limits, interference could not occur with the new 4.3-mc intermediate frequency.

The present f-m broadcast band — 88 to 108 mc — encompasses a band of 20 mc; and therefore, the 4.3-mc intermediate frequency had to be changed to avoid image frequency interference. Some of the intermediate frequencies used for this new band were at 8.3 mc, but, since twice this frequency is equal to 16.6 mc, which is *less* than the 20-mc width of the new band, image interference was possible. The intermediate frequency generally used today is 10.7 mc, and this value is now accepted as standard by most manufacturers.

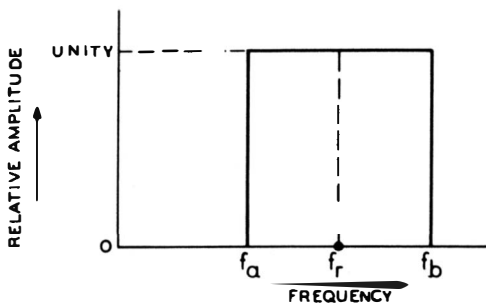

Fig. 2-7. An ideal selectivity curve cannot be realized in practice with the use of a single i-f transformer network.

## F-M SUPERHETERODYNES

The ideal selectivity characteristic for an f-m signal would be a flat-top response curve as illustrated in Fig. 2-7 where only frequencies between  $f_a$  and  $f_b$  will be accepted and all will have the same amplitude. However, such a curve cannot be realized in practice with the use of a single i-f transformer network. Methods that help approach the shape of such a curve entail the use of more than one i-f transformer network, and preferably of three.

High gain and the necessary skirt selectivity can be procured by a number of methods. In most of these, three i-f transformer networks are used. The number of i-f stages is a determining factor in the amount of i-f gain, but the type of coupling and  $Q$  of the i-f transformer circuits is the determining factor in the amount of bandwidth. The three principal types of i-f transformer coupling arrangements are as follows:

1. All three i-f transformers are single-peaked, somewhat under critical coupling, to the same resonant frequency.
2. The first and third i-f transformers are single-peaked just under critical coupling, and the second i-f transformer is overcoupled to produce a double-peaked response curve for this latter transformer. All three have the same resonant frequency.
3. All three transformers are single-peaked, but the resonant frequency of each is slightly different. Usually, the first transformer has the lowest resonant frequency, the third has the highest, and the second is between the other two. This system is known as *stagger-tuned* i-f transformers.

The first arrangement is very simple. Each i-f transformer is tuned to the same resonant frequency; and, if the circuits have a low  $Q$ , the individual gain will be low but the bandwidth will be increased. Using three such circuits will increase the gain to a point where it is sufficient for detection purposes. This type of arrangement, although common, does not provide too great a bandwidth, because there is a limitation as to how low the  $Q$  of the circuits can be and still give sufficient over-all gain. The bandwidth of each individual circuit is the same, so the over-all bandwidth is the same as that of an individual transformer.

Also quite common, the second type of arrangement affords a better method of obtaining a broad selectivity of the over-all i-f systems. In this circuit, not only do low  $Q$  circuits broaden the over-all bandwidth, but also the overcoupled i-f circuit helps to make it somewhat broader. Fig. 2-8 will make this much clearer. The response curves of the individual i-f transformers are illustrated, along with the over-all response curve of the complete i-f system. The first and third i-f transformers are single-peaked and have the same response curve. The bandwidth of these

## SUPERHETERODYNE RECEIVERS

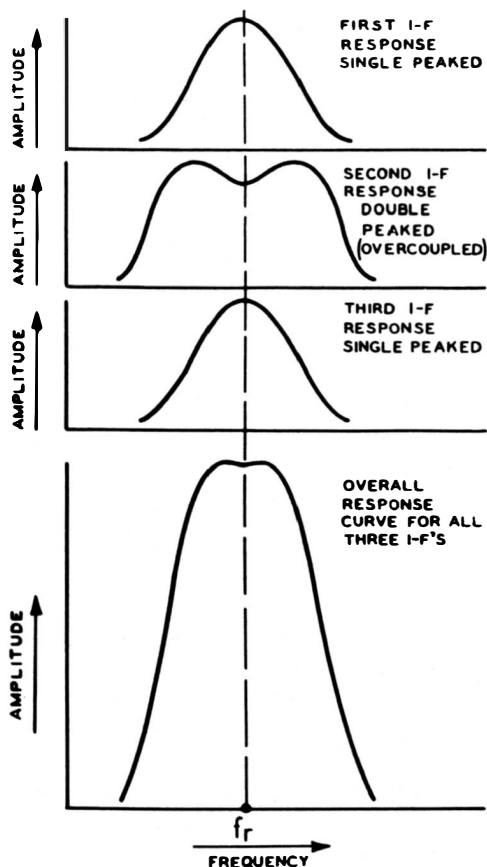

Fig. 2-8. By using three i-f stages a somewhat broad, flat-top over-all response curve can be obtained.

single-peaked circuits is not enough, so the overcoupled double-peaked response of the second i-f transformers is inserted to broaden the over-all pass-band. The over-all response curve of the i-f system is obtained by combining the individual response curves of each i-f transformer. This over-all response curve definitely shows that the bandwidth is wider than any one single-peaked i-f response curve.

The third method is not used so often as the two just described, but it is interesting to know how the broad-band effect is obtained by this arrangement. The i-f transformers are 'stagger-tuned,' and hence the resonant frequency of each is different. The individual response curves and the over-all response curve are illustrated in Fig. 2-9. The upper part of this picture represents the individual i-f response curves; and the lower part, the addition of these curves, resulting in the over-all i-f curve. To

## F-M SUPERHETERODYNES

clarify this discussion, we will assign frequency values to the individual stages. To obtain the stagger-tuned effect, the first has a resonant frequency of 10.6 mc, the second of 10.7 mc, and the third of 10.8 mc. The shapes of the individual i-f response curves are such that, when plotted on the same graph, they will *overlap* each other to a degree, predetermined by the individual i-f bandwidths and resonant frequencies. This is shown in the upper part of Fig 2-9. The bandwidth of each individual i-f circuit is not so broad as desired, but the overlapping effect produces an over-all i-f response as shown in the lower part of Fig. 2-9. Examination of this resultant curve immediately reveals that there is broad selectivity. The total bandwidth easily exceeds 200 kc.

Such i-f arrangements as these are excellent for producing broad selectivity, flat-top response, and good skirt selectivity; but these circuits have drawbacks when used in f-m receivers. First of all, each individual i-f resonance must be known in order to align the circuits, and each i-f circuit must be aligned at a different frequency. This procedure is time-consuming, since the signal generator has to be reset for each stage. Another reason why this circuit is seldom used in f-m receivers is that such a system contributes very little to the over-all gain of the receiver. This is readily seen by comparing the amplitude of the over-all i-f response curves of Figs. 2-8 and 2-9. Since i-f gain is an important criterion in the successful operation of f-m receivers, it would appear that another three-stage stagger-tuned i-f system would have to follow the first three in order

Fig. 2-9. By having three single-peaked i-f stages stagger-tuned, in such a manner that their individual response curves adjacent to each other overlap one another, a broad-band over-all response curve can be obtained.

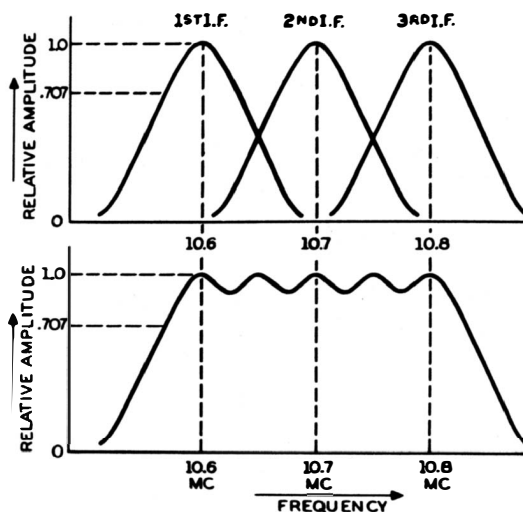

## SUPERHETERODYNE RECEIVERS

to raise the gain of the complete system. Such an arrangement is too costly for commercial f-m receivers, since six i-f stages would have to be employed. Stagger-tuned i-f systems are used frequently in television work, where the bandwidth required may be anywhere from 4 to 10 mc, depending on the system in which it is used.

### 2-6. Methods of Demodulation

After the i-f section of the f-m receiver, we reach the point where there is a marked difference between the f-m and a-m receiver. In both receivers, the next thing with which we are concerned is the detection of the modulated signal. In a-m receivers, the detector is usually a conven-used. All three methods are wholly different from that employed in the a-m systems, and, consequently, warrant a detailed discussion. These three methods of detection are commonly known as the *limiter-discriminator arrangement*, the *ratio detector*, and the *oscillator detector*. Each one of these special detector circuits will be discussed in detail in order of their appearance on the market.

### 2-7. Limiter Stage

Since the limiter stage of the limiter-discriminator detector system is considered a separate section of the receiver and since it precedes the discriminator, it will be discussed before the discriminator itself. The limiter stage of the f-m receiver immediately follows the final i-f stage and its circuit appears very similar to an i-f stage. In fact, this limiter system may be considered as the last i-f stage of the receiver. Although the limiter is an amplifier which receives the i-f signal, its primary purpose

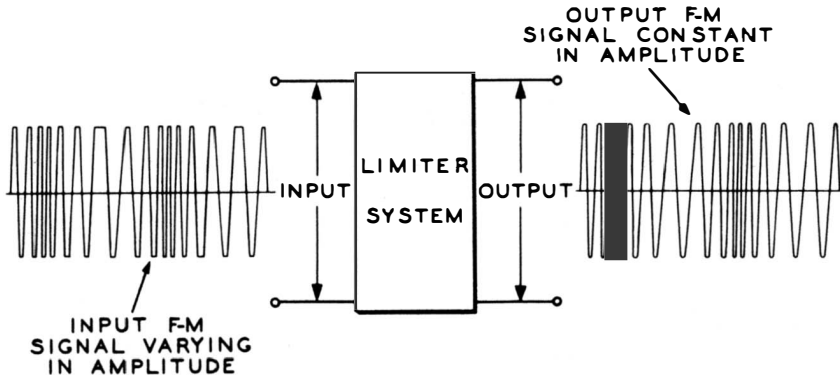

Fig. 2-10. The action of the limiter in an f-m receiver is to clip off the amplitude variations of the input signal.



## F-M SUPERHETERODYNES

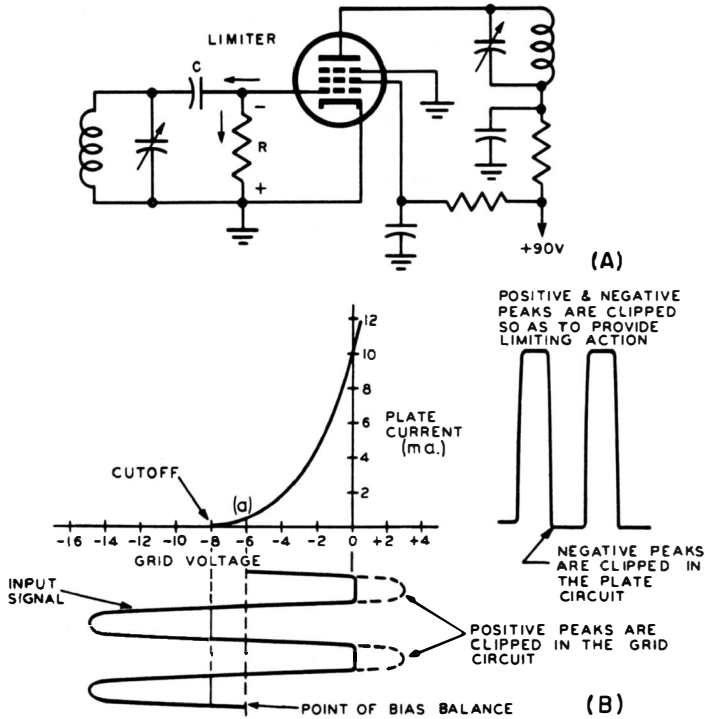

Fig. 2-11. A typical limiter circuit is shown at (a). The clipping action on the input signal is illustrated in the characteristic curve at (b).

is not one of amplification, but rather, is one of amplitude variations that may be present in the f-m signal. The resultant output from the limiter will be an f-m signal that is varying in frequency only and that has a constant amplitude.

The function of the limiter is shown in Fig. 2-10. The input to the limiter is an f-m signal that is varying in amplitude as well as in frequency. The amplitude variations are undesired and, by the action of the limiter, are *clipped off*; and the output is an f-m signal of constant amplitude.

For an amplifier to act as a limiter, the operating voltages are chosen so that the tube will overload easily with a small amount of signal input. A number of special operating conditions are combined to make the limiter function properly. First, the amplifier tube used is usually of the sharp cut-off type, such as the 6SJ7 or 6SH7. Low values of screen and plate voltage and little or no control grid bias are applied to the

## SUPERHETERODYNE RECEIVERS

tube, so that it will quickly overload and plate current saturation will be rapidly reached.

A typical limiter circuit is shown in Fig. 2-11 (a). As the i-f signal arrives at the grid, the grid draws current on the positive half-cycles. Current flows through bias resistor  $R$ , causing a voltage drop across the resistor. This voltage acts to bias the grid. Now, suppose there are amplitude fluctuations in the i-f signal fed to the limiter. When the amplitude increases, the bias increases and reduces the limiter's output to compensate; when the amplitude decreases, the bias decreases and the output increases accordingly. The plate voltage is low enough so that plate current saturates with a relatively small positive input signal and no further increase in plate current is possible. Negative peaks drive the grid to the cut-off, and negative amplitude is limited by that point. These actions are illustrated in Fig. 2-11 (b).

The bias resistor  $R$  and the voltage developed across it are, for several reasons, of special importance to the technician in his troubleshooting work. First, in f-m receivers that have AVC, the AVC voltage may be obtained from this resistor. Several variations of the limiter circuit and methods for obtaining AVC voltage are shown in Fig. 2-12.

In troubleshooting, the limiter bias voltage is a valuable indicator, showing the relative strength of the i-f signal reaching the limiter grid.

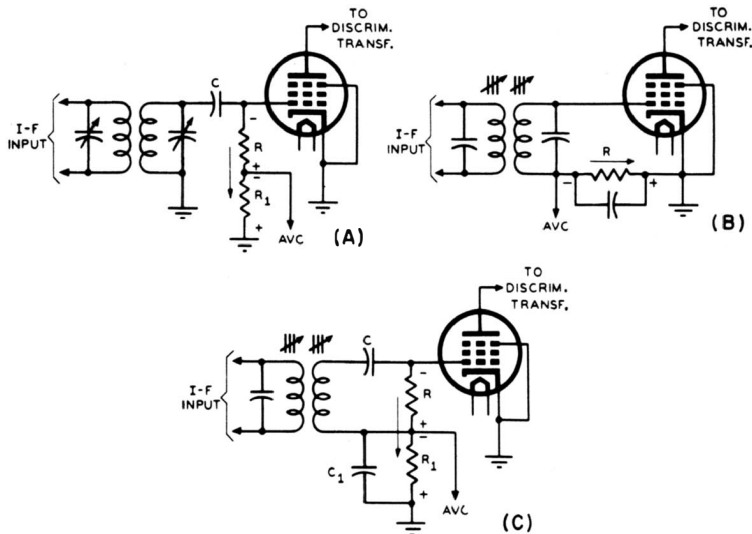

Fig. 2-12. Three limiter stages with different grid circuits. In each, due to the grid current flowing, the voltage developed across  $R_1$  in (a) and (c) and across  $R$  in (b) can be used for AVC.

## F-M SUPERHETERODYNES

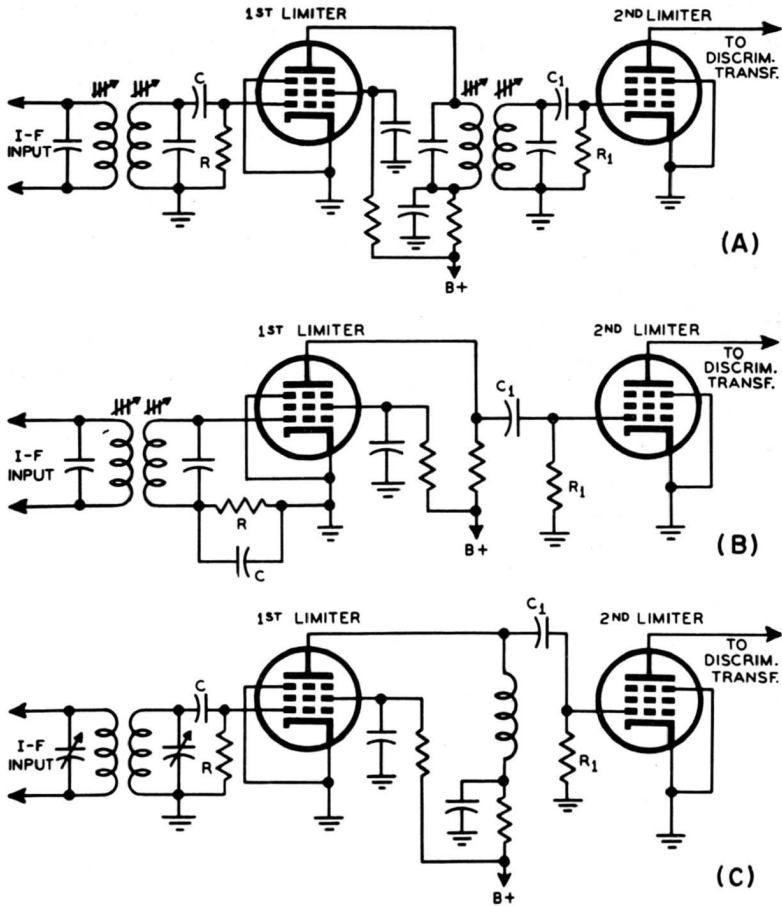

Fig. 2-13. When two limiters are used in cascade, the method of coupling used between them may vary widely. In (a) transformer coupling is used. In each case the time constant for the first stage is established by R and C and in the second stage by R<sub>1</sub> and C<sub>1</sub>.

In alignment of both front-end and i-f amplifier sections, this voltage is about the only dependable indicator of peaking, since after the limiter, amplitude variations are *ironed out*.

In visual alignment, the oscilloscope vertical circuit is connected to the limiter grid resistor to provide a sweep pattern. Even for simple testing and isolation of troubles, measurement of the d-c voltage across the limiter grid resistor shows whether trouble is before or after that point in the receiver circuit.

## SUPERHETERODYNE RECEIVERS

Sometimes, in more elaborate f-m tuners and receivers, two limiter stages are used in cascade. This provides more complete limiting and makes limiting effective over a wider range of rates of amplitude variation. The amplitude fluctuation rates to which a limiter will respond are determined by the R-C constant of grid capacitor and resistor. When the cascade limiter circuit is used, a different R-C constant is used for each stage, thus allowing each stage to handle a different range of amplitude fluctuation rates. Typical cascade limiter arrangements are illustrated in Fig. 2-13.

### 2-8. The Phase Discriminator

Almost every receiver that has a limiter employs the Foster-Seeley phase discriminator for demodulation. This circuit is not at all new to the veteran technician who has been servicing a-m broadcast receivers, since, whenever AFC is used in these, the phase discriminator is the agency that provides control voltage for the reactance tube.

Because of its connection with AFC in a-m receivers, the phase discriminator has been discussed at some length in Chapter 1. A detailed consideration of the principles of operation of the phase discriminator is rather involved and is beyond the scope of this book. We shall, however, review briefly what it does, since this is of particular importance in troubleshooting.

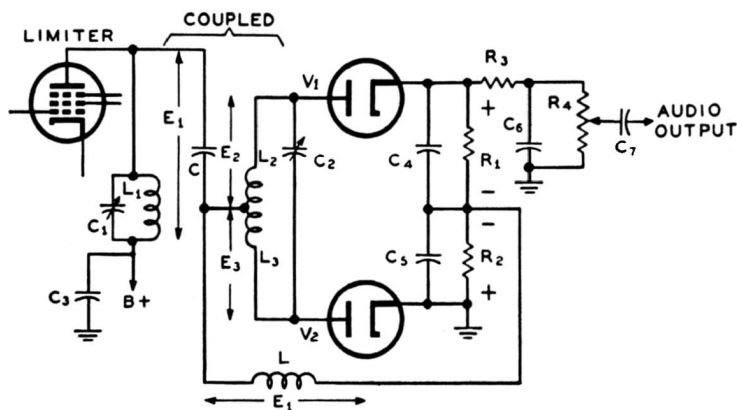

Fig. 2-14. Schematic of the phase discriminator.

## F-M SUPERHETERODYNES

Figure 2-14 is a schematic diagram of the Foster-Seeley phase discriminator. This is the same circuit which we considered in Fig. 1-23, except that here it demodulates the incoming signal and provides the a-f signal rather than a d-c control voltage.

L1 and L2-L3 compose a transformer which is like the other i-f transformers in the f-m receiver except that the secondary winding is center-tapped. This center tap is not grounded, but is coupled to the output of the limiter through a capacitor, as shown. The i-f voltage applied to diode V1 is then equal to the sum of E1 and E2, and the i-f voltage applied to diode V2 is equal to the sum of E1 and E3. As a result of rectification by the diodes, these applied i-f voltages cause direct currents to flow in R1 and R2, and thus, a d-c voltage drop across each resistor, as shown.

Note that the voltages across R1 and R2 are of opposite polarity, so that between point A and ground the d-c voltage is equal to their arithmetical difference.

The relative phase of E2 and E3 with respect to E1 changes according to whether the i-f signal is at, above, or below the resonant frequency of the tuned circuit of the transformer secondary. As a result of these phase variations, the voltage between point A and ground varies in accordance with the frequency of the i-f signal received by the discriminator. The result is as follows:

1. *I-f signal exactly at resonant frequency:* D-c voltages across R1 and R2 are equal, and d-c voltage at point A is *zero* with respect to ground.
2. *I-f signal above resonant frequency:* D-c voltage across R1 is greater than d-c voltage across R2, and thus voltage at point A is *negative* with respect to ground.
3. *I-f signal below resonant frequency:* D-c voltage across R2 is greater than d-c voltage across R1, and thus voltage at point A is *positive* with respect to ground.

The discriminator, therefore, actually translates input i-f signal frequency variations into output d-c voltage variations. The frequency of the carrier of the f-m transmitter is modulated so that the rate of its frequency variations corresponds to the audio-frequency input signal. The a-f modulation signal is recovered at the output of the discriminator.

It should be noted that the d-c output voltage at point A can be very helpful in checking the alignment of the receiver. Once the tuned circuits of the discriminator transformer have been set accurately at the precise intermediate frequency used, the local oscillator can be aligned using an unmodulated R-F input signal. With the dial properly set, the oscillator is adjusted until the voltage at point A (measured by a vacuum



## F-M SUPERHETERODYNES

the total voltage across C3-C4 constant. Since the total voltage across both capacitors is constant, the mid-point between them must vary according to the a-f modulation signal.

The limiting effect of the circuit arises from the fact that any amplitude fluctuations in the input i-f signal result only in a tendency to change the voltage across R (and thus the *total* voltage across C3-C4) but not the mid-point voltage between these capacitors, where the a-f signal is tapped off. In other words, the a-f signal is proportional to the *ratio* of the voltages across these two capacitors, and it is from this fact that the detector gets its name.

The voltage across R is useful in alignment, since it varies according to the *amplitude* of the i-f signal being applied to the detector. Since no limiter is used with the ratio detector, the i-f stages can be aligned for peak response, using the ratio detector load-resistor voltage as an indicator.

### 2-10. The Locked-Oscillator Detector

The third type of detector used in f-m receivers is the locked-oscillator circuit illustrated in the schematic diagram of Fig. 2-16. This detector employs the principle that an oscillator can be made to lock its frequency to an external signal injected into its circuit. The local oscillator in the detector circuit is made to lock into the incoming i-f signal and follow its frequency variations. Limiting is provided, because as long as the i-f signal is strong enough to provide locking, amplitude variations in the i-f signal do not affect the amplitude of the local-oscillator signal.

In Fig. 2-16, L2-C2 is the tuned circuit of the local oscillator, which employs a Colpitts circuit. This oscillator uses the cathode and grids 1, 2, and 4 of a special tube designed particularly for this use. This tube resembles a pentagrid converter. The i-f signal is applied to grid 3.

The tube is so biased that the i-f and oscillator signals each set up trains of pulses of plate current. As the i-f signal frequency changes during modulation, the relative phasing of these pulses changes. The pulses in the plate circuit are fed back into the oscillator circuit through the tuned circuit L3-C3, which is coupled to the oscillator coil. The interaction between these circuits is such that the plate current of the tube changes in accordance with the changes in frequency of the i-f signal at grid 1. This variation in plate current appears as a voltage drop across R2 and is coupled from there to the a-f amplifier.

## SUPERHETERODYNE RECEIVERS

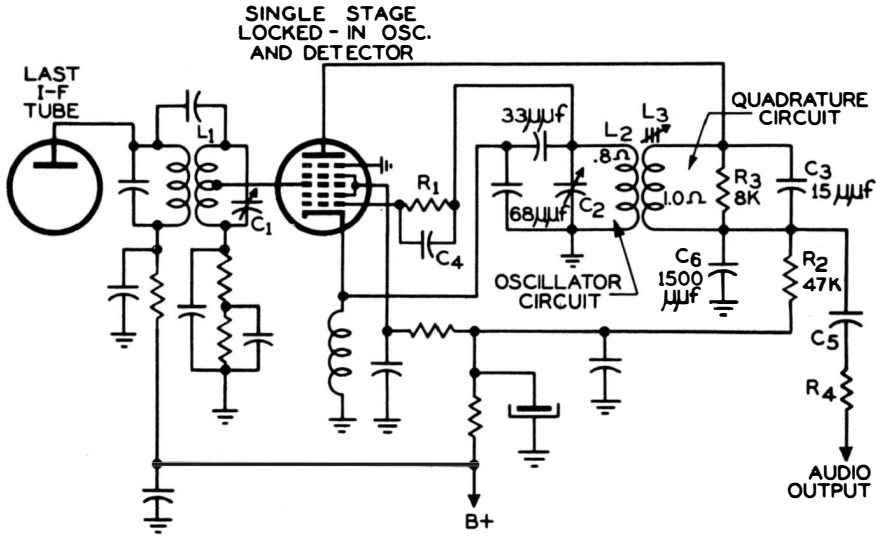

Fig. 2-16. The locked-in oscillator detector circuit of the Philco Model 46-1213 receiver. The detector circuit of Philco Model 48-482 is essentially the same.

### 2-11. The Gated-beam Detector

Although we have mentioned that there are three main systems of demodulation, which we have already described, there is still another type which may be encountered occasionally. This is known as the *gated-beam* detector. The circuit is built around the special tube, the 6BN6, whose interior construction is illustrated in Fig. 2-17. The schematic diagram of the circuit is shown in Fig. 2-18. Limiting is obtained by focusing the electron flow into a narrow beam as it passes from the cathode through the other elements to the anode. The *quadrature grid* is connected to a tuned circuit resonated at the intermediate frequency.

The action of the tube is such that the plate current rises to a full limited value when the grid voltage goes slightly above cut off. A series of plate current pulses thus results from application of the i-f signal to



## F-M SUPERHETERODYNES

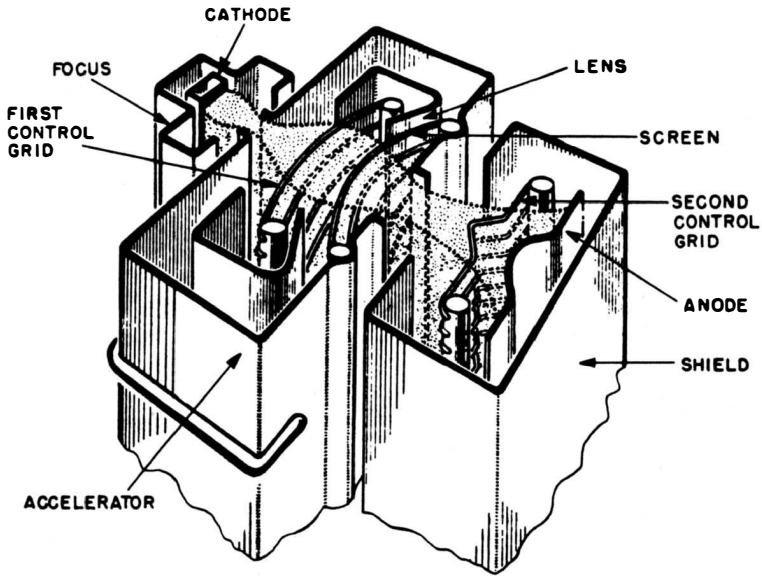

Fig. 2-17. Internal arrangement of the 6BN6 tube.

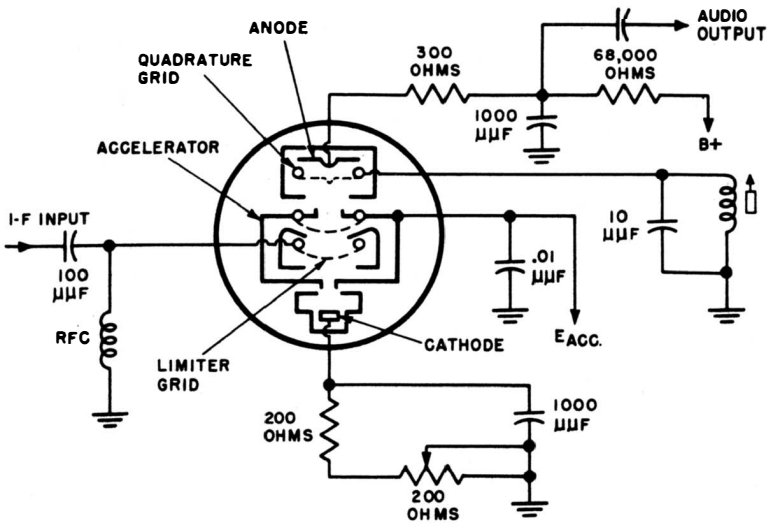

Fig. 2-1B. Schematic diagram of the 6BN6 detector circuit.

## SUPERHETERODYNE RECEIVERS

the control grid. These pulses in the plate circuit, plus their effect on and through the quadrature circuit, cause the plate current to vary in accordance with the frequency, and thus with the modulation, of the i-f signal. The voltage drop across a resistor in the plate circuit is the a-f signal and is coupled through a capacitor to the a-f amplifier.

### 2-12. Combination A-M/F-M Receivers

We have already mentioned that combination a-m/f-m receivers constitute the greater part of the technician's work in the troubleshooting of f-m receivers. Since these are a combination of the necessary parts of both a-m and f-m receivers, we have discussed the simple f-m receivers first. It now merely remains to show how it is combined with the a-m receiver.

Only in rare cases is the f-m portion of a combination receiver completely separate from the a-m portion. In a few instances, the r-f amplifier and the converter sections are common to both the a-m and f-m portions, with the i-f amplifier and detector separate, and with a common a-f amplifier. However, the most common arrangement is illustrated in Fig. 2-19.

The r-f amplifier and the mixer are used for both a-m and f-m reception, the change being made by switching coils in these sections. In the i-f amplifier section, no switching is necessary because *combination a-m/f-m transformers* are used. These transformers are so designed that, for

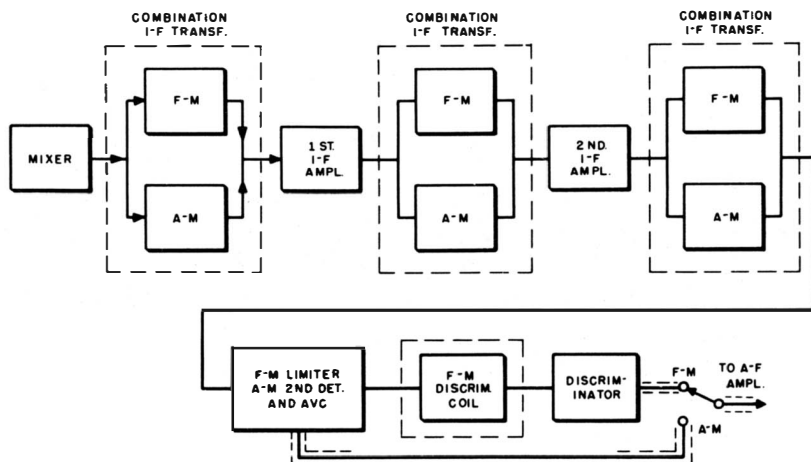

Fig. 2-19. Most common arrangement for combination a-m/f-m receivers.

## F-M SUPERHETERODYNES

455-kc signals, their f-m portion remains unused; and for 10.7-mc signals, the a-m portion is unused.

Figure 2-20 (a) shows the physical construction and Fig. 2-20 (b) the electrical connections for a typical combination transformer.

Since the i-f values are so far apart, the inductances of the coils differ greatly, and when operated on the a-m band, the f-m coils L13 and L14 in Fig. 2-20 (b) offer very little reactance, so that they appear as a short circuit to the 456-kc i-f. When the tuned circuits, which are parallel *LC* arrangements, are operated on the f-m band, the capacitive reactances of the a-m capacitors C1 and C2 at 10.7 mc present virtually a short circuit to this frequency.

The capacitors used in this i-f combination are fixed in size, but they are not the familiar fixed mica capacitors. Instead, they are formed by coating thin sheets of mica with silver deposits varying in size, the mica serving as the dielectric and insulator. The value of some of the

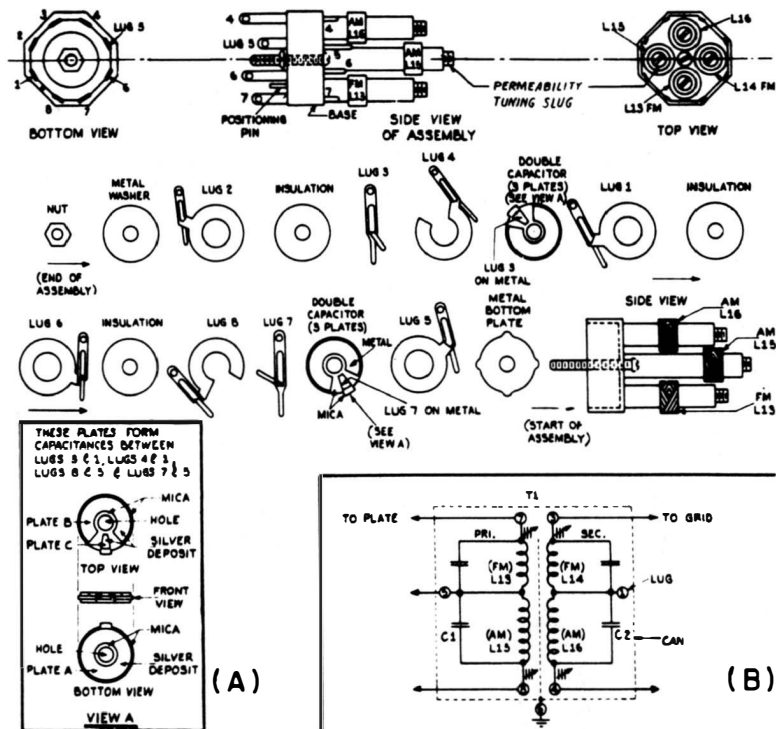

Fig. 2-20. The arrangement of the components making up the f-m and a-m i-f transformers used in a Zenith receiver is shown at (a). The series-connected primary and secondary coils and the capacitors across them are shown in the schematic in (b).

## SUPERHETERODYNE RECEIVERS

capacitors, besides being determined by the distance between the silver deposits, is also dependent on the common area between two silver-coated plates. The mechanical details of these capacitors are evident from the drawing of Fig. 2-20 (a).

In some receivers, a single tube is capable of performing the function of a-m and f-m detection. Other receivers have separate tubes for a-m and f-m detection; but in some instances, one of these detector tubes has another function besides detection. Whatever the type of circuit, the important prerequisite is that it functions only on a-m when the receiver is tuned to the a-m broadcast band, and only on f-m when it is tuned to the f-m band.

When separate detectors are used, they are similar to those already discussed, and differences in circuitry are simply those involved in switching from one to the other. In the late models, there has been a tendency to combine as many functions as possible in one tube in this part of the circuit, and several types have been developed expressly for this purpose. An example of such a tube is the 6S8GT, which combines a single diode, a double diode, and a triode.

Figure 2-21 shows a typical circuit using the 6S8GT in a Farnsworth receiver. When the receiver is tuned to the f-m band, the f-m i-f signal is fed through a series of three i-f amplifiers and then coupled to the 6S8GT tube through the ratio detector transformer. The plates and

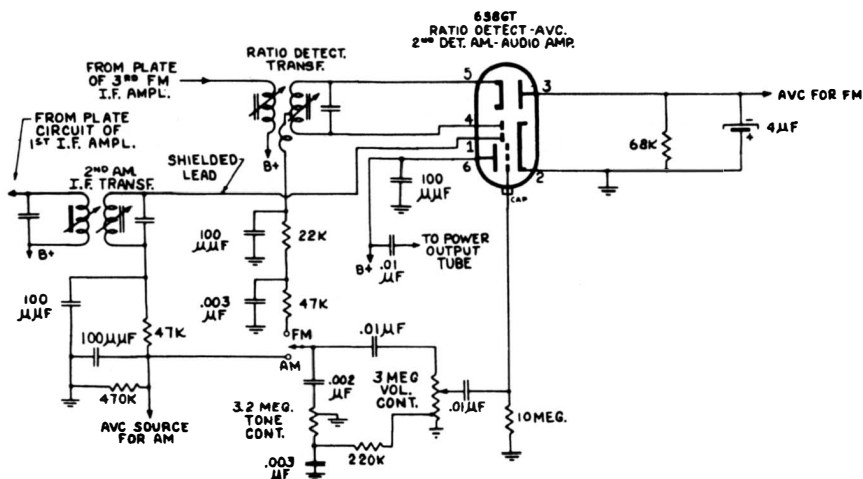

Fig. 2-21. The 6S8GT tube is used in the Farnsworth Model GK-085 as a ratio detector, AVC tube, a-m detector, and audio amplifier.

## F-M SUPERHETERODYNES

cathodes of pins 2, 3, 4, and 5 are connected in a conventional type of ratio detector circuit as seen in Fig. 2-21. AVC for f-m is taken from the negative side of the  $4\ \mu\text{f}$  electrolytic capacitor in the output circuit of the ratio detector. This point is used because the output voltage there changes in accordance with the varying average strength of the incoming signal.

The 22,000-ohm resistor and  $0.003\text{-}\mu\text{f}$  capacitor in the tertiary winding of the ratio detector transformer forms the de-emphasis network of the receiver. The audio-signal output from this circuit is fed to a volume and tone control network through the f-m section of the switch as shown in Fig. 2-21. The audio signal is finally coupled to the grid of the triode section of the tube through a  $0.01\text{-}\mu\text{f}$  capacitor. The plate, pin 6, and cathode, pin 2, are the other electrodes of the amplifier. Bias for this amplifier is obtained by the d-c voltage drop across the 10-megohm resistor in the grid circuit. The signal output from the plate of this first audio amplifier is then coupled to the grid of the audio power output tube.

Up to this point, the cathode, pin 2, has been used for two separate applications: one for the ratio-detector circuit, and the other for the audio amplifier. It also has a third application—as part of the a-m detector circuit. Let us now examine this circuit when the switch is thrown to the a-m band. In this position, the a-m i-f signal passes through only one stage of i-f amplification and is then coupled to the plate, pin 1, of the 6S8GT tube through the second a-m i-f transformer. This electrode, together with the grounded cathode, pin 2, functions as a conventional diode detector for a-m signals. Since no f-m i-f signal is present at the ratio detector transformer, the other electrodes, pins 3, 4, and 5 of the 6S8GT tube, are not operative.

The two  $100\text{-}\mu\text{mf}$  capacitors and the 47,000-ohm resistor in the secondary circuit of the second a-m i-f transformer serve as an i-f filter. The output signal from this filter is audio and is applied to the volume and tone control circuits of the receiver through the a-m section of the switch. This output signal from the i-f filter is used as an AVC source for a-m. The AVC voltage for the necessary circuits is obtained after the audio signal is properly filtered in the customary manner.



**PART II**  
**FUNDAMENTAL TROUBLESHOOTING**





## CHAPTER 3

### FUNDAMENTAL TROUBLESHOOTING SYSTEMS

#### 3-1. Troubleshooting Systems

In troubleshooting a receiver, it may often appear outwardly that we are jumping rather haphazardly from one operation to another. However, we know that, if we are to be most efficient, we must follow certain orderly lines of thought as well as lines of action. To the inexperienced observer, the integrated plan in our procedures may not be apparent, because we have learned to eliminate all measures that do not apply to the case at hand. But we have first thought about each measure in a line of orderly troubleshooting procedure.

There are several fundamental systems for troubleshooting, which are based on slightly different philosophies of approach. Although each system has enthusiasts who favor that one system above the others, the wise technician is prepared to make use of *any and all systems*, whenever they can help him to find the source of trouble. Accordingly, we shall, in this chapter, consider preliminary tests and observations, static tests, signal tracing and signal injection, and the use of the oscilloscope, each in its proper perspective. We shall then have something to say about using each in its proper place and combining the systems for any given troubleshooting problem, whenever this is desirable.

#### 3-2. Importance of Service Data

The nature of circuitry, variety of parts, etc. have become so extensive for modern receivers that even the most experienced technician cannot know the details and wiring arrangements for most of the receivers he is called upon to service. But he can frequently save much time and expense in troubleshooting by having available complete servicing data, so that he will immediately "know his way around," even if he has never before seen the particular type of receiver. Such data should include a schematic diagram, parts list, tube layout diagrams, circuit description, alignment information, voltage and resistance charts.

These data are available for most receiver types from the manufacturer. However, since there are so many manufacturers and so many

## FUNDAMENTAL TROUBLESHOOTING

models, it would be highly inconvenient for the technician to attempt to keep up to date receiver-by-receiver. There is a source of complete information from which the technician can obtain this information in complete, compiled form. This source is John F. Rider, Publisher, 480 Canal Street, New York City, who publishes the famous *Rider Manuals*. These manuals contain service information about practically every receiver manufactured. Particularly timely service data are available in the various technical servicing magazines.

### 3-3. Quick Preliminary Tests

The service man would be missing a good bet for the quick finding of receiver trouble if he did not follow certain preliminary procedures before actually getting out his instruments and starting extended tests and measurements.

One very important way to determine the exact nature of the trouble is by entering into conversation with the owner of the receiver. Often, by so doing, he can tie down exactly what the complaint is. Information supplied by the owner can be instrumental in a quick, on-the-spot discovery of the trouble source, or may at least be helpful in later tests.

When friendly but pointed questions have extracted all possible information about the complaint, the technician should make his own preliminary observations. Here are a number of things he can check quite quickly:

1. *Is the owner expecting too much from his receiver in its present location?* For instance, is he expecting high fidelity from a midget receiver with a three-inch speaker? Is he expecting high-quality f-m reception with limited antenna facilities from stations over 100 miles away? Is his trouble night-time loss of selectivity on a broad t-r-f receiver? Is he located in some hopeless noise area, where man-made noise sources are all about him? In all these cases, the receiver may be operating as well as it ever did or should; but the owner may not realize this, and it must be explained to him.
2. *Is there some obvious electrical or mechanical difficulty?* For example, noisy and erratic volume controls are frequently encountered and can be easily detected almost immediately. Often, components which have burned out leave evidence of charring and smell, leading directly to the trouble or the general area of the trouble. Then, too, among the obvious indications, there is always the single tube which does not light. Broken dial mechanisms, dial cords, and other controls are usually quite obvious to the technician who is alert for them.

## FUNDAMENTAL TROUBLESHOOTING SYSTEMS

By this time the technician will have placed the receiver trouble in one of the symptom categories which make up the later chapters of this book—namely, *Undesired Signals*, *Weak Signals*, *Distortion*, *Noise*, and *Dead Receiver*. The preliminary observations are important if only to start our thinking along one of these lines.

Thus, preliminary observations can usually provide one or more of the following benefits before the receiver has even been moved from the owner's home:

1. Make sure the complaint to be remedied is the one the customer has in mind, and that its nature is clear.
2. Provide a clue which leads to direct discovery of the trouble source on the spot.
3. Provide indirect clues which categorize the type of trouble, suggest first courses of action, and general method of attack in later static or dynamic tests.

### **3-4. Troubleshooting Equipment**

Certain basic types of equipment are essential to proper troubleshooting. Of course, it would be nice if we all had all the equipment available on the market to make just the right test on any receiver trouble which presented itself. Obviously, this is not economically feasible, and it is good sense to limit our equipment to those units which will provide the greatest return per dollar.

Certainly, a good volt-ohm-milliammeter and/or vacuum-tube-voltmeter and a good test-signal source are *musts* for every service technician. What additional units he may acquire depends on such things as his personal tastes and abilities, the volume of his business (actual or prospective), and the nature of the receivers and equipment he will most frequently be called upon to service. In the following pages, we shall refer to a number of test instruments that are appropriate to the troubleshooting operations being described. The technician does not need *all* these instruments, but he can see to what uses each instrument can be put and can then decide for himself the specific equipment he needs.

### **3-5. Static Tests**

We shall define *static tests* as those which do not require an external input signal to the receiver. Primarily, these tests include resistance (or continuity) and voltage measurements: they also may include capacitance and current measurements, and measurement of resonant frequency with a grid-dip oscillator. Measurement of inductance with an inductance bridge is occasionally desirable.

## FUNDAMENTAL TROUBLESHOOTING

Tube checking is definitely a static test. It will be assumed that the technician has available some kind of tube tester, so that obviously defective tubes can be spotted as a routine operation.

Fundamentally, static tests may be divided into two main groups: those which require no power applied to the receiver from either batteries or a-c line, and those which do require such power. The first group includes resistance, (continuity), capacitance, inductance, and resonant frequency tests. The second includes voltage, current, and power tests.

Whether power-off or power-on tests are to be used in a particular instance depends on the type of trouble, type of receiver, and other factors. In most cases, a combination of the two kinds of tests is most productive. In any event, for the sake of orderly presentation, they must be discussed separately here.

### **3-6. Resistance Measurements**

In troubleshooting by resistance measurements all tests are made with the a-c power off. We use one instrument almost exclusively—the ohmmeter. It may be a separate instrument, part of a volt-ohm-milliammeter, or part of an electronic volt-ohmmeter. All these instruments in their modern form are capable of resistance measurements suitable for troubleshooting requirements; the electronic type is better for very high resistances (hundreds of megohms) but has the disadvantage of requiring power from the a-c line.

Fortunately, accuracy is not much of a problem, since seldom is a reading closer than  $\pm 20$  percent required, and many are more of the nature of continuity tests, simply indicating whether or not there is a complete circuit.

We must first realize that the modern radio receiver is full of devices having resistance values. If we were confined in resistance-measurement troubleshooting merely to checking resistors, this test would not be nearly as effective as it is. Transformer windings, tuning coils, choke coils, loudspeaker field coils and voice coils, and other components have their own resistance values; they combine in a receiver to produce combination resistance values at various points with respect to ground or between points in the circuit. The resistances of the individual components may be combined in the circuit in series, in parallel, or in series-parallel combinations. The technician must therefore be familiar with series, parallel, and series-parallel circuits if he is to recognize the interrelation of the various resistance values.

The principle underlying the validity of the resistance-measurement troubleshooting method is the fact that, when components fail, they

## FUNDAMENTAL TROUBLESHOOTING SYSTEMS

nearly always change their resistance. When a resistance check shows that the resistance of a circuit is not what it should be, we know that there is trouble in that particular circuit.

But, you may ask, how do we know what the resistance should be? The answer is that the resistors are usually marked by color code. But what about the other components? And, must one sit down and wade through groups of resistors just to see what the total resistance at a given point, with respect to ground or to some other point *should* be? Of course not; otherwise, resistance measurement for troubleshooting would have been given up long ago! This is where the importance of servicing data comes in.

In servicing information issued by receiver manufacturers, and in the Rider Manuals, a *resistance chart* for each receiver is often included. This chart indicates the proper resistance between each tube pin and ground or B—. To make a resistance analysis of a defective receiver, we simply place one lead of our ohmmeter on ground. We then touch the other lead successively to the socket terminals for each tube, comparing the resistance readings obtained with those indicated in the manufacturer's resistance chart. When we encounter a resistance value that is substantially different from the one specified, we realize there must be trouble in the circuit associated with that terminal. We then consult our schematic diagram to see what components are connected in the path between this point and ground, and check each individually.

Of course, there are many *standard* resistance checks which apply equally well to most receivers. Some of these are:

1. *Resistance across a-c plug.* (After removal from the power socket, of course!) In straight a-c receivers, in which there is a power transformer, we would be testing the resistance of the power cord, plus the primary winding of the power transformer, provided the receiver "on-off" switch is in the "on" position. These resistances are low, and the reading across the plug is normally from 3 to 7 ohms if there are no defects. If the switch is in the "on" position and there is no continuity indication, then the line cord, the switch, the transformer winding, and fuses (if any) are individually checked for continuity until the defective component is found.

In an a-c/d-c or other transformerless receiver, the line-plug resistance is the sum of the resistance of the tube heaters, which are connected across it.

2. *Resistance from B+ to ground.* This test is very dependable for checking for burned-out filter capacitors or by-pass capacitors in the plate and screen circuits. We know that if the resistance between B+ and

## FUNDAMENTAL TROUBLESHOOTING

ground is very much less than about 10,000 ohms, the power supply will be overloaded, and we must check along the plate and screen supply leads for our trouble. In most cases of capacitor failure, the resistance will drop to a low value except when the defective capacitor is connected with a resistor between it and the power supply, as is frequently the case with screen-grid by-pass capacitors. In some cases, especially where electrolytic types are involved, a defective capacitor may not show a short circuit until voltage is applied; in this event, resistance measurement fails.

3. *Resistance across transformer windings.* No transformer can operate properly unless both its primary and secondary windings show proper continuity.
4. *Resistance across loudspeaker field coils and voice coils.* A loudspeaker of the electrodynamic type cannot operate properly unless its field coil is continuous. Series-field coils run from 50 ohms to about 1000 ohms. Shunt-field coils connected from B+ to B- (now seldom used) average 10,000 or 20,000 ohms. Voice coils of loudspeakers have a very low resistance, usually several ohms, and must be disconnected from the secondary winding of the output transformer to be checked.

In stating the proper resistance values, manufacturers also frequently specify how the controls of the receiver should be set during resistance measurements. This is important because volume controls and tone controls can often affect the resistance readings in various parts of the circuit. Also frequently specified are position of the band-switch (if any), position of radio-phone switch, and of any other controls the receiver may contain. The technician should remember to observe all these conditions in order to obtain useful readings.

Although a capacitor in good condition should show an open circuit, the instantaneous rush of current from the ohmmeter into the capacitor is a good indication of its capacitance, even if it is not short-circuited. Thus, the instant the ohmmeter leads are touched across the capacitor, the meter needle jumps suddenly to what appears to be a low resistance, then somewhat more slowly returns to "open-circuit" or "infinite-resistance" position. The amount of "jump" and its rapidity have long served as a rough indication to servicemen of the capacitance and condition of a capacitor.

When measuring resistance in circuits that contain electrolytic capacitors and high-value resistors, the recovery of the meter needle from its jump may take as much as a minute if high-impedance electronic ohmmeters are used. Care should be used in making such readings, lest the first jump be incorrectly taken as an indication of low resistance or

## FUNDAMENTAL TROUBLESHOOTING SYSTEMS

short circuit; always wait a moment to make sure whether the meter needle is moving back.

### 3-7. Voltage Measurements

Perhaps even more basic than resistance measurement is voltage measurement. It is very effective in all circuits except those which require a signal to operate, such as diode detectors and AVC circuits.

In par. 3-6 it was pointed out that manufacturers sometimes provide information about the resistance which should be expected from each socket terminal to ground. Even more frequently, a *voltage chart* is included with service information. This chart lists the *voltages* to be expected between each socket terminal and ground (or B-). These measurements may appear at the tube pins on the schematic diagram or on a separate bottom view of the chassis, depending on how the manufacturer prepares his data.

The philosophy behind the voltage method of troubleshooting is similar to that for resistance measurement—namely, that when there is a defect in the receiver, it will show up, in a large number of cases, as an abnormal voltage or as no voltage at all at some point or points in the circuit. Of course, this is true of both signal voltages and power voltages; however, we are concerned here with *power voltages*, as long as we talk about *static* tests. Signal voltages are discussed under signal tracing and signal injection.

Let us review some of the useful voltage tests we can make in troubleshooting a receiver. In our review, we shall use a skeletonized schematic diagram of a typical a-m broadcast receiver (Fig. 3-1), showing the power circuits and the important troubleshooting voltage-measurement points. Where our voltage measurements should start depends a good deal on the type of trouble symptom, and more will be said about this in chapters on trouble symptoms. However, let us outline the *general* approach, suitable for the majority of receivers.

Voltages normally are measured with the tubes *in the receiver*. The voltage distribution through the receiver depends on proper currents flowing through the tubes as well as through the other components in the receiver. Usually, it will be necessary to remove the chassis from the cabinet and make measurements from the underside of the chassis. However, the physical layout of the receiver sometimes is such that some voltage checks can be made by lifting the tubes slightly out of the socket, so that the test probe from the meter can be touched against the desired tube pin. We will assume the technician will use his ingenuity in making the necessary readings in the most convenient and rapid manner.

## FUNDAMENTAL TROUBLESHOOTING

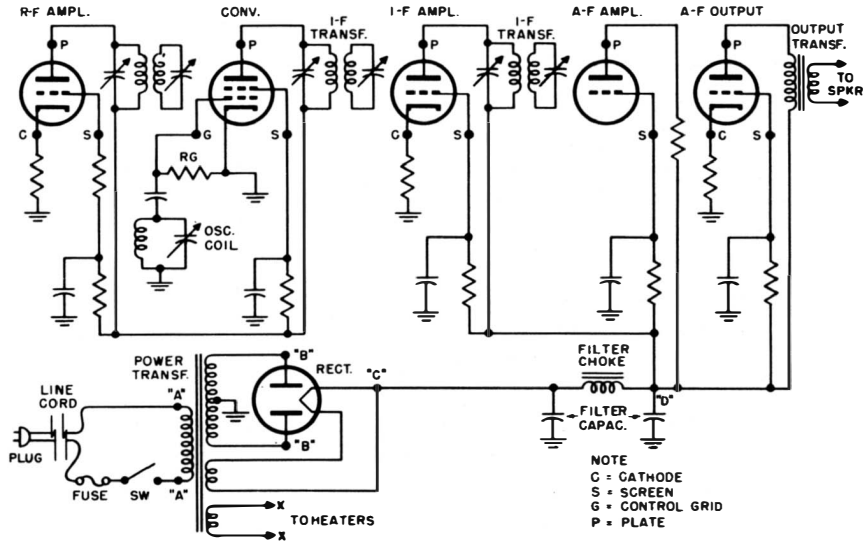

Fig. 3-1. Skeleton circuit of a-m broadcast receiver showing the various points at which voltage measurements are made in troubleshooting.

Now let us trace through the voltage readings as they appear in Fig. 3-1.

1. Between points marked "A," we set our meter for a-c and test for power line voltage. This checks continuity through the power cord, the fuse, and the switch (which, of course, must be "on").
2. With the meter still set for a-c, we can check between each of the points marked "B" and ground, thus checking the voltage on each side of the center tap of the secondary winding of the power transformer. Such a test should be made with great care, because the peak voltage across each half of the secondary often runs as high as 400 volts or more, while the total voltage between points "B" may approach a peak of 1000 volts.
3. The a-c voltage across the filament and heater secondaries can be checked, but remember that the rectifier filament winding is hot with the B+ voltage!
4. We have now checked everything through the power transformer. We can now set the meter for d-c and check the B+ voltage from the rectifier at point "C." The common lead of the meter is connected to the chassis (or to B- if the power supply is floating). If there is a



## FUNDAMENTAL TROUBLESHOOTING SYSTEMS

short circuit or excessive load in the  $B+$  circuit, the meter will read lower than normal, and the rectifier will tend to run hot.

5. We may now wish to proceed with a pin-by-pin tube check. It is probably more convenient to check all plate and screen voltages first, then cathode voltages and oscillator grid voltage, rather than going completely through each tube at a time. In Fig. 3-1, we have labeled plate-voltage test points "P" and screen-voltage test points "S." If plate voltage seems to be lacking on all tubes, we should check point "D"; perhaps the filter choke is burned out and voltage from point "C" is not reaching point "D."
6. A rather important reading is that of the oscillator grid voltage. The oscillator cannot oscillate without the flow of rectified grid current. This current develops a voltage drop across grid resistor  $R_g$ , which is the bias. Thus, if there is oscillation, it can be detected as a *negative* d-c voltage between point "G" and ground. The measurement is preferably made with a vacuum-tube voltmeter, but a meter with a 20,000-ohms-per-volt sensitivity is satisfactory.

The following tabulation gives the average d-c voltage developed across the oscillator grid leak in representative modern all-wave and broadcast-band receivers at various operating frequencies. The tabulated voltages are measured with a vacuum-tube voltmeter and an isolating probe.

These are average values in typical receivers; variations of 50 per cent are likely to be encountered in other receivers, due to differing design characteristics. Normal variations in tube characteristics will likewise affect the resulting oscillator d-c voltage.

### *A-C/D-C Superheterodynes*

	<i>Dial frequency (in kc)</i>				
	600	1000	1400	6000	18,000
	$E_{osc}$ (d-c volts)				
11	11.5	13	10.5	5.8	

### *A-C Superheterodynes*

	$E_{osc}$ (d-c volts)				
19	19	19	12	14	

### *Automobile Superheterodynes*

	$E_{osc}$ (d-c volts)		
19	18	19	

7. Also important are cathode voltages, wherever a cathode resistor is used. In Fig. 3-1, we have marked the cathode voltage test points "C."

## FUNDAMENTAL TROUBLESHOOTING

Ordinarily, the converter and detector-first a-f amplifier tubes have their cathodes grounded, so there will be no voltage between cathode and ground to read.

Some technicians prefer to make all their plate voltage readings *between plate and cathode* terminals on the tube. In this way, the completeness of the plate current circuit is checked all at once, including the plate-to-power supply and cathode-to-ground circuits. The same thing can be done when measuring screen voltages. Of course, this method cannot check variations in bias due to change in resistance value of a cathode resistor. For this the cathode voltage must be checked alone.

It can probably be said that, after a complete tube check, the preceding resistance and voltage checks will uncover trouble in about 75 per cent of all defective receivers. They fail only when there are troubles which affect only *signals* and not power voltages; in such cases, either signal-tracing or signal injection is required. But even then, final checks of suspected components must be made with static tests.

### **3-8. Capacitance, Inductance, and Resonance Measurements**

Capacitance, inductance, and resonance frequency measurements are useful mainly after the troubleshooting procedures have isolated the trouble to one particular section of the receiver. For example: after we have found by preliminary readings that the oscillator is not functioning, we may be interested in knowing whether the grid coupling capacitor is good and its capacitance approximately correct.

Several good capacitance-measuring instruments are available on the market. These indicate not only the capacitance value, but also the *power factor*, which is a criterion of the quality of the capacitor and whether or not it has a tendency toward leakage. A number of devices are available for checking the operation of an electrolytic capacitor when rated d-c voltage is applied.

Inductance values can be read by means of an *inductance bridge*; but such checks are rarely made in regular service work, except for cases in which the filter choke may be suspected of being defective. Resonance measurements can be made by means of a *grid-dip meter*. However, this instrument is useful only for f-m receivers, since the frequency range of most of the meters available is limited to a range over 2 mc.

### **3-9. Current Readings**

In the early days of radio servicing, current readings were frequently made, and *set testers* were quite popular. These included a cable and

## FUNDAMENTAL TROUBLESHOOTING SYSTEMS

plug for each tube; the plug would be inserted in each socket in the receiver, and the tubes from the receiver would be placed in the set tester. Appropriate current and other readings would then be made. However, because of the length of the leads and the resulting inductance and capacitance introduced, such an arrangement is no longer practical in servicing modern receivers. Although current readings can still tell us much about a receiver, the fact that the circuit must be broken makes them impractical.

### **3-10. Advantages of Signal Tracing**

What do we mean when we speak of signal-tracing in connection with servicing receivers? Basically, it is a means of locating a defect by observing the performance of the receiver upon a test signal fed into the antenna input system of the receiver. To accomplish this end, signal tracing calls for observation of the presence, absence, and character of the test signal at key points of the receiver system. Supplementing this test is measurement of those control voltages which are in any way associated with the signal. Final conclusions are reached by measurement of the operating voltages in those circuits where the signal-tracing process has localized the fault.

The signal test is considered the primary, or fundamental, test. The secondary tests are those associated with the various voltages already mentioned. Of these two voltages, control and operating, the first is considered to be the more important, although both are placed in the same category. As a follow-up of the voltage tests, we also employ, when necessary, a d-c resistance test. However, the d-c resistance test is not always employed after the voltage test. If the results of the signal-tracing test localize the defect as being in a certain component, it is possible to dispense with the voltage test and to apply the d-c resistance test to the component in question. Thus, the actual routine subsequent to the signal-tracing test depends entirely on existing conditions.

The sequence of testing, expressed in its simplest terms, is as follows: The test signal is traced through the receiver until some point is reached where it is no longer normal. Then, supplementary tests are made at that point where the signal departs from normal, or in that portion of the system that is related to the particular section of the receiver where the signal first departs from normal. Signal tracing, therefore, becomes a *functional test* (1) of a complete receiver, (2) of complete sections of a receiver, and (3) of the individual components of a receiver—*all with respect to the signal*.

## FUNDAMENTAL TROUBLESHOOTING

The first major advantage of signal tracing is that the receiver being tested is checked in actual operation or, at least, under operating conditions. This is of tremendous importance because many defects manifest themselves only when the system is in an operative state. The state of operation may not be productive of a normal signal because of the defect; but in order to be able to locate the defect, it is necessary that the receiver power be "on."

Another extremely important advantage of the signal-tracing method of trouble localization over other methods is its complete freedom from limitations due to circuit design. This is a broad statement to make, but it is a fact nevertheless—a fact proved by actual practical experience in various radio fields.

### **3-11. Preliminary Tests**

Before we proceed with our signal-tracing tests, we must make certain that the receiver is in condition for testing. Obviously, if there is a major short circuit or an open circuit in the power supply system, the voltages on all tubes will be seriously altered or totally absent. Under such conditions, attempting to operate the receiver while making signal-tracing tests may result in damage to some components which have not already been affected.

A preliminary test of the power consumption of the receiver will immediately reveal any serious condition of this type. This need not be a precision measurement of the wattage consumed by the receiver; if any major short or open circuit exists in the power supply, the power consumption will be far above or below normal. Small variations from normal do not concern us, since they do not interfere with the signal-tracing procedure.

The power consumption test may be made with a wattmeter or wattage indicator. To avoid damage to the wattmeter due to overload, the power supply of any receiver in which the power transformer overheats should be immediately checked for short-circuits *before* a power consumption test is attempted. Naturally, no power check of a receiver that causes line fuses to blow need be made. The presence of a short is apparent.

The power test may also be made by a current-measurement method, which may be interpreted in terms of watts by calibrating the instrument on a basis of the average power factor encountered in radio power transformers. This method has the advantage of speed, convenience, and a safety factor which eliminates any possibility of damage through accidental overload in normal use.

## FUNDAMENTAL TROUBLESHOOTING SYSTEMS

### 3-12. Signal Source for Signal Tracing

A good test oscillator (signal generator) will be needed for most signal-tracing tests. Such an instrument provides a signal which can be controlled as to strength and frequency and also permits a steady modulating voltage. However, in making aural observations of distortion in receiver circuits, a broadcast signal is preferable because it is easier to note distortion in music or speech than on the single-tone modulation universally used with test oscillators.

In using an oscillograph for testing distortion visually, the single-tone signal is necessary, since the departure from a pure tone is readily noted on the oscillograph screen while a varying complex tone would be impossible to check. For gain-per-stage measurements in audio-frequency circuits, a steady modulation or separate a-f oscillator is essential.

In checking for noise, hum, oscillation, and other troubles which are present when no signal is being fed to the receiver, the noise, hum, or oscillation itself constitutes the signal and is traced in the same manner. In such cases, you do not need an external signal source.

The test-signal frequency should be adjusted to some point near the low-frequency end of the standard broadcast band, such as 600 kc. If some local broadcast signal causes interference when the test oscillator is connected to the receiver and the set is tuned to 600 kc, then the test oscillator may be readjusted to a point either higher or lower in frequency, where no interference occurs.

In an f-m receiver, the signal source must be adjustable for carrier frequencies within the 88-108 mc f-m broadcast band. For all except a-f section testing, it is not necessary to use a frequency-modulated signal. An unmodulated carrier can be traced with suitable instruments right up to the ratio detector; or, if a phase discriminator is used, it can be detected in the output circuit of the discriminator as a d-c voltage. For determining whether the a-f amplifier section is functioning, an a-m signal from a test oscillator or signal generator can be fed from the antenna circuit right through the receiver, since sufficient audio will come through for a qualitative test. As with the a-m receiver, an actual received broadcast signal is the best check for distortion.

It is apparent that, for the purpose of trouble localization, a signal-tracing test at a frequency within the standard broadcast band is applicable even to an all-wave receiver. If the trouble is common to all bands, then it may be localized by testing on the standard broadcast band. If the trouble is present only on a short-wave band, then it must be due to some defect in the r-f, mixer, or oscillator sections, since all other sections of the receiver function the same on all bands. The oscillator and mixer

## FUNDAMENTAL TROUBLESHOOTING

sections may be separately checked, thus narrowing the search for the defective component to the few remaining parts in the r-f section.

A test-signal frequency of 600 kc is chosen because the gang-condenser tuning capacity will be high at this frequency and the slight additional capacity which is added when a test probe is connected to the circuit will cause negligible detuning effect.

### 3-13. Tracing Instruments

We shall from time to time illustrate the points being discussed by references to the *Rider Chanalyst*. This is not to say that the Rider Chanalyst is the only signal-tracing instrument, but rather, it is a natural consequence of the fact that the Chanalyst was the pioneer signal-tracing instrument to which other commercial instruments owe their existence. It was not until the Rider Chanalyst had demonstrated conclusively the advantages of signal tracing that other instruments made their appearance. Of course, these instruments are not identical with the Chanalyst and it is not our purpose here to show all the variations possible in signal tracing instruments. For just as there are many receivers, ranging all the way from cheap midgets to high-fidelity receivers, so are there many signal-tracing instruments. With all these variations we are not concerned, but we do want to discuss the fundamental requirements of signal-tracing instruments.

In applying signal-tracing methods, we have seen that it must be possible to check the signal at every point in the receiver, starting at the antenna and following right through to the voice coil. Since the natural starting point of the signal is in the r-f section of the receiver, it is logical for you to ask about the instrument used for tracing the signal in this part of the receiver. What type of instrument is required for this purpose?

Essentially, of course, the radio-frequency part of our signal-tracing instrument, which for convenience we shall call the *r-f/i-f channel*, must be a vacuum-tube voltmeter of some kind. It must have sensitivity enough to pick up the signal right from the antenna coil, where the signal level is measured in microvolts. But it cannot be a vacuum-tube voltmeter of conventional design, because such voltmeters do not have sufficient sensitivity, and, in addition, place too great a load upon the circuit being checked. Both these difficulties are eliminated by using a tuned amplifier type of vacuum-tube voltmeter with a special test probe. The r-f/i-f channel in the Rider Chanalyst employs such an arrangement, and its advantages will be clear from the description given here.

Let us start with the input circuit to the channel used for checking r-f signals. Of the greatest importance is the probe which connects the

## FUNDAMENTAL TROUBLESHOOTING SYSTEMS

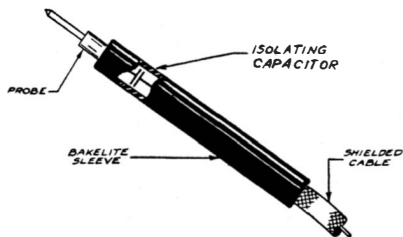

Fig. 3-2. The special test probe at the right makes it possible to measure r-f voltages without detuning the circuit. The cable and input capacity are isolated by means of the air-gap capacitor near the probe tip.

instrument to the receiver under test. As Fig. 3-2 shows, this probe is of special design and construction so as to minimize reaction on the receiver under test. Referring to the illustration, you will observe that the probe point is not connected directly to the shielded conductor but instead a small air gap isolates the probe point from the conductor. Effectively, this means that the probe point is joined to the instrument through a small capacitor, the value of which is regulated by the size of the air gap. In the Rider Chanalyst, this air gap forms a capacitor of about  $1.5 \mu\mu\text{f}$  capacity. Now, since this air gap is close to the point at which the probe is touched to the receiver under test, it means that the capacity shunted across the test point is less than  $2 \mu\mu\text{f}$ .

In a real sense, the entire procedure of signal tracing depends on the probe arrangement we have just described. By means of this special probe, we can connect directly across tuned circuits to the controlled grid and plate of tubes—in fact, to any point where there is an r-f or i-f signal—and measure the signal voltage without any appreciable detuning or loading of the circuit. At the same time, it is possible for us to use a shielded flexible cable of convenient dimensions to connect the probe

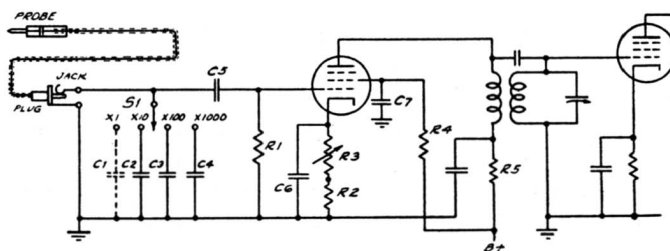

Fig. 3-3. The input circuit of an amplifier suitable for signal-tracing measurements. The multiplier switch S1 and the control R3 make it possible to compare signal levels at different points in the receiver under test.

## FUNDAMENTAL TROUBLESHOOTING

to the input of the instrument. Of course, the air gap prevents this cable capacity and the input capacity of the instrument from appearing between the test point and ground.

As mentioned earlier, a tuned amplifier must be used to obtain the sensitivity required in r-f signal tracing, as well as to supply the selectivity necessary to distinguish among signals of different frequency which are often present at the same point. The input circuit of such an amplifier is shown in Fig. 3-3. The shielded cable is plugged into a jack on the instrument panel which connects through C5 to the grid of the first amplifier tube. By means of the switch S1, it is possible to select any one of four values of capacity which shunt the grid to ground.

Each of these capacitors forms a capacity divider in conjunction with the small isolating capacitor formed by the air gap in the probe. Thus, when the switch is in the X1 position, one-hundredth of the signal present at the probe point is applied to the input grid. This, of course, is because the capacity of C1 is 100 times as great as the probe capacity of 1.5  $\mu\mu\text{f}$ . C1 is shown dotted because it is not made up of an actual capacitor but consists of the capacity of the shielded cable, the switch, the tube, and the wiring. In the X10 position, a similar action takes place. Here the capacity of C2 is made 1,000 times as great as the probe capacity so that only one-thousandth of the signal reaches the input grid. Similarly, C3 and C4 are made progressively larger to provide additional attenuation so that, in all, the switch S1 supplies multiplier values of 1, 10, 100, and 1000. Thus, it provides us with a simple means for determining the relative strength of signals.

S1 provides us with a means for determining the relative strength of signals in steps of ten. To obtain a continuous attenuation over a range of ten to one, the circuit in Fig. 3-3 is provided with a cathode rheostat R3 which varies the gain of the stage over a 10-to-1 range. In conjunction with S1, R3 enables us to obtain continuous attenuation over a range of 10,000. This has been found to be sufficient to handle the problems which occur in the course of signal tracing.

We need not discuss in detail the three-stage tuned r-f amplifier that follows the input circuit. In many respects, it is similar to a modern tuned r-f receiver, except that special attention is given to securing a flat response over the complete tuning range. In the Rider Chanalyst, special transformers with the primaries resonated below the low-frequency end of the band are used in order to obtain a flat response.

The detector circuit used following the amplifier is a diode rectifier. The output of this circuit is arranged so that it controls a 6E5 electron-ray indicator tube which is used to supply a reference output level cor-



## FUNDAMENTAL TROUBLESHOOTING SYSTEMS

responding to the signal required to close the shadow completely. At the same time, provision is made in the output for connecting headphones so as to listen to the signal, or an oscilloscope so as to be able to view the waveform. For practically all purposes, as we have previously seen, the check of output level provided by the 6E5, or the check of quality made by listening to the signal, is sufficient.

The quality of the signal, whether noise is present, etc., can conveniently be determined by using a pair of crystal phones across the diode load to listen to the signal. Where a visual check is desired, the waveform can be examined by plugging an oscilloscope into the jack to connect its input across the diode load. In this way, the r-f amplifier in the signal-tracing instrument supplements the oscilloscope by providing the necessary r-f gain. Since the oscilloscope amplifiers do not function at radio frequencies, the sensitivity of the oscilloscope is, of course, not great enough to permit connecting it directly to the receiver. In fact, even where the oscilloscope has a wide-band amplifier, the input capacitance is ordinarily of the order of 30  $\mu\mu\text{f}$  or more so that it cannot be connected directly across a tuned circuit.

Signal tracing in a-f circuits is very much simpler than signal tracing in r-f circuits, and so also, are the instruments required. One of the earliest instruments for signal tracing in a-f circuits was a set of headphones. All technicians have used this crude form of a-f signal tracing at one time or another and are therefore familiar with its limitations. In the first place, high-impedance circuits often encountered are loaded excessively by the phones, so that it is difficult to determine just what is taking place in the circuit. A second disadvantage of the headphones is that it is difficult to determine approximately how much step-up in signal is obtained as the signal is traced through successive stages.

Both these disadvantages can be removed by using a single stage of a-f amplification. Because of the high input resistance of the vacuum tube, the loading of the circuit being checked is minimized. It is, of course, desirable to use a shielded cable and probe; but no special isolating arrangement need be used because the input capacity is not important at audio frequencies. As far as the check of relative signal strengths is concerned, a calibrated potentiometer can be used in the input or cathode circuit of the a-f stage. This, in conjunction with a simple multiplier switch, can easily be arranged to check signals ranging from less than 0.1 volt to 200 volts.

In the output circuit of the single-stage amplifier, a diode rectifier circuit feeding a 6E5 can be arranged to serve as a reference indicator. This is similar to the arrangement used in the case of the r-f/i-f channel

## FUNDAMENTAL TROUBLESHOOTING

and no further discussion is required. Provision for listening to the signal is desirable and a jack across the output should be provided for this purpose. Unlike r-f measurements, a-f signal-tracing can be conducted directly with the oscilloscope, since the internal amplifiers provide sufficient sensitivity for checking the signal even in the low-level stages. However, for rapid work and for tracing noise, it is very convenient to use the headphones in the output jack of the a-f stage.

Where the frequency of the oscillator is within the range of the r-f/i-f channel, this section of the signal-tracing instrument can be used to check the oscillator voltage. To avoid reaction or loading of the oscillator circuit, the special test probe containing an isolating capacitor is used; this is the same probe illustrated in Fig. 3-2. The reaction on the circuit can be reduced to considerably less than  $1 \mu\mu\text{f}$  by holding the probe close to, but not in contact with, the high side of the oscillator section of the tuning capacitor; any other appropriate point in the oscillator circuit instead of the capacitor can, of course, be selected.

Tracing instruments for troubleshooting f-m receivers have generally the same requirements as those for a-m receivers, plus the added factor of high frequency, which makes problems of *probe loading* more severe.

A popular instrument for both signal measurement and signal tracing at high frequencies (for both f-m and t-v receivers) is the *crystal probe*. This probe has a germanium or silicon detector built into it, plus a by-pass capacitor and load resistor. Since rectification of the traced signal takes place very close to the point of the probe, loading effects are minimized.

A typical crystal probe circuit is shown in Fig. 3-4. When the pointer end of the probe is touched against a source of modulated r-f carrier (or coupled to it), the signal is demodulated and the modulation signal alone is delivered to the probe output circuit. This output circuit is usually connected to a coaxial lead, which delivers it to the remainder of the tracing equipment.

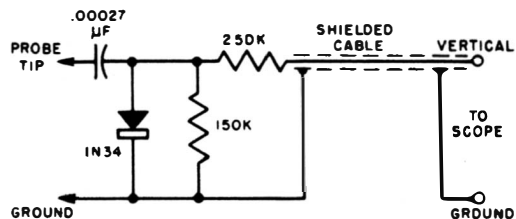

Fig. 3-4. Typical crystal probe circuit for signal tracing.

## FUNDAMENTAL TROUBLESHOOTING SYSTEMS

The output of the probe can be used in any several ways. First, it can be applied to a high-gain a-f amplifier. Any audible amplitude modulation in the original signal is then heard from a loudspeaker or headphones at the output of the high-gain a-f amplifier. Or, it can be applied to the vertical amplifier of an oscilloscope, so that the modulation waveform can be examined on the screen of the scope.

### 3-14. Signal Injection

As has been mentioned, signal tracing is not the only method in which *signals* are used for troubleshooting. Another equally important method is known as *signal injection*. Signal tracing and signal injection are sometimes grouped together under the general heading "Dynamic troubleshooting."

The difference between signal tracing and signal injection is illustrated in Fig. 3-5. In the signal-tracing method, we apply a signal to the receiver or we use a received signal. In either case, the point of applica-

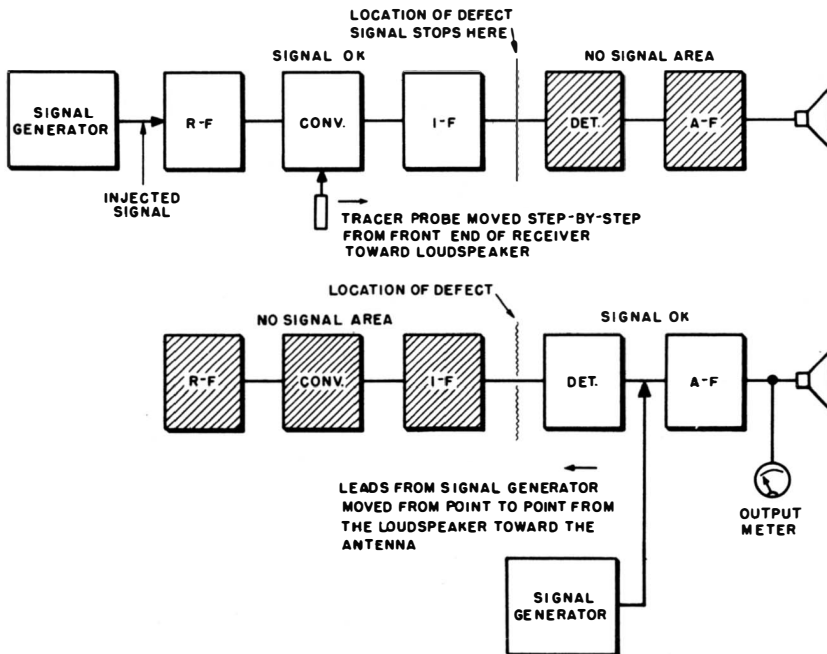

Fig. 3-5. Diagrams showing the difference between signal tracing and signal injection.

## FUNDAMENTAL. TROUBLESHOOTING

tion of the signal in signal tracing usually remains fixed (antenna circuit) while the tracing instrument is moved through the circuit from the antenna toward the loudspeaker until the signal either stops or becomes abnormal.

In signal injection, the signal indicator is ordinarily the receiver's loudspeaker or an added output meter. This indicator remains fixed in the output circuit of the receiver, while the source of signal is moved from the output circuit back toward the antenna circuit. When the output signal ceases, the signal source has passed the trouble location.

As is true with signal tracing, signal injection requires that the basic power supply system be functioning. For example, if a filter capacitor is defective and there is no B+, then a signal cannot be passed through any part of the receiver, and both tracing and injection are impractical. The trouble must then be detected by preliminary tests in which filament (heater), plate, and screen voltages, and perhaps also tubes, are checked before dynamic analysis is attempted.

Signal injection has one important advantage as a *qualitative* analysis, and that is the fact that the loudspeaker of the receiver itself can be used as the indicator. Balancing this advantage is the fact that three different types of signal must be available for a complete analysis. First, we start with an a-f signal, which we apply to the primary or secondary winding of the output transformer, to check the condition of the loudspeaker. If we hear the a-f tone, the speaker is operating. Then we move back with our signal source to the grid of the output tube. We use an a-f signal back into the detector, each time listening for the tone from the speaker. Each time we hear the tone, we know that the portion of the circuit between the signal source and the speaker is operative.

When we pass through the detector, we must change to an i-f signal. We use the i-f signal back into the converter (or mixer) and must then change to an r-f signal. Actually, we can get along without the a-f signal, since failure of output from the speaker when an i-f signal is applied to the detector input circuit narrows trouble to the detector and a-f amplifier sections, while the a-f amplifier can be checked by placing the finger on the grid of the first a-f amplifier tube and listening for the characteristic howl or hum which indicates proper operation.

Exactly the same principles are applied in signal injection in f-m receivers. The signal source must, of course, be adjustable to some frequency in the 88-108 mc-band and to the standard intermediate frequency of 10.7 mc (or, for some receivers, 8.3 mc). As was previously mentioned, in spite of limiting action, useful signal can usually be obtained throughout the receiver circuit with an amplitude-modulated signal.

## FUNDAMENTAL TROUBLESHOOTING SYSTEMS

### 3-15. Gain Measurements in Troubleshooting

So far we have discussed dynamic analysis in a *qualitative* sense; that is tests as to whether or not a signal will pass through a receiver or a receiver section. When the trouble is a weak signal, and sometimes with other troubles, it is important to know the degree to which a signal is being passed through a section—in other words, the *gain* of the section. This is important especially in those cases in which no component has completely failed, but some may have deteriorated, or in which alignment or other adjustments are not proper. Signals become weak, but do not stop entirely. By determining the stage or stages in which the gain is lower than it should be, we localize such troubles.

What is *gain*? It is simply the ratio of the *output voltage* of a stage or section to its *input voltage*. In a voltage amplifier, it is the ratio of the signal voltage at the plate to the signal voltage at the grid. It is the same in power amplifiers; but it must be remembered that in the latter, the load impedance is usually much lower than the grid impedance, so the output voltage is relatively lower than in voltage amplifiers. In other words, in power amplifiers some gain is sacrificed in favor of power amplification.

Very accurate gain measurements require special equipment. Fortunately, gain figures in troubleshooting need be only approximate. Useful estimates can usually be made with ordinary service equipment.

Some manufacturers supply gain data for each stage of their receivers, and this information is also included in some service manual sheets. However, even if such data are not available, the technician can make certain generalizations about what the gain of each stage should be.

*R-F Amplifier.* This is a voltage amplifier, and for a-m broadcast receivers averages from 5 to 25. For f-m receivers, due to the high r-f signal frequency, gains will be relatively low, and seldom exceed 5.

*I-F Amplifier.* There is where the main amplification of the receiver is obtained and the stage gain is therefore usually high. In a-m receivers, it will run from 100 to 300, sometimes even higher in special cases. In f-m receivers it will average about 15 or 20 per stage, with two or three stages used to bring the total i-f section gain up to about that of the one-tube i-f section of a-m receivers.

*Conversion Gain.* This is the ratio of the i-f signal output voltage to r-f signal voltage input of the converter section. Its value depends not only on the mixer tube and its circuit design, but also on the amount of oscillator voltage injected. Conversion gain is greatest in pentagrid converters and least in the triode mixers sometimes used in f-m receivers.

## FUNDAMENTAL TROUBLESHOOTING

In a-m receivers, it will ordinarily be from 20 to 80, and in f-m receivers, 15 or below.

*A-f Amplifier Gain.* The gain from the grid of the first a-f stage (detector output) to the grid of the power amplifier tube should be in the range 20 to 80. The gain between the grid of the power amplifier tube and the plate of the power amplifier tube averages about 10 for a-m receivers. Note that, as far as voltage is concerned, there is actually a *loss* between the primary and secondary windings of the output transformer. The transformer must be of the *step-down* type, in order to match the low impedance of the loudspeaker to the relatively higher impedance of the output tube plate circuit. The output transformer secondary voltage is thus not a fair value to use in determining voltage gain of the output stage. The plate signal voltage is more appropriate.

How do we *measure* gain? Fundamentally, of course, we simply feed a signal into the receiver, then measure the input and output voltages of the stage whose gain we wish to determine. What makes it not so simple as it may sound is that the signal voltages in the receiver, especially those near the front end, are very small. Ordinary meters do not have scales low enough to measure the minute voltages in the r-f amplifier, mixer, and i-f input circuits. Besides, the instrument used must have a high input impedance, so as not to load or detune the circuit in which the measurement is being taken. Thus, we need a high-gain (sensitive) instrument with a very high input impedance and negligible reactance at high frequencies. The signal-tracing instrument can be used, providing it is equipped with an attenuator and a suitable output indicator.

The Rider Chanalyst is such an instrument, and, since we have already described certain features of this instrument in par. 3-13, let us now consider how the Chanalyst would be used to measure stage gain. First, we feed a signal into the antenna circuit of the receiver. The intensity of this signal should be lowest necessary for comfortable signal volume from the speaker with the volume control well advanced.

Now, suppose we wish to measure the gain of the i-f stage. We place our tracer probe at the grid of the i-f stage and tune the signal for greatest response at the intermediate frequency. Now we adjust the attenuator step control and continuous adjustment until the indicating eye just closes. Next, we move the probe to the diode plate (or grid of the next i-f amplifier stage, if there is one) and recheck the tuning to the i-f signal. The attenuator must now be readjusted to compensate for the increased signal, until the indicating eye again just closes. The ratio of the two attenuator readings is the gain of the stage.

## FUNDAMENTAL TROUBLESHOOTING SYSTEMS

Take an example. Suppose for our first reading, the eye just closed when the step attenuator was set for X10 and the continuous attenuator for 5. Then suppose the reading at the grid of the next stage is X100 and 3. This first reading is equivalent to  $5 \times 10 = 50$ , while the second reading is equivalent to  $3 \times 100 = 300$ . Thus, the gain is the ratio of 300 to 50, or 6.

This method can, of course, be used in checking the gain with any tracer instrument having some indication of relative signal strength. For instance, a vacuum-tube voltmeter equipped with a crystal probe is suitable, provided the scale indication is low enough for the signals to be measured. A communications or other type of receiver equipped with a signal meter can be adapted to read gain, by a technician with a little ingenuity.

An alternate method of measuring gain is available to the technician who has a signal generator with a fairly accurate attenuator. In this method, an output meter is connected to the loudspeaker circuit; this can be any a-c meter and need not be very accurate. The signal generator is then coupled very loosely (through a small capacitor) to the i-f grid. After the attenuator of the signal generator is adjusted for the lowest signal which will give a convenient reading on the output meter with the a-f gain well advanced, the signal generator attenuator reading is noted. The signal generator is then similarly coupled to the next-stage grid or the detector plate, and the signal generator attenuator is readjusted until the output meter reads the same as before. The ratio of the two signal generator attenuator readings is the gain.

It will be noted that most methods for measuring gain prescribe keeping output signal conditions the same for both readings. This avoids the effect of AVC on gain. Actually, the gain of the controlled stages of a receiver varies considerably with the intensity of the input signal, as indeed it should, since this is the purpose of the AVC system! Most gain figures are specified for the lowest possible signal when AVC action is at minimum, or with AVC disabled and a fixed bias substituted. It is thus important that, in checking gain, we keep the signal to the minimum intensity necessary to obtain a readable voltage.

### **3-16. Alignment in Troubleshooting**

Basically, alignment as a separate operation is not part of troubleshooting. However, it is a troubleshooting function to determine whether or not alignment is necessary, and whether the source of trouble is misalignment. Each manufacturer prescribes the proper procedure for alignment of his receivers; information about this procedure should be

## FUNDAMENTAL TROUBLESHOOTING

obtained from service literature whenever this is possible. However, the technician will occasionally encounter a receiver about which no alignment information is available. If alignment adjustments are necessary, he may have to determine for himself the intermediate frequency and other pertinent information. We therefore review here the methods useful in such a situation. Trouble symptoms which indicate that alignment is necessary are considered under the appropriate chapters on symptoms.

### **3-17. Determining Unknown Intermediate Frequency**

The problem of unknown intermediate frequency is likely to arise only with a-m broadcast receivers, since f-m receivers are pretty well standardized at 10.7 mc (with an occasional one at 8.3 mc). For a-m broadcast receivers, we know that the intermediate frequency will be somewhere between 100 and 550 kc. Our method of determining the true frequency is simply to feed a signal into the i-f section and then vary the signal frequency until a response is obtained, as indicated by output from the receiver loudspeaker or other indicator.

However, since a signal generator puts out harmonics, we shall discover a series of frequencies at which we can obtain response in the receiver. For example, suppose the receiver's i-f section is peaked at 400 kc. This i-f section will then produce response when the input signal is set at 400 kc (fundamental), 200 kc (one-half the i-f), 133.3 kc (one-third the i-f), 100 kc (one-quarter the i-f), and so on, as low in frequency as the signal generator will go. The response gets weaker as the multiple between the frequencies gets greater, but all the ones mentioned will normally come through with rather good volume under average conditions. It is often difficult to identify them by signal strength.

How, then, can we say which response represents the true intermediate frequency? One important fundamental principle helps us—namely, *no subharmonics are present in either the signal generator or receiver.* For instance, in our example above, the signal generator set at 100 kc will produce harmonic signals at 200, 300, 400 kc, etc., but *none at 50 kc, 25 kc, etc.* This means that, if we tune our signal generator to the highest frequency at which a response is heard, we should have reached the correct intermediate frequency. We can check whether we have the correct one by tuning the signal generator carefully through all the frequencies between this frequency and twice this frequency. If no response is heard in this range, we can be sure that we have the correct intermediate frequency.



**PART III**

**COMMON SYMPTOMS AND REMEDIES**



## CHAPTER 4

### UNDESIRE SIGNALS

*In the earlier chapters* of this book, we reviewed the types of receivers and receiver circuits the technician is likely to encounter in a-m and f-m troubleshooting and the fundamental methods of accomplishing this troubleshooting. We now proceed to discuss each of the main types of trouble symptoms and the most likely causes and remedies for each. In this chapter we shall discuss "Undesired Signals," a very common complaint in superheterodyne receivers. Then, each succeeding chapter covers another type of symptom and its variations. While we cannot attempt to cover all possible trouble types, we shall present a sufficiently wide variety to provide a coverage of most troubleshooting problems.

#### **4-1. Causes and Sources of Undesired Signals**

By nature, the superheterodyne receiver is subject to interference from undesired stations, unless great care is exerted in design and construction. In most of the lower-priced receivers of today, certain sacrifices in shielding, layout, and basic design must be made in favor of low price. Thus, an undesired signal (frequently referred to as a *spurious response*) may be either a defect in the receiver or a deficiency in design, and the technician should keep this in mind.

Most spurious responses result because of, and through the action of, the local oscillator and the i-f amplifier. The i-f amplifier, since it is tuned to a band centered on the intermediate frequency, must accept and amplify any signal in that band. Any signal, therefore, whether operating directly within the pass-band of the i-f amplifier or beating with the local oscillator and causing a sum or difference frequency within the band, will be amplified and demodulated and will thus interfere with the desired signal.

The mixer circuit is designed to provide efficient heterodyning between the local oscillator and the received signals. Because of this design, heterodyning between other pairs of signals is also encouraged, if they arrive at the mixer in sufficient strength. Practically all these heterodyning conditions depend on some undesired signal, at other than

## COMMON SYMPTOMS AND REMEDIES

the frequency of the desired station, getting through the r-f section and into the mixer. Accordingly, receivers which contain one or more r-f amplifier stages are less subject to spurious responses in the a-m broadcast band. However, if the r-f amplifier is not operating properly (as, for example, too much bias is causing rectification) or if a received signal is extremely strong, its response may become nonlinear. Cross-talk between received signals may take place in the r-f stage, and its selectivity not fully realized.

We shall see that undesired heterodyning can take place between received signals, between a received signal and the oscillator signal, between harmonics of the oscillator signal and received signals, and between heterodynes between received signals and the oscillator signal. A signal operating on the intermediate frequency may be picked up directly in the i-f amplifier, without any heterodyning necessary. The signal may "leak" through the front end of the receiver, or it may be coupled into the i-f amplifier from the antenna or from the air. In the latter case, of course, the i-f amplifier input circuit must be poorly shielded or else the lead dress and wiring arrangement is poor. To prevent leakage through the front end, many receivers include i-f traps.

It is worthy of note that most heterodyne interference results because *the r-f selectivity is not sufficient to eliminate undesired signals from the front end*. This is a deficiency in receiver design—and must be recognized as such by both the technician and the receiver owner. In such a case, not much can be done in the receiver, but judicious use of wavetraps is a way out. Or, of course, the purchase of a better receiver!

If interference from an external source directly on the intermediate frequency is present, it is quite likely that the i-f section is out of alignment and is responding to a different frequency. Note the following, quoted from FCC Rules & Regulations [7.206 (b) (2) ]

In consideration of the fact that the frequency of 455 kc is widely used as a standard intermediate frequency for the superheterodyne type of receiver, applications requesting assignment of one or more frequencies 448, 452, 454, 460, and 462 kc (to transmitting stations) will be considered in relation to the possibility of general interference with the operation of receiving equipment of this type.

One particular type of heterodyne interference is so widely known and experienced that an introductory word about it is in order. This is *image interference*.

### **4-2. Image Interference**

From our basic theory of superheterodynes, we know how the desired incoming broadcast signal is changed in frequency so that it may be amplified by an i-f amplifier. It is also possible for *undesired signals* to

## UNDESIRE SIGNALS

be converted to the intermediate frequency and therefore to be amplified by the i-f stages, thus causing interference. For instance, if the receiver were tuned to a weak 10,000-kc incoming signal, the oscillator normally would function at 10,450 kc to produce the desired 450-kc i-f signal. But if a strong 10,900-kc signal were likewise present in the antenna circuit, it might force its way through to the mixer along with the desired 10,000-kc signal. Since the oscillator is functioning at 10,450 kc, it will beat with not only the 10,000-kc signal but also with the 10,900-kc signal and thus change the frequency of each to 450 kc, because the difference between 10,900 kc and 10,450 kc is the same as that between 10,000 kc and 10,450 kc. Both the desired and the undesired signals will then be present in the i-f amplifier, and interference will result.

This type of undesired response is known as *image-frequency response*. The image frequency always differs from the desired frequency by twice the intermediate frequency. Whether the image frequency is higher or lower than the desired frequency to which the receiver is tuned depends on the relation of the oscillator frequency to that of the incoming signal. In most cases, the oscillator frequency is higher than the desired signal frequency. Then the image frequency must also be higher if the i-f signal is to result. In some receivers, particularly on higher frequency bands, the oscillator frequency is lower than that to which the receiver is tuned. Then the image frequency also must be lower in frequency. Thus, if the receiver were tuned to 20,000 kc and the oscillator frequency is 19,550 kc, the i-f signal is 450 kc, and the image frequency becomes 19,100 kc.

Image-frequency responses is particularly troublesome at very high frequencies, since the percentage frequency difference between the image frequency and the desired frequency is small, if the i-f is of the order of 450 kc. Under such conditions, the selectivity which can be attained by the r-f amplifier is not sufficient to exclude strong undesired signals when the receiver is tuned to a weak signal. The difficulty becomes more pronounced as the i-f is lowered; that is why an i-f of the order of 175 kc is not used in all-wave receivers.

### **4-3. Important Factors about Interference Symptoms**

Now that we have reviewed the ways in which undesired signals are generated and accepted by the superheterodyne receiver, we can progress to a specific discussion of each type as classified by the symptoms it produces. First, we shall discuss symptoms in a-m receivers; then we shall add those special symptoms which are peculiar to f-m receivers. For the

## COMMON SYMPTOMS AND REMEDIES

sake of clarity and simplicity, we shall refer to the diagram of Fig. 4-1 in discussing the various kinds of undesired signals in this chapter.

### 4-4. Symptoms and Contributing Causes

In this listing we shall make brief mention of the possible reasons for the condition listed and you are to check the parts of the receiver referred to as the possible reason or reasons for the condition. The items contained in the listings to follow can be considered as being applicable to all types of a-m superheterodyne receivers; that is, receivers of all wave bands and receivers intended for automobile use. The symptoms listed are those which you may experience in actual practice. After observing the action of the receiver which appears defective, make certain that you understand just what symptom exists. When signals or beats interfere, analyze the frequencies. Then seek the listing of the same symptom. It is possible that certain conditions are not covered in this list of symptoms and contributing causes, but we feel that we cover the majority experienced in practice. More than likely, the contributing causes for the one with which you may be dealing, but which is not listed, will become evident to you upon an analysis of the possible reasons, in accordance with the basic underlying theory contained in this volume. Troubles experienced with superheterodyne type short-wave converters are listed exactly as if these combination units were complete superheterodyne receivers.

### 4-5. Interfering Station Frequency Is 10 KC from Desired Station Frequency

*Explanation of Symptom.* This is what is known as poor adjacent-channel selectivity. In the a-m broadcast band, U. S. stations are assigned channels 10 kc apart. If the receiver is tuned to one channel and its adjacent channel selectivity is not sufficiently good, a strong signal in the next channel higher or lower in frequency can interfere. If the over-all response of the receiver is broad enough, a 10 kc whistle may be heard. This is the audible heterodyne between the carriers of the two stations. Interference may also take the form of "spill-over;" that is, rough, scratchy, and sometimes partly musical sounds during peaks of modulation of the interfering station. If the selectivity of the receiver is very poor, interference may simply be "cross-talk," with both signals heard at the same time.

*Figure 4-1 Reference.* In this case  $f_u$  and  $f_D$  are 10 kc apart. Both signals heterodyne with the oscillator, forming two i-f signals separated

## UNDESIRE SIGNALS

by 10 kc. These, in turn, heterodyne in the second detector to produce the 10-kc audible beat.

### *Probable Causes, and Remedies*

- Coupling between antenna lead or circuit with tuned r-f or mixer or oscillator circuits, through channels other than normal. Check position of antenna and ground lead inside of receiver.
- Imperfect shielding of r-f, mixer, and oscillator circuits. See that all shields are properly grounded and that shield and shield base make good contact.
- Possible pickup by r-f, mixer, or oscillator tube grid leads or tube elements. Shielding of these tubes is possible remedy.
- Slightly incorrect adjustment of r-f and/or mixer trimmers. Most likely to exist at "high" and "low" ends of the tuning scale.
- Oscillator trimmer slightly "off," with r-f and mixer trimmers properly adjusted. The discrepancy may be slight, yet sufficient to cause trouble of this type. Can be checked by readjustment of oscillator.
- Incorrect tuning of i-f transformers. Defect in i-f transformer circuit.

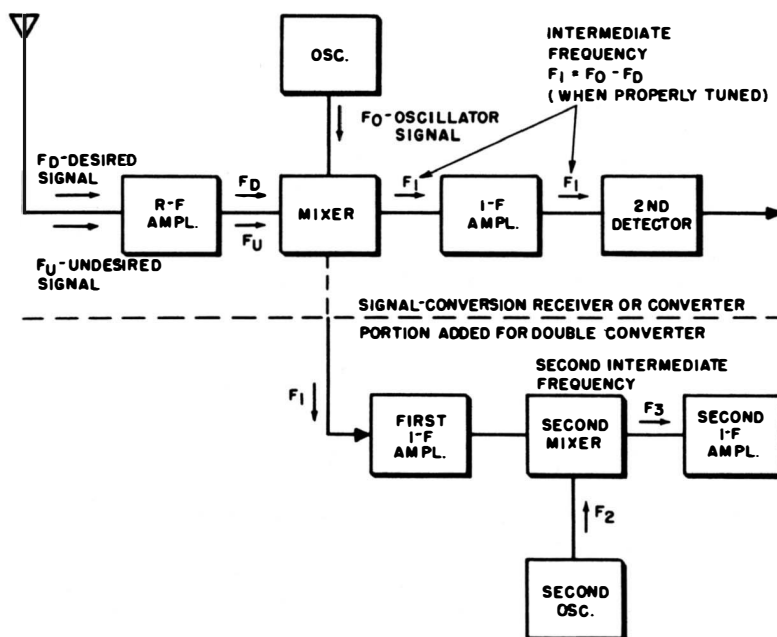

Fig. 4-1. Block diagram for interfering-signal analysis.

## COMMON SYMPTOMS AND REMEDIES

- g. Defect in r-f or in mixer or oscillator tuned circuits, whereby broadening of resonance curve is secured. This may be moisture-soaked windings or shorted turn. Imperfectly grounded tuning capacitor, excessive leakage in tuning or trimmer, capacitor, high resistance joints, poor connections, etc. are additional troubles related to a defect in the aforementioned tuned circuits.

*NOTE:* On a country-wide basis, the FCC has assigned channels to a-m broadcast stations every 10 kc through the range of 540 to 1600 kc. However, assignments within a given listening area (in which the local stations are heard well both day and night) are kept a *minimum of 40 kc apart*. Adjacent-channel interference thus should not be likely, except at night when powerful distant stations on channels adjacent to those of desired locals put through a strong signal.

### **4-6. Interfering Frequency Equal to the Frequency of the Desired Station, Plus Twice the Numerical Value of the Intermediate Frequency**

*Explanation of the Symptom.* This is image interference as explained in par. 4-2, and is the case in which the oscillator frequency is *higher* than the received-station frequency.

*Figure 4-1 Reference.* Here,  $f_o$  is higher than  $f_b$  by amount equal to  $f_i$  and  $f_u$  is higher than  $f_o$  by  $f_i$  and is therefore higher than  $f_b$  by  $2f_i$ .

#### *Probable Causes, and Remedies*

- a. Excessive signal strength of the interfering station.
- b. Possible coupling between the antenna or ground lead both of which may pick up the interfering signal and couple it into the mixer circuit.
- c. Imperfect shielding of r-f, mixer, and oscillator circuits, with consequent pickup by these circuits.
- d. Image-frequency suppressor circuits incorrectly tuned or defective.
- e. R-f (antenna) coil affected by moisture, burned by lightning, short-circuited, or Litz wire strands broken to lower  $Q$ .
- f. Short-circuit or leakage in r-f or mixer tuning section of gang capacitor.
- g. Defective by-pass capacitors in r-f or mixer section.

### **4-7. Interfering Frequency Equal to Desired Frequency, Minus Twice the Intermediate Frequency**

*Explanation of the Symptom.* This is another case of "image frequency" interference, in a receiver which utilizes the heterodyning oscillator at a frequency lower than that of the desired station. See contributing causes listed for symptom in par. 4-6.



## UNDESIRE SIGNALS

### **4-8. With Converter, Interfering Frequency Equal, or Close, to Intermediate Frequency of Converter**

*Explanation of the Symptom.* This is a case of signal pickup by the broadcast receiver, which is the intermediate frequency amplifier for the superheterodyne and short-wave converter. In some instances, the signal pickup is made by the leads connected between the converter and the broadcast receiver, particularly when the converter secures its power from the receiver. In still other cases, the metal mass of the converter picks up the signal and feeds the signal to the t-r-f amplifier in broadcast receiver, which is tuned to the frequency of the interfering signal, hence is most responsive. This is particularly true when the receiver has its back exposed and the physical separation between the converter and the t-r-f receiver components is not very great.

*Figure 4-1 Reference.* ( $f_u = f_i$ ).

*Probable Causes, and Remedies*

- a. Imperfect operation of the i-f trap circuit in the converter, if one is used.
- b. Pickup by the power leads to the converter and proximity between the converter power lead and the receiver power lead. The r-f filters in the converter or receiver power line lead are possible remedies.
- c. Imperfect shielding of the feed lines between converter and broadcast receiver.
- d. Local station of substantial power operating upon i-f amplifier peak frequency. Slight shifting of this peak frequency by tuning of receiver and readjustment of converter may help solve the difficulty.
- e. Pickup by converter antenna lead due to excessive strength of local transmitter and modulation of desired short-wave carrier and passage through converter into receiver. The insertion of a trap circuit, tuned to the converter i-f peak in the antenna circuit feeding the converter, may solve the trouble. Such a trap is useful, if the converter is not already equipped with one.

### **4-9. With Converter, Interfering Frequency within 20 or 30 KC of Converter Intermediate Frequency**

*Explanation of the Symptom.* This is a case of signal pickup, as in par. 4-8, except that the signals are not of the intermediate frequency. To the contributing causes listed for symptom 4-8, add:

- a. Imperfect tuning of the broadcast receiver t-r-f amplifier.
- b. Defect in the tuned circuits of the broadcast receiver t-r-f amplifier.

## COMMON SYMPTOMS AND REMEDIES

### **4-10. Interfering Frequency Differs from Desired Frequency by Value of the Intermediate Frequency**

*Explanation of the Symptom.* This is a case of heterodyning between the two stations themselves, either in the mixer circuit of the receiver, or in some nearby external nonlinear medium.

*Figure 4-1 Reference.* The numerical difference between  $f_u$  and  $f_d$  is equal to  $f_i$ .

#### *Probable Causes, and Remedies*

- a. Incorrect location of the antenna lead in proximity to the mixer system.
- b. Excessive strength of the interfering station.
- c. Pickup by mixer tube circuit of strong local interfering signal.
- d. Incorrect r-f and mixer trimmer adjustment in low i-f peak receivers.
- e. Undesired coupling between r-f and mixer circuits.
- f. AVC or detector circuit defective, causing excessive bias on r-f tube, which acts as mixer.
- g. R-f tube defective and acting as mixer.
- h. Receiver operating near overhead power-line connections, metal duct work, etc., with nonlinear properties, mixing the signals of the desired and undesired stations.

*NOTE:* A *tunable whistle* should be present, and varies at normal rate in pitch as the desired station is tuned in. This audible beat results from the heterodyning between the i-f signal normally produced by the desired station and the i-f signal produced by the beat between the desired and undesired stations.

### **4-11. Interfering Frequency Differs from Desired Frequency by Slightly More or Less Than the Intermediate Frequency**

*Explanation of Symptom.* This is a case of heterodyning between stations and also the production of a steady beat note as a background, due to the difference-frequency between the heterodyning oscillator frequency and the interfering station carrier.

*Figure 4-1 Reference* ( $f_u$  differs from  $f_d$  by slightly more or less than numerical value of  $f_i$ .)

*Probable Causes, and Remedies.* These are listed in par .4-10. In addition, consider the coupling between the antenna or ground lead in the receiver to the oscillator tube.

*NOTE:* Whistle tunable at normal rate results due to the audible beat between the undesired signal and the oscillator signal.

## UNDESIRE SIGNALS

### *Example:*

The desired station is operating on 700 kc, the receiver i-f section is peaked at 455 kc, and the oscillator is set at 1155 kc. If a 1150-kc signal finds its way into the mixer circuit, it will beat against the 700-kc signal and, at the same time, will be mixed with the 1155-kc heterodyning signal. The signal due to the desired station and the signal due to the undesired station will bear the difference frequency between the heterodyning oscillator frequency of 1155 kc and the 1150-kc signal or a 5000-cycle signal. This whistle will appear as a background to the desired as well as the undesired signals. The same condition will occur if the undesired 1150-kc signal finds its way into the oscillator circuit via undesired coupling. Variation of the tuning dial varies the pitch of the whistle.

### **4-12. Interfering Station Appears During Lapse of Desired Station Modulation without Any Change of Dial Setting (Reception May Be Fuzzy or Blurred at Times or Accompanied by Wobble or Low-Pitched Hum)**

*Explanation of Symptom.* A signal from a distant station, assigned to the same frequency channel as the desired station, is just strong enough to be audible through the desired station carrier. A sudden up-fade of the distant interfering station may occur at a null point in the beat between the two stations, if this beat is of very low frequency. If the beat (difference between their carrier frequencies) is somewhat higher, only a wobble or low growl may be heard.

*Figure 4-1 Reference* ( $f_u$  differs from  $f_d$  by 40 cycles or less—U.S. stations).

*Probably Causes, and Remedies.* The causes of this interference are obviously external to the receiver and result from the manner in which frequency channels are assigned and the relative location of the receiver with respect to the two station transmitters. Thus, there is no remedy as far as the receiver is concerned.

*NOTE:* The FCC rigidly limits the power and directivity of transmitters operating on the same channel and within range, but a certain amount of this interference will occur at some times during the day and in some seasons of the year. U.S. a-m broadcast stations are required to maintain frequency within  $\pm 20$  cycles, so the beat between two co-channel stations cannot exceed 40 cycles. However, some foreign stations allow greater frequency variations, and beat notes up to 500 cycles may be heard when these stations heterodyne U.S. stations.

## COMMON SYMPTOMS AND REMEDIES

### **4-13. Police, Amateur, Aircraft, or Other Short-Wave Interference of a Frequency Higher Than the Tuning Range of the Receiver**

*Explanation of the Symptom.* It is possible that the interfering signal is the *image* for some station operating upon the high-frequency end of the tuning dial when the receiver intermediate frequency is high; or, in the average superheterodyne, the interfering station finds its way into the mixer circuit and beats against one of the harmonics of the heterodyning oscillator to produce a signal of intermediate frequency.

*Figure 4-1 Reference.* Image interference, given as in par. 4-6. Oscillator harmonic type:  $f_u$  is such as to differ from  $2f_o$ ,  $3f_o$ ,  $4f_o$ , or any other integral multiple of  $f_o$ , by  $f_i$ , so that it beats with the oscillator harmonic to produce an i-f signal.

#### *Probable Causes, and Remedies*

- a. Excessive signal strength of the interfering station, due to location.
- b. Excessive strength of heterodyning oscillator harmonics.
- c. Undesired coupling between antenna or ground circuit and mixer or oscillator tube.
- d. Pickup by power leads in receiver and proximity of these leads to tuned circuits in receiver.
- e. Imperfect shielding in receiver.
- f. Defect in antenna or r-f coil or tuned circuit.
- g. Defective by-pass capacitors in r-f stage or mixer input.

*NOTE:* If a desired station is being tuned in, a tunable whistle results from the audible beat between the normally produced i-f signal and the i-f signal produced by heterodyning between the oscillator harmonic and the interfering short-wave station. If the oscillator *second* harmonic is involved, the whistle will tune at normal rate; if a higher harmonic, the whistle will tune more rapidly.

#### *Example:*

Desired station on 1280 kc, i-f at 455 kc, the oscillator frequency is then  $1280 + 455$  kc, or 1735 kc. Second harmonic of oscillator is then at  $1735 \times 2 = 3470$  kc. An amateur station signal on 3925 kc finds its way into the mixer where it beats against the 3470-kc harmonic to produce 455-kc i-f signal, thus interfering with the desired signal at 1280 kc.

### **4-14. Untunable, Intermittent Code or Speech Interference (Is a Background to All Desired Stations, Regardless of the Setting of Receiver Dial)**

*Explanation of the Symptom.* This type of trouble is due to pickup by the i-f amplifier. The interference is localized to places where airway range and beacon stations operate and to the localities bordering upon

## UNDESIRE SIGNALS

the coast line of the United States, including the Great Lakes. For that matter, wherever direction and long-wave marine stations operate. This type of interference oftentimes emanates from powerful stations several thousand miles away. The higher the degree of instability in an i-f amplifier, the more likely is the system to respond to such forms of interference.

*Figure 4-1 Reference ( $f_u = f_i$ ).*

*Probable Causes, and Remedies*

- a. Antenna or ground or power line lead near i-f amplifier.
- b. Imperfect shielding of i-f amplifier circuit.
- c. Imperfect condition of i-f unit shields.
- d. Absence of shielding over i-f amplifier tubes.
- e. Excessive instability in the i-f amplifier.
- f. Pickup by power line and passage through transformer.
- g. Defect in tuned circuits of r-f stage or mixer.
- h. Improperly adjusted i-f wavetrap.
- i. Improper i-f alignment.
- j. Change i-f peak to new frequency and set oscillator accordingly.

*NOTE:* Interfering signals of the type stated above, and also previously mentioned, may be due to "floating" shields. In other words, the i-f transformer shield is not properly grounded to the chassis. This may be due to electrolysis action or corrosive action between the chassis and the shield. The result is that the shield is floating. This mass of metal acts as an antenna and picks up the interfering signal and actually feeds it into the coil, which it was supposed to shield from external fields. Interference of the type mentioned is neither fixed or constant. It may be experienced during certain periods of each hour in certain localities and, in others, it may be experienced during the entire period of use. In still other places, there will be no interference. U.S. Coast Guard Beacon stations operate on frequencies between 260 and 320 kc. Airway beacon stations operate right on the intermediate-frequency band. Marine long-wave stations of various service classifications, likewise operate all through the range used for intermediate frequencies. (See FCC quote in par. 4-1.)

### **4-15. Nearby Transmitter Signal Blankets Certain Spots on Tuning Dial but Does Not Interfere with Other Distant Stations**

*Explanation of the Symptom.* A condition of this kind is created by harmonics of the interfering station mixing with harmonics of the heterodyning oscillator when the receiver is tuned to the desired stations.

## COMMON SYMPTOMS AND REMEDIES

No particular relationship appears to exist between the fundamental frequencies of the stations which are blanketed by the local fundamental; yet definite relations exist between the harmonic of the interfering fundamental and the harmonics of the heterodyning oscillator, with respect to the intermediate frequency. It is impossible at this time to list all the possible combinations for all the intermediate frequencies now in use. You will have to identify this situation by recognizing what is taking place and by making one of two computations.

*Figure 4-1 Reference.* Here  $2f_o$ ,  $3f_o$ ,  $4f_o$ , etc. beat against  $2f_w$ ,  $3f_w$ ,  $4f_w$ , or any other integral multiple of  $f_w$  to produce a heterodyne whose frequency is  $f_i$ .

### *Probable Causes, and Remedies*

- a. Interfering station signal too strong. Install wavetrap in antenna input circuit and tune it to the frequency of the undesired signal.
- b. Operation of the r-f or mixer circuits at such a low level, that the control grid bias applied results in the operation of the amplifier tubes as rectifiers and the production of harmonics in the output circuit.
- c. Excessive harmonic content of the heterodyning oscillator. Possible defect in the circuits which control the harmonic output.
- d. Antenna system is too responsive to the local signal. Alter it accordingly.

### *Example:*

Suppose a very strong signal at 600 kc is causing the interference. When the receiver dial is tuned to 672.5 kc with an i-f of 455 kc, the oscillator frequency will be 1127.5 kc. The second harmonic of the oscillator (2255 kc) beats against the third harmonic of the 600-kc. signal (1800 kc) to produce a 455-kc i-f signal. Similarly, interference would result at 696.4 kc ( $5 \times f_u$  against  $3 \times f_o$ ); 896.4 kc ( $6 \times f_u$  against  $3 \times f_o$ ); 972.5 kc ( $4 \times f_u$  against  $2 \times f_o$ ); and many others.

### **4-16. Signal from Powerful Local Station Appears at Several Points along Dial (Repeat Tuning with Single-Dial Receiver)**

See explanation offered in connection with symptoms in par. 4-15.

### **4-17. Heterodyne Whistle at 910 KC in Receiver with 455-KC Intermediate Frequency**

*Explanation of the Symptom.* This is due to heterodyning between the second harmonic of the intermediate-frequency peak and a 910-kc carrier. The pitch of the heterodyne signal may be high or low, depending on the exact adjustment of the oscillator, with respect to the beat

## UNDESIRE SIGNALS

note desired—that is, the exact value of the i-f peak. If the i-f signal differs from the rated value by 250 cycles and the second harmonic of this signal beats against exactly 910 kc, the audible beat note would be 500 cps.

*Figure 4-1 Reference.* Here,  $f_u$  is  $2f_i$ , derived from the i-f section of the receiver itself, and  $f_D$  is 910 kc and beats against  $f_u$ .

### *Probable Causes, and Remedies*

- a. Defective r-f filter in the detector output circuit. Ex-choke, if used, and by-pass capacitors. Ungrounded choke or capacitors. Defective connections. Defective shielding. Check position of detector tube circuit connection.
- b. Undesired coupling between antenna or ground leads and output or input circuits of detector tube. Antenna and ground circuit leads should be far removed from detector circuits.
- c. Check shielding of i-f transformers and i-f tube.
- d. Check shielding of detector tube.
- e. Check for overloading of detector.

*NOTE:* Similar interference is, of course, also just as possible with lower intermediate frequencies, and it may occur more than once in the a-m broadcast band. The whistle is tunable at normal rate when it is the second harmonic of the i-f interfering. For lower intermediate frequencies (when a higher harmonic of the i-f is involved), the tuning rate of the whistle may be very rapid. The following table lists the a-m broadcast frequencies (kc) at which this kind of interference can be experienced for various intermediate frequencies.

I-F Peak in Receiver	Broadcast Frequencies at Which, or Near Which, Beat Notes May be Experienced, for the Condition Listed Above					
172.5		690	860	1040		
175		700	875	1050	1225	1400
177.5		710	890	1065	1240	1420
178		720	900	1080	1260	1440
180	540	720	900	1080	1260	1440
181.5	540	730	910	1090	1270	1450
252.5	760	1010	1260	1515		
260	780	1040	1300	1560		
265	530	795	1060	1325	1590	
370	740	1110	1480	1850	2220	
445	890	1335	1780	2225	2670	
450	900	1350	1800	2250	2700	
455	910	1365	1820	2275	2730	
456	910	1370	1820	2280	2740	
460	920	1380	1840	2300	2760	
465	930	1395	1860	2325	2790	

## COMMON SYMPTOMS AND REMEDIES

I-F Peak in Receiver	Broadcast Frequencies at Which, or Near Which, Beat Notes May be Experienced, for the Condition Listed Above				
470	940	1410	1880	2350	2820
480	960	1440	1920	2400	2800
485	970	1445	1940	2425	2910
525	1050	1575	2100	2625	3150
535	1070	1605	2140	2675	3210
550	1100	1650	2200	2750	3300
600	1200	1800	2400	3000	3600
950	1900	2850	3800	4750	5700
1000	2000	3000	4000	5000	6000
1010	2000	3030	4040	5050	6060
1300	2600	3900	5200	6500	7800

### 4-18. High-Frequency A-M Broadcast Stations Received at Low End of Dial

*Explanation of the Symptom.* The presence of the interfering signal is due to heterodyning between the fundamental signal carrier and the harmonic of the oscillator when it is adjusted to a lower frequency signal. Thus, if the receiver employs a 455-kc peak and the receiver is tuned to 550 kc, the heterodyning oscillator frequency is 1005 kc. The second harmonic of this frequency is 2010 kc. If this signal is allowed to beat against either a 1560-kc signal or a 1550-kc signal, beat signals of 450 and 460 kc, respectively, will be produced. These are apt to pass through the 455-kc peaked i-f amplifier and be audible in the output. A situation such as this may exist in receivers with other intermediate frequencies, but is worst with lowest i-f values because of the smaller frequency spacing between  $f_u$  and  $f_o$ , allowing the signal at  $f_u$  to overcome the r-f selectivity better. Note that this is the same kind of interference as in par. 4-13, except that here the interference station is in the a-m broadcast band.

*Figure 4-1 Reference.* Here  $2f_o$  (or other integral multiple of  $f_o$ ) beats against  $f_u$  to produce heterodyne at  $f_i$ .

#### *Probable Causes, and Symptoms*

- a. Location of the antenna lead close to the mixer tube.
- b. Excessive pickup from the interfering station. A switch-controlled trap tuned to the frequency of the interfering station and wired into the antenna circuit or r-f input stage may help.
- c. Excessive harmonic output from heterodyning oscillator. Check harmonic suppressor resistors, capacitors, and grid leak in oscillator circuit.



## UNDESIRE SIGNALS

- d. Check shielding of oscillator and mixer coils.
- e. Defect in r-f coils, tuning capacitors, or by-pass capacitors.

*NOTE:* Tunable whistle results; pitch of this whistle varies at normal rate if second harmonic of oscillator is involved. If higher harmonic is involved, tuning of whistle will be more rapid.

### **4-19. Converter With Tunable Whistles at Various Frequencies**

*Explanation of the Symptom.* Indicates coupling between the broadcast receiver r-f input circuit (used as i-f) and the antenna circuit of the converter, causing the same kind of condition as the symptom in par. 4-17. See par. 4-17 for other information.

### **4-20. Converter or Double-Conversion Receiver With Tunable Heterodyne Whistles at Random Frequencies**

*Explanation of the Symptom.* The local oscillator in the broadcast receiver or other receiver into which the output of the converter is fed is being coupled back into the antenna circuit of the converter (or double-conversion receiver as a whole). The harmonics of this second oscillator fall into the tuning range of the converter or front end of the double-conversion receiver.

*Figure 4-1 Reference.* Harmonics of  $f_2$ , ( $2f_2$ ,  $3f_2$ ,  $4f_2$ , etc.) become  $f_u$  and fall into the tuning range, interfering with  $f_d$ .

*Probable Causes, and Remedies*

- a. Coupling between input leads to receiver antenna circuit of converter. Provide better shielding of wiring between these, or correct lead dress. Check shielding in receiver (second conversion section) and wiring between receiver oscillator stage and antenna circuit.
- b. Excessive harmonics in second oscillator signal. Check oscillator coils, bias, by-pass capacitors, grid leak, and tube.

*NOTE:* Whistles will tune very rapidly, due to high order of harmonics usually involved. These whistles are often called "birdies."

### **4-21. Strong Tunable Whistle from Beat Frequency (C-W) Oscillator**

*Probable Cause, and Remedy.* Beat oscillator in i-f section operating when it should not. Check BFO switch.

### **4-22. Strong Tunable Whistle on Each Station, with No Beat Oscillator**

*Explanation of the Symptom.* An i-f (or possibly r-f) amplifier stage is probably oscillating and beating against the received signal.

## COMMON SYMPTOMS AND REMEDIES

*Figure 4-1 Reference.* Here  $f_u$  is result of undesired oscillation in amplifier stage and is close enough to  $f_i$  (if in i-f section) or to  $f_b$  (if in r-f section) to produce audible beat.

### *Probable Causes, and Remedies*

- a. Defective output filter capacitor.
- b. Open grounds at shields or shield contacts.
- c. Poor contact at r-f, mixer, or i-f control grid or plate circuits. Open capacitors or other defects related to these units in these circuits.
- d. Incorrect location of control grid or plate leads in r-f, mixer, and i-f circuits.
- e. Shorted grid filter resistors in r-f, mixer, and i-f circuits.
- f. Open by-pass capacitors in AVC voltage feed circuits.
- g. Pickup of strong, unmodulated carrier by excessively long antenna.  
Reduce antenna length.

### **4-23. Whistle or Growl Background to All Stations**

*Explanation of the Symptom.* Local oscillator not working properly, or some kind of oscillation in the i-f or a-f amplifier section.

*Figure 4-1 Reference.* Oscillation at  $f_o$ ,  $f_i$  or audio frequencies in abnormal manner and so broad as to not be tunable but receivable with most signals.

### *Probable Causes, and Remedies*

- a. Excessive regeneration, due to application of unbalanced operating potentials.
- b. Excessive resistance in grid circuits.
- c. Imperfect bias resistors.
- d. Presence of parasitic oscillatory circuits within oscillator system.
- e. Imperfect by-pass capacitors across bias and grid filter resistors.
- f. Oscillatory condition in i-f amplifier or a-f amplifier.

### **4-24. Station Can Be Tuned in at Two Points on Dial**

*Explanation of the Symptom.* Several conditions may create such a fault. One of these is excessive signal strength combined with operation of the receiver at a low level because of high AVC grid bias on r-f and mixer tubes. The fundamental signal may find its way into the r-f circuit, where, because of possibly excessive grid bias, or overloading, second harmonic production takes place; and, when the receiver is tuned to a frequency approximating the second harmonic of the station, response will be had. For that matter, if the station is of sufficient strength, its second harmonic will be tunable, and response will be had when the

## UNDESIRE SIGNALS

receiver is tuned to the second harmonic of the station. Another possible reason is incorrect tracking of the oscillator capacitor. Maybe incorrect tracking of the image frequency suppressor circuit capacitor or some defect in this circuit exists, so that instead of keeping its resonant signal out of the circuit, it feeds this resonant signal into the circuit.

*Figure 4-1 Reference.* Here  $f_u$  is twice the frequency of some broadcast station, and falls at or near  $f_D$ .

*Probable Causes, and Remedies*

- a. Oscillator trimmer adjustment.
- b. R-f tuning trimmer adjustment.
- c. Excessive pickup from station. Use wavetrap.
- d. Mixer circuit trimmers.
- e. Incorrect location of antenna leads.
- f. Imperfect shielding.
- g. Excessive control grid bias on r-f and mixer tubes.

*NOTE:* A steady, nontunable whistle results because the undesired second harmonic and the desired station signal are both on fixed frequencies, and the audible beat is between them.

### **4-25. Whistle at Frequencies Slightly Lower or Higher Than I-F Peak**

*Explanation of the Symptom.* A condition of this type is due to undesired coupling between the mixer input or output circuit and the detector input or output circuit. What actually happens is that the i-f signal harmonic beats against the signal produced by the heterodyning oscillator. This is different from the beat signal produced as a result of the mixing of the i-f signal harmonic and carrier signal frequencies, as outlined in par. 4-17.

*Figure 4-1 Reference.* Harmonic of the i-f signal at  $3f_i$ ,  $4f_i$ , etc., beats against  $f_o$  to produce another i-f signal at  $f_i$ .

*Probable Causes, and Remedies*

- a. Incorrect placement of leads in mixer and detector tube circuits.
- b. Proximity of mixer tube leads and detector tube circuit leads to some wire, in some other circuit, which may act as a coupling link between the mixer and detector.
- c. Imperfect shielding of mixer and detector units.
- d. Imperfect ground contacts or open ground contacts to shields.
- e. Imperfect filtering in AVC circuits which are common to detector tube and mixer tube.

*NOTE:* The harmonic of the i-f signal must be higher than the second, because for second harmonic to beat against oscillator the os-

## COMMON SYMPTOMS AND REMEDIES

illator frequency would need to be the intermediate frequency, a condition never allowed in design. Since the harmonic must be a high one, the tunable whistle resulting will show a rapid change in pitch with dial tuning.

### *Example:*

If the intermediate frequency is 455 kc, its third harmonic is at 1365 kc. When the receiver dial is tuned to 910 kc, the oscillator is also at 1365 kc; and as the 910-kc station is tuned in, a tunable whistle whose pitch changes rapidly is heard as the i-f signal harmonic and the oscillator approach each other at 1365 kc.

### **4-26 Receiver Operative Over a Portion of Dial**

#### *Explanation of the Symptom*

- a. Oscillator stops oscillating over part of its tuning range.
- b. Oscillator padder prevents tracking at low-frequency end.

*Figure 4-1 Reference ( $f_o$  present over only part of tuning range).*

#### *Probable Causes, and Remedies*

- a. Poor oscillator tube.
- b. Oscillator trimmer or padder capacitor out of alignment.
- c. High resistance in oscillator tuned circuits.
- d. Imperfect alignment of r-f, mixer, or oscillator trimmers in multiwave band receivers; or defective tuned circuits.
- e. Defective coupling between oscillator input and output circuits. Defective coupling between oscillator and mixer.
- f. Defective switch contacts in tuned circuits of dual-wave receivers.
- g. Leak or short circuit between tuning capacitor plates when the tuning dial is to a certain point—that is, where the receiver becomes inoperative.
- h. A combination of oscillator trimmers and i-f trimmers incorrectly adjusted.
- i. Oscillator trimmer prevents tracking at high-frequency end of dial.
- j. Imperfect operation of tuning-range switches.
- k. Imperfect grounding of shields around tuned coils, causing shields to act as absorbing masses.
- l. Imperfect grounding of unused portions of windings in multiwave band receivers.
- m. Defective resistor capacitor in oscillator tube circuit.
- n. Excessive leakage between tube elements across the receiver socket terminals.

## UNDESIRE SIGNALS

### **4-27. Desired Station Disappears Gradually and Other Station Signal Slowly Comes In**

*Explanation of the Symptom.* This is known as *oscillator frequency drift* and is result of gradual change in circuit constants which determine the oscillator frequency. After interfering station has replaced desired station, condition can be checked by retuning the dial to see if adjustment will restore desired signal. Nearly all the lower-price midget a-m broadcast receivers will exhibit some of this when tuned near the high-frequency end of the tuning range, and especially when the receiver has just been turned on and is cold. The physical changes in coils and capacitors, and the change in dielectric constant due to increase in temperature, change the resonant frequency and thus the frequency of the oscillator. A certain amount of this is basically the fault of poor design and cannot be overcome easily.

*Figure 4-1 Reference.* Here  $f_o$  gradually changes, thus changing the  $f_b$  which can heterodyne to produce proper  $f_i$ .

#### *Probable Causes, and Remedies*

- a. Defective by-pass capacitors in the oscillator circuit. Defective in this instance does not mean short circuited. Instead, it means intermittent operation, high resistance contacts to the leaves of the capacitor coil, high resistance joints, and excessive leakage.
- b. Moisture absorption by the dielectric of the solid dielectric trimmers used in the oscillator tuned circuit.
- c. Imperfect ground connection to the tuning capacitor rotor in the oscillator and to the oscillator coil shield, if one is used. Corrosion between the oscillator coil shield and the coil shield base.
- d. Defective resistances in the oscillator circuit, particularly in the grid circuit. Resistance which varies in value during operation, because of changes in current flow as the frequency of the oscillator circuit is varied, will cause frequency drift.
- e. Imperfect mounting of oscillator coils and windings. Variation of the position of the windings will cause a change in frequency output.
- f. Variation in the spacing between the tube elements within the tube envelope, as a result of heat developed.
- g. Fluctuations in the applied operating voltage.

### **4-28. Interfering Signal Appears After Period of Use (Although R-F, Mixer, and Oscillator Circuits Are Perfectly Aligned and Desired Signal Strength Is Substantially Normal)**

*Explanation of the Symptom.* This is not a frequent complaint, but, upon several occasions, was found to be due to defective i-f trimmers,

## COMMON SYMPTOMS AND REMEDIES

particularly in receivers which employed one i-f transformer. If one of these capacitors changes its tuning adjustment; the effect is to broaden the resonance curve of the transformer, and signals which normally were rejected by the i-f system appear in the output.

*Figure 4-1 Reference.* The i-f response is broadened sufficiently to accept both  $f_u$  and  $f_v$ .

### *Probable Causes, and Remedies*

- a. Defective dielectric in i-f transformer.
- b. Absorption of moisture of i-f trimmer dielectric.
- c. Cracked dielectric.
- d. Adjusting screw thread worn.
- e. Temporary short-circuiting of turns in the i-f transformer windings.

The usual remedy is replacement of the entire i-f transformer.

### **4-29. Frequent Readjustment of I-F Trimmers Required**

See listing under symptom in par. 4-28. Disregard references to interfering signal, unless experienced in practice.

### **4-30. Steady Howl on All Stations**

*Explanation of the Symptom.* This could be due to improper operation of the oscillator or a-f oscillation in one of the amplifier stages.

### *Probable Causes, and Remedies*

- a. Oscillator grid leak changed to wrong value. Check and replace if necessary.
- b. Defective oscillator tube.
- c. Defective output filter capacitor in power supply.
- d. In battery receivers, defective decoupling capacitor connected across the B- battery input.
- e. Defective resistors or capacitors in decoupling network.

### **4-31. Steady Rushing Noise over Part, or All, of Tuning Range, with Trace of Some Signals through it**

*Explanation of the Symptom.* Probably the local oscillator is *super-regenerating*—that is, it is going rapidly in and out of oscillation.

*Probable Cause, and Remedy.* Oscillator grid leak has changed to a much higher value than it should be.

### **4-32. Whistle Heterodyne Sweeps Rapidly Back and Forth Across Desired Signal During Normal Reception, or Gradually Lowers or Raises in Pitch and Settles at One Steady Tone, without Any Adjustment of Receiver**

*Explanation of the Symptom.* A nearby receiver is being tuned to, or through, a frequency equal to its i-f below the desired station frequency

## UNDESIRE D SIGNALS

to which the receiver under observation is tuned. The other receiver's oscillator is radiating a signal at the desired station frequency and is heterodyning with the desired station's signal in your receiver.

*Figure 4-1 Reference* ( $f_u$  is equal to the  $f_o$  of a nearby receiver).

*Probable Causes, and Remedies*

- a. Excessive radiation from interfering receiver.
- b. Two receivers using same antenna or antenna lead.

*NOTE:* Unfortunately, it is not feasible to construct low-price receivers in which oscillator radiation is so low that nearby receivers cannot pick it up. Of course, in more elaborate receivers with r-f amplifiers, radiation is negligible and this trouble is seldom experienced.

### **4-33. Roughly Modulated Signal, Unstable, Received About Every 16 Kc through The A-M Broadcast Band and on Short Waves, Heterodyning Whenever Signals Are Received**

*Explanation of the Symptom.* This is interference due to radiation of harmonics from the horizontal sweep deflection circuit of a local TV receiver. The fundamental frequency of this signal in the TV receiver is 15,750 kc; but due to the special saw-tooth waveform, it is rich in harmonics right up through most of the short-wave bands.

*Figure 4-1 Reference.* Here  $f_u$  is a harmonic (or rather, various harmonics) of 15,750 kc, which is in the receiver tuning range.

*Probable Causes, and Remedies*

- a. Interfering harmonics coming to receiver through power line. Install line filter at TV receiver or a-m receiver, or both.
- b. Harmonics received through the air. If a-m receiver has loop antenna, try orienting it so as to discriminate against interfering signals.

*NOTE:* This kind of interference has been a problem since TV receivers first became prevalent. Manufacturers are attempting to cure it, and their efforts may someday be successful.

## UNDESIRE D SIGNALS IN F-M RECEIVERS

### **4-34. F-M Receivers Less Susceptible to Interference**

F-M broadcast receivers are less subject to interference and to undesired signals of the types previously discussed because of the following:

1. The oscillator frequency is in the order of 100 mc. The nearest harmonic (second) is about 200 mc, and is thus so far separated from the received-signal frequencies that troubles from heterodyning of oscillator harmonics are negligible.
2. Desired station frequencies are similarly high (88-108 mc), and for

## COMMON SYMPTOMS AND REMEDIES

the same reason, troubles involving harmonics of the received signal are negligible.

3. Any audible heterodynes between carrier frequencies are *amplitude-modulated* and therefore tend to be swamped out by the receiver's limiting action.
4. Signals in and around the frequency range of the f-m broadcast band are (except under very special conditions) transmitted by ground wave, and the range is limited to about 100 miles or so. There is, therefore, less of a variety of possible interfering stations on susceptible frequencies.

For these reasons, it is natural that our list of symptoms in this category should be shorter than for a-m receivers. However, there are a few important sources of undesired signals to be considered.

As with a-m receivers, whistle heterodynes will be an important indication of interference. However, they will often sound different on an f-m receiver, because heterodyning with an f-m signal will cause the heterodynes themselves to be frequency-modulated, so they sound "broken up" and somewhat varying in pitch.

Although some receivers use a different value, 10.7 mc is quite well standardized as the intermediate frequency and will, in the following pages, be assumed universal.

### **4-35. Interference from a Station 21.4 Mc Higher Than Desired Station**

*Explanation of the Symptom.* This is image interference with the standard 10.7-mc intermediate frequency used in the receiver. It is true that this intermediate frequency is high enough to throw the image interference frequency outside the 88-108 mc broadcast band, and thus image interference from other f-m broadcast stations is not possible. But this does not prevent image interference! There are stations operating outside the f-m band which could cause such interference, especially when one considers the fact that the *percentage* of spacing of image frequency from desired frequency is much less for f-m broadcast than for a-m broadcast with 455 kc.

*Figure 4-1 Reference* ( $f_u$  is equal to  $f_d + 2f_i$ ).

*Probable Causes, and Remedies*

- a. R-f selectivity poor. Check r-f alignment, coil, tuning capacitor, and tube.
- b. Interfering station signal too strong. Try reorienting antenna to discriminate against interference without losing desired stations. Use wavetrap in antenna circuit.



**4-36. Whistle Sweeps Across Received Signal Frequency or Slowly Settles Down to Steady Frequency-Modulated Whistle**

*Explanation of the Symptom.* Same as in par. 4-32, but occurring in f-m receiver. Other information same as in par. 4-32, except that orientation of the antenna may eliminate or minimize interference without complete loss of desired signal.

**4-37. Desired Signal Becomes Distorted and Fades, Adjacent Channel Comes in**

*Explanation of the Symptom.* This is oscillator drift, as explained for a-m receivers in par. 4-27. Oscillator drift naturally tends to be worse in f-m broadcast receivers than in a-m broadcast receivers because of the higher frequency at which the oscillator must operate. This is partly offset by the fact that more care is usually put into the design of f-m receiver oscillator circuits, many of them including temperature-compensated tuned circuits. In most f-m receivers, drift does occur when the receiver is first turned on, but should stop after from 10 to 20 minutes of operation.

*Probable Causes and Remedies.* Same as par. 4-27. In addition; defective temperature-compensating capacitor in oscillator tuned circuit. Check and replace, if necessary.

**4-38. Desired Station Suddenly Disappears and Another Station Takes its Place; New and Desired Stations Change Off Intermittently**

*Explanation of the Symptom.* This is due to freak conditions in which distant stations are transmitted extra distances with unusual signal strength, to interfere with other stations on the same channel. The condition is due to a meteorological phenomenon called *temperature inversion*. This causes the refraction of the signal in boundaries between warm and cool layers of air, allowing it to bend around the curvature of the earth to greater distances. It is the nature of f-m signals that, when one signal becomes only a little stronger than another on the same channel, it takes over completely and the lesser signal seems to drop out, hence the sudden change-over between the two signals.

*Figure 4-1 Reference* ( $f_u = f_v$ , with relative signal strengths changing).

*Probable Causes, and Remedies.* This interference results from fixed same-channel frequency assignments which are ordinarily noninterfering, and from special propagation effects in nature. There is no remedy except, perhaps, orientation of the antenna to favor the desired signal. These conditions are fortunately quite rare.

## COMMON SYMPTOMS AND REMEDIES

### **4-39. Signal on Adjacent Channel Interferes**

*Explanation of the Symptom.* This case is parallel to that of par. 4-5 for a-m receivers. F-m broadcast channels are spaced 200 kc from carrier center frequency to carrier center frequency. As with a-m broadcast stations, f-m stations in one listening area are assigned with several channels between, in order to minimize local interference. However, in many locations part way between listening areas, adjacent-channel interference is possible between the stations of the two areas. If an adjacent-channel station is extremely strong, it can interfere, even though its center frequency is 200 kc away. On strong peaks of modulation, important sideband components are formed as far as 120 kc from the carrier center frequency, and can thus “spillover” into the desired station channel. Of course, this is not a frequent occurrence, but it does happen. Some of the best-designed receivers have such good skirt selectivity that they reject most of this, but the interference that actually extends into the desired-station channel, of course, still remains.

*Figure 4-1 Reference* ( $f_u$  is 200 kc from  $f_D$ ).

*Probable Causes, and Remedies.* As explained above, this trouble results from location and fixed-frequency assignments and not much can be done except to orient the antenna to favor the desired signal over the undesired signal.

## CHAPTER 5

### WEAK SIGNALS

*Weak signals*, as a symptom, is not subject to many variations. Signals are either weak or they are not, although they may, at the same time, be accompanied by other effects. Weak reception all over the tuning range of the receiver is one big symptom and the most frequently encountered. For this reason, we shall first discuss this main symptom at some length, considering it first from the standpoint of static tests and then from the standpoint of signal tracing. We shall then consider cases in which the weakness of the signal is accompanied by extra effects, such as fading, distortion, etc., and treat these special cases in the same way as the symptom variations presented in Chapter 4.

#### **5-1. Importance of Testing Tubes**

Weak or otherwise defective tubes are one of the principal causes of weak signals. It will be assumed in the following discussions that the reader realizes the importance of checking the tubes early in the trouble-shooting procedure, either to find a defective one as the cause or to eliminate them as a trouble source before proceeding with other matters. Although we shall occasionally refer to tube conditions, we shall at all times assume that everything has been done to check tube condition.

#### **5-2. Static Tests in Weak Receivers**

Since the weak signal condition is one in which the signal is getting through but not in sufficient degree, static tests are not as useful as dynamic tests such as signal tracing. However, certain more or less routine checks are in order before signal tracing begins. Of course, the first natural question is: "Is signal getting to the receiver?" A quick preliminary check should show whether the antenna is adequate for the receiver and the location. There are very few locations in which there is not at least one local a-m broadcast station close enough to provide adequate signal for full receiver a-f output. It should not, therefore, take very long to determine whether or not the weak condition applies particularly to the receiver itself.

## COMMON SYMPTOMS AND REMEDIES

Line voltage is important. An a-c voltmeter is a handy gadget to have with you, especially in rural areas, where long low-voltage lines may drop the voltage to 85 volts or less at the receiver plug. When this happens, plate and heater voltages both drop proportionately, tube emission sags, and general weak operation naturally results. With some experience, one can notice the difference in the brightness of the heaters or filaments in the glass tubes.

If preliminary checks do not indicate much, the receiver must be pulled, and routine checks can be made. Look for low voltages on the plates or screens or for high voltages on the grids or cathodes. A signal may even feed through an r-f or i-f amplifier tube which has *no plate or screen voltage* and result in weak output. The general run of voltage checks in a routine test are outlined in par. 3.7

If a signal generator (test oscillator) and a signal tracer are available, it is well to switch over to the signal-tracing method after the basic voltages have been tested in static tests.

### **5-3. Signal Tracing in Weak Receivers**

If the receiver operates but the sound volume is below normal, we know that the signal must be present at all points along its normal path and that some portion of the set is not functioning at full efficiency. Our first test, as with inoperative receivers, is to measure the wattage consumption. Power-supply overload, resulting from a short circuit in some portion of the voltage distribution network, will be indicated by excessive wattage consumption, if of sufficient magnitude. Minor breakdowns, such as by-pass capacitors in resistance-capacity filters, will not cause sufficient increase in power consumption to be readily recognized in this preliminary test, though such breakdowns are quickly detected by signal tracing. If the power consumption is excessive, the first step is to check the power supply system. If no excessive wattage reading is obtained, we trace the signal along the same path as for inoperative receivers.

In tracing the signal in an inoperative receiver, our interest is confined to determining whether or not the signal is present at each test point. In weak receivers, however, we are interested in the *strength* of the signal at each of these test points. We know that r-f, i-f, and a-f amplification, and mixer conversion gain in a superheterodyne receiver, are determining factors in the ultimate strength of the signal which is fed to the speaker. Therefore, our tests must include a measurement of the gain which occurs in each amplifying stage. In modern receivers, precision measurements of gain-per-stage are not necessary in servicing, since

## WEAK SIGNALS

the sensitivity normally available is usually considerably in excess of that actually required for satisfactory reception. When reception is weak, it usually means that a very great reduction in gain, or even a loss, occurs in one or more amplifying stages. Just what the normal gain per stage should be varies widely in different receivers, but the table of average gain-per-stage values given in par. 3-15 will provide sufficient guidance to determine if any serious trouble is present in the tubes or circuits under test. After each receiver is repaired, it is a good idea to mark the stage gain on the schematic for future reference.

Let us refer to the partial schematic shown in Fig. 5-1. We shall assume that the test oscillator is connected to the antenna and ground terminals of the receiver and a 600-kc signal, modulated at an audio frequency, is being fed to the operating receiver. After tuning the set to 600 kc, the tuned v-t voltmeter probe is placed upon the antenna post, point 1, and the signal reference level is determined in the manner described before. This reference level is noted on the channel indicator eye, or meter, (if a Rider Chanalyst is used), or on the indicating device provided in whatever other type of instrument is being used for this test.

When we place the probe on point 2, an *increase* in signal strength should be indicated by the testing device. This signal amplification or gain is produced entirely by transformer action when the secondary circuit is tuned to resonance with the signal frequency. Therefore, this gain should be indicated even if the receiver power switch is turned off, since no tube amplification takes place in the antenna circuit. The gain from point 1 to point 2 will vary between 2 and 10 in home receivers, averaging around 5.

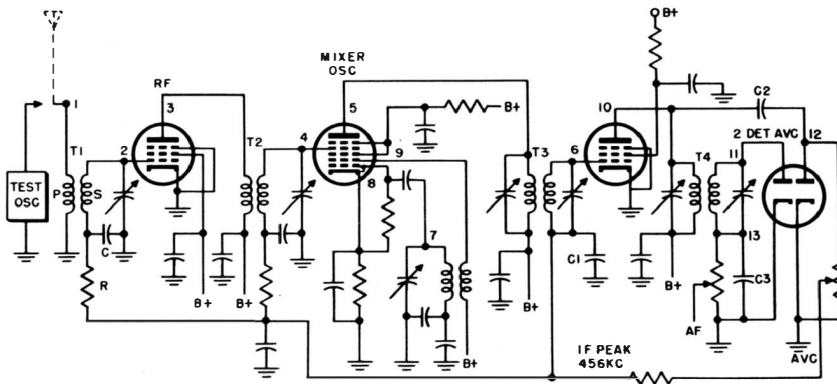

Fig. 5-1. Partial schematic of a typical receiver which is analyzed in the text from a signal-tracing viewpoint.

## COMMON SYMPTOMS AND REMEDIES

If a loss, instead of a gain, is indicated at point 2, then some trouble must be present in this circuit. If the by-pass capacitor *C* were shorted, no AVC bias would be applied to the r-f tube control grid; consequently, grid current would flow when a signal voltage reached the grid. This condition would reduce the gain by loading the secondary circuit. A simple check is to turn the set off while noting the signal level at the control grid. If the gain increases appreciably, then some loading effect is taking place. A slight change in gain, while making this test, is normal because of the slight change in tube input capacitance which results when the r-f tube is not operating; this may be corrected by re-tuning the secondary circuit.

An open-circuited secondary will cause a severe loss in signal strength, though the capacity-coupling through the tube and transformer will provide a faint signal which will be amplified and reproduced by the speaker. If the signal gain is normal at point 2, we continue our tests by placing the probe at point 4. At this point, we are measuring the over-all gain from point 1 to point 4, which embraces the gain in the antenna coil previously measured, plus the gain of the r-f tube and T2. There should be a slight increase in signal level at point 4, above that obtained at point 2. The actual gain will be dependent on the strength of the incoming signal, since the r-f tube is controlled by AVC. To obtain the true gain, the AVC tube should be removed or the AVC rendered inoperative in some other manner. When this is done, the over-all gain should increase. If the gain to point 2 were 5, then the over-all gain to point 4 should become 50 or more. This means that the r-f tube and circuit would contribute a gain of 10 or more. With the AVC acting, and an input signal of 5 to 10 millivolts at the antenna, the over-all gain will range from 10 to 30 or more.

Our primary interest in checking the gain at point 4, however, is to find out if the signal strength increases or decreases at this point, over and above the reading obtained at point 2. If a slight loss is indicated, then the r-f tube and alignment may require checking. Poor tracking, however, seldom causes sufficient loss to cause weak reception since the first effect is to decrease the AVC voltage, which in turn increases the gain. A severe loss, though, indicates a major defect in the operation of the circuit and warrants a test of the voltages and components affecting the operation of this circuit.

Assuming that a normal signal is found at point 4, the next step is to check the i-f signal at point 5 or point 6. This test is made by tuning the voltmeter probe to 456 kc and measuring the signal level. As a result of conversion gain in the mixer, the i-f signal should be stronger than

## WEAK SIGNALS

the r-f signal at the mixer control grid. Again, the conversion gain will be decreased by AVC action, and in case little or no gain is obtained, the AVC voltage should be measured. If a conversion loss is indicated when the i-f signal is measured at point 6, place the test probe on point 5. If conversion gain is present at point 5, then the loss is due to some trouble in the coupling circuit. Normally, there is no gain in the i-f transformer, and in many designs a slight loss is normal. But if the signal level at point 6 is considerably below that at point 5, the circuit is not operating properly. Perhaps the trouble is simply misalignment. (In this connection, remember that the application of the test probe has some detuning effect, which may be appreciable with some tuned v-t voltmeters in which the probe capacity is in excess of 1 or 2  $\mu\mu\text{f.}$ ) A decrease in the coupling between the primary and secondary coils of T3, loosening or shorting of turns in the secondary winding, loading due to grid current in the i-f tube; these are a few possible causes.

Conversion loss, as measured at point 5, the mixer plate, may result from misalignment, incorrect voltages on the mixer tube elements, open screen or B-supply by-pass capacitors, low oscillator voltage, or a defective mixer tube. Another cause, often difficult to locate by other test methods, is lowered i-f transformer efficiency, due to moisture absorption. If the possible sources of difficulty mentioned previously have been eliminated, the i-f transformer should be checked by substitution. By signal-tracing, we localize the trouble to the specific circuit.

A quick test of the screen by-pass capacitor in the mixer circuit can be made without removing the capacitor or unsoldering leads. This is done by placing the test probe of the tuned v-t voltmeter on the screen socket terminal and checking for the presence of the i-f signal at this point. If the screen by-pass capacitor is open, a strong i-f signal will be noted; if the by-pass capacitor is functioning properly, the i-f signal will be by-passed. Hence, little or no signal will be indicated, depending on the sensitivity of the test instrument. In making this test, some signal pickup will be noted when the probe is held near, but not on, the screen socket terminal. This is due to the stray field and capacity-coupling to the plate lead. This signal level should be greatly reduced when the probe is actually in contact with the by-passed terminal, though some slight pickup may still be noted. This functional test of by-pass action can be applied in any portion of the radio receiver and is particularly useful in a-f circuits, where stray pickup effects are not present.

Continuing our signal-tracing tests, we check next the i-f signal at point 10. There should be considerable amplification in this i-f stage, as indicated in the gain-per-stage values given in par. 3-15. Therefore,

## COMMON SYMPTOMS AND REMEDIES

the signal level should be much higher at point 10 than at point 6. Low gain can be investigated in the same manner as discussed above. At point 12, we check the i-f signal transfer from the plate of the i-f tube to the AVC diode rectifier. Absence of any signal at point 12 would make the AVC system inoperative; this trouble could be caused by a short-circuit in the AVC diode plate circuit or an open circuit in C2 or its connecting leads to the diode plate and the i-f plate.

The signal transfer to the second detector diode is checked at point 11. The loading effect of the diode on the i-f transformer secondary causes the signal level at the diode plate to be normally less than at the i-f tube plate. This step-down in voltage ranges from approximately 1.5 to 1 to 3 to 1. The i-f signal should be by-passed by C3, so no i-f signal should be present at point 13. If C3 or its connecting leads are open, a strong i-f signal will be noted when the i-f test probe is placed on point 13. Possible causes of low gain in the i-f stage are similar to those discussed previously and may be checked in like manner.

### 5.4 Tracing the A-F Signal in Weak Receivers

If tests of the r-f and i-f sections of the receiver have shown a strong signal at the second detector, then in all probability the audio amplifier is not providing sufficient gain for the speaker to operate properly. If the speaker field is in shunt with the power supply, we can make a preliminary check for field excitation by placing a screwdriver or other magnetic metal object against the speaker core and noting the magnetic attraction which should result. If this check indicates that field excitation is present, then we may proceed with gain measurements in the a-f system.

*The A-F Reference Level.* The first step is to obtain an a-f reference level. With the signal generator still feeding a modulated r-f signal to the receiver input, turn the receiver volume control to maximum and place the test probe of the a-f test instrument on point 1 in Fig. 5-1. Adjust the sensitivity of the test instrument to maximum and adjust the attenuator of the test oscillator until sufficient audio signal is present at point 1 to give a reference indication on the a-f indicating device.

Now move the test probe to point 2. The signal level should remain substantially the same as at point 1. If the signal is appreciably weaker, check for grid current at point 2, using an electronic voltmeter designed to measure d-c. Grid current will cause a negative voltage to be developed at point 2, due to rectification. This condition would be caused by a shorted cathode by-pass C3 or a cathode-heater short in the first a-f tube.



## WEAK SIGNALS

If the signal is normal at point 2, place the a-f probe on point 3. If the first a-f tube is a high-mu triode, we should expect a gain of about 30 at this point. (See average gain-per-stage values, par. 3-15.) Low gain at this point could be caused by a defective tube, incorrect cathode or plate voltage, or some trouble in the plate load circuit. A shorted coupling capacitor C2 could cause this trouble, since then the plate voltage would be applied to the power tube grid, causing grid current and thus loading the output circuit of the a-f tube.

The a-f signal at point 4 should be substantially the same as that at point 3. A severe drop in signal voltage would result from a high-resistance joint in the coupling capacitor lead connections or at other junctions between points 3 and 4. This condition could likewise be caused by a shorted cathode bias on the power tube, resulting in grid current and rectification of an applied signal. A gassy power tube would also cause a decrease in signal level at point 4. Grid current due to rectification causes a voltage drop in such direction that the power tube grid becomes *negative* with respect to the grid return point; grid current due to gas causes the grid to become *positive* with respect to the grid return point.

If the signal is normal at point 4, check the signal level at point 5, the power tube plate. The signal should be further amplified at this point. Normally, the gain will range from 8 to 20 when pentode power tubes are employed. Decreased gain will result from faults in the power tube, incorrect voltages, short-circuited turns in the output transformer primary, or a shorted secondary winding.

The maximum signal voltage is developed at the output tube plate. This signal voltage is stepped down by the output transformer, since the speaker voice coil is a low-impedance circuit. Therefore, the signal voltage at the voice coil is much lower than at the plate. A voltage step-down of at least 25 to 1 is normal when checking from a power pentode tube plate to a 10-ohm voice coil. Transformer losses, which are especially high in low-priced receivers, will lower still further the voltage at the voice coil.

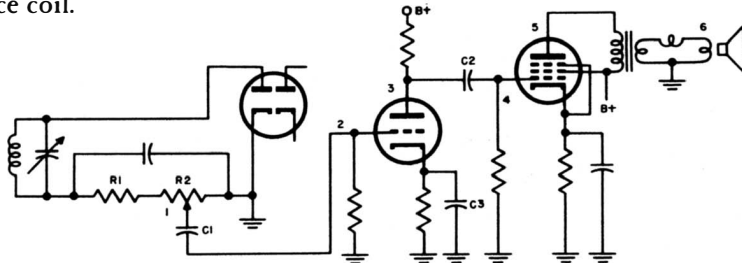

Fig. 5-2. A typical second-detector audio system.

## COMMON SYMPTOMS AND REMEDIES

If the signal is normal even at the last test point, the trouble must be in the speaker voice coil in its connections to the output transformer secondary, or in the field.

### **5-5. Check List of Most Common Causes of Weak Signals**

Now that we have discussed the measures in static tests and signal-tracing for troubleshooting a receiver that gives weak reception all over the dial, it might be well to review in list form the most common causes of this symptom as a whole. This list has been compiled from the most common types of failures in actual servicing work.

To avoid repetition of words and needless expenditure of space, the word *defective*, when used in this listing and applied to coils, capacitors, transformers, resistors, junctions, switches, etc., means "open-circuited," "short-circuited," or as "having high-resistance contacts or connections."

- a. Defective antenna or ground system, with respect to length, height, nature of shielding, and other related items.
- b. Defective r-f, mixer, oscillator, and i-f transformers of all types used in short-wave converter combinations and in single and multiwave-band superheterodynes.
- c. Lack of correct coupling between windings of r-f, mixer, oscillator, and i-f transformers as stated in (b).
- d. Defective hand-changing switches.
- e. Defective trimmer capacitors in r-f, mixer, oscillator.
- f. Incorrect alignment of r-f, mixer, oscillator, and i-f transformer circuits.
- g. Defective image-suppressor circuit.
- h. Grounded r-f, mixer, oscillator, or i-f transformer circuits.
- i. Shorted turns in r-f, mixer, oscillator, and i-f transformer circuits; condition is related to incorrect alignment, although replacement of the transformer must be made.
- j. Defective grid filter circuit resistors and capacitors tied in with the AVC circuit.
- k. Defective operation of channel control systems which "lock" audio amplifier tube.
- l. Too low control voltage in DAVC system.
- m. Defective crystal filter circuit in i-f amplifier, when used.
- n. Defective tuning capacitor.
- o. Incorrect alignment of main tuning capacitor gang.
- p. Low oscillator output.
- q. Excessive AVC voltage due to defective circuit elements.
- r. Shorted turns in r-f, mixer, oscillator, and i-f transformers.

## WEAK SIGNALS

- s. Defective link between AVC or detector tube or channel control tube and noise-suppressor circuit.
- t. Gassy noise-suppressor tube.
- u. High-resistance connections to or within tuning capacitors and r-f, mixer, oscillator, and i-f trimmers, inclusive of units used in all wave bands of multiwave-band receiver.
- v. High-resistance connections to or within by-pass capacitors in r-f, mixer, oscillator, and i-f tube control grid, screen, cathode, suppressor, and plate circuits, wherever used.

As it appears, this is quite a formidable list. Yet, if we were confronted with trouble of this type, we would pay the greatest amount of attention to those items which are related to imperfect alignment. If readjustments failed to correct the condition, then we would consider the remainder in whatever order is most convenient.

### **5-6. Distinguishing between Failure of R-F and A-F Sensitivity**

It is often possible that a weak condition can be traced to the r-f/i-f section or to the a-f section by listening to and interpreting the sound of the signal.

If the front end of the receiver is defective, there will be a tendency toward reception of fewer signals, and those that are received will be accompanied by a higher noise level.

If the a-f section is defective, a large number of signals may be heard and with a relatively low noise level, but they will all appear to be weak. In other words, the signals are getting into the i-f amplifier, but between there and the loudspeaker something is preventing the a-f volume from being what it ought to be at the loudspeaker.

### **5-7. Other Variations of the Weak-Signal Symptom**

We have now discussed the main symptom—namely, weak signals generally. We shall now consider variations in which the weakness of the signals is accompanied by certain specific effects which help in tracing the source of the trouble.

### **5-8. Weak Signals over a Part of Tuning Range (Sometimes Accompanied by Distortion)**

*Explanation of the Symptom.* This type of problem is most likely due to incorrect trimmer alignment in the r-f, mixer, or oscillator circuits, particularly if the fault exists over a section of the complete tuning range (starting with minimum or maximum) and response (both as to signal intensity and tone quality) is satisfactory over the balance of the tuning range. Obviously, the r-f and mixer tubes do not possess the

## COMMON SYMPTOMS AND REMEDIES

power of discrimination as to the selection of a frequency band over which these systems will work best. Hence, the trouble must lie in the tuned circuits. However, it is possible that the oscillator circuit is generating a beating signal which is not of uniform intensity but which decreases in intensity as the tuning range approaches its minimum or maximum limits.

### *Probable Causes, and Remedies.*

- a. Alignment of r-f, mixer, and oscillator trimmers over the part of the band where the receiver affords low output.
- b. Unsuitable antenna system.
- c. The condition of the oscillator tube may be poor.
- d. Defective coupling between input and output circuits of oscillator tube. (Some oscillator circuits employ both inductive and capacitative coupling.)
- e. Defective coupling between oscillator and mixer tubes, or defective pentagrid converter tube.
- f. The resistors or capacitors in the oscillator circuit may be defective.
- g. Incorrect adjustments of antenna trimmer.
- h. Defective tuning capacitor, created when capacitor rotor is revolved past certain point in arc of travel.
- i. All other items listed under symptom in par. 4-26.

### **5-9. Weak Signals Over Certain Bands of a Multiband Receiver**

*Explanation of the Symptom.* See explanation for symptom in par. 5-6.

*Probable Causes and Remedies.* Same as in par. 5-6, plus the following,

- a. Poor contacts at band switches.
- b. Defective coupling coils brought into play for those bands.
- c. Defective ground contacts.
- d. Defective coils.
- e. Imperfect shielding and interaction between coils.
- f. Defective image-suppressor circuit. (These trap circuits are usually removed from the receiver circuit, when wave band is changed to short waves.) Will interfere, if allowed to remain in system.
- g. Synchronous operation of all band-switch sections not obtained.
- h. Defective by-pass capacitors. Effect more pronounced at high frequencies.
- i. Poor ground.

## WEAK SIGNALS

### **5-1. Weak Signals Over Part of Tuning Range, with Converter**

*Explanation of the Symptoms.* See explanation for symptom in par. 5-6.

*Probable Causes, and Remedies.* Any under symptom in par. 5-6 which might apply to converters, plus:

- a. Grounded antenna lead between converter and broadcast receiver.
- b. Defective ground connection between converter and broadcast receiver.
- c. Defective i-f amplifier (t-r-f amplifier in broadcast receiver). (The possibility of a defect of this type exists in those converter combinations wherein the actual tuning is done by tuning the i-f amplifier.)
- d. Defective range switch in converter which comes under the classification (c) above.

### **5-11. Switching Lights or Appliances On or Off Causes Weak Signals**

*Explanation of the Symptom.* Indoor or loop antenna is located so that coupling between electric wiring causes bad effect on antenna pickup. This effect tends to be worse on short-wave bands, where house wiring may resonate.

*Probable Causes, and Remedies*

- a. Indoor antenna in wrong location. Relocate.
- b. Indoor antenna wrong length. Change length; change position.

### **5-12. Distant Station Gradually Becomes Weak, Then Returns Gradually to Full Strength; Locals Remain Steady**

*Explanation of the Symptom.* This is a case of ordinary conventional fading, due to the fact that the distant station is being received by means of *sky-wave* propagation. The signal is being reflected from the ionosphere, which shifts its position and characteristics. This sort of thing is more pronounced in short-wave stations, where the fade is deeper and more rapid, on the average.

*Probable Cause.* Since this a natural phenomenon for the frequency range in which it occurs, there is nothing which the technician can do about it.

### **5-13. In Battery Receiver, All Stations Gradually Get Weaker**

*Explanation of the Symptom.* This is due to the fact that the B-battery is reaching the end of its life, although the A-battery can do the same thing when weak. More frequently, when the A-battery gets weak, it causes operation to cease altogether.

*Probable cause and remedy.* Battery used up. Replace it.

## COMMON SYMPTOMS AND REMEDIES

### **5-14. Midget Receiver with Loop Antenna Gives Weak Reception When Used in Normal Operating Location**

*Explanation of the Symptoms.* The loop antenna is probably against, or very close to, a metal surface, which shields it from normal signal pickup.

*Probable Causes, and Remedies.* Loop antenna close to metal container, sink, tub, stove, etc. Change location of receiver or at least move antenna away from the metal. Also, if desired operating location permits, orient antenna (and receiver) for best reception.

### **5-15. Receiver with R-F Stage and/or Two or More I-F Stages Produces Weak Signals, with Steady or Tunable Rushing Noise**

*Explanation of the Symptom.* The rushing noise is probably internal receiver noise. It usually accompanies signal reception when insufficient signal voltage is reaching the r-f amplifier grid.

*Probable Causes, and Remedies*

- a. Antenna system inadequate. Provide better antenna.
- b. Antenna lead disconnected.
- c. Defect in antenna transformer. Check it for continuity of both windings; inject signal before and after transformer.
- d. Weak r-f amplifier tube. Check it.
- e. Defect causing excessive AVC or other bias on r-f amplifier tube.
- f. Oscillator injection voltage too low. Check pentagrid converter or separate oscillator tube and circuit.

## WEAK SIGNALS IN F-M RECEIVERS

### **5-16. Weak Signals but No Other Sound from Loudspeaker Even with Volume Control Advanced**

*Explanation of the Symptom.* This must be trouble in the a-f amplifier section, since if there is a defect in the front end, there will usually be a background rush and distortion with weak signals.

*Probable Causes, and Remedies*

- a. A-f amplifier tube trouble.
- b. Coupling capacitor open in a-f section.
- c. Plate voltage missing from one of the a-f amplifier tubes, due to failure of decoupling network resistors or capacitors or failure of plate load resistor. Open circuit in primary winding of output transformer or speaker field.
- d. Screen voltage missing from one of the a-f amplifier tubes because of failure of screen grid resistors or by-pass capacitors.

## WEAK SIGNALS

e. Open cathode bias resistor in a-f section.

*NOTE:* Many of the above causes could also result in dead receiver. It is assumed here that they are the cases in which a tube is disabled but sufficient signal voltage feeds through its interelectrode capacitance to produce weak output signals.

### **5-17. Weak Signals with Rushing Noise, Volume Control Well Advanced**

*Explanation of the Symptom.* This usually indicates that the i-f portion and the mixer are working, but are receiving insufficient signal at the r-f amplifier or mixer input. The rushing noise is tube and resistance noise and is normal in f-m receivers when no signal is received. If there is insufficient signal voltage at the input of the receiver to override this residual noise and to operate the limiter, the above symptom usually results. Distortion is also normal when signals are very weak, since the f-m detector does not then work properly.

#### *Probable Causes, and Remedies*

- a. Antenna inadequate or not properly oriented.
- b. Open in antenna lead-in or lead-in connections.
- c. Antenna disconnected at receiver.
- d. Strands of lead-in wire short-circuiting between antenna terminals of receiver.
- e. Antenna coupling circuit to first r-f amplifier tube defective. Inject signal at antenna terminals, then at r-f grid.
- f. Weak r-f amplifier or mixer tube.
- g. Excessive bias on r-f amplifier or mixer tube.
- h. Insufficient oscillator injection voltage. Check oscillator tube, grid resistor, blocking capacitors, and tuned circuit.
- i. Short circuit of leakage in sections of gang tuning capacitor.
- j. Low heater or plate voltage on r-f amplifier or mixer or oscillator tube.

## CHAPTER 6

### DISTORTION

#### DISTORTION IN A-M RECEIVERS

##### **6-1. Nature of Distortion Troubleshooting Problem**

Distortion is one of the most commonly encountered receiver trouble symptoms. It has a variety of forms and variations, as we shall see in this chapter. Its most significant characteristic is a modification of a received signal. In other words, the signal must be received before distortion is experienced. This means that the basic power voltages and currents are, to a large extent, behaving normally and testing with a signal is immediately possible.

There are two ways to trace distortion: (1) Use a signal from a station and trace by noting the quality of the audio signal as heard through headphones or loudspeaker. (2) Inject into the receiver a carrier modulated by a reasonably pure audio tone, then note by ear or by observation of the waveform on an oscilloscope, the presence or lack of distortion. This is done in each case for various points through the receiver circuit, so that the point at which the distortion begins can be determined.

As mentioned above, distortion is primarily a *signal* problem. The use of static tests is therefore limited. However, a quick test of plate and screen voltages may not be amiss before dynamic tracing starts. It is debatable whether it is desirable to check the tubes first or to proceed to signal tracing right away, testing only the isolated tube later.

In any event, one of the most useful instruments for tracing distortion is the *oscilloscope*. For this reason, we have included an oscilloscope waveform with the discussion of each symptom, showing the significant indications in the shape of the wave for each case.



## 6-2. Tracing Distortion

The signal generator or a broadcast signal will be required to test for distortion; likewise, headphones or a cathode-ray oscilloscope. If headphones are used, then a broadcast signal is preferable, since distortion of music or speech is more apparent than on a 400-cycle modulated signal. Alternatively, a signal generator modulated by recorded music or speech from an electrical pickup and amplifier may be used for headphone distortion tracing. If a cathode-ray oscilloscope is available, single-tone modulation as supplied with most test oscillators is essential. This modulation should be substantially free from distortion.

*Distortion Tracing with the Oscilloscope (R-F and I-F Circuits).* Let us first consider the application of the tuned v-t voltmeter in connection with the oscilloscope for distortion tracing. The receiver is set up for test in the manner already described for signal tracing. Instead of checking the signal level at each test point, we examine the waveform of the signal as it passes from stage to stage. This waveform is compared with an initial image, representing that of the signal at the receiver input. Should the two waveforms differ, some receiver circuit is adding distortion. Components affecting the operation of the receiver, at the point in the normal signal path where distortion is first noted, are then checked until the trouble is located. By using the oscilloscope in connection with the tuned v-t voltmeter and the isolating probe, it is possible to test for distortion in tuned circuits without disturbing the circuit under test.

With the test oscillator feeding a 600 kc modulated signal to the receiver input, our first step is to obtain our initial reference waveform. The oscilloscope is connected to the output jack of the tuned v-t voltmeter, the test probe of the latter is placed on point *I* of Fig. 5-1 and a strong, modulated signal is fed to the receiver. The oscilloscope vertical-amplifier gain control is then adjusted until an image of convenient height appears. The horizontal sweep is then adjusted until the wave is synchronized. This is the initial reference waveform. Typical initial waveforms are shown in Fig. 6-1, (a) for a-f modulation alone and (b) for modulated signal.

We can now check the signal waveform at any point in the r-f or i-f system. To save time, it is convenient to test first at readily accessible points, such as the control grid of each tube in the r-f, mixer, and i-f sections. At each of these test points, the signal should become progressively stronger. Therefore, the image on the oscilloscope will correspondingly increase in height. *DO NOT* change the oscilloscope amplifier adjustments; maintain an image of constant height by readjusting

## COMMON SYMPTOMS AND REMEDIES

the input controls to the tuned v-t voltmeter or by decreasing the signal from the test oscillator, if the receiver under test is not equipped with AVC. This is done to avoid overloading of the tuned v-t voltmeter. It is desirable to maintain a fairly strong signal, when the receiver employs AVC, since distortion is often caused by defective AVC action and will not be evident on weak signals.

To proceed with our testing, place the test probe on the input to the following stage at point *f*. After adjusting the oscilloscope image height, examine the image for distortion and note whether the image is perceptibly different from that of the initial reference waveform. If regeneration is present, or if the input grid is drawing current, the waveform will be altered. Other defective conditions can likewise cause distortion at this point. Checking AVC voltage, tube voltages, wiring, and components affecting the operation of this stage will reveal the cause.

*Distortion Tracing with Headphones (R-F and I-F Circuits)*. The procedure for tracing distortion with headphones instead of the oscilloscope is substantially the same as that described above. Our initial reference signal should be a weak but clear signal in the headphones, as picked up at the receiver antenna post when the set is connected to a good antenna and a broadcast program is being received. If the set employs AVC, the volume control should be set at minimum while checking the r-f and i-f systems, to avoid masking the signal by the operation of the loudspeaker. Alternatively, the speaker voice coil circuit may be opened or shorted. The latter will be desirable when a set without AVC is being tested and for a-f system tests.

Testing follows the usual signal-tracing order. The character of the signal at the point on which the test probe is placed is compared

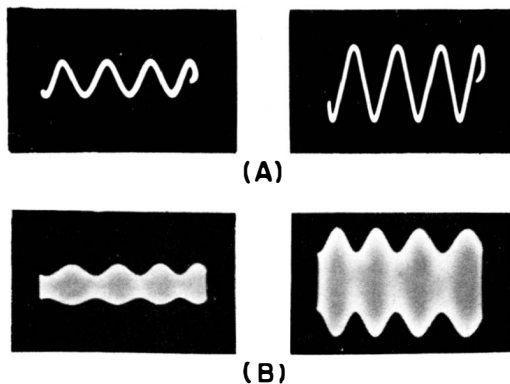

Fig. 6-1. Typical waveforms for (a) a-f and (b) modulated signal.

## DISTORTION

with that at the antenna post by simply replacing the probe on the antenna post from time to time, and readjusting the input controls of the tuned v-t voltmeter to keep a constant signal level.

### 6-3. Distortion Tracing (A-F Circuits)

To localize distortion in a-f systems, the a-f v-t voltmeter or channel is used in connection either with headphones or an oscilloscope as a distortion indicator. The reference audio signal is developed first across the diode load and should be observed at a point corresponding to point 1 in Fig. 5-2 in the receiver under test. This a-f signal should be of sufficient intensity to be clearly audible in headphones connected to the output of the a-f testing device.

If the reference a-f signal is distorted, then there is trouble in the circuit under test or in the character of the modulated signal produced by the test oscillator. The test oscillator signal may be checked by noting the character of the modulation as indicated by a test in the r-f system of the receiver, as described in r-f and i-f testing procedures given before. If there is slight distortion in the test oscillator signal, this will not preclude its being used for test purposes. We need merely to note any *increase* in distortion which occurs during the signal-tracing tests.

If we have our test probe on point 1 in Fig. 5-2 and we have determined that distortion is present, let us see what the cause might be. We note that point 1 is coupled to point 2 by means of the coupling capacitor C1. Then any distortion which may be present at point 2 will likewise be noted at point 1. If the cathode by-pass capacitor C3 were shorted, then there would be no grid bias on the first a-f tube. Consequently, any a-f signal applied at point 2 would cause the grid to draw current on the positive half of the signal wave, thereby causing distortion. If there were no plate voltage on the first a-f tube, the same effect would be noted; for then there would be no plate or cathode current and therefore no voltage drop across the cathode resistor would appear. Consequently there would be no grid bias voltage for the first a-f tube. So distortion results, just as in the preceding case.

The same condition occurs when the a-f test probe is placed on point 3. Any defect which causes the power-tube grid to draw current in this type of circuit will cause distortion at point 3 as well as at point 1. In any case where distortion is noted, it is well to check for grid current, using a microammeter or an electronic voltmeter or check with v-t voltmeter for a negative grid d-c voltage which varies with signal voltage. Care should be taken that the circuit is not being overloaded by using too high a test signal voltage. In such cases, grid current will show even

## COMMON SYMPTOMS AND REMEDIES

if the current is normal. If the cathode bias or the grid-bias voltage is normal, then the tube is being overloaded. If the tube is gassy, a *positive* rather than a *negative* voltage will appear at the power tube grid, with no signal input. This voltage is positive with respect to the grid return point and tends to buck the normal negative bias; therefore, it limits the signal voltage which may be applied at point 4 without causing distortion.

Another cause of a positive voltage at point 4 is leakage in C2. A simple method of differentiating between these two causes of positive voltage at this point is to connect an electronic voltmeter to point 4, with the set turned off. When the set is turned on, if the positive voltage is the result of capacitor leakage, then the voltage will appear as soon as the receiver power supply operates; if the voltage is due to gas, it will take some time to reach a maximum, usually several minutes.

*NOTE:* Although it has been stated that *aural* tests for distortion are best performed with the use of a received signal, record player modulating a signal generator, etc., this is generally not true when an oscilloscope is used as the indicator. In that case, a fixed tone modulation is used on an r-f carrier from a signal generator or an a-f signal is injected at the detector. The tone must of course have a low percentage of distortion to start with, and in its form as the envelope of the amplitude modulated r-f signal.

In the specific trouble symptoms which follow, it is assumed that the oscillograms are derived by connecting the vertical lead from the scope to the a-f output transformer primary and adjusting the oscilloscope horizontal circuit to sync at some convenient submultiple of the modulation (or injected a-f) frequency.

### **6-4. Rough, Nasal Sound Accompanied by Whistle**

*Explanation of the Symptom.* Oscillation in r-f or i-f amplifier stages.

*Oscillogram* (see p. 135)

*Probable Causes, and Remedies*

- a. Faulty by-pass capacitors in r-f and i-f sections.
- b. Incorrect lead dress. Check for coupling between grid and plate leads in r-f and i-f amplifiers.
- c. Improper shielding. Check r-f mixer, and i-f transformer shield cans to see that they make good contact with the chassis.
- d. Improper grounding. Check all ground connections between the antenna and detector to see that they make good contact.
- e. Faulty output filter capacitor. See if this capacitor is open or low in capacitance.

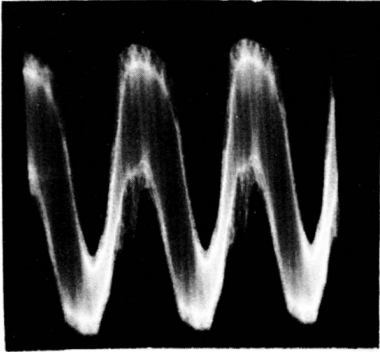

Oscillogram for Par. 6-4

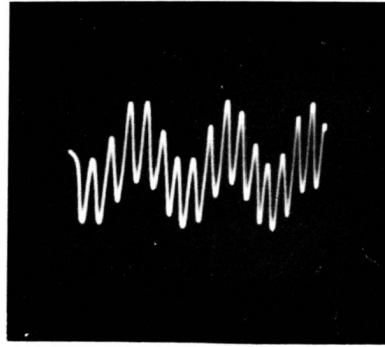

60 CPS

Oscillogram for Par. 6-5

**6-5. Hum Modulation on All Signals, Breaking up Modulation**

*Explanation of the Symptom.* Alternating currents from the power supply or heater circuits are mixing somewhere with the received signal.

*Oscillogram* (see above)

*Probable Causes, and Remedies*

- a. R-f, i-f, mixer, or oscillator grid leads too close to filament or power a-c leads. Check lead dress.
- b. Defective by-pass capacitors. Check all by-pass capacitors for low capacitance and leakage. Don't forget the a-c line by-pass; if none is used, try adding one.
- c. Improper sequence of heater connections in series heater string. Starting from the hot side of the line, this sequence should be: rectifier, a-f output tube, i-f tube, converter, detector/a-f amplifier. If the detector/a-f amplifier is not at the grounded end of the string, or if the others are greatly out of order, hum modulation of signals may occur.
- d. Defective filter capacitors. Check them for low capacitance as well as short circuit. In small receivers, it is often more convenient to check this by simply making a replacement.
- e. Heater-to-cathode short circuit in tube. This is especially likely in a-c/d-c receivers and often happens in a-f output tubes (like the 50L6) which have their heaters at a relatively high potential above ground in the series heater string.

## COMMON SYMPTOMS AND REMEDIES

- f. Open or disconnected loop antenna. The loop antenna normally forms the return path for the mixer or r-f amplifier grid. When the loop antenna becomes disconnected or open, the grid is left floating, and while some signals are often heard, they are accompanied by a loud hum which modulates them.
- g. Open volume control. This produces an effect similar to that of (f) except that it is the grid of the first a-f stage that is left floating.
- h. Fixed bias not present. This again causes a grid to float and pick up hum, this time in the a-f output stage.
- i. Fixed bias supply filter capacitor defective. Check for open circuit or low capacitance.

### 6-6. Rough, Scratchy Distortion; Worse on Modulation Peaks (Louder Passages)

*Explanation of the Symptom.* This is the sound resulting when there is excessive bias on one or more of the amplifier tubes. The signal then operates in the lower curved portion of the  $E_g-I_p$  curve, causing non-linear response and even flattening of the waveform as cut-off point is passed (when amplifier tube is sharp cut-off type).

*Oscillogram* (see below)

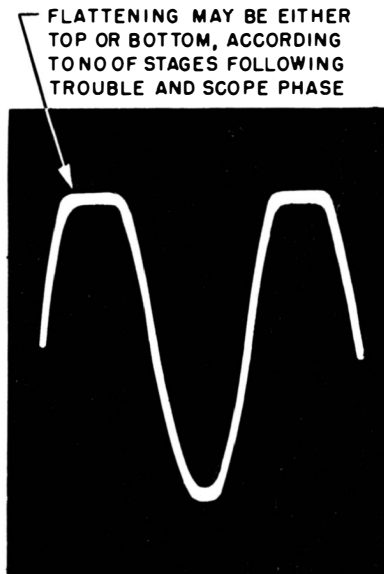

Oscillogram for Par. 6-6

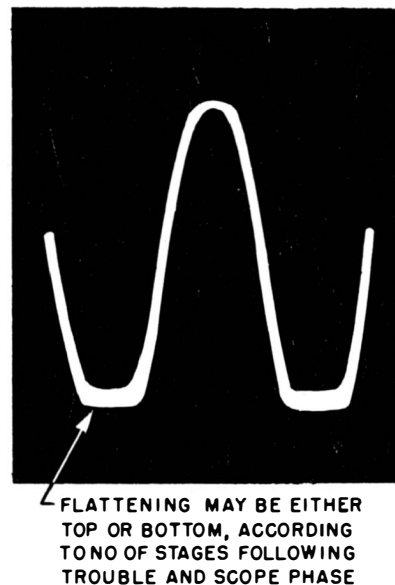

Oscillogram for Par. 6-7

## DISTORTION

### *Probable Causes, and Remedies*

- a. Cathode bias resistor aged to higher value. Check all cathode voltages.
- b. AVC not operating properly. Check detector load resistors and by-pass capacitors.
- c. Defective fixed bias voltage divider. Check plus side of divider for lowered resistance or partial short circuit.

### **6-7. Rough, Scratchy Distortion, with Tendency of Receiver to Go Completely Silent (Block) on Strong Signals**

*Explanation of the Symptom.* Combination of excessive signal strength and/or too little bias on amplifier tubes causes signal overload.

*Oscillogram* (see p. 136)

### *Probable Causes, and Remedies*

- a. Defect in AVC system. Check for improper values of load resistors and capacitors in detector and AVC circuits.
- b. Main AVC by-pass capacitor (usually  $0.5 \mu\text{f}$ ) short-circuited or leaky.
- c. Short circuit in cathode resistor by-pass capacitor.
- d. Short circuit in by-pass capacitor at low end of grid windings of r-f and i-f transformers.

### **6-8. Very Rough, Scratchy Distortion with Considerable Blocking on Stronger Signals**

*Explanation of the Symptom.* Leaking coupling capacitor in capacitance-coupled r-f amplifier or in a-f amplifier.

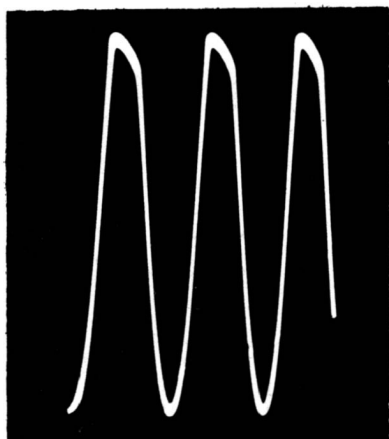

Oscillogram for Par. 6-8

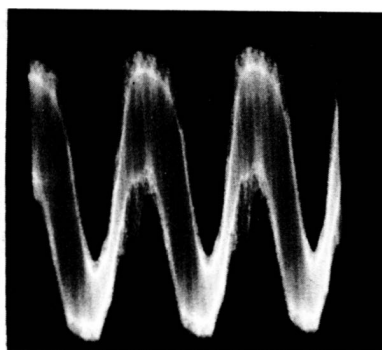

Oscillogram for Par. 6-9

## COMMON SYMPTOMS AND REMEDIES

*Oscillogram* (see p. 137)

*Probable Causes, and Remedies.* Check voltage at these grids with a v-t voltmeter. If they are positive, replace coupling capacitor and recheck for normal grid bias.

### **6-9. A-F Signal Broken up and Modulated by Unstable Whistle or Squeal**

*Explanation of the Symptom.* Defective output filter capacitor. Capacitor does not perform its normal function of providing low power-supply impedance to signal frequencies; thus instability and oscillation may result.

*Oscillogram* (see p. 137)

*Probable Cause, and Remedy.* Low capacitance in output filter capacitor. Check for open circuit or leakage.

### **6-10. Rough, Scratchy Harmonic Distortion at Almost All Signal Levels, without Overloading, in Receivers with Push-Pull Output**

*Explanation of the Symptom.* Phase inverter or push-pull stage out of balance, causing harmonic distortion.

*Oscillogram* (see below)

*Probable Causes, and Remedies*

- a. Weak first a-f amplifier or phase-inverter tube.
- b. One push-pull tube bad. Replace each tube with one known to be good, or check in tube checker.
- c. First a-f amplifier or phase-inverter cathode-bias resistor or capacitor defective. Check cathode voltages.

Oscillogram for Par. 6-10

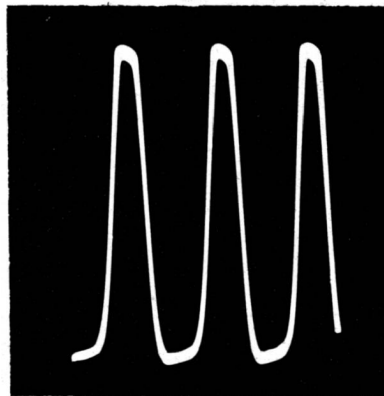



## DISTORTION

- d. Grid-circuit voltage-divider resistors (from which phase-inverter grid gets its signal) defective.
- e. Shorted turns or short circuit to ground in primary winding of push-pull output transformer.

### **6-11. Signal Gradually Becomes Distorted, with Fading**

*Explanation of the Symptom.* This occurs mainly at night, at distances from 20 to 100 miles from the broadcast station, or, for short-wave stations, at almost any time of the day or night. It is known as *selective fading* and results from interference between the ground wave and sky wave of the signal at the receiving location. Its severity varies with the seasons of the year. Because of the irregularity and variety of the nature of the forms of this distortion, and because a steady tone is seldom available on a received signal, no oscillogram is given for this.

*Probable Cause.* Because this distortion results from a natural phenomenon, depending on the location of the receiver, time of year, time of day, etc., there is nothing the technician can do but explain to the receiver owner what is happening.

### **6-12. Fuzzy Rattling and Buzzing with A-F Signal**

*Explanation of the Symptom.* Indicates mechanical troubles, in which parts of solid materials are striking or scraping each other. Since this is mechanical, there is no oscillogram.

#### *Probable Causes, and Remedies*

- a. Dirt or other foreign matter between voice coil and pole piece of speaker. Blow foreign matter out with breath or with gentle pressure from an air hose.
- b. Foreign matter on or against speaker cone. Remove.
- c. Speaker rim does not fit tightly against hole in cabinet, and vibrates against cabinet. Install rubber or felt gasket around rim.
- d. Cabinet resonates at certain frequencies, and loose parts vibrate. Tighten loose parts and try to deaden resonance by adding felt inside cabinet.

### **6-13. A-F Signal Broken up by Heterodyne Whistles from Interfering Signals**

See Chapter 4 for various causes and remedies.

## COMMON SYMPTOMS AND REMEDIES

### DISTORTION IN F-M RECEIVERS

#### **6-14. Problems Similar to Those in A-M Receivers**

Distortion problems in f-m receivers are not much different from those in a-m receivers, with the following exceptions:

1. Overloading in the r-f and i-f stages is not a difficulty unless it actually attenuates the signal seriously, since the frequency modulation will be unaffected. In fact, the limiter stage is actually operated as an overloaded amplifier.
2. The nature of the f-m receiving process is such that weak signals become distorted even though the receiver is operating properly, because of the inability of these weak signals to operate the detector or limiter properly.

Thus, we have one symptom to add for f-m receivers. That is the case of distortion of the signal, accompanied by the characteristic rush of receiver noise, resulting simply because the received signal is out of range, or because some defect in the antenna system or input circuit is preventing sufficient signal voltage from reaching the r-f amplifier or mixer grid.

Distortion can also result from oscillator drift or mistuning. If the receiver is tuned only a few kilocycles away from its proper setting for a station, the signal becomes distorted; and the same thing effectively happens when drift occurs. This is a natural result of the manner of detection (demodulation) and not much can be done except to tune the receiver properly and to keep the drift of the oscillator to a minimum. (Oscillator drift was discussed in Chapter 4.)

## CHAPTER 7

### NOISE

#### 7-1. What Is "Noise"?

In radio and other electronics work, *noise* has taken on special meanings. Its use in describing sounds coming from the loudspeaker is quite conventional. But its meaning has been extended to include the voltages and currents in the receiver which correspond to noise effects at the loudspeaker.

Let us frame a general definition: Noise is sound produced in a loudspeaker (or in headphones) that is not intended to be present. The term also includes the electrical and electromagnetic waves and currents associated with the sound.

In this chapter we are going to exclude noise due to *interference effects*. Heterodynes, such as whistles and growls from undesired signals, fall under our definition of noise; but these troubles have been thoroughly discussed in Chapter 4, so we shall now discuss other types.

*Random noise*, a special type, we shall discuss first. It is different from other types to be covered, in that it is often produced as part of normal operation and must therefore be distinguished from other types which indicate receiver trouble.

#### 7-2. Random Noise

Random noise is of two main types: *thermal agitation noise*, which originates in resistors or resistance of any kind; and *shot effect*, which arises from random distribution of electrons in the electron stream of a vacuum tube.

At their source, such noises are voltages of very low intensity. For this reason, we do not ordinarily hear them reproduced unless the source is followed by considerable amplification. Random noise is more noticeable at higher radio frequencies, because of the naturally lower signal-to-noise ratio.

## COMMON SYMPTOMS AND REMEDIES

Accordingly, we will notice random noise mainly in a-m receivers which have at least one r-f amplifier stage, two or more i-f amplifier stages, or both. A whole book can be written about the nature of noise, but we are considering here the practical matter of distinguishing it from other effects in troubleshooting a receiver.

What does random noise sound like? If you have listened to an f-m receiver with the gain well advanced and no received signal, you know. It is a steady, smooth, rushing or hissing sound. In normal operation of either a-m or f-m receivers, presence of a good received signal causes the noise to disappear, although this effect is more pronounced in f-m receivers because of the limiting action.

In a sensitive a-m receiver, random noise will be particularly noticeable when a weak signal is being received, or when signals are not getting through to the r-f or mixer tube. It will tend to modulate the weak carriers and be more severe as stations are tuned in. In f-m receivers, weak signals are partially covered up by the noise, and sound is distorted. *In either case, the noise itself, if of the random type, is not an indication of trouble.*

### 7-3. Other Types of Noise

We are accordingly concerned primarily in troubleshooting with noise other than the random type. We must, however, recognize the latter when it bears a relation to other troubles.

Practically every other type of noise indicates trouble in the receiver. One advantage in tracing noise trouble is that most noises have characteristic sounds, which allow us to classify each type when we hear it. The type of sound gives a clue to its possible causes.

### 7-4. Static Tests

In the troubleshooting of a noisy receiver, static tests are secondary, but are still important as preliminaries. As was explained in Chapter 6 in connection with distortion, even though the noise is a very convenient signal for tracing, certain routine tests of a static nature are in order, and may eliminate the need for further measures.

A quick test of the power-supply voltages is certainly in order. Sometimes, a particular kind of noise will tend to indicate trouble in a certain section just by the character of its sound; it would then be well to make some voltage and resistance measurements in that section, before starting general tracing procedures.

### 7-5. Tracing Noise

When noise is present in a receiver, the noise is our signal and we require no test-oscillator signal. We trace the noise just as we would trace a radio signal, with the object of finding out just where, along the normal path of the signal, the noise *first* appears.

It is better to trace noise by means of an aural test, by plugging phones in the output jack of the test instrument. The character of the noise heard in the phones can be compared with that reproduced by the speaker, and the noise can then be definitely identified.

Referring again to Fig. 5-2, the test probe is placed on each test point in numerical order until the presence of noise is indicated. In r-f and i-f sections of the receiver, the tuned v-t voltmeter is used, while for power-supply and a-f checking, the a-f v-t voltmeter is employed. If noise is found at the plate of an amplifying tube, check the noise level at the B+ terminal. If the noise level is the same at both points, the power supply should be checked for noise. If the noise level is high, fluctuating voltages will result which will cause noise in all stages of the receiver. By checking the power-supply components, the defective component or connection can be located.

In receivers employing AVC, it is often possible to make a general localization of the noise by simply turning the volume control from maximum to minimum setting and noting whether the noise level changes. If the noise disappears with the volume control at minimum setting, then the trouble is not in the power-supply section which feeds the a-f tubes. If the noise is equally loud at both volume control settings, then the trouble is in the a-f or power-supply sections.

If noise is found at the plate terminal of a socket but not at the grid, the tube may be at fault; this can be checked quite simply by substituting another tube. In transformer-coupled a-f stages, the inter-stage transformer occasionally may cause noise due to electrolysis or other defects. This trouble is readily localized, once the tube has been eliminated as a possible cause. When the noise is not present at the tube grid, but is noted at the plate, check the noise level at the B+ and plate terminals of the transformer primary winding. If the noise is much stronger at the plate, the transformer is at fault. If the noise is equally strong at the B+ and plate terminals, the trouble is not in the transformer. The secondary circuit may be checked in like manner. This same type of test is applicable to r-f, i-f, and a-f transformers.

Having discussed noise trouble in general, we can now proceed with a review of the specific types of noise encountered in troubleshooting.

## COMMON SYMPTOMS AND REMEDIES

### **7-6. Sputtering and Frying, Sometimes with Intermittent Buzzing**

*Explanation of the Symptom.* Component is breaking down under applied voltage and is sparking or arcing.

*Probable Causes, and Remedies*

- a. Plate by-pass capacitor failing.
- b. Thermal cycling at break in transformer winding.
- c. Noisy defective composition-type resistor.
- d. Speaker field or filter-choke winding arcing over to ground.

### **7-7. Loud Ringing or Distorted Tone, Starting or Stopping when the Receiver Is Jarred**

*Explanation of the Symptom.* Microphonic tube.

*Probable Causes, and Remedies.* Tap all tubes, one by one, with eraser end of pencil. When noise is localized to one tube, replace it as a check.

### **7-8. Scratching Noise when Volume Control Is Adjusted**

*Explanation of the Symptom.* Volume control contact dirty or the element is defective.

*Probable Cause, and Remedy.* Replace defective volume control with new one.

### **7-9. Scratching Noise When Dial Is Tuned to Certain Frequencies**

*Explanation of the Symptom.* Something is short-circuiting tuning capacitor as it moves through part or parts of its range, or is causing poor ground contact.

*Probable Causes, and Remedies*

- a. Variable capacitor plates touch or scrape. If only certain parts have warped, straighten them. If whole rotor displaced, try adjustment of end screw at bearing.
- b. Dirt or other foreign matter in bearings or defect in ground contact. Clean, and secure connections.
- c. Bare wire or stator lead located so as to short between rotor and stator of variable capacitor when adjusted. Dress leads, and add insulation where necessary.

### **7-10. Motorboating ("Putt-Putt" sound)**

*Explanation of the Symptom.* This is actually a very-low-frequency oscillation, and occurs when an appreciable impedance to low-frequency signals is developed across the power supply or is otherwise common to two or more stages.

*Probable Causes, and Remedies*

- a. Low capacitance in output filter capacitor.
- b. Defective resistors and capacitors in decoupling network.
- c. Defective AVC by-pass capacitor.
- d. Open grid circuit. Test resistance from grid to ground in each stage, comparing result with what ought to be there.

**7-11. Steady Howl**

*Explanation of the Symptom.* This may be a result of the same kind of condition as in par. 7-10, except frequency is higher. May also be due to improper local oscillator operation.

*Probable Causes, and Remedies.* Same as for symptom in par. 7-10, plus:

- a. Defective resistor in oscillator grid circuit, or radical change in its value.
- b. Defective coupling capacitor or tube in oscillator circuit.

**7-12. Steady Roaring or Buzzing, Stopping Periodically; Sometimes Coming on Only at Certain Times of the Day**

*Explanation of the Symptom.* Appliance noise or power leak (man-made noise).

*Probable Causes, and Remedies*

- a. Vacuum cleaner, razor, welding machine, or other device in vicinity radiating noise to receiver. Attempt to locate offending device and put line filter on it. Also try filter at receiver. If receiver has loop antenna, try reorienting it.
- b. Power leak in overhead lines or at pole transformer. Localize as much as possible with portable receiver, then notify power company. Telephone poles are usually numbered. If trouble can be localized to the vicinity of one pole, its number should be reported.

*NOTE:* The subject of man-made noise in radio reception is a large one and naturally cannot be completely covered here. It is suggested that the technician consult the literature of capacitor manufacturers and other companies who deal in interference eliminators for further information.

**7-13. On Short Waves, a Series of Popping or Sputtering Noise Pulses, Having a Regular but Variable Frequency, and Synchronized to Automobile Engine or Other Gasoline Engine**

*Explanation of the Symptom.* Except for models actually installed in cars, this noise is seldom experienced in a-m broadcast reception, but

## COMMON SYMPTOMS AND REMEDIES

is most severe from 10 mc up through the vhf range. It is called *ignition noise*.

### *Probable Causes and Remedies*

- a. Short-wave antenna favors direction of busy highway.
- b. Unshielded antenna lead-in is picking up noise. Try coaxial lead-in or other shielded type, with shield grounded. Also try to make impedance match of lead-in to antenna as good as possible at the desired frequencies.
- c. Use a noise-balancing antenna.
- d. For communications reception, where only voice is involved, a noise-limiter circuit in the receiver is useful. Noise limiters cause considerable distortion on reception of music.

### **7-14. Noise Problems in F-M Receivers**

The f-m system of transmission and reception was developed to minimize the effects of man-made and receiver random noise, and this it does very efficiently. Such noises can then be eliminated as problems for f-m receivers, assuming there are no defects which interfere with the noise-combatting properties of the receiver. Random noise is very definitely present when the gain is advanced and the receiver is tuned between stations, or when insufficient signal is present to provide limiting and to operate the detector properly.

Of course, all those types of noise troubles which involve interaction between different parts of the receiver itself, such as howling, motorboating, etc., are encountered in f-m receivers as well as in a-m receivers.

There is one type of noise which sometimes causes appreciable trouble in f-m receivers, especially if signals are somewhat weak and the noise source is nearby. This is *automobile ignition noise*. With a strong signal, even strong ignition noise should be "swamped out" by the limiter (or limiting action of the ratio detector) if the receiver is properly aligned and in good operating condition. However, for weaker signals, such noise may ride through if very strong (especially on the smaller, lower-price receivers).

If the receiver is functioning properly otherwise, the best ways to combat ignition noise are as follows:

1. Mount antenna as high and as much "in the clear" as possible.
2. Orient antenna to discriminate against the direction from which the noise comes (usually a road).
3. If necessary, use shielded lead-in with grounded shield, to minimize lead-in pickup.



## CHAPTER 8

### DEAD RECEIVER

#### **8-1. Nature of the Dead-Receiver Symptom**

Service technicians usually like to work on a dead receiver, because the symptom is final and definite, and the results of tests and remedial measures are immediately apparent.

What do we mean by the term *dead receiver*? We mean that there is no sound from the loudspeaker, no matter how we adjust the controls. In practice we temper this definition a little, of course, since a receiver which produces a very weak hum and nothing else would also be referred to as *dead*, and this hum is one of our helpful clues in troubleshooting.

Here we have another symptom like that of weak signals—there are practically no variations as far as loudspeaker indications are concerned. We must draw our clues from other indications, such as information from the owner as to how the receiver failed, observation of whether heaters are lighted, whether there is any odor or evidence of charring, overheated tubes, etc.

#### **8-2. Can Power Be Safely Applied?**

Many times the owner of a receiver realizes that it is a good idea to turn off his receiver as soon as a defect in performance appears, to prevent further damage. Further application of power by the technician may increase damage and obscure evidence as to the original failure. Thus, it is important that, before making either static tests or dynamic tests, we determine whether or not application of power will damage receiver components.

We appreciate the difficulty of establishing whether or not the fault is of such type that, if the receiver is turned “on,” it will damage some parts, but that is one of the problems of servicing. Of course, the safest method of locating the fault, provided that it is of the type which will manifest its presence during a routine point-to-point test, is to make

## COMMON SYMPTOMS AND REMEDIES

the test with the receiver disconnected from the power line and with the tubes out of the sockets. After this test is completed and it has been determined that the fault is not one of circuit constants, the test for resonance and open capacitors can be applied. If, however, the fault lies in one of the transformers, r-f, mixer, oscillator, i-f, or audio systems, it will become evident during the point-to-point test. The replacement is made or the remedy applied and the receiver placed into operation without need for any further tests, other than what would be a routine check-up of the alignment.

### **8-3. Preliminary Static Tests to Determine Whether Power Should Be Applied**

Based on an analysis of experience in the field, we have come to the conclusion that the safest method of operation when you are confronted with the problem we have been discussing is to proceed as follows:

1. Disconnect the receiver from the power line, and with all tubes in the sockets, check the d-c resistance across the output of the rectifier tube. If the measured value approximates the d-c resistance of the filter choke or chokes, (as the case may be), you can be certain of the existence of a short circuit somewhere in the system, thereby establishing the fact that you cannot turn on the power for routine testing, because of the possibility of damaging some of the units in the receiver. As a matter of fact, if the measured d-c resistance across the rectifier tube output is not much greater than the d-c resistance of the filter choke, which may be the speaker field, it is unsafe to test with the power on. The measured value of resistance must be substantially greater than that of the filter choke. This establishes sufficient resistance across the rectifier output to prevent damage to the rectifier tube or other parts in the receiver. A good minimum value to look for is 10,000 to 13,000 ohms, as explained in Chapter 3. Of course, under "power on" conditions, with heaters operating, the effective resistance is much lower.
2. If test 1 reveals no trouble and the power pack employs a step-up transformer, the next step is to make a routine d-c resistance test of the secondary windings of the transformer.
3. If test 2 reveals no trouble a simple d-c resistance test upon the primary winding will establish its condition, with respect to the application of power to the receiver as a unit. The original power may come from a vibrator operated from the storage battery or from the d-c or the a-c power line.

### 8-4. Static Tests in Dead Receivers

After the preliminary tests of par. 8-3 have been completed, the technician should know whether he can apply power to the receiver. If this is feasible, he may find it profitable to conduct signal tracing or signal-injection tests from this point on, or he may elect to make a few more static tests before doing so. The individual circumstances will have much to do with this decision.

On the other hand, if the preliminary tests show that it is not advisable to apply power, he *must* be limited to making resistance measurements.

There is no way to lay out a program of resistance measurements for such a case, since the results of one reading will govern the choice of the next. However, it is recommended that the procedure outlined in par. 3-6 be followed, plus checks of all capacitors for short circuit and of resistors for changed value or open circuit. Open coils and transformers are an important possibility. Of course, the same information which we find in the tests in par. 8-3 also tells us it is unsafe to apply power to the receiver; it also usually gives us important clues as to where to start making the resistance checks. For example, if there is low resistance between B+ and ground, we look for shorted screen or plate by-pass capacitors. Undoubtedly, the majority of cases are those in which power *can* be applied. We may then make voltage tests outlined in par. 3-7 or use signal-tracing as we shall now explain.

### 8-5. Signal Tracing in Dead Receivers

Now, let us assume that we have before us on the test bench a dead receiver. Since the receiver will not reproduce any signal which is fed to its input circuit, we know that at some point along the normal signal path, some defect exists which causes the signal to disappear. This trouble may be present in the very first circuit we test; in that case, no matter how well stages which follow may be performing, the signal will not be passed along to them. Again, the trouble may occur at the fourth or fifth test point, or even at the last point of test. Then we shall find the signal normal at all preceding points along our test path. Our signal-tracing tests continue stage-by-stage as long as we find a normal signal present at each test point. But when we reach the point where no signal is present, we check the components which affect the signal at that point, until the defect is located. This stage-by-stage test enables us to uncover many faults which otherwise might pass unnoticed, since we can make certain that each tube and circuit is performing as it should before proceeding to the next test point.

## COMMON SYMPTOMS AND REMEDIES

In Fig. 5-1, we show a partial schematic of this receiver which we are to test by signal tracing. This is a diagram of a conventional a-c superheterodyne employing an r-f stage, a combination mixer-oscillator, one i-f stage and a dual-function second detector and AVC diode. This receiver normally operates over the standard broadcast band, from 540 kc to 1700 kc.

Since this receiver is inoperative, we shall assume that a wattage consumption test has already been made and has shown that no serious trouble exists in the power supply. Therefore, we can apply our signal-tracing tests. Connecting our test oscillator leads to the antenna and ground terminals of the receiver, we tune both the receiver and the test oscillator to 600 kc. We make certain that the signal is actually being applied to the receiver by placing the isolating probe of our tuned v-t voltmeter upon the antenna terminal and tuning the voltmeter to the test signal frequency. The test-oscillator attenuator is then adjusted until an indication is obtained on the tuned v-t voltmeter output indicator. The indication so obtained should be one that can be readily duplicated; if a channel "eye" is the indicating device, the eye should just close. If a meter indicator is used, the pointer deflection should be noted. This indication is termed the *reference level* and will be required for gain-per-stage measurements.

If we have previously used the test oscillator and tuned v-t voltmeter on a normally operating receiver, we know just about where the test-oscillator attenuator should be adjusted to produce this reference level. It is possible that when we connect the test oscillator to an inoperative receiver we shall not be able to obtain sufficient signal output from the test oscillator to produce this reference level. Let us see what could cause this condition. Examining the diagram, we note that the test oscillator is supposed to be connected across the antenna and ground terminals of the receiver which, in turn, are across the primary of the antenna transformer. Now, if this antenna coil is shorted or the antenna post has become grounded in some manner, we shall be unable to obtain our desired reference level. Therefore, the input to the receiver is short-circuited, and this trouble must be cleared before the receiver can operate.

If the antenna transformer primary circuit is open, then we shall obtain our reference indication when checking the signal at point 1, but this signal will not be present at point 2, which is the next point of test along the natural path of the signal. The test at point 2 may be made by placing the test probe either on the control-grid cap of the first r-f tube or on the stator of the tuning capacitor. The latter test point is more conveniently accessible when the receiver employs single-ended

## DEAD RECEIVER

tubes, such as the 6SK7. At point 2, the signal should be stronger than at point 1, since there is a voltage step-up in the antenna transformer. We can measure this gain in signal strength, but in the case of an inoperative receiver, we are primarily interested in finding the point where the signal disappears completely, and not in the actual gain.

Absence of the signal at point 2 could be caused by a shorted tuning or trimmer capacitor, control grid to cathode short in the r-f tube, or open-circuited antenna transformer secondary. If the signal is absent at this point, we check this portion of the circuit by visual examination and ohmmeter measurements until the fault is located. If the signal is present, we continue to trace the signal.

The next point of test may be either point 3, the r-f tube plate, or point 4, the mixer control grid or the stator of the tuning capacitor. The latter point is usually more accessible. If the signal is absent at point 4, we can check back to point 3. If it is present at point 3, then the trouble must be in the mixer input circuit and could be caused by defects similar to those enumerated above. No signal at point 3 would indicate some trouble in the r-f tube circuit, such as an open transformer primary, open or shorted voltage supply to the screen grid or plate, open cathode, or some defect in the tube itself.

If the signal is present at point 4, then we may proceed to check the set oscillator at point 7. The oscillator signal frequency should be 1056 kc when the receiver is tuned to 600 kc, thus combining with the incoming signal to produce the required intermediate frequency, 456 kc. If the oscillator is functioning properly, signal tracing continues by testing the i-f signal at either point 5 or point 6, followed by tests at point 10 and point 11. Since the intermediate signal frequency is 456 kc, the tuned v-t voltmeter should be adjusted to this frequency when checking the i-f amplifier circuits.

### 8-6. Sectional Trouble Localization

If the i-f signal is present at the second detector plate, this is conclusive evidence that the r-f, mixer, oscillator, and i-f sections of the receiver are in operating condition. When the receiver under test is inoperative, such as we are considering now, presence of the i-f signal at point 11 immediately localizes the trouble in the detector or the a-f system. By the same token, absence of the i-f signal at point 11 indicates that the source of trouble exists in or ahead of the second detector. For rapid trouble localization in inoperative receivers, it is often convenient to check the signal at point 11 *first*, thus confining stage-by-stage tests to

## COMMON SYMPTOMS AND REMEDIES

a limited number of stages. This test is applicable to any superheterodyne receiver, whether or not AVC is employed.

In receivers employing AVC, a measurement of the AVC voltage which should result from a strong signal applied to the receiver input can likewise be used to localize the cause of failure to operate. Failure to obtain an AVC voltage reading indicates that stage-by-stage tests of the sections ahead of the AVC tube are necessary, while the presence of AVC voltage indicates that all sections ahead of the AVC tube are functioning. Signal tracing, in the latter case, can then start at the second detector.

### 8-7. Tracing the A-F Signal in Dead Receivers

Now that we have followed the signal through the r-f, mixer, and i-f stages to the second detector, the next step is to trace the signal through the audio system. A typical detector-audio system is shown in Fig. 5-2. The audio signal should first appear across R1 and R2. To test this signal, we shall require a test instrument or channel capable of indicating a-f voltages and having an input impedance which is high in comparison with that of the circuit under test.

The normal path of the audio signal corresponds to the numerical order of the numbered points on the diagram, Fig. 5-2. To trace the audio signal, place the a-f probe on point 1, making certain that the volume control is at maximum. If no audio signal is present, (indicated by failure of the test instrument to show a reading), check the components in this circuit. If the signal is present at point 1, continue signal tracing by placing the probe on point 2, thus checking the signal transfer through the a-f coupling capacitor C1. Absence of the signal at point 2 indicates an open circuit, since a short circuit would likewise eliminate the signal at point 1.

At point 3, the signal will normally be amplified and will be so indicated on the a-f test instrument. The amount of amplification or gain which thus results is of no consequence for this test, since our primary concern with an inoperative receiver is in finding the point in the normal signal path where the signal *first* disappears, and not the relative strength of the signal at the various test points. When this desired point is reached, we test the components affecting the operation of that particular circuit under test until the defective component is located, just as was described in signal tracing through the r-f and i-f sections. At point 3, absence of the a-f signal might indicate an open plate resistor, an open cathode resistor, or a grounded plate in that specific stage. The same

## **DEAD RECEIVER**

reasoning applies in signal testing at any other of the numbered test points in the amplifier circuit. If the signal is present even at the last test point, 6, we know the speaker circuit is at fault, since no sound results.

## INDEX

### A

Adjacent channel interference, 116  
Adjacent channel selectivity, 96-98  
Alignment, imperfect, 125  
Alignment, in troubleshooting, 89  
Amateur interference, 102  
Amplifier, i-f, 18-19  
Antenna, cause of weak signal, 124  
Antenna, loop, 128  
Appliances, switching, 127  
Audio frequency amplifier, 24-27  
Audio frequency sensitivity, 125  
Audio frequency, tracing, in dead receiver, 152-153  
Audio reference level, 122  
Audio signal, tracing, in weak receivers, 122-124  
Automatic frequency control, 31-34  
Automatic volume control, 11, 27-31, 89, 108, 124, 132-133, 137, 151-152

### B

Basic sections, importance of, 9  
Battery weak, 127  
Beat frequency oscillator, 107  
Blanket effect, 103-104  
Blocking of receiver, 137  
Blurred reception, 101  
Buzzing, 139, 145  
Buzzing, intermittent, 144

### C

Capacitors, cause of weak signal, 125  
Chanalyst, 80-82, 88-89  
Code interference, 102  
Combination AM/FM receivers, 60-63  
Conversion, double, 34-36  
Conversion section, 11-12, 41-45  
Converter, 12, 107  
  oscillator section, 15-16  
  pentagrid, 12-14  
  separate oscillator, 16  
  triode-heptode, 14-15  
  triode-hexode, 14-15  
  weak signals in, 127  
Crystal filter, 36  
Crystal probe, 84-85

### D

Data, service, 67-68  
Dead receiver, 147-153  
  nature of symptom, 147  
  signal tracing, 149  
  static tests in, 149  
  tracing a-f signal in, 152-153  
Demodulation, methods of, 50  
Demodulator, 19-24  
Detector, 50  
  FM, 54-60  
  gated-beam, 58-60  
  ratio, 56-57  
  second, 19-24  
Dial, operation over only part of, 110  
Discriminator, 54-56  
Distortion, 130-140  
  in AM receivers, 130-139  
  in FM receivers, 140  
  gradual, 139  
  nature of problem, 130  
  oscilloscope tracing of, 131-132  
  tracing, 131-134  
  tracing with headphones, 132-133  
Double-conversion, 107

### E

Equipment, troubleshooting, 69

### F

Fading, 127, 139  
Filter, crystal, 36  
Foster-Seeley discriminator, 54-56  
Frequency drift, oscillator, 111  
Frequency, intermediate, 5  
Frequency modulation detectors, 54-60  
Frequency modulation, image interference, 114  
  interference, 113-116  
Frequency modulation receiver, 37-39, 113-116  
Frequency modulation receivers, weak signals in, 129  
Frying, 144  
Functional receiver sections, 6  
Fundamental troubleshooting problems, 67-69



## INDEX

- G**
- Gain measurements, 87-89  
 Gated-beam detector, 58-60  
 Grid voltage, oscillator, 75  
 Growl background, 108
- H**
- Harmonic, of i-f signal, 109  
 Headphones, tracing distortion  
   with, 132-133  
 Heptode, 14-15  
 Heterodyne interference, 93-94,  
   100, 104-106  
 Heterodyne whistle, 139  
 Hexode, 14-15  
 High frequency stations, at low end  
   of dial, 106-107  
 Howl, 112, 145  
 Hum, 101, 135
- I**
- Ignition noise, 145-146  
 Image interference, 17, 94-95, 98  
 Injection, signal, 85-86  
 Instruments, for signal tracing, 80-  
   85  
 Interference, adjacent channel, 116  
   amateur, 102  
   code, 102  
   direct i-f, 99  
   due to temperature inversion,  
   115  
   from nearby transmitter, 103  
   heterodyne, 93-94, 100  
   high frequency stations at low  
   end of dial, 106-107  
   image, 17, 94-95, 98  
   police radio, 102  
   poor adjacent channel selectivity,  
   96-98  
   symptoms, 95-96  
 Intermediate frequency, 5, 16-18  
   common values, 18  
   determining unknown, 90  
   interference, 99  
 Intermediate frequency amplifier,  
   18-19, 45-50  
 Intermediate frequency circuits,  
   distortion in, 131-132  
 Inverter, phase, 25-27
- L**
- Limiter, 38, 50-54  
 Loop antenna, 128  
   coupled to light circuit, 127
- M**
- Measurements, gain, 87-89  
   resistance, 70-73  
   voltage, 73-76  
 Microphonic tube, 144  
 Mixer, 12  
 Modulated signal interference, 113  
 Modulation, hum, 135  
   peaks, 136  
 Motorboating, 144  
 Multiband receivers, weak signals  
   in, 126
- N**
- Nasal sound, 134  
 Noise, 141-146  
   definition, 141  
   problem in FM receivers, 146  
   random, 141-142  
   tracing, 143
- O**
- Ohmmeter, 70  
 Oscillation, 5  
   in r-f or i-f stages, 134  
 Oscillator, beat frequency, 107  
   critical circuits, 15-16  
   drift, in FM, 115  
   frequency drift, 111  
   grid voltage, 75  
   separate, 16  
 Oscilloscope, tracing distortion  
   with, 131-132, 134
- P**
- Pentagrid converter, 12-14  
 Phase discriminator, 54-56  
 Phase inverter, 25-27  
 Police interference, 102  
 Power, application to dead  
   receiver, 147-148  
 Preliminary tests, signal tracing, 78
- Q**
- Quick preliminary tests, 68-69
- R**
- Radio frequency circuits, distortion  
   in, 131-132

## INDEX

- Radio frequency section, 9-11, 39-41
- Radio frequency sensitivity, 125
- Random noise, 141-142
- Ratio detector, 56-57
- Rattling, 139
- Receivers, AM/FM, 60-63
  - comparison of types, 3-6
  - FM types, 37-39
  - function, 3
  - sections, 6
  - t-r-f, 4
- Reference level, audio, 122
- Resistance measurements, 70-73
- Ringing noise, 144
- Roaring, 145
- Roughness, 134
- Rushing noise, 112, 128
- S
- Scratchy distortion, 136
- Scratchy noise, when dial tuned, 144
- Second detector, 19-24
- Sections, a-f amplifier, 24-27
  - basic, importance of, 9
  - conversion, 11-12
- i-f amplifier, 18-19, 45-50
  - r-f, 9-11, 39-41
  - of receiver, 6
- Sectional trouble, 151-152
- Selectivity, 5
  - adjacent-channel, 96-98
- Sensitivity, loss of, 125
- Service data, importance of, 67-68
- Signals, undesired, 93-116
- Signal injection, 85-86
- Signal tracing, 77-85
  - advantages, 77-78
  - a-f signal in dead receiver, 152-153
  - in dead receiver, 149-151
  - instruments, 80-85
  - preliminary tests, 78
  - signal source for, 79-80
  - in weak receivers, 118-122
- Single-peaking, of i-f transformers, 47
- Sky wave, 127
- 156
- Source, signal, 79-80
- Spurious response, 93-94
- Sputtering, 144
- Stagger-tuning, 47
- Static tests, 69-70, 142
- Static tests, on dead receiver, 148-149
  - in weak receivers, 117-118
- Superheterodyne, 3-8
  - AM, arrangements, 6-8, 3-36
  - double-conversion, 34-36
  - FM, 37-63
- Switching lights affects reception, 127
- Systems, fundamental troubleshooting, 67-90
- T
- Television, sweep circuit interference, 113
- Temperature inversion, causing FM interference, 115
- Tracing, a-f distortion, 133-134
  - audio in weak receivers, 122-124
  - distortion, 131-134
  - instruments, 80-85
  - noise, 143
  - signal, 77-85
- Trimmers, i-f, 111-112
- Triode-heptode, 14-15
- Troubleshooting equipment, 69
- Troubleshooting, and receiver function, 3
- Tubes, testing, 117
- Tuned radio-frequency receiver, 4
- Tuning, at two points, 108
- Tunable whistle, 100, 107-108
- U
- Undesired signals, 93-116
- V
- Voltage chart, 73
- Voltage measurements, 73-76
- Volume control, scratchy, 144
- W
- Weak signals, 117-129
- Whistle, 134
  - near i-f peak, 109
- Whistle interference, 112-113
  - to FM, 115
- Wobble, 101



# Other Rider Books

## **BASICS OF PHOTOTUBES & PHOTOCELLS**

by David Mark

Phototubes and photocells are prominently used in a great many applications of electronic devices. Science, industry, government agencies, television, and many communication facilities employ them. This book is devoted to the explanation of the principles and practices surrounding phototubes and photocells, with the utmost in visual presentation to make the subject most understandable. It is tantamount to a "picture course" . . . yet it is authoritative and modern.

Soft Cover, 136 pp., 5½ x 8½", illus.

#184.....Only \$2.90

## **INTRODUCTION TO PRINTED CIRCUITS**

by Robert L. Swiggett

Here is a really comprehensive text on PRINTED CIRCUITS, the recent development that has revolutionized the electronics industry. The author, who is an acknowledged expert on the subject, gives complete coverage to the various manufacturing processes used. Numerous practical applications are discussed, and the maintenance techniques peculiar to printed circuits are clearly explained.

*This authoritative book is of particular interest to technicians, engineers . . .*

and all industrial personnel who are associated with any phase of commercial or military electronics production.

Soft Cover, 112 pages, 5½ x 8½", illus.

#185.....Only \$2.70

## **HOW TO USE METERS**

by John F. Rider

Explains in detail the construction and operation of all types of electrical meters. Gives special emphasis to the details of what kinds of meters to use for making different kinds of measurements in electronic and electrical equipment. Also explains how to make the measurement . . . namely, where to connect the meters.

Soft Cover, 144 pp., 5½ x 8½", illus.

#144.....Only \$2.40

## **HOW TO USE SIGNAL & SWEEP GENERATORS**

by J. Richard Johnson

Discusses all types of signal and sweep generators, and their applications in AM, FM radio, and TV.

Soft Cover, 144 pp., 5½ x 8½", illus.

#147.....Only \$2.10

## **HOW TO USE TEST PROBES**

by A. Ghirardi & R. Middleton

The only book of its kind! Complete step-by-step explanations with practical examples of applications of all types of test probes used with test scopes, VTVM's, and VOM's.

Soft Cover, 176 pp., 5½ x 8½", illus.

#165.....Only \$2.90

## **OBTAINING & INTERPRETING TEST SCOPE TRACES**

by John F. Rider

Explains screen traces seen on test oscilloscopes in clearly understandable, non-mathematical language. Contains over 800 scope traces in the sinusoidal family, square, rectangular, trapezoidal, saw-toothed, differentiated and integrated waveforms. Shows ideal and practical examples with description and explanation to foster recognition. It also deals with alignment waveforms and response waveforms for all varieties of communication equipment. Shows how to connect the scope and operate the scope for many varieties of observations.

Soft Cover, 190 pp., 5½ x 8½", illus.

#146.....Only \$2.40

## **TV SWEEP ALIGNMENT TECHNIQUES**

by Art Liebscher

An expert of long standing explains in detail the principles and practices of alignment techniques for television receivers. This is the most complete explanation of the subject available in any textbook. Covers the front end, the video and sound I-F's, the sound channel, and response curves of the video amplifier.

Soft Cover, 128 pp., 5½ x 8½", illus.

#145.....Only \$2.10

## **HOW TO LOCATE & ELIMINATE RADIO & TV INTERFERENCE**

by Fred D. Rowe

An expert from the Northern California Electrical Bureau tells how to locate sources of radio and TV interference and how to correct them. This is not a theory or "perhaps" book. Its content is completely practical . . . tells what to do and how to do it. It deals with all varieties of interference-producing sources.

Soft Cover, 128 pp., 5½ x 8½", illus.

#158.....Only \$1.80