

**ELECTRONIC TECHNOLOGY SERIES**

# **AMPLITUDE MODULATION**

**a** **RIDER** **publication**

**\$1.25**

# **AMPLITUDE MODULATION**

Edited by  
**Alexander Schure, Ph. D., Ed.D.**



**JOHN F. RIDER PUBLISHER, INC.**  
480 Canal Street • New York 13, N.Y.

*Copyright 1956 by*

**JOHN F. RIDER PUBLISHER, INC.**

All rights reserved. This book or parts thereof may not be reproduced in any form or in any language without permission of the publisher.

**FIRST EDITION**

*Library of Congress Catalog Card No. 56-11337*

**Printed in the United States of America**

## PREFACE

A radio system is usually designed for the purpose of transmitting speech and music, code, or video information. The originating frequencies of these signals are low compared to the radio frequencies at which they are transmitted through space. This book deals with the process by which the original signals are changed to radio frequencies. More specifically, the text treats the modulation process wherein the *amplitude* of the carrier wave is varied as a function of the instantaneous value of another wave called the modulating wave.

The material covers both the basic principles of amplitude modulation and certain of the methods used to accomplish this modulation. The more important of the numerous methods and devices used in modulating the amplitude of a carrier wave are given. Outmoded techniques and those of an experimental nature have been omitted. The techniques presently in popular use are variations on the basic device of applying the modulating signal to one or more electrodes of a vacuum tube r-f amplifier stage. Aside from this common feature, the impedances, currents, and voltages at the various electrodes are considerably different in the various methods of modulation. As a result, an individual approach and treatment is required and given in each case discussed.

The book explains the fundamentals of the modulated signal, modulation amplitude considerations, power in the modulated wave, improper modulation, asymmetrical modulation, basic design consideration, and frequency stability and linearity. The explanations are essentially non-mathematical.

Grateful acknowledgment is made to the staff of the New York Technical Institute for its assistance in the preparation of the manuscript for this book.

*New York, N. Y.*  
*June 1956*

A. S.

## **CONTENTS**

<i>Chapter</i>		<i>Page</i>
1	Fundamentals of the Modulated Signal .....	1
2	Principles of Plate Modulation .....	18
3	Control Grid Modulation .....	32
4	Screen Grid and Suppressor Grid Modulation .....	39
5	Cathode Modulation .....	46
6	Amplitude Modulation Checking and Monitoring .....	49

## Chapter 1

### FUNDAMENTALS OF THE MODULATED SIGNAL

Modulation, broadly speaking, is the process whereby one quantity,  $X$ , is caused to vary in accordance with the changes in another quantity,  $Y$ . Applying this definition to the field of communication, quantity  $X$  becomes a periodic wave, and quantity  $Y$  becomes a signal containing some form of information. In face-to-face voice communication, we employ our vocal cords to produce a periodic wave of sound in the air, and by properly modulating this wave in pitch and intensity, we convey our thoughts and emotions to the ear of the listener. If we knew how to employ mental telepathy, we could transmit the intelligence in its pure form, and there is some evidence to indicate that certain individuals are able to accomplish this feat, at least to a limited degree. Ordinary mortals, however, find it necessary to make use of a sound wave as the vehicle, or carrier, of the information they wish to convey.

Electrical communication is similar to face-to-face voice communication, and involves the same basic problems, plus the additional advantage of allowing distance between speaker and listener. As this distance increases, we reach a point where sound waves, vocal cords, and auditory systems become unable to maintain the required communication, even when assisted by the most powerful public address amplifier, and we must resort to a new vehicle such as telephone or radio to transport our information across the intervening space.

In many cases, the limitations of the telephone render it inadequate for our purpose, so our next recourse is the use of radio waves. Except for the change in vehicle, our techniques will include much the same elements we used in voice communication: a device for generating a periodic wave, a device for modulating the wave so as to impress upon it the information we wish to transmit, and a device for emitting the modulated wave in an effective, efficient manner, suitable for reception by the desired receiver. In radio communication, the information signal is a varying electric current, such as a sine wave or voice current. This is impressed on another current, which has a radio frequency and is called the *carrier*. Radio carrier waves are of high frequency, ranging from 10 kc or so per second up into the thousands of megacycles. The transmission of electromagnetic waves of audio frequency is actually not impossible. However, the tremendous antennas required and the inherent energy losses involved make it an impractical process. For this reason, we normally choose a carrier wave in the radio-frequency spectrum to act as the carrier for our information.

Once we have selected the carrier frequency, and designed an oscillator to generate this frequency, we must determine the most suitable method of modulating this carrier wave. Of the various methods available, we will assume for the purposes of this discussion that amplitude modulation is the one that has been selected.

### **1. Nature of Amplitude Modulated Wave**

For simplicity, we will establish the frequency of our carrier wave at 1,000,000 cycles per second, and adjust our oscillator circuit to operate at this frequency. By feeding the oscillator output through a stage of power amplification to an appropriate antenna, we could broadcast a continuous one-megacycle wave of constant amplitude. A properly adjusted receiver tuned to this frequency would emit a steady pure note, constant in pitch and volume. If we connect a telegraph key in the circuit so that it interrupts the oscillator output when the key is open, we can cause our transmitter to broadcast the one-megacycle signal in spurts by closing and opening the key. This is the basis of "continuous wave" transmission, wherein we emit our carrier wave as a series of long and short pulses, using the International Morse Code, and spelling out our message letter-by-letter. We can consider CW transmission a special

case of amplitude modulation in which the carrier wave is broadcast at its maximum amplitude when the key is closed, and at zero amplitude when the key is open.

When we undertake to transmit a spoken message, or the sound produced by an orchestra, we cannot convey this information by

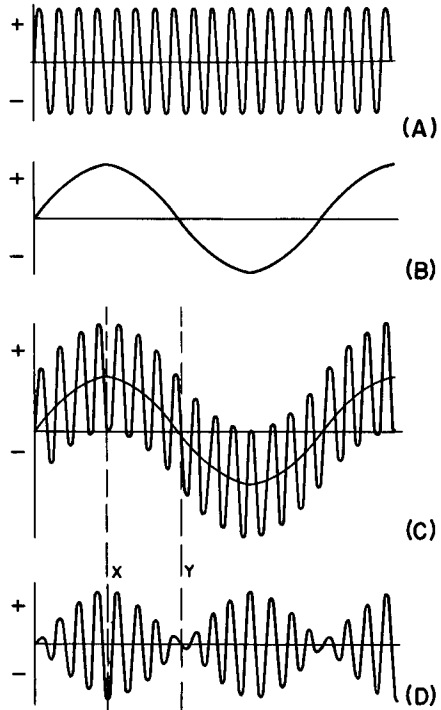

Fig. 1. (A) unmodulated 1-mc carrier wave. (B) audio signal to be used for modulation. (C) wave forms of carrier and audio voltages impressed simultaneously across a resistor. (D) wave forms of carrier and audio voltages impressed simultaneously across a non-linear load.

simple "on-off" operation of our transmitter, but must employ a means of impressing sets of complex audio waves on the carrier wave, as illustrated in Fig. 1.

The unmodulated 1-mc carrier is shown at *A*, and the audio signal that we wish to convey to the listener is shown at *B*. To simplify the explanation we will assume that this audio signal is a pure 1-kc note. If we inject both the carrier and the audio signal into a circuit containing only a pure, fixed resistance, a graph of the voltage across the resistance (or the current flowing through it) would appear as shown at *C*. The overall amplitude of the carrier



does not change, but the instantaneous polarity of its zero-axis line varies at the 1000-cycle audio rate. Since the radio receiver has no means of examining the absolute polarity of an incoming wave, and recognizes only variations in amplitude, it would see only a 1-mc wave of constant amplitude, were we to broadcast the waveform shown at *C*. Obviously, attempting to mix the audio and radio waves in a fixed linear circuit (a circuit that operates in simple accordance with Ohm's Law) results in failure to convey the audio information.

If, however, we mix the two waves in a circuit where the current flow is not uniformly proportional to the applied voltages, we find that we can cause one wave to vary the amplitude of the other in the manner shown at *D* in Fig. 1. Here the amplitude of the 1-mc carrier is no longer constant, but becomes larger and smaller in synchronism with the variation of the 1000-cycle signal. Measurement of the peak-to-peak amplitudes of waves *C* and *D* at the two instants *X* and *Y* shows the difference between the two situations. In *C* the amplitudes at *X* and at *Y* are equal to the amplitude measured at any other instant, while in *D* the instantaneous amplitudes range from almost twice normal (at *X*) down to almost zero (at *Y*).

The modulated wave at *D* presents an amplitude variation that is recognizable by the radio receiver. By employing circuits that in effect reverse the modulation process, the received demodulates or "detects" the modulated carrier, lifting out the audio signal for presentation at the loudspeaker.

## 2. Frequency Components of Modulated Waves

The various devices that can be used to amplitude-modulate a carrier will be described in detail in later chapters. Each has its own advantages and drawbacks, but all have one property in common: in the process of modulating a carrier by an audio signal, new frequency components are created. Examining the modulated wave in *D* of Fig. 1, we might expect that the radiated signal will be only a 1,000,000-cycle wave whose amplitude fluctuates at an audio date. Actually, the output of the mixing (modulating) circuit is found to contain waves of four different frequencies: the 1000-cycle audio wave; the 1,000,000-cycle carrier wave; a wave that is the sum of these two frequencies, 1,001,000 cycles; and a wave that is the difference between the two frequencies, 999,000 cycles. The existence

of these sum and difference frequencies has been proven mathematically, and their presence can be demonstrated readily by means of appropriate filters and indicating instruments. With such equipment, an actual modulated wave can be divided into carrier and sideband components. The audio signal is of course too low in frequency to be radiated, but the remaining three frequencies will appear in the radiated signal and must all be reckoned with as part of the signal to be transmitted and received.

When we modulate the carrier with a single audio note, only a single pair of new frequency components (referred to as "beats") is created. However, in transmitting speech or music, we modulate with a large group of audio frequencies simultaneously, and since each modulating frequency produces a unique pair of sum and difference frequency components, we in effect transmit two bands of frequency components along with the carrier. The group of sum frequency components is designated the "upper side band," and the group of difference frequency components is correspondingly designated the "lower side band." A little analysis reveals that if we modulate with audio signals covering the range up to 10,000 cps, our transmitted signal will occupy a band extending 10 kc above and below the carrier frequency. We create interference in adjacent channels when we approach them too closely, because the sideband of one modulated signal overlaps the sideband of a modulated signal in the adjacent channel. This makes it imperative that we confine our modulation frequency range, and thus our bandwidth, to a practical minimum. Fortunately, we can transmit speech, without loss of intelligibility, using only the audio frequencies up to 3000 cps, requiring a transmission bandwidth of only 6 kc. Good reproduction of musical programs can be achieved using a bandwidth of 10 kc or less. For maximum utilization of the r-f spectrum, and minimum interference with adjacent channels, our equipment should be designed, and its adjustments maintained, to occupy the minimum practical bandwidth.

### **3. Modulation Amplitude Considerations**

While the frequencies used for modulation are an important factor in the operation of transmitting equipment, the degree of modulation (the extent to which we vary the amplitude of the carrier) is of even greater importance, because of the far-reaching effects on the quality, strength, and character of the transmitted

signal. Figure 2 illustrates the effect of modulation on instantaneous carrier amplitude.

In *A* of Fig. 2 we have the unmodulated carrier. The modulating signal is shown in *B*. The waveform at *C* shows the modulated carrier. As the amplitude of the modulating signal increases in a

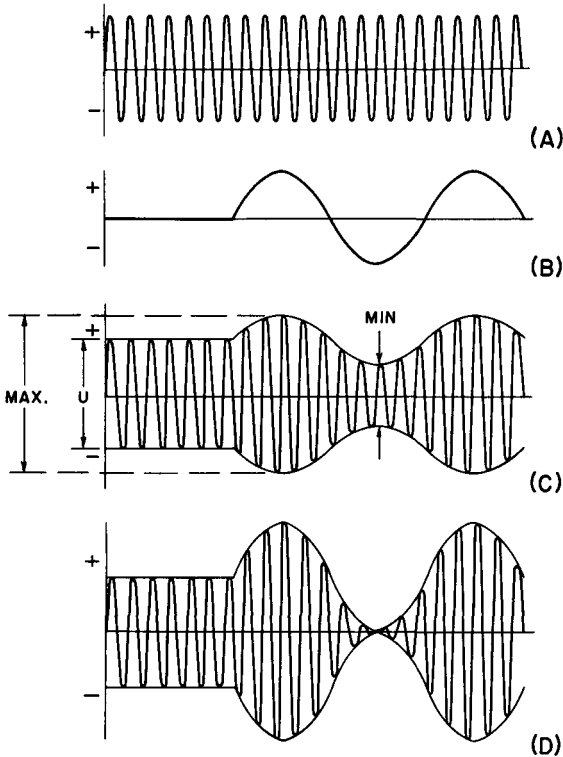

Fig. 2. (A) unmodulated carrier. (B) modulating signal. (C) modulated carrier, low modulation percentage. (D) modulated carrier, high modulation percentage.

positive direction, the amplitude of the carrier becomes correspondingly greater than normal. When the amplitude of the modulating signal increases in the negative direction (below its zero axis), the amplitude of the carrier becomes correspondingly less than normal. The upper envelope of the carrier becomes a faithful reproduction of the modulating signal, while the lower envelope of the carrier becomes a mirror image of the upper envelope.

Now, it must be borne in mind that the radio receiver is interested only in the *variations* of the carrier, and not in the carrier

itself. If we started out with a carrier whose normal amplitude is twice that shown in *C* of Fig. 2, and applied the same modulating signal, the net variation in amplitude would be the same, and the receiver would see no increase in signal power after eliminating the carrier. If, however, we increase the amplitude of the modulating signal at *B* of Fig. 2, so that we modulate the carrier more deeply as shown in *D*, an increase in receiver output will result, since we have increased the *variation* of the carrier amplitude. The deeper the modulation, the stronger the audio output at the receiver will be, and for most efficient use of our carrier we should modulate as deeply as possible.

For convenience, the depth of modulation is normally expressed as a percentage of the normal (unmodulated) carrier amplitude.  $U$  in Fig. 2 represents the amplitude of the unmodulated carrier.  $MAX$  represents the peak-to-peak amplitude of the modulated wave at the maximum positive excursion of the modulating signal.  $MIN$  represents the peak-to-peak amplitude at the maximum negative excursion of the modulating signal. The percent modulation is equal to:

$$\text{percentage modulation} = \frac{MAX - U}{U} \times 100 \quad \text{or} \quad \frac{U - MIN}{U} \times 100$$

If the modulating wave is a pure sine wave as shown in *B* of Fig. 2 these two percentages will be identical. However, if the negative and positive peak excursions of the modulating wave are unequal, the larger of the two percentages is usually the one specified. The waveform at *D* in Fig. 2 represents 100 percent modulation, since the maximum amplitude is twice the normal (unmodulated) amplitude, and at the minimum-amplitude point the carrier amplitude is reduced just to zero.

#### 4. Power in the Modulated Wave

Power is the product of volts times in-phase amperes. When we are dealing with a fixed load in a d-c circuit, the volts-amperes product gives the amount of power that must be furnished to the load. A power supply that will deliver the required current at the required voltage satisfies the power requirements for the system.

In an a-c circuit the power conditions require more careful consideration. The voltage and current in an a-c circuit continually vary from zero to maximum values many times a second. Assuming that the voltage and current are in phase, the power will

accordingly vary from zero to maximum in the same manner. Were we to measure the power being expended at any given instant, this measurement would not give us a worthwhile indication of the power requirements of the circuit, since the measured value could lie anywhere between zero and the maximum value, depending upon the particular instant chosen for measurement. If, however, we average all the successive instantaneous power measurements taken over any number of full cycles, we derive a worthwhile value of power, which can be used in designing an appropriate power supply or signal generator. In our modulated wave example, making the assumption that the carrier and modulating signal are both pure sine waves further simplifies the design problem, as will be seen.

The sine waves in Figs. 1 and 2 can be considered graphs of the current (or voltage) as measured in the signal-forming circuits of a typical transmitter. (In practice the ratio of carrier frequency to modulating frequency is much greater, but the principle is the same.) While a pure sine wave is seldom used as a modulating signal in actual practice, it is the one usually used in discussing, analyzing, and testing modulation systems, because it makes the results easy to calculate mathematically, and because it provides a common, understandable basis for comparison of various circuits and systems. Speech and music waveforms vary continuously and erratically, both in frequency and amplitude, making them inherently unreliable as a reference standard, and are awkward to use in measurement or comparison. The assumption of sine-wave modulation, besides simplifying calculations, helps to ensure adequacy of design, since for a given set of conditions, modulation by voice or music requires less power than does sine-wave modulation. The ratio of peak power to average power is greater for voice or music. Accordingly, we will use the wave shown in *D* of Fig. 2, consisting of the carrier at *A* modulated 100 percent by the sine wave at *B*, in examining the power situation in a modulated wave.

If  $U$  represents the amplitude of the unmodulated voltage wave, and also the amplitude of the unmodulated current wave, the relative power in the unmodulated wave can be represented by the product of these two quantities,  $U^2$ . (We normally employ a load that is resistive at modulating frequencies, so that current and voltage are in phase.) At the peak of the modulation upswing, the amplitudes of the voltage and current are double the normal (unmodulated) values. The power at this instant (known

as “peak” power) is  $2U$  times  $2U$  or  $4U^2$ . Obviously, the peak power is four times the power of the modulated carrier. At the bottom of the modulation down-swing, the voltage and current are both zero, and the power at this instant is consequently zero. This situation holds true for a 100 percent modulated wave regardless of the modulation waveform or the method of amplitude modulation used — the power in the modulated wave at any instant is proportional to the square of the wave amplitude at that instant. However, using sine-wave modulation, it has been found that the *average* power in the 100 percent modulated wave is just  $1\frac{1}{2}$  times the power in the unmodulated carrier, providing us with a convenient basis for the design of modulation equipment. The transmitting equipment must be adequate to provide a 50 percent increase in average power with sine wave modulation. We are then assured that the peak power (power at the top of the modulation upswing) will be four times the unmodulated carrier power. Equipment so designed will easily handle modulation by complex waveforms such as speech and music, since for a given maximum percentage of modulation these waveforms require only about half the extra power entailed in sine wave modulation.

The additional power generated when a carrier is modulated is expended entirely in the sidebands, half in the upper sideband and half in the lower sideband. This is actually the only useful power in the radio system, since the receiver removes the carrier as it transposes the radio frequency signals to audio frequencies. Design effort in the modulator and transmitter is directed toward getting power into the sidebands, and broadcasting as much of this sideband power as possible. This has given rise to such expedients as single-sideband transmission, where only one of the sidebands is transmitted, and suppressed-carrier transmission, where the carrier is omitted, with consequent savings in power requirements. It goes without saying that the efficiency of the equipment will determine how much of the input power becomes radiated power. Anyone can radiate a strong signal if he has large quantities of power available. The objective is to radiate a clean signal of maximum intensity, using a minimum of apparatus and power.

## 5. Improper Modulation

If we design our transmitting equipment to produce an undistorted sine wave carrier of unwavering frequency, we thereby

establish a basis for generating a good, clean signal. If we do not exercise care in the design and adjustment of our modulating equipment, we can nullify the value of our excellent carrier; we also produce a number of effects that impair our ability to establish

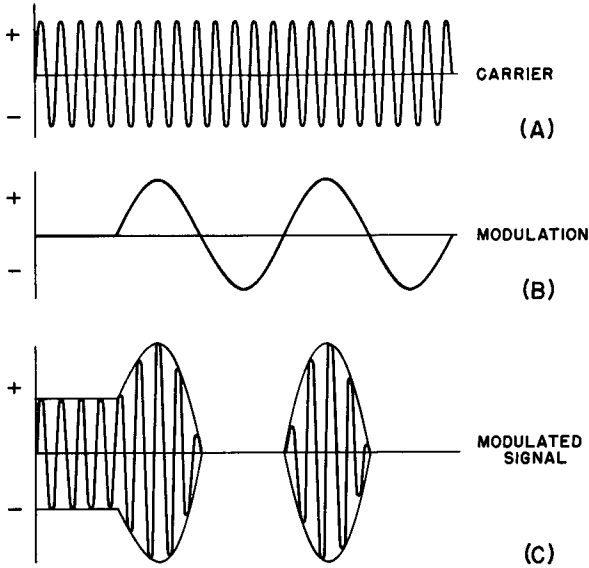

Fig. 3. (A) unmodulated carrier. (B) modulating signal. (C) modulated carrier showing effects of overmodulation.

communication. Such undesirable effects also interfere with other stations and violate regulations of the Federal Communications Commission.

One of the simplest ways to acquire a bad reputation is to overmodulate the transmitter. As we saw in *D* of Fig. 2, when the peak downward modulation is 100 percent, the carrier signal is reduced just to zero as the modulating wave reaches the bottom of its downswing. Were we to increase the amplitude of the modulating wave, the carrier would be cut off completely for some interval, resulting in an output wave like that shown in Fig. 3. These abrupt discontinuities in the carrier represent a serious distortion of the modulation envelope, and result in the generation of harmonics of the modulating frequency. These harmonics combine with the carrier to produce additional sideband frequencies

(referred to as “splatter”) which contribute nothing to the transmitted intelligence, decrease the clarity of the received signal, widen the channel occupied by the signal, and show up as interference in neighboring channels. If, for example, we modulate a 1-mc signal with a 3-kc sine wave, and overmodulate sufficiently to produce the

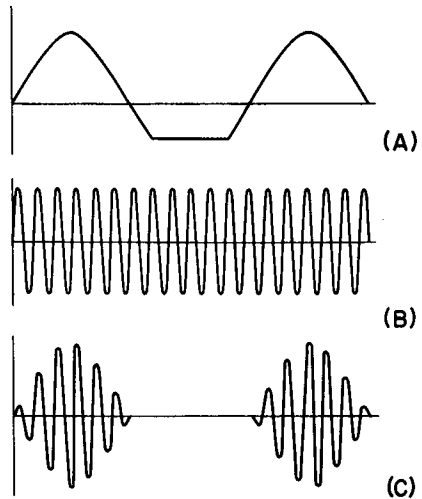

Fig. 4. (A) modulating signal. (B) carrier to be modulated. (C) modulated carrier showing distortion resulting from use of improper modulating signal.

sixth harmonic of the modulating signal (18 kc), we will radiate the sum and difference frequencies of 1,018,000 cycles and 982,000 cycles, in addition to the carrier and normal sideband frequencies. This represents an effective bandwidth of 36 kc, which obviously overlaps into several other channels in the broadcast frequency spectrum.

As we said before, it is the “abruptness” of the change of slope of the modulation waveform that makes the modulated wave contain high-frequency harmonics and broadens the bandwidth. Although this abruptness can result from modulation over 100 percent (called “overmodulation”), it can also result from defects in other parts of the transmitter, or it can be normal because the normal waveform of the signal to be transmitted is “flattened” on the lower peak or has some other discontinuity that makes transmission of harmonics necessary.

For example, suppose it is necessary to transmit, by amplitude modulation, a modulation signal of the waveform shown at A of Fig. 4. This signal is applied as modulation to a carrier of wave-



form *B*. The resulting modulated signal, with 100 percent modulation, is shown at *C*. Because of the high-frequency harmonics necessary for the reproduction of the desired modulation signal, the bandwidth of the modulated signal is much greater than for a sine wave modulation signal of the same frequency. However, without allowing sufficient bandwidth for important harmonic modulation components, the desired modulation signal cannot be transmitted.

Notice that the modulated wave in *C* of Fig. 4 has the same kind of waveform as that of *C* in Fig. 3. However, in Fig. 3 the flattened portion of the modulated wave envelope is not present in the modulation signal, but results from overmodulation. In this case, the harmonics transmitted are unnecessary and troublesome. The same harmonics in the case of Fig. 4 are required and desirable.

Thus the necessary and required bandwidth of the modulated signal depends upon the fundamental frequency of the modulation signal and its waveform. If the envelope of the modulated signal is an exact copy of the modulation waveform the bandwidth occupied by the signal is most efficiently used. If the modulation process introduces harmonic components not present in the modulation signal, excessive bandwidth is being occupied and distortion is introduced. It is therefore important to keep the shape of the modulated wave envelope as nearly as possible an exact replica of the waveform of the modulation signal to be transmitted. If we overmodulate, we produce an excessively broad modulated signal.

## 6. Asymmetrical Modulation

When we modulate the carrier 100 percent in the downward direction, we reduce the instantaneous carrier power to zero at the extreme negative swing of the modulating signal. Since instantaneous carrier power cannot be reduced to less than nothing, zero represents the limit of swing of modulation voltage in the downward direction. However, the power output can be *increased* to any desired value without limit, provided only that our equipment is capable of handling this power. When the modulated signal envelope has upward and downward excursions that are unequal, the modulation is said to be *unsymmetrical* or *asymmetrical*. Figure 5 illustrates this condition. The upward excursion of the modulating signal at *A* is twice the downward excursion, and the signal shown at *B* represents a carrier modulated 100 percent in the down-

ward direction by this signal. The upward modulation in this case is 200 percent, and since the voltage and current at the peak of the upswing are three times the normal value, the *peak* power required will be nine times the average carrier power. (Power is proportional to square of voltage.) If our equipment is capable of handling this peak power demand, the asymmetrical signal will be faithfully reproduced, but if this power drain overloads some part of the system, a distorted signal output will result, or some component will fail.

If we employ the signal at *A* of Fig. 5 to modulate our carrier only 100 percent in the upward direction, our downward modulation percentage will be only 50 percent. This represents a loss of

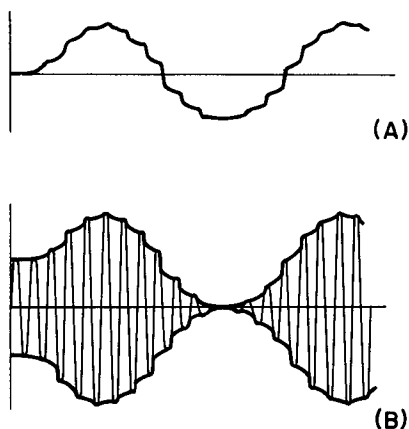

Fig. 5. (A) asymmetrical modulating signal. (B) carrier 100 percent modulated in downward direction.

efficiency, because we are not taking full advantage of the capabilities of the system. Rather than undermodulate in this manner, it is better to design for the accommodation of power peaks, for most efficient use of the available apparatus.

## 7. Basic Design Considerations

Regardless of the method used for amplitude modulation, there are certain basic requirements that must be satisfied to ensure an undistorted modulation envelope (one that contains all the original modulating frequencies, and only these frequencies,

in their original form). As indicated below, these requirements affect the power supply and transmitter, as well as the modulator itself.

### **8. Power Supply Impedance**

Since the plate current drawn by an amplitude-modulated r-f amplifier fluctuates at an audio rate, the plate power supply is in effect called upon to furnish an alternating current as well as a steady direct current. If the power supply has appreciable internal impedance, the flow of alternating current through this impedance will cause the supply output voltage to fluctuate in accordance with the current variations. The output filter capacitor of the supply serves to bypass these voltage variations, since it presents a very low impedance to the audio frequencies. However, if the capacitance is too small, it may be incapable of bypassing all the frequencies to a satisfactory degree, and the ability of the transmitter to modulate equally well at all audio frequencies will be impaired. This condition can be avoided by making the capacitance of the output filter capacitor (in microfarads) at least 25 times the ratio of the d-c plate current (in milliamperes) to the d-c plate voltage (in volts) of the modulated stage. As an example, if the modulated amplifier draws 200 milliamperes at 1000 volts, the capacitor should be at least

$$25 \times \frac{200}{1000} = 5 \text{ microfarads.}$$

In choosing the other power supply filter components, hum reduction must also be considered. The values of inductance and capacitance used must be sufficient to reduce the output ripple to less than 1 percent of the d-c output voltage. Power supply ripple will modulate the carrier and introduce an objectionable hum if the filtering is inadequate. For maximum hum reduction and minimum internal impedance, the inductance and capacitance used should be as great as practicable within the physical and economic limitations, up to the values which make ripple negligible.

### **9. Frequency Stability**

For an acceptable amplitude-modulated signal, the frequency of the carrier must remain constant at its established value. If we were to apply the modulating signal directly to a master oscillator,

we would alter the operating characteristics of the oscillator circuit and cause the carrier to vary in frequency during modulation. Frequency modulation in an amplitude-modulated system widens the channel occupied, impairs reception of the signal, and introduces distortion, inevitably causing interference with other stations. To avoid affecting the carrier frequency, the oscillator circuit is isolated from loading effects by feeding its output to the modulated r-f amplifier through a buffer stage. Although this

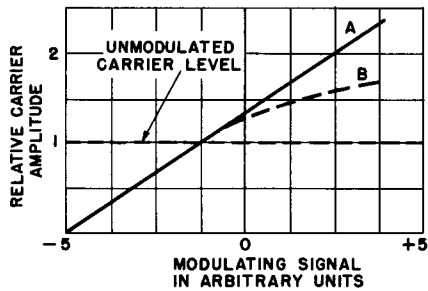

Fig. 6. Modulation characteristic graph: curve (A) linear modulation characteristic, curve (B) non-linear modulation characteristic.

buffer stage may amplify the oscillator signal, its primary purpose is to absorb the demands of the modulated stage and permit the oscillator to operate into an undisturbed circuit.

### 10. Linearity

In order that the modulation envelope be an exact reproduction of the modulating signal, the amplitude of the output signal must be directly proportional to the amplitude of the modulating wave at every instant. To meet this requirement, the transmitting system must have a linear (straight line) modulation characteristic, as illustrated by curve *A* in Fig. 6. As the modulation signal varies above and below its zero axis, the amplitude of the carrier increases and decreases from its normal, unmodulated value in exact proportion. When the modulation signal reaches its extreme negative position (-5), the carrier amplitude is reduced to zero. When the modulation signal reaches an equal value in the positive direction (+5), the carrier amplitude is twice its normal value. As described, this represents 100 percent modulation in both di-

rections. Curve *A* cannot be extended in the downward direction since, as previously pointed out, the carrier power cannot be reduced to less than zero. If we modulate more than 100 percent in the upward direction, curve *A* will be extended as a straight line in its upward direction, provided the modulation characteristic remains linear. When the characteristic is non-linear, the carrier amplitude is not always exactly proportional to the modulation amplitude. Curve *B* shows a non-linear characteristic. Note that as the modulation signal increases in the upward direction, the rate at which the carrier amplitude increases begins to slacken, so that at the normal 100 percent modulation point the carrier does not have double its normal amplitude. This condition produces distortion in the modulated wave by flattening the positive peaks of the wave, resulting in the generation of unwanted harmonics. As previously indicated, these harmonics produce an impaired signal and generate interference on other frequencies in the spectrum.

The ability of a transmitter to accept modulation without producing objectionable distortion is known as its "modulation capability." This can never be greater than 100 percent in the downward direction, though it can exceed 100 percent in the upward direction. For most efficient use of the available apparatus, the modulation capability should be as near as possible to 100 percent. Lower values are due either to poor design or to improper adjustment of equipment.

The foregoing material has covered the basic principles involved in amplitude modulation, without considering the particular method used to accomplish the modulation. The chapters that follow describe the modulation techniques in detail, with a minimum of basic modulation theory. Although numerous methods and devices have been used, or proposed for use, in modulating the amplitude of a carrier wave, and continual experimentation is being conducted in this field, these chapters cover only those methods which are in extensive practical use at the present time. Outmoded methods and those of an experimental nature are interesting as novelties, but are somewhat outside the range of a practical discussion of amplitude modulation. As indicated by the chapter headings, the techniques presently in popular use are actually variations on a basic device: the application of the modulating signal to one or more electrodes of a vacuum tube r-f amplifier stage. Although they have this feature in common, the voltages, currents, and impedances at the various electrodes differ markedly

from each other, and require an individual approach in each case. Accordingly, each approach is given individual treatment.

### 11. Review Questions

- (1) Define modulation.
- (2) Assuming a carrier wave of 3 mc, and a pure audio modulation tone of 1 kc, list the frequency components that must be transmitted.
- (3) Draw a representation of an amplitude modulated wave.
- (4) What is meant by the "degree of modulation"?
- (5) Express percentage of modulation in terms of a formula.
- (6) Explain why overmodulation is undesirable in an a-m transmitter. Illustrate with a diagram.
- (7) What is "splatter"? How is this obtained? Illustrate "splatter" by a numerical example.
- (8) Define peak power.
- (9) List the essential basic design requirements of a transmitter power supply; of a transmitter modulator.
- (10) Explain "modulating capability."

## Chapter 2

### PRINCIPLES OF PLATE MODULATION

Because of its simplicity, efficiency, and ease of adjustment, plate modulation is the most widely used of the amplitude-modulation methods. The method is shown in its basic form in Fig. 7. The carrier signal is applied to the grid of an r-f amplifier stage, and the modulating signal is applied in series with the plate circuit. In the absence of modulation, the r-f stage amplifies the carrier signal, which then appears in its plate circuit, from which it is transformer-coupled to the load as a constant-amplitude r-f signal. When modulation is applied, the amplitude of the plate circuit signal is caused to vary in synchronism with the modulating signal, and the modulated carrier signal appears across the load. This is the situation regardless of whether the r-f amplifier is operated class A, AB, B, or C.

#### 12. Classes of Amplifiers

When an amplifier stage is operated class A, the grid bias and alternating grid signal voltages are such that plate current flows in the tube at all times. Distortion is inherently low in a class A amplifier, whether push-pull or single-ended. Its low efficiency limits its most frequent use to voltage amplification, or power amplification of audio frequencies. Operation of a class A amplifier is illustrated graphically in Fig. 8. Class A<sub>1</sub> operation is

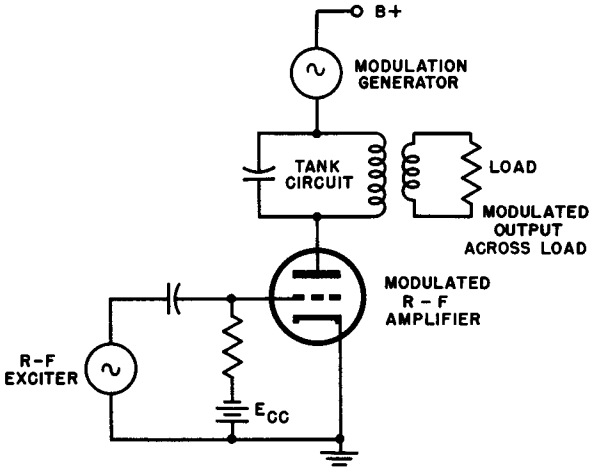
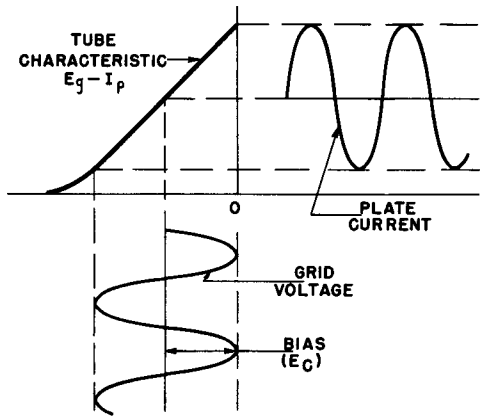

Fig. 7. Basic form of plate modulation circuit.

Fig. 8. Grid voltage-plate current relationships in a class A amplifier.



shown (the subscript 1 indicating that grid current does not flow during any part of the input cycle), because class  $A_2$  operation (where grid current flows during the positive peaks of the input cycle) is seldom used because of the complications introduced by the current drawn through the grid circuit.

In a class B amplifier, the grid is biased approximately at cutoff, so that plate current flows during the positive half-cycle of



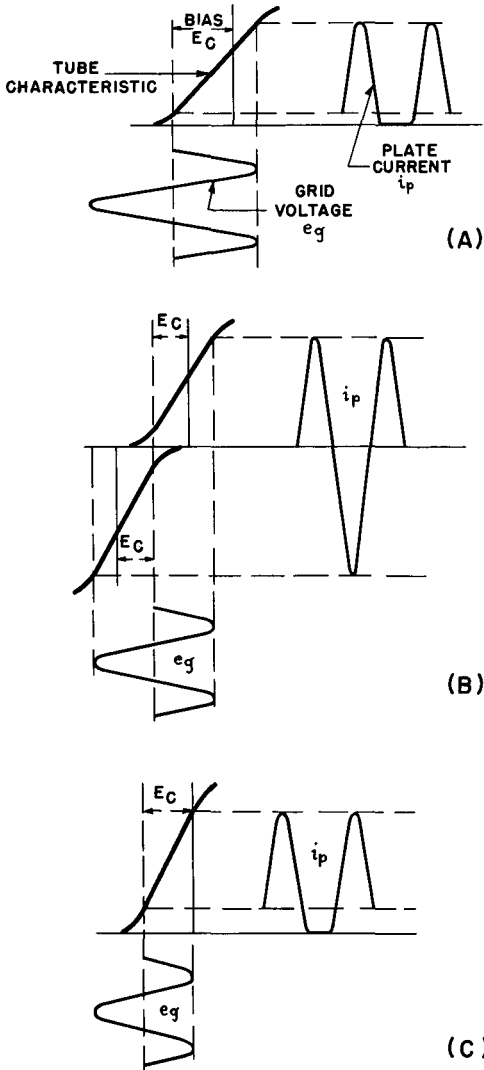

Fig. 9. (A) grid voltage-plate current relationships in a single tube class B amplifier. (B) grid voltage-plate current relationships in a push-pull class B amplifier. (C) grid voltage-plate current relationships in a single tube class AB amplifier.

the input signal, and is cut off during nearly all the negative half-cycle. Class B operation of a single-ended amplifier is shown in Fig. 9A. To take full advantage of the capability of a class B amplifier, it is necessary to drive the grid into the grid current region (class B<sub>2</sub> operation) as shown. Obviously, the output signal is a highly-distorted version of the input signal, and it is therefore

necessary to operate two tubes in push-pull as graphed in Fig. 9B to achieve a symmetrical output signal, unless a tuned circuit is used in the plate circuit to suppress harmonics. Although their harmonic output is greater than that of class A amplifiers, the ability of class B amplifiers to deliver large amounts of power at higher efficiency recommends them for use as audio-frequency power amplifiers, and they are frequently encountered in the modulator output stage of plate-modulated transmitters. They are also used for r-f power amplifiers following the modulated r-f amplifier of some transmitters.

The class AB amplifier is midway between the class A and class B amplifiers in that plate current flows for more than half but less than the entire input cycle, as shown in Fig. 9C. Because of the distorted output signal from a single ended stage, class AB stages are operated in push-pull for *audio* power amplification, and are used where their higher power and greater efficiency recommend them as substitutes for class A operated stages. Class AB<sub>1</sub> operation has low drive power and regulation requirements because it operates without the grid current entailed in class AB<sub>2</sub> operation. As mentioned above for the class B amplifier, using a tuned circuit as the plate load suppresses the harmonics generated by a single-ended r-f amplifier operated class AB. However, the higher efficiency of the class C amplifier makes it a natural choice for tuned r-f amplification.

Figure 10 shows the operation of a class C amplifier in graphic form. The grid is biased considerably beyond cutoff, so that plate current flows for appreciably less than half of the input cycle. The inherently great distortion produced by this amplifier, even when operated in push-pull, makes it unsuitable for audio amplification, but it is eminently suited for r-f power amplification, being the most efficient of all the amplifier classes. The tuned plate load circuit has a "flywheel" effect, which keeps the output voltage a sinewave even though the load circuit is excited only by pulses of plate current.

The most popular system for plate modulation is shown schematically in Fig. 11. The carrier signal is applied to the grid of a class C r-f amplifier, while the modulating signal is applied through a push-pull class B power amplifier stage (the modulator) whose output is applied in series with the r-f amplifier plate circuit by transformer *T*<sub>2</sub>. The d-c plate power for both the amplifier

and the modulator may be obtained from the same power supply as shown, but this is not essential, and can even be detrimental to the over-all operation of the system. The fluctuating load of the modulator on the power supply may cause excessive variation of amplifier plate voltage, if the same power supply is employed. If possible, separate sources should be used.

As pointed out earlier, the additional power in the modulated wave (as compared with the unmodulated carrier) must be sup-

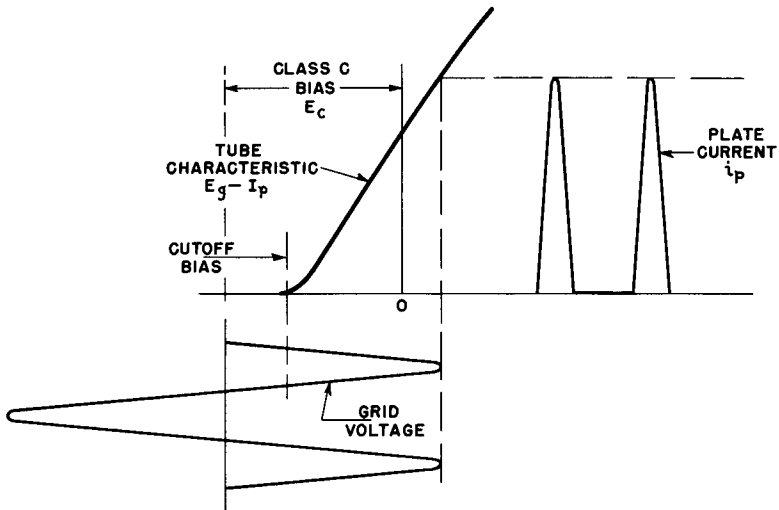

Fig. 10. Grid voltage-plate current relationships in a single tube class C amplifier.

plied by the modulator in a plate-modulated system. For 100 percent modulation by an audio sine wave this power will be 50 percent of the unmodulated plate power input to the r-f amplifier, and the modulator must accordingly be capable of furnishing this power without overloading. To achieve 100 percent modulation of the carrier, the turns ratio of  $T_2$ , as well as the power output of the modulator, must be arranged so as to cause the r-f amplifier plate voltage to swing between zero and twice the quiescent operating voltage. This satisfies the requirement for 100 percent modulation by causing the amplitude of the output signal to vary in a corresponding manner between twice normal and zero. Figure 12 is a graphic representation of the operation.

For optimum transfer of modulation power to the modulated stage, the modulator output impedance must be matched to its external load by establishing the proper turns ratio in transformer *T2*. The load resistance presented to the modulator by the r-f

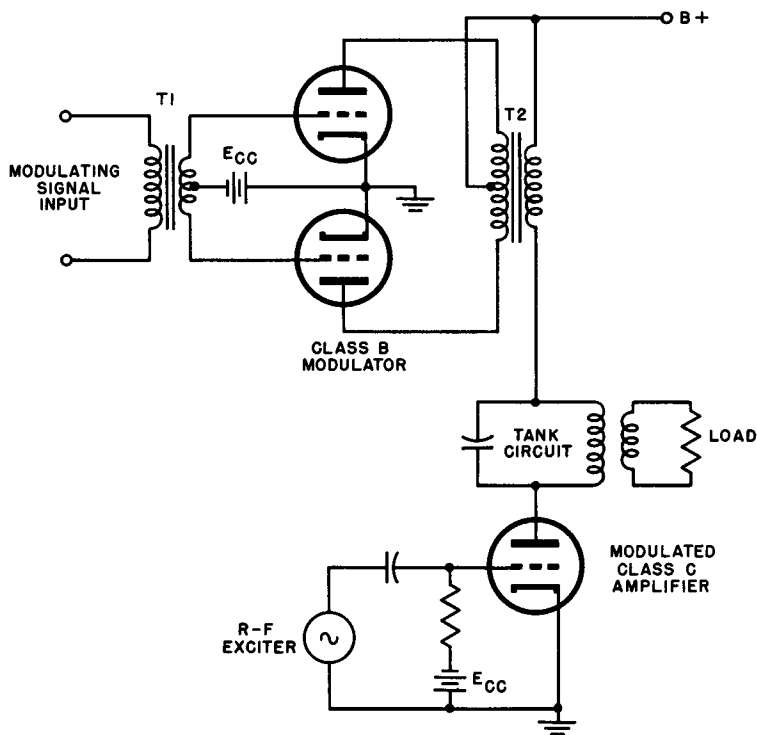

Fig. 11. Class B modulation of a class C RF amplifier.

amplifier stage (commonly called the modulating impedance) can be found as follows:

$$\text{Modulating impedance } Z_m = \frac{E \times 1000}{I} \text{ ohms}$$

where *E* and *I* are the d-c plate voltage (in volts) and plate current (in milliamperes) of the r-f amplifier, measured in the absence of modulation.

For linear modulation, the amplitude of the r-f output voltage must be directly proportional at every instant to the plate voltage of the r-f power amplifier. Stated another way, the power output must vary as the square of plate voltage at every instant. This condi-

tion can be very closely approached in a class C r-f power amplifier, provided that the stage has been correctly designed, and provided also that the circuit has been properly adjusted and is furnished the proper grid excitation and bias, as indicated below.

### 13. Adjustment of Plate-Modulated Transmitters

Since the design of transmitters is outside the scope of this discussion, it will be assumed that the r-f power amplifier stage

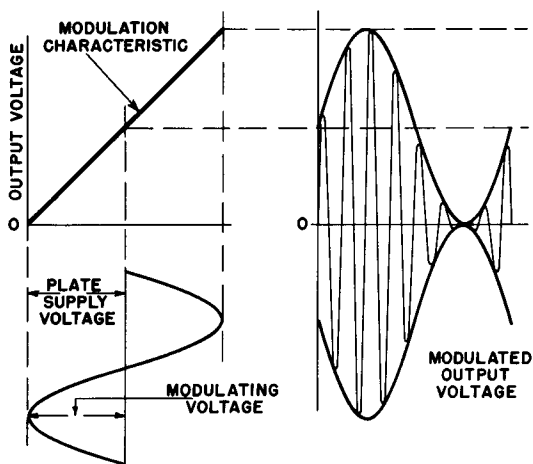

Fig. 12. The application of the modulating signal to the modulation characteristic to produce 100 percent modulation.

and the modulator have been correctly designed, and that the necessary d-c power is available from a low-impedance source. Then for proper, efficient operation of the system, we must take care to establish and maintain the conditions upon which the design was originally based. These include the d-c plate voltage, load impedance, d-c grid bias, a-c grid excitation, and peak plate voltage. The currents and voltages on the tube elements must be such that the maximum ratings of the tube are not exceeded under any normal operating condition, which means that we must check the operation both with and without modulation. If, for example, we adjust the circuit so that the tube is operated at maximum plate dissipation in the absence of a modulating signal, we will overload

the tube when we modulate the carrier. The plate dissipation increases by 50 percent at 100 percent modulation, making it necessary to operate the tube at no more than two-thirds its rated dissipation in the absence of modulation. Then when sine-wave modulation of 100 percent is applied, we have ensured that the maximum rating will not be exceeded. If voice modulation is to be used, the quiescent plate dissipation can be increased somewhat over the two-thirds limitation, since the increase in dissipation for 100 percent modulation by voice will be less than a full 50 percent.

The d-c grid bias should be adjusted so that plate current flows during approximately 130 degrees of the a-c grid signal cycle (full cycle equals 360 degrees). This bias should be a combination of fixed and grid leak bias, for linearity of tube operation. Using a fixed bias of approximately the cutoff value, and developing the remaining required bias by the grid leak method will also establish an automatic safeguard for the tube, since a failure of grid excitation will leave the cutoff bias in effect and prevent the plate current from rising to a destructive value.

Non-linearity can be detected by observing the plate voltage and plate current (as measured on d-c meters) when modulation is applied. Sine-wave modulation produces symmetrical variations in the plate voltage and current, so that their increase during the positive half of one cycle is counterbalanced by an equal decrease during the negative half of the cycle. Since a d-c meter cannot follow these rapid individual variations, it will register only the average d-c value of plate voltage or current, which will be a constant value if the tube is being properly operated. Should the d-c value change when modulation is applied, this will be an indication of non-linearity. If a thermocouple type r-f ammeter is connected in the output transmission line, this meter will show a current increase when modulation is applied. For 100 percent modulation, the total power output increases with modulation to 1.5 times the unmodulated power. The current is proportional to the square root of the power and therefore increases to  $\sqrt{1.5}$  or 1.225 times its unmodulated value (a 22.5 percent increase).

The plate tank circuit of the modulated stage must be tuned to resonance at the carrier frequency. This can be done by tuning for minimum d-c plate current, maximum load voltage, or maximum circulating current in the tank circuit. The tank circuit acts like a pendulum that is kept swinging through its maximum arc

by a small momentary push applied at regular intervals. If the push is applied at exactly the right instant, a maximum amount of energy is applied to the pendulum; if it is applied earlier or later, some of the energy is wasted. The class C amplifier applies momentary pulses of current to the tank circuit, and if these pulses are applied in synchronism with the oscillations in the tank circuit, they will replenish the power in the tank, replacing the power drawn off by the load. A detuned tank circuit will not be in exact synchronism with the applied pulses, resulting in reduced efficiency, and will be more receptive to the unwanted harmonics present in

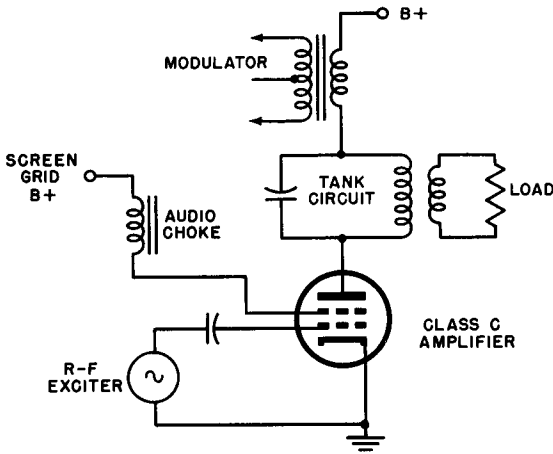

Fig. 13. The use of an audio choke to produce tandem plate and screen grid modulation in a beam tetrode.

the amplifier plate signal, with consequent distortion of the transmitted signal.

Other sources of distortion are the regeneration due to incomplete plate neutralization, and parasitic oscillations. Techniques for eliminating these defects will vary with the configuration of the circuit, and, being part of transmitter design and operation, are beyond the scope of this book.

As previously indicated, 100 percent modulation with a sine wave signal results in an average output power increase of 50 percent over the power in the unmodulated carrier, and this extra power must be furnished by the modulator, in a plate modulated

transmitter. Stated another way, the modulator must be capable of a power output equal to one-half the normal (unmodulated) carrier power. Looking at this situation in reverse, we can see that when the modulator can furnish only a limited amount of power it would be pointless to employ a normal carrier power larger than twice the modulator output power, since 100 percent modulation of a more powerful carrier would be beyond the capability of the modulator. The d-c plate input power to the r-f amplifier can be adjusted to provide the requisite carrier power by varying the load on the modulated r-f amplifier until the d-c plate voltage and current of that amplifier are such that their product equals twice the available modulator power. Needless to say, the tank circuit must be kept tuned to resonance during this adjustment. As outlined earlier, the modulator output coupling transformer must have the proper turns ratio to match the modulator to the "modulating impedance" presented by the r-f amplifier under these conditions.

#### 14. Plate Modulation of Tetrodes and Pentodes

Plate modulation of screen-grid tubes is entirely practicable, provided the modulation is applied to the screen-grid as well as to the plate. Since the screen-grid acts like the plate of a triode, and the plate functions largely as a collector of electrons, introducing the modulation only into the plate circuit of a screen-grid tube would be ineffective, and would at best result in a non-linear modulation characteristic, unless special measures were taken. One simple expedient, usable with beam tetrodes, is to connect an audio choke in series with the screen as shown in Fig. 13. The audio-frequency variations that occur in the screen current when modulation is applied in the plate circuit induce a corresponding voltage in the choke, effectively modulating the screen in tandem with the plate. For successful application, the reactance of the choke at the lowest audio frequency to be used should be at least equal to the screen impedance (roughly, the d-c screen voltage divided by the d-c screen current).

A second method for introducing modulation into the screen circuit is shown in Fig. 14. Here the modulation is applied to the screen through resistor  $R$ , which drops the B+ voltage to the normal screen value. The required value of  $R$  can be found by dividing the rated screen current (in amperes) into the difference between



the plate and screen voltages. The modulating impedance and modulator power requirements can be calculated as outlined previously, but the current value used should be the sum of the d-c plate and screen currents.

Although the circuit in Fig. 14 is a simple one, it wastes modulation power in the dropping resistor,  $R$ . This is avoided in the

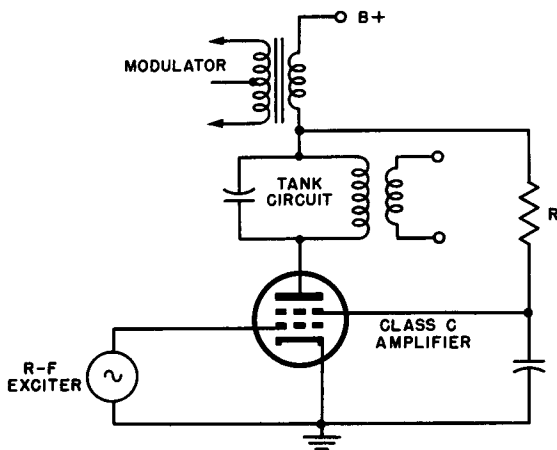

Fig. 14. The use of a resistor to introduce screen grid modulation.

system shown in Fig. 15. The screen-grid is connected to a separate supply voltage through a second output winding on the modulator coupling transformer, utilizing the efficiency of transformer coupling in both plate and screen circuits. For proportional distribution of modulation power, the turns ratio between the two secondary windings should be approximately the same as the ratio of the corresponding plate and screen voltages used.

## 15. Heising Modulation

Heising, or choke-coupled, modulation is one of the oldest types and is still used in some applications. The basic system is shown in Fig. 16. The modulation power is fed into the plate

circuit by employing a choke as a common impedance for the modulator and the r-f amplifier. Only a single modulator tube is required. Since the modulator stage must be operated in class A to obtain an undistorted audio signal, the output power and plate efficiency of the modulator are low. No coupling transformer is used, making it necessary to adjust the plate voltage and current

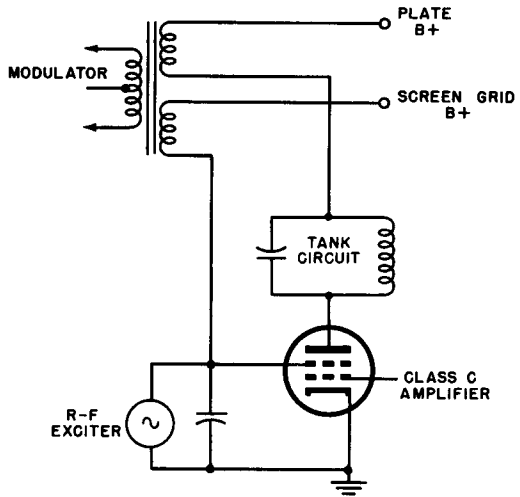

Fig. 15. The use of a multi-winding transformer to introduce efficient screen grid modulation.

of the r-f amplifier to achieve the proper impedance match for the modulator. Power input to the r-f stage must be held to a maximum of twice the audio-frequency power output of the modulator.

If the plate voltage of the modulator stage swings to zero (as it must if 100 percent Heising modulation is to be achieved), considerable distortion of the audio-frequency signal will result, due to the non-linearity of the tube characteristic at very low values of plate voltage. With the circuit as shown in Fig. 16, it would be necessary to limit the modulation to about 75 percent. To avoid this, the parallel combination of resistor  $R$  and capacitor  $C$  can be inserted in series with the r-f amplifier plate circuit at point X. This gives the modulator a plate voltage higher than that of the r-f amplifier, enabling the modulator plate to swing far enough to modulate the r-f amplifier 100 percent without the necessity of dropping

all the way to zero voltage. The proper value of resistance for  $R$  will depend upon the tube type used for the modulator. The voltage drop across the resistor must equal the lowest instantaneous plate voltage encountered by the modulator tube under normal

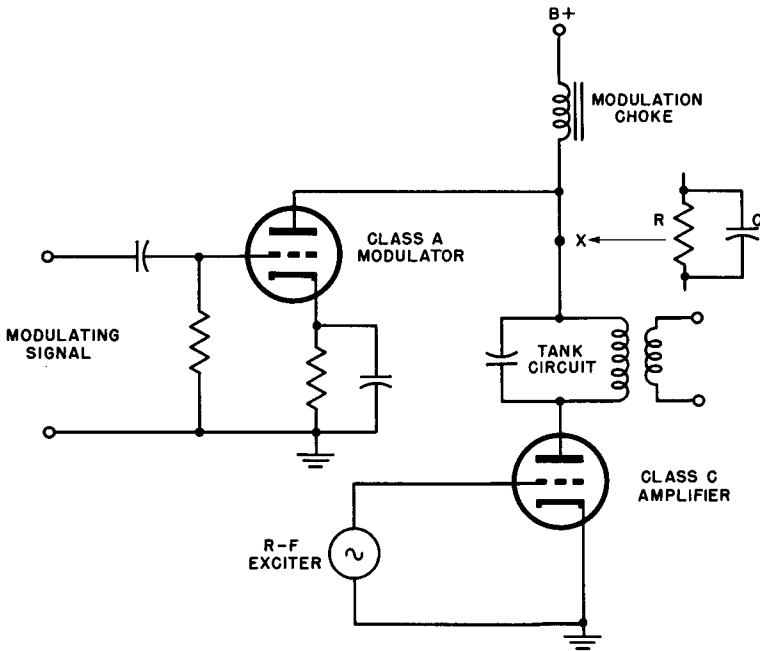

Fig. 16. Basic Heising modulation system.

operation. Capacitor  $C$  acts to by-pass audio frequencies around  $R$ , and should have a reactance (at the lowest audio frequency used) of less than one-tenth the resistance of  $R$ .

## 16. Review Questions

- (1) Give three reasons for the popularity of plate modulation systems.
- (2) Explain the operation of a class A r-f amplifier; a class AB amplifier.
- (3) How do class B and class C r-f amplifiers differ from class A and class AB amplifiers?
- (4) Draw the schematic diagram of a plate modulated output stage.
- (5) At 100 percent modulation caused by an audio sine wave, what additional power is supplied by the modulator in a plate modulated system?

- (6) What are the audio frequency power requirements for 100 percent modulation?
- (7) Is it desirable to operate an a-m transmitter at 100 percent modulation? Why?
- (8) Explain the pertinent adjustments necessary for plate modulated transmitters.
- (9) How would non-linearity, in question 8, be detected.
- (10) Explain, by discussion and illustration, the characteristics of the Heising modulation system.

## Chapter 3

### CONTROL GRID MODULATION

As mentioned in Chap. 2, applying modulation to the plate circuit of an r-f power amplifier requires a modulator capable of supplying audio power equivalent to half the power in the unmodulated carrier. To eliminate the expense of a high-power modulator, we could consider introducing the modulating signal into the transmitter in some other way, so that only voltage amplification or very low power amplification will be required of the modulator. One expedient to be considered would be introducing the modulation into an early transmitter stage, and feeding the modulated signal through additional voltage amplifiers and a driver stage to an r-f power amplifier. Unfortunately, the output voltage of a class C amplifier is not proportional to its input grid voltage, and grid modulated signal envelope is not reproduced in its output with any degree of fidelity. This means that we are forced to use a class B r-f amplifier, with its inherently lower efficiency. For a given power output, then, the saving in modulator cost is offset by the increase in the cost of the r-f power amplifier, not to mention the increased difficulty in its adjustment to maintain acceptable linearity. This indicates that our most practical approach is to retain the class C r-f power output stage, and to apply the modulating signal to this stage via a grid.

Regardless of how the modulation is applied, we still cannot avoid the fact that the transmitter average output power increases

50 percent with 100 percent sine-wave modulation, and that this extra power must come, if not from the modulator, from some other source in the equipment. If no external circuit is available to furnish the additional power, it must be generated within the r-f power stage. In grid modulation, the modulator power requirements are light, but the burden of supplying all the required output power is placed upon the r-f stage. As will be seen, this places definite limitations on the output capabilities of the transmitter.

Grid modulation differs from plate modulation chiefly in that the plate supply voltage is constant, and the extra output power

Fig. 17. Variation of plate current and plate efficiency with modulating signal in grid modulation.

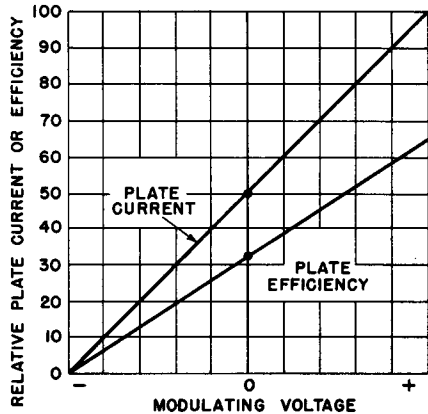

required for modulation is obtained by causing the plate current and the plate efficiency to vary in accordance with the modulating signal. Figure 17 shows these relationships graphically. As we saw in Chap. 1, 100 percent modulation by sine wave produces a peak output power equal to four times the unmodulated carrier power. Examining Fig. 17, we note that at the peak of the modulation swing in the positive direction the plate current has doubled, which would indicate (assuming a constant plate voltage) that the output power has also doubled. However, we see by the second curve in Fig. 17 that the tube plate efficiency also has doubled at this same peak instant, effectively redoubling the output power. As a result, the peak power output is four times the normal carrier power, fulfilling the condition for 100 percent modulation. It is imperative, of course, that the transmitter be carefully adjusted to provide optimum op-

erating conditions; otherwise, the curves in Fig. 17 will depart markedly from linearity and the analysis will not hold true. Careful adjustment can produce a peak plate efficiency of as much as 80 percent, but adjusting for maximum linearity usually reduces this to between 65 and 70 percent.

With a peak plate efficiency of 70 percent, the plate efficiency in the absence of modulation will be approximately half this value, or 35 percent. For a given tube, the output power available is only about one-quarter that available when plate modulation is employed. Obviously, we are paying for our reduced modulator cost either by a reduction in output power or by an increase in r-f power stage cost, and accepting a circuit that is more critical in its requirements for operation and adjustment. Other things being equal, the linearity obtainable with grid modulation is somewhat poorer than that obtained with plate modulation, and the likelihood of introducing distortion and splatter through careless adjustment is greater in the grid-modulated system. On the other hand, the modulator required for grid modulation can be a simple, light-duty unit, since it is called upon to supply only the power dissipated in the grid circuit of the r-f power stage. This seldom exceeds 10 watts, and is usually much less than this value.

### **17. Plate Circuit Requirements for Grid Modulation**

As previously mentioned, the establishment of proper operating conditions for grid modulation is a more critical operation than in plate modulation. The plate load should be large, so that at the positive peak of modulation the voltage across the load will closely approach the value of the plate supply voltage; in other words, the minimum instantaneous plate voltage should be small. For linear modulation, the power output in the absence of modulation will be one-fourth the peak power reached during modulation, and the voltage swing across the load (when the carrier is unmodulated) will be approximately one-half the plate supply voltage. Accordingly, in the absence of modulation, the minimum instantaneous plate voltage will be high, and the plate circuit efficiency consequently will be low, in the neighborhood of 30 percent. At the negative peaks of modulation, the output and the efficiency will be almost zero; at the positive peaks the efficiency should be double the normal value, or about 60 percent.

In achieving optimum operating conditions and maximum linearity, a high plate voltage is a necessity. For this reason, the r-f amplifier tube is usually operated at the maximum permissible rating specified by the manufacturer. The d-c plate power input should not be greater than 1.5 times the rated plate dissipation of the tube, to avoid an operational overload.

In determining the proper ratio of inductance to capacitance for the plate tank circuit, the calculation should employ a value of plate current equal to twice the unmodulated plate current. Using merely the unmodulated value can result in a tank circuit with a very low  $Q$ , making it impossible to achieve proper coupling from the tank to the output circuit.

As an example of the procedure for determining proper operating conditions, let us assume that we plan to use an r-f amplifier tube with a plate dissipation rating of 100 watts. The maximum allowable input power will be 1.5 times 100, or 150 watts. If the maximum plate voltage rating for the tube is 1000 volts, the average plate current will be

$$I = \frac{W}{E} = \frac{150}{1000} = 150 \text{ milliamperes}$$

where  $W$  = Input Power in watts  
 $E$  = Plate Voltage in volts

With an efficiency of 30 percent, the unmodulated output will be 0.30 times 150, or 45 watts. The ratio of plate voltage to plate current, using twice the unmodulated plate current value, is

$$\frac{E_p}{I_p} = \frac{1000}{300} = 3.33$$

and this is the ratio to be used in selecting the tank circuit components.

Although the foregoing material is a preliminary to the discussion of control grid modulation, these basic principles are equally applicable to screen grid and suppressor grid modulation, because the essential operational characteristics are similar regardless of the particular grid employed for introducing the modulation.

A typical control grid modulated power amplifier circuit is shown schematically in Fig. 18. Just as in plate modulation, the control grid biased well beyond cutoff by a fixed d-c bias source, and the carrier signal is applied to this grid. The modulating signal, however, is applied in series with the fixed bias lead. The a-f signal from the speech amplifier is amplified in the modulator final stage and coupled into the bias circuit by transformer  $T1$



(1:1 turns ratio), effectively superimposing the a-f voltage fluctuations on the original d-c bias. The instantaneous bias on the control grid accordingly varies at this audio rate, resulting in corresponding variations in the output and the efficiency of the r-f power stage.

Since the control grid is driven positive in class C operation, grid current will flow, and this current will vary with amplitude

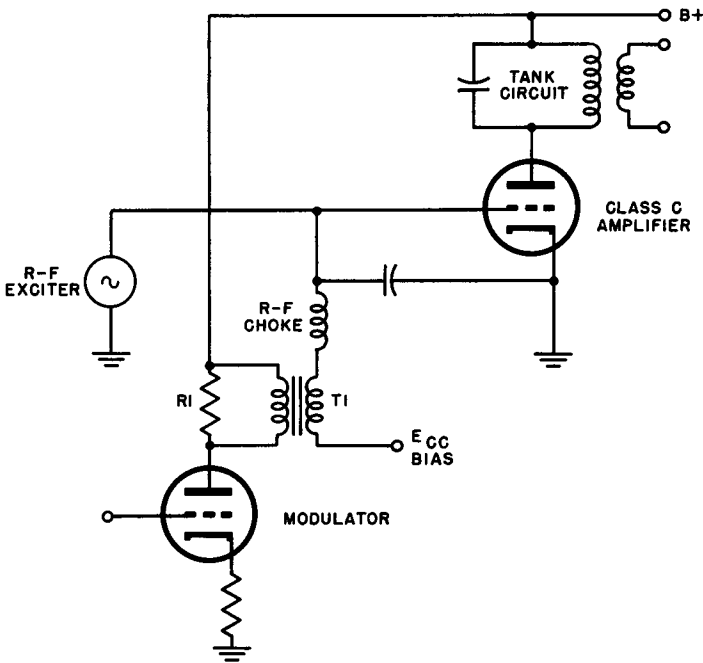

Fig. 18. Typical control grid modulated power amplifier circuit.

of the grid voltage, presenting a variable load to the modulator. To minimize the resultant distortion, resistor  $R1$  is connected as a constant load across the output circuit of the modulator to reduce the load variation. The resistance of  $R1$  should be approximately equal to the normal rated load of the modulator. In addition to  $R1$ , it is common practice to employ large amounts of negative feedback in the modulator to achieve a very low internal impedance, thereby reducing still further the reaction of the modulator to the varying load.

The grid circuit of the r-f power stage also represents a varying load to the driver stage, and will accordingly tend to cause the excitation voltage to vary. This could result in non-linear operation. To avoid this, the driver stage should have a power output capability of two to three times that required for driving the r-f

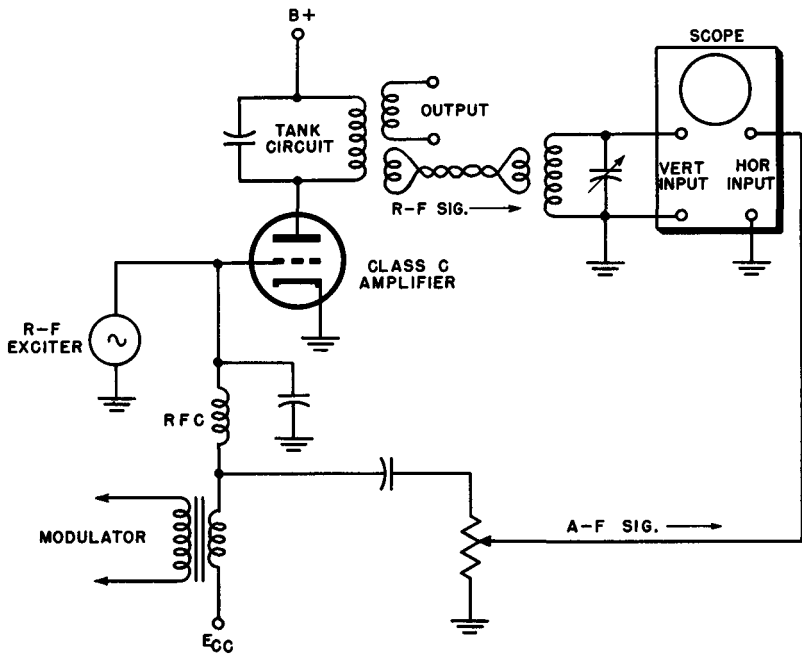

Fig. 19. Method of connecting oscilloscope for adjustment of control grid modulated transmitter.

stage, and its output should be preloaded as described for the modulator stage.

For the sake of simplicity in the preceding discussion and Fig. 18, we have assumed that a triode tube is used as the r-f power amplifier. No change is entailed if we substitute a screen-grid tube in place of the triode, provided the screen is supplied with the required value of voltage, and the screen by-pass capacitor is large enough to by-pass the audio as well as the radio frequencies.

## 18. Adjustment of Control Grid Modulated Transmitters

The adjustment of the grid modulated stage is primarily an adjustment of the linearity of the modulation characteristic, and is best accomplished with the use of an oscilloscope. First determine the proper plate current for the modulated stage by the method described earlier in this chapter. Then, with plate voltage and carrier excitation applied, adjust the plate load to produce this plate current, being careful to keep the tank circuit continually tuned to resonance. Connect the oscilloscope to the outputs of the modulator and r-f stages as shown in Fig. 19 (refer to Chap. 6 for details), and apply modulation. To achieve a usable, steady pattern on the oscilloscope, a tone source of modulation should be used. The inherent fluctuations in voice modulation will result in a flickering pattern that will make close calibration difficult to achieve.

Using the trapezoidal pattern as discussed in Chap. 6, we can observe the linearity of the modulation characteristic by examining the sloping sides of the pattern; the straighter the slope, the greater the linearity. Increase the modulating voltage until the slope shows curvature. If this occurs much below 100 percent modulation, it is an indication that the plate efficiency is too high. In this event, remove the modulation, increase the plate loading and decrease the excitation so as to maintain the same plate current, then reapply the modulation and again examine the slopes of the trapezoid. Optimum adjustment will have been achieved when the slope has been made as linear (straight) as possible from the horizontal axis to twice the carrier amplitude.

## 19. Review Questions

- (1) What objections arise if modulation is introduced into early transmitter stages?
- (2) What is "control grid modulation"?
- (3) Explain the operation of a grid modulation circuit.
- (4) Draw a schematic to illustrate Question 3.
- (5) List the advantages and disadvantages of grid modulation.
- (6) What differences are there between plate and control grid modulation?
- (7) What are the plate circuit requirements for control grid modulation?
- (8) Explain the adjustment procedures for control grid modulation.
- (9) Show, by sketch where an oscilloscope would be connected in the adjustment procedure.
- (10) Why is a tone source of modulation necessary in the adjustment procedure?

## Chapter 4

### SCREEN GRID AND SUPPRESSOR GRID MODULATION

Beam tetrodes and pentodes offer distinct advantages over triodes as r-f power amplifiers. Chief among these is the circuit isolation made possible by the additional electrodes. The excitation, load, and modulating signal can be placed in separate circuits, making it easy to adjust each one independently of the others. In the case of screen modulated tetrodes, the fixed bias supply can be dispensed with, and an economical grid leak bias used instead, while a suppressor modulated pentode permits the use of a voltage amplifier stage as a modulator. However, the basic principles of grid modulation, as outlined at the beginning of Chap. 3, still apply, and the unmodulated output is still limited to approximately half the rated plate dissipation of the r-f power amplifier tube.

#### 20. Screen Grid Modulation

Although it is not always satisfactory when used with pentodes, screen grid modulation can yield an excellent modulation characteristic when applied to a tetrode. As shown in Fig. 20, the modulating signal is usually transformer-coupled into the screen circuit. The d-c screen grid voltage is approximately half the rated maximum voltage for cw operation. The full rated maximum screen grid voltage is the peak modulating voltage for 100 percent modulation. At zero screen voltage, the ideal tetrode would be com-

pletely cut off, and the plate current and output power consequently would be zero. This does not happen in practice, and it becomes necessary to drive the screen somewhat negative to achieve complete cutoff. For this reason, the peak modulating voltage required for 100 percent modulation is approximately 10 percent greater than the d-c screen voltage.

The audio power required of the modulator is approximately 25 percent of the screen input power required for cw operation of

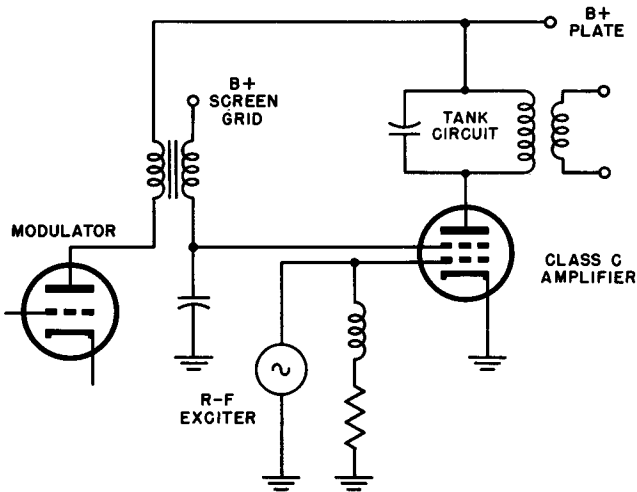

Fig. 20. Method of obtaining screen grid modulation in a tetrode.

the power amplifier. Since there is a non-linear relationship between screen voltage and screen current in the tetrode, the load presented to the modulator will be a varying one, and represents an inherent source of distortion. The remedies for this condition are the same as those given above for control grid modulation: negative feedback and pre-loading of the modulator output stage. There is no direct method for calculating the value of the loading resistor in this case, however, making it necessary to determine the proper load by using an adjustable resistor and observing the results on an oscilloscope.

The turns ratio for the modulator coupling transformer can be calculated as follows (if we assume that the modulator tube is fully loaded by the combination of the screen and the loading resistor) :

$$\frac{\text{secondary turns}}{\text{primary turns}} = \frac{E_s}{2.5 \sqrt{PR}}$$

$E_s$  represents the rated d-c screen voltage for cw operation.

$P$  represents the rated audio output power of the modulator tube.

$R$  represents the rated load resistance of the modulator tube.

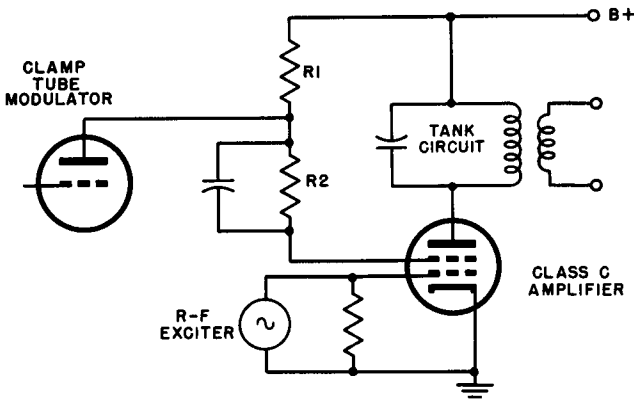

Fig. 21. Use of a screen clamp tube as a screen grid modulator.

## 21. Screen Grid Modulation with Clamp Tube

When the transmitter employs a screen grid clamp tube to protect the r-f power amplifier against damage in the absence of excitation, the clamp tube itself can be used as a modulator by applying the audio signal to its control grid. This system is shown schematically in Fig. 21. Comparing it with Fig. 16, we can see that it is very similar to choke modulation, with the screen grid resistor,  $R1$ , acting as the common impedance in place of the choke. The clamp tube is operated as a class A triode amplifier, and the load resistor ( $R1$ ), the normal screen dropping resistance required for cw operation of the r-f power amplifier, should be approximately

three times the rated load required by the modulator tube for optimum output.

As we saw in the analysis of choke-coupled modulation, we cannot drive the modulator plate voltage to zero without introducing serious distortion, which means that we cannot modulate 100 percent unless special means are employed to provide a higher plate voltage source for the modulator. In addition, since the screen must be driven somewhat negative to achieve 100 percent modulation, an even wider plate voltage swing will be required of the modulator. The plate supply voltage as a result must be 30 or 40 percent higher than the screen voltage for the r-f amplifier. As in the case of choke-coupled modulation, an auxiliary screen-dropping resistor ( $R_2$ ), in parallel with an audio by-pass capacitor, is connected in series with the screen grid circuit to permit operating the modulator plate at higher voltage.

## 22. Adjustment of Screen Modulated Transmitters

The simplest and most accurate method of adjustment is by means of an oscilloscope. The procedure is the same as indicated above for control grid modulation, and the scope connections are as shown in Fig. 19, except that the sweep voltage connection is made to the screen grid rather than to the control grid. The r-f amplifier grid current should be held at the value where a decrease will result in a drop in the r-f output, and the amplifier should be heavily loaded. Operating the tube at this low grid current point reduces the screen current required, and consequently requires less power from the modulator.

When the tube is modulated 100 percent, the screen grid will be driven somewhat negative, and the oscilloscope pattern will show a slight irregularity at the point corresponding to zero screen voltage. This departure from linearity is an inherent source of distortion, but it can be corrected by  $R$ - $C$  coupling a portion of the modulation signal to the control grid, and adjusting the coupling so as to eliminate the irregularity in the scope pattern.

If an oscilloscope is not available, the screen-modulated transmitter can be adjusted by taking measurements of current and voltage, though the results will not be quite as precise. The r-f output stage should be heavily loaded and, as previously indicated, the grid current should be reduced to a point where the output

just begins to fall off. (Under this condition, the dip in plate current as the tank circuit is tuned through resonance may be somewhat difficult to detect, since the change is usually slight.) The normal rated d-c screen-grid voltage for cw operation should be applied to the stage, which should be tuned first for maximum output with modulation disconnected. Then read the plate current and r-f antenna current, and reduce the d-c screen voltage until the plate current drops to half its original value. If the adjustments have been properly made, the antenna current should also decrease to about half its former value. Apply modulation, and increase the modulating voltage until the plate current just begins to rise. This is the 100 percent modulation point. The plate current should remain steady when voice modulation is applied, except for an occasional momentary jump during an exceptionally high modulation peak.

Adjustment of the clamp tube modulated circuit is accomplished in the same way as described above, either by oscilloscope observation or by measurement of current and voltage. When the latter method is used, adjustment is first made for cw operating conditions with the clamp tube removed. The tube is then reinserted, and its cathode resistor is adjusted so as to reduce the r-f amplifier plate current by one half, as previously outlined.

### **23. Suppressor Grid Modulation**

Screen grid modulation of pentode tubes is often unsatisfactory due to the inherently poor modulation characteristic. Much better results are achieved by employing a pentode class C amplifier and applying the modulating signal to the suppressor, as shown in Fig. 22. Since the suppressor grid is never at a positive potential, no current is required, and the modulator tube is not called upon to supply any power. A voltage amplifier can therefore be used, and the peak voltage required for 100 percent modulation will be the same value as the d-c bias voltage on the suppressor.

Adjustment of a suppressor-modulated transmitter is the same as for screen grid modulation, except that the oscilloscope sweep voltage is taken from the suppressor. When the adjustment is to be made by meter readings, the r-f amplifier is first adjusted for optimum output under cw operating conditions, with zero bias on the suppressor. The suppressor bias is then connected, and ad-



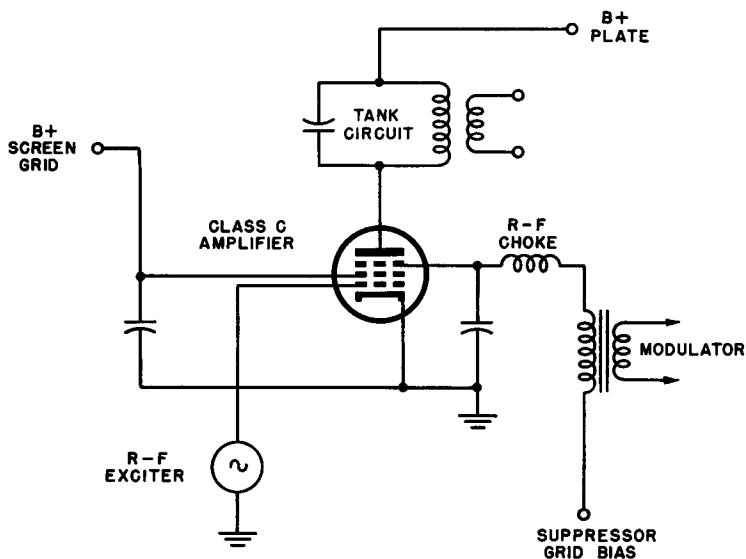

Fig. 22. Suppressor grid modulation of an RF pentode.

justed in a negative direction until the plate current and r-f antenna current have been reduced by one-half. The system is then ready for modulation.

## 24. Review Questions

- (1) What are the chief advantages inherent in the use of beam tetrodes and pentodes as r-f power amplifiers?
- (2) Define "screen grid" modulation.
- (3) List the characteristics of screen grid modulation, including the formula for computing the turns ratio of the modulator coupling transformer.
- (4) Draw a schematic diagram showing screen grid modulation.
- (5) Is the screen grid modulation technique used primarily with tetrodes or pentodes? Why?
- (6) Show a schematic diagram of a transmitter employing a clamp tube and screen grid modulation.
- (7) Detail the adjustment procedures for a screen grid modulated transmitter by means of an oscilloscope.

- (8) How would the screen grid modulated transmitter be adjusted if an oscilloscope were not available?
- (9) How does suppressor modulation differ from screen grid modulation?
- (10) Draw a schematic illustrating a suppressor modulation circuit.

## Chapter 5

### CATHODE MODULATION

Having applied our modulating signal to the plate and to the various grids in the preceding chapters, we will now discuss means of applying it to the one remaining electrode — the cathode. The term “cathode modulation” is somewhat misleading, however, because the modulation actually takes place in the grid and plate circuits. This can be seen in the circuit shown in Fig. 23. The modulating signal is coupled to the cathode circuit by means of a tapped transformer, *T1*. The full secondary voltage of *T1* is applied to the plate circuit, while a portion of this secondary voltage, as determined by the adjustable tap, is applied to the grid circuit. When properly adjusted, the plate efficiency of the r-f amplifier will be 50 to 60 percent, and the modulator is called upon to supply a power input equal to about one-fifth of the d-c plate input.

Since the method involves control grid modulation, the plate efficiency of the r-f amplifier will vary with the modulating signal, as we saw in Chap. 3. Accordingly, the efficiency in the absence of modulation must be less than the efficiency at peak modulation, to enable the variation to take place. How much the efficiency must be lowered will depend upon the ratio of grid modulation to plate modulation, as determined by the fraction of modulation voltage delivered at the grid tap on the modulator output transformer; as the grid voltage fraction is increased, the plate efficiency (unmodulated) must be proportionately decreased.

Efficient operation of the system requires that the modulator tubes be properly matched to the modulation impedance by choosing the correct turns ratio for the modulator output transformer. The modulation impedance can be estimated as follows:

$$Z_{mod} = \frac{\text{percent modulation}}{100} \times \frac{E_{dc}}{I_{dc}}$$

$E_{dc}$  is the d-c plate voltage of the r-f amplifier, in volts.

$I_{dc}$  is the d-c plate current of the r-f amplifier, in amperes.

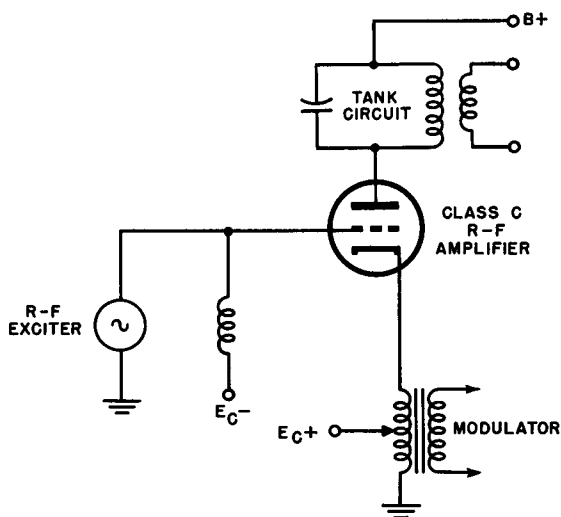

Fig. 23. Basic cathode modulation circuit.

## 25. Cathode Modulation Operating Conditions

In establishing optimum operating conditions, we must continually bear in mind that cathode modulation is a combination of grid and plate modulation. If the percentage of grid modulation is large, the considerations listed in Chap. 3 for a grid-modulated stage will be of major importance. For example, a bias source of low internal impedance will be needed, because of the appreciable variation in grid current. On the other hand, if the percentage of grid modulation is small, and the tube is operated more like a plate-modulated amplifier, the conditions listed in Chap. 2

for plate modulation will apply most strongly. Because the grid current variation will be small, we can use a combination of fixed bias and grid leak bias. (If used, the grid leak should be bypassed for audio.) The weight given to each of the two types of modulation will naturally determine the basic characteristics of the circuit, and our adjustment procedures in turn must be selected in accordance with these characteristics.

Regardless of the distribution of modulation between the plate and grid, there are several common requirements that must be met to achieve optimum linearity. The grid should be biased well beyond cutoff; the cathode circuit of the r-f power amplifier must be isolated from the remaining transmitter stages. This means that when the modulated stage uses directly heated tubes, an independent filament transformer must be used to supply heater current to this stage. The filament bypass capacitors should be large enough to bypass the radio frequencies, but small enough to avoid shunting the audio frequencies.

Adjustment of the cathode-modulated stage will be essentially the same procedure described earlier for grid modulation, and the oscilloscope connection will be as shown in Fig. 19. If the trapezoidal pattern is observed, and the grid bias excitation and antenna loading properly adjusted, very good linearity can be achieved. When the modulated stage is properly adjusted, there will be virtually no change in cathode current when modulation is applied or removed.

## 26. Review Questions

- (1) Why is the term "cathode modulation" misleading?
- (2) Draw a circuit illustrating cathode modulation.
- (3) What is the plate efficiency of the cathode-modulated r-f amplifier when properly adjusted? What power input must the modulator supply?
- (4) Why does efficiency in the absence of modulation vary from modulation conditions?
- (5) How can the modulation impedance be estimated?
- (6) List the factors pertinent to cathode modulation operating conditions and adjustments.

## Chapter 6

### **AMPLITUDE MODULATION CHECKING AND MONITORING**

For visual indication of the proper adjustment and operation of a transmitter, the best device by far is the oscilloscope, because of its ability to give an immediate, direct, precise picture of circuit conduct. Although meters are frequently used for checking and monitoring transmitter operation, they are less satisfactory, because their indications must be translated into other quantities, and because they are often subject to misinterpretation. Since both meters and oscilloscopes are widely used, it will be worthwhile for us to examine both methods in detail.

#### **27. Modulation Checking with Oscilloscope**

There are two ways of using the oscilloscope for examining the operational characteristics, identified by the type of display pattern involved; they are the wave envelope pattern and the trapezoidal pattern. To obtain the wave envelope pattern, the vertical plates of the oscilloscope are coupled to the plate tank circuit of the modulated stage (preferably through a tuned circuit to eliminate radio-frequency harmonics) as shown in Fig. 24. The horizontal sweep of the oscilloscope is adjusted to a sub-multiple of the modulation frequency, and the result is a picture of the modulated carrier, similar to those illustrated in Chap. 1. This is an interesting phenomenon, but it provides far less specific information than does the trapezoidal pattern.

To obtain the trapezoidal pattern, vertical plates of the oscilloscope are coupled to the output tank circuit, and the horizontal plates are capacitively coupled to the modulating signal source, using a voltage divider as shown in Fig. 24 to reduce the voltage to a point where the display pattern is small enough to be seen in its entirety on the oscilloscope screen. Figure 24 shows the hori-

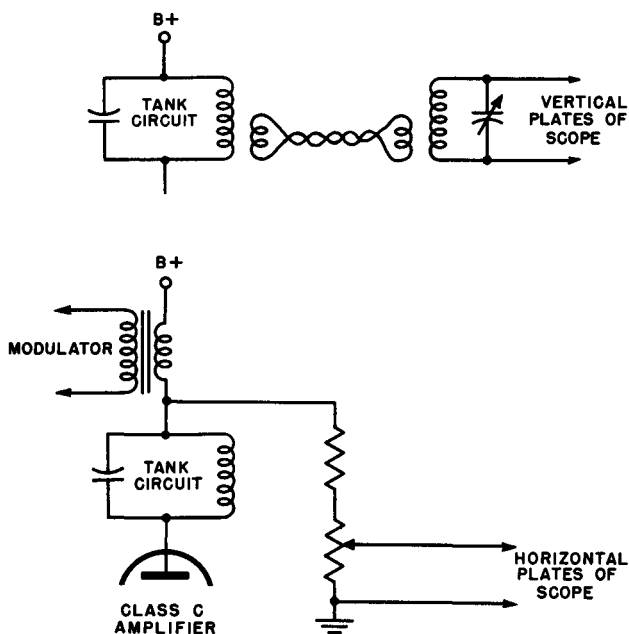

Fig. 24. Method of connecting oscilloscope to display wave envelope pattern.

zontal connection used with plate modulation, while Fig. 19 shows the connection for checking a grid-modulated stage. For screen or suppressor modulation, the connection is made to the modulated electrode; for cathode modulation it is usually made to the control grid circuit. The resulting patterns are shown in simplified form in Fig. 25.

In the absence of both excitation and modulation, the undeflected spot appears in the center of the screen. When excitation is applied, the spot swings upward and downward in unison with the carrier voltage variations, producing a vertical line on the scope

screen, Fig. 25 (B). The length of this line represents the peak-to-peak amplitude of the carrier, and should be adjusted to somewhat less than half the screen diameter. When modulation is applied, the trapezoid-shaped pattern shown in Fig. 25 (C) is produced. This represents 100 percent modulation of a correctly-adjusted ideal transmitter, while Fig. 25 (D) and (E) show a lower percentage modulation and over-modulation respectively. When the carrier is modulated 100 percent, the wide end of the trapezoid

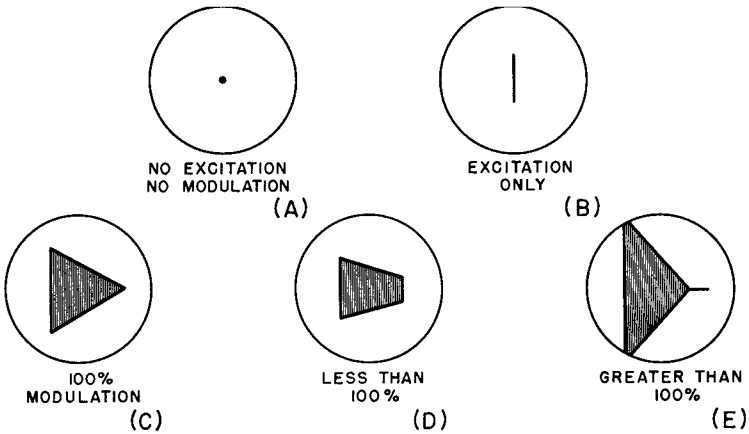

Fig. 25. Trapezoidal patterns for various modulation conditions.

will be just twice the height of the carrier amplitude line of Fig. 25 (B), while the narrow end will just come to a point; this condition is illustrated in Fig. 25 (C). Reducing the modulation reduces the horizontal width of the pattern, so that the wide end of the trapezoid does not reach full amplitude, nor does the narrow end reduce completely to a point. Figure 25 (D) illustrates this condition.

Over-modulation over-extends the pattern horizontally in both directions, as shown in Fig. 25 (E). The wide end of the trapezoid will have a vertical amplitude greater than twice the height of the "carrier only" amplitude if the modulation exceeds 100 percent in the upward direction, and an extension of the X axis will be seen beyond the pointed end of the pattern if the modulation exceeds 100 percent in the downward direction.



The sloping sides of the trapezoidal pattern represent the modulation characteristic of the transmitter. Curvature, discontinuity, or other departure from straightness consequently will represent a non-linear characteristic, indicating the presence of distortion in the system.

Since the oscilloscope presents an actual graph of the modulation characteristic, it simplifies enormously the job of transmitter adjustment. The effect of an adjustment can be seen directly, permitting optimum settings to be accurately and rapidly established. When the audio signal applied to the modulator is a clean sine wave, the presence of even-harmonic distortion in the speech amplifier or modulator can be detected by means of the trapezoidal pattern. If such distortion is absent, the pattern will extend horizontally an equal distance on each side of the vertical "carrier only" line. The presence of even-harmonic distortion will unbalance the pattern, so that it extends further in one direction on the horizontal axis than it does in the other.

## **28. The Use of Meters for Modulation Checking**

Although it is not as accurate or definite as oscilloscope observation, the use of meters will give satisfactory results if they are properly calibrated and correctly interpreted. Aside from the actual quantitative measurements used to determine the correct operating conditions, the meter furnishes an indication of the modulation performance by its actions during modulation.

When the transmitter output stage is properly adjusted and properly modulated, a milliammeter connected in its plate circuit will indicate an almost constant plate current as modulation is applied and removed. If the stage were perfectly linear, there would be no change at all in the plate current, but since perfect linearity is never actually achieved in practice, some variation is to be expected. A strong shift upward or downward with application of modulation, however, is a symptom of improper operation.

In a plate-modulated stage, an increase in plate current as modulation is applied can be due to overmodulation, or to parasitic oscillation or incomplete neutralization of the output amplifier. A decrease in plate current can result from a variety of conditions. Poor regulation in the plate power supply due to high internal impedance, or to inadequate filter capacitance, will produce

this effect directly, and resistance in the a-c supply line will give a similar result due to the voltage drop produced when the modulator draws current through the line.

Improper loading of the plate-modulated stage, so that it presents the wrong value of impedance to the modulator, will produce a plate current dip when modulation is applied, as will low excitation or insufficient grid bias. Additional sources are excessive d-c input, low filament voltage, and weak filament emission in the output stage.

In grid-modulated transmitters, a correctly adjusted and properly modulated output stage will show no more than a 10 percent increase in plate current when sine-wave modulation is applied. A greater increase would indicate overmodulation, or incomplete neutralization of the modulated stage. When screen modulation is used, low screen voltage is a suspect, while in the case of suppressor or control grid modulation, excessive bias voltage may be the cause.

A dip in plate current as modulation is applied may be due to excessive excitation, too high a plate efficiency in the unmodulated condition, or inadequate filter capacitance in the plate power supply. Where control grid modulation is used, inadequate grid bias and high resistance in the bias supply are possible causes.

A steady plate current in a grid-modulated stage as modulation is applied and removed cannot be considered positive assurance that the system is operating properly. If overmodulation in the downward direction is exactly balanced by flattening of the positive peaks, the meter will not register a change in the average current. This situation is readily possible in grid modulation, and can occur occasionally with plate modulation. Positive determination of proper modulation can be achieved only by means of the oscilloscope.

## **29. Modulation Monitoring**

For the most effective use of the transmitting equipment, the output stage should be modulated 100 percent, yet if we exceed this value, we produce distortion and generate interference in neighboring channels. This makes it mandatory that we incorporate some type of permanent indicator somewhere in the system to monitor the modulation performance. The oscilloscope is the ideal instrument for this purpose, since it gives an exact, easily-inter-

puted indication of the percentage of modulation. Although the use of meters for modulation monitoring is acceptable, their results are questionable unless they are calibrated initially by means of an oscilloscope.

As previously indicated, the plate milliammeter in the modulated stage can be used as an overmodulation indicator, since modulation greater than 100 percent will cause an increase in the plate current for this stage. But, as was also pointed out, a steady plate current is no guarantee of proper modulation, unless verified by oscilloscope.

A rectifier-type voltmeter with a resistance of at least 1000 ohms per volt can be used as a modulation monitor by connecting it across the output of an audio driver stage. It will be necessary, however, to employ an oscilloscope in calibrating the instrument, in order to observe the output voltage corresponding to 100 percent modulation of the r-f output.

When a class B modulator is used, a millimeter in the plate circuit of the class B stage will serve as a convenient modulation monitor. Here again, an oscilloscope must be employed initially, to determine the voice intensity and the gain control adjustment that will produce 100 percent modulation of the output, and to permit observing the meter reading that corresponds to this condition.

Obviously, modulation monitoring by meters provides only an indirect view of the modulation performance; only the oscilloscope will give first hand information of the operation of the modulated amplifier.

### **30. Indicators for Preventing Overmodulation**

The most serious type of overmodulation, and probably the most commonly encountered, is overmodulation in the negative direction. A simple device for detecting this type in a plate modulated transmitter is shown in Fig. 26. The diode has its cathode connected to the modulation input lead, while its plate is connected to a low positive potential. Whenever the diode's cathode is driven more negative than its plate, the diode will conduct, and the resultant current flow will produce a reading on the ammeter. When the plate connection is made at the ground end of the bleeder, a reading will be observed as the cathode drops below ground potential, indicating that the modulation has exceeded 100 percent.

If the diode plate is connected to a point higher up on the bleeder, the meter will register a current flow before the diode cathode reaches actual ground potential, since the diode will conduct as soon as its cathode becomes more negative than its plate. This is

Fig. 26. A negative over-modulation indicator.

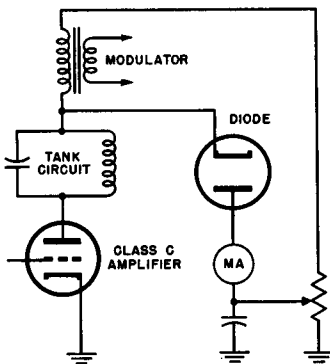

a useful feature, since it permits adjusting the indicator to provide a warning before the modulation reaches a full 100 percent. By initially calibrating the indicator with an oscilloscope, it is possible to set it to indicate at any desired degree of modulation up to 100 percent.

### 31. Review Questions

- (1) What two methods may be employed when using an oscilloscope for examining a-m operational characteristics? Identify them by name.
- (2) What specific information does the trapezoidal pattern show?
- (3) How is this pattern obtained?
- (4) Illustrate, by diagram patterns for 100 percent modulation; for under-modulation; for overmodulation.
- (5) What do the sloping sides of the trapezoidal pattern represent?
- (6) What indications on a plate circuit milliammeter of the transmitter output stage show modulation?
- (7) If meters are utilized, indicate, for each of the modulation systems reviewed, the correct adjustments and/or variations to be expected for all conditions of modulation.
- (8) Describe the two types of equipment utilized in modulation monitoring, and the way each type is connected and used.
- (9) What is the most serious type of overmodulation?
- (10) How may this type of overmodulation be corrected?

## INDEX

- Adjustment of plate-modulated transmitters, 24, 25, 26, 27
- Amplitude modulated wave, nature of, 2
- Amplitude modulation monitoring, 49
- Asymmetrical modulation, 12, 13
- Average power, 9
  
- Cathode modulation, 46, 47, 48
- Cathode modulation operating condition, 47, 48
- Choke-coupled modulation, 28, 29, 30
- Classes of amplifiers, 18, 19, 20, 21
- Continuous wave transmission, 2, 3
- Control grid modulation, 32, 33, 34
- Control grid modulated transmitters, adjustment of, 38
- Curvature of trapezoid patterns, 52
  
- Demodulation, 4
- Depths of modulation, 7
- Design considerations, 13, 14
- Discontinuity of trapezoid pattern, 52
- Distortion sources, 25, 26
  
- Flywheel effect, 21
- Frequency components of modulated waves, 4, 5
- Frequency stability, 14, 15
  
- Heising modulation, 28, 29, 30
- Hum reduction, 14
  
- Improper loading, 53
- Improper modulation, 9, 10, 11, 12
  
- Linearity, 15, 16, 17
- Linear modulation characteristic, 15
  
- Maximum hum reduction, 14
- Minimum internal impedance, 14
- Modulated impedance, 23, 27, 28
- Modulated signal fundamental, 1, 2
- Modulation amplitude considerations, 6, 7, 8
- Modulation capability, 16
- Modulation checking by meters, 52, 53
- Modulation checking with oscilloscope, 49
- Modulation, definition of, 1
- Modulation impedance, 47
- Modulation monitoring, 53, 54
  
- Non-linearity, 25
  
- One hundred percent modulation, 7
- Optimum transfer modulation power, 23
- Output ripple, 14
- Overmodulation, 54
- Overmodulation indicators, 51, 52, 53, 54, 55
  
- Peak power, 8, 9
- Peak-to-peak amplitude, 4
- Percentage modulation, 7
- Periodic wave, 2
- Plate circuit requirements for grid modulation, 34, 35, 36, 37
- Plate efficiency, 46
- Plate modulation of tetrodes and pentodes, 27, 28
- Power in the modulated wave, 7, 8, 9
- Power supply ripple, 14
- Principles of plate modulation, 18
  
- Radio waves, 2
- R-C coupling, 42
  
- Screen grid and suppressor grid modulation, 39-43
- Screen grid modulation with clamp tube, 41, 42
- Screen modulated transmitters, adjustment of, 42
- Sidebands frequency, 9, 10
- Splatter, 11
- Suppressor grid modulation, 43
  
- Trapezoid modulation pattern, 38
- Trapezoid pattern, 50, 51, 52
- Turns ratio, 41
  
- Unsymmetrical modulation, 12
- Upper and lower envelope, 6