

# TELEVISION EQUIPMENT THEORY and OPERATION

Manual for  
TELEVISION TECHNICAL  
TRAINING PROGRAM



BROADCAST EQUIPMENT SECTION  
ENGINEERING PRODUCTS DEPARTMENT  
RADIO CORPORATION OF AMERICA  
CAMDEN, N. J.

# TELEVISION TECHNICAL TRAINING MANUAL

## STAFF

J. E. Landy, **Managing Editor**

### Associate Editors

**W. H. Carver**

**E. G. Keith**

**M. M. Brandt**

**L. E. Anderson**

**E. T. Griffith, Business Manager**

### Art, Photography, and Production

**P. F. Gallo, Art**

**J. O. Gaynor, Photography**

**J. Hurst, Jr., Production**

## CONTRIBUTORS

### **J. S. Almen**

Broadcast Studio Equipment Merchandising Group  
Engineering Products Dept., RCA, Camden

### **L. E. Anderson**

Broadcast Studio Equipment Engineering  
Engineering Products Dept., RCA, Camden

### **D. W. Balmer**

TV Antenna Engineering  
Engineering Products Dept., RCA, Camden

### **A. J. Banks**

Broadcast Studio Equipment Engineering  
Engineering Products Dept., RCA, Camden

### **W. Baston**

NBC Engineering Dept.  
New York, N. Y.

### **J. A. Bauer**

Theater and Sound Engineering  
Engineering Products Dept., RCA, Camden

### **T. J. Boerner, Manager**

Special Purpose Transmitter Group  
Engineering Products Dept., RCA, Camden

### **M. M. Brandt**

Broadcast Studio Equipment Planning Group  
Engineering Products Dept., RCA, Camden

### **G. W. Bricker**

Broadcast Studio Equipment Merchandising Group  
Engineering Products Dept., RCA, Camden

### **R. W. Byloff**

NBC Engineering Dept.  
New York, N. Y.

### **W. H. Carver**

Instruction Book Section  
Engineering Products Dept., RCA, Camden

### **F. E. Cone**

Broadcast Studio Equipment Engineering  
Engineering Products Dept., RCA, Camden

### **R. W. Crotinger**

Engineering Supervisor, WHIO-TV  
Dayton, Ohio

### **C. C. DeWitt**

Broadcast Studio Equipment Engineering  
Engineering Products Dept., RCA, Camden

### **W. T. Douglas, Jr.**

Broadcast Transmitter Engineering  
Engineering Products Dept., RCA, Camden

### **O. O. Fiet**

TV Antenna Engineering  
Engineering Products Dept., RCA, Camden

### **T. U. Foley**

TV Antenna Engineering  
Engineering Products Dept., RCA, Camden

### **H. E. Gihring, Manager**

TV Antenna Engineering Group  
Engineering Products Dept., RCA, Camden

### **T. M. Gluyas**

Broadcast Transmitter Engineering  
Engineering Products Dept., RCA, Camden

### **E. M. Gore**

Broadcast Studio Equipment Engineering  
Engineering Products Dept., RCA, Camden

### **I. E. Goldstein**

Broadcast Studio Equipment Engineering  
Engineering Products Dept., RCA, Camden

### **J. L. Grever**

Broadcast Studio Equipment Engineering  
Engineering Products Dept., RCA, Camden

### **E. T. Griffith, Manager**

Broadcast Promotion Group  
Engineering Products Dept., RCA, Camden

### **M. E. Gunn**

Broadcast Studio Equipment Merchandising Group  
Engineering Products Dept., RCA, Camden

Printed by Advertising Printing Company, Camden, New Jersey

## CONTRIBUTORS – (Continued)

**Dr. H. M. Gurin**  
NBC Engineering Dept.  
New York, N. Y.

**W. O. Hadlock**  
Managing Editor, Broadcast News  
Engineering Products Dept., RCA, Camden

**P. C. Harrison**  
Broadcast Studio Equipment Engineering  
Engineering Products Dept., RCA, Camden

**N. L. Hobson**  
Broadcast Studio Equipment Engineering  
Engineering Products Dept., RCA, Camden

**A. F. Inglis, Manager**  
Broadcast Studio Equipment Planning Group  
Engineering Products Dept., RCA, Camden

**A. E. Jackson**  
Broadcast Studio Equipment Engineering  
Engineering Products Dept., RCA, Camden

**R. Johnson**  
RCA Tube Division  
Harrison, N. J.

**R. S. Jose**  
Broadcast Transmitter Engineering  
Engineering Products Dept., RCA, Camden

**J. E. Joy**  
Special Purpose Transmitter Engineering  
Engineering Products Dept., RCA, Camden

**E. G. Keith**  
Broadcast Studio Equipment Engineering  
Engineering Products Dept., RCA, Camden

**N. P. Kellaway**  
Broadcast Studio Equipment Engineering  
Engineering Products Dept., RCA, Camden

**C. D. Kentner, Manager**  
Broadcast Transmitter Engineering Group  
Engineering Products Dept., RCA, Camden

**R. N. Knox**  
Theater and Sound Engineering  
Engineering Products Dept., RCA, Camden

**H. Kozanowski**  
Broadcast Studio Equipment Engineering  
Engineering Products Dept., RCA, Camden

**J. E. Landy**  
Broadcast Promotion Group  
Engineering Products Dept., RCA, Camden

**H. J. Lavery**  
Broadcast Studio Equipment Planning Group  
Engineering Products Dept., RCA, Camden

**J. Q. Lawson**  
Special Purpose Transmitter Engineering  
Engineering Products Dept., RCA, Camden

**A. H. Lind**  
Broadcast Studio Equipment Engineering  
Engineering Products Dept., RCA, Camden

**E. N. Luddy, Manager**  
Broadcast Transmitting Equipment Planning Group  
Engineering Products Dept., RCA, Camden

**A. C. Luther**  
Broadcast Studio Equipment Engineering  
Engineering Products Dept., RCA, Camden

**W. L. Lyndon**  
Broadcast Studio Equipment Engineering  
Engineering Products Dept., RCA, Camden

**R. J. Marian**  
Broadcast Studio Equipment Engineering  
Engineering Products Dept., RCA, Camden

**V. S. Mattison**  
Broadcast Studio Equipment Planning Group  
Engineering Products Dept., RCA, Camden

**R. L. Meisenheimer**  
Special Purpose Transmitter Engineering  
Engineering Products Dept., RCA, Camden

**G. M. Nixon**  
NBC Engineering Dept.  
New York, N. Y.

**C. R. Monro**  
Broadcast Studio Equipment Engineering  
Engineering Products Dept., RCA, Camden

**W. N. Moule**  
TV Antenna Engineering  
Engineering Products Dept., RCA, Camden

**C. R. Myers**  
TV Antenna Engineering  
Engineering Products Dept., RCA, Camden

**I. T. Newton**  
Broadcast Transmitting Equipment Planning Group  
Engineering Products Dept., RCA, Camden

**S. L. Paschal**  
TV Antenna Engineering  
Engineering Products Dept., RCA, Camden

**W. J. Poch, Manager**  
Broadcast Studio Equipment Engineering  
Engineering Products Dept., RCA, Camden

**E. H. Potter**  
Broadcast Transmitter Engineering  
Engineering Products Dept., RCA, Camden

**A. Reisz**  
Broadcast Studio Equipment Engineering  
Engineering Products Dept., RCA, Camden

**J. H. Roe**  
Broadcast Studio Equipment Engineering  
Engineering Products Dept., RCA, Camden

**C. A. Rosencrans**  
Broadcast Studio Equipment Engineering  
Engineering Products Dept., RCA, Camden

**R. T. Ross**  
Broadcast Studio Equipment Engineering  
Engineering Products Dept., RCA, Camden

**CONTRIBUTORS — (Continued)**

**C. A. Runyon**

Broadcast Transmitting Equipment Planning Group  
Engineering Products Dept., RCA, Camden

**E. H. Shively**

TV Antenna Engineering  
Engineering Products Dept., RCA, Camden

**G. A. Singer**

Broadcast Studio Equipment Engineering  
Engineering Products Dept., RCA, Camden

**N. F. Smith**

Formerly Engineer-in-Charge of TV  
WOR-TV, New York, N. Y.

**R. J. Smith**

Broadcast Studio Equipment Engineering  
Engineering Products Dept., RCA, Camden

**C. J. Starner**

Special Purpose Transmitter Engineering  
Engineering Products Dept., RCA, Camden

**F. E. Talmage**

Broadcast Transmitter Engineering  
Engineering Products Dept., RCA, Camden

**R. G. Thomas**

Broadcast Studio Equipment Engineering  
Engineering Products Dept., RCA, Camden

**M. A. Trainer, Manager**

Broadcast Product Planning Section  
Engineering Products Dept., RCA, Camden

**W. E. Tucker**

Broadcast Studio Equipment Engineering  
Engineering Products Dept., RCA, Camden

**W. R. Wadden**

TV Antenna Engineering  
Engineering Products Dept., RCA, Camden

**H. H. Wescott**

TV Antenna Engineering  
Engineering Products Dept., RCA, Camden

**P. W. Wildow**

Broadcast Studio Equipment Engineering  
Engineering Products Dept., RCA, Camden

**L. J. Wolf**

TV Antenna Engineering  
Engineering Products Dept., RCA, Camden

**H. G. Wright**

Broadcast Studio Equipment Engineering  
Engineering Products Dept., RCA, Camden

**R. H. Wright**

TV Antenna Engineering Dept.  
Engineering Products Dept., RCA, Camden

**J. E. Young, Manager**

Broadcast Transmitter and Antenna Section  
Engineering Products Dept., RCA, Camden

**R. L. Zahour**

Westinghouse Electric Corp.  
Bloomfield, N. J.

# A U D I O

**THEORY AND OPERATION OF AUDIO SYSTEMS FOR TV..... A- 1**

**AUDIO OPERATION AND EQUIPMENT DESCRIPTION**

A Flexible TV Audio System..... A- 4  
 Intercom Systems for TV..... A-12

**Custom Equipment for TV Installations**

WWJ-TV Custom Equipment..... A-15  
 WNBT-TV Studio/Audio Console..... A-18  
 WCAU-TV Studio/Audio Console..... A-22  
 WOR-TV Custom Equipment..... A-23

**Special TV Audio Considerations**

TV Microphone Techniques..... A-42  
 TV Studio Acoustics ..... A-49  
 Studio Pickup Techniques ..... A-52  
 Planning Radio and TV Studios..... A-60



# Theory and Operation of Audio Systems for TV

Most of the engineers going into television have had experience in audio broadcast work. It therefore appears unnecessary to spend much time on the theory of audio alone. Instead we can go directly into the problems connected with adding sound to the TV picture. In doing so we will encounter ways in which the equipment must vary from that used in AM or FM broadcasting.

The following pages will discuss some of the possible systems into which the component units may be arranged so a homogenous system applicable to TV operation will result.

In the years past, many stations entering television have neglected their audio facilities; their prime objective being the video facilities. However, after some operation under limited and inflexible systems, they have discovered that the audio system can not and must not be neglected in the overall plan.

The plan of a system should be evolved only after a careful study of present operating needs, together with a careful examination of possible facility expansion in the future.

Quality of equipment in the system should not be disregarded. A low cost amplifier of poor or mediocre quality, or a switch, or relay that fails to perform its task, will indeed become a very costly piece of equipment should

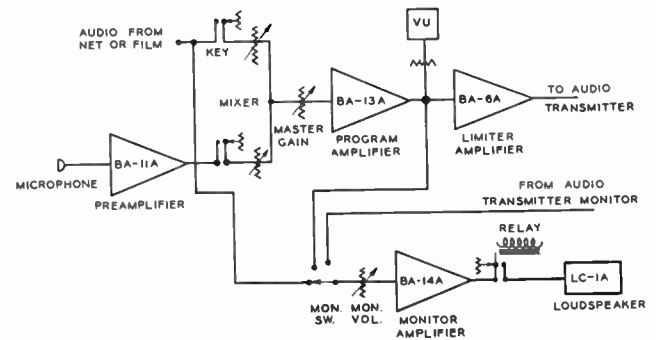

FIG. 1. Block diagram of a simple audio system for television.

it fail during a sponsored program. High quality equipment because of its dependability and superior construction, will cost less to use over a period of time.

## Simple System

In an installation that requires programming of only film or perhaps network programs together with announce facilities, the audio system may become very simple. A system meeting the above mentioned requirements is shown in Figure 1. Two inputs are provided; one for film or network audio, and a second for a microphone to be used by the local announcer. Two mixers, and a master gain control are provided.

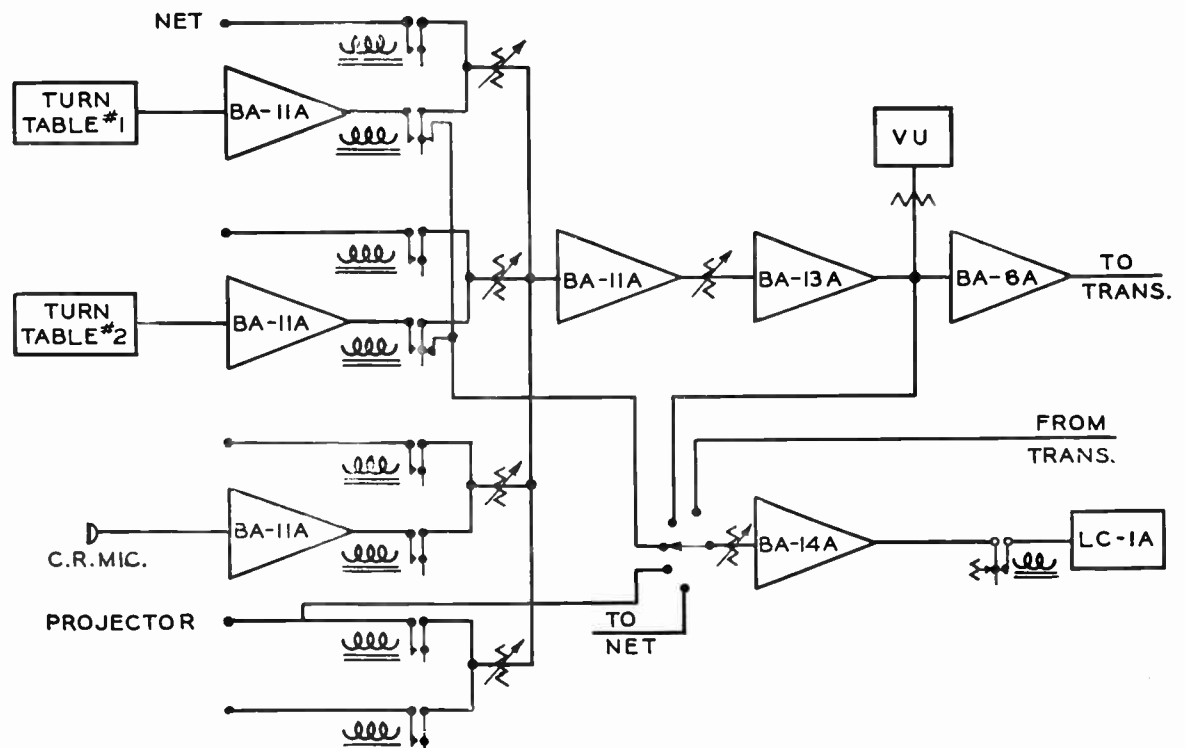

FIG. 2. Schematic diagram of the TC-4A audio circuit in its simplest form.

Those not initiated in the field of audio may have a question as to why variable attenuators are used in the system, rather than gain controls on amplifiers. Several reasons appear quite readily. If an interstage gain control were used, all the amplifiers would have to be located at the control position. If long lines were run between the amplifiers and controls, considerable noise may be picked up, together with a deterioration of frequency response due to higher impedance interstage controls. When low impedance variable attenuators are used, comparatively long lines may be run to rack mounted equipment without deterioration of frequency response or the problem of noise pickup. Attenuators are designed mechanically and electrically for constant use without becoming noisy or failing mechanically. Attenuators are relatively constant impedance devices which present a uniform load to transformers regardless of frequency or attenuator setting. This tends to improve frequency response and insure low distortion in the amplifier.

A monitor selector switch connects either the film or network, the transmitter monitor, or the program channel to the monitoring amplifier input. A relay is provided for speaker muting during local announcements.

Of course, a volume indicator is a must in the program circuit. In general, all V.U. meters are used in conjunction with a multiplier network, which may be adjusted so various levels may be indicated on the meter. The multipliers are usually designed to increase the V.U. meter indication by an integral number of db from one db through twenty-seven db. It may well be noted here that the basic meter without multipliers, will indicate 4 V.U. when connected in series with a 3600 ohm resistance across a 600 ohm terminated line.

The "standard output level" for radio broadcasting systems, as set forth in the R.E.T.M.A. Standards, shall be as follows:

1. For facilities feeding telephone lines the "standard output level" shall be + 18 DBM.
2. For facilities feeding radio transmitters the "Standard output level" shall be + 12 DBM.

A limiter amplifier such as the RCA type BA-6A is a very valuable asset in the program circuit. When properly used it will insure a high average program level, together with protection against severe overloads should the operator fail to "ride gain" properly.

### TC-4A Audio/Video Console

It is true that a station may get on the air and provide basic programming facilities with a system such as the one previously described. However, in due time the station may find need for more line inputs, turntable facilities, and microphones; in general a more flexible system. To

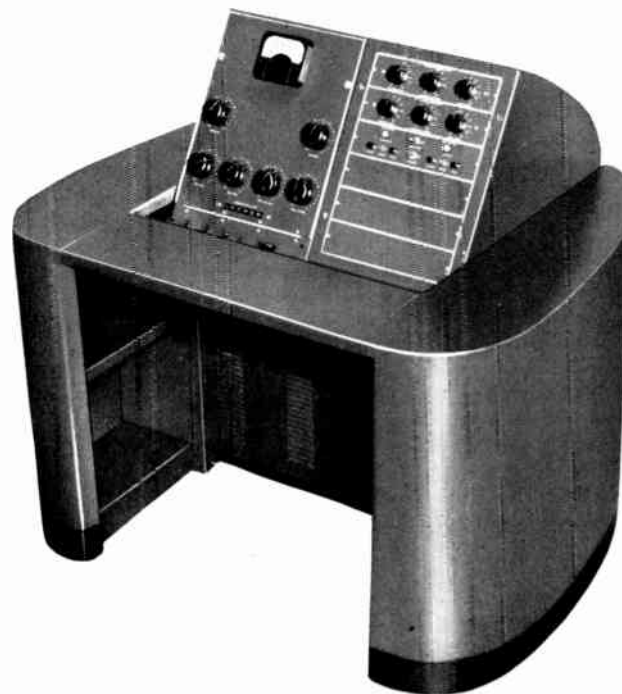

FIG. 3. Photo of the TC-4A Audio/Video Console.

provide facilities for a compact, flexible, easily expandable system the RCA TC-4A Audio/Video Console was designed. Figure 5 is a block diagram of the TC-4A. In such an arrangement much of the same equipment used in the system indicated in Figure 1 will be used. This consists of a system using four mixers, together with a relay

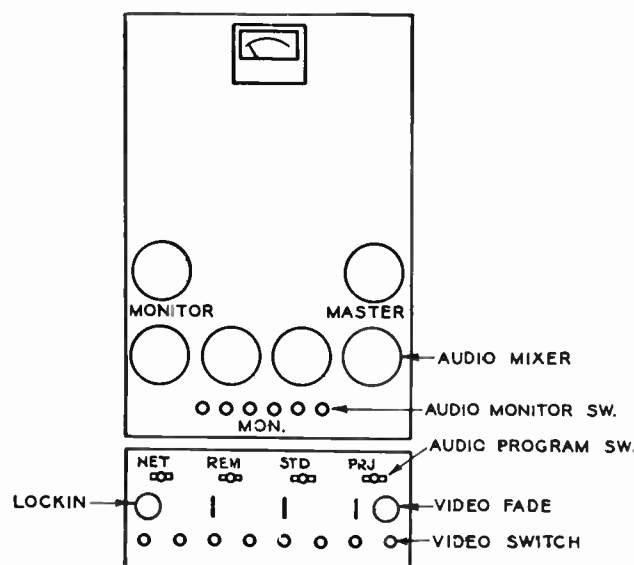
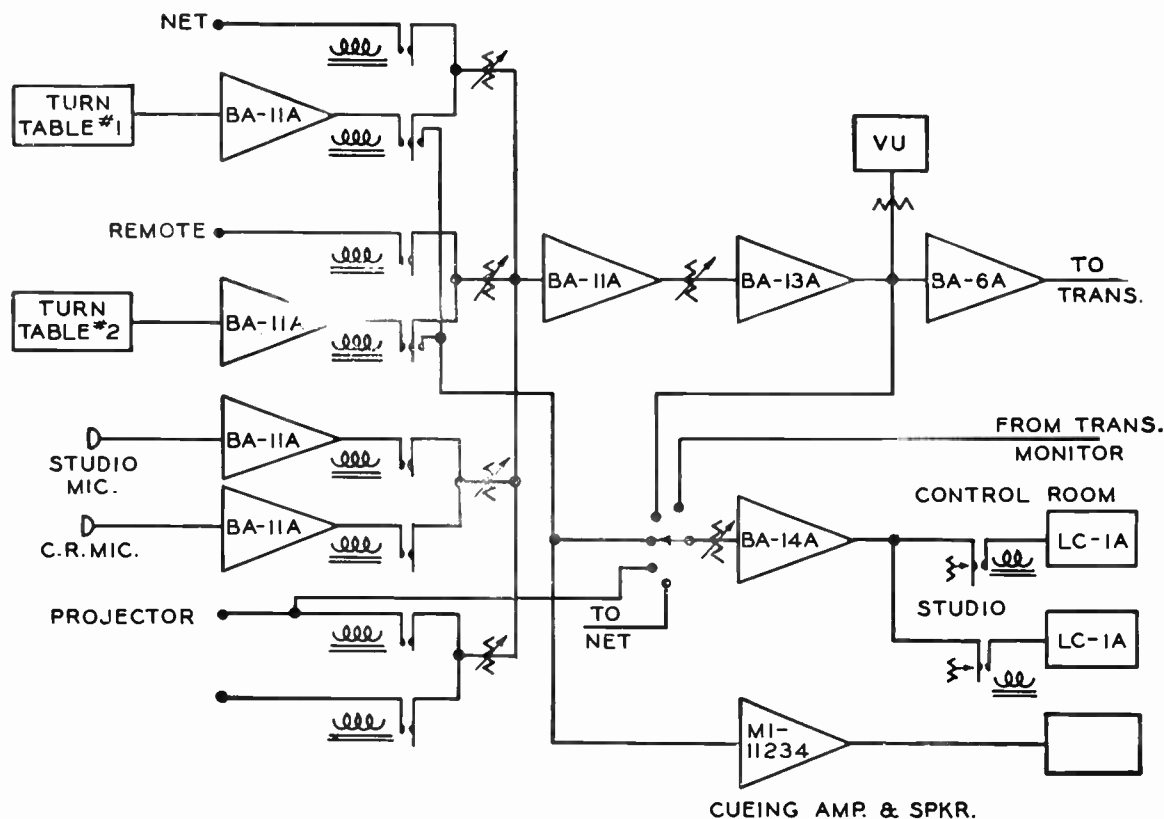

FIG. 4. Panel layout of the audio section of TC-4A Console.



FIG. 5. Schematic diagram of an expanded TC-4A arrangement for a more complex audio circuit.



switching system. This system allows eight inputs to be connected to these mixers.

Four of these eight inputs may be connected to the mixers at any one time. It should be noted that, for instance, either "net" or "turntable 1" can be selected for "mixer 1" but not both simultaneously.

The use of relays makes it easy to combine audio and video switching functions. A high degree of isolation between audio and video circuits is obtained by using this method of switching. The relays are operated by lever key switches; thus switching audio independently of video. When combined switching is desired the functions are "locked in," and the relays are controlled by the push button switches.

A very desirable feature of such a system is that a separate audio signal may be switched into the program circuit without "locking out" the switching functions. As an example let us assume that audio and video signals from a film program are "locked in." It is desired to break in for a special announcement. This may be accomplished by throwing the lever key switch controlling the control room microphone or the studio microphone, this being followed by proper manipulation of the mixers.

From Figure 5 it will be noted that inputs from two turntables, two microphones, audio from one film chain, a remote line, a network line, and a spare are provided.

Complete monitoring facilities are provided. Push button switches connect net, projector, turntable cue, program or transmitter monitor to the monitor input.

The TC-4A provides a very flexible type of control system. The system is designed so that initially a simple system may be set up, which may be "added to" without causing the initial system to become obsolete. In its most complex form the TC-4A offers approximately the maximum amount of facilities one operator may effectively handle. The TC-4A audio/video console affords a station a truly "one man" operation of audio and video control functions.

#### For Expanded Studio Requirements

In the event that large studio productions are to be tried, the above equipment may become inadequate. However, it can become the master control function, and the "Studio" position will connect to a console in the studio control room. Studio productions are generally conceded to require at least two operators; one each for audio and video. The audio requirements, beyond the usual mixers and monitors, are for plenty of microphone inputs. The action moves from one scene to another, and the microphone cannot always follow. Thus another microphone must be ready at the new scene. A typical installation for the studio is given on the following page under the title "A Flexible TV Audio System."

# A FLEXIBLE TV AUDIO SYSTEM

The audio equipment described here will satisfy the needs of most TV stations having a single studio, an announce booth, a film projection room plus network and remote lines.

For the most part, the audio equipment for a layout of this nature does not vary a great deal from an AM/FM installation. One major difference is in the increased number of microphone facilities. Also, an intercomm type of communication system is a necessity in order to integrate the various sources of program material.

Four main items are required:

- One BC-2B consolette
- One BCM-1A auxiliary mixer console
- One BCS-13A auxiliary control console
- One rack containing amplifiers, equalizers, jacks, etc.

The BC-2B consolette (as shown in Fig. 1) is a complete high fidelity speech input system in itself. There are mixers for four microphones, two turntables, one network and one remote, a total of eight. By means of lever keys each program source may be switched to a program or an audition output. Keys for the microphone positions also provide studio speaker control so that the

speaker is locked out during a broadcast. Talkback facilities allow communication to the studio except during "on-air" periods.

The microphone facilities of the BC-2B may be expanded considerably by the addition of the auxiliary mixer console BCM-1A. A single line diagram of this unit is shown in Fig. 2. Twelve microphone circuits may be connected permanently to the console and by means of lever type switches, four can be assigned to preamps and faders. Each fader has a key switch to select either audition or program.

There are two possibilities for connecting the BCM-1A to the BC-2B. One type of connection parallels the audition and program buses of both units. In this way, eight instead of four microphone faders are available. A speaker interlock circuit is provided on the audition/program switches.

Another type of operation is to connect the program output of the BCM-1A to one of the microphone inputs of the BC-2B. The microphone fader on the BC-2B then becomes a submaster for the microphones connected to the BCM-1A. This type of operation is desirable in an

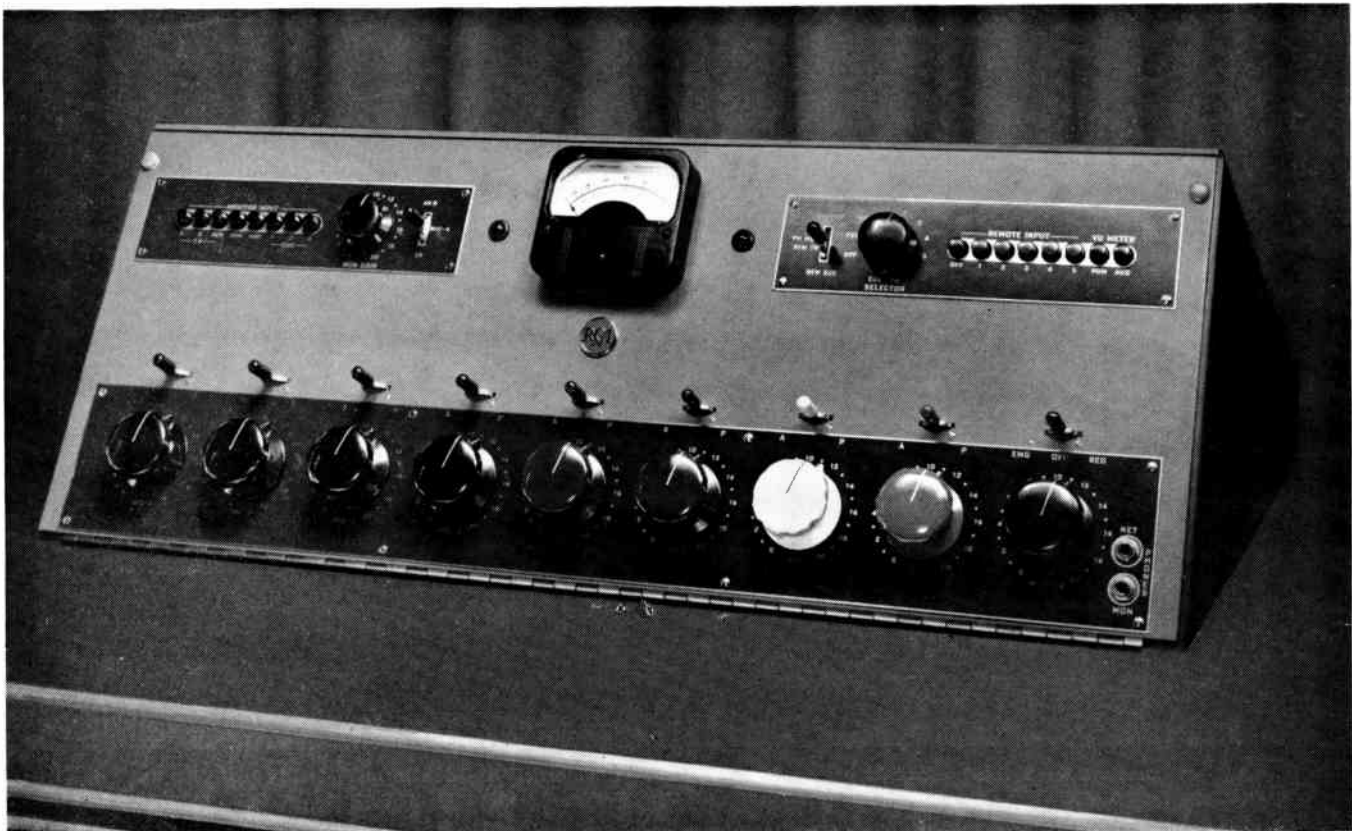

FIG. 1. The RCA BC-2B Consolette serves as the foundation for many flexible TV systems.

orchestral pickup, whereby proper instrumental balance can be obtained by settings of the individual faders. One fader on the consolette can then provide cut-off or fading for the entire group. The BCM-1A requires a separate power supply, Type BX-1E.

Another unit which adds to the flexibility of the TV Audio system is the BCS-13A auxiliary console. It contains a VU meter with selector and attenuator, a turntable volume control with studio playback switch, a spare attenuator and six telephone ringdown circuits with relays. A DC power supply is required for operation of lamps and relays. Fig. 3 is a single-line block diagram of the unit.

One rack of associated equipment is used for this TV Audio system. Units in the rack include two BA-14A

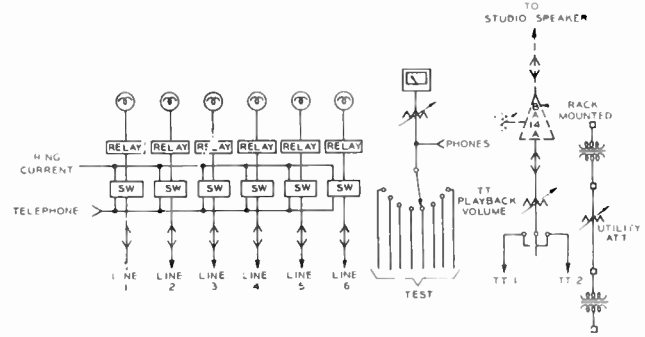

FIG. 3. Simplified diagram of BCS-13A auxiliary console.

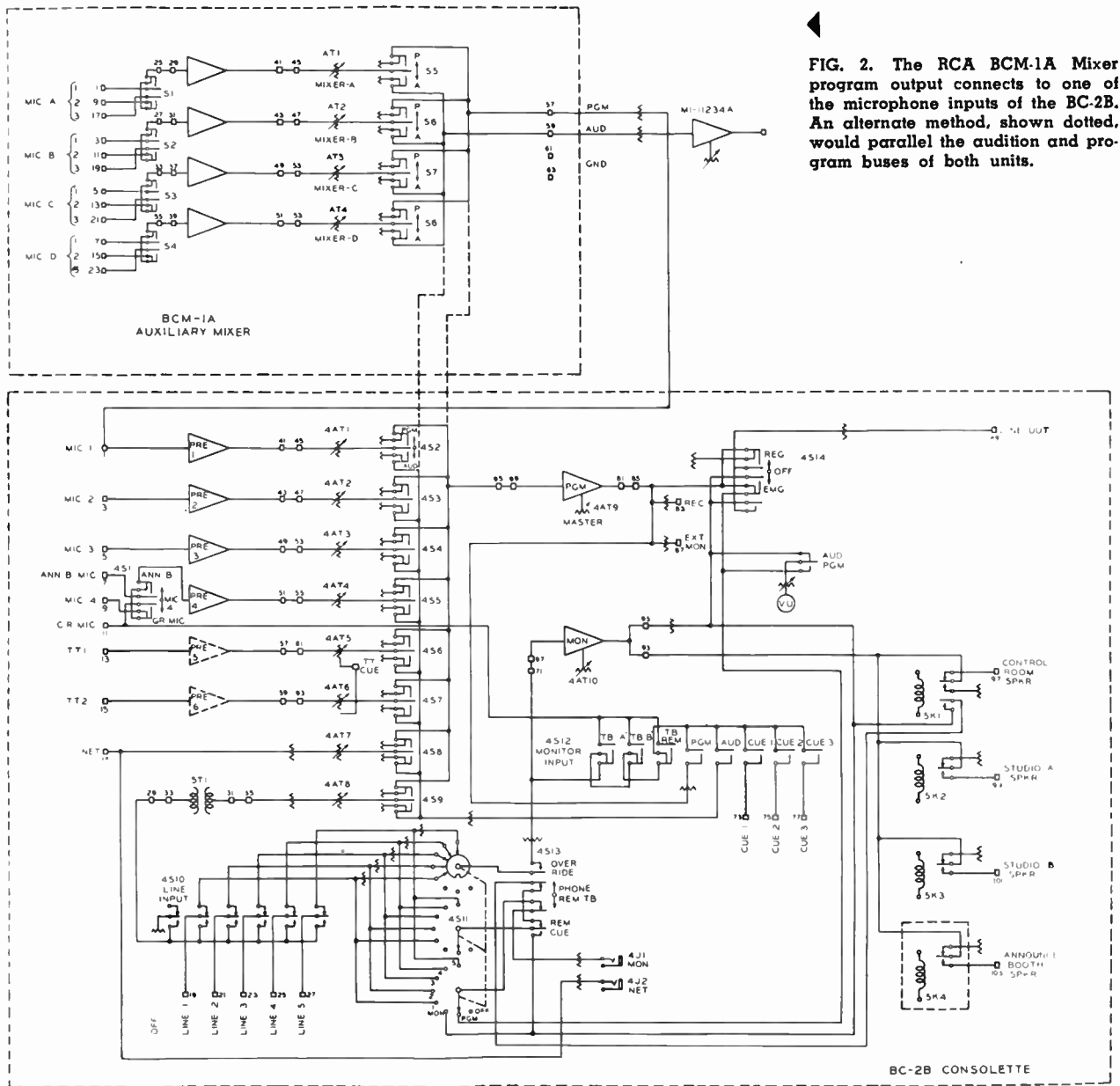

FIG. 2. The RCA BCM-1A Mixer program output connects to one of the microphone inputs of the BC-2B. An alternate method, shown dotted, would parallel the audition and program buses of both units.

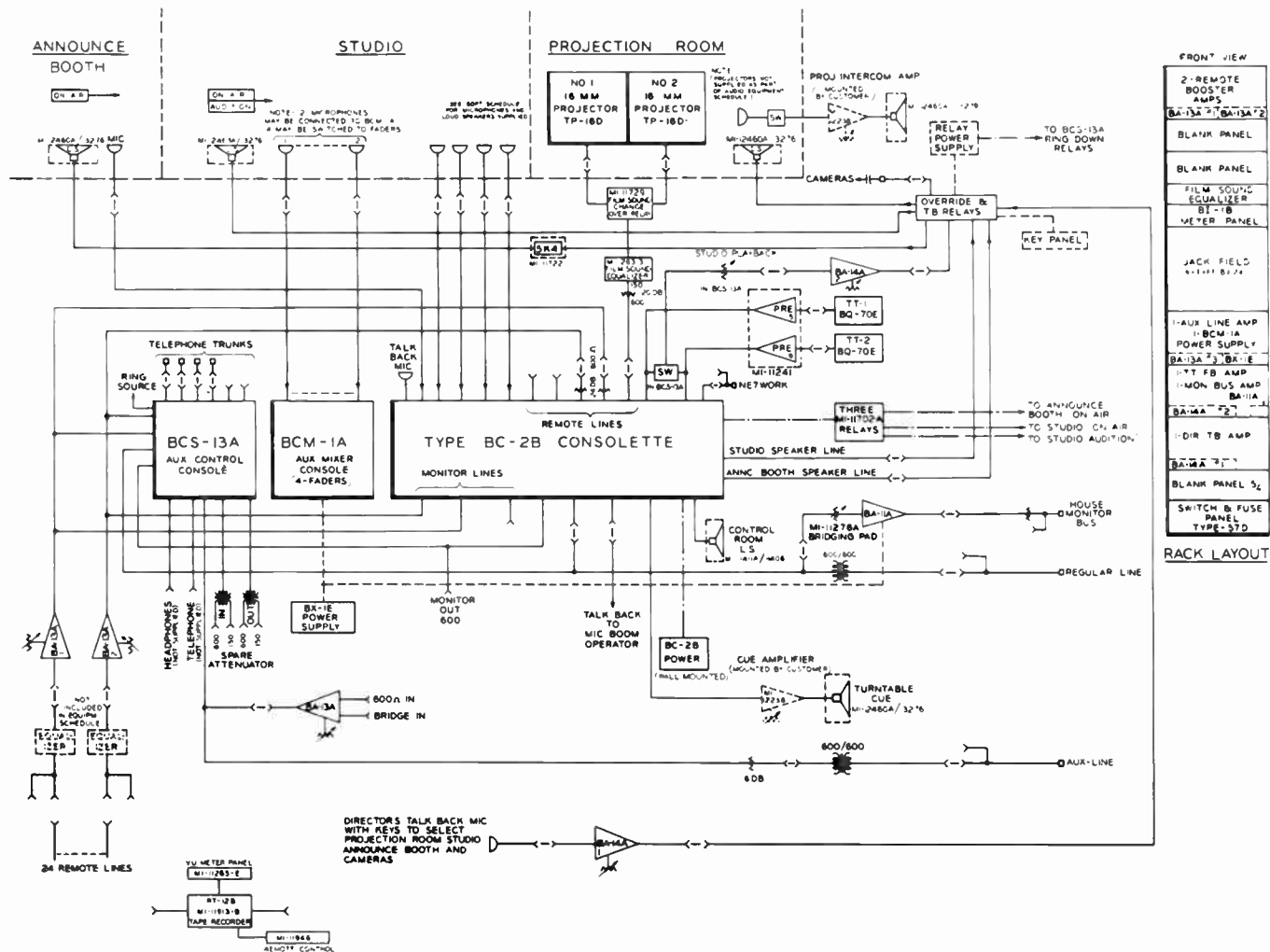

FIG. 4. BCM-1A, BC-2B, and BCS-13A combined gives flexibility to a TV audio system.

amplifiers, two BA-13A amplifiers, one BA-11A amplifier, plus jacks, coils and relays. The functions of these units will be described on the following pages.

Fig. 4 is a block diagram showing how the BC-2B console is combined with the other units to make up a television audio system. The studio is shown as having a total of 16 microphone outlets. Twelve are connected to the BCM-1A and four to the BC-2B. These circuits are normalled through jacks located on the rack.

The quantity and types of microphones to be used are generally determined by the type of programming that is contemplated. Simple productions usually involve simpler microphone techniques and many presentations can be handled very effectively with the following three arrangements: (1) a microphone placed on a movable boom stand, (2) the addition of a floor stand microphone, and (3) addition of a desk type microphone for commentary or announcement purposes.

Productions of a more complex nature, such as dramatic presentations where more than one set is involved, pre-

sent a greater problem. To do the job effectively and have the microphone in the right place at the correct time, requires the use of a quiet operating, highly flexible boom stand providing a large range of extension and a wide vertical and lateral swing. There are two types of microphone boom stands in general use today for television service: one of a semi-adjustable type, the MI-11070, which can have its extension and elevation adjusted beforehand and then wheeled into position. This type of stand can be used quite effectively in such productions that will permit the microphone to be placed above the scene being televised and not requiring any extensive movement of the microphone during the show.

Shows of a variety or dramatic type where there is considerable movement of the artists, require another type of boom stand that will literally permit the microphone to follow them around the set. This type of stand is in general use in the motion picture industry, and one model recommended for TV programming is the MI-26574 (see Figs. 7 and 8). This particular stand provides an operating station for the boom operator and the whole structure

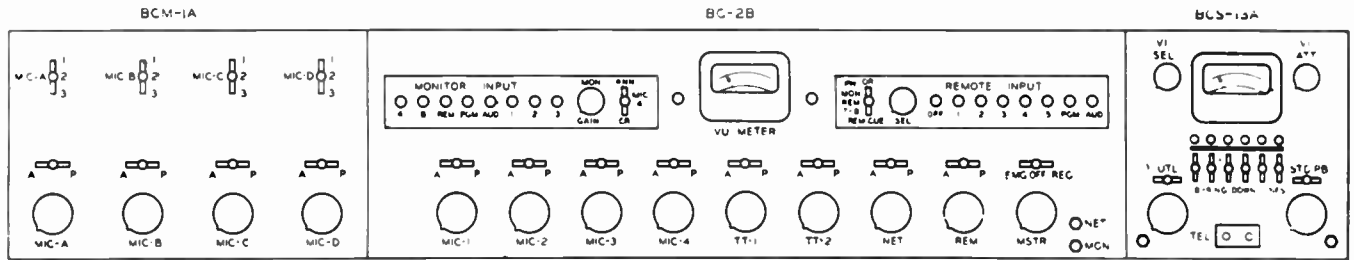

FIG. 5. Panel layout and engraving for block equipment shown in Fig. 4.

is mounted on rubber-tired wheels which permit it to be readily moved across the floor. The length of the boom can be extended from 7 feet to 17 feet and the microphone can be "gunned" through an angle of 280 degrees. This boom stand, in the hands of a trained operator, can do much to offset the disadvantages of picking up sound at a greater distance from the source than is encountered in the regular AM or FM system of broad-

casting. In selecting this latter type of stand, consideration should be given to amount of space available in the studio where it is to be operated. In small stations where staging is at a minimum, it would be more practical and more economical to use the semi-adjustable MI-11070.

Microphones that are used for broadcast service can also be employed for television programming. Such types as the 44BX, BK-1A, BK-4A, and 77D are in general use.

FIG. 6. This arrangement of model TV units shows how equipment items of a studio control room might be placed.

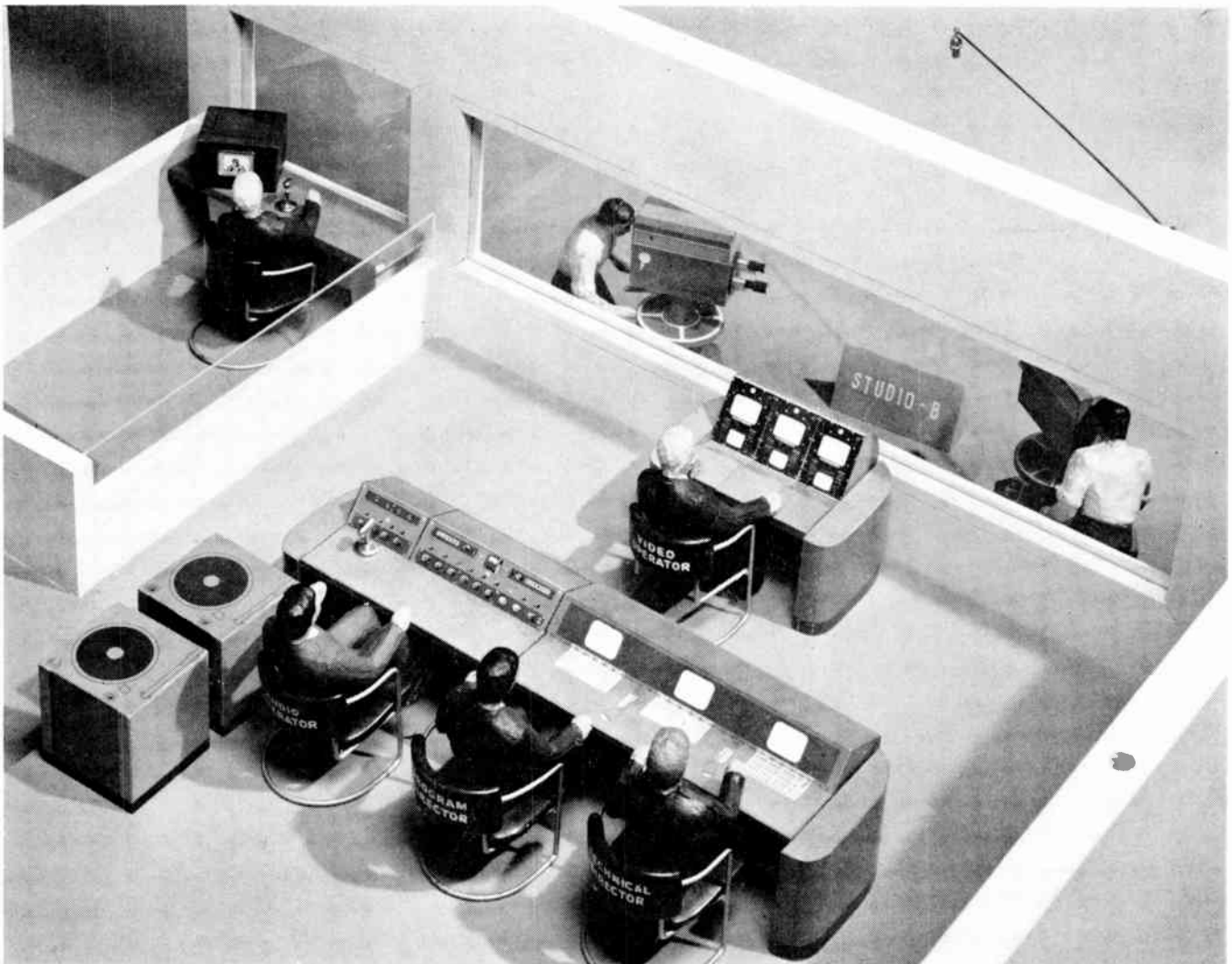

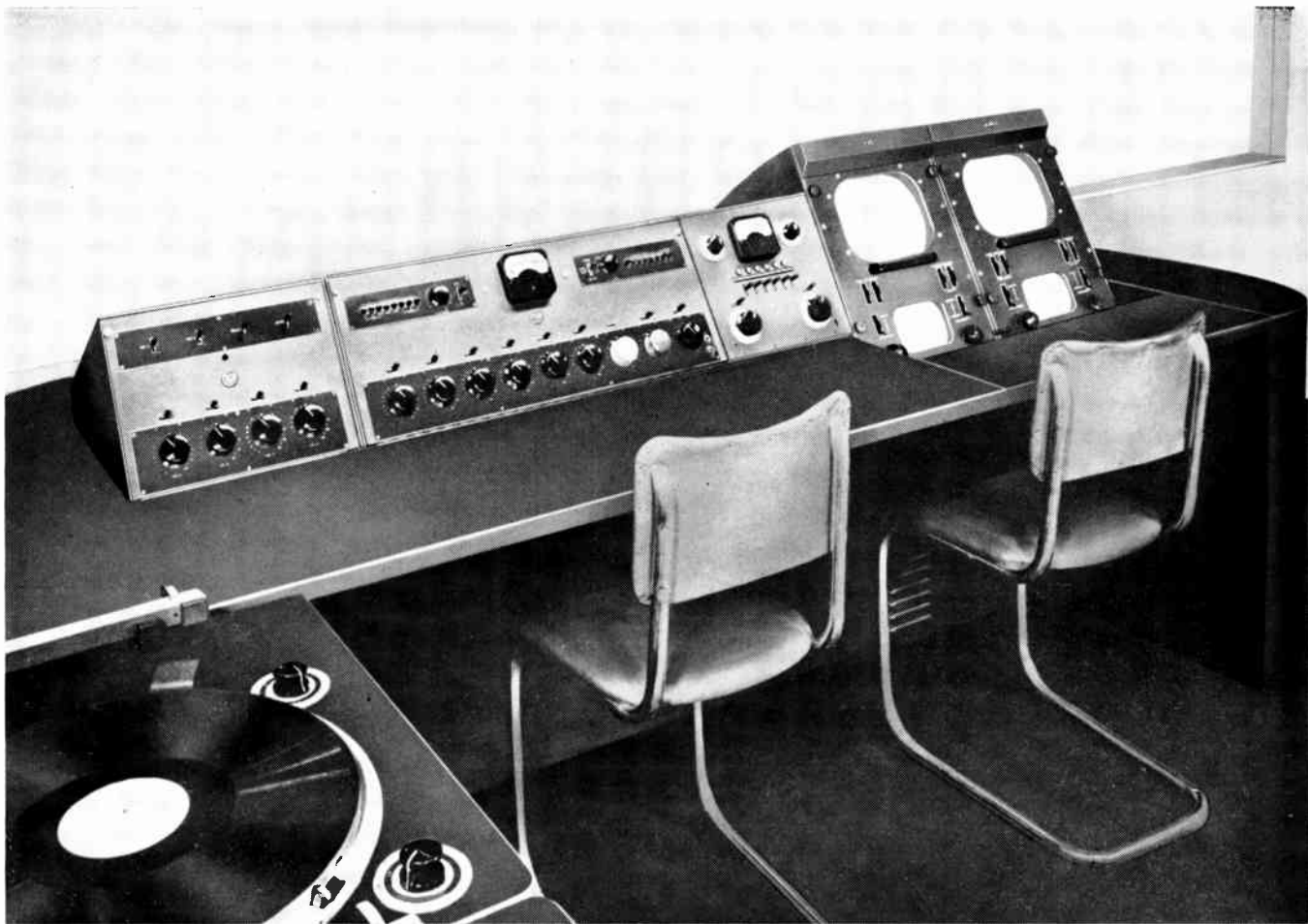

FIG. 7. Audio operating position, at the left, for handling of turntables, BCM-1A auxiliary mixer, BC-2B consolette, and BCS-13A auxiliary console.

The 44BX is a bi-directional ribbon type used for orchestra or band setups and certain commentary programs where its appearance in the picture is not a center point of distraction. Due to its bi-directional characteristic and its mechanical construction, it is not generally recommended for boom operation where there is likely to be extensive movement of the boom during the show.

The type BK-1A pressure microphone is a high fidelity instrument of the pressure-actuated type, especially designed for announcing and remote pickup. It is suitable for reproducing both music and speech. It is effectively non-directional when mounted vertically and is semi-directional when mounted horizontally. The relatively high output level provides a good signal-to-noise ratio. A desk stand, MI-11008, is expressly designed for use with this microphone.

The microphone generally recommended for boom service is the type 77D. This is basically a ribbon microphone operating on a velocity-pressure principle. It has three directional characteristics; namely, uni-directional, bi-

directional, and non-directional. For boom service it is generally set in the uni-directional position, which will permit artists to operate at a greater distance from the microphone and its directive characteristic will favor reduction of reverberation and background noise level.

The BK-4A is a miniature ribbon-pressure type microphone having a slim contour and styled to be unobtrusive. Hence, it can be used on a stand without interfering with the view of the performer or artist's face. Individual data sheets on the four type of microphones in general use are included at the back of this section of the Manual for reference.

In addition to the studio microphones, stands and booms—a studio loudspeaker is employed to serve the following three functions:

1. Talk back from control room
2. Program cue
3. Effects.

The latter function permits sound effects or other transcriptions to be fed into the studio for special purposes while the studio is on the air.

"On-air" and "Audition" lights in the studio are controlled by relays in the rack. Operation of the relays depends upon whether the consolette is "switched up" for program or audition purposes.

The equipment in the announce booth consists of a loudspeaker for cue, a microphone, and an "On-air" warning light. A type BK-1A microphone is suitable for most applications, and may be concealed if desired for use in stations where a studio camera chain is associated with the announce booth. The announce microphone uses the same fader as studio microphone number four. A lever key selects one or the other and also provides interlock so that the announce booth speaker will not be on during a broadcast. The announcer's microphone may be used to supply commentary for slides or silent motion pictures in addition to commercials and station breaks.

The audio equipment for the projection facilities would normally consist of two type TP-16 series 16mm projectors

whose output level is approximately 4 dbm. A change-over relay is used to select the audio from the projector that is "on camera." The relay is actuated by the dower mechanism of the TP-16 projector.

Due to the wide variation of frequency response in various types of presently available films, it is recommended that an equalizer, MI-26313, be inserted in the audio circuit. A control is used to select any one of three steps of high frequency boost, or the position which provides no boost (flat with 7 db insertion loss). The maximum insertion loss is 14 decibels. This unit is mounted in the rack along with the changeover relay. The output of the equalizer feeds into one of the remote positions of the consolette. There is a pad in the circuit which may require changing, if the output from the equalizer is too low to give a satisfactory range on the remote fader.

Two circuits are provided in the audio equipment rack for equalizing and amplifying any programs received from a remote source. Jacks are provided to terminate

FIG. 8. Microphone boom MI-26574 using an RCA 77-D microphone.



**FIG. 9. Typical scene where boom must be raised rapidly from seated figure to rising position for wide-angle picture.**



24 outside lines. The line to be used is patched into an equalizer, the output of which is fed into a BA-13A amplifier. This amplifier has a gain control so that the equalizing loss can be compensated and output set at some predetermined level. This level can be read on the VU meter in the BCS-13A console. A pad in the circuit attenuates the signal to the proper level for feeding into a remote position on the BC-2B. The output of the remote booster also feeds into a monitor position so that an aural check may be made. The two remote program circuits described, complete with amplifiers and equalizers are desirable because the occasion frequently arises when one remote follows another.

There are times when disc transcriptions become a vital part of a television program in supplying background music, sound effects and fill in for slides and silent motion pictures. In this TV audio system two RCA type 70-D turntables are used. The output of each one feeds into a BA-12A preamplifier and then into a TT fader on the BC-2B.

On the BCS-13A there is a lever key to select the output of either preamplifier and feed it into a BA-14A

so that it can be played back into the studio speaker. This by-passes the speaker cut-off relay in the BC-2B.

A typical example of the use of this circuit is the case where an actor "on camera" appears to be thinking of something having a direct bearing on the plot or program. The thoughts that are running through the actor's mind are on tape and the audience hears them as the tape is fed into the console. By also playing the tape recording back into the studio, the actor can hear and thus properly coordinate actions and facial expressions.

The regular line output of the BC-2B feeds through a line transformer. Jacks are provided on the input and output of this transformer. This output line is bridged by a BA-11A amplifier which provides isolation to feed a house monitoring bus.

A spare BA-13A amplifier is provided with a 600 ohm input and a bridging input on jacks. The output is normally through jacks to a pad and a line transformer to provide a spare output circuit. The output of this spare amplifier may be checked by means of the VU meter in the BCS-13A.



In the beginning it was stated that some intercommunication facility is a necessity if a television program is to be put on with any degree of success. In the BCS-13A there are six telephone ringdown circuits which may be connected to outside points. In addition to this, a separate intercomm system is necessary to provide loud-speaker talk-back to the following points:

- |                    |                   |
|--------------------|-------------------|
| 1. Projection room | 3. Announce booth |
| 2. Studio          | 4. Order wire.    |

The intercomm system includes a microphone, a BA-14A and relays with control keys. These keys should be located near the director's place of operation.

The RCA TS-10A camera switching equipment has provisions for two-way communication to the camera operators. There are many concepts of intercomm facilities but those just mentioned will serve the needs of a great many stations.

FIG. 10. The RCA RT-12B console model tape recorder, which is available with a remote control unit, may serve for special or sound effects, musical backgrounds, or commercials and station breaks when pre-recorded tape is used. It is a valuable device for recording the audio portion of political speeches, special events, etc.



# TELEVISION INTERCOM SYSTEMS

An intercommunication system is an essential part of any television installation that has live talent shows, film, or remote programs. Reliability is important since instantaneous communication between control room, projection room, and studio is necessary for shows having minimum rehearsal time. Intercommunication for television may be classified into two types:

1. Amplified intercom (Similar to public address systems)
2. Telephone communications (May be termed interphone)

RCA broadcast intercom equipment is composed of basic units that may be arranged to suit most installations. Other requirements can be met by custom equipment.

For future expansion, crossbar type switching is used, which permits added inputs and outputs. The switching is usually accomplished by relays that are conveniently rack mounted. The system described is for use in an "A Prime"\* station, however, the same system is suitable for studio control room operation in a larger station where an RCA TC-5A Program Directors' console is employed. The same amplified system is suitable for master control operation.

## Amplified Intercom

A primary intercom system will be described, (See fig. 1.), wherein the directors and projectionist talk over an amplified system, switching at speaker level in a crossbar manner. The studio floor personnel talk back to the control room personnel over an interphone system.

The directors' instructions are amplified and dispatched at speaker level to any of six parties. The projectionist talks back over an amplified system to the control room. Dynamic-type microphones are used by the projectionist and by the directors. The directors' key panels have lever keys representing each party to be called. Each key switch operates a corresponding relay that switches the directors' instructions to the selected party.

The following is a typical list of parties that a technical director may select and call:

- |                           |                    |
|---------------------------|--------------------|
| 1. Audio Boom Operator    | 4. Cameraman       |
| 2. Lighting Operator      | 5. Announce Booth  |
| 3. Studio Floor Personnel | 6. Projection Room |

\* See "Four Versatile TV Station Equipment Plans for VHF and UHF," in the Video Section of this manual.

The following is a typical list of parties that a program director may select and call:

1. Studio Floor Personnel
2. Cameraman
3. Announce Booth
4. Projection Room
5. Men's Dressing Room
6. Ladies' Dressing Room

It is often desirable to increase the level of the directors' instructions approximately 6 db during adverse ambient noise conditions in the area of the party being called. An additional lever key or foot switch will operate a relay that bypasses a 6 db pad.

The directors receive communication from the cameramen and studio floor people by means of telephone headsets. At the camera, each telephone headset is of the double earpiece type, so that one earpiece is connected to the interphone circuit and the other is connected to a program cue circuit.

During "On Air" announce periods, the announce booth intercom speaker is automatically muted by utilizing contacts of the speaker muting relay. During "On Air" periods in the studio, its intercom speaker is muted in a similar manner.

Muting of the announce booth and studio speakers during "On Air" intervals is shown using "A Prime" audio equipment, however, the same principle would apply when using a BC-2B Console or other audio facilities. The projection room speaker is never muted. An interlocking arrangement mutes the control room intercom speaker only when either director calls the projection room. This gives priority of call to the directors and permits them to be heard at all times.

## Telephone Communications

Systems requirements for interphone vary considerably from station to station. An interphone system is normally used congruently with an amplified system. Communication between the directors and the cameraman and studio floor personnel may be an interphone system, yet supplemented with an amplified intercom system to address the studio floor people and the projection room.

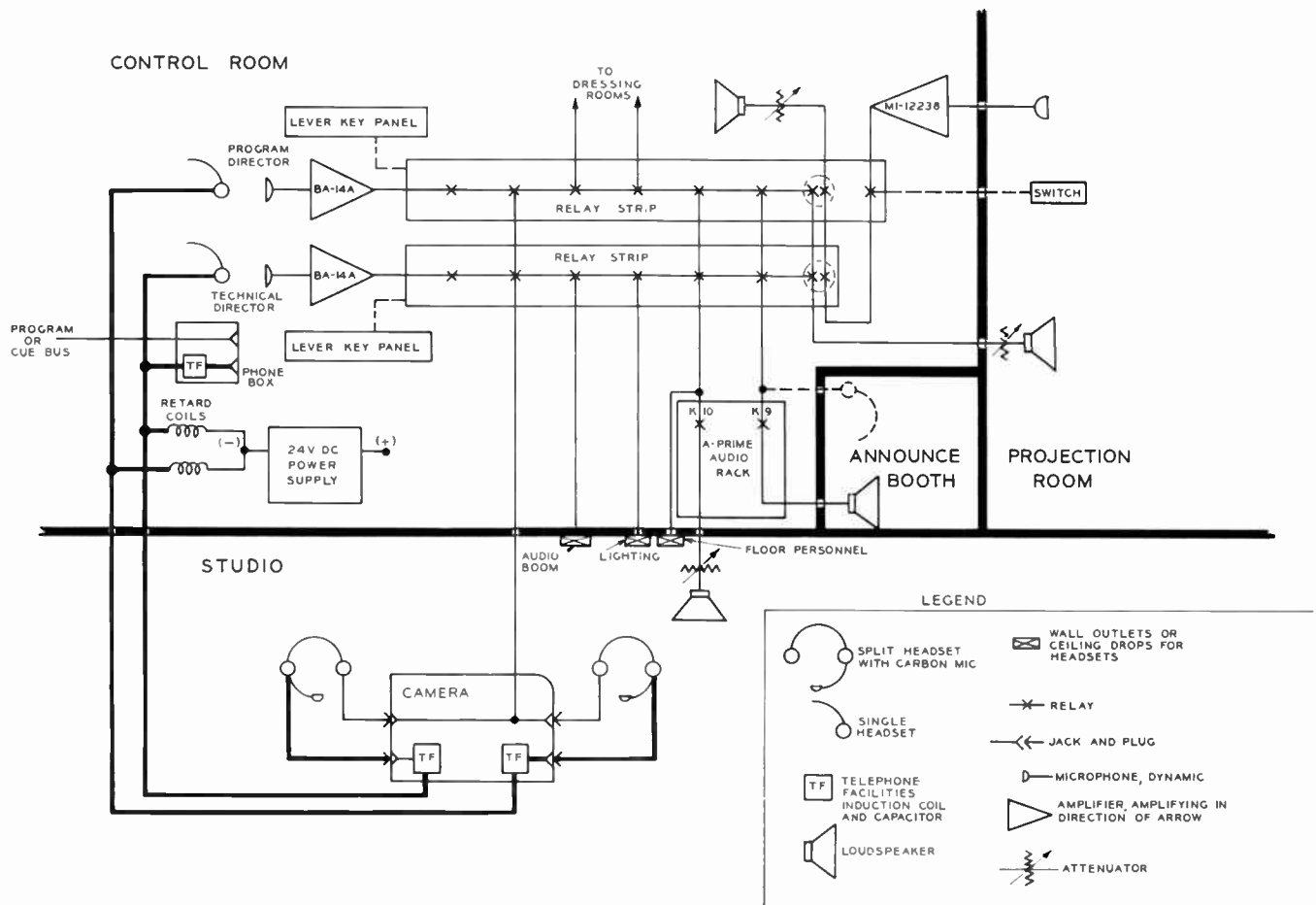

FIG. 1 (above). Combination of amplified intercom and interphone shown on this schematic is used as basis for the discussion of a primary intercom system.

An interphone system, as shown in Fig. 2, utilizes the camera interphone facilities; jack boxes, headsets, retardation coils, and a power supply. Additional jack boxes for headsets may be added in a parallel manner for such functions as the camera control operator, the lighting operator, and the assistant program director.

A primary type of interphone system will be described. The technical and program people in the control room each normally have two-way talking facilities to their respective party on the studio floor. The program director's switch may be operated to place everyone on a conference bus. The technical director's switch may be operated to permit him to talk with a remote point over a private line.

An induction coil and a capacitor designated as "TF" are used to provide an anti-side tone feature that results in local sounds partially canceling in the local earpiece.

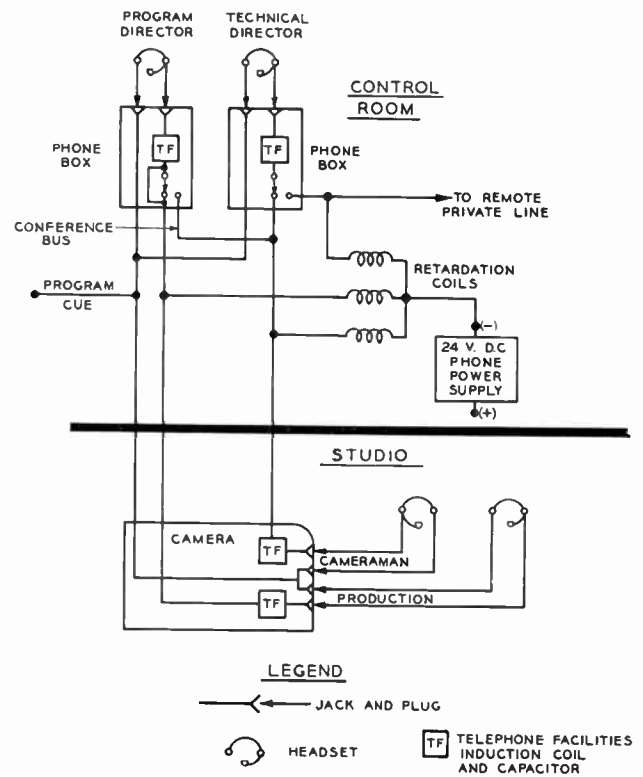

FIG. 2. Schematic diagram of a primary interphone system which shows the simplicity of such a system.

The headsets shown are the split type where one earpiece is entirely separate from the phone system. Program cue commonly feeds all separate earpieces. Headsets with paralleled earpieces may be used to receive interphone signal in both ears.

The power supply in a common battery-type system is in series with a retardation coil, and the combination is paralleled across a telephone line. Retardation coils minimize the effect of the power supply lowering the telephone line impedance at voice frequencies, yet permit adequate flow of direct current.

With successively more cameras, which means more phones in parallel, the signal-to-noise ratio becomes such that noise conditions exist for considerable periods, overriding the interphone signal at the cameraman's ear. An interphone system provides an adequate signal-to-noise ratio during relative quiet and average noise conditions in a studio; but for continuous intelligibility, the director's instructions to the camera and floor personnel must be amplified during intervals of loud music, crowd cheering, or applauding.

Recognizing the signal-to-noise limitations, the interphone system simplicity, coupled with its relative low cost, permits its use in many instances.



FIG. 3. The double headset (split type) uses one earpiece in the cue circuit and the other is used in the interphone circuit.

# Custom Equipment For TV Installation

The rapid growth of TV programming and the increasing complexity of switching operations have shown a definite need for special or "custom" equipment. As in the case of the larger AM installations, it has also been found in many TV stations that standard items of equipment are not designed to satisfy the many special switching and operating requirements encountered. These requirements are created by many factors, such as studio floor layout, number of studios, number of live shows, number of auditions, remotes and network affiliations.

Since no two television stations have the same operating requirements, the corresponding equipment needs naturally differ for each installation, ranging from special equipment for small and medium size stations to complex systems for large network installations.

## WWJ Installation

To illustrate how custom equipment for TV installations can solve the many complex situations which arise, several examples are described and illustrated on the following pages.

The first example of "custom" handling of TV program distribution is the new WWJ-TV installation. The block diagram below illustrates the method used by WWJ-TV to handle their required program facilities in master control room.

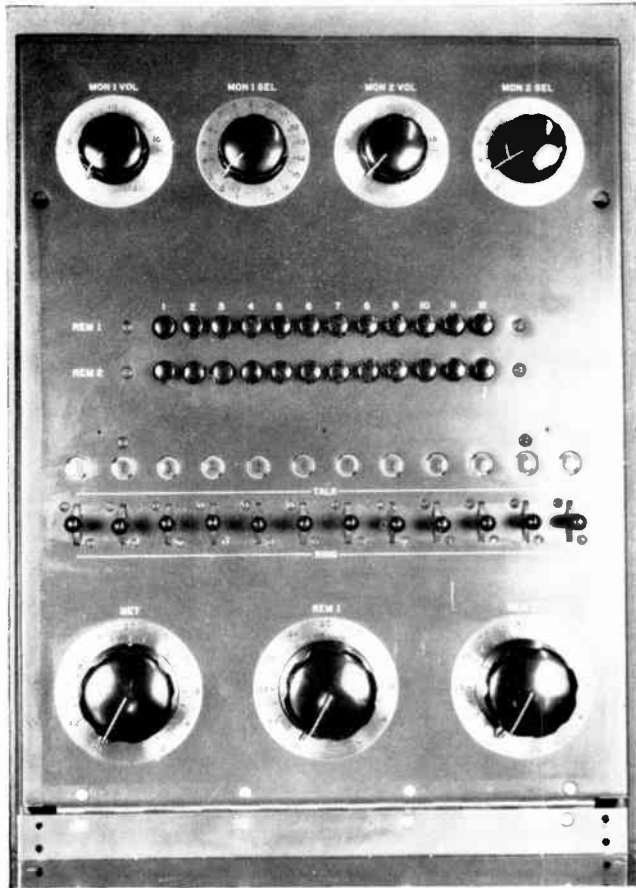

FIG. 1 (at left). WWJ-TV Master Control Audio Ringdown and Remote Panel. Ring and Talk facilities are provided for 12 talk lines. Two remote busses are provided with mechanically interlocked selection for 12 incoming program lines. Gain controls are provided for each remote bus as well as the network bus. Two sets of monitor selector and volume controls are provided for the use of master control operator.

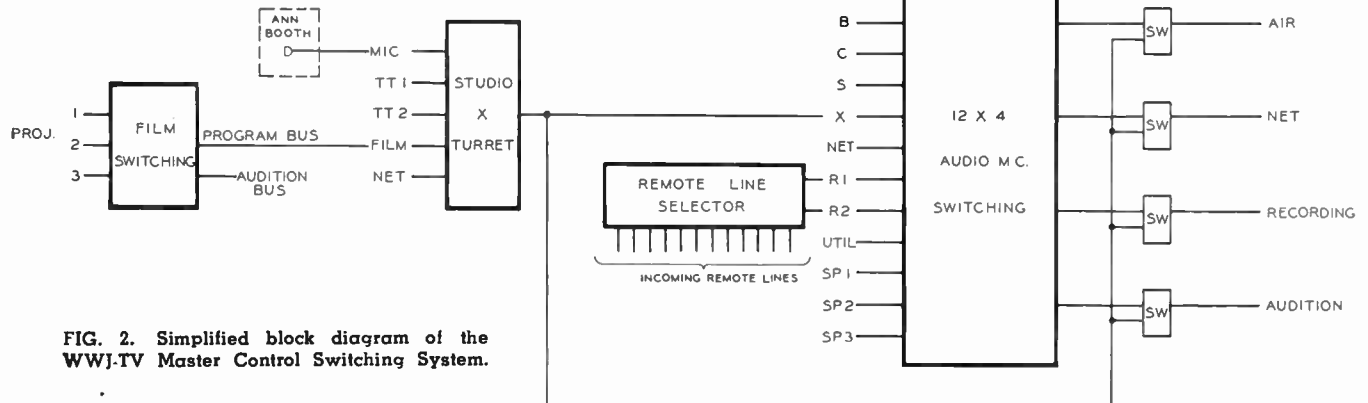
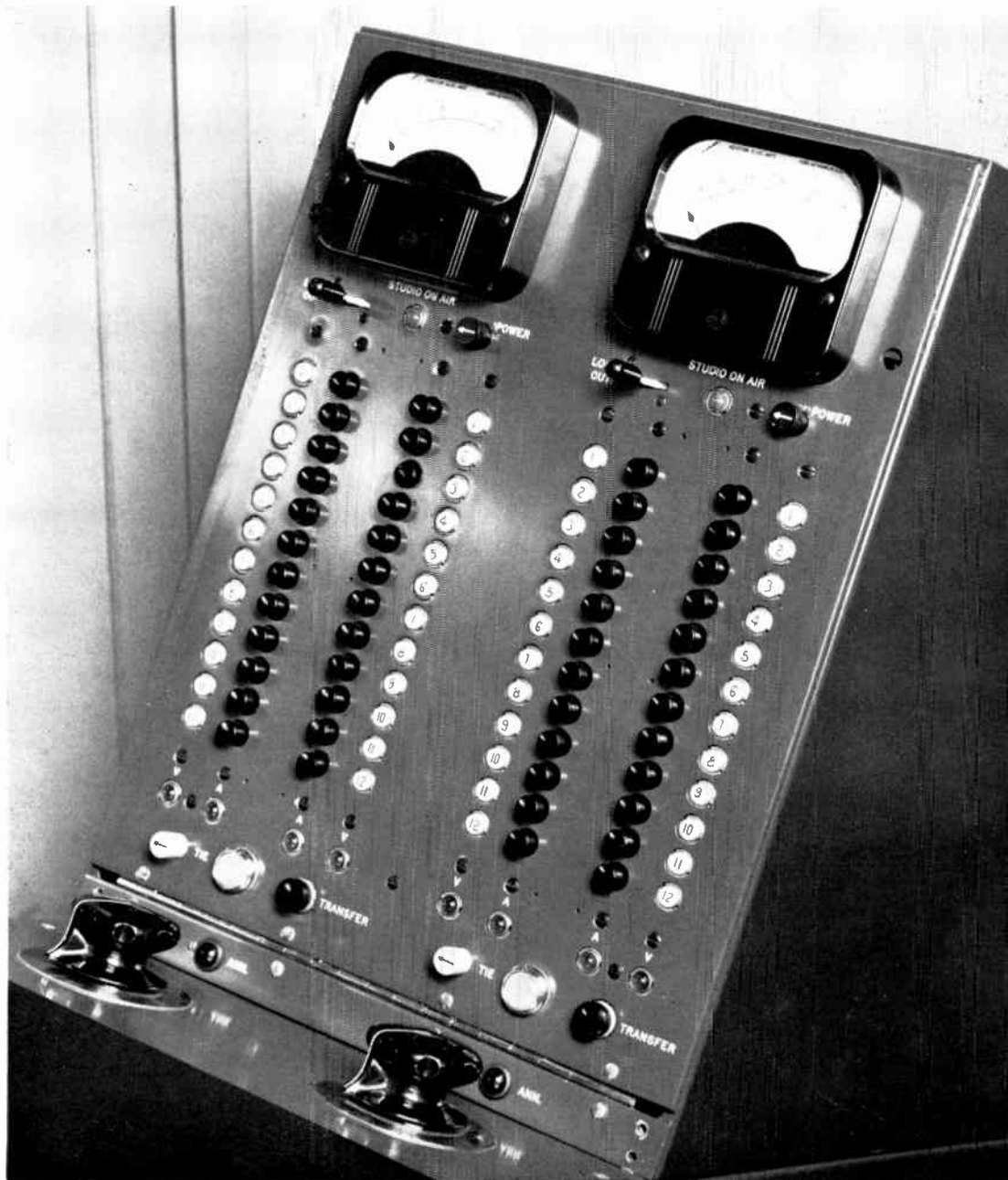

FIG. 2. Simplified block diagram of the WWJ-TV Master Control Switching System.

FIG. 3. WWJ-TV Master Control Audio Switching Panel. This panel switches 12 inputs to 2 outgoing feeds. Each outgoing channel has a left and right bank, one of which may be used for preset while the other is in use. The "Transfer" switch at the bottom of panel accomplishes the switching. Mechanically interlocked push buttons are used for operating audio relays. With the "Tie" switch on and the "Tie" lamp illuminated, the audio relays follow video switching. Tally lights adjacent to each audio push button indicate the corresponding selected video input. The "lock out" lever key maintains supervision on studio transfer operation. A "power" switch is provided for each channel. The "Studio On Air" lamp when illuminated indicates proper operations have been made to feed master control. A VU meter is supplied for each channel. A master gain control is provided for each channel. An "Announce" lamp indicates override operation on each channel.



The audio and video switching is normally combined so that the audio follows the video switching. The audio, however, can be divorced from the video switching and switched separately. The switching is of a pre-set type which allows one pre-set ahead of the existing program.

It is possible for the studio "X" announcer to override any or all of the four outgoing audio channels. The studio "X" audio operator has control over this function. Late hour program material, such as network or film, can be handled by the studio "X" console.

The projectionist has facilities for switching the output of any one of three projectors to a program buss and any one of the remaining projectors to an audition buss. The program buss has priority.

#### WOR-TV Installation

An example of special treatment of audio facilities for TV is the WOR-TV installation which is completely described on the following pages. This includes studio and master control custom equipment and shows how video and audio switching facilities are combined.

#### WNBT Installation

Another example, which illustrates the possible program complexity encountered in audio switching, is the description of the NBC custom consoles by Mr. R. W. Byloff. In this case, the large number of complex TV shows to be handled dictated the design of a custom audio console. The facilities handled by this console are numerous and

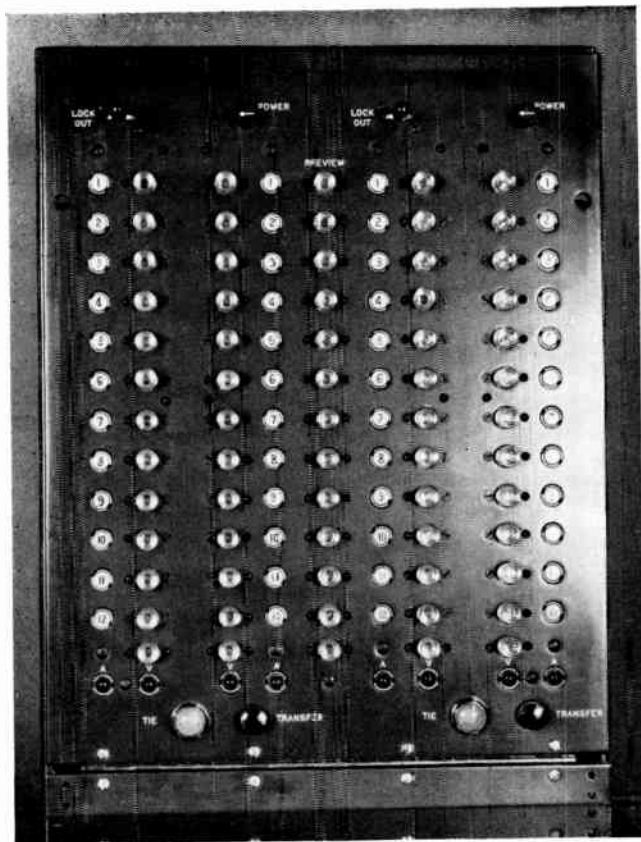

FIG. 4. WWJ-TV Master Control Video Switching Panel. This panel switches 12 inputs to 2 outgoing feeds and a preview bus. Each outgoing channel has a left and right bank, one of which may be used for preset while the other is in use. The "Transfer" switch at the bottom of panel accomplishes the switching. The preview channel may be punched up on any input. Illuminated non-locking type push-button switches are used for operating video relays. Tally lights adjacent to each video push button indicate the corresponding selected audio input. When the "Tie" lamp is illuminated, the audio follows video switching. The "Lock Out" lever key maintains supervision on studio transfer operation. A "Power" switch is provided for each channel.

many unique features may offer some solutions to your audio switching and control problems.

#### Basic Considerations for Custom Equipment

Before any intelligent planning for custom equipment can be made, certain basic considerations must be known. To assist the TV planning engineer in determining the facilities required, a check list is included here for ready reference.

##### Studio Equipment

1. Number of studios to be equipped.
2. Type of installation:
  - a. Self-contained console.
  - b. Separate rack and console.
3. Type of console:
  - a. Metal construction most practical for self-contained consoles.
  - b. Separate consoles are cheaper if constructed from wood.
4. Number of mixer positions (list each studio separately):

- a. Microphones.
- b. Turntables.
- c. Remote or net (no pre-amps required).
5. Special features:
  - a. Echo mixers.
  - b. Sound effect filter.
6. Location of turntables:
  - a. Studio.
  - b. Control room.
7. Single or dual channel.
8. Order wire circuits.
9. Talk back features.
10. Floor plan:
  - a. Space for equipment.
  - b. Location of windows and doors.
  - c. Size of doors.
11. Preferred relay voltage.
12. Other requirements.

##### Master Control Room

1. Number of inputs to be switched (to be itemized).
2. Number of output channels.
3. Type of switching:
  - a. Pre-set with master switching only.
  - b. Pre-set with modifications for studio switching.
  - c. Straight switching using mechanically interlocked push buttons.
  - d. Straight switching using interlocked relays. These may be operated from remote points, thus providing a means for switching directly from a studio. This type of switching provides flexibility that enables a station to operate with reduced personnel.
4. Number of studios controlled from master control desk.
5. Facilities in studios controlled from master.
6. Type of desk construction—size, material, etc.
7. Number of incoming, remote program lines.
8. Equalizers:
  - a. Fixed.
  - b. Variable.
9. Is program cue desired for remote lines.
10. Number of order wires.
11. Number of master monitors.
12. Number of monitor buses.
13. Test equipment.
14. Special features:
  - a. Echo room amplifiers.
  - b. A.T.T. reversal equipment.
  - c. Tone signals.
15. Floor plan:
  - a. Space for equipment.
  - b. Location of windows and doors.
  - c. Size of doors.
16. Relay supply voltage.
17. Other requirements.

In conclusion, we wish to state that the facilities of the custom engineering group are available to you. We will welcome your inquiries, regardless of how large or small your problem may be.

# WNBT TV Studio/Audio Console\*



FIG. 1.

## Introduction

As the size and complexity of television studio productions have grown, it has become obvious that a studio audio system specifically designed for television was needed. Such a system had to incorporate not only the special facilities demanded by television but, at the same time, in the interests of standardization, it was necessary that it be equally usable for radio production. This last requirement was given added importance when it became the practice to use the same program simultaneously for television and sound radio.

An investigation of the requirements of such a studio audio system disclosed that it must be more flexible and larger than one to be used for sound broadcasting alone. Specifically, the investigation showed that the system must include more fader positions, more facilities for combining or mastering these faders, a simple way of

handling program sources (nemos) outside the studio, special equalization to compensate for unavoidably poor microphone placement, a switching system for special effects filters, special control lighting and indexing, automatic gain control, and provision for built-in video monitoring.

A system, designed from these requirements and described herein, has actually been built and is installed in several new television studios. Among these are the world's largest dramatic studio and the world's largest television theater.

## Mechanical Features

The principles used in the mechanical design of the console were as follows:

1. The console to be as small as possible in all dimensions to allow its use in the normally crowded spaces allotted to television control rooms, and to allow good visibility over the console.
2. All controls to be within easy reach.
3. Space to be provided for a script or cue sheet.

\* By Robert W. Byloif, Engineering Department, WNBT (NBC Inc.), New York, N. Y.



4. Primary operating controls to be on the front panel and properly indexed, and secondary and preset controls to be on the side panels.
5. Space to be provided for five video monitors in the console, since video monitoring for the audio operator is essential in keeping the microphone boom out of the picture.
6. The video monitor portion to be attachable as a separate item to allow use of the console in radio studios or any locations not requiring picture monitoring.
7. The console equipment to be accessible for maintenance from the front of the console to the extent necessary to provide maximum flexibility of console location in the control booth.
8. All equipment, not requiring manipulation by the operator, to be mounted elsewhere to save operating space and to permit easy maintenance.

Fig. 1 is a view of the console. The unit as shown is 66 inches long, 36 inches deep, and 41 inches high. Without the video monitoring portion, the depth is reduced to 23 inches and the height toward the front to 36 inches. The distance from the center of one side panel to the other is 45 inches, which permits easy reach to either side. The desk top is wide enough to allow legal size sheets of paper, which is normal script size, to be placed on it without overhang. The sloping portions of the top allow the panels to be set down and thus reduce overall height. This feature also allows the operator's hands to reach the top controls on the front panel more comfortably. On the right side of the desk top is a sliding panel which covers a well in which the microphone preamplifier inputs appear on drop cords. These drop cords (similar to telephone switchboard cords) are used for microphone selection, and can be patched into the microphone receptacle jacks in the jackfield directly above the well.

The front panel, sloped at 20 degrees from vertical for maximum operating ease, has in its top row of controls 12 microphone faders. The center group of controls in the lower row are the red, white, and green submaster faders, a studio master fader and a remote master fader. These submaster faders are color coded to provide a convenient visual tie-in with fader assignments as described below. The controls on the ends of the panel are for studio playback and reverberation. All faders on the front panel have dials, which are illuminated when they are in use. Each dial is calibrated and, in addition, contains an illuminated pointer enabling the operator to tell at a glance the position of the fader. Above each microphone fader is a translucent window which lights up red, white, or green depending on whether the fader is assigned to be mastered by the red, white, or green submaster. The window is dark when the fader is unassigned. The surface of the window is roughened to allow the operator to pencil and erase any supplementary information he wishes on it. He may, for example, write "orchestra" or "cast" or "boom" on these windows, and the light behind the window makes his writing show up in the darkened control room. Thus these windows indicate to the operator

whether or not the fader is connected, the submaster to which it is connected, and any other information about that channel he may wish to indicate. Lever keys on the front panel select remote programs, sound preview remote programs, control sound effects filter, and do auxiliary switching. An illuminated volume indicator in the center of the panel shows the volume level on the output of the system.

The right side panel contains a jackfield for patching up effects, equalizers, microphones, and other program sources, and for emergencies. This panel also contains equalizer controls for microphone equalization, and a control for the selection of limiting or compression in the program amplifier.

The left side panel at the top contains four microphone faders in a separate four position auxiliary mixer which is used for audience reaction and is normally preset. Controls for monitoring and sound effects filter frequency response and gain are contained at the bottom of the panel. In the center of the panel are push buttons, for assigning faders to submasters. There are four buttons for each fader: a red, a white, a green, and a black one for "off". Pressing the red button for fader 1, for example, connects it to the red submaster and lights up the indicator window above fader 1 in red. Another set of push buttons on this panel is used for effects switching as described below.

The housing attached to the back of the console allows five 10-inch video monitors, set on dollies with their kinescope faces up, to be placed in the console. These kinescopes are viewed by reflection from a front surfaced mirror set in the housing. These monitors enable the audio operator on a television program to observe the outputs of all of the cameras and also the program leaving the studio. This is particularly important to him from the standpoint of keeping the mike out of the picture. The housing is completely independent of the rest of the console and may be removed if not required.

The three panels inside the kneehole of the console are removable for maintenance of the equipment. The front panel is hinged and drops forward; the side panels are removable with thumb screws.

The jackfield located in rack equipment is used primarily for maintenance checking. The racks contain preamplifiers, boosters, power supplies, relays, and monitoring amplifiers for the system.

#### Electrical Features

Fig. 2 (top of next page) shows a simplified block diagram of the over-all system. No attempt has been made in this drawing to show specific circuit components, which are known to anyone familiar with audio practices.

Twenty-four microphone outlets are available at the console, and may be connected to the twelve preamplifier inputs by drop cords. These sources are then normalled through preamplifiers to the twelve regular faders. A push button control system as described previously at the fader outputs enables each fader to be connected to

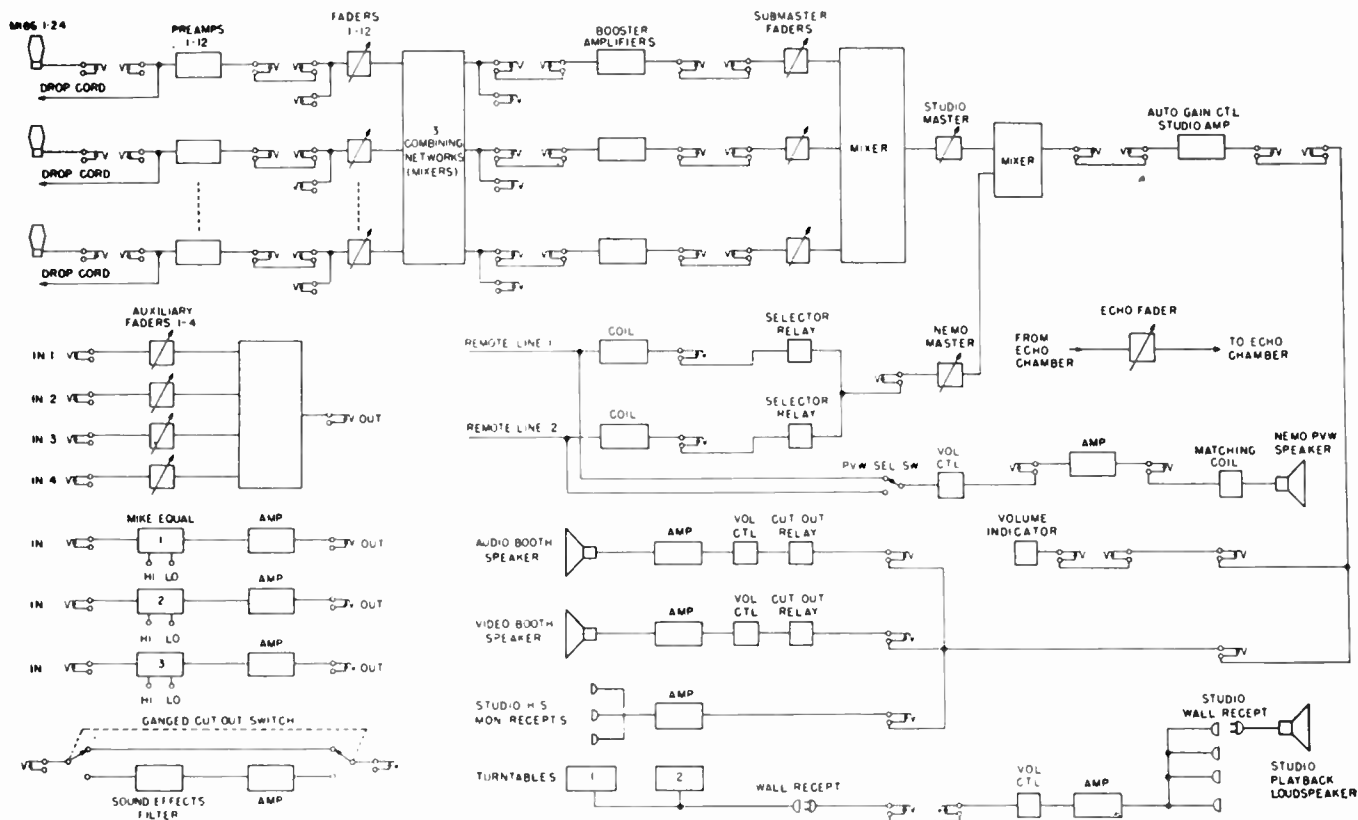

FIG. 2.

any of three mixers. The reason for having three mixers is to permit mastering in three groups. This grouping reduces the need for individual fader manipulation and confines much of the operator's attention to three controls. The outputs of these mixers, following amplification are connected to the three submaster faders. The outputs of the submasters are then mixed and routed to the studio master fader. The studio master fader output is mixed with a nemo (or remote) master output which in turn goes to the studio amplifier to bring the program level to studio bus level, or to line level if the output is to feed telephone lines. The studio amplifier is a special automatic gain control amplifier with selection of either limiting or compression characteristics. The characteristic to be used is selected by the audio operator by means of a key at the console. One of the advantages of an amplifier of this type in the system is that it permits greater latitude in gain settings and thus assists the operator in that respect on a program.

The input of the nemo master fader comes from selector relays, which choose one of two remote program inputs which are sent to the studio by the transmission section of the studio plant. Selection of the proper nemo program is made either by the audio engineer with a key at his position or, if he desires, it may be accomplished by the picture switcher. When this set-up is used, audio and video switching to remote programs is done together automatically. Having the nemo master fader and studio master in parallel enables the audio operator to fade out his studio program and fade in the remote program with these two knobs alone. This feature is desirable par-

ticularly for commercial film insertions in a studio program.

Bridges are taken off the remote lines as they enter the studio system and are brought to a key for selection. The selected program is then amplified and sent to a small loudspeaker so that the audio man may listen to the remote program on a preview speaker before he puts it on the air.

Two turntables are usually provided in television studios for bridge music, themes, and actions where a voice intending to portray the thoughts of the actor is heard. These bits must be played back to the studio so that the actors may better know what is happening. In the console the turntable outputs are normalled to the input of the studio loudspeaker volume control which goes to a loudspeaker amplifier, the output of which is sent to outlets in the studio. A portable loudspeaker may be placed near the scene of the action and plugged into the nearest outlet. This placement enables low volume level on the loudspeaker and avoids excessive echo in the studio. Actual program from the turntables is connected to a program fader for transmission and control.

The auxiliary four-position mixer has four input jacks going to four faders. These fader outputs are combined and appear on a jack which may be used to patch this system to any console input. This mixer allows applause control of four microphones using only one regular fader position.

Monitoring feeds from the studio bus or line go to the console volume indicator, to the video and audio booth

speaker amplifiers, and to a headset monitoring amplifier. The booth speaker amplifiers have cutoff relays on their inputs to avoid feedbacks when the studio address system in the control booth is used. The headset monitor amplifier output is fed to studio receptacles for the use of sound effects technicians, orchestra leaders, and stage managers.

All equalizers and sound effects filters in the system are arranged for zero insertion loss by providing amplification in these circuits to compensate for filter losses. The three microphone equalizers have low- and high-frequency control and are on jacks, so that they may be connected to any microphone channel desired. The sound effects filter has a by-pass switch around it, so that it may be inserted on cue, and a gain control to compensate for different settings of the filter.

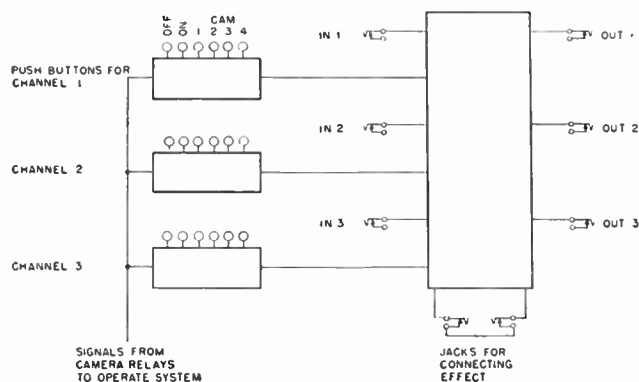

FIG. 3.

The effects switching system is shown in Fig. 3 (above). This is a relay switching system with three inputs and three outputs. If three microphone channels are connected through this system, they may each be connected, through operation of appropriate relays, to any effect required such as a sound effects filter, an echo chamber, or simply a volume control. This switching then allows an echo chamber, for example, to be inserted in different microphone channels during a program without repatching. In television audio work this facility is important because a special filter or echo microphone cannot be assigned for use by the actors as the program demands, and so these effects must be available on several microphones. The system is also useful in telephone conversation effects where both ends of the conversation are shown with first one party on filter, and in the next instant, the other party on filter. Control of these relays is provided at the console. This control may be done either by the engineer at the console with simple on-off buttons or he may elect to tie the system to camera switching. If so, the filter switching is caused by the switching of cameras. A tally panel in the console shows the audio operator which camera is on the air.

In addition to the above facilities, the system contains contrast controls on the console for the video monitors, rack to console tie trunks, jack multiple strips, auxiliary isolation coils, talkback facilities to the studio address speaker and to the headphones of the boom oper-

ator, telephone facilities to other studios and to master control, and telephone facilities to other audio operators in the same studio. Multiple jacks on microphone channels are provided for connecting to an auxiliary public address system if the console is used in an audience studio. This provision allows for individual microphone public address, which has been found to be essential for television studio public address systems.

An unusual feature of the console is the microphone channel mixer. In the past when a split mixer was provided, it was necessary to have switching keys of complex configuration for connecting the microphone channel to one or the other mixer. This complexity was required because the mixer was a matched impedance system and whenever a fader was removed, a resistor of the same impedance had to be substituted for the fader in order to keep the same loss through the mixer. If the mixer must be split three ways, the complexity of the switching key becomes so great as to be impractical. Therefore, a bridging mixer was employed. In this system, the series resistors going to the faders are large enough to keep the mixer from knowing whether a fader is connected or not. Terminating resistors are provided at each of the twelve inputs to terminate the faders properly. Some compromise must be made in this system to prevent excessive loss of level. The compromise agreed on was to allow a 2-decibel variation in mixer loss between the extremes of having one or twelve faders connected to the same mixer. With this compromise it was possible to design a mixing system with approximately 7 decibels more loss than in a conventional matched impedance mixer. This loss is easily made up in modern high-gain amplifiers. The mixing system employed is shown in Fig. 4 (below).

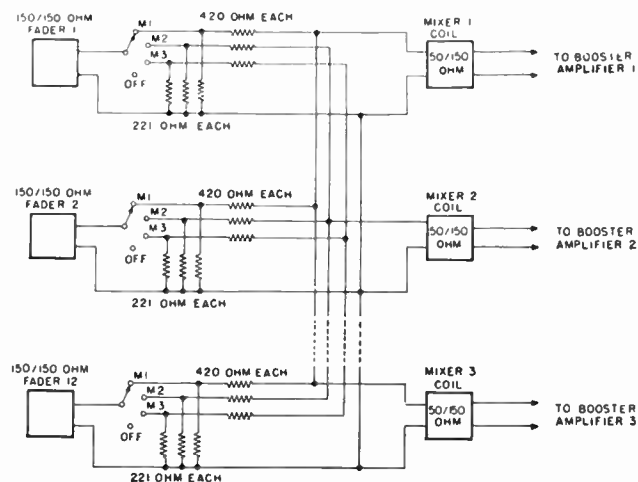

FIG. 4.

### Performance Data

Performance of the overall system is of interest. Frequency response is essentially flat from 30 to 15,000 cycles per second. Distortion at 10 decibels higher than normal level through the system is less than 0.5 per cent and the signal-to-noise ratio is 77 decibels below the level at which the distortion measurements were made.

## WCAU's TELEVISION MASTER CONTROL ROOM

The TV Master Control Room includes a custom-built relay switching system built by RCA to WCAU's specifications. Twelve video and seven audio input circuits provide for studios, film chains, network and remotes. Three output circuits feed the main transmitter, network and an audition or preview channel from any of the inputs. Monitor switching controls the connecting of video monitors among the three outgoing channels. There are provisions for pre-setting as many as three inputs in advance. The audition channel can be used as a preview circuit for the transmitter and network outputs. A memory circuit is incorporated to operate flashing lights contained within the pushbuttons. This notifies the operator that a new "pre-set" has not yet been made on a specific row of buttons. The operator then clears the "flash" warning by pre-setting any desired input. Relay switching with essentially the same system used for video is also used for audio circuits. Both video and audio relays can be tied together for simultaneous switching, if desired, or they can be separated for individual control. Of the twelve video inputs, six would correspond to identical audio inputs such as network, remote, Studio #1, etc. Six video inputs from the projection room may have their corresponding audio mixed at an audio console in master control. A dissolve super-imposition circuit, with a mixing amplifier is available, using any two of the input circuits. It is used to good advantage for film inserts with live program, live inserts with film program, multiple points of origination and for commercial spots, on a fade or super-imposition basis. Audio and video "lever" type faders in this circuit are independent of each other but are physically arranged so that both levers may be grasped in one hand and operated as a unit. A second switching console, with duplicate facilities, which may be required for future expansion, is planned. Space is allowed for it and rack space is provided for the relays and associated equipment.

FIG. 1. This is the WCAU TV Master Control Room as seen through the window from the main lobby. The film and announce camera monitoring positions are at the long console on the far side of the room. The master control switching console, especially built by RCA to WCAU's specifications is at the extreme right. Part of the projection room can be seen through the window at the left. The window further right looks into the announce booth, and through a second window into the part of the projection room where the announce cameras are located.

FIG. 2. Closeup of the master switching console which was custom built by RCA to WCAU's specifications. Seven audio and twelve video input circuits are brought to this console. By means of pushbuttons which control switching relays, the operator can connect any of these to any of three outgoing circuits.

# **WOR-TV Custom Audio / Video Equipment\***

*For a complete description of the WOR-TV Audio/Video facilities, see next page.*

\* The following information is a portion of a complete article, "WOR-TV Studios," which appeared in the September-October, 1950 issue of BROADCAST NEWS. This material was prepared by Newland F. Smith, Engineer-in-Charge of Television, WOR-TV, New York City, N. Y.

# STUDIO

# WOR-TV STUDIO PROGRAM

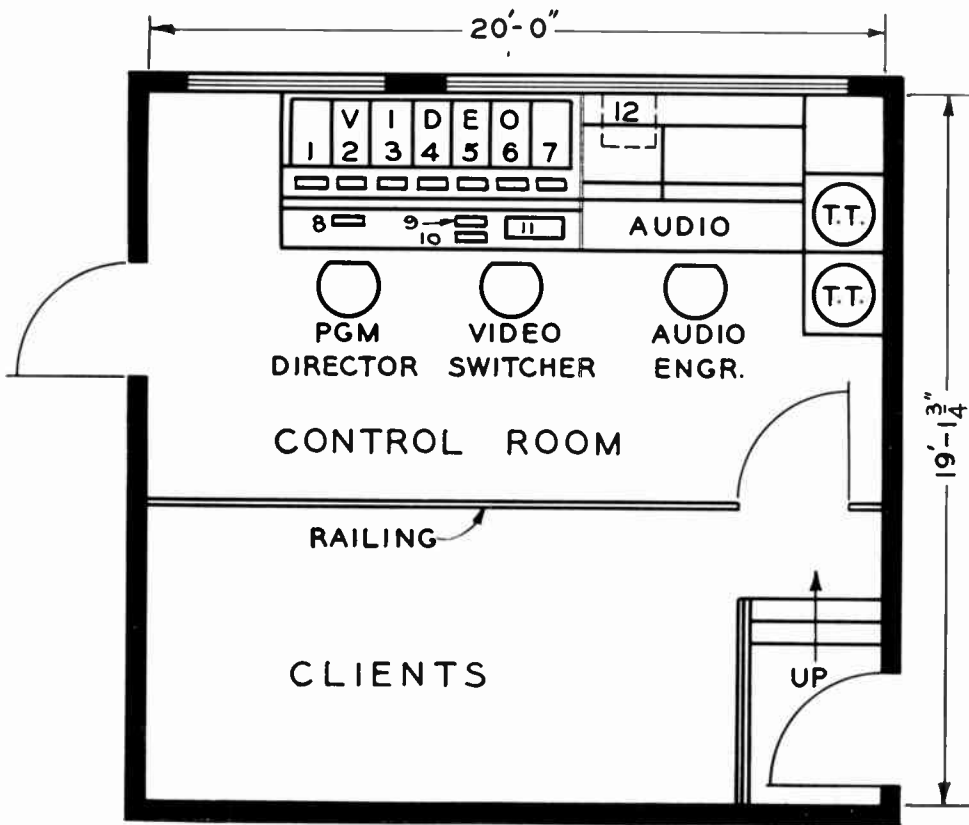

Three program control rooms are provided at the 67th Street Studios, all of which are identical as regards facilities. One of these control rooms is used normally with each of the two large studios—Studios A and B. The control room floor level is about two feet above the studio floor. A large window from the control room permits good visibility into the studio.

Note that this article starts with Fig. 10 because it is only part of an article which appeared in BROADCAST NEWS.

FIG. 10 (at left). Typical floor plan of one of WOR-TV studio control rooms. All three control rooms are practically identical as to facilities. Video console components: 1. Preview Monitor—1. 2. Camera Monitor—1. 3. Camera Monitor—2. 4. Camera Monitor—3. 5. Camera Monitor—4. 6. Line Monitor. 7. Preview Monitor—2. 8. Director's Intercom Panel. 9. Projection Room Remote Control. 10. Technical Director's Intercom. 11. Switching Panel. 12. Receiver Monitor.



FIG. 11. View of Control Room "A" showing the WOR-TV Program Director's Console at left and the Audio Console at right.

## CONTROL ROOMS "A", "B" and "C"

The third control room (Studio C Control Room) is normally used for handling of remote programs or film programs. Film inserts on remotes are easily handled in this control room by routing the remote signal through the Studio C switching system. In addition, all station breaks and film spot announcements introduced in the station break period are handled in the Studio C Control Room. Studio C Control Room is therefore one of the busiest spots in the station, and is manned at all times when the station is on the air.

### Program Relay Switching Accomplished by TS-20A System

Each of the studio camera switching systems consists of a sixty button switching control panel located on each of the program consoles. *These buttons merely*

*operate d-c control circuits that switch the video by means of the TS-20A switching relays located centrally in the Camera Control Center for all studios. Each switching control panel contains five horizontal rows of buttons which fundamentally allow for twelve inputs and five outputs. The twelve inputs provide normally for eight local cameras, that is, video signals without sync, three inputs for composite or remote signals, and one input which is the "Effects" input. All of the inputs appear on the coaxial patch panels in the Camera Control Center, and therefore any of the three camera switching systems can be set up with any of the camera circuits or other signals required for a given programming. The five outputs of the camera switching relays are generally used as follows:*

The lower bank selects any one of the input signals for the program output circuit for that studio, and is set up for "over-lap" switching. The next two banks are used for setting up the so-called "Effects" amplifier inputs. That is, any two of the inputs may be selected for feeding a mixer amplifier, for producing lap dissolves, super-positions, and fades. The fader control is located directly to the right of these "Effects" buttons. The upper two rows of buttons are used to select inputs to the two preview monitors located at either end of the program console.

In summarizing the available camera switching sequences, any of the following specific combinations are obtainable with the camera switching equipment used (provided Master Control has patched in the required signals).

FIG. 12 (below). Studio Control Room "B" during program operation (Program Director at left watches seven monitors; Preview 1, Cameras 1, 2, 3 and 4, Preview 2 and Line Monitor). Video Switcher sits at director's right and audio engineer at audio mixing controls.



# WOR-TV STUDIO PROGRAM

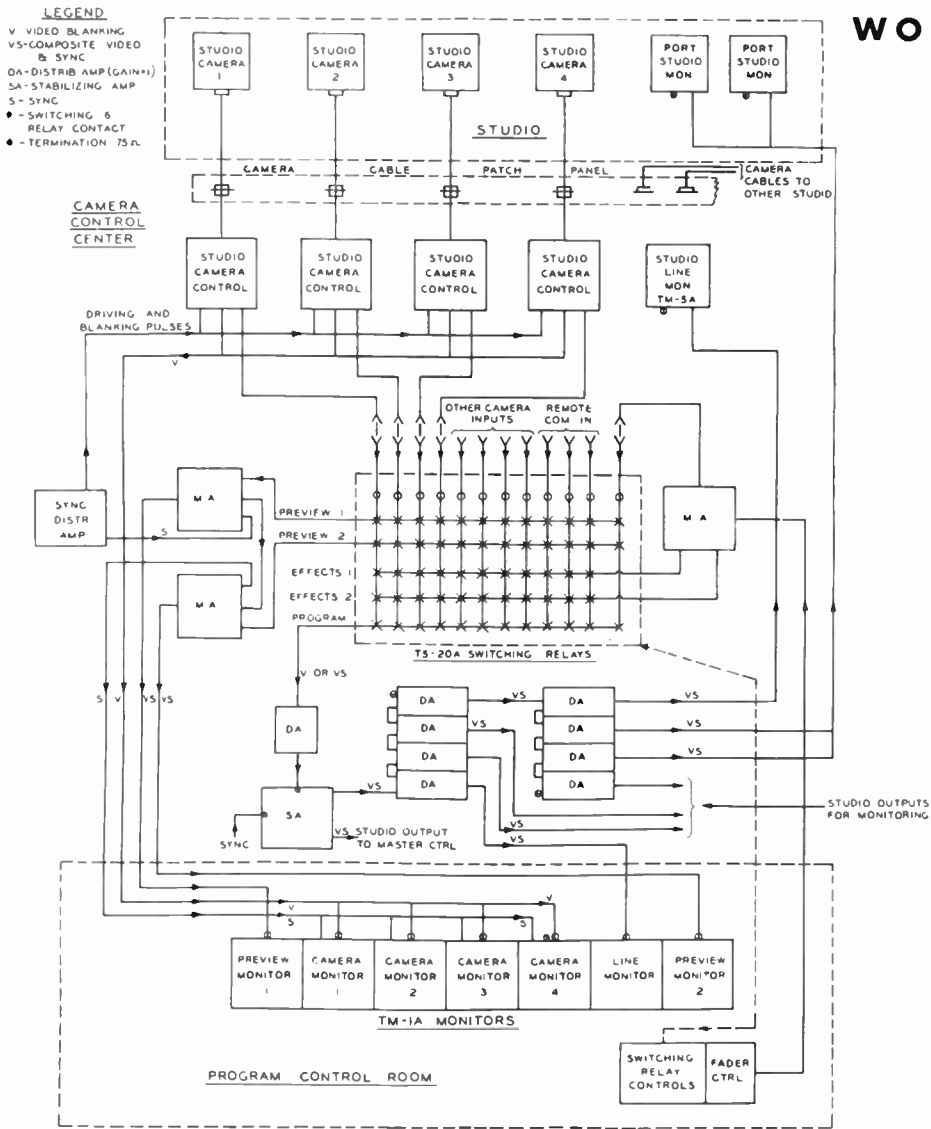

## Switching Possibilities Available

### A. PROGRAM BANK

This controls the signal which is sent out to Master Control.

1. Instantaneous switch between any two studio and/or film cameras.
2. Instantaneous switch between any local camera and a remote signal.
3. Instantaneous switch between any two remote signals.
4. Instantaneous switch between any local camera and an "Effect" as set up on #12 input (such as a superposition of any two local cameras).
5. Instantaneous switch between any remote signal and an "Effect" as set up on #12 input.

FIG. 13 (left). Simplified schematic of the studio program switching system employed at WOR-TV.

FIG. 14 (below). Closeup of the WOR-TV Program Director's Console showing the Video Switching Control Panel containing the Preview 1, Preview 2, Effects 1, Effects 2 and Program Banks.

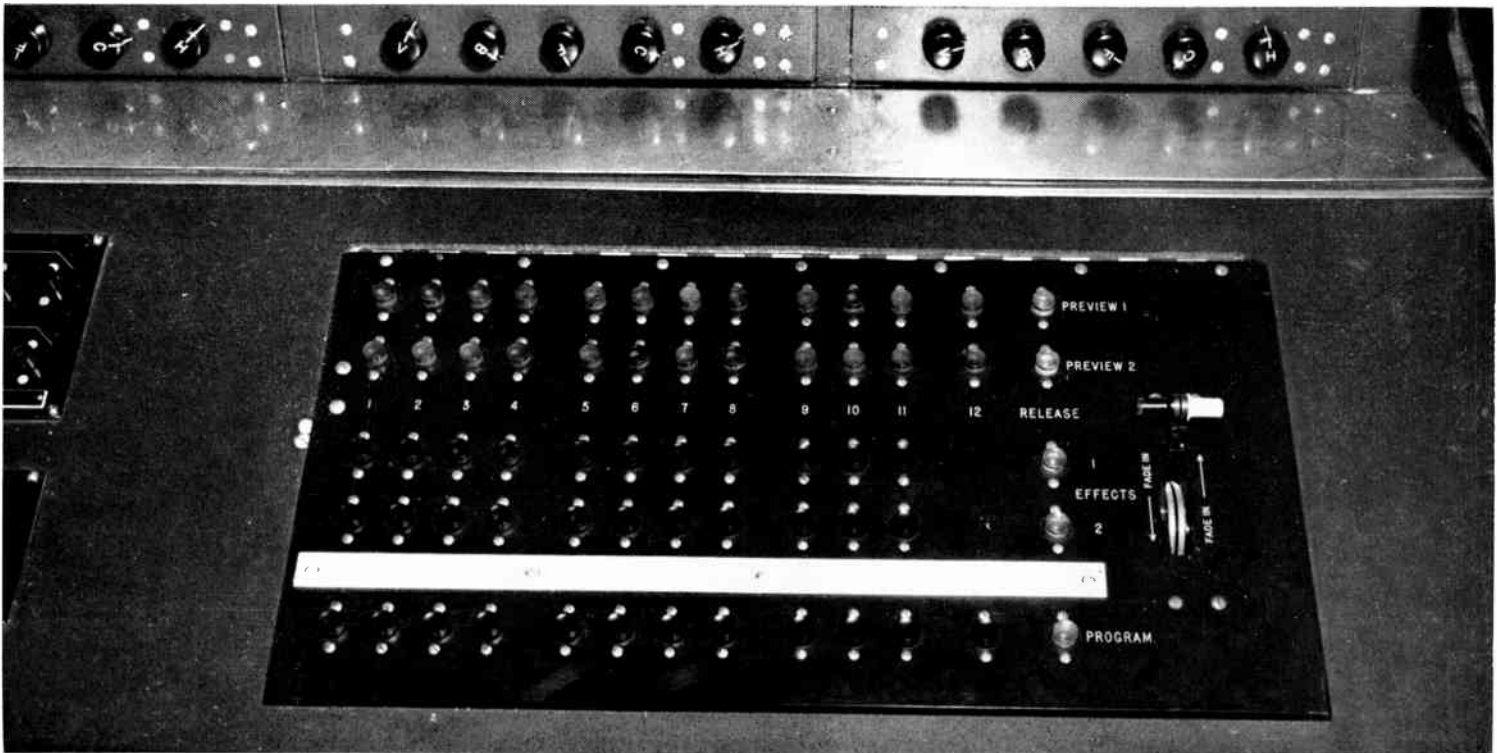



## CONTROL ROOMS "A", "B" and "C" (Cont.)

6. Instantaneous switch between any of the above signals and black.

### B. EFFECTS BANKS 1 AND 2

The output of these two channels are mixed according to the setting of the two fader levers on the right of the switching panel. The resultant mixed output is fed back into the #12 input of the switching system where it can be previewed on either of the two preview monitors and/or switched on the program line.

1. Lap dissolve between any two studio and/or film cameras.

2. Fixed superposition of any two studio or film cameras.

3. Fade down between any studio or film camera and black.

4. Fade up between black and any studio or film camera.

5. Any of the above fades, laps, or superpositions between local cameras and a remote signal when used in conjunction with the "Genlock" in Master Control.

The "Effects" input also provides for the addition at a later date of additional equipment for other special effects, such as horizontal and vertical "wipes", "roll butts", split between two cameras, automatic fades, etc.

### C. PREVIEW 1 AND 2 BANKS

1. Preview monitor may be switched instantaneously to any of the signals set up for this switching system: i.e., local cameras, film cameras, remotes, or "Effects".

In addition to the switching control panel on the programming console, there are located two intercom control panels. One of these is used for the program director's intercom, and the other for the video switcher's intercom. These enable the desk-type talk-back microphones to be switched to the various circuits required for direction of a studio production.

There is also located on the program console a small panel which contains buttons for the remote starting and stopping of any of the film projectors located in the Projection Room. Control is given by the projectionist to the particular studio involved each time a projector is started and stopped. Lights internal in the buttons indicate when this control is available and when the projector is running.

FIG. 15 (below). View of Control Room "C" showing arrangement of technical equipment. Program Director's Console with switching facilities is at left and Audio Console at right.



# FOUR OF THE MANY WOR-TV SWITCHING POSSIBILITIES

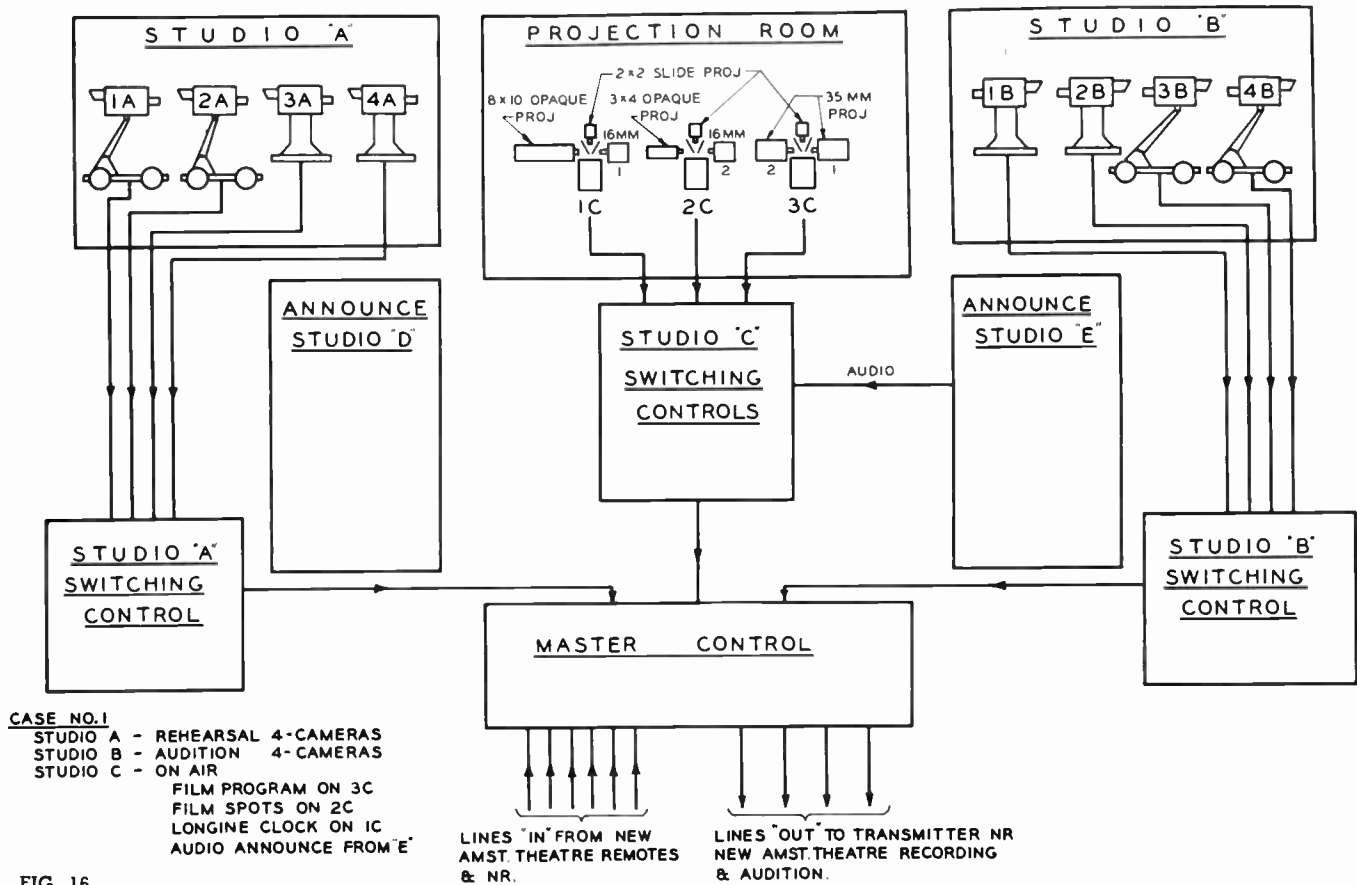

FIG. 16.

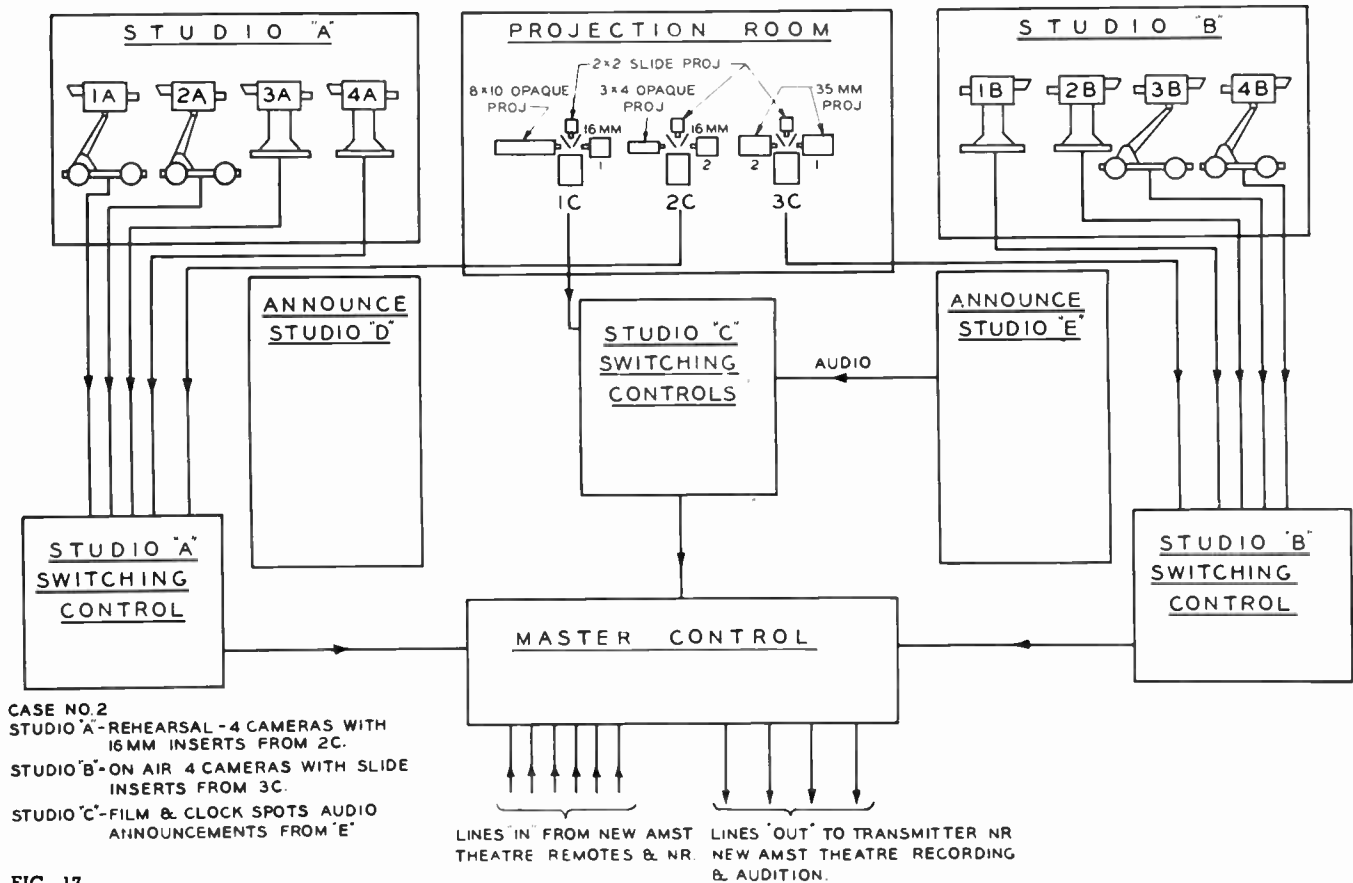

FIG. 17.

# MADE POSSIBLE BY THE TS-20A SWITCHING SYSTEM

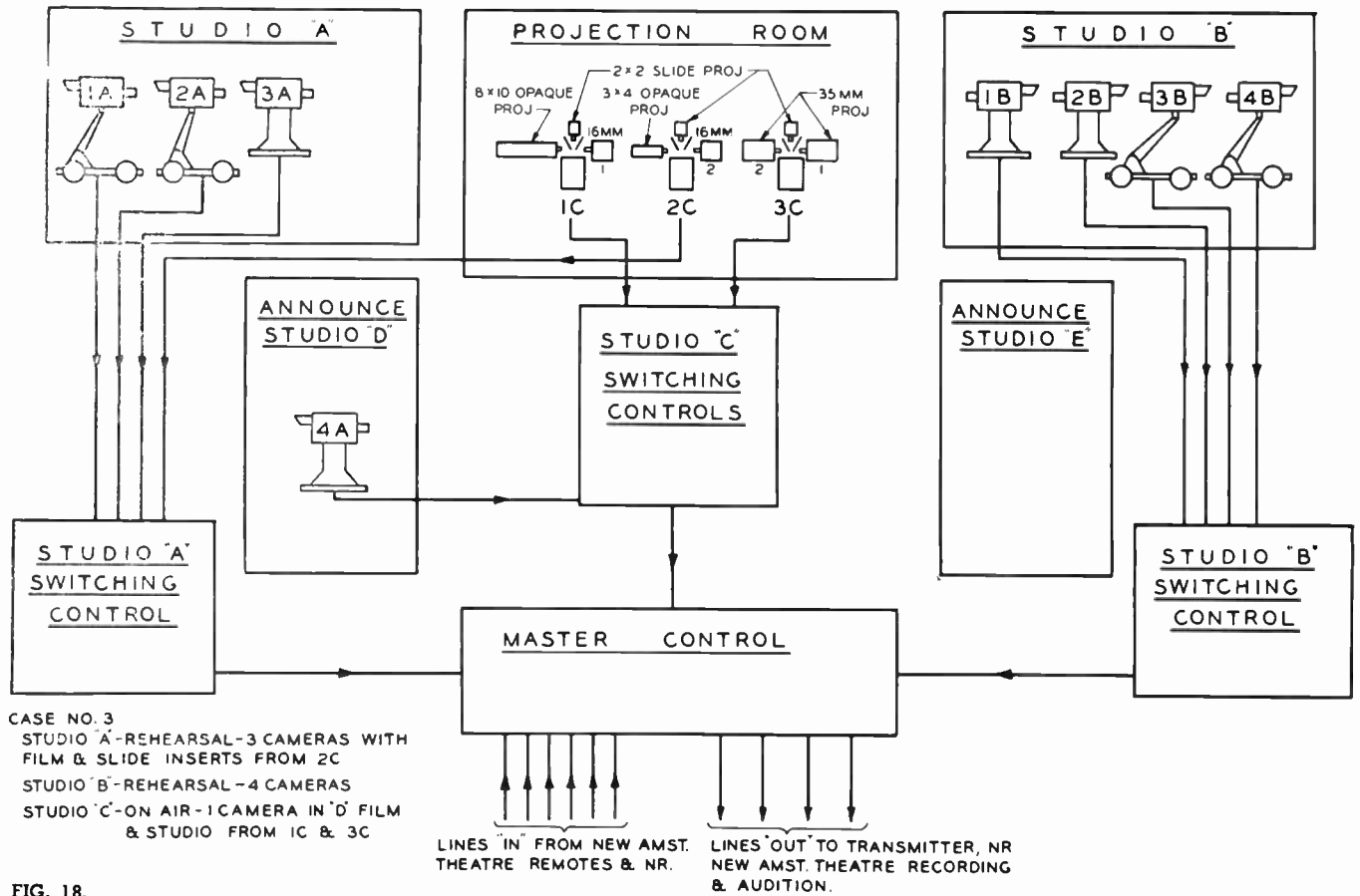

FIG. 18.

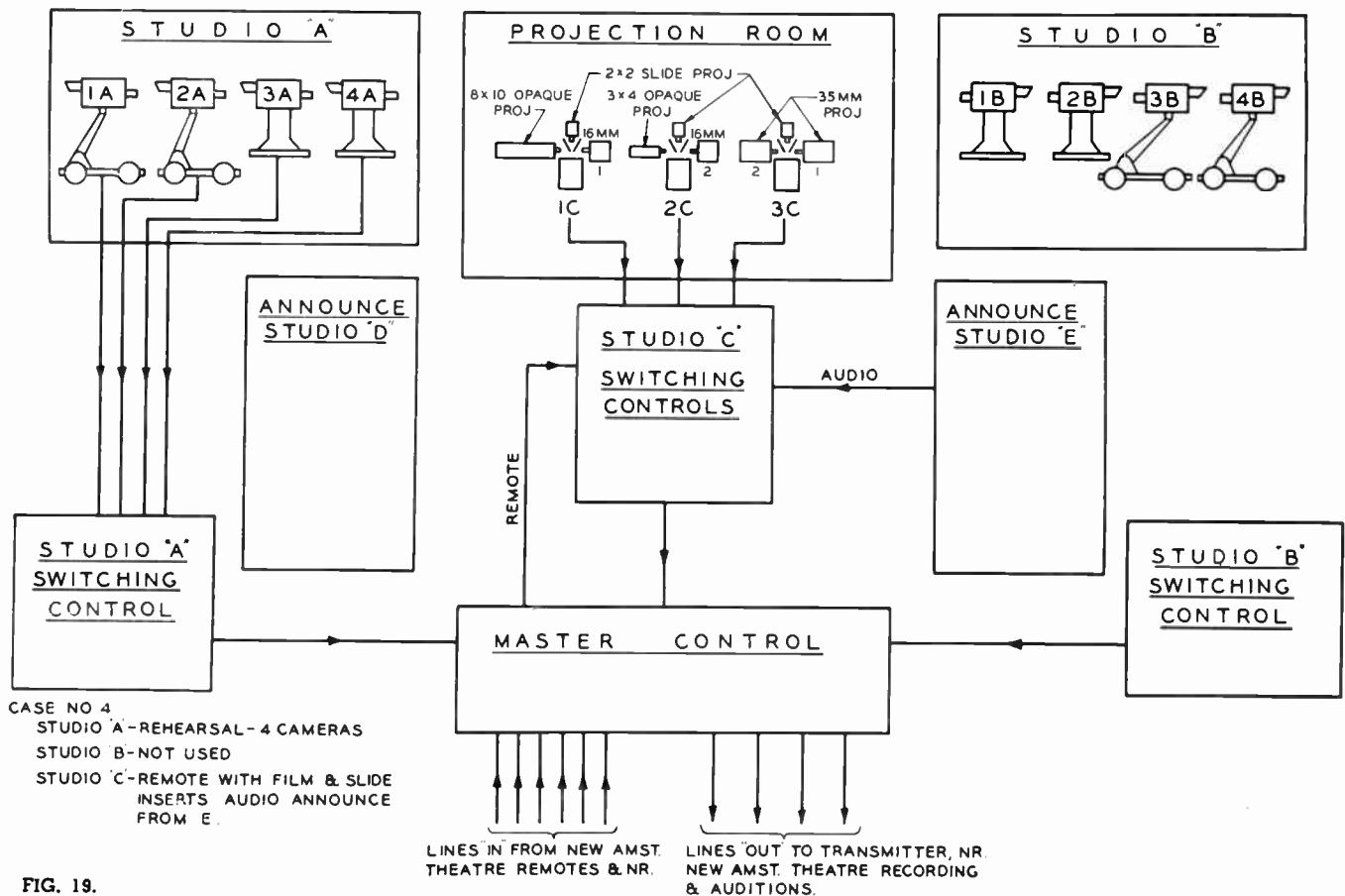

FIG. 19.

## WOR-TV AUDIO CONTROL, ANNOUNCE BOOTHS "D" & "E"

The audio system in each control room is an assembly of standard RCA components. A 76-B4 audio console forms the basic part of the system. This is augmented for additional microphone inputs by two OP-7 mixer amplifiers mounted in a specially built cabinet matching the 76-B. Each of the OP-7 outputs appears on an input fader of the 76-B, thus providing a sub-master gain control on each of two groups of microphones.

In addition, each set of inputs to the OP-7's can be switched to any one of five groups of microphone outlets by means of relays, thus providing for a maximum of forty pre-set microphones about the studio which can be used on different sets as called for. Two microphone outlets in the studio normally used for the boom microphones appear directly on the 76-B fader.

Two turntables and lines from Master Control for film and remotes complete the audio system.

Master Control does all the program output switching and permits audio to be switched with the video or independently. This allows the signal source of the audio to come from a different point than that of the video. Provision is further made for turntable playback over the studio speaker.

Thus, the audio control equipment employed in control rooms A, B, and C provide complete facilities for the handling of microphones, turntables, film sound, and remotes. Remotes are patched to the proper control room in Master Control.

### Announce Booths "D" and "E"

Two announce booths are provided, and each booth is situated so that a view of

the studios is available from them. Each booth may be controlled from two of the three control rooms. This makes a very flexible system in case spot announcements are to be inserted into film or remote programs. It also provides an isolated booth that may be used with the associated studio to allow for the changing of scenes within the studio. Announce booth "E" is about 8 feet by 16 feet, and "D" approximately 10 feet by 20 feet. Either booth can be used in emergencies for a small "one-camera" show if required (see Fig. 21).

The basic equipment and facilities employed in each announce booth are similar, and consist of a TM-1A announce monitor, announce microphones, and required terminations for intercom camera cables and monitoring circuits (see Figs. 22 and 23).



FIG. 20. Partial closeup view in studio "B" control room showing the audio control setup. Facilities consist of an RCA 76-B Console which is supplemented by two RCA OP-7 Mixer Amplifiers.

FIG. 21. When the occasion arises, Announce Studio "D" may be used for a program setup as shown here during an introduction to the "Mystery Rider" film program.



FIG. 22 (above). View of Announce Studio "B" showing left to right, 44-BX Microphone, TM-1A Announcer's Monitor, and announce desk microphone.



FIG. 23 (at right). Closeup of special terminal box located in Announce Studio "E" for microphones, intercom, camera cables, monitor video, monitor power.



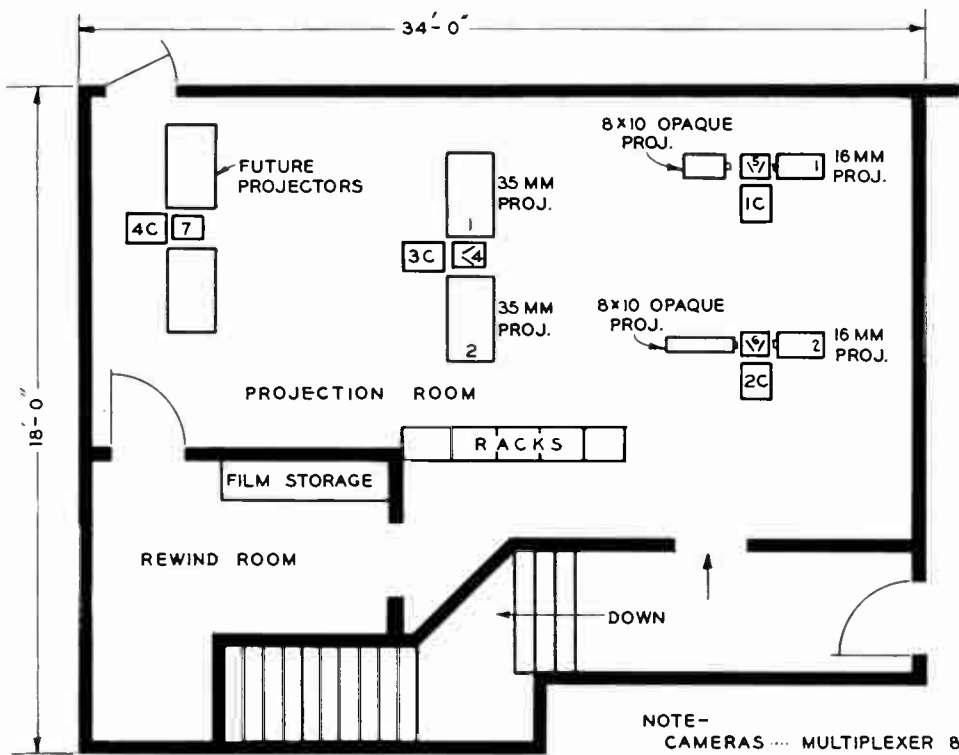

FIG. 24. Floor plan layout of WOR-TV Projection Room facilities located on the second floor.

NOTE-

CAMERAS	MULTIPLEXER &
1C	2x2 SLIDE PROJ.
2C	4
3C	5
4C(FUTURE)	6
	7(FUTURE)

## WOR-TV FILM PROJECTION

The film projection facilities are located on the second floor above the studio control rooms. In this room, which is approximately 18 feet by 34 feet, are located three TK-20A film cameras with space and trench facilities for locating a fourth when required. Each film camera is associated with a film multiplexer for combining optically three sources of film or slides. Two 16mm projectors, two 35mm projectors, one Gray Telop, one opaque projector, and three 2 x 2 slide projectors comprise the projection facilities, distributed as listed below as shown in the sketch of Fig. 24.

### Camera 1-C

16mm Film Projector #1, 8 x 10 Opaque Projector, 2 x 2 Slide Projector.

FIG. 25 (below). View of one end of the Projection Room; the two 35mm projectors and the projection room monitoring racks at left with the TM-1A picture monitors mounted at top.

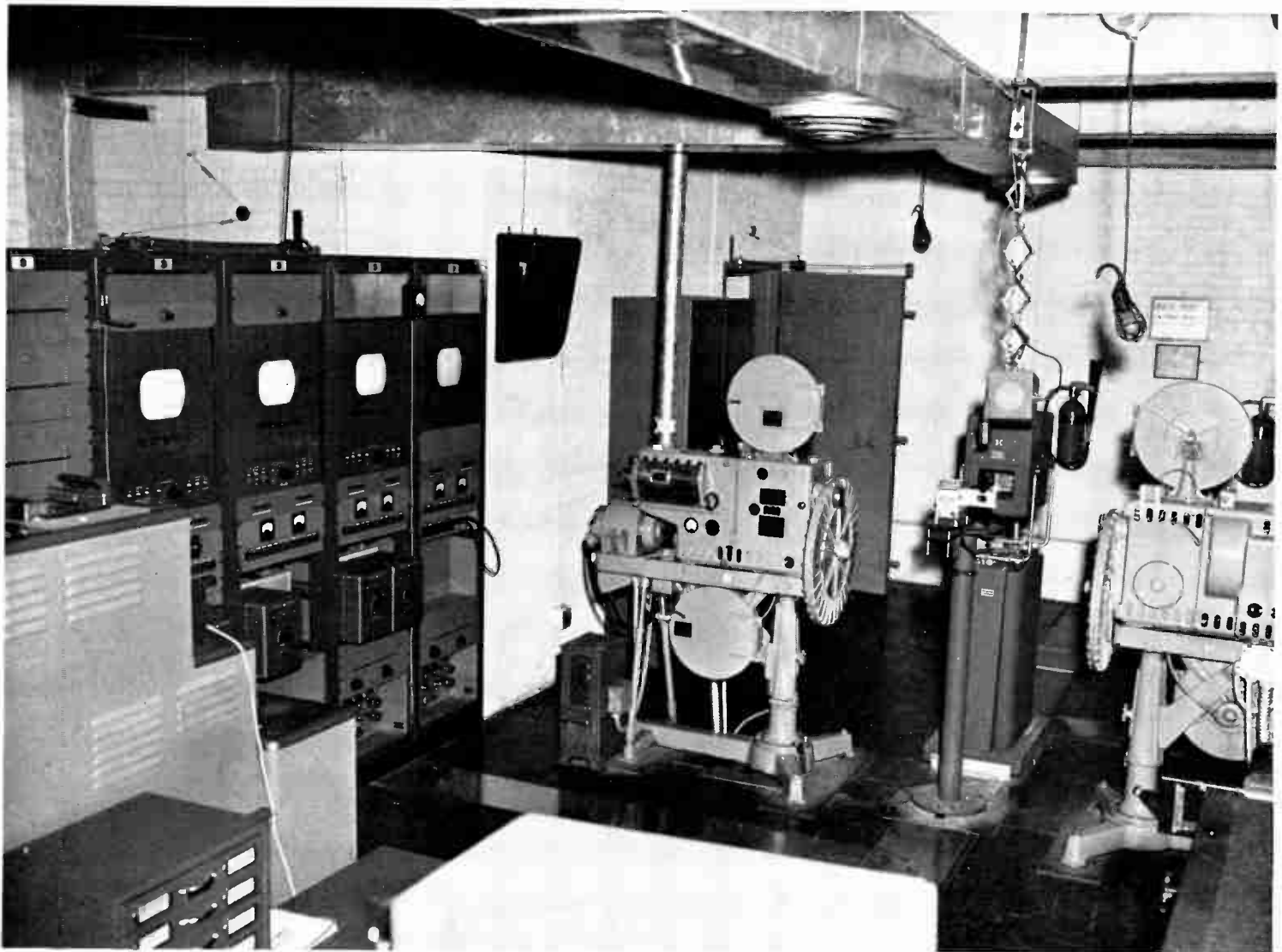

## ROOM (STUDIO "C")

### Camera 2-C

16mm Film Projector #2, 3 x 4 Opaque and Slide Projector and Special Telefax or Scroll Titles, 2 x 2 Slide Projector.

### Camera 3-C

35mm Film Projector #1, 35mm Film Projector #2, 2 x 2 Slide Projector.

Above each film multiplexer, and hung on a sky-hook from the ceiling is a small intercom speaker and talk-back microphone. This is used for direction between the program console and the projectionist. By patching arrangement each of the three projection room intercom assemblies may be set up for communication in any combination with the three program control rooms. Thus, one projector and film camera assembly may be working with Studio A

Control Room for an "On-the-Air" program, while #2 camera chain and projector assembly might be working with Studio B Control Room for an audition. The talk-back microphone on each of the intercom assemblies is opened up by means of a pedal foot switch located near the base of each film multiplexer. In this way the projectionist does not need to use his hands when talking back to a studio control room.

Five racks of equipment are also located in a row along the side of the Projection Room. In these racks are located amplifiers for the projector audio and the intercom systems. Four TM-1A monitors, rack mounted, are also provided for monitoring the output of each film camera chain. A switching panel for each monitor provides for switching the monitor from either the camera output to any of the studio out-

puts, or to transmitter line. Remote control starting, stopping, and dousing circuits are brought over to the racks for centralized control of all projectors. In addition, switches are provided on the racks for each projector, so that remote control may be extended to any of the three studio control rooms or to a remote control panel located in the Camera Control Center. Local starting of any projector is provided at the projector itself by means of a foot pedal switch conveniently located on the floor beside that projector.

Directly off from the Projection Room is located a film rewind and storage room designed for the handling of 35mm nitrate film. Film storage cabinets are provided here with exhausts directly from the cabinets to the outside, in accordance with standard City regulations.

FIG. 26 (below). Another view of Projection Control Room showing location of other equipment. Two RCA TK-20 film cameras with Gray Telop are visible in foreground.

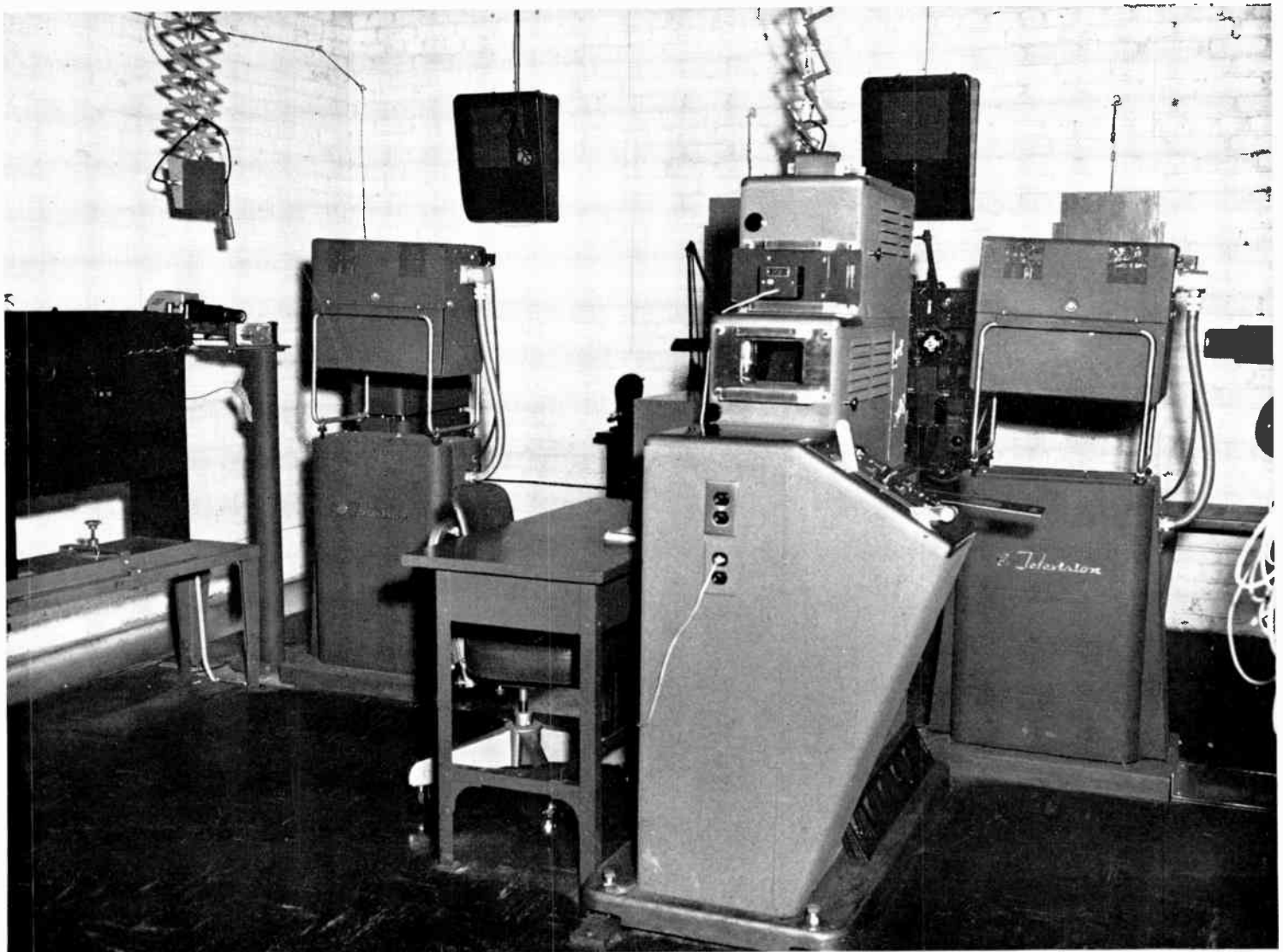

# WOR-TV MASTER CIRCUIT DIAGRAM OF THE VIDEO SYSTEM LAYOUT

## LEGEND

- VDR VERTICAL DRIVING
- HDR HORIZONTAL DRIVING
- BL BLANKING
- DR DRIVING PLUS BLANKING
- S MIXED SYNC
- V VIDEO LESS SYNC
- VS COMPOSITE VIDEO AND SYNC
- DA DISTRIBUTION AMPLIFIER UNITY GAIN
- MA MIXING AMPLIFIER
- SA STABILIZING AMPLIFIER
- C CONTROL CIRCUIT
- 75 OHM PLUG IN TERMINAL
- ✕ SWITCHING RELAY CONTACTS
- VIDEO JACKS
- NOTE—ALL VIDEO JACKS ARE IN RACKS 5 & 6
- R-1 EQUIPMENT LOCATED IN RACK 1
- U-45 EQUIPMENT DESIGNATED AS UNIT 45  
(See floor plans TD-831 and TD-833. Also see equipment placement within Racks TD-3 788 thru 791)
- CHASSIS TYPE COAXIAL CONNECTOR
- DIRECTION OF SIGNAL FLOW
- CAMERA CABLE CONNECTOR
- ↔ VIDEO JACKS NORMALLED

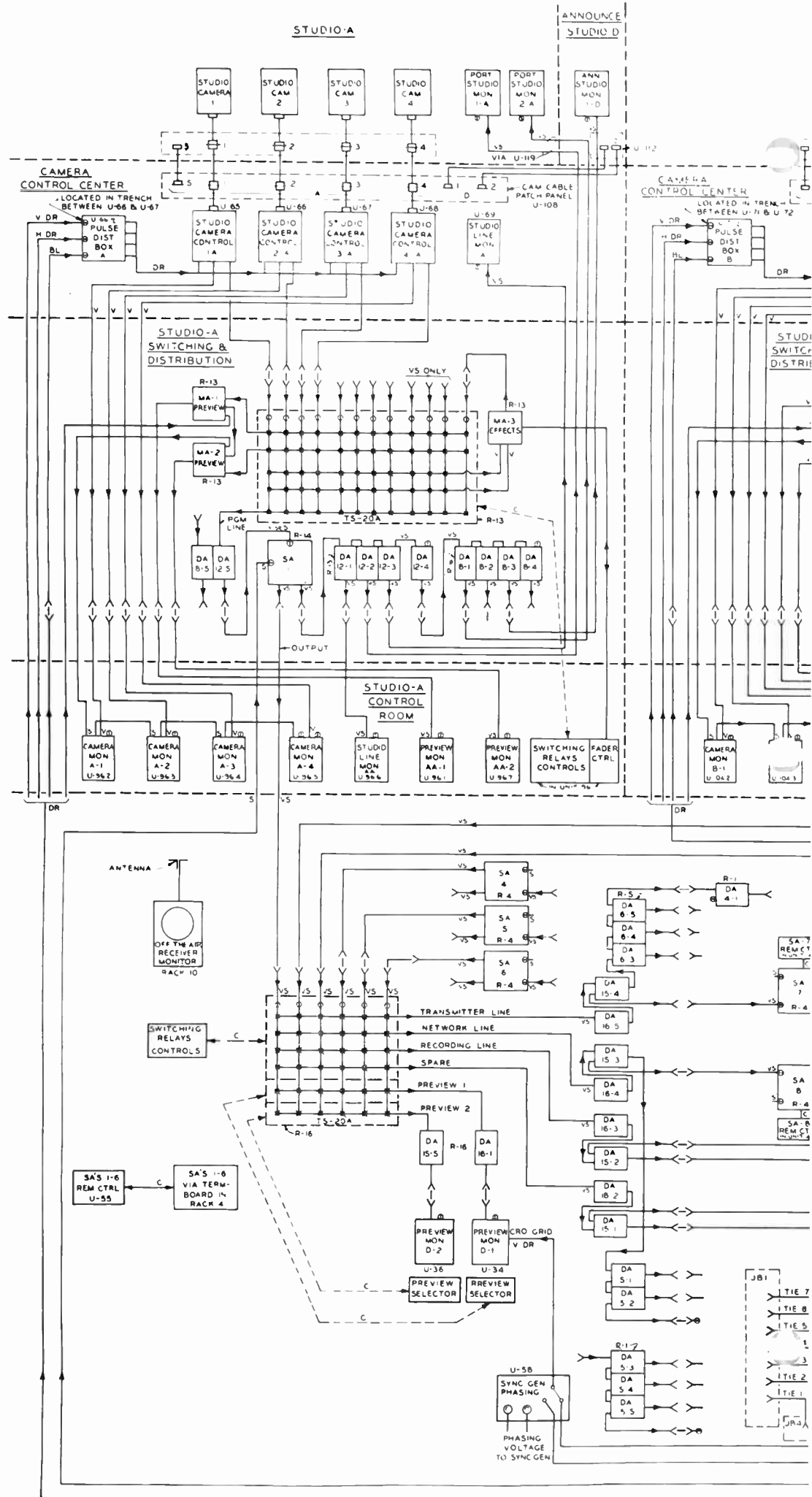



STUDIO B

ANNOUNCE  
STUDIO E

STUDIO C

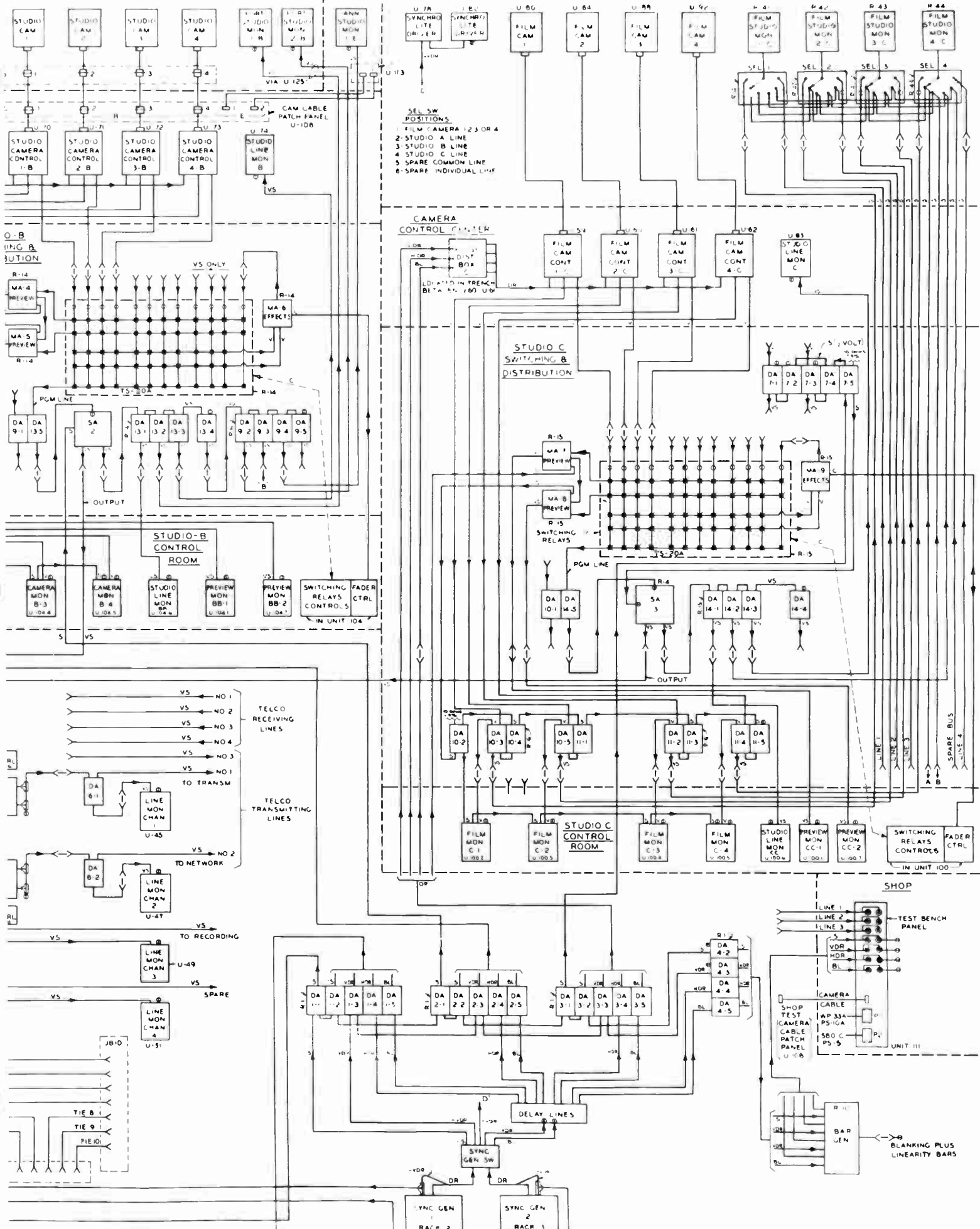

**SEL SW POSITIONS**  
 1. FILM CAMERA 1, 2, 3 OR 4  
 2. STUDIO A LINE  
 3. STUDIO B LINE  
 4. STUDIO C LINE  
 5. SPARE COMMON LINE  
 6. SPARE INDIVIDUAL LINE

**CAMERA CONTROL CENTER**  
 FILM CAM CONT 1-C (U 51)  
 FILM CAM CONT 2-C (U 52)  
 FILM CAM CONT 3-C (U 53)  
 FILM CAM CONT 4-C (U 54)  
 STUDIO LINE MON C (U 81)

**STUDIO C SWITCHING & DISTRIBUTION**

**STUDIO C CONTROL ROOM**  
 FILM MON C-1 (U 102)  
 FILM MON C-2 (U 103)  
 FILM MON C-3 (U 104)  
 FILM MON C-4 (U 105)

**SHOP**

**TEST BENCH PANEL**  
 LINE 1  
 LINE 2  
 LINE 3  
 VDR  
 HDR  
 BL  
 CAMERA CABLE  
 WP 33A  
 PS-10A  
 PS-10C  
 PS-5  
 UNIT 111



FIG. 27. Center section of the WOR-TV "Camera Control Center" is devoted to film camera controls on right, and master control preview monitors with remote control panels at left. Small windows face the film projection room.

FIG. 28. A special Camera Cable Patching Panel designed by the WOR-TV engineering staff is located in the "Master Control Center."

FIG. 29. The studio camera shading and monitor controls are centrally located in this console. At the extreme left part of the film shading and monitor controls are also visible.

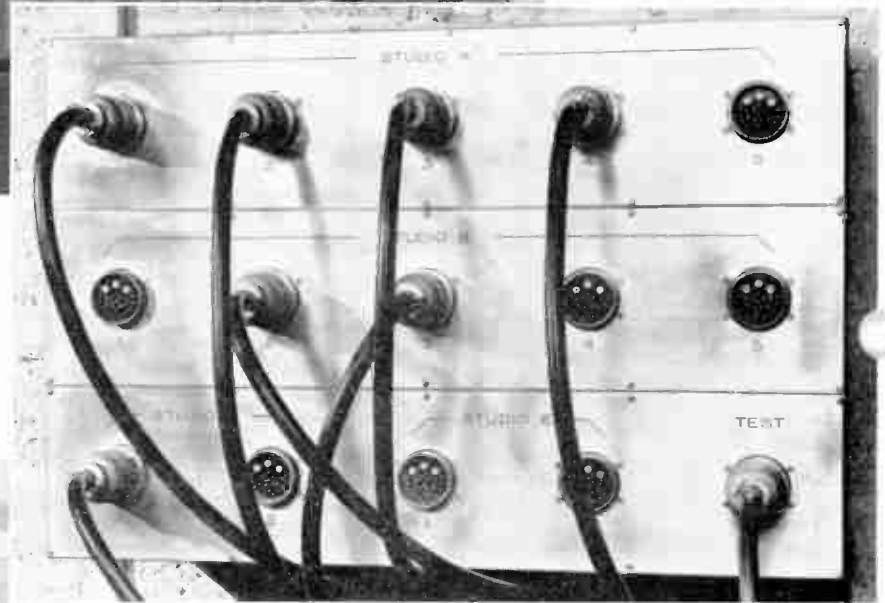

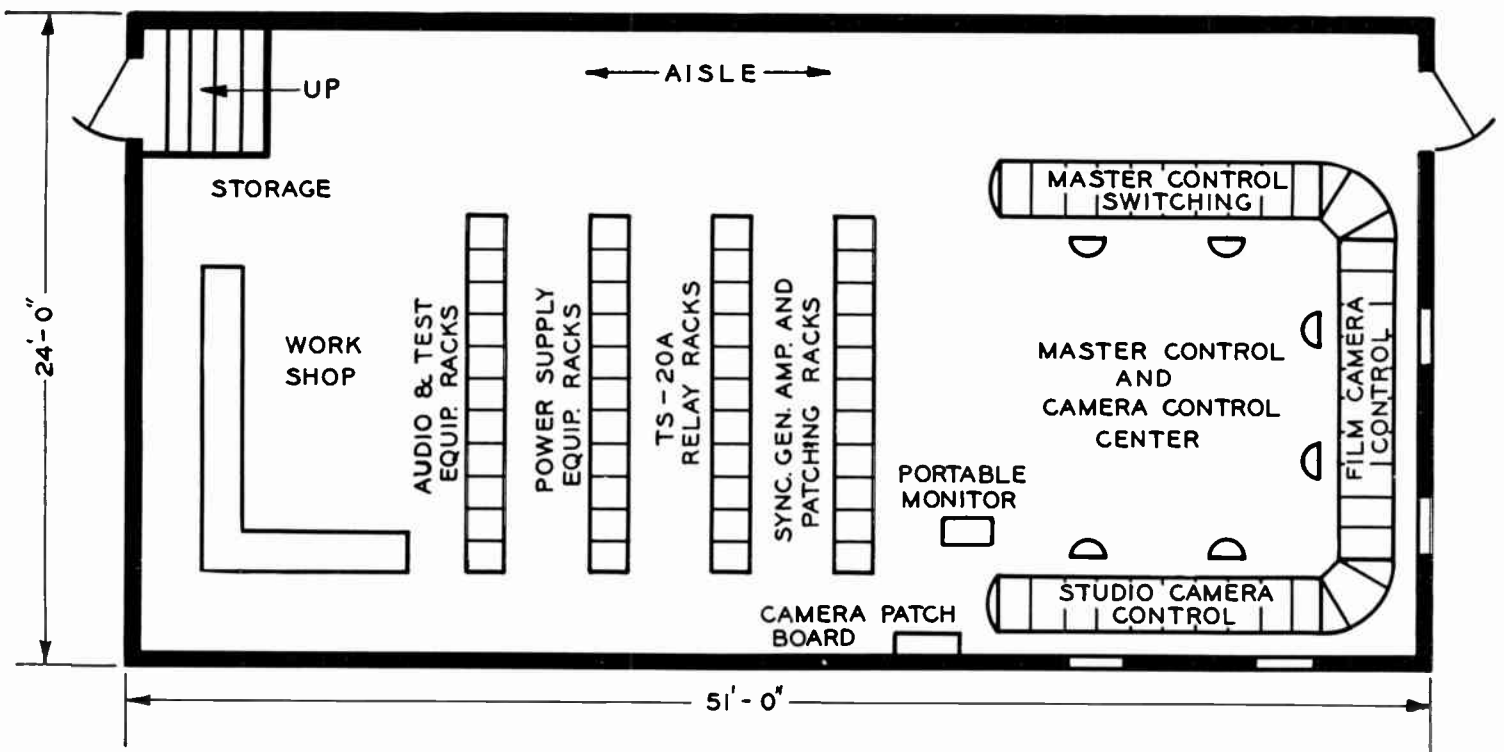

FIG. 30. Floor plan layout of WOR-TV "Master Control" and "Camera Control Center" showing the arrangement of the technical facilities.

## WOR-TV MASTER CONTROL

Adjacent to the film projection room on the second floor is located the combined Camera Control Center and Master Control Room (see sketch of Fig. 30). This is a large room approximately 24 feet by 51 feet. About one-third of this room is taken up by the main operating console space, one-third by the rack equipment, and one-third for a small maintenance shop.

The operating console is a large "U" shaped assembly of standard console sections (MI-26266). The side of the "U" nearest the door contains all of the Master Control switching facilities. The section of the console facing the studios contains all of the studio camera control units. The section facing the Projection Room houses the film camera control units and some master control equipment.

### Camera Control Section

In the Camera Control Center section eight studio camera controls and two line monitors form the section facing the studios. A window into the upper section of each of the two large studios provide visibility for the camera control operators into the studios. This is not considered essential, but it was easy to provide. A

special feature of the Camera Control Center is the camera cable patch panel shown in the photograph. This is mounted on the wall directly adjacent to the camera control units. The sockets mounted on this panel correspond to cables leading to the various studios. Five cables lead to Studio A, five to Studio B, two each to the Announce Studios, D and E, and one to the shop test bench. The camera cable pigtailed that plug into these sockets correspond to the eight studio camera control units. Thus, the eight camera controls can be distributed in any combination among the fifteen circuits to the various studios, depending upon the program requirements for that particular operation. This adds greatly to the flexibility of the over-all system, and enables us to take care of most any special requirement that can arise. It furthermore reduces the total number of camera chains required in such a setup involving several studios. Also, in case of trouble in the equipment during a program or rehearsal, it is very easy to patch in a spare camera control unit so that the equipment in trouble can be released for maintenance. In addition to the patching of the camera control units to any of the studios, it is, of course, necessary to patch the video outputs of the camera controls on the jack panels to the

corresponding program control room where the switching is to be done.

Besides patching the video outputs of the camera controls to the particular switching systems involved, it is, of course, important that tally circuit information and intercom facilities for that camera and camera control follow the particular companion program console. For this purpose a special tally and intercom patch panel is provided directly above the video patching panels. Here, a three-circuit plug for each of the studio and film camera chains is provided with jacks corresponding to the inputs on each of the three control room switching systems so that any camera control can be set up on any input to any of the three switching systems for tally and intercom control.

At each section on the camera control console is mounted an intercom box and jack. This is tied in with the corresponding camera intercom system. Thus, a camera control operator may plug in a headset at one of the sections he is working with and have complete two-way intercom with the video switcher down in the program control room that he is assigned to and also with the cameraman. In addition, on a separate earphone he may listen to the program audio from that studio.



FIG. 31. Front view of the WOR-TV Master Control Switching Console which consists of facilities for switching six incoming circuits to four outgoing channels.

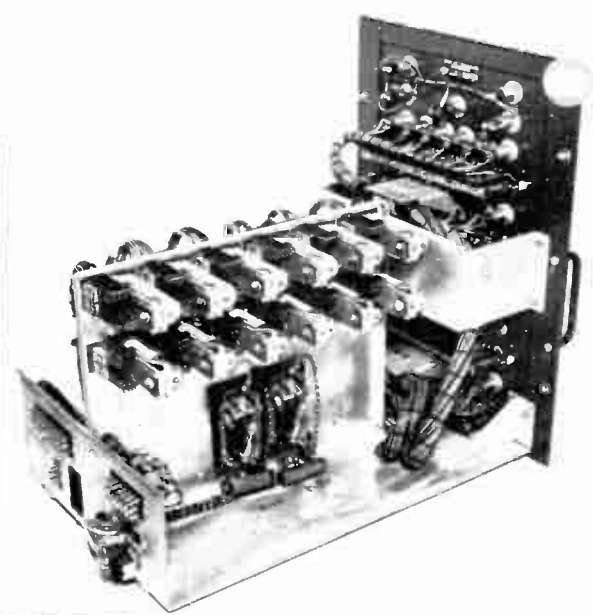
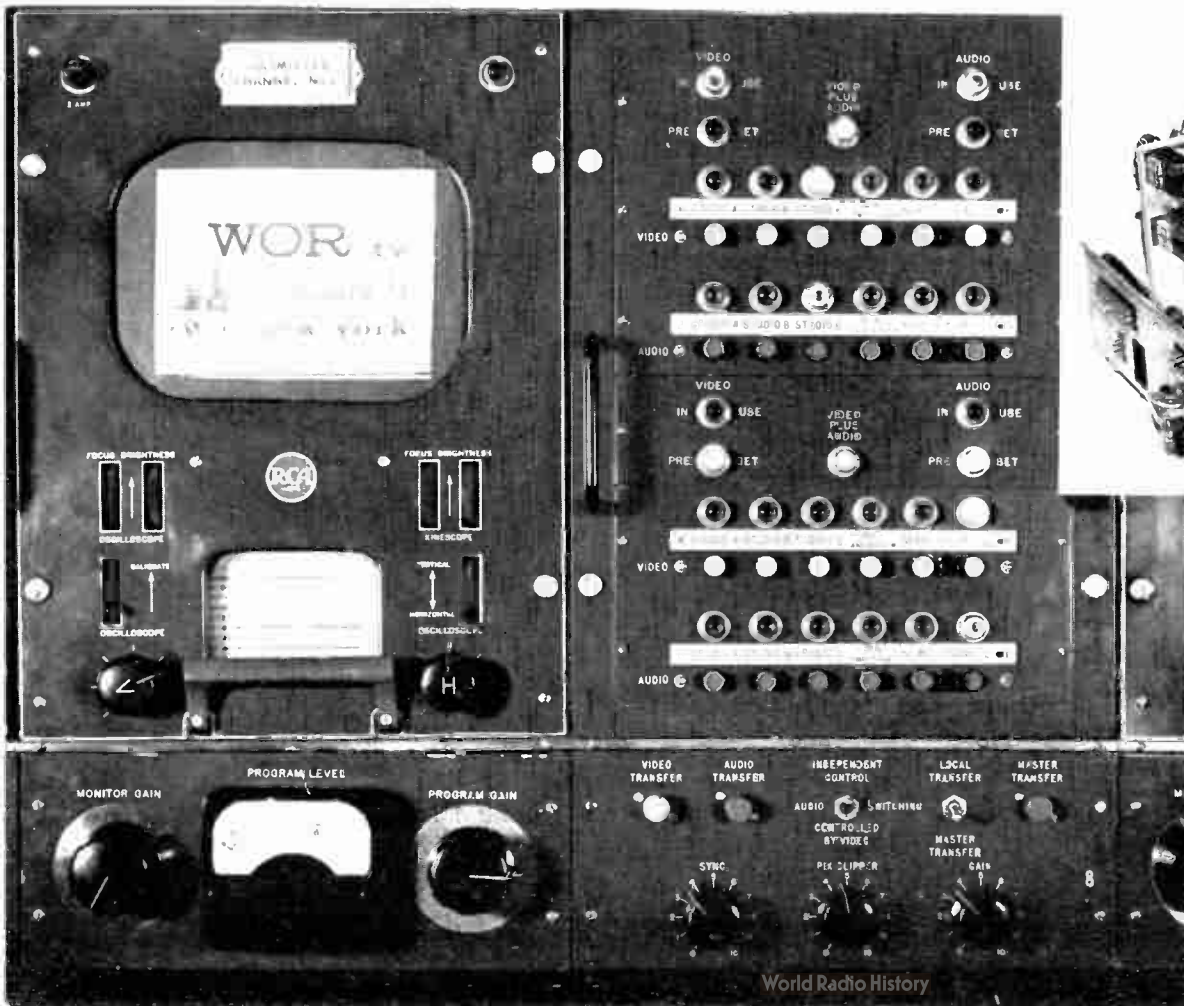

FIG. 32. View of one of the switching panels removed from console to show the construction and arrangement of the switching relays.

FIG. 33. Closeup of one of the WOR-TV Master Switching panels showing panel arrangement of controls, tally lights and push buttons associated with one channel.

## WOR-TV MASTER CONTROL (Continued)

The master control switching comprises facilities for switching six incoming channels to four outgoing circuits. This is set up for a pre-set system with provision for either independent audio-video switching or simultaneous audio-video switching as required. All four outgoing channels may be tripped by a single master button, or any group can be switched together, leaving out other channels. A picture monitor, TM-5A is associated with each outgoing channel in addition to an audio monitor and VU meter. Controls on each outgoing channel provide for the setting of video and audio levels independently.

### Master Switching (Thru TS-20A Relays)

Master switching is facilitated by the use of the TS-20A video relay system which frees control equipment and switching from usual operating restrictions. For example, the relays are controlled by simple d-c lines from any desired point. Thus, push-button control panels are conveniently located for the operator, with relays and associated equipment "rack-mounted," as desired (see rack equipment on following pages).

The actual switching control panel on each outgoing channel is mounted in a standard console housing section which is

made up as a unit with the audio switching mounted on a chassis behind the panel (see Fig. 32). In cases where simultaneous audio-video switching is done, the switching is controlled by the video switching relays, which in turn drive the audio switching relays from the tally contacts on the video relays. The push buttons used for pre-setting and switching control are made up of a standard RCA push-button switching assembly mounted on an adapter panel. The whole system comprises eight of the standard console sections in width, and makes a very flexible master control switching system. Only composite video signals are handled here, such as the studio outputs, theatre, and remotes, so that no fading or lap dissolving is done. Switches are made only at the end of a complete show which comes from one of the studios.

### Monitoring and Other Facilities

Two TM-5A Master Monitors located in the console section to the right of the master control switching console are used as preview monitors for master control switching. Each of these monitors can be switched to any of the six inputs to the master control switching for checking levels and matching the outputs of the several studios and remotes before they are actually switched to the outgoing lines. These

monitors are fed from two additional banks on the master control relays (TS-20A). In between these two TM-5A preview monitors are located remote controls on six stabilizing amplifiers. These are the stabilizing amplifiers that are used to feed the normal inputs to the master control switching system. Therefore, at this one point it is possible to adjust the synchronizing and picture levels on each of the studio outputs and all the remotes to the standard level while watching the oscilloscope on the TM-5A. It is also possible at this point to check the phase of the vertical synchronizing pulse on a remote coming in with that of the local sync generator. This is done by using the vertical driving pulse from the local sync generators as a negative blanking pulse on the grid of the cathode ray oscilloscope in the preview monitor.

An adjacent console section houses remote controls on the synchronizing generators. This consists of a remote control sync generator switch, enabling a standby sync generator to be switched in at this point. In addition, two 60 cycle selsyns provide a continuously variable phase for the 60 cycle lock-in on each synchronizing generator. A TG-45A Genlock unit has been installed which enables the local sync generators to be phased with a remote incoming signal line-by-line, as well as field-by-field.

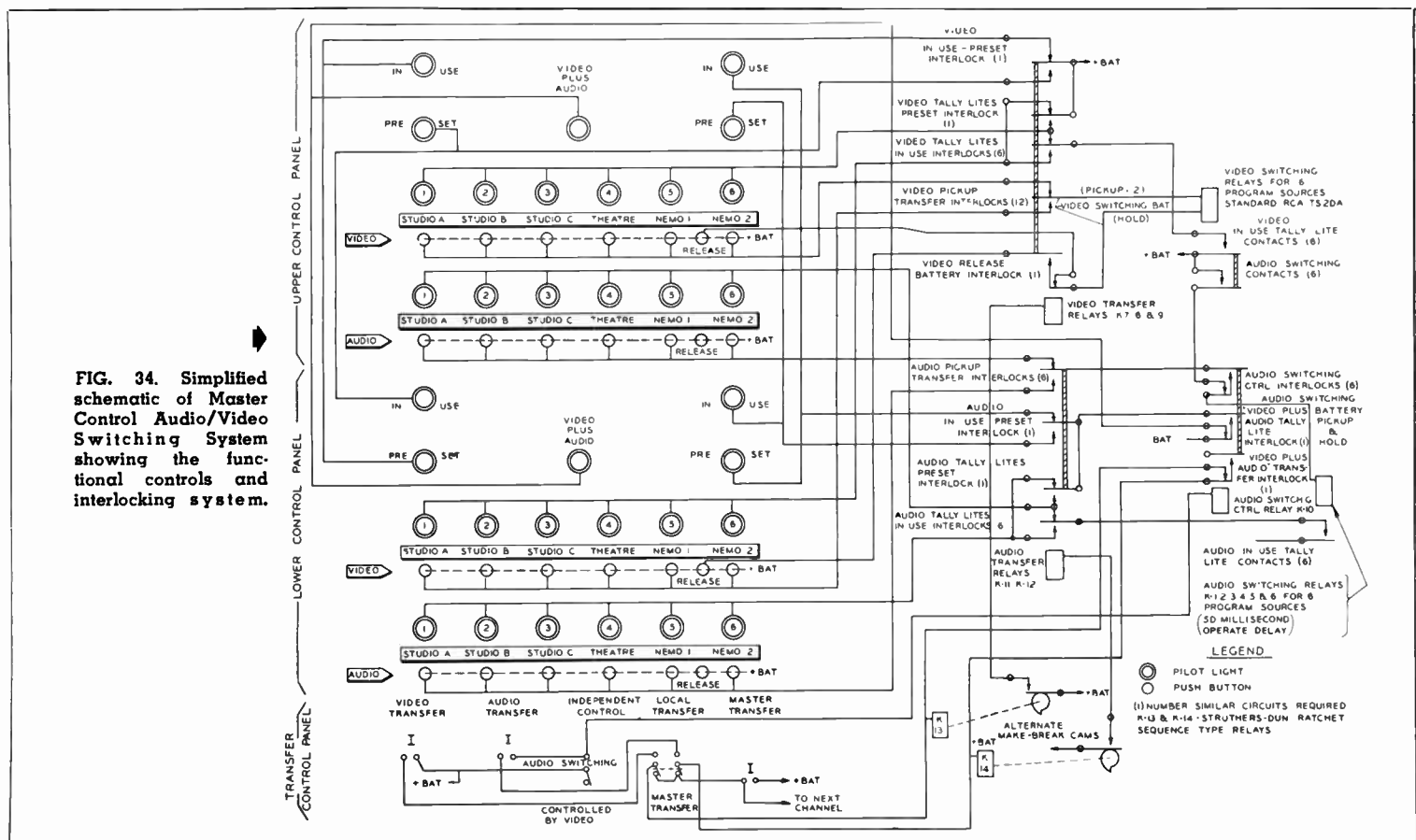

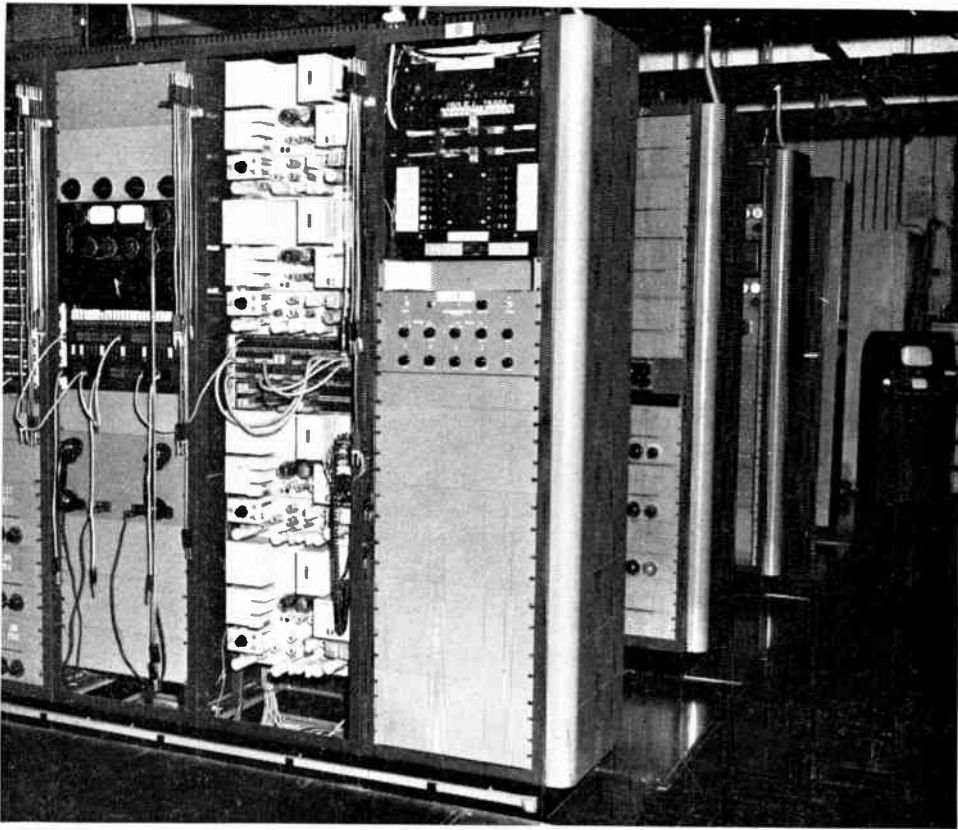
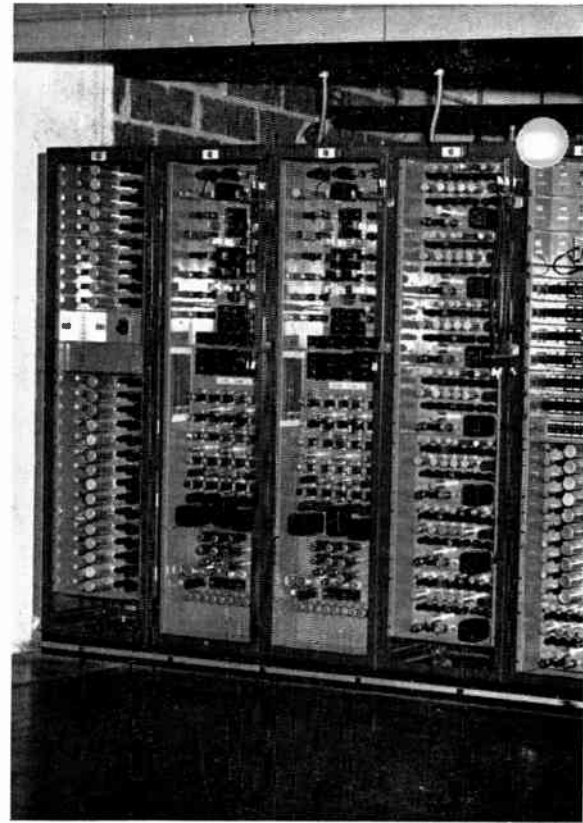

FIG. 35. View of the overall lineup of WOR-TV Master Control Equipment Racks. Complete arrangements consist of four rows of ten racks each.



## WOR-TV MASTER CONTROL EQUIPMENT RACKS

A total of forty equipment racks divided into four rows house all of the power supplies, amplifiers, synchronizing generators, switching relays, patching facilities and telephone company equipment for the whole plant. The first row of equipment racks is devoted to sync generators, audio/video patching, stabilizing amplifiers and distribution amplifiers.

In the second row of racks are located the TS-20A video switching relays. A separate rack is assigned to each of the studio switching systems and to the master control switching system. Besides the relays, each rack contains the mixer amplifiers used for fader application and for the pre-view monitor sync mixing, and, in addition, the distribution amplifiers associated with each studio switching system. Other racks in this row contain the audio amplifiers associated with the master control switching.

The last two rows of racks contain mainly power supplies. Approximately 150 power supplies are mounted here to provide power for all monitors, amplifiers, and camera chains in the plant. All a-c power distribution to the rack equipment is carried by means of 4 x 4 overhead ducts from the main circuit breaker distribution

panel located on the wall in the Master Control Room. "Greenfield" is used to bring the a-c power down from the overhead duct into each rack where required. Within the rack the a-c power is distributed through a 2 x 2 duct having pigtails branching out at the appropriate points with motor connectors to plug into the power supplies.

All d-c circuits and signal circuits are fed out through the bottom of each rack through trenches in the floor to the appropriate equipment. All WP-33B and 580-C power supplies were slightly modified to allow 115 volts a-c to be brought out on the Jones connector as well as the d-c circuits. Thus, only a single multi-wire cable is required to take the complete power from the Jones connector on the power supply to the monitor in its console. This eliminates the need for any junction point at an intermediate terminal strip. The whole installation was therefore considerably simplified. A .020 inch copper grounding strip 10 inches wide passes through all trenches and each rack and console housing is tied into this grounding strip, which in turn is carried to the building ground. All external circuits to and from Master Control are handled by tele-

phone lines. About twenty-four lines are used for this purpose. These are routed to and from various points in the city, such as remote pickup points, theatre studio, and two outgoing lines.

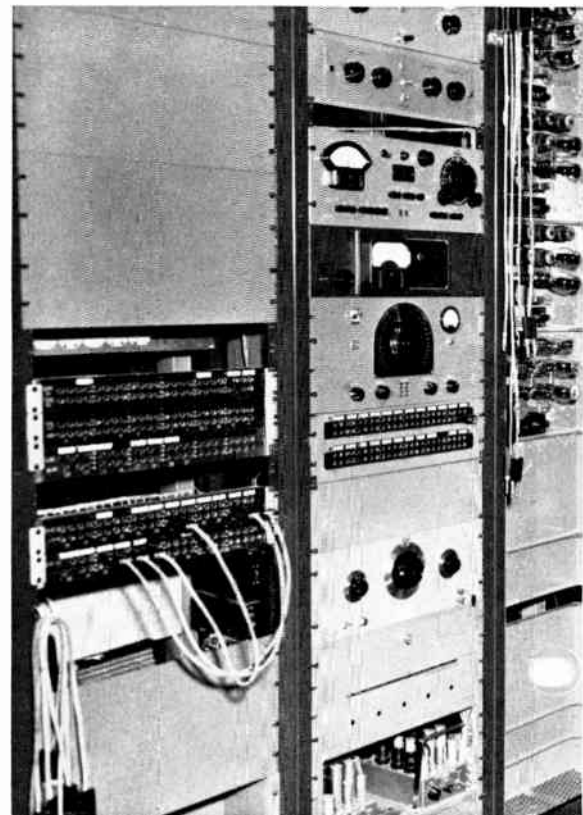

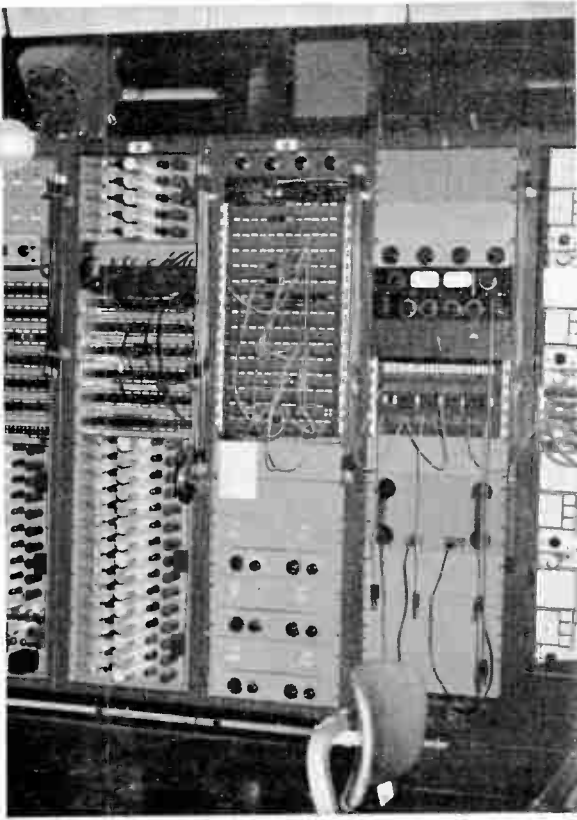

FIG. 36 (above). First row of Master Control Racks containing synchronizing generators, audio-video patching, "TelCo" equipment, and amplifiers.

FIG. 39 (below). Fourth row of Master Control Racks which include the audio test equipment and additional power supply equipment.



FIG. 37 (above). Second row of Master Control Racks which house TS-20A Video Switching Relays—one rack assigned to each studio system.

FIG. 38 (below). Third row of Master Control Racks showing centralized power supplies for monitors, amplifiers and WOR-TV camera chains.

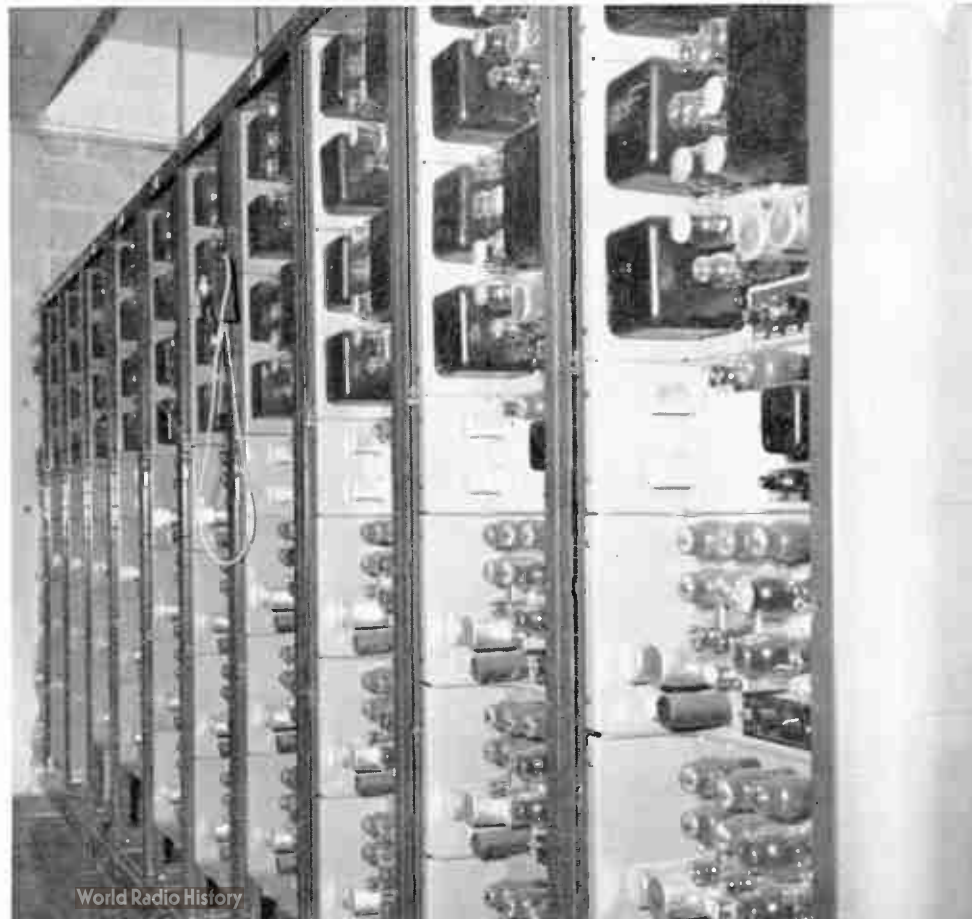

# Television Microphone Techniques\*

Many of the microphone techniques which have been successfully used on standard broadcasting may also be used in television programming. From the standpoint of microphone techniques, TV shows may be classified into three major groups:

1. Programs, in which the visual presence of a microphone or microphones is accepted as part of the program (panel discussion shows, sporting events, news programs and some types of interview programs, dance orchestras and small informal musical productions, etc.).
2. Programs in which some microphones may be visible while others are not (amateur programs, quiz programs and some variety programs).
3. Programs in which microphone appearance would be a disturbing element (dramatic shows, large variety programs and interview programs where an air of informality is to be preserved, etc.).

The microphone techniques for shows in which the appearance of the microphone is not considered objectionable are, in general, similar to usual sound broadcasting practice. One important difference is that the microphone must not obscure the artists or other important scenic elements.

It should be emphasized that no hard and fast rules can be laid down for TV audio techniques, each situation must be explored for its full potentialities. In all cases the final criteria of achievement is the creation of an effect which is judged to be most satisfactory.

Television, being a medium which combines sight and sound for the creation of entertainment, necessarily leads to a measure of compromise between the audio pickup techniques and the visual requirements of the programs. In general, such compromises place an additional burden on those charged with the responsibility of obtaining the optimum sound pickup; in a similar fashion, the audio requirements frequently limit the scope of action of those concerned principally with the visual elements of the program. The ideal television program would, of course, combine the best audio pickup with the most suitable visual effects.

The direction taken by deviations from the ideal must be dictated by the needs and scope of the program. There would be no question that on a program featuring a concert orchestra, the end product of which is the enjoyment of good music, no compromise of sound quality would be considered; however, many of the lovely creatures who perhaps too frequently flit across the screens of the nation can, in the opinion of many "experts," be thoroughly enjoyed in complete *silence!* It is a safe assumption then, that typical TV programs will present audio pickup problems somewhere between the two extremes described above.

\* By Whitney M. Baston, NBC Engineer.

Radio broadcasting has concentrated on the creation of many illusions and effects through the medium of the spoken voice. Delicate shades of meaning and emotional states can, and are, artfully produced by trained voices. The audiences have been conditioned to this circumstance and this highly developed art has been understood and enjoyed for many years. The techniques necessary to capture each subtle nuance of meaning in terms of tone shadings would call for microphone placement, which despite any of the visual requirements of TV, might be considered as either undesirable or unnecessary in TV programming. These subtleties can be conveyed perhaps more naturally and effectively in TV by the facial reactions and movement of the artist.

The audio man making the transition from sound broadcasting to TV must be prepared to change his concepts to meet the needs of the new art. It is almost axiomatic that a TV program is never a radio show with cameras, but rather an entity unto itself. The above does not suggest that the audio man forego any attempt to obtain suitable sound pickup in TV, but rather that he should be cautious in applying sound-broadcasting standards to TV programming.

Certainly, there is a very large area of agreement in the general methods used to obtain good audio pickup in both media. The audio man undertaking TV assignments will draw heavily on his broadcast experience, but he should also preserve an open mind to some of the seeming conflicts which occur. Experience has shown that these men make the transition easily and that their broadcast experience is a distinct asset.

It has long been recognized that the ideal television studio should be able to provide many different acoustic conditions varying from outdoor scenes to interiors of large halls and small living rooms. The current practice in most instances is to keep the actual reverberation characteristic of the studio as low as possible. The reverberant effect furthermore helps to muffle to some extent the background noise from off-the-set activities. Liveness can then be gained by the addition of hard flats which constitute the scenery, sacrificing weight but retaining high frequency reflections. The rather wide use of sets having hard surfaces frequently alters the acoustic characteristics in the microphone pickup area and suitable adjustments must be made in microphone placement. Sometimes acoustic absorbent flats are used as a band shell and enclosure to isolate an orchestra from the cast when both groups are functioning within the same television studio.

The types of microphones currently in use in television range from the familiar broadcast types, such as the 77-D, 44-BX, to the new models like the BK-1A "Commentator" and the new pencil type microphone exemplified by the BK-4A "Starmaker."



The problem of sound pickup on TV programs includes many considerations not present in sound broadcasting. One of the most important points that must be considered is that of unwanted noise which is the natural result of motion of the actors, cameras, microphone boom, scenery, etc., all necessary to the show, but collectively a source of noise which must be minimized if a successful sound pickup is to result.

A convenient concept is to consider the existence of an imaginary line drawn between the scene of action and the camera. With this division, it will be found that a large majority of the unwanted noise will originate on the camera side of the line and almost all of the desired sounds from the particular scene will originate on the other side of the line. Such a set of circumstances suggests the use of a uni-directional microphone, such as obtainable with the RCA 77-D. A consideration of typical TV scenes would suggest that the imaginary line referred to above would shift from scene to scene, it is obvious then that the microphone must be movable. The boom provides the answer to this problem: typical boom microphones are arranged so that from one position of the boom the microphone can be moved a distance of ten feet and can swing in an arc of 280° with adjustable radius from 7 to 17 feet. In addition to the horizontal motion, the microphone can be raised and lowered above and below the horizontal. The microphone is thus capable of occupying various positions in a rather large solid angle.

Approaching the ambient noise problem from a somewhat different point of view the signal to noise ratio *at the microphone* is determined by the ratio which exists between the direct or desired sound and the unwanted sound. It is obvious that an increase in the direct sound level will be desirable. This can be done by following the action with the boom microphone so that the distance between the performer and the microphone is kept reasonably constant at perhaps three feet or slightly more. The directional pattern most frequently used in TV is the uni-directional pattern; however, many uses exist for bi-directional and spherical pickup patterns. Examples of typical program setups given later will show uses for the several patterns. In the foregoing somewhat over-simplified explanation of the use of the boom microphone, no mention was made of the practical day to day problems which arise.

The usual use of a boom microphone is for scenes in which the microphone should not be seen by the TV audience (Figure 1). The scenes taken by the TV camera will range from closeup to wide angle shots, so that a boom microphone positioned for good sound pickup on a closeup would be in the picture on a medium or wide angle shot. In usual studio practice the audio engineer, or mixer, previews the picture on a TV monitor and talks to the boom operator over the inter-communication system advising him of the position of his microphone and warning him if there is danger of the microphone showing in the picture. If such a danger should be present, and it invariably is, the boom operator must either raise the microphone above the artist



FIG. 1. TV studio scene showing the use of a "boom" microphone.

or "rack" the boom in, i.e., shorten the length of the boom arm. Obviously the change in the position of the boom microphone will influence the quality of the sound pickup. Had the microphone been positioned near to the artist for the closeup, moving it up or away would cause a marked change in quality. It is the usual practice to anticipate such changes and not bring the microphone too near the artist on the closeup, so that the change in quality, when the microphone is moved, will not be too pronounced.

Consider a scene in which two persons are engaged in a conversation and the action calls for them to separate while still carrying on the conversation. Such a case is usually called a "split" and is handled in several ways depending on the circumstances. In some cases no preference is to be given to either person as far as microphone pickup is concerned; in this case, when the actors were close together the microphone would be placed a reasonable distance away, so that when the "split" occurs the quality will be substantially the same as on the closeup.

Frequently, however, the boom operator is instructed to "favor" one character or the other. A possible example of such a scene would be where a principal is seated and is approached by a servant who says a few words when close, and withdraws to the rear to answer a question. Here, since the servant is seen to go toward the background, a

FIG. 2. Studio scene illustrating the use of the RCA "Starmaker," an unobtrusive microphone.



FIG. 3. Designed for rugged duty—the BK-1A proves itself at the National Political Conventions.

somewhat thinner quality would be expected and would seem entirely natural, so that the boom microphone would not necessarily follow the servant. Other examples are combinations involving a strong male voice and a rather thin female voice, usually in such cases the weaker voice is favored. In many instances one actor may be seated and another standing so that the distance from the microphone to each actor must be adjusted by selecting a suitable compromise position. It is obvious that one microphone cannot be expected to take care of all situations; in some instances concealed microphones are used to pick up one or more of the voices.

Where several microphones are required great care should be exercised in selecting microphones of similar effective frequency response characteristics to that of the boom microphone to avoid a noticeable change in sound quality in going from one microphone to the other. It is also important that such changes be kept to an absolute minimum because in most cases concealed microphones are placed in close proximity to a variety of surfaces or objects which lead to serious wave interferences and undesirable phasing effects.

Recently, great strides have been made in developing unobtrusive microphones which are styled to blend in with the television scene without detracting from the principal subjects. The BK-4A "Starmaker" ribbon-pressure microphone was especially developed to fill this

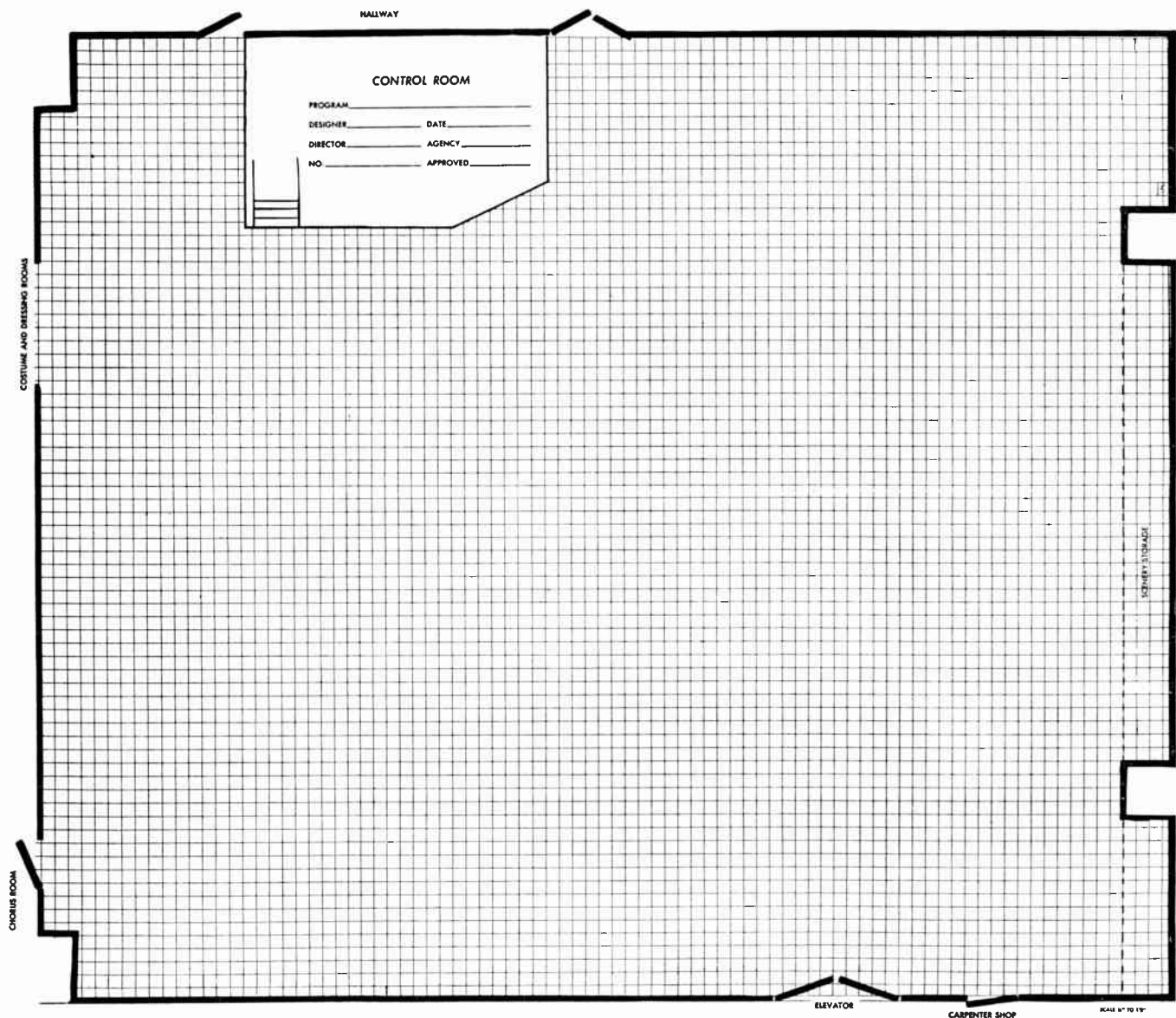

FIG. 4. Sample studio floor plan which may be used to plan "Mike" placement in advance.

requirement without sacrifice of high electrical and acoustical performance. Its slim contour makes it particularly suitable for applications where the microphone must be concealed in the scene, as in a bouquet of flowers or a table lamp. The "Starmaker" is also well adapted to audience participation shows where an announcer carries the microphone to someone being questioned or interviewed, as illustrated in Figure 2.

The BK-1A "Commentator" microphone, illustrated in Figure 3, is a small, rugged pressure microphone also styled to match the television scene. Rugged and insensitive to wind mechanical shock, it is equally well suited for audience participation shows where a hand held microphone is desired, sports broadcasts, and round table panel discussions.

One of the most serious problems faced in microphone placement for television is the need to make the sound

accompanying the picture suit the apparent distances shown. Two means are available in achieving the purpose which sometimes is referred to as "sound perspective." One is by controlling the apparent reverberation either electrically by the use of filter circuits or through an echo chamber and the other is by control of the volume or loudness level. Thus, if a camera is to be used to take a long shot, the volume associated with it is turned down an appropriate amount to produce the desired psychological effect and the reverberation control opened to give an increase in the apparent reverberation effect. Another scene taken by a camera having a long focal length lens for a closeup shot would require more direct sound and full volume. Such a system implies an automatic switching arrangement between camera and audio controls and is necessarily complicated, requiring great skill and long rehearsals to avoid ludicrous effects which might completely nullify the intent of the picture itself. Sometimes a solution

is automatically obtained by merely raising the microphone boom far enough to be out of the picture, giving the desired over-all effect. The difficulty, however, lies in returning to the subject on a "closeup" rapidly enough so as not to lose the sound.

It is customary on the larger dramatic and variety presentations for the audio engineer to attend the "dry rehearsal." This is effectively a meeting held by the production staff, the technical director, the lighting director, and the audio engineer. All concerned discuss various points concerning their special field of interest. At this meeting the audio man sizes up the over-all situation and brings attention to any trouble spots. Quite often the originally planned boom moves may be very difficult, impractical, or the element of risk too great; by discussing the problem with the group, compromises may be worked out so that before the actual rehearsal gets under way the audio man has had an opportunity to make more definite plans for boom placement, etc. When a "tight" situation develops, for example, a change of microphone placement which cannot safely be made in the time as originally allotted, the director may rearrange the scene slightly to give the boom man time to move.

The devices used to gain time are many and varied. One example would be where a character on leaving a room says, "Goodnight" as he walks through the door; this scene might be followed by action elsewhere on the set. The boom microphone must be moved from the door to the other action almost instantly. The scene may be rearranged so that "Goodnight" is said while he is a few feet from the door, he then turns, smiles and leaves. During the period of silent action the boom operator has a chance to make his move.

Many productions are carefully planned in advance and a layout is prepared on a floor plan of the studio which has cross-section lines each representing one foot spacing so that the position of sets, cameras, booms, etc., may be outlined and trouble spots analyzed in advance. Figure 4 shows the floor plan of a typical studio. It is not unusual for additional changes to be required but this method saves time, particularly on larger shows.

The boom microphone positions and moves must be made so as not to interfere with the freedom of movement of the camera, artists, technicians, or other personnel. This calls for very careful planning of each boom position necessary for the particular show. Every effort should be made to find locations for the boom which will permit a maximum area to be covered with a minimum of boom moves. It is also necessary to plan the moves so that after a run-through the boom may be easily returned to its original position for the beginning of the rehearsal or air show.

The use of the boom microphone on TV shows, moving as it does from one position to the other, often leads to boom shadow problem. The boom should be positioned with respect to the principal source of illumination so that the microphone shadow does not fall on the faces of the artists, on sets, or other places where it would be disturbing to

the scene. The lighting man and the boom man must work out the problem so that shadow-free shots are obtained.

On large shows where many boom positions are used it is customary for the boom man to mark the boom positions on the studio floor, so that after the rehearsal the boom can be placed in the exact position for the air show. The boom must compete with camera, sets, props, etc., for floor space. Where fast boom transitions are to be made, it is imperative that the boom be accurately positioned. Figure 5 shows a layout of a typical television studio as used for an average network show.

Some examples of shows in which the microphone is visible in the picture and which are generally handled very similar to radio programs are "Who Said That," a panel type of show in which 77-D microphones are placed in wells in the panel table and while inconspicuous are actually visible; "Americana," a quiz type of program in which 77-D microphones were concealed in school desks. Figure 6 shows the "Starmaker" used on an informal interview program.

The Ford show, featuring Kay Kayser, used boom microphones for skits, etc., and visible microphones for the orchestra. The interviews between the MC and the contestants were picked up by a 77-D placed on the lectern in full view of the audience. The "Lucky Strike Hit Parade" uses some visible orchestra microphones, while the balance of the show is picked up either on boom microphones or other concealed microphones. News programs usually feature visible microphones and are quite similar to the radio counterpart in presentation. Most of the simpler dramatic programs are done entirely by boom microphones and occasional transition microphones.

Some of the larger dramatic shows, such as Philco Playhouse, and Kraft Television Theater, etc., often use as many as three boom microphones and in many cases a total of ten or more microphones. Programs which feature vocalists who accompany themselves on the piano frequently open at the piano and after a short interlude the vocalist leaves the piano, often continuing the song to the accompaniment of a small orchestral group. To cover the transition, a microphone is placed just above the keyboard of the piano on the far side away from the camera. The two microphones should be of the same type so that when the artist rises from the piano and the boom microphone takes over to follow the subsequent action no noticeable change in quality is evident.

Some typical examples of concealed microphones placement which have been used are as follows: action calls for a character to talk into old fashioned wall type telephone located near a corner, a microphone on a regular stand was set up next to the telephone but just around corner, in this particular scene only a small area around the phone was visible so that microphone did not appear. The more obvious methods of concealment such as behind books on desk or table, behind flower, etc., are frequently used. Where foliage is used on sets, the pencil type microphones have been concealed in bushes and trees, etc.

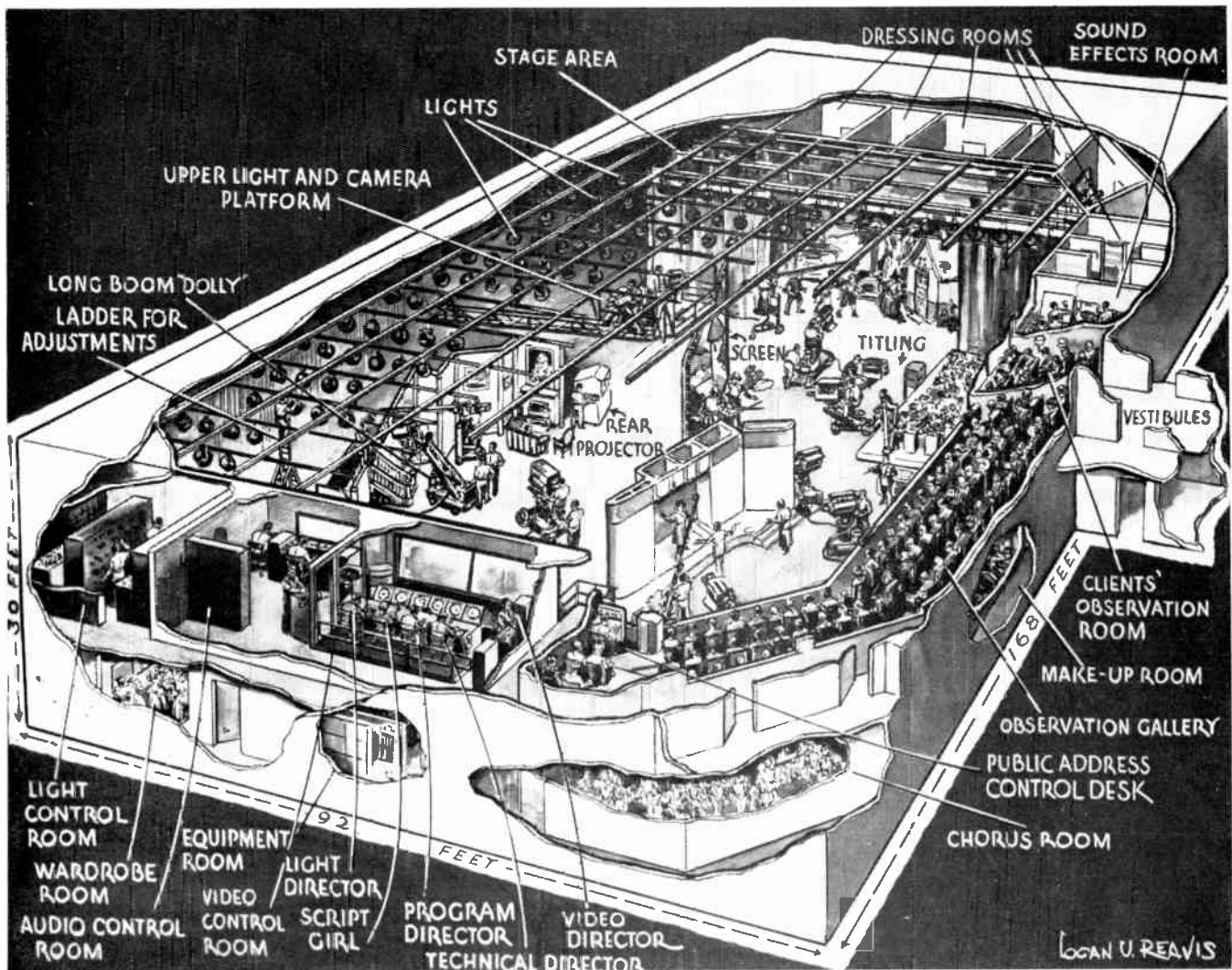

FIG. 5. Layout of a typical TV studio as used for an average network show.

In one dressing table scene, a microphone was concealed in a box used for cleansing tissues, in another scene of a theatrical dressing table, the microphone was placed near the mirror and was concealed by placing a few telegrams in the mirror frame, this is a customary habit of theatrical people and the appearance of the telegrams in the picture would be perfectly natural. Perhaps this illustration points out an important idea in concealed microphone placement — seek some perfectly natural object to shield the microphone from view. A pencil type microphone concealed in a corsage of flowers has been used very successfully in some scenes. This type of microphone has also been concealed behind a man's tie, the camera avoided the lower portion of the artist's body so that the microphone cord was not seen.

On one program which features a ventriloquist and his friend, interviews are held with members of the audience who are directed to a chair on stage, the microphone is placed behind the chair out of view but in good position to pick up both the guest and the performer. In presenting a

ventriloquist's show, the audio-man has been known to bring the boom microphone closer to the dummy for its part of the dialogue, a perfectly natural mistake.

Once in a while the selection of a place of concealment leads to a situation which earns a chuckle when retold, but which is not so humorous at air time. In a scene on one of the largest shows on the air, a vocalist was shown singing a song while lying on the grass in a typical hill-billy scene — to add a touch of rural atmosphere, a live goat was on stage also in the scene. The microphone used for this pickup was hidden behind a log; during the song, impelled by motives of his own, the goat started to lick the microphone — the resulting sounds were not exactly musical.

No hard and fast rules can be stated for correct microphone placement, but some general principles can be outlined. The boom microphone usually is placed from three to five feet in front, and about two feet above an artist, with the microphone inclined at a 45° angle. It is the usual custom to use the 77-D microphone with its uni-directional

pattern and in one of the voice positions. This setting is also quite common for musical pickup, largely because of the increase in pickup of extraneous noise which is prevalent during most TV programs.

During rehearsal or during unrehearsed programs the boom microphone is often inclined so as to be almost parallel to the floor; this lessens the discriminations between sounds from several sources, and while it does not give optimum results, it greatly reduces the number of moves necessary during a rehearsal.

Rapid movement of the boom microphone should be avoided because of air noise, caused by air rushing past the ribbon. In working too close to several subjects, rapid turning of the microphone should be avoided because of mechanical noise caused by the motion of the microphone hanger.

Because of the ever present danger of a microphone appearing in the scene, it is a natural reaction for many boom men to keep the microphone high, even when a better pickup would be possible. As an aid to detecting the boom before it actually is seen in a shot, some engineers attach a piece of string about a foot long to the microphone, in this way the string appears in time to give a warning.

During the average TV show the microphone will be used on closeups and may be quite close to the camera. If the camera blower motor is running its noise may be heard. It is customary to turn off the blower before such a scene. Some instances have occurred in which the filament of lamps in lighting fixtures has made a singing noise (this usually indicates a defective lamp) which when picked up by the microphone can be very annoying.

A word of caution is in order, the boom microphone is quite heavy and in the course of its operation care must be exercised to see that *both* ends have freedom of motion. The counter-weight may strike a person while it is being swung around during the operation of the boom. The counter-weights which balance the microphone should be adjusted carefully for the *particular* microphone used, if this is not done the boom will be unbalanced and will be difficult to handle. If the counter-weight is too light the microphone will drop downward when the locking screw is released, and may inflict injury on persons beneath it.

Acknowledgment is due Mr. H. Gurin of NBC for much of the information contained herein, also to the many engineers in NBC who have contributed many of the actual examples included.



FIG. 6. Studio scene showing the use of the "Starmaker" mike in an informal interview.

# TELEVISION STUDIO ACOUSTICS

Sound recording in television studios differs from that in radio studios chiefly by the greater microphone distances which have to be employed to keep the pick-up device outside the camera angle. In order to maintain, for maximum intelligibility, a low enough ratio of reflected to direct sound at the microphone, the reverberation time in television studios must be made considerably shorter. This applies both to the television stage proper, as well as to any auditorium area, if such exists.

The acoustic treatment of the stage should be highly absorbent as well as durable and fire-proof. Perforated hardboard or asbestos board backed by 2 inches of rock wool constitutes an effective treatment, if large flat surfaces of the board are avoided. A large perforated hardboard panel gives rise to very pronounced high frequency echoes, even when the board is backed by rock wool. For this reason it is desirable to install the material on the stage walls and ceiling in the form of triangular corrugations, none wider than 3 feet, and at least 6 inches deep; or better still, to apply it in the form of cylindrical sections. In this manner the sound becomes dispersed, and the effect of echoes is re-

duced to a negligible degree. As is well known, the wavefront of a beam of sound reflected from a convex surface is considerably longer than that from an equally large flat surface, provided that the wavelength of the incident sound is small compared to the dimensions of the reflecting surface. Fig. 1 shows this relationship graphically, and it is seen that the wavefront reflected from the convex splay is, for the condition illustrated, several times longer than the sum of the two reflected from the flat panels. The figure shows also the construction of the wavefronts, analogous to the optical case. The center of the reflected wavefront coming from the curved surface is one-half the radius of the convex splay (assuming the source to be at some distance from the surface).

Fig. 2 shows how, in Television Studio E at NBC Hollywood, a convex reflective stage splay is being planned to be converted to a convex absorptive splay employing perforated hardboard for the "facing" and 2 inches of rock wool for the sound absorbent. This studio had previously been used for radio programs

only, and was found to be too live for television programs.

Many television programs employ the music of a band for accompaniment or effect. If the orchestra is placed in front of the stage, the intelligibility of the performers' dialogue is sometimes markedly reduced in the auditorium during high music levels. This is so even when the transmitted program has considerable intelligibility, because music and dialogue microphones can be controlled individually, although in small rooms and at moderately high music levels it may become difficult to secure enough acoustic separation between speech and music at the dialogue microphone to obtain there an adequate balance.

For this reason an orchestra pit or lateral placement of the band in the room is desirable. The latter means is not too effective, since some scenes may at times have to be laid on the same side of the room where the orchestra is located. An orchestra pit, on the other hand, may extend partly

\* By M. Rettinger, RCA Victor Division, Radio Corporation of America, Hollywood, Cal.

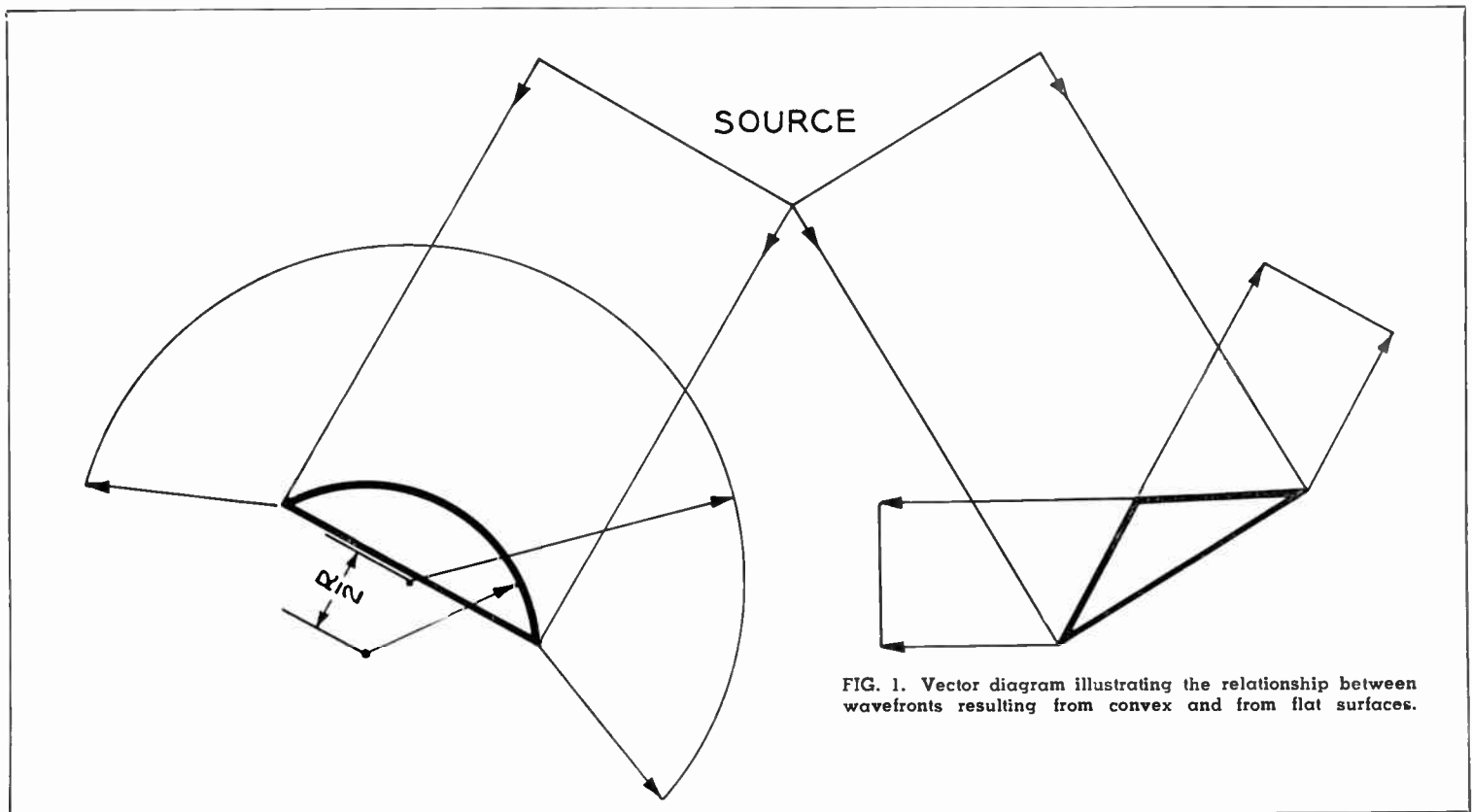

FIG. 1. Vector diagram illustrating the relationship between wavefronts resulting from convex and from flat surfaces.

below the stage, and provides considerable acoustic screening between the individual pick-up units.

It is a frequent complaint of television program attendants that their attention is distracted and their sight to the stage obstructed by the various booms and lights and their operators on the stage. For this reason it may be desirable to have a suspended platform along each side of the stage some 10 or 12 feet high on which these devices can be placed, together with the personnel. At the KECA Studio in Hollywood, for instance, (previously the "Tom Brennaman Breakfast Studio" and converted by the writer), the sides of the stage are dressing rooms, the roofs of which are strong enough to accommodate light, booms, and operators.

Television cameras appear far less disturbing, however, and may be assumed to be part of the show. Even so, an auditorium level which is higher than the stage does much to improve observation for the spectators as shown in Fig. 3. For this rea-

son, television studios of the future, which are intended to accommodate an audience, may have a balcony, even when the studio is not very large.

No less important than the acoustic treatment of the stage is that of the auditorium proper. Durability of wall and ceiling treatment appears somewhat less important in this part of the studio, however, while decorativeness or appearance become more significant. For this reason a fire-proof tile which is soft, and hence a good low-frequency absorbent, represents a desirable material. Many such products can be painted without impairing their absorptivity, quite unlike porous ceramic tiles.

Much as in a theatre, the rear wall should carry the most effective treatment. The side-walls as well as the ceiling should be covered with sufficient treatment to secure in the house a reverberation time no longer than two-thirds that accorded to the auditorium were it used for radio shows only. Needless to say, the rear wall should

not be made concave, even when it is intended to treat it heavily acoustically, and the side-walls should not be parallel but should be angled and/or splayed.<sup>1</sup>

Television stages without audience accommodations should have as low a reverberation time as possible. The reason for this is that, in general, the ratio of (set-) reflected-to-direct sound at the microphone is sufficiently high to provide enough of an impression of reverberation quality so that the pictured scene will have a natural character. If the stage walls are insufficiently absorptive, the added reflections will tend, not only to destroy the illusion of the picture, but also to reduce the intelligibility of the dialogue. It has, therefore, become almost customary to line the stage walls either by nailing a 2 inch rock wool blanket to the wall studs or by packing the space between the studs with rock wool. As a protective measure, muslin and wire mesh are usually applied over the wool. Fiberboard, hair felt, cork, acoustic plaster, etc., are useless for the purpose of treating the stage acoustically. A glance through absorptivity tables of acoustic materials will quickly show that mineral wool, also called rock wool, has by far the highest absorption for the frequencies in the recording spectrum.

Rock wool is made by melting silica and other compounds (notably magnesia, alumina, and lime) and shredding the molten mass into fine fibers by one of many patented processes. Some manufacturers prefer to use glass for the raw material, calling the final product either glass wool or referring to it by a trademarked name (Red Top Insulating Wool, for instance). This type of wool is characterized by a relatively low density (1.5-3 pounds per cubic foot) and a very clean, white appearance. Ordinary mineral wool varies in density from 3 to 12 pounds per cubic foot, the average run being 7.5 pounds per cubic foot. In color, it ranges from a very dark gray, almost black, to a white resembling that of glass wool. The density of the material has a considerable bearing on its absorptivity, the light wools being less absorptive than those of higher density.

Regarding its color, it can be said that dark wool indicates the presence of certain elements (phosphorus, sulfur, etc.) or the lack of silica, which may have a bearing on the longevity of the wool. A recently examined installation of very dark wool

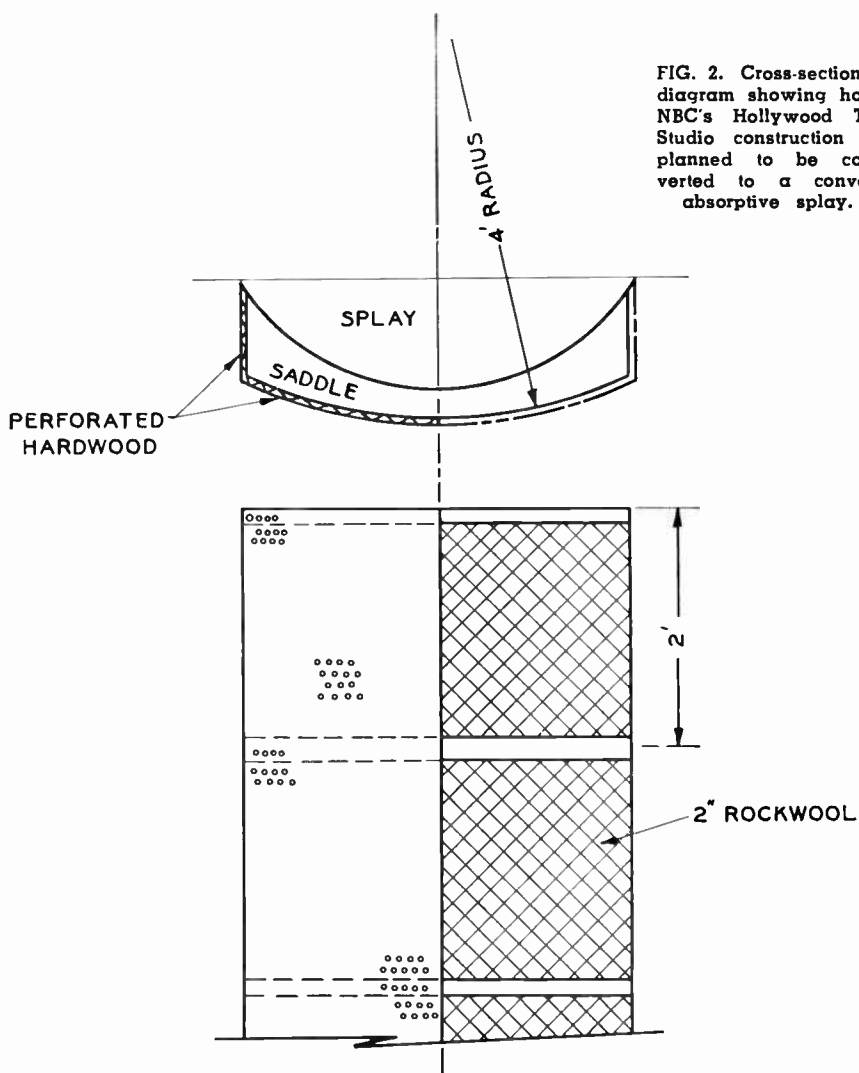

FIG. 2. Cross-sectional diagram showing how NBC's Hollywood TV Studio construction is planned to be converted to a convex absorptive splay.

<sup>1</sup>For further details of auditorium design, see "Applied Architectural Acoustics," by M. Rettinger, Chemical Publishing Company, Brooklyn 2, N. Y.



in a motion picture sound stage over twelve years old, showed that a considerable portion of the wool had disintegrated and had settled, in a more or less powdery form, to the lower portions of the structure. However, other portions of the same installation, either because of less contact with a moist atmosphere or because less subject to vibrations, had stood up considerably better.

Regarding the texture of the wool, so-called shot (solid globules of material) is of course useless for sound-absorptive purposes. Studio specifications usually exclude wool with shot having a diameter in excess of  $\frac{1}{8}$  inch. Another shot restriction excludes wool having solids in excess of 30 percent by weight or 2 percent by volume.

The preferred method of applying rock wool to stage walls consists in nailing 2-inch thick blankets directly to the studs of the walls, rather than packing the space between the studs with the wool. The latter method is undesirable from a workman's point of view (since the incident mineral dust is injurious to skin and lungs), and also because it provides neither increased absorptivity nor a saving in cost. This is true even in the case where the blanket carries heavy wrapping paper on one side (the one facing the studs) and muslin on the other, instead of muslin on both sides, as did the early and more expensively manufactured mineral wool blankets. The use of the paper in no way detracts from the absorptivity of the product, and even tends to increase it at the low frequencies. Some manufacturers (particularly of low-density wool) glue the paper to the wool, and then merely stretch muslin over the face of the blanket after its application to the studs. For heavier wools, however, muslin and paper are sewed together, approximately every four inches, with a special sewing machine, the stitch running the length of the (usually) four-foot-wide and fifteen-foot-long blanket. The type of paper used varies from forty-pound (per ream) basis Kraft paper to the very strong sixty-pound paper. The muslin is frequently specified as 44-40 count, weighing six ounces per square yard.

If a blanket has been fabricated this way, it can be nailed to the studs with ordinary box nails, although so-called foundry nails (large-headed nails) are sometimes thought to provide greater security. Certainly the use of 1-inch diameter tin washers in conjunction with the nails to give greater security to the installation appears superfluous, judging from the many blankets which have been nailed

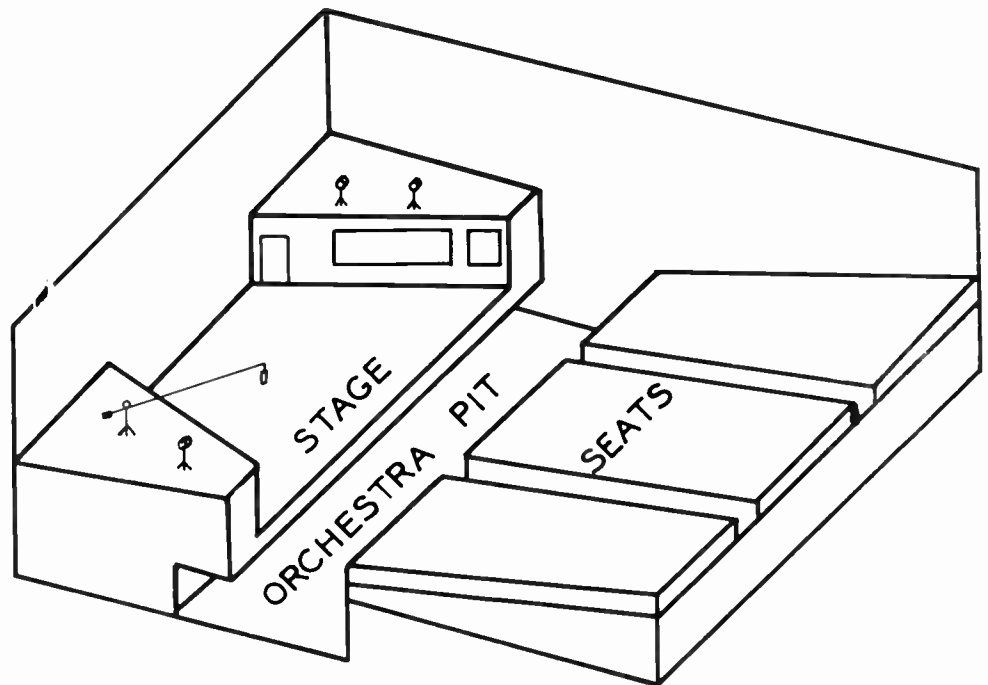

FIG. 3. An auditorium level higher than that of the stage and the removal of mike booms and lights to a raised level at the sides improves the viewing for spectators.

to the studs with no more than  $2\frac{1}{2}$ -inch long plasterboard nails 2 feet on center.

The use of a wire mesh over the blanket for protective purposes is recommended. This mesh need not extend from floor to ceiling, but may be applied to a height of approximately 16 feet from the floor. Ordinary  $1\frac{1}{2}$ -inch chicken-wire is frequently employed for the purpose, although 1-inch hexagonal wire mesh (somewhat more expensive) is used by some studios. A 6-inch baseboard and a 2-inch by 6-inch nailer 4 feet from the floor usually complete the treatment of such a stage wall.

If for any reason the recorded dialogue is to sound reverberant, this can be accomplished by means of a reverberation chamber. The sound is reproduced in this chamber and the output from a microphone in it is mixed with the original. Unlike other methods, electrical or mechanical, of adding a reverberating note to a recording, the chamber method provides both the proper growth characteristic and the decay quality of sound in a live enclosure. Delay networks, magnetic tape recordings, and other devices for achieving synthetic reverberation usually permit only provision for the decay characteristic; no attempt is made to introduce the growth characteristic since the latter is held less essential in an approach to total reverberation.

The following recommendations for reducing acoustic difficulties on television sets are presented as a guide in set design to reduce sound pick-up difficulties often encountered during programs.

1. All alcoves, window recesses, concave spaces of any type, should be made of cloth to eliminate boominess.
2. Avoid parallel walls in sets such as kitchens, offices, boat interiors, etc., unless opposite walls are made of cloth. When opposite hard walls are angled, the slope should come to 1 foot in 10 feet.
3. Where ceilings are used, they should be made of cloth. It may be noted that dialogue can well be recorded by placing the microphone on the other side of the "ceiling", that is, above the thin cloth representing the ceiling.
4. Whenever possible, the treads of stairways should be covered with soft material and the stairs so constructed as to eliminate squeaks.
5. The use of glass in windows should be kept to a minimum. Wherever possible, black gauze or narrow glass borders should be used. Large plane glass surfaces reflect a large percent of the incident sound which reinforces the direct sound, particularly at the low frequencies, causing these frequencies to be over-accentuated. Indeed, "boominess" of recorded dialogue is probably the most common acoustic defect experienced on television sets.
6. Noise from footsteps, vehicles, etc., on gravel walks can be reduced through the use of chipped cork in place of gravel, which gives the identical appearance of gravel when televised.



# STUDIO PICKUP TECHNIQUE\*

Progress in the engineering development of broadcasting equipment and studios has been greatly accelerated in the last decade, and noteworthy contributions have been made in this field.<sup>1</sup> As a result, the expectations of higher standards of technical perfection and performance may be justified. The usefulness of any improvement is premised on the skill with which this information can be applied so that the quality of the performance can keep pace with technical advances placed at one's command.

In broadcasting, whether it is AM or TV, the primary purpose is to bring to the listener, in the most pleasing and intelligible manner, whatever information may be transmitted. For speech, one would normally look for intelligibility and naturalness of the reproduced sound so that a mental picture of the person and his surroundings may be formed as well as the message being clearly understood. In music,

faithful reproduction without distortion and the enhancement of musical programs to heighten the listeners' personal pleasure are the major objectives.

The transmission of sound from a broadcasting studio, to achieve the results mentioned above, involves a number of technical factors among which are:

- a. The acoustics of the studio.
- b. The electrical system characteristics, (amplifiers, filters, microphones, etc.).
- c. The studio pickup and microphone technique.

It is with the last mentioned item that this article is primarily concerned, and only some comments will be made of the first two factors. Since the program is to originate in a broadcasting studio of conventional design, it is assumed that: (1) the frequency/reverberation time characteristic of the space is acceptable, (2) that the volume is adequate for the intended programs and audiences, if any, (3) that

the diffusion of the sound field obtained by proper acoustic treatment and geometrical configuration is satisfactory and that no unusual grouping of resonant frequencies exists.<sup>2</sup> It is further assumed that in the electrical system<sup>3</sup> (1) there is no discrimination in any of the component parts against any frequency within the range under consideration unless specifically desired for special effects, (2) there is a minimum of phase distortion, (3) there is a minimum of harmonic distortion, (4) there is a minimum of extraneous noise.

\* By H. M. Gurin, Engineering Department, National Broadcasting Co.

<sup>1</sup> Nygren, A.—*FM and Television*, May 1946, Vol. 6, No. 5, p. 25; Voikmann, J. E.—*Journal of Acoustical Society of America* XIII 234 (1942); Olson, H. F.—*RCA Review*, Vol. 1, No. 4, p. 68 (1937); Olson & Massa, "Applied Acoustics," P. Blakiston Sons, Philadelphia.

<sup>2</sup> Morse, P. M. & Bott, R. H.—*Rev. Mod. Phys.* XVI, 69, 1944.

<sup>3</sup> NBC Engineering Department Bulletin—"Down to Earth on High Fidelity"—O. B. Hanson, C. A. Rackey, G. M. Nixon.

## Studio Pickup Technique

Of the factors listed, probably the most controversial is that relating to studio pickup technique, which includes the applications and placement of microphones and performers. It is important to remember that the system we are dealing with is monaural and lacks the ability to discriminate as to the location of a sound, although it can differentiate as to apparent distance between the source of sound and the microphone.

When sound is generated in a space, the collecting system, via the microphones, is generally so oriented that the first sounds come from the source directly and are followed by the sound reflected from the surrounding surfaces. When the absorption between boundaries equals the output of the source, the steady state condition is reached. The ratio of reflected to direct sound is considered the effective reverberation of the collected sound. It is obvious that an increase in the total number of reflections reduces the energy density of each reflection and permits a more uniform and diffusive sound field to exist.

The proportion of reflected to direct sound in a pickup is determined only partly by the acoustical characteristics of the studio. The directional character of the sound source and the receptive angle of the microphone used as well as its distance from the source are also important.

Fig. 1 illustrates the relationship of reflected to direct sound energy,  $E_r/E_d$ , with respect to distance of the sound source from a ribbon velocity microphone in a suitably treated studio for frequencies between 200 and 1000 cycles. It is readily apparent that any enhancement of the tonal quality of a singer or instrumentalist by the acoustical properties of the studio is negligible when the performer is too close to the microphone. Fig. 2 shows the energy response for various microphones in a typical studio.

Since most musical sounds and human voices produce sound waves of a complicated series of harmonics, each with a different wavelength, frequency, and amplitude, two or more microphones placed at unequal distances from the source of the waves will receive them successively, rather than simultaneously. The time interval will cause the composite wave to present a different arrangement of its harmonics to each microphone at a given instant. If the outputs of these microphones are then blended and reproduced by a single loudspeaker,

**TABLE I**  
**General Properties and Characteristics of Microphones**

Model	Type	Frequency Response**	Output Impedance	Output Level*	Directional Characteristics
RCA 44-BX	Ribbon Velocity	30-15,000 ±6 db	30/150/250†	-55 vu	Bi-directional
RCA 77-D	Combination Ribbon Velocity and Pressure	30-15,000 ±5 db	30/150/250††	-54.3 vu -57.3 vu -60.3 vu	Bi-directional Uni-directional Non-directional
RCA BK-1A	Pressure (moving coil)	60-10,000 ±5 db	30/150/250	-53 vu	Semi-directional
RCA BK-4A	Ribbon Pressure	70-15,000 ±5 db	30/150/250	-60 vu	Non-directional
WE 633-A	Pressure (moving coil)	50-9,000 ±3 db	20	-59 vu	Non-directional
WE 639-A	Combination Ribbon Velocity and Pressure	40-10,000 ±4 db	35	-55 vu -61 vu -61 vu	Uni-directional Bi-directional Non-directional
WE	Condenser (with assoc. amplifier)	50-15,000 ±6 db	(Amp. Out.) 30-50/200 250	(Amp. Out.) -45 vu	Uni-directional Bi-directional Non-directional

---  
\* Input level of 10 dynes/cm<sup>2</sup>.  
\*\* Manufacturer's specifications.  
† Earlier models were 50/250.  
†† Earlier models were 50/250/600.

**TABLE I (above). General properties and characteristics of microphones.**

**FIG. 1 (below). Ratio of reflected to direct sound energy with respect to distance from a ribbon velocity microphone.**

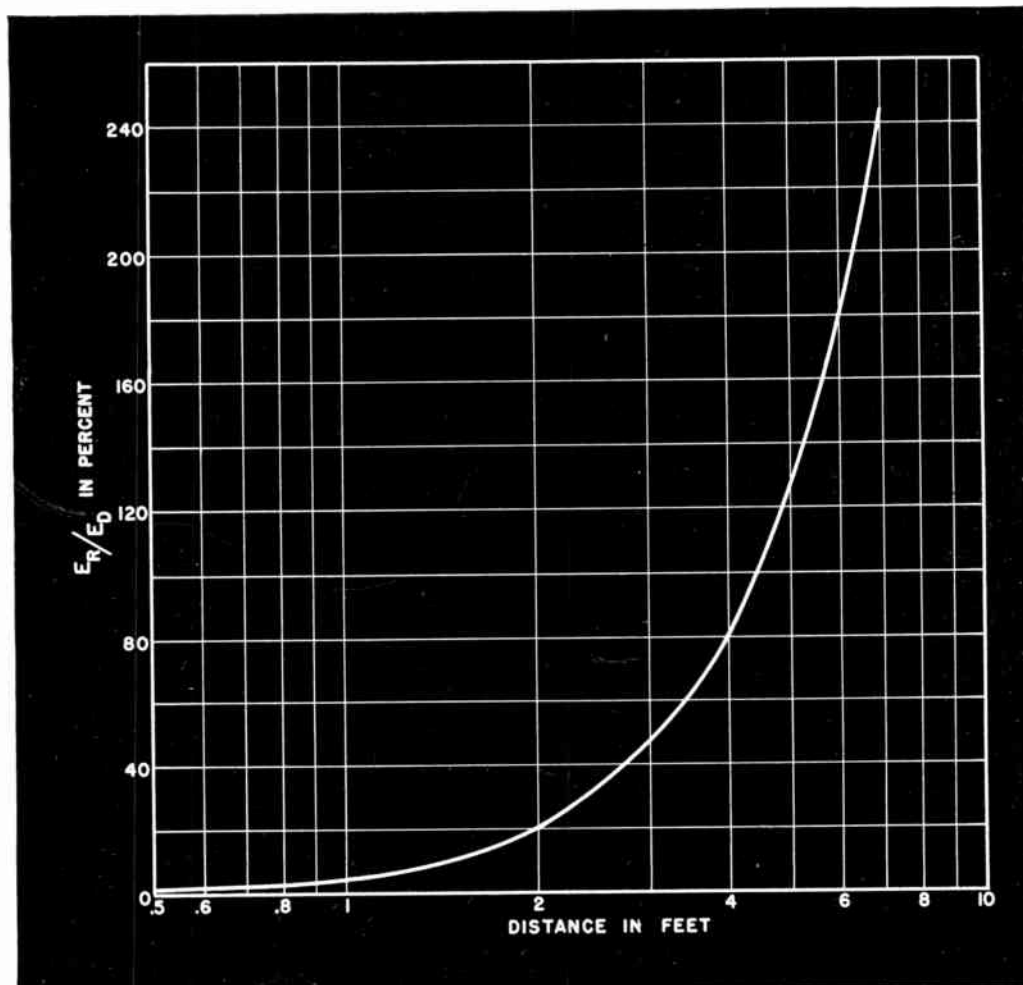

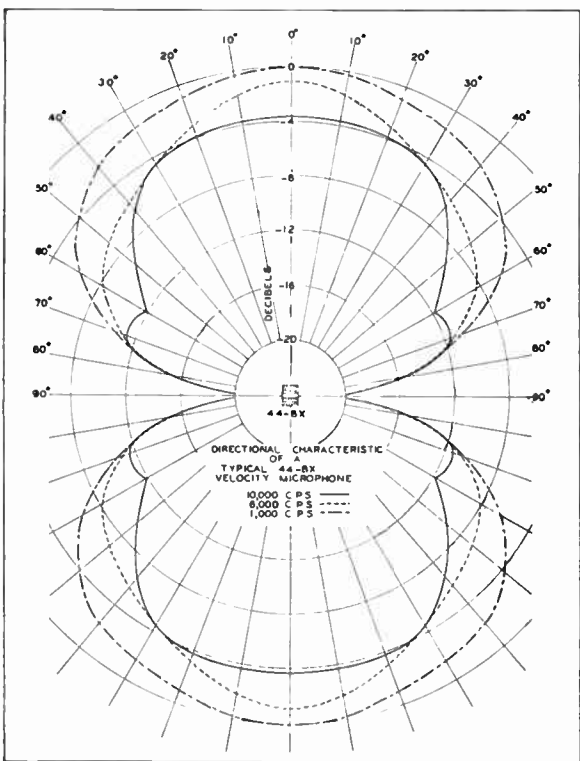
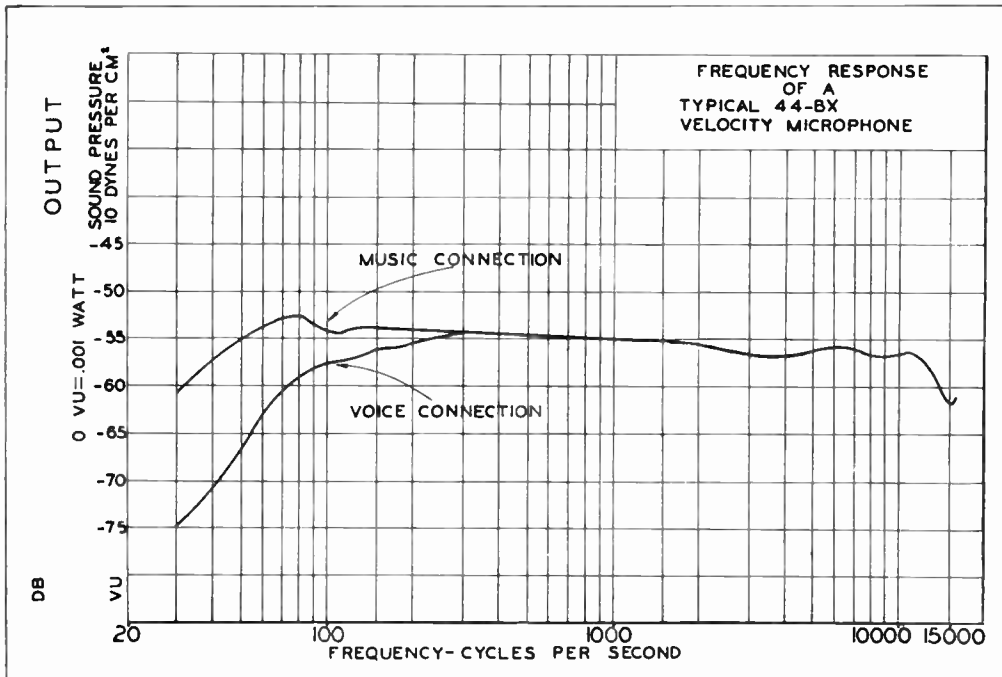
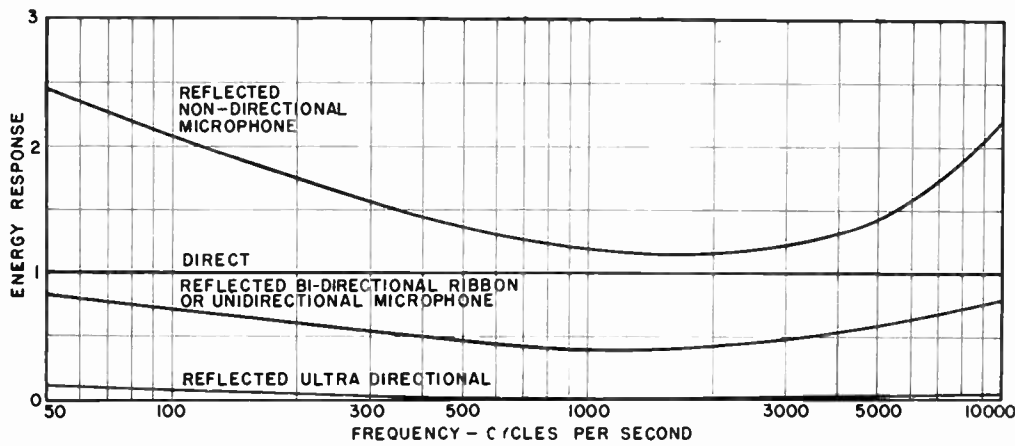

FIG. 2 (top). Energy response curves for direct and reflected sounds in a typical studio.

FIG. 3 (middle). Frequency response of the RCA Type 44-BX microphone.

FIG. 4 (left). Directional characteristics of the RCA Type 44-BX microphone.

the results manifest themselves as raspiness and raucous tones, particularly at the higher frequencies. It is for this reason that single mike pickups are recommended, particularly for musical programs. However, if multiple microphones are required to obtain full coverage, considerable care must be exercised to avoid distortion caused by wave interference and phasing.

A general understanding of the characteristics of the microphones commonly used in broadcasting is of material assistance in selecting the proper type for a specific task to obtain optimum results. The tabulation, Table 1, shows the general properties and characteristics of several such microphones.

Figs. 3-4 graphically show the directional and frequency response characteristics of the RCA-44-BX ribbon velocity microphone. Fig. 5 illustrates the RCA-77-D combination velocity and pressure microphone characteristics.

The acceptability of the final outcome depends in a large measure on the subjective reaction of the individual responsible for the performance as well as on the listener, and for this reason no hard and fast rules can be established. Instead, some illustrations will be given in which various acoustical problems have been met and from which general principles may be derived as a guide to acceptable practice.

When an interview for an individual is conducted or a brief address is being delivered from a small speaker's studio, a bi-directional microphone can be used, from both sides if necessary. The receptive sides of the microphone should be located at least 8 feet from the nearest reflecting wall so that no distortion due to wave interference results. Since the major portion of the sound is direct, as it should be, when articulation is important, the reverberation time should be low. This condition may be carried too far, and sometimes sounds artificial and unrealistic. Under practical application, the apparent reverberation may be increased by increasing the microphone distance from the speaker, thereby increasing the ratio of reflected to direct sound at the pickup point. The bi-directional microphone is particularly suitable for a speaker in a "dead" studio, because the microphone responds to sounds originating both in front and behind it, thereby increasing the apparent reverberation. Of course, where the background noise is excessive or the studio reverberation time is high, a uni-directional microphone which discriminates

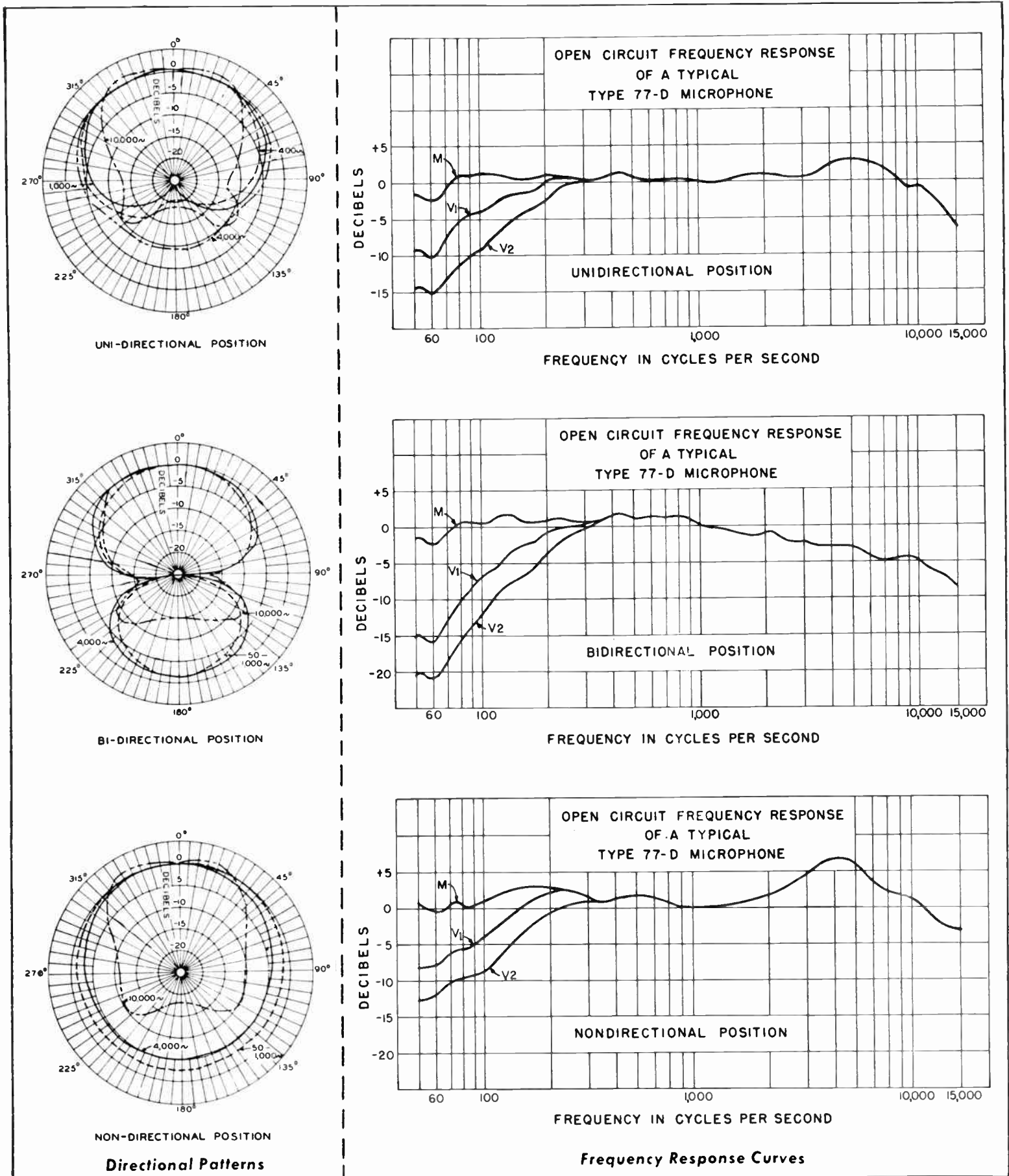

FIG. 5 (above). Directional patterns and frequency response curves for the RCA Type 77-D microphone.

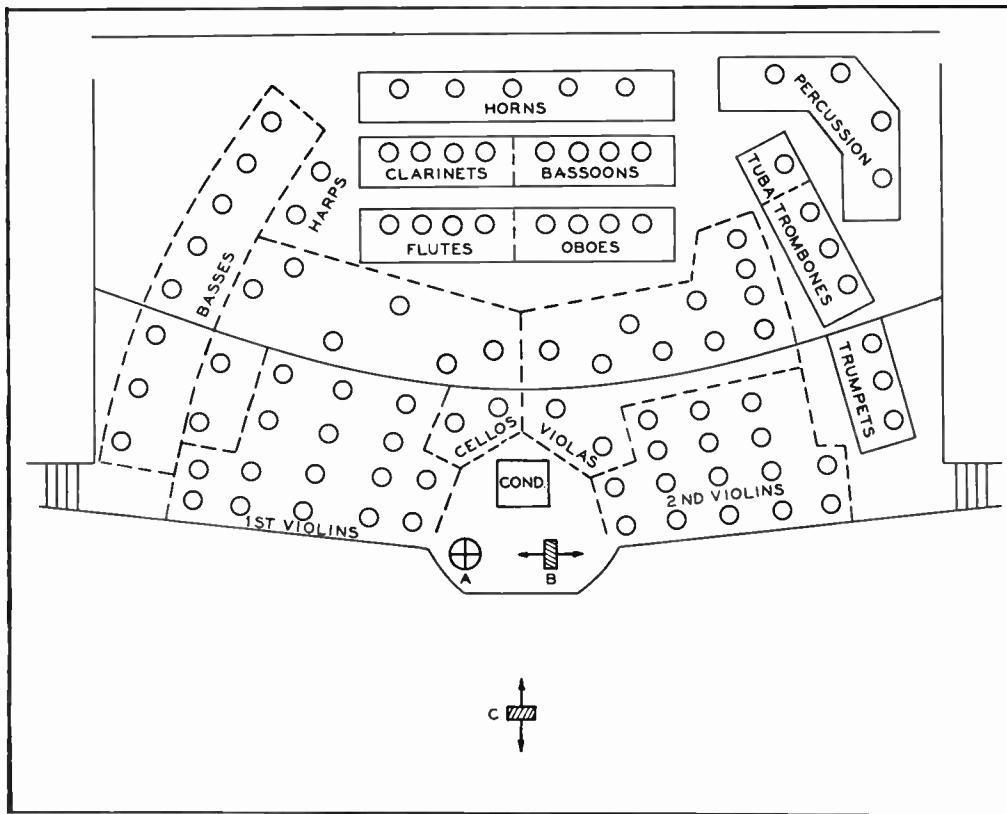

FIG. 11 (above). Arrangement and microphone placement for symphony orchestra and soloist.

11 and 12, are the seating plan and microphone position for the NBC Symphony Orchestra.

The optimum distance and height of the microphone in any pick-up can be determined when all the factors, such as

acoustical conditions, random noise, size and character of performing group, type of microphone selected, etc., are known. Laudable efforts<sup>4</sup> have been made in setting up some mathematical basis for determining the position but the elements of personal judgment plus the individual

acoustical character of the space from which the program originates are too important to be neglected.

The varying directional characteristics of the orchestral instruments themselves must be considered; for example, strings, woodwinds and percussion are practically non-directional, while brasses project strongly in the direction of their bells. Since the microphone is essentially monoaural, it is strongly affected by the directivity of the instruments and since the apparent volume of sound at a given angle is inversely proportional to the distance of the source from the microphone, the strings should be placed nearest and well within the effective response angle of the microphone in use. On the other hand, the percussions are not only non-directional, but capable of almost unlimited volume. Consequently, they should be located at the maximum distance and anywhere within the limits of the response angle. It will be noted that this arrangement is quite similar to the usual concert seating plan.

When a soloist is accompanied by an orchestra, the pick-up for the orchestra remains the same as described above, but the soloist may have a separate microphone, and placed so that its position toward the orchestra is at its minimum response angle as shown in Fig. 11. Frequently, in the case of instrumentalists or vocalists with strong, well-projected voices,

<sup>4</sup> J. P. Maxfield—"Liveness in Broadcasting"—*W. E. Oscillator*, Jan. 1947.

FIG. 12 (below). Microphone elevation and platforms for orchestra for NBC Symphony.

FIG. 13 (below). Microphone pickup for small concert orchestra.

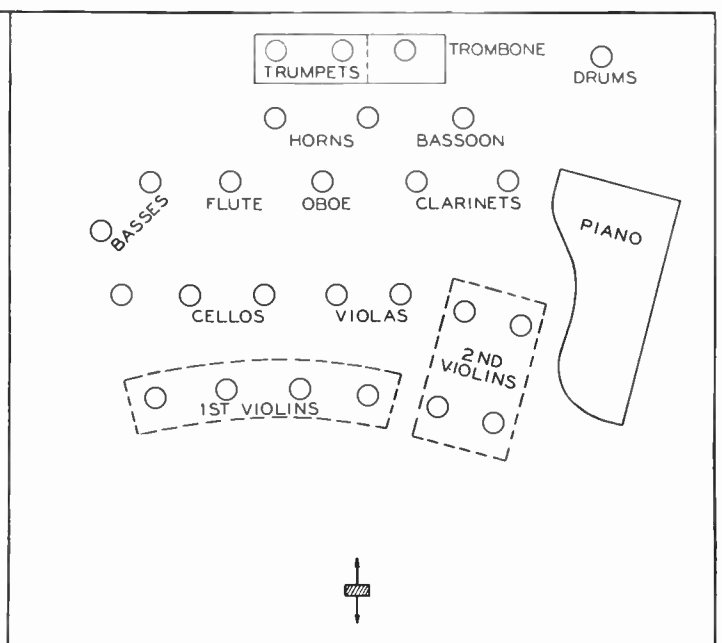
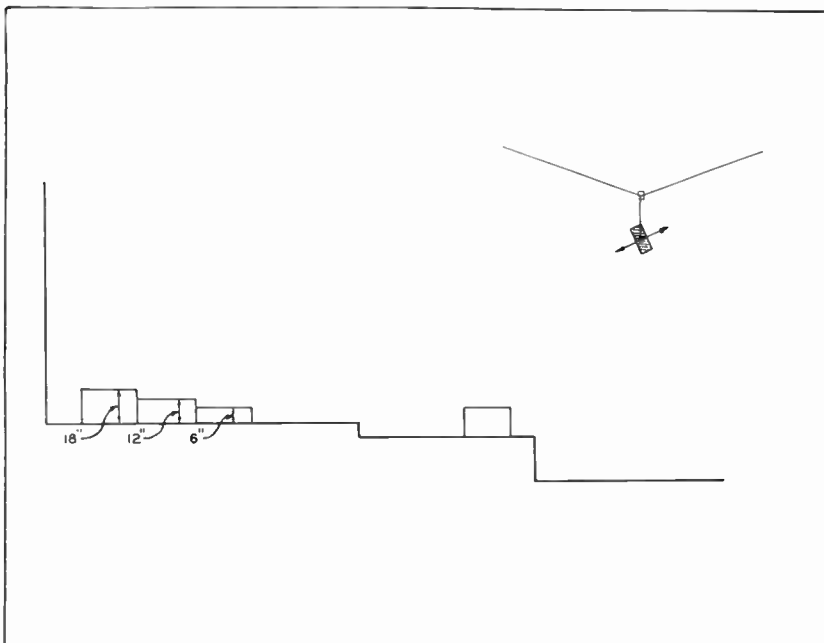

additional microphones are not required, and the orchestra mike serves as the sole pick-up.

### Smaller Groups

For smaller groups, such as a salon orchestra or 20 to 30 piece orchestra, the fundamental treatment is the same as previously described. The principles of directivity and volume of the instruments must be kept in mind, and the weaker, non-directional strings, woodwinds, etc., placed in a correspondingly more favorable location, as illustrated in Fig. 13.

A departure from the single microphone pickup for a musical group is frequently justified when a popular dance band is being broadcast. The use of multiple microphones in many cases is absolutely necessary. When the program originates in night-clubs, hotels, ballrooms, etc., considerable random noise exists. As a result, it is necessary to place the mike as close to the source as possible to exclude the unwanted noise. Because of the proximity of the microphone to the band, all the instruments cannot be included within its effective response angle, and additional microphones are necessary to obtain full coverage.

Another equally important reason for the use of multiple microphones with a dance band is the prominent use of low volume sounds such as a muted trumpet or trombone, and other special effects, which are an inherent part of the musical content itself. Frequently a rhythm section, consisting of piano, drums, bass viol, and guitar are grouped together and separated from the brass and strings. Because of these special effects, a popular singer almost always requires his own microphone. Two illustrations at right, Figs. 14 and 15, show the setup for popular dance bands with and without a vocalist. In most cases, the special effects achieved by use of multiple mikes are considered more important than any detrimental effects due to wave interference.

The foregoing principles as to methods and applications constitute only an outline and indicate the results that might be expected using the various pick-ups, microphones, and acoustical conditions. They are intended as a guide rather than strictly formulated rules. There is no known substitute yet for individual judgment, taste, or listeners' reactions, which are the principal guides in achieving the optimum

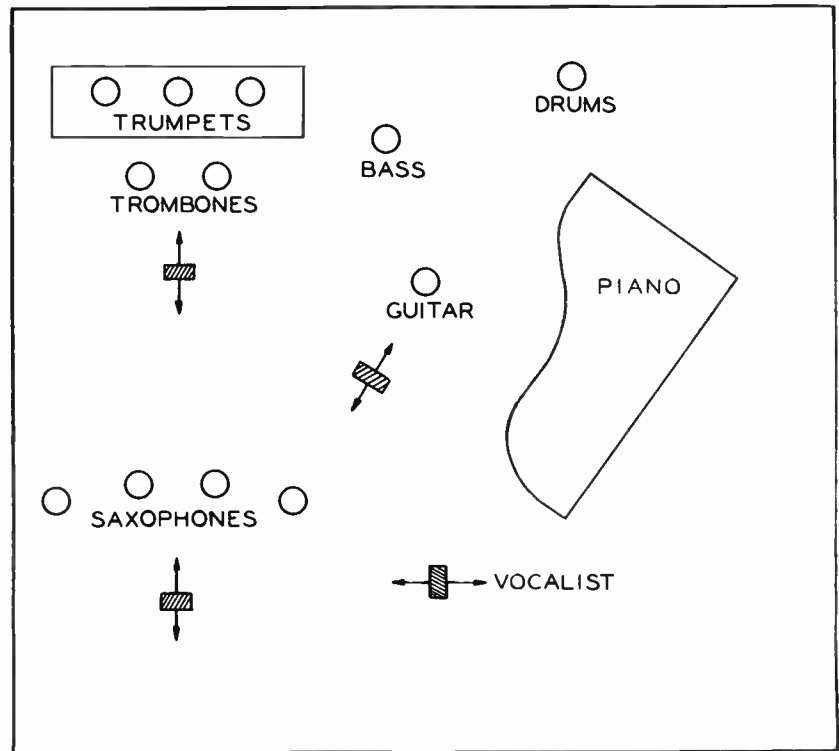

FIG. 14 (above). Typical arrangement for dance orchestra.

results. The success of every broadcast depends on sound fundamental principles intelligently applied with flexibility and originality, taking full advantage of every technical advance to meet the needs of a particular situation. In this way, only, can the skill in technique of broadcasting keep pace with the engineering developments so frequently being provided.

The author wishes to acknowledge the generous help of the NBC staff and is particularly indebted to Rinehart and Company for permission to reproduce Figs. 9 to 15 from their current book "Broadcasting Music," by E. La Prade (1947).

Thanks are hereby extended to Audio Engineering for artwork and additional material.

FIG. 15 (below). Microphone pickup for dance orchestra with strings and a vocalist. A—Principal microphone. B—Vocalist's microphone. Other microphones for group accentuation.

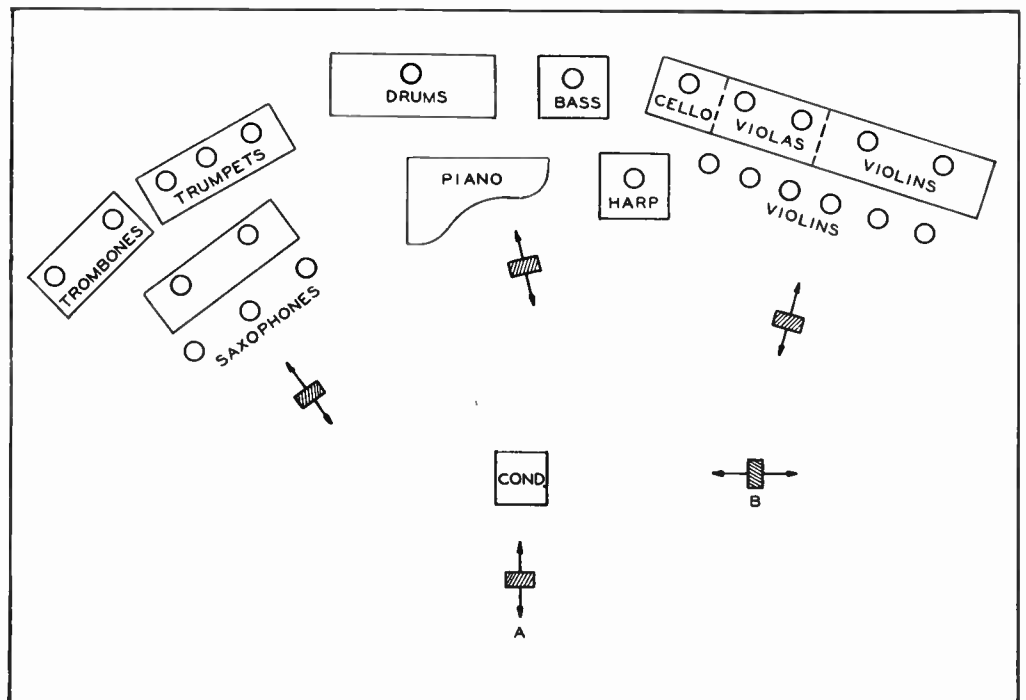

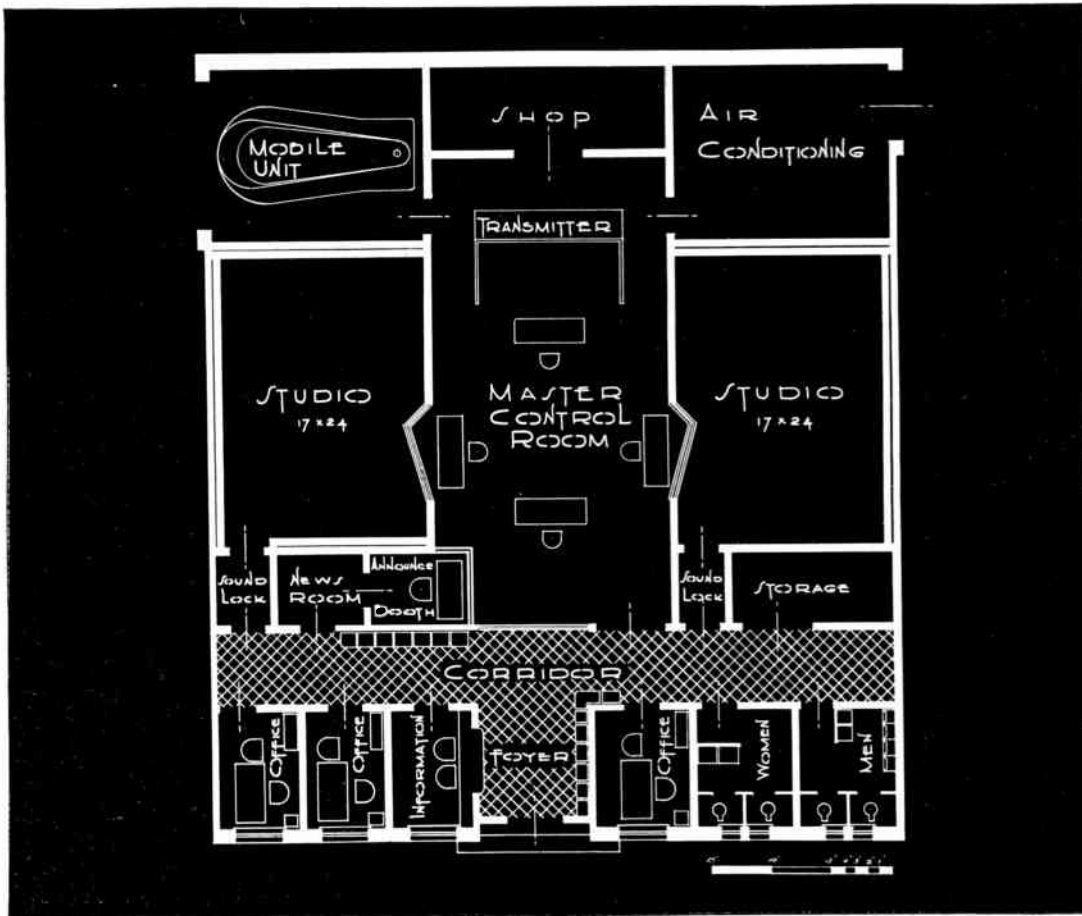

FIG. 1. Floor plan of building designed to house studios, transmitter, offices and other facilities of a small television station.

FIG. 2. More elaborate facilities can be added to building shown in Fig. 1 to make provision for expanding activities of a television station.

# PLANNING RADIO AND TELEVISION STUDIOS

The planning of sound and television broadcast studios requires very careful consideration and coordination of a number of technical and economical factors to insure the satisfaction of present and anticipated requirements and the provision of sufficient means to accommodate future needs. The size of the plant, the number of studios, and similar questions must be answered, in large part by the station management itself as it is best equipped to determine whether it will originate a large number of live talent programs, use recorded material to a considerable extent, or rely to an appreciable degree on receiving programs from a network.

The general technical problems involved in the selection of the studio plant location are in the main quite similar whether

the plant is for sound or television broadcasting. Television studio broadcasts involve scenery, props or appreciable size, etc., which must be conveyed to the studio, removed from it and stored so that convenient location near the ground level is to be preferred. Television broadcasting, where live talent studios are involved, will occupy about 3 or 4 times as much space as sound broadcasting, consequently, economic considerations may dictate lower rental space or more economical land. There is no fundamental difference between the planning of Standard (AM) Broadcasting and Frequency Modulation (FM) Broadcast studio facilities as the difference between these two types of broadcasting occur in the RF portion of the link between the studio and the listener.

## Space

There is considerable experience in sound broadcasting to indicate the space required for the studio plant. The number, size, and types of studios selected influence space requirements particularly if an appreciable audience is to be admitted to the broadcast. The number and type of studios planned should be adequate to accommodate the contemplated types and sizes of performing groups with an adequate allowance for rehearsal time. The total floor space required for the plant varies considerably dependent on the building but is usually 3 to 6 times the area of the studio space.

There is not yet the background or experience in television broadcasting as in

\* By George M. Nixon, Manager, Engineering Development, National Broadcasting Co., Inc., New York.



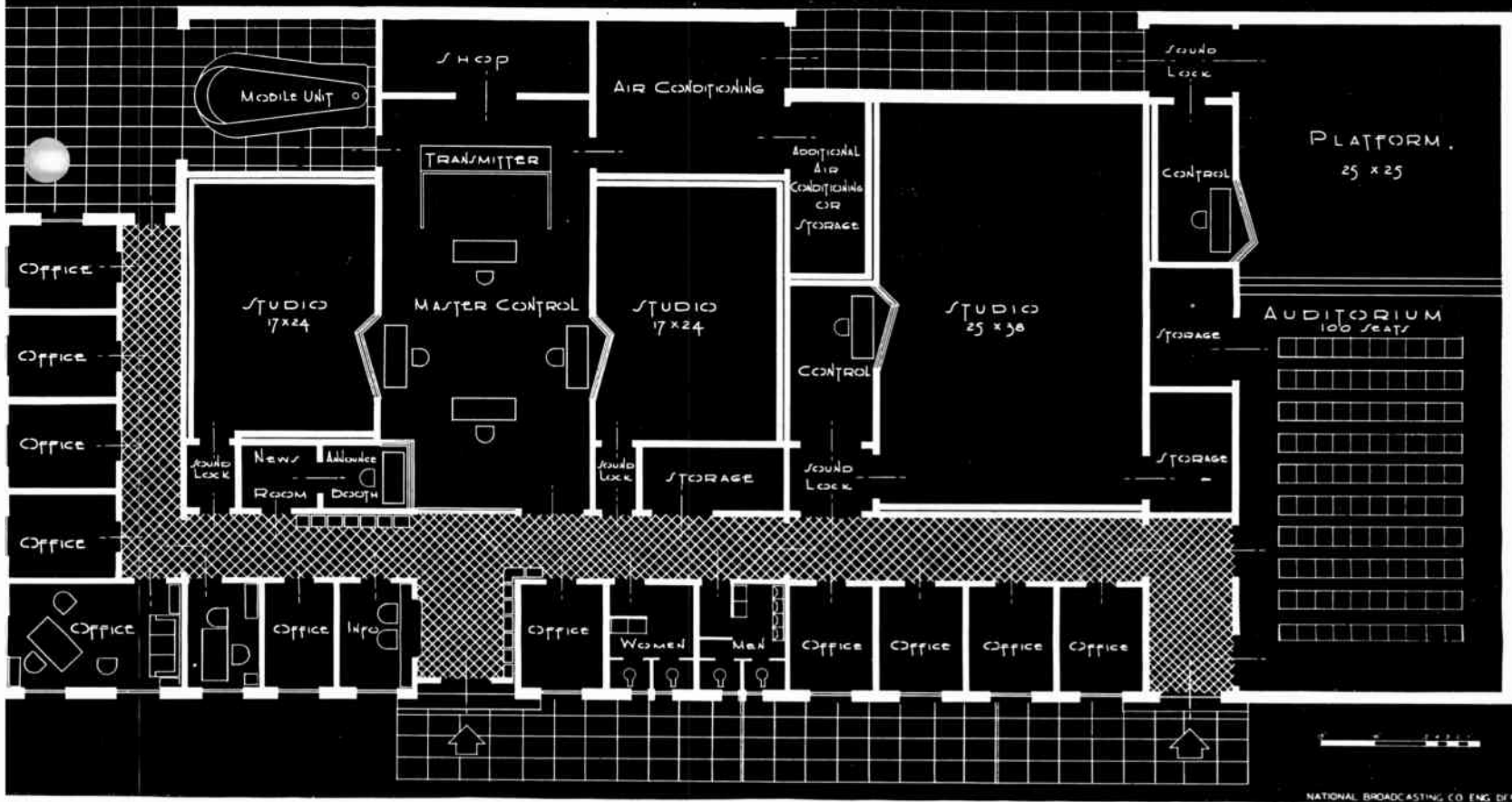

sound broadcasting to indicate as definitely the amount of space required except to state generally that, where an appreciable number of live talent programs are to be originated, the space requirements will be about 3 to 4 times that of sound broadcasting. It is most important in planning that provision be made for future space expansion so that as television broadcasting develops and grows the plant may keep pace with its growth.

There are two main ways in which the studio plant may be developed.

- (a) The horizontal plan
- (b) The vertical plan.

The horizontal plan which involves the location of the studios on the same level is adaptable to existing structures for small plants, but larger plants would require the erection of a building specifically designed to house the studios. The larger

plants will involve considerable land area which in some cities might require its location too remote from the business and entertainment areas. Future expansion is in general most easily accomplished by this type of studio arrangement. A suggested arrangement of studio facilities is shown in Fig. 1, and those same facilities expanded are shown in Fig. 2.

The vertical plan is adaptable to either an existing building or one specifically

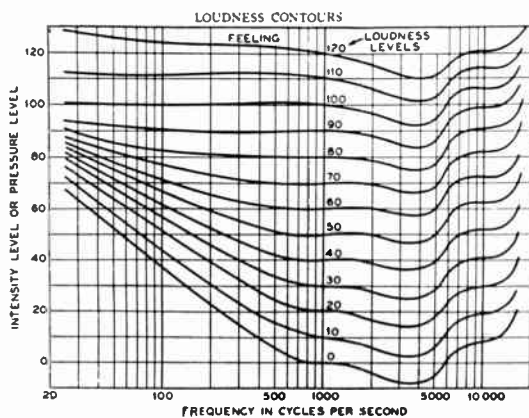

FIG. 3. Loudness intensities of the ear.

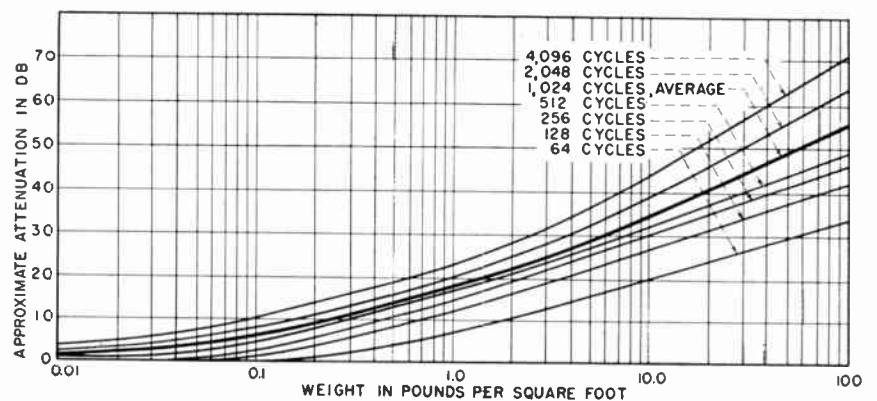

FIG. 4. Increase in sound attenuation in terms of weight of various homogeneous materials.

built to house the studios. Appreciable expansion sometimes results in a scattering of work areas in different parts of the building with resultant inconvenience unless included in the original planning.

### Location

The location of the studio plant is a most important decision to make. It should be located so that convenient transportation is available to performers, technical personnel and general public.

The major potential technical difficulty to be studied is that of noise. Noise is transmitted in two ways.

- (1) Airborne
- (2) Vibration of the ground or elements of the building structure.

The airborne sounds exterior to the plant include those due to thunder, railways, busses, aircraft, streetcars, industrial activities, automobile traffic, etc. Certain of these such as railways, streetcars, industrial activities, etc., may transmit sound by vibration of the ground to the studio plant. The rental of space in an existing structure requires investigation of the activities of present tenants, and also the restriction placed on future tenants as to their noise producing activities. Major sources of noise within the building may include printing presses, pumps, industrial machinery, punch presses, and the like. Conversely, it should be kept in mind that noise from a broadcast plant can be just as annoying to others, particularly professional people such as doctors, or dentists in the conduct of their work.

The problem of noise is stressed as it is one for which the precautions must be taken in the construction of the studio plant. It is for that reason that a survey should be made at the proposed location with a sound level meter so that the magnitude of the noise is known and the isolation to be provided can be determined.

The use of a sound level meter is preferable but in the event one is not available some indication of the noise level may be obtained by the use of a portable field amplifier which practically all broadcast stations have available. The absolute magnitude of the noise may be calculated approximately by obtaining the sensitivity of the microphone from the manufacturer.

In those cases where the noise is from a source which develops considerable vibration, the solution may not be economically feasible. The location of the studios on the floor directly above or below a bank of large printing presses is such an example. The amount of vibration generated

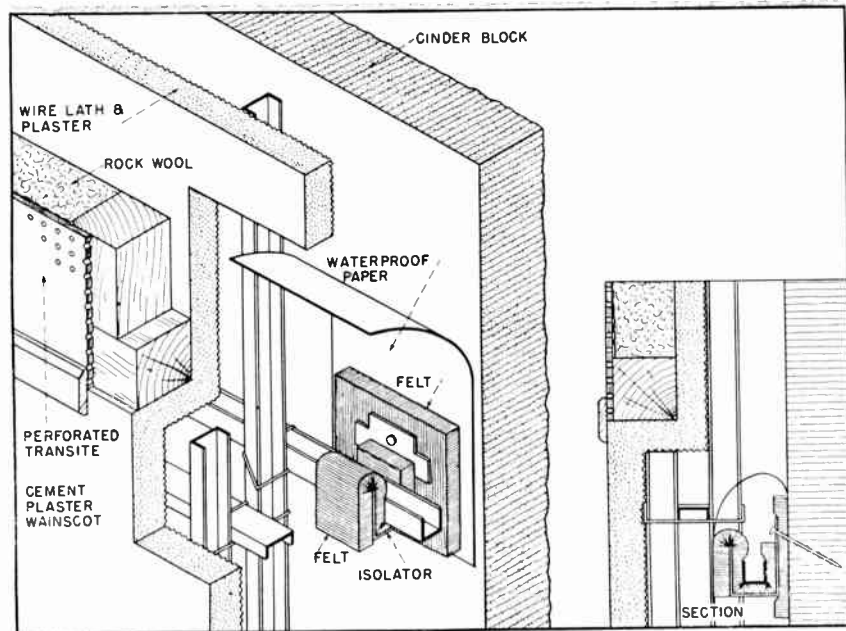

FIG. 5. Construction of a wall for sound isolation between studios.

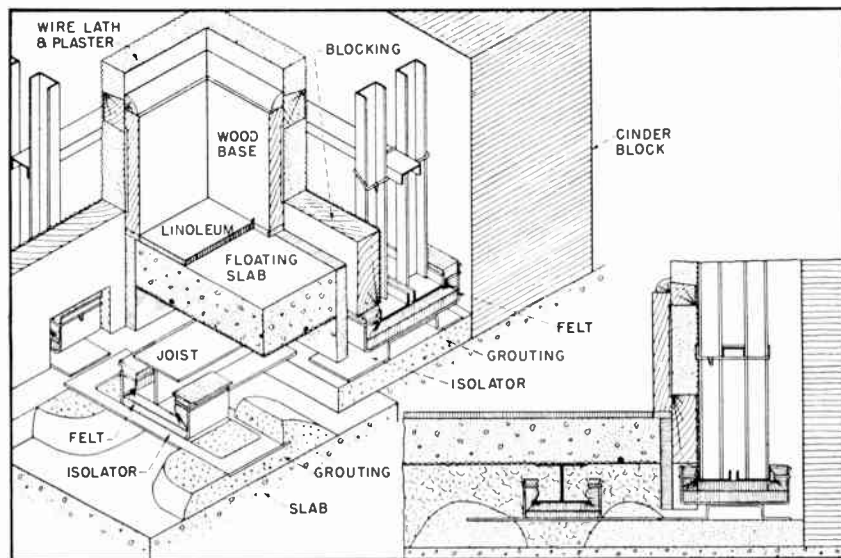

FIG. 6. Typical acoustic treatment for a floor to isolate sound from below.

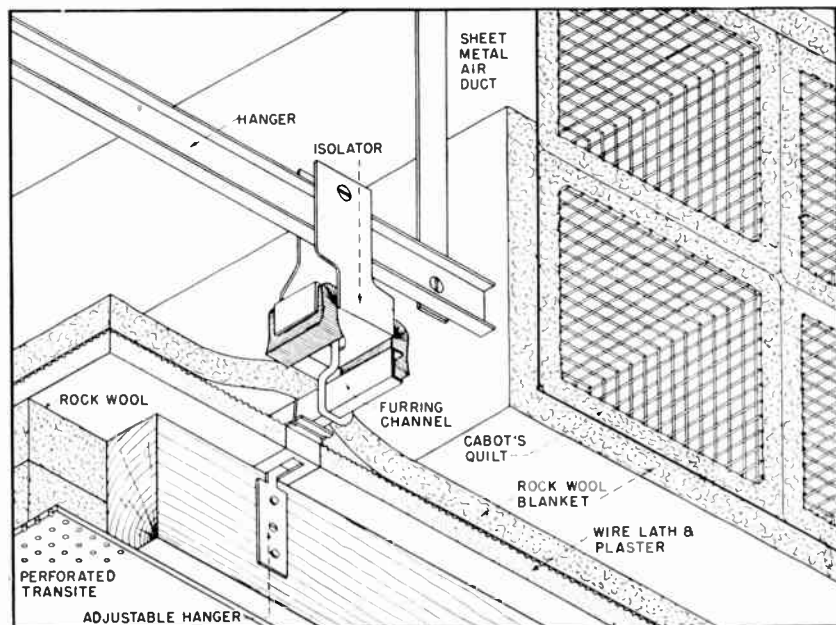

FIG. 7. Mechanical details of suspended ceiling and acoustically treated air duct.

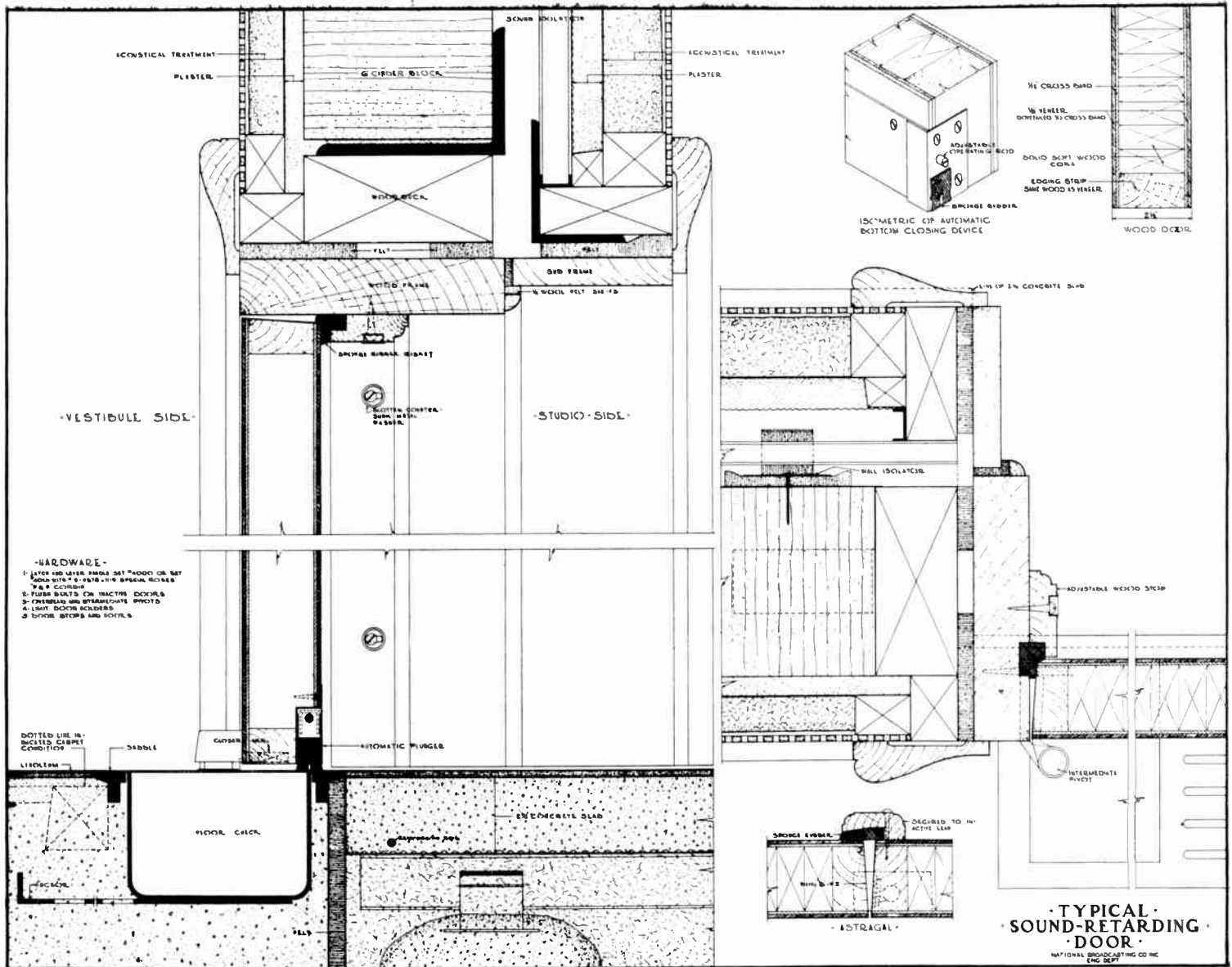

FIG. 8. Construction details of sound retarding studio door.

by the presses is of such a magnitude that there is no practical and economic means to reduce it to a satisfactory value. Further, it is not possible to predict accurately the reduction which will be effected because of the many related factors. Studios have been built in substantially this type of location and as far as is known trouble has always ensued—sometimes to the extent of making necessary the installation of a high pass filter in the program circuit to reduce the noise and compromise the overall quality.

The maximum tolerable noise level in studios is as follows:  
Sound level meter

- Scale A—less than 25 db\*
- B—less than 35 db
- C—less than 45 db

\* (db above the threshold of hearing . . .)

Scale C is substantially “flat” as regards frequency response and Scales B and A correspond respectively to the Loudness Intensity curves of the human ear.

It will be noted in Fig. 3 that the ear at moderate intensities is less sensitive at the lower frequencies than at medium and high frequencies. This is fortunate as sounds of these frequencies are most difficult to control.

#### Sound Control at Boundary Surfaces

The attenuation of airborne sounds is dependent largely on mass of the material rather than other characteristics of the material itself. This is a generalized statement, to which there are some exceptions, and cinder concrete appears to have some advantage over other materials for studio partitions. The increase in attenuation with mass is at a relatively slow rate as

may be seen in Fig. 4. For example, a 6-inch wall (45 pounds per square foot) of solid cinder concrete may be expected to have an average attenuation (128 cycles to 4096 cycles) of about 48 db and a 12-inch wall (90 pounds per square foot) about 54 db.

Two 6-inch solid cinder concrete walls with an intervening air space of more than 6 inches may be expected to produce an attenuation of about 60 db. The use of double walls is to be preferred to single walls, because of the increased sound attenuation over a single wall, the reduction of impact sounds, and the lesser weight for a given degree of sound attenuation. The partitions should extend from the floor slab to the under portion of the floor slab above (or the roof). Cinder block walls have appreciable sound absorbing properties which absorb sound in the intervening space between walls and also are fairly

free from pronounced resonances which are manifest as reduced attenuation over a band of frequencies.

The use of two 6-inch solid cinder block partitions (each plastered on one side) separated by an air space is the minimum that should be provided between adjacent studios. The use of partition block of smaller dimensions, say of 4 inches thickness and hollow instead of solid will permit the transmission of more sound than is desirable.

Commercial sound isolation systems are effective in attenuating airborne sounds but experience has shown them to be less effective than is desirable in reducing the transmission of vibration at lower frequencies (of about 100 cycles and lower). There are advantages in their use where weight becomes a factor. Construction details of sound isolation systems for walls, floors, and ceilings are shown respectively in Figs. 5, 6, and 7.

There are types of multiple wall structures of light weight which are effective in reducing sound transmission but usually such walls occupy appreciable space, are relatively expensive and require careful supervision of their installation to insure proper performance.

Attention must also be given to the ceiling and floor surfaces to insure the maintenance of the high degree of sound attenuation provided by the partitions. In the buildings with stone concrete floor slabs of adequate thickness (4 to 6 inches thick), adequate isolation from the floor above is usually obtained by the installation of a "suspended" or "hung" ceiling. (It is presumed in this case that the occupants of the floor above are engaged in "quiet" activities.) Such a ceiling is required for light fixtures, concealing duct work and the like. The ceiling should be supported on resilient mountings, as the increased cost due to their use is quite small, and

covered by loose rock wool fill, blanket or similar sound deadening material.

The floor on which the studios are mounted should be also studied as to noise coming from the floor below and additional cinder fill topped by smooth concrete finish added or a sound isolated floor installed.

Buildings with wooden floors present some problems as to loading bearing capabilities which may require re-arrangement of the studio grouping to obtain isolation by "separation" rather than structural means.

If the space surrounding the studios is quiet these precautions may be relaxed somewhat, but the effect of sounds from the studio to the surrounding space should be considered.

The observance of these precautions at the boundary surface of the studio will provide satisfactory noise conditions in

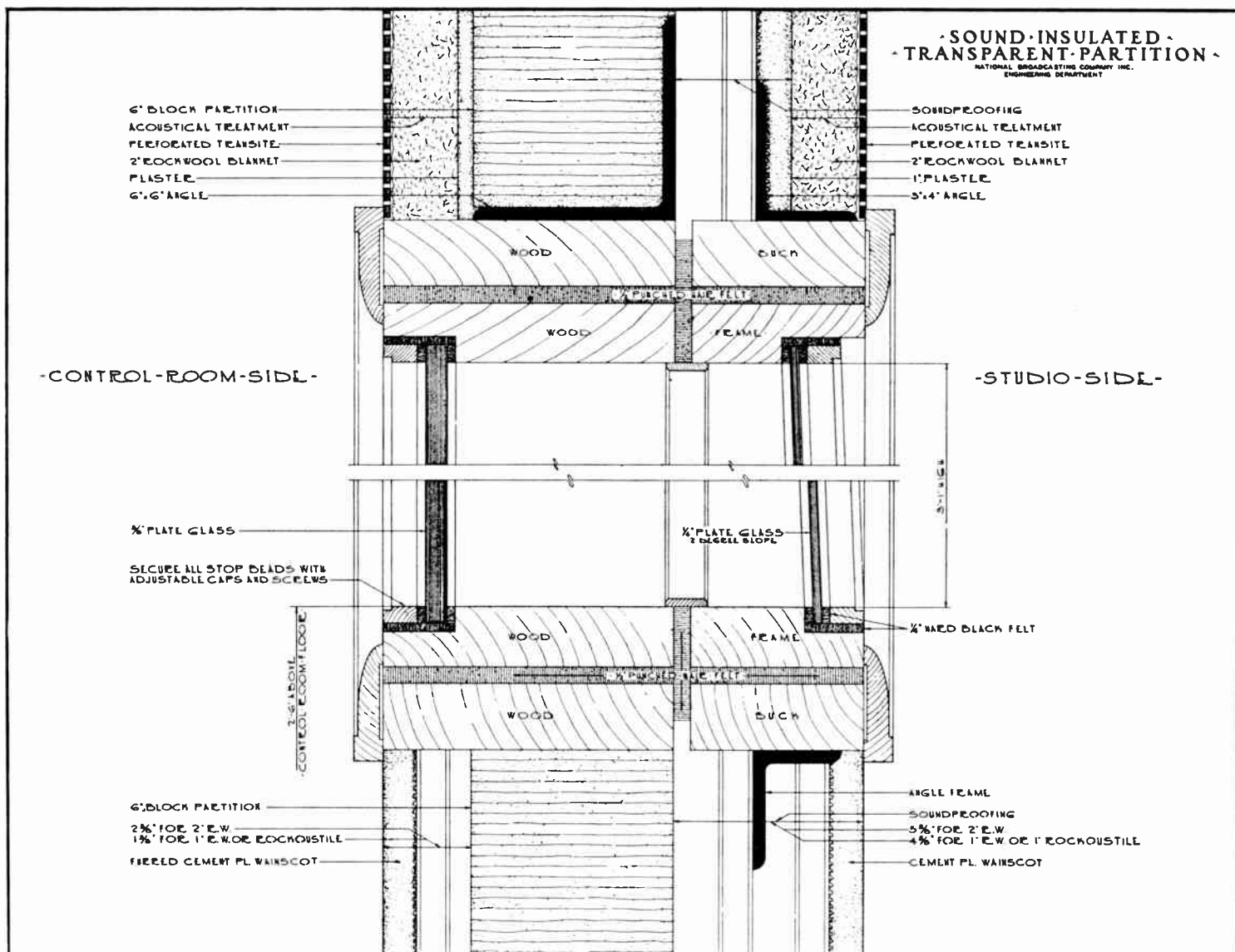

FIG. 9. Details of a sound insulated transparent partition.

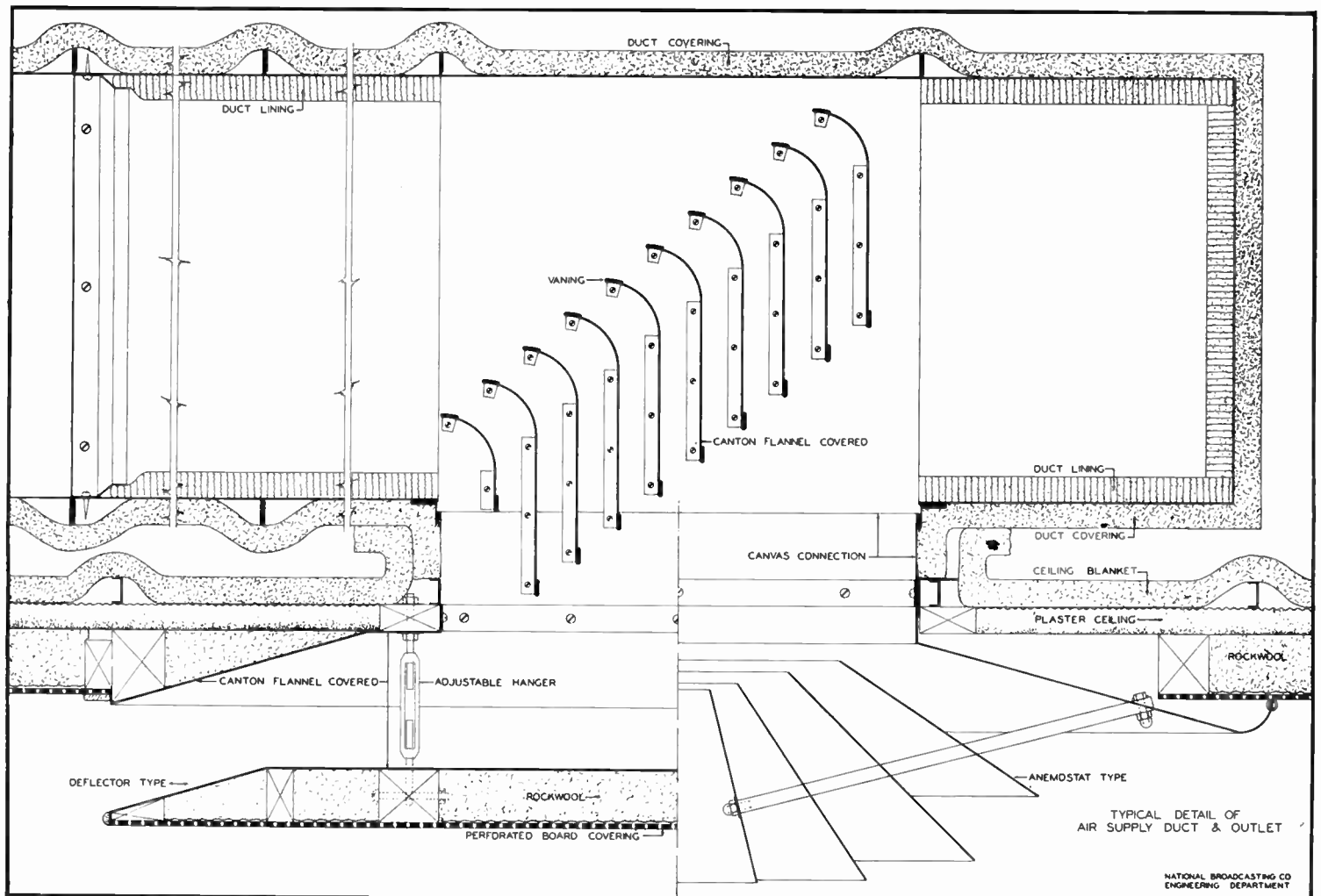

FIG. 10. Mechanical detail of an air supply outlet of deflector or "Anemostat" type.

most all cases. Practically, these surfaces must be pierced by windows, doors, and duct work and where so pierced every precaution must be exercised to maintain the sound isolation provided originally.

#### Doors

Entrance to a studio should be effected through two doors separated by a vestibule which is acoustically treated over as much of the areas as is possible. Experience has shown satisfactory performance with 2½" solid wood doors fitted with an automatic bottom closer and gasketed on the head and side, at each end of the vestibule. Construction details of a satisfactory sound retarding door are shown in Fig. 8.

#### Windows

Windows are needed for observation purposes in the control booth and public observation booths. The use of double glass of "lights" ¼" and ½" thickness respectively separated as widely as possible will provide sufficient isolation. The isolation is improved to the extent of 6 to 10 db by acoustical treatment of the boundary surfaces between the panes or "lights" of glass. Construction details are shown in Fig. 9.

Outside windows should be "sealed" by masonry or treated in the same general manner as control booth windows if retained, to prevent transmission of sound between the studio and outside spaces. If no ventilating system is provided, and windows must be opened during the summer, the sound isolation system of the studio is greatly reduced in efficiency. The studio may be oriented so the windows face a quiet location, but thunder, aircraft and similar noises will undoubtedly prove disturbing.

#### Air-Conditioning and Ventilating Systems

There are four general sources of noise due to ventilating systems:

- The fan (which inherently generates a fairly turbulent air stream).
- The system of duct work which may transmit sounds through it or along its surfaces.
- The supply and return outlets.
- Rotating or reciprocating machinery such as pumps, compressors, fans (vibration), etc.

All rotating and reciprocating machinery together with its driving sources should be

mounted on a sound isolated base. Suitable isolation materials or springs include rubber in shear, metallic coil or leaf springs, cork, etc. The performance of practically all these materials is dependent on loading and the material should be deflected as much as possible (within the limits of the material) to obtain as low a natural resonant frequency as possible thereby providing the greatest amount of isolation. All connections to the equipment should be as flexible as possible, electrical wiring should be enclosed in flexible armour rather than conduit, etc.

Duct work should be connected to the fan through a canvas collar and the same procedure employed in connecting the duct work to the supply and return outlets. The duct work should be wrapped where it pierces the wall and wrapped within the confines of the studio. The duct of dimensions of 12" x 12" or smaller should be lined for a distance of 16 feet between the fan and first outlet; and between outlets in studio and other spaces. Duct work to listening areas, such as control booths when of this dimension or smaller should be lined for a distance of at least

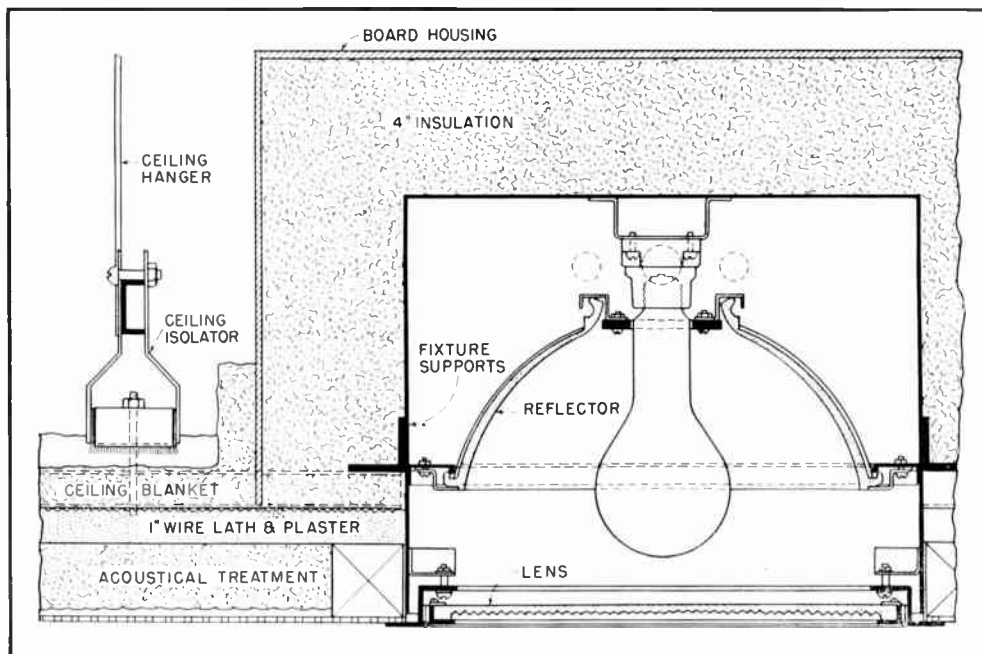

FIG. 11. Detail of acoustical treatment around recessed lighting fixtures.



FIG. 12. A speaker's studio simulating a living room can double as conference or sales room.

8 feet. The lining should bridge partitions which are pierced by several feet on each side of the partition.

Lining is adequate for small ducts but most studios will require larger ducts, in which case, lining alone is not sufficient. In the case of a duct 12" x 48", it should be lined as indicated above and divided at 12" intervals or less by absorbing material so that in effect 4 small ducts in parallel are created.

The supply and return outlets are another source of noise if the air velocity is too high or the duct work is not ar-

ranged for a smooth flow of air. Guiding radial vanes should be employed as required which will aid in the distribution of the air in the studio and also result in quieter conditions. The details of a satisfactory supply outlet of the "pan" deflector or "Anemostat" type are shown in Fig. 10.

Air velocities which have been found satisfactory are 1200 feet per minute or less in main duct work; 500 feet per minute or less for supply outlets and 300 feet per minute at return outlets.

Pumps and compressors are sometimes troublesome acoustically as completely flexible joints or coupling to piping are not too practical and also the liquid column may be substantially "solid" so sound is transmitted along the piping in that way. Such equipment should be located as remotely as possible from the studios and the piping suspended by resilient mounting to prevent transmission of the vibration to the building structure.

Recessed light fixtures pierce the ceiling constructions and the manner in which sound precautions are observed is shown in Fig. 11.

### Types of Sound Broadcast Studios

There are three major types of broadcast studios from which live talent programs may originate:

- (a) **SPEAKERS' STUDIO**—This type of studio is usually small, 12 by 18 feet or similar, designed to simulate a living room and intended only for speech. Where economy is a factor, such a studio may also serve as an audition room, conference room, or sales room. A studio of this type is shown in Fig. 12.
- (b) **GENERAL PURPOSE STUDIO**—This studio is intended primarily for the accommodation of the performers, with the visible audience, if any, of secondary consideration. Its size may range from 15 feet by 25 feet to 50 feet by 80 feet. A photograph of a small studio of this type is shown in Fig. 13.
- (c) **AUDITORIUM STUDIO**—The auditorium studio is intended for accommodating a visible audience and the presentation of the program from a platform or stage, and has no prescribed limits on size. The degree to which stage furnishings are provided is dependent on the amount of "show" desired. Such studios may be used for other purposes, such as demonstrations, cooking lessons, meetings, etc., as a part of the station's activities. A studio of this type is shown in Fig. 14.

### Shape

The proportions of the studio should be pleasing and at the same time technically correct. The desired proportions of 2:3:5 for height, width and length have proven to be a practical guide in studio construction. In larger studios, economy and practical considerations may result in a lowering of the ceiling height to a value somewhat below the proportions stated.

Fig. 15 shows the preferred studio dimensions together with the recommended "maximum occupancy" (including per-

formers and audience) and the "acoustical optimum" which refers to the number of performers only.

The object of incommensurate room dimensions is to avoid a grouping of the harmonics of natural room frequencies. These proportions will result in reasonably uniform distribution of these frequencies. In the case of larger studios these "resonances" become of lesser importance as the natural frequencies are extremely low and their harmonics within the audible range substantially weaker.

### Reverberation Time Frequency Characteristic

The optimum reverberation time at 1000 cycles becomes larger as the studio size increases. The optimum shown in Fig. 16 is based on practical experience and the critical judgment of a large number of people. Reverberation Time may be defined as the length of time required for a sound, having reached steady intensity in an enclosure, to decay 60 db or to one millionth of its original power. The relation between reverberation time and frequency provides a longer reverberation time at lower frequencies than at medium and high frequencies to compensate partially for the characteristic of the human ear and provide some aural decay period at all frequencies. The Sabine-Eyring Knudsen formula for calculation of reverberation time has been found to provide good correlation between calculated and measured value. Fig. 17 shows the relation between the function ( $\alpha$ ) or average absorption and the value  $-\log_e (1-\alpha)$ .

$$T = \frac{.05V}{-S \log_e (1-\alpha) + 4 mV}$$

Where

T = Reverberation time in seconds. (The time required for a sound having reached steady state intensity to decay 60 db).

V = Volume Cubic Feet.

S = Total Surface Area—square feet.

a = Average absorption co-efficients.

$$\alpha = \frac{a_1 s_1 + a_2 s_2 + a_3 s_3}{S}$$

m = Co-efficient of absorption of air at 50% R.H. (varies with frequency).

### Acoustical Treatment

The required total absorption is easily calculated from the optimum frequency reverberation time characteristic by use of the Eyring formula. There remains, however, the selection of the type and thickness of material and distribution in conjunction with reflective areas.



FIG. 13. The acoustical treatment of a general purpose studio.



FIG. 14. A typical auditorium type studio.

There are several general types of acoustical materials.

- (a) Plaster
- (b) Draperies and carpets
- (c) Tiles
- (d) Membrane covered absorbing materials.

*Acoustical plaster* is usually of only moderate absorbing efficiency at medium and high frequencies but the absorption is subject to some variation dependent on job conditions—the manner of mixture,

pressure of the trowel (or applicator), etc. Its relatively poor resistance to abuse restricts its use to ceilings, if used at all, in studios.

*Draperies* and *carpets* in general have little absorption at the lower frequencies and the absorption increases with the frequency. Draperies, lined and interlined, hung 100 percent full (twice the area of material is required for the area of wall to be covered) and 1 foot or so from a wall will have very appreciable low fre-

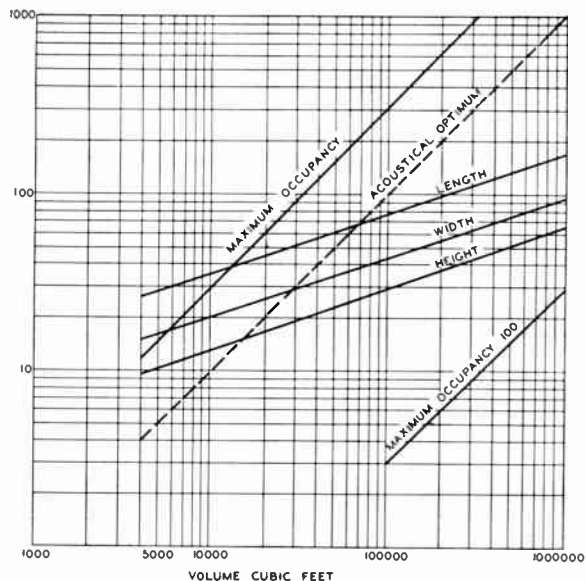

FIG. 15. Preferred studio dimensions and maximum occupancy.

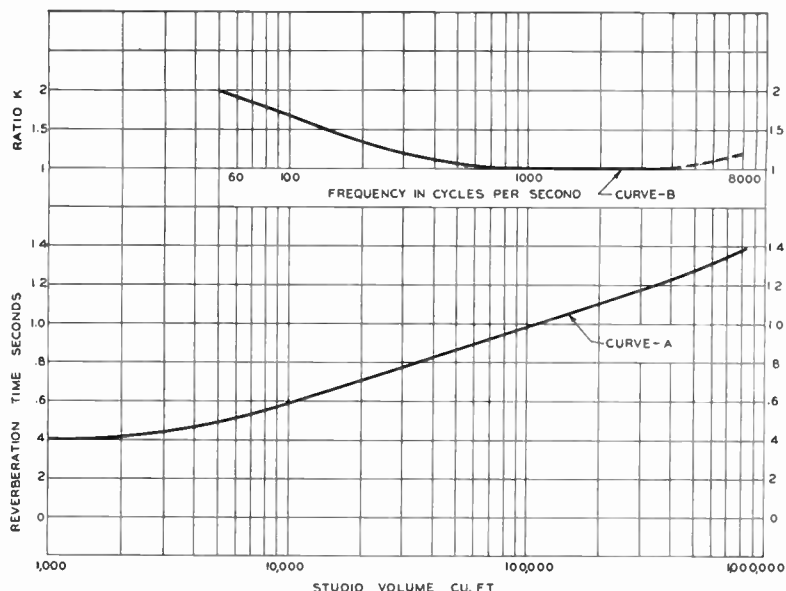

FIG. 16. Optimum reverberation time and frequency characteristics.

quency absorption. Draperies are perhaps the most economical means of providing adjustable acoustical conditions. They are useful in this regard particularly on the rear stage wall of an auditorium type studio to provide an acoustical change in that area. Carpeting is useful in seating sections on the walking area of auditorium studios, on the floor of speaker's studios, under microphone stand to reduce "scuffing" of feet and in certain cases to reduce the noise of footsteps in corridors.

*Acoustical tiles* provide fairly high absorption at medium and high frequencies and a lesser degree at low frequencies dependent on the manner in which they are mounted on ceilings or walls. Certain types which are homogeneous and rely on the porosity of the material for absorption tend to be fragile and subject to discoloration due to "breathing." ("Breathing" is the discoloration due to temperature and pressure differentials which tend to entrap the dirt on surfaces due to the passage of air through the tile near the exposed surface.) (Plaster is also subject to this effect.) In common with acoustical plaster, porous tiles may be subjected to indiscriminate painting when redecoration is necessary and even careful painting invariably substantially reduces the absorbing efficiency. Typical cases have shown a reduction from 50 to 60 percent down to 20 to 30 percent.

*Membrane covered absorbing materials* are those in which the perforated membrane whether it be metal, asbestos board, or hardboard, serves as an acoustically transparent covering of the absorbing material up to about 4000 cycles after which the covering becomes increasingly reflective. These coverings are fairly abuse

resisting and capable of painting several times without adverse effects on the absorbing efficiency.

The decision as to which type or combination of types of treatments is determined by the total absorption required, decorative schemes and economy. In general, if it is expected that the treatment is to last for more than five years the best economy ultimately is to provide the best, the most durable and a type capable of re-decoration.

The control of absorption at the low frequencies can be accomplished by an increase in thickness of one or more of the materials selected, the furring or mounting of the treatment at some distance from the wall or the use of large areas of generally "reflective" curved surfaces which have appreciable absorption at low and medium frequencies and almost none at high frequencies.

#### Distribution of Treatment

One objective in studio design is to provide a reasonably diffuse sound field but it is not believed desirable to obtain or even approach complete diffusion as indications are that this results in a "confusion" of sound. The desired diffusion is achieved by the arrangement of acoustical treatment generally throughout the studio interspersed with plane, splayed, serrated and diffusely reflective surfaces. Care should be exercised that any large and opposed flat reflective surface are avoided to prevent persistent discrete reflections manifest as "rattles" or "flutters."

*Speakers Studios* to resemble a living room should employ a carpeted floor (with lining) and an untreated ceiling. The

walls may be treated with an appropriate area of commercial acoustical treatment or heavy draperies. Since these rooms may be small and used mostly for speech, particular attention should be given to provide adequate low frequency absorption to avoid a "boomy" and unnatural speech sounds. Where draperies are employed it may be necessary to mount 2 inches or more of rock wool blanket or similar material behind the drapery to raise the low frequency absorption.

*General purpose studios* should have a floor covering of linoleum or similar sound reflective material. The wainscot or chair rail should be of abuse resisting material such as cement plaster about 3 feet 6 inches or 4 feet high.

There are almost an infinite variety of arrangements of wall and ceiling treatments; consequently only generalized suggestions can be made. The peripheral area of the ceiling may be untreated so long as the distance from the side walls is less than 3 to 4 feet. If this distance becomes larger the area should be convexly curved, splayed or a band of acoustical treatment provided. Large areas of reflective surfaces parallel to the floor centrally located must be avoided, because of the danger of persistent vertical reflection in the microphone field. The wall treatment should be arranged in some decorative pattern of curved or serrated reflective surfaces alternated with absorbing areas. It may be noted that convexly curved wooden surfaces are in current use. There is no objection to wood, but the major virtue appears to be in the shape of the curvature rather than the material which forms the curve. (There is some difficulty in certain cities in the use of wood because of fire-proof-



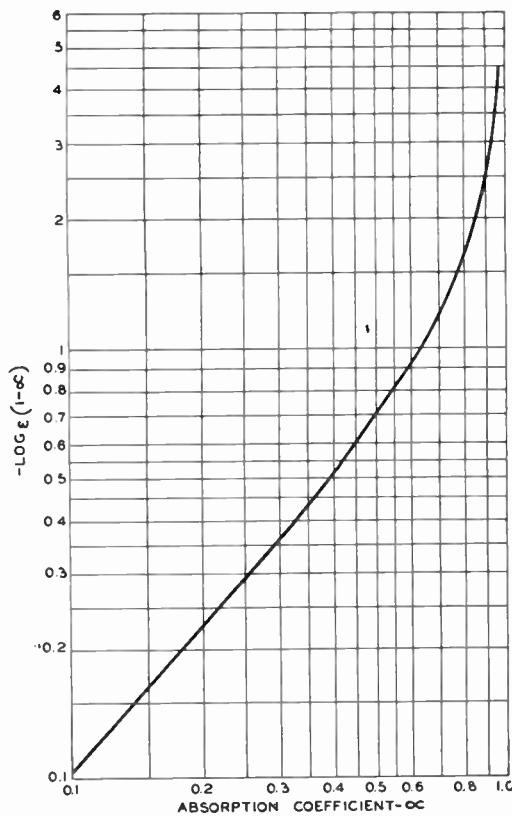

FIG. 17. Value of expression  $-\text{Log}_e(1-\alpha)$ .

ing requirements of Fire and Building Departments.)

*Auditorium studios* are divided into two sections where the platform is in effect a stage and so equipped. Where the platform is merely a platform the division is less obvious but the same general procedure follows.

The stage floor should be linoleum covered. The side walls treated in much the same way as the general purpose studio. The rear wall should be entirely reflective but serrated or contain convexly curved surfaces. The rear wall should be provided with a draw curtain so that adjustment of acoustical conditions is possible. (See Fig. 18.) The stage ceiling should be generally serrated and by a suitable sawtooth arrangement border lights may be concealed from the seating section. This obviates the use of masking borders as their extensive use tends to reduce excessively the reverberation time at higher frequencies.

The seating section should contain upholstered seats thereby providing substantially the same absorption in this area whether empty or fully occupied. The floors on the walking areas should be carpeted to deaden foot falls and scuffing of feet. The ceiling above the seating section may be left untreated as an aid in the propagation of sounds from the stage to the listeners. The forward portion of the side walls (perhaps 2/3 or 3/4 of the

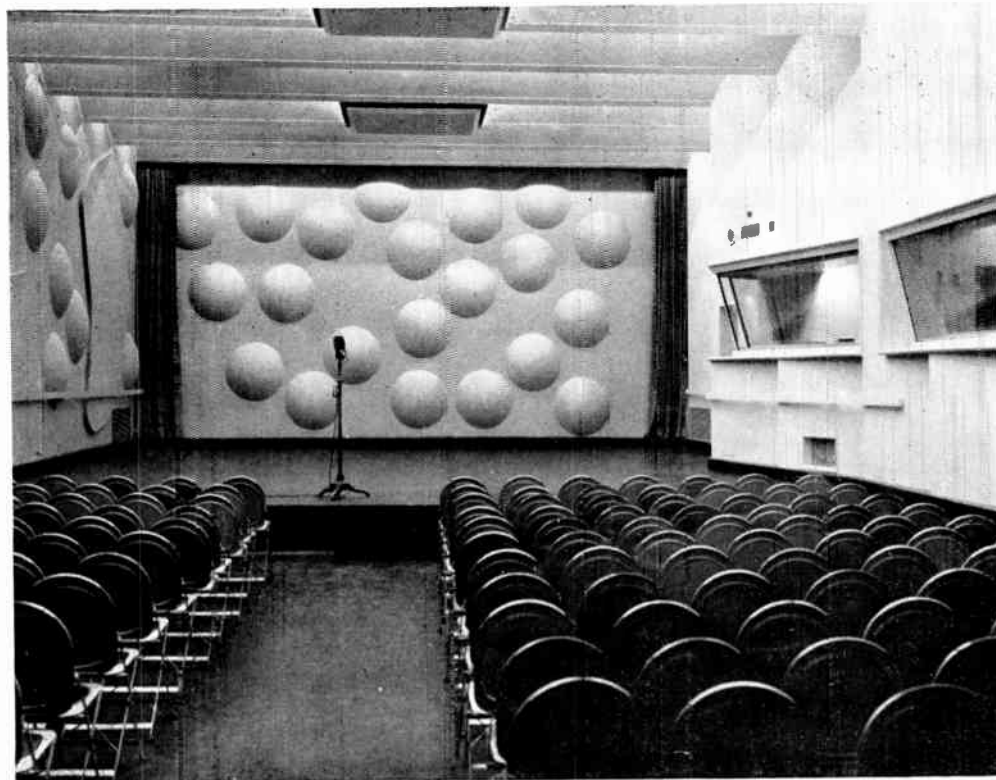

FIG. 18. Rear wall of auditorium stage is reflective with draw curtains to vary acoustical conditions.

distance from the stage) may be untreated provided they are splayed so that opposed surfaces are non-parallel. It may be necessary to treat the rear portion of the side walls to reduce delayed reflection back to the stage. The rear wall should be heavily treated and if desirable to appear architecturally as curved with a radius near the stage apron, the wall should be arranged in a series of convex curves or serrated. Despite the fact that some 80 percent or more of the sound energy may be absorbed, a relatively large area reflecting sound energy to a concentrated small area can and has caused trouble. Where the difference in path length between direct sound and reflected sound is 50 feet or more the plans should be examined carefully as appreciable reflected sound energy of this path difference will tend to be manifest as a fairly distinct echo.

#### Absorption Due to the Air

The increased attention to higher frequencies in sound transmission and reproduction indicates a review of acoustical techniques in this field. The information of the performance of acoustical materials generally available includes a frequency range of only 100 cycles to 2000 or 4000 cycles as contrasted to reliable information from 30 to 15,000 cycles to most available communications engineers. This is a serious limitation in which only some progress has been made in the extension

of the range but the information is not generally available.

The absorption of the air itself becomes a factor at about 4000 cycles and above 10,000 cycles is the controlling factor. At a relative humidity of 50 percent the absorption due to the air itself is such that even though the walls, ceiling and floor were perfectly reflective, no studio regardless of volume, can have a reverberation time greater than 1.5 seconds at 10,000 cycles and about 1.0 seconds at 15,000 cycles. Fig. 19 shows the reverberation time at various frequencies (regardless of the volume of the enclosure) when the total absorption is that due to the air alone. Attention is called to this factor, not that appreciable control can be exercised, but rather that it be known and recognized in the planning. The absorption due to the air rises gradually to a peak in absorption at 20 to 30 percent relative humidity and at higher values (above 50 percent) decreases appreciably.

#### Control Booths

The floor of control booths should be sound reflective, covered by linoleum or similar material. The ceiling should be treated over about 80 percent of the area with a material equivalent to 2 inches rock wool covered by perforated asbestos board. The treatment of the walls will depend somewhat on the particular booth, but if an entrance door is assumed on one end wall, a general statement may be made.



FIG. 20. A typical television studio set showing microphone and camera placement.

The wall opposite the control booth window and the adjoining wall (opposite the entrance door) should be treated above a wainscot 3 feet or 3 feet 6 inches high over the entire area with a material equivalent to the ceiling treatment. (If the control booth ceiling is 8 feet high, the treatment may be started 3 feet above the floor and stopped 7 feet above the floor—in a 4-foot panel.) This would be a more economical procedure as perforated asbestos board is usually supplied in sizes

of 2 feet by 2 feet or 2 feet by 4 feet. The same condition would apply horizontally where an additional 6 inches or so would involve cutting and fitting.

#### Television Studios (Live Talent)

There is not the same amount of experience with live talent television studios as in sound broadcasting but the experience of a period of eight years with a studio 30 feet by 50 feet and 18 feet high has taught some lessons. The observations of the experience of others in this field have also proven helpful. The problem in the television studio is different acoustically in that a set with three sides or even two sides tends to determine the acoustical quality of the sound pickup in that set. The studio itself should be substantially non-reverberant or acoustically "dead." The studio, by its very nature, cannot be a showplace in the usual sense so that decorative effects may be subordinated very definitely to practical requirements. It is to be expected that provision must be made for a visible audience in some cases, but the flexible use of the studio and the screening of viewing action by the sets themselves will tend to locate such an audience adjacent to the control booth or at some other location well above the floor level of the studio and in a sense out of it.

The acoustical treatment in a television studio would approximate that of a motion picture studio (not a scoring stage).

The entire area of the walls and ceiling should be covered by 2 inch rock wool blanket or similar material. To prevent "dusting" of the material another covering of flame-proof muslin should be applied on the ceiling and upper wall surfaces. The wall surfaces to a height of about 12 feet should be covered with perforated asbestos board or similar material painted a light matte-gray or aluminum color. The upper wall and ceiling surfaces should be covered by 1/2 inch or 1 inch mesh screening.

The noise requirements are perhaps more stringent than in sound broadcasting as the microphone is located 3 to 6 feet from the performers and will receive a higher ratio of random to direct sound than in sound broadcasting. Figs. 20 and 21 show typical views of a television studio.

The light levels in sound broadcasting require 20 to 30 foot candles incident on a horizontal plane about 3 feet above the floor. This is roughly equivalent to about 6 watts per square foot of floor area. Television lighting requires between 200 and 500 foot candles of incident light on the set even with the more sensitive pick-up tubes. This amount of light is required for artistic lighting and while the camera pick-up tubes will work at lower light levels, the increased ease of operation with the lens "stopped down" with attendant greater depth of focus is a desirable feature. These light levels are roughly equivalent to 20 to 30 watts per square foot of floor area. The difference is that broadcast studios are uniformly illuminated whereas in television the lighting is concentrated on one or more sets. The lighting may be on two at the same time as in a small studio the proximity of the sets is such that some spilling of light from one to the other is unavoidable. The increased lighting load requires increased air-conditioning (or ventilation) to dissipate and carry away this heat. A noise problem is introduced by reason of the fact that duct sizes become increasingly larger and there will be a tendency to increase the velocity of air to reduce the size of the duct. The increase in velocity in the duct in the main run is not objectionable provided that adequate sized ducts run to the studio properly treated so that the noise generated in the main run due to the velocity of the air is effectively attenuated. The desired practice of introducing the air at a height of about 15 feet above the floor and removing air at the ceiling and floor tends to bring the supply outlets closer to the probable microphone locations.

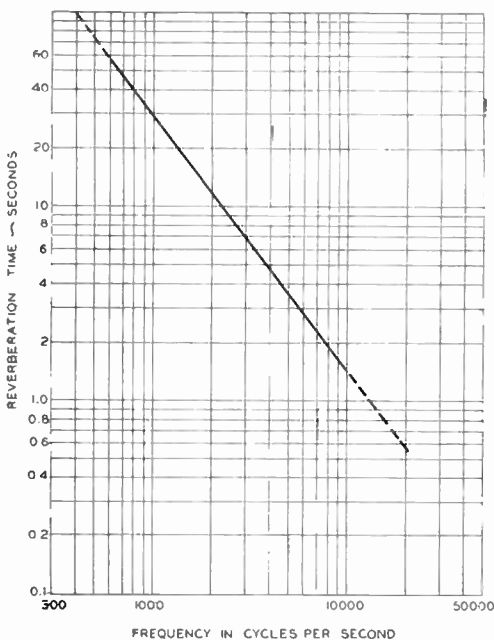

FIG. 19. Reverberation time at various frequencies with total absorption due to air alone.

The same general conditions as to air-conditioning or ventilation apply in the control booth, particularly if appreciable equipment is located in that space. The power load per camera chain dependent on auxiliaries such as monitors, etc., is about 3 KW. A separate exhaust system over the equipment itself to remove its heat is desirable. The occupants of a sound broadcast control booth may range from a minimum of one to a maximum of two or three. (These numbers refer to persons performing useful functions and do not include the usual onlookers.) The occupants of a television control booth will range from four to seven dependent on the manner in which technical and program production is accomplished. The acoustical requirements for listening are just as critical and the same attention must be given to sound control as in sound broadcasting. It is evident (see Fig. 22) that the television control booth is, of necessity, considerably larger than a sound broadcast booth.

The size of television studios will be appreciably larger particularly as to height to permit light bridges, cat walks and the like. The experience in a studio 30 feet by 50 feet by 18 feet high has shown that the low ceiling is a disadvantage and that this studio is almost the minimum size. A minimum sized television studio would be about 25 feet by 40 feet by 22 feet high. A more desirable minimum size is about 40 feet by 60 feet by 25 feet high.

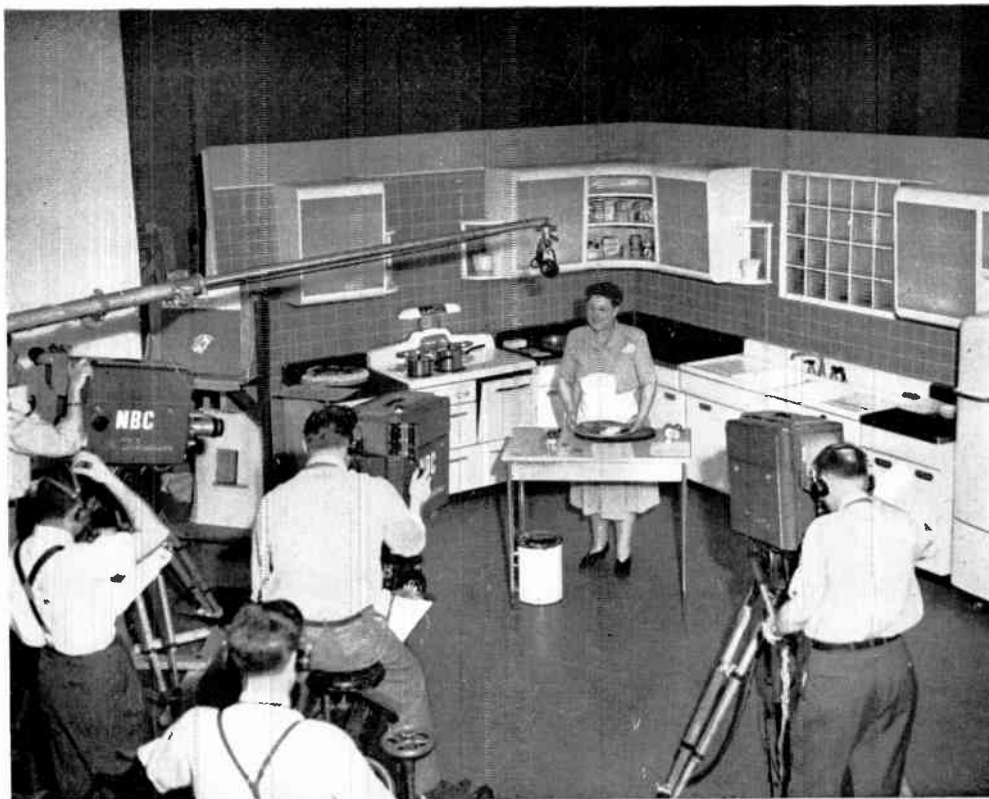

FIG. 21. Another typical television studio set.

There is another difference and that concerns the control booth. In sound broadcasting location of the control booth  $1\frac{1}{2}$  to 2 feet above the studio floor level and at one end is generally satisfactory. In the case of television for flexibility and adequate vision the control booth floor

should be located midway on the long side of the studio and should project into the studio for a distance of several feet.

#### General

It is desirable to appreciate that studio planning is based on satisfying the opinions, wishes, and desires of people. That is, the end result is the subjective opinion of people rather than the objective measurements by means of a technical instrument. It is not to be expected that any plant will completely satisfy everyone that uses it or views or hears the product of its output. It is to be expected that the proper planning will satisfy about 70 percent of the people and that the remainder will admit perhaps grudgingly that it is at least tolerable. Because such planning involves subjective judgment there is a probability of change in requirements as tastes in general may change. These changes may not be of a fundamental nature but in details or in a tendency more toward one direction than the other. It was for that reason that mention was made of planning for future expansion so that future requirements may be accommodated. It is hoped that the material presented will be some help to those concerned with present and future planning.



FIG. 22. View of a television studio control room showing video and audio monitoring facilities.

# == NOTES ==

# == NOTES ==

# == NOTES ==

# V I D E O

## VIDEO EQUIPMENT THEORY

Review of Basic Concepts.....	B-1
Fundamental Circuit Theory.....	B-15

## OPERATION, TESTING AND MEASURING OF VIDEO EQUIPMENT

Composition of Video Waveform as Seen on the Scope.....	B-35
Standardizing and Measuring Video Levels in a TV Station.....	B-38
How to Adjust Frequency Response in Video Amplifiers for TV.....	B-42
Test and Alignment Procedures for Video Amplifiers.....	B-54
How to Get the Best Picture Out of Your Image Orthicon Camera.....	B-61

## FOUR TV STATION EQUIPMENT PLANS

Introduction to Plans.....	B-65
General Planning Considerations.....	B-66
Plan "A" (Network and Film Only).....	B-70
Plan "A-Prime" (Network, Film and Single Camera Studio).....	B-76
Plan "B" (Network, Film and Two-Camera Studio).....	B-82
Plan "C" (Network, Film, Two Live Studios and Remote Facilities).....	B-94

## VIDEO EQUIPMENT

### Cameras

TV Camera Equipment (General).....	B-106
Studio and Field Cameras (TK-11A and TK-31A).....	B-108
The Film Camera Chain.....	B-119
Film Camera (TK-20D).....	B-121
Vidicon Film Camera.....	B-127
Monoscope Camera (TK-1B).....	B-130
A Versatile Video Special Effects System.....	B-132
The Slide Scanner (TK-3A).....	B-140

### Switching

Switching and Fading Equipment (TS-10A).....	B-146
Field Switching System (TS-30B).....	B-151
Remote Control Switching.....	B-154
Relay Switching Layouts.....	B-158

### Synchronizing

Sync Generator.....	B-166
The Genlock for Improved Programming.....	B-171

### Film

Film Projectors for TV.....	B-173
Film Recording for TV.....	B-186
How to Handle Film in a TV Station.....	B-191

### Video Monitors

.....	B-195
-------	-------

### Amplifiers

Stabilizing Amplifier.....	B-204
Distribution Amplifier.....	B-206
Mixing Amplifier.....	B-208

### Field and Relay

TV Mobile Unit.....	B-209
Microwave Relay Equipment.....	B-212
Directional Microwave Antenna Systems.....	B-216
Polarity Diplexing of a Microwave System.....	B-224

### Studio Illumination

.....	B-226
-------	-------

## OTHER EQUIPMENT AND SPECIFICATIONS

Monitran, House Monitoring Transmitter, TM-30A.....	B-236
Film Multiplexer, TP-9C.....	B-238
Metal Tripod, TD-11A.....	B-239
Tripod Dolly, TD-15A.....	B-240
Studio Camera Pedestal, TD-1A.....	B-241
Studio Camera Dolly, TD-5A.....	B-242
Television Studio Cranes, TD-30B, C, D.....	B-243
Regulated Power Supply, 580-D.....	B-245
Regulated Power Supply, WP-33B.....	B-246
Current Regulator.....	B-247
Television Oscilloscope, TO-524D.....	B-248





# Video Equipment Theory

## A Review of the Basic Concepts of the System and Their Effect on the Design of Studio Equipment

### Introduction

The problems which arise in the design of television equipment involve a branch of electronics which is strange to many technicians entering the field for the first time. This is especially true of those who have long experience in the field of sound broadcasting and reproduction, but whose education and experience antedate the post-war television boom as well as the war-time period, during which were developed so many of the techniques of electronic pulsing circuits. Basically the art involves the generation and reproduction of high-speed transient phenomena at both regular and irregular intervals and the consequent need for understanding circuits used for amplifying and transmitting wide bands of frequencies. Not only are the techniques new, but a whole new language has been developed to aid in their expression. It is hoped to provide here at least a brief glimpse of this new field and its language, thus helping the beginner to a firmer grasp of the tools he must now employ.

### Limitations

No true appreciation of any system can be realized without some understanding of its basic limitations, and a discussion of the television system should therefore begin by reviewing these. The most serious limitation of a television system, as in the case of an aural system, is "noise." The same phenomena that cause hum, crackle, and hiss in the background of a sound broadcast, cause bar-like shadows, random blotches, and "snow storms" in the background of a television picture. The word, noise, has been carried over from aural terminology into television terminology with the same connotation; thus, any spurious elements in a television picture are generally called noise. In reading the following discussions, it will be helpful to remember that much of the reasoning behind the methods used in the television system is based on the need to minimize the effects of noise.

Spurious noise components in the signal arise from three general sources, (a) shot noise and thermal agitation in vacuum tubes and other circuit elements, (b) pickup from associated or remote electrical apparatus, and (c) microphonics. The best means for minimizing noise is to maintain a high signal-to-noise ratio in all parts of the system; but where this is impossible, special circuits are a distinct aid in extending the useful range of operation.

Noise, limits among other things, the ability of the system to resolve fine detail. However, a more direct limitation on the resolving power of the system is the frequency bandwidth available in the transmission system. This limitation has commercial aspects of more significance than the technical aspects because of the limited room available in the radio spectrum. As a result, the decisions of the Federal Communications Commission effectively determine the limits of resolution within the noise-free service area of any station. Long years of field testing have shown that a six-megacycle channel will provide adequate resolution and at the same time will yield a reasonable number of channels.

Other factors which limit overall performance are the fineness of scanning apertures,\* the degree of accuracy with which tonal gradations are reproduced, and the brightness range of which the reproducing device is capable. However, if it can be assumed that the transmission system between the pickup and reproducing devices is reasonably linear, then the problems arising from these particular limitations are confined largely to the pickup and reproducing devices themselves, and do not affect system considerations to the same extent as limitations described in the preceding paragraphs, and as certain economic factors do.

Economic factors usually limit the degree to which technological development is used to improve the quality of performance. Methods may be known by which some of the physical limitations of the system can be overcome, but sometimes such methods are not used for a long time after their discovery because means for applying them economically are not developed simultaneously. In other words, their use increases the cost of equipment excessively. This is especially true in the case of receiving equipment which must be produced in large quantities at low unit cost.

\* The use of the word aperture in television probably arose from the use of scanning disks where the light passed through small holes which traversed the projected area of the scene. Small holes traversing closely spaced lines in the area were capable of greater resolution than larger holes traversing more widely spaced lines. Though scanning disks are no longer used, the term aperture is still applied to the scanning device in a general sense. In electronic television, the diameter of the "aperture" is simply the diameter of the scanning beam of electrons in the plane of the scanned image. Similarly the term aperture correction is applied to means (usually the use of special circuits) for compensating the picture signal for loss of resolution caused by finite size of the beam and by non-uniform distribution of electrons over the cross-sectional area of the beam.

Such methods often do find their way into transmitting equipment, where low unit cost is not so important and where quality of performance is paramount. Quality is stressed in transmitting equipment to provide reliability and to reduce the need for including in the receivers complicated and expensive corrective circuits. Examples are circuits for automatic correction of scanning linearity, and clamp circuits for accurate re-establishment of black level, or d-c restoration, as it is often called.

### Standards

During the decade preceding the entrance of the United States into World War II, Radio Corporation of America carried on an extensive program of research and development in television which has been largely responsible for the formulation of the standards governing our present black-and-white system. The earliest work on standards was done through the medium of the Radio Manufacturers' Association. Much more extensive work on standards was carried on later by the National Television System Committee and the Radio Technical Planning Board, the former body being set up to deal exclusively with television standardizing problems and to bring about agreement among the several interested groups on suitable standards for recommendation to the FCC. With the approach of commercial broadcast service, the FCC adopted the recommendations of these bodies as the basis for tentative standards of good operating practice. Activity of the RMA has continued on television and its recommendations have been extended to cover much of the detail of studio and transmitter operation, and of receiver design. While a considerable portion of this material still exists only in the form of recommendations to the FCC, it will undoubtedly constitute the major part of the final standards.

One of the most important standards recommended is the one which describes the waveshape of the picture signal. This standard is outlined in detail in a drawing which is reproduced in Fig. 5. Reference will be made to this drawing from time to time in discussing the system, and an attempt will be made to clarify the reasoning involved in establishing many of the specifications included in it.

### Scanning System

The standard system of scanning in television is one in which the scene or image is traversed by the aperture in lines which are essentially horizontal, from left to right, and progressively from top to bottom. The aim is to have the aperture move at constant velocity both horizontally and vertically during actual scanning periods because this type of motion is simple to duplicate in the reproducing aperture and because it provides a uniform light source in the reproducer. At the end of each line the aperture, or scanning beam, moves back to the start of the next line very rapidly. The time occupied by doing this is called the *fly-back* or *retrace* period. In a similar way, the beam moves from the bottom

back to the top after the end of each picture scan. Motion during retrace periods need not be linear. The complete traversal of the scene is repeated at a rate high enough to avoid the sensation of flicker. This rate has been set at 60 times per second because most of the power systems in the United States are 60-cycle systems, and synchronism with the power system minimizes the effects of hum and simplifies the problem of synchronizing rotating machinery in the television studio (film projectors) with the scanning.

It has appeared rather recently that the choice of 60 cycles for the vertical scanning frequency was a fortunate one for another reason. The progress of the art has included means for obtaining brightness levels in the reproduced pictures which are appreciably greater than those used in motion picture theatres. It is well known that the threshold of flicker increases as the brightness increases. Thus, 48- or 50-cycle flicker would be noticeable to some observers at modern brightness levels in television receivers. Persistence of vision varies in different people, and those whose persistence characteristics are short are conscious of the 60-cycle flicker in the bright pictures on some present-day receivers. Therefore it appears that a still higher vertical frequency would be desirable if other factors would permit. Needless to say, the interline flicker, mentioned later in connection with interlacing, is also less objectionable with the higher scanning rate.

Another important factor affecting flicker is the persistence characteristic of the screen material in the receiver. This can be made long enough to overcome any appearance of flicker, even with scanning rates less than 50 cycles per second, but, if carried too far, such long persistence causes ghost-like trailing after moving objects in the scene. Judicious choice of screen persistence is a great aid in reducing flicker.

Obviously the scanning apertures in the pickup and reproducing parts of the system must be in exact synchronism with each other at every instant. To accomplish this, synchronizing information is provided in the form of electrical pulses in the retrace intervals between successive lines and between successive pictures. The retrace intervals are useless in reproducing picture information, hence are kept as short as circuit considerations permit, but are useful places in which to insert the synchronizing pulses. These pulses are generated at the studio in the same equipment that controls the timing of the scanning of the pickup tube, and they become part of the complete composite signal which is radiated to the receiver. Thus scanning operations in both ends of the system are always in step with each other. Synchronizing is discussed in more detail in a later section.

The number of scanning lines is the principal factor determining the ability of the system to resolve fine detail in the vertical direction. The number of scanning lines is also related to the resolving power in the horizontal direction because it is desirable to have the same

resolution in both directions. Thus, as the number of lines increases, the bandwidth of the system must also increase to accommodate the greater resolution required in the horizontal direction. The present system employs 525 lines, a number arrived at after thorough consideration of the related questions of channel width and resolution by the N.T.S.C. and the R.T.P.B.

### Interlacing

One of the most interesting features of the television scanning system is the interlacing of the scanning lines, a scheme which is used to conserve bandwidth without sacrificing freedom from flicker. The sensation of flicker in a television image is related to the frequency of the illumination of the entire scene. It has no relation to the number of scanning lines nor to the frequency of the lines themselves. Therefore a system which causes the entire area of the scene to be illuminated at a higher frequency, even though the same lines are not scanned during successive cycles of illumination, results in greater freedom from flicker. Interlacing does just this by scanning part of the lines, uniformly distributed over the entire picture area, during one vertical scan, and the remaining part or parts during succeeding scans. Thus, without changing the velocity of the scanning beam in the horizontal direction, it is possible to obtain the effect of increased frequency of picture illumination.

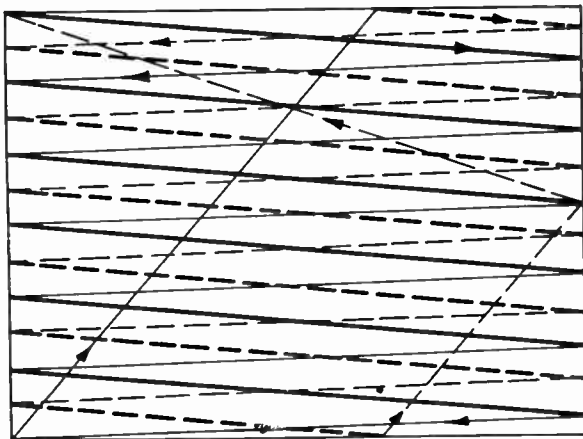

FIG. 1. Odd-line interlaced scanning system with 13 lines. Consecutive fields are indicated by solid and dotted lines, respectively.

In the standard two-to-one interlaced system, alternate lines are scanned consecutively from top to bottom, after which the remaining lines, that fall in between those included in the first operation, are likewise scanned consecutively from top to bottom. (Figs. 1 and 2 illustrate this principle.) In the 525-line system, each of these groups, called a *field*, consists of  $262\frac{1}{2}$  lines. Two consecutive fields constitute a *frame*, or complete picture, of 525 lines. Each field is completed in  $1/60$  of a second and each pair of fields or frame, in  $1/30$  of a second. The effect on the observer's eye, from the standpoint of flicker, is that of repetition of screen illumination every  $1/60$  of a second, yet the complete picture is spread out over  $1/30$  of a second.

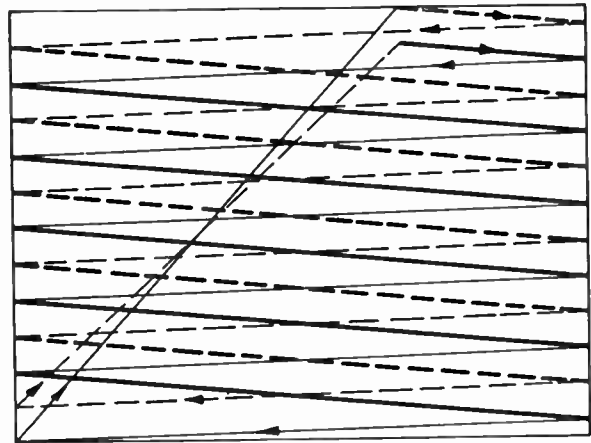

FIG. 2. Even line interlaced scanning system with 12 lines.

The important result of interlacing is a reduction in the bandwidth of the frequencies generated in the picture signal, for a given value of limiting resolution, as compared to the bandwidth produced in a system using sequential scanning. This may be understood as follows. In either system, interlaced or sequential, the vertical scanning frequency must be the same and must be high enough to avoid the sensation of flicker. In the standard television system this frequency is 60 cycles per second. In a sequential system, *all* of the scanning lines must be traversed in the basic vertical scanning period. However, in the two-to-one interlaced system, only *half* of the scanning lines are traversed in the same period. Thus, obviously, the horizontal velocity of motion of the aperture in the interlaced system is only half of the velocity in the sequential system, and likewise the signal frequencies are reduced by the same factor.

Interlaced scanning has certain inherent faults among which are interline flicker, and horizontal break-up when objects in the scene move in the horizontal direction.

Interline flicker results from the fact that adjacent scanning lines are separated in time by  $1/60$  of a second, and that each line is repeated only at intervals of  $1/30$  of a second. It is apparent in any part of a scene where some detail of the scene is largely reproduced by a few adjacent scanning lines, and where the contrast in the detail is high. For example, the top edge of a wall which is oriented in the scene so as to be nearly parallel to the scanning lines might be reproduced by only two or three adjacent lines. The 30-cycle flickering of the line segments forming the edge of the wall would be quite noticeable. In the limiting condition, where the wall is exactly parallel to the scanning lines, the edge would be reproduced by only one line repeated at intervals of  $1/30$  of a second. This is probably the worst possible condition, but one which is encountered rather infrequently. The top and bottom edges of the raster nearly always produce objectionable interline flicker because they are nearly parallel to the scanning lines. Interline flicker, like any other type of flicker, is most objectionable in scenes where the highlights are very bright and the contrast is high. When the brightness and contrast are low, interline flicker becomes negligible.

Break-up exists when an object in the scene moves in the horizontal direction rapidly enough to cause the total motion in  $1/60$  of a second to be equal to one or more picture elements. Then vertical edges of the object become jagged lines instead of smooth lines and there is apparent loss in horizontal resolution. This is roughly illustrated in Fig. 3 where two rectangles are shown, the upper one being stationary, and the lower one moving toward the right. The moving rectangle is shown as though it started moving from a position directly below the other. In the moving rectangle, signal is generated, *in both fields*, from the starting position of the left edge because of the storage of information in the pickup tube during the interval between fields. Thus the storage effect causes actual blurring of the trailing edge of a moving object. This is illustrated by the thin extensions of the scanning lines in the second field at the left side. The leading edge of the moving object may have a more definite jagged appearance because the storage effect in the pickup tube cannot fill in the spaces. In non-storage pickup devices, both edges will appear jagged.

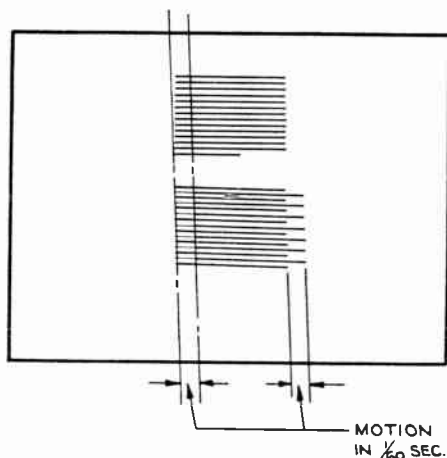

FIG. 3. Effect of horizontal motion on resolution of vertical edges in 2-to-1 interlaced system. Upper object stationary. Lower object moving to right.

The geometrical distortion, illustrated by the tendency for the moving rectangle to become rhombic, is characteristic of any scanning system, whether interlaced or sequential. It is similar to the effect produced by a focal-plane shutter in a photographic camera.

Further consideration makes it clear that higher ratios of interlacing would produce these troubles in aggravated form, which would be intolerable. Another objection to higher ratios of interlacing is an illusion of crawling of the scanning lines either up or down, depending on motion of the observer's eyes. The effect is extremely annoying and tends to distract the observer's attention from the scene.

The type of interlacing adopted for commercial television is known as *odd line* interlacing. The total number of lines is an *odd* integer. Thus the number of lines in each of two equal fields is a whole number plus a half. In this system, the use of perfectly uniform vertical

scanning periods (equal to half the product of the total number of lines and the period of one line) and constant vertical scanning amplitude, results in consecutive fields which are displaced in space with respect to each other by half a line, thus producing interlacing of the lines, as illustrated by the 13-line system in Fig. 1. Specifically, as stated above, the total number of lines in the standard system is 525; the number per field is  $262\frac{1}{2}$ ; the vertical scanning frequency is 60 cycles per second; the number of complete pictures (frames) per second is 30; and the horizontal scanning frequency is  $60 \times 262\frac{1}{2}$ , or 15,750 cycles per second.

Interlacing may also be obtained when the total number of lines is an *even* number, but *even-line* interlacing requires that alternate fields be displaced vertically one-half line with respect to each other by the addition of a 30-cycle component to the amplitude of the vertical scanning sawtooth wave (see Fig. 2). This frame frequency component must have a degree of accuracy that is impractical either to attain or maintain. Hence even-line interlacing is not used for commercial television.

One other factor has influenced the choice of the particular number of scanning lines. This is the need for an exact integral relationship between horizontal and vertical scanning frequencies. It has been the practice to attain this relationship by using a series of electronic counting circuits. To secure a high degree of stability, the characteristic count of each circuit was limited to a small integer less than ten. Thus the h/v frequency ratio was required to be related to the combined product of several small integers. In the RCA synchronizing generator equipment, for example, there are four such circuits counting the numbers 7, 5, 5, and 3 respectively. The combined product of these four numbers is 525, the number of lines per frame. The product of 525 and 60 is 31,500 which is the frequency of the master oscillator in the sync generator. To obtain the correct frequency for the horizontal scanning system, another counter circuit divides the master oscillator frequency by two to yield the required frequency of 15,750 cycles.

#### Synthesis of the Picture Signal

The basic part of the signal applied to the reproducer is the series of waves and pulses generated during the actual scanning lines in the pickup or camera tube. No matter what else is done in the equipment intervening between the two ends of the system, this basic part of the signal should be preserved in character with the greatest possible accuracy. However, during the retrace periods, the pickup tube may generate signals which are spurious or which at least do not contain valuable picture information. Furthermore, retrace lines in the reproducing tube itself, especially during vertical retrace, detract from the picture. It is therefore desirable to include in the picture signal, components which will eliminate spurious signals during retrace and the retrace lines themselves in the reproducer. These results may be obtained by adding synthetically some pulses known as blanking pulses.

Blanking pulses are applied to the scanning beams in both the camera tube and the kinescope in the receiver. *Camera blanking* pulses are used only in the pickup device and never appear directly in the final signal radiated to the receiver. They serve to close the scanning aperture in the camera tube during retrace periods. In orthicon tubes, the picture signal during retrace thus goes to reference black or to some level constantly related to reference black. This is a useful result to be discussed later. In iconoscopes, no such constant relationship to black exists during retrace, and the only function of camera blanking is to prevent spurious discharge of the mosaic during the retrace periods.

*Kinescope blanking* or *picture blanking* pulses are somewhat wider than corresponding camera blanking pulses. They become integral parts of the signal radiated to the receiver.

The function of the kinescope blanking pulses is to suppress the scanning beam in the kinescope (reproducing tube), or in other words, to close the aperture in the receiver during the retrace periods, both horizontal and vertical. They are simple rectangular pulses having duration slightly longer than the actual retrace periods in order to trim up the edges of the picture and eliminate any ragged appearance. They are produced in the sync generator from the same basic timing circuits that generate the scanning signals; hence they are accurately synchronized with the retrace periods. Typical wave-shapes of a basic camera signal and blanking pulses are illustrated in Fig. 4, A and B respectively. Only parts

of two scanning line periods are shown, and the pulse in B is therefore a single *horizontal blanking pulse*. The result of adding the signals in A and B is shown in C, where it may be seen that the unwanted spurious part of the camera signal has been pushed downward out of the territory of the basic picture signal. This unwanted part may now be clipped off and discarded, leaving the signal illustrated in D.

The blanking signal, shown only in part in Fig. 4B, actually contains pulses for removing visible lines during both horizontal and vertical retrace periods. The horizontal pulses recur at intervals of  $1/15,750$  of a second and are only a small fraction of a line in duration; but at times corresponding to the bottom of the picture they are replaced by *vertical blanking pulses* which are just like the horizontal pulses, except that they are of much longer duration, approximately 15 scanning lines long, because the vertical retrace is much slower than the horizontal. The period of recurrence of the vertical blanking pulses is of course  $1/60$  of a second. Both horizontal and vertical blanking pulses, and their approximate relationship, are shown in diagrams 1 and 2 of Fig. 5.

The picture signal shown in D of Fig. 4 may be considered as partly natural and partly synthetic. It is important to point out here that the natural part, or basic camera signal, may contain certain noise components arising from the fact that the output of the pickup tube usually is not large compared to the noise threshold of the first picture amplifier stage or some other part of the system, such as the scanning beam in an image orthicon. On the other hand, the blanking pulses, or synthetic parts of the signal, are added at a relatively high-level part of the system and are therefore noise-free (at least in the transmitted signal). The importance of noise-free blanking pulses will become apparent in the discussions of other functions which they perform.

Details of horizontal blanking pulse shape are shown in diagram 5 of Fig. 5. That part of the diagram below the point marked Blanking Level is a synchronizing (sync) pulse which will be considered later. The overall vertical dimension  $\beta$  is the maximum height of a blanking pulse. Thus the top horizontal line is Reference White Level, as indicated in diagram 3. The duration, or width, of the pulse must be sufficient to cover the horizontal retrace in the most inefficient receiver. Thus, the circuit limitations in such receivers set a minimum limit to the horizontal blanking width which was the basis for the RTMA specification in Fig. 5. This minimum is indicated by the width near the peak (lower end) of the pulse and is prescribed by the sum of two dimensions  $x + y$ , the value of which is 16.5% of the horizontal period,  $H$ . The impossibility of producing infinitely steep sides on the pulse is recognized in the greater maximum width (18% of  $H$ ) allowed at the upper end of the pulse and in the obviously sloped sides.

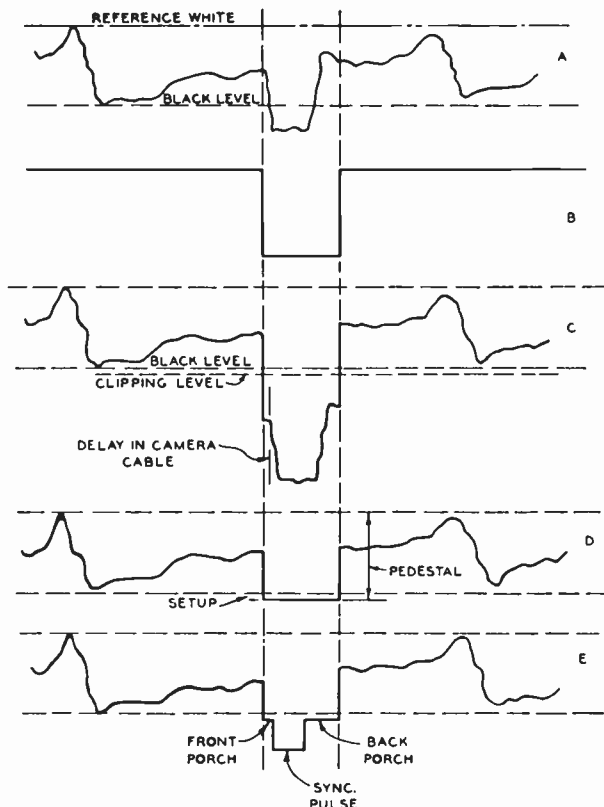
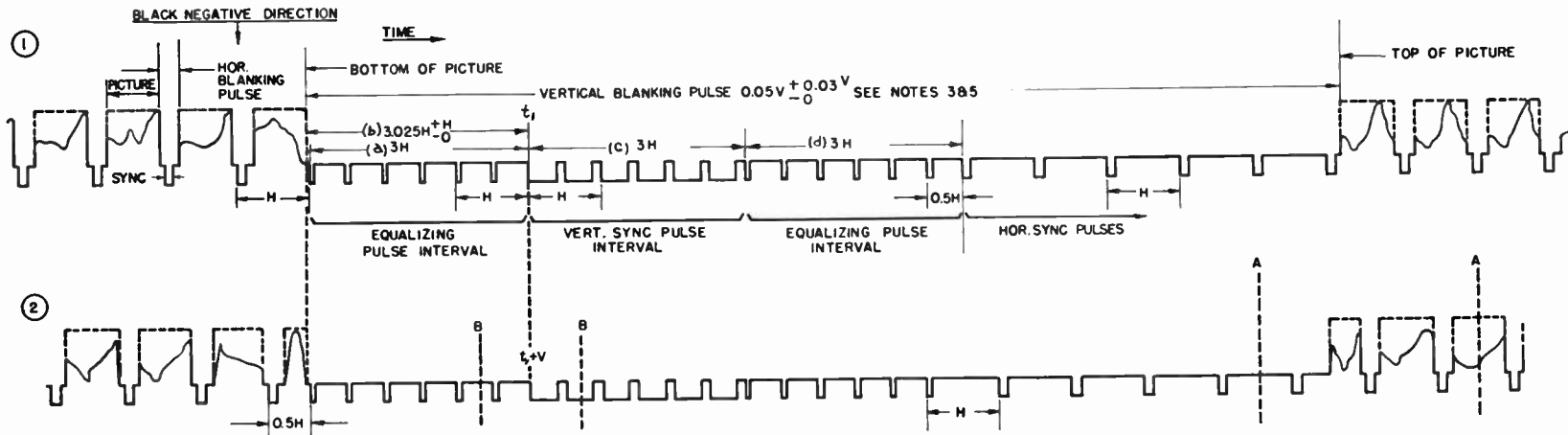

FIG. 4. Steps in synthesis of picture signal.

PICTURE LINE AMPLIFIER STANDARD OUTPUT

SYNCHRONIZING SIGNAL AMPLITUDE  $\alpha$  SHALL BE HELD CONSTANT WITHIN  $\pm 4\%$  DURING ANY TRANSMISSION.  
 $\alpha$  MAY HAVE ANY VALUE BETWEEN 0.375 AND 0.625 VOLTS.  
 THE RATIO  $\frac{\alpha}{V}$  SHALL BE 0.25.  
 DRAWINGS NOT TO SCALE.



3 DETAIL BETWEEN A-A IN 2

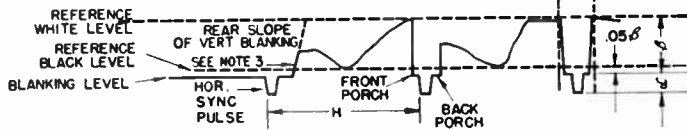

4 DETAIL BETWEEN B-B IN 2

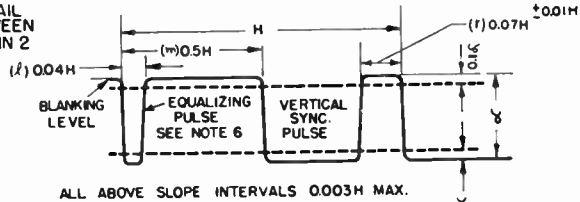

ALL ABOVE SLOPE INTERVALS 0.003H MAX.

5 DETAIL BETWEEN C-C IN 3

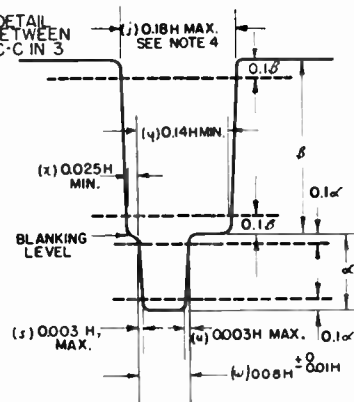

NOTE :-

- 1.H= TIME FROM START OF ONE LINE TO START OF NEXT LINE.
- 2.V= TIME FROM START OF ONE FIELD TO START OF NEXT.
- 3.LEADING AND TRAILING EDGES OF VERTICAL BLANKING SHOULD BE COMPLETE IN LESS THAN 0.1H.
- 4.LEADING AND TRAILING SLOPES OF HORIZONTAL BLANKING MUST BE STEEP ENOUGH TO PRESERVE MIN. & MAX. VALUES OF (x+y) AND (i) UNDER ALL CONDITIONS OF PICTURE CONTENT.
- 5.ALL TOLERANCES AND LIMITS SHOWN IN THIS DRAWING APPLY FOR LONG TIME VARIATIONS ONLY AND NOT FOR SUCCESSIVE CYCLES.
- 6.EQUALIZING PULSE AREA SHALL BE BETWEEN 0.45 AND 0.5 OF THE AREA OF A HORIZONTAL SYNC PULSE.
- 7.ALL SLOPE INTERVALS TO BE MEASURED BETWEEN 0.1 AND 0.9 AMPLITUDE REFERENCE LINES.
- 8.THE OVERSHOOT ON BLANKING SIGNAL MUST NOT EXCEED 0.02 $\alpha$  AT THE BEGINNING OF THE FRONT PORCH AND MUST NOT EXCEED 0.05 $\alpha$  AT THE END OF THE BACK PORCH. THE OVERSHOOT ON SYNCHRONIZING SIGNALS MUST NOT EXCEED 0.05 $\alpha$ .

HPG - 213

RMA SUB-COMMITTEE ON STUDIO FACILITIES APPROVED JAN. 22, 1946  
 REVISED OCT. 9, 1946

FIG. 5. Standard television signal.

Because of inevitable discrepancies at the extremes of the sides of the pulse, all measurements of pulse widths are made at levels slightly removed from the extremes of the sides. These levels are shown by dotted horizontal lines in diagram 5 of Fig. 5, spaced 10% of  $\beta$  from top and bottom of the pulse.

Details of the vertical blanking pulses are shown in diagrams 1 and 3 of Fig. 5. The width of the pulses is not limited by circuit considerations, as is the width of horizontal blanking. The limitation here is the requirement of television film projectors of the intermittent type, that the scene be projected on the pickup tube only during the vertical blanking period. The maximum period of 8% is ample for the operation of present-day film pickup systems, the criterion being that enough time must be allowed for projection so that there is adequate storage of photoelectric charges on the sensitive surface of the pickup tube. The minimum period of 5% is an indication of expected system improvements in the future, when it will be possible to reduce waste of picture transmission time in vertical blanking. The present usefulness of the 5% minimum is to require receiver manufacturers to maintain vertical retrace periods at less than 5% and thus avoid the need for modifying old receivers when improvements are made in the system. The problem of film projectors is discussed in a later section.

The final step in synthesizing the complete composite picture signal which goes to the modulator in the transmitter is to add the synchronizing pulses which are required for triggering the scanning circuits in the receiver. These pulses, like blanking pulses, are essentially rectangular in shape. The blanking pulses serve as bases or pedestals (inverted) for the sync pulses, as shown in E of Fig. 4. Here is one of the most important reasons for having noise-free blanking. The synchronizing function in the receiver is a very critical one, and it is important that nothing be allowed to distort the sync pulses either in shape or timing, as noise during the blanking intervals would do. The nature of the vertical sync signal is rather complicated; it is not illustrated in Fig. 4, but will be discussed later along with other details of synchronizing.

The sync signal is not added individually to the output of each camera, but is added at the studio output so that switching from one camera to another will not cause even momentary interruptions in the flow of synchronizing information to the receivers.

#### The D-C Component of the Picture Signal

The visual and aural senses differ in one important respect which places a requirement on the television transmission system which has no counterpart in the sound transmission system. The response of the ear to sound is actually a response to variations in air pressure. While the ear is very sensitive to rapid variations in pressure, it is completely unconscious of absolute values of air pressure, or of slow variations in pressure, as

sound. In other words, there is a definite low limit to the frequency of pressure variations which the ear accepts as sound. Therefore there is no need, for a sound transmission system, to pass frequencies below the aural limit which is somewhere in the neighborhood of 15 cycles per second. The circuits may be a-c coupled without loss of essential information. Even the best of practical systems have a low-frequency cutoff at about 30 cycles, and most others cut off somewhere between 50 and 100 cycles.

The eye, on the other hand, is sensitive to absolute intensities of light and to slow variations of intensity. As the frequency of variation increases, the eye rapidly loses its ability to follow the changes and tends to produce a sensation which is an average of the variations. It is this averaging ability that enables the eye to interpret a rapid succession of still pictures as a portrayal of smooth motion. This phenomenon is the basis of both motion picture and television systems.

The important point, in the present discussion, is that the eye recognizes a slow change in light intensity. The period of the change may be a fraction of a second or it may be a minute, an hour, or a half-day in length. A television system must be capable of conveying these slow changes, no matter how long the period, to the receiver. The rapid scanning of the image of the scene in the camera produces a signal containing these slow changes as well as very rapid variations caused by the passage of the scanning beam over small light and dark areas of the image. The slow changes often have periods so long that they may be considered as d-c levels which simply change value occasionally. Hence, the signal is said to contain a d-c component. The television system must either pass the entire spectrum, including the d-c component, in each of its stages, or the signal must contain such information that it will be possible to restore the d-c component, which would be lost in an a-c coupled system, when it finally arrives at the reproducer. Because of the well-known difficulties in constructing multistage d-c coupled amplifiers, it is desirable to use an a-c coupled system. It is fortunate that relatively simple means are known for d-c restoration, thus making possible the use of an a-c coupled system.

Fig. 6(a) illustrates a signal which contains a d-c component in the form of a temporary change in the

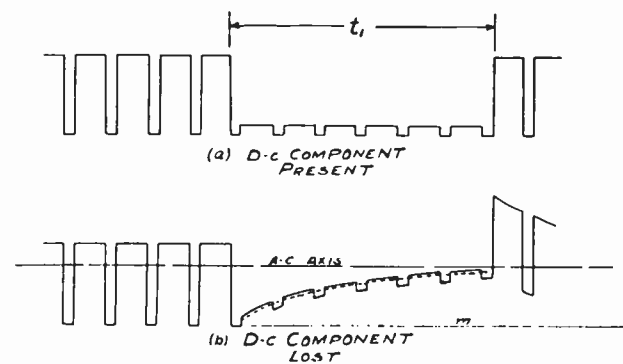

FIG. 6. D-C component.

amplitude of the pulses. The period  $t_1$  embracing the low-amplitude pulses may be of any arbitrary length. The original signal is characterized by the constant level of the negative peaks of all the pulses, regardless of amplitude. After passing through an a-c coupled system (in which the time constants of the coupling networks are short compared to the period  $t_1$ ), the signal becomes distorted approximately as shown in Fig. 6(b). Here the negative pulse peaks no longer fall on a constant level, but the signal tends to adjust itself in a consistent manner about an axis called an a-c axis.

The a-c axis of a wave is a straight line through the wave, positioned so that the area enclosed by the wave above the axis is equal to the area enclosed by the wave below the axis. The broken line marked a-c axis in Fig. 6(b) is actually the correct axis only for a wave composed of large pulses like the first four at the left. During the transient condition following the first short pulse, the line shown is not the true a-c axis, but represents the operating point of the amplifier in the a-c coupled system. The actual a-c axis of the short pulses (shown by the dotted line) gradually adjusts itself to coincide with the operating point of the amplifier. This adjustment is shown by the exponential rise of the signal during the interval  $t_1$ , but it is interrupted before completion by the resumption of the large pulses. Thence a second transient condition takes place, leading to a gradual restoration of the signal to its original form.

The departure of the pulse peaks from the original constant level indicated by the line  $m$ , is called *loss of the d-c component* or loss of "lows". It is interesting to note that this loss causes an increase in the peak-to-peak amplitude of the signal, a condition which is undesirable, especially in high-level amplifiers.

### Black Level

An absolute system of measurement must have a fixed standard reference unit or level. This rule applies to the problem of reproducing absolute light intensities. The simplest and most obvious reference for such a system is zero light, or *black level* as it is often called. This is a reference level which can be reproduced arbitrarily at any point in the system. Now if the television signal can be synthesized in such a way that frequent short intervals have some fixed relationship to actual black in the scene, then it becomes possible to restore the d-c component by forcibly drawing the signal to a fixed arbitrary level during these intervals.

### D-C Insertion and D-C Restoration

Because the blanking or retrace periods are not useful for transmitting actual picture information, they offer convenient intervals for performing special control functions such as d-c restoration as mentioned in the previous paragraph. If the peaks of the blanking pulses are coincident with black level, or differ from black level by a constant amount, then d-c restoration can be accomplished simply by restoring these peaks to an arbitrary

reference level. Thus, in Fig. 6(b), if the peak of each pulse can be restored to the line  $m$ , then the signal will appear as in (a) and the d-c component will have been restored. Small errors will remain, corresponding to the displacements in level between pulses, but these are usually negligible and in any case do not become cumulative. Hence the restoration is essentially complete.

It now becomes apparent that an extremely important step in the synthesis of the television signal is that of making the peaks of the added blanking pulses bear some fixed relationship to actual black level in the scene. It was pointed out previously that the peaks of these pulses are produced by clipping off unwanted portions of the signal, as illustrated in Fig. 4, C and D. A second, and most important, function is performed when the clipping is controlled in such a way that the resultant peaks have the required fixed relationship to black level. This process of relating the blanking peaks to actual black level is called *d-c insertion*, or insertion of the d-c component. A subsequent process, later in the system, of bringing these peaks back to an arbitrary reference level is called *d-c restoration*. D-c restoration must be accomplished at the input of the final reproducing device (the kinescope) in order to reproduce the scene faithfully.

It is desirable to restore the d-c component at other points in the system also, because the process reduces the peak-to-peak excursions of the signal to a minimum by removing increases in amplitude caused by loss of the d-c component. In a similar way, it is possible to remove switching surges, hum, and other spurious signal components which have been introduced by pure addition to the signal. Maintaining minimum excursion of the signal is important, especially at high-level points in the system, in order to avoid saturation in amplifiers and consequent distortion of the half-tones in the scene. For a specific example, d-c restoration helps to maintain constant sync amplitude in high-level amplifiers. In other words, it makes possible economies in the power capabilities of amplifiers such as the final stage in the picture transmitter.

Diagram 3 in Fig. 5 illustrates part of a typical picture signal including two horizontal blanking pulses. It may be seen that there is a distinct difference between actual black level and blanking level which is prescribed as 5% of maximum blanking pulse amplitude. This difference is usually called *setup* and its magnitude was set as a reasonable compromise between loss of signal amplitude range and the need for a tolerance in operating adjustment. Setup is desirable as an operating tolerance in the initial manual adjustment of the clipper in that part of the system where the d-c is *inserted*. It simply insures that no black peaks in the actual picture signal are clipped off.

The accuracy with which setup is maintained depends on characteristics of the pickup or camera tube. Some types of pickup tubes produce signals during blanked retrace periods which are the same as, or are constantly



related to, black level. In systems where such tubes are used, the magnitude of setup may be held constant automatically at whatever value is determined in the initial manual adjustment of the clipper circuit. In general, pickup tubes employing low-velocity scanning, such as the image orthicon, provide this kind of basic black level information. The iconoscope differs from orthicons in this respect, because the secondary emission resulting from the high-velocity scanning produces a potential distribution on the mosaic in which black level is far from the level existing during the retrace periods when the beam is cut off. In fact, the difference between black level and blanking level varies continuously as the scene brightness changes, because the potential distribution caused by resetting of the secondaries likewise changes. Automatic maintenance of setup, or pedestal height, cannot therefore be obtained by reference to the signal during blanked retrace periods in the iconoscope, but may be obtained by reference to actual black peaks in the picture signal. Where such reference is not practical, a manual control may be readjusted from time to time to keep the setup at the required value.

### Synchronizing

The horizontal and vertical scanning circuits in a receiver are two entirely independent systems, both of which require extremely accurate information to keep them in step with the corresponding scanning systems in the camera, where the signal originates. Because the duration of sync pulses may be rather short, these pulses may be added to the picture signal in such a way as to increase the overall amplitude of the final signal without increasing the average transmitted power level very much. Thus, simple amplitude discrimination can be used to separate the synchronizing information from the incoming composite signal in the receiver. It is, however, desirable that a second increase in amplitude should not be used to distinguish between horizontal and vertical sync. The reason for this is that a further increase in signal amplitude would make necessary an increase in the peak power rating of the transmitter or else would unnecessarily restrict the power available for the picture and horizontal sync portions of the signal.

A synchronizing system has therefore been chosen in which both vertical and horizontal pulses have the same amplitude, but different waveshapes. Frequency discrimination may then be used to separate them in the receiver. The shapes of these pulses and their relation to the blanking pulses are illustrated in detail in Fig. 5. Fig. 7 is a functional block diagram showing the steps necessary to "utilize" the sync signals.

Diagrams 1 and 2 of Fig. 5 illustrate a typical complete composite picture signal in the neighborhood of the vertical blanking pulse in each of two successive fields. Interlacing of the scanning lines is shown by the time displacement of the horizontal blanking pulses in one diagram with respect to those in the other diagram. This displacement is one-half of the interval of a scanning line ( $H/2$ ).

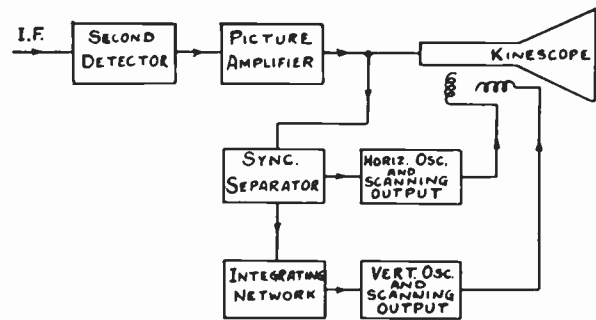

FIG. 7. Block diagram of picture-signal amplifier and scanning circuits in typical receiver.

All sync pulses appear below black level in an amplitude region which is sometimes called *blacker-than-black*; hence they can have no effect on the tonal gradation of the picture. Horizontal sync pulses (except during the first portion of the vertical blanking interval) are simple rectangular pulses, such as those appearing at the negative peaks or bases of the horizontal blanking pulses and during the last portion of the vertical blanking pulses. The duration of a horizontal sync pulse is considerably less than that of the blanking pulse, and the leading edge of the sync pulse is delayed with respect to the leading edge of blanking, forming a step in the composite pulse which is called the *front porch*. Correspondingly, the step formed by the difference between the trailing edges of sync and blanking is called the *back porch*. The purpose in forming the front porch is to insure that the horizontal retrace in the receiver (initiated by the sync pulse) does not start until after the blanking pulse has cut off the scanning beam. It also insures that any discrepancies which may exist in the leading edge of blanking do not effect either the timing or the amplitude of sync.

The choice of the nominal width of horizontal sync ( $0.08 H$ , see diagram 5 of Fig. 5) was influenced by three factors. First, the width should be as great as possible so that the energy content of the pulses will be large compared to the worst type of noise pulses which may be encountered in the transmission process, thus providing maximum immunity to noise. Second, the width should not be greater than is necessary to meet the first condition, because average power requirements of the transmitter may thereby be minimized. Modulation of the picture transmitter is such that sync pulses represent maximum carrier power; hence it is desirable to keep the duty cycle as small as possible. Third, the horizontal sync pulses should be kept as narrow as possible so as to maintain a large difference between these pulses and the segments of the vertical sync pulses described in the following paragraph. Such a large difference makes it easier to separate the vertical sync from the composite sync signal. It has also been recognized that the back porch is useful for a special type of clamping for d-c restoration. Hence it should be as wide as possible.

Vertical sync pulses are also basically rectangular in shape, but are of much greater duration than the hori-

zontal pulses, thus providing the necessary means for frequency discrimination to distinguish between them. However, each vertical sync pulse has six *slots* cut in it, which make it appear to be a series of six wide pulses at twice horizontal frequency, *i.e.*, wide compared to horizontal sync pulses. The slots contribute nothing to its value as a vertical sync pulse but do provide means for uninterrupted information to the horizontal scanning circuit.

Before and after each vertical pulse interval are groups of six narrow pulses called *equalizing pulses*. These also are for the purpose of maintaining continuous horizontal sync information throughout the vertical sync and blanking interval. The repetition frequency of the equalizing pulses and the slots in the vertical pulses is twice the frequency of the horizontal sync pulses. This doubling of the frequency does two things. First, it provides an arrangement in which the choice of the proper alternate pulses makes available some kind of a horizontal sync pulse at the end of each scanning line in either even or odd fields. Second, it makes the vertical sync interval and both equalizing pulse intervals exactly alike in both even and odd fields. The importance of this latter result will become evident in following paragraphs. It is important to point out that the leading edge (downward stroke) of each horizontal sync pulse and of each equalizing pulse, and the trailing edge (again the downward stroke) of each slot in the vertical pulses are responsible for triggering the horizontal scanning circuit in the receiver; hence the intervals of  $H$  or  $H/2$  apply to these edges.

Perhaps the most difficult problem in synchronizing, and the one in which there is the largest number of failures, is that of maintaining accurate interlacing. Discrepancies in either timing or amplitude of the vertical scanning of alternate fields will cause displacement, in space, of the interlaced fields. The result is non-uniform spacing of the scanning lines, which reduces the vertical resolution and makes the line structure of the picture visible at normal viewing distance. The effect is usually called *pairing*. The maximum allowable error in line spacing in the kinescope, to avoid the appearance of pairing, is probably 10% or less. This means that the allowable error in timing of the vertical scanning is less than one part in 5000. This small tolerance explains why so much emphasis is placed on the accuracy of vertical synchronizing.

The presence of a very minute 30-cycle component in the *vertical* scanning invariably causes pairing. The fact that the rasters produced in alternate fields are displaced with respect to each other by half a line means that the *horizontal* sync signal has an inherent 30-cycle component. It is this situation, and the need to prevent any transfer of the 30-cycle component into the vertical deflection, which account for the introduction of the double-frequency equalizing pulses before and after the vertical sync pulses. The vertical sync pulses are separated from the composite sync signal, before being applied to the vertical scanning oscillator, by suppressing the hori-

zontal sync pulses in an integrating network similar to that illustrated in Fig. 8.

Most receivers employ integrating networks of three stages instead of the two illustrated. However, the general character of the circuit action is clearly shown by the wave-form diagrams in Fig. 8. In simple terms, the equalizing pulses before the vertical sync pulses cause the integrating network to "forget" the difference between alternate fields by the time the vertical sync pulses begin. This is illustrated by the gradual convergence of curves  $f$  and  $g$  during the equalizing pulse interval, as the result of integration in the first stage alone. The effect of further integration in the second stage is shown by curve  $h$ , which is typical of the pulses applied to the vertical oscillator in a receiver. Thus, the 30-cycle component is effectively eliminated, from the standpoint of accurate timing of the start of vertical retrace, by the addition of the first set of equalizing pulses and the slots in the vertical pulse itself. The second set of equalizing pulses which follow the vertical pulse affect to some extent the impedance of the circuit to which the vertical scanning oscillator is coupled, and thus affect the amplitude of its output; hence these pulses help to provide more nearly constant output of the oscillator. Both sets of equalizing pulses contribute materially to the necessary accuracy of vertical synchronizing.

The width of an equalizing pulse is half the width of a horizontal sync pulse (see diagram 4 of Fig. 5, and Fig. 8). This width is chosen so that the a-c axis of the sync signal does not change at the transition from the line-frequency horizontal sync pulses to the double-frequency equalizing pulses. The curves  $f_2$  and  $g_2$  in Fig. 8 illustrate the undesirable effect of making the equalizing pulses the same width as the horizontal sync pulses. There is a slight rise in the integrated wave during the equalizing pulse interval, which could cause premature triggering of the vertical oscillator in the receiver if the hold control were adjusted near one end of its range. This rise in the integrated wave results from the change in the a-c axis.

The width of the slots in the vertical sync pulses is approximately equal to the width of the horizontal sync pulses. The slots are made as wide as possible so that noise pulses or other discrepancies occurring just prior to the leading edge of a slot (*i.e.*, near the end of the preceding segment of a vertical pulse) do not trigger the horizontal oscillator. Premature triggering can happen if the noise pulse is high enough and if it occurs very close in time to the normal triggering time. Increased time-separation (a wider slot) reduces likelihood of such premature action. Here again, the requirements of special clamping also are met more easily if the slots are made as wide as possible.

A further important advantage of the RTMA system of separating the vertical sync by frequency discrimination is that the integrating network is a potent factor in reducing the effect of noise on vertical synchronizing. Noise signals contain mostly high-frequency components; hence they are almost completely suppressed by the integrating circuit.

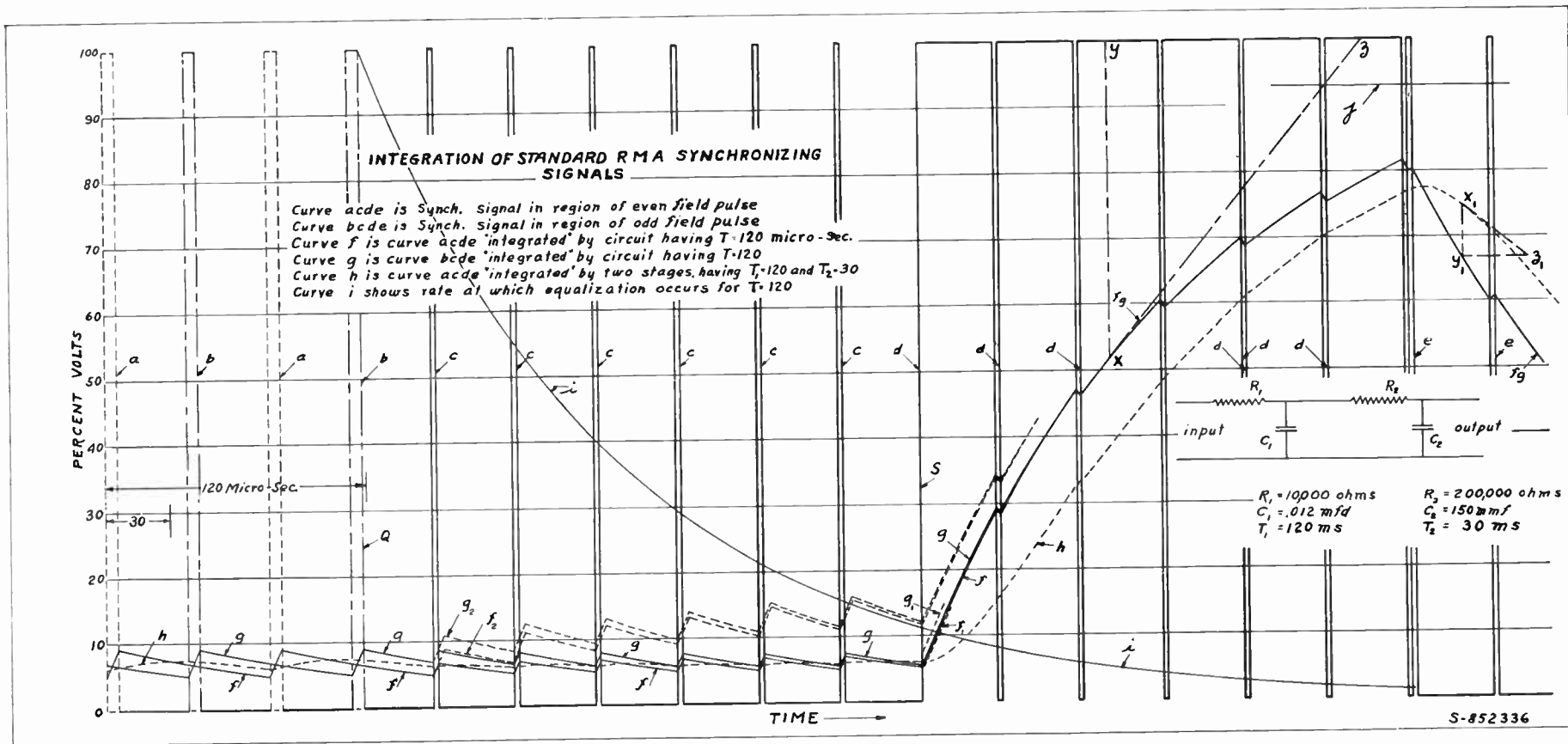

FIG. 8. Integration of RTMA synchronizing signals.

Differentiation, or suppression of the low-frequency components, of the sync signal before it is applied to the horizontal scanning oscillator is done sometimes, but it is not necessary, and has not been indicated in Fig. 7.

The methods just described for synchronizing the scanning circuits in a television receiver are complicated by the need for transmitting the complete information over a single channel. In the case of the scanning circuits in the cameras, however, the situation is very different. The cameras and the synchronizing generator are so close to each other that there is no problem in providing as many wire circuits as may be desired. Therefore it is customary to use what are called *driven* scanning circuits in cameras and sometimes in picture monitors used with the cameras. Separate pulse signals, called *driving signals*, are produced in the synchronizing generator for exclusive use in the terminal equipment. Horizontal and vertical driving signals are completely independent of each other in the RCA system and are carried on separate transmission lines to the points of application. The driving signal pulses trigger directly the sawtooth generators which produce the scanning wave forms. This method reduces interlacing errors in the terminal equipment to the errors inherent in the driving signals.

Fig. 9 illustrates a portion of the scanning lines appearing on a kinescope as a result of the application of a television signal composed of RTMA sync and blanking pulses. The group of lines shown are those occurring in the neighborhood of the vertical retrace period including a few before and a few after the vertical blanking pulse. As noted on the diagram, the triggering of the lines has been displaced both vertically and horizontally so that the shadows produced by the sync and blanking pulses appear near the center of the raster rather than in the normal positions at the edges of the raster. This displacement is brought about simply to clarify the illustration of the effect of the pulses on the raster.

The shadows produced thus are called a *pulse cross*. When expanded vertically so that individual scanning lines become easily apparent, the pulse cross becomes a ready means of checking the performance of the sync generator. The shadows produced by the different pulses are indicated clearly on the diagram. With linear scanning, the horizontal dimensions of the shadows are measures of time or pulse width, and, because of the expanded scale, they provide a relatively accurate means of measuring pulse width. Furthermore, by counting appropriate lines, the numbers of equalizing pulses, slots, vertical sync pulses, etc., can be checked easily.

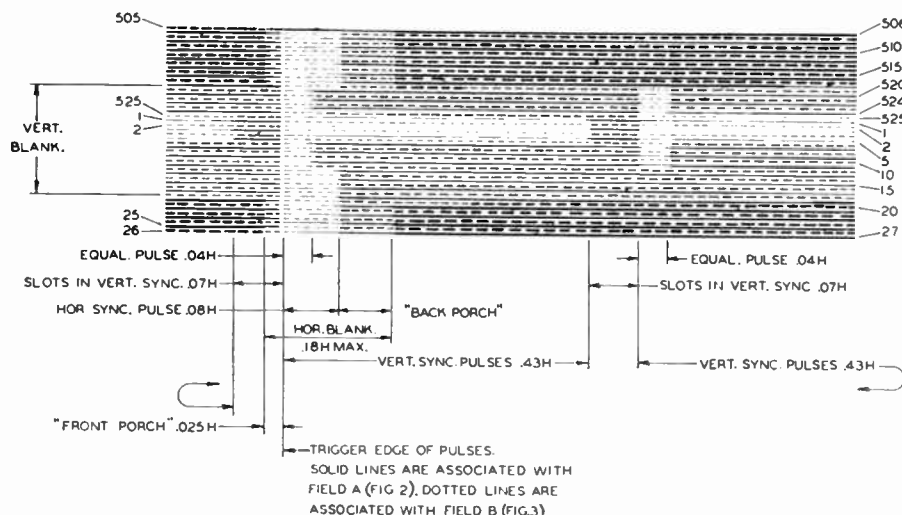
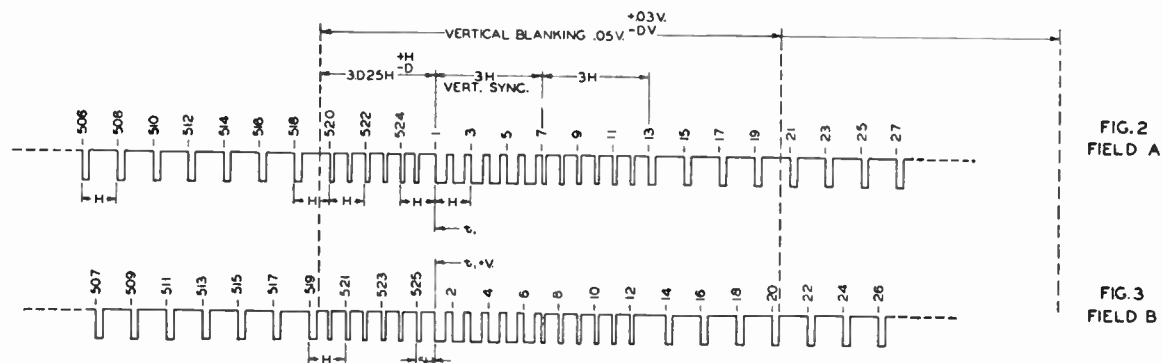

FIG. 9. Television synchronizing signal and pulse cross.

FIG. 2  
FIELD A  
  
FIG. 3  
FIELD B

FIG. 1  
SCANNING LINES AS THEY  
APPEAR ON KINESCOPE  
WHEN SYNC IS DISPLACED  
SO AS TO APPEAR NEAR  
CENTER OF RASTER.

A useful piece of station test equipment can be made by modifying the deflection circuits in a picture monitor to provide the displacement of the lines and the extra large vertical expansion described.

### Automatic Frequency Control of Scanning

The constant search for means of immunization against the effects of noise has brought about the development of automatic frequency control (afc) of the scanning circuits in television receivers. In triggered circuits, each scanning line (and each field) is initiated individually by a pulse in the incoming signal. In contrast to this, in an afc system, scanning generators are governed by stable oscillators which, in turn, are controlled by voltages obtained from phase comparison of the incoming sync pulses with the scanning signals themselves. The time-constant of the comparison circuit is usually made long, compared to the period of the scanning, so that random noise pulses have very little effect on the resulting control voltage, and correspondingly little effect on the scanning frequency. The fact that such afc circuits are keyed provides a further immunization factor by eliminating the possible effect of all noise pulses except those which coincide with the short keying intervals. The use of afc scanning circuits makes possible accurate synchronizing of a receiver under such bad conditions of noise that the masking of the picture by the noise renders it completely unusable. Thus, failure to synchronize may be largely eliminated as a limiting factor in picture reception.

AFC may be used with both vertical and horizontal scanning circuits, but so far is being used commercially for horizontal circuits only. One reason for not using afc with the vertical circuits is that the time-constant must be very long to provide a stable control voltage. As a result, the circuit will not recover from an extended interruption of the incoming signal until an intolerably long time has elapsed. The frequency of the oscillator drifts during an interruption, and may not recover for a large number of seconds after the signal returns. During the period of recovery, the raster rolls over continuously at a decreasing rate until control is restored. The time-constant of the horizontal circuit, on the other hand, may be short enough so that recovery takes place in less than one field. Triggered scanning circuits, of course, recover from signal interruptions very rapidly, but they do not have the same high immunity to noise that the afc circuits have.

As a result of the use of afc circuits in receivers, a high degree of frequency stability is required in the horizontal sync and blanking signals. Frequency modulation of the horizontal pulses is intolerable because it causes the right- and left-hand edges of the blanked raster in the receiver, as well as vertical lines in the scene, to assume the same shape as the modulating wave. As shown in Fig. 10, the border of the complete raster in the receiver is rectangular, but frequency modulation of the horizontal sync and blanking will distort the shape of the border produced by blanking. Frequency modulation by a 60-cycle sine wave is illustrated.

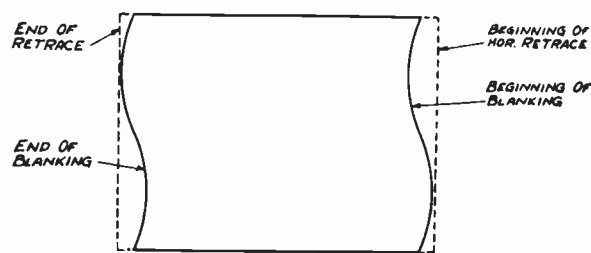

FIG. 10. Effect of frequency modulation of horizontal sync and blanking on shape of raster in receiver with AFC of horizontal scanning.

Horizontal retrace begins along a straight vertical line regardless of timing; and since this retrace is controlled by a stable oscillator in the receiver which is not responsible to short-time changes in sync timing, the presence of variations in sync timing and of corresponding changes in blanking pulse timing, will show as a displacement of the edges of the blanked raster. The frequency stability of the sync generator must therefore be at least equal to the stability of the oscillators used in afc receivers. The maximum rate of change of frequency allowable in a sync generator has been specified by RTMA as 0.15% per second. This is a rather strict tolerance, as indicated by the fact that it allows a total displacement of only 1/32 of an inch (approx.) in a period of one field in a picture 10 inches wide.

### Film Projection

The use of standard sound motion picture film for television program material offers a special problem which arises from the difference in the picture repetition rates use. For reasons explained previously, the rate used for television is 30 frames and 60 fields per second. The standard speed for sound film, both 16mm and 35mm, is 24 frames per second, and since each frame is projected twice, the picture rate is 48 per second. The basic problem of reconciling the frequency difference has been met by using special projectors for television, in which alternate frames of the film are projected twice and the remainder are projected three times. In this way, 60 pictures are obtained in place of the usual 48, but the average speed of the film through the projector is unchanged; hence the sound take-off is entirely normal.

Another problem also presents itself in the use of intermittent film projectors for television. The vertical scanning period occupies from 92% to 95% of the total period. If the projected image is to be thrown on the pickup tube during the scanning period at all, it must be for the entire time so that all parts of the area will be subject to the same lighting conditions. Such an arrangement would leave only the vertical retrace period (5% to 8% of the total, or approximately one thousandth of a second) in which to pull down the film to the next frame. 35mm film will not stand up under accelerations produced by sprocket-hole pull-down in such a short period; hence some other scheme must be used. The method which has been adopted for use with intermittent projectors makes use of the storage property of certain kinds of pickup tubes, such as the iconoscope. The frame of film is projected with very intense illumination during

the vertical blanking period only, while neither the pickup tube nor the receiver is being scanned. Then the light is cut off and the pickup tube is scanned in the absence of any optical image from the film. The signal generated during this scan results from charges stored on the sensitized surface during the preceding flash of light. While the light is cut off during the scan there is ample time to pull the film down before the next flash of light, without exerting destructive forces. The pulses of light may be obtained by chopping the output of a continuous source with a rotating disk, or (with a special type of arc lamp) by pulsing the source itself by electronic means. The storage properties of pickup tubes for this purpose must be sufficiently good so that dissipation of the stored charges is negligible between light pulses. Appreciable dissipation causes loss of contrast at the bottom of the picture.

Another solution to the problem of film projection in television is the use of a continuous projector, a type which produces a stationary image from continuously moving film by means of moving mirrors or lenses. This solution has not been accepted commercially so far because of practical difficulty in making the optical system sufficiently accurate to stop motion of the image completely.

The film problem in England, Europe, and other areas where 50-cycle power systems are standard, and where the television field frequency is also 50 cycles per second, is simpler in one respect, namely that it is not necessary to use the two-three ratio for projection of alternate frames of film. Instead, the film is projected as it is in theaters where each frame is projected twice. No attempt is made to compensate for the difference between the 24 frame taking speed and the 25 frame projection speed. The results are an approximate 4% increase in the apparent speed of motion of objects in the scene (which is probably negligible) and a slight rise in the pitch of all sounds. This latter effect is the more objectionable of the two, though generally it is not noticeable in speech and many other ordinary sounds. The change in pitch is undoubtedly noticeable to the trained musician in the case of musical sounds and must produce an unpleasant mental reaction to the music. However, no easy solution to the problem is known, and the situation is accepted without serious complaint. The other aspects of the film problem are not affected by the use of 50 fields instead of 60.

## References

The preceding discussion is necessarily brief and cannot serve as much more than an outline for further reading. There are many papers dealing more comprehensively with the details and problems associated with the various parts of the television system. References to some of these are included in the following bibliography. Most of the papers referred to also include references to others which, *in toto*, comprise a comprehensive list.

One book deserves special mention as a reference covering much of the engineering background of our television system. It is entitled, "Television Standards and Practice," (McGraw-Hill Book Co., 1943), and is essentially an abridged version of the proceedings of the National Television System Committee, as edited by Donald G. Fink. It includes a statement of the standards recommended by the Committee to the Federal Communications Commission, discussion of the investigations on which the recommendations were based, and references to pertinent papers.

## Bibliography

### SYNCHRONIZING AND SCANNING

1. "A Study of Television Image Characteristics," W. W. Engstrom, Proc. IRE, Dec. 1933, Apr. 1935.
2. "Scanning Sequence and Repetition Rate of Television Images," R. D. Kell, A. V. Bedford, M. A. Trainer, Proc. IRE, Apr. 1936.
3. "Television Synchronization," E. W. Engstrom and R. S. Holmes, Electronics, Nov. 1938.
4. "Determination of Optimum Number of Lines in a Television System," R. D. Kell, A. V. Bedford, G. L. Fredendall, RCA Review, July 1940.
5. "Postwar Television Standards," A. N. Goldsmith, Televiser (Fall), 1944.
6. Slotted Vertical Sync Pulses, U. S. Patent 2,192,121, A. V. Bedford.
7. Integration of Slotted Vertical Sync Pulses and Use of Double-frequency Equalizing Pulses, U. S. Patent 2,207,775, A. V. Bedford; U. S. Patent 2,223,812, A. V. Bedford.
8. A Synchronizing Generator for the RMA Synchronizing Signal, U. S. Patent 2,258,943, A. V. Bedford.
9. "A Precision Television Synchronizing Signal Generator," A. V. Bedford and J. P. Smith, RCA Review, July 1940.
10. "A New Synchronizing and Blanking Signal Generator," E. Schoenfeld, W. Milwitt, W. Brown, RCA Licensee Bulletin LB-678, Aug. 1, 1946.

### PICKUP TUBES

11. "Television Pickup Tubes with Cathode-ray Beam Scanning," H. Iams and A. Rose, Proc. IRE, Aug. 1937.
12. "The Image Iconoscope," H. Iams, G. A. Morton, V. K. Zworykin, Proc. IRE, Sept. 1939.
13. "Television Pickup Tubes Using Low-velocity Beam Scanning," A. Rose and H. Iams, Proc. IRE, Sept. 1939.
14. "The Orthicon, A Television Pickup Tube," A. Rose and H. Iams, RCA Review, Oct. 1939.
15. "The Image Orthicon, A Sensitive Television Pickup Tube," A. Rose, P. K. Weimer, H. B. Law, Proc. IRE, July 1946.

### THE D-C COMPONENT

16. "D-C Picture Transmission," H. N. Kozanowski, Broadcast News, Aug. 1944.
17. "The Clamp Circuit," C. L. Townsend, Broadcast Engineering Journal, Feb., March 1945.
18. "New Television Field Pickup Equipment Employing the Image Orthicon," J. H. Roe, Proc. IRE, Dec. 1947.
19. "Television D-C Component," K. R. Wendt, RCA Review, March, 1948.
20. "How to Use the Television Stabilizing Amplifier," J. H. Roe, Broadcast News, May 1948.

### MOTION PICTURE PROJECTORS FOR TELEVISION

21. "Some Television Problems from the Motion Picture Stand-point," G. L. Beers, E. W. Engstrom, I. G. Maloff, Jour. SMPE, Feb. 1939.
22. "Application of Motion Picture Film to Television," E. W. Engstrom, G. L. Beers, A. V. Bedford, Jour. SMPE, July 1939.
23. "Film Projectors for Television," R. V. Little, Jr., Jour. SMPE, Feb. 1947.

### RECEIVERS

24. "Television Receivers," E. W. Engstrom and R. S. Holmes, Electronics, April 1938.
25. "Television Receiving and Reproducing Systems," E. W. Engstrom, Jour. App. Phys., July 1939.
26. "Automatic Frequency and Phase Control of Synchronization in Television Receivers," K. R. Wendt and G. L. Fredendall, Proc. IRE, Jan. 1943.
27. "Television Receivers," A. Wright, RCA Review, March 1947.

### GENERAL

28. "Television Standards and Practice—N.T.S.C." edited by D. G. Fink, McGraw-Hill Book Co., Inc., New York, 1943.
29. "Principles of Television Engineering," D. G. Fink, McGraw-Hill Book Co., Inc., New York, 1940.
30. "Television," V. K. Zworykin and G. A. Morton, John Wiley and Sons, New York, 1940.
31. "Cathode-ray Tube in Television," I. G. Maloff and D. W. Epstein, McGraw-Hill Book Co., Inc., New York, 1938.
32. "Television"
  - Vol. I, RCA Institutes Technical Press, N. Y., July 1936.
  - Vol. II, RCA Institutes Technical Press, N. Y., Oct. 1937.
  - Vol. III, (1938-1941) RCA Review, RCA Laboratories Div., Jan. 1947.
  - Vol. IV, (1942-1946) RCA Review, RCA Laboratories Div., Jan. 1947.
33. "Television—A Bibliography of Technical Papers by RCA Authors (1929-1946)," pamphlet published by RCA Review, Nov. 1946.
34. "Noise in Resistances and Electron Streams," J. R. Pierce, Bell System Tech. Jour., Jan. 1948.

# Fundamental Circuit Theory

## Introduction

The foregoing discussion of basic concepts shows that television circuits use vacuum tubes and components in ways that differ significantly from audio- or radio-frequency circuit applications. Sinusoidal wave forms are the exception rather than the rule. Usually the complex wave forms observed in television circuits are rectangular pulses, sawtooth shapes, or combinations of both. Vacuum-tube grids may be driven from a point well below cut-off potential into the positive region where grid current flows. The vacuum tube may operate as a switch in which total voltage and current values are used rather than small incremental quantities. Also time becomes an important factor since certain circuits must function in a particular manner with respect to time. The following notes are concerned with some fundamental television circuits employing concepts outlined above.

## Overdriven Amplifier

An overdriven amplifier is one in which the grid voltage is varied from a point below the tube cut-off voltage to some value in the positive region where grid current flows. This type of amplifier may be used as a limiting or clipping device or as a pulse amplifier. A circuit diagram is shown in Fig. 11.

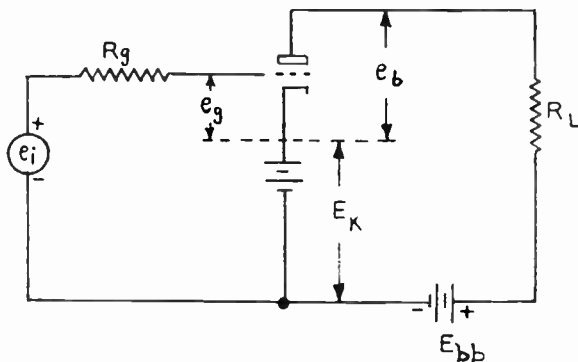

FIG. 11. Overdriven amplifier.

In the overdriven amplifier the following symbols apply:

$r_p$  = d-c plate resistance =  $e_b/i_p$ . For  $e_g = 0$  assume  $r_p$  constant

= 10,000 ohms approximately for 6SN7.

$r_g$  = d-c grid resistance =  $e_g/i_g$ . Assume  $r_g$  constant for given tube

= 1,000 ohms approximately for 6SN7.

$E_{co}$  = grid voltage for plate current cut-off  
=  $E_{bb}/\mu$  for triodes only.

$R_g$  = grid limiting resistor which limits grid voltage to a value slightly positive with respect to the cathode.

Fig. 12 shows an equivalent circuit and the resultant wave forms when a sinusoidal voltage  $e_i$  is applied to the grid. In this equivalent circuit, switches  $S_1$  and  $S_2$  are open when the grid voltage is below cut-off. They are closed when the grid voltage is positive with respect to the cathode.

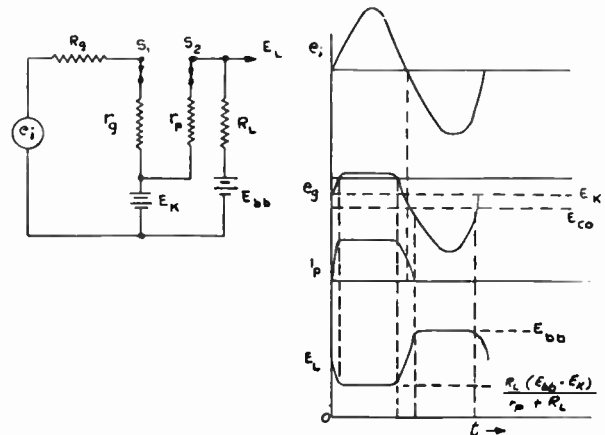

FIG. 12. Overdriven amplifier, equivalent circuit and wave form.

When  $e_i = 0$ , the grid voltage  $e_g$  is equal to  $E_k$ . When  $e_i - E_k = 0$ , grid current flows and limits  $e_g$  to a slightly positive value. The grid voltage remains positive and constant, because of the drop across  $R_g$  (note that  $R_g \gg r_g$ ), until  $e_i$  approaches the 180-degree point of the cycle. During the first half-cycle  $i_p$  rises rapidly to a value determined by  $r_p$ ,  $R_L$ ,  $E_k$ , and  $E_{bb}$ , and then remains constant until  $e_g$  becomes negative. When  $e_i + E_k$  is equal to the cut-off voltage,  $i_p$  falls to zero and no plate current flows for the remainder of the cycle. During the time that  $e_g$  is zero or slightly positive,

$$E_L = \frac{R_L (E_{bb} - E_k)}{r_p + R_L}$$

When plate current is cut off ( $S_2$  open),

$$E_L = E_{bb}.$$

In this circuit the sinusoidal input voltage has been clipped at both top and bottom to give a rough square-wave output voltage.

## Cathode Follower

A linear cathode-follower stage differs from the ordinary amplifier circuit in five ways: (1) the signal polarity is not inverted, (2) the gain is less than 1, (3) the out-

put impedance is low, (4) the input impedance is high, and (5) the input capacitance is lowered. It may be used (1) after a pulse-shaping circuit to prevent loading of the circuit, (2) to drive tubes requiring grid power without altering the waveshape, or (3) as a device to match high to low impedances. It can deliver high currents to a low-impedance load without altering the waveshape. The basic circuit and equivalent circuit are shown in Fig. 13 for incremental quantities.

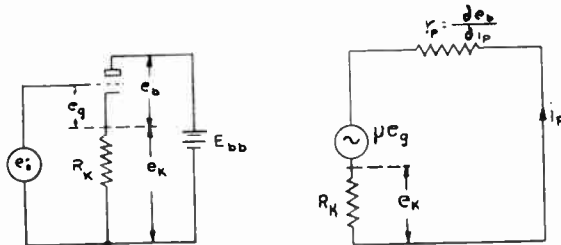

FIG. 13. Cathode follower circuit.

From Fig. 13 it may be seen that  $e_g = e_i - e_k$ ; hence  $\mu e_g$  becomes  $\mu(e_i - e_k)$ . Then in the equivalent circuit

$$i_p = \frac{\mu(e_i - e_k)}{r_p + R_k}$$

and the output voltage  $e_o$  is

$$\begin{aligned} e_o = e_k &= i_p R_k \\ &= \frac{\mu(e_i - e_k) R_k}{r_p + R_k} \end{aligned}$$

from which the gain  $A$  is expressed

$$A = \frac{e_k}{e_i} = \frac{\mu R_k}{r_p + (\mu + 1) R_k}$$

If the amplification factor  $\mu$  is large, compared to 1, the gain  $A$  becomes

$$A = \frac{\mu R_k}{r_p + \mu R_k}$$

In another form, the gain may be expressed

$$\begin{aligned} A &= \frac{\frac{\mu}{r_p} R_k}{1 + \frac{\mu}{r_p} R_k} \\ &= \frac{g_m R_k}{1 + g_m R_k} \end{aligned}$$

The last equation resembles the equation for the gain of an ordinary amplifier stage reduced by the factor

$$\frac{1}{1 + g_m R_k}$$

The grid-to-cathode input capacity is reduced by the same factor, and the total input capacity becomes

$$C_i = C_{gp} + \frac{C_{gk}}{1 + g_m R_k}$$

Similarly, the output impedance is reduced to

$$Z_o = \frac{R_k}{1 + g_m R_k}$$

## Multivibrators

A multivibrator is a circuit arrangement in which two tubes operate as switching elements to control the duration of current flow in the two load resistances. It may be compared to an oscillator, in that its action can be self-sustained. Such a multivibrator is called a "free-running" multivibrator. It may be synchronized to a desired frequency by either a sine wave of the given frequency or by a pulse whose repetition rate is equal to the desired frequency. There is also a type of multivibrator known as a "flip-flop", "one-kick", or "one-shot" multivibrator. This type of multivibrator performs one cycle of operation only when triggered by an external synchronizing signal.

Fig. 14 is a circuit diagram of an unbiased free-running multivibrator. Capacitor  $C_1$  couples the grid of

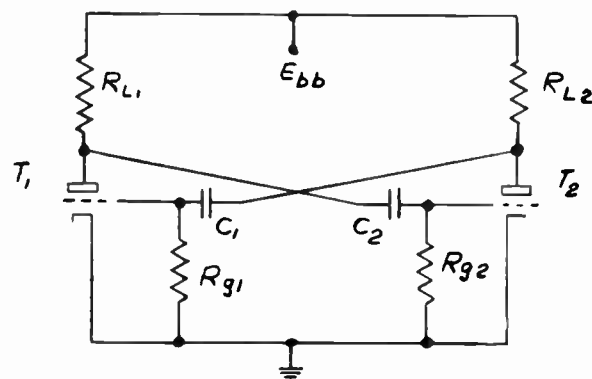

FIG. 14. Unbiased free-running multivibrator.

$T_1$  to the plate of  $T_2$ . Similarly,  $C_2$  couples the grid of  $T_2$  to the plate of  $T_1$ . The circuit operates as follows: Suppose  $E_{bb}$  is applied when both tubes tend to conduct. Any small difference in circuit values or tube characteristics will result in one tube carrying more current than the other. Suppose more current flows in  $T_1$ . The greater voltage drop in  $R_{L1}$  is impressed on the grid of  $T_2$ , making that grid more negative and decreasing the current flow in  $T_2$ . The plate potential of  $T_2$  rises, and this drives the grid of  $T_1$  toward positive potential, causing  $T_1$  to draw a still greater current. The effect is cumulative and results in  $T_1$  carrying maximum current while  $T_2$  is cut off.

The cycle of operation following the cut-off of  $T_2$  is shown in Fig. 15. The plate voltage of  $T_1$  drops to a value equal to

$$\frac{r_p}{r_p + R_{L1}} E_{bb}$$



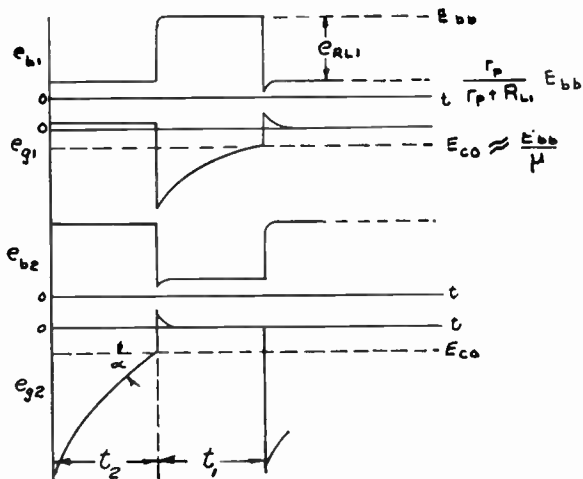

FIG. 15. Operating cycle of free-running multivibrator.

Since the grid of  $T_2$  is coupled to the plate of  $T_1$  through  $C_2$ , the grid voltage of  $T_2$  also drops below zero by an amount equal to  $e_{RL1}$ . Grid voltage  $e_g$  tends to go positive because  $e_{b2}$  rises to  $E_{bb}$  when  $T_2$  is cut off; however,  $C_1$  charges quickly through  $R_{L2}$  and  $r_{p1}$  and leaves  $e_{g1}$  at approximately zero potential. Capacitor  $C_2$  begins to discharge exponentially through  $R_{g2}$  and  $R_{L1}$  and  $r_{p1}$  in parallel. The equivalent circuit, for  $C_2$  discharging, is shown in Fig. 16.

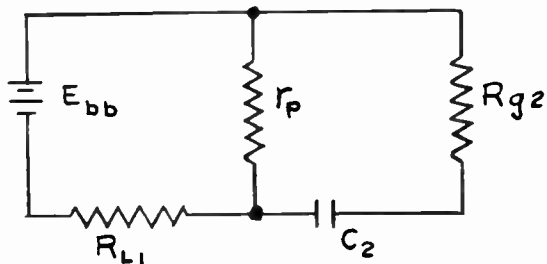

FIG. 16. Capacitor discharge circuit.

The equation for the discharge of a capacitor is

$$e_c = E_0 \epsilon^{-t/RC}$$

where  $e_c$  = voltage on capacitor at time  $t$

$E_0$  = total discharge voltage

$RC$  = time constant of discharge circuit.

Since we are interested primarily in  $e_{g2}$ , we shall consider the voltage across  $R_{g2}$ . At the beginning of the discharge  $e_{g2} = e_{RL1}$ . The steady-state condition toward which  $e_{g2}$  is tending is zero volt; however, when  $e_{g2}$  reaches cut-off voltage, tube  $T_2$  will begin to conduct, and tube  $T_1$  will be cut off.

From Fig. 10 it can be seen that the total resistance in the discharge path is

$$R_{g2} + \frac{r_{p1} R_{L1}}{r_{p1} + R_{L1}}$$

Stray capacity is neglected in the calculations, but tends to round the corners of the plate-voltage wave form as

shown in Fig. 15. From the foregoing we may write the equation for the voltage on the grid of  $T_2$ :

$$e_{g2} = e_{RL1} \epsilon^{-t/RC}$$

$$E_{c0} = e_{RL1} \epsilon^{-t_2/\left(R_{g2} + \frac{r_{p1} + R_{L1}}{r_{p1} R_{L1}}\right)C_2}$$

(specific equation to point of cut-off).

In the usual design problem all the constants are known or can be determined, with the exception of  $R_{g2}$  and  $C_2$ . The value of  $R_{L1}$  is determined by the amplitude of plate-voltage change desired.  $E_{c0}$  and  $r_{p1}$  depend upon the tube type. The time interval  $t_2$  is known for a particular application and is the time that  $T_2$  is not conducting. The product  $R_{g2}C_2$  may be calculated from the equation for voltage across  $R_{g2}$ .

The operation of  $T_1$  follows an identical cycle when it is cut off. The sum  $t_1 + t_2$  of the cut-off periods determines the total period of the cycle. The frequency of the multivibrator may be varied by varying either or both grid resistors.

It will be noted in Fig. 15 that  $e_g$  approaches  $E_{c0}$  at the angle  $\alpha$ . Since this angle is small, any variation in tube characteristics or components causing a shift in  $E_{c0}$  will alter the cut-off period  $t$  because the point of intersection of  $e_g$  with  $E_{c0}$  will change. When it is essential that  $t$  remain nearly constant over a long period of operation, the grid may be returned to  $E_{bb}$  as shown in Fig. 17.

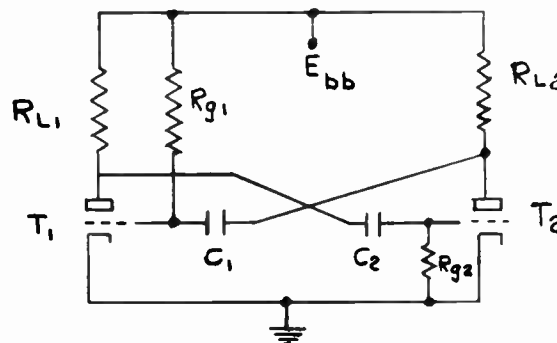

FIG. 17. Grid return circuit.

The discharge wave form for  $e_{g1}$  is shown in Fig. 18. In this example,  $e_{g1}$  is heading for  $E_{bb}$  instead of zero potential as in the previous case, and the angle  $\alpha$  is large. Small variations in  $E_{c0}$  will not greatly alter the

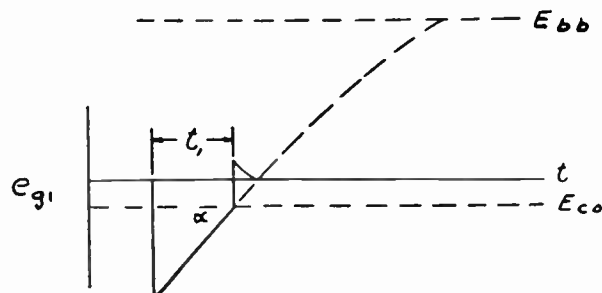

FIG. 18. Grid voltage wave form.

intersection of  $e_{g1}$  and  $E_{co}$ , and thus  $t_1$  will remain very nearly constant. The equation for the discharge of  $C_1$  becomes

$$E_{bb} + E_{co} = (e_{R_{L1,2}} + E_{bb}) e^{-t_1/RC}$$

An example of the so-called "flip-flop" multivibrator is shown in Fig. 19 with the associated wave forms. Tube  $T_2$  is normally conducting, and plate-current flow through  $R_k$  keeps  $T_1$  cut off. When the grid of  $T_1$  receives the trigger pulse,  $e_{p1}$  decreases and drives the grid of  $T_2$  below cut off.  $T_2$  remains cut off until  $C_2$  dis-

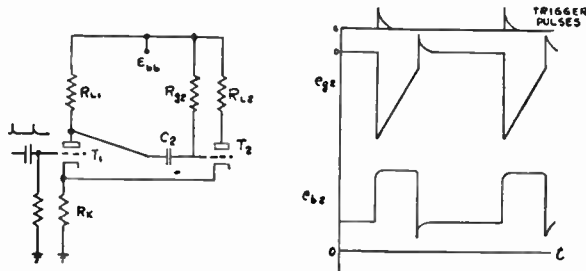

FIG. 19. "Flip-flop" multivibrator.

charges to the cut-off potential, at which point  $T_2$  resumes conduction until another trigger pulse is received.

### Cathode-Coupled Multivibrators

The multivibrators discussed thus far operate well, up to pulse repetition rates of several thousand pulses per second. At higher repetition rates, stray capacity tends to cause unstable operation. To minimize stray-capacity effects and extend the stable range of operation, one can resort to cathode coupling between stages.

A cathode-coupled multivibrator is shown schematically in Fig. 20.

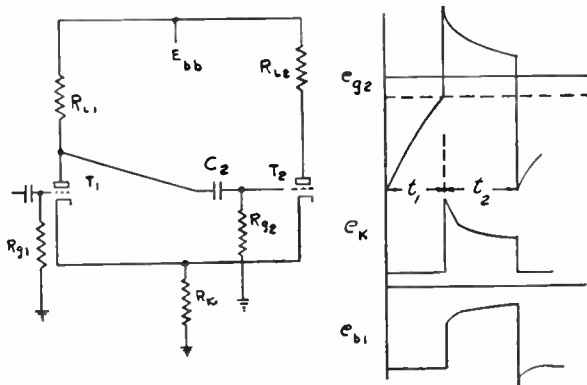

FIG. 20. Cathode-coupled multivibrator.

When  $+B$  voltage is applied to the circuit, plate-current flow establishes across  $R_k$  a bias voltage common to both tubes. At the same time the voltage drop across  $R_{L1}$  is impressed on the grid of  $T_2$ , reducing the plate current in  $T_2$  and lowering the bias voltage across  $R_k$ . With lower bias voltage,  $T_1$  carries a larger plate current, and the resulting plate-voltage drop drives the

grid of  $T_2$  more negative. The process is cumulative and rapid, so that  $T_2$  is cut off quickly.

Capacitor  $C_2$  discharges in normal manner until the grid reaches cut-off potential. This cycle is shown, during  $t_1$ , in Fig. 20. Then  $T_2$  begins to conduct. The flow of  $T_2$  plate current through  $R_k$  reduces the plate current in  $T_1$  because of increased bias. The plate voltage of  $T_1$  rises as the plate current decreases, and this voltage rise is coupled to the grid of  $T_2$  through  $C_2$ . The grid of  $T_2$  is driven positive by this cumulative process. Heavy current in  $T_2$  cuts off  $T_1$ .

Now  $C_2$  begins to charge through  $R_{L1}$  and the parallel combination of  $r_p$  and  $R_{g2}$ . It charges quickly until the grid voltage is reduced to cathode potential. Then  $T_2$  grid current ceases, and  $C_2$  continues to charge through  $R_{L1}$  and  $R_{g2}$ . At the end of the time interval  $t_2$  plate current in  $T_2$  has been reduced sufficiently to allow  $T_1$  conduction. From this point on, the cycle is repeated.

This circuit does not have a stable state, because neither tube can keep the other in cut-off condition, thus it is free-running and unstable. The effect of stray capacity is reduced by interstage coupling to one grid only, and the input capacity of that grid is reduced by cathode-follower action. The controlling signal is coupled between stages by a low-impedance circuit in the cathodes, in which the effect of stray capacity is lessened. A multivibrator of this type may be operated in reliable manner at a pulse repetition rate of a million pulses per second.

### Clipping Circuits

Clipping circuits are used to eliminate undesired portions of complex wave forms by limiting the amplitude excursion in either the positive or negative direction, or in both directions. Clippers or limiters are usually applied in circuits in which pulses are formed and shaped to desired specifications.

Fig. 21 illustrates a simple peak-clipping circuit which may be used to form a square wave from a

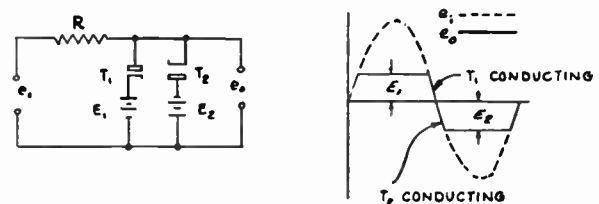

FIG. 21. Peak clipping circuit.

sinusoid. Two diode elements,  $T_1$  and  $T_2$ , are connected as shown. Bias battery  $E_1$  keeps tube  $T_1$  cut off until input voltage  $e_i$  increases in the positive direction to a value equal to  $E_1$ . Further increase in  $e_i$  causes conduction of  $T_1$  and results in a voltage drop across  $R$ . As  $e_i$  increases, both the current in  $T_1$  and the voltage drop across  $R$  increase so that the output voltage  $e_o$  is fairly constant after  $e_i$  becomes slightly greater than  $E_1$ . A similar condition holds for the negative half-cycle of the input voltage. In this, the output voltage increases in the negative direction until bias  $E_2$  is overcome. Then

conduction in  $T_2$  limits the output voltage to a fairly constant value. Wave forms for the cycle of operation are shown in Fig. 21.

To produce, from a sine wave, a square wave with a short rise time by using a clipper of this type, it is necessary to connect several stages in cascade, inserting amplifiers between stages.

The overdriven amplifier discussed on previous pages may also be used for performing a clipping operation. Fig. 22 is a practical triode clipper circuit utilizing a

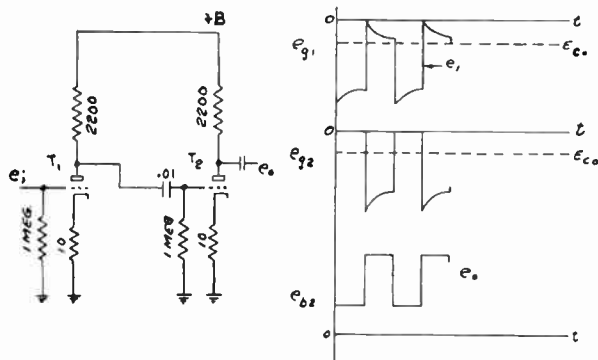

FIG. 22. Triode clipper circuit.

type 6SL7 tube. It may be desirable, for example, to remove overshoots or distortion in the tops of a square wave such as  $e_i$  in Fig. 22. If  $e_i$  is symmetrical about the a-c axis, the grid of  $T_1$  will assume a bias voltage, due to grid current, which will permit just the tip of the pulse to reach zero potential with respect to the cathode. If the pulse amplitude is sufficiently large, the negative excursions will drive the tube beyond cut off and eliminate the overshoot on the negative half-cycle.

The signal on the plate of  $T_1$  consists of a square wave with overshoots eliminated in the positive half-cycle. By passing this signal through  $T_2$ , the overshoot is eliminated in the negative half-cycle, and a clean square wave is obtained in the output.

In the foregoing examples of clipping circuits, the action was symmetrical about the a-c axis. In some cases it may be desirable to clip only the tips of positive pulses, retain the tips, and eliminate the remainder of the wave form. Such a circuit and the appropriate wave forms are shown in Fig. 23. Suppose the input voltage consists of alternate positive and negative pulses ob-

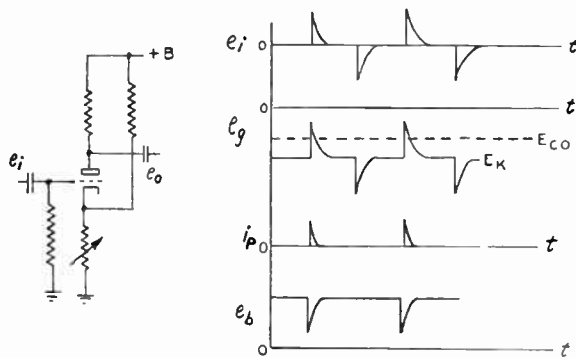

FIG. 23. Clipper circuit.

tained by differentiating a square wave. It is desired to clip the positive pulses midway between the axis and the tips. Voltage relationships are shown in Fig. 23.

The clipping level is set by adjusting the bias in the cathode circuit so that, without signal, the tube is biased beyond cut-off. Only the positive tips of the input pulses cause plate current to flow.

In the clipping circuits described thus far, no attempt has been made to compensate for the inherent curvature near cut-off in the plate-current-cut-off type of clipper. Where the clipper is used to clip the blanking pulse and establish black level, as (c) in Fig. 4, it is imperative that the slope of the grid characteristic curve remain constant to the clipping point; for this will prevent squashing of the video signal near black level and avoid change in the transfer characteristic. The linear clipper shown in Fig. 24 accomplishes the desired result.

The linear clipper circuit includes a pentode  $V_1$ , a load resistor  $R_2$  in series with a diode section  $V_2$ , and an additional load resistor  $R_1$  in parallel with  $R_2$  and  $V_2$ .

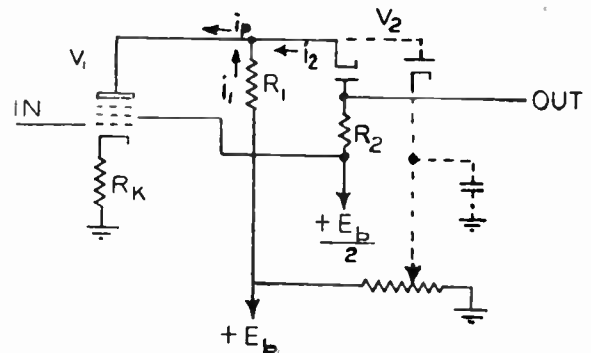

FIG. 24. Linear clipper circuit.

The value of  $R_1$  is approximately 20 to 30 times that of  $R_2$ . Both plate and screen supplies are regulated.

Fig. 25 shows the characteristic curve for the linear clipper.

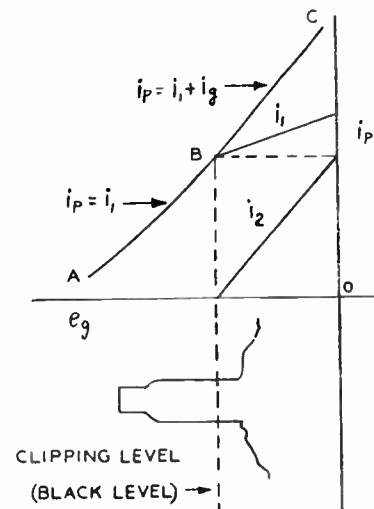

FIG. 25. Linear clipper characteristic.

When  $V_1$  is operating on the linear portion  $B-C$ , the plate current  $i_p$  is  $i_1 + i_2$ , and the plate voltage is less than  $E_b/2$ ; hence  $V_2$  conducts and causes signal current  $i_2$  to flow in  $R_2$ . At point  $B$  the plate voltage of  $V_1$  is equal to  $E_b/2$ . Between  $B$  and  $A$  the cathode voltage of  $V_2$  is greater than  $E_b/2$ ; therefore  $i_2$  is zero, and there is no change in signal output voltage. Thus the blanking pulse is clipped at black level. Only the linear portion of the curve between  $B$  and  $C$  is used for the picture signal.

Cut-off in this clipper is abrupt. The use of a pentode tube permits an abrupt change in external load resistance without affecting plate current. As  $i_2$  approaches zero, the ratio  $i_1/i_2$  changes rapidly, resulting in a rapid change of  $V_2$  cathode voltage in the cut-off region.

By adjusting the equivalent bias on  $V_1$ , point  $B$  can be made to coincide with black level.

A serious drawback of the linear clipper is capacity feed-through of transients. This trouble can be cured by connecting a second diode element, as shown by the dotted lines in Fig. 24. By proper bias adjustment the second diode can be made to conduct at a potential just above cut-off of the limiter so that unwanted signals are shunted to ground when the limiter is inoperative.

### Blocking Oscillators

A blocking oscillator is a form of self-pulsed oscillator that is used as a simple means for obtaining a short pulse at some desired repetition rate. Fig. 26 is a schematic diagram of a simplified blocking oscillator circuit. The coupling coefficient of the iron-core transformer  $T$  is very nearly unity. The connection polarities of the trans-

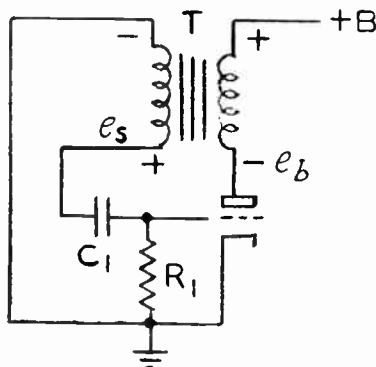

FIG. 26. Blocking oscillator circuit.

former must be as shown. Wave forms for the operating cycle are given in Fig. 27.

When  $B^+$  is applied and plate current starts to flow, a voltage develops in the primary winding, due to the inductance drop  $L di/dt$ . This voltage is coupled to the secondary so as to cause the grid voltage to rise in the positive direction. Thus, the plate current is further increased. The effect is cumulative and causes the grid to go positive quickly. As the grid is driven positive, two actions occur: Grid current flows and charges  $C_1$ ; and plate voltage is reduced to such a low value that further increase in grid voltage will not increase the

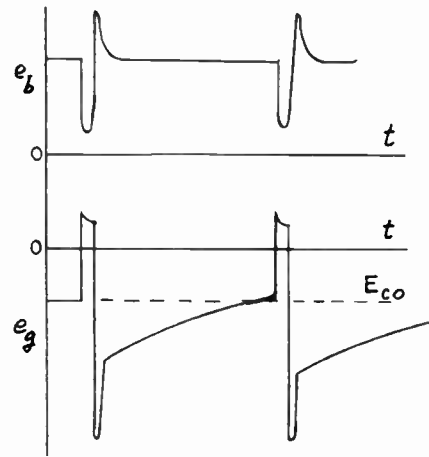

FIG. 27. Blocking oscillator operating cycle.

plate current. The secondary voltage then ceases to increase, and  $C_1$  begins to discharge. The discharge of  $C_1$  lowers the grid voltage, causing a decrease in plate current. The induced voltage in the secondary is in the negative direction, due to the change in  $di_p/dt$ , and the grid is driven quickly below cut-off. Then  $C_1$  is discharged through  $R_1$  and the transformer secondary until the grid voltage is less than cut-off. When plate current starts to flow, the cycle is repeated. The unbiased blocking time is roughly 2 or 3 times  $C_1 R_1$ , depending upon the transformer turns ratio, inductance values, and self-resonant frequency. The blocking oscillator frequency may be controlled by varying the bias on the grid or on the cathode, or by varying  $R_1$ .

The blocking oscillator may be synchronized by applying either a sine-wave or a pulse voltage across a resistor in the ground lead of the transformer secondary.

### Step-Charging Circuits

A step-charging circuit is one in which the potential across a capacitor is built up in a series of steps. Its fundamental use is in a frequency-dividing system in which a blocking oscillator is triggered after a number of steps have been completed. Fig. 28 shows a simple step-charging circuit and the resultant wave forms.

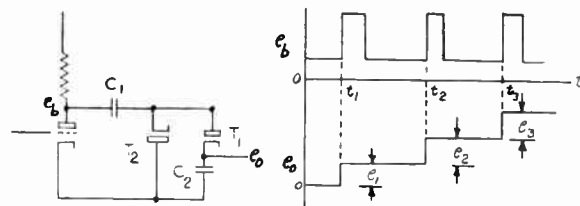

FIG. 28. Step-charging circuit.

Assume that the plate voltage  $e_b$  rises quickly at time  $t_1$  and that  $e_g = 0$ . Diode section  $T_1$  will conduct and charge  $C_1$  and  $C_2$ . The voltage across  $C_2$  is given by the equation.

$$e_1 = \frac{e_b C_1}{C_1 + C_2}$$

When  $e_b$  returns to its minimum value, diode section  $T_2$  will conduct and discharge  $C_1$ . At time  $t_2$  diode  $T_1$  conducts again, charging  $C_1$  and  $C_2$ . This time, however, the total change in  $e_b$  is not divided between  $C_1$  and  $C_2$  since  $C_2$  has on it the voltage developed at time  $t_1$ . Let  $e_1$  denote voltage to which  $C_2$  was charged during the initial pulse. Then

$$e_2 = \frac{(e_b - e_1) C_1}{C_1 + C_2}$$

Each succeeding step may be calculated in the manner shown above. The voltage on  $C_2$  during the preceding step must be subtracted from the peak-to-peak plate voltage in determining the amplitude of the next step.

At the end of a given number of steps, a blocking oscillator is triggered,  $C_2$  is discharged, and the cycle is repeated.

### Non-Linear Mixers

In some television applications, specifically in the synchronizing generator, it is necessary to mix two pulses in such a manner that the resultant signal is not the algebraic sum of the two pulses. In effect, a third pulse is created which differs in character from the original pulses. Consider the circuit in Fig. 29. The 6L7 tube is biased at such a high value that both grids must receive positive pulses before the plate current can flow. During the time that a positive pulse exists on both grids, plate current flows and gives an output voltage as shown.

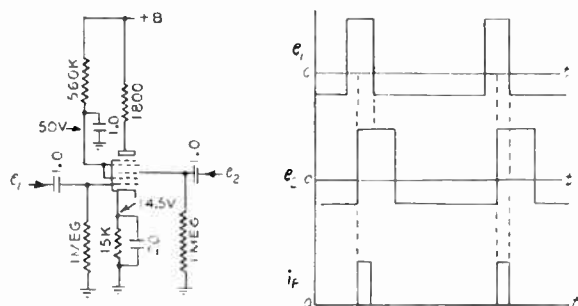

FIG. 29. Non-linear mixer.

Fig. 30 is a curve taken on a type 6L7 tube for the electrode voltages shown. If the bias voltage is set

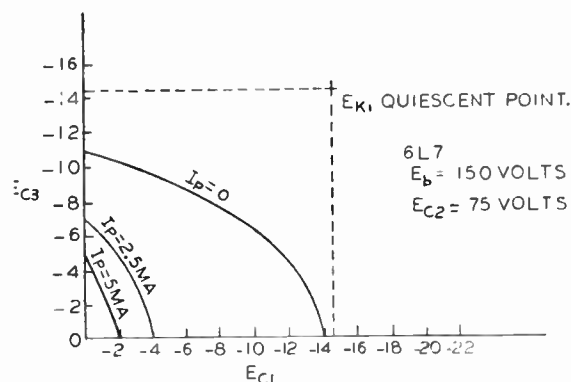

FIG. 30. Characteristics of Type 6L7 Tube.

at  $-14.5$  volts as indicated, either grid potential may be reduced to zero without plate current flow.

### A-F-C Discriminator Circuit

To improve receiver performance, certain limitations have been recommended by the RTMA Committee on Standards for the maximum acceleration of the synchronizing-signal frequency. Also, it is desirable to lock the frequency of the sync generator to a local 60-cycle power supply so as to simplify studio and remote operation. Since the local power-supply frequency may change by an amount exceeding RTMA standards during sudden load changes, a means of delayed frequency control must be devised, in which the acceleration of frequency, in cycles-per-second per-second, does not exceed the recommended standard. Such a circuit is the lock-in circuit shown in Fig. 31.

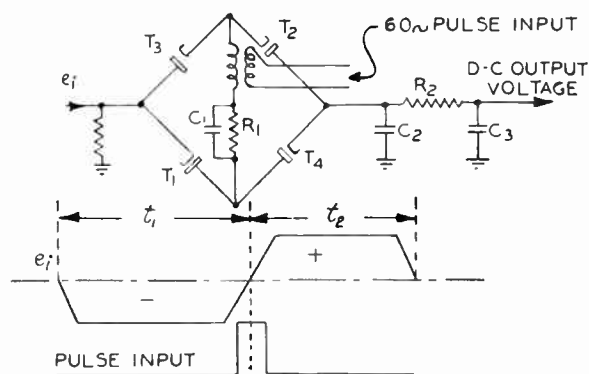

FIG. 31. Frequency control circuit.

The circuit consists of four diode elements in a balanced bridge network. The sine wave of the local 60-cycle supply is clipped and applied across the bridge. A 60-cycle pulse voltage, derived from the synchronizing signal oscillator, is applied to the center leg of the bridge through a transformer. The phase of the local power supply voltage is adjusted so that the pulses occur at the zero-voltage point.

With reference to Fig. 31 it may be seen that, normally,  $T_1$  and  $T_2$  would conduct during the negative half-cycle; however, a bias voltage, built up across  $R_1C_1$ , prevents conduction. Similarly,  $T_3$  and  $T_4$  would normally conduct during the positive half-cycle, except for the bias voltage. The pulse voltage overcomes the bias voltage when the clipped sine wave is passing through zero, and  $T_1$  and  $T_2$  conduct briefly during a small portion of the negative half-cycle, while  $T_3$  and  $T_4$  conduct momentarily during a small portion of the positive half-cycle. If the pulse voltage is in phase with the power line voltage and of the same frequency, the net charge on  $C_2$  will remain the same.

If, however, the frequency relationship between  $C_1$  and the pulse voltage should change, the charge on  $C_2$  will change because the diodes will conduct more during one of the half-cycles than during the other. The time constant of  $R_2C_3$  may be adjusted to provide for slow

changes in the d-c output voltage, thus preventing erratic changes in power-line frequency from appearing in the control voltage.

The d-c output voltage is used to control a reactance tube for changing the frequency of the pulse voltage.

### Reactance Tube Circuit

A reactance tube is used for controlling the frequency of an oscillator by varying the effective tank circuit in the plate of the oscillator. Fig. 32 shows a typical reactance tube circuit.

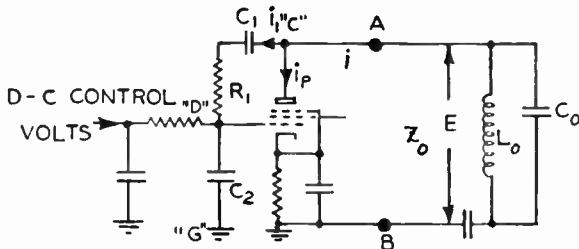

FIG. 32. Reactance tube circuit.

In this circuit,  $R_1 \gg 1/j\omega C_1$ . Let the impedance between points "C" and "D" be  $Z_1 = R_1$ . The impedance from "D" to "G" is  $1/j\omega C_2$ , which we shall call  $Z_2$ . Then we may draw the equivalent circuit shown in Fig. 33.

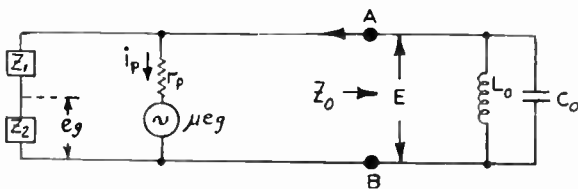

FIG. 33. Reactance tube equivalent circuit.

$$\text{If } Z_1 \gg Z_2, e_g = \frac{E Z_2}{Z_1 + Z_2} \cong \frac{E Z_2}{Z_1}$$

$$\text{If } Z_1 + Z_2 \gg r_p, i_p \cong i$$

$$\text{but } i_p = g_m e_g = \frac{g_m Z_2 E}{Z_1}$$

The admittance, looking into the reactance tube plate is

$$Y_{AB} = \frac{i}{E} \cong \frac{g_m Z_2}{Z_1}$$

or

$$Y_{AB} = \frac{g_m}{j\omega C_2 R_1}$$

Thus, the admittance of the reactance is equivalent to an inductance which would vary with  $g_m$ . The vector diagram of current and voltage relationships is shown in Fig. 34.

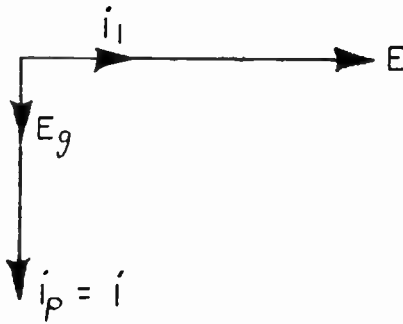

FIG. 34. Reactance tube circuit vector diagram.

Mutual conductance of the reactance tube is varied by changing the d-c grid bias. This circuit, in conjunction with the lock-in circuit previously described, may be used to keep the frequency of an oscillator synchronized to a local power source.

### Sawtooth Generators

A sawtooth generator is a device whose output voltage has a repeating triangular wave shape of which the positive slope is constant. Thus

$$\frac{de}{dt} = \text{Constant}$$

This type of voltage is used as a time base for the scanning of cathode-ray or kinescope tubes. In view of the present television standards, we shall be concerned with sawtooth wave forms whose frequencies are 60 cycles and 15,750 cycles per second.

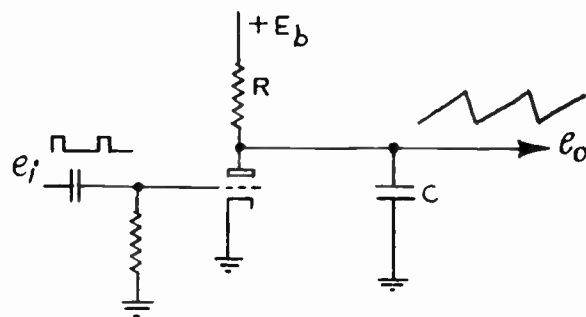

FIG. 35. Sawtooth generator circuit.

Fig. 35 is a circuit diagram of a sawtooth generator commonly used in television equipment.

Assume that  $C$  is charged at the beginning of a cycle. Pulse  $e_i$  is applied to the grid with sufficient amplitude to drive the grid positive. The triode conducts heavily, discharging  $C$ . During the positive pulse interval, the flow of grid current produces a bias voltage across the grid resistor of sufficient amplitude to cut the tube off when the pulse goes negative. Capacitor  $C$  charges exponentially through resistor  $R$  while the tube is cut off between pulses.

In the analysis of the sawtooth generator, certain assumptions will be made. First, we shall assume complete discharge of  $C$  during the pulse. Usually  $r_p \ll R$

and  $t_i$  is long enough to permit the voltage across  $C$  to discharge to  $E_b r_p / (r_p + R)$ . With  $r_p \ll R$ , we have  $e_i \cong 0$ .

Now we shall define a linearity factor  $\lambda$ . Consider Fig. 36 in which we have a linearly increasing voltage

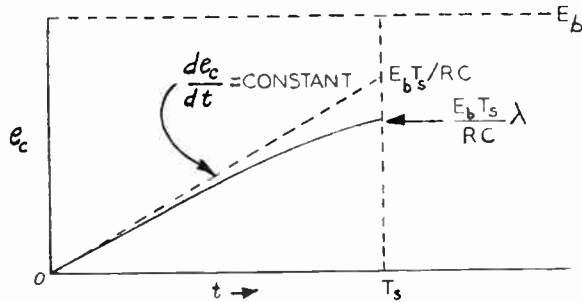

FIG. 36. Analysis of sawtooth voltage.

of constant slope  $de_c/dt$ . Such a voltage may be obtained by making the charging current constant, or

$$\begin{aligned} e_c &= \frac{1}{C} \int_0^t i dt \\ &= \frac{i}{C} t \\ &= \frac{E_b t}{RC} \end{aligned}$$

In the ordinary sawtooth generator circuit, the charging current is not constant, but varies exponentially so that the voltage on  $C$  at the time  $T_s$  is less than the voltage for the ideal case by a factor  $\lambda$ , or

$$e_c = \frac{E_b T_s \lambda}{RC}$$

The linearity factor  $\lambda$  is thus expressed as the percentage of ideal voltage to which  $C$  charges in a simple circuit.

From the simple circuit we know that

$$e_c = E_b (1 - e^{-T_s/RC});$$

hence

$$\lambda = (1 - e^{-T_s/RC}) \frac{RC}{T_s}$$

If we expand the exponential term about zero by means of a McLaurin's series we obtain

$$\begin{aligned} \lambda &= \left[ 1 - \left( 1 - \frac{T_s}{RC} \right) + \left( \frac{T_s}{RC} \right)^2 \frac{1}{2} - \left( \frac{T_s}{RC} \right)^3 \frac{1}{6} + \left( \frac{T_s}{RC} \right)^4 \frac{1}{24} + \dots \right] \frac{RC}{T_s} \\ &= 1 - \left( \frac{T_s}{RC} \right) \frac{1}{2} + \left( \frac{T_s}{RC} \right)^2 \frac{1}{6} - \left( \frac{T_s}{RC} \right)^3 \frac{1}{24} + \dots \end{aligned}$$

Let us take the first two terms and rearrange

$$\frac{2}{\lambda} - 2 = \frac{T_s}{RC} \frac{1}{\lambda}$$

If we restrict the value of  $\lambda$  to the limits 0.75 to 1, we may write

$$\frac{T_s}{RC} \cong \frac{2}{\lambda} - 2$$

Substituting, we obtain

$$\begin{aligned} e_c &\cong E_b \left( \frac{2}{\lambda} - 2 \right) \lambda \\ &\cong 2 E_b (1 - \lambda) \end{aligned}$$

The preceding equations are useful for determining the charging time constant and output voltage for a given supply voltage and linearity requirement. The linearity factor usually varies from 0.90 to 0.95.

### Blocking Oscillator Sawtooth Generator

The sawtooth generator described above requires a pulse driving signal of fairly good rectangular wave shape. If the driving pulse fails, no sawtooth output is obtained. A blocking oscillator can be used as a sawtooth generator to provide output voltage even though the synchronizing source may fail. Fig. 37 is a circuit diagram of such a generator.

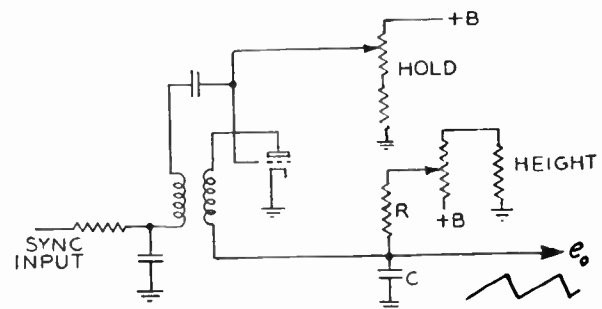

FIG. 37. Blocking oscillator sawtooth generator.

In this circuit,  $R$  and  $C$  form the sawtooth through the charging and discharging action of the tube. Assume that  $C$  is charging through  $R$ . Then the blocking oscillator conducts heavily, discharging  $C$ . When the grid is driven below cut-off, the tube ceases conduction, and  $C$  charges through  $R$ . The blocking oscillator is synchronized by a pulse signal whose wave form need not be rectangular. Frequency is adjusted to the synchronizing signal by the "hold" control. Amplitude of the sawtooth is adjusted by the "height" control.

### Linearity

The linearity of the output voltage from the conventional sawtooth generators described above varies with the time constants used; and the voltage always is an exponential, instead of a linear, function of time. Special methods may be applied to improve the linearity of the sawtooth. One means by which linearity may be corrected is shown in Fig. 38.

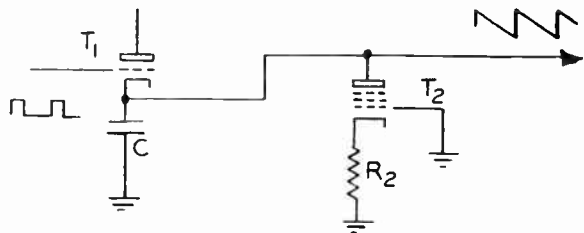

FIG. 38. Sawtooth linearity circuit.

In this circuit  $C$  is charged during the input pulse and discharged through a constant-current pentode  $T_2$ . Since the discharge current is very nearly constant, the voltage on the capacitor becomes

$$e_c = -\frac{1}{c} \int_0^t i dt$$

$$= \frac{Kt}{c}$$

The plate resistance of the pentode can be increased by using a large cathode resistor  $R_2$ , thus increasing the effective plate resistance by  $1/(1 - g_m R_2)$ .

It will be noted that the output is inverted from the conventional sawtooth generator.

By the use of feedback to the pentode of Fig. 38, a perfect sawtooth may be obtained. In Fig. 39 a por-

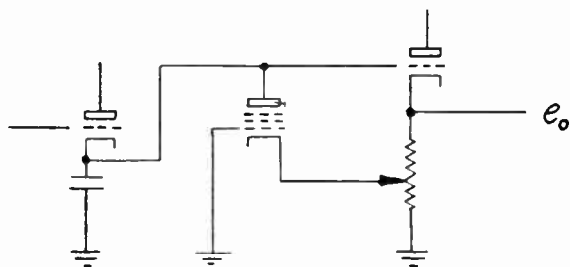

FIG. 39. Linearity feedback circuit.

tion of the sawtooth output is fed back to the cathode of the constant-current pentode. The effective plate resistance is high as  $C$  begins to discharge, and decreases as the discharge proceeds. Not only may a linear sawtooth be obtained, but a strong overcorrection may be attained.

These, and other methods of linearity correction, are described in the December 1946 issue of "Electronics" in the paper "Linear Sweep Circuits," by Robert P. Owen.

### References

- Puckle, O. S., *Time Bases*, John Wiley and Sons, Inc., New York, 1943.
- Owen, Robert P., "Linear Sweep Circuits," *Electronics*, December, 1946.
- Brainerd, J. G., *Ultra-high Frequency Techniques*, D. Van Nostrand Company, Inc., New York, 1942.

### Magnetic Deflection

Deflection of the electron beam in kinescope and camera tubes is accomplished by a uniform magnetic field at right angles to the tube axis. When it travels through the magnetic field, the electron is subjected to a transverse force which causes it to move along an arc of a circle. On leaving the magnetic field, the electron continues along a straight line which is tangent to the arc at the field boundary, as shown in Fig. 40. The elec-

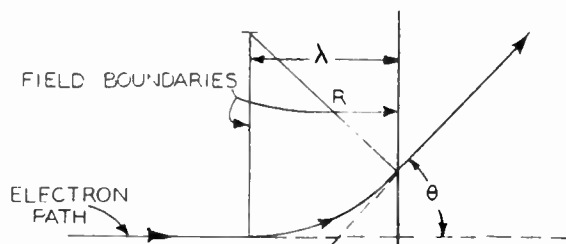

FIG. 40. Electron path at field boundary.

tron emerges from the field at an angle  $\theta$  with respect to the original direction of motion. The total angle of deflection is  $2\theta$ . In present-day kinescope tubes, the maximum angle of deflection is  $50^\circ$  and is limited by inside neck diameter and length of field  $\lambda$ .

The magnetic field required for deflecting the electron beam in a television kinescope or pick-up tube is produced by passing a sawtooth current through a pair of series-connected coils on opposite sides of the tube neck. Formerly, the coils which make up the yoke were wound on a flat rectangular template, and then formed around a cylinder of a diameter equal to, or greater than, the tube neck. Present coils are machine-wound, and the cylindrical forming occurs during the winding process. Fig. 41 is a rough sketch of a modern yoke winding.

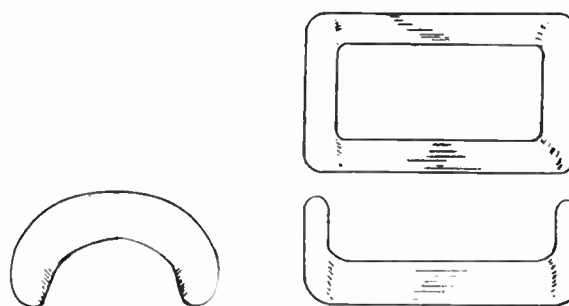

FIG. 41. Deflection yoke winding.

The number of ampere-turns required to produce a given angle of deflection is calculated from

$$NI = \frac{2.68 l_o \sin \theta \sqrt{E_a}}{\lambda}$$

- where  $NI$  = ampere-turns of winding  
 $l_o$  = length of air gap, inches  
 $\lambda$  = length of magnetic field, inches  
 $\theta$  =  $1/2$  total deflection angle  
 $E_a$  = accelerating potential, volts.



Note that the above value  $NI$  is for half the total deflection angle. To obtain  $NI$  for the total deflection angle, multiply by 2.

For a standard 4:3 aspect-ratio television raster, the value of the horizontal-winding ampere-turns is

$$(NI)_H = 0.8 NI$$

while for the vertical winding it is

$$(NI)_V = 0.6 NI.$$

### Vertical Deflection Circuit

Fig. 42 shows a vertical deflection circuit in its simplest form. The vertical yoke winding is transformer-

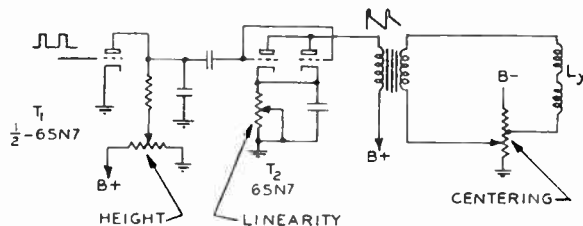

FIG. 42. Vertical deflection circuit.

coupled to a 6SN7 triode,  $T_2$ , with both sections parallel-connected. The driving sawtooth is generated in a conventional sawtooth generator,  $T_1$ .

Practical values for the vertical winding of the yoke are  $L = 48$  millihenrys and  $R = 70$  ohms. At the vertical scanning frequency the load impedance becomes

$$Z_y = 70 + j18.1$$

In the design of the transformer and driving circuit, the inductive component of the load is neglected. The problem then becomes one of designing a transformer which will match the yoke resistance to the driver tube and present sufficient primary inductance for good low-frequency response. A type 6SN7 triode provides sufficient output to deflect a 9-kv beam. The plate resistance of the 6SN7, parallel-connected, is approximately 3500 ohms. For maximum power output, the load should be  $2r_p$ ; therefore the reflected load of the yoke should appear as 7000 ohms on the primary side. The transformer turns-ratio becomes

$$N_p/N_s = \sqrt{Z_p/Z_s} = \sqrt{7000/70} = 10/1.$$

Good low-frequency response is obtained by making the primary inductance large. In the *RADIOTRON DESIGNER'S HANDBOOK* the ratio of low-frequency gain to mid-band gain is given as

$$A_r = \frac{1}{\sqrt{1 + (r_p/L_p)^2}}$$

If the response at 60 cycles is to be 1 db down,  $A_r$  becomes 0.89, from which

$$L_p/r_p = 1.94.$$

For the circuit of Fig. 42 the primary inductance should

be 18 henrys. Actually, for standard vertical-deflection transformers,  $L_p$  varies from 40 to 60 henrys.

Some control of linearity may be obtained by varying the bias voltage of  $T_2$ . Usually, the sawtooth amplitude and bias are adjusted together to place the operating point in the most linear portion of the tube curves.

The picture is centered by adjusting the centering potentiometer so that a steady d-c current flows in the yoke. Current may be caused to flow in either direction to move the picture in either direction.

No external damping of the yoke winding is required, in the majority of cases, since the plate resistance of the tube is reflected to the transformer secondary. If external damping is required, a resistor of proper value may be placed across the yoke winding.

### Automatic Linearity Control

Picture linearity may be corrected by the linearity correction devices previously discussed. Additional tubes and circuit components are required, however, and if the expense is justified, an automatic control may be used.

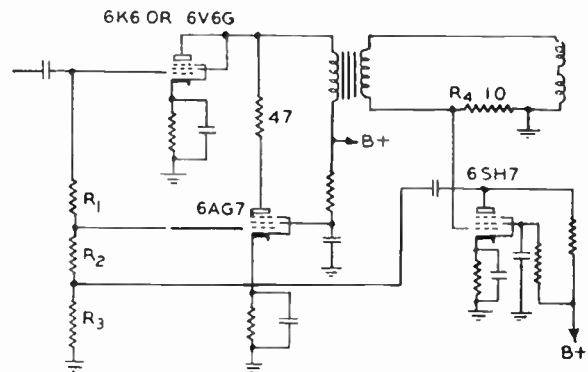

FIG. 43. Automatic linearity control circuit.

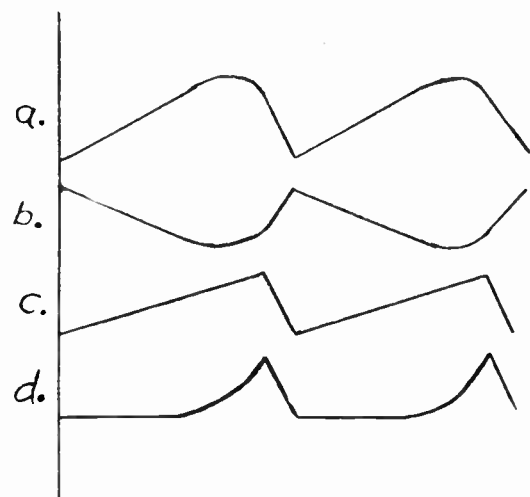

FIG. 44. Sawtooth linearity control.

- a. Current sawtooth containing distortion.
- b. Plate 6SH7 sawtooth plus distortion.
- c. Input sawtooth.
- d. Grid 6AG7 distortion only.

Fig. 43 shows an automatic linearity control circuit developed by the Advanced Development Section, Home Instruments Department.

The circuit operates as follows. A pilot voltage is developed across  $R_4$  in the yoke circuit, which is proportional to the current in the yoke. This voltage contains the distortion of the current sawtooth and is shown in Fig. 44(a).

The distorted sawtooth is amplified in a high-gain pentode and fed to the top of  $R_3$ . A sawtooth of good linearity is fed into the driver tube, 6K6 or 6V6, and also to  $R_1$ . In the resistance network  $R_1R_2$  the linear sawtooth is compared to the distorted sawtooth, and the existing distortion is placed on the grid of the 6AG7. The distortion signal causes the plate of the 6AG7 to draw a current which cancels the original distortion.

In this system, picture size may be changed over wide limits with negligible vertical distortion. The values of  $R_1$  and  $R_2$  should be less than one-half megohm to prevent integration of the linear sawtooth.

### Horizontal Deflection Circuits

Circuit design for magnetic deflection of the electron beam at horizontal-line frequencies requires a different approach than for vertical deflection. At 15,750 cycles-per-second, the yoke presents a load which is almost entirely reactive. Unless means are devised to recover a portion of the power fed into the yoke during trace time, a relatively high amount of power must be expended in deflecting the beam. An ideal cyclic system requires wattless power. Such a system will form the basis for study of the horizontal-deflection problem.

$$\frac{di}{dt} = \frac{E}{L}$$

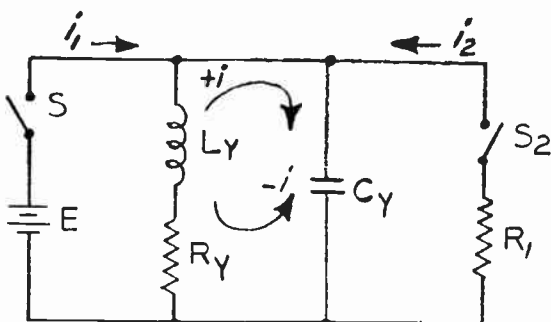

FIG. 45. Equivalent horizontal deflection circuit.

Consider the simple circuit of Fig. 45. The yoke is represented by  $L_y$ ,  $C_y$ ,  $R_y$ . Suppose that switches  $S_1$  and  $S_2$  are open at the time  $t = 0$ . At the beginning of the deflection cycle,  $S_1$  is closed, applying voltage  $E$  across  $L_y$ ,  $R_y$ , and  $C_y$ . If it were not for  $R_y$ , the current through  $L_y$  would increase linearly with time, as expressed by the relation

$$\frac{di}{dt} = \frac{E}{L}$$

Since  $R_y$  is present, the current rises exponentially until

switch  $S_1$  is opened. At this point, the beam has been deflected to the right-hand side of the picture. The magnetic field must be reversed quickly in order to return the beam to the left-hand side of the picture, to begin another trace.

Since  $L_y$ ,  $C_y$ , and  $R_y$  form a resonant circuit, the fastest means for reversing the field is to permit the winding to oscillate for approximately one-half cycle at its natural resonant frequency.

When  $S_1$  is opened, the magnetic energy stored in the field of  $L_y$  is converted into potential energy by the flow of  $+i$  into  $C_y$ , and back into magnetic energy by the flow of  $-i$ , resulting in an almost complete reversal of the field. Losses in the resonant circuit limit the completeness of reversal to

$$\frac{i_1}{i_2} \cong e^{-\pi/2Q}$$

Fig. 46 indicates the current and voltage waveshapes in the yoke for a complete deflection cycle.

When the current in the yoke has reached the value  $i_2$  in the negative direction, switch  $S_2$  is closed, which places damping resistor  $R_1$  across the oscillating circuit. If  $S_2$  were not closed, the yoke would continue to oscillate,

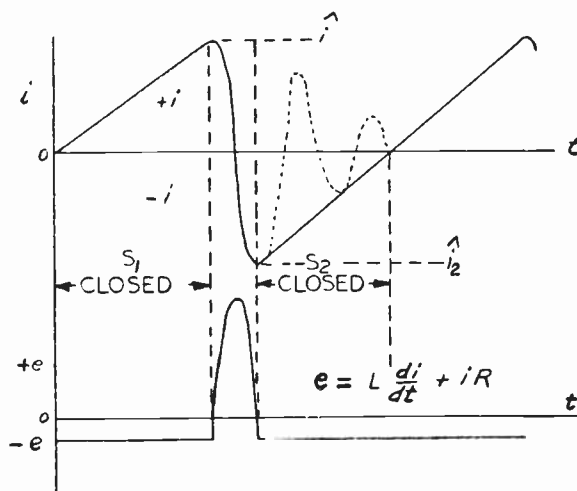

FIG. 46. Deflection-cycle waveshapes.

late, as shown by the dotted lines in Fig. 46. Closing of  $S_2$  causes the oscillatory circuit to be slightly overdamped, so that  $-i$  decays exponentially. When  $-i$  reaches zero,  $S_1$  is closed again to begin another cycle.

Because of the presence of the  $iR$  drop in the inductance, the resultant current wave form in the yoke is exponential instead of being linear with time, as desired. If the  $iR$  drop can be canceled, the total voltage  $E$  may be applied to  $L_y$ , resulting in a linear current in the yoke. Suppose we insert a generator in series with  $E$ , whose characteristic is

$$\frac{\Delta e}{\Delta i} = -R.$$

Then the linear rise of current in  $L_y$  may be obtained. Reference to the plate-family of curves for a vacuum

tube reveals that a tube may serve as such a generator and as an electronic switch to replace  $S_1$ . Also, we may use a vacuum tube to replace  $S_2$  and add  $-R$  for the oscillatory phase. Such a circuit is shown in Fig. 47.

The operation of the tube may be plotted from its family of curves. Refer to Fig. 48. The load line  $-R$  is so drawn that it intersects the plate-voltage, or zero-current, axis at the point  $E - L di/dt$ . A plot of current-versus-time is obtained from the intersection of the  $-R$  line with the grid-voltage lines. The grid-voltage wave-

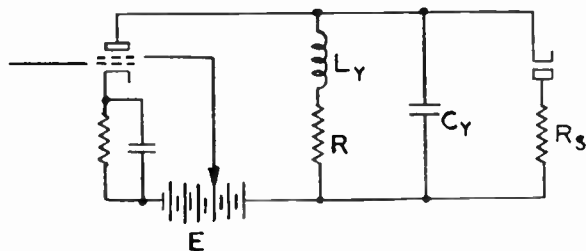

FIG. 47. Electronic switch and generator circuit.

shape  $e_g$  is obtained for the tube by plotting  $E_{c1}$  against time for corresponding values of current  $i$ .

The diode characteristic is plotted in a similar manner. The voltage causing diode conduction, however, becomes  $L di/dt$  and is equal to the drop across the

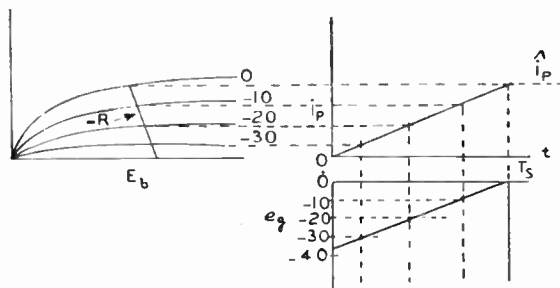

FIG. 48. Tube operating curves.

inductance during trace time. The load line for the diode must be drawn for  $r_d + R_s$ , where  $r_d$  is the diode resistance. Linearity in the diode circuit occurs when

$$R_s = [E - (i_1 R + E_d)]/i_2.$$

The circuit operation may be improved by replacing the diode with a controlled triode. For simplification, a transformer is added, and the circuit becomes the one shown in Fig. 49.

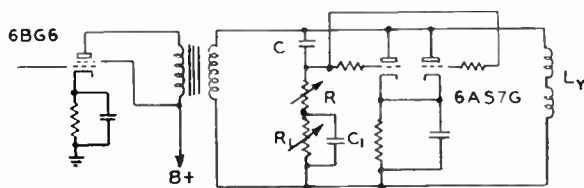

FIG. 49. Improved switching circuit.

The combined characteristics of the beam tetrode and the triode are shown in Fig. 50. Note that the characteristics resemble those of the ordinary push-pull arrangement.

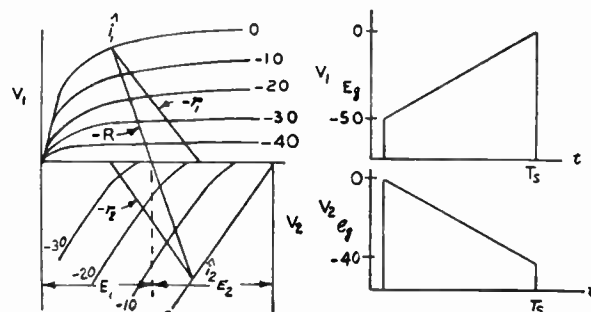

FIG. 50. Combined characteristics of beam tetrode and triode.

In the ideal case, in which there are no losses, the 6BG6 driver tube supplies half the deflection current, and the 6AS7 triode damper supplies the remainder from the stored energy. Such utilization of current is shown in Fig. 51. Because of losses in the actual circuit, the driver tube must supply about 60% of the total deflection current.

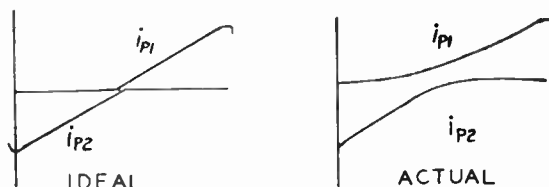

FIG. 51. Deflection circuit operation.

The control-grid voltage for the triode damper is generated by differentiation of the pulse voltage across the yoke. The values of  $RC$  are determined by the equation

$$\frac{T_s}{R_c} \cong \frac{2}{\lambda} - 2$$

where  $\lambda =$  linearity of voltage rise = 0.3 to 0.8.

Usually  $R$  is made variable for adjusting linearity.

The combination  $R_1 C_1$  has a long time-constant and is placed in the grid circuit for establishing grid bias for the triode by the flow of grid current on the peaks of the grid voltage.

## References

- Maloff, I. G. and Epstein, D. W., *Electron Optics in Television*, McGraw-Hill Book Co., Inc., New York, 1938.
- Schade, O. H., "Magnetic Deflection Circuits for Cathode-Ray Tubes," *RCA Review*, September, 1947.

## Video Amplifiers

REQUIREMENTS—The nature of the picture signal imposes certain requirements upon the video ampli-

fier, which must be met if fine picture detail is to be resolved. First, the bandwidth must satisfy the relation

$$f_n = A_r n \frac{10^6}{H_a \times 2}$$

where  $f_n$  = fundamental frequency for  $n$  lines  
 $A_r$  = aspect ratio = 4/3  
 $n$  = number of lines to be resolved  
 $H_a$  = active trace time, microseconds.

Since horizontal blanking occupies 16% of the horizontal period, the active trace time,  $H_a$ , is  $0.84 \times 63.5 = 53.3$  microseconds. To resolve 400 lines, the bandwidth must be

$$f_n = \frac{4}{3} \times \frac{400 \times 10^6}{53.3 \times 2} = 5 \text{ megacycles}$$

In practice, the output of the video transmitter is specified by standards to include all frequencies between 30 cps and 4 megacycles per second. Hence, the video amplifier must amplify, without discrimination, at least those frequencies between 30 cps and 4 megacycles per second. Usually, the video amplifier is designed with a bandwidth exceeding these limits.

Also, the video amplifier must have a minimum time-delay discrimination. This requirement is fulfilled when the phase angle between input and output voltages is proportional to frequency.

Finally, there are requirements for the video amplifier which are set by standards or practice, some of which are output-voltage levels, terminal impedances, permissible signal-to-noise ratio, etc.

**FREQUENCY RESPONSE**—Low-frequency response of an RC-coupled amplifier is determined by the time-constant of the coupling capacitor and grid-leak resistor. In practice, good low-frequency response is obtained by making the time-constant large or by using clamp circuits.

High-frequency response is limited by shunt capacity across the plate-load resistor. This shunt capacity includes the tube input and output capacity, wiring capacity, and stray capacity of circuit components. Good high-frequency response is obtained by utilizing the various shunt capacities as elements of a low-pass coupling filter.

Fig. 52 is a diagram of a constant-K low-pass filter consisting of one full section and one half-section terminated in its characteristic impedance. The terminating

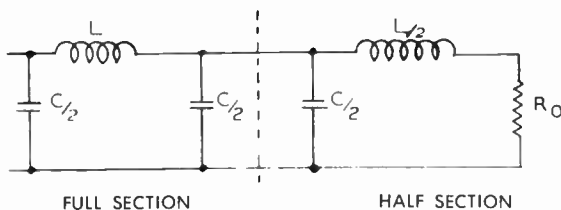

FIG. 52. Constant-K low-pass filter.

half-section is added for impedance matching purposes. When the low-pass filter is properly designed and terminated, the characteristic impedance is constant to almost the cut-off frequency. Connection of the coupling filter to the amplifier tubes is shown in Fig. 53. In

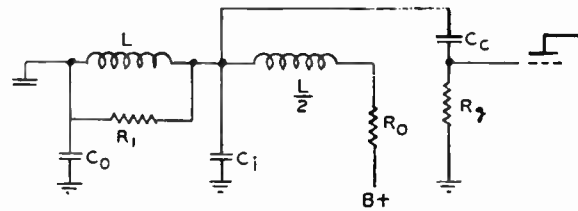

FIG. 53. Coupling filter-connection.

Fig. 53  $C_o$  and  $C_i$  are output and input capacities of the tubes. For this particular type of low-pass filter, the following equations apply:

$$f_c = \text{cut-off frequency}$$

$$R_o = \frac{1}{f_c C_i}$$

$$L = R_o^2 C_i$$

$$C_o = \frac{C_i}{2}$$

$$R_1 = (5 \text{ to } 10) R_o$$

$$A = g_m R_o$$

The resistor  $R_1$  is added to lower the  $Q$ -factor of the series inductance. A peak in the response curve will result prior to cut-off if the  $Q$ -factor is not optimum.

The characteristics of the constant-K low-pass filter depend upon the components being pure inductances and pure capacitances. It has been shown that distributed coil capacity converts the constant-K type into an M-derived filter, as shown in Fig. 54.

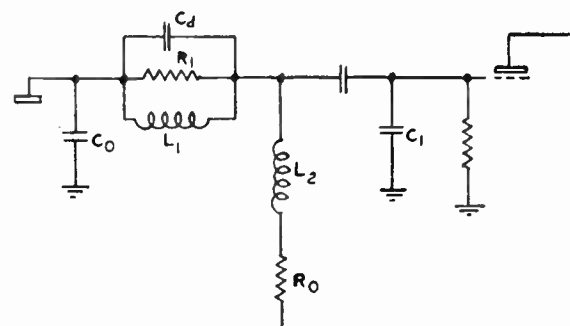

FIG. 54. Effect of coil capacity on constant-K filter.

Equations for the M-derived filter are as follows:

$$M = \sqrt{1 + \left(\frac{C_d}{C_o}\right)^2} - \frac{C_d}{C_o}$$

$$R_o = \frac{M}{\pi f_c C_i}$$

$$L_1 = R_o^2 C_i$$

$$L_2 = 0.8 L_1 \text{ approx.}$$

$$R_1 = (5 - 10) R_o$$

$$A = g_m R_o$$

Practical video amplifiers use the M-derived low-pass filter as a means of coupling amplifier stages.

Diagnosis curves are given in Figs. 55 and 56 to aid in the alignment of video amplifiers using low-pass filter coupling.

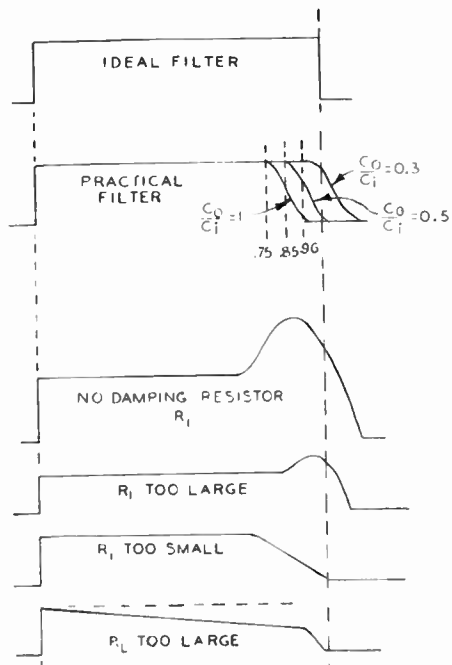

FIG. 55. Diagnosis Sheet #1.

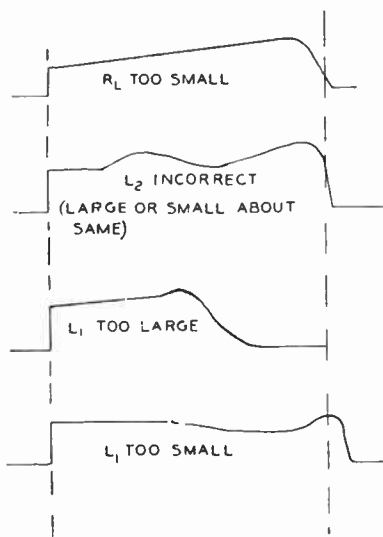

FIG. 56. Diagnosis Sheet #2.

### Clamp Circuits

The clamp circuit is often used as a "D-C Restorer"; however, it can also be used to restore low frequencies in a video amplifier. Its operation in the latter application will be described first.

Consider the video signal for a half-black, half-white picture applied to the input of a video amplifier whose frequency response is very poor below the horizontal-scanning frequency. Assume that horizontal blanking pulses are also introduced at the amplifier input, and that they are of greater amplitude than any other part of the video signal. A sketch of the picture and the corresponding video signal with horizontal blanking is shown in Fig. 57.

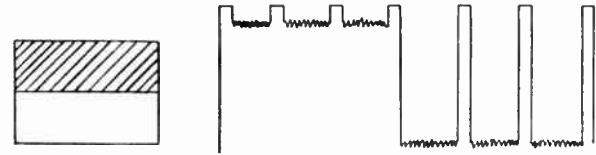

FIG. 57. Half-black, half-white picture and video signal.

After this signal has passed through the amplifier, the low-frequency components will be missing, and the signal will distribute itself about an a-c axis as shown in Fig. 58. Low-frequency components are, in this case, considered to be any components of less than the horizontal scanning frequency. The transitory periods immediately following the change from black to white are not shown in Fig. 58.

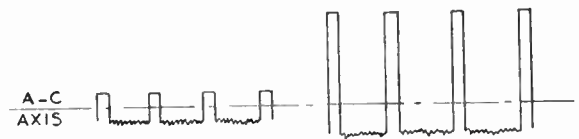

FIG. 58. Video amplifier output signal.

Note that, if we could bring the peaks of the horizontal blanking pulses that occur during the "black" portion of the picture to the same level as the peaks of those that occur during the "white" portion, the signal would again be identical to that in Fig. 60. In other words, the low-frequency components would then be restored because the output signal would be similar in shape to the input signal.

Fig. 59 shows a hypothetical circuit for bringing all of the blanking pulses to the same level. The time-constant of  $R$  and  $C$  must be sufficiently small so that

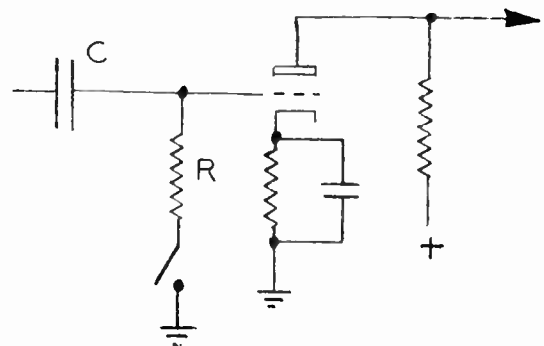

FIG. 59. Simplified clamp circuit.

$C$  is discharged before the blanking pulse is over. The switch is so controlled that it closes at the start of the blanking pulse and opens *before* the end of the pulse. Because of these conditions (grid of the tube floating during the time the switch is open, grid-side of  $C$  being always brought to ground potential during the pulse, and switch opening before the pulse is over), *the remaining portion of the pulse always falls at the same point on the tube's operating characteristic.* As explained in the preceding paragraph, this is equivalent to restoring the low-frequency components.

A clamp circuit, shown in Fig. 60, is electrically equivalent to the arrangement of Fig. 59. The diodes replace the switch of Fig. 59, and the switch control is supplied by the diode keying pulses. The circuit "clamps" on the periodic pulses in the video signal, which in the given example are horizontal blanking pulses; hence its name.

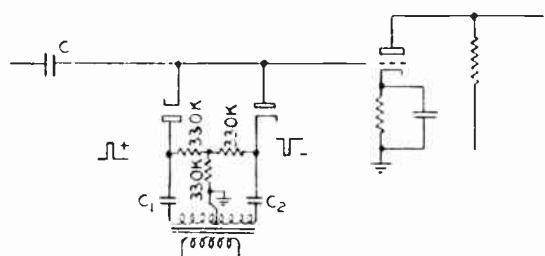

FIG. 60. Clamp circuit.

The keying pulses (which should not be confused with the clamp pulses) are 180 degrees out of phase, so that both diodes become conducting simultaneously. By using this balanced arrangement, the keying pulses cancel out at the grid of the amplifier tube, and are therefore not added to the desired signal. It is essential that the keying pulses end before the clamp pulses, as explained above. Horizontal synchronizing signal makes ideal keying pulses. The amplitude of the keying pulses must also be greater than the clamp pulses, so that the diodes can be made conducting during keying time. Practice has shown that the keying pulses should be one-and-a-half to two times as large as the clamp pulses.

It is important to note that pulses other than horizontal blanking can be used to clamp on. The only requirements are that they be greater in amplitude than any other part of the video signal, that their peaks represent constant amplitude in the input signal, and that their frequency be sufficiently high for the amplifier to pass them without frequency or phase distortion. Of course, they must not interfere with the desired signal. Hence, for television work, they must occur at horizontal blanking time. Their polarity, with respect to the video signal, is unimportant.

The coupling capacitor  $C$  and the resistance between grid and ground during keying time must have a sufficiently small time-constant for  $C$  to discharge during

keying time. For 15-kc clamp pulses, the value of  $C$  can be between 100 and 500  $\mu\text{f}$ . The coupling capacitors,  $C_1$ , and  $C_2$ , are also somewhat critical because the diodes are self-biased by them and their associated "leak" resistors. The bias developed is proportional to the amplitude of the keying pulses, in a manner similar to that of a conventional diode detector. Values for  $C_1$  and  $C_2$  are best determined by experiment. Values which have been used in the past lie between 0.003  $\mu\text{f}$  and 0.1  $\mu\text{f}$  for the leak resistances shown.

In some cases it may be desirable to return the grid of the amplifier tube to a fixed-bias source instead of to ground. The bias source is then introduced in series with the ground lead shown in Fig. 60.

The source of the keying pulses is of importance. A center-tapped transformer is desirable because it provides balanced pulses easily, and the source-impedance is low. A tube with load resistors in both plate and cathode circuits (cathode-follower type of phase inverter) can be used to provide keying pulses. This tube should preferably operate with a negative-polarity pulse on its grid, so that the tube is cut off during keying time. Otherwise, the source-impedance will be different for the positive and negative output pulses, due to cathode-follower action. An unbalance in the source-impedance may adversely affect the operation of the clamp circuit.

The clamp circuit can be modified to advantage when only single-polarity keying pulses are available. This is

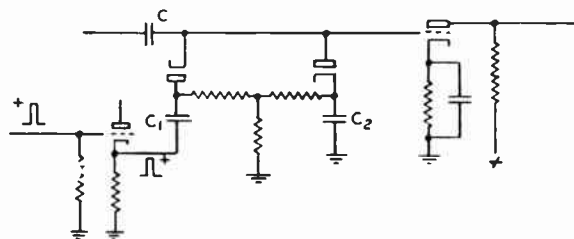

FIG. 61. Clamp circuit for single-polarity keying pulses.

shown in Fig. 61. In this circuit, a single keying pulse makes both diodes conducting because they are in series, as far as the keying pulse is concerned. The disadvantage of this circuit is that a small amount of the keying pulse is super-imposed on the video signal because of the unbalance. When horizontal sync pulses are used as keying pulses, this circuit will add a small amount of sync to the video signal; this will sometimes be an advantage rather than a disadvantage. If vertical sync is unavoidably present along with the horizontal, the coupling capacitors  $C_1$  and  $C_2$  should be increased to 0.5  $\mu\text{f}$ .

Another version of the clamp circuit is shown in Fig. 62. Only single-polarity keying pulses are required. The source-impedance of the keying pulses can be high, but the circuit provides a low-impedance path between grid and ground during keying time.

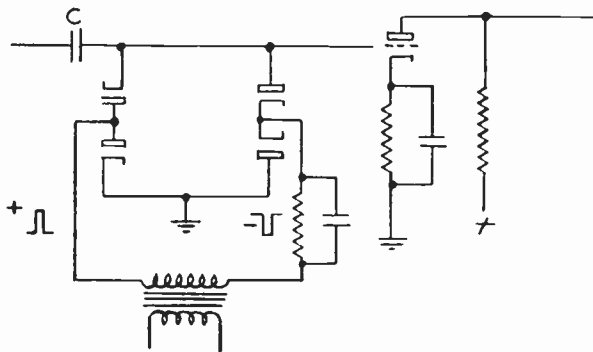

FIG. 62. Clamp circuit for single-polarity keying pulses.

### The Clamp Circuit as a D-C Restorer

Since, as was just shown, the clamp circuit effectively restores low frequencies, the same reasoning can be extended to say that the clamp circuit will also restore the d-c component of the video signal. Without d-c restoration, the a-c axis of any signal will pass through the operating point of the tube characteristic to which that signal is applied. However, when the clamp circuit is used on the grid of an amplifier tube (or kinescope), the clamp pulses in the signal are always referred to the same point on the characteristic, regardless of signal amplitude or wave form. In other words, the a-c axis is shifted as the signal amplitude and wave form vary, and a shift in the a-c axis of a wave is equivalent to adding a d-c component. The clamp circuit has the advantage over the simple, single-diode type of d-c restorer in that it responds very quickly to signal changes, whether they be increasing or decreasing; whereas the simpler type has appreciable time lag when the signal suddenly decreases.

### Pick-up Tubes

**TYPES**—Three types of pick-up-tubes are in general use today, namely, the iconoscope, the image orthicon and the Vidicon. The iconoscope dates back to about 1923, when it was developed by Dr. V. K. Zworykin. It is still being used for motion-picture pick-up. The image orthicon has replaced the iconoscope for live-talent pick-up. Image orthicon development was hastened by war-time requirements, and progress on the stabilization and improvement of this tube has been rapid. The Vidicon, most recently developed of the three, has a sensitivity that is half-way between the other two. It may be used for film or live pick-up.

**ICONOSCOPE**—The iconoscope pick-up tube may be used where the scene is illuminated by incident light of approximately 1500 foot-candles. Under ideal lighting conditions, the pictures obtained have excellent resolution and low noise-level. The intensity of illumination, however, limits the use of the iconoscope for outdoor events. When incandescent lighting is used in studios, the problem of removing the heat arises. At present, the iconoscope is used in film cameras only where the motion-picture projector provides ample illumination on the iconoscope mosaic.

The iconoscope contains a photo-sensitive mosaic, a collector ring, and an electron gun. A sketch of the tube

is shown in Fig. 63. The electron gun is set at an angle with the mosaic in order to clear the front of the tube, so that an optical image may be focused on the mosaic.

A uniform mica plate, 0.001 inch thick, is the basic structure upon which the mosaic is constructed. A fine coating of silver oxide is sifted upon the mica. Then, the structure is baked in an oven. The heat produces pure silver from the silver oxide. The pure silver congeals into thousands of small droplets. Then the mica plate is placed in the presence of cesium vapor and oxygen, and a glow discharge is passed through the tube. Silver oxide, cesium oxide, and pure cesium are formed. By this process, small photo-sensitive islands are formed on the mica. The mosaic is completed by coating the rear of the mica with colloidal graphite to form the signal plate which is capacity-coupled to the photo-sensitive surface. Better color response is obtained by the process of silver sensitizing, in which a small particle of pure silver is heated in a filament while the tube is on the pumps. Silver vapor settles on the photo-sensitive islands and gives the mosaic better response toward the blue end of the visible spectrum.

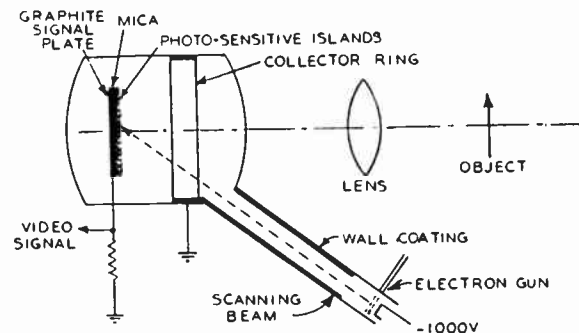

FIG. 63. Iconoscope pick-up tube.

The iconoscope is a storage-type device in which the varying illumination of an optical image on the mosaic causes emission from the photo-sensitive islands. The charge on each picture element represented by the photo-sensitive element remains constant until released by the scanning beam. The operation of the iconoscope is best understood by considering first the action resulting from scanning the mosaic in darkness, *i.e.*, with no optical image or light on the mosaic.

With the collector ring grounded and the cathode potential fixed at  $-1000$  volts, the beam acquires a kinetic energy of 1000 electron volts by the time it reaches the mosaic. On striking the mosaic, the beam causes secondary emission of electrons from the photo-sensitive islands, *i.e.*, each beam electron knocks several secondary electrons off the photosensitive island. The ratio of secondaries to beam electrons is 6:1 under dark conditions. The secondary electrons, for the most part, rain back on the mosaic. Enough secondaries travel to the collector ring for the collector-ring current to be equal to the beam current (since the mosaic is completely insulated, the current leaving it must equal the current arriving in the scanning beam).

Figuratively speaking, the scanning beam plows along the mosaic, causing an eruption of secondary electrons from the photo-sensitive surface. The element under the scanning beam charges up to about 2 volts, due to loss of electrons. This value represents the maximum charge which the element can attain by secondary emission and is known as the white level. As the scanning beam moves across the mosaic, part of the electron shower can fall back on the scanned area and reduce the positive charge on picture elements just scanned. At the right-hand edge of the mosaic, however, the scanning beam is turned off for retrace, and no more secondaries are generated to discharge the last part of the trace. Similarly, the beam is cut off at the bottom of the mosaic for vertical retrace; therefore, the last few scanning lines do not receive a proportionate share of the electron rain and remain partially charged. Remember that this action is occurring in complete darkness.

As the electron beam starts scanning the second frame, it encounters elements of the mosaic on the right-hand side and on the bottom that are partially charged, due to the loss of electrons. These elements appear as though they had been exposed to white light. When the beam scans them, fewer secondaries are emitted, and a signal voltage is impressed on the signal plate. This voltage has the waveshape shown in Fig. 64 vertical and horizontal scans. It is an unwanted signal, that is due to uneven redistribution of secondary electrons, and it is called a shading signal. For eliminating shading signals,

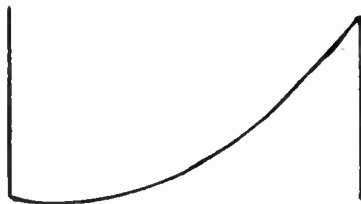

FIG. 64. Shading signal waveshape.

equal-amplitude opposite-phase signals are fed into an amplifier stage following the pick-up tube. The unwanted signal may, fortunately, be effected by a combination of parabolic and sawtooth signals which can be generated quite easily.

Now we may consider the action of the scanning beam when the mosaic is illuminated by a scene. Bright areas in the scene cause the islands to emit electrons. These electrons travel to the collector ring or redistribute themselves over the mosaic. Suppose a gray tone causes a photo-sensitive island to charge up to +1.5 volts. Then, when the scanning beam comes along, this particular element can only be charged by a differential of 0.5 volt to the white level. On the other hand, a black area leaves the element discharged until it is scanned, at which time the element can charge to the full 2-volt white level. The video signal current in the load resistor is shown in Fig. 65.

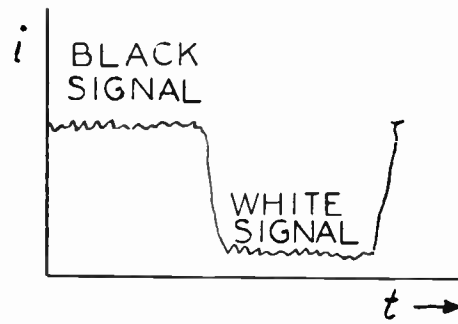

FIG. 65. Video signal for illuminated scene.

In Fig. 63 the electron gun for the iconoscope is shown at an angle with the mosaic. This geometrical arrangement produces an effect known as keystone. For a given angle of deflection of the scanning beam, more of the mosaic top is scanned than the bottom. If no correction were applied to the horizontal scanning generator, the resultant pattern on a monitor would appear as shown in Fig. 66.

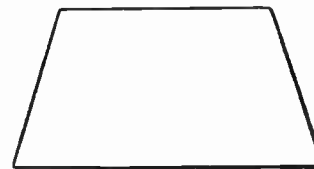

FIG. 66. Keystone pattern.

To correct for keystone, the horizontal scanning generator is modulated by a 60-cycle sawtooth that increases the horizontal scanning current peak-to-peak linearly at a 60-cycle rate, so that the angle of deflection becomes larger as the beam is deflected vertically.

**IMAGE ORTHICON PICK-UP TUBE**—The image orthicon is at least 100 times more sensitive than the iconoscope. Also, it is free from the annoying shading and edge-flare effects of the iconoscope. It will deliver a satisfactory picture, without readjustment, when the scene brightness changes by a factor of 100 to 1. A satisfactory picture may be obtained when the incident light on the scene is only 10 foot-candles. The sensitivity of the image orthicon makes it an ideal tube for pick-up of outdoor events.

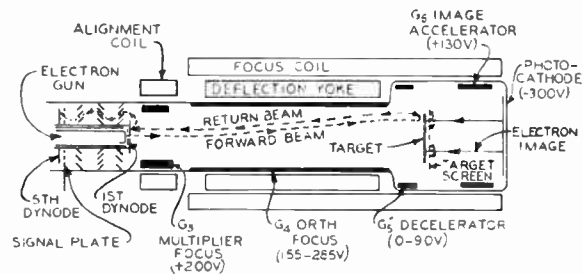

FIG. 67. Image Orthicon pick-up tube.

A sketch of the image orthicon tube construction is shown in Fig. 67. The tube contains an electron gun



with a grid for controlling the current in the scanning beam. The #3 grid, sometimes called the "persuader", causes electrons from the first dynode to go to the second dynode. The #4 grid, which is the coating on the tube wall, together with the magnetic focusing field, focuses the electron beam on the target. The decelerating ring, grid #5, produces an electric field which improves corner focus.

The target is a special glass membrane stretched in a metal ring. The thickness of the glass is approximately 0.0001 inch. On the image side of the target, and at a distance of 0.001 inch, is a mesh screen having 250,000 holes per square inch.

Grid #6 is a ring placed between the target and photocathode. It aids the focusing of electrons from the photocathode on the target.

The photocathode is a transparent layer of cesium in type 2P23 tubes, antimony in type 5769 tubes, and bismuth in type 5820 tubes. The cesium tubes have high infra-red response, while the antimony and bismuth tubes have a more uniform color response in the blue regions.

**IMAGE ORTHICON OPERATION**—When an optical image is focused on the photocathode, electrons are emitted in proportion to the light and dark areas of the scene. Since the photocathode is at a potential of about -300 volts with respect to the ground and the target screen, the electrons are accelerated toward the target. The action of the focusing coil and the #6 grid focuses the electrons on the target. Thus the optical image is converted into an electron image which bombards the target.

Bombardment of the target causes an emission of the electrons from the glass. Secondary electrons released by the target are collected by the screen. Secondary emission leaves a positive charge pattern on the front of the target, corresponding to the electron image.

Because of the thinness of the glass target, it does not matter, for the electron beam, on which side of the glass the positive charge lies. Upon its arrival near the target rear surface, the beam deposits enough electrons to neutralize the charge. The remainder of the beam turns around and heads toward the rear of the tube. During frame time, the deposited electrons flow through the glass and unite with the positive charge.

The returning electron beam is equal to the electrons emitted by the cathode (nearly a constant number) minus those electrons deposited on the target. The returning beam, therefore, is the original beam modulated by the video signal.

An electron multiplier is located at the rear of the tube. The construction of this multiplier is shown in Fig. 68.

It is such as to offer an almost opaque surface to the electrons entering from the front. Electrons leaving

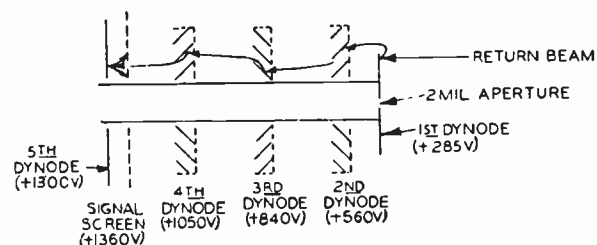

FIG. 68. Electron Multiplier for Image Orthicon.

each dynode, however, find negligible resistance to their travel.

The return beam containing the video information strikes the first dynode, causing secondary emission. The secondary electrons are persuaded to the second dynode by the action of the "persuader," or multiplier focus electrode. As the beam travels from dynode to dynode, the original return beam is multiplied by secondary emission. The final signal is removed from the signal plate. The overall gain in the electron multiplier can be as high as 2000.

In tube manufacture, the electron gun may become tilted with respect to the tube axis. Electrons emitted from such a gun would enter the focus field with a transverse component of velocity. A force would be developed, which would cause the beam to travel in a radius about the tube axis. The net effect is a spiraling of the beam down the tube. To correct for misalignment of the electron gun, an alignment coil is placed just in front of the gun. It produces a transverse field which cancels the deflection of the beam due to gun tilt.

**VIDICON THEORY AND OPERATION**—The sensitivity of the vidicon lies between that of the iconoscope and that of the image orthicon. The characteristics of this tube are ideal for film pick-up. For live pick-up good pictures may be produced when the scene illumination is 500 foot-candles or more. As the illumination is decreased, moving objects in the scene begin to produce a "smeared" appearance, even though the signal-to-noise ratio remains very good.

The mode of operation of the vidicon scanning is similar to that of the orthicon section of an image orthicon. An axial focus field is produced by the solenoidal focus coil. The electron stream is accelerated by the electron gun and an image of the final aperture of the electron gun is formed at the photoconductive surface by the focussing action of the magnetic field. A raster is scanned on the photoconductive surface by the action of transverse fields from the two sets of deflection coils. See Fig. 69.

When the electrons arrive at the fine mesh screen, they are traveling at their maximum velocity. Upon passing through the screen, they enter the decelerating electric field between the screen and the photoconductive layer. The electrons strike the layer and charge the gun side of it down to approximately the potential of the thermionic cathode of the electron gun. See Fig. 69.

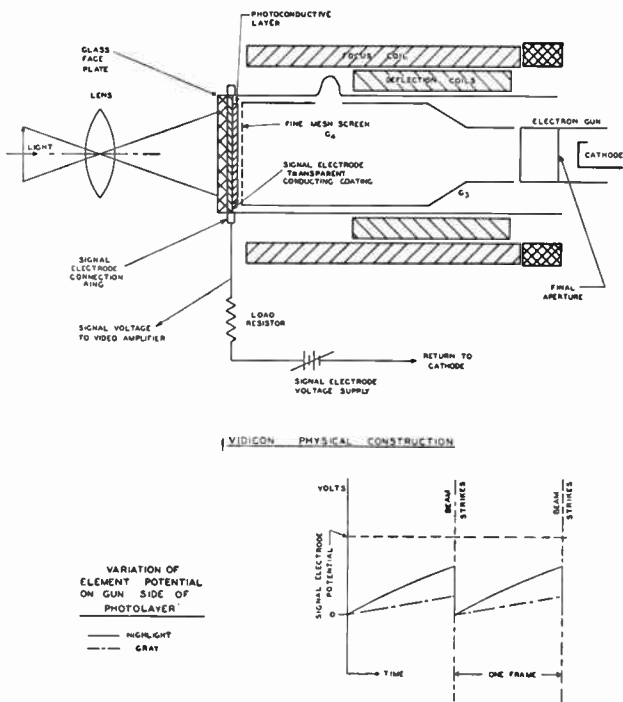

FIG. 69. Physical construction of the Vidicon.

The photoconductive layer is designed to have very low lateral conductance so that the charges representing adjacent picture elements do not discharge appreciably into each other during one frame time. The conductivity through this layer at each point varies with the illumination of that point. During the time when a picture element is not being scanned, the surface charge deposited by the beam leaks through the photoconductive layer to a degree which is determined by the illumination of that element. The signal electrode is operated at a positive potential in the range of 20-100 volts with respect to the cathode of the electron gun.

The signal output is the current pulse produced when the beam strikes the element and charges it back down to approximately zero potential. This current pulse passes through the capacitance of the element to the signal electrode and develops a signal voltage across the load resistor (and stray capacitance) connected to the signal lead.

The excess beam electrons arriving at the photoconductive surface return to the mesh and are collected. Thus only the landing position of the beam is utilized, in contrast to the image orthicon where the returned electrons carry the signal. Alignment coils are used to start the beam parallel to the axis of the tube.

# COMPOSITION OF THE VIDEO WAVEFORM AS SEEN ON THE SCOPE\*

The most common oscilloscope pattern seen in television is that of the standard RETMA video signal in its entirety when viewed at sweep frequencies of 7,875 and 30 cycles. An analysis of why these patterns look different from the standard textbook representation brings many things to light.

\* \* \*

When first seeing the waveforms of the standard RETMA video signal swept out on an oscilloscope at the "horizontal" viewing frequency of 7,875 cycles and the vertical viewing frequency of 30 cycles, the technician usually remarks how different they are from what he expected.

In Fig. 1 is shown an oscilloscope pattern as it would be seen when viewing the standard RETMA video signal at the sweep frequency of 7.875 cycles (sawtooth). This is generally referred to as the "horizontal"

pattern, since during any one sweep of the scope beam, two horizontal lines will have taken place and thus be traced out on the screen. A linear sweep is used on the scope since the scanning of the television picture takes place linearly with respect to time.

The trace shown in Fig. 1 is seen to consist of the horizontal blanking pulses, "a", also referred to as the pedestal; the horizontal sync pulses, "b"; the video line structures, "c"; a blanking level line, "d"; and a group of interrupted lines, "e".

The first question which arises about the trace shown is why the video, "c", appears as "grass" instead of the standard wavy line shown in textbook drawings of a horizontal line. Then we realize that each line of a normal picture would differ in its shape because of differing light intensities in the makeup of the picture. In the trace shown, light intensities for the video components would increase vertically upward from line "f", which would be black. During the scanning of the video signal by the scope, all the lines of the picture were cov-

ered in 1/30th of a second. We recall that motion pictures move because of the persistence of our vision, which is too long to single out any one frame of the number of frames shown in one second. Therefore, because of the persistence of our vision (and of the oscilloscope screen), we see all the lines of the picture traced out on top of each other. Consequently, the trace of video appears as "grass".

The two video traces we see are not the even and odd lines as is sometimes assumed. They cannot be with the continuous scope sweep because as the beam sweeps the first time across the screen, the first two odd lines of the picture will be traced out. Since the camera will be tracing only odd numbered lines during this time and for a number of lines to follow (until one field has been scanned) both odd and even numbered lines will be seen in the "grass" of each of the traces shown.

\* By Robert M. Crotinger, Remote Engineering Supervisor, Station WHIO-TV.

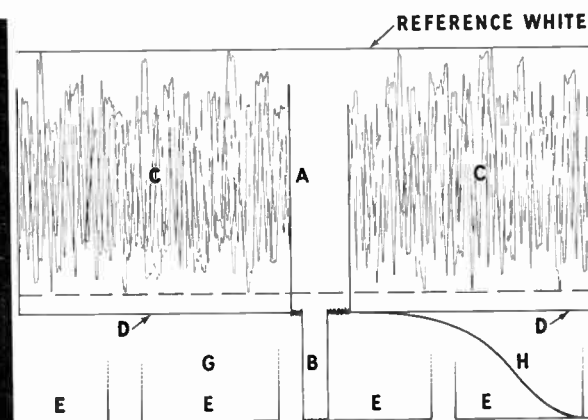
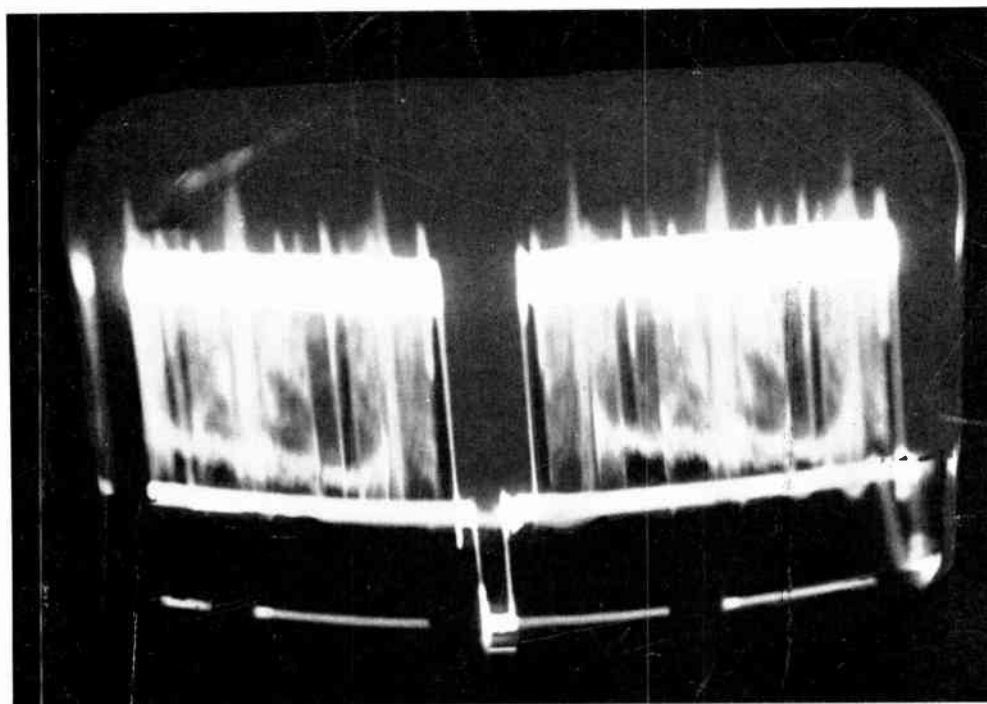

FIG. 1. The photograph from the monitor screen (at left) shows the waveform pattern as it would normally be seen when viewing the standard RETMA video signal at the sweep frequency of 7,875 cycles (sawtooth). The diagram above identifies the various parts of the waveform in the photograph at the left. Explanation of the letter symbols is given in the text.

FIG. 3. In order to accurately reproduce these waveforms the oscilloscope used must have a response of at least ten times the horizontal pulse frequency. Either the regular monitor scope (which has a response 300 times the pulse frequency) or any scope with comparable frequency response may be used.

The blanking level is represented by the peak of the blanking pedestal, "a", which is different from the actual black level "f" by at least five percent of "a". The line "f" does not appear on the trace but is shown to indicate the five percent difference, which difference is intended to allow turning the kinescope brightness up high enough to see the "blackest black picture element" and still not see the retrace lines. The "reference white" line is also not seen on the scope trace but is used to indicate the "whitest white" transmitted.

It will be noted that the entire pattern shown in Fig. 1 is upside down compared to the usual textbook drawing; that is, the sync pulse increases in a downward direction. This pattern was made in proportionate dimensions from a standard television station monitor screen. The polarity of the pattern seen on any scope will of course depend on which stage of the system the measurement is made, inverting for each stage of amplification.

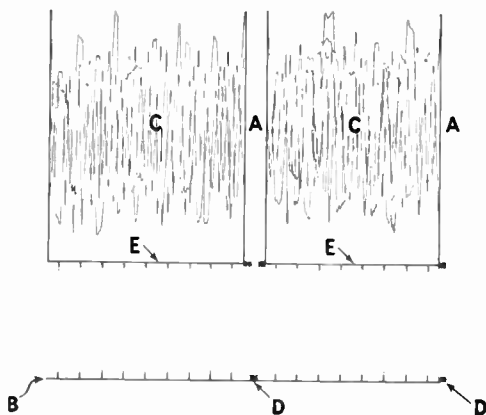
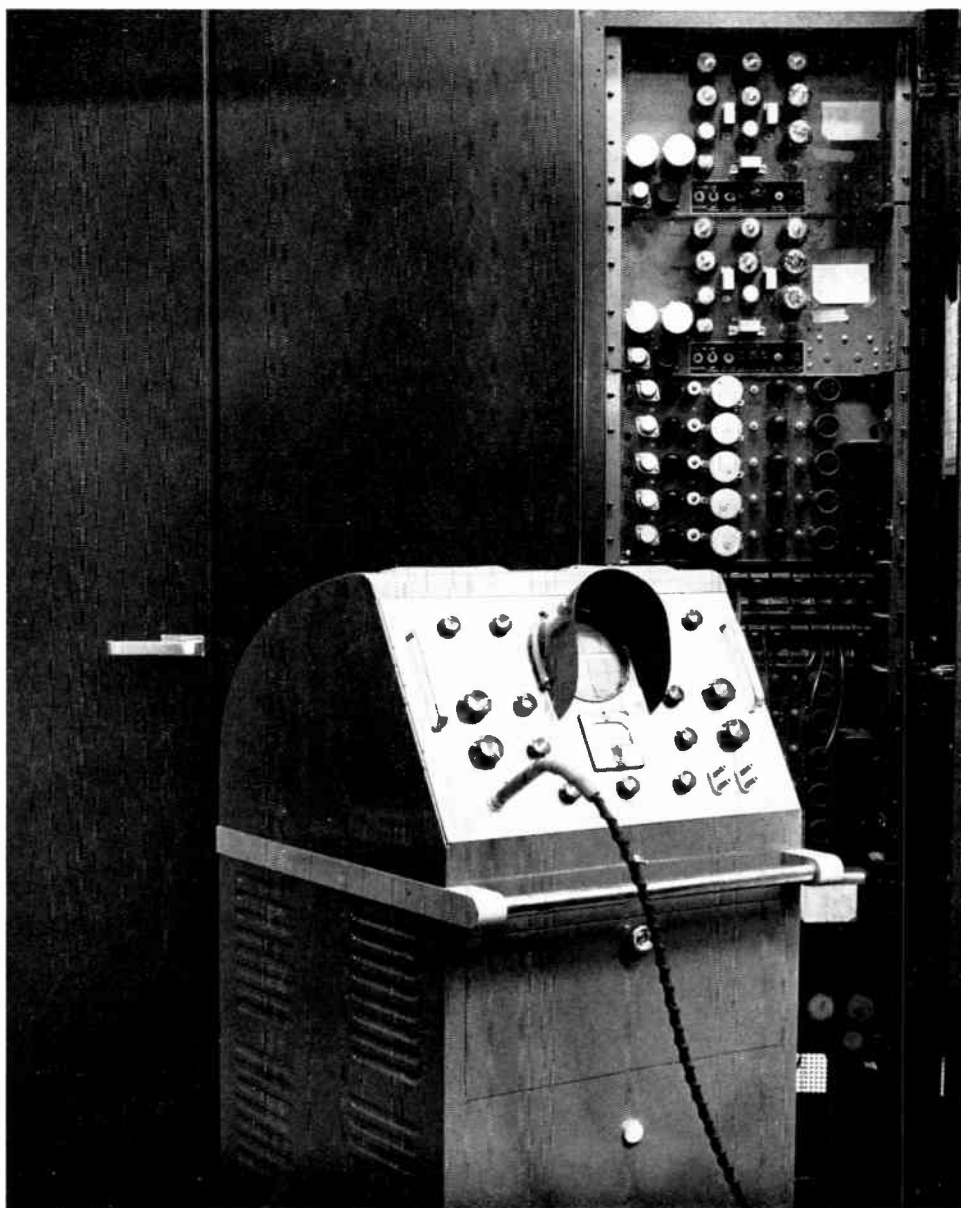
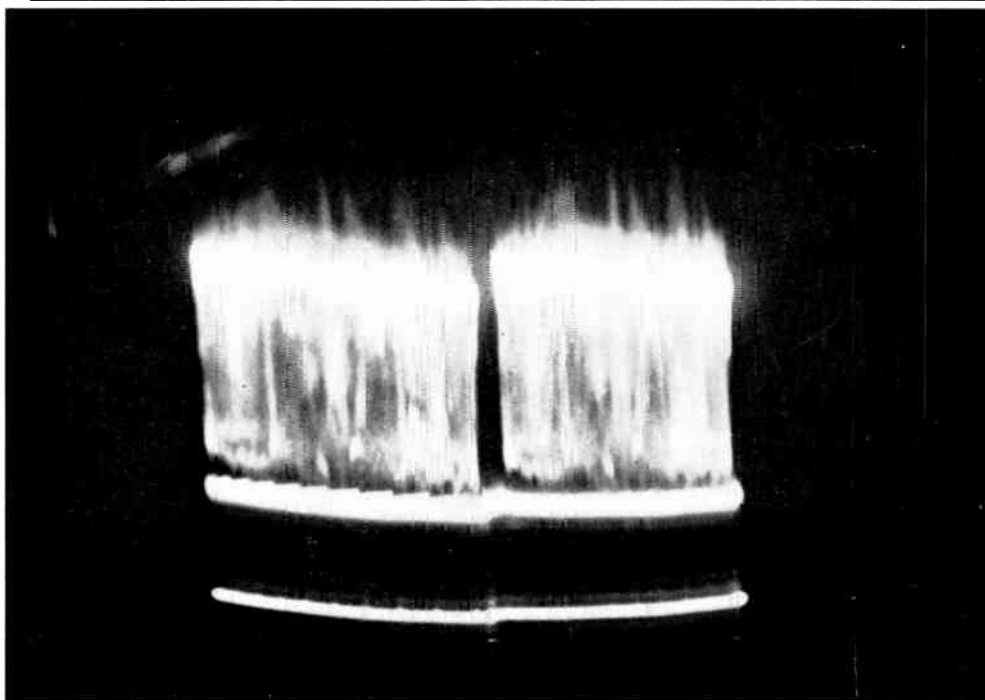

FIG. 2. The photograph from the monitor screen (at the right) shows the waveform pattern as it would normally be seen when the sweep frequency is half the frame frequency (i.e., 30 cycles). The diagram above identifies the various parts of the waveform in the photograph at the right. Explanation of the letter symbols is given in the text.



The question always arises as to what line "d" is and why it appears where it does. It certainly is not shown in the conventional text drawing of a line of video signal. To explain this it will be recalled that the oscilloscope is still sweeping the screen during the time the camera beam is returning from the bottom of the picture to the top. This return takes several horizontal lines duration to accomplish, and during this time the vertical blanking pedestal is applied to the video signal to blank the receiver beam. Since the beam in our oscilloscope is not blanked out and the sweep oscillator is still functioning during this time, it will trace out a horizontal line at position "d", which is the vertical blanking pedestal level.

Having explained this line, we have also explained the interrupted lines "e". These are obviously the vertical sync pulses placed on top of the vertical blanking pedestal. It is recalled that the vertical sync pulse is serrated. Also their duration is longer than the horizontal sync pulse. Another look at the pattern shows these pulses plainly.

It is also recalled that the front or attack side of the vertical pulse which occurs at the time when a horizontal pulse would otherwise occur, must be at the same time as the horizontal pulse if it were continued. This is done to keep the horizontal oscillators of the receivers in synchronism during the vertical retrace period. Thus the left (attack) end of the horizontal sync pulse "b" in Fig. 1, is also the attack side of vertical sync pulse "g". The top of pulse "b" is brighter than the rest of the lines of the pattern. This is partly because of the application of both the front of the vertical sync pulse "g" and the pulse "b"

at this point on the screen, but is mostly because the horizontal pulses are repeated or traced many more times than the vertical serrated pulses.

The final point to remember about this trace is that whatever part of the signal is missing between the right side of the trace and the left side of the trace is that part of the signal which happened during the retrace time of the scope. In the case of this pattern, it was the back side of the second horizontal sync pulse and the back porch of the blanking pedestal. This appears "stretched out" on the retrace as line "h".

It will be noted that the much faster retrace time of the scope has made the rear side of the pulse slope much more than it does when shown on the forward trace. This substantiates the fact that the sides of the pulses are not perfectly perpendicular. If they were, no vertical sides of the pulses would be seen, only the peak horizontal line. It requires a scope having a response of at least ten times the horizontal pulse frequency to accurately reproduce these pulses. Station monitors have a bandwidth of around 300 times the pulse frequency and thus reproduce the horizontal pulses very accurately.

In Fig. 2 we see the trace made on a scope when the sweep frequency is half the frame frequency, or 30 cycles. Here we do see the even numbered lines of the picture in one video trace and the odd numbered lines in the other. However, we do not know which is which. In any event, it would be of no particular value if we did. Since the scope beam scan takes place in 1/30th of a second, the lines of the first field will be traced out in the first

half or 1/60th of a second. The vertical blanking pedestal appears at "a" and the serrated vertical sync pulse at "d". The serrated pulses making up the vertical sync pulse are not definable as such since their time duration is so small compared to the sweep of the scope.

However, several small pulses will be seen to make up the line "b". Since it is apparent that the retrace of the scope includes the video components which are missing between the right and left sides of the trace, in this case the back porch and a few of the lines of the first video trace are *spread out* along the retrace. The much faster retrace motion of the scope beam has elongated the portion of the signal which occurred during the retrace time.

Good practical use can be made of the above in observing the vertical serrated pulses and their components. The fine frequency control of the scope sweep oscillator can be moved very slightly and the second vertical sync pulse "d" made to roll off on the retrace. It will then be elongated and the number of vertical pulses can be actually counted. There should be six equalizing pulses preceding (to the right of) the actual vertical sync pulse, then six longer vertical sync pulses, and finally six more short equalizing pulses to the left of the vertical pulses.

The line "e" is made up of the horizontal blanking pulses for each of the lines of that field. Of course line "b" is made up of the horizontal synchronizing pulses for the lines traced out above it. Since there are  $262\frac{1}{2}$  lines, blanking and sync pulses for each of the traces shown, these pulses appear on the screen as a horizontal line.

FIG. 1. Waveforms showing significant levels and details of the standard scale for measuring video levels.

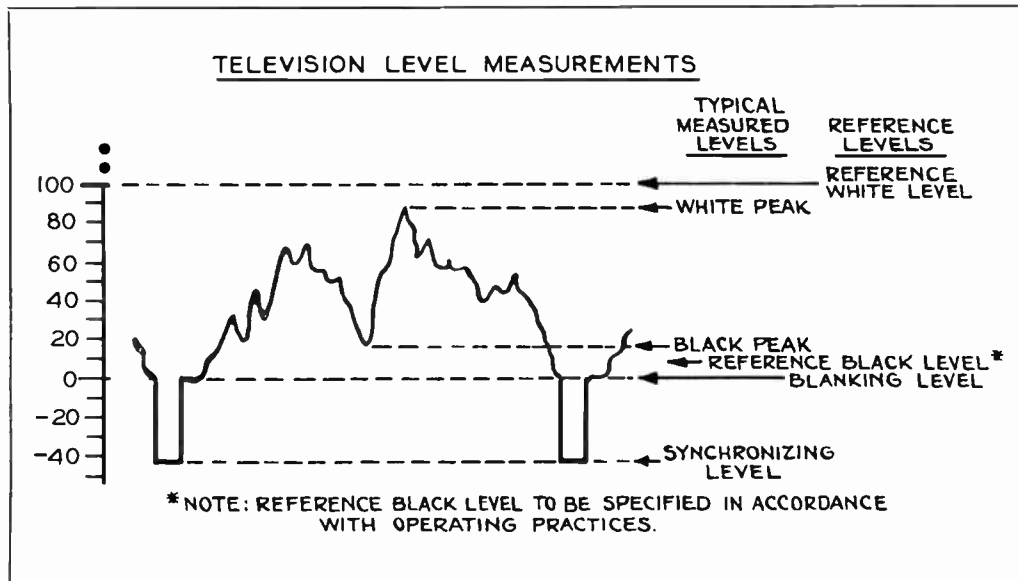

# Standardizing and Measuring Video Levels in a TV Station

## Introduction

The subject of video levels in television broadcasting, from standpoints of both standardization and measurement, has been going through a slow process of evolution ever since the early experimental broadcasts in the 1930's. At first, as should be expected, the significance of all the factors was not fully appreciated, and, as a result, accepted values and methods have been changed from time to time in an effort to keep pace with the advances in techniques and equipment. There is no assurance that this evolution has now reached its final stage, but substantial changes which have developed recently are a sufficient reason for restating the situation as it appears to be at present.

## Review of Past Practices

In 1936, the first major installation of television broadcasting equipment in New York was made in the studios of NBC in Radio City. One feature of this installation which bears on the subject of levels was a mile and a quarter of coaxial transmission line connecting the studios to the transmitter in the Empire State Building. With the lines and equalizers used at that time, it was thought necessary to feed the input of the line at a level of about 5 to 10 volts, peak-to-peak, in order to secure an acceptable signal-to-noise ratio at the transmitter input. This situation set

the pattern for line amplifiers at the studio output until the approach of the development of commercial equipment during the last year of World War II. Video levels within the studio plant during that period were generally set at about 1 volt, peak-to-peak.

In connection with post-war developments, there was activity in technical committees of the Radio Manufacturers' Association (now the RETMA) to evolve suitable standards for commercial television equipment. Among the standards adopted by these committees in 1946, was one which specified that studio output amplifiers should be capable of producing a level of 2 volts, peak-to-peak, of composite picture signal, including about 0.5 volt of sync. At that time, there were some wire line interconnections in use in New York provided by the Telephone Company and consisting of ordinary telephone cable pairs with equalizers spaced at frequent intervals. The 2-volt level was considered high enough to avoid objectionable noise, and low enough to avoid noticeable cross talk in the telephone cables. Furthermore, it appeared to be possible to develop this voltage efficiently with acceptably low distortion, on a 75-ohm transmission line load by using a single 6AG7 tube in the output stage of a studio amplifier. It was also felt that the use of a 2-volt level would permit simple and economical de-

signs of picture monitors with a minimum amount of video signal amplification.

In RCA pickup equipment, the 2-volt level was adopted as standard on nearly all 75-ohm interconnecting circuits carrying composite signals, and a 1.5-volt level on 75-ohm circuits carrying non-composite signals (no sync present).

The cathode ray oscilloscope (CRO) has been used universally, during all these various stages of evolution, primarily as a level indicator, but in addition as an indicator of quality of the picture signal. One typical example of its use as a quality indicator is found in the adjustment of shading signal controls where the CRO gives a more critical indication of uniform background than does the eye by direct observation of the monitor kinescope.

## Recent Trends

The rapid and continuing growth of network facilities, together with the almost unbelievable expansion of studio facilities in some of the larger stations with all their highly complex interconnections, has made evident some weaknesses in the adopted video level standard as related to the design of equipment which is in widespread use at present. It has become apparent that the earlier concept of acceptable amplitude distortion limits in line amplifier stages has to be modified when applied to a large system where the number of equipment units is greatly increased as compared

to that involved in a small operation. For example, a signal originating in an outlying studio of a large station may be passed through as many as ten line amplifier stages before arriving at the transmitter. If the signal is fed through a cross-country cable network, it may pass through several hundred repeater amplifiers before reaching its destination. It is obvious that the distortion in any one amplifier must be held to an extremely low value if the cumulative distortion in such a system is to be tolerably small.

Amplitude distortion of a television picture signal results in unnatural tones of gray in the reproduced scene. The most common type of distortion changes tonal gradation in the light grays and near-whites. Faces may look too white and washed-out, and lack any appearance of depth. In order to illustrate the significance of a small amount of distortion in a single amplifier unit which is part of a large system of many similar units, let us assume that the permissible limit of compression of the whites accumulated in the entire system is 25%. This particular value has no special significance, but it is an amount of compression which is observable, and may be assumed for purposes of discussion. In the case of a system having 100 amplifiers in cascade, the compression per unit would have to be less than 0.3 of 1% to stay within the assumed limit.

Fortunately, the network equipment is designed to avoid distortion to an acceptable degree. On the other hand, many studio amplifiers do not have adequate linearity to provide satisfactory operation in cascade in large numbers with a level of 2 volts. Rather than recommend modification or replacement of the large number of such amplifiers now in use, with attendant high cost and inconvenience, it seemed preferable to recommend a reduction in the standard signal level which would make possible a noticeable decrease in distortion without an appreciable increase in noise.

FIG. 2. Operating scale No. 1 for use at camera controls.

Reference white at 100  
Reference black at 10  
Blanking level at 0

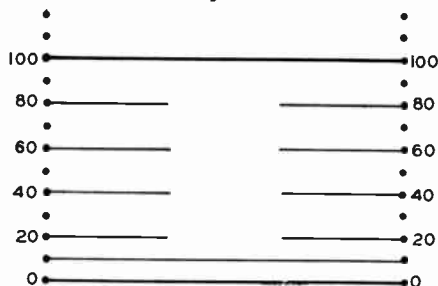

This problem came to a head early in 1950 in New York, which had by that time become the principal source of network programs on television. Another problem had also been adding to the confusion, namely, that in spite of the RETMA standard 2-volt level for video amplifiers, there was no adherence to any operating standard in this matter. The levels put out by the New York stations were nearly all different, determined largely by requirements of common carrier equipment used for interconnections and for networking. These varying requirements resulted from the fact that common carrier terminal equipment had grown up with the demand; it represented, in some cases, different stages of development, and did not adhere to one standard in the matter of levels.

The situation was given special attention by an informal committee composed of representatives of the six television stations in New York City and of the Telephone Company and of some interested manufacturers of television equipment. This group held several meetings between May and September and proposed a standard operating level of 1.4 volts, peak-to-peak, of composite signal as outlined in Fig. 1. The new level has subsequently been adopted by the New York stations as well as by some others. It has been agreed that this level will be satisfactory in the common carrier operations though there will be a transition period required for modernizing some of the existing equipment during which it may be necessary to continue the use of other levels.

#### The IRE Standard Scale

The choice of the new level of 1.4 volts was guided, of course, by the need for reduced distortion, but in addition, it was influenced by the recently adopted IRE Standard\* which included, among other things, a standard scale for measuring video levels. This scale is shown in Fig. 1 which is a reproduction of the diagram in the IRE Standard. The special committee of

New York broadcasters and television manufacturers decided to recommend correlating the new video level in volts with the arbitrary units in the IRE scale. The desired relationship is given by the expression:

$$\text{Video Signal in Volts} = \frac{\text{Number of IRE Scale Units}}{100}$$

#### Practical Scales for CRO Tubes

The three scales shown in Figs. 2, 3, and 4 were recommended by the Special Committee for practical use on the faces of 5-inch CRO tubes as follows:

##### SCALE 1 (Fig. 2)

To be used with either studio or film camera controls where non-composite (no sync) signals are used. Blanking level is at 0; reference black is indicated at 10; and reference white is at 100. Total deflection is 2 inches between 0 and 100.

##### SCALE 2 (Fig. 3)

To be used at studio or master control outputs, or for preview monitors, or for any monitor where composite signals are present. Sync peaks are at -40; blanking at 0; reference black is indicated at 10; and reference white is at 100. Total deflection is 2 inches between -40 and 100.

##### SCALE 3 (Fig. 4)

To be used at the transmitter location where composite signals are present and where it is desired to measure depth of modulation. Scale numbers on the left

FIG. 3. Operating scale No. 2 for use with composite signals.

Reference white at 100  
Reference black at 10  
Blanking level at 0  
Sync peaks at -40

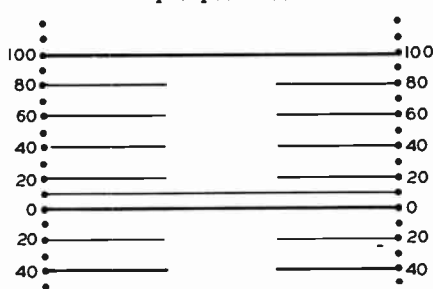

\* STANDARD, 50 IRE 23.S1—TELEVISION: METHODS OF MEASUREMENT OF TELEVISION SIGNAL LEVELS, RESOLUTION, AND TIMING OF VIDEO SWITCHING SYSTEMS, 1950. This standard was published in the May, 1950 issue of Proceedings of the IRE. Reprints may be purchased from the Institute of Radio Engineers, 1 East 79th Street, New York City, for \$0.70 each.

FIG. 4. Operating scale No. 3 for use at a transmitter location where depth of modulation is to be measured.

Reference white at 100, 12.5% carrier  
Zero carrier at 120, 0% carrier  
Reference black at 10  
Blanking level at 0, 75% carrier  
Sync peaks at -40, 100% carrier

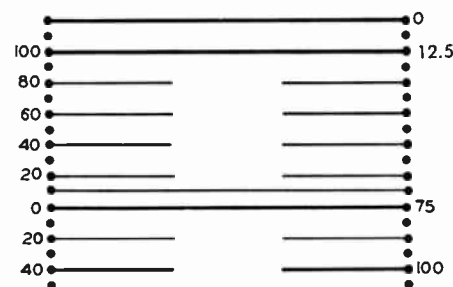

hand side are the same as for Scale 2. On the right hand side, the numbers are per cent of modulation. Total deflection is 2 inches between -40 and 100, or between 100 and 12.5 on the per cent scale.

The value of 2 inches for vertical deflection on the CRO using the new scales was adopted after tests which indicated that this deflection was reasonably linear in present equipment. Units which were not linear at 2 inches of deflection were found to contain subnormal amplifier tubes.

A fortuitous relationship between the IRE standard and the proposed operating level is evident in Fig. 4. Here the numbers on the right hand side of the scale indicate per cent of modulation of the r-f carrier and show how it relates to the IRE scale. By setting zero carrier opposite 120 on the IRE scale, and maximum carrier opposite -40, blanking level (or zero) corresponds with 75% of maximum carrier, and reference white (or 100) corresponds to 12.5% which is the minimum allowable carrier level. Thus the F. C. C. specifications on carrier levels are embodied in this same scale.

#### Recommended Use of New Scales

Experience over several months of operation in a number of television stations has shown that the new voltage level and the new scales are a substantial aid in attaining improved performance. As a result of this experience, a recommendation has been sent to the RETMA that its standard be revised to specify a video level range of 1.4 volts, peak-to-peak, for studio equipment. The recommendation is now being considered in the technical committees of the RETMA.

It is highly recommended that all television stations adopt this level in operating practice as soon as practicable. It will not only improve performance, but it will do a great deal to facilitate the interconnection of stations and the exchange of programs through the networks.

#### Availability of Printed Scales

TM-6B has scale built in. For those users of TM-5B Master Monitors, or other equipment employing 5-inch CRO tubes, scales, similar to those shown in Figs. 2, 3, and 4, printed in black on thin clear plastic, may be obtained by writing to the Editor, BROADCAST NEWS, Building 15-7, RCA Victor, Camden 2, New Jersey. These scales may be applied to the faces of CRO tubes with pieces of transparent adhesive tape. This type of scale is not as durable nor as easily visible as is consid-

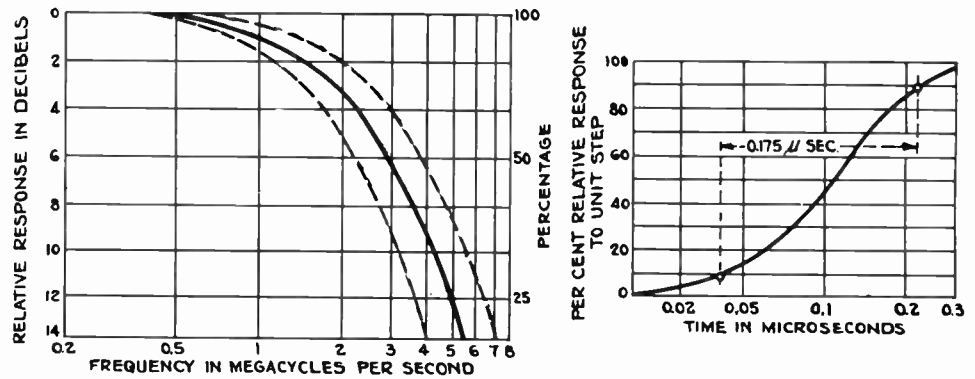

FIG. 5. Curves showing frequency and time response for a standard oscilloscope.

ered desirable, but it is being made available as a temporary measure until the design of a more satisfactory type can be completed.

#### Setup

The term setup, though not officially recognized, has been, for a long time, applied to the *difference* in level between blanking level and reference black. In a perfect television system, it might be possible to hold setup to zero with satisfactory results. By doing so, it would be possible to obtain the most efficient utilization of video, r-f, and i-f amplifier characteristics. However, perfect signals would be required, without amplitude distortion (overshoots in the black direction), and very careful adjustment of the background controls in receivers would be required to avoid retrace lines or clipping of blacks in the kinescope.

By raising setup to some reasonable value, it is possible to realize much more practical operating conditions. Small black overshoots can be present without extending into sync territory, and in the receiver it is possible to adjust the background control so that retrace lines are surely blanked out without clipping black peaks in the picture signal.

In the PICTURE LINE AMPLIFIER STANDARD OUTPUT adopted by RETMA (Revised Oct. 9, 1946)\*, the recommended amplitude of setup is 5% of the difference between blanking level and reference white level. This corresponds to 5 units on the IRE scale. Experience in most stations has shown the desirability of increasing this amplitude to about 10%. The increase reduces the utilization of amplifier characteristics, but it improves overall performance by allowing more tolerance for overshoots in the blacks, and by permitting final clipping at blanking level in stabilizing ampli-

fiers in order to eliminate overshoots in the sync region. This clipping usually reduces setup somewhat below 10%, a process which would not be permissible if the initial value of setup were only 5%. For these reasons, the scales adopted for operating use include a line at 10 to indicate the maximum amount of setup. This 10% line, as well as the zero line, is made continuous across the scale to emphasize its importance.

The maintenance of constant setup, *at all times*, is extremely important in order that brightness adjustments in receivers should not require changing. This is important in successive scenes in any one program, and it is equally important in successive programs, whether they originate in the same station or not. It is, therefore, urgent that all stations adopt uniform procedures and uniform instrumentation which will make possible accurate measurement of this and other video levels.

It is recognized that the proposed scales do not permit a high degree of accuracy in measurement, but universal use of the same methods and tools will at least provide the first step on the way toward achievement of uniformity.

#### Instruments for Measuring Video Levels

The cathode ray oscilloscope has been regarded almost universally as the only suitable instrument for the measurement of video levels. Probably, the principal reason for this is that the television signal is a composite of several signals, each having levels that need accurate measurement individually and in their relationship to each other. Circuitry is rather well known which would make it possible to measure any of these quantities by means of a meter with the same advantages that are inherent in the use of audio level meters. However, it is not possible to provide simultaneous measurement of all the quantities in a single meter, and the circuit com-

\* See "The Philosophy of Our TV System," by J. H. Roe, Fig. 5, BROADCAST NEWS, No. 53.



plexities involved in using several meters at each monitoring position would be greater than those associated with a CRO. Furthermore, because of inherent sluggishness, both electrical and mechanical, the meter system is incapable of indicating the presence or amplitude of isolated narrow peaks in the signal. It is also incapable of indicating any information about waveshape in the measured signal, and therefore fails as a monitor of quality.

Because the CRO does measure all levels simultaneously, at the same time giving detailed information about waveshape, and because it has no appreciable sluggishness, it can serve as a universal instrument for indicating both level and quality. Its use as a level indicator over such a long period has undoubtedly established an acceptance which would be difficult to change. In any case, there has been no definite trend as yet away from the use of the CRO in television monitors.

#### The IRE Standard Frequency Characteristic for CRO's

Post-war experience gained in the use of television equipment has shown that the presentation on the face of a CRO tube is easily misinterpreted in the measurement of levels if there are any spurious overshoots in the signal. Overshoots may arise from any of several causes such as faulty circuits or tubes, or from a type of distortion introduced by single-sideband transmission circuits. Sometimes, the overshoots may arise in the measuring instrument (CRO amplifier) itself. It has been found that when spurious peaks are present, different operators do not interpret their significance in the same way. In measuring levels, one operator may discount the presence of the overshoots completely, while another may regard them as a part of the signal to be measured. In network operation, it is particularly important that levels be measured on the same basis at all monitoring points, and it is hardly less important in studio equipment. A desirable solution to the problem of uniformity is to make the measuring instrument insensitive to such spurious overshoots, and thus remove the human factor of interpretation.

To accomplish this result, the previously mentioned IRE Standard also includes a specification of a frequency characteristic for CRO's which are to be used *for measuring levels only*. This characteristic is reproduced in Fig. 5 from the IRE Standard. The bandwidth is considerably re-

stricted and the "roll-off" at the upper end of the band is gradual. The resultant effect is to eliminate most of the higher frequency components in the signal, including most of the overshoots. Corners of the pulses in normal signals become rounded, but the amplitudes of blanking pulses and low frequency signal components are not affected. Because nearly all scenes contain at least a few relatively large areas of average contrast, the loss of high frequency response in the CRO amplifier does not often affect the accuracy of level measurement. Practical experience indicates that use of CRO's with this response characteristic does help to reduce disagreements among operating personnel about levels.

It should be emphasized that this type of restricted bandwidth is not suitable for gauging the quality of a picture signal, but *only* for measuring levels, and then only to minimize the errors introduced by spurious overshoots. It is rather interesting to note that one early type of television studio monitor (RCA Type KE5, designed in 1936) employed CRO's with a restricted pass band very similar to that in the present IRE Standard. In later versions (RCA Types 542 and TM5) the pass bands were extended to several megacycles to make them more suitable for judging quality. Present design trends are to make both types of frequency characteristic available by switching.

To illustrate the effect of reducing the frequency response, several oscillograms are reproduced in Figs. 6 to 9 inclusive. The wide-band CRO used to obtain the pictures in Figs. 6 and 8 was an RCA Type 715B. The narrow-band CRO used to obtain the pictures in Figs. 7 and 9 was a modified TM-5B Master Monitor. The signal source in every case was a TK-1B Monoscope Camera. Overshoot distortion for Figs. 8 and 9 was produced artificially, and is more severe than is usually encountered, but nevertheless, it serves to show the effect of the restricted band pass of the CRO. Horizontal sweep rate in each case is at one half of scanning line frequency.

#### Modification of Master Monitors

A discussion of methods by which the RCA TM-5A and -B Master Monitors may be modified to provide the IRE roll-off characteristic is available from RCA Victor, Broadcast Marketing Division.

FIG. 9 (at right). Oscillogram showing the same signal as in Fig. 8, but shown on the Master Monitor with IRE roll-off in the CRO amplifier.

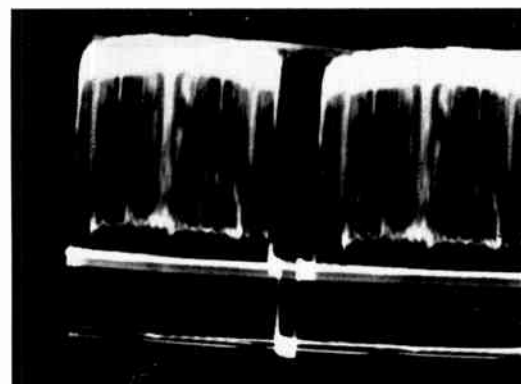

FIG. 6 (above). Oscilloscope showing a normal monoscope signal on a wide-band CRO (RCA Type 715B).

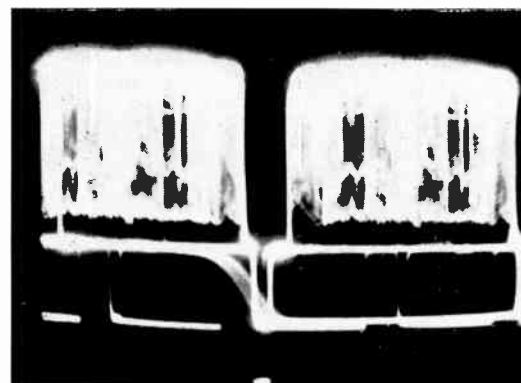

FIG. 7 (above). Oscillogram showing a normal monoscope signal on CRO in a modified TM-5 Master Monitor (CRO amplifier with IRE roll-off).

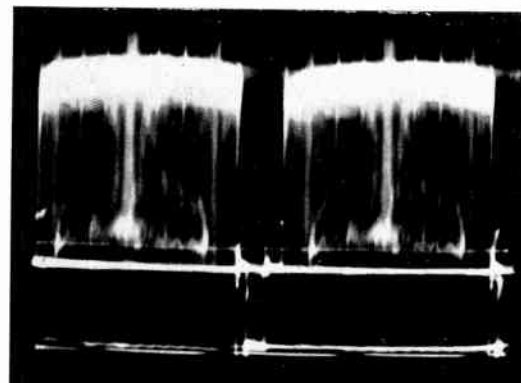
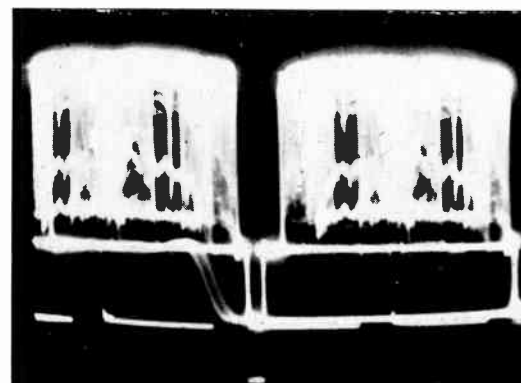

FIG. 8 (above.) Oscilloscope showing the monoscope signal with severe overshoot distortion as shown on a wide-band CRO (RCA Type 715B). Note black overshoot in sync region.



# HOW TO ADJUST FREQUENCY RESPONSE IN VIDEO AMPLIFIERS FOR TV

Along with all the problems connected with operating and maintaining a television station, the maintenance of video amplifiers requires certain techniques which are very likely new to the station owner and his engineers who have had past schooling and experience mainly in the handling of audio equipment. The difficulties in handling these new techniques arise mainly from the relatively high frequencies included in the upper end of the video band. If measurements and adjustments are made without adequate test equipment, or without adequate knowledge of suitable methods, the results may be erroneous and misleading. Therefore, it is the purpose of this article to outline some methods of measuring the performance of video amplifier circuits and for adjusting them, thus providing at least some of the "know-how" required for satisfactory maintenance.

The problem will be discussed almost entirely from the qualitative angle because that is the most important aspect to the maintenance man. In other words, an effort will be made to describe what happens in the circuit when changes are made in certain components, but little space will be given to theory which is thoroughly covered in existing literature. A qualitative

sense, or sense of "direction", is a most valuable asset in dealing with the practical operation of circuits.

## Typical Circuits

Wide-band video amplifier design is based almost exclusively on the use of resistance-capacitance coupled amplifiers, the important basic elements of which are illustrated in the simplified schematic of Figure 1. Some of the practical elements of the circuit, such as B supply, bias supply, or screen grid filter, have been omitted because it is assumed that they have been designed so as to have negligible impedances for any signal frequencies involved.

The discrete components of the circuit are shown in solid lines, while another important component (stray capacitance) is shown in dotted lines. Most circuit components also include residual or stray inductance, but this is not shown because components are chosen and arranged in practical circuits so as to have negligible inductive reactance in the band of frequencies used in TV amplifiers. *Stray capacitance*, however, is not negligible, and care should always be exercised in working on video amplifiers not to disturb the general arrangement of wiring and components in

such a way as to change the stray capacitance appreciably.

Because of the wide-band requirements, the effective load impedance is held to characteristically low values. Usually  $R_L$  (Figure 1) constitutes the principal load on the plate circuit. In other words,  $R_L$  is small compared to  $R_g$  so that  $R_g$  may be neglected in calculations involving load impedance. However, in some circumstances, the situation may be reversed so that  $R_g$  becomes the principal load and  $R_L$  becomes relatively large. This case will be discussed under output circuits.

The frequency response characteristic of an uncompensated amplifier, such as that shown in Figure 1, has the general appearance of the curve of Figure 2(a) where  $e_o$  is the alternating signal voltage appearing at the output terminals across an ideal purely resistive load when a signal at constant voltage is applied to the input terminals. Usually there is a mid-range where the output is reasonably constant (where the curve is said to be "flat") while on either side of the mid-range the response of the amplifier falls off toward zero.

It is convenient to choose some frequency, say  $f_1$ , in the mid-range which divides the curve into two parts. At frequencies above  $f_1$ , the curve is usually flat for an appreciable range, indicating that neither the stray shunting capacitance nor the coupling capacitance,  $C_c$ , affects the response. In other words, the reactance of  $C_c$  is negligibly small, and that of the strays is negligibly large, so that the circuit is purely resistive. However, as the frequency increases further, the shunting

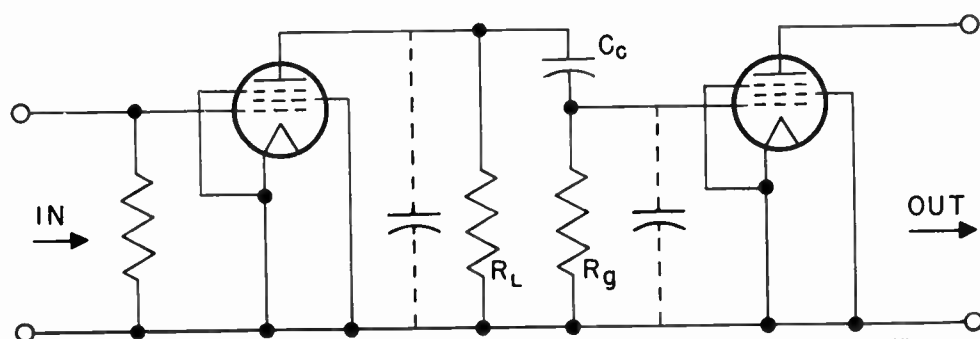

FIG. 1. Simplified schematic circuit of a typical resistance-capacitance coupled amplifier.

of the strays becomes increasingly effective, causing the output to fall off gradually. Below  $f_1$ , the shunting effect of the stray capacitance is obviously negligible, but the reactance of  $C_c$  increases as the frequency decreases, so that the voltage across  $R_g$  decreases correspondingly, and the output of the amplifier falls off to zero. Because one reactive element operates effectively on one side of  $f_1$ , and the other reactive element operates on the other side, it is easy to treat the frequency response of the amplifier in two corresponding parts which are independent of each other. These two parts are commonly called the "highs" and the "lows" respectively.

Measurement and adjustment of the highs should always be made first because from this measurement the correct value for  $R_L$  is determined. The magnitude of  $R_L$  also influences low frequency compensation, but its value is fundamentally to correct adjustment of the highs; therefore, once it has been determined, other elements affecting the lows must be adjusted for compensating purposes without disturbing  $R_L$ .

### High Frequency Compensation

Numerous circuit arrangements have been used to improve the high frequency response of video amplifiers. Of these, two have come into common use in RCA equipment, as well as in other types. The first is illustrated in Figure 3. Here the two shunt capacitors shown in Figure 1 have been combined into one which resonates with a small inductance in series with  $R_L$ . This is commonly known as a "shunt-

\* The performance of an amplifier is measured in terms of both gain and bandwidth. These are mutually dependent factors. As one increases, the other decreases, so that the product remains constant. It is therefore common practice to refer to the product of these two factors (gain  $\times$  bandwidth) as the *figure of merit* of the amplifier. For example, if a given amplifier has a gain of 20 and a bandwidth of 4 mc., the same amplifier may be rearranged to have a bandwidth of 8 mc. and a gain of 10 by reducing  $R_L$  to one half its original value and making corresponding changes in the values of  $L_1$  and  $L_2$ . Thus, any improvement in circuit performance obtained by improved design or execution may be used (a) to increase the bandwidth, (b) to increase the gain, or (c) to increase both by a lesser amount.

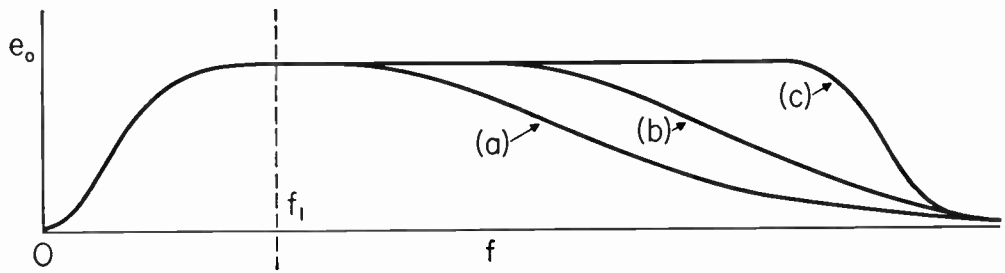

FIG. 2. Typical curves of frequency response for various kinds of compensating circuits.

peaked" circuit. Because  $R_L$  is in series with  $L_2$ , the  $Q$  of the circuit is very low, and there is no prominent resonance peak in the output voltage. When the values of  $R_L$  and  $L_2$  are correctly adjusted, the effect on the frequency response is about as illustrated by Figure 2(b). The flat part of the curve has been extended, but the cut-off is still reasonably gradual.

The circuit of Figure 3 is used occasionally where the need for increased bandwidth (or gain) is not great, and where simplicity and reasonably linear phase characteristics are important.

The more frequently used circuit, however, is shown in Figure 4, where it may

be seen that a second inductive element has been added in series with the plate connection of the first amplifier. This added coil has the effect of dividing the stray capacitance into two parts and thus forming a single section of a low-pass filter in which the characteristic  $C$  is only a fraction of the total stray capacitance. Therefore, the characteristic (terminating) impedance of the circuit is considerably higher than is possible in a circuit where the stray capacitance is not divided. This means simply that a higher value of  $R_L$  may be used. The figure of merit\* (gain  $\times$  bandwidth) of the circuit is appreciably larger than for the circuit of Figure 3. The frequency response curve is illustrated

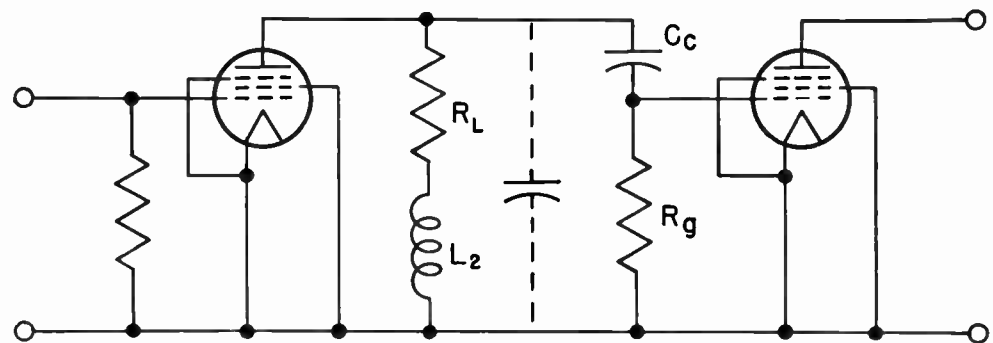

FIG. 3. "Shunt peaked" video amplifier.

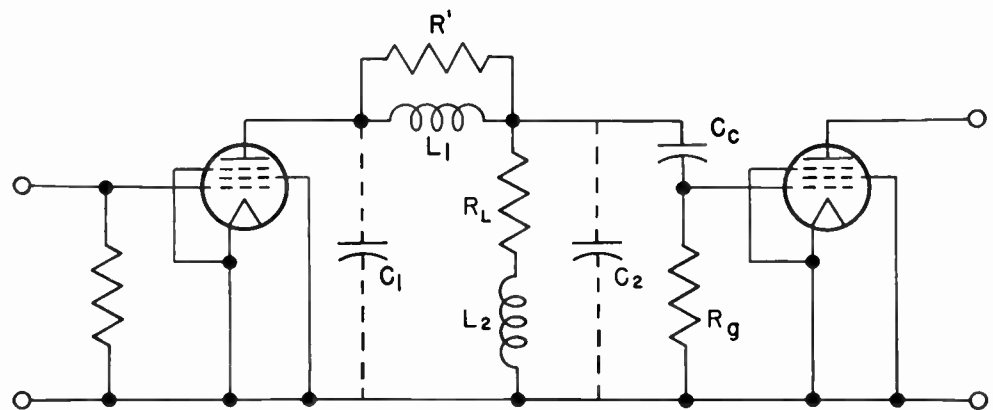

FIG. 4. Video amplifier using both shunt and series peaking.

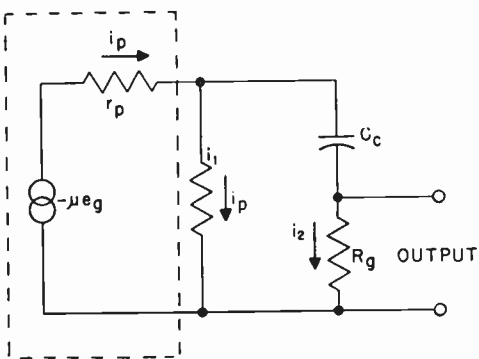

FIG. 5. Simplified circuit including only those elements which affect low frequency response.

in Figure 2(c). It should be noted that the cut-off is relatively abrupt, and that the phase response is more non-linear near cut-off than in the simpler circuits.

### Low Frequency Compensation

The small coils added to the circuit for high frequency compensation have negligible reactance at frequencies below  $f_1$ . Hence, in considering the "lows", the circuit may be reduced to that shown in Figure 1, but with the shunting capacitances omitted also. It must be remembered, however, that the value of  $R_L$  has been determined by the needs of the "highs" and it should not be disturbed in compensating the "lows".

Because the functioning of some low frequency compensating circuits may not be understood, a little discussion of simple theory will be given here.

Figure 5 shows a simplified arrangement of the circuit of Figure 1 suited to study of the low frequency performance. The first amplifier tube is shown as a generator, with internal series resistance  $r_p$ , within the dotted enclosure. The second tube is not shown, but output terminals are shown which would be connected normally to the grid and cathode. Grid conductance is assumed to be negligible. The following relations are essentially true for screen grid tubes used in TV video amplifiers:

$$r_p \gg R_L$$

$$R_g \gg R_L$$

Therefore, it may be concluded that:

- $i_p$  is in phase with the generator voltage because  $r_p$  (a pure resistance) is the principal impedance in the load circuit.
- Both  $Z_L$  and  $R_g$  may be changed considerably within their respective orders of magnitude without changing the magnitude or phase of  $i_p$ . ( $Z_L$  includes  $R_L$  and any reactive element which may be added, as in Figure 6.)

- The current,  $i_1$ , is essentially equal to  $i_p$  in phase and magnitude.
- The voltage drop across  $R_L$  is in phase with  $i_p$ .
- The current,  $i_2$ , is displaced in phase by the reactance of  $C_c$ .
- The output voltage ( $i_2 R_g$ ) is likewise displaced in phase.

To obtain undistorted amplification, the output voltage should be kept exactly in phase with the generator voltage and  $i_p$ . There are several ways to accomplish this:

- Make the reactance of  $C_c$  negligible at the lowest frequency in the band (make  $C_c$  larger).

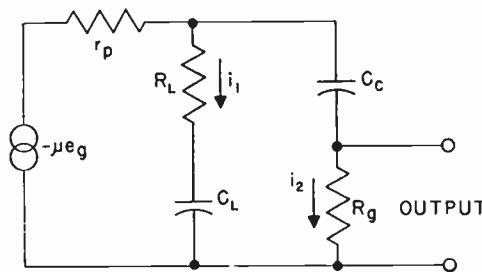

FIG. 6. Simplified circuit with addition of low frequency boost.

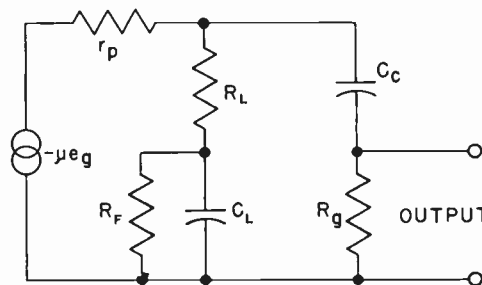

FIG. 7. Simplified circuit with addition of decoupling resistor  $R_F$ .

- Make  $R_g$  larger so that the reactance of  $C_c$  is comparatively very small.
- Shift the phase of the voltage across the plate load circuit so that  $i_2$  is in phase with  $i_p$ .

The limit of the first method is reached when the coupling capacitor becomes too large to fit in available space, or when its size causes an intolerable increase in stray capacitance, thus causing deterioration of the high frequency response.

The magnitude of  $R_g$  is limited, of course, largely by the maximum resistance which can be allowed in the grid circuit of the tube to insure stable operation. This maximum is specified by the tube manufacturer to prevent gas current to the grid (positive ion current) from causing an excessive increase in average plate current.

In many cases, methods 1 and 2 are sufficient, within their limitations, to produce satisfactory results. When they are not adequate, however, method 3 is employed. The desired phase shift may be secured simply by making the two parallel branches of the load circuit *similar* in impedance characteristics, i.e. with equal phase angles, but not necessarily equal magnitudes. Addition of  $C_L$ , as shown in Figure 6, accomplishes this. The two branches now contain like impedance elements, and if  $C_L$  is chosen so that  $R_L C_L = R_g C_c$ , then  $i_1$  and  $i_2$  will have the same phase angle. This must be the same phase angle as that of  $i_p$  (under the assumptions A, B, and C) because  $i_1 + i_2 = i_p$ ; therefore,  $i_2 R_g$ , the output voltage, has been corrected to be in phase with  $i_p$  and with  $-\mu e g$ . The relationship will continue to hold as the frequency decreases until the reactance of  $C_L$ ,  $\left(\frac{1}{\omega C_L}\right)$ , becomes appreciable in magnitude as compared to  $r_p$ , and therefore begins to affect the magnitude and phase of  $i_p$ . This does not usually occur until the frequency becomes extremely low, well below the useful video band.

Figure 6 is not a practical circuit because it does not provide a d-c path to the anode of the first amplifier tube, but it illustrates an important principle. To make the circuit practical, another resistor,  $R_F$ , must be added as shown in Figure 7. This resistor will not affect circuit performance as long as  $R_F$  is large compared to  $\frac{1}{\omega C_L}$  at the lowest frequency in the band. However,  $R_F$  is limited in size by the available B supply voltage; i.e., the d-c drop in  $R_F$  must not reduce the operating potential on the plate of the tube below a satisfactory level.

When  $R_F$  cannot be made suitably larger than  $\frac{1}{\omega C_L}$ , then exact compensation

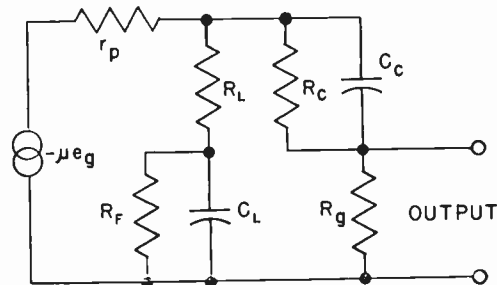

FIG. 8. Simplified circuit with addition of resistive shunt across  $C_c$ .

may be restored by adding a resistor  $R_c$  in shunt across  $C_c$  to restore the similarity of the two parallel branches of the plate load circuit. This is shown in Figure 8. The proper relations for equal phase angles in the two branches are:

$$R_L C_L = R_g C_c$$

$$\text{and } R_F C_L = R_c C_c$$

Obviously, this change provides an unwanted d-c path from the plate of one tube to the grid of the next. This necessitates a final addition in the form of a capacitor  $C'$  in series with  $R_c$  as shown in Figure 9. Of course the circuit similarity of the parallel branches is lost again by this change, but by proper choice a satisfactory compromise may be achieved which is capable of providing excellent response down to extremely low frequencies. The criterion is that  $\frac{1}{\omega C'}$  must be small compared to  $R_c$  at the lowest frequency in the band.

Figure 9 not only shows this final change, but shows the complete video amplifier circuit with all the elements for both high and low frequency compensation accumulated in one diagram. Note that  $R_c$  is divided into two parts as an aid in isolating the stray capacitance of  $C'$  from the main circuit. Also note that  $R_g$  is made adjustable so that reasonably exact setting of the response is possible. By such adjustment, the one low-frequency compensating circuit may serve to correct the errors introduced by more than one coupling or de-coupling circuit, provided that no one error, nor the sum of the errors, is very large. This last point is important if several errors are to be corrected by one compensating circuit.

### Test Methods and Equipment

Both high-frequency and low-frequency response characteristics may be measured with test equipment which is readily available commercially. High-frequency response is usually determined with a frequency modulated, or sweep oscillator which sweeps over the desired band, from a point somewhat above the low end to the high end, at an approximately uniform rate, and which repeats at regular inter-

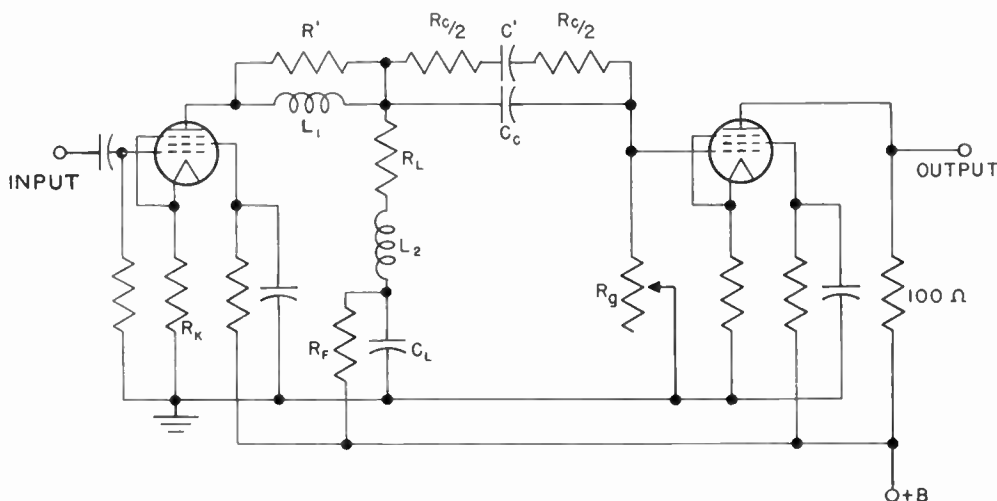

FIG. 9. Complete circuit showing all elements for both low and high frequency compensation.

vals. For convenience, the repetition rate is usually 60 cycles. In the intervals between sweeps, the signal is cut off. Care is taken to provide reasonably uniform amplitude during each sweep. The signal produced by such a sweep generator appears about as shown in Figure 10-A. diode detector yields a 60 cycle rectangular wave as shown in Figure 10-B. Such a wave may be observed easily on a cathode ray oscilloscope which has good low-frequency response so that distortion of the 60 cycle rectangular wave is not introduced by the oscilloscope. The oscilloscope used for this purpose need not have high-frequency response beyond 50 to 100 KC.

The sweep oscillator signal is applied to the amplifier to be tested, and the output of this amplifier is coupled into the diode detector. Variations in frequency response of the amplifier then appear as distortion of the wave-shape of the rectangular wave. In other words, the oscilloscope draws the graph of output voltage vs. frequency of the amplifier being tested. Arrangement of equipment is illustrated in Figure 11.

Sweep oscillators are generally provided with tunable, calibrated absorption markers which produce a small notch in the demodulated wave to indicate points on the frequency scale.

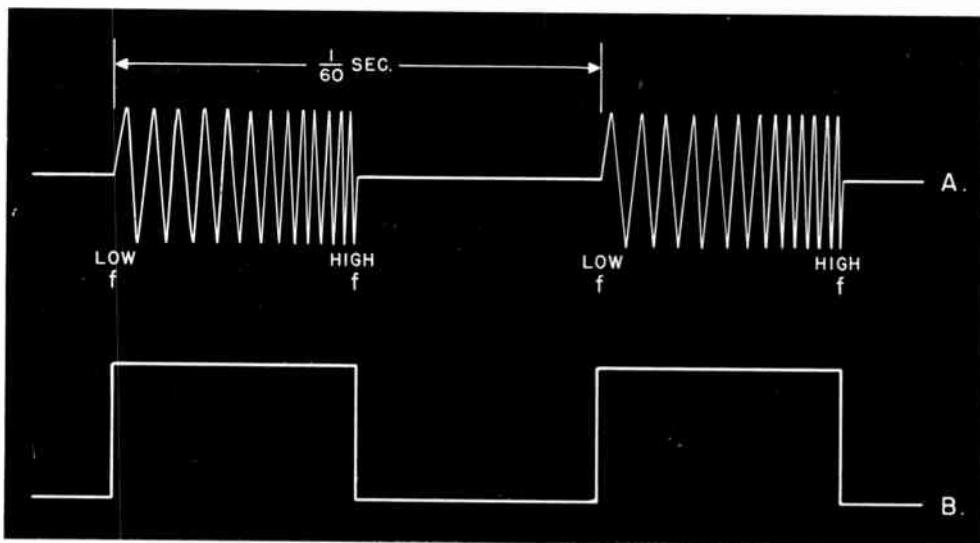

FIG. 10. Wave forms of sweep oscillator output—A. Direct; B. Demodulated.

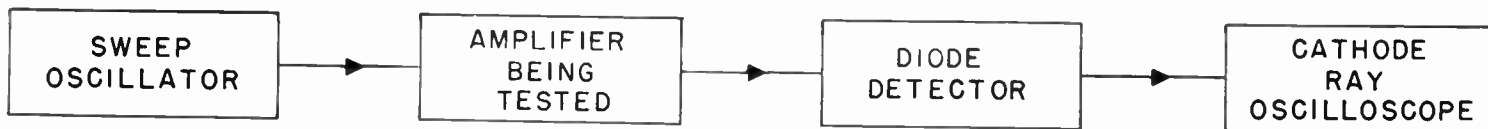

FIG. 11. Block diagram of equipment for measuring high-frequency response.

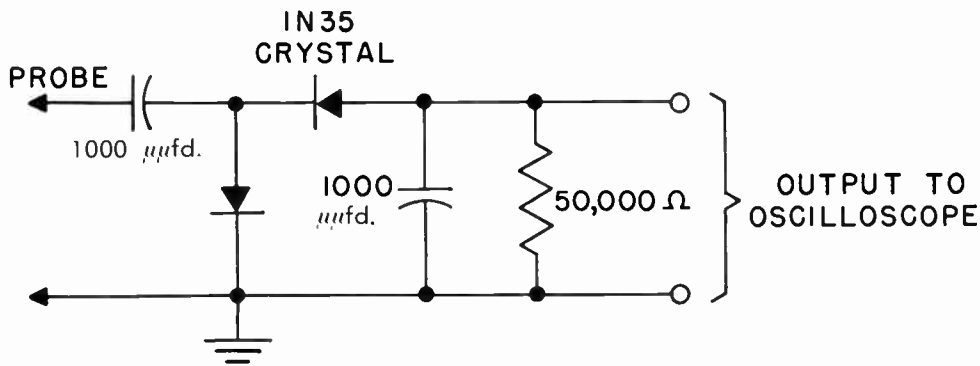

FIG. 12. Schematic circuit of peak-to-peak diode detector for use with a sweep oscillator.

The RCA WA-21B Video Sweep Generator provides a sweep range adequate for the video amplifiers in television terminal equipment, as well as a suitable frequency calibration marker and an output attenuator. The low end of the sweep range extends to about 100 KC and the high end to about 10 mc.

A suitable diode detector with good sensitivity may be constructed quite easily by using a pair of crystals as illustrated in Figure 12. A dual diode, such as the 6AL5, may be used with equally good results in the same circuit, but it has the disadvantage of requiring a heater supply. Germanium crystals, such as the 1N35, are a simpler arrangement. The circuit of Figure 12 is a peak-to-peak rectifier which provides more output signal than a single half wave rectifier, and which also tends to average out discrepancies in wave form, from stage-to-stage of the amplifier being tested, if the signal generator has second harmonic distortion. In constructing such a unit, care should be used to make it compact, and to keep stray capacity of the probe and input to a minimum.

Application of this equipment to the measurement of the frequency response of amplifiers cannot be made in an indiscriminate and careless manner without obtaining spurious results. Well defined and relatively simple procedures are available and should be adhered to, to secure correct results. The reason why care must be used is that connecting test equipment to parts of an amplifier circuit which are compensated for, or are critical to, stray capacitances will cause mis-adjustment of the compensation because of the stray capacitance added by the test equipment. The following general procedure will avoid pitfalls of this kind.

The output of a television amplifier is almost invariably a low impedance circuit intended for feeding a coaxial transmission line. Its impedance is so low (75 ohms or less) that a diode detector may be coupled to it directly without serious effect. Therefore, it is desirable to connect the detector at this point, and leave it there for sweep oscillator tests on any or all stages of the amplifier. Test and adjustment of each stage in a multi-stage amplifier may be

made with this arrangement by testing the stages in reverse order, beginning with the one which just precedes the output stage, and progressing toward the input. By these means the performance of each stage is measured through stages which have been adjusted previously to be satisfactorily "flat", and after adjustment of the final (input) stage, the performance of the entire amplifier is observable.

Figure 13 shows a diagram of a typical amplifier with indications of the proper points for application of the test equipment. The output terminal should be bridged with a resistor equal to the characteristic impedance of the transmission line normally connected there, but the line should *not* be connected during test of the amplifier because it is desirable to avoid discrepancies which might be introduced by line reflections. The effect of the transmission line and its termination should be treated separately. With the detector connected to the output as shown, the sweep oscillator should be connected at (a) when aligning circuit (A), at (b) when aligning circuit (B), and so on in alphabetical order until all circuits are completed.\* Sometimes it is desirable to disconnect the plate circuit of the preceding tube when connecting the sweep oscillator to a grid in order to avoid the loading effect of the plate circuit on the sweep generator. For example, in Figure 13, the circuit would be opened temporarily at the point marked X when connecting the sweep generator at (a).

If some intermediate stage requires special treatment which necessitates testing without association with the rest of the amplifier, then the plate circuit of the tube following the circuit in question should be connected temporarily as a low impedance output circuit similar to the output stage shown in Figure 13. Some high-gain multi-stage amplifiers become unstable when an effort is made to test all the stages at once because the connections to the test equipment provide unavoidable paths for feedback. In such cases the amplifier may be tested in two parts by using the technique just described of converting one of the in-

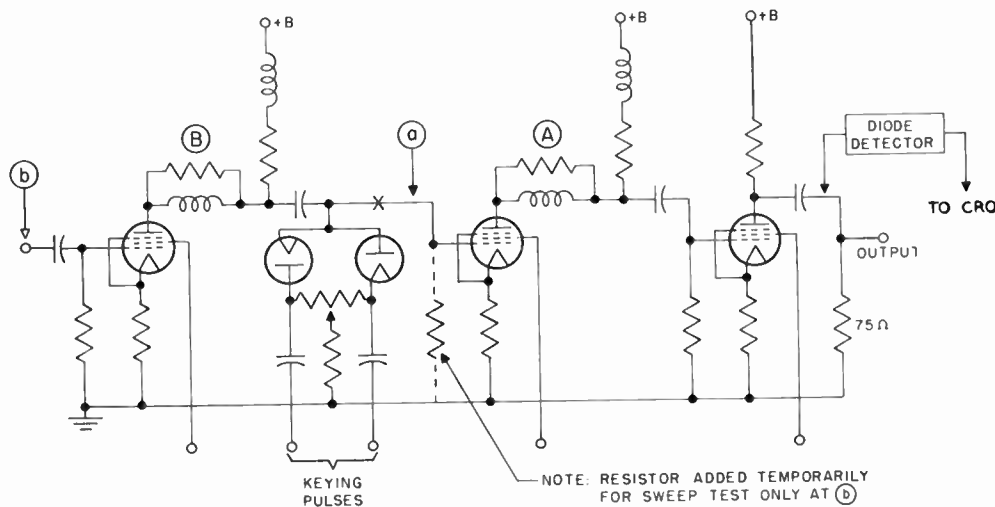

FIG. 13. Typical schematic of multi-stage amplifier showing points where test equipment should be connected.

\* A note of caution should be added about the use of the sweep generator. The attenuator and output circuit of the sweep provide very low resistance across the output terminals. The circuit does not include a blocking condenser; therefore, it should *never* be connected to any part of an amplifier where there is a d-c voltage, as, for example, directly to the plate circuit of an amplifier. If this should be done, the sweep generator would be seriously damaged.

intermediate stages temporarily to a low impedance output arrangement for use in testing the low level or head-end section.

Another special case exists where a clamp circuit is used as shown between the first two stages in Figure 13. The clamp, if left in operation, would cause spurious results because the sweep generator does not provide television blanking pulses on which the clamp normally operates. Therefore, it becomes necessary to immobilize the clamp. This may be done by adding a grid leak (of about 0.1 megohm) as noted in Figure 13, and by substituting a "dummy" diode (one in which the heater circuit has been opened by cutting off a base pin) for the normal clamp diode. This latter is necessary in order to maintain the stray capacitances in the amplifier circuit at their normal values without any diode action.

Another method is possible which makes it unnecessary to immobilize the clamp circuit. This method involves the introduction of blanking pulses into the sweep signal so that the clamp operates in its usual fashion. Such mixing should not be attempted on a simple basis in temporary equipment. However, it may be done satisfactorily by using the RCA TK-1B Monoscope Camera which has an auxiliary input terminal provided for such a purpose. If such a setup should be used, it would be necessary to regard the Monoscope Camera as part of the sweep generator, and to be sure that the performance of the complete equipment is satisfactory for use as a signal generator.

Still another special case is encountered when it is desired to determine the overall frequency characteristic of a camera pre-amplifier. This amplifier usually contains two circuits which do not have flat frequency response individually, but rather they are complementary so that the overall response is flat. The two circuits in question are the input circuit where the pickup tube is coupled to the amplifier, and the so-called "high peaker" circuit.

The input circuit comprises not only the load resistor normally connected to the pickup tube, but also the stray capacity of the circuit including the signal plate of the pickup tube and the grid of the first amplifier with necessary wiring and coupling capacitor. It is not satisfactory to couple the sweep oscillator directly to the input of such an amplifier because it changes the impedance from a relatively

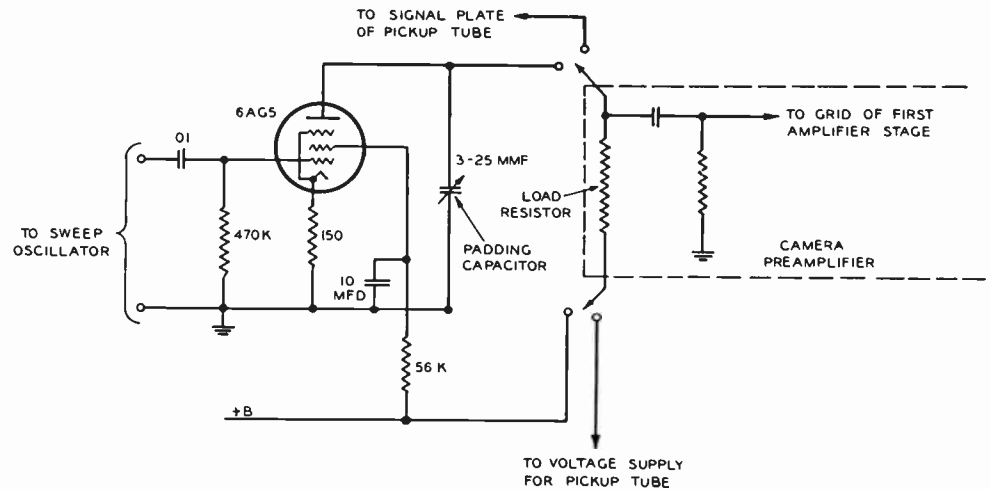

FIG. 14. Buffer amplifier for coupling sweep oscillator to preamplifier.

high value to a very low value, and, therefore, it upsets the normal configuration of the circuit which is to be checked.

A satisfactory method of coupling to an input circuit of this kind is to use a low-gain pentode tube as a buffer between the sweep oscillator and the input terminal of the amplifier. The plate load for the buffer should be the same load that is normally used for the pickup tube, with such changes in supply voltages as may be necessary for suitable operation of the buffer. Signal input and gain of the buffer should be adjusted so as to provide no more than normal signal level at the amplifier input. Careful measurement of the stray capacity normally present in the input circuit, with the pickup tube connected to it, should be made. Then when the pickup tube is disconnected, and the buffer is connected, the circuit should be padded with additional capacity until the total is the same as that which was measured in the normal circuit.

A typical circuit arrangement for such a buffer stage is shown in Figure 14.

Low-frequency response may be measured most quickly and satisfactorily by the square wave method. Square waves with a fundamental frequency equal to the field frequency of the television system (60 cycles for the American system) are adequate. Several commercial generators are available to provide such a signal. For observation of the results, a cathode ray oscilloscope similar to that required for the sweep signal tests may be used, good low frequency response being the principal requirement. The technique for applying the test equipment to the amplifier under test is similar also. The oscilloscope should

be connected to the output circuit which does not contain elements critical to frequency response. The signal is applied to each stage in succession and progressively toward the input until the entire unit is tested.

Square wave response tests (at low frequencies) need to be applied only to those parts of an amplifier which *follow* a clamp circuit. Other parts which precede the clamp are usually *intended* to have poor low frequency response in order to minimize microphonics or other disturbances, and therefore testing them is pointless. The clamp restores the low frequency components in the video signal which are lost in such circuits.

It is generally considered sufficient to make the two tests described in the foregoing paragraphs even though they leave the intermediate region from 60 cycles to 100 KC unchecked. If both such tests indicate proper adjustment, there is little likelihood that there is serious trouble in the intermediate region. However, if it is desired to make a check covering this range, it may be done simply by changing the frequency of the square wave generator to about 15 KC, and observing the accuracy with which the wave shape is reproduced. Faulty response is indicated by tilted peaks on the waves, or by transient overshoots on wave fronts, or by badly rounded corners on the peaks of the waves. The last two faults are indications of poor high-frequency response which would show very prominently in the sweep test. For such an intermediate frequency test, a wide-band oscilloscope is required.

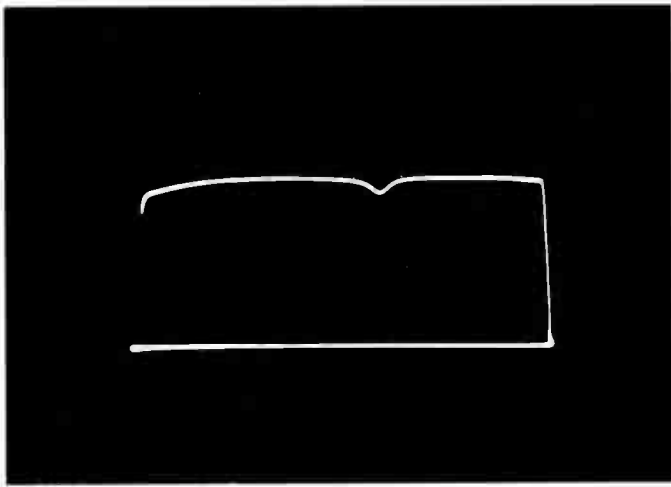

FIG. 15. Demodulated output of the video sweep oscillator. Minimum frequency less than 1 mc, maximum 12 mc, marker notch at 7 mc.

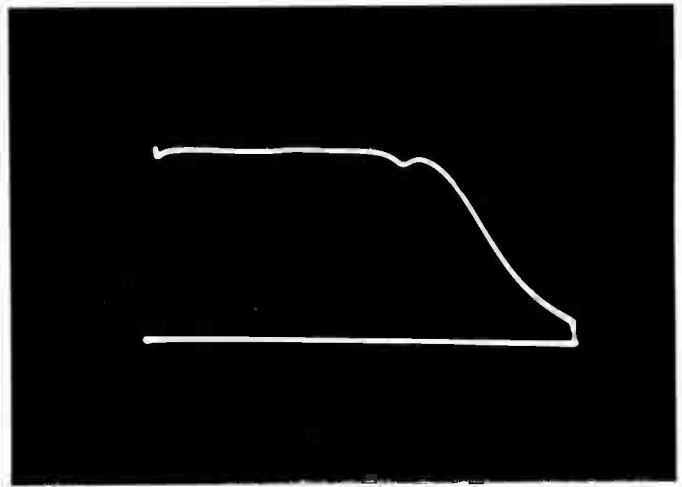

FIG. 16. Output of single compensated amplifier stage as in Fig. 9, with circuit adjusted normally. Marker notch at 7 mc.

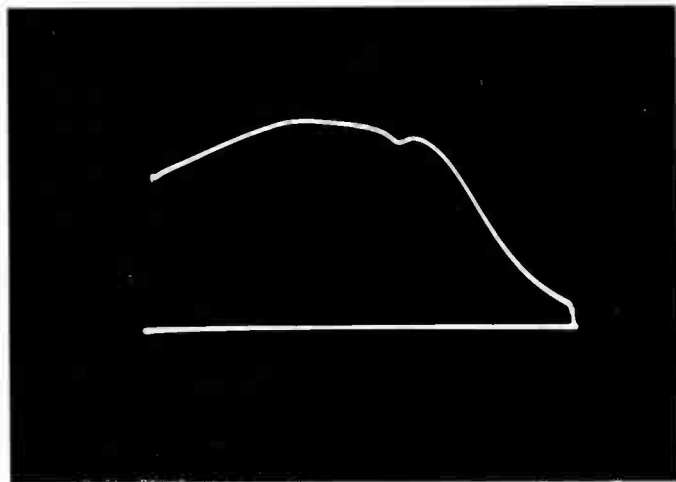

FIG. 17.  $R_1$  too small. Note reduced output at low frequencies and upward slope of curve toward middle range. High frequency end of curve unchanged.

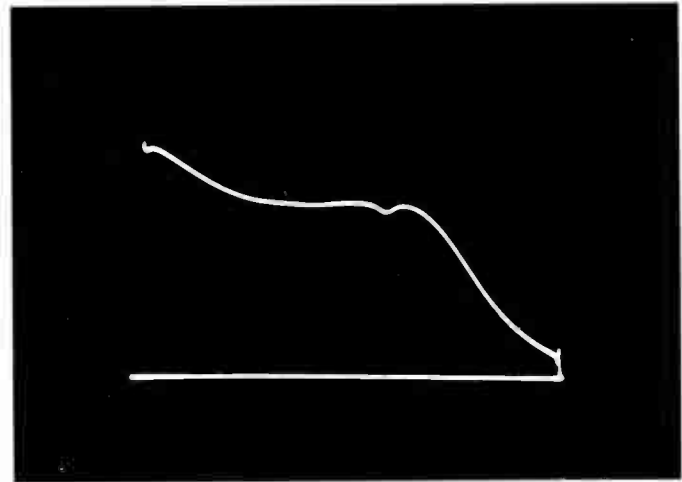

FIG. 18.  $R_1$  too large. Note excess output at low frequencies, and particularly the downward slope toward the middle range.

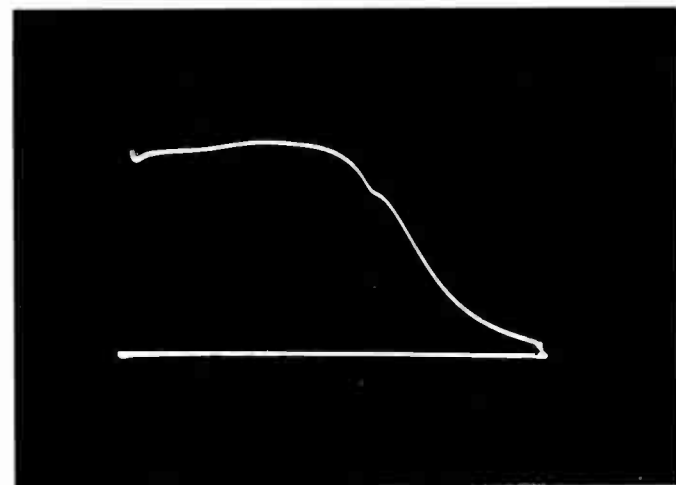

FIG. 19.  $L_1$  too large. Principal effects are reduced cutoff frequency and slight upward slope from low end toward mid-range. Conversely, with  $L_1$  too small, the cutoff frequency will be larger and low-frequency output too large.

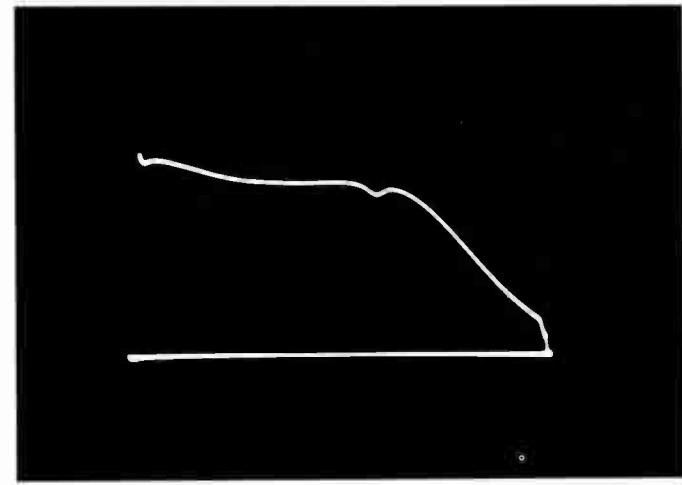

FIG. 20.  $L_2$  too small. Note reduced gain in upper frequency range.



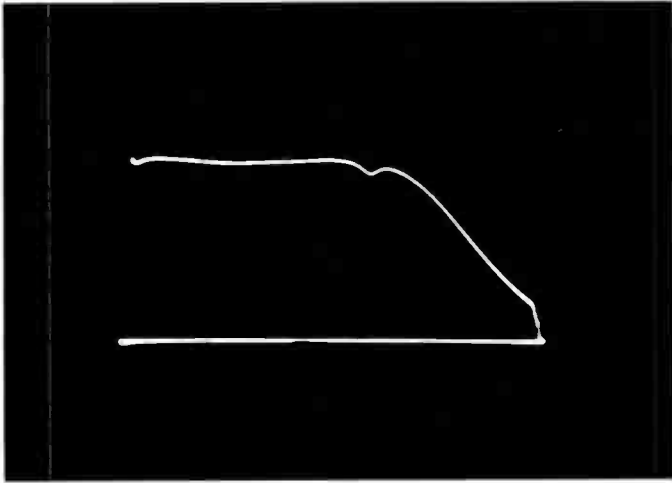

FIG. 21.  $L_2$  same as in Fig. 20, but with  $R_1$  also reduced to level off the low-frequency response. Results are reduced output and slight sag in mid-range as compared to Fig. 16.

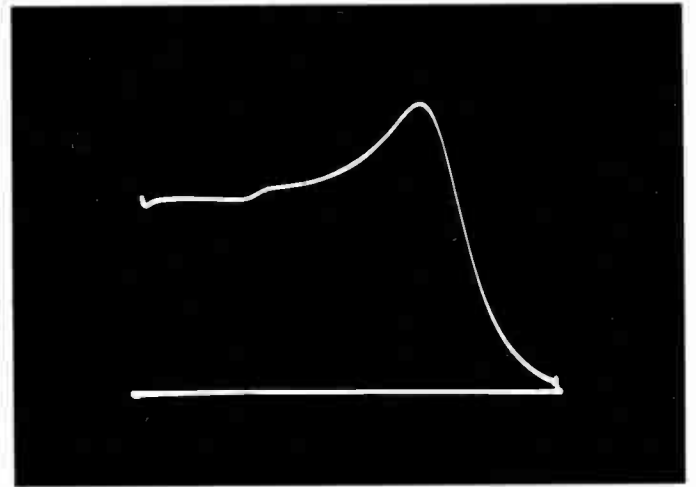

FIG. 23.  $R^1$  too large. Note reduction of both the fundamental and second harmonic resonances compared to Fig. 22. Marker notch not used.

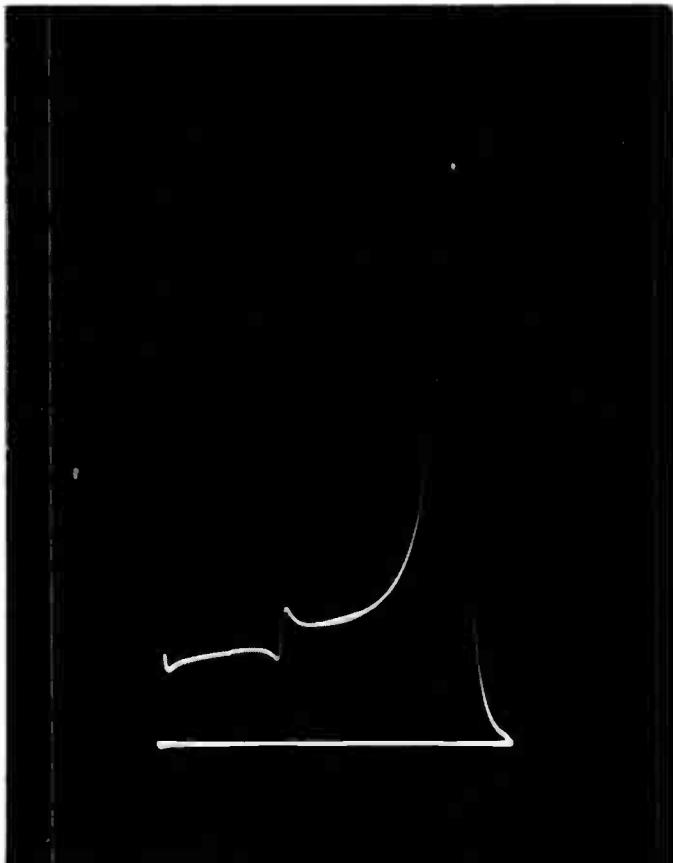

FIG. 22.  $R^1$  completely removed permitting characteristic resonant peak at cutoff frequency. Small resonance at mid-range caused by the second harmonic content of the sweep oscillator signal. This latter is characteristic of most signal generators, and the result is not caused by a fault in the amplifier.

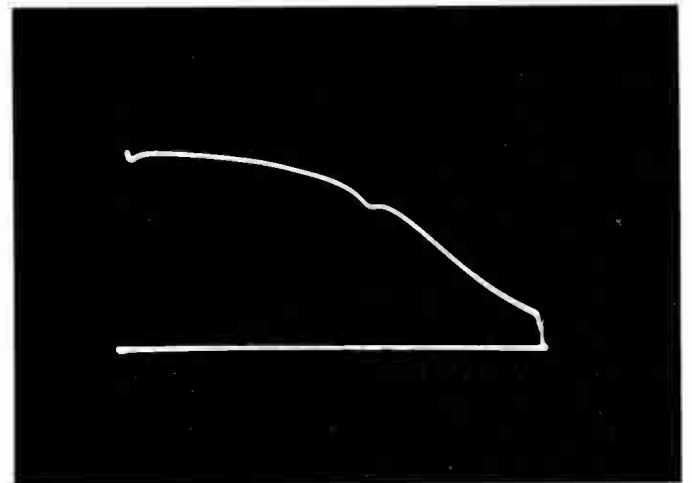

FIG. 24.  $R^1$  too small. Note overdamping of fundamental resonance and long downward slope of curve with absence of pronounced cutoff.

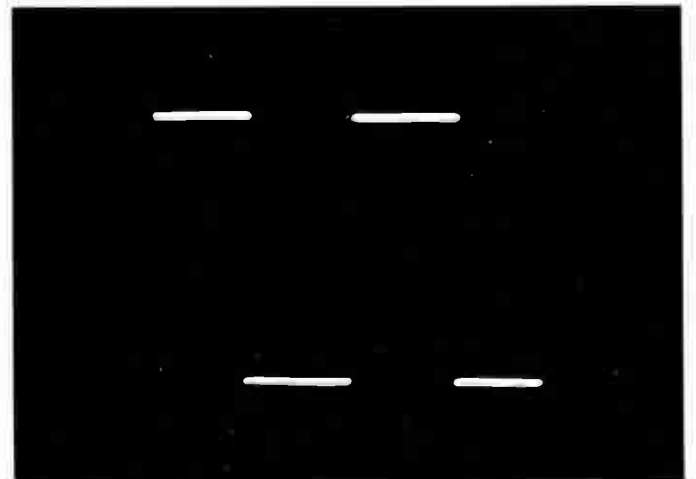

FIG. 25. 30 cycle square wave at output of amplifier of Fig. 9. This picture illustrates the input signal equally well as there was no observable difference in wave shape.

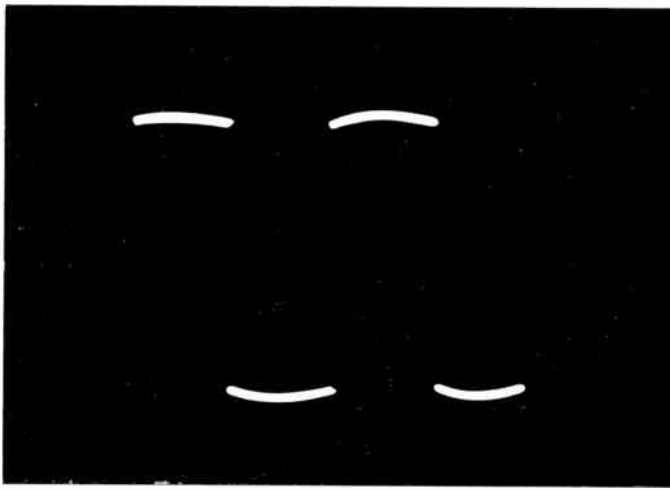

FIG. 26. Distortion resulting when  $R_c$  shunt across  $C_c$  is opened.  $R_k$  readjusted to give optimum results.

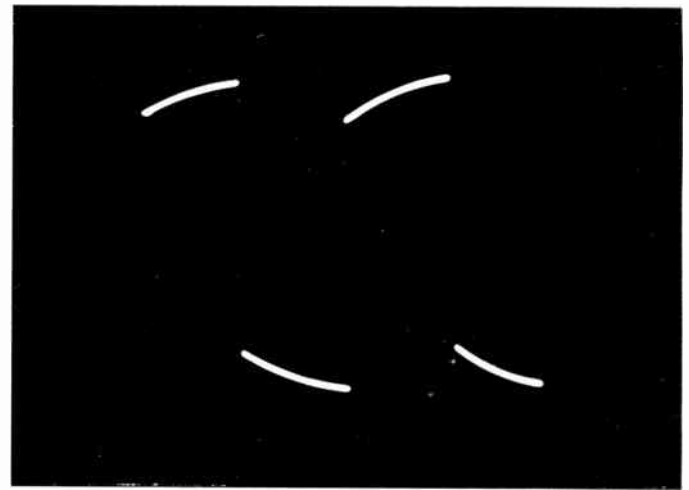

FIG. 27.  $R_k$  made too large resulting in rising slope of positive peaks, or "gain in lows."

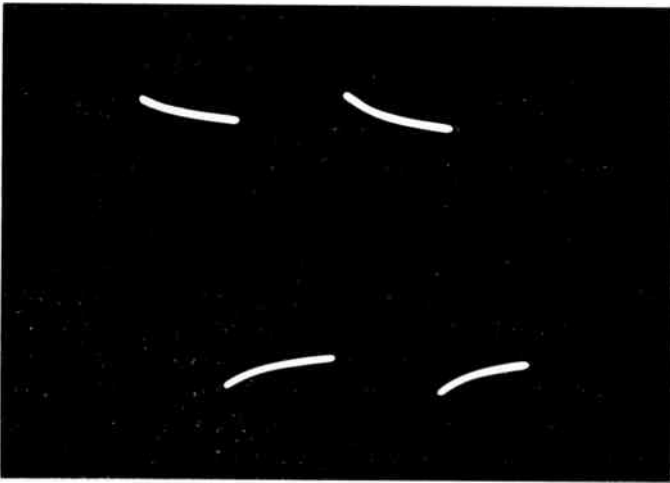

FIG. 28.  $R_k$  made too small producing "loss in lows."

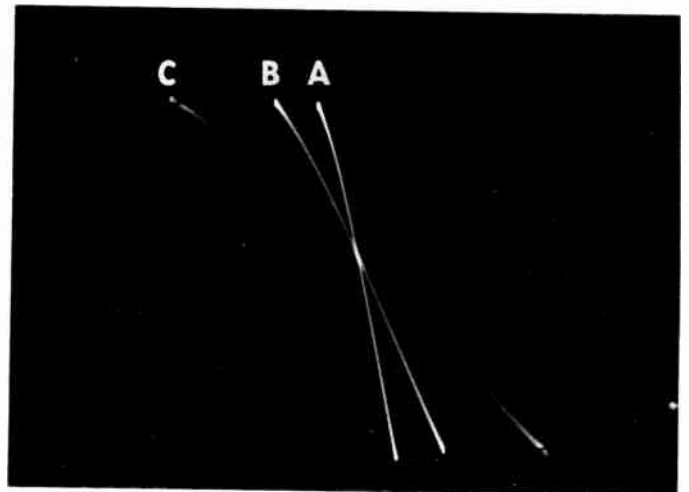

FIG. 29. (a)  $Z_k$  nearly zero ( $R_k$  by-passed by large C).  
 (b)  $R_k = 560$  ohms.  
 (c)  $R_k = 1700$  ohms.  
 Abscissas indicate input voltage; ordinates indicate output voltage with circuit of Fig. 30-A.

In making both high and low-frequency tests it is imperative to guard against saturation either in the amplifier under test or in any of the test equipment including the oscilloscope. Even partial saturation can result in serious misinterpretation of actual conditions. Furthermore, in making high-frequency tests with the sweep generator, it is important to be sure that a stage already adjusted does not cut off at a frequency lower than the stage under test. If this happens, the operation of this latter stage will be partially masked by the cutoff of the first circuit.

#### TYPICAL RESULTS AND THEIR INTERPRETATIONS

##### High-Frequency Tests (Figures 15 through 24)

The oscillograms shown were photographed from tests of a circuit of the type

shown in Figure 9. This circuit was chosen for discussion because it is the most commonly used circuit, and because the number of variables is rather large and confusing. The story of each oscillogram is given in its legend in order to facilitate use of the illustrations for reference. Normal adjustments are illustrated first, while succeeding pictures show the results of misadjustments of the various circuit elements. In each such case only one element has been changed from the normal value of Figure 15 unless otherwise indicated.

##### Low-Frequency Tests (Figures 25 through 28)

Reference should be made to Figure 9 in this case also. The fundamental frequency of the square waves used in producing the oscillograms was 30 cycles. This

low frequency was chosen to accentuate the effects shown. It also indicates the excellent performance which may be obtained when the circuit is properly adjusted. As before, each oscillogram illustrates the effect of misadjusting only one circuit element as compared to the correct result of Figure 25, unless otherwise noted.

#### Linearity of Amplifiers

Maintenance of a linear relationship between input and output voltages in a video amplifier is important. One of the best methods for securing such a relationship is the use of negative (degenerative) feedback. An unbypassed resistance in the cathode of an amplifier is a simple and effective way of obtaining negative feedback which is satisfactory over a wide frequency range. This type of feedback is

useful in wide-band television amplifiers because the cathode circuit impedance is so low (when tubes of high transconductance are used) that no frequency compensation in the cathode circuit is required even though the resistor used is relatively large. Negative feedback of this kind is indicated in the circuit of Figure 9 by the resistor  $R_K$ .

In addition to its inherent low impedance a degenerative cathode circuit has the usual properties of all negative feedback circuits such as:

- (a) increasing loss of gain with increasing degeneration.
- (b) more nearly linear operation as the degeneration increases.

The oscillogram of Figure 29 shows the change in gain when three different values of cathode circuit impedance are used with a 6SN7-GT tube. The curves were obtained by applying the voltage from the signal generator to the horizontal deflection plates of the oscilloscope, and the output of the amplifier being tested to the vertical deflection plates as illustrated in Figure 30-B.

In order to show the effect on linearity, which is not easily discernable in Figure 29, the curves are repeated in Figure 31 with the horizontal deflection of the oscilloscope adjusted in each case to give the same amount of deflection. The improvement in linearity with increasing  $R_K$  is obvious.

As a matter of interest, the curves of Figure 32 are included to verify the previous statement that the internal impedance of a cathode circuit is low. As indicated in the legend for case (a), the (a) curve shows the cathode signal voltage produced across a cathode resistor of 1700 ohms. The circuit is illustrated in Figure 33. For case (a), both switches,  $S_1$  and  $S_2$ , are open. For case (b),  $S_1$  is closed connecting plate and cathode *only* of the second triode in parallel with the first. Note that the signal voltage on the cathode is seriously compressed and distorted just as though the cathode resistor had been reduced to a low value. In fact, this is just what has been done by shunting the cathode of the second triode across that of the first. The internal cathode resistance of a tube is approximately equal in magnitude to  $\frac{1}{g_m}$ , where  $g_m$  is the transconductance of the tube. Published data on

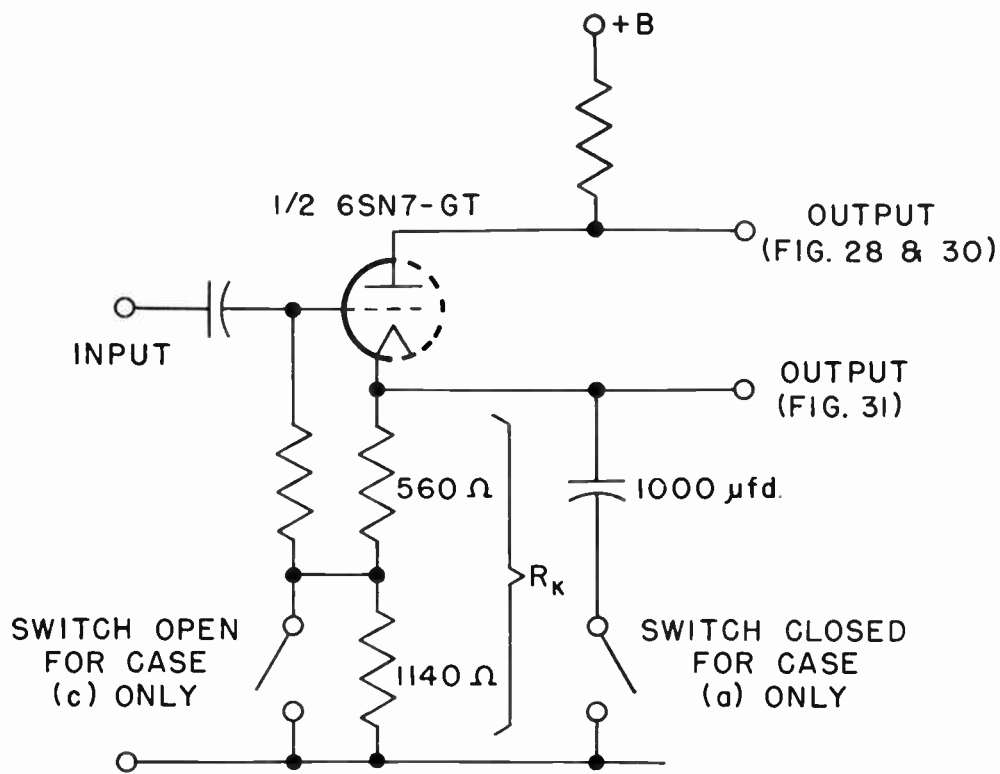

FIG. 30-A. Circuit used in obtaining the oscillogram shown in Fig. 29.

the 6SN7-GT gives  $g_m = 3100$  micromhos, which in turn gives a value of about 325 ohms for the internal cathode resistance. Thus, closing  $S_1$  has changed the cathode resistor for the first triode from 1700 ohms to a parallel combination of 1700 and 325, or about 275 ohms. Case (c) was obtained by closing  $S_2$  (leaving  $S_1$  closed) which causes the second triode to contribute to the output signal by driving its grid with input signal. The two triodes now function as a single triode having twice the transconductance of one, giving a slight increase in output as indicated by the increased length of the slanting line.

### Output Circuits

Output amplifier stages in wide-band video amplifiers are not usually spoken of as power amplifiers because it is not possible to match the internal tube impedance for maximum power output. The load has very low impedance to accommodate the wide frequency band, and as a result the amplifier operates very inefficiently. In fact, this statement applies equally well to all types of video amplifiers. In television terminal equipment, output stages are used to feed signal to low impedance transmission lines, usually coaxial lines of 75 ohms characteristic impedance. A properly ter-

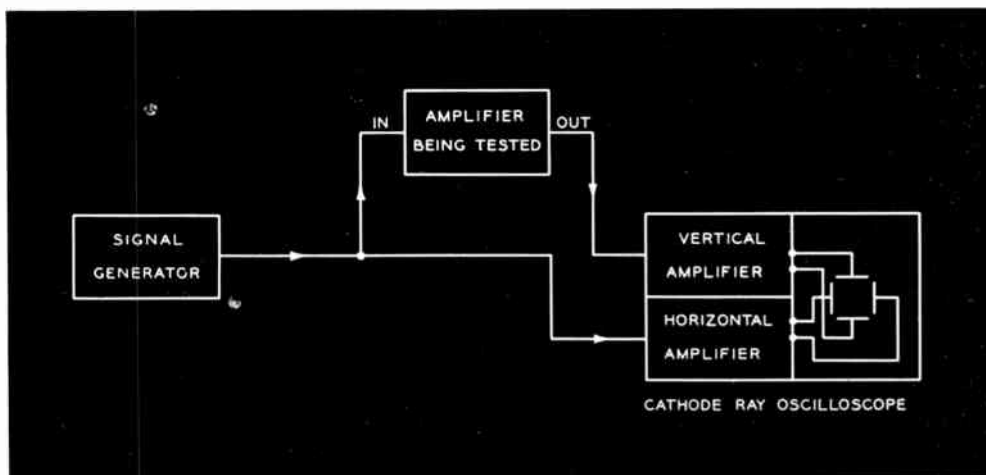

FIG. 30-B. Arrangement of equipment for obtaining linearity curves.

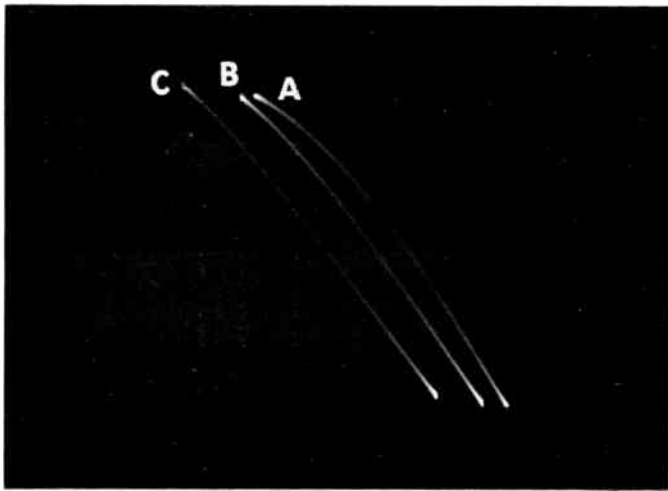

FIG. 31. Same conditions as Fig. 29, but with equal horizontal deflection in each case to show change in linearity.

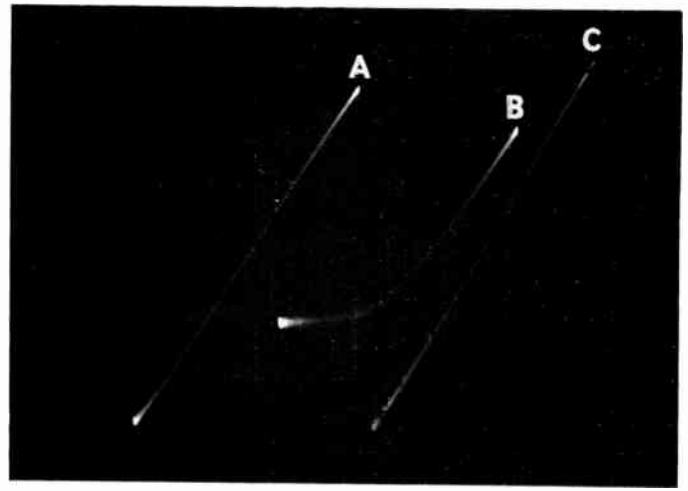

FIG. 32. Loading effect of internal cathode impedance:  
 (a) Cathode signal voltage with one triode,  $R_k = 1700$  ohms.  
 (b) Second triode added in parallel, cathode and plate only.  
 (c) Grid of second triode also added in parallel.

minated transmission line acts as a purely resistive load and therefore accepts all frequencies equally well. To the amplifier the line appears simply as a resistance. Therefore, the problem becomes one of providing proper coupling to the low resistance presented by the line.

The cathode follower is often regarded as the most acceptable circuit arrangement for feeding a line. Where direct coupling to the line is possible, it has some advantages, namely, excellent low frequency response all the way down to zero (dc), general simplicity, and the property of

providing (with slight modification) a termination at the sending end of the line which helps to minimize reflections. However, it has one disadvantage which is rather serious; with direct coupling, the d-c component of the cathode current of the amplifier tube flows in the transmission line. This is an objectionable feature because many of the transmission circuits now provided by the common carriers, such as the A. T. and T. Co., include wide band transformers which cannot accommodate any d-c. If direct coupling is to be avoided, very large coupling capacitors must be used. Because of this situation, it has become customary to avoid the use of cathode followers for line driving, and to resort to plate output circuits in their stead.

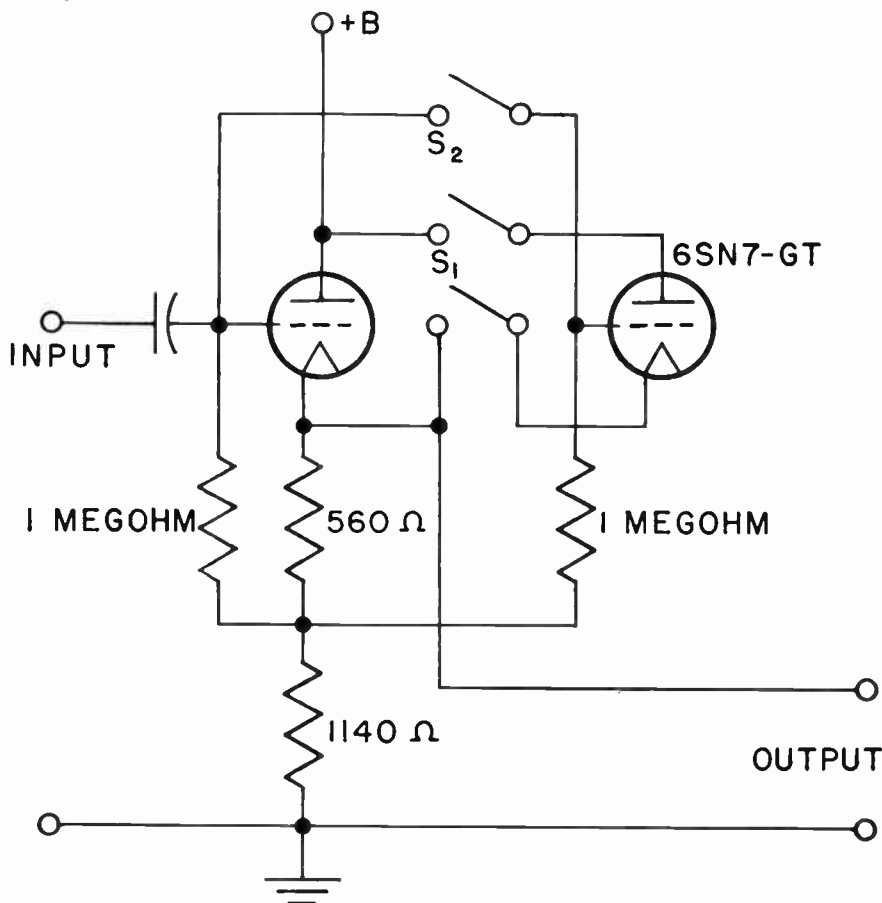

FIG. 33. Schematic of test circuit of a typical cathode follower used in obtaining the curves of Figs. 28-31.

Plate coupled output amplifiers require blocking capacitors too, but much better low frequency performance can be obtained as will be seen from the following discussion. Figure 13 includes a plate-coupled output stage which is redrawn in Figure 34 for convenience. The low frequency performance of a network like this may be measured in terms of the time constant of the loop which includes the coupling capacitor; i.e., the product,  $RC$ , where  $R$  is the total resistance around the loop. In Figure 34,  $R = R_p + R_o$ , assuming negligible resistance in the power supply. For good performance,  $RC$  should be as large as possible. By adding the frequency,  $f$ , at the low end of the band as a third factor, a figure of merit for low frequency performance may be determined, i.e.,  $RfC$ . Circuits having values of  $RfC$  less than 20

are usually not considered satisfactory, and larger values are desirable.

In cases of coupling between amplifier stages, the same rule applies, and, in the terminology of Figure 1, the time constant becomes  $(R_L + R_k) C_c$ . In this case, however,  $R_L$  is usually negligible compared to  $R_g$ , so that the time constant becomes practically  $R_g C_c$ . On the other hand, in Figure 34,  $R_p$  is not negligible; it is the principal resistance as compared to  $R_o$ . Therefore, it may be seen that the low frequency performance is almost entirely dependent on the size of  $R_p$  and  $C$ , and almost independent of how small  $R_o$  becomes.

In practical cases,  $R_o$  is usually 75 ohms, and  $R_p$  is made as large as the plate supply voltage will permit. Let us say, for example, that  $R_L$  is 3000 ohms for a 6AG7 tube and a plate supply of 280 volts. At 60 cycles, if we choose 20 for the minimum figure of merit, then  $C$  must be

$$\frac{20}{R_f} = \frac{20}{3075 \times 60} = 108 \times 10^{-6} = 108 \text{MFD.}$$

Obviously if  $R_o$  is reduced to 50 ohms or even less, there will be almost no change in the capacitance required to give equally good performance.

Figures 35 and 36 are oscillograms showing the low-frequency performance of a

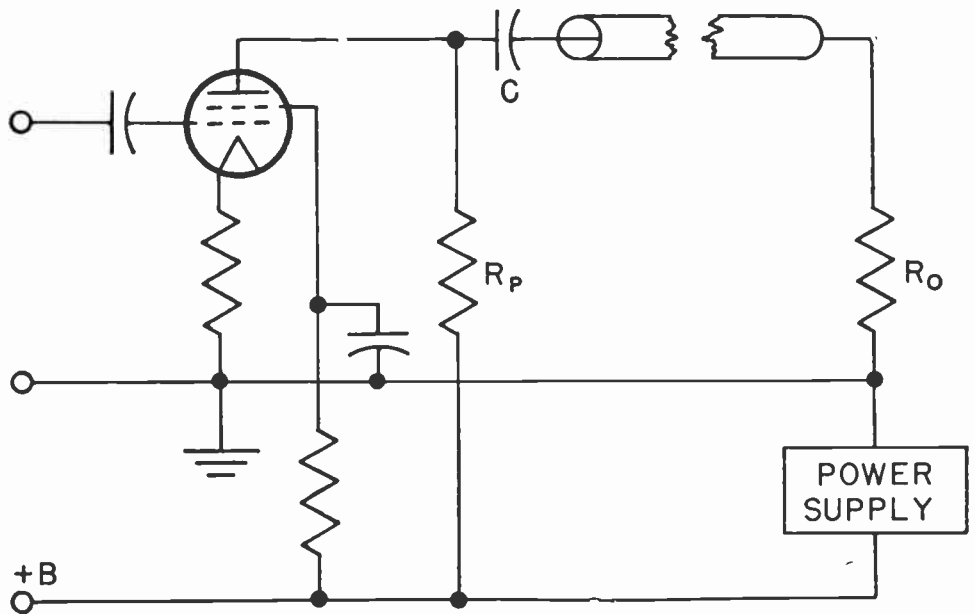

FIG. 34. Schematic of typical plate output stage for coupling to a low impedance transmission line.

plate coupled output stage with adequate and inadequate values of  $R_p$  respectively, no other circuit changes being made.

Considering the cathode follower in the light of the expression for figure of merit, it becomes obvious that a very large capacitor is needed. For example, again using a 6AG7 for illustration,

$$R_k = \frac{1}{g_m} = \frac{1}{.011} = 90 \text{ ohms.}$$

Let us choose  $C = 2000 \text{ MFD.}$

Then the figure of merit  $= (R_o + R_k) fC$

$= 165 \times 60 \times 2000 \times 10^{-6} = 19.8,$  a satisfactory figure. However, it would be difficult to attain this in practice because the cathode circuit would have to be shunted with a resistor (not considered above) to provide a d-c path for the cathode current. This resistor would have to be small to limit the voltage applied to the 2000 MFD capacitor to its rated value. The shunt resistor would reduce the figure of merit appreciably. Such a circuit would be used only in cases where other considerations are controlling.

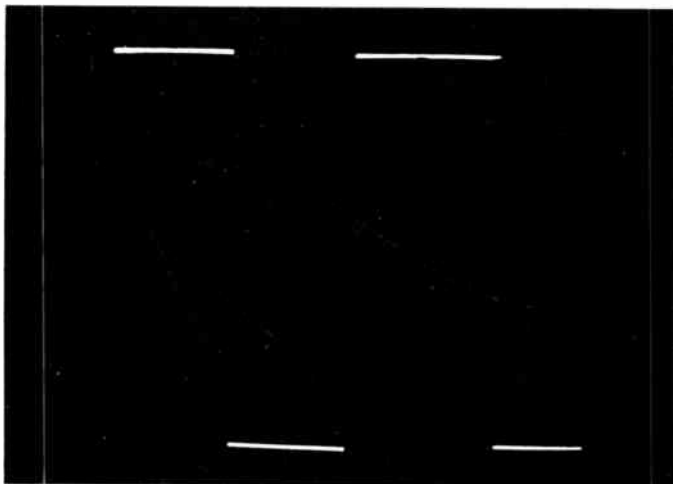

FIG. 35. Signal across  $R_o$  with 6SN7 plate coupled output.  $R_o = 100 \text{ ohms}$   $R_L = 10,000 \text{ ohms}$   $C = 125 \text{ MFD}$



FIG. 36. Same as Fig. 35, except  $R_L = 500 \text{ ohms.}$

# TEST AND ALIGNMENT PROCEDURES FOR VIDEO AMPLIFIERS

EDITOR'S NOTE: Procedures mentioned here are for equipment that has been superseded except for the TM-6B Master Monitor. They are included here because many of these equipments are still in use. Instruction books on all new equipment give the alignment procedures for that unit.

It is the purpose of this article to provide a general step-by-step guide or approach for the testing and alignment of video amplifiers<sup>1</sup> as well as specific alignment procedures for individual units of the RCA television terminal equipment.

Television station engineers and technicians concerned with the operation and maintenance of video amplifiers and other TV equipment should find this information particularly useful. Since many of the video testing procedures and techniques are relatively new and must be performed at relatively high frequencies, suitable test methods, adequate test equipment (which is available commercially) and sufficient care in making measurements are recommended.

The video signal is made up of many frequencies of varying amplitudes and characteristics. Faithful reproduction of this signal is obtained only when the amplifiers are relatively free from frequency, amplitude, and phase distortion over the required frequency band. Therefore, the testing procedures described in this article are confined to those characteristics which are most likely to affect the performance and quality of the video signal.

## Transmission Characteristics of Video Amplifiers

The frequency response characteristic of an amplifier indicates frequency distortion directly and is a means of judging

<sup>1</sup>J. H. Roe, "How to Adjust Frequency Response in Video Amplifier for TV". BROADCAST NEWS, No. 58, March-April, 1950, pp. 54 to 65, incl.

CONTENTS	
Transmission Characteristics of Video Amplifiers Specific Test Procedures:	
<b>I. TK-20A Film Camera Chain</b>	
A.	Film Camera, MI-26020 & MI-26020-A
B.	Film Camera Control, MI-26075
C.	Master Monitor, MI-26135-A
D.	Master Monitor, MI-26136 & MI-26136-A
<b>II. TK-1A Monoscope Camera, MI-26030 &amp; MI-26030-A</b>	
<b>III. TK-30A &amp; TK-10A Image Orthicon Camera Chains</b>	
A.	Field & Studio Cameras, MI-26000 & MI-26000-A; MI-26010 & MI-26010-A
B.	Studio Camera Control, MI-26055
C.	Field Camera Control, MI-26065
<b>IV. Amplifiers &amp; Switchers</b>	
A.	TA-1A Distribution Amplifier, MI-26155
B.	TA-5B Stabilizing Amplifier, MI-26160
C.	TA-5C Stabilizing Amplifier, MI-26160-B
D.	TM-1A Program Monitor, MI-26140
E.	TS-10A Studio Switching System, MI-26235
F.	TS-30A Field Switching System, MI-26215
G.	TA-10A Mixing Amplifier, MI-26281

phase distortion. This characteristic may be obtained by the well known point-to-point method. However, this is a time consuming task and is too cumbersome. A more convenient method uses a sweep frequency generator, a crystal detector, an oscilloscope with a good frequency response, and a square wave generator for 30 cycles and 7.5 kilocycles.

The sweep generator recommended is the RCA WA-21A. It consists of a fixed frequency oscillator and a sweep oscillator, frequency modulated at 60 cycles. The swing of the frequency modulated oscillator ranges from a few kilocycles on one side of the frequency of the fixed oscillator to 10 mc. on the other side. The beat frequency output over the usable range (100 kc. to 10 mc.) is of constant amplitude within 1 db. This gives a well-defined zero frequency reference. The frequency

marker pip which is available, covers the usable range of the sweep. Blanking is provided internally (60 cycle) to blank out the signal during retrace.

In conjunction with the sweep, a crystal detector is shown schematically in Fig. 2. It is a voltage doubler and rectifier which converts the frequency modulated signal to its envelope.

The efficiency of rectification is about 90%; hence in setting up a specific output level of 1.5 volts, the signal output of the detector should be approximately 1.35 volts. In constructing such a detector it is important that leads of components be kept as short as possible. Distributed capacity should be reduced to a minimum. The method of obtaining the frequency response of an amplifier is

divided into two parts, the high frequency response (100 kc. and above) and the low frequency response.

## High Frequency Response

For this measurement, the sweep generator, the crystal detector, and the oscilloscope are used. The method consists of coupling the low impedance output of the sweep generator to the grid of an amplifier stage, the plate circuit of which contains the circuit to be checked or adjusted. The detector should be connected to some low impedance point of the following stage such as the un-bypassed cathode.

The circuit of Fig. 3 indicates a typical video amplifier stage. Removing the cathode bypass capacitor makes this second stage a cathode follower. The cathode resistance is on the order of 100 ohms so

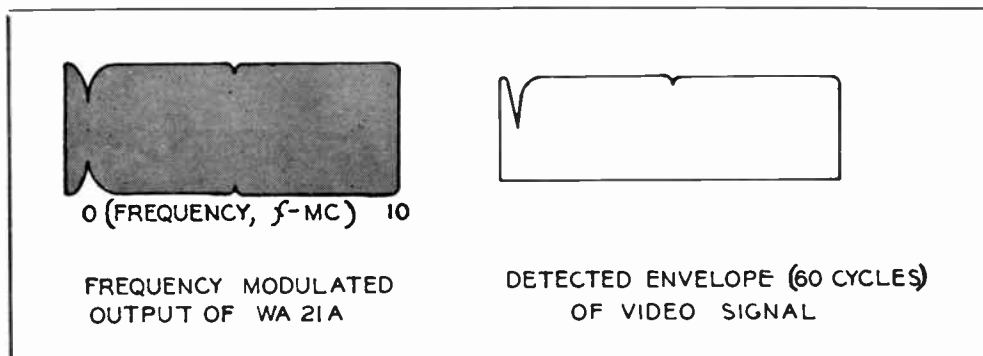
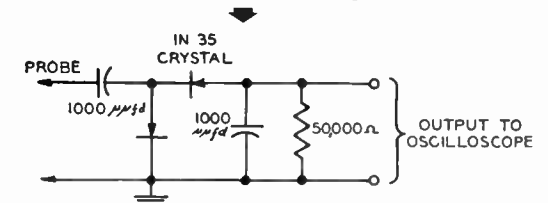

FIG. 1. Wave forms showing output characteristic of the WA-21A sweep generator.

FIG. 2. Schematic circuit of a peak-to-peak diode detector for use with sweep oscillator.



that the effect of feed-through capacity will be negligible.

An alternative to this scheme is to leave the cathode bypass capacitor in place and connect a 100-ohm resistor across the peaking coils of the second stage to shunt both the series and shunt peaker. By attaching the detector across this resistor, this stage would then be a plate output stage.

Most of the amplifiers of the television terminal equipment are terminated with low impedance plate output stages or cathode followers. This affords a convenient point to attach the detector since the effect of the added capacity falls outside of the frequency band being considered. Hence, the detector is usually left there for the duration of the test.

The video sweep signal is then injected at the grids of the preceding stages, starting at the output end and progressing towards the amplifier input. Care should be exercised not to overload the amplifier, creating the illusion of a good response. The test signal should be the same as that handled by the amplifier during normal operation.

The specification given for various responses is representative of typical production equipment. Reasonable variations in response can be expected between units of the same type due to normal manufacturing tolerances.

In amplifiers where clamping, blanking, and sync signals are added, precautions are taken to maintain normal operating conditions. Clamping tubes add considerable capacity and affect circuit tuning. Such a tube is replaced with a tube of the same type that has its filament pins removed. A temporary grid leak resistor is added (470,000 ohms for 6AC7) to the opened grid.

Blanking is usually inserted by an amplifier, the plate of which shares a common plate load resistance with one of the video amplifiers. In addition to the circuit capacity it contributes, quiescent voltages of the video amplifier are dependent on the current drawn by the blanking amplifier. Thus, blanking cannot be removed by simply removing the blanking amplifier. Instead, the tube that drives the blanking amplifier (usually 1/2 6SN7) is replaced

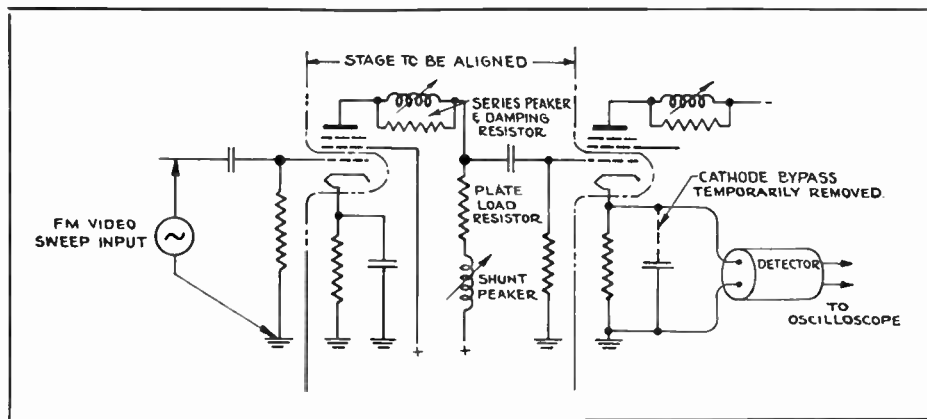

FIG. 3 (above). Typical Video Amplification Stage used in Television Terminal Equipment.

by a tube with its grid, plate, and cathode pins removed. These tubes should be plainly marked, possibly with red paint, to identify them. This will help prevent them from being left in the equipment.

It may occur that a high gain amplifier tends to regenerate and oscillate due to leads being attached to it. In such cases the alternative of disrupting the amplifier in the middle and checking the amplifier in parts will be sufficiently accurate to insure proper performance.

Beware of rapid variations in amplitude as shown in Fig. 4. Such variations of frequency response are accompanied by severe

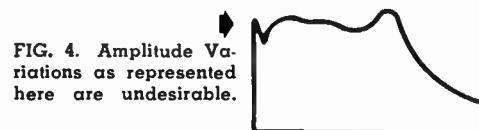
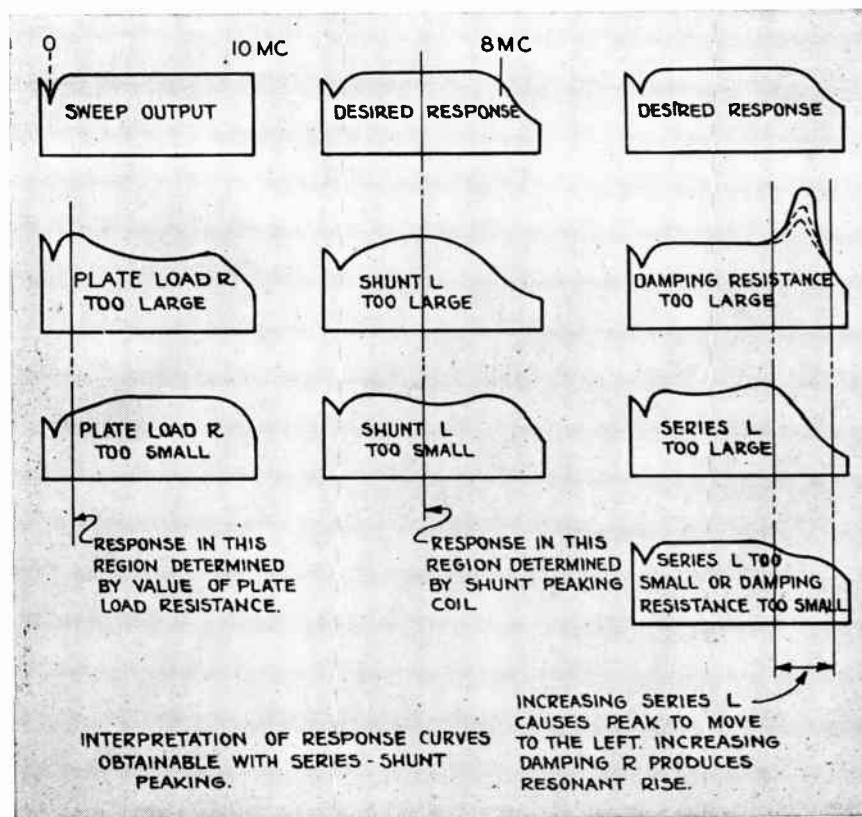

FIG. 4. Amplitude Variations as represented here are undesirable.

variations of the phase characteristic of the amplifier and may cause ringing or reflections in the video signal.

In carrying the frequency response of the typical series-shunt peaked stage out to 6 or 7 megacycles, the phase response should be good out to 5 or 6 megacycles. Assuming this phase response to be adequate, the difficulty of making phase measurements is eliminated.

FIG. 5 (below). The wave shapes below illustrate the interpretation of response curves obtainable with series-shunt peaking.



# ALIGNMENT PROCEDURES

## Low Frequency Response

The response of an amplifier at the low frequency end is usually determined by the time constant of the inner-stage coupling networks. The low frequency response requirements vary from unit to unit depending on their relationship with clamping. With clamping occurring at a horizontal rate, 30 cycle response is not necessary. However, the amplifier should pass a 7.5 kc. square wave with less than the specified maximum amount of tilt. This requires good phase response down to 7.5 kc. which implies good amplitude response down to 1/50 or less of this frequency when no special low frequency compensating circuits are employed. The 7.5 kc. square wave corresponds to a signal such as a bar extending the full width of the scene.

After clamping, the amplifier response should be such that the tilt should be less than the specified maximum for a 30 cycle square wave.

After alignment of any amplifier the final check should be the passage of a signal through it and close inspection of the signal on a monitor. The RMA Resolution Chart\* is a very useful signal source. The wide range of picture resolution gives rise to a wide range of frequency components and will be a good overall check.

\* See Bulletin #ED-2502-A prepared by TR4 Committee on Television Transmitters, Transmitter Section, RMA Engineering Department.

## I. RCA Film Camera Chain

### A. Film Camera—MI-26020, MI-26020-A

#### 1. High Frequency Response

- Disconnect output of iconoscope.
- Connect detector across R32.
- Align T-9, T-8, and T-7 associated with V-17, V-16, V-15, and V-14.

The response of these four stages should be essentially flat to 6.5 mc.

- Using V-14 as a cathode follower, connect detector to pin #2.
- Remove V-15.
- To eliminate high peaker circuit disconnect C-4 and change the connection of C-7 to other end of R-9.
- Align T-6.
- Ground grid of V-12 and inject sweep on cathode, pin #2.
- Align T-5.

The overall amplifier response, with peaking circuit eliminated, should be essentially flat to 6.5 mc.

- Return unit to normal operating condition.

### 2. Low Frequency Response

- Check to be made with high peaker circuit eliminated as outlined in "f" of High Frequency Response.
- Connect CRO across R32.
- Ground pin #1 and insert 7.5 kc. square wave at P-2 of V-12.  
Note: It may be necessary to check amplifier in two steps as in High Frequency Response.

Tilt should be less than 10%.

- Return unit to normal operating condition and adjust high peaker with test pattern being fed in iconoscope.

### B. Film Camera Control—MI-26075

#### 1. High Frequency Response

- Replace V-9 with 6SN7, pins 4, 5, and 6 cut off (removes blanking).
- Replace V-2 with 6AL5, heater pins cut off (removes clamping).
- Add grid-leak (temporarily) of 500,000 ohms on V-3, pin 4 to ground.
- Turn BLACK LEVEL CONTROL (S-1) to OFF.
- Transient suppressor, R-24, should be at its maximum clockwise position.
- Terminate PICTURE OUTPUT and REMOTE MONITOR with 75-ohm terminations (not cables). Terminate MONITOR OUTPUT with 200 mmfd.
- Ground pin 4 to V-1.
- Connect detector across PICTURE OUTPUT and REMOTE MONITOR.
- Align T-3, T-2. Inject signal for T-1 alignment at pin 5 of V-1.

The overall response should be essentially flat to 6 mc.

- Return unit to normal operating condition.

#### 2. Low Frequency Response

- With conditions "a" to "g" inclusive of part 1 in effect, attach CRO across PICTURE OUTPUT.
- Insert 7.5 kc. square wave at pin 5 of V-1.

Tilt should be less than 10%.

- Insert 60 cycle square wave to pin 4 of V-3.

Tilt should not exceed 20%.

- Return unit to normal operating condition.

### C. Master Monitor—MI-26135-A

#### 1. High Frequency Response

##### a. Kinescope Amplifier

- Remove kinescope socket (see below). Using an isolating capacitor in series with cathode side (terminal 6) connect the detector between grid (terminal 7) and cathode terminal of socket.

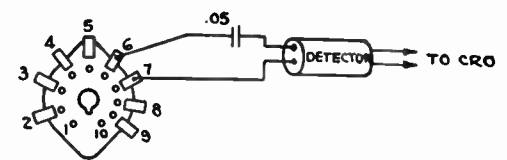

WIRING SIDE

FIG. 6. Socket connections used between CRO and Kinescope (1816P4).

- Turn S-6 to DOWN position and set kinescope contrast (R-155) to maximum.
- Align T-105 and T-104.

Response should be essentially flat to 7.5 mc.

##### b. CRO Amplifier

- Set S-2 in VERTICAL position.
- Apply 0.5 volt signal to PICTURE INPUT, J-2.
- Align T-101, T-102, and T-103 by observing undetected output on Master Monitor CRO screen.

Response should be essentially flat to 4 mc. Tilt of the axis should not exceed 15% of the peak-to-peak signal.

#### 2. Low Frequency Response

##### a. Kinescope Amplifier

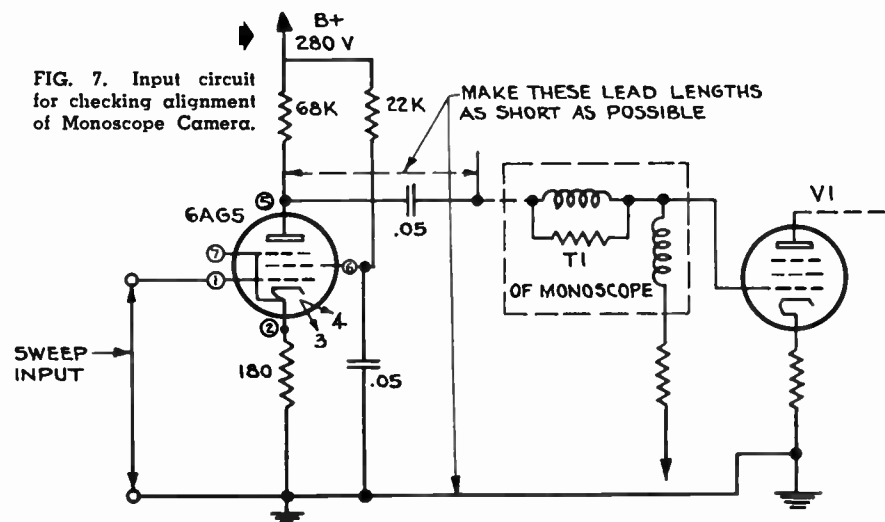

FIG. 7. Input circuit for checking alignment of Monoscope Camera.



# ALIGNMENT PROCEDURES

- (1) Switch S-6 DOWN.
- (2) Turn KINE CONTRAST maximum clockwise.
- (3) Apply 1.0 volt p-p 60 cycle square wave to PICTURE INPUT, J-2.

Signal at V11-3 as observed on a Cathode Ray Oscilloscope with good low frequency response should be 5% tilt or less.

## b. CRO Amplifier

- (1) Switch S-6 DOWN.
- (2) Switch S-2 in VERTICAL position.
- (3) Apply 1.0 volt p-p 60 cycle square wave to PICTURE INPUT, J-2.
- (4) Adjust CRO GAIN for 1.0" of deflection.

Tilt observed on monitor CRO shall be 5% or less.

## D. TM-6B Master Monitor—MI-26136 and MI-26136-A.

### 1. High Frequency Measurement

#### a. Kinescope Video Amplifier

- (1) Remove Horizontal driver and damper tubes, V18 and V19. Remove kinescope socket, V12.
- (2) Connect diode detector at the junction of C15 and Kine Cathode lead.
- (3) Install dummy 6AH6 (filament dead) in XV5.
- (4) Apply Sweep signal to grid of V3. (pin 8 or 9) adjusting L5 and L6 for flattest response to 8 mc. *Note*, this is a high impedance circuit and the input capacity of the diode should be approximately 5 mmf. to simulate the capacity of the Kinescope.
- (5) Apply sweep signal to grid of V2 (pin 1) and adjust L3 and L4 for flattest response to 8 mc.
- (6) Connect sweep to *Pict Input*, J1, and set Kinescope Contrast control at mid position. Adjust L1 and L2 for flattest response to 8 mc.
- (7) Slight readjustment of peaking coils may be in order to produce the flattest overall response curve.
- (8) Replace V5 with normal 6AH6.

#### b. CRO Vertical Amplifier

- (1) Remove V9 and V10 and connect diode detector to grid of V9 (pins 8 or 9).
- (2) Close B+ Interlock, S4. Set *Calibrate-Wide-Narrow* Switch to *Wide*. Set CRO Vert-Hor.-Pulse Cross switch to Vert.
- (3) Apply sweep signal to grid of V8 (pin 1). Adjust L8 for flattest response to 4 mc.
- (4) Apply sweep signal to *Pict. Input* and adjust L7 for flattest response to 4 mc.
- (5) Open B+ Interlock, S4 and install V9 and V10. Close B+ Interlock. Switch *CRO Expand* switch, S5 to Expand. Adjust the CRO Expand potentiometer (R168) to center video signal.
- (6) Adjust I.9 and L10 for flat response ( $\pm 5\%$ ) to 4 mc. as observed of the CRO, V13.
- (7) Slight readjustment of peaking coils may be in order to produce the flattest response curves.

- (8) Switch S1 to Narrow. The response curve should lie approximately midway between the limits of the recommended IRE response curve.

Freq.	Nominal Response	Limits
2 mc.	70% (-3 db) of mid band	55-80%
3 mc.	50% (-6 db)	36-63%
4 mc.	35% (-9 db)	20-49%

### 2. Low Frequency Response

#### a. Kinescope Amplifier

With kinescope gain control, R4 at Mid position, and V5 removed, apply 1 volt peak-to-peak to cycle square wave to *Pict Input* (J1). The output at the junction of C-15 and Kinescope cathode lead shall not exceed 10%.

#### b. CRO Amplifier

With *CRO Gain* control R70 at mid position and 1 volt (p-p) 60 cycle square wave fed in at J1. Adjust L. F. Phase (R202) for a minimum tilt.

## II. RCA Monoscope Camera—MI-26030 and MI-26030-A.

- A. Attach detector to PICTURE OUTPUT or MONITOR OUTPUT terminated with 75 ohms.
- B. Remove Blanking Signal.
- C. Set PICT.-EXT. switch, S-2, to EXT.
- D. Align T-7, T-6, T-5, and T-4. Response should be essentially flat to 8 mc.
- E. Insert 60 cycle square wave at pin 4 on V-6. Square wave should have less than 10% tilt and 10% overshoot.

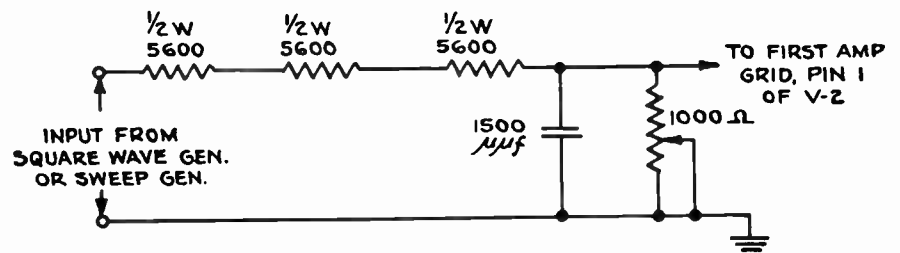

FIG. 8. Input circuit for checking response of Image Orthicon Camera.

- F. Remove V-2 and replace clamper tube V-9 with 6H6 with its filament pins removed.
- G. Add temporary grid leak (500 K) to pin 4 on V-6.
- H. Attach detector to pin 5 of V-6.
- I. Disconnect R-5 and add temporary grid leak to pin 4 of V-1.
- J. Align T-3 and T-2. Response should be essentially flat to 8 mc.
- K. Insert 7.5 kc. square wave. Square wave should have less than 10% tilt.
- L. To align T-1, reconnect R-5 to grid (pin 4) of V-1. Remove temporary grid leak at this point.
- M. The circuit shown in Fig. 7 is one way to simulate the output capacity of the Monoscope tube and provide the means of injecting the video sweep. The tube designated here might well be changed to any pentode such as 6AK5, 6AC7, etc.

Because of the size of the plate load resistor, input circuit of V-1 becomes principal signal load.

- N. With circuit connected as above, inject sweep at pin 1 of 6AG5. Response of input circuit should be essentially flat to 8 mc.

O. Return unit to normal operating condition.

## III. RCA Image Orthicon Camera Chains (for Master Monitor see I. Film Camera Chain)

### A. Field and Studio Cameras—Studio, MI-26000 and MI-26000-A; Field, MI-26010 and MI-26010-A.

#### 1. High Frequency Response

- a. Disconnect input capacitor, C-13. to PICTURE AMPLIFIER, V-2, and remove image orthicon socket.
- b. Close S-6 by compressing turret handle and fasten in this position. This opens coaxial line and inserts 51-ohm resistor.
- c. Attach detector to low side of R-23, 150-ohm resistor directly below V-7.
- d. Maintaining amplifier output at approximately  $\frac{1}{2}$  volt peak-to-peak, align T-8 and T-7. Response should be essentially flat to 8 mc.
- e. Set gain control to maximum and high peaker to its mid-capacity position.
- f. Using the network of Fig. 8, feed a 100 kc. square wave to pin #1 of V-2.

Set the 1000-ohm pot at the input so that the square wave is reproduced with *no tilt*. Do not change the setting of potentiometer. Remove square wave generator and insert video sweep, through network. Align T-5 and T-6 using signal inserted at this point.

Overall amplifier frequency response should be essentially flat to 7 mc. Gain of amplifier connected as above shall be equal to or greater than 1/10 the signal fed into the input network.

- g. Return unit to normal operating conditions.

#### 2. Low Frequency Response (Applicable only to units modified according to Technical Bulletin #JB65.)

- a. Repeat step "f" of High Frequency Response using 7.5 kc. square wave. Tilt shall be less than 10%.

### B. Studio Camera Control—MI-26055

1. If control is to be checked by itself, the following procedure is recommended:

# ALIGNMENT PROCEDURES

## a. High Frequency Response

- (1) No driving or blanking pulses to be applied.
- (2) Replace V-14 with a 6AL5, with filament pins removed.
- (3) Add temporary grid leaks, 470,000 ohms, pin 4 of V-16 and V-13 to ground.
- (4) Connect 75-ohm terminations on PICTURE OUTPUT, J-9, and REMOTE MONITOR OUTPUT, J-6. Add 200 mmfd. capacitor across MONITOR OUTPUT to simulate monitor cable capacity.
- (5) Set Cable Switch to 100 feet and set TRANSIENT SUPPRESSOR, R-22, to maximum clockwise position.
- (6) To align T-3, connect detector at PICTURE OUTPUT and inject signal at pin #4 of V-13. Output signal level should be 2.0 volts.
- (7) Align T-2 and T-1, maintaining 1.5 volts output at PICTURE OUTPUT. Input to first picture amplifier should be made at pin #24 of camera cable receptacle.

Overall response should be essentially flat to 6.5 mc. Switching the CABLE LENGTH switch to 500 feet, the response characteristic should remain unchanged at the low frequency end but rise uniformly to be approximately 1.5 times the low frequency response at 6.5 mc. Similarly, switch to 1000 feet. The response characteristic should remain unchanged at the low frequency end but rise to be approximately 2.5 times the low frequency response at 6.5 mc.

- (8) The output at REMOTE MONITOR should show the same frequency response at PICTURE OUTPUT.
- (9) Return unit to normal operating conditions.

## b. Low Frequency Response

- (1) With conditions 1 to 5 inclusive of part (a) in effect, attach CRO across PICTURE OUTPUT.
- (2) Insert 60 cycle square wave at pin 4 of V-13. The square wave shall have less than 10% tilt.
- (3) Return unit to normal operating condition.

2. If the STUDIO CAMERA CONTROL is to be checked with a monitor, etc., the following procedure is recommended:

## a. High Frequency Response

- (1) Remove blanking pulses by replacing V-12 with 6SN7 with pins 1, 2, and 3 removed.
- (2) Replace V-14 with a 6AL5 with filament pins removed.
- (3) Add temporary grid leak, 470,000 ohms, to pin 4 of V-13.
- (4) Turn GAIN potentiometer to maximum.

- (5) Connect 75-ohm terminations of PICTURE OUTPUT, J-9, and REMOTE MONITOR, J-6.

- (6)
  - (7)
  - (8)
  - (9)
- These steps are same as those outlined in part 1-a.

- (10) Return unit to normal operating condition.

## b. Low Frequency Response

- (1) With conditions 1 to 5 inclusive of part (a) in effect, attach CRO PICTURE OUTPUT.

Procedure and response same as those outlined in part 1-b.

## C. Field Camera Control—MI-26065

### 1. Picture Amplifier

#### a. High Frequency Response

- (1) Replace V-12 with 6SN7 with pins 1, 2 and 3 removed.
- (2) Replace V-4 with 6H6 with pins 2 and 7 removed.
- (3) Insert 500,000 ohms resistor from pin #4 of V-3 to ground.
- (4) Turn GAIN to maximum and terminate PICTURE OUTPUT.
- (5) Attach detector to PICTURE OUTPUT and align T-8, T-3, T-2, and T-1, injecting sweep at grids of picture amplifiers V-7, V-3, V-2, and V-1 respectively, maintaining 2 volt signal at output.

The response of V-7 stage falls off gradually starting at approximately 5 mc. The overall response is made essentially flat to 6.5 mc. by over compensation of the preceding stages.

#### b. Low Frequency Response

- (1) With conditions 1 to 4 inclusive of part a. in effect, attach CRO across PICTURE OUTPUT.
- (2) Insert 60 cycle square wave at pin 4 of V-3.

The square wave shall have less than 10% tilt.

- (3) Insert 7.5 kc. square wave at pin 4 of V-1.

The overall square wave response shall have less than 10% tilt.

### 2. Kinescope Amplifier

- a. Remove kinescope socket (see below). Using an isolating capacitor in series with the cathode side (terminal 6), connect detector between grid (terminal 5) and cathode terminals of socket.
- b. Align T-5.

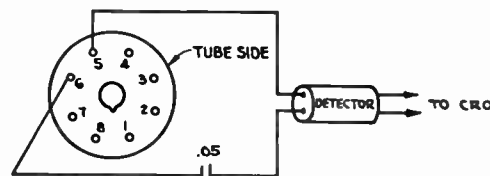

FIG. 9. Socket connections used between Field Camera Control Kinescope (7CP4) and "CRO".

The response from pin #4 of V-1 to pin #5 of V-30 should be flat to 5.5 mc. and then fall off gradually.

- c. Varying the CONTRAST from minimum to maximum should increase the amplitude approximately 50% without affecting frequency response.

- d. Square wave response shall be same as outlined in part 1-b.

### 3. CRO Amplifier

This is best observed directly on the camera control CRO as a video envelope.

- a. Align T-6 with V-11 removed and T-7 with V-10 removed. The response with V-10 and V-11 in place should be essentially flat to 5.5 mc.

- b. Square wave response should be same as that outlined in part 1-b.

- c. Return unit to normal operating conditions.

### D. Field and Studio View Finders—MI-26015, MI-26005

1. Remove kinescope socket. Using an isolating capacitor in series with cathode side (terminal 7) connect detector between grid (terminal 5) and cathode. (See Fig. 10.)

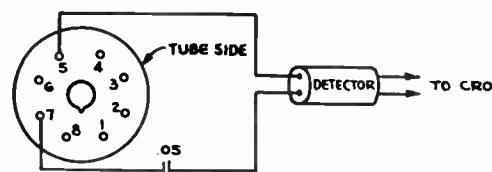

FIG. 10. Socket connections used between View Finder Kinescope (5FP4) and "CRO".

2. Turn CONTRAST to maximum.
3. Align T-5 and T-4.

Response of amplifier should be essentially flat to 5.5 mc. Contrast should cover range of approximately 6 to 1. Overall gain should be approximately 40.

4. Return unit to normal operating condition.

## IV. RCA Amplifiers and Switchers

### A. TA-1A Distribution Amplifier—MI-26155

#### 1. High Frequency Response

- a. Set GAIN to approximate mid-position.
- b. Terminate output in 75 ohms.
- c. Apply a 2.0 volt peak-to-peak video sweep to the input jack.
- d. Align T-1.

Response should be essentially flat to 8.5 mc.

Repeat the above test for each of the five sections individually.

Note: Where input and output is greater than 2.0 volts peak-to-peak, but no greater than 4.0 volts peak-to-peak (such as from a synchronizing generator), remove the 5600-ohm resistor in the plate circuit of input tube. This change limits high frequency response. Amplifier is then used strictly for pulse distribution.

# ALIGNMENT PROCEDURES

2. Low Frequency Response
  - a. Terminate output jack with 75 ohms.
  - b. Feed 2.0 volts peak-to-peak 60 cycle square wave to input.
  - c. Adjust GAIN for unity gain (2.0 volts peak-to-peak out).
  - d. Adjust L. F. PHASE for minimum tilt and best flat topped square wave.

## B. TA-5B Stabilizing Amplifier—MI-26160

1. High Frequency Response
  - a. Replace diodes V-10, V-14, and V-15 with dummy tubes (filaments open).
  - b. Return grids of V-7 and V-9 to ground through 0.5 megohm resistors.
  - c. Cut off V-5. (Place grid at -22 volts through approximately 470,000 ohms.)
  - d. Terminate PICTURE OUTPUT and MONITOR OUTPUT in 75 ohms.
  - e. Apply video sweep to pin 4 of V-7. Align T-5 for response as in Fig. 11.

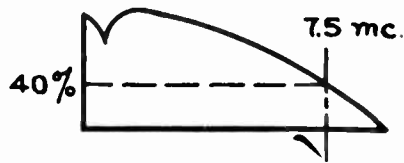

FIG. 11. Frequency Response of Stage including "T-5" of TA-5B Stabilizing Amplifier.

- f. Align T-4 to compensate for T-5 so that response is flat to 7.5 mc.
- g. Align T-3, T-2, and T-1.

Response should be essentially flat to 8 mc.

2. Low Frequency Response
  - a. Feed 60 cycle square wave to pin 4 of V-7.
  - b. Signal at terminated PICTURE OUTPUT and MONITOR OUTPUT should have less than 10% tilt.
  - c. Return unit to normal operating condition.

## C. TA-5C Stabilizing Amplifier—MI-26160-B

1. High Frequency Response
  - a. Terminate PICTURE OUTPUT and MONITOR OUTPUT in 75 ohms. (Do not terminate Sync Output.)
  - b. Place S-1, LOW-HIGH switch, in LOW position.
  - c. Set R-93, MONITOR GAIN, and R-49, SYNC LEVEL, at mid-position.
  - d. Connect a 470,000 ohm resistor between pin 4 of V-4 and ground. It may be necessary to return the resistor to a negative bias voltage.
  - e. Insert a dummy 6AC7 and 6H6 (filaments open) for V-9 and V-14 respectively.
  - f. Connect sweep detector to PICTURE OUTPUT.
  - g. Apply video sweep to V6-4. Align L-4A and 4B for response as in Fig. 12.
  - h. Align L-3A and 3B for response as in Fig. 13.
  - j. Adjust input signal to 0.25 volt peak-to-peak. Align L-2A and 2B to obtain response as in Fig. 14.

- k. Inject signal at PICTURE INPUT jack and adjust PICTURE GAIN for 0.1 volt peak-to-peak at V1-4 (if it is necessary to use last 25% of maximum counter-clockwise rotation on PICTURE GAIN, switch S-1, LOW-HIGH switch, to HIGH and readjust signal to 0.1 volt peak-to-peak at pin 4 of V-1. Align L-1 to give Fig. 15.

The overall frequency response should be essentially flat to 7 mc.

## 2. Low Frequency Response

- a. Apply a 60 cycle square wave pin 4 of V-5 to obtain 1.5 volts at PICTURE OUTPUT.

The tilt should be less than 10%.

- b. Return unit to normal operating condition.

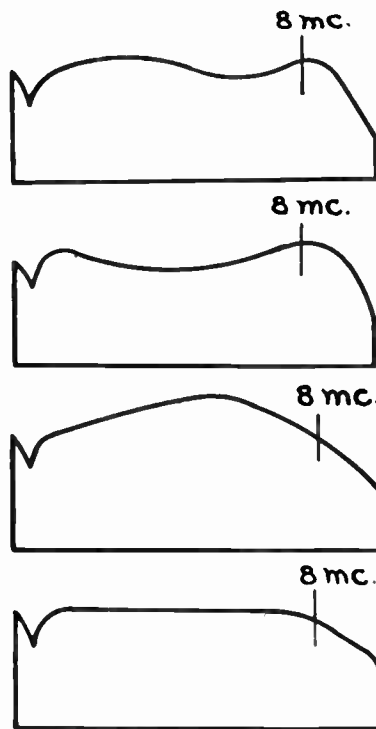

FIGS. 12, 13, 14 and 15 (above). Intermediate and overall Frequency Response Curves of TA-5C Stabilizing Amplifier.

## D. TM-1A Program Monitor—MI-26140

1. High Frequency Response
  - a. Remove V-17 kinescope socket.
  - b. Connect detector between terminal 7 of socket and terminal 6, inserting a .05 mfd. blocking capacitor between the latter.

- c. Turn CONTRAST maximum clockwise.
- d. Align Z-2 and Z-1.

Response should be essentially flat to 7 Mc.

## 2. Low Frequency Response

Inject 60 cycle square wave, 1.0 volt peak-to-peak, to PICTURE INPUT, J-1.

Tilt at kinescope socket should be 10% or less.

Return unit to normal operating condition.

## E. TS-10A Studio Switching System—MI-26235

### 1. Monitor Amplifier

- a. Apply video sweep of 1.0 volt peak-to-peak to J-7, MONITOR PICTURE INPUT. Set MONITOR SWITCH in 1st position.
- b. Connect detector to MONITOR jack, J-9, terminated in 75 ohms.
- c. Adjust MONITOR GAIN for 1.0 volt peak-to-peak-sweep out at MONITOR jack.
- d. Align T-1.

Response should be essentially flat to 8 mc.

- e. Connecting sweep to Aux. #5 or Aux. #6 with AUX. GAIN controls at maximum should give same response as above. (Change monitor switch to positions #2 and #3 respectively.)

### 2. Channel "A" and "B"

- a. High Frequency Response.
  - (1) Terminate PICTURE OUTPUT in 75 ohms.
  - (2) Apply video sweep to CAMERA CONTROL #1 jack, J-1.
  - (3) Push up A and B selector buttons for this input.
  - (4) Connect detector to PICTURE OUTPUT.
  - (5) Operate PICTURE FADING controls together from "A" to "B" channel maximum gain position.

The response at either maximum gain position shall be essentially flat to 10 mc. At mid-gain position the response should be down approximately 10% of mid-band response.

- (6) Repeat above for J-2 to J-6 inputs.

Note: When testing at jacks J-5 and J-6, switching MONITOR SELECTOR switch to positions #2 and #3 respectively will tend to decrease frequency response, but only very slightly.

## F. TS-30A Field Switching System—MI-26215

### 1. Picture Amplifier

FIG. 15. Square Wave Response of TA-5C Stabilizing Amplifier.

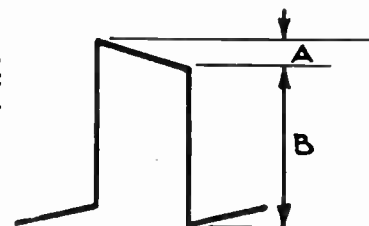

$$\% \text{ TILT} = \frac{A}{B} \times 100$$

# ALIGNMENT PROCEDURES

- a. Connect 470,000 ohm resistor from pin #4 of V-8 to ground.
- b. Replace V-6 with 6H6 with filament pins clipped.
- c. Remove sync input, and switch SYNC to EXT.
- d. Set PICTURE GAIN at mid-position.
- e. Attach detector at PICTURE OUTPUT.
- f. Align T-26 and T-25 respectively, maintaining 1.5 volts peak-to-peak output.

Response should be essentially flat to 8 mc. Gain should be unity.

- g. Check 6 input positions.

## 2. Monitor Amplifier

- a. Terminate MASTER MONITOR, J-30, (output jack) with 75 ohms.
- b. Switch monitor switch to SPARE INPUT TO MONITOR and insert sweep signal, 1.5 volts peak-to-peak.
- c. Set MASTER MONITOR GAIN to mid-position.
- d. Align T-28.

Response should be essentially flat to 8 mc.

## 3. Sync Amplifier

- a. Insert video sweep at SYNC INPUT, J-32, and turn SYNC GAIN, R-71, to maximum position. The gain shall be at least 0.35.
- b. Turn SYNC switch, S-26, to EXT.
- c. Attach detector to PICTURE OUTPUT, J-31.
- d. Align T-29.

Response should be essentially flat to 3 mc.

- e. *Return unit to normal operating condition.*

## G. TA-10A Mixing Amplifier—MI-26281

### 1. High Frequency Response

- a. Attach detector to output, J-9, terminated in 75 ohms.
- b. Insert 2.0 volts peak-to-peak sweep to CHANNEL #1.
- c. With FADER CONTROL to maximum for CHANNEL #1 and minimum for CHANNEL #2, align Z-1.

Response should be essentially flat to 7 mc.

- d. Fade to CHANNEL #2, inserting sweep at CHANNEL #2 input.
- e. Readjust Z-1 if necessary to compromise response for both channels.

### 2. Low Frequency Response

- a. Adjust fader to maximum position for CHANNEL #1, minimum for CHANNEL #2.
- b. Set bias at maximum clockwise position.
- c. Insert 60 cycle square wave, 2 volts peak-to-peak, at input, J-1.
- d. Adjust L.F. PHASE, R-10, for square wave response.

Tilt should be less than 10%.

- e. Insert signal at INPUT #2 and fade from CHANNEL #1 to CHANNEL #2.

Without adjustment, tilt should be same as for CHANNEL #1.

# How to Get the Best Picture Out of Your Image Orthicon Camera

Since the image orthicon camera was introduced commercially in 1945 it has developed from an interesting possibility for outdoor television pickup into a workhorse which can handle adequately any field or studio television pickup assignment. During the early period of field tests it was regarded as a mysterious and almost mystical device whose performance required the full-time attendance of an engineer. Now the image orthicon camera is almost universally used, and its adjustment and operation are so well understood that almost anyone with a little training and experience can produce a reasonably good picture with the equipment. However, television stations are no longer satisfied with reasonably good pictures, but insist on the best possible pictures that can be obtained from their cameras.

For this reason it is vital to review critically the many factors that go into making the best image orthicon picture and from this to present a guide to be followed in setup and operation of image orthicon field and studio equipment. One of the most disturbing feelings which operators have experienced is that of obtaining an excellent picture at one time with a given setup and only a passable or mediocre picture at another time under apparently the same conditions and with the same equipment. It is hoped that the following discussion will bring out the reasons for paying attention to those operating conditions which will insure the best possible and the most uniform picture production from day to day and from camera to camera.

The analysis which follows is based directly on the premise that the operator is familiar with the material covered in the instruction manual for field and studio camera equipment and has, therefore, a working knowledge of the location of controls and the procedures recommended for set-up and adjustment. The approach to the problem is that of clarifying and emphasizing the information in the instruction manual and pointing out as concretely as possible the effect on picture quality of the various factors under control of the operator. It is not intended for use in in-

structing an operator on procedures for producing an image orthicon picture, but rather as an organized set of procedures for making an image orthicon picture better.

## Alignment

A logical starting point in producing the best picture is the matter of scanning beam alignment. This alignment is accomplished by the use of a rotatable yoke over the electron gun of the image orthicon tube. Current from the focus field regulated supply is passed through the windings of this yoke to establish a crossfield in the gun region. The magnitude of the field is controlled by the setting of the alignment potentiometer and its direction is controlled by mechanical rotation of the yoke assembly with respect to the tube. In this way it is possible to correct electrically any small mechanical misalignment of the electron gun which may be present with respect to the longitudinal axis of the tube. Alignment removes the radial component of the scanning beam, and causes it to coincide with the scanning axis of the tube. Proper alignment conditions can be recognized by the following easy test:

When alignment is correct the picture as seen on the kinescope will not rotate or swirl as the orthicon focus voltage is varied about its best-focus position; it will merely go in and out of focus. An even more critical test is that of observing dynode or multiplier spots which are most prominent with no illumination on the photocathode when the amplitude and direction of alignment are varied. When alignment is correct such spots will not rotate, but will simply go in and out of focus as the orthicon focus control is varied. The importance of best alignment on resolution, signal-to-noise ratio and overall picture quality cannot be overemphasized.

With present tubes which are very carefully assembled the alignment current required is very small. Therefore, it is reasonable to start with the alignment potentiometer very close to its zero position and to rotate the coil with small changes in this current to determine conditions for correct alignment as previously discussed.

It should be pointed out that if the focus field current is changed the alignment may no longer be correct for the new operating condition. A fixed value of 75 ma. in the focus field current, which corresponds to a magnetic field of 75 gauss in the center of the focus coil is recommended for optimum performance in both field and studio cameras and should be used for aligning the scanning beam.

Do not attempt to adjust performance by varying the focus field current as it leads to misalignment of beam, change in orthicon focus voltage, and change in image focus voltage. This unduly complicates adjustment procedures, offers no advantages over the standard methods which have been recommended and should, therefore, be avoided. One should keep in mind that a given focus field automatically determines both the orthicon focus voltage and the image focus voltage for an image orthicon tube. Manufacturing tolerances are now held to such narrow limits that tubes can be switched in a camera and after alignment of the scanning beam, only vernier adjustments of orthicon and image focus voltages are necessary to get optimum focus conditions.

To summarize:

1. Adjust scanning beam alignment current and direction until the viewed picture does not rotate or swirl as the orthicon focus voltage is varied about its "optimum focus" value, but merely goes in and out of focus.
2. "Multiplier spots," visible with no light on photocathode (or lens capped) can be used very effectively in making alignment adjustments. They should not rotate or swirl, but should merely go in and out of focus on adjusting the orthicon focus control.
3. Operate at a fixed focus field current of 75 ma. for field and studio cameras, and make alignment adjustments under these conditions. This will give orthicon focus in the neighborhood of 180 volts and image focus in the neighborhood of 450 volts.

4. Do not attempt to adjust for best operation by varying the focus field current. This introduces complications which are very difficult to handle in practice.
5. Practice the technique of alignment until it becomes intuitive. Once this procedure has been acquired it becomes precise and can be carried out in as little as two to three minutes with assurance of uniform performance. Remember that a poorly-aligned camera will never give a good picture no matter how carefully we carry out the other essential conditions which are still to be discussed.

### Scene Reproduction and Picture Quality

In order to restrict the scope of this discussion we shall assume that the orthicon decelerator grid voltage  $G_5$  has been set to get best corner focus or flattest field, that the multiplier focus voltage is set to obtain maximum signal output consistent with a flat field, and that the image accelerator,  $G_6$ , is set to get minimum "S" distortion (about 80% of image focus voltage). The camera should then be in such adjustment that we can discuss the problem of scene reproduction and picture quality effectively.

Television scenes can be divided into two main types as far as the camera is concerned. The first occurs in televising outdoor events in which the lighting is not under the operator's control, and the second, of which studio pickup is an example, is such that the lighting is, or can be, under almost complete control. Let us examine the conditions required for best pictures in these two categories.

In an outdoor pickup, using an f:2.8 lens and an RCA 5820 image orthicon tube, the minimum incident scene illumination for satisfactory signal-to-noise ratio is 5 to 10 foot candles. For the RCA 5826 the minimum is 10 to 20 foot candles. On those infrequent occasions when the light level falls below these values the picture will suffer some deterioration, principally by an increase in noise content, but will still be quite usable if the camera is given a chance to work to best advantage.

It is perhaps most instructive to start from a "normal" outdoor lighting level of 300 to 500 foot candles on the scene and to trace the importance of factors which *can be* under an operator's control and to show that these factors play a very impor-

tant part in determining picture quality at any light level. The 300 to 500 foot candle level chosen for discussion is rather arbitrary since much higher levels can be encountered on bright sunny days.

An operator has the following factors to consider in the pickup of a scene:

1. Focal length of camera lens.
2. Lens opening or f: number setting.
3. Target potential of image orthicon.
4. Beam current setting of image orthicon.
5. Scene composition.

How does he make a proper and practically automatic choice of these factors to obtain the best possible picture the equipment can produce?

With the lens turret on the image orthicon camera there are four possible choices of lens focal length. The lenses may vary from a wide-angle to a 25 inch telephoto and the one selected will depend entirely on the distance of a camera from the scene and the field of interest required at any given moment. So far, these observations fall into the "irrelevance of the obvious" category. In brief, the operator chooses the lens he needs.

From this point on, things get more interesting. The amount of light falling on the image orthicon can be varied by 130 to 1 for the 50mm Ektar lens, or 30 to 1 for the 135mm Ektar by variation of the iris settings in these lenses. The image orthicon is a remarkable tube in its latitude to light, but gets much more cooperative when treated with consideration. How much light shall we give it?

The best way to answer this question is to observe the scene we have chosen for discussion with a camera, starting with the iris at f:22 and gradually opening the iris until it is wide open. The picture will start out by being noisy and will improve as the lens is opened, the highlight signal output growing with the increase in the amount of light. However, a well-defined iris setting is soon reached where the highlight signal no longer rises as rapidly as before. The transition point is called the knee of the image orthicon operating curve. The recommended operating conditions are those with the highlights slightly above the knee of the curve. These will give the most natural scene reproduction with "black" blacks and best gray scale possible. Operation with highlights farther above the knee

will result in poor grays and compressed highlights and give a picture which is "artificial" and not too pleasing to the viewer. This matter of light-level adjustment is so important that it is worthwhile restating the argument in the following form:

"For the most natural appearance of television subject or scene, an image orthicon should be operated so that the highlights on the photocathode bring the signal output slightly above the knee of the signal-output curve for the type of illumination utilized. The knee is that point where the signal from the highlights begins to drop appreciably as the lens opening is decreased in size. Operation at this point is especially important for studio pickup in order to obtain the best gray-scale in the picture and to reduce the possibility of image retention."

"For outdoor scenes where a wide range of illumination may be encountered, and the best lens opening cannot be set for each scene, the optimum setting is that at which the highlights of the least illuminated part of the scene bring the signal output just above the knee. The camera will then be able to handle, without serious deterioration of picture quality, all other degrees of illumination in the scene without any changes in the lens stop. In other words, the camera should be set for the darkest area of the scene, and then panned into lighter areas, as opposed to being set on a bright area and panned into a dark area."

These paragraphs have been quoted directly from general suggestions on image orthicon operation prepared by the Tube Department of the RCA Victor Division.

### Beam Current and Target Potential

This discussion of light-level control by adjusting the lens opening or iris setting has been based on the best operating conditions for the image orthicon tube. At this point it is essential to define these conditions more precisely. The two adjustments which have direct bearing on picture quality are image orthicon beam current and target voltage. How do we choose the correct settings?

The beam current starting at the electron gun is strictly d-c or constant in time. In the process of scanning, electrons are attracted to the target to neutralize the

target charge image created by light falling on the photo-cathode. These are subtracted from the original beam current to *modulate* the returning beam, thus forming the video signal. The return beam going through the five-stage paddle-wheel electron multiplier undergoes *current* multiplication to produce video signals which are 500 or more items greater than those available in the return scanning beam. These currents flow in an output resistor, giving a high-level video signal voltage which is amplified and compensated in the usual manner.

It is immediately evident that in a black portion of a scene *all* of the scanning electrons come back to the multiplier. In the highlights, however, only a fraction of the electrons return, as the others are removed from the original beam to neutralize the charge on the target.

Let us assume that for a given picture the beam current is deliberately increased. In the black portions of the picture *all* scanning electrons return to the multiplier. In the highlights, only a small fraction of the beam electrons are required for discharge, the remainder returning to the multiplier. The percentage modulation is poor and since the beam noise is proportional to the square root of beam current, the signal-to-noise ratio of the picture deteriorates. The technique of obtaining highest signal-to-noise ratio is that of operating with just enough beam current to "hold down" or discharge the highest highlight in a scene. In practice some allowance or reserve must be provided for the possibility of a still higher highlight being introduced during the action. However, there is nothing to be gained by the use of "excess" beam current and very much to be gained by the careful adjustment previously discussed. This brings up the observation that isolated highlights which have nothing to do with scene continuity or dramatic importance should be religiously avoided. Holding down such highlights may require such an increase in beam current that the "normal" portions of the picture will suffer in signal-to-noise ratio. Scenes which have a controlled contrast range are much more readily and smoothly handled than those in which highlights "run away." In general, studio pickups will permit careful control of scene composition. In the case of outdoor pickups such as baseball, boxing and similar events the best solution to the difficulty is to avoid extreme highlights wherever possible. Pointing at the ceiling

to show that the lights are turned on is certainly not a vital part of a boxing match.

We are now in a position to discuss target voltage and its effect on picture quality. The range of target voltage control is approximately  $-3$  to  $+3$  volts d-c. If this setting is made more negative while viewing a picture, a point will be reached where no picture will be seen. This is the cut-off voltage of the target. Careful study has shown that the best operating voltage for the target is 2 to 2.5 volts more positive than the cut-off voltage, with the beam current adjusted to discharge the highest highlights under these conditions. The cut-off point and correct operating voltage can be determined and set using a high resistance voltmeter from the center arm of the target potentiometer to ground. In the beginning, it is advisable to check this setting on a camera rather than to rely on the intuition which comes only with continued practice in setup and operation.

If the target is operated closer to cut-off than has been recommended, the gray scale rendition will deteriorate, with compression of the blacks, and the signal-to-noise ratio will suffer. To prove the importance of target voltage on transfer characteristic or gray-scale rendition, one can try to obtain a picture with the target operated at a fraction of a volt above cut-off. The results can be summarized in one word: horrible. The blacks and grays will be compressed to the point where there is practically no discernible detail in the lowlights, the picture is muddy and the signal-to-noise ratio is very poor. The transition from correct operating voltage to the absurd case which was used as an object lesson is smooth, and the choice of "best" target voltage is therefore one of the more subtle variables in operating techniques.

The more positive the target, the more beam current is required for discharge of highlights. The upper limit is therefore set by the ability of maintaining a well-focused beam to obtain resolution in the highlight details. Therefore the target setting can be made slightly less positive than this upper limit to provide some latitude in scene illumination range, with practically no sacrifice in gray-scale rendition. At times there is a temptation to "hold down" highlights by operating with a more negative target potential when the correct procedure is to stop down the lens iris to the appropriate setting as previously discussed. The target-biasing procedure leads to gray-scale compression and should be avoided.

## Scene Illumination

A guide to scene illuminations required for satisfactory pickup is very useful. The following section is directly quoted from recommendations made by the Tube Department of the RCA Victor Division on image orthicon operation.

"Before attempting to televise a particular scene, it is good practice to check its illumination with a light meter to determine whether the light level is adequate for a picture of good quality. In general, the illumination should be measured in a vertical plane with the light meter at the scene pointing toward the camera."

With an f:2.8 lens, the minimum incident illumination on the scene is given in the following table for the different types of image orthicons. The values are conservative and will vary somewhat for individual tubes.

MINIMUM SCENE ILLUMINATION (Foot-Candles) WITH f:2.8 LENS			
Tube Type	Tungsten Light		
	Daylight	(incandescent)	Fluorescent
RCA 5820	5-10	5-10	5-10
RCA 5826	10-20	10-20	10-20

When lens openings smaller than f:2.8 are used to obtain greater depth of focus, the illumination required will increase with the square of the ratios of the f: numbers.

For daylight scenes using the RCA 5820 set the lens opening in accordance with the following table:

INCIDENT ILLUMINATION ON SCENE	Lens Stop
Clear Sun—10,000 foot candles.....	f:22*
Bright Daylight .....	f:22
Hazy Sun—1,000 foot candles.....	f:16
Cloudy Bright .....	f:11
Open Shade—140 foot candles.....	f:8
Cloudy Dull .....	f:5.6
Deep Shade—30 foot candles.....	f:3.5

\* Used with neutral density filter of 25% transmission.

The use of a lens shade is beneficial under almost all conditions. A lens shade effectively prevents stray light (from points outside the picture field) from reaching the photocathode. Since the image orthicon tube is very susceptible to stray light as far as gray scale rendition is concerned, remarkable improvements in tone-reproduction have been observed under stray-light conditions when a sunshade is used.

The various factors which go to make up picture quality have now been discussed

sufficiently to provide a logical background for setup and operation of cameras. If the recommendations in this discussion are followed in practice, uniformly excellent pictures are the reward.

From the viewpoint of producing the best possible television picture the discussion so far has touched on "normal" operating factors and has assumed that these exist in practice. It is therefore necessary to list departures from normal and point out their effects. These have been summarized in a publication by the Tube Department of the RCA Victor Division as "Don't's." Because of their importance and for the sake of completeness, they are included in somewhat revised form. They are:

1. Don't operate an image orthicon without scanning.
2. Don't underscan target.
3. Don't use an image orthicon for pickup until it has come up to normal operating temperature.
4. Don't focus an image orthicon on a stationary bright scene for more than a few minutes.
5. Don't operate an image orthicon having an ion spot.

A brief discussion of each of these points will give the reason for observing the recommendations which have been made.

1. Failure of scanning for even a few minutes when light is incident on the photocathode may permanently damage the surface of the target. The damaged area will show up as a spot or a line in the picture during subsequently normal operation.

If scanning should fail, cut off the beam current at once by increasing the image orthicon beam bias to its most negative value. When the camera is left unattended, precautions against possible damage due to scanning failure should be taken either by cutting off the beam current or capping the lens.

2. The target should always be scanned to full size. Full-size scanning can be assured by first adjusting the horizontal and vertical deflection controls to make the corners of the target visible in the picture, and then reducing the scanning until the corners just disappear. In this way, since the maximum scanning area is used, maximum signal-to-noise ratio and maximum resolution capabilities of the tube can be realized.

It must be noted that *overscanning* the target produces *smaller* than normal-sized objects in a picture, as viewed on a monitor kinescope.

Underscanning of the target should never be permitted. If the target is underscanned for any appreciable length of time, a permanent change of target cut-off voltage of the underscanned area takes place with the result that the underscanned area thenceforth will be visible in the picture when full-size scanning is restored.

3. When a camera is turned on, the image orthicon tube will warm up from the ambient room temperature to its recommended operating temperature in one-half to one hour. The element which is most sensitive to operating temperature is the glass target, the electrical resistivity of which decreases rapidly with increase in temperature.

The operating temperature of the target in the RCA 5820 tube should be at least 35° C., and that of the target in the RCA 5826, at least 45° C. Operation at lower than the above temperatures will be characterized by the appearance of a rapidly disappearing "sticking" picture of opposite polarity from the original when the picture is moved.

The operating temperature of the target should never exceed 65° C. Operation at too high a temperature will cause loss of resolution and possibly permanent damage to the tube. Resolution is regained only by waiting for the temperature to drop below 65° C.

For outdoor pickups in cold weather, it may be necessary to use the target heater to shorten warmup time and to maintain correct operating temperature. Ordinarily, with the blower operating, the temperature will not exceed 65° C. unless the target heater is on for a long period. In very hot weather, the direct rays of the sun should be kept from reaching the camera.

4. If a camera is focused on a stationary bright picture for more than a few minutes, retention of scene, sometimes called a "sticking picture" may result. Often this picture will disappear in a few seconds, but sometimes may persist for long periods before it completely disappears.

To avoid retention of a scene, always allow the tube to warm up properly before pickup of a scene, and never allow the tube to be focused on a stationary bright scene for more than a few minutes. Never use greater lens iris opening than necessary.

A retained image can generally be removed by focusing the image orthicon on a matte white surface and operating with a fairly high illumination level. Another

possibility is that of switching the lens turret to an open position and using general room illumination directly on the photocathode to carry out the "wipe-off" process.

5. An ion spot may occasionally be observed in an image orthicon. It can be identified as such if it occurs in the center of the raster and does not change in size when the orthicon focus is varied, under conditions of no light on the photocathode. If the spot begins to grow in size with continued operation, the tube should be removed and returned for reprocessing. Continued operation, with ion spot, will eventually damage the target permanently.

After an image orthicon tube has been operated for 200 to 300 hours, it should be given an idle period of three to four weeks during which time it will regain much of its original resolution and sensitivity.

Spare image orthicons should be placed in service for several hours at least once a month in order to keep them free from any traces of gas which may be liberated during prolonged storage. New image orthicons should be tested immediately on receipt. They should be operated for several hours before being set aside as spares.

This discussion has presented recommendations on image orthicon operation and pointed out pitfalls which may be encountered both in setup and in operation. It is in a sense a digest of the available research, development and field experience. Those who are interested in a detailed critical analysis of the effects which have been discussed will find the paper of Janes, Johnson and Moore, published in *RCA REVIEW* in 1949, of great value. The series of papers by Otto Schade in the *RCA REVIEW* on electro-optical characteristics of television systems contains undoubtedly the most thorough analysis of the television pickup and reproduction process and includes an excellent discussion of the transfer characteristics of the image orthicon.

The Television Terminal Equipment Group is indebted to Dr. Janes and Mr. Schade for many discussions on the problems of image orthicon operation and for access to much of the material presented in this discussion.

## References

- "Development and Performance of Television Camera Tubes." R. B. Janes, R. E. Johnson and R. S. Moore. *RCA REVIEW*, 1949.
- "Electro-Optical Characteristics of Television Systems." Otto H. Schade, Parts I to IV. *RCA REVIEW*, Vol. IX, No. 1, 2, 3 and 4. RCA Tube Bulletins for Types RCA 5820 and RCA 5826. Tube Dept., RCA, Harrison, N. J.



# FOUR VERSATILE TV STATION EQUIPMENT PLANS FOR VHF and UHF

## Plans Completely Cover Four Station Categories for "Combined" Studio-Transmitter Operation

(NOTE: A few of the equipments mentioned in this article have been superseded by newer models.)

### Introduction to Plans

The careful and considered planning of the technical equipment for a Television station is the logical step after early planning has been completed. Early plans usually involve such considerations as the market to be served, site selection, effective radiated power, antenna height and gain, sources of program material, station policies, personnel and extent of programming, capital investments, future expansion, and the planning of the building.

These plans covered do not necessarily represent any existing station but they do illustrate several ways in which the very latest equipment may be arranged to perform efficiently with a minimum of equipment and personnel.

### Equipment Plans Are Divided into Four Classes of Operation

"Hand-in-hand" with the building design and construction goes the proper selection and layout of technical equipment to satisfy contemplated programming requirements.

Since programming requirements will vary widely and range from simple to complex, four general equipment plans were selected to represent well-equipped TV stations for four specific categories of operation. The need for building and companion equipment plans that may grow logically at minimum cost was considered essential in selecting the following equipment groupings. Plan "A", "A-Prime" and "B" are versatile and permit expansion of both the building and equipment at minimum cost. Plan "C" represents a larger

type of operation and is not a direct outgrowth of any of the other plans. Although individual station requirements, budget appropriations, and scope of operations are seldom alike—the four plans are considered adequate to satisfy a majority of cases. The four distinct groupings of equipment or classes of operation range from Plan "A" (a film and network only station) to Plan "C" (a fairly large, "two-studio" station with remote facilities). TV stations with more complex arrangements of program sources than Plan "C" will fall into the "custom" planning category requiring special consideration and investigation. Description of this type of station, therefore, is beyond the scope of this article. It should not be expected that the four plans treated here will not require any special considerations—because it has been found in practice that even the simplest station plans have small deviations that require special attention.

The four station plans are divided into station groupings as shown below. The "A-Prime" layout corresponds almost exactly, from an equipment standpoint, to the popular RCA "Basic Buy" station.

All equipment setups correspond to or parallel very closely (from a programming and operation standpoint) those included in the previously published material listed below. Thus, together with the information presented in this article, the TV planner has available fully integrated plans which will provide him with the necessary source material to estimate Operating, Equipment and Building costs.

"Considerations in the Early Planning of TV Stations," by J. L. Herold, BROADCAST NEWS No. 69, May-June, 1952.

"TV Station Operating Costs," by J. L. Herold, BROADCAST NEWS No. 68, March-April, 1952.

"Television—What and How to Build," by Ben Adler and Rene Brugnioni, BROADCAST NEWS No. 72, Jan.-Feb., 1953.

Station Group	Transmitter Power	Program Sources
† "A"	TTU-1B, 1-KW, UHF TT-2AL/AH, 2-KW, VHF TT-500, 500 watt	Film, slides and network
† "A-Prime"	TTU-1B, 1-KW, UHF TT-2AL/AH, 2-KW, VHF	Same as above, plus "Single-Camera" Live Studio
* "B"	TT-10B, 10-KW, UHF TT-10AL/AH, 10-KW, VHF	Same as above, but "2-Camera" Live Studio
* "C"	TT-10B, 10-KW, UHF TT-25BL/BH, 25-KW, VHF TT-50AL/AH, 50-KW, VHF	Same as above, with "2-Studio" Live and Remote

FIG. 1. Chart showing the four station categories and associated transmitters and program sources.

† Transmitters of higher power are equally applicable where space permits.

\* Transmitters of lower power are equally applicable to these plans.

# GENERAL PLANNING CONSIDERATIONS

## Considerations in Choosing an Equipment Plan

In order to reduce the number of variables and simplify the presentation of this material, all four equipment plans chosen cover only "combined" types of operation where studio and transmitter equipment are located in the same building. It is worthy of note, however, that the equipment plans presented are also practical when "divided-up" and applied to situations where transmitting and studio equipment are remotely located. In these cases, coaxial cables, equalized lines or microwave facilities would be required to link the two functions, (see Fig. 2) plus the possible addition of video amplifiers at the transmitter location.

The TV Planner's choice of one of these equipment layouts will depend to a large degree on factors which he has already determined such as: the type of programming, area or community to be served, network facilities available and extent of remote programming. Transmitting equipment requirements for the various plans will be quite similar except for the possible use of different values of Effective Radiated Power. This requires the use of different transmitter power levels and antenna gains.

If the station is a network origination point located in a large city, requirements may dictate a multiple studio installation employing several cameras, associated control equipment, master control equipment and extensive distribution facilities. On the other hand, a network affiliated station in a small community may need only simple studio facilities. In some instances, network affiliated stations in small communities may not have any origination facilities except a single studio camera chain for announce pickups, simple interviews, and advertising sets. A slide projector and movie projectors with a film camera chain would round out the system for a start.

Of course, the simplest and most inexpensive type of television station to equip would be one that plans to use network programs entirely. However, in such a station there would be no means of presenting essential local advertising material or station call letters. A more practical station is one which can present local film programs interspersed with network (such as Plan "A"). Because film is a very important part in TV Station programming, editing, rewind, splicing and storage facilities are included in each plan.

One step further, and perhaps a wise one, is to equip the station with a small studio to produce live program material, as well as film (such as Plan "A-Prime"). A studio of the size shown in Plan "A-Prime" is not intended to be adequate for the handling of elaborate studio shows but does permit local live talent showings, personal interviews, and showing of the sponsor's products. In both plans, "A" and "A-Prime", all video controls and transmitter controls are located in the same room, at a centralized console.

A great many stations will find it economically feasible to start with provisions for a moderate-sized, two-camera studio with a separate control room (such as included in Plan "B") in order to accommodate larger TV shows. Plan "C", of course, with its two full-sized studios, control rooms, and remote facilities is equipped for more elaborate programming suitable for metropolitan-type operation.

For the advanced "B" and the "C" station plans presented, single camera chains, amplifiers, monitors, or the like may be added at will without greatly altering the rest of the station's equipment. Moreover,

these units are of matched design and operate at standard levels into standard impedances. Thus, most input and output connections may be patched in or out, as desired. Units are also alike in styling and appearance and are the same equipment as that employed by the largest network stations.

## Basic Control Room Considerations

All TV installations, large or small, are alike in many respects. The difference in size, for instance, is mostly a matter of the number of cameras and studios involved. The single studio of a small station and its associated control room may be almost identical to one of the studios and associated control rooms of a larger station. Thus, the general arrangements of the equipment for the control room may also be quite similar. Moreover, the equipment for all stations is made up from the same basic units. And finally, the basic control system used in all of them performs the same functions.

However, this article would be incomplete if it failed to point out that there are various deviations in arrangement of studio and control room facilities to suit special conditions and personal tastes. For example, it is not necessary that video control operators be able to see into the studio since their primary function is to maintain control of the picture signals emanating from a camera. It is more important that the program director be able to see the production.

It would be possible to place a program director's console directly in front of the studio window, and locate the camera controls at one side or even in a different room, if the switching unit and a picture monitor for each signal source are located in a console on the platform directly in front of the director. In some large stations, all of the camera controls have been placed in master control. This, of course, centralizes all the operational equipment in one spot but requires remote video relay switching and fading to be effective in saving personnel and avoiding many long cable runs. The program director also has control of switching either directly or indirectly. The audio operator should also be able to see the studio action to be able to ride gain properly.

On the other hand, for economic reasons primarily, some stations may require that the camera controls must be located in front of the studio window in order that

FIG. 2. Equipment plans may be "divided-up" so that studio and transmitter facilities are remotely located, in which case microwave or coax links could be employed.

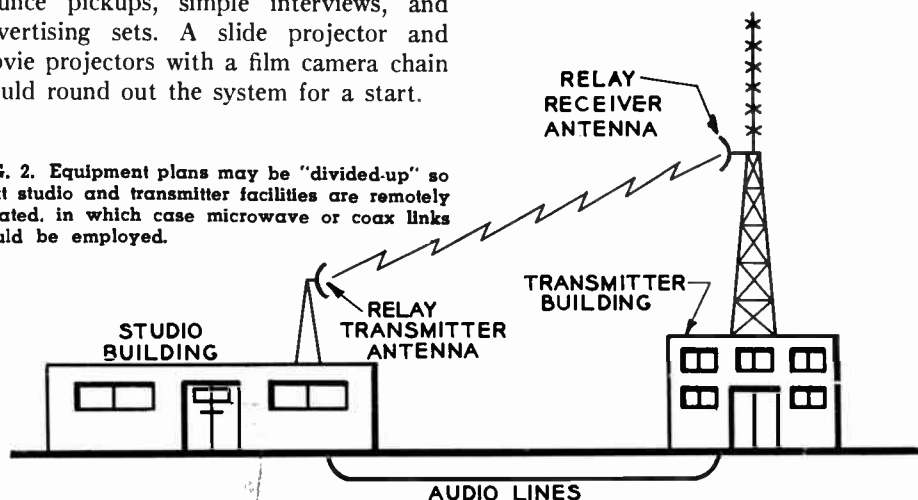

the program director in the back of the control room, who is located on a raised platform, may see both the studio action and the associated monitors at a glance (see Fig. 3). This arrangement requires fewer monitors but causes the view of the program director to be restricted by the presence of the video operators.

In smaller installations, all controls may be located where a view of the transmitter, projection room, announce booth, and even a small studio is possible. Such operating conditions are satisfied by the "A" and "A-Prime" plans.

### Studios and Announce Booths

The TV studio should be large enough to provide for as many sets as possible which may be successive scenes in a play or advertising program; while control rooms should be made large enough to admit additional equipment as the station grows. As a matter of fact, the floor plan of "A" can serve as a basic building block for plans "A-Prime" and "B". At least one announce booth is essential in any TV Station layout. Such a booth is provided with the necessary audio facilities and a

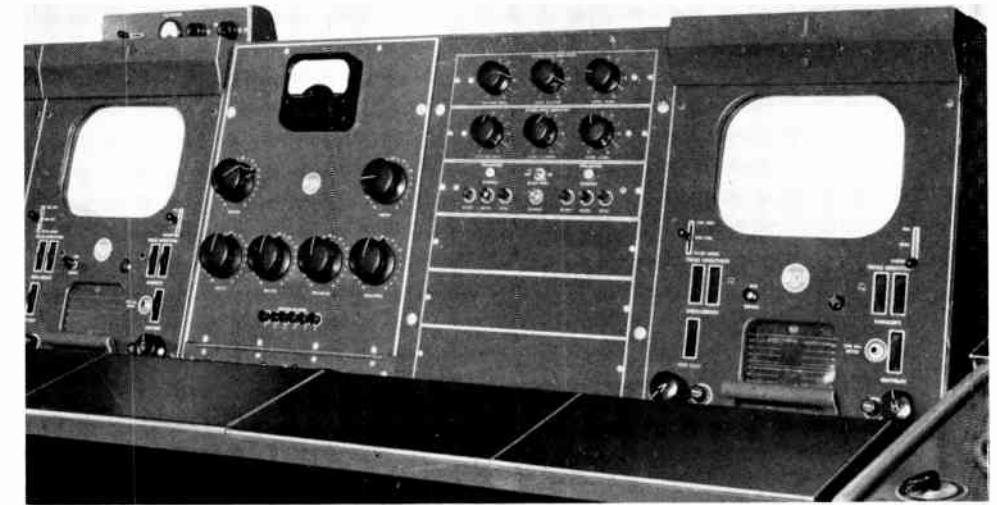

FIG. 4. Closeup of the four console sections which are used as the basic "building block" for the combination transmitter/master control rooms in all four plans.

era, include video control consoles which are made up of standard sections referred to as camera control units. There is one of these control units for each studio camera and one for each film camera. Each unit contains a picture monitor showing at all times the picture picked up by the associated camera. It also contains an oscilloscope for "wave-form" monitoring and the necessary controls for adjusting brightness, contrast and electrical focus. The

signals from the cameras are mixed (or switched) in the same manner as microphone and transcription inputs are mixed at the audio console. From the video switching console, the picture signal is fed either directly to the transmitter line or to a master control room together with signals from other studios, network line, or outside points. In practically any TV station setup, the supervision of the individual camera signals is exercised by the "video operator" who sits at the video console.

### Basic Audio Considerations

The audio equipment used in a television station is very much like that used in a standard broadcast station. There are, however, several minor differences. One is occasioned by the fact that microphones are usually kept out of sight and that performers must work farther from the microphones. This usually requires more microphones or the use of elaborate boom mounts (see Fig. 7).

The boom operator, under the direction of the audio engineer, maintains the placement of the boom microphones for best sound pickup. He must also keep the boom and microphone out of the view of the camera. Good communication, therefore, must be maintained between audio engineer and boom operator.

Audio switching is normally "tied-in" or interlocked with video switching. However, provision can be made to divorce the two functions, if necessary. The TV audio control operator, in addition to performing his normal job of riding gain, must maintain close following of the overall program and generally keep step with video control.

### Video Switching Considerations

The location and arrangement of facilities for video switching varies widely with

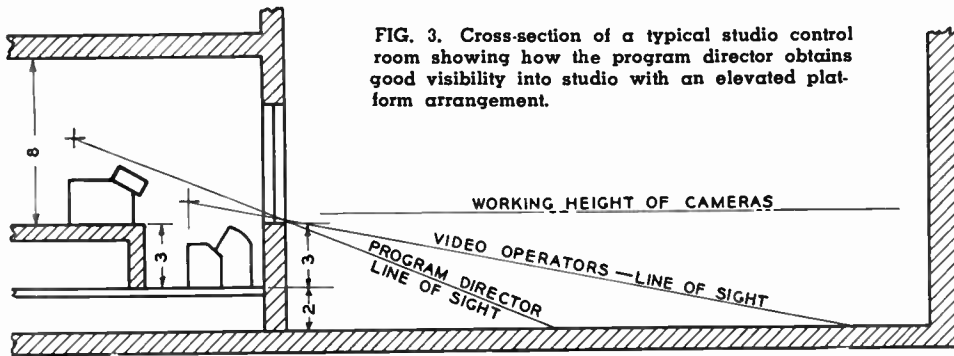

FIG. 3. Cross-section of a typical studio control room showing how the program director obtains good visibility into studio with an elevated platform arrangement.

picture monitor. It enables a commentator, for example, to see the picture upon which he is commenting. If this announce booth is to serve also for station identification, it is advisable to locate the booth so that visual "cue" may be given from the studio control console. It may be desirable on some occasions to point a camera at the announcer through the announce booth window, and this possibility has been taken into consideration in the plans of "A-Prime", "B", and "C". This has been accomplished by existing TV stations with varying degrees of success. To overcome the problem of reflections, some stations have found that the use of inclined windows contributed to improved performance, while others use non-reflective glass.

### Basic Studio Equipment Considerations

The Television Equipment units, in addition to the familiar studio and film cam-

video operator uses these controls to keep the several camera pictures in optimum adjustment at all times. Thus, the technical director, or switching operator, is free to concentrate on the action without being concerned about the camera adjustments.

In the layouts of Plan "A" and Plan "A-Prime", a single combination audio/video console (see Figs. 4 and 5) is located in the transmitter room and provides all switching, camera control, monitoring and previewing facilities. Additional monitoring sections and camera controls may be added for future expansion. In Plans "B" and "C", separate studio control consoles are employed. However, regardless of the location of individual sections, the output of each studio or film camera is fed into one of the input positions on the TS-10A Video Switching and Fading Console (see Fig. 6). At this console position, the video

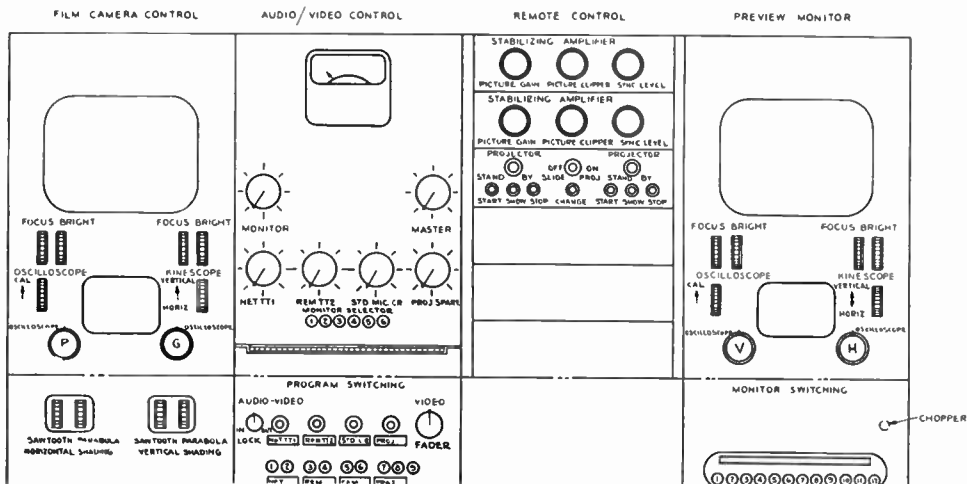

FIG. 5. Detailed panel layout showing the controls, meters and pushbuttons provided by the four console sections. Additional studio camera control and film camera control sections are added as the plans increase in size and scope of programming.

the type of setup (and with the personal preference of station planners). In medium-sized stations (such as depicted by Plan "B"), a simple but effective arrangement consists of adding to the video console two additional monitor sections. One of these acts as a master (or program) monitor. On its screen appears at all times the picture output of the control room. There is a space in this console for a panel containing pushbutton switches with lap-dissolve levers, signal lights, etc. The technical director uses these controls to select the picture for transmission. The second monitor is used as a "preview" monitor. The technical or program director uses a set of pushbuttons to select any of the camera inputs he proposes to use. This allows him to monitor (for quality and action) any upcoming shot. This monitor may also be used to take visual "cue" from a preceding program by switching to the video line from the preceding origination point.

The average television program consists of a succession of camera pickups, plus the occasional inclusion of signals from remote points or other studios. A simple example of the latter is the insertion, into the program, of a station identification slide or short picture sequence originating in the film projection room. Another is the occasional (although less frequent) insertion of outdoor scenes or sporting events picked up by field equipment and fed to the station by line or microwave relay. Thus, even though the major part of any one program will originate in one studio, with control of the program centered in its control room, some provision must be made for coordinated control of the remote signals, as well as control of the signals emanating from the projection room.

In almost any television station, it is desirable to be able to switch from local to remote and network signals in master control. A feature of the layouts described here is that remote and network signals as well as signals from other studios may also be brought into any of the camera switching systems by means of a video patch panel, thereby allowing control of all program source material within any studio control room.

### House Monitoring Considerations

House monitoring is an important function and consideration before construction begins will make a much neater installation. One simple and inexpensive method is to transmit the required signals to the several locations where there are standard re-

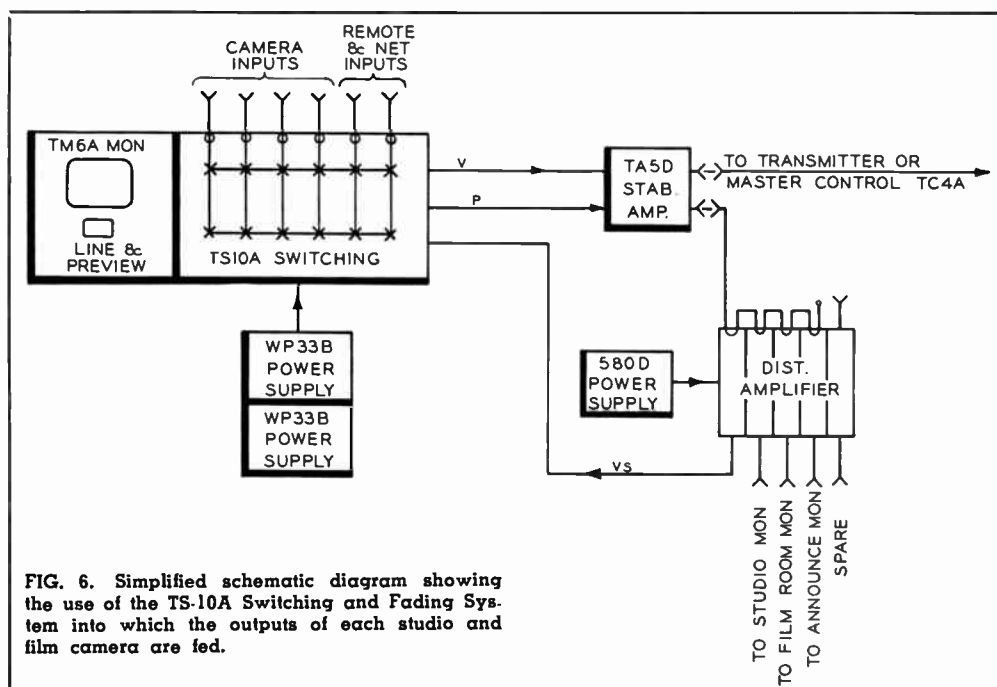

FIG. 6. Simplified schematic diagram showing the use of the TS-10A Switching and Fading System into which the outputs of each studio and film camera are fed.

FIG. 7. In good TV Audio pickup practice, the microphone must usually be kept out of sight. This requires the use of an extension or "boom-type" mike stand like those shown in layout photos to follow. The "perambulator" type shown below is another possibility for consideration in larger studios where greater mobility and manipulation are required.



ceivers. The Type TM-30A Monitran is a miniature television broadcasting transmitter intended for use in television stations to "close-circuit" feed standard TV receivers used as monitors. It develops both a picture and sound carrier on any one of the twelve VHF television channels.

### Lighting Considerations

In general, the two main classes of lighting considered are: (a) lighting of plant operational and administrative areas, and (b) studio lighting. Both of these planning factors are described in the station plans that follow as applied specifically to each layout. Basically, the lighting system for a TV studio is determined by the architectural properties, degree of flexibility desired, nature of the program material, and by the lighting requirements (both artistic and technical) of the TV productions to be staged.

### Basic Intercom Considerations

Intercommunication and talkback facilities for a television station will be more elaborate than those required by most AM and FM stations. In even the most modestly equipped TV station, the intercom system will be called upon to perform these functions: (1) talkback (over-ride, carrying cue or orders to studio, projection room and announce booth—a function of the audio facilities); (2) Order-Wire (telephone facilities to offices and to outside lines); (3) *Headset Intercom* (to provide private and conference communications for production and for technical personnel).

Since the intercom requirements of the individual stations will vary considerably, the plans that follow include diagrams and descriptions that apply to each station.

### General Size Considerations

It will be noted from the floor plans to follow that, wherever economically feasible some space allowance has been made for incorporating transmitters of several different power ratings. However, when considering transmitters larger than those indicated, the planner should *be sure to provide the additional space.*

It will be noted that sideband filters or diplexers are ceiling mounted to conserve floor space, and that the engineer's desk can be conveniently moved to general office areas to provide space for accommodating a VHF or UHF 10-KW transmitter. Some additional space for mounting associated components and/or power equipment is

also available in the engineering workshop or heating and ventilating room (see Plan "B"). On the other hand, Plan "B" would not be suitable for a 25-KW or 50-KW transmitter — unless associated rectifier, power and control equipment could be located on a basement floor or elsewhere.

Another suggestion is to compare the sizes of doorways to those of individual components to *assure entrance of such items as transmitter cubicles and Filterplexers.*

In general, the planner should consider carefully both his present and future space needs and balance this with his planned expenditure. Usually, the provision of a little extra space will be more than repaid by the ease with which later expansion can be made.

### "Ductwork" of "Trench" Planning

The careful planning and layout of wiring trenches or ducts is essential to every station planner, once the amount of technical equipment has been determined accurately. It is practical to plan "trench runs" to accommodate the future addition of console sections, equipment racks and transmitter cabinets. A typical transmitter and console ductwork diagram is shown in Fig. 8 for reference, but no attempt is made in this article to illustrate complete station duct layouts. This is deemed as a consideration, unique for each station, and is perhaps best jointly solved by the station engineer, a qualified systems consultant, and the TV equipment engineers involved.

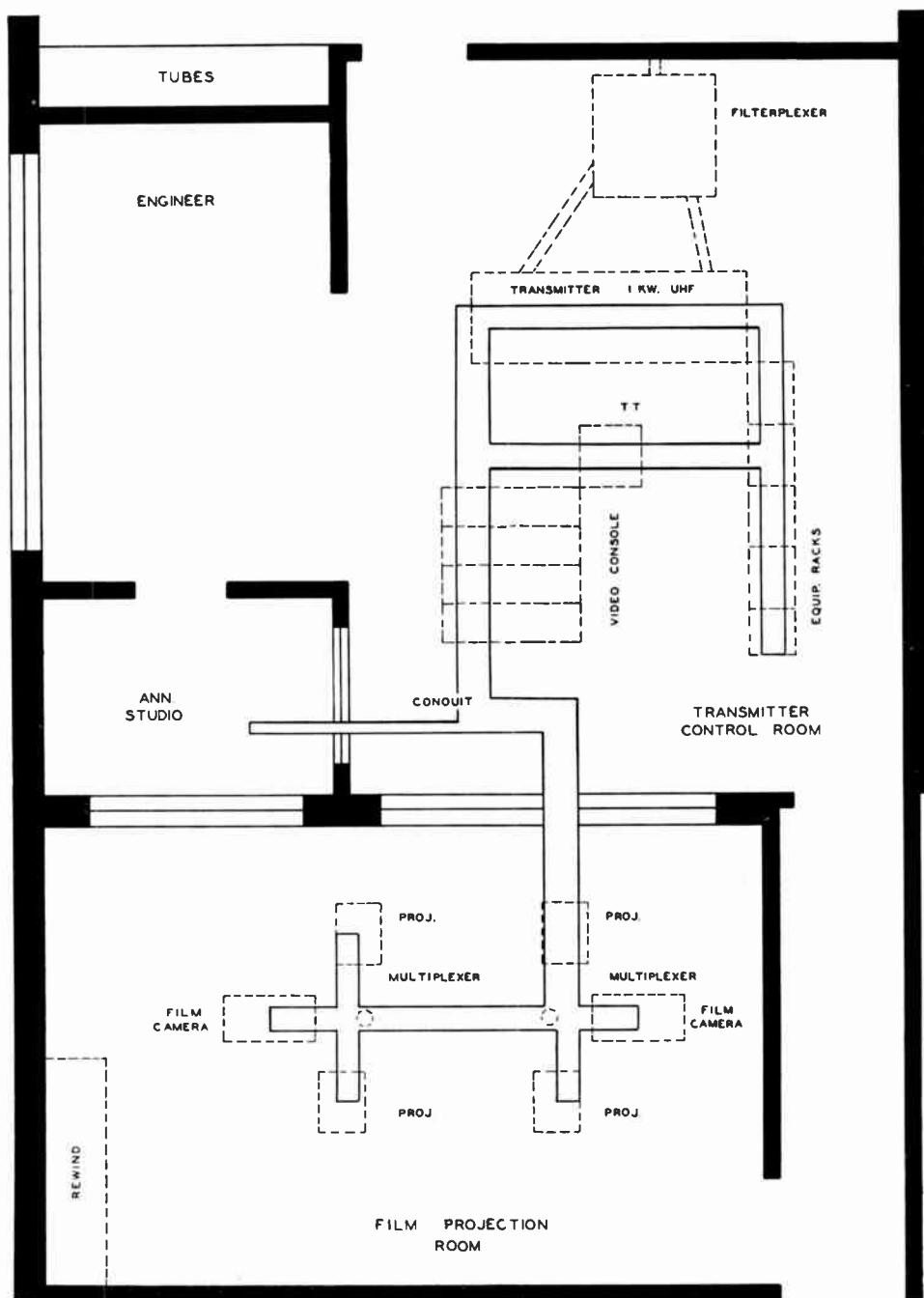

FIG. 8. A sample transmitter, rack and console duct layout. Practical planning should make provision for possible future addition of racks, console sections and transmitter cabinets.

# TV STATION PLAN "A" (Network and Film Only)

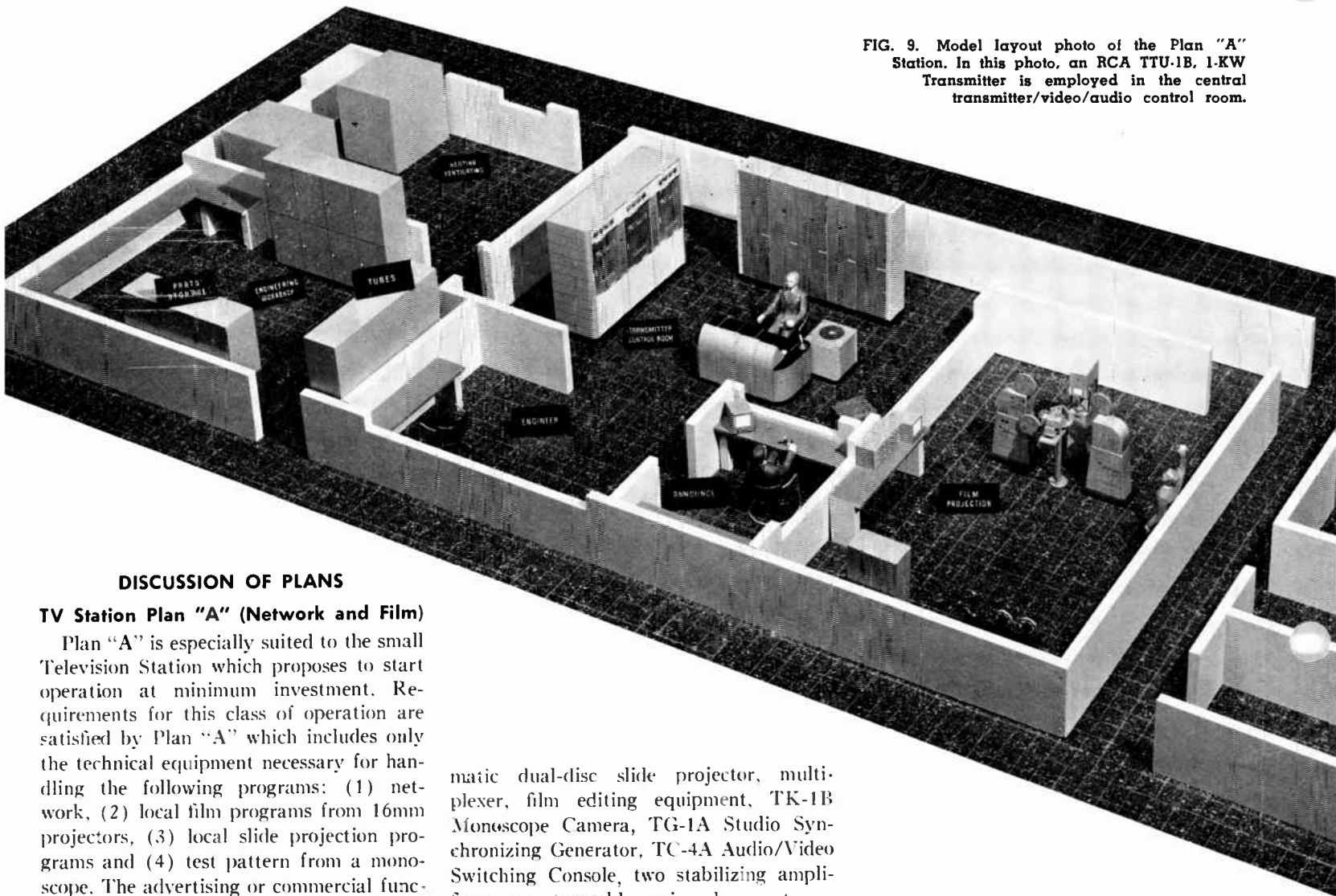

FIG. 9. Model layout photo of the Plan "A" Station. In this photo, an RCA TTU-1B, 1-KW Transmitter is employed in the central transmitter/video/audio control room.

## DISCUSSION OF PLANS

### TV Station Plan "A" (Network and Film)

Plan "A" is especially suited to the small Television Station which proposes to start operation at minimum investment. Requirements for this class of operation are satisfied by Plan "A" which includes only the technical equipment necessary for handling the following programs: (1) network, (2) local film programs from 16mm projectors, (3) local slide projection programs and (4) test pattern from a monoscope. The advertising or commercial function can be of either local or network origin.

### General Facilities

Overall housing facilities of Plan "A" include Sales, Administrative, program offices and storage space, in addition to the space provided for the technical operation (see Figs. 9 and 10). Floor space for technical equipment is separated into: a combined transmitter and video control room, announce booth, film projection room, film editing and storage, engineering workshop and parts storage, and heating and ventilating.

Major items of the equipment required to perform programming operations consist essentially of a Type TK-20 Film Camera Chain, TM-6A Master Monitor, two TP-16, 16mm Film Projectors, an auto-

matic dual-disc slide projector, multiplexer, film editing equipment, TK-1B Monoscope Camera, TG-1A Studio Synchronizing Generator, TC-4A Audio/Video Switching Console, two stabilizing amplifiers, one turntable, microphones, transmitter, antenna, audio equipment and miscellaneous accessories such as rack mounted power supplies, etc. A pictorial diagram illustrates the major equipments incorporated in Plan "A", and accompanying floor plans and "exact-scale" model photos show their approximate location. Video power supplies, distribution amplifier, stabilizing amplifiers, monitoring equipment, sync generator, audio equipment and test equipment are housed in five standard cabinet racks located near the console (see Fig. 12).

### Transmitter and Antenna Equipment

The choice of transmitter, antenna and transmission line will, of course, depend upon the individual station's power and frequency requirements (UHF or VHF).

All other items included in Plan "A" remain the same for any "A" type TV Station, regardless of power.

In Plan "A", the transmitter is located in the central control room at the right of Audio/Video control console (see Fig. 12). Transmitter test and monitoring equipment required to fulfill FCC requirements are mounted in equipment racks behind the control console. The "Filterplexer" (a combination sideband filter/diplexer) is ceiling-mounted to conserve floor space. Plan "A" indicates the use of a 1-KW transmitter (RCA TTU-1B) or a 2-KW transmitter (RCA TT-2AL/AH). However, Broadcasters planning to increase to 10-KW later on with "add-on" amplifiers may do so by moving the engineer's desk into another office, thus providing the extra

space. Either the 1-KW UHF transmitter or the 2-KW VHF transmitter and a high-gain antenna will provide powers up to 20 KW, ERP. The 10-KW transmitters and a high-gain antenna will provide Effective Radiated Powers of up to 100 KW for VHF and up to 200 KW for UHF.

### The Plan "A" Centralized Console

Smooth and successful performance of this console is made possible to a large extent by the proper grouping of important controls to make them easily accessible to the operator. This is accomplished by using TC-4A Audio/Video Switching Console (which consists of two console sections) plus one film camera and one switchable TM-6A Master Monitor also mounted in standard console sections. These four standard sections are arranged "in-line" (with the TC-4A sections

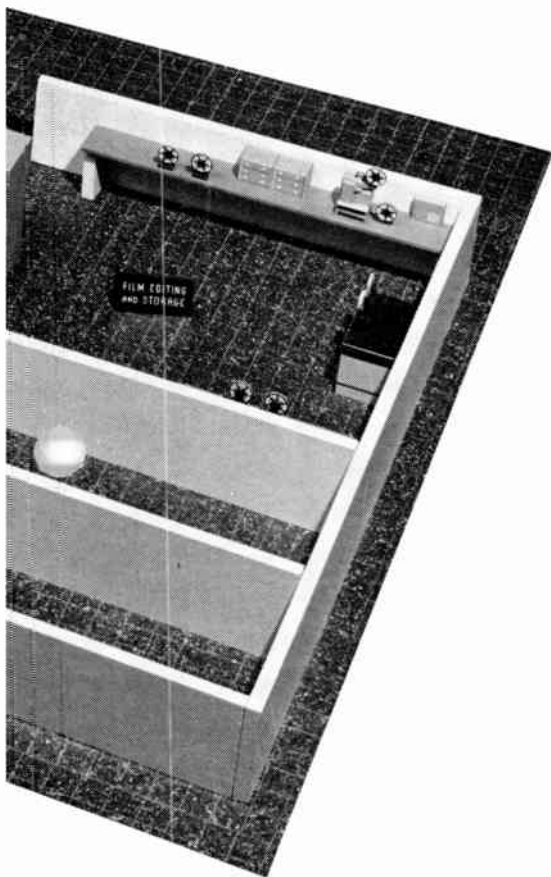
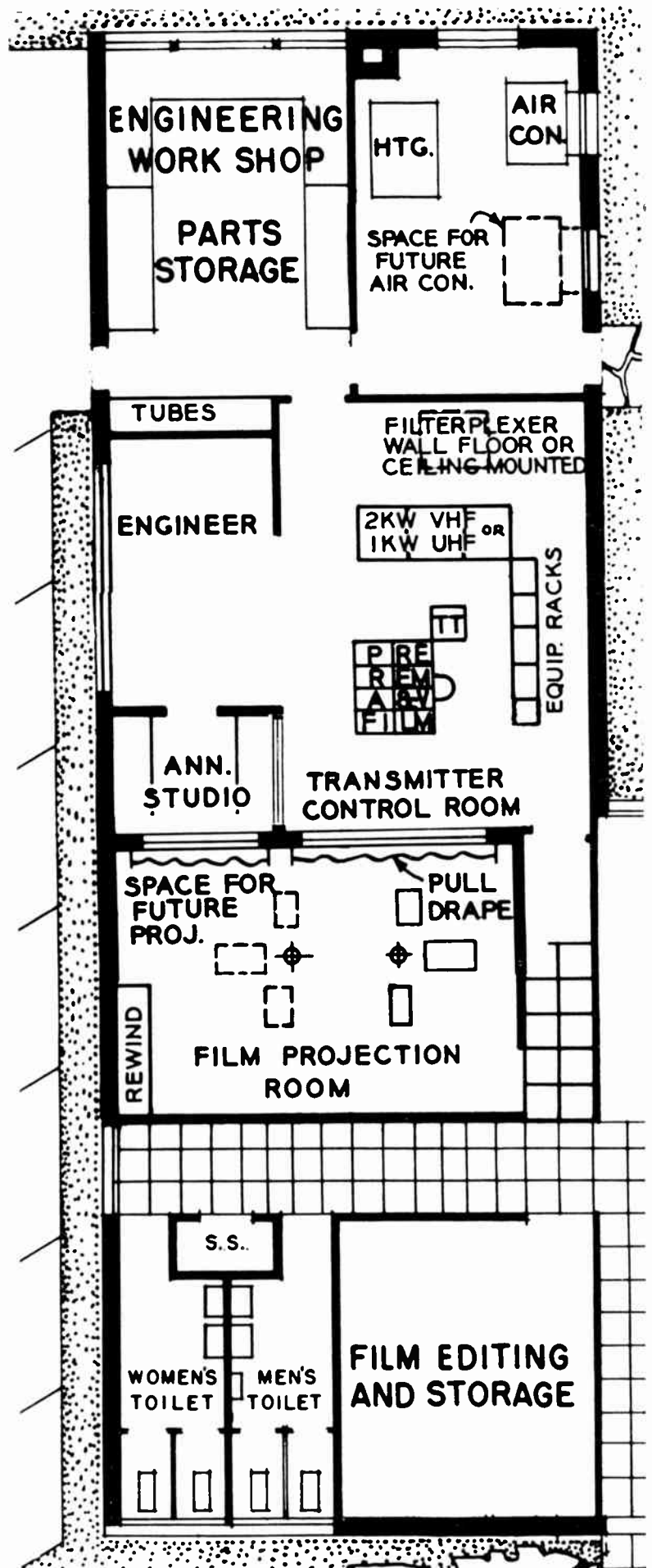

FIG. 10. Corresponding floor plan showing the technical facilities for the PLAN "A" STATION.



in the center) to form the simple unified console of Plan "A" (see Fig. 4). This console is coupled with a film camera control and forms the nucleus of a complete Television operation. It may be used by small and large stations alike, as is described later. The section at the extreme left of the console (see photo and panel layout) houses the film camera control unit. In the upper part of this console section is a TM-6A Master Monitor which has a ten-inch picture tube and a five-inch CRO tube. In the lower portion of the housing is the film camera control chassis. It supplies the blanking and driving signals to the film camera and reproduces a picture generated by the film camera. Controls for the adjustment of picture levels and shading are located on the sloping desk panel of this console section. The film camera control is located at the left end of the TC-4A Console for convenience of operation. However, the unit

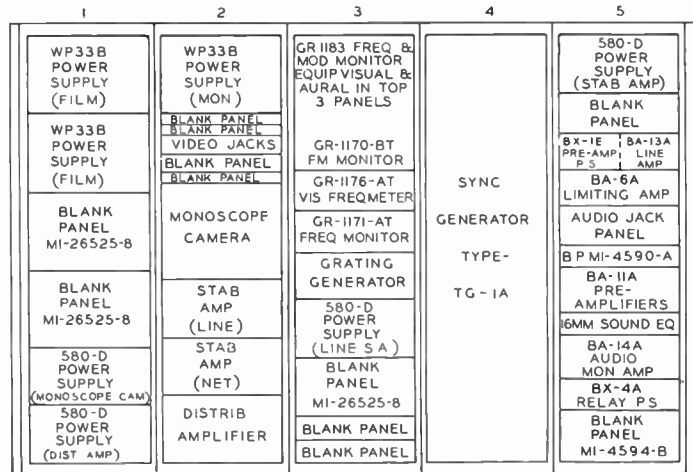
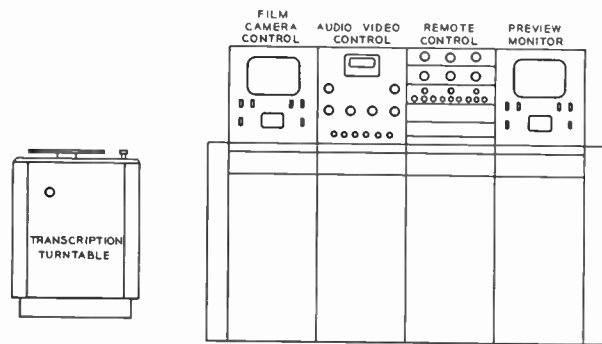
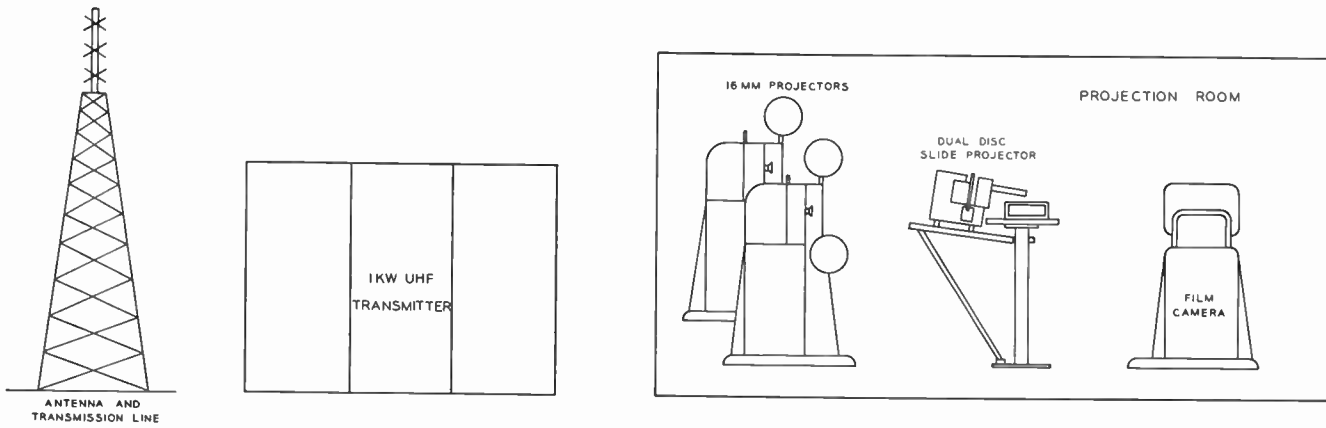

FIG. 11. Pictorial sketch showing the major items of equipment used in the Plan "A" Station which is a "film and network only" operation.

may be removed from this position if desired, and placed at another location without disturbing the functions of the remainder of this switching console.

### TC-4A Sections

The TC-4A equipment is composed of the two center sections of the operating console and provides audio and video controls and audio monitoring facilities. All major console control panel circuits are brought out to coaxial and plug connectors at the rear or bottoms of the panels to provide access for test, wiring or maintenance.

The two center console sections that comprise the TC-4A Console, reading from left to right, are:

1. Audio control with combined Audio/Video program switching.
2. Remote control section.

On the sloping portion of the Audio/Video section (second from left) (see photograph) are located the program switching controls composed of one row of key switches for Audio control, one row of pushbuttons for Video control, a Video clip-fader control and a tie-switch for combining Audio and Video switching, controlled from the Video pushbuttons.

The combined Audio/Video switching is obtained by using relays. This system pro-

vides for eight inputs of Audio and eight of Video with one output for each.

### Plan "A" Audio Control

The Audio portion provides for eight inputs to four mixer positions. Audio key switches provide means of selecting any input such as turntable, projector, studio, remote or network. The inputs are relay operated so they can be controlled by the Video selector switch when desired, simplifying the Audio/Video combination switching (actual circuits are kept apart thereby preventing crosstalk). The relays are also interlocked to prevent accidental doubling of the circuits. A selector switch allows a monitor amplifier and speaker to check most of the Audio circuits including transmitter input and output, and turntable cueing. It is visualized that a separate cue-

ing amplifier and speaker may be used in most applications.

One rack of equipment houses the pre-amplifiers; program monitor, and limiting amplifiers; and power supplies. Jacks are provided for all amplifier inputs and outputs.

### Plan "A" Video Control

The Video pushbuttons also provide a means of selecting any one of eight signals, such as film, studio, monoscope, remotes or network for transmission. In addition, by using the "lock-in" switch on the left side of the panel, certain Audio and Video signals may be switched simultaneously by means of the Video pushbuttons. When switching from local to remote or network signal, contacts on the switches provide automatic removal of the local synchronizing signal.

On the right side of the switching panel is a remote "clip-fade" control. By means of this control, the signal may be faded to black, at which time an instantaneous switch may be made to a new signal, and then the new signal faded up, thus letting "roll over" occur during the black period, when switching from local to "remote" or "network".

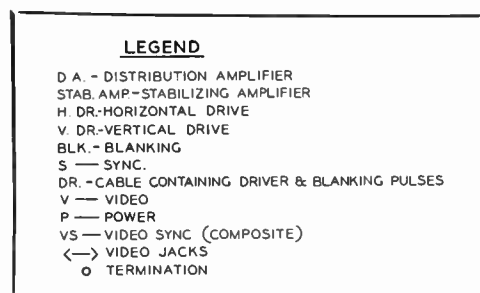



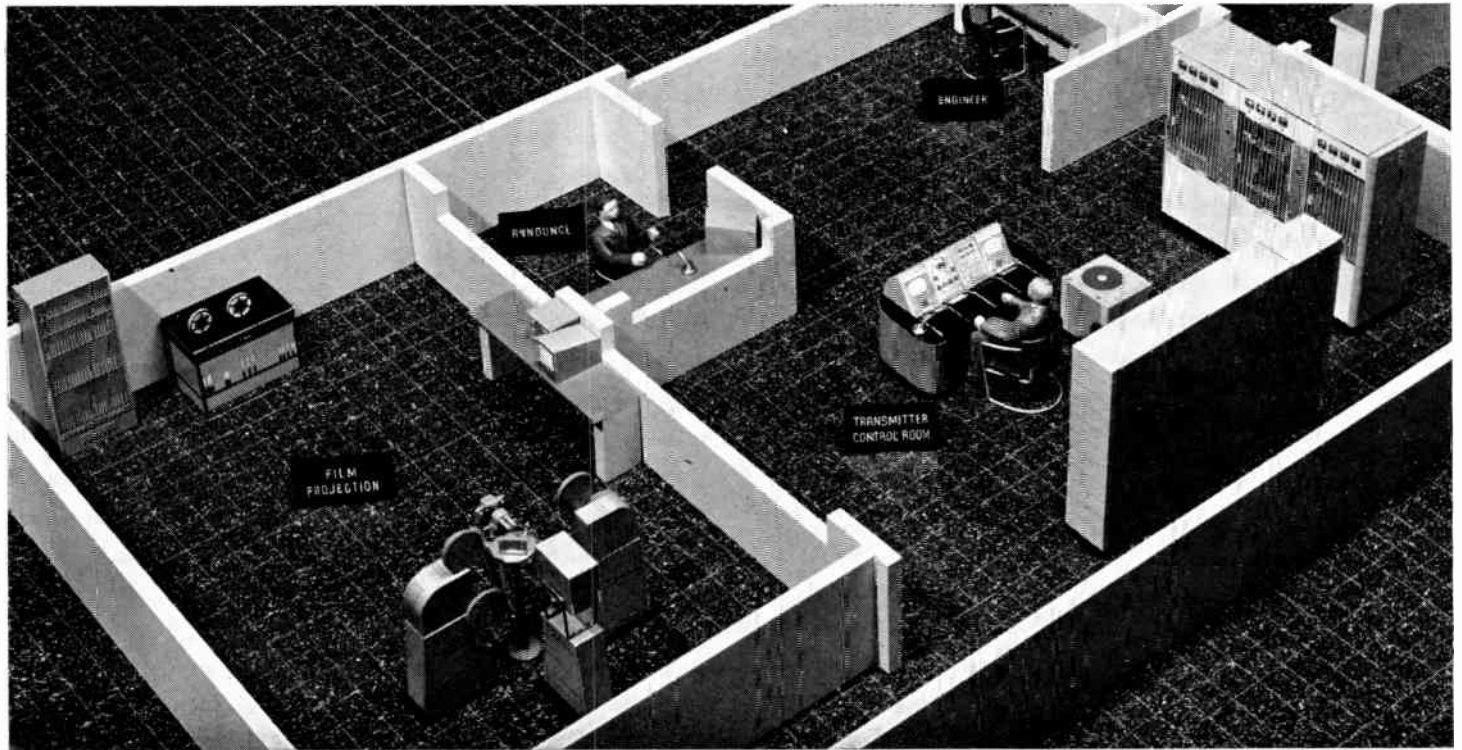

FIG. 12. Closeup photo showing the film projection room and transmitter control room of Plan "A" with the RCA 1-KW UHF Transmitter. Note space available for addition of another Film Camera Chain, when desired.

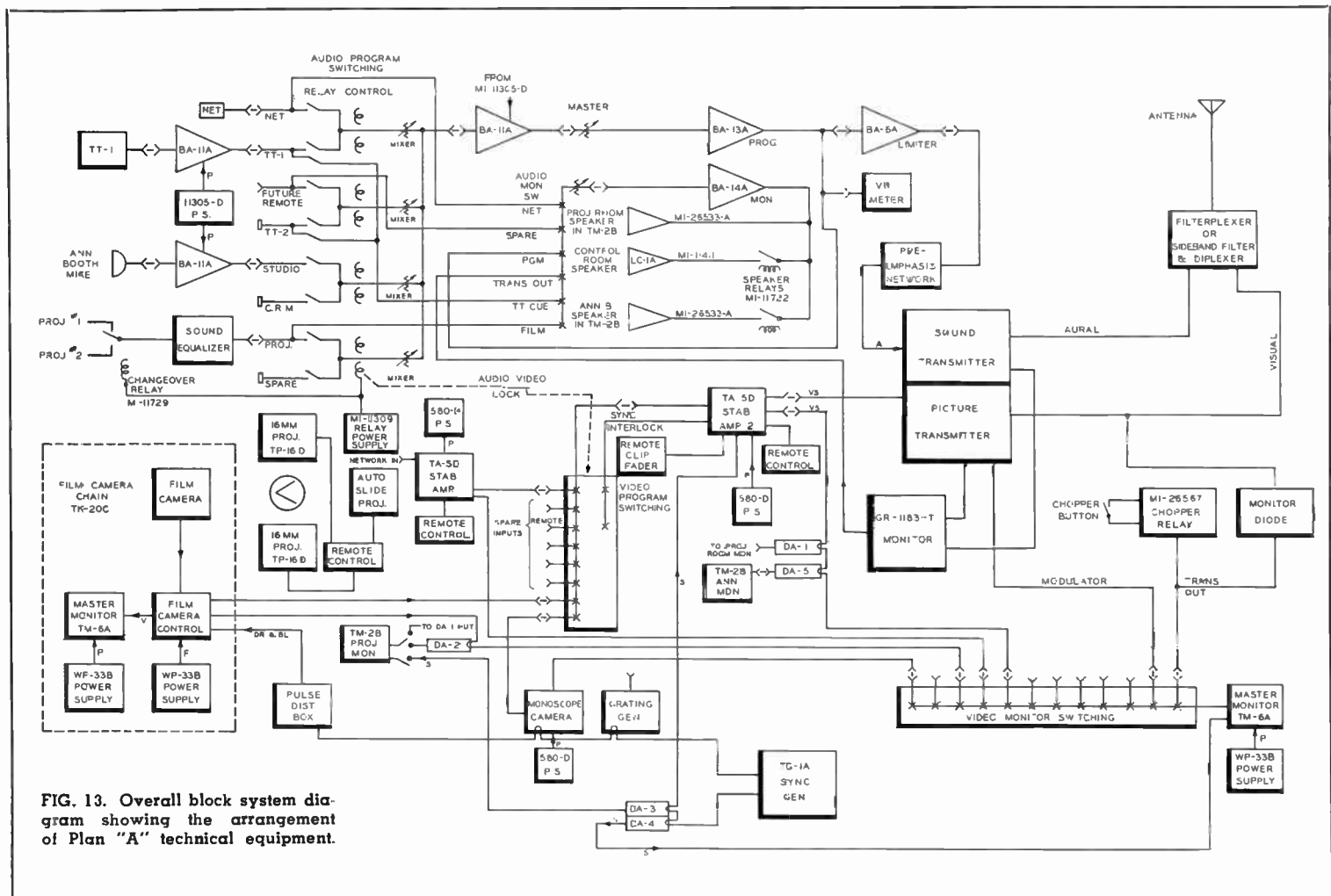

FIG. 13. Overall block system diagram showing the arrangement of Plan "A" technical equipment.

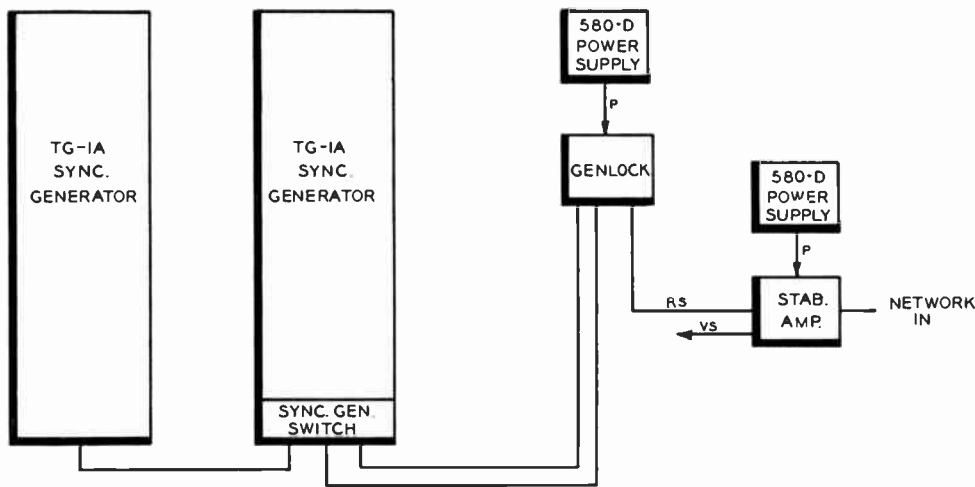

FIG. 14. Where lap dissolves or superpositions are considered essential, the TS-10A Switcher and Fader can be added as a fifth section to the central console. However, plans should also provide for the addition of the associated equipment illustrated above, except the (already available) Sync Generator at the extreme left.

Lap dissolves or superpositions cannot be made with this arrangement. However, with the flexibility of the unit-type construction, necessary equipment to accomplish this type of programming may be added. (See Fig. 14.) This would include the addition of a studio sync generator, sync generator switch, genlock and 580-D power supply, in addition to a fifth console section to house the TS-10A switcher and fader. This also applies to use of this equipment for Plan "A-Prime".

#### Remote Control Section

The other section of the TC-4A (third from left) houses all the remote controls that are necessary to provide finger tip operation of those equipments that are necessary for simple basic programming.

The two top panels control the stabilizing amplifiers. One of these amplifiers is

for network or remote signals and the second is for controlling any signal to the transmitter. The second stabilizing amplifier is also used for mixing the "sync" and local Video signals, since some form of local signal is necessary for advertising purposes. The third panel in this section is the projector switching control. Three groups of pushbuttons and tally lights are located on this panel. The groups at either end composed of three buttons and a separate lamp are identical while one pushbutton and toggle switch are located in the center. The center toggle switch is for turning the power on and off a slide projector. The pushbutton directly under the switch has a tally light built in and may be used to switch slides in the slide projector.

The tally light at the top of the panel at either end indicates when control has been transferred from the film projector to this

remote operating position. The pushbutton on the left of the group is used to start the projector and has a built-in tally light to indicate that the machine is running. The center button of the group with built-in tally light is for transferring sound and picture from one machine to the other, when two film projectors are used. The third button is for stopping the projector, and does not have a built-in light.

Another group of buttons at the other end of the panel is identical and performs the same functions for a second projector.

Further controls may be added in the blank panel positions for additional film projectors, stabilizing amplifier, power switching, monoscope camera, etc.

#### TM-6A Master Monitor

The fourth section at the extreme right-hand end of the console contains a TM-6A Master Monitor, and on the sloping desk surface are located the pushbutton switches for monitor selection. Each switch is mechanically interlocked. Provision is made for twelve inputs and one output. This unit may be used to monitor all the necessary transmitter signals in addition to serving as a preview monitor for remotes and networks. In the normal operation, this monitor will register the line signal. The output of the switch is fed from a cathode follower, which receives its power from the master monitor associated with it. Located in the monitor switching panel, a pushbutton for chopper control is provided to select a calibrating signal for indicating percentage of picture modulation to the transmitter.

#### Plan "A" Film Projection Room

As shown in the layout photos and "A" floor plan, the film projection facilities include a TK-20D Film Camera, two TP-16D, 16mm Projectors, a Multiplexer/Automatic "Dual-Disc" Slide Projector and a Utility Monitor. The Multiplexer/Automatic "Dual-Disc" Slide Projector is on a common mounting to assure best operation (see Fig. 15).

In both the "A" and "A-Prime" plans, TP-16D projectors are illustrated; however, stations may employ the TP-6A Professional Projector, where extensive film programming dictates the services provided by this type projector. The TP-6A is equipped with additional control features and larger 4000-foot reels. (See Plan "B".)

FIG. 15. A film projection room layout in which two RCA, TP-6A Professional Projectors are employed to provide additional control features and larger 4000-foot reels. Note in center (opposite the film camera) the use of the dual-disc slide projector. This photo also shows the optional use of an RCA 2-KW, VHF Transmitter, and the BQ-1A Fine Grove Turntable.

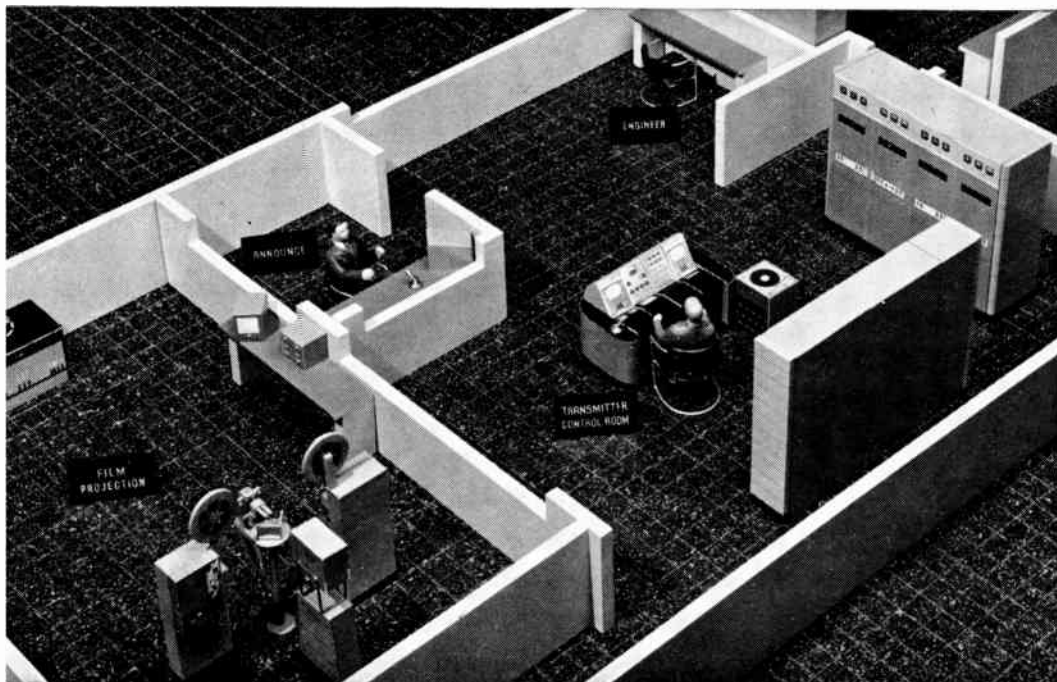

Control of the projectors is extended by use of a projector control panel located at the centralized "transmitter room" console. Complete provision is made for station breaks and spots during network hours.

Windows provide visibility into the transmitter control room and announce booth, in the event visual cue is desired. Pull drapes are shown so that "darkened room" operation may also be accomplished, since the operator at the central console has program switching control and complete film monitoring and talkback facilities.

Space is provided for a rewind bench and storage cabinet in the projection room. Since film programming will make up a large part of the station activity, space is provided for the future addition of a duplicate film projection setup. This would also require the addition of a second film camera control section to the main console in the transmitter room. Some planners may elect to start with a dual setup. Another possibility is the addition of a "Telop" projector and a second film camera for the handling of "opaques" and other program material mentioned later.

#### Film Editing and Storage

A separate room provides space for film accessory equipment to accommodate film handling, editing and storage needs. Some stations, because of expanded film programming, may find a need to enlarge these facilities. As previously mentioned, part of this equipment is installed in the film projection room for convenience in handling daily shows. An approximate equipment list for Plan "A", representing minimum requirements, is shown below:

- 2 film splicers
- 1 pair rewinds
- 1 measuring machine
- 1 small viewer
- 1 or 2 editing tables or benches
- 4 2x2-inch slide file cabinets
- 1 open face rack for large reels aired daily
- 1 permanent type storage cabinet
- 12 2000-foot flat steel reels
- 12 1600-foot flat steel reels
- 12 400-foot flat steel reels
- 50 100-foot flat steel reels
- 1 14-inch steel rewind flange DAF-26
- 1 small screen preview projector
- 1 34x50-inch screen on tripod or wall mount.

Space requirements for handling film may vary; however, room should be provided for editing, splicing, rewinding, commercial insertion and storage for both "daily and upcoming" shows that are to be aired. The editing area will also be needed to accommodate last minute "hurry-up"

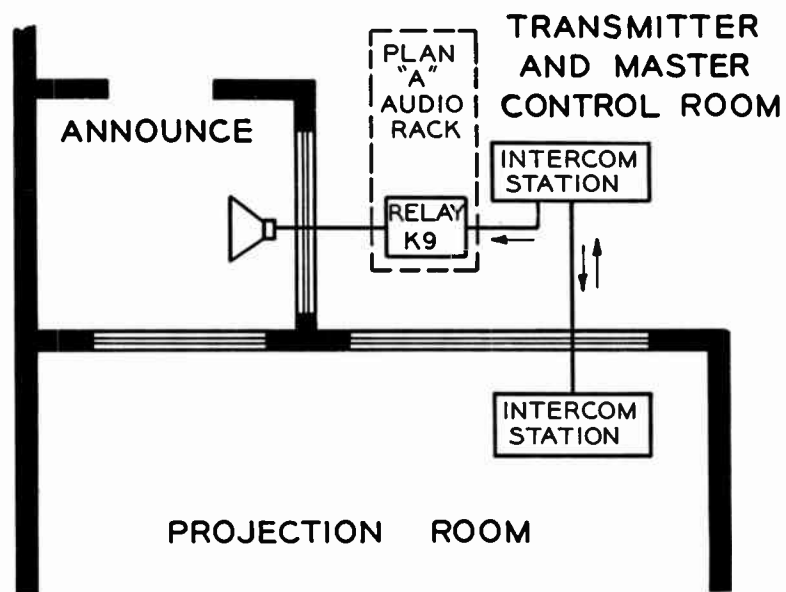

FIG. 16. Diagram showing the provision in Plan "A" for intercommunication facilities.

changes so frequently encountered in the preparation of film for airing.

#### Plan "A" Intercom

The transmitter or master control room operator should have continuous two-way communication with the projection room and talking facilities only to the announce booth (see Fig. 16).

During "on-air" announce periods, the announce booth intercom speaker is automatically muted by utilizing available contacts of the announce booth speaker muting relay (K-9).

#### Plan "A" Lighting

Since the station of Plan "A" does not include a studio for live pickups, only the lighting of the operational and administrative areas is required. In general, the two kinds of lighting for such areas are task light and general light.

General lighting provides the required average level of light for the overall lighting of each room. In control, traffic and office areas, this lighting reduces eye strain and discomfort caused by looking at strong contrasts between light and dark areas. By the proper choice of wall and ceiling fixtures, the general lighting can enhance architectural features. Fluorescent fixtures can efficiently light office areas and provide at least 30 foot-candles of incident light to working surfaces, or a perimeter type of general lighting using wall valances gives a pleasing effect and can be hidden within the architectural features.

Task light is direct high light focused at the required angles and work area and is provided by recessed spots or wall, desk

and floor fixtures in close proximity to the work area. In relation to the general lighting, the task lighting is always of greater intensity and at least 40 to 50 foot-candles are recommended.

Possibly, the most important lighting problem is found in the film and control rooms. The room's general light level should be kept at a low or medium level with indirect lighting fixtures or by use of recessed units, located so that no reflections are noted on the monitor scopes. By such lighting, the strong contrast between the TV tube and surrounding areas is prevented. To the technical personnel of the control room, this means less eyestrain and fatigue while watching the monitors. The normal routine also requires them to read scripts, check schedules, record the station log, and operate the controls immediately before them. To best facilitate this, a small spot is mounted in the ceiling above the console. The unit with a focused beam and using a 100 or 200 watt lamp should have four-way shutters to enable full beam shape control. Units of this type are made by Century or Kliegl.

Similar units can also be used in the operational areas of the film room to highlight special work functions of the film activity. Spill and stray light into the iconoscope camera is thus minimized and full concentration is afforded the lighted portions where the operator may view monitors and controls.

These considerations of general plant lighting requirements are also applicable to Plans "A-Prime", "B" and "C" and are not repeated as a part of the following descriptions of those plans.

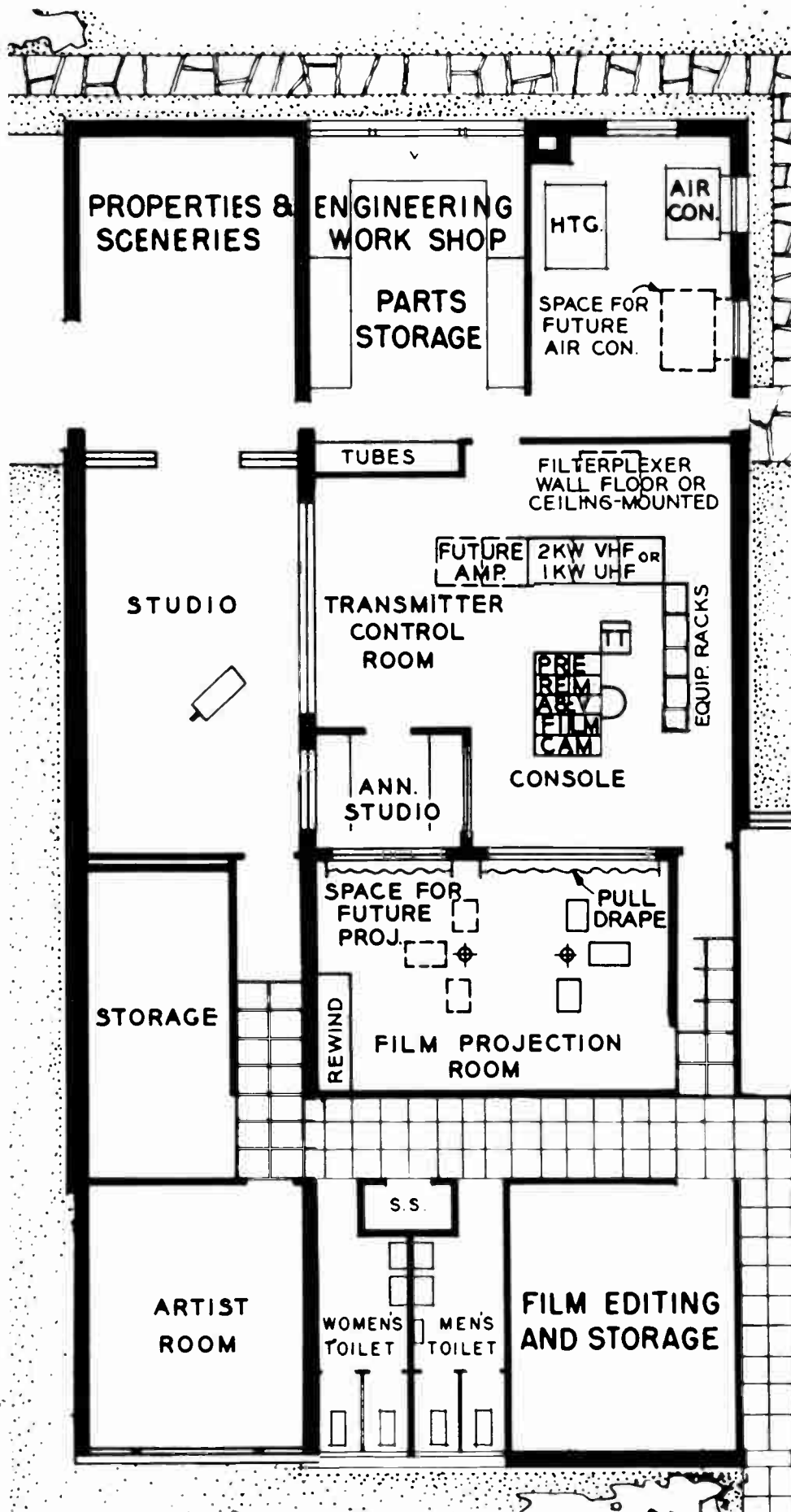

## TV STATION PLAN "A-PRIME" (Network, Film and Single-Camera Studio)

### DISCUSSION OF TV STATION PLAN "A-PRIME"

(Network, Film and Single-Camera Studio)

TV Station Plan "A-Prime" is practically identical to the "A" station, previously described. The major difference is the addition of a small "single-camera" live talent studio together with the necessary space for properties and scenery handling plus an artist's room. Additional studio

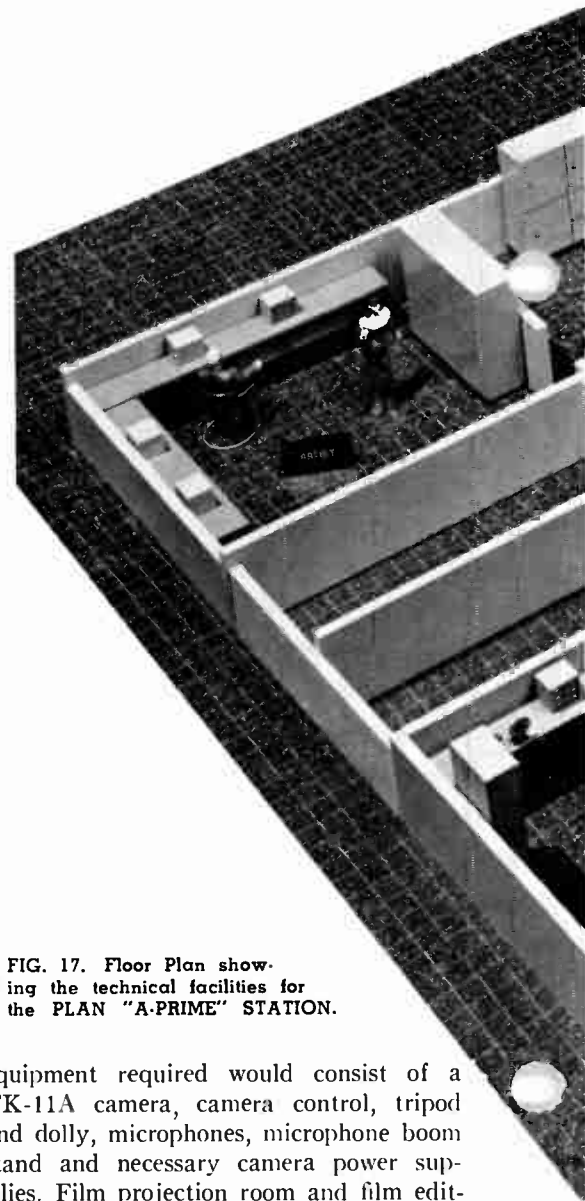

FIG. 17. Floor Plan showing the technical facilities for the PLAN "A-PRIME" STATION.

equipment required would consist of a TK-11A camera, camera control, tripod and dolly, microphones, microphone boom stand and necessary camera power supplies. Film projection room and film edit-

ing and storage facilities are the same as that of Plan "A". (See Figs. 17 and 18.)

Plan "A-Prime" is suited for a "small community" station with the possibility of future growth to a larger studio such as included in Plan "B". Expansion can be made from "A-Prime" to Plan "B" with modest alterations and modifications.

### Programming

The facilities included in Plan "A-Prime" provide all of the programming possibilities of "A" plus the handling of live pro-

grams. Thus, the following programs may be accommodated by Plan "A-Prime" (see Figs. 19 and 20):

- (1) network
- (2) local film programs from 16mm projectors
- (3) local slide projection
- (4) test pattern from the monoscope camera and

era control section to the Audio/Video console to accommodate the single studio camera. Also, it will be noted that the engineers' quarters can be moved to the office area to provide additional space. This space can be utilized by the installation of a 10-kw transmitter such as the TT-10AL/AH or TTU-10B for VHF and UHF, respectively (see Fig. 21). As in Plan "A", five equipment racks are used to house stabilizing amplifiers, power supplies, test, monitoring and audio equipment. However, if the budget permits, the installation of an extra rack will be repaid

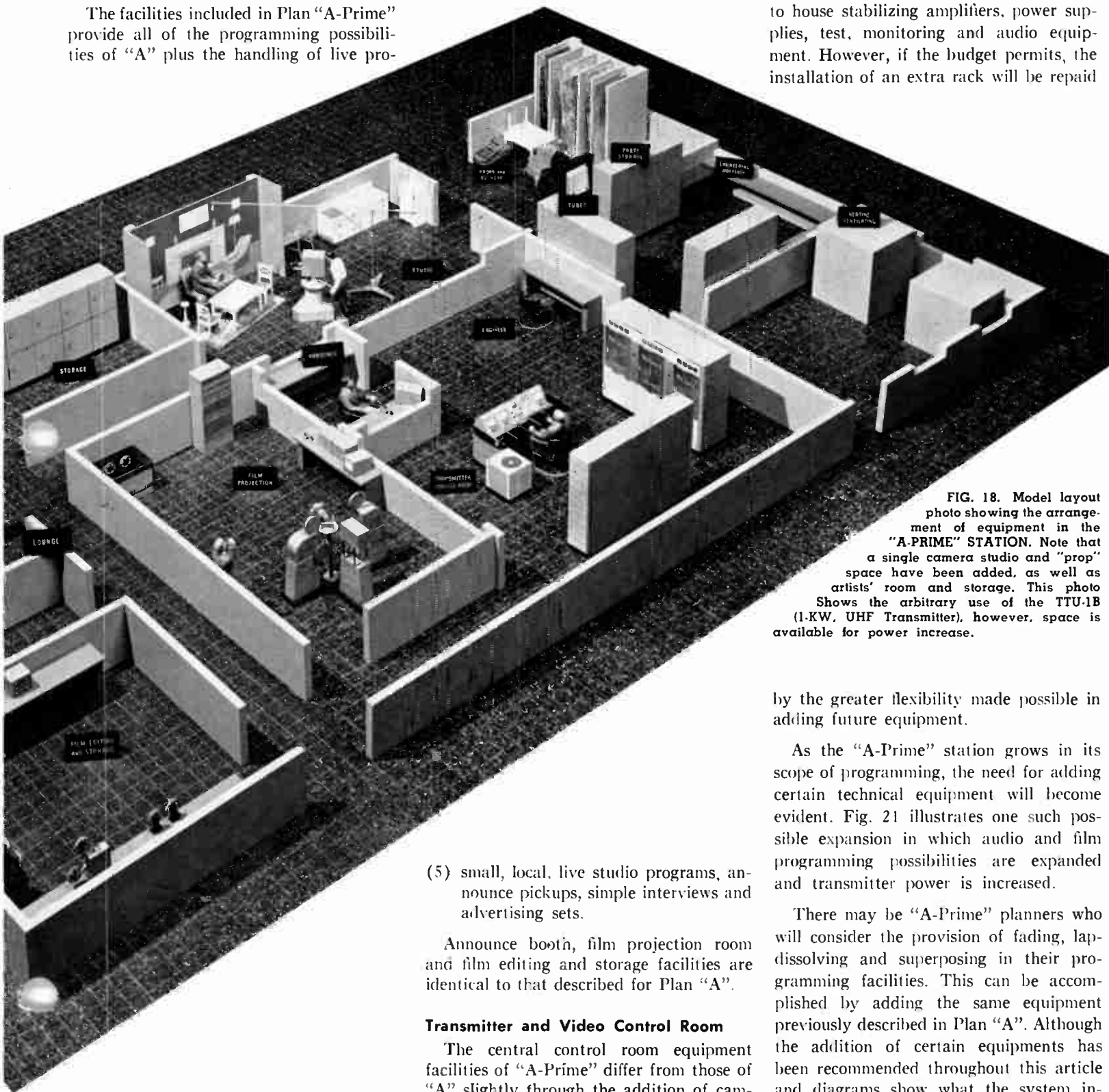

FIG. 18. Model layout photo showing the arrangement of equipment in the "A-PRIME" STATION. Note that a single camera studio and "prop" space have been added, as well as artists' room and storage. This photo shows the arbitrary use of the TTU.1B (1-KW, UHF Transmitter), however, space is available for power increase.

- (5) small, local, live studio programs, announce pickups, simple interviews and advertising sets.

Announce booth, film projection room and film editing and storage facilities are identical to that described for Plan "A".

### Transmitter and Video Control Room

The central control room equipment facilities of "A-Prime" differ from those of "A" slightly through the addition of cam-

by the greater flexibility made possible in adding future equipment.

As the "A-Prime" station grows in its scope of programming, the need for adding certain technical equipment will become evident. Fig. 21 illustrates one such possible expansion in which audio and film programming possibilities are expanded and transmitter power is increased.

There may be "A-Prime" planners who will consider the provision of fading, lap-dissolving and superposing in their programming facilities. This can be accomplished by adding the same equipment previously described in Plan "A". Although the addition of certain equipments has been recommended throughout this article and diagrams show what the system in-

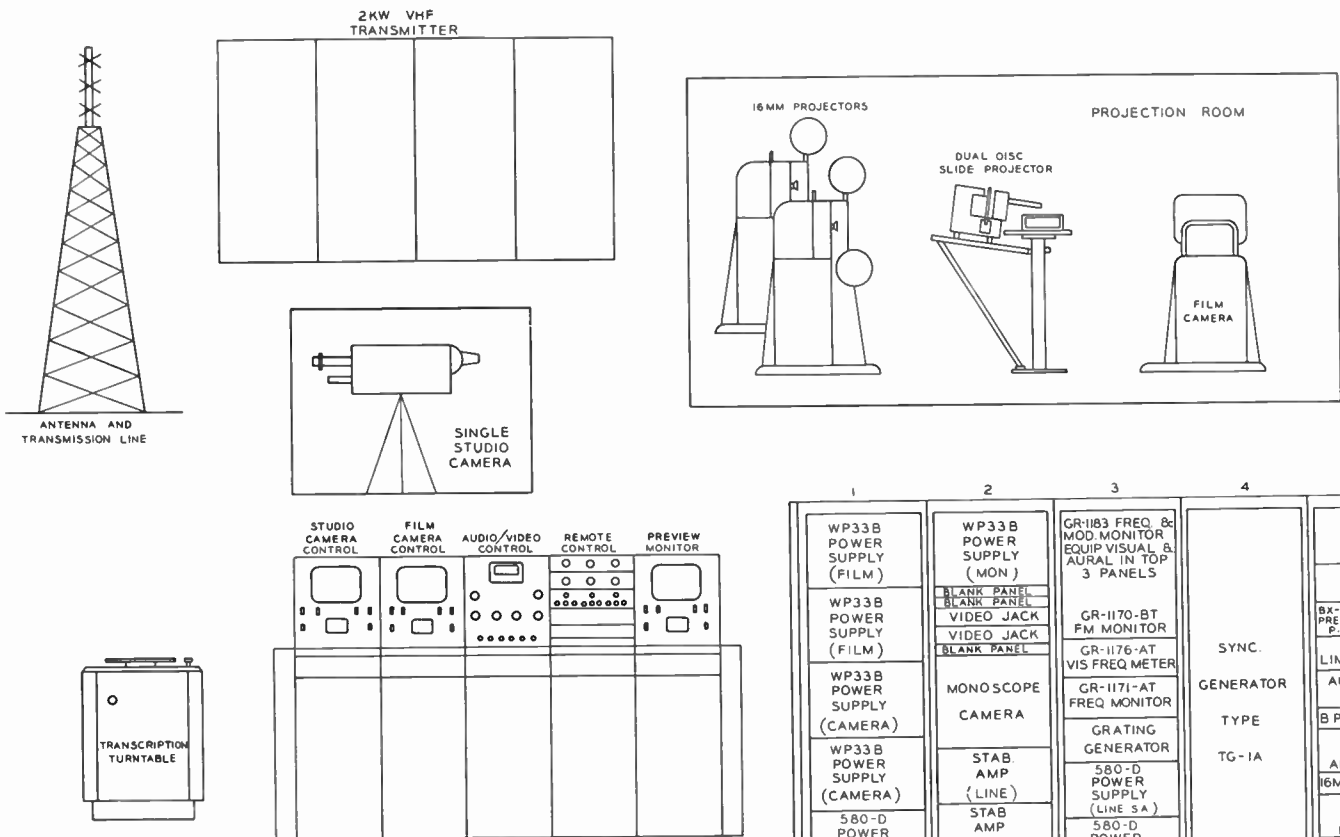

FIG. 19. Pictorial layout showing the major items of equipment required in Plan "A-Prime".

1	2	3	4	5
WP33B POWER SUPPLY (FILM)	WP33B POWER SUPPLY (MON)	GR-1183 FREQ & MOD. MONITOR EQUIP VISUAL & AURAL IN TOP 3 PANELS	SYNC. GENERATOR	580-D POWER SUPPLY (S A)
WP33B POWER SUPPLY (FILM)	WP33B POWER SUPPLY (FILM)	GR-1170-BT FM MONITOR		BLANK PANEL
WP33B POWER SUPPLY (CAMERA)	MONOSCOPE CAMERA	GR-1176-AT VIS FREQ METER	TG-1A	BX-1E PRE-AMP P.S.
WP33B POWER SUPPLY (CAMERA)	STAB AMP (LINE)	GR-1171-AT FREQ MONITOR		BA-13A LINE AMP
580-D POWER SUPPLY (MONOSCOPE CAM)	STAB AMP (NET)	GRATING GENERATOR	BA-6A LIMITING AMP	BA-6A AUDIO JACK PANEL
580-D POWER SUPPLY (DIST AMP)	DISTRIB AMPLIFIER	580-D POWER SUPPLY (LINE S A)	BPMI-4590-A	BA-11A PRE-AMPLIFIERS
		580-D POWER SUPPLY (NET)	16MM SOUND EQ	BA-14A AUDIO MON AMP
		580-D POWER SUPPLY (CAMERA)	BX-4A RELAY P.S	MI-4594-B
		CURRENT REGULATORY		
		BLANK PANEL		

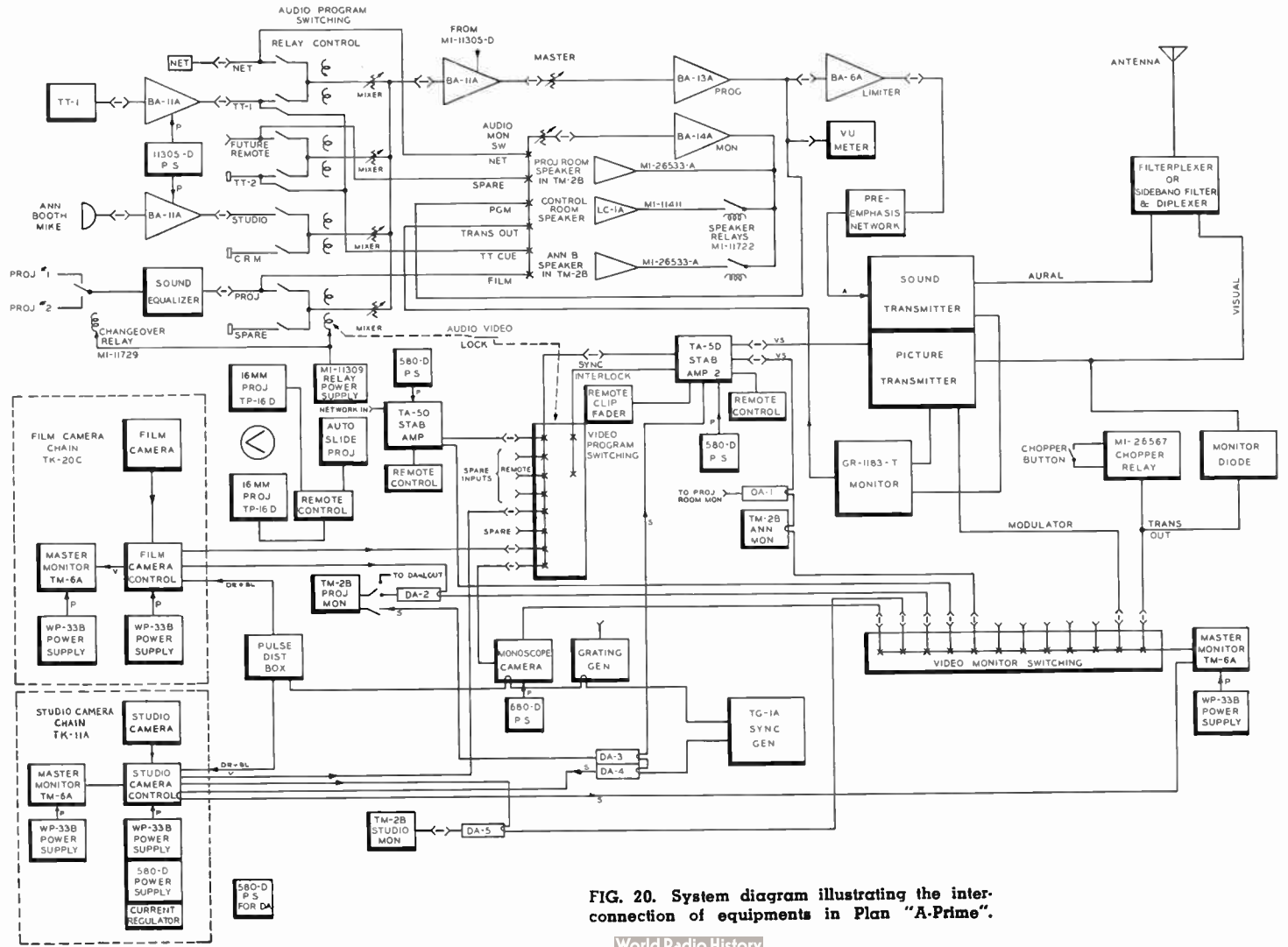

FIG. 20. System diagram illustrating the interconnection of equipments in Plan "A-Prime".

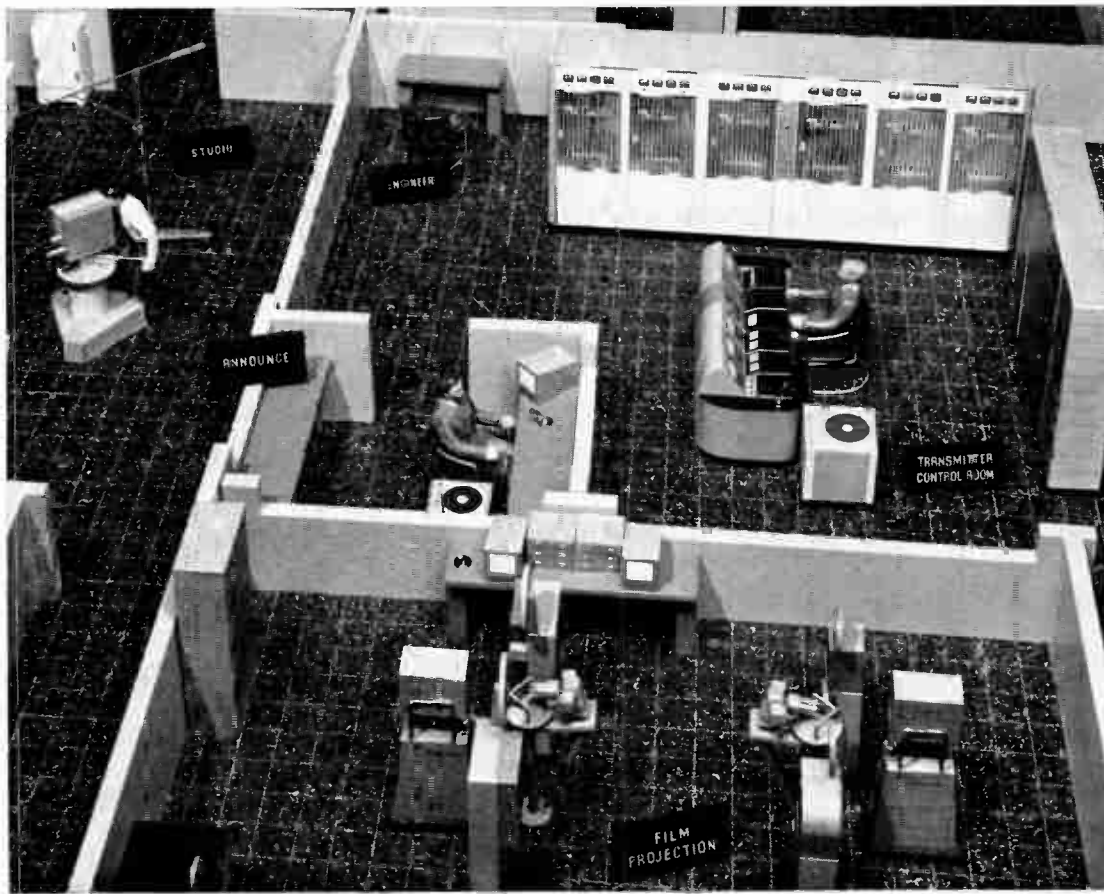

FIG. 21. Model layout of an "A-Prime" Station which employs an RCA TT-10AL (10-KW, VHF Transmitter). Note that this particular station has expanded by adding a second TP-16D Film Setup, additional TM-2B Film Monitor, and an RCA BQ-1A Fine Groove Turntable to announce booth for disc jockey shows.

cludes (as, for example, for fading and lap-dissolving or "Genlock" operation), the planner is cautioned that a system study should be made to determine if other equipment is needed to fully integrate the addition.

#### Plan "A-Prime" Intercom

In the "A-Prime" Plan, the control room operator has continuous two-way communication with the projection room and has talking facilities only to the announce booth and studio.

During "On-air" announce periods, the announce booth intercom speaker is automatically muted by utilizing available contacts of the speaker-muting relay. During "On-air" periods of the studio, its intercom speaker may also be muted in a similar manner (see Fig. 22). The camera control operator has continuous two-way "headset" interphone communication with the cameraman.

#### "A-Prime" Studio Lighting

The general and task lighting for the Plan "A-Prime" plant is the same as that described for "A". However, the lighting of the studio for best programming quality requires further consideration.

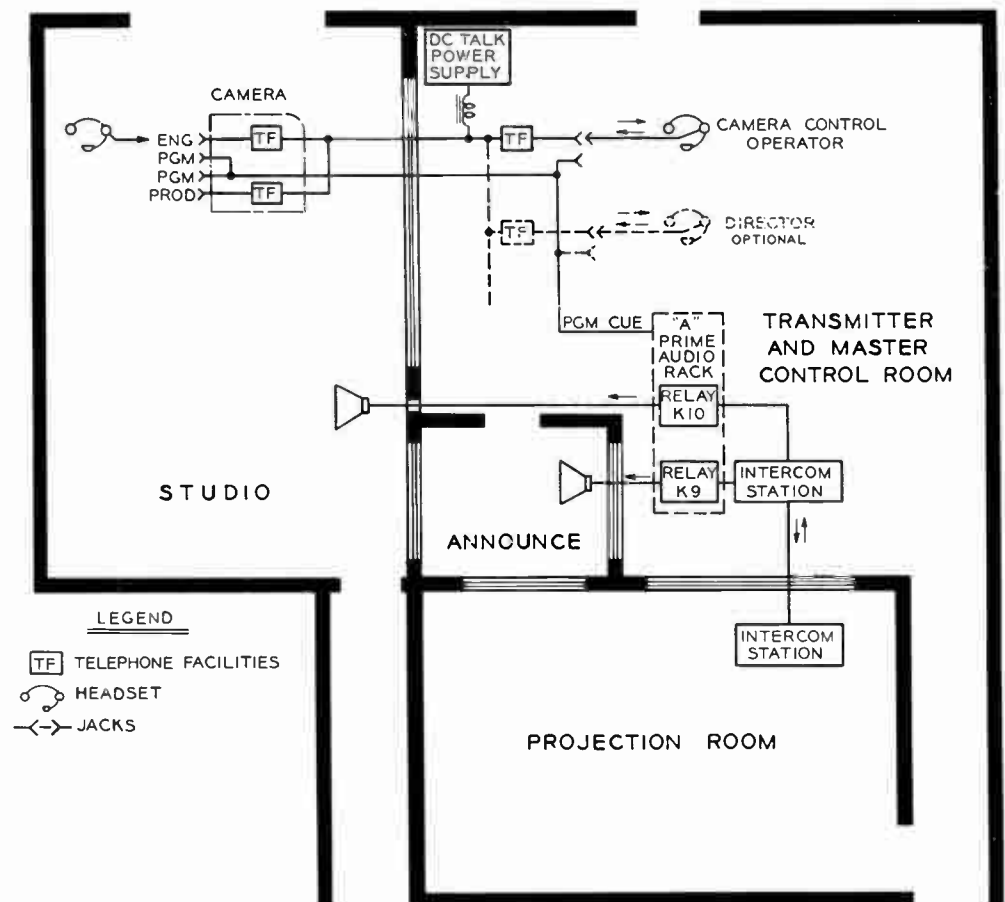

FIG. 22. "Intercom" "flow" diagram for the "A-Prime" Station.

In a studio with this plan, a single camera is provided which will undoubtedly be used for repetitive type of programming. Local, unrehearsed shows such as panel discussions, interviews, local spots, kitchen shows or demonstrations will be predominant. Although the studio is a small 16 by 26-foot unit, it can accommodate a permanent kitchen set and an office scene as suggested in Fig. 23. Space is also available for displaying the sponsor's products and advertising placards.

The lighting system for such a studio may be investigated from the standpoint of application tools, wiring and control de-

vices, and sources. The Plan "A-Prime" lighting system described is shown in Fig. 24.

### Lighting Application Tools

Unobstructed flexibility of camera and mike boom is required on the studio floor; therefore, the lighting is done from overhead. The means of supporting the lighting fixtures is facilitated by the application tools—viz., grid-work and pantographs.

The ceiling height of 14 to 18 feet in the "A-Prime" studio prompts the use of a primary-secondary type of grid structure using 1¼-inch black iron pipe. The pri-

mary grid (pipes A of Fig. 24) is installed as close to the ceiling as possible—allowing clearance for raceways, ducts, and sprinklers. From this permanent group of parallel pipes is suspended a secondary grid, pipes B of Fig. 24. The secondary pipes are suspended by means of double "C" clamps or chain from the primary pipes and are perpendicular to them. The criss-cross network formed should be on 6- to 8-foot centers to insure adequate facilities for suspension of fixtures. The secondary pipes allow flexibility, as they can be repositioned to any point on the scene required. Normally, the resulting grid is spaced 12 to 14 feet from the studio floor. From this grid the fixtures can be hung directly, or through pantograph hangers.

Pantographs permit raising and lowering of lighting fixtures and when used with crossarms can support a number of fixtures. Current pantographs can support weights up to 60 pounds and allow for a vertical travel from 8½ to 12½ feet at maximum extensions. A number of pantographs supported from the grid have a great advantage for rapid vertical adjustment. Their most important use in the "A-Prime" studio is the support of base lights which, for best pictures, should be 8 feet from the floor.

### Lighting Wiring and Control Devices

Mounted to the secondary pipes are three connector strips, each with 5 outlets. These outlets are pigtailed of 3- or 4-foot cables with female stage connectors attached. A total of 15 ceiling outlets are therefore provided in the studio of Plan "A-Prime".

From each connector strip, a 12-conductor cable brings the branch circuits directly, or through 4 by 4-inch duct to the studio lighting control. The control board is located on the studio floor such that the operator can view the scene or the control room for cues, and has sufficient switches and dimmers for the accurate and noiseless control of each outlet.

The switchboard should contain a master switch to make possible blackouts and control of everything but work lights. The power is fed to fifteen individually fused and switchable outgoing 20 amp circuits—one for each ceiling outlet. If the finances of the station are such that a dimmer board can be added, then even greater

FIG. 23. Scenic layout of the "A-Prime" Studio.

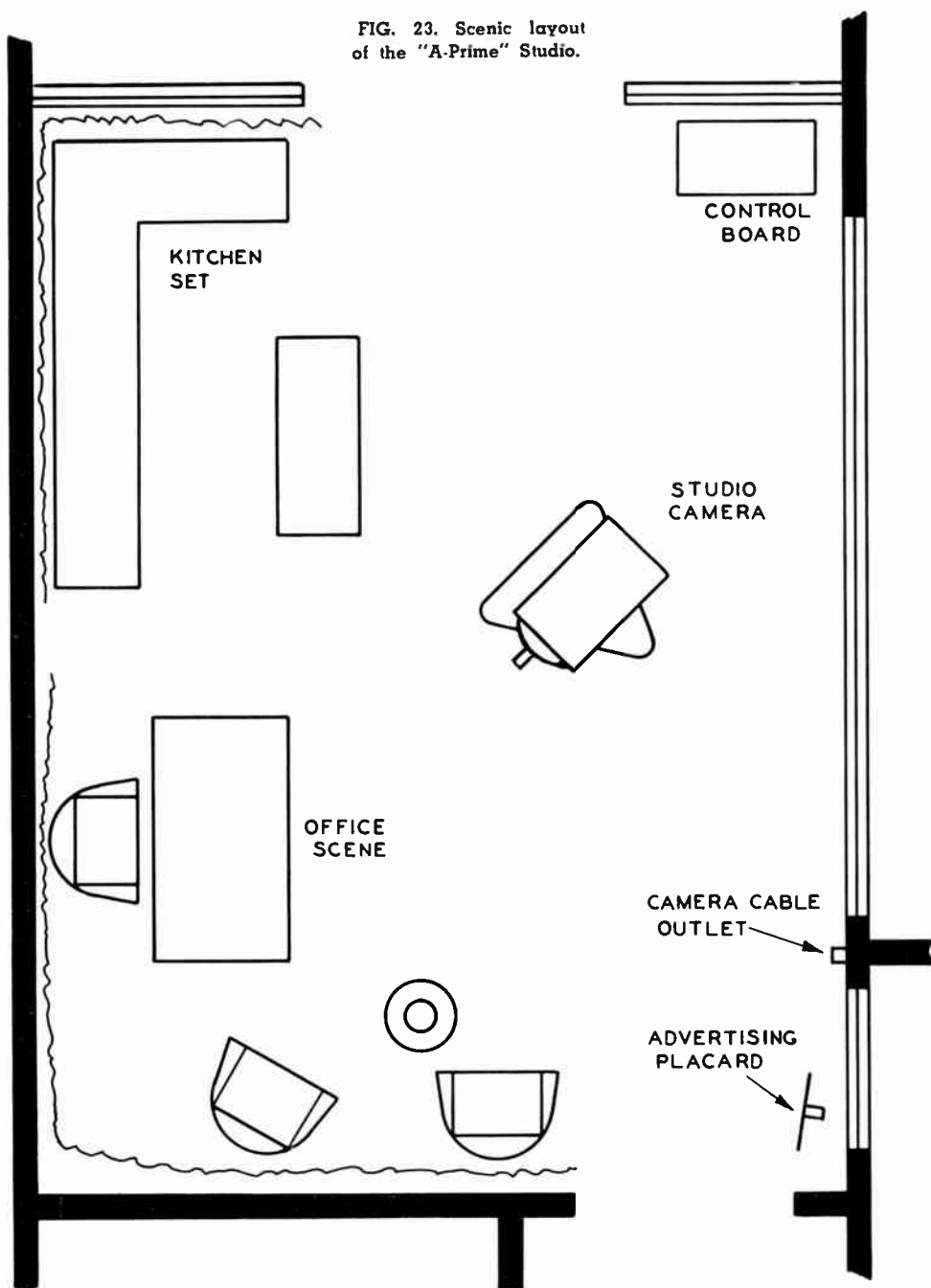



flexibility is obtained. Dimming makes possible special effects, transitions, and control of overall light level.

Practical considerations have limited the studio lighting system to a-c operation. The total a-c power service recommended for the switchboard input is 15 kw from a 3-phase, 4-wire, 60-cycle system. In addition to this, a special floor outlet box (as seen in Fig. 24) is recommended. This outlet in the middle of the scenic studio area has a 60-amp capacity female outlet and 3-pole switch for providing power to special high current equipment such as an electric range in the kitchen set.

The wiring system of this studio should have, in addition, outlets and connectors of suitable uniformity to make possible complete interchangeability of cable, outlets, or instrument. An equipment ground, carried throughout the system, insures the safety of all personnel.

### Lighting Sources

The scoop is a practical source to be considered for use in the Plan "A-Prime" studio. Three or four of these units on each scene can provide easily the desired wide angle base light of about 100 foot-candles. This light level will vary with the mood of the scene to be televised. When mounted on the pantograph hanger, they can be adjusted with the result that their beam strikes the scene at an angle no greater than 20 degrees and, with diffuser frames, give the proper breakup of the harsh light.

A number of fresnel spotlights and kliegs can provide the key and modeling light for the scenes. These units, together with suitable barn doors, can provide the proper, narrow-angled light to supply form for the scene. Their level should contribute 20 or 30% greater intensity to the average base lighting.

These spotlights can also provide the backlight of 50% greater intensity than the base light. The purpose of backlight is to separate the main actors from the background scenery.

The lighting system here described for the studio of Plan "A-Prime" is, we feel, entirely flexible and is a basic one. Only by utilizing their full capabilities together with the proper techniques can consistently good lighting be obtained. A suggested "A-Prime" basic lighting equipment list is shown here:

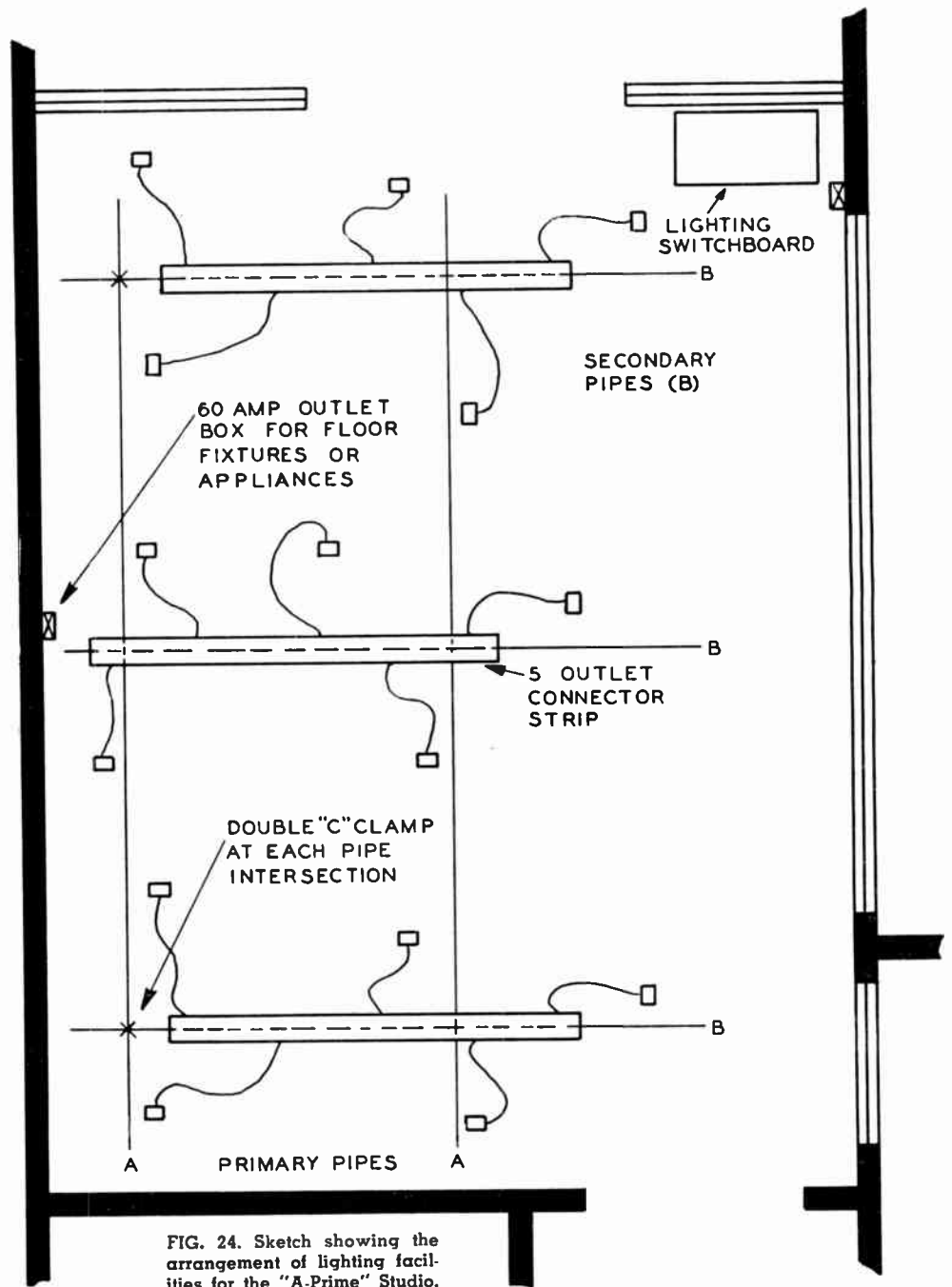

FIG. 24. Sketch showing the arrangement of lighting facilities for the "A-Prime" Studio.

### PLAN "A-PRIME" Typical Lighting Fixtures

Qty.	Fixtures
4	300-500 w. Baby Scoop
4	750/1000/1500/2000 w. 18-in. Scoop
4	250/500/750 w. Fresnel Spot
2	1000/1500/2000 w. Fresnel Spot
1	500 w. Klieg
1	250/500 w. Klieg

### Accessories

2	Diffuser for Baby Scoop
2	Diffusers for Scoops
2	Diffusers for Spots 44N6TVG
1	Roll Spun Glass Diffuser Cloth
2	2-Way Barn Doors for 44N8TVG

2	Roller Caster Stands
2	Extension Cables, 955G Connectors
2	Counterbalance Hangers

### Wiring and Control Devices

1	Portable Connector Strip Set, with 5 4-ft. pigtails, and 20-ft. cable
1	Portable Connector Strip Set, with 5 4-ft. pigtails and 25-ft. cable
1	Portable Connector Strip Set, with 5 4-ft. pigtails and 35-ft. cable
1	Dimmer Switchboard, with 15 dimmable circuits, 6 4-kw dimmers, master 3-pole switch, and master dimmer arm
2	Location Feeder Box, 60 amp circuit and switch

# TV STATION PLAN "B"

## (Network, Film and Two-Camera Studio)

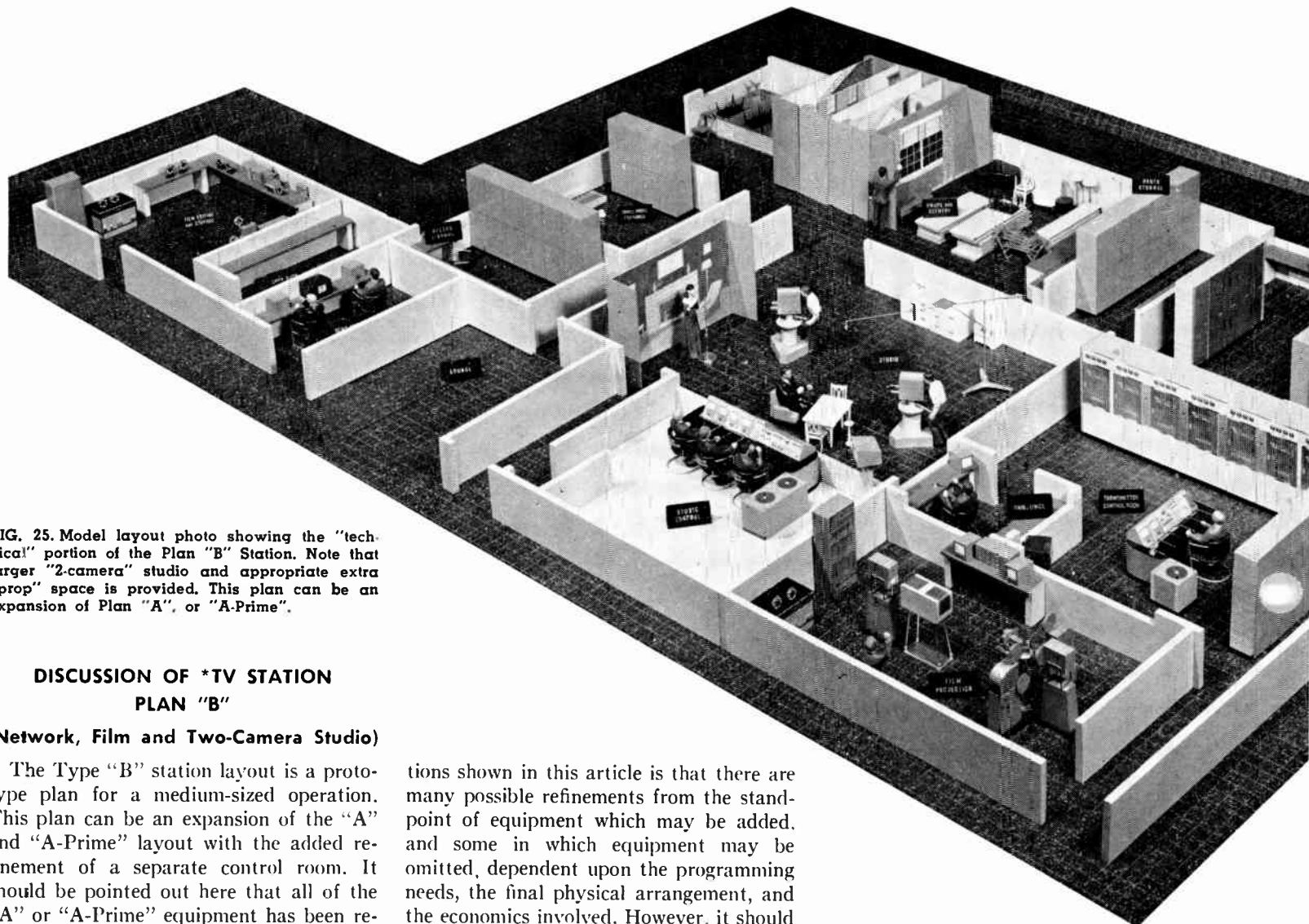

FIG. 25. Model layout photo showing the "technical" portion of the Plan "B" Station. Note that larger "2-camera" studio and appropriate extra "prop" space is provided. This plan can be an expansion of Plan "A", or "A-Prime".

### DISCUSSION OF \*TV STATION PLAN "B"

#### (Network, Film and Two-Camera Studio)

The Type "B" station layout is a prototype plan for a medium-sized operation. This plan can be an expansion of the "A" and "A-Prime" layout with the added refinement of a separate control room. It should be pointed out here that all of the "A" or "A-Prime" equipment has been retained to form the "B" or "Alternate B". Furthermore, it should be noted that field equipment may be used in place of the more permanent studio type, especially if economy is a more important or limiting factor than the permanence or maximum flexibility attained with the two sets of studio camera equipment shown. (See Figs. 25 and 26.)

One further observation which applies principally to the "B" and "C" type sta-

\* Note that for Plans "B" and "C", Audio schematic diagrams are not included for reasons of simplicity. Complete descriptions of applicable TV audio systems are available in previous issues of BROADCAST NEWS. (See Jan-Feb. 1951 BROADCAST NEWS, "A Flexible TV Audio System," and July-Aug. 1951 BROADCAST NEWS, "A New AM-FM-TV Console.")

tions shown in this article is that there are many possible refinements from the standpoint of equipment which may be added, and some in which equipment may be omitted, dependent upon the programming needs, the final physical arrangement, and the economics involved. However, it should be remembered that each of the items of equipment illustrated in the functional diagrams serves a definite and useful purpose. (See Fig. 27.)

The functional diagram illustrates how Plan "B" station provides the facilities necessary for broadcasting the following types of programs:

- (1) Local studio programs.
- (2) Standard 16mm film entertainment and commercial film.
- (3) Slides, opaques and news releases.
- (4) Network programs.
- (5) Test pattern from the monoscope camera.

- (6) Remote programs—programs picked up at points remote to the studio with portable field equipment (programs are sent back to the station by coaxial cable or microwave relay).

The facilities for the type "B" layout include: one average-sized, live talent studio with associated control room (see Fig. 26), a "two-film-camera" projection room, an announce studio and master control or transmitter control room. In some larger stations the film projection room may have its own associated control room, but in this plan the film camera controls are located in the transmitter control room which serves very well as a master control

center. Video equipment racks (see Fig. 29) are located in the centralized control room and in the engineering workshop.

### Studio Equipment

Equipment for the "B" plan studio consists of two complete Type TK-11A Image Orthicon Cameras plus the necessary lighting equipment and scenery for producing live talent shows. The cameras are complete with electronic view finders studio type pedestals, video cue monitor and cueing speaker. The necessary microphones

with program stand mountings and boom mountings are also included. In both "A-Prime" and "B", it is desirable to locate a TM-2B Utility Monitor in the studio. Plan "B" studio can be utilized as a "three-scene" studio with the additional feature (also provided in Plan "A-Prime") of pointing a camera through the announce booth window for "disk-jockey", news or announce shows, where this type of operation can be satisfactorily accomplished.

### Studio Control Room Equipment

Refer to the diagram of Fig. 28 which shows the arrangement of the control equipment. Reading from left to right are the two studio camera controls which contain the TM-6A Master Monitors with 10-inch picture monitor tubes and 5-inch waveform monitor tubes. Next is the TS-10A switcher with the same type picture tube and waveform monitor as provided in the camera control sections. Next in line is the preview monitor operating from a new type (MI-26227) monitoring switch installed in a standard console housing. The associated monitor is the same as that mentioned previously for camera controls and switcher. Next is the remote control section, BCS-13A VI and Ringdown Console, the audio console, and turn-

tables. The remote control section houses the controls for the stabilizing amplifiers, monoscope camera and projector control. Shown in the block diagram (above the operating console) are two utility monitors. A third utility monitor is shown "dotted-in" as an alternate.

Before describing the functions of the control room equipment, it should be noted here, as has been mentioned in the introduction, that the location of video consoles is a matter of personal choice dictated by the mode of operation preferred. For example, the program director may be seated on a raised platform directly behind the operating console where he can easily view all of the monitors and see into the studio as well. It is also possible to remove the TS-10A Switching Unit from the line-up and place it on the program director's platform where the director may control the switching functions and also have "fingertip" communication to cameras.

Remote starting of projectors may be accomplished by providing a remote control panel at director's position. Control may be transferred to this point by the projectionist as soon as he has the projector loaded with film.

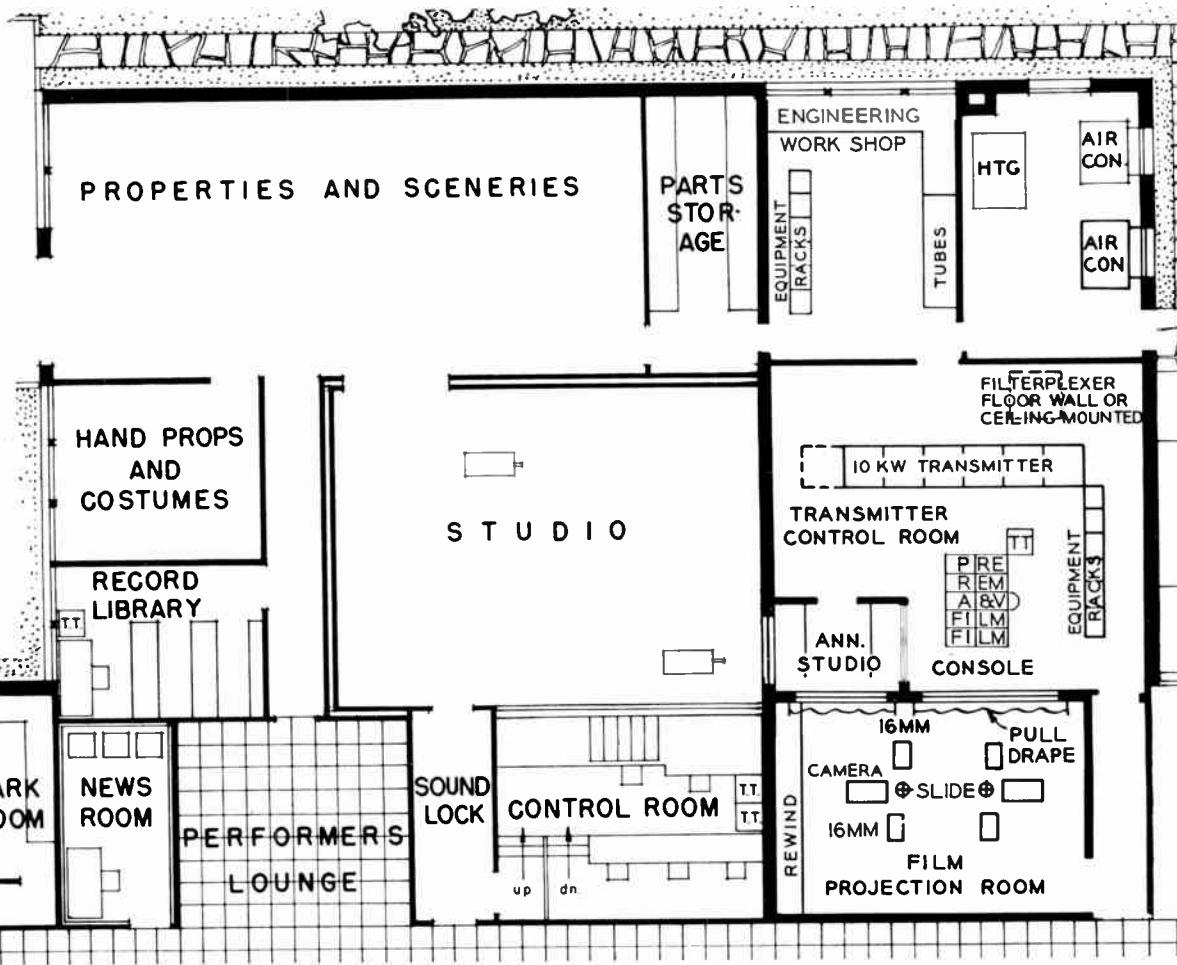
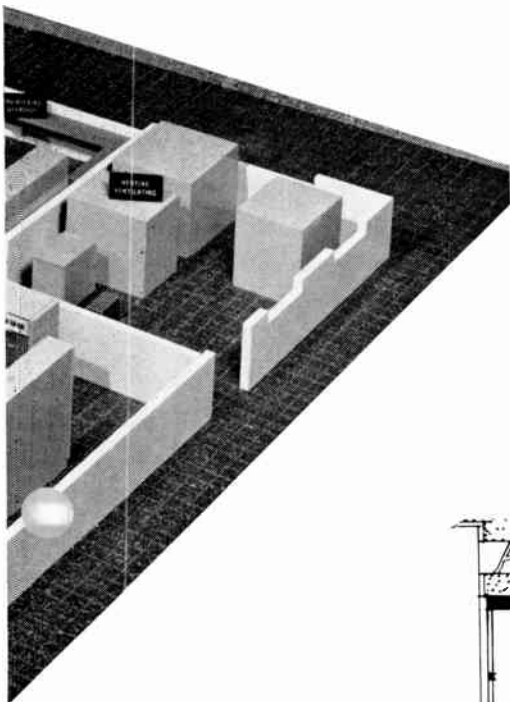
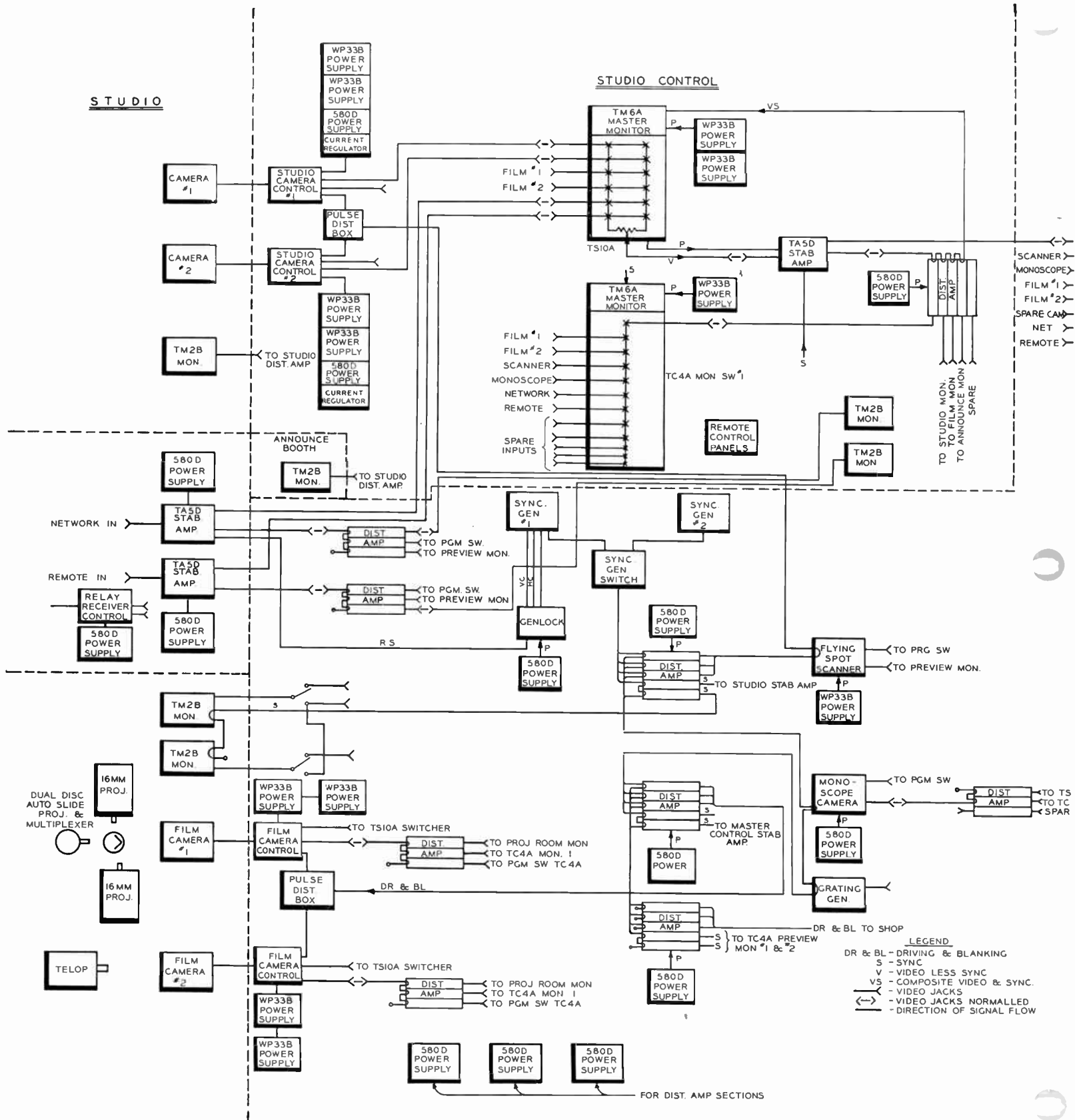
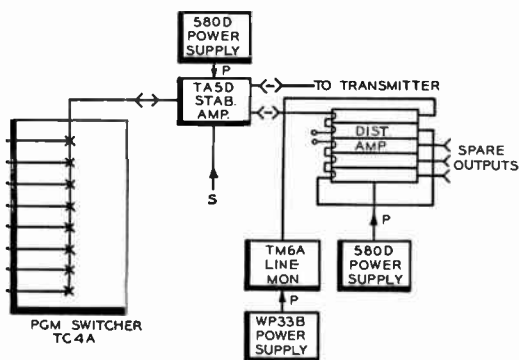

FIG. 26. Floor plan showing the technical facilities for the Plan "B" Station.

FIG. 27. Video system diagram showing the interconnection and arrangement of the Plan "B" equipment. Note that audio components required for TC-4A operation are not shown, but are like those shown in "A-Prime", Fig. 20.



MASTER CONTROL



10A SW.  
4A MON SW  
E

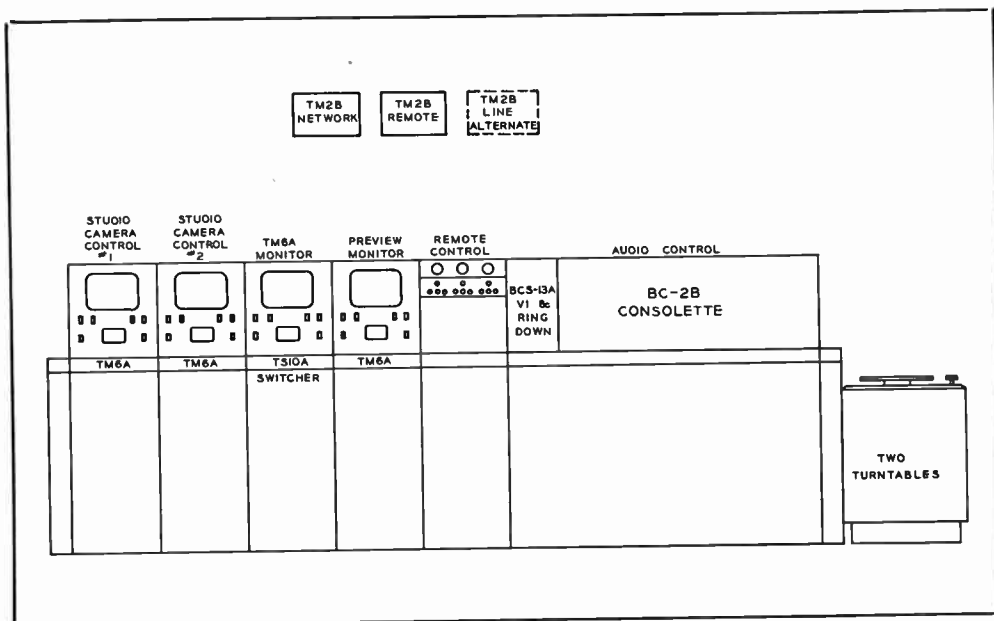
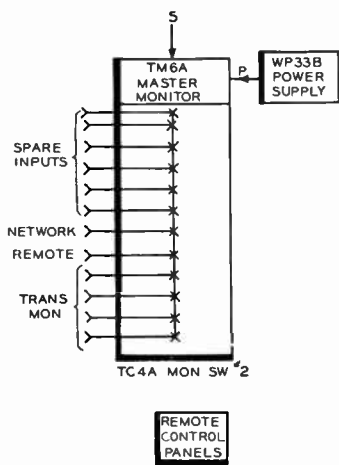

FIG. 28. The basic Plan "B" Studio has its own control room where video and audio control monitoring and TS-10A mechanical switching facilities are arranged as shown above.

In either system, the video operator has control of the picture signals emanating from each studio camera. He maintains the proper shading and contrast. He may, in certain instances, perform the switching functions at the request of the program director. However, it is possible that the director may perform his own selection of signals and at the same time preview the signals on the adjacent monitors. The preview monitor switching in that case may have to be performed by the video operator, and the preview monitor should then be located to the right of the switching and fading unit for convenience. It is possible to preview network and remote signals on the TS-10A Switching and Fading Unit, but it is not always possible if local signals are fed into those positions. Furthermore, it is more desirable to keep one monitor in the outgoing signal at all times while previewing all signals on a separate monitor. In addition, it is also desirable to have a good waveform monitor for line and preview functions in order to adjust the video signal levels properly and correlate all readings to one unit as a standard. Therefore, the preview monitor is added, and all signals may be previewed on this monitor before they are switched on the air.

The console section, next in line, contains the remote control panels, which may regulate the functions of the stabilizing amplifiers, the monoscope camera, film projectors and slide projectors. Incidentally, this is an alternate position for these controls because in many instances it may be desirable to place them in master control. As a matter of fact, the projector con-

trols may be located at both places; in which case, it is necessary to provide a switch that will transfer control to one location or the other.

Next in the line is the audio console and the BCS-13A VI/Ringdown Console. The RCA BCS-13A Auxiliary Console is available on a "semi-custom" basis, and is included in both "B" and "C" Plans. A rack of associated equipment located in the studio control room is required for use with this unit. It should also be noted that *this rack is not included among those shown in Figs. 29, 49 and 50.*

In most cases, it is well that the audio operator be in a position to see the studio clearly in order that he can properly ride gain, when the actors are moving about the studio.

A sufficient number of inputs, both video and audio, should be provided for studio projectors, turntables, announce, remote, and network signals. Where more than one studio is used it is well to provide additional inputs for the second studio.

The BCM-1A Auxiliary Mixer Console, which is utilized in Plan "C", should be considered as a possibility for Plan "B" where the extensive use of microphones is planned. The BCM-1A permits the use of any four of twelve additional microphone inputs and can be mounted alongside the console.

Studio or "Video-Relay" Switching

Where requirements dictate a still more flexible switching system or where more than six video inputs are used, it is recom-

mended that a relay switching system be considered. (See Figs. 31-32.) The studio relay-switching system used here is designated as the Type TS-20 Switching Equipment. Basically, it consists of the TC-5A program console with its monitors, banks of momentary-contact pushbuttons and tally lights, and fader controls mounted on the console desk, plus associated rack-mounted equipment such as relay panels, fader amplifiers and stabilizing amplifiers. As can be seen in the drawing of Fig. 32, signals from all cameras including monoscope test cameras, network and relay signals, when patched into the relay system, can be switched to master control. These local signals may also be lap-dissolved and faded.

WP33B POWER SUPPLY CAMERA	WP33B POWER SUPPLY CAMERA	WP33B POWER SUPPLY TS10A SWITCHER	WP33B POWER SUPPLY FLYING SPOT SCAN	580 D POWER SUPPLY DIST AMP	580 D POWER SUPPLY MONOSCOPE
WP33B POWER SUPPLY CAMERA	WP33B POWER SUPPLY CAMERA	WP33B POWER SUPPLY TS10A SWITCHER	580 D POWER SUPPLY RELAY RCVR CONT.	580 D POWER SUPPLY DIST AMP	580 D POWER SUPPLY GENLOCK
580 D POWER SUPPLY CAMERA	580 D POWER SUPPLY CAMERA	WP33B POWER SUPPLY PREV. MON.	580 D POWER SUPPLY NET STAB AMP	580 D POWER SUPPLY DIST AMP	BLANK
CURRENT REGULATOR CAMERA	CURRENT REGULATOR CAMERA	WP33B POWER SUPPLY PREV. MON.	580 D POWER SUPPLY REMOTE STAB AMP	580 D POWER SUPPLY DIST AMP	BLANK
WP33B POWER SUPPLY FILM	WP33B POWER SUPPLY FILM	WP33B POWER SUPPLY PGM. LINE MON.	580 D POWER SUPPLY TC4A STAB AMP	580 D POWER SUPPLY DIST AMP	BLANK
WP33B POWER SUPPLY FILM	WP33B POWER SUPPLY FILM	BLANK	580 D POWER SUPPLY DIST AMP	580 D POWER SUPPLY DIST AMP	BLANK
BLANK	BLANK	BLANK	BLANK	BLANK	BLANK

FIG. 29. Rack layouts for the Plan "B" Station. Racks are divided between the centralized transmitter room and the engineering workshop.

SYNC. GENERATOR NO.1 TYPE TG-1A	SYNC. GENERATOR NO.2 TYPE TG-1A	DISTRIB AMPLIFIER	RELAY RECEIVER CONTROL	DISTRIB. AMPLIFIER	DISTRIB. AMPLIFIER	GR-1183 FREQ. & MOD. MONITOR EQUIP VISUAL & AURAL IN TOP 3 PANELS	BLANK		
		DISTRIB AMPLIFIER	MONOSCOPE CAMERA	DISTRIB AMPLIFIER	BLANK		GR-1170-BT FM MONITOR	BLANK	
		DISTRIB AMPLIFIER	STAB AMPLIFIER TS10	BLANK	BLANK		GR-1176-AT VIS. FREQ METER	BX-1E PRE-AMP P. S.	BA-13A LINE AMP
		GRATING GENERATOR	STAB AMPLIFIER REMOTE	JACK PANEL	BLANK		GR-1171-AT FREQ MONITOR	BA-6A LIMITING AMP	
		GENLOCK	STAB. AMPLIFIER NET	JACK PANEL	BLANK		BLANK	AUDIO JACK PANEL	
		BLANK	STAB AMPLIFIER MASTER CONTROL	JACK PANEL	BLANK		BLANK	B.P.MI-4590-A	
		CKT BKT	BLANK	BLANK	BLANK		BLANK	BA-11A PRE- AMPLIFIERS	
		CKT BKT		DISTRIB. AMPLIFIER	BLANK		BLANK	16MM SOUND EQ.	
				DISTRIB. AMPLIFIER	BLANK		BLANK	BA-14A AUDIO MON AMP.	
			SYNC GEN SWITCH	BLANK	BLANK		BLANK	BX-4A RELAY P.S.	
				BLANK	BLANK PANEL MI-4594-B				

The TC-5A Program Director's Console is another outstanding feature of the video relay control system. This console is designed expressly for use by program and technical directors in supervising studio programs. The console is only 37 inches high (which allows full view over the top and into the studio). It can accommodate as many as five 10-inch monitors, which are recessed below the desk top to prevent direct light from striking the screens. These five monitors can provide the directors with preview pictures of all cameras, if desired, plus pictures from a network signal and the program line.

The illustrations show the use of five monitors in the console (see Fig. 31). The first three monitors are permanently associated with the two cameras and a possible third; the fourth monitor displays the upcoming signal which is selected by one row of pushbuttons and the fifth is on the program line which is also associated with one

row of pushbuttons, usually called program line.

The director's console is unique in that the program and technical directors have large bright pictures of the program directly before them and need not depend on their ability to see the monitors in the video operator's console, which may be located several feet away or in a different room. In this setup, the technical director would ordinarily do the necessary switching at the request of the program director. Both directors can use the intercom and talkback system built into the console for communicating with production and technical personnel at the cameras and in the control room, projection room, dressing rooms, etc. The program director's console contains the pushbutton switching panel which operates rack mounted relays (located remotely) for camera switching. It also contains 10-inch monitors which pro-

vide the director with the necessary picture information which he may select.

With the video relay switching systems, all video inputs may be handled at one central location, thereby simplifying the video cable distribution system. Several other advantages, such as simultaneously switching audio and video, "sync" interlock, extended control of tally lights, and previewing of special effects may be easily accomplished.

#### Plan "B" Master Control

Master Control is that portion of a switching system which selects the desired composite signal for final transmission, be it for network, transmitter or both.

It is imperative, therefore, that some means be provided to monitor both audio and video incoming and outgoing signals. In the cases of both audio and video a means of adjusting voltage levels must be provided. A "VU" meter usually provides

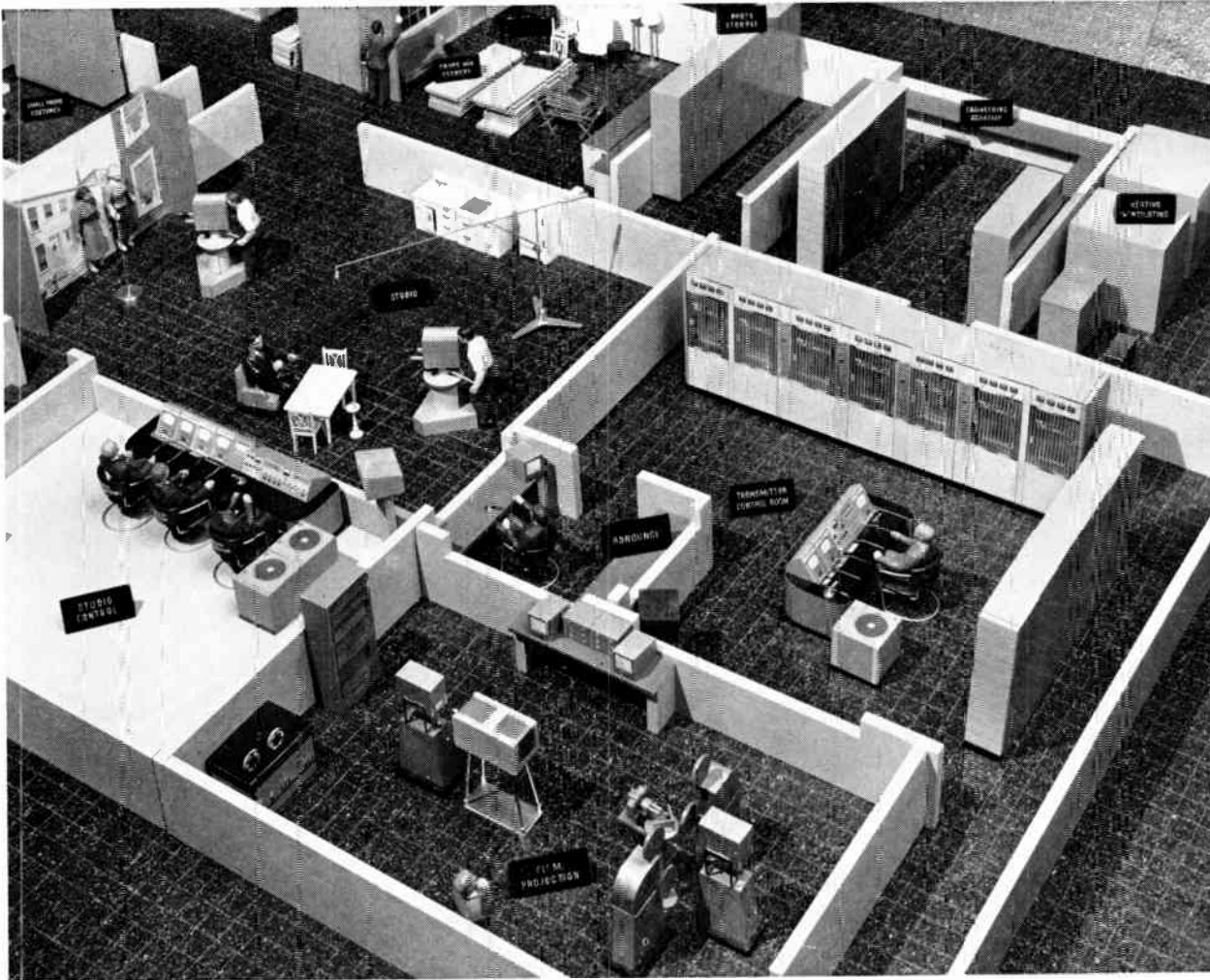
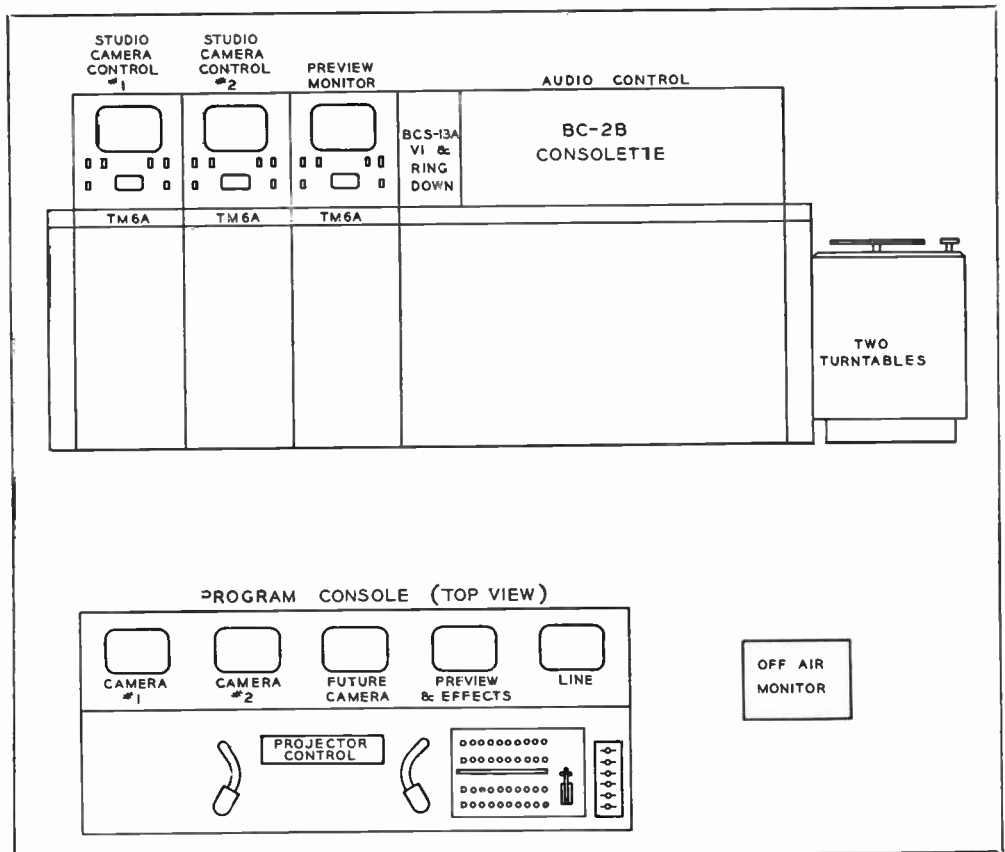

FIG. 30. Closeup of a portion of the "B" Plan Station showing the heart of the technical activity. In the control room (from left to right) are: the video operator at the camera monitors, the program director at the TS-10A Switcher and Remote Control Section, and the audio operator at the BC-2B Console. The film room shows the use of the TK-20D Film Camera and a Telop Projector as the second film chain to provide for opaques. This photo also illustrates the use of the TTU-10A (RCA 10-KW, UHF Transmitter) with the water cooler and transformer located in the heating and ventilating room.

this service for the audio signal while a cathode ray oscilloscope acts in a similar fashion for the video signal. Generally these indicators are provided as "built in" adjuncts of various items of equipment. For instance, the VU meter is a part of the audio console and the TC4A switching system, while the cathode ray oscilloscope or waveform monitor is an integral part of the RCA TM6A Master Monitor.

In considering any master switching system, it should be borne in mind that some means must be provided for monitoring audio and video inputs and outputs, and also to measure and establish proper signal levels. Obviously, an ideal system would be one which provides monitors for all signals at all times, but such a system could be quite cumbersome, complex and expensive. The next simpler and more practical system is one in which a monitor is always on the outgoing line, while another is switchable to any of the incoming signals.

FIG. 31. An "alternate" arrangement of control room equipment in Plan "B" where the TC-5A Program Director's Console is employed to provide further flexibility with video-relay switching.



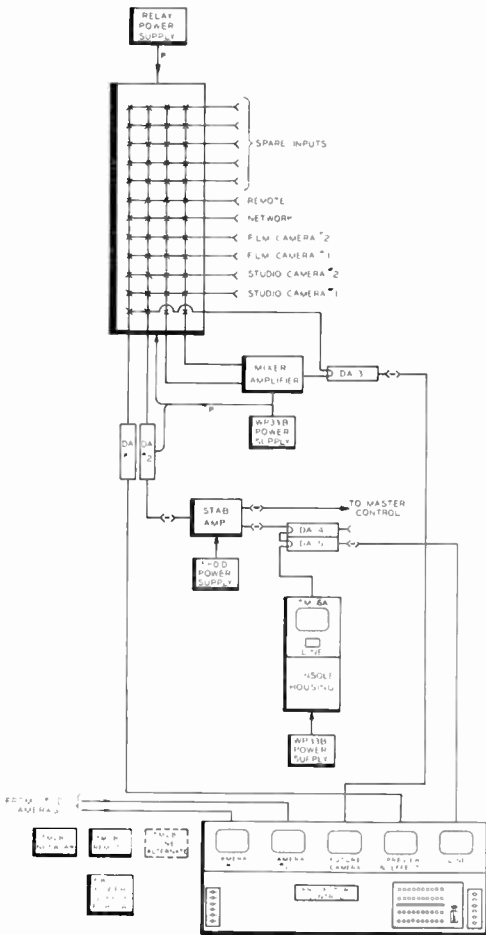

Some systems planners feel that further economy is necessary and, therefore, provide an inexpensive monitor on the outgoing lines and make the switchable one a TM-6A master monitor type, which has a high quality video system and a waveform monitor.

Where a separate master control room is used, it is customary to bring incoming network and remote lines into this central (clearing house) point.

All necessary adjustments and the distribution of these signals is accomplished in Master Control. They are then fed to their respective points of use by means of a system of jacks. In these cases, it is also a practice to provide inexpensive monitors which are always on the line merely to indicate that there is a signal present. The switchable monitor, as mentioned before,

**FIG. 32.** Simplified diagram showing the "alternate B" control room with the TC-5A Program Console providing five monitors. Note that the "future camera" monitor is connected to the "effects" bus permanently to permit continuous monitoring of the fader circuit. In addition, effects and other signals may be "punched-up" and observed on the "Preview" Monitor.

is used to make the necessary technical checks and adjustments. In each of these cases the same conditions are assumed for audio and video signals. Furthermore, as illustrated previously, duplicate monitoring facilities may be provided in the studio control room.

A simple arrangement for the type "B" layout is to use the RCA TC4A switching system as shown in the drawing of Figs. 27 and 28. This in effect, is the same basic system as that employed for stations "A" and "A-Prime" and treats the studio output as a remote signal. In this instance, however, the TC4A in Master Control serves a dual function. In addition to being a master switching console, it provides programming service when the studio equipment is being used for rehearsal, or is completely shut down, thereby keeping the cost of operation to a minimum. The monitoring section of the TC4A may be used to preview all video and audio signals, and also monitor the several transmitter signal check points.

There are also other means of switching signals at Master Control, as for example, the simplest form using bridged T networks, designated as RCA's TS-1A switch-

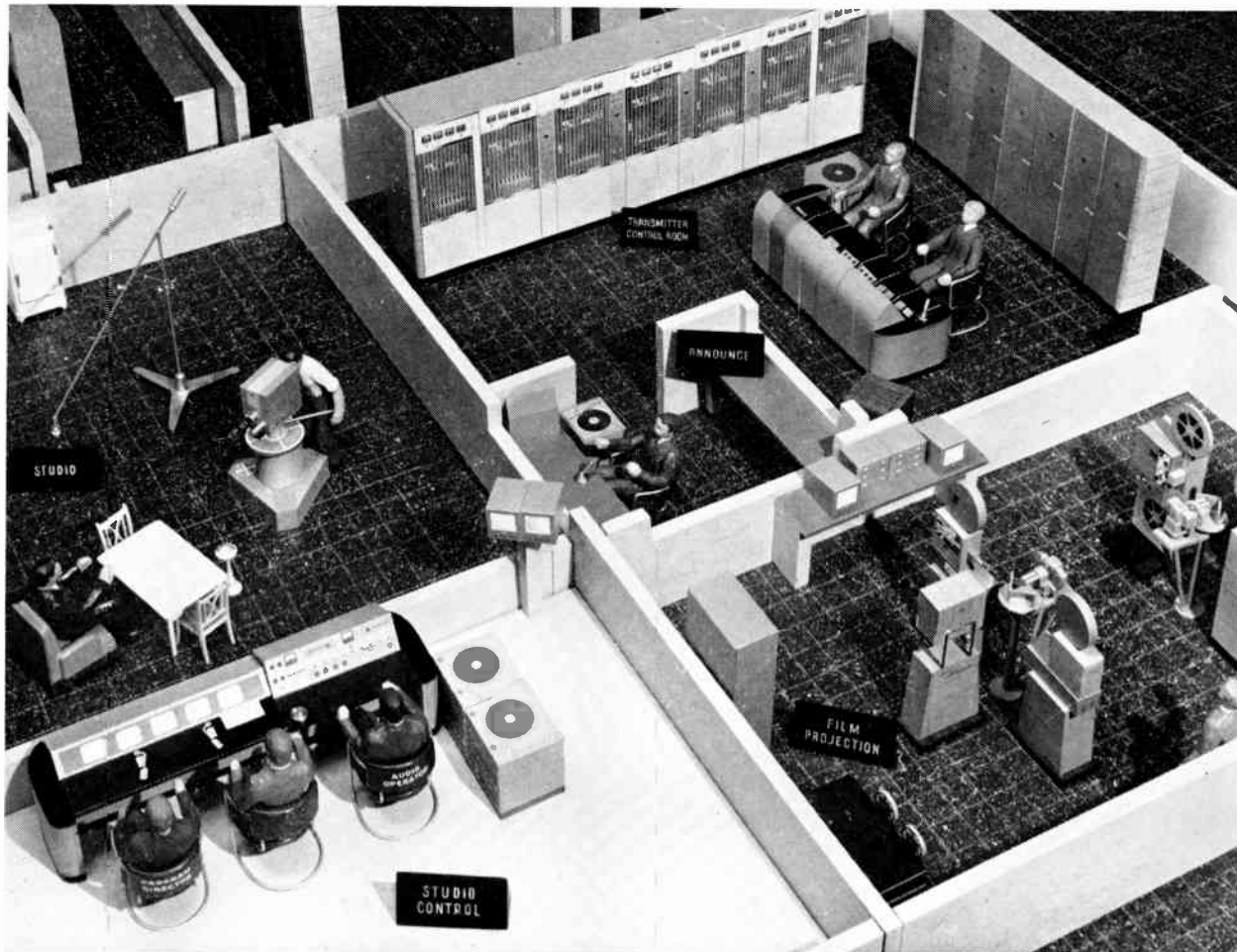

**FIG. 33.** Model layout showing the alternate "B" arrangement of the studio control room where the TC-5A Program Director's Console is used. Note transmitter control room where provision is made for studio camera controls, film camera controls, audio/video switching, remote control and "Preview". This permits complete control and switching at this point, when desired.



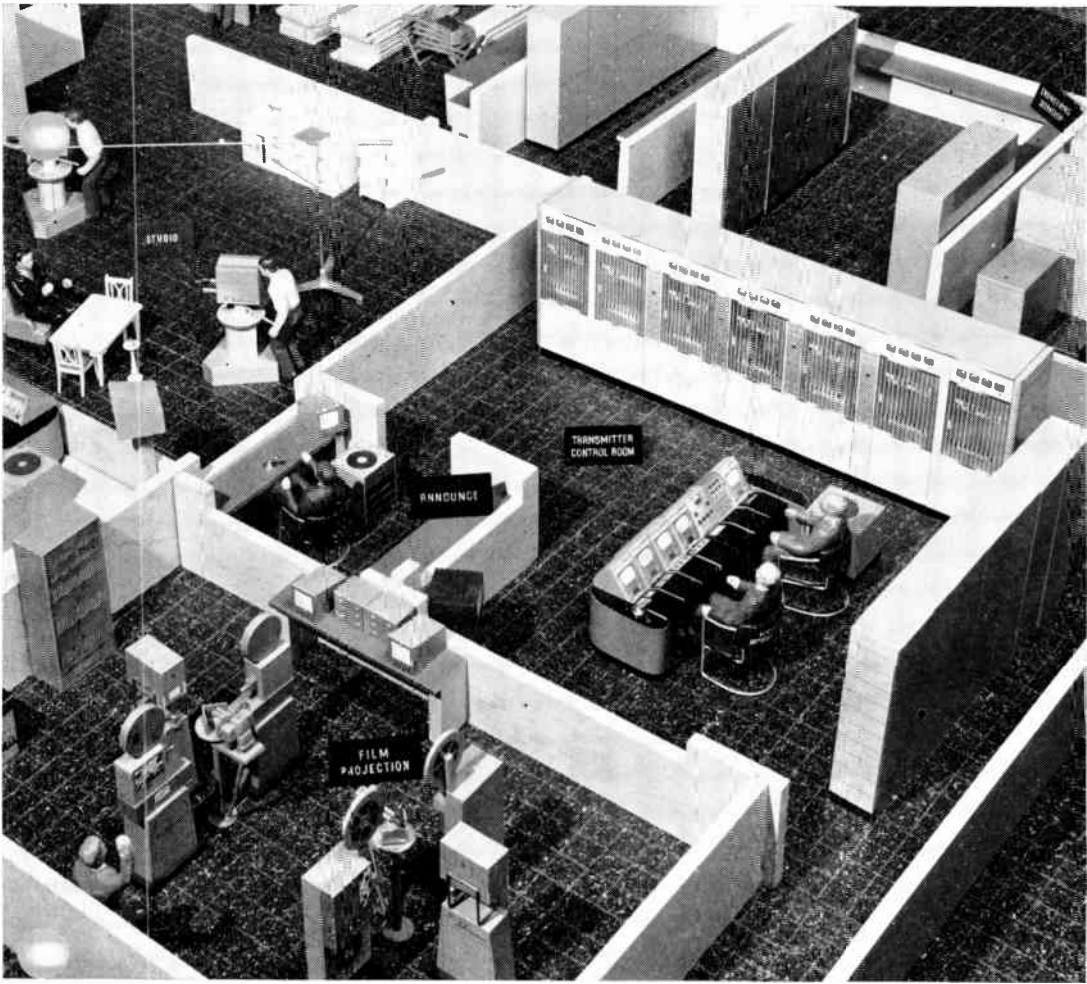

FIG. 34. Another view of the Plan "B" alternate arrangement which shows a front view of the transmitter "centralized" console where camera controls are located. Also shown more clearly is the film projection room. Note that, in this case, two TP-35, 35mm Film Projectors have been added for the second film chain. Power supply equipment racks are located in the engineering workshop, and video equipment racks in the transmitter control room.

room shall be all inclusive of the necessary film facilities (see Figs. 39 and 40). Almost any station of this size should have at least two film camera chains with a combination of two 16mm projectors and a slide projector for one film camera, and a choice of additional 16mm projectors, 35mm projectors, slide projector or a Telop for the second film chain. Naturally these choices will be dictated by the type and extent of programming the station plans to use. However, present operating techniques and costs invariably lead to an installation of at least two 16mm projectors and a slide projector for one film chain, with local condition and personal choice providing the selection for the second camera. In some instances a third film camera has been installed and if this is planned, the appropriate extra space should be provided.

One important source for the second film camera would be the use of a Telop projector which makes use of 3 x 4 transparencies, opaques and news tape, and has a stage for handling small objects like watches and other jewelry pieces. To be able to fade and lap dissolve with this pro-

ing panel (see diagram of Fig. 35). This consists of a mechanically interlocked system with six inputs and three outputs, two for line and one for monitor. It is normally a rack mounted panel for video only, and requires the distribution amplifier sections in close proximity in order to maintain good frequency response. By means of an extra contact on each switch position, relays may be actuated to switch audio and video simultaneously. The TS-1A Switching Panel may also be adapted for mounting in the RCA MI-14905 table turret combination which can be used adjacent to, or "in-line" with other operating consoles (see Fig. 36). Since the lower portion of this table is fitted with rack mounting angles, the distribution amplifier can be conveniently mounted within, and leads from the TS-1A can be kept short.

**Film Projection Equipment, Editing, Processing**

As in Plans "A" and "A-Prime", the film facilities may again be regarded as a vital income producer of the station. It is, therefore, important that the projection

FIG. 35. Simplified diagram showing the possible use of the RCA TS-1A Master Control Switching Panel which provides six inputs and three outputs.

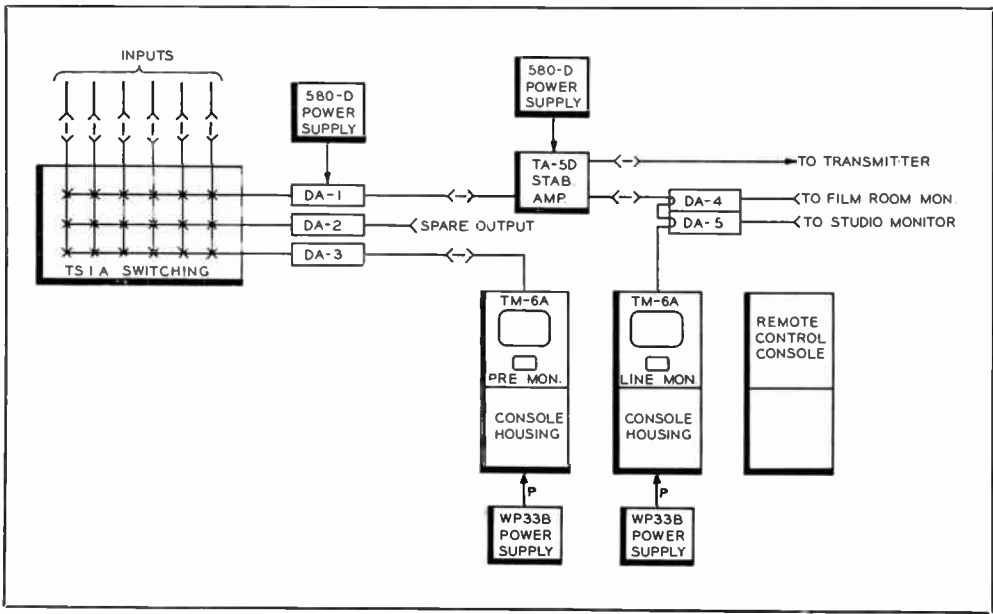

A still more flexible method of performing master switching is to use the video-relay system, which is described in detail under Plan "C". Here, as in the Studio Camera Relay Switching, the same advantages of shorter video cables, greater flexibility, and more complete control are realized (see Figs. 37 and 38).

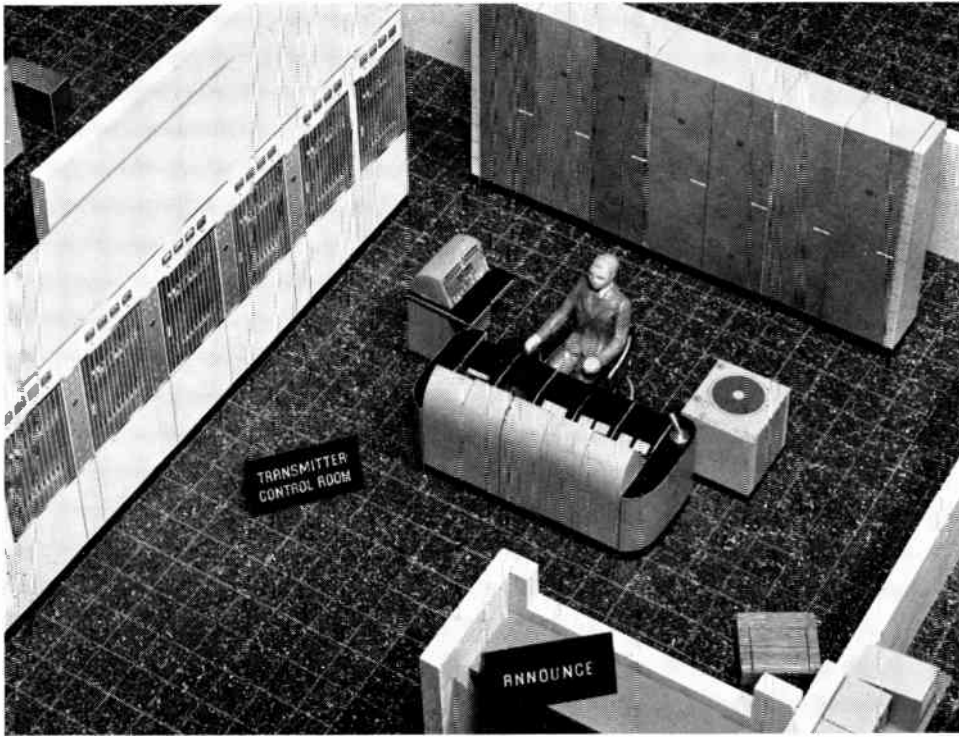

ways a picture on the screen even during slide changing intervals. This is accomplished by using a dual set of lenses, projector lamps and slide containers. When one slide is projected, the next slide on the second disc moves into position. All of this operation may be performed by one pushbutton operation. In other words the projector is semi-automatic in operation. Another item of film projection room equipment worthy of consideration for use in any of the four plans is the Gray Model 556 TV camera turret and pedestal. This permits the rotation of the camera so that "multiplexer-reflected" images can be picked up from several film projectors and Telop slide projector (as shown in Fig. 41). Four detents or stops on the rotatable turret enable the film camera to be swung to the desired picture image source.

The film projection room should be large enough to provide a work bench, with rewind facilities, film splicing equipment and film storage. Sufficient space should also be

jector, adds greater flexibility to the operation. The Gray Telop II projector will perform this function very well, requiring a minimum of space and power.

In some instances, there may be a use for 35mm projectors, and two would usually be required, because feature length film is furnished in several reels and would, therefore, necessitate switching between two machines.

Many operations, by virtue of their programming requirements, may be of such a nature that they require a type of 16mm projector which has special features beyond the normal requirements of those demanded of the TP-16D. In those cases the RCA TP-6A is recommended, since it has many features that deserve careful consideration in the preliminary planning stages. It offers: automatic projection lamp change in less than  $\frac{3}{4}$  second, dual focus control, quick exciter lamp change, 4000-foot reel capacity, providing about 1 hour and 50 minutes of program time, and "2-3 claw" intermittent with sapphire tooth inserts for long life.

Fig. 40 shows a recent addition to the RCA projector line, known as the Dual-Disc Automatic Slide Projector which is utilized to advantage in all four plans. It can be mounted on the conventional Multiplexer stand, thereby projecting an image directly on the mosaic of the iconoscope tube. This projector may also be operated by a remote control pushbutton. It has a total capacity of twelve 2 x 2-inch slides and the advantage that there is al-

FIG. 36. Model layout illustrating how the TS-1A Master Switching Panel can be housed in the RCA, MI-14905 table turret combination and conveniently located near the operating consoles.

FIG. 37. Model photo showing a closeup of the video-relay switching panel located in a console section to provide master switching in the transmitter control room.

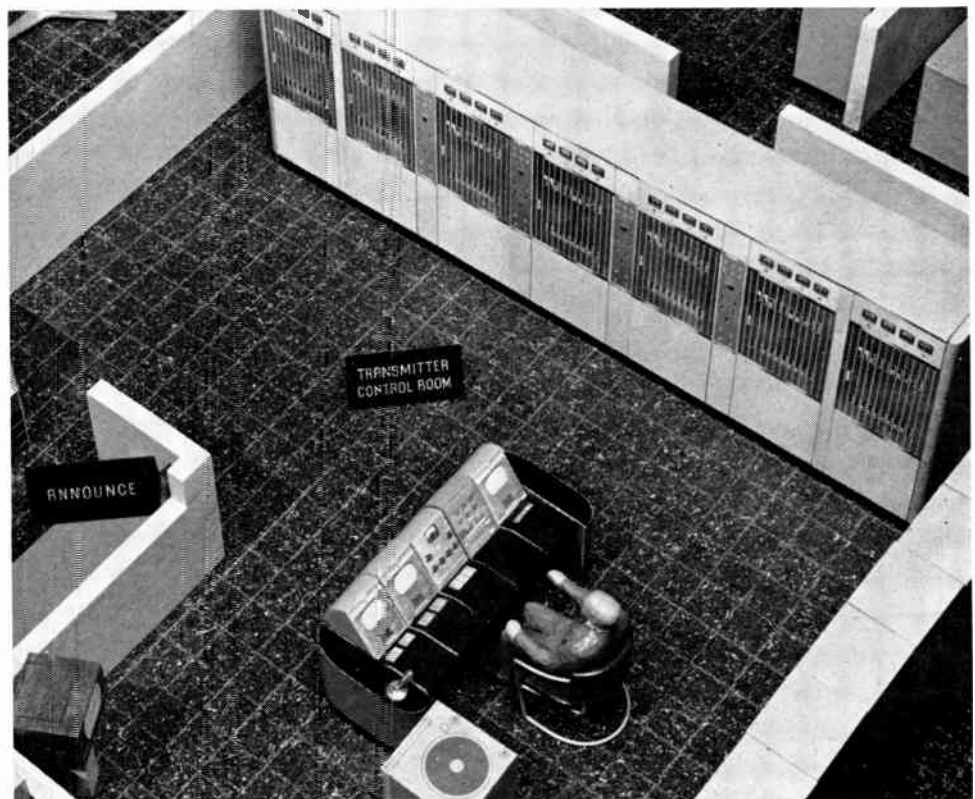

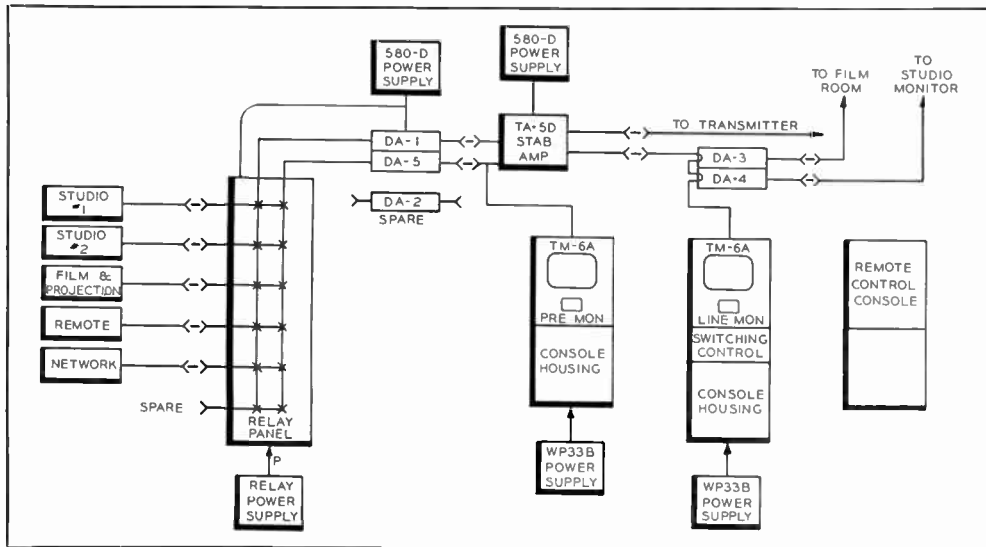

FIG. 38. Diagram illustrating the possible use in Plan "B" of "2 x 6" video-relay switching panel (six inputs and two outputs) for master switching.

size, number of cameras, number of projectors, work benches, clearance space around equipment, film storage facilities, intercom, lighting, film processing (dark room) are all important factors.

### Plan "B" Intercom

The Master Control Room Operator has two-way intercommunication with the Projection Room, Studio Control Room, and talking facilities only to the Announce Booth. During "on-air" periods of the Announce Booth, the "intercom" speaker is automatically muted by utilizing available relay contacts. Optional headphones in the Announce booth can continuously receive from the Master Control Operator, as well as from the Studio Control Director.

The Studio Control Director has two-way "intercom" with the Projection Room, Master Control Room, and talking facilities only to the Announce Booth and Studio. The "intercom" speaker of the Studio is muted in a manner similar to that of the Announce Booth.

The interphone headset facilities are used only between the Studio Control

provided (as is done in Plan "B") for a separate film editing room which is a tremendous asset. In this room, preview projectors, film storage cabinets, viewers and other supplemental storage and accessory equipment can be located.

Serious consideration should also be given to providing a small dark room (see Fig. 39) where local film processing and other photographic processes may be performed when the occasion demands. Perhaps every station in need of dark room facilities will have varying requirements, however, listed here are some of the items that can be considered.

### Description

- Eastman Silent 16mm Cine-Kodak special with S 1.9 Lens, 100-foot Chamber.
- 4 x 5 Crown Speed Graphic Camera with 6 3/8-inch Ektar Lens.

- Graflex Flash Gun.
- 4 x 5 Enlarger—Omega Enlarger D2, no lens/no color head.
- 6 3/8-inch Enlarging Ektar Lens.
- Kodak Professional 5 x 7 All Metal Printer (Bromberger).
- Graylack #168 Electric Timer.
- Burke and James Rexo Double Duty Dryer. 110 v. d-c, 220 v. a-c, 220 v. d-c.

### Accessories

- G. E. Light Meter Model PR-1.
- 4 x 5 Developing Tank F-R (Finke-Roselieve).
- Kodak Stirring Rod Thermometers.
- Stainless Steel Trays 11 x 14 inches.
- Film Washer — Kodak Automatic Try Siphon.

Because of the importance of the film facilities, all station planning should have careful consideration of every detail. Room

FIG. 39. Model layout showing a possible arrangement for the film editing and storage, dark room, as well as news room, record library, and small props and costumes.

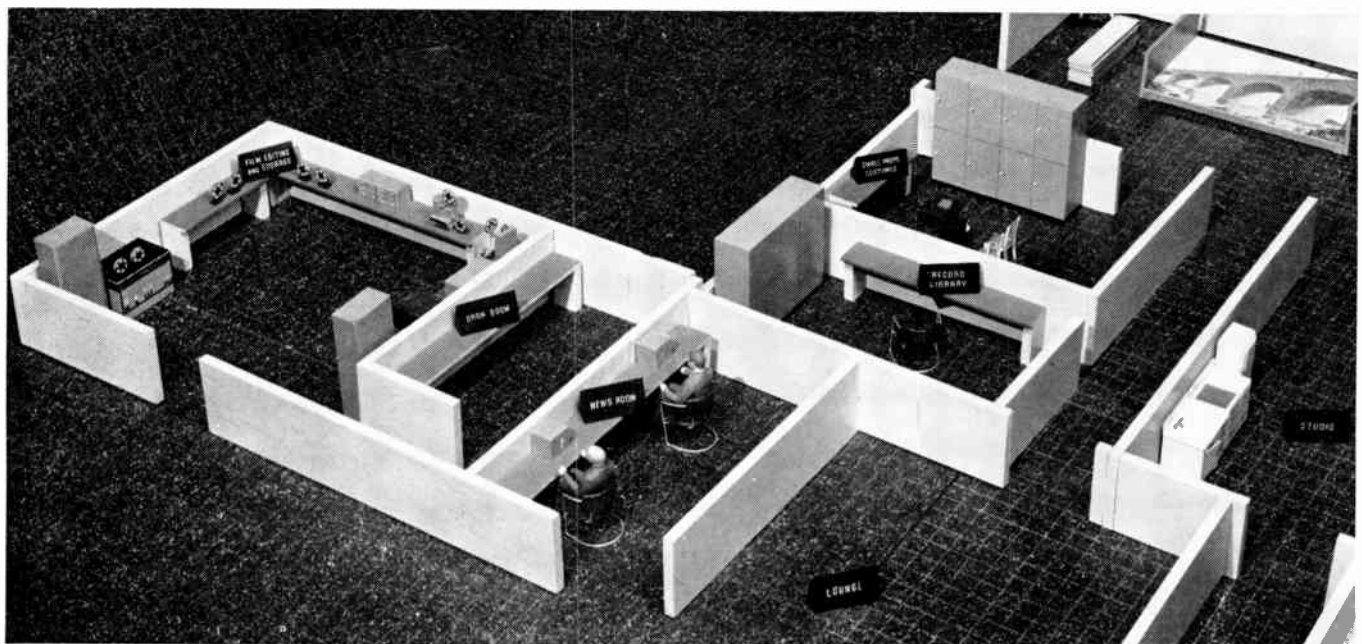

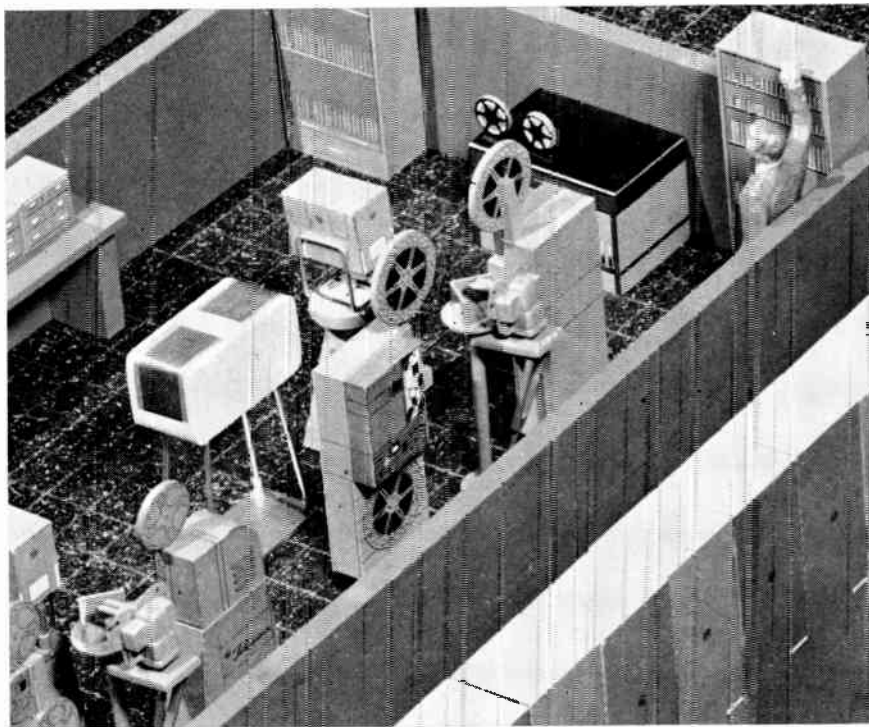

FIG. 40. Closeup showing the model equipment arrangement suggested in Fig. 41. Also note use of new TP-6A Professional Projectors in one grouping.

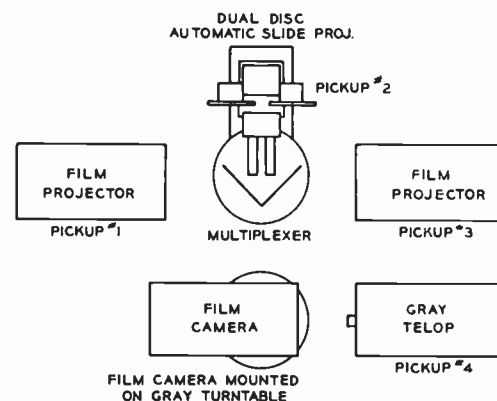

FIG. 41. Sketch showing the optional use of a Gray 556 Turret so that the second film camera may be swung to various picture image sources.

Room and Studio area personnel. Prior to "on-air" periods, members of the technical staff can communicate with one another, as can members of the program staff. At program time, all phones can be tied together by operation of a switch to provide necessary "intercom" between the technical and program staffs (see Fig. 42).

### Plan "B" Studio Lighting

The studio of Plan "B" might be classified as a general utility or "workshop" type of studio. Unlike the Plan "A-Prime" studio, it is capable of handling somewhat more complex programming involving more frequent setup changes. Dramatic, planned, or restricted sequence programs will originate from this (26 by 35 by 14 to 18-foot) studio. The lower half plan of Fig. 43 shows a typical multi-scene dramatic program.

To fulfill the requirements of present and future programming, the lighting arrangement for this studio must be as flexible as possible. As seen in the upper half plan of Fig. 43, a crisscross pipe grid on 6-foot centers and spaced 12 to 14 feet from the floor is used. With such a network and spacing, it is always easy to relocate a fixture on a desired point in a scene. Besides the fixtures themselves, the grid also supports the connector strips and pantograph hangers. Since the latter brings the fixtures within arm's reach, they facilitate the adjustment of fixtures with a minimum amount of time and effort on the part of electricians or other production personnel.

In many instances, it is also convenient to hang drapery or other scenery material from the grid.

Safety and flexibility in the studio wiring system is assured by the use of five connector strips. Each has five pigtail female outlets and is fed from a terminal box on a 4-inch duct through rubber cable. Spaced uniformly on the secondary pipes, they provide 25 ceiling outlets or approximately one outlet for every 30 square feet of studio space. Seven other double outlet circuits are provided 1 to 2 feet from the floor on the walls. The total of 36 branch circuits available make it possible to always find a convenient outlet in the studio. A uniform type of connector throughout the lighting system is suggested to permit interchangeability.

All ceiling and floor outlets are wired to the switchboard where they are switchable or dimmable either collectively or individually, by a patchboard where each outlet is provided with a counterbalanced, retractable cord and male plug. They are patched into the desired bank of grouped female jacks, and, in turn, can be energized by breaker switches. The patching feature makes it possible to group all the fixtures associated with a particular scene to one master and dimmer. Lastly, the studio light control must be capable of supplying 25 KW of fused power or almost 30 watts per square foot of studio floor space.

From an engineering standpoint, the lighting sources must provide the proper

quality and quantity of light needed to produce a good TV picture. Practically, it has been found that incandescents or a combination of fluorescents and incandescents can provide the quality of light to insure proper tonal rendition. The quantity of light reflected from the TV scene must be sufficient to allow the camera to produce a picture of acceptable signal-to-noise ratio.\* The average lighting level is 100 foot-candles, but it is recommended that sufficient sources be available to produce 200 F.C. of incident light in order that there be proper flexibility in control and lens stops.

Artistically, the lighting sources must be capable of fulfilling the following functions: (1) General or Base light, (2) Key light, (3) Modeling light, (4) Back light, and (5) Special Effects light.

Each of these functions of light will be discussed in Plan "C", and it is sufficient at this time to indicate that they can be provided by the various standardized floods and spotlights suggested for Plan "B".

The incandescent scoops or slimline fluorescent lamps provide the soft edge, wide angle beams for base (fill) lighting. Fresnel lens spotlights and elliptical spots provide controllable beams for accent lighting; i.e., key, model, and back light. Special effects such as simulated background scenery can, of course, be provided by

\* BROADCAST NEWS, April, 1949.

slide projectors or motion picture projectors featuring high brightness lamps.

The inclusion of barn doors, diffusers, iris, shutters, and other accessories permits these fixtures to be utilized to their fullest extent. Together then, with a versatile selection of efficient fixtures capable of rotating 360 degrees and tilting 85 degrees from the horizontal, it is possible to artistically enhance the TV scene.

From an economic sense, only a small number of fixtures will be used at any one time; and could, therefore, be moved from one scene to the next as required by the production. This is not feasible in TV, since time and manpower are at a premium; therefore, it is recommended that sufficient fixtures be provided initially to light the entire studio.

Of further importance in regard to fixtures is the possible use of fluorescents, which are practical in studios where heat dissipation or air-conditioning is a problem. When used, they must be reinforced with scoops up to 50% of the total light output. However, scoops alone are by far the cheaper to install and maintain, and are, therefore, recommended for the more maneuverable kind of base light for the Plan "B" studio.

The cost and type of lamp bulbs to be used with these fixtures is another economic consideration in the TV studio. By choosing a good quality, long-life lamp, and by standardizing on only a few types of lamps,\* it is possible to enjoy reduced maintenance costs. Aside from the cost of the lamps and the labor of replacing them, it is important that the cost of electricity be included as an item of studio expense. The overall cost (less bulbs) of the lighting equipment for Plan "B" can be estimated at approximately \$6.00 per square foot of studio floor area.

**Possible Addition of Remote Facilities to Plan "B"**

It is quite possible that some TV planners utilizing Plan "B", "A-Prime", or even "A" will rely on remote pickups to provide an important part of the station's income. In this event, plans should include garage facilities to accommodate the TJ-53A Mobile Vehicle (see Plan "C"). Also, careful consideration should be given in the selection of the equipment provided in the vehicle since it may well serve as a spare control room, particularly useful for emergency operation.

\* Note that approximately 2900-degree K incandescents and 3500-degree K or 4500-degree K fluorescent lamps are recommended.

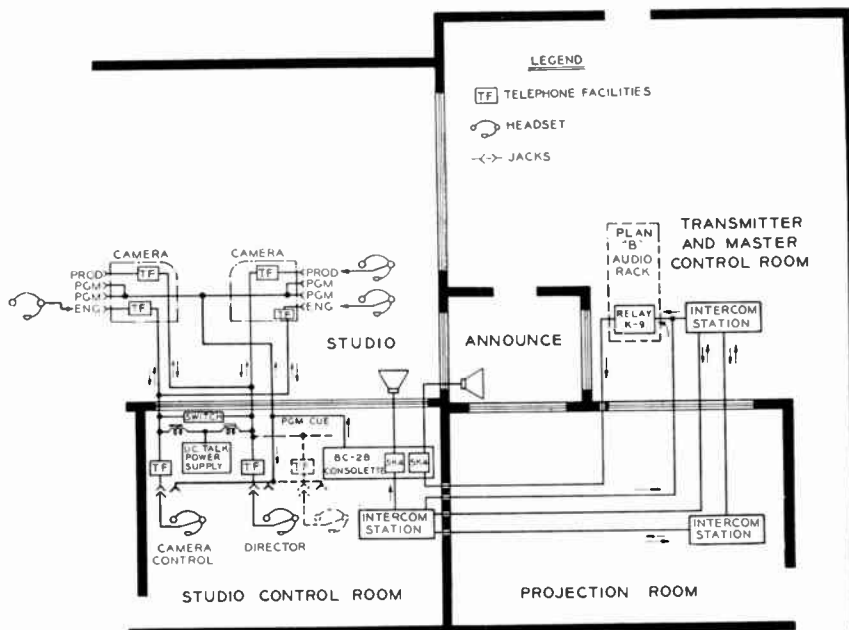

FIG. 42. "Intercom" "flow" diagram for Plan "B" Station.

NOTE: LAYOUT IS SYMMETRICAL, UPPER HALF PLAN BEING CEILING ARRANGEMENT AND LOWER HALF SCENIC

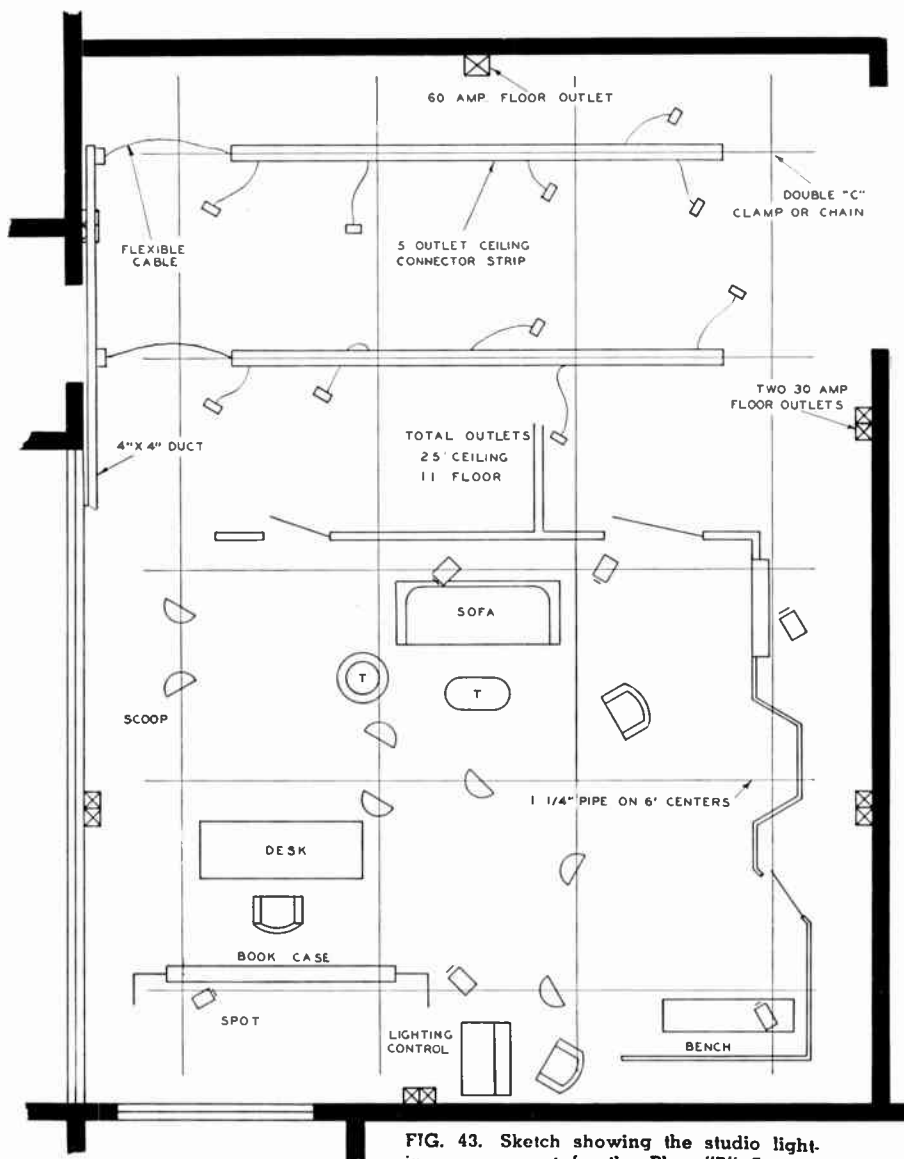

FIG. 43. Sketch showing the studio lighting arrangement for the Plan "B" Station.

# TV STATION PLAN "C", (Network, Film, Two Live Studios and Remote Facilities)

## DISCUSSION OF PLAN "C" (Network, Film, Two Live Studios and Remotes)

The first considerations in the planning and building of a TV station of the Plan "C" size are: (1) the use of two or more live talent studios, (2) expansion of the customary film facilities, and (3) the use of a separate master control setup. This type of station also includes facilities for originating and broadcasting network shows.

Specifically, such a station is usually provided with the following, which are included in Plan "C". (See system block diagram of Fig. 51 and plates of 44-48.)

1. Film projection rooms which may have a separate control room, if desired.
2. Two or more studios with individual control rooms so that rehearsals may be carried out while other studio programs are "on-the-air".
3. Facilities for picking up remote events.

4. Master Control room where desired program material may be selected from any of the previously mentioned sources for network and broadcast purposes. Master Control may or may not be a combined transmitter control room depending on the particular conditions involved.

### General Plan "C" Considerations

The same general considerations described for the smaller stations also apply to Plan "C" and there are several additional points that deserve attention. First, it should be understood that the Plan "C" station is not the ultimate as far as "all-inclusive" programming and studio facilities are concerned. However, it does

illustrate one possible arrangement of studios and the companion equipment needed for the larger or "master-type" station.

In some instances, the physical arrangement of various control units may be such that differences in electrical time between various pulses in the system become greater than can be endured for proper operation. In that case, it becomes necessary to compensate for these differences. If the differences are small, it may be practical to use

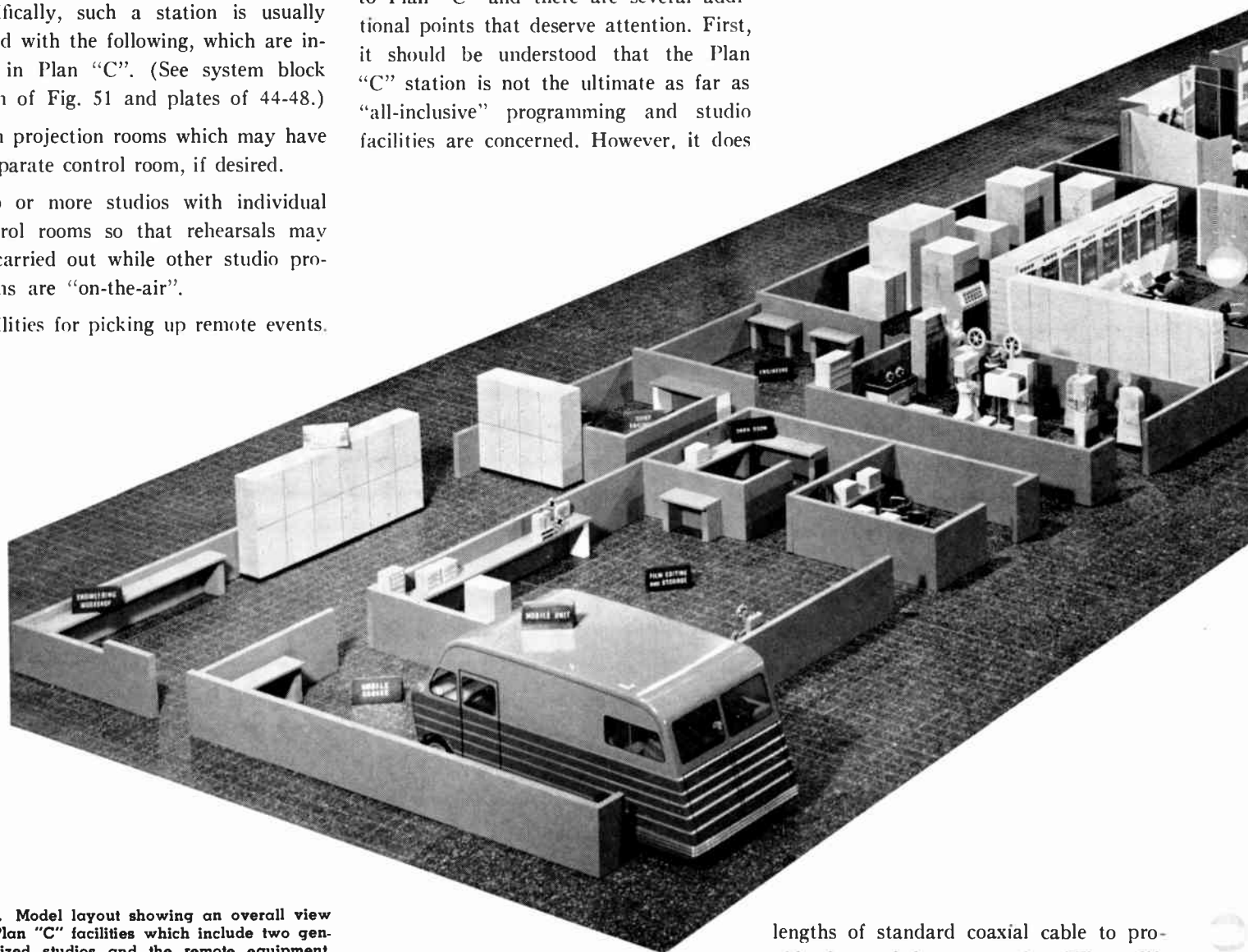

FIG. 44. Model layout showing an overall view of the Plan "C" facilities which include two generous sized studios and the remote equipment.

lengths of standard coaxial cable to provide the needed compensation. Where differences are appreciable, it may be more practical to use a delay line designed specifically for the purpose.

The Plan "C" station can be considered as a prototype for all stations larger than Plan "B". Although Plan "C" is illustrated as employing a minimum of standard video components, many additional innovations and "spare" equipment features can be easily added.

It is apparent from the block diagram of Fig. 51, that a high degree of flexibility

Each studio has its associated control room with elevated platform setups to provide good visibility into programming areas. Space is provided, as in Plan "B", for operation with a program director seated at the TC-5A Console on a platform at a second level, or with the director seated at the same level as that of the video and audio operators in front of a common "in-line" console. (See Fig. 52.)

of a Type BC-2B Console, BCS-13A VI and Ringdown Console for the smaller "two-camera" studio. Equipment is located in line with companion video consoles. Mixing and switching facilities are provided by the BC-2B Audio Console. Each of its eight possible simultaneous inputs is controlled by a high level mixer. Talkback facilities, turntable mixers with built-in

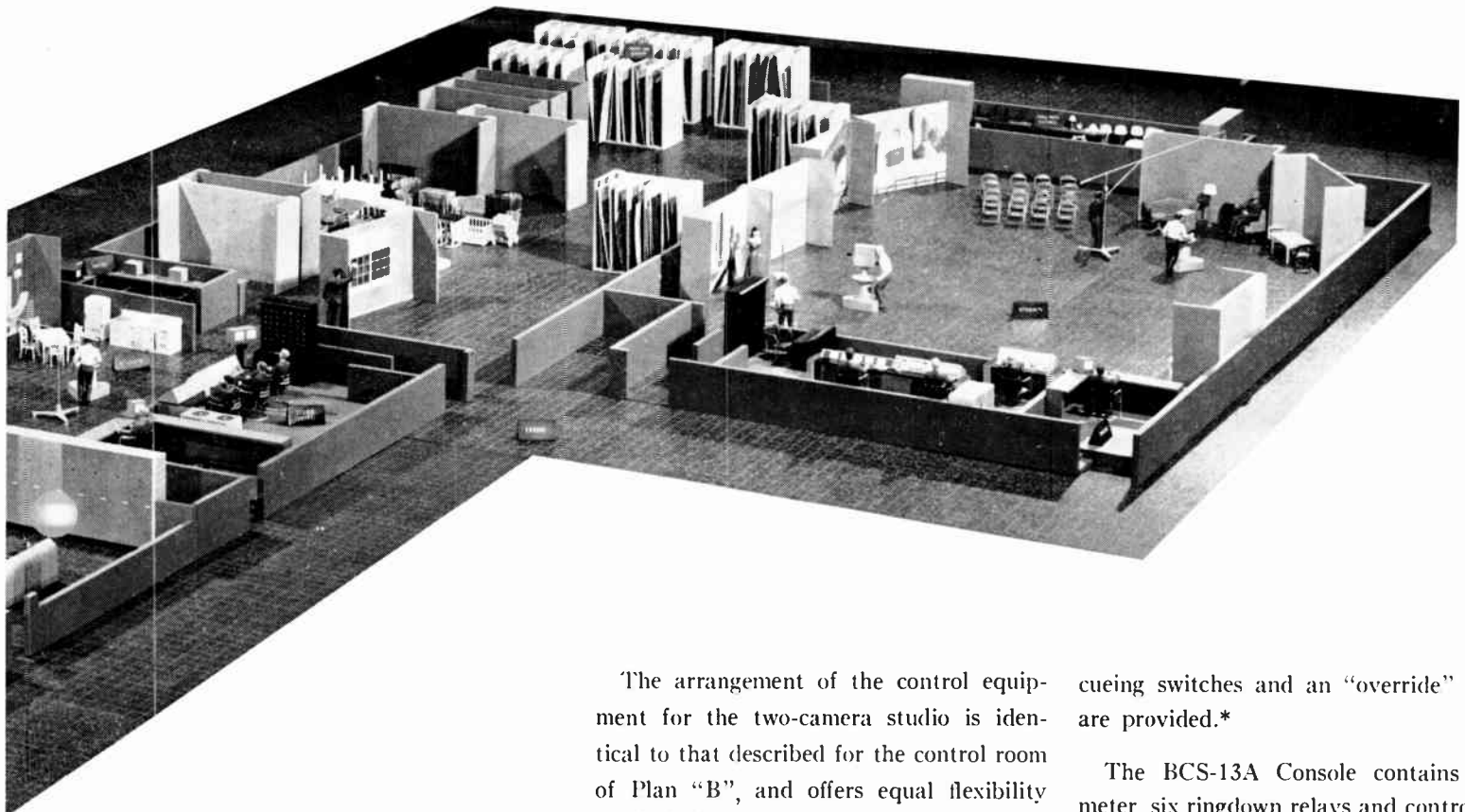

is maintained throughout this system as well as in those previously described.

### Plan "C" Studios and Studio Control

Plan "C" is equipped with two studios, one large "three-camera" unit and a somewhat smaller "two-camera" unit. Additional microphones (program stand, "hand-held", desk and boom type) are recommended, as are additional studio monitors, and studio loudspeaker for turntable feed and talkback. Since programming for this station is on a much more elaborate scale, the space provided to accommodate properties and sceneries is proportionally larger. Other auxiliary facilities such as record library, dark room and additional offices are provided in this plan.

The arrangement of the control equipment for the two-camera studio is identical to that described for the control room of Plan "B", and offers equal flexibility or choice in mode of operation. Video consoles may be located to suit personal operational preferences. Monitoring, switching and remote control features are all similar and need not be again described. The possibility of employing video-relay switching, as previously described, also applies to the studio control rooms of Plan "C" (see Fig. 55). The "three-camera" studio control room has the same facilities as that of the smaller unit except for the addition of another camera control console.

### Plan "C" Audio

The audio control equipment needed to satisfy the requirements of Plan "C" are similar to that of Plan "B" and consist

cueing switches and an "override" switch are provided.\*

The BCS-13A Console contains a VI meter, six ringdown relays and control keys for private line telephone facilities. Turntable outputs can be fed to loudspeakers for vocalist accompaniment or background purposes. A rack of associated equipment for use with the BCS-13A is usually located in the control room.

The larger "three-camera" studio-audio facilities are identical except for the possible addition of the BCM-1A Auxiliary Mixer Console (see Fig. 48) which would provide for the use of any four of twelve additional microphone inputs. It is also mounted alongside the console.

\*For complete description of Audio Facilities, see Jan.-Feb. 1951 BROADCAST NEWS, "A Flexible TV Audio System" and July-Aug. 1951 BROADCAST NEWS, "A New AM-FM-TV Console."

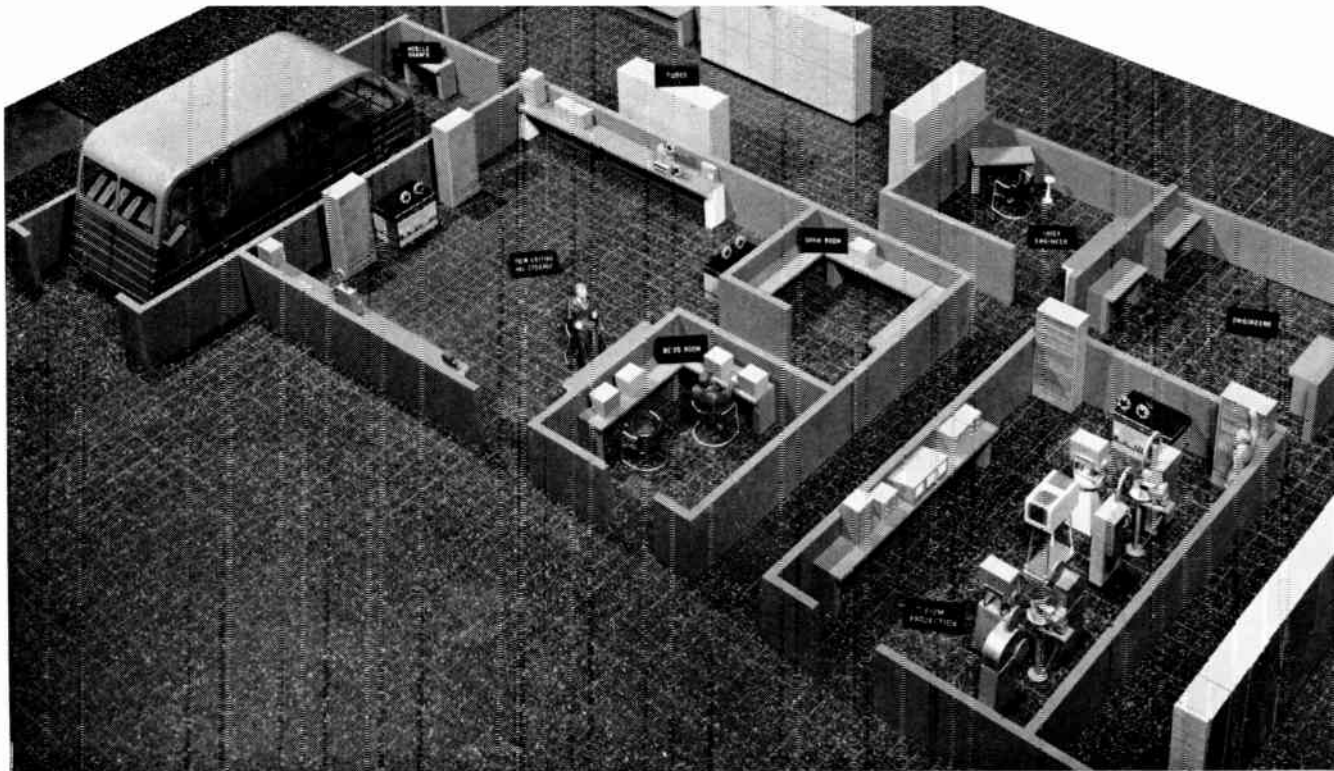

FIG. 45. Closeup showing the "left-hand" portion of the Plan "C" Station, including mobile unit, film editing and storage, news room, dark room, parts storage, film projection room, engineering workshop and engineers' offices.

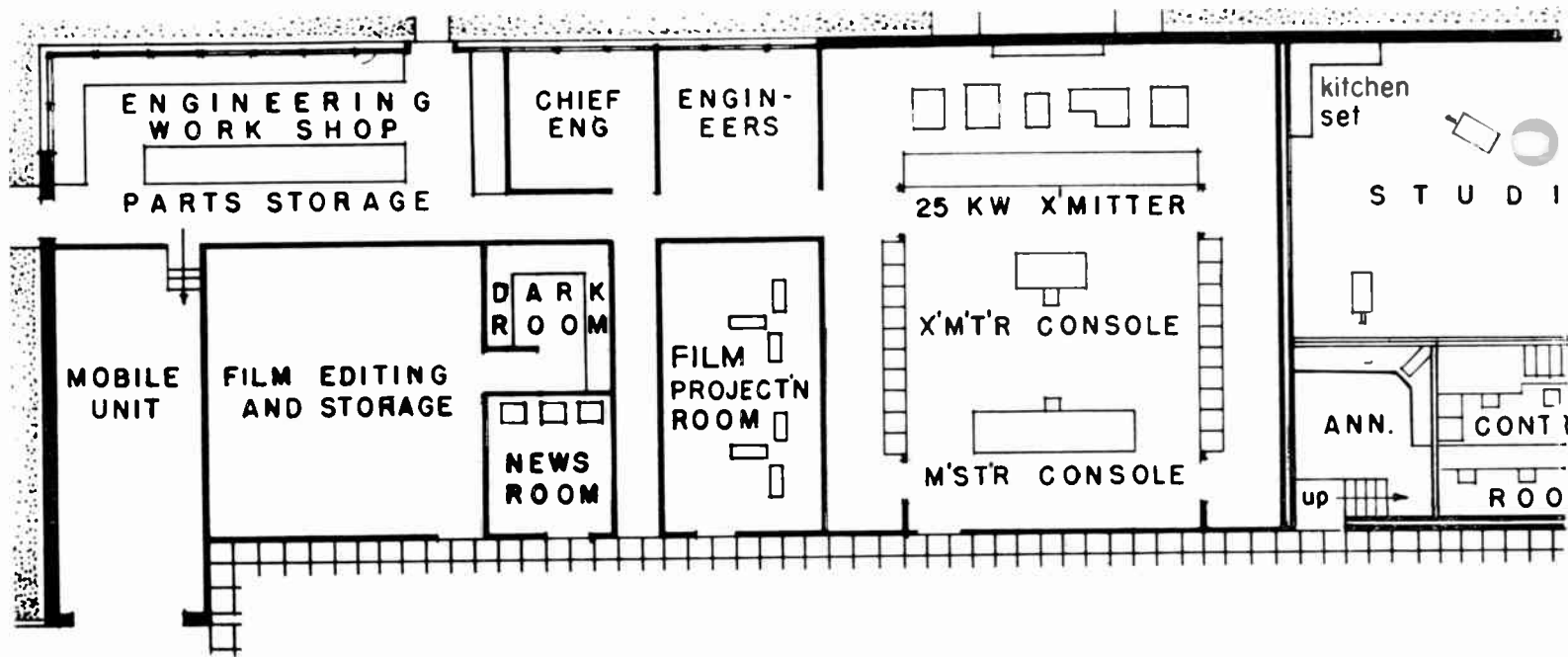

FIG. 46. Floor plan layout showing the technical facilities for the Plan "C" Station.

### Plan "C" Master Control

Referring to the floor plan of Fig. 46, it will be noted that there are two studios; one large, with its associated control room and a smaller studio with its control room. There is also a film projection room with its associated controls located in the master control room (see Fig. 47).

Each studio is a complete unit capable of producing live talent shows. The output from the film controls, as well as from

each studio, and signals from networks and remote pickups are routed through master control.

Facilities are available for handling a number of remote signals by telephone company lines and by microwave relay. Stabilizing amplifiers are available on the same jack panels as the incoming signals so that they can be connected into the circuits. The stabilizing amplifiers are designed to set the proper synchronizing-to-

picture ratio and to improve the quality of the synchronizing signal of incoming remotes. The stabilizing amplifier utilizes clamp circuits to remove hum, bounce, and other line disturbances.

The relay receivers and the stabilizing amplifiers are rack-mounted in the master control room and their remote controls are brought to a console section for convenience in setting-up and operating the equipment. Each of these pieces of equip-



ment has two outputs available at jack panels so that signals can be fed to the master switching system or to the studio camera switching system independently. In master control, the desired signal can be fed to any one of the outgoing lines.

Here again, it should be understood that the same arrangement of equipment as that outlined in Plan "B" may be used.

**Plan "C" Master Relay Switching**

The use of more inputs, sync interlock, and shorter coax cable runs fits in naturally with relay switching, which makes

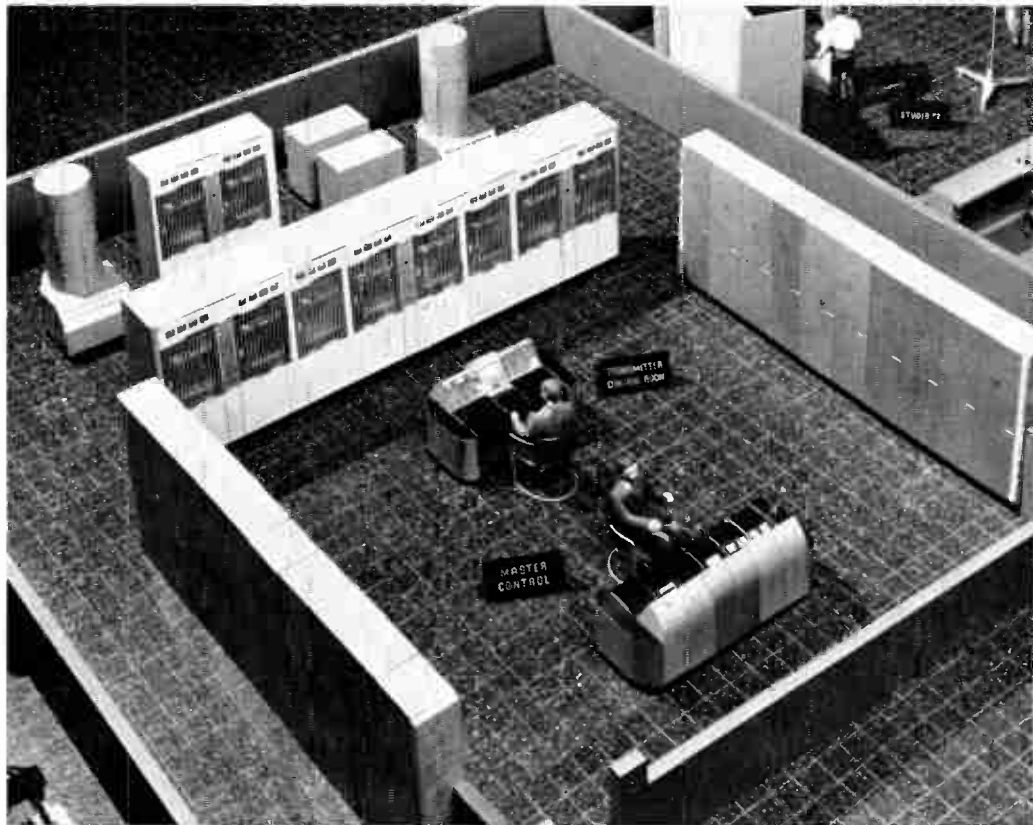

FIG. 47. View of the central part of Plan "C" showing the use of an RCA, 25-KW VHF Transmitter. Note that power amplifier, power control, switchgear and distribution equipment are located at the rear of the transmitter. A separate transmitter supervisory console is employed in Plan "C"; a video/audio console and associated rack equipment are also located at the same "master control" point, as shown.

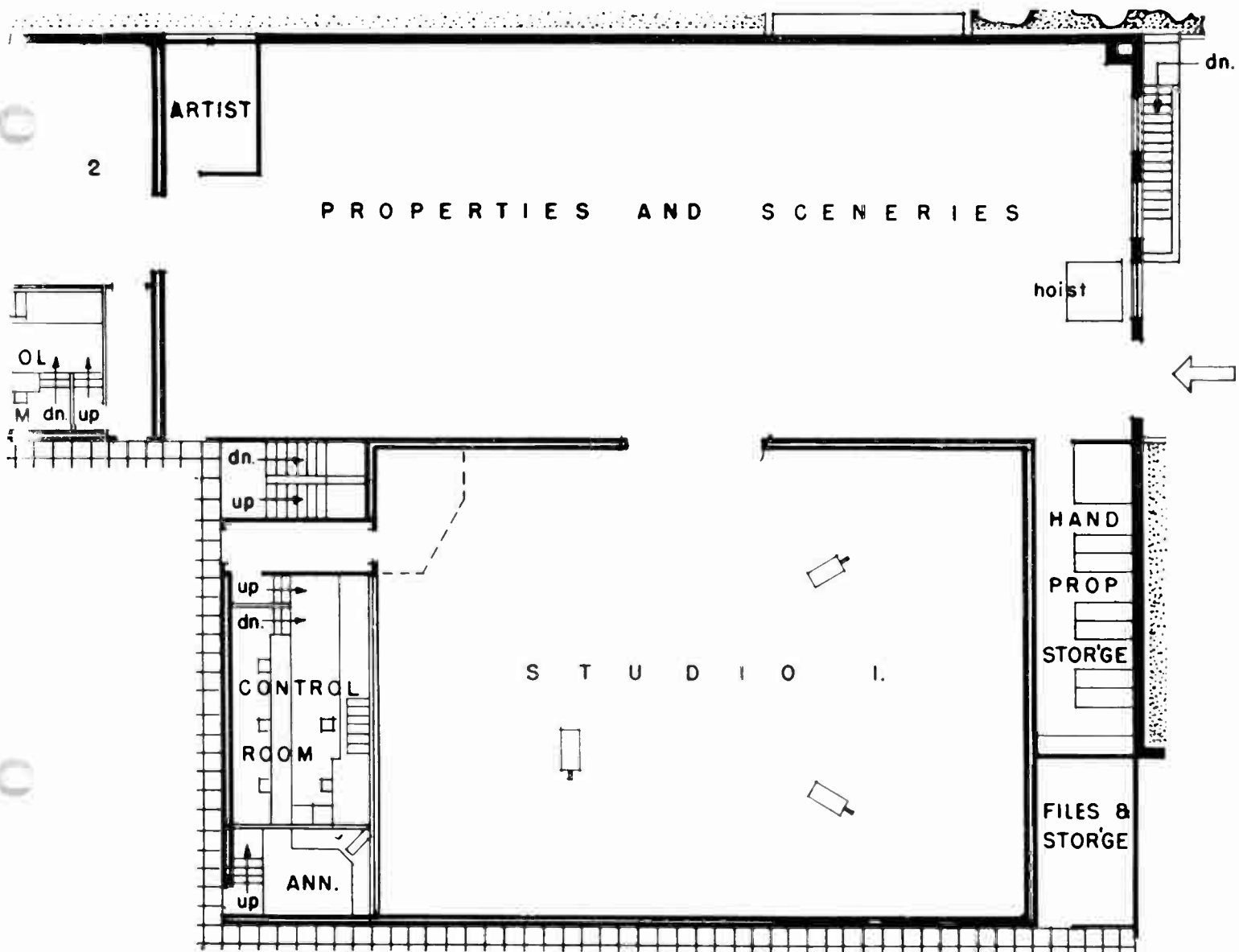
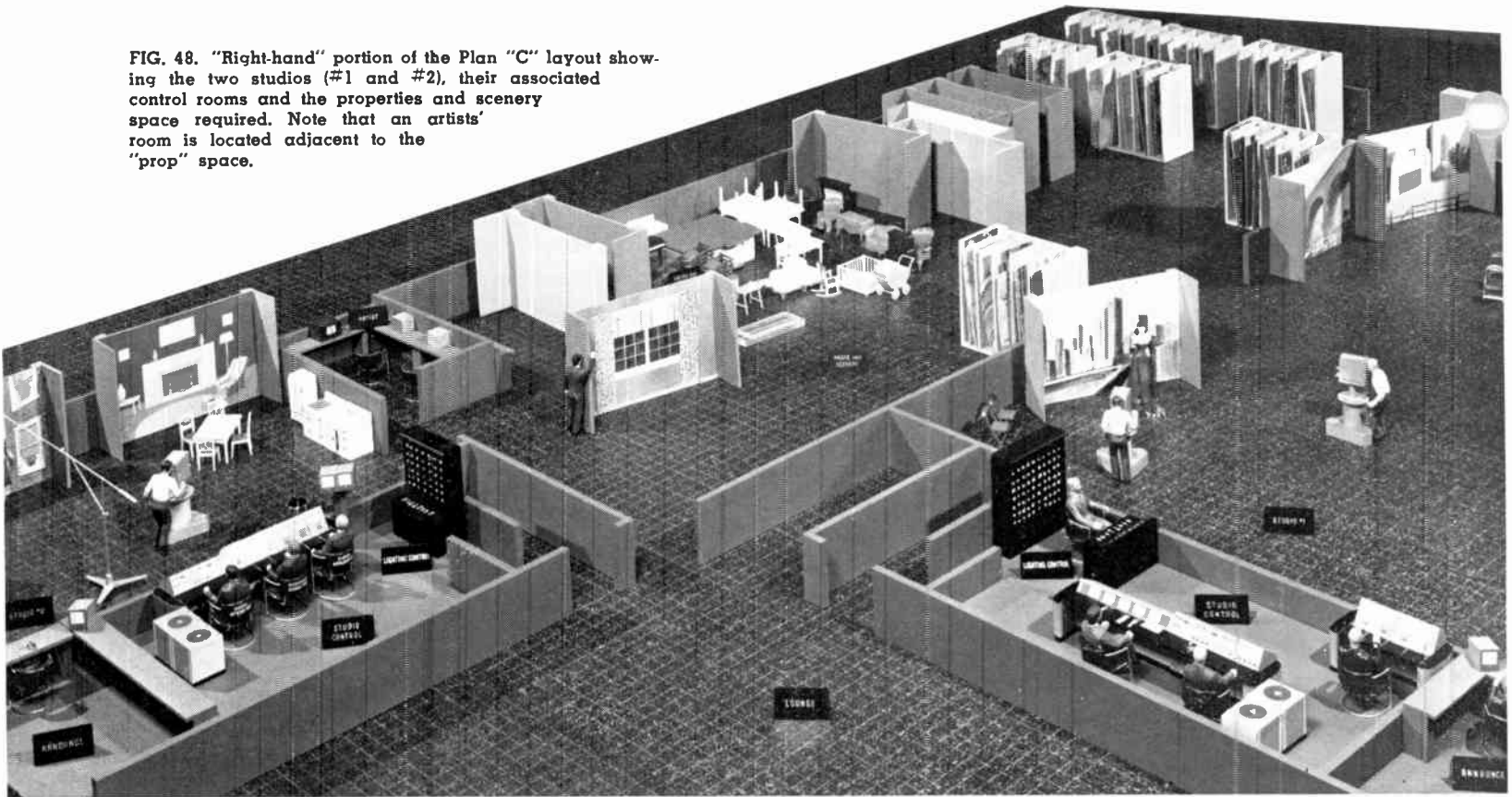

FIG. 48. "Right-hand" portion of the Plan "C" layout showing the two studios (#1 and #2), their associated control rooms and the properties and scenery space required. Note that an artists' room is located adjacent to the "prop" space.



programming smoother and easier. It also provides a means of switching audio and video simultaneously, and includes a greater number of tally light controls necessary in larger operations.

A simple relay switching system is one comprised of six inputs and two outputs (see Fig. 38).

For a more comprehensive system, it is possible to extend functions to twelve in-

puts and six outputs. For an operation of this size, requirements usually become more involved than those previously mentioned and should be discussed at length with a systems planning group.

There are many who feel that their programming requirements are such that some means of switching and fading should be included in Master Control (particularly where it is desirable to superimpose local advertisements on network programs). In

such instances, a system using the TS-10A Studio Switcher, the TS-30B Field Switcher, or a video relay system in conjunction with the "Genlock" is necessary. The output, of the system chosen, could be fed into one of the Master Switching inputs mentioned earlier.

All switching for the station (including studio camera switching) may be accomplished by relays located in the Master Control Room. Video signals, local and

FIG. 49. Rack layout showing arrangement of video amplifiers, sync generators, audio and monitoring equipment.

SYNC GENERATOR NO.1 TYPE TG-1A	SYNC GENERATOR NO.2 TYPE TG-1A  SYNC GEN SWITCH	DISTRIB AMPLIFIER PULSE	RELAY RECEIVER CONTROL	BLANK PANEL	DISTRIB AMPLIFIER	DISTRIB AMPLIFIER	GR-1183 FREQ. & MOD. MONITOR EQUIP VISUAL & AURAL IN TOP 3 PANELS	BLANK	
		DISTRIB. AMPLIFIER PULSE	MONOSCOPE CAMERA	STAB AMP STUDIO A	DISTRIB AMPLIFIER	STAB AMP TC4A		GR-1170-BT FM MONITOR	BLANK
		DISTRIB AMPLIFIER PULSE	GRATING GENERATOR	MIXER AMP BLANK PANEL	BLANK PANEL VIDEO JACK PANEL VIDEO JACK PANEL VIDEO JACK PANEL	BLANK PANEL VIDEO JACK PANEL VIDEO JACK PANEL BLANK PANEL		GR-1176-AT VIS FREQ METER	BX-1E PRE-AMP P.S. BA-13A LINE AMP
		DISTRIB AMPLIFIER PULSE	STAB AMP TS10A	BASIC RELAY CHASSIS	BLANK PANEL	BLANK PANEL	GR-1171-AT FREQ MONITOR	BA-6A LIMITING AMP	
		GENLOCK	STAB AMP NET	AUX RELAY CHASSIS	DISTRIB AMPLIFIER	BLANK PANEL	BLANK	AUDIO JACK PANEL	
		BLANK PANEL	STAB AMP REMOTE		DISTRIB AMPLIFIER	BLANK PANEL	BLANK	B PMI-4590-A	
		BLANK PANEL	BLANK PANEL		DISTRIB AMPLIFIER	CKT BKT	BLANK	BA-11A PRE-AMPLIFIERS	
					DISTRIB AMPLIFIER	CKT BKT	MONITRAN	16MM SOUND EQ	
							BLANK	BA-14A AUDIO MON AMP	
								BX-4A RELAY P.S.	
						BLANK PANEL			
						MI-4594-B			

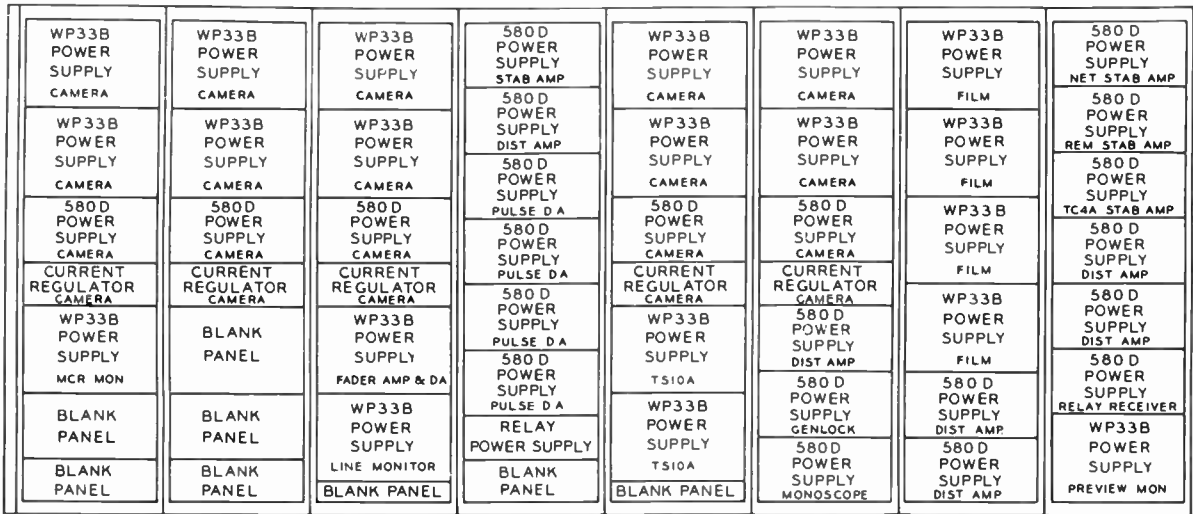

FIG. 50. Rack layout of the power supply equipment for Plan "C".

FIG. 51. Overall video system schematic of Plan "C" showing the interconnection arrangement of equipment units. Audio components for TC-4A, not shown, are like those of "A-Prime" (see Fig. 20).

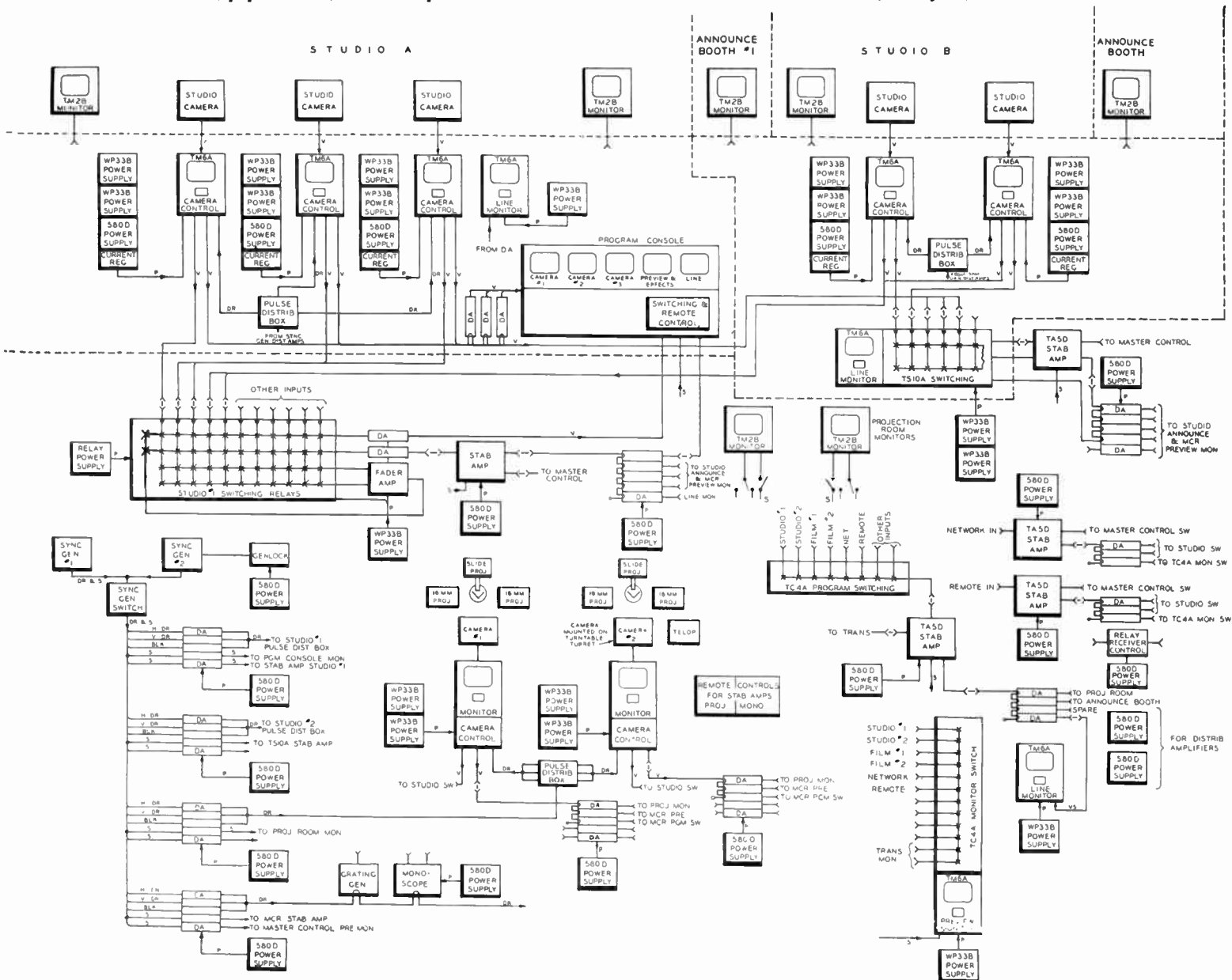



FIG. 52. View of large Studio #1, companion control room and the nearby "prop and scenery" storage area. Note that, in this setup which uses the TC-5A Program Director's Console, the video monitors have been located away from the control room window. The program director and audio operator are at a second level, with the lighting control operator and his equipment plus the video monitors at a lower level. (Actually these camera controls could be located in a different room.)

remote, are fed to jack panels where they can be connected through to the corresponding video switching relays. These relays are controlled from pushbuttons located in the various switching positions. Each studio control room has associated with it four banks of interlocked relays, two for the fader amplifier and one for the preview monitor and one for the program line and monitor. Two synchronizing generators (one a spare) are provided in the Master Control Room with a switch to select the desired generator for use (see Fig. 14). This then feeds distribution amplifiers to distribute the blanking, driving, and synchronizing signals to the various parts of the system. In case the differences in physical separation of the Master Control Room and the individual studio control room is great, delay compensation can be inserted between the sync generator and the various distribution amplifiers.

This overall system is extremely flexible as it provides numerous combinations of camera facilities for programming and rehearsal. Cameras and remotes can be patched into any studio switching system

so that the program director at his console in a studio control room can have complete control over the switching of any studio cameras, film cameras, or remotes that he may require to make up a given program. A complete film program can be run entirely from the Master Control Room when so required. In this way, the facilities of an individual studio may be used for rehearsals while another studio or film is put on the air. One film chain may be used for a program while other film is previewed in a client's room without interference. Thus, almost any combination of facilities may be used to suit the particular requirements that may arise.

#### Plan "C" Intercom

The Master Control Operator has two-way intercommunication with the Projection Room, Studio No. 1 Control Room, Studio No. 2 Control Room, and talking facilities only to Announce Booth No. 2. During "on-air" periods of Announce Booth No. 2, its intercom speaker is automatically muted by utilizing available contacts of the Announce Booth No. 2

speaker muting relays. Optional headphones in Announce Booth No. 2 can continuously receive from the Master Control Operator as well as from the Studio No. 2 Control Director.

The Studio No. 1 Control Director has two-way intercommunication with the Projection Room, Master Control, Studio No. 2 Control, and talking facilities only to Announce Booth No. 1 and to Studio No. 1. During "on-air" periods of Announce Booth No. 1, its intercom speaker is automatically muted by its relay (see Fig. 57). During "on-air" periods of Studio No. 1, its intercom speaker is muted by its relay.

The Studio No. 2 Control Room Director has "two-way" intercommunication with the Projection Room, Master Control, Studio No. 1 Control, and talking facilities only to Announce Booth No. 2 and Studio

FIG. 54 (at right). A view of Studio #2 and Studio #2 control room showing a possible two-level arrangement, with TC-5A and Audio at upper level, video monitors below, and lighting console in the studio.

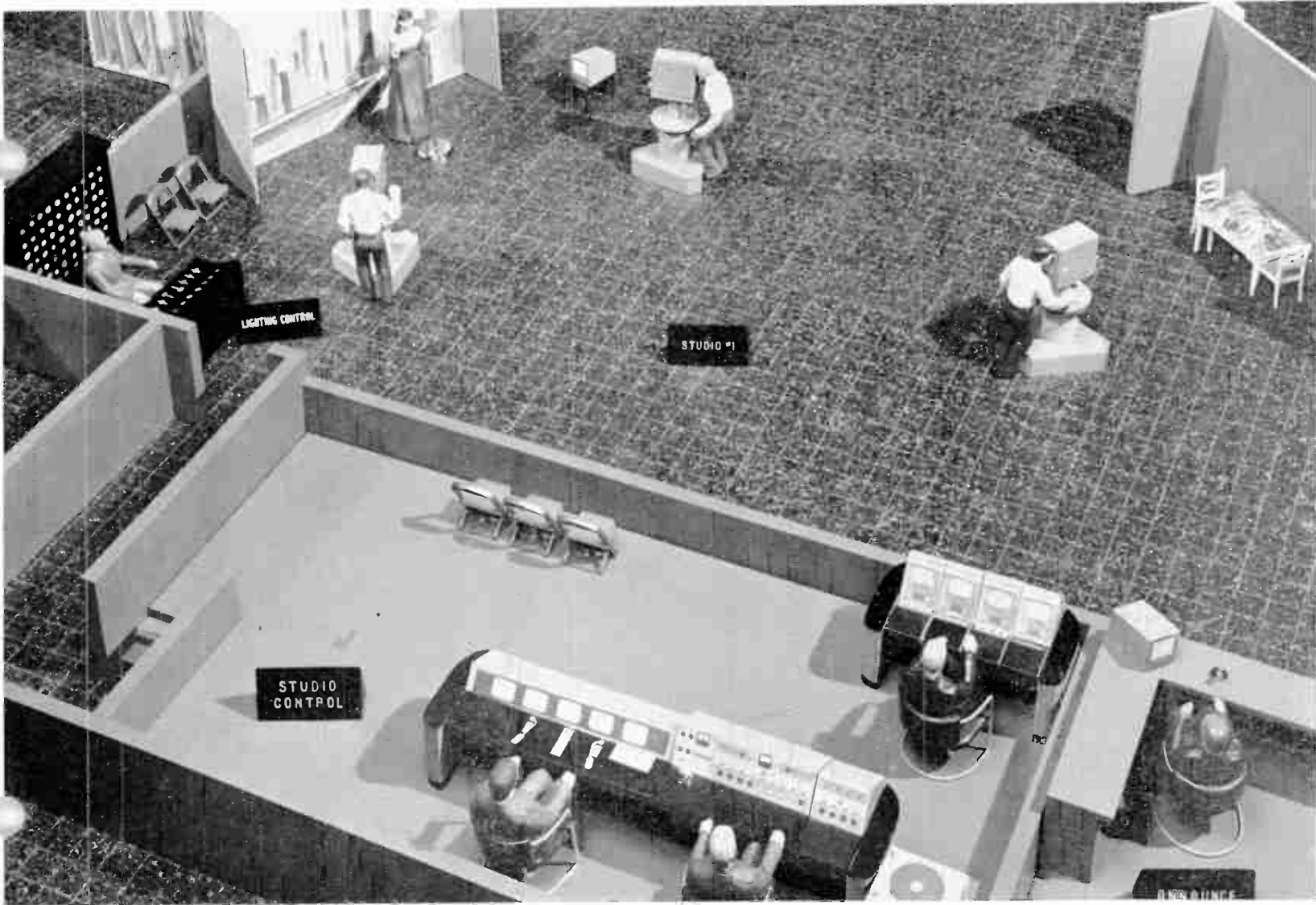
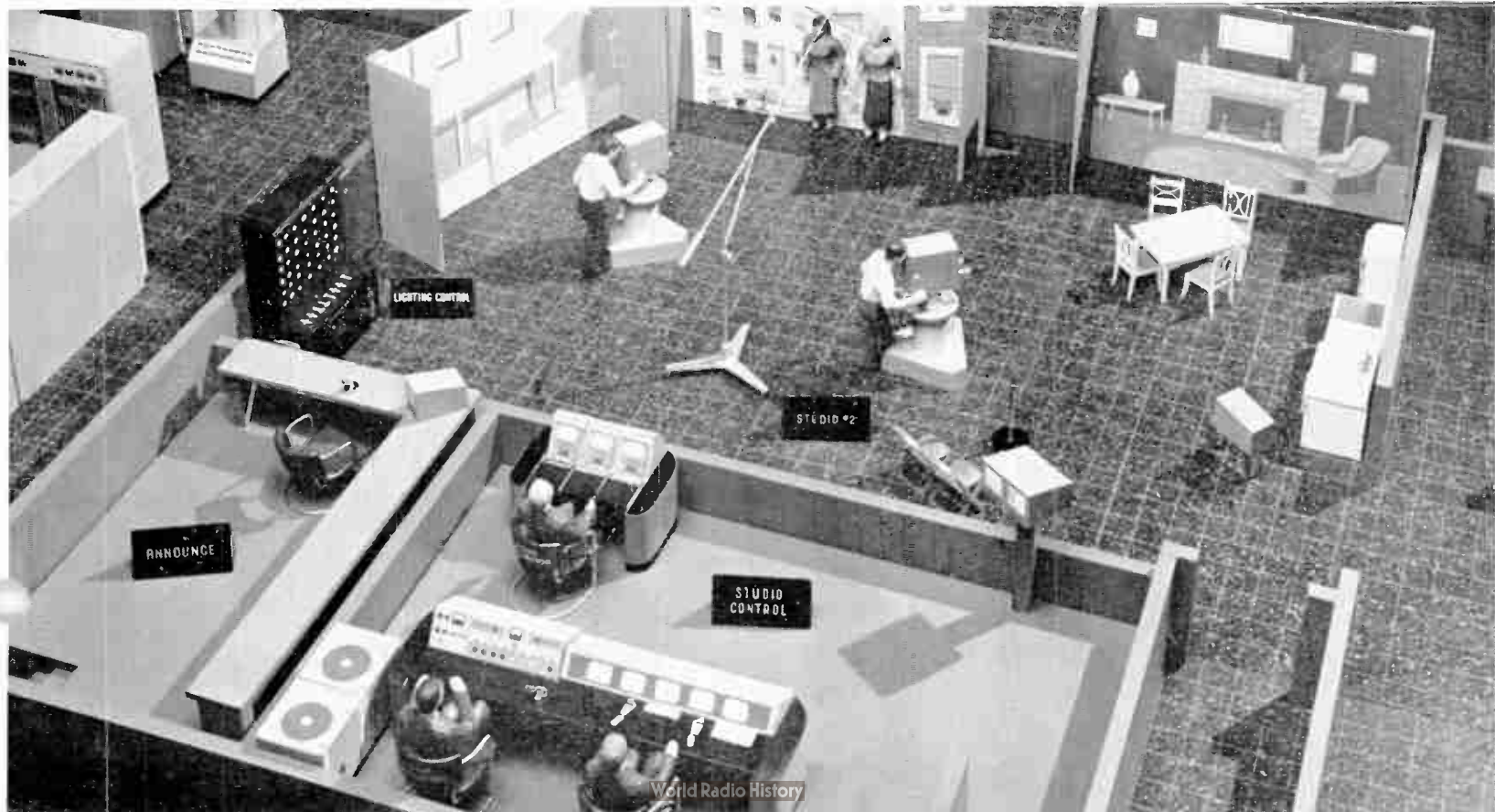

FIG. 53 (above). Another arrangement of the Studio #1 control room in which the lighting control operator and his console are moved into the studio.



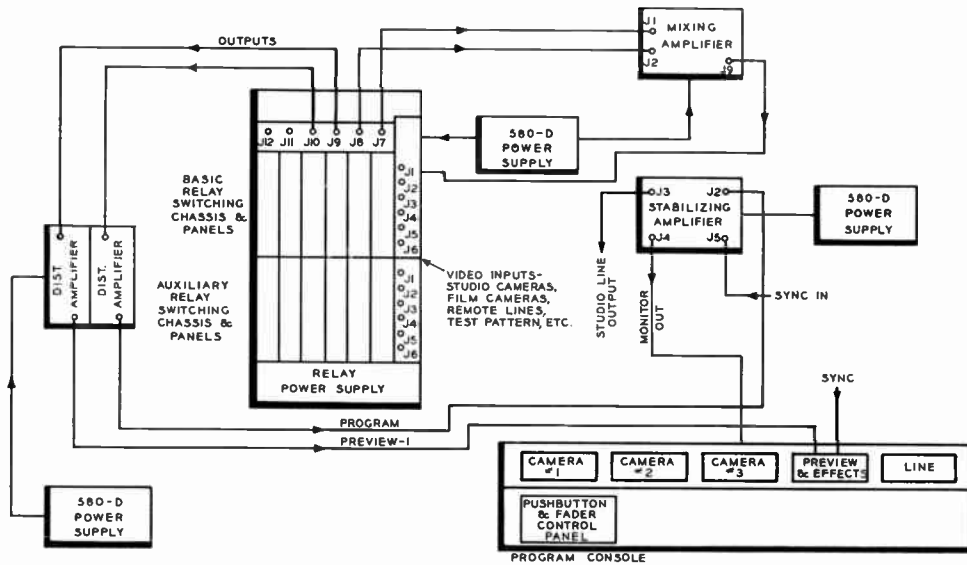

FIG. 55. Diagram illustrating the use of the TC-5A Program Director's Console and video-relay switching in the studio control rooms of Plan "C".

No. 2. During "on-air" periods of Announce Booth No. 2 or Studio No. 2, the intercom speaker would be muted for "on-air" areas.

### Plan "C" Remote Facilities (Mobile Unit)

Plan "C" includes complete garage facilities for the Type TJ-53A Mobile Unit which permits the "C" station to in-

clude "remote pickups" in its programming plans (see Fig. 58). This 1½-ton mobile vehicle answers the remote needs admirably and serves as a spare studio, always ready to move when needed.

It houses the essential equipment for a remote pickup: cameras, sync generators, switching facilities, power supplies, and a means for relaying picture information back to the station. Those items normally

operated from the control room, such as camera controls, are transported in their operating position. Other items such as cameras, tripods, dollies, cable reels, and microwave transmitters have space allotted inside the vehicle for transportation. Outside doors to the storage cabinets permit direct side-loading of all heavier equipment. The inside of the Mobile Unit is divided into two separate and distinct compartments: an operating compartment and a storage compartment. The entire front section is the operating or control room and is separated from the storage section in the rear by a partition fitted with a sliding door. Entrance to the control room is through the front side doors. The door windows and windshield may be readily covered by a curtain secured with snap fasteners to exclude outside light. Forward in this compartment are two cushioned chairs, one located in the driver's position and the other alongside it on the curb-side. The curb-side chair is rotatable and may be used to provide a seat for the Program

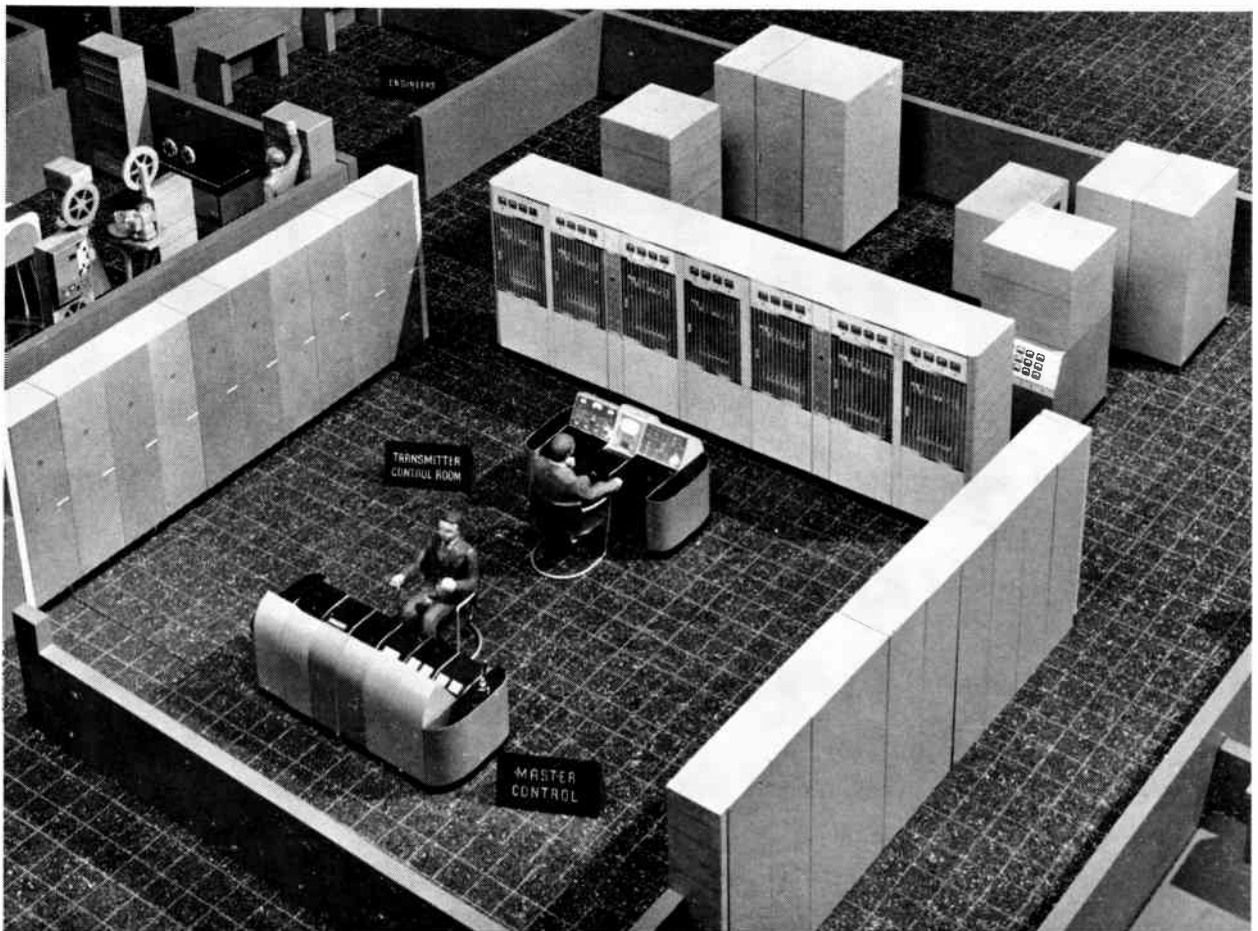
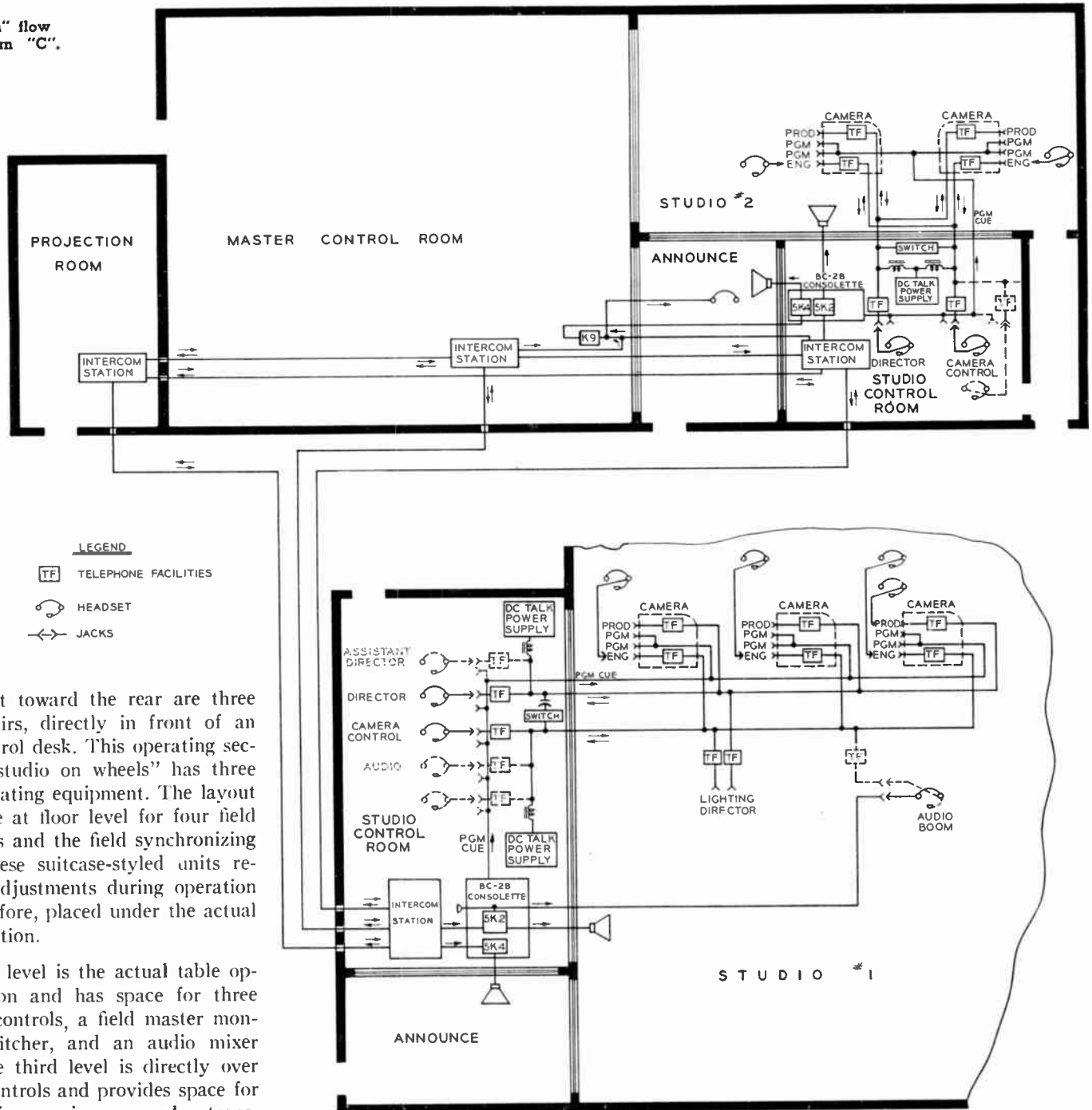

FIG. 56. An alternate arrangement of the master control/transmitter control room using the RCA TT-50AL (50-KW, VHF Transmitter). Note that the power amplifiers, control, switchgear, distribution and transformer equipment are located at the rear of the transmitter. The film projection room is visible at left.

FIG. 57. "Intercom" flow diagram for Plan "C".



Director. Next toward the rear are three cushioned chairs, directly in front of an operating control desk. This operating section of the "studio on wheels" has three levels for operating equipment. The layout provides space at floor level for four field power supplies and the field synchronizing generator. These suitcase-styled units require a few adjustments during operation and are, therefore, placed under the actual operating position.

The second level is the actual table operating position and has space for three field camera controls, a field master monitor, field switcher, and an audio mixer amplifier. The third level is directly over the camera controls and provides space for the air conditioner, microwave relay transmitter control, and power control panel. The roof is reinforced to support the weight of personnel and operating equipment such as cameras and tripods.

### Plan "C" Studio Lighting

The basic station of Plan "C" is characterized by two studios. The "Studio 2" (of 25 x 50 by 19-foot ceiling dimensions) will originate small scale programming which may be repetitive in nature. As such, its facilities can be patterned after those of the 26 x 35-foot, Plan "B" studio.

The larger "Studio 1", on the other hand, will offer even greater versatility. As a general purpose or workshop studio, it will originate a variety of dramatic

shows, commercial sequences, and any number of musical and speech groupings.

### Lighting System

The maximum mobility in scene changes and camera movements essential to this type of studio is obtained with the lighting system shown in Fig. 59. Having a 50 by 70-foot working space, "Studio 1" requires a total of 122 branch circuits or approximately one for each 30 square feet of floor area. Branch circuits may be grouped as the scenery requires by means of a patch or rotary selector board, and they, in turn, are switched and dimmed at the control board which is capable of

at least 600 amperes total load. Ceiling connector strips are fed from a 4 by 4-inch (direct running the full length of the studio center and a number of floor outlets are adequately dispersed about the studio perimeter.

For greater flexibility, adjustable pipe battens are recommended when the studio height is at least 27 feet. Rope or wire cable is used to connect the 1¼-inch iron pipe to the side of the studio and is run down to a tie board or load. Adjustable weights should be used to counterbalance the load on the batten. The ceiling connector strips, at the same time, can be

FIG. 58. Overall view of TJ-53A Mobile Unit used to provide complete facilities for remote pickups.



attached to the battens and energized through draped lengths of flexible cable to a terminal box on the main feedline duct.

Such a grid system makes possible the suspension of backdrops and adjustment of the fixture level for varying "scenery-set" heights (see Fig. 60). Low front-light, from fixtures mounted on this counterweighted batten, makes it possible to minimize facial shadows and avoids the microphone boom shadow. Lastly, rapid and safe manipulation and maintenance of the lights is made possible. Their combined use with a non-swaying pantograph hanger enhances the vertical adjustment of single fixtures while maintaining others fixed on any one batten.

Equally as important as the manipulation of the lighting system is the proper choice of beam pattern and fixture. Such can be easily studied by an investigation of the techniques of lighting.

#### Studio Lighting Techniques

Every television lighting system should be capable of providing the following functions:

1. Base or General Lighting.
2. Modeling Lighting.
3. Back Lighting.
4. Effects Lighting.

*Base lighting* is that uniform, wide angle illumination which covers the whole scene to be televised and which should establish the mood, i.e., daylight, evening, interior,

exterior, etc. The minimum level is limited to a value which will produce an acceptable signal-to-noise ratio. The actual value of incident light required is also determined by the depth of field and normally ranges from 6 to 120 foot-candles for average lens stops. Productions may require even greater variations than this, and for our plans, we will specify 100 foot-candles for an average interior. This base or general light can be provided by incandescent floods (scoops), long range scoops, or banks of fluorescent lamps. *Base lighting* can also be obtained by using the fresnel spots placed overhead at sharp angles.

*Modeling light* is directional light at an angle to the camera axis which develops forms in the scene. Such light can also project through a window, open door, or fireplace to the subject or main acting area. Shadows are then produced, and give an illusion of depth to the subject. This can be obtained by unbalanced base light without destroying the illusion of the space effect. More generally, however, Fresnel lens spotlights provided with diffusers and barn doors can effectively create the form and enhance the appearance of the scene. The intensity of this lighting should be 20 to 30% greater than the base light in the scene.

*Back lighting.* The purpose of back lighting is to separate the actors from the background, and, therefore, strip lights projecting from the floor can also

be used. The level of this backlight should approach an intensity 50% greater than that of the base light, and should be applied with caution since light should never enter the television camera lens.

*Effects lighting* is specialized lighting which injects reality to the televised scene. Such effects as clouds, snow, rain, lightning, firelight, and window light can be obtained by rear projection or by simple silhouettes in front of a light source. Many types of lighting equipment are available for other special beam patterns. The background projector has been used more recently. It can project a simulated background which may be stationary as produced from a slide or moving objects from motion picture film. For proper picture quality, the highlights thus projected should be equal to or at least half of those of the live scene highlights.

The proper combination of these various functions of light can give the illusion of three dimensions to the television picture and impart the desired artistic results. Complete flexibility in all phases of the lighting system will be necessary for the techniques of present day television.

#### CHECK POINTS AND PRECAUTIONS IN USE OF PLANS

To present all of the equipment planning considerations necessary in the proposed construction of a Television station would be beyond the intended scope of this article and, further, would require an exces-



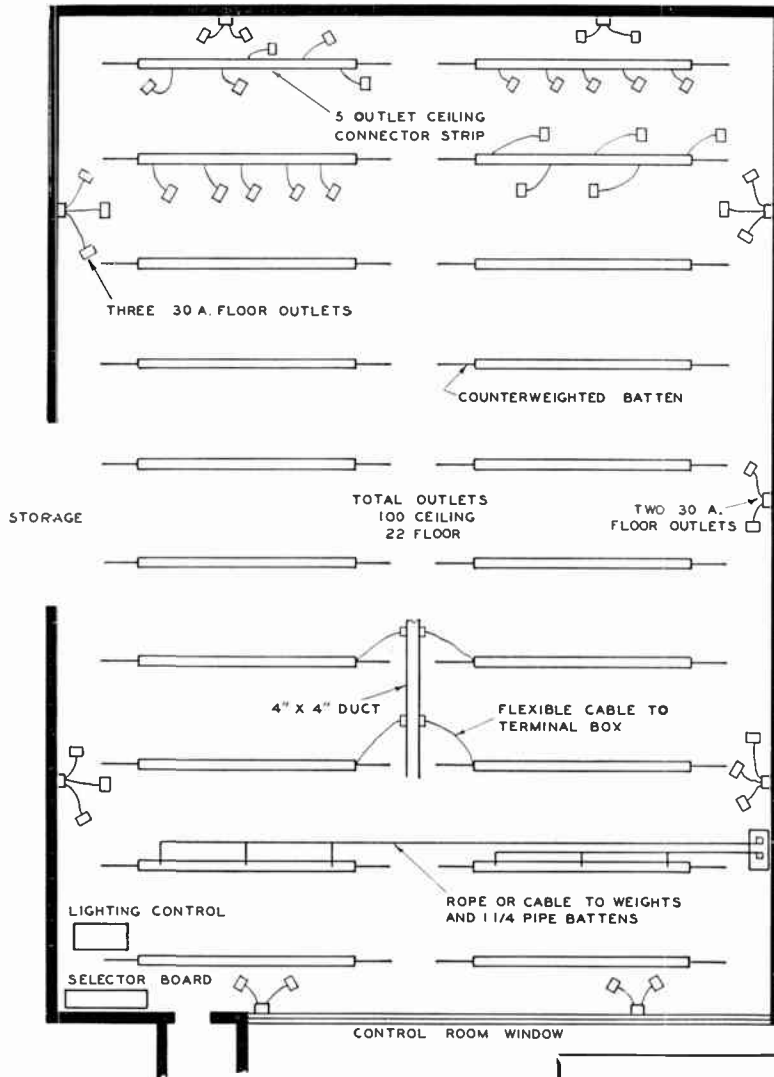

FIG. 59. Studio #1 lighting plan for the "C" Station. The lighting for Studio #2 is similar to that of the Plan "B" Station. (See Fig. 44.)

9. Control room and master control arrangements.
10. Extent of film programming.
11. Film previewing, processing, editing and storage.
12. Clients' rooms.
13. Audience participation space.
14. Provide enough monitors to achieve smooth program performance.
15. Check necessary Audio and Intercom facilities.
16. Studio lighting.
17. House monitoring systems.
18. Mobile unit for remotes.

FIG. 60. Plan "C" studio arrangement for proper ceiling height to permit varying "scenery set" heights.

sive amount of editorial space. However, it is recommended that the following "check points" be kept in mind. It is further recommended that the services of a qualified Engineering Consultant be obtained to assist in this development of the basic planning and preparation of an application in its final form for presentation to the FCC.

1. Effect of future expansion of operations.
2. Transmitter Power Increases.
3. Site selection, antenna heights, and coverage for UHF.\*
4. Provide good power source.
5. Trench or duct layouts.
6. Floor loadings.
7. Check sizes of doorways to permit entrance of individual equipment units and scenery.
8. Avoid TV operation in vicinity of AM station or other interference generators.

\*"UHF in Portland" by John P. Taylor, Sept.-Oct. 1952, BROADCAST NEWS.

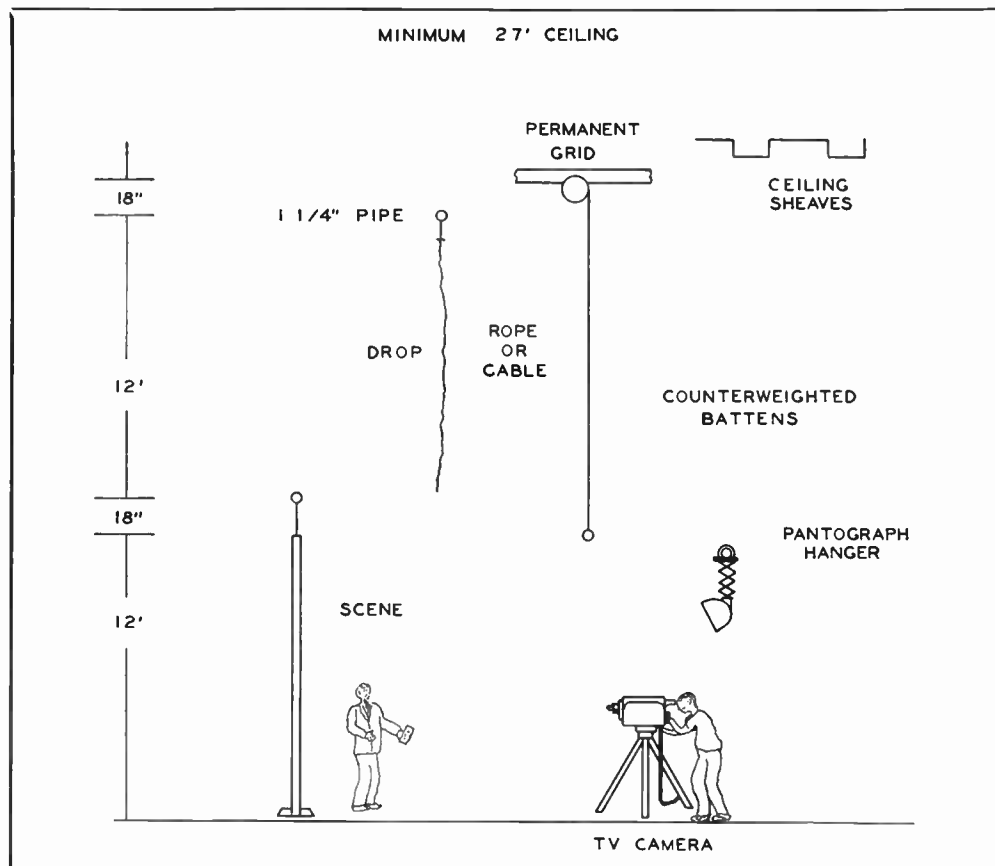

# Television Camera Equipment

## Introduction

The basic element or building block in a television system at the point of program origination is the camera. It corresponds to the microphone in the pickup of a purely aural program. A TV camera, of course, is a much more complex piece of equipment than a microphone, and likewise the auxiliary control equipment associated with the camera is also more complex than its aural counterpart.

In a TV station, there are three distinct types of program sources which require the use of local cameras, and these require three corresponding kinds of camera equipment. They are:

1. Studio programs utilizing live talent in performances which are usually rehearsed prior to broadcasting. Equipment for this purpose is called studio equipment.
2. Remote pickups of events which also involve live talent, but which are usually unrehearsed. Examples are baseball and football games, parades, prize fights, conventions, etc. Equipment for this purpose is called field or portable equipment.
3. Film programs which utilize standard motion picture film as the source of both picture and sound. Equipment for this purpose is known as film equipment.

Studio and field cameras themselves are identical, but the control equipments for the two types are not the same in physical form, though the circuits in them are essentially alike. In the *field* equipment, all of the auxiliary control units are packaged in housings shaped like suitcases which make it possible to transport the equipment quickly and easily to the program source. Camera tripods and dollies are relatively light and are made collapsible to facilitate moving to location. On the other hand, the auxiliary equipment associated with *studio* cameras is designed for permanent installation in consoles and racks. Camera mounts (dollies, pedestals, etc.) used in studios are relatively large and massive to permit smooth control of motion across the floor. It should be noted that the *field* equipment may be used in a studio location as well as elsewhere.

*Film* equipment bears some resemblance to studio equipment in that the auxiliary control units are also intended for permanent installation in consoles and racks. The *film camera* itself, however, bears little resemblance to either field or studio cameras. It employs a different kind of camera tube (pickup tube) better suited to film reproduction, and furthermore is usually mounted in a fixed position with respect to the film pro-

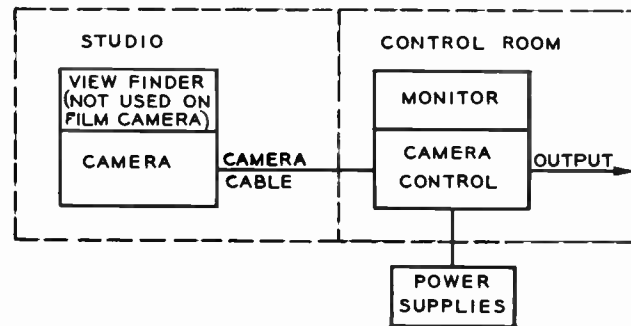

FIG. 1. Simplified block diagram showing the basic items which make up the camera chain.

jectors. A still further difference lies in the absence of lenses in a *film* camera, since the optical elements required are integral parts of the projectors. Conversely, the lenses required in *studio* and *field* operations are integral parts of the cameras.

## The Camera Chain

In spite of differences just discussed, all three kinds of camera equipments have certain basic similarities in circuits, in the division of equipment into major units, and in the manner of operation. Portions of the auxiliary equipment are common to the entire system, while other parts are associated with individual cameras. From the standpoint of keeping the number of major units small, it might be considered desirable to house all of the equipment directly associated with a camera in the camera itself, but this would result in a large unwieldy camera. Furthermore this arrangement would put an impossible burden of complex control on the camera operator. Therefore the cameras are designed to provide minimum size and weight consistent with satisfactory performance, and to provide a minimum of control functions for the camera man. Other parts of individual camera equipments are placed in control consoles and racks. The camera and those control and auxiliary units which must be duplicated for each camera are commonly called a *camera chain*.

Fig. 1 is a block diagram which portrays the arrangement of the major units in a camera chain. All three kinds of camera equipment conform to this basic arrangement with exceptions as indicated. The way in which several camera chains fit into a station installation is illustrated in Fig. 2, though many essential details are omitted in this block diagram. More detailed information on station layouts may be found in the section on Systems, but this basic arrangement will be found in all examples.

### Circuits in Camera Equipment

The allocation of major circuits among the units in the camera chain follows the same pattern in all the types of camera equipments. Among other things, this makes it possible to use a single standard type of camera cable for interconnecting cameras and camera controls in all cases. Briefly the general plan of allocation is as follows:

#### Camera Circuits

1. Video preamplifier.
2. Complete horizontal and vertical deflection circuits for the camera tube.
3. High voltage supply for the camera tube.
4. Heater supply for all tubes (except in film camera).
5. Miscellaneous preset controls.
6. Intercommunication circuits (except in film camera).
7. "On the air" tally.

#### View Finder

1. Video amplifier for driving grid of view finder kinescope.

2. Complete horizontal and vertical deflection circuits for kinescope.
3. High voltage supply for kinescope.
4. Heater supply for all view finder tubes.
5. All operating controls for view finder circuits.

#### Camera Control Circuits

1. Video amplifier including:
  - (a) Video gain control.
  - (b) D-C insertion (Blanking level control).
  - (c) Addition of shading signals.
  - (d) Two or more multiple outputs for line output and monitoring.
  - (e) Gamma.
2. Heater supply for all tubes in the camera control.
3. All operating controls for maintaining picture quality at the output of the chain.
4. Link circuits connecting intercom in camera to program directors position.

#### Power Supplies

1. Regulated B supply for all tubes in camera, view finder, and camera control.
2. Regulated current supply for focussing field coil in camera. (Not used in film camera.)

FIG. 2. Block diagram showing how several camera chains fit into a TV station installation involving two studios.

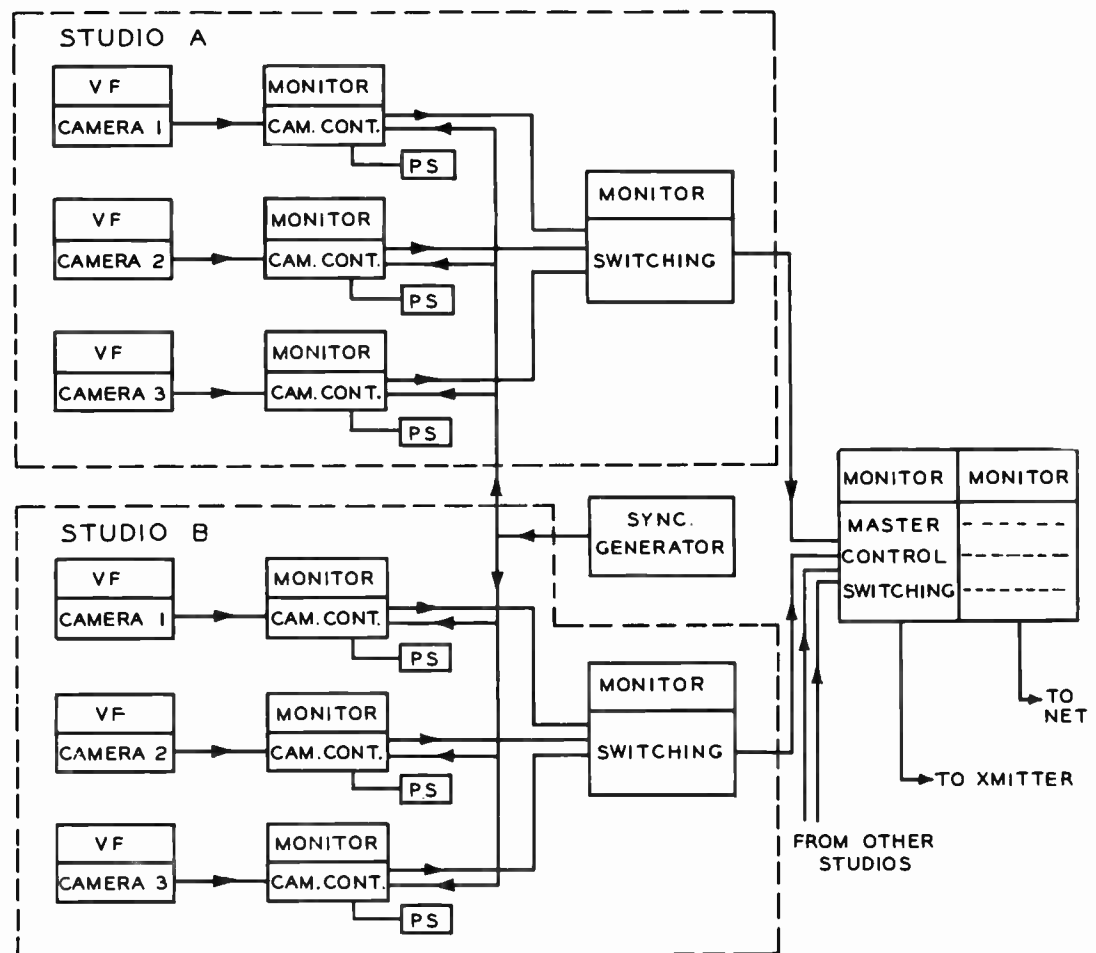

# The TK-11A and TK-31A TELEVISION CAMERAS for Studio and Field Use

The TK-11A and TK-31A Image Orthicon Camera Equipments for monochrome television pickup supersede the TK-10 and TK-30 equipments. Each equipment embodies many improvements and features not found in earlier or competitive types, and continues to include all of the desirable basic characteristics of the earlier models which have proved so successful in daily studio and field operations.

In contrast to the previous models, the design is centered around a single type of all-purpose camera which may be used *for either studio or field application*. Associated with the camera is an electronic view finder, also available in only a single design which matches the camera. Past practice in the packaging of studio and field camera controls and power supplies has been continued, but with improvements and new features. The general appearance and characteristic styling of the RCA equipment have been preserved, making it possible to mix new and old equipment without sharp contrast in appearance.

Almost complete interchangeability with the TK-10 and TK-30 equipments has been achieved. The interchangeability extends to all of the major units, lenses, and interconnecting cables with the exception of the field power supply. In this case, the TK-30A power unit may *not* be substituted for the TK-31A power unit because of the increased power requirements of the new field camera chain. However, the new

field power supply may be substituted for the old unit.

For the most part, operating techniques are the same as for the TK-30A models. The principal operating controls have been retained in the same form and in the same locations. However, because of added features, many of the secondary controls have

been relocated or eliminated and some new controls have been added.

The over-all objective of greater stability and flexibility in performance have been achieved, together with greatly improved mechanical design which will permit less expensive and more rapid manufacturing and greater ease in servicing.



FIG. 1. Close-up of the camera from the cameraman's operating position. ▶

Figs. 2 and 3 show block diagrams for the TK-11A and TK-31A camera chains.

### General Description of Camera and Viewfinder

The camera comprises a mounting for the image orthicon pickup tube together with its focus, deflection, and alignment coils, complete horizontal and vertical deflection circuits, a video pre-amplifier, and an optical system consisting of a turret with four lens positions and means for adjusting optical focus and iris openings. It is entirely self-contained except for a B power supply and certain electrical controls which are located, for operating convenience, at the camera control. All electrical connections are made through a single

cable and plug which carry input power and sync generator signals to the camera, and video output and control circuits from it.

Physically, the camera is divided into three main compartments. In the center compartment is located the pickup tube with its deflection, focus and alignment coils. The two side compartments, accessible by opening the side doors, contain the video and deflection amplifiers respectively. On the front end of the camera is the lens turret, and on the rear are some of the electrical controls and the control handle for rotating the turret. On the right-hand side of the camera (from the rear or operating position) is the optical focus control



FIG. 4. View of TK-31A camera mounted on a TD-1A Studio Camera pedestal.

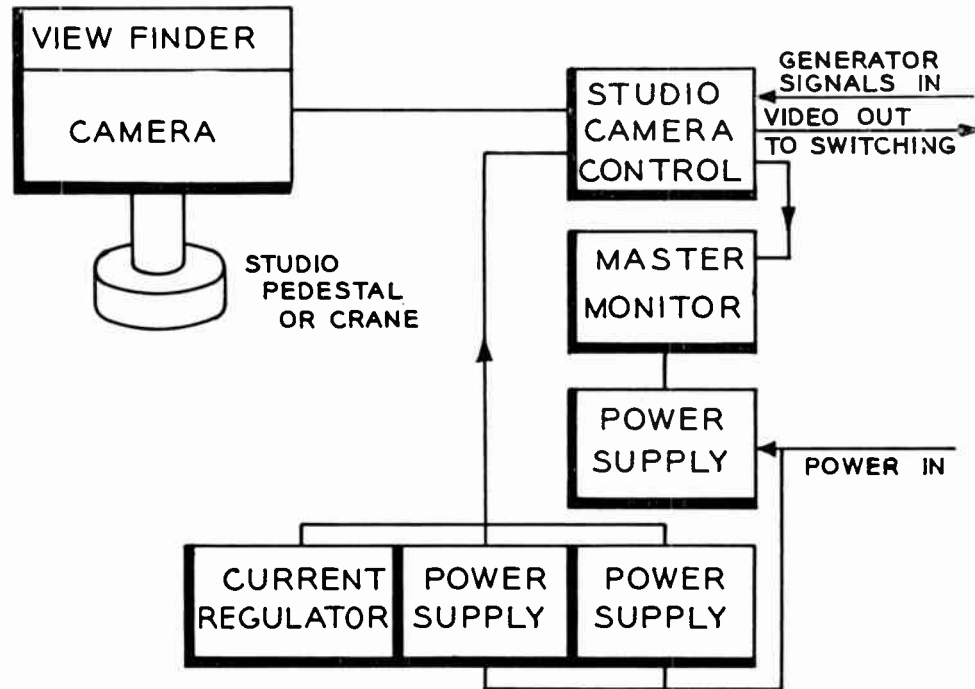

FIG. 3. Typical equipment lineup showing the Field Camera chain.

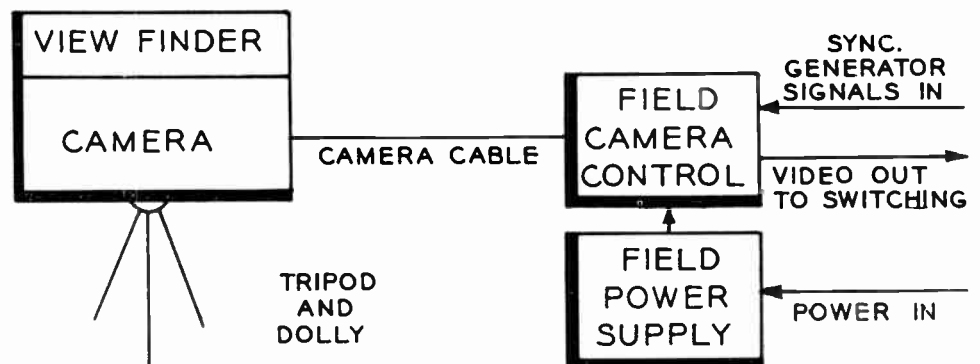

FIG. 2. The Studio Camera chain includes associated control equipment and power supplies as shown above.

handle. This focus control and the turret handle are normally the only two controls which require the attention of the camera man during a program.

The camera focus coil-yoke-alignment coil assembly moves on ball bearing slides. Although rigidly fastened to the frame when in position, the entire assembly is removable in a few moments for servicing because it is indeed a plug-in unit. This suspension is smoothly driven through its entire travel for optical focusing by  $2\frac{1}{4}$  turns of a focus knob. The knob remains

in place when the side door is opened. This drive mechanism imparts a non-linear motion so that relatively great image orthicon motion per degree of knob rotation is obtained for long focal length lenses and close ups. In contrast, a vernier motion is provided near infinity focus where rapid motion would make accurate focussing difficult. (See Fig. 8.)

The TK-31A yoke (see Fig. 7) provides better shading, less geometric distortion and improved shielding of deflection fields

from the image section. A simple wrap-around mu-metal shield extends from the image end past the alignment coils for quite complete shielding against external magnetic fields.

An improved alignment coil assembly has been incorporated in the camera. It comprises two pairs of coils in space quadrature so that independent control of currents in the two pairs of coils will produce a correcting cross field in any direction required. In this system, no mechanical adjustment of the coil is required; it is rigidly

**FIG. 5.** "Inside-out" accessibility seems to best describe the mechanical layout and design which makes camera and viewfinder circuits easy to reach.

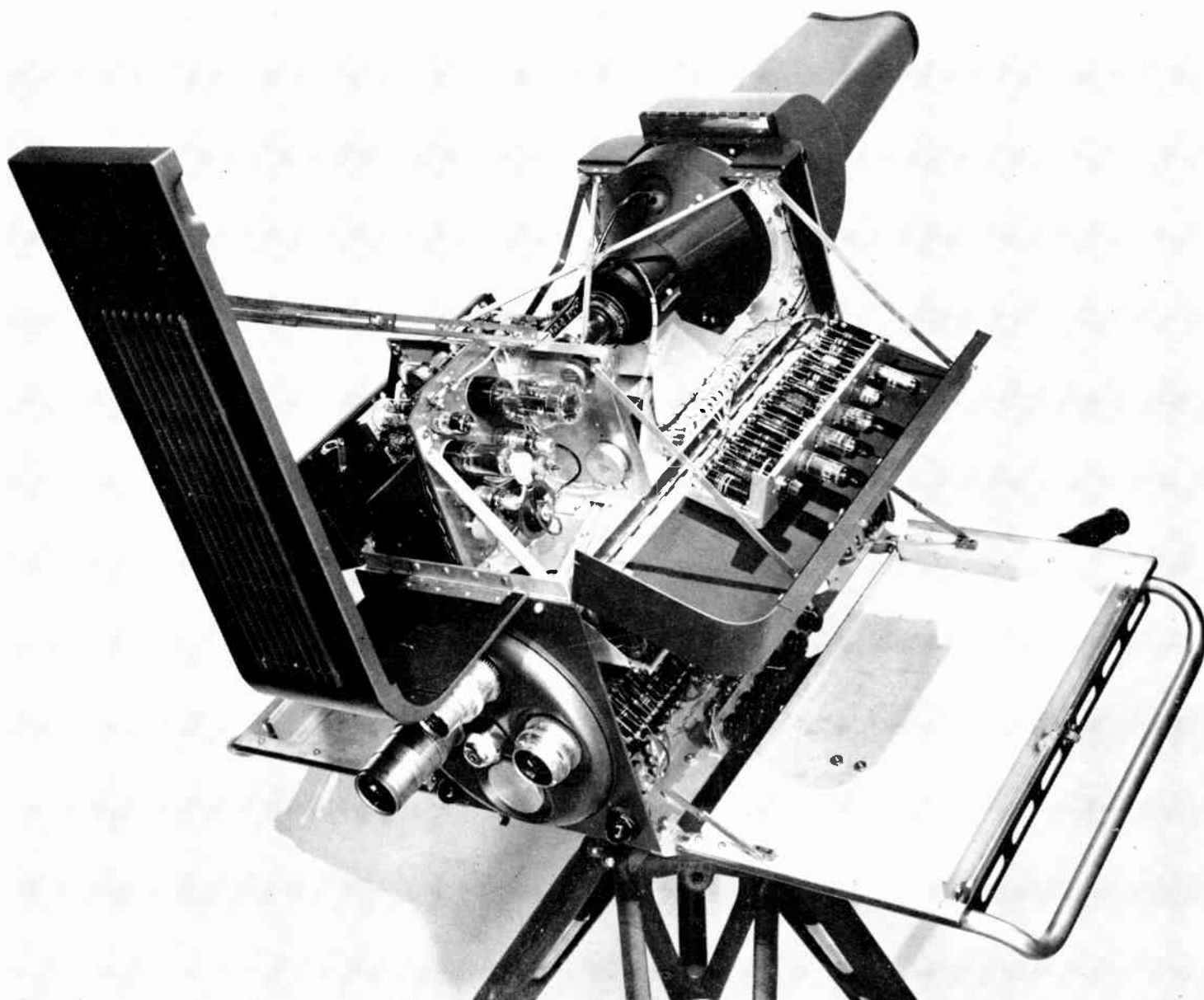

mounted. The alignment procedure involves the simultaneous adjustment of two potentiometer controls which determine the currents in the two sets of coils.

In order to simplify the alignment procedure, an auxiliary orthicon focus control has been included in the camera. Temporary control of orthicon focus at the camera may be selected by operating a switch on the rear of the camera. The camera man himself may then "rock" the focus back and forth to check the setting of the alignment controls without requiring the services of a second operator at the camera control position. At the conclusion of this adjustment procedure, the selector switch may be returned to normal, and the control of orthicon focus thereby restored to the camera control position.

The blower is readily unplugged and removed from underneath the camera and when slipped in place makes connection with a gas mask type hose which directs the cooling air to the base end of the image orthicon. This air is restrained at the base end by a gasket and is forced between the tube and deflection coils and between the yoke and focus coil where



FIG. 6. Side view of camera with viewfinder removed. Note convenient carrying handles.

space has now been provided. A redesigned shoulder socket and retaining mask permit exit of air in the front while a preset thermostat contained in the mask (in intimate contact with the photocathode) sam-

ples tube temperature to activate a relay-rectifier circuit for blower cycling free from electrical surge. This arrangement is capable of automatically maintaining proper orthicon operating temperature for stable performance and longer tube life. Provisions are also made for continuous operating of the blower and the target heater to meet extreme conditions.

To facilitate proper adjustment of the light reaching the photocathode of the pickup tube, a system for remote control of the iris in the objective lens has been included in the camera. The system includes both control and indication of iris setting. This is provided at the camera control position. The movement of the iris is obtained with a small d-c motor and gear train mounted directly on the lens and

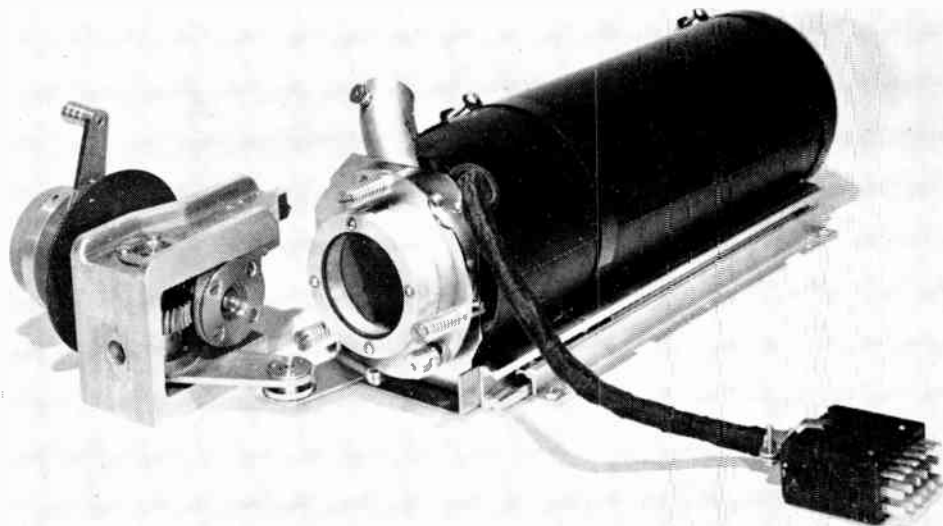
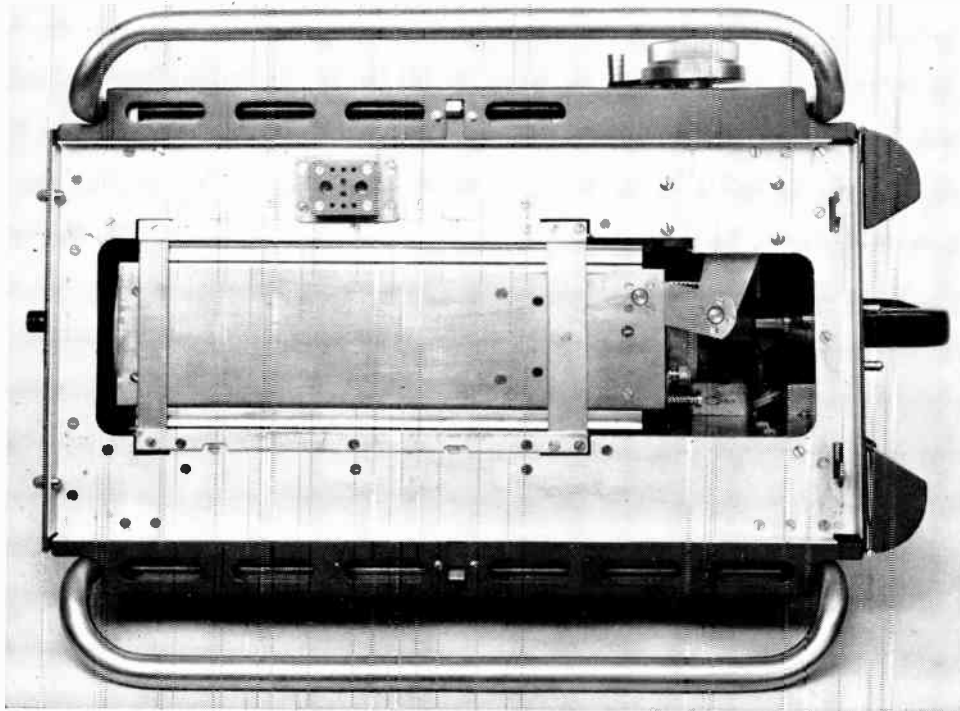

FIG. 7. Yoke assembly and focus drive mechanism removed from the camera. Note blower hose fitting and plug for electrical connections.



**FIG. 8.** Top view of the camera with viewfinder removed. Note the yoke assembly mounting and rigid focus drive mechanism.

coupled to the control circuit through brush contacts on the turret. A potentiometer, also part of the motor assembly, geared directly to the iris gives an electrical potential which indicates the iris position. This indication is presented on a meter at the control position. The circuit connections for both motor control and indication are made through the camera cable by superimposing these circuits on the existing program sound circuit. The only operating control is a two-way lever key (telephone type) which provides for reversal of the motor for opening or closing the iris. Motion over the whole range is accomplished in about 6 seconds. A control panel, including motor power supply, control key, and meter, is available as part of either the field or studio type of camera control.

Lens turret control is positively indexed with an improved hand grip and a hollow shaft for the use of special lenses. A one-piece turret shaft, with a large opening from end-to-end, is employed. Space is provided behind the turret for a filter disc to control light without impairing control of

focus depth. Write-in tabs indicate the lens in use.

Side compartments are enclosed by hinged covers. Sturdy handle bars on the doors provide easy portability. Adequate ventilation is allowed but a splash plate protects the camera interior. A strong catch mechanism holds the door secure but can be easily released with one finger. When open, the doors are held horizontal with knuckle type stays to provide a ready service shelf.

Protection of the Image Orthicon is assured through the use of a protection circuit which cuts off the tube when there is a loss of driving signals, deflection circuit failure, or failure of the activating relay.

Vertical deflection incorporates feedback and phase correction for excellent linearity and stability without need for linearity adjustments. Target blanking insertion is at

**FIG. 9.** View (from cameraman's position) of lens changing handle and camera "setup" controls.

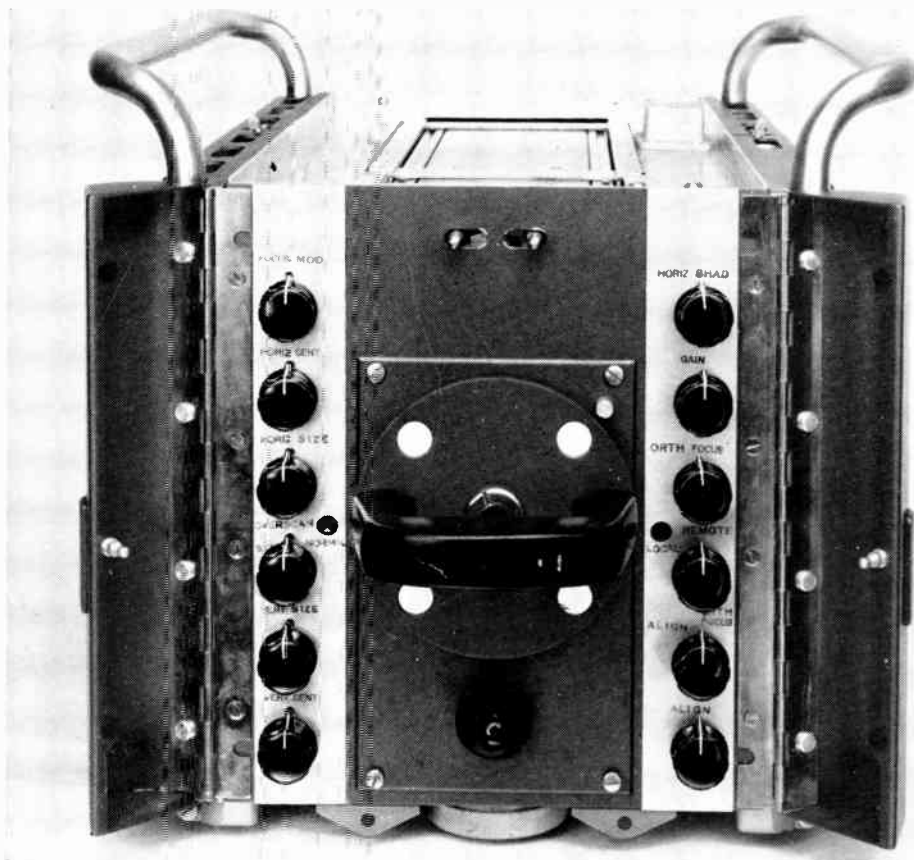



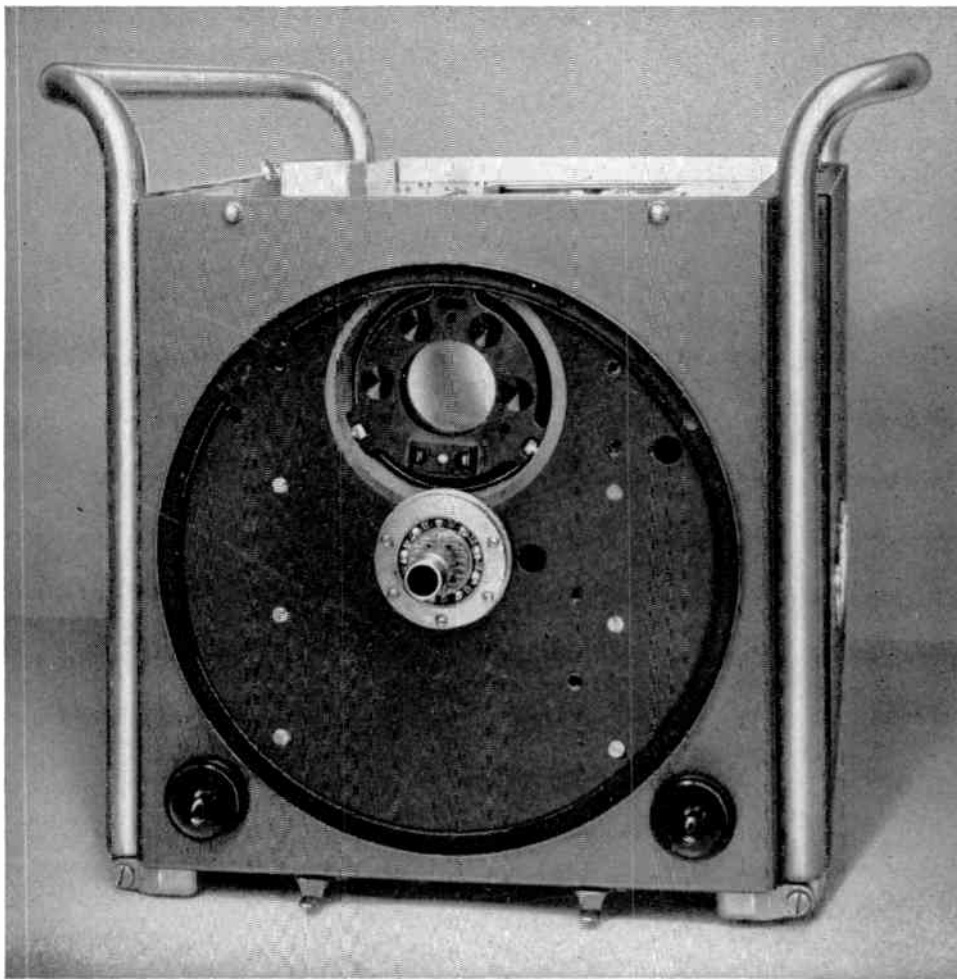

FIG. 10. Front of camera with lens turret removed. Note turret indexing and blower thermostat mounting in mask.

low impedance to eliminate crosstalk problems. Horizontal deflection has excellent linearity, single knob linearity control, and freedom from transients by an improved push-pull type circuit and a novel ferrite output transformer. A seven microsecond return time insures good operation even with the extreme delay conditions associated with 1000 foot camera cable operation. Adequate and symmetrical centering controls are available. Both deflection circuits can be switched from normal scan to 15% over-scan to guarantee against burned target areas during warm-up and rehearsals, while maintaining linearity and aspect ratio.

A pulse type high-voltage supply provides stable picture tube operating potentials and, incidental to this, a resistive configuration maintains constant loading

on the -500 volt supply as image focus is varied to speed the narrowing-down process when operation is being optimized during setup.

Focus modulation circuitry provides low-impedance feed of horizontal and vertical parabolic waveshapes in a 4/3 aspect ratio to the orthicon wall to provide continuous beam focus over the usable target area. Improved corner resolution results as does also the possibility of defocussing all multiplier blemishes simultaneously with a minimum of sacrifice in resolution.

The decelerator control is continuously variable from 0-135 volts for accurate "port hole" control. Image accelerator control provides "S-distortion" correction. Vertical deflection reversal is provided by a switch for quick transformation to operation with our TP-10A portable film projector for field film insertions. Switch is made at the same time to a preset centering potentiometer to insure operation with the same target area. Horizontal deflection reversal is possible in that two coaxial leads

FIG. 11. Underside view of the TK-31A camera. Note at right, blower assembly is made to pull out easily.

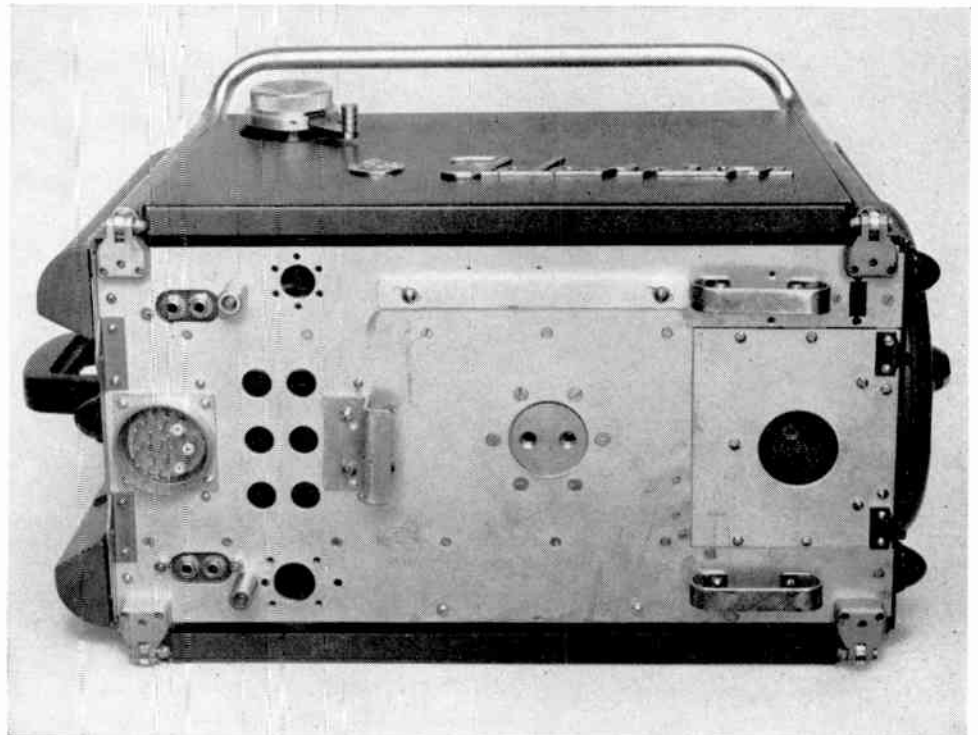

feed the yoke so that a simple change of the yoke connections at the yoke plug will permit, for example, multiplexer operation.

Horizontal shading at the camera position allows shading the viewfinder picture. A multiplier video gain control allows a cure in the rare case of dynode overload. A line voltage tap switch compensates for line voltage drop associated with different cable lengths. An elapsed time indicator records hours of tube operation conveniently.

Three miniature sensitive 24 volt relays are used—one for tally light service. Interchangeability with existing units is maintained but it is a simple wiring change here and in the new field control if 24 volt tally operation is desired.

The video pre-amplifier is a plug-in unit with all power connections made through a single plug and receptacle, and with three small coaxial connectors for the input, main output, and view finder output signal connections. The amplifier is mounted on rubber to minimize the effects of vibration and shock.

Ample gain insures a bright viewfinder picture with even a low-limit camera tube. Two stages of cathode high-peaking eliminate overshoot and smear by very accurately compensating for the amplifier input loss of high frequencies while reducing microphonics associated with conventional high peaking. Low frequency response is excellent here and on into the new controls to insure against "clamped-in streaking", which otherwise would appear as long "contrasty" streaks. A response uniform to 8.5 Mc transmits faithfully the entire orthicon capability. A feedback pair output stage adds viewfinder isolation, sending-end cable termination, linearity, and stability.

#### TK-31A Viewfinder

The TK-31A viewfinder (Figs. 5 and 14) permits the camera operator to evaluate

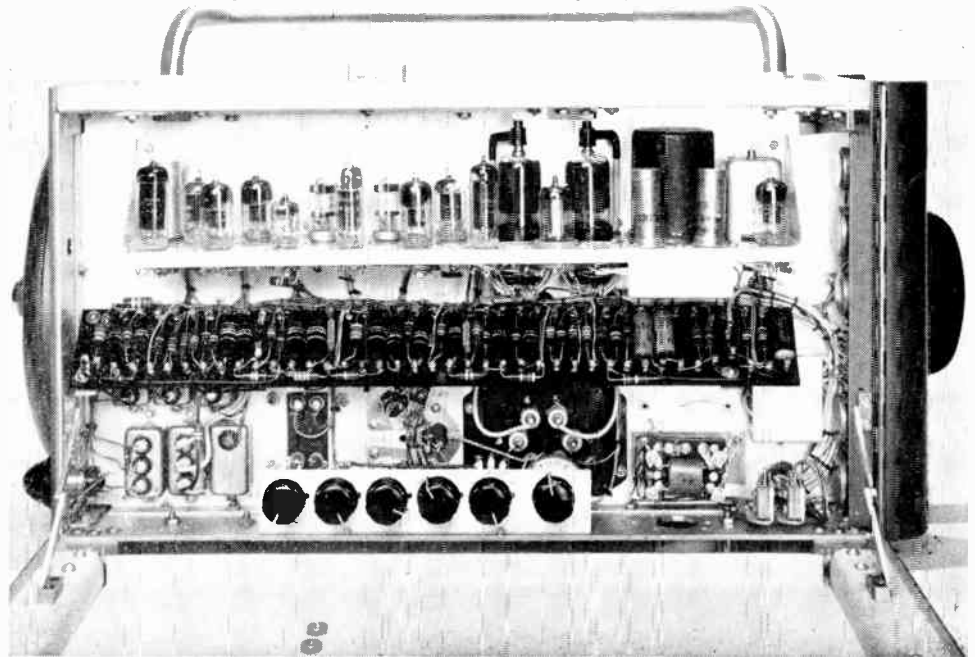
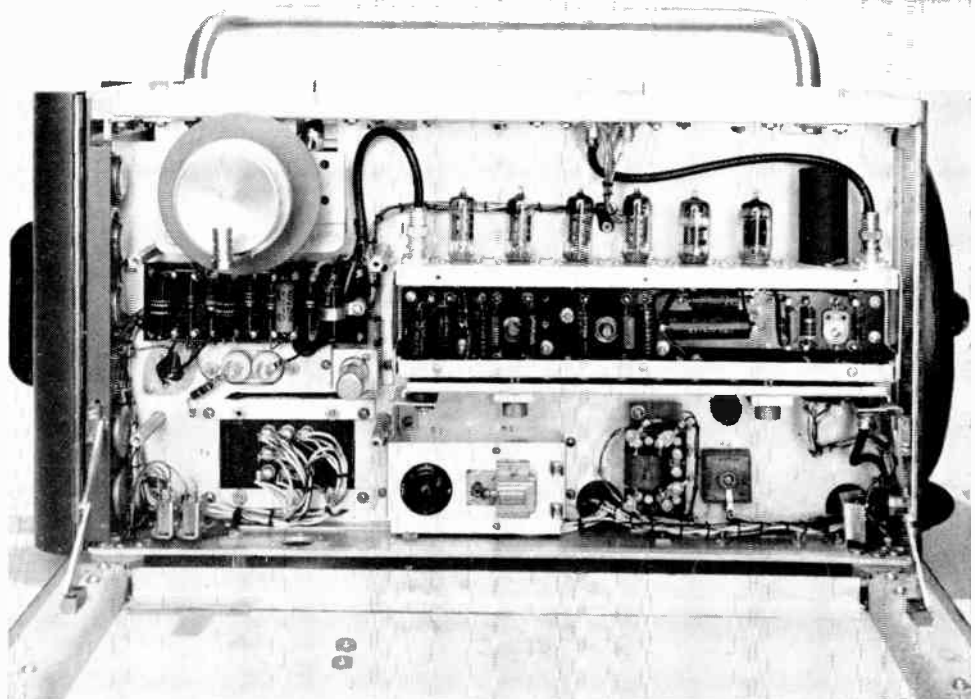

FIG. 12. View of deflection side of camera with door opened. Note miniaturized components, accessibility and convenient grouping of "setup" controls.

framing, focus, field of view and scene content. With its top lifted and sides open, components and circuitry are readily accessible. A 7-inch kinescope (used also in the field control) provides the cameraman with a larger picture to better evaluate his operation. It has aluminized backing, a

flat face, and a good gun with electrostatic focus to yield high brightness, excellent contrast, improved spectral characteristics, good overall focus, and resolving power such that the kinescope is not the limiting factor in detail reproduction. The front is easily detached for kinescope removal.

FIG. 13. Video side of the TK-31A camera. Cover is removed to show "plug-in" amplifier mounted in place. Note that focus knob is still in place for use.



Variable-width blanking permits the cameraman to see the "on-the-air" picture for accurate framing. Horizontal deflection is highly efficient; vertical deflection is a duplicate of the camera circuit; the video amplifier is wide band; and a driven clamp provides accurate DC restoration. An improved release mechanism is a two-finger, one-hand type.

A detachable viewing hood (See Fig. 16) may be rigidly mounted to the mask assembly to prevent stray light from striking the face of the kinescope. The number of exposed operating controls has been reduced to three (contrast, brightness, and focus) with rim-type control knobs protruding through the rounded corners of

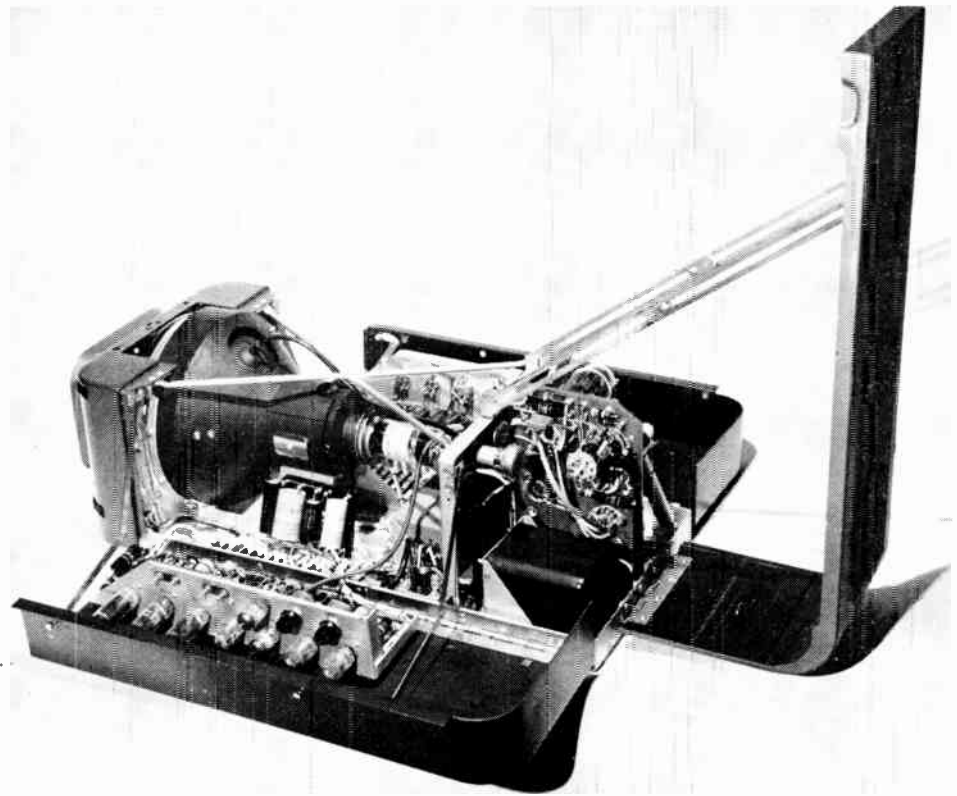
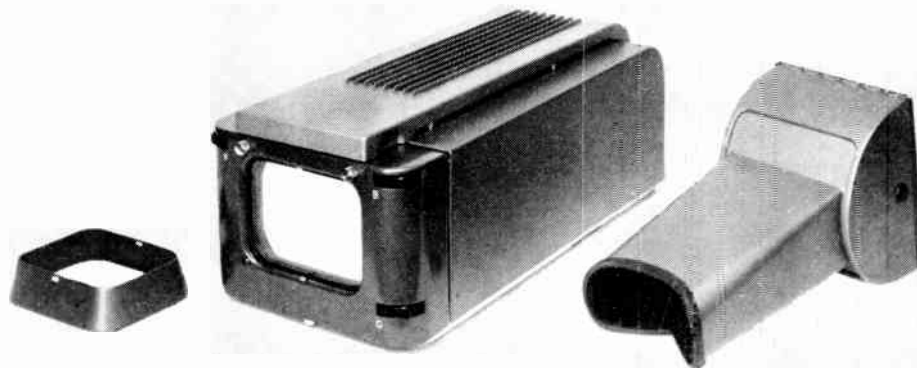

FIG. 14. Viewfinder opened up to show accessibility to 7" Kinescope and components. ▶



2. Synthesize the picture signal to be delivered to the video switching equipment (adjust signal level, add picture blanking signal, insert d-c component and shading, and provide monitoring signal).
3. Provide terminal facilities for the camera cable and other cable connections to the camera and the rest of the system.

◀ FIG. 16. Left to right: Light Shade, "Plug-in" Viewfinder and Viewing Hood.

the kinescope mask assembly. Other controls are normally pre-set and are located on the amplifier chassis. No interaction exists between the viewfinder and the camera.

#### General Description—Studio and Field Camera Controls

The basic functions performed by either camera control are the following:

1. Provide control of electrical performance of the pickup tube in the camera (electrical focus, beam current, etc.).

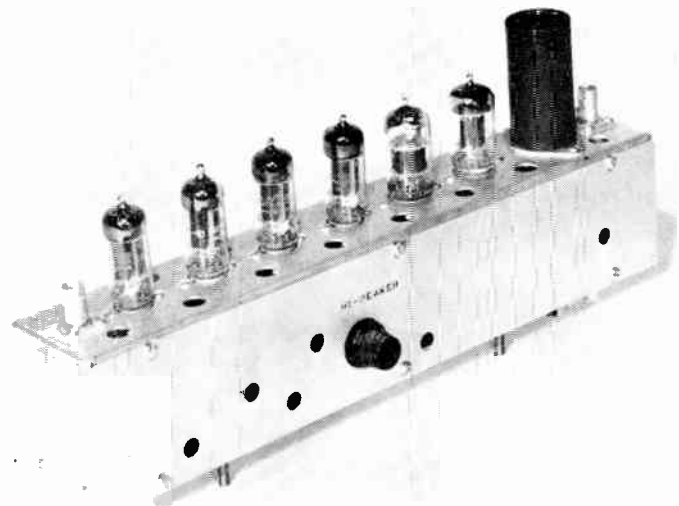

FIG. 15. "Plug-in" video amplifier of the new TK-11A and TK-31A Cameras. ▶

▶  
**FIG. 17. View of the TK-11A Studio Camera Control chassis which mounts in a standard console housing. All controls are accessible on removal of console front panels.**

The TK-11A studio camera control (see Figs. 17 and 18) closely duplicates the field control unit, which will be described on the next page, in so far as video circuitry is concerned. Regenerative blanking, gray scale alteration, sinewave clamping, fixed blanking set-up, shading addition, synchronization insertion, and stability due to feedback output are again provided. Synchronizing signals for preview monitoring are added to only one of the three identical outputs provided. Convenient "tip-jack" test points permit quick check of the unit by removing only the front console cover.

The connectors for camera cable, power cable, pulse input, and intercommunication

**FIG. 18. View of the Studio Control chassis shown mounted in standard console housing.**

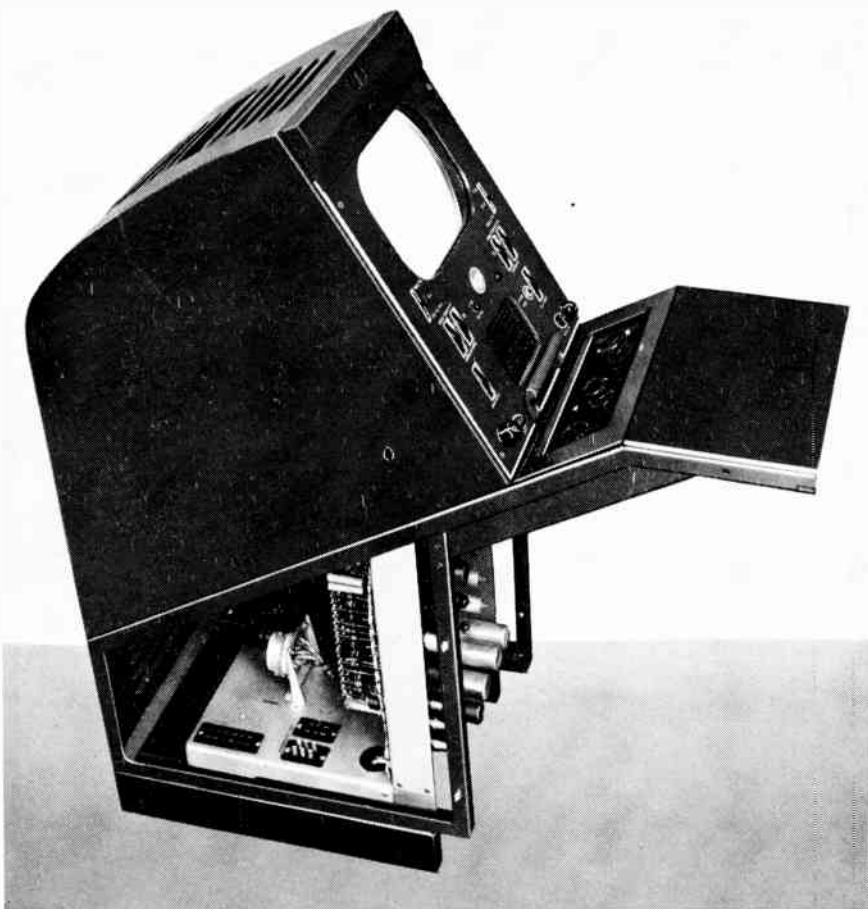
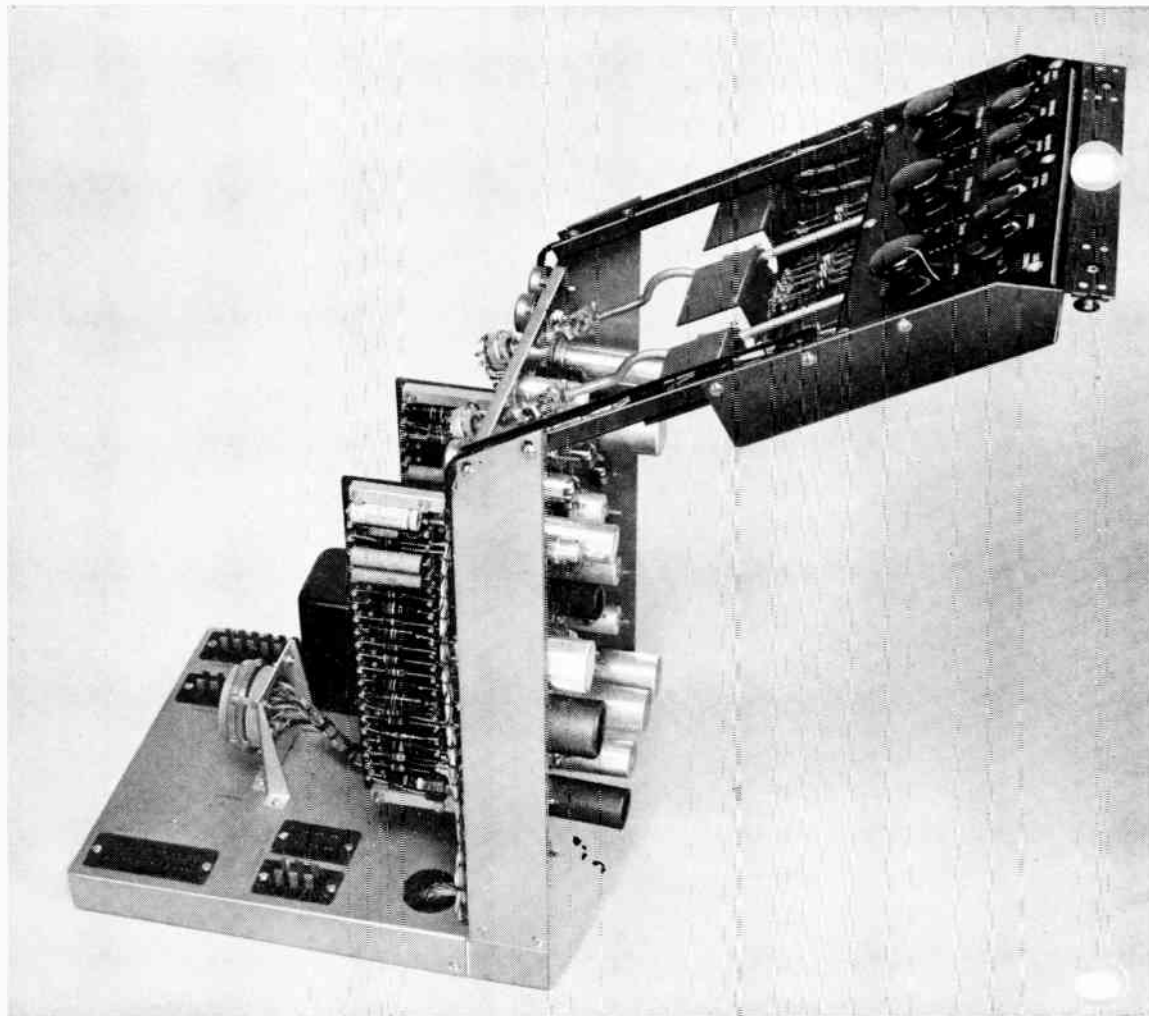

cables are located on the rear apron of the chassis in order to provide additional space for tubes and components on the main panel, and to simplify the process of withdrawing the unit from the console housing. Only the coaxial cable connectors for signal outputs are located on the front (tube) side of the main panel.

The TK-11A studio camera control is electrically and mechanically interchangeable with that used for the TK-10A, and may be used as a direct replacement for it with either TK-10A or TK-11A image orthicon cameras. The chassis and attached control panel are intended for mounting in the standard console housing.

A special lucite panel with matte black surface and edge lighting permits soft illumination of panel lettering without stray light, thus facilitating darkened control room operation.

The TK-31A field camera control for use in remote pickups employing RCA image orthicon cameras is a suitcase type of unit similar in appearance to TK-30A designed units of field equipment. It is interchangeable with the control used in TK-30A image orthicon cameras. However, the increased power drain of the TK-31A requires the use of an MI-26091 field power supply.

The field camera control is housed in a suitcase which is slightly higher than the TK-30A model, but otherwise is the same in size, making it possible to utilize the same shock mounts, consoles, and arrangements of equipment. Familiar placement of major controls and cable connectors has likewise been retained.

The mechanical construction of the suitcase has been modified to realize the benefits of sub-assembly construction as far as possible. A small blower has been included to give better cooling of the unit. Though the number of circuits and components has increased, the accessibility has been improved, thereby making servicing much easier.

The TK-31A field camera control design employs sine-wave clamping at three places to effectively establish black level and improve gray scale rendition while providing no high-frequency unbalance to damage the blanking waveform. A regenerative type blanking circuit stabilizes blanking insertion. Fixed blanking set-up adds a controlled amount of "blacker-than-black" blanking. Two "black-white" stretch circuit switches permit selection of four different conditions of gray scale alter-

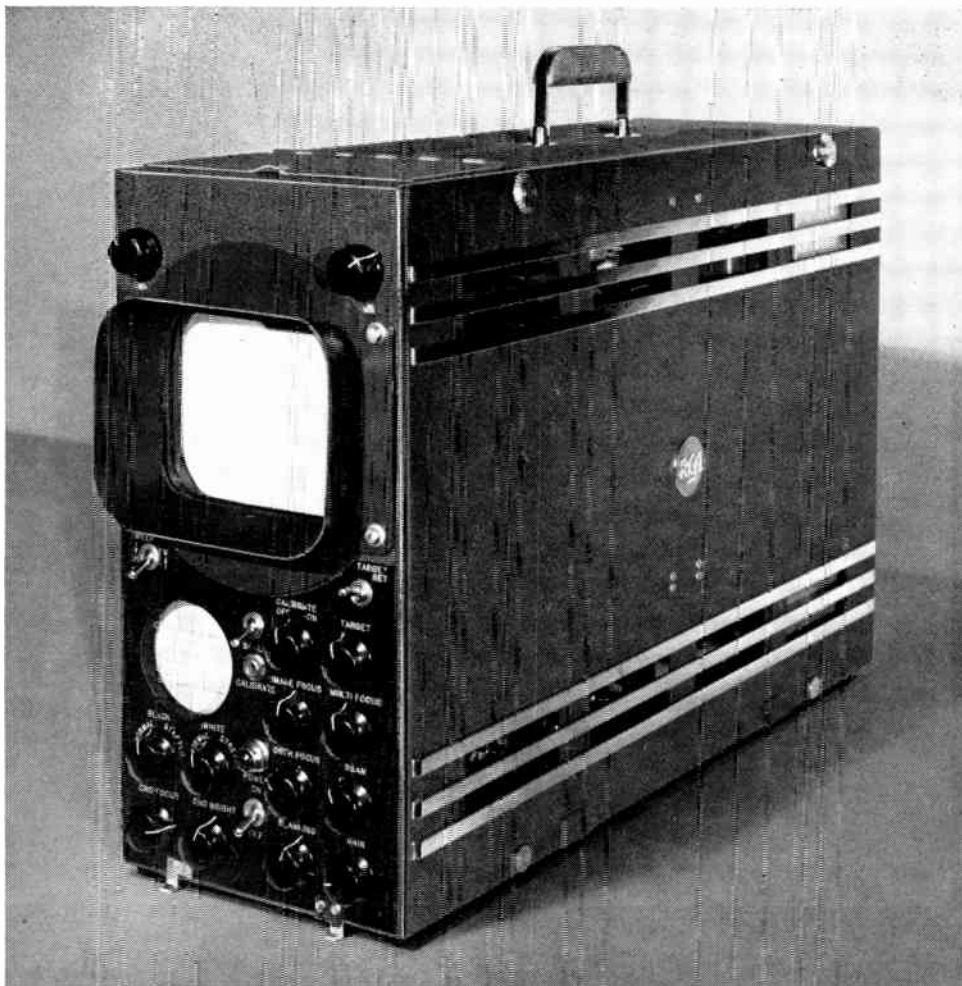

FIG. 19 (Top right.) TK-31A Field Camera Control is mounted in a "suitcase" type housing.

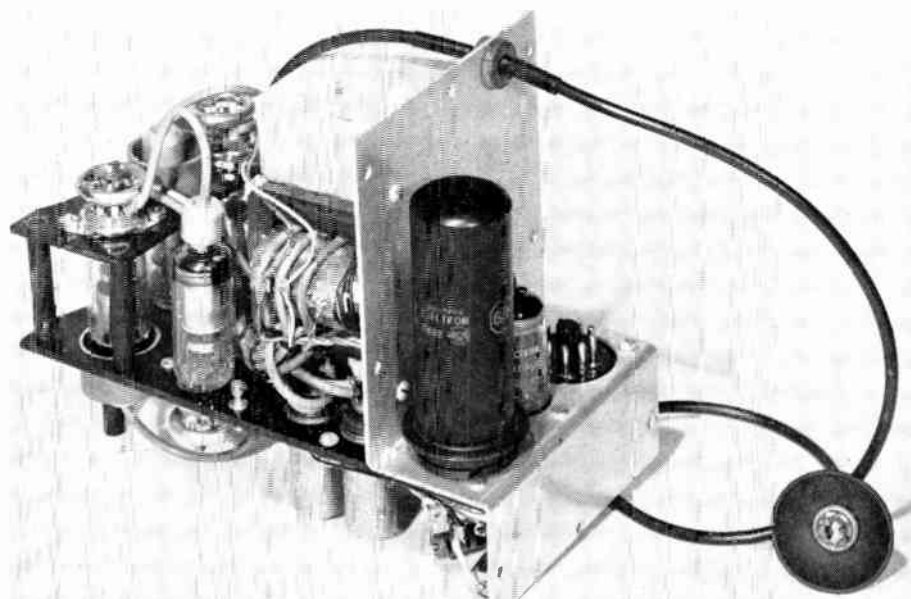

FIG. 20 (Bottom right). "Plug-in" R-F Power Supply for Field Camera Control. (Also used in TM-6A Master Monitor.)

ation while keeping overall video amplitude constant. The amount of stretch desired has previously been established by screw-driver adjustment. Synchronizing signals can be added in the unit. Provision is made so that all of the synchronizing generator signals can be readily bridged to other units before termination is made.

Two identical isolated video outputs are available from a feedback output stage for direct outgoing-line monitoring. This circuit also yields sending-end termination, improved linearity, and stability by virtue of its feedback nature.

Horizontal kinescope deflection is almost identical to its camera counterpart, as is vertical deflection. An extremely compact, efficient, and well shielded plug-in rf high voltage unit supplies a regulated 10-KV to the kinescope second anode, as well as kinescope focus, waveform monitor second anode, and bias voltages for the control unit, divorcing it in large measure from

the power frequency for "off-frequency" operation.

The waveform CRO is fed from a wide-band video amplifier with stable half-line or frame horizontal sweep speeds selected

by a switch. Astigmatism control yields a well defined spot. An illuminated standard scale with simplified calibration permits accurate level setting.

Camera operating controls are, of course, provided with "target-set" made automatic. Both vertical and horizontal saw-tooth shading signals of either polarity are available. Video response is compensated by a "3-position" switch for various cable lengths in common use.

The MH-26091 field power supply with improved cooling, greater power handling capability, and better series regulator balance provides a maximum of 1250 ma. at 285 volts regulated; 180 ma. at 380 volts unregulated; 75 ma. of regulated focus current; and centering current for the entire camera chain. It will regulate down to 600 ma. and it can be used with previous field equipment.

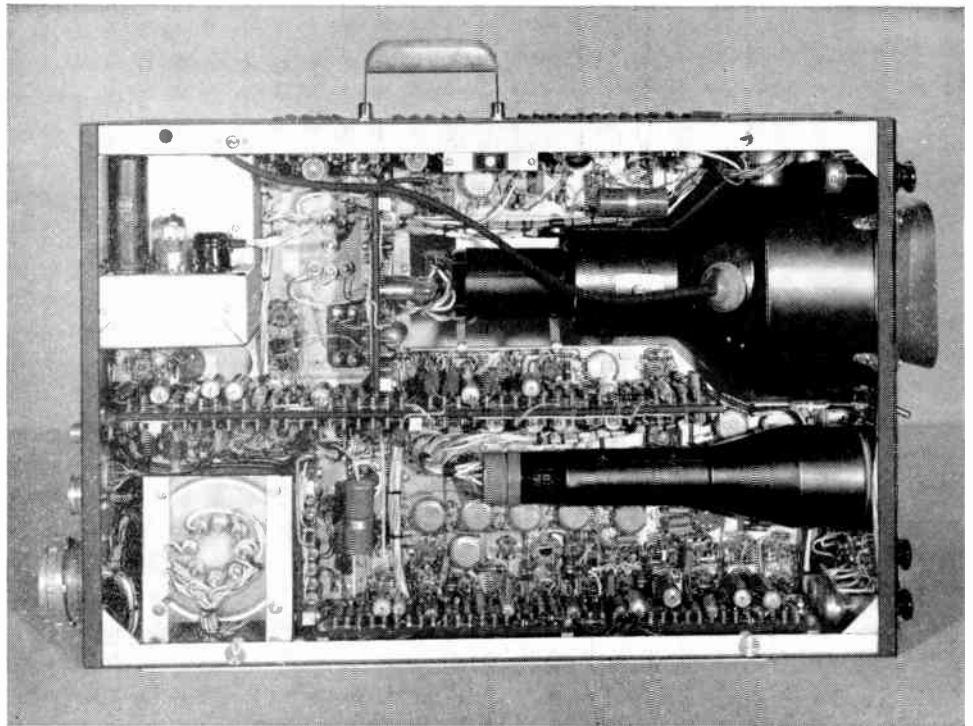

FIG. 21. View of the Field Camera Control unit with side removed to show access to Kinescope, CRO, r-f power supply, wiring, and small components.

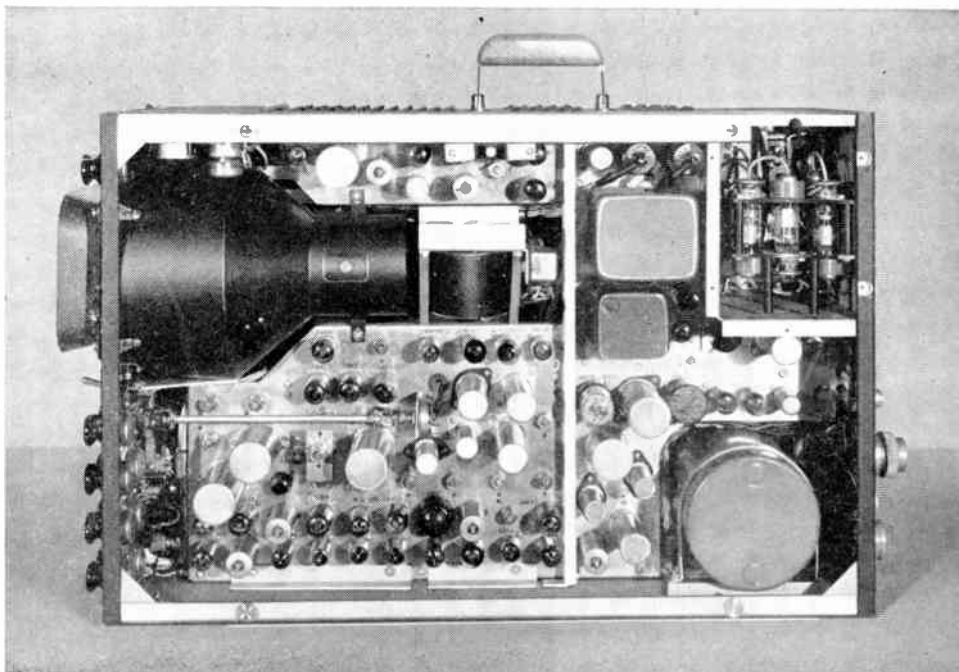

FIG. 22. Tube side of Field Camera Control unit showing how components are made accessible.

# The Film Camera Chain

The film camera described here and in the next article employs the type 1850-A *iconoscope* pickup tube which will produce a high quality television picture when operated with a TV motion picture film projector or slide projector. The camera houses the iconoscope bulb in the lower part of the case, and provides space for the neck of the tube, the deflecting yoke, and the video and deflection amplifiers in the upper part. Hinged covers provide access to the various compartments for servicing, adjust-

ments, and replacements. There are two special sources of light, one for bias lighting and one for edge lighting of the iconoscope. The picture is projected onto the mosaic of the iconoscope through an open window on the front end of the camera case. The film camera itself does not require any lenses or optical focussing mechanism.

Unlike the studio camera, the film camera is usually mounted on a fixed pedestal which is firmly fastened to the floor (see Fig. 1), though occasionally movable mount-

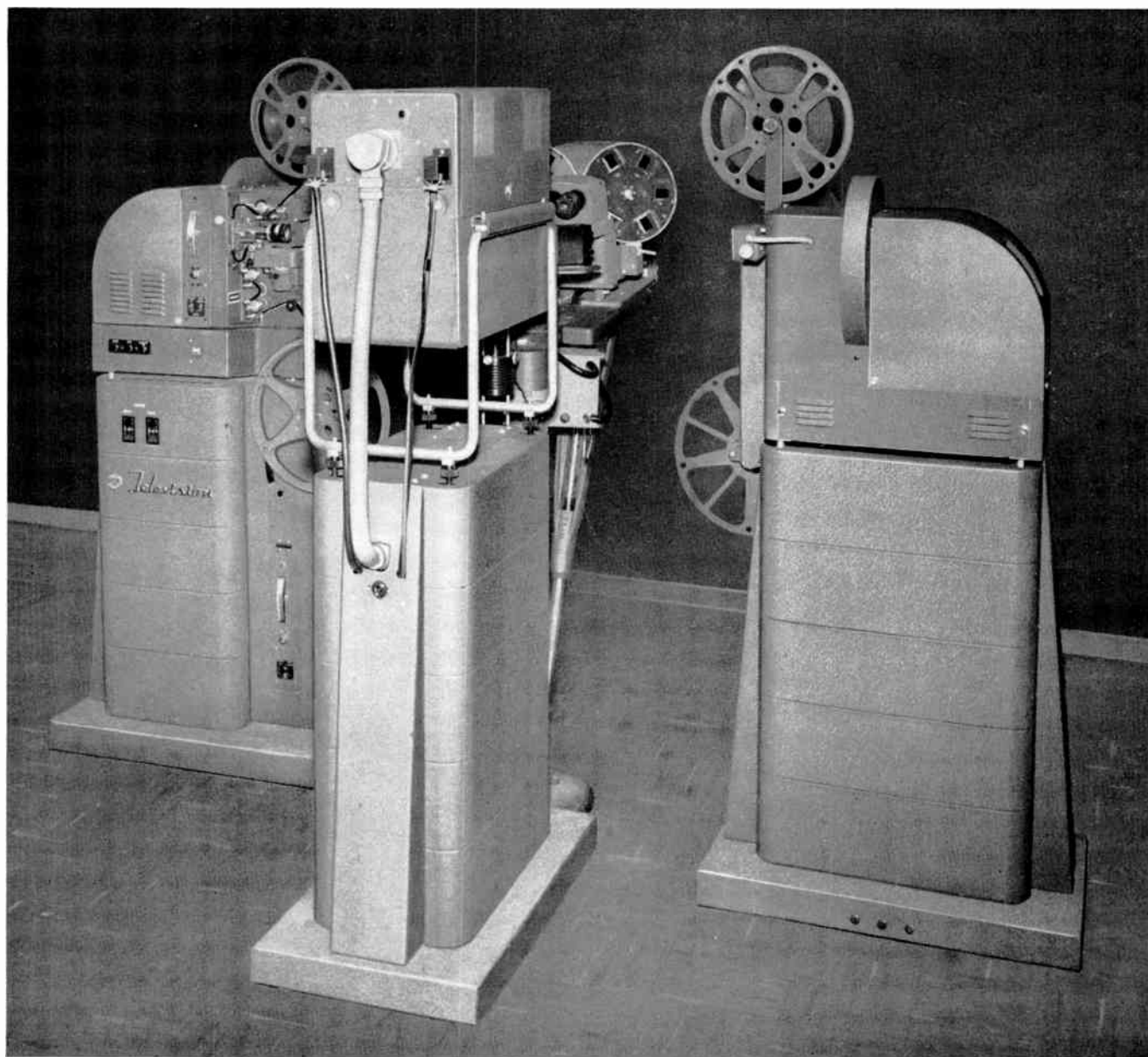

FIG. 1. Two 16mm TV motion picture projectors and a dual-disc slide projector being multiplexed into a TK-20D Film Camera.

ings are provided so that a variety of projectors may be used with a single camera. The most common practice is to fix the camera in one position and use the RCA Film Camera Multiplexer, also shown in Fig. 1, with two motion picture projectors and a dual disc slide projector.

Circuits and electrical connections follow the same general design as in the studio camera. Video and deflection amplifiers are located respectively in two side compartments. The deflection amplifiers, both horizontal and vertical, are completely within the camera. Certain preset controls are likewise located there. The standard type of camera cable is used, but is provided with a metallic external shield on that portion which is not otherwise enclosed within the pedestal in order to conform to fire regulation applying to many projection rooms.

The film camera normally requires no direct attention during periods of operation. Thus, only one man is necessary (at the camera control) to supervise the operation of a film chain.

### **Film Camera Control**

The film camera control is similar to the studio camera control. Physical arrangements of chassis controls, monitor, and housing are similar. The differences lie in the variations of circuits and controls which are peculiar to each camera and pickup tube. All operating controls are placed at the operator's finger tips on the panel at the bottom of the master monitor panel. Other less used controls are under the hinged panel. Housings containing studio camera controls and film camera controls may be placed adjacent to each other in the same operating console.

### **Power Supplies**

Two type WP33B regulated power supplies, both rack mounted, are required to operate a complete film chain, one for the master monitor, and the other for the camera and camera control. The total power required is approximately 1100 watts, 117 volts, 60 cycles, single phase.



# IMPROVED FILM PICTURE PERFORMANCE WITH THE TK-20D FILM CAMERA

Developments in the art of television broadcasting during the past few years have shown very forcibly that programming is depending more and more heavily on film material either as a basic source of programs or for continuity in live broadcasts as well as for the usual advertising sources. It has also been recognized that the quality of film transmission as compared to live-talent material leaves, in many cases, much to be desired. An ideal situation would be one in which the home viewer would not be aware whether the source of broadcast material were live talent or film recording. With the now wide-spread and continuing increase of kine-photography this criterion of performance becomes more and more vital to the success of any long-range operation. Recent studies on methods of improving motion picture reproduction in television broadcasting have arrived at very encouraging conclusions. The iconoscope film chain, when suitably operated and improved according to these studies, can produce pictures which closely approach studio quality.

Factors as investigated were:

1. Video Amplifier
2. Mosaic Illumination
3. High Peaking and Microphonics
4. Amplifier Over-Load
5. Black-Level Control

## 1. Video Amplifier

The predominant source of noise in an iconoscope chain is not the iconoscope itself but the first-stage amplifier. Extensive study of this problem resulted first in the development of a cascode preamplifier using the Western Electric 417A triode for the input, feeding an RCA 6J6 as the output tube. This preamplifier unit physically replaces the conventional triode-connected RCA 6AK5 stage used in previous equipment. Since the transconductance of the 417A tube is approximately 25,000, the improvement in equivalent noise resistance over the RCA 6AK5 is 5 to 1 giving an equivalent reduction in noise voltage which is the square-root of this number, or 2.24 to 1. This means that for the same voltage amplification the signal-to-noise ratio of the chain increases by at least a factor 2. This is certainly of primary importance. In addition, the use of the cascode amplifier makes the Miller effect relatively small as compared to that which exists in the conventional triode preamplifier. The overall voltage gain of the WE417A, RCA 6J6 cascode amplifier with a 1000 ohm load resistance is 24 as compared to approximately 8 for the original RCA 6AK5 stage. The 417A-6J6 cascode amplifier is particularly subject to parasitic self-oscillation in the region of 80 to 240 Mcs.

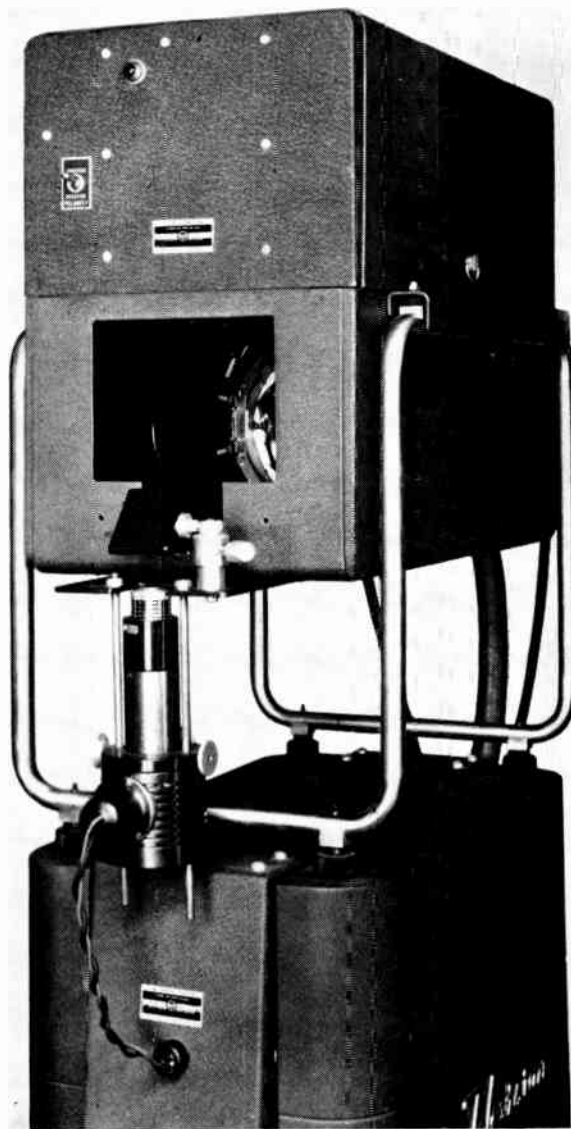

These have been suppressed by the use of small resistors in the first and second grid circuits and in the output-plate coupling condenser lead. By-pass condensers of very low inductance have also been provided in the filament circuits to provide stability against parasitic oscillations and pickup from filament supply. We have found it essential to operate the heaters of the cascode amplifier from D.C. in order to eliminate completely the familiar sharp 60-cycle "glitches" which exist on practically all 60-cycle power lines. The matter of heater power supply will be discussed in detail later. It has been found that the use of the RCA 6J6 in the second stage of the cascode amplifier entails practically no sac-

rifice in performance and at the same time allows the tube to be operated within the heater-to-cathode rating.

Later, a second preamplifier which now is used in the TK-20D Camera was developed. This unit makes use of two 6BQ7A triode tubes in parallel for the input section, and a single 6AG7 tube for the second half of the cascade preamplifier. Comparable performance is obtained from this new unit while making use of low cost receiving tube types.

## 2. Mosaic Illumination

### A. EDGE LIGHTING

This problem is one of the most subtle problems connected with the correct operation of an iconoscope chain. It is perhaps interesting to outline the function of an edge light in this manner: Any iconoscope which has "normal" sensitivity resolution and storage will have a rather restricted range of beam current (0.1 to 0.2 microamps.) within which satisfactory operation can be obtained. This is determined fundamentally by the effectiveness of edge lighting in providing sufficient photoemission from the mosaic frame to suppress edge and bottom flare associated with a given beam current. Restating the situation: It is important to operate with a maximum beam current within the above limits which can be used with the available edge lighting to produce a substantially flat and "flare-free field *when the active portion of the mosaic is in complete darkness.*" This edge-lighting requirement may vary between iconoscopes. The reason for choosing an unilluminated mosaic as a reference lies in the fact that flare is particularly prominent and annoying in fades to black and in low-key scenes. If the field can be made flat and black by the control of edge-light intensity and by introduction of electrical shading signals, all other modes of operation at higher light levels on the mosaic are non-critical of adjustment. It is important to point out that when correct and adequate edge-lighting is used, the flare is no longer dependent on the picture content of the active portion of the mosaic and therefore edge-lighting is introduced as a fixed adjustment during the initial setup of the iconoscope and need not be changed during actual use.

### B. EFFECTS OF STRAY LIGHT ON STORAGE

A factor which cannot be ignored is the effectiveness of edge-lighting in the illumination of the edges of the mosaic, also called the frame or mask, without at the same time throwing an appreciable amount of useless stray light on the active mosaic area. This useless light produces two effects which are inter-related. We are here concerned primarily with motion picture operation with light-pulse exposure occurring during vertical blanking time. In this case, all available picture information is on the mosaic as a stored charge image and should ideally persist at full amplitude from top to bottom of the vertical scan. Stray light from any source, either edge light-

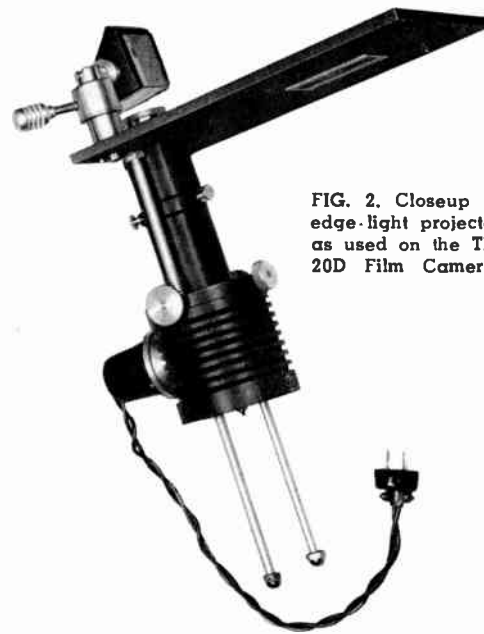

FIG. 2. Closeup of edge-light projector as used on the TK-20D Film Camera.

ing, back lighting, or accidental ambient room light, falling on the mosaic will tend to wipe out the charge image, giving a poor storage characteristic, and will produce a signal of progressively decreasing amplitude from top to bottom of the picture. This can, of course, be electrically shaded to have a flat axis but will show progressive slumping of detail contrast from top to bottom of the picture. Evidence from pulsed-light single-frame operation of stationary film indicates that, in the absence of edge, back, and stray light, the average iconoscope storage characteristic is excellent, but deteriorates rapidly with an increase in the intensity of stray light falling on the working surface of the mosaic.

The mechanism of the effect of stray light on the mosaic can be outlined by the following argument. Assume that the light application pulse is rectangular and lasts for 5% of the total field scanning time and that the light input-mosaic potential relationship is substantially linear. Then the average value of lighting is 1/20th of the rectangular light pulse peak. Now let us further assume that the stray light is uniformly distributed over the mosaic. What must be its maximum permissible value in order to have a tolerable small effect on storage? If the light range of film material is 40 to 1, a typical value for motion picture film, the black gamma step would be represented by 0.5 foot-candles on the mosaic and the white level step by 20-foot candles. Now if there is an area at the bottom of the mosaic which is black, 0.5 foot-candles, as a result of the light application pulse, an increment of a 0.5 foot-candles due to stray light will raise the effective potential of this area to that corresponding to one-foot candle; whereas the highlight potential has at the time been raised to 20.5 foot-candles equivalent, decreasing the effective charge image contrast ratio from

40 to 1 to 20.5 to 1. Thus a stray-light level of 2.5% of the average projector light intensity is sufficient to knock down the contrast ratio in the image by 2 to 1 at the bottom of the raster. Tests have been made of this reasoning by the use of a calibrated grey-scale wedge at the top and bottom of the picture under pulse-light or motion picture operating conditions.

Using an external projector to produce uniform stray light and adjusting the stray light to equal the average projector illumination, it is very easy to bracket the limits for permissible stray light. Using neutral density filters having 1, 2, and 5% transmission, one can demonstrate that 5% produces intolerable wash-out of storage, 2% is quite noticeable, while 1% represents an adequately low and readily attainable value. It should be pointed out that the effect of stray light is cumulative, having very little influence immediately after the light pulse and having greater and greater effect towards the bottom of the scan. The edge-lighting produced by a line source filament and the opaque slotted mask results in rather poorly defined edge-lighting and a rather large amount of scattered light on the active mosaic area when compared with the same "effective" edge-lighting intensity from an external edge-light projector. This is due to a great extent to the necessity for firing the edge-lighting image through the lower glass seal region of the iconoscope front face plate. This region may be inhomogeneous, striated, and quite variable from tube to tube. "Effective" edge lighting intensity is that which will sup-



FIG. 3. Film Camera Control Chassis mounted below Master Monitor.

press the edge and bottom flare in the iconoscope output signal *with no light on the mosaic* at the maximum operable beam current without causing the storage characteristic to deteriorate markedly. Various possibilities for edge lighting were investigated. An external projector edge-light mounted on the camera has been developed which has excellent performance and which does not hamper the chain operationally. This is shown in Figs. 1 and 2. As a result of our tests, it is our opinion that many iconoscopes criticized for poor storage actually have adequate storage but may work under severe handicaps as a result of limitations in the edge-lighting or back-lighting sources.

### C. INFRA-RED FILTERS

The use of infra-red and heat absorbing filters in the projector light path and in edge lighting sources has been investigated by several independent groups. It has been found that a polished plate of Corning #9788 filter glass\* approximately 5mm in thickness or equivalent does an excellent job in attenuating the high-energy infra-red and red components of the incandescent source to which the iconoscope is normally quite sensitive and thereby gives improved detail contrast and apparent gain in resolution.

The improved contrast with the use of a red cut-off filter for technicolor movies is truly startling, the contrast range going from very small values with no filter to completely acceptable values with the filter. A probable explanation of the observed effect is that when the lens is focused for a visible light image, the infra-red image is out of focus or diffuse, but still responsible for a large proportion of the mosaic photo emission. Removal of this component by the filter leaves only the sharp image information which results in gain of both resolution and contrast ratios. In the case of color film, the transmission of infra-red components between various color dyes in the various sections of the picture is substantially the same, producing practically no differential contrast. With removal of the infra-red, the dye absorption of visible light previously masked by the over-riding infra-red transmission is again normal and gives the observed increase in contrast.

### D. BIAS OR BACK-LIGHTING AND AUTOMATIC BLACK LEVEL CONTROL

The main function of variable intensity bias lighting is the illumination of the photosensitive walls of the iconoscope in order to furnish an easily adjustable source of low velocity electrons which act to stabilize the D.C. photoemission of the mosaic, the "floating" mosaic frame, and to actually increase the signal output of the iconoscope itself. It was pointed out by Schade in an unpublished memorandum in 1942 that with correct adjustment of edge and back-lighting intensity, taking precautions to keep stray light from the useful picture area of the mosaic, the iconoscope is capable of true D.C. oper-

\* Corning Catalogue #9788 ground to Transmission Curve 4-97, approximately 5mm thick. Can be obtained from: Esposito and Stuhler Optical Co., 911 Willow Avenue, Hoboken, N. J.

ation. The iconoscope under these conditions generates a constant "peak white" signal in its output load resistor which is determined by wall and edge illumination and is generated during the horizontal and vertical blanking intervals when pulses are applied to the control grid of the iconoscope to cut off the beam current. This peak white signal is substantially independent of the illumination of the mosaic itself and once adjusted remains fixed for a given value of beam current. By adding to this peak white signal a constant "black pulse" or blanking wave, the resultant output wave behaves normally and, using circuits essentially identical to those in the image orthicon field and studio chains, gives a close approximation to true d-c presentation. Thus, an unilluminated mosaic will give zero pedestal height and a "fully" illuminated mosaic will give maximum pedestal height. With a slide, the action is fully automatic and produces a video signal in which elemental signal amplitude is directly related to the elemental mosaic illumination. Under pulsed-light motion-picture operation conditions, the black level setting addition is a fairly good approximation to the ideal, even when the iconoscope is used as a full storage device, where the picture is pulsed on the mosaic during the vertical retrace interval. We believe that this "d-c" mode of iconoscope camera operation is one which has great operational importance since, with the other improvements, it makes it unnecessary for the operator to manipulate any pedestal height controls for artificial black-level setting. In addition, with controllable but fixed edge-and-back-lighting, any motion picture having tolerable transmission characteristics can be shown over the chain without touching *any* controls. This appears to us a major step forward from the present mode of operation where shading and pedestal control variation during a program has become a fine art requiring a well-developed sense of anticipation or reflex action, or has been ignored altogether.

The primary function of the back lighting in our mode of operation is that of effectively cancelling the application pulse signal in the video amplifier which is developed during vertical retrace time which has no direct functional part in operation but is the cause of serious amplifier overload. It is quite normal for this video pulse signal during retrace time to be 5 to 15 times as large as the useful video signal during the scan cycle. It is essential in setting up a chain to use the minimum amount of edge-and-back lighting to achieve flare suppression and application-pulse cancellation for smallest signal deterioration due to stray-light effects over the active mosaic surface.

Tests have shown that the present back-light source operated from D.C. and using an infra-red filter with additional diffusion is adequate for our purpose.

### 3. High Peaking and Microphonics

Detailed study of the high peaking problem as it applies to iconoscope input circuits compensation has shown

that our present high impedance R-C plate compensating circuit can be replaced by a two-stage R-C low impedance cathode peaking arrangement with substantial improvements both from the standpoint of compensation and freedom from microphonics. Calculations have shown that the frequency characteristic of the iconoscope output resistor shunted by the stray capacity can be compensated completely by a two-stage cathode high peaker arrangement having two time-constants which are substantially independent of each other in adjustment. The short time-constant peaking circuit affects only the high-end of the passband and the long time-constant peaking circuit affects only the low-end (45 kc). These two circuits can be adjusted exactly for no high frequency overshoot or low frequency trailing by a technique which is almost intuitive and very easy to acquire. It is important to point out that some very low frequency trailing may probably be present in the picture which is not affected by either of the cathode peaker controls. This is due to inadequate phase and frequency fidelity in the video amplifier low-frequency coupling circuits and can be practically eliminated by the use of a suitable low-boost circuit in the camera preamplifier. In order to suppress residual streaking in the film with a wide range of picture content the low frequency amplitude and phase characteristics of all video preamplifiers should be good to 300 cycles or even lower instead of to half-line frequency as had previously been assumed.

A very important improvement which results directly from the change in high-peaking arrangement is that of eliminating of microphonics. The present high-peaker is driven from two video amplifiers in series, having a total gain of 50, through the R-C-R divider having a low frequency attenuation of the order of 200 to 1. This means that with a 10 millivolt signal at low frequencies from the iconoscope 2.5 millivolts appear at the high peaker grid. Laboratory tests indicate that with tubes of the 6AK5 variety the equivalent sine wave voltage for an "average" microphonic tube is at least of this order of magnitude. Thus with a "microphonic" excitation of this reference amplitude the signal-to-microphone ratio is unity. With the cathode high peaker which has been developed the previous sampling network is no longer necessary and the low frequency input signal rises to 0.5 volts giving signal-to-microphonic ratio for the same microphonic excitation, of 200 to 1. The new arrangement allows us to use 6AK5's throughout and has shown that the microphonics problem due to the high-peaker has been eliminated.

On occasions we have definitely traced an appreciable portion of amplifier shot noise to the presently used high peaker. Since low frequency video input voltage to the high peaker grid is 1/4th of that existing at the iconoscope, sufficient amplification must be provided to bring this up to standard level, the tube behaving as another first stage and contributing shot noise.

#### 4. Amplifier Over-Load

With the 417A-6J6 cascode input stage and two-stage cathode high peaking compensation we get considerable increase in system gain. This excess gain has been absorbed in additional cathode degeneration, in order to obtain greater signal latitude for the video and application pulse signals and to minimize the problem of amplifier overload. It is important to point out that adjustments of bias lighting and edge-lighting will decrease, cancel, or reverse the polarity of the useless high amplitude video signal generated during the vertical blanking interval. Therefore, in actual operation, it is desirable to adjust back-lighting so as to just cancel the application-pulse signal, providing a condition of greatest freedom from amplifier setup and overload.

#### Effects of Deflection Non-Linearity and Yoke Distortion

The effectiveness of appropriate edge lighting on suppression or cancellation of flare is based on uniform or constant scanning velocity at the mosaic during horizontal and vertical sweep time. This requires careful adjustment of horizontal and vertical mosaic sweep linearity. Any serious non-linearities may produce false flare signals which cannot be controlled by the action of edge light but which will disappear when the sweep is adjusted to be linear. Excessive geometric distortion or bowing in the deflection yoke particularly at the bottom will make it difficult to suppress bottom flares completely over the whole mosaic width at the same time. In this case, it may be necessary to replace the yoke.

#### Gamma Characteristics

During the past year, there has been a great deal of discussion resulting in conflicting recommendations for modifying the transfer characteristic of the iconoscope film chain. Tests made on a wide variety of motion picture film subjects and accurately calibrated grey-scale step film, have shown that at least a range of 50 to 1 can be transmitted by the iconoscope and a conventional kinescope so that the gradation between adjacent steps can be definitely recognized. This indicates that, with a kinescope gradient of 2.5, the iconoscope transfer gradient is substantially less than unity, approaching square root, in its upper light range. Attempts at white expansion with fixed peak kinescope brightness result in a final display with compressed blacks.

Our demonstrations have indicated that by using a linear amplifier transfer characteristic, with the iconoscope as the gradient-determining element in the system, a grey-scale range of at least 50 to 1 can be used. It is possible that with some films and kine-recordings which crush whites, white-expansion may be useful. However, we believe that this does not hold true in general for normal, typical motion picture film.

#### Concepts Involved in the Overall Operation of an Iconoscope Film Chain

In order to clarify the procedures involved in operating an iconoscope chain so as to obtain the best possible picture we can tabulate the variables involved as:

1. Film characteristics
2. Projector lamp intensity
3. Beam current
4. Video gain
5. Edge and back lighting
6. Shading signal

Average photographic film has a typical density range  $D = 0.2$  to  $D = 1.8$ , or a range of 40 to 1, in release prints where density  $D$  is defined as  $\log 1/T$  and  $T$  is the transmission in per cent. With  $D = 0.2$  or a transmission of 62% the minimum open-gate illumination from the projector should be 32-foot-candles to obtain a 20-foot-candle highlight illumination on the mosaic. For these conditions the low-light mosaic illumination will be 1.6% of 32-foot-candles or 0.5 foot-candles. Increased illumination in the projector above this level does not produce radical changes in the appearance of the picture because of the wide latitude of the iconoscope characteristic. However, decrease of illumination may cause the picture to deteriorate, primarily because of lower output signal and hence poorer signal-to-noise ratio, and accentuation of residual flare and local defects which would ordinarily be unnoticed with normal illumination. For this reason we have found that stopping down the projector lens to obtain greater sharpness or depth of focus of the projected image produces poorer overall performance.

Since the standard f:2.6 Kollmorgen Projector Lens has a television resolution of at least 1200 television lines at the magnification used, it alone does not represent a limitation in 16mm film reproduction. All cases investigated, in which significant improvement in resolution was noted on stopping down the lens, were traced to clamping strain distortion of the front surface multiplexer mirrors, or were due to insufficient care in aligning the iconoscope itself to coincide with the focal plane of the projection system. When these difficulties were eliminated there was no noticeable difference in resolution between wide-open and stopped-down lens operation. Providing depth of focus by stopping down the lens to take care of system errors is a rather uneconomical method of operating the iconoscope chain. The adjustable iris in the present lens furnishes a convenient means of checking these factors and of decreasing light output for special films in which this may be advantageous. In order to obtain maximum light output, it is important to make sure that the condenser lens system and the reflector in the projection lamp path are clean and that the projector lamp is operated close to rated voltage since a 5% decrease in lamp terminal voltage produces a 16% decrease in the light output.

It is apparent that the success of a motion picture film chain depends directly on the quality of the film itself.

In general, the resolution and grey scale of commercial 35mm film releases are excellent, whereas 16mm film has appreciably poorer resolution and more variable range characteristics. It is beyond the scope of this discussion to analyze the factors involved in poorer film quality, but it is only fair to point out that poor film does not make good television pictures. Side-by-side comparisons of 16mm and 35mm motion picture film material using a well-adjusted iconoscope film chain are very striking; the 35mm film giving quality very close to that obtained in a studio shot, while 16mm film is decidedly softer and lacks snap. In such a comparison the only variables in an instantaneous mechanical switching or dousing operation are the two film sources and projectors, the iconoscope chain adjustment remaining untouched.

One must be quite sure that in the process of evaluating film chain performance the quality of the film used is adequate. Otherwise, this evaluation becomes a comparison of relative film performance, which in 16mm film is a bottleneck limiting performance at much lower levels than the capabilities of the iconoscope chain itself allow. Even the currently available 16mm television test film prints used for checking television performance leave a great deal to be desired particularly in the resolution and detail contrast in the various resolution frames of the film. One can verify this easily by examining such frame sections under a microscope, using a magnification of 30 to 50 times. The same criticism holds true for available 2 x 2 television test slides, except that, in addition, the performance of the still projector lens often limits resolution seriously. We have found that a simple circular front-of-lens stop  $\frac{3}{4}$  to  $\frac{5}{8}$  inch in diameter produces a decided improvement in picture appearance and still provides sufficient light for good operation. This test is very easy to try and provides a method for producing an optical image on the mosaic which approaches the quality required to obtain meaningful information on system performance.



FIG. 4. Beam Current Metering Control Panel.

### Beam Current Edge and Back Lighting

As previously mentioned, with adequate provisions for edge lighting and back lighting, the iconoscope should be operated with the maximum permissible beam current which can be accommodated to produce a flare-free field. This beam current will be between 0.1 and 0.2 microamperes. The video gain is then adjusted with normal illumination on the mosaic to provide an output signal of 1 volt peak-to-peak across the 70 ohm output line. It has been found that with a continuous indication of beam current, one can duplicate accurately the results with a given chain from day to day. In the absence of beam current metering facilities the operator is governed entirely by intuition and he is likely to set up for smaller than normal beam current, making up for decreased iconoscope signal output by increasing video amplifier gain at the expense of poor signal-to-noise ratio or will select a beam current which is higher than normal and will sacrifice overall performance from the standpoint of excess flare. The addition of a beam current metering circuit makes it possible to provide straightforward means of setting up and maintaining a high standard of operating quality.

Edge lighting and back lighting should be used to provide satisfactory cancellation of flare, cancellation of light application video pulse and to improve signal output. It is again important to point out that these factors should be handled with some discretion in order to minimize stray light and to preserve good storage characteristics with acceptable grey-scale rendition.

In principle, it is possible to manipulate edge-lighting intensity and distribution and back lighting amplitude so as to produce an output signal from the chain which requires no addition of electrical shading signals. However, the problem is made much simpler if edge-lighting is used primarily to control the abrupt flare components at the sides and bottom of the picture and electrical shading is introduced horizontally and vertically in the familiar available sawtooth and parabolic waveforms to produce flat output and flat shading. Our experience has shown that with preliminary setup of edge lighting, back lighting and electrical shading using an unilluminated mosaic as the most difficult condition, it is thereafter unnecessary to touch either the edge lighting, back lighting or the electrical shading signal controls during the reproduction of film.

# The Vidicon Film Camera

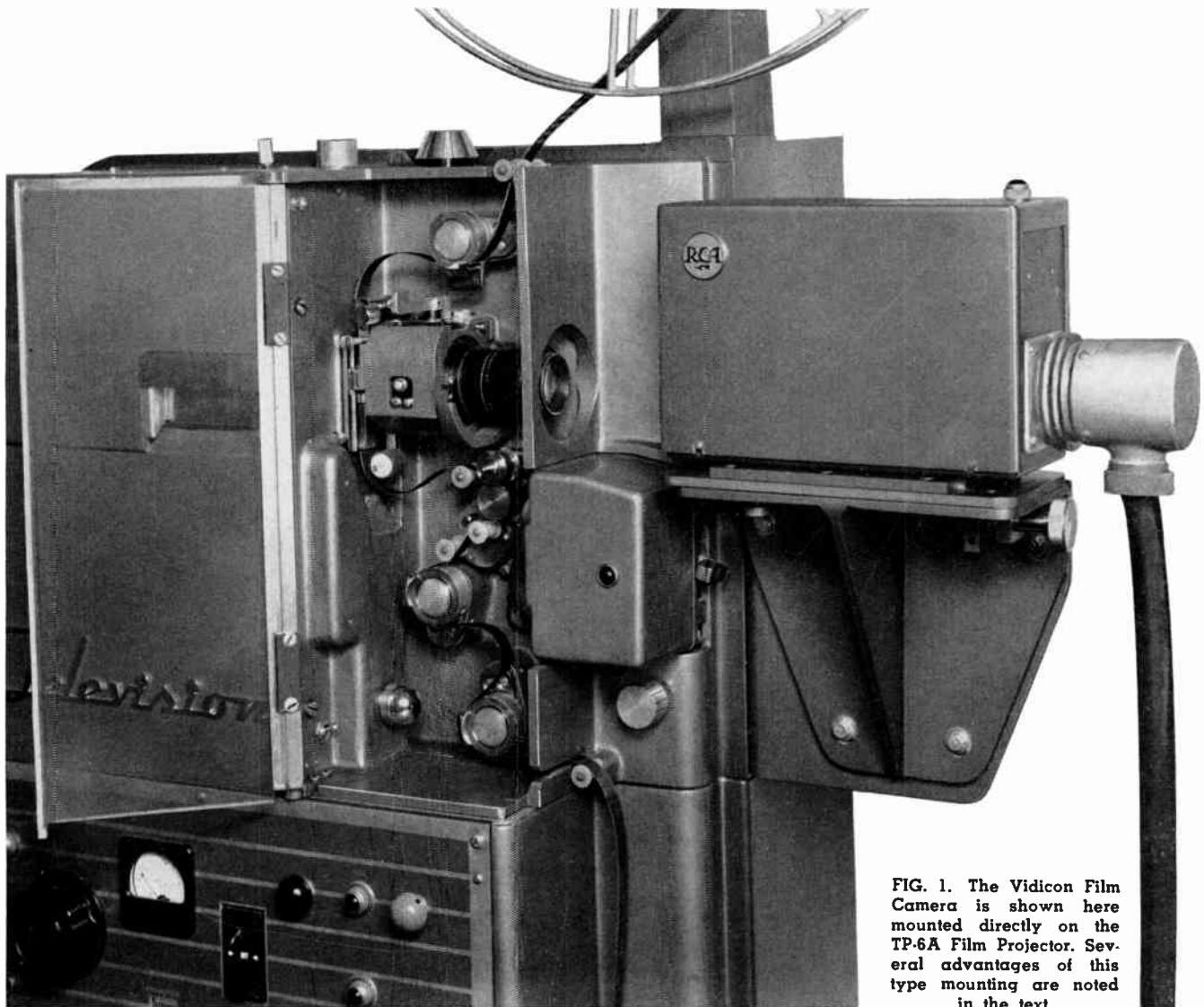

FIG. 1. The Vidicon Film Camera is shown here mounted directly on the TP-6A Film Projector. Several advantages of this type mounting are noted in the text.

## General

At the present time filmed programs are no longer just supplementary to studio programs, but are in direct competition. There has been a definite trend in the direction of recording certain programs directly on film for reasons of smoother performance, possibilities of editing, less strain on actors and the increased versatility provided by the application of well-developed motion picture techniques. In this case, the ultimate goal is picture quality which will make it impossible for the home television viewers to know whether the program material is live or is recorded on film. So, to keep pace with the increase in quality of studio pictures and the latest advances in the film industry, the new Vidicon Film Camera has been developed.

The criteria by which this camera has been designed are: good resolution, high signal to noise ratio, aperture response correction, high transfer or gamma characteristics, and low light source requirements. The heart of this new camera is the Type 6326 Vidicon Tube. This tube has a limiting resolution that is in excess of 700 lines, with a measured response of 35% at 350 lines compared with zero line number as a base.

The signal-to-noise ratio of the system is determined solely by the first few stages of amplification in the video amplifier. Therefore, by the proper design in these stages, and, in particular, the design of the cascode preamplifier, a signal-to-noise ratio of 300-1 is obtained. The vidicon is the first pickup tube or system available that has high enough signal output or low enough inherent noise in its signal to use aperture correction effectively without seri-

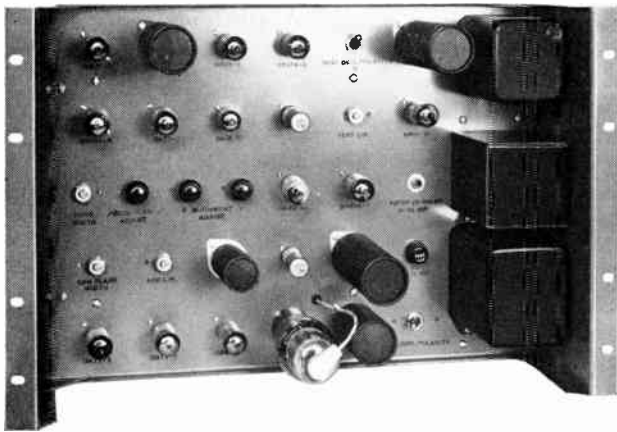

FIG. 2. The Vidicon Film Camera deflection chassis.

ously impairing the signal-to-noise ratio of the reproduced picture. With this excellent signal-to-noise ratio, aperture correction (a scheme for amplifying the high frequencies with respect to the low frequencies without phase distortion) may be added to the signal to compensate for the finite size of the scanning beam. An examination of the amplitude response of the tube shows that to fill the transmitted bandwidth adequately, the response at the higher line numbers should be boosted by a factor of three for a 4.5 mc channel. Since the noise in this type of picture is predominantly high frequency, this boost in high frequency detail will also boost the effective noise in the picture. With this boost by a factor of three, the aperture response has been raised from 35% to 100% @ 350 lines resolution and the signal-to-noise ratio is approximately 100-1 in the final picture, still being much higher than any other type of commercial pickup device.

Since the vidicon tube is essentially an orthicon or low-velocity device, as far as the scanning process is concerned, there is inherently no spurious shading signal developed. In the Vidicon Camera, no electrical shading cancellation signals are required, thus no shading controls are used in this equipment nor is edge lighting or any other type of lighting required for flat field.

The gamma or transfer characteristic which is inherent in the vidicon surface itself, has a log-log slope of 0.65 when signal output current is plotted against light on the photo-conductive target. This produces a dynamic range of 150-1 or more. The slope is constant over a wide range of lighting and gives a more realistic reproduction. Light source requirements under the most favorable conditions, using commercially available lenses, are of the order of 300 foot candles, average, measured at the film gate. Since practically all intermittent-type television motion picture projectors used with the iconoscope have an exposure shutter opening of approximately 7%, phased under blanking, this 300 foot candle average corresponds to about 4000 foot candles peak. Optimum Vidicon Camera results are obtained using approximately 1/3 of the maximum light output available in the standard television

projectors, and this decrease in light requirement permits operating the projector lamp at lower voltage and, therefore, greatly prolongs lamp life when the Vidicon Camera is mounted directly on the film projector.

Non-synchronous operation of the projector with respect to the sync generator is a desirable attribute obtained with the Vidicon Film Chain. In smooth network operation, it is often necessary to insert commercial or local film material in station-break intervals. With a 3-2 intermittent projector using long exposure time, such as the TP-6A, this is now possible with optimum results. Furthermore, the TP-16 or the TP-35 can be used if a slight pulse application bar can be tolerated.

The "unattended operation" possibilities of the Vidicon Camera are unusually attractive. Tests with a wide range of film material have shown that it is practically unnecessary to ride video gain. Black level control is inherent in the tube and gives an absolute black reference, when light is interrupted the video signal always drops to zero, and no shading knobs are provided or required. From a day to day operational basis, only two variables require adjustment. These are the wall focus, which determines electrical scanning beam focus and therefore picture resolution; and beam bias controlling the number of electrons available for discharging the target. The controls are stable and simple.

#### Mechanical

The Vidicon Camera has the advantage of being extremely small. The camera volume occupies only one-eighth cubic foot. By its size, it may be mounted directly

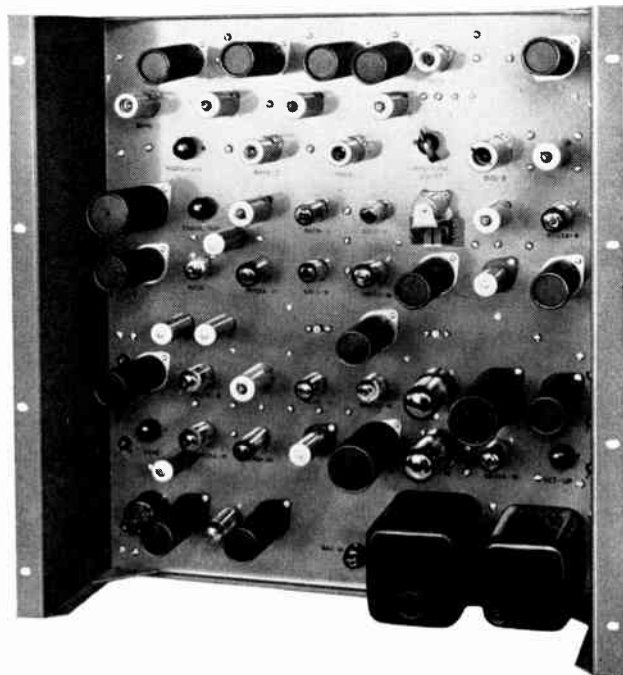

FIG. 3. The Vidicon Film Camera control chassis.



on either a 16mm or 35mm projector or integrated into an optical multiplexing system. The camera chain consists of the camera connected by the standard 24 conductor camera cable to the camera control chassis and deflection chassis which may be located up to a distance of 200 feet from the camera.

In keeping with the trend of removing as much equipment as possible from the console housing, all control circuits have been rack-mounted for better servicability, ease of maintenance and performance checks, and to reduce the heat dissipated at the operating position. Only the remote control panel, which contains operating controls, is located in the console housing. This remote control panel uses only d-c control voltages and it can be placed at any reasonable distance from the camera control and camera deflection chassis, governed only by the size of wire used for interconnection. It is intended that the control panel be mounted in the sloping portion of the console housing associated with a Master Monitor. The camera control and the camera deflection chassis occupy 31½ inches of rack space.

### Electrical

No tube circuitry for deflection of the vidicon is located in the camera. The deflection voltage is generated in the camera deflection chassis in the rack and delivered to the camera via the camera cable. Because of its high frequency spectrum, horizontal deflection is brought through the camera cable on a coaxial line. The horizontal deflection yoke is arranged in a constant resistance network at the camera to provide proper termination for the coaxial line. Since the frequency spectrum of the vertical deflection signal is much lower, it is carried to the camera over unshielded leads in the camera cable.

Some video circuitry is located in the camera for adequate preamplification; such as the cascode amplifier and

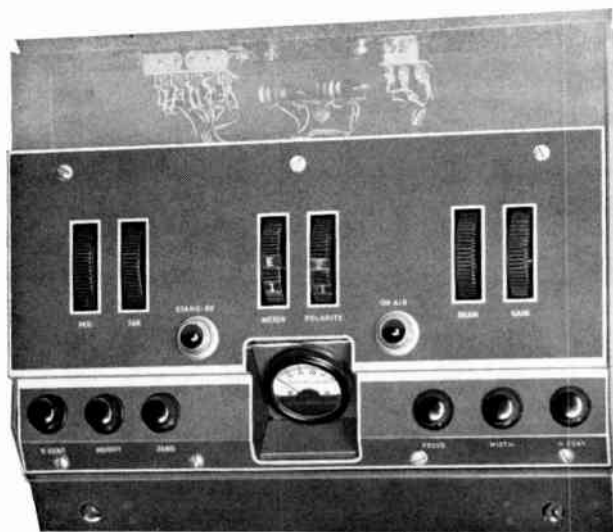

FIG. 4. Remote control panel for the Vidicon Film Camera.

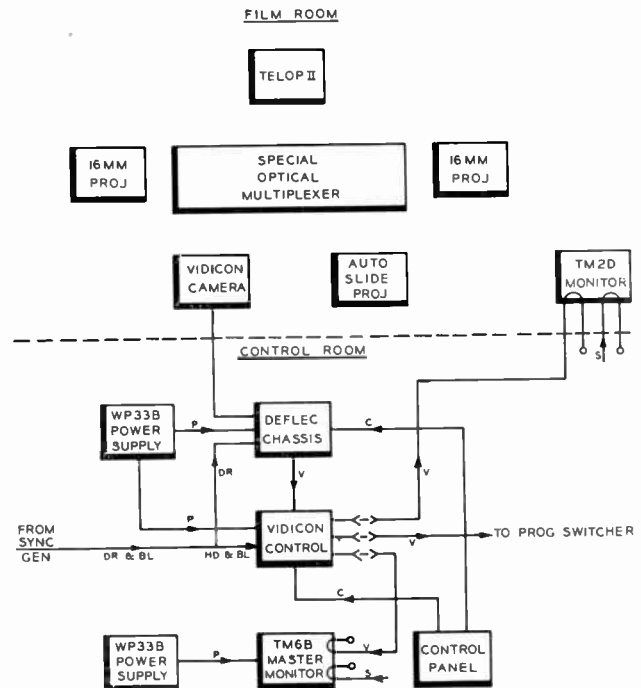

FIG. 5. Functional block diagram of the Vidicon Film Camera using a multiplexer.

camera blanking circuits. A cathode follower is used to send the video signal to the camera control over another coaxial line in the camera cable. Although negative film is not recommended for best results, a polarity switch is located on the remote control panel for this purpose. In the camera control, blanking is added, black level is set, aperture correction is introduced, and sync addition is provided, if required. An output amplifier is included which is capable of driving three 75-ohm lines with sending-end termination. For reasons of multiplexing, both horizontal and vertical deflection reversing switches are included.

The remote control panel contains the following controls:

- Pedestal
- Gain
- Wall Focus
- Signal Electrode
- Beam
- Horizontal Size
- Horizontal Centering
- Vertical Size
- Vertical Centering

A meter is used on this panel to monitor signal electrode voltage and beam current of the vidicon. A zero adjustment is also provided for this meter.

# MONOSCOPE CAMERA, TK-1B

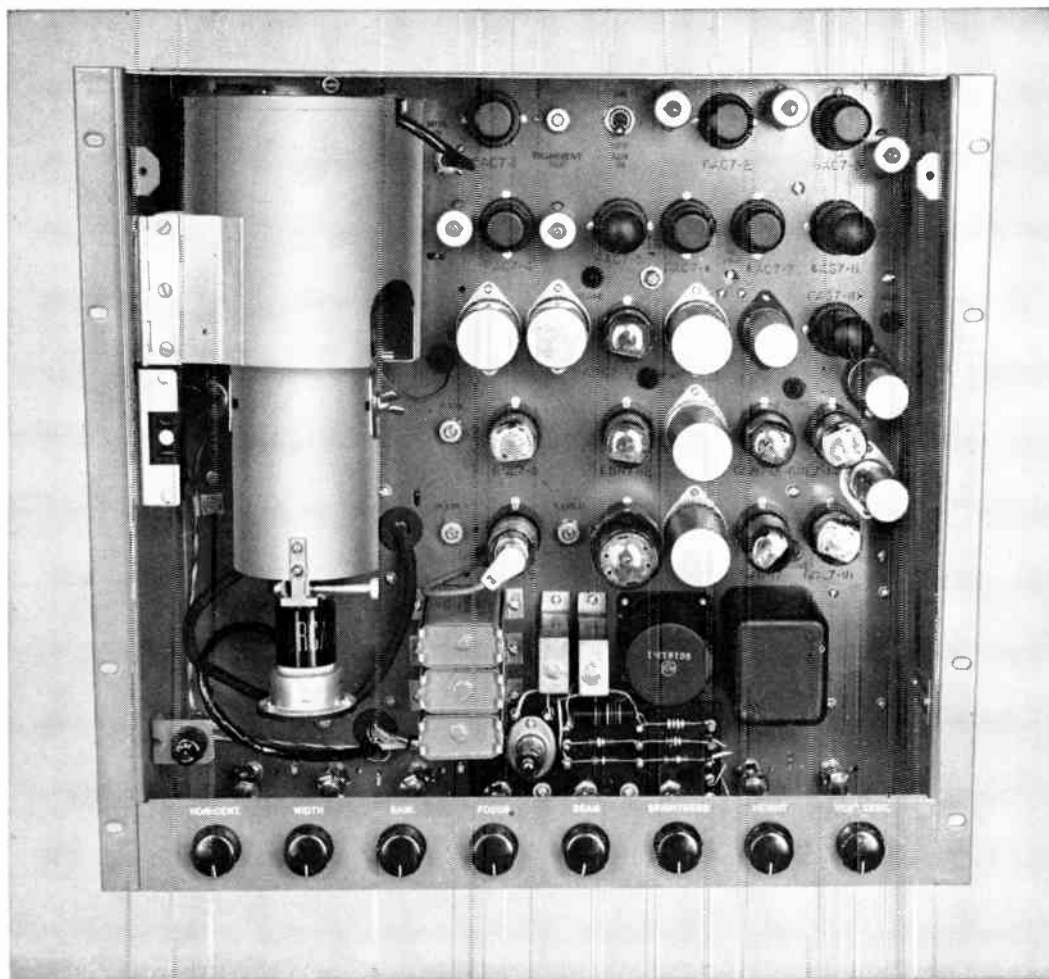

The Type TK-1B Monoscope Camera may be used as a convenient means of obtaining an image for video testing of television transmitting equipment, or a "test pattern" to be transmitted during warm-up and stand-by periods. In the latter case, the station call letters may be made a part of the pattern, thereby providing station identification. It may, likewise, be used in the television transmitting station as a readily available source of video signal, of known quality, to be used in place of the studio camera when making tests or adjustments on other units of the system. In the laboratory, factory, or service bench, the equipment may be used as a source of video signal to test or adjust television receivers, video amplifiers, and picture tubes. With the addition of a source of blanking, driving and sync signals and an RF signal generator, it produces a complete television picture signal simulating that received off the air, and thus provides a means of testing receivers under conditions equivalent to actual use.

The TK-1B Monoscope Camera comprises the monoscope tube, the scanning generators, the video output amplifiers, and the high voltage power supply for the monoscope tube. This equipment is built on the familiar recessed "bath tub" type of chassis which fits into a standard nineteen-inch rack. All tubes and large components are located on the front of the chassis, while the wiring and smaller components are on the rear. The controls are grouped on a narrow control panel along the bottom of the chassis. When installed and in operation, the front is covered by a large cover plate which conceals everything but the control panel. This cover plate is interlocked to protect operating personnel from the high voltages present in the equipment.

The monoscope tube in the TK-1B is mounted in a vertical position at the left of the chassis. The upper part of the tube is enclosed in a mu-metal shield. The

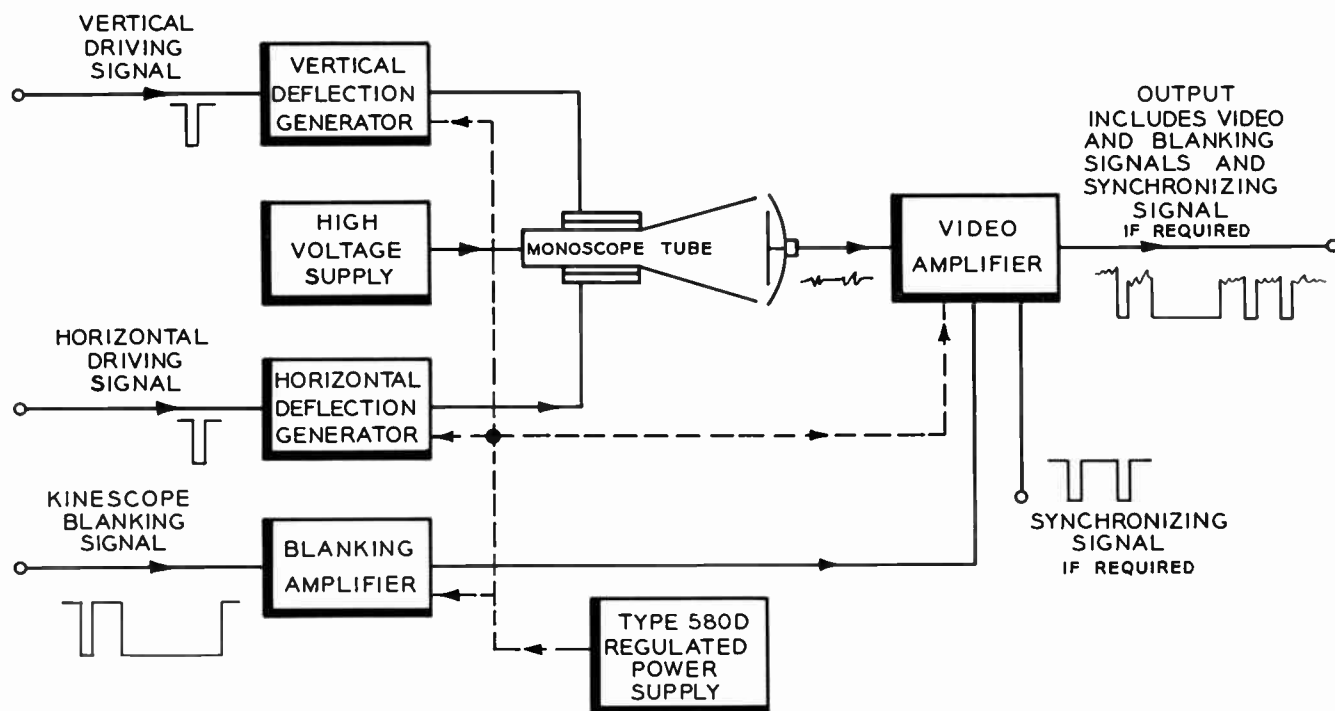

BLOCK DIAGRAM OF THE TYPE TK-1B MONOSCOPE CAMERA

magnetic deflecting coils are mounted within the shield, and are attached to it. By disconnecting the tube socket, anode, and signal leads, the whole assembly—tube, coils, and shield—may be swung outward. This arrangement allows the tube to be changed very easily, and, at the same time, is very economical of rack space.

The Vertical Deflection Generator consists of four tubes and associated circuits. The first of these tubes amplifies the driving signal received from the synchronizing generator and generates a saw-tooth voltage wave which is amplified in the second, third, and fourth tubes. The output is applied to the magnetic deflecting coils of the monoscope tube. Negative feedback is employed to improve scanning linearity.

The Horizontal Deflection Generator includes three tubes and associated circuits. The first tube is the driving signal input amplifier and sawtooth voltage generator; the second and third tubes amplify the output wave and

feed it to the horizontal deflecting coils of the monoscope tube.

The Blanking Amplifier is used to provide the proper level and polarity of the blanking pulses received from the synchronizing generator before these pulses are fed into the Video Amplifier for mixing with the video signal.

The Video Amplifier includes six stages of video amplification—together with a clipper stage which is inserted between the fifth and sixth stages. The monoscope output signal is fed directly into the first stage of this amplifier, and the blanking signal is introduced in the output of the fourth stage. The output of the fifth stage (which contains both video and blanking signals) is fed to a clipper stage which adjusts the height of the blanking "pedestals". The clipper feeds an output stage which consists of two tubes having their grids tied in parallel, but with the plate circuits separate. This provides two separate outputs—one for picture output and one for monitoring purposes.

# A Versatile Video Special Effects System

## Introduction

Special effects, both optical and electrical, play important parts in modern television productions. It is frequently desirable to combine two or more scenes into a single picture or to remove a portion of one scene to replace it by a portion of another scene. Such effects can be especially satisfying to the sponsor of a program because it is possible to display a commercial on a portion of the raster without interrupting the show.

In the past, such special effects have been most frequently accomplished with optical techniques. Systems of mirrors and sliding shutters were used to combine pictures. Background projection is sometimes used to provide a suitable setting for live shows. The results obtained in the motion picture industry in the form of wipes, fades and dissolves were desirable but most of the motion picture techniques were not applicable to live television shows, since they depended upon film splicing operations which were time consuming.

Electrically accomplished special effects are particularly desirable because of their increased speed. Fades, dissolves and superpositions are simple examples of electrical TV program effects now in common use. In some equipment, the fades and dissolves have been accomplished at controlled speeds by means of electrical circuits. Electrical division of the raster into two separate areas

by a straight line for displaying two independent video signals is another effect which has been sometimes employed. A major difficulty which has prevented the combination of signals from widely separated cameras, driven by independent synchronizing generators, has been the lack of control of the relative frequency and phase of the synchronizing signals. Partial solution of this problem has been achieved by RCA engineers through the development of the "Genlock."

## "Effects" Considerations

Several possibilities of combining two video signals have been investigated. It is desirable to have some means of blanking out one video signal from any one or more areas of a given picture so that video information from another signal can be inserted if desired. It also is desirable to separate these areas with a boundary of any desired shape and to be able to move or change the shape of the boundary without interruption of the video signals.

These latter considerations indicate that a purely electrical blanking system is not widely applicable. Even though simple boundaries can quite easily be generated, as in the RCA Special Effects System, irregular boundaries of predictable shape require impractical complex circuits. A suitable type of optical-electrical system can meet the requirements on the boundary shapes because optical masks can be easily cut to the desired configuration.

FIG. 1. Block diagram of the RCA Special Effects System.

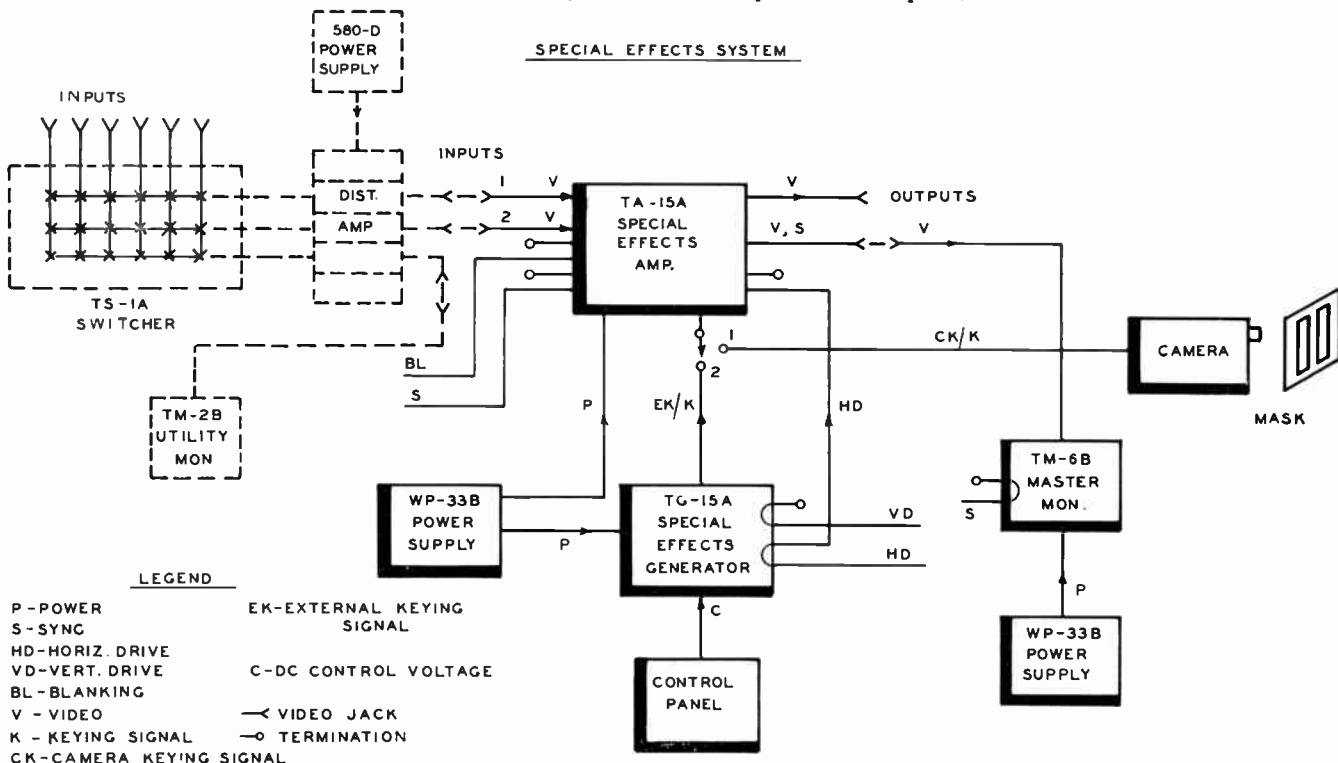

The RCA Special Effects System requires use of the TG-15A Special Effects Generator, MI-26271, the Control Panel, MI-26272, and the TA-15A Special Effects Amplifier, MI-26150, plus monitor and power supplies. The Special Effects Amplifier provides a means for combining two video signals from independent sources into a composite television picture. The boundary line between the two pictures is determined by a keying signal from a third source, a television camera (field, studio, film, or flying-spot type) or from the Special Effects Generator which produces synthetic keying signals.

The control panel provides facilities for push-button selection of various keying signals and a "joystick" for positioning the boundary line so as to obtain wipes, inserts, etc.

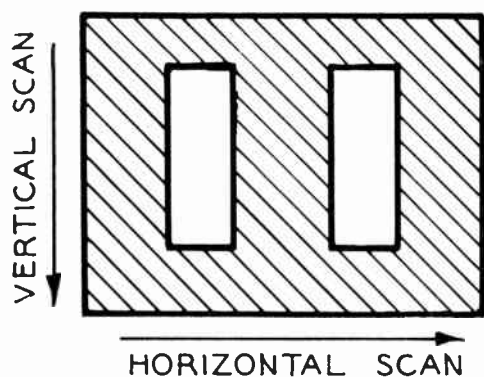

FIG. 3. This sketch of a simple mask (as used with the Slide Scanner) plus the waveform sketches of Figs. 4, 5, 6, 7 and 8 illustrate the "Effects" system operation.

With the RCA Special Effects System, the two pictures are not superimposed, but occupy adjacent portions of the scanned area independently. The boundary line between these two adjacent areas is determined by means of push buttons which position a stepping switch to select the desired shape. At any time, the boundary line may be moved across the raster to produce a wipe, a corner insert or an iris action insert, depending on the shape chosen. The motion is smooth, with the rate controlled by means of a joystick, and may be stopped at any time for any desired length of time, then reversed or continued in the original direction until one picture has been completely replaced by another.

When the optical mask is used, a television camera is used to generate the switching signal defined by the mask. This camera may be of the flying light spot type where the mask is scanned optically or it may be the conventional television camera where an electron image of the mask is scanned with an electron beam.

The signal from the camera which is used to generate the switching function would ideally consist only of two distinct values—one value corresponding to white areas and the other to black areas of the mask. Because of the presence of noise, stray light and other factors, the camera output signal has much gray information, even when the camera views areas which are black and white. There-

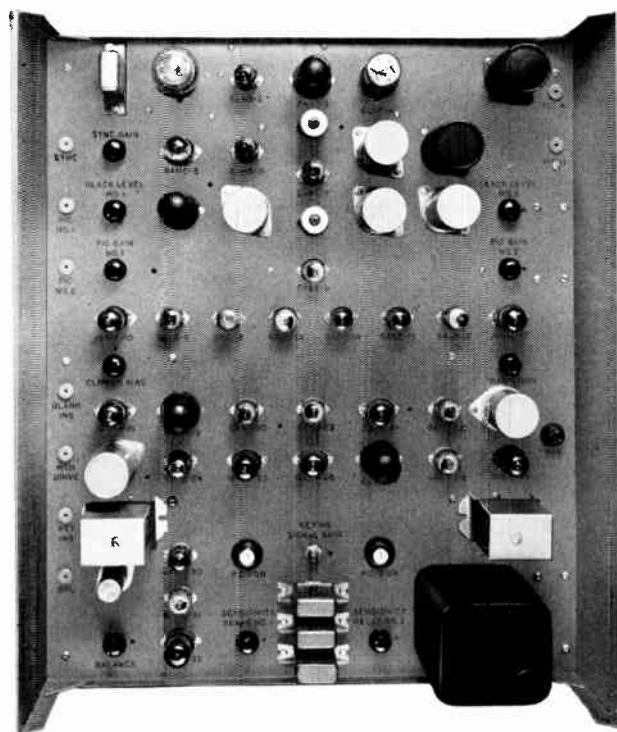

FIG. 2. Closeup view of the TA-15A Special Effects Amplifier which is contained in a bathtub type chassis for rack mounting.

fore, this signal is fed into amplifiers and clippers—the output of which is a squared wave with very fast transitions. The output of the clipper is fed to a polarity splitter to provide two outputs of opposite polarity. These two outputs constitute the switching signals.

The switching signals are used to control two switching amplifiers—one for each of the video signals to be switched. These amplifiers are so adjusted that only one of them transmit video information at any one instant. The amplifier which transmits depends on whether black or white areas of the mask are being scanned.

The outputs of the switching amplifiers are combined in a common load resistance and the black level is set by a clipper. The necessary amplifiers are included to provide the correct signal amplitude and polarity into a coaxial cable. This single video output can be fed into a switcher and treated as another signal source.

In order to maintain the d-c component of the video and switching signals, several clamp circuits are employed. These permit movement of the mask or change of the mask while the output signal is being viewed as well as allowing for change of the average level of the video information.

#### Illustration of Operation

The series of sketches (Figs. 3, 4, 5, 6, 7 and 8) illustrates the manner of operation of the system for a masking signal which is generated by two vertical white stripes on a black background. All of the waveform sketches are for a single line interval. Note that portions of the line of video #1 are blanked out and that these blanked portions are filled in with information from video #2.

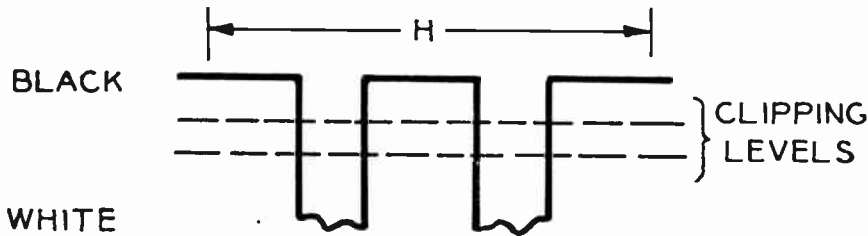

FIG. 4 (above). The output signal from the Flying Spot Camera appears as shown here, with black positive.

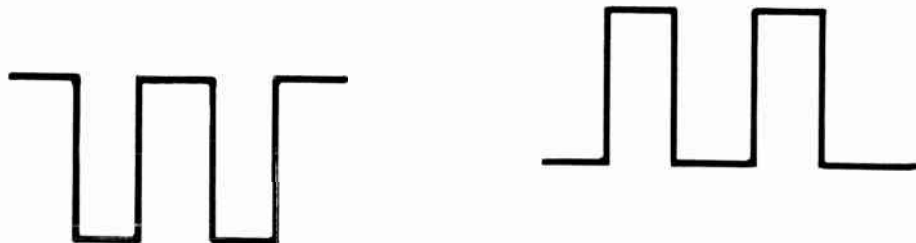

FIG. 5 (above). As indicated in this waveform sketch, the signal is clamped and clipped (clipping levels are adjustable). The clipped signal is fed into the polarity splitter, yielding outputs of opposite polarity.

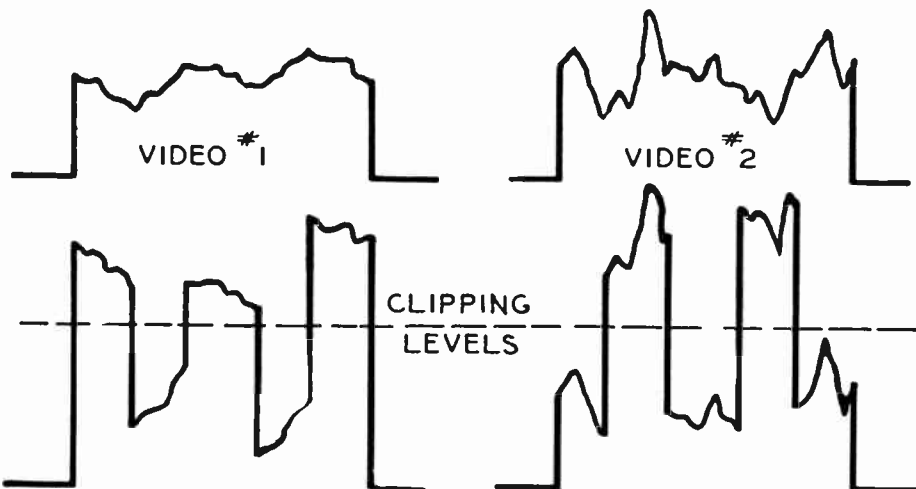

FIG. 6 (above). These waveforms illustrate how the two switching signals are clamped during the blanking interval and are mixed with their respective video signals (video signals are also clamped).

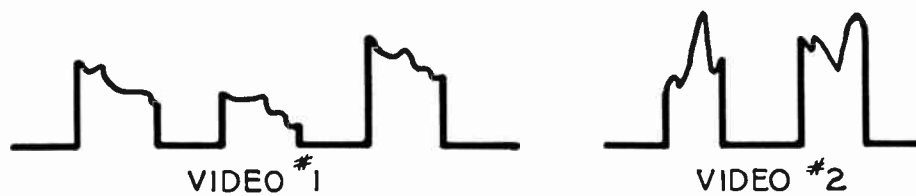

FIG. 7 (above). The useful portions of the mixed video signals are those shown in the waveform diagrams above.

### COMPOSITE OUTPUT SIGNAL

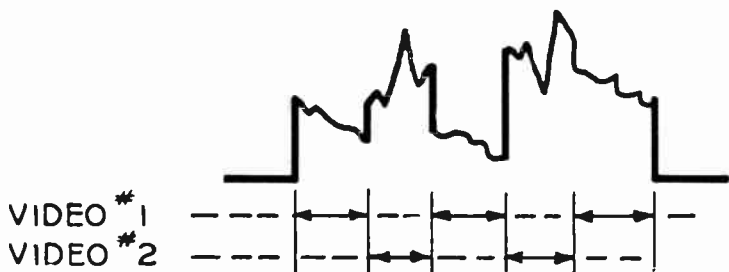

FIG. 8. Finally, the two signals are mixed in an amplifier to obtain the desired composite signal, as shown here. In this case, the video signal #1 is displayed when the flying spot is behind the mask. Video signal #2 is displayed when the phototube is illuminated by the flying spot. (Black level is set to the desired level by means of a clipper.)

## The TA-15A Special Effects Amplifier

The RCA TA-15A Special Effects Amplifier is a single rack-mounted unit which accepts the two signals to be mixed and the masking signal, and delivers the desired composite signal. Standard 19-inch bathtub construction is used. The amplifier requires 21 inches of rack height.

A few of the effects which may be performed with this system are shown by the accompanying photographs which were taken from a monitor kinescope. A flying spot scanner and opaque masks were used to generate the switching signals.

Fig. 9 is a series of photographs demonstrating a horizontal wipe where the first picture was progressively replaced by the second picture as the mask was moved through the flying spot scanner. It should be noted that there is no restriction on the shape of the mask used for wipes nor on the direction in which the wipes are made.

Fig. 10 is a series of photographs illustrating the replacement of an area of one picture with picture information from the corresponding area of a second signal. A keyhole slot was used as a mask for a special effect.

Figs. 11 and 12 illustrate the use of masks of particular shapes to impart additional information to the viewer. In Fig. 11, a sharp pointer was placed in the focal plane of the flying spot scanner and was easily moved to designate points of interest in the picture. In Fig. 12, the arrow was cut into the opaque mask. The second video signal was black for both Figs. 11 and 12. The photographs in Fig. 13 were made using a crudely cut mask and several different types of video information for the second signal. Many effects are possible, such as wedge, diagonal, or vertical division and keyhole insertions of either polarity. Each of these masks may be used for wipes as well as for fixed divisions. The mask shapes are limited only by the imagination of the producer or program director.

## Associated Equipment

Although most of the work on this system has been done using flying spot type cameras to generate the switching signals, studio and film cameras have also been used successfully. The principal requirements of the camera signal are that it be capable of reproducing the edges of the mask to the required degree of accuracy and that a noise-free switching signal can be derived from it by clipping.

Some form of switching system at the video inputs of the special effects equipment may be desirable so that any two



FIG. 9. These photos taken directly from the monitor screen illustrate how horizontal wipes may be used in progressive steps or continuously. Many arrangements can be made up from any two program sources.



FIG. 10. Dramatic video effects may also be obtained when an area of one picture signal is replaced by that of a second signal. Any form of cutout (as the keyhole effect above) may be used.

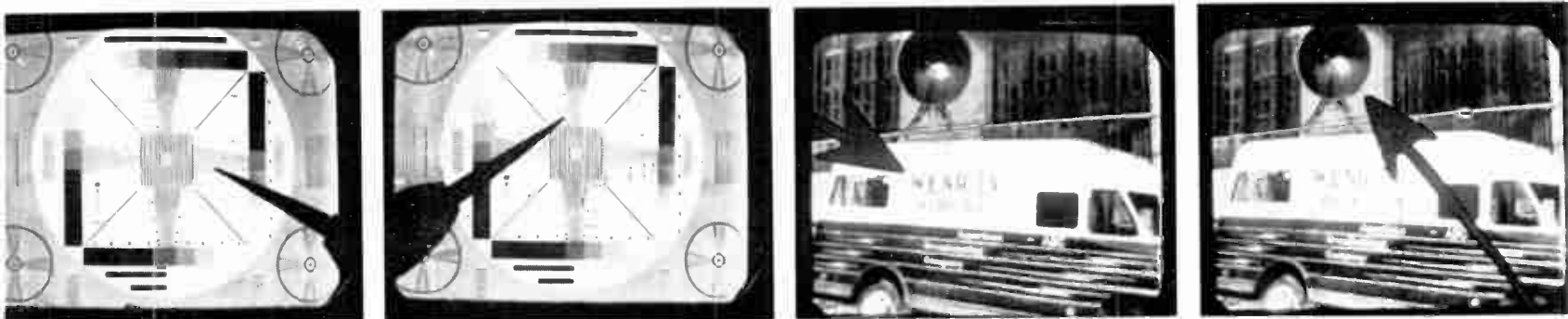

FIG. 11. A sharp, pointed object may be used effectively to emphasize points of interest in a scene. The pointer may be moved to any position.

FIG. 12. In the pictures above the arrow or pointer is cut into the opaque mask. The background signal is black for these pictures and for those shown in Fig. 11.

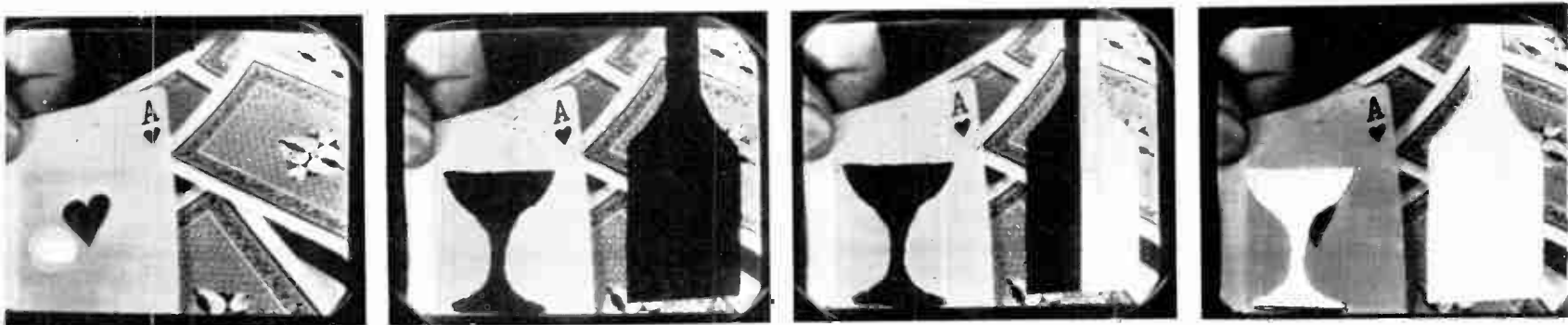

FIG. 13. A crudely cut cardboard mask serves to illustrate how a variety of effects may be produced. These shapes can be made to appear all black, all white or in "black-and-white" combinations.

video signals may be introduced. Interchange of the blanked out and the transmitted portions of the two video signals may easily be accomplished by interchange of the input video lines although it is also possible to accomplish the same result by reversal of the switching signal polarity.

Masks may be cut out of suitable paper and placed on a contrasting background when using a studio camera or opaque projector for generating the switching signal. For cameras using transparencies, the masks may be cut from opaque paper or cardboard or opaque markings may be made on glass or plastic. A means of providing smooth controllable movement of the masks is desirable when making wipes or other movements of the blanked areas of the raster.

### The TG-15A Special Effects Generator

The TG-15A Special Effects Generator, MI-26271, is designed for use with the RCA TA-15A Special Effects Amplifier and the RCA TG-15A Special Effects Control Panel, MI-26272. The generator chassis contains the circuits necessary to produce synthetic keying signals which will provide eleven different special effects. The control panel contains push buttons for selecting the desired effect and a joy-stick for control of that effect so as to produce wipes or inserts. Pushbutton selection of external keying signal is also provided.

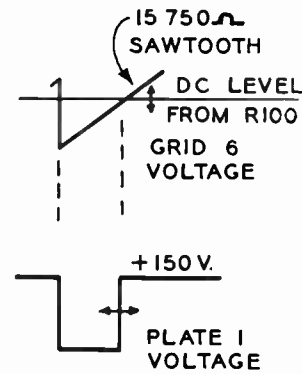

The Special Effects Generator generates four basic signals; namely, a sawtooth wave and a triangular wave, each at field and line frequencies, and operates as follows. Consider effect number 1 which is a corner insert at the upper left hand corner of the raster. This requires use of the horizontal sawtooth wave and the vertical sawtooth wave. Pushing the proper button on the control panel positions a rotary selector switch so as to select the proper wave shapes and apply them to the proper points in the circuitry. The horizontal sawtooth is applied through a cathode follower stage to grid 6 of the horizontal clipper stage V7. At the same time, potentiometer R101, which is geared to the joystick, supplies a positive dc

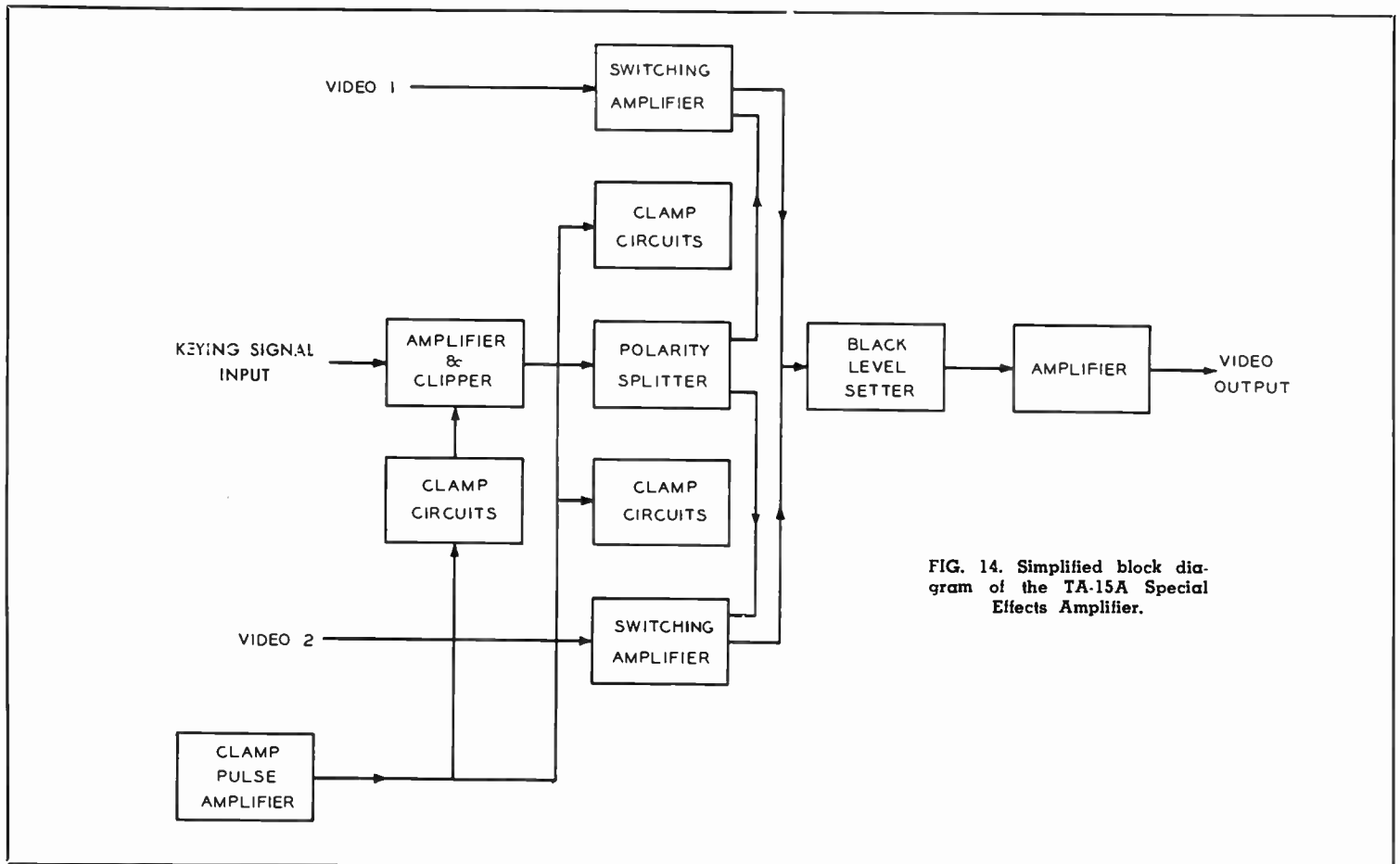

FIG. 14. Simplified block diagram of the TA-15A Special Effects Amplifier.



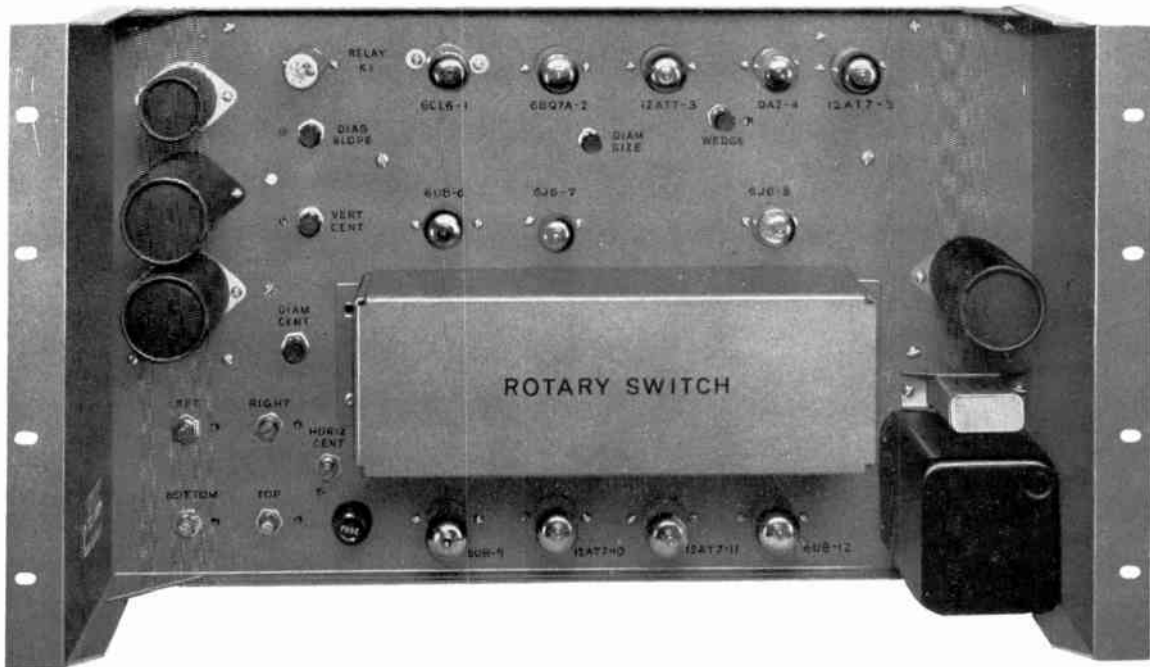
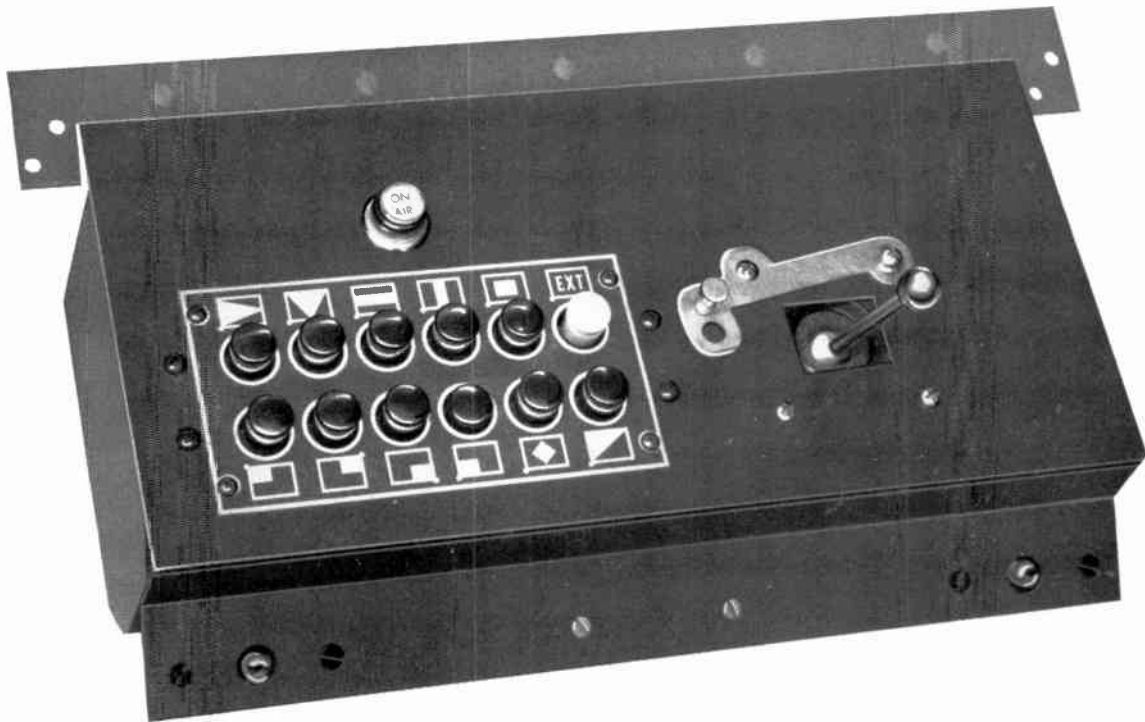
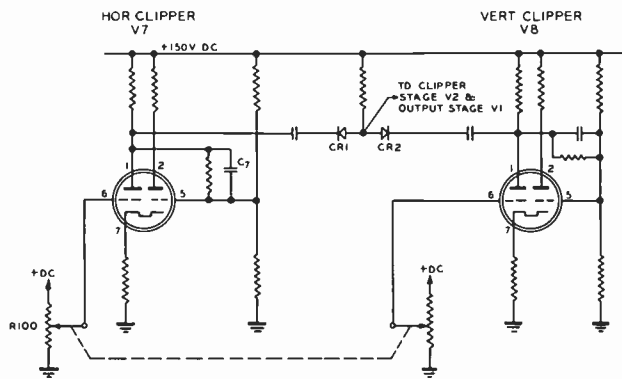

FIG. 15. The recently developed RCA Special Effects Generator provides greater flexibility in the RCA Special Effects System.

FIG. 16. The Control Panel for the TG-15A Special Effects Generator showing the eleven different boundaries which are obtained and the joystick on the right which permits smooth insertion.



voltage to grid 6 of V7. The positive bias on grid 5 of V7 causes plate 2 to be normally conducting, and the resultant positive cathode voltage holds plate 1 normally non-conducting. When the positive dc voltage from R101 is sufficiently large, it overcomes the cathode bias on grid 6, causing plate 1 to conduct. The resulting drop in voltage at plate 1 is coupled through C7 to grid 5, causing plate



2 to become non-conducting. This condition lasts as long as the dc voltage from R101 is sufficient to overcome the cathode bias on grid 6. This dc level from R101 intersects the horizontal sawtooth wave at two points and plate 1 conducts during the time between these two points of intersection. Raising or lowering the dc level therefore increases or decreases the conducting time of plate 1. When plate 1 conducts, the drop in plate 1 voltage is coupled to grid 5, causing a drop in current through plate 2, and a resultant drop in cathode bias. This causes plate 1 to drop still further, depressing grid 5 even more. This action occurs rapidly due to the short time constant of the coupling circuit through C7. The regenerative effect drives plate 1 almost to saturation, thus clipping the horizontal sawtooth input, and the rapid action gives fairly vertical sides to the output pulse. Thus, the outputs appearing at plates 1 and 2 are square pulses occurring at line frequency of 15,750 cycles per second. The pulse from plate 2 appears only during the time plate 1 is not conducting and that from plate 1 appears when plate 2 is non-conducting. The widths of the output pulses are varied by horizontal motion of the joystick in the control panel. A similar action occurs to the vertical sawtooth in a vertical clipper stage, V8. The output of V7 is taken from plate 1 and mixed with the output of V8, plate 1, in the common plate resistor R15 of crystal diodes CR1 and CR2. This results in a composite square pulse having a vertical 60 cycle component whose width is varied by vertical motion of the joystick, and a horizontal 15,750 cycle component whose width is varied by horizontal motion of the joystick. This composite pulse is further clipped and squared in clipper stage V2 where cathode mixing with horizontal drive is employed to effect operation of the tally light circuits in the TA-15A Special Effects Amplifier. The output V2 is fed to the output stage, V1, which supplies sufficient current to provide a square pulse of 1.5 V peak-to-peak amplitude across a

75 ohm load to match a 72 ohm coaxial cable. This is the keying signal output of the Special Effects Generator, and its nature varies according to which button is pushed on the control panel. For example, to produce pattern 5, which is a diamond, the vertical and horizontal triangular waves are used but are superposed on grid 6 of horizontal clipper V7 instead of being fed into separate clippers as above. The vertical triangle causes the horizontal triangle to move up and down vertically at a 60 cycle rate with respect to the dc level from the joystick; thus, the generator output keying pulse width varies from zero to a maximum width determined by the dc level and back to zero, at a 60 cycle rate, producing the diamond shaped pattern. Changing the dc level changes the maximum width of the keying pulse, and hence the size of the pattern, from no pattern to full raster size.

In the TA-15A Special Effects Amplifier, the output will be the video signal present at the PIC 1 in jack, in the absence of a keying signal. The keying signal then brings PIC 2 in and out of the television picture. When the keying signal is supplied by the TG-15A Special Effects Generator, the width of PIC 2 is determined by the width of the horizontal component of the composite keying signal. The height of PIC 2 is determined by the width of the vertical component of the keying since this component, in effect, turns the horizontal component on and off.

The control panel, MI-26272, contains the joystick, eleven push buttons, each providing a different boundary line, and a twelfth push button which disconnects the Special Effects Generator output jack from the generator and connects it to any previously selected external keying signal. This external keying signal may be from a flying spot scanner in an existing set-up. The joystick has no control on the picture when the external keying signal is being used.

The control panel also contains an "On Air" light which indicates when the picture is under the control of the Special Effects Generator. Opposite each push button is an engraved strip which shows the shape of the effect provided by that button, with a dot to indicate the starting position of the joystick.

The push buttons provide boundary lines to produce the following effects:

- 1 to 4. Corner inserts—all four corners. The size of the insert is controllable by means of the joystick, both horizontally and vertically. May also be used to provide a *horizontal* wipe from left to right or right to left, or a *vertical* wipe from top to bottom or bottom to top.
5. Diamond wipe—iris action, may be halted at any point, by means of the joystick.
6. Diagonal wipe—boundary line cuts upper right and lower left corners, when in center of picture, and is made to move horizontally by means of the joystick.
7. Wedge wipe—horizontal motion.
8. Wedge wipe—vertical motion.

9. Vertical wipe from center out.
10. Horizontal wipe from center out.
11. Rectangular center insert—size controllable with joystick, horizontally and vertically. By means of an auxiliary guide lever, this may be converted to iris action.

Provision has been made for suppressing transients during switching. The generator consists of a single, rack-mounted, standard 19 inch bathtub unit, requiring  $10^{15}/_{32}$  inches of rack height. The control panel may be mounted in the standard RCA console, MI-26255-B.

With the addition of switching equipment, maximum versatility is obtained. As one example, the TS-1A switcher is illustrated in the dotted portion of the block diagram. With such circuitry it is possible to select and feed to the TA-15A any two of the six inputs.

#### **Self-Keying**

If a highlighted object is placed in front of a black background, such as a felt curtain, the video signal from

the camera on that object may be connected to the video #2 input and the keying signal input of the Special Effects Amplifier. This produces self-keying and enables the use of live moving objects as keying signals. For example, dancing figures may be made to appear on the tops of pianos, tables, etc. However, this requires special lighting techniques so as to avoid shadows in the object used to generate the keying. These shadows have the same effect as the background in that no keying signal is produced when they are scanned. The effect is that the object appears to have holes in it. The self-keying technique is only useful in special applications, such as in a novelty program.

The use of the "Genlock" feature of the TA-15A Amplifier makes possible the combination of remote and of network programs with the local programs. In any case, the video signals and the switching signals used must all be precisely synchronized at both field and line rates.

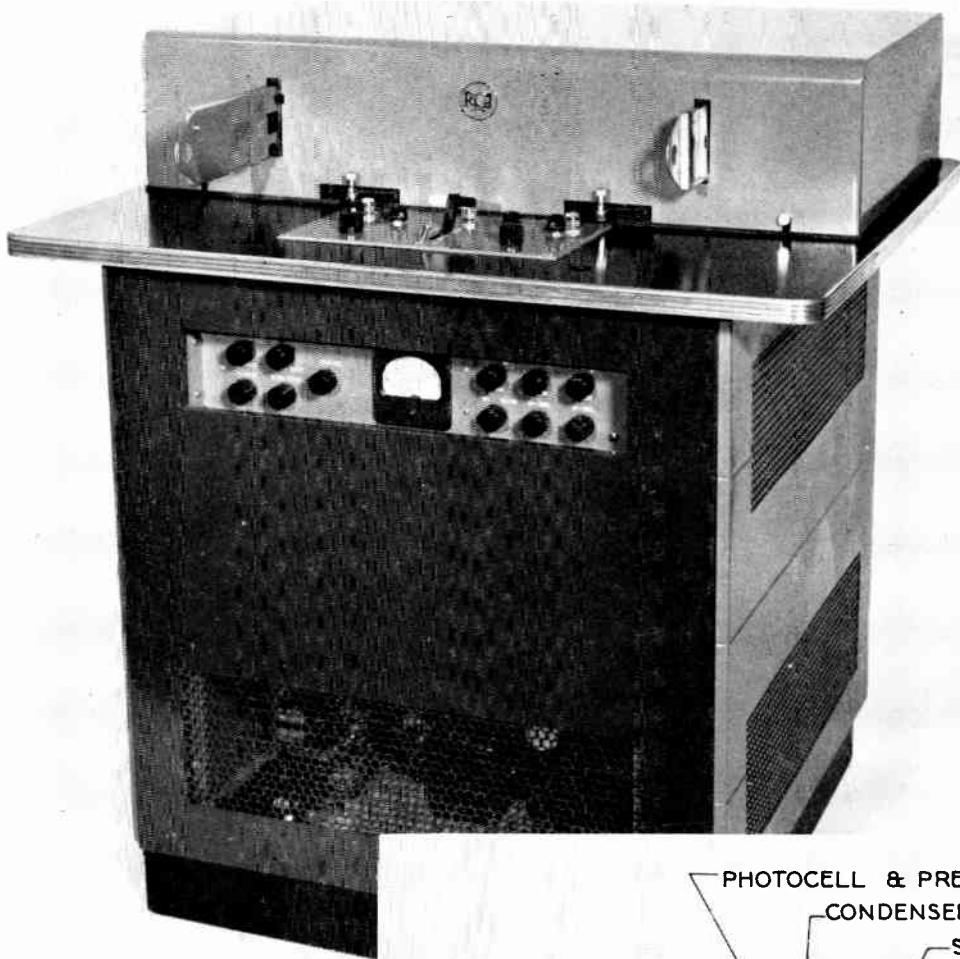

FIG. 1. Full view of the Slide Scanner, which is designed so that operating controls are at a convenient desk-top or turntable height.

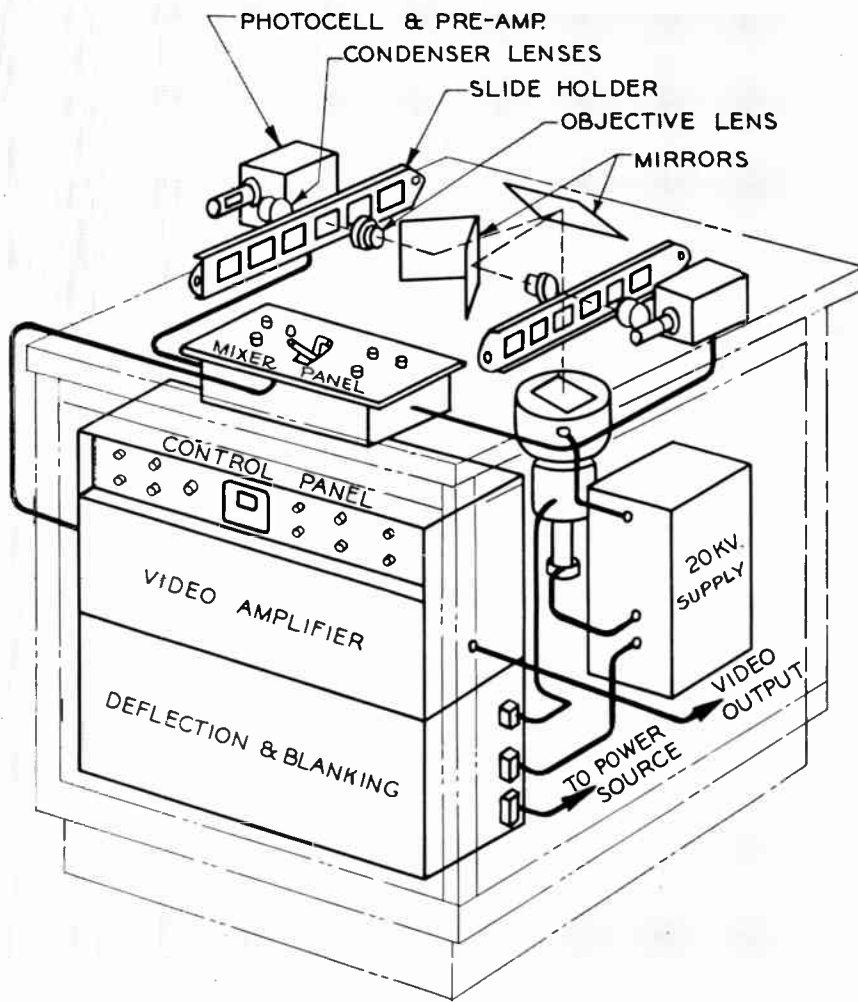

FIG. 2. Phantom sketch showing the location of various major components and circuit elements of the TK-3A. Heavy black lines denote circuit connections made between different stages.

# The Slide Scanner, Type TK-3A

## Introduction

In any television broadcasting activity considerable application is found for still subjects. These may be the simple pictures and titles which are used extensively for announcements and commercials, or they may be the test patterns which most stations transmit every day. For these applications, the analogy to the familiar record turntable indicated a need for a television camera unit of comparable scope and application. Further, the field of use of this new picture source is not limited solely to TV broadcasting. The television laboratory and factory find use for fixed test signals and, in addition, will find the ability to change slides at will advantageous in testing equipment under more widely varying conditions than are possible with a single test pattern.

## Slide Size Considerations

The insertion of advertising material or station identification must be done quickly and smoothly, whether the material is a very short 'Spot' announcement during station break or a full sequence of separate pictures. To accomplish this, the subject matter must be small and convenient to obtain and handle. Therefore, 2" x 2" slides were chosen as subject matter, after consideration of such factors as cost, ease of processing, and storage. The material to be presented, whether a live subject, an inanimate subject, or a poster, is first photographed on 35mm film. Then either the negative or a positive print is mounted in a slide holder. From that point, there are no more problems of lighting or placement: the subject has been condensed into a form which meets the conditions set forth above for size and convenience.

## Camera Unit Considerations

The camera unit must be as simple as possible in its operation and adjustment. These factors, plus those of compactness and cost, led to the choice of the flying spot principle of picture generation instead of the more familiar iconoscope or image orthicon system. This principle offers sev-

eral advantages which are particularly well-suited to the special needs of the subject matter proposed. These are, for example, excellent resolution and noise characteristics, freedom from picture burn-in effects, and relatively low cost.

## Theory of Operation

In describing the Slide Scanner it might be helpful to review briefly the theory which gives rise to its name. Strangely enough, it is an almost complete return to the same principles first used in the earliest history of commercial television. With the Slide Scanner (as was done in early television) a spot of light is made to move across, or scan, the object to be televised in an orderly manner which can be reproduced at the receiving end of the system. This spot of light is reflected, or passed on

through (if the object is transparent) in varying degrees according to the gray scale density of the object. To convert this light variation into a television signal requires only the use of a photocell, since the scanning has already been done.

The only basic difference between the early systems and the present flying spot system lies in the means of generating the scanning, or flying spot of light. Previously, a spirally perforated disc, or scanning wheel, was rotated in front of a steady source of light. A similar wheel, running in synchronism with the first, was used at the receiving end. Mechanical considerations, however, limited the usable definition to very coarse values because of spot size and wheel speeds. This limitation is overcome in the flying spot equipment by the use of a kinescope for the source of light.

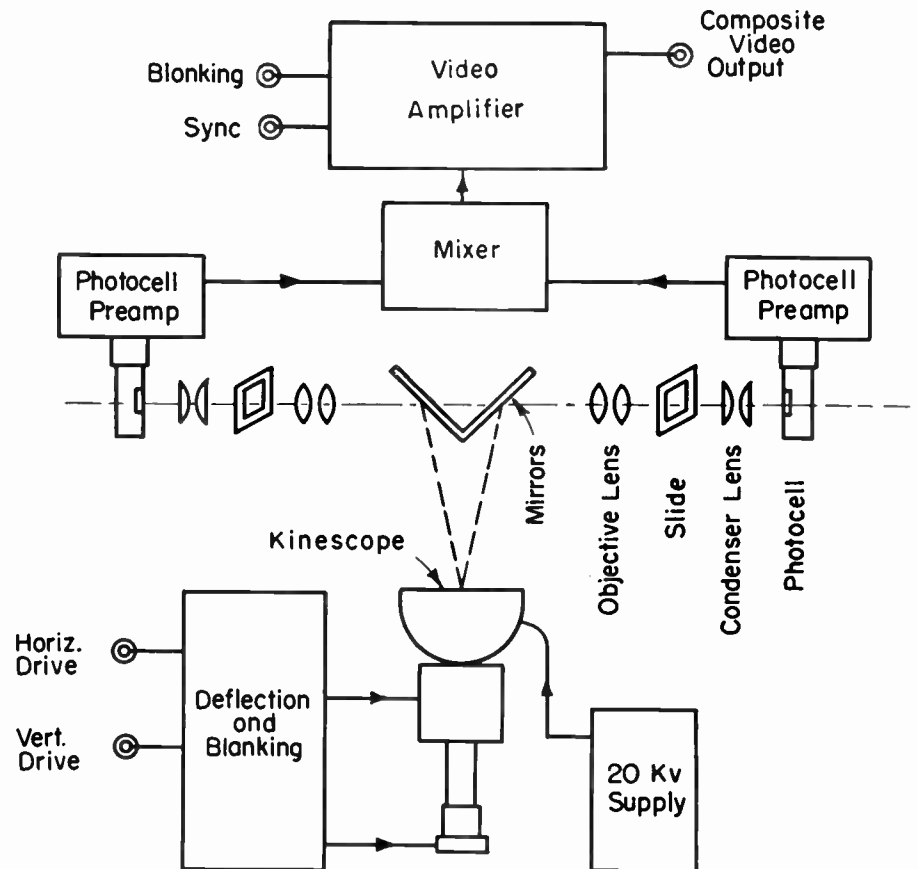
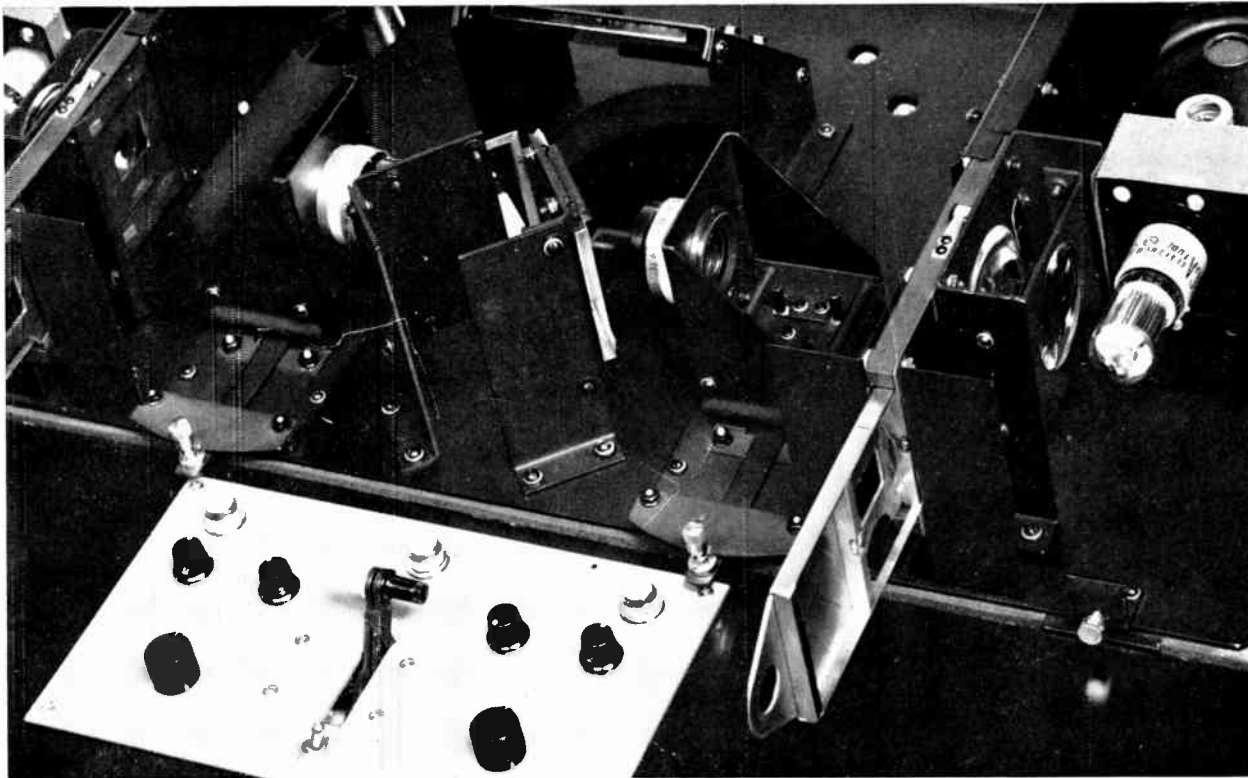

FIG. 3 (above). Simplified block diagram showing the various elements and the general operation of the Slide Scanner.



◆  
**FIG. 4. Closeup view of Slide Scanner with top cover removed to illustrate the optical system employed.**

To complete the analogy between old and new, the spot of light is the sharply focused spot on the phosphor of the kinescope face. The scanning wheel is replaced by deflection of the kinescope beam at standard television frequencies thus fitting the new system directly into commercial standards. A limitation of the new system appears in the kinescope, in that the light output from the kinescope phosphor limits the subject matter to relatively small size. Fig. 2 is a block diagram which outlines the various optical and electrical elements of the Slide Scanner.

### Description

The complete Slide Scanner is illustrated in Fig. 1. As mentioned before, the basic idea of this project was to build a television equivalent of the familiar record turntable. The same convenient desk-top height is used and all of the often-used electrical controls are placed on top along with the slide changing and optical focus controls. The 5"-kinescope is within the base cabinet, mounted towards the back and in a vertical position. This way, all of the top area is available for the slides and lenses, and also maximum protection for the kinescope is afforded by its steel

shield. This shield also contains the 20 kv high voltage supply, permitting a very short second anode lead to the kinescope.

In programming where slide stills are to be shown in sequence or in conjunction with live subjects, it is very desirable to have smooth transition between individual pictures. In other RCA television studio equipment, this transition is accomplished very smoothly by means of manually-operated levers which permit either fading or superposition of two picture signals. To apply this useful scheme to the flying spot camera unit, an arrangement whereby two pictures may be obtained from the one kinescope is required. As shown in Figs. 3 and 4, this is accomplished with maximum light efficiency by the use of two mirrors placed above the kinescope so as to reflect the raster into two separate objective lens and slide carrier assemblies. Two photocells, with appropriate condenser lenses, are mounted behind the slide holders and their outputs fed to a mixer circuit controlled by the same type of fader levers mentioned above. Thus, as many as twelve slides may be shown without the annoying motion of slide changes being seen, if the slides are mounted in alternating sequence in two of the six-space slide holders illustrated in Fig. 5.

All of the remaining electronic circuits, including the video amplifier, control circuits and deflection circuits are contained in a standard "bathtub type" chassis which is in turn mounted on hinged rails in the front of the table cabinet. Tubes are accessible from the front, by removing the snap-on cover as shown in Fig. 6. Wiring is then seen by lowering the chassis until it is held parallel to the floor by stop-chains. This may be seen in Fig. 7.

The various controls needed for setup and occasional adjustment appear on this chassis. Those which might be needed from day-to-day, such as beam current, centering, size, etc., are mounted on a narrow panel at the top of the chassis and are accessible through an opening in the front cover. A meter which may be switched to read either kinescope beam current or high voltage is also located on this panel. Other controls, such as linearity and compensation, which are normally set and locked are located on the chassis itself.

All power connections to the main chassis and between this chassis and the mixer and pre-amplifier chassis are made with plugs to permit easy disassembly for service. All video connections are made through standard coax connectors.

## Control and Operating Features

The video operator need have no fear of a maze of controls, all requiring constant attention as various objects are shown. First of all, the controls required for operation of the Slide Scanner are few in number and, in fact, most of them require only a check at the beginning of each operating day. For example, of the kinescope controls, only beam current and focus need attention and then only at setup time. Much can be done toward smooth operation by proper choice of the original material to be photographed and by processing slides which are to be shown in sequence so that they are of the same average density. The video gain controls will then require no adjustment during showing time.

The slide holder has been made very accurately so as to locate each slide exactly and consistently. Hence, if the slide mounts are all of one type, optical focus will remain the same for all slides. Either positive or negative slides may be accommodated by means of a polarity switch in the output of the mixer circuit which inverts the electrical signal.

Finally, in order to provide additional variety and flexibility, a selection is offered, by means of switches, of either lap dissolve, fading through black, instantaneous switching, or combinations of all three. A switch selects the use of either the fader mechanism or a toggle switch for transfer from one photocell output to the other. Also, the two levers comprising the fader mechanism may be operated together for lap dissolve, or separately for fading and superposition.

## Typical Applications

One need only to observe the operation of a typical television station to see many possible uses for the Slide Scanner. Test pattern is usually originated either in a monoscope camera with a special call letter monoscope tube or a slide projector and film camera. The Slide Scanner can supply this test pattern and in addition offer a variety of material for station call, commercials, or special occasions. In TV stations where film cameras are normally tied up for these operations, the addition of the Slide Scanner would free them for use in rehearsals, previewing, or maintenance. These considerations are probably most valuable in the studio, but would

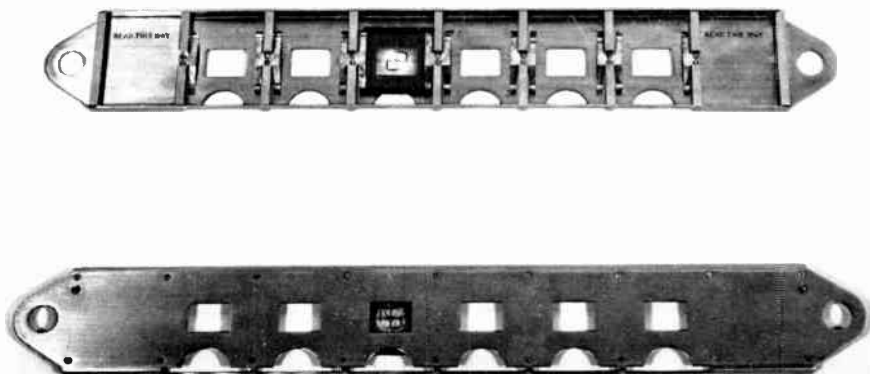
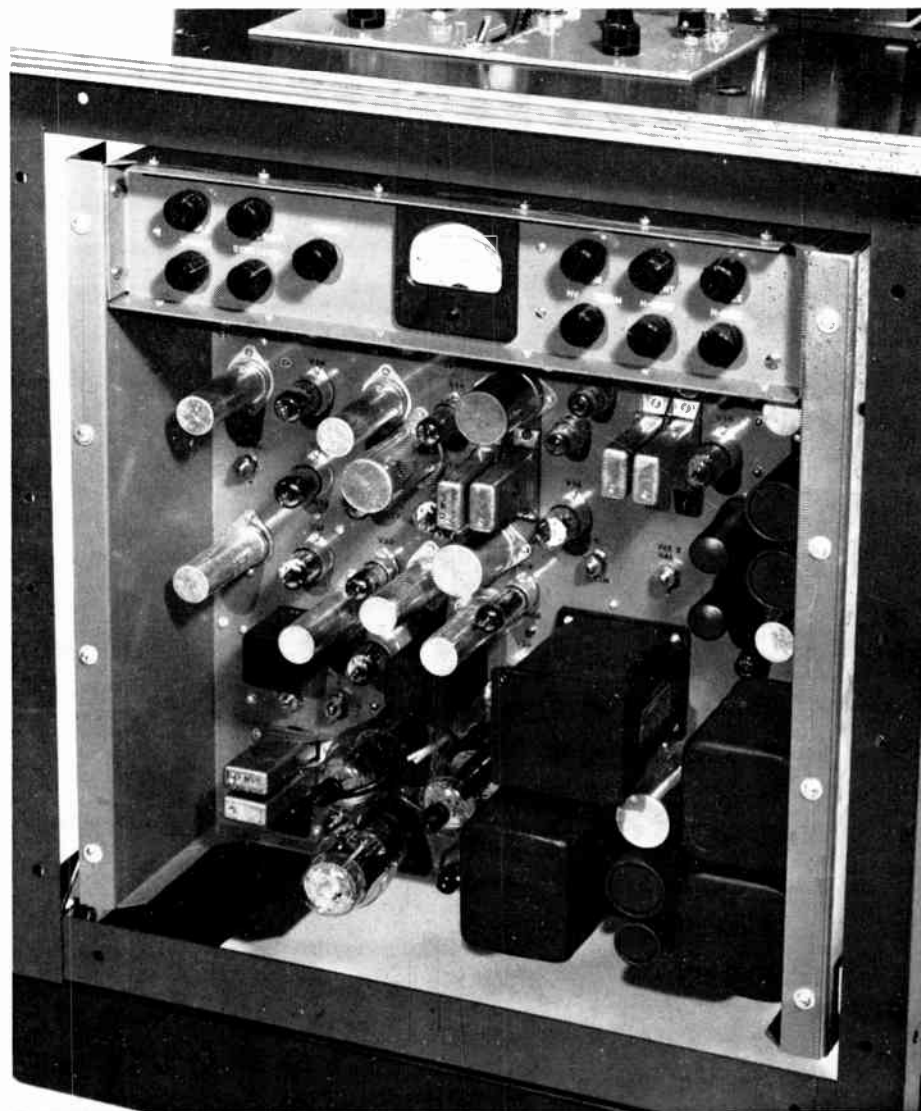
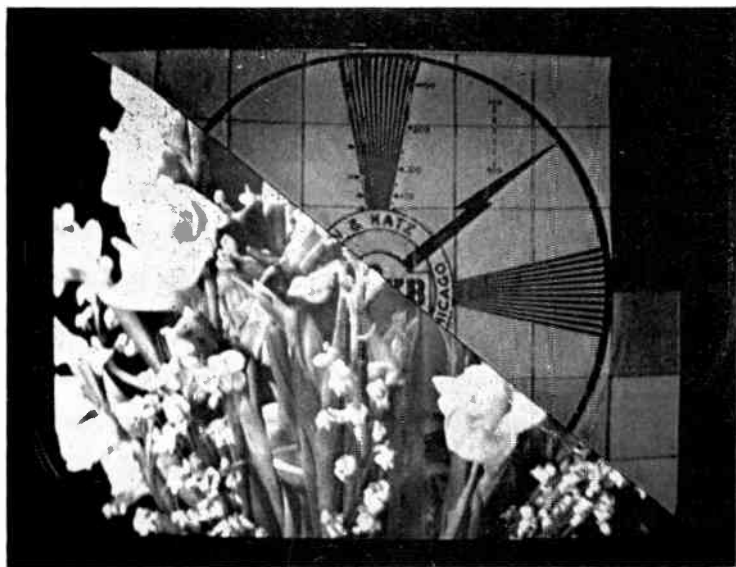

FIG. 5 (above). View of the two "six-space" slide holders which allow twelve slides to be shown in succession.

FIG. 6 (below). As shown here, the cover panel is removable so that all tubes are accessible from the front.



# THE SLIDE SCANNER TYPE TK-3A (Continued)



ANGLE WIPES, from lower left to top right, or vice versa, may be applied to any two picture signals from any source.

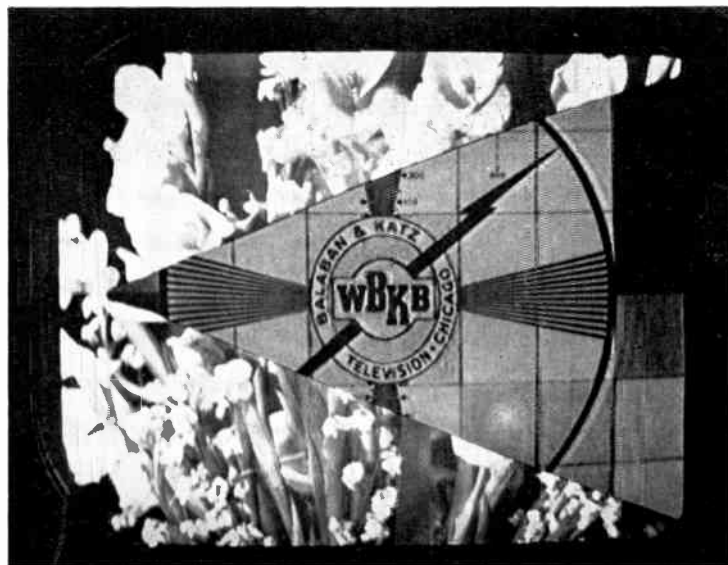

POINTED WIPES in which a wedged shaped area of one picture moves into—or out of—the area of another picture, are possible.

## THE NUMBER OF DRAMATIC

apply equally well when the transmitter site is at a distant point from the studio. Then, too, the small station with only a network program source would find the Slide Scanner very useful for inserting local announcements.

For actual program use, the turntable kinship mentioned before offers flexibility in application. For instance, with every dramatic production a list of characters is presented. This could easily be handled with the Slide Scanner while a studio camera, normally used for the purpose, would be freed for other uses. In the same way, short commercials, announcements, weather reports, or phone numbers may be setup, shown, and put away with a minimum of complications.

Not mentioned so far, but again illustrating the versatility of the Slide Scanner, is its use with the recently announced RCA Special Effects equipment. By means of a special mask assembly which may be fitted into one of the slide holder channels

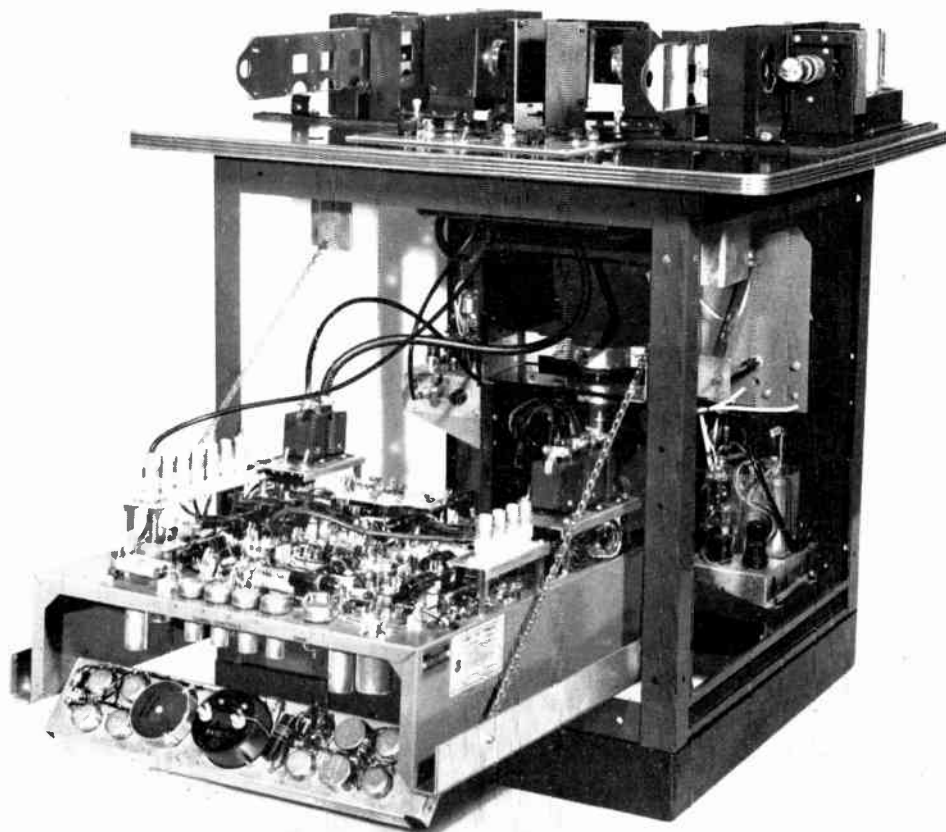
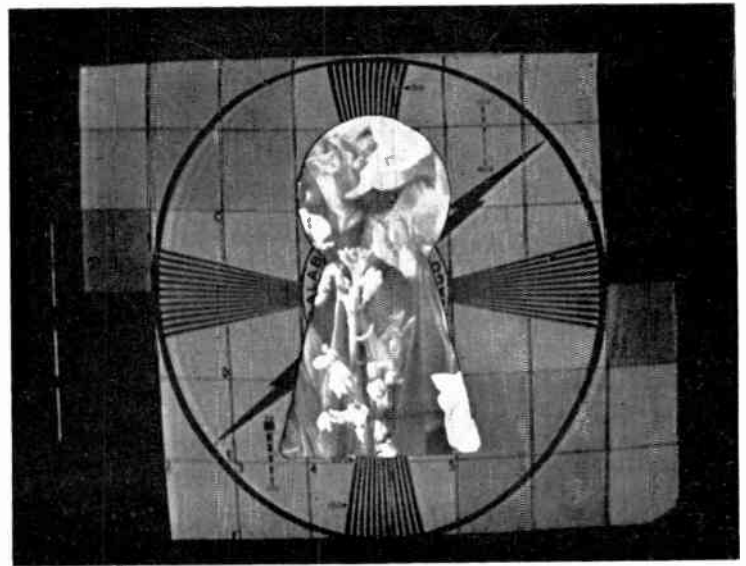

FIG. 7 (left). View with front cover removed and with Video and Deflection chassis hinged down to make all wiring and small components accessible.





**STRANGE SHAPED INSERTS**, of any kind that the imagination can conceive, can be obtained by making a mask of the shape desired.



**REVERSAL** of the two pictures is accomplished by simple switching. Pictures from studio, remotes, film camera, etc., can be used.

## “VIDEO-EFFECTS” COMBINATIONS IS PRACTICALLY UNLIMITED

and actuated by an external lever, mask signals for the Special Effects keying may be generated. Infinite variety is possible, both for fixed cut-outs, or wipe effects when the sliding mask assembly is moved across the scanned area.

### General Specifications

Slide holders.....6 slides each

Slides.....2x2, double 35mm frame size

Output...Standard RETMA level (1 v. peak to peak on 75 ohm line—1.4 v. with sync) 2 isolated output circuits

Limiting resolution (horizontal) ..600 lines

Linearity .....2%

Auxiliary equipment....1 WP-33B Regulated Power Supply

### Dimensions:

Table top.....30½ x 26 inches

Base .....25 x 25 inches

Height to table .....28 inches

Height over cover.....34½ inches

Stock Identification .....MI-26963

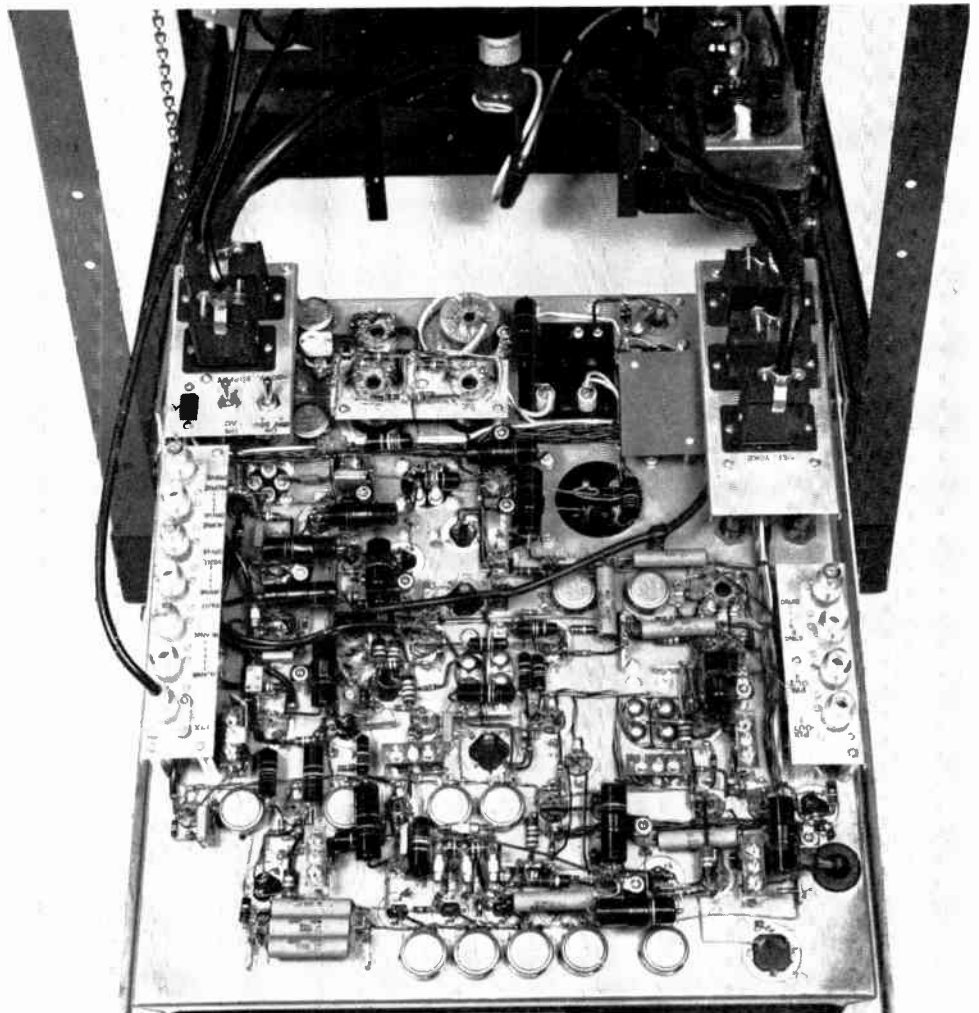

**FIG. 8.** Closeup view of chassis as lowered for inspection.

# TS-10A Switching and Fading Equipment

The operational experience of a majority of television stations has proven the program production requirements for some method of performing fading, lap-dissolves or superpositioning of video signals in order to round out the station capabilities for adequate commercial advertising as well as special effects. In addition to the ability to offer smooth and effective means of telecasting the commercial part of a program, it is of even greater importance to the program director in studio work . . . to have under his direction the technical means of switching from camera to camera in such a way as to control the television picture through fading, lap-dissolving, or superpositioning.

The TS-10A Switching System has been designed to provide all the controls necessary to perform these effects on the picture signal output from any one of four local camera positions and two remote sources and feed the signal to a master control room or to a television transmitter.

When used in television stations equipped to produce live-talent studio programs, the TS-10A can be installed in the studio control room together with the Camera Controls for each camera used in the studio (see Fig. 1). The TS-10A Switching Equipment and the Camera Con-

trol Equipment are so designed that the desk-type sections of each can be fastened together to form an operating console and thus provide a control center for camera switching, monitoring and other technical aspects of programming.

In stations where no live-talent programming is planned, but where facilities are employed for film projection, broadcast of network programs and relay pickups, the TS-10A Switching Equipment can be located in the transmitter room or in the projection control room together with the film camera control. The TS-10A can also be used in conjunction with field equipment for studio purposes and provide equivalent performance.

From the operating standpoint, the TS-10A Studio Camera Switching Equipment enables a single video operator to do these things: (1) select any signal from six input lines; (2) switch, fade or superimpose the desired local signal into the program line and also perform the same functions with remote or network signals when used in conjunction with an RCA TG-45 Genlock; (3) fade out the previously selected signal and fade in another, simultaneously and at any speed; (4) switch instantly from one signal to another; and (5) superimpose two signals with any desired degree of brightness

FIG. 1. Block diagram showing arrangement of units in a typical studio layout.

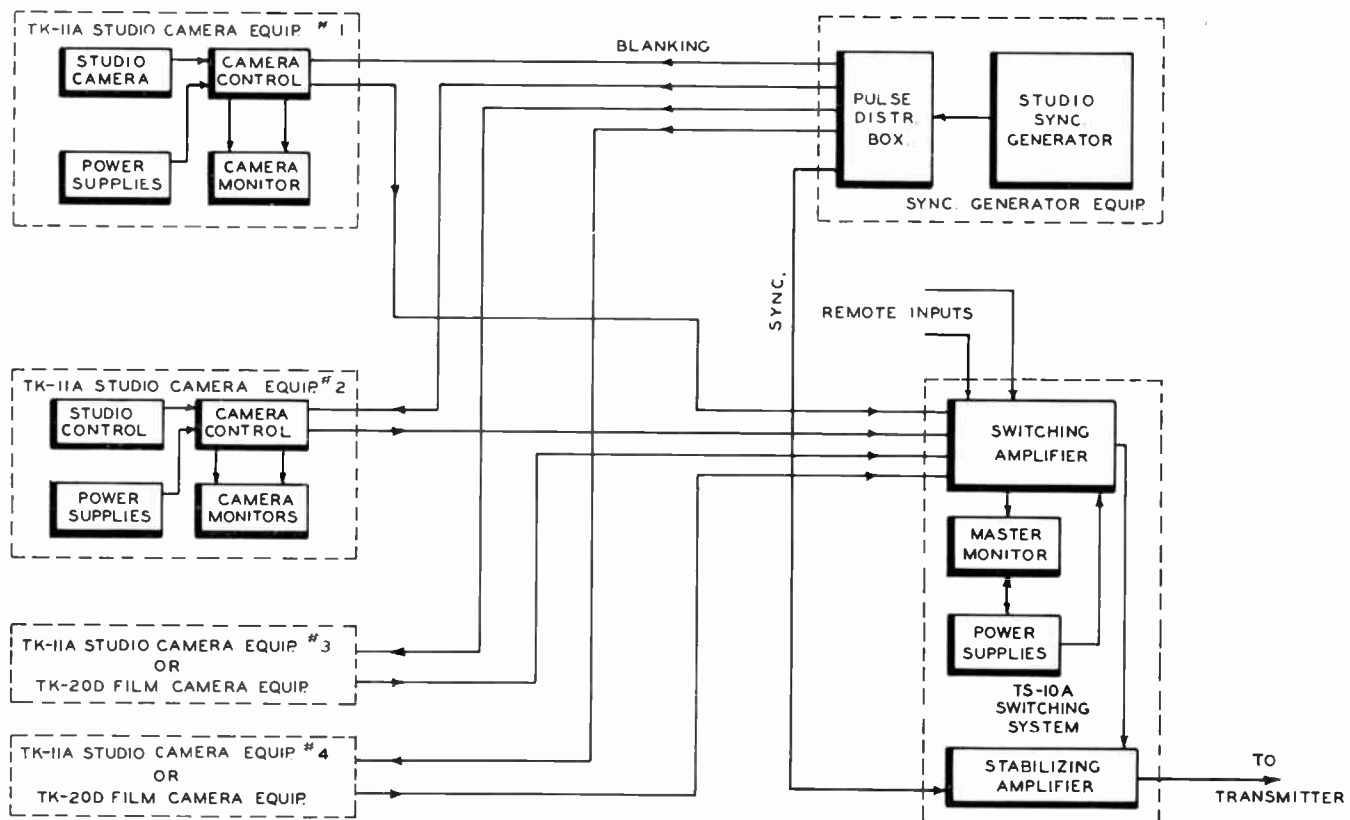

for each signal. All these functions can be accomplished at the switching panel, which is mounted on the inclined portion of the desk top.

Electrically, the TS-10A Studio Camera Switching Equipment includes all the circuits necessary to accomplish four operations, namely:

1. Video Switching: A six push-button selector provides for selecting any one of six input signals for transmission to a master control room or to the transmitter.

2. Sync Addition: Amplifier circuits in the TS-10A system combine sync from the studio sync generator with the camera video signals to form the composite video signal.

3. Monitor Switching: A three position switch provides for selection of either of two remote (network or relay pickup) signals for preview, or the output of the

TS-10A. These signals are displayed on the TM-6B Master Monitor which is part of the TS-10A equipment.

4. Intercom Switching: A communication system in the TS-10A permits the technical director and program director to converse with all engineering and production personnel.

The TS-10A Studio Camera Switching Equipment consists of the switching amplifier chassis-type unit, an RCA TM-6B Master Monitor, two type WP-33B Power Supplies and a TA-5D Stabilizing Amplifier. The switching amplifier is mounted in the lower compartment of a desk-type console section, and the TM-6B Master Monitor is mounted above it. The Stabilizing Amplifier and Power Supplies are designed for rack mounting.

The switching amplifier consists of 3 two-stage picture amplifiers and 2 two-stage sync relay interlock amplifiers.



FIG. 2. Closeup of the TS-10A Switching Panel showing the controls and switches located on sloping top panel of desk.

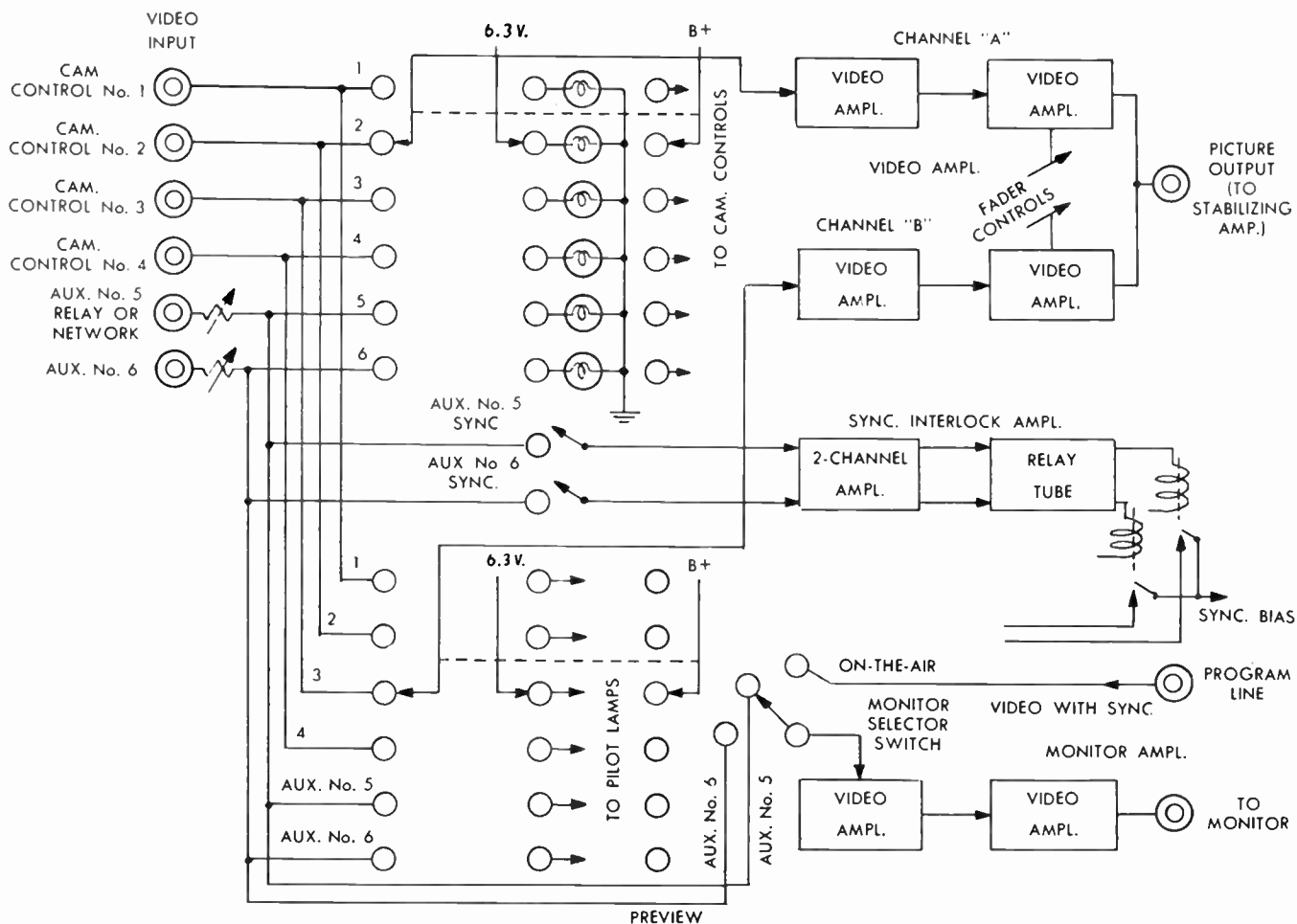

FIG. 3. Simplified block diagram showing the arrangement of video switching, mixing and amplifying circuits of the TS-10A.

Two of the picture amplifiers have their inputs connected to separate banks of camera selector switches. They have a common output, however, so that they can serve one camera singly or two cameras in a lap-dissolve or superimposition. The third picture amplifier feeds the monitor input. The two sync amplifiers automatically add local sync to the video signal when remote sync fails or local sync is otherwise required.

Controls for the switching amplifier project through the inclined top panel of the desk, as shown in the photo, Fig. 2. The controls are as follows: (1) two banks of push buttons from which the on-the-air signal is selected; (2) two toggle switches for preventing local sync from being added to incoming remote positions 5 and 6; (3) gain controls for the remote signals; (4) a three-position switch for selecting either the on-the-air signal or one of the two remote signals for display on the monitor; (5) fading and lap-dissolving controls; and (6) tally lights to show which inputs are being used. Also control circuits

are provided to energize tally lights at the camera control positions and on remote equipment.

The video circuits of the TS-10A Switching Equipment are shown in the diagram Fig. 3. Coaxial input jacks accommodate the video (without sync) signals fed from the camera controls of studio and film cameras, plus the video signals from remote pickup gear or network program lines (aux. #5 and aux. #6). Remote signals are accompanied by sync from the remote source. Two banks of pushbutton switches connected to these jacks serve as selectors for the signals to be fed to the rack-mounted stabilizing amplifier for the addition of sync, prior to being fed to the television transmitter. As can be seen, the two selectors feed separate amplifiers which have their outputs connected together for superimposing or lap-dissolving two pictures. For example, by pressing #2 camera in one bank and #3 camera in the other, the signals are fed through "Channel A" and "Channel B" amplifiers respectively and com-

bined in the output. The desired relative brightness for each picture can be obtained by adjusting the respective fader (gain) control, even to fading out either picture entirely. Instantaneous switching between one camera and another is done by use of one bank of switches, and a gap switching design prevents overlap.

Although the network or relay signals fed to these jacks usually contain sync signals supplied at their source, in the event that the sync in these signals fail, or becomes inadequate for proper synchronization, the sync interlock amplifier automatically activates relays which feed in sync from the local sync generator at the stabilizing amplifier.

The intercommunication circuits of the TS-10A Switching Equipment provide communication between camera men, camera control operators, technical director, program director and any assistant production men who may be stationed near the cameras. In addition, they provide for distribution of program sound to all personnel.

To accomplish this, each operator is provided with a double earphone headset and microphone. One earphone reproduces the program sound while the other reproduces the operator's conversation. The headsets are provided with dual plugs which provide a five-wire connection. Operators at the control position plug these headsets into the jacks on the switcher. Camera men and production men at the cameras, plug theirs into jacks on the cameras.

An Intercom Control Box allows the technical director and program director to talk directly with their respective engineering and production personnel, and thus coordinate all aspects of the television program. Two banks of pushbuttons on the control box—one bank for engi-

neering, and one for production personnel—allow a wide choice of speech circuits.

The technical director, for example, can communicate directly with any one of his camera men by pressing the proper "Cam" pushbutton in the "Engineering" bank. Also, he can converse with all engineering personnel by pressing the "All Cam" pushbutton. Pushbutton "PL" connects him into a private line which may run to the studio. Likewise, by use of the "Production" pushbuttons, the program director can communicate with all assistant production men. Moreover, he can talk (one way) to all production and engineering personnel by pressing the "Prog. Line" (program line) pushbutton. This connects his microphone into the line which supplies program sound to all personnel.

Fig. 4 is a simplified functional diagram of the overall intercommunication system. It shows what talking circuits are available to directors and assistants for both engineering and production personnel. For example, when pushbutton "Cam #1" is pressed, the technical director can talk with the engineer at Camera #1. At the same time, his assistant can talk with engineers at Cameras #2, #3 and #4. Circuits at the same cameras are also available to the program director and his assistant.

The circuits of the TS-10A Switching system are designed so that it is possible to have intercommunication without use of the intercom control box if desired. A dummy plug can be inserted into the 18-pin connector on the chassis, making separate conference communication possible for all production and for all engineering personnel.

Plate Power is supplied to the TS-10A Studio Camera Switching Equipment by two electronically-regulated power supplies, RCA Types WP-33B. The WP-33B is a special heavy-duty power supply which furnishes plate and screen voltages to both the switching amplifier unit and the stabilizing amplifier. The second WP-33B provides B + voltage for the TM-6B picture monitor. These power supplies are designed for mounting in the studio control room equipment rack, with other control room units.

The TA-5D Stabilizing Amplifier consists of video-amplifier, sync-stretching and clamp-circuit components mounted on a recessed type chassis designed for standard racks. As part of the TS-10A Switching Equipment, the TA-5D combines the sync signal from the studio generator with the video from the cameras, producing the composite video signal for the transmitter.

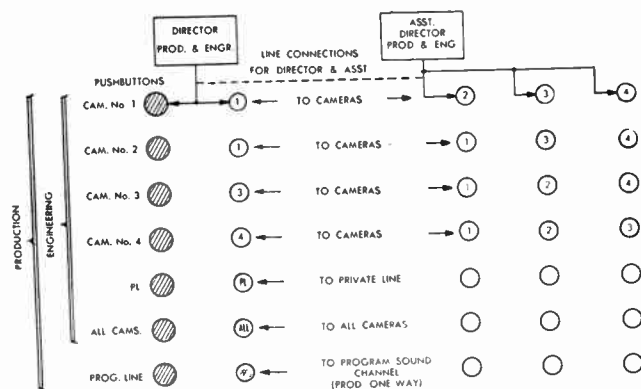

FIG. 4. Simplified schematic of the Intercommunication Circuits of the TS-10A.

Circuits in the TA-5D automatically correct faulty video-sync ratios, and eliminate any spurious interference caused by the switching of video circuits.

Electrical and mechanical specifications of the TS-10A are:

Power Line Requirements. .100-120 volts, 50/60 cycles,  
60 watts

**Input Signal:**

Local Input (video from camera control).....1.0 v. peak-to-peak

Auxiliary Input (as remote).....1.0 v. min. peak-to-peak video, 18-33% sync

**Input Impedance:**

Local Input.....75 ohms

Auxiliary Input..75 ohms, adjustable line termination

Output Impedance.....75 ohms

**Mechanical Specifications (Console Section):**

Overall Dimensions...41" High, 13" Wide, 36" Deep

Weight .....46 lbs.

Finish.....Dark umber gray



FIG. 5. View of the "Intercom" control box which contains two banks of pushbuttons for engineering and production personnel.

# TS-30B Field Switching System

One of the most important operations in television programming is that of switching from one camera to another. Switching must be accomplished smoothly without either interrupting or disturbing the receiver synchronizing, even momentarily. If precautions are not taken to avoid surges in switching, it is possible that the sync. may be clipped later in the system during the period of surge. Some receivers are very sensitive to such interruptions. Cases have been known in the past where switching surges have been so large as to overload the transmitter and throw it off the air. It is not possible to experience such difficulties in properly designed television systems today because means are used to maintain constant black level at all points where surges are harmful. Since switching is likely to produce surges, it is desirable to eliminate them at this point. A successful means for accomplishing this is the clamp circuit which was described previously in the section on the circuit theory. This circuit restores the picture signal to some

arbitrary reference level at the end of each scanning line; *i.e.*, during the retrace or blanking period. It is independent of anything that takes place in the signal. Thus no surge can exist longer than the period of one line.

Since more than one camera will often be used at a single location, a flexible unit designated as a Field Switching System, serves as a means for transferring camera outputs. In addition to instantaneous switching, a fader circuit permits fading, super-impositioning, lap-dissolving, and other effects. Also included are monitor, intercommunication and program sound (for video personnel) switching circuits, a picture amplifier, and synchronizing pulse mixing circuits to produce a composite picture signal as shown on the block diagram Fig. 1.

As illustrated in Figs. 2 and 3, the field switcher contains two six-section pushbutton switches which permit

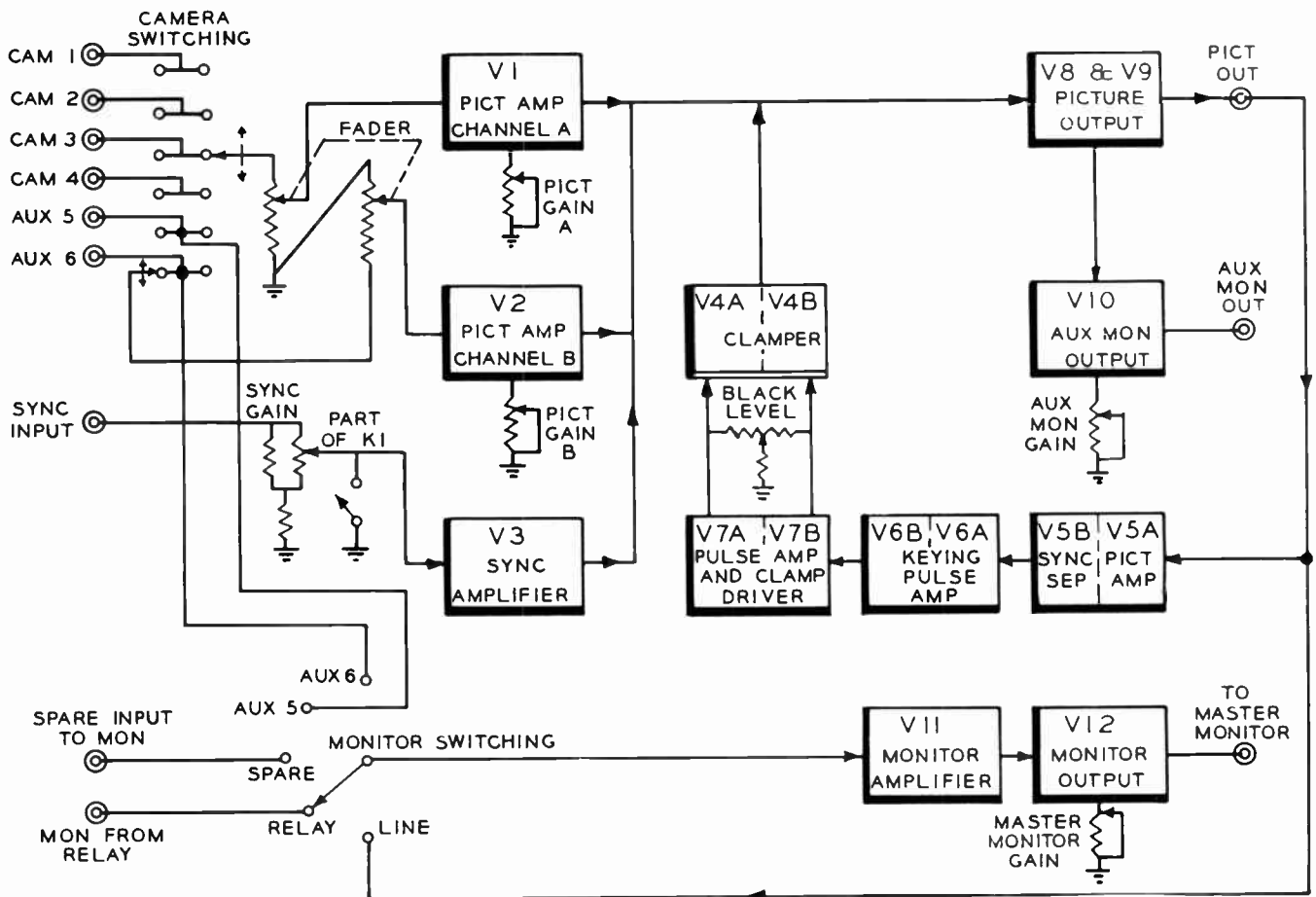

FIG. 1. TS-30-B Field Switching System.

selective switching of the picture signal outputs from four cameras to a picture transmission line. Two auxiliary input terminals are provided so that picture signals from either a relay receiver or a video program line may also be fed to the transmission line (with local or remote sync as desired). The fader assembly permits fading and other effects between any two of the input signals whose sync is from the same source.

Switching from one camera to another is accomplished without interruption of the synchronizing signal. A series of tally lights indicate which camera is "On the Air." A five-position rotary switch controls the input to the monitor to check either composite picture signals fed into the transmission line from cameras or the picture signals at the auxiliary inputs. Pushbutton switches, fader levers, camera input, indicating lights, the monitor switch, and the power switch are grouped on the lower front panel. The switches for the intercommunication circuits are grouped at the top of the front panel. A hinged cover immediately below this panel gives access to a bank of 12 intercommunication jacks.

The sound system includes switches that provide means of intercommunication between operating personnel at the camera pick-up chains and over private lines to program and engineering personnel at the trans-



FIG. 2. Field Switching System.

mitter. In addition, all operating personnel are furnished program sound in one earpiece (see Fig. 4).

On the rear panel of the switching unit are four nine-terminal plugs for the intercommunication and tally circuits to the camera controls, a twelve-terminal connector for power to the monitor, four three-terminal connectors for program sound input and producer and engineering private lines, a twelve-terminal power-input connector, and twelve coaxial connectors for picture signal inputs and outputs.

The switching and control panels, on the front of the case, are covered during transportation by a removable cover. A hinged cover, over a depression in the top of the case, gives access to the intercommunication system power supply controls and program sound volume control.

The left-side panel is fitted with an interlock switch that opens the power supply circuit when the panel is removed. A separate shorting plug clipped to the panel enables the interlocks to be bypassed when necessary during servicing.

The picture amplifier consists of three stages, the last one being a cathode follower which feeds the picture line to the relay transmitter, or a line directly to the main studio (75-ohm coaxial). A blocking capacitor separates the line from the cathode, so that no direct current

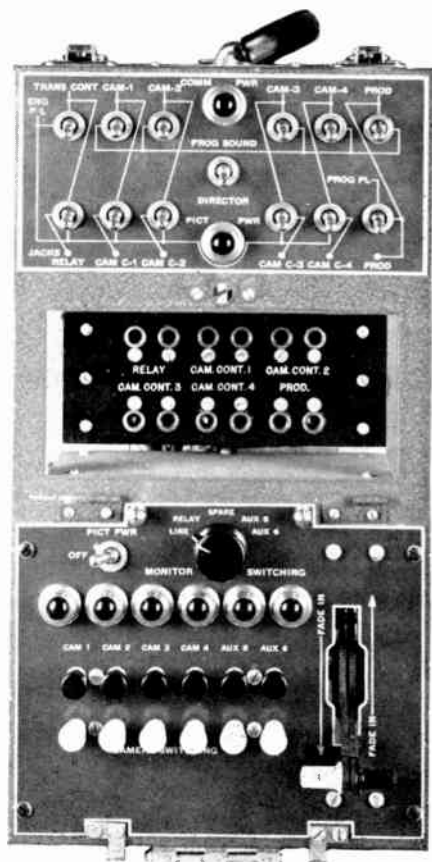
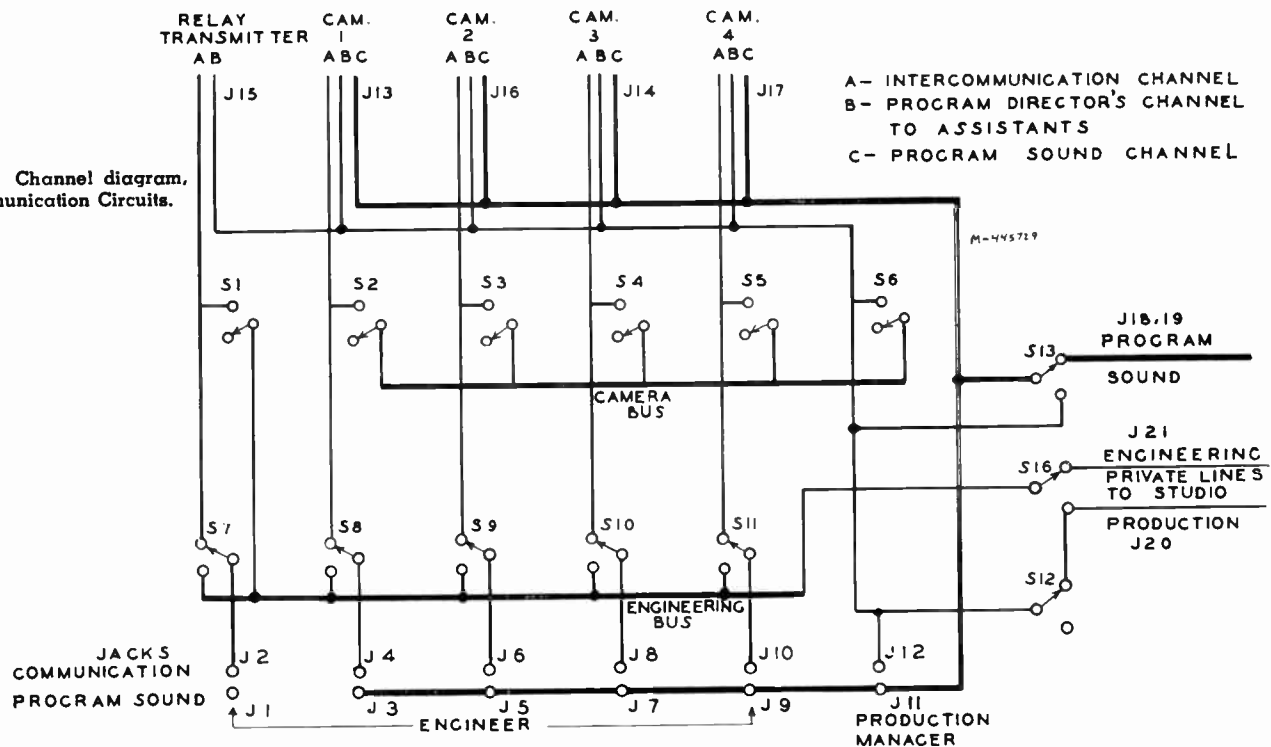

FIG. 3. Front view of Switching Unit showing panel detail.



FIG. 4. Channel diagram.  
Communication Circuits.



flows in the line. The grid of this cathode follower is subjected to the action of the clamp circuit. Hence, no surges appear on the outgoing line.

Two other coaxial lines also provide signal to other parts of the system. One of these is connected to a line monitor, or field master monitor. It is fed through a separate unity-gain amplifier contained in the switching system. The input of this amplifier may be switched with the rotary switch to any of several points in the pickup equipment. The second line may be used to feed an additional monitor for the use of spectators or an announcer, or it may feed a stand-by relay transmitter. All three output lines carry identical signals.

The synchronizing signal is mixed with the camera signal in the switching system to form the final composite picture signal. The synchronizing signal is usually supplied to the switching system directly from the pulse shaper, and is coupled to the picture output line through an amplifier. Thus, the synchronizing pulses are always transmitted independently of the camera switching. In cases where picture signal already including the synchronizing pulses is being received over one of the auxiliary input circuits, the local synchronizing signal is disconnected automatically.

Keying signal for the clamp circuit is derived from the sync. signal. The sync. is separated, as in a receiver, and delayed so that keying is done on the "back porch,"

*i.e.*, on the peaks of blanking just following the sync. pulses.

Circuits are included in the switching system for communication between the various technicians operating the equipment. Two sets of telephone jacks are mounted in each camera, one for the cameraman and the other for a program assistant stationed at the camera. Connections for these telephone sets are included in the camera cable. These intercommunication circuits all terminate in the field switching system where the technicians operating the camera controls and switching system, and the program director may connect their telephone sets. Private telephone lines to the main studio also terminate here, and may be connected to the local circuits. A variety of communication network combinations may be secured with the set of toggle switches on the upper front panel.

Each telephone set consists of a carbon-button microphone and two earpieces. The microphone and one earpiece are used for the intercommunication circuits. The second earpiece is connected to a separate circuit which carries program sound. Thus, each operator can hear the program sound at all times, and get useful cueing information from it.

Power for operation of the telephone circuits is obtained through a selenium-disk rectifier from the power lines, and is entirely independent of the power for the picture-amplifier circuits.

# TV REMOTE CONTROL SWITCHING

## Video Relay Switching Systems Handle Many and Complex Variations of TV Programs Economically

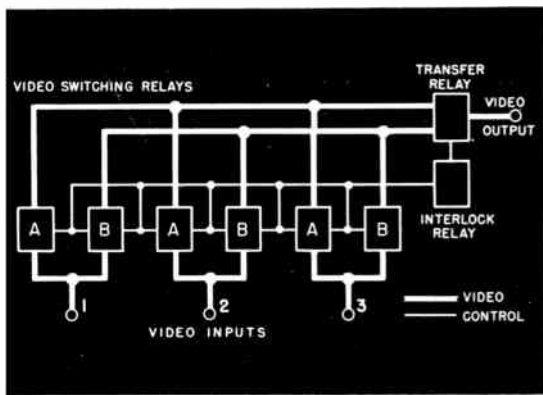

FIG. 1 (above). Block diagram showing fundamental switching scheme of RCA Remote Control Switching System. Relays A and B are electrically operated by push buttons.

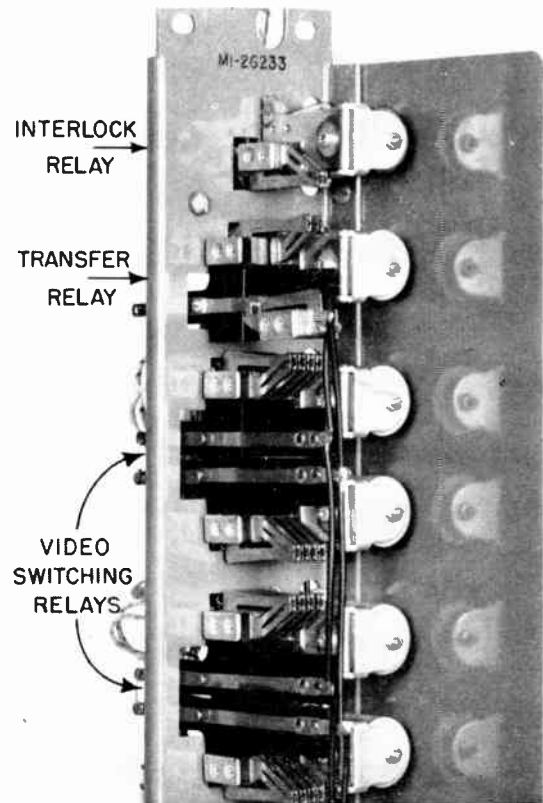

FIG. 2 (above). Sectional view of basic relay panel illustrating interlock, transfer and video switching relays employed.

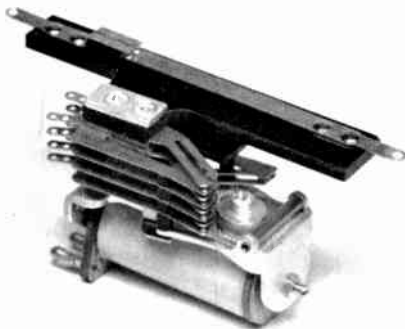

FIG. 3. Closeup view of video switching relay showing construction and design.

A television station is called upon to handle many variations of program material in its operating schedule. Maximum flexibility must therefore be had in the performance and utilization of all equipment. One means for accomplishing this is to provide video switching in one or more studios, wherein the program is assembled from all necessary sources, and then passed on to the second control point for final distribution to transmitter and network.

In a relatively small station, or more especially in a large plant, where studios may be located some distance from each other, many video lines must be laid to tie studios together and provide the spare lines for possible program combinations and new facilities.

The question of future expansion is an important consideration. Even the smallest station must consider the cost of discarding present facilities at a later date or installing equipment now that may be later expanded at minimum additional expense.

In a television system the video signals originating in field cameras, studio cameras, or film cameras are fed through coaxial lines to associated rack-mounted equipment. If the video switches themselves can be located directly in the video lines, and these switches controlled from a remote location, then the video lines may be completely centralized and a practical solution of the problem is engendered. Video relays are the answer.

There are other functions which must be performed, such as providing for tally light operation, line termination, isolation of video inputs and outputs, and sync interlocking. The mechanical arrangement of the components must be such that the basic equipment will provide economical switching for the small station and, at the same time, provide a firm foundation of basic equipment for larger installations.

The circuits must have a minimum of capacity across the video contacts as well as the smallest possible capacity to ground

in order to reduce "cross talk" and line losses. Other requirements include the use of simple non-locking push keys to operate the relay coils, relays to be operated in a lock-up type circuit—interconnected to drop out any operated relay when another is operated. The switch-over time should be as short as possible, and switch-over should be arranged so that either gap or overlap can be obtained.

It has been found that, for minimum picture disturbance during switch-over, a slight overlap or make-before-break sequence is desirable. A zero transfer interval would be ideal, but is impractical. Overlap is chosen to avoid occurrence of black areas when switching between two similarly lighted scenes. The circuits can be arranged so that double termination is picked up during the transfer to prevent undesirable flashes. This arrangement is commonly used for camera switching. For preview monitors, however, the switching must cross over active lines without introducing any disturbances. For this application, a gap (break-before-make) sequence is desirable. The same condition exists in Master Control switching. Although, in this case, switching is most often done only between programs, the transfer interval, as in camera switching, again appears on the outgoing video signal and hence must be as short as possible.

In the course of the development of the relay switching system, several fundamental circuits were tested for conformance to the specifications set up. The simplest circuit used a mechanically interlocked push-button assembly to operate the video relays. This, however, becomes the worst case for switch-over timing, since both the push-button assembly and the relays themselves will contribute variations in the timing. The next general circuit was one in which the latching action was electrical. Briefly, on operation each relay switches itself to a "hold" bus which is in turn controlled by a separate control relay

group. In this way, a gap sequence may be set up in which a push button initiates a step sequence through the control relays to release the hold on any relays already operated, restore the hold bus, and then operate the desired new video relay. Here again the switch-over time was governed by the operate and release times of the relays involved. Either timing adjustments must be provided for each relay or all of the relays must be adjusted for very critical uniformity. Also, this circuit was not easily adaptable for overlap switching, although a system using double coil relays, carefully adjusted for timing and uniformity, has been made to work quite satisfactorily. It must be remembered that we are aiming for a switch-over time of less than 10 milliseconds.

The circuit finally chosen met all of the requirements for timing and yet the switching interval was influenced only by one transfer relay instead of by all the relays involved. A short description of the circuit and physical arrangements follows: (see video diagram, Fig. 1 and relay arrangement, Fig. 2). For circuit details, refer to Fig. 4.

Each incoming video channel is connected to make contacts on a pair of switching relays. The other side of these contacts connect to two video bus wires which in turn run to a transfer relay. When a channel selecting push button is operated, one of the switching relays (let us call it "A"), will close, connecting the incoming line to one of the transfer bus wires. Next, other contacts on this switching relay operate the transfer relay to connect the outgoing line to the video bus wire and so to the incoming circuit. When some other push button is pressed, a circuit from separate contacts on the transfer relay will tell this video switching pair that the "A" bus is in use and so the "B" switching relay will operate. The video contacts on the "B" relay close to connect the new incoming video line to the "B" video transfer bus wire. Other contacts on the "B" relay close to operate an interlock relay which in turn releases the transfer relay. The outgoing line is thus transferred from the original input to the new one. As the transfer relay releases, the same "busy" circuit releases its hold on the old circuit's "A" relay. This process repeats as subsequent push buttons are operated. Actual transfer, as seen by the

output circuit, is therefore accomplished in the time it takes for contact travel on the transfer relay. Also, an arrangement of contacts is provided such that either gap (break-before-make) or overlap (make-before-break) switching may be chosen by making appropriate connections to the video transfer bus wires. All of the switching relays are now freed from critical timing problems and short time— $\frac{1}{2}$  to  $1\frac{1}{2}$  milliseconds—transfer is easily and consistently accomplished. Two separate sets of contacts, parallel connected on each video switching pair, are provided for the signal or control circuits of camera tally lamps and sync interlock. Since the relay circuit is completely self latching, any type of push button or key may be used, provided only that, if mechanically interlocked, their sequence is break-before-make. Also, some other relay switching circuit may serve as the control as might be done in audio-video switching or in a preset system. For all of these variations, the transfer timing is determined entirely by the transfer relay.

Mechanically, the video switching relays (see Fig. 3) are of the small telephone type. The video contacts are arranged on a bakelite insulator, spaced well away from the relay frame. The input side of the video contacts extend down through the chassis and the output side stands above the relay frame. In this way, both stray-to-ground and lead-through capacities are very low. The relays are mounted on long narrow panels which in turn mount in a chassis for rack mounting. One type of panel termed "basic" provides for six input circuits and one output through the transfer relay. A second type of panel termed "auxiliary" provides for six additional inputs, without a transfer relay, since it is to be used only to extend the basic panel. The chassis for basic panels includes six input video line terminations and a cathode follower isolation amplifier for each of the six panels which may be mounted in it. The basic chassis is normally supplied with two panels in place, the additional panels being added at the customer's op-

FIG. 4. Detail diagram showing how relays operate in a typical TS-20A video switching system.

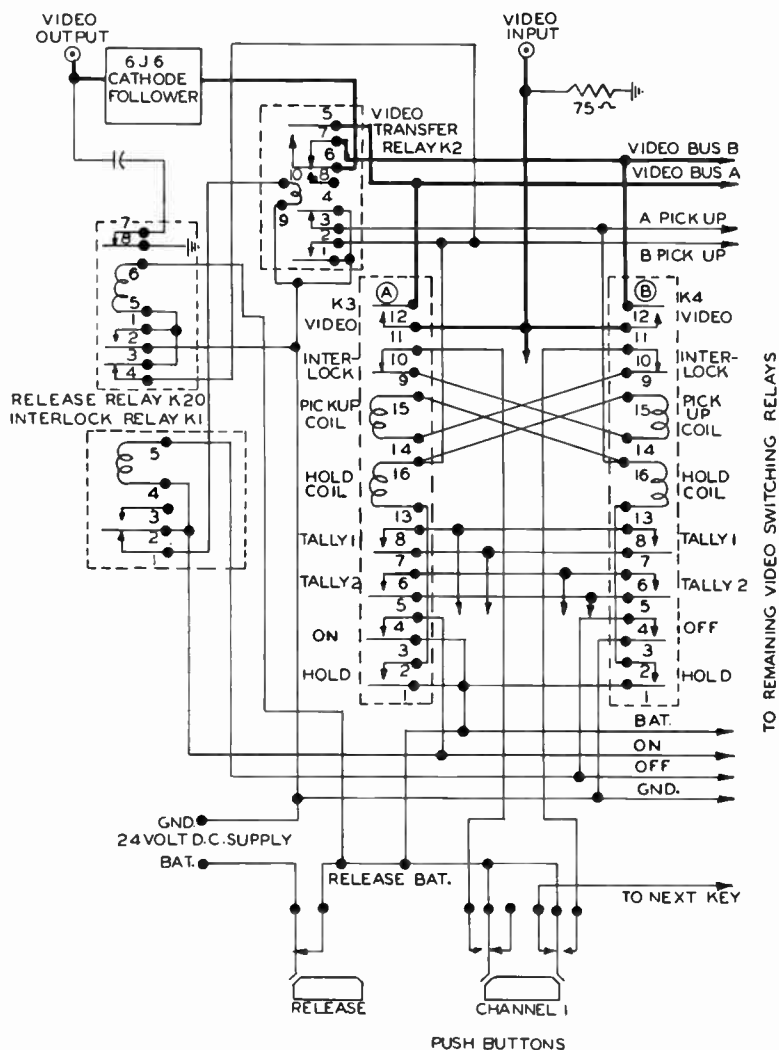

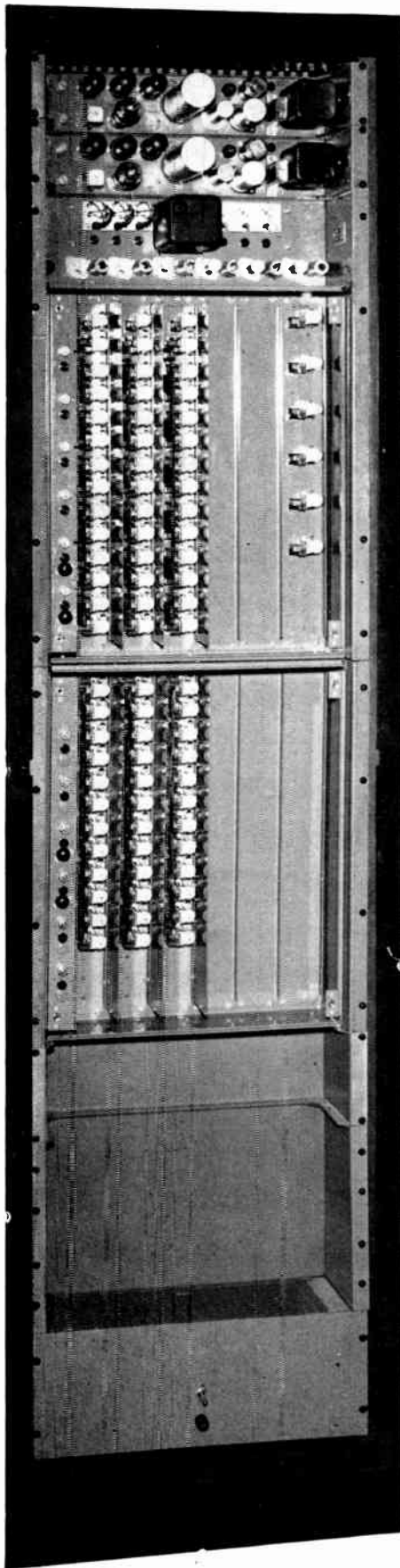

FIG. 5 (above). TS-20A remote switching equipment mounted in standard television cabinet rack (shown with dust covers removed).

tion. Another relay is provided in each output to short circuit the video when the release button is pushed to clear all of the video switching relays. Its circuit is arranged to hold it operated as long as any switching relays are operated and so its action does not appear in normal transfer switching. The chassis for the auxiliary panels includes only the input terminations, since the auxiliary relays work into the same transfer relays and output circuits appearing in the basic chassis.

In order to employ relay switching, it must form a part of a coordinated system. The RCA Type TS-20A relay switching equipment covers a group of related units which may be used in various combinations to cover widely different conditions. (See Fig. 5 for mounted equipment.)

The TS-20A equipment consists of several types of units in each of the following categories:

1. The video relay switching chassis and the panels which are used to extend the functions of the basic units.
2. The push-button panels, for operating the video relays, which are available for several switching schemes and mounting arrangements.
3. The utility or master monitors, for use in conjunction with the push-button panels.

4. The various consoles for mounting the push-button panels and monitors.
5. Standard components.

The fundamental video relay switching equipment consists of the basic chassis which provides the relays and circuits for connecting six inputs to two outputs. If more outputs are required, basic relay panels can be added, one for each output. If additional inputs are required, six more can be accommodated by using the auxiliary relay chassis with the appropriate number of auxiliary relay panels. Since either gap or overlap switching is available, the switching system may be used for studio, monitor, or master control room switching.

A tally light relay panel is also available for mounting in either the basic or auxiliary chassis. It is used to extend the number of different tally and sync interlock circuits normally handled by the video switching relay units.

Panels using non-locking push buttons (see Fig. 7) are designed for mounting in a program director's console. Up to twelve inputs and four outputs are available, with provisions for manual fading between two of the outputs.

Panels using locking type push buttons are designed for mounting in a console section. Up to six inputs and two outputs are available, either with or without manual fading provisions, between the outputs.

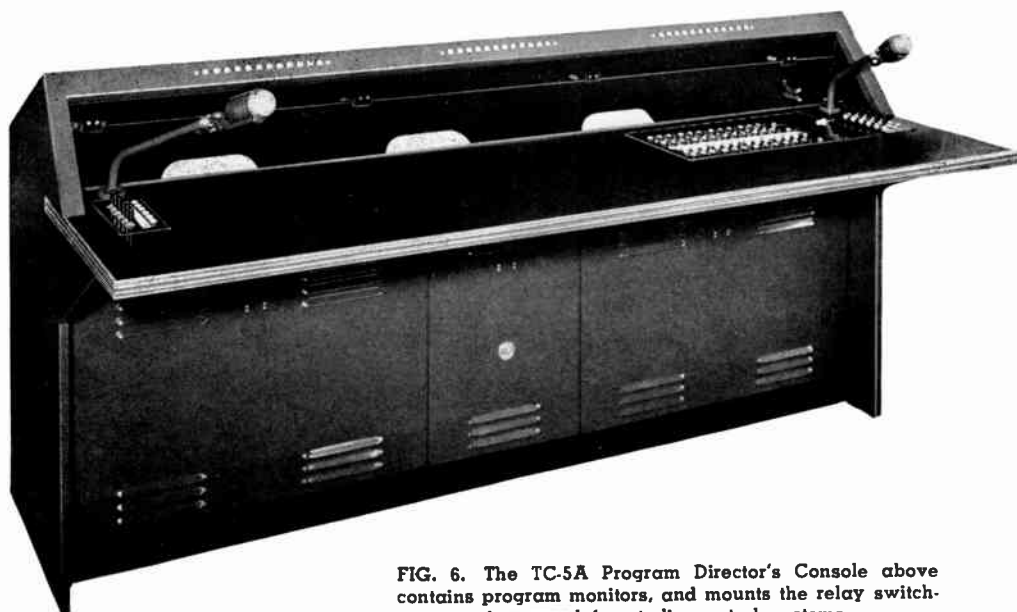

FIG. 6. The TC-5A Program Director's Console above contains program monitors, and mounts the relay switching panel for studio control systems.

Tally lights, for each push button, are furnished as a part of each switching panel.

Two types of monitors are available. The utility monitor (see Fig. 8) is designed particularly for mounting in the program director's console. The master monitor is the familiar combination of kinescope and oscilloscope which may be mounted in a console section with video switching facilities.

To facilitate the smooth handling of studio productions, a program director's

console is available (see Fig. 6). This console provides space for the video switching panel, intercom switching panels, and microphones, in a convenient desk top arrangement at which both the program director and technical director may sit. Monitors, mounted below and behind the desk top, are viewed by means of a mirror for optimum viewing distance and an unobstructed view into the studio.

A console section is available to harmonize with the standard RCA camera

controls for those applications in which the switching facilities, monitors, and camera controls are to be located as a unit. The appropriate push-button panels for video switching mount in this console section.

In order to complete the system, certain standard video distribution and mixing amplifiers and power supplies are required. The number and use of these units will vary in accordance with the individual station requirements.

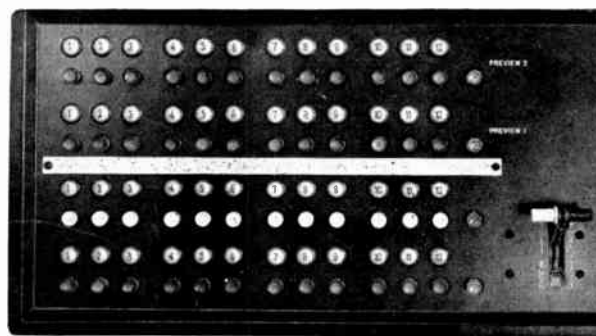
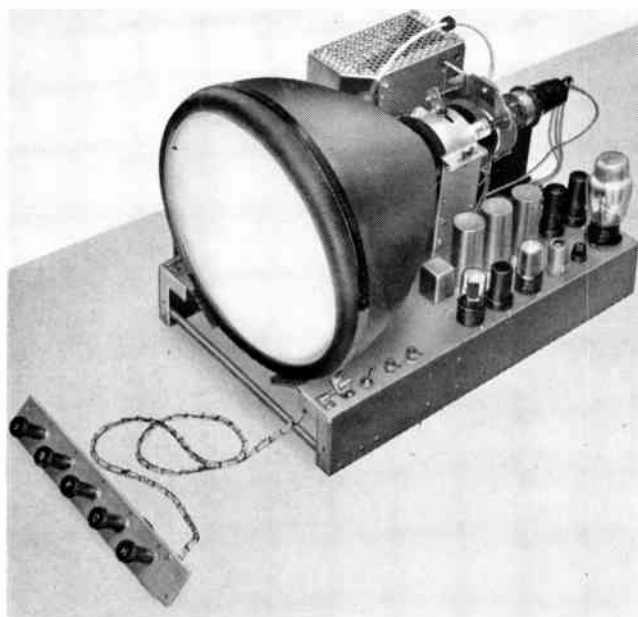

FIG. 7 (above). Closeup of push-button switching panel (MI-26220-1) which is available for mounting in the Program Director's Console, TC-5A (shown in Fig. 9).

FIG. 8 (left). Utility monitor chassis showing components and adjustment positions. (This unit is designed for mounting in TC-5A Program Console.)

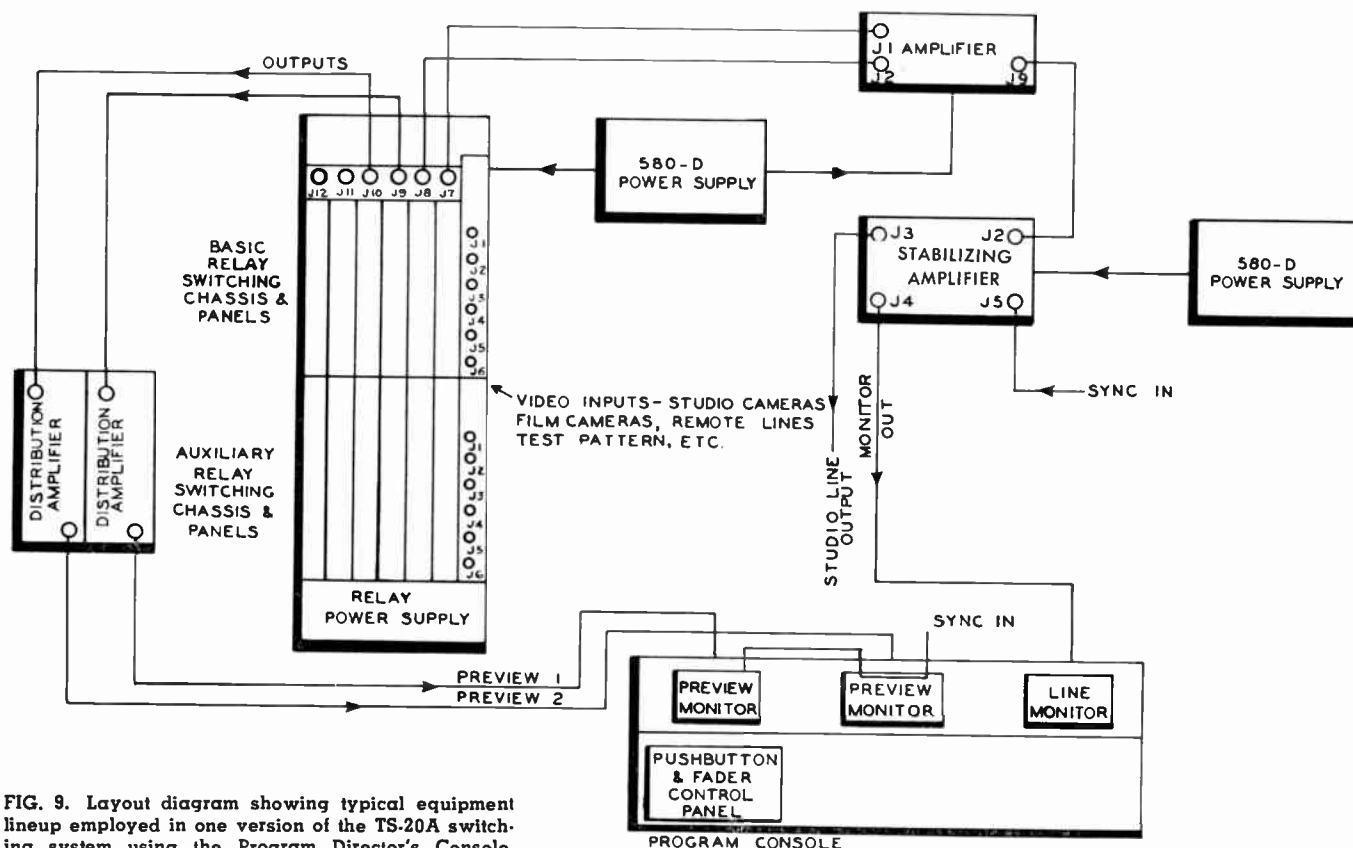

FIG. 9. Layout diagram showing typical equipment lineup employed in one version of the TS-20A switching system using the Program Director's Console.

# VIDEO RELAY SWITCHING LAYOUTS

It is the purpose of this article to discuss the so-called "push-button" portion of the television broadcasting plant and to show some of the many variations possible in the layout of control consoles and video switching equipment. The preceding article has covered in detail the circuits and physical arrangement of the RCA TS-20A Video Switching System. This is itself a building block item because the system type number covers a wide assortment of switching and control units to meet the various specific needs. It is built around a relay switching circuit for video which is made in units of 6 inputs and 1 output with an electrical, self-latching arrangement to control timing. This matter of timing is a serious one in television switching since long breaks result in streaks, disturbing black screens, or even in some cases, loss of sync and a resultant roll-over or tear when the next picture comes on. In fact, for camera switching, an overlap sequence is used to eliminate breaks completely. This, however, cannot be used in all applications since undesirable cross-ties during switching might occur. One solution is to reduce the gap to a minimum value. The RCA video switching relay banks offer a choice of an overlap or gap sequence approximately 1 millisecond in duration.

As the individual studios are described in detail further on in this article, one point should underlie the whole discussion. This is that we are not expounding the merits of one fixed layout—rather we recognize the infinite variety brought about in station design by each management's own individual considerations of budget, available building and floor space, and most important their own imagination and originality. It is intended to look backstage in some typical systems to illustrate reasons and ideas which will serve as a guide toward further uses and new applications.

## Studio Control Room Switching Facilities

Let us consider first the live talent studio control room facilities. It is here that the program director finds himself the center of all activity. Following the script or continuity, he issues orders to each cameraman to set up each scene desired; then, having seen the pictures produced on monitors placed in easy view, he determines which is to be used and sent out on the air. To control the transition between scenes or to produce superposition and dissolve effects, switching and fading equipment is available to him in the form of push buttons and fader levers. Depending upon the size and operating personnel of the

particular station or network center, the program director may or may not actually operate this console. In some cases a technical director performs this function, the two sitting at the same desk so as to see all the monitors.

The switching equipment shown in Figure 1 provides for six incoming lines which would include the cameras in the studio, direct lines to the film cameras for slides and movie portions of the show, and other lines to remote inputs if pictures from other studios or outside the station are to be used. The console is arranged so as to permit viewing both camera pictures on their own camera control monitors and the line output of the studio on another monitor. It is made up of standard RCA camera control and monitor console sections. The actual push buttons and fader unit mount in one of the console housings with the line monitor. In the diagram and illustrations, an improvement in operation has been effected by the addition of a third panel of relays on the relay bank to feed a separate monitor which may be switched to any of the inputs. This is termed the preview monitor since it permits viewing the other incoming pictures before switching them on the air.

## For Larger Studios—More Than 6 Inputs

For a larger studio, built to handle full scale dramatic plays or musical revues, more cameras are used in the studio itself and the inserted portions from film, slides, or other studios might easily require more than six inputs. Also, more studio monitors are required in the control room to keep track of the additional activity. For this the large RCA TC-5A Program Director's Console is available, into which a twelve-input switching control panel is built, and which may contain as many as five RCA TM-2C utility monitors.

The console itself may be located against the studio window, or on a raised platform behind the camera controls, so as to permit the program and technical directors to see their own monitors, the camera monitors, and also into the studio. The video block diagram for these layouts appears in Figure 2. Note that by the addition of an auxiliary relay chassis, the number of inputs in the video switching rack has been extended to 12. Also, the video operator has been provided with a preview monitor by the addition of another panel of relays. A further extension of these control facilities which has found increasing use recently is the addition of a "program bus" row of push buttons to the control panel as shown in Figure 3.

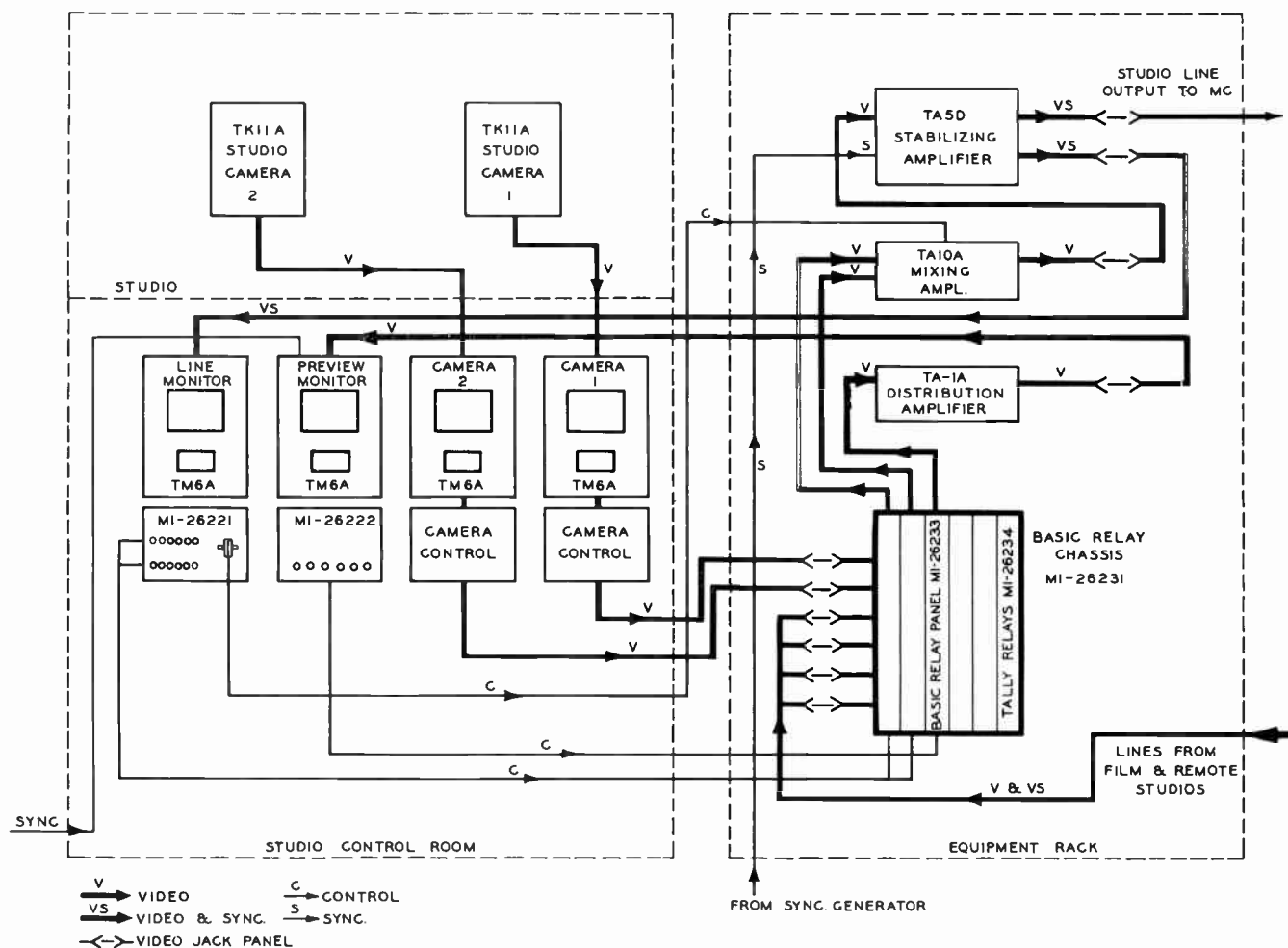

FIG. 1 (above). Block diagram showing the Studio Control Room Video facilities for six incoming lines. In this schematic and others which follow, the TM-6B may replace the TM-6A.

This permits previewing of the output of the fader channel since any input may be put directly on the air through the program bus or sent through the fader channel for special picture effects. Also, a different arrangement of monitors is shown. The program console now contains two preview monitors to increase its usefulness, and four studio cameras are connected to the video operator's console.

### TS-20A Switching Includes Film Studios

Although the preceding discussion was based on a live talent studio, the same facilities are equally useful for a film studio which contains several cameras and projectors. Similarly, a large network center fed from several remote points such as theaters and sports arenas may also use a set of these control facilities, handling the complete station programming of shows and commercials without tying up master control facilities.

Obviously there are endless variations possible, the illustrations given here serving only as examples. The

video console in the film control room is arranged to handle the two film cameras and also the master control facilities, which will be described later. In Figure 4, the film studio is located on a different floor of the building, with its control room adjacent to it. Or, the film control could be combined with studio facilities in a single control room arrangement. With sufficient monitoring facilities, it is even possible to locate the studio control room separately so as to eliminate the usual connecting window area and so make more floor area available in the studio. The basic reason for all of this should be kept in mind since it is actually the key to the much desired "new and different" operation. Production people are constantly searching for new ideas of presentation and they must, wherever practical, be provided with the necessary facilities. The need becomes obvious for smooth-running operation during all the cutting and trimming that occurs in the building of a show. All of this must go on while the show unfolds; there is no time for retakes or changes because the audience is literally looking over your shoulder.

## TS-20A Relay Switching for Master Control

The live talent and film studio control facilities do not comprise the only application of video relay switching in a television plant. In Master Control, program material from all the available sources, whether studios or remotes, is chosen at the proper time and sent out to the transmitter or network. Operating schedules call for split-second timing with no errors and a minimum of delay in meeting emergency or unusual requirements as for rehearsals and special client showings.

Here again, video relay switching finds its place in providing a flexible system. The actual switching panels used differ widely, however, in following each different station's operating philosophy. The master control monitoring and switching facilities may be combined with film control consoles. In Figure 4, the master control room is in a different part of the building. The block diagram shown

in Figure 5 illustrates the typical connections for these facilities using standard console sections and master monitors. Appropriate push-button panels are mounted in the consoles.

## Audio-Video Switching

Many are now using "tied-in" audio switching in which audio channel relays are operated from the video system or just the opposite in which an audio console and its associated relays have provisions for operating the video relay bays. A further variation, is provision for either separate or tied-in operation.

Although the timing requirements for transfer time are quite different in the two systems, the RCA video switching relay strips fit in without change. It is the usual practice to provide a gap switching sequence in the audio channels as a part of the relay interlocking circuits which

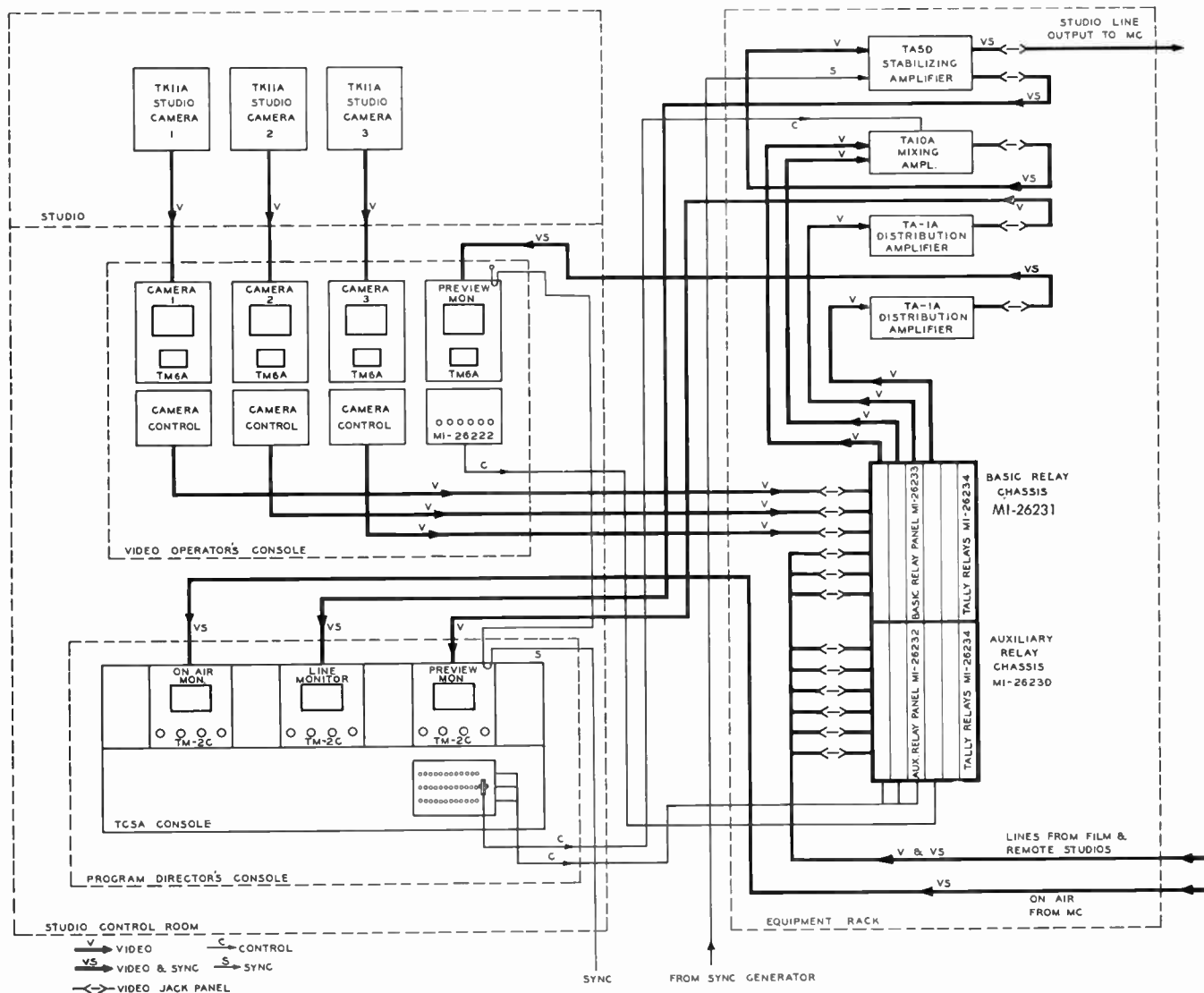

FIG. 2 (above). Block diagram of video facilities for layouts which include the Program Directors Console.



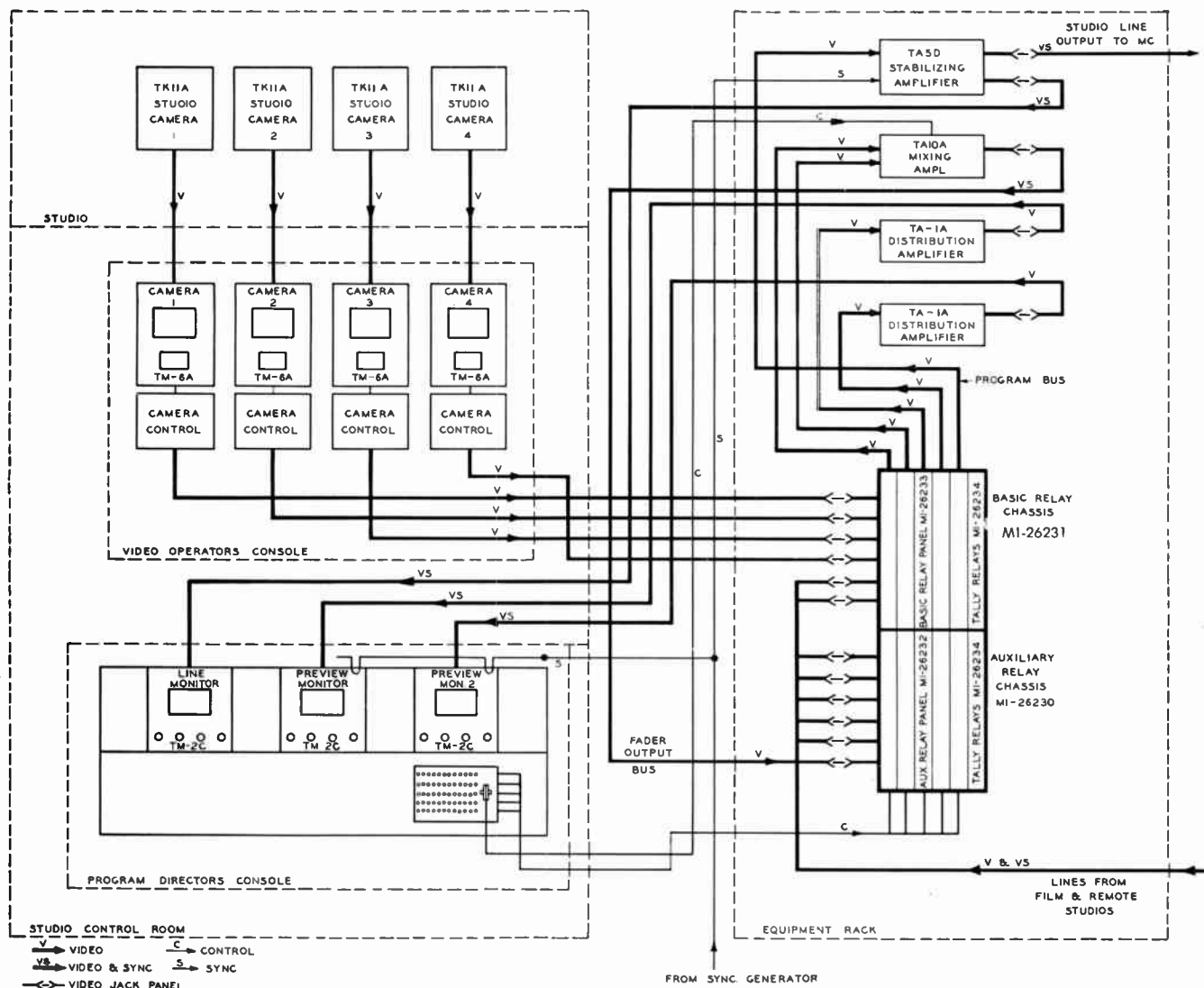

FIG. 3. Block diagram showing how the video facilities may be extended by adding the Program Directors Console with Program Bus output.

is very long compared to the value tolerable for video. When operated from such a system, however, the video relays transfer at their own rapid rate independently of the audio timing. In the opposite arrangement, audio relays operated from the video channels should be provided with "operate" delay coils to restore the usual audio gap.

### Preset Switching

A considerable improvement in operating ease and accuracy may be brought about by the use of a "preset" switching system. With this arrangement, the rotary or push-button switch usually used for channel selection is normally dead and may then be set up for the next channel arrangement to be put on the air. Then, at the proper instant, one trip button will cause one or several channels to transfer to the new "preset" schedule. One type of

preset control circuit is shown in Figure 6. Only one outgoing channel is shown here; several are normally used side-by-side. For operation of individual channels the preset switch is set to the desired incoming channel, then the local operate button is pushed at the proper instant. For master operation of several channels simultaneously, the channels to be used are set up and then switched to master position. Then, the master operate button will transfer all the channels at the same time.

A similar circuit, extended to include control of an audio switching system is shown in Figure 7. Normally, the audio and video relays are both operated from the selector decks of the video preset switch. However, complete interlocking circuits for the audio relays are included so they may be operated separately or in conjunction with the video relays either on the same or different incoming

channels. An additional feature is a form of "double" preset in which the outgoing channel trip circuits may be connected to either of two master busses. This way, two program arrangements may be preset and then put on the air in sequence. For instance, during a program change, a local commercial introducing a certain show might be picked up on the transmitter line using the Master Preset A circuit; then, without disturbing the transmitter feed, the network line would be switched to the same program at the conclusion of the announcement by operating the Master B circuit.

Another form of "double preset" that has been considered uses two Master Preset busses which operate the input selection circuits for each output channel. Two preset switches are provided for each outgoing channel. First, one choice of input, then a second choice, may be put on the outgoing line in sequence. This, of course, applies either to one or several outgoing channels as determined by "Local-Master" switches. Practical use of such

a circuit probably would only occur in a station operating schedule which calls for the handling of short announcements during station break by Master Control. Normally, such activity in Master Control is not desirable, particularly in a large plant, and may be avoided by adding these short program units to the beginning or end of regular, long shows.

As mentioned before, the video relays may also be operated from an audio preset system of one of the well-known types used in standard broadcasting. Figure 8 extends the flexibility of Preset Master Control still further—in that direct switching is possible without the "preset" then "trip" operation required by the previous circuits. The push-button leads from the video and audio relays are transferred from one "on-the-air" panel of push buttons to another "preset" panel. An on-off step relay circuit is used to accomplish this transfer and is actuated by "Local Operate" or "Master" push buttons as desired. The audio and video preset systems employ separate push buttons

FIG. 4 (below). Typical Television Broadcasting Station layout in which facilities are located on two floors.

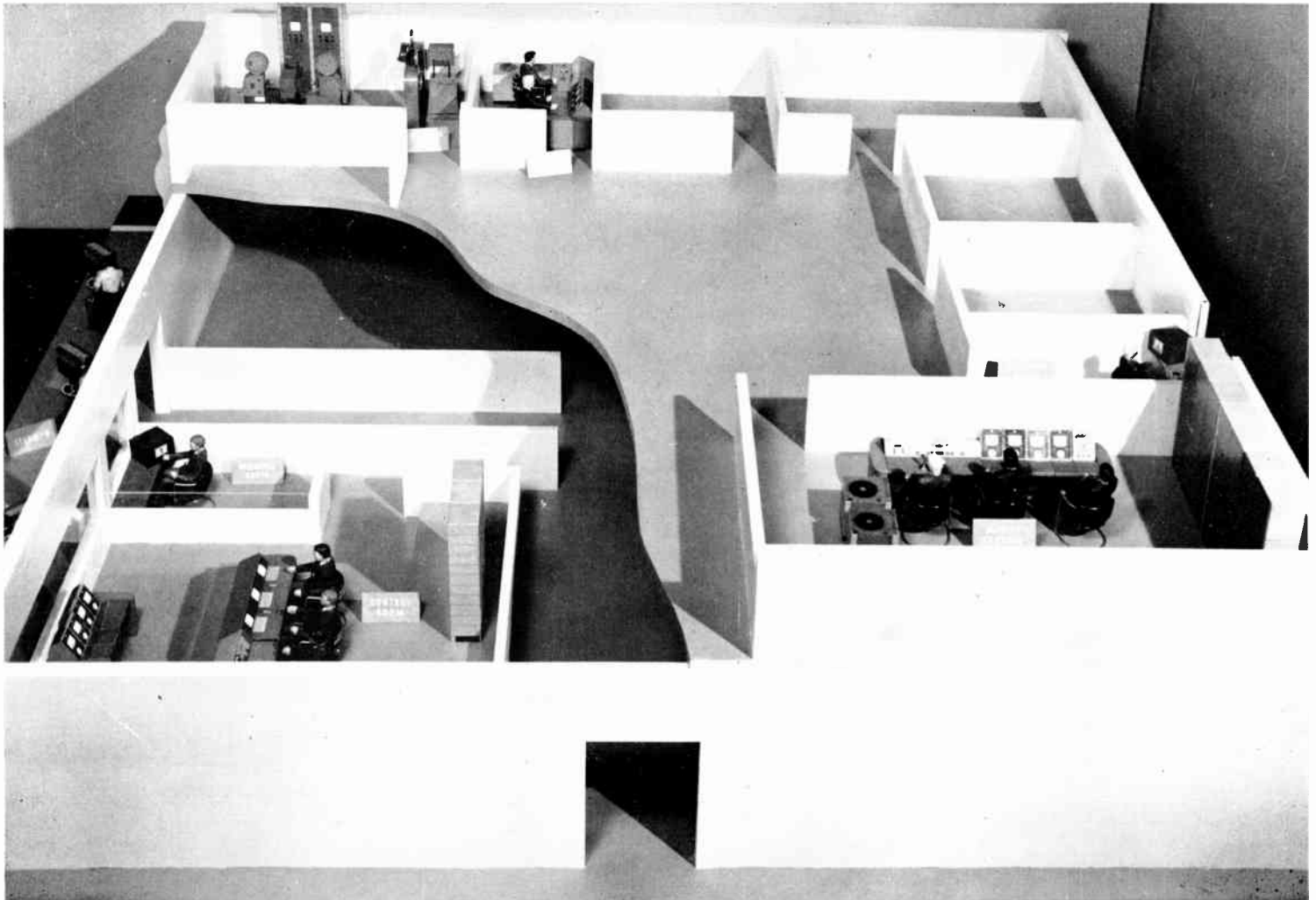

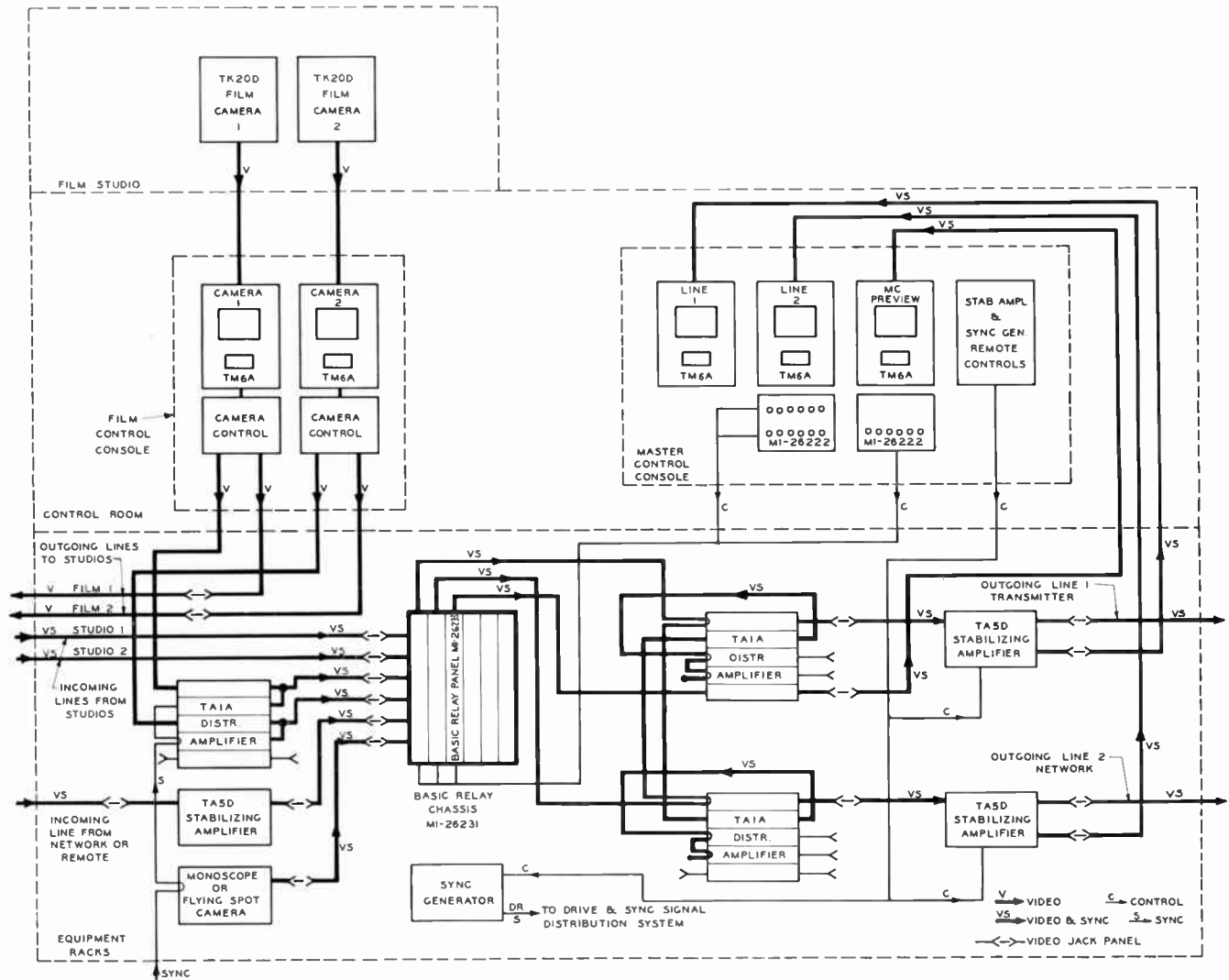

FIG. 5 (above). Block diagram showing Master Control facilities made up of standard console sections.

so that they may be operated either independently or tied together. When a push-button panel is "on the air," direct switching may be done without the additional manual operation of one of the preset trip buttons. This proves very useful for emergency and test conditions and may also be used for such a program function as insertion of local commercials in a remotely originated show.

There is another approach to allowing master control to handle program functions particularly for "spot" commercials between programs or announcements during a remotely originated show. With the use of the RCA "Genlock" (BROADCAST NEWS No. 58, March-April 1950) to synchronize local and remote signals, the fader mechanism used in the studio control room is found useful in master control to permit studio type picture effects without requiring extra studio facilities or personnel. An arrangement similar to Figure 1 for studios may be used.

### Studio Control of Master Switching

So far, we have considered the studio control room and the master control room as being entirely separate, at least operationally, if not physically. This is not essential as illustrated in Figure 9 by a scheme of optional control from either of two studios, of the relay bay which feeds outgoing lines to the transmitter and network. The switching panels are duplicated in each studio and transfer of controls is made according to the program schedule of each studio. This circuit uses remotely controlled relays for the transfer operation which are interlocked to prevent accidental mixups and which operate "on-the-air" and "ready" lights in each studio.

In many cases extra outputs are available in the standard video relays bays. These are often put to use to feed preview or rack monitors and also are available as emergency program channels, and for house monitoring lines.

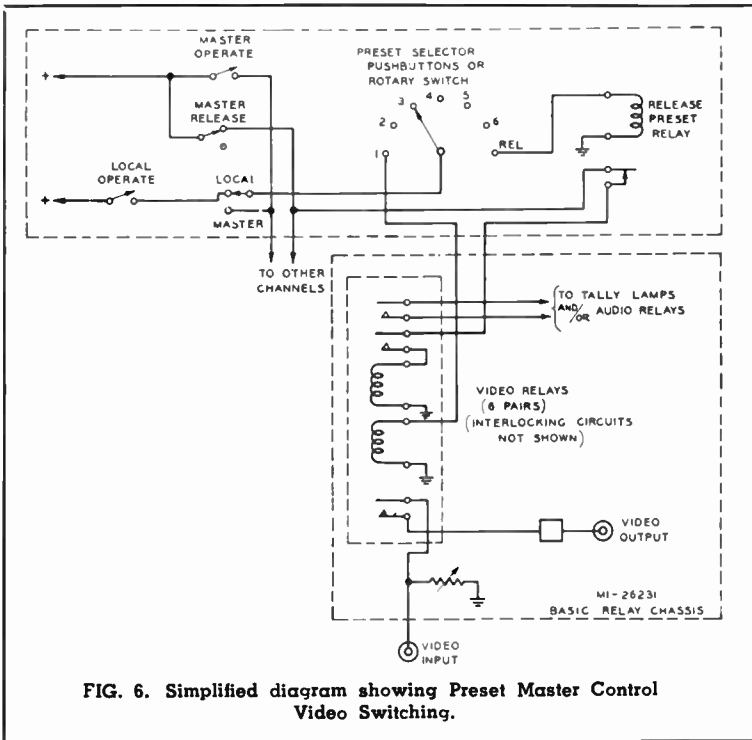

FIG. 6. Simplified diagram showing Preset Master Control Video Switching.

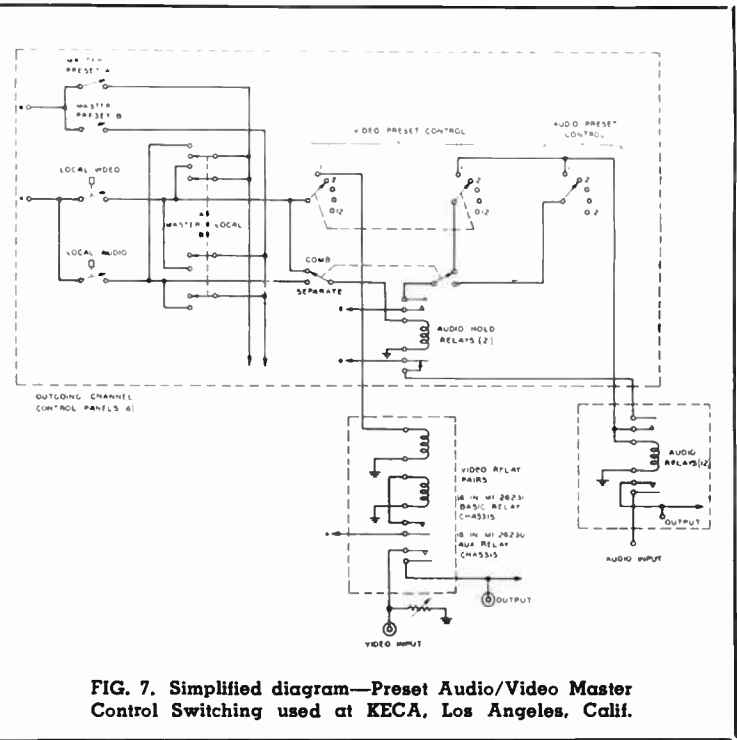
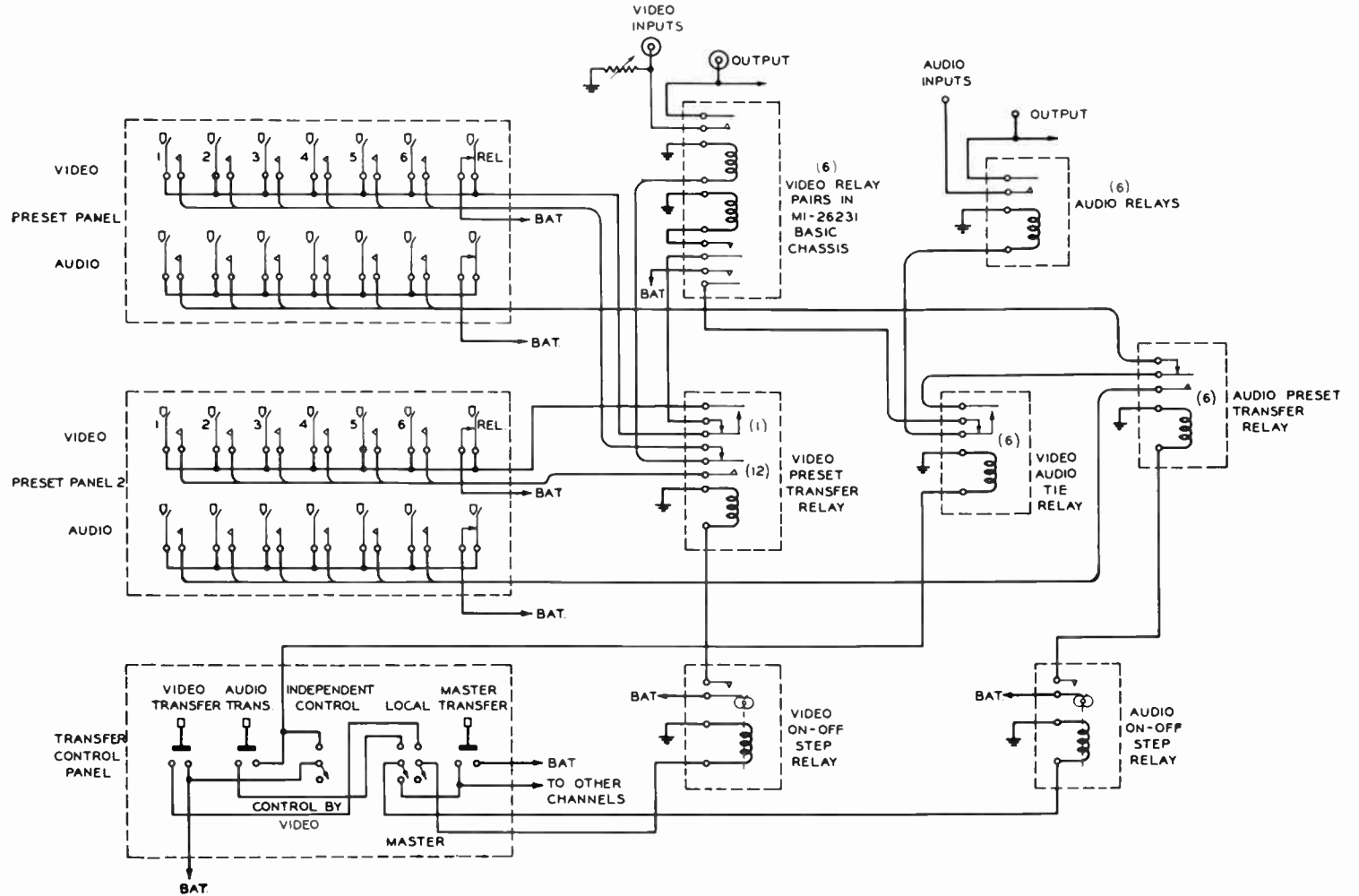

FIG. 7. Simplified diagram—Preset Audio/Video Master Control Switching used at KECA, Los Angeles, Calif.

FIG. 8 (below). Simplified diagram showing Preset Audio/Video Master Control Switching used at Station WOR-TV, New York.



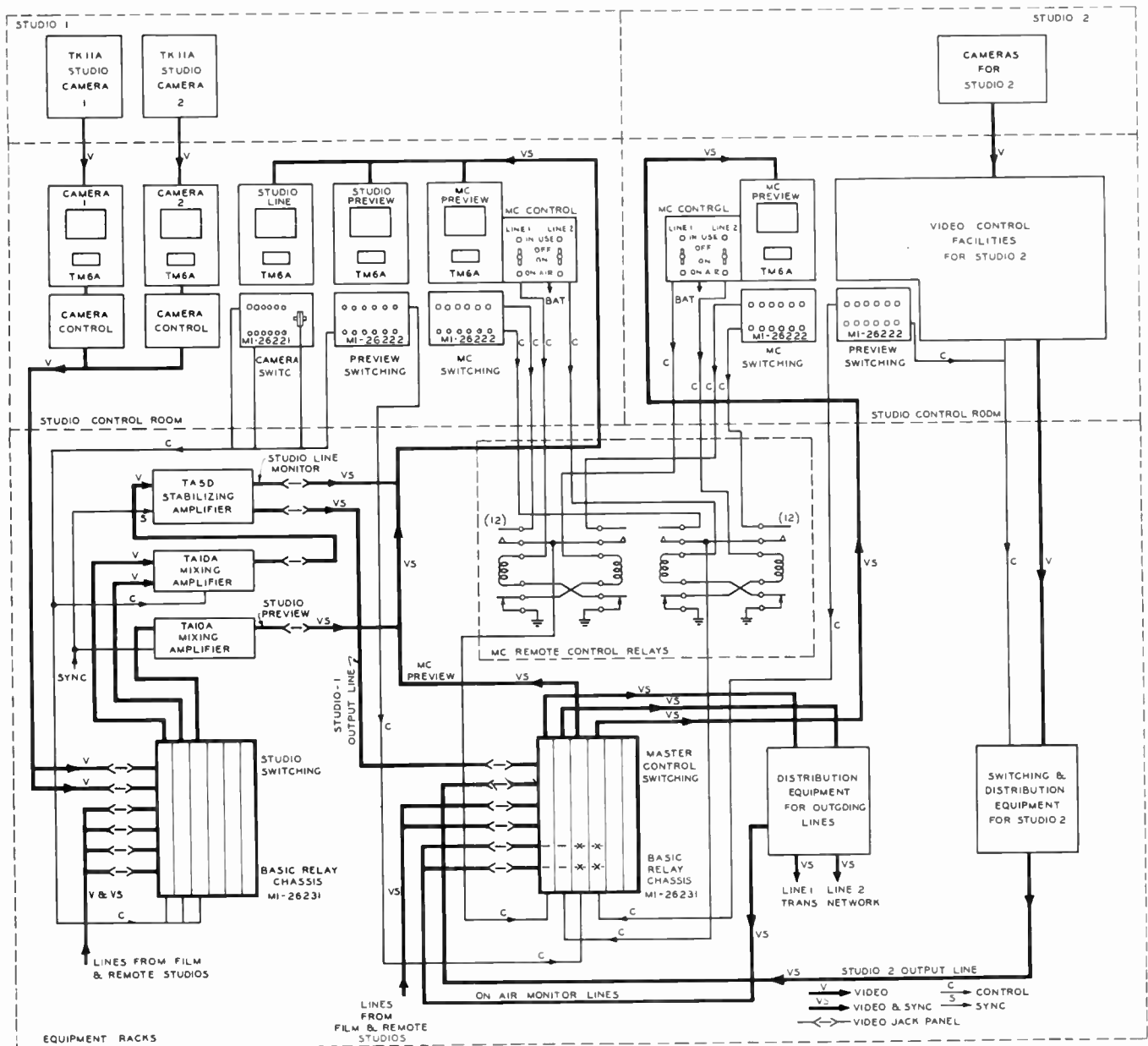

FIG. 9 (above). Simplified diagram illustrating a two-studio control arrangement of Master Control Video Switching.

The future will bring even more uses and variations for remote control switching. In the large network centers even present patch-cord arrangements may be replaced with push-button or dial-controlled switching units as more and more program, rehearsal, and test traffic must be handled.

### Conclusion

In the preceding illustrations, several video relay switching setups have been described. These represent but a few of the many TV switching problems which are easily solved by use of the RCA TS-20 Relay System in combination with other catalog items readily available.

As such, this equipment does for TV master or studio control what Audio Relay Systems have done for aural broadcasting with parallel advantages such as instant, push-button switching, unlimited flexibility, centralization of control and operations, and provision for long range future planning. These advantages of Video Relay Switching are equally important to existing TV installations or to new stations. In conclusion, the design of Video Relay Equipment has provided a basic element which may be used with companion RCA TV studio equipment to permit full and efficient utilization of equipment, as well as the smooth presentation of diversified program material.

# SYNCHRONIZING GENERATOR TG-2A

## Introduction

The importance of the sync generator in a television pickup system is likely to be overlooked. While it does not appear so prominently as the camera equipment in a television production, it is depended upon by the entire studio equipment for the timing and synchronizing information required by the scanning circuits in both camera and receivers. As such, the sync generator is often referred to as the “heart” of the TV system.

The synchronizing generator provides four output signals which are used throughout the television plant. Two of these signals—synchronizing and blanking appear in the transmitted signal. Consequently, they are subject to the requirements of the “Standards of Good Engineering Practice” of the FCC. These specify standard pulse durations, number of pulses, time of rise and decay, and tolerances. In addition, the synchronizing generator supplies the horizontal and vertical driving pulses which are used locally for synchronization of the studio equipment.

The RCA synchronizing generator is available on a 21-inch bathtub chassis for rack mounting, type TG-2A, requiring only 117-volt 60 cycle power input.

The circuits of the synchronizing generator employ *stabilized* multivibrators for all pulse generating and timing functions. This type of multivibrator is designed such that the circuit operation is essentially independent of tube characteristics, supply voltages, and temperature; hence the term “stabilized”. The stabilized multivibrator has a great advantage for a sync generator; namely, it results in extreme simplicity while maintaining the precise performance required of such a unit. Of the 40 tubes in the TG-2A, 27 tubes perform all of the timing and pulse generating operations for the four output signals previously listed. The other 13 tubes are the regulated power supply and auxiliary circuits which will be discussed later. Such a small number of tubes for sync generation, with no sacrifice of individual circuit performance, results in a high degree of reliability and dependability.

## Timing Pulse Generation

The circuit layout of the sync generator may be seen by referring to the block diagram, Fig. 1. The common source for all signals is the 31,500 cycle master multivibrator. Two other frequencies which appear in the out-

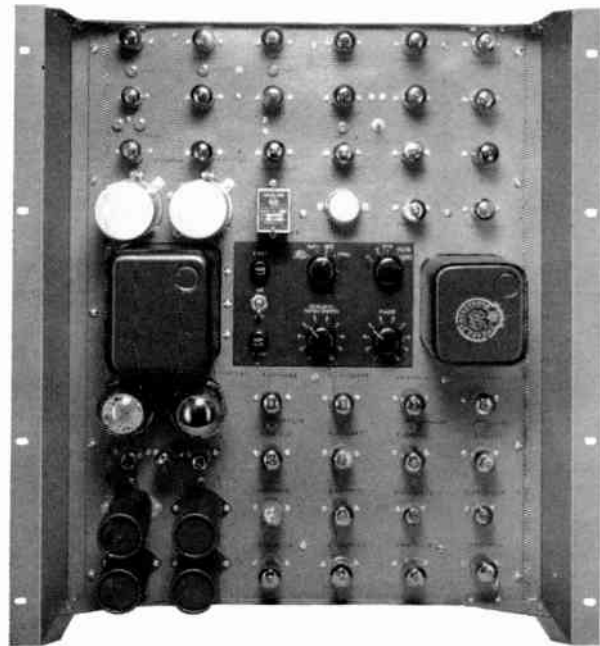

The TG-2A Sync Generator for rack mounting.

put signals, 15,750 cycles, and 60 cycles, are obtained from the master multivibrator by frequency-dividing circuits. The 60-cycles for the vertical frequency of the television system is obtained by dividing the master frequency by 525, the number of lines. This division takes place in steps of 7, 5, 5, and 3 in four multivibrators. In similar fashion, a 2:1 counting multivibrator provides the 15,750 cycle pulse. Counting in a multivibrator is accomplished by operating the multivibrator to run for slightly less than the period of the number of input-frequency cycles to be counted; then the multivibrator stops and is immediately re-triggered on the very next input pulse to begin a new timing cycle. No adjustment is required on the counters except for the count of 7. This circuit, once adjusted will maintain its count with ageing and replacement of tubes.

## Blanking and Driving Pulse Generation

The output of the 2:1 counter at 15,750 cycles triggers the horizontal blanking multivibrator for precise determination of this pulse width. Similarly, the vertical blanking pulse is generated from the 60-cycle output of the 525:1 counter chain by the vertical blanking multivibrator. The two blanking pulses are mixed in the blanking mixer such that during the vertical blanking pulse the horizontal blanking pulse is completely suppressed. The blanking output stage is driven from the blanking mixer

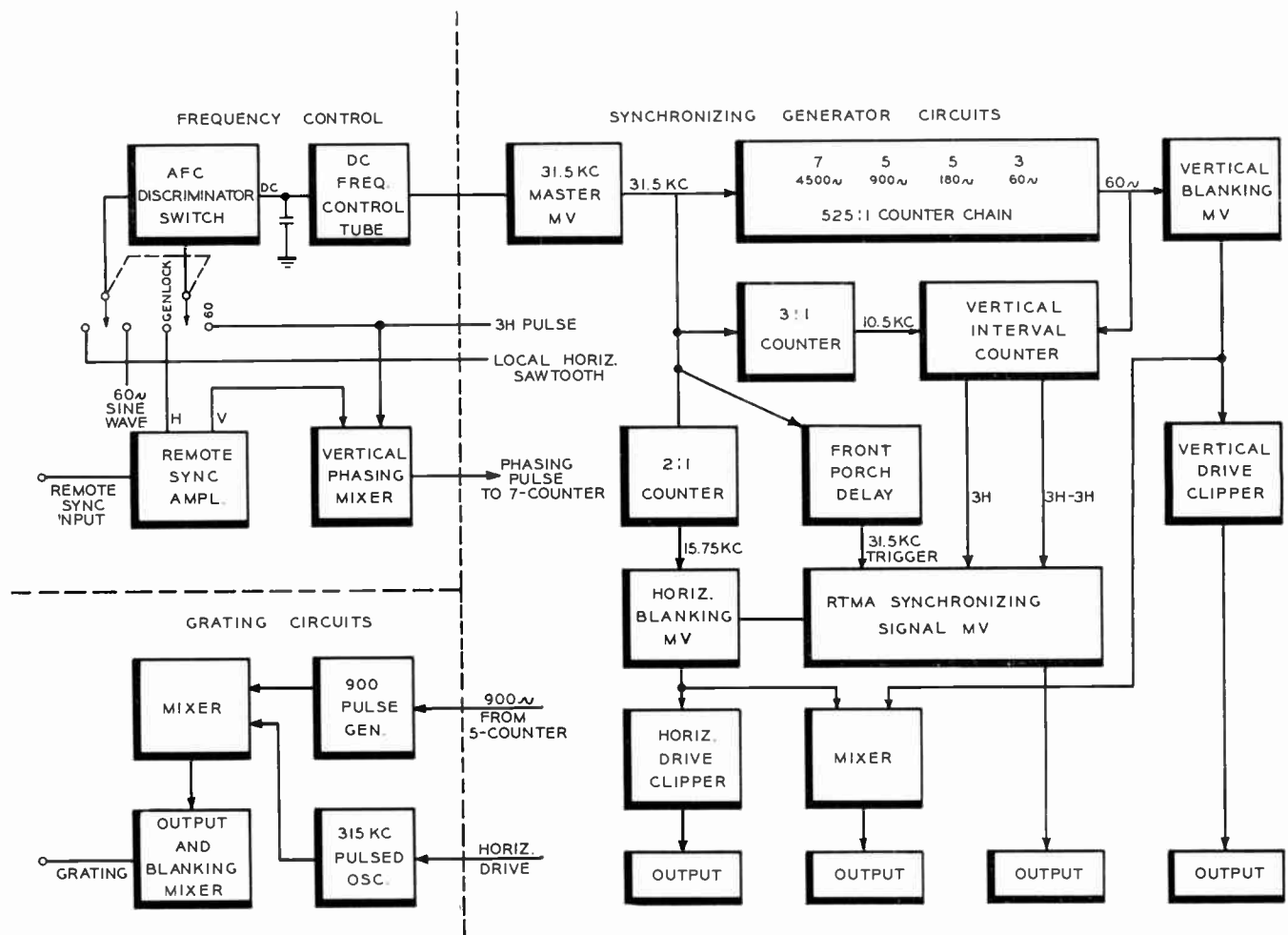

FIG. 1. Simplified block diagram—TG-2A Sync Generator.

and is capable of providing the 4.0 volt standard pulse level on a terminated 75-ohm line with sending-end termination. Level controls on all outputs allow precise setting of pulse voltages. Horizontal and vertical driving pulses are obtained from their respective blanking multivibrators by a stabilized differentiation circuit which generates the required driving pulse widths and prevents the possibility of driving pulse ever becoming wider than blanking. The output amplifiers for these pulses have essentially the same characteristics and capabilities as the blanking output.

### Synchronizing Signal Generation

The standard synchronizing signal, which is composed of pulses of three different frequencies and three different widths, precisely related to one another, is generated by the action of a single multivibrator in the TG-2A. The sync signal is delayed with respect to the horizontal blanking and horizontal driving pulses by an adjustable, but accurately controlled time, usually referred to as the "front porch". The manner in which this is accomplished

is shown in Fig. 2. The master oscillator pulses (line 1), by appropriate triggering paths, simultaneously initiate the timing cycle of the 2:1 counter (line 3), horizontal blanking (line 4), and a front porch delay pulse, (line 2). Actually, the horizontal blanking is triggered via the 2:1 counter, so that it occurs for only every other master pulse. However, the front porch delay generator operates directly from the master oscillator, thus it pulses at 31,500 cps. The synchronizing signal multivibrator operates at the trailing edge of the front porch delay pulse so that sync will be delayed essentially by the width of the front porch pulse.

In order to generate the standard synchronizing signal in a single multivibrator, it is necessary to provide means of controlling both the pulse duration and the frequency of the multivibrator. The synchronizing signal is composed of 15,750 cycle pulses except during a 9-line interval immediately after the start of vertical blanking when the pulse rate must switch to 31,500 cycles. The 9-line interval is further divided into three 3-line intervals. The first and third 3-line intervals each contain six

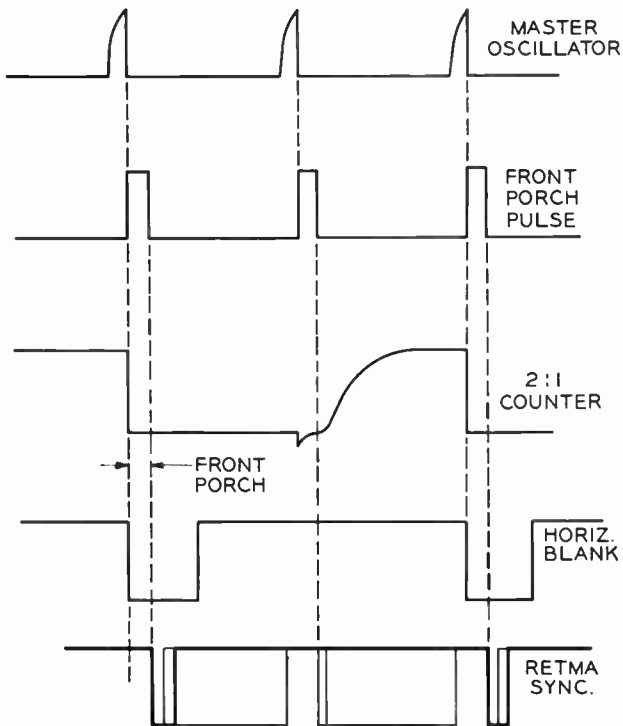

FIG. 2. Horizontal timing diagram.

pulses, the pulse width being half of the normal horizontal sync width. The center 3-line interval is the vertical sync pulse which is serrated by five narrow slots so that it looks like six wide 31,500 cycle pulse. This waveform is shown by line (g) of Fig. 3.

The control signals required for the sync multivibrator then are a 9H gate to change the frequency from 15,750 to 31,500 cycles; a pair of 3H gates separated 3H (usually called 3H-3H gate) to reduce the pulse width for the equalizing pulses; and a 3H gate delayed 3H to switch the multivibrator to wide pulse operation for the vertical sync pulse. These gates are shown by lines (b), (c), and (d) of Fig. 3.

A pair of stabilized multivibrators are connected to trigger each other so that following a starting trigger from the output of the 525:1 counter chain a sequence of three pulses will be produced; first and third pulses are in one multivibrator, and the second pulse is in the other multivibrator. This circuit is called the vertical interval counter. Each multivibrator has a precise pulse width of 3-lines, stabilized by trigger pulses from the 3:1 10,500 cycle counter acting as timing marks. Therefore, the first multivibrator produces the 3H-3H equalizing pulse gate and the second multivibrator makes the 3H vertical sync gate. The 9H gate is derived simply by adding the 3H-3H and the 3H gates.

For horizontal sync, the sync multivibrator, which is receiving 31,500 cycle triggers from the trailing edge of the front porch delay pulse, is gated by the horizontal blanking signal so that a sync pulse can only be generated when a horizontal blanking pulse occurs. Thus no

sync pulse is produced for the 31,500 cycle trigger which occurs between horizontal blanking pulses. During the 9-line vertical interval, horizontal blanking is gated out of the sync multivibrator by the 9H gate so that the circuit is free to make a sync pulse for every 31,500 cycle trigger.

The pulse width of the sync multivibrator is changed by switching the amplitude of the sawtooth timing waveform in the circuit according to the principle that the pulse width of a multivibrator is proportional to the voltage to which the timing capacitor is initially charged. Two tubes are arranged so that when one conducts during the 3H-3H gate, the nominal pulse width will be cut in half for equalizing pulses. When the other tube is made conducting by the 3H gate, the amplitude of the timing waveform is increased enough to make pulses roughly five times the nominal horizontal sync width. Fig. 3 (f) shows the sync multivibrator timing waveform during the vertical interval. This signal is clipped below the dotted line of Fig. 3 (f) by the output circuits to produce the output waveform shown by Fig. 3 (g).

### Frequency Control

So far nothing has been said of the way in which the frequency of the master multivibrator is controlled. As a matter of fact, there are five different modes of frequency control in the TG-2A which may be selected by a front panel control. These modes, with their purpose and description are listed below.

1. *60-cycle AFC*. The normal operation in a monochrome television system is to lock the sync generator frequencies to the 60-cycle power line such that the vertical-frequency pulses stay in the same relative phase with respect to the power line sinusoidal voltage. Then it is possible to operate film projectors with synchronous motors directly from the A.C. power lines and maintain synchronization with the TV system.

For 60-cycle AFC, a sine wave from the 60-cycle heater voltage in the unit is compared in phase to the 60-cycle vertical sync control pulse by the AFC discriminator switch circuit. This circuit is a switch operated from the 3H pulse and the power line sine wave so

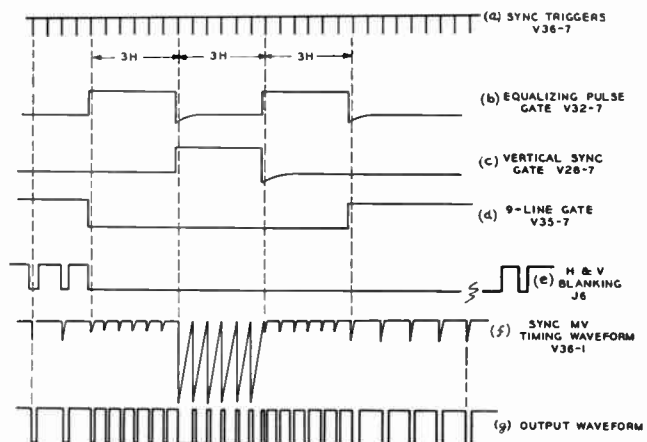

FIG. 3. Synthesis of RTMA Sync TG-2A.



that a capacitor is charged up to the instantaneous voltage of the sine wave at the time of the pulse. The voltage on the capacitor is used to control the frequency of the master multivibrator so that the system will "lock-in". The D.C. voltage on the capacitor then assumes a steady value at the voltage which will make the master oscillator frequency divided by 525 exactly equal to the power-line frequency. Further variations of either sync generator or power line are automatically corrected so that an exact frequency lock and a very accurate phase correspondence is maintained. Filtering circuits are included in the AFC correction loop to prevent the sync generator frequency from changing too fast and causing tearing in receivers. The required slow response is obtained with a satisfactory transient response to prevent "hunting".

2. *Crystal Control*—In some cases, the local power line frequency may not be the correct value, or it may be unstable so that satisfactory 60-cycle AFC operation would be impossible. Under these conditions the next best operation is to put the sync generator exactly on frequency and let it control itself. A crystal oscillator is built in to facilitate this type of operation. The crystal runs at 94,500 cycles, which is then fed to the master oscillator operating as a 3:1 frequency divider at exactly 31,500 cycles.

3. *Free Running*—Provision is made for the master oscillator to be operated without any auxiliary synchronization. This is useful for checking the adjustment of the oscillator itself, and it may further be used for a marginal check of the overall sync generator by the following method: The circuit of the TG-2A which performs counting and pulse generation falls into the general class of go-no-go circuits. In other words, they operate correctly or not at all. Consequently, it is possible for the sync generator to be operating quite normally, but in reality it may be on the "ragged edge". This is spoken of as a lack of "margin" in the circuit, and it is highly advantageous to be able to make a simple test which will indicate when the margin is decreasing so that impending failures may be caught before they cause an actual outage.

It is a further property of the circuits of this sync generator that they always have a certain definite operating range over which the master oscillator frequency may be varied without causing loss of counting or number of pulses. This range is  $\pm 5$  percent of the master oscillator frequency. A control is provided on the rear of the sync generator chassis which has this  $\pm 5$  percent range when the master oscillator is free-running. Its normal setting is at the center of its range, and when everything is normal, if the sync signal is viewed on a pulse-cross display monitor, no change except overall frequency should be observed for the whole range of this pot.

However, it is usual after the sync generator has been in service for some time for the operation to become erratic at the ends of the range of this pot due to tube ageing. The growth of this region of instability may be observed as the equipment ages, and when it comes close

to the normal operating point maintenance tests should be made to eliminate the unreliable condition.

In this manner simple periodic checks may be made to determine when further operation of the sync generator without maintenance is becoming risky. This procedure is known as "marginal checking".

4. *External Frequency Control*—The external frequency control operation provides for directly synchronizing the master oscillator from a source external to the sync generator. The most important use of this type of control is for the RCA Color TV system where the sync generator must be exactly synchronized with a 31,500-cycle signal derived from the 3.58 megacycle subcarrier crystal oscillator.

5. *Genlock*—Genlock frequency control allows the synchronizing generator to operate in synchronism with a standard sync signal from a remote source. In this manner the studio sync generator may be locked in to the synchronizing information from a remote or network video signal so that this signal may be switched or faded with local video signals without any sync disturbances to the receiver. Genlock becomes an absolute necessity when it is desired to lap-dissolve or superimpose signals from two otherwise unrelated television systems. The TG-2A contains built-in circuits for Genlock frequency control.

Two distinct operations are needed to accomplish a complete lock-in between two sync generators. First, the frequencies of the two master oscillators must be made exactly equal. This is done with an AFC system which compares the two horizontal frequencies and applies a control voltage to the master oscillator of the genlocking sync generator to produce a lock-in. However, even with the two master oscillators exactly on frequency, the vertical pulses from the two systems will not in general be completely coincident. The two vertical frequencies will be the same, but this still allows 525 different phase relationships which are possible, only one of which is correct.

Therefore, the second operation of the Genlock is to bring the vertical pulses from the two systems exactly into phase. Since the two sync generators are counting down by exactly 525 from the same master frequency, it is necessary to cause a miscount to make one vertical pulse "slip" with respect to the other.

The remote vertical synchronizing signal is separated by integration and is mixed with an opposite-polarity local vertical sync gate pulse. When vertical phasing is not correct, both pulses will be present in the output of the mixer, and one of them (the local) is applied to the 525:1 counter chain in such a way as to cause miscounting. However, when the correct phase approaches, the remote vertical pulse will begin to cancel the local pulse, which slows down the miscounting. Finally, the miscounting will completely stop when the two signals come precisely into phase and the cancellation is complete. This phasing action, which takes a time depending on the initial phase of the two signals, occurs at a slow enough rate that the receiver is not ordinarily disturbed. The

average phasing time is about 2 seconds, although it may take as much as 4 seconds if phasing begins at the most unfavorable time.

It is further desirable that the genlock circuit function properly in the presence of noise which might be picked up in the remote signal transmission system. The most vulnerable portion of the circuit in this respect is the horizontal locking AFC system. For best noise immunity, a long time constant is required in the horizontal AFC; but such a circuit would then lock-in slowly and be very critical to operate. In order to have fast lock-in and non-critical adjustments, the time constant is kept short for initial lock-in by a relay which is held open by the presence of the vertical phasing pulse. Once lock-in and phasing is completed, the phasing pulse disappears, the relay closes, and the time constant is automatically lengthened. If for some reason, the lock is momentarily lost, the phasing pulse will immediately reappear, the relay will open, and the Genlock will rapidly recover.

The Genlock operates from the synchronizing portion of the remote video signal, but it is necessary to have the remote and local *blanking* signals exactly in phase so that switching of video signals will not cause the blanked raster to jump from side to side. Therefore, adjustment of the relative horizontal phasing of the two systems is a highly desirable feature. This is particularly important when the remote signal has come a long distance because the width of the front porch may be changed by small faults in the large number of transmission equipments of the system. Therefore, an adjustment in the horizontal AFC is provided for phasing, or front porch correction;

so that local and remote horizontal blanking may be exactly lined up even if the front porch of the received remote signal is incorrect.

### **Grating Generator**

It is a great convenience in the lining up of camera and monitoring equipment to have available a grating linearity test pattern. Furthermore, the job of generating this pattern may be most easily done right at the sync generator where the required frequencies are already available and exactly tied in with the sync generator frequencies. Therefore, a grating generator circuit has been built in to the TG-2A sync generator. A 900 cycle signal is taken from the second counter of the 525:1 chain for timing the horizontal grating bars. This signal is shaped for the horizontal bars. Timing for the vertical bars is obtained from a 315-kilocycle oscillator pulsed from the horizontal driving signal. Narrow pulses for the grating lines are generated from the 315-KC sinewave by an inductive peaker circuit. Five combinations of grating bars are available on a 75-ohm line at the grating signal output. These are horizontal bars alone, vertical bars alone, horizontal and vertical grating, and two sizes of dots produced by the intersections of the grating lines. Small dots (one or two line-widths dimensions) are used for scanning linearity testing with the RETMA ball chart; and large dots (8-10 lines) are provided for convergence of tri-color kinescopes. All patterns provide an array of 13 x 17 bars or dots, and blanking is added at all times so that bars or dots do not appear on the retrace.

# The Genlock For Improved TV Programming

## Introduction

The need for better techniques in video programming has become more and more apparent, particularly as picture quality has improved, thus focusing attention on ideas for adding some of the finer touches. Special effects, used for a long time in the motion picture industry, are rapidly approaching the category of "musts" for television programs.

One of the gaps in the present programming structures arises from the lack of synchronization between two distinct program sources which may supply successive parts of a program. Separate sync generators are used at the two sources and even though they are locked to the same power supply as a frequency reference, there is not a fixed relation in phase between the field and line scanning frequencies produced in the two generators. The field frequency pulses may be phased together by manual adjustment and they will stay so as long as the same power source is the reference for both generators, but there is no such simple solution to the problem of phasing the line frequency pulses. Usually

there is a continuously changing random variation in the phase of one with respect to the other, though the average frequency is constant and the same in both generators.

Lack of tight lock-in between two such systems results in several programming limitations. For example, when the program line is switched from one system to the other, the receivers have to adjust themselves to the new sync signal. The horizontal (line frequency) scanning changes very quickly in most cases, but the vertical (field frequency) scanning circuits have much more inertia and do not respond quickly. If the vertical pulses in the two systems happen to be in phase at the moment of switching, there will be almost no disturbance in receivers. However, such a condition is a rare occurrence, and in most cases the pulses will be out of phase. The usual result is therefore that the picture on a receiver will "roll over," much to the annoyance of the viewer.

Another limitation is the impossibility of using lap-dissolves and superpositions involving pictures from two unrelated television pickup systems. The increasing use of lap-dissolves and superpositions in studio

programs makes it seem more and more desirable to provide means to produce the same effects at all times regardless of the sources of the signals to be treated. To make them possible, the sync generators must be locked together tightly, field for field and line for line, just as though the whole system were operating on one generator instead of two.

The most direct solution to this problem is to provide means for locking the local sync generator, as a slave, to the remote generator, as a master. This is the direct solution because it requires no additional transmission facilities, between the two pickup points, beyond those already necessary for program connection. The remote signal, received at the main studio for connection to the transmitter, may be used for comparison with the local sync generator signal, thus providing an error signal which can be used to control the operation of the local generator. The equipment for making the comparison and for producing the error signal is located at the main studio. No special equipment is needed at the remote pickup point. Once the equipment for this control of the local generator is functioning, the remote signals may be treated as local signals in any of the common types of switching transitions and superpositions, thus making it possible to go back and forth from one source to the other without concern as to the point of origination.

A few telecasters have developed equipment for their own use\* to make possible smooth integration of remote and local programs. These have served quite successfully, but so far as is known, they require very precise initial manual adjustments in order to establish the proper phase relationships.

Foreseeing the need and the demand for simple, automatic, and fool-proof means for tying two television pickup systems together, RCA engineers have developed a device called the Genlock, which accomplishes the desired lock-in automatically without any manual phasing adjustment whatever.

\* "Mixing Local and Remote Television Signals," W. E. Wells and J. M. Weaver, TELETECH, January 1950.

FIG. 1 (below). Front panel view of the Genlock which is designed for standard rack mounting.

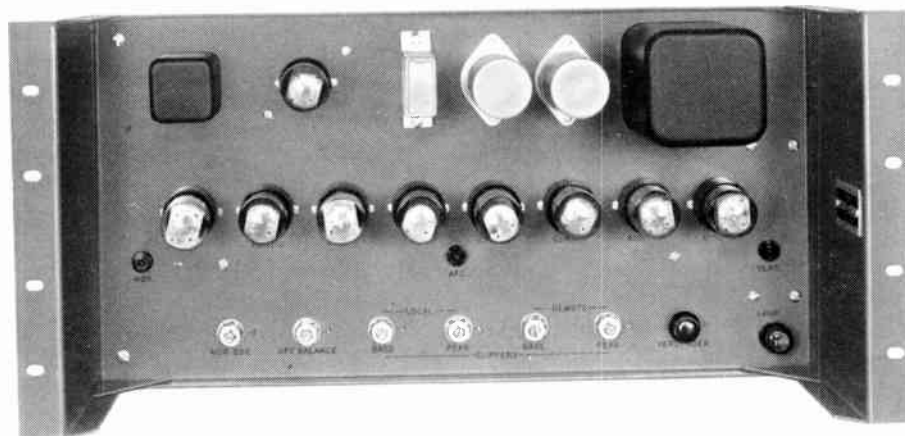

## How It Works

The Genlock is a unit which combines two separate circuits which serve to provide control signals to the line frequency and field frequency sections, respectively, of the local sync generator.

The first consists of an afc discriminator which derives a varying d-c error signal from the comparison of the horizontal driving signal (from the local sync generator) with the separated sync signal derived from the remote picture signal. This latter sync signal must be separated from the composite picture signal in some other equipment such as the RCA TA-5D stabilizing amplifier. No separator circuit is provided in the Genlock. The error signal is applied to the reactance tube in the local sync generator, thus directly controlling the frequency and phase of the master oscillator. The control is rigid, allowing no perceptible horizontal drift or instability between the two pictures.

The second circuit compares the sync signals, one from the local sync generator and the other from the sync separator operating on the remote picture signal, and from this comparison derives an error signal in the form of a positive pulse recurring at field frequency. As long as the two field frequency signals are out of phase, the pulse exists, but as soon as they become coincident, the error pulse ceases to exist. The error signal is applied to the 7:1 counter circuit in the local sync generator (RCA TG-1A or TG-10A) in such a way as to cause it to miscount. As long as the error signal continues to recur, the local field frequency drifts at an accelerated pace causing the two signals to approach in phase. At the instant of coincidence the error signal disappears and the counter circuit begins to operate normally. Thereafter the two signals remain in phase as long as the Genlock continues to function.

The operation of the line frequency control circuit is quite rapid so that lock-in of the horizontal scanning circuits appears to be almost instantaneous. The field frequency control circuit, however, requires a variable amount of time to assume full control depending on the initial phase difference between the two signals. Phase shift brought about by the control occurs at a definite rate of 3 scanning lines per field. The maximum amount of shift ever required is one full field, or 262.5 lines. Thus the maximum time required to achieve control is about 1.46 seconds.

The accompanying block diagram illustrates the functioning of the two control

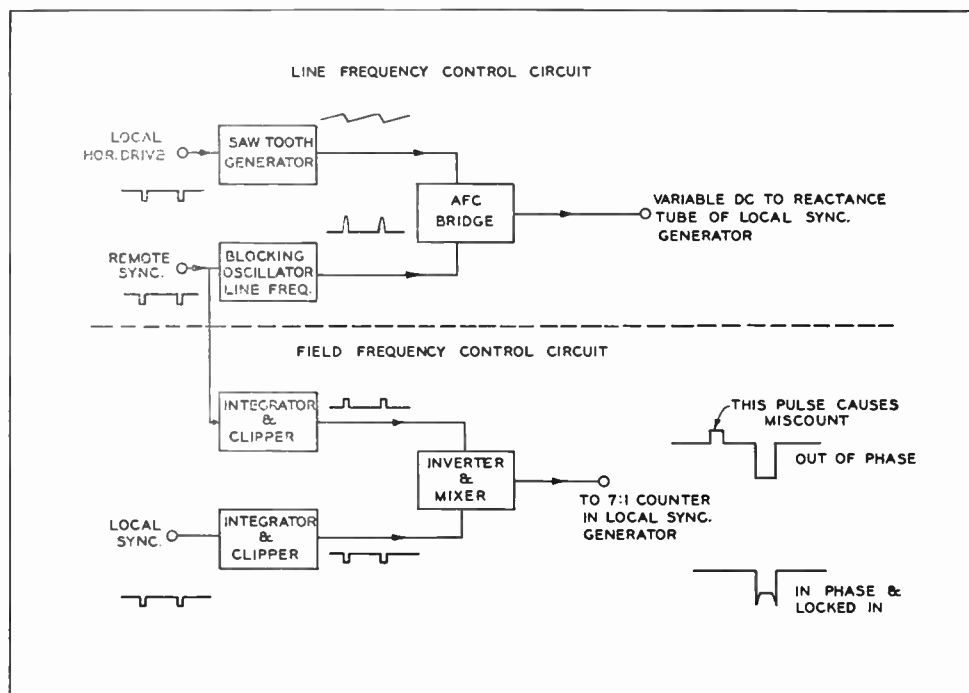

FIG. 2 (above). Simplified block diagram illustrating operation of the Genlock.

circuits in the Genlock. From the local horizontal drive signal, a sawtooth wave is generated at line frequency, while the remote sync signal serves to produce a pulse signal at line frequency by means of a blocking oscillator. The sawtooth and pulse signals are then applied to an afc bridge in the usual manner, thus producing the variable d-c error signal. Coincidence of the steeper slope of the sawtooth with the blocking oscillator pulse produces an error voltage of the proper polarity to maintain lock-in.

In the case of the field frequency control circuit, the two sync signals are passed through identical integrators to remove the line frequency components, and the remaining field frequency pulses are then clipped twice in similar clippers to produce well-shaped pulses of equal amplitude but slightly different width. These two pulse signals are then mixed in such a way that the wider pulse produces a negative pulse signal of large amplitude, while the narrow pulse produces a positive pulse signal of relatively small amplitude. When the two pulses are not coincident, the mixed signal appears as a combination of positive and negative pulses separated in time as illustrated in the block diagram. However, when the pulses coincide in time, the positive pulse is completely swallowed by the larger and wider negative pulse about as indicated. Since the 7:1 counter is not responsive to negative pulses, the miscounting ceases as soon as the coincidence occurs.

The Genlock never requires more than one field to bring the field frequency pulses into phase. The reason is that when it causes the counter in the sync generator to miscount, it is possible, under the proper conditions, to bring about a conversion of an "even" to an "odd" field, or vice versa. This may be understood as follows. As stated before, the rate at which the field frequency phase shift occurs is three lines per field because the pulse which causes the miscount is three lines wide. Just preceding the final cycle of miscounting, however, the positive and negative pulses may be in partial coincidence with respect to time. This partial coincidence will result in a positive pulse less than three lines wide. In fact, the pulse will have a width which is some integral number of half lines in magnitude, say, 1, 2, 3, 4, or 5 half lines. If the number is odd (1, 3, or 5), the miscount will be  $\frac{1}{2}$ ,  $1\frac{1}{2}$ , or  $2\frac{1}{2}$  lines respectively, and the field sequence will be shifted automatically from "even" to "odd," or vice versa. If the number is even (2 or 4), the miscount will be 1 or 2 lines respectively, and there will be no shift in field sequence.

Thus it may be seen that the Genlock is entirely automatic in operation, and requires only the proper information in the form of suitable signals to bring about a solid "marriage" of the two sync systems. The only control necessary is a switch for disconnecting the normal frequency reference standard and at the same time connecting the output of the Genlock to the proper circuits in the local sync generator.

# FILM PROJECTORS for TELEVISION

## Introduction

The Television broadcasting industry uses motion picture film in four separate ways. They are:

- (1) As an inexpensive program source by the use of standard motion pictures produced primarily for exhibition through other media.
- (2) As a means of packaging a tailored show by producing motion pictures solely for exhibition on television.
- (3) For kinescope recording, a means of recording television productions for rebroadcasting in other localities.
- (4) To provide scenic motion as a background for studio productions.

Of the above applications the first three must be filmed in such a manner that they may be televised on the same equipment. That is, they should be made to the same standards. The fourth, which is called "background projection," is not a program in itself, therefore, need not be considered in film pick-up equipment. (However, the same projection techniques are employed and except for the additional light requirements the standard television projectors may be used.) Since nearly all motion picture producing equipment is made for theater standards and since there is a vast potential reserve of program material in theater film productions, it is imperative that television film equipment operate on these established standards. Let's compare these standards to television standards.

## Film Standards

Motion picture practice has standardized on a projection rate of 24 pictures or "frames" per second for both 16 mm and 35 mm sound films. The method of theater projection is such that the projected light is interrupted two or more times per frame; once to permit pull-down of the film to the successive frame without the motion of the film being projected on the viewing screen, and one or more times during the interval the frame is stationary to give an additional interruption to the picture image. This repeated showing of each frame reduces the sensation of flicker to the eye by increasing the repetition rate of the flicker. Since each picture or frame is actually seen several times, the flicker or field frequency is 48 or more times per second, high enough to give the illusion of no flicker at all at the picture brightness normally employed in theaters.

## Television Standards

The present monochrome television operating standards include a condition that the system can be tied in with the 60 cycle power lines which are widely used in America. The repetition frequency of television pictures, therefore, is 60 fields per second, well above the perceptible flicker rate. The use of interlacing, which is a system of transmitting all the odd-numbered scanning line detail in one field, followed by all the even-numbered scanning line detail in the next field, produces one completely scanned picture in one frame or 1/30 second. This gives an effect which is quite analogous to the action of the shutter in standard theater projectors.

FIG. 1. Representation of a standard television signal.

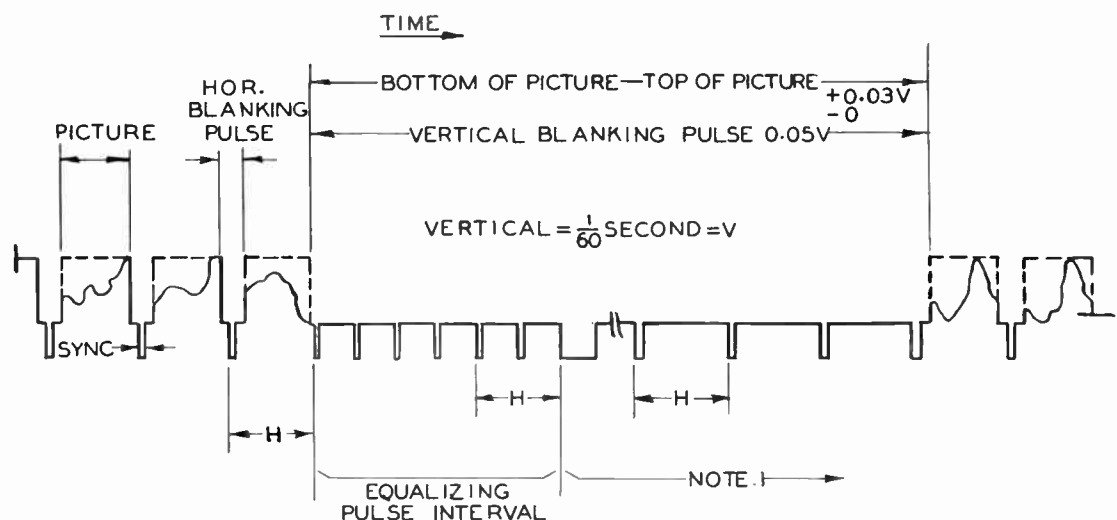

REF.: RMA SUB-COMMITTEE  
ON STUDIO FACILITIES  
JAN. 22, 1946.

NOTE .1  
PORTION OF HORIZONTAL &  
VERTICAL SYNC PULSES  
OMITTED.

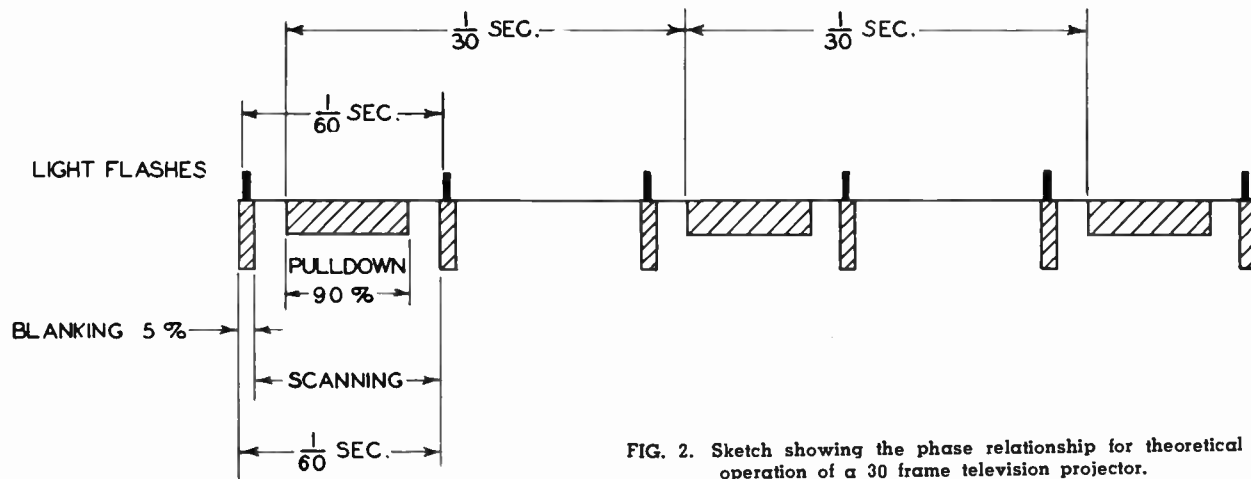

FIG. 2. Sketch showing the phase relationship for theoretical operation of a 30 frame television projector.

### Basic Problem

Here we have the basic problem in the design of television film projectors; to convert motion pictures operating at a 24 frame per second rate into a video signal operating at a 60 field per second or 30 frame per second rate.

In discussing the solution of the problem we shall confine ourselves to the most commonly used method of converting motion pictures into a video signal. This method utilizes an intermittent type film projector to flash the motion picture image on the photosensitive surface of a "storage" type television pick-up tube.<sup>1</sup> The video signal is generated at this point by the process of electrically scanning this "stored" image during a time interval the photosensitive surface is in complete darkness.

### Basic Operation

By referring to Figure 1, which is a practical representation of the standard composite monochrome video signal, it can be seen that there is considerable time (5 to 8%) devoid of picture information between television fields. This time is required for vertical "retrace" of the scanning beam from the bottom of the photosensitive surface. The image must then be retained as an electrical charge long enough for the scanning beam to completely scan one field. During the succeeding blanking interval the picture image may again be flashed on the photosensitive surface and the cycle repeated.

If motion picture film was taken at a 30 frame per second rate we could project it so that two light flashes would be passed through each frame between pull-down periods. This method would fit in with the television system (see Figure 2), but if standard 24 frame per second film was projected at a 30 frame rate, we would have an intolerable speed-up of action and the accompanying audio. For this reason ingenious methods of film pull-down must be reverted to in order that the film speed be

<sup>1</sup>"Storage" is the ability of the pick-up tube to momentarily retain a photo-electric charge image corresponding to the illuminated picture pattern flashed on its light sensitive surface.

maintained at an average 24 frame rate and still maintain the 1/60 second film field or light pulse rate.

In the sequence diagram, Figure 3A, the pull-down cycle of the standard 35 mm theater projector is shown in time relationship to that of the television scanning cycle. When operating as described above, with a light pulse through the film during each vertical blanking interval, it can readily be seen that during the third and sixth blanking periods portrayed in this chart, light pulses would be flashing through the film while it was in motion. This would result in a type of blurred image which is known as "travel ghosts." This pull-down requires such a long interval that it is impossible to use a conventional 35 mm projector and have the required information available for scanning.

### 2-3 Intermittents

Mr. A. V. Bedford of RCA Laboratories, Princeton, described in U. S. Patent #2,082,093 the method of film movement shown on diagram "B" of the time sequence diagram, Figure 3. In this method, the first showing interval can be shortened to accommodate two blanking intervals for the projection of the first film frame, and the second frame can be held for a longer time to accommodate three blanking periods as indicated. In such a manner two exposures are made of one frame and three of the following frame. Thereby, we have made five television fields out of two frames of 1/24 second each. This gives us 60 television fields or 30 television frames per second from film running at 24 frames per second.

### Short Pull-down Intermittents

For 16 mm film, where mass and resultant accelerating forces permit a much shorter pull-down interval, another method of obtaining the desired relationship may be employed. This method shown in Figure 3B, Diagram "A," requires only a slight increase in the standard 16 mm pull-down speed in order to allow two showings to be centered in one frame and three showings in the following frame without resorting to any change in the time ratio of the intermittent mechanism from frame to frame. U. S.

(A) 16 MM TELEVISION PROJECTOR TP16  
(EVENLY SPACED PULLDOWN)

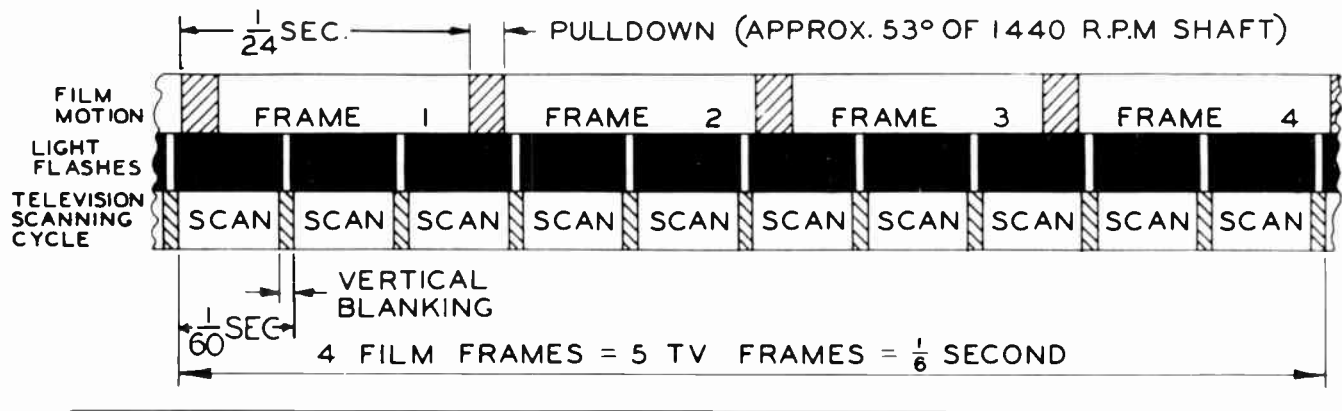

(B) 16 MM TELEVISION PROJECTOR TP 6  
(2-3 PULLDOWN)

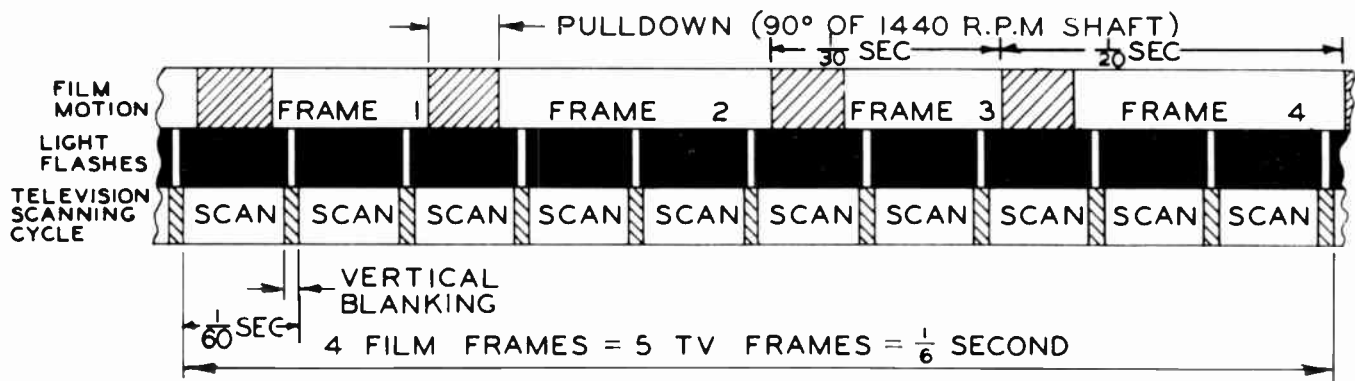

FIG. 3.

Patent #2,303,960, Stuart Seeley, RCA Licensee Laboratories, describes this method of televising motion pictures.

The design of a 35 mm television projector with a comparable pulldown interval does not appear practical because cutting the allowable time in half increases the acceleration forces by four times. These forces would exceed the elastic limit of the film; the mass of the film in this case represents the major part of the load.

### Light Sources

In the above discussion of intermittents it was assumed that a light pulse of sufficient intensity could be made to occur within the vertical blanking interval. However, let us now consider these light pulses in more detail. The projection light must be of sufficient intensity that the time-average of the illumination reaching the pick-up tube is slightly greater than the illumination necessary for the non-storage operation of this same pick-up tube. Since it is desirable both to cover film pulldown and to present uniform picture information to the pick-up tube, the light pulses must be limited to the time interval of vertical blanking, which is at the maximum only 8% of the available time. Therefore, the intensity of this light pulse must

be greatly increased over that required for non-storage operation. If this intense light should fall on the photosensitive surface of the pick-up tube during the scanning process, an action similar to overexposure would occur and all picture information scanned during this period of overexposure would be wiped out. This appears on the television monitor as a white horizontal bar called an "application bar." An adequate light source for the Iconoscope, which is the most widely used film pick-up tube, must be capable of producing in excess of 50 foot-candles average illumination on the mosaic with no film in the machine. There are two methods of obtaining a suitable light pulse for the Iconoscope: First, an adequate light source with a shutter can be made to give accurate timing of the projection interval; Second, a type of light source which can provide the correct illumination by switching this source on at the proper instant for the correct exposure duration.

### Shutter and Incandescent Lamp

The first method, using an incandescent lamp as light source and a shutter for pulsing, has been more widely used because of its simplicity and low cost. The shutter,

for maximum efficiency, should be located where the light beam to be interrupted is small compared to the shutter opening used; by this method fast opening and closing is obtained, thus permitting a considerable interval of fully opened time. Also its location should be behind the aperture so that light and associated heat are on the gate only during the actual exposure interval. In order to obtain the largest practical opening, the shutter generally has but one opening and is driven at 3600 RPM. It may be either mechanically or electrically interconnected to the intermittent drive mechanism so that proper phase between light pulse and pulldown may be maintained.

Mercury vapor lamps have been employed in some installations in preference to the incandescent lamp, but the associated problems prevent a general adoption of them as a light source.

### High Intensity Pulsed-Light

The alternative method of obtaining useable light pulses for Iconoscope pick-up involves the pulsing of a special Xenon filled gap lamp. Xenon emits a brilliant light when ionized. The technique used consists of charging an LC circuit during the scanning interval when no light is de-

sired, then triggering this charge with a television pulse, thus allowing the stored energy to dissipate through the lamp. This current flow through the lamp ionizes the Xenon which in turn emits the light pulse. The television pulse used for triggering, called "vertical drive," has its leading edge coinciding with the beginning of vertical blanking. By using this leading edge as the triggering signal, the light pulse is always properly phased with respect to the television system. The duration of the light pulse is fixed by choosing a time constant for the LC network such that it will never exceed 5% of the cycle.

### Low Intensity Pulsed-Light

A low intensity pulse light has been adopted by RCA for use in a film projector designed especially for Image Orthicon pick-up. This light, called a "Glow Modulator," was developed by Sylvania for facsimile work. It is such a low energy consuming device that it can be driven with an amplified vertical drive pulse. The rectangular shape of this pulse makes it ideal for time efficiency; i.e., the ability of maintaining full light intensity over the entire time available for the light pulse. Since the vertical driving pulse, by definition, must stay within the vertical blanking period there are no light phasing problems.

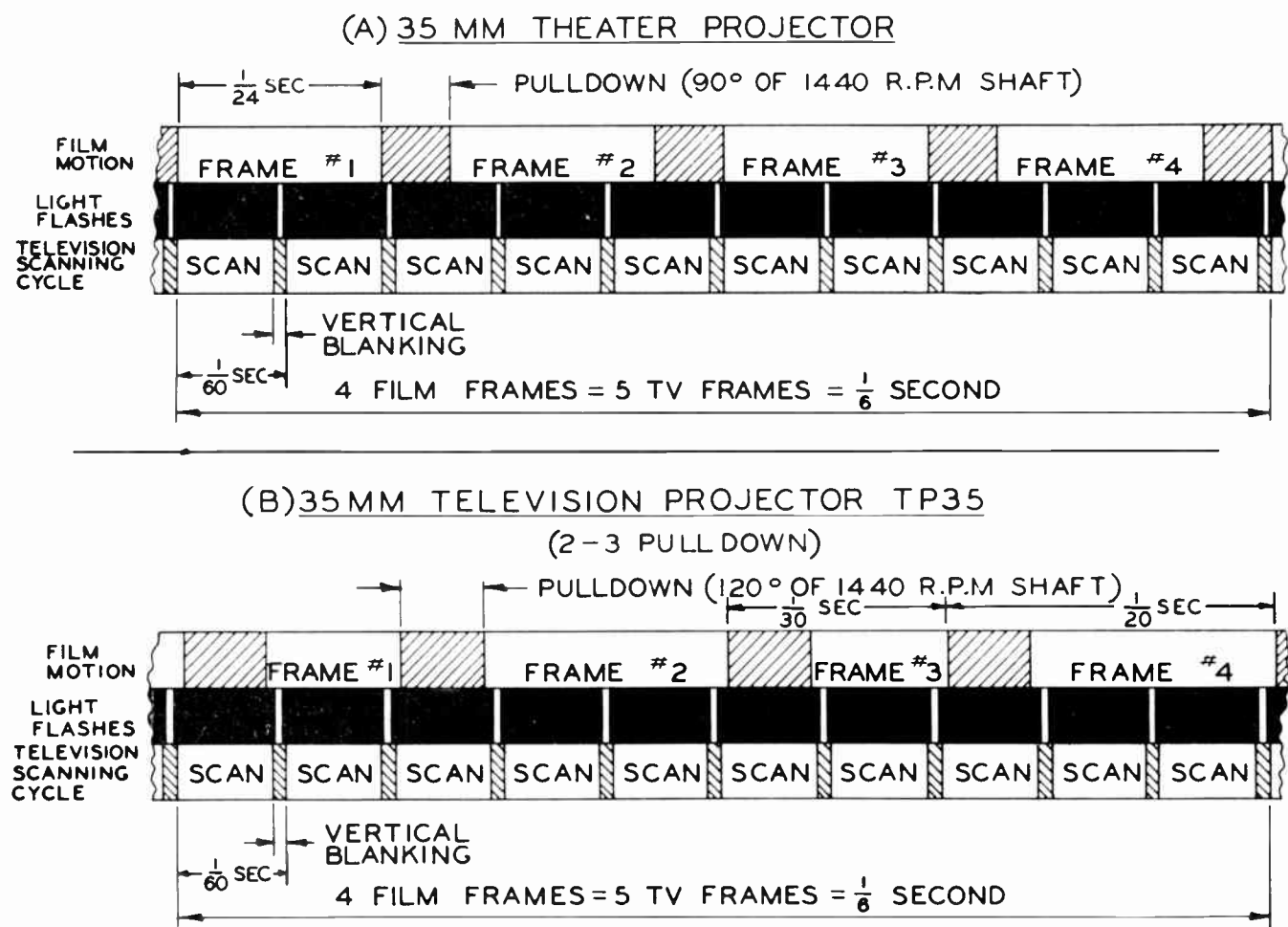

FIG. 4.



### **Projector—Camera Phasing**

A fundamental requirement of a projector operating on the storage principle is its ability to be synchronized accurately with the television system. Synchronization is accomplished by virtue of the fact that both the television synchronizing generator and the projector drive motors have a common source of alternating current power supply and can be locked to this power supply at some predetermined phase relationship. The projector drive motor then must fulfill several requirements. First, of course, it must lock-in with the power line, and second, since a standard synchronous motor has a minimum of two lock-in positions, we must select the proper one. With two lock-in positions, a projector can be incorrectly phased in such a manner as to be projecting a picture during scanning time; that is, a lock-in 180 degrees out of correct phase.

Several methods may be employed to eliminate this possibility. The motor may be built with a wound rotor having polarized field coils so that it will automatically lock-in with only one phase relationship. In another motor the same thing may be accomplished by incorporating a permanent magnet on the rotor. The remaining method of insuring this lock-in is the use of a standard synchronous motor along with a pulse-generating device in one of the rotating members. This pulse then must be electrically compared to some predetermined phase reference and the signal generated used to switch the motor power on and off until the proper phase lock-in is obtained.

Another requirement for the drive motor used is that the torque angle change is small with changes in load so as to avoid any tendency to hunt, and to maintain accuracy of lock-in for any changes in load due to film loading or changes in adjustment of the projector during operation.

### **Iconoscope—Light Considerations**

The Iconoscope, the tube generally used for film pick-up is capable of motion picture presentation comparable to the "live" productions. However, one of the problems associated with its use is that of controlling the spectral content of the projection light. Although the Iconoscope is most sensitive to light in the blue-green portion of the spectrum, it does have some response in the red and infra-red region. Projection lenses usually are not corrected for light waves beyond the visible spectrum, therefore, any infra-red light reaching the photosensitive surface of the Iconoscope is out of focus and results in a blurring of the television picture. There is an additional blurring of detail, termed "cloud-effect," caused by the longer wave length reds and infra-red when this tube is operated on storage. A large portion of the energy emitted from an incandescent lamp is in the red and infra-red region which must be filtered out for optimum picture quality when such a lamp is used as a projection light.

On the gap lamp this problem does not exist. Because the lamp was designed for use with the Iconoscope, it has comparatively low red and infra-red emission. Some

of these lamps, however, have an undesirable feature which requires the same type of filtering. The electrodes heat to incandescence and emit a steady light. Since no shutter is used in conjunction with a pulsed light, this incandescent glow from the electrodes passes through the film during pulldown and projects a moving image on the Iconoscope. This motion causes travel ghosts to appear in the television picture. Filtering out red and infra-red effectively reduces this glow enough so that the travel ghosts are eliminated.

Monochrome reproduction of color film is greatly improved by attenuating the red light. The same filter as required to correct the above conditions works nicely for this also; therefore, the same filter may be used for all three corrections.

Although the Iconoscope can produce good pictures through a wide range of overall illumination, the level of the video signal does vary with such change. In many installations, one Iconoscope Film Camera is employed to receive film information from two or more projectors. It is desirable to have some method of setting the overall illumination levels of these projectors so that they may be used sequentially without wide variations in video level when switching from one machine to the other. On pulsed-light sources such control generally is accomplished by varying the lamp current. With incandescent sources, because of their high current consumption, the more economical method is that of incorporating an adjustable iris in the projection lens.

### **Image Orthicon Film Pickup**

In addition to the Iconoscope, the image orthicon has been successfully employed as a film pick-up device. It can be operated as a storage device in the same manner as the Iconoscope employing the same projection equipment. Generally, however, because of the difference in size of the photosensitive surface, a different projection lens must be provided for the film projector. Since the image orthicon needs only about 1/100 the amount of light required for the Iconoscope, a smaller projection light must be substituted or the regular lamp operated at reduced voltage. Also, this tube is much more sensitive to overall light level changes. Therefore, it is sometimes desirable to adjust this level from scene to scene. This can be readily accomplished by the use of a Variac in series with the projection lamp as a light level control. In the RCA TP-10A projector, which employs the low intensity pulsed projection light, provision has been made for adjusting the intensity of this light either at the projector or remotely at the camera control.

The standard studio or field type image orthicon cameras may be used as film cameras by reversing the vertical deflection circuit. This then permits the film image to be projected directly on the photosensitive surface of the tube. If an intermediate translucent screen is used, the vertical deflection in the camera need not be reversed. However, because of the low light levels used, a cumbersome shadow box is required to keep out all stray light.

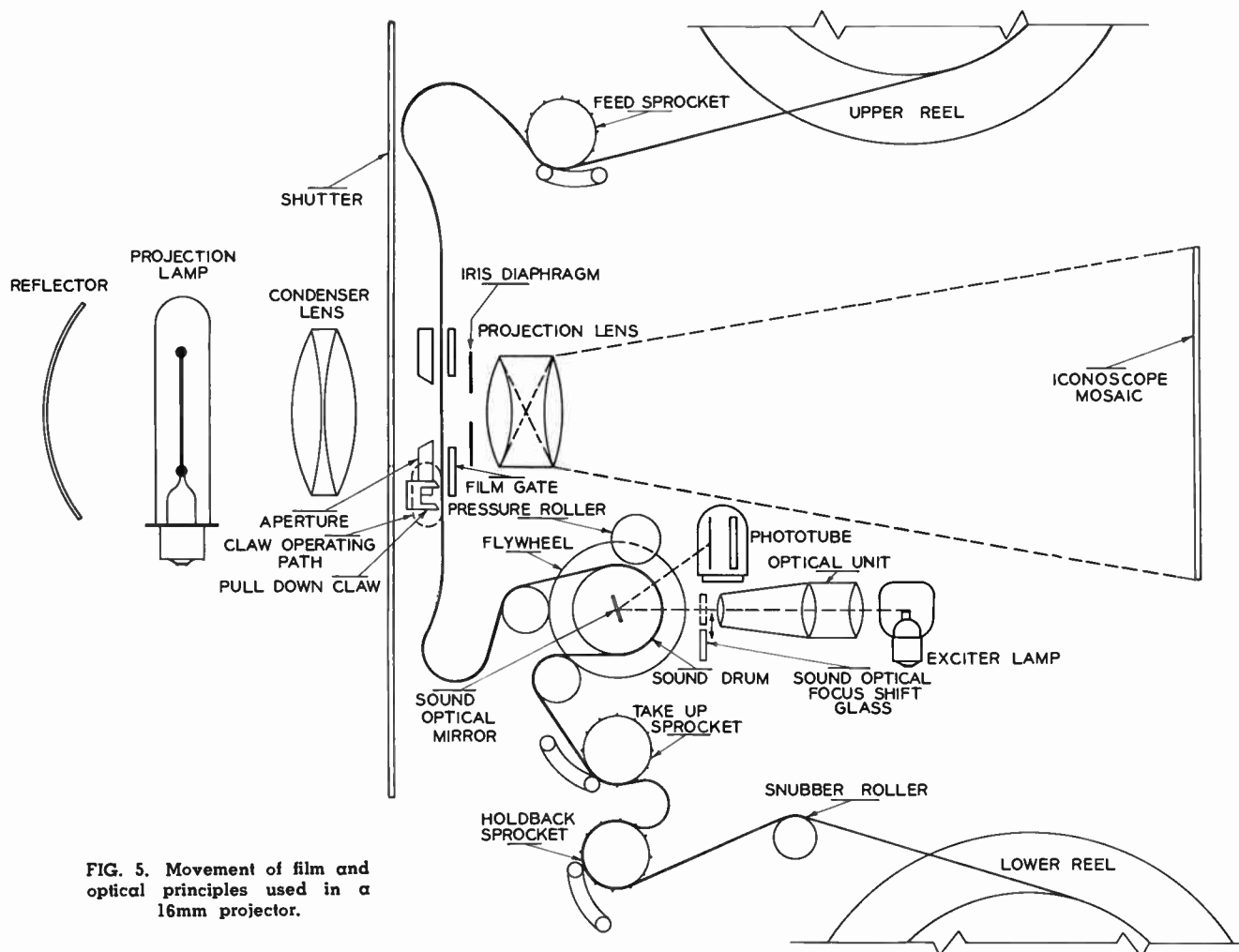

FIG. 5. Movement of film and optical principles used in a 16mm projector.

### Additional Requirements for TV

In addition to the basic consideration in the preceding discussion, the quality standards, split-second timing, and commercialization of television programs have imposed performance standards on film projectors only approached in the best theater-type projectors. Television programming runs on split-second schedules, often allotting only ten or fifteen seconds for filmed commercials. A very minor failure of some functional part of the projector could cause complete loss of such an item. For this reason, elapsed-time indicators must be built in the projectors in order that a strict preventive maintenance and service schedule be maintained. Also parts which have relatively short life, such as lamps, must be logged so that preventive replacement may be made before their expected life has elapsed. There must be provisions for emergency replacements of both projection and sound exciter lamps so that off-the-air time is limited to seconds in case of premature failure.

Also, with this tight scheduling is the demand for centralized control of film facilities. This requires provisions for remote control for starting, stopping, and changeover from one projector to another. Because of the complications in cueing, starting, and stabilization, time must be kept to a minimum.

### Picture Steadiness

The tendency of the film to stop at slightly different locations from frame to frame when being projected results in jumping and weaving of the projected image. Since television pictures are viewed on comparatively small screens with the stationary edges of these screens in the field of vision, a small amount of such motion becomes very annoying. Therefore, television projectors must be built to keep jump and weave to a minimum. However, if this jump is recorded in the film (as it sometimes is) due to faulty cameras or printing equipment, it cannot be corrected by the film projector.

### Projection Lenses

Projection lenses used for these projectors must be of the highest quality. Their ability to resolve detail in sharp contrast is one of the basic requirements. Although the standard 16 mm film can reproduce only about 90 lines per mm. of film, improvement in the definition of television pictures of such film can be obtained by using the highest quality lenses available. The reason is that the detail contrast increases with increased resolving power. The inclusion of an adjustable iris is desirable for adjustment of the illumination level.

On 16 mm lens mounts, provision must be made for rapid shifting of the focal plane to compensate for film

which may have portions with the emulsion on the reverse side. Film, although approximately .006 inch thick, has picture information in a surface coating of emulsion, .005 inch thick. Since the side of the film with relation to the

sprocket holes on which this coating is applied is not standardized, it can be on either side. When the lens is at optimum focus for the emulsion on one side and then a strip comes through with the emulsion on the other side, the thickness of the film is great enough to cause a noticeable out-of-focus condition on the mosaic and a degradation of the television picture.

### Film Sound

Film-sound for television has placed a challenge on the moving picture industry to maintain improved standards of excellence, since television uses frequency modulation sound transmission and the public has learned to appreciate higher standards. Sound-track reproduction from 35 mm motion picture film has a fidelity comparable with that of the best vinyl recording transcriptions. Such quality approaches the requirements for television sound broadcasting. Sixteen mm film can produce good sound quality useful to about 7000 cycles, but wide variations in 16mm sound recording and processing techniques makes a 5000 cycle cutoff characteristic desirable at times. Variation in recording techniques also make necessary the use of an adjustable frequency compensating device which in RCA projection equipment is a separate unit for rack mounting with other control room audio facilities.

A general outline of the principles involved in the optical method of reproducing an audio signal from film is of value to the user of film projection equipment. The section of the film carrying the audio recording, called the sound track, is a narrow area along the edge of the film opposite the sprocket holes on 16 mm film. The recorded audio signal consists of a series of light and dark areas in the sound track emulsion. These areas vary in spacing according to the frequency of the recorded sound and vary either in area or in contrast according to the amplitude of that sound. To convert this film recording to an electrical signal, a narrow beam of light is passed through this section of the film while it is advanced at a very uniform rate. (See figure 5) The opaque areas then modulate this light beam both in frequency and intensity. This modulated light, when picked up by a photoelectric cell becomes the audio signal.

On 16 mm film, the high frequencies give very close spacing of these light and dark areas. Therefore, it is desirable that the light beam be as narrow as possible so that it may be fully modulated by each of these areas. The finite width of this beam causes some attenuation at the high frequencies and this is called "slit loss." Light from the sound exciter lamp passes through a converging lens system which is adjusted to given optimum focus on the film emulsion. If the emulsion should then come on the opposite side of the film, an out-of-focus condition would exist causing the light beam to be wider and hence attenuation and distortion of the higher frequencies. Therefore, for television use, some means of quickly changing the optimum plane of focus for the sound optical unit must be provided.



FIG. 6. Overall view of the RCA TP-35A Projector.

## Film Quality

A television film reproduction can be no better than the quality of the film print used. As mentioned previously, jump and weave may be inherent in the film. Hash and scratch in the audio can be the result of dirt or scratches on the sound track. Another important factor is the contrast of the print. Standard motion pictures are produced with contrast ratios in individual scenes as high as 150 or 200 to 1. However, television pick-up tubes, under normal conditions, have a more limited range in the order of 40 or 50 to 1. For this reason standard motion picture prints may suffer a loss of detail in either the light or dark portions of the reproduced picture. Films made especially for television reproduction are planned to have a contrast ratio of 40 to 50 to 1, and will give superior quality pictures. It is also important that the highlight density of the film be 0.3 or less, giving a light transmission of 50% or greater in the highlights. Departure toward greater densities tends to produce poorer signal-to-noise ratio in the video signal.

Television newsreels and some kinescope recordings are used within days or even hours after their production. The moisture absorbed in the developing process does not have a sufficient opportunity to evaporate and keeps the emulsion soft. Any rough surface in the film path of the projector may scrape off bits of this soft emulsion which not only ruins the film for reshowing, but causes emulsion pile-up. This pile-up can act as an adhesive and increase film friction to the point where it seriously upsets the normal performance of the projector. To prevent this, all surfaces in sliding contact with the film must be highly polished.

## RCA 35 mm Television Projector

Figure 6 shows an RCA TP-35C projector which has been designed for utilizing standard 35 mm sound motion pictures. This projector is entirely enclosed. Shatterproof glass windows permit viewing the operation of the mechanism without opening any door or cover.

The projector is made up of several basic units one of which is the projector head. This head is a modification of the well-known RCA BX100, noted for its sturdy design, automatic lubrication, and outstanding performance. It employs a geneva driven, sprocket type intermittent, (Figure 8), especially designed to give the 2:3 pulldown ratio shown in Line B of Figure 4.

A high intensity, electronically switched pulsed light is employed as the projection light source thus eliminating the need for a shutter. The projection lens combines the favorable features associated with high quality lenses, such as: flatness of field, freedom from color fringes, excellent contrast, and high definition. Durable anti-reflective coatings increase light transmission and improve image contrast through elimination of internal reflections.

Immediately below the projection head is the sound head (see Figure 6). This is the standard RCA high quality unit used in conjunction with the BX100 theater

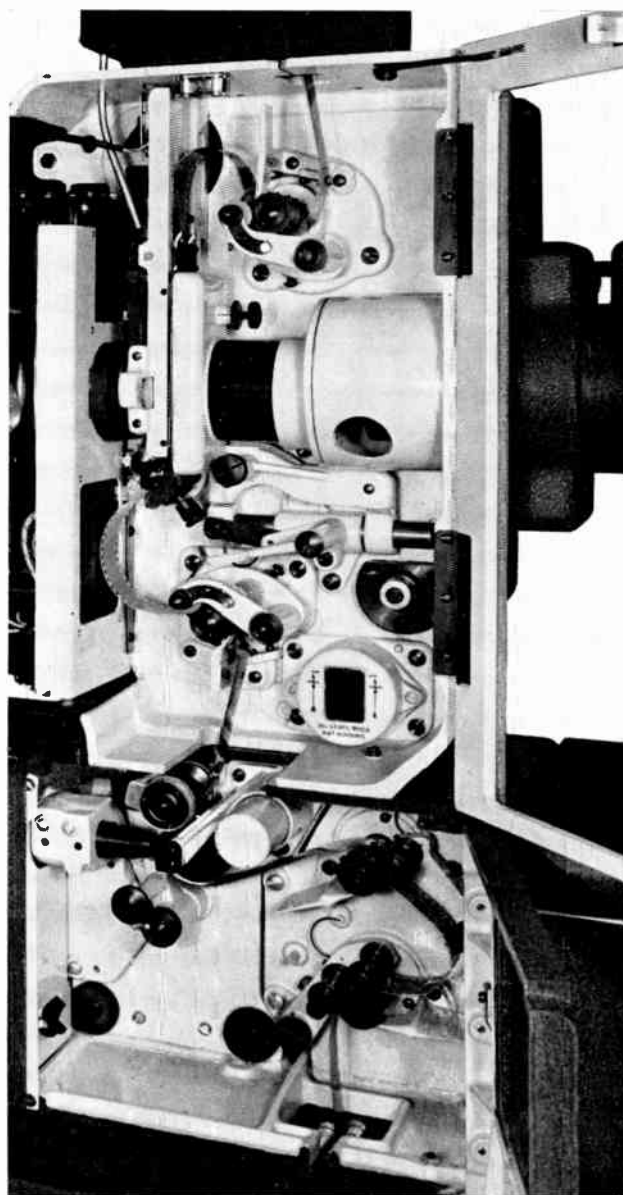

FIG. 7. Closeup of gear and film transport system of the TP-35C.

projector. The sound exciter lamp is operated on d-c power and provisions are incorporated for its quick replacement in case of failure during a show. The audio response is flat to 6,000 cycles. The projector drive motor, mounted with this unit is a special synchronous motor requiring d-c excitation of the field.

Enclosed film magazines are provided, with the take-up or lower reel magazine being an integral part of the sturdy cast base pedestal. Also contained in the pedestal is the d-c power supply for the motor field.

A control box at the rear of the projector contains the necessary switches for starting and stopping. For the use of two projectors with one film camera, a changeover panel is available. This panel, which can be either rack or console mounted, contains switches for remote starting

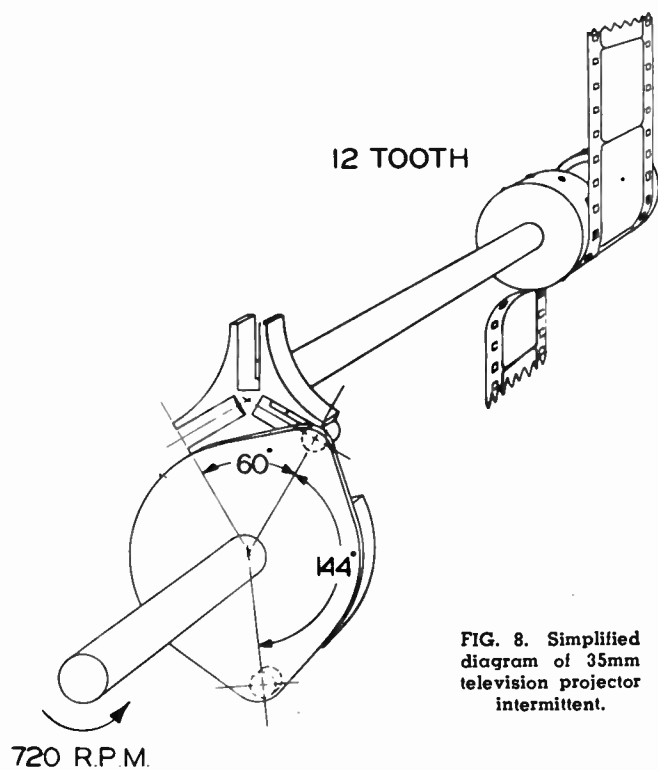

FIG. 8. Simplified diagram of 35mm television projector intermittent.

and stopping either projector, and for changing-over from one projector to the other. The changeover switches control relays which switch the optical system (douse and undouse), as well as the sound circuits.

The power supply for the pulsed light is a separate unit made for rack mounting. It utilizes 110 V a-c power and is controlled by the vertical drive pulse obtained from the synchronizing generator.

#### RCA 16 mm Television Projector (TP-16F)

Figure 9 shows an RCA TP-16F projector which is designed to utilize standard 16 mm sound motion picture film. The projector is a self-contained unit and the projector and pedestal house the sound preamplifier, d-c power supply, line circuit breakers, and control relays.

The projector is equipped with a blower cooled 1,000 watt incandescent lamp which can be adjusted in position to correct for filament variations. A Pyrex reflector and a two element aspherical condenser system are used. The lamp is quickly replaceable if failure occurs and a spare lamp and door assembly is provided in a convenient spot on the pedestal. The projection lens is of the highest quality. This lens is a  $3\frac{1}{2}$ " focal length, F2.3 coated lens with an adjustable iris. In addition to the regular focusing adjustment for the lens a focus adjustment clamp is included so that the lens can be focused (while the projector is running) to compensate for emulsion on either side of the film. A special 3,600 RPM synchronous motor with a d-c polarizing feature drives the shutter and the projector. This shutter provides a light pulse of approximately six per cent duration. The intermittent is a claw type (see

Figure 10), and operates on the evenly spaced pulldown principle (Figure 3, Diagram "A"). The pulldown is slightly accelerated by the use of eccentric gears to drive the pulldown cam.

The surfaces upon which the film rests in the gate are specially polished to reduce emulsion build-up to a minimum. A knob for framing adjustment is provided readily

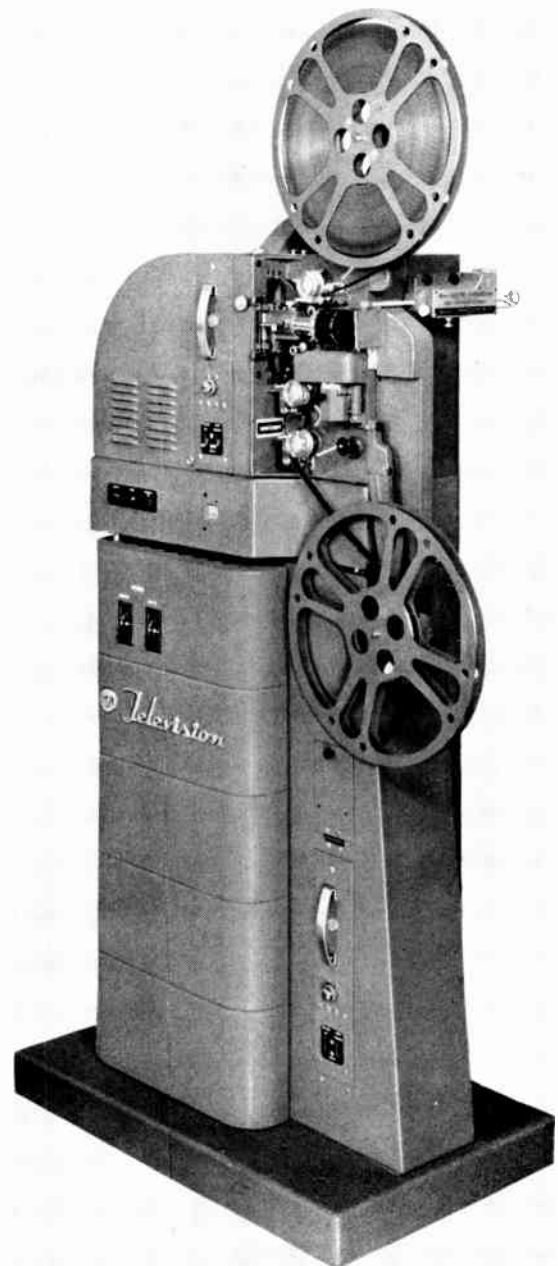

FIG. 9. Overall view of the RCA TP-16 16mm projector.

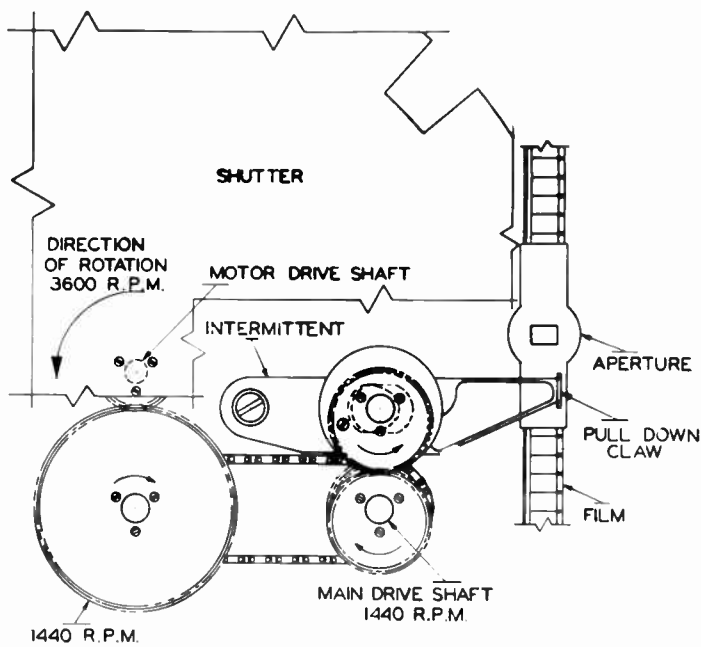

FIG. 10. Diagram of RCA TP-16F intermittent.

accessible from the operating side of the projector. The sound projection system operates in the conventional manner, using an exciter lamp, optical lens unit, sound drum, and photocell. (See Figure 5). A balanced flywheel connected to the sound drum in conjunction with a damping idler maintains uniform film speed during operation. A holdback sprocket removes any variation in sound due to improper take-up tension. Other features provided include a quick change exciter lamp and an in-out lens for sound optical focus adjustment for emulsion on either side of the film. Two toggle switches are provided on the projector for "local" operation. A push-button switch is provided to give control of the projector either at the local position or from a "remote" position. The cabinet type projector pedestal houses a control panel which includes line circuit breakers, "remote" and "local" control relays, lamp preheat resistors, and automatic brake. The spare lamp assemblies and the motor field d-c power supply are also mounted in the pedestal.

**RCA 16 mm Television Projector (TP-6A Tungsten Operation)**

Figures 11 and 13 show a TP-6A projector. This projector is designed to utilize standard 16 mm sound motion picture film. The projector is a complete self-contained unit including: projector, high quality preamplifier, and controls. Standard motion picture projection and also still-frame projection is possible with this machine. Television requirements of long, trouble free life and easy maintenance have been given special attention in the design of the TP-6A projector.

The film transport mechanism is built with precision helical gears running in oil baths. The intermittent is a cam driven, claw type designed to give 2-3 cycle as shown in Figure 3, Diagram "B" and Figure 12. This mechanism

utilizes ball bearings and runs in an oil bath. The claw has 3 teeth with the upper tooth sapphire lined for long life. The film path is simple and easy to thread and it includes a holdback sprocket to prevent take-up reel disturbances from affecting the sound sprocket. A permanent magnet synchronous motor using single phase 115 V 60 cycle power drives the film transport system. The take-up is driven by a separate motor and is a weight compensated device which will adequately handle reels of from 400 ft. to 4000 ft. capacity. Film tension is maintained between 10 and 5 ounces. The upper reel shaft is equipped with a drag device which is easily adjusted. The gate of the projector includes a film pressure shoe with adjustable



FIG. 11. Overall view of the RCA TP-6A 16mm projector.

pressure and the parts of the gate touching the film are mirror finished to reduce emulsion pile-up to a minimum. The side pressure shoes are sapphire lined to reduce wear.

The lamp and lens system utilizes high quality optical components. The projection lens is f1.5, 3½" focal length and includes an adjustable iris. This lens has been especially designed for television applications. The lens is supported in a rigid gate which is not moved for the threading operation. The focus mechanism is an anti-back-lash arrangement and focusing knobs are provided on both sides of the projector.

The condenser lens assembly is easily removable for cleaning. The assembly contains a red-infrared filter for use with an Iconoscope pick-up tube. The projection lamp used is a 1000 watt base-up type lamp. Two of these lamps are mounted in a turret type lamphouse which automatically changes the lamp in use in case of failure. This change takes place in less than one second. A door is provided for replacing lamps in the turret. The shutter is driven by a separate, permanent magnet type, synchronous motor which uses single phase 115V 60 cycle power.

The sound system of the projector uses an exciter lamp which mounts in a horizontal plane. The lamp is operated on direct current and is rated at 10V 5 amp. A unique

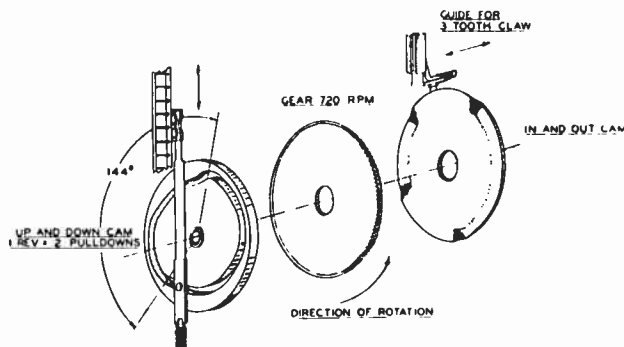

FIG. 12. Diagram of the RCA TP-6A intermittent.

quick change feature is gained by mounting two of these lamps on a special socket. Simply pressing a lever which extends outside of the lamp cover puts a new lamp in place. This operation can be performed while the machine is operating. The optical system employed utilizes high quality components and produces a slit of .0005 inch height with good uniformity of illumination. Near the front end of this lens system, a lever is provided for adjustment of the focus of the lens from one side of the film to the other. The sound drum is equipped with a balanced flywheel which, in conjunction with a damping idler mechanism, keeps flutter to a minimum. A solenoid operated "kicker" applies force momentarily to the flywheel when the machine is started to reduce the sound stabilization time. This same device brakes the flywheel when the machine is stopped. The light which passes through the film is picked up by a spherical mirror which concentrates it on a type 927 photocell. The entire sound

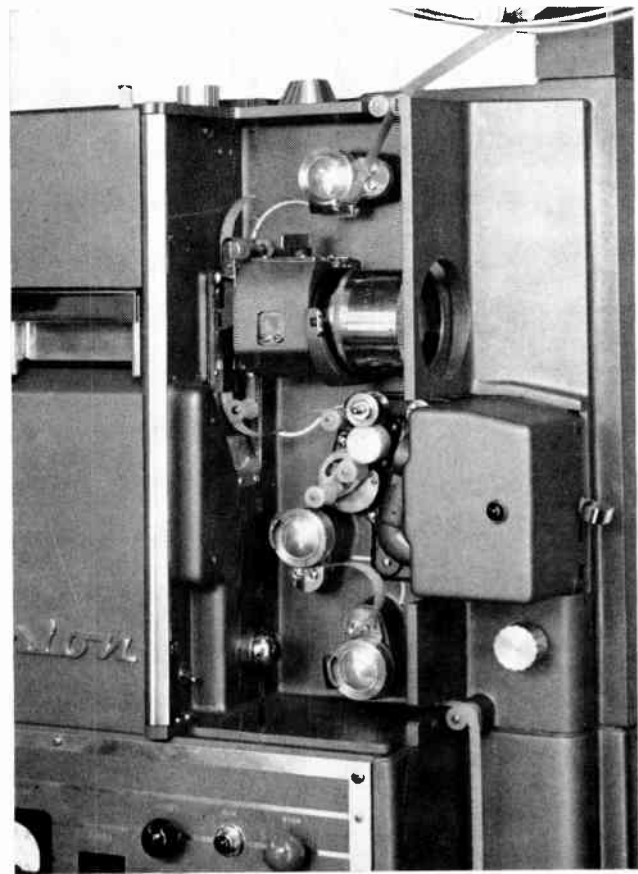

FIG. 13. Closeup of projection optical system and film transport of the TP-6A projector

take-off assembly is isolated from the main frame by the use of shock mounts. The pre-amplifier is located in close proximity to the photocell and is a plug-in unit. A control provides for three frequency response curves. A level setting control and tip jacks for measuring the output are included.

The control circuits are housed in a large casting which is the base for the projector. These circuits are mounted on hinged panels and allow easy access. Provision has been made for remote as well as local control. A variac is provided along with a voltmeter for lamp voltage control. A pilot lamp indicates when a projection lamp failure has occurred. The projector head is mounted on a sturdy pedestal with a heavy cast base. Leveling is provided for by four screws in this base. Space for mounting the pre-amplifier and exciter lamp power supplies is available in the pedestal.

### 16 mm Portable Television Projector

Figures 14 and 15 show the RCA TP-10A Portable TV Projector. This projector, designed to be used only with image orthicon pick-up, makes possible the use of one of the standard cameras participating in a "live" production as a film camera for the insertion of commercials or other filmed material. It is ideal for inserting film commercials

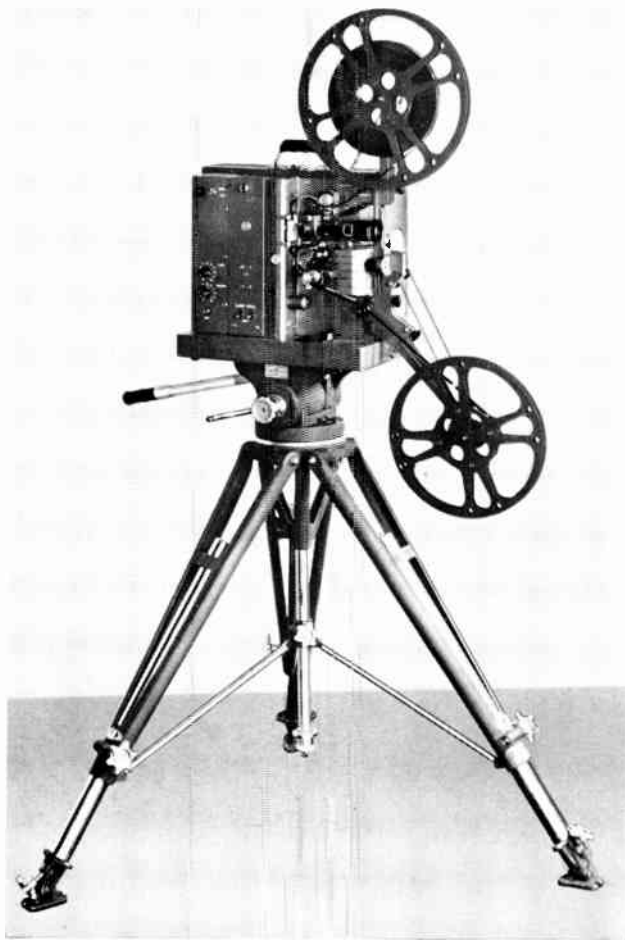

FIG. 14. Overall view of RCA TP-10A.

at the spot in the production of remote television programs, or as an auxiliary for studio production facilities.

It features very quiet operation so that it may be employed in studios to relieve other film facilities of relatively short film insertions. An ingenious coupling mechanism provides rapid and accurate alignment of the projected image on the camera tube. A handy light shield keeps out all undesired light so that the unit may be operated outdoors or in fully lighted studios. With a few simple modifications to the standard field or studio camera, it is possible to take the camera from "live" pick-up to film presentation in less than one minute.

The projector employs a low intensity pulse light, permitting the projection of stills or strips. Intensity of illumination can be controlled either at the projector or remotely at the camera control so that it may be adjusted from scene to scene if desired.

Because of the availability of abundant light, the pulse width may be reduced to about 3%. This allows the use of the 65° pulldown, otherwise the operating cycle is similar to that in Figure 3. Diagram "A."

The projector, employing the claw type pulldown and other fundamental principles of the RCA 400 projector, is driven by a special 3,600 RPM permanent magnet type synchronous motor. Phasing of the projector pulldown is accomplished by rotating the motor frame by means of an external phasing knob.

Audio output level and impedance are such that the audio signal may be piped into the regular microphone channels. This eliminates the requirements for special equipment on remote pick-ups. A volume control is provided so that the audio level may be matched to that of the microphones used in the "live" portions of the program.

The projector is a self-contained unit including pulse-light power supply, audio amplifier and sound exciter lamp supply. Power consumption of the entire unit is only 85 watts at 110V AC. In addition to the 110V AC, a vertical driving pulse is needed for the operation of the pulsed light.

FIG. 15. View showing operation of RCA TP-10A into image orthicon camera.





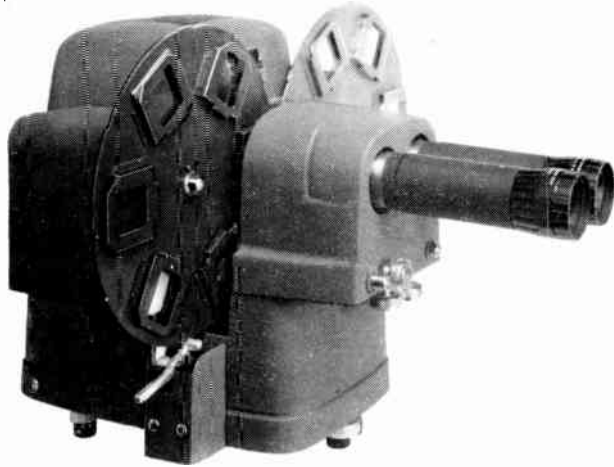

FIG. 16. TP-3A Dual Disc 2" x 2" slide projector.

### Other Film Equipment

No discussion of television film projectors is complete without the inclusion of still projectors. These are used in various degrees for insertion of station call letters, spot commercials, news flashes, test patterns, emergency announcements, etc. Generally they are arranged so that they share the same film camera along with one or more motion picture projectors. The RCA Film Camera Multiplexer is a unit which, through the use of mirrors, permits the permanent installation of two motion picture projectors to operate into one film camera. The RCA Slide pro-

jector mount allows the operation of a slide projector into the same film camera. The remote control panel includes provision for control of this slide projector as well as the two motion picture projectors.

The 2" x 2" slide projector which is shown in Figure 16 features automatic slide changing. Push button operation both at the projector and at a remote control panel is provided. The slide discs which hold a total of 12 slides are easily removed and replaced. Extra discs are available for pre-loading an entire day's program.

A de luxe type projector for stills is also available which handles opaques and transparencies up to 3 x 9 inches. The mounting itself is 4 x 5 inches. Almost any combination of slides or small objects can be projected. Special effects can be obtained by fading in or out between two slides by varying the intensities of the dual projection lamps or by mechanically flipping mirrors. Accessories for this basic equipment are available to accommodate both vertical roll stock, or horizontal news ticker tape, to be used in conjunction with some stationary slide.

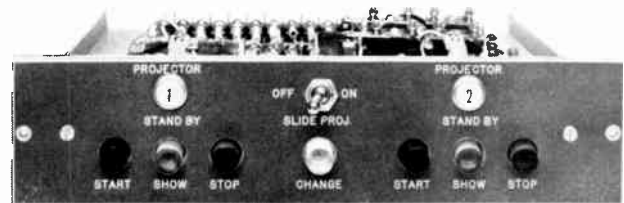

FIG. 17. MI-26256 Projector Remote Control Panel.

# Television Film Recording



The recording of television shows and commercials on motion picture film has been increasing at such a rapid rate within the last few months, that the combined network stations in New York City alone use in excess of one million feet of film per month for this service. These motion picture recordings, made by photographing the visual images on special kinescopes with specially adapted cameras, are being made by broadcasters for many important reasons, chief among which are the following: to record programs for delayed broadcast to larger evening audiences; to record programs for documentary, historic, legal, and advertising purposes; for syndication of television programs to remotely located network stations; and for rebroadcast of programs because of differences in time zones.

To make possible kinescope recordings of rebroadcast quality, RCA developed special equipment which is in operation in many of the key network stations. The RCA television recording system includes a high quality photographic monitor which produces precision visual images, a motion picture camera especially designed for photographing television pictures, and the equipment for sound recording which can be accomplished simultaneously with the picture recording in the camera. As an alternative sound may be recorded separately by using a double film system with separate recording equipment (see Fig. 6).

A glance at the simplified block diagram of the RCA photographic monitor will help explain more graphically the functioning of the system. Beginning at the upper left corner of Fig. 3, standard RETMA video signals are supplied directly to the equipment from the studio coaxial lines in the television studio.

The signal is fed to a video amplifier where it is amplified and separated for the two basic functions of a television system:

FIG. 1. The unretouched enlargements, at left, made from 16mm film recordings, of various television programs, show the clarity and definition of the RCA Kinephoto recording equipment.

a signal for synchronizing the scanning raster of the kinescope with the television pickup camera; and a modulating signal which is amplified and used to control the kinescope beam which forms the visual image. The synchronizing signals control the deflection amplifier, which in turn supplies deflection power to the deflection yoke on the kinescope. A high voltage supply of 25 kilovolts is required for the kinescope operation and a regulated power supply furnishes necessary plate voltages to all units. The controls functions of the equipment are grouped on a centrally located panel with metering circuits to indicate proper operating adjustments.

The kinescope, RCA Type 5WP11, is a special 5-inch flat face aluminized projection type cathode-ray tube having a short persistence blue phosphor screen of high actinic value which makes possible the use of high resolution low-cost positive type film stock.

The equipment has been designed and manufactured to the high quality standards set by the broadcast industry.

#### The Camera

The 16 mm motion picture recording camera was developed by RCA especially for use in television to compensate for the timing differences in the television system which has a frame frequency of 30 per second and the conventional motion picture system which exposes film at the rate of 24 frames per second.

To understand how the conversion in exposure is made from the conventional to the television system frame rate, reference is made to Fig. 5. The figure is divided into intervals of  $1/60$  of a second, representing the television field frequency. Since the  $1/24$  second frame is  $2\frac{1}{2}$  times  $1/60$ , five television fields represent  $1/12$  of a second or  $2/24$  of a second which is the

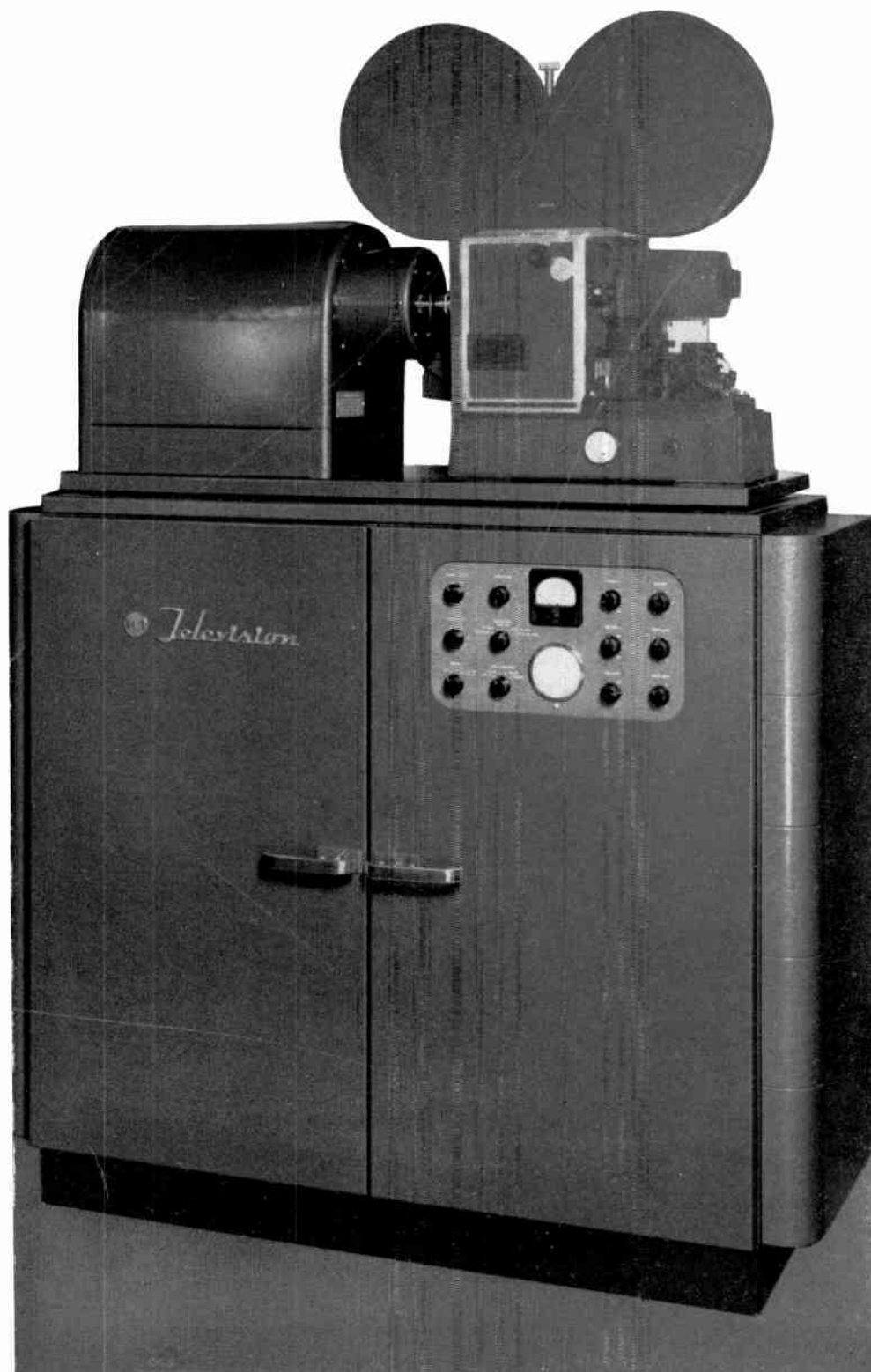

FIG. 2. Overall view of the TMP-20B Kinephoto Equipment which consists basically of a projection type Kinescope associated control panel, deflection circuits and power supplies. Shown in light gray tone are the 16mm motion picture camera TVK-75B and companion Sound Recording Equipment which are available as accessories.

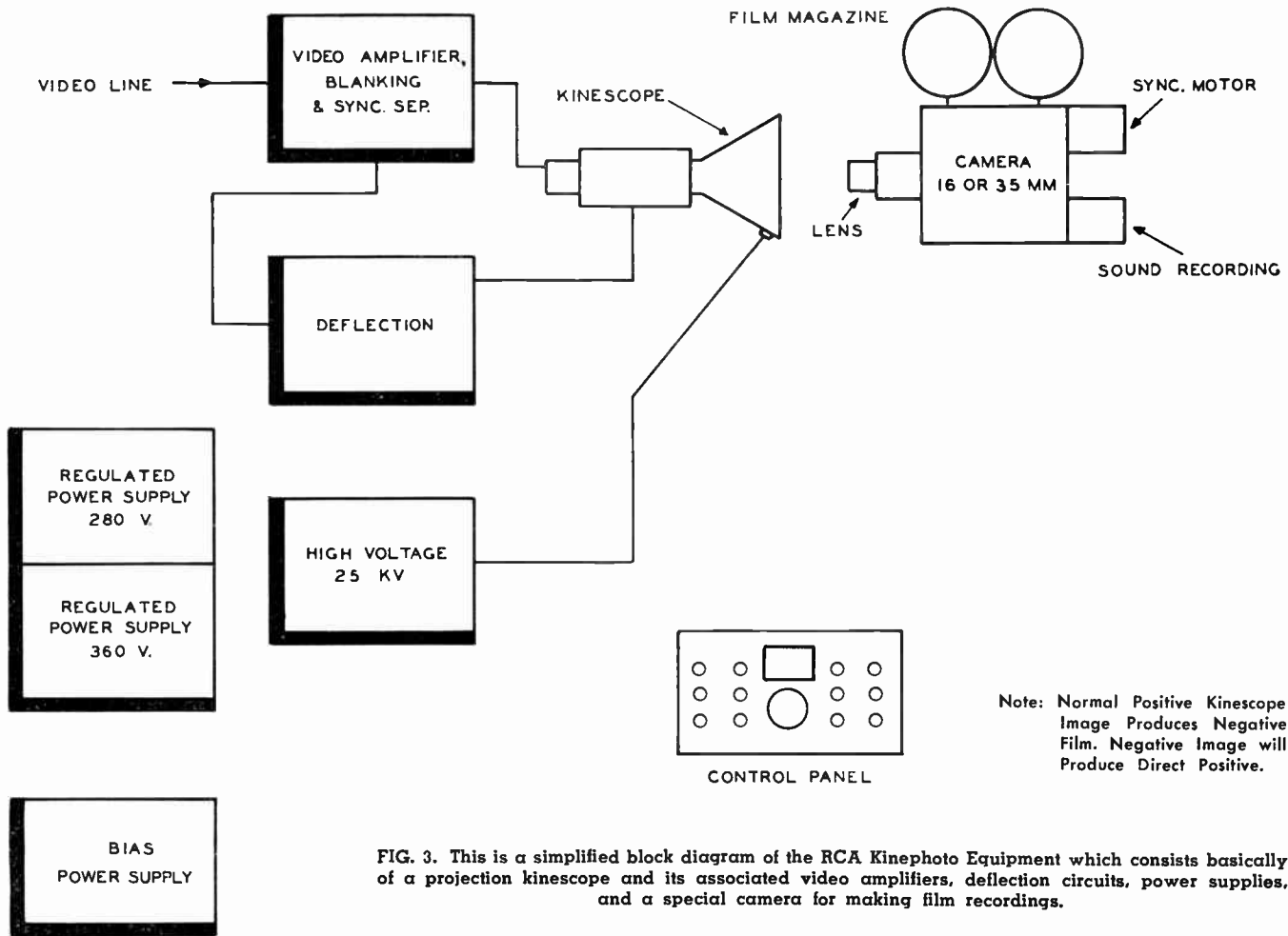
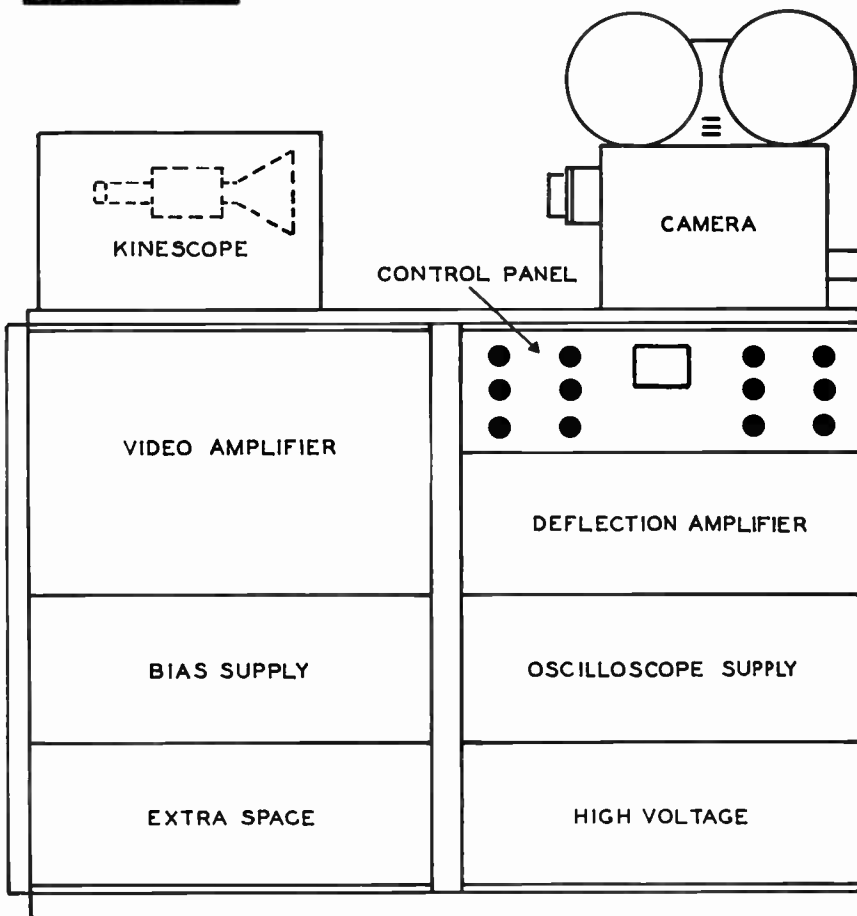

FIG. 3. This is a simplified block diagram of the RCA Kinephoto Equipment which consists basically of a projection kinescope and its associated video amplifiers, deflection circuits, power supplies, and a special camera for making film recordings.



time interval of two motion picture frames. The problem then is to fit the exposure and film transport of two film frames into five television fields. If we expose the film starting at field "A" and continuing to the end of field "B," we have one exposure of 1/30 of a second, a complete interlaced television frame. Two fields of the television picture have been used and two more are required for a second exposure, leaving one field out of five to be used for two film transport intervals. This means that half a field, or 1/20 of a second is available for each film pull-down.

Following the first exposure, allowance is made for the pull-down interval which is the middle of the next television field "C". It is here that the exposure must begin and continue for another television frame of 1/30 of a second; this is the middle of field "E". Pull-down of the film follows to complete the cycle.

The camera is of professional quality throughout and every effort has been made to produce the finest camera for this service.

FIG. 4. This line drawing of the RCA unit shows the layout of the various components which are mounted in the double cabinet racks. An electronic exposure control unit is supplied as optional equipment.

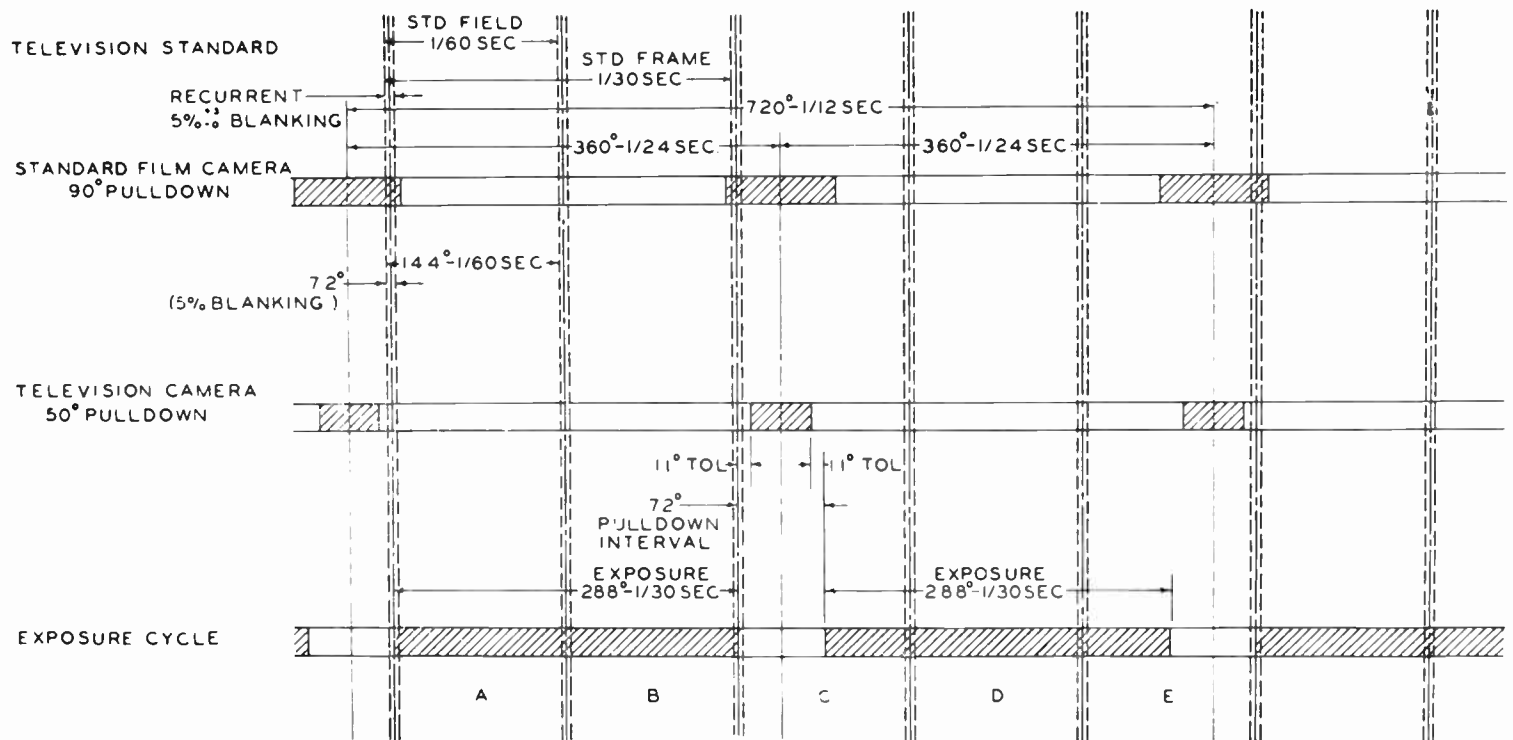

**FIG. 5.** The chart above shows a comparison between the exposure and pull-down timing of a conventional motion picture camera and a special camera designed to accommodate the television field rate. Note, the exposure in the special camera occurs between TV pull-down intervals which take place twice in every five fields.

### Exposure

The camera exposure time in terms of the television system must be accurate to less than one half of a scanning line or roughly one part in 30,000. It must be timed to expose exactly the proper number of picture lines for each frame, or 525 lines, no more or less, or an effect known as "banding" will take place on the exposed film. This exposure is controlled by either of two type of shutters, mechanical or electronic.

Mechanically, the camera and shutter are driven by synchronous motors which are in synchronism with the entire television system. The shutter drive which is isolated from the main camera drive is driven by a 3600 rpm synchronous motor which drives the shutter at the necessary 1440 revolutions per minute through a set of precision gears. Another motor, working in synchronism with this, drives the film transport and intermittent mechanism.

This arrangement insures rotational accuracy and freedom from inter-action of the camera drive and shutter drive mechanisms.

The density of film recording depends not only on the length of exposure but on the brightness of the cathode-ray picture tube. Since the exposure time is fixed, the highlight brightness of the picture is varied by means of the video gain control; the kinescope bias control will set black level or point of visual extinction of the return lines. The beam current of the picture tube is measured by a microammeter on the control panel of the monitor; since there is a direct relationship between the light output of the tube, the measurement of the beam current provides a good index to the brightness of picture.

Normally, motion pictures taken of the positive kinescope images on standard film produce negative images which can be used for rebroadcast by reversing the video phase in the film camera. The film negative

is then available to produce as many prints as desired. For applications where direct projection is required, such as in theatres, a polarity switch makes it possible for kinescope to produce negative images. Such images can be photographed and processed as direct positives for immediate projection. RCA has special processing equipment, with which it is possible to take pictures and project the finished pictures on the motion picture screen in a very short period of time.

Either 16mm or 35mm motion picture cameras can be used with the RCA television monitoring equipment. 16mm film has been chosen initially for television recording because of the importance of costs of the film stock and the film processing together with the safety problems involved. The handling of 35mm film requires elaborate safety precautions because of the rigid fire regulations in the handling of this type of film.



FIG. 6. The typical TMP-20B Kinephoto installation shown here (sound recording equipment at left) provides facilities for either the "single-film" or "double-film" system.

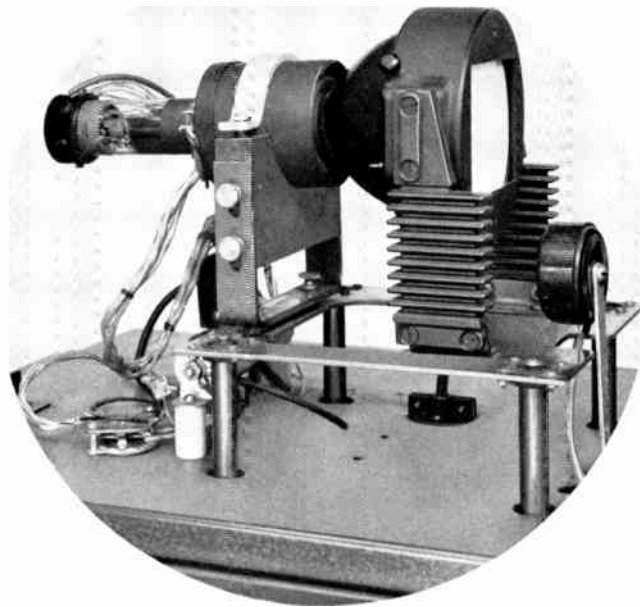

FIG. 7. Picture above shows the television projection tube assembly with the kinescope shield removed. Shown are the projection kinescope, RCA Type 5WP11, the kinescope and deflection yoke assemblies, and the insulator tube supports. The photonic cell mounted at extreme right of kinescope face is connected with meter in control panel and provides a relative indication of the tube's light output.

# HOW TO HANDLE FILM IN YOUR TV STATION



Film plays a very important part in the program structure of the television station. When you consider that the average television station's "air time" is between 30 and 40% film, it then becomes apparent that as much sound planning and thinking is required in providing adequate facilities for handling this important program source as that of any other department in a television station. Film is just as important to television as disc and tape are to AM broadcasting. While it is not the intent of this rather brief discussion to imply that handling film in a television station is extremely difficult, we do intend to point out to the broadcaster some problems not ordinarily encountered in AM broadcasting.

## Care and Cleanliness Pay Off

Film is delicate, and should receive careful attention at all times. Just as in an instantaneous recording a certain degree of deterioration occurs each time the film is used. The exact amount depends entirely on the treatment it receives in projection, rewinding, previewing, handling, and shipping. To produce good pictures, cleanliness

is a *must*. As it is projected and rewound (due to certain atmospheric conditions) a static charge will build up on the film and it actually becomes a magnet for the attraction of dust and dirt particles. Therefore, wherever film is handled in the station, it should be kept as clean and dust free as possible. A very good and quick method of cleaning film during rewind is to allow it to pass through a "hand-held" Kleenex which has been moistened with carbon tetrachloride. There are, of course, many other special application cleaners, restorers, and film cleaning devices that can be considered.

## Space Considerations

Space requirements for handling film will vary with the various station installations. However, there are two focal points in planning film facilities; (1) the projection room and (2) the area required for inspecting and previewing film. In the projection room, adequate space should be provided for editing, splicing, rewinding, commercial insertion, and daily storage for shows that are to be aired. Just as it is in

any other line of business, permanent storage is always a serious problem and perhaps a good rule to follow is to double whatever your space requirements might figure to be. This really is not as foolish a statement as it might at first appear. Some of your film suppliers have incorporated a very useful method to help themselves, but it may present a real problem to you. They will often advise you to hold film and ship upon receipt of their advice. However, it usually turns out that a considerable length of time has elapsed and you are left with the filing problem. So it is a good practice to return every foot of film that you do not own or do not intend to use in the very near future.

In this article it is impossible to cover the problem of fire and permanent storage of film. It is suggested that a copy of "Special Bulletin No. 283", published by the National Board of Fire Underwriters, be obtained and also a booklet published by Eastman Kodak Company called "Handling and Storage of Nitrate and Safety Motion Picture Film" be secured. Briefly, 16mm film used in television stations is a

safety type film. The word safety doesn't mean that it will not burn, but means that it can be handled easier and will not present the problems connected with handling and storing nitrate film. Safety film will burn, but it won't blow up. Normal safety precautions that apply in an office concerning waste baskets, trash, etc., apply also in the handling of 16mm safety motion picture film. The handling and storage of nitrate film is in itself a subject of its own, and the only thing that need be said is—extreme caution should be observed whenever any nitrate film is found in a television station. Your local fire authorities should be consulted as to what their requirements will be in your film department installation.

#### Editing Area Is Needed

In addition, an editing area should be situated to best accommodate last-minute, hurry-up changes so frequently encountered in the preparation of film for airing. The actual design of the editing table or bench will depend on local conditions and the particular likes and dislikes of the operat-

ing personnel. However, the following basic equipment will be needed.

- 1 Film Splicer
- 1 Pair Rewinds
- 1 Measuring Machine
- 1 Small Viewer
- 1 Editing Table or Bench
- 1 2" x 2" Slide File Cabinet
- 1 3¼" x 4" Slide File Cabinet
- 1 Open Face Rack for Storing Large Reels that will be Aired During the Day
- 1 Permanent Type Storage Cabinet
- 12 2000' Flat Steel Reels
- 12 1600' Flat Steel Reels
- 12 400' Flat Steel Reels
- 50 100' Flat Steel Reels
- 1000' Blank Leader
- 1 14" Steel Rewind Flange
- 1 Small Screening Projector
- 1 34" x 50" Screen on Tripod or Wall Mount.

These are minimum requirements and larger operations will call for larger quantities of the various items.

#### Film Equipment Accessories

A word now about some of the film equipment accessory items that are needed in the successful handling of film in a TV station.

**FILM SPLICER**—This instrument is used to splice film and should be considered as a precision instrument. A word of caution about film splicing! One faulty splice can cause a show, commercial, or presentation to be either a success or a flop. Even though time is important in a television station, **THERE IS NO SHORT CUT TO MAKING A SPLICE IN FILM.** There are certain basic operations to be performed, in the proper order, and a definite amount of time is required to make a good splice. Faulty splices can usually be traced to dirty splices, incomplete removal of emulsion, wrong kind or old cement, improper adjustment of splicer, and insufficient drying time of the splice.

**SCRAPING TOOLS**—The usual instruments used in scraping off the emulsion of the film to be spliced are single edge razor

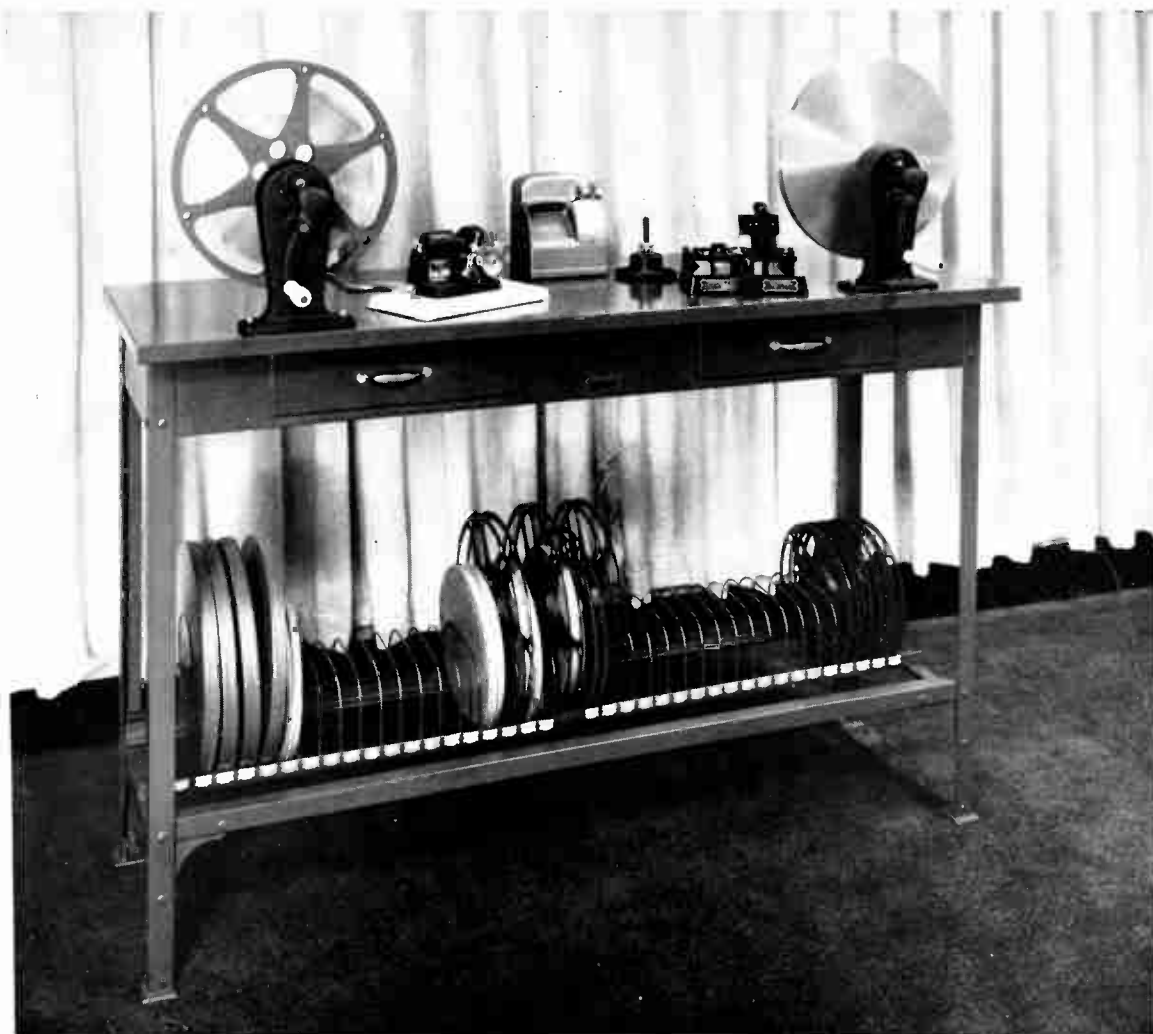

FIG. 1. View of a typical TV film editing bench setup for Television stations. Note that rewinds, splicer, viewer and measuring machine are needed.



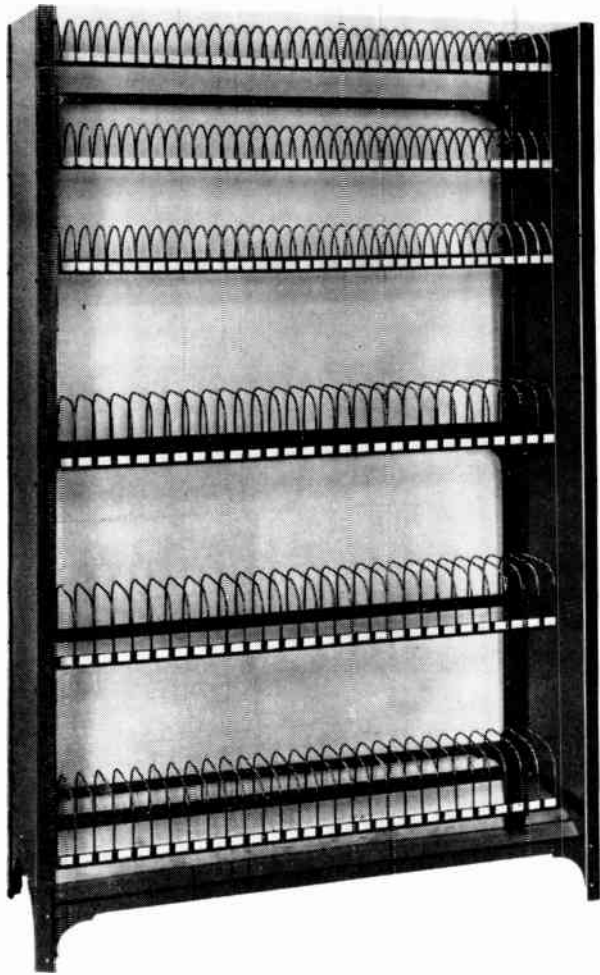

FIG. 2. A sturdy, metal type film storage cabinet is a necessary convenience for any TV film room.

### "Screening" or Previewing

Volumes could probably be written on the subject of "Whether Film Should be Previewed Before It Is Aired." However, in pointing out some of the things that *have* happened and omitting many things that *could* happen, it will at least stimulate your thinking and the decision rests with you as to whether film should be inspected or previewed before it is aired. Even today stations receive film that is patched together with tape. You obviously are aware of what happens when you try to run a tape slice through a projector. It just won't work. Brand new prints have been received with the sound track printed backwards, wrong sound with wrong picture, picture printed backwards, torn sprocket holes, commercials left in by the previous station, and many other difficulties too numerous to mention at this time. In other words, you can't tell what the film is or its condition just by looking at it on the reel, and we suggest that some method of inspection or previewing be set up in your station. A complete previewing report form should be filled out for each film listing all the necessary data that would be required by the Sales and Program Departments.

If space is provided for screening and previewing film, a small projector and screen will be necessary.

### Scheduling Commercials

Just as in AM broadcasting, an accurate system must be used in scheduling spots. In TV the spots appear in the form of 10 second, 20 second, and one minute, lengths of film. If not furnished by the agency or supplier, leader must be spliced to these short lengths of film so they may be threaded in the projectors. Scheduling must provide all parties concerned with the proper information as to whether a spot is to be tacked on the head of a certain show, tail of a certain show, or run individually.

### Receiving and Transhipment

A responsible party should be assigned these duties; they are important. An accurate receiving and transhipment record should be made on all film and should contain the following basic information: date, time received, source, type, PPD or collect, disposition after airing, person receiving film, mounted on reel or core, shipping case.

You will receive film from many sources. Let's consider commercials first. Most of these spots will, as in AM, come from the advertising agencies or their suppliers direct

blades, emery boards, and various types of commercial scrapers. Double edge blades should never be used.

**FILM CEMENT**—Used in cementing the splice together after it has been prepared for splicing in the film splicer. It should be placed in a handy applicator bottle and when not in use kept tightly sealed. If the cement is allowed to become exposed to air for a period of time, its adhesive properties are destroyed and weak splices are sure to result.

**SMALL VIEWER**—This is used for "quick" editing and is very handy for previewing short sequences, interchanging spots or scenes and checking continuity of film strip or show.

**REWINDS**—Most TV projectors do not incorporate automatic rewinding mechanisms so these are, of course, needed for rewinding film after it has been aired, and for editing purposes.

**FOOTAGE COUNTER**—Used for accurately measuring the time of a spot or any length of film. Previewing projectors are not nor-

mally equipped with sync motors and accurate timing cannot be secured by projecting and timing with watch or clock. A 16mm. sound film is projected at a speed of 36 feet per minute and by measuring the length of the film on the footage counter, it is, of course, very easy to determine the exact amount of time it will take to air the film.

**DAILY STORAGE RACK**—Some form of rack must be provided in the projection room for the temporary storage of daily films to be aired. This rack should be able to accommodate at least a week's film supply. A very good method is to set up the file according to days of the week. This will enable the scheduling department to keep ahead of projection and save a frantic hunt at the last minute for a film that is to be aired immediately.

**SLIDE STORAGE CABINET**—A filing cabinet to accommodate both 2 x 2 and 3 x 4 slides must be provided in the projection room for storing slides used every day or even occasionally.



FIG. 3. The careful and orderly filing of slides in cabinets like the above is recommended.

to you. (In some cases, the client will furnish it.) Films will be in various quantities and physical size. Some of them will be tied together and it will be necessary for you to break these down, place on small reels, catalogue them, and file for future reference. Others will come to you individually on plastic cores or sometimes on small 100-foot reels. A word about reels—especially the larger size. Inaugurate this rigid policy at the very beginning:

(a) If you receive a film on a plastic core, ship it back on a plastic core after you are finished with it.

(b) If you receive a film on a reel, ship it back on the same size reel after you are finished with it.

(c) Reels are expensive! In other words, if you receive a film on a plastic core and ship it back on a professional reel, *you* lose. Over a period of a year, this can amount up to a very sizable figure.

Under the present system of bicycling kinescopes, the following procedure is fairly well established by now. The network or originating station will film the show and release to various stations throughout the nation for a delayed play date. The network will advise each station where it should forward the film after it has aired the film and from what station it will receive its next film. So remember that you are just as dependent on a station for getting your show in good condition and on time as he is dependent on you for the same service. This is a responsible duty and conscientious personnel should be selected to supervise these duties. Many packaged shows and "kines" are open-ended, and

space is allowed for insertion of local cut-ins or individual commercials. Needless to say, it is extremely important to see that the show leaves you in as good or better condition than you received it.

#### Mailing Charges

This brings us to the subject of express or mailing charges, which is a very important item. For an average station film operation, the express charges for film directly chargeable to program expense will run between \$5000 and \$7000 per year. When you consider that kind of expense, the need for constant vigilance is apparent in select-

ing air express versus regular express. Check and recheck your play dates, and whenever possible, ship and order all film to be shipped by regular express.

#### Slide Making and Film Processing Facilities

The local advertiser, along with many national accounts, cannot incorporate in their advertising budgets the price of having commercials made by a professional 16mm. producer. The average price of a one-minute, sound-on-film television spot made by a 16mm. producer is between \$250 and \$1000 upwards, depending on the type of spot desired. This means the advertiser will turn to the television station operator for an economical answer, and the operator, who can provide slide making and film processing facilities, will be in a better position to sell the air time. It is another instrument to help the Sales Department in providing a complete customer service and will help lower sales resistance. This is especially true with slides. Virtually every commercial or show will require very frequent changes in slides. Slides are inexpensive to make and if handled properly can provide the station operator an additional source of revenue.

As we said in the beginning, handling film in a television station is not difficult, but it does warrant serious preliminary planning and thinking when the facilities are laid out. Your nearest RCA Field Representative can tell you about the complete RCA line of accessories available and will be glad to assist you in your planning.



FIG. 4. Since films are expensive, a good sturdy shipping case is suggested.

# VIDEO MONITORS

In order to comply with Federal Communication Commission requirements, and to assure successful performance of any television station, it is necessary to monitor the picture signal at several points. It is further necessary, at certain points of the television system, to monitor the video signal shape and amplitude. For these applications, RCA supplies two types of monitors, the TM-6B Master Monitor and TM-2C or TM-2D Utility Monitor.

## MASTER MONITOR

The master monitor, TM-6B, fulfills the requirement for a high quality video and waveform monitor for the television system. It is used as a precision unit to carefully examine a number of details of the video signal and to check the performance of associated camera, amplifying, mixing or switching equipment.

The picture monitor section of the unit gives a precise picture display of all the video information in the signal. A wide band video amplifier, linear horizontal and vertical deflection circuits and a special aluminized, straight gun, electrostatically focused kinescope form this section of the unit. The additional feature of the *pulse-cross* display as illustrated in Fig. 4 extends the visual check to even the normally blanked portion of the composite signal. This provides a quick, accurate means of determining if the sync and blanking information is complete and according to the FCC requirements.

The oscilloscope section of the Master Monitor uses a 5UP1 cathode ray tube, employing electrostatic focusing and electrostatic deflection. Operating voltages are obtained from the -1600 volt output of a regulated high voltage supply. The cathode is operated near -1600 volts, and the second anode and deflection plates are operated near ground potential.

Horizontal sweep circuits permit the operator's choice of a sawtooth time base at either a 30 cps or a 7875 cps rate. A sweep expander circuit permits an eight-to-one expansion of the center portion of either the 30 cps or the 7875 cps time base.

The vertical deflection channel consists of a wideband amplifier and d-c restorer circuits. The amplitude-frequency response characteristic of the wideband amplifier can be switched to a narrow band characteristic when desired for signal level measuring purposes.

A circuit for producing a calibration signal for the vertical deflection amplifier is also included.

## Kinescope Video Amplifier

The theory covering the high and low frequency compensation of the video amplifiers is covered in detail in the article "How to Adjust Frequency Response in Video Amplifiers for TV" in this manual. The contrast control stage for the video amplifier is shown in Fig. 1. It is basically a cathode follower. The two ends of the contrast potentiometer are at the same d-c potential to eliminate

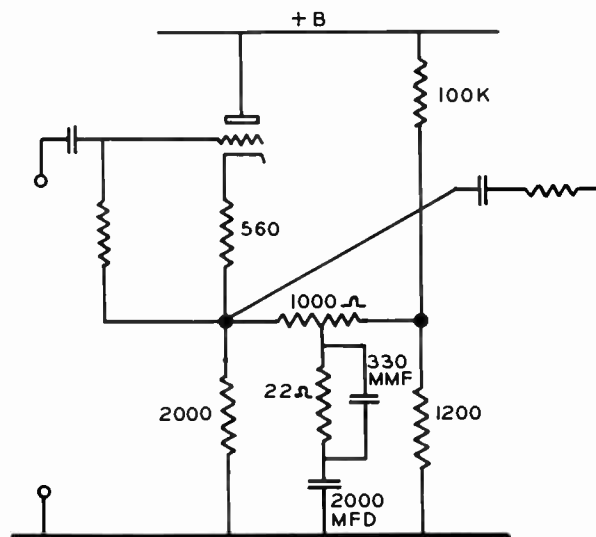

FIG. 1. Contrast control stage for the video amplifier.

sluggishness of control. The increase or decrease of contrast is accomplished by a corresponding change in the impedance of the cathode follower. The 22 ohm—330 mmf network in series with the control arm of the potentiometer flattens out a rise in the high frequency response at low contrast settings.

The kinescope, designed expressly for the Master Monitor, produces a high resolution high contrast picture. The high voltage electrostatic focusing combined with a straight electron gun produces a fine beam current, sharply focused at the kinescope face. Astigmatism is minimized because the gun and focusing elements are accurately aligned along a common axis. Aluminization of the tube produces a high contrast picture at reasonable beam currents.

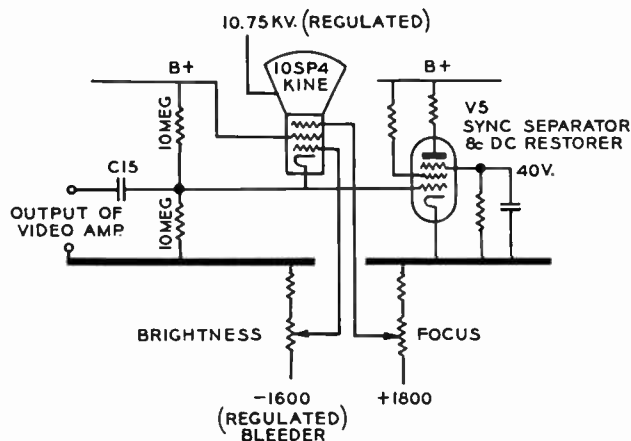

FIG. 2.

### Kinescope Drive, D-C Restoration

The manner in which the kinescope is driven differs from the usual in that the cathode is driven and the control grid is a-c grounded. Fig. 2 shows the circuitry in which V5 is acting both as a sync separator and as a d-c restorer. The control grid and cathode of V5 operate as a diode, and grid current flows during the most positive portion of the driving signal—in this case the tip of sync. This is illustrated in the waveform diagram,

Fig. 5. The amplitude of this signal was chosen as a typical amount of drive required. With the kinescope grid adjusted sufficiently negative so that cutoff occurs at  $-10$  volts on the cathode, the kinescope beam current is turned on by the video portion of the signal. Reference black level which is usually about 10% of the video signal is indicated at  $-10$  volts. C15 in the circuit diagram, is sufficiently large so that the beam current of the kine does not produce a noticeable reduction of its charge.

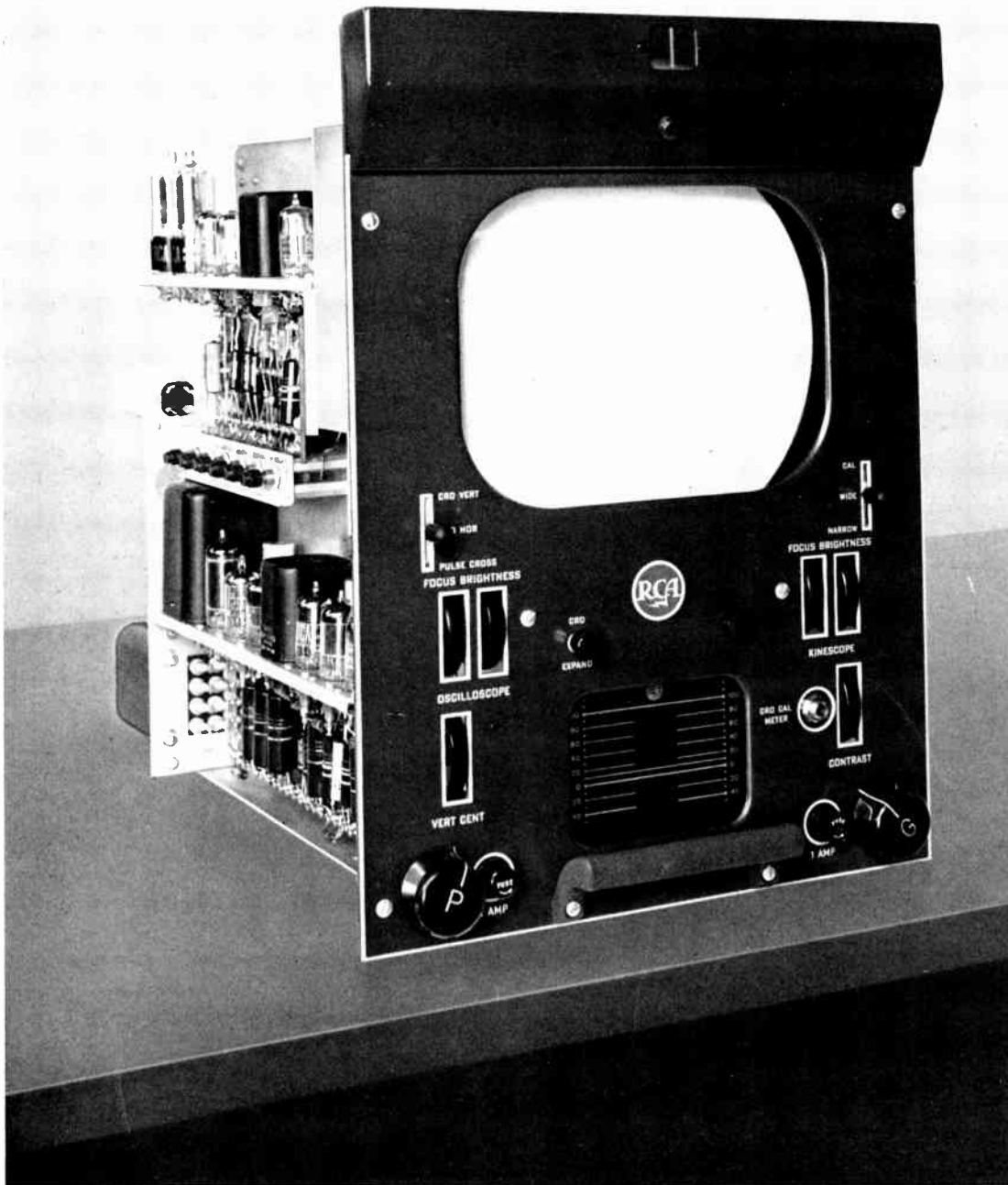

FIG. 3. View of the TM-6B Master Monitor. Note cover at very top which protects several additional controls and operating adjustments.

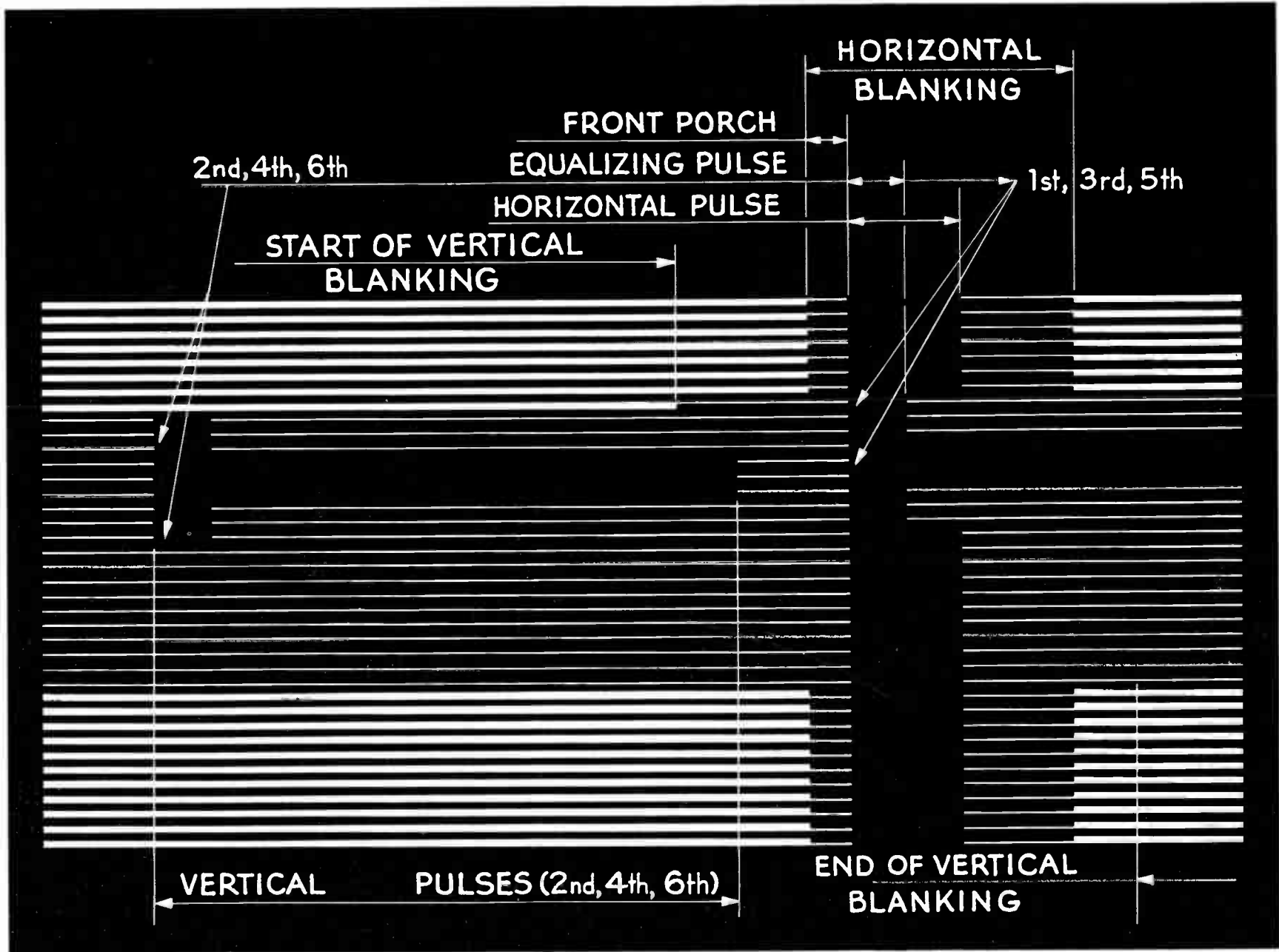
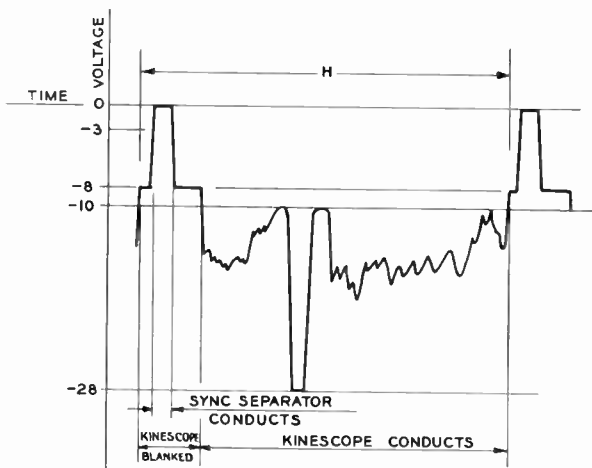

FIG. 4.



ONE HORIZONTAL LINE OF A TYPICAL KINESCOPE DRIVING SIGNAL AND THE RELATIVE VOLTAGES OF PORTIONS OF THAT SIGNAL.

FIG. 5.

The beam current that flows during any one line is then replaced to C15 during the interval that V5 conducts.

The ten megohm resistor between B+ and C15 prevents the blocking of the d-c restorer by switching transients which may appear on the incoming video signal. The second ten megohm resistor between C15 and ground prevents the possible heater to cathode breakdown of the kinescope were V5 removed during video alignment or fail due to filament burn out.

### Sync Separation

Sync separation at V5 results from operating the pentode at low screen voltage. This restricts the zero bias to cut-off range of control grid so that the tube will conduct only during the sync interval. Reproduction of the sync information in the plate circuit of any reasonable amplitude requires only the judicious choice of the plate resistor value.

### Kinescope Deflection

The scanning circuits of the picture monitor have been designed to be linear within one per cent of picture height. This specifies that the positional error of any point will be within this distance of its correct position. This degree of linearity makes the Master Monitor an excellent secondary standard for use in making camera scanning linearity adjustments. Care has been exercised to insure the maintenance of linearity in switching from a normal raster to the pulse-cross display. The dimensions shown in Fig. 4 may be reduced to scale dimensions.

Linearity of the vertical deflection circuit is achieved by virtue of the current feedback amplifier circuit shown in Fig. 8. In this circuit, the sawtooth generator produces a very linear sawtooth—the amplitude being only 5 volts of the 280 volt charging curve. With this sawtooth as a reference, a voltage developed across a resistor in series with the yoke current is fed back to the cathode of the comparison amplifier. The effective grid to cathode voltage of this stage is the difference between the two

voltages. A non-linearity of the yoke current results in a difference waveform which is compensated to overcome non-linearity. The job of the feedback circuit is made easier by the shaping network at the grid of the Vertical Deflection Amplifier. This shaping, in addition to the non-linearity of the output tube's transfer characteristic is in the direction to compensate for some of the non-linearity in the output transformer. Height is varied by adjusting the amount of feedback (the amplitude of the difference waveform).

The horizontal deflection in Fig. 6 is basically that discussed in the theory section of this manual. Initially the driver tube controls the flow of current to the yoke or the energy stored in its magnetic field. The kinescope beam is deflected to the right as this field builds up. The driver tube is cut off and the yoke allowed to go through one half cycle of oscillation. The magnetic field quickly reverses and the current in the yoke is now a maximum in the opposite direction. This transition moves the beam quickly from the right hand to the left hand edge of the raster. The damper tube is turned on by its control grid waveform. The transformer coupling to the damper tube is such that the  $L \frac{di}{dt}$  voltage shown in the diagrams is positive on the plate of the damper. The plate current

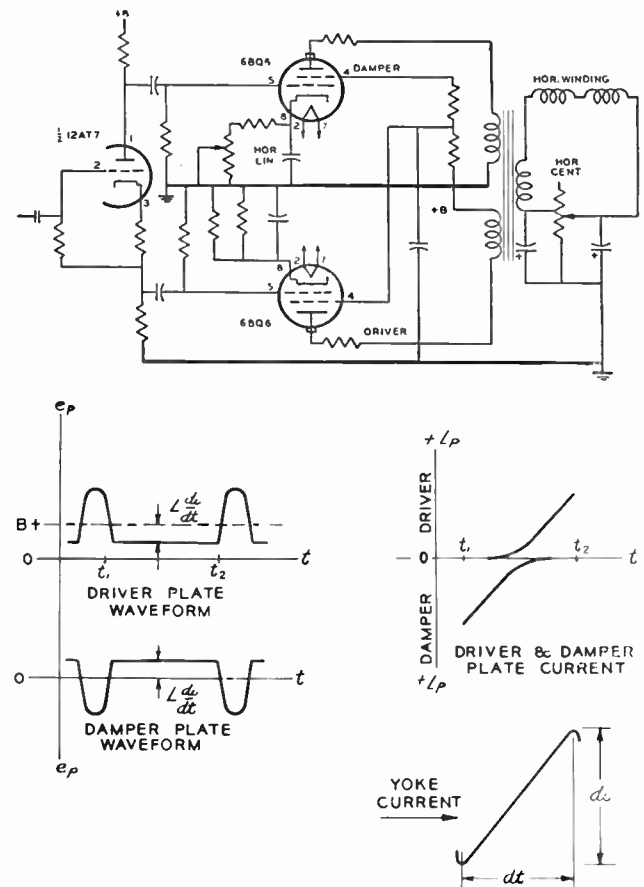

FIG. 6. Horizontal deflection circuit and waveforms at various points in circuit.

that flows controls the discharge of the yoke's magnetic field. As this transition takes place, the kinescope beam moves back to the center of the raster. Better waveform symmetry results when the driver and damper are the same type tubes. Improved linearity is more easily obtained. The transients produced by leakage inductance and stray capacitance which normally plague any deflection circuit are overcome by a unique transformer design.

Synchronization of the deflection circuits is possible by either RETMA sync or drive pulses. The choice depends on the monitor application. By switching it is possible to operate on sync separated from a composite video signal fed into the kinescope video amplifier or sync fed into a coaxial connector on the connection panel in the rear of the unit. Sync operation is generally used when the monitor is used as a switching monitor or line monitor. A third position on the same monitor switch enables the deflection circuits to operate on drive pulses. The camera equipment (field, studio, or film) usually use the monitor in this manner. A variation on this scheme of sync switching is encountered when it becomes desirable to view both composite and non-composite video signals without manually switching S3 and readjusting kinescope

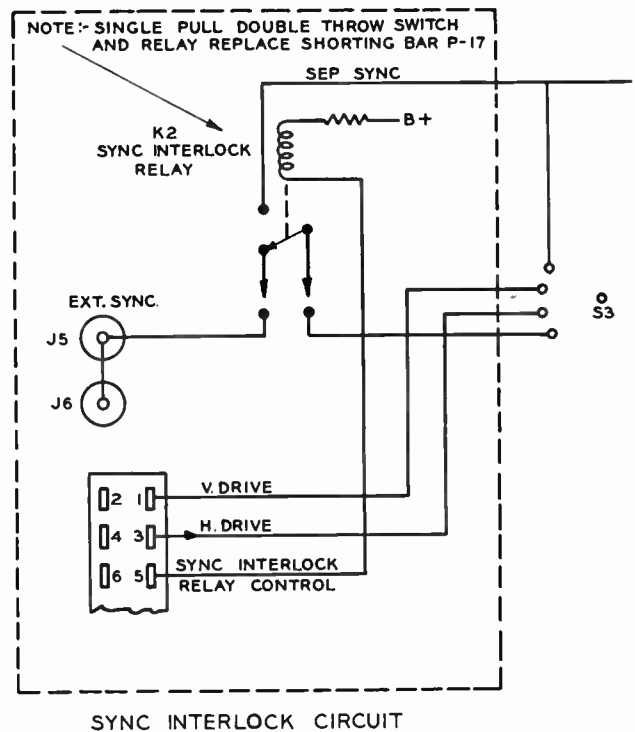

FIG. 7. Sync Switching arrangement for the TM-6B. Reference is made to Fig. 9, the block diagram of the TM-6B.

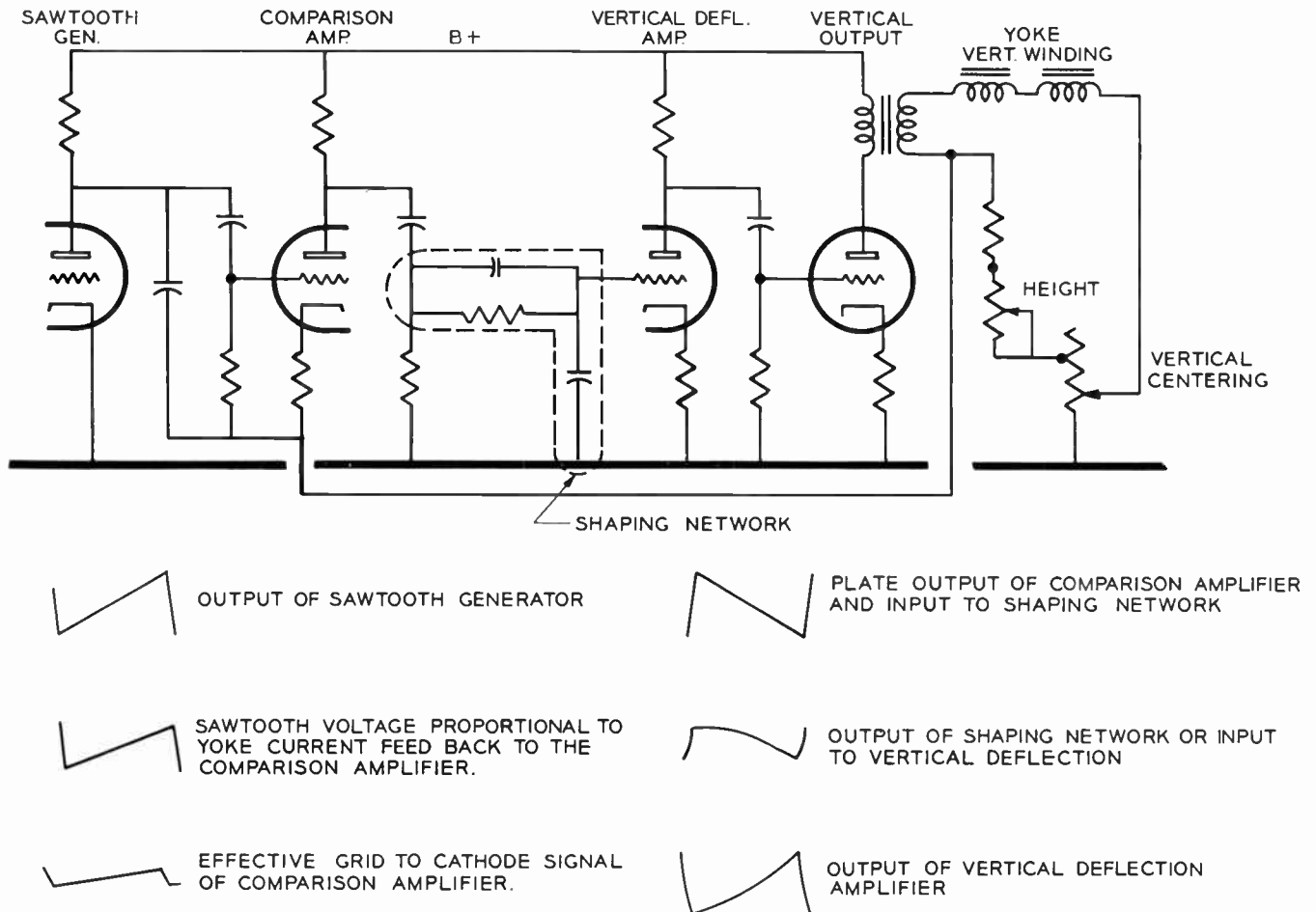

FIG. 8. Vertical Deflection Circuit.

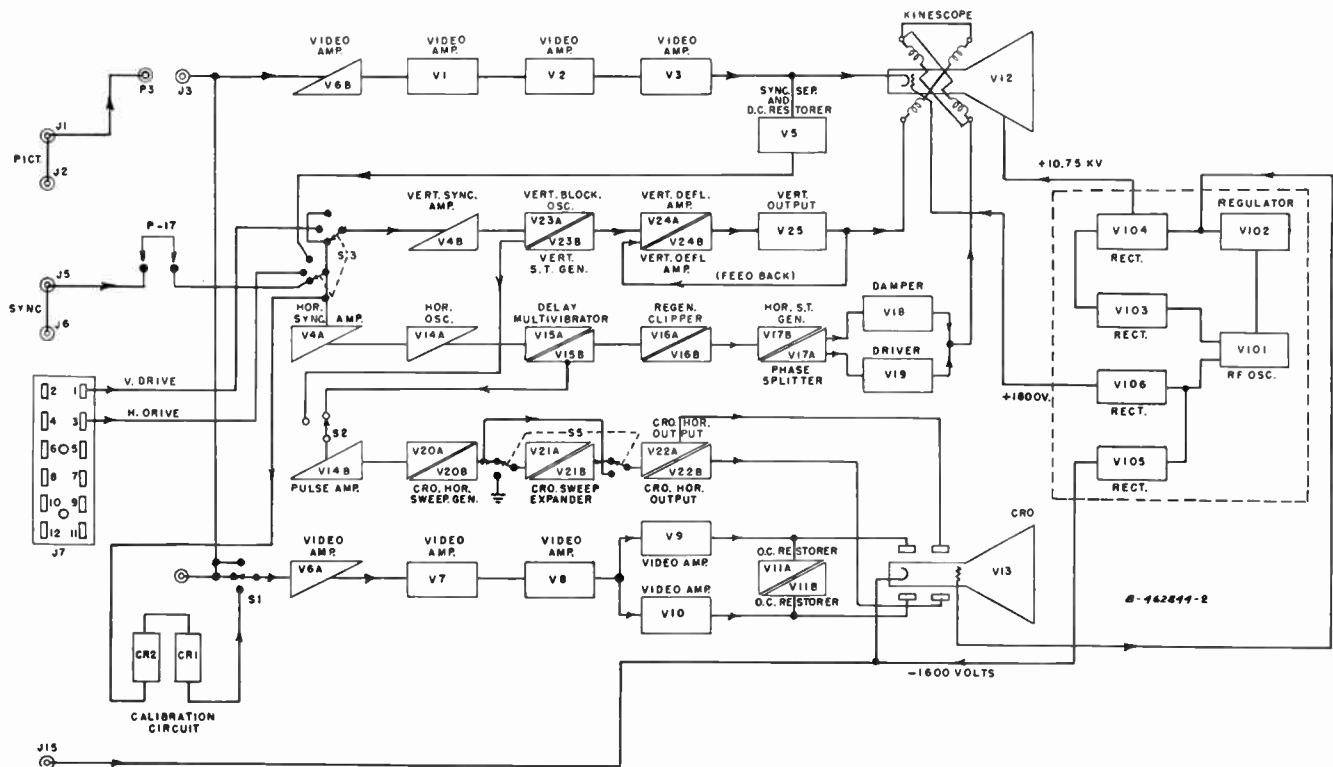

FIG. 9. Block diagram of the TM-6B Master Monitor.

brightness. The shorting plug, P17, shown in the block diagram is removed and the Sync Interlock relay MI-26544 is installed in its place. One side of the relay coil is connected to B+ via a dropping resistor while the other side is returned to the switching equipment. The relay is actuated by grounding this point in the switching equipment. Fig. 7 shows the details of the switching operation.

An auxiliary brightness control (not shown) adjusts the proper amount of additional bias to make the kinescope cut-off occur at black level on the composite signal. The amount of bias required will be different depending on the setting of the Kine Contrast Control which in turn is dependent on ambient lighting conditions. For a particular installation, this is usually set once and not changed unless there is a radical change in the ambient lighting.

### Half Frequency Sawtooth Generator

A half frequency sawtooth generator circuit is used to generate either a 30 cps or a 7875 cps sawtooth voltage waveform from vertical frequency pulses (60 cps) or horizontal frequency pulses (15,750 cps) respectively. The circuit is shown in Fig. 10. Suppose that there are no triggering pulses present at the input; hence the circuit is free-running. When B+ voltage is applied, the voltage across  $C_g$  begins to rise by the charging action of B+ through  $R_g$ . Approximately 58 volts appears at the grid of V1, and V1 conducts enough current to bring the cathode to almost 58 volts also. The crystal CR1 is

biased off by the positive voltage on its cathode. In the case when  $C_g = 330$  micromicrofarads the 470 micromicrofarad capacitor charges simultaneously with  $C_g$ . When the 0.1 micromicrofarad capacitor is added in  $C_g$  the 470 micromicrofarad capacitor is charged more rapidly through the back resistance of CR1 than through the cathode of V2; therefore, in this case the potential of the cathode of V2 rises to the potential of the cathode of V1 (approximately 58 volts) much more rapidly than the potential of the grid of V2 rises. When  $C_g$  has the smaller value, the V2 grid voltage goes above the potential of the V1 cathode causing CR1 to conduct and the voltage at the cathode of V2 to drop suddenly. When  $C_g$  has the larger value, the V2 grid voltage passes through cut-off going positive and cuts on V2 and CR1. In either case there is a relative grid-to-cathode voltage transition in the positive direction, resulting in an amplified drop in

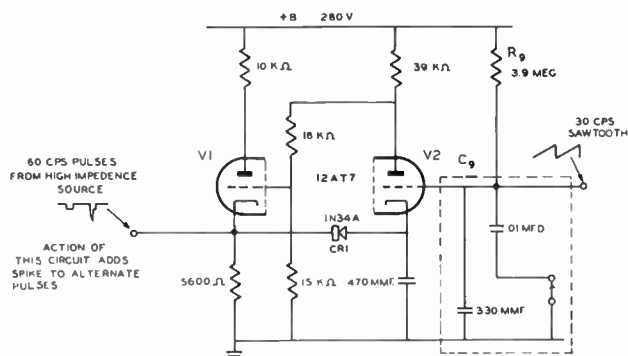

FIG. 10. Half Frequency Sawtooth Generator.



potential at the V2 plate. This drop in potential is transmitted to the grid of V1, driving it below cut-off. The cathode potential of V1 drops and a low-resistance path is created for the discharge of  $C_g$ , which must take place through the grid of V2. As the grid voltage of V2 drops, the cathode voltage also drops, and likewise, the cathode voltage of V1. Conduction begins again in V1, and the cathode voltage rises again to approximately 58 volts, biasing off CR1. The charging of  $C_g$  through  $R_g$  then begins again.

For triggering purposes either 60 cps pulses or the differentiated leading edges of 15,750 cps pulses are fed to the cathode of V1 from a high impedance source. With 60 cps pulses, the parallel combination of 330 micro-microfarads and 0.1 microfarads comprises  $C_g$ . With 15,750 cps pulses  $C_g$  consists of the 330 micromicrofarad capacitor alone. In each case the free-running frequency is slightly less than the desired output sawtooth frequency. The amplitude of the trigger pulses is such that only every other pulse will drive the cathode of V1 negative and cause the retrace portion of the output sawtooth to begin. Alternate pulses occur at a time when the grid of V2 is not far enough positive to cause forward conduction through CR1.

#### Sweep Expander Circuit

The sweep expander circuit utilizes a 12AX7 dual triode. The two sections are cathode coupled as shown in Fig. 11. The grid of V1 conducts on the positive peaks

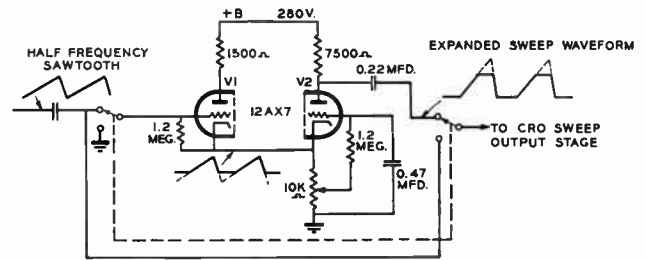

FIG. 11. Sweep Expander.

of the applied sawtooth and its most positive potential is set at approximately the cathode potential. As long as V1 is conducting, the grid waveform is transmitted to the cathode, but the amplitude of the applied sawtooth is such that the negative peaks extend below cut-off. The cathode voltage resulting is a sawtooth with its negative peaks clipped off. The positive peaks of the cathode waveform extend beyond cut-off of V2 and are therefore clipped in going through this tube. The slope of the transitions are measured about eight times.

The setting of the potentiometer in the cathode circuit determines the bias of V2 and therefore the point of clipping of the positive peaks. The bias setting of V2 affects the average potential of the cathodes, which in turn affects the cut-off voltage of V1. These effects are such that increasing the bias of V2 causes more positive peak clipping and less negative peak clipping, with the greater effect in the positive clipping.

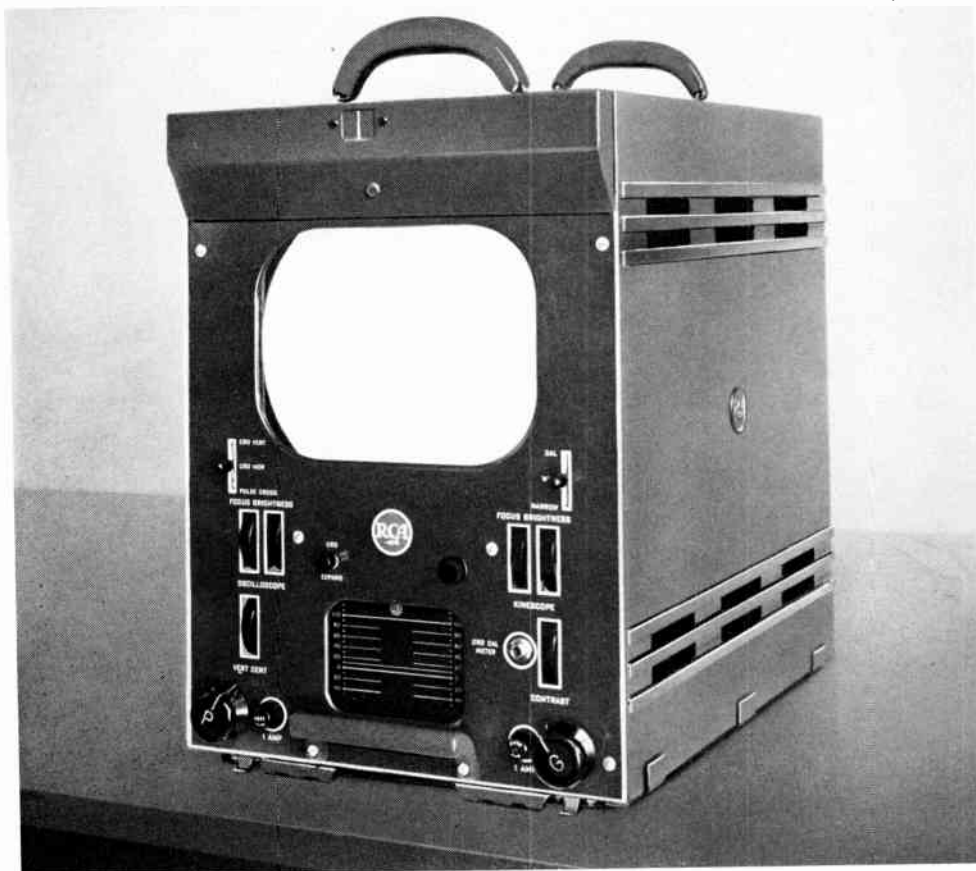

FIG. 12. View of the TM-6B Master Monitor mounted in suitcase type enclosure for field use.

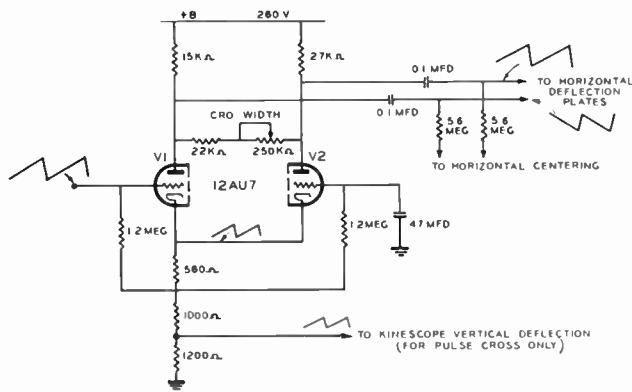

FIG. 13. CRO Horizontal Sweep Output.

The sweep expander circuit may be by-passed by means of the ganged input and output switches.

### CRO Horizontal Sweep Output Stage

The two sections of a 12AU7 are cathode coupled to provide push-pull voltages for the horizontal deflection plates. The circuit is shown in Fig. 13. The grid of V2 is by-passed to ground to give a-c grounded-grid operation of this tube. The grid-to-cathode signals of the two triodes are of opposite polarity, making the plate signals also of opposite polarity. The grid-to-cathode signal of V1 is larger than the grid-to-cathode signal of V2. The plate load resistance of V2 is larger than that of V1 in order that the plate output voltages may be nearly equal. The output voltages are a-c coupled to the horizontal deflection plates, the d-c potentials of which are established by means of a HORIZONTAL CENTERING dual potentiometer connected in parallel with a similar dual potentiometer used for VERTICAL CENTERING. The CRO WIDTH control permits varying the plate-to-plate output voltage by adjusting the degree of coupling between the two plates. When all the resistance of the CRO WIDTH control is out of the circuit, there is a maximum of coupling. Since the signals on the two plates are of opposite polarity, there is cancellation between the two signals and the plate-to-plate swing is a minimum.

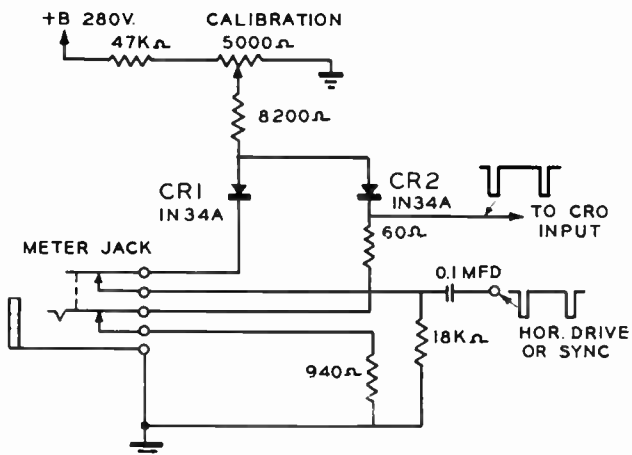

FIG. 14. Calibration Pulse Circuit.

The unbalanced cathode current swing in the two tubes results in a difference current in the common cathode resistance. A portion of the voltage swing so developed is used to drive the kinescope vertical deflection circuit at a 30 cps rate when the pulse cross is being displayed.

### CRO Calibration Pulse Circuit

The calibration pulse circuit is shown in Fig. 14. An RCA MI-21200-C1 plug-in meter is required for setting the amplitude of the signal that is formed. The meter has a full-scale sensitivity of 1.5 milliamperes and offers a resistance of 940 ohms. With this meter inserted there is 1000 ohms in the cathode circuit of CR2, and the cathode circuit of CR1 is open. It may be desired to set the calibration pulse circuit to produce 1.4 volt pulses. In this case the CALIBRATION potentiometer is set to cause 1.4 milliamperes to flow through the meter. The voltage on the cathode will then be 1.4 volts, because the impedance to ground will be  $60 + 940$  or 1000 ohms. Removal of the meter plug automatically substitutes 940 ohms for the meter resistance and places an 18,000 ohm resistor in the cathode circuit of CR1. Negative horizontal drive or RETMA synchronizing pulses are capacitively coupled to the cathode of CR1. During the time between negative pulses the amount of current through CR1 is negligible because there is 18,000 ohms in its cathode circuit compared with only 1000 ohms in the cathode circuit of CR2. During this time the cathode of CR2 is at 1.4 volts and the common anode connection is at a very slightly higher potential. The cathode potential of CR1 is less than the anode potential by the drop across the crystal. The negative pulses on the cathode of CR1 extend below ground and cause this crystal to conduct enough current to drop the anode potential below ground also. The impedance in the anode circuit permits this drop in anode voltage. The voltage at the cathode of CR2 appears as a "chopped" 1.4 volt signal, with notches coinciding with negative pulses at the input. This signal of known amplitude is fed to the vertical deflection amplifier for calibration purposes.

### CRO Video Amplifier and D-C Restorer

The CRO video amplifier uses a gain control stage at the input similar to that described for the picture amplifier. Following this stage are two stages utilizing series

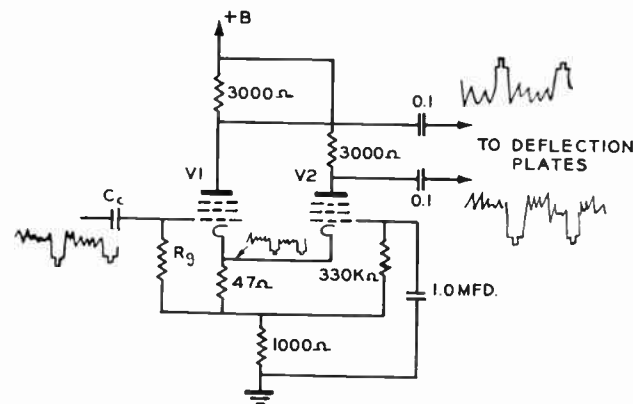

FIG. 15. Video Amplifier Output Stage.

peaking for high-frequency compensation. The theory of the high and low frequency compensation employed is discussed in the article "How to Adjust Frequency Response in Video Amplifiers for TV", also in this manual. The output stage is a differential amplifier, illustrated in Fig. 15. There is cathode coupling between V1 and V2, and the circuit parameters are such that the cathode signal is roughly one-half of the input signal at the con-

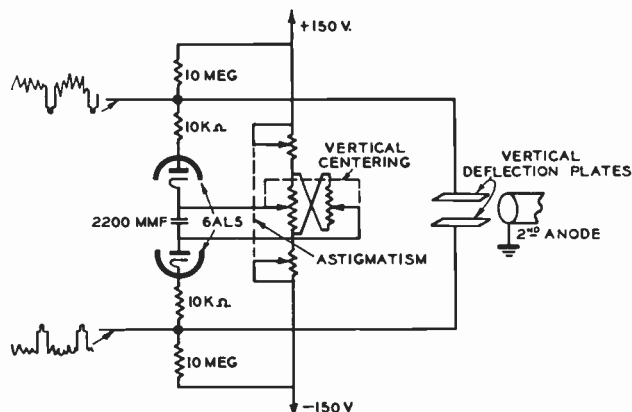

FIG. 16. CRO D-C Restorer.

trol grid of V1. These signals have the same polarity; and, therefore, the grid-to-cathode signal of V1 is approximately one-half of the input. The control grid of V2 is by-passed to ground; therefore, the grid-to-cathode signal is approximately one-half the amplitude of the input signal and opposite in polarity to the grid-to-cathode signal on V1. The plate circuits of both V1 and V2 utilize shunt and series peaking (not shown in Fig. 15) and the outputs are coupled to the vertical deflection plates of the CRT.

Two sections of a 6AL5 serve as d-c restorers for the two signals. The circuit is shown in Fig. 16. (The diode d-c restorer is described elsewhere in this manual.) The tips of sync (or the blanking pulses, if sync is not present on the signal) are set at the potentials of the two arms of the VERTICAL CENTERING dual potentiometer. The potential difference between the two arms determines the average potential difference between the deflection plates and therefore the vertical position of the CRT presentation. The dual potentiometer permits varying the potential difference above and below zero. The 2200 micro-microfarad capacitor by-passes the resistance in the centering circuit. In the monitor, the HORIZONTAL CENTERING CONTROL is another dual potentiometer in parallel with the VERTICAL CENTERING control.

The ASTIGMATISM control permits setting the average potential of the deflection plates with respect to the second anode potential. These potentiometers constitute a portion of a bleeder connected between +280 volts and -1600 volts. The 10,000 ohm resistors associated with the diodes serve to isolate the diode capacitances.

The oscilloscope video amplifier normally has an amplitude response flat within  $\pm 1$  db to 4 megacycles. The IRE standard roll-off response is obtained by switching a shunt capacitance into one of the interstage coupling networks. The IRE roll-off is described in the article "Standardizing and Measuring Video Levels in a TV Station" in this manual.

## UTILITY MONITOR

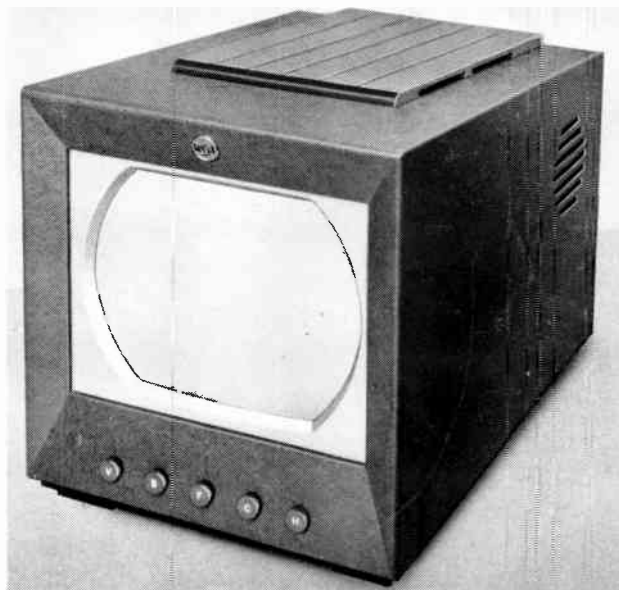

In places where picture monitoring only is sufficient, the Utility Monitor is used. In particular, the monitor is used in the program console, in the announce booth, for cueing in the projection room and the studio, and for supplying a high quality picture in administrative offices and customer viewing rooms. Probably one of the most important places is the last one mentioned, for picture quality here contributes to customer satisfaction.

In the design of this unit, the emphasis was not only on picture quality, but simplification of construction.

The video amplifier of the monitor is essentially flat from 60 cycles to 7 megacycles to insure the preservation of picture detail. The picture tube used may be a ten or twelve inch kinescope. The choice here depends on the application. For close viewing, the ten inch tube should be used. This restricts the field of view so that the person using the monitor can easily observe the whole scene. Where the monitor is to be viewed by a group of people at greater distance, the twelve inch tube is used.

In either case, the basic unit is the same. As a 10 or 12-inch monitor, the TM-2C, it may be rack mounted or housed in the program console. The TM-2D is a 12-inch monitor housed in an attractive leatherette cabinet. There is additional provision in this cabinet for a speaker to permit the use of sound if it is desired.

# The Stabilizing Amplifier

The TA-5D Stabilizing Amplifier is an indispensable item in a television studio system. It is designed to correct for a number of signal deficiencies, to adjust the sync-to-picture ratio, and to mix local video and sync signals.

This unit is constructed on a recessed type chassis which may be installed in a standard 19 inch relay rack. There are two 75 ohm input terminals, one for video (with or without sync) and the other for local sync. There are three outputs: Line, Monitor, and Sync. The Line Output has a 75 ohm source impedance in order to minimize reflections that may occur in long video cables. The input circuit can accommodate a composite video signal of 0.2 to 15.0 volts peak-to-peak. The output circuits will deliver a signal of 0.75 to 1.5 volts peak-to-peak of video plus 0 to 1.5 volts peak-to-peak of sync. Both video and sync output amplitudes can be independently adjusted. The frequency response of the TA-5D is uniform to 7 mc. and it will pass a 30 cycle square wave with less than 5% tilt.

In order to insure against front porch lengthening, the TA-5D uses a delay line which establishes the correct phase relationship between video and sync at the mixer stage where the two signals are again combined.

The regulated +B voltage for the TA-5D is obtained from an external source such as the RCA Type 580-C Power Supply, but the filament supply is self contained.

The four basic applications are:

1. *Use with Remotes* — Incoming remote signals frequently have excessive low frequency disturbances, a.c. hum, and other transients mixed with the video. Also, the sync signal may have been saturated while passing through the preceding system so that the ratio of sync-to-picture amplitudes is no longer correct. It is, of course, highly desirable to restore such signals as nearly as possible to their original form before their use in the studio. This is one of the most important stabilizing amplifier applications.

To perform this function, the TA-5D removes the sync pulses from the composite input signal, amplifies and shapes them to their original form and frees them of overshoots and other disturbances. Meanwhile, the video is subjected to a clamping action which removes the hum and low frequency disturbances, after which it is once more reunited with the sync pulses to form the composite output signal. The oscilloscope waveforms shown in Figures 2, 3, 4, and 5 illustrate the degree of improvement that is possible through the use of this amplifier on degraded signals.

2. *Use After Video Switching* — In all RCA switching systems, whether studio or master control, a stabilizing amplifier is installed directly following the output of

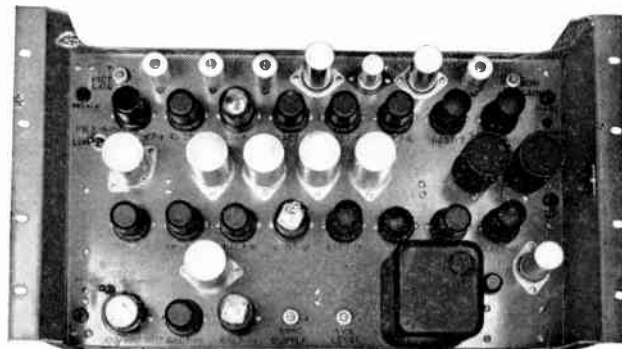

FIG. 1. Front panel view of the TA-5D Stabilizing Amplifier.

the program bus. Even the best switching system will produce transients during the switching interval. These may be successfully removed by the TA-5D. It is also standard practice to add sync pulses to the local video signals only *after* switching. This prevents a momentary loss of sync in home television receivers during the picture switching interval since sync is not switched with the video. For this purpose, the stabilizing amplifier contains sync addition circuits which are capable of being disabled when remote signals are selected by the switching system. This disabling function is necessary in order to prevent the addition of local sync pulses to any remote video signals that are selected for transmission.

The picture and sync gain controls of this amplifier make possible a convenient overall gain adjustment of an outgoing studio channel. Remote controls are provided to enable video operators in making these gain adjustments while seated at a control console.

3. *Use with Video Transmitter* — Most transmitter installations include a TA-5D inserted between the incoming coaxial line, or microwave relay link, and the transmitter input. This is for the purpose of removing any hum or other disturbances that may have been introduced between the studio and transmitter, and also to give them one final point at which video and sync level adjustments may be made before transmission. Pre-emphasis of the sync signal is another very important function of the stabilizing amplifier at the transmitter. Since most transmitters tend to compress the sync, it is necessary to compensate for this in the input signal to the transmitter by proper adjustment of the TA-5D sync gain control.
4. *Use with Genlock* — The function of the Genlock is to lock the local sync generator tightly in phase with another sync generator which is located at the source of an incoming remote picture signal. When the two sync generators are held in phase, lap-dissolves, fades, switches, and other special effects between remote and local signals may be made with ease.

In other words, remote video signals may be treated as though they were of local origin.

To perform this programming function, the Genlock requires as one of its inputs the sync pulses that are attached to the incoming remote video signal. The TA-5C stabilizing amplifier contains circuits which

remove the sync from an incoming remote signal and deliver it to an output jack where it may be connected to the Genlock. This can be the same stabilizing amplifier that is used to remove hum or other low frequency disturbances from the incoming remote video as described earlier in this write-up.

## OPERATION OF STABILIZING AMPLIFIER SHOWN BY SCOPE PICTURES

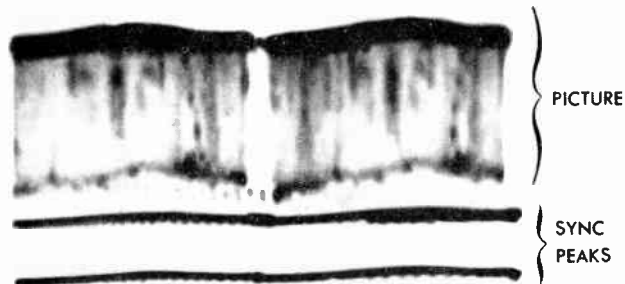

FIG. 2. An oscillogram of a typical noise-free signal generated by a Monoscope camera. The sweep frequency is 30 cycles, therefore, the gap in the center is a vertical blanking interval.

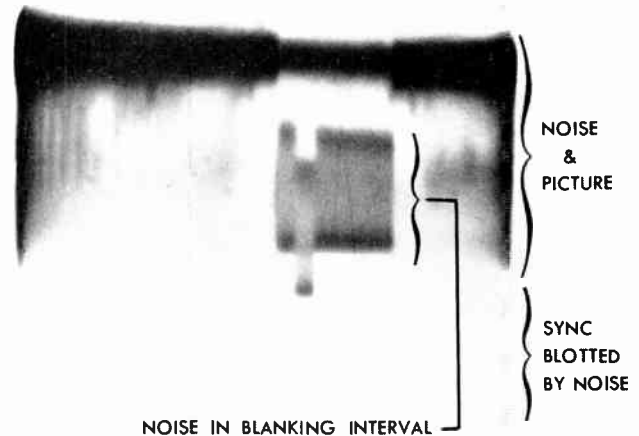

FIG. 3. An oscillogram of the Monoscope signal adulterated with a high-frequency hiss signal. A 60-cycle sine wave sweep frequency was used in this case to magnify the vertical blanking interval and thus show to better advantage the effect of adding the hiss signal. As can be seen, the hiss has almost obliterated the horizontal sync pulses.

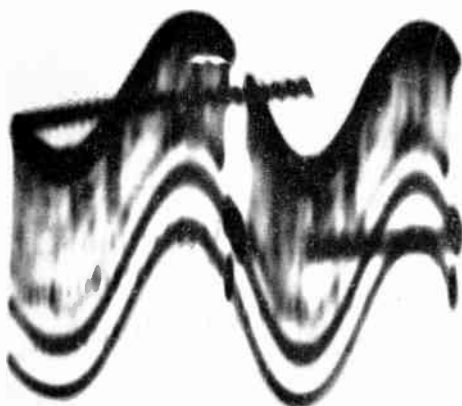

FIG. 4. An oscillogram of the Monoscope signal after addition of 70-cycle hum. A 30-cycle sweep frequency was used in producing this oscillogram.

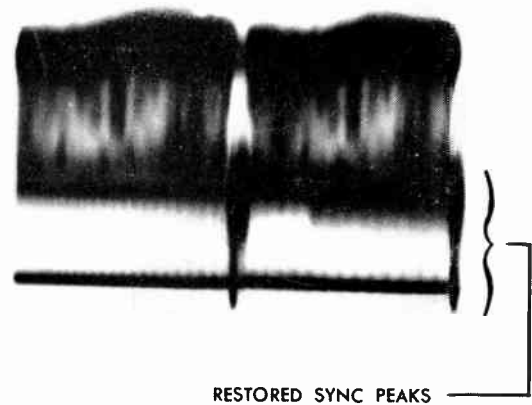

FIG. 5. An oscillogram of the signal obtained from the TA-5D after feeding the composite signals of Figs. 3 and 4 into the Stabilizing Amplifier. Note the increase in both sync-picture ratio and signal-to-noise ratio in the sync. Also the hum has been completely eliminated. A 30-cycle sweep frequency was used here.

# Distribution Amplifier

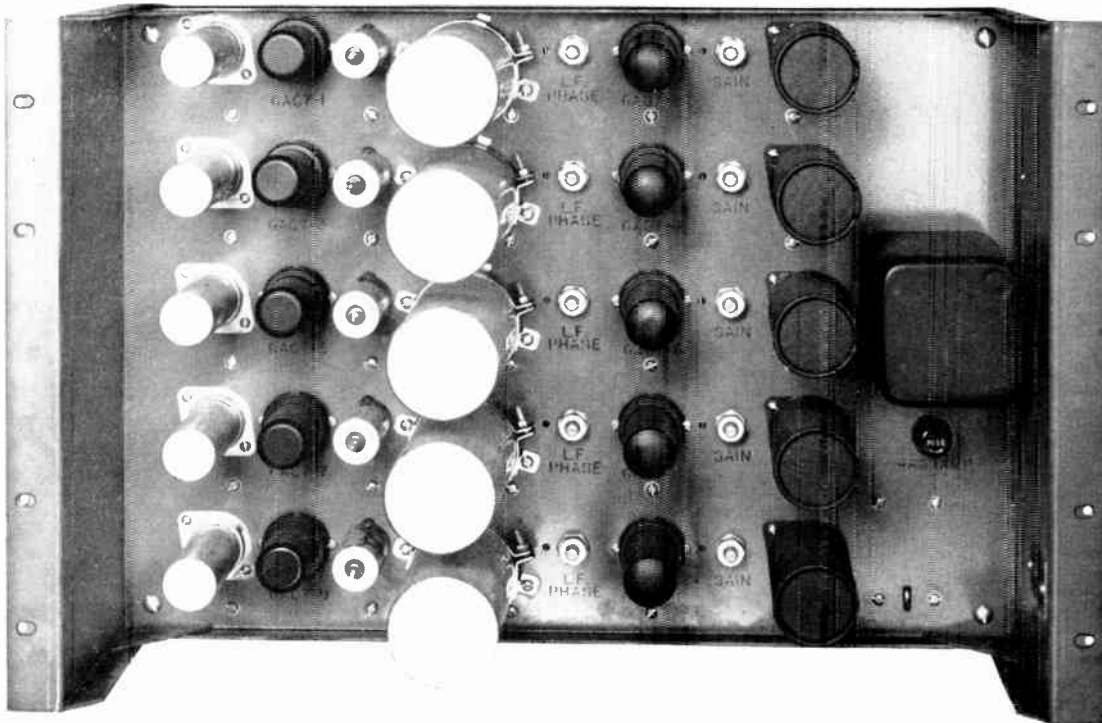

FIG. 1. Front view of the TA-1A Distribution Amplifier which is supplied for rack mounting.

One of the most widely used amplifiers in the RCA television equipment line is the Type TA-1A Distribution Amplifier shown in Figure 1. Basically, it consists of a rack-mounted chassis containing five separate two stage amplifier sections each having essentially unity gain. (A small gain variation of 10% above and below unity may be obtained by adjustment of the gain potentiometer.) Each of these amplifiers has a high impedance input and an output designed to feed a 75 ohm line. A low frequency phase correction circuit is incorporated along with shunt and series peaking to make the frequency response uniform within  $\pm 1$  db. to 10 mc. with ideal 60 cycle square wave response. It requires an external source of regulated + B voltage, but has a self-contained filament supply.

The multiple functions which this amplifier may perform account for its extreme popularity in television studio systems. A list of these functions and a brief explanation of each are given below:

1. *Pulse Distribution* — The pulses generated by a synchronizing generator are normally distributed to several different points within a television studio building. Since these points may be widely separated physically, and since they should be isolated from each other, the TA-1A is commonly used for this purpose. The synchronizing pulses are fed into several amplifier inputs in parallel, and their outputs branch out to distribute them to the desired locations.

2. *Picture Distribution* — This application is similar to that of pulse distribution except that video signals, instead of pulses, are distributed to the various places. An example of this application may be as follows: A station may wish to permanently connect the output of a film camera to each of four studio switching systems and to the master switching system. This would permit the technical director in any studio, or M.C.R., to select the film camera output by simply pushing a button on his switching console rather than pre-setting the connection at the patch panel and running the risk of having someone remove the patch cord at a crucial moment.

Since the film camera chain has only two outputs, some device must be provided to increase them to five outputs. The TA-1A may be used here very nicely. One of the camera outputs may be fed into two amplifier sections in parallel, and the other output may be fed into three sections in parallel. This provides the necessary five outputs which may then be routed to the various control rooms for permanent connection to the video switching systems.

Another example might be the distribution of video outputs from master control. Frequently, the outgoing channel must be fed, not only to the telephone company line, but also to the house monitoring system, clients, booths, "air" monitors in other studios, etc.

The distribution amplifier is often used for this purpose.

3. *Sync Mixing* — Occasionally, it is necessary to mix sync pulses with a video signal to produce a composite picture for some particular application. An illustration of this function may be as follows: Most master control switching systems switch composite signals only. Since film camera signals are not composite at the output of the camera chain, some means of adding sync is necessary if the film signal is to be fed directly to master control. This may be accomplished by introducing the video signal into one distribution amplifier section and a sync signal of the proper amplitude into another. The two amplifier outputs are then paralleled, thus producing a composite signal.
4. *Amplification* — While each amplifier section has essentially unity gain, amplification by a factor of approximately two or three may be obtained by the simple expedient of paralleling both the inputs and outputs of two or three sections and feeding the signal to be amplified through the combination.

Another method of amplification for low level signals may be obtained by feeding the low level signal into one section of the TA-1A and terminating its output with a 500 ohm potentiometer instead of a 75 ohm load. The variable arm of this potentiometer is then connected to the input of a second amplifier section whose output feeds the normal 75 ohm load or cable. This not only amplifies the signal to normal level, but also provides a means of gain control.

5. *Bridging* — The high input impedance of the TA-1A allows it to perform very effectively as a bridging amplifier. In this application, a 75 ohm video line may be bridged for monitoring, or other purposes, without disturbing the termination of the line.
6. *Isolation* — The distribution amplifier may also be used for isolating one circuit from another, thus preventing disturbances on the output side of the amplifier from being reflected back into the signal source on the input side.

There are other applications of the distribution amplifier, but they are of lesser importance. The above list should serve to indicate its versatility and importance to any television studio installation.

# Mixing Amplifier

This amplifier, Type TA-10A, was designed primarily for use with the RCA Video Relay Switching System, Type TS-20A, but has other important uses as well. It is built on a rack-mounting chassis (see below) with two high impedance inputs and one output designed to feed a 75 ohm line. The two input stages have variable gain from zero to unity, which may be remotely controlled, so that their

results in a lap-dissolve, but if a signal is introduced into only one input, a fade from full picture to black screen, or vice versa, is produced by moving the lever.

A second function of the TA-10A is its use as a sync interlock amplifier. To illustrate this, let us consider a preview monitor associated with a studio switching system such as the TS-20A. There may be both local, non-com-

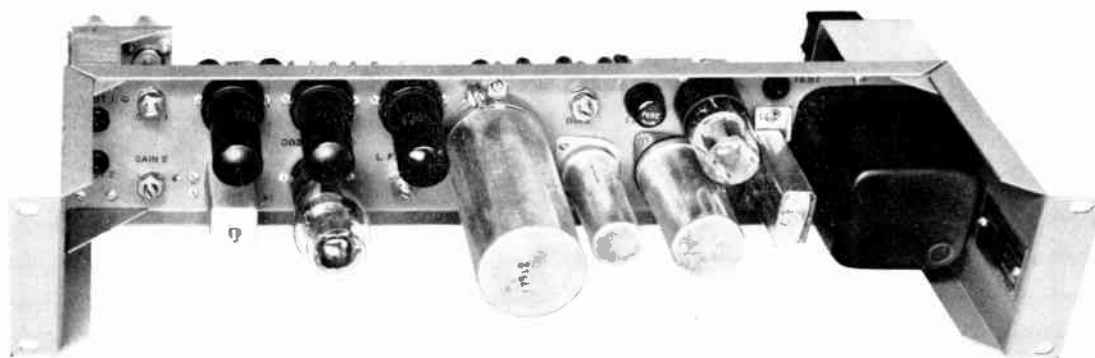

View of the TA-10A Mixing Amplifier chassis which is arranged for standard 19" rack mounting.

signals may be mixed in any proportion in the single output stage. This gain variation is accomplished by varying the bias voltage on the grids of the input tubes. A "built-in" bias supply on the amplifier chassis provides the negative voltage which is used for this purpose. A low frequency phase correction circuit is combined with shunt and series peaking to make the frequency response uniform within  $\pm 1$  db. to 8 mc. with ideal 60 cycle square wave response. The unit requires an external source of regulated + B voltage, but has its own self-contained filament supply.

The primary function of this unit is the production of fades and lap-dissolves between two video signals. A fader lever is provided on the Type TC-5A Program Director's Console which remotely controls the bias voltage on the two input stages. This fader is so arranged that the bias increases on one stage at the same time that it decreases on the other. At both limits of fader lever travel, one input stage is cut off while the other is at full unity gain. Therefore, if picture signals are introduced into both inputs, movement of the fader lever from one extreme to the other

posite signals, and remote, composite signals as inputs to the studio. As a result, the preview monitor must operate only on composite signals in order to accommodate the remote picture inputs; therefore, some arrangement must be made to add sync to the local signals that are previewed, and refrain from adding it to the remote signals. The mixing amplifier lends itself ideally to this function since video may be fed into one input and sync into the other. Then, by proper arrangement of the contacts on the preview switches, the sync input stage may be disabled when a composite video signal is previewed.

A third use, which has been suggested in the previous paragraph, is that of sync mixing. This differs from the sync interlock function in that sync is added to the video signal continuously with no provision for removing it automatically. An advantage of the TA-10A for this function lies in the fact that any amount of sync may be added to the video by a proper choice of the bias network which controls the input stage gain.





## THE TELEVISION MOBILE UNIT

Some of the most important sources of programming material for present day television broadcasting are sporting events. There are also many other events of local and national interest that are remotely located from TV studio facilities. In order to telecast these events it is necessary to provide a full complement of video and audio equipment which will permit complete programming. Therefore some means is necessary to transport the equipment to the remote point and back to the studio. One of the most satisfactory means of accomplishing this is to use a vehicle designed specifically to provide control room space, and arranged with ample storage facilities. When not in use for "remotes" it is a simple matter to employ the same equipment for studio programs.

Experience has enabled RCA to design such a vehicle with control and storage areas independently accessible. The RCA Mobile Unit consists essentially of a standard 1½ ton type Ford chassis on which is constructed a custom body, attractively styled and well engineered for practical application of remote television pickups. This Mobile Unit has been engineered to serve as a studio always ready to move when needed and ready for operation in a minimum of time. Space has been provided to accommodate three camera chains, a synchronizing generator, a field switching system with master monitor, a microwave relay transmitter equipment, and audio equipment necessary to complete the programming facilities.

Those items normally operated from the control room of the unit, such as the camera controls, are transported in their operating position. Other items such as cameras, tripods, dollies, cable reels, and microwave transmitter have space allotted inside the vehicle for transportation. Outside doors to the storage cabinets permit direct side loading of all the heavier pieces of equipment.

The inside of the Mobile Unit is divided into two separate and distinct compartments: An air conditioned Operating Compartment and a Storage Compartment. The entire front section is the operating or control room and is separated from the storage section in the rear by a partition fitted with a sliding door. Entrance to the control room is through the front side doors. The door windows and windshield may be covered by a curtain secured with snap fasteners to exclude outside light. Forward in this compartment are two cushioned chairs, one located in the driver's position and the other on the curb-side. The curb-side chair is rotatable and may be used to provide a seat for the program director. Next toward the rear, are three cushioned chairs directly in front of an operating control desk. This operating section of the "studio on wheels" has three levels for operating equipment.

The layout provides space at floor level for four field power supplies and the field synchronizing generator. These suitcase-styled units require a few adjustments dur-

ing operation and are, therefore, placed under the operating table. The power supplies are completely enclosed. They are placed in position through doors in the front. These doors have small windows through which the meters on the power supplies may be read. At the left side of the power supply compartment, an exhaust fan is installed and on the other a port to the outside, through which the cool air enters the system. The heat from the power supplies may also be diverted into the operating section if it is so desired for heating purposes in cold weather.

The second level is the actual table operating position. The front or operating portion of the table has a Micarta surface, while the rear area is of wood and suitable for fastening shock mountings to accommodate the operating equipment. The rear area of the table has space for as many as three field camera controls, a field master monitor, a field switcher, and an audio mixer amplifier. These items are located directly over the field power supplies and sync generator. All of these equipments are within easy reach of the operators seated at the control desk. There is ample room between the rear of the control table and the partition with the sliding

door so that the various equipments may be interconnected with the standard cables provided with the units.

The third level is directly over the camera controls. It contains an air conditioner, and provides space for the microwave relay transmitter control, and the power control panel. The incoming power cable terminates in this panel which forms the distribution center for the Mobile Unit. Breakers located on the panel provide for overload protection. Pushbuttons for remote control of the motor-driven voltage regulator are also located on the power control panel. Both the motor driven voltage regulator and an isolation transformer are available as optional equipment. The air conditioner is mounted at the rear of the compartment with air intake louvres on the driver's side.

The rear section beyond the sliding doors is completely partitioned into various sizes of cabinets. Although many of them are designed for equipments which are loaded directly from the outside, the equipments may also be reached from inside the vehicle. Locations are specified for the isolation transformer and motor-driven transtat of the voltage regulator, the control for which is located

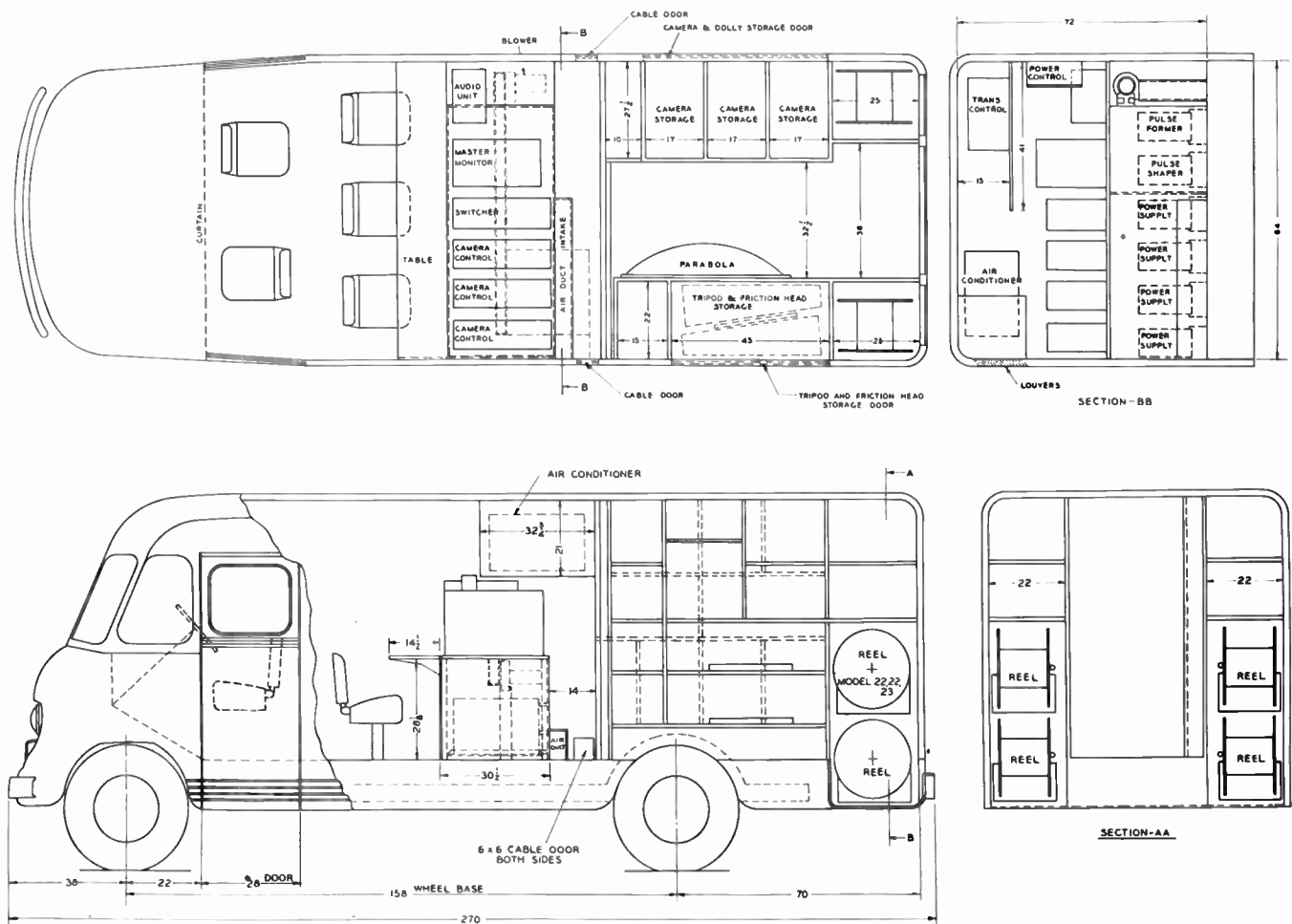

FIG. 1. Cutaway view of the TJ-53A Mobile Unit showing provisions made for accommodating the complete TV "Remote" Programming Equipment.



are mounted on the inside of the curb-side rear door, permitting ready access to the roof.

The roof is reinforced to support the weight of personnel and operating equipment such as cameras and tripods. It is insulated, as are the side walls of the operating or control section of the mobile unit. The roof surface is made of steel Diamondette floor plate. Anchor loops are welded in the roof along the edges for lashing down the operating equipment. The parabolic reflector for the microwave equipment may be clamped to the roof for transporting. A metal pipe receptacle welded to the roof plate on the curb side will permit insertion of a 1½-inch pipe to provide a cable anchorage for sidewalk clearance. A small handrail on the roof at the rear provides easy access to the roof when using the collapsible type steps on the rear door.

FIG. 2. Interior view of the TJ-53A Mobile Unit showing the power control panel and bench where camera controls are mounted.

on the power control panel in the operating compartment. At the very rear, four large cable reels are installed, two on either side of the center aisle and one above the other. These reels are crank-operated and can be reached from the street level.

All vehicle lights may be switched from battery to external AC power by means of a switch on the dashboard. All entrance and outside storage doors have handles with key locks of the recessed type, minimizing damage by the handles, particularly when the vehicle is in motion. There are side openings for cable entrances and utility outlets. Several utility outlets furnish regulated voltage when the isolation transformer and transtat are used. Fold up steps



FIG. 4 (above). Rear view of the RCA TJ-53A Mobile Unit showing easy access to cable reels and compartment storage areas. Note convenient steps leading to roof area.

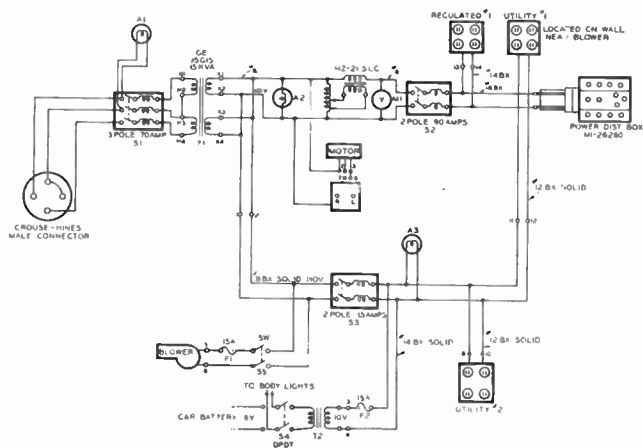

FIG. 3. Schematic diagram of the power circuits used in the TJ-53A Mobile Unit.

# Microwave Relay Equipment

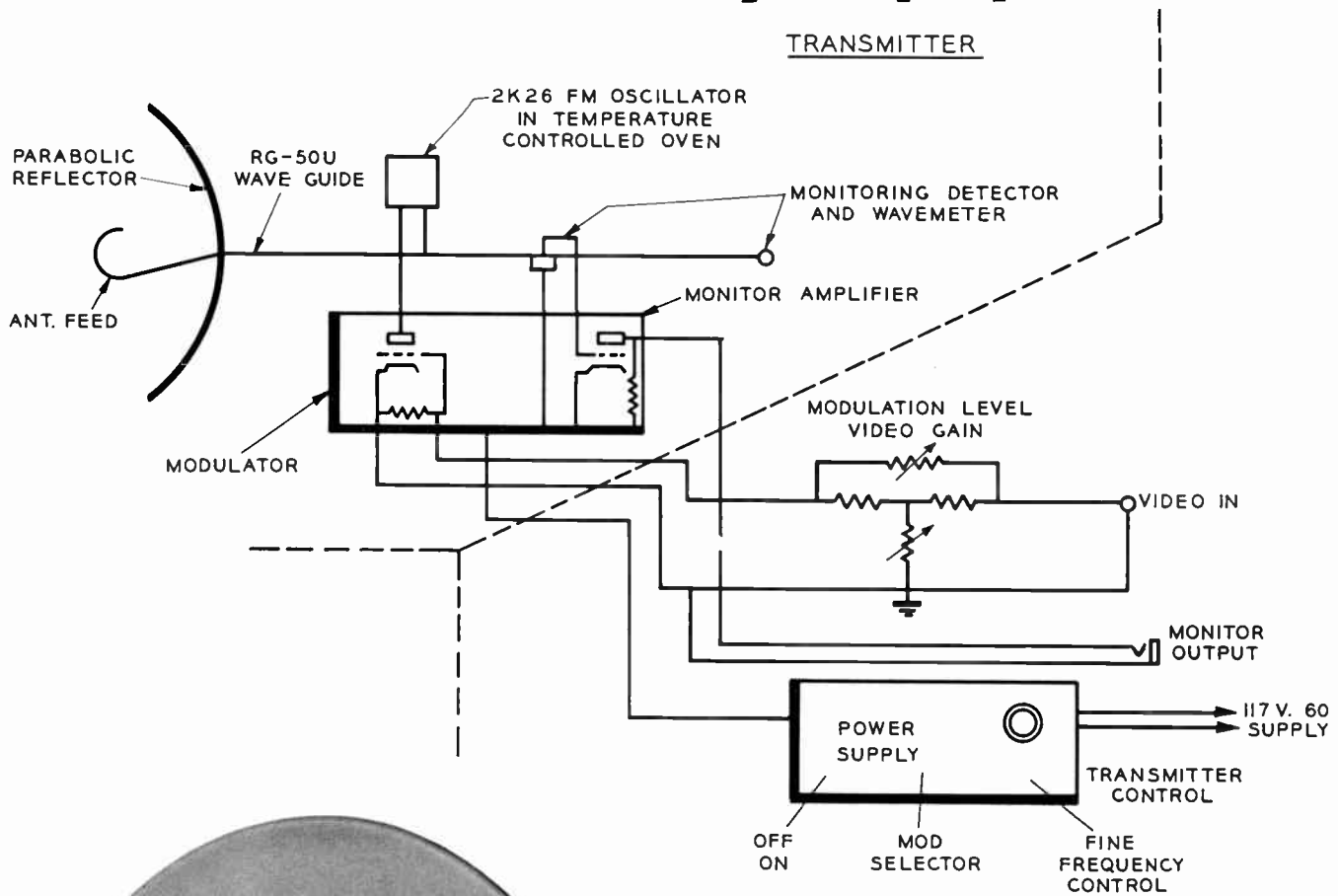

FIG. 1 (above). Block diagram showing the RCA Microwave Relay Transmitter.



FIG. 1(a). Front view of parabolic reflector showing slotted center hole for removing waveguide antenna feed assembly.

The problem of making available for broadcast such program material as sporting events, on-the-spot news pickups and other occurrences of this general nature has long been a major problem to the operator of a television station. Ordinary telephone wire lines cannot serve as they do for sound broadcasting for they are not capable of handling the frequency band required. In some instances they can be compensated to a degree sufficient to allow their use but usually radio or special coax circuits supply the solution.

Before the war, special portable radio transmitters and receivers were designed for the relaying of television signals. These operated on what are now considered low frequencies, the highest being around 500 Mc. Good performance and picture quality were obtained, but the transmitters in particular were bulky and required rather cumbersome antenna arrays to obtain even moderate directivity and gain.

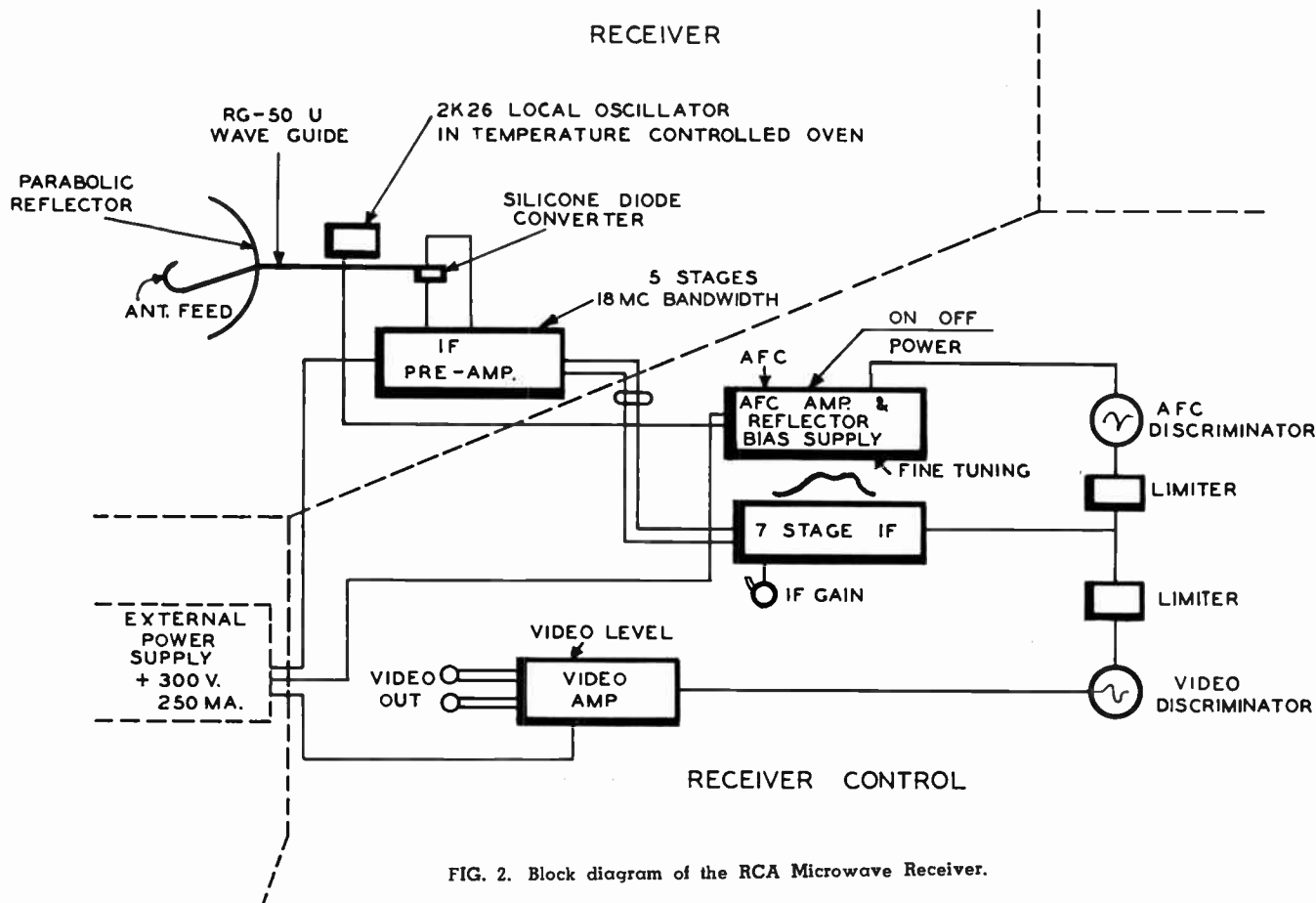

FIG. 2. Block diagram of the RCA Microwave Receiver.

With the advent of the klystron and its war-time development, a new attack on the problem was possible. It was now feasible to generate and modulate signals at frequencies of 10,000 Mc. and higher. Although the actual power available is only a small fraction of a watt, very great antenna gains are readily obtainable. The fraction of a watt exciting a high gain antenna can be made to do the same job as a high power low frequency transmitter, with the added advantage of having a very directional radiation pattern.

At the same time power supply requirements are also diminished, with the net result that the equipment can be assembled in packages that are portable in size and weight.

The commercial results of RCA's work in this field are the TTR-1B and TRR-1C Microwave Transmitter and Receiver. These units are designed to operate in a frequency modulated system transmitting in the band between 6500 megacycles and 7050 megacycles. The nominal power output is one hundred milliwatts — the direct output of a reflex klystron originally intended for use as a heterodyne oscillator in a radar receiver. This same type klystron serves as the heterodyne oscillator in the receiving portion of the television relay system.

Physically, the transmitting equipment consists of the antenna, transmitter, and transmitter control. The antenna utilizes a parabolic reflector four feet in diameter and a

means for mounting this assembly on a standard camera tripod. This complete assembly is the "transmitter" and is connected to the transmitter control by means of a special multiconductor cable. All power requirements are supplied by the transmitter control unit. In addition, the functions of modulation control, frequency adjustments, and other associated controls are directly available to the operator.

The receiving equipment has a corresponding arrangement: an antenna, receiver, and receiver control. The antenna is identical with that used with the transmitter. However, only a portion of the complete receiving system is incorporated in the receiver mount. Located here are the local oscillator, mixer, and five of the twelve I.F. stages. The interconnecting cable between the receiver and receiver control is the same as for the transmitting equipment. Functional similarity between transmitter and receiver stops at the receiver control, for the receiver control incorporates only the remaining circuits associated with the receiver — the remainder of the I.F. amplifier, video and A.F.C. discriminators, an A.F.C. amplifier, and a video amplifier, together with the necessary manual controls. The power supply requirements are easily met by a number of standard power units and so far have not been incorporated as part of the system.

This equipment is capable of an operating range of better than 30 miles over a line-of-sight path. Usually,

this means that the user more often finds his range limited by the lack of a line-of-sight path rather than by limited transmitting power. The relay picture quality is excellent; a properly adjusted system is capable of transmitting a 525 line test pattern with little or no degradation.

The basic circuit functions of the system are illustrated in the following block diagrams. Figure 1 shows the transmitter.

An RCA 2K26 Reflex Klystron is directly coupled to a short section of RG50/U wave guide which is extended and formed to direct the R-F energy towards the parabolic reflector. A small portion of the R-F output of the klystron is fed towards the monitoring detector and wavemeter. The klystron itself is arranged in a temperature-controlled oven so that its mean temperature is maintained within fairly close limits in order to achieve good frequency stability. The monitoring detector and wavemeter enable the operator to keep the transmitter on frequency at all times.

The modulator makes up the remaining part of the transmitter. This is a simple one-stage video amplifier, the output of which is applied directly to the reflector electrode of the klystron. A single stage monitor amplifier is included as part of the modulator assembly, although its function is simply to raise the output of the monitor detector to a useful level.

The monitoring function is provided to enable the operator to maintain the transmitter at its proper frequency. The output is in terms of the A.M. output incidental to the normal F.M. and as such it does not provide a picture signal.

The transmitter and transmitter control are connected by a single multiconductor cable — the same cable as is used with the field and studio cameras. The length of cable which may be used is limited by its effect upon the video response — and the power loss in the power leads. The maximum length recommended is 200 feet, although upon some occasions longer cables have been used.

The transmitter control is the operating position. Here are located the modulation level controls, modulation selection switch, fine frequency control, and a monitoring meter. The unit is essentially a power supply furnishing the required A.C. and D.C. voltages. Since the voltages and current drain are quite low, the unit is quite simple and straightforward in its design.

Figure 2 shows the block diagram of the receiver. It appears rather complicated by comparison with the transmitter, but actually the A.F.C. is the only function which may not appear in the usual superheterodyne type of receiver. Since this receiver is designed to accept a signal in the 7000 megacycle region, the converter must use a silicon diode as a converter. An RCA 2K26 supplies the

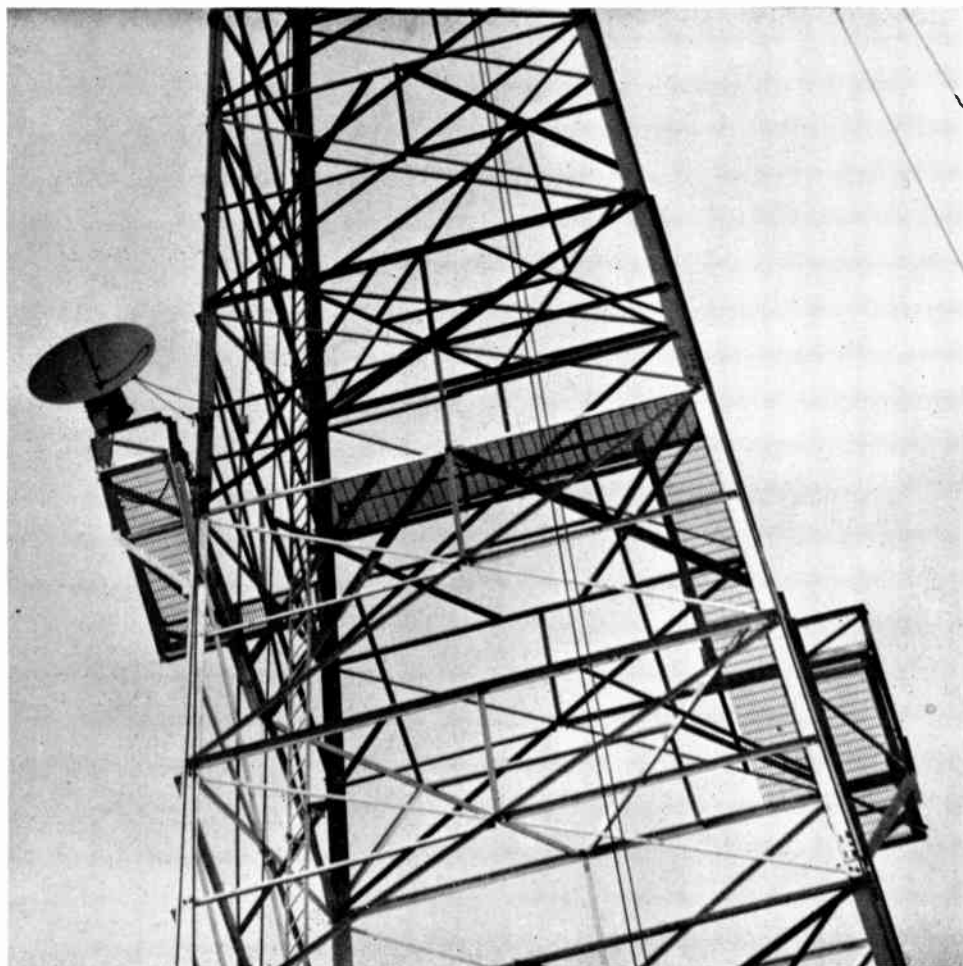

FIG. 3. WTAR-TV's microwave receiving dish on the 210-foot elevation of the tower. Two platforms with connecting catwalks were provided so that the dish can pick up a signal on any point of the compass since the dish can be rotated over 200° in each of the two positions.

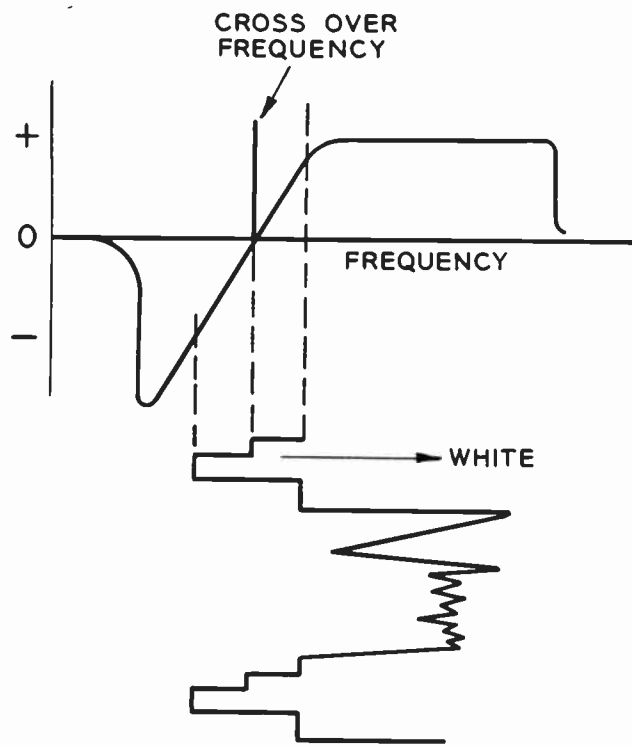

FIG. 4. Wave shape of the discriminator characteristic.

local oscillator power to produce a converter output at an I.F. center frequency of 128 megacycles.

The structure again follows almost the same layout as was used for the transmitter. The local oscillator, converter, and I.F. preamplifier are arranged so as to be close to the reflector, thus permitting the use of a very short wave guide between the "antenna" and receiver converter. As is usual in most microwave receivers, the first I.F. stages are placed close to the converter in order to maintain the best signal-to-noise ratio. With this arrangement, it is practical to carry the I.F. signal to the remainder of the receiver over some useful length of co-axial transmission line, in this instance as much as 200 feet may be used without sacrificing overall performance.

The remainder of the receiver is in the receiver control. It consists of seven additional I.F. stages, two limiters and two discriminators as shown in the diagram. The video discriminator employs an adaptation of one of the first schemes for demodulating an F.M. signal. The I.F. output is supplied to each of two amplifiers, each of which is tuned to different frequencies and drives separate diode rectifiers. The effective circuit Q's and resonant frequencies are so chosen that when the rectifier outputs are subtracted an effectively linear relation exists between frequency and output voltage over the frequency band required. In addition, the levels of each rectifier at the center frequency are made equal, resulting in zero output. Thus the overall characteristic obtained is the same as that for a conventional F.M. discriminator.

A slightly different discriminator is used in the A.F.C. system. Here, we required that the picture content of the signal should not affect the receiver tuning as it would do if the symmetrical discriminator were used to derive the

tuning error signal. Therefore, the shape of the discriminator characteristic was modified to that shown in Figure 4. The frequency for zero output is near one edge of the I.F. passband and is so related to the modulation that zero output will be obtained only when the synchronizing signal portion of the modulation is in the relative position shown. Note that due to the particular shape of the discriminator characteristic and the fact that both rectifiers have long time constant load circuits, any signal deviation in the white direction will not increase or change the D.C. output of the discriminator. Thus, the D.C. output is essentially independent of the character of the picture signal as long as the synchronizing signal is present. Since the total slope of the useful portion of the discriminator is only 2 to 3 megacycles, the frequency shift (or change in tuning) from the condition of only sync modulation to no modulation is very small, but if the whole modulation frequency spectrum shifts either direction in frequency, there will be either a positive or negative D.C. output depending upon the direction of shift. This voltage can then be used to control the tuning of the receiver. It is done in this instance by controlling the output of the A.F.C. amplifier and bias supply and consequently, the frequency of the 2K26. This bias is derived by rectifying the amplified output of an oscillator operating at about 100 Kc; the exact frequency is unimportant. Included in the amplifier is a bridge circuit maintained at the desired degree of unbalance (and so 2K26 bias voltage) by the main receiver tuning control. The introduction of the A.F.C. error signal then controls the degree of unbalance in the proper direction to maintain the receiver tuning at the desired frequency.

The remainder of the receiver is a video amplifier to increase the level of the video discriminator to that required to feed a 75 ohm line at about 2 volts peak-to-peak.



FIG. 5. View of transmitter control unit and close-up of connection panel for the TTR-1B.

# Directional Microwave Antenna Systems



**Operating notes and formulae for determining power gain, beam width, radiation pattern and other important characteristics of television microwave relays.**

**FIG. 1a.** View of receiving dish and TRR-1C Microwave relay receiver. Dish is mounted on lightweight metal tripod.

Before the commercial application of microwave relay equipment to television relaying, most radio link circuits were operated at frequencies between 170 and 350 MC. At these frequencies, however, such severe interference was picked up from broadcast transmitter harmonics, "ham" transmitters, ignition noise, and high frequency generators used in diathermy, that the lower frequency equipment was soon considered unsatisfactory for television relaying. Even though directional antennas were employed, the transmitted beam was so broad that multi-path propagation effects were quite serious. For ranges greater than a few miles, the equipment was too large to be portable and required considerable power for operation.

When microwave equipment was generally adapted for television relaying, most of the previous conditions of interference were no longer experienced. Microwave equipment operating in the 6875 to 7050 MC range today

serves well over 90% of the stations and provides virtually noise-free transmission over line-of-sight paths of 30 miles or more. The equipment is so compact that it is portable and so efficient that with a transmitter power of only 100 milliwatts an equivalent power of 500 watts is obtained.

A more common type of antenna system employed in microwave systems uses an elementary radiator and parabolic reflector to form a highly directive antenna. Some of the characteristics of such an antenna and the problems involved in its use with RCA Television Microwave Relay Equipment are described in the following pages of this article.

## **Power Gain**

The effectiveness of any antenna system in radiating or intercepting energy in the desired direction is referred to as directivity or gain. The power gain of any directive



antenna can be defined as the ratio of the power density in the direction of maximum radiation to the power radiated in the same direction by a standard antenna. The standard or "reference" antenna is usually a fictitious "isotropic" antenna which radiates equally in all directions, resulting in a spherical radiation pattern in three-dimensional space. (A perfect isotropic radiator is not actually realizable physically, and often a half-wave dipole is used as a reference. However, in this discussion, the isotropic radiator is used as the basis of comparison).

The receiving antenna can be pictured as intercepting or "capturing" a certain amount of energy from the passing wave front. A commonly used measure of the amount of energy intercepted by a receiving antenna of a given type is known as the effective area of the antenna. The maximum amount of power that any antenna in "free space" can extract from the passing wave is equal to the energy passing through an area of the wave front equal to the effective area of that particular antenna. The gain, in the receiving sense, of a given antenna in "free space" (isolated from all reflecting surfaces such as the earth and the ionosphere) is the ratio of the power available at the receiver input (under matched conditions) to the power which would appear at the receiver input if the given antenna were replaced with a standard antenna.

Since the power available at the input terminals of the receiver is equal to the power flow per unit area of the wave front multiplied by the effective area of the antenna, it is apparent that the power gain of any antenna system can be obtained by comparing its effective area to that of the standard antenna.

Or, in equation form:

$$\text{Power Gain} = P/P_1 = P_0 a/P_0 a_1 = a/a_1 \quad (1)$$

where  $P_0$  is the power density (Watts/meter<sup>2</sup>) of the incoming wave front. "a" and "a<sub>1</sub>" are the effective areas of the given antenna and the standard antenna respectively, and P & P<sub>1</sub> are the receiver input powers available with the given antenna and the standard antenna respectively.

The effective area of an isotropic radiator is  $\lambda^2/4\pi$ , and when this is substituted for "a<sub>1</sub>", equation (1) becomes:

$$\text{Power Gain} = 4\pi a/\lambda^2$$

The effective area of an antenna system employing a parabolic reflector may be given as .65 times the projected area ("mouth" area) of the dish. Equation (1) then becomes:

$$\text{Power Gain} = (4\pi A/\lambda^2) .65 \quad (2)$$

where A is the projected area of the parabolic reflector and  $\lambda$  is the wavelength ( $\lambda^2$  must be expressed in the same units as A).

Although the above analysis is based on the receiving properties of an antenna, equation (2) is equally applicable to a transmitting antenna since nearly all of the properties of an antenna apply equally to transmission and reception. In long distance communication different parts of the directive pattern might be utilized at the transmitting and receiving points, with considerable de-

parture from "reciprocity"; however, for the relatively short distances involved in point-to-point communication this reciprocity holds quite well.

Equation (2) will be only slightly in error as long as  $\lambda$  is small compared to the diameter of the reflector. From this simple equation the effect of various changes in antenna systems may be compared. It can be seen that the gain is directly proportional to the effective area, the frequency squared, or inversely proportional to the wavelength squared. Curves showing these first two relations are shown in Fig. 1.

### Relative Power

Often questions arise as to the relative merits of two transmission systems utilizing the same type of antennas but operating on different frequencies. The two may be compared quite simply with the aid of equation (2) or

$$\frac{\text{Power Gain—System A}}{\text{Power Gain—System B}} = \frac{4\pi A_A/\lambda_A^2}{4\pi A_B/\lambda_B^2} \quad (3)$$

When both antennas have the same area this becomes

$$G_A/G_B = \lambda_B^2/\lambda_A^2 \text{ or } f_A^2/f_B^2 \quad (4)$$

in terms of frequency. Consider for example two transmitting antennas of equal area operating at 1100 MC and 7000 MC respectively. From equation (4), it is seen that the ratio of gains is approximately 40 to 1. Thus the transmitter operating at 1100 MC needs approximately 40 times more power than the one operating at 7000 MC

FIG. 1. Curves showing antenna system power gain as a function of reflector diameter.

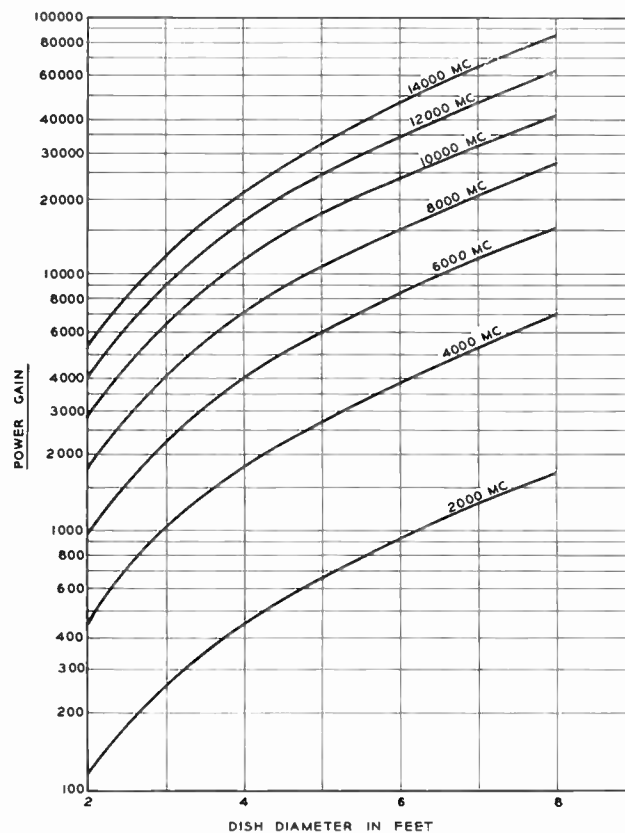

to provide the same signal at the receiving location. The curve of Fig. 2 gives the relation of equation (3) based on a frequency of 7000 MC. The antenna systems are assumed to have the same effective area.

### Beam Width

The beam width of a directional antenna system is usually defined in terms of the angle through which the antenna system must be rotated in order to reduce the power available at the receiver to  $\frac{1}{2}$  of the maximum value. Often, twice this angle is called the half-power beam width. An expression for this is as follows:<sup>1</sup>

$$\theta = 70(\lambda/d) \text{ degrees} \quad (5)$$

$\lambda$  = wavelength.

$d$  = diameter of parabolic reflector (in same units as  $\lambda$ ).

Equation (5) is quite accurate for angles less than  $20^\circ$ .

Thus, a parabolic reflector 4 feet in diameter used at 7000 MC ( $\lambda = 5.28$  cm) would be expected to have a half power beam width of  $2.46^\circ$ . Practically, the figure is subject to variations, and production antennas have a half-power beam width of approximately  $3^\circ$ . Fig. 3 presents equation (5) both in terms of wavelength (frequency) and reflector diameters.

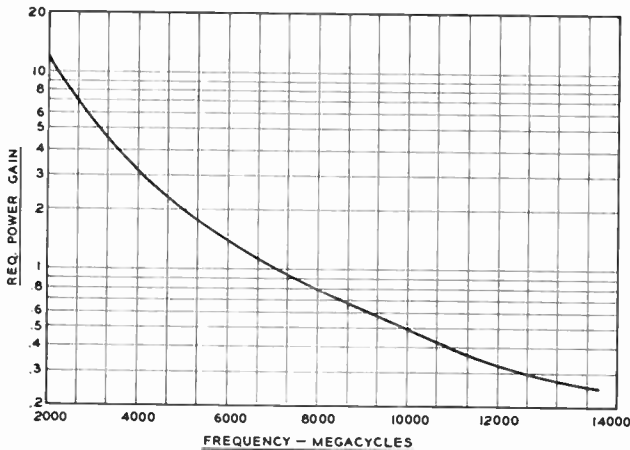

FIG. 2. Relative merit of 7000 MC transmission system used on different frequencies.

It is possible to calculate the power available at the receiver for most practical setups. All cases are based upon line of sight propagation paths as determined from the actual terrain elevations and normal curvature of the earth. The formula is given in equation (6).

$$P_R/P_T = (a_R a_T)/D^2 \lambda^2 \quad (6)$$

where

$P_T$  = power generated at transmitter.

$P_R$  = power available at receiver.

$a_R$  = effective area, transmitting antenna.

$a_T$  = effective area, receiving antenna.

$D$  = line of sight distance between transmitter and receiver.

$\lambda$  = wavelength.

<sup>1</sup> Reference Data for Radio Eng., 2nd Edition, page 219.

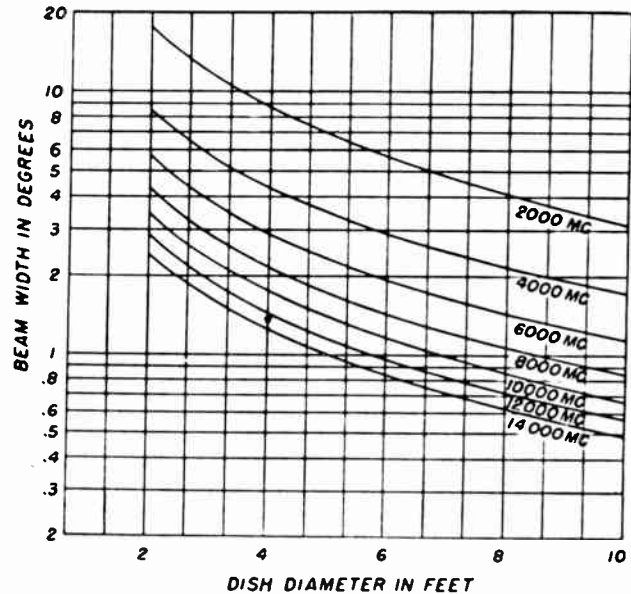

FIG. 3. Curves for half power beam width vs. reflector diameter at different frequencies.

Where both antennas are parabolic reflector systems equation (6) may be arranged so that actual projected areas rather than effective areas can be used. It is also desirable to replace  $\lambda$  with frequency. Equation (6) then becomes

$$\frac{P_R}{P_T} = \frac{A_R A_T f^2}{D^2 \times 2290 \times 10^{15}} \quad (7)$$

where

$f$  is in cycles per second

$A_R, A_T,$  and  $D^2$  are in  $\text{ft.}^2$

The relations existing in any field setup are shown by this equation. Notice that the power available at the receiver is proportional to the frequency squared, the area of an antenna, and inversely proportional to the square of the distance between the transmitter and receiver. It is these proportional relations which are of interest to the engineer planning a field installation. The operation of a proposed installation may be readily evaluated in terms of the known performance of some other arrangement.

As a simple illustration suppose the performance of a system using 4 foot reflectors operating over a range of 10 miles ( $d_1$ ) is to be duplicated over a distance of 20 miles ( $d_2$ ). Several choices not involving frequency are available although doubling the frequency would be one solution. First, the transmitter power could be increased by a factor  $\frac{(d_2)^2}{(d_1)^2}$  or 4. A more practical arrangement would be to increase the area of the reflectors, each by a factor of 2. Practically, this means that 6 foot reflectors would be used in place of the 4 foot reflectors.

### Radiation Patterns

The factors determining beam width have been discussed briefly in the preceding section but there remains the question as to the nature of the radiation pattern. This

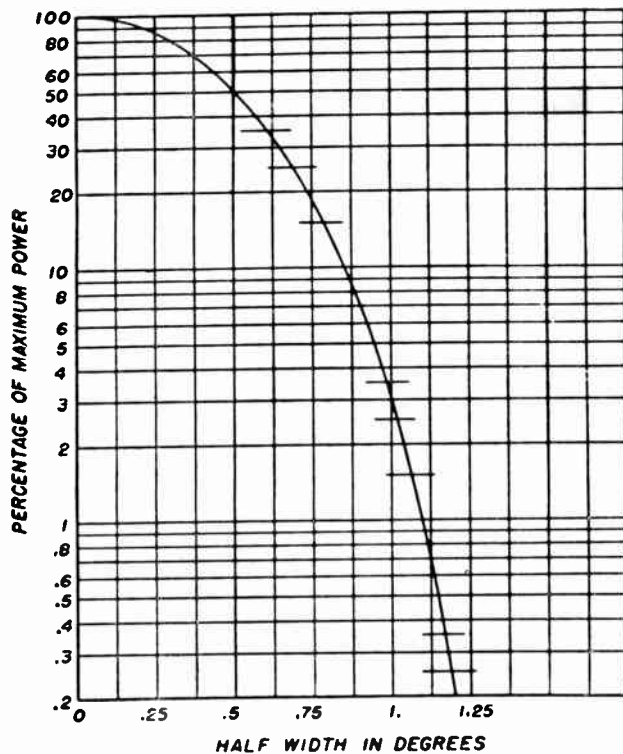

FIG. 4. Characteristics of normalized radiation pattern assumes symmetry about the axis of the reflector based upon a system having a unity half-power beam width.

pattern is not completely specified by the beam width alone. It is a function of the electrical arrangement of the antenna reflector and feed (radiating element). For the purpose of this article the following discussion will be based upon the use of a normalized pattern shown in Fig. 4. This plot assumes the pattern to be symmetrical about the axis of the reflector, and is based upon a system having a half power beam width of 1°. Consequently, it can be used to specify the pattern of any antenna of this type by multiplying the  $\theta$  scale by the beam width of the antenna.

It should be realized that this curve is not a complete pattern of the type obtained by actual measurements. A complete pattern would be something like that shown in Fig. 5 and would vary in detail from antenna to antenna. However, the normalized curve is useful in the solution of several field problems likely to be encountered in practice.

For example, consider the problem of determining the power level of the interfering signal between two systems operating on the same frequency but differing in physical location. A simple case is illustrated in Fig. 6. Assume that both are using identical equipment; 3° reflectors, 0.1 watt power, and a frequency of 7000 MC. In order to solve the problem it is first necessary to evaluate the angle  $\theta$  and the distance X.

From the simple geometrical relation

$$\tan \theta = \frac{1000}{5 \times 5280} = .0379,$$

$$\theta = 2.1 + \text{degrees} \quad (8)$$

$$X = \frac{5}{\cos \theta} = \frac{5}{.9993} = 5 \text{ miles (approx.)}$$

Since the path length of the "B" system is almost exactly the same as the path length for the interfering signal the transmission loss over both paths may be taken to be the same. This leaves the interfering signal attenuated only by the directivity of the "B" receiving antenna and the "A" transmitting antenna. This attenuation may be obtained from Fig. 4. (The horizontal scale of figure 4 must be multiplied by 3 for a 3° beam width.) At 2.1 degrees off the center of the beam the power is approximately 0.23 of maximum. Since this reduction occurs at both antennas the total reduction is  $.23 \times .23$  or .05 (approximately) or 20 times. A similar calculation for the interfering signal at Receiver A from Transmitter B gives a reduction of approximately 5 times.

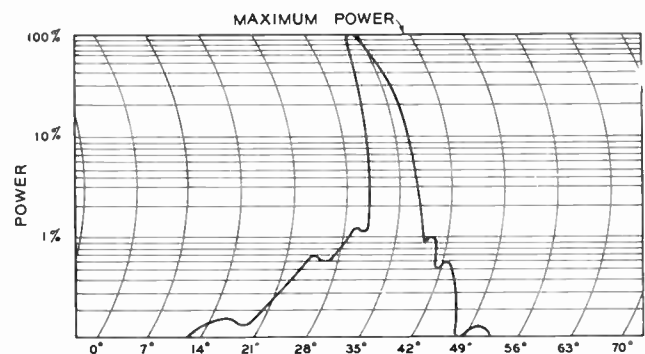

FIG. 5. Graph showing system radiation pattern obtained through actual measurement.

### Calculating Line-of-Sight Path

Before any installation is made involving situations where the transmitter is not distinctly visible from the receiver, a plot should be made in order to determine the terrain clearance existing along the path. Good maps are required; contours should show at least 10 foot elevation intervals.

The usual procedure is to lay out the path on the map and obtain elevations at frequent intervals along the whole path. These elevations must then be corrected to allow for the curvature of the earth. This correction may be calculated for each elevation from the equation

$$e = \left( \frac{D}{1.23} \right)^2 - \left( \frac{D-d}{1.23} \right)^2 \quad (9)$$

where e is in feet

D = 1/2 distance in miles between terminals

d = the distance in miles from terminal to point on the path for which the elevation is being calculated

This is derived from the basic equation:

$$D = 1.23\sqrt{H} * \quad (10)$$

where D is the line of sight distance in miles to the horizon, and H is the elevation (in feet above sea level) of the sighting point.

Fig. 7 shows a typical profile plot. The allowance for terrain clearance depends upon many things, but it is generally considered good practice to choose sites which provide a minimum clearance of at least 100 feet above the terrain. If this area is wooded or built-up, due allowance should be made for the height of the buildings or trees. Where the profile shows questionable clearance, it is best to make a test transmission over the path as a final check of the performance to be expected.

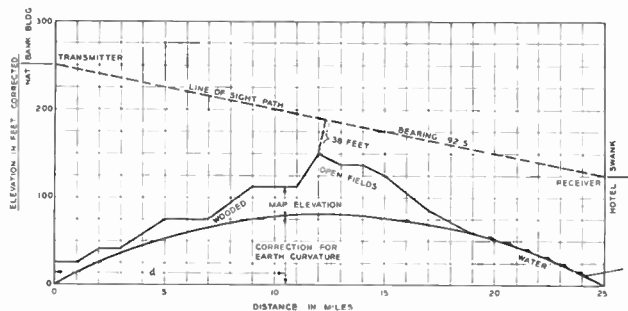

FIG. 7. Typical profile plot for line-of-sight path calculations.

### Special Considerations

So far, no consideration has been given to the interference caused by single or multiple reflections from reflecting surfaces adjacent to the line-of-sight path. Although the simultaneous reception of the same signal from more than one direction occurs in all kinds of radio wave transmission, the effects are particularly disturbing in television reception because of the greater sensitivity of the eye in detecting delayed signals (ghosts).

The general problem is pictured in Fig. 8. A receiving antenna at distance D subtends an angle  $\theta$ . An isolated, smooth reflecting surface is at a distance (a) from the transmitter and subtends an angle B. The orientation of the surface is such that a wave front approaches it at an angle  $\phi$ . The wave reflected from the surface leaves at an angle  $\alpha$  travelling toward the receiving antenna. Some general conclusions may be shown as to the effects to be expected without the elaborate calculations required to obtain a quantitative answer.

\* This equation can be derived from a consideration of the simple geometric relations of Fig. (9). A right triangle is formed having as its sides D (the line-of-sight distance between T and R), H + R (the distance from the receiving antenna to the center of the earth), and R (distance from the transmitting antenna to the earth's center). Since, in a right triangle, the square of the hypotenuse equals the sum of the squares of the sides:

$$(R + H)^2 = R^2 + D^2 = R^2 + 2RH + H^2$$

but H is very small compared to R so  $H^2$  is neglected;  
then:  $D^2 = 2RH$ .

Substituting  $R \cong 4000$  miles and changing H from units of miles to feet we obtain:  $D = 1.23 \sqrt{H}$ .

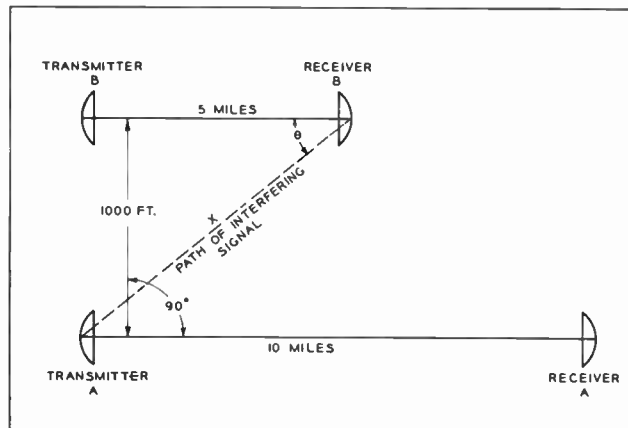

FIG. 6. Diagram for determining interfering signal power level between two systems in different locations on the same frequency.

First, the energy reaching the receiving point due to the reflector ( $P_R$ ) is proportional to the power received over the direct path ( $P_D$ ) multiplied by the ratio of the squares of the distances travelled by the two waves, or  $P_R \cong [D^2/(a + b)^2]P_D$ . This is further reduced by the factors  $P_\phi$  and  $P_\alpha$  where  $P_\phi$  is the relative or "normalized" power radiated at an angle  $\phi$  off the center of the transmitted beam and  $P_\alpha$  is the relative power received at an angle  $\alpha$  off the center of the receiving antenna pattern. Since most surfaces are not perfect reflectors, some absorption of energy occurs at the reflector, and  $P_R$  will be still further reduced by a factor E depending upon the reflective efficiency of the surface.

When the reflector is a plane surface having a very large area, the reflected energy reaching R will be approximately:

$$P_R = D^2/(a + b)^2 P_\phi P_\alpha E P_D \quad (11)$$

where  $P_D$  is the power received over the direct path.

In practice, however, the situation is seldom as simple as that used in the illustration. The theory still applies but the solution is complicated by the fact that the nature and number of the possible reflectors is usually difficult to determine. Actual reflectors are seldom found to have plane surfaces so these may be effectively a large number of reflector systems operating at one time with a consequent reduction in the energy reaching the receiver. Nevertheless, the problem does illustrate the advantages of

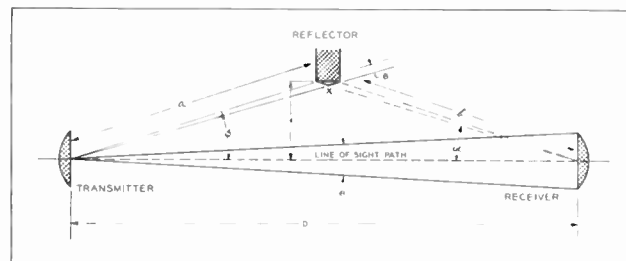

FIG. 8. Diagram illustrating multi-path transmission problem.

the highly directive transmitting and receiving systems in reducing the overall effects of multi-path transmission.

Although indirect-path transmission is normally undesirable, it can be put to good use as an expedient in getting a signal "around a corner" in the case of an obstructed line-of-sight path (see "Powerless Relay").

In some instances, operators of television broadcast stations have relatively inaccessible locations such as the top of a high building or tower available for the installation of the RCA TRR-1C relay receiver. The parabolic antenna system used with this receiver is very directive and must be aimed on the transmitter each time the transmitter is moved to a new location. Quite often the location of the receiving antenna is such that it becomes a serious problem to change the antenna from one direction to another.

Various positioning mechanisms may be designed for remote control of the antenna in both azimuth and elevation. All such mechanisms are complicated and expensive but can be simplified a great deal if control of one of these functions (azimuth angle or elevation angle) is omitted. We will, therefore, consider the possibilities of a system in which the receiving antenna is to be controlled in azimuth but fixed in elevation.

Consider, for example, the possibilities of a typical system in which the receiving antenna is controllable in azimuth angle but fixed in elevation angle (figure 9). The elevation of the receiving antenna is 518 feet above the ground. The calculated distance to the horizon is therefore 28 miles (from eq. 10)—just about the maximum range for consistently good equipment performance. The question arises as to how the power at the receiver will vary as the transmitter is moved toward the receiver and the receiving antenna left aligned on the horizon. The diagram of Fig. 9 illustrates the general problem.

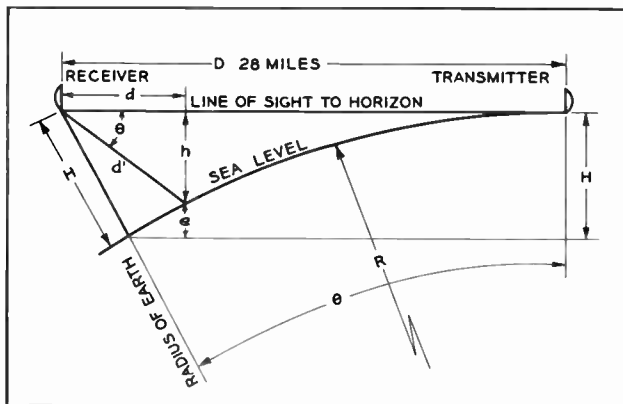

FIG. 9. Diagram of the circumstances in illustrative example used to study the possibilities of a system that is fixed in elevation but controllable in azimuth.

Tower height at receiver = 518 feet (above sea level)

Distance to transmitter =  $D = 1.23 \sqrt{H} = 28$  miles  
(when transmitter is on the horizon) (12)

where D is in miles, H is in feet.

For any other distance d the increase in signal as the transmitter is moved toward the receiver is proportional to  $(28)^2/d^2$ . At the same time the receiving antenna is left aimed at the horizon. Therefore, due to the curvature of the earth, the transmitter moves below the original line of sight path by the angle  $\theta$  and the distance h. Now

$$D - d = 1.23 \sqrt{h} \quad (13)$$

or  $h = (D - d)^2 / (1.23)^2$

$$\text{and} \quad \cot \theta = d \times 5280 / h \quad (14)$$

or

$$\cot \theta = \frac{(1.23)^2 d \times 5280}{(D - d)^2} = \frac{7989 d}{(D - d)^2}$$

It is true that the actual distance between the receiving antenna and the transmitter is  $d'$  and not d. However, for the small angles involved the error is small when d is used. For instance,

Let  $d = 1.4$  miles = 7392 feet

then  $h = 470$  feet (from eq. 13)

$$\text{and} \quad \cot \theta = \frac{7989 \times d}{(28 - 1.4)^2} = \frac{7989 \times 1.4}{(26.6)^2} = 15.7$$

$$\theta \cong 3.6^\circ$$

$$d/d' = \cos \theta = .9980$$

$$d/\cos \theta = d' \text{ or } 7407 \text{ feet} \quad (16)$$

The error here is 15 feet or .24% and decreases as d becomes larger.

In order to obtain the relative signal power at the receiver for each new position of the transmitter both  $\theta$  and d must be known. The solution is then as follows:

The increase in power due to the transmitter being moved from  $D = 28$  miles to d is

$$P_d/P_D = D^2/d^2 \quad (17)$$

The decrease in power due to the receiving antenna no longer being aimed at the transmitter is taken from the curve of Fig. 4; a normalized antenna gain curve in terms of relative power and the angle off the main axis for an antenna having  $1^\circ$  beam width. If we assume that our receiving antenna has a  $4^\circ$  beam width, the angle coordinates on the curve (horizontal scale) must be multiplied by 4. If the power ratio obtained from this curve be  $P_\theta$ , then the net power ratio for any location d is:

$$(P_d/P_D) P_\theta \quad (18)$$

By use of this equation, it is possible to predict the variations in received power to be expected (in a system in which the antennas are oriented correctly in azimuth) when the distance between transmitting and receiving antennas is changed. A plot of this is shown in Fig. 10. Note that as the transmitter is moved in toward the receiver, the power at the receiver first increases, but as d becomes small compared to D the power rapidly decreases.

Although the curve of Fig. 10 illustrates the solution of the general problem, it will be recalled that the solution was based on a smooth earth's surface which is very seldom found in practice.

In the practical case of Fig. 11, the line-of-sight distance to the actual horizon differs slightly from the

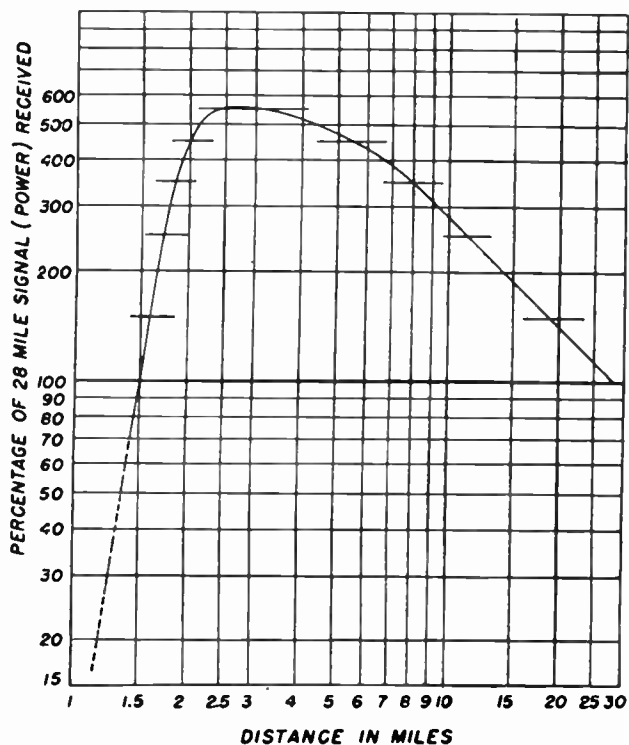

FIG. 10. Curve showing percentage of signal strength at receiver as transmitter is moved toward receiver from point of horizon.

distance to the "smooth earth" horizon, calculated from the equation  $D = 1.23\sqrt{H}$  for smooth earth conditions.

In Fig. 11, the new location of the transmitter at a line-of-sight distance of 28 miles is now above the line of sight to the smooth earth horizon by some elevation  $E$  and an angle  $\phi$ . It can be seen that the general solution is much the same as before. One new problem arises, however, and that is the positioning of the receiver's antenna. If it is aligned on the new transmitter location which is now at an elevation of  $H + E$ , the angle  $\theta$  of the first case is increased by the angle  $\phi$ . For  $E = 500$  feet,  $\phi$  would be approximately 11 minutes and would not affect the results obtained appreciably. The effect of  $E$  as the transmitter is moved toward the receiver is generally to improve the signal level over that calculated for the smooth earth condition.

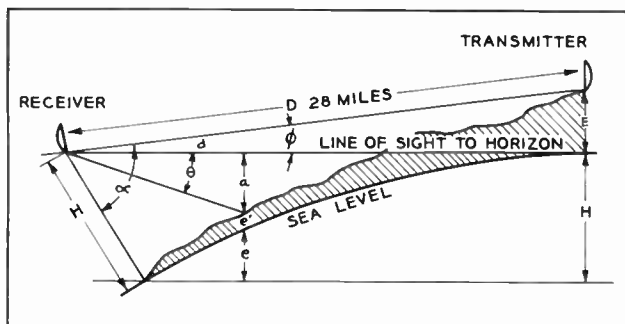

FIG. 11. Diagram of problem similar to that shown in Fig. 9 except that more usual contour of the earth is considered.

It will be noted that the preceding discussions have been based on optical or "line-of-sight" paths to the horizon. The "radio path" to the horizon is slightly longer than the optical path due to refraction or bending of the wave caused by the decrease, with height, of the index of refraction of the lower atmosphere. Communication is therefore possible at times even though the actual line-of-sight path between the transmitter and receiver intercepts the surface of the earth. However, operation under these conditions is subject to severe fading at times when the density of the lower atmosphere is changing, and is therefore often erratic and unreliable.

### Receiver Aligned in Azimuth

One may conclude that it is quite feasible to locate a receiving antenna so that it need be aligned in azimuth only and still supply sufficient power to the receiver for normal operation. However, each such installation should be considered a special case and calculations should be made to find out whether or not the results will be as desired.

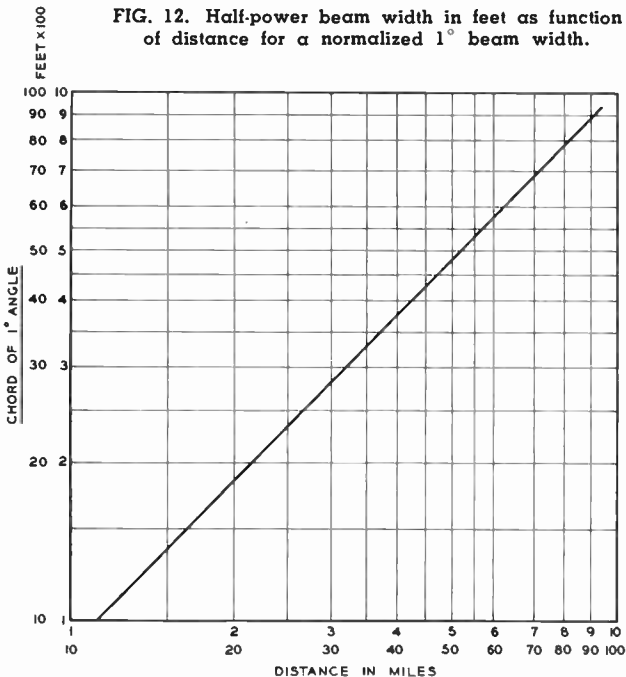

FIG. 12. Half-power beam width in feet as function of distance for a normalized 1° beam width.

The methods used in the preceding example may be applied to a special case in which the azimuth angle is fixed and the elevation made the variable. This is essentially what is done in the solution of the interference problem. However, it is of interest at times to know the half-power beam width in feet as a function of distance. This function is plotted in Fig. 12 for the normalized 1° beam.

NOTE: It will be noticed that in all problems involving the antenna patterns the vertical pattern has been taken to be the same as the horizontal pattern. This is sufficiently accurate for most cases involving large parabolic

reflectors although not entirely correct. Other antennas such as horn arrays, or modified parabolic systems may have entirely different horizontal and vertical patterns and this must be considered in special cases. The effect of ground reflections may also affect results in some instances where the line of sight path is near grazing. The general solution will nevertheless follow the same pattern.

### Powerless Relay

It is possible that occasions may arise in practice when it is necessary to set up a system in which the transmitter and receiver are not in line of sight. The question of how to get the signal around the corner naturally arises.

One possible method would be the use of an "indirect" path via a plane reflecting surface, which was covered in principle under "Special Considerations." It should be noted that the smaller the angle  $\theta$  becomes, the larger the reflecting surface must be if the loss at the reflector is to be kept at a minimum. For very small values of  $\phi$  the losses become excessive and the system becomes very difficult to align. Practical considerations indicate that values of  $\phi$  less than  $45^\circ$  may prove to be very difficult to handle.

A second possible method, involving an auxiliary set of "powerless" antennas, is very inefficient since the energy propagated in the new direction is not a mirror reflection, but is due to radiation from another antenna.

Suppose we consider a setup similar to that illustrated in Fig. 13. T is the transmitter having a power of  $P_T$  watts; R the receiver, and D the line-of-sight distance between T and R. R' and T' are the auxiliary receiving and transmitting antennas at the relay points, a distance  $d_1$  from T and  $d_2$  from R.

We may now calculate the ratio of the power received by the receiver R over the relay path to that over the direct path. (Under line-of-sight conditions.)

Power at R'

$$\frac{P_{R'}}{P_T} = \frac{A_{R'} A_T}{d_1^2} C \quad (19)$$

where

$P_T$  = transmitter power

$P_{R'}$  = receiver power (auxiliary)

$$C = \frac{1}{\lambda^2} = f^2 / v^2 = \text{constant}$$

( $v$  is the velocity of propagation of a radio wave)

$A_{R'}$  = area of receiving antenna

$A_T$  = area of transmitting antenna

$d_1$  = distance between transmitter T and receiving antenna R'

Next assume this amount of power be transmitted by transmitter T'. In this case the power at R will be

$$\frac{P_R}{P_{T'}} = \frac{A_R A_{T'}}{d_2^2} C \quad (20)$$

where

$P_{T'}$  = transmitted power

$A_R$  = area of receiving antenna

$A_{T'}$  = area of transmitting antenna

$d_2$  = distance from T' to R

$C$  = same constant as defined above

or

$$P_R = \frac{P_{T'} A_R A_{T'}}{d_2^2} C \quad (21)$$

Since  $P_{R'} = P_{T'}$  equation (19) may be written

$$P_{T'} = \frac{P_T A_{R'} A_T}{d_1^2} C \quad (22)$$

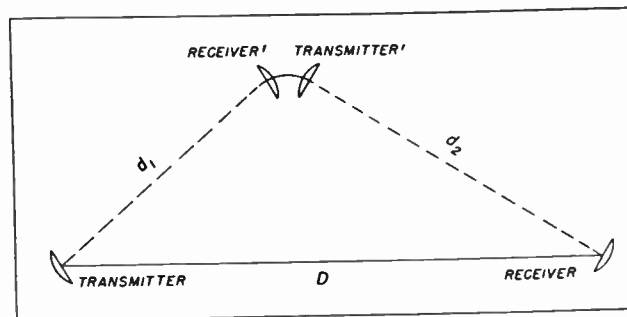

FIG. 13. Diagram showing antenna positions for relays that are not in the direct line of sight.

Substituting (22) in (21) and introducing frequency " $f$ "

$$P_R = \frac{P_T A_{R'} A_T f^2 (A_R A_{T'}) f^2}{d_1^2 C_1 d_2^2 C_1} \quad (23)$$

$$= \frac{P_T A_{R'} A_R A_{T'} A_T f^4}{d_1^2 d_2^2 C_1^2} \quad (24)$$

(where  $C_1 = v^2$ )

The power which would have been received over the direct path D is

$$P_R = \frac{P_T A_R A_T f^2}{D^2 C_1} \quad (25)$$

The ratio of the two paths is therefore (24)/(25) or

$$\frac{A_{R'} A_{T'} D^2 f^2}{d_1^2 d_2^2 C_1} \quad (26)$$

Often  $d_1 + d_2 \cong D$  where the paths are long so that (26) may be written,

$$\frac{P_{\text{relay}}}{P} = \frac{A_{R'} A_{T'} (d_1 + d_2)^2 f^2}{(d_1 d_2)^2 C_1} \quad (27)$$

Both equations (26) and (27) must be modified by a factor E to take into account the efficiency of the coupling between the two relay antennas.

It may be seen that the efficiency of the relay system as a whole is very poor, although it will increase when  $d_1$  is made smaller than  $d_2$  or vice-versa. Efficiency also increases as antenna size increases.

The chief advantage of this type of "relay" over a system utilizing a plane reflector is the relative ease with which it may be set up inasmuch as the two antennas may each be adjusted individually. However, the losses are so high as to make it impractical except for very short distances.

# HOW TO APPLY POLARITY DIPLEXING TO MICROWAVE RELAY SYSTEMS

There are times when the operators of television broadcast stations employing several microwave circuits would find it to their advantage if their microwave equipments were all operated in the same channel. Some rather special setups can be operated in this manner with no change in the existing equipment. For example, a station operating both an S.T.L. and a remote pickup circuit may find it possible to operate them both on the same frequency by observing the following conditions—first, that the remote receiver be located near the studio (the S.T.L. transmitter), and second, that the remote receiver be located at least 100 feet to the rear of the S.T.L. transmitter. Remote pickups requiring multiple hops may also be operated in the same manner if the repeater is more or less in line with the terminal transmitter and receiver and there is roughly a 100-foot separation between the repeater receiver and repeater transmitter. However, other system arrangements usually have required the use of more than one channel for successful operation.

The propagation characteristics and antenna patterns associated with microwave transmission systems lend themselves to the applications of a system of diplexing we have called "polarity diplexing". This offers an effective solution to some system problems. In its simplest form, two signals having the same frequency are transmitted along the same path to two receivers. One antenna is arranged to radiate a vertically polarized wave and the other a horizontally polarized wave. Matching antennas are employed at the receivers. Under ideal conditions, the cross-talk between the two systems, even though they are operating at the same frequency, may have an extremely small value.

Practically, however, cross-talk levels lower than  $-20$  db may be difficult to obtain, although in a carefully arranged setup, a  $-30$  db level might be expected. Several factors enter the problem and may greatly influence the results obtained. First, the radiation from an antenna system employing a parabolic reflector will not be entirely of one polarity. There will be found a small component polarized at  $90^\circ$  to the main field. Second, in the case of a portable setup, it will be found rather difficult to orient the two transmitting antennas so that the fields are exactly  $90^\circ$  to each other and at the same time make the normal elevation and azimuth adjustments.

The results obtained will also be modified by the presence of any reflecting system in the transmission path. A plane reflector may generate a cross polarized signal unless its horizontal or vertical axis is exactly parallel to the wave front of the incident wave.

Experimentally, Bob Connor, formerly of KLAC, found it possible to obtain satisfactory operation with the RCA TTR and TRR equipments through the use of a combination of polarity diplexing and a small frequency separation. Each transmitter is shifted slightly from the normal adjustment; one moved about 3 mc. higher in frequency and the other moved 3 mc. lower. This results in an effective frequency separation of 6 mc., which, together with the diplexing, results in an effective cross-talk level of  $-30$  db or better and consequently, negligible interference. Successful operation has been obtained using this technique applied to an S.T.L. circuit. Experimental antenna-feeds similar to that shown in Fig. 1 have also been supplied to other users of the RCA equipments.

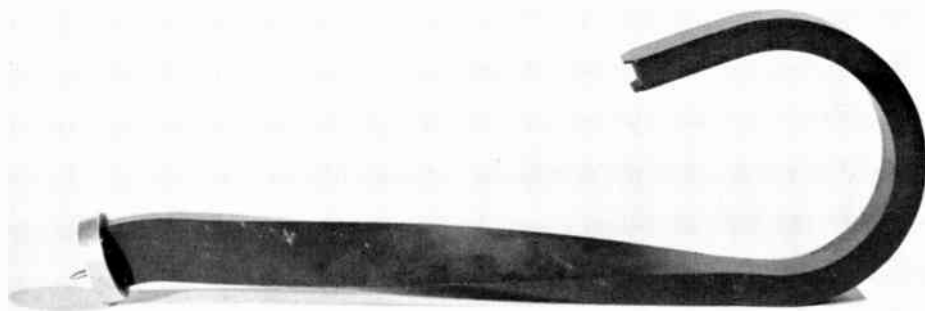

FIG. 1. The "twisted" feed line for RCA TTR Relay equipment designed to provide vertical polarization. This is interchangeable with the standard feed line.



0

0

0

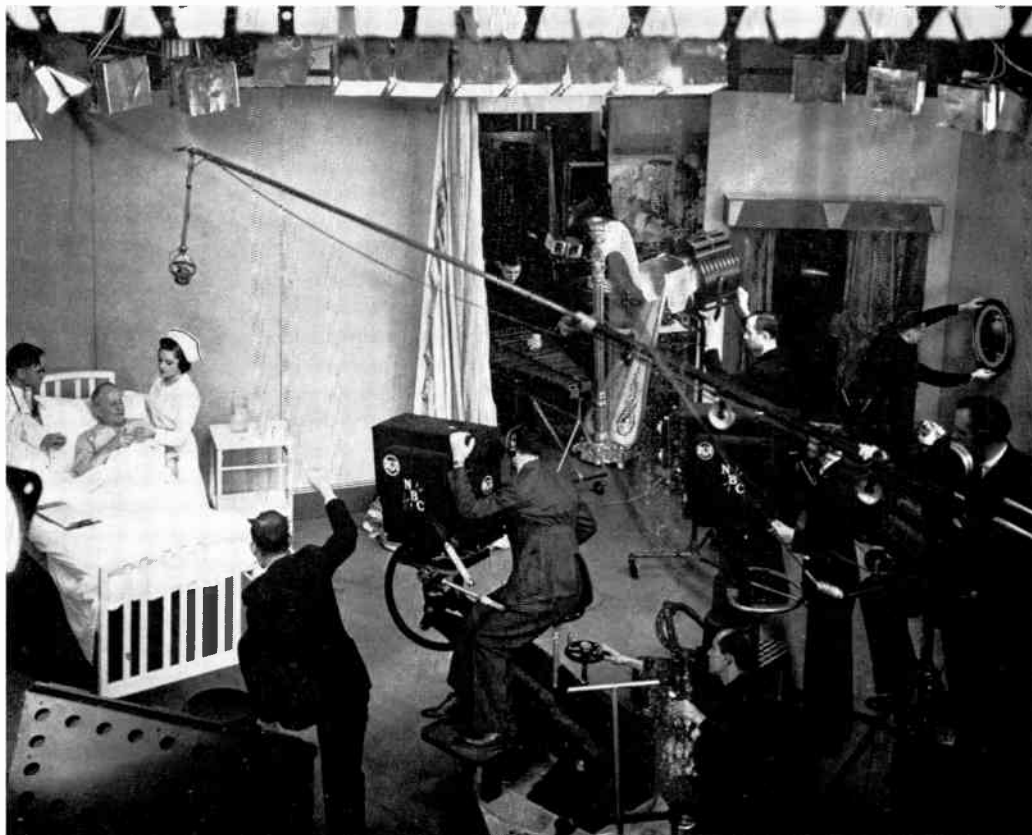

FIG. 1 (at left). In early television, studio lighting techniques and equipment were patterned after motion picture practices.

# TV STUDIO ILLUMINATION\*



The evolution of television has been so rapid that the present equipment and results can scarcely be identified with the original apparatus. The advances in new studio equipment transmission and reception have created entirely new requirements for present day operation on a sound technical and economic basis. One of the most significant elements which has contributed to this advance has been the development of highly sensitive camera pickup tubes. Since studio illumination plays such an important part in realizing the advantages to be gained from the proper use of these new pickup tubes, it is appropriate that the methods and techniques employed be carefully scrutinized.

In the early days of television experimentation around 1936, lighting equipment was similar to that used in the motion picture industry, Fig. 1. Very shortly thereafter it became apparent that the actual use of some of this equipment had to be radically altered from motion picture practice because of the mobility and the number of cameras required for simultaneous use. In addition, because of the relative insensitivity of (the iconoscope) the camera pickup tube, which was then employed, a tremendous amount of light, in the order of 1000 to 2000 footcandles incident, was required. As a result, large cumbersome units, radiating an uncomfortable amount of heat, were displaced by clusters of reflector lamps mounted in special fixtures as shown in Fig. 2. This system led to a much greater flexibility in manipulating the light sources and clearing the floor for greater camera freedom and provided broad diffuse light but did not solve the problems of heat. A further difficulty existed in obtaining a satisfactory degree of modelling light because of the high foundation light necessary to obtain a satisfactory picture.

The introduction of the present image orthicon was a major step forward in obtaining the excellent results some of the more fortunate people in the larger cities have almost learned to take for granted.

\* By H. M. Gurin, National Broadcasting Company, New York City, and R. I. Zahour, Westinghouse Electric Corp., Bloomfield, N. J.

FIG. 2 (at left). A progressive step was the installation of clusters of lights providing greater flexibility.

FIG. 3. Spectral characteristics of various image orthicon tubes. Advent of these tubes was a major step in solution of many lighting problems.

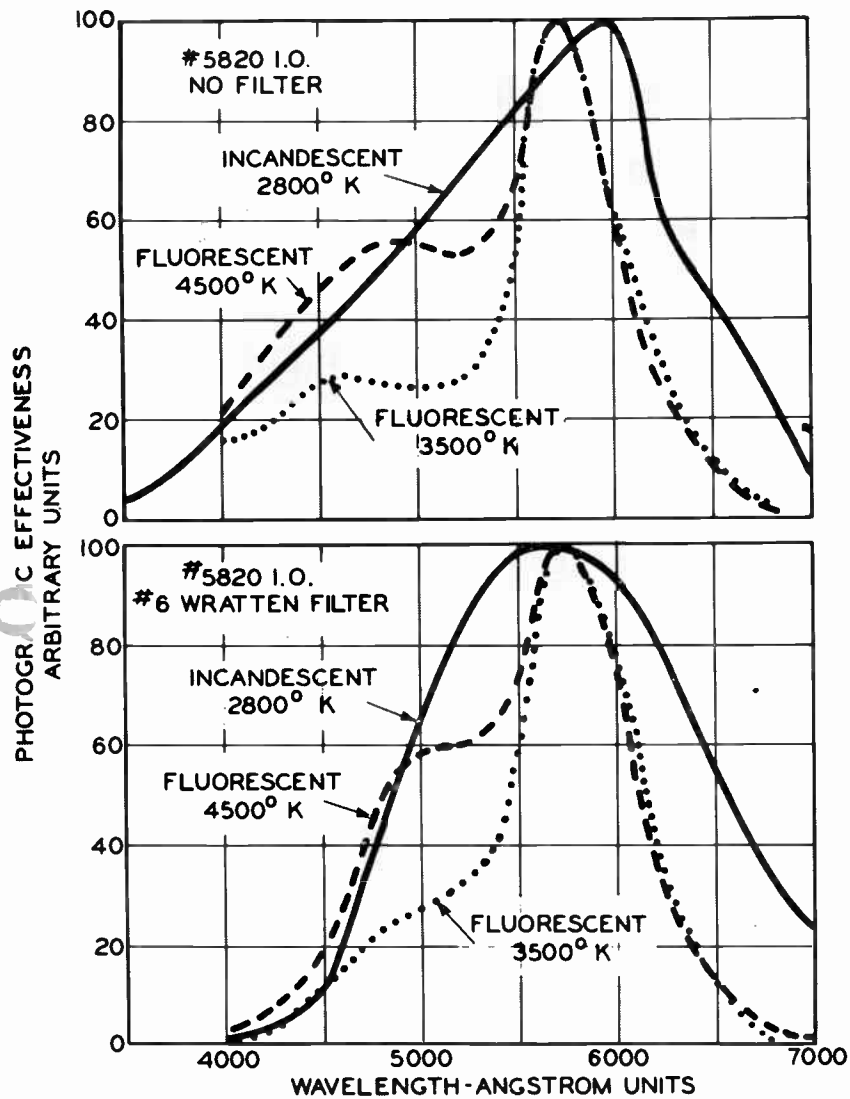

FIG. 5. Curves showing the spectral characteristics of the human eye, sunlight and incandescent light.

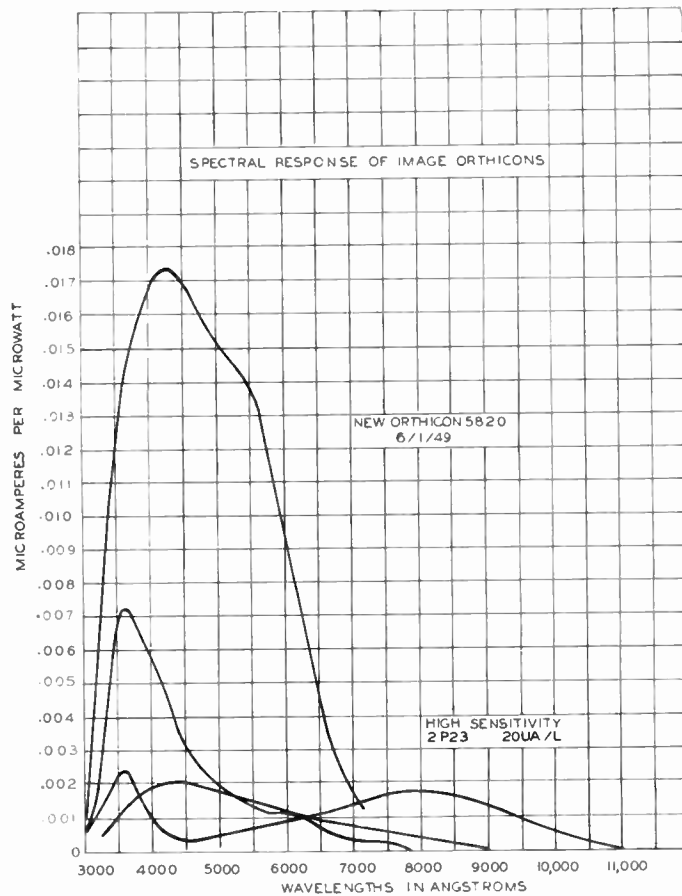
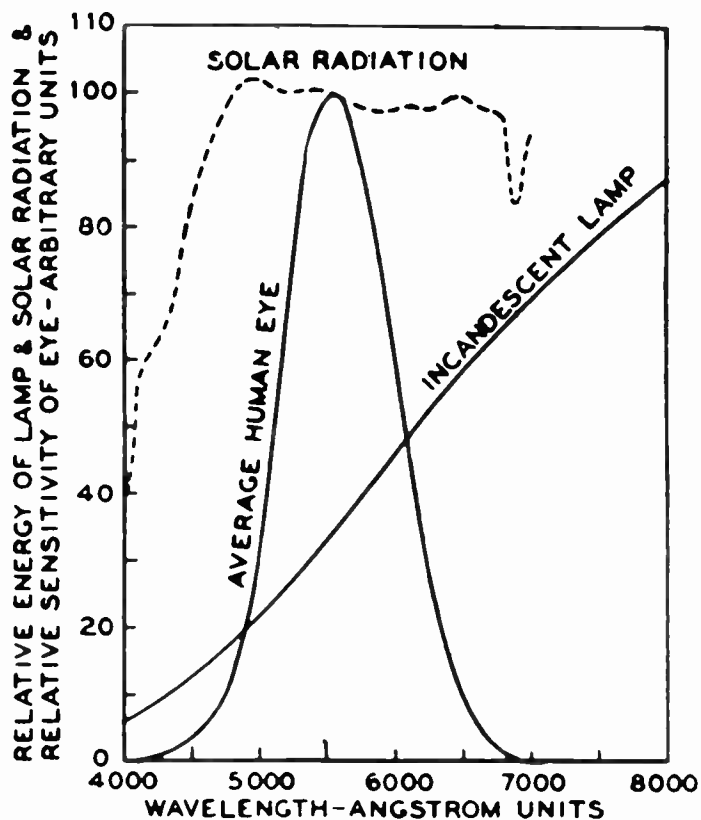

FIG. 4. Curves illustrating the spectral responses or photographic effectiveness of various commercially available incandescent and fluorescent lamps.



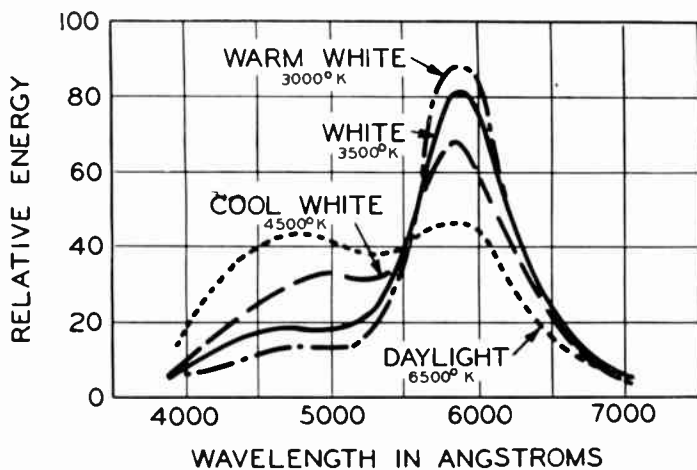

FIG. 6. Overall photographic responses may be obtained when relative sensitivity of the pickup tube and relative energy of the source (as shown by curves at left) are known.

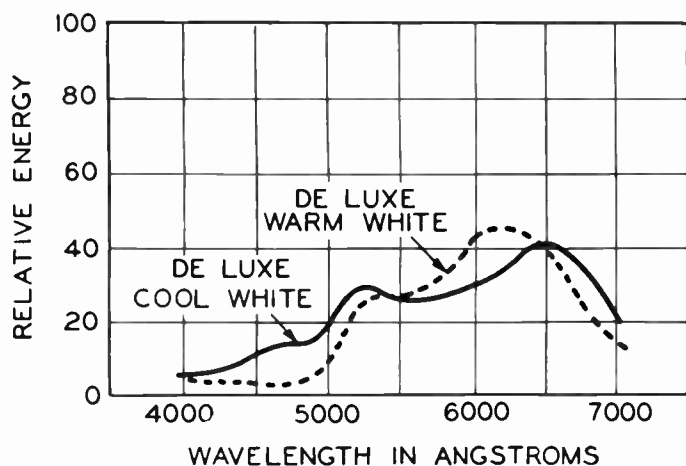
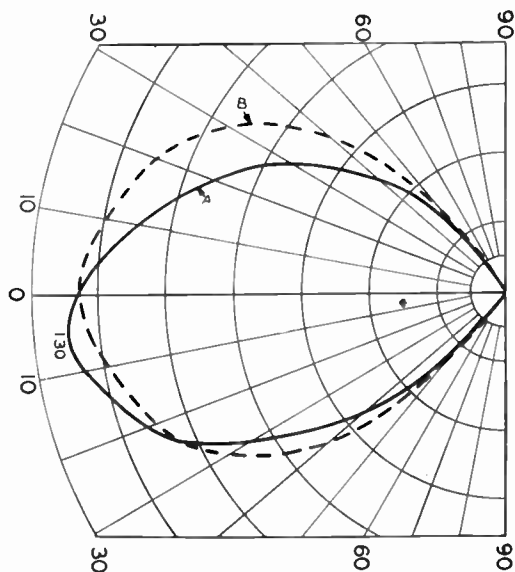
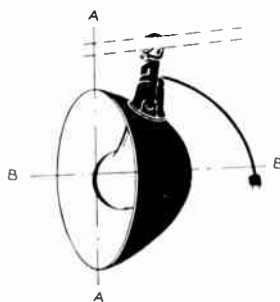

FIG. 7. Shown here is a typical incandescent floodlight used in television studio lighting to produce a wide, uniform distribution curve.



It must be borne in mind that the overall picture is affected not only by the studio lighting but by a great many other factors which are probably not so obvious to the casual viewer. The alignment of the camera pickup tube itself with respect to its tonal gradations of the gray scale (or transfer characteristic), the studio equipment, the operation of the transmitter, external interference from diathermy machines, aircraft, ignition systems, r.f. multiple reflections, antenna orientation, etc. and, last but not least in importance, the actual alignment and adjustment of the receiver, all affect the end result. Unfortunately, criticism of the picture quality too often has been directed to the lighting without due consideration of the factors just mentioned.

### Problem

The ability to obtain suitable lighting in a television studio is complicated by the need for uninterrupted action which can be instantaneously transferred from one field of view to another. There is no time to halt action on the set while resetting camera positions, adjusting lenses for different depths of field, readjusting lights, etc., as is possible on a motion picture set where usually only one camera is used. The instantaneous switching from one scene to another without mutual interference of lights adds to the complexity of the operation.

A problem, however, common to both motion pictures and television studio practice, is the need of selecting the proper quality of light for a given camera pickup characteristic to obtain a satisfactory rendition of colors in a suitable gray scale for black and white pictures. The solution of this difficulty will permit the use of color

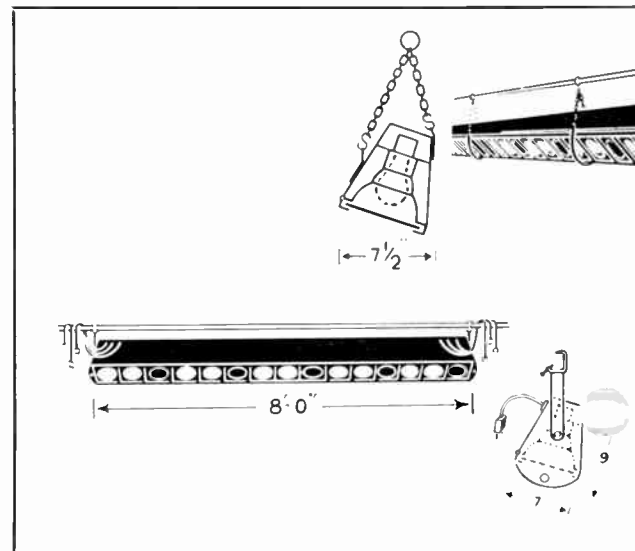

in scenery and costuming with its associated favorable psychological effect on the performers.

Another problem which faces television has been the limited space, usually converted broadcast studios, in which operations were carried out. As a result, the physical factors of size, weight of equipment, ease in manipulation and general handling are important considerations. In addition, the problem of heat dissipation for the required illumination cannot be ignored.

### Methods of Attack

The need for suitable lighting has long been recognized and even with the advent of the image orthicon pickup tube the problems of correct illumination properly applied have not been completely solved but definite strides to an acceptable solution have been made. It has been found that a light source should provide spectral characteristics correctly related to that of the camera pickup tube used and psychologically suited to the participants within the television studio. The spectral characteristics of several different image orthicon tubes are illustrated in Fig. 3. Figs. 4 and 5 show the spectral characteristics of a number of available fluorescent lamps as well as that of sunlight, the average eye response and of the conventional filament or incandescent light.

When the various light sources are combined with a #5820 image orthicon, the pickup tube now being rapidly accepted for studio use, an over-all photographic response can be plotted by multiplying

FIG. 10 (below). Strip lights made up of a series of incandescents are supplied in lengths from three to eight feet.

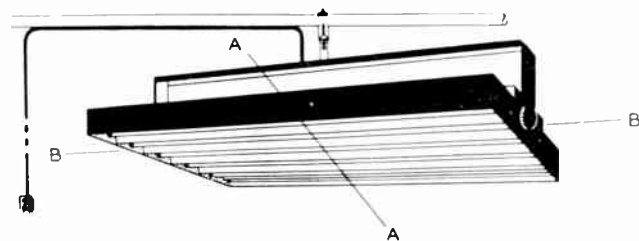
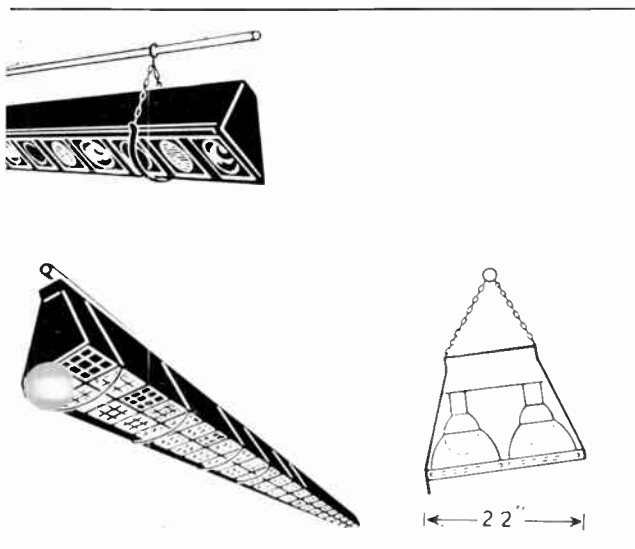

FIG. 8. Typical fluorescent floodlights (equipped with reflectors for four or six lamps) also produce wide, uniform distribution curves.

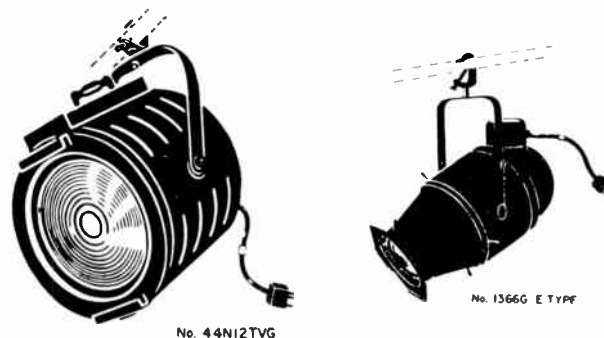
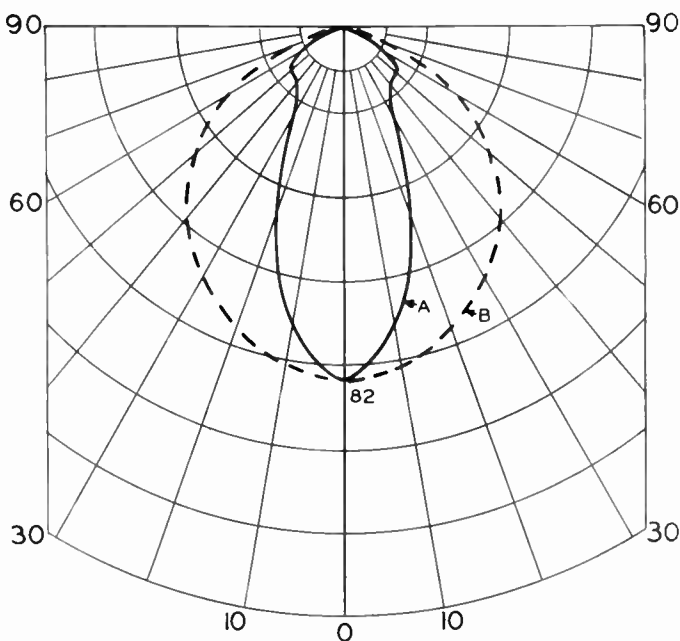
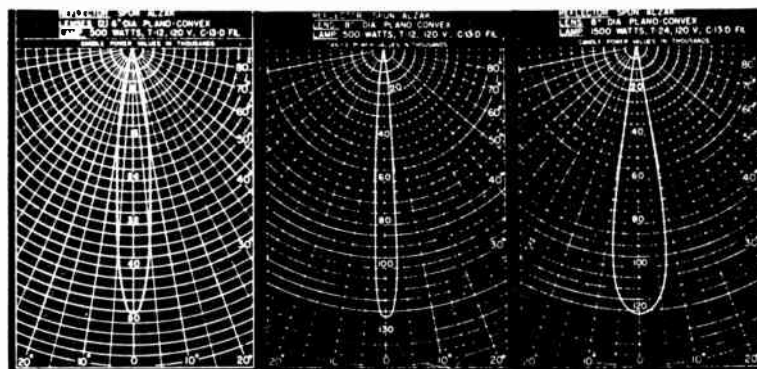
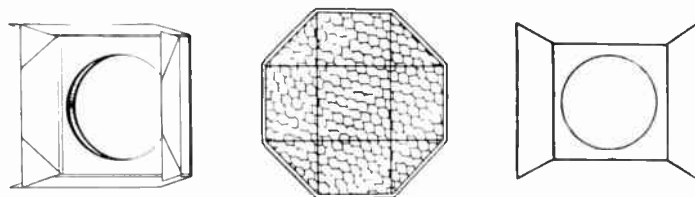

FIG. 9. Spotlights like those shown here are usually furnished with spherical Alzak reflectors.



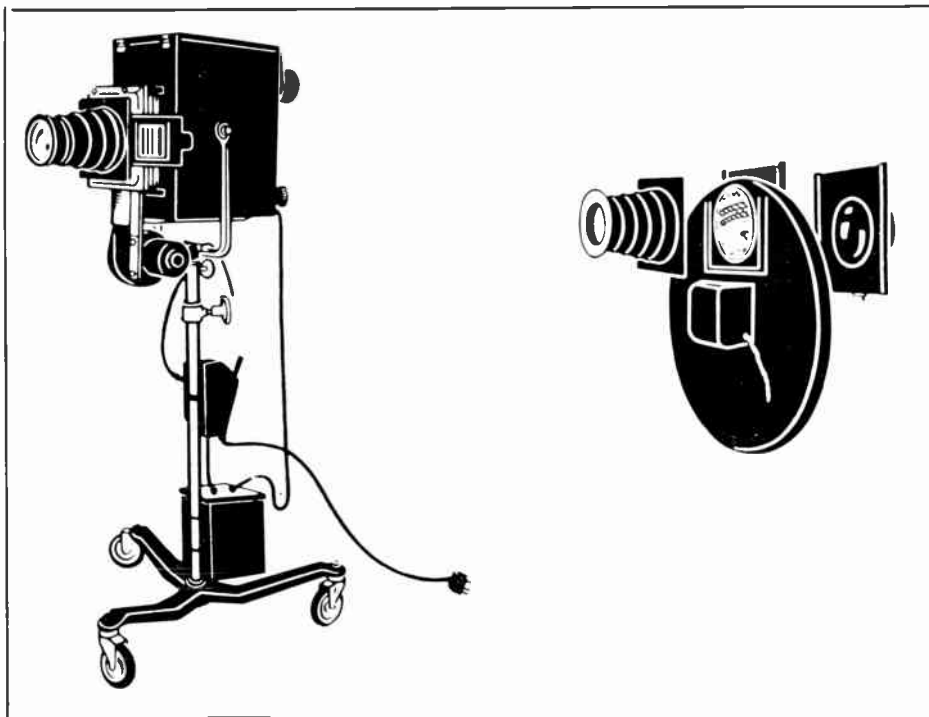

FIG. 11 (above). Effects lighting is sometimes created by use of projectors with motor-driven effects discs.



the relative sensitivity of the pickup tube with the relative energy of the source as shown in Fig. 6.

It will be noted that when an incandescent light source is used, the combination leads to a curve which approaches the contour of the average eye response. This is significant since it leads to a tonal rendition in the gray scale which can be readily reconciled to the actual colors used in the scene. This objective can also be obtained with fluorescent light if a Wratten #6 filter is used at the camera. Because of these fortunate circumstances, fluorescent lights can be mixed with incandescent to excellent advantage.

No light source, however well matched to the pickup device, is efficiently utilized without a satisfactory reflector and housing.

In television studio lighting such equipment may be classified into four types:

- |                   |                    |
|-------------------|--------------------|
| 1. Floodlights    | } with accessories |
| 2. Spotlights     |                    |
| 3. Strip Lights   |                    |
| 4. Effects Lights |                    |

1. In general, floodlights are of the incandescent or fluorescent type.

Incandescent floods are scientifically designed hyperbolic aluminum reflectors of matte Alzak finish weighing about 5 to 7 pounds. Fig. 7 illustrates a typical incandescent floodlight and its wide, uniform distribution curve. Floods are made in sizes from 10 to 18 inches in diameter for use with lamps from 250 to 2000 watts. They are useful in providing a wide angle distribution of uniform illumination of moderate intensity.

Fluorescent floodlights consist of a rectangular aluminum housing 44 to 65 inches long, 3½ to 5 inches deep, and 16 to 44 inches wide, equipped with 60 degree specular parabolic reflectors for either four or six lamps. Fig. 8 illustrates a typical fluorescent floodlight unit with its wide, uniform distribution curve. The lamp circuits of a 6-lamp fixture, for example, may be wired to permit 1/3, 2/3 and full operation. Fluorescent fixtures weigh from 39 pounds with 6—64 inch Slimline lamps to 64 pounds with 6—40-watt pre-heat fluorescent lamps. Ballasts are usually housed separately from the fixture and located as remotely as possible to reduce transmission of audible hum.

FIG. 12 (at left). TV studio lights are often suspended on pantograph devices as shown here.

2. Spotlights usually assume the form of a cylindrical ventilated metal housing built in sizes for plano-convex or Fresnel lenses of 3 to 16 inches diameter, with projection lamps from 75 to 5000 watts respectively. These spots are generally provided with spherical Alzak specular reflectors and lampholders with an external adjustment handle which permits beam spread variations of 5 to 50 degrees, Fig. 9. A frame on the front accommodates such accessories as barn doors or diffusers to mask the beam pattern or soften the light. Some spotlights have an inbuilt iris which permits a variation of sharply defined beam spreads of high intensity for creating artistic effects.

3. A strip light, as the name implies, is a metal trough-like fixture which houses a series of similar incandescent sources such as the PAR-38 or R-40 lamps, either spot or flood, or aluminum reflectors with 200- to 500-watt lamps, Fig. 10. They are made in lengths from 3 to 8 feet with 6 to 15 outlets respectively usually wired to 3 circuits. Strip lights produce general shadowless illumination of low intensities, and serve in providing a uniform light on backgrounds, walls and such, from overhead or side borders. Spread lens roundels and diffusers are available for modifying light beams of the individual lamps.

4. Effects lighting creations are often produced by a projector equipped with a motor-driven "effects disc" painted to create scenes such as moving clouds, moonlight water ripple, rising fire or smoke, falling leaves, ocean waves, and many other effects. Fig. 11 shows a schematic view of an effects device.

### Equipment Facilities

Good television studio practice favors the installation of a permanent grid which resembles an architectural system of rigid 1½ inch iron pipe cross members four to six feet apart, and hung as close to the ceiling as possible, with sufficient clearance for electrical raceways, sheaves, conduits or ventilation ducts above. The grid may also be temporary. When temporary, the grid structure is supported by heavy vertical pipes which are rigidly anchored to the floor or walls, but can be readily removed.

FIG. 14 (at right). View of TV studio lighting arrangement where flexibility is essential to accommodate a variety of programs.

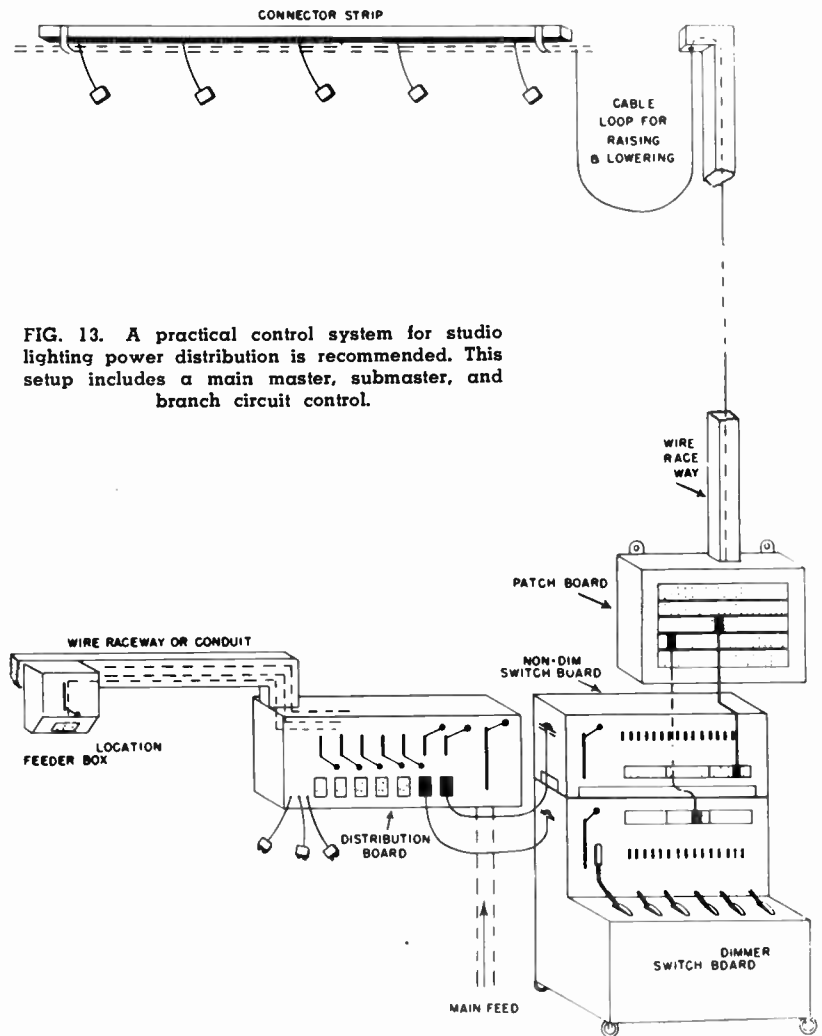

FIG. 13. A practical control system for studio lighting power distribution is recommended. This setup includes a main master, submaster, and branch circuit control.

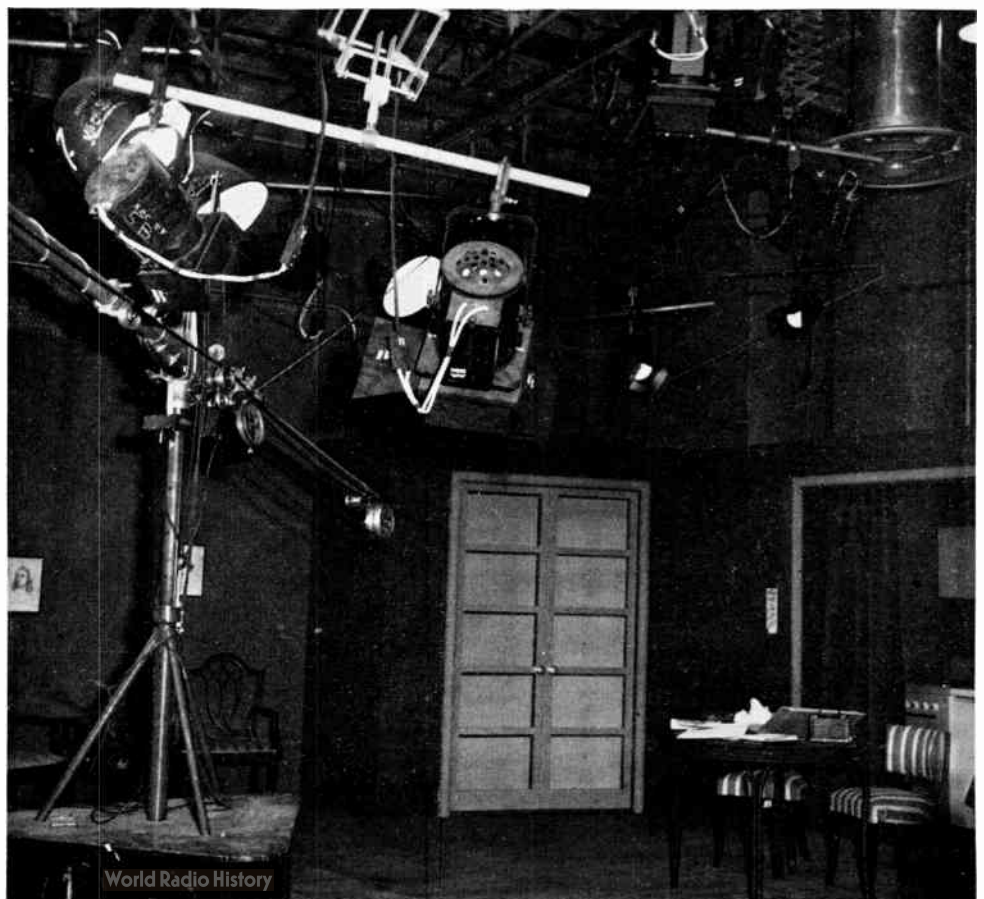

FIG. 15. A lighting arrangement in which frequent scenery changes and camera movements may require rapid manipulation of lights.



FIG. 16 (below). In this studio scene overhead spots and floods are manipulated to produce desired lighting effect.



In some television studio installations, catwalks above or around the grid are used for making adjustments, hanging scenery, etc. However, the sacrifice in the effective studio height due to catwalks may in some cases present a serious disadvantage.

It has been found good practice to suspend lighting equipment on pantograph devices spaced on 4- to 6-foot centers and fastened rigidly to the grid structure, Fig. 12. The pantograph is constructed to prevent any side-sway, yet it permits raising or lowering of a lighting unit with its cable feeder from 18 feet to 4 feet above the floor, while a universal clamp allows 360-degree horizontal rotation and 90-degree tilting of the fixture.

#### Electrical Control

An adequate electrical control system for television studio lighting consists of:

1. A system of power input.
2. A system of controls.
3. A circuit terminating patch or connecting panel for conveniently energizing branch circuits.
4. A system of branch circuits permanently and conveniently distributed over the studio area.



### 1. Power Input.

Experience and present practices indicate that 20 to 40 watts per square foot of studio area is adequate for power requirements. Meters are usually provided on input lines so that the loads may be balanced and phased properly on a 3-phase system.

### 2. System of Controls.

A practical system of control in which power input is distributed, consists of a main master, submaster, and branch circuits which are easily manipulated through controls and switches that operate quietly. Since blackouts should be possible, a master switch is provided for all studio lights except "work lights", while a submaster switch controls all studio lights over a given work area. Fig. 13. Fused branch circuits terminate at a switching panel which are connected by a patching or connecting system to outlets distributed throughout the studio. All panels and switchboards should be located at a convenient position within the studio so that the lighting man can view the scene. In the over-all scheme, power is patched to the dimmers and the dimmed output is then connected through switch controls to the individual branch circuits appearing on wall patch panel. Dimmers are used only for effects such as fades, but not for control of the amount of light.

Branch circuits are usually heavy enough to carry up to 2000 watts capacity. For special lighting effects, some grid circuits are wired to carry 5 KW. A majority of the branch circuits terminate at the grid, while the others feed wall outlets. It is considered good practice to provide one branch circuit for 20 to 30 feet of floor area.

### Applications

The application of these basic principles for power distribution and lighting controls can be adapted to various sizes of studios which can be classified into three categories.

The first, which requires the greatest degree of flexibility, may be called the general purpose or workshop studio. Herein originate a wide variety of dramatic performances, commercial sequences, and almost any type of small musical or speech groupings. In a studio of this type the maximum mobility in scenery changes and camera movements are essential. As a result, the lighting system must also be capable of matching these requirements both in physical manipulation and in beam pattern and intensity control. Figs. 14,

FIG. 17. In theatre type studios where audiences are present, modelling light equipment may be located in the wings.

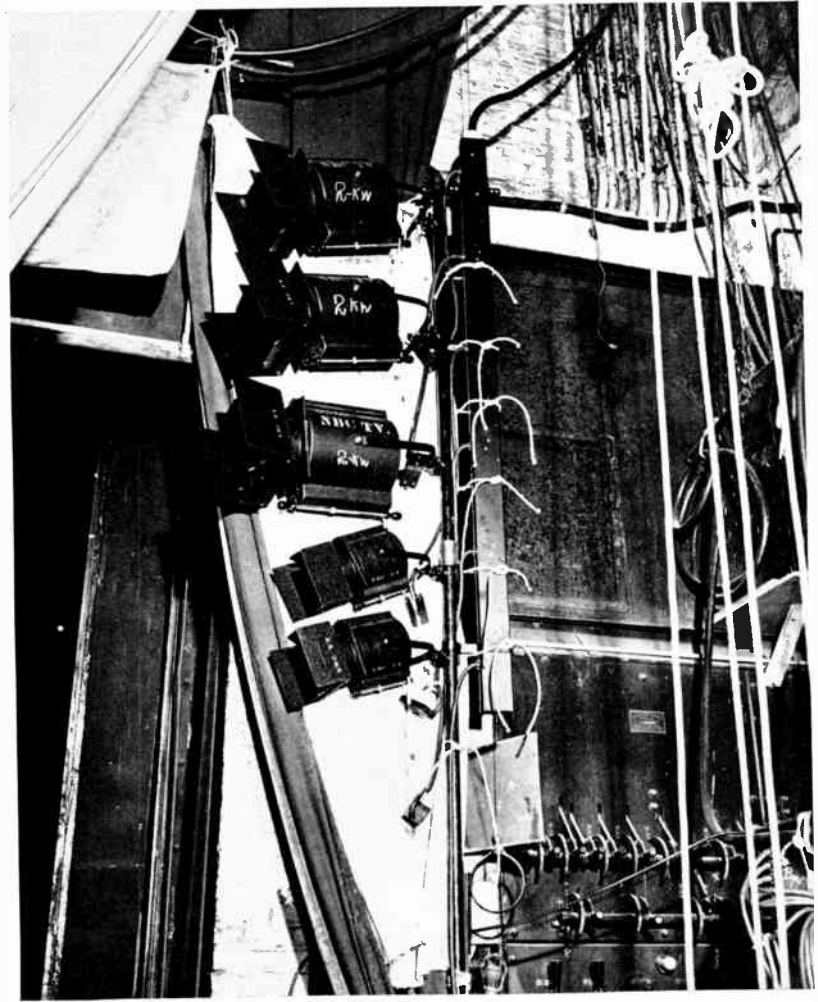

FIG. 18 (below). Another possible position for theatre studio lighting equipment is on a platform adjacent to a loge.

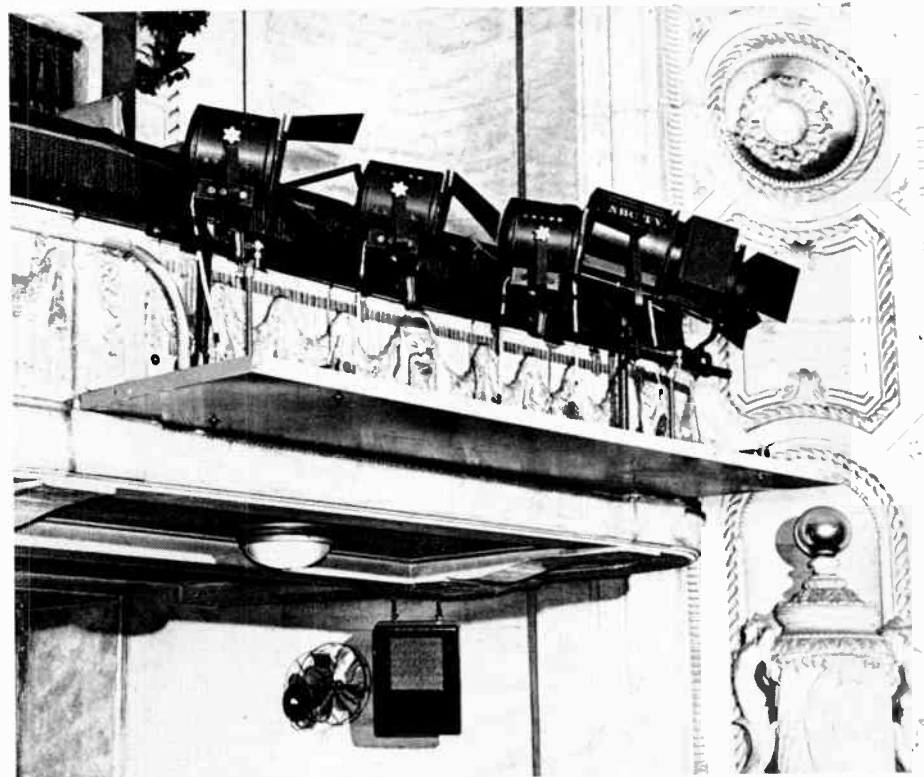



FIG. 19 (above). View of an NBC theatre studio illustrating the lighting arrangement utilized.

15 and 16 illustrate studios wherein the most recent developments have been incorporated.

The second type of studio frequently used for television programming is the one in which an audience is present and which is used chiefly for theatrical presentations as in a variety show of the "Your Show of Shows" type. Here the television point of view is that of an observer in the theatre and varies primarily not so much from different angles as from the area of view between a close-up and a long-shot. The lighting problems are consequently not as complicated as in the workshop studio but results suffer sometimes from inadequate front fill light. Footlights are used only to a limited extent because of the unnatural effects produced. Follow spots have been found to be satisfactory for long-shots but usually fail to improve the appearance of the principal characters on close-ups because the sharp beam creates harsh shadows, and lines around the eyes, nose and mouth. Color gelines (frequently used in theatres to create pleasing

color tones to the theatre audience) are almost completely lost to the television audience and introduce an undesirable change in the gray scale.

Much lighting equipment is supported on battens and hoisted above the stage together with other scenic material. Lower angle light for modelling is obtained by the use of standards located in the wings or on the sides of the theatre, Figs. 17 and 18. Fig. 19 illustrates how the lighting effects are produced in the NBC Studio at The International Theatre in New York City.

The third type of studio to which the facilities previously described can be applied on a small scale, is the one in which the set is essentially fixed in position and the program material is repetitive. The lighting can be fixed if desired once the original plan has been established. Under such conditions there is little reason for not achieving desirable artistic effects obtained with spotlights for backlighting, accents, together with floods for fill and base lighting since they add a great deal to

the pictorial quality. Such a studio can be used, for example, for newscasting, interviews, quiz programs, kitchen demonstrations, etc.

Having described the equipment and space in which the programs are to originate, the development of applications and techniques can be more readily studied.

### Quantity of Light

For general illumination over a working area, intensities ranging from 2 to 150 foot-candles may be used, depending upon the nature of the scene. This general illumination or incident light is measured with the color-corrected light sensitive surface of the meter facing the camera lens and perpendicular to the lens axis.

As a guide, the average footcandles of incident light required for the Type 5820 orthicon, range between 32 and 64, with a lens opening of f:8. Lens stops normally used to give sufficient depth of field lie between f:5.6 and f:8. The Table, Fig. 21, lists footcandles of incident light for various lens openings. The inherent characteristics of the pickup tube limit the high-light to shadow or contrast ratio for an average scene to approximately 30 to 1.

### Studio Lighting Technique

Studio Lighting technique may be described in accordance with the following types:

1. Base or General Lighting.
2. Key Lighting.
3. Accent Lighting.
4. Fill Lighting.
5. Effects Lighting.

1. *Base Lighting* is a uniform, wide distribution of low intensity illumination which covers the set, and may be provided with either incandescent floodlights or fluorescent lamps.

Where fluorescent equipment is used for base illumination, and provides a considerable percentage of the total illumination on the set, a #6 Wratten filter should be used on the camera lens to correct for color rendition.

2. *Key Lighting* is principal illumination which falls on a subject from light coming through a window, an open door, or fireplace, or at any point where action takes place. Spotlights with accessories and effects lighting devices are engaged to produce this key light.

Modelling lights are used to enhance the appearance of a subject, and for creating artistic effects. For this purpose, Fresnel lens spotlights, equipped with adjustable blinds and diffusers, find application.

Back Light is used to create the illusion of separation between the subject and the background, and to produce the artistic effects such as glistening highlights from the hair. Fresnel lens spotlights, with "barn doors" to control the spill light or shape the beam patterns, are used for this application.

3. *Accent Lighting* includes key lighting, modeling lights, and back lighting.

4. *Fill Light* is employed to add more light to portions of the subject or set to bring out more detail in the shadows, by adding some diffused light on the face of a subject opposite to a key light source. Narrow beam floodlights equipped with diffusers, or Fresnel lens spotlights with diffusers, are engaged for this purpose.

5. *Effects Lighting*—An important part of the interest in a television performance is maintained by the special lighting effects which are introduced to simulate realistic scenes. This is particularly true in the case of firelight, cloud effects, and window light created by equipment previously described. More recently, a technique was borrowed from the motion picture studios in simulating backgrounds and moving scenery as from a train window, the back of a car, etc., by using rear screen projection. Fig. 20 indicates how this is done. Care must be exercised in relation to perspective; distance between the live subject and the screen to avoid unwanted shadows; and the amount of front light to avoid washing out the projected picture. If motion pictures are used, the problem of synchronizing the frame frequency of the projector to the television camera must also be overcome. Fortunately, new equipment has been built which has satisfactorily solved this difficulty. It is obvious that outdoor settings can be quickly and economically reproduced. When stills can be used, the cost of backgrounds has also been sharply reduced and the variety of settings increased in proportion to the number of slides available.

### Conclusion

With an accumulation of experience and knowledge of the requirements, television studio lighting techniques have reached a point where definitely planned schemes and practices can be recommended to produce artistic effects and good pictures. The best results, however, can be obtained only through imagination and originality in applying the fundamental principles.

It may be well to point out that the final criterion in appraising studio lighting cannot be judged by results obtained on the home television receiver alone. The studio-to-home span includes not only a

properly lighted studio scene, but also properly-functioning transmission facilities, and a good quality, correctly adjusted home receiver and antenna. Good pictures are the result of efforts on the part of all of those who form the chain of facilities which link the studio scene to the television receiver.

Our appreciation and thanks are expressed for the helpful aid received from the engineering staffs of NBC, RCA, and Westinghouse Lamp Division, in the completion of the material and charts contained herein.

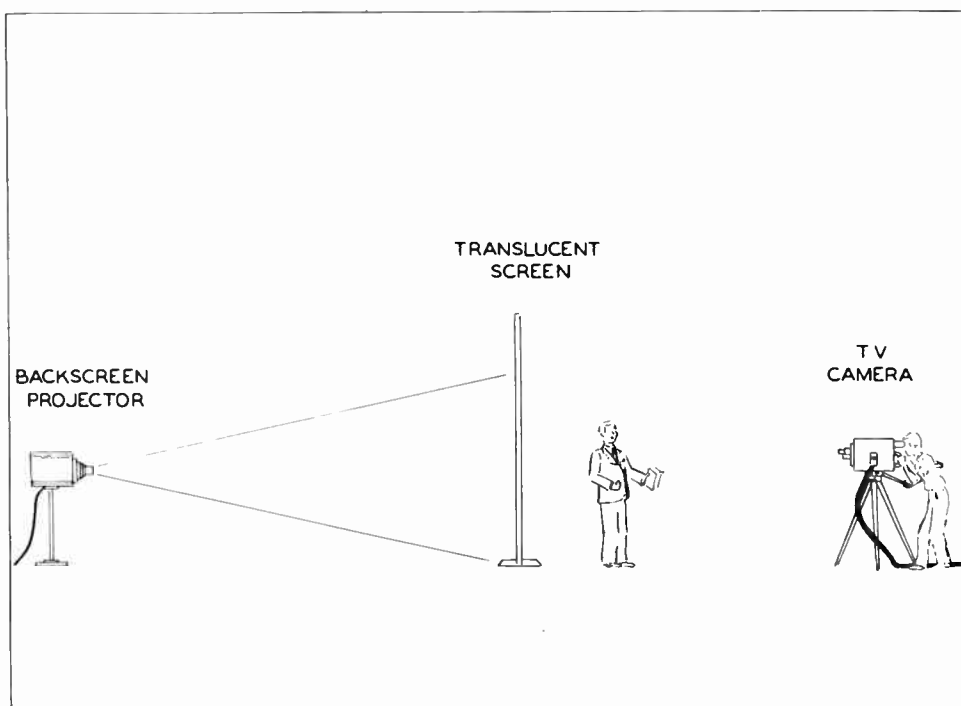

FIG. 20 (above). Moving scenery may be simulated by means of back-screen projection.

### INCIDENT LIGHT REQUIRED FOR RCA IMAGE ORTHICON 5820

LENS STOP	INCIDENT LIGHT
f:1.9	2-4 Footcandles
2.8	4-8
3.5	6-12
* 5.6	16-32
* 8	32-64
11	60-120
16	120-240

\* Normally used.

FIG. 21. Table.

# Monitran, House Monitoring Transmitter, TM-30A

## FEATURES

- Single coaxial r-f distribution for TV station monitoring
- Crystal controlled picture and video signals for closed circuit
- Transmits on any one of the standard TV channels (2 to 13)
- Designed for rack mounting
- Internal 400 cycle modulation or external program audio
- Multiple operation of units to a single distribution cable
- Operates as a non radiating transmitter
- No video distribution amplifiers required

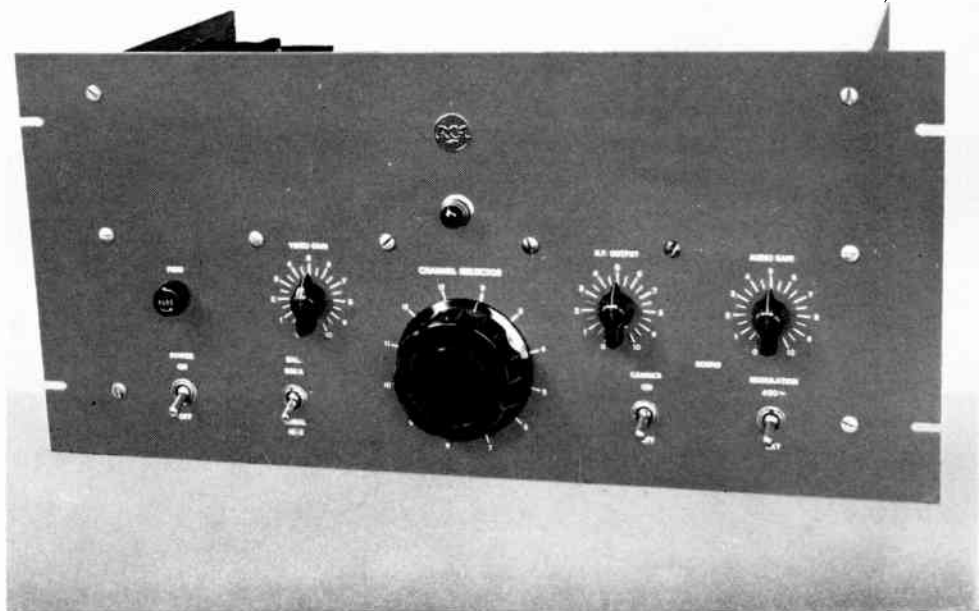

## USES

The RCA Type TM-30A Monitran is designed to produce a standard TV broadcast signal for the closed circuit distribution of monitoring signals to standard TV receivers. The unit develops both a picture and a sound carrier on any one of the VHF channels 2 to 13 and requires only a single coaxial cable to feed its monitoring signal to a number of receivers at any point in the studio building.

In using standard TV receivers for monitoring, it was previously necessary to deface the receiver in order to provide both video/audio connections and at the same time required two cables running from the master control. Due to long runs and mismatches, high quality was rarely available to properly operate the receivers. By incorporating the Monitran, however, only a single cable need be run and the termination made on the antenna input of the receiver.

A number of Monitran units can be used simultaneously on different channels to provide a selection of signals at the TV monitor receiver. For example, three units could be incorporated by tying their outputs together by an inexpensive resistor matching network and the common r-f output in turn connected to the house coaxial feed line.

If we'll say the three units were transmitting respectively the audio and video signals of "Audition," "On Air," and "Network" on channels 2, 7, and 11, then any one of the monitoring receivers can tune to any channel desired.

## DESCRIPTION

The Monitran consists of a twelve channel crystal controlled oscillator, frequency multiplier, and amplifier turret which produces the r-f picture carrier on each TV channel. Rapid channel selection is obtained by a selector switch on the front panel with no adjustments necessary when switching from channel to channel. The r-f output is 50,000 microvolts into a 75 ohm terminated coaxial cable and can be varied by means of an accessible control. The video signal is obtained from an external source of 75 ohms impedance and 1 volt peak-to-peak. A continuously variable front panel input control permits varying the percentage of picture modulation from 0 to 87%.

The FM sound carrier has two components 4.5 mc above and below the picture carrier; only the upper sideband is used by the TV receiver while rejecting the lower. Modulation of the sound carrier is obtained from the associated 6 milliwatts audio signal of the picture program or by means of a switch as the panel be modulated by a 400

cps internal audio oscillator. A standard 75 microsecond pre-emphasis network is incorporated, and 40 kc deviation can be obtained. The deviation is continuously variable by means of a panel control. Sound modulation may be turned "ON" or "OFF" by means of a panel switch. A switching facility is also available to change the external audio input from 600 ohms to unbalanced high impedance.

An electronically regulated power supply assured stable performance regardless of line voltage fluctuations between 105 to 125 volts.

The Monitran is finished in standard RCA dark umber gray and standard coaxial connectors are used for all video and r-f terminations at the rear. The audio is terminated in a Jones type barrier strip also at the rear of the chassis.

Finish ..... Dark umber gray  
 Weight ..... 45 lbs.  
 Shipping Weight (approx.) ..... 50 lbs.

**Electrical**

R-f Output:  
 Frequency.....Picture and sound on any one of VHF Channels 2 to 13  
 Accuracy.....Picture carrier to 0.01%, sound carries to  $\pm 4.5$  kc  
 Level.....Variable to 50,000 microvolts  
 Termination .....75 ohms  
 Video:  
 Input Impedance .....75 ohms  
 Input Level.....1 volt peak-to-peak (black neg. polarity)  
 Carrier Modulation.....Variable from 0 to 87%  
 Audio:  
 Input Impedance .....Balanced 600 ohm or high Z  
 Internal Modulation.....Switchable to 400 cycle osc.  
 Carrier Deviation.....0 to 40 kc  
 Input Level.....6 milliwatts  
 Power Input and Supply...80 watts, 60 cycle, single phase, 105-125 VAC

**SPECIFICATIONS**

**Mechanical**

Panel Width ..... Standard 19"  
 Panel Height ..... 8 $\frac{3}{4}$ "  
 Depth ..... 10"

**Tube Complement**

2 12AJ7	1 5Y3GT
1 6BE6	1 NE 16/991
1 6U8	1 12AT7
1 12AX7	2 6AU6
1 6Y6G	1 6AS6

Stock Identification ..... MI-26499  
 (Complete with one set of tubes)

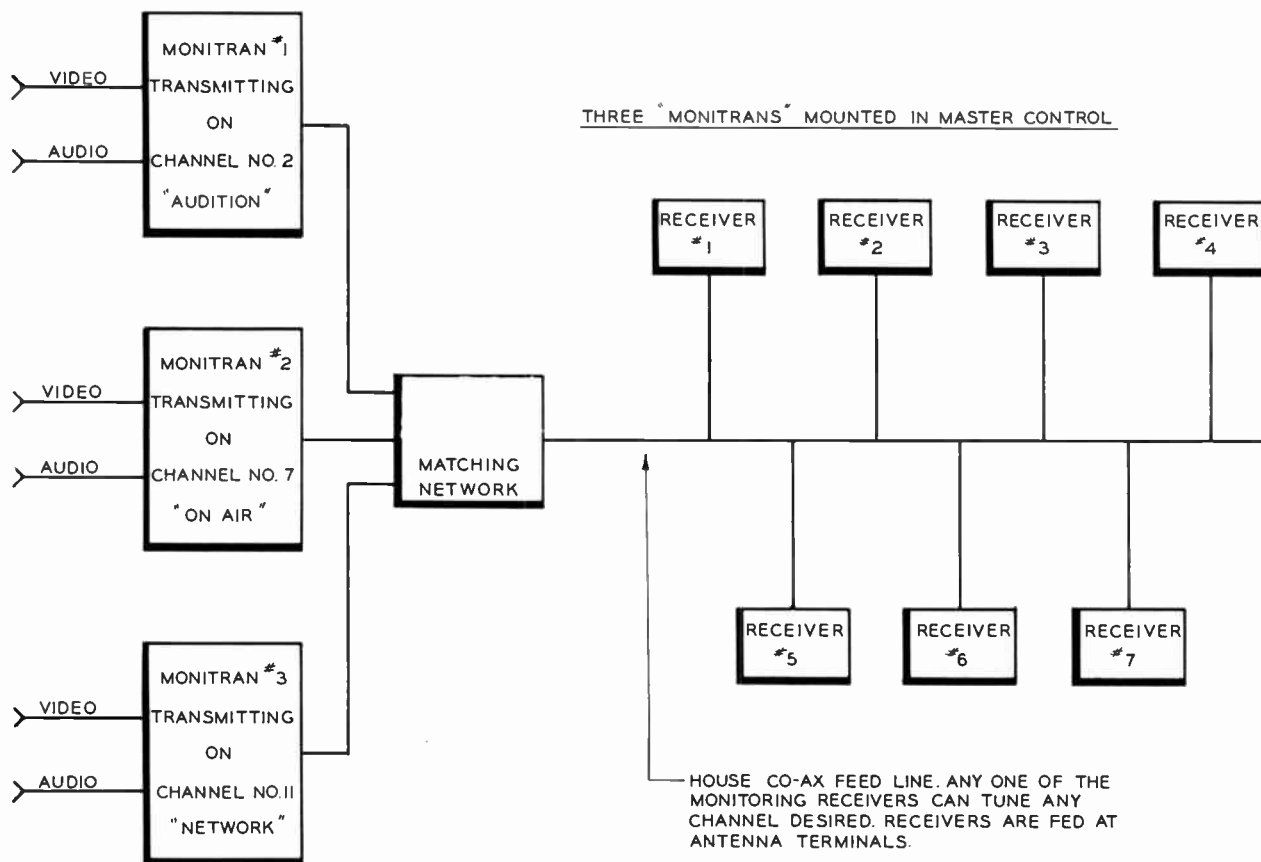

# Film Multiplexer, Type TP-9C

## FEATURES

- Uses only one film camera for two or more projectors
- Employs optical type front surface mirrors
- Mirror position adjustable
- Adds program continuity
- Designed for use with 16mm or 35mm projectors
- Employs no moving parts

## USES

A Film Multiplexer is used in the television projection room for reflecting images from two motion picture or slide projectors into a single film camera. This permits the permanent arrangement of film equipment for the maximum program efficiency. Either projector can be switched on or off electrically while the mirrors remain in fixed position.

## DESCRIPTION

The Film Multiplexer consists of a pipe-like pedestal and suitable mounting flanges. Two adjustable front surface mirrors are mounted on top of the pedestal. The pedestal

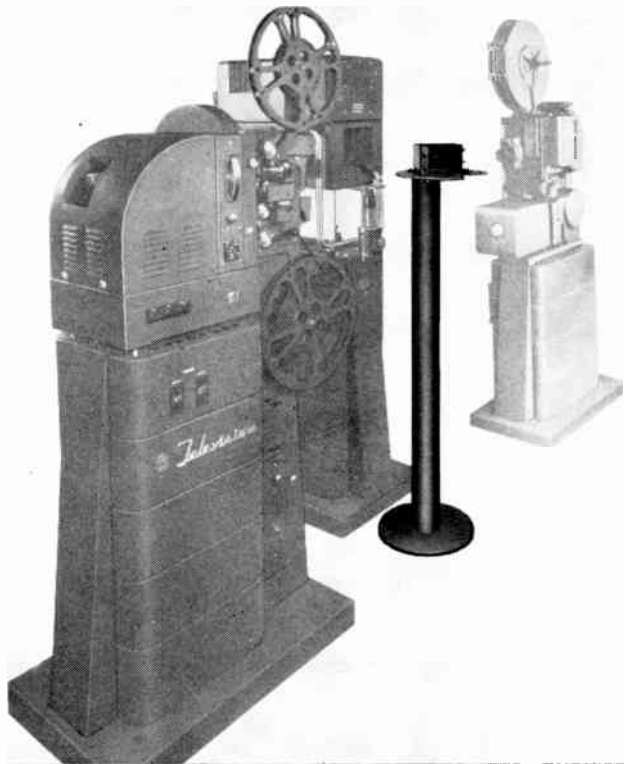

Film Projection Room Setup showing use of TP-9C Multiplexer with RCA Film Camera, TP-16D Projector and TP-35, 35mm Projector.

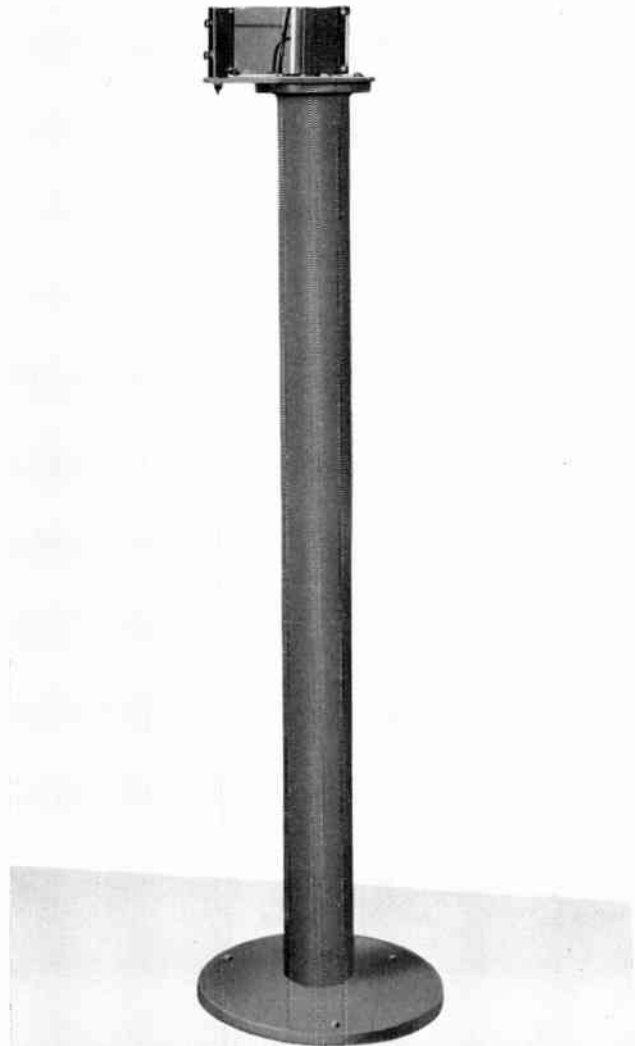

is fitted with a flange at the bottom for bolting to the floor. The Multiplexer is finished in umber gray to match other RCA television equipment.

A mount (MI-26597-X) for an automatic Slide Projector can be attached to the Multiplexer. This mount will clamp around the pedestal and at the foot of the Multiplexer.

## SPECIFICATIONS

Height .....	54"
Width .....	13"
Optical Center Above Floor .....	48"
Weight .....	40 lbs.
Stock Identification .....	MI-26318-BX

## Accessory Equipment

Slide Projector Mount .....	MI-26597-X
-----------------------------	------------

# Metal Tripod, TD-11A

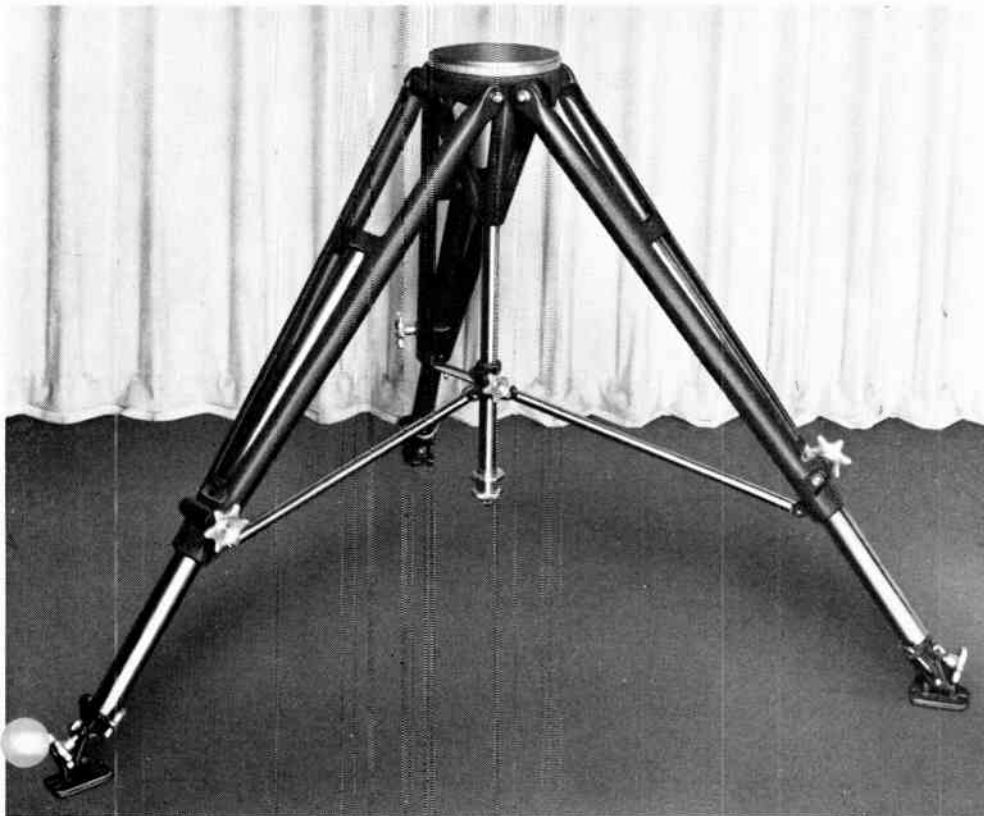

## FEATURES

- Three-point leg bracing with individual tie rods and sturdy center post insure rigidity and stability
- Extremely light in weight—yet rugged in design
- Provides mountings for field or studio cameras MI-26010A and MI-26000A respectively
- May be readily used with Tripod Dolly TD-15A
- Folds into small, compact, self-locking package for carrying
- Individual leg calibrations aid in accurate positioning and adjusting
- Attractively finished in deep umber gray wrinkle and hard chrome

## USES

The type TD-11A tripod is designed to accommodate tilt head MI-26206 which may be used in conjunction with microwave relay transmitter (TTR-1B) and microwave receiver unit (TRR-1B). The type TD-11A tripod may also be used in supporting RCA television studio and field cameras (with friction head MI-26205). When used with television tripod dolly type TD-15A, it provides a maximum of convenience and mobility for dolly operations.

## DESCRIPTION

The type TD-11A consists of an all-metal tripod structure of aluminum castings and tubular steel construction which provides a compact, lightweight, yet rugged design. It folds into a small-size unit which is easily portable. When collapsed for carrying, legs are latched to the center stabilizing post, thus preventing leg spread during transport.

In operation the TD-11A provides a "working-height" range of approximately 25 to 42 inches. Outstanding in design are individual tie rods which connect to and brace all tripod legs (these same three tie rods also couple to the center stabilizing post and provide a stable, rigid support).

The lower tubular portion of each leg is easily adjusted and slides within a long-length bearing which is held to

close tolerances. Thus, minimum play and maximum rigidity are assured throughout the working range. When tripod legs are adjusted for desired height, they may be locked in position by means of hand-operated, clamp screws. The lower end of each leg is provided with a self-aligning, universally-mounted casting, which in one plane has a flat surface for use on level flooring—and in another plane has a steel spike for use on rough surfaces. The flat-surface also provides a suitable mounting for use with Tripod Dolly, TD-15A.

## SPECIFICATIONS

Recommended Operating Heights:	
Minimum .....	25 $\frac{5}{8}$ "
Maximum .....	42 $\frac{1}{2}$ "
Maximum Diameter at Feet (legs extended).....	70"
Dimensions (folded for transport):	
Overall Height (legs collapsed).....	31 $\frac{5}{8}$ "
Overall Diameter .....	10"
Weight .....	25 lbs.
Stock Identification .....	MI-26046-A

## Accessories

Camera Friction Head .....	MI-26205-B
Tilt Head for Microwave Relay Transmitter and/or Receiver .....	MI-26204
Tripod Dolly, Type TD-15A .....	MI-25042

# Tripod Dolly, Type TD-15A



## Features

- Provides mobility for tripod camera mounting.
- Folds into compact lightweight self-locking package for carrying.
- Large diameter 5" wheels permit easy movement.
- Wheel stops provide for locking tripod in position.
- Tripod firmly locked to dolly.
- Attractively finished in hard chrome.

## Use

The Tripod Dolly is designed for use on tripods fitted with television cameras. When tripods are used indoors, which is very often the case, use of the dolly precludes any possibility of marring the floor, and provides greater mobility for the tripod. Used in the field with reasonably flat terrain, the dolly makes it convenient and easy to change the position of the tripod.

*Dolly Fitted to Camera Tripod, TD-11A*



## Description

The Tripod Dolly consists of a lightweight triangular-shaped steel structure supported on three swivel wheels, five inches in diameter. The finish is hard chrome. For convenience in transporting, the dolly folds into a package 8 x 14 x 29 inches. When extended and fastened to the tripod, it occupies a circular area 57 inches in diameter. The dolly is fastened firmly to the tripod by a clamp at each leg. Spring-loaded stop feet at each wheel serve to hold the tripod in a fixed position. Wheels may be removed readily if such should be required.

## Specifications

Dimensions (unfolded and extended) :

Height \_\_\_\_\_ 6 in.  
Diameter \_\_\_\_\_ 57 in.

Folded for transport:

Height \_\_\_\_\_ 8 in.  
Width \_\_\_\_\_ 14 in.  
Length \_\_\_\_\_ 29 in.

Weight \_\_\_\_\_ 25 1/4 lbs.  
Stock Identification \_\_\_\_\_ MI-26042

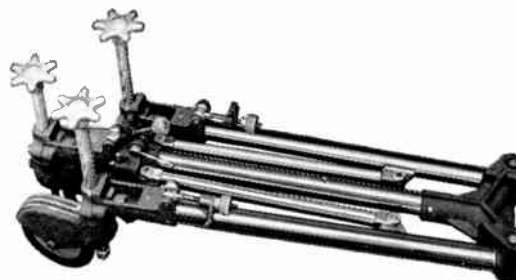

*Dolly Folded for Transportation*



# Studio Camera Pedestal, TD-1A

## FEATURES

- Pedestal moves smoothly and silently
- Ruggedly constructed for durability
- Mechanically balanced for ease of operation
- Easily maneuvered in small areas
- Attractively finished in wrinkle enamel and stainless steel

## USE

The Studio Camera Pedestal, MI-26035 provides a convenient and useful mounting pedestal for the television camera. It is designed for use in the studio and in other indoor places where telecasts might be made. Mounted on the pedestal, the camera can be moved freely and quietly about the telecasting site. A crank handle on the pedestal raises or lowers the camera to any height between approximately 40 inches and five feet above the floor. Panning and tilting of the camera is provided by a Friction Head, which although shown in the photograph, is supplied separately, as MI-26205-B. The Friction Head, which can be used to mount either field or studio type RCA cameras to the pedestal, is described in detail on a separate sheet.

## DESCRIPTION

The illustrations show the Studio Camera Pedestal with and without camera mounted. As previously mentioned, the wheel with the crank handle is used for raising and lowering the camera. Because of fine mechanical balance in the gear mechanism, very little effort is required either to raise or lower the camera.

The large wheel steers the three rubber-tired wheels on which the pedestal rides. In steering, these three wheels turn in any direction simultaneously because of a chain which links them together. The small pedal shown lowers a caster which effectively raises a wheel and makes the pedestal maneuverable about a point. The pedestal is

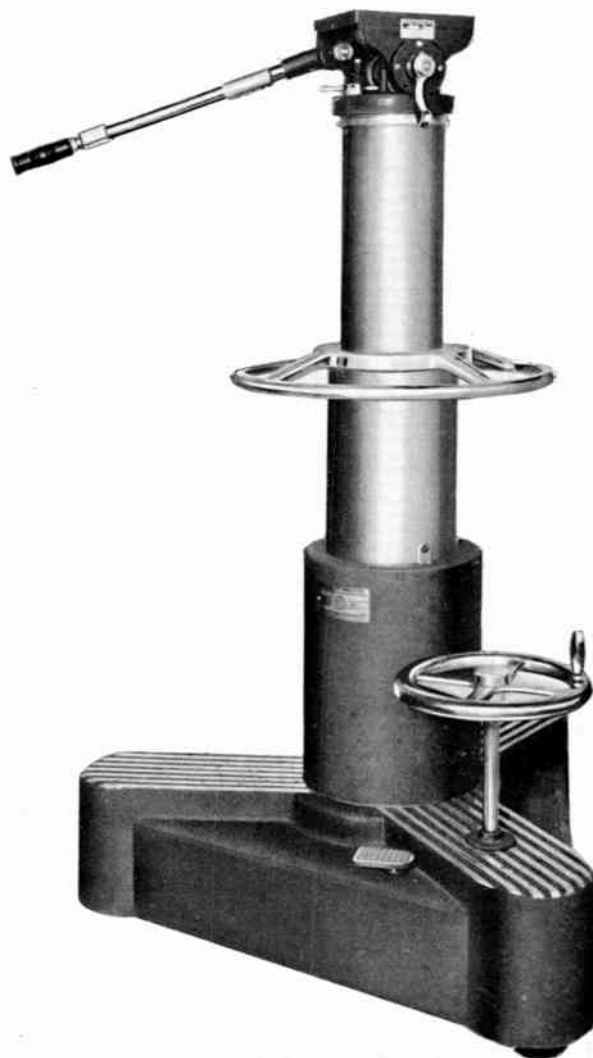

Fully extended, the overall height of pedestal is 54". Friction Head for mounting camera is supplied separately as MI-26205-B.

finished in umber gray and is styled to match other RCA television equipment.

## SPECIFICATIONS

Overall Dimensions (not including Friction Head):	
Height (maximum) .....	54"
Height (minimum) .....	32"
Width and Depth (maximum at base) .....	39"
Weight .....	450 lbs.
Stock Identification .....	MI-26035

### Accessory

Friction Head .....	MI-26205-B
---------------------	------------

# Studio Camera Dolly, Type TD-5A

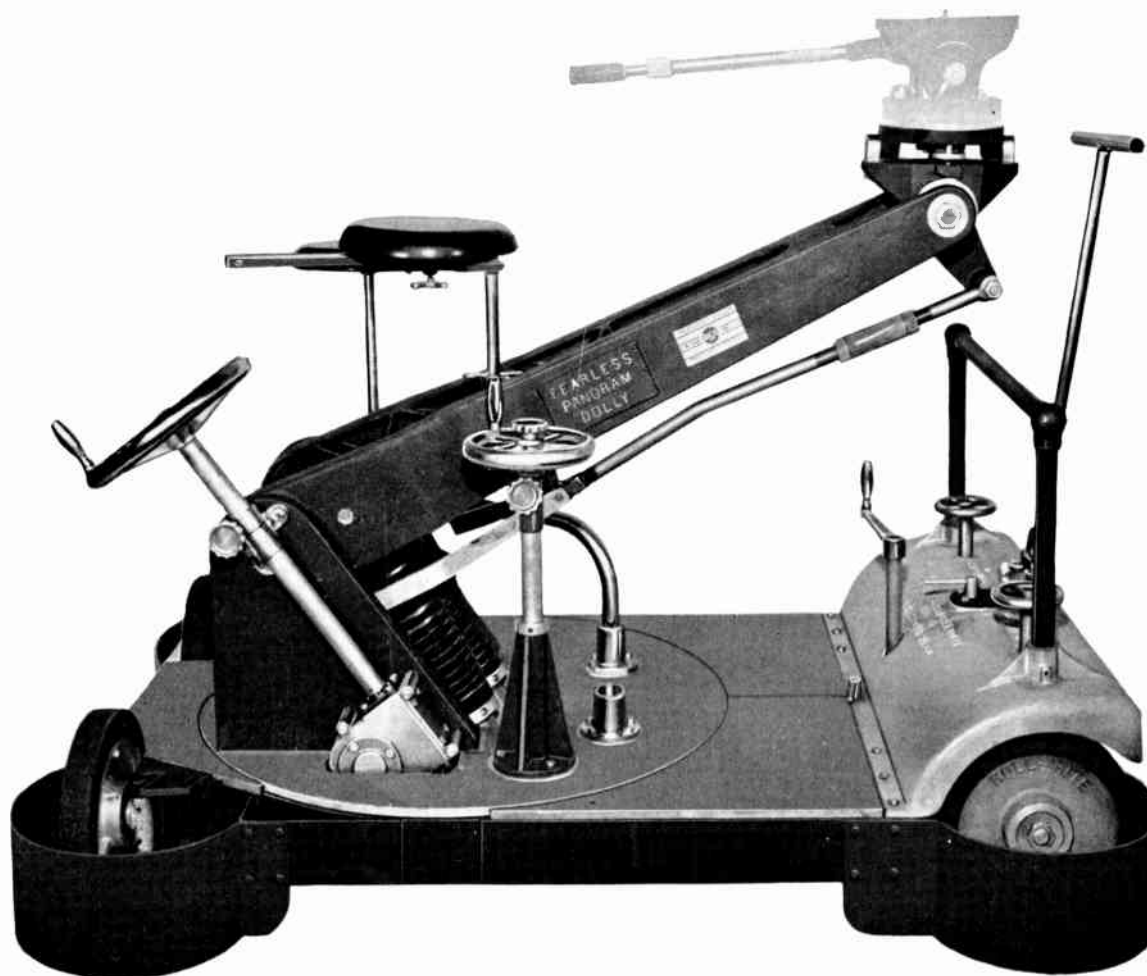

*View showing rear wheels turned at right angles. Friction head for mounting camera is supplied separately as MI-26205.*

## Features

- Rubber-tired wheels insure smooth, quiet movement.
- Provision for turning rear wheels 90°.
- System of counterbalanced weight makes controls easy to operate.
- Stops provided for holding dolly in fixed position.
- Finished in umber gray wrinkle and stainless steel.

## Uses

The Studio Camera Dolly is designed for use in television studios. One of the most important uses of the dolly is to dolly the camera in and out of scenes. The boom upon which the camera is mounted can be raised or lowered, or swung completely around. Shots can be made from unusual angles, and movement of the camera can be slow and steady. Thus, it provides the television station with facilities to produce more effective, more interesting programs. The dolly is usually manned by two operators, one who maneuvers the dolly and the other who trains and focuses the camera.

## Description

The Studio Camera Dolly is similar to the dolly used in film productions. An important difference is that the rear wheels of the television dolly can be turned at right angles as shown in the photo. This allows the rear end of the dolly to be

swung around, while the front end of the chassis pivots on a caster. The caster is lowered simultaneously with the turning of the rear wheels. The control for this operation is the "trolley-switch" handle near the front of the chassis. This feature of turning the wheels and lowering a fifth wheel permits the dolly to be moved sidewise, which is of course advantageous in small studios. The crane boom on which the camera is mounted can be raised to a height of 74 inches (above the floor) or lowered to a height of 23 inches. This boom is raised and lowered by the inclined control wheel at the rear. The control wheel in front of this turns the boom turret on the chassis. Mechanical design is such that very little effort is required to turn the control wheels.

## Specifications

Overall Dimensions (without Friction Head) :

Height (Maximum)	68 inches
Length (Including Boom)	81 inches
Length (Chassis)	65 inches
Width (Chassis)	35 inches
Weight	745 lbs.
Stock Identification	MI-26040

## Accessory

Friction Head \_\_\_\_\_ MI-26205-A

# Television Studio Cranes, Types TD-30B, C, D

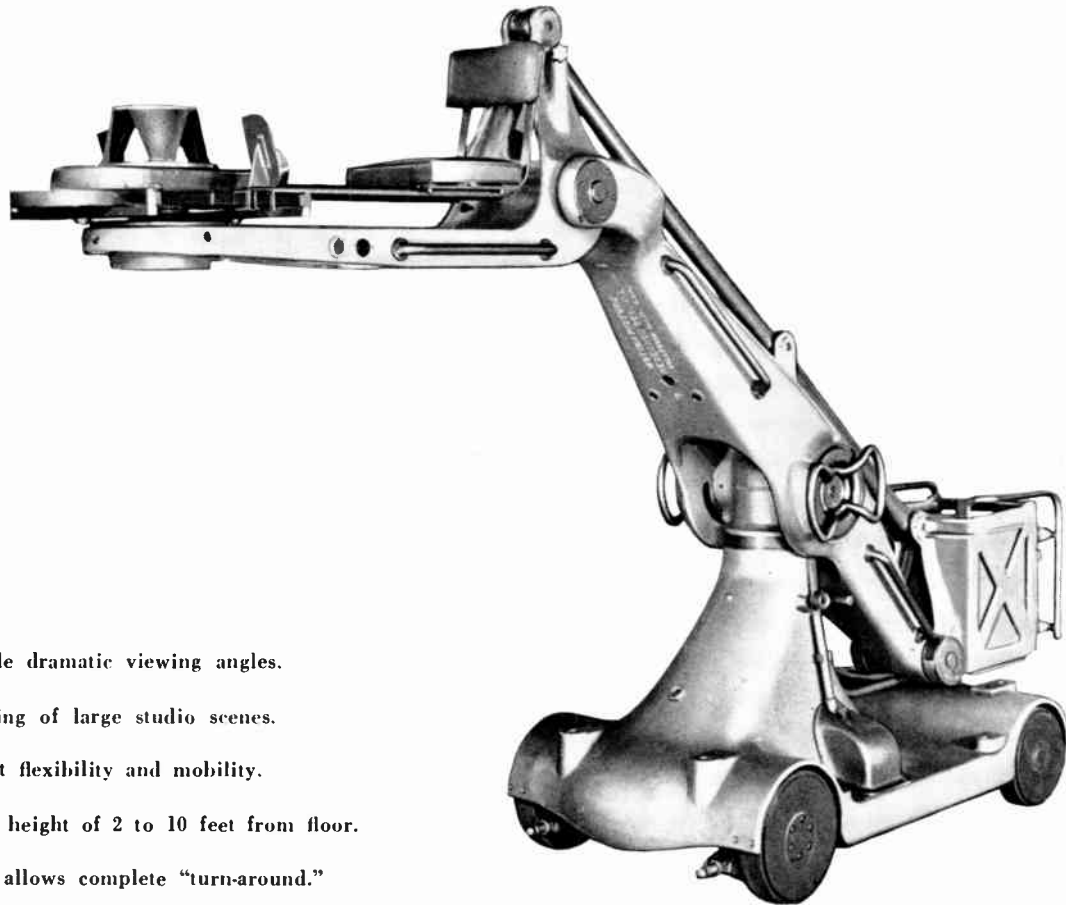

## Features

- Makes possible dramatic viewing angles.
- Smooth panning of large studio scenes.
- Provides great flexibility and mobility.
- Provides lens height of 2 to 10 feet from floor.
- Steering unit allows complete “turn-around.”
- Operator’s seat and foot-operated panning controls provided.

## Uses

The Houston Television Cranes are designed for use in large television studios and enable the operator to obtain dramatic viewing angles, smooth panning of large scenes, approaches and retreats that add life and interest to television programs.

## Description

The Model TD-30B DeLuxe Television Crane provides a lens height of from 2 to 10 feet from the floor, full 360-degree panning around the crane base, 180-degree panning of the turret table, and 100-degrees up and down lift. The crane will pass through a doorway 36 inches wide by 6 feet high, and weighs approximately 1,200 pounds. The Models TD-30C and TD-30D Cranes differ from the Model TD-30B only in the accessories included. The crane consists of the base, platform,

boom arm, and parallel arm made of cast aluminum alloy, the weight box, the center post with panning and tilt brake, the steering unit and the turret table. The optional equipment that determines the type of crane consists of the drive unit, jacks and hydraulic pump.

The turret table is an integral part of the crane and is permanently mounted on the platform. It is capable of 180-degree rotation, and contains the operator’s seat, foot pedals for rotating the turret table and an adjustable friction type turret lock within the operator’s reach.

The center post is a telescoping tube. It permits the boom to be panned a full 360-degrees and lifted up 55-degrees and down 45 degrees from the horizontal position. A hydraulic cylinder with 15-inch extension is mounted in the telescoping tube. It is manually operated by a hydraulic pump with the handle on the side of the base. A flow restrictor, located in the cylinder base, limits the down stroke speed in case of accidental dam-

age to the hydraulic lines. The panning brake is hand-operated by moving the small lever on the base. It can be adjusted to any degree of friction desired. An automatic locking pin prevents the use of the hydraulic pump when the panning brake is out of its neutral position. The tilt brake is operated by handles on both sides of the boom casting and can be set to any degree of friction.

The steering unit is of a special design that permits the crane to be completely turned around within a 6-foot radius and it allows it to be placed squarely against a wall with very little maneuvering. It incorporates a "lock-preventing arm" which allows a sharp turn without running the risk of jamming the steering mechanism.

The motor drive unit consists of a specially designed 2-hp 110-volt d-c series-wound motor, supported on rubber mounts. It is coupled to a 10 : 1 differential drive by a Morse-Morflex Coupling to provide smooth silent operation. A control unit that contains the motor control, reversing switch and brake control permits various degrees of acceleration and deceleration. The control unit (not shown) can be operated at the crane, or remotely, if desired. The brake is a solenoid-operated friction, air-cooled disk type, controlled by a carbon pile that gives the operator a braking power proportional to the pressure applied to the brake handle.

### Specifications

Main Boom Panning Angle \_\_\_\_\_ 360°  
 Turret Table Panning Angle \_\_\_\_\_ 180° or 90° each side of center  
 Overall Length (maximum) \_\_\_\_\_ 13 ft. approx.  
 Overall Height (maximum) \_\_\_\_\_ 8½ ft. approx.  
 Overall Width \_\_\_\_\_ 3 ft. approx.

#### TYPE TD-30B DELUXE TELEVISION CRANE

Complete with Power Drive, Remote Control Unit, Hydraulic Lift, Jack Assembly, Electrical Circuitry and Model TCT Turret Table.

Shipping Weight (crated) \_\_\_\_\_ 3,250 lbs. approx.  
 Stock Identification \_\_\_\_\_ MI-26037-1

#### TYPE TD-30C TELEVISION CRANE

Complete with Hydraulic Lift, Hand Brake and TCT Turret Table. (Power Drive, Remote Control Unit, Jack Assembly and Electrical Circuitry not included.)

Shipping Weight (crated) \_\_\_\_\_ 3,080 lbs. approx.  
 Stock Identification \_\_\_\_\_ MI-26037-2

#### TYPE TD-30D TELEVISION CRANE

Basic Crane Unit complete with TCT Turret Table and Hand Brake. (Does not include accessories listed with other models.)

Shipping Weight (crated) \_\_\_\_\_ 3,000 lbs. approx.  
 Stock Identification \_\_\_\_\_ MI-26037-3

### Accessory

Friction Head \_\_\_\_\_ MI-26205-A

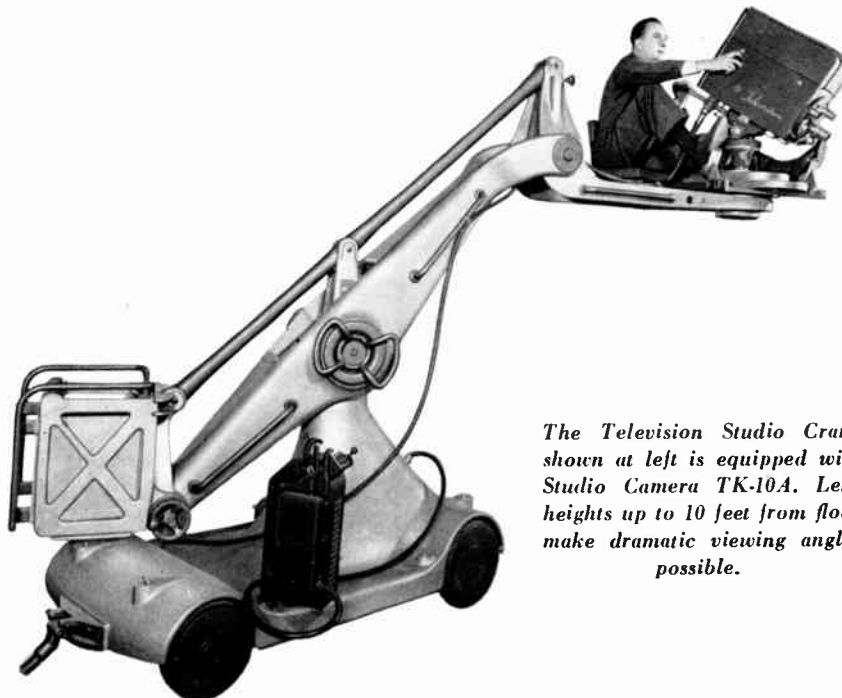

*The Television Studio Crane shown at left is equipped with Studio Camera TK-10A. Lens heights up to 10 feet from floor make dramatic viewing angles possible.*

# Regulated Power Supply, Type 580-D

## FEATURES

- Extremely well-regulated output
- Unusually low output ripple
- Low output impedance
- Components and connections easily accessible
- Compact, neat in arrangement



## USES

The RCA Type 580-D Regulated Power Supply fills the need for a well-regulated source of d-c at loads of 50 to 400 milliamperes. The output is adjustable between 260 and 295 volts, with variations of less than 0.5 volts from minimum to maximum load. Thus it is suitable for laboratory, industrial, and communications applications in which an unusually well-regulated source of d-c is required. As a-c ripple in the output is less than 0.015 volts peak to peak per cent, the output voltage may be used for most purposes without additional filtering.

The Type 580-D is especially suited for use with RCA television equipment, which it matches in appearance and construction.

## DESCRIPTION

The regulating circuit employed in the 580-D is of the series type. The output impedance is less than 0.7 ohms.

This Power Supply is assembled on a recessed chassis of the "bath-tub" type. Tubes and filter condensers project from the front of the chassis, while transformers, resistors, and wiring are at the rear. The chassis is standard rack width and may be mounted either in one of the enclosed-

type RCA cabinet racks, or on a standard "open-face" rack. In the latter event a blank panel may be mounted over the Power Supply if desired. Controls are centralized on a small, plainly-marked panel at the bottom of the unit. In addition to the power "on-off" switch there is provision for switching from a load range of 50-80 ma. to 80-400 ma., as well as a potentiometer for adjusting output voltage. A meter selector switch and a meter jack provide for plugging in a meter to read individual tube plate currents, output current, and output voltage. A special meter (MI-21200-C1) is available for this purpose.

## SPECIFICATIONS

Output Voltage.....	Adjustable 260 to 295 volts
Output Current.....	50 to 400 ma.
D-c Regulation.....	Less than 0.25 volts, minimum to maximum load
A-c Ripple.....	Less than 0.015 volts peak to peak
Power Supply.....	105/125 volts, 50-60 cycles
Power Input.....	370 watts (maximum)
Tube Complement:	
	2 RCA OD3/VR150
	2 RCA 5R4GY
	1 RCA 6SL7GT
	5 RCA 6Y6G
	1 NE 32
Dimensions.....	10 1/2" high, 19" wide, 12" deep
Weight.....	58 lbs.
Stock Identification.....	MI-21523-C2

## Accessory

Plate Current Meter.....	MI-21200-C1
--------------------------	-------------

# Regulated Power Supply, WP-33B

## FEATURES

- Extremely well-regulated output
- Unusually low output ripple
- Low output impedance
- Components and connections easily accessible
- Centering-current supply included
- Compact and neat in arrangement
- Output voltage during starting does not exceed final regulated value

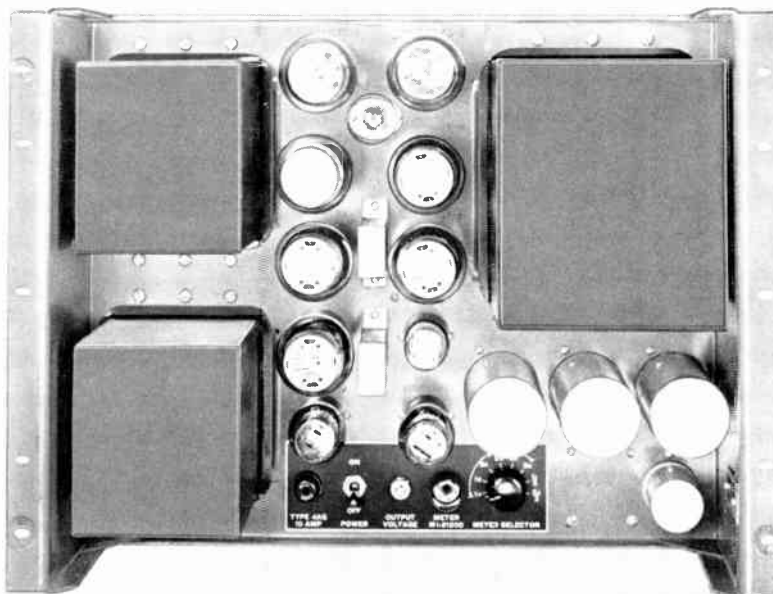

## USES

The RCA WP-33B Power Supply is intended for laboratory, industrial and communications applications requiring a well-regulated source of d-c voltage at loads of 200 to 600 milliamperes. The output is adjustable between 260 and 295 volts, and varies less than 0.20 volts from minimum to maximum load. A-c ripple in the output is less than 0.01 volt peak to peak, so that the output voltage may be used for most purposes without additional filtering.

The Type WP-33B is especially suited for use with RCA television equipment, which it matches in appearance and construction.

## DESCRIPTION

The regulating circuit employed in the WP-33B is of the series type. The output impedance of this Power Supply is less than 0.5 ohms.

The WP-33B is assembled on a recessed chassis of the "bath-tub" type. Tubes, filter condensers, and transformers project from the front of the chassis, while transformer terminals, resistors, and wiring are at the rear. The chassis is standard rack width and may be mounted in one of the new enclosed-type RCA cabinet racks or on a standard "open-face" rack. In the latter event, a blank panel may be mounted over the Power Supply if desired.

Controls are centralized on a small, plainly-marked panel at the bottom of the unit. In addition to the power "on-off" switch, there is a potentiometer for adjusting output voltage. A meter selector switch and a meter jack make provision for plugging in a meter to read individual tube plate currents, output current, and output voltage. A special meter (MI-21200-C1) is available for this purpose.

## SPECIFICATIONS

Output Voltage.....	Adjustable 260 to 295 volts
Output Current.....	200 to 600 ma.
D-c Regulation.....	Less than 0.20 volts, minimum to maximum load
A-c Ripple.....	Less than 0.01 volt peak to peak
Power Supply.....	105/129 volts, 50/60 cycles
Power Input.....	400 watts (maximum)
Tube Complement:	
4 RCA 5R4GY	3 RCA 6AS7G
1 RCA 6SL7GT	2 RCA OD3/VR150
	1 NE 32
Dimensions.....	14" high, 19" wide, 9" deep
Weight .....	82 lbs.
Stock Identification .....	MI-26085-B

## Accessory

Plate Current Meter.....	MI-21200-C1
--------------------------	-------------

# Current Regulator, MI-26090

## FEATURES

- Counteracts current variations in camera focus coil circuit
- Current can be manually adjusted over a range from 65 to 85 milliamperes
- Common tube types . . . tubes easily replaced from front of unit



## USE

The Current Regulator is an electronic device which maintains constant current in the focus coil of the TK-10A Studio Camera. Variations in the magnitude of current flowing through the coil are brought about by temperature changes, which would ordinarily impair the focus of the camera. The Current Regulator counteracts these variations and also provides a means for adjusting the focus coil current to the proper value.

## DESCRIPTION

All components of the Current Regulator are mounted on a recessed chassis designed for rack mounting. The unit employs an RCA 6SL7-GT twin triode as a d-c amplifier, and an RCA 6Y6-G current regulator tube. The cathodes of the d-c amplifier are kept at fixed levels by voltage regulator tubes.

The 6Y6-G current regulator tube is effectively in series with the camera focus coil and its 400-volt source of d-c so that the internal resistance of the 6Y6-G, which is controlled by the d-c amplifier, determines the magnitude of current flowing in the coil circuit. The input of the d-c amplifier is connected across a small resistor also connected in series with the focus coil. Thus variations in the voltage developed across the small resistor (as a result of current changes in the focus coil circuit) are fed to the d-c

amplifier which in turn raises or lowers the conductance of the 6Y6-G to counteract the current change taking place. Regulation is, of course, instantaneous and the result is a constant flow of current through the focus coil of the camera. The Current Regulator will maintain constant current at a preset value over wide ranges of resistance change in the load and over wide ranges of input voltage.

## SPECIFICATIONS

### Power Requirements:

A-c.....	Single phase 117 volts, 60 cycles, 15 watts (for fil. transformer)
D-c.....	400 volts from Type 580-C Power Supply

### Chassis Dimensions:

Depth .....	5 1/2"
Width .....	19"
Height .....	.8"
Weight .....	9 lbs.

## Tube Complement

- 1—RCA OD3/VR150 Voltage Regulator
- 1—RCA 991 Voltage Regulator
- 1—RCA 6SL7-GT D-C Amplifier
- 1—RCA 6Y6-G Current Regulator

Stock Identification .....MI-26090

## Accessories

Plate Current Meter.....MI-21200-C1





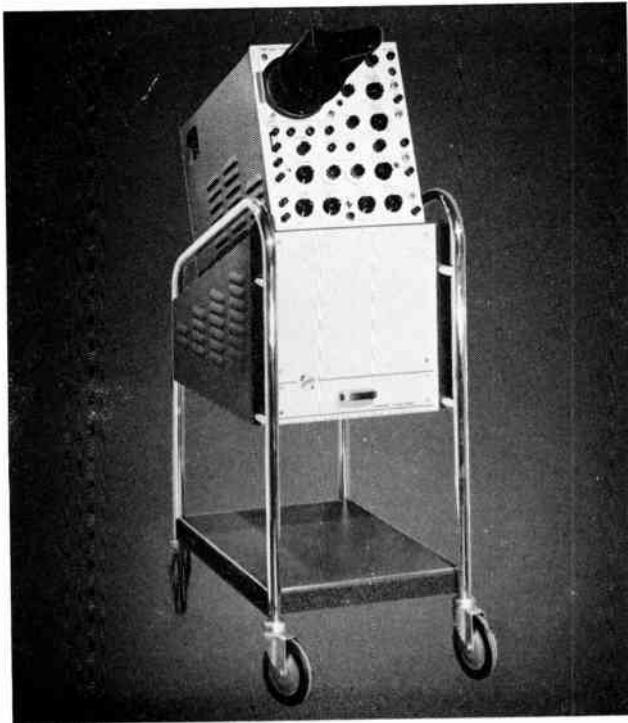

Calibrated attenuator and sensitivity controls permit the sensitivity to be reduced continuously to 50 volts per centimeter. The amplifiers are adjusted for optimum transient response rather than maximum bandwidth. The rise time is 0.04 microseconds with no overshoot.

The sweep circuit of the TO-524-D can be triggered from the sync pulses of the composite video signal. It includes a sync separator and adjustable sweep delay to permit any portion of the composite signal to be viewed at any available sweep speed. A field-selector control permits the sweep to synchronize with either field of a frame. A completely new sweep magnifier circuit expands any desired portion of the signal horizontally three times or ten times with the expanded portion remaining centered on the screen. Accuracy of the magnification is within 5 per cent. Accurately calibrated sweep speeds from 0.01 seconds per centimeter to 0.1 microseconds per centimeter are provided which can be triggered by pulses as short as 0.05 microseconds or synchronized by a 10-megacycle sine wave. Also included is a phased 60 cycle sine wave sweep.

Regulated d-c voltages throughout maintain the stability of the presentation and the accuracy of the calibrations over a line-voltage variation between 105 and 125 volts.

The cathode-ray tube accelerating potential is 4000 volts, providing a brilliant trace. When incorporated with a "scope-mobile" as shown above, the units become even more flexible. This useful accessory has 20° tilt, a-c outlets, and cable drawer.

## Auxiliary Circuits

The IRE—Normal switch, located on the access panel on the left rear, controls the response of the output of the vertical amplifier. Its two connections are: (1) for normal, 10 mc bandwidth, and (2) for bandwidth reduced to 2.7 mc to comply with that specified by the FCC for standard TV level measurements. Also located on the access panel one connection for capacitively coupling to the vertical deflection plates and direct connection to the horizontal deflection plates of the cathode-ray tube.

A line-indicating video circuit provides a video signal output on which is superimposed a positive gate synchronized with the 524-D sweep. Applied to a television video monitor such as the TM-2C or 2D, it indicates (by a bright line on the monitor roster) the line of the composite video signal being displayed on the oscilloscope.

## SPECIFICATIONS

Sweep Circuit.....	Hard tube type, triggered or recurrent operation as desired.
Sweeps.....	Continuously variable, 0.01 sec/cm to 0.1 $\mu$ sec/cm. Calibration accuracy 5%.
Trigger Requirements.....	0.5 to 50 v. (peak). Pulses as short as 0.05 $\mu$ sec. Signal under observation producing 0.5 cm deflection or more. Composite television signal—1 v. peak to peak external or 0.05 v. to vert. amp.
Sweep Magnification.....	Magnifier expands the sweep to left and right of center. Either 3 times or 10 times magnification is available.
External Sweep Input.....	Coupled via 100k potentiometer, sweep magnifier, and direct coupled sweep amplifier. Maximum deflection sensitivity, 0.25 v/cm d-c or a-c peak to peak.
Time Markers.....	Four markers: 1 $\mu$ sec, 0.1 $\mu$ sec, 0.05 $\mu$ sec, and 200 per television line. Accurate within 2%.
Vertical Amplifier.....	5 stage. 3rd, 4th, and 5th stage direct coupled push-pull. Distributed output (5th) stage.
A-c Vertical Deflection Sensitivity.....	Continuously variable from 0.015 v/cm to 50 v/cm, peak to peak.
D-c Vertical Deflection Sensitivity.....	Continuously variable from 0.15 v/cm to 50 v/cm, peak to peak.
Input Impedance.....	1 megohm shunted by 40 $\mu$ f. With probe, 10 megohms shunted by 12 $\mu$ f.
Vertical Amplifier Response.....	D-c to 10 mc (3 db down) sensitivity of 0.15 v/cm; 2 cps to 10 mc (3 db down) sensitivity of 0.015 v/cm.
Vertical Amplifier Transient Response.....	Rise time (10%-90%) 0.04 $\mu$ sec.
Signal Delay Network.....	Provides 0.25 $\mu$ sec signal delay. Permits observation of the waveform that triggers sweep.
Calibrating Voltage.....	Variable duty cycle square wave. Seven ranges, 0.05 v. to 50 v. full scale, continuously variable, accurate within 3%. Duty cycle variable from 1% to 99%.
Cathode Ray Tube.....	A 5ABP1 cathode-ray tube is furnished with the Type 524-D unless a P7 or P11 phosphor is specified as the optional choice. An accelerating potential of 4 kv is used ( $\pm$ 2.5 and $\pm$ 1.5 kv).
Construction.....	Completely self-contained, cabinet and chassis made of electrically welded aluminum. Photo etched front panel.
Dimensions.....	15 $\frac{5}{16}$ " high, 12 $\frac{7}{8}$ " wide, 22 $\frac{3}{8}$ " deep
Weight.....	.61 lbs.
Power Requirements.....	105-125 or 210-250 volts, 50-60 cycles, 500 watts
Finish.....	Dark amber gray
Stock Identification.....	MI-26500
	(Complete with set of tubes, viewing hood, 42 inch high impedance probe, and instruction book)

## Accessories

Type TO-500 "Scope-mobile".....MI-26501

# NOTES

# NOTES

# == NOTES ==

# == NOTES ==

# == NOTES ==

# NOTES

# NOTES



# TRANSMITTERS

## TRANSMITTER EQUIPMENT THEORY

Principles of TV Transmitter Design.....	C-1
--	-----

## TRANSMITTER OPERATION AND DESCRIPTION

TT-2AL/AH 2-KW TV Transmitter.....	C-20
TT-10AL/AH 10-KW TV Transmitter.....	C-23
TT-25BL/BH 25-KW TV Amplifiers.....	C-30
TT-50AH 50-KW TV Transmitter.....	C-38
TTU-1B 1-KW UHF Transmitter.....	C-41
TTU-10A 10-KW UHF Transmitter.....	C-51
TTC-1B TV Transmitter Control Console.....	C-52
ES-19203 Input and Monitoring Equipment.....	C-55
BW-5A Sideband Response Analyzer.....	C-57

## SPECIFICATIONS

### VHF Transmitter Data

TT-2AL/AH 2-KW TV Transmitter.....	C-66
TT-10AL/AH 10-KW TV Transmitter.....	C-68
TT-25BL/BH 25-KW TV Amplifier.....	C-70
TT-50AH 50-KW TV Transmitter.....	C-72

### UHF Transmitter Data

TTU-1B 1-KW UHF Transmitter.....	C-74
TTU-10A 10-KW UHF Transmitter.....	C-76

### Transmitter Monitoring Equipment

BW-5A Sideband Response Analyzer.....	C-78
GR-1183-T TV Station Monitors.....	C-79

# Principles of TV Transmitter Design

## CHARACTERISTICS OF A TELEVISION SYSTEM

### Introduction

Although this section deals specifically with the television transmitter, the scope is broadened to include a brief description of a television system to show some of the fundamental limitations on picture quality and to what extent good transmitter design can influence the overall result. In this connection, some of the FCC regulations, RTMA standards, and RCA specifications are discussed, particularly with regard to the considerations which determine the tolerances of the various specifica-

tions. No attempt is made to set down all of the applicable standards, since these can be found readily in FCC publications and RTMA standards. Following this, there is a discussion of some of the transmitter problems unique to television and a description of the special circuits that have been developed to handle these problems. Finally there is a discussion of the design and operation of a grid modulated RF amplifier, which is perhaps the most interesting and least understood part of the television transmitter.

### PRINCIPLES OF TV TRANSMITTER DESIGN Table of Contents

#### CHARACTERISTICS OF A TELEVISION SYSTEM

Introduction  
Frequency Response Throughout a Television System  
Limitations in System Performance  
Monitoring

#### REGULATIONS, STANDARDS & SPECIFICATIONS

Picture Polarity  
Pedestal Level and Black Level  
White Level  
Carrier Stability  
Variation of Output During One Frame  
Hum  
Linearity  
Frequency Response  
Stability of Power Output

#### PROBLEMS UNIQUE TO TV TRANSMITTERS

Components of a Television Transmitter  
Modulation Method  
Transmission of D-C Component  
Clamp Circuit  
Linearity Control

Circuits for Direct Coupling of Video Amplifiers and Modulators

D-C Transmission and Power Supply Regulation  
Video Impedance of Power Supply

Incidental Phase Modulation  
Monitoring Peak Power Output  
Principles of a Reflectometer

Calibration of Power Measurement  
RF Circuits for Grid Bias Modulated Amplifiers and Linear Amplifiers

Broadband RF Circuits  
Aural Operation

#### OPERATION OF A GRID MODULATED RF AMPLIFIER

General Principles  
Effects of Power Supply Voltages and Load Impedance

Linearity of Grid Bias Modulated Amplifiers and Linear Amplifiers

Angle of Plate Current Flow

Adjustment of an Over-Coupled Double Tuned Circuit

Adjustment of an RF Driver

Description of a Sideband Analyzer

### Frequency Response Throughout a Television System

A block diagram of a complete television system is shown in Fig. 1. The television transmitter consists of the portions shown within the dashed lines. The incoming video signal passes through a stabilizing amplifier which reduces the effects of extraneous hum and noise in the input signal.

As the television signal progresses through this system it undergoes certain changes in its frequency characteristics which are delineated in Fig. 2. The input signal

is not artificially limited in bandwidth and may extend appreciably beyond 5 mc. with a gradual reduction in amplitude at still higher video frequencies as shown in Fig. 2-a. This is considerably wider than the overall system bandwidth will permit. The system bandwidth necessarily is limited to less than 4.5 mc at the television receiver output terminals in order to provide protection against adjacent channel interference and to prevent video interference from the aural signal. The frequency characteristic (2-b) of the modulator is generally made

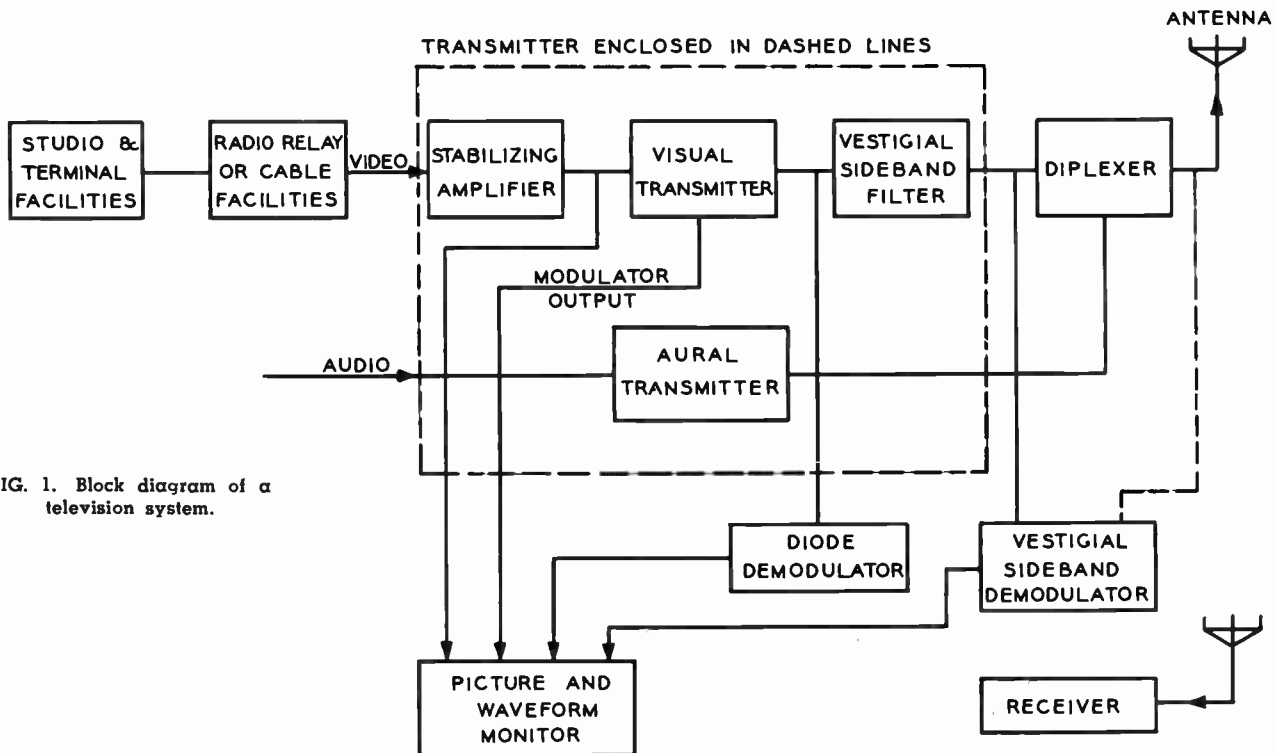

FIG. 1. Block diagram of a television system.

flat to approximately 5 mc, but not more than this because of the high cost of modulating a wider frequency band than necessary.

The R-F circuits in the transmitter following the modulated stage are adjusted for the maximum power output that can be obtained consistent with a flat frequency response throughout the upper sideband. This adjustment leads to some attenuation of the lower sideband as shown in Fig. 2-c. The signal is then passed through a vestigial sideband filter which sharpens the lower sideband cutoff and prevents appreciable energy from being radiated in the lower frequency adjacent channel. The result is shown in Fig. 2-d. Finally the visual signal is mixed with the aural signal in the diplexer and radiated by a common antenna. If a Notch Diplexer is employed, the visual signal is attenuated at the aural carrier as shown by the dashed line of Fig. 2-e. If a Bridge Diplexer is employed the visual signal is not affected. The receiver has a frequency response shown in Fig. 2-f.

The product of transmitted signal (2-d) and the receiver characteristic 2-f combine to deliver a video signal after detection, having the video frequency characteristic shown in Fig. 2-g.

### Limitations in System Performance

There are two basic reasons, and some incidental ones, why the picture received at home can not equal in quality the latent picture generated in the television transmitter. One of the reasons is that the bandwidth through the system is limited to a maximum of slightly more than 4 mc. The second reason is that some of the picture information is lost or distorted in the process of vestigial sideband transmission. These small defects are the price

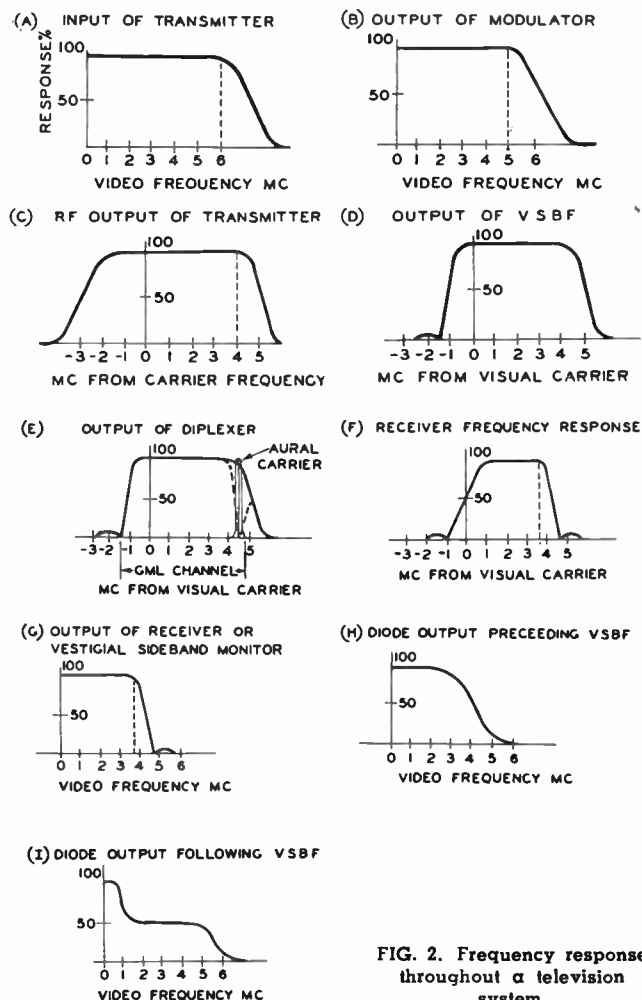

FIG. 2. Frequency response throughout a television system.

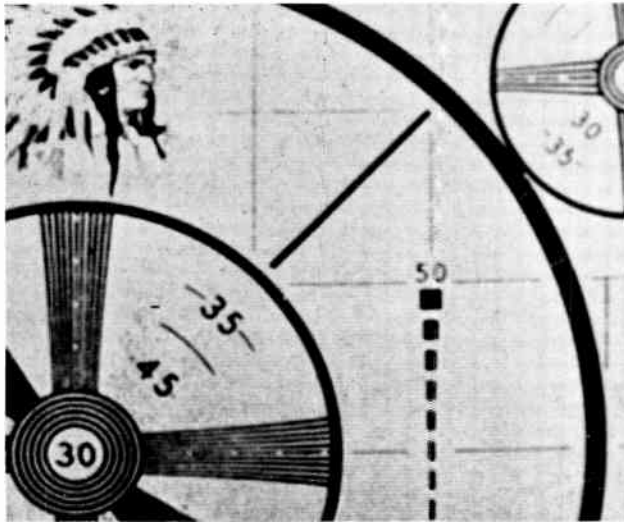

FIG. 3. Picture through a broadband double sideband system employing a television transmitter and a diode monitor.

of a transmission system which results in efficient use of the available frequency spectrum, permitting the greatest number of channels.

The abrupt high frequency cutoff (Fig. 2-f) gives rise to a slight ringing after sharp edges in the picture. This is especially noticeable when transmitting a test pattern, as can be observed in Fig. 4. Fig. 3 shows the picture transmitted through the same transmitter adjusted for double sideband transmission and received on a double sideband receiver having no artificial limitation in bandwidth.

The requirement for eliminating most of the lower sideband results in a type of picture distortion which produces faint white regions before a transition from white to black and a trailing smear following transitions from black to white. These defects can be observed in Fig. 4 and are marked in this picture for easy identification. This distortion exists because of lower sideband suppression and will be evident regardless of where the lower sideband is suppressed in the visual transmitter system. It is inherent in the vestigial sideband system, but could be minimized by pre-distortion at the transmitter. Phase and amplitude correcting networks have been developed in the laboratory but no commercial units have been produced.

The distortion described above have definitely related square wave characteristics shown in Fig. 5. A sharp white to black transition is equivalent to modulating the transmitter with a square wave and observing the wave shape in the vicinity of the leading edge of the square wave response. Leading whites, trailing smears, ringing, and lack of detail are identified with the square wave response in Fig. 5.

FIG. 5 (at right). Squarewave response in a band restricted vestigial sideband system. Defects exaggerated.

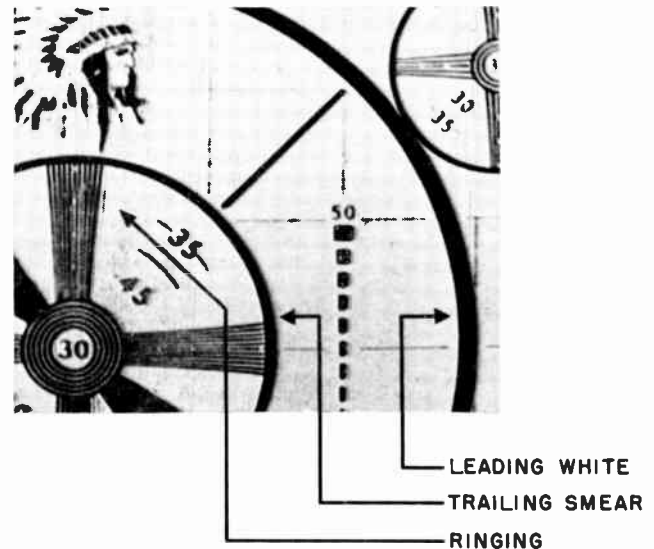

FIG. 4. Picture through vestigial sideband system employing television transmitter and a WM-20A demodulator with sound notches.

### Monitoring

The block diagram of Fig. 1 shows two video and three RF monitoring positions that have been used in various installations. This includes the alternate monitoring position of the vestigial sideband demodulator as shown by the dotted line. This is the preferable monitoring point but requires more attenuation in the monitor for the aural carrier. The diode monitor employed ahead of the vestigial sideband filter will usually produce a good picture and will be adequate for monitoring the video wave form with an oscilloscope. However, the picture will not be a true representation of either the single or double sideband transmitted picture because the transmitter may partially attenuate the lower sideband (Fig. 2-c). Since both the upper and lower sideband add in the detector to produce the final result, the video frequency characteristic out of the diode detector will be as shown in Fig. 2-h. The loss of high frequency response represented by this characteristic will cause the picture to be slightly soft. A diode detector used after the vestigial sideband filter would produce an unuseable picture because the sharp cutoff of the lower sideband would produce the demodulated frequency response of Fig. 2-i. A true reproduction of the picture will be

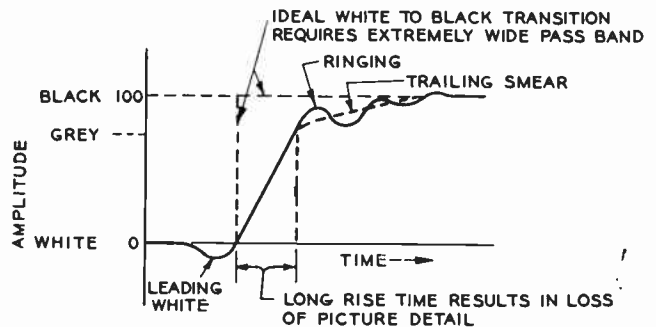
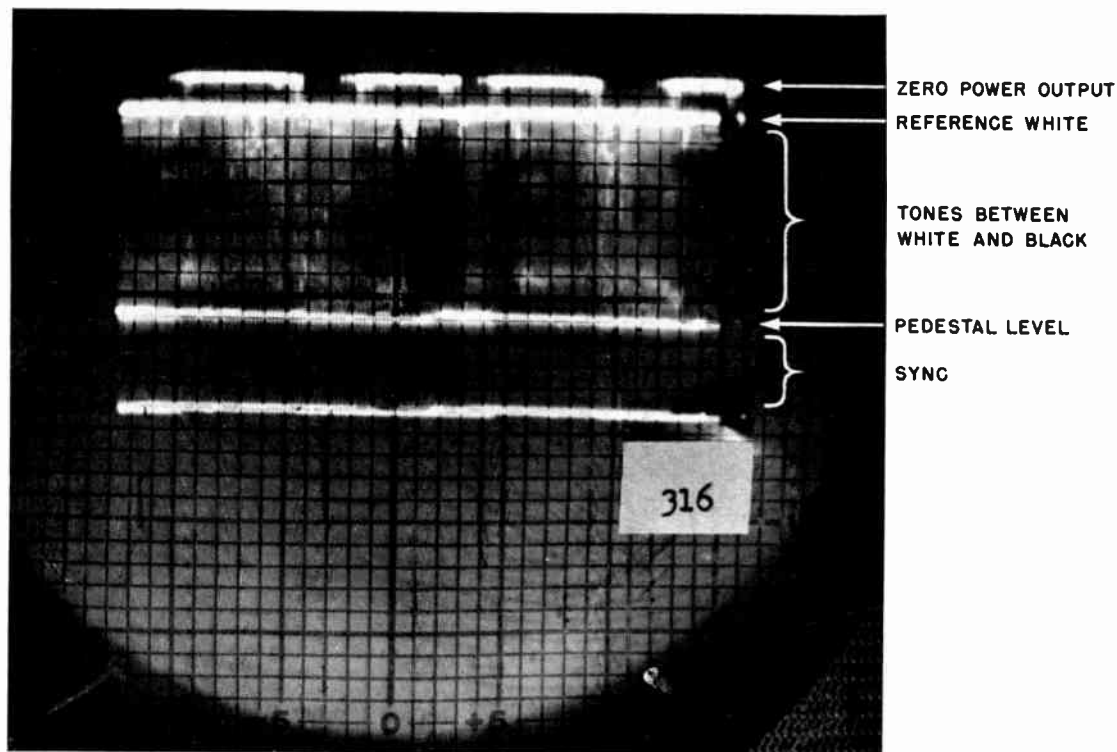

FIG. 6. Video waveform from RF monitor, chopped at 120 cycle rate, and displayed at frame frequency.



produced by a vestigial sideband monitor having the characteristics of a high quality television receiver. It will also reproduce the defects inherent in the vestigial sideband system: ringing, leading whites, and trailing smears. The monitor will produce a signal representative of the picture at a good receiver location although individual locations will differ considerably due to propagation variances.

A monitoring system for UHF application employs a directional coupler in the transmission line to provide a signal to the vestigial sideband monitor. This has the advantage that reflections from the antenna are not seen by the monitor except as they are re-transmitted by the transmitter. Consequently, a very true reproduction of the actual radiated picture is obtained.

In addition to monitoring the picture from the transmitter, it is also necessary to observe the depth of modulation and other characteristics of the waveform by presentation on an oscilloscope. It is common practice to periodically short circuit the output of the detector in the monitor with a chopper or vibrator so that an additional line is obtained on the oscilloscope representing zero power output. This enables an operator to set the white level of the picture to a specified depth of modulation. Fig. 6 shows the oscilloscope pattern produced when transmitting a monoscope pattern having some black and some half tone printing on a solid white background. Since the picture contains more white than any other tone it is easy to see the depth of modulation. In this case white is at 10% of the peak synchronizing level. Operational maladjustments are readily observed

with such a presentation. Not only is the transmitter modulated too deeply but the synchronizing amplitude is too great. Other defects in this pattern will be discussed in connection with the following section on transmission standards.

#### REGULATIONS, STANDARDS, AND SPECIFICATIONS Picture Polarity

At the video input to the transmitter and at all monitoring points, it is standard to have the blacks of the picture represented by the most negative voltage in the waveform. In RF transmission, it is standard to have the synchronizing represented by the maximum power output of the transmitter. This results, at least in theory, in noise pickup in the receiver producing specs in the picture which are blacker than black and, therefore, not noticeable. This standard also makes possible a relatively simple AGC circuit in the receiver. It has the incidental advantage that the average transmitter power is lower than would be required if the whites of the picture were transmitted as an increase in power.

#### Pedestal Level and Black Level

The pedestal level is transmitted at 75% of the synchronizing peak amplitude. This is held to within a tolerance of  $\pm 2.5\%$  of sync peak at all times including the effects of variation of picture content. This close tolerance is necessary since the d-c is reinserted in many receivers by leveling on the tips of the synchronizing signal and if the pedestal varied with respect to the sync peaks, the retrace lines would be visible, from time to time, in the picture. Also, the shadow areas occasion-

ally would be blocked. The close tolerance is also necessary to obviate receiver readjustment when switching from station to station.

The blacks of the picture are normally transmitted with a 5-10% setup. It is becoming standard to produce pictures in the studio with a 10% setup. Setup is the unused amplitude between the blackest parts of the picture and pedestal level expressed as a percentage of the peak-to-peak video signal. The setup may be reduced somewhat but not to less than 5% after passing through a stabilizing amplifier for the purpose of flattening the pedestal level and improving the shape of the synchronizing pulse. In Fig. 6 the blacks extend to the pedestal level but this is poor operating practice.

#### **White Level**

It is standard to transmit the whites of the picture at a level of  $12\frac{1}{2}\% \pm 2\frac{1}{2}\%$  of synchronizing level. This close tolerance is required for two reasons. If reference white is specified at a particular level, then there is less necessity for readjusting the receiver contrast with program changes or in switching stations. Secondly, the whites of the pictures must never drop below 10% because there would then be insufficient visual carrier amplitude for correct operation of intercarrier sound receivers which depend upon the beat between visual and aural carriers to supply the 4.5 mc. signal to the sound discriminator.

#### **Carrier Stability**

Current FCC Rules and Regulations require that the visual carrier be maintained within  $\pm 1000$  cycles of the authorized frequency. The aural carrier has to be held within  $\pm 4000$  cycles of the assigned aural frequency, or alternatively, 4.5 megacycles above the actual visual carrier frequency within  $\pm 5000$  cycles. The deviation limit between aural and visual carriers is primarily required for receivers incorporating the intercarrier sound principle. This stability can be achieved by offsetting one carrier from the other using a heterodyne principle, but in general it has been found simpler and cheaper to provide crystal oscillators of the required stability.

#### **Variation of Output During One Frame**

The variation of output during one frame should not exceed 5% of the average synchronizing peak level. This specification includes the effects of hum, noise, and low frequency distortion. Noise, due to such causes as fluctuating line voltage, will produce objectionable brightness flutter in the picture. Hum produces broad horizontal bands of light and dark shading in the picture which are not normally noticed unless the camera and synchronizing generator are operated from a 60 cycle

source which is slightly different in frequency from the transmitter or receiver power source. When this occurs, hum in either the transmitter, receiver, or both, produces light and dark bands which drift through the picture at a rate equal to the difference frequency in the two 60 cycle sources. This is very objectionable especially if it affects the horizontal synchronizing in the receiver and causes the vertical lines of the picture to weave.

Poor low frequency response can produce a number of undesirable effects including retrace lines in the picture due to distortion of the vertical blanking pulses and deterioration of the synchronizing level which may cause vertical lines in the picture to be distorted or kinked in the vicinity of masses of black or white in the picture. It may also produce some extraneous shading of the background from top to bottom of the picture. This latter effect is not usually very objectionable.

#### **Hum**

Although hum is covered to some degree in the requirements for the variation during one frame, an additional tolerance is placed on this because the amount of hum required to produce objectionable effects is quite small if the beat frequency between the picture generator power supply source and the transmitter supply source is large. The present specifications require the hum to be at least -30 db below complete modulation of the transmitter and in many of the RCA transmitters, the hum is less than -45 db.

#### **Linearity**

The transfer characteristic of the transmitter, that is the ratio of RF output voltage to video input voltage, should be essentially linear. Of course, the transfer characteristic of other parts of the television system or even the system as a whole is not ordinarily made linear. The linearity or gamma of the studio equipment is controlled so that the pictures have the proper gray scale as observed on a picture monitor whose transfer characteristic is generally similar to that of a home receiver. Since the linearity of the picture generating equipment is controlled to make the picture look good, the balance of the system between the studio and the receiver should be linear. The tolerance specified for the transmitter is that the non-linearity should be less than 10%. Fig. 7 is a linearity curve to illustrate what is meant by a 10% non-linearity. A departure from linearity in the synchronizing region has no effect on the picture quality and the proper ratio of synchronizing to picture signal can be adjusted at the stabilizing amplifier. Non-linearity in the transmitter generally has the effect of "washing out" the highlights and creating images of people with blank looking faces. If a double curvature exists in the transfer characteristic, the shadows are apt to be blocked and

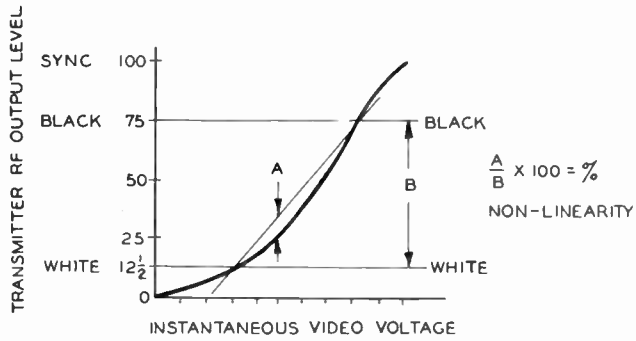

FIG. 7. Linearity of a television transmitter.

lacking in detail. A non-linearity of 10% will cause a noticeable although perhaps tolerable reduction in picture quality and transmitters are generally made to be better than this specification.

### Frequency Response

The overall frequency response of the transmitter as specified by the RTMA, which is at present a closer tolerance than the FCC standard, allows for an attenuation of as great as 4 db at 4 mc. and departures ranging from 2 to 3 db throughout the video frequency spectrum. Transmitters are usually designed for better response than this. Variations of approximately  $\pm 1$  db throughout most of the band with a fall-off to as great as  $-3$  db at 4 mc are typical of a transmitter including modulator, modulated RF stage, linear amplifier (if any), and side-band filter. Some of the newer transmitters have been designed to be flat within 1 db at 4 mc.

It is important to know how much variation can be tolerated in the overall frequency characteristic. The allowable variation depends upon the character of the irregularity in the frequency response. If the frequency response oscillates in amplitude through the band from 0 to 5 mc., this will have exactly the same effect in the picture as an echo commonly seen in home receivers due to multipath transmission. If the echo is well defined and close to the main signal it may be as weak as 5% ( $-26$  db) and still be noticeable in the picture. This is identical to a frequency characteristic which oscillates in a regular and rapid manner with an amplitude variation of  $\pm 5\%$ . The most common source of this type of frequency characteristic is a mismatched transmission line either at radio frequency or video frequency. However, identical effects can occur by multiple distortions in the frequency characteristic which add up to the same overall amplitude vs. frequency response. Fig. 8 illustrates a signal, which is transmitted through a system with a 10% mismatch on a transmission line giving rise to  $\pm 10\%$  variations in the frequency response. A 5% mismatch would also be objectionable and would be more noticeable on a receiver than in a photograph because of the motion imparted to the defect by changing scenes.

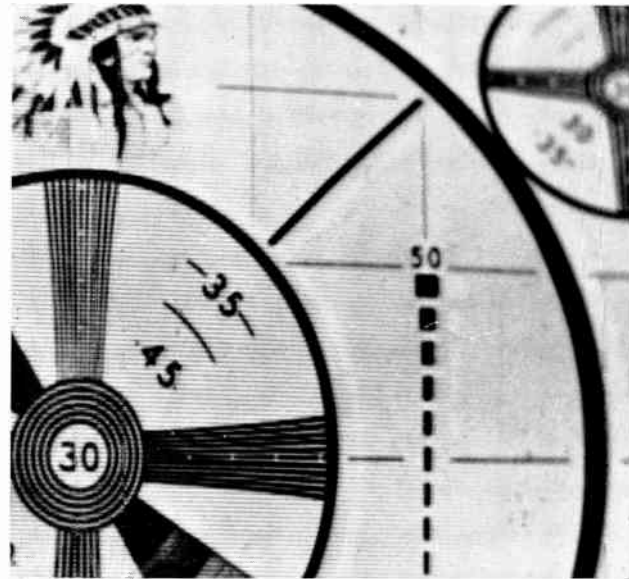

FIG. 8. Effect of  $\pm 10\%$  regular variations on the frequency vs. amplitude response caused by a mismatched coaxial cable.

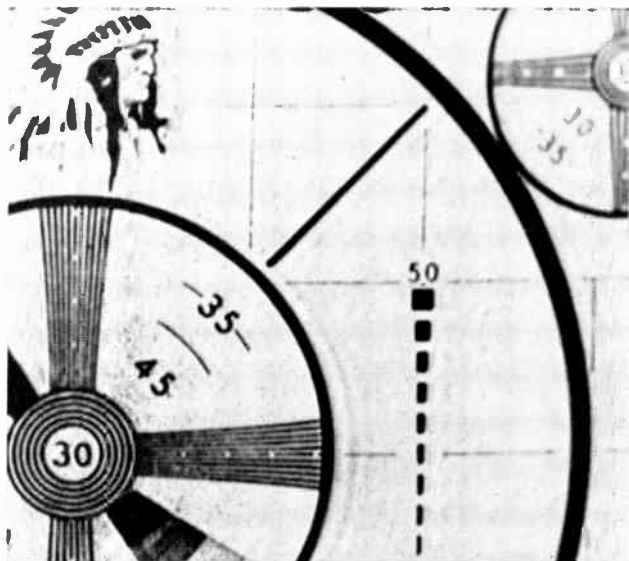

FIG. 9. Effect of a 20% nick in the video frequency response at 1.5 mc.

Whereas regular oscillations in the frequency response produce a distinct echo in the picture, a single hole or bump in the frequency characteristic will produce ringing, or a series of echos, which occur at a repetition rate corresponding to the frequency of the discontinuity. Fig. 9 shows the results of a 20% hole in the frequency characteristic at 1.5 mc. Much smaller distortions than this can be observed; 5% nicks or bumps are noticeable.

Perhaps the worst effect of all is minor variations in the frequency response in the neighborhood of 15 KC. to 250 KC. Distortions in this frequency range result in objectionable streaking especially noticeable following bold titles where a black smear follows a black character. Discontinuity of this type also gives rise to synchroniz-

ing difficulty in some receivers, since this trouble produces cross-talk between picture and synchronizing information and may show up as kinks in vertical lines of the picture. Sometimes a very minute amount of this trouble can be detected in the picture. Distortions as small as 2% (-34 db) in the amplitude-frequency characteristic produce just noticeable picture defects. Interference and other types of perturbing signals (not directly related to the frequency characteristic) as small as -40 or -45 db can be detected in the picture under certain conditions.

A gradual decrease in high frequency response is perhaps the least objectionable form of distortion since the major effect is to produce a softening of the picture.

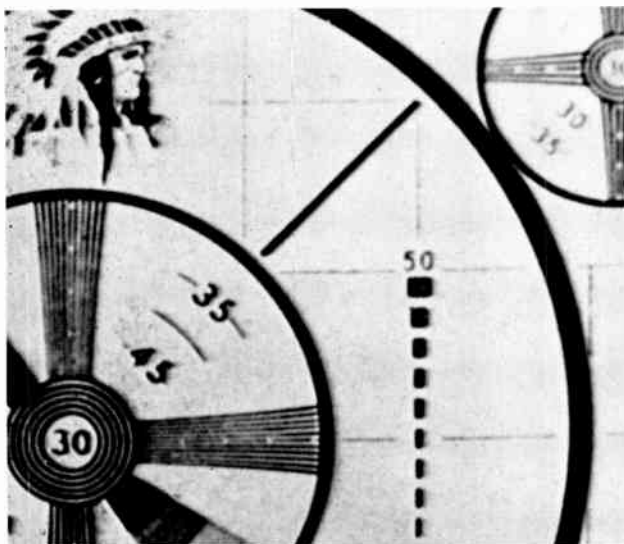

FIG. 10. Effect of poor high frequency response. Response is -6 db at 4 mc.

This effect is offset to a degree by the advantage that ringing in the picture is reduced. Fig. 10 is a photograph of a signal with reduced high frequency response. The response at 4 mc. is -6 db. Greater attenuation than this results in a rapid deterioration of the picture.

### Stability of Power Output

The power output of the transmitter must be held within +10% -20% of the rated power at all times. This includes changes due to line voltage variations, drift in the pedestal level, and regulation of the transmitter in going from an all black to an all white picture.

The variation in output in going from a black to a white picture should not exceed 10% of the amplitude of an all black picture. Transmitters are usually designed to be well within this specification and a variation of 3% in going from a black picture to a white picture is typical.

### PROBLEMS UNIQUE TO TV TRANSMITTERS

The block diagram of a hypothetical television transmitter is shown in Fig. 11 and will serve to point out the special features of a television transmitter. With the exception of the linear amplifier which may or may not be included, all of the other blocks in this diagram represent necessary portions of a transmitter. In the visual transmitter it should be noted that the d-c component of the picture signal is reinserted in the modulator which must be then direct-coupled to the modulated RF amplifier. Following the point of modulation broadband over-coupled RF circuits are used in order to transmit the visual signal without attenuation of the sidebands. Their position in the television circuit is marked in Fig. 11.

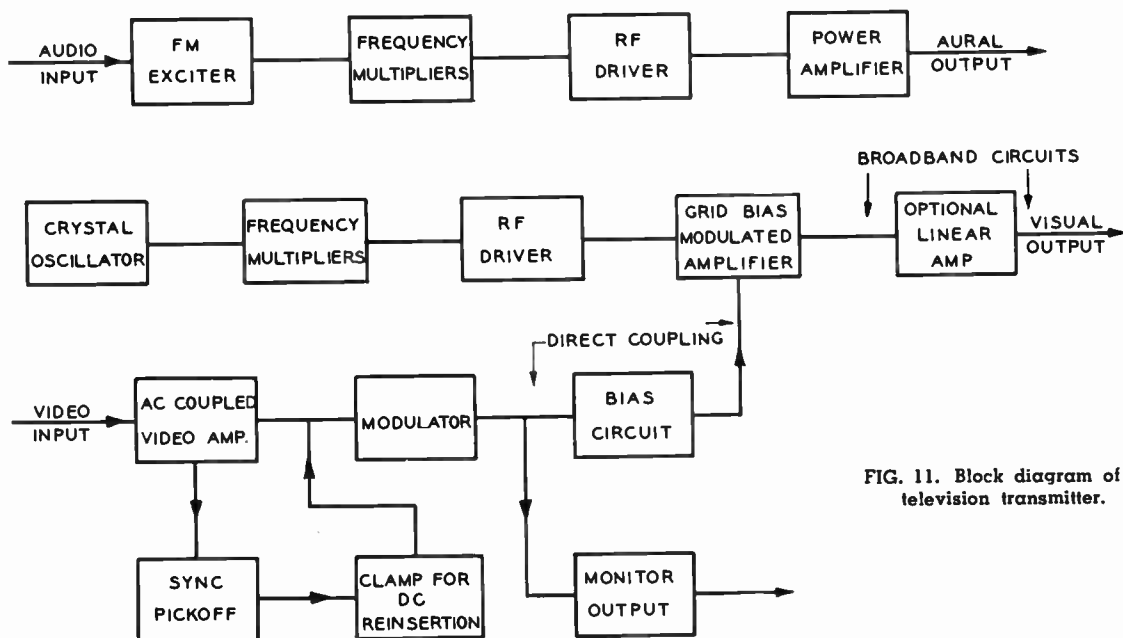

FIG. 11. Block diagram of a television transmitter.



## Modulation Method

Of the various methods of modulating a radio frequency amplifier only grid bias modulation has proven to be practical for television. At very low levels plate modulation is possible, but for most practical problems it is not economical to develop large video voltages across the capacity of the RF amplifier tube and circuit. For economy, the grid is modulated because the peak-to-peak video voltage required is small. Grid modulation of a grounded grid amplifier is not entirely practical because the variation in input impedance of the tube over the modulation cycle produces load impedance modulation of the driver. If picture distortion is to be avoided, the driver must then have a broad-band radio frequency characteristic throughout the modulation cycle. Although this problem is not insurmountable, grounded cathode operation of the modulated radio frequency stage is to be preferred, since, in the absence of RF feedback, no sidebands occur in the input circuit and only the output circuit of the stage must have a wide bandwidth.

## Transmission of D-C Components

Since the average brightness of a scene represents useful picture information, and since the output of the transmitter is inversely proportional to the scene brightness, it follows that the average power of the transmitter must change from scene to scene. Black level is represented by a definite power output from the transmitter. In other words, the transmitter must transmit the d-c components of the picture information.

Since video signals are sent through various a-c coupled amplifiers in going from the studio to the transmitter, the d-c information is lost and must be restored at the transmitter. This is done by clamping on the "back porch" of the blanking pedestal in a manner which is described in the section dealing with terminal equipment theory. This is generally done at the grid of the modulator and the modulator is then direct coupled to the grid of the modulated radio-frequency stage. The video connection to the RF amplifier must be arranged in a manner so that the modulator is not excessively loaded by the capacity to ground of the RF circuits. One method of achieving this result is shown in Fig. 12. Here the RF driver provides a voltage  $E_p$  in excess of the required grid swing  $E_g$ . A small coupling capacitor  $C_1$  then acts in conjunction with the input capacity of the amplifier tube  $C_2$  as an RF voltage divider. The modulator is connected through a radio-frequency choke to the amplifier grid. The video load on the modulator is then  $C_1$  plus  $C_2$ , but  $C_1$  is very small.

The d-c information could be inserted at the grid of the modulated RF stage except that this would require large clamp pulses with a peak value in excess of the video signal. Even if d-c were inserted at the grid of the RF amplifier, to permit a-c coupling between the modulator and the modulated stage, the d-c information

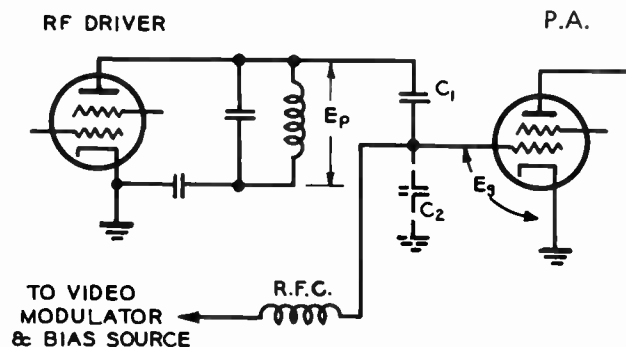

FIG. 12. Video connection for grid bias modulation.

would also be reinserted at other places in the video amplifier and modulator for reasons of design and economy and linearity control. Fig. 13 shows that the peak-to-peak value of a video signal after passing through an a-c coupled amplifier may exceed the peak-to-peak of a d-c coupled signal by 60%. It will be recalled from the discussion in the section on terminal equipment theory that a non sinusoidal wave in an a-c system is disposed about the bias axis in such a way that the area included by the curve above the axis is equal to that included by the curve under the axis. Since the peak-to-peak voltage a high level modulator can handle without distortion is one of the chief factors affecting the size and cost, it will be apparent that reinserting the d-c component ahead of the modulator is desirable from a cost reduction viewpoint.

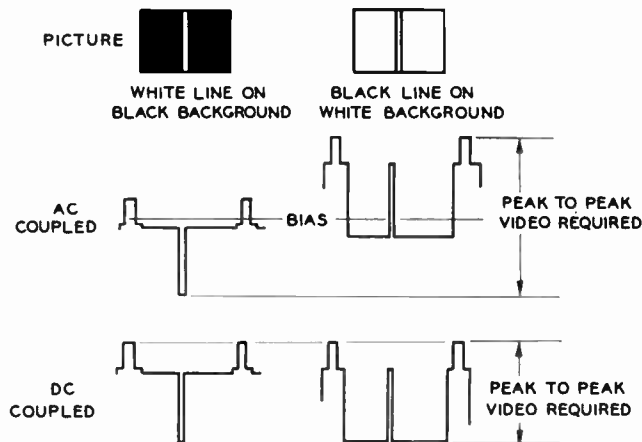

FIG. 13. Video amplitude in a-c coupled and d-c coupled systems.

## Clamp Circuit

Although the basic principles of clamp circuits are discussed in the section on terminal equipment theory, the transmitter circuits differ slightly for the reason that larger pulse voltages are required. Fig. 14 shows the clamp circuit included in the TT-5A transmitter. The synchronizing signal is separated by the 6J5 and charges a pulse transformer. The pulse transformer is damped during this interval by the plate resistance of the synchronizing separator. Following the synchronizing pulse, the 6J5 is cut off, and the pulse transformer rings

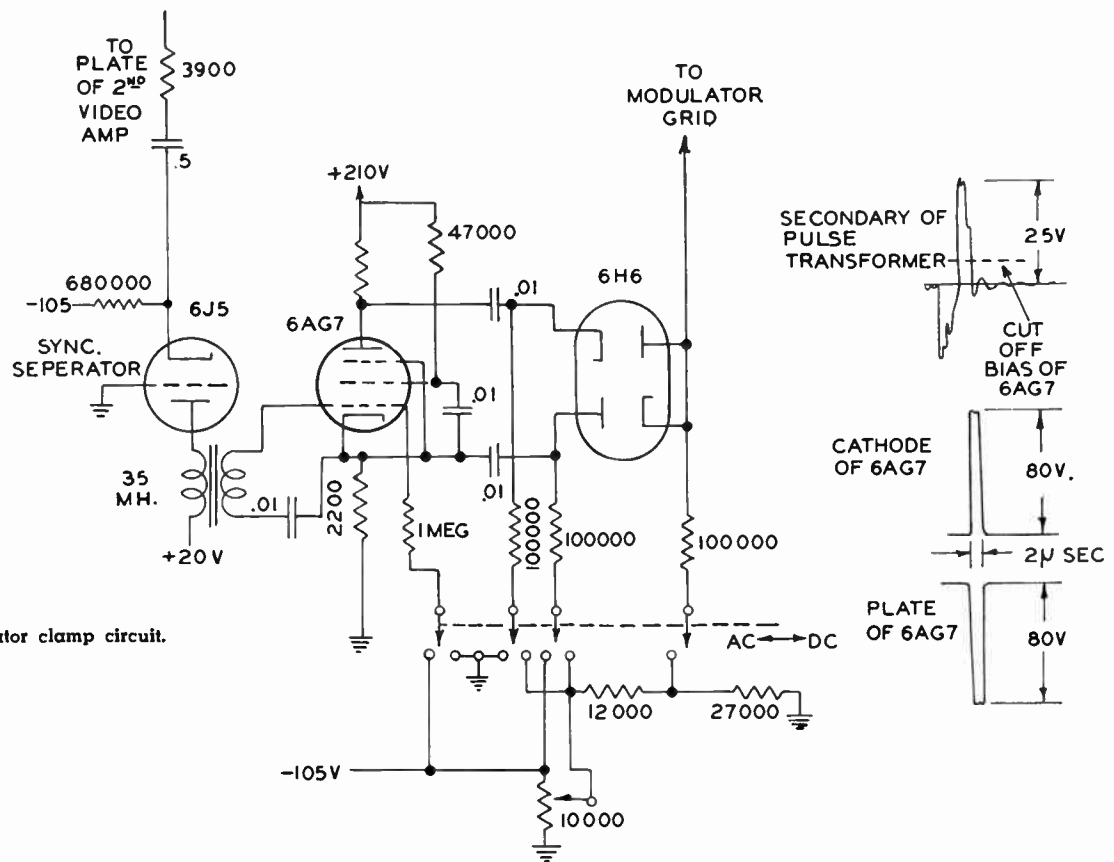

FIG. 14. TT-5A modulator clamp circuit.

with a damped oscillation having a half period of approximately 2 microseconds. The damped oscillation is applied between grid and cathode of a 6AG7 pulse amplifier and phase inverter which selects and amplifies the first half cycle of the damped oscillation. This connection is known as a "boot strap" circuit because the output pulse at the cathode of the 6AG7 lifts the secondary winding of the pulse transformer above ground. This arrangement avoids degeneration of the input pulse, and consequently large push-pull voltages are developed by the pulse amplifier with a relatively small output voltage from the pulse transformer. The pulses are applied to a 6H6 diode which clamps the modulator grid to the required instantaneous bias at the instant corresponding to the back porch of the pedestal. The pulses charge up the coupling capacitors in series with the diode. This maintains a cutoff bias for the diode so that it does not conduct during the picture interval between blanking pulses.

#### Linearity Control

Since the process of grid bias modulation introduces some amplitude distortion, it is desirable to control the over-all transmitter linearity by some predistortion in the video amplifier portion of the transmitter. If the linearity is to be controlled, it is necessary to reinsert the d-c components at the point in the video amplifier where the predistortion is generated. The d-c component may be reinserted on the grid of a video amplifier either by leveling or through the use of a clamp circuit. After this is done each value of plate current will represent a picture brightness level and the transfer characteristic of any portion of the signal can be controlled by changing

the linearity of the amplifier through a specified range of plate currents. This has been done by several methods.

One method consists of paralleling several tubes having various amounts of threshold bias so that different numbers of tubes are in parallel over various portions of the transfer characteristic. Another technique is to apply feedback from one stage to another through biased diodes so that the feedback operates in a different degree over different parts of the transfer characteristic. A circuit of this type with just one diode is shown in Fig. 15. A third method is to provide several load impedances in parallel for a video amplifier. The loads are then automatically

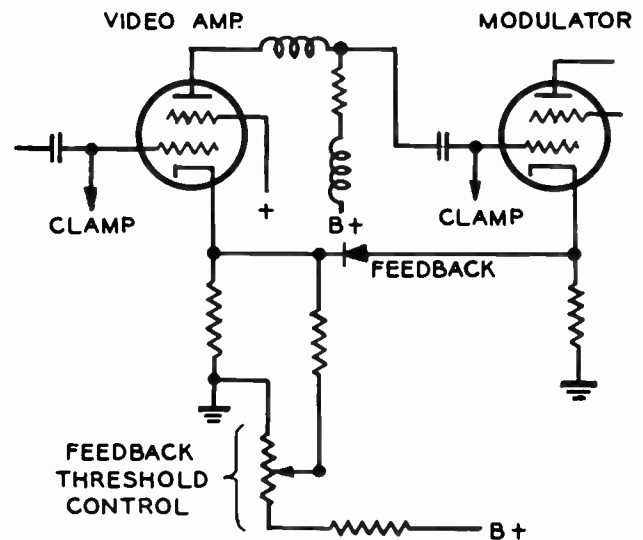

FIG. 15. A circuit for linearity control.

connected and disconnected over parts of the transfer characteristic by suitably biased diodes.

In the past, linearity control in the transmitter has been used to stretch the synchronizing signal in order to maintain the proper picture to synchronizing signal ratio. More recently circuits have been developed to control the linearity in the white region of the picture in order to reduce the harmful effects of white saturation discussed earlier.

### Circuit for Direct Coupling of Video Amplifiers and Modulators

Direct coupling is employed between the point of d-c reinsertion in the video amplifier and the grid of the modulated RF amplifier. Since the plate potential of one stage will not be the correct bias for the grid of the following stage, some circuit is needed to insert the correct bias without changing the video load impedance for the amplifier. Fig. 16 shows 5 circuits that have been used for accomplishing this. The first two circuits are suitable only if no grid current is required from the bias supply, and may be used between a video amplifier and a class "A" modulator. The next three circuits show arrangements which permit grid current to flow without destroying the relation of the d-c video component. These circuits may be used either preceding or following the modulator.

In Fig. 16-A the bias supply is not connected to ground except through its incidental stray capacity, consequently slow changes in the plate potential of

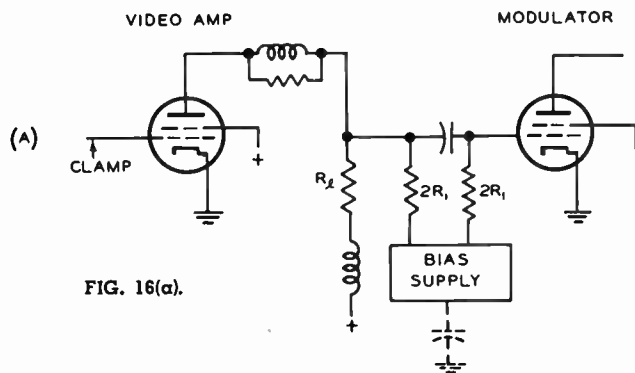

FIG. 16(a).

FIGS. 16 (a, b, c, d, e). Circuits for direct coupling of video amplifiers or modulators.

the video amplifier will be correctly reproduced at the grid of the modulator. A bias supply of this type generally requires transformers with shielded windings. The video frequencies are attenuated with respect to the d-c response in the ratio  $R_1/(R_1+R_1)$ . Consequently,  $R_1$  is made as large as possible. In Fig. 16-B tube V-1 is connected so that it draws a constant current through resistance R. Consequently, the voltage drop across R will be constant and changes in the d-c component at the video amplifier will be correctly reproduced at the modulator grid. The video frequencies are attenuated with respect to the d-c component in the

ration of  $R/R_1$ .  $R_1$  is the effective plate resistance of tube V-1 which should be made as high as possible. A high value of plate resistance is obtained by choosing a tetrode of desirable characteristics and operating it with considerable negative feedback. The negative feedback is obtained by the use of a large un-bypassed cathode resistor  $R_k$ .

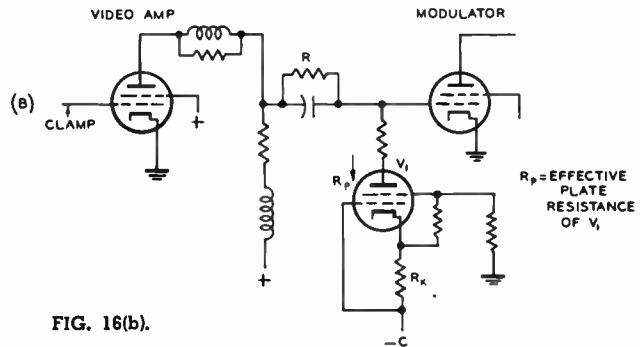

FIG. 16(b).

In Fig. 16-C voltage drop between the modulator and the PA grid is obtained by the use of gas filled regulator tubes V2, V3. These have a definite internal impedance for slow changes in current. If this internal impedance is small compared to  $R_2$  then the response for slow changes (d-c response) can be made approximately equal to the video frequency response.

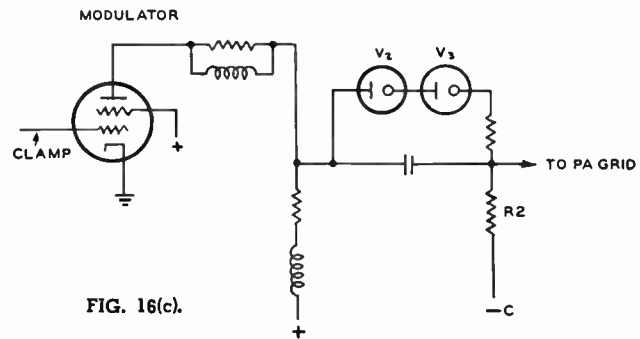

FIG. 16(c).

The circuit shown in Fig. 16-D includes a modulator whose cathode circuit is connected to a large negative voltage. The plate load circuit is grounded and the drop across the load resistor furnishes the correct bias for the PA grid. This can be varied to some extent by changing the steady current through the modulator or providing a steady current through the load resistance R. One of the disadvantages of this arrangement is that

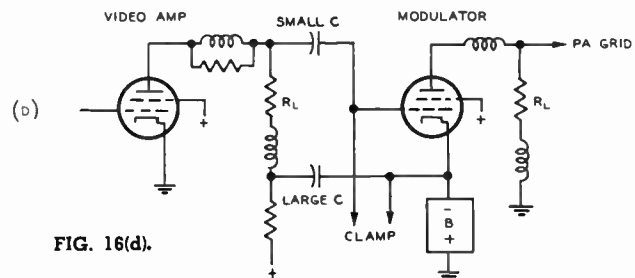

FIG. 16(d).

hum and other disturbances in power supply "B" appear in the input circuit of the modulator. This can be overcome to some extent by providing a large coupling condenser connected to the load resistor of the previous stage as shown. Power supply variations in B then appear equally on the cathode and grid of the modulator and are not reproduced in the modulator input. The clamp circuit connected as shown further reduces the effects of hum and noise.

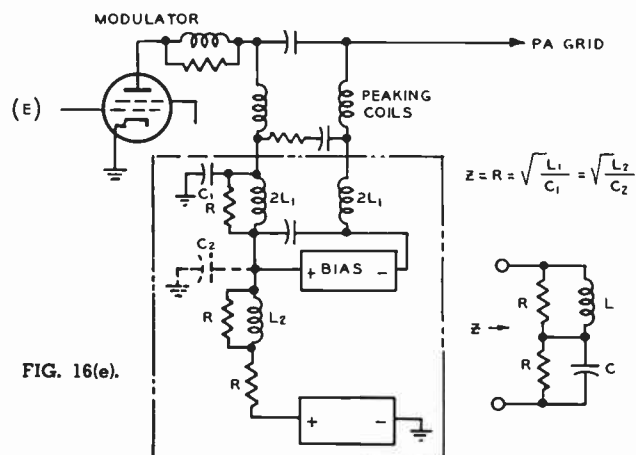

FIG. 16(e).

Another arrangement that has been used to connect between the modulator and the PA grid circuit is shown in Fig. 16-E. Here the capacitance to ground of the bias supply is used as part of a constant resistance network. Since the network has a constant resistance at all video frequencies, the modulator will have a good frequency response in spite of the large capacity to ground of the bias supply. The circuit elements of the constant resistance network are shown enclosed by the broken lines. This is actually a two stage network where one of the resistors R of the simplified network (shown in 16-E) is replaced by another constant resistance network. Networks of this type will give excellent performance but are not often used because of the difficulty of accurately adjusting the many inter-related component values. It has one outstanding advantage over the other circuits shown in Fig. 16. That is, the internal resistance of the power supply can be used to an advantage as part of the resistance arm of the network. The modulator will then have good frequency response down to d-c, and changes in brightness level will be accurately reproduced. The other circuits shown in Fig. 16 may require a regulated power supply for adequate d-c response.

#### D-C Transmission and Power Supply Regulation

Because of the spec. which requires the power output of the transmitter to be independent of the picture background, special attention is necessary to the problem of power supply regulation. In going from a white to a black picture, the current drawn by the modulated radio

frequency stage or RF linear amplifier may increase by as much as 3 to 1. Similar changes occur in the modulator and certain video amplifier stages. The power supplies must have adequate regulation so that the effects of the corresponding voltage changes do not reduce the power output of the transmitter by more than a few percent. The problem is one of determining the change in voltage that will occur in each power supply in going from a white to a black picture and computing the effect of this change on the power output. For example, the change in screen voltage for a radio frequency stage may be quite small and produce only a small change in power output if the plate voltage throughout the radio frequency cycle does not dip below the screen voltage. On the other hand, a different choice of tube or operating condition may result in large changes of screen current. The required screen voltage regulation may be so severe as to demand the use of an electronically regulated power supply.

#### Video Impedance of Power Supply

In addition to the problem of providing adequate power supply regulation for changes in the d-c demand, the power supply must also have adequately low impedance at all video frequencies. Video amplifiers, modulated RF amplifiers, and linear amplifiers all have video currents flowing in the grid circuits, screen circuits, and plate circuits. These currents produce a perturbing signal across the power supply impedance whose magnitude can be calculated readily from the power supply impedance and the peak to peak currents involved. Since the power supply impedance is almost always a function of the video frequency, any voltage developed across these impedances will act on the transmitter to produce picture distortion. The magnitude of the effect can be calculated in the same way that the effects of power supply regulation are calculated.

For example, if the plate current of a radio frequency stage changes by one ampere in going from black level to white level and if the power supply impedance is say 100 ohms at some video frequency, then a signal of 100 volts may be produced at this frequency. From the tube characteristics it will be possible to predict the depth of modulation produced by the 100 volt power supply variation. If it is calculated that a 100 volt change will modulate the transmitter by 5%, it follows that a power supply impedance of 100 ohms may introduce variations in the overall amplitude vs. frequency characteristic of the transmitter up to 5%. If large grid currents are involved, a similar calculation will reveal that only very small impedances can be tolerated in the bias supply and it follows that the video impedances of the filament circuit must likewise be small even for an RF amplifier.

A special example of the design of power supply impedance is the selection of the output capacitor of the plate power supply. This is chosen so that the power supply voltage does not fall off more than a predeter-

mined amount during the period of the vertical blanking pulse. The amount that the voltage can fall off during this interval is the amount necessary to modulate the transmitter by 2%, since it is generally desired to maintain the vertical blanking flat to better than this value. Another problem, due to use of relatively large tubes and components, is that bypass condensers must occasionally be placed some distance from the video or RF amplifiers and this is complicated by the frequent need for operating two or more capacitors in parallel. For example, in a radio frequency amplifier it is necessary to provide a plate blocking capacitor to bypass the radio frequency current. This is in parallel with a filter capacitor, which may be placed some distance away. The lead interconnecting these capacitors has appreciable inductance, and in conjunction with the two capacitors, produces a parallel circuit which resonates at some video frequency. Consequently, the power supply impedance (in the broad sense of including the RF blocking capacitor and interconnecting leads as part of the power supply) has a very high impedance at the resonant frequency.

This difficulty can be overcome by including in the lead a resistor equal to twice the reactance of the capacitor at the resonant frequency. This critically damped circuit will have a maximum resistance approximately equal to the value of the resistor. A value of resistance equal to the resonant impedance, although not quite the condition for critical damping, is a slightly better choice when the whole video spectrum is considered. Even this value may be too high for satisfactory per-

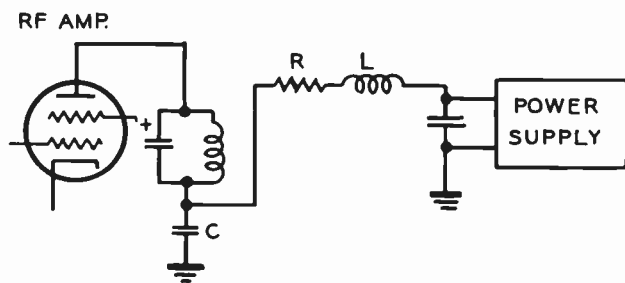

$L = 2\mu\text{H}$  WIRING INDUCTANCE

$C = .002$

$R = 30\ \Omega = X_C = X_L$  AT 2.5 MC

FIG. 17. Circuit for reducing effect of power supply circuit resonance.

formance and, if so, the circuit must be rewired for lower inductance or a larger blocking capacitor must be used so that the circuit can be critically damped with a reasonably small resistor. The problem is illustrated in Fig. 17, above.

### Incidental Phase Modulation

Although amplitude modulation of the visual transmitter is employed, the modulation process generally introduces a small amount of phase modulation. This

effect is aggravated by any RF feedback due to improper neutralization and is in general worse in UHF transmitters than in VHF ones. Incidental phase modulation is produced by changes in transit time when the amplifier is modulated. The effect also exists in linear amplifiers. Transit time refers to the time required for an electron to traverse the interelectrode space in the tube. This produces a phase shift between input circuit and output circuit which varies with changes in the transit time. Fortunately tubes which have adequately low transit time for efficient operation have sufficiently low incidental phase modulation to avoid harmful effect in the picture and sound providing that there is no undue RF feedback.

Incidental phase modulation of the visual transmitter may cause trouble in sound transmission. In receivers which employ the intercarrier sound principle, the 4.5 mc. IF is obtained as a beat between the picture carrier and the aural carrier. If the visual carrier is phase modulated by the picture signal, then the 4.5 mc. IF will also be phase modulated and the sound will contain noise due to picture modulation.

A harmful effect is produced in the picture also because the incidental phase modulation produces an extra set of sidebands which would cancel each other in a double sideband amplitude detector, but which add directly to the AM sideband in a single sideband receiver. Since the vestigial sideband system of transmission is used, the lower video frequencies are transmitted double sideband and the higher video frequencies are transmitted single sideband. The output of the vestigial sideband system is then different for low and for high video frequencies. This trouble produces picture defects similar to any other type of trouble which causes variation in the video frequency characteristics. The magnitude of incidental phase modulation which can cause trouble in the picture is roughly the same as the magnitude necessary to produce noise in the sound and when the effect is made low enough to receive good sound on an intercarrier system, the picture distortion is negligible.

### Monitoring Peak Power Output

Since the transmitter is rated in terms of peak power, and since the average power of the transmitter changes as the brightness of the picture changes, a device is necessary for monitoring the peak power. Such a monitor usually consists of a peak reading diode detector connected to a directional coupler. The combination is known as a reflectometer since the directional coupler can measure either the direct wave from the transmitter to the antenna or the wave reflected from the antenna. Since the power reflected from the antenna must be small in order to transmit a picture of satisfactory quality it follows that a reflectometer which measures the power in the direct wave will measure, to a close approximation, the radiated power.

### Principles of a Reflectometer

A cross section of a directional coupler and an equivalent schematic diagram are shown in Fig. 18. The loop has both capacitive and magnetic coupling to the transmission line. A voltage is induced in the loop which is directly proportional to the current flowing in the transmission line and whose phase angle is 90° with respect to the line current. There is also a voltage produced in the resistor due to the current which flows through the capacitor. If the capacitive reactance is very large compared to the resistance, then the current which flows through the resistor will be in quadrature with the transmission line voltage. The voltage induced in the loop and the voltage drop in the resistor are connected in series. Consider a wave traveling in one direction. The voltage across the transmission line and the current in the transmission line are in phase and are related to each other in magnitude by the characteristic impedance of the line. Since the voltage in the loop is in quadrature with the line current and the voltage in the resistor is in quadrature with the line voltage, it follows that the voltage in the loop is in phase with the voltage in the resistor and the two add directly to give the output voltage of the directional coupler.

If the loop is reversed or if the wave travels down the transmission line from the opposite direction, the voltage induced in the loop will then be out of phase with the voltage drop in the resistor, and if these two are made equal (by adjustment of either the capacitor or the loop) the directional coupler will not produce an output from the wave traveling in the undesired direction. It, therefore, sorts out the wave going in one direction from the wave going in the other. This permits a measurement of power flowing to the antenna. By rotating the directional coupler or comparing the reading from two which are permanently fixed in opposite directions a measurement of the load mismatch will be obtained.

### Calibration of Power Measurements

Although the reflectometer is constructed so that it reads in proportion to the peak power output, it must be calibrated by transmitting a known power. The standard procedure for making this calibration is to feed the transmitter into a dummy load. While transmitting an all black picture, the transmitter should be carefully adjusted so that the pedestal level is at 75% of peak output. The average power in the dummy load is measured and the peak power output computed. The average power may be measured with a dummy load such as RCA MI-19024A which is a secondary standard and has been calibrated at the factory. The original calibration is based upon calorimetric measurement of power by dissipating all of the power in a water column and measuring the temperature rise in the water. This technique can be duplicated with fair accuracy using one of the MI-19024A "Secondary Standard" loads if a water flow meter is available. These are equipped with a heat exchanger between a volume of coolant, in which a load resistor

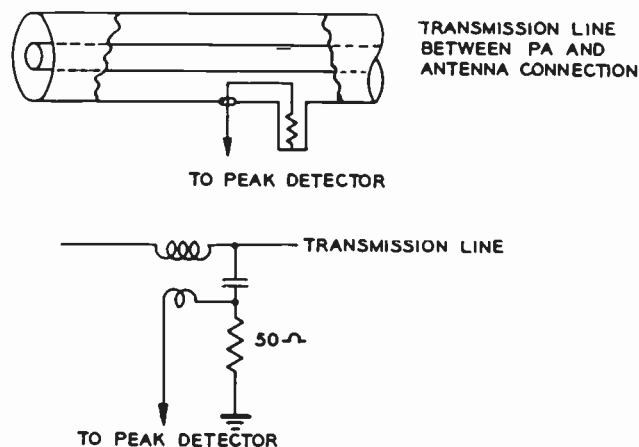

FIG. 18. Directional coupler.

is immersed, and a water supply. By inserting two thermometers close to the input and output water connections, and obtaining a steady flow of water through the load, the power absorbed in the water can be measured according to the following formula:

$$\text{Power in KW} = .263 \times \text{GPM} \times \Delta T$$

Where  $\Delta T$  = Temperature difference between inlet and outlet water in °C.

GPM = Water flow in gallons per minute.

In this type of load there is a small heat loss due to radiation which does not show up as a rise in water temperature, consequently the power read by this method will be approximately 5% less than the actual power. Another precaution is that it requires approximately 15 minutes of steady operation to reach an equilibrium condition and obtain an accurate reading.

The peak power output of the transmitter is 1.68 times the average power provided the average power is carefully measured while transmitting sync only (all black picture) and provided that the pedestal level is carefully maintained at exactly 75% of the sync peak amplitude. The ratio of average to peak power is derived as follows:

Amplitude	Power Level	Time	Average Power
Sync 100%	100%	× 8%	= 8%
Pedestal 75%	56%	× 92%	= 51.5%
			Total = 59.5%

$$\text{Ratio of Average Power/Peak Power} = 59\frac{1}{2}\% \text{ or } .595$$

$$\text{Ratio of Peak Power/Av. Power} = 1/.595 = 1.68$$

The sync pulse occurs for 8% of the time. Pedestal level is transmitted for 92% of the time.

### RF Circuits for Grid Bias Modulated Amplifiers and Linear Amplifiers

It is an objective in the circuit design to obtain constant amplitude vs. frequency response throughout a television channel and at the same time obtain the maximum

load impedances for the tubes. There are a few exceptions to this which will be made evident in the following paragraph. This basic principle is the same regardless of whether the circuit is to be used with a grid modulated RF amplifier or a linear amplifier.

In some transmitters modulation is accomplished at relatively low power levels and a series of linear amplifiers are used to attenuate the lower sideband. If grid bias modulation is employed at high level, there will be an insufficient number of tuned circuits between the RF amplifier and the load (antenna) to attenuate the lower sideband. In this case, a vestigial sideband filter is used to remove the lower sideband. This does not result in power loss by the transmitter, since the final stage is operated into an identical circuit whether it is a linear amplifier or not. In the case of the linear amplifier, the lower sideband is simply not present to any great degree in the input of the final amplifier. In the case of a grid bias modulated stage the upper and lower sidebands are generated equally in the modulation process, but the lower sideband is attenuated to some degree by the selectivity of the plate tank circuit. The power input to the final stage of the transmitter and the useful power output is the same in either case.

### Broadband RF Circuits

The broadband circuits employed are in general various forms of double tuned over-coupled circuits because these circuits develop the maximum impedance that can be obtained over a television channel with a reasonable number of circuit elements. The impedance that can be obtained for a particular bandwidth or the bandwidth that can be obtained for a specified impedance is about 40% greater for an over-coupled circuit than for a single tuned circuit. There is an occasional exception to this, which comes about when it is not possible to use a higher load impedance than can be obtained with a single tuned circuit due to various limitations, which will be apparent in one of the following sections. If the tube and circuit capacities can be made low enough to obtain a satisfactory value of load impedance, then a single tuned circuit may be chosen for reasons of simplicity. This is especially true in UHF transmitters where circuit losses may represent a sizeable limitation in performance and the power increase obtained in going from a single tuned circuit to an over-coupled circuit of higher impedance may be wasted in added circuit losses.

Some of the forms of over-coupled circuits, which have been used in television transmitters, are shown in Fig. 19. In the low frequency VHF channels these are sometimes formed of lumped constants (19-a, b, c) but in the upper VHF channels and UHF channels the circuits are almost always sections of coaxial transmission lines (19-d, e). When the coaxial circuits become very short compared to their diameter they may appear more as boxes than sections of coaxial lines and in this case they are generally known as cavities.

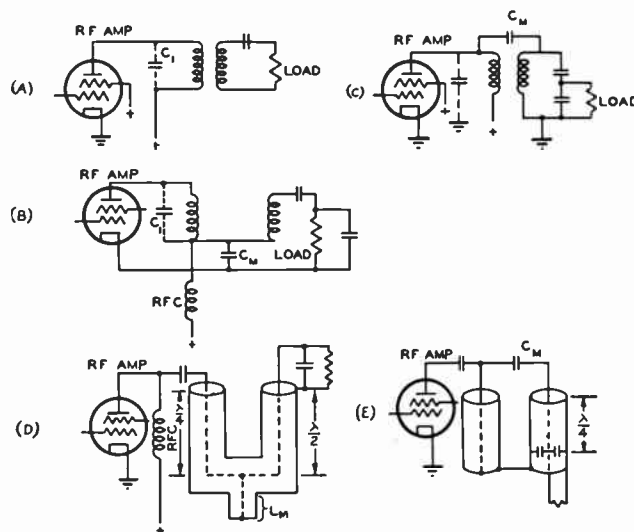

FIG. 19. Forms of double tuned over-coupled circuits for TV transmitters.

Regardless of the type of coupling, the circuits perform in a similar manner. The input impedance of the circuit, which determines the power that a tube can develop, is determined by the capacitor C-1 of Fig. 19. This capacitor is made up principally of the unavoidable interelectrode capacity of the tube. On the lower VHF channels a large portion of C-1 may consist of stray circuit capacitance, which should be kept at a minimum in order to maximize the impedance. The shape of the band pass characteristic is determined to a large degree by the secondary "Q" which is the ratio of the energy stored in the secondary to the energy dissipated per cycle. Since the secondary capacitance can be made as small as desired, the designer has control over the secondary "Q". If this is large, the over-coupled circuit will have a sag in the center of the pass band with peaks near the cutoff frequencies. On the other hand, if the secondary "Q" is small and most of the stored energy is in the primary circuit, then the shape of the band pass characteristic will approach that of a heavily loaded single tuned circuit. These effects are shown in Fig. 20. The choice that is usually made is shown by curve  $D = \sqrt{2}$ . This gives a perfectly flat curve near the middle of the band with slight tailing off near the band edges.

If the coupling between the primary and secondary is increased, more resistance will be reflected into the primary. The load impedance presented to the tube will be reduced and the ratio of stored energy to power in the primary will go down. Consequently, the shape of the curve will change from that shown by  $D = \sqrt{2}$  to one similar to  $D = 1$  or  $D = 2$  and the bandwidth will be increased. It is apparent that the shape of the curve depends not only upon the secondary "Q", but also upon the coupling. However, since only one adjustment will yield a correct bandwidth, circuit constants can be chosen so that the RF band pass characteristic will have the proper shape when the circuit is adjusted for the correct bandwidth.

Under the heading "Frequency response throughout a television system," it was stated that in order to obtain the maximum load impedance for the RF amplifier tube the carrier should be placed, not at the center of the pass band, but somewhat to one side. This permits the bandwidth of the over-coupled circuit to be less than would otherwise be required. This procedure cannot be carried to an extreme. The curve of Fig. 20 is the transfer impedance of the network. It is the voltage delivered

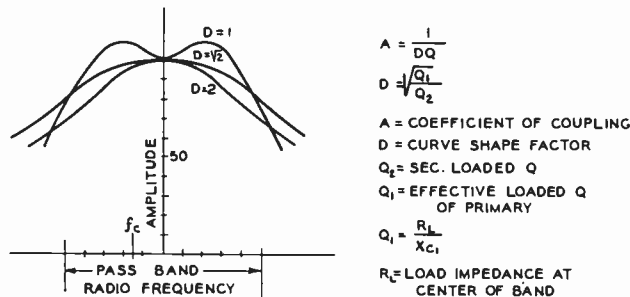

FIG. 20. Amplitude characteristic of coupled resonant circuits.

to the load for a constant current into the primary. The corresponding input impedance of the circuit is not constant throughout the pass band. Curves of input impedance, magnitude, and phase angle are shown in Fig. 21.

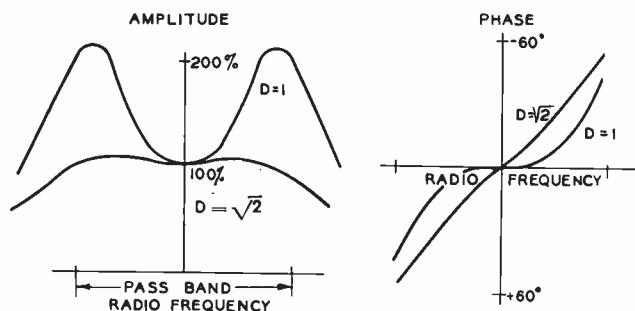

FIG. 21. Input impedance of coupled resonant circuits.

Thus the load on the tube either changes in magnitude or becomes reactive as the carrier is displaced from the center of the pass band. Moving the carrier toward the edge of the band may result in reduced power output if the tube is being worked near the limit of its power output. Although the choice of band center frequency is not critical, the carrier is usually placed at the point  $f_c$  on the curve of Fig. 20. Some more characteristics of over-coupled circuits are discussed under the heading: "Adjustment of an over-coupled double tuned circuit."

### Aural Operation

The principle difference in operation between the visual and aural transmitter is that the bandwidth of the aural RF amplifier is ordinarily wider than necessary so that tuning the RF circuits for proper operation presents no difficulty. The requirement for AM noise is more

severe in the case of the aural transmitter and this requirement is met by some form of amplitude saturation in the amplifier and/or the driver. If the amplifier is a tetrode, saturation is achieved by adjusting the RF circuits, the RF drive, and the plate power supply voltage so that the RF swing on the plate of the final amplifier causes the minimum instantaneous plate voltage to dip below the screen voltage. Under these conditions the d-c screen current will rise sharply with an increase in driving power or an increase in plate load impedance. Any tendency for an increased plate swing will increase the screen current at the expense of anode current and thus tend to limit the power output to a constant value. The technique of saturating a tetrode amplifier is simply to adjust the circuit so that a reasonable amount of screen current is indicated. Since the stage is saturated under these conditions it will be difficult to change the power output by adjusting the driver. The power output can be altered by adjusting the load impedance (tuning of the RF circuit) or increasing the plate supply voltage.

### OPERATION OF A GRID MODULATED RF AMPLIFIER

#### General Principles

Operation of the grid modulated amplifier is the most interesting portion of the transmitter. The principles of operation will be discussed with reference to Fig. 22. The transmitter is operated with a constant RF grid swing  $E_G$ . If the bias on the transmitter is made sufficiently negative "X" the RF grid swing will not exceed the cutoff bias of the amplifier at any point throughout the RF cycle. No plate current will be developed and the power output will be zero. If the bias is decreased to a value equal to cutoff and the RF grid swing is superimposed, pulses of plate current will flow as shown. Since the bias was adjusted to plate current cutoff, the plate current will flow as distorted half sine wave pulses. The angle of plate current flow will be  $180^\circ$ . These

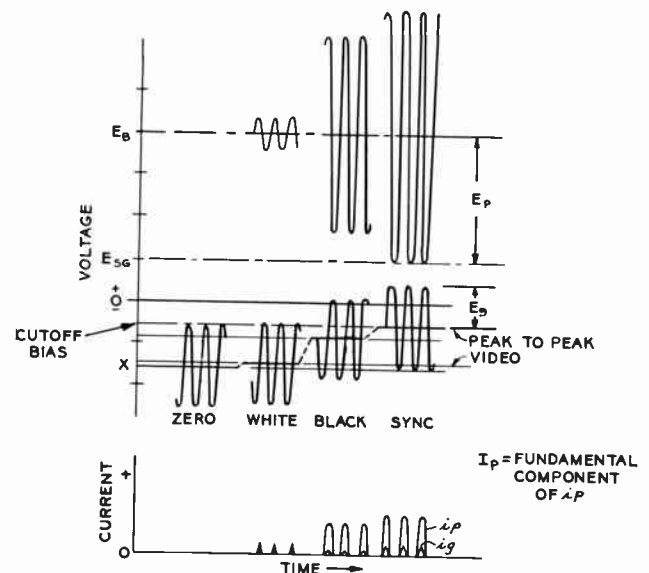

FIG. 22. Relations between grid and plate RF voltages and currents in a grid bias modulated amplifier.



pulses of plate current have a fundamental component at the carrier frequency. If the fundamental component of plate current is multiplied by the load impedance connected to the tube the result will be the peak plate voltage swing  $E_p$ . From Ohms law:  $E_p = R I_p$ , where the voltage and current are the fundamental components.

If the bias is increased from the cutoff value to a value shown as "black" the peak value of the plate current pulses will be reduced and the angle of plate current flow will be reduced. The output voltage  $E_p$  reduces for two reasons: (1) The carrier frequency component of the current pulse is reduced. (2) The magnitude of the pulse is reduced. The operation shown with a bias equal to "white" is an extension of this principle. From Fig. 22 can be seen the relationships between RF grid voltage, RF plate voltage, bias, grid current and plate current at various video levels: white, black, and sync.

It has been represented in this figure that the transmitter is adjusted so that the instantaneous bias at the synchronizing peak is equal to the cutoff bias of the tube and, therefore, the plate current flows throughout  $\frac{1}{2}$  cycle at the carrier frequency. Grid bias modulated amplifiers are generally designed to operate under these conditions.

#### Effects of Power Supply Voltage and Load Impedance

Now refer to Fig. 23. This shows a typical set of grid-plate characteristics for a tetrode. Suppose the RF circuits associated with the grid modulated amplifier have been designed, and the maximum load impedance available for the tube, determined. Suppose that the

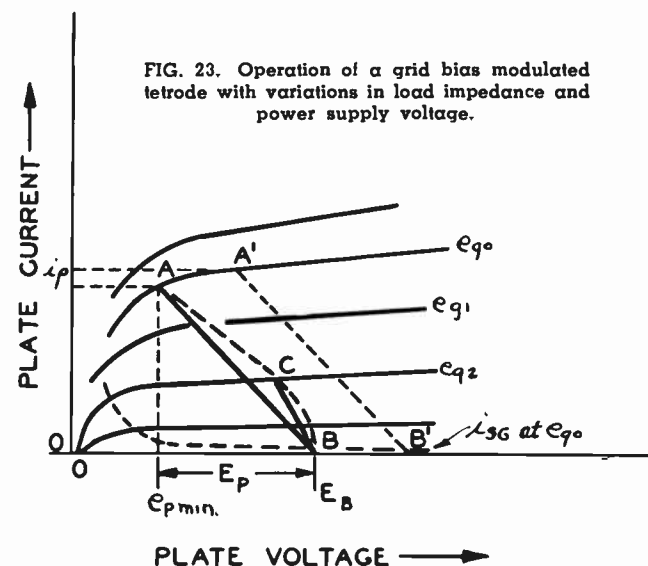

FIG. 23. Operation of a grid bias modulated tetrode with variations in load impedance and power supply voltage.

bias at the synchronizing peak level (maximum power output of the transmitter) has been chosen to equal the cutoff bias of the tube. The grid swing may be chosen so that the peak grid voltage  $e_{g0}$  is approaching the maximum plate current capability of the tube. The

plate current will flow for  $\frac{1}{2}$  of an RF cycle, and from Fig. 24, it can be seen that the fundamental component of the plate current is equal to  $\frac{1}{2}$  of the peak plate current. This value multiplied by the load impedance for the tube gives the peak plate voltage swing  $E_p$ . (Fig. 23.) The minimum plate voltage is chosen so that the line AB does not extend into the crowded region on the tube characteristics. In other words the minimum plate voltage is not allowed to dip appreciably below the screen voltage, for if this happens the screen will rob electrons from the plate, saturating the plate current and severely increasing the screen current. The plate voltage is determined as shown in Fig. 23 by adding the plate voltage swing to the minimum instantaneous plate voltage. The line AB is related to the load impedance of the tube.

If the plate voltage is increased to  $B^1$ , the load line  $A^1B^1$  will be unaffected in slope. The peak plate current will be increased slightly. The power output will be increased slightly. The screen current will be reduced slightly, but the power input and consequently the dissipation peak will be substantially increased. Therefore, for maximum efficiency a plate voltage B will be chosen. For slightly better linearity and slightly increased power the plate voltage  $B^1$  would be chosen. It is easy to see from this figure why some transmitters may be operated with appreciable sync saturation. Either the load impedance is made too high or the plate voltage too low so that point A is pushed into the crowded region of the tube characteristic.

There are a number of fundamental limitations which determine the maximum power output that can be obtained once the load impedance has been determined from the required bandwidth. The tube is generally limited in dissipation, maximum plate voltage, maximum plate current, grid, screen, and anode dissipation. The operating grid, screen, and plate voltages are set so that none of these limitations are exceeded.

#### Linearity of Grid Bias Modulated Amplifiers and Linear Amplifiers

Line CB on Fig. 23 illustrates the conditions for some other point in the video cycle other than the synchronizing peak. As shown, it would represent an instant when the picture is gray. The bias on the amplifier would be somewhere between white and black of Fig. 22. Since the bias has been increased beyond cutoff, the peak grid voltage  $e_{g2}$  is not so high and consequently the peak plate current is small. Also the angle of plate current flow is shorter and the ratio of the fundamental component of plate current to the peak plate current has been reduced. Both of these factors reduce the plate swing  $E_p$ . Although the actual load impedance connected to the modulated stage has not changed, the line CB is steeper than AB because it is the fundamental component of the plate current pulse and not its peak value which determines the slope CB. If the tube were a linear amplifier instead of a grid bias modulated one, point C

would fall on the curve AB. The peak plate current would vary over the modulation cycle, but the angle of plate current flow would remain constant. It is this factor which results in the superior linearity of linear amplifiers compared to grid bias modulated amplifiers.

### Angle of Plate Current Flow

In all of the above discussion, it was shown by way of example that the plate current flow angle was  $180^\circ$  when the transmitter was developing peak power output (sync). Indeed, this is the usual design choice but it is not of fundamental importance. If the flow angle at the peak of the synchronizing pulses is less than  $180^\circ$  then the fundamental component of the current pulse will be reduced and it will be necessary to drive the tube harder to obtain the required power output. If the tube is working close to its maximum peak plate current, it may not be possible to obtain the required power output with increased bias. Operating with higher bias at the synchronizing level results in increased efficiency at the expense of increased driving power. The peak to peak video voltage required and the resulting linearity will not be greatly affected. Operating with longer than  $180^\circ$  flow angle at the synchronizing peak level has the opposite effect. The RF driving power required is reduced, but the plate efficiency is less. Consequently the dissipation is higher.

Referring to Fig. 22 it should be apparent that the same peak grid voltage can be developed if the bias represented by the instantaneous video signal is higher and the RF grid swing is larger. It follows that the adjustment of the RF driving power and the grid modulated amplifier bias are not critical, but they are inter-related. If the bias and the RF driving power are simultaneously altered the bias adjustment should be made on the RF amplifier and not on the modulator. The

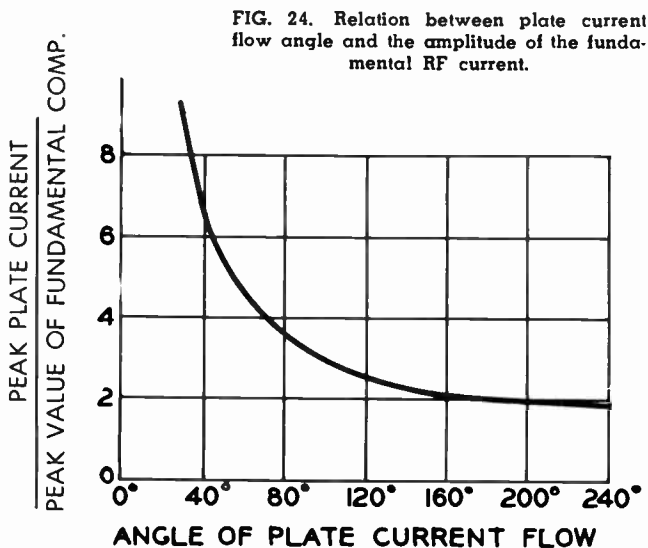

FIG. 24. Relation between plate current flow angle and the amplitude of the fundamental RF current.

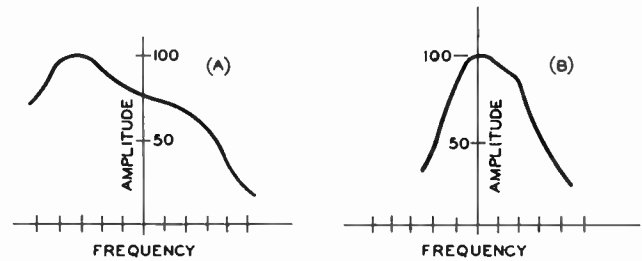

FIG. 25. Coupled resonant circuit with primary and secondary tuned to different frequencies.

modulator bias is chosen to place the video signal on the most linear portion of the modulator transfer characteristic (grid voltage vs. plate current).

### Adjustment of an Over-coupled Double Tuned RF Circuit

The principles of band pass RF circuit design and the operation of a grid bias modulated amplifier have been discussed. With this background, the technique of adjusting an over-coupled circuit will be described. A sideband analyzer, the WM-20B, has been developed which makes it possible to display the RF spectrum of the transmitter when a video sweep generator is applied to the video input terminals. This piece of equipment is discussed in detail in later paragraphs. The effects that can be observed while manipulating the tuning controls are interesting.

If a tetrode is used as a radio frequency amplifier, its effective plate resistance is very high compared with the load resistance. If a grounded grid triode amplifier is used, a high mu triode is usually chosen. Its plate resistance will normally be several times the load resistance. The tetrode behaves as a constant current generator while the grounded grid triode acts like a relatively high impedance generator. Consequently, most of the load in the over-coupled circuit is on the secondary side and this fact makes the tuning adjustments relatively easy. If the primary and secondary circuits are tuned to the same frequency, the band pass characteristic will be symmetrical about some center frequency (Fig. 20) which may or may not be the carrier frequency. If the two circuits are not tuned to exactly the same frequency, the curve may appear as shown in Fig. 25a. The larger peak will represent the undamped resonant circuit; in this case, the primary circuit. In this example the frequency response would be improved by tuning the primary to a higher frequency. Increasing the coupling will increase the spread between peaks and increase the dip in the center of the pass band. It will also lower the power output. Reducing the coupling beyond a critical value will result in a single peaked curve, but it will still be possible to detect whether the primary is tuned higher or lower than the secondary by a distortion of the curve as shown in Fig. 25-b. If the curve can be flattened without excessive peaks at the edge of

*This page Very important in Tuning  
Xmitter*

the band, but the bandwidth appears to be too narrow, the conclusion is that the secondary "Q" is too high and the coupling too low.

In using a sideband analyzer it is not possible to observe the shape of the RF characteristic throughout a band greater than twice the video bandwidth of the modulator. In other words a true indication will be obtained only over a 10 mc. spectrum. In making adjustments with the sideband analyzer it is therefore best to start with rather loosely coupled circuits and work up to the proper bandwidth.

Even without a sideband analyzer a good "feel" for the tuning of an over-coupled circuit is possible for the following reason: when the primary and secondary are each on resonance the input impedance at the center of the band is at a minimum. It is definitely the wrong thing to do to adjust an over-coupled circuit by tuning the primary and secondary individually for maximum power output. This will invariably lead to a curve similar to Fig. 25-a. The primary and secondary circuit will be adjusted to different frequencies as a result of obtaining a favorable load impedance. The proper technique is to adjust the circuits until the lowest load impedance is obtained for a particular coupling adjustment. One way of doing this is to lower the plate voltage and increase the RF drive until some screen current (or grid current if a triode) is observed when the primary circuit is tuned through resonance. The primary circuit should be tuned back and forth through resonance for a series of adjustments of the secondary circuit. The proper adjustment of the secondary circuit is the one which gives the smallest peak in screen current when the primary is tuned through resonance. Under these conditions the primary and secondary circuits will be tuned to the same frequency and a symmetrical band pass characteristic will be obtained. It will be possible to then shift the resonance of each of these circuits to a slightly higher frequency, but this final adjustment is best made with the sideband analyzer. Having made this adjustment, the power output and plate current at normal plate voltage should be noted. If the plate current is too high for the observed power output then the load impedance is too low, and the bandwidth too great. The adjustments should be repeated with reduced coupling between primary and secondary.

To obtain a perfectly flat frequency response requires not only the proper tuning adjustment and coupling, but also the proper secondary "Q". Since the transmitter is designed to work into a resistive load, the secondary "Q" will not be correct if the value of load resistance is changed or if the load is reactive.

#### Adjustment of RF Driver

If the RF driver employs a single tuned circuit between the plate of the driver and the grid of the RF amplifier, then the adjustment is obvious. Where the

driver includes a tuned plate circuit separate from the tuned grid circuit of the amplifier, whether or not these two circuits are separated by a length of coaxial cable, the adjustment is more complex and to a degree is similar to the adjustment of an over-coupled output circuit of a broad band amplifier. This is true even though there are no side bands present in the input circuit. It is typical of poor procedure to resonate the driver plate and the amplifier grid circuit for maximum RF drive. If this turns out to be insufficient, the coupling is increased and it is then found that a new tuning condition is obtained for maximum drive, but that the drive is the same as before. What has been done is to severely over-couple the circuits with the secondary circuit mistuned in order that the driver will work into its optimum load impedance. This characteristic occurs automatically in the quest of maximum driving power and may result in undue circuit drift and microphonics due to operating the circuits off resonance.

Another typical mistake is to make the tuning and coupling adjustment for maximum grid drive while the driver is operating at reduced current. Little if any increase in drive is then obtained when the driver is operating at increased current. The reason is that the load impedance was adjusted for optimum value at low plate current and is incorrect for the high level of plate current. A better procedure is to make the circuit adjustment with the RF driver operating near maximum level and to follow the procedure described in connection with broad band adjustment of adjusting the secondary circuit for the greatest load on the driver when the driver is tuned through resonance. Increased driving power may be obtained by reducing rather than increasing the coupling between the circuits.

#### Description of Sideband Analyzer

The sideband response analyzer is a device for measuring the overall "amplitude versus frequency" characteristic of a television transmitter. In conjunction with an oscilloscope it visually presents and separates both the upper and lower sideband response. Its primary use is a tool for tuning the over-coupled broadband RF circuits of television transmitters and measuring their amplitude response characteristic. Since it includes a video sweep oscillator, it can also be used in adjusting video amplifiers, modulators, etc.

Essentially the device consists of a video sweep oscillator and narrow-band detector. If a transmitter is modulated by the video sweep oscillator, the input of the transmitter will include the carrier, and the two sidebands which are also varying in frequency. If a narrow-band detector, whose selectivity is sufficiently great to select one of the sidebands and reject the carrier and the other sideband, is also tuned in synchronism with the video sweep oscillator the amplitude of the signal from

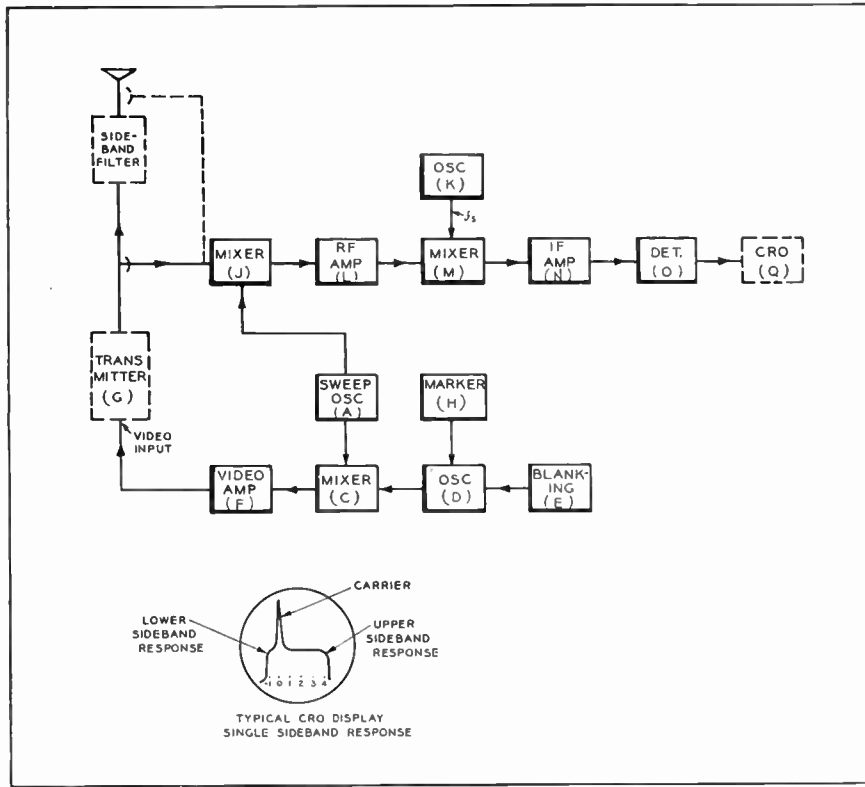

FIG. 26. Block diagram of BW-5A TV Sideband Response Analyzer showing method of operation.

the detector, when viewed on an oscilloscope, will show the "frequency versus amplitude" characteristic of the transmitter.

For a more detailed description of the principle of operation as it might be applied to one of the high band television channels refer to the block diagram, Fig. 26 and to the article on the BW-5A Sideband Analyzer on page C-57. A video sweep signal is obtained by beating together a sweep oscillator (A) and a fixed oscillator (D). The center frequency of the sweep oscillator is chosen so that it will go above and below the fixed oscillator by approximately equal amounts. During the period the frequency ( $f_3$ ) of the sweep oscillator (A) is higher than the frequency ( $f_2$ ) of the fixed oscillator (D), the carrier ( $f_0$ ) will be modulated by a frequency  $f_3 - f_2 = f_v$ . The signal fed to the antenna will contain three components  $f_0$  (carrier),  $f_0 + f_v = f_1$  and  $f_0 - f_v = f_1'$ . If this signal is heterodyned with the output of the sweep oscillator (A) in a mixer (J), the output of this mixer will contain the following components:

$$\begin{aligned}
 f_0 - f_3 &= f_0 - f_2 - f_v \\
 f_1 - f_3 &= f_0 - f_2 \\
 f_1' - f_3 &= f_0 - f_2 - 2f_v \\
 f_0 + f_3 & \\
 f_1 + f_3 & \\
 f_1' + f_3 &
 \end{aligned}$$

The balance of the circuits, K, L, M, N, and O form a conventional narrow-band detector. If this detector accepts only the frequency  $f_0 - f_2$ , which is the frequency associated with the upper sideband, the output of the detector will be proportional to the upper sideband response when  $f_3$  is greater than  $f_2$ . Similarly it can be shown that when the frequency ( $f_3$ ) of the sweep oscillator (A) is lower than the frequency ( $f_2$ ) of the fixed oscillator (D), the output of the detector will be proportional to the lower sideband response. If the sweep repetition rate is high enough, the trace on the CRO will indicate the frequency versus amplitude characteristic of the transmitter.

# TT-2AL/AH Television Transmitter (2KW)

The two kilowatt TV transmitters type TT-2AL and TT-2AH are designed for application where effective radiated powers of two to twenty kilowatts are required. Where it is desired to start with a smaller transmitter on channel 7-13 the TT-500B may be used, and later converted to a TT-2AH by addition of two cabinets containing the required amplifiers, power supplies and other parts.

The TT-2AH and TT-2AL use proven circuits in a simple and rugged assembly which is easy to adjust and maintain. Stability is excellent. The 5762 output tubes used in the output amplifier are simple and have excellent life

## General Description

The TT-2AL transmitter is for operation on channels 2-6 and the TT-2AH is for channels 7-13. They are the same size and shape and each meets FCC and RTMA performance specifications. The visual portions provide 2 kw

output at the peak of sync and the aural portions provide a frequency modulated carrier output of 1 kw. Each transmitter is housed in four 25" square cabinets which with end panels for trim make a total length of 106" and a depth of 31 1/16" including door handles. Height is 84". A vestigial sideband filter, part of the transmitter, is external to the cabinets and may be conveniently mounted from the ceiling. All other components of the transmitter are completely enclosed within the cabinets. All operating controls are accessible, either on the front control panels or through non-interlocked doors. All doors which give access to dangerous potentials are interlocked as required for safety and by FCC rules. All tubes and the cabinets are cooled by filtered air. Critical air blowers are interlocked with the control circuits to prevent damage to tubes. All important circuits are provided with meters for checking operation and for logging. High speed overload relays protect all power circuits. All r-f circuits are single ended and only three of these are broadband in each transmitter.

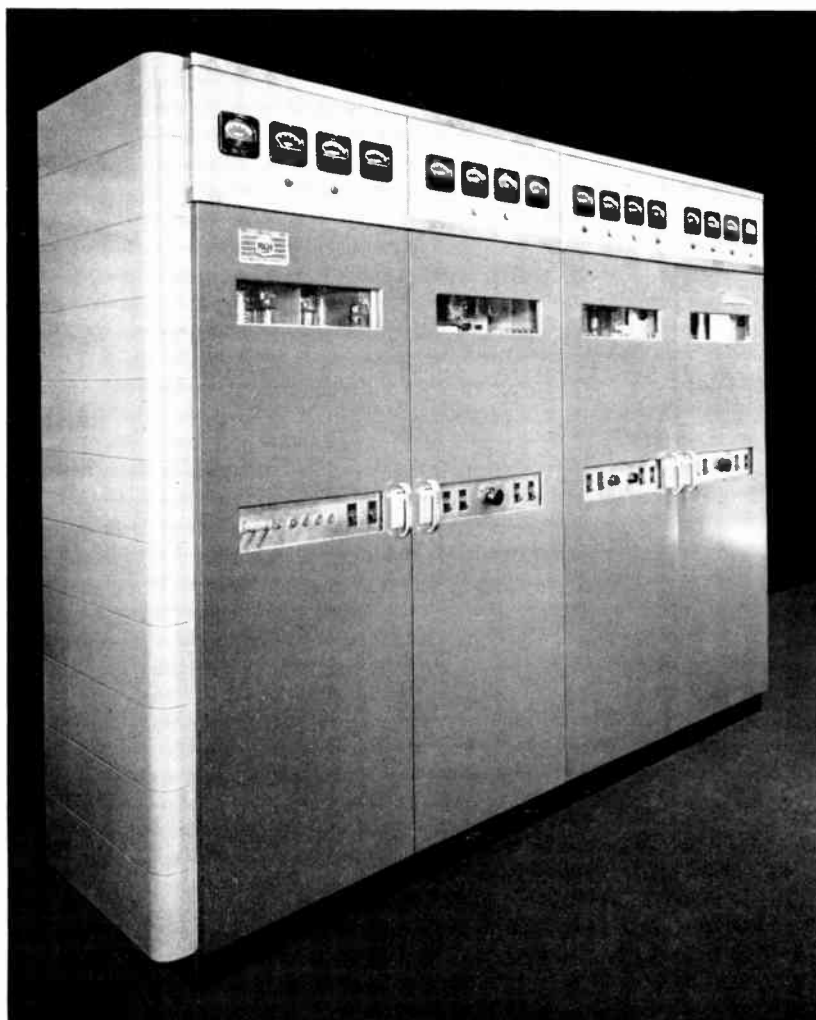

FIG. 1. Front view of 2 kw VHF transmitter.

## CIRCUIT DESCRIPTION TT-2AL

### Visual Portion

The visual crystal oscillator stage uses a TMV 129C-2 crystal and a 6V6 tube operating at one-twelfth the carrier frequency. It is followed by a 6V6 doubler, and 807 tripler, and a 4-125A/4D21 doubler which drives the two 4-250A/5D22 tubes in the modulated stage. The output stage is a 5762 triode, operated in a grounded grid circuit as a linear amplifier. The carrier frequency tolerance is  $\pm 1$  kc.

The modulator consists of three wide-band video stages. The first two stages each use a 6AG7 tube. A 6AC7 is connected in parallel with the second stage and so operated that it conducts only during the sync pulses, thus expanding, or "stretching" the sync amplitude. The amount of sync stretching is adjustable and is useful to compensate for compression which may have occurred in transmission systems preceding the transmitter or may occur in the transmitter modulator or power amplifier. The third stage of the modulator uses three 807 tubes in parallel, d-c connected to the modulated power amplifier grids. The positive terminal of the plate supply for the third stage is grounded so that the drop in the plate load resistor also provides the grid bias for the power amplifier. The d-c component of the input signal is restored at the grids of the 807's by a clamp circuit using a 6AL5 and two 6C4 tubes and main-

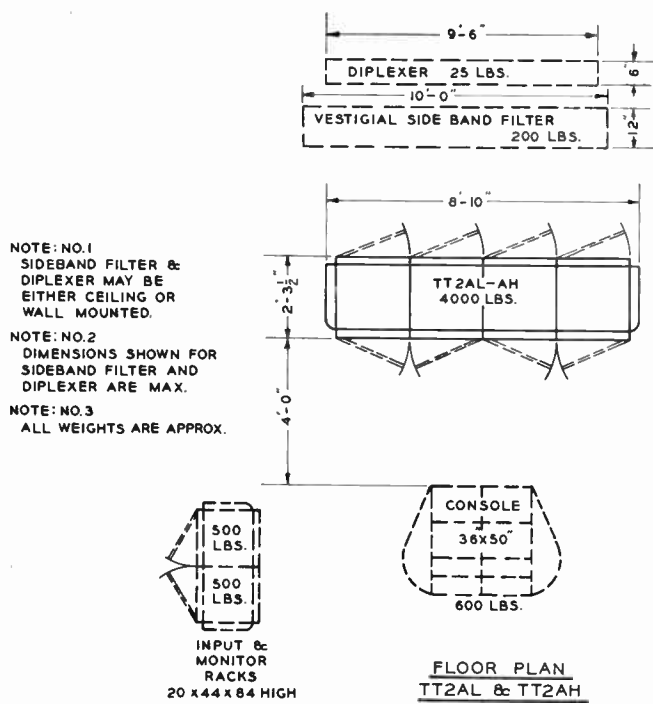

FIG. 2. A suggested transmitter room arrangement for the 2 kw transmitter and associated components. Approx. room size 20'x25'.

tained through the stage by the d-c coupling between the modulator and the power amplifier. The modulator output is sampled through a flat frequency compensated divider and delivered through a 6V6 tube, plate coupled to a 75 ohm transmission line, for monitoring purposes at the transmitter console.

The output circuit of the modulated power amplifier is tuned by a pair of coupled inductances connected in parallel. One of them is moveable by means of a front panel control for tuning. With the remaining elements in the output circuit it forms a network equivalent to a critically coupled double tuned transformer between the output tubes and a 51.5 ohm coaxial transmission line. This line is fitted with a reflectometer and a diode type monitor. The end of the transmission line feeds the cathode circuit of the grounded grid 2-kw power amplifier. The cathode circuit of the amplifier is a broadband Pi network which couples the 51.5 ohm transmission line to the cathode impedance of the amplifier. The reflectometer on the transmission line is a very effective means of adjusting the cathode circuit to match the transmission line. This circuit is very broad and is properly tuned when it matches the transmission line. All r-f circuits up to the amplifier cathode are made of conventional lumped elements. The grid bias voltage for the 5762 amplifier is controlled by an electronic regulator using a 6AS7G as a shunt variable impedance, with a 6SH7 and three glow type regulator diodes to provide the required signal voltage for the 6AS7G grid. The bias voltage of the 5762 amplifier is maintained at a constant potential (about -110 volts) for all variations of

grid current which may occur due to modulation of the RF signal.

The amplifier output tank circuit is coaxial, effectively one-quarter wave long. The secondary coupling loop is one or two turns depending upon frequency, and is adjustable in position to vary the coupling. It is tuned by two adjustable capacitors, one of which controls the resonant frequency while the other controls the effective loaded "Q" of the secondary. Thus the bandwidth and flatness of response of the output circuit may be adjusted to provide the required performance. This adjustment is best performed by use of a sideband analyzer such as the one described on page C-57.

The output transmission line from the amplifier is fitted with two reflectometers and a diode monitor. It also has connections for a sideband analyzer and for a carrier frequency monitor. One of the reflectometers is used to measure and monitor transmitter power output. The other may be used in conjunction with the first one to measure standing wave ratio on the output transmission line. The second one is also used continuously as an overload sensitive device to remove plate power from the transmitter if dangerous overvoltages in the output circuit develop due to mismatch of the transmission line to the antenna. Such mismatch might occur because of damage to the antenna or transmission line. The output transmission line is 1 5/8 51.5 ohm coaxial line for coupling to the vestigial sideband filter. The vestigial sideband filter is intended for



FIG. 3. Closeup view of the final stage of the 2 kw transmitter showing the RCA 5762 air-cooled triode.

ceiling mounting, so that it does not increase the requirements for floor space, although other mounting arrangements are possible if necessary. As in all other RCA transmitters, the power lost in the vestigial sideband filter of the TT-2AL is negligible and is allowed for in the transmitter output rating. The vestigial sideband filter output connects to the diplexer which may be any of the several types supplied for different antenna systems.

### **Aural Portion**

The aural portion of the TT-2AL is similar in design to the RCA FM transmitters of equivalent power, but with circuit dimensions and constants selected for operation between 54 and 88 mc. The complete aural transmitter is housed in two cabinets. It uses the RCA direct FM exciter which supplies an output of about 5 watts frequency modulated at one-half the carrier frequency. The exciter is followed by a 4-125A/4D21 doubler which in turn drives a pair of 4-125/4D21 tubes in parallel as an amplifier. All circuits up to this point use lumped constants. The 4-125A/4D21 amplifier is coupled by a modified pi network to a short flexible transmission line which is tapped on the 5762 amplifier cathode line at a point which produces best power transfer to the amplifier. The cathode and output circuits of the output amplifier are coaxial with lumped capacity added to reduce the required dimensions of some of the lines and to provide fine tuning controls. Like the visual output stage, the aural stage is grounded grid, but it is operated class "C" with grid leak bias. The output circuit coupling and tuning are adjustable to provide correct loading of the amplifier. The output transmission line mounts a current pickup device which rectifies a small portion of the line current to provide an indication of antenna current on a panel meter. TT-2AL aural output is also 1 $\frac{5}{8}$ " coaxial transmission line for connection to the diplexer.

The visual and aural portions of the TT-2AL are independent transmitters designed to work together. If desired they may be operated separately, and may even be separated mechanically where station room dimensions require.

## **TT-2AH CIRCUIT DESCRIPTION**

### **Visual Circuits**

The circuits of the TT-2AH visual transmitter are mostly similar to the TT-2AL. The differences are chiefly those which result from the operation of the modulated amplifier at higher frequencies and use of different tubes. The circuits following the crystal oscillator are a 6V6 tripler, a 2E26 doubler and a 4-65A tripler and a 4X150A doubler which drives four parallel connected 4X150A's at the carrier frequency. The four 4X150A tubes are the modulated stage. As in the lower frequency transmitter the output stage is a linear amplifier using a 5762 tube. Except for minor differences the modulator is similar to the TT-2AL modulator. Both have three stages using 6AG7 tubes in the first two, but the TT-2AH has only two 807's

in parallel for the third. In the TT-2AH the 807's are operated with the negative terminal grounded and with two glow type regulator tubes as a means of subtracting a constant voltage from the plate potential of the 807's to permit d-c coupling between the modulator plates and the PA grids. The TT-2AH uses 6J6 tubes instead of 6C4's in the clamp circuit, and the sync stretching is obtained by feedback between the third and second stage cathodes, controlled in amount by a variable bias on a IN34 germanium diode. This circuit performs the sync stretching function without adding the extra capacity of a tube to any of the broadband video circuits.

As in the TT-2AL, all r-f circuits up to the modulated amplifier grids use lumped elements. The modulated amplifier plate circuit is a novel arrangement of coaxially mounted bellows forming a coaxial line which can be varied in length. This is capacity coupled to a resonant section of coaxial line, which with a lumped annular capacitance forms a circuit analagous to the corresponding circuit in the TT-2AL. This circuit is connected to a 51.5 ohm coaxial transmission line which connects to the cathode circuit of the 5762 linear amplifier. The 5762 cathode circuit consists of coaxial sections of transmission line, the first being a variable impedance transformer and the second being a variable capacitance section. The amplifier cathode is connected to the junction of the two sections. As in the TT-2AL this circuit is correctly adjusted when it matches the 51.5 ohm transmission line and is adjusted by means of the reflectometer coupled to the transmission line.

The 5762 plate tank and output circuits are like the TT-2AL circuits except for dimensions which are chosen to suit the higher frequencies involved.

### **The Aural Circuits**

The circuits of the TT-2AH aural transmitter are like those of the visual transmitter with the following exceptions:

- (1) The first three r-f stages are replaced by an RCA Direct FM exciter.
- (2) The modulator is omitted and a fixed plus grid leak bias is used on the four 4X150A tubes in parallel.
- (3) Fixed plus grid-leak bias is used for the 5762 PA grid.

### **Power Circuits**

The power circuits of the TT-2AH are different from the TT-2AL, but they use the same tried and proven principles and provide the same high speed protection.

### **Control and Monitoring of TT-2AL/AH**

A control console TTC-2B may be used with either TT-2AH or TT-2AL Transmitters and ES-19203 Series of Monitoring Equipment racks to obtain a complete packaged monitoring system which greatly simplifies operation of the transmitter and provides all the measuring and monitoring equipment required for routine operation.

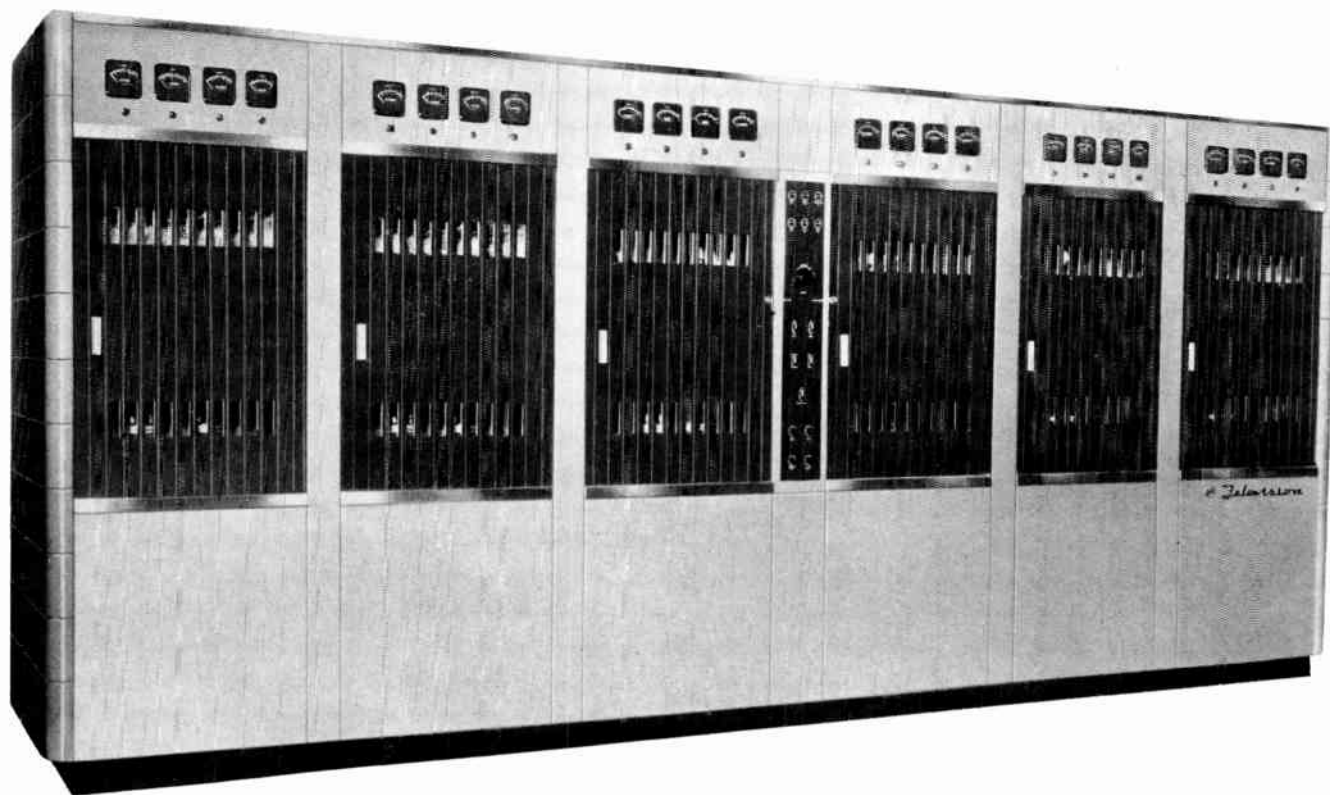

## TT-10AL/AH TELEVISION TRANSMITTER (10KW)

### Introduction

The TT-10AL/AH is a complete aural and visual transmitter operating in channels 2 through 13 and conforming to FCC and RTMA standards. When a composite video signal at a nominal 2 volt level is introduced at the input of this transmitter, a visual synchronizing peak power up to 10 KW is delivered to the antenna system. Up to 6 KW carrier power output is delivered by the aural section of the transmitter. The wide experience of RCA with all previous transmitter designs is incorporated in this equipment. Completely new concepts and features of simplicity give operating reliability, convenience, and economy to make this unit the standard of TV transmitters in its power classification.

All the elements of the transmitter proper, excepting two external plate power transformers, are included in a floor area of 43.3 square feet. The important advantages of sliding access doors of the transmitter will be very apparent to the station owner from the standpoint of compactness and convenience in maintenance.

A unified appearance is achieved by constructing the transmitter in six identical rack units (Fig. 1) which join together on a common base; connecting trim strips give the complete assembly unified styling.

The components and circuitry of the aural and visual sections of these transmitters has been kept identical as far as possible, affecting considerable saving on spare parts and simplifying maintenance and operation.

Built-in wiring ducts and preformed cable harness eliminate many of the time consuming details of installation. Only essential tuning controls are brought out to panel positions. Other controls are screwdriver adjustments.

Adequate metering has been provided to eliminate "guesswork" in servicing and routine tests.

The RF exciter and driver stages are straightforward narrow band class "C" amplifiers which can be quickly and accurately tuned by meter indications.

Video picture modulation is applied at high level in the grid circuit of the 10 KW PA tube. Improved clamp circuit DC restoration is employed with picture transmission. Provision is made for AC modulator coupling and mid-characteristic operation during tests with sine waves, square waves, or video sweep signals.

Essential transmitter operating controls are duplicated at the console control panel. Key points of the system have monitoring connections so that the operator at the console may, by push button selection, monitor the aural and visual signals at various points.



## Station Layout

Included with the specifications sections of this manual is a suggested floor plan of a 10 KW TV transmitter installation. Arrangement of the components of the system will vary from this in any particular case but the layout shown will aid the engineer in visualizing the problem.

## Transmitter Description

A completely air cooled transmitter results from the use of a VHF power tetrode (RCA type 6166) which is a single ended tube of 10 KW plate power dissipation. Fig. 3 is a photograph of the 6166 tube.

This tube is used in output stage of aural as well as visual portions in both the TT-10AL and TT-10AH transmitters.

As in previous designs, high level modulation is employed at the grid of the 6166 power amplifier stage and a vestigial sideband filter (MI-19085-L/H) provides sideband attenuation in compliance with standards of TV transmission. This system provides the greatest possible simplicity in operation since the only transmitter tuning adjustment which affects the video frequency response characteristic is in the final stage output circuit.



FIG. 3. Photograph of the RCA type 6166 VHF power tetrode which is used in the aural and visual power amplifier stages.

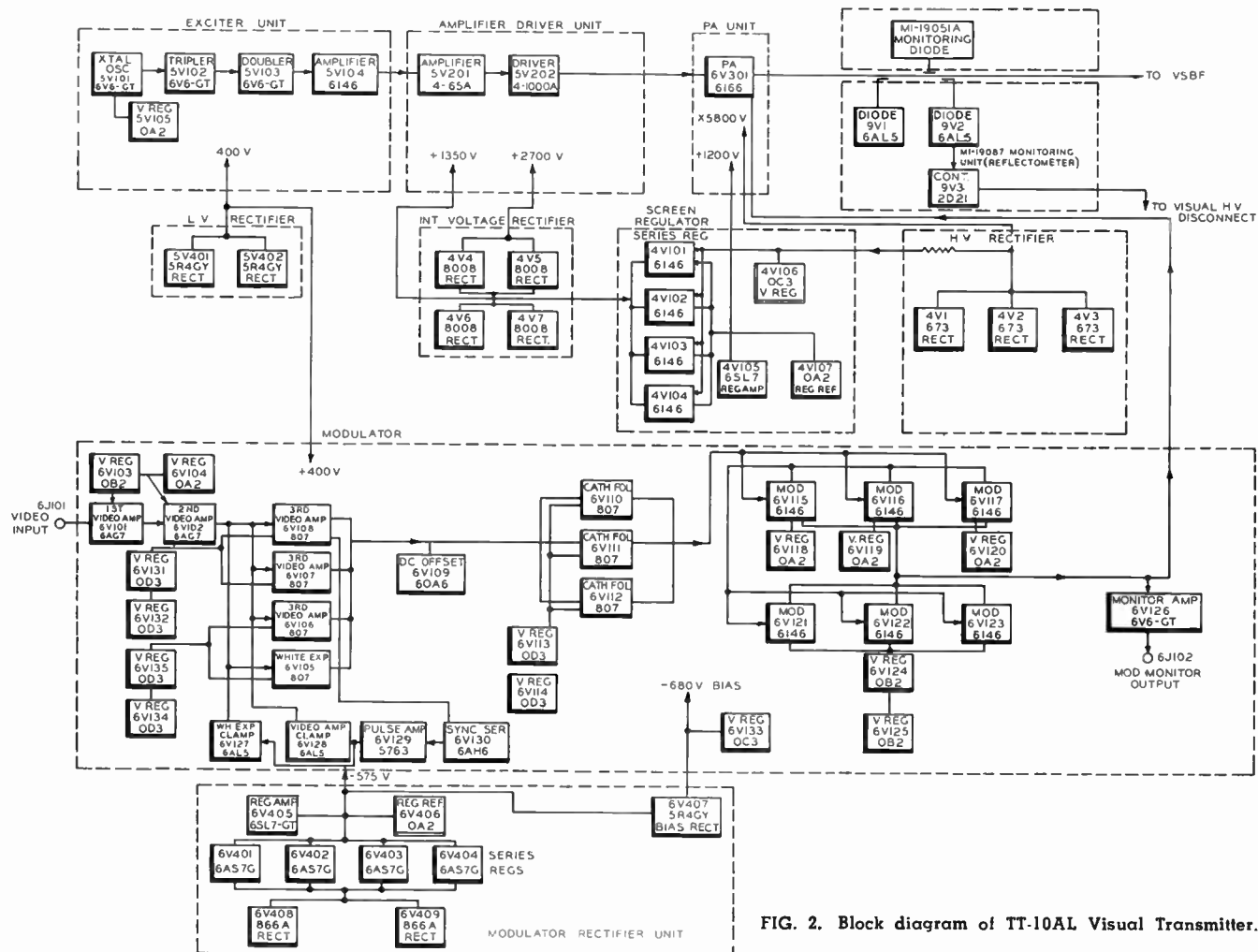

FIG. 2. Block diagram of TT-10AL Visual Transmitter.

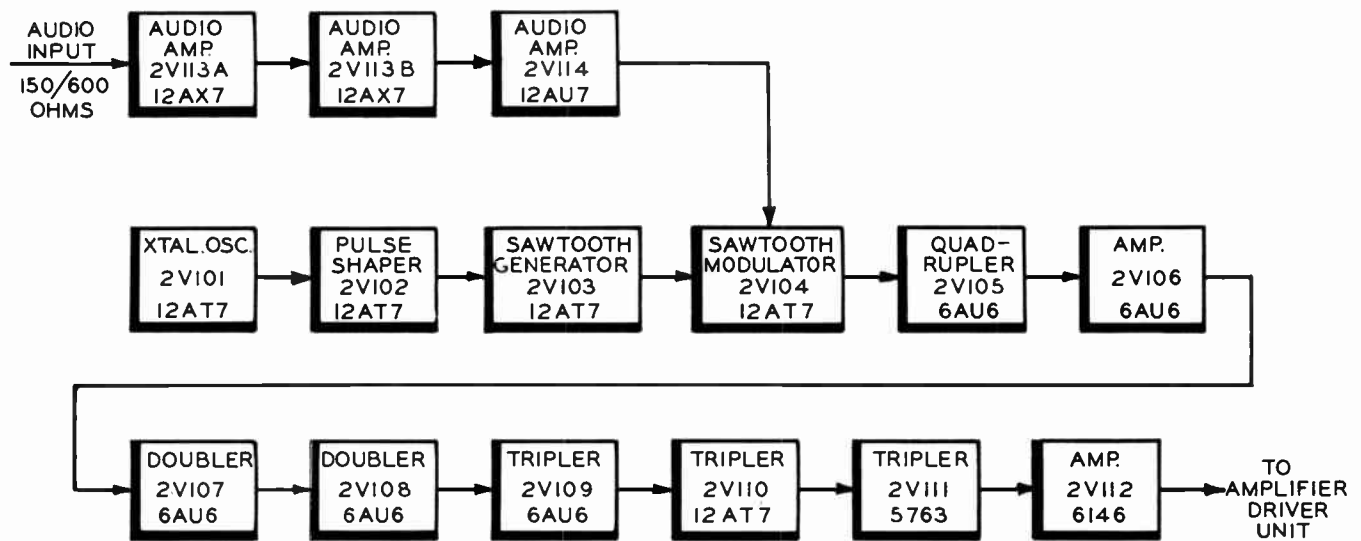

FIG. 4. Block diagram of FM Exciter for TT-10.

### R. F. Exciter

Crystal control is used to maintain frequency accurately to  $\pm 1$  KC in the visual transmitter. This order of stability is of great importance when offset carrier operation is employed.

This stability is achieved through the very careful application of temperature control to the crystal. This crystal is operated in a low power crystal oscillator circuit (RCA 6V6-GT) from which the output frequency is one-sixth of the assigned frequency of the TT-10AL and 1/18 the assigned frequency of the TT-10AH.

Three additional stages are associated with the low power crystal oscillator and together constitute the visual exciter unit.

This RF Exciter unit is the same for both TT-10AL and TT-10AH versions of the transmitter.

### Aural Exciters

In the aural section of the transmitter an FM exciter unit replaces the visual exciter described above. Power output and frequency ranges are nearly the same for aural and visual exciters, hence the succeeding amplifier stages are similar.

Fig. 4 is a block diagram of the FM exciter. In this unit a crystal oscillator and pulse shaper produce narrow pulses which are used to drive the linear sawtooth generator (RCA 12AT7) at crystal frequency. The linear sawtooth pulses are then clipped in the sawtooth modulator at a level which is a function of the audio frequency information. When these clipped pulses are used to drive a tuned circuit, a phase modulated result is obtained. An appropriate amount of frequency multiplication then results in an output at carrier frequency for channels 2-6 and 1/3 of the carrier frequency for channels 7-13.

A pre-emphasis circuit is built into the audio amplifier of the FM exciter. However the change of a single connection restores the exciter to a flat modulation response

so that pre-emphasis may be inserted elsewhere in the system.

### Intermediate RF Amplifiers

The RF power tube line-up for the low band transmitter following the exciter unit includes three stages. First is an RCA 4-65A amplifier stage operating as a straight through amplifier. Following the 4-65A stage is the 4-1000A driver stage which has an associated "swamping" resistance load. By "swamping" is meant deliberately dissipating a part of the driver power output; a more constant RF voltage is then available at the modulated PA grid since the magnitude of variations in driver load over the modulation cycle become a lesser part of the total driver load.

The tube line-up for the high band (TT-10AH) transmitter is shown in block diagram by Fig. 5. In this application the crystal control and low power exciter stages are exactly the same as used in the TT-10AL. The first following stage, an RCA 4-65A, is used as a frequency tripler. This stage is followed by two stages of straight through amplification. First is a 4X500 amplifier followed by a grounded grid stage using the RCA 5762 tube. In this transmitter "swamping" is also applied between the output of the driver and the grid circuit of the modulated PA.

### Power Amplifiers

The 6166 tube (see Fig. 3) is especially designed for VHF broad band television transmission. Due to the high power capability of this tube it was possible to build a single ended power amplifier stage and take advantage of somewhat simpler construction. At the same time the need for a balun was eliminated, since the transmitter is single ended throughout.

A modulated PA stage has been designed with particular attention to:

1. The plate tuned circuit which must have the proper band pass characteristics and at the same time present the correct load impedance to the PA tube.
2. The grid circuit wherein the RF excitation from the driver stage must be delivered to the PA grid so that video modulation may be also applied to the grid.
3. Feedback considerations.

With respect to (1) above, basic considerations of tuned coupled circuit practices apply. In this part the problems of the TT-10AL and the TT-10AH are the same, except for frequency difference which calls for different values of inductance and capacitance. Over-coupled circuit response characteristics are obtained by suitable adjustment of coupling between the primary (plate) and the secondary (output) tuned circuits.

Items 2 and 3 are interrelated, particularly in the high channel transmitter. In general, the solution to item 2 above is the use of a "half wave" grid circuit in which a blocking capacitor is not required. By this scheme the modulator load capacitance is reduced to the sum of the tube capacitance and the distributed RF circuit capacitance. Due to the difference in frequency the physical form of the grid circuit varies between the AL and the AH

versions of the transmitter. In the TT-10AH power amplifier the half wave grid circuit is entirely coaxial while in the TT-10AL an equivalent half wave grid circuit is composed of lumped elements.

Item 3 above is not a problem in the TT-10AL transmitter because of the low radio frequency. However, in the high VHF channels, tube interelectrode capacitances result in an appreciable amount of amplifier feedback and corrective steps have been taken.

Power output indication and SWR protection of the transmitters is provided by externally mounted reflectometer units. These units attach to the 3/8" output transmission line from both aural and visual units and are wired to their respective transmitter control circuits. Peak power output indication is the chief function of the reflectometer assembly; however, the transmission line SWR may be read at the transmitter. Additionally, the reflectometer trip-off control circuit removes plate voltage from the transmitter in the event of a transmission line arc or other fault which results in a high value of SWR.

### Power Supply

The high power rectifier, which employs 3 RCA type 673 mercury vapor rectifier tubes, incorporates individual arc back indication for each tube. Should an arc back

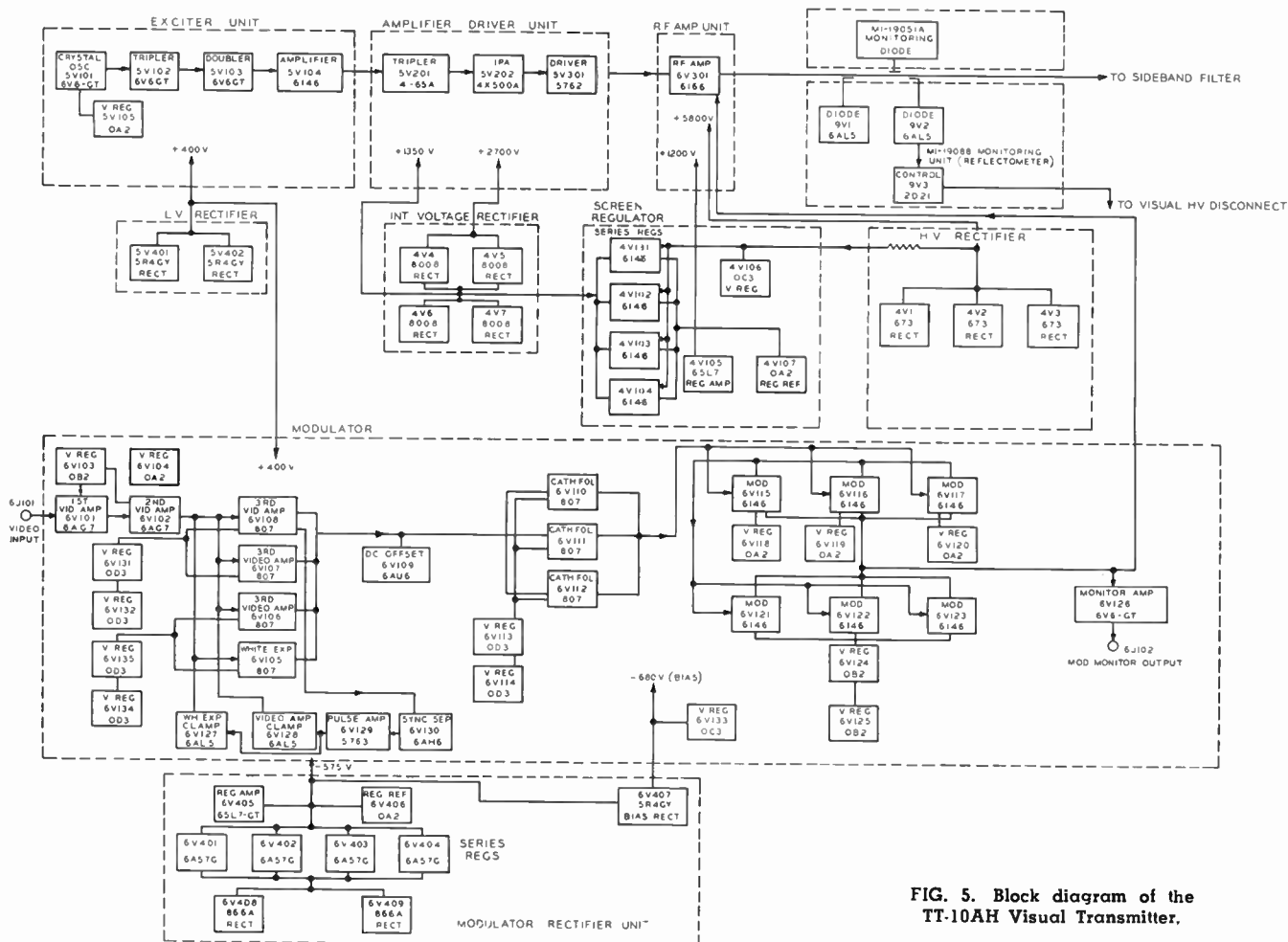

FIG. 5. Block diagram of the TT-10AH Visual Transmitter.

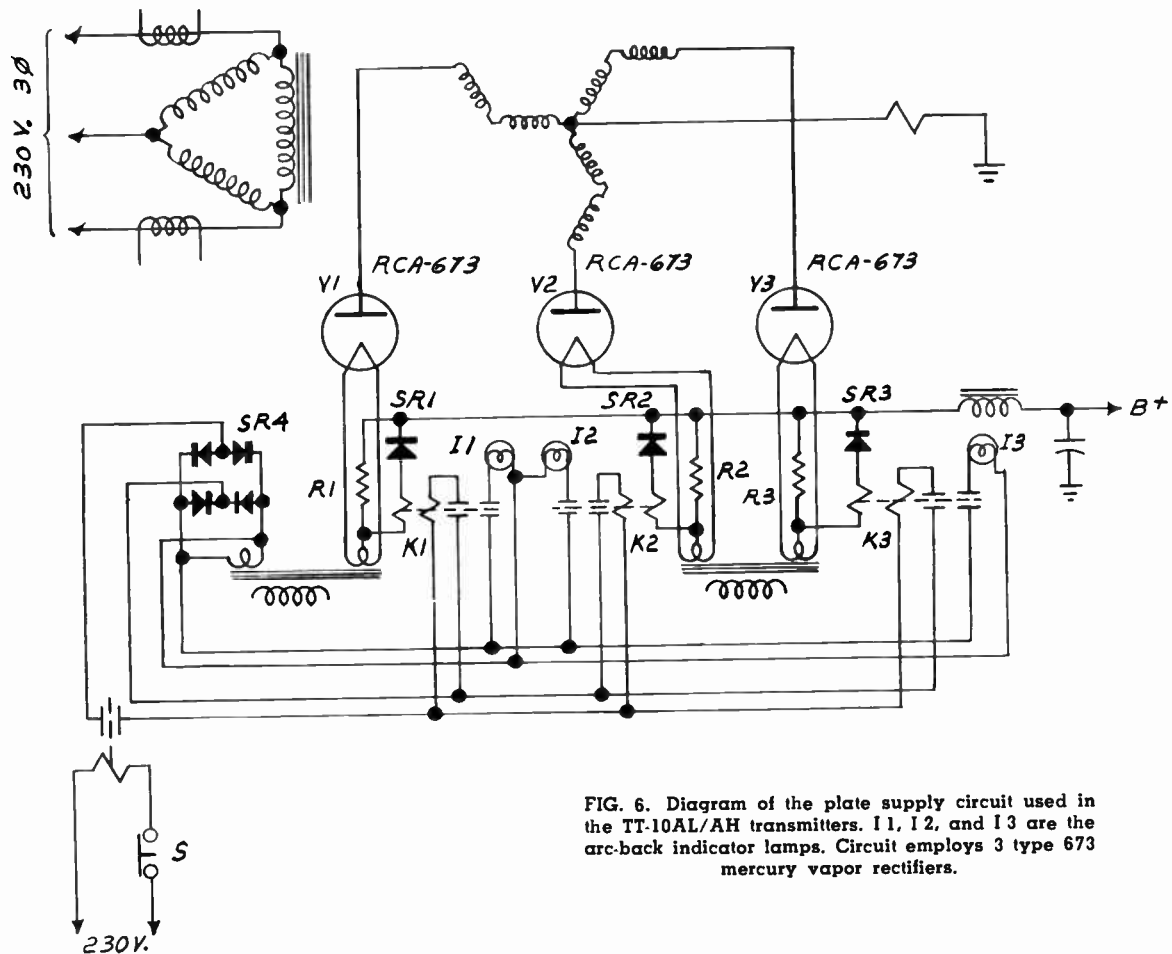

FIG. 6. Diagram of the plate supply circuit used in the TT-10AL/AH transmitters. I1, I2, and I3 are the arc-back indicator lamps. Circuit employs 3 type 673 mercury vapor rectifiers.

occur due to faulty rectifier tube an indicator lamp associated with the offending tube will come on and remain lighted until the system is reset. Fig. 6 shows the schematic diagram of the arc back indicator as applied to the high power rectifier of the TT-10AL/AH transmitter.

R1, R2 and R3 are low value resistors which conduct the individual rectifier tube plate currents to the load circuit.

Rectifiers SR1, SR2 and SR3 are connected in such polarity as to be non-conducting for the normal operation of the rectifier tubes. However, for the arc back reverse current which may occur in one of the 673 tubes, the associated selenium rectifier is conducting and the resulting current closes relay K1, K2, or K3 associated with the faulty tube. The relay is held in a closed position following the arc back by means of auxiliary relay contacts and a holding voltage from SR4. Panel indicator lamps I1, I2 and I3 are located near the rectifier tubes and remain lighted after an arc back until the reset switch S1 is operated.

#### Modulator

The function of the modulator in the visual section of the TT-10AL/AH transmitter is to vary the grid voltage of the r-f power amplifier grid in accordance with the video signal input to the transmitter.

Basically, the modulator consists of a five stage video-amplifier designed to operate into a non-linear load, the load being the r-f power amplifier grid current and the capacitance associated with the grid connection.

In addition to the five video amplifier stages, the modulator contains a clamp circuit, and provision for altering the transmitting system's response in the vicinity of the color sub-carrier frequency.

A block diagram of the modulator is shown on Fig. 7. The first two stages of the video portion of the modulator are conventional shunt-series peaked video amplifiers employing 6AG7's and providing an overall gain of approximately 40. Following this is another shunt-series peaked video amplifier composed of 3-807's in parallel. This stage provides a gain of approximately 10, and is direct coupled to a cathode follower stage. The cathode follower employs 3-807's in parallel, pentode connected, and is operated with plates grounded. These, in turn, are direct-coupled to the output stage of the modulator. This stage employs 6-6146's in two parallel connected branches of three each.

The output stage is somewhat unconventional in its mode of operation. The operation of the circuit may perhaps be made more clear by reference to the following simplified schematic:

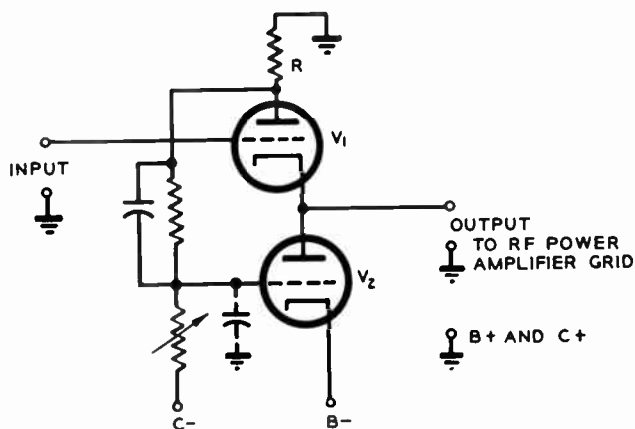

For purpose of simplification, three of the 6146 pentodes are denoted by  $V_1$ , and the other three by  $V_2$ .  $V_1$  and  $V_2$  are in series for D-C across the power supply. For D-C level changes (and for low frequencies), the circuit operates as a cathode follower with a high value of cathode resistance (the pentode plate resistance of  $V_2$ ). Plate current flows during the entire cycle for these slow changes, or in other words, the circuit operates in class "A".

For input signals with rapid rates of transition from one level to another, e.g. square waves, or, what is equiv-

alent, high frequencies, the circuit operation changes. For positive going transitions,  $V_1$  will conduct heavily and charge the grid capacity of the r-f power amplifier. This current, flowing through  $R_1$ , is applied to  $V_2$  in such a polarity as cut  $V_2$  off. Conversely, negative going transitions cut  $V_1$  off, allowing the bias on  $V_2$  to decrease to zero so that  $V_2$  conducts heavily and discharges the grid capacity.

In other words, for sufficiently fast transitions of the input signal, plate current does not flow through a complete cycle, or the circuit operates in a mode similar to class "B".

This latter operation is particularly advantageous, because it is only necessary to provide a *peak* current capability in the output stage sufficient to charge or discharge the capacity on the output. In the case of the TT-10, this peak current is on the order of 1 ampere for a square wave having a rise time (or decay) of .08 microsecond. Since the output impedance of the modulator is quite low, this peak current need only be supplied for a very short time. This means that it is not necessary to use tubes whose plate dissipation is large enough to supply this current continuously, as in, for example, a cathode follower. The continuous plate current in a cathode follower which could replace the output stage would be on the order of 1.3 amperes, and a plate loaded stage would draw even

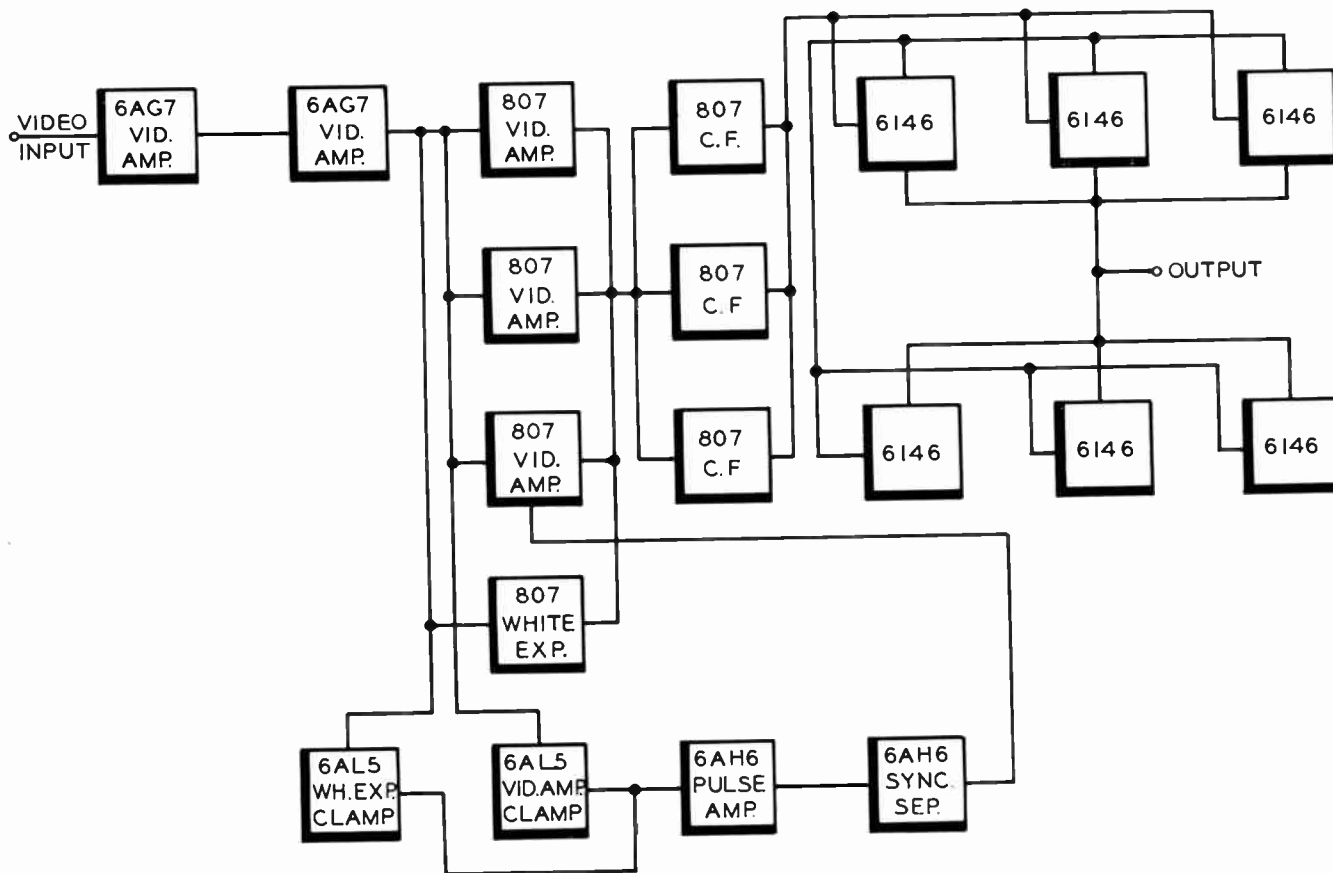

FIG. 7. Block diagram of TT-10AL/AH Modulator.

more. In contrast, the total plate current for the output stage varies between 100 and 200 ma. and the stage has a rated peak charging current capability of approximately 1.2 amperes. The output impedance of the output stage and its cathode follower driver is so low as to preclude the necessity for any form of peaking.

By returning the cathode of  $V_2$  to the negative terminal of a regulated power supply, the output voltage range is such as to allow direct connection of the output to the grid of the r-f power amplifier without the necessity of introducing a voltage off-setting arrangement.  $V_1$  absorbs the grid current of the r-f power amplifier. The impedance offered to this current is so low that the output

voltage does not change appreciably because of it nor is the dissipation of  $V_1$  exceeded.

The clamp circuit, with its attendant advantages of hum and microphonic reduction, reinserts the television D-C component, or clamps, at the grids of the 3—807's video amplifier stage. The circuit itself consists of a 6AH6 sync separator, a 5763 pulse former and two 6AL5 clamp diodes. One of the 6AL5's is used in the grid circuit of the 3—807's while the other is used to control the white expander. The clamp circuit can be arranged to clamp either on peak of sync or back porch. Whichever is used, the circuit returns the transmitter to approximately black level power output in the event of loss of picture signal input.

# TT-25AL/20AH Amplifiers

## TT-25BL/25BH Amplifiers

### INTRODUCTION:

These equipments are high power amplifiers for use with 5 and 10 kilowatt television transmitters. The TT-25AL and TT-25BL operate on channels 2 through 6 and will provide up to 25 KW peak visual power and 15 KW aural power. The TT-20AH operates on channels 7 through 13 and will supply up to 20 KW peak visual power and 12 KW aural power. The TT-25BH operates on channels 7 through 13 and will supply up to 25 KW peak visual power and 14 KW aural power. The TT-25AL/20AH are designed to operate with the RCA TT-5A television transmitter but can also be furnished for use with any other 5 KW television transmitter meeting the FCC and RTMA specifications. The TT-25BL/25BH are designed to operate with the TT-10AL/AH television transmitters.

Fig. 1 is a block diagram of the TT-25AL/TT-20AH equipment. The internal circuits of the 5 KW driver are not changed. The video and audio signals are fed to the driver and the modulation occurs in this unit. The RF output from the visual driver is fed to a class "B" linear amplifier. The aural amplifier is similar to the visual amplifier except that it may be operated class "C" since the sound carrier is frequency modulated. The block diagram for the TT-25BL/BH is the same as shown on this page except for use of the TT-10AL/AH.

### CONSTRUCTION:

The power and control equipment for the amplifiers are housed in four cabinets which match the cabinet of the drivers with which they are intended to operate. These cabinets may be placed either in line with the driver or at right angles. Several suggested floor plans are shown in the specification pages of this manual. Since the two power supply cabinets do not contain any operating controls or meters, they can be mounted either with the other cabinets or in the rear as shown in the second floor plan.

The RF circuits are housed in two cylindrical cabinets illustrated in Fig. 2. The units for the visual and for the aural amplifier are mechanically almost identical. The lower rectangular section of the amplifier unit houses the blower, filament transformers, meters and tuning controls while the upper cylindrical section contains the tubes and RF circuits. Air for cooling the tubes is drawn in through two filters on the sides of the bottom section and is expelled out the top of the unit. Access to the tubes is obtained through four hinged doors near the top of the unit. All other parts are easily accessible for servicing by removing the top dust cover, the side plates or the filters. The reflectometer and monitor circuits are contained in a separate unit which may be inserted in any convenient place in the output line.

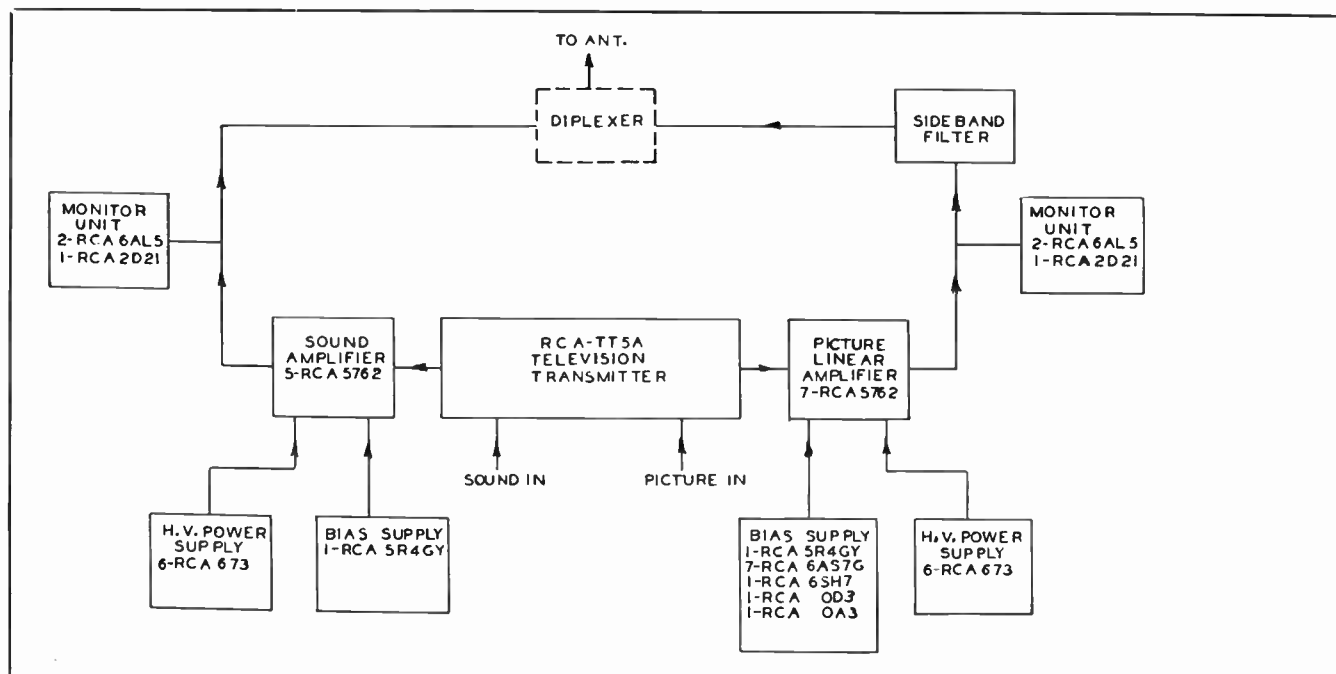

FIG. 1. Block diagram of TT-25AL/20AH Transmitter. The block diagram of the TT-25BL/25BH Transmitter is identical except a TT-10A Driver Transmitter is utilized.

### CIRCUIT DESCRIPTION:

The visual RF amplifiers for both the low-band and the high-band equipments each employ seven RCA-5762 air cooled tubes operating in parallel in a grounded grid circuit. The tubes are placed in a circle as shown in Fig. 3. The aural amplifier also contains seven RCA-5762 tubes in an almost identical circuit, however, the filaments of two of the seven tubes may be turned off if desired, leaving only five operating tubes. The general appearance of the low and high band units are similar but the internal circuits necessarily differ in several important respects. Both the low and the high band units will be described separately below in more detail.

*Low-band Amplifier:* The operation of the low-band unit can best be understood by referring both to the simplified equivalent circuit Fig. 5 and the cut-away view of the amplifier shown in Fig. 4. The plate tank circuit is tuned by (L-10). As can be seen in the cut-away view, this inductance is a co-axial tank formed by the outer shell, and an inner cylinder and varied by a shorting bar located below the tubes. The shorting bar is motor driven and controlled from the front panel. The output transmission line is brought up through the center of the tank and coupled to the plate circuit through a variable capacitor (C-40). This capacitor is also motor driven and controlled from the front panel. What is equivalent to a second tuned circuit is formed by inserting a shunt capacitor (C-10) in the output transmission line approximately one quarter wave from C-40. This secondary circuit is tuned by sliding capacitor (C-10) along the line. The inductance L-30 shown in the equivalent circuit is actually the first quarter wave of the output trans-



FIG. 3. Closeup showing the cluster of seven air-cooled 5762 triodes used in the 25 KW amplifier equipment.



FIG. 2. External view of the high band amplifier for channels 7 to 13.

mission line. By a suitable selection of the value of capacitor (C-10) and proper adjustment of the coupling capacitor (C-40) a broadband flat-topped circuit can be obtained as illustrated in Fig. 6. The optimum circuit has been found to be  $8\frac{1}{2}$  to 10 megacycles wide between half power points and almost flat over the six megacycle channel.

The input or cathode circuit is also essentially a co-axial tank circuit tuned by a shorting bar shown near the center of Fig. 4 just above the tube level. In the equivalent circuit this is shown as a variable inductance (L-40). Because of the high input capacity of seven tubes in parallel this tank is actually much less than a quarter of a wavelength long. A large part of the inductance is formed in the tube and by the tube leads. The input line is fed through the center of the cathode tank and is connected in series with the input circuit at a low impedance point. In order to match this impedance to the line from the driver two quarter-wave transformer sections T9 and T10 are employed. In the cut-away view these are shown built into the  $3\frac{1}{8}$ " input line by using the proper size center conductors for the quarter-wave sections.



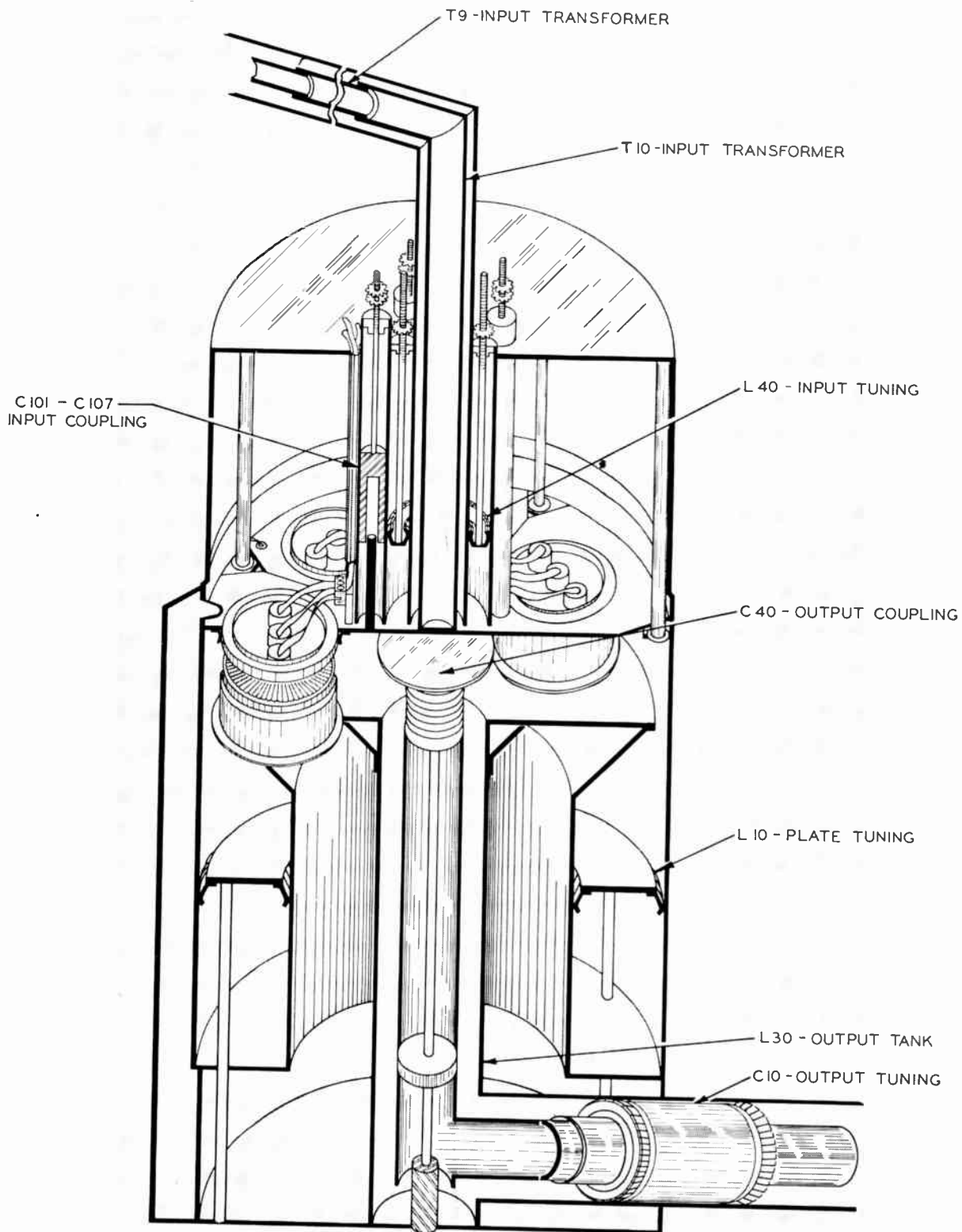

FIG. 4. Cut-away view showing R-F circuits of the 25 KW low band amplifier.

To allow for variation in tube input capacity and for variation in feed-through power, a means for making some adjustment to the input coupling must be provided. In the

low band amplifier this is accomplished by adding in shunt capacitors C-101—C-107. As can be seen in Fig. 4 these capacitors take the form of seven co-axial capacitors. To

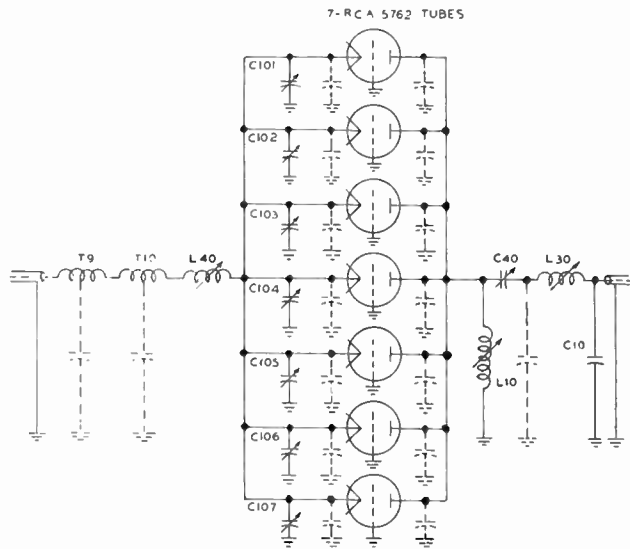

FIG. 5. Simplified equivalent circuit of the 25 KW (low band amplifier).

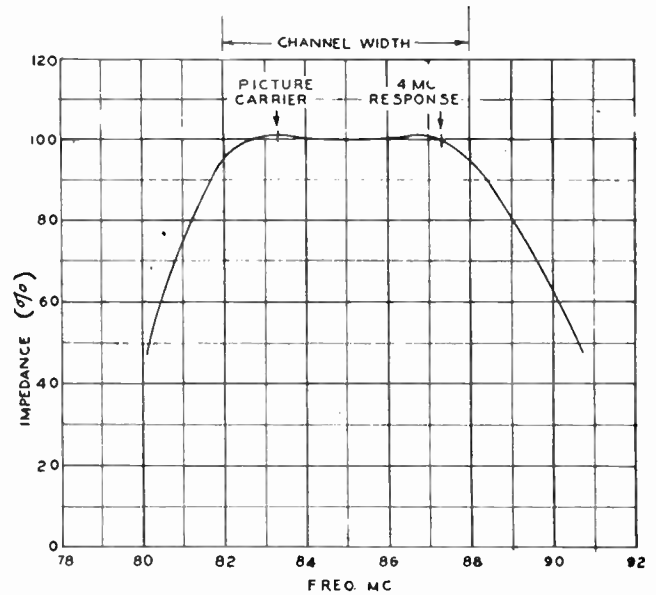

FIG. 6. Curve showing typical response of 25 KW output circuit, channel 6.

vary the capacity a mycalex cylinder which has a dielectric constant of approximately 6 is inserted between the center and outer tubes. These seven mycalex cylinders are mechanically ganged together and driven by a tuning motor. Since the tube leads from a portion of the tank inductance these capacitors are not actually in parallel with the tube input but are part way down the tank circuit where it has been found that they serve as a coupling adjustment and have little effect on the resonant frequency of the circuit.

**High Band Amplifier:** A cut-away view of the high band amplifier is shown in Fig. 8 and the simplified equivalent circuit is shown in Fig. 9. The general appearance of this unit is similar to the low band unit, but the circuit actually differs in several important details. Because the operating frequency is much higher, it would be impractical to use a simple quarter wave concentric line tank similar to that used in the low band amplifier since there would be little or no tank circuit left outside of the tubes themselves. To overcome this, two co-axial tank circuits are employed. One of these tanks is inside the other as shown in Fig. 8. These function as inductances in parallel and thus raise the effective resonant frequency. In the equivalent circuit these inductances are (L-10) and (L-20). The output is coupled to the inner of these plate tank circuits across a shunt inductance L-60. To preserve the circuit symmetry this inductance is actually made up of seven small adjustable shorted transmission lines connected in parallel and located on a circle just inside the inner plate tank. Like the low band unit, the secondary or output circuit is formed by inserting a shunt capacitor C-10 in the output transmission line and is tuned by sliding this capacitor along the line.

Because the two circuits are coupled at a low impedance point this capacitor is located approximately  $\frac{1}{2}$  wave length along the line. This secondary circuit, coupled to the plate circuit by means of a mutual reactance L-60, forms the necessary elements of an over-coupled broadband circuit whose response is equivalent to that shown in Fig. 6 for channel 6.

The cathode circuit, like the plate circuit, cannot be made a conventional quarter-wave tank because the first low impedance point will occur on the tube straps. To

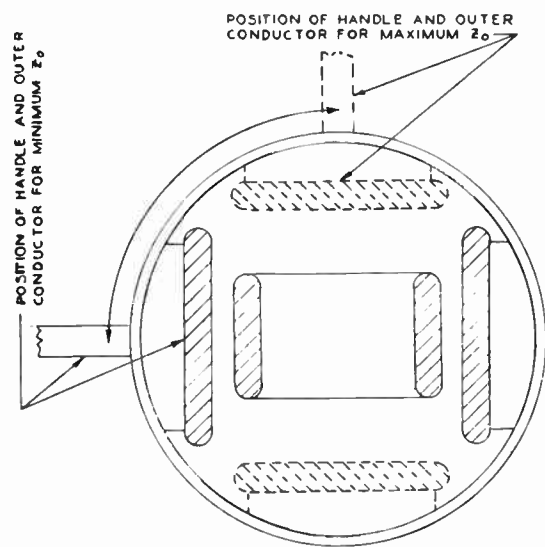

FIG. 7. Cross-section view of variable  $Z_0$  transformer used in high band amplifier.

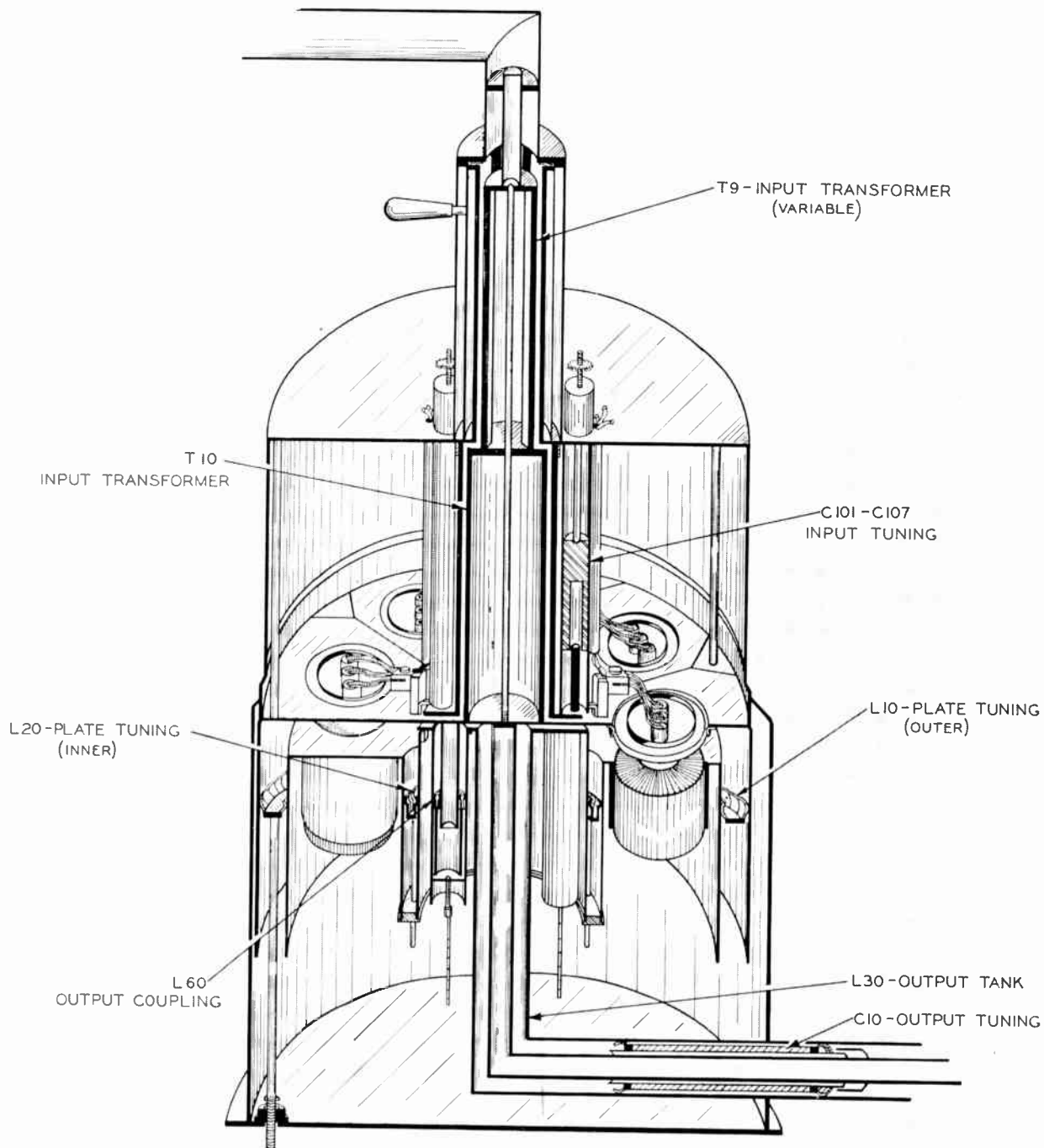

FIG. 8. Cut-away view showing R-F circuits of the high band amplifier.

compensate for this extra inductance of the straps, the seven co-axial capacitors C-101 — C-107 are connected in series with the tube leads instead of in shunt as was the case in the low band amplifier. These capacitors are variable and when mechanically ganged together serve as the input tuning control. This cathode circuit is matched to the

72 ohm input by two quarter-wave transformer sections in series. To provide for an input coupling adjustment one of the transformers (T-9) is constructed so as to have a variable characteristic impedance as the outer shell is rotated through 90°. A cross sectional view of this transformer is shown in Fig. 7 on the preceding page.

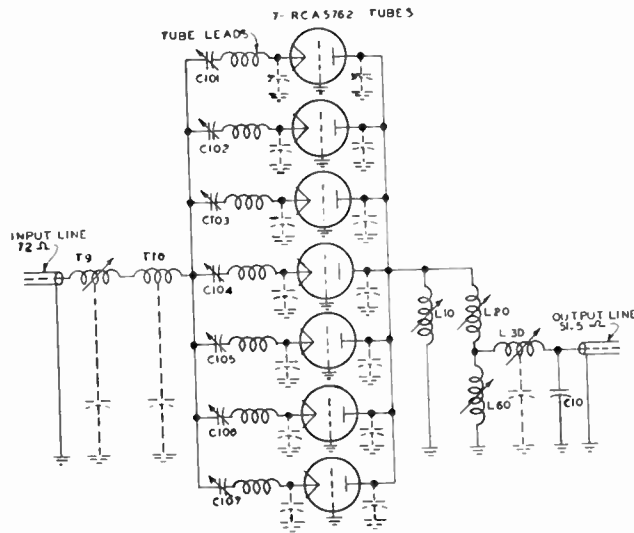
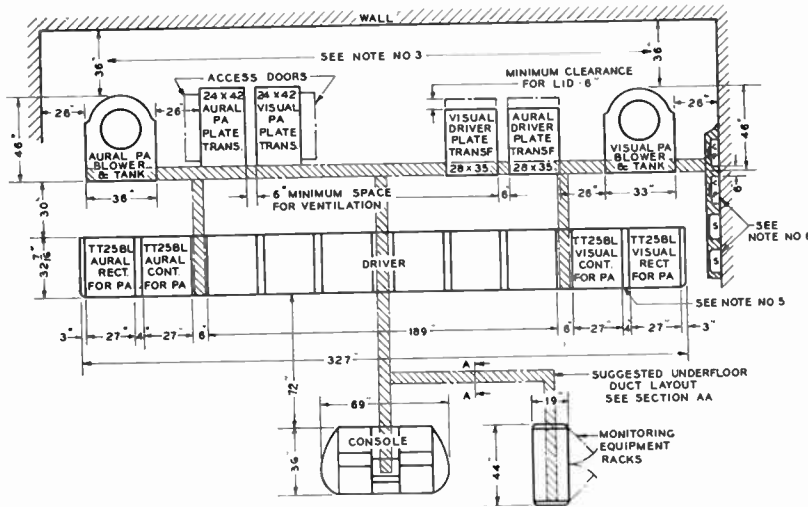

FIG. 9. Equivalent circuit of the 25 KW high band amplifier for channels 7 to 13.

### POWER & CONTROL EQUIPMENT:

The control equipment is of conventional design. An instantaneous trip relay is connected in the cathode return circuit of each of the seven power amplifier tubes. In addition, a total d-c current relay is provided and a-c relays are inserted in the primary leads of the high voltage plate transformer. The overload system has an automatic reset feature. After an overload occurs the plate voltage will be removed momentarily then automatically returned twice. If the overload persists for the third time the plate voltage will remain off. All circuits such as the filament bus, the blower and the bias supply are protected by breakers with built-in overload trip coils. The control equipment for the aural transmitter is identical to that for the visual transmitter and the two are arranged so that the two carriers may be turned on and off independently.



**NOTE NO. 1**  
PLATE TRANSFORMERS SHOULD BE LOCATED NEAR THE ASSOCIATED RECTIFIERS TO AVOID LONG RUNS OF HIGH VOLTAGE WIRING.

**NOTE NO. 2**  
ALL CLEARANCE DIMENSIONS ARE MINIMUM.

**NOTE NO. 3**  
REQUIRED CLEARANCE BEHIND THE AMPLIFIER UNITS MAY BE REDUCED TO 24 BY SPECIAL ARRANGEMENT IF NECESSARY

**NOTE NO. 4**  
SIDE BAND FILTER AND DIPLEXER FOR THE TT25BL ARE DESIGNED FOR CEILING OR WALL MOUNTING AND NORMALLY DO NOT REQUIRE ANY ADDITIONAL FLOOR AREA. DWG. (B-463046, B-463030, TT25BL) (B-463066, B-463030, TT20BH) SHOW THE OUTLINE DIMENSIONS FOR THESE UNITS AND SHOULD BE CONSIDERED WHEN PLANNING THE INSTALLATION.

**NOTE NO. 5**  
TWO (2) OF MI-19365, 4" CHANNEL ASSEM REQUIRED.

**NOTE NO. 6**  
TWO FILAMENT REGULATOR CONTROL PANELS DRAWING B-466363 AND TWO TUNE-OPERATE SWITCHES DRAWING B-466384 ARE SUPPLIED WITH THE INSTALLATION MATERIAL KIT THE CONTROL PANELS SHOULD BE MOUNTED ON THE WALL AT A CONVENIENT PLACE NEAR THE TRANSMITTER ASSEMBLY. THE SWITCHES SHOULD BE MOUNTED ON THE WALL AT A CONVENIENT PLACE NEAR THE PLATE TRANSFORMERS.

**NOTE NO. 7**  
LENGTH OF TRANSMISSION LINE BETWEEN AURAL DRIVER AND AURAL AMPLIFIER TO BE LIMITED TO SOFT. MAX. LENGTH OF TRANSMISSION LINE BETWEEN VISUAL DRIVER AND AMPLIFIER REFER TO TABLE BELOW.

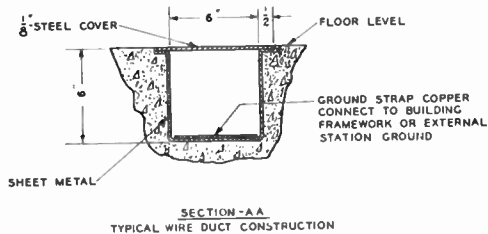

CHAN NO	A	1/2 WAVE LENGTH	1/4 WAVE LENGTH
2	146 ± 6	104	252 ± 6
3	128 ± 6	94	222 ± 6
4	109 ± 6	84	204 ± 6
5	105 ± 6	75	200 ± 6
6	148 ± 6	69	216 ± 6
7-13	180 MAX	---	---

LENGTH OF LINE BETWEEN VISUAL DRIVER AND VISUAL AMPLIFIER USE A DIM IF POSSIBLE. IF THIS IS NOT POSSIBLE ADD 1/2 WAVELENGTH

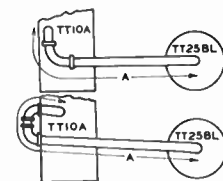
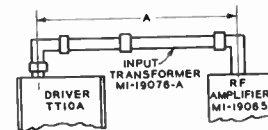

ABOVE OUTLINES SHOW SEVERAL WAYS OF RUNNING THE LINE TO OBTAIN THE CORRECT LENGTH.

FIG. 10 (above). One of the many floor plans that are possible using the TT-10AL/AH transmitter and the 25 KW amplifier.

Except for the bias supply and slight differences in the high voltage filter, the power equipment for the aural and visual equipments are identical. The high voltage rectifiers for each employs six RCA-673 mercury vapor rectifier tubes in a three-phase full wave circuit with a balance coil. The bias supply for the visual amplifier is well regulated, its output voltage remaining constant for large changes in grid current. The bias for the aural amplifier is essentially obtained from grid leaks with just enough fixed bias to protect the tubes when there is no drive.

#### INSTALLATION:

The layout shown on page C-35 is only one of the many possible arrangements. Here the amplifiers are shown in the rear of the driver. Actually they can be located at the ends or at right angles to the driver. This feature should be of particular interest to those stations which already have their 5 KW or 10 KW driver and are limited in available space to add an amplifier. The important thing to keep in mind is that the length of transmission line between the driver and the amplifier should be kept as short as possible. Distances between the output of the driver and the center line of the amplifier of 15 feet or less should be satisfactory. If the distance is much greater than this it will be difficult to obtain the required bandwidth. To understand why the line cannot be too long it should be remembered that the amplifier input circuit is essentially a single tuned circuit and can terminate the line exactly at only one frequency. To provide for a line of indefinite length, it would have to have a standing wave ratio of better than 1.1 to 1 over the six megacycle channel. This would mean that the bandwidth of the terminating circuit be 60 megacycles between half power points. On channel 2 this is equivalent to having a Q of 1 which is obviously an impractical condition. It is necessary, therefore, that the input circuit of the amplifier must be a part of the driver output circuit. On the low channels it is not only important that the length of line be kept short but the effective length of line should be in approximate multiples of  $\frac{1}{2}$  wave-length. Fig. 10 gives a table of the recommended length of line for the low band channels. This line does not necessarily have to be straight but can have a right angle bend or a 180° fold as shown in the two bottom views in Fig. 10.

#### PERFORMANCE:

A summary of the performance specifications is shown on page C-70 in the specifications section of this manual

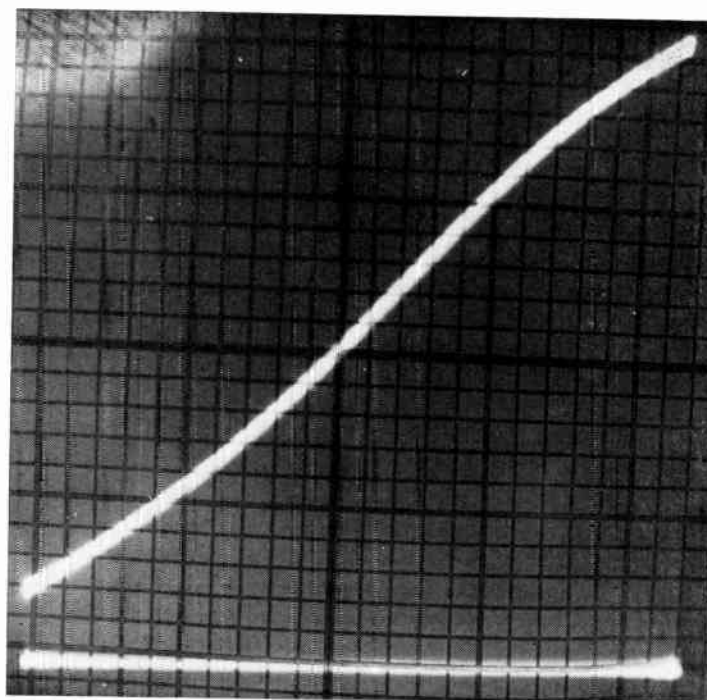

FIG. 11. Overall linearity curve of the TT-20AH including the TT-5A driver.

When these amplifiers are used with either the TT-5A or TT-10A the overall performance will meet all the RTMA and FCC requirements. The overall linearity curve is shown in Fig. 11 and the linearity curve for the input signal is shown in Fig. 12. From these two curves we

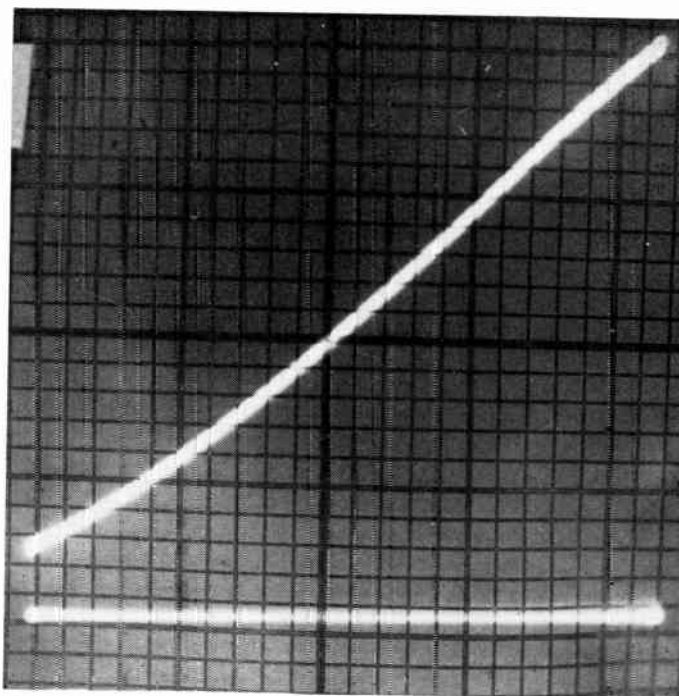

FIG. 12. Linearity curve of the TT-5A driver made under the same conditions as those of Fig. 11.

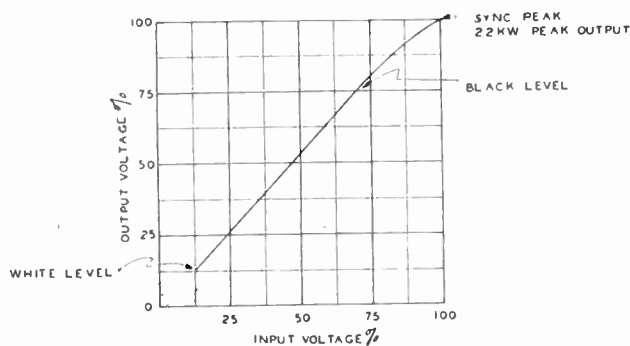
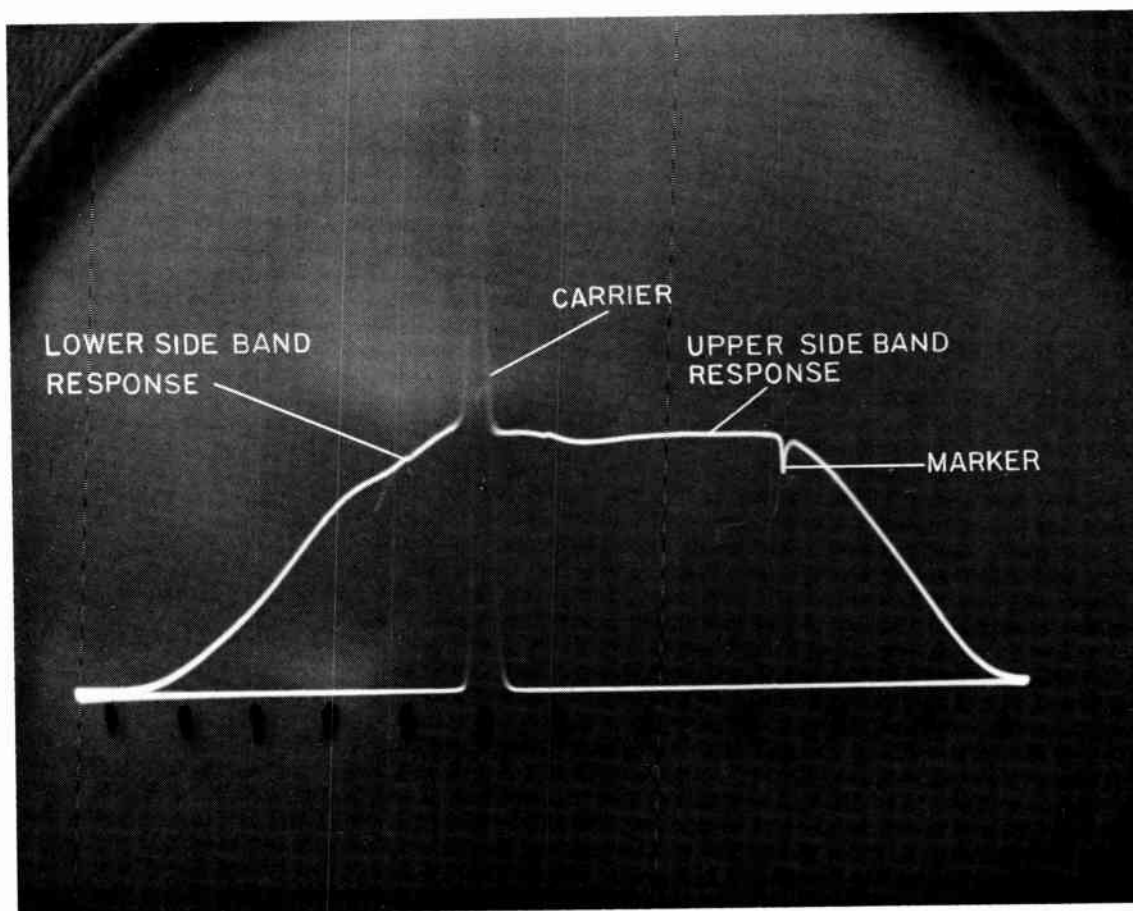

FIG. 13. Linearity curve of the amplifier only. This curve was plotted by comparing figures 11 and 12.

have plotted the linearity of the amplifier alone. This is shown in Fig. 13. It will be noted that the amplifier introduces almost negligible amplitude distortion except in the sync region where it can be easily compensated for by the sync stretcher.

A typical overall frequency response curve without a sideband filter as viewed on the sideband response analyzer is shown in Fig. 14. Note that the response at 4 mc. is considerably better than the 4 db limit proposed by the RTMA standard.

FIG. 14. Overall frequency response of the TT-20AH Transmitter including the TT-5A Driver. Measurements were made on channel 13 with the side band response analyzer.



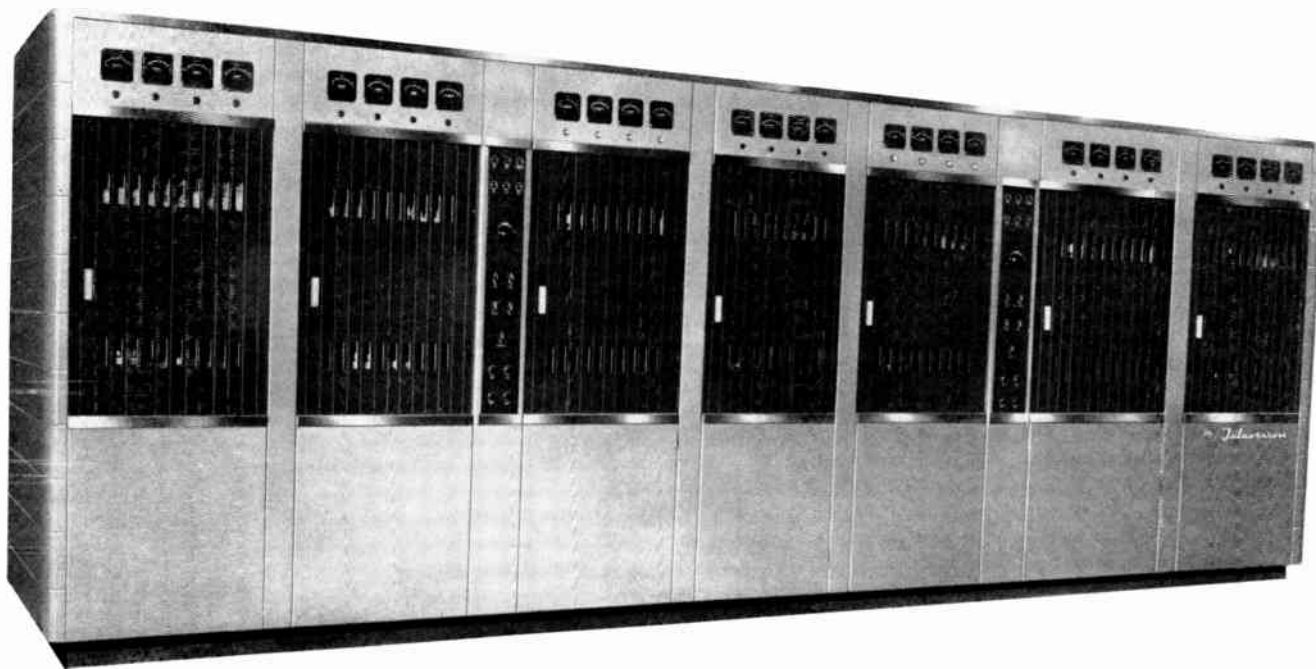

FIG. 1. Photo of cabinet line-up for the TT-50AH Transmitter.

## TT-50AH VHF TRANSMITTER (50KW)

The TT-50AH is a complete aural and visual transmitter, producing modulated RF power in any given channel, 7 through 13 and capable of delivering a synchronizing peak power of 50 KW to an antenna system. It is completely air-cooled.

Briefly, it consists of the RF modulating sections of the TT-10AH, followed by amplifiers to raise the power level to the specified 50 KW. These amplifiers, visual and aural, are very similar in circuitry and construction to those used in the TT-25BH transmitter. DC power supplies and AC switchgear are common to both the visual and aural sections, with DC switching and isolation to facilitate servicing.

### Low Power

Complete units from the TT-10AH are used for the low-power section. These provide an aural r-f section up to and including the driver and a visual section up to and including the modulated amplifier.

### Power Amplifiers

The air cooled visual and aural power amplifiers are similar electrically and mechanically, with the exception of biasing and video bypassing. The following discussion will hold true therefore for either of the power amplifiers.

In order to obtain the required power output from each amplifier, five of the type RCA 6166 air cooled tetrodes are used in parallel in a grounded grid circuit.

The tubes are physically located in a ring so that each of the tubes can be driven equally, and output power coupled from each tube in the simplest manner.

The input to the amplifier contains a variable  $Z_0$  transformer in order to match the 51.5 ohm output of the driver to the low impedance of the amplifier input circuit. This transformer is constructed the same as the one used in the TT-25BH amplifier and is controlled from the front panel of the amplifier. The input circuit consists of the tube elements, a short section of fixed line, and a variable capacitor which is common to all five tubes and the variable  $Z_0$  transformer.

The plate circuit consists of the tube elements and two variable tanks which act as inductors. In order to reach the top frequency limit and maintain large enough components to handle the required power the variable tanks operate in parallel. The output circuit consists of the first quarter wave length of output line, and a lumped capacity which is variable along the quarter wavelength. This configuration in conjunction with the plate circuit gives a broad band output with the proper impedance for feeding a side band filter.

The front panel of the amplifier contains the tuning motor switches, individual tube meters, tuning indicators, plate ON switches and status lamps.

From the standpoint of servicing and conservation of space the amplifier cabinet is essentially square. The

tubes are located at approximately waist height behind hinged access doors, and are of the plug in type so that rapid changes can be made. The resistors, capacitors, motors and other electrical components are mounted in the unit behind panels which have quick disconnect fasteners.

Air requirements for the amplifiers are satisfied by using two separate external blowers, one for the aural amplifier and one for the visual amplifier.

### Power Equipment

Power equipment in general is common to both the aural and visual sections. A 460 volt, three-phase supply enters the switchgear cubicle, which contains line and distribution circuit breakers, the main rectifier plate contactor, voltage regulators, and a distribution transformer. The blowers are fed through appropriate contactors and circuit breakers at 460 volts. All filaments and low-power rectifiers are fed through an automatic voltage regulator to take care of small line variations. Bias supplies are electronically regulated. Protection is supplied both for DC overloads and nominal AC overloads.

### Rectifiers

One main rectifier and one screen rectifier supply power for both aural and visual sections. DC switching and isolation is provided. The main rectifier uses six RCA type 857-B mercury vapor tubes in a wye connected full-wave circuit, with half voltage taken from the neutral. Separate filters are used in the high voltage supply to the visual and aural amplifiers, to prevent interaction.

One filter, common to all unmodulated stages, is used on the center tap 2900 volt supply. The 1200 volt screen rectifier, using three RCA type 673's (mercury vapor tubes), in a three phase half wave rectifier, is common, but a separate filter is used for aural and visual sections.

### Isolation and Switching

DC power is routed into a switching cabinet and distributed to the various amplifiers through appropriate remotely controlled switches. The transmitter control circuits are so arranged as to provide proper sequencing and to provide "cold break" switching. In the event of a fault in either the visual or aural sections, the usual three shot reclosing system will attempt to return the transmitter to the air. If the fault persists, the transmitter will be "locked out" and status lights, located at strategic front panel positions, will indicate the location of the trouble. The operator can, by means of a switch on the front panel, isolate the faulted side and return the non-affected side to the air. At the same time the air interlocks, the personnel interlocks, and the other protective interlocks are bypassed, so that with normal safety precautions, the faulted side can be serviced while the non-affected side continues in operation.

### Low Power Cabinets

The seven cabinets shown in the front line, in effect, make up the front panel of the transmitter and can be considered as a unit. The two end cabinets are TT-10 units, containing all r-f circuits for power to the 10 KW level.

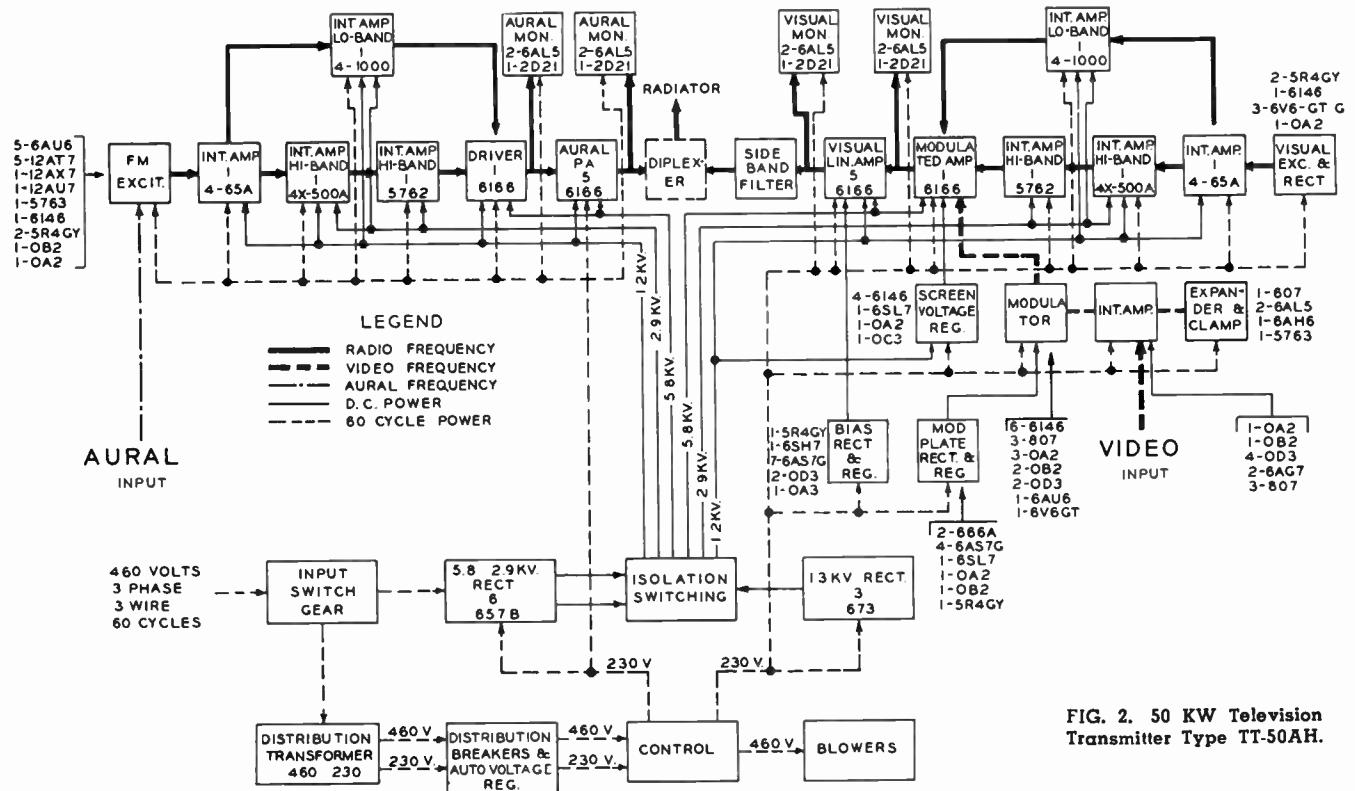



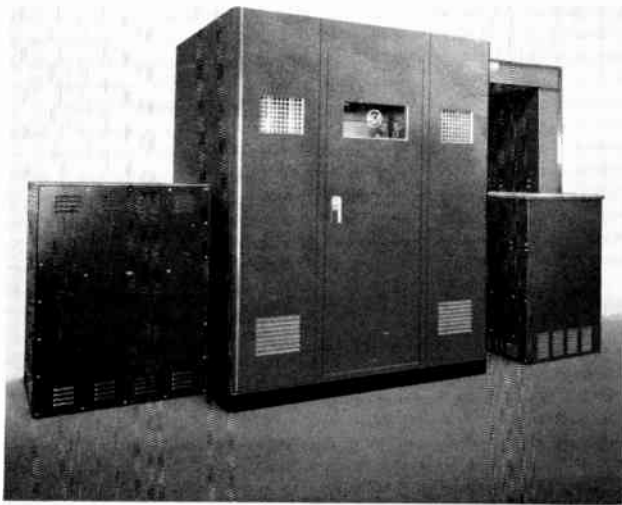

**FIG. 3.** Photo of high voltage rectifier cabinet with high voltage plate transformer on right and filter reactors on the left.

The control cabinet contains all control and sequencing relays, low power contactors, and distribution circuit breakers. Mounted in the control cabinet are the indicating instruments and protective relays associated with the aural PA.

The switching cabinet contains the screen rectifier, a portion of the visual filter capacity, as well as the high voltage switching. This cabinet is interlocked front and back for personnel protection.

The auxiliary rectifier cabinet contains the screen grid regulator for the 10 KW modulated amplifier and the regulated bias supply for the 50 KW visual amplifier. Additionally, it contains indicating instruments and protective relays associated with the visual PA.

#### **Power Equipment**

The power input equipment, rectifier and plate transformer can be disposed as required. For instance, the main rectifier could be in line with the front line equipment while the filter reactor and plate transformer could be on the floor below. It should be kept in mind that the reduced power switch and main circuit breaker are located in the switchgear cubicle.

#### **Blowers**

The blowers and filter may be located one floor below the rest of the equipment or to suit, as long as adequate duct work is supplied. Each blower handles approximately 2500 CFM of air at approximately 4 inches static pressure, and ducts must be adequate to handle this with nominal loss.

#### **Interconnection**

Control wiring and low voltage power wiring may be run through floor trenches or race ways as indicated. High voltage wiring between the high voltage rectifier and the switching cabinet will be overhead, in either conduit or race way. High voltage wiring between the switching cabinet and the two PA's will be in overhead conduit, to provide the most direct and shortest run. This is a requirement based on location of the visual amplifier filter capacity. Wiring between front line cabinets will be in the wiring race ways formed by the front and rear mounting "rails".

#### **Component Size**

All transmitter units, excepting VSBF, can be disassembled in the field to unit sizes of approximately 32 x 50 x 84 maximum. They will be shipped as shown. Disassembly to the 32 x 50 size can be accomplished without special tools, cutting torches or hack saws, but a certain amount of disassembly and reassembly labor should be anticipated.

#### **Customer Requirements**

1. Power Input—Approximately 193 KW, black level, 153 KW, average picture; 460 volt, three phase, 60 cycle.
2. Installed KVA should not be less than 225 KVA.
3. Short circuit capacity should not exceed 25,000 amperes into bus to bus fault.
4. Volume of Exhaust Air
  - (a) Rectifier—117 CFM.
  - (b) Regulator—88 CFM.
  - (c) Control—49 CFM.
  - (d) Driver each—400 CFM each.
  - (e) 10 KW PA—400 CFM each.
  - (f) 50 KW PA—2500 CFM.

# The TTU-1B 1-KW UHF TV Transmitter

The RCA, 1-KW UHF Transmitter is considerably smaller than the original pioneer UHF television transmitter. Its predecessor, the TTU-1A, operated as an experimental station at Bridgeport, Connecticut<sup>1</sup>

for nearly three years, and was later moved to Portland, Oregon<sup>2</sup> to become the nation's first commercial UHF television transmitter. The TTU-1B has a visual power rating of 1 KW and a corresponding aural power of 500 watts. The power rat-

ings apply to the power at the output of the filterplexer.

<sup>1</sup> BROADCAST NEWS No. 57, Jan. and Feb. 1950, "First UHF Transmitter Shipped."

<sup>2</sup> BROADCAST NEWS No. 71, Sept. and Oct. 1952, "UHF in Portland—How is it Doing?" John P. Taylor.

FIG. 1. The TTU-1B is housed in three easy-access, space-saving sliding door cabinets.



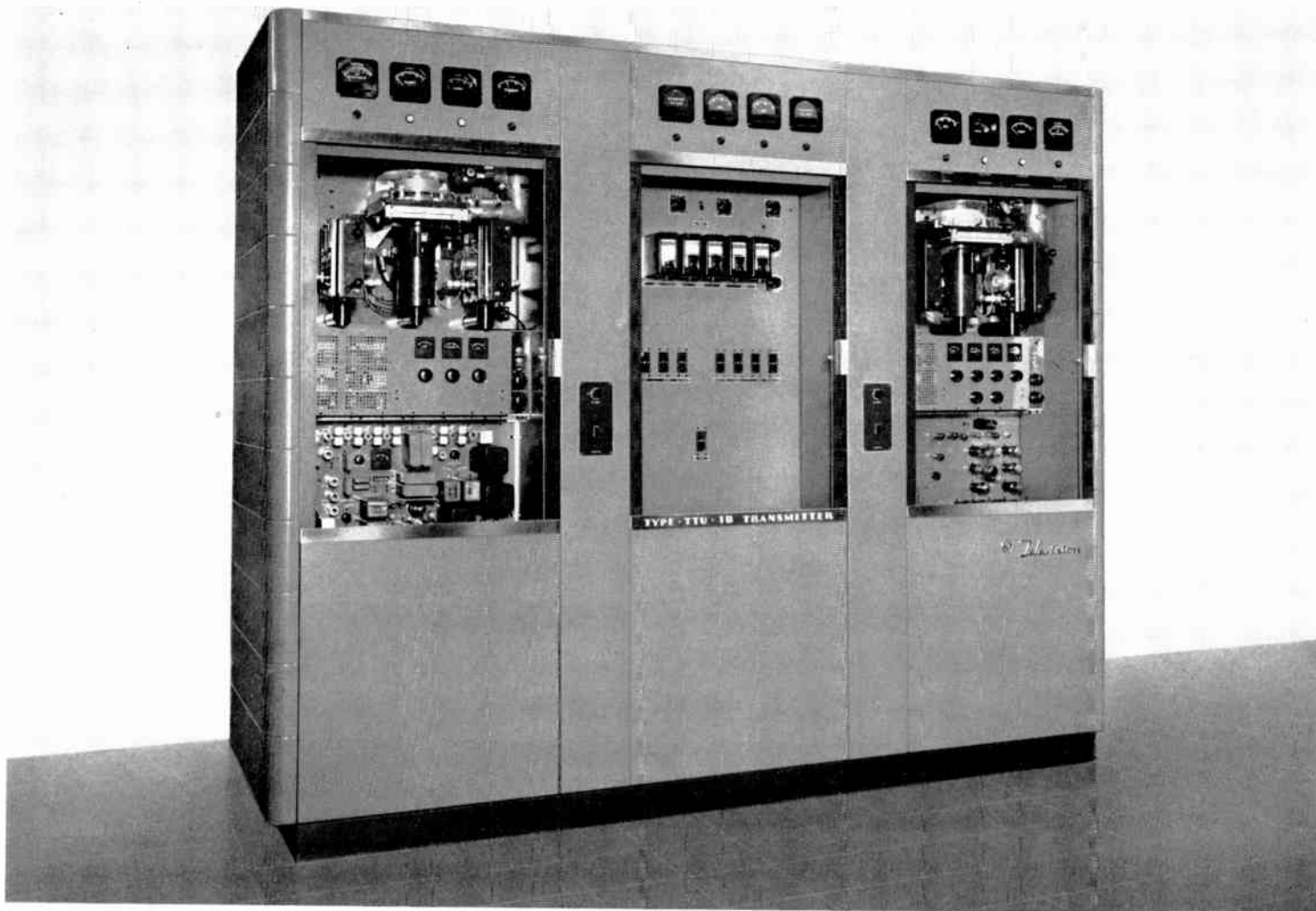

FIG. 2. The TTU-1B may be operated with sliding doors open or closed.

### General Description

This transmitter is housed in three sliding door cabinets which conserve floor space and increase operating convenience. The center cabinet contains the necessary switches, relays, and circuit breakers for separate operation and overload protection of visual and aural transmitters, and a single blower which draws filtered air in through the rear lower section of the center section and supplies cooling air to the various tubes and units in the other two cabinets. It is the only rotating unit employed. The right hand cabinet contains the visual transmitter and the left hand cabinet contains the aural transmitter.

Except for the low level R-F stages and the video modulator, the aural and

visual transmitters are practically identical. The frequency and power multiplier stages, IPA units, the final stages, and the high voltage plate supplies are the same in aural and visual portions of the transmitter. The aural and visual portions may be operated independently of each other except for the common cooling air supply. Some of the other mechanical features may be observed by inspection of the photographs. The sliding front doors are not interlocked and the transmitter may be operated with these doors open as shown in Fig. 2. Fig. 3 is a rear view of the visual transmitter with the door open. This photograph shows the clean, simple construction and the ready accessibility of all components. Except for the necessary

air ducts seen in this photograph, all components are mounted on the center vertical aluminum panel in order that they may be inspected, tested, and if necessary, easily repaired.

Fig. 4 shows a front view of the essential portions of the aural transmitter. The bottom third is occupied by the FM exciter which will be described in following paragraphs. The middle portion contains, behind an interlocked hinged panel, the middle level R-F stages ranging up to a power of 50 watts at a frequency of approximately 400 mcs. (half the final frequency). The three UHF cavities appear in the upper section of the photograph. These circuits are likewise described in greater detail in following paragraphs.

Fig. 5 is a block diagram of the visual transmitter.

### Radio Frequency Circuits

Since the aural and visual R-F circuits are identical except for the very low level stages most of the description of the visual circuit which follows will apply to the aural transmitter. Block diagrams of the visual and aural transmitters appear as Figs. 5 and 6.

The visual transmitter frequency is controlled by third overtone crystals to reduce the multiplication factor required to reach the high UHF channels and to insure the good stability necessary to meet requirements of "off-set" carrier operation which requires a final frequency stability of  $\pm 1000$  cycles.

Stability is also enhanced by accurate thermostatically controlled crystal heaters, low voltage regulated plate supply for the crystal oscillator, and a buffer stage.

The output of the visual crystal buffer stage is coupled to an RCA 6146 amplifier for channels 14 to 41 or tripler for channels 42 to 85. The 6146 is followed by two stages using RCA 4X150A tubes which triple or double respectively for the above mentioned channels. Including a 6161 doubler stage, to be described later, the frequency multiplication factor is 18 for the lower channels, and 24 for the higher channels.

The resonance output of the second 4X150A is one-half final frequency, and above the present VHF bands so the tuned circuits depart from conventional lumped constants. Thus the anode circuit consists of a pair of parallel plates with a movable shorting bar.

The doubler and IPA stages use RCA 6161 triode tubes, operated grounded grid, in special tuned circuits commonly called "cavities". The final amplifier is an air cooled tetrode—type 6181—in another special "cavity". To allow meter monitoring of power output, two reflectometers are coupled to the output transmission line, and read peak output power or standing wave ratios. An external filterplexer is used to combine the aural and visual signals

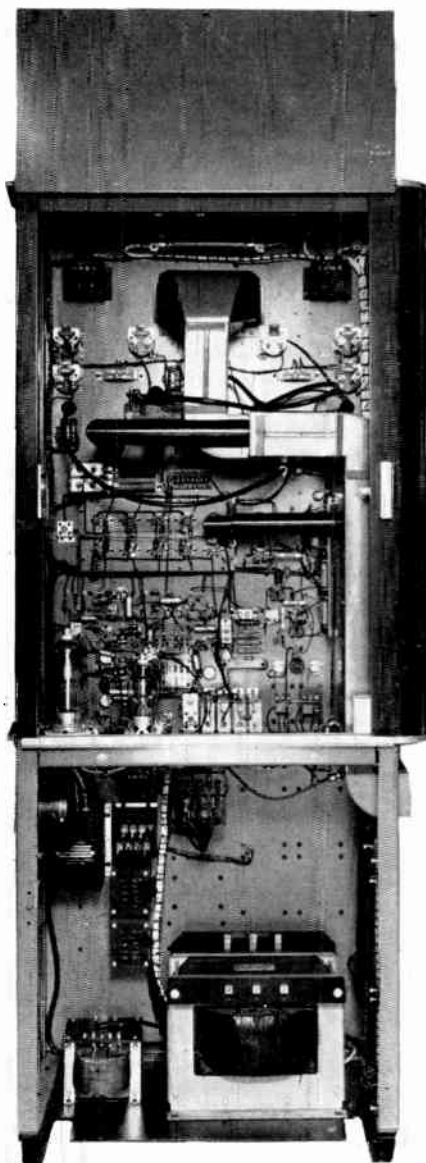

FIG. 3. Rear view of the visual transmitter shows the simplicity of construction and the ready accessibility of all components.

and to attenuate the undesired visual sideband as required by the FCC.

### Video Modulator

Video modulation is introduced into the cathode circuit of the power amplifier tube. A simplified schematic diagram of this portion of the circuit is shown in Fig. 7. The plate current of the PA flows through eight RCA 6146 tubes which are operated in parallel as the modulator. The modulator stage itself is preceded by three video amplifier stages which utilize negative feedback from the modulator to the second video stage. This improves the linearity of the modulator and maintains a flat amplitude vs. frequency response in the last two

video amplifier stages without the use of peaking coils.

In addition to the negative feedback loop, a second feedback path will be observed to the cathode of the first video amplifier. This is a positive feedback circuit whose frequency characteristic is opposite in amplitude and phase to the characteristics of the resistance-capacitance coupling elements between the first and second video amplifier stages. The positive feedback complements and corrects the amplitude vs. frequency characteristic of the first video amplifier stage. A variable capacitor in the positive feedback circuit furnishes a convenient adjustment for making the overall video response flat with frequency or it may be adjusted to give an overall rising frequency characteristic to compensate for the loss in high frequency response in the coupling network between the modulator and the modulated radio frequency amplifier.

The DC component of the television signal is restored at the grid of the modulator which is in turn direct coupled to the modulated power amplifier. The DC restoration circuit is a conventional clamp circuit.

The TTU-1B is used in conjunction with a TA-5C stabilizing amplifier. The picture and sync controls for the stabilizing amplifier are included in the transmitter console so that the depth of modulation and the synchronizing to picture ratio can be monitored and adjusted from the operating position. Since the transmitter is always preceded by the stabilizing amplifier which, among other things, adjusts the sync/picture ratio, no sync stretching is built into the transmitter proper. No white stretching is required because of the excellent linearity resulting from the use of negative feedback and explained in detail on a following page.

### FM Aural Exciter

A block diagram of the FM aural exciter is shown in Fig. 6. The FM aural exciter is direct crystal controlled, and has a frequency stability of 4000 cycles at final frequency. The crystal oscillator in the phase modulator operates at 130 KC, and the large multiplication required to reach

the final frequency would result in a large deviation not only at the desired modulating rate, but for noise components as well. To keep the noise level down, it is necessary to translate the carrier and its side-band components to a higher frequency without increasing the frequency deviation. This is done by a heterodyning process using a second crystal oscillator.

A low frequency crystal oscillator and a pulse shaper produce a series of narrow pulses which are used to synchronize a sawtooth generator. The sawtooth produced is very linear, but is clipped at a level corresponding to the instantaneous audio modulation applied. New pulses are formed from the clipped sawtooth but the new pulses vary in time at an audio rate. These pulses, still at the oscillator frequency, are fed to a series of frequency multipliers and are restored to sinewave form. The second crystal oscillator and mixer translates the frequency modulated signal to a new portion of the spectrum without altering the initial deviation. Amplifiers which follow the mixer increase the signal level and act as selective filters to prevent any other signal components from being passed to the remainder of the transmitter.

Since this unit is a phase modulator, a frequency selective device is provided at the audio input terminals to make the audio output of the second audio amplifier vary inversely with frequency. This is done to maintain a frequency deviation independent of the modulating frequency. A pre-emphasis network is included in the modulator.

#### **Cavities for the 6161 Tubes— Doubler and IPA**

Three cavities were shown in the upper portion of the photograph, Fig. 4. The right hand rectangular cavity is a doubler employing a 6161 tube which reaches the final frequency with a power output of approximately 90 watts. The left hand rectangular cavity is an IPA stage also employing a grounded grid 6161 triode. The power output of this stage is approximately 150 watts. Although one of these cavities is a doubler and the other an amplifier they are very similar in construction and will

be described simultaneously. Fig. 8 is a closer view of the rectangular cavity showing the top side or output circuit and the bottom side or input circuit. Fig. 9 is similar but with the top and bottom cover plates removed to show the internal construction.

The term "cavity" has grown in meaning to describe almost any kind of UHF circuit where the radio frequency currents flow on the inside of and are entirely contained by a metal box or structure of almost any shape. At lower frequencies it is possible to talk about lumped circuits, parallel lines, or coaxial lines. At ultra high

frequencies so much of the circuit is contained with the tube, and the external circuit is so short and complicated by mechanical requirements and R-F blocking capacitors, that it is no longer possible to distinguish between coaxial lines, radial transmission lines, or resonant spaces of irregular shape. All of these are lumped under the generic term "cavity".

The resonant circuit formed by the 6161 tube and its cavity consists of the coaxial circuit within the tube plus the circuit formed by two parallel completely enclosed plates which make up the rectangular cavity circuit. As may be seen in

FIG. 4. R-f circuits of the aural transmitter.

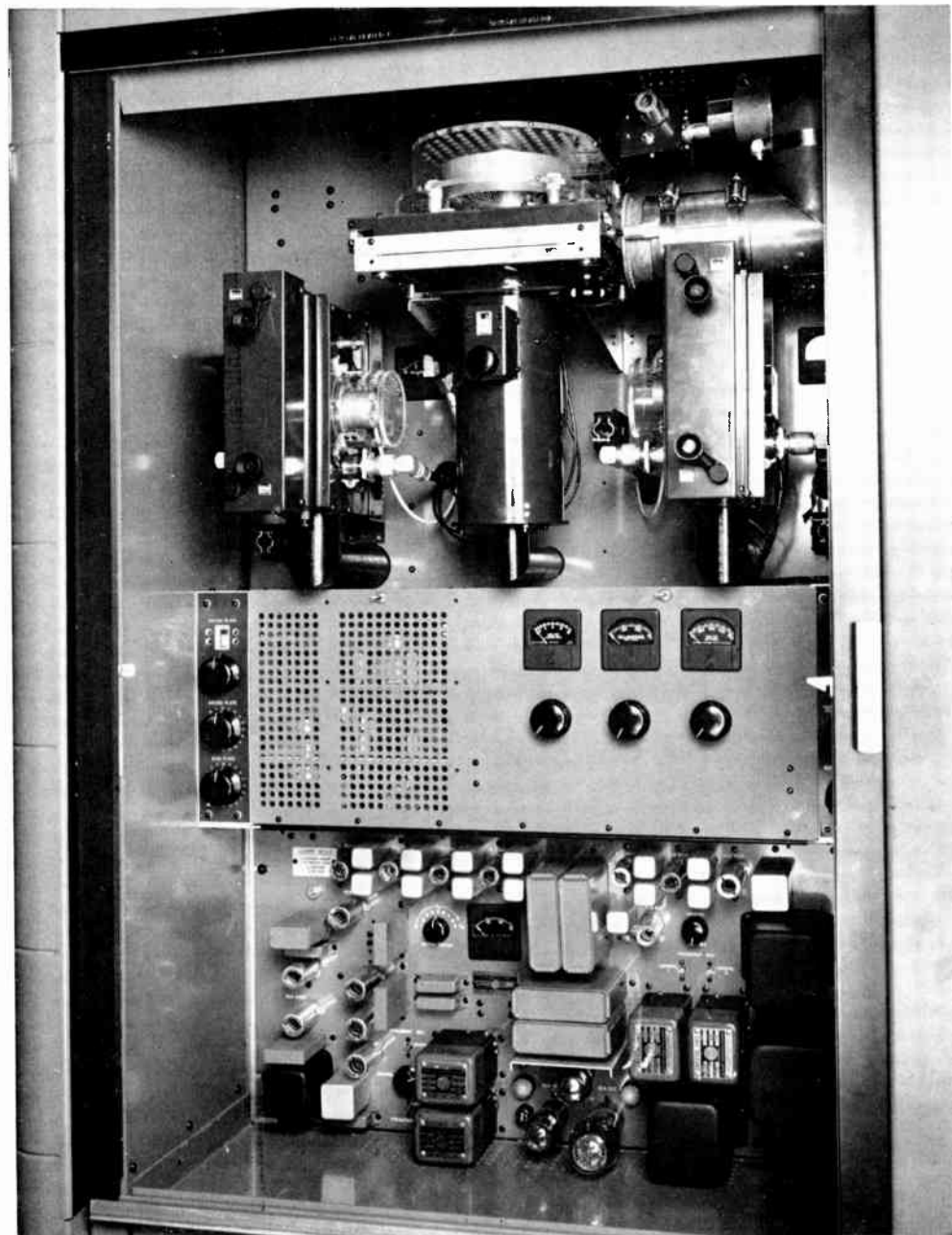

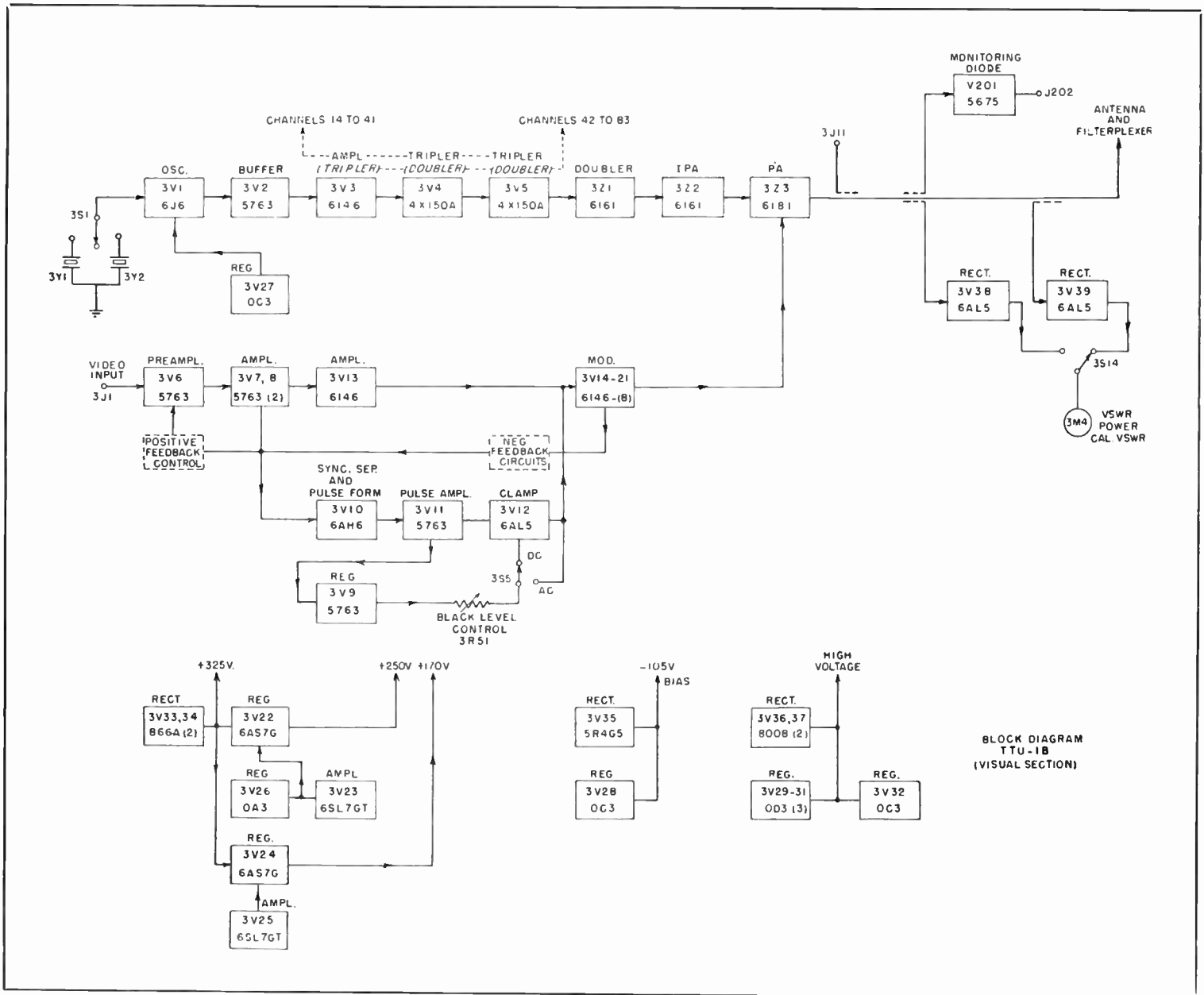

FIG. 5. Block diagram of TTU-1B visual transmitter.

Fig. 9 there is a central common plate which is connected through a blocking capacitor to the grid of the 6161. One side of this plate carries current for the output circuit and the other side of this plate carries the current flowing in the input circuit. It would perhaps be more descriptive of the mode of operation if the stage were called a *grid separation circuit* rather than a *grounded grid circuit*.

Tuning or cavity resonance is accomplished by moving a pair—one on either side of the tube—of shorting bars in unison toward or away from the tube. Each shorting bar has some six hundred sliding contacts to insure a connection of low R-F

resistance between the parallel plates. These are formed by a silver clad coil spring which tips over to form numerous contacts of uniform pressure between the flat plates and the grooved shorting bars.

The cathode-grid and grid-anode sections are similar except for lumped capacity sections around the tube itself chosen to obtain the required tuning range with minimum circuit loss. The output circuit is operated in the  $\frac{1}{4}$  wave mode and the load is capacitively coupled to the output circuit by the disc shaped probe visible in the photograph. The input circuit is operated in the  $\frac{1}{4}$  wavelength mode when the cavity is arranged as a doubler, and in the

$\frac{3}{4}$  wave mode when the cavity is arranged as an amplifier. In the amplifier, advantage is taken of the phase reversal in the input circuit between the first and second quarter wavelength. This gives an out-of-phase voltage useful in neutralizing the stage.

A probe leading from the output to the input circuit through a small hole in the center plate picks up enough of the energy in the cavity to balance out and neutralize the energy coupled through the cathode to plate capacitance of the 6161 tube.

When the cavity is used as a doubler the capacity loading is arranged so that the input circuit, when it is tuned in the  $\frac{1}{4}$  wavelength mode at the input frequency,

will not simultaneously resonate at the final frequency. This arrangement makes the doubler stable and neutralization is not required. For convenience in metering and for safety the cavity is operated at ground potential. All of the electrodes; cathode, grid, and plate, are bypassed to the cavity with a series of silvered mica capacitors shown scattered around in the photograph, Fig. 9.

Flexible coaxial cables are used to couple the ultra high frequency energy from the output of one cavity to the input circuit of the following cavity. It is highly desirable although not absolutely necessary to match the impedance of the cable at its termination. This prevents excessive circulating current in the cable which would cause overheating and excessive tuning drift. Impedance matching is accomplished by adjusting the coupling and the tuning of the input circuit until the cable is properly terminated. A plug-in reflectometer is furnished for measuring the standing wave ratio in the interconnecting cable. Type RG8U cable is used to interconnect the cavities with the exception of the cable between the IPA and PA. The cable used here is RG87A/U which is similar to RG8U except that Teflon insulation is used to avoid any possibility of the cable short circuiting due to overheating as a result of an impedance mismatch and excessive circulating current. Cable fittings are type HN, similar to type N except they are a high voltage variety, to eliminate the danger of flash-over if the cavities are misadjusted.

#### PA Cavity

A composite photograph (Fig. 10) shows a top and bottom view of the PA cavity. Fig. 11 is a photograph of a disassembled cavity and Fig. 12 is a photograph of a 6181 tube. The 6181 tetrode employed in the final amplifier is operated grounded grid grounded screen. The screen grid is bypassed to the output circuit; the control grid is bypassed to the input circuit. In addition, the two grids are bypassed to each other.

The output circuit operates in the  $\frac{1}{4}$  wavelength mode and a broadly tuned loop

couples energy from the output circuit to the  $3\frac{1}{8}$ -inch 50 ohm coaxial output transmission line. The output coupling is adjusted by rotating the loop. The tuning of the output circuit is achieved by simultaneously moving four shorting bars which are apparent in Fig. 11 as segments of a circle. These segments are driven from the tuning knob by a chain drive and racks and pinions. When the circuit is adjusted for the highest possible frequency the four segments move together to form a circle around the tube except for a small opening which is occupied by the output coupling loop. Thus at the upper end of the band, the circuit is contained almost entirely within the tube.

The input circuit is an open ended coaxial transmission line. It has an electrical length of  $\frac{1}{2}$  wavelength for the lower channels and one wavelength for the upper channels. The circuit capacitance is small compared to the tube capacitance so it is possible to introduce modulation into the cathode circuit while maintaining a low capacity to ground for the video signal. A tuned  $\frac{1}{4}$  wave choke is used to connect the cathode and filament of the 6181 to a low capacity filament transformer and to the modulator.

Cooling air is circulated through all of the cavities. In the case of the 6161 doubler and 6161 IPA the air is brought into the cavity and then out through the radia-

FIG. 6. Block diagram of TTU-1B aural transmitter.

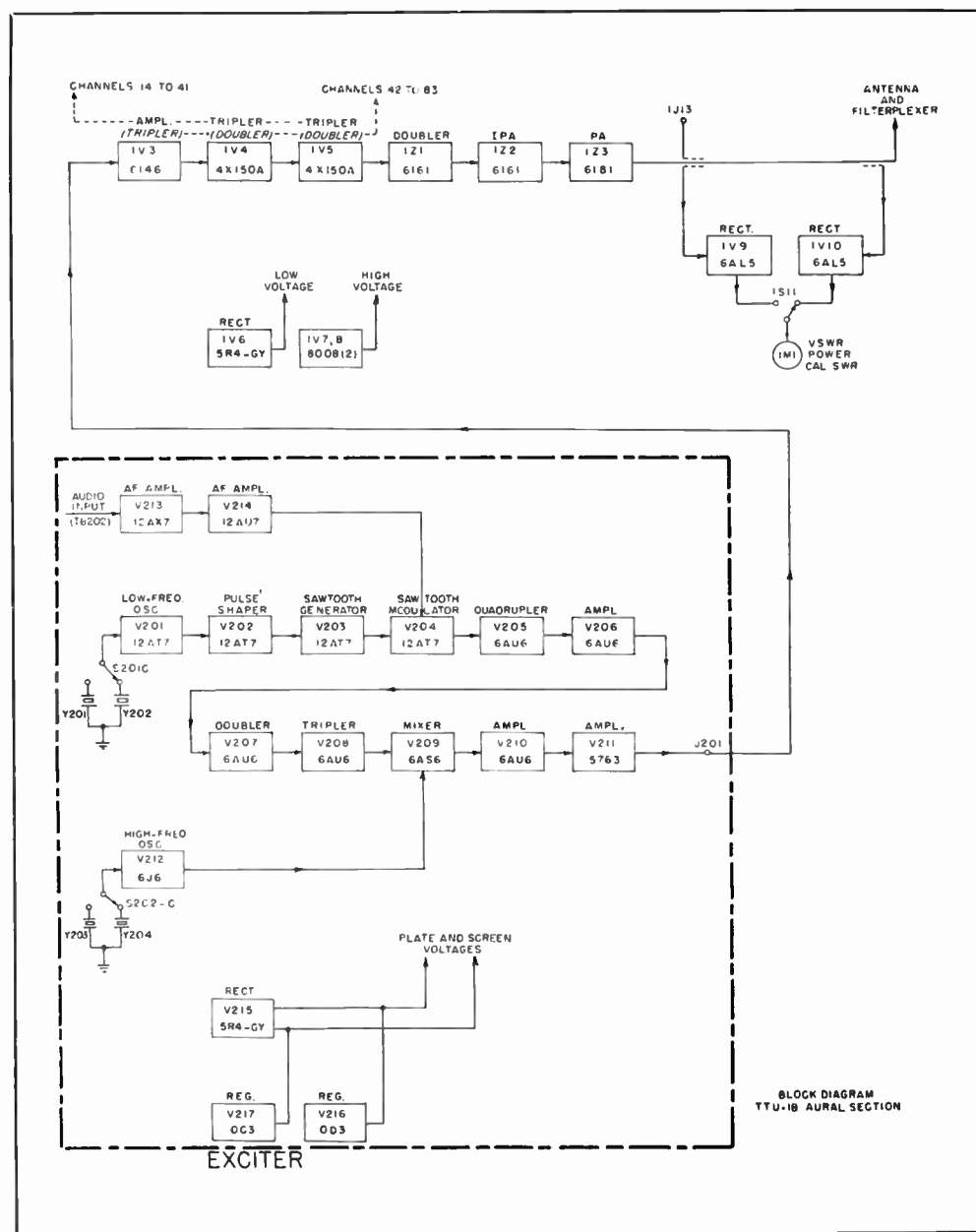

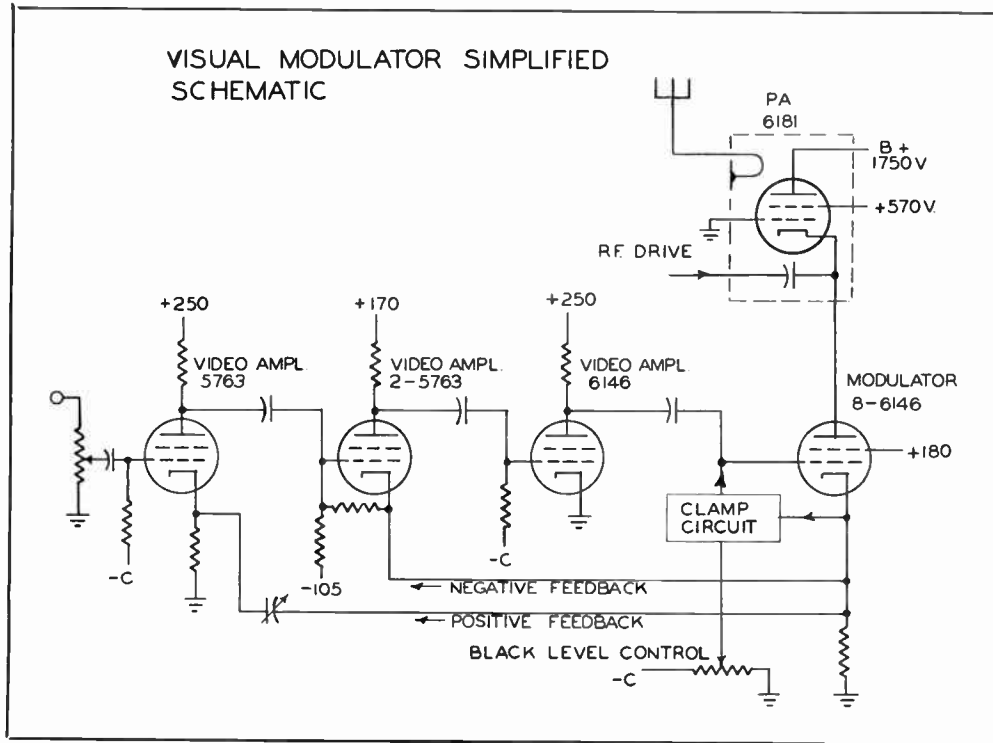

FIG. 7. Visual modulator simplified schematic.

tor of the tube. In the PA, three separate sources of air are provided. Air is supplied via a Teflon tube up the center of the input cavity to blast the filament seal. Another source of air leads in through the rear of the cavity between the control grid and the screen grid sections to cool the remaining tube seals and the output cavity. Finally the main source of air enters a

plastic shield on top of the cavity and exhausts through the 6181 radiator out of the top of an interlocked cover.

#### Features and Performance Information

One of the design objectives was to make the linearity superior to any previously designed television transmitter; yet some early experience indicated that it would be

FIG. 8. Rectangular cavity for 6181 grounded grid doubler or amplifier.

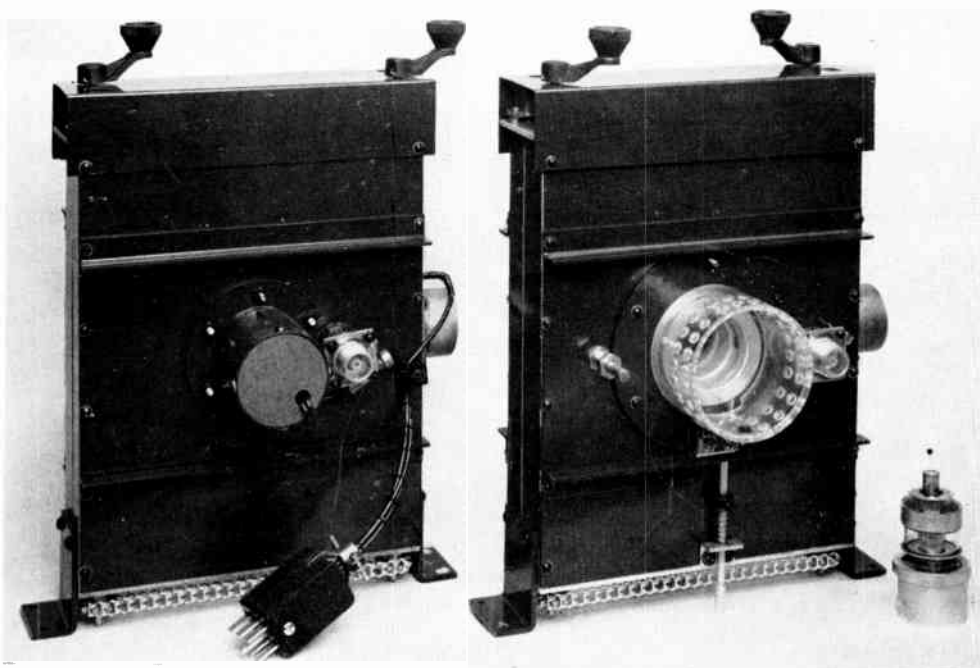

more difficult to obtain good linearity at UHF than at VHF.

The non-linearity problem was tackled boldly by negative feedback. Since the PA and modulator are connected in series, the modulator plate current and the power amplifier plate current are identical. Consequently, the negative current feedback from the modulator to the video amplifier insures that the plate current of the PA will be a linear function of the instantaneous video signal. By virtue of this negative feedback not only the PA plate current, but the overall transmitter performance was made linear. The results are shown in Fig. 13. Fig. 13A shows the entire modulation characteristic. The curve, Fig. 13B, is restricted in amplitude to the excursion produced by the picture information; that is, the curve reports the entire range from black to white. To draw a comparison with AM broadcast operation the total harmonic distortion was measured for the conditions as shown in Fig. 13B. The distortion was 2½% for Fig. 13A, and 1% for Fig. 13B. This is the first television transmitter ever produced with distortion comparable to an AM broadcast transmitter.

#### Frequency Response

Maintaining a good flat frequency response in broadband R-F circuits at UHF is not easy. To obtain reasonably flat response in over-coupled circuits, individual tuned circuits can hardly be allowed to wander off tune by as much as 1 mc. Yet the slightest change in the electrical contact to the tube or in the tuning element may produce such a frequency shift. Ordinary heating due to R-F currents or to heat flow to the circuit from the vacuum tube can also produce appreciable frequency change. In the TTU-1B it was possible to avoid all over-coupled circuits, and the associated problem of keeping them in tune. Modulation is applied to the final tube so that the output tank is the principal UHF circuit determining the transmitter frequency response. Since the 6181 tube works at relatively low voltage and high current it must be heavily loaded. This produces a very wide bandwidth in the single tuned output circuit. When the load is adjusted for maximum power output, the bandwidth automatically comes out to be about 15 mc. The power amplifier operates full double sideband and the frequency response is not radically affected by circuit adjustment.



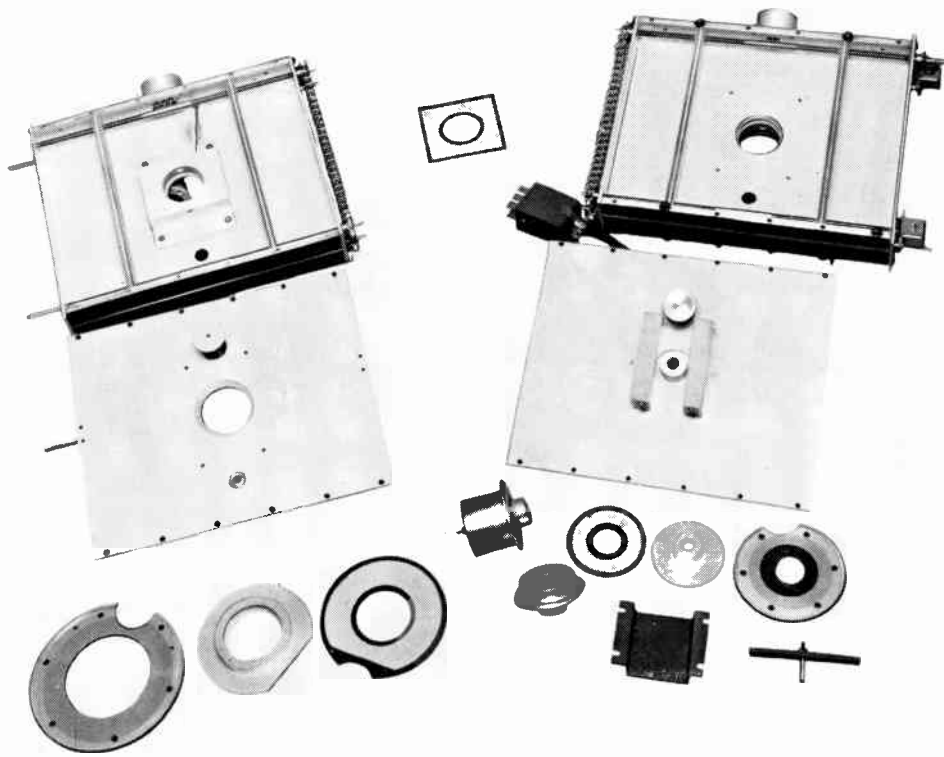

FIG. 9. Rectangular cavity for 6161 disassembled.

The modulator frequency response is adjusted by a single trimmer condenser in the feedback circuit to obtain a slightly rising frequency response which compensates for the frequency characteristic of the tuned circuit in the output of the mod-

ulated R-F amplifier. The overall response is flat and the bandwidth is determined principally by the modulator cutoff. Fig. 14 shows the overall response of the transmitter. The marker is set to 4.5 mc. The frequency response in this figure is taken

ahead of the filterplexer and, of course, the response at the output of the filterplexer must contain a deep notch at 4.5 mc. similar to that produced by the sound traps in a television receiver. The frequency response shown in Fig. 14 is the output of a diode demodulator ahead of the filterplexer. The apparatus arrangement is shown in the block diagram of Fig. 15. Photograph of a picture on a kinescope fed by the same diode demodulator is shown in Fig. 16.

#### Problems Associated with Grounded Grid Operation

In order not to leave a false impression by over-simplifying the problem of high quality picture transmission, an interesting dilemma of UHF transmitter design will be discussed. At any television broadcast frequency it is extremely difficult to prevent feedback around the modulated amplifier to the degree required for high quality picture transmission. The slightest lack of neutralization is cause for the R-F drive, which should be steady, to be modulated by the video signal. At UHF the problem is much worse due to the lower reactance of the feedback capacitance at the ultra high carrier frequency. If grounded cathode operation is attempted, the problem of adequate neutralization is considerable. By operating grounded grid,

FIG. 10. Photo "A" (left) shows completely assembled PA cavity. Photo "B" (right) shows bottom view, partially disassembled.

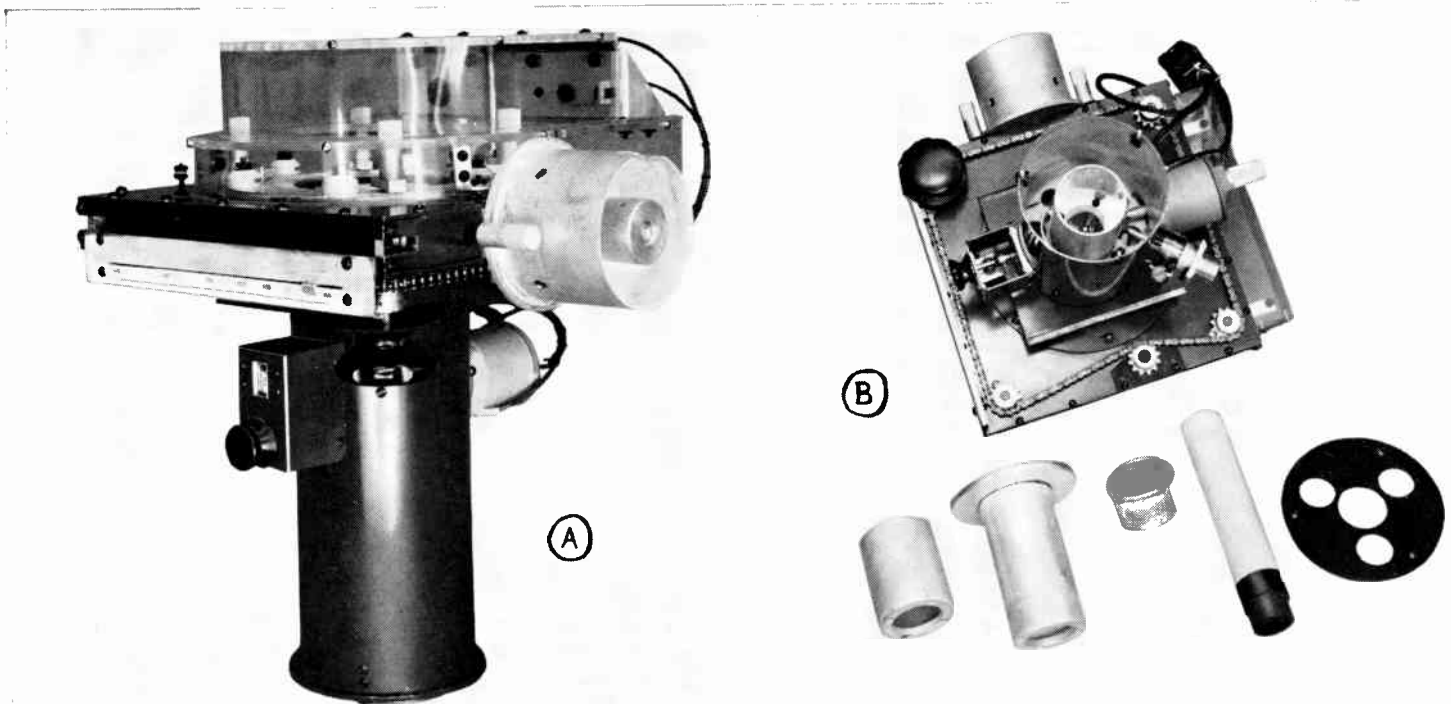



FIG. 11. PA cavity completely disassembled.



FIG. 12. 6181 tube used in both aural and visual outputs.

grounded screen, two electrostatic shields are interposed between the input and output circuits so the problem of electrostatic feedback is negligible; however, the plate current then flows in both the input and output circuits and there is strong conductive coupling. At UHF some of this same difficulty occurs even in grounded cathode operation. If complete neutralization were possible in the grounded cathode stage, there would still be considerable

modulation of the R-F driving signal by the video signal because the input circuit of the modulated stage is loaded due to transit time effects and this load is proportional to plate current.

In the TTU-1B transmitter, grounded grid, grounded screen operation was chosen so the problem of neutralization is avoided but there is appreciable incidental load impedance modulation of the R-F driver.

Since it is difficult to maintain a flat frequency response in the R-F circuits between the driver and the power amplifier, this incidental modulation results in some picture degradation. This defect is minimized in two ways. The cable between the IPA and the PA is chosen to be a multiple of  $\frac{1}{2}$  wavelength so that the IPA and the PA act like a simple overcoupled circuit with amplitude but not phase modulation. More important than this is the subtle effect of the "cure-all" negative feedback employed in the modulator. This feedback makes the plate current of the power amplifier directly proportional to the video signal regardless of any perturbing influence such as the incidental modulation of

FIG. 13A (left) and FIG. 13B (right). Curves showing linearity of TTU-1B.

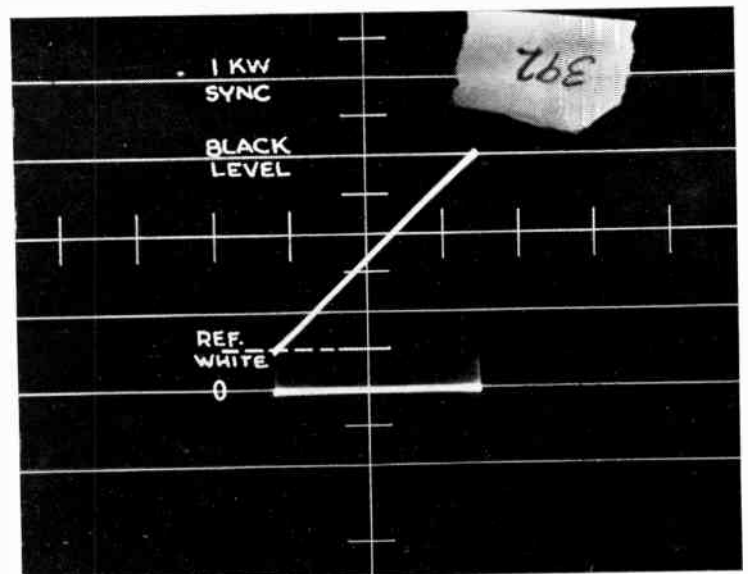
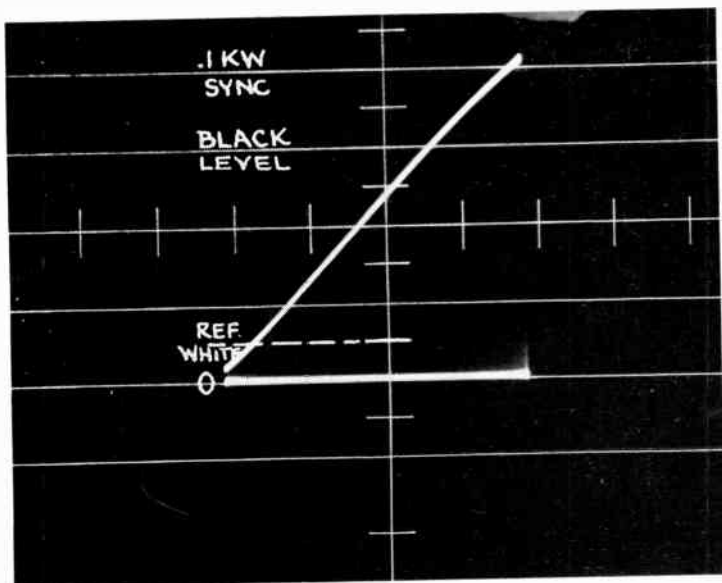

the R-F driver. Since the changing R-F excitation cannot influence the power amplifier plate current it simply shifts the bias of the PA producing a change in plate current flow angle which results in a small second order disturbance in the picture. Stated as simply as possible the effect is that the constant current modulator absorbs the distortion that would otherwise be produced by the incidental modulation of the driver. The curious result is that the picture distortion seen in the demodulator on the output transmission line or on the air is very, very slight, but the distortion is considerably more noticeable on the monitor takeoff point from the modulator. Thus, if one wishes to see the picture quality of which the modulator is capable, it is necessary to remove the R-F excitation by turning off the crystal and putting a positive bias on the power amplifier to restore the modulator plate current to the normal value.

### BLOCK DIAGRAM OF APPARATUS USED IN MAKING PERFORMANCE MEASUREMENTS

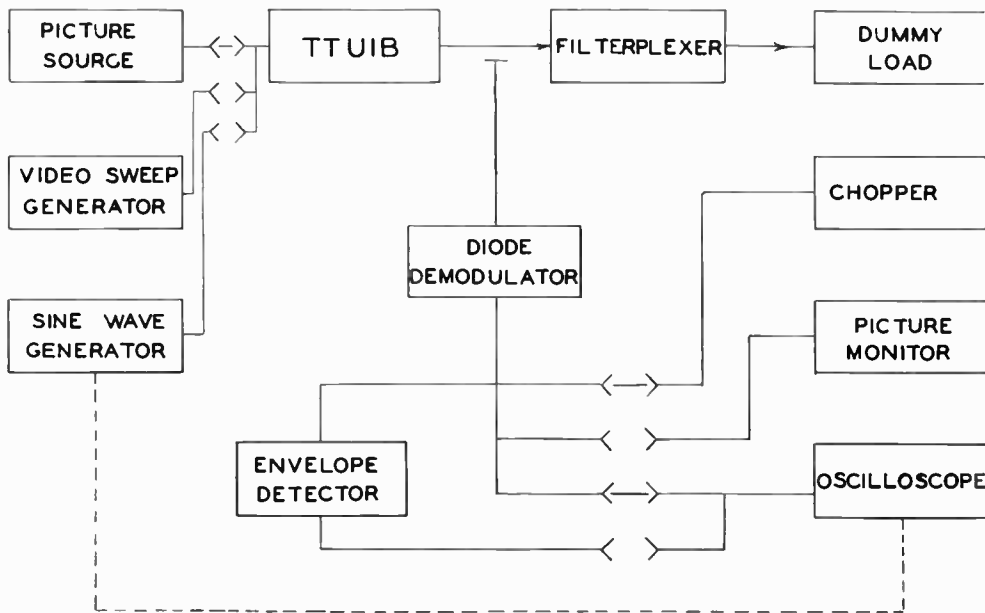

FIG. 15. Block diagram of apparatus arrangement used in making performance measurements.

### Summary of Performance

In spite of the new and difficult problems that were encountered in the design of this ultra high frequency transmitter, important improvements in picture quality were made over the earlier VHF transmitters which have been doing such a good job of broadcasting since about 1946. The linearity of the transmitter which controls the ability to reproduce the delicate shading in the highlights and shadows has been markedly improved. The frequency response of this new transmitter is slightly better than in the earlier VHF transmitters. More important than this, the good

frequency response is obtained during transmitter tuneup almost automatically by virtue of circuit simplification and negative feedback. Thus, picture reproductions from the TTU-1B transmitter are of consistently high quality.

FIG. 16. Kinescope photograph of TTU-1B output.

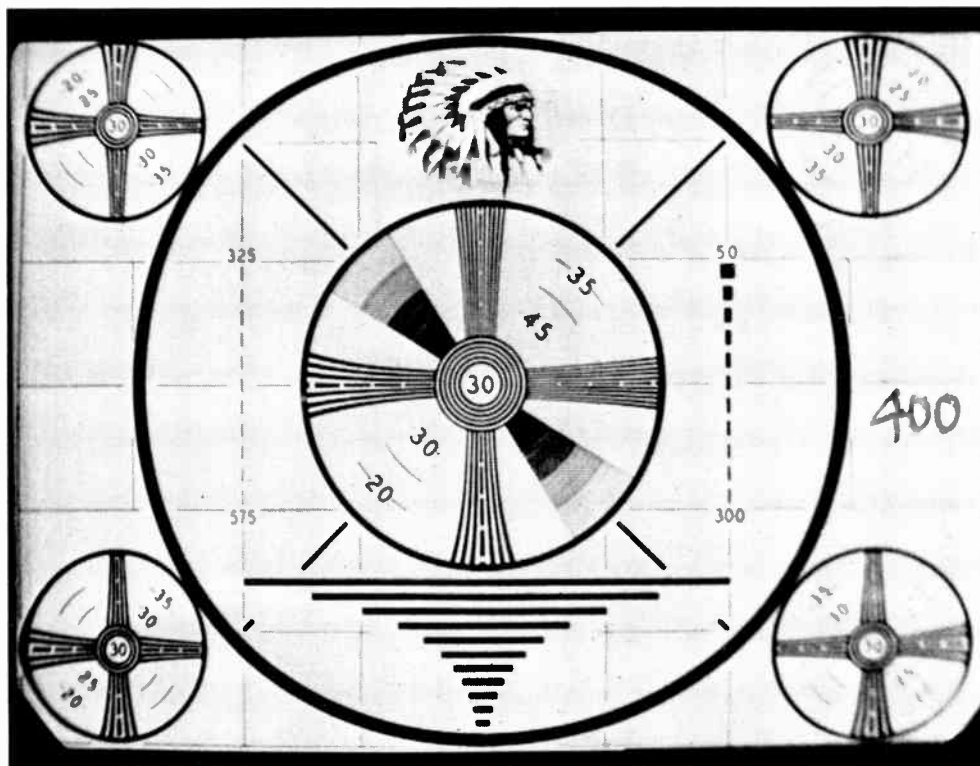
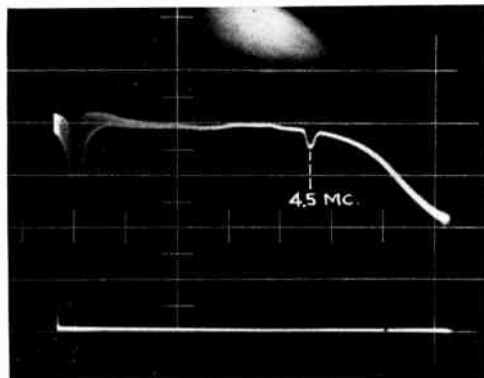

FIG. 14. Overall frequency response of the TTU-1B—Marker at 4.5 mc.



# TTU-10A (UHF) TELEVISION TRANSMITTER

For the television needing more power at UHF than is available from the TTU-1B, RCA offers the TTU-10A 10 KW television transmitter. The TU-10A can be purchased as a complete transmitter as shown elsewhere, or the 10 KW amplifier can be added to an already existing TTU-1B installation.

The TTU-10A in conjunction with a TFU-24 UHF slotted antenna will provide peak picture powers in the order of 200 kilowatts.

The initial stages of the TTU-10A are identical with the TTU-1B transmitter previously described. The aural and visual final RF power amplifier each employ a new, high gain UHF power tetrode. The visual unit operates as a linear amplifier. The RF cavity circuits associated with the final power amplifier tube are of the coaxial type and are designed for optimum broad-band transmission of the UHF television signal. Single control of input and output circuits make for extremely simple tuning and loading. The output coaxial line contains a reflectometer which provides an indication of the transmitter output power. It also serves to provide transmitter protection in the event of excessive standing wave ratio.

The equipment comprising the tetrode power amplifier is housed in four cabinets. Two of the cabinets contain the visual and aural power amplifiers. The control circuit components and power supplies, except for the main plate transformer, are housed in the other two cabinets.

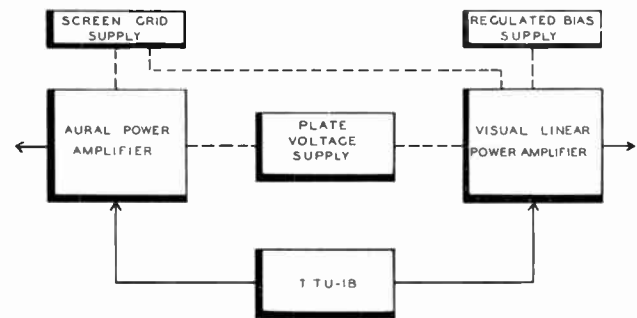

BLOCK DIAGRAM  
TTU-10A UHF TRANSMITTER

Three power supplies are used to operate the amplifiers. One is a regulated bias supply of a new type which provides the control grid bias for the visual amplifier. The second supply provides approximately 1000 volts for the screens, while the third is a single high-voltage supply which provides six kilovolts for both the visual and aural power amplifiers. The transformer for the plate supply is located external to the cabinets.

For a sketch of the transmitter and a proposed floor plan, the reader is referred to the rear of this section. Technical specifications are also listed.

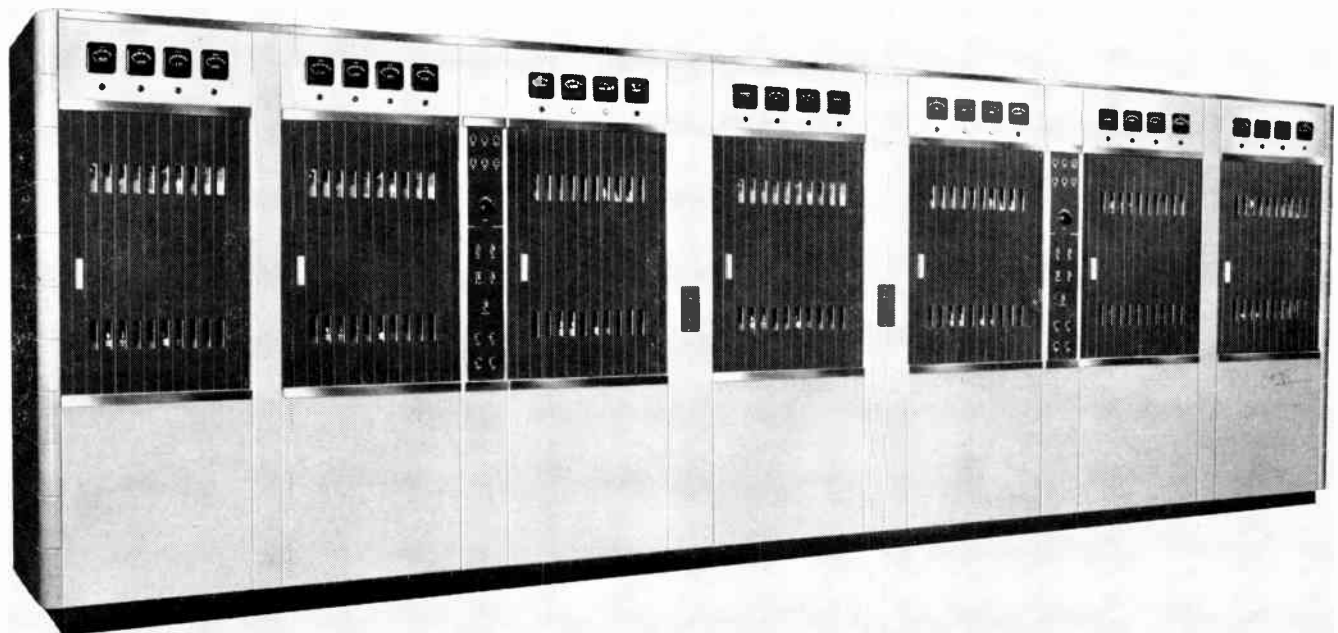



## TTC-1B TV TRANSMITTER CONTROL CONSOLE

The RCA TTC1B Universal Television Transmitter Control Console provides transmitter control and monitoring facilities for all current RCA TV transmitters except VHF transmitters of less than 10 kw output. These facilities are provided in a unit styled to match the AM and FM universal consoles which have been offered previously and can readily be combined with them to form a large and complex control and monitoring console for any combination of RCA AM, FM, and TV Transmitters. In addition, where desired, it may be combined with many items of RCA TV studio control and switching equipment for control of cameras, switching and such devices. However, its main purpose is TV *transmitter* control and monitoring; and other TV functions can often be better performed at a point separate from the transmitter console.

### Description

This console is divided into 3 major units, the left-hand or Power Control turret, the master monitor, and the

right-hand or Monitor Control turret. Each of these units is mounted in or on a standard universal console housing or desk section.

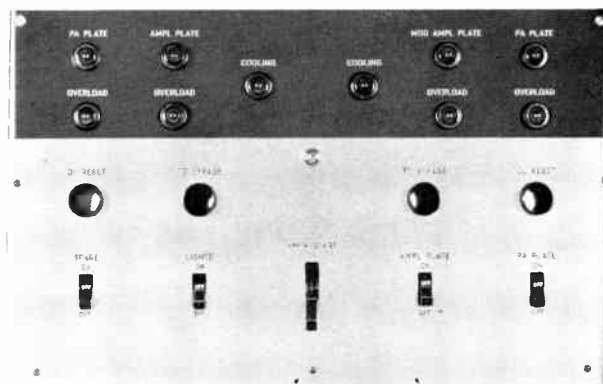

FIG. 2. The Power Control turret.

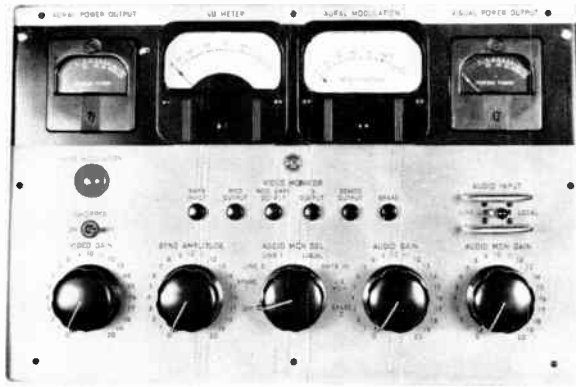

FIG. 3. The Monitor Control turret.

The Power Control turret contains switches, overload reset pushbuttons, and indicator lamps for transmitter supervisory control and operation. Although adapted especially to RCA transmitters these circuits could be used with almost any *contactor controlled* transmitter.

The TM-6B Master monitor which is mounted in a standard housing occupies the center of the console and receives its power from a power supply, mounted in an external rack, while its input signals come from the monitor control turret on the right.

The Monitor Control turret is designed to work in conjunction with RCA ES-19203 series of input and monitoring equipment racks and requires one set of these racks or equivalent components, for full use of its facilities. It includes four major circuit functions and other related ones.

1. Meter circuits
2. Audio monitor circuits
3. Video monitor circuits
4. Aural and visual input signal level indication and control

The four meters provide for continuous indication of visual power output, aural power output, aural transmitter input level, and aural percentage modulation. The power output functions are provided by meters which duplicate the reflectometer meters on the transmitter. The aural transmitter input level is indicated by a Weston type-30 VU meter with a suitable multiplier pad connected to the input line of the aural transmitter; and the aural modulation percentage is indicated by a meter which matches the VU meter but repeats the indication of the aural monitor in the racks. The meter provided is suited to the General Radio 1183T series of monitors.

In addition to the audio metering described above the aural monitor circuits provide means of switching the input of an audio monitoring amplifier and speaker to any

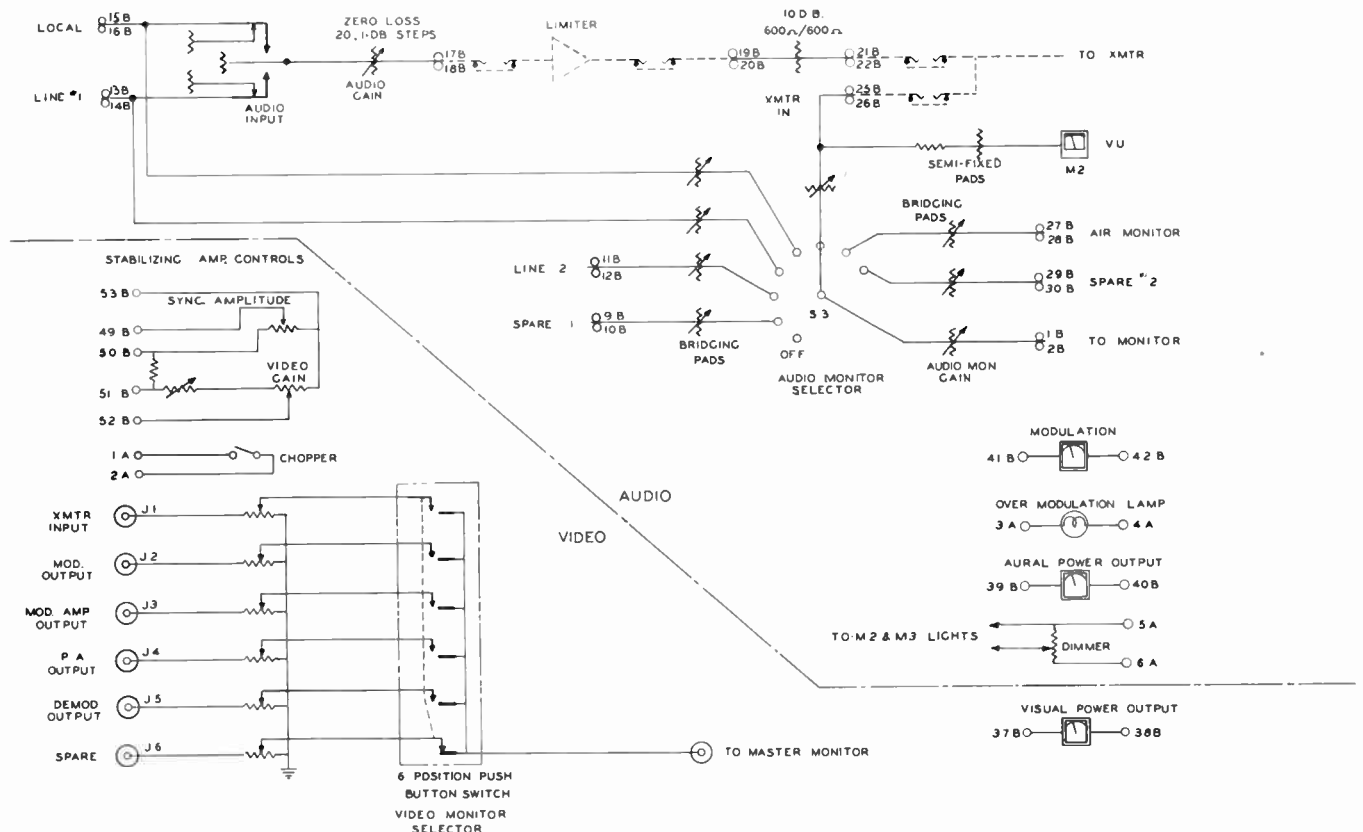

FIG. 4. Function diagram of the TTC-1B Monitor Control turret.

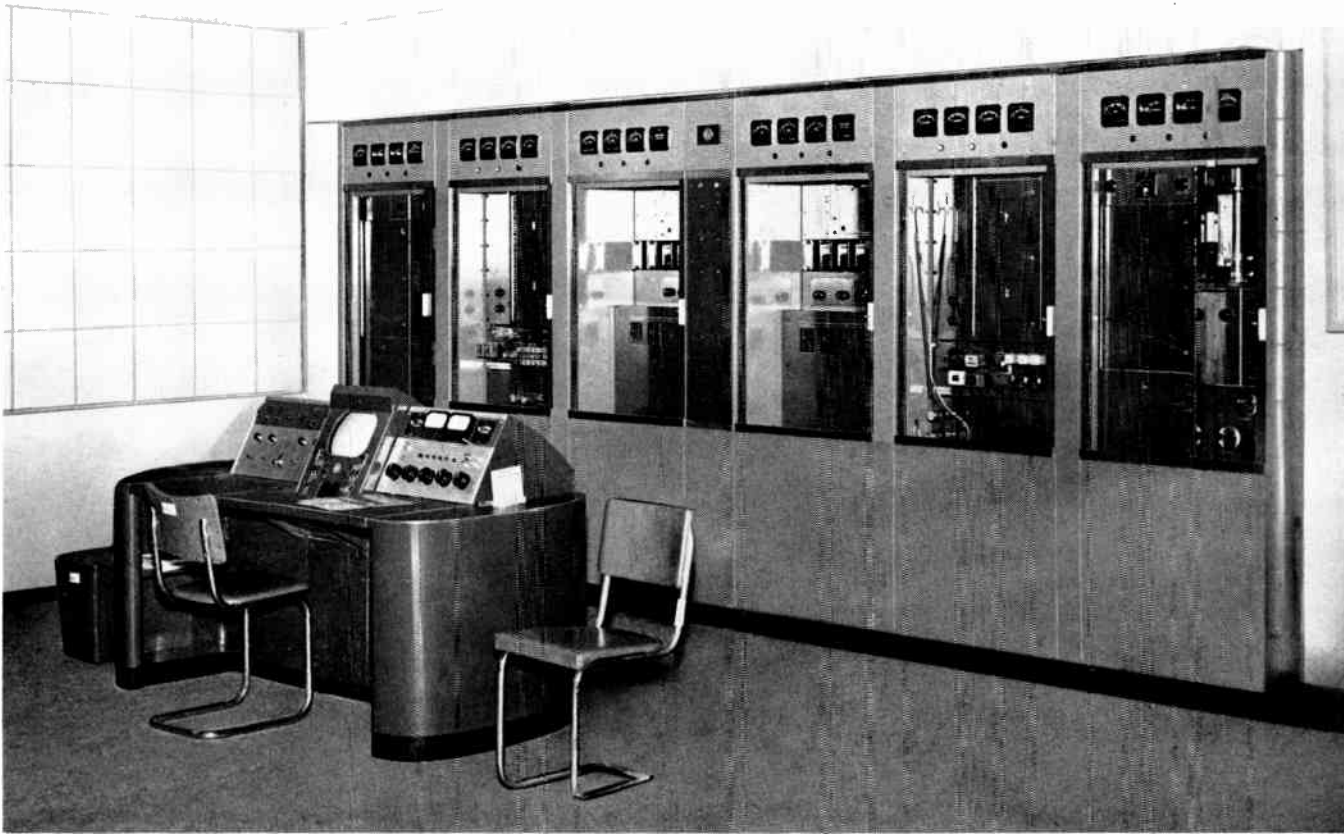

FIG. 5. Photo of typical transmitter installation showing the use of the TTC-1B Transmitter Control Console.

of seven points in the aural system from input line to off the air monitor. Two of these positions are spares which may be used for any desired auxiliary function.

The video monitoring circuits provide for switching the input to the master monitor to any of six positions in the visual transmitter system, one of these is a spare, and like the audio monitoring spares may be used as desired.

In order to make the above monitoring facilities more useful, an audio gain control with 20-one db steps is provided for connection ahead of the program amplifier (usually a limiting amplifier) so that the aural input to the transmitter can be controlled. Similarly gain and sync amplitude remote controls for a stabilizing amplifier (which is normally used ahead of the visual transmitter) are provided to control the input to the visual transmitter.

In addition to the above circuits a lamp in parallel with the overmodulation flasher of the aural monitor and a switch to control the chopper of the visual monitor are provided in the monitor control turret. Also the monitor is provided with a rheostat to dim the lights in the meters to suit the ambient light around the console to eliminate unnecessary operator annoyance and fatigue from meter lights which are brighter than necessary.

Fig. 5 shows a typical system in which a TTC-1B console is used with an RCA transmitter to provide convenient and flexible monitoring and control the transmitter. Note that extra monitoring and control facilities are provided so that one can start with a relatively low-powered transmitter and later increase power by adding R.F. amplifiers; the console will provide complete facilities for the larger transmitter.

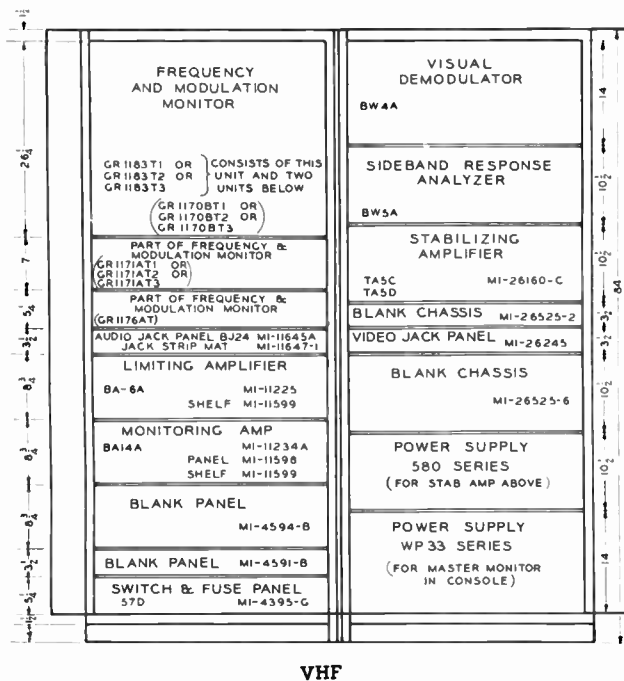

VHF

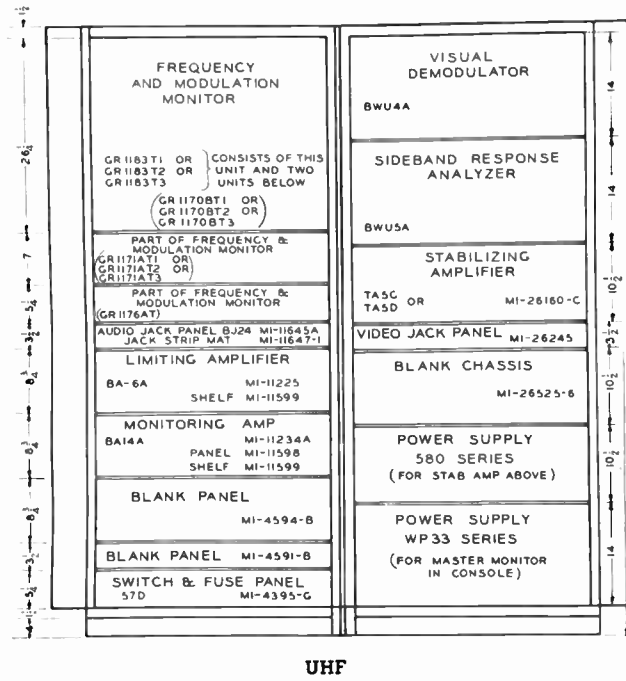

UHF

# TRANSMITTER INPUT AND MONITORING EQUIPMENT (ES-19203)

These equipments meet the requirements for monitoring and input control of any RCA television transmitter. They are intended to be used in conjunction with an RCA TTC-1B or TTC-2B Transmitter Console to provide full monitoring requirements, control of aural and visual input signals, and in addition include a sideband response analyzer.

The ES-19203 Series of monitoring equipment are supplied in 4 different arrangements.

- 1) ES-19203-A includes factory wired racks for VHF TV transmitters
- 2) ES-19203-B same as ES-19203-A except less wiring\*
- 3) ES-19203-C includes factory wired racks for UHF TV transmitters
- 4) ES-19203-D same as ES-19203-C except less wiring\*

The equipment included is shown in Fig. 1 and in the accompanying lists. The function of each item can be best learned from a study of the block diagrams Fig. 2 and Fig. 3 which show in one-line diagrams, the interconnections of all units to a typical TV transmitter system.

Each item supplied in these racks has been determined to be necessary to meet either the requirements of the FCC and the requirements of good operating practice. They are arranged in the racks in a manner which makes

\* Includes racks, all units, terminal boards and brackets included in wired racks, but does not include any wire.

them most effective and as compact as possible with due regard to convenience of operation, grouping of related units and easy connections.

When these monitoring equipment racks are used with a TTC-1B or TTC-2B console, these units provide everything required for routine TV station monitoring. The functions monitored are:

1. Visual Carrier Frequency.
2. Aural Carrier Frequency.
3. Aural Modulation. (This meter is on GR1183T and is repeated on the TTC-1B console).
4. Visual Modulation (CRO on Console).
5. Aural Signals at all points where aural signals are available. Level of Transmitter input signal by VU meter; and sound quality by means of the monitoring amplifier and an external loudspeaker.
6. Visual Signals at all points where visual signals are available. Levels are measured by the CRO in the master monitor of the console and picture quality is observed on the kinescope.

Video and audio jack panels are provided and so arranged that equipment elements in the system are separated from each other by a pair of jacks. All power, video, audio, and R.F. connections to individual units are by means of easily separated plug and socket connectors, thus facilitating routine inspection and maintenance. Special connections for testing each of the units in the rack or in the transmitter may be readily set up by means of the jack panels.

In addition to the monitoring functions listed above, the racks provide:



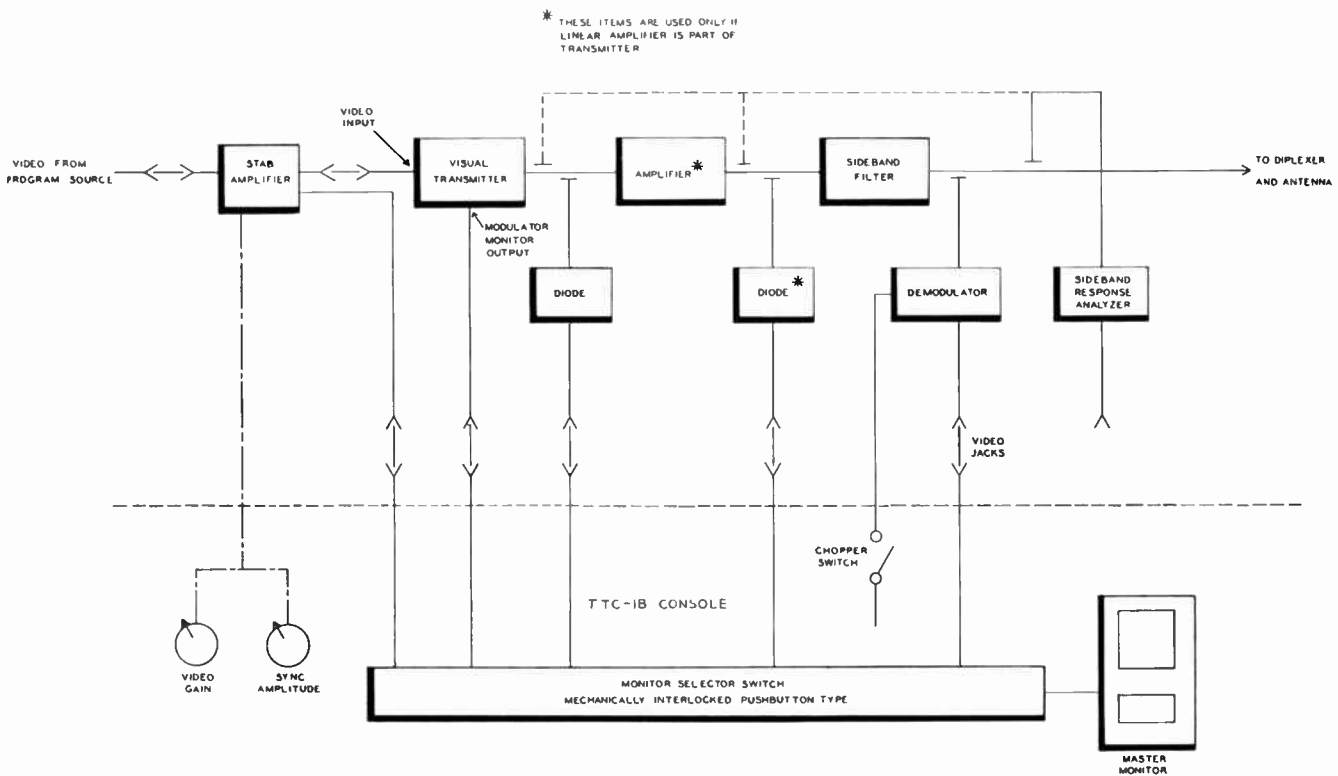

FIG. 2. Line diagram of the video input control and monitoring functions described in this article.

- a) Limiting amplifier BA-6A for the aural signal before application to the transmitter.
- b) Stabilizing amplifier for the visual signal to the transmitter.
- c) Sideband response analyzer, BW-5A. This unit provides a special video sweep and a synchronized selective receiver for adjusting transmitter broadband response.

The output of the sideband analyzer is fed through a cable to an external oscilloscope of standard design which may be located anywhere in the transmitter room. The resultant pattern on the "CRO" is a plot in which the horizontal dimensions are related to modulating frequency, and the vertical dimensions are proportional to the sideband response of the transmitter at each modulation frequency.

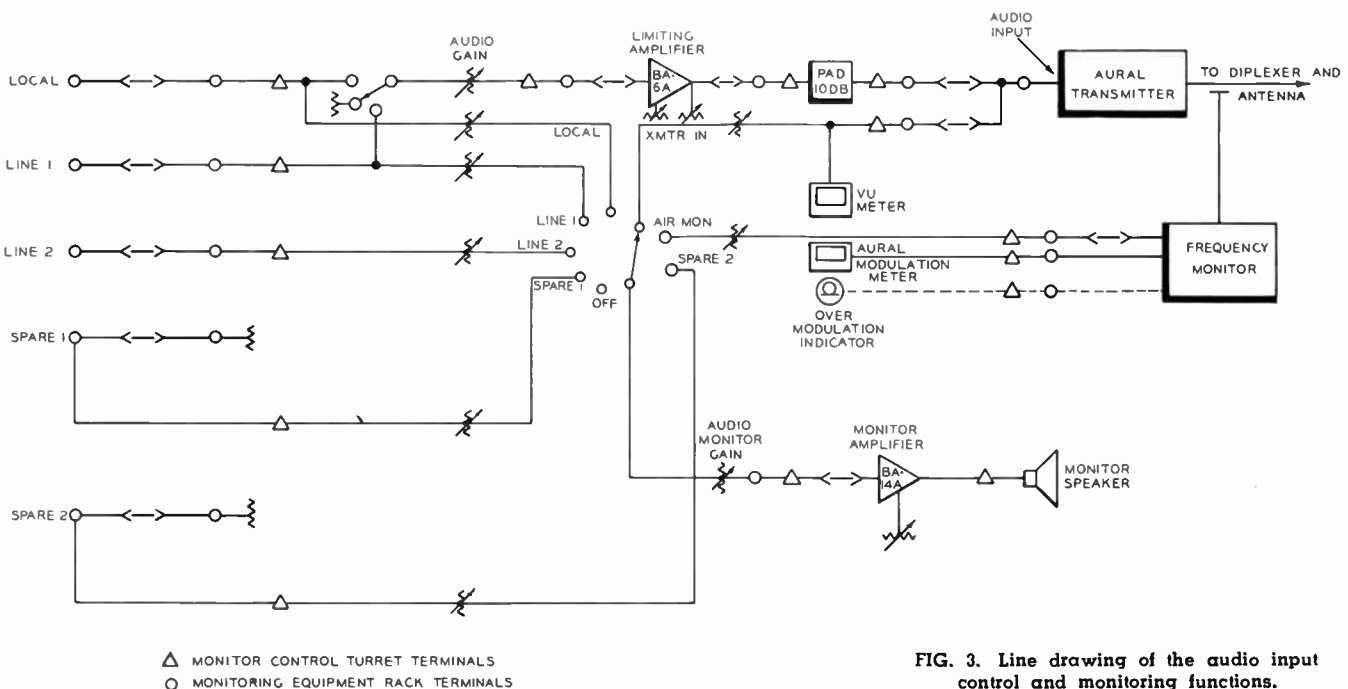

FIG. 3. Line drawing of the audio input control and monitoring functions.

# THE RCA BW-5A TELEVISION SIDEBAND RESPONSE ANALYZER

## Introduction

Accurate information on the RF bandwidth of his transmitter is important to any broadcaster who wishes to deliver a higher quality picture to his television viewers. Improvements being made in picture quality at the studio and from film projectors are daily adding to the importance of this question. The television audience should enjoy the full benefit of these improvements.

Broadcasters realize that every bit of information picked up by the camera and delivered in the form of video signal is combined with blanking and synchronizing signals to form the composite video signal. This composite signal is then used to modulate the picture carrier which is then radiated together with the resultant sideband frequencies which are informative of the picture being transmitted. While most commercial television transmitters which meet with RTMA Standards are capable of transmitting high quality pictures, one of the principal operational problems is to provide means for optimum tuning adjustment of the transmitter so that none of the picture information sidebands will become lost or degraded.

While this is important for monochrome television operation it will become still more important if the NTSC Color Standards are adopted. The amplitude versus frequency response of the transmitters will then have to be maintained to closer standards of accuracy to insure that the Color Subcarrier will not become degraded.

The UHF band also offers special problems brought about by the higher frequencies and greater number of channels which

commercial transmitter equipment must now be capable of handling.

The solution was to devise a simple method of accurately measuring and displaying the amplitude versus frequency response of the transmitter circuits while simultaneously observing the effect of the tuning adjustments. The BW-5A Television Sideband Response Analyzer shown in Fig. 1 is the practical new tool which now enables the broadcaster to see the sidebands as he tunes his transmitter. In this way he is assured that his public is receiving all the information that is required for a high quality picture, that his transmitter has optimum tuning and is operating at peak efficiency.

The BW-5A Sideband Analyzer accomplishes this by the special arrangement of a highly selective receiver which remains continuously tuned to the sidebands as they are generated by a video sweep generator. The output of this receiver then furnishes the signal for the continuous display of the transmitter's overall frequency response characteristic on a cathode ray oscilloscope (CRO). This will be discussed in greater detail as we progress further with the article.

Fig. 2 presents a brief review of the frequency response to be expected throughout a television transmitter. Curve A is the ideal response for the video input signal. Curve B is the response of the video modu-

FIG. 1. Front view of the BW-5A.



(A) INPUT OF TRANSMITTER

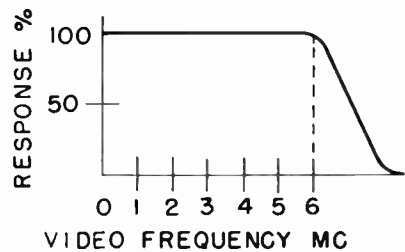

(B) OUTPUT OF MODULATOR

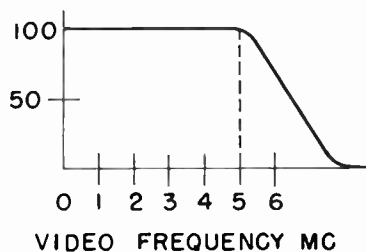

(C) RF OUTPUT OF TRANSMITTER

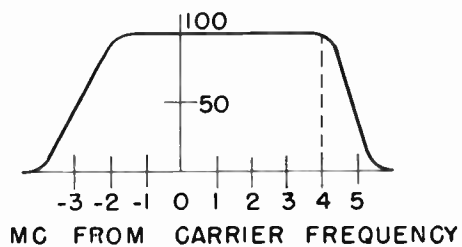

(D) OUTPUT OF VSBF

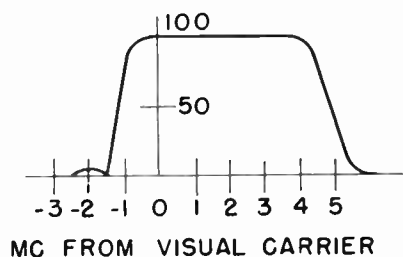

FIG. 2. Typical television frequency response curves.

lator. Curve C is a typical overall response of transmitter RF circuits before the sideband filter, while Curve D is the overall response showing the lower sideband sharply cut off by the vestigial sideband filter. While the last curve shows the desired overall response, Curve C is probably the one more often seen during transmitter tune-up, particularly when one or more stages of linear RF amplifiers are employed. Note that the lower sideband is only partially attenuated. To cut this off too sharply would result in distortion of the overall response. To pass too much of the lower sideband would lower the transmitter efficiency. It can be seen therefore that an instrument which accurately and quickly shows both the upper and lower sideband response is of great value to the transmitter operator in obtaining and maintaining the proper transmitter tuning adjustments.

At this point it would be well to examine briefly other methods which have previously been used in an attempt to obtain the desired information.

#### Video Sweep and Diode Method

One method of measuring the overall frequency response of a television trans-

mitter is shown by the block diagram in Fig. 3. Here, a video sweep generator is connected to the video input terminals of a television transmitter and a diode is coupled to the output transmission line. The output of the diode is rectified and fed to a CRO. Since the diode is a broadband detector it will average both upper and lower sidebands yielding a typical CRO presentation as shown in Fig. 4. Here the diode has been connected to the output of the sideband filter and it will be noted that both the upper and lower sidebands in the immediate neighborhood of the carrier add up. This method has been satisfactory where a pre-tuned sideband filter is available and where only one RF stage is used. The chief disadvantage is that it does not separate upper and lower sideband response. Fig. 5 further shows the limitation of the frequency response obtained with a diode. Here, the lower sideband is only partially cut off and it is obviously difficult to evaluate the effect of tuning adjustments on these circuits without being able to observe separately the effect on upper and lower sidebands.

#### RF Sweep Method

Fig. 6 shows the block diagram of another method commonly used in attempting to adjust the RF circuits of television

FIG. 3. Block diagram of diode method.

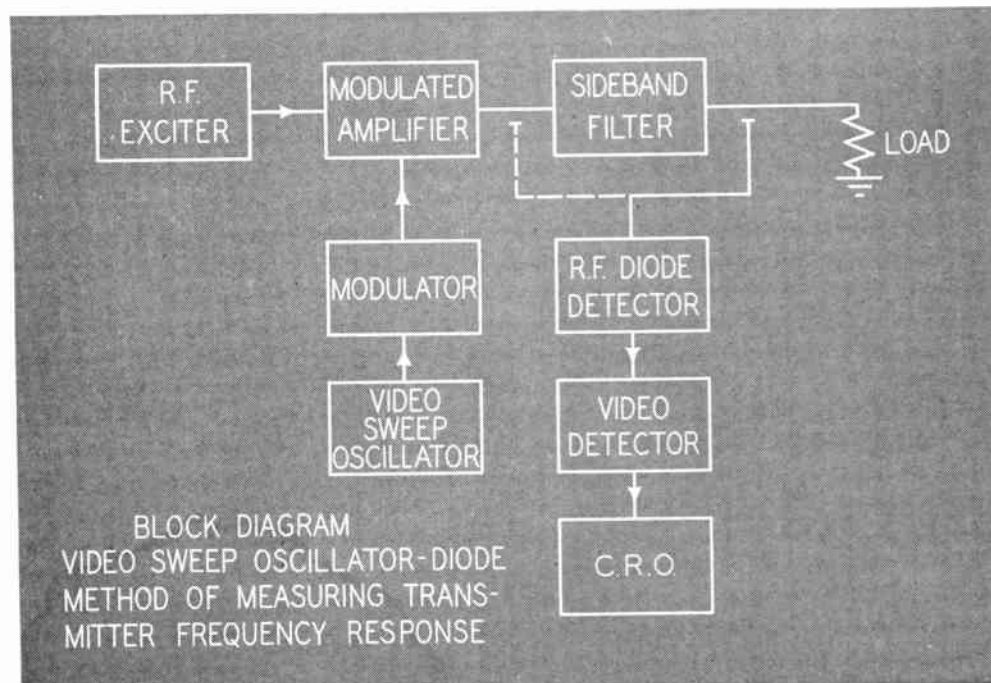

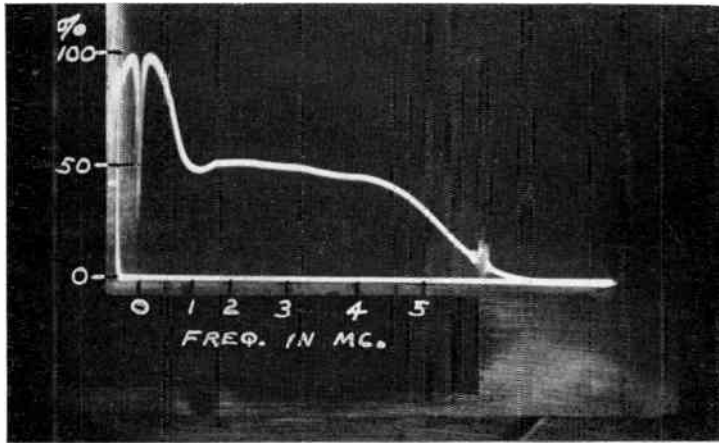

FIG. 4. Amplitude vs. Video Frequency after sideband filter using video sweep and diode method.

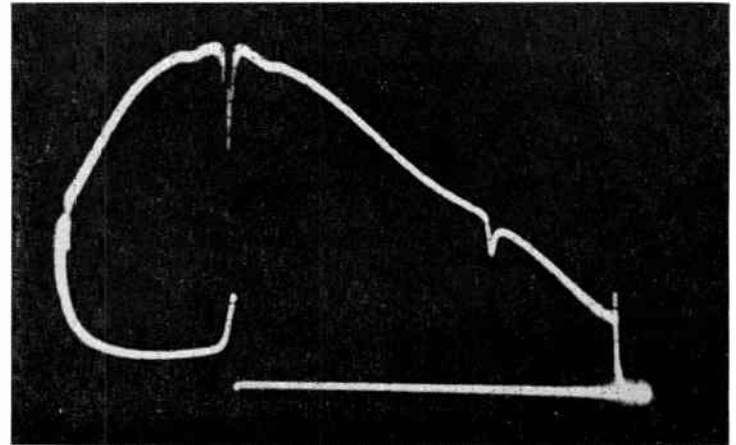

FIG. 5. Another response obtained by the diode method when the lower sideband is partially cut off.

transmitters. In this method, an RF sweep oscillator is coupled to the input of the circuit to be tested and a diode detector is coupled to the output as shown. The rectified output of the diode is then connected to an oscilloscope to obtain a visual indication of the response. There are several disadvantages to this method:

A. Extreme care must be taken in coupling the sweep oscillator and diode to the circuit under test in order to minimize

errors introduced by the method of coupling.

B. Video resonances in the plate, grid, and cathode return leads will not show up since there is no video component in the currents produced when an RF sweep is used. Note: An actual example of cathode lead resonance is shown in Fig. 7 as displayed by the BW-5A Analyzer. This is shown both before and after damping was applied to the cathode lead.

C. When the circuit is excited by an RF sweep oscillator the dynamic voltages are often at a much lower level than when the transmitter is in actual operation. Unless suitable compensating measures are taken the frequency response of the circuit may actually be different during operation due to changes in tube loading, etc. This is particularly true if the driven load on the circuit is the input of a linear amplifier where the amount of grid current determines the amount of loading.

D. The response indicated by the RF sweep method will not include the modulator response. A separate video sweep oscillator must then be used to check and adjust the modulator.

E. Any errors (such as would be caused by improper neutralization) introduced by the modulated amplifier itself would not show up by this method. Note: An actual example of this condition as displayed by the BW-5A Analyzer is seen in Fig. 8. Here, the inequality of the upper and lower sidebands in the immediate neighborhood of the carrier indicates improper neutralization. A second curve shows the condition obtained with proper neutralization.

F. The UHF channels have introduced other special problems. It is a relatively

FIG. 6. Block diagram of RF sweep method.

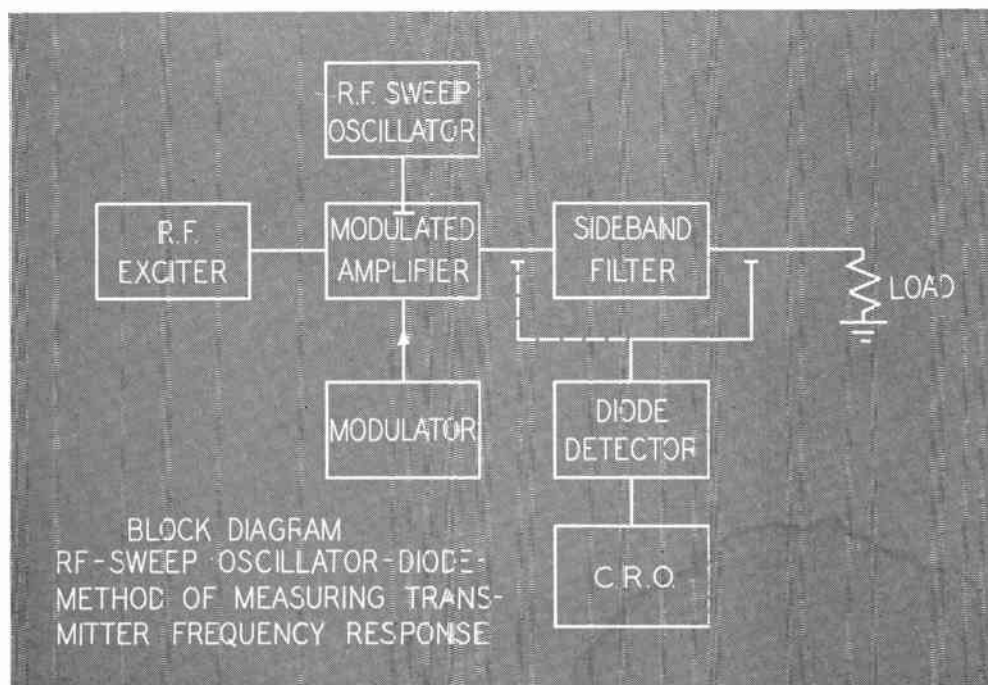

difficult matter to design an RF sweep oscillator which will have sufficient output with flat enough frequency response for the large number of new channels. Accurate markers also present a problem because ultra-high frequencies are involved.

#### Advantages of the BW-5A Sideband Analyzer Method

The BW-5A Sideband Analyzer has none of the disadvantages outlined in the two methods described and has several features which are found in neither. These are worthy of special notice:

A. No internal changes are required to be made in the transmitter while measurements are being made. The transmitter is operating under normal conditions of power output, drive, etc., while adjustments are being made.

B. For input signal the video sweep output may be plugged into the modulator at the jack panel. Only a small amount of RF output signal is necessary to feed to the Sideband Analyzer.

C. Practically all of the more critical circuits in the BW-5A such as the sweep oscillator, video amplifier, and marker are independent of the transmitter carrier frequency. These are accurately adjusted at the factory before shipment.

D. While the frequency of the narrow band detector must be changed in accordance with the picture carrier frequency assignment this adjustment is no more difficult than tuning an ordinary broadcast receiver. Also, it is not critical since any detuning will affect the amplitude but not the shape of the response curve.

E. The design of this equipment necessarily includes a video sweep oscillator which is therefore available for aligning the modulator and other video amplifiers normally associated with the television transmitter.

F. If there are any harmonics present in the output of the transmitter they will not affect the shape of the response curve. This is because any beats with harmonics produced in the mixer will not be of the proper frequency for acceptance by the narrow band detector.

#### Theory of Operation

One method of obtaining a check on a transmitter's performance with regard to upper and lower sidebands is to use a very fundamental point by point method. For example, a 61.25 Mc picture carrier fre-

FIG. 7. Cathode lead resonance shown by BW-5A before and after damping.

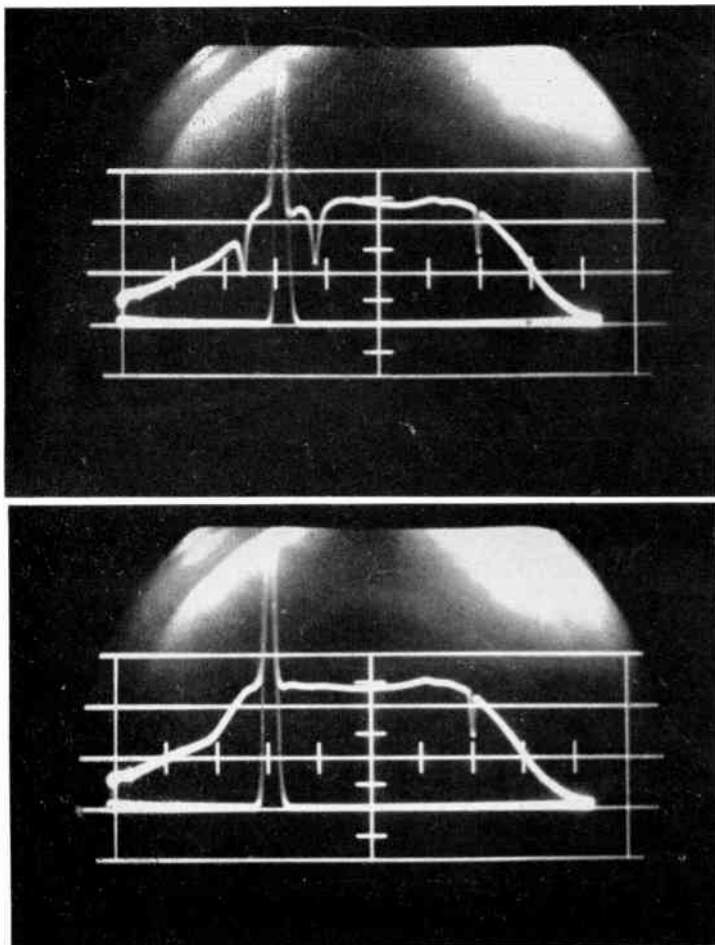
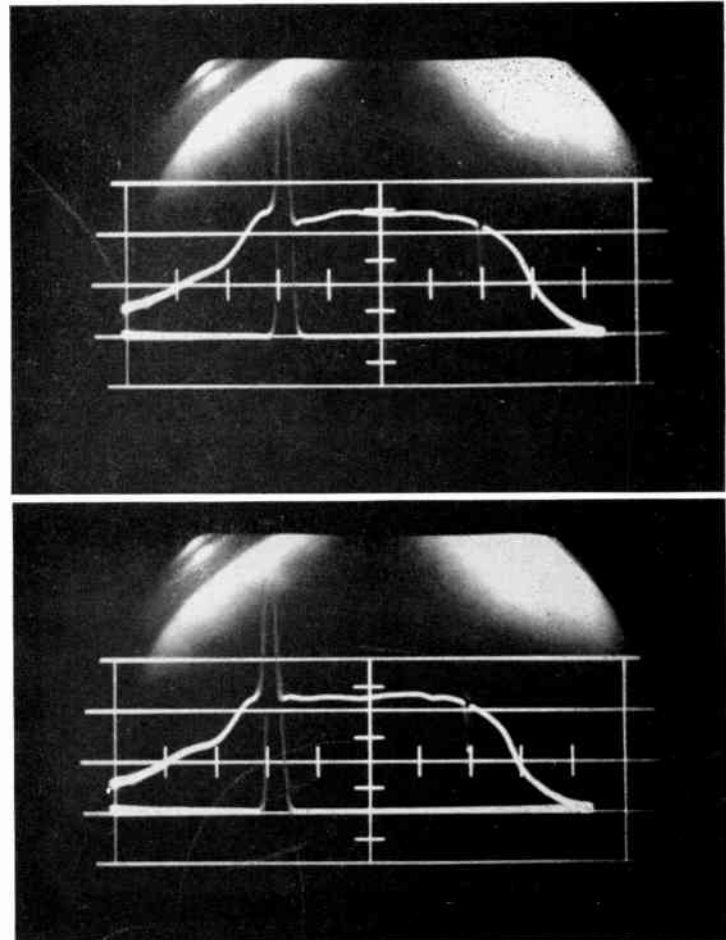
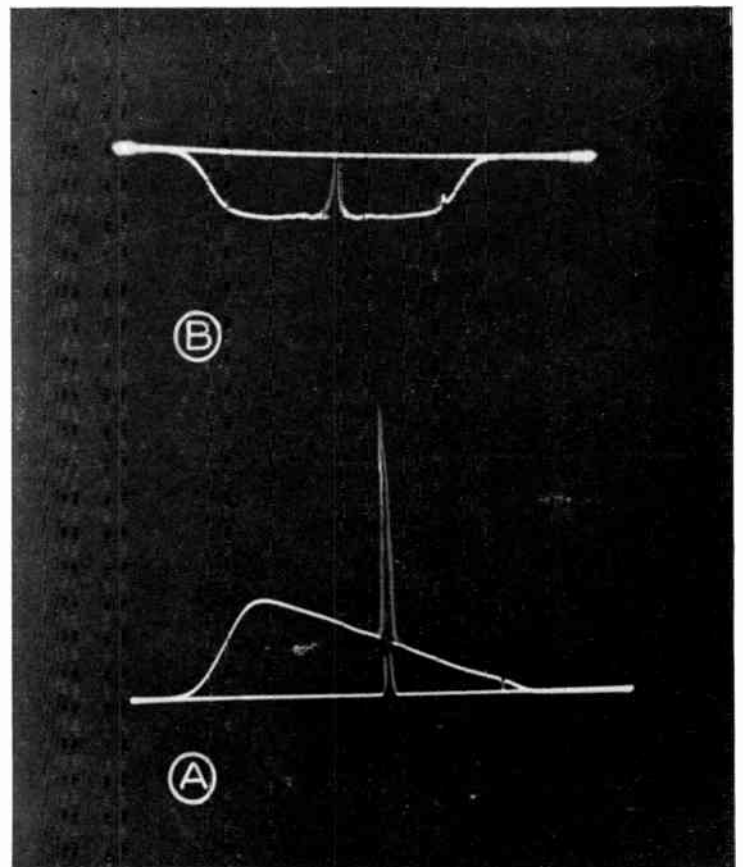
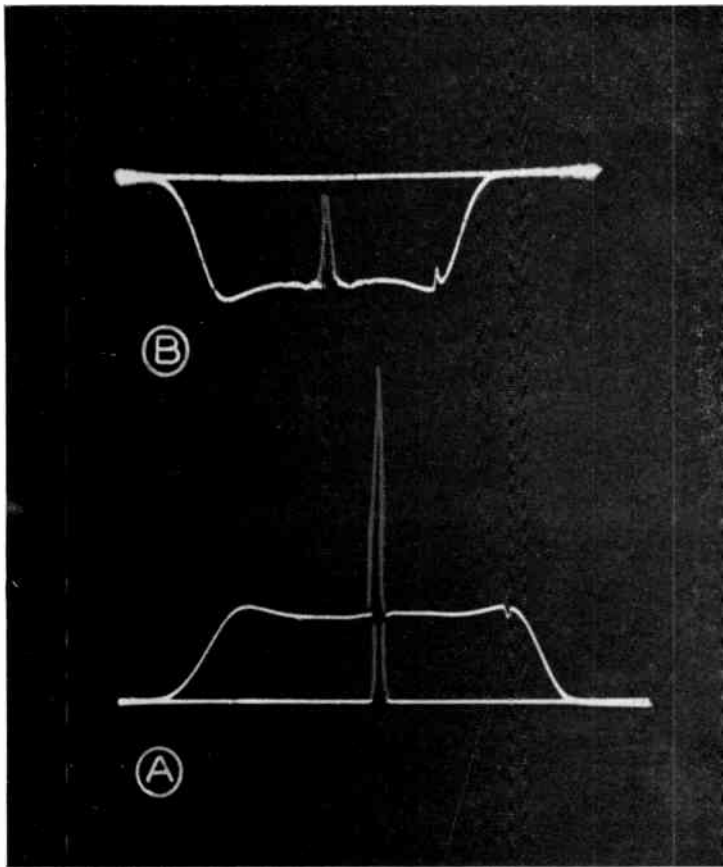

FIG. 8. Upper and lower sideband inequality shown before and after proper neutralization using the BW-5A.





FIGS. 9 & 10. Sideband analyses of small laboratory TV transmitter compared with diode response.

9A. Sideband response—transmitter properly tuned.  
9B. Diode response—transmitter properly tuned.

10A. Sideband response—transmitter improperly tuned.  
10B. Diode response—transmitter improperly tuned.

quency may be modulated with a sine wave of 2 MC to create sideband frequencies of 63.25 and 59.25 MC. A selective receiver can readily be tuned to these frequencies which are present in the output of the transmitter. If the receiver has sufficient linear response and is equipped with an output indicator we may measure the relative amplitudes of these sideband frequencies by comparing them with the carrier used as 100% reference. After recording these values the modulating frequency may be changed to 3, 4 or 5 MC, or 1000, 500, 200 or 100 KC. Upon retuning the receiver corresponding sideband amplitudes may again be measured and recorded. Provided that the percentage of modulation has been maintained constant during the test run a curve may then be plotted using the recorded data which will indicate the amplitude of the sidebands with respect to each other and the carrier.

If a truly smooth and representative curve is desired the points must be plotted closer together so as to search out any irregularities which may show up between the very few modulating frequencies suggested above. Moreover if the amplitudes of the sideband frequencies are not satisfactory and an adjustment of the transmitter is required, such as a change in the output tuning, then the curve must be re-plotted for each adjustment until a satisfactory response curve is obtained. Following this procedure would be tedious and so time consuming as to make it impractical for regular daily performance checks.

Now suppose a very large number of points could be measured in sufficiently rapid succession to permit display of the response curve on an oscilloscope. The BW-5A TV Sideband Response Analyzer does this, and yields the following results.

### Performance and Results

The usefulness of the BW-5A Sideband Analyzer will be better appreciated by referring to Fig. 9A. This is the sideband analysis of a small laboratory type TV transmitter with double sideband output as displayed by the BW-5A. The symmetry of both upper and lower sidebands indicates that the output stage has been prop-

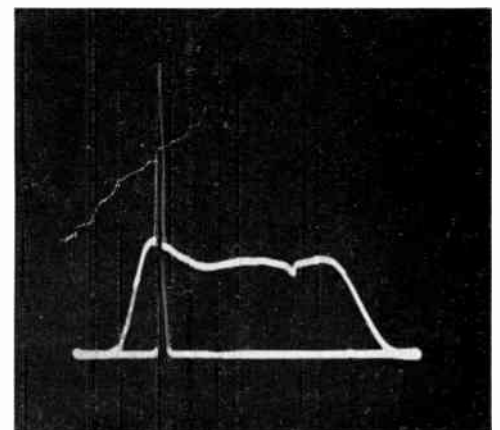

FIG. 11. Sideband analysis of a typical station signal sampled after sideband filter.

erly aligned, the tall spike in the center of the pattern represents the transmitter carrier while the marker pip appearing in the upper sideband indicates satisfactory response out to 5.5 MC above the carrier. The marker position is controllable and can be moved into the lower sideband region as required. Fig. 9B shows the diode detector response for the same condition of transmitter alignment (this happens to be in a negative direction). Fig. 10A shows the same laboratory transmitter with its output stage deliberately misaligned to favor the lower sideband. Under the same tuning conditions the diode response, Fig. 10B, would seem to give evidence of satisfactory performance even though the transmitter is misaligned. This is due to the fact that the diode detector averages both upper and low sidebands in the detection process as has been mentioned before.

Fig. 11 indicates a typical sideband analysis of a Channel 4 station recently obtained. The sampling was obtained from the transmission line after the vestigial sideband filter. An excellent job of lopping off the lower sideband is apparently accomplished by the filter and the marker is at 4 MC indicating essential flatness even beyond this point.

Several curves taken from a 20 KW transmitter in our Camden plant are shown in Figs. 12 A, B, and C and illustrate the

use of this equipment in aligning multi-stage transmitters. The overall sideband analysis shown in Fig. 12C indicates flat response to 4 MC. Fig. 12D indicates the effect of too-tightly coupled RF circuits and shows the typical dip in the frequency response when this condition exists. With this type of display it is a relatively simple matter to re-adjust the circuits for a flat response.

#### How the BW-5A Sideband Response Analyzer Works

The operation of the BW-5A Sideband Analyzer is basically very similar to the point-by-point procedure outlined above. As before, a selective receiver is required to tune in the particular sideband frequency. But the BW-5A provides means to do this automatically as the sideband is generated. The resulting output is displayed on an oscilloscope. Referring to Fig. 13 the block diagram shows a receiver having an IF of 10.7 MC and an input tuning range of approximately 40 to 85 MC.

If the case of a transmitter operating on Channel 10 is followed through, the operation of the Analyzer will become clear. The heart of the new instrument is the FM Sweep Oscillator in the center of the Fig. 13 diagram. If at one instant the sweep oscillator frequency is 130 MC, the same as the frequency of the fixed oscillator, then the output frequency of the RF mixer will

be 0. The output frequency of the TV transmitter will simply be the carrier at 193.25 MC. This carrier mixed with 130 MC from the FM oscillator in the RF converter will yield the difference frequency of 63.25 MC to which the receiver is tuned. If, at the next instant the FM oscillator is on 132 MC, then mixing with 130 MC the difference frequency of 2 MC appears in the output of the RF mixer. When this is applied through the video amplifier to modulate the transmitter its output then consists of 193.25 MC with sidebands of 191.25 and 195.25 MC. These frequencies mixing with the 132 MC in the RF converter will yield the difference frequencies of 59.25, 61.25 and 63.25 MC. These represent the lower sideband, carrier and upper sideband respectively. Since the receiver is tuned to 63.25 MC, it will therefore detect the upper sideband and give information on its amplitude. Because the receiver is highly selective other frequencies appearing at the output of the converter will be rejected. Similarly if the FM oscillator frequency is 129 MC at a later instant the output from the transmitter will be 192.25, 193.25 and 194.25 MC. The corresponding output of the converter will be 63.25, 64.25 and 65.25 MC. The receiver being tuned to 63.25 MC will therefore detect the lower sideband and give information on its amplitude. It will

FIG. 12A. Response of driver incorrectly aligned for double sideband response.

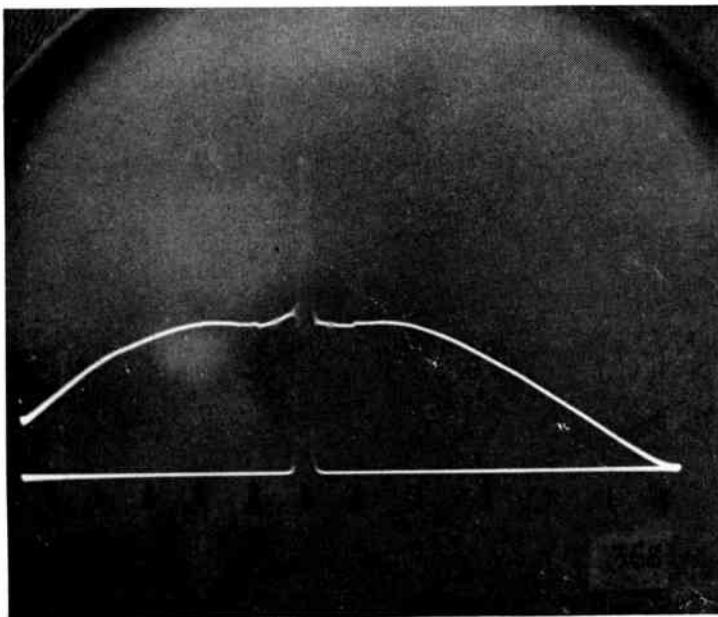
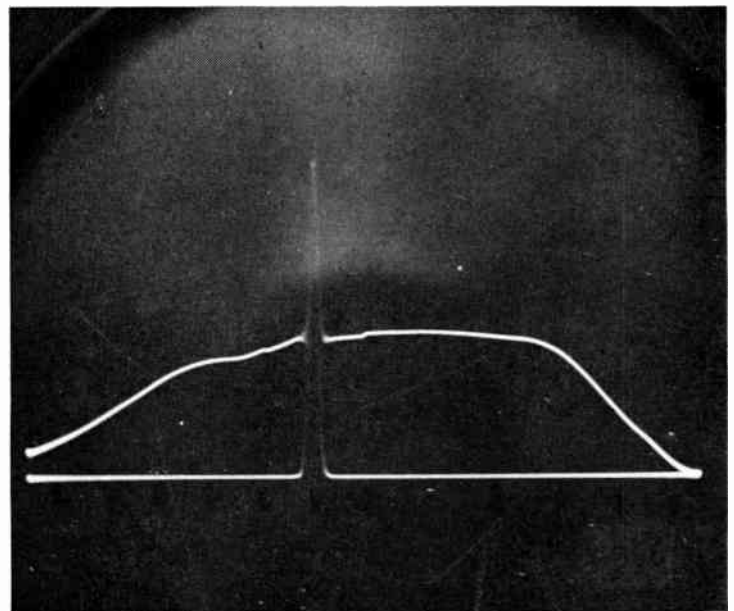

FIG. 12B. Response of driver correctly aligned with carrier offset.



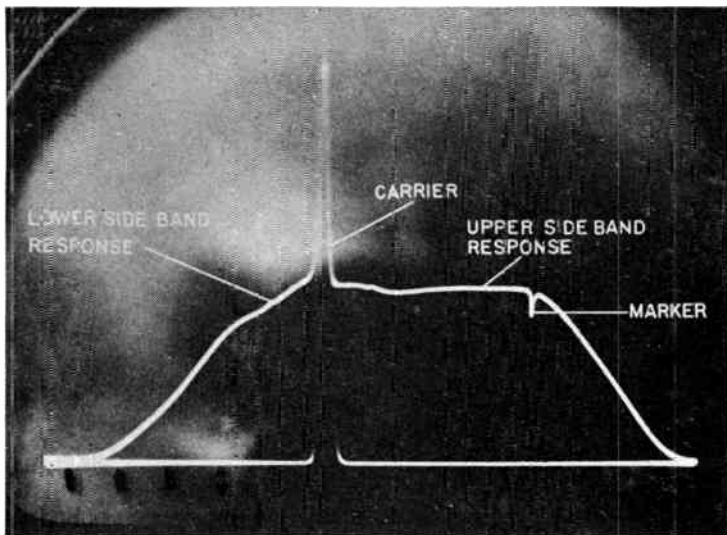

FIG. 12C. Overall response of 20 KW transmitter including amplifier but less sideband filter.

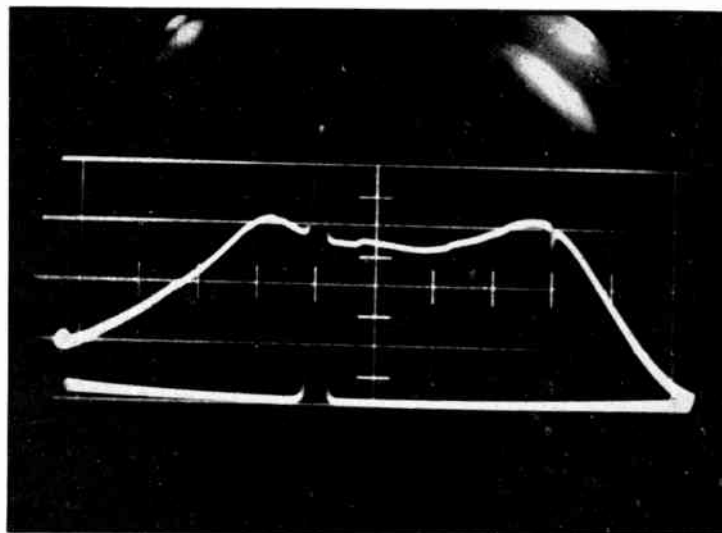

FIG. 12D. Overcoupled RF circuits.

therefore be seen that as the frequency modulated oscillator swings through the range of 123 to 137 MC continuous information on both upper and lower sidebands generated by the transmitter will be displayed on the face of an oscilloscope. The blanking circuit provides an optional zero output base line during the retrace time.

By studying Fig. 13 more closely it can readily be seen that by obtaining an appropriate sample of RF, sideband analyses can readily be obtained at various points:

- A. 5 KW Driver Transmitter Output
- B. 20 KW Linear Amplifier Output
- C. Vestigial Sideband Filter Output
- D. Antenna Feed Line

Point B is a particularly valuable spot for using the Sideband Analyzer since its use is practically essential in aligning the linear amplifier with ease and rapidity.

In many cases suitable RF pickup loops are already installed in Broadcast Stations such as those used to feed demodulators. Simple loop or capacity coupling may be used but directional couplers will yield more consistent results, especially if reflected waves are present during initial tune-up.

FIG. 13. Block diagram of BW-5A sideband analyzer.

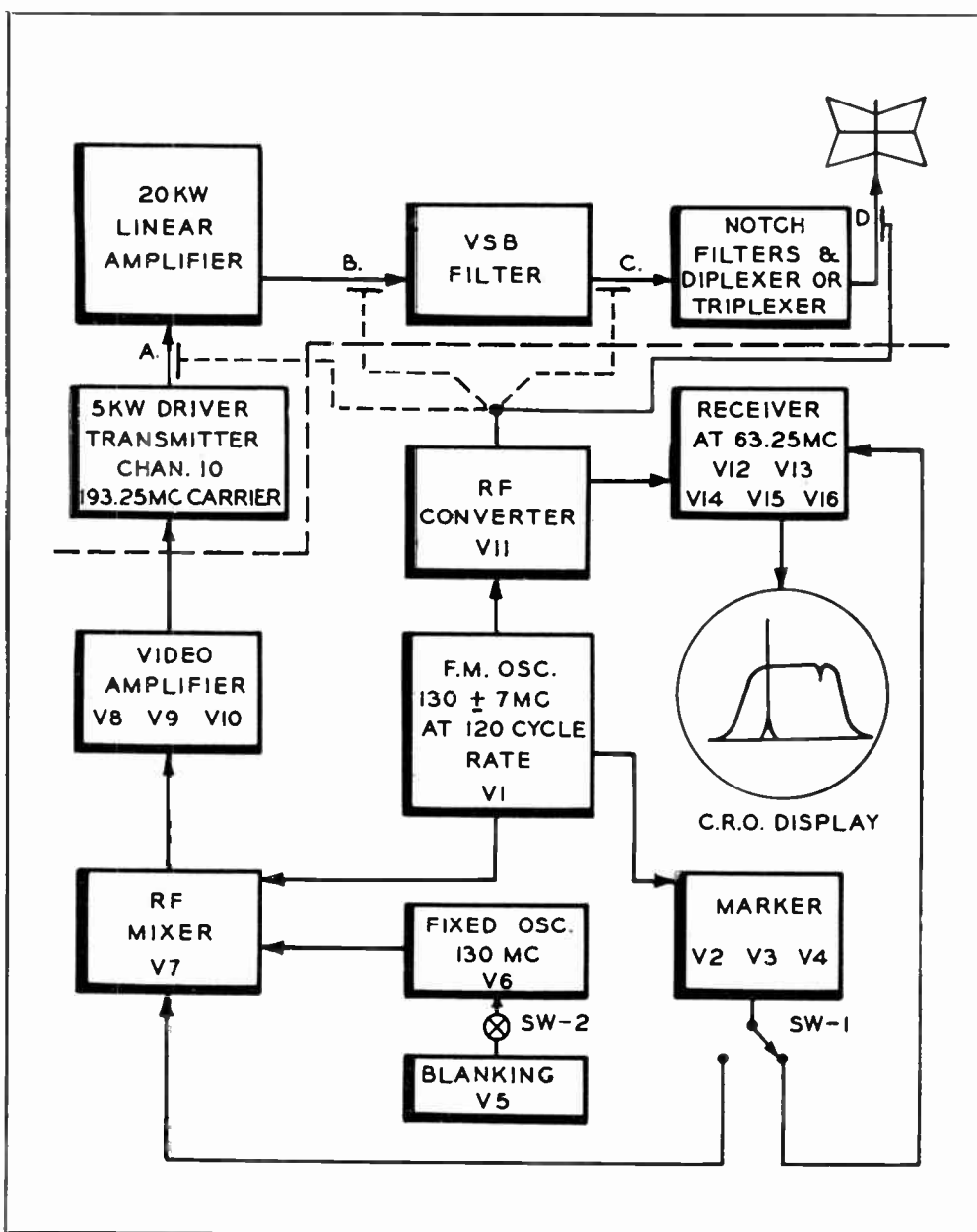



Preliminary results obtained from tests both in Camden and in the field indicate that a great deal will be learned with regard to television system performance when the sideband analyzers come into more common use. It is easy to see, for example, that best results can not be expected from a monitoring demodulator if the transmitter is not putting out the necessary sideband information. Moreover, a diode detector placed between the transmitter and the vestigial sideband filter may not indicate the true quality of the picture radiated because the diode can not differentiate the upper and lower sideband response. The Sideband Analyzer provides a reference with which visual monitoring equipment can be compared.

### Physical Description

By studying Fig. 1 again and looking at Fig. 14, familiar with the performance features of the Sideband Analyzer will be gained and the simplicity of the instrument will be appreciated. An RF sample from an appropriate point in the transmitter system is brought to a coaxial chassis connector in the rear of the chassis. Another coaxial chassis connector in the rear supplies the video to modulate the transmitter. The female plug on the panel supplies both vertical signal and horizontal sweep voltage to the oscilloscope to be used.

The top right-hand knob on Fig. 1 is the video sweep output control. This con-

trol in conjunction with the meter above it governs the amount of video sweep signal modulating the transmitter under test. The detector peak control serves as a vernier tuning control for the selective receiver in the analyzer. The detector gain knob controls the amount of output fed to the oscilloscope by the receiver. The marker knob controls the frequency of the marker pip seen in the sideband analysis pictures. The frequency of the marker is indicated on the dial above the control. Dial markings are in megacycles and confusion is avoided by having only one marker to indicate whether this is above or below the carrier frequency. The scope phasing knob is useful when the instrument is used without blanking so that the "go" and "return" traces may be superimposed. The sweep position knob controls the center frequency of the FM oscillator which produces a change in position of the carrier on the oscilloscope.

FIG. 14. View with door open and cover removed.

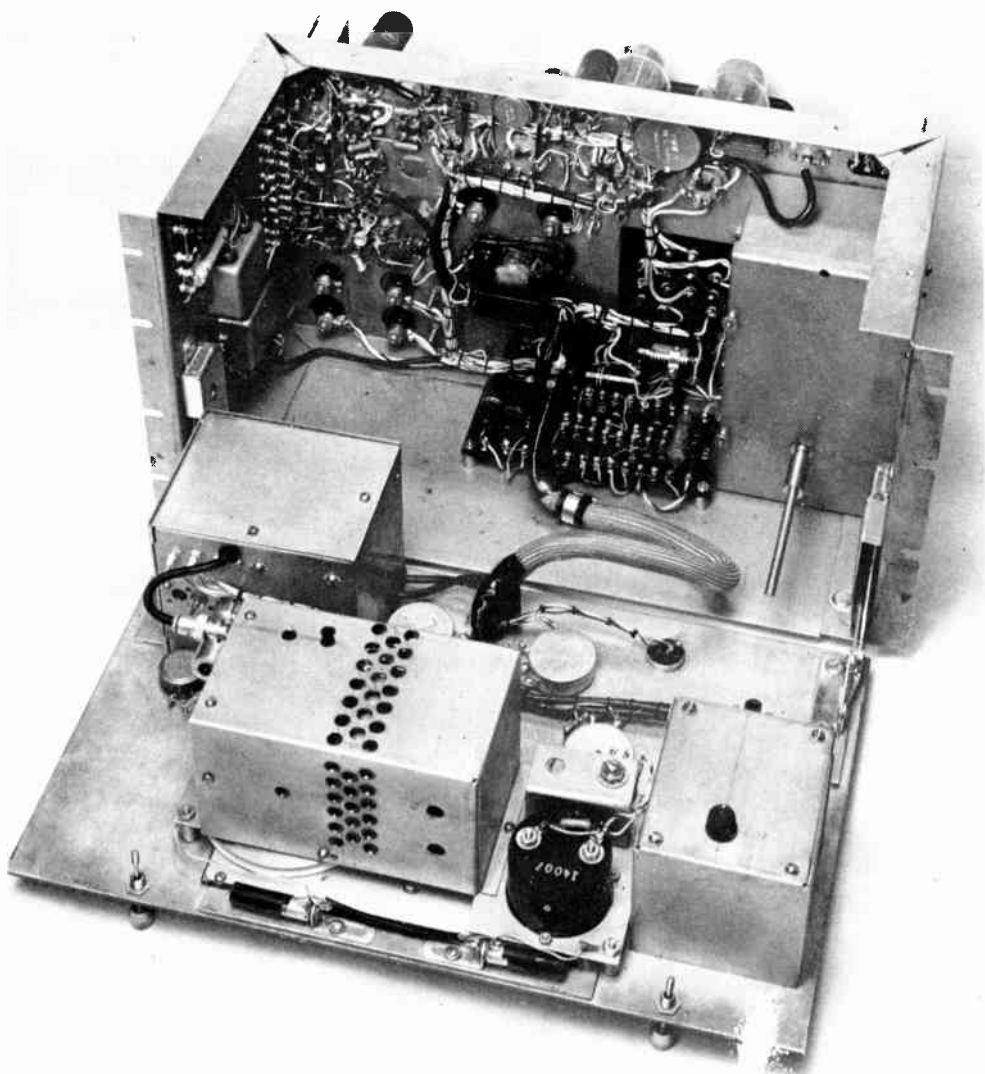

Fig. 14 shows the sub-assembly method of constructing the analyzer. The box located near the left hand edge of the front panel near the hinge houses the FM oscillator. The perforated box next to it houses the marker circuits. The box near the right hand edge of the front panel contains the RF converter. The box in the bathtub chassis shields the receiver.

The new instrument makes use of a relay rack mounting bathtub type chassis. This type chassis has been a favorite in the past for broadcast monitoring equipment. The front panel swings out on hinges to permit ready access to circuit components, while tubes are accessible from the rear. Ten and one-half inches of panel space are required for mounting and the depth is 14½ inches. The color is dark umber gray in keeping with our transmitter apparatus.

Type BWU-5A Sideband Analyzer is the companion unit for the UHF channels.

# **SPECIFICATIONS**

# TT-2AL/AH VHF Transmitter-2KW

## SPECIFICATIONS

### Electrical:

	<i>Aural</i>	<i>Visual</i>
Type of Emission.....	F3	A5
Frequency Range:		
TT-2AL .....	Channels 2-6	Channels 2-6
TT-2AH .....	Channels 7-13	Channels 7-13
Power Output (from sideband filter):		
TT-2AL .....	1.0 kw	2.0 kw peak
TT-2AH .....	1.0 kw	2.0 kw peak
R-f Output Impedance .....	51.5 ohms	51.5 ohms
R-f Output Connection .....	1 5/8" line	1 5/8" line
Carrier Frequency Stability.....	±4000 cycles	±1000 cycles
Modulation Capability .....	±40 kc	90%
Method of Modulation.....	Reactance tube	Grid amplitude
Input Impedance .....	150/600 ohms	75 ohms
Frequency Response .....	* Uniform ±1 db 30 to 15,000 cy.	* ±2 db at 0.5 mc ±2 db at 1.25 mc ±2 db at 2.0 mc ±2 db at 3.0 mc +2 db at 4.0 mc -3 db at 4.0 mc
Input Level .....	+10 ±2 dbm	1 v. peak to peak
Maximum Audio Frequency Distortion .....	50 to 100 cy. 1.5% 100 to 7500 cy. 1.0% 7500 to 15,000 cy. 1.5%	
Noise Level:		
FM Noise Below ±25 kc Swing .....	60 db	
AM Noise, rms .....	50 db (below carrier)	40 db (below 100% mod.)
Amplitude Variation Over One Frame of Picture.....		Peak to peak less than 5% of the synchronizing peak level
Power Line Requirements:		
Transmitter:		
Line .....	208/230 v., 60 cy. 3 phase	
Power Consumption (approx.) .....	Black picture	10,200 watts
Power Factor (approx.)....		0.90
Crystal Heaters:		
Line .....	115 v., 60 cy., single phase	
Power Consumption .....		56 watts

### Mechanical:

Dimensions:	
Overall Length .....	106"
Overall Height .....	84"
Overall Width (including Door Handles).....	31 1/16"
Weight (approx.).....	4000 lbs.
Finish.....	Two tone umber gray with brushed chrome trim fittings

### Tube Complement

TT-2AL TRANSMITTER			TT-2AH TRANSMITTER		
Quan.	VISUAL	Type	Quan.	VISUAL	Type
1	4-125A/4D21		1	OA3	
2	4-250A/5D22		2	OD3	
1	6AC7		1	2D21	
2	6AG7		3	5U4G	
4	6AL5		4	6AL5	
2	6C4		1	6AS7G	

\* For pre-emphasized response, the pre-emphasis filter (MI-4926-A) may be inserted in the 600 ohm audio input at the most effective point.

\*\* Maximum variation with respect to the idealized rectified vestigial sideband response.

### Tube Complement (Cont'd)

TT-2AL TRANSMITTER			TT-2AH TRANSMITTER		
Quan.	VISUAL	Type	Quan.	VISUAL	Type
3	6V6GT		1	6SH7	
1	6X5GT		5	8008	
4	807		2	OA2	
4	866A		3	OB2	
5	8008		1	2E26	
5	OC3		1	4-65A	
1	OA3		5	4X150A	
2	OD3		2	6AG7	
1	2D21		2	6AS7G	
1	5U4G		2	6J6	
1	6AS7		1	6SL7GT	
1	6SH7		3	6V6GT	
41			1	6X5GT	
			2	807	
			43		
Quan.	AURAL	Type	Quan.	AURAL	Type
1	2BP1		1	5U4G	
1	2D21		3	8008	
2	2E26		1	2BP1	
4	5U4G		2	2E26	
5	6AC7		1	4-65A	
1	6AL5		5	4X150A	
4	6SH7		3	5U4G	
1	6V6		5	6AC7	
1	OC3		1	6AL5	
2	OD3		1	6SH7	
3	4-125A/4D21		4	6V6	
4	1614		4	6X5GT	
4	8008		1	OC3	
33			2	OD3	
			4	1614	
			2	8008	
			37		

### Equipment List

TT-2AL: (ES-19221)		
Quantity		Unit
1	500 Watt Visual Transmitter	
1	Visual Power Amplifier, Power and Control	
1	Aural Exciter, Power and Control	
1	Aural I.P.A. and P.A.	
1	Set of Installation Accessories	
1	Installation Kit	
1	Frequency Determining Kit	
2	TMV-129C2 Crystal Units	
2	TMV-129G Crystal Units	
2	Monitoring Diodes	
1	Set of Tubes	
1	Vestigial Sideband Filter	
1	Touch-up Kit	
2	Instruction Books	
1	Installation Instruction Book	
TT-2AH: (ES-19222)		
1	500 Watt Visual Transmitter	
1	Visual Power Amplifier, Power and Control	
1	Aural Power Amplifier, Power and Control	
1	250 Watt Aural Transmitter	
1	Set of Installation Accessories	
1	Installation Kit	
1	Frequency Determining Kit	
2	TMV-129C3 Crystal Units	
2	TMV-129G Crystal Units	
2	Monitoring Diodes	
1	Set of Tubes	
1	Vestigial Sideband Filter	
1	Touch-up Kit	
2	Instruction Books	
1	Installation Instruction Book	

## Equipment Supplied

TT-2AL 2 KW TV Transmitter, Channels 2-6, including one set tubes, two sets crystals, and sideband filter ..... ES-19221

## Equipment Supplied

TT-2AH 2 KW TV Transmitter, Channels 7-13, including one set tubes, two sets crystals, and sideband filter ..... ES-19222

## Optional Equipment

Set Complete Spare Tubes for TT-2AL ..... ES-19225  
 Set FCC Spare Tubes for TT-2AL ..... ES-19226  
 TTC-2B Transmitter Control Console ..... ES-19266-A  
 Vestigial Sideband Filter ..... MI-19114-A  
 BW-5A Sideband Response Analyzer ..... ES-34010  
 Input and Monitoring Equipment (Unwired Racks) ..... ES-19203-B

## Optional Equipment

Set Complete Spare Tubes for TT-2AH ..... ES-19227  
 Set FCC Spare Tubes for TT-2AH ..... ES-19228  
 TTC-2B Transmitter Control Console ..... ES-19266-A  
 Vestigial Sideband Filter ..... MI-19114-B  
 BW-5A Sideband Response Analyzer ..... ES-34010  
 Input and Monitoring Equipment (Wired Racks) ..... ES-19203-A

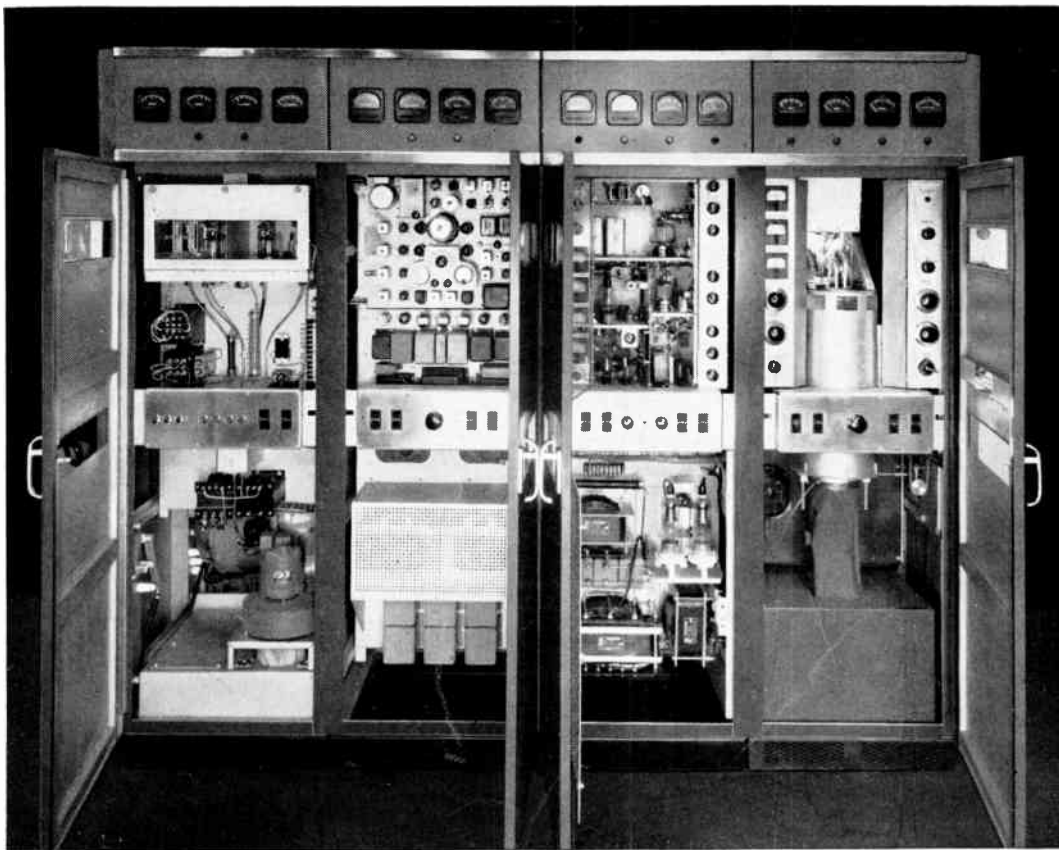

Front view of the 2 kw Transmitter with doors opened to show cabinet arrangement.

# TT-10AL/AH VHF Transmitter-10KW

## SPECIFICATIONS

### Electrical:

	<i>Aural</i>	<i>Visual</i>
Type of Emission.....	F3	A5
Frequency Range:		
TT-10AL .....	Channels 2-6	Channels 2-6
TT-10AH .....	Channels 7-13	Channels 7-13
Power Output (from sideband filter) .....		
TT-10AL .....	6.0 kw	10.0 kw peak
TT-10AH .....	6.0 kw	10.0 kw peak
R-f Output Impedance.....	51.5 ohms	51.5 ohms
R-f Output Connection.....	3 1/8" no flange line	3 1/8" no flange line
Frequency Response .....	*Uniform $\pm 1$ db 50 to 15,000 cy. referred to standard pre-emphasis curve	** $\pm 2$ db at 0.5 mc $\pm 2$ db at 1.25 mc $\pm 2$ db at 2.0 mc $\pm 2$ db at 3.0 mc $\pm 2$ db at 4.0 mc
Carrier Frequency Stability.....	$\pm 1$ kc	$\pm 4$ kc
Modulation Capability .....	$\pm 40$ kc	90%
Method of Modulation.....	FM	Grid amplitude
Input Impedance .....	600/150 ohms	75 ohms
Input Level .....	+10 $\pm 2$ dbm	1 v. peak to peak
Max. Audio Frequency Distortion .....	50 to 100 cy. 1.5% 100 to 7500 cy. 1.0% 7500 to 15,000 cy. 1.5%	
Noise Level:		
FM Noise below $\pm 25$ kc Swing .....	60 db	
AM Noise, r.m.s. ....	50 db (below carrier)	40 db below 100% mod.)
Amplitude variation over One Frame of Picture.....		Peak to peak less than 5% of the synchronizing peak level
Regulation, Black to White.....		5%
Power Line Requirements:		
Transmitter:		
Line.....	208/230 volts, 60 cycles, 3 phase	
Power Consumption (approx.):		Black Picture Average Picture
TT-10AL .....	39 kw	33.5 kw
TT-10AH .....	42 kw	36.5 kw
Power Factor .....		0.9
Crystal Heaters:		
Line.....	115 volts, 60 cycles, single phase	
Power Consumption.....		56 watts

\* Pre-emphasis is provided within the aural transmitter. If desired, this circuit may be disconnected and a pre-emphasis Filter (MI-4926-A) inserted in the 600 ohm audio circuit at another point.

\*\* Maximum variation with respect to the idealized rectified vestigial sideband response.

### Mechanical:

Dimensions:	
Overall Length .....	195"
Overall Height .....	84"
Overall Depth .....	32 1/8"
Weight (approx.) .....	6000 lbs.
Finish.....	Two tone umber gray with polished stainless steel trim and fittings

### Tube Complements

TT-10AL Transmitter			TT-10AH Transmitter		
VISUAL SECTION			VISUAL SECTION		
Qty.	Type	Function	Qty.	Type	Function
1	6V6-GT	Crystal Oscillator .....	1	6V6-GT	Crystal Oscillator .....
1	6V6-GT	Tripler .....	1	6V6-GT	Tripler .....
1	6V6-GT	Doubler .....	1	6V6-GT	Doubler .....
1	6146	Amplifier .....	1	6146	Amplifier .....
1	4-65A	Amplifier .....	1	4-65A	Amplifier .....
—	—	Tripler .....	1	4X500A	Amplifier .....
1	4-1000A	Amplifier .....	1	5762	Amplifier .....
1	6166	Modulated Amplifier .....	1	6166	Modulated Amplifier .....
1	6AG7	1st Video Amplifier.....	1	6AG7	1st Video Amplifier.....
1	6AG7	2nd Video Amplifier.....	1	6AG7	2nd Video Amplifier.....
3	807	3rd Video Amplifier.....	3	807	3rd Video Amplifier.....
1	807	White Expander .....	1	807	White Expander .....
3	807	Cathode Follower .....	3	807	Cathode Follower .....
6	6146	Modulator .....	6	6146	Modulator .....
1	6V6-GT	Video Monitor .....	1	6V6-GT	Video Monitor .....
1	6AH5	Sync Separator .....	1	6AH6	Sync Separator .....
1	5763	Clamp Pulse Amplifier.....	1	5763	Clamp Pulse Amplifier.....
2	6AL5	Clamp Diode .....	2	6AL5	Clamp Diode .....
4	6AS7-G	Voltage Regulator .....	4	6AS7-G	Voltage Regulator .....
4	6146	Voltage Regulator .....	4	6146	Voltage Regulator .....
2	6SL7-GT	Regulator Control Amp.....	2	6SL7-GT	Regulator Control Amp.....
7	OA-2	Voltage Regulator .....	7	OA-2	Voltage Regulator .....
4	OB-2	Voltage Regulator .....	4	OB-2	Voltage Regulator .....
1	OC-3	Voltage Regulator .....	1	OC-3	Voltage Regulator .....
1	6AU6	Bucking Bias .....	1	6AU6	Bucking Bias .....
3	673	Rectifier .....	3	673	Rectifier .....
4	808	Rectifier .....	4	8008	Rectifier .....
2	866	Rectifier .....	2	866	Rectifier .....
3	5R4-GY	Rectifier .....	3	5R4-GY	Rectifier .....
2	6AL5	Reflectometer .....	2	6AL5	Reflectometer .....
1	2D21	Reflectometer .....	1	2D21	Reflectometer .....
6	OD-3	Voltage Regulator .....	6	OD-3	Voltage Regulator .....
71	Total		72	Total	
AURAL SECTION			AURAL SECTION		
1	12AT7	Crystal Oscillator .....	1	12AT7	Crystal Oscillator .....
1	12AT7	Pulse Shaper .....	1	12AT7	Pulse Shaper .....
1	12AT7	Sawtooth Generator .....	1	12AT7	Sawtooth Generator .....
1	12AT7	Sawtooth Modulator .....	1	12AT7	Sawtooth Modulator .....
1	6AU6	Quadrupler .....	1	6AU6	Quadrupler .....
1	6AU6	Amplifier .....	1	6AU6	Amplifier .....
1	6AU6	Doubler .....	1	6AU6	Doubler .....
1	6AU6	Doubler .....	1	6AU6	Doubler .....
1	6AU6	Tripler .....	1	6AU6	Tripler .....
1	12AT7	Tripler .....	1	12AT7	Tripler .....
1	5763	Amplifier .....	1	5763	Amplifier .....
1	6146	Amplifier .....	1	6146	Amplifier .....
1	12AX7	Amplifier .....	1	12AX7	Amplifier .....
1	12AU7	Amplifier .....	1	12AU7	Amplifier .....
1	4-65A	Amplifier .....	1	4-65A	Amplifier .....
—	—	Tripler .....	1	4X500A	Amplifier .....
1	4-1000A	Amplifier .....	1	5762	Amplifier .....
1	6166	Amplifier .....	1	6166	Amplifier .....
1	OA-2	Regulator .....	1	OA-2	Regulator .....
1	OB-2	Regulator .....	1	OB-2	Regulator .....
3	673	Rectifier .....	3	673	Rectifier .....
4	8008	Rectifier .....	4	8008	Rectifier .....
2	5R4-GY	Rectifier .....	2	5R4-GY	Rectifier .....
2	6AL5	Reflectometer .....	2	6AL5	Reflectometer .....
1	2D21	Reflectometer .....	1	2D21	Reflectometer .....
31	Total		32	Total	
		TT-10AH total 104 Tubes (26 Types).			TT-10AL total 102 Tubes (25 Types).

## Equipment Supplied

TT-10AL Transmitter with one set of tubes, two sets of crystals, and sideband filter.....	ES-19231
TT-10AH Transmitter with one set of tubes, two sets of crystals, and sideband filter.....	ES-19232

## Optional or Accessory Equipment

Complete Spare Set of Tubes for TT-10AL.....	ES-19233
FCC Spare Set of Tubes for TT-10AL.....	ES-19234
Complete Spare Set of Tubes for TT-10AH.....	ES-19235
FCC Spare Set of Tubes for TT-10AH.....	ES-19236
TTC-1B Console with Master Monitor, but Less Master Monitor Power Supply.....	ES-19240
BW-5A Sideband Response Analyzer.....	ES-34010
Input and Monitor Racks, Wired.....	ES-19203-A
Input and Monitor Racks, Unwired.....	ES-19203-B
R-F Load and Wattmeter.....	MI-19199

Typical layout of the TT-10AL/AH Transmitter showing equipment placement and wire duct arrangement.

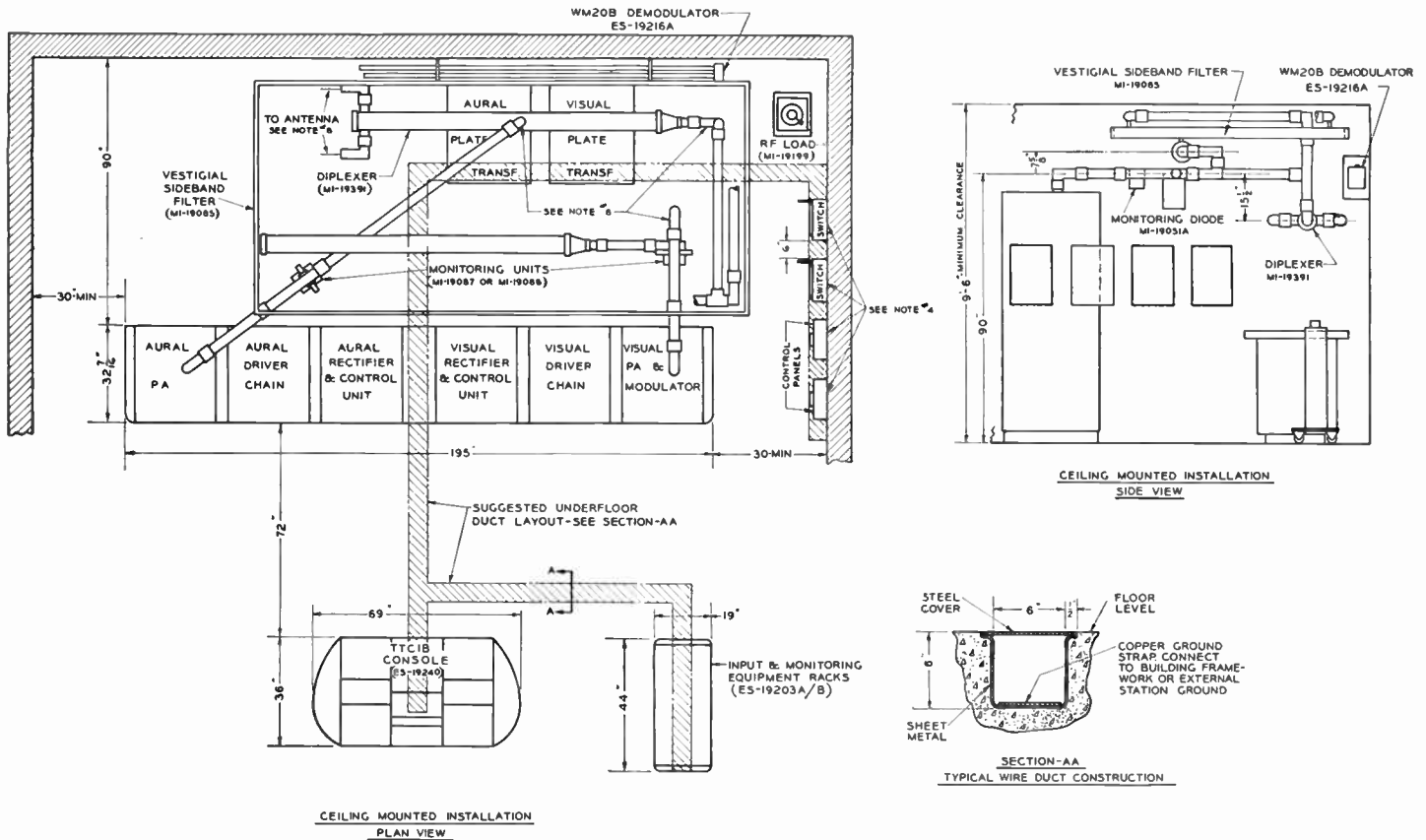

# TT-25BL/BH VHF Transmitter

## 25KW

### SPECIFICATIONS

#### Electrical:

Type of Emission.....	Aural F3	Visual A5
Frequency Range:		
TT-25BL .....	Channels 2-6	Channels 2-6
TT-25BH .....	Channels 7-13	Channels 7-13
Power Output (from side-band filter):		
TT-25BL .....	15 kw	25 kw peak
TT-25BH .....	14 kw	25 kw peak
R-f Output Impedance.....	51.5 ohms	51.5 ohms
R-f Output Connection.....	3 1/8" no flange line	3 1/8" no flange line
Frequency Response .....	** Uniform $\pm 1$ db 50 to 15,000 cy.	*** $\pm 2$ db at 0.5 mc $\pm 2$ db at 1.25 mc $\pm 2$ db at 2.0 mc $\pm 2$ db at 3.0 mc $\pm 2$ db at 4.0 mc -3
Carrier Freq. Stability.....	$\pm 4000$ cycles	$\pm 1000$ cycles
Modulation Capability .....	$\pm 40$ kc	90%
Method of Modulation.....	FM	Grid amplitude
Input Impedance .....	600/150 ohms	75 ohms
Input Level .....	+10 $\pm 2$ dbm	1 v. peak to peak
Max. Audio Freq. Distor.....	50 to 100 cy. 1.5% 100 to 7500 cy. 1.0% 7500 to 15,000 cy. 1.5%	
Noise Level:		
FM Noise below $\pm 25$ kc Swing .....	60 db	
AM Noise r.m.s. ....	50 db (below carrier)	40 db (below 100% mod.)
Amplitude variation over One Frame of Picture.....		Peak to peak less than 5% of the synchronizing peak level
Regulation of Sync Pulse Peak from White and Black Pix		5%
Power Line Requirements:		
Transmitter:		
Voltage .....	208/230	
Phase .....	3	
Frequency .....	60 cycles	
Instantaneous Reg. ....	3%	
Power Factor (approx.)....	0.90	
Approx. Power Consumption (TT-25BL):		
	Driver	Amp. Total
With Black Picture and 15 kw Aural Power .....	29 kw	65 kw 94 kw
With Average Picture and 15 kw Aural Power .....	26.5 kw	53 kw 79.5 kw
Approx. Power Consumption (TT-25BH):		
With Black Picture and 14 kw Aural Power .....	34 kw	70 kw 104 kw
With Average Picture and 14 kw Aural Power .....	31 kw	58 kw 89 kw
Power Factor .....		0.90
Crystal Heaters:		
Line 115 volts, 60 cycles, single phase power consumption.....		56 watts

#### Mechanical:

Dimensions (approx.): (cab. assem.)	
Overall Length .....	327"
Overall Height .....	84"
Overall Depth .....	32 7/16"
Weight (approx.) .....	10,500 lbs.
Finish.....	Two tone umber gray with polished stainless steel trim and fittings

#### Tube Complement

See Page C-68 for the TT-10AL/AH Tube Complement which is used as a driver for the amplifier portion of the TT-25BL/BH. The Tube Complement for the TT-10AL/AH and the tubes listed below comprise the entire tube complement for the TT-25BL/BH.

Quan.	Description	Type
6	Visual Power Supply.....	673
7	Visual Power Supply.....	6AS7G
1	Visual Power Supply.....	6SH7
2	Visual Power Supply.....	OD3
1	Visual Power Supply.....	OA3
1	Visual Power Supply.....	5R4GY
6	Aural Power Supply .....	673
1	Aural Power Supply .....	5R4GY
2	Visual Monitor .....	6AL5
1	Visual Monitor .....	2D21
2	Aural Monitor .....	6AL5
1	Aural Monitor .....	2D21
7	Visual Power Amplifier.....	5762
7	Aural Power Amplifier .....	5762

45

#### Equipment List

Equipment consists of all equipment for the standard TT-10AL/AH plus the following 25 kw amplifier items:

Item	Qty.	Unit	Item	Qty.	Unit
1	1	Visual Power Amp.	7	1	Visual Plate Transf.
2	1	Aural Power Amp.	8	1	Aural Plate Transf.
3	1	Visual Control and Distribution	9*	1	Vestigial Sideband Filter
4	1	Aural Control and Distribution	10	2	Monitoring Units
5	1	Visual Power Supply and Filter	11	1	Set of Tubes
6	1	Aural Power Supply and Filter	12	1	Set of Access. (End Shields, Bases, etc.)
			13	2	Instruction Books
			14	1	Instal. Instruc. Book

#### Equipment Supplied

TT-25BL—25 kw TV Transmitter, channels 2-6, including one set of tubes, two sets of crystals and sideband filter.

TT-25BH—25 kw TV transmitter, channels 7-13, including one set of tubes, two sets of crystals and sideband filter.

#### Optional and Accessory Equipment

Set of Complete Spare Tubes for the TT-25BL Transmitter.....	ES-19229
Set of Complete Spare Tubes for the TT-25BH Transmitter.....	ES-19229
Set of FCC Spare Tubes for the TT-25BL Transmitter.....	ES-19230
Set of FCC Spare Tubes for the TT-25BH Transmitter.....	ES-19230
TTC-1B Transmitter Control Console.....	ES-19240
Input and Monitoring Equipment.....	ES-19203-A/B
R-f Load and Wattmeter.....	MI-19193
BW-4A Demodulator .....	ES-34006
BW-5A Sideband Response Analyzer.....	ES-34010

\* May not be required on some installations. To be determined at the time of sale.

\*\* Pre-emphasis is provided within the aural transmitter. If desired, this circuit may be disconnected and a pre-emphasis filter (MI-4926-A) inserted in the 600 ohm audio circuit at another point.

\*\*\* Maximum variation with respect to the idealized rectified vestigial sideband response.

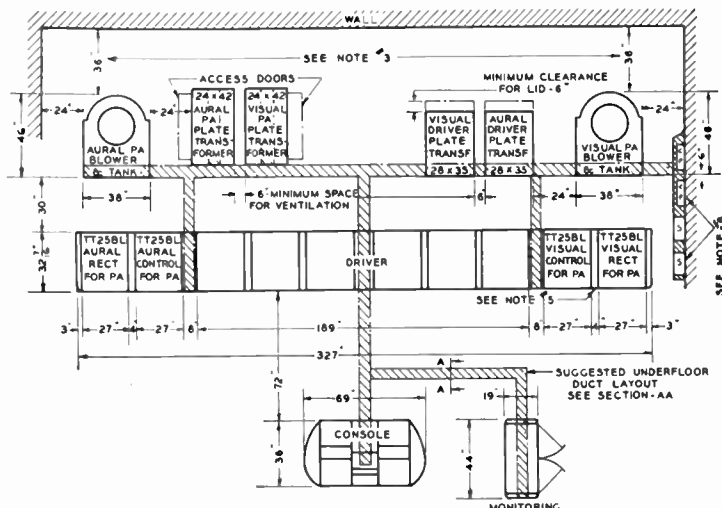

An "in-line" arrangement of the six driver cabinets with a visual rectifier cabinet at one end and aural rectifier cabinet at the other. PA tanks, and PA plate transformers are located behind transmitter.

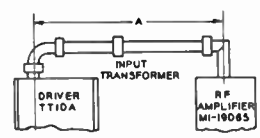

CHAN NO	A	WAVE LENGTH	AP WAVE LENGTH
2	148 ± 8	104	252 ± 6
3	126 ± 6	94	222 ± 6
4	112 ± 6	86	198 ± 6
5	90 ± 6	75	165 ± 6
6	80 ± 6	60	149 ± 6
7-13	180 MAX		

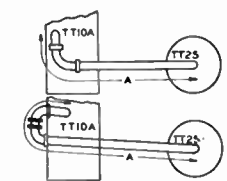

ABOVE OUTLINES SHOW SEVERAL WAYS OF RUNNING THE LINE TO OBTAIN THE CORRECT LENGTH.

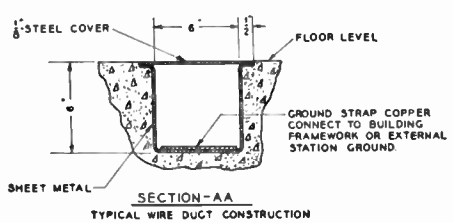

LENGTH OF LINE BETWEEN VISUAL DRIVER AND VISUAL AMPLIFIER USE A DIMENSION IF POSSIBLE IF THIS IS NOT POSSIBLE ADD WAVE LENGTH

Below—Photo of cabinet line-up of the TT-25BL/BH Transmitter. In this photo rectifier cabinets are shown on the ends of the transmitter.





# TT-50AH VHF Transmitter-50KW

## SPECIFICATIONS

### Electrical:

Type of Emission.....	Aural F3	Visual A5
Frequency Range:		
TT-50AH .....	Channels 7-13	Channels 7-13
Power Out. (sideband filter).....	30 kw	50 kw peak
R-f Output Impedance.....	51.5 ohms	51.5 ohms
Frequency Response .....	*Uniform $\pm 1$ db 50 to 15,000 cy. referred to pre- emphasis curve	* $\pm 2$ db at 0.5 mc $\pm 2$ db at 1.25 mc $\pm 2$ db at 2.0 mc $\pm 2$ db at 3.0 mc $\pm 2$ db at 4.0 mc -3
Carrier Frequency Stability.....	$\pm 4000$ cycles	$\pm 1000$ cycles
Modulation Capability .....	$\pm 40$ kc	90%
Method of Modulation.....	FM	Grid amplitude
Input Level .....	+10 $\pm 2$ db	1 v., peak-to-peak
Input Impedance .....	600/150 ohms	75 ohms
Max. Audio Frequency Distortion .....	1.5%	
	100 to 7500 cy.	
	1.0%	
	7500 to 15,000 cy.	
	1.5%	
FM Noise Below $\pm 25$ kc Swing	60 db	
AM Noise (rms).....	50 db (below carrier)	40 db (below 100% mod.)
Amplitude Variations over One Frame of Pictures.....		Peak to peak less than 5% of the synchronizing peak level
Regulation, Black and White....		5%
Power Line Requirements.....	460 v., 3 ph., 60 cy.	
Instantaneous Regulation .....	3%	

Slow Time Variation.....	Aural 5%	Visual Average picture
Power Consumption (approx.)	Black picture	
TT-50AH .....	193 kw	153 kw
Crystal Heaters:		
Line.....	115 volts, 60 cycles, single phase	
Power Consumption .....	56 watts	

### Mechanical:

Dimensions:	
Overall Length .....	18' 11"
Overall Height .....	84"
Overall Depth .....	32 $\frac{9}{16}$ "
Weight (approx.) .....	23,000 lbs.

### Equipment Supplied

TT-50AH Transmitter with one set of tubes, two sets of crystals, and sideband filter..... ES-19270

### Optional or Accessory Equipment

Complete Set of Tubes for TT-50AH.....	ES-19274
FCC Spare Set of Tubes for TT-50AH.....	ES-19275
TTC-1B Console with Master Monitor but less Master Monitor Power Supply .....	ES-19240
BW-5A Sideband Response Analyzer.....	ES-34010
Input and Monitor Racks, Wired.....	ES-19203-A
Input and Monitor Racks, Unwired.....	ES-19203-B
R-f Load and Wattmeter.....	MI-19191

\* Pre-emphasis is provided within the aural transmitter. If desired, this circuit may be disconnected and a pre-emphasis Filter (MI-4926-A) inserted in the 600 ohm audio circuit at another point.

\*\* Maximum variation with respect to the idealized rectified vestigial sideband response.

Finish.....Two-tone umber gray, polished stainless steel trim

## Tube Complement

TT-50AH Tube Complement (ES-19272)		VISUAL SECTION		TT-50AH Tube Complement (ES-19274)		TT-50AH Tube Complement (ES-19272)		AURAL SECTION		TT-50AH Tube Complement (ES-19274)	
Qty.	Type	Function		Qty.	Type	Qty.	Type	Function		Qty.	Type
1	6V6-GT	Crystal Oscillator .....		1	6V6-GT	1	12AT7	Crystal Oscillator .....		1	12AT7
1	6V6-GT	Tripler .....		1	6V6-GT	1	12AT7	Pulse Shaper .....		1	12AT7
1	6V6-GT	Doubler .....		1	6V6-GT	1	12AT7	Sawtooth Generator .....		1	12AT7
1	6146	Amplifier .....		1	6146	1	12AT7	Sawtooth Modulator .....		1	12AT7
1	4-65A	Amplifier .....	Tripler	1	4-65A	1	6AU6	Quadrupler .....		1	6AU6
—	—	Amplifier .....		1	4X500A	1	6AU6	Amplifier .....		1	6AU6
1	4-1000A	Amplifier .....		1	5762	1	6AU6	Doubler .....		1	6AU6
1	6166	Modulated Amplifier .....		1	6166	1	6AU6	Tripler .....		1	12AT7
5	6166	Linear Final Amplifier .....		5	6166	1	5763	Amplifier .....		1	6146
1	6AG7	1st Video Amplifier .....		1	6AG7	1	6146	Amplifier .....		1	12AX7
1	6AG7	2nd Video Amplifier .....		1	6AG7	1	12AX7	Amplifier .....		1	12AU7
3	807	3rd Video Amplifier.....		3	807	1	4-65A	Amplifier .....	Tripler	1	4X500A
1	807	White Expander .....		1	807	1	—	Amplifier .....		1	5762
3	807	Cathode Follower .....		3	807	1	4-1000A	Amplifier .....		1	6166
6	6146	Modulator .....		6	6146	5	6166	Power Amplifier .....		5	6166
1	6V6-GT	Video Monitor .....		1	6V6-GT	2	6SL7-GT	Rectifier .....		2	5R4-GY
1	6AH6	Sync Separator .....		1	6AH6	11	6AS7-G	Voltage Regulator .....		1	OA-2
1	6783	Clamp Pulse Amplifier.....		1	6783	1	6AU6	Bucking Bias .....		1	OB-2
2	6AL5	Clamp Diode .....		2	6AL5	1	OA-2	Voltage Regulator .....		1	OB-2
4	6146	Voltage Regulator .....		4	6146	4	6AL5	Reflectometer .....		4	6AL5
1	6SH7	Voltage Regulator .....		1	6SH7	2	2D21	Reflectometer .....		2	2D21
2	6SL7-GT	Regulator Control Amplifier.....		2	6SL7-GT	2	OD-3	Voltage Regulator .....		2	866-A
11	6AS7-G	Voltage Regulator .....		11	6AS7-G	2	866-A	Rectifier .....		2	866-A
1	6AU6	Bucking Bias .....		1	6AU6	4	5R4-GY	Rectifier .....		4	5R4-GY
9	OA-2	Voltage Regulator .....		9	OA-2	4	6AL5	Reflectometer .....		4	6AL5
1	OA-3	Voltage Regulator .....		1	OA-3	2	2D21	Reflectometer .....		2	2D21
6	OB-2	Voltage Regulator .....		6	OB-2	6	857B	Main Rectifier .....		6	857B
2	OD-3	Voltage Regulator .....		2	OD-3	3	673	Auxiliary Rectifier .....		3	673
2	866-A	Rectifier .....		2	866-A						
4	5R4-GY	Rectifier .....		4	5R4-GY						
4	6AL5	Reflectometer .....		4	6AL5						
2	2D21	Reflectometer .....		2	2D21						
1	OC-3	Voltage Regulator .....		1	OC-3						

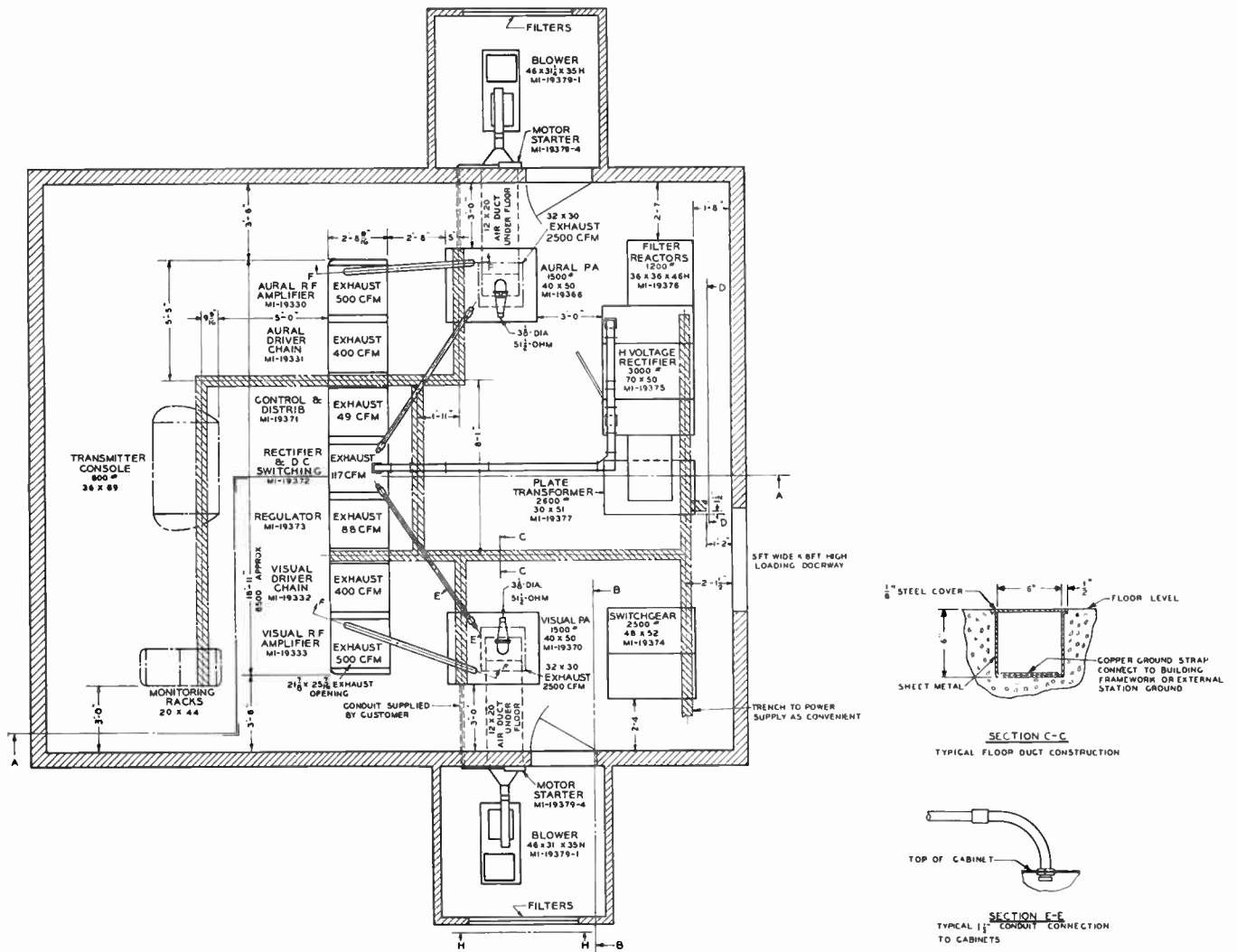

Floor plan diagram showing details of component location and ductwork planning in one of the TT-50AH Transmitter arrangements that might be used.

# TTU-1B UHF Transmitter-1KW

## SPECIFICATIONS

### Electrical:

Type of Emission.....	Aural F3	Visual A5
Frequency Range:		
TTU-1B.....	Channels 14-83	Channels 14-83
Power Output.....	0.6 kw	1 kw peak at out- put of Filter- plexer
R-f Output Impedance.....	50 ohms	50 ohms
R-f Output Connection.....	3 1/8" Teflon line	3 1/8" Teflon line
Frequency Response.....	Uniform $\pm 1$ db 30 to 15,000 cy. referred to standard pre- emphasis curve	* $\pm 2$ db at 0.5 mc $\pm 2$ db at 1.25 mc $\pm 2$ db at 3.0 mc $\pm 2$ db at 4.0 mc -3
Carrier Frequency Stability.....	$\pm 4000$ cy.	$\pm 1000$ cy.
Modulation Capability.....	$\pm 40$ kc	90%
Method of Modulation.....	FM	Cathode ampli- tude
Input Impedance.....	600/150 ohms	75 ohms
Input Level.....	+10 $\pm 2$ dbm	1 v. peak to peak
Maximum Audio Frequency		
Distortion.....	50 to 100 cy. 1.5% 100 to 7500 cy. 1.0% 7500 to 15,000 cy. 1.5%	
Noise Level:		
FM Noise below $\pm 25$ kc		
Swing.....	60 db	40 db (below 100% modu- lation)
AM Noise, r.m.s.....	50 db (below carrier)	Peak to peak less than 5% of the synchronizing peak level
Amplitude Variation over One Frame of Picture.....		5%
Regulation, Black to White.....		5%
Power Line Requirements:		
Line Voltage.....	208/230 volts	
Phase.....	Single	
Frequency.....	60 cycles	
Instantaneous Regulation.....	3%	
Slow Time Variation.....	5%	
Power Consumption (approx.).....	Black Picture 9.6 kw	Average Picture 8.6 kw
Power Factor.....		0.9
Crystal Heaters:		
Line.....	115 v., 60 cycle single phase, 56 watts max.	

### Mechanical:

Dimensions:	
Width.....	103"
Height.....	84"
Depth.....	32 3/16"
Weight.....	3,000 lbs. (approx.)
Finish.....	Two-tone umber gray with brushed chrome trim fittings

### Equipment Supplied

TTU-1B Transmitter with one set of tubes, two sets of crystals, and filterplexer.....	ES-19250
--	----------

\* Pre-emphasis is provided within the aural transmitter. If desired this circuit may be disconnected and a pre-emphasis filter (MI-4926-A) inserted in the 600 ohm audio circuit at another point.

\*\* Maximum variation with respect to the idealized rectified vestigial sideband response.

### Tube Complement

Visual Section:		
1.....	6J6	Oscillator
1.....	5763	Buffer
1.....	6146	Buffer
1.....	4X150-A	Doubler-Tripler
1.....	4X150-A	Doubler-Tripler
1.....	6161	Doubler
1.....	6161	Intermediate Power Amplifier
1.....	6181	Modulated Power Amplifier
1.....	5763	Video Amplifier
1.....	5763	Video Amplifier
1.....	5763	Video Amplifier
1.....	6146	Video Amplifier
8.....	6146	Modulator
1.....	6AH6	Sync Separator
2.....	5763	Sync Amplifier
1.....	6AL5	Clamp Diode
1.....	5R4-GY	Low Voltage and Bias Rectifier
2.....	866-A	Rectifier
2.....	8008	H. V. Rectifier
2.....	6SL7-GT	D. C. Amplifier
2.....	6AS7-GT	Control Tube
4.....	VR-150	Regulator
2.....	VR-105	Regulator
1.....	VR-75	Regulator
2.....	6AL5	Reflectometer
Aural Section:		
1.....	12AT7	Crystal Oscillator
1.....	12AT7	Pulse Shaper
1.....	12AT7	Sawtooth Generator
1.....	12AT7	Sawtooth Modulator
1.....	6AU6	Quadrupler
1.....	6AU6	Amplifier
1.....	6AU6	Doubler
1.....	6AU6	Tripler
1.....	6AU6	Amplifier
1.....	6J6	High Frequency Oscillator
1.....	6AS6	Mixer
1.....	5763	Amplifier
1.....	12AX7	Audio
1.....	12AU7	Audio
1.....	5R4-GY	Rectifier
1.....	VR-150	Regulator
1.....	VR-105	Regulator
1.....	4X150-A	Doubler-Tripler
1.....	4X150-A	Doubler-Tripler
1.....	6161	Doubler
1.....	6161	Intermediate Power Amplifier
1.....	6181	Power Amplifier
1.....	5R4-GY	Low Voltage Rectifier
2.....	8008	H. V. Rectifier
2.....	6AL5	Reflectometer
1.....	6146	Buffer

### Optional or Accessory Equipment

Complete Spare Set of Tubes.....	ES-19251
FCC Spare Set of Tubes.....	ES-19252
TTC-1B Console with Master Monitor, but Less Monitor Power Supply.....	ES-19240
BWU-5A Sideband Response Analyzer.....	ES-34009
Input and Monitor Racks, Wired.....	ES-19203-C
Input and Monitor Racks, Unwired.....	ES-19203-D
R-f Load and Wattmeter.....	MI-19197
BWU-4A Demodulator.....	ES-34007

NOTES FOR DIAGRAM

Note 1—Main line voltage, 208/230 volts at 60 cycles, single phase enters cabinet MI-19351 at Rear. No. 6 wire recommended. Approximately 10 kw input.

Note 2—Wire ducts, monitoring racks, and control console not supplied with transmitter. (Control console ES-19240 and monitoring equipment rack, MI-19203-C or -D.)

Note 3—This dimension not critical, however allowance must be made for adequate flow of air to MI-19351 control cabinet. Input air filter located rear lower portion of this cabinet. Approximately 850 CFM air. Air leaves transmitter at top of MI-19350 aural and MI-19352 visual.

Note 4—Minimum clearance determined by considerations other than technical, allow 24" minimum.

Note 5—Filterplexer MI-19086 Ch. 14-83 (channel specified) has the following dimensions. Folded: 6'-2" long,

3'-7" wide, 3'-4" high. Extended: 10'-2" long, 3'-7" wide, and 3'-4" high. Dimensions given are for lowest frequency unit and will be smaller for higher frequencies. It can be operated folded or extended (shipped folded). Can be floor, wall, or ceiling mounted. Visual and aural input lines and antenna line 3/8" 50 ohms. Unit should not be subjected to drafts.

Note 6—MI-19364 monitoring diode. Requires 110 volts at 60 cycles (negligible power) RG-11/U cable to control console. Can be located at any position in length L.

Note 7—BWU-4A demodulator directional coupler pickup. Demodulator mounted in monitoring rack and lead length up to 50' allowable. Position in line not important.

Note 8—3 extra equipment racks shown to include synchronizing generator and power supplies and equipment necessary for "Basic Buy."

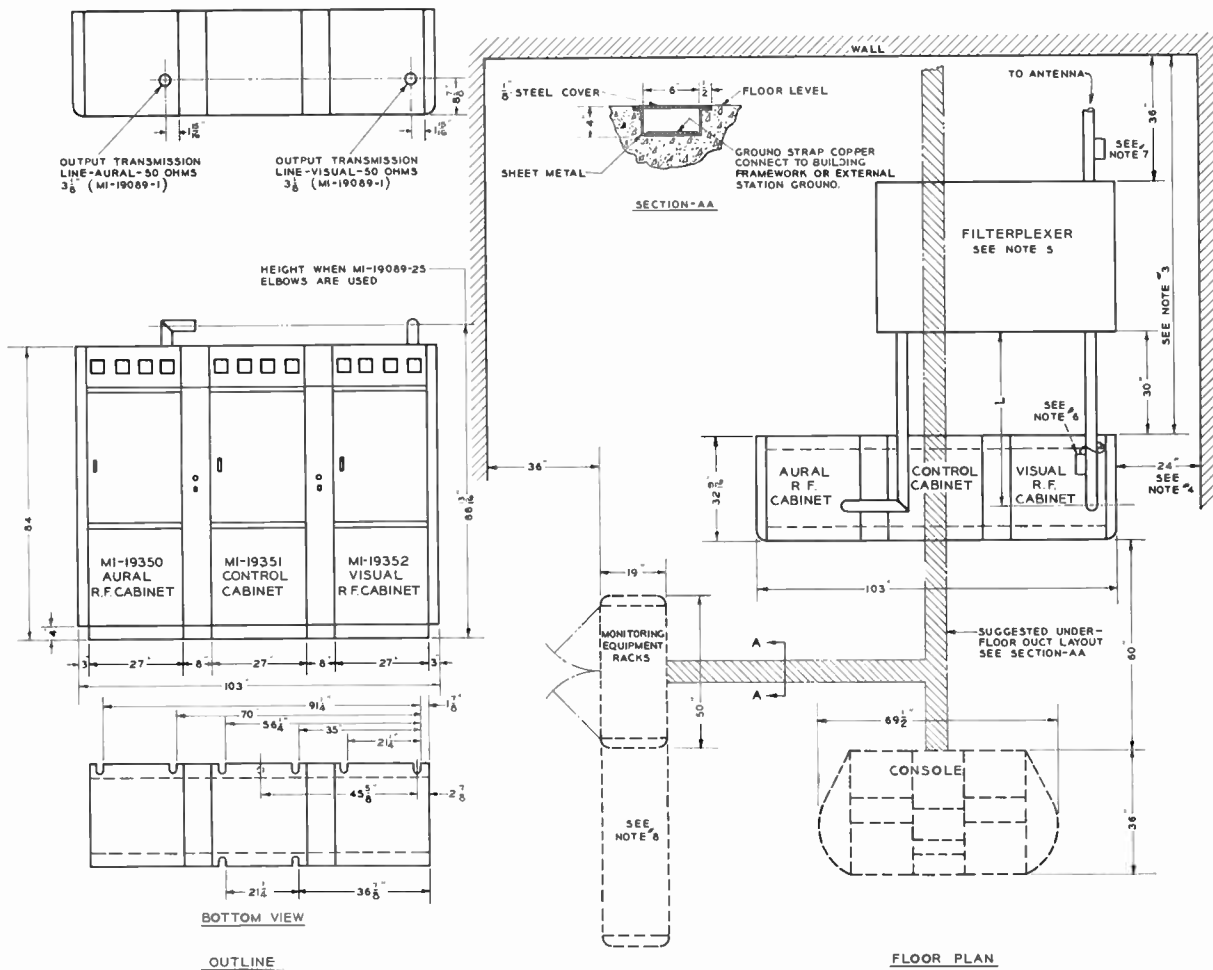

Floor layout for the TTU-1B with ductwork locations and construction details. Also shown are top, front, and bottom outline views of the transmitter.

# TTU-10A UHF Transmitter-10KW

## SPECIFICATIONS

### Electrical:

	Aural	Visual
Type of Emission.....	F3	A5
Frequency Range:		
TTU-10A .....	Channels 14-83	Channels 14-83
Power Output (from sideband filter):		
TTU-10A .....	6 kw	10 kw peak
R-f Output Impedance .....	50 ohms	50 ohms
R-f Output Connection.....	3 1/8" Teflon line	3 1/8" Teflon line
Frequency Response .....	*Uniform $\pm 1$ db 30 to 15,000 cy.	** $\pm 2$ db at 0.5 mc $\pm 2$ db at 1.25 mc $\pm 2$ db at 2.0 mc $\pm 2$ db at 3.0 mc $\pm 2$ -3 db at 4.0 mc
Carrier Frequency Stability.....	$\pm 4000$ cycles	$\pm 1000$ cycles
Modulation Capability .....	$\pm 40$ kc	90%
Method of Modulation.....	FM	Grid amplitude
Input Impedance .....	600/150 ohms	75 ohms
Input Level .....	$\pm 10 \pm 2$ dbm	1 v. peak to peak
Maximum Audio Frequency Distortion .....	50 to 100 cy. 1.5% 100 to 7500 cy. 1.0% 7500 to 15,000 cy. 1.5%	
Noise Level:		
FM Noise below $\pm 25$ kc Swing .....	60 db	
AM Noise, rms below Carrier .....	50 db	40 db below 100% modulation
Amplitude Variation over One Frame of Picture.....		Peak to peak less than 5% of the synchronizing peak level

### Power Line Requirements:

#### Transmitter:

Line.....	208/230 volts, 60 cycles, 3 phase
Power Consumption (approx.):	
Black Picture .....	110 kw
Average Picture .....	75 kw
Power Factor .....	0.9

#### Crystal Heaters:

Line.....	115 volts, 60 cycles, single phase
Power Consumption .....	.56 watts

\* Pre-emphasis is provided within the aural transmitters. If desired this circuit may be disconnected and a pre-emphasis filter (MI-4926-A) inserted in the 600 ohm audio circuit at another point.

\*\* Maximum variation with respect to the idealized rectified vestigial sideband response.

### Equipment Supplied

TTU-10A Transmitter with one set of tubes, two sets of crystals and Filterplexer..... ES-19260

### Optional or Accessory Equipment

Complete Spare Set of Tubes.....	ES-19261
FCC Spare Set of Tubes.....	ES-19262
TTC-18 Console with Master Monitor, but less Master Monitor Power Supply.....	ES-19240
8WU-5A Sideband Response Analyzer.....	ES-34009
Input and Monitor Racks, Wired.....	ES-19203-C
Input and Monitor Racks, Unwired .....	ES-19203-D
R-f Load and Wattmeter.....	MI-19198
BWU-4A Demodulator .....	ES-34007

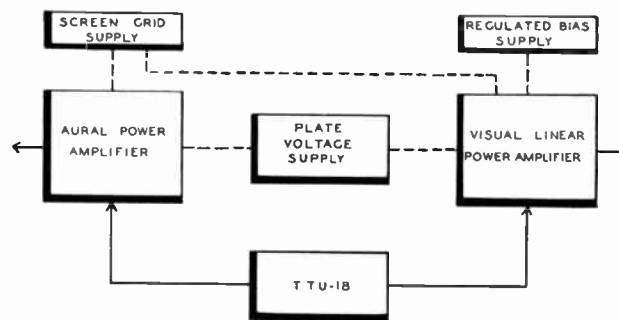

BLOCK DIAGRAM  
TTU-10A UHF TRANSMITTER

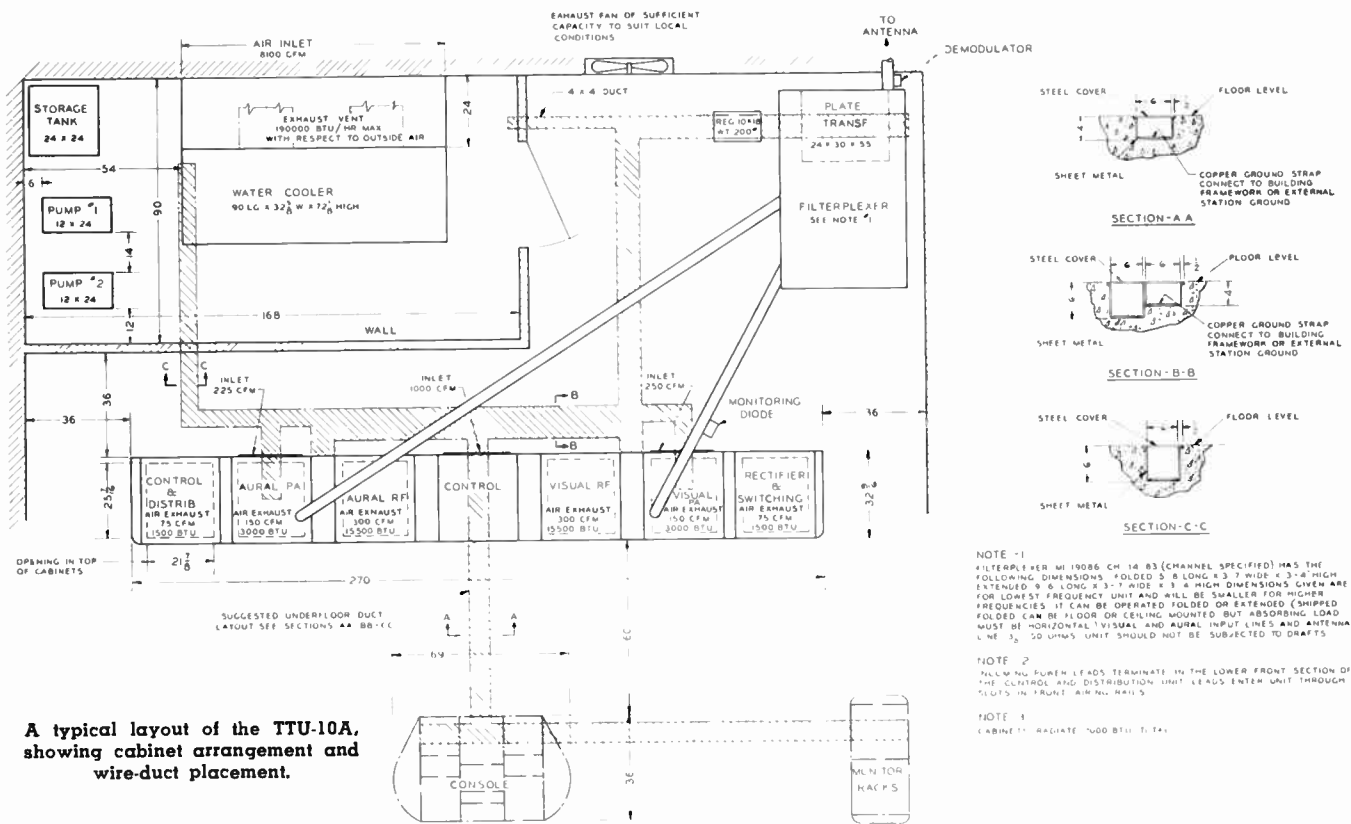

A typical layout of the TTU-10A, showing cabinet arrangement and wire-duct placement.

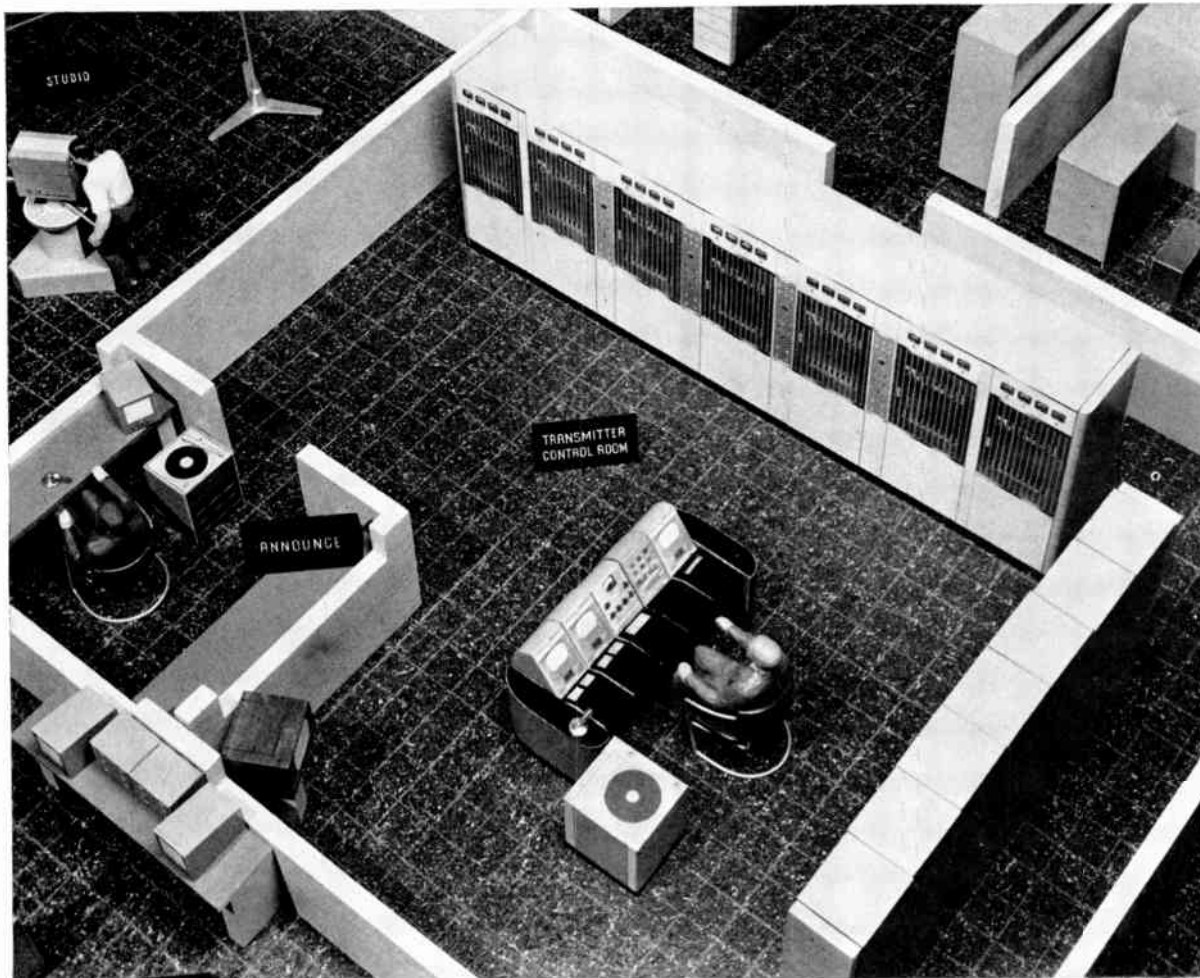

Model layout photo showing the TTU-10A UHF Transmitter as used in a typical TV transmitter control room.

# BW-5A TV SIDEBAND RESPONSE ANALYZER

## SPECIFICATIONS

### Video Sweep

Frequency Range	10-0-10 mc Cont. variable by panel control
Output	0-2 V (P.P.) Cont. variable by panel control
Rep. Rate	120 cycles (for 60 cycle power supply)
Hum Level	-50 db below 2.0 V (P.P.)
Output Impedance	72 ohms
Metering System	2" dia. meter—panel mount—calibrated in volts P-P with blanking, Germanium diode rectifier
Sweep Frequency Response	±0.5 db 0.2 to 4.0 mc ±1.0 db 0.2 to 7.0 mc
Blanking	"On-Off" panel control
Blanking Phase	Chassis control (Fact. adj.)
Center Frequency Control	±2.0 mc (Panel adj.)
Marker Accuracy	200 kc throughout range (Self calibration at carrier frequency)
Marker Width	50 kc approximately
Marker Range	Carrier frequency ±10 mc
Marker Amplitude	Chassis control (Min. 5% of demodulated response)

### R-F Synchronous Mixer

Input Frequency Range	55.25—83.25 mc (channels 2-6) 175.25—211.25 mc (channels 7-13)
Output Frequency Range	42-84 mc
R-f Input (direct)	0.5—1.5 volts
R-f Input (with 10 db pad)	1.5—5.0 volts
Input Impedance	51 ohms
V.S.W.R.	1.1 maximum (channels 2-13)
Input Connector	UHF Type N Female (Male plug, but no cable supplied)

### Receiver

R-f Input	Internal from r-f Mixer
I-f Frequency	10.7 mc
Maximum Output	7.0 volt (demodulated carrier peak) into 500 ohms load with r-f input of 1.5 volts to sync. mixer
Maximum Sensitivity	Approximately 2.5 volts (demod. carrier peak) into 500 ohms load with r-f input of 0.5 volts to sync mixer
Shielding	Sufficient for satisfactory operation in r-f field of 0.5 volts per meter
Gain Control	Panel control—continuously variable over a 40 db range
Receiver Osc. Stability	.025% in 15 minutes after 15 minute warmup
Distortion	Less than 5% at output levels between 1.0 and 3.0 volts (P-P) across 500 ohms load
Hum Level	Greater than 40 db below 1.0 volt P.P. output across 500 ohms
Output Connector	3 prong jack with cable (panel)

### Oscilloscope Deflecting Signal

Open Circuit Voltage	18 volts (P.P.) minimum
Internal Impedance	985-5600 ohms (varies with phasing control)
Frequency	Same as power line
Waveform	Same as power line
Range of Phase Adjustment	135° total change
Output Connector	3 prong jack with cable (panel)

### Operating Conditions

Ambient Temperature Range	+5°C to +45°C
Humidity	0-95% relative

### Mechanical:

Mounting—Relay Rack	10 1/2" high x 19" wide x 14 1/2" deep
Color	Dark umber gray (smooth)
Weight	58 lbs.

### Electrical:

Supply Voltage	105-125 volts a-c
Supply Frequency	50-60 cycles
Power Consumption	200 watts
Power Receptacle	1" male motor-plug (power cord supplied)
Power Supply	Internal (260 volts d-c regulated)

### Tube Complement

2—6J6	1—6AK6
3—12AU7	1—5R4G
1—6SQ6	1—6C4
2—6BA6	1—6AS7G
3—6AS6	1—6SJ7
2—6AH6	1—OD3/VR150
1—6AG7	

### Stock Identification

BW-5A VHF TV Sideband Response Analyzer Equipment	ES-34010
Including:	
1 MI-34000 Analyzer (tubes in place)	
1 MI-19396-1 Directional Coupler	
1 MI-19396-3 Transmission Line Section for mounting MI-19396-1 Directional Coupler	
1 MI-34011 Type "N" Connector	
BW-5A VHF TV Sideband Response Analyzer less R-f Pickup Unit	MI-34000

### Optional or Accessory Equipment

Set of Spare Tubes	MI-34012
Type TO-524-D Oscilloscope	MI-26500
Directional Coupler	MI-19396-1
Transmission Line: Section for Mounting MI-19396-1 Directional Coupler	MI-19396-3
Type "N" Connector for MI-19396-1	MI-34011
R-f Pickup Unit	MI-19057-A

# GR-1183-T TV Station Monitors

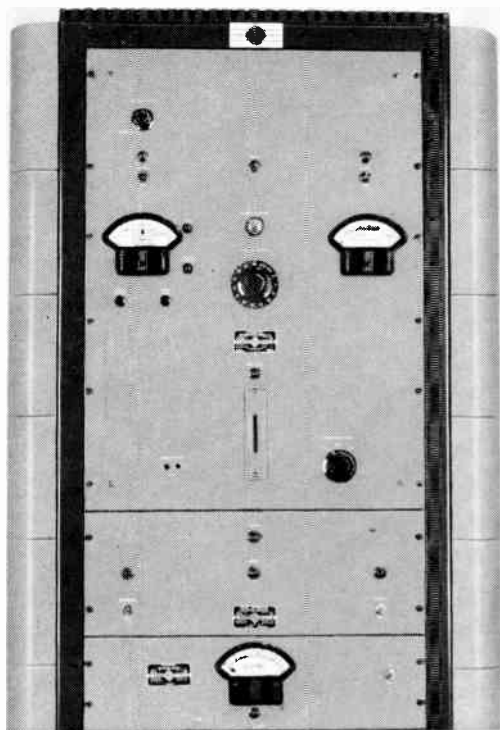

## USES

The 1183-T Television Station Monitor is a General Radio monitoring system for television transmitters. Consisting of three integrated instruments, rack-mounted together, this equipment provides facilities for monitoring the frequency and percentage modulation of the aural transmitter, and the frequency of the visual transmitter. The GR type 1183-T Television Station Monitor is supplied as follows:

For Channels 2-6 (GR type 1183-T1)

- 1—GR-1170-BT1 FM Monitor
- 1—GR-1171-AT1 Visual Transmitter Frequency Monitor
- 1—GR-1176-AT Frequency Deviation Meter

For Channels 7-13 (GR type 1183-T2)

- 1—GR-1170-BT2 FM Monitor
- 1—GR-1171-AT2 Visual Transmitter Frequency Monitor
- 1—GR-1176-AT Frequency Deviation Meter

For UHF Channels 14-83 (GR type 1183-T3)

- 1—GR-1170-BT3 FM Monitor
- 1—GR-1171-AT3 Visual Transmitter Frequency Monitor
- 1—GR-1176-AT Frequency Deviation Meter

## DESCRIPTION

### TYPE 1170-BT FM MONITOR

This instrument gives a continuous indication of center-frequency and percentage modulation (frequency deviation) of television aural transmitters and also furnishes a

high-fidelity output for measuring distortion and noise, and a 600-ohm output for audio monitoring. It is designed to operate at TV frequencies between 44 and 900 megacycles (channels 2 to 83), and meets the FCC requirements for these services.

A multiplier chain supplies a harmonic of the master-reference crystal oscillator which beats with the transmitter frequency to produce a 150-kc signal. This 150-kc signal is then amplified and filtered and is applied to a counter-type discriminator. The d-c output of the discriminator is used to operate the center-frequency indicator. The a-c output, suitably amplified and filtered, operates the modulation indicators and is available for audio monitoring and for distortion and noise measurements. The frequency of the master-reference crystal oscillator can be adjusted from the front panel of the Type 1170-BT FM Monitor.

### TYPE 1171-AT VISUAL TRANSMITTER FREQUENCY MONITOR

Another multiplier chain excited from the FM Monitor supplies the same harmonic of the master-reference crystal oscillator to a mixer, where it beats with the visual-transmitter carrier to produce a 4.35 mc signal. This 4.35 mc beat frequency is further heterodyned with a crystal oscillator to produce a 1.75 kc beat ( $\pm$  the frequency deviation of the visual-transmitter carrier) which is supplied to the Frequency Deviation Meter.

### TYPE 1176-AT FREQUENCY DEVIATION METER

The Frequency Deviation Meter is the indicating device for the visual transmitter monitor. The circuit consists of an input amplifier, followed by a series of clipping and limiting amplifiers, and a cycle-counter circuit used as a discriminator to drive the deviation-indicating meter, which indicates in cycles per second the deviation of actual transmitter operating frequency from the assigned carrier frequency.

Both transmitters are monitored against the same master-reference crystal, and an adjustment of the frequency of the master-reference crystal oscillator therefore affects both monitor indicators equally. After the visual carrier has been set by this means, a front-panel adjustment in the metering circuit of the aural monitor sets the aural-carrier indicator independently.

Changes in amplitude and wave form of the input signal do not affect the indication, and a well-regulated power supply eliminates the effect of line-voltage changes. Terminals and circuit are provided for connecting a remote center-frequency meter externally.



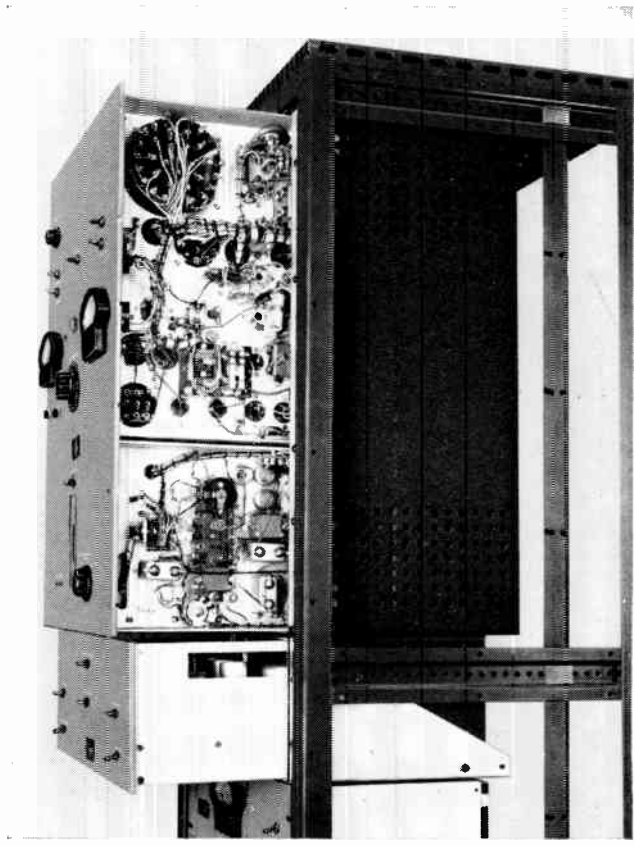

The GR-1183-T Monitor Equipment is removable from the front of the rack for servicing and inspection.

## SPECIFICATIONS

### VISUAL TRANSMITTER CARRIER

(FCC requirement  $\pm 1000$  cycles for all channels)

GR-1183-T1 VHF Ch. 2	$\pm 500$ cycles in 90 days
GR-1183-T2 VHF Ch. 13	$\pm 500$ cycles in 36 days
GR-1183-T3 UHF Ch. 14	$\pm 500$ cycles in 18 days
GR-1183-T3 UHF Ch. 83	$\pm 500$ cycles in 10 days

### AURAL TRANSMITTER CARRIER

(FCC requirement  $\pm 4000$  cycles for all channels)

Maximum aural monitor error, when appropriate visual frequency checking schedule is followed,  $\pm 1000$  cycles per year.

Generally necessary to check only visual carrier frequency.

For purposes of completing the accuracy statement in Section V-C of the Federal Communications Commission Filing Form #301, Paragraphs 6.(a) and 6.(b), the following simple over-all tolerance statements may be used:

6.(a) Visual Monitor	$\pm 500$ cycles
6.(b) Aural Monitor	$\pm 1000$ cycles
Total Weight (for 3 instruments)	138½ lbs.
Total Height (for 3 instruments)	38½"
Width	19"
Depth (max.)	13¼"
Total Power Consumption	425 watts, 230 or 115 volts, 50/60 cycles

## TYPE 1170-BT FM FREQUENCY MONITOR

Transmitter Frequency Range	Type 1170-BT1 Channels 2-6
	Type 1170-BT2 Channels 7-13
	Type 1170-BT3 Channels 14-83

Note: Different R-F Tuning Units used.

### RF Input Impedance:

Channels 2-13, high impedance, Type 874 Connector. Capacitance attenuator for adjusting input.

Channels 14-83, low impedance in UHF range with adjustable-coupling-loop input.

Input Sensitivity.....1 volt or better on high impedance input. 500 milliwatts, or less, on low impedance input.

Input Level Indicators.....R-f input level meter at chassis rear; signal pilot and center frequency pilot indicators.

I-F Frequency.....150 kc for zero-offset assignment, 140 kc for -10 kc offset, 160 kc for +10 kc offset, 75 kc bandwidth minimum.

Discriminator.....Pulse-counter type, linear to better than 0.1% over a range of  $\pm 100$  kc.

Center Frequency Indication.....200 cycle divisions, -6000 to +6000 cycles (all channels).

Center Frequency Accuracy..... $\pm 2$  parts per million (when received); center frequency adjustable  $\pm 25$  parts per million.

Center Frequency Stability (overall)..... $\pm (0.5$  parts per million +200 cycles), or better (ten day period) or  $\pm (1.5$  parts per million +200 cycles), or better (thirty day period).

Percentage Modulation.....Indication meter calibrated from 0 to 133% (100% modulation corresponds to 25 kc deviation), accuracy is  $\pm 5\%$  modulation, over-modulation indicator flashes when level is exceeded (dial setting 0 to 120% modulation provided).

### Output Circuits (For Distortion and Noise Measurements):

Residual Distortion	Less than 0.1% (100 kc deviation)
Response	50 to 30,000 cycles $\pm 1/2$ db
Maximum Output	1.5 volts into 100,000 ohms
Residual Noise Level	-65 db or better (25 kc deviation)
Sensitivity	Full output down to 6 kc deviation
Audio Monitoring Output	Impedance 600 ohms unbalanced; Output -12 dbm at 25 kc deviation; Response 50 to 15,000 cycles $\pm 1/4$ db.

Crystal.....Temperature controlled at  $(60 \pm 0.15)^\circ$  C. Temperature coefficient is 2 parts per million, or less, per degree C.

Remote Indicators.....Circuits and terminals for connecting externally, Center-frequency Indicator, Percentage-Modulation Meter, and Over Modulation Lamp.

Power Supply.....105/125 volts, 50 to 60 cycles

Power Input.....300 watts

Mounting.....19" relay-rack panel

Dimensions.....Panel, 19" width x 26¼" height x 13¼" depth

Net Weight.....88 lbs.

Panel Finish.....Umber gray

## Tube Complement

1-6AK6, 2-6AG7, 1-6AC7, 1-6SN7-GT, 1-6AG5, 2-2050, 2-6SJ7,  
6-6AL5, 4-6SL7-GT, 2-6C4, 1-815, 2-OD3/VR150, 1-5964,  
1-991, 1-6SK7, 1-6AS7-G, 1-OC3/VR105, 2-3-4, 1-12AU7.

### R-F Tuning Units:

Type 1170-P1.....1-6BE6, 1-6AG5  
Type 1170-P2.....1-6BE6, 2-6AG5  
Type 1170-P3.....3-6AG5, 1-9005, 1-6J6

## Accessories Supplied

All tubes, coaxial connector for r-f input, power line connection cord,  
power supply plug.

## SPECIFICATIONS

### TYPE 1171-AT VISUAL-TRANSMITTER FREQUENCY MONITOR

Transmitter Frequency Range.....Same as Type 1170-BT1, BT2, BT3  
R-f Input Impedance.....High impedance (channels 2-13);  
Low impedance (UHF range).

Input Sensitivity.....1 volt or better (high impedance input)

Input Level Indicator.....Provided at rear of chassis

I-f Crystal Oscillator.....4.35175 mc for all channels (non-offset)

Accuracy.....Overall  $\pm 100$  cycles (for companion instruments  
1171-AT and 1176-AT).

Stability.....Overall  $\pm$  (0.5 parts per million + 100 cycles) or better  
(ten day period) or  $\pm$  (1.5 parts per million + 100 cycles) or  
better (30 day period).

When visual and aural transmitter are adjusted to show zero deviation  
on the deviation indicators, the intercarrier separation is  
4.5 mc  $\pm 300$  cycles.

Power Supply.....115 or 230 volts, 50-60 cycles a-c

Power Input......75 watts

Mounting.....19" relay-rack panel

Dimensions.....19" width x 7" height x 11 1/4" depth

Net Weight......31 lbs.

Panel Finish.....Umber gray

## Tube Complement

2-6AU6, 1-6C4, 1-6BE6, 1-OD3, 1-6J6, 1-2D21, 1-5Y3-GT.

### R-F Tuning Units:

Type 1171-P1.....1-6AG5, 1-6BE6  
Type 1171-P2.....2-6AG5, 1-6BE6  
Type 1171-P3.....1-6AG5, 1-6J6, 1-9005

## SPECIFICATIONS

### TYPE 1176-AT FREQUENCY DEVIATION METER

Range.....-1.5 kc to +1.5 kc (50 cycle divisions)

Accuracy..... $\pm$  [20 cycles + (60 cycles per 30 days)]

Input Voltage......025 to 150 volts

Input Impedance......05 megohms

Power Supply.....105 to 125 (or 210 to 250) volts, 50 to 60 cycles

Power Input......50 watts

Mounting.....19" relay-rack panel

Dimensions.....19" width x 5 1/4" height x 11 1/4" depth

Net Weight.....19 1/2 lbs.

## Tube Complement

1-6H6, 1-6SQ7, 1-6X5, 1-6SN7-GT, 1-6J5-GT, 2-6SJ7, 1-6V6,  
1-OA3, 1-3-4.

## Ordering Information

Channels 2-6 .....GR-1183-T1

Channels 7-13 .....GR-1183-T2

Channels 14-83 .....GR-1183-T3

Note: Specify exact channel (and carrier offset, if any) when ordering.

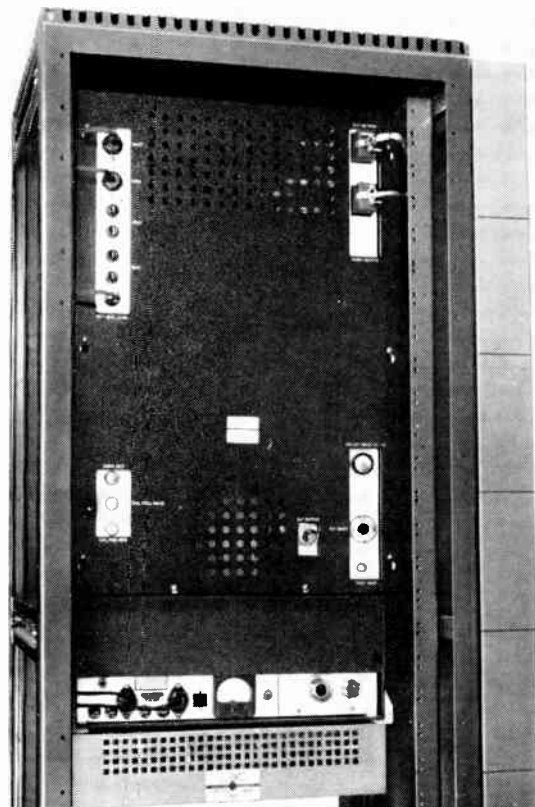

Rear view of the monitor showing the power and r-f terminals.  
Easy access to the rear of the equipment is assured by removable cover plates.

# == NOTES ==

# == NOTES ==

# NOTES

# A N T E N N A S

<b>INTRODUCTION AND GENERAL DEFINITIONS</b> .....	D-1
<b>ANTENNA COMPONENTS OPERATION AND DESCRIPTION</b>	
Vestigial Sideband Filters.....	D-4
VHF Diplexers and Filterplexers.....	D-7
R. F. Load and Wattmeters.....	D-11
Demodulator, WM-20B.....	D-15
Demodulator, BW-4A and BWU-4A.....	D-21
Superturnstile Antennas .....	D-24
Supergain Antennas .....	D-32
VHF Custom Antennas .....	D-37
Towers .....	D-41
UHF Filterplexer .....	D-45
VHF and UHF Transmission Lines and Fittings.....	D-49
Transmission Line Switching.....	D-56
Waveguides .....	D-59
UHF Pylon Antennas .....	D-61
UHF Custom Antennas.....	D-69
<b>APPENDIX "A" (BASIC THEORY)</b> .....	
Transmission Lines .....	D-76
Resonant Sections .....	D-77
Standing Wave Measurements.....	D-78
Cavity Resonators .....	D-89
Waveguides .....	D-91
Waveguide Application .....	D-93
<b>APPENDIX "B" (APPLICATION DATA)</b> .....	
Diplexer and Sideband Filter Power Ratings.....	D-96
VHF Antenna Data.....	D-97
Superturnstile Antenna Specifications.....	D-98
Beam Tilting and Vertical Pattern Shaping.....	D-99
UHF Antenna Data.....	D-113
UHF Directional Antenna Filing Data.....	D-114
Sample Computation and Pattern for Cardioid.....	D-116
Sample Computation and Pattern for Bi-directional .....	D-118
Transmission Line Efficiency.....	D-120
	D-122



# Introduction to TV Broadcast Antennas and Associated Equipment

## TV Broadcast Antennas and Associated Equipment

After the required r-f power is generated and modulated in the transmitter, the signal is passed through a number of filters and combining networks, monitored by suitable devices, and finally radiated from an antenna system. In this section, these components will be described in detail, giving the purpose of such units, the specifications that apply, the principle of operation, the construction of the units and some application notes which will help in utilizing the equipment most effectively. Fig. 1 shows block diagrams for VHF and UHF equipment. These indicate the units and their functions.

In the antenna section, the first portion deals with general definitions used in antenna work. After this, each component starting with the one closest to the transmitter will be described in turn.

### General Definitions Used in Antenna Work

The following definitions are commonly used in TV antenna work. These definitions may not be exactly rigorous but are given here primarily to clarify the ensuing text. The definitions, while general in nature, have special emphasis in TV antenna work.

### Infinite Line

Transmission line (usually coaxial type) which is infinitely long and has no discontinuities so that no reflections occur. In usual practice, the line is terminated in its characteristic impedance and thus simulates an infinite line.

### Characteristic Impedance

This is also called surge impedance or iterative impedance. It is dependent upon the dimensions of the line and is equal to the value of the pure resistance which will terminate the line so that no reflections occur. The characteristic impedance is also defined as the "driving-point" impedance which the line would have if it were of infinite length.

### VSWR (Voltage Standing Wave Ratio)

This is the ratio of the amplitude of a standing wave at an anti-node to the amplitude at a node. It is usually expressed as a ratio greater than unity, but may be expressed in DB.

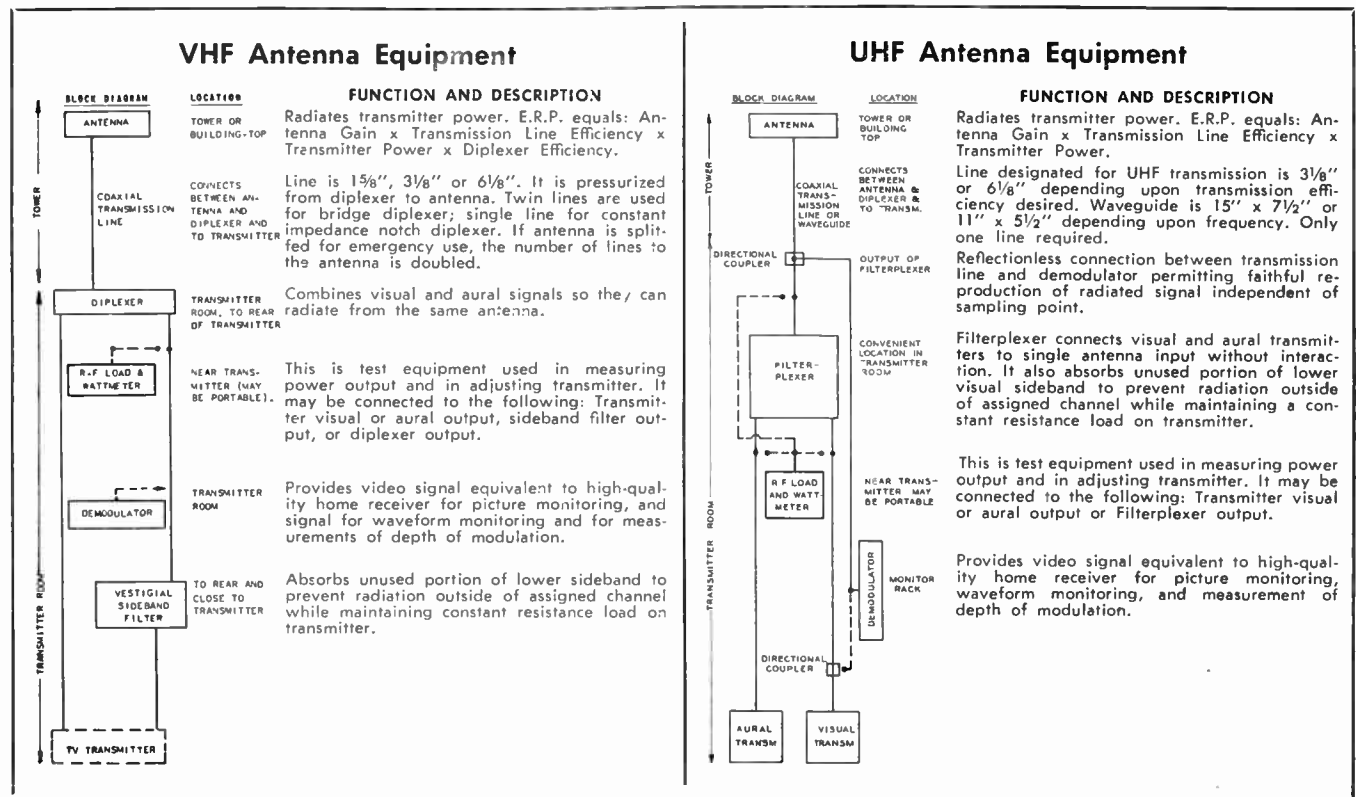

FIG. 1.



### $\lambda/4$ (One-Quarter Wavelength)

Often used in coaxial line work in describing phase delay. since the phase is delayed 90 electrical degrees by a matched line having an electrical length of one-quarter wavelength. In an unmatched line, the impedances of two points separated by a quarter wavelength have a conjugate relationship; that is, the reactances have opposite signs and the impedances are defined as  $Z_c = \sqrt{Z_1 Z_2}$

### Impedance Transformation

An impedance transformation of a coaxial line is accomplished by inserting in the overall transmission line a section of line with a dissimilar characteristic impedance. Both resistance and reactance can be controlled by the characteristic impedance, length, and position of the "inserted section" which is considered a "transformer."

### Isotropic Radiator

Theoretical point source of radiation used in calculations. The isotrope radiates equally in all directions through the sphere having the isotrope at the center.

### Power Gain

Power gain is the product of directivity and efficiency of an antenna at the picture carrier frequency.

### Directivity

Directivity referred to an isotrope is the ratio of maximum power flow per unit of solid angle to the average power flow at the same distance and for the same power input.

An isotropic radiator as defined above radiates equally in all directions. When an antenna is designed so that certain directions are favored, for instance, radiation in horizontal directions at the expense of radiation in an upward or downward direction, the antenna is said to possess vertical directivity.

Directivity can be measured by several methods. The most common method is a measurement of the vertical pattern of the antenna; that is, radiation in a plane perpendicular to the earth where the antenna is in its normal operating position, in a sufficient number of planes so that a complete spherical pattern is available. If the vertical patterns are not the same in various directions, they are averaged. The average pattern is then multiplied by the cosine of the vertical angle since the area of a band around a sphere decreases at higher angles as compared to the "equator" thus limiting the total power flow. The resultant vertical pattern is plotted on rectangular paper in volts<sup>2</sup> (to give power) vs. vertical angle. The area under this curve is then compared to the area of a rectangle having the maximum volts<sup>2</sup> value as one of its sides and the base line in vertical angle as the other. The ratio of these areas is the power gain compared to an isotrope.

In the television industry, gain compared to a dipole is used. Since a dipole has a gain over an isotrope of 1.641 the ratio obtained is divided by 1.641 to give the gain over a dipole.

Most antennas radiate energy which is cross polarized, as for instance energy that is vertically polarized when horizontal polarization is desired. This energy must be taken into account in the gain figure by measuring it separately or determining its value by other means and subtracting it from the overall gain. This is true since the cross polarized energy is of no direct benefit to the receiver and hence is wasted energy.

### Antenna Efficiency

Antenna efficiency is the ratio of total power radiated from the antenna to the total power input times 100 and is expressed as a percentage. These losses are quite difficult to arrive at by measurement and are generally calculated. Losses in the radiators themselves are practically always negligible in good designs. The I<sup>2</sup>R losses in the feed system contribute most to the losses present in the antenna. Feedlines are usually chosen so that efficiency of the antenna is well over 90%.

### Dipole

This is the classical radiating element of an antenna and is used as a reference. As usually used, it is lossless, and is one-half wave in length, and has a sinusoidal current distribution. Its power gain over an isotropic radiator is 1.641.

### Batwing

Variations of a dipole used in the Superturnstile antenna. A batwing section can be approximately simulated by a pair of crossed dipoles separated about 1/2 wavelength.

### Section

A basic antenna unit consisting of single radiators or a characteristic grouping of radiators. For instance, in the Superturnstile antenna, a group of four batwings is called a section.

### Superturnstile Antenna

An antenna based on the turnstile or quadrature feed principle but using batwings in place of dipoles for greater bandwidth.

### Balanced Line

A transmission line whose two conductors have equal magnitudes of voltage with respect to ground. Commonly referred to as "Balanced to ground."

### Unbalanced Line

A transmission line whose two conductors have unequal magnitudes of voltage with respect to ground. Commonly referred to as "unbalanced to ground."

### Balun

"BALanced to UNbalanced." Electrical network to transform from BALanced two-line circuit to UNbalanced single-line circuit. In the usual case, the single-line circuit

is a single coaxial line. The two-line circuit is two separate coaxial lines with the two outer conductors connected together and grounded, and the two inner conductors fed 180 degrees out-of-phase.

**Bridge-Balun**

Electrical network which combines a balun with two adjacent arms of a Wheatstone bridge circuit. The "bridge" balun has four coaxial line connections. As normally used, two of the connections feed independently of each other into the other two arms. The bridge-balun is used in the basic circuit of the bridge diplexer, the filterplexer, the constant impedance notch diplexer and the power equalizer.

**Power Equalizer**

Bridge-balun circuit used in quadrature fed antenna to assure that the powers in the N-S and E-W sections of the antenna are equal.

**Diplexer**

Unit to combine transmission of two signals on single circuit.

**Vestigial Sideband Filter**

A filter which attenuates the energy which appears beyond the lower edge of a television channel.

**Filterplexer**

Combination vestigial sideband filter and diplexer.

**AISC:**

American Institute of Steel Construction (Manual).

**C:**

Degrees, Centigrade (Example: 100°C).

**F:**

Degrees, Fahrenheit (Example: 100°F).

**—:**

Feet, - Inches (Example: 30-6; 30 feet 6 inches).

**Kips:**

One thousand pounds.

**mc:**

Megacycles per second.

**mph:**

Miles per hour.

**psf:**

Pounds per square foot.

**psi:**

Pounds per square inch.

**RTMA or RETMA**

Radio and Television Manufacturers Association.  
Radio, Electronics and Television Manufacturers Association.

**V:**

Wind velocity in mph.

# VESTIGIAL SIDEBAND FILTER

## Purpose

The filter attenuates the lower sidebands of the visual transmitter and provides a constant impedance load for the output stage of the visual power amplifier. The services in the frequency band below the television channel are protected against interference, and the factory tuned filter minimizes transmitter operating adjustments.

## Specification

The vestigial sideband filter is a part of the television transmitter. As the power amplifier of the visual transmitter is matched with a standing wave ratio of 1.1 to 1, the sidebands that fall below the television channel are attenuated by 20 db. or more. There is a minimum of

attenuation in the range of frequencies utilized by the television home receivers stretching from approximately three-quarters of a megacycle below the picture carrier to a maximum of four and a half megacycles above the picture carrier. The transmitter visual output power is measured at the output of the filter so that the insertion loss of the unit need not be considered in computing the effective radiated power of the television station.

The filters are coaxial transmission line networks. The input and output connections have standard dimensions for  $3\frac{1}{8}$  inch and  $1\frac{5}{8}$  inch transmission lines. The earlier units had a characteristic impedance of 72 ohms, and the later units 51.5 ohms. For optimum operating conditions, the transmission line connecting the power amplifier to the filter should not be greater than ten feet. The ambient

FIG. 1. Front view of the MI-19085 VHF Vestigial Sideband Filter for Channel 10.

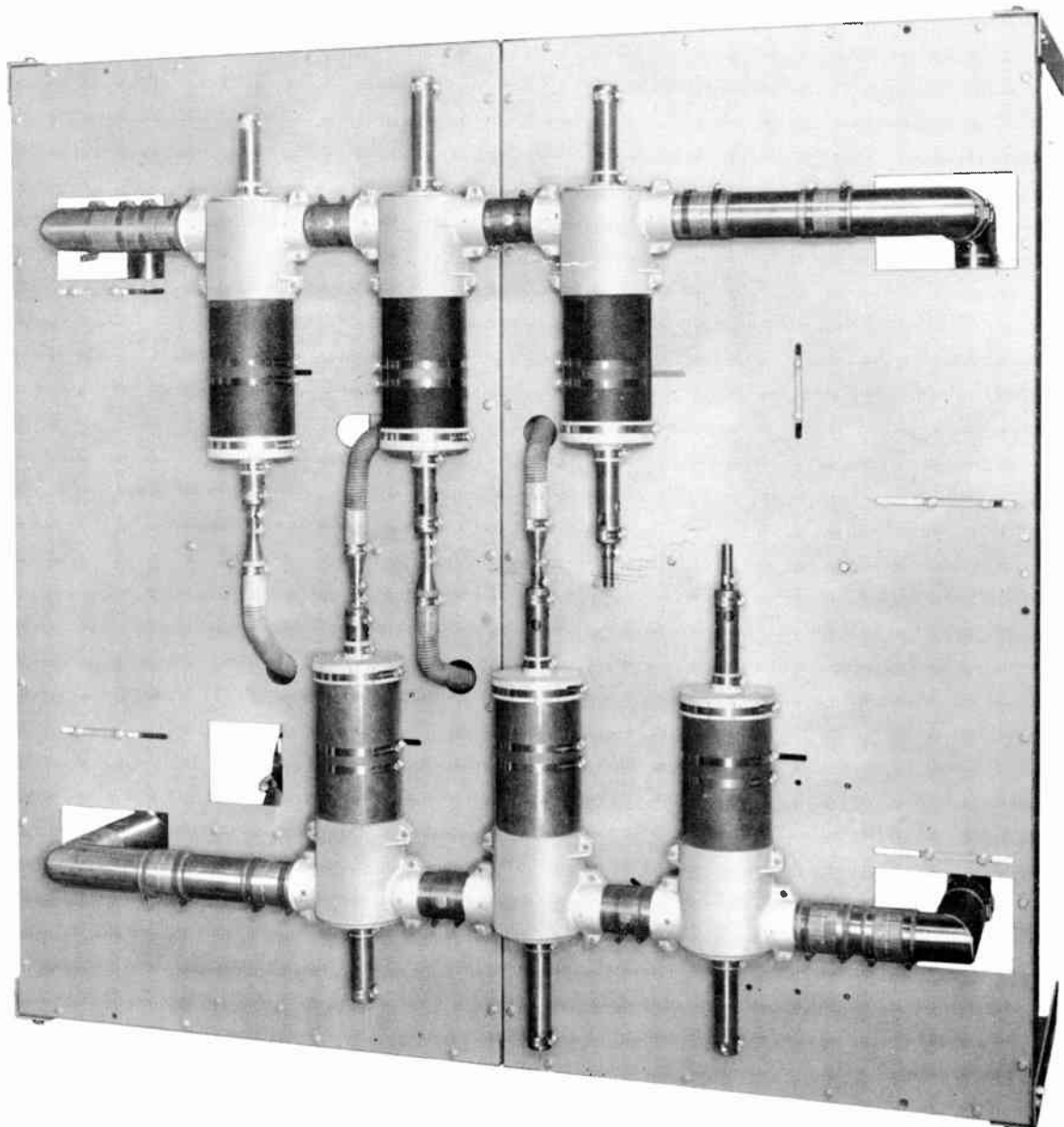

temperature of the air about the filter should not exceed maximum of 45° C. for the transmitter operation.

### Principles of Operation

The vestigial sideband filter passes the visual signal energy of the television channel from the power amplifier to the antenna feed system. The small amount of energy that falls below the assigned channel is dissipated in an absorbing resistor. Several types of filters are now in use. One is a combination of a low pass and a high pass filter to give constant impedance characteristics. Another type uses a bridge arrangement with balanced high pass filters.

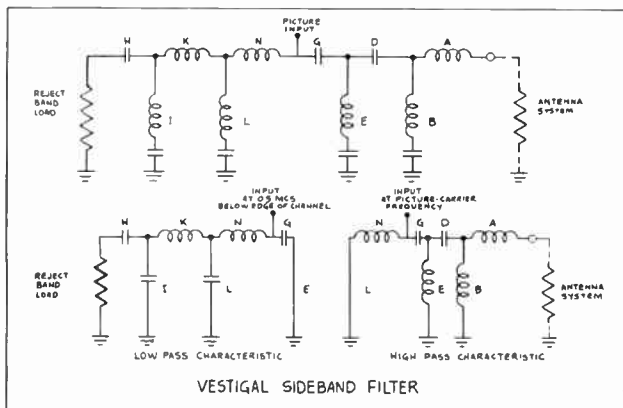

FIG. 2.

The combination of the high pass and the low pass filters in parallel (Fig. 2) gives a constant input impedance for the radio frequency energy. The high pass section terminated by the antenna system allows the picture carrier energy and the sideband energy inside the television channel to go to the antenna. The small amount of energy below the lower channel edge goes through the reject section to the load. The combination of the two filters present a constant input impedance to the transmitter over the entire double sideband.

The bridge circuit with the high pass filters is used with the higher power transmitters. The visual energy enters the bridge balun similar to the antenna diplexer (Fig. 3), passes through two parallel coaxial lines each having three cavities which are series resonated for three reject frequencies and parallel resonated for the picture carrier. All of the reject frequencies are below the lower edge of the channel. The cavities operate in pairs. Cavi-

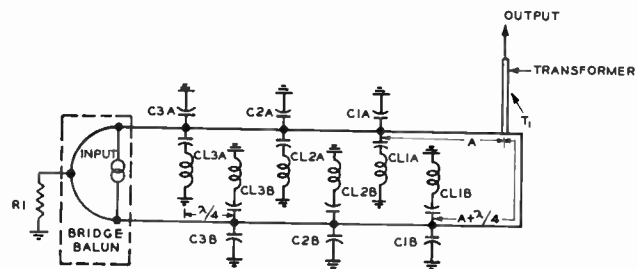

FIG. 3.

ties 3A and 3B are tuned to the same frequency, but are separated by  $\lambda/4$  as shown in Fig. 3. Since the cavities place a very low impedance across the line at their series resonant frequency, the energy at this frequency is almost totally reflected. However, since the energy in cavity B must travel  $\lambda/2$  further in a round trip than the energy in cavity A, a phase reversal occurs so that the energy does not return to the input but is dissipated in resistor R1. The same procedure applies to the other set of cavities. Hence the proper attenuation characteristic is achieved while monitoring a constant load to the transmitter over the double sideband.

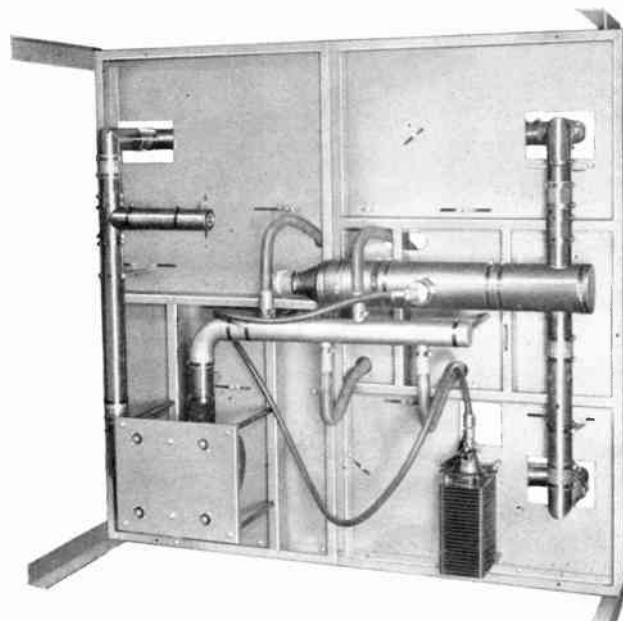

FIG. 4. Rear view of the MI-19085 high-band Vestigial Sideband Filter shown in Fig. 1.

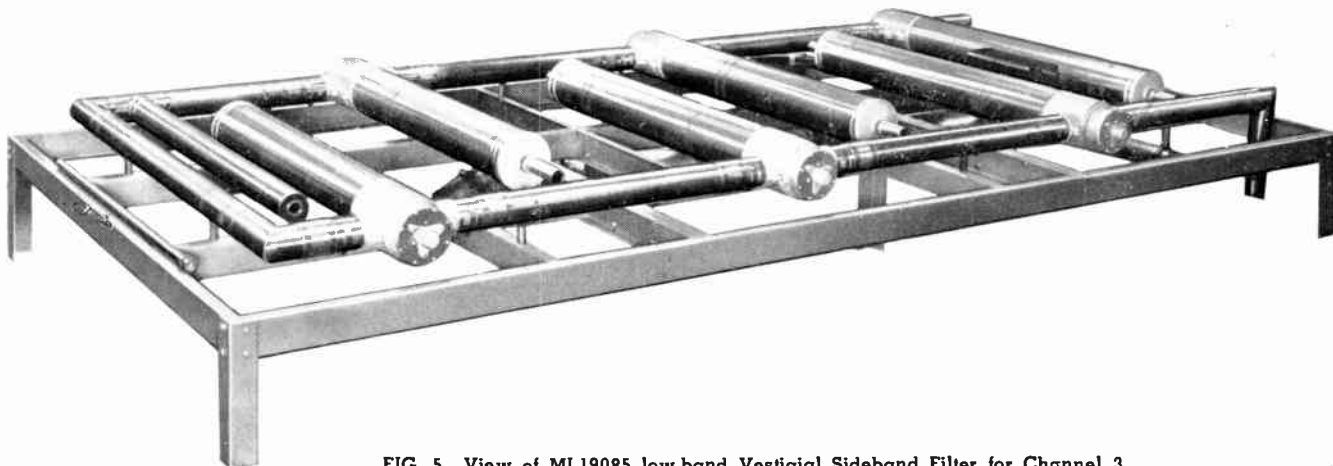
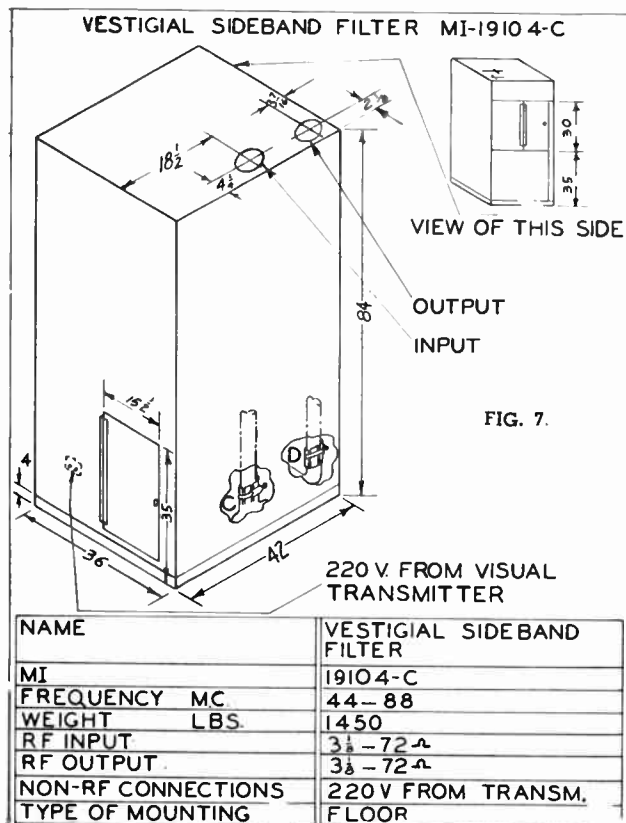
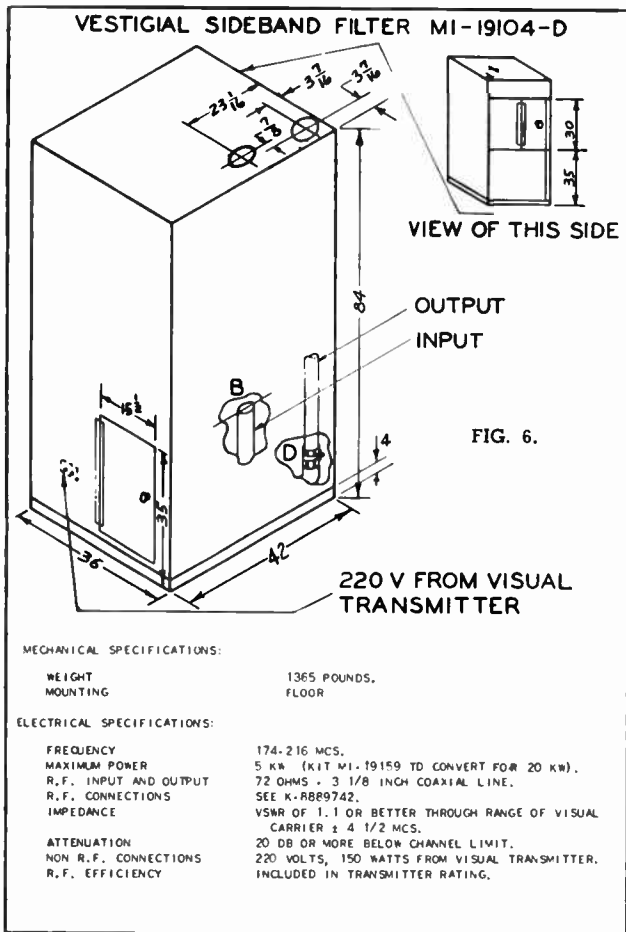

FIG. 5. View of MI-19085 low-band Vestigial Sideband Filter for Channel 3.



### Construction

The high-low pass combination filter construction varies with the power rating. A unit for operation in a lower power transmitter is the MI-19114. The series resonant section (BEL&I) (Fig. 2) are 3 inch coaxial transmission lines at least one-half wave length long with stepped elements. The series elements (ADGKNH) are tucked in one end of the half wave section and the transmission lines to the reject load and antenna (Fig. 8). The larger filter, MI-19104, has the series resonant transmission lines folded along the side of the 5 inch diameter isolating sections containing the series elements.

The bridge type filter consists of a rectangle of 3 1/8 inch 51.5 ohm transmission line. A bridge balun is mounted at one end and the output transformer at the other end. Each of the two sides contains three resonant transmission line cavities. The input and output connections are 3 1/8 inch, 51.5 ohm transmission line.

The construction of the MI-19085 filter is illustrated in Figs. 1 and 4. The resonant transmission line cavities are shown in Fig. 1. Cooling air is supplied to four of the cavities by hose connections to the cavities. The reverse side is shown in Fig. 4. The input bridge balun is in the right center, the output tee in the left center and the absorbing load in the lower center of the photograph. The blower motor for cooling is in the lower left corner.

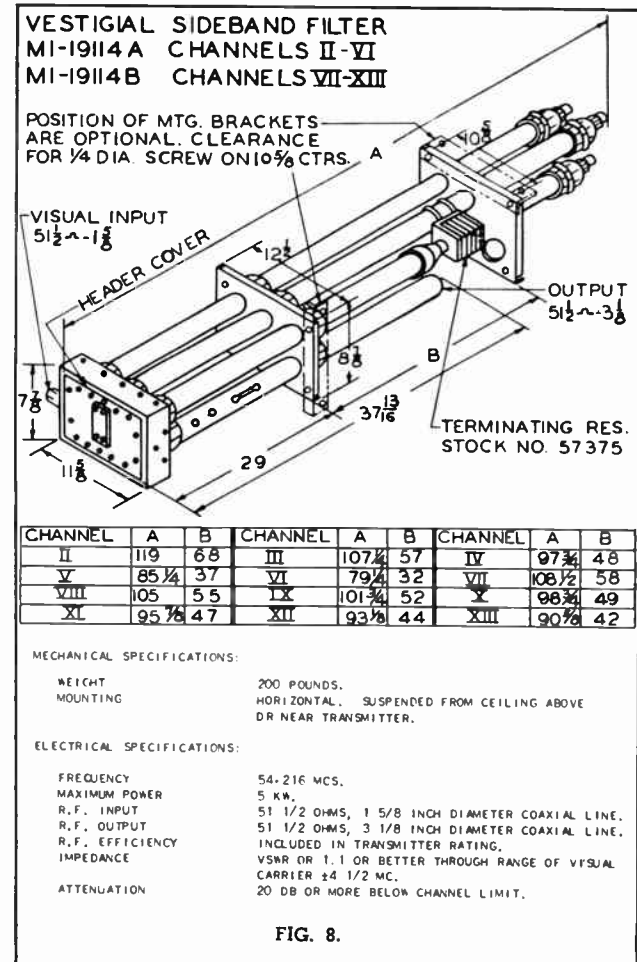

# VHF DIPLEXERS & FILTERPLEXERS

## Purpose

The diplexer permits the simultaneous transmission of visual and aural signals into a single antenna without interaction between the two signals. There are three types in use: namely, the bridge diplexer, constant impedance notch diplexer and the filterplexer. When used in conjunction with the Superturnstile Antenna and Channel 7 to 13 Supergain Antenna, the bridge type delivers equal power to the N-S and E-W radiators from visual and aural transmitters. For Channel 2 to 6 Supergain application, the notch diplexer or filterplexer is used in combination with tuned cavities thereby providing simultaneous feeding of both sound and picture signals through one transmission line. The filterplexer, which combines the operation of the notch diplexer and the vestigial sideband filter, has practically supplanted the notch type.

## Specifications

The diplexer, when terminated in equal loads, provides almost perfect isolation between visual and aural inputs. The antenna loads are seldom perfect however, therefore, some visual energy appears at the aural input and vice versa. Under usual conditions this crosstalk is less than 30 db. This degree of isolation insures against either loss of power or cross modulation.

The input VSWR of the diplexer is also dependent on the antenna loads. The diplexer itself has a visual input VSWR of 1.05/1.0 or better when correctly terminated.

The diplexer is designed for input and output impedances to match the standard transmission line characteristic impedance. It has a low insertion loss—usually less than 0.5% because it uses no tuned traps or other circuits carrying high circulating current. The power handling capacity is correspondingly high because the power dissipated is roughly equivalent to that of an equal length of transmission line of the same dimensions.

The diplexer should be mounted where the ambient temperature will not exceed 45°C and where the altitude is not more than 5,000 feet above sea level for published ratings.

When used in the filterplexer, the diplexer has greater sound insertion loss. This is compensated for in the transmitter so that 50% sound power as compared to peak picture power can be achieved with all RCA transmitters except the TT-2AL/2AH.

## Types

1. Bridge MI-19390 and MI-19391
  - a. Principle of Operation

The type of diplexer most used in television broadcasting today is the bridge type. This is the type

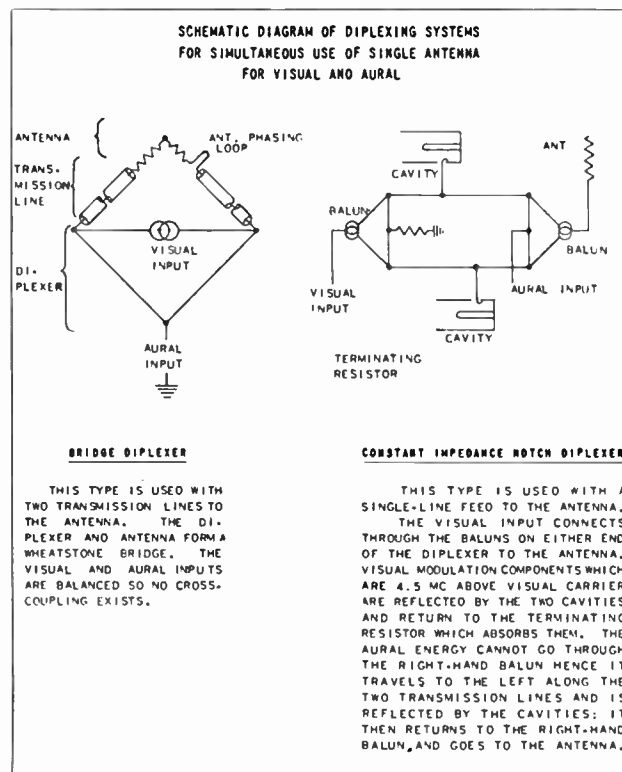

FIG. 1.

generally used with the Superturnstile Antenna which has equal input impedances of the two halves (N-S and E-W sides) of the antenna. Figure 1 shows that the diplexer, together with the antenna circuit, is equivalent to a Wheatstone Bridge circuit. The two equal resistive arms of the bridge represent the N-S and E-W sides of the antenna, respectively, while the diplexer contains the two equal reactive arms. The visual and aural inputs are connected as shown; and from each, the power divides equally to feed to the two sides of the antenna without interaction between visual and aural. Note that an important feature of this type of diplexer is the ability to transmit visual and aural r-f energy of the same frequency; thus, the upper visual sideband at 4.5 megacycles modulation is the same as the aural carrier frequency, but both are transmitted without interaction.

## b. Construction

The construction of the coaxial bridge type, as shown in Figure 2, is based on the split balun in which the outer conductor of a coaxial line is split for a quarter wavelength with the inner conductor connected to one side of the end of the split section. The two ends of

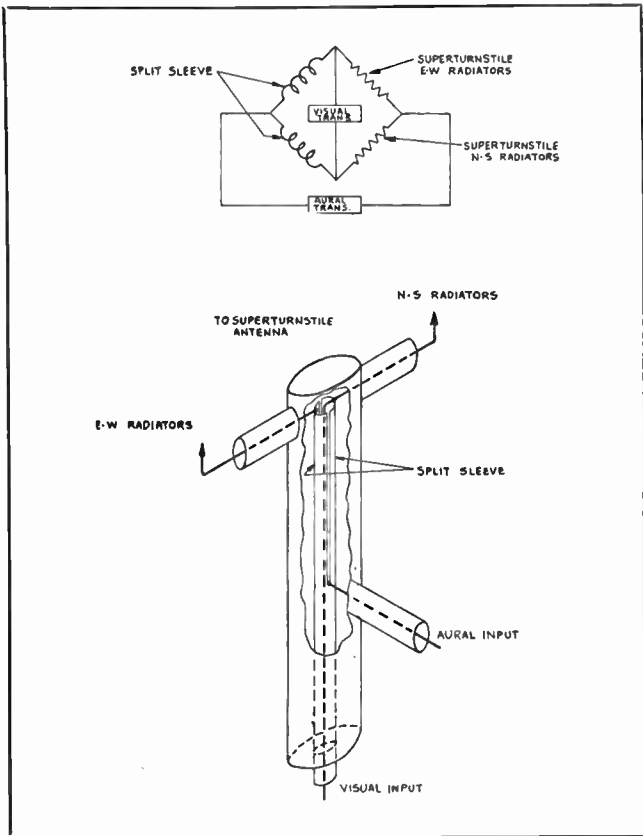

FIG. 2. The Bridge-type diplexer is simply constructed and equivalent to a Wheatstone Bridge.

the split section assume opposite polarities; therefore, the single ended input is thus converted to a double ended circuit. This outer conductor is surrounded by a coaxial shield which forms the new electrical outer conductor. The aural input circuit inner conductor is connected to the crotch of the split section so that aural energy flows along as on two parallel conductors connected push-push. The external appearance of the split balun type is shown in Figures 3 and 4.

c. Application Notes

The diplexer should be mounted near the transmitter where ambient temperature will not exceed 45°C (113°F), free circulation of air will be obtained, and the diplexer will not be exposed to the outside weather.

2. Constant Impedance Notch Diplexer

The constant impedance notch type of diplexer is normally used with an antenna having only a single input transmission line such as the Supergain antenna for Channels 2 to 6. As shown in Figure 1, this type uses two bridge balun units, connected back-to-back and includes two high-Q cavity circuits which are spaced one-quarter wavelength apart—one on each of the two interconnecting coaxial transmission lines. The

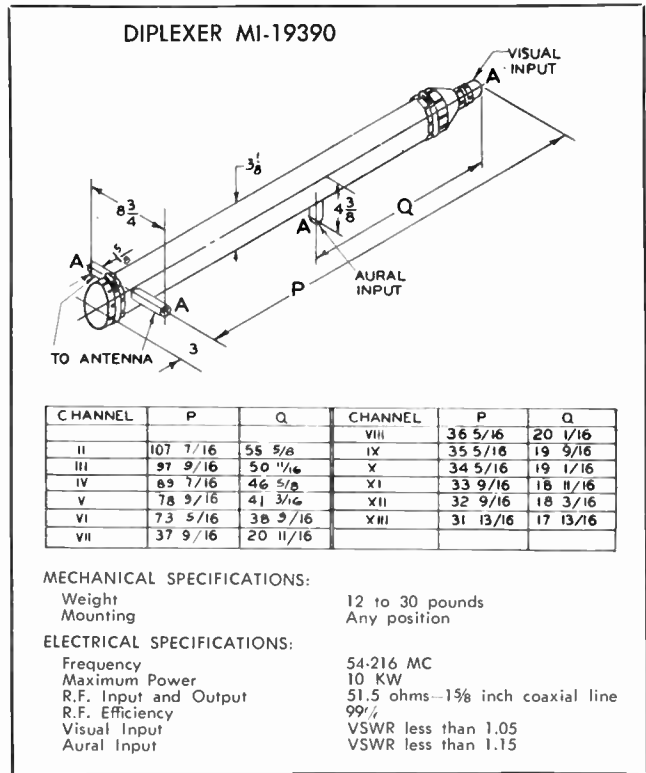

FIG. 3.

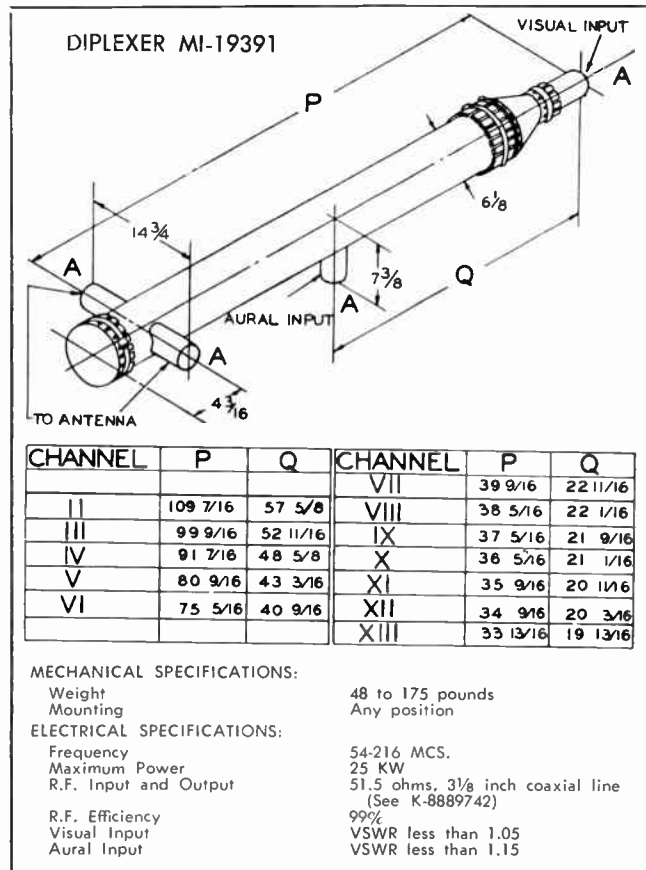

FIG. 4.

operation of the notch diplexer is similar to that of the filterplexer except that the filterplexer represents a combination of the vestigial sideband filter and constant impedance notch diplexer, assembled as a single unit. Because filterplexer units are built at lower costs than the combined cost of the Constant-Impedance Notch Diplexer and Vestigial Sideband filter units, savings are realized when filterplexer units are used for TV installations with single line feed into the antenna. The notch type of diplexer may be obtained on special order.

### 3. Filterplexers

#### a. Principle of Operation

The purpose of the VHF filterplexer is to attenuate the lower sideband of a double sideband visual transmitter, and to feed the outputs from the visual transmitter and the aural transmitter simultaneously through a single coaxial line to an antenna.

The filterplexer includes two bridge baluns, No. 1 and No. 2 (as shown in Figure 5) connected by two equal lengths of interconnecting coaxial transmission line and three filter circuits (cavities) on each of the two interconnecting coaxial transmission lines.

The operation of the filterplexer is similar to the vestigial sideband filter explained previously. Referring to Figure 6 note that cavity No. A is tuned to the sound frequency and presents an electrical short circuit for sound energy. The sound transmitter is fed into the network, as indicated, in phase on both coaxial lines. The reflection, due to the electrical short circuit, will be equal except that the reflected components of the upper transmission line will have travelled a path length difference of  $180^\circ$ , as compared to the lower transmission line. Since the reflected sound components are now out of phase by  $180^\circ$ , they will not re-enter the sound transmitter line but will emerge to the antenna in a single coaxial transmission line. Leakage of sound power beyond the sound cavities is discharged through the terminating resistor.

Cavity Nos. B and C are used to obtain the vestigial response characteristics of the visual input. This section of the unit operates similarly to the sideband filter with the pass band travelling directly to the antenna and the lower side band being reflected and absorbed in the reject load.

Figure 6 displays the high quality performance characteristics of the filterplexer. The insertion loss is less than 1 db to a point 4 megacycles above picture

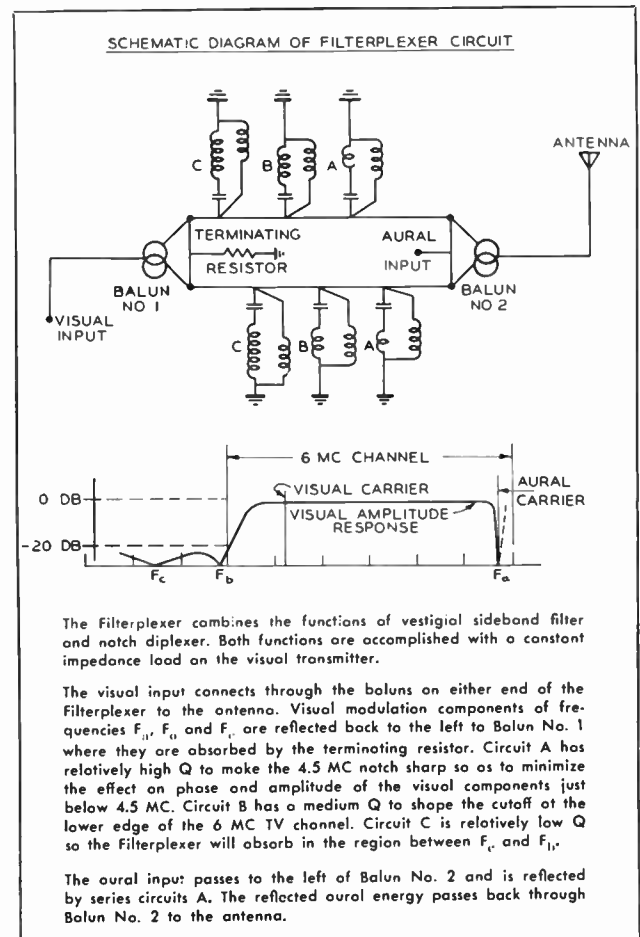

FIG. 5.

carrier frequency, which represents a very desirable band pass characteristic. The vestigial sideband characteristics are also maintained by having the lower sideband frequencies attenuated to more than 20 db from the low end of the channel (1.25 megacycles) to 4.25 megacycles below the picture carrier.

#### b. Construction

The construction is as shown in Figure 6. The mounting dimensions of a typical unit are shown in Figure 6.

#### c. Application notes

The filterplexer is usually mounted in the area at the rear of the transmitter as this provides the most convenient transmission line arrangement. The unit can be supported from overhead, or it may be placed against a wall. In either case, the transmission lines from the transmitter should be as short as conveniently possible. If the unit is supported overhead, it is usually possible to have it directly back of the transmitter, just



high enough to clear the transmitter doors. In this way the area below the filterplexer is useful for access to the transmitter and filterplexer, and serves as a passageway. The filterplexer is arranged for unpressurized non-flanged fittings since it is to be used within the transmitter room. When mounted overhead it is important to make sure the ambient temperature does not exceed the rated value since hot air pockets often exist above the transmitter.

There are no adjustments that require attention during normal installation or operation, however an RCA Service engineer should check the tuning of the resonant lines at the time of installation to make sure nothing has shifted during shipment. If carrier offset is used, this should be stated on the order so that the aural resonant line adjustment can be optimized at the carrier frequency. The terminating load which absorbs the unwanted energy at frequencies below the channel is equipped with a crystal pickup which can be used to indicate the relative power absorbed. This will show an increased amount absorbed during the warm-up period since the resonant line tuning is optimized for normal power operation.

It is important to note that any change in adjustments should be done by RCA Service engineers as they have the necessary test gear and have received the required training in the testing and adjustment of this equipment.

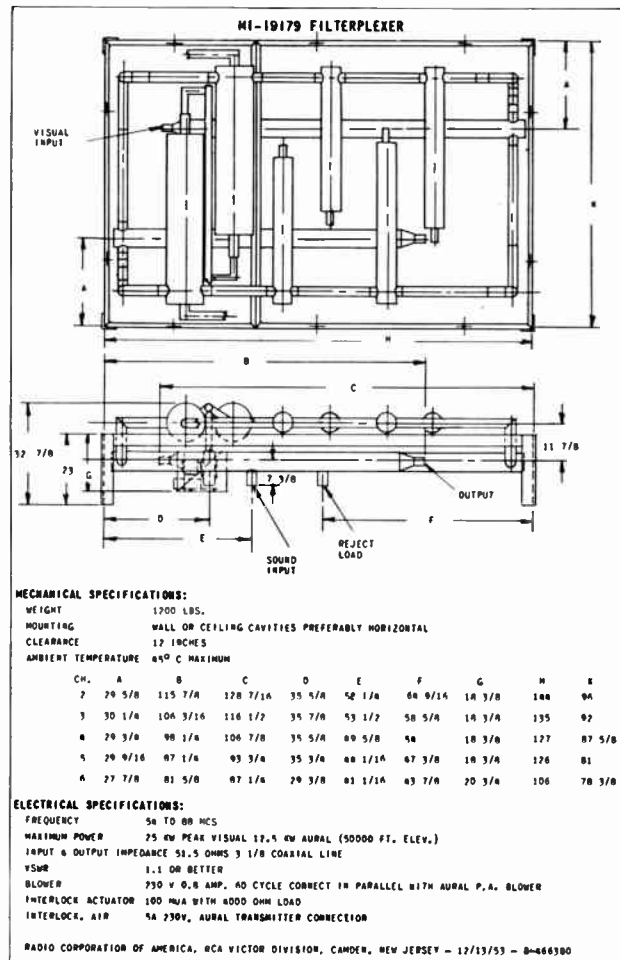

FIG. 6.

# R-F LOAD and WATTMETERS

## Purpose

The R-F Load and Wattmeter serves the following purposes:

1. It serves as a secondary standard for power measurements as required by FCC regulations.
2. It can be used as a matched load on either the visual or aural side of the transmitter for tests and adjustments. Thus it can be used for calibration of the reflectometers and for similar purposes without the necessity to radiate a signal.
3. It can be used for various types of emergency operation in case of failure of part of the transmission line system. For instance in a system using a bridge diplexer, the load may be temporarily connected to the diplexer output to replace a transmission line that has become faulty. In this way service is maintained with the remaining part of the antenna.
4. It can be used as a temporary spare for the terminating resistor of the filterplexer or vestigial sideband filter.

## Specifications

Several sizes are available, with power ratings as shown below. The ratings are based on average power (not peak power). Inasmuch as the average power on either the visual or the aural side of the transmitter does not exceed 60% of the rated transmitter power, (black level) the load ratings are also based on 60%. For instance a 0.6 kw load would be used with a 1.0 kw transmitter. A load of this rating would take care of all possible requirements with one exception—it would not handle the combined

visual and aural transmitter outputs. This would be required only in terminating the combined output of a filterplexer, and this is not required in usual practice. Should provision for such operation be desired for any reason, the next larger size load can be ordered. However, this would provide somewhat less accuracy for either the visual or the aural transmitter alone.

## Principle of Operation

As indicated in the name, this device fulfills two functions: (1) terminating a transmission line in its characteristic impedance, and (2) measuring the power dissipated.

The load resistor has a total resistance equal to the characteristic impedance of the transmission line section. The outer conductor of the resistor is tapered exponentially so that the characteristic impedance is equal to the remaining resistance at any point along the resistor. For instance at the Dotted Line,  $Z = R$ . See Fig. 1. This exponential taper results in an unusually broad frequency coverage.

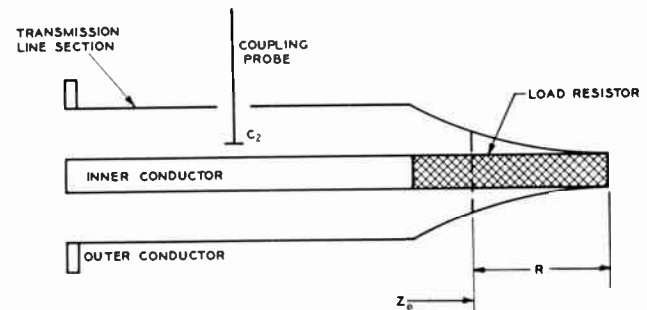

FIG. 1. Schematic of R-F Load.

## R-F Load and Wattmeters for TV Transmitters

MI Number	Average Power Rating	Usable Range	Type of Cooling
19196	1200 W VHF	240 to 1200 W	Natural Air Convection
19197	1200 W UHF	240 to 1200 W	Natural Air Convection
19199	6 KW VHF	1.0 to 6 KW	Tap Water (2 GPM)
19198	7.5 KW UHF	1.5 to 7.5 KW	* Tap Water and Pumped Coolant (2.5 GPM)
19193	25 KW VHF	3.0 to 25 KW	* Tap Water and Pumped Coolant (10 GPM)
19191	50 KW VHF	6.0 to 50 KW	* Tap Water and Pumped Coolant (25 GPM)

\* Units have coolant to remove heat from resistor, and heat exchanger through which coolant is circulated to transfer the heat to the tap water.

Two types of power indicating devices are used, one in which voltage is measured across the load itself and the other in which energy is coupled from the coaxial transmission line.

In the MI-19193, 25 kw load, Fig. 2, power is measured across the terminating resistor as a function of voltage. A rectifying crystal converts the r-f to d-c. The resistance of the termination is essentially constant; thus enabling a voltmeter connected across it to be calibrated in power indications (kilowatts). Measuring volts in terms of power necessitates the use of a square law scale on the wattmeter.

The MI-19197 1.2 kw RF Load, Fig. 3, uses a directional coupler for power indication. A socket is provided on the side of the transmission line coupling section to accommodate a calibrated wattmeter element. The element plugged into this socket will be coupled to the transmission line and develop a d-c current approximately proportional to the forward wave voltage across the load resistor. This current

is supplied to a remote meter calibrated to indicate directly the power dissipated in the load.

The complete resistor unit is immersed in a coolant liquid which is used to remove the heat developed in the resistor. In the smaller size units, the coolant circulates by convection so that the heat is transferred to the case. The case has cooling fins to aid in the transfer of the heat to the surrounding air. In the medium power units the heat is removed from the coolant by a coil of finned copper tubing which is located in the upper part of the case, away from the r-f circuits. Tap water is circulated through the finned tubing at a rate sufficient to prevent excessive temperature rise in the coolant. The design of the high dissipation loads includes a motor driven pump to force the coolant past the resistor at a high velocity and thus to carry the heat away at a higher rate. This unit also includes a coolant-to-water heat exchanger through which tap water circulates. In order to prevent excessive use of tap water during the time the r-f power is at a low level, a water saver is used in some cases.

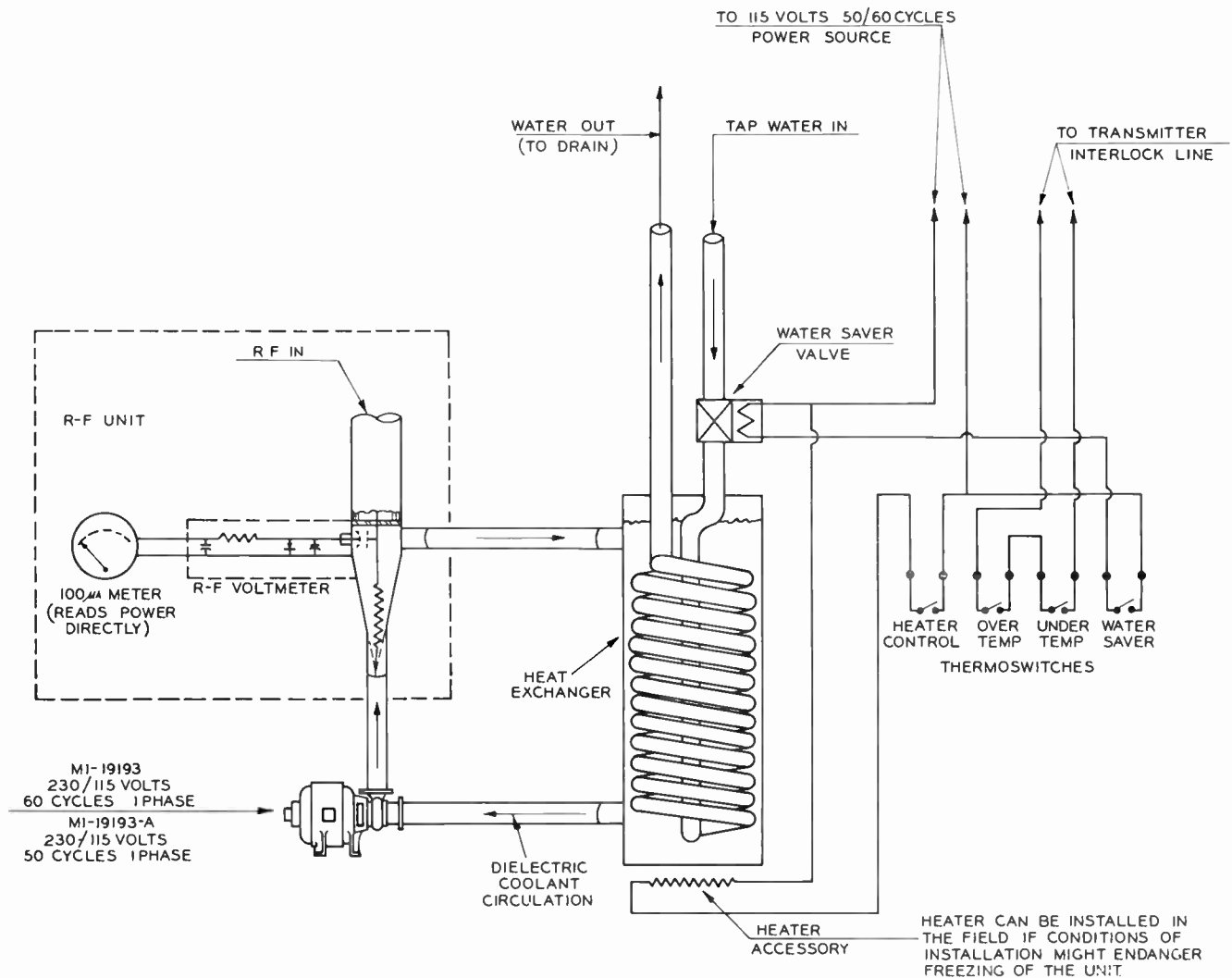

FIG. 2. Schematic diagram of MI-19193, 25 KW load.

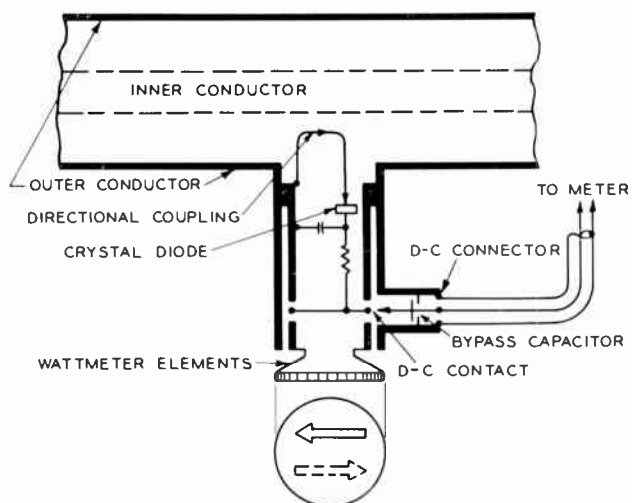

FIG. 3. Wattmeter element schematic diagram.

This consists of a thermostatically controlled solenoid valve which allows the water to flow only when needed. In this case the coolant is of a special type which has a very high specific heat, since this aids in keeping the temperature of the resistor at a safe value. This special coolant solidifies at about 65° F; hence, the design of the load has provision for a thermostatically controlled heating element to keep the coolant in the liquid state when the unit is idle.

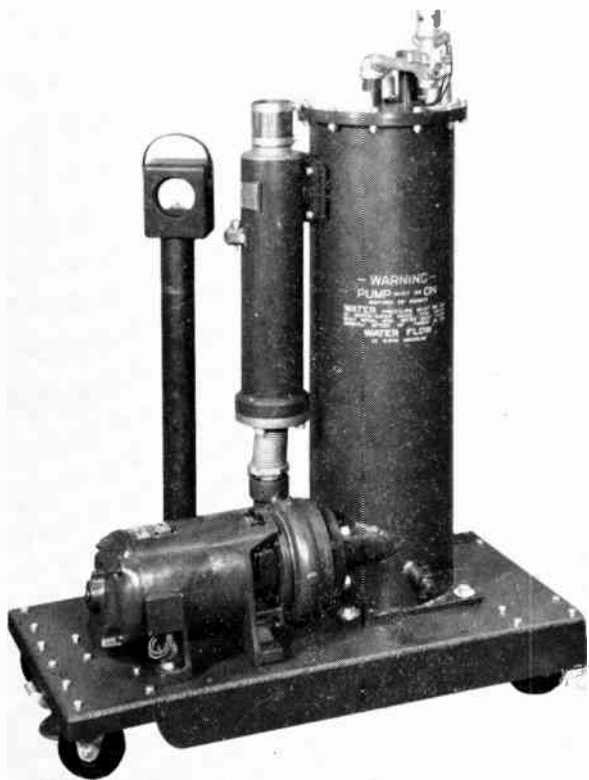

FIG. 4. MI-19193 25 KW R-F Load and Wattmeter.

## Construction

The construction of two of the available types of units is shown in Figs. 4 and 5. The air and water cooled types are readily distinguishable.

## Application Notes

The use of these power loads is convenient if precautions are taken in the layout of the transmission line. This layout should be such that the load can be centrally located, with short connections to the five possible places to which the load may be connected, as shown in Fig. 6. This attention to the transmission line layout within the station is important for the high dissipation loads, since the connections must be of 3-1/8" transmission line. In general the problem can be solved in either of three ways:

1. Locate load in fixed position. Make up five sets of connection lines and keep them on a suitable rack so that any of the planned connections can be made whenever desired.

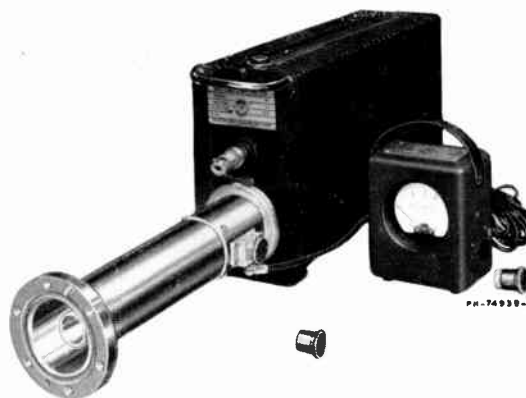
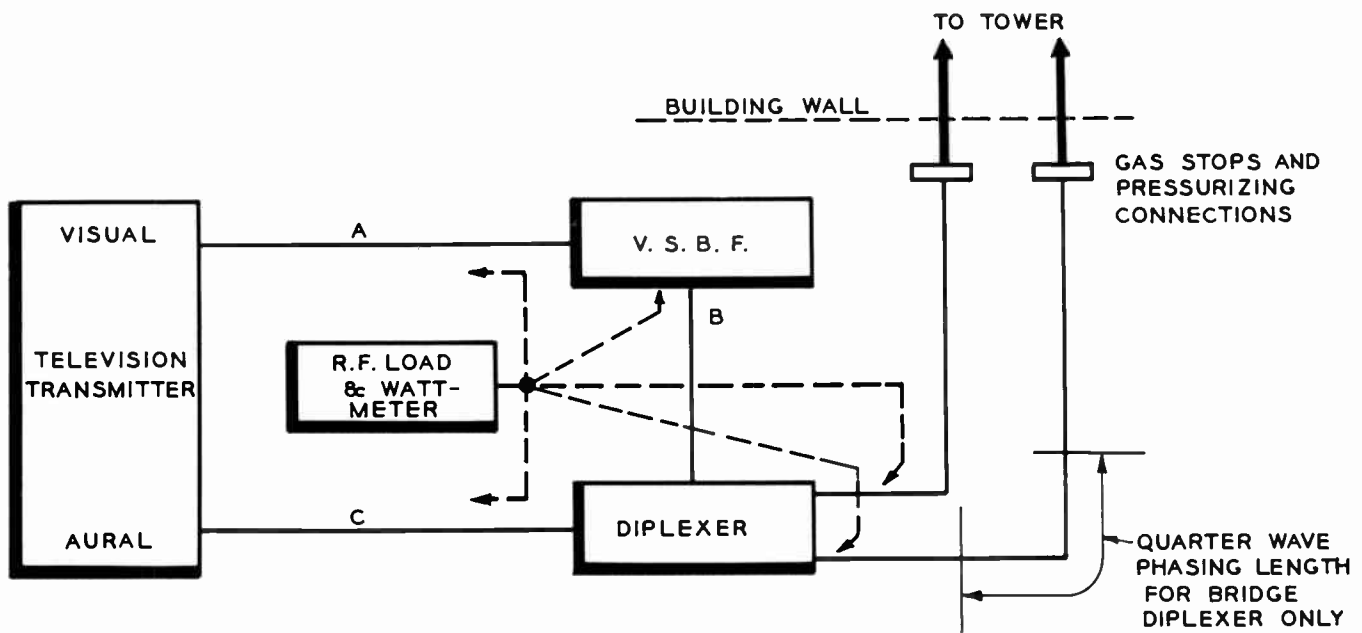

FIG. 5. MI-19197 1.2 KW R-F Load and Wattmeter.

2. Arrange transmission line so that load can be placed in position and connected with one or two previously made up connection lines.
3. Plan a layout utilizing either the manual transfer panel or coaxial switch which are described under the article "Transmission Line Switching."

The loads which are cooled by tap water are provided with interlocks which should be connected into the transmitter overload circuit to prevent operation if the coolant is too hot.

The d-c resistance of the non-inductive resistor is stamped on the nameplate. Using an accurate Wheatstone bridge, the unit can be checked to make certain the resistance has not changed. Since each load carries the manufacturer's guarantee, servicing should not be attempted in the field but the unit should be returned to the manufacturer for repairs. If, for any reason, the load should be opened, the guarantee is voided.



1. Line A should be as short as practical (not over 10 to 15 feet).
2. All components should be placed so that the A, B, and C and the Antenna lines will each have at least one elbow to facilitate installation and test.
3. The R-f Load and Wattmeter must connect for test purposes to any one of the five positions shown. For the sizes rated at one kilowatt and above, the load can be permanently mounted. Loads rated at more than five kilowatts require rigid line connections which must be made up from elbows and straight lengths of line. The layout of the station should be such that these lengths are as direct as possible.
4. Inside connections are not gassed, hence flanged connections are not required.

FIG. 6. Five possible places to which R-F load may be connected.

# DEMODULATORS, THE WM-20B

## Purpose

The demodulator for the vestigial sideband system of picture transmission is a critical monitor for the output of the visual portion of the transmitter. Response characteristics of this unit simulate the ideal response or design goal of the television receiver. Depth of modulation can also be determined by means of a chopper when the output is displayed on an oscilloscope.

## Specification—WM-20B

The WM-20B Vestigial Sideband Demodulator MI-19216 provides the master monitor with a signal indicative of the picture as may be seen on a high quality home receiver. This unit is factory tuned to a specified channel from 2 through 13 and cannot be retuned to any other channel. The input coupling unit is mounted on a 1-5/8" or 3" diameter line. Outputs of the video unit and the Monitoring Diode provide up to 1.5 volts peak-to-peak, with synchronizing pulses negative, across a 72 ohm line. Sound rejection by combination of video and r.f. traps is greater than 40 db.

## Principle of Operation—WM-20B

The WM-20B visual monitor equipment monitors the visual signal during transmitter operation and also gives an envelope response during transmitter adjustment when using a video sweep generator.

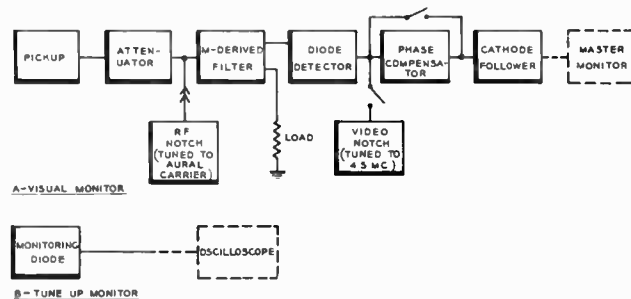

FIG. 2. Block diagram WM-20B.

The Monitoring Diode MI 19051-A during video sweep alignment of the visual transmitter shows the addition of low frequency sidebands (Fig. 2). The vestige of the lower sidebands in the region between the visual carrier and the lower edge of the channel adds to the higher sidebands to give 100% response in the low video frequencies. The relative amplitudes of the additive sidebands are about equal. Distortion of the relative amplitudes occasionally hidden in the diode response may be indicated by the visual monitor.

The visual monitor response approximates that of an ideal receiver. A constant impedance m-derived filter determines the attenuation characteristic in the visual carrier region, and two traps (radio-frequency  
*(Continued on page D-21)*



FIG. 1. The WM-20B Sideband Demodulator for VHF.

# WM-20B DEMODULATOR OPERATION

In the following pages there are photographs of five test patterns which were taken of both the diode and the demodulator output at the power amplifier and at the vestigial sideband filter. These clearly show the effects introduced by the vestigial transmission system.

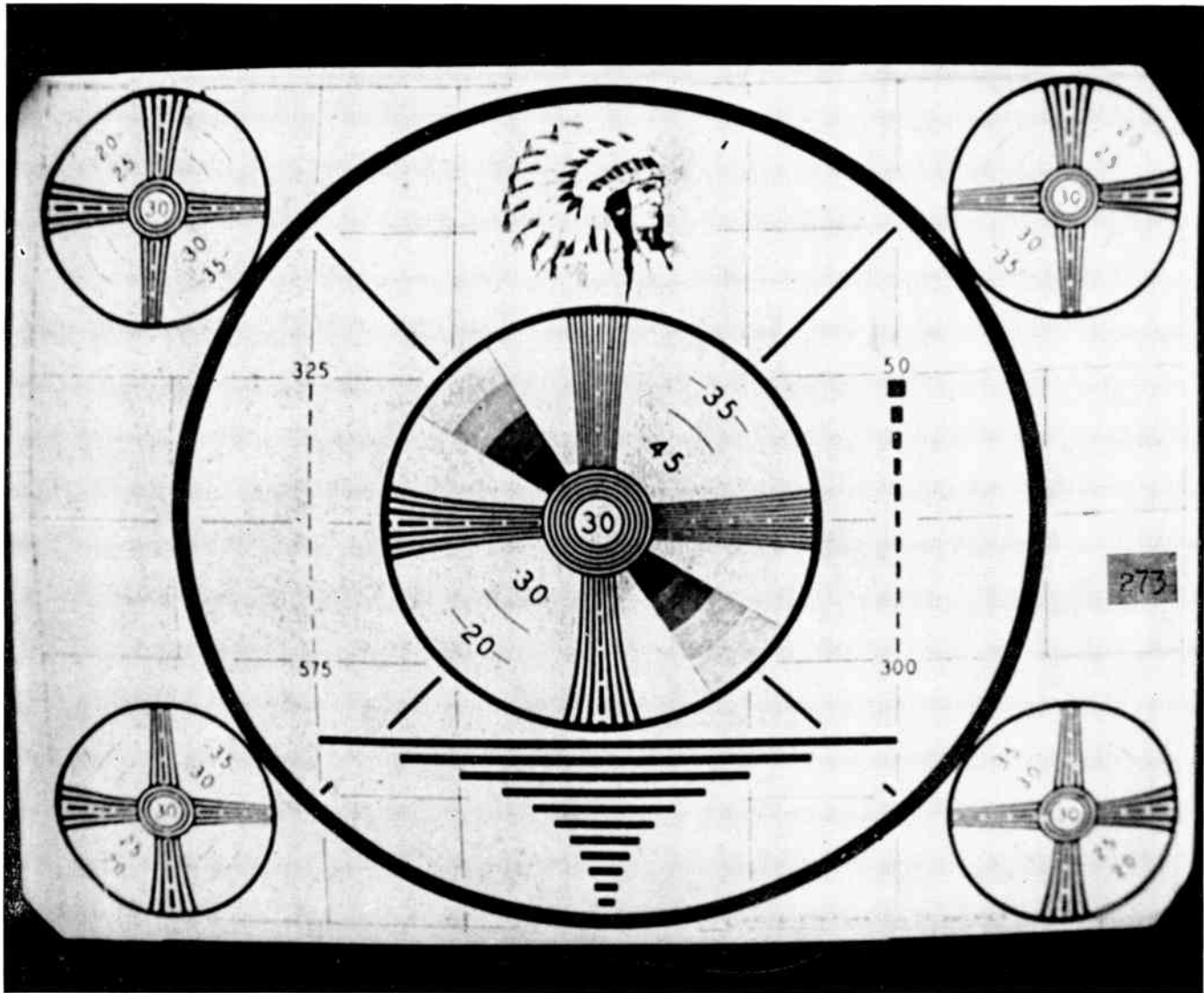

## Input to Power Amplifier

The video signal shows fine detail where the unrestricted band width is fully used. The high frequency

cut-off is over 4 megacycles. There is little evidence of phase shift, smear, leading white, or trailing smear.

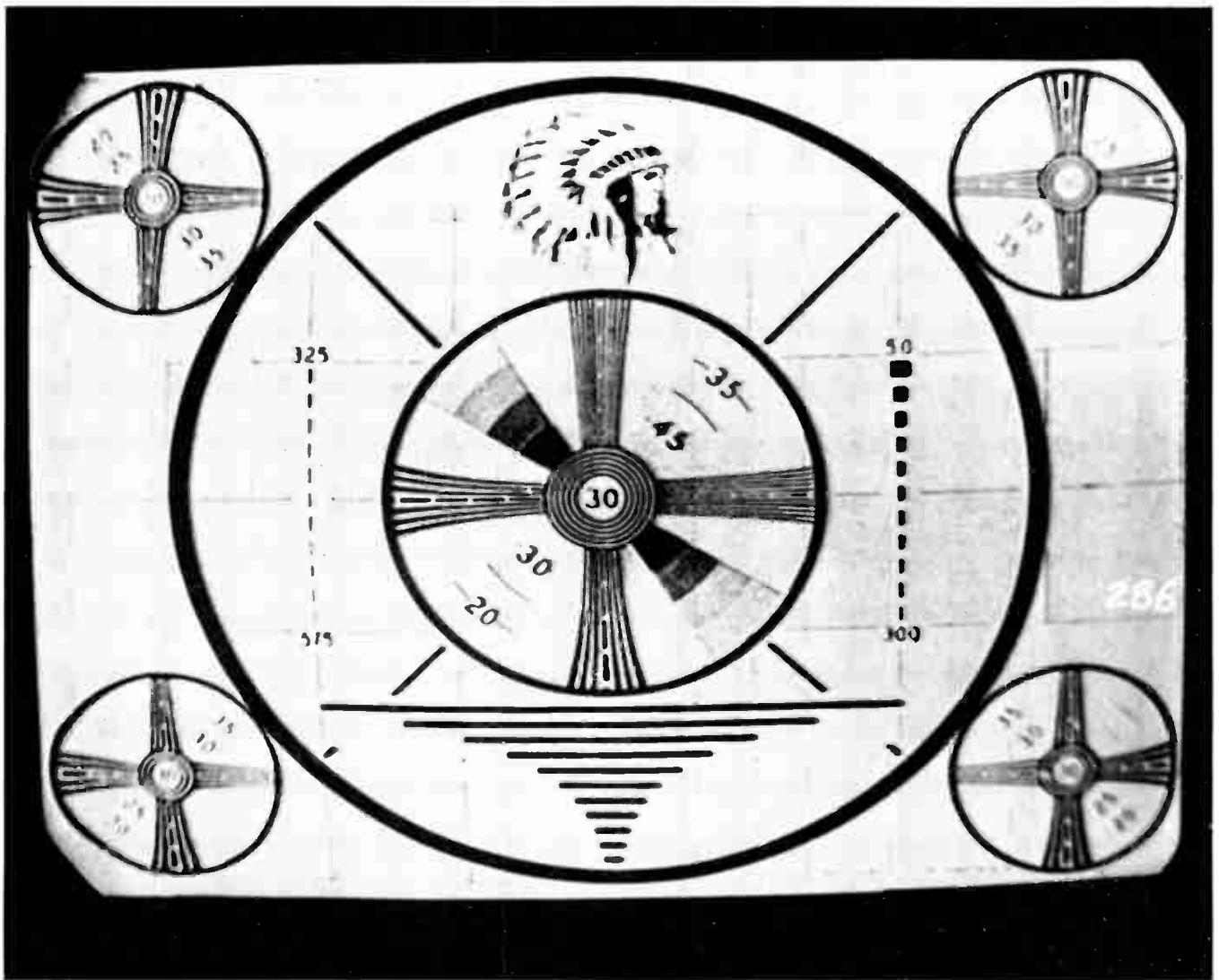

## Output of Power Amplifier (WM 20-B Diode Output)

Somewhat less fine detail is evident here, as well as some leading white. With balanced double sidebands the phase shift and resulting leading white would be less evident. (Refer to the picture of the input to the power amplifier.) Further unbalance of the double sidebands

will create greater phase shift, with more evident leading white and trailing smears, as observed with the diode output, since the diode is a double sideband detector. Quality of the observed picture will vary with transmitter tuning.



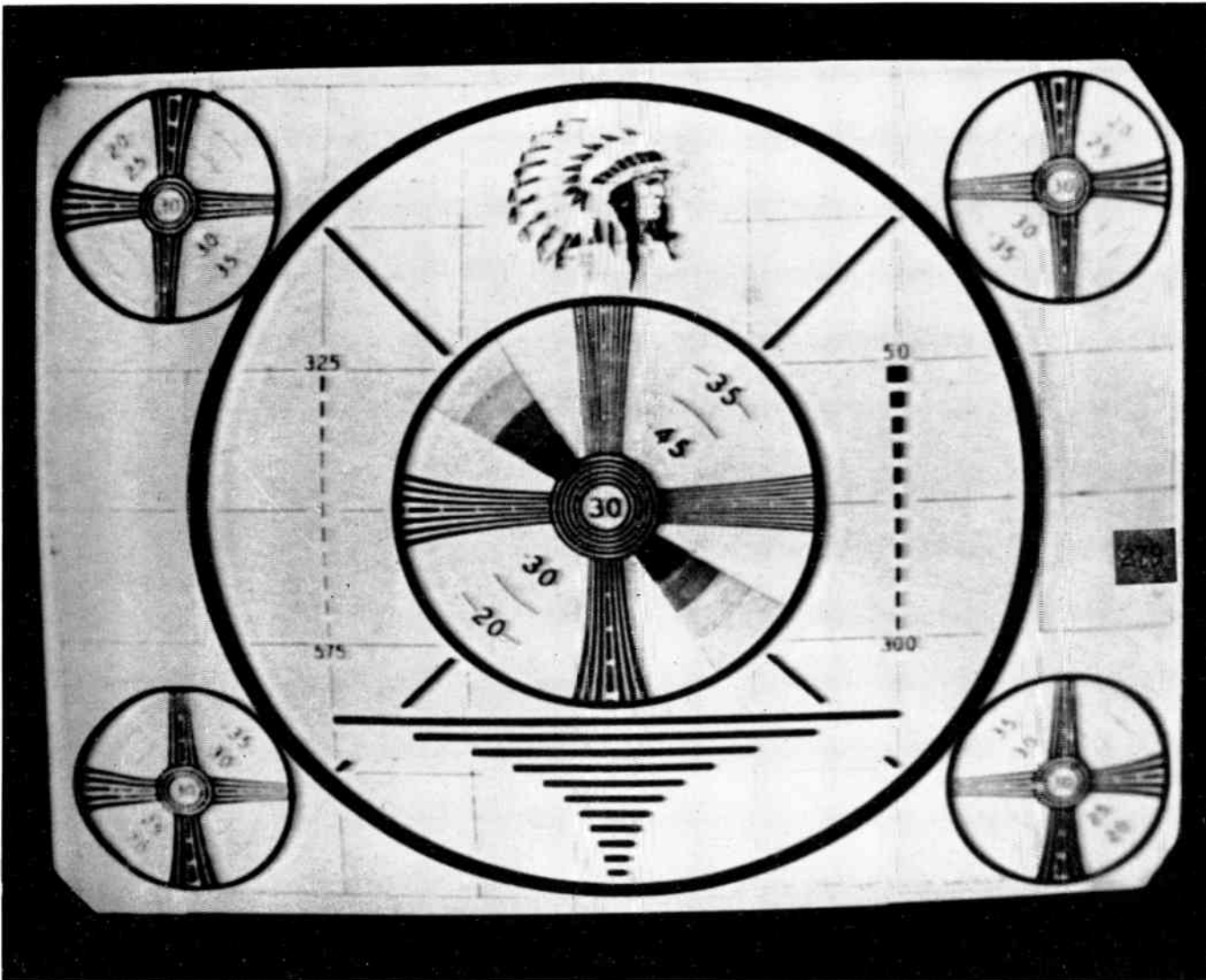

## Output of Vestigial Sideband Filter (WM20-B Diode Output)

Trailing smear is clearly more evident than in the picture preceding this due to phase shift incurred in the limiting of the lower sidebands by the requirements of the vestigial system. Smear is particularly evident at the right edges of the vertical wedges. The larger low frequency amplitude in the diode output yields intense blacks in the larger areas and a gray black in the small areas. The

diode output is essentially double sideband for lower video frequencies (1.25 mc and below) whereas the diode output is essentially single sideband above 1.25 mc. Thus a lower amplitude response is obtained at the higher video frequencies and this step in the amplitude response results in smearing of the elements at black-to-white transitions. Normally a diode should be used only when monitoring a double sideband output.

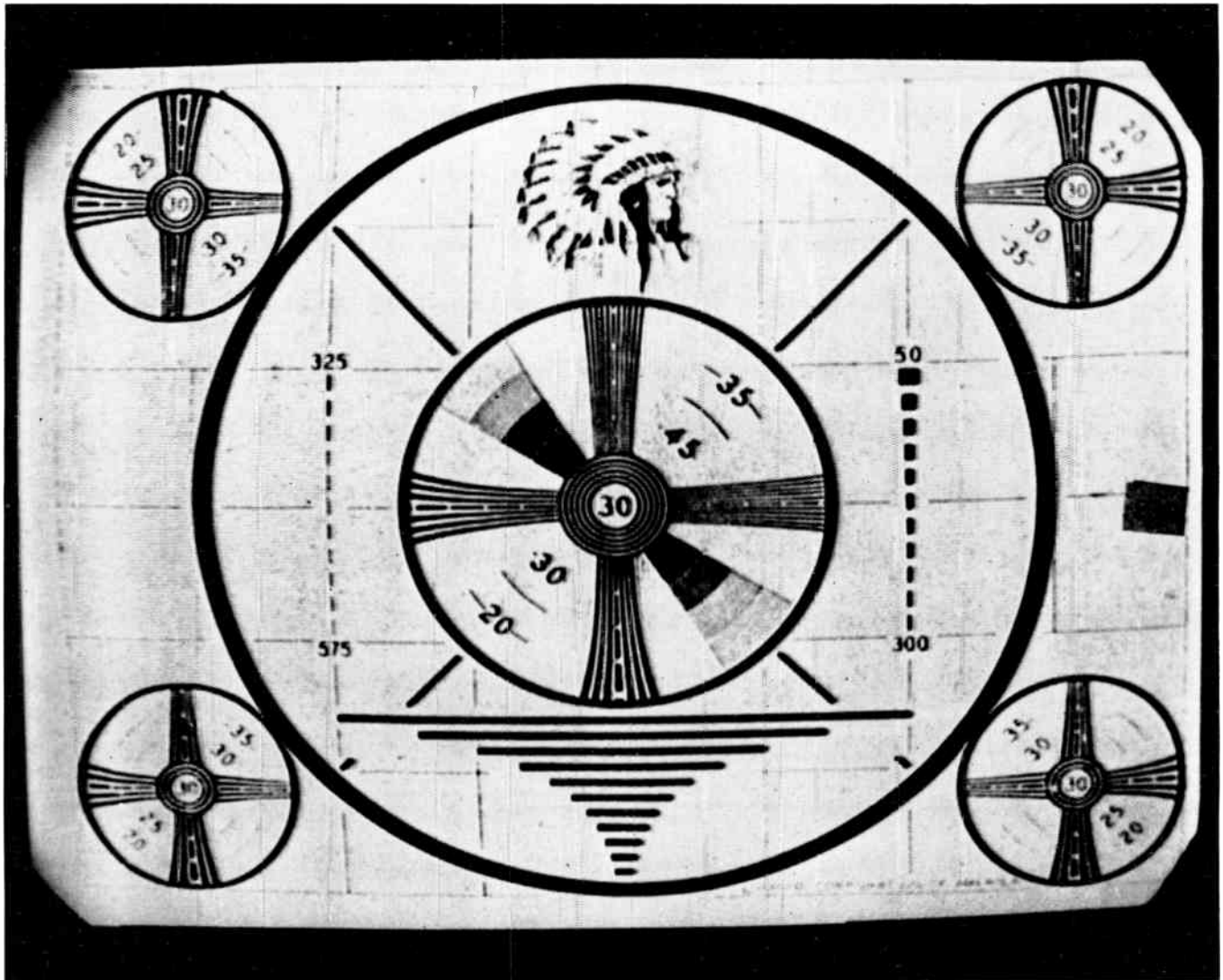

## Output of Vestigial Sideband Filter (Demodulator Output)

This photo shows the WM-20B demodulator circuit output with the 20 db R-F sound notch in the circuit and with the video sound notch switched out. Also the phase compensator circuit is switched out. Smear is not as pronounced as in the photo showing the diode output. However the leading white at the sudden transition of signal from white-to-black, on the left edges of the circles and

the vertical wedges, is more apparent. These are the result of transients caused by the suppression of the lower sidebands and the attendant phase shift. Ringing is slightly evident in the inner circle after the vertical lines, and results from the sharp cut-off at the sound frequency by the R-F notch.

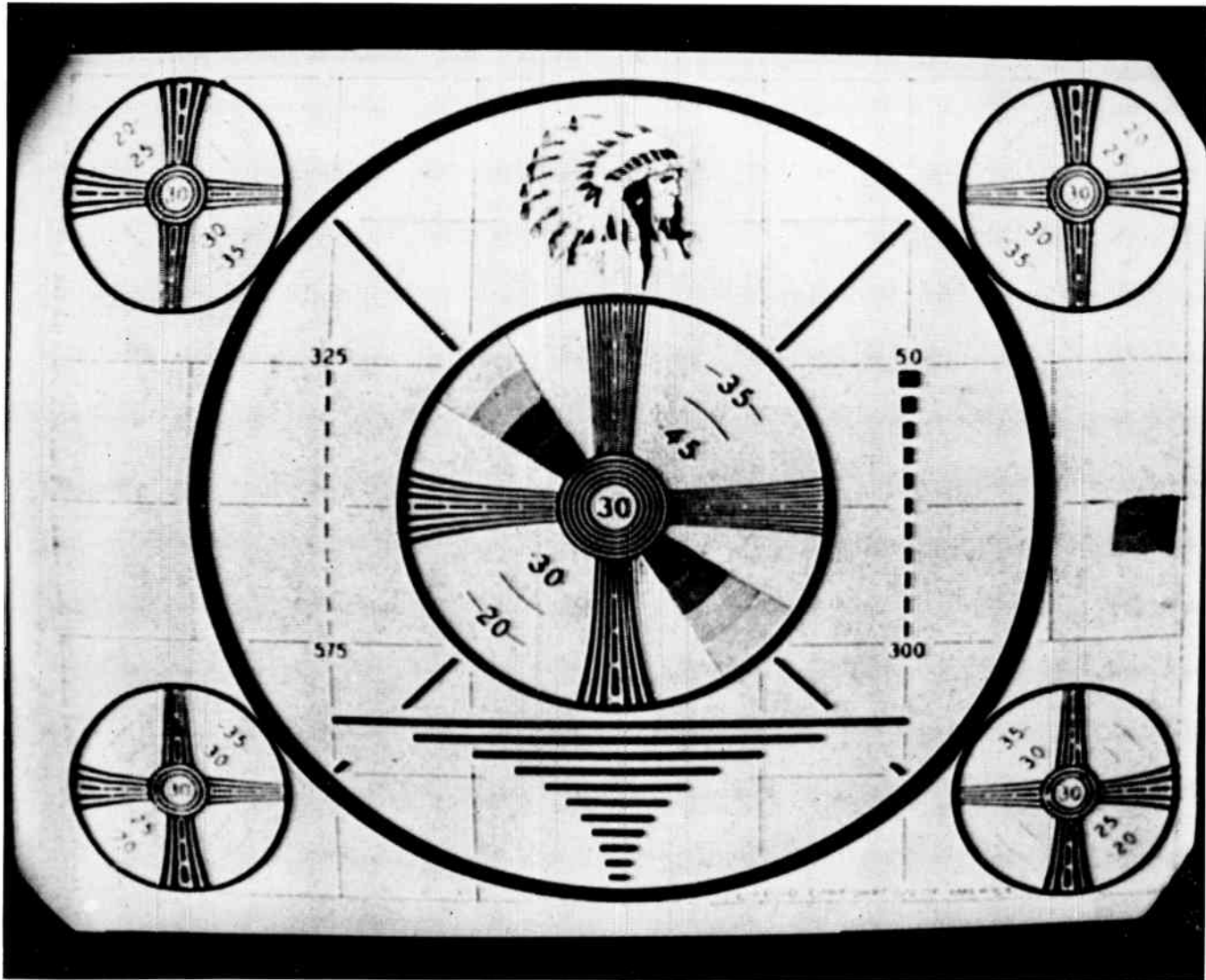

## Output of Vestigial Sideband Filter

This photo shows the WM-20B demodulator output with both the R-F and video sound notches in the circuit with a total of 20 db sound rejection. The broad sound trap decreases the higher frequency video components. The gradual change of amplitude near the broader sound trap softens the fine detail and decreases the ringing amplitude although the spread of the ringing is increased due to the greater depth of the sound notch.

In general the three effects noted, namely, the leading white, the trailing smear, and the ringing are inherent

in the vestigial transmission system and would exist even if every component were perfect. The leading white and trailing smear are a result of the phase shift introduced by the cutoff from a point below visual carrier to the lower channel edge, and the ringing is a result of the phase shift introduced by the sound notch required in every receiving device. When the ringing is not evident, it is due to lack of response in the region from 3 to 4 mcs above picture carrier which causes a lack of detail in the overall picture.

(Continued from page D-15)

and video) minimize sound carrier interference with the picture. Energy in the lower part of the channel not utilized in vestigial sideband reception is absorbed by a terminating load. The visual signal from the filter is detected by a simple diode and fed to a 72 ohm video line by a cathode follower. The pick-up, mounted on the transmission line from the transmitter, secures radio-frequency energy through a hole in the line. The attenuator minimizes coupling reflections in the cable to the filter. The phase compensator may be used to minimize the inherent distortion of the vestigial sideband method of transmission.

The spectrum saving vestigial sideband system of picture transmission has several unique phenomena. Attenuation of the visual carrier and adjacent sideband causes a low-frequency phase-shift in the demodulated video signal. Leading white and trailing smear produced by the phase shift may be minimized by phase compensation for the optimum utilization of the system. Transmission of the high-frequency picture components with the necessary sound isolation accentuates the phase shift at the upper end of the band. The phase shift and cut off at the sound carrier frequency yield a "ringing" known as the Gibb's effect.

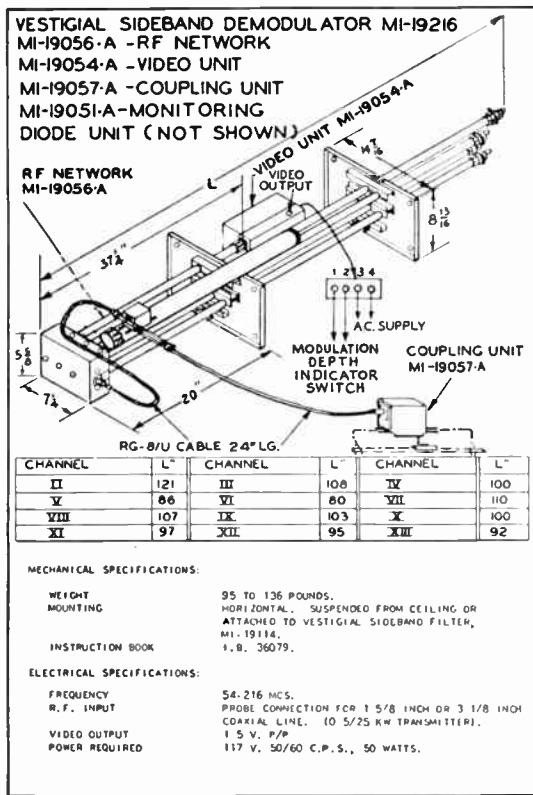

FIG. 3.

## THE BW-4A DEMODULATOR

### Purpose

The RCA types BW-4A and BWU-4A Television Demodulators are designed to produce a video signal that, when applied to a master monitor, will permit visual observation of the signal delivered to the TV transmitting antenna. The picture information is equivalent to that obtainable from a high quality television receiver.

The type BW-4A is used to cover the VHF television channels, 2 to 13 and the BWU-4A is used for UHF channels 14 to 83. These units are nearly identical except for circuit design in the r-f converter sections.

### Description

The TV demodulator is basically a superheterodyne receiver designed for vestigial sideband reception and includes a crystal-controlled r-f to i-f frequency converter, a sound rejection circuit, four stages of i-f amplification, a video detector, and a video output stage. The frequency conversion circuits are assembled on a small, separate chassis which is mounted on the main i-f and power supply chassis.

A directional coupler, MI-19396-1, designed to mount in a 3 1/8 inch transmission line, is included as part of the

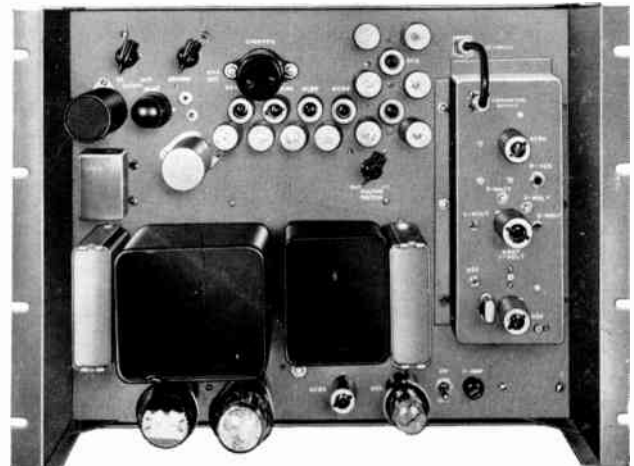

FIG. 1. View of the BW-4A Demodulator.

demodulator equipment. This coupler samples the transmitter output and supplies the resultant signal to the converter unit.

### Application

The directional coupler may be inserted into the transmission line at any of several points between the vestigial sideband filter and the antenna. By installing the directional coupler in one of the feed lines between the di-

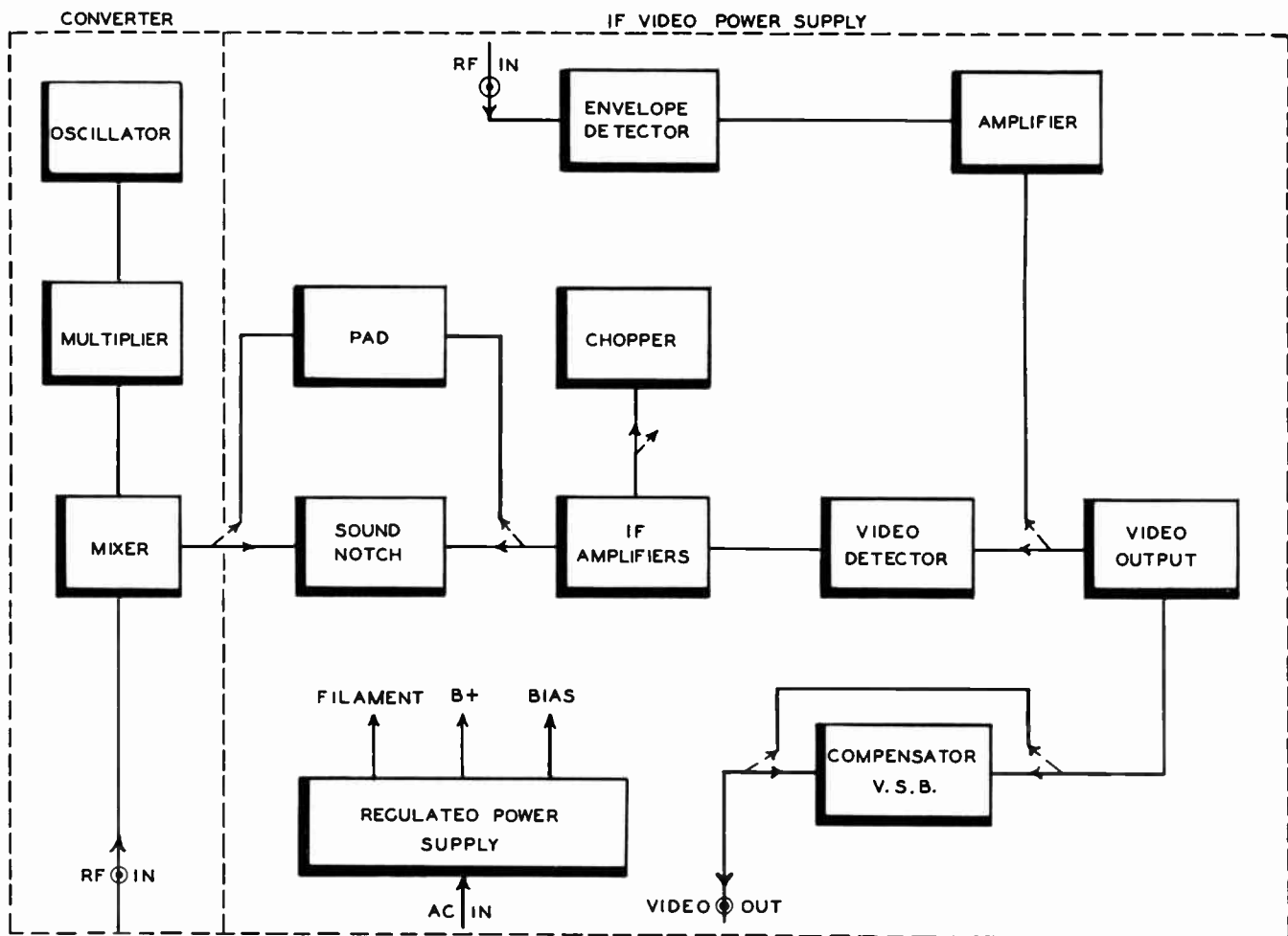

FIG. 2. Block diagram of BW-4A and BWU-4A Demodulator.

plexer and the antenna, mismatches in the line being monitored will be readily evident. With this installation, however, mismatches may not be detected in the second antenna feed line unless provision is made for sampling the signal in this line also.

Alternatively, the directional coupler may be inserted into the transmission line between the sideband filter and the diplexer. This location will not be as sensitive to antenna mismatch as the antenna feed line installation.

If a filterplexer is used, the directional coupler must be installed between the filterplexer and the antenna. It should be pointed out that monitoring next to the antenna places a more stringent requirement upon the sound rejection notch in the demodulator due to the presence of full sound carrier power in the transmission line.

When tests are to be made of the video transmitter outside of regular program periods, the aural transmitter may be shut down and the sound notch on the TV demodulator switched out of the circuit. This gives a wider amplitude response and an improved high frequency phase characteristic. Such characteristics are useful in monitoring the transient response of the transmitter.

Vestigial sideband transmission of television signals introduces a characteristic phase distortion into the detected video signal. Although not usually discernible during regular program telecasting, this distortion will be clearly evidenced by leading whites and trailing smears when a test pattern is used. To correct this distortion, a phase compensating network which may be switched into the video output circuit is provided. This corrects the low frequency phase error of the demodulator.

A mechanical 50/60 cycle chopper, which may be controlled from a remote location, is included as part of the i-f section. When this chopper is energized, it will apply a negative cut-off bias to tubes in the i-f section at a 50/60 cycle rate, and thereby provide a zero level base line on the monitor oscilloscope screen.

The output signal from the TV demodulator includes synchronizing pulses and video from the transmitted signal, and is intended to be coupled to the master monitor through a 75-ohm coaxial line.

The envelope detector is used to enable observation of the overall response envelope of the television transmitter when the transmitter is being modulated by a video sweep

generator. For this application, the lead from the directional coupler, normally connected to the converter unit at the converter r-f input jack, is connected to the diode input jack. When the video output is connected to the vertical terminals of an oscilloscope the swept response of the transmitter may be observed.

**Specifications BW-4A, BWU-4A**

**Frequency Range:**

- BW-4A .....Channels 2-13
- BWU-4A .....Channels 14-83

**Inputs:**

- Power.....105-125 volts, 50/60 cycles, 250 watts
- Signal.....From directional coupler approximately  
1.5 volts RMS into 50 ohms

Output....1.5 volts peak to peak into 75 ohms (max.)  
negative sync

I. F. Bandwidth.....-1.5 db at 4 mc with sound notch  
-1.5 db at 5 mc without sound notch

Low Frequency Response.....less than 2% tilt to  
60 cycle square wave

Sound Rejection....More than 50 DB to aural signal at  
 $\pm 25$  kc deviation from carrier frequency

**Transient Characteristics:**

Tested with 100 kc square wave,

- Anticipatory Undershoot.....18% of axis separation
- Rise Time.....With sound notch .13 microseconds  
Without sound notch .09 microseconds
- Ringing Frequency.....4.5 mc with sound notch
- Amplitude of first positive  
overshoot.....10% of axis separation
- Amplitude of first negative  
overshoot.....6% of axis separation

Monitoring Error....DC base line error less than 1/2%

**Mechanical:**

- Dimensions.....14" high, 19" wide, 9" deep
- Weight.....32 lbs. excluding directional coupler
- Mounting.....Standard 19" rack

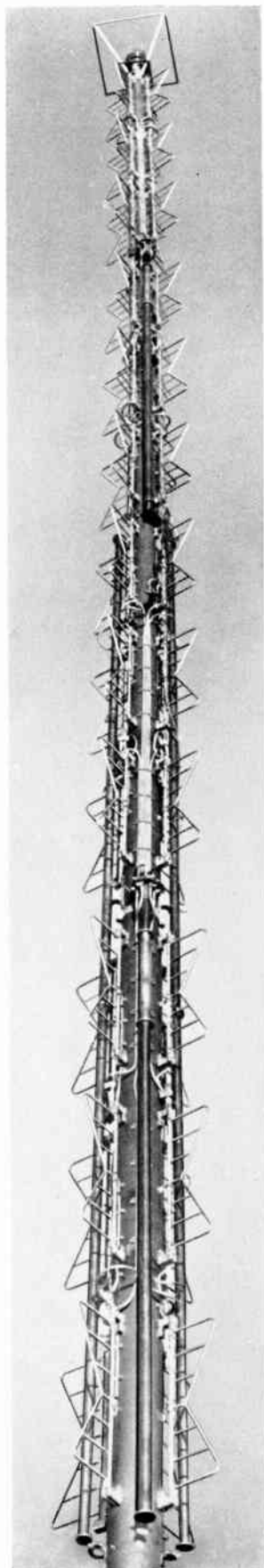

FIG. 1. A TF-12BH 12-section Superturnstile Antenna.

# S U P E R T U R N S T I L E A N T E N N A S

## Purpose

The antenna has as its purpose the reception of energy from the transmitter by way of a transmission line and the conversion of that energy, with a maximum efficiency, into the form of a radiation field having desired characteristics of directivity and polarity.

## Specifications

To meet the above requirement for television signals, the RCA Superturnstile antenna has been developed to have the following characteristics:

1. Electrical:
  - a. Polarization of the radiated wave is horizontal.
  - b. The antenna has very wide bandwidths. Three sizes of radiators are used to cover, respectively, the 54-66 Mc (low) band, the 66-88 Mc (mid) band and the 174-216 Mc (high) band. Small changes in the spacing between the radiators and the pole and slight variations in the size of the input transformers make possible the meeting of a 1.1 to 1 VSWR specification for any channel in these bands. Correct spacer plates and transformers are shipped with the antenna for use on its intended frequency.
  - c. The gain varies with each channel. It approaches a value of roughly 1.0 per bay at the center channel of each band. The gain is obtained by measuring the vertical and horizontal field patterns and taking into account losses in the feed system and in the radiators. Account is also taken of the energy lost in radiation having a vertical polarization. Reference is made to individual specification sheets on pages to follow for the gain values for each type of Superturnstile Antenna.
  - d. Theoretically, the horizontal pattern is circular. Actually, because of the presence of feedlines and transmission lines between the radiators, and because the antenna is not a point source, the pattern departs from this slightly. In the larger types, the large pole size also affects the pattern, resulting in a tendency to "square" the circle. However, in no case does the pattern deviate by more than  $\pm 2$  db from circular.
  - e. The TF-6BM and the TF-6AL, as well as all twelve-bay antennas, will handle 50 kw of input power. The TF-12AM and TF-12AL will, in addition, operate safely with 50 kw applied to either the top six or bottom six sections. (Operation in this manner is desirable in emergencies and is accomplished by means of the Combining Network to be described later). The TF-12AH and the TF-12BH, similarly, may be operated with 35 kw into either half of the antenna and the TF-6AH, correspondingly, is rated at 35 kw. The 3 and 5 bay antennas are rated from 18.8 to 24.6 kw, depending on frequency, and the 6A1

(high-band six-section) has a rating of 14 kw. All ratings are in terms of "TV Power." They represent the power at peak of sync of the visual carrier at the antenna input. Total average power values will be 1.1 times these ratings, since average visual power is approximately 0.6 times power at peak of sync and average aural power is usually 0.5 times power at peak of sync.

- f. By using the turnstiling principle and the bridge circuit of the diplexer, both visual and aural power can be simultaneously transmitted over the same antenna.
- g. One of the outstanding features of the antenna is its stability under varying weather conditions. Very small effect due to changing temperature or to rain or snow is found. Where severe icing conditions are likely to occur, deicing equipment is available to prevent changes in electrical characteristics.
- h. Undesirable effects on the picture due to swaying of the antenna under very high winds have been reduced to a negligible amount by provision of poles of adequate stiffness.

2. Mechanical

- a. Low wind resistance is achieved as a result of the open radiator construction.
- b. The pole is designed for high stress. Steel plate and tubing having ultimate tensile strength of more than 65,000 pounds per square inch is used. Since the pole is stressed to only 20,000 pounds per square inch under the rated wind loadings, a high factor of safety is provided.
- c. All components of the antenna are designed to withstand the windloading resulting from an actual (not "indicated") wind velocity of 110 miles per hour without ice or of 85 miles per hour with 1" of radial ice on all members. This corresponds to a load on projected areas amounting to 50 pounds per square foot on flat members and 30 pounds per square foot on round members. (The necessity for a distinction between "actual" and "indicated" wind velocities arises from the fact that wind velocity readings formerly taken with a 4 cup anemometer were found to have an instrumental error on the high side of approximately 35%. These readings, including the error, are called "indicated velocities." They are still used by some manufacturers in statements of rating. Readings made with more accurate equipment now give "actual" or true wind velocities.) Reference is made to the article on towers for a more complete explanation of the method of determining windloading.
- d. Radiators, radiator supporting brackets, feedline clamps, and hardware are hot-dip galvanized, to provide against the effects of weather. The pole is painted during manufacture and again upon erection.

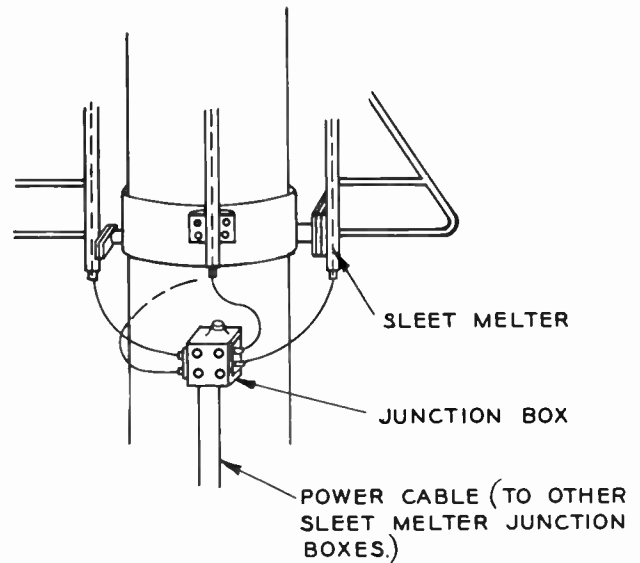

**SLEET MELTER JUNCTION BOX AND POWER CABLES**

FIG. 2.

- e. Feedline components are designed to withstand the effects of swaying of the pole.
- f. De-icing is done chiefly for electrical reasons and only secondarily to reduce wind loading. Since the electrical characteristics are affected by icing of the radiator section nearest the pole, only this portion is de-iced. Heaters are inserted in these sections through the bottom end, as shown in Fig. 2. Power requirements for the heaters are as follows:

Antenna Type	Watts per Radiator	Kilowatts per Bay
54-66	750	3
66-88	500	2
174-216	250	1

De-icing equipment is not included with the antenna. It may be obtained in kits which contain all necessary material for one section (4 radiators). That is, a kit includes four radiating elements, a power cord junction box, and enough cable to make connection with the next lower power cord junction box. Holes are provided in the pole for clamp hardware. Junction box supports are furnished with the antenna.

**Principle of Operation**

- 1. To obtain the bandwidth necessary for television, the Superturnstile makes use of the principle of combining a parallel-resonant with a series-resonant circuit. Such a combination circuit using lumped parameters is shown in Fig. 3. Combination of the reactance vs. frequency curves is seen to result in an overall curve which is very flat, or in effect almost wholly resistive, over a broad range of frequencies.



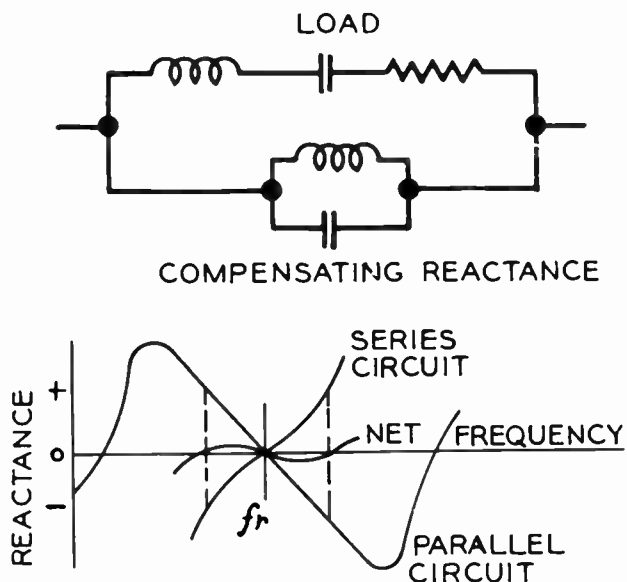

FIG. 3. Combination circuit using lumped parameters.

Now, if two co-linear radiating elements are considered, with a stub inserted to form the compensating reactance, a distributed parameter equivalent of the circuit in Fig. 3 is obtained, as shown in Fig. 4 (A). The reactance chart of this circuit is shown in Fig. 4 (B). It is seen that the stub reactance cancels that of the radiating elements over a considerable frequency range.

By altering the length of the first stub to give half its original susceptance and adding a similar one in parallel with it, as in Fig. 4 (C), the electrical characteristics are not altered but rigidity is added. An added advantage is gained in that a second ground point is also provided.

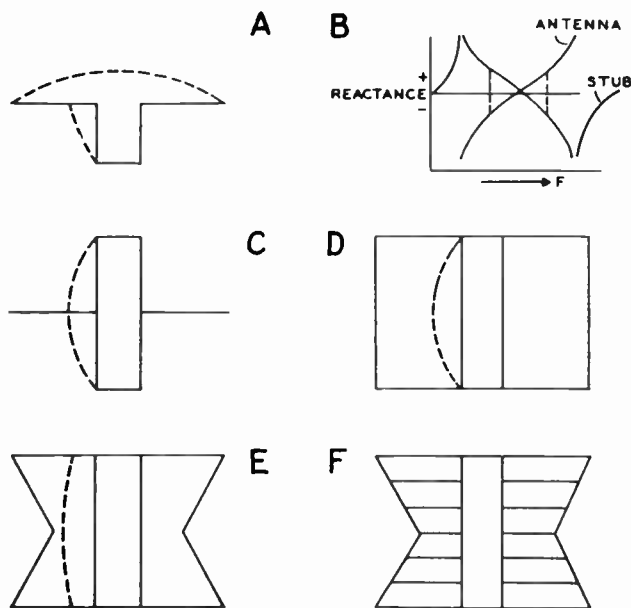

FIG. 4. Sketches showing co-linear radiating elements with stubs inserted to form compensating reactance.

In general, radiators with large diameters tend to have a more constant impedance over a given band since the ratio  $X_L/R$ , and hence the "Q", is smaller. Since a large diameter is not suitable for mechanical reasons, the same advantages are obtained by using a large flat sheet. (See Fig. 4 (D)). This sheet can be visualized as a series of dipoles, each carrying a current proportional to the current distributed along the two stubs.

By notching-in the sides, the current in the upper and lower edges of the radiators, also called "batwings", are increased, which flattens the vertical pattern and increases the gain. (See Fig. 4 (E)). One radiator has approximately the same gain as two dipoles spaced one-half wavelength apart.

By experimentally determining the minimum number of rods that can be used instead of a solid sheet, wind resistance is considerably reduced. (See Fig. 4 (F)).

### Turnstiling

We now have an antenna with wide-band characteristics. To obtain a circular pattern, turnstiling is applied. This involves arranging two sets of radiators at right angles, as shown in Fig. 1, and feeding them with a phase difference of 90 degrees. (This is done by making the

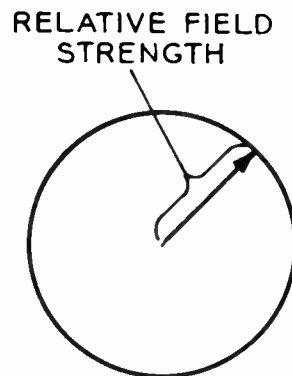

FIG. 5. Energy radiated from a point source.

electrical path length to one pair a quarter-wave length—or 90 degrees—shorter than to the other.) This is in addition to a 180 degree phase difference between radiators in the same plane, accomplished by feeding one radiator from the inner conductor of its feedline and the other from the outer conductor of its feedline. The net effect is that in all directions the signals from the two dipoles add vectorially to give a resultant whose magnitude is approximately constant.

### Stacking Elements

The energy radiated from a point source in space, measured at a given distance from the source, is constant in value. This may be represented by a sphere about the point, the distance from the source to any point on the sphere representing the field strength at that point. If a vertical slice is made through the

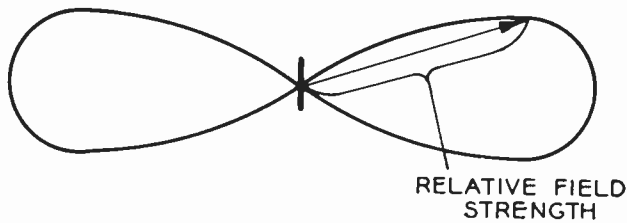

FIG. 6. Field strength from two point sources  $\lambda/2$  apart.

source, the field strength values will appear as a circle, as shown in Fig. 5.

If a similar diagram is made for a pair of Superturnstile radiators, the shape of the field strength "pattern" at right angles to the radiators and in the vertical plane will be as shown in Fig. 6. It is seen that the field strength directly above and below the radiators is zero, increasing to a maximum in the horizontal direction.

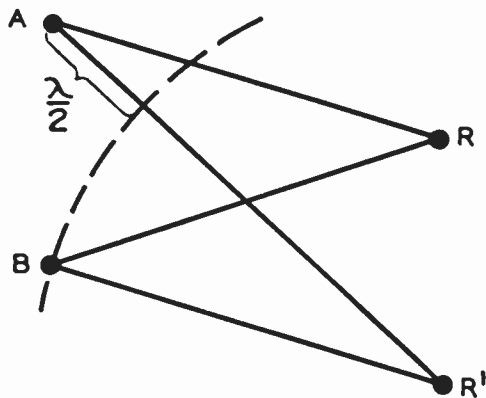

FIG. 7. Effect of stacking two radiating elements "A" and "B".

As a method of indicating the effectiveness of an antenna it is customary to compare the power obtained at the receiver from the antenna considered to the power which would be received from a half-wave dipole having the same input power. The ratio of these powers is known as the "gain" of the antenna.

It can be seen that if more of the radiated energy can be directed at the receiver, the antenna will be more effective. This is accomplished in the case of Superturn-

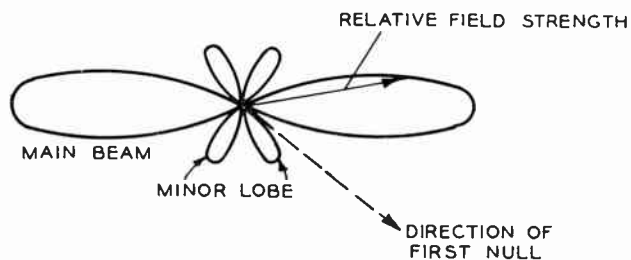

FIG. 8. Field strength at constant distance from array of four point sources (or two Superturnstile Sections).

stile antennas, by stacking radiators vertically. Fig. 7 shows the effect of stacking two elements, A and B.

If the receiver is placed at R, its distance from A and B will be the same. As a result, the waves radiated from the two will add in phase. At R', on the other hand, the distances to A and B differ by a half wavelength. As a result, there is a cancellation and no energy is received. This is known as a null condition.

If the receiver is moved in a vertical plane at a constant distance from an array of four point sources and field strength is represented on a diagram as before, the result will be shown in Fig. 8.

The result is seen to be a more narrow main beam than in Fig. 6, indicating a greater gain, with minor lobes, and a null condition at an appreciable angle from the vertical.

As more radiating elements are added, the main beam becomes still more narrow, the angle made by the first null with the vertical becomes still greater, and the gain increases. Also more minor lobes appear.

The spacing between radiators stacked in an array is critical. The ideal condition, of course, is that of an infinite number of radiating elements so closely spaced that the energy emitted is constant over an entire area enclosing the elements. Such an area is known as a "uniformly illuminated aperture." (Electrically the aperture or "equivalent radiating area," may or may not be the same in physical dimensions as the area of the group of radiators itself.)

On practical antennas, where a finite and relatively small number of radiators are used, it has been found possible to very closely approximate the conditions of uniform illumination by proper spacing of the radiators. This has been done with the Superturnstile antennas, using a distance between radiator centers of about one wavelength.

It should be noted that since the maximum gain possible is achieved when the aperture is uniformly illuminated and that since the spacing of the Superturnstile radiators is such as to effectively give this condition, the addition of more radiators between the existing ones, or the change of the gain characteristics of the individual radiators, will not improve the overall gain of the antenna. Only an increase in the aperture will do so.

For more detailed information you may request the booklet entitled "Determination of VHF Superturnstile Antenna Gains," from RCA, Broadcast Marketing Div., Camden, N. J.

### Vertical Pattern Shaping

With high gain antennas, both the narrowness of the main beam and the presence of areas of low signal strength at considerable distance from the antenna pose serious problems.

To obtain a more uniform signal strength at all points in the area covered, the nulls should be filled-in to some extent. There are several methods by which this can be done:

1. Unequal amounts of power can be fed to the separate radiators. This prevents the occurrence of certain of the cancellations to a degree depending upon the combination of power values used.
2. The phases of the signals fed to the separate radiators can be varied with respect to each other.
3. The main beam can be tilted downward. This is normally accomplished by feeding the top half of the antenna out of phase with the bottom half, so that this method may be considered a special case of the above.

The advantages obtained by null-filling are somewhat offset by an accompanying loss in gain. A typical case would be the loss of about 4 percent in gain to obtain a fill-in of around 12 per cent in the first null.

In the use of any of these methods, the various nulls are not filled in equally. Normally, the first one below the horizontal, affecting as it does an area about two miles from the antenna (in the case of a 12 section antenna on a 1000 ft. tower), is the most important.

In the above case, if unequal powers are fed to the upper and lower halves of the antenna, this first null is filled in to some extent, but the second null is not affected. On the other hand, varying the phasing will accomplish a partial filling of all nulls, but will be accompanied by a smaller gain. The RCA 12-section Superturnstile, Type TF-12AH for channels 7 thru 13, employs the first method, while the TF-12BH, for the same channels, utilizes the second. Typical patterns for the two types are shown in Fig. 14.

#### Construction

The sets of crossed radiators are mounted on tapered flagpoles as shown in Fig. 1. The number of sections is determined by the gain desired. This, in turn, is determined by the type of transmitter available and by the maximum power allowed by the Federal Communications Commission. There is both an economic and an electrical limit to the number of sections which can be so stacked. Economically, the antenna cost becomes very high, and electrically the width of the radiated beam so narrow that close-in coverage is diminished.

The types included in the following chart have been found practical and are being made.

<i>Freq. (MC)</i>	<i>Standard</i>
54-66	3-Section TF-3C, 5-Section TF-5B 6-Section TF-6AL, 12-Section TF-12AL
66-88	3-Section TF-3D, 5-Section TF-5A1 6-Section TF-6BM, 12-Section TF-12AM
174-216	6-Section TF-6AH 12-Section TF-12AH, TF-12BH

In each case the "batwing" shaped radiators are secured to the pole by being bolted to lugs welded directly on the pole or to rings which in turn encircle the pole and are clamped to it.

The radiators are fed by coaxial lines, terminated at the points of feed (ie, at the centers of radiators) by appropriate endseals and joined at their input ends

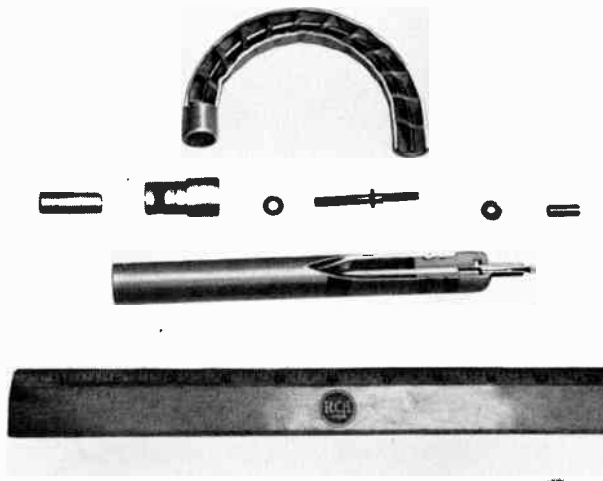

FIG. 9. View of a section of Styroflex feedline with segments cut out to illustrate construction.

through junction boxes to the larger incoming transmission lines.

In the cases of the post-freeze design of the six- and twelve-bay antennas, feedlines are  $\frac{3}{4}$ " in diameter, and have an aluminum outer conductor, a copper inner con-

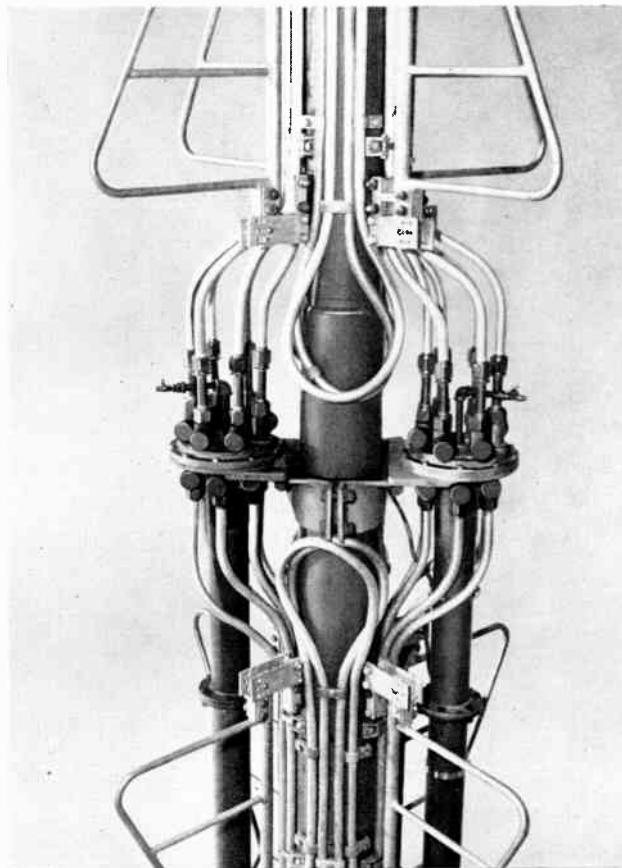

FIG. 10. Closeup view of junction boxes as they appear installed on a 12-section antenna.

**TRANSMISSION LINE SYSTEMS FOR FEEDING ANTENNAS OF SIX OR LESS LAYERS**

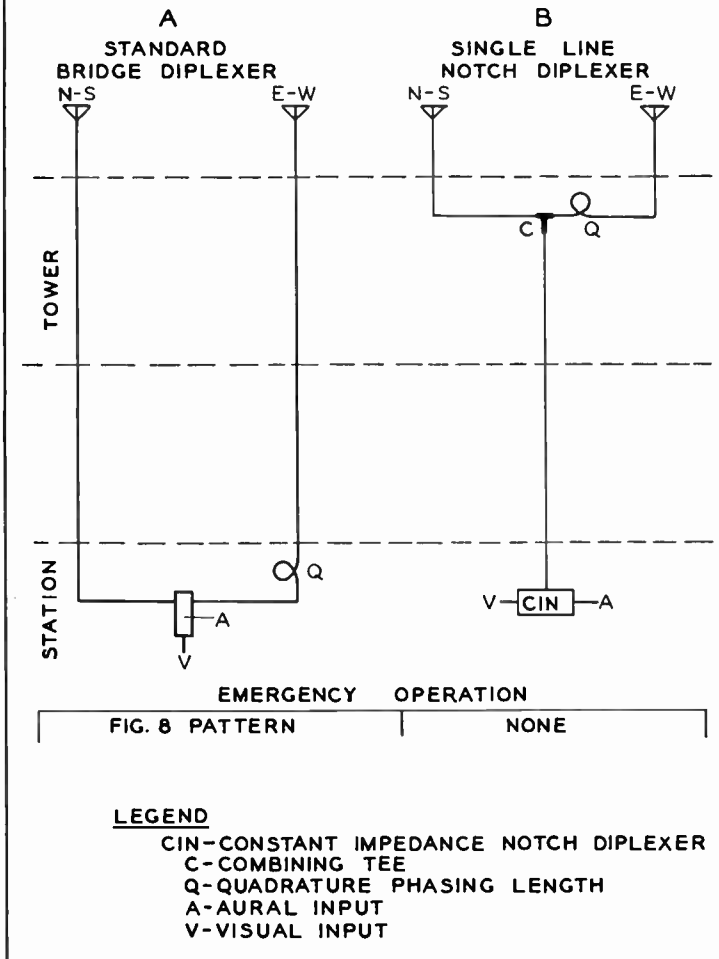

FIG. 11. Transmission line systems chart showing two transmission line arrangements available for 6-Section Antennas.

ductor, and a helically wound polystyrene insulation formed of many layers of 1/8" wide ribbon wound on top of each other. The successive turns of the helix are about 5/8" apart and the helix is tightly encased in double windings of broad polystyrene tape, forming a moisture proof tube inside the aluminum outer conductor. The line may be bent to radii as small as 6 inches without dangerous distortion of the helix and without impairing the electrical characteristics of the line. (See Fig. 9.) These feedlines are part of the gassed system of the antenna and are fed by dry air or nitrogen through the transmission lines and junction boxes. Suitable valves are provided at each endseal for "bleeding" or releasing the air through the line.

The standard three- and five-section units have feedlines with copper outer conductor, silver plated invar inner conductor (to prevent effects of expansion due to heating) and beaded type insulation. These latter lines may be bent to 8 inch radii without endangering their characteristics.

Junction boxes are of cast brass, with the required number of feedline outlets (e.g. 12, in the case of the 12 bay antennas) and with 1-5/8" transmission line (for 3 and 5 section antennas) or 3-1/8" transmission line (for all others), feeding them (see Fig. 10).

In a three-section antenna, three radiators, each having a feedpoint impedance of 154.5 ohms, are fed in parallel, resulting in a combined surge impedance of 51.5 ohms, matching that of the incoming transmission line. For other types the combined impedance is different from 51.5 ohms, requiring a coaxial transformer immediately below the junction box to bring about a match. (See Fig. 12.)

The main Transmission lines must be combined either at the tower top or at the station to provide for connection to the two-line output of a bridge diplexer or to the one-line output of a notch diplexer. The method of combining must also provide for the required quarter-wave difference in length of lines leading to the turnstiled radiators.

On the twelve-section antennas, the combining network is used to obtain other desirable conditions. We have seen

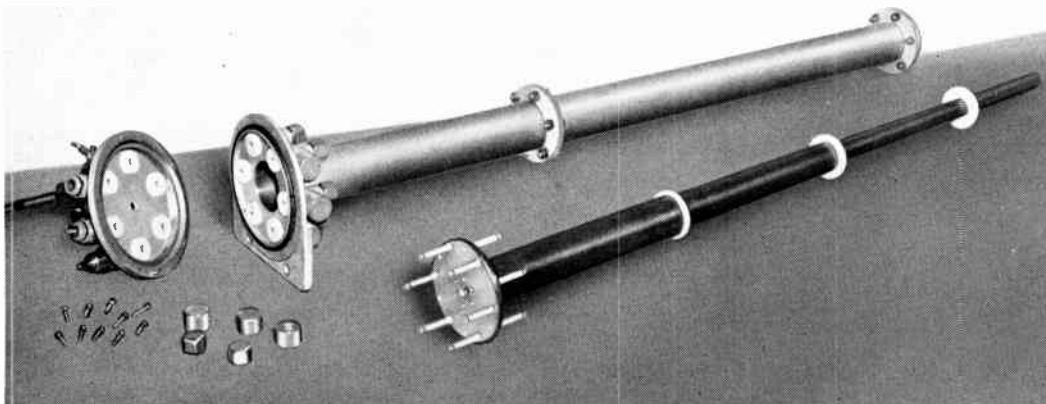

FIG. 12. View of a coaxial transformer assembly.

that an unequal division of power can be used in these antennas to achieve a more uniform field. Power dividing transformers in the combining network accomplish this. With suitable alteration of the transformers, any desired ratio other than the standard 70-30 or 50-50 divisions may be obtained.

Continued operation of half of the antenna in the event of failure of the other half is possible with 12 section antennas due to the configuration of the combining network. Tilting of the main beam of radiation may be obtained by shifting of the relative phase of the signals entering the upper and lower halves of the antenna. This is done by providing a longer transmission line path to the half whose phase is to be retarded.

The six-section antennas require a combining network only when one transmission line instead of two is used from the ground to the tower top. Since no unequal power division is used, no power dividing transformers are required.

Figs. 11 and 13 show various types of combining Networks for the six- and twelve-section antennas.

### Application

#### 1. Location

The antenna may be mounted on a building, a tower, or a high point of natural terrain. Various combinations of Superturnstiles with Supergain antennas,

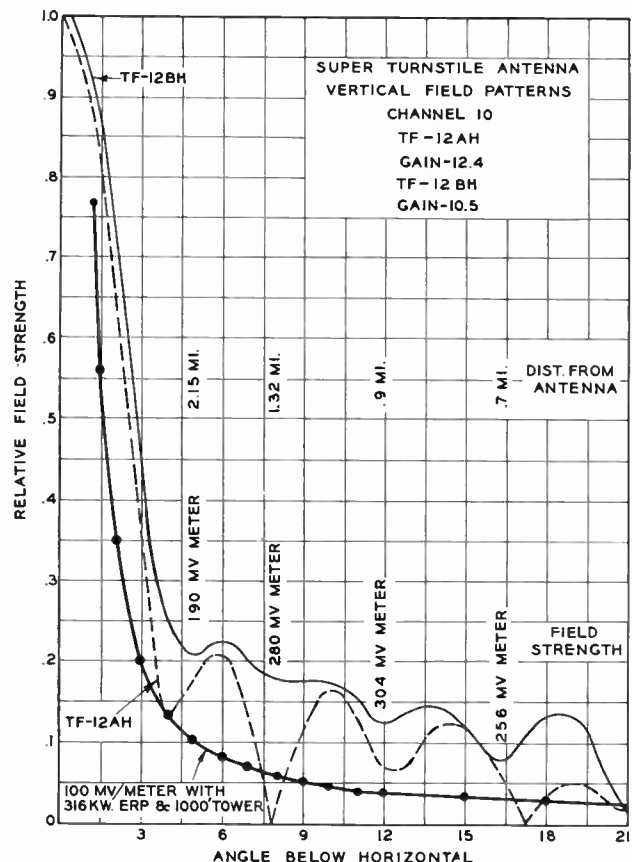

FIG. 14. Vertical field patterns for the TF-12AH and TF-12BH.

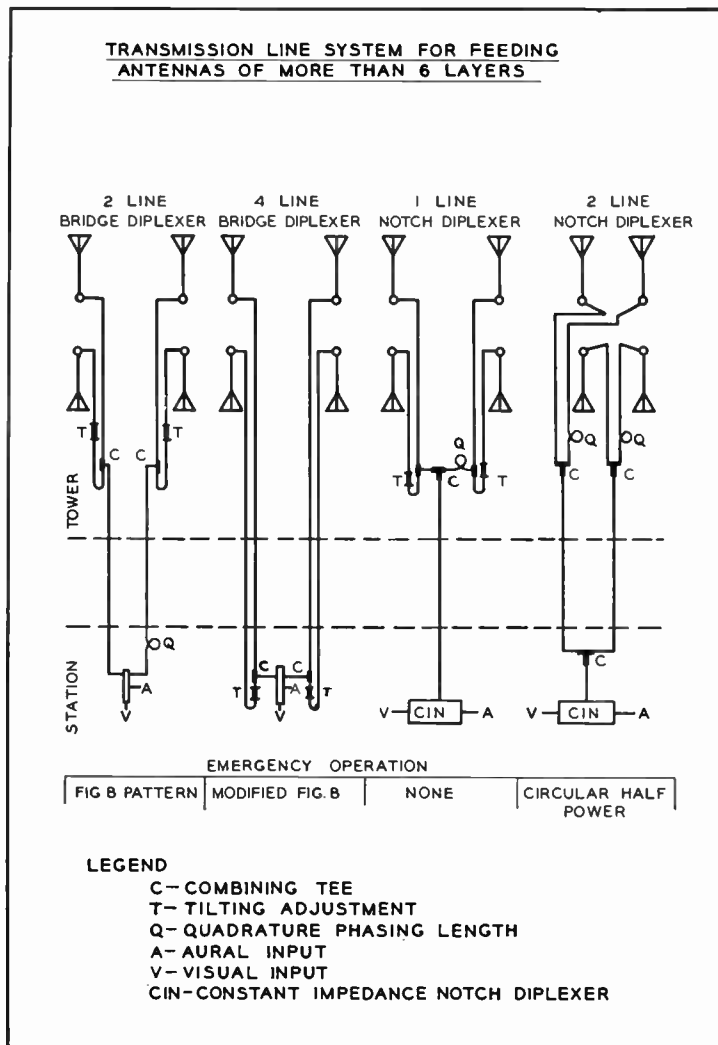

FIG. 13. Chart showing versatility of transmission line systems available with 12-Section Antennas.

FM Pylons, UHF antennas, or other Superturnstiles are practical. Characteristics of the supporting structure are discussed elsewhere.

#### 2. Shipment

All antennas are shipped disassembled. The pole will be shipped in two or more sections depending upon its length and weight.

The table on Fig. 15 gives details of each type of pole. Note that no section exceeds 8000 pounds in weight or 30 feet in length. These are values found most practical as limits in shipping and erection.

#### 3. Erection

The smaller antennas up to and including the TF-6AL in size, are readily raised completely assembled. The larger ones will normally be erected piecemeal. Where a choice exists, assembly in one piece is recommended. In either case the antenna should be assembled completely on the ground and tested before erection. For final assembly, the pole sections must be

Type	Overall Length	Depth of Bury in Tower	Total Weight Tons	Pole of Tower Top		Pole at Top of Antenna		Pole Sections		
				Dia.	Wall Thickness	Dia.	Wall Thickness	No.	Weight of Heaviest	Length of Longest
3-C	61'-0"	12'-0"	2 <sup>3</sup> / <sub>4</sub>	10 <sup>3</sup> / <sub>4</sub> "	.500"	5"	.247	3	1266	24'-0"
3-D	50'-0"	10'-0"	1 <sup>3</sup> / <sub>4</sub>	8 <sup>5</sup> / <sub>8</sub> "	.500"	5"	.247	3	1138	30'-0"
5-A	85'-2"	16'-5"	4	12 <sup>3</sup> / <sub>4</sub> "	.500"	5"	.247	5	1863	29'-0"
5-8	103'-0"	20'-0"	6	16"	.500"	5"	.247	5	3591	42'-0"
6-A1	47'-3"	10'-0"	1 <sup>1</sup> / <sub>4</sub>	8 <sup>5</sup> / <sub>8</sub> "	.322"	5"	.247	2	630	26'-8"
6-AM	99'-2"	16'-5"	5	16"	.500"	5"	.247	4	2600	29'-0"
6-AL	121'-0"	20'-0"	7	20"	.500"	5"	.247	6	2700	26'-0"
12-AH	84'-5"	11'-6"	4	12 <sup>3</sup> / <sub>4</sub> "	.843"	5"	.247	4	2200	26'-8"
12-AM	190'-9"	24'-0"	22	25"	1.500"	5"	.247	11	5600	28'-8"
12-AL	232'-0"	30'-0"	40	26 <sup>1</sup> / <sub>2</sub> "	2.500"	5"	.247	16	7000	26'-0"

FIG. 15. Mechanical details for each type of antenna pole.

field welded. The table on Fig. 15 gives key dimensions of the various poles.

Particular care must be used in the assembly of the feed system as its components are easily damaged. Close attention must be paid to the instruction given in Instruction Book and the manual entitled "Erecting RCA VHF Superturnstile Television Antennas," furnished with each antenna. Assembly must be done under competent engineering supervision, preferably RCA Service Company personnel.

Certain tests must be made at various stages of the erection to check:

1. Gas leaks
2. D-C resistance
3. Electrical leakage and breakdown
4. VSWR over the band, with panoramic sweep equipment

The RCA Service Company has experienced men and suitable equipment to perform the necessary supervision and testing, and it is a standard RCA policy to include in the sale of each VHF antenna the services of one of these engineers for a period normally adequate to cover all assembly and tests made before the antenna is raised to the tower top and final tests after it is raised.

The presence and services of the Service Company engineer assure the customer of minimum assembly time, correct installation and comprehensive and thorough test.

#### 4. Riggers

It is most economical to use the same riggers who are erecting the tower. The same gin poles, donkey engines, etc., can often be used. This requires close scheduling.

In order to provide tower erectors with adequate information on the assembly of the newer types of Superturnstile, RCA has conducted a Training Course for erectors from all parts of the United States.

It is recommended that only construction companies having men trained and experienced in antenna erection and equipped with the best of erection equipment be employed.

#### 5. Painting

The pole and radiators are shipped with one coat of red lead and one coat of International Orange paint for protection in transit and during erection. They should be painted in the manner prescribed by CAA after erection. All portions, except the end seals, can be painted, although there is no need to paint the feed lines.

#### 6. Maintenance

Periodic inspections, preferably twice yearly, should be made. The mechanical and electrical condition of all components of the antenna should be carefully checked in accord with a definite checklist. Painting is the most repetitive expense item and the one most often neglected. It should be done before signs of corrosion become evident.

Great care must be taken that all portions of the feed system outside the transmitter building are always gassed and under pressure. Loss of pressure denotes failure of some part of the system mechanically or electrically. A minimum of time should elapse before a search for the cause is started, as rapid deterioration and expensive damage may result unless corrective action is taken at once.

# VHF SUPERGAIN ANTENNAS

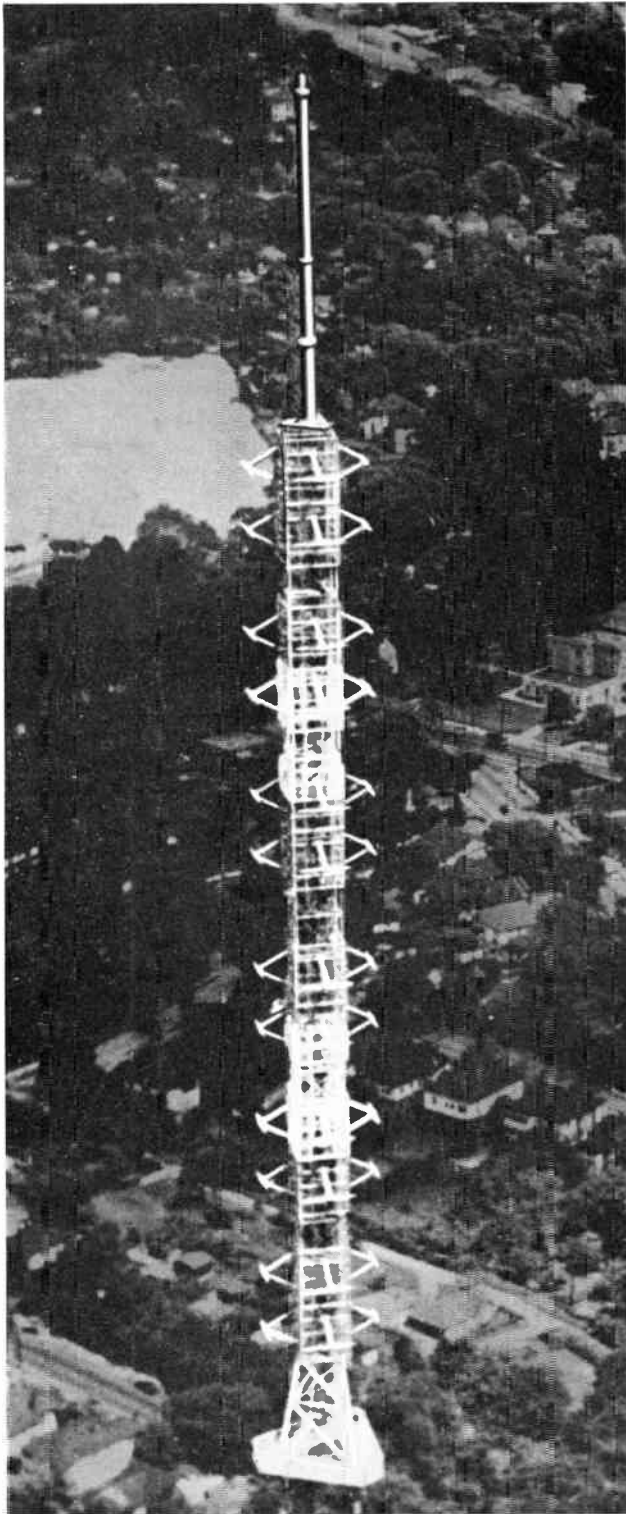

FIG. 1a. Supergain Antenna at WSB, Atlanta, Ga. Since this photo was made, antenna has been changed from 12-section to 14-section Supergain type.

## Purpose

Supergain antennas are custom built for applications where standard antennas are not suitable or cannot be used. These cases fall into three categories:

1. *Special gain*—In those cases where no standard antenna has the required power gain, it is sometimes better to use a custom built antenna of the supergain type. As an instance of this, for emergency use an antenna with a gain of one or two could be specified to mount around a tower. No standard antenna is available for this service but a custom-built Supergain type could be manufactured. Another example would be an antenna having a gain of more than 12. No standard antenna is available but a Supergain type could be built.
2. *Stacking*—When it is required to put two or more antennas on the same structure, it is in many instances best to use the Supergain type for all except the uppermost antenna. In this way a rigid structure with a maximum degree of accessibility is achieved.
3. *Directional*—Several choices of directional patterns can be achieved with custom antennas. Directional patterns which can be achieved with the Supergain type are more suitable for international usage where the 10 db rule does not apply.

## Specifications

These antennas are constructed to the customer's specifications; however, these specifications should take into account the inherent electrical and mechanical capabilities of the supergain type of array.

*Electrical*—The gain for a circular pattern supergain antenna is approximately 0.8 per section. The exact value of gain depends on the type of feed system used, on the number of sections, and other factors. It is, therefore, necessary to calculate the gain for each arrangement.

The power handling capability depends on the components used in the feed system. Antennas have been built with ratings of from 10 to 50 kw.

Inasmuch as the feedlines are often the limiting component, it is usually found that the higher gain antennas can handle inherently more power since this power is divided into a larger number of feedlines.

The circularity for a circular-pattern antenna will meet a  $\pm 3$  DB specification in all cases. A circularity

of  $\pm 1.5$  to 2 DB can be met with certain feed systems and with the dipoles and screens slanted on the supporting tower.

The input impedance of the supergain antennas can be specified to match the  $51\frac{1}{2}$  ohm transmission line to a VSWR of 1.1 or better throughout the channel.

**Mechanical—Wind Load**—The electrical parts supplied consist of the dipoles and screens, together with the feed system components. All of these will stand any conceivable wind load since they are anchored to the supporting structure. The supporting tower structure must therefore be designed to meet the specified wind loading. This requirement applies to that part of the tower below the array as well as that part within it.

The wind loading of the antenna is dependent on the type of tower used, since the screens and the tower members shadow each other to a considerable degree. For this reason the wind load of the antenna is never equal to the sum of the load of the dipoles and screens plus that of the tower. The wind load of the combination must be determined from consideration of the projected area of the combination. This can best be done by the tower designer.

### Principle of Operation

The supergain antenna consists of one or more sections of dipoles with each dipole having a reflecting screen between it and the tower. Thus each dipole radiates in a direction outward from the tower only, as compared with the superturnstile type of radiator which radiates in two directions. Other characteristics peculiar to the supergain antenna are as follows:

**Turnstiling**—With some types of feed system used for supergain antennas, the turnstile connection is used. When connected in this manner, adjacent pairs of radiators are fed with currents which are  $90^\circ$  out of phase. As described later the use of this quadrature feed has important advantages for pattern circularity, power equalizing, and diplexing.

**Broad banding**—power equalizing. The principle of power equalizing is explained in detail in the July 1949 PROC. of the IRE, "A Power Equalizing Network for Antennas", by R. W. Masters.

The power equalizer circuit functions to broad-band the antenna input impedance and to assure equal power division in the two sides of the antenna circuit.

Referring to Fig. 1, combined visual and aural power is transmitted over the main transmission line from the television transmitter to the balun of the power equalizer. The currents at A and B are equal and  $180^\circ$  out of phase. At N-S and E-W the currents remain equal but are  $90^\circ$  out of phase since the path on one side is  $90^\circ$  longer than the other due to the quadrature phasing length. If N-S and E-W are not perfectly matched to the respective feedlines, reflected power will return to A and B but the currents will now be out of phase because the round trip length is  $180^\circ$

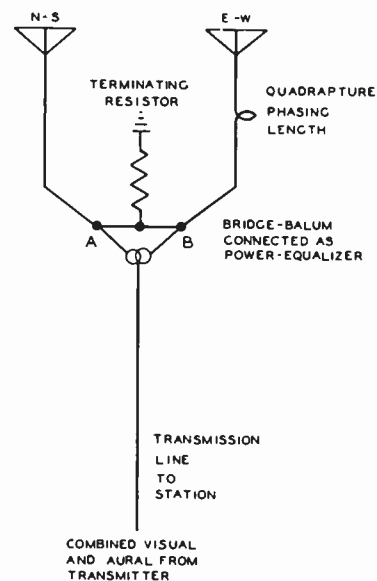

FIG. 1. Schematic diagram of power equalizer connections.

longer on one side. The reflected power will therefore be absorbed in the terminating resistor instead of returning to the transmitter. Thus no echoes due to antenna mismatch will be radiated.

The power absorbed in the terminating resistor is very small, since it is proportional to the square of the reflected voltage wave. For instance if the VSWR of the antenna elements were 1.2 at a certain frequency in the band, then the reflected voltage is 0.2 and the absorbed power is 0.04, or 4% of the total input power to the antenna.

It is necessary to use the power equalizer circuit in some cases, Channels 2 to 6, because a dipole in front of a screen has insufficient bandwidth to cover a television channel; for instance a 10% bandwidth is required at Channel 2. In such a case the antenna could be made to match the line perfectly at midband, but at visual and aural carriers the VSWR might be worse than 1.1 and reflections would be evident on the main transmission line. An additional difficulty would be the unequal division of power between the N-S and E-W sides of the antenna. For instance if the VSWR into the two sides were 1.2, then the voltage at the two sets of dipole terminals would be in the ratio of  $1.2/0.8$ . The power delivered to the two sets would then be in the ratio of  $1.5/1$  and hence one side would receive more than double the power of the other. The use of the power equalizer circuit in this case results in equal powers in the two sides at the cost of less than 1% of the power as shown in Fig. 1.

**Stacking of elements**—The vertical spacing between sections (or layers) of radiators is usually 0.77 wavelength, measured vertically from center to center. This spacing is chosen because it results in the least



amount of change of mutual impedance between radiators, hence gives the best possible bandwidth.

*Feed systems*—Several types of feed systems are used with supergain antennas; the choice depending on the channel, the gain, and the sectionalization requirements. Some of the possible systems are shown on Figs. 2, 3, and 4. A suitable feed system for almost any specification can be devised. Provision can be made for tilting the main vertical beam in order to provide better coverage in some areas, just as is done in the Product Line antennas which have more than six sections. Power division, which provides almost uniform field strength coverage throughout the service area, can also be achieved through a suitable arrangement of the feed system.

*Accessories*—Supergain antennas can be provided with sleet melter resistors to minimize the formation of ice on the dipoles. These resistors are installed in the dipole support arms, two resistors being used for each dipole assembly.

### Construction

As shown in Fig. 5, the Supergain type of antenna can be constructed of one or more sections of dipoles to provide any one of a variety of gains and patterns.

*Dipoles and screens*—Each dipole is approximately one-half wavelength long and is supported about three-tenths wavelength in front of the reflecting screen. The dipole is mounted on vee-shaped supports so that it will be rigid and can withstand the forces of extreme wind velocity, falling ice, etc. The supporting screen is constructed with stiff side angles and cross members so that it will provide a rigid support for the dipole. Reinforced bars are provided to form steps for climbing purposes. As regularly supplied, the screens must be secured to the tower with suitable brackets. The dimensions of the screens are determined by the wavelength. Larger screens cannot be used for a non-directional antenna as the circularity of the horizontal pattern would deteriorate.

The dipoles are usually mounted directly on the screens, with the dipole supports bolted to pads on the

## ANTENNA FEED SYSTEMS

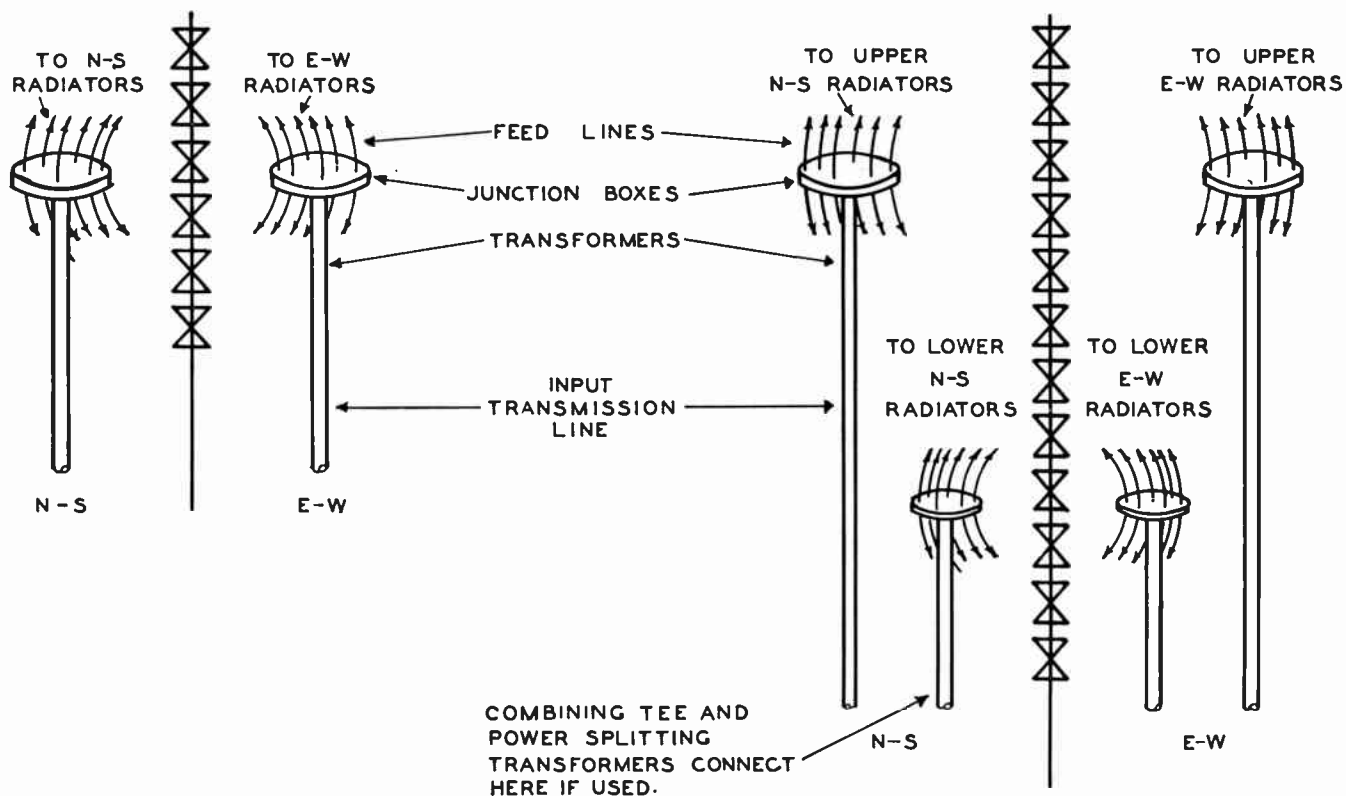

6 SECTION ANTENNA

12 SECTION ANTENNA

FIG. 2.

TYPICAL SCHEMATIC OF ANTENNA FEED SYSTEM  
14 LAYERS — NONDIRECTIONAL

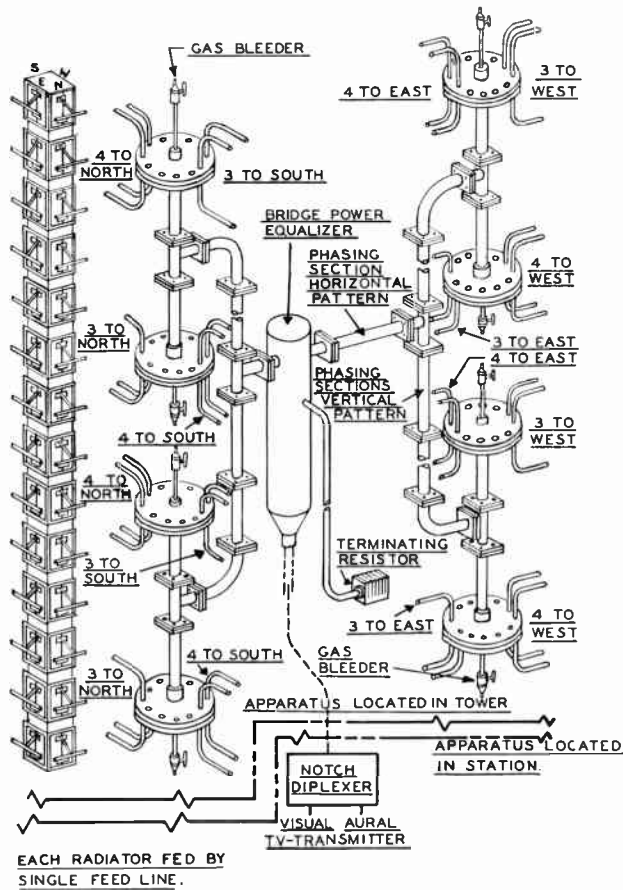

FIG. 3.

screens. When a non-directional antenna uses a power equalizer, the dipoles may be slanted to give improved circularity of the horizontal pattern. Wedge blocks are furnished; these wedges are inserted between the pads on the screen and the dipole supports so that the dipoles will be slanted away from a line which is parallel to the screen. The dipoles remain in the horizontal plane when the slanting wedges are used. All dipoles are slanted the same way—that is, either clockwise or counter clockwise looking down on the antenna.

Feedlines and feed system.—The feedlines and feed system consist of the following items which are identical or similar to those used in the superturnstile antennas:

1. Feedlines to connect between dipoles and junction boxes.
2. Junction boxes with transformers.
3. Feed system, consisting of transmission line which is usually  $3\frac{1}{8}$  and which interconnects junction boxes, combining tees, beam tilt lines, power equalizer and power division combining tees.

From each dipole a single feedline connects to the junction box as previously described in the paragraph on feed systems. These feedlines are usually of the Styroflex type which has a semi-flexible aluminum outer conductor, with spirally wrapped layers of insulating material to position the copper inner conductor. Note that this line is constructed differently than the helical membrane line which has only a thin section of insulating material supporting the inner conductors.

Application Notes

The material furnished to construct a Supergain antenna consists of the electrical components only, without the tower supporting structure. The supporting structure within the supergain array is of the same type as the tower structure below the antenna, and hence can be made more economically as part of the main tower. In many cases the structure is to be used for mounting more than one antenna and hence must be especially designed for the application. RCA can supply the tower as well as the Supergain antenna since it has available the tower design experience for Supergain antennas. In all cases it is necessary to have close liaison with the tower designer.

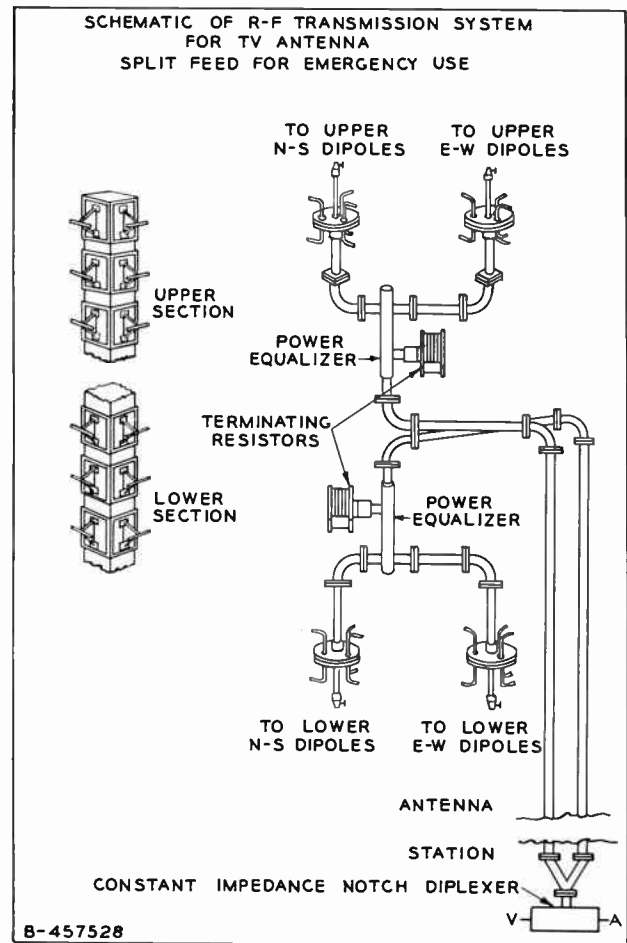
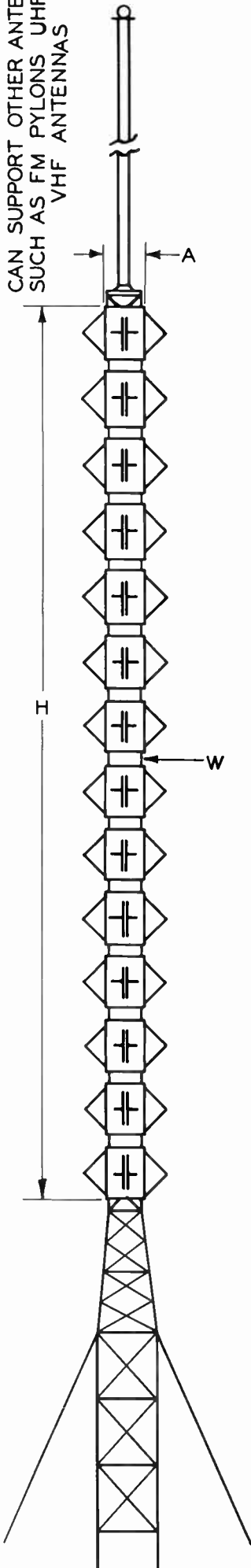

FIG. 4.

CAN SUPPORT OTHER ANTENNAS  
SUCH AS FM PYLONS UHF OR  
VHF ANTENNAS



## TV SUPERGAIN ANTENNAS FOR VHF

### 1. PURPOSE

The Supergain is used for special requirements of gain and pattern and in multiple stacked antenna systems.

### 2. MECHANICAL DESCRIPTION

The Supergain consists of vertical stacked array of horizontal dipoles each backed by reflecting screen. Radiators vertically spaced 0.77 wavelength apart are used. Antenna fed by single transmission line on Channels 2-6 and dual line on Channels 7-13.

### 3. ELECTRICAL PERFORMANCE

Gain determined by number of layers and is approximately 0.8 times number of layers. Directional patterns, providing much higher gain values in favored directions can be obtained by grouping dipoles on one or more sides of the tower or by dispersing them to obtain desired pattern.

### 4. ASSOCIATED EQUIPMENT

Notch diplexer or Filterplexer needed to feed aural and visual signals when single line is used. A bridge power equalizer in antenna system tends to make all dipoles take equal power. For Channels 7-13 a bridge diplexer is used to feed dual transmission line. Transmission line 3 1/8" or 6 1/8", depending on power to be handled.

### 5. FEATURES

- Additional feature of controlled vertical pattern to provide constant field strength through coverage area of antenna can be provided.
- Beam tilting, to increase field strength in desired close-in area, can also be arranged.
- R-F switching, to sectionalize the antenna, for emergency operation can be supplied.

FIG. 5.

CH.	H (HEIGHT) 14 LAYER	H (HEIGHT) 12 LAYER	H (HEIGHT) 6 LAYER	A (WIDTH) FACE TO FACE OF SCREENS	W WINDLOAD
2	184'-4"	157'-8"	77'-11"	9'-1 1/4"	COMPOSITE CALCULATION BY TOWER MANUF. OF RCA SCREENS AND DIPOLES PLUS TOWER STRUCTURE
3	166'-3"	142'-3"	70'-3"	8'-2 1/4"	
4	151'-11"	130'-0"	64'-2"	7'-5 1/2"	
5	132'-5"	113'-3"	55'-11"	6'-5 1/2"	
6	123'-5"	105'-7"	52'-1"	6'-0"	
7	59'-3"	50'-8"	25'-0"	2'-10"	
8	57'-4"	49'-0"	24'-2"	2'-10"	
9	55'-8"	47'-8"	23'-7"	2'-10"	
10	53'-9"	46'-9"	22'-8"	2'-6 3/4"	
11	52'-2"	44'-7"	22'-0"	2'-6 3/4"	
12	50'-9"	43'-5"	21'-6"	2'-6 3/4"	
13	49'-6"	42'-5"	21'-0"	2'-6 3/4"	

DIMENSIONS AND INFORMATION RELATING TO OTHER  
NUMBERS OF LAYERS ON APPLICATION

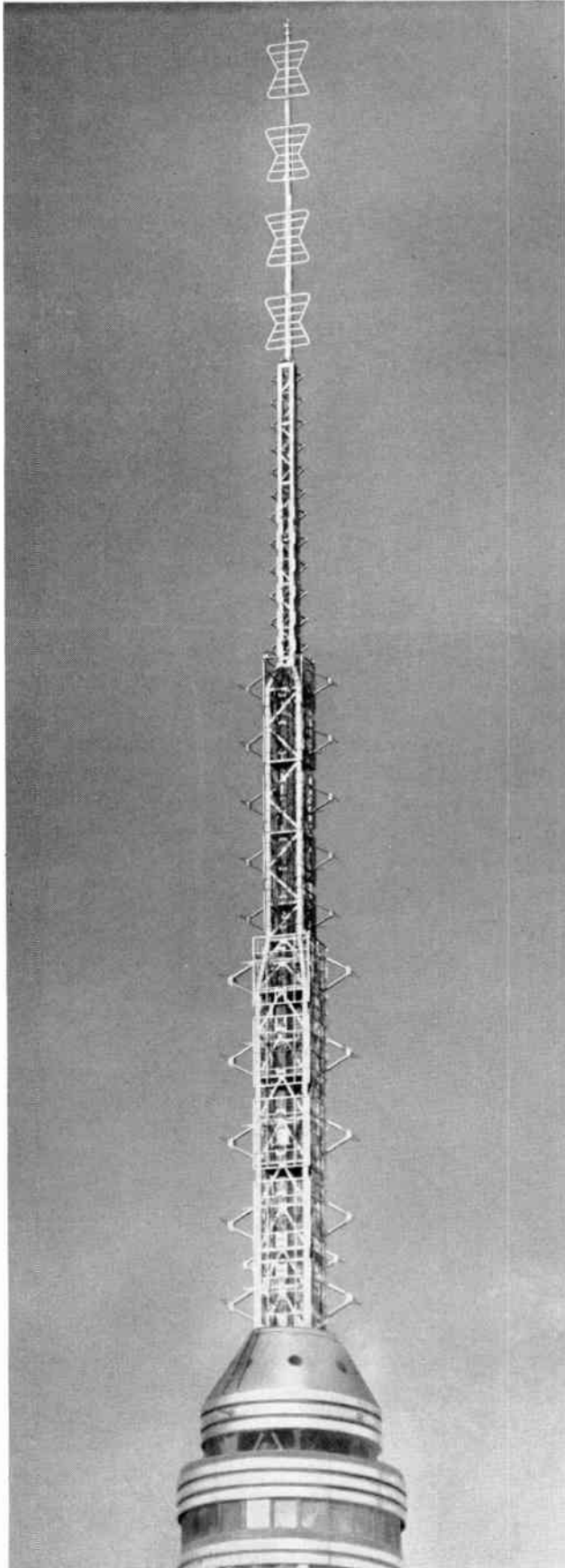

# VHF CUSTOM BUILT ANTENNAS

## Purpose

There are occasions when a Custom Built Television Antenna is required to meet specifications which are unique. Factors that dictate unique specifications are many. A few are antenna stacking, special horizontal patterns, special vertical patterns, special gain, special wind loading and increased power handling capability. In most cases the superturnstile and supergain types are used for custom built application, however other types are available and can be used where they are more desirable.

## Types

### 1. *Antenna Stacking*

The best known example of antenna stacking is the multiple TV-FM antenna installation atop the Empire State building in New York City which combines a superturnstile with supergain arrays.

#### a) Specifications:

Aside from the great amount of detail as to power handling, gain, impedance, split feed systems, and the like, one of the major concerns, was the degree of isolation between arrays that was required for independent separation of the stations. It was finally agreed that 26 DB decoupling would be satisfactory. The assumption was that all stations would have approximately the same gain and go on the air initially with 5 KW. Under these conditions 20 DB decoupling would be satisfactory since tests had shown that this degree of decoupling did not result in cross-modulation between transmitters or in other detrimental effects. However, if one station increased its power four times to 20 KW while a second station continued to operate at 5 KW, an additional 6 DB decoupling would be required to prevent interference, making a total of 26 DB. The antennas themselves have standard components.

b) Principle: Many tests were made in Camden to determine the practicability of stacking such a complex array. Verification of the principle came with the successful completion of the Empire State Antenna project. The antennas are stacked according to wave-length with the low frequency Supergain antennas located below the higher frequency antennas.

- c) Construction: Mechanical problems require careful analysis. When RCA Supergain antennas are to be stacked, there must be adequate room at any cross section of the array for the electrical components of the antenna, and for the transmission lines carrying power to the antennas above. If an RCA Superturnstile antenna is to be mounted on top of a channel 7-13 Supergain, inset screens are recommended so that maximum room is available inside the Supergain tower section. Not all stacking combinations of standard antennas are possible; some are impractical. RCA retains the licensed Engineering firm of Edwards and Hjorth of New York City for certification of the mechanical design of our standard as well as our custom built antennas.

## 2. *Special Horizontal Patterns* (Directionals)

The technique of horizontal pattern shaping is quite highly developed in the field of AM broadcasting. In the field of TV broadcasting rapid advances are being made.

- a) Specification: The FCC in their 6th Report placed a 10 DB limit for the maximum variation of field strength in the horizontal plane for any television antenna coming within their jurisdiction. Therefore, any directional antenna in the USA and possessions must meet this basic requirement.
- b) Principle of Operation: Various directional patterns can be obtained with the Superturnstile antenna. Two methods are available. One is a process of rephasing the N-S system with respect to the E-W system to produce a pattern which looks similar to a filled-in figure 8. The second process uses a division of power between the N-S and E-W systems other than 1 to 1 but maintains the 90° horizontal phasing. The second of the two methods produces a much more elongated filled-in figure 8. pattern.
- c) Construction: Directional horizontal patterns obtained by these methods use antennas identical to the standard antennas with only slight variations. They are usually single-line fed antennas; that is, both sound and picture power come up the tower on a single transmission line or for antenna splitting features, dual line with single output from the diplexer is used.
- d) Application Notes: Any TV antenna which has a horizontal pattern altered so as to produce a pattern different from a nondirectional pattern must be considered a directional antenna. All directional TV antennas must have a maximum variation not greater than 10 DB in the horizontal plane. For directional antennas the maximum ERP is figured for the maximum direction and for omnidirectional antennas the maximum ERP is figured on the basis of the RMS value of horizontal pattern. This in effect reduces the service area of the directional antenna relative to the omnidirectional antenna.
- Even with this handicap it may be desirable to use a directional where it is desired to conserve power: for example, when a station is located on the edge of a large body of water and the concentration of population is within a semicircular area. Also directionals can perform an important function in minimizing interfering reflections, for example, when a station is located beside a mountain range.

## 3. *Special Vertical Patterns*

- a) Specifications: The electrical specifications for an antenna with a special vertical pattern are similar to those for a standard antenna. It is preferable for a consultant to determine the vertical pattern shape when it is desired to fit special terrain conditions. There are some variations in vertical patterns that can be made quite easily; for example, it is possible to change the phase of the currents fed to the individual elements.
- b) Principle of Operation: The following is a list of the practical methods for changing vertical patterns:
- 1) Variation in current distribution.
  - 2) Variation in phase of current.
  - 3) Tilting electrically or mechanically.
  - 4) Variation of spacing between elements.
- c) Construction: The construction of an antenna with a special vertical pattern would be very much like that for a standard antenna. Power splitting transformers and feed lines of various lengths are needed to accomplish the necessary phase and amplitude distributions required in shaping. Special pedestals can be built for mechanically tilting the antenna, when a combination of mechanical and electrical tilt is found desirable. When antennas are mechanically tilted, the mechanical stresses should be recalculated.
- d) Application Notes: The advantage of a high elevation may be wasted unless the vertical beam is tilted. Pattern minimums in the vertical plane, that were satisfactory at low elevations, may become problems at the high elevations, therefore, null filling should be incorporated.

## 4. *Special Gain*

- a) Specifications: The electrical specifications again are practically standard. Where specified gains are required, such as an extremely high gain, many supergain sections can be mounted on top of one another.
- b) Principle of Operation: The principle of operation is identical to that for standard antenna.
- c) Construction: The construction of a special gain antenna is practically the same as that for a standard antenna. Attention should be called however to the same precautions as were men-

tioned in the stacking of antennas relative to the space inside the tower for electrical components.

- d) Application Notes: The increased cost of any special antenna should be balanced against all the other considerations that go into planning a broadcasting plant. This should be done on a long time basis so that the initial and operating costs of the transmitter and special antenna are compared with the initial and operating costs of a transmitter and standard antenna.

In some cases an antenna is required for emergency use and a special design is indicated; for instance a few sections of supergain components can be placed around the tower if the tower is designed to withstand the loading and to have the required cross-sectional dimensions.

#### 5. *Special Wind Loading*

- a) Specifications: The electrical specifications are unchanged from those for a standard antenna. Antennas capable of withstanding wind pressures up to 90 pounds per square foot of projected area on flat surfaces have been designed.
- b) Construction: The electrical requirements for RCA Superturnstile antennas dictate that the outside diameter of the pole be unchanged. Therefore to design an antenna that will withstand high velocity winds it is necessary to increase the wall thickness of the pipe while maintaining the same outside diameter.
- c) Application: Wherever there are strong wind conditions as in tornado belts, in hurricane areas and on high mountain peaks, a specially designed pole is required.

#### 6. *Special Power Handling Capability*

- a) Specifications: These antennas can be designed to meet the same specifications that apply to the standard superturnstile or supergain antennas, except that components of greater power handling capability are required to permit the increased power rating.
- b) Principle of Operation: The increased power rating is achieved through the use of one or more of the following: A larger size of transmission line, junction boxes of larger size or constructed of materials which will either have lower losses or will carry more power without deterioration, feedlines of greater power handling capability, or a rearrangement of radiators to permit the use of a greater number of feedlines so that the power per feedline is reduced to a value which is within the safe rating.
- c) Construction: These antennas have a construction which is in general identical to that of a standard antenna.

- d) Application Notes: Antennas of higher power handling capability are primarily of use where a very wide vertical pattern is desired. Thus a 3-section antenna may have the desired vertical pattern width, but will not handle the required input power. A special feed system for higher power is thus indicated.

#### 7. *Maintenance*

It is essential to set up a maintenance schedule upon the completion of the installation as this will help to prevent interruptions to service.

When the antenna installation is checked out by the RCA Service Company engineer, the data he has taken on the d-c resistance and hi-pot measurements are included in the data supplied to the station. A maintenance schedule can then be set up to repeat these measurements at regular intervals which can be of the order of one month apart. Such measurements will require the following test equipment:

- 1 Megger. Preferably 1000 volts, but a 500 volt megger is acceptable.
- 1 Micro-ohmmeter. This is a wheatstone bridge instrument having separate voltage and current leads in each probe so measurements can be made accurately on resistances which are less than one ohm.

R-f sweep equipment is also desirable and if the equipment can be made available, tests of the antenna using this equipment should be added to the maintenance schedule.

The d-c resistance checks consist of measurements of the d-c resistance looking into the transmission line from the station. Any significant increase in the resistance may be an indication that trouble is brewing in the transmission line or antenna, since the d-c circuit on most antennas goes all the way through to the end seals of the radiators.

The hi-pot test requires that the end seals be disconnected with most antenna feed systems. This test can therefore be scheduled for less frequent intervals, but should be made at least twice a year. A check should be made in the fall before bad weather sets in, and again in the spring. Any significant decrease in the leakage resistance indicates a defective component, such as a feed line or insulator.

The R-F sweep test can be made more often—perhaps once weekly—since it is only necessary to disconnect the transmission line in the station to make this test.

An inspection by a rigger experienced in antenna work should be made at least twice yearly (fall and spring) since some of the electrical components are subject to damage by the weather. For instance the end seal connection straps are necessarily made of thin material so that no excessive strain will be applied to the end seals. These thin straps tend to bend in the wind and hence will eventually fatigue and break. Replacement every

year or so is indicated. On some antennas, steatite insulators are used to stiffen the radiator supports. One of these may break without affecting the functioning of the antenna, but the insulator should be replaced as soon as possible to avoid further damage.

The inspection should also cover the tightness of the bolts holding the various components, and the corrosion of the steel parts. Most of the steel components, such as radiators, are galvanized and thus will last indefinitely unless the galvanized finish has been damaged.

On all types of antennas using radiators of the dipole type, the feedlines which carry power to the radiators are necessarily either in or close to an intense r-f field. For instance in the Supergain type the screens shield the interior of the tower from most, but not all of the radiated field. As a consequence the interior of the tower, where the feedlines are located, may have a considerable con-

centration of r-f field. Structural members, ladders, and the feedlines themselves are in this field and high currents may be induced if the configuration happens to be resonant to the frequencies of the transmitter. This circumstance should be investigated thoroughly, not only at the time when the antenna is first operated at high power, but at the regular maintenance intervals since changes made in the interior of the tower may set up resonant pickup circuits and cause eventual failure of the feedlines or other components. If circuits are found which result in undue heating of the feedline outer conductors, or the structural members, either the routing of the cables, or the placement of the interior supports should be changed.

Periodic painting is desirable. Care should be taken to avoid painting the end seals or insulators since this will affect the antenna performance.

# TELEVISION TOWERS

## Purpose

**TV** Towers are designed to support one or more antenna systems at heights which will provide adequate coverage in the service area.

The use of a single tower for two or more TV stations is good engineering practice from the standpoint that all receiving antennas in the area will automatically be oriented in the proper direction for all channels used. The advantages of multiple usage may offset the essential expensiveness of such structures.

Inasmuch as the transmitting antenna must have sufficient height to avoid shadowing of receiving areas and to clear intervening obstacles, it is important to make profile studies to find if shadowed areas exist. This requires a study of the profiles on all important radials from the station. The study may be accomplished by the flash bulb method, in which photographs are made of a three-dimensional relief map with a lamp illuminating the map from a point corresponding to the proposed antenna location, or by study of profiles made from topographical

survey maps. In using topographical surveys care should be taken to make sure the information is correct since serious errors have been found in such maps.

## Specifications

Since wind and ice conditions vary throughout the country, the geographical location of the tower will determine design parameters.

The wind pressure map shown in Figure 1 was prepared for RCA by Edwards and Hjorth, structural consultants of New York. It indicates by means of shaded areas the wind pressure that should normally be specified for any section of the U. S. This information is based on U. S. weather bureau records and has been adjusted to an assumed 750 ft. elevation. Mountains and other topographical features and areas subject to heavy icing conditions should be given special consideration. Wind pressures for these localities should be determined only after a careful study of local conditions.

Experienced tower builders rarely design for less than a 30/20 lb. loading. This means that the tower members are designed to resist a horizontal wind pressure of 30 lbs.

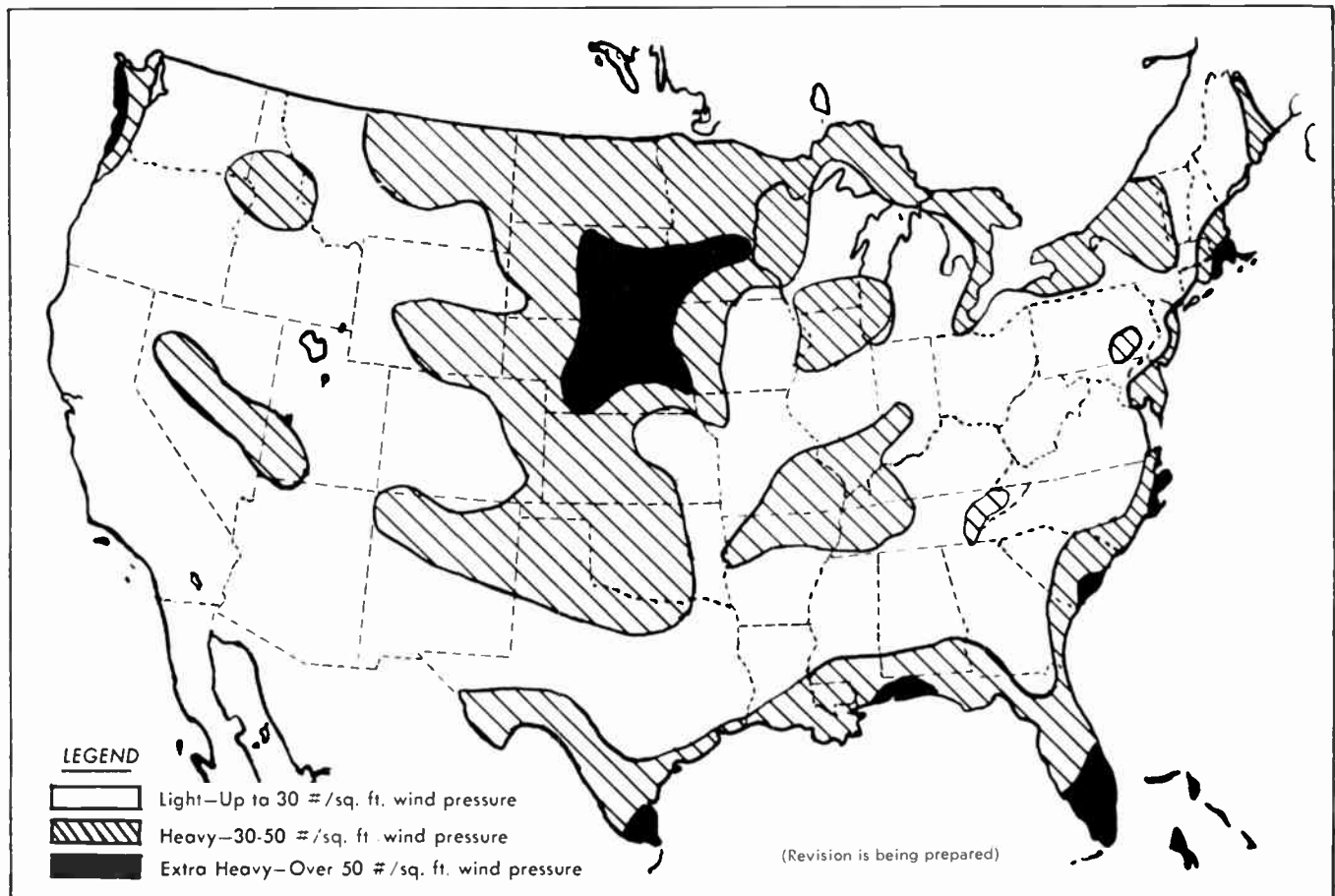

FIG. 1. Wind pressures which would be normally specified for any section of the U. S.



per sq. ft. of projected area on all flat surfaces and 20 lbs. on round surfaces. This is the equivalent of an "actual" wind velocity<sup>1</sup> of 85 miles per hour. Provision should be made for all additional loadings caused by the attachment of guys, antenna, ladders, transmission and power lines, etc. and should be applied to the projected area of the structure. The total load thus specified should be applied to the structure in the direction which will cause the maximum stress in the various members. Where high winds or heavy icing is prevalent, a 50/30 lb. loading is often specified.

Excessive tilt of a TV superturnstile or a UHF pylon in relation to its base caused by high winds, may result in variations in the received signal strength. The choice of the rated velocity should be determined by consideration of the number of times per year that partially affected service is acceptable. Wind velocity records throughout the country based on a twenty-five times a year average (approximately 45 miles per hour) can be used as a basis for allowable tilt of the tower top plate. This degree of tilt should be specified to the tower builder from RCA antenna data sheets. The installation of RCA-UHF antennas requires that the tilt of the tower plate be held to a somewhat closer figure than superturnstiles, since higher gains are realizable at UHF.

### Types

Where heights greater than 500 ft. are required, guyed towers are usually specified and the normal cross sectional shape is triangular so that three point guying can be used. The main disadvantage of guyed structures is the land area involved for guy anchorage (Fig. 2). A useful method for estimating the land required is to consider the distance to the farthest guy anchorage as being approximately  $\frac{5}{8}$  the tower height. Self supporting towers are especially advantageous in city and congested districts where land is expensive. For estimating required space for a self supporting tower, the distance between tower legs can normally be considered as  $\frac{1}{8}$  the height of the structure. (Fig. 3.)

### Construction

Towers may or may not be galvanized. If the tower members are designed to RETMA specifications and the structure is painted frequently and properly maintained, galvanizing may not be necessary. Where corrosive action

<sup>1</sup> RCA data sheets refer to true ("actual") wind velocities as distinguished from indicated velocities. These "indicated" figures were measured with a Robinson 4 cup anemometer. They were formerly used in the industry with an instrumental error correction applied, but have been discontinued by most designers since 1928 when a change was made to a 3 cup unit which had smaller errors. Since 1932 corrections for instrumental errors were applied to the data before publication.

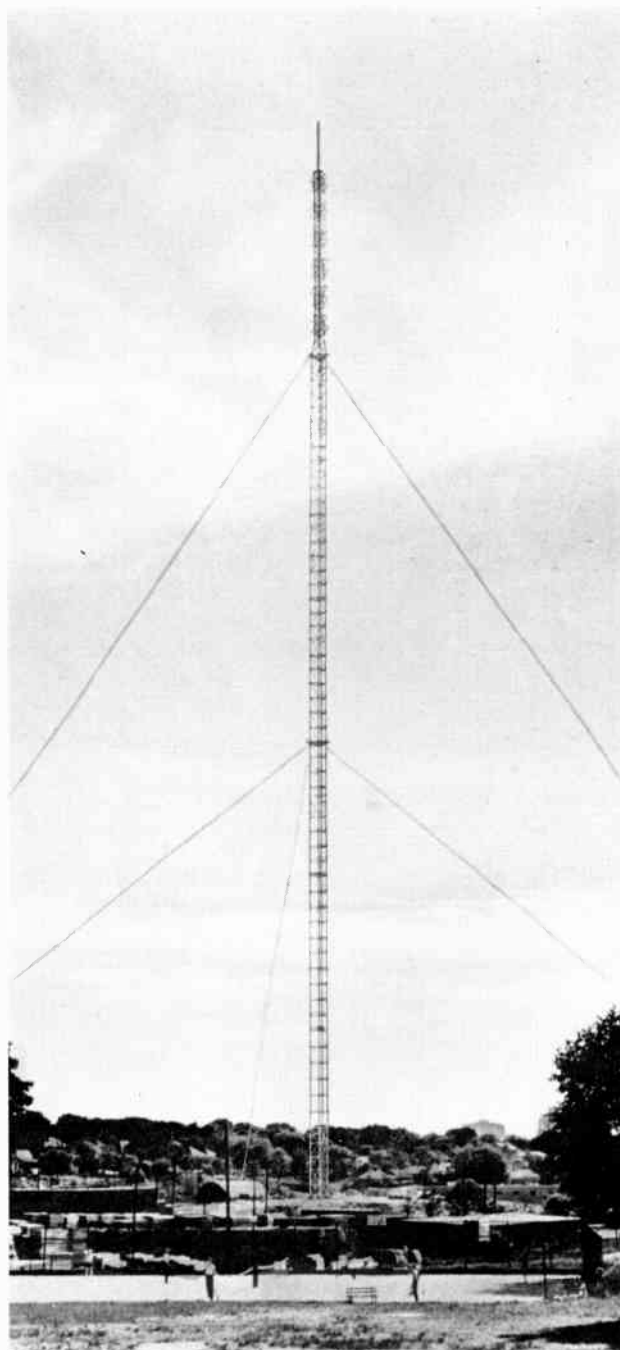

FIG. 2. 1000-foot guyed tower of WSB, Atlanta, Georgia, gives some idea of the land area involved when using guyed towers.

due to fumes, salt air, etc., is likely to occur, galvanizing will offer additional protection. Painting of a galvanized structure, to meet CAA requirements, requires either pre-treatment of the surface, or weathering for a few months before the paint is applied.

Climbing ladders should be located inside the tower if at all possible and preferably near the tower legs. By placing the ladder within the tower, the lattice braces form a safety cage for the servicemen. The ladder is also

an excellent support for transmission line runs as it is accessible at all times. The type of hangers (usually direct mounting) should be specified so that proper supporting members can be provided in the tower.

Platforms for rest and maintenance purposes should be planned at convenient intervals. Where railings at the tower top are required, it is preferable that the platform level be lower so that the height of the rail does not extend above the top of the tower.



FIG. 3. Self-supporting tower of WBAL-TV, Baltimore, Md. Note the small amount of land area involved and the proximity of tower to residential area.

Structures over 750 ft. in height may be equipped with elevator facilities. Hoist or man lift elevators can be supplied by the tower builder.

#### Application Notes:

Suggested steps to follow in planning a suitable structure:

1. New Tower:
  - A. Determine location and height.
  - B. Procure CAA approval, if necessary.
  - C. Determine whether guyed or unguyed from land available.
  - D. Consult RCA's Broadcast Representative who will provide helpful recommendations on these following items:
    - (1) Height.
    - (2) Guyed or unguyed.
    - (3) Wind load on which design should be based. (Recommendations on map, Fig. 1.)
    - (4) What antenna's tower will support.
    - (5) Permissible deflection.
    - (6) Transmission line support and number of lines.
    - (7) Location of ladder.
    - (8) Railings desired.
    - (9) Hoist, if any.
2. Existing Tower—May be desirable to locate a TV antenna on top of an existing tower by:
  - a. Using the inherent strength of the tower.
  - b. By decreasing the height.
  - c. By displacing other antennas.

#### Maintenance

Materials of construction, fastenings, climatic conditions and required length of life, determine maintenance requirements.

About six months after a tower has been erected, or after its first winter, all bolts should be tightened and any showing signs of corrosion painted or replaced. Subsequent tightening need only be done once a year, but signs of misalignment or damage should be promptly attended to.

Guys should be checked four times a year or after severe storms. Painting is the most costly repetitive item and the one most often neglected. It should be done before signs of corrosion become evident.

The planning and selection of television towers and antenna systems carries with it the responsibility of securing the services of competent tower builders and riggers. Improper designing and poor installation technique can prove very costly. RCA, through its field representatives will be glad to assist in selecting the tower and erectors best suited for each particular requirement.

## WIND VELOCITIES AND CORRESPONDING PRESSURES

TRUE "EXTREME" VELOCITY MILES PER HOUR (Note No. 1) $V_{ii}$	FLAT SURFACES Pressure in Lbs./Sq. Ft. of Projected Area $P = 0.0042V_{ii}^2$	CYLINDRICAL SURFACES Pressure in Lbs./Sq. Ft. of Projected Area $P = 0.0025V_{ii}^2$	INDICATED VELOCITY MILES PER HOUR (Note No. 2) $V_i$
10	.42	.25	11
15	.95	.56	17
20	1.7	1.00	23
25	2.6	1.6	30
30	3.8	2.3	37
35	5.2	3.1	44
40	6.7	4.0	50
45	8.5	5.1	57
50	10.5	6.3	64
55	12.7	7.6	71
60	15.1	9.0	78
65	17.8	10.6	85
70	20.6	12.3	91
75	23.6	14.1	98
80	26.9	16.0	105
85	30.4	18.1	112
90	34.0	20.3	118
95	37.9	22.6	125
100	42.0	25.0	132
105	46.3	27.6	138
110	50.8	30.3	145
115	55.5	33.1	152
120	60.5	36.0	159
125	65.6	39.1	166
130	70.9	42.3	173
135	76.5	45.6	180
140	82.3	49.0	187
145	88.3	52.6	194
150	94.5	56.3	201
155	100.9	60.1	208
160	107.5	64.0	215
165	114.3	68.1	222
170	121.4	72.3	229
175	128.6	76.6	235
180	136.1	81.0	243
185	143.7	85.6	250
190	151.6	90.3	257
195	159.7	95.1	264
200	168.0	100.0	271
205	176.5	105.1	278
210	185.2	110.3	285
215	194.1	115.6	292
220	203.3	121.0	297
225	212.6	126.6	304

THESE FIGURES ARE NOT SUBSTANTIATED BY ACTUAL TESTS BUT ARE EXTRAPOLATED

NOTE No. 1—Since 1932 published weather data based on 5 minute average known as "Maximum" and frequently on fastest mile known as "Extreme." Selection of antenna loads should be based on Extreme (increase "Maximum" by 15% if no data on Extreme).

NOTE No. 2—RCA bases strength of antennas on True Velocities, not Indicated. Indicated Velocities are those given by the Robinson 4 Cup Anemometer (now obsolete).

# UHF FILTERPLEXER

## Purpose

The UHF filterplexer as shown in Fig. 1, is a unit which connects the aural and visual transmitters to a common antenna feedline with negligible interaction or crosstalk, and shapes the transmitter frequency response to conform to the RTMA and FCC standards for vestigial sideband television transmission.

## Specifications

### Mechanical Description:

Weight (Approx.)	500 lbs. net 700 lbs. gross
Maximum Dimension	
Height	42"
Width	45"
Length	72"

Mounting—open frame suitable for ceiling or floor mounting.

### Electrical Description:

Frequency—UHF channels 14 to 83 as specified, pre-tuned and tested at the factory.	
Max. Power	10 KW peak visual
Min. Efficiency	90%
Input Impedances (Aural and Visual)	50 ohms
Max. Input VSWR	1.1/1
Max. Altitude at Full Power	5000 ft.*
Min. Bandwidth (both sidebands)	9 mc.
Max. Ambient Temperature	45°C (113°F)
Min. Ambient Temperature	15°C (59°F)

The entire unit is gassed with approximately one atmosphere pressure of dry nitrogen when shipped from factory. (Nitrogen tubing, tank, and tank regulator are not included). Gassing kit and two-stage regulator should be ordered separately.

The UHF filterplexer, MI-19086-14 to -83 is supplied completely assembled and adjusted for operation in any one of the UHF television channels. Every filterplexer is pre-tuned and adjusted to the specified channel and it may not be possible to re-adjust to other channels.

## 1. Maximum Power Output

The filterplexer is designed for 10 KW visual power and 5 KW aural power; thus any customer purchasing a 1 KW transmitter may use the same filterplexer when he later installs a 10 KW amplifier.

\* For elevation in excess of 5000 ft. special precautions may be required for some channels.

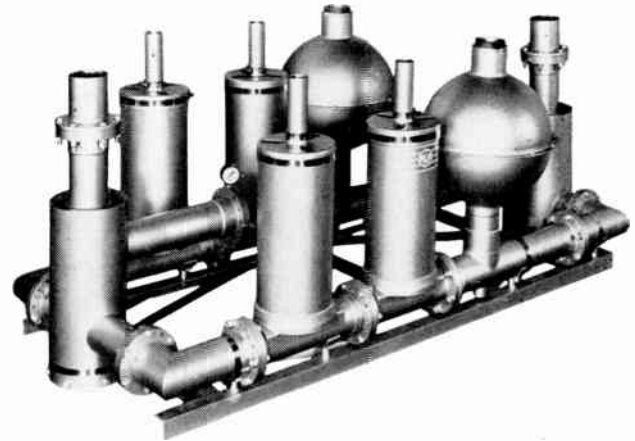

FIG. 1. The UHF Filterplexer. Slight modifications in the mounting bracket have been made since this picture was taken.

## 2. Input Impedance and VSWR

By using a new non-reflecting circuit as shown in Fig. 3, the input impedance is a nearly constant 50 ohm resistance with a VSWR of 1.1 or less over the entire 9 mc. bandwidth. The VSWR curve of a typical production unit is shown in Fig. 2.

This constant input impedance feature of the filterplexer permits tuning the transmitter for best performance without regard to the lower sideband response, and certain types of tests may be made at the output of the transmitter to facilitate proper transmitter adjustment and maintenance which would not be possible if a reflecting or reactive type of filter were used. The visual output frequency response is determined by the filterplexer and no additional lower sideband attenuation is required in the transmitter.

## 3. Frequency Response

The theoretical and measured frequency response and phase shift curves of a typical UHF filterplexer are shown in Fig. 4. This response is in conformance with transmission characteristics as specified by the FCC and RTMA, and meets the NTSC compatible color television standards. Through many years of research and development, circuits have been evolved which attain sufficient lower sideband attenuation without additional attenuation in the transmitter at UHF television frequencies.

## Principle of Operation

The visual signal which is fed to the input diplexer divides equally and is 180° out of phase through two branches as shown in Fig. 3. Due to the diplexer-balun action, there will be no potential difference across the absorbing load resistor R. As signals pass down along

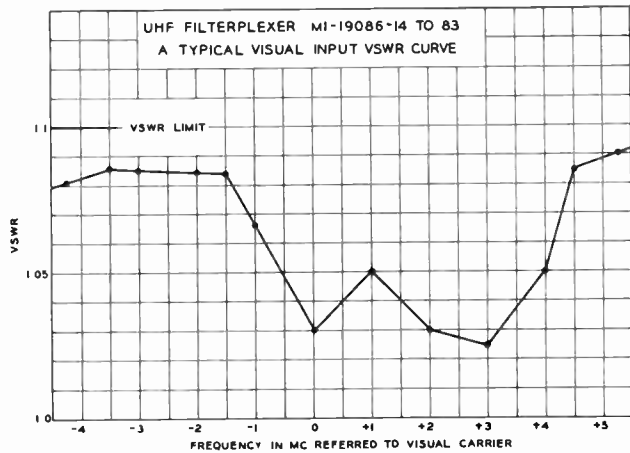

FIG. 2.

two branches to cavities A and A', they will reflect back at the resonant frequency of the cavity. (A and A', B and B', and C and C' are identical pairs). Since the locations of A and A' are different by a quarter wave length, the total round trip phase delay is  $\frac{1}{2}$  wave length or  $180^\circ$ . This added to the  $180^\circ$  phase difference incurred in the diplexer results in the reflected waves from the branches

to the diplexer being in phase. Thus, the in-phase reflected waves produce no potential difference across the visual input but will be dissipated in absorbing resistor R.

By following the same reasoning, it can be shown that the cavities B and B' have the same action as the cavities A and A'. The resonant frequencies of cavities A and A', and B and B' are tuned to frequencies lower than the visual carrier. Therefore, their function is to attenuate the lower sideband in conformance with RTMA and FCC specifications to obtain vestigial sideband TV transmission.

The aural signal is fed to the output diplexer shown in Fig. 3 and divides equally into each branch. The aural signals in the two branches are in phase and thus cannot feed into the push-pull antenna circuit directly. The aural carrier waves must go back along the branches until they reach the sound notch cavities C and C'. The aural signal is totally reflected back towards the antenna since the cavities C and C' are of high Q selective elements and are tuned at aural carrier. Due to the quarter wave length displacement of cavities C and C', the reflected waves from the two branches to the output diplexer will be out of phase ( $180^\circ$ ). Thus the out-of-phase reflected waves produce no potential difference across the aural input of the output diplexer and will feed to the antenna circuits.

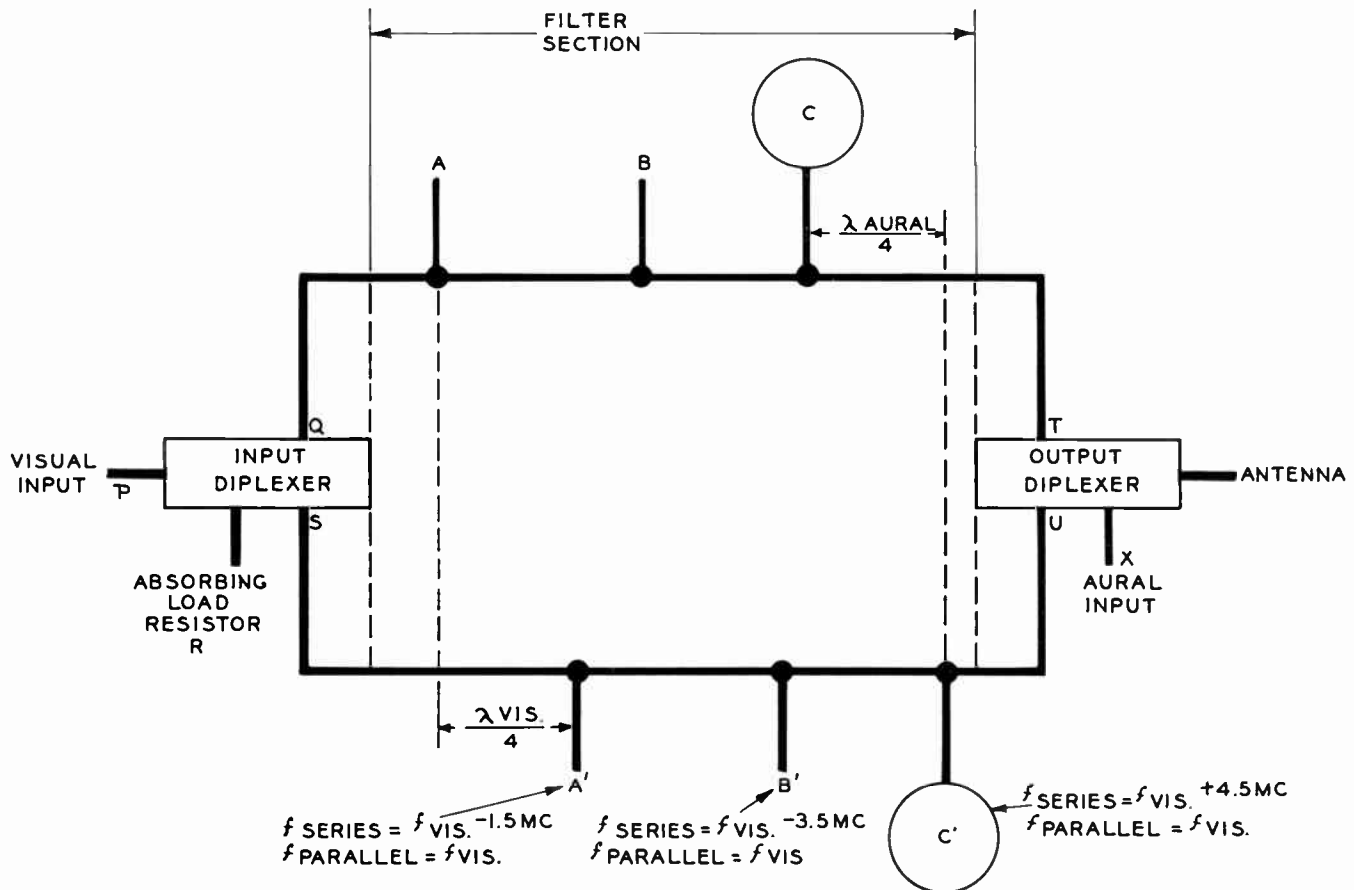

FIG. 3. Simplified schematic diagram UHF Filterplexer.

FIG. 5. The RCA "Filterplexer" is shown mounted in a special cradle slung from overhead girders.

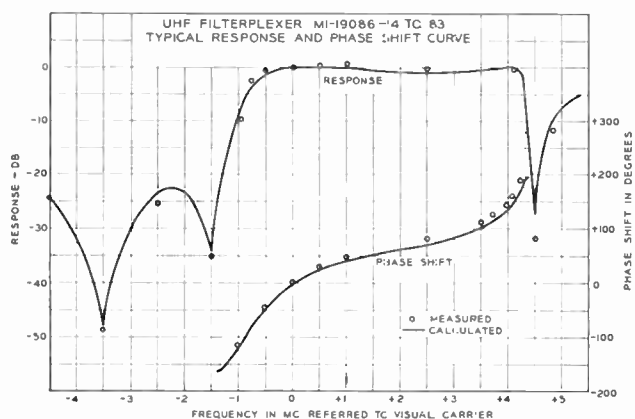
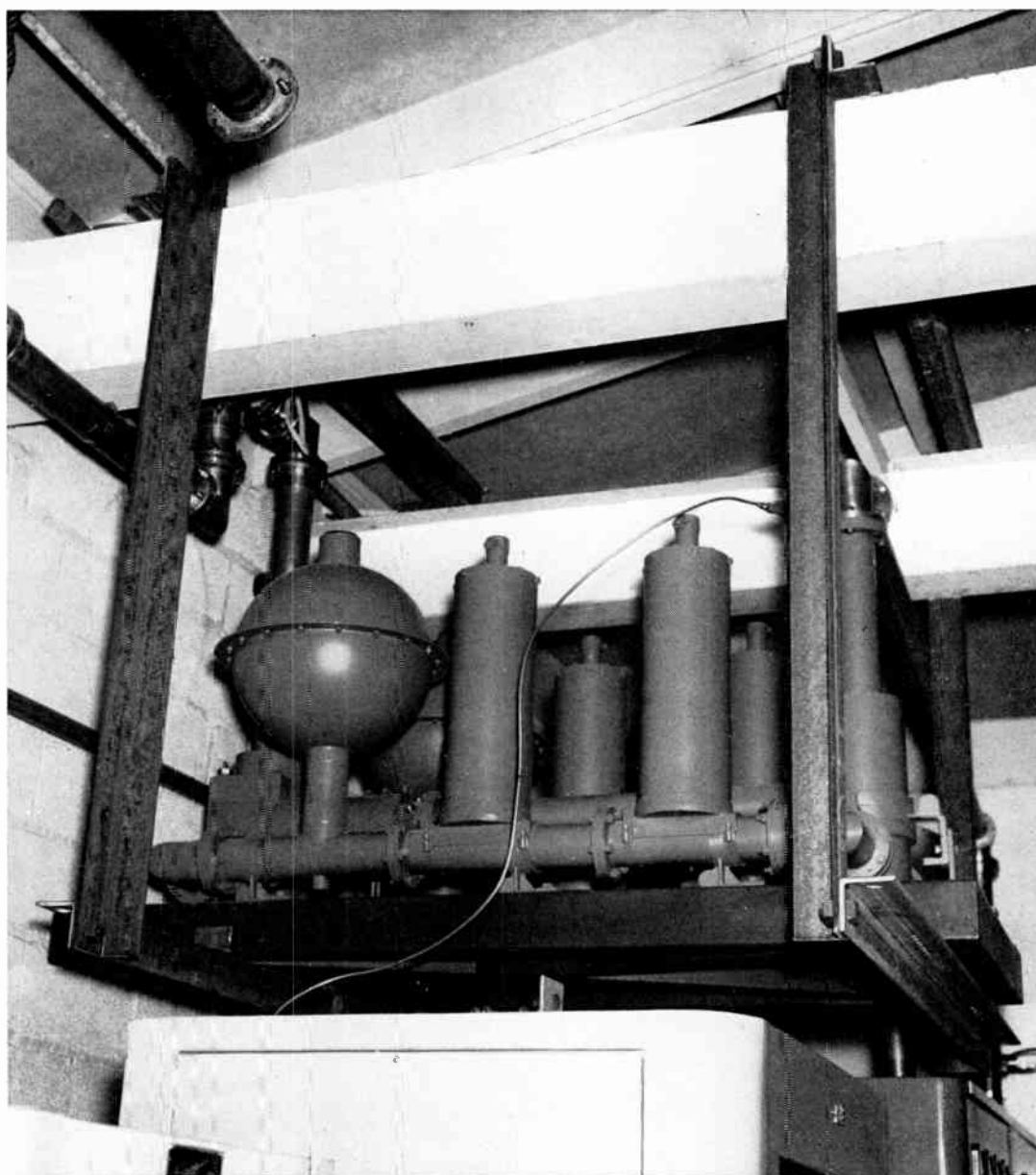

FIG. 4.

### Construction

The filterplexer is assembled in an open frame providing maximum ventilation and is suitable for convenient floor or ceiling mounting. The unit is pressurized with dry nitrogen to prevent deterioration and changes in tuning caused by variations in absolute humidity. Fig. 5 shows a typical installation.

### Application

The filterplexer is shipped in a substantial wooden box. Extreme care should be exercised in handling this box and in uncrating the filterplexer. Dents or distortions caused by dropping the box or careless handling of uncrating tools is almost certain to upset the filterplexer performance.

The filterplexer is shipped completely tuned and tested and does not require tuning or adjustment at any time unless damaged by improper handling or operation.

All circuit elements of the filterplexer are carefully set at the factory with special equipment that is capable of making the precision adjustments required. **UNDER NO CIRCUMSTANCES SHOULD THESE ADJUSTMENTS BE CHANGED.**

Installation may be at any convenient interior location where a free circulation of air will be obtained, but the unit should not be exposed to drafts or direct sunlight. The ambient temperature of the filterplexer location should be between 15°C and 45°C. Although not imperative, it is recommended that the filterplexer be installed as close to the transmitter as possible. A table top mounting or platform suspension from the ceiling is recommended for simplicity and accessibility.

The MI-19197 absorbing load must be mounted horizontally. It should be installed at a convenient location where free circulation of air is available to dissipate the power in the absorbing load. A location clear of the filterplexer should be chosen to prevent unnecessary or unbalanced heating of the filterplexer. The length of transmission line connecting the absorbing load to the filterplexer is not critical. The absorbing load wattmeter should be at a convenient, easy to read location. The wattmeter will prove to be a very useful indicator for simple rough checks on operating performance of the filterplexer.

In planning the layout of interconnecting transmission lines, thought should be given to ease of partial disas-

sembly. For routine checks and trouble-shooting it will be necessary to insert dummy loads and measuring lines in various parts of the system. Careful pre-planning of transmission line runs will make disassembly for checks simple, easy, and fast.

For proper operation of the filterplexer dry nitrogen at a pressure of 12 lbs. per square inch must be used. A pressure gauge and a factory-set precision pressure regulator are part of the filterplexer. Nitrogen tanks should be procured locally. The required gassing kit and two stage regulator (not part of filterplexer) should be ordered separately.

The UHF filterplexer is a precision instrument and as such requires extreme care in handling. Experienced RCA Service Company engineers may be obtained by arrangement with RCA Broadcast Equipment Regional Field Sales Representative to facilitate installation, adjustment, and test of the station equipment. It is strongly recommended that these services be utilized. The use of this engineer during the installation or adjustment period will aid the customer in obtaining the best possible picture quality and will insure that the guarantee will not become void because of damage or mistuning by inexperienced personnel.

It is anticipated that no particular maintenance of a UHF filterplexer will be necessary except the proper maintenance of nitrogen pressure. **DO NOT ATTEMPT TO OPERATE THE FILTERPLEXER WITHOUT THE USE OF DRY NITROGEN AT PROPER OPERATING PRESSURE.**

# VHF AND UHF TRANSMISSION LINES AND FITTINGS

## Purpose

Transmission lines are used to connect the visual and aural transmitters to the filterplexer or bridge diplexer and the filterplexer output to the antenna.

## Specifications

1. *Nominal Transmission Line Characteristic Impedance and Sizes.*

51.5 ohms for  $3\frac{1}{8}$  inch O. D. MI-19113-B VHF line (Steatite Insulated).

51.5 ohms for  $3\frac{1}{8}$  inch O. D. MI-19313 VHF line (Teflon Insulated).

51.5 ohms for  $6\frac{1}{8}$  inch O. D. MI-19314 VHF line (Steatite Insulated).

50.0 ohms for  $3\frac{1}{8}$  inch O. D. MI-19089 UHF line (Teflon Insulated).

75.0 ohms for  $6\frac{1}{8}$  inch O. D. MI-19387 UHF line (Teflon Insulated).

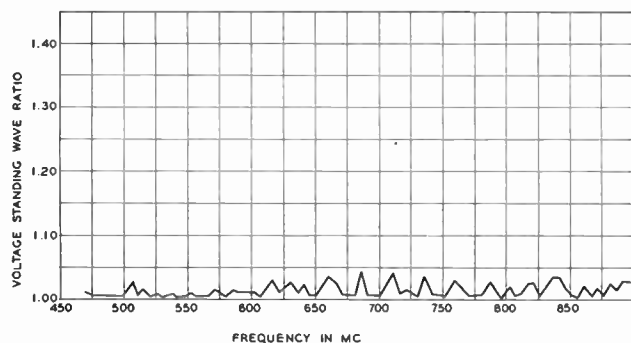

FIG. 1. Voltage standing wave ratio of MI-19089 ( $3\frac{1}{8}$  inch) UHF line.

## 2. Voltage Standing Wave Ratio

In general all line used for television must have a VSWR that is low enough to assure that the VSWR of the complete system from the transmitter to the antenna will be 1.1 or better over the channel used. Fig. 1 shows the standing wave characteristic of a run of MI-19089 ( $3\frac{1}{8}$  inch) UHF line. The standing wave characteristic shown in Fig. 2 was obtained on a run of MI-19387 ( $6\frac{1}{8}$  inch) UHF line.

## 3. Attenuation and Efficiency

The efficiencies of MI-19089-1 and MI-19387-1 UHF transmission lines and MI-19314-1 and MI-19113-1 VHF transmission lines are shown in tables on pages D-122 to D-132 of Appendix B. It should be noted that these efficiency figures are based on measured data

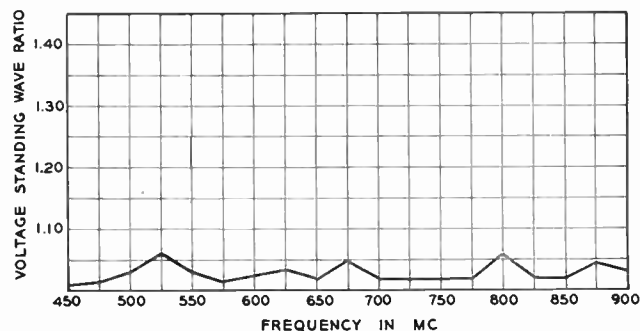

FIG. 2. Voltage standing wave ratio of MI-19387 ( $6\frac{1}{8}$  inch) UHF line.

which takes into account surface roughness, higher order modes at insulators, and higher than theoretical dielectric losses. These losses may add to the usual calculated attenuation values obtained at UHF by considering only copper and theoretical dielectric losses. Care should be exercised when filing a television station application to use measured efficiency and attenuation data since theoretical efficiencies may be somewhat higher than actual performance. Figs. 3 and 4 give a comparison of measured and calculated attenuation for RCA MI-19089-1, MI-19113-1, MI-19134-1 and MI-19387-1 coaxial lines.

## 4. Power Rating

The power rating of MI-19089-1 ( $3\frac{1}{8}$ " UHF line and MI-19113-1 ( $3\frac{1}{8}$  inch) VHF line are shown in Fig. 5. The power rating of MI-19387-1 ( $6\frac{1}{8}$  inch) UHF line and MI-19314-1 ( $6\frac{1}{8}$  inch) VHF line are shown in Fig. 6. These established power ratings are based on measured attenuation curves shown in Figs. 3 and 4.

## Principle of Operation

Two types of air-dielectric lines are presently in use. If the insulators are closely spaced (less than a quarter wavelength) to make the line behave somewhat like a uniformly loaded line, each insulator may add shunt capacity without adverse effect. However, the characteristic impedance is a function of frequency. The MI-19113-B (disk insulated) and MI-19314 (pin insulated) VHF Steatite lines are of this type. The spacing of the insulators is at one foot intervals in each line. These insulators together with the inner conductor form a series of low pass "T" filter sections.

An alternate approach is to compensate the insulators by undercutting them so that there is no net insulator discontinuity. Therefore, the insulators need only be close enough together for mechanical support with less resulting



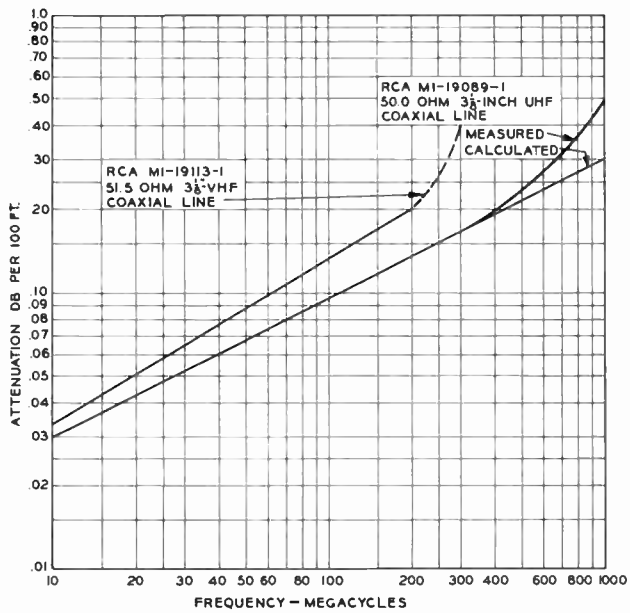

FIG. 3.

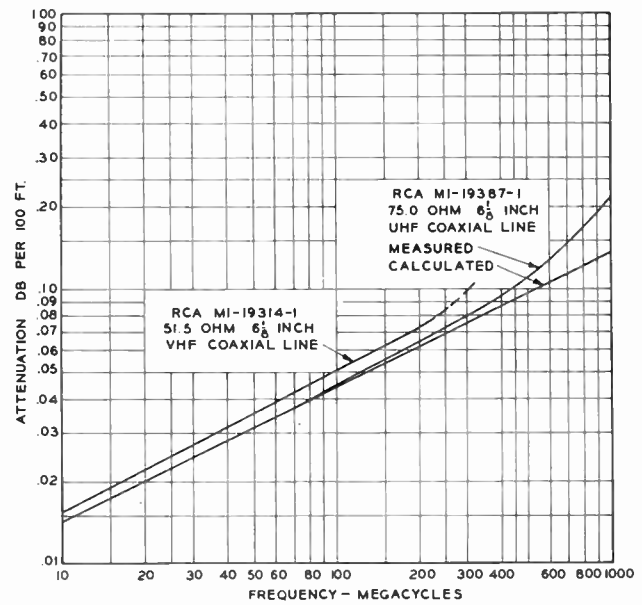

FIG. 4.

attenuation. The MI-19313 VHF teflon, MI-19089 and MI-19387 UHF teflon insulated lines are of this type. Fig. 7 shows a cross-sectional view of an undercut teflon electrically transparent insulator of the type used in the above lines.

The lines with transparent insulators do not have a characteristic standing wave pattern between insulators such as exists in the closely spaced steatite insulated line when properly terminated, see Fig. 8. Consequently, the teflon line may be cut without regard to insulator loca-

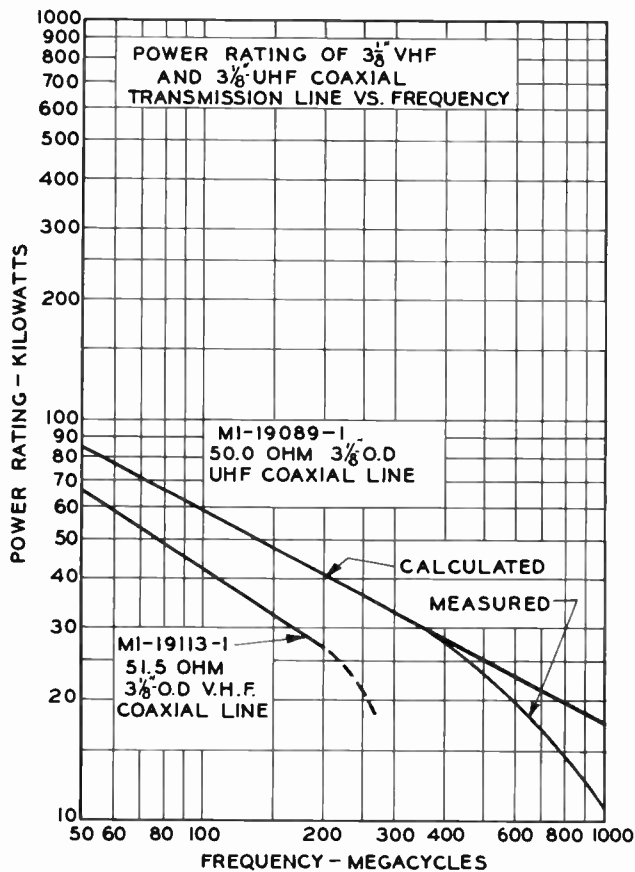

FIG. 5.

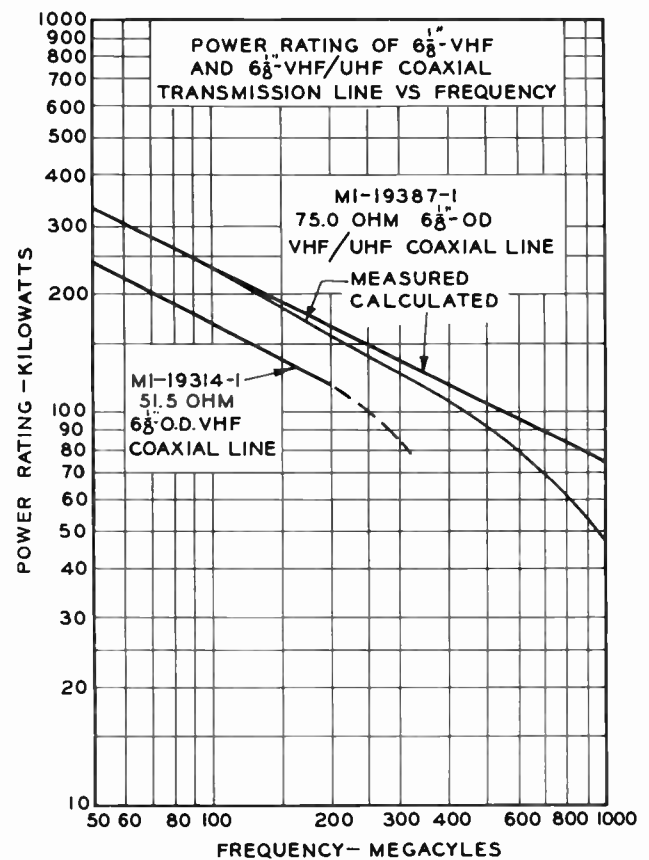

FIG. 6.

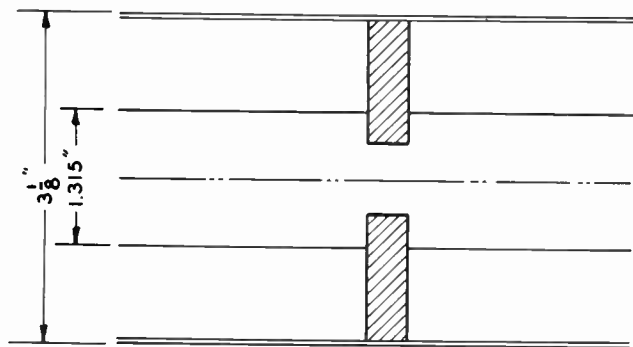

FIG. 7. Cross-sectional view of undercut insulator.

tion without changing the operating impedance. Of course, the teflon line should not be cut so near the undercut insulator that the length of inner conductor tube remaining on the end is insufficient for the standard inner conductor connector or at a point through the insulator support which would destroy its electrically transparent character.

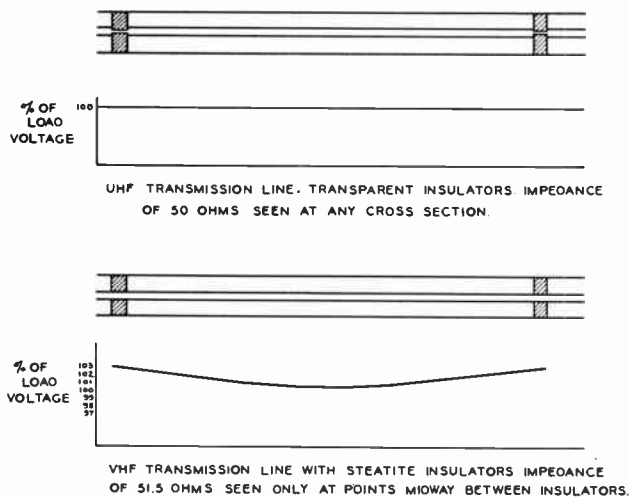

FIG. 8. Voltage distribution on UHF and VHF transmission lines.

### Construction

The lines used for television consist of a copper outer conductor and a copper inner conductor supported by insulators as previously described. For VHF inside use, sleeve connections are used since there is no requirement to keep this line pressure-tight. Fig. 10 shows the roughing-in dimensions of a typical one of the series of lines available for television use. This drawing shows the assembly dimensions of several of the fittings which are available in this series.

The MI-19113, MI-19314 and MI-19313 series of transmission lines and fittings use expansion bullets of the spiral type for the connection between inner conductors. These bullets permit the inner conductors to slide the slight amount necessary to allow for differential

expansion between inner and outer conductors. Each outer conductor has a rolled groove near one end. When mounted vertically the lines should be installed with the groove at the lower end so the inner conductor will not fall out. When mounted in horizontal runs, the lines should be installed with the grooves alternated so the inner conductors will not creep.

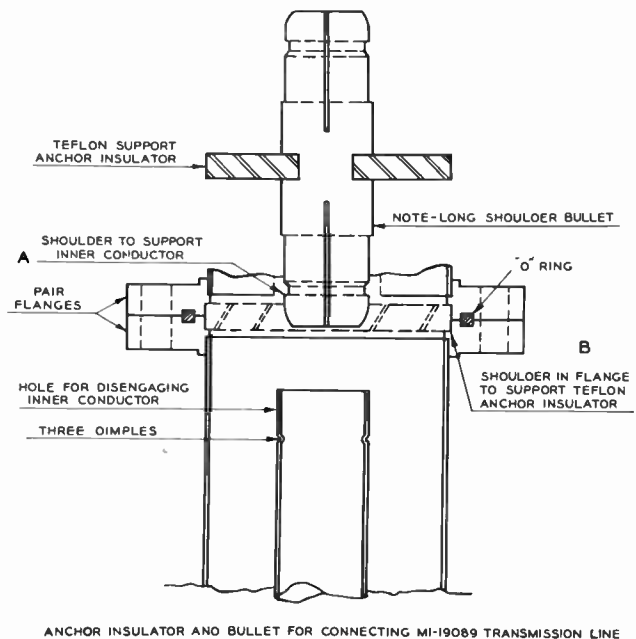

FIG. 9.

The construction of the UHF transmission line (MI-19089 and MI-19387) is similar to the VHF lines except that an undercut anchor insulator is used instead of a rolled groove to hold the inner conductor in place. See Fig. 9. The rolled groove, as used in VHF, introduces too great an electrical discontinuity for a UHF line. The same reason holds in the case of sleeve connections on UHF. Therefore, only flanged line and fittings are used on UHF even though some line in the station may be ungasged.

### Application Notes:

#### 1. Choice of Line

The choice of the line to be used is based on both the required efficiency and the power handling capability. In most cases, however, the choice is further simplified because a line which will have a sufficiently low attenuation will be large enough to carry the required power. The attenuation charts and tables in the Appendix "A" and in the Transmission Line Catalog show the efficiencies for various lengths of all the available types of lines. A line should be chosen which will permit the desired effective radiated power, with some reserve, so that the transmitter need not be used at the extreme limit of its rating. A large size having a very low attenuation may increase the

**MI-19113A  $3\frac{1}{8}$  5 $\frac{1}{2}$ -OHM TRANSMISSION LINE AND FITTINGS**  
**OUTLINE DIMENSIONS**  
**INNER CONDUCTORS FURNISHED BUT NOT SHOWN**

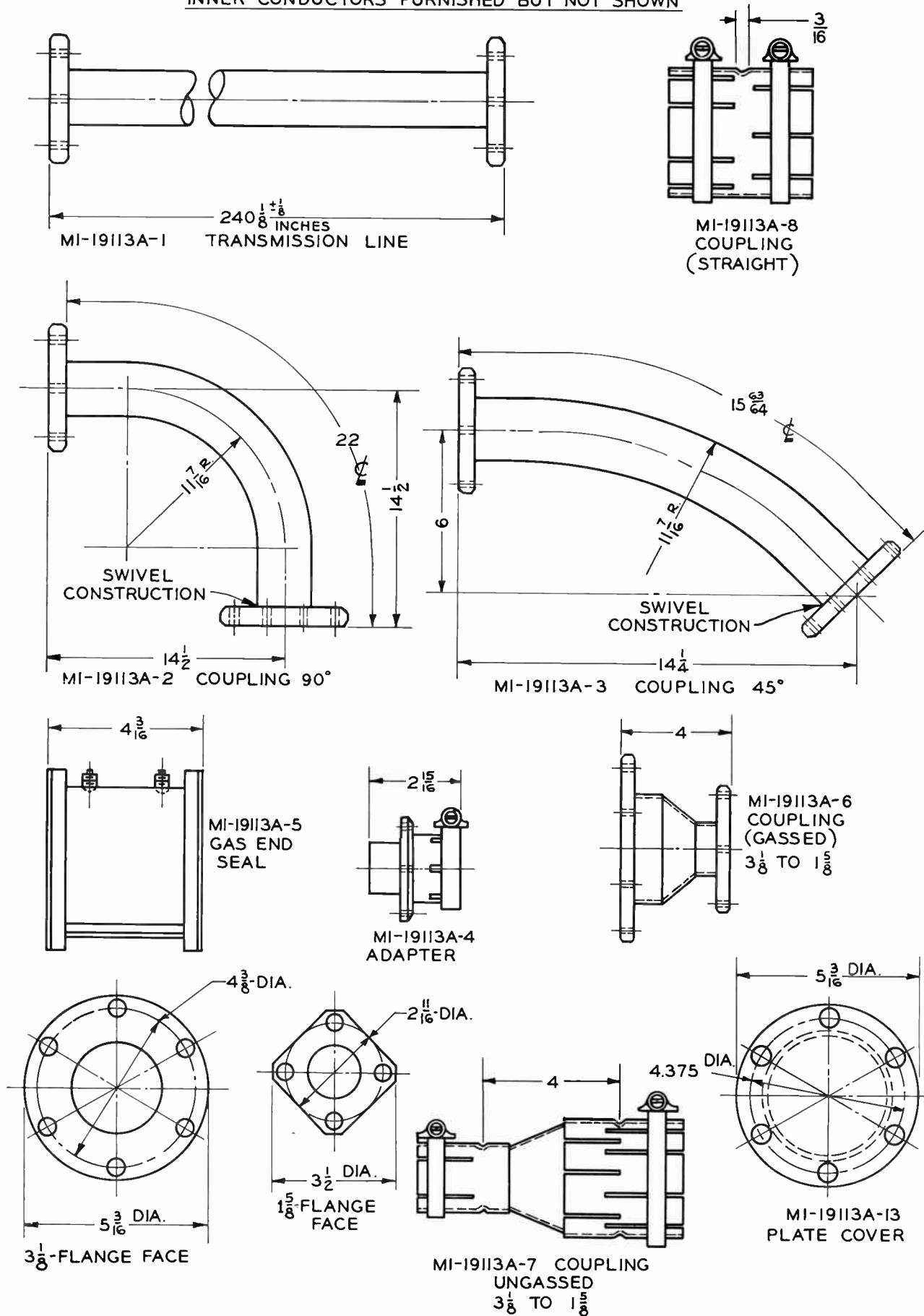

FIG. 10. Roughing in dimensions of components of one of the series of transmission lines available for television use.

cost of the installation not only because of the increased cost of the line, but also because the windload on the tower will be increased by the larger projected area with a resulting increase in the tower cost.

### 2. Method of Supporting in Tower

Differential expansion between line and tower is accommodated by suspending the line from spring hangers within the tower. Two hangers at the top of the tower are fixed so that the line cannot move vertically through them. The rest of the hangers are of the spring type which permit the line to move vertically. Each hanger exerts an upward force equal to the weight of ten feet of line. The hangers are spaced at ten foot intervals and hence there is no tension on the line under the average temperature condition. The line moves upward or downward in the hangers as differential expansion takes place. At the tower base the vertical movement is permitted to deflect the horizontal run as expansion takes place. In a similar manner, movement of the horizontal run from transmitter building to tower deflects the bottom few feet of the line in the tower. The amount of deflection that is permissible is limited to values which will not cause mechanical damage to the line or result in change in impedance. Bending of the line should be limited to 6 inches in 20 feet for  $3\frac{1}{8}$  inch line, or 1 inch in 20 feet for  $6\frac{1}{8}$  line.

Isolation of the transmission line in a tower used for medium frequency broadcasting is accomplished by using insulated hangers in the tower for a distance from the base equal to a quarter wavelength at the medium frequency.

### 3. Precaution During Installation

Precautions should be taken in making the line installation to make sure the line is not seriously dented or otherwise damaged. In the case of VHF line such treatment can cause insulating bead damage which will result in high VSWR and a reflection on the received picture.

The line layout should be made with a minimum number of elbows, both to reduce cost and to keep the number of connections down to a minimum. If a pair of lines is used, as in a quadrature-fed antenna system, the lines should be kept paired all the way from the antenna to the diplexer, with the quarter-wave phasing section located right at the diplexer.

Dents in the line may cause severe impedance disturbances and ghosts in UHF television and very great care must be exercised to prevent denting the line. The effect of dents in UHF transmission line is serious, and one should not conclude that they can be disregarded on the basis of previous VHF experience.

The mating flanges are kept pressure-tight through the use of O-ring gaskets. The flange faces should be kept clean so good contact will result. Good contact between adjacent flanges at the inside edge of the flange is essential

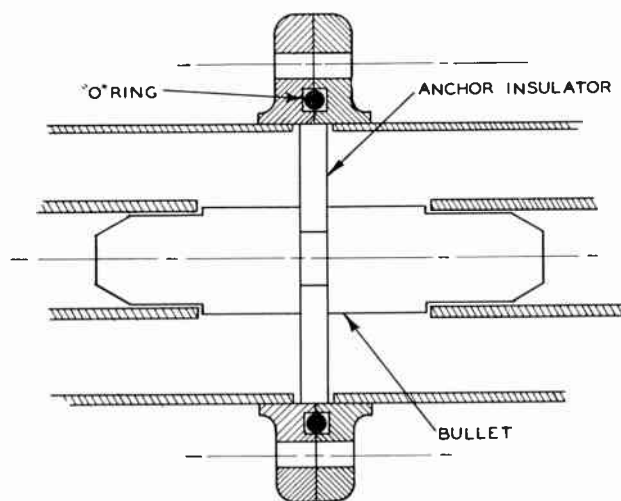

## UHF TRANSMISSION LINE JOINT

FIG. 11.

so that the outer conductor has no discontinuities. The O-rings should be carefully located in the grooves, especially in horizontal runs, to avoid pinching of the O-rings with resultant gas leaks.

This contact is assured by manufacturing each flange with a face which is slightly convex (the inner surface projects a few thousandths beyond the outer surface). When two flanges having convex faces are brought together, there will be a small gap around the periphery

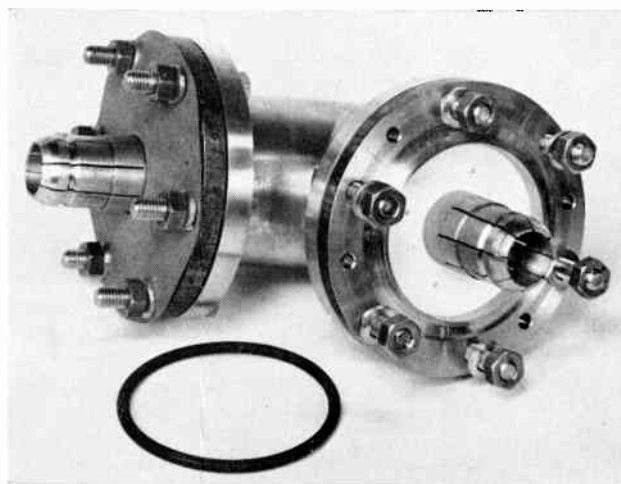

FIG. 12. MI-19089-2 90° mitre elbow  $3\frac{1}{8}$ -inch, 50 ohm.

and the contact will be around their inner diameter. When the flanges are clamped together, the contact surfaces will be tightly pressed together, thus assuring good electrical contact. It is essential that the flanges be checked before assembly to make sure they are slightly convex and that they are clean all the way around the contact surface.

# RCA TRANSMISSION LINE

1 $\frac{5}{8}$ " MI-19112 AND 3 $\frac{1}{8}$ " MI-19113

Steatite Insulated

## DIRECTIONS FOR CUTTING AND SPLICING

The standard line consists of an inner conductor supported by steatite discs at 1-foot intervals.

The equivalent circuit is a series of T filter sections.

If the line must be cut, it is best to do it midway between insulators as marked because the 51.5 ohm line impedance is realized only at the junctions of the T filters.

If a fractional-foot length must be used to make the layout come out right, cut the outer conductor at the required place but cut the inner conductor back midway between insulators. Use a piece of special conductor, MI-19112-9 or MI-19113-9, and an inner conductor connector, MI-19112-11 or MI-19113-11, to make the ends of the inner and outer conductor come out even.

The electrical requirements are thus met because the splicing conductor with no insulators forms a 51.5 ohm line.

Sometimes it is more convenient to put the section of splicing conductor in the center.

If the section of splicing conductor were only an inch or so long, there would be no room for the inner conductor connectors so an extra foot can be cut from the regular inner conductor.

If the odd-length of transmission line is only about one or two feet long, and is used between fittings with firmly-held inner conductors (such as between two elbows), the splicing conductor can run the whole length.

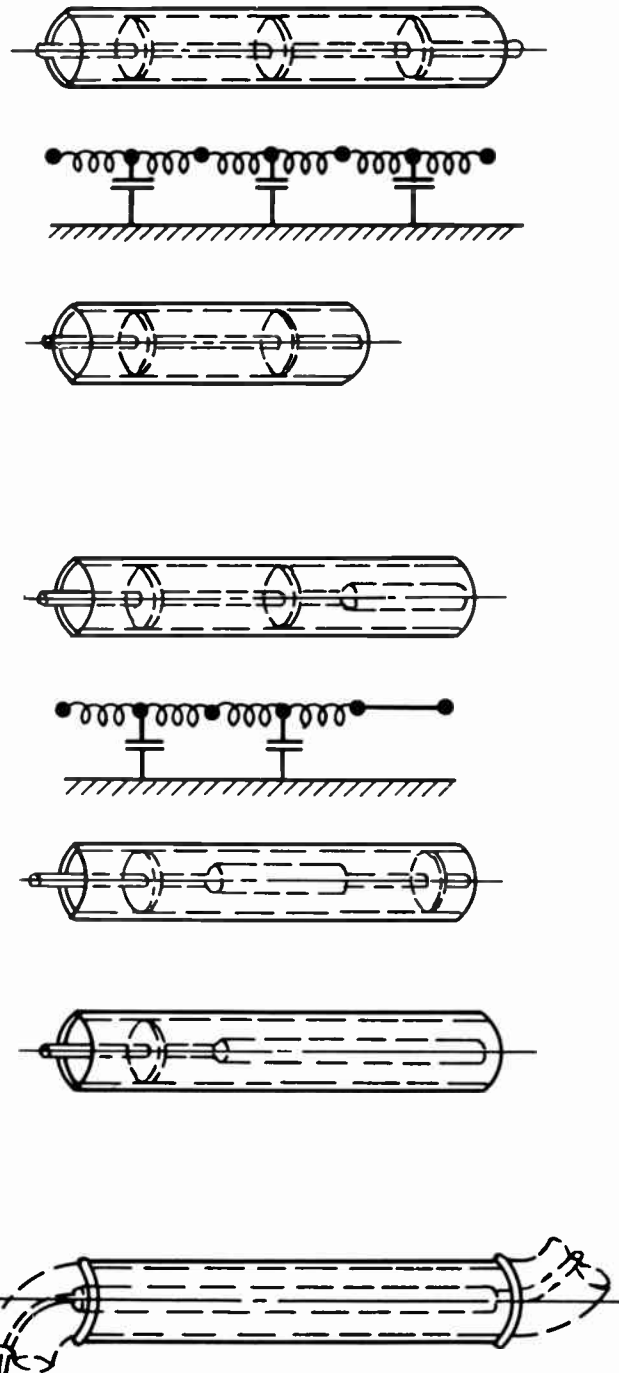

FIG. 13.

#### 4. Pressurization

Pressurization is used so that moisture will not enter the lines. It is necessary to maintain only a very small pressure (one to ten psi) to keep the line interior clean and dry. Either dry nitrogen, or dehydrated air may be used. Automatic and semi-automatic dehydrators are available to maintain the air pressure. Dry nitrogen is recommended for UHF line installations.

#### 5. Odd Sized Lengths

Rigid transmission line is available in standard lengths of 20 feet. When it is necessary to cut a section of line to fit a layout, certain precautions are necessary on both the inner and the outer conductors. These precautions are described in detail in the Transmission Line Catalogs and will therefore be described only briefly here.

Fig. 13 shows the precautions required on the inner when it is desired to cut a length of the steatite beaded type such as the MI-19113 series. On other types of line such as the teflon beaded type the line can be cut anywhere except at or within two or three inches of an insulator.

The treatment of the outer conductor when a line is cut depends on the type of line and the service for which it is used. Flanged line which is used for pressurized service is shipped with flanges at each end. These are carefully brazed in place with silver solder at the factory so that a strong pressure-tight joint results. There are four ways to proceed when the station layout indicates that a section shorter than 20 feet will be required:

*a.* Order sections of the desired length when the rest of the line is ordered. If this is impossible, or if the need develops during the installation, have the riggers install a temporary section, with flanges soft-soldered in place, and order sections with brazed flanges of the correct length. The temporary sections can be replaced when the permanent ones are received. This method is particularly applicable if the short sections are on the ground or in the station.

*b.* Use flange adapters wherever a section of line has been cut. VHF adapters have a tough rubber gasket with an imbedded contact-making spring, so that a good contact and pressure-tight joint is maintained. UHF adapters are similar except they use a flat coiled spring for good contact.

*c.* Order extra flanges and braze or solder these in place. This is not recommended because of the specialized skill and equipment required for a satisfactory job.

*d.* Order soft-soldered sleeve flange adapters. These flanges have a sleeve section of sufficient length to insure a pressure tight flange of ample strength.

#### 6. Brazing of Flanges

The method used in the factory can be used as a guide if it is necessary to make a brazed joint in the field. This method starts with a thorough cleaning of the parts. Use one of the silver solders which melt at about 1150° F. together with the specified flux. Note that copper softens under prolonged exposure to this temperature, hence the joint should be made as quickly as possible. Use a hot plate or a multiple jet torch to get the joint up to the temperature quickly. Apply the brazing material to the joint so that capillary action will cause it to flow between the parts then quickly remove the heat and allow the joint to cool. After the joint has cooled it should be cleaned.

#### 7. Lead Soldering of Flanges

Lead soldering should be done only where no mechanical strain will exist and should therefore be avoided on the tower run. Clean the parts thoroughly using abrasive paper. *Do not use acid flux.* Heat the parts with a multiple jet torch or a hot plate so that the parts will come up to the melting temperature of the solder as quickly as possible, apply the solder so it will flow between the parts by capillary action, then quickly remove the heat and allow the joint to cool. Clean the completed joint with abrasive paper or the equivalent, *and with a solvent for the flux* (such as alcohol) to avoid future corrosion.

#### 8. Lead Soldering of Sleeve Flange Adapters

Follow the same procedure as outlined for lead soldering of flanges.

9. Unflanged line is used for VHF service only for interconnections between transmitter and diplexer, etc. Connections are made by sleeves on the outer conductors. These sleeves are secured by means of clamps. No special treatment is necessary except to make sure the outer conductors are inserted to the stops in the sleeve and the clamps are made tight.

# TRANSMISSION LINE SWITCHING

## Purpose

The RCA Manual Coaxial Transfer Panel and the Motor-Driven Coaxial Switch enable convenient and rapid switching of the R-F power circuits which extend between the transmitter and the antenna. Functions such as power cut-back, dummy load switching, emergency antenna connections, spare antenna, and spare transmitter switching are readily accomplished by means of these switches. Electrically, these switches are similar.

## Specifications

1. *VSWR*—The voltage standing wave ratio of either switch is better than 1.05 to 1 throughout the VHF band.
2. *Power*—The power rating of either switch is the same as the mitered elbows used on  $3\frac{1}{8}$ " MI-19113 transmission line.
3. *Cross Talk*—Both the manually operated and the motor-driven switches provide for coaxial feed-through and complete disconnect, therefore, no cross-talk can be introduced through use of either switch.
4. *Time Cycle*—The time cycle of the motor-driven switch is one second from one position to the next and less than four seconds from the first to the fourth position.

The time cycle of the manual type depends on the speed and skill of the operator and the complexity of the switch. Normal switching requires approximately one to two minutes for the average operation.

## Types

### 1. Manual Transfer Panel

#### A. Principle of Operation

This series of switches utilizes the standard MI-19113 transmission line fittings which are mounted on a steel panel in such a way that switching functions are readily accomplished by the "patch cord" method.

In this case, the jacks are  $3\frac{1}{8}$ " fittings, and the plugs are composed of a pair of  $3\frac{1}{8}$ " elbows which are joined to form a "U" section. Therefore the transmission line impedance is maintained throughout the switch.

#### B. Construction

The manual Transfer Panel is made up of a sturdy steel panel reinforced with angle bends on all four sides. Holes are provided in side angles for mounting. The MI-27331 panel is provided with three jacks and one "U" type connectors while the MI-27332 panel has seven jacks and three "U" type connectors. The jack is made up of a plate for mounting to panel and the plate is brazed to a slotted sleeve which is a sliding fit for the "U" shaped connector. Adjustable clamps are provided for clamping the sleeve. An added feature is a bent bracket that is soldered to the slotted sleeve for the purpose of retaining the adjustable clamp while it is loose.

There are two different size inner connectors provided. The straight connector is used for MI-19113 transmission

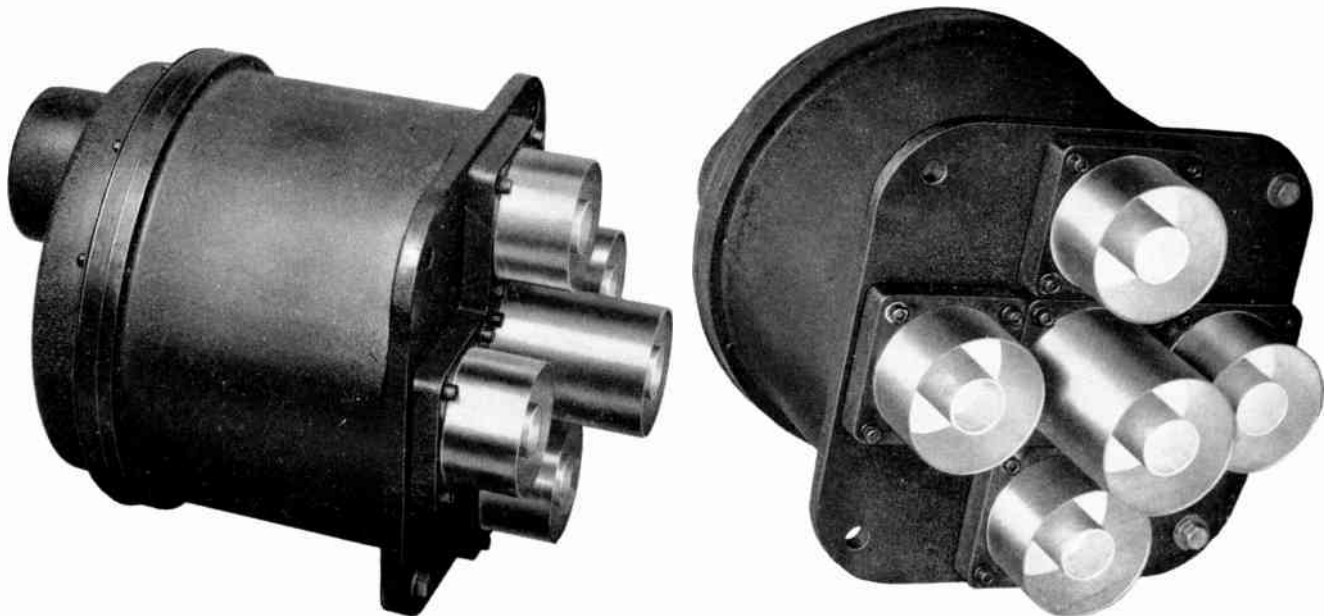
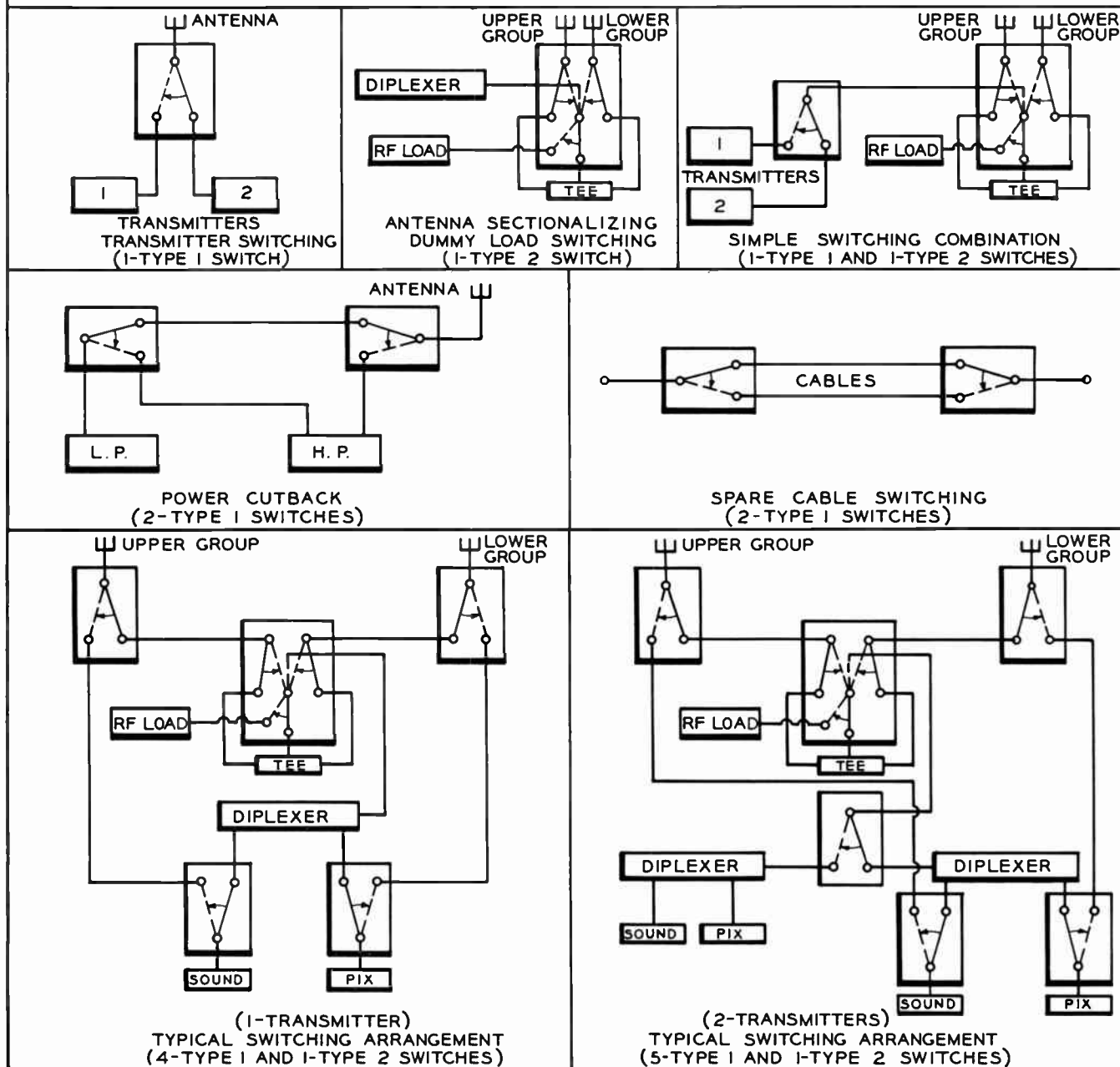

FIG. 1. Two views of the RCA MI-27309 motor-driven rotary coaxial switch.

## SUGGESTED USES FOR COAXIAL SWITCHES



THESE ARRANGEMENTS SHOW SOME OF THE COMBINATIONS AND FUNCTIONS THAT CAN BE ACCOMPLISHED WITH THE TYPE 1 AND TYPE 2 SWITCHING PANELS. OTHER COMBINATIONS ARE ALSO POSSIBLE THROUGH THE USE OF THESE AND OTHER SPECIAL TYPES OF PANELS.

FIG. 2.



line while the adapter connector with a shoulder is used for MI-19313 line. The "U" type connector is made of two standard miter elbows coupled with a soldered sleeve.

### C. Application Notes

A screw driver for quick disconnect of clamps is mounted on the front of the panel with clips.

The Manual Transfer Panel may be mounted either vertically or horizontally and should be as near to the transmitter equipment as is practical so as to avoid long runs of transmission line. The mounting should be rigid to withstand the force required to engage or disengage the "U" type plug.

To make a change in connections, the following operations are required:

1. Shut off power.
2. Remove screw driver from panel and loosen adjustable clamps.
3. Pull out "U" type connector and reinsert in the proper  $3\frac{1}{8}$ " jack for new connection.
4. Tighten adjustable clamp and turn power on.
5. Replace screw driver in holder.

## 2. Rotary Type

### A. Principle of Operation

The MI-27309 motor-driven rotary coaxial switch is similar in principle to the manual transfer panels. As the name implies, it is motor driven with a provision for emergency manual operation. This switch is a single-pole four-position design.

### B. Construction

Fig. 1 shows the construction of this switch. It consists of a heavy brass housing containing a "U" shaped coaxial double elbow element. The center of the "U" section is held centered by a bearing. The action of the mechanism is as follows: First the "U" section is pulled back by cam action to disengage the coaxial contacts of the outer end. Then the outer end is rotated to the next switch position and is accurately aligned by an indexing pin. Finally the cam action pushes the "U" section forward, engaging the coaxial contacts.

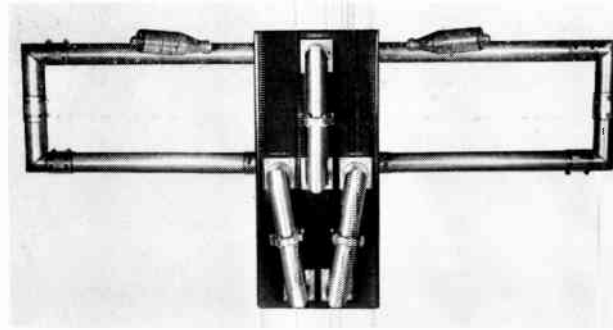

FIG. 3. Special development model of a manual transfer panel. Other custom designs can be made to suit various requirements.

Two sets of micro switches are provided at each position, one set being used to control the motor and the other set for electrical position indicating or inter-locking of transmitter high voltage.

### C. Application Notes

The application of the MI-27309 Motor-Driven Coaxial Switch is similar to that of the manual transfer panel.

To make a change in connections the following operations are required:

1. Normal Operation
  - a. Shut off transmitter power.
  - b. Operate selector switch to desired position.
  - c. Re-apply power to the transmitter.
2. Emergency (Manual) Operation
  - a. Shut off transmitter power.
  - b. Rotate small wheel on motor by hand. Position indicator (rod) on back of switch should be flush with housing when switch is in operating position (contact made).
  - c. Re-apply power to this transmitter.

The above procedure emphasizes the necessity for removal of power during the switching cycle, since failure to do so can be hazardous to operating personnel and would undoubtedly damage the switch due to arcing. The connecting transmission line, diplexer, sideband filter or transmitter may also suffer damage. However, the rotary coaxial switch has an additional micro switch at each pole position providing facilities for inter-locking the transmitter high voltage to automatically shut-down and restore power during a switching cycle.

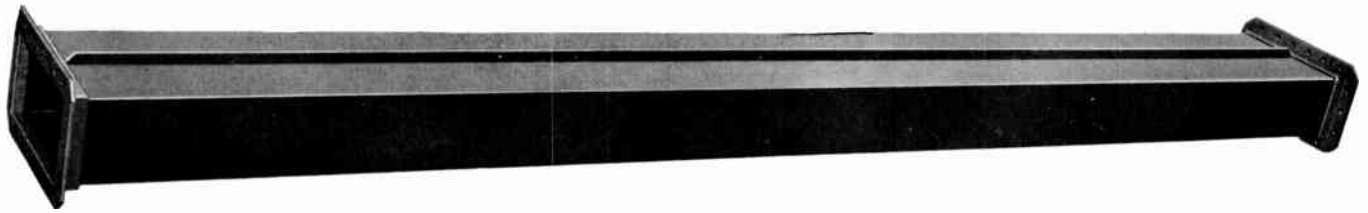

# WAVEGUIDES

## Purpose

Waveguides are used when greater transmission efficiency is required than can be obtained from 6 $\frac{1}{8}$ -inch UHF coaxial transmission line.

## Specifications

### 1. Size.

Two sizes of rectangular waveguide are used to cover the UHF television band. Dimensions of the WR1150 waveguide are 5 $\frac{3}{4}$  inches by 11 $\frac{1}{2}$  inches and its useful frequency range is 650 to 1000 megacycles. Those for the WR1500 waveguide are 7 $\frac{1}{2}$  inches by 15 inches and its useful frequency range is 450 to 750 megacycles.

### 2. Standing Wave Ratio.

The standing wave ratio of a complete waveguide run for a station should be better than 1.1 to 1. Waveguide transitions (or coupling sections from waveguide to transmission line, for coupling to the filterplexer and antenna)

must be impedance compensated for the operating frequency and therefore are frequency selective, however, the transition has a VSWR of 1.02 or better over several television channels. Long sweep elbows in 45° sections may be used in both the "E" (electric field) plane and "H" (magnetic field) plane bends; these are not frequency selective.

### 3. Attenuation.

The calculated and measured attenuation curves of the WR1500 and WR1150 copper clad steel waveguides are shown in Fig. 1. The difference between calculated and measured results is due to normal surface roughness and other factors. The reason for using copper instead of aluminum in constructing waveguides is that the latter has about 30% higher attenuation than copper.

### 4. Power Rating.

As there is no inner conductor in waveguides, all the losses occur on the wall of the guide where heat is quickly

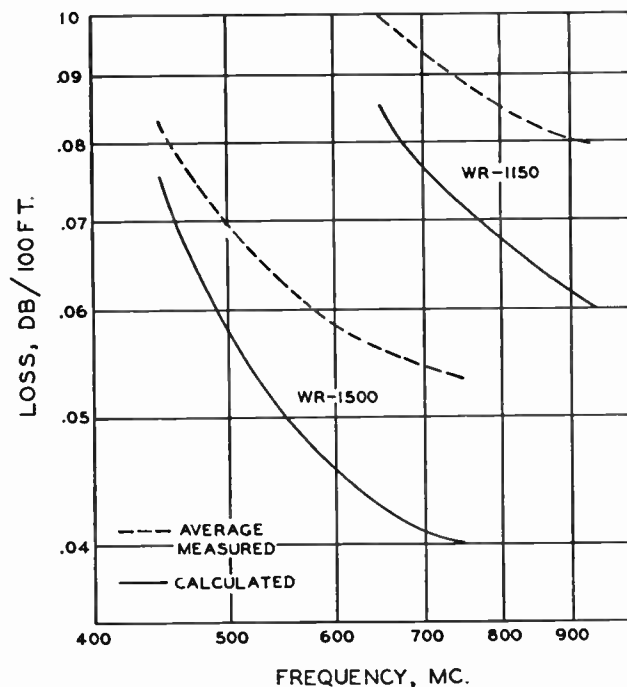

FIG. 1.

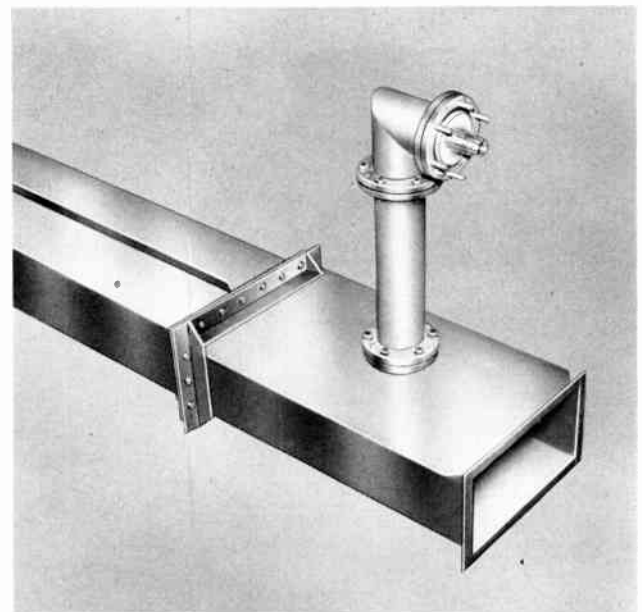

FIG. 2. A WR-1150 waveguide transition to 3 $\frac{1}{8}$  inch 50 ohm transmission line.

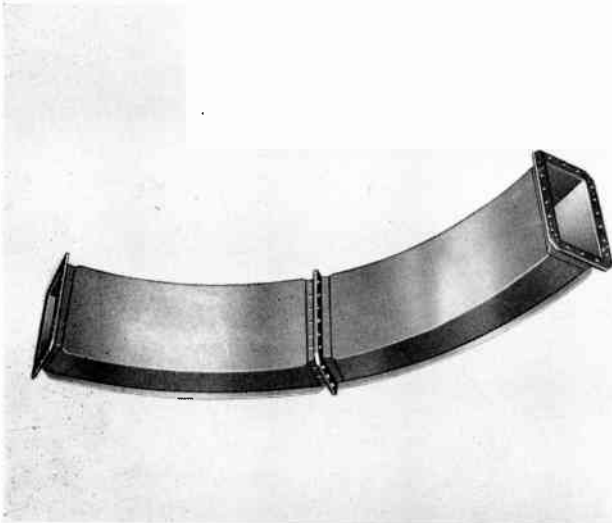

FIG. 3. A WR-1150 90° "E" plane bend consisting of two 45° "E" plane sections.

dissipated. Therefore, the power handling ability is limited by the power rating of the coaxial line feeding the guide.

#### Principle of Operation

See page D-93 of addenda section "A".

#### Construction

The construction of RCA copper clad waveguides is shown at the top of the preceding page. Particular attention is given to flange connectors to assure no "Bump" is introduced which would increase the standing wave ratio. Centering pins are located in the flanges and precision finish assure good electrical continuity. Fig. 2 shows a 3/8-inch coax to WR-1150 waveguide-transition.

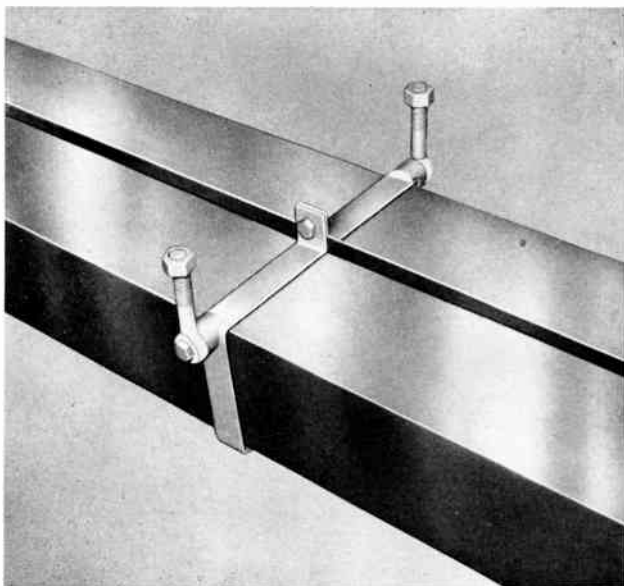

FIG. 4. A rigid hanger installed on a WR-1150 guide.

#### E. Application and Installation

The installation of a waveguide in the tower is much the same as with UHF coaxial line and the same precautions should be used. Rigid hangers can be used instead of using spring loaded hangers, because the copper clad steel waveguide will have approximately the same coefficient of expansion as the steel towers. Transitions must be ordered on a specific channel basis as they are impedance compensated for their operating frequency band.

Special care must be used not to dent the waveguide in installation and special care is necessary to protect the flanges since good contact between sections is essential. It is advisable to keep protective cover plates in place on each section until just before bolting the line together. To check tightness of flanged connections, a light should be held inside the guide.

Transitions must be used at each end of the waveguide as the filterplexer output and UHF antenna input are coaxial.

The waveguide will not be pressurized, but the coaxial lines connected to it must be, except in the case where the transition is inside the transmitter building. Therefore, a built in gas stop insulator at the transition point is necessary to seal off the transmission line. As the harness on the UHF series of antennas and the short connecting length of coaxial line must be pressurized, a pressurizing tube may be run down the tower beside the waveguide to either a nitrogen bottle or the lower coaxial line pressurizing system.

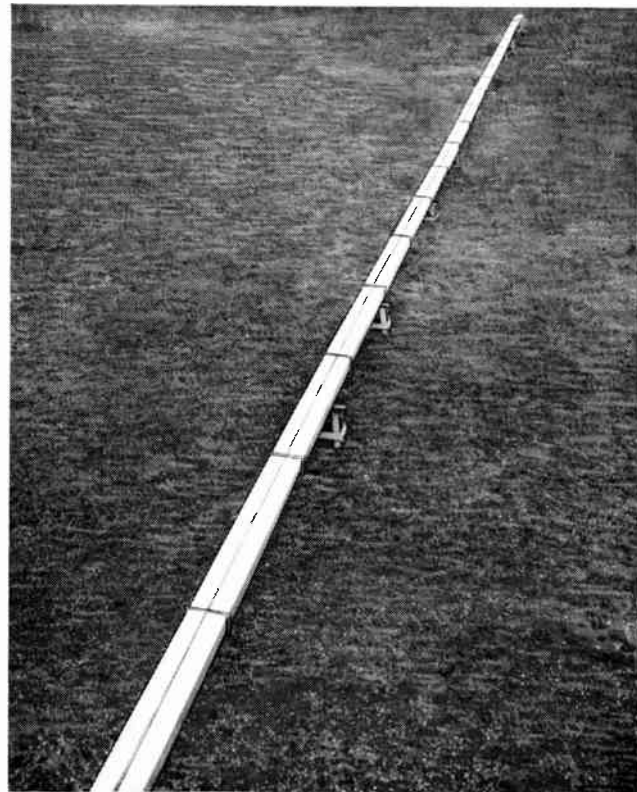

FIG. 5. A test run of WR-1500 wave guide.

# UHF PYLON ANTENNAS

## Purpose

### *UHF TV Transmitting Antenna:*

The antenna is used to radiate the transmitter energy into space in a controlled manner which gives a minimum of radiation at high angles where the signal is not required for residential reception. The figure of merit regarding conservation of power radiation in undesired directions is called power gain, which has been defined in the section on general antenna principles.

This antenna is of the slotted cylinder type, combining utmost mechanical simplicity with excellent electrical performance.

## Specifications

### 1. Electrical:

Gain	21 to 27, depending on type
Circularity	0.5 db total variation
Power Rating	10 kw up to 10,000 ft. elevation
VSWR	1.1 over 6 mc. channel
Input Connection	single 3-1/8, 50 ohm UHF Coaxial flanged fitting

### 2. Mechanical:

Safe Wind Load	50 lb./sq. ft. on flats 33 lb./sq. ft. on rounds
Finish	Hot dipped galvanized steel Stainless steel and aluminum alloy fittings

## Principle of Operation

The radiating portion of the antenna is the surface of the pole without external appendages, as shown in Fig. 3.

The horizontally polarized radiation is due to circumferential currents produced by the driving voltages applied across the centers of the slots. Vertically polarized radiation is inherently negligible in this system, being of the order of 0.3 to 0.5%. Driving voltages are the result of energy extracted from the magnetic field inside the pipe by the coupling loops.

The inside of the antenna consists of a coaxial transmission line for which the antenna mast serves as outer conductor. The antenna is fed near the center to eliminate undesired beam tilt with change in frequency. The feed point may be shifted from normal position for an intentional vertical pattern tilt if desired for the particular installation by loosening one clamp and shifting the harness

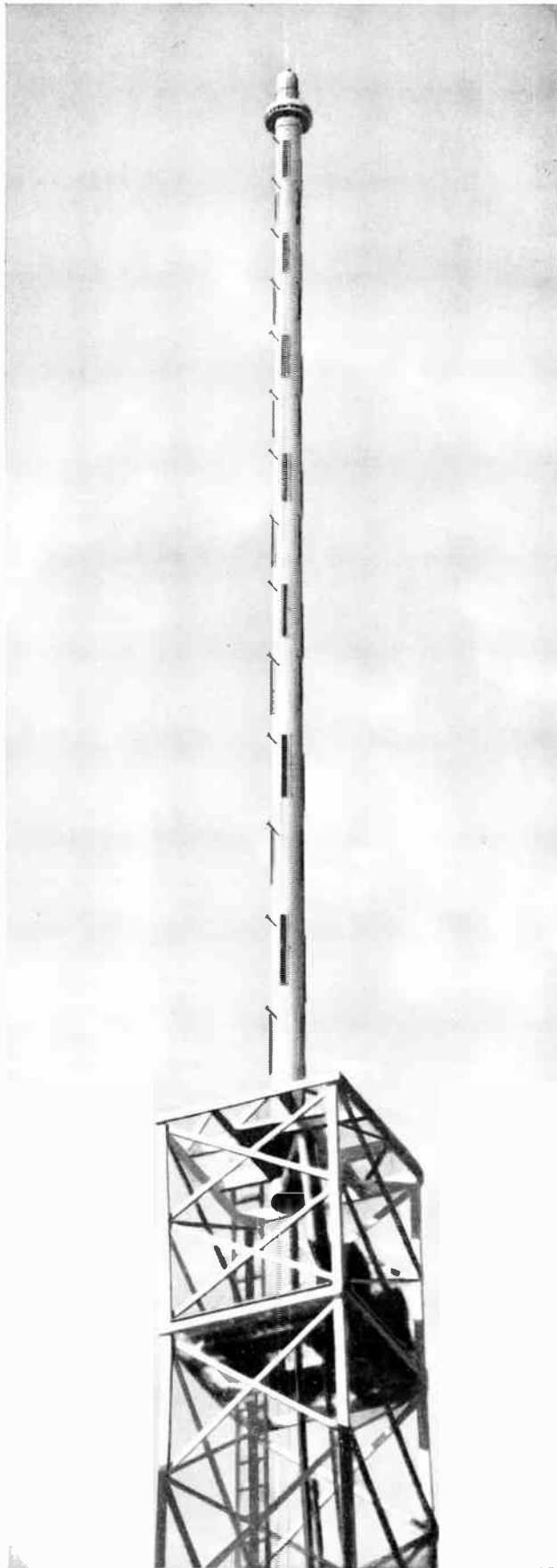

FIG. 1.

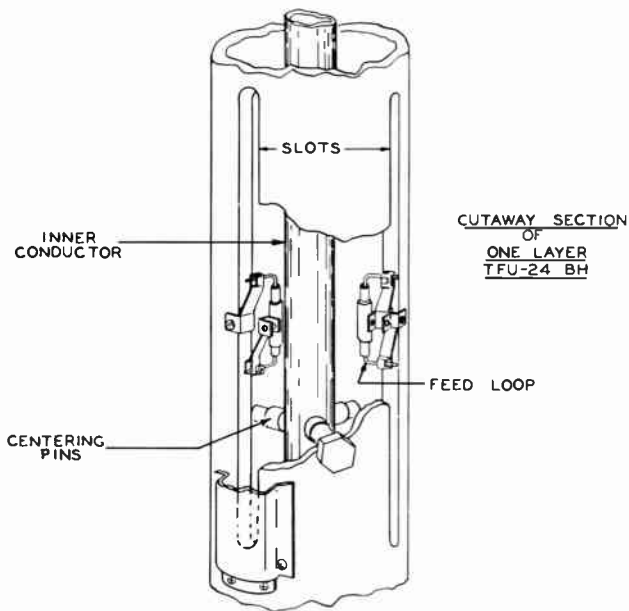

FIG. 2.

with respect to the mast. A simplified circuit of the antenna feed system is shown in Fig. 4 together with a plot of the current standing wave inside the mast. The photograph (Fig. 1) shows the clean, external appearance due to the absence of radiating appendages.

*Off Center Feed Principle:*

This is now the standard antenna feed for both omnidirectional and directional antennas. The feed point is displaced from center by several slot lengths and equal

power is fed into the two sections having different numbers of elements. The power per element is thus different in the top and bottom groups, and a graph of the power distribution along the length of the antenna is "stepped," as in Fig. 4.

The power gain is about 95% of the gain of an equivalent center fed antenna without null fill and this same "stepped" principle is applied to both the peanut and cardioid directional antennas. The letter in the type number designates the amount of feed point displacement employed and thus the degree of null fill. In the D series the feed points are shifted two layers of slots downward and in the S series, one. For example, a TFU-24DM,

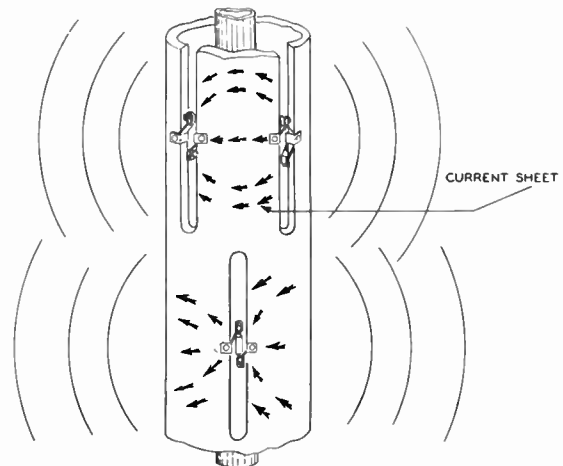

FIG. 3.

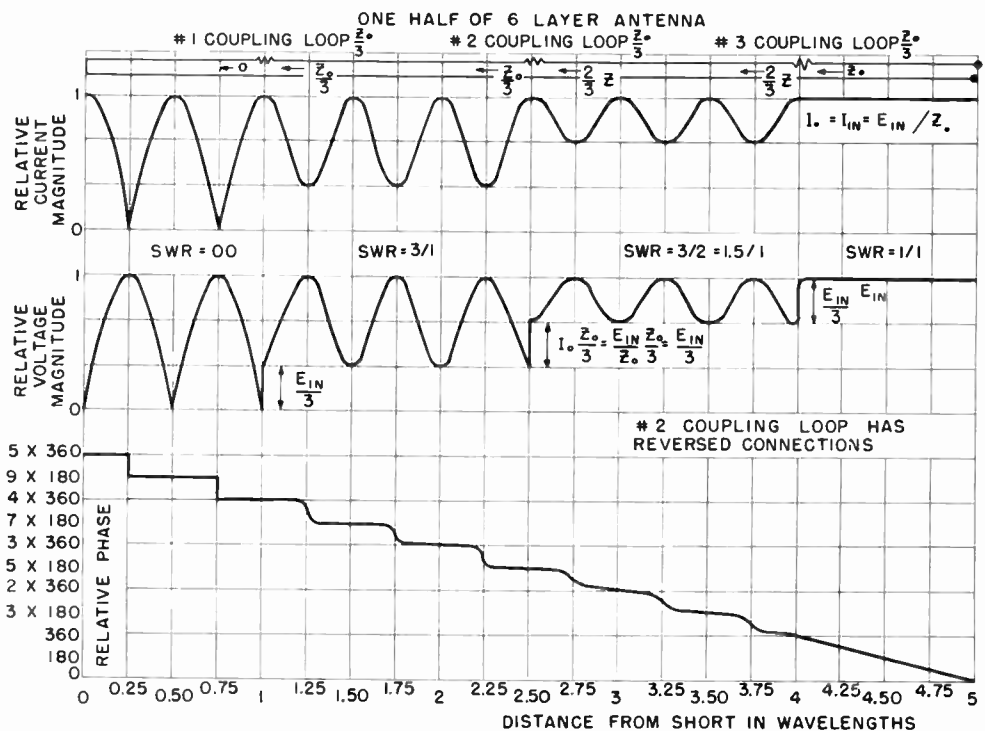

FIG. 4. Simplified illustration of current and voltage distribution principle used in the UHF TV Pylon antenna feed system.

16 layers, employs 10:6 power division while a TFC-24BM(S) with the same number of layers employs 9:7 power division. Both require the same shift of the harness for equal beam tilt.

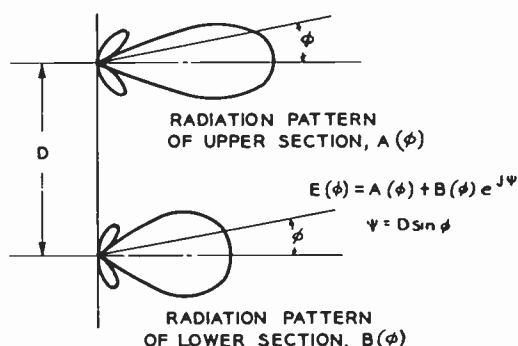

FIG. 5. "Stepped" antenna considered as two antennas.

#### Reduced Gain:

The UHF television pylon is available in low gain sections having two, four, six, or eight layers of slots with power gains of 3, 6, 9, and 12 respectively, the power rating decreasing with decreasing gain.

The construction is very similar to that of a standard antenna except for the length and the fact that the low gain antennas are end-fed instead of center-fed. Therefore, they are not provided with the beam-tilting feature.

Fig. 6 shows a typical measured and calculated vertical pattern.

The gain vs. frequency characteristic is shown in Fig. 9. Note the extremely wide and flat shape of the curve.

#### Construction

The sturdy and inherently simple antenna consists of an array of slots in one steel tube. The 70 UHF channels are covered by three different pipe sizes: 6", 8" and 10" nominal diameters, in lengths from 35 to 55 feet, the lower frequency range by the largest diameter pipe, etc. Mounting dimensions, overturning moments and other mechanical design data are given in the catalog section. The number of layers of slots depends on the required gain, but is usually 14 to 18 layers for power gains of approximately 21 to 27. The gain is approximately 1.5 times the number of layers. Each layer consists of three slots approximately 1.2 wavelengths long equally spaced around the circumference. The layers are spaced 1.5 wavelengths for minimum vertical side lobes. Adjacent slot layers are staggered 60 degrees.

The basic construction may be visualized with the aid of Fig. 7. Note the outer slotted pole, the coupling loop in each slot, the inner conductor or harness, the end seal which prevents escape of dry nitrogen from the transmis-

sion line, the ceramic centering pins which locate the harness radially, and the shorts which support and electrically connect the harness to the pole at each end.

Particular attention has been given to sturdy construction. The antenna support and radiator tube is constructed of hot rolled, open hearth steel which is hot dip galvanized for a structural life exceeding 50 years. All structural welds are made by automatic machines and are of a quality exceeding the highest American welding standards. All welds are gamma rayed, and the record of the weld is filed by the manufacturer for a period of ten years. Special attention has been given to all attached hardware to assure compatibility and absence of galvanic corrosion. Hot dipped galvanized pole steps and trim strips, stainless steel hardware and aluminum castings are used to assure galvanic compatibility and trouble-free service. Painting is required to meet CAA regulations only. Only one end seal is used in the entire antenna feed system and this is readily removable and at a well-protected location on the harness within the antenna. The harness is pressurized with dry nitrogen to prevent any possible entrance of moisture.

Special anti-oxidant and ultra-violet inhibiting dye is used in the polyethylene slot covers to prevent chemical change due to exposure to sunlight. Similar covers used on the original Bridgeport antenna evidenced no signs of deterioration after three years of exposure to the elements.

#### Application Notes

##### Electrical Beam Tilt:

The use of high gain antennas requires careful consideration of the installation site with respect to the area to be served. The RCA UHF antennas have a vertical pattern tilt adjustment which can be easily adjusted to optimum at the time of installation. The ease of vertical pattern tilt adjustment will be a marked advantage to those interested in obtaining the best possible service.

In practically every case, beam tilting will increase the close-in coverage (1 to 10 miles) up to several fold while decreasing the signal strength at distant points very slightly. A slight decrease in field strength (10 to 25%) is not noticed on the television receiver but an increase of four or five times will certainly be noticed and in many cases will mean the difference between an outdoor and an indoor antenna.

Fig. 8 shows the advantages of beam tilting in a typical installation. Note that the signal strength at 5 miles has been increased 6 times and the overall coverage is much more uniform than without tilt. Note that the signal strength at 30 miles is still 90% of that without tilt.

Beam tilting is accomplished with a minimum of adjustment; all that is required is to loosen three clamp bolts and raise the harness an amount dictated by Fig. 11. Electrical beam tilting depresses the beam in all directions, umbrella-fashion.

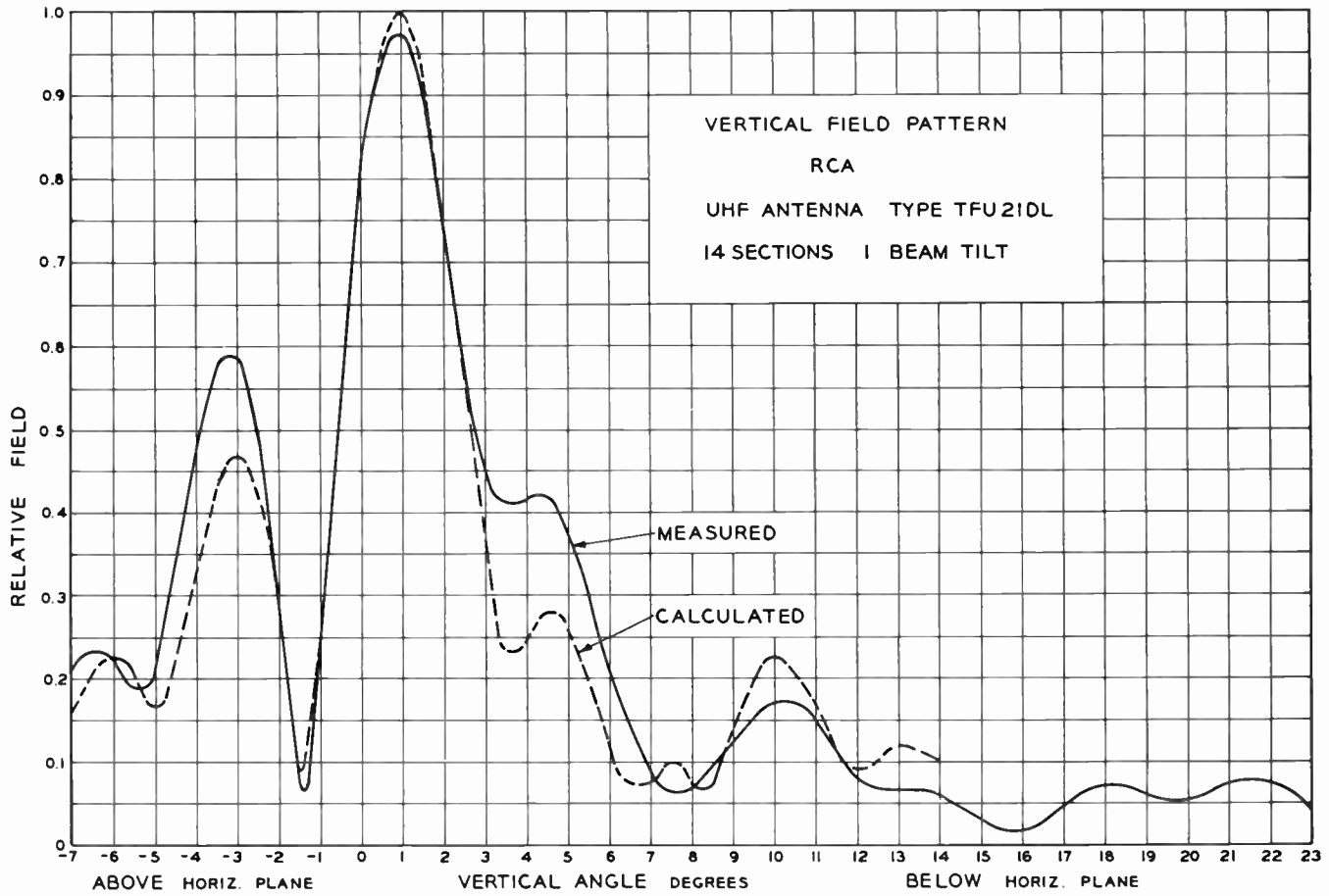

FIG. 6.

The gain decreases with tilt as shown in Fig. 12, but even so the resulting coverage is improved greatly as is obvious in Fig. 9.

**Mechanical Beam Tilt:**

In addition to electrical beam tilt, the axis of the antenna may be tilted from vertical by means of tapered

washers, or "leveling plates" which are inserted between the pole mounting flange and the tower top plate.

These leveling plates are supplied with the antenna and are used to set it vertically if the tower top plate is not exactly horizontal. By the proper rotation of the plates relative to each other, any angle of tilt up to the maximum of approximately two degrees may be obtained.

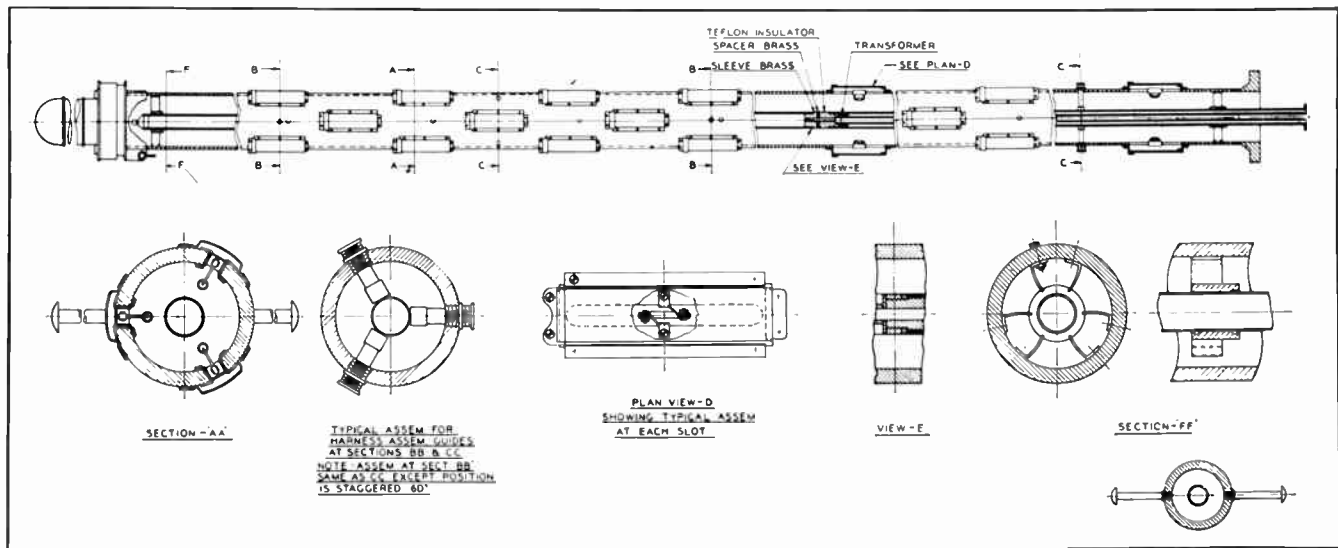

FIG. 7. Cross section of the UHF Pylon Antenna Assembly.

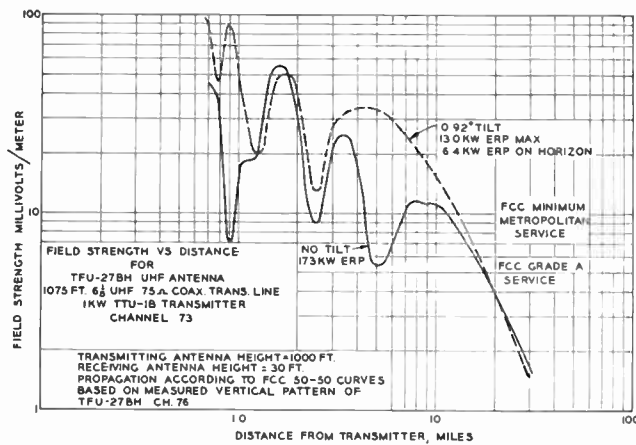

FIG. 8. Effects of beam tilting.

Many combinations of electrical and mechanical tilt may be used to suit existing terrain conditions. The proper use of the leveling plates is described in the instruction book for the antenna.

**Wind Load:**

Because of the smooth cylindrical construction (without protruding radiators, supports, or feed cables) the wind load of the RCA UHF antenna is quite low, making it adaptable to many existing supporting structures which are not capable of supporting large wind loads. Typical wind load data is shown in the specification pages of the catalog section for the RCA Type TFU-21-27 antennas.

The maximum design wind pressure of 50 lb. on flats and 33 lbs. on rounds, per square foot of projected area

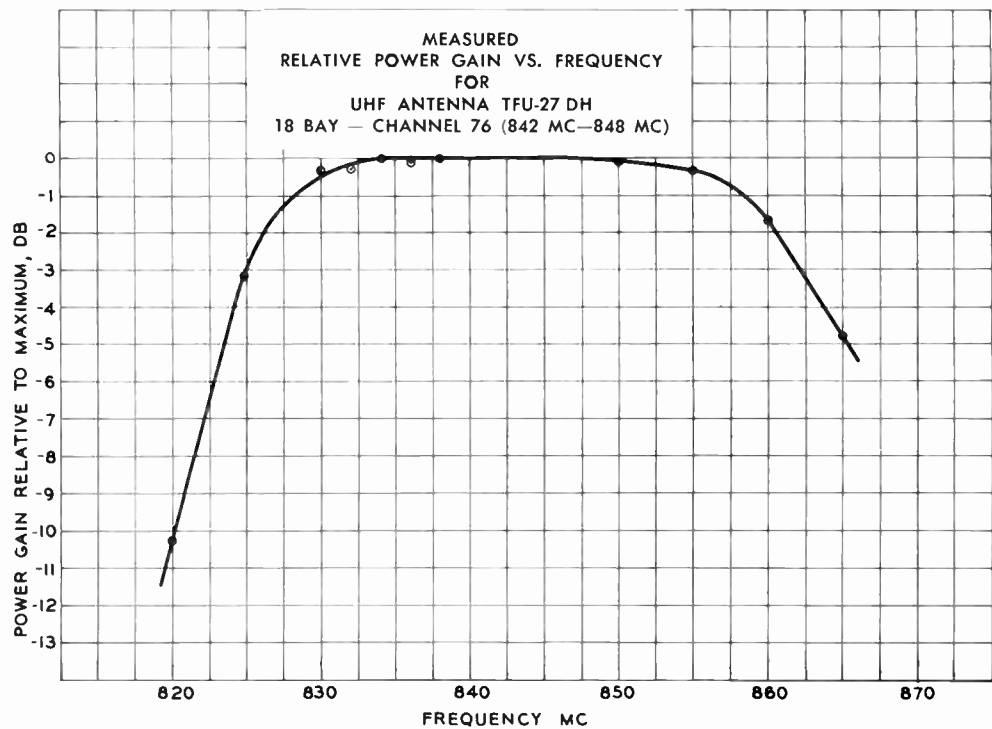

FIG. 9. Typical Measured Power Gain vs. Frequency for the TFU-27DH Antenna.

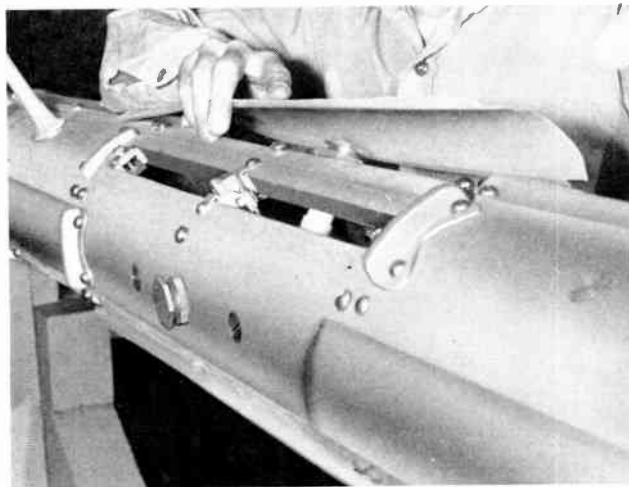

FIG. 10. Closeup of UHF Pylon antenna showing removal of slot cover.

(which corresponds to 110 miles per hour actual velocity or 147 miles per hour indicated velocity at sea level) produces a maximum bending stress of only about 9000 psi as against permissible structural stresses of 20,000 psi commonly applied to steelwork. This low stress is the result of design dictated by allowable deflection.

The basis for wind load is more conservative than the RETMA industry standards and is explained in the general mechanical considerations of antennas and supporting towers.

**Deflection of Antenna and Tower:**

Because of the narrow vertical pattern attained in high gain UHF antennas, it is necessary to consider deflection of the supporting structure during high winds. The gain is limited to a value which permits the use of economical and practical supporting structures.



FIG. 11.

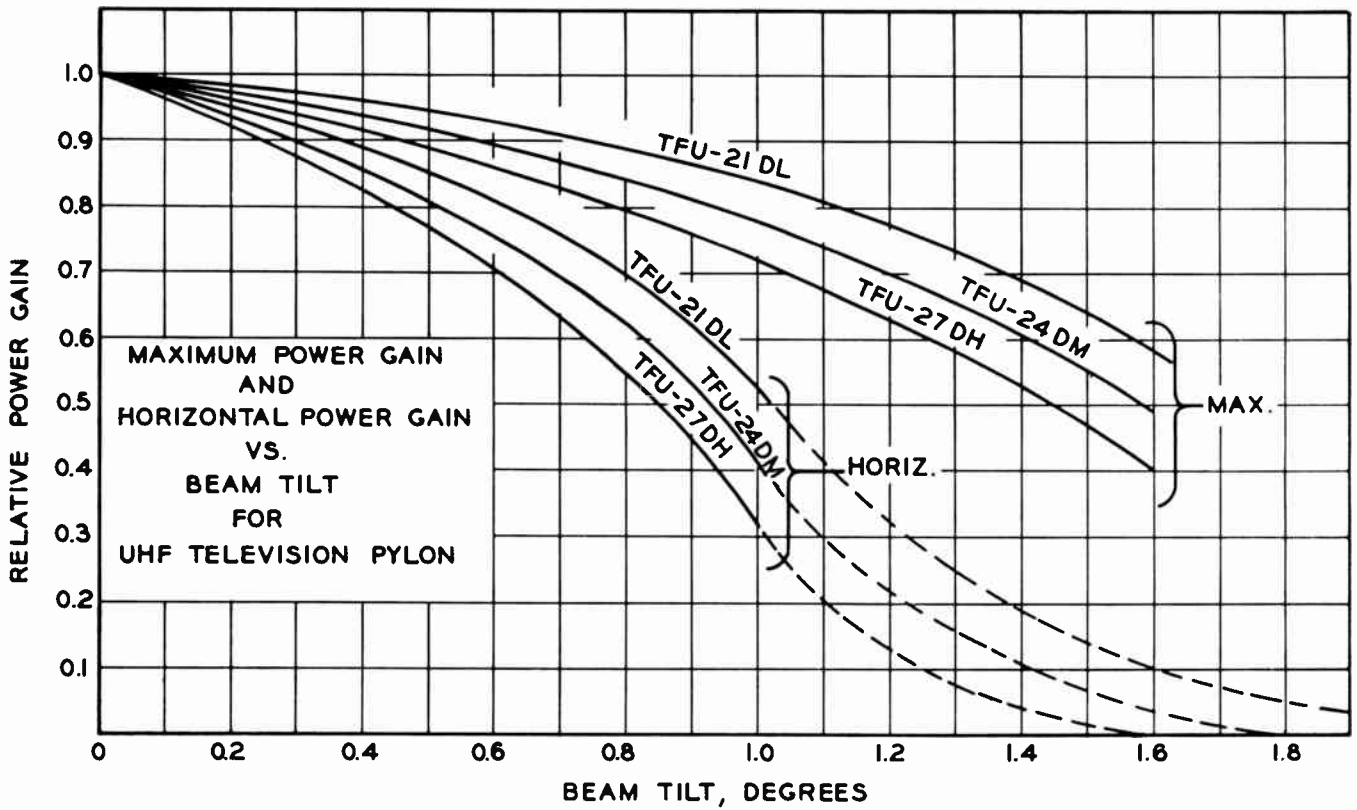
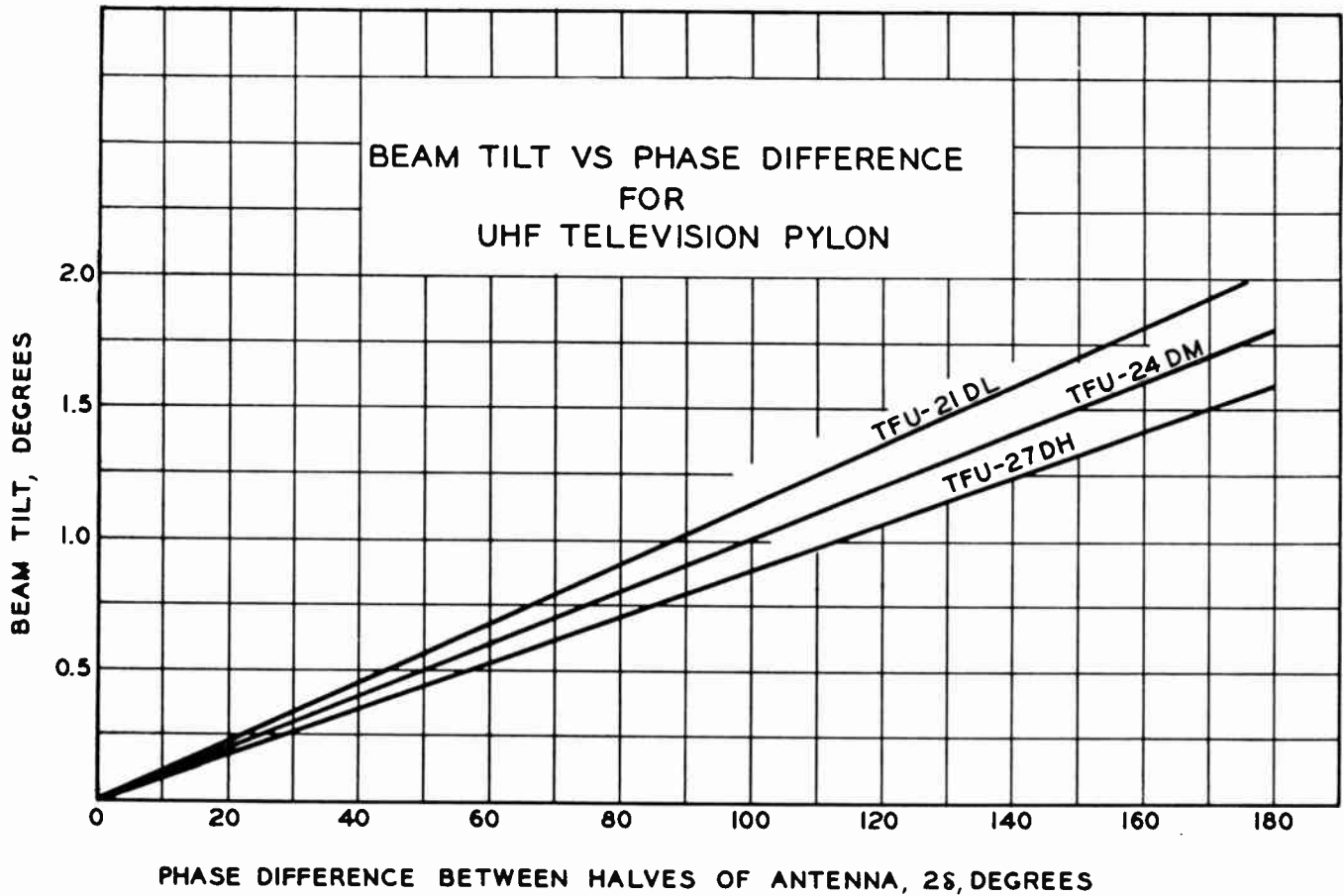

FIG. 12.

During high winds which occur only a few times a year, the antenna and supporting structure will oscillate at the natural mechanical resonant frequency of the antenna and supporting structure. This mechanical swaying will cause the received signal to vary in intensity at the natural mechanical frequency of the antenna and support system (usually 0.5 to 1 cycle per second).

Since AGC is used in all UHF receivers, this effect has not been found troublesome in the present installations. Because of the great rigidity of the antenna itself, the tower deflection is usually the limiting factor in these installations.

#### *De-Icing:*

Experience with the prototype antenna installed at Bridgeport, Connecticut, indicated that although the input impedance did change during an ice storm, the station was able to operate in a satisfactory manner without de-icing. The electrical performance characteristics of Type TFU-21-27 antennas are less critical than those obtained for the Bridgeport antenna, and consequently, the effect of ice will be further reduced. However, the signal will be attenuated somewhat. If the customer considers de-icing desirable, a de-icing system may be purchased as an accessory.

#### *Installation:*

No special field work is required to prepare the antenna for installation other than mounting the beacon and its cable and an impedance test to check for possible damages incurred in transit.

The antenna may be tested while in a horizontal position and elevated six to eight feet above the ground without disturbing its impedance characteristics. An accurate standing wave ratio measurement on the ground is recommended to assure the antenna is in good operating condition before installation. The RCA Service Company will provide suitable equipment and experienced personnel to make the recommended check measurements before and after installation. This service may be obtained through your regional RCA Broadcast Equipment Field Sales Representative.

**UNDER NO CIRCUMSTANCES SHOULD THE LOCK FLANGE AT THE LOWER END OF THE HARNESS BE REMOVED.**

The impedance matching transformers in the harness are secured in place by this lock flange and serious impedance difficulties may attend its removal.

The antenna may be painted on the ground before erection after first applying a coat of "Bonderite," vinegar, or similar primer for galvanized surfaces. Primers containing ferrous sulfate are desirable; those employing copper sulfate should be avoided. A necessary precaution is to make sure the slot covers are not painted.

Dry nitrogen is recommended in preference to dry air for pressurizing the transmission line system and antenna harness. Nitrogen is very economical to use in a properly installed and maintained transmission line system and will assure a minimum of corrosion and deterioration of the transmission line and harness characteristics with time.



**FIG. 13. Test set-up to study the effect of icing conditions on the RCA UHF Pylon Antennas.**

*Maintenance:*

Very little maintenance is ordinarily required because of the sturdy construction and weather resistant hardware employed. Since the beacon will have to be re-lamped occasionally, a quick overall inspection of the antenna should be made when re-lamping is required.

Any loose hardware should be tightened at this time and the harness inspected for slippage from its installed position.

Lightning damage to the beacon is not anticipated on the present antennas which are provided with lightning rods. For those antennas which have been supplied without, the station engineer should install adequate rods.

Leaks in the harness and antenna system should not be neglected since experience has shown that they will eventually lead to serious and expensive outages. Since a nitrogen pressurized system will become expensive to maintain if leaks occur, the use of nitrogen should assure prompt attention to leaks when they first appear.

A good periodic test of the tightness of the transmission line system is to close the nitrogen supply valve from the tanks to the line. If the pressure drops any appreciable amount over a period of several hours, it is an indication of a leak.

An RCA Service Company engineer should be consulted before any repair work on the antenna system is attempted.

# UHF CUSTOM ANTENNAS

## Purpose

These antennas are designed for those applications where a special design is desired in order to take full advantage of the existing operating conditions. Examples of these special designs are the directional antennas, shaped vertical patterns, high wind velocity types, and low gain antennas. All high gain types have null fill-in included.

In addition to custom built antennas, this section deals with special mounting applications of standard antennas, such as atop other antennas, the "birthday-cake" arrangement, colinear mounting, etc. This is the least standardized of all the custom work and special consideration must be given to each installation.

## General Specifications

### Electrical:

VSWR—Less than 1.1 over 6 mc channel

Input Connection—Single 3 1/8, 50 ohm UHF coaxial flanged fitting

Gain—Included in description of each antenna

Circularity—0.5 db max. variation for "circular" patterns

—10 db max. variation for directional patterns

Power Rating—10 kw up to 10,000 ft. altitude

### Mechanical:

Wind Load—50 lb./sq. ft. on flats  
33 lb./sq. ft. on rounds

## Special Antennas

### 1. Directionals:

The two most common directional antennas radiate the "cardioid" uni-directional and "peanut" bi-directional horizontal patterns although other attractive possibilities may be had on special order. These are slotted-cylinder UHF antennas similar in appearance and vertical pattern shape to the standard antenna but with higher gains due to the horizontal directivity. Like the standard antenna, beam tilt may be employed without any complex electrical adjustments. The directionals are supplied as a completely assembled and tested package and no field assembly or adjustment is required other than the recommended impedance check before hoisting.

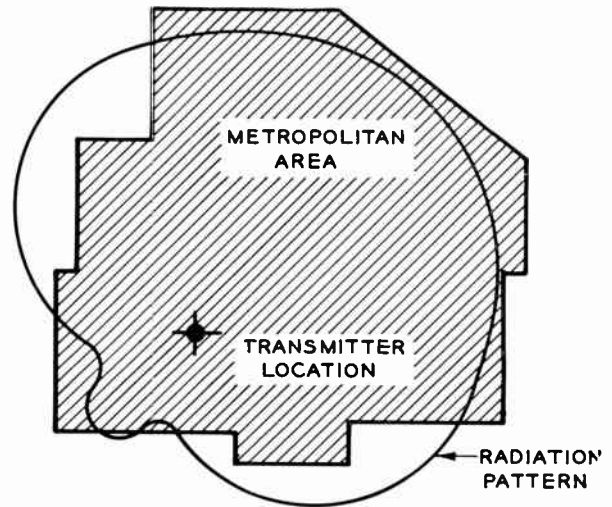

FIG. 1. Typical application of cardioid.

### (a) Cardioid Pattern:

A typical application of this antenna is shown in Figure 1. Note that the variation in field strength is very close to the FCC maximum of 10 db. The cardioid finds its application in locations where most of the population is concentrated on one side of the transmitter, such as when the station is on the edge of a city; or when the station is on a mountain and the city is in a valley; or in coastal installations. Although the vertical pattern is essentially similar to that of a standard antenna (the same null fill principles mentioned in the standard antenna section are applied to directionals), the gain is higher because of the horizontal directivity, and for the pattern shown in Fig. 1, the power gain is approximately 35 to 40.

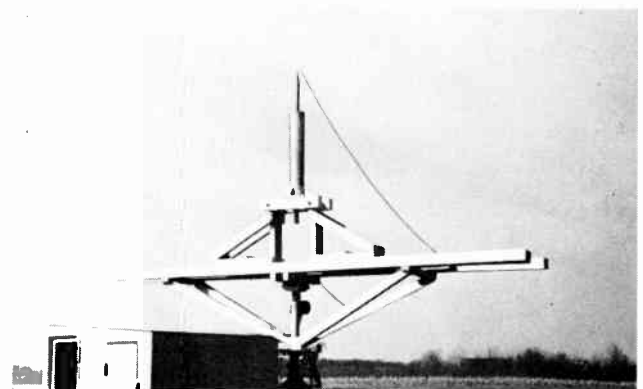

FIG. 2. Developmental single layer model of UHF Custom Antenna under pattern test.

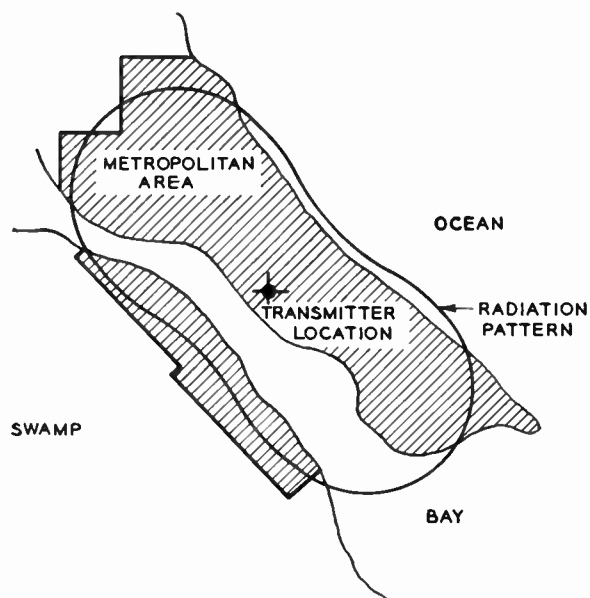

FIG. 3. Typical application of peanut pattern.

This antenna differs from the standard in having only one slot per radiating element instead of the three of the standard product. For the horizontal pattern of Fig. 1, all the slots are colinear on one side of the pole, though the pattern may be modified by staggering successive slots. Fig. 2 shows a single layer developmental model under pattern test while Fig. 5 shows the completed antenna.

(b) *Peanut Pattern:*

The designation "peanut" is a perfect description of the horizontal pattern shape, as is apparent in Fig. 3. Here, also, the variation in field strength approaches the FCC limit of 10 db.

This antenna finds its field of application where the greatest population density is distributed on two opposite sides of the transmitting site. Coastal areas, cities between mountain ranges and in deep valleys are typical sites for this pattern.

Here, again, the vertical pattern is similar to the standard product, though the gain is higher because of horizontal directivity. For the pattern shown in Fig. 3, the gain is approximately 35 to 50. This antenna utilizes two slots per radiating element instead of the standard three, and all slots are ordinarily colinear, though some modification of horizontal pattern shape may be effected by staggering successive layers of slots.

**Shaped Vertical Pattern**

The vertical patterns of standard and custom antennas are ordinarily as shown in published data (standard patterns available upon request) wherein the choice of beam tilt and null fill may be made to approximate the required pattern for the particular installation. This is ordinarily specified by the consultant.

It is sometimes advantageous to depart from the conventional choices of vertical pattern in order to meet a specific coverage requirement. In many cases, a standard antenna may be modified to give the desired vertical pattern.

For example, it may be the station management's wish to saturate a limited area with a strong signal and there is no interest in coverage beyond this area. This condition has traditionally been solved in the past by the choice of a low gain antenna of few radiating elements. This is undesirable because:

1. Half the power is radiated above the horizon and wasted.
2. The coverage is not uniform within the desired area.

The ideal pattern would be such that the above conditions do not exist. Within the coverage area, the FCC propagation curves may be used to arrive at an "ideal" pattern to yield constant field strength with distance. (In free space, the ideal is a cosecant pattern.)

At the angle of depression of the coverage area limits, the pattern would depart from the ideal curve, becoming flat for several tenths of a degree to allow for tower and antenna wind sway, and then cut off to zero radiation for lower depression angles. Fig. 15 is such a pattern.

Notice that the ordinary low gain antenna wastes much power in high angle radiation and that by the use of high gain antenna with beam tilt and excessive null fill, the ideal pattern may be achieved rather closely. Note also that if the low gain antenna has sufficient radiation at the edge of the coverage area, it will have an excess near the transmitter with resulting power waste. This means that with a suitable vertical pattern, a more uniform level of signal could be maintained over a greater area than in the case of a low gain antenna. Fig. 6 shows the near constant field with a shaped vertical pattern.

**High Wind Loading**

The diameters and wall thicknesses of pipes chosen for all standard UHF antennas, and for directionals unless specified otherwise, allow maximum wind loadings as shown in Table 1 of page D-75. For installations made in

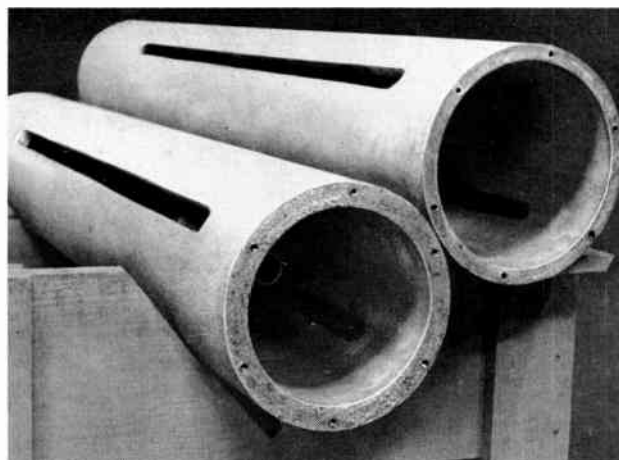

FIG. 4. View showing difference between normal 8-inch pipe and pipe used for 75/47 lb. windloading.

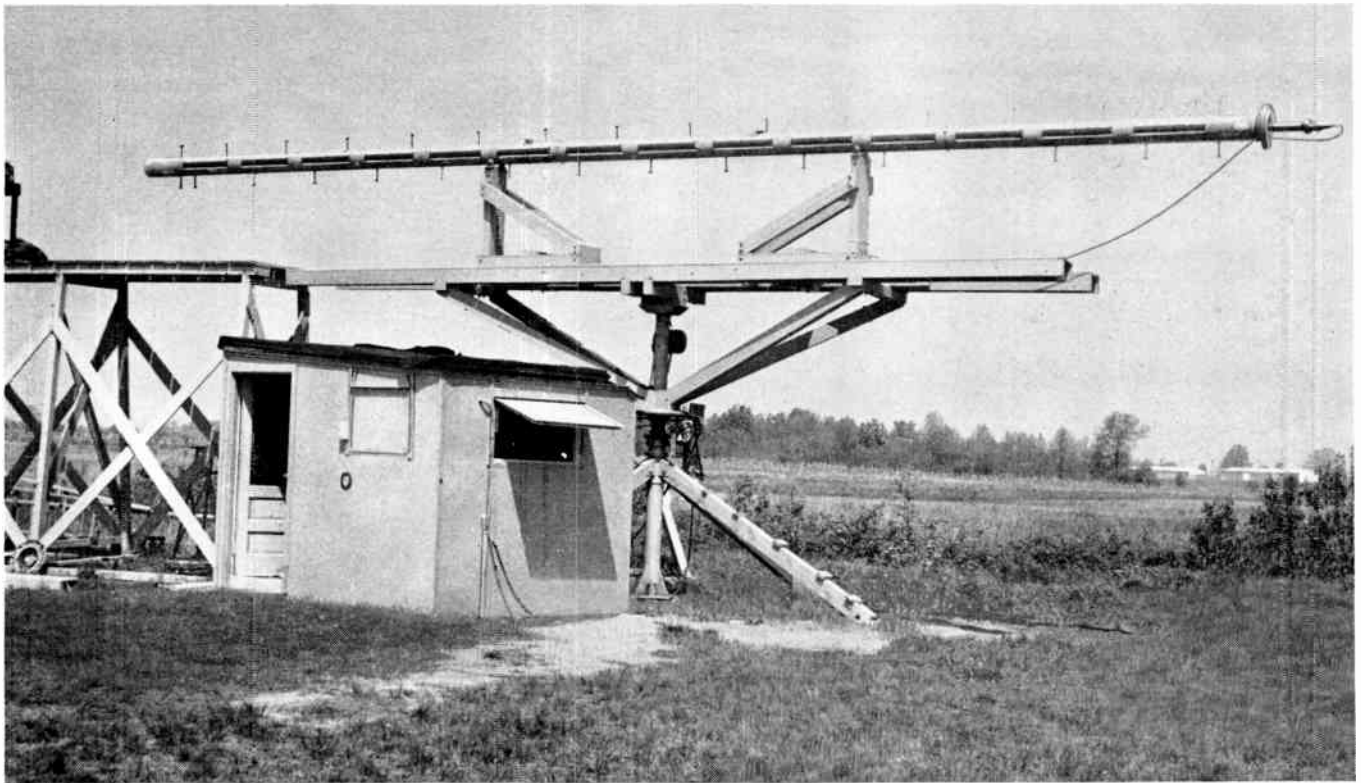

FIG. 5. UHF Custom Antenna, in this case for a directional cardioid pattern on Channel 24, is shown under pattern test at RCA's antenna testing location.

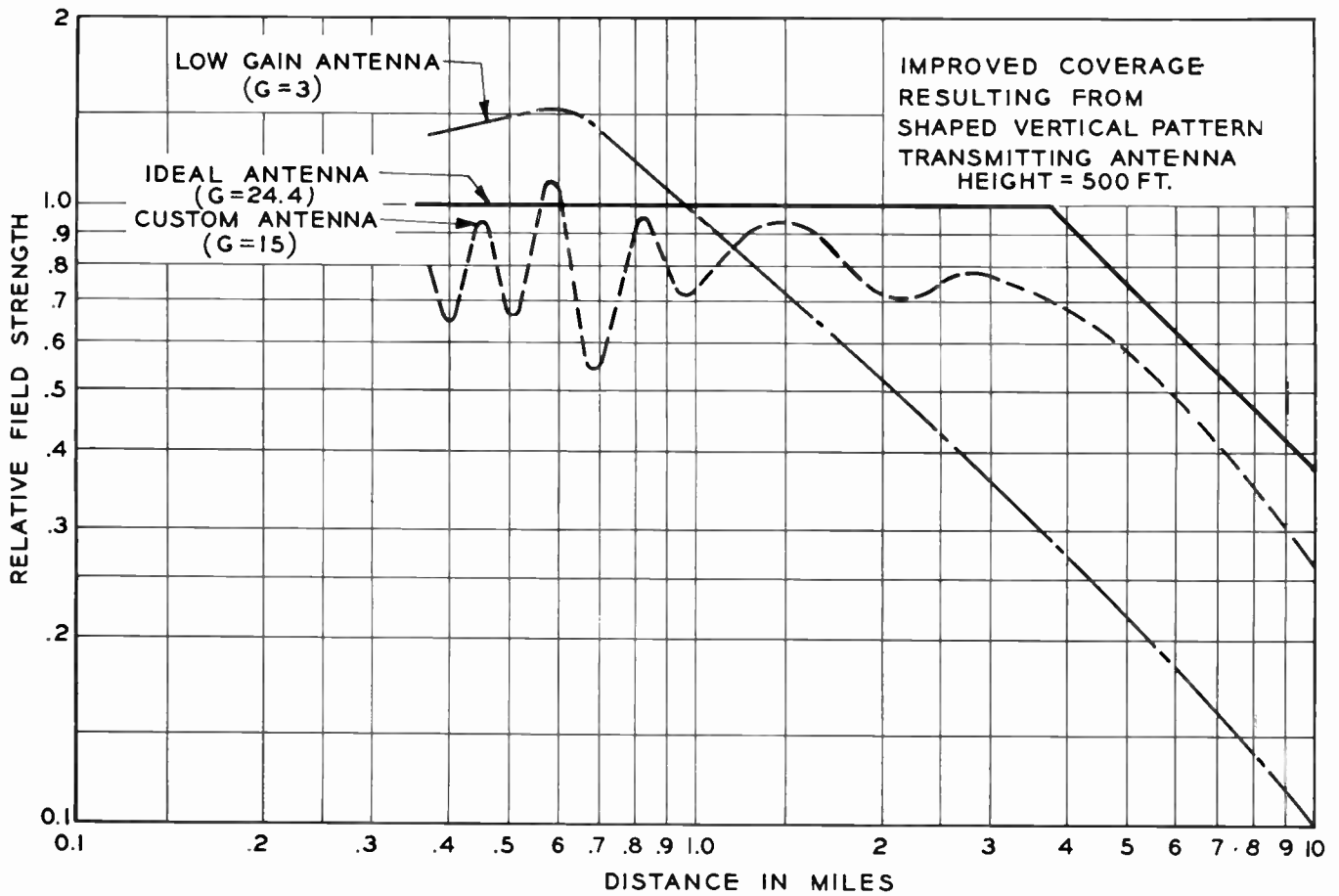

FIG. 6.

hurricane areas where a higher wind loading is desirable, some extra design may be necessary. Sometimes a detailed engineering study of a borderline case may reveal that an antenna previously rejected for structural reasons may actually be acceptable. When doubt exists, RCA engineers will, upon request, examine the standard antenna carefully before specifying a custom built antenna.

For cases where a custom built antenna is clearly required, a heavier wall pipe can usually be chosen so that the allowable stresses are not exceeded. In other respects, the antenna is exactly like its counterpart in the normal wind loading classification. Fig. 4 shows two single layer developmental models for a "peanut" horizontal pattern directional antenna, one the normal 8-inch pipe, the other a pipe for 75/47 lb. loading.

### Special Application

#### 1. Stacking:

10 kw UHF television pylons cannot be mounted one atop the other due to mechanical deflections encountered, but one may be mounted on a VHF superturnstile, on a VHF supergain, or on an FM pylon. The combinations permissible are shown in Fig. 8.

For mounting the 10 kw pylon on the FM pylon, a pedestal is required (see Fig. 7) so that the transmission line may be brought out the base of the upper pylon and down the side of the lower. A short

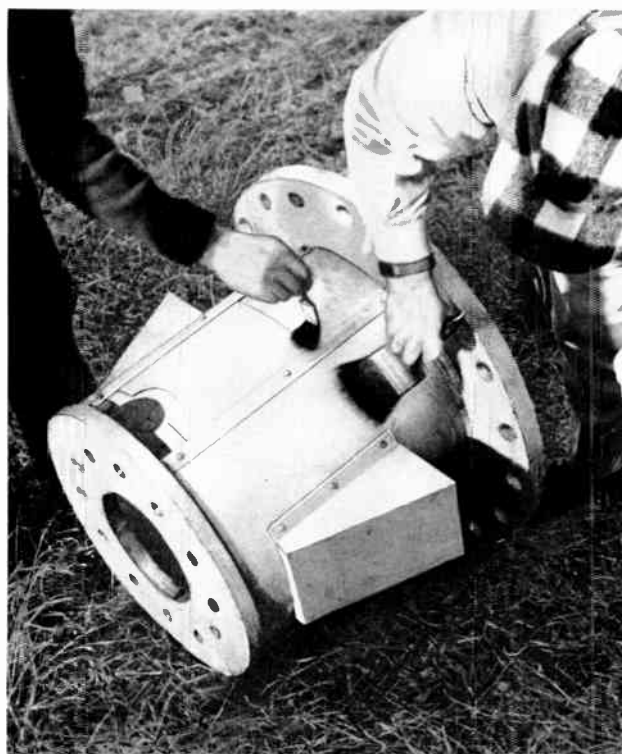

FIG. 7. Pedestal required for mounting UHF antenna atop others.

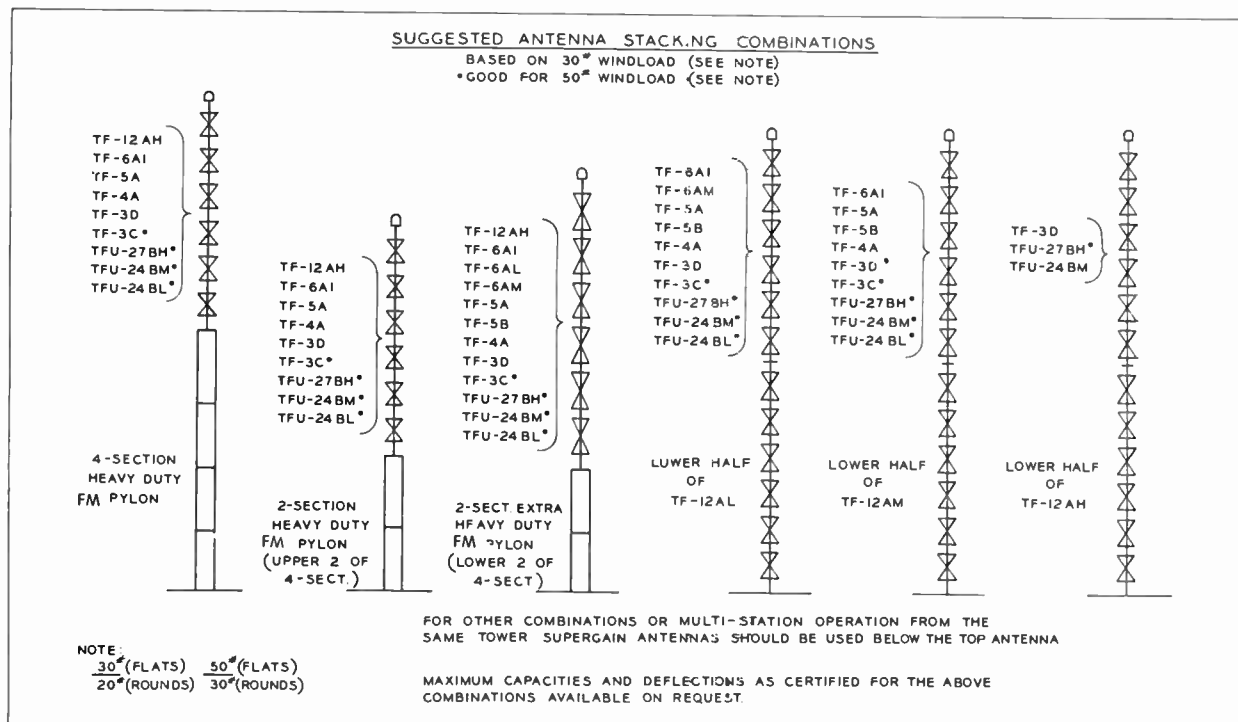

FIG. 8. Suggested antenna stacking combinations.

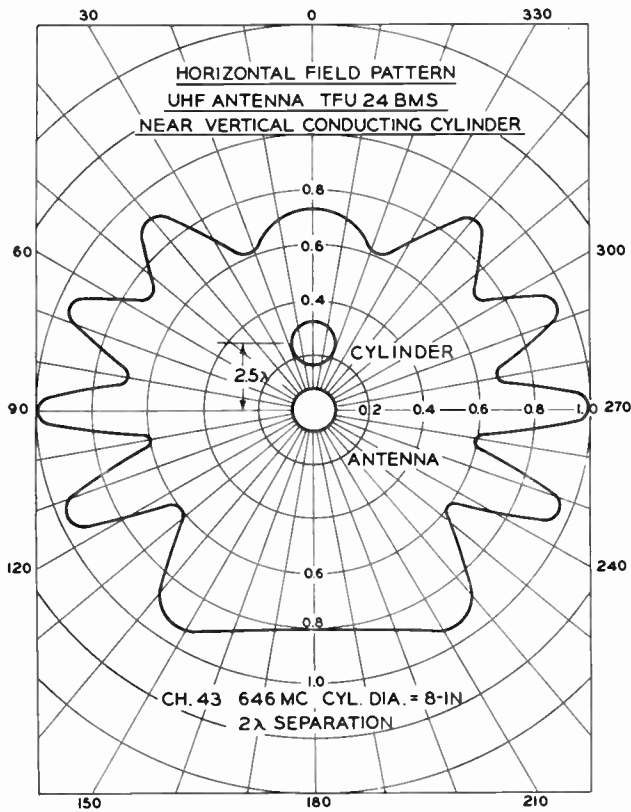

FIG. 9.

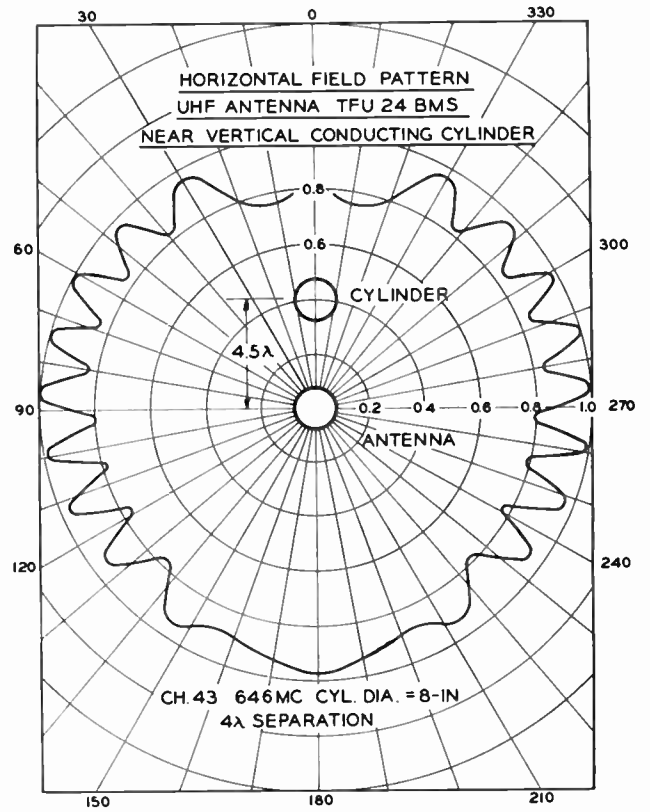

FIG. 10.

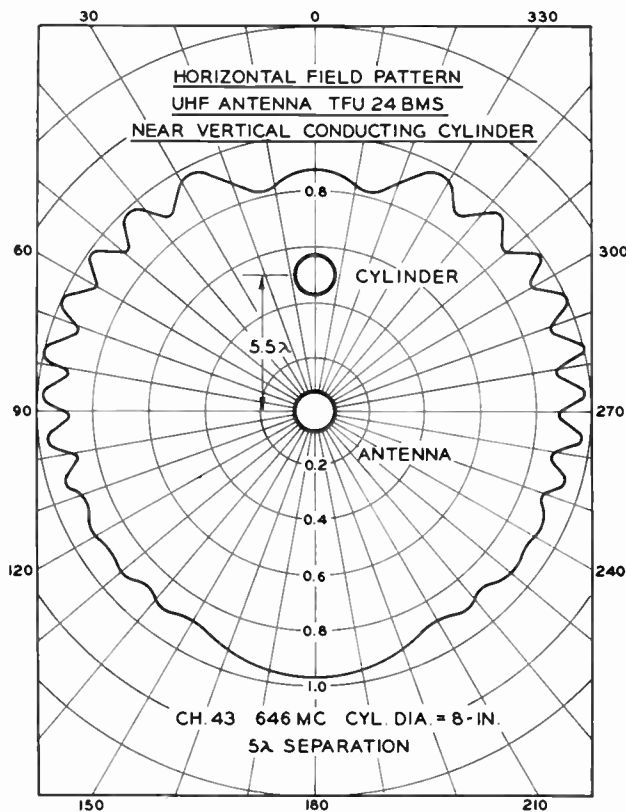

FIG. 11.

transmission line section or special mitre elbow without bullet on one end is used to connect to the harness. For mounting the 10 kw pylon on a superturnstile, a special socket pedestal is required, since the pole size varies with different superturnstiles.

On a supergain antenna, the mounting problem is simplified since the lower antenna is built around a small tower section. It is merely necessary to provide a top plate on this section, tapped to take the upper antenna. This is left to the tower fabricator.

## 2. "Birthday Cake" Arrangement:

When it becomes necessary to mount two 10 kw UHF antennas on the same tower, one solution is to mount them side by side in a manner similar to candles on a birthday cake.

Preliminary impedance tests have shown that there is no appreciable disturbance to the input impedance of one as long as the other is 10 wavelengths away. It is probable that they may be spaced much closer than this by making minor impedance adjustments.

With antennas mounted in the "Birthday-Cake" fashion, each antenna will inevitably have some effect on the horizontal pattern of the other, the effect in general extending in all horizontal directions. In this respect the horizontal pattern will be similar to that of a driven and a parasitic element. Figs. 9, 10, and 11 show typical horizontal patterns for a driven and a passive TFU-24BM(S) at various spacings.



3. Interior Mounted:

Another method of mounting two 10 kw pylons on the same tower is to mount one on the top plate in the usual manner and suspend another inside the tower and concentric with it.



FIG. 12. Pattern test set-up for UHF custom antenna mounted within a tower.

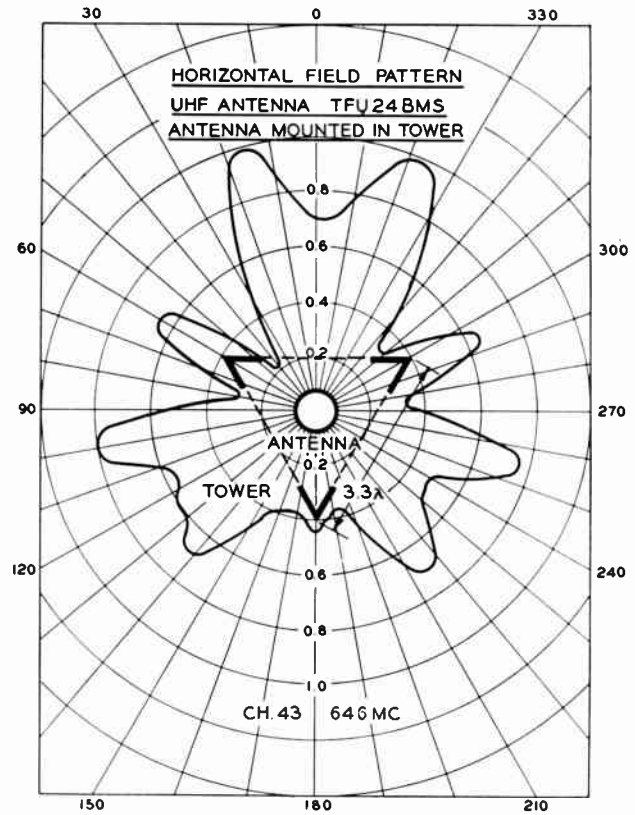

FIG. 13.

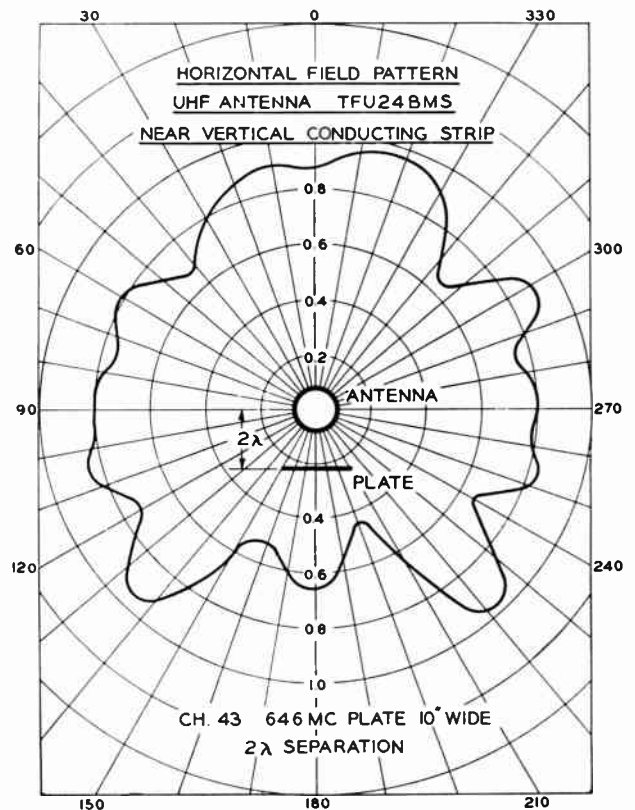

FIG. 14.

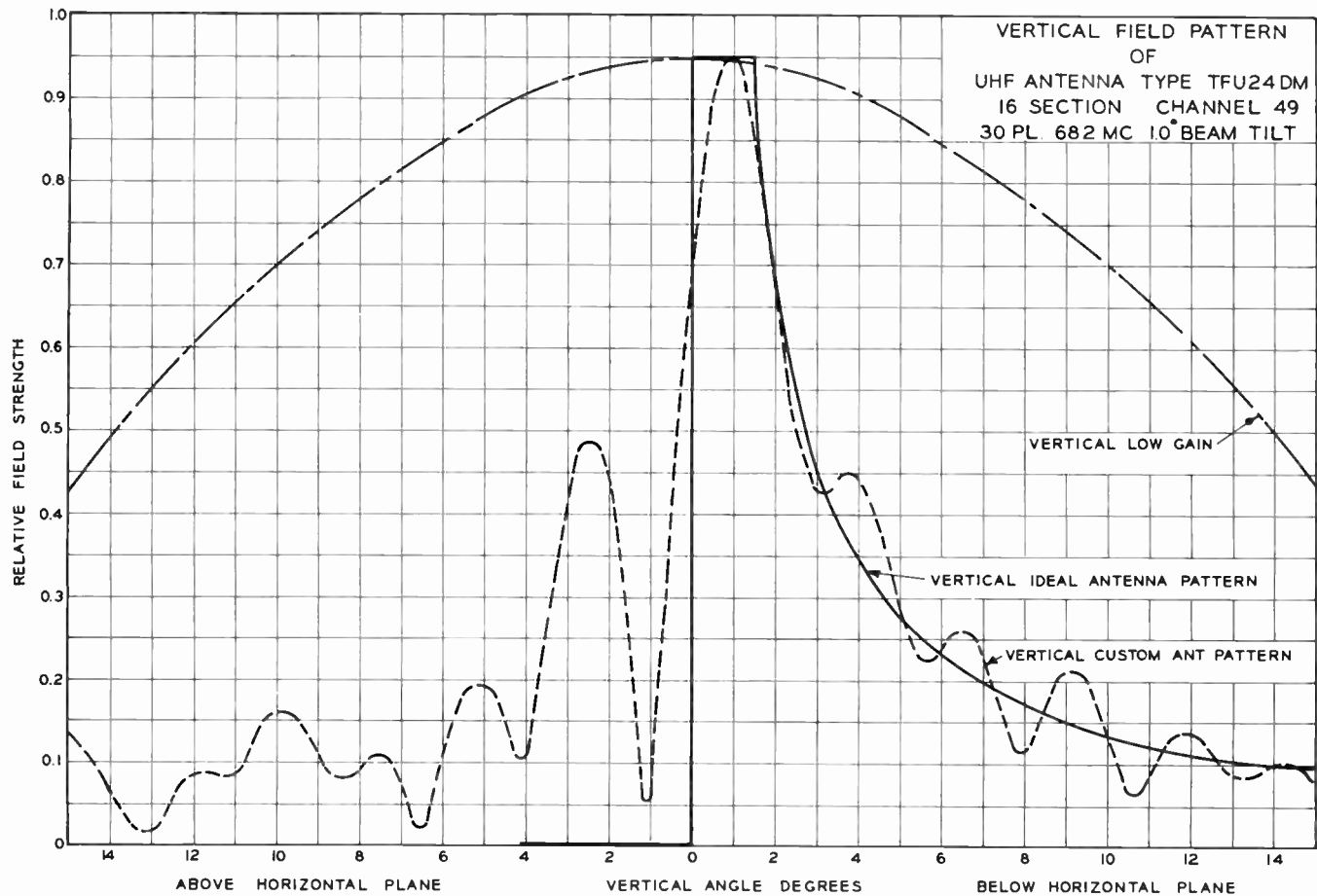

FIG. 15.

This is to be preferred both electrically and mechanically, since there is very little cross-coupling and mechanical loading of the tower is uniform. There is some effect on the impedance and horizontal pattern due to the tower corners and cross bracing, though the latter effect of cross bracing is of secondary importance. In order to provide data on which customers and consultants may base decisions, RCA has constructed a special mockup of a tower mounted antenna, Fig. 10, by which the effects on the pattern and impedance of the "Birthday Cake" and in-tower mountings may be measured. Some of the test results are shown in Figs. 13 and 14.

Note that the corners of the tower only affect the pattern (and rather severely) in this case of a tower of small cross-section. For larger towers a corresponding

decrease in non-circularity would result. Since each of these applications is a special one, the mounting arrangements are left to the tower fabricator. In this, as in most custom designs, close liaison is required between the customer, the consultant, and RCA.

*Customer-Consultant-RCA Coordination*

It is the policy of the RCA Engineering Products Department to provide as much information as necessary to the customer and consultant to allow a suitable decision on equipment to be made.

In the majority of cases, a standard antenna will be found adequate but in some applications a custom installation may better fulfill the requirements. In any event every effort will be made by RCA to work closely with the customer and consultant so that the very best installation may be had at lowest possible cost.

**Table I**  
**WIND LOADING**

WIND LOAD	TYPE			
	TFU-21DL	TFU-24DL	TFU-24DM	TFU-27DH
30		14-16		51-57
35		17-22	31-35	58-68
40	14-18	23-29	35-42	69-79
45	19-23	30-31	43-49	80-83
50	24-28		50	
55	29-31			

# APPENDIX "A"

<b>TRANSMISSION LINES</b> .....	D-77
Standing Waves on Lines .....	D-77
Standing Wave Ratio .....	D-77
Position of Voltage Minimums and Maximums .....	D-77
Impedance of Different Points Along the Line .....	D-78
Summary Effects of Line Termination .....	D-78
<b>RESONANT SECTIONS</b> .....	D-78
Quarter-Wave Shorted Section .....	D-78
Quarter-Wave Open Section .....	D-79
Half-Wave Shorted Section .....	D-79
Half-Wave Open Section .....	D-79
Tuning Characteristics of Resonant Sections .....	D-80
Quarter-Wave Line "Inverts" the Load .....	D-80
Characteristics of Line Section .....	D-80
Tuning Characteristics of Resonant Sections and Conventional Circuits .....	D-81
"Tuning Out" the Reactance .....	D-82
Tuned-Line Sections—Types of Construction .....	D-83
Quarter-Wave Sections as Transformers .....	D-83
Co-Ax Arms on Tuned Sections .....	D-83
Miscellaneous Application of Tuned Sections .....	D-83
<b>CHARACTERISTIC LINE IMPEDANCE</b> .....	D-84
Velocity Constant of Lines .....	D-85
Standing-Wave Indicators for Open-Wire Lines .....	D-86
Slotted Measuring Line .....	D-86
Additional Data on Standing Waves .....	D-87
<b>STANDING WAVE MEASUREMENTS</b> .....	D-89
Smith Chart for Determining $Z_L$ .....	D-90
Position of Standing Waves for Various Loads .....	D-91
Load Connected Directly at End of Slotted Line .....	D-91
Note on Obtaining Maximum Voltage Point .....	D-91
<b>CAVITY RESONATORS</b> .....	D-91
Developing a Simple Resonant Cavity .....	D-91
Modes of Operation of Cavity Resonators .....	D-92
Resonant Frequency "Q" and "Ro" .....	D-92
Forms of Actual Cavity Resonators .....	D-92
Tuning Slugs for Cavity Resonators .....	D-93
<b>WAVE GUIDES</b> .....	D-93
Types of Propagation .....	D-94
Transmission of R-F Energy in Wave Guides .....	D-94
<b>WAVE GUIDE APPLICATION</b> .....	D-95
Wave Guide Coupling .....	D-95
Slotted Section .....	D-95
Test Antenna .....	D-95

# TRANSMISSION LINES

A *transmission line* is a means of transferring r-f energy from a source to a load in an efficient manner.

For simplicity, most of the illustrations in this booklet show parallel-wire transmission lines, but the information also applies to coaxial lines. The similarity between a section of parallel-wire line and a coaxial section may be seen by rotating a parallel-wire section about one wire so the outer arm forms a cylinder as shown.



The *r-f voltmeter*, referred to in the text, usually consists of an r-f rectifier and meter which indicates the rectified peak amplitude of the r-f voltage at any point along the line.

## Standing Waves on Lines

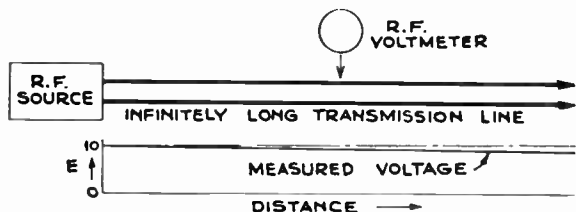

In this illustration, an r-f source is feeding r-f energy into a transmission line. If the line is infinitely long, the signal never reaches the end, and therefore cannot be reflected, so there are no "standing waves." The r-f voltage measured along the line gradually decreases due to losses in the line.

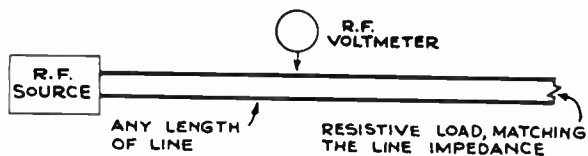

If the line is *terminated* in a resistive load that matches the line impedance (also termed "surge" or "characteristic" impedance), the outgoing signal is completely absorbed by the load. As a result, there are no reflections and no standing waves, and the voltage is essentially the same at all points along the line.

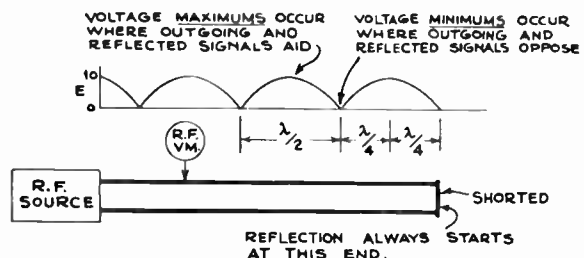

If the load is not resistive and matched to the line impedance, it reflects signal back into the line. *The combina-*

*tion of the outgoing and reflected signal produces a standing wave on the line.*

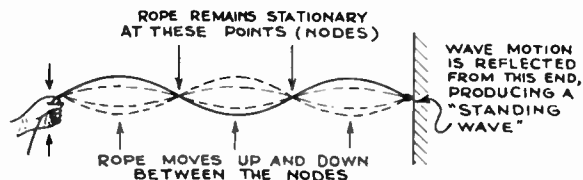

This analogy shows standing waves produced by wave motion and reflection on a rope. A similar analogy can be made to standing waves of sound along a pipe.

## Standing Wave Ratio

$$\text{The standing-wave ratio} = \frac{\text{Maximum Voltage}}{\text{Minimum Voltage}}$$

*This ratio indicates the ratio of mismatch of the load impedance.*

In the example shown below, the voltage at minimum's is 5, and the voltage at maximum's is 15.

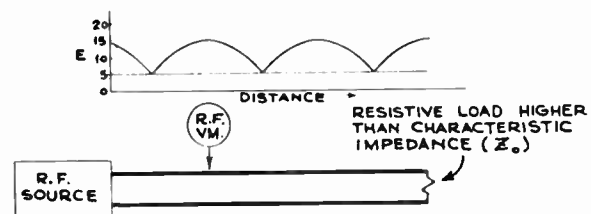

The ratio is  $\frac{15}{5}$  or 3 to 1.

Hence, the load impedance is either 3 times larger than the line impedance, or one-third of the line impedance. (In the foregoing example, the voltage at the load is maximum, so the load impedance is higher than the line impedance.)

*If the load has an appreciable reactive component the standing-wave ratio is only a rough indication of the impedance mismatch. This can be seen from the curves in the appendix.*

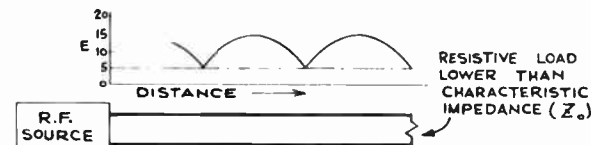

In the example shown above, the voltage at the load is minimum, so the load impedance is lower than the line impedance.

## Position of Voltage Minimums and Maximums

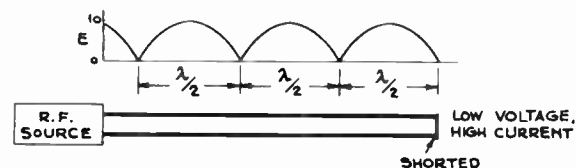

If the end of the line is shorted, the voltage at the short is low and the current is high. The first voltage minimum occurs a half-wave back from the end of the line.

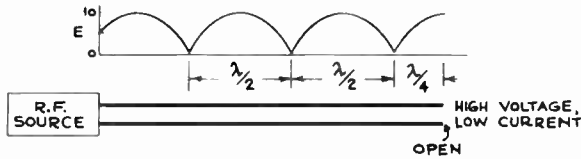

If the end of the line is open, the voltage at the end is high, and the current is low. The first voltage minimum occurs a quarter-wave back from the end of the line.

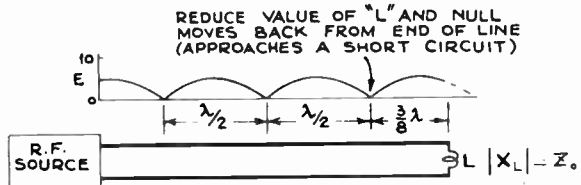
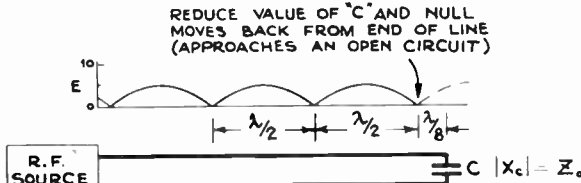

For loads containing reactance, the standing-wave will be shifted, depending on the nature of the load.

Often it is desirable to speak of electrical degrees rather than fractions of a wave-length:

$\frac{1}{8}\lambda = 45^\circ$	$\frac{1}{2}\lambda = 180^\circ$	$\frac{7}{8}\lambda = 315^\circ$
$\frac{1}{4}\lambda = 90^\circ$	$\frac{5}{8}\lambda = 225^\circ$	$\lambda = 360^\circ$
$\frac{3}{8}\lambda = 135^\circ$	$\frac{3}{4}\lambda = 270^\circ$	

### Impedance at Different Points Along the Line

The impedance at any point along the line is determined by the ratio of voltage to current at that point: If the voltage is high, the current at the same point is low, and therefore the impedance at that point is high.

If the line has low losses, and no energy is absorbed by the termination, the low-impedance points are equivalent to short-circuits, and the high-impedance points are equivalent to open circuits. If there is energy loss in the line or termination, the impedance tends to become more uniform along the line. When the load matches the line, the impedance becomes uniform along the line, and is equal to the "characteristic" impedance.

It should be noted that an open circuit, a short-circuit

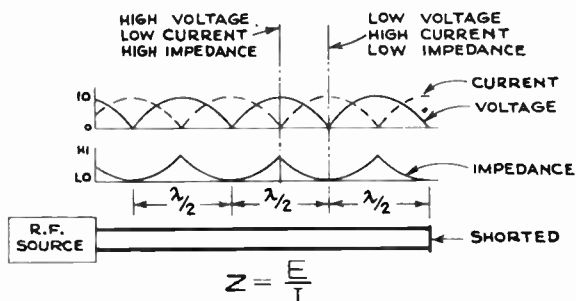

or a pure reactance at the end of the line will not absorb power. Standing-waves will therefore exist with such loads.

### Summary—Effect of Line Termination

- (1) If a line of any length is correctly terminated with a resistive load that matches the line impedance, there are no reflections, and no standing-waves.
- (2) If a line is not correctly terminated, the signal is reflected back from the load and this results in standing-waves.
- (3) The value and nature of the load determines the ratio of voltage at maximum and minimum points along the line, and also the position of these maximum and minimum points.

In most applications where a line is used to connect a signal source to a load (for instance, to connect a transmitter to an antenna) it is generally desirable to make the load match the line. If the load is not matched, the length of the line becomes critical, and incorrect length may affect the power output and frequency of the source. When the load is matched to the line, the length of the line is not critical. ("Matching" means that the load must be resistive and equal to the line impedance.)

### RESONANT SECTIONS

Quarter-wave and half-wave sections and their action as tuned circuits will now be considered. This action will be explained on the basis of change in impedance produced by standing waves along an opened or shorted line.

When sections of line are used as tuned circuits, their action depends on the existence of reflections and standing-waves to produce the effect of high-impedance and low-impedance tuned circuits. Therefore, sections of lines, when used as tuned circuits or transformers are either effectively shorted or opened at the end to produce the maximum standing-wave ratio and the highest or lowest possible input impedance, as desired in the application.

#### Quarter-Wave Shorted Section

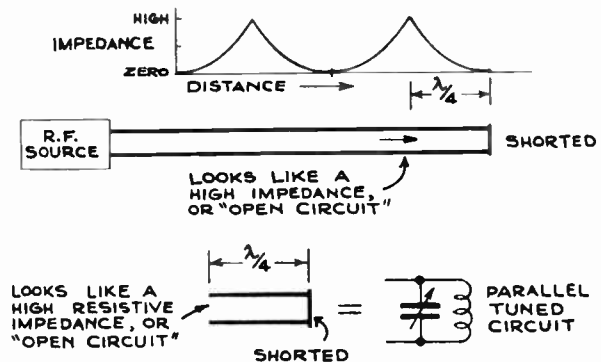

The quarter-wave shorted section at the end of the line looks like a high-impedance to the input signal, and being tuned, it is resistive. The equivalent conventional circuit is a parallel-tuned circuit, for it also has high-resistive impedance at the resonant frequency.

The action of a quarter-wave section may also be explained as follows:

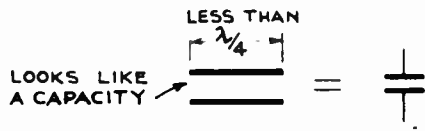

A section of line open at each end and less than a quarter-wave long acts like a capacity.

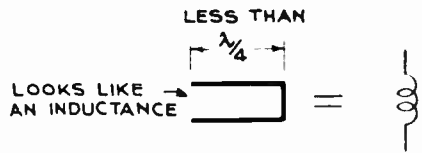

A section of line shorted at one end and less than a quarter-wave long acts like an inductance.

The capacitive reactance of a section of line one-eighth wave-long, open at the ends, is equal to the inductive reactance of a section of line one-eighth wave long, shorted at one end: The values of these reactances are equal to

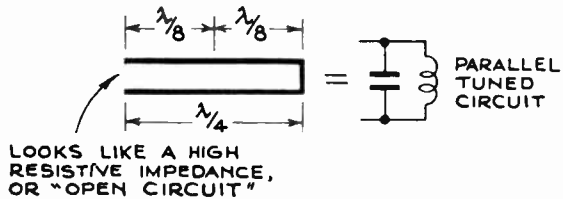
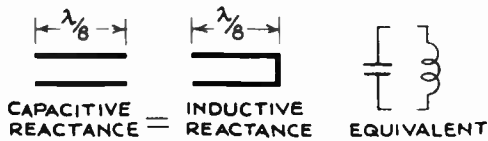

the "characteristic" impedance. (The "characteristic" or "surge" impedance depends on the size and spacing of the conductors.)

If the two sections are combined, the result is a resonant circuit that has high-resistive impedance, like a parallel-tuned circuit.

(This example is given because it is simple to visualize. Naturally, any two sections that add in length to equal one-quarter-wave electrically will have equal reactance and will produce the same result.)

The voltage, current, and impedance relations for a quarter-wave section are shown below:

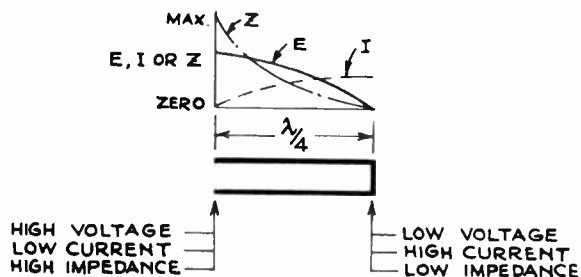

### Quarter-Wave Open Section

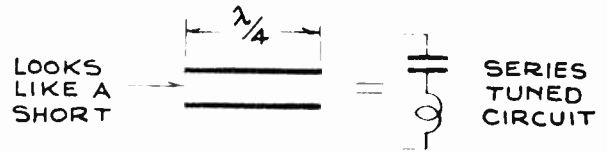
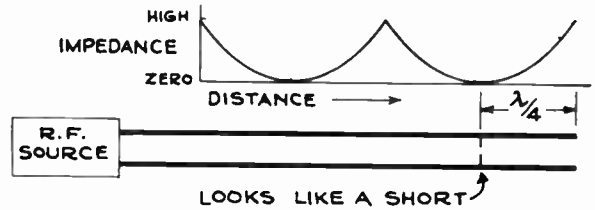

The quarter-wave section at the end of the line has very low input impedance, and, being tuned, it is resistive. It is equivalent to a conventional series-tuned circuit.

### Half-Wave Shorted Section

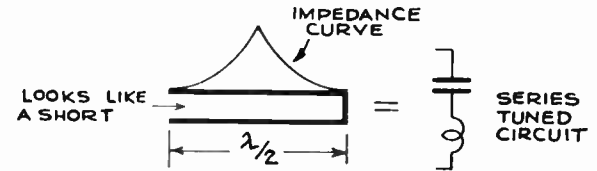
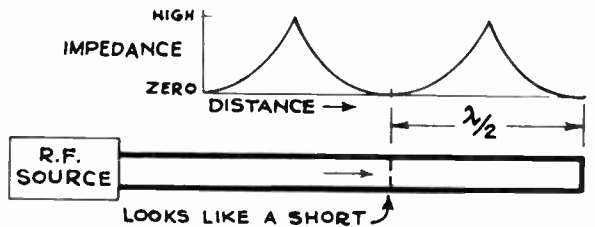

The half-wave shorted section at the end of the line also has low resistive input impedance. It corresponds to a series-tuned circuit.

### Half-Wave Open Section

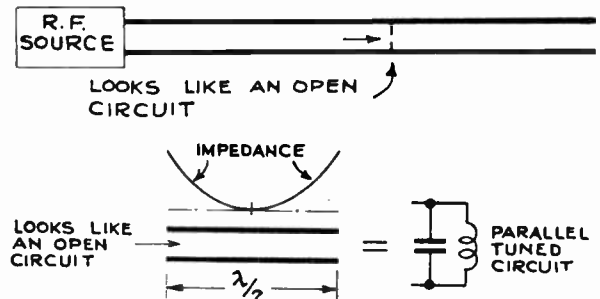
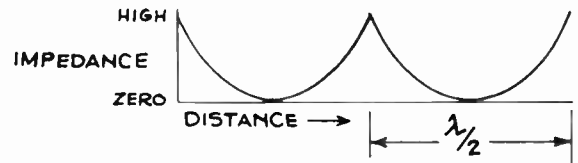

The half-wave open section at the end of the line has high input impedance. This section corresponds to a parallel-tuned circuit.

### Tuning Characteristics of Resonant Sections

We have seen the four principal resonant sections:

- |                          |   |
|--------------------------|---|
| 1. Quarter-wave, shorted | } Equivalent to a parallel-tuned circuit. |
| 2. Half-wave, open       |   |
| 3. Quarter-wave, open    | } Equivalent to a series-tuned circuit.   |
| 4. Half-wave, shorted    |   |

If a section of line is tuned above or below the resonant input frequency (by making the line shorter or longer) the effect is the same as in a conventional tuned circuit. The section will no longer look resistive. Either capacitive or inductive reactance will predominate. This is shown further in the tables on page 6 and in the graphs at right.

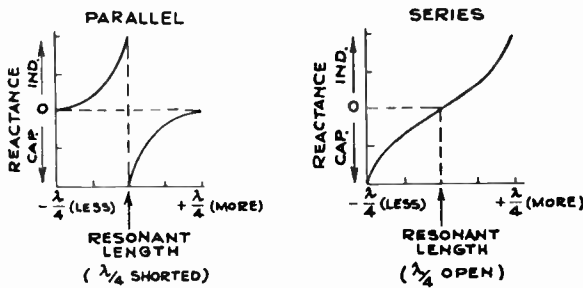

### Quarter-Wave Line "Inverts" the Load

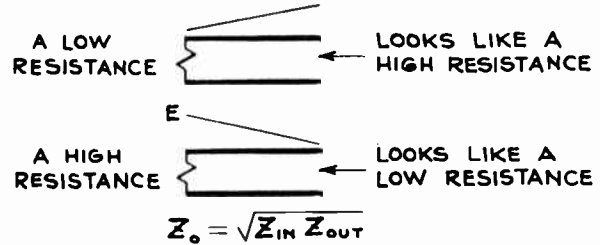
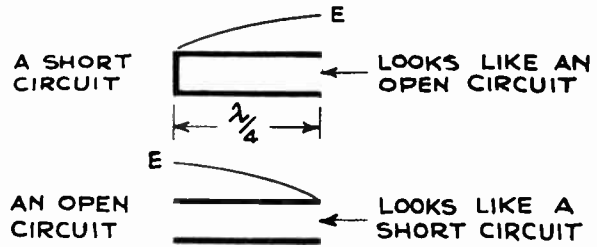

A quarter-wave line "inverts" the load as seen by source.

The input impedance in the above cases can be determined as follows:



$$\text{Input impedance} = \frac{(\text{Line impedance})^2}{\text{Load impedance}}$$

### Characteristics of Line Sections

OPEN-CIRCUIT LINES		SHORT CIRCUIT LINES	
	LOOKS LIKE A CAPACITY LESS THAN $\lambda/4$		LOOKS LIKE AN INDUCTANCE LESS THAN $\lambda/4$
	LOOKS LIKE A SERIES RESONANT CIRCUIT, OR SHORT CIRCUIT		LOOKS LIKE A PARALLEL RESONANT CIRCUIT, OR OPEN CIRCUIT
	LOOKS LIKE AN INDUCTANCE BETWEEN $\lambda/4$ AND $\lambda/2$		LOOKS LIKE A CAPACITY BETWEEN $\lambda/4$ AND $\lambda/2$
	LOOKS LIKE A PARALLEL RESONANT CIRCUIT, OR OPEN CIRCUIT		LOOKS LIKE A SERIES RESONANT CIRCUIT, OR SHORT CIRCUIT

CHARACTERISTICS REPEAT WHEN MULTIPLES OF AN ELECTRICAL HALF WAVE ARE ADDED.

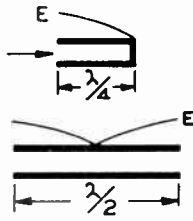
## Tuning Characteristics of Resonant Sections and Conventional Circuits

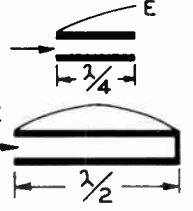
WHEN INPUT FREQUENCY IS CONSTANT, AND THE CIRCUIT IS ADJUSTED		CONVENTIONAL CIRCUIT	RESONANT SECTION	WHEN THE CIRCUIT IS CONSTANT, AND THE INPUT FREQUENCY IS ADJUSTED.	
ABOVE RESONANCE (SECTION MADE SHORTER) LOOKS LIKE	BELOW RESONANCE (SECTION MADE LONGER) LOOKS LIKE			ABOVE RESONANCE LOOKS LIKE	BELOW RESONANCE LOOKS LIKE
INDUCTANCE ( $X_c > X_L$ )	CAPACITY ( $X_L > X_c$ )	 AT RESONANCE THESE CIRCUITS LOOK LIKE A HIGH RESISTIVE IMPEDANCE, OR "OPEN CIRCUIT"		CAPACITY ( $X_L > X_c$ )	INDUCTANCE ( $X_c > X_L$ )
CAPACITY ( $X_c > X_L$ )	INDUCTANCE ( $X_L > X_c$ )	 AT RESONANCE THESE CIRCUITS LOOK LIKE A LOW RESISTIVE IMPEDANCE, OR "SHORT CIRCUIT"		INDUCTANCE ( $X_L > X_c$ )	CAPACITY ( $X_c > X_L$ )

TUNED LINE CHARACTERISTICS REPEAT WHEN MULTIPLES OF AN ELECTRICAL HALF WAVE ARE ADDED

### Quarter-Wave Matching Section

The "inverting" property of a quarter-wave section can be put to practical use when it is necessary to match a line of one impedance to a load of a different impedance. To do this, the section must have an impedance calculated as follows:

$$Z \text{ matching section} = \sqrt{Z_{\text{line}} \times Z_{\text{load}}}$$

For example: A 500-ohm line can be matched to a 72-ohm dipole through a quarter-wave section of 190 ohms.

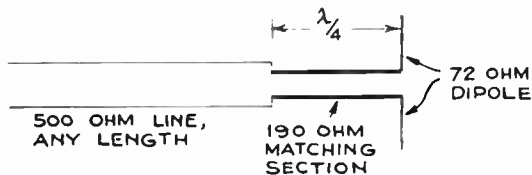

The *line* looks into a load of  $\frac{(Z \text{ of matching section})^2}{Z \text{ of load}}$  or 500 ohms.

The *antenna* looks into a source of  $\frac{(Z \text{ of matching section})^2}{Z \text{ of line}}$  or 72 ohms.

### "Inversion" of Capacity and Inductance

Inversion of capacity and inductance can be explained as follows:

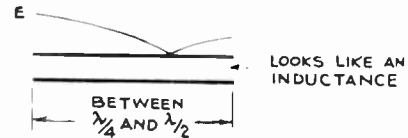

An open section of line between one-quarter and one-half wave long looks like an inductance to the source.

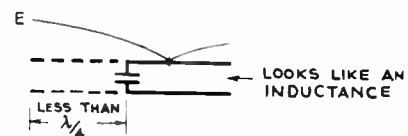

If a part (less than one-quarter wave) is replaced by a capacity (an open section less than one-quarter wave looks like a capacity), the section still looks like an inductance to the source.

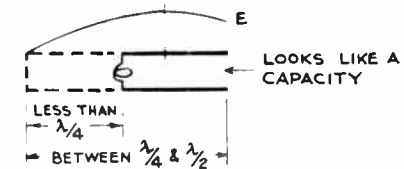

A shorted section between one-quarter and one-half wave looks like a capacity. If part (less than one-quarter wave) of the shorted end is replaced by an inductance, the section will still look like a capacity to the source.



### Sections Less than Quarter-Wave

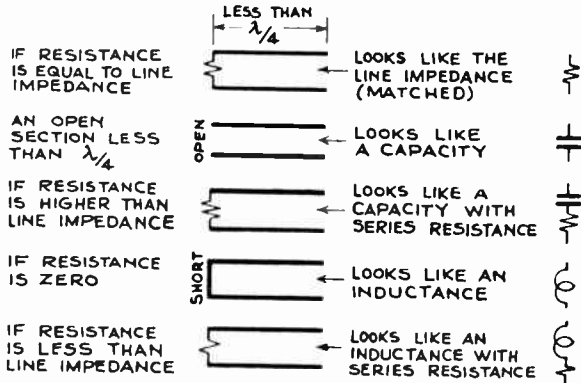

### Sections Between One-Quarter and One-Half Wave

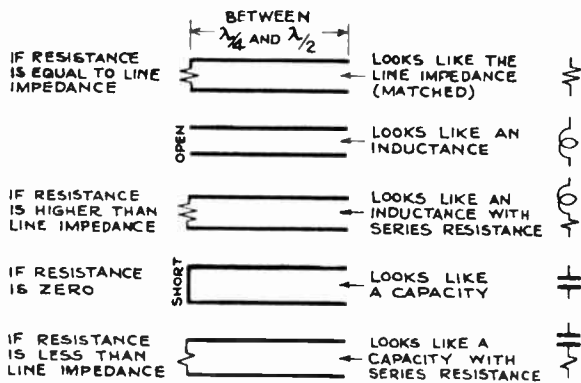

### Half-Wave Line "Repeats" the Load

A half-wave line acts as a "double inverter" and hence will "repeat" whatever appears on the far end:

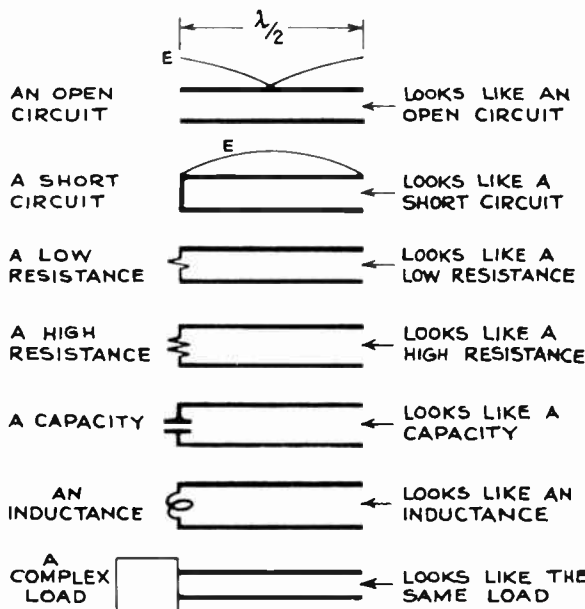

A line that is any multiple of one-half wave has the same characteristics.

The action of a half-wave section, or a line cut to a multiple of a half-wave, is used extensively in practical applications. For example, if a dipole antenna with an

impedance of 73 ohms is to be coupled to the output of a transmitter, through an open-wire line (spaced pair) with a characteristic impedance of several hundred ohms, the line can be cut to a multiple of an electrical half wave.

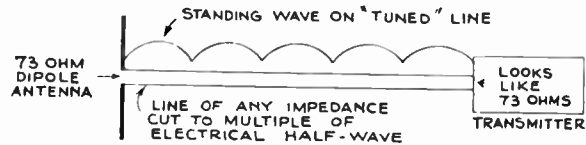

The transmitter will look into a load of 73 ohms, regardless of the impedance of the line.

### "Tuning Out" the Reactance of a Load

One of the important applications of tuned-line sections is to "tune out" the effects of residual capacitive or inductive reactance in a load, so the load will look like a pure resistance.

For example, assume that a 70-ohm resistor is used to terminate a 70-ohm line. If this line, with its resistor termination is connected to a slotted line and checked for match over a wide range of frequencies, it will be found that at some frequency the termination looks resistive. This is the resonant frequency of the resistor. Above and below this frequency the resistor has capacitive or inductive reactance and no longer matches the line. In other words, the resistor is not a "pure resistance" at most frequencies.

At the required operating frequency, the resistor may look like a resistance with shunt capacity as shown in "A." If an inductive section of line is connected to the termination as shown in "B," it may be adjusted to resonate with the capacity, to look like a parallel-tuned circuit.

The line, therefore, instead of seeing a resistance with shunt capacity, now sees a resistance with a shunt parallel-tuned circuit, as shown in "C."

The parallel-tuned circuit looks like a high resistive impedance as shown in "D," and, therefore, has little effect on the total resistance. If the combined resistance is correct, the line will be "matched."

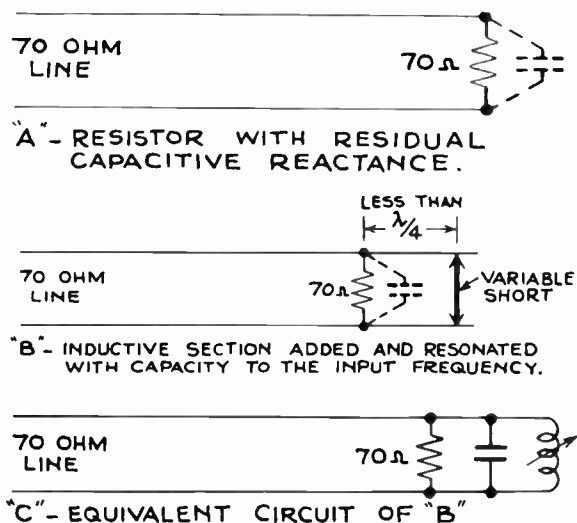

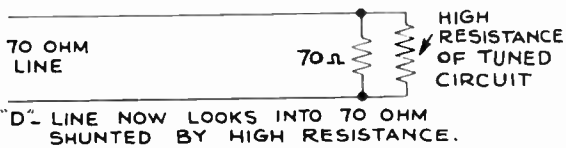

### Tuned-Line Sections—Types of Construction

The characteristics of tuned lines are used to good advantage in UHF equipments. Quarter-wave and half-wave sections are used as parallel- and series-tuned circuits, as step-up and step-down transformers, as impedance and

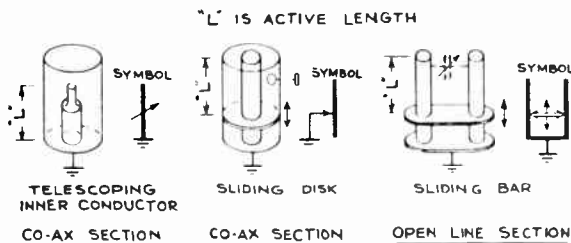

phase inverters, and even as insulators. Such sections of line take the place of conventional tuned circuits which become too small and inefficient at ultra-high frequencies. The tuned-line sections are made in both co-axial form, and in open-line type, from metal tubes and rods; generally silver-plated to reduce r-f losses. Some representative types of construction are sketched above. Methods of adjustment to resonate the sections are indicated.

Some sections are cut short, and resonated with an adjustable capacitor (indicated by dotted lines) instead of being resonated with a sliding disc or bar.

### Quarter-Wave Sections as Transformers

A quarter-wave section (co-ax or "open-line" type) shorted at the end, may be used as a step-up transformer, similar to a parallel-tuned auto-transformer. When a resonant section is "loaded" with reactance, for example, connected to the grid of a tube, the section must be readjusted to obtain electrical resonance).

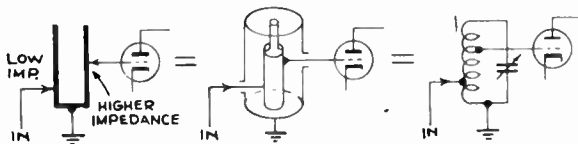

A quarter-wave shorted section may be used as a step-down transformer.

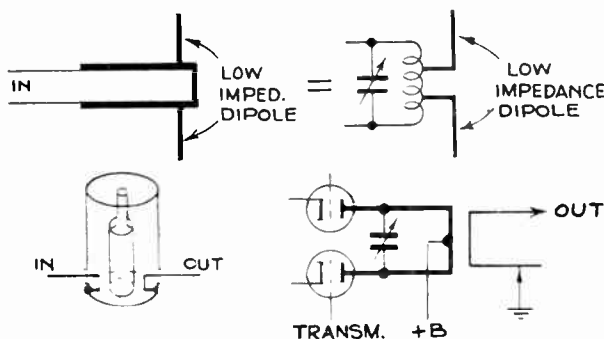

Inductive coupling to tuned sections is sometimes done as shown in the following two different examples:

### Co-Ax Arms on Tuned Sections

In push-pull UHF circuits, lengths of co-ax are frequently used to form the arms of one-quarter or one-half wave shorted sections. This is done for several reasons, including:

- (1) The inner conductors may be used to carry d-c and a-c supply voltages, or low-frequency signals, to the tube elements.
- (2) The outer conductors can be grounded.
- (3) A sliding bar on the outer conductors can be used to adjust the electrical lengths of the section mentioned in (1) above.

In such applications, capacitors are used at the end of the co-ax to place the inner and outer conductors at the same r-f voltage.

An example of co-ax arms forming tuned sections is shown in the illustration.

"A" is the quarter-wave shorted section required for input tuning. But it is necessary to take the diode currents

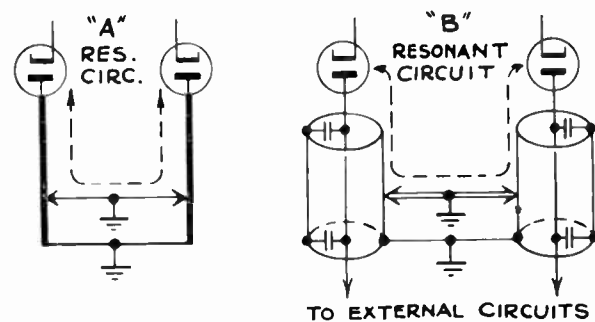

to external circuits, and (for constructional reasons) the arms of the section must be grounded. "B" shows how "A" is rearranged to do this. *The co-ax lines do not act as tuned sections by themselves, but form the arms of the quarter-wave shorted section shown in "A."*

### Miscellaneous Application of Tuned Sections

Tuned sections are put to many uses in addition to that of replacing conventional tuned circuits.

Some miscellaneous uses are described to indicate several of the many applications.

#### (1) Use of Sections in Switching Circuits

In some equipments it is necessary at times to prevent signals from "A" getting to "B." This is accomplished by shorting the end of the one-half wave section. By virtue

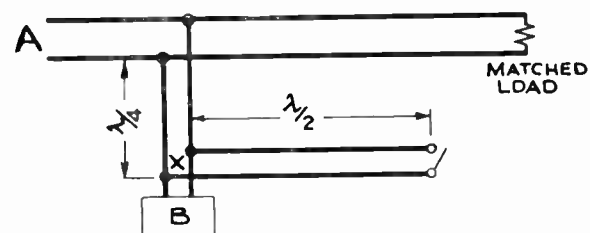

of the action of one-half wave sections, this short appears as a short across "B" input line at "X." The one-quarter-wave line, being thus shorted at "X," looks like a high impedance to the signal from "A."

When it is desired to leave signals through to "B," the switch is opened at the end of the one-half-wave line. At "X," the one-half-wave resonant line now looks like an open circuit. With no short at "X," the one-quarter-wave section is simply an ordinary part of the line, and signals can pass to "B."

**(2) Quarter-Wave Shorted Section Used as an Insulator**

(a) A quarter-wave shorted section looks like a high resistive impedance. This fact is utilized in some antenna systems by employing one-quarter-wave shorted sections as metallic stand-off insulators to support and space a dipole antenna one-quarter wave from a reflecting surface, as shown below:

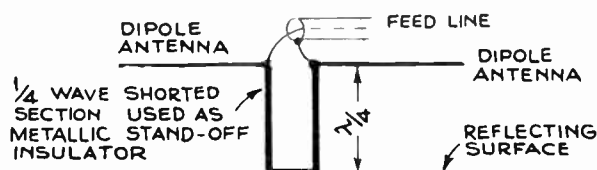

The quarter-wave section looks like a high impedance to the antenna feed line. (The feed line can be run inside one arm of the quarter-wave section.)

(b) Another example of a quarter-wave "insulator" is shown below, together with an analogy of a conventional parallel-tuned circuit.

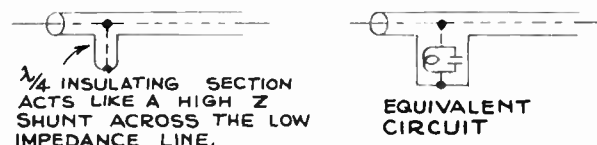

**(3) Line Balance Converter (Bazooka)**

In some applications, it is necessary to change from a co-axial transmission line (unbalanced, since outer conductor is grounded) to a balanced transmission line or load (both conductors approximately the same impedance above ground).

A "bazooka" is used for this purpose. The action is shown in the sketches, and may be explained as follows:

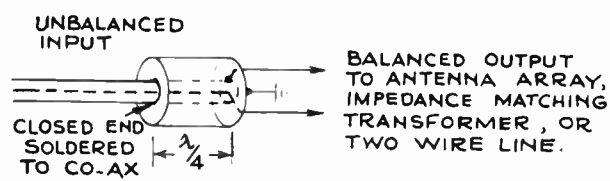
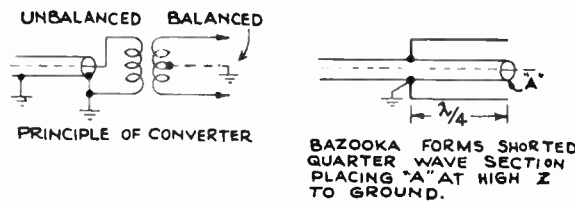

1. The quarter-wave shorted section effectively removes the r-f ground from the end of the outer conductor of the co-axial line.
2. Both the inner and outer conductors of the co-axial line are now at a relatively high impedance above ground, and effectively balanced to ground.
3. The bazooka may be used in reverse manner to feed from a balanced circuit to an unbalanced circuit.

**(4) Half-Wave Phase and Impedance Converter**

The following arrangement is used in some applications. The action may be reversed, to feed from high-impedance balanced input to low-impedance unbalanced output.

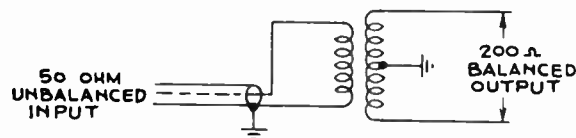
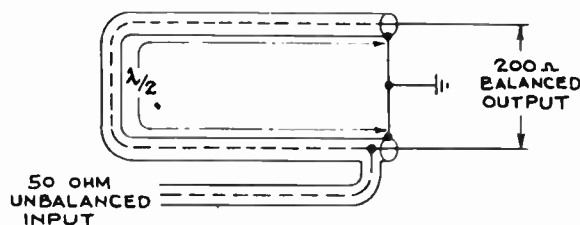

**(5) "Folded" Resonant Section**

At relatively low frequencies, the physical length of a resonant section may be too long for convenient use, and a "folded" section may be used. The effective length of the folded section is indicated by the dotted line. More than one "fold" may be used for further reduction of the physical length.

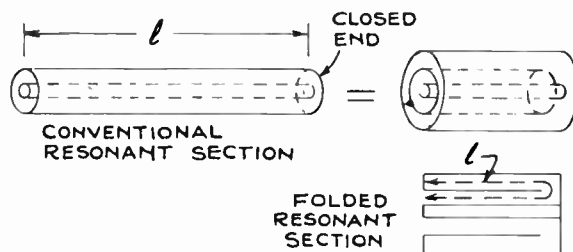

**Characteristic Line Impedance**

The impedance of a line (also termed "surge" or "characteristic" impedance) depends on the dimensions and spacing of the conductors, and the dielectric constant of the insulating material.

**Neglecting Losses—**

$$Z_{OHMS} = \sqrt{\frac{L \text{ HENRYS}}{C \text{ FARADS}}}$$

In solid dielectric lines (as compared with air dielectric) the impedance is reduced by the factor  $\sqrt{1/k}$ , where

"K" equals the dielectric constant of the insulating material (and has the effect of increasing "C" per unit length in the general formula).

*Aircraft Antenna Cable*, using solid dielectric is frequently 70 or 50 ohms. Seventy (70)-ohm cable is convenient for use with half-wave dipoles and other antennas

that have a radiation resistance of 70 ohms. Fifty (50)-ohm cable is used extensively in conjunction with suitable matching on low-impedance array-type antennas.

The two charts on the following page show how the impedance of co-axial and parallel-wire lines varies with the dimensions and spacing of the conductors.

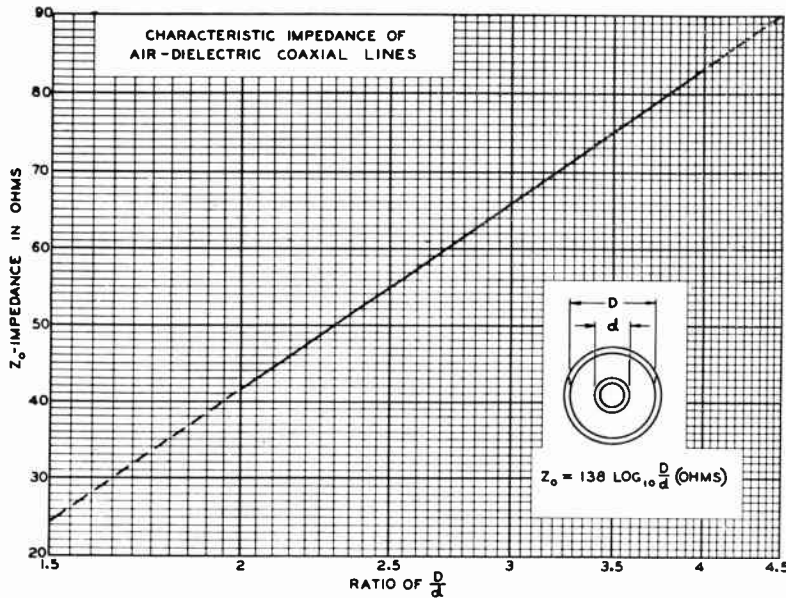

### Impedance Chart for Air-dielectric Co-axial Lines

Example: For a 50-ohm line, "D" is 2.3 times larger than "d."  
For a 70-ohm line, "D" is 3.2 times larger than "d."

### Impedance Chart for Parallel-wire Lines

Example: To obtain a line impedance of 500 ohms, using No. 14 wire, the spacing (S) must be approximately 2 inches.

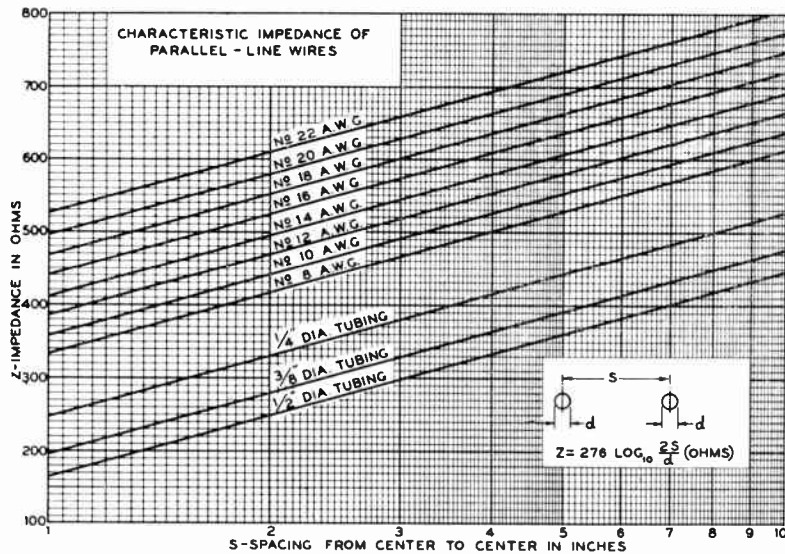

### Velocity Constant of Lines

Radio waves travel at a speed of 300 million meters per second in air. The speed is reduced in lines that have spacing insulators or solid dielectric. In a slotted measuring line, with no spacing insulators, the speed is essentially the same as in air.

The speed in solid-dielectric lines of high quality, such as UHF aircraft antenna cable, is about 60-70 per cent of speed in air. Reels of such cable are tagged with the measured velocity constant of a sample cut from the reel.

The fact that the velocity is less in the cable than in air means that a wavelength in the cable will be shorter than in air; since the wavelength equals velocity divided by frequency. For example, a wavelength in air at 100 mc. is 3 meters, but in a solid-dielectric cable with a velocity constant of 65 per cent, a wavelength at 100 mc. is only  $3 \times .65$ , or 1.95 meters.

The lower velocity in solid-dielectric lines is illustrated below. A 100 mc. signal is fed through a slotted line (air

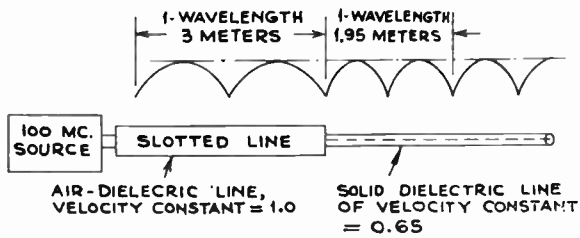

dielectric) and into a solid dielectric line that has a velocity constant of 0.65 (65 per cent of that in air).

A slotted line can be used to check the velocity constant of a co-ax cable.

The equipment is set up as shown:

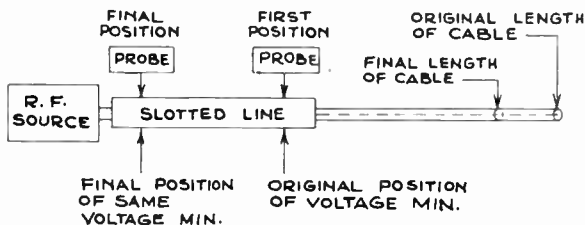

The end of the cable is left open. Standing waves are therefore set up along the cable and slotted line. The probe is set accurately at the first point of minimum voltage at the cable-side of slotted line. A piece of cable is cut off at the end of the line. This shifts the voltage minimum point to the left, and the probe is reset accurately to the new position of the voltage minimum.

The ratio of the length of the piece of cable cut off to the distance that the probe is moved is the velocity constant of the cable. (In practice, small increments of cable are cut off until nearly the entire length of the slotted line has been traversed by the probe. Each step is plotted, and the slope of the line indicates the velocity constant).

As an example, if the length of cable cut-off is 1 foot, and the probe has been moved 2 feet, the velocity constant is .5, or 50 per cent.

### Standing-Wave Indicators for Open-Wire Lines

A small neon bulb may be used to show existence of standing waves on open-wire lines. If the line is correctly terminated (no standing waves) the bulb will have constant brilliance as it is moved along the line.

Better indication can be obtained by using a crystal or diode rectifier and a meter, capacitively coupled to the line as shown.

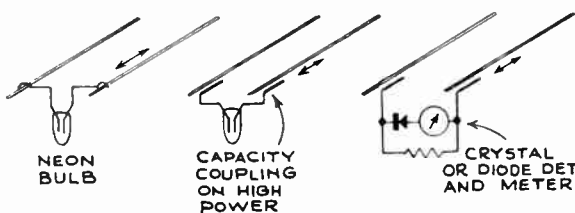

### Slotted Measuring Line

A "slotted line" is a section of co-axial line with a slot along the outer tube to permit loosely coupling an r-f voltmeter probe to the inner conductor.

The slotted line is used to determine:

- (1) Ratio of voltages at maximum and minimum voltage points of standing waves along the line.
- (2) Position of these points with respect to a "Reference" point.

From this data it is possible to determine the resistive and reactive nature of a load at a specified frequency.

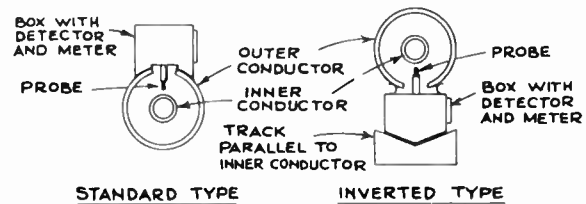

### Some Principal Applications Are

- (1) To adjust antennas for correct match to a line at a specified frequency.
- (2) To determine the resistive and reactive components of a load at a specified frequency, or over a range of frequencies; i.e., impedance and phase angle.
- (3) To adjust input systems of receivers, dummy loads, etc., for correct match to a line.

Considerable care is taken in the design and construction of slotted lines to secure:

- (1) Uniform impedance throughout the length.
- (2) Uniform spacing of the probe in its travel along the inner conductor.
- (3) Good grounding of the probe box to the outer conductor.
- (4) Rigidity of the co-ax assembly, and minimum slop in travel of the voltmeter probe.

The impedance of the slotted line should equal the impedance of the associated co-ax line. Some slotted lines are equipped with two or more mechanically interchangeable inner conductors of different diameters so the impedance can be changed to match the impedance of commonly used co-ax lines (70 and 50 ohms, and some 63 and 40 ohms).

The r-f voltmeter used in conjunction with the slotted line is usually a diode or crystal detector with a current meter and tuned input, capacitively coupled to the inner conductor.

Diode and crystal detectors are insensitive and require a high-output UHF oscillator to excite the line. It is sometimes possible to use the UHF receiver (from an equipment) as an indicator, fitting the input of the receiver with a suitable probe. In this case, owing to the high sensitivity of the receiver, a low-powered UHF generator may be used for the source.

When adjusting antennas, the object in most cases is to "match" the antenna to the line. This is usually done

by changing the antenna length and/or the antenna matching stub for *minimum* standing-wave ratio.

For some antennas, and in other applications of the slotted line, it is necessary to determine the resistive and reactive components and phase angle.

This requires checking both the standing-wave ratio and the distance from a minimum (or maximum) voltage point with respect to a "reference" point. This subject is covered in the appendix.

### Additional Data on Standing Waves

An *a-c* wave may be drawn as a change in *voltage* during a period of *time*, as shown below.

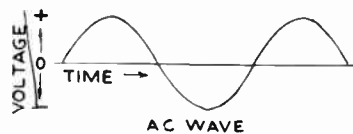

A *standing wave* is not as easy to show, because it involves changes in *voltage* with *time*, and with *distance* along the line.

The *voltages between node points* of a standing wave changes from positive to negative values and back during the time equivalent to one cycle of the r-f source. This r-f change in voltage is roughly indicated by curves 1 to 5 and back in the following sketch.

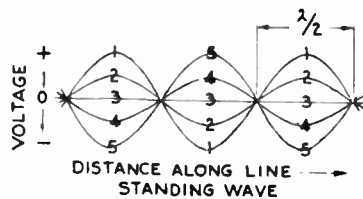

At some instant, the voltage along the line may be shown by one of these curves. It will be noted that the term "standing" wave can be misinterpreted. In a standing wave the *position* of max. and min. points does stand still, but the voltage changes at the r-f rate.

When an r-f voltmeter is moved along the line, it indicates the relative amplitude of the r-f voltage variation at each point along the line. The rectified r-f current in the meter circuit may be zero at nodes, and increases to a max. when the r-f voltmeter is moved to each voltage max. point. Thus the *measured* standing wave appears as shown below. (This is a sine wave with the negative half-cycles "flopped up.")

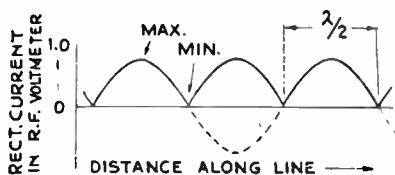

By turning one of the half-cycles down, as shown in dotted lines, it will be seen that the curve is a sine wave.

The *standing wave that exists on the line is a sine wave*, providing the r-f source is sine wave; that is, a *fundamental frequency with no harmonics*. For slotted-line

measurements, the generator must furnish sine wave output. If harmonics are present, some of the min. points, with the line open or shorted will not be zero.

If the standing wave on the line is sine wave, the *measured* standing wave will be sine wave, providing the r-f voltmeter is *linear*.

If the rectifier in the r-f voltmeter is not linear, the measured standing wave will not be sine wave, but will appear as shown.

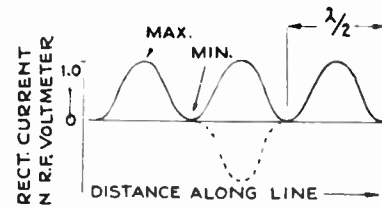

By turning one of the half-cycles down, as shown in dotted lines, it will be seen that the standing wave, as measured with a non-linear detector, is far from being a sine wave.

It will be noted that with a non-linear detector, the voltage min. points are not as "sharp" as indicated in the preceding illustration, which shows a standing wave measured with a linear detector.

The graph on page 38 shows how a non-linear detector introduces distortion in measuring a sine wave standing wave.

This non-linearity causes error in measuring standing wave ratios. In some applications of the slotted line, as for example when adjusting an antenna to "match" the line, this error may be ignored.

In other applications where it is necessary to determine the standing wave ratio accurately, correction can be determined in this way:

1. Plot the standing wave as measured with *the particular detector* at the *desired frequency*, with the line open or shorted, and with the generator output adjusted for exactly full-scale deflection at the max. voltage points.
2. Construct a sine wave (half-cycle) on top of the measured standing wave, with zero and max. points coinciding as shown in the graph on page 24. The sine wave indicates the current that would flow if the detector were linear.

Assume that a particular load produces a standing wave with a measured ratio of

$$\frac{\text{VOLTAGE MAX.}}{\text{VOLTAGE MIN.}} = \frac{0.6}{0.21} = 2.86$$

Reference to the curve shows that the value of 0.21 on the *measured* curve corresponds to 0.39 on the sine wave curve.

Also the value of 0.6 on the measured curve corresponds to 0.71 on the sine wave curve. The corrected standing wave ratio is therefore

$$\frac{0.71}{0.39} = 1.82 \text{ (instead of 2.86).}$$

### Effect of Non-Linear Detector

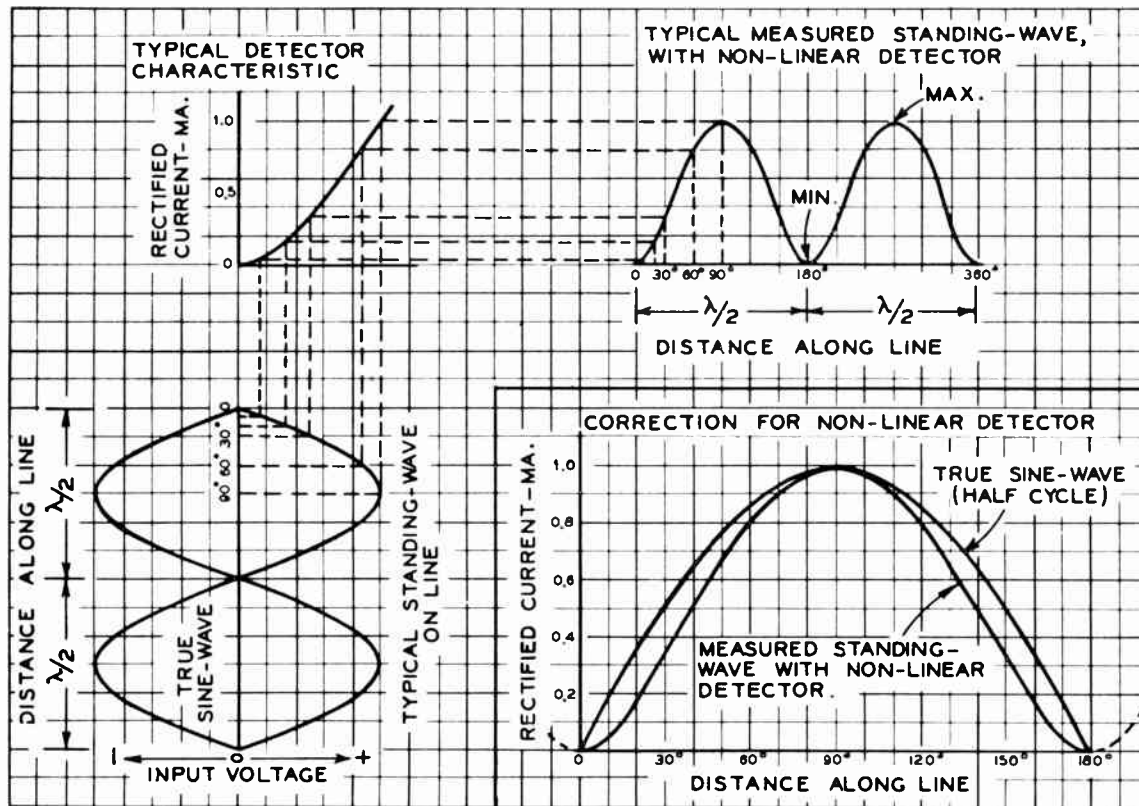

### Ratio of Power Loss in Unmatched Line

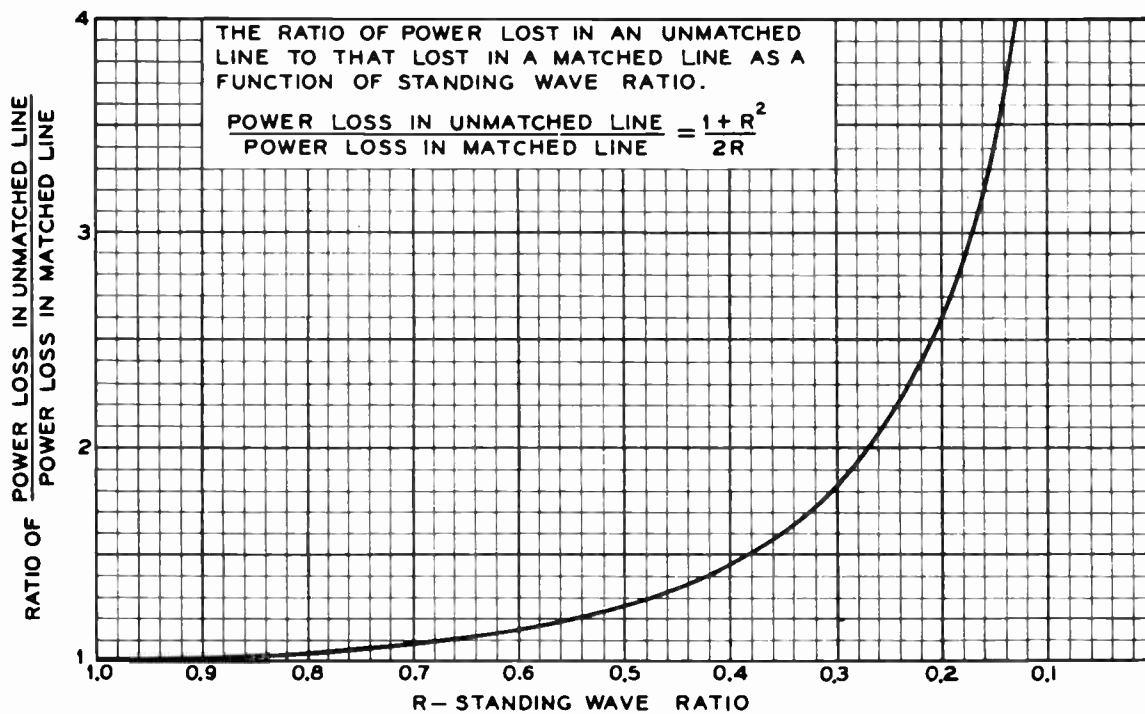

## STANDING WAVE MEASUREMENTS

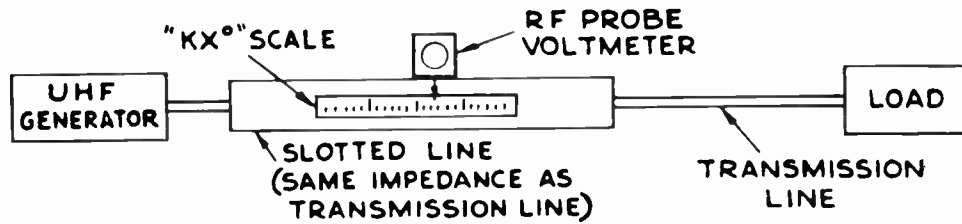
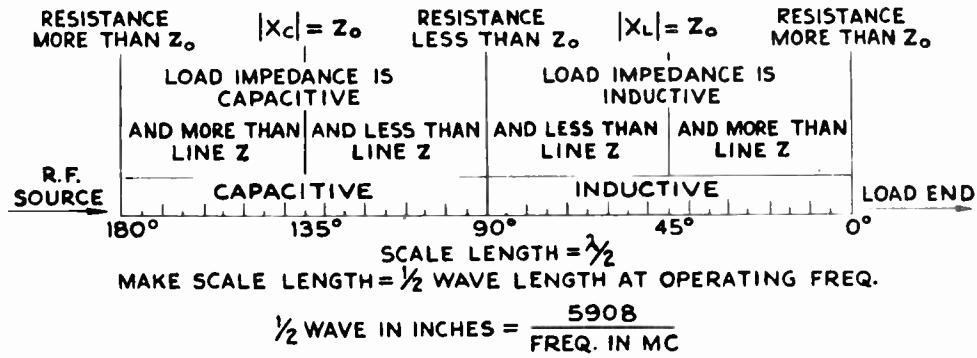

(This length is based on the use of an air-dielectric slotted line with velocity constant practically the same as air.)

By making a few simple measurements on the slotted line (at the desired frequency) it is possible, with the aid of the chart on the next page, to determine the impedance and phase angle of any load.

The procedure is as follows:

1. Locate a 'reference point' as follows:
  - (a) Short circuit the far end of the transmission line, at the load. The short circuit must be as direct and effective as possible for accurate results.
  - (b) Adjust the generator for correct frequency. Move the probe to a voltage max. point, and adjust generator output for exactly full-scale reading on probe voltmeter.
  - (c) Move the probe along the slotted line and note the position of min. voltage points. Select a min. near the center of the slotted line and locate this point accurately. This min. will be referred to as the "reference point."
2. Remove the short circuit.
3. Check and if necessary readjust the generator for correct frequency.
4. Move the probe along the scale and accurately locate the point of min. voltage.

The "reference point" scale reading minus this scale reading is the "minimum position shift." This distance, divided by the length of a wave in free space at this frequency is the min. shift in wave-lengths:

$$\theta = \frac{\text{M.S. distance}}{\lambda}$$

Note that the sign of  $\theta$  is the sign of the phase angle of the load impedance.

5. Note the voltmeter reading at the min. voltage point. Determine the ratio of  $\frac{\text{max. voltage}}{\text{min. voltage}}$ . This is

the standing-wave ratio, referred to as " $\rho$ ." (If the rectifier in the r-f voltmeter is non-linear, the ratio may be corrected as described previously.)

Having determined values of " $\theta$ " and " $\rho$ ," it is then necessary to use the Smith chart to determine the impedance and phase angle of the load.

On the Smith chart, the standing-wave ratio is represented by a circle with center at the center of the chart and passing through the resistance axis at that value of  $\rho$ .

Electrical angles along the transmission line are represented as the angle between the resistance axis and a vector drawn from the center of the chart to the circumference.

A point on the chart representing a complex impedance, is thus located by the intersection of a circle (standing-wave ratio, or  $\rho$ ) and a radius (electrical angle along line, or  $\theta$ ).

As an example:

$$\rho, \text{ the standing-wave ratio } \frac{\text{max. voltage}}{\text{min. voltage}} = 2.0$$

$$Z_0, \text{ the line impedance} = 50 \text{ ohms}$$

$$\theta, \text{ the min. shift} = 36^\circ$$

Draw a circle with  $R = 1.0$  as center and passing through  $R = 2.0$ .



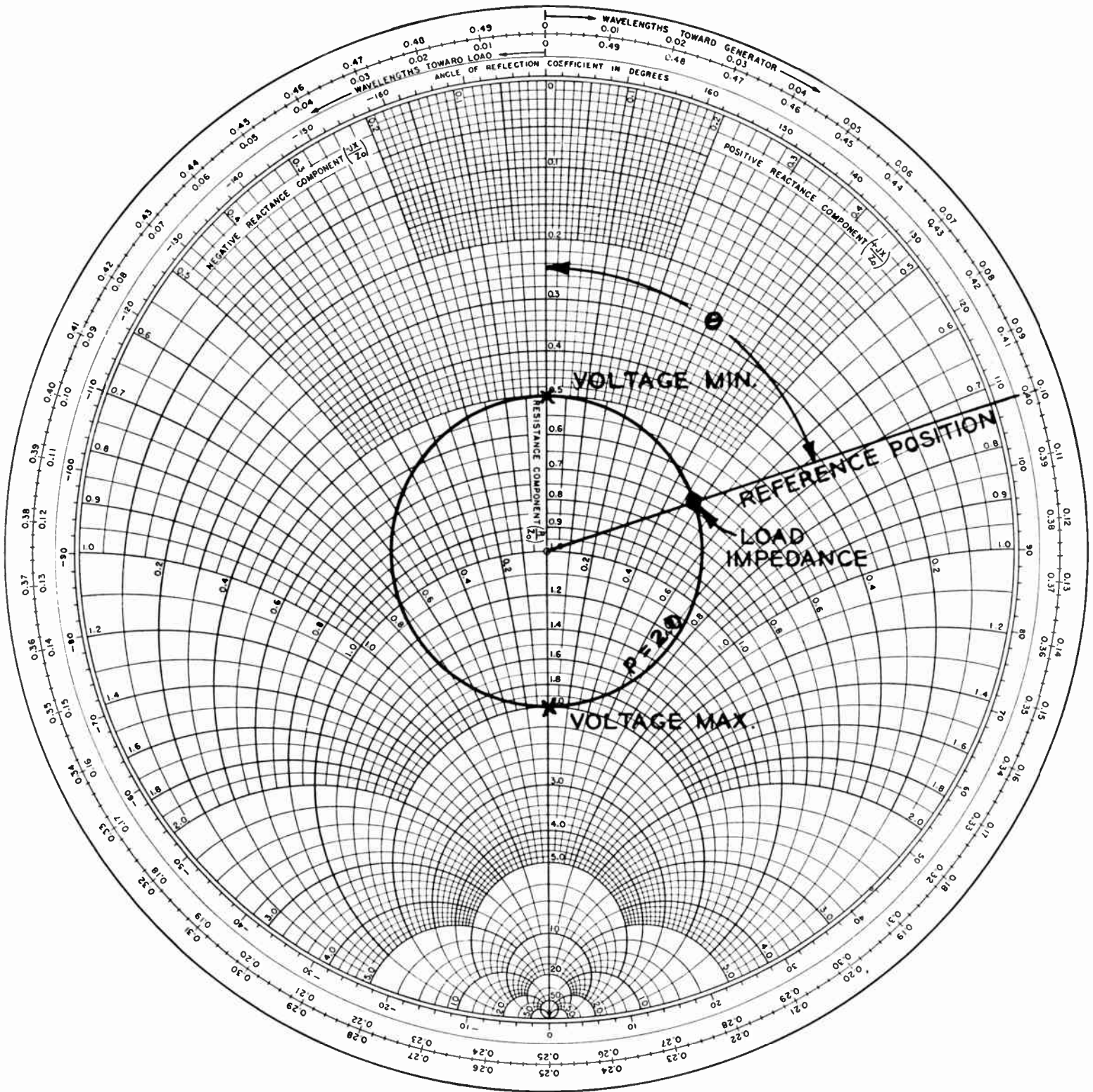

SMITH CHART PLOT FOR DETERMINING  $Z_L$

Since  $\theta$  is positive, a positive load impedance is indicated, and so a radius is drawn  $36^\circ$  around the circle from the R axis. Since  $36^\circ$  is 0.1 wavelength, the radius line is drawn from the center of the circle to intersect the 0.1 point on the outer scale. "Wavelengths toward Generator."

This is the reference point, equivalent to the end of the transmission line. Note that in the measurements, by going  $36^\circ$  from the reference point toward the load, a voltage minimum point was found.

This point is on the R axis, and is found on the chart by following the circle counter-clockwise to the R axis.

At the intersection of the  $\rho = 2.0$  circle and the radius for  $\theta = 36^\circ$  is read the load impedance

$$\frac{Z_L}{Z_0} = .68 + j.48$$

therefore, since  $Z_0 = 50$  ohms,

$$Z_L = 34 + j24 \text{ ohms}$$

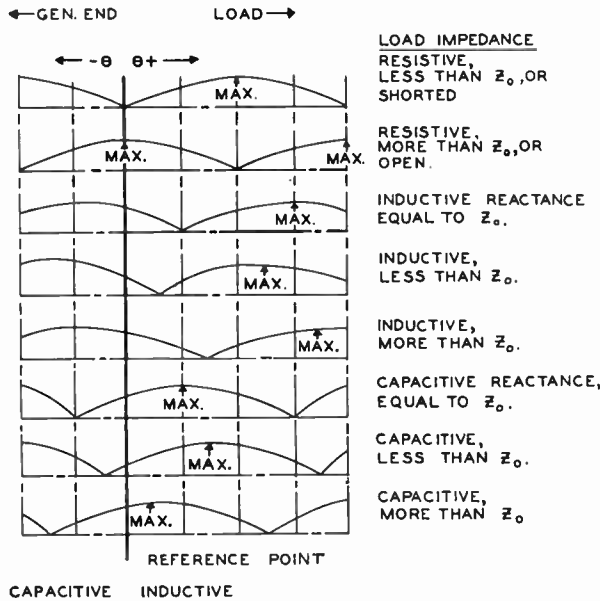
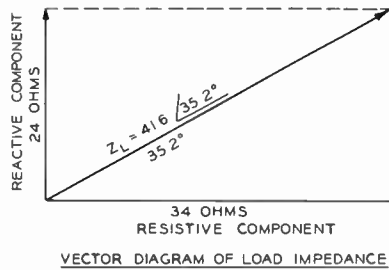

POSITION OF STANDING WAVES FOR VARIOUS LOADS

### Load Connected Directly at End of Slotted Line

In some applications, the load is connected directly to the end of the slotted line, without using a transmission line. In this case the question of using the minimum or maximum voltage point again depends on the required operating frequency and the length of the slotted line.

With relatively high frequencies, use the first procedure (in which a voltage minimum is used in determining  $\theta$ ).

With relatively low frequencies, use the point where the load is connected to the slotted line as the "reference point." Place the scale so the zero degree mark is at this reference point. The first minimum or maximum voltage point, from the reference point whichever can be measured, determines  $\theta$ .

### Note on Obtaining Maximum Voltage Point

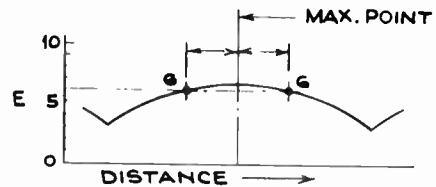

As an aid in obtaining accurate location of maximum voltage points, it is suggested that two voltage points of equal magnitude be selected, one on each side of the maximum point, then choose the distance half way between these two points as the maximum point. This same system may be used to determine the location of *minimum* voltage points.

## CAVITY RESONATORS

Cavity resonators are tuned resonant circuits for extremely high frequencies where it becomes impossible or impractical to use tuned lines or lumped circuits.

No unique definition of L, C and R can be found in a cavity resonator. A cavity resonator is similar to a wave guide in that electro-magnetic lines of force oscillate back and forth within the cavity in some particular mode, depending upon the shape and method of excitation of the cavity.

UHF cavity resonators may be compared to conventional acoustic resonators. An example is the boomy sound in a room with smooth hard surfaces (good acoustic reflectors). Sound from a source will be reflected from wall to wall with only slight absorption of energy at each reflection. If the frequency of the sound is such as to produce standing waves between two surfaces, or combination of surfaces, the sound is reinforced. The resonant frequency depends on the room dimensions. The "Q" depends on the reflectivity of the walls and other losses.

### Developing a Simple Resonant Cavity

$$L \text{ --- } C \approx \left[ \begin{array}{|c|} \hline L \\ \hline \end{array} \right] \text{ --- } \left[ \begin{array}{|c|} \hline C \\ \hline \end{array} \right] \text{ WHERE } f_r = \frac{1}{2\pi\sqrt{LC}}$$

If it is desired to increase the resonant frequency, we can parallel the inductances "L," thus making the equivalent "L" quite small. There are limits as to how small "C" may be made practically, so the only thing left to do is decrease the effective "L" of the circuit in order to tune to a higher frequency. See diagram at right.

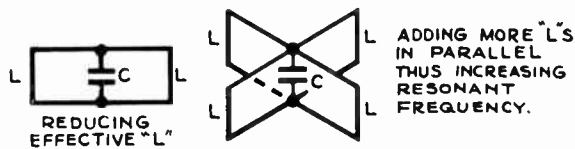

As shown at the right above, more and more inductive stubs may be added, thus decreasing the effective "L" and increasing the resonant frequency. If this is carried on to the extreme, a closed chamber or resonant cavity results. (Strictly speaking, it is not proper to talk of the inductance of a cavity resonator.)

### Modes of Operation of Cavity Resonators

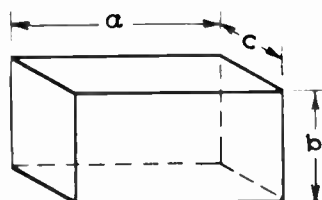

Consider a rectangular section. The description of the "Mode" would be given in terms of electro-magnetic fields and various frequencies. Various frequencies of oscillation (different modes) are possible, because wave energy may be propagated and reflected from various surfaces. There is also the possibility of an oscillation that is a harmonic of the basic wave. Two important points in cavity resonators are (1) how oscillations are forced and (2) how energy is removed. They will affect the mode of operation.

The r-f energy may be introduced to or removed from the resonant cavity, inductively, capacitively, or by radiation.

The energy is in the electrostatic field at one instant and in the magnetic field an instant later, oscillating from one field to the other at the frequency of the applied energy.

In referring to cavity resonators the idea that a conductor is always an "equipotential surface" is untrue; voltages and currents reverse themselves in a space measured in centimeters. An *electrostatic field* can terminate only on electrical charge, hence there must be appropriate distribution of charge on the surface. A *magnetic field* can cease suddenly only on a surface carrying current, hence there must be current flowing in the inside surface of the resonator (only penetrates a very thin skin of the metal surface and cannot be detected on the outside of the resonator).

A general statement, for simple resonators, can be made that it is necessary to have a dimension of an electrical half wave or multiples of a half wave since the electrostatic field is a maximum at the center and minimum at the sides of a simple resonator, otherwise the electrostatic field would be shorted out. (Refer to the data covering a section of wave guide used as a tuned circuit.)

### Resonant Frequency "Q" and "Ro"

The resonant frequency can be calculated from the shape of the cavity for very simple types of resonators possessing symmetry.

The "Q" can be determined through knowledge of the rate at which energy is lost. A large "Q" may be obtained when the ratio of volume to surface is large. Approximate values of "Q" may be 28,000, 31,000 and 26,000, for a cube, cylinder, and sphere, respectively, when not loaded.

High "Q" does not necessarily imply high shunt resistance ("Ro") in a resonant cavity.

### Forms of Actual Cavity Resonators

Cavity resonators may take various shapes such as, cube, sphere, cylinder, sphere dimpled on top and bottom, cylinder "dented" at one end (with ends forming grids as in an HF tube, for instance), etc.

Several possible types of cavity resonators are shown below. The electrostatic lines of force are shown for one possible mode of operation:

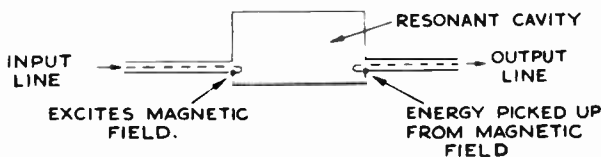
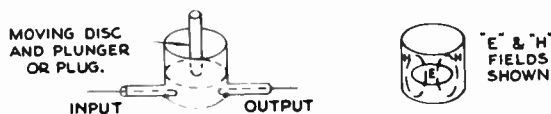
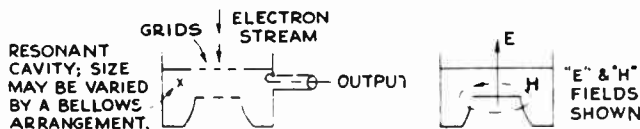
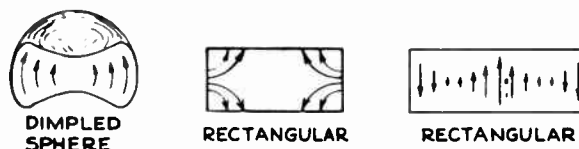
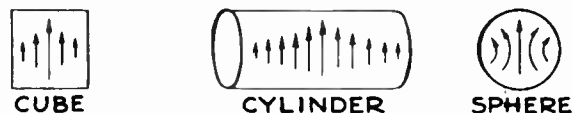

The cavity (box) cannot resonate if it is too small for the wavelength concerned. If the r-f energy is the correct frequency for the cavity, high amplitude centimeter waves (fields) will propagate across and from top to bottom of the cavity.

### Tuning Slugs for Cavity Resonators

For the purposes of explanation, a metal sphere is shown in a rectangular resonant cavity, with the "E" lines of force for this particular operation as shown below:

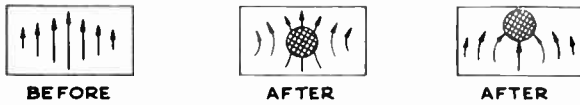

- (1) The slug shortens electrostatic (E) lines of force, hence the capacity is said to *increase*.
- (2) The magnetic (H) lines of force are normally weak at the center and are not appreciably affected.
- (3) The wavelength *increases* (frequency lower).

If the slug is inserted at one side or the other, the result is as follows:

- (1) The slug shortens the magnetic lines of force (H), hence the effective inductance is said to *decrease*.
- (2) The electrostatic lines of force (E) are normally weak at the side and are not appreciably affected.
- (3) The wavelength *decreases* (frequency higher).

Since the two positions of the slug, namely, in the maximum (E) field, and maximum (H) field, change the resonant frequency in opposite directions, it would be expected that a position where no change in wavelength would result might be found.

### WAVE GUIDES

A wave guide is a simple hollow metal tube having no central conductor. The losses are relatively low, since they will be produced mainly by the "inner skin" of the tube (which is of large perimeter and hence gives low loss). The *inner surface* should be clean and smooth. The *outer surface* can be grounded at any point since the r-f penetrates only a thin skin of the inner surface. All bends and twists are arranged to prevent a change in "mode" of propagation, or reflections. Instead of a hollow metal guide, a *solid dielectric* may be used as a wave guide. The action in this case is comparable to light waves traveling inside a *lucite rod*. In general, the loss in a solid dielectric wave guide is greater than in a hollow wave guide.

A wave guide cannot be conveniently treated like an ordinary transmission line. Wave guides must be approached from the viewpoint of an electro-magnetic wave in a dielectric, using the same basis of treatment as that of radiation.

Wave guides may be rectangular, round, or oval. At the present time, rectangular wave guides are most simple and common; this discussion will refer to rectangular wave guides for the most part, but much of this information can be extended to guides of other shapes.

The following development of a simple type wave guide is intended to serve as a means of bridging the gap between transmission lines and wave guides, although they operate on different principles.

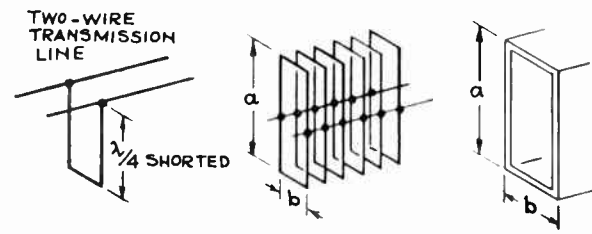

Above at left is shown a section of two wire transmission line. A quarter-wave resonant stub has been added across the line. The ends of the stub where connected to the transmission line, will represent a high impedance—many times higher than the impedance of any practical two wire transmission line. As a result the stub will have a negligible effect.

Suppose an infinite number of quarter-wave shorted stubs are added, resulting in a continuous pipe of rectangular cross section, or one type of wave guide. See illustration above.

"a"—Has a minimum dimension of half a wavelength (in order to propagate a signal) but it may be greater. The "cut-off" frequency depends on dimension "a."

"b"—Is not critical except for voltage breakdown or the possibility of operation in a wrong "mode."

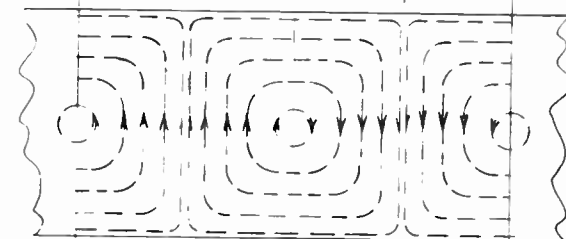
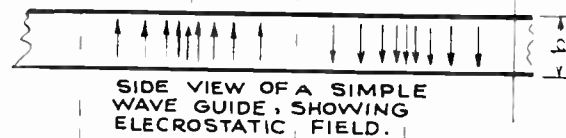
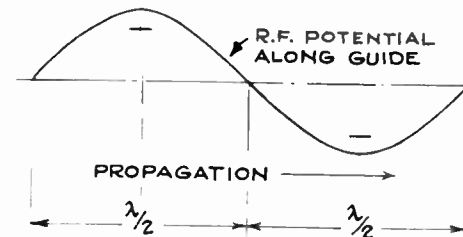
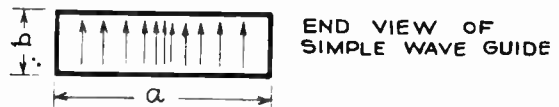
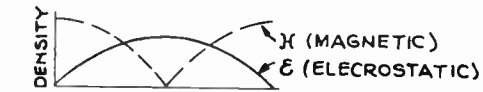

TOP VIEW OF A SIMPLE WAVE GUIDE, SHOWING MAGNETIC FIELD.  
WAVE-GUIDE FIELDS

For a simple rectangular wave-guide, the electrostatic lines of force and density of distribution of the E & H fields are shown in the illustration. The electro-magnetic lines of force may be thought of as "whirlpools" in a plane, perpendicular to the electrostatic lines of force, traveling down the tube in the direction of propagation. A rectangular wave guide will transmit satisfactorily if the component of the electric field tangent to the side surface is zero at every point on the surface.

A two-wire and a co-axial transmission line are shown with the magnetic and electrostatic fields indicated. A transmission line may be thought of as a guide for magnetic and electrostatic fields.

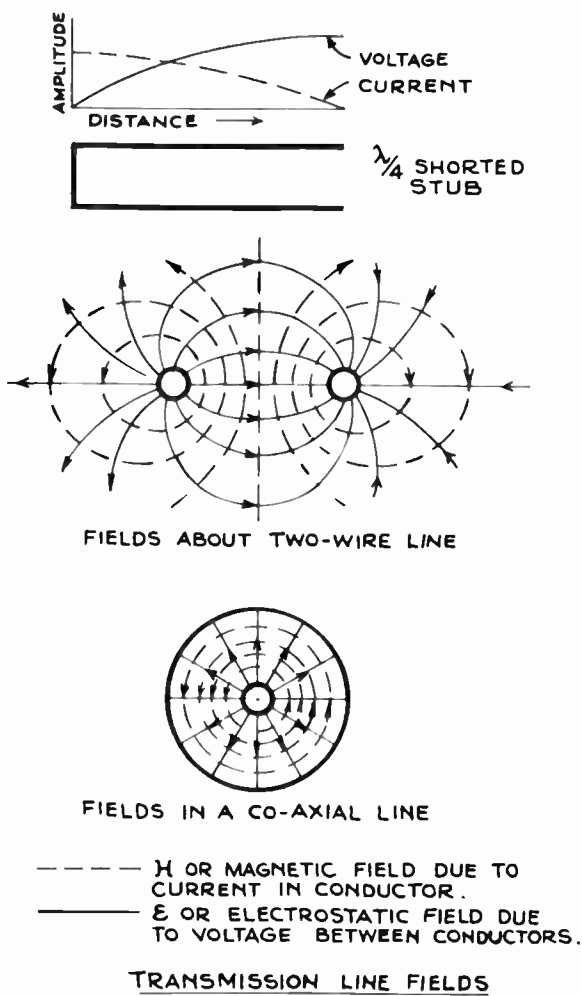

### Types of Propagation

"*TM*" propagation refers to *transverse-magnetic*, and is applied to the fact there is no magnetic field (H) in the direction of propagation down the tube. The electric field (E) does have a longitudinal component in the direction of propagation. There are numerous modes of operation (or oscillation) depending upon the cross section of the hollow metal tube and how it is excited from the r-f source. Different modes of operation are identified by sub-numerals after the letters "TM."

"*TE*" propagation refers to *transverse-electrostatic*, and is applied to the fact that the magnetic (H) field is in the direction of propagation and the electric (E) field is transverse. There are numerous modes of operation; identified as mentioned in the paragraph above. It may be of interest to note that "*TE<sub>0</sub>*" mode has the lowest "cut off" frequency of any that can be transmitted through a given tube. The fields shown in this booklet are *TE<sub>0</sub>-1*.

### Transmission of R-F Energy in Wave Guides

Electro-magnetic fields may be propagated down a hollow metal tube provided:

1. The frequency is high enough.
2. The fields have certain definite distributions.

*Wave Guides* are essentially ultra-high frequency devices since the frequency must be high before a field can be transmitted (from a practical point of view) through a wave guide. A wave guide has a definite cut-off frequency, as determined by the cross section of the hollow tube, and will not operate at a frequency lower than the cut-off frequency. When the guide is half a wavelength in width (dimension "a") the wave reflects back and forth across the guide making no progress at all (hence cut-off frequency). It may be considered that the wavelength of the r-f energy must be short enough to fit into the cross-sectional dimensions of the wave guide.

*The velocity of propagation* (group velocity) of r-f energy in a wave guide is *slower* than the speed in air. This is due to the fact that the wave does not travel straight through the guide, but is reflected from wall to wall. The length of the path that the wave travels is longer than the actual length of the guide. This action is comparable to the reflection of radio waves by ionized layers above the earth as illustrated.

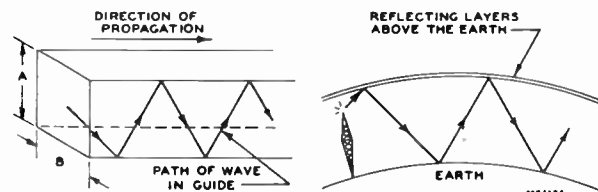

The group velocity is dependent on the frequency and the tube dimensions (dimension "a" in a rectangular guide). For a given size of rectangular guide, the group velocity—

- (1) Increases as the wavelength becomes shorter since there are fewer reflections from the wave-guide walls for a given amount of forward travel (see illustration "1") but is always less than the speed of light.
- (2) Decreases as the wavelength becomes longer (up to the cut-off frequency) since there are more reflections from the wave-guide walls for a given amount of forward travel (see illustration "2").

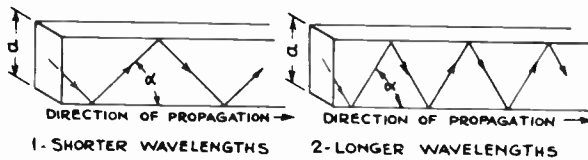

Phase Velocity (apparent speed) is greater than the speed of propagation; or the speed of travel in an unrestricted medium.

$$\text{Apparent speed} = \frac{\text{(true speed)}}{(\cos \alpha \text{ between wall and direction of travel.})}$$

Thus the apparent speed is greater since the waves are striking the wall at an angle.

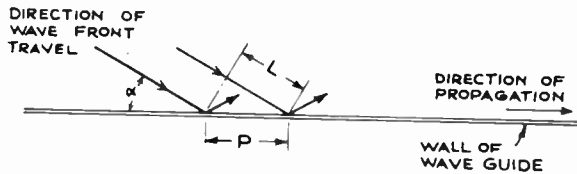

In the time required for the wave front to move the distance "L," the point of reflection has moved the greater distance "P." Thus the apparent speed (phase velocity) is greater than the true velocity of propagation.

The wavelength in a hollow wave guide (as measured on a slotted wave guide) is always greater than, or at the limit equal to, the wavelength in air.

The characteristic impedance is different for every mode of operation. In a round wave guide the lowest characteristic impedance is about 350 ohms. In a rectangular wave guide the characteristic impedance may be any value as both dimensions are varied. The impedance is directly proportional to the narrow dimension "b" and if the other dimension "a" and the frequency are fixed, the impedance may be any value between approximately 0 and 465 ohms. The impedance approaches zero as the narrow dimension "b" is reduced.

The "Q" of a wave guide is a function of frequency. It is also directly proportional to the ratio of volume to inside area of the guide. "Q" may be of the order of 25,000.

## WAVE GUIDE APPLICATION

### Wave Guide Coupling

Current flow through a waveguide is determined by the distribution of the magnetic and electric fields set up by the wave. For a certain distribution, the current circulates around the waveguide as shown. A narrow slit may be cut down the wide part of a waveguide and not cause attenuation or reflections. This is due to the fact that the potential across the slot is zero. For the same reason, a slot may be cut on the narrow side perpendicular to the line of propagation. Another type of opening in the waveguide is the circular hole on the narrow side such as is used to couple energy from the waveguide. Across this type of opening there is a potential difference causing energy to be propagated.

### Slotted Section

Energy can be removed from or coupled into a waveguide by inserting a probe in a slotted section of waveguide. In general, the energy coupled out of or into the line depends on the position of the probe along the line, the depth of the probe within the line, and the orientation of the probe with respect to the axis of the line. When this type of coupling is used for test purposes it can be seen that the probe is receptive to reflected energy within the line as to the direct energy being transmitted through the line. Obviously, this fact will complicate measurements and may result in incorrect data. Further, since it is difficult to re-establish the exact position of the probe it cannot be determined exactly whether variations in measurements are caused by changes in the r-f system itself or in the positioning of the probe.

### Test Antenna

For test purposes, another method of sampling transmitter energy that is being transmitted along a transmission line is the use of a test antenna located within the radiation pattern of the antenna load. The position and orientation of the test antenna must be fixed in such a way that it can be re-established at will. The initial position of the test antenna is influenced by the surrounding objects which through the reflection of energy, tends to add variables in any measurements obtained. Since it is difficult to obtain the same coupling conditions each time comparative data is taken, the test antenna method of transmission measurement is limited in accuracy.

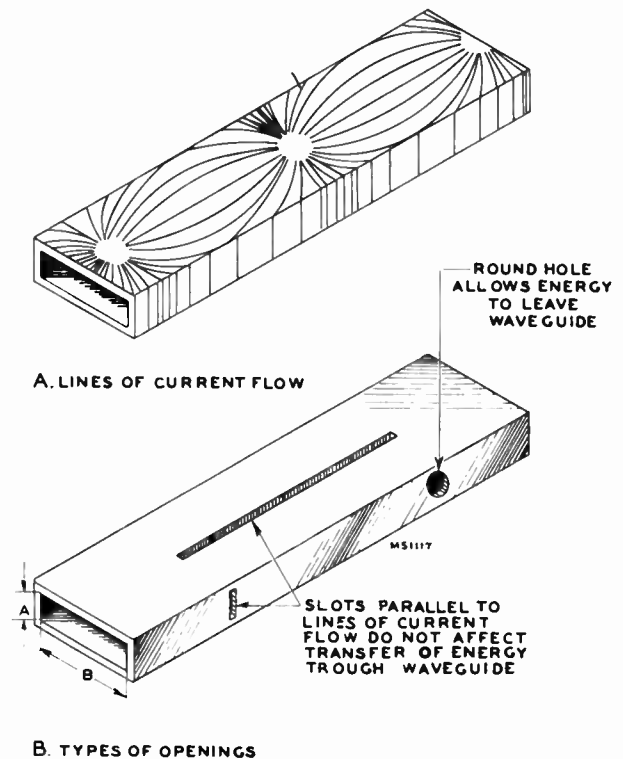

EFFECT OF OPENINGS IN WAVEGUIDE

# APPENDIX "B"

**DIPLEXER AND SIDEBAND FILTERS POWER RATINGS**..... D-97

**VHF ANTENNA DATA**..... D-98

**SPECIFICATIONS**

TF-3C Tower Mounted Superturnstile Antenna..... D-99

TF-3C Pedestal Mounted Superturnstile Antenna..... D-100

TF-3D Tower Mounted Superturnstile Antenna..... D-101

TF-3D Pedestal Mounted Superturnstile Antenna..... D-102

TF-5A1 Tower Mounted Superturnstile Antenna..... D-103

TF-6AL Tower Mounted Superturnstile Antenna..... D-104

TF-6BM Tower Mounted Superturnstile Antenna..... D-105

TF-6BH Tower Mounted Superturnstile Antenna..... D-106

TF-12AL Tower Mounted Superturnstile Antenna..... D-107

TF-12AM Tower Mounted Superturnstile Antenna..... D-108

TF-12AH Tower Mounted Superturnstile Antenna..... D-109

TF-12AH Pedestal Mounted Superturnstile Antenna..... D-110

TF-12BH Tower Mounted Superturnstile Antenna..... D-111

TF-12BH Pedestal Mounted Superturnstile Antenna..... D-112

**BEAM TILTING AND VERTICAL PATTERN SHAPING**..... D-113

**UHF ANTENNA DATA**..... D-114

**ENGINEERING DATA FOR UHF ANTENNAS**..... D-115

**FILING DATA FOR UHF DIRECTIONAL ANTENNAS**..... D-116

**SAMPLE PATTERN AND COMPUTATION (CARDIOID)**..... D-118

**SAMPLE PATTERN AND COMPUTATION (BI-DIRECTIONAL)**..... D-120

**TRANSMISSION LINE EFFICIENCY**..... D-122

# Diplexer and Sideband Filters Power Ratings

## VHF VESTIGIAL SIDEBAND FILTER POWER RATINGS

MI Number	TV Power Rating		Remarks
	KW	DBK	
***19104	5.0*	6.99	Floor Mounting
19114	5.0	6.99	Ceiling Mounting
19085	25.0	13.98	Ceiling Mounting
**27315	50.0	16.99	Floor Mounting

\* Rating is increased to 25 KW (13.98 DBK) by addition of MI-19158/19159 Conversion Kit.  
 \*\* Sideband Filter losses are included in the Transmitter Visual Peak Power Rating.  
 \*\*\* MI-19104 discontinued. Rating included for equipment previously in use.

## VHF BRIDGE DIPLEXER POWER RATINGS AND EFFICIENCY

MI Number	TV Power Rating		Aural		Visual		Remarks
	KW	DBK	EFF	DB Loss	EFF	DB Loss	
*19021	25.0	13.98	99.0%	.043	99.0%	.043	Floor Mounting
*19022	5.0	6.99	99.0%	.043	99.0%	.043	Horizontal Surface
*19028	10.0	10.0	99.9%	.004	99.9%	.004	Ceiling Mounting
*19028-C	25.0	13.98	99.9%	.004	99.9%	.004	Ceiling Mounting
19390	10.0	10.0	99.9%	.004	99.9%	.004	Ceiling Mounting
19391	25.0	13.98	99.9%	.004	99.9%	.004	Ceiling Mounting
19394	50.0	16.99	99.9%	.004	99.9%	.004	Ceiling Mounting

\* These types discontinued. Ratings listed for equipment previously in use.

## VHF/UHF FILTERPLEXER POWER RATINGS AND EFFICIENCY

MI Number	TV Power Rating		EFF	Aural DB Loss	Visual	Remarks
	KW	DBK				
19179	25.0	13.98			Visual losses included in Transmitter Peak Power Rating	Constant Impedance combination VSBF and Notch Diplexer Single Line Feed to Antenna
			95%	.223		
27316	50.0	16.99			Visual losses included in Transmitter Peak Power Rating	Constant Impedance combination VSBF and Notch Diplexer Single Line Feed to Antenna
			95%	.223		
19086	10.0	10.0			Visual losses included in Transmitter Peak Power Rating	Constant Impedance combination VSBF and Notch Diplexer Single Line Feed to Antenna
			90%	.457		

Note 1: Filterplexers may be used with all RCA VHF Transmitters within power rating. Reduced visual Peak Power is required with the TT-500B, TT-2AL and TT-2AH.  
 Note 2: MI-19086 is included as a part of UHF Transmitters TTU-1B and TTU-10A.



# VHF Antenna Data

Type No.	Number of Sections	H <sub>1</sub>	H <sub>2</sub>	Channel	Db Gain	Power‡ Gain	**TV Power Rating KW	Dbk
TF-3C (Pedestal Mtg. TF-3CP)	3	25'	49'	2	4.62	2.9	24.6	13.9
		32'1"	56'1"	3	4.91	3.1	23.1	13.6
TF-3D (Pedestal Mtg. TF-3DP)	3	20'4"	40'	4	4.62	2.9	21.8	13.4
		28'4"	48'	5	4.91	3.1	19.8	13.0
				6	5.19	3.3	18.8	12.7
TF-4A* (Custom-Built)	4	27'10"	54'8"	4	6.02	4.0	21.8	13.4
				5	6.23	4.2	19.8	13.0
				6	6.44	4.4	18.8	12.7
TF-5B* (Custom-Built)	5	42'	83'	2	6.90	4.9	24.6	13.9
				3	7.08	5.1	23.1	13.6
TF-5A1	5	35'	68'9"	4	6.90	4.9	21.8	13.4
				5	7.24	5.3	19.8	13.0
				6	7.32	5.4	18.8	12.7
TF-6AL	6	50'6"	101'	2	7.71	5.9	50	17.0
				3	7.85	6.1	50	17.0
TF-6BM	6	42'	82'9"	4	7.78	6.0	50	17.0
				5	8.06	6.4	50	17.0
				6	8.13	6.5	50	17.0
TF-6AH	6	19'3"	37'3"	7	7.92	6.2	All Channels	
				8	7.99	6.3	35	15.4
				9	8.26	6.7		
				10	8.26	6.7		
				11	8.33	6.8		
				12	8.33	6.8		
				13	8.39	6.9		
TF-6A1 (Pedestal Mtg. TF-6A1P)	6	19'3"	37'3"	7	7.71	5.9	14.0	11.5
		26'7"	44'7"	8	7.78	6.0	14.0	11.5
(Discontinued—Superseded by TF-6AH)				9	8.06	6.4	14.0	11.5
				10	8.06	6.4	14.0	11.5
				11	8.13	6.5	14.0	11.5
				12	8.13	6.5	14.0	11.5
				13	8.20	6.6	14.0	11.5
TF-12AL†	12	121'11"	202'	2	10.57	11.4	50.0	17.0
				3	10.61	11.5		
TF-12AM†	12	100'10"	166'9"	4	10.72	11.8	All Channels	
				5	10.79	12.0	50.0	17.0
				6	10.83	12.1		
TF-12AH† (Pedestal Mtg. TF-12AH-P)	12	44'3½"	72'11"	7	10.61	11.5	All Channels	
				8	10.68	11.7	50.0	17.0
				9	10.83	12.1		
				10	10.93	12.4		
				11	10.83	12.1		
				12	10.72	11.8		
				13	10.68	11.7		

## General Notes

H<sub>1</sub>: Height of radiation center above top of tower.

H<sub>2</sub>: Overall height above top of tower (does not include any necessary obstruction lighting).

\* Four and Five Section Superturnstiles are fabricated on order. The Standard Line on 3, 6 and 12 Section Superturnstiles are recommended where feasible.

\*\* The power rating shown is the "TV Power" rating and represents the power at peak of Synch. of the visual carrier of the equipment input. With black level condition, the average visual power is 0.6 times the rating shown. To this is added the aural power of one half the value at peak of Synch. is assumed, giving a total average power of 1.1 times the "TV Power" rating indicated in the chart. Under conditions other than as assumed, the total average power must not be larger than the above value times 1.1, as otherwise the rating will be exceeded.

† The TF-12AL, TF-12AM and TF-12AH incorporate with provision for power splitting for null fill-in, and phasing for beam tilt.

‡ Gain Figures above are for 70/30 power division. For 50/50 power division Power gain is 4% higher and electrical center (H3) is reduced to the following heights: TF12AL—101'6", TF12AM—84'0", TF12AH—37'3", TF12AH-6—39'9".

# 3 Section Superturnstile Tower Mounted (Channels 2-3)

**ENGINEERING DATA FOR TF-3C TOWER MOUNTED (54-66 MC)  
SUPERTURNSTILE TELEVISION ANTENNA**

**MECHANICAL SPECIFICATIONS**

WEIGHT	5500#	H <sub>2</sub>	49°-0"
A	9°-0"	H <sub>3</sub>	25°-0"
B	44°-7"	J	5" O.D.
C	2'-8 1/2"	K	10 3/4" O.D.
D <sub>1</sub>	23°-9"	L	17°-0"
D <sub>2</sub>	12°-0"	M	10°-7"
H <sub>1</sub>	61°-0"		

SHIPPING LENGTHS: (17°-6") (23°-0") (24°-0")  
 SHIPPING WEIGHTS: ( 324# ) ( 774# ) (1266# )  
 TRANS. LINE CONN.: 16°-0" ABOVE TOWER TOP

**LOADING (NO ICE)**

	50/30 psf	30/20 psf	(MAX. LOAD. 60/35)
R <sub>1</sub>	2265	1510	
R <sub>2</sub>	4483	2960	
R <sub>3</sub>	6748	4470	
R <sub>1</sub> x D <sub>1</sub>	53800 ft.#	35000 ft.#	

SUGGESTED BASE STABILITY: 2°

**DESIGN ASSUMPTIONS**

WIND VELOCITY: MAX. WIND VELOCITY (1" RAD. ICE) 85 mph  
 MAX. WIND VELOCITY (NO ICE) 110 mph  
 WIND VELOCITIES ARE TRUE, NOT INDICATED

DESIGN STRESSES: A. I. S. C. 20,000 psi (IN BENDING)

**ELECTRICAL SPECIFICATIONS**

CIRCULARITY: ± 2 DB  
 INPUT IMPEDANCE: TO MATCH 51.5 OHM MI-19112 LINES OVER DESIGNATED CHANNEL WITH TRANS. LINE CONN. SHOWN BELOW (V.S.W.R. 1.1 OR BETTER)

**GAIN (AT VISUAL CARRIER) & POWER RATING**

CHANNEL	2	3
GAIN	2.0	3.1
POWER RATING	24.6	23.1

**ACCESSORIES**

SLEET MELTERS: 3 OF MI-19009-B-1 POWER REQUIRED: 9 KW, 230 VOLTS 3φ, OR 460 VOLTS 1φ OR 3φ

**TRANSMISSION LINE CONNECTIONS**

TYPE NO.	LINES	DIPLEXER	DWG. AND TYPE
TF-3C	TWO-1 5/8	BRIDGE	B-464591-A

GUIDE FLANGE DWG: 445695-1  
 POLE SOCKET DWG: 445694-1

# 3 Section Supertturnstile Pedestal Mounted (Channels 2 and 3)

**ENGINEERING DATA FOR TF-3C PEDESTAL MOUNTED (54-66 MC)  
SUPERTURNSTILE TELEVISION ANTENNA**

**MECHANICAL SPECIFICATIONS**

WEIGHT	5391#	H <sub>3</sub>	32'-1 1/2"
A	9'-0"	J	5" O.D.
B	44'-7"	K	10 3/4" O.D.
C	9'-10"	L	17'-0"
D <sub>1</sub>	28'-3"	M	10'-7"
H <sub>2</sub>	56'-1 1/2"		

SHIPPING LENGTHS: (17'-6") (23'-0") (19'-1 1/2")  
 SHIPPING WEIGHTS: (324#) (774#) (1040#)  
 TRANS. LINE CONN.: 23'-1 1/2" ABOVE TOWER TOP

LOADING (NO ICE)

	50/30 psf	30/20 psf	(MAX. LOAD. 50/30)
R <sub>1</sub>	2550	1700	
R <sub>1</sub> × D <sub>1</sub>	72165 ft.#	48100 ft.#	

SUGGESTED BASE STABILITY: 2°

DESIGN ASSUMPTIONS

WIND VELOCITY: MAX. WIND VELOCITY (1" RAD. ICE) 85 mph  
 MAX. WIND VELOCITY (NO ICE) 110 mph  
 WIND VELOCITIES ARE TRUE, NOT INDICATED

DESIGN STRESSES: A.I.S.C. 20,000 psi (IN BENDING)

**ELECTRICAL SPECIFICATIONS**

CIRCULARITY: ± 2 DB  
 INPUT IMPEDANCE: TO MATCH 51.5 OHM-MI-19112 LINES OVER DESIGNATED CHANNEL WITH TRANS. LINE CONN. SHOWN BELOW (V.S.W.R. 1.1 OR BETTER)

**GAIN (AT VISUAL CARRIER) & POWER RATING**

CHANNEL	2	3
GAIN	2.9	3.1
POWER GAIN	24.6	23.1

**ACCESSORIES**

SLEET MELTERS: 3 OF MI-19009-B-1 POWER REQUIRED: 9 KW, 230 VOLTS 3Ø, OR 460 VOLTS 1Ø OR 3Ø

TRANSMISSION LINE CONNECTIONS

TYPE NO.	LINES	DIPLEXER	DWG. AND TYPE
TF-3C	TWO-1 5/8	BPIDGE	B-464591-A

PEDESTAL DWG: 728294-1

# 3 Section Superturnstile Tower Mounted (Channels 4, 5 and 6)

ENGINEERING DATA FOR TF-3D TOWER MOUNTED (66-88 MC)  
SUPERTURNSTILE TELEVISION ANTENNA

MECHANICAL SPECIFICATIONS

WEIGHT	3500#	H <sub>2</sub>	40'-0"
A	6'-11"	H <sub>3</sub>	20'-4"
B	36'-10"	J	5" O.D.
C	1'-11"	K	B 5/8" O.D.
D <sub>1</sub>	19'-8"	L	14'-1"
D <sub>2</sub>	10'-0"	M	8'-8"
H <sub>1</sub>	50'-0"		

SHIPPING LENGTHS: (21'-6") (30'-0")  
SHIPPING WEIGHTS: (386#) (1138#)  
TRANS. LINE CONN.: 10'-5" ABOVE TOWER TOP

LOADING (NO ICE)  
50/30 psf 30/20 psf (MAX. LOAD. 60/35)

R <sub>1</sub>	1680	1120
R <sub>2</sub>	3309	2206
R <sub>3</sub>	4989	3326

R<sub>1</sub> x D<sub>1</sub> 33000 ft.# 22000 ft.#  
SUGGESTED BASE STABILITY: 2°

DESIGN ASSUMPTIONS  
WIND VELOCITY: MAX. WIND VELOCITY (1° RAD. ICE) 85 mph  
MAX. WIND VELOCITY (NO ICE) 110 mph  
WIND VELOCITIES ARE TRUE, NOT INDICATED  
DESIGN STRESSES: A.I.S.C. 20000 psi (IN BENDING)

ELECTRICAL SPECIFICATIONS

CIRCULARITY: ± 2 DB  
INPUT IMPEDANCE: TO MATCH 51.5 OHM MI-19112 LINES  
OVER DESIGNATED CHANNEL WITH TRANS.  
LINE CONN. SHOWN BELOW.  
(V.S.W.R. 1.1 OR BETTER)

GAIN (AT VISUAL CARRIER) & POWER RATING

CHANNEL	4	5	6
GAIN	2.9	3.1	3.3
POWER RATING	21.8	19.8	18.8

ACCESSORIES

SLEET MELTERS: 3 OF MI-19009-C-1 POWER REQUIRED: 6 KW.  
230 VOLTS 1Ø OR 3Ø, OR 460 VOLTS  
1Ø OR 3Ø

TRANSMISSION LINE CONNECTIONS

TYPE NO.	LINES	DIPLEXER	DWG. AND TYPE
TF-3D	TWO-1 5/8	BRIDGE	E-464591-A

GUIDE FLANGE DWG: 445695-2  
POLE SOCKET DWG: 445694-2

# 3 Section Superturnstile Pedestal Mounted (Channels 4, 5 and 6)

PEDESTAL DWG: 728293-1

**ENGINEERING DATA FOR TF-3D PEDESTAL MOUNTED  
(66-88 MC) SUPERTURNSTILE TELEVISION ANTENNA**

**MECHANICAL SPECIFICATIONS**

WEIGHT	3985#	H <sub>3</sub>	28"-4"
A	6'-11"	J	5" O.D.
B	36"-10"	K	8 5/8" O.D.
C	9"-11"	L	14"-1"
D <sub>1</sub>	25"-0"	M	8"-8"
H <sub>2</sub>	48"-0"		

SHIPPING LENGTHS: (21'-6") (28'-0")  
 SHIPPING WEIGHTS: ( 386# ) (1093# )  
 TRANS. LINE CONN.: 18'-5" ABOVE TOWER TOP

LOADING (NO ICE)

30/20 psf (MAX. LOAD. 40/25)

R<sub>1</sub> 1276  
 R<sub>1</sub> x D<sub>1</sub> 31900 ft.#

SUGGESTED BASE STABILITY: 2°

**DESIGN ASSUMPTIONS**

WIND VELOCITY: MAX. WIND VELOCITY (1" RAD. ICE) 85 mph  
 MAX. WIND VELOCITY (NO ICE) 110 mph  
 WIND VELOCITIES ARE TRUE, NOT INDICATED

DESIGN STRESSES: A.I.S.C. 20,000 psi (IN BENDING)

**ELECTRICAL SPECIFICATIONS**

CIRCULARITY: ± 2 DB  
 INPUT IMPEDANCE: TO MATCH 51.5 OHM MI-19112 LINES OVER DESIGNATED CHANNEL WITH TRANS. LINE CONN. SHOWN BELOW (V.S.W.R. 1.1 OR BETTER)

**GAIN (AT VISUAL CARRIER) & POWER RATING -**

CHANNEL	4	5	6
GAIN	2.9	3.1	3.3
POWER RATING	21.8	19.8	18.8

**ACCESSORIES**

SLEET MELTERS: 3 OF MI-19009-C-1. POWER REQUIRED: 6 KW.  
 230 VOLTS 1Ø OR 3Ø, OR 460 VOLTS 1Ø OR 3Ø

**TRANSMISSION LINE CONNECTIONS**

TYPE NO	LINES	DIPLEXER	DWG. AND TYPE
TF-3D	TWO-1 5/8	BRIDGE	B-464591-A

# 5 Section Superturnstile Tower Mounted (Channels 4, 5 and 6)

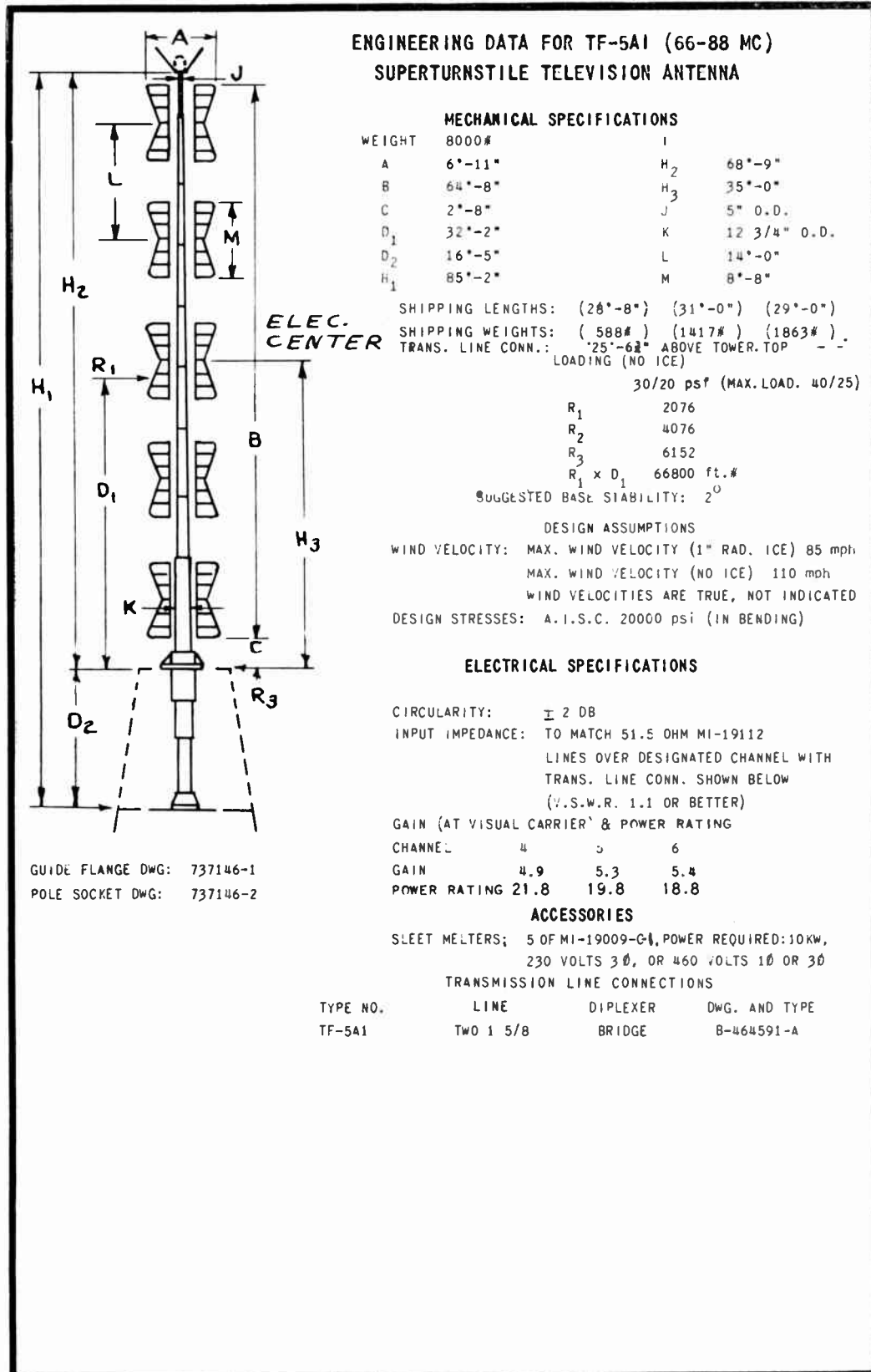

# 6 Section Superturnstile Tower Mounted (Channels 2 and 3)

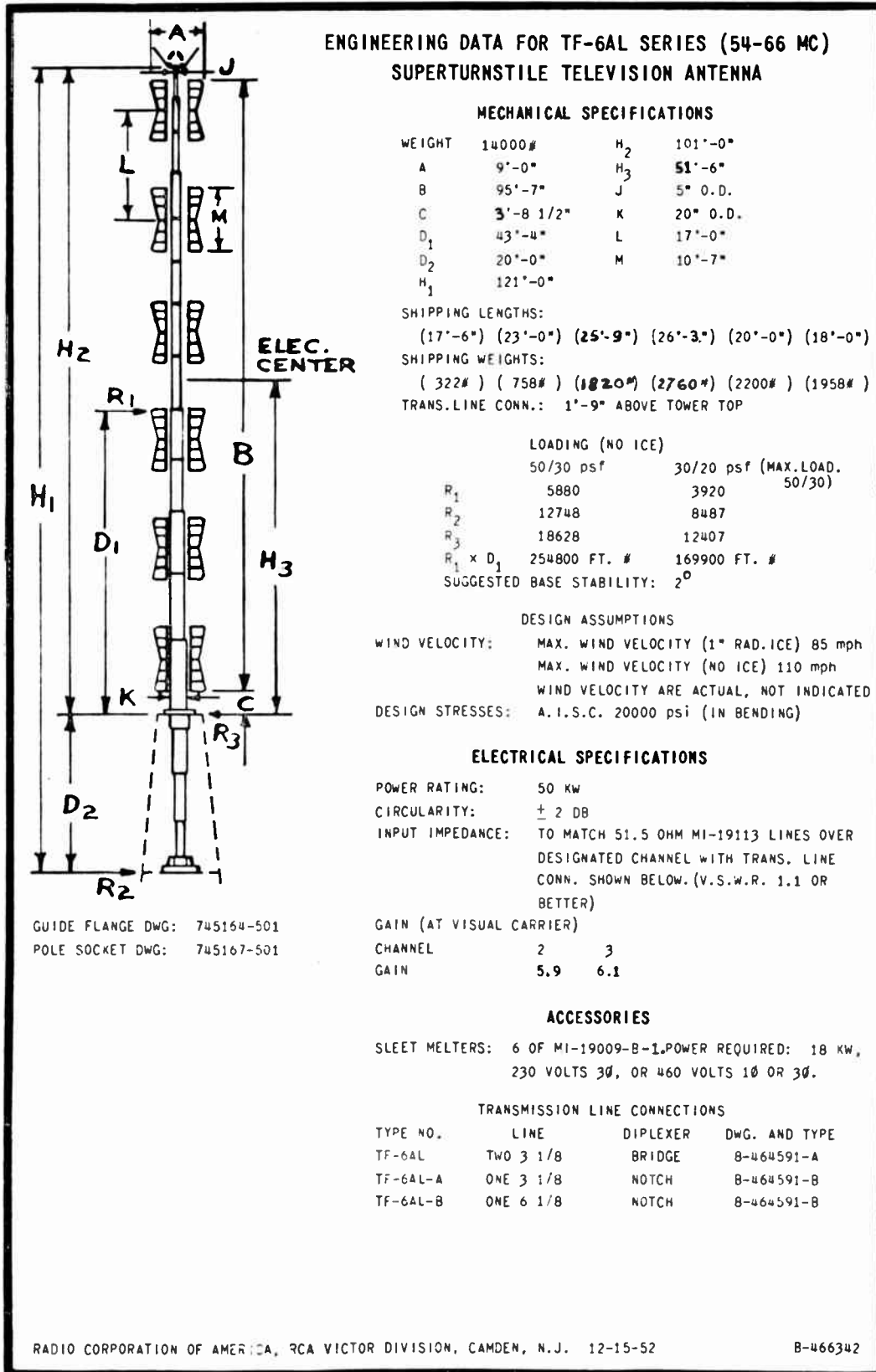

# 6 Section Superturnstile Tower Mounted (Channels 4, 5 and 6)

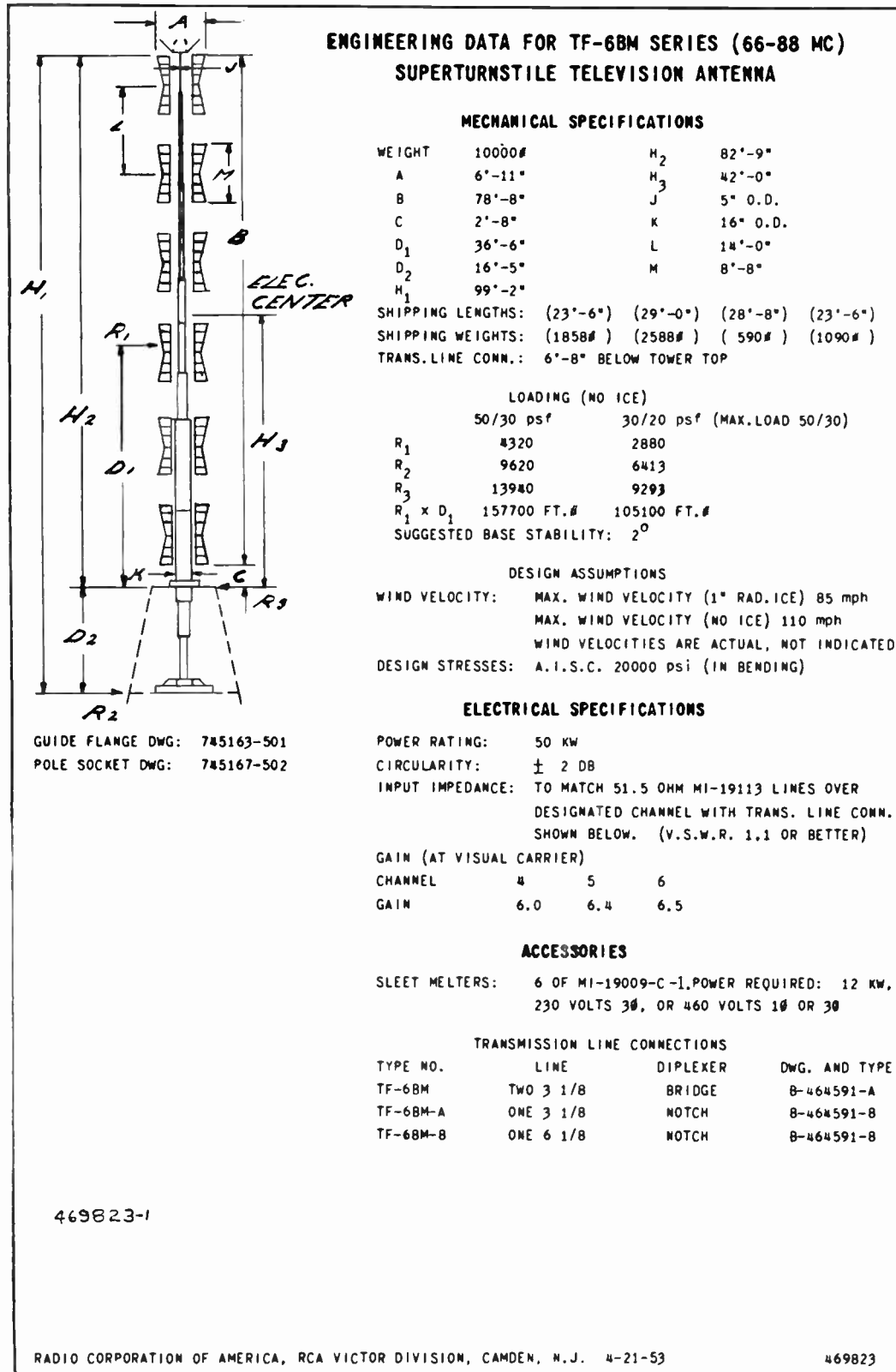



# 6 Section Superturnstile Tower Mounted (Channels 7 to 13)

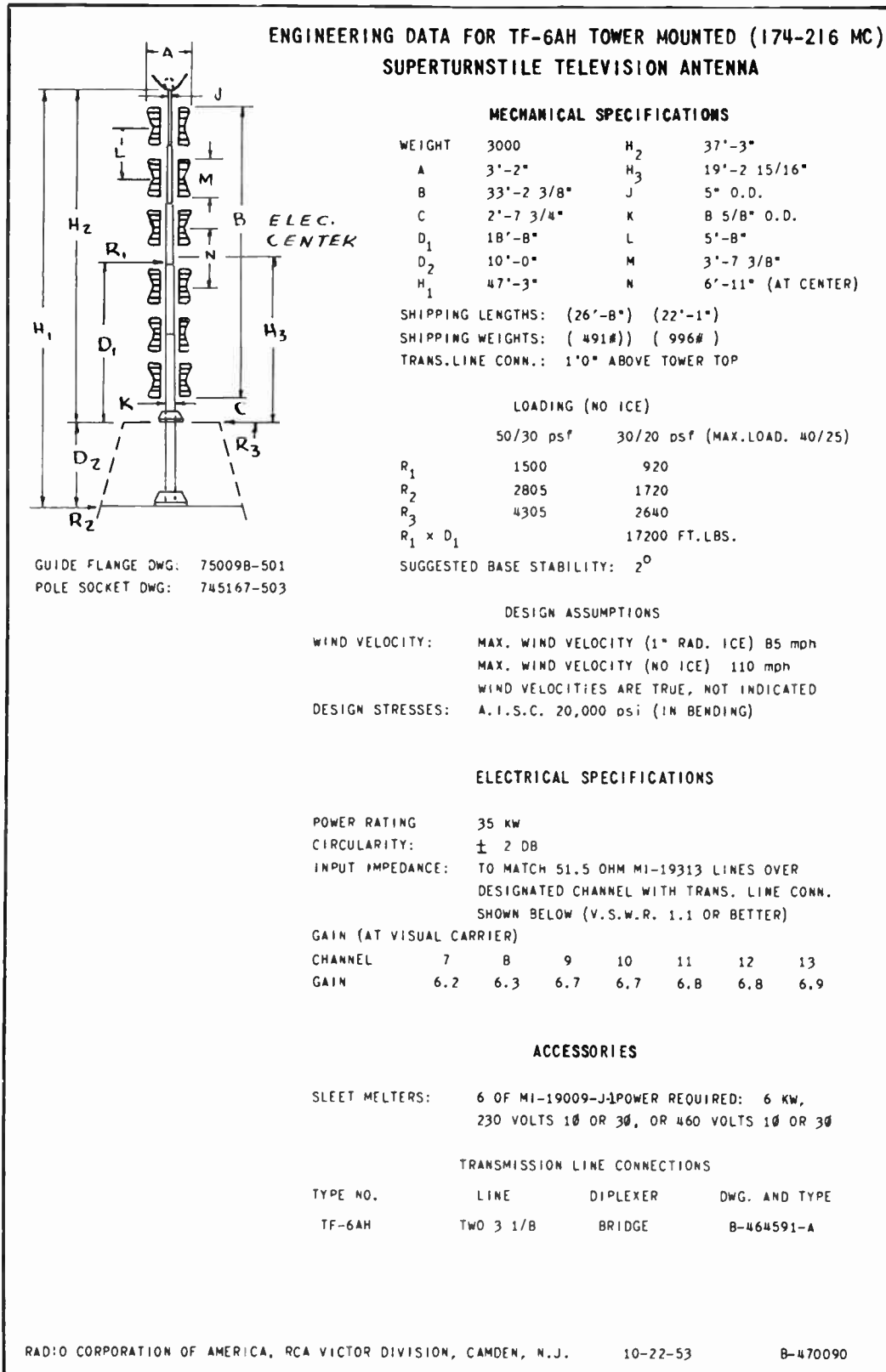

# 12 Section Superturnstile Tower Mounted (Channels 2 and 3)

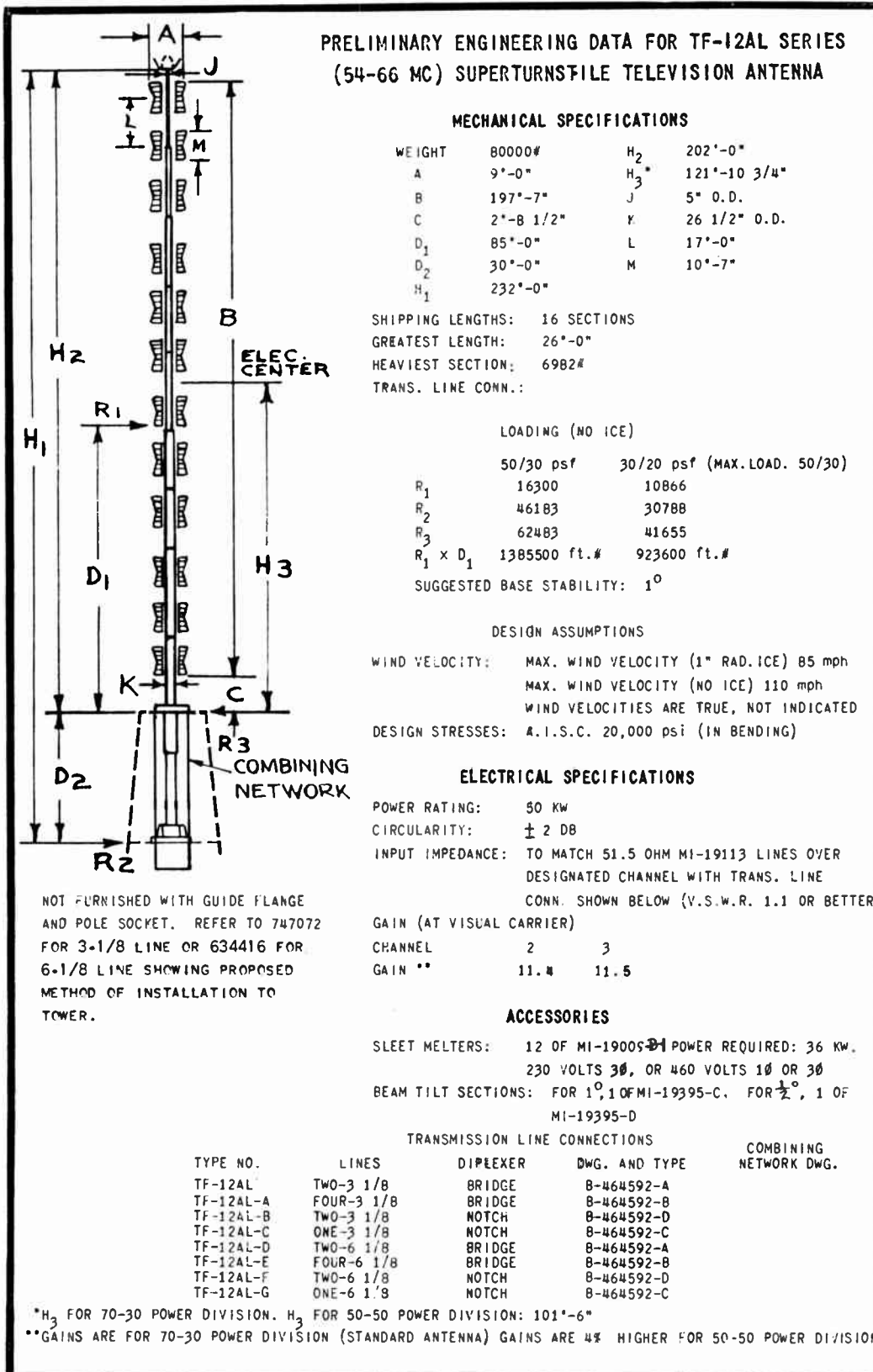

# 12 Section Superturnstile Tower Mounted (Channels 4, 5 and 6)

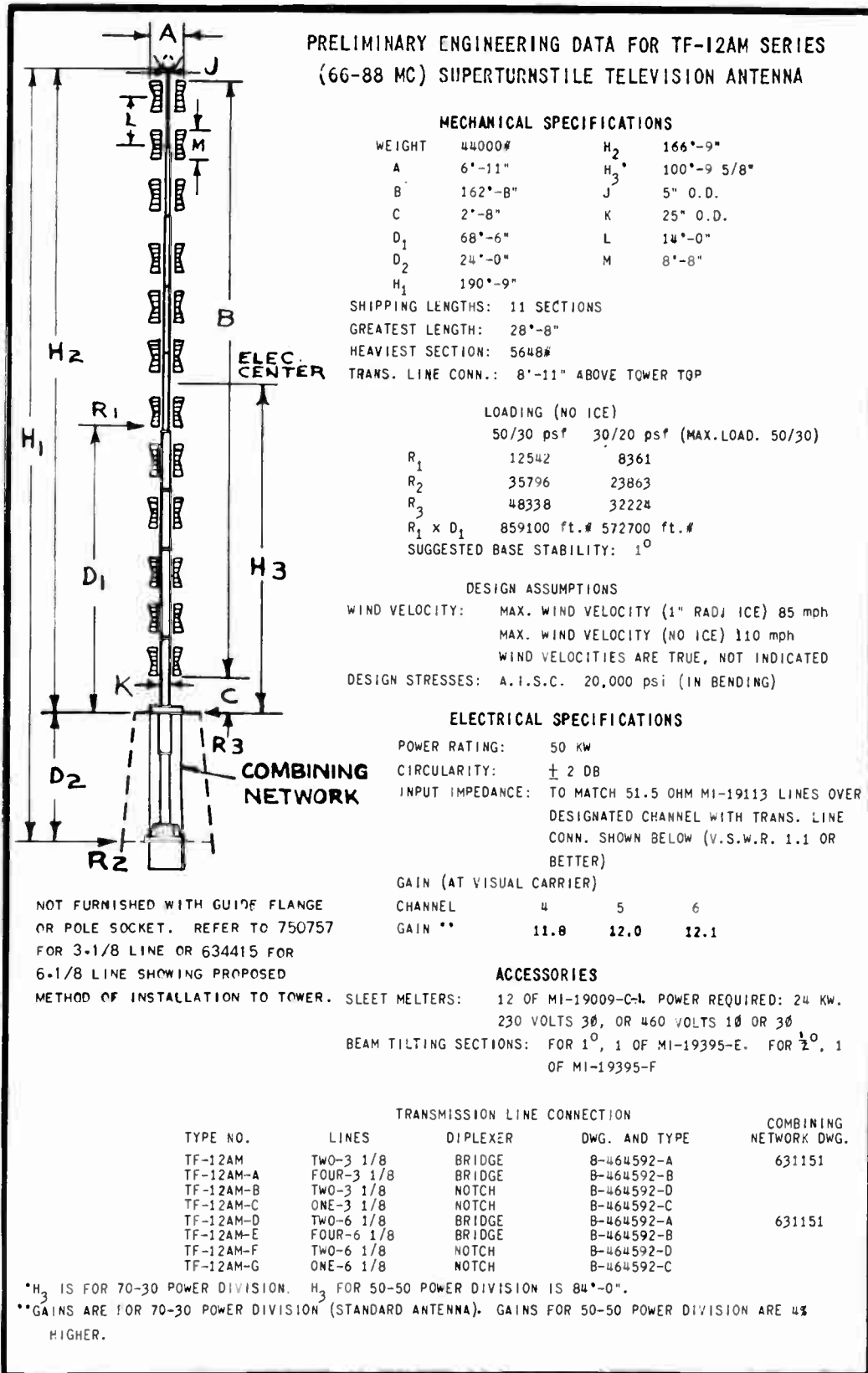

# 12 Section Supertturnstile Tower Mounted (Channels 7 to 13)

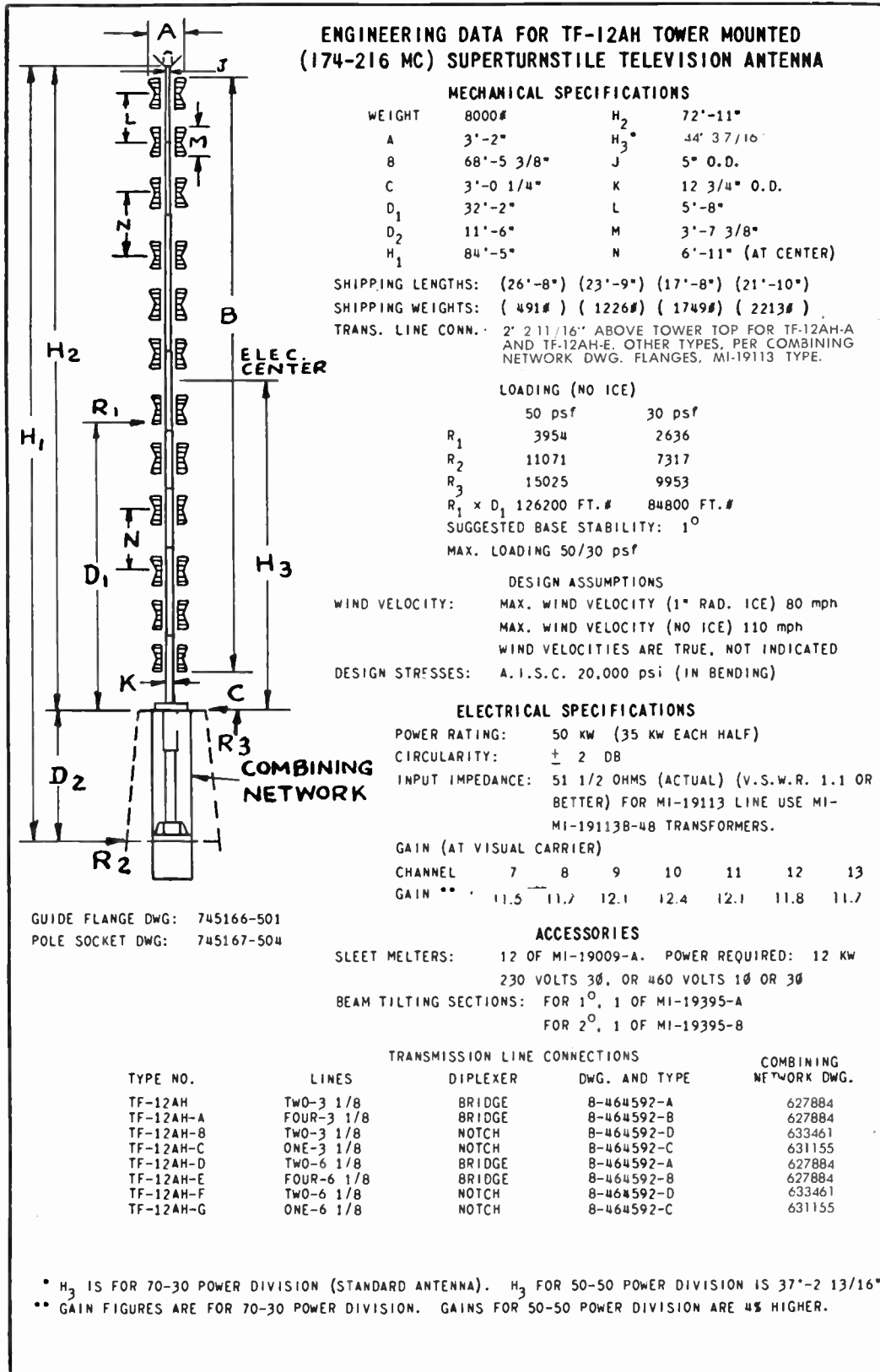

# 12 Section Superturnstile Pedestal Mounted (Channels 7 to 13)

**ENGINEERING DATA FOR TF-12AH-P PEDESTAL MOUNTED  
SERIES (174-216 MC) SUPERTURNSTILE TELEVISION ANTENNAS**

**MECHANICAL SPECIFICATIONS**

WEIGHT	7675#	H <sub>3</sub>	44'-3 1/8"
A	3'-2"	J	5" O.D.
B	68'-5 3/8"	K	12 3/4" O.D.
C	5'-5 7/8"	L	5'-8"
D <sub>1</sub>	38'-0"	M	3'-7 3/8"
H <sub>2</sub>	75'-4 5/8"	N	6'-11" (AT CENTER)

SHIPPING LENGTHS: (26'-8") (23'-9") (17'-8") (10'-9 5/8")  
 SHIPPING WEIGHTS: (491#) (1226#) (1749#) (1112#)  
 TRANS. LINE CONN... 4' 9 3/16" ABOVE TOWER TOP FOR TF-12AH-PA  
 AND TF-12AH-PE. OTHER TYPES PER COMBINING  
 NETWORK DWG. FLANGES, MI-19313 TYPE.

LOADING (NO ICE)  
 30/20 psf (MAX. LOAD.)\*\*

R<sub>1</sub> 2700  
 R<sub>1</sub> x D<sub>1</sub> 92800 ft. #

SUGGESTED BASE STABILITY: 1°

**DESIGN ASSUMPTIONS**

WIND VELOCITY: MAX. WIND VELOCITY (1" RAD. ICE) 80 mph  
 MAX. WIND VELOCITY (NO ICE) 110 mph  
 WIND VELOCITIES ARE TRUE, NOT INDICATED  
 DESIGN STRESSES: A.I.S.C. 20,000 psi (IN BENDING)

**ELECTRICAL SPECIFICATIONS**

POWER RATING: 50 KW (35 KW EACH HALF)  
 CIRCULARITY: ± 2 DB  
 INPUT IMPEDANCE: 51½ OHMS ACTUAL. (VSWR 1.1 OR  
 BETTER). † FOR MI-19113 LINE USE  
 MI-19113B-4B TRANSFORMERS.

GAIN (AT VISUAL CARRIER)

CHANNEL	7	8	9	10	11	12	13
GAIN ***	11.5	11.7	12.1	12.4	12.1	11.8	11.7

**ACCESSORIES**

SLEET MELTERS: 12 OF MI-19009-D-1. POWER REQUIRED: 12 KW.  
 230 VOLTS 3Ø, OR 460 VOLTS 1Ø OR 3Ø

BEAM TILTING SECTIONS: FOR 1°, 1 OF MI-19395-A.  
 FOR 2°, 1 OF MI-19395-B

TYPE NO.	LINES	TRANSMISSION LINE CONNECTION.		COMBINING NETWORK DWG.
		DIPLEXER	DWG. AND TYPE	
TF-12AH-P	TWO-3 1/8	BRIDGE	B-464592-A	627884
TF-12AH-PA	FOUR-3 1/8	BRIDGE	B-464592-B	627884
TF-12AH-PB	TWO-3 1/8	NOTCH	B-464592-D	
TF-12AH-PC	ONE-3 1/8	NOTCH	B-464592-C	
TF-12AH-PD	TWO-6 1/8	BRIDGE	B-464592-A	627884
TF-12AH-PE	FOUR 6 1/8	BRIDGE	B-464592-B	627884
TF-12AH-PF	TWO-6 1/8	NOTCH	B-464592-D	
TF-12AH-PG	ONE-6 1/8	NOTCH	B-464592-C	

PEDESTAL DWG: 463057-501

\* H<sub>3</sub> FOR 70-30 POWER DIVISION. H<sub>3</sub> FOR 50-50 POWER DIVISION IS 39'-8 9/16".  
 \*\* SUBJECT TO PEDESTAL DESIGN FOR HIGHER LOADING.  
 \*\*\* GAINS ARE FOR 70-30 POWER DIVISION (STANDARD ANTENNA). GAINS ARE 4S HIGHER FOR 50-50 POWER DIVISION.  
 FOR VERTICAL PATTERN DATA SEE B-466344

# 12 Section Superturnstile Tower Mounted (Channels 7 to 13)

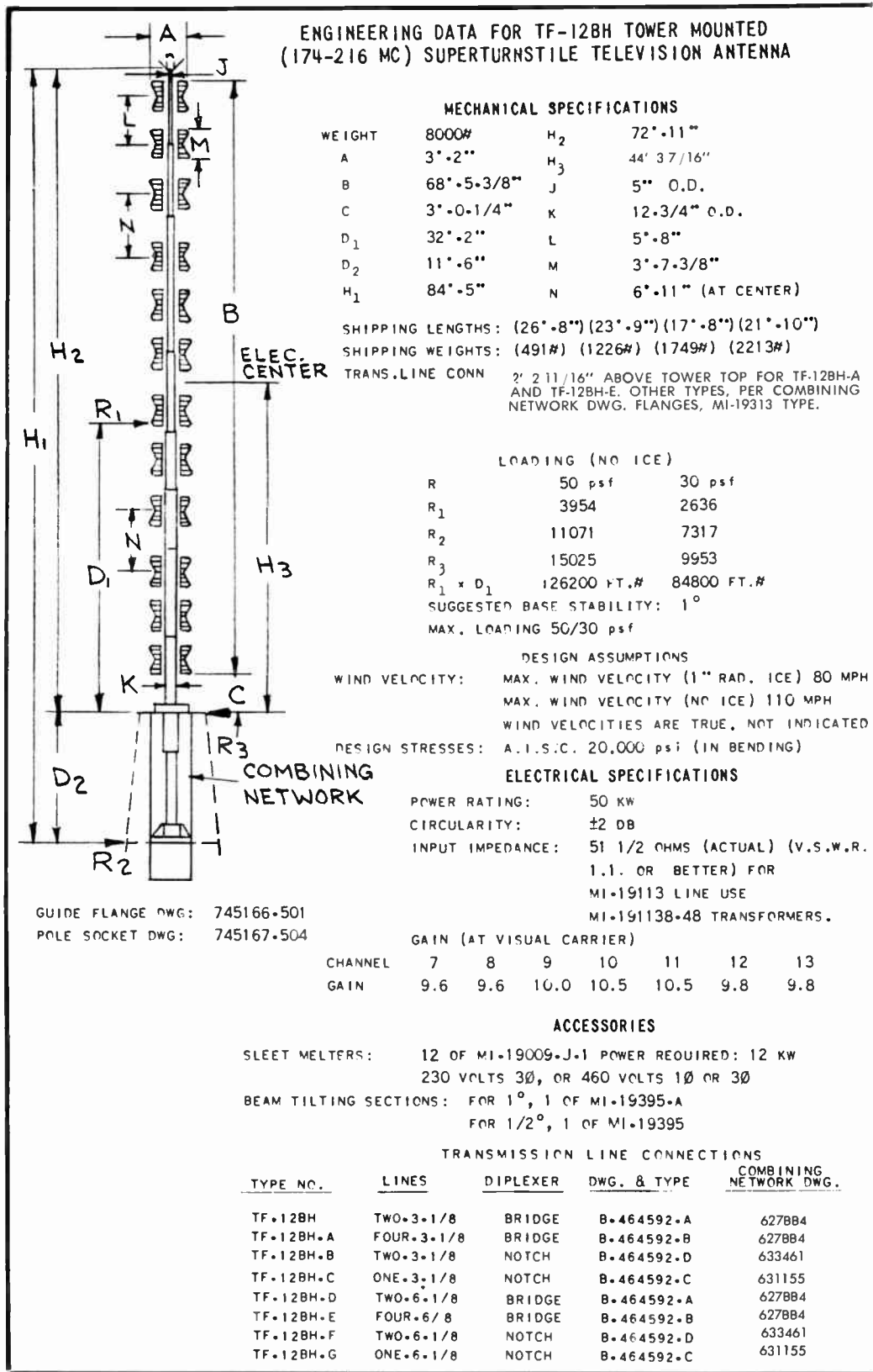

# 12 Section Supertturnstile Pedestal Mounted (Channels 7 to 13)

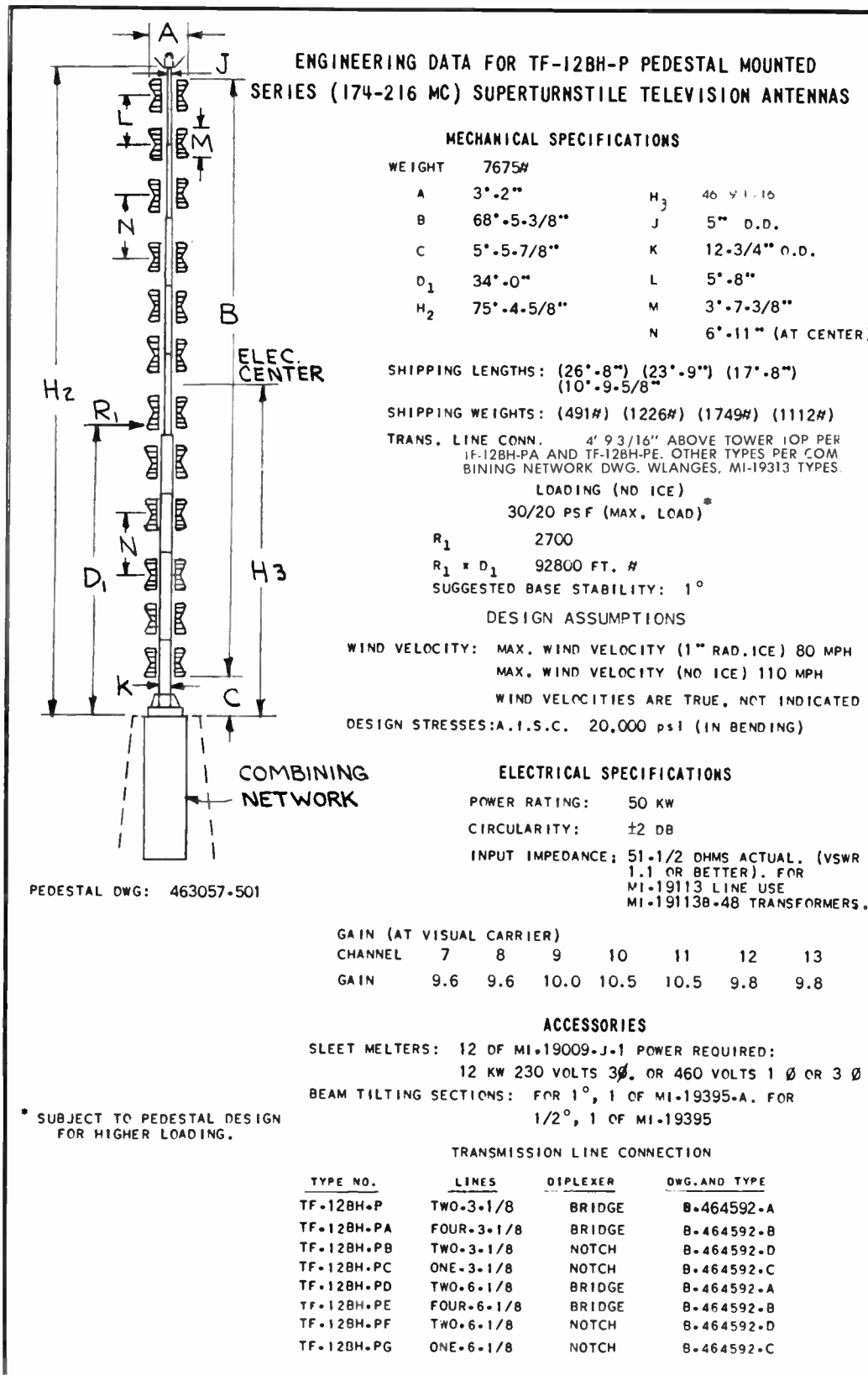

# Beam Tilting and Vertical Pattern Shaping

## VHF HIGH GAIN ANTENNAS

### PATTERN SHAPING FOR UNIFORM FIELD STRENGTH

RCA 12-section VHF antennas can be furnished to provide a substantially uniform service throughout the primary service area of the TV station. This assures effective "close-in" coverage and is accomplished by the use of optimum power ratios between upper and lower halves of the antenna.

Unless otherwise specified by the customer, 12-section VHF antennas will be supplied with a 70/30 ratio of power division between upper and lower sections which is a discreet choice which applies for the majority of applications.

### BEAM TILTING FOR SPECIAL CONDITIONS

The beam tilting feature, easily obtained with RCA 12-section Superturnstile antennas, provides greater field strength for selected portions of the primary service area. This is obtained by changing the phasing between the upper and lower halves of the antenna with the standard feed system.

## UHF HIGH GAIN ANTENNAS

The high gain RCA UHF antennas, those having a gain of 21 and over, incorporate a "built-in" vertical angle adjustment of beam tilt to provide tailored coverage for selected areas or different terrain.

### ADVANTAGES OF "UHF" BEAM TILTING

- Adjusts the antenna for optimum coverage.
- Easily adjusted atop tower without need of heavy equipment.
- Virtually no energy wasted in vertical radiation.

### ADVANTAGES OF HIGH GAIN ANTENNAS

1. Lower initial plant investment.
2. Lower plant operating cost.
3. Ground reflection nulls less severe.
4. Less close in blanketing important for high powers.



# Engineering Data for UHF Antennas

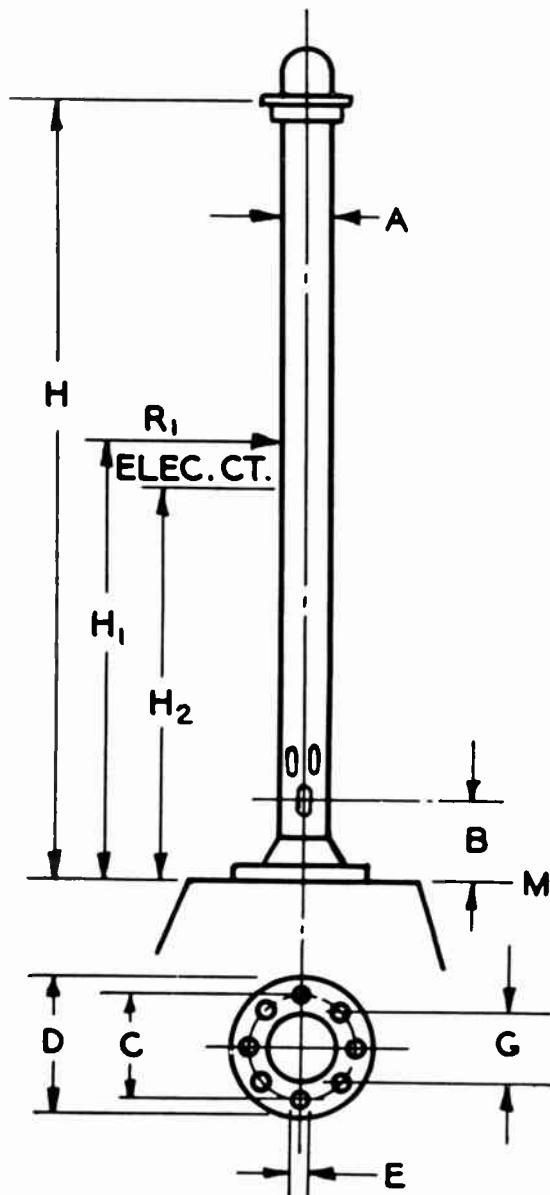

## ELECTRICAL SPECIFICATIONS

Power Handling.....10 kw up to 10,000 ft.  
 Maximum Ambient Temperature, at Full Power.....45° C.  
 Input Impedance.....50 ohms, V.S.W.R. less than 1.1/1  
 Input Connection.....Single 3/8 UHF flanged coaxial line  
 Hor. Pattern Circularity.....±0.5 db

## MECHANICAL SPECIFICATIONS

### Design Assumptions

- Max. wind velocity (1/2" rad. ice) 95 mph.
- Max. wind velocity (no ice) 110 mph. (50/30 p.s.f.).  
Tensile stress below 20,000 p.s.i.
- Actual wind velocity.
- Max stress on bolts 18,000 p.s.i.

Channels (approx.)	14 to 30 incl.	14 to 30 incl.	31 to 50 incl.	51 to 83 incl.
Type Number	TFU-21BLS	TFU-24BLS	TFU-24BMS	TFU-27BHS
MI Number	MI-19195-D*	MI-19195-A*	MI-19195-B*	MI-19195-C*
AND				
Type Number	TFU-21DL	TFU-24DL	TFU-24DM	TFU-27DH
Type Number	MI-19304-D*	MI-19304-A*	MI-19304-B*	MI-19304-C*
Weight, (Pounds)	Varies with Channel — See Table 1			
A, Inches (Diam.)	10 3/4	10 3/4	8 3/8	6 3/8
B, Inches	37 to 32	37 to 32	32 to 28	30 to 25
C, Inches (Bolt Circle)	15 1/4	15 1/4	13	10 3/8
D, Inches (Diam.)	17 9/16	17 9/16	15	12 1/2
E, Inches (Bolt Diam.)	1 1/8	1 1/8	1	7/8
F, Number of Holes	16	16	12	12
H, Feet	Varies with Channel — See Table 1			
H <sub>1</sub> (All channels)	H <sub>2</sub> + 1 ft.			
H <sub>2</sub> (Elect. Ctr.)	Varies with Channel — See Table 1			
R <sub>1</sub> (50/30 P.S.F.) No ice	Varies with Channel — See Table 1			
M, Ft./Lbs. (Moment) (30 p.s.t.)	Varies with Channel — See Table 1			
Relative Gain	21	24	24	27
G, Top Cap Hole (Diam.)	9 3/4"	9 3/4"	7 3/4"	5 3/4"

\* NOTE: Suffix Number added to MI number indicates Channel Number.

# UHF Antenna Data

Channel	Type	No. of Sections	Gain in Db	Power Gain	*TV Power Rating	
					KW	DBK
14-83	TFU-24C	16	13.8 (e)	24 (e)	50.0	17.0
14-30	TFU-3BL*	2	4.77	3	2.0	3.01
	TFU-6BL*	4	7.78	6	4.0	6.02
	TFU-9BL*	6	9.54	9	6.0	7.77
	TFU-12BL*	8	10.79	12	10.0	10.0
	TFU-21DL	14	13.22	21	10.0	10.0
	TFU-24DL	16	13.80	24	10.0	10.0
31-50	TFU-3BM*	2	4.77	3	2.0	3.01
	TFU-6BM*	4	7.78	6	4.0	6.02
	TFU-9BM*	6	9.54	9	6.0	7.77
	TFU-12BM*	8	10.79	12	10.0	10.0
	TFU-24DM	16	13.80	24	10.0	10.0
51-83	TFU-3BH*	2	4.77	3	2.0	3.01
	TFU-6BH*	4	7.78	6	4.0	6.02
	TFU-9BH*	6	9.54	9	6.0	7.77
	TFU-12BH*	8	10.79	12	10.0	10.0
	TFU-27DH	18	14.31	27	10.0	10.0
14-30	TFU-21DAL (Custom)	14				
	TFU-24DAL (Custom)	16				
31-50	TFU-24DAM (Custom)	16				
51-83	TFU-27DAH (Custom)	18				

THESE FOUR TYPES ARE DIRECTIONAL TYPES. HORIZONTAL PATTERN SHAPES, RMS AND MAXIMUM POWER GAINS ARE DEPENDENT UPON CHANNEL. BEAM TILTING AND NULL FILL-IN FEATURES OPTIONAL. ALL DIRECTIONAL ANTENNAS ARE CUSTOM BUILT AND SPECIFICATIONS ARE SUBJECT TO INDIVIDUAL STUDY AND APPLICATIONS.

\* Beam tilting not available for low gain antenna.

\*\* Power ratings given are maximum visual power to input of antenna and assume aural carrier of one-half peak of visual sync. rating. For other values of aural carrier the total average power is 1.1 X TV power rating listed above.

(e) Estimated.

# Filing Data for UHF Directional Antennas

Applications proposing the use of a UHF antenna having a horizontal pattern which is directional are affected by FCC Rule 3.685(e) and 3.685(f) (1-4 incl.). These rules refer specifically to antennas designed to have directivity in the horizontal plane; however, the terms of Section 3.685(e) are also applied (see FCC Public Notice 53-279 dated March 12, 1953) to omni-directional antennas when electrical and/or mechanical beam tilting is used to direct the major lobe at angles other than horizontal, in so far as compliance with the definitions of licensed power and power limitations are concerned.

In the case of true directionals, those designed to have horizontal directivity with or without beam tilting, a statement is attached to Form 301, Section V-G (Antenna) showing:

## 1. Complete description of the proposed antenna system.

Certain portions of this information are unique to the design of the particular directional antenna, i.e., slotting arrangement and power distribution to slots. In all other respects, the descriptive information is the same as that applicable for standard non-directional RCA antennas. The description of the slotting arrangement and power distribution will be furnished to the applicant by RCA upon completion of the design specifications for the antenna.

## 2. Orientation of array with respect to true north, time phasing of fields from elements (degrees leading or lagging), space phasing of elements (in feet and degrees), and ratio of fields from elements.

The first of these considerations is determined by the geographical location of the antenna site and the coverage desired, and is determined and specified by the applicant or his consultant.

The remainder of the information required in this paragraph will be furnished to the applicant by RCA for the filing statement, since these specifications are unique to the design of the particular directional antenna.

## 3. (a) Horizontal and vertical plane radiation patterns showing the free space field intensity in mv/m at one mile, and the effective radiated power in dbk, for each direction.

The horizontal plane radiation pattern is calculated and furnished for the particular channel and directivity requirement by RCA. Calculated patterns are supplemented by measured patterns made on an identical single layer model antenna. Calculated vertical radiation patterns for omni-directional antennas are available for the applicable channels and beam tilts. Since the vertical pattern is not appreciably affected by horizontal pattern shaping, these patterns are valid for filing data and the derivation of predicted fields, etc. Upon completion of the directional antenna, measured vertical patterns in the directions of maximum and minimum horizontal radiation are furnished.

It is suggested that, due to the time cycle between design of a directional antenna and the completion, the initial application for construction permit be made on the basis of calculated patterns and data. Measured horizontal and vertical patterns and measured power gain will be furnished upon completion of the antenna and may be filed at time of the filing for license.

Tabular data showing the relative power gain, power gain in db, and free space fields at one mile for 1 kw in the horizontal plane and in the major lobe if tilted are furnished for the hori-

zontal pattern at 15° intervals, as required above. From this table the applicable values for ERP and free space fields for the particular transmitter power and transmission line efficiency factors can be readily calculated by the applicant.

(b) Section 3.685(f)(3) further requires statements describing the methods by which radiation patterns are calculated or measured and data to support the validity of the calculations or measurements. Since either of these statements would be quite lengthy and complex, and the design data and measurements techniques are common to all directionals for this slotted cylinder type antenna, it is suggested that this be accomplished by referencing the following literature:

1. "Slotted Cylinder Antenna Patterns"  
George Sinclair, *Proceedings of the I.R.E.*, December, 1948, pp. 1487-1492.
2. "A New UHF Television Antenna"  
O. O. Fiet, *Broadcast News*, Vol. 68, March-April, 1952, pp. 8-23.
3. "Pattern Testing the TFU-24B UHF Antenna"  
E. H. Shively, *Broadcast News*, Vol. 69, May-June, 1952, pp. 42-51.

Sample horizontal field patterns and the applicable data for these patterns are shown on the following pages. Where directional data required by Section 3.685(e) is required for an antenna considered as directional, by reason of beam tilting, although having an omni-directional horizontal radiation pattern, the information above is also required. However, the determination of ERP and free space fields cannot be obtained directly from a calculated horizontal pattern, but must be obtained by calculation of the relative horizontal field, in the horizontal plane, by com-

bining the circular horizontal pattern for a non-directional with the vertical pattern for the conditions of electrical and/or mechanical tilt used. From this relative field pattern of the tilted antenna the ERP and free space fields may be calculated. This method also must be adopted where a true directional involving mechanical tilt is considered, since the FCC defines the horizontal radiation pattern as that pattern developed in the horizontal plane.

Consideration should be given to proper orientation physically of the tower structure and antenna to accomplish the desired orientation of the horizontal directivity pattern. This requires careful liaison between the station, consultant, tower fabricator, erector, and the manufacturer, to insure accurate interchange of information which will insure that the antenna, when completed and erected, will be properly oriented to meet the coverage requirements.

Techniques of beam tilting and null fill of the vertical pattern may be used with directionals as well as with omni-directional antennas. The effects of beam tilt on power gain in the major lobe of the vertical pattern, and in the horizontal plane, are the same as the effects with omni-directionals; thus, the curves shown elsewhere of beam tilt vs. per cent of untilted power gain for the major lobe and horizontal plane are also applicable for directional types. The vertical patterns are essentially symmetrical around the vertical axis of the antenna except for amplitude. The phase lead in the upper section, above the feed point, over the lower section, is the same as in omni-directional types. Thus, the filing description, in so far as vertical characteristics are concerned, is the same as for the standard omni-directional antennas. The number of vertical layers used is the same as for an omni-directional of equivalent RMS power gain at the same channel, and the vertical apertures and spacings are the same.

Channel 24

532 mc

 $D/\lambda = 0.388$ 

Area Ratio = 1.91

## SAMPLE CALCULATED PATTERN

Degrees Azimuth	$f_2$	Relative Power Gain Untilted Major Lobe	Gain-db Untilted Major Lobe	Free Space Field Untilted Major Lobe mv/m**	Relative Power Gain 0.7° Tilt Major Lobe	Gain-db 0.7° Tilt Major Lobe	Free Space Field 0.7° Tilt Major Lobe mv/m**	Relative Power Gain 0.7° Tilt Horizontal Plane	Gain-db 0.7° Tilt Horizontal Plane	Free Space Field 0.7° Tilt Horizontal Plane mv/m**
0	1.910	40.10	16.03	872	36.50	15.62	830	30.00	14.77	753
15, 345	1.784	37.50	15.74	842	34.10	15.32	805	28.10	14.49	730
30, 330	1.705	35.80	15.54	822	32.60	15.13	787	26.80	14.28	712
45, 315	1.624	34.10	15.33	805	31.00	14.91	765	25.50	14.07	695
60, 300	1.520	31.90	15.04	778	29.00	14.62	740	23.90	13.78	671
75, 285	1.145	24.10	13.82	675	21.90	13.40	645	18.05	12.57	585
90, 270	0.868	18.20	12.60	587	16.55	12.19	560	13.63	11.35	508
105, 255	0.572	12.00	10.79	476	10.90	10.40	454	8.40	9.24	398
120, 240	0.334	7.02	8.46	364	6.39	8.05	347	5.26	7.21	316
135, 225	0.264	5.55	7.44	323	5.05	7.03	310	4.16	6.19	280
*140, 220	0.264	5.55	7.44	323	5.05	7.03	310	4.16	6.19	280
150, 210	0.276	5.80	7.63	331	5.28	7.22	316	4.35	6.38	287
165, 195	0.352	7.40	8.69	374	6.73	8.28	358	5.54	7.43	323
180	0.412	8.65	9.37	406	7.87	8.96	385	6.48	8.11	351

0° Azimuth in line with row of slots.

\* Point of minima.

\*\* Free Space Field at 1 mile for 1 kw input to antenna, in mv/m.

 $f_2$  = power ratio to non-directional gain.All gains relative to a  $\lambda/2$  dipole. These values are not ERP.

Maximum to minimum field ratio 8.56 db.

TFU-21DAL Special Cardioid Pattern

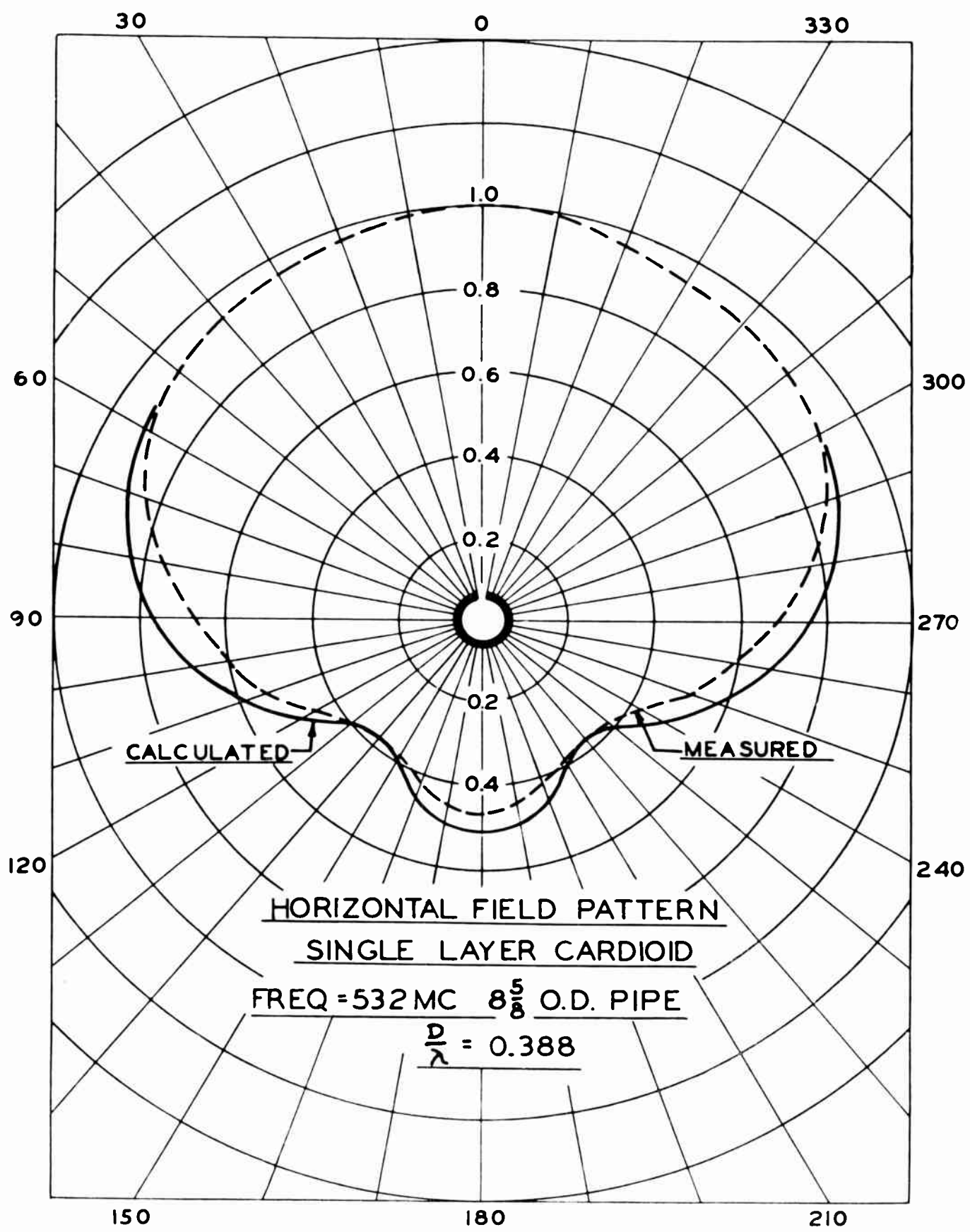

Channel 17

490 mc

 $D/\lambda = 0.358$ 

Area Ratio = 2.28

## SAMPLE CALCULATED PATTERN

Degrees Azimuth	$f_2$	Relative Power Gain Untilted Major Lobe	Gain-db Untilted Major Lobe	Free Space Field Untilted Major Lobe mv/m**	Relative Power Gain 0.5° Tilt Major Lobe	Gain-db 0.5° Tilt Major Lobe	Free Space Field 0.5° Tilt Major Lobe mv/m**	Relative Power Gain 0.5° Tilt Horizontal Plane	Gain-db 0.5° Tilt Horizontal Plane	Free Space Field 0.5° Tilt Horizontal Plane mv/m**
0	0.322	6.76	8.30	358	6.22	7.93	344	5.48	7.39	322
15, 345*	0.284	5.96	7.75	337	5.48	7.39	322	4.83	6.84	303
30, 330	0.372	7.81	8.92	385	7.19	8.56	368	6.32	8.00	347
45, 315	0.712	14.90	11.73	530	13.70	11.36	510	12.08	10.82	478
60, 300	1.369	28.75	14.58	737	26.45	14.22	707	23.30	13.67	665
75, 285	2.016	42.10	16.24	893	38.70	15.87	855	34.10	15.33	803
90, 270	2.280	47.90	16.80	952	44.10	16.44	915	38.80	15.89	856
105, 255	2.016	42.10	16.24	893	38.70	15.87	855	34.10	15.33	803
120, 240	1.369	28.75	14.58	737	26.45	14.22	707	23.30	13.67	665
135, 225	0.712	14.90	11.73	530	13.70	11.36	510	12.08	10.82	478
150, 210	0.372	7.81	8.92	385	7.19	8.56	368	6.32	8.00	347
165, 195*	0.284	5.96	7.75	337	5.48	7.39	322	4.83	6.84	303
180	0.322	6.76	8.30	358	6.22	7.93	344	5.48	7.39	322

0° Azimuth in line with row of slots.

\* Point of minima.

\*\* Free Space Field at 1 mile for 1 kw input to antenna, in mv/m.

$f_2$  = power ratio to non-directional gain.

All gains relative to a  $\lambda/2$  dipole.

Maximum to minimum field ratio 9.0 db.

TFU-21DAL Special Bi-Directional Pattern

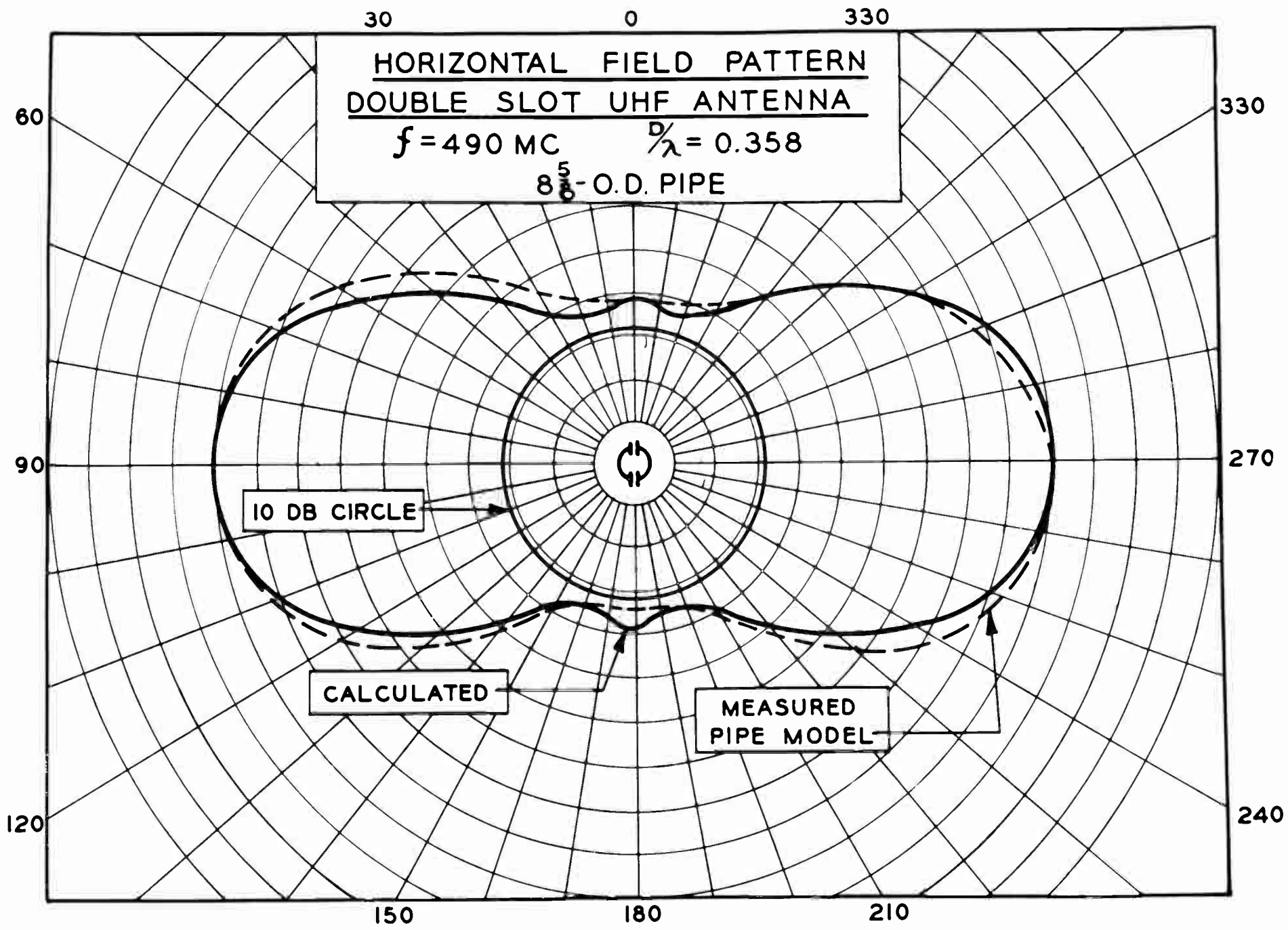

D-121



# UHF TRANSMISSION LINE EFFICIENCY AT VHF (CHANNELS 2-9)

## EFFICIENCIES IN %

Length in Feet	CHANNEL 2		CHANNEL 3		CHANNEL 4		CHANNEL 5		Length in Feet
	MI-19089-1 3-1/8" Teflon	MI-19387 6-1/8" Teflon	MI-19089-1 3-1/8" Teflon	MI-19387 6-1/8" Teflon	MI-19089-1 3-1/8" Teflon	MI-19387 6-1/8" Teflon	MI-19089-1 3-1/8" Teflon	MI-19387 6-1/8" Teflon	
100	98.4	99.2	98.3	99.2	98.2	99.1	98.1	99.1	100
200	96.9	98.4	96.7	98.3	96.5	98.2	96.3	98.1	200
300	95.4	97.6	95.1	97.5	94.9	97.4	94.6	97.1	300
400	93.8	96.9	93.5	96.6	93.2	96.5	92.7	96.2	400
500	92.2	96.0	91.9	95.8	91.6	95.6	91.0	95.5	500
600	90.8	95.2	90.4	95.0	89.9	94.9	89.3	94.4	600
700	89.4	94.6	88.9	94.3	88.4	94.0	87.6	93.5	700
800	87.9	93.9	87.4	93.5	86.9	93.2	85.9	92.6	800
900	86.5	93.1	86.0	92.6	85.5	92.4	84.3	91.8	900
1000	85.1	92.4	84.5	92.0	83.8	91.5	82.9	91.0	1000
1200	82.4	90.9	81.7	90.4	80.9	90.0	79.6	89.4	1200
1400	79.9	89.4	79.0	88.9	78.1	88.4	76.8	87.6	1400
1600	77.3	88.0	76.4	87.4	75.3	86.9	73.9	86.0	1600
DB Loss per 100 ft.	.0700	.0345	.0730	.0365	.0770	.0382	.0820	.0410	DB Loss per 100 ft.

## EFFICIENCIES IN %

Length in Feet	CHANNEL 6		CHANNEL 7		CHANNEL 8		CHANNEL 9		Length in Feet
	MI-19089-1 3-1/8" Teflon	MI-19387 6-1/8" Teflon	MI-19089-1 3-1/8" Teflon	MI-19387 6-1/8" Teflon	MI-19089-1 3-1/8" Teflon	MI-19387 6-1/8" Teflon	MI-19089-1 3-1/8" Teflon	MI-19387 6-1/8" Teflon	
100	98.0	99.9	97.2	98.6	97.1	98.6	97.1	98.6	100
200	96.1	98.0	94.4	97.1	94.4	97.1	94.3	97.0	200
300	94.4	97.0	91.9	95.9	91.7	95.8	91.6	95.7	300
400	92.4	96.1	89.3	94.5	89.1	94.4	88.9	94.3	400
500	90.6	95.2	86.7	93.1	86.5	93.0	86.3	92.9	500
600	88.9	94.3	84.3	91.8	84.1	91.7	83.9	91.6	600
700	87.1	93.4	81.9	90.5	81.7	90.4	81.4	90.2	700
800	85.4	92.5	79.6	89.4	79.3	89.1	79.0	88.9	800
900	83.6	91.5	77.4	88.0	77.0	87.8	76.7	87.6	900
1000	82.1	90.6	75.1	86.7	74.7	86.6	74.4	86.4	1000
1200	78.9	88.9	71.0	84.4	70.7	84.1	70.3	83.9	1200
1400	75.9	87.2	67.1	82.0	66.7	81.7	66.3	81.5	1400
1600	72.8	85.5	63.3	79.7	62.9	79.4	62.4	79.1	1600
DB Loss per 100 ft.	.0860	.0425	.1240	.0615	.1260	.0625	.1280	.0635	DB Loss per 100 ft.

# UHF TRANSMISSION LINE EFFICIENCY AT VHF (CHANNELS 10-13)

EFFICIENCIES IN %

CHANNEL 10		CHANNEL 11		CHANNEL 12		CHANNEL 13		Length in Feet	
Length in Feet	MI-19089-1 3-1/8" Teflon	MI-19387 6-1/8" Teflon	MI-19089-1 3-1/8" Teflon	MI-19387 6-1/8" Teflon	MI-19089-1 3-1/8" Teflon	MI-19387 6-1/8" Teflon	MI-19089-1 3-1/8" Teflon	MI-19387 6-1/8" Teflon	Length in Feet
100	97.0	98.5	97.0	98.5	97.0	98.5	96.9	98.5	100
200	94.2	97.0	94.1	97.0	94.0	96.9	94.0	96.9	200
300	91.4	95.6	91.3	95.6	91.1	95.5	90.9	95.5	300
400	88.7	94.2	88.5	94.1	88.3	94.0	88.1	94.0	400
500	86.1	92.8	85.9	92.7	85.7	92.6	85.5	92.5	500
600	83.6	91.4	83.4	91.4	83.1	91.3	82.9	91.1	600
700	81.1	90.1	80.9	90.0	80.7	89.8	80.4	89.7	700
800	78.7	88.8	78.4	88.6	78.1	88.5	77.8	88.3	800
900	76.4	87.5	76.1	87.4	75.7	87.1	75.4	86.9	900
1000	74.1	86.2	73.8	86.0	73.4	85.7	73.1	85.6	1000
1200	69.9	83.6	69.5	83.5	69.2	83.2	68.8	83.0	1200
1400	65.8	81.3	65.3	81.0	64.9	80.7	64.5	80.4	1400
1600	62.0	78.9	61.5	78.6	61.0	78.3	60.6	78.0	1600
DB Loss per 100 ft.	.1300	.0645	.1320	.0655	.1340	.0665	.1360	.0675	DB Loss per 100 ft.

# UHF TRANSMISSION LINE EFFICIENCY (CHANNELS 14-21)

EFFICIENCIES IN %

Length in Feet	CHANNEL 14		CHANNEL 15		CHANNEL 16		CHANNEL 17		Length in Feet
	MI 19089-1 3-1/8" Teflon	MI 19387 6-1/8" Teflon	MI 19089-1 3-1/8" Teflon	MI 19387 6-1/8" Teflon	MI 19089-1 3-1/8" Teflon	MI 19387 6-1/8" Teflon	MI 19089-1 3-1/8" Teflon	MI 19387 6-1/8" Teflon	
100	95.1	97.7	95.0	97.7	95.0	97.7	95.0	97.6	100
200	90.4	95.4	90.3	95.4	90.2	95.4	90.2	95.3	200
300	85.9	93.2	85.8	93.2	85.7	93.1	85.6	93.1	300
400	81.7	91.0	81.6	91.0	81.4	91.0	81.3	90.9	400
500	77.6	88.9	77.5	88.9	77.4	88.8	77.2	88.7	500
600	73.8	86.9	73.7	86.7	73.5	86.7	73.3	86.6	600
700	70.2	84.8	70.0	84.8	69.8	84.7	69.6	84.6	700
800	66.7	82.9	66.6	82.9	66.3	82.7	66.1	82.6	800
900	63.4	81.0	63.3	81.0	63.0	80.8	62.7	80.6	900
1000	60.3	79.1	60.1	79.1	59.8	78.9	59.6	78.7	1000
1200	54.5	75.4	54.3	75.4	54.0	75.2	53.7	75.0	1200
1400	49.2	72.0	49.1	72.0	48.7	71.8	48.4	71.5	1400
1600	44.5	68.7	44.3	68.7	44.0	68.4	43.7	68.2	1600
DB Loss per 100 ft.	.220	.102	.221	.102	.223	.103	.225	.104	DB Loss per 100 ft.

EFFICIENCIES IN %

Length in Feet	CHANNEL 18		CHANNEL 19		CHANNEL 20		CHANNEL 21		Length in Feet
	MI 19089-1 3-1/8" Teflon	MI 19387 6-1/8" Teflon	MI 19089-1 3-1/8" Teflon	MI 19387 6-1/8" Teflon	MI 19089-1 3-1/8" Teflon	MI 19387 6-1/8" Teflon	MI 19089-1 3-1/8" Teflon	MI 19387 6-1/8" Teflon	
100	94.9	97.6	94.9	97.6	94.8	97.6	94.8	97.5	100
200	90.1	95.3	90.0	95.2	90.0	95.2	89.9	95.2	200
300	85.5	93.0	85.4	92.9	85.3	92.9	85.3	92.8	300
400	81.1	90.8	81.0	90.7	80.9	90.6	80.8	90.5	400
500	77.0	88.6	76.8	88.5	76.7	88.4	76.7	88.3	500
600	73.1	86.5	72.9	86.4	72.8	86.3	72.7	86.1	600
700	69.4	84.4	69.1	84.3	69.0	84.2	68.9	84.0	700
800	65.8	82.4	65.6	82.3	65.5	82.1	65.3	82.0	800
900	62.5	80.4	62.2	80.3	62.1	80.1	62.0	80.0	900
1000	59.3	78.5	59.0	78.4	58.9	78.2	58.8	78.0	1000
1200	53.4	74.8	53.1	74.6	53.0	74.4	52.8	74.2	1200
1400	48.1	71.3	47.8	71.1	47.6	70.8	47.5	70.6	1400
1600	43.3	67.9	43.0	67.7	42.9	67.4	42.7	67.2	1600
DB Loss per 100 ft.	.227	.105	.229	.106	.230	.107	.231	.108	DB Loss per 100 ft.

# UHF TRANSMISSION LINE EFFICIENCY (CHANNELS 22-29)

EFFICIENCIES IN %									
CHANNEL 22		CHANNEL 23		CHANNEL 24		CHANNEL 25			
Length in Feet	MI 19089-1 3-1/8" Teflon	MI 19387 6-1/8" Teflon	MI 19089-1 3-1/8" Teflon	MI 19387 6-1/8" Teflon	MI 19089-1 3-1/8" Teflon	MI 19387 6-1/8" Teflon	MI 19089-1 3-1/8" Teflon	MI 19387 6-1/8" Teflon	Length in Feet
100	94.8	97.5	94.8	97.5	94.7	97.5	94.7	97.5	100
200	89.8	95.1	89.8	95.1	89.7	95.0	89.7	95.0	200
300	85.1	92.8	85.1	92.7	85.0	92.6	85.0	92.6	300
400	80.7	90.5	80.6	90.4	80.5	90.3	80.5	90.2	400
500	76.5	88.2	76.4	88.1	76.3	88.0	76.2	87.9	500
600	72.5	86.0	72.4	85.9	72.3	85.8	72.2	85.7	600
700	68.7	83.9	68.6	83.8	68.5	83.6	68.4	83.5	700
800	65.1	81.8	65.0	81.7	64.9	81.5	64.8	81.4	800
900	61.7	79.8	61.6	79.6	61.5	79.4	61.3	79.3	900
1000	58.5	77.8	58.3	77.6	58.2	77.5	58.1	77.3	1000
1200	52.5	74.0	52.4	73.8	52.2	73.6	52.1	73.4	1200
1400	47.2	70.4	47.0	70.2	46.9	70.0	46.7	69.7	1400
1600	42.4	66.9	42.2	66.7	42.1	66.4	41.9	66.2	1600
DB Loss per 100 ft.	.233	.109	.234	.110	.235	.111	.236	.112	DB Loss per 100 ft.

EFFICIENCIES IN %									
CHANNEL 26		CHANNEL 27		CHANNEL 28		CHANNEL 29			
Length in Feet	MI 19089-1 3-1/8" Teflon	MI 19387 6-1/8" Teflon	MI 19089-1 3-1/8" Teflon	MI 19387 6-1/8" Teflon	MI 19089-1 3-1/8" Teflon	MI 19387 6-1/8" Teflon	MI 19089-1 3-1/8" Teflon	MI 19387 6-1/8" Teflon	Length in Feet
100	94.7	97.4	94.7	97.4	94.6	97.4	94.6	97.4	100
200	89.7	94.9	89.6	94.9	89.5	94.9	89.5	94.8	200
300	84.9	92.5	84.9	92.5	84.7	92.4	84.7	92.3	300
400	80.4	90.1	80.3	90.1	80.2	90.0	80.1	89.9	400
500	76.1	87.8	76.0	87.8	75.9	87.7	75.8	87.5	500
600	72.1	85.5	72.0	85.5	71.8	85.4	71.7	85.2	600
700	68.3	83.4	68.1	83.4	67.9	83.2	67.8	83.0	700
800	64.6	81.2	64.5	81.2	64.3	81.1	64.2	80.8	800
900	61.2	79.1	61.1	79.1	60.8	79.0	60.7	78.6	900
1000	57.9	77.1	57.8	77.1	57.5	76.9	57.4	76.6	1000
1200	52.0	73.2	51.8	73.2	51.5	73.0	51.4	72.6	1200
1400	46.6	69.5	46.4	69.5	46.1	69.3	46.0	68.8	1400
1600	41.8	66.0	41.6	66.0	41.3	65.7	41.2	65.2	1600
DB Loss per 100 ft.	.237	.113	.238	.113	.240	.114	.241	.116	DB Loss per 100 ft.

# UHF TRANSMISSION LINE EFFICIENCY (CHANNELS 30-37)

## EFFICIENCIES IN %

Length in Feet	CHANNEL 30		CHANNEL 31		CHANNEL 32		CHANNEL 33		Length in Feet
	MI 19089-1 3-1/8" Teflon	MI 19387 6-1/8" Teflon	MI 19089-1 3-1/8" Teflon	MI 19387 6-1/8" Teflon	MI 19089-1 3-1/8" Teflon	MI 19387 6-1/8" Teflon	MI 19089-1 3-1/8" Teflon	MI 19387 6-1/8" Teflon	
100	94.6	97.3	94.5	97.3	94.5	97.3	94.4	97.3	100
200	89.4	94.8	89.3	94.7	89.3	94.7	89.2	94.7	200
300	84.6	92.3	84.4	92.2	84.3	92.1	84.2	92.1	300
400	80.0	90.0	79.8	89.7	79.7	89.6	79.5	89.6	400
500	75.6	87.4	75.4	87.3	75.3	87.2	75.1	87.2	500
600	71.5	85.1	71.3	85.0	71.1	84.8	70.9	84.8	600
700	67.6	82.8	67.4	82.7	67.2	82.6	67.0	82.6	700
800	63.9	80.6	63.7	80.5	63.5	80.3	63.2	80.3	800
900	60.4	78.5	60.2	78.3	60.0	78.1	60.0	78.1	900
1000	57.2	76.4	56.9	76.2	56.6	76.0	56.4	76.0	1000
1200	51.1	72.4	50.8	72.2	50.5	72.0	50.3	72.0	1200
1400	45.7	68.6	45.4	68.4	45.1	68.2	44.8	68.2	1400
1600	40.9	65.0	40.6	64.7	40.3	64.5	40.0	64.5	1600
DB Loss per 100 ft.	.243	.117	.245	.118	.247	.119	.249	.119	DB Loss per 100 ft.

## EFFICIENCIES IN %

Length in Feet	CHANNEL 34		CHANNEL 35		CHANNEL 36		CHANNEL 37		Length in Feet
	MI 19089-1 3-1/8" Teflon	MI 19387 6-1/8" Teflon	MI 19089-1 3-1/8" Teflon	MI 19387 6-1/8" Teflon	MI 19089-1 3-1/8" Teflon	MI 19387 6-1/8" Teflon	MI 19089-1 3-1/8" Teflon	MI 19387 6-1/8" Teflon	
100	94.4	97.3	94.3	97.3	94.3	97.2	94.2	97.2	100
200	89.1	94.6	89.0	94.6	88.9	94.5	88.8	94.5	200
300	84.1	92.1	84.0	92.0	83.9	91.9	83.6	91.9	300
400	79.4	89.5	79.2	89.5	79.1	89.4	78.8	89.3	400
500	74.9	87.1	74.7	87.0	74.6	86.9	74.2	86.8	500
600	70.7	84.7	70.5	84.6	70.3	84.5	69.9	84.4	600
700	66.7	82.4	66.5	82.3	66.3	82.2	65.9	82.0	700
800	63.0	80.2	62.8	80.0	62.5	80.0	62.1	79.7	800
900	59.4	78.0	59.2	77.8	59.0	77.7	58.5	77.5	900
1000	56.1	75.9	55.9	75.7	55.6	75.5	55.1	75.3	1000
1200	50.0	71.8	49.7	71.6	49.4	71.4	48.9	71.2	1200
1400	44.5	67.9	44.2	67.7	43.9	67.5	43.4	67.3	1400
1600	40.0	64.3	39.4	64.0	39.1	63.8	38.5	63.6	1600
DB Loss per 100 ft.	.251	.120	.253	.121	.255	.122	.259	.123	DB Loss per 100 ft.

# UHF TRANSMISSION LINE EFFICIENCY (CHANNELS 38-45)

EFFICIENCIES IN %									
CHANNEL 38		CHANNEL 39		CHANNEL 40		CHANNEL 41			
Length in Feet	MI 19089-1 3-1/8" Teflon	MI 19387 6-1/8" Teflon	MI 19089-1 3-1/8" Teflon	MI 19387 6-1/8" Teflon	MI 19089-1 3-1/8" Teflon	MI 19387 6-1/8" Teflon	MI 19089-1 3-1/8" Teflon	MI 19387 6-1/8" Teflon	Length in Feet
100	94.1	97.2	94.1	97.2	94.1	97.1	94.0	97.1	100
200	88.6	94.5	88.6	94.4	88.5	94.3	88.4	94.3	200
300	83.4	91.8	83.3	91.7	83.2	91.6	83.1	91.5	300
400	78.6	89.2	78.4	89.1	78.3	89.0	78.1	88.9	400
500	74.0	86.7	73.8	86.6	73.6	86.4	73.5	86.3	500
600	69.6	84.3	69.4	84.1	69.3	83.9	69.1	83.8	600
700	65.6	81.9	65.3	81.8	65.1	81.5	64.9	81.4	700
800	61.8	79.6	61.5	79.4	61.3	79.1	61.0	79.0	800
900	58.1	77.3	57.9	77.2	57.6	76.9	57.4	76.7	900
1000	54.7	75.2	54.5	75.0	54.2	74.6	54.0	74.0	1000
1200	48.5	71.0	48.2	70.8	48.0	70.4	47.7	70.2	1200
1400	43.0	67.1	42.7	66.8	42.4	66.4	42.2	66.2	1400
1600	38.1	63.3	37.8	63.1	37.5	62.6	37.3	62.4	1600
DB Loss per 100 ft.	.262	.124	.264	.125	.266	.127	.268	.128	DB Loss per 100 ft.

EFFICIENCIES IN %									
CHANNEL 42		CHANNEL 43		CHANNEL 44		CHANNEL 45			
Length in Feet	MI 19089-1 3-1/8" Teflon	MI 19387 6-1/8" Teflon	MI 19089-1 3-1/8" Teflon	MI 19387 6-1/8" Teflon	MI 19089-1 3-1/8" Teflon	MI 19387 6-1/8" Teflon	MI 19089-1 3-1/8" Teflon	MI 19387 6-1/8" Teflon	Length in Feet
100	94.0	97.1	93.9	97.1	93.8	97.0	93.8	97.0	100
200	88.3	94.2	88.2	94.2	88.1	94.1	87.9	94.1	200
300	83.0	91.5	82.8	91.4	82.6	91.4	82.5	91.3	300
400	78.0	88.8	77.8	88.7	77.6	88.6	77.3	88.5	400
500	73.3	86.2	73.0	86.1	72.8	86.0	72.5	85.9	500
600	68.9	83.7	68.6	83.6	68.3	83.4	68.0	83.3	600
700	64.7	81.2	64.4	81.1	64.1	81.0	63.8	80.8	700
800	60.8	78.9	60.5	78.7	60.1	78.6	59.8	78.4	800
900	57.2	76.5	56.8	76.4	56.4	76.2	56.1	76.1	900
1000	53.7	74.3	53.3	74.1	53.0	74.0	52.6	73.8	1000
1200	47.4	70.0	47.0	69.8	46.6	69.6	46.3	69.4	1200
1400	41.9	66.0	41.5	65.8	41.1	65.6	40.7	65.3	1400
1600	37.0	62.2	36.6	61.9	36.2	61.7	35.8	61.5	1600
DB Loss per 100 ft.	.270	.129	.273	.130	.276	.131	.279	.132	DB Loss per 100 ft.

# UHF TRANSMISSION LINE EFFICIENCY (CHANNELS 46-53)

## EFFICIENCIES IN %

Length in Feet	CHANNEL 46		CHANNEL 47		CHANNEL 48		CHANNEL 49		Length in Feet
	MI 19089-1 3-1/8" Teflon	MI 19387 6-1/8" Teflon	MI 19089-1 3-1/8" Teflon	MI 19387 6-1/8" Teflon	MI 19089-1 3-1/8" Teflon	MI 19387 6-1/8" Teflon	MI 19089-1 3-1/8" Teflon	MI 19387 6-1/8" Teflon	
100	93.7	97.0	93.7	97.0	93.6	96.9	93.6	96.9	100
200	87.9	94.1	87.7	94.0	87.7	94.0	87.5	93.9	200
300	82.4	91.2	82.2	91.2	82.1	91.1	81.9	91.0	300
400	77.2	88.5	77.0	88.4	76.8	88.3	76.6	88.2	400
500	72.4	85.8	72.1	85.7	71.9	85.6	71.7	85.5	500
600	67.8	83.2	67.5	83.1	67.4	83.0	67.1	82.9	600
700	63.6	80.7	63.3	80.6	63.1	80.4	62.8	80.3	700
800	59.6	78.3	59.3	78.1	59.1	78.0	58.7	77.8	800
900	55.9	75.9	55.5	75.8	55.3	75.6	54.9	75.4	900
1000	52.4	73.6	52.0	73.5	51.8	73.3	51.4	73.1	1000
1200	46.0	69.3	45.6	69.1	45.4	68.9	45.0	68.7	1200
1400	40.4	65.1	40.0	64.9	40.0	64.7	39.4	64.5	1400
1600	35.5	61.3	35.1	61.0	34.9	60.8	34.5	60.6	1600
DB Loss per 100 ft.	.281	.133	.284	.134	.286	.135	.289	.136	DB Loss per 100 ft.

## EFFICIENCIES IN %

Length in Feet	CHANNEL 50		CHANNEL 51		CHANNEL 52		CHANNEL 53		Length in Feet
	MI 19089-1 3-1/8" Teflon	MI 19387 6-1/8" Teflon	MI 19089-1 3-1/8" Teflon	MI 19387 6-1/8" Teflon	MI 19089-1 3-1/8" Teflon	MI 19387 6-1/8" Teflon	MI 19089-1 3-1/8" Teflon	MI 19387 6-1/8" Teflon	
100	93.5	96.9	93.4	96.9	93.4	96.8	93.3	96.8	100
200	87.4	93.9	87.3	93.8	87.2	93.8	87.0	93.7	200
300	81.7	91.0	81.6	90.9	81.4	90.8	81.2	90.7	300
400	76.4	88.1	76.2	88.1	76.0	87.9	75.7	87.8	400
500	71.5	85.4	71.2	85.3	71.0	85.1	70.6	85.0	500
600	66.8	82.8	66.5	82.6	66.3	82.4	65.9	82.3	600
700	62.5	80.2	62.2	80.1	61.9	79.8	61.5	79.7	700
800	58.4	77.7	58.1	77.6	57.8	77.3	57.3	77.1	800
900	54.6	75.3	54.3	75.1	53.9	74.8	53.5	74.7	900
1000	51.1	72.9	50.7	72.8	50.3	72.4	49.9	72.3	1000
1200	44.6	68.5	44.3	68.3	43.9	67.9	43.4	67.7	1200
1400	39.0	64.3	38.6	64.1	38.3	63.7	37.8	63.5	1400
1600	34.1	60.4	33.7	60.2	33.4	59.7	32.9	59.5	1600
DB Loss per 100 ft.	.292	.137	.295	.138	.298	.140	.302	.141	DB Loss per 100 ft.

# UHF TRANSMISSION LINE EFFICIENCY (CHANNELS 54-61)

EFFICIENCIES IN %									
CHANNEL 54		CHANNEL 55		CHANNEL 56		CHANNEL 57			
Length in Feet	MI 19089-1 3-1/8" Teflon	MI 19387 6-1/8" Teflon	MI 19089-1 3-1/8" Teflon	MI 19387 6-1/8" Teflon	MI 19089-1 3-1/8" Teflon	MI 19387 6-1/8" Teflon	MI 19089-1 3-1/8" Teflon	MI 19387 6-1/8" Teflon	Length in Feet
100	93.2	96.8	93.1	96.7	93.1	96.7	93.0	96.7	100
200	86.7	93.6	86.7	93.6	86.6	93.5	86.5	93.5	200
300	81.0	90.6	80.8	90.5	80.6	90.5	80.5	90.3	300
400	75.4	87.7	75.2	87.6	75.0	87.5	75.9	87.3	400
500	70.3	84.8	70.1	84.7	69.8	84.6	69.7	84.4	500
600	65.5	82.1	65.3	82.0	65.0	81.9	64.8	81.6	600
700	61.1	79.4	60.8	79.3	60.5	79.2	60.3	79.0	700
800	56.9	76.8	56.6	76.7	56.3	76.6	56.1	76.3	800
900	53.0	74.4	52.7	74.2	52.4	74.1	52.2	73.8	900
1000	49.4	71.9	49.1	71.8	48.8	71.6	48.5	71.3	1000
1200	42.9	67.4	42.6	67.2	42.2	67.0	42.0	66.6	1200
1400	37.3	63.1	36.9	62.9	36.6	62.7	36.3	62.3	1400
1600	32.4	59.1	32.0	58.8	31.7	58.6	31.5	58.2	1600
DB Loss per 100 ft.	.306	.143	.309	.144	.312	.145	.314	.147	DB Loss per 100 ft.

EFFICIENCIES IN %									
CHANNEL 58		CHANNEL 59		CHANNEL 60		CHANNEL 61			
Length in Feet	MI 19089-1 3-1/8" Teflon	MI 19387 6-1/8" Teflon	MI 19089-1 3-1/8" Teflon	MI 19387 6-1/8" Teflon	MI 19089-1 3-1/8" Teflon	MI 19387 6-1/8" Teflon	MI 19089-1 3-1/8" Teflon	MI 19387 6-1/8" Teflon	Length in Feet
100	93.0	96.7	92.9	96.6	92.8	96.6	92.8	96.5	100
200	86.4	93.4	86.3	93.3	86.2	93.3	86.1	93.2	200
300	80.3	90.3	80.2	90.2	80.0	90.1	79.8	90.0	300
400	74.7	87.3	74.5	87.1	74.3	87.0	74.1	86.9	400
500	69.4	84.3	69.2	84.1	69.0	84.0	68.7	83.9	500
600	64.5	81.5	64.3	81.3	64.0	81.7	63.7	80.0	600
700	60.0	78.8	59.7	78.5	59.4	78.4	59.1	78.1	700
800	55.8	76.1	55.5	75.9	55.2	75.7	54.9	75.4	800
900	51.8	73.6	51.5	73.3	51.2	73.1	50.9	72.8	900
1000	48.2	71.1	47.9	70.8	47.5	70.6	47.2	70.3	1000
1200	41.7	66.4	41.3	66.1	41.0	65.9	40.6	65.5	1200
1400	36.0	62.1	35.7	61.7	35.3	61.5	35.0	61.1	1400
1600	31.1	58.0	30.8	57.5	30.4	57.3	30.1	56.9	1600
DB Loss per 100 ft.	.317	.148	.320	.150	.323	.151	.326	.153	DB Loss per 100 ft.



# UHF TRANSMISSION LINE EFFICIENCY (CHANNELS 62-69)

EFFICIENCIES IN %									
CHANNEL 62		CHANNEL 63		CHANNEL 64		CHANNEL 65			
Length in Feet	MI 19089-1 3-1/8" Teflon	MI 19387 6-1/8" Teflon	MI 19089-1 3-1/8" Teflon	MI 19387 6-1/8" Teflon	MI 19089-1 3-1/8" Teflon	MI 19387 6-1/8" Teflon	MI 19089-1 3-1/8" Teflon	MI 19387 6-1/8" Teflon	Length in Feet
100	92.7	96.5	62.6	96.5	62.6	96.4	92.5	96.4	100
200	85.9	93.1	85.8	93.0	85.7	92.9	85.6	92.9	200
300	79.7	89.9	79.5	89.7	79.3	89.6	79.2	89.5	300
400	73.9	86.7	73.7	86.5	73.5	86.4	73.3	86.2	400
500	68.5	83.7	68.2	83.5	68.0	83.3	67.8	83.1	500
600	63.5	80.7	63.2	80.5	63.0	80.3	62.7	80.1	600
700	58.8	77.9	58.6	77.7	58.3	77.4	58.0	77.1	700
800	54.6	75.2	54.3	74.9	54.0	74.6	53.7	74.3	800
900	50.6	72.5	50.3	72.2	50.0	71.9	49.6	71.6	900
1000	46.9	70.0	46.6	69.7	46.3	69.3	45.9	69.0	1000
1200	40.3	65.2	40.0	64.8	39.6	64.5	39.3	64.1	1200
1400	34.6	60.7	34.3	60.3	34.0	59.9	33.6	59.5	1400
1600	29.8	56.5	29.4	56.1	29.1	55.7	28.8	55.3	1600
DB Loss per 100 ft.	.329	.155	.332	.157	.335	.159	.338	.161	DB Loss per 100 ft.

EFFICIENCIES IN %									
CHANNEL 66		CHANNEL 67		CHANNEL 68		CHANNEL 69			
Length in Feet	MI 19089-1 3-1/8" Teflon	MI 19387 6-1/8" Teflon	MI 19089-1 3-1/8" Teflon	MI 19387 6-1/8" Teflon	MI 19089-1 3-1/8" Teflon	MI 19387 6-1/8" Teflon	MI 19089-1 3-1/8" Teflon	MI 19387 6-1/8" Teflon	Length in Feet
100	92.4	96.3	92.4	96.3	92.3	96.3	92.2	96.2	100
200	85.4	92.8	85.3	92.7	85.2	92.7	85.0	92.6	200
300	79.0	89.4	78.8	89.3	78.6	89.2	78.4	89.1	300
400	73.0	86.1	72.8	86.0	72.6	85.9	72.3	85.7	400
500	67.5	83.0	67.3	82.8	67.0	82.7	66.7	82.5	500
600	62.3	80.0	62.1	79.7	61.8	79.6	61.5	79.4	600
700	57.6	77.0	57.4	76.8	57.1	76.7	56.7	76.4	700
800	53.3	74.2	53.0	73.9	52.7	73.8	52.3	73.5	800
900	49.2	71.5	48.9	71.2	48.6	71.0	48.2	70.8	900
1000	45.5	68.9	45.2	68.6	44.9	68.4	44.5	68.1	1000
1200	38.9	63.9	38.6	63.6	38.2	63.4	37.8	63.0	1200
1400	33.2	59.3	32.9	58.9	32.6	58.8	32.2	58.4	1400
1600	28.4	55.1	28.1	54.7	27.8	54.5	27.3	54.1	1600
DB Loss per 100 ft.	.342	.162	.345	.164	.348	.165	.352	.167	DB Loss per 100 ft.

# UHF TRANSMISSION LINE EFFICIENCY (CHANNELS 70-77)

EFFICIENCIES IN %									
CHANNEL 70		CHANNEL 71		CHANNEL 72		CHANNEL 73			
Length in Feet	MI 19089-1 3-1/8" Teflon	MI 19387 6-1/8" Teflon	MI 19089-1 3-1/8" Teflon	MI 19387 6-1/8" Teflon	MI 19089-1 3-1/8" Teflon	MI 19387 6-1/8" Teflon	MI 19089-1 3-1/8" Teflon	MI 19387 6-1/8" Teflon	Length in Feet
100	92.2	96.2	92.1	96.1	92.0	96.1	91.9	96.0	100
200	84.9	92.5	84.8	92.4	84.7	92.3	84.5	92.1	200
300	78.3	89.0	78.0	88.8	77.9	88.6	77.7	88.4	300
400	72.1	85.6	71.8	85.4	71.7	85.1	71.5	84.9	400
500	66.5	82.3	66.2	82.0	65.9	81.8	65.7	81.5	500
600	61.2	79.2	60.9	78.9	60.7	78.5	60.4	78.2	600
700	56.4	76.2	56.1	75.8	55.8	75.4	55.5	75.1	700
800	52.0	73.3	51.6	72.8	51.3	72.4	51.1	72.1	800
900	47.9	70.5	47.5	70.0	47.5	69.6	46.9	69.2	900
1000	44.2	67.8	43.8	67.3	43.5	66.8	43.2	66.4	1000
1200	37.5	62.7	37.1	62.2	36.8	61.7	36.5	61.2	1200
1400	31.8	58.0	31.4	57.4	31.1	56.9	30.8	56.3	1400
1600	27.0	53.7	26.6	53.1	26.4	52.5	26.1	51.9	1600
DB Loss per 100 ft.	.355	.169	.353	.172	.362	.175	.365	.178	DB Loss per 100 ft.

EFFICIENCIES IN %									
CHANNEL 74		CHANNEL 75		CHANNEL 76		CHANNEL 77			
Length in Feet	MI 19089-1 3-1/8" Teflon	MI 19387 6-1/8" Teflon	MI 19089-1 3-1/8" Teflon	MI 19387 6-1/8" Teflon	MI 19089-1 3-1/8" Teflon	MI 19387 6-1/8" Teflon	MI 19089-1 3-1/8" Teflon	MI 19387 6-1/8" Teflon	Length in Feet
100	91.8	95.9	91.8	95.9	91.7	95.9	91.6	95.8	100
200	84.3	92.1	84.2	92.0	84.0	91.8	83.9	91.7	200
300	77.5	88.3	77.2	88.2	77.0	88.0	76.8	87.8	300
400	71.1	84.7	70.9	84.6	70.6	84.3	70.3	84.1	400
500	65.3	81.3	65.0	81.1	64.7	80.8	64.4	80.5	500
600	60.0	78.0	59.7	77.8	59.3	77.5	59.0	77.1	600
700	55.1	74.8	54.8	74.6	54.4	74.2	54.0	73.9	700
800	50.6	71.8	50.2	71.5	49.8	71.1	49.5	70.7	800
900	46.5	68.9	46.1	68.6	45.7	68.2	45.3	67.7	900
1000	42.7	66.1	42.3	65.8	41.9	65.3	41.5	64.8	1000
1200	36.0	60.8	35.6	60.5	35.2	59.9	34.8	59.5	1200
1400	30.3	56.0	30.0	55.6	29.6	55.1	29.2	54.6	1400
1600	25.6	51.5	25.2	51.2	24.8	50.6	24.5	50.0	1600
DB Loss per 100 ft.	.370	.180	.374	.182	.378	.185	.382	.188	DB Loss per 100 ft.

# UHF TRANSMISSION LINE EFFICIENCY (CHANNELS 78-83)

EFFICIENCIES IN %							
CHANNEL 78		CHANNEL 79		CHANNEL 80			
Length in Feet	MI 19089-1 3-1/8" Teflon	MI 19387 6-1/8" Teflon	MI 19089-1 3-1/8" Teflon	MI 19387 6-1/8" Teflon	MI 19089-1 3-1/8" Teflon	MI 19387 6-1/8" Teflon	Length in Feet
100	91.5	95.7	91.4	95.6	91.3	95.5	100
200	83.7	91.6	83.6	91.4	83.4	91.2	200
300	76.6	87.6	76.4	87.4	76.2	87.2	300
400	70.1	83.9	69.8	83.6	69.6	83.3	400
500	64.1	80.2	63.8	79.9	63.5	79.5	500
600	58.7	76.8	58.3	76.4	58.0	76.0	600
700	53.7	73.5	53.3	73.0	53.0	72.6	700
800	49.1	70.3	48.8	69.8	48.4	69.3	800
900	44.9	67.3	44.6	66.7	44.2	66.2	900
1000	41.1	64.4	40.7	63.8	40.4	63.2	1000
1200	34.4	59.0	34.0	58.3	33.7	57.7	1200
1400	28.8	54.0	28.4	53.3	28.1	52.7	1400
1600	24.1	49.5	23.8	48.8	23.4	48.0	1600
DB Loss per 100 ft.	.386	.191	.390	.195	.394	.199	DB Loss per 100 ft.

EFFICIENCIES IN %							
CHANNEL 81		CHANNEL 82		CHANNEL 83			
Length in Feet	MI 19089-1 3-1/8" Teflon	MI 19387 6-1/8" Teflon	MI 19089-1 3-1/8" Teflon	MI 19387 6-1/8" Teflon	MI 19089-1 3-1/8" Teflon	MI 19387 6-1/8" Teflon	Length in Feet
100	91.2	95.4	91.2	95.4	91.1	95.3	100
200	83.3	91.1	83.1	90.9	83.0	90.8	200
300	76.0	86.9	75.8	86.7	75.6	86.5	300
400	69.3	83.0	69.1	82.6	68.8	82.4	400
500	63.2	79.2	63.0	78.8	62.7	78.5	500
600	57.7	75.6	57.4	75.1	57.1	74.8	600
700	52.7	72.1	52.3	71.6	51.9	71.3	700
800	48.0	68.8	47.7	68.3	47.3	67.9	800
900	43.8	65.7	43.5	65.1	43.1	64.7	900
1000	40.0	62.7	39.6	62.1	39.3	61.7	1000
1200	33.3	57.1	32.9	56.4	32.6	56.0	1200
1400	27.7	52.0	27.4	51.3	27.0	50.8	1400
1600	23.1	47.3	22.7	46.6	22.4	46.1	1600
DB Loss per 100 ft.	.398	.203	.402	.207	.406	.210	DB Loss per 100 ft.

# == NOTES ==

# NOTES