

PROSCAN

RCA

LASERDISC

Technical Training Manual

THOMSON CONSUMER ELECTRONICS INC./TECHNICAL TRAINING

P.O. BOX 1976 INDIANAPOLIS IN 46206

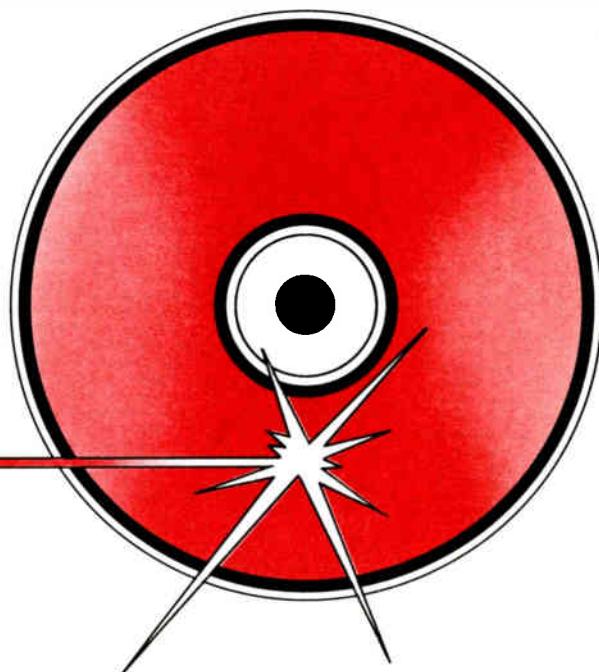

FOREWORD

This technical training manual addresses the operation and troubleshooting of the ProScan model PSLD40 and RCA model LDR300. The principles of operation and troubleshooting techniques presented in this manual can be applied to all laser disc players.

NOTE: This manual is intended to be used as a servicing aid and is not intended to replace the service data. Service data for these instruments contain specific information on parts, safety, and alignment procedures. Service data should be consulted before performing any service.

Safety Information Caution

Safety information is contained in the appropriate RCA or ProScan Service Data. All product safety requirements and testing must be completed prior to returning the instrument to the consumer. Servicers who defeat safety features or fail to perform safety checks may be liable for any resulting damages, and may expose themselves and others to possible injury.

CAUTION; The laser diode emits invisible infrared radiation, which is dangerous to the eyes. When servicing the laser disc player do not look directly into the laser lens.

NOTE: All integrated circuits and many other semiconductors are electrostatically sensitive and require special handling techniques.

Prepared by
Thomson Consumer Electronics, Inc.
Technical Training
600 N. Sherman Drive
Indianapolis, Indiana 46201

First Edition 9043 - First Printing
Copyright 1990 by Thomson Consumer Electronics, Inc.
Trademark(s) Registered Marca(s) Registrada(s)

CONTENTS

Introduction	5
Features	5
Laser Disc Overview	6
Video Disc	7
Digital Audio	11
The Laser Disc Player	13
Overview LDR300	17
Mechanism	17
System Control	18
Servo	18
Signal Processing	21
Overview PSLD40	23
Mechanism	23
System Control	25
Servo	26
Signal circuits	27
Service Procedures	28
System Control	29
LDR300	29
PSLD40	30
Servo Section	34
Focus Servo	34
Height Servo	38
Tracking Servo	39
Slider Servo	41
Tilt Servo	43
Time Base Correction Servo	46
Signal Processing Section	50
Video Section	50
Digital Audio	52
Analog Audio	54

Appendixes	
Appendix A	
Test Mode	56
Appendix B	
Laser Power Confirmation	59
Appendix C	
Laser Lens Cleaning	60
Appendix D	
IC201 (Digital Audio Decoder)	61
Appendix E	
IC11 (Mode Control Microprocessor)	63
Appendix F	
IC801 (Mechanical Control Microprocessor).....	64
Appendix G	
IC601 (Servo Controller)	66
Appendix H	
IC901 (Time Base Correction Servo)	67

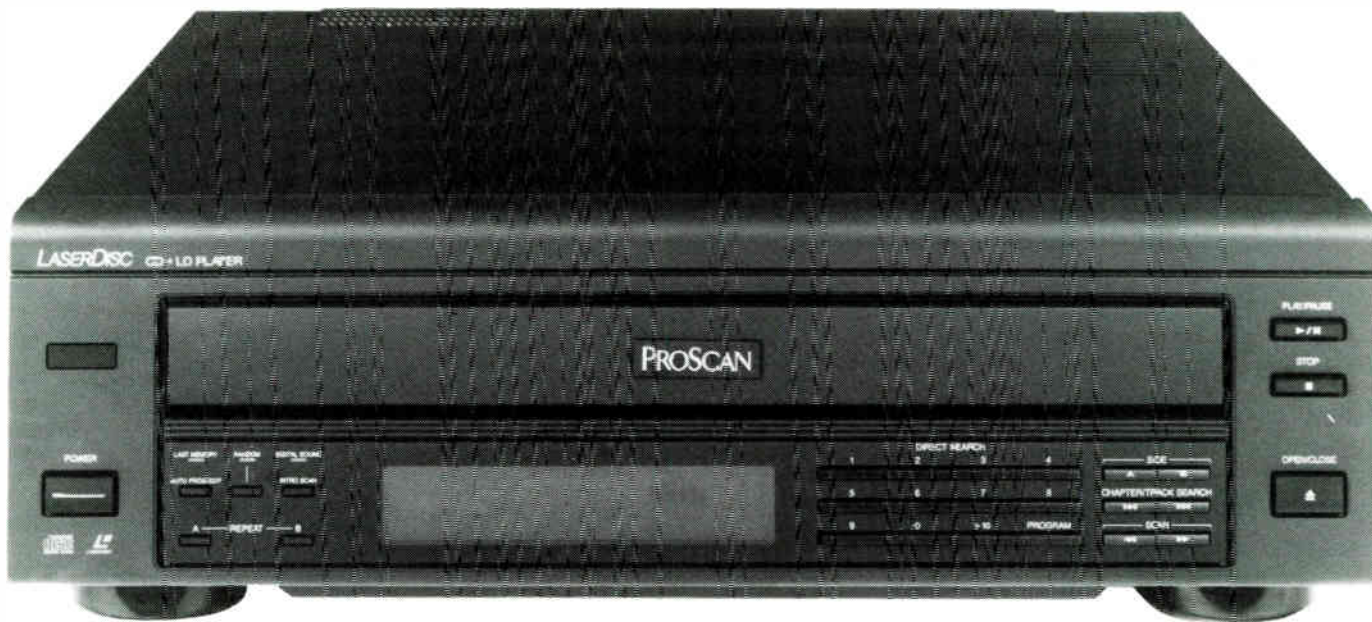

Fig. 1 - ProScan PSLD40

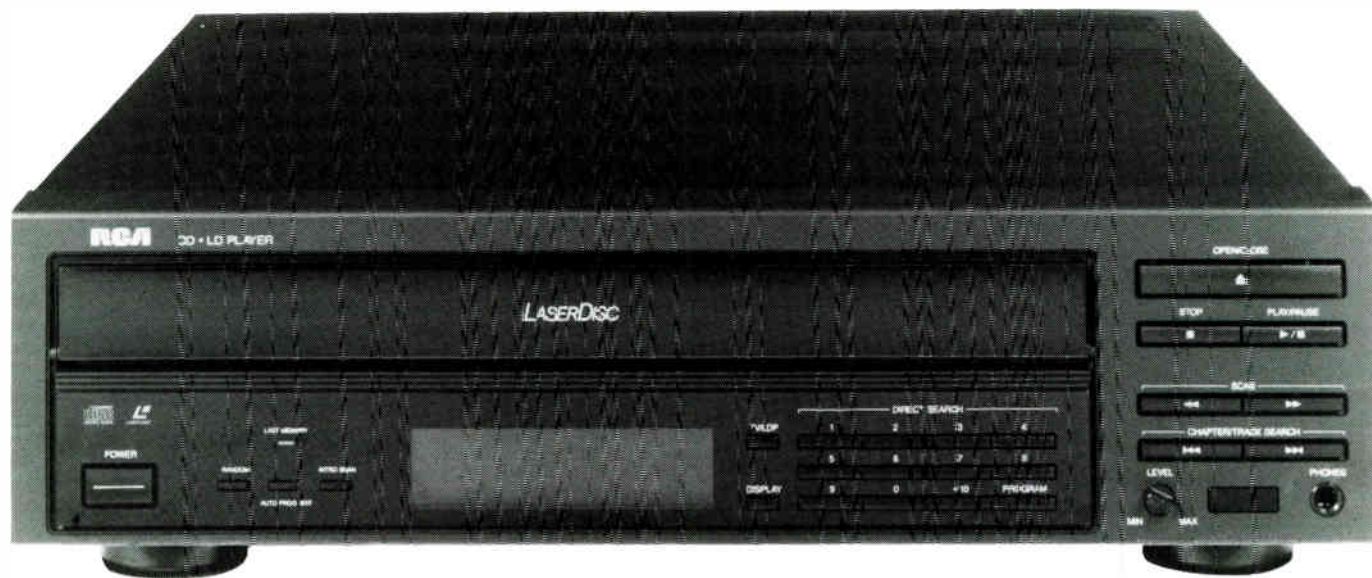

Fig. 2 - RCA LDR300

INTRODUCTION

The ProScan PSLD40 and the RCA LDR300 can be grouped into a new category of laser disc player. This category is called multi players, these players have the ability of playing all available laser disc formats. The advantage of a multi player is the elimination of separate components to play video discs and compact audio discs. This advantage alone saves space and greatly simplifies connecting the laser disc player to the audio video system.

Both the RCA and ProScan disc players implement new features not previously found in laser disc players. One of these features is a one bit digital to analog converter. The new design generates less noise in the conversion process when compared to multi-bit converters.

The PSLD40 has an additional feature of dual side playback. This enables the PSLD40 to play both sides of a laser disc without having to remove the disc from the player. This allows remote control selection of information from either side of a laser disc.

Features

Some additional features of the PSLD40 and the LDR300 are.

On-Screen Programming

Displays the operating status of the player on the television screen, and on the front of the unit. Plus, video prompts are used to assist the operator in programming the players features.

Direct Access Play

Instantly accesses any point on a disc for playback. The player searches for that point and resumes normal playback from that point forward.

Memory Repeat

On the operator's command, memorizes a location on a disc. The player will then search for that point and resume playback.

Still Frame

On CLV (Constant Linear Velocity) formatted discs the laser disc player can still pause on one frame of video. Because there is no physical contact between the pickup of the player and the disc, this pause can be held indefinitely.

Intro Scan

Plays the first 8 seconds of each chapter or track on a disc. This gives a preview of all the material recorded on the disc.

Random Playback

Plays chapters or tracks of a disc in a random order. This allows familiar disc to be played back in a unfamiliar order.

Auto Program Editing

Automatically calculates the length of songs, or tracks on a disc that will fit in order, on each side of a tape. Stores the time into memory and uses this information to place the laser disc player in pause mode, when one side of the tape is full. This greatly simplifies dubbing from laser disc to tape.

Compu Program Editing

Determines the length of the songs, or tracks on a disc. Then resequences the songs or tracks to fit the maximum amount of material on each side of a tape. The laser disc player then plays them back in that order for recording onto a tape. In this mode the laser disc player will automatically go into pause mode when one side of the tape is full.

Videolink™ Remote Compatibility

Permits RCA stereo monitor-receivers with Videolink™ remote control to command the laser disc player.

LASER DISC OVERVIEW

In the reproduction of video and audio signals, the laser disc format has definite advantages over the tape and LP records. In video reproduction the laser disc can reproduce up to 425 lines of horizontal resolution, out performing broadcast, cable, and video tape formats. Audio reproduction with the laser disc player provides the clearest, and cleanest audio available for home use.

In the laser disc system a laser beam is focused on the surface of a rotating disc. The disc has a series of bumps (commonly called pits) etched spirally from the inside edge to the outside edge of its surface. Information is stored on the disc by varying the length of these pits. To detect this information the laser disc player monitors the level of light that is reflected from the disc's surface back into the optics of the laser disc player. For example, if the laser beam strikes a flat surface on the disc, all of the beam is reflected back into the optics of the player. In comparison, if the beam strikes a bump (or pit) on the disc surface some of the light is reflected away from the optics reducing the amount of laser light entering the

optics. The laser light that is not reflected away from the optics is canceled by the laser light being transmitted by the laser assembly. This cancellation is caused by the height of the bump above the disc surface. This height is $1/4$ wavelength, when the laser beam strikes the bump its phase is shifted by 180 degrees (See Fig 3). When the phase shifted reflected signal strikes the transmitted laser light the two signals cancel out, further reducing the amount of laser light being reflected back into the optics of the laser disc player.

The light that is reflected back into the optics of the player varies in amplitude as the beam strikes the different surfaces of the disc. This varying light is separated from the transmitted light by the optics of the laser assembly. Once separated the reflected light is applied to a sensor that converts the varying levels into an electrical signal. This electrical signal is called the RF signal. The frequency of the RF signal is related to the length of the pits (See Fig 4). The RF signal is then passed into the signal processing stages where it is demodulated.

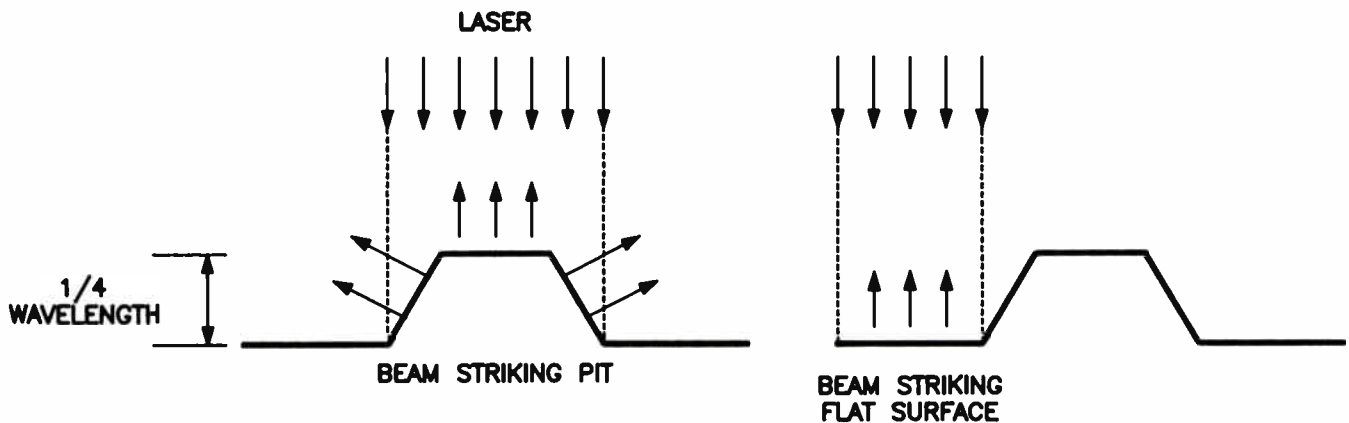

Fig. 3 - Pit Detection

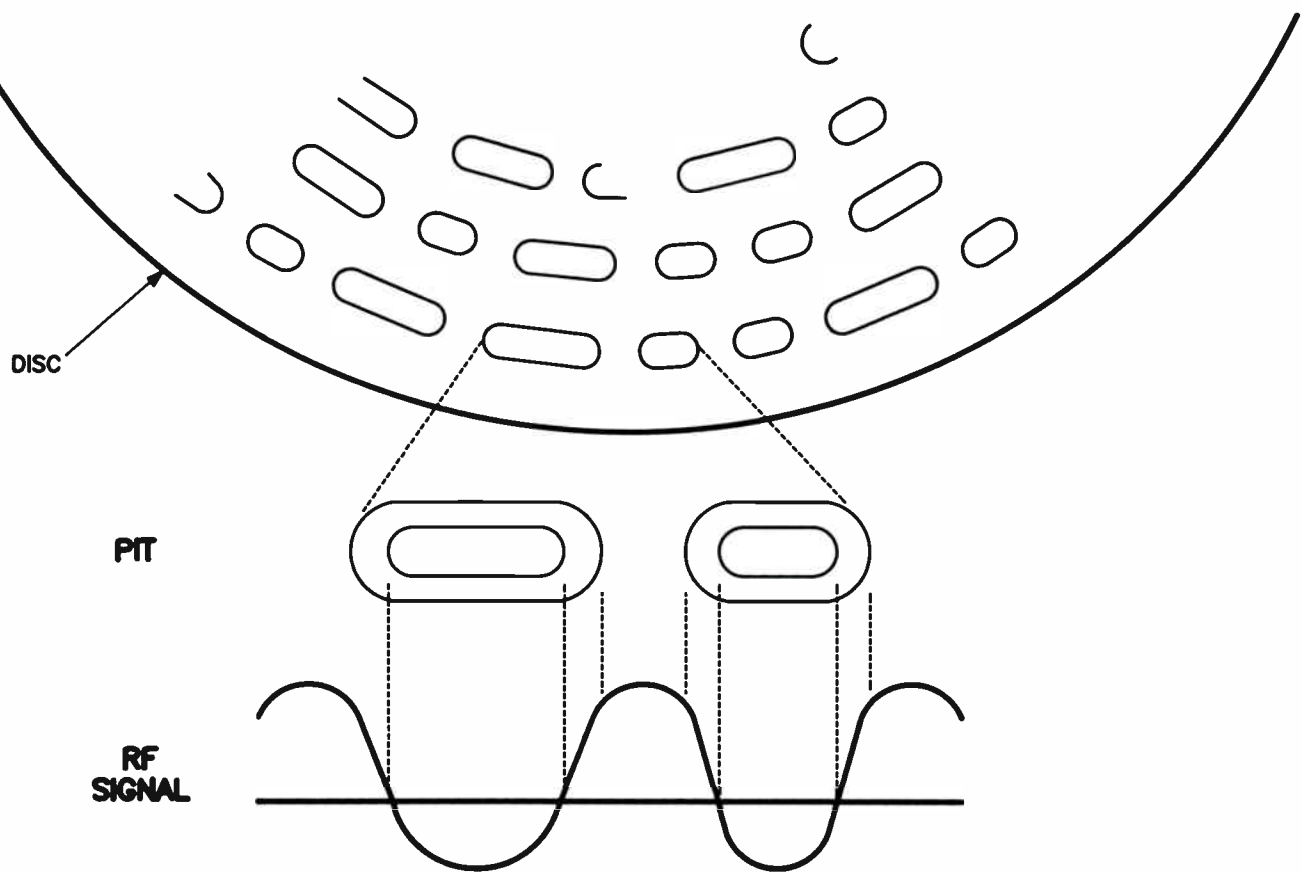

Fig. 4 - RF Signal

The processing and demodulation of the RF signal depends on the type of information recorded on the disc. For example, to process an RF signal that carries video information, the signal must be FM demodulated. A RF signal that contains a digital audio signal must go through processing to convert it back to an analog signal.

Video Disc

In the video disc format, the video information and the analog audio information are independently FM modulated and recorded on the disc. A digital audio signal can also be added to some discs. This digital audio signal is optional, and is not included on all discs. When included on a disc it is multiplexed with the FM modulated signals for recording on the disc.

The frequency spectrum for the different signals recorded on a video disc is shown in fig 5. The video information is FM modulated with a center frequency of 8.5 MHz and a deviation of ± 1.7 MHz. Unlike VCR format the video disc format does not separate the chroma information from luminance information for recording. This reduces the processing involved to play the signal back and provides a clearer picture. The two analog audio channels are FM modulated at 2.3 MHz for channel 1 and 2.8 MHz for channel 2. Both the analog audio channels have a deviation of ± 100 KHZ. The digital audio information occupies the 0 to 2 MHz region of the spectrum.

A block diagram of the laser disc record process is shown in fig 6. The video and analog audio information are independently FM modulated. Once modulated the

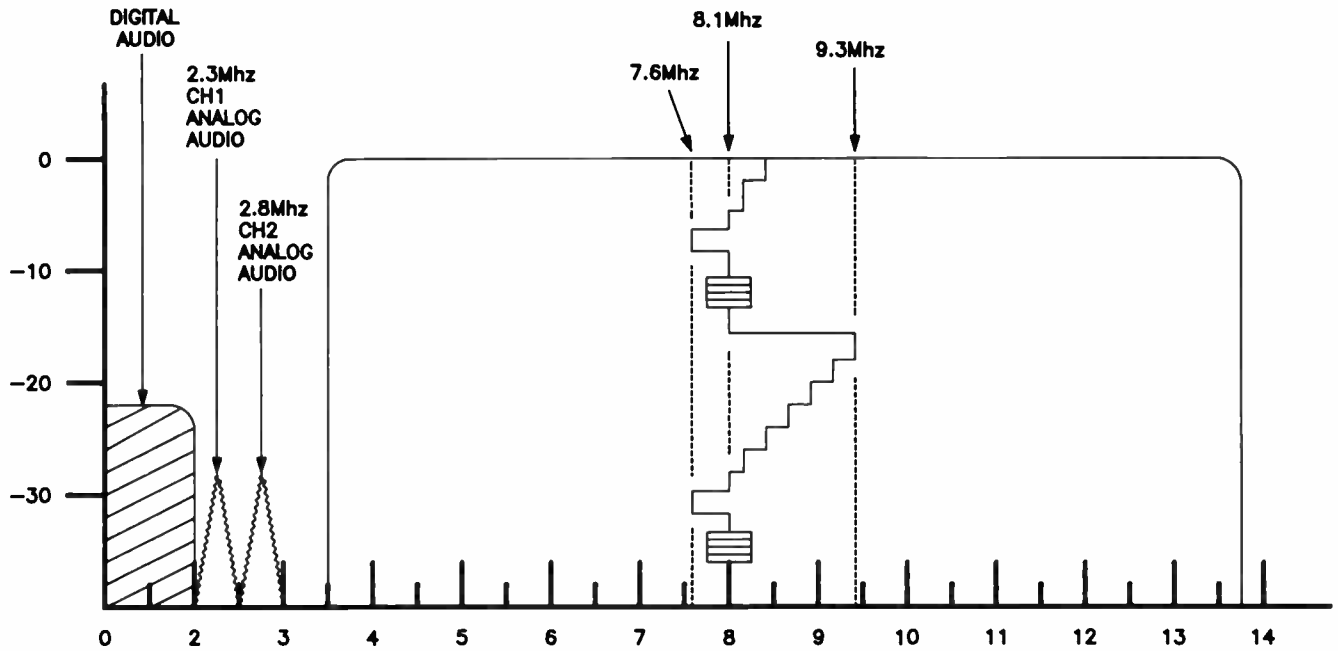

Fig. 5 - Frequency Spectrum of LD Player

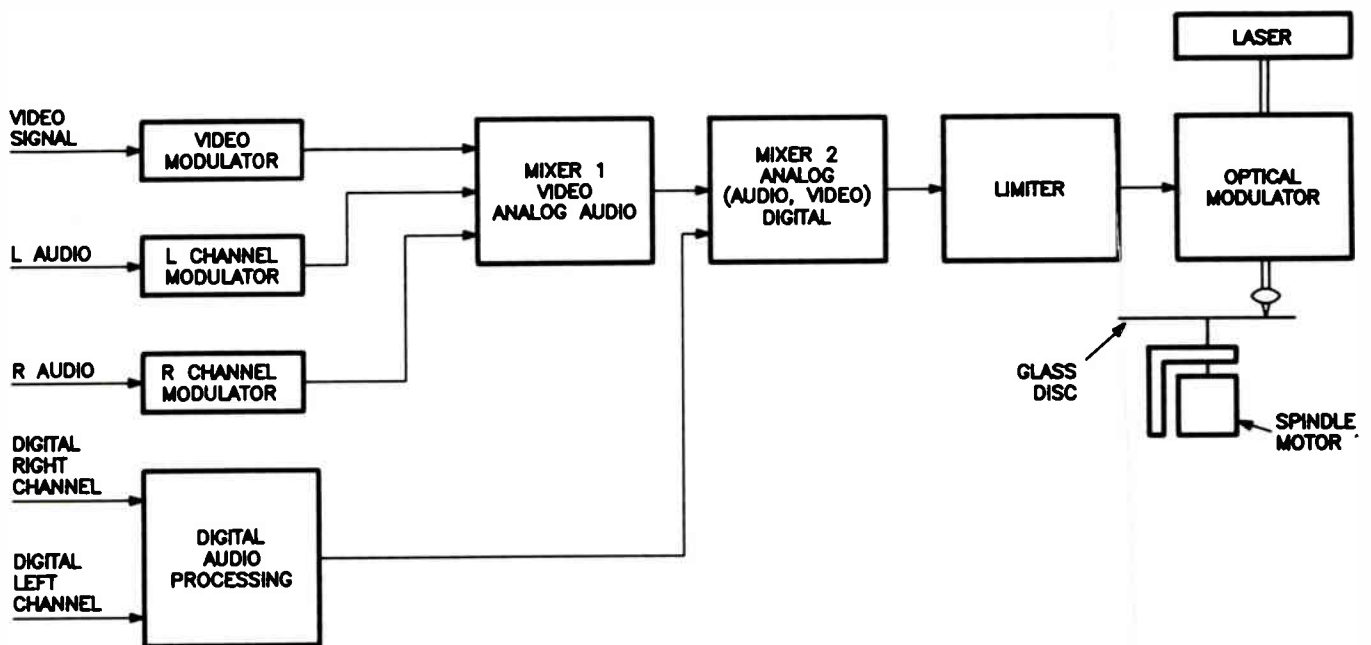

Fig. 6 - LD Record Process

three FM signals (video, CH1 audio, CH2 audio) are applied to mixer 1 where they are combined. The output of mixer 1 is then applied to mixer 2. Mixer 2 is only used on laser discs that include digital audio. The purpose of mixer 2 is to combine the FM modulated analog signals with digital audio. Before this occurs the digital audio signal must be produced by converting an analog audio signal to a digital signal. The process for doing this is the same procedure used in the manufacturing of compact discs and will be covered in the digital audio section of this manual.

The output of mixer 2 is a composite signal that includes the FM signals with digital audio. This composite signal then is amplitude limited and applied to an optical modulator. The optical modulator takes the limited composite signal and uses it to control the on/off operation of a laser.

This laser cuts the pits (or bumps) on a multi layer glass disc. This glass disc is treated to have a layer of photo resist on the surface of it. The laser beam strikes this layer exposing it. The glass disc is rotated by a spindle motor, while the laser is pulled from the center of the disc to the outside edge. This creates a long track of exposed portions of photo resist running from the center to the outside edge of the disc. When exposing is completed the photoresist layer is developed to reveal the pits caused by the laser exposure. The disc then has a

layer of nickel deposited on it to make the master disc. The master disc is the mold from which the reproduced disc are made.

In the exposing of the master disc, it is very important that the manufacturing environment is free of dust. The reason for this is due to the size of the information recorded on the disc. With the average bump diameter of .4 micro meters and the spacing between the tracks of 1.67 micro meters, a speck of dust can cover large areas of information. If a large number of dust particles are present in the mastering process the disc could even be rendered unplayable.

The speed in which the disc is rotated, and the rate the laser is pulled across the disc surface, is determined by the format of the disc. Video laser disc come in three formats; CAV (Constant Angular Velocity), CLV (Constant Linear Velocity), and CAA (Constant Angular Acceleration). These three formats can be recorded on either a 8" disc or a 12" disc.

In the CAV format the disc is rotated at a constant 1800 RPM. The video information is laid out so each rotation of the disc consists of one frame, or two fields. In this format the horizontal blanking and sync pulses are aligned into two narrow strips radially across the disc (See Fig 7).

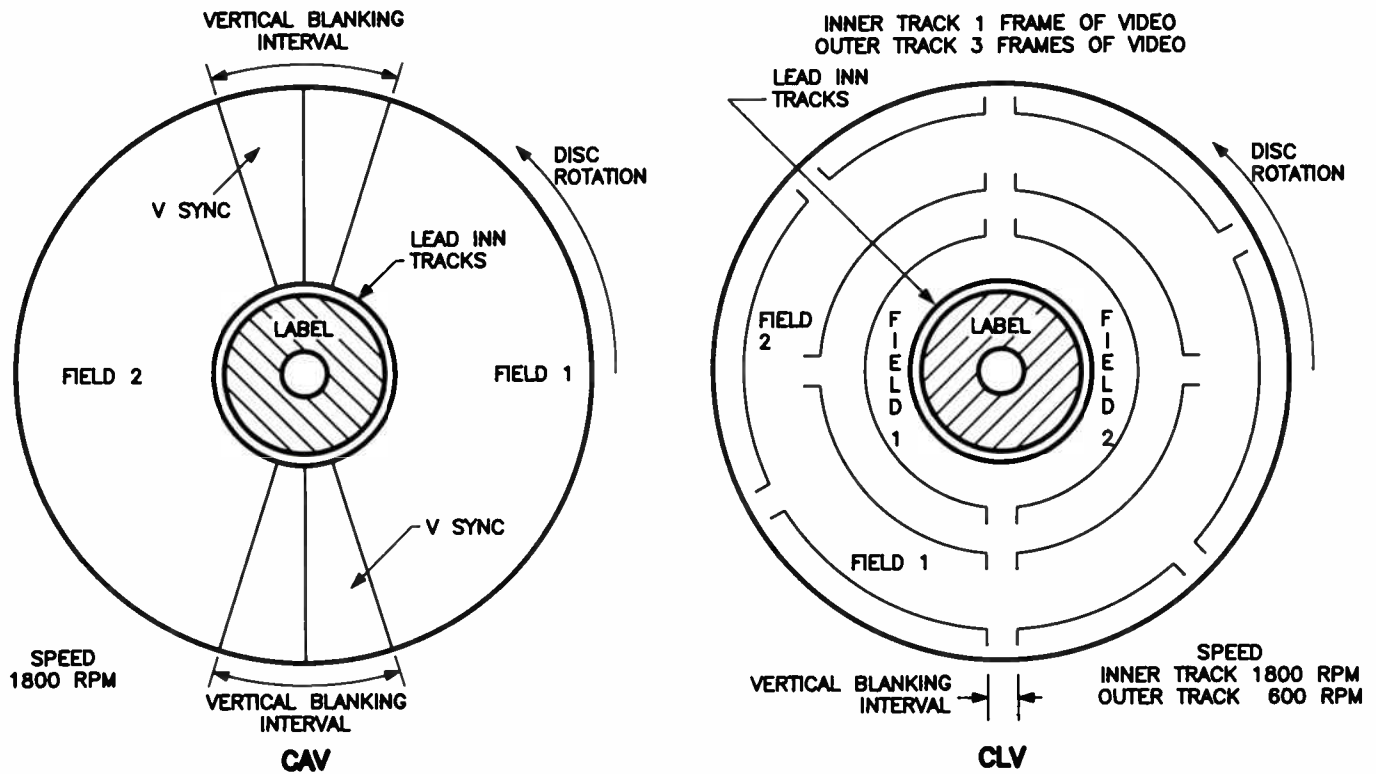

Fig. 7 - LD Format

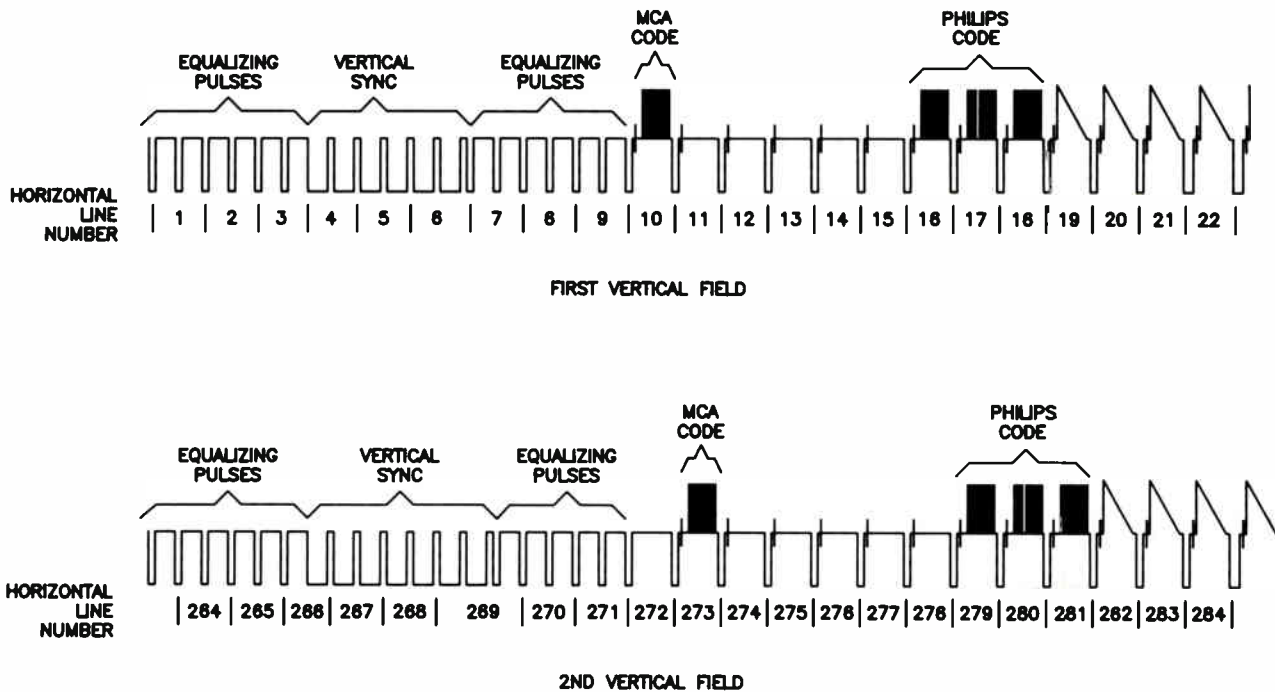

Fig. 8 - Philips Code Location

In the CAV format each frame is assigned a number from 1 to 54000, plus separate numbers called chapter numbers can also be encoded on the disc. These numbers can be used to find a location on the disc, or to find the start of a segment of video. In the CAV format the maximum playing time is 30 minutes per side.

In the CLV format a constant velocity is maintained between the data on the disc and the pickup assembly. To keep the velocity constant the rotation speed of the disc must decrease as the pickup moves outward. This allows more information to be stored in the outer tracks of the disc than can be stored in the inner tracks. In the CLV format the center of the disc produces one frame of video per revolution and has a rotation speed of 1800 RPM. The outside edge of the disc will have three frames of video per rotation and has a rotation speed of 600 RPM. The advantage of the CLV format is that it stores twice as much information as the CAV format. CLV formatted discs can store up to 1 hour of video per side. This allows complete films to be stored on one disc. The disadvantage of CLV formatted discs is that special effects cannot be easily done. This is because of the varying amount of information stored in one revolution of the disc.

CAA format disc addresses one problem that seriously affected the quality of the picture of a CLV disc. This problem was interference between adjacent tracks of video. This interference appeared as a vertical line that floats through the picture. The cause of the interference is imperfections in the disc (disc warping, incorrect centering, or uneven track-to-track spacing). These imperfection can be great enough to allow the laser beam to strike the horizontal sync pulse of the adjacent track, resulting in the interference. To correct this problem the CAA formatted disc is recorded in many sections, each section is at one constant speed. As the information moves away from the center of the disc the speed in which the sections are recorded is reduced. When playing a CAA disc the laser disc player plays a section of the disc at one speed, then increments to the next lower speed to play the next section. This is unlike CLV formatted discs, in which the speed slows gradually as the pickup moves away from the center of the disc. The advantage of slowing the speed in increments is that the video tracks of the same speed can be lined up to prevent sync tip interference. CAA discs are often referred to as CLV discs because of there 1 hour playing time.

The laser disc player has the capability of identifying locations of the information on a disc. There are three methods for identifying the information on a disc. The first method is to number the boundaries of the information on a disc, similar to chapter numbers in a book. These numbers are even referred to as chapter numbers, and are usually indexed on the jacket of the disc. The next method is to number each frame of video on a disc. This number is called the frame number and is only used on CAV discs. The last method is to indicate the elapsed time from the start of the disc. This time is recorded on the disc in the same fashion as frame numbers. This method is used for identifying locations on the CLV disc and CAA discs.

In all three methods of identifying the information on a video disc, every field of video must have data giving the location of that field on the disc. This information is located in the Philips code of the vertical sync interval (see fig 8). During playback, this information is read from the disc and sent to the system control microprocessor for display and special effect functions. Along with the location data the Philips code also contains status information. Status information is data recorded on the disc to tell the laser disc player the size of the disc, if digital audio is present on the disc, and if noise reduction is used on the analog audio.

Digital Audio

In the video disc format, the digital audio is processed in the same manor as the digital audio recorded on a compact disc. This allows the same circuitry to be used in both the laser disc player as in the compact disc player. The block diagram for the record process of digital audio is shown in fig 9.

In the record process, the first step is to convert the analog audio signal to a digital signal. To do this a analog signal is first applied to a low pass filter. This low pass filter has a cutoff frequency of 20 KHz to keep higher frequencies from causing interference in the digital conversion stages. After Low Pass Filtering the analog signal is applied to the Analog to Digital converter.

This converter samples the analog audio signal at 44 KHz rate (double the audio frequency) and assigns a 16 bit digital word for each sample. This processing is done for each channel of audio. After conversion the 16 bit codes for each channel are multiplexed together. The output of the multiplexer is a string of 16 bit words alternating from the left to right audio channel. This string of alternating data is applied to the CIRC (Cross Interleave Reed Solomon Code) stage. This stage is for correcting data drop outs in the play mode. The CIRC is a digital data correcting code that corrects for errors in two ways:

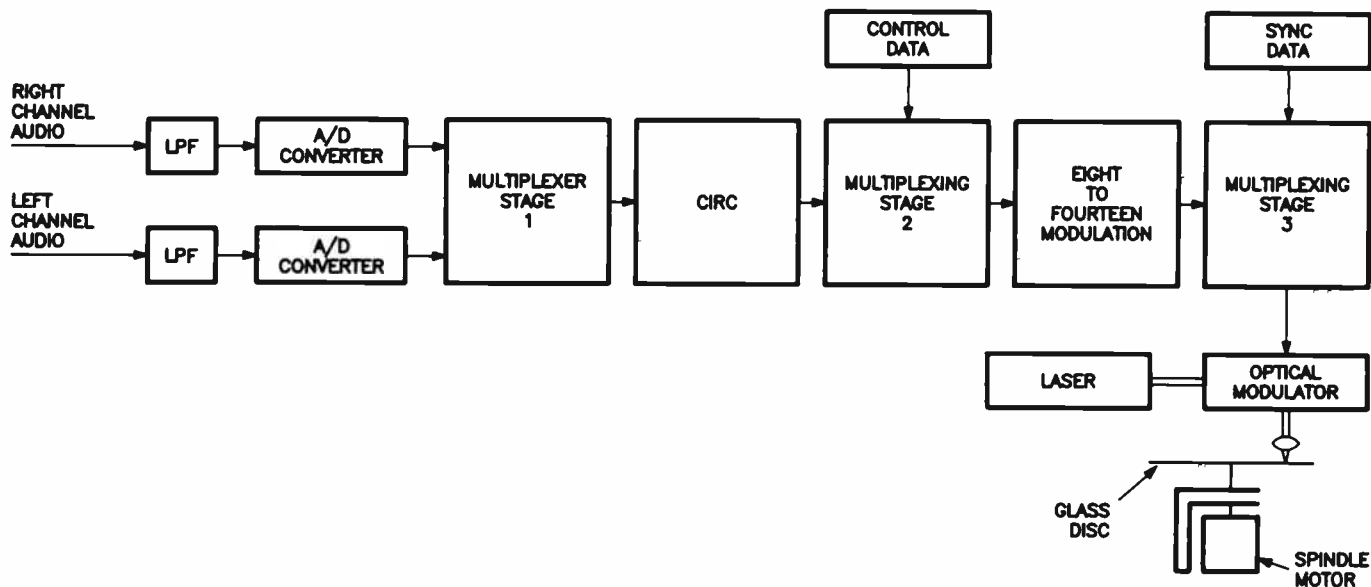

Fig. 9 - CD Record Process

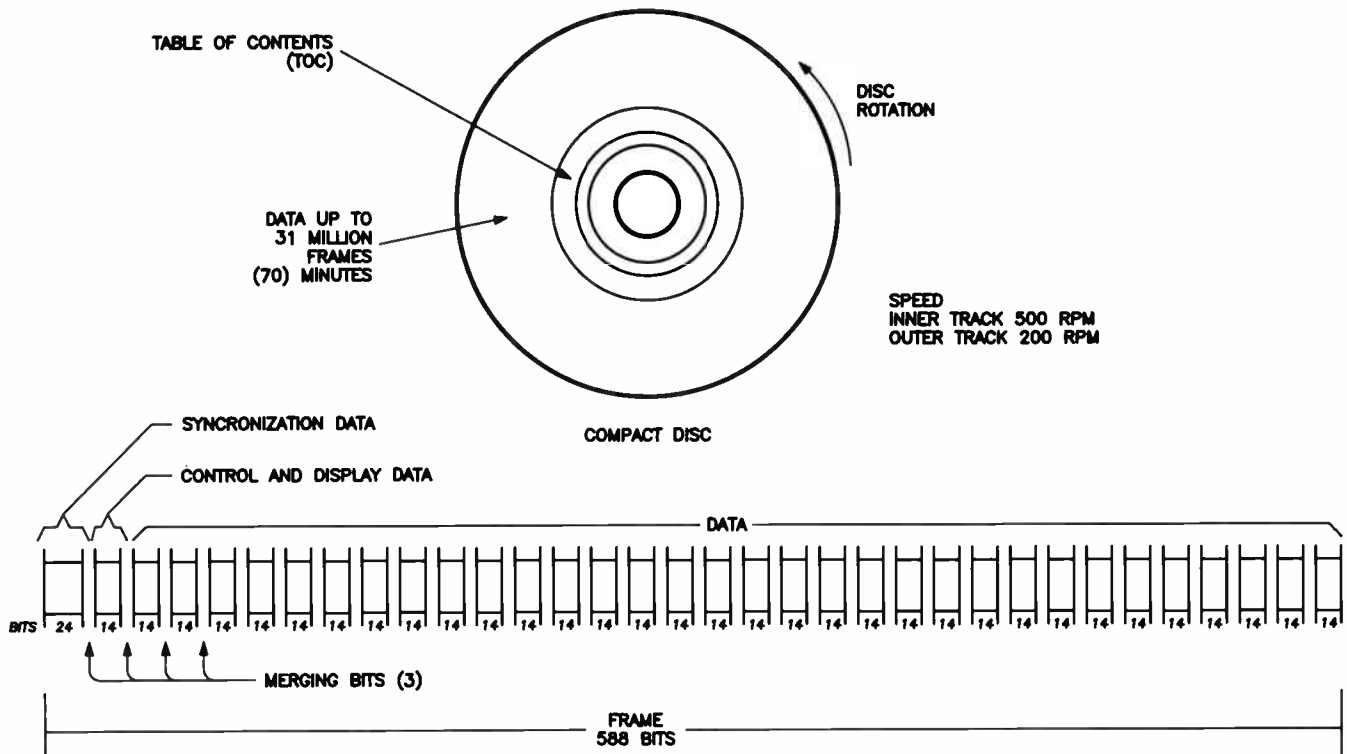

Fig. 10 - CD Format

A. The first method corrects for random errors of missing bits of data. This type of error is usually a random one or two bits of missing data. To correct for this extra bits of data are inserted into data groups. These bits are either 1's or 0's and called parity bits. Whether a 1 or a 0 is added to the data depends on the amount of 1's or 0's in the data stream. For example if all the 1's in a data stream add up to an even number, the parity bit would be a 0. If all the 1's in a data stream add up to an odd number, the parity bit would be a 1. In the playback process the parity bits are read and compared to the data stream to determine if data is missing.

B. The second method of error correction is for burst errors. Burst errors are groups of missing data, usually caused by scratches or finger prints on the disc surface. To prevent this type of error from making the disc unplayable, adjoining bits of data are separated when recorded on the disc. By recording adjoining symbols in places remote from each other, the risk of losing consecutive bits of data can be reduced. This process is called

interleaving and is very similar to shuffling a deck of cards in a predetermined order. Naturally, if the data is shuffled in record, it must be unshuffled in the same order when played back.

After interleaving, the CIRC stage divides the data into groups of 8 bits. These 8 bit groupings (named symbols) are then applied to a second multiplexer stage. This multiplexer takes the data and groups it into frames of 32 symbols. To separate the frames, an 8 bit control word is added to the start of each frame. This control symbol (8 bits) is only one piece of a larger control word that is spread out over 98 frames of data. The control word initially informs the system how many tracks are included on the disc, and how long the disc can play. This information is referred to as the table of contents, and must be read before the disc will actually start playing.

To read the complete control word, the player must read 98 frames of information. Each frame of information is read and stored into memory until the complete word is stored. The time it takes for the laser disc player to read the 98 frames is approximately 13.3 mSec. Once the control word is read and stored into memory the remaining control words on the disc are used to keep the memory updated.

Once the control word is added, the data is now sent to an eight-to-fourteen bit modulator. The EFM (Eight-to-Fourteen Modulator) breaks the frame into eight bit symbols. The symbols are then assigned a fourteen bit code to indicate their value. With eight bits of data there are only 256 possible combinations. By using a 14 bit code the number of possible combinations increases to 16,384. By having this many possible codes to chose from, codes can be chosen to meet some specifications.

1. One of these specifications is that a code cannot have more than 10 consecutive 1's or 0's. If there are more than 10 consecutive bits of the same data, the laser disc player will have problems tracking and decoding the information.
2. The second specification is that the difference between codes used must be great enough that if one bit of data is missing, a different usable code could not be created.

Once 14 bit codes are chosen they are assigned to an 8 bit code for the conversion process. After conversion, 3 bits are added to separate 14 bit codes from each other. This is done to prevent 10 consecutive bits of data being created when the 14 bit words are added together. These bits are named merging bits.

The final stage of the encoding process is the addition of the sync signal by the third a multiplexer. The sync signal is a 24 bit code added to the start of each frame of data. The sync signal tell the player the start of each frame of data. Once the sync signal is added to the composite signal it is applied to a optical modulator, for recording on a compact disc. When recording on a video disc, the composite signal is added to the FM modulated analog signals, and then recorded on the disc.

The CD composite signal is shown is fig 10. In the figure one frame of information is made up of 588 bits, this includes the sync and the control data. The disc shown in fig 10 is a example of the format of a compact disc. In the compact disc format the speed varies from 500 RPM

on the inside tracks, to 200 RPM on the outside tracks of the disc. In the compact disc format, the frames of data are recorded on the disc very similar to the CLV format laser disc.

The Laser Disc Player

For a laser disc player to receive and decode the information recorded on a disc it must be able to;

1. Keep the laser beam focus on the laser disc as it rotates.
2. Keep the laser centered on the row of pits as as it spirals outward on the disc.
3. Maintain a constant rotational speed, that can be varied with the different formats of laser discs.

A block diagram of a basic laser disc player is shown in fig 11. The pickup assembly is responsible for retrieving the reflected laser light. The reflected laser light is converted to a RF signal and applied to the signal processing stages. The pickup assembly also generates the error signals. These error signals are applied to the different servo loops to keep the laser focussed and tracking correctly throughout the disc.

Focus Servo

The focus error signal is the most important error signal for the operation of the laser disc player. Without proper focus of the laser beam on the disc surface data cannot be retrieved. The focus error signal is applied to the focus servo. The focus servo develops a drive signal for pickup assembly. The drive signal is applied to the focus coil which moves a lens in the optics of the pickup. When this lens is moved up and down the focal point of the laser beam is varied, allowing the pickup assembly to keep the laser beam focused on the disc.

Tracking Servo

The tracking error signal is used to keep the laser beam following the track of information on the disc as it spirals outward. An error signal is generated in the pickup assembly. This signal is applied to the tracking servo. Like the focus servo, the tracking servo uses this error signal to develop a correction signal. This correction signal is then applied to the pickup assembly, where it is used to drive the tracking coil. Unlike the focus coil the tracking coil moves the lens side to side. This side to side movement keeps the laser beam centered on the track of information as it moves spirals outward.

The high frequency component of the error signal is used to correct for horizontal jitter in the video signal.

When playing a audio compact disc the laser disc player cannot use the horizontal sync signal from the video section. In this case the laser disc player uses a error signal generated in the digital audio processing section. This error signal is developed from the sync signal that is recorded at the start of each digital audio frame. This sync signal is compared to a master clock in the digital processing IC and a error voltage is generated from the difference of the 2 signals. This error signal is then sent to the TBS section for generation of the spindle motor correction signal.

In order for the TBS to operate, it requires a input from either the digital audio section, or the video processing section. These signals are generated from the data recorded on the laser disc. If the spindle motor is not rotating near the correct speed information cannot be read from the disc. To get the spindle motor rotating close to the correct speed, FG pulses are generated from a sensor mounted on the spindle motor. The TBS section uses these pulses to get the spindle motor running at a predetermined speed. At this speed the pickup assembly is able to read the data from the laser disc. Once the data is read from the disc the TBS section switches over to the error signal generated in the signal processing sections.

System Control

The system control section is responsible for the overall operation of the laser disc player. It receives the front panel commands from the operator, and relays that information to the appropriate section. It also receives the data from the disc to tell it the chapter number, frame number, and the elapsed time. This data is then used for the special effect functions, and the displayed on the front of the laser disc player.

The most important function of the system control section is to control the operation of the servo sections of the laser disc player. In most laser disc players the focus servo is the first servo that is energized. Once the focus servo is focused it sends a focus lock command to the system control. The system control then starts the spindle motor rotating, and allows the tracking servo to lock onto the track of data.

During the time the spindle motor is rotating FG pulses are monitored. When the predetermined speed is reached, the system control section switches the TBS over to monitor horizontal sync or digital audio sync. This order of operation is varied with the different laser disc players, but every laser disc player must have a start up sequence to operate.

Video Processing

The video processing section receives the RF signal from the pickup assembly and demodulates it. Once demodulated, horizontal sync pulses are sent to the TBS section for spindle speed correction. The video processing section also receives a input from the TBS section to correct for horizontal jitter that is too high of a frequency for the spindle motor to correct for. The output from the video processing section can be sent to either a RF modulator or to a character generator, depending on the laser disc player.

Analog Audio Processing

The analog audio section receives the RF signal from the pickup assembly. It then separates the two RF carriers for the right and left channel and demodulates them separately. Once demodulated, the right and left audio signal is then applied to a audio switch. This switch is controlled by the system control micro and determine if digital audio or analog audio is sent to the audio output jacks and the RF modulator.

Digital Audio Processing

The digital audio section receives the RF signal and decodes it. Because this signal is not FM modulated it must be processed differently than the analog signals. One of the major differences is establishing the logic levels of the signal being applied. After this is done the signal is then sent through the error correction stages. Following error correction the digital signal is converted from a 14 bit word to a 8 bit word. Then the last process is to convert it back to the original analog signal.

The digital audio section must also send a error signal to the TBS section to keep the spindle motor operating at the correct speed. This error signal is only used when the player is playing a compact audio disc. If the digital audio signal is from a video disc the TBS section uses the horizontal sync from the video processing stages to control the spindle motor speed.



LDR300 Service Position

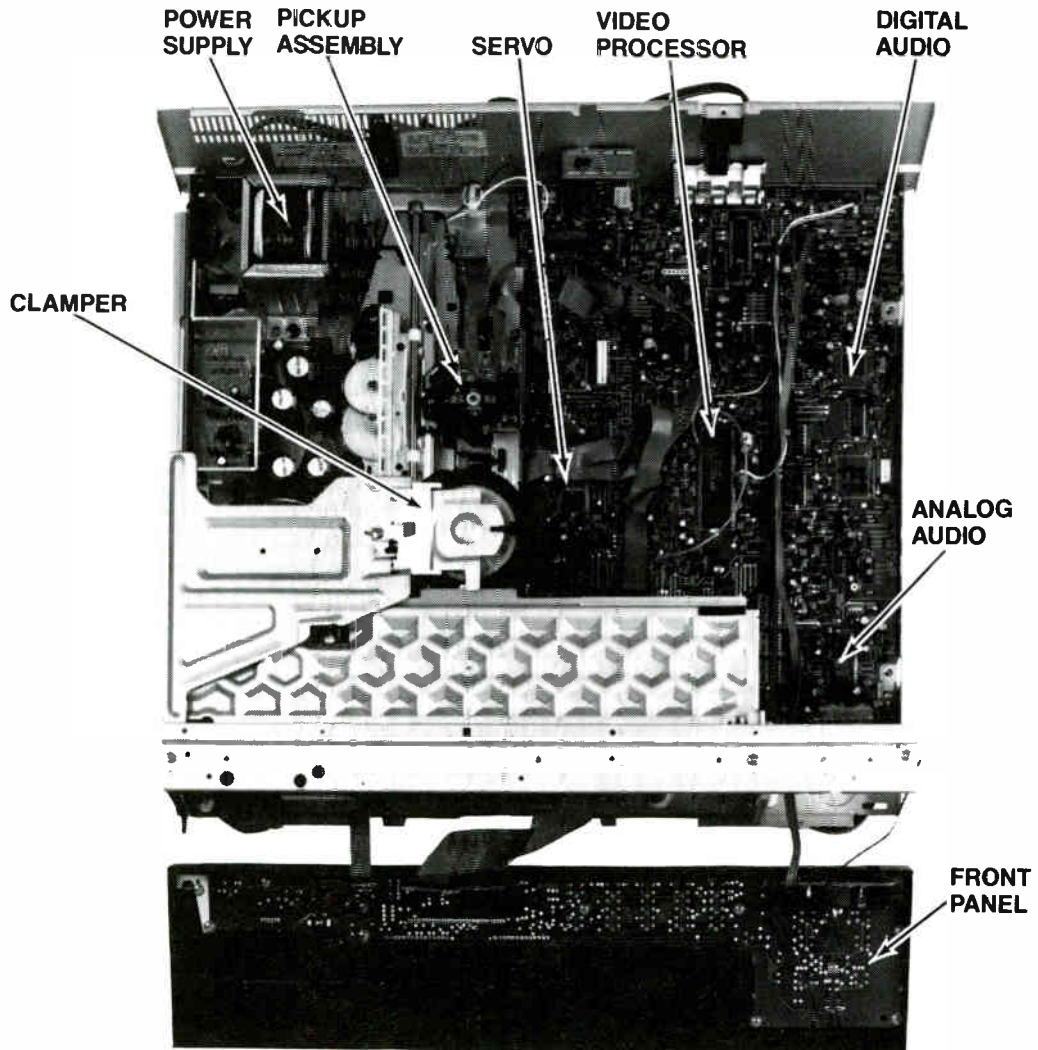

Fig. 12 - LDR300

OVERVIEW LDR300

The service position and board location for the LDR300 is shown in fig 12. To put the player into the service position the top cover and the disc tray must be removed. At this point the back cover of the player is loosened to allow the RF modulator, audio, and video jacks to be released. The screws holding the main circuit board can now be removed allowing the circuit board to be stood on end. This service position allows access to both sides of the main circuit board while keeping the laser disc player fully operational.

The block diagram of the LDR300 is shown in fig 13. The circuits of the LDR300 can be divided into 4 circuit areas, mechanism, system control, servo, and signal processing.

Mechanism

The mechanism of the LDR300 uses one motor to perform 3 functions. These functions are:

1. Move the disc tray in and out to let the operator place a disc onto the tray.
2. Once the tray is moved back into the machine, the tray is lowered and the disc is clamped onto the spindle motor.
3. After the loading sequence is completed, the loading motor is then used to drive the tilt mechanism.

In the LDR300 the drive to the tilt loading motor is supplied from a motor drive IC. This drive IC receives 3

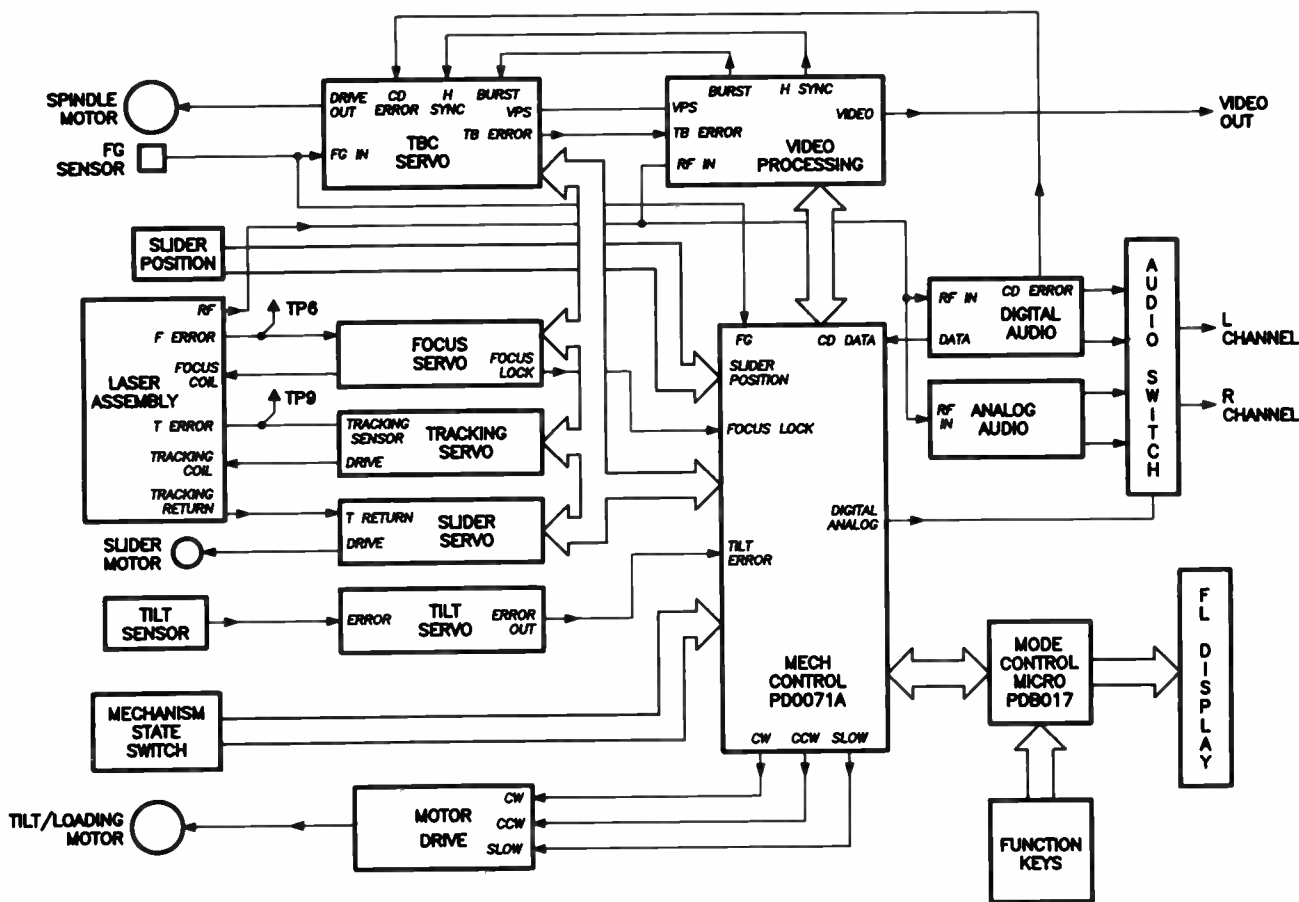

Fig. 13 - LDR300 Block Diagram

inputs from the system control microprocessor. The these inputs are CW, CCW, and slow. The CW and CCW inputs control the rotation direction of the spindle motor. The slow input is a high logic level during loading and unloading to increase the speed of the motor. The logic level is then pulled low to slow the speed of the motor. This is done when the loading motor is used to operate the tilt mechanism.

The position of the mechanism is monitored by the mechanism state switch. This switch sends different logic levels to the mechanical control micro as the loading motor moves the mechanism through its different positions.

System Control

The system control section consists of a mode control microprocessor, and a mechanical control microprocessor. The mode control microprocessor performs the following functions;

1. Decodes the function input keys and the remote control input signal, then sends commands to the mechanical control micro.
2. Controls the information displayed on the front panel, and the television on-screen display.
3. Monitors the communications of the mechanical control micro. If a communication problem occurs, the mode control microprocessor initializes a system reset.

The mechanical control microprocessor receives commands from the mode control micro, and sends control signals to the appropriate sections. The mechanical micro also receives data from the different circuit areas to determine the status of the player.

After a disc is completely loaded the mechanical control micro tells the focus servo to search for focus. If focus is not achieved, the mechanical control micro then moves the laser assembly inward to a position determined by the slider position switch, and once again looks for a focus condition. The position of the laser assembly when focus lock is achieved, tells the mechanical microprocessor whether a compact audio disc, or a laser disc is in the machine.

The mechanical control microprocessor then communicates the type of disc to the different sections of the disc player. This must be done to properly process the RF signal read from the disc. After this information is pro-

cessed the mechanical control microprocessor then starts the spindle motor rotating to its predetermined speed. This speed is monitored by the FG pulses sent to the mechanical control microprocessor. The micro not only monitors the frequency of the pulses but also monitors the amount of time it takes the spindle motor to reach its predetermined speed. The microprocessor uses the time information to determine what size of video disc is being played (8" or 12"). During spindle rotation the tracking servo is enabled, and the laser assembly is moved to the inside tracks of the disc. Once the laser disc player as gone through this sequence of events it enters the play mode. This sequence is done every time a disc is loaded into the machine. If a problem occurs somewhere in this sequence, the mechanical control micro processor will place the player in the stop mode.

Note; The system control section of the LDR300 has a built in test mode. This test mode allows the servicer to manually step through the different operations to get the player to the play mode. This greatly simplifies the troubleshooting of the laser disc player. See appendix A of this manual for the operation of the test mode.

Servo

The LDR300 laser disc player uses 5 servo sections to provide the correct control of the focus, tracking, and spindle rotation.

The focus servo is the first servo in operation after a disc is loaded into the laser disc player. The first step the focus servo must takes is to find the initial focus point. A search action is started by the mechanical control microprocessor when the laser diode is turned on. When searching, the focus servo generates a ramp voltage that is used to drive the focus coil in the laser assembly. The focus coil moves a lens in the laser assembly up and down with the ramp voltage. This varies the focal point of the laser beam throughout its range of movement. An error signal is then generated by monitoring the reflected laser light as it strikes the opto electrical converter.

The opto electrical converters main sensor section is divided into four sections (see fig 14). These 4 sections are paired together and the output of the 2 pairs is applied to a comparator. If the distance from the disc to the laser assembly is too far, the error voltage is positive. If the distance is too close the error voltage is negative,

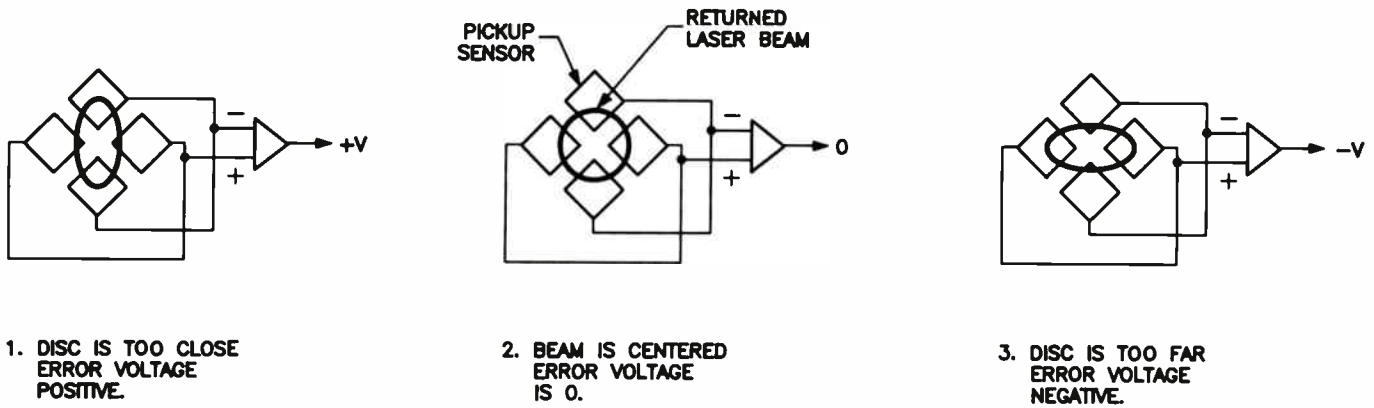

Fig. 14 - Focus Error

and at optimum focal distance the error voltage is zero. With the ramp voltage varying the focal distance, the focus error voltage is also varying. The circuitry in the focus section monitors the focus error, and stops the ramp generator when the error voltage is zero. At this point the focus servo is in the locked or closed loop mode. The error signal is now used to keep the focus distance at optimum. A focus lock signal is sent to the system control microprocessor to inform it that focus lock has been achieved.

The tracking servo keeps the laser beam following the track of information as it spirals around the disc. The single laser beam is split into 3 beams in the optics of the pickup assembly. These 3 beams are shifted so the lead beam is slightly right of the center beam, and the rear beam is slightly left of the center beam (see fig 15). The lens in the optics of the laser assembly that splits the beam and controls the stagger of the beams is called the grating lens. The 3 beams are sent to the disc and the reflected signals are monitored. The center beam is used for focus and data retrieval, and the outside beams are used to control the tracking system. As in the focus system, the reflected signal from the 2 outside beams are detected by 2 separate sensors on the optical electrical converter IC. The outputs from the sensors are then applied to different inputs of a comparator. If the beams

deviate to the right side of the row of pits, the error voltage is then positive. If the deviation is to the left side the error voltage is then negative, and for optimum beam landing the error voltage is zero. This error voltage is sent to the tracking servo. In the tracking servo, the error voltage is processed and used to develop the drive to the tracking coil. When drive is applied to the tracking coil a lens is moved from side to side in the laser assembly. This lens is the same lens that is moved in the focus operation, and by moving it side to side the beam landing point on the disc moves side to side. The tracking servo then assures that the center beam is striking the row of pits in the center.

The slider servo works in conjunction with the tracking servo. The lens in the laser assembly does not have enough range to track the row of pits as it spirals outward. The slider servo moves the complete pickup assembly outward to keep the tracking servo operating within its range. The slider servo monitors the DC level on the tracking coil. The higher the DC level the closer the tracking coil is to the end of its operating range. When this level exceeds a level determined by the circuitry in the slider servo, a drive signal is sent to the slider motor to move the pickup assembly. By moving the pickup assembly the slider servo keeps the tracking servo operating within its range.

The TBC (Time Base Correction) servo controls the rotational speed of the spindle motor. After focus lock is obtained the mechanical control microprocessor starts the spindle motor rotating. FG pulses are generated by a FG sensor and sent to the TBC servo and the mechanical control microprocessor. The TBC servo uses the FG pulses for a reference in the spin up sequence of the spindle motor. When the the FG pulses reach a frequency of 1600 RPM the TBC servo uses the horizontal sync from the video section. The mechanical control microprocessor times the amount of time it takes the FG pulses to reach 1600 RPM. This information is used determine what size of laser disc is in the machine (8" or 12"). If the spindle motor takes too much time to reach its predetermined speed, the mechanical control microprocessor then will put the player into the stop mode. Once the spindle motor is up to speed, the TBC section stops monitoring the FG pulses and starts monitoring horizontal sync pulses. The phase of the horizontal sync pulses are then compared to a reference signal generated in the TBC servo. The difference in phase between the 2 signals is used to generate a error signal. This is one of the error signals used by the TBC servo to provide time base correction. The other error signal is generated by

comparing the chroma burst signal to a second reference signal developed in the TBC servo. This burst error signal is sent to the video processing section for color phase correction. The burst error signal is also added to the horizontal error signal to make a composite time base correction signal. This composite correction signal is then used for speed correction of the spindle motor and time base error processing in the video processing section.

When a compact audio disc is played, an error signal is supplied from the digital audio section. This error signal replaces the error signal generated from the video processing section, and is only used to develop the drive for the spindle motor. In the LDR300 the spindle motor is driven by a PWM signal that is developed from either the CD error signal or the video error signal.

The tilt servo is used to keep a 90 degree angle between the disc and the laser beam. If the angle between the laser beam and the disc is less than, or more than 90 degrees cross talk may result, or skipping may occur. The tilt angle is monitored by a sensor mounted on the

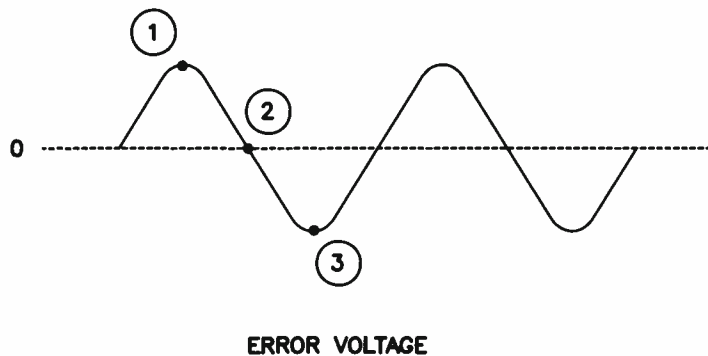
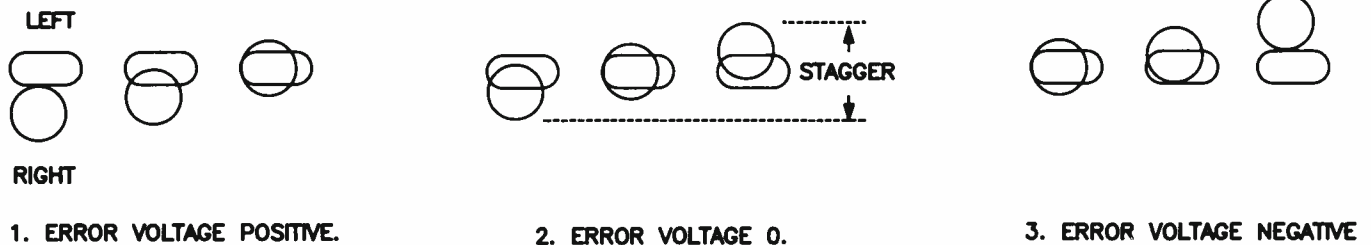

Fig. 15 - Tracking Error

pickup assembly. This sensor consists of an IR transmitter, and 2 IR receivers mounted besides the transmitter. If no warp is present, the reflected signal from the transmitter to both the receivers is equal. If the disc is warped the reflected signals to the receivers will be different depending on the direction of the warp. The outputs from the two receivers are summed together, and supplied to the tilt servo. The tilt servo provides some error signal processing, and sends the error signal to the mechanical control microprocessor. The mechanical control processor then uses this error signal to develop a drive signal for the tilt loading motor. The mechanical control microprocessor also checks the location of the pickup on the disc before sending drive to the tilt loading motor. The tilt sensor is mounted beside the lens on the pickup assembly. On the outside edges of a disc, the tilt sensor may be past the edge of the disc and provide improper information. The mechanical microprocessor then monitors the location of the pickup on the disc, and shuts the tilt servo off before the edge of the disc is reached.

Signal Processing

The signal processing stages receive an RF signal from the pickup assembly. The RF signal is constructed by summing the opto/electrical IC's 4 center sensors. These are the same sensors used by the focus servo to generate a focus error. The output level of the RF signal from the opto/electrical IC is approximately 500mV. This signal is then applied to the 3 signal processing sections in the LDR300.

The video processing section receives the RF signal and demodulates it. After demodulation the video signal

goes through drop out compensation, time base error compensation, and chroma phase compensation. After compensation the video signal is sent to the OSD (On-Screen Display) IC. The output from the OSD IC is then sent to the CH3/4 RF modulator and video out jacks on the rear of the unit. The time base and chroma phase corrections are accomplished by correction signals supplied from the TBC servo section. To generate the correction signals the TBC servo receives horizontal sync pulses, and a chroma burst signal from the video processing section.

The analog audio processing stage receives the RF signal from the pickup assembly, and runs it through a band pass filter. This filter separates the right channel and left channel audio carriers from the RF signal. These signals are demodulated and applied to the audio switch.

The RF signal is also applied to the digital audio processing section. In the digital processing section the RF signal is sent through separate filtering for the different types of disc that contain digital audio information (Laser discs and compact audio discs). After filtering, the RF signal is converted to a binary signal, and sent for decoding. The output from the decoder is a pulse width modulated signal (1 bit D/A) that is converted to analog audio. The analog audio signal is sent to the audio switch. The audio switch determines whether the analog audio signal, or the digital audio signal is applied to the RF modulator and audio output jacks. When playing a compact audio disc the digital audio section must send an error signal to the TBC servo to control the spindle motor speed. This signal is not needed when playing a laser video disc, because the video processing spindle loop is controlling the speed of the spindle motor.

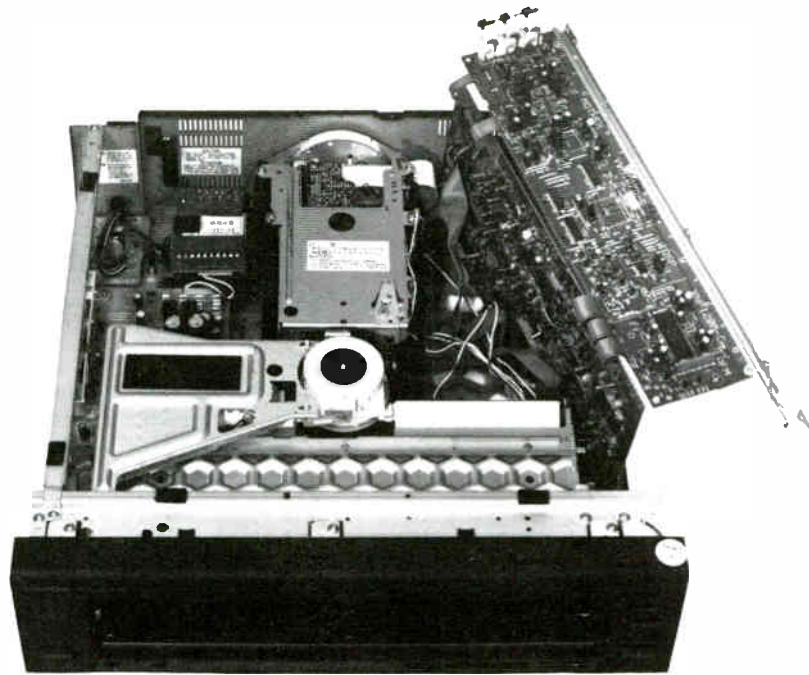

PSLD40 Service Position

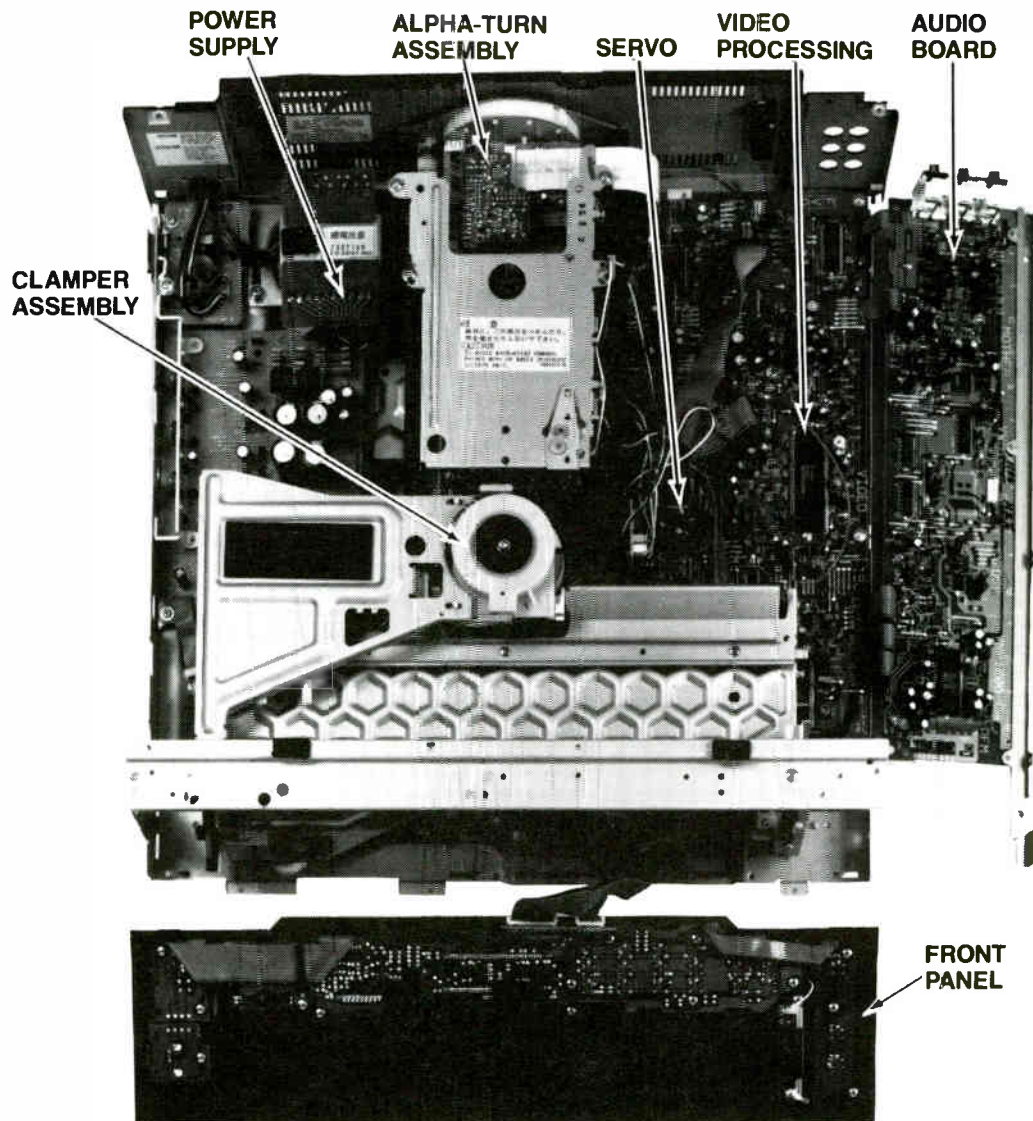

Fig. 16 - PSLD40

OVERVIEW PSLD40

The service position and board locations for the PSLD40 is shown in fig 16. To put the unit into the service position the top cover and the disc tray must be removed. After the tray is removed a jumper must be installed to defeat the disc tray position switch. This switch is located behind the disc door on the mechanism (see service data for installation procedure). Once this is done remove the screws holding the audio processing circuit board and fold the board down. With the audio circuit board folded down the screws holding the main circuit board can be removed. After the screws holding the main circuit board are removed, the boards can be lifted and placed into the service position. This service position allows both sides of the circuit board to be serviced while keeping the player fully operational.

The block diagram for the PSLD40 is shown in fig 17. Notice the block diagram for the PSLD40 is very similar to the block diagram of the LDR300. The major differences between the 2 disc players is the extra circuitry

required to operate the alpha-turn mechanism. This mechanism is used by the PSLD40 to play both sides of a laser disc without removing the disc from the player. Like the LDR300 the PSLD40 can be divided into four circuit areas; mechanism, system control, servo, and signal processing.

Mechanism

The alpha-turn mechanism is the main reason for the circuitry differences between the LDR300 and the PSLD40 (Fig 18). With the alpha-turn mechanism the PSLD40 plays side A of a laser disc in the same fashion as the LDR300. At the end of side A instead of stopping and ejecting the disc, the PSLD40 moves the pickup assembly into the inversion mechanism. The inversion mechanism then rolls the pickup assembly over and resumes playback of side B. This operation allows both sides of a laser disc to be played without operator assistance.

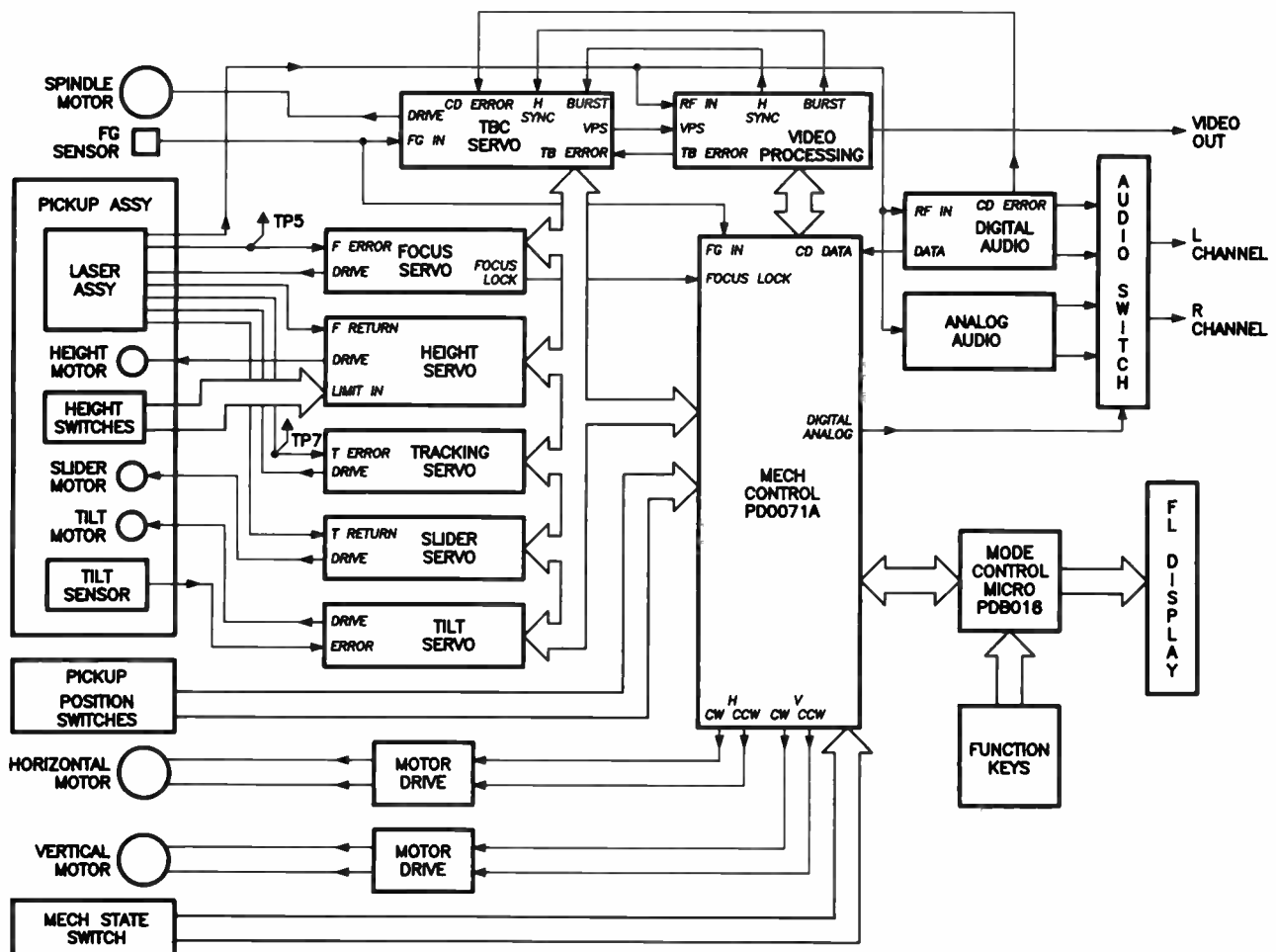

Fig. 17 - PSLD40 Block Diagram

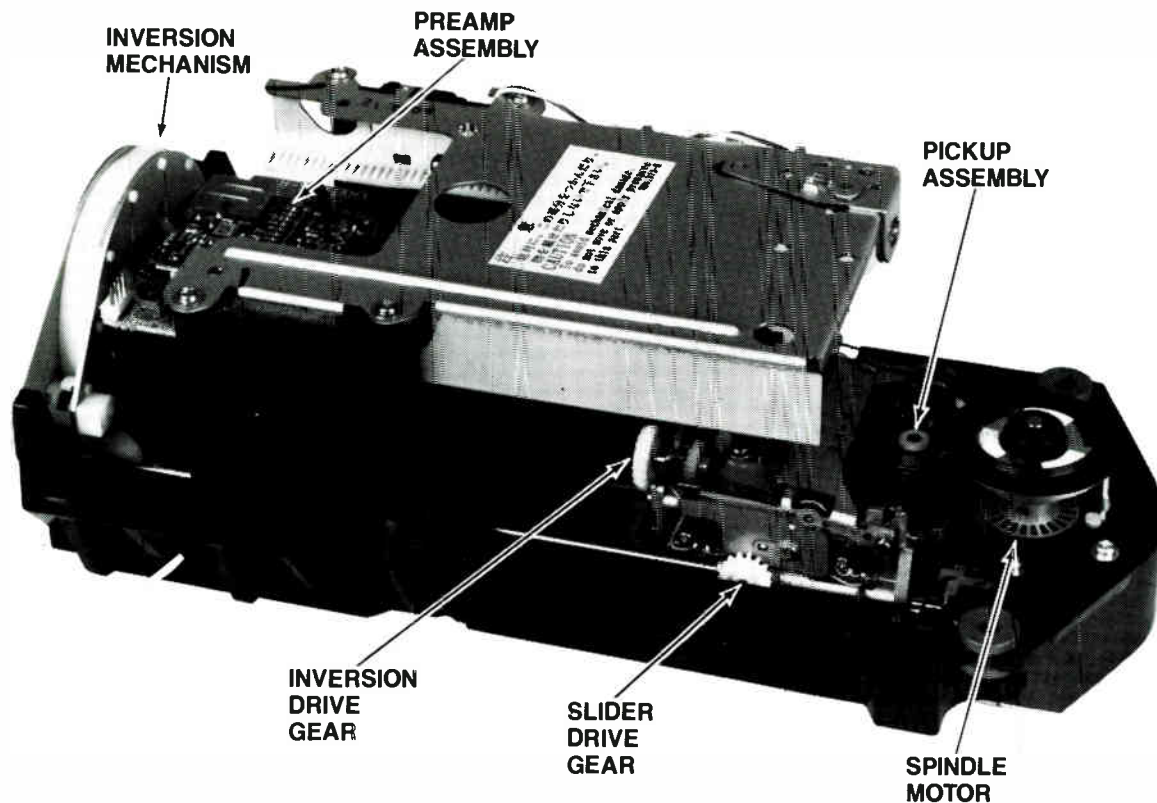

Fig. 18 - Alpha-Turn Mechanism

The operation of the alpha-turn mechanism is in 2 separate stages. The first stage is to perform the pickup inversion. The inversion process is done at the end of side A playback. Instead of the slider motor stopping at the end of the disc, it continues to pull the pickup assembly towards the inversion mechanism. The pickup assembly is guided towards the inversion mechanism by carriage shaft A and is loaded on to the inversion mechanism by the guide shaft (see fig 19).

In the inversion mechanism the slider motor continues to drive engaging the inversion drive gear. This gear is powered by the slider motor and provides drive to the inversion mechanism. The inversion mechanism now rolls the pickup assembly over aligning its guide shaft with carriage shaft B. At this point the slider drive gear is engaged with the side B drive track. This will pull the pickup assembly off of the inversion mechanism and onto carriage shaft B. The slider motor continues driving until it is stopped by the side B inside switch. The second step of the rotation process is done before focus is attempted on side B. This step is to reclamp the disc onto the spindle motor. The reason for reclamping is

that in the manufacturing of a laser disc, each side of the disc is made separately then glued together. The hole in the center of the disc is cut before the 2 sides of the disc are glued together. When the hole is cut it is centered on each side as close to the center of the disc as possible. Due to manufacturing tolerances, the hole for each side of the disc may not be in the same location. When loaded into the player the disc is clamped using side A. If the player were to play side B without reclamping the disc, side B may have too much eccentricity causing a loss of color in the playback video. To prevent this, the PSLD40 uses a dual-centering clamber to reclamp the disc for each side. To clamp side A of the disc, after the mechanism loads the disc, the clamber is lowered to its first level. At the first level hub-A is used to center the disc (See Fig 20). When the pickup assembly is inverted, the clamber mechanism is lowered even closer to the disc. This causes the centering hub-A to retract and releases the centering hub-B. Hub-B then literally shifts the disc position to recenter it, using the side B hole. Whenever a side change is perform, the mechanism lifts the clamber assembly from the disc and then lowers it back onto the disc reclamping it.

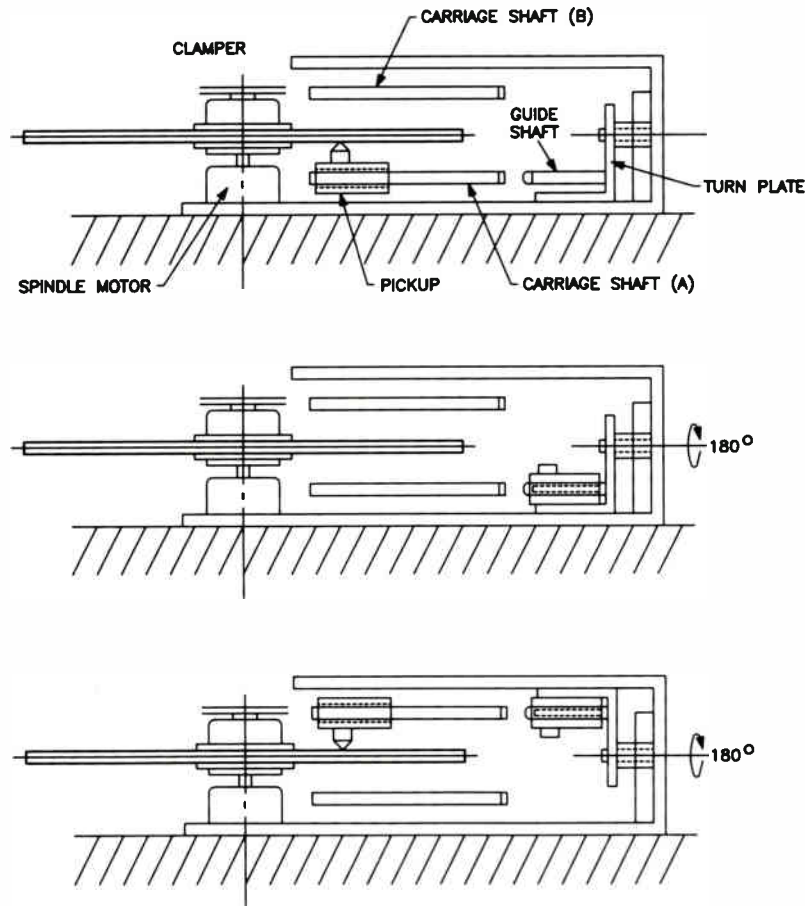

Fig. 19 - Alpha-Turn Mechanism

The mechanism of the PSLD40 uses a horizontal and a vertical loading motor to load and unload a disc. The horizontal motor is responsible for the movement of the disc tray in and out. The vertical motor lifts and lowers the disc onto the spindle motor, plus drives the clamping operation. The position of the mechanism is monitored by the mechanism state switch. The mechanism state switch sends different logic levels to the mechanical control microprocessor as the mechanism cycles through its operations.

System Control

The system control section of the PSLD40 is very similar to the system control section in the LDR300. The major differences of the system control section in the PSLD40 is;

1. The control of 2 loading motors
2. Control of the height servo
3. Control of the Alpha-turn mechanism

After a disc is loaded and clamped onto the spindle motor, the mechanical control microprocessor enables the height servo. This is done to move the pickup assembly within the operating range of the focus servo. The height servo pulls the laser assembly away from the disc during side changes and loading operations. Once the pickup assembly is moved within range of the focus servo, the mechanical control microprocessor looks for a focus lock condition. As in the LDR300, if a focus lock is not obtained at the first location, the pickup assembly is moved inward, and focus is attempted again. The pickup position where focus lock is obtained tells the mechanical control microprocessor what type of disc is in the machine (laser disc, or compact audio disc). The position of the pickup assembly is monitored by the pickup position switches, and the data from the switches is sent to the system control microprocessor. Once a focus lock is achieved the mechanical control microprocessor starts the spindle motor rotating, and monitors the FG pulses being returned from the spindle motor. As

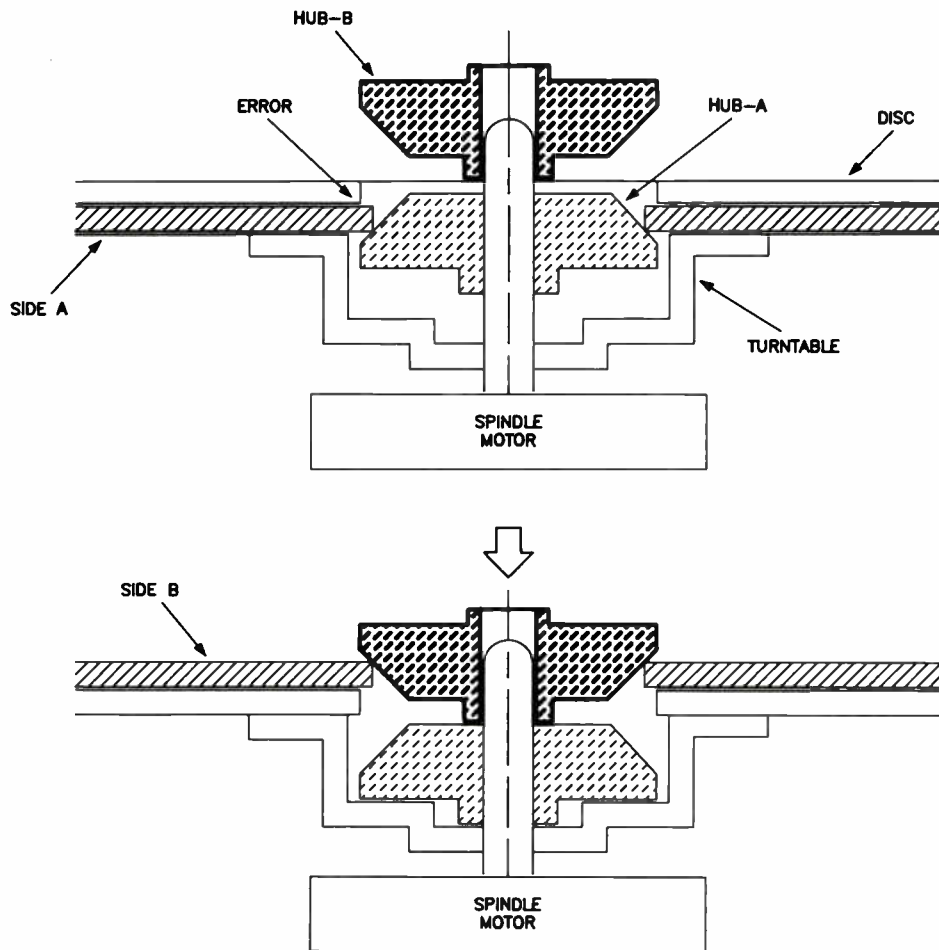

Fig. 20 - Dual Centering Clamper

in the LDR300, the time in which the spindle motor takes to reach its predetermined speed is monitored by the mechanical control microprocessor. This is used when playing laser discs to determine the size of the disc in the machine (8" or 12"). As the spindle motor is rotating up to speed the tracking servo is enabled, and the slider motor moves the pickup assembly to the starting tracks and begins normal playback. In the PSLD40 when one side of a disc is completed, the height servo pulls the laser assembly away from the disc to its lowest position. The slider motor is then used to move the pickup assembly into the inversion mechanism, and onto the side B of the disc. Once on side B the height servo moves the laser assembly within focus servo range, and the focus servo is activated. Once a focus lock is obtained the spindle motor is started rotating, but because the laser assembly it now inverted the motor is rotated in the opposite direction. As in side A playback, after the spindle motor reaches its predetermined speed the tracking servo loop is closed and normal playback is resumed.

Note; The system control section of the PSLD40 has a built in test mode. This test mode allows the servicer to manually step through the different operations to get the player to the play mode. This greatly simplifies the troubleshooting of the laser disc player. See appendix A of this manual for the operation of the test mode.

Servo

The PSLD40 laser disc player uses 6 servo sections to provide control of focus, tracking, and spindle rotation. The operation of some of these servos is identical to the LDR300. For this reason the following discussion only addresses the operation of the sections that are not covered in the LDR300 servo explanation.

The height servo is used to keep the focus servo within its operating range when the pickup is in its inverted position (side B playback). When the pickup assembly is on side B, the distance from the disc to the focus lens can be quite different than on side A. The height servo

then adjusts the height of the pickup assembly to keep the focus lens in its optimum operating distance. When the laser disc player is first turned on, the height servo moves the pickup assembly down to the lowest point for the loading operation. It then motors upward for approximately 1.7 seconds to get the focus assembly within operating range for a focus lock. Once focus lock is achieved the height servo monitors the DC level on the focus coil return line and to minimize any DC offsets. Two height switches are used to limit the upper and lower travel of the laser assembly. A separate motor is used to drive the height mechanism in the pickup assembly.

The tilt servo in the PSLD40 is different than the LDR300 because of the alpha-turn mechanism. However, The method of developing the error signal to oper-

ate the tilt servo is the same. The differences are in mechanism to change the tilt angle. In the PSLD40 the tilt servo has a separate motor. The drive for the motor comes from the tilt servo and not from the mechanical control microprocessor.

The TBC servo drive circuitry is changed to allow the drive to the spindle motor to be reversed. The overall operation is the same as the LDR300.

Signal Circuits

The signal circuits in the PSLD40 are the same as the LDR300.

SERVICE PROCEDURES

The first step in servicing either the LDR300 or the PSLD40 is to determine the section of the disc player that is not functioning. This can be done by going through the operations of the player. For example;

1. If the player does not power up when the power button is pressed
 - A. Check operation of the power supply
 - B. Check the operation of the system control section (Pg. 29).
2. If the player powers up, but disc tray does not move when open button is pressed.
 - A. Check mechanism for jamming or broken pieces.
 - B. Check the operation of the system control section (Pg. 29).
3. If the player loads the disc and then ejects the disc.
 - A. Confirm the mechanism is completing its loading operation.
 - B. Check the operation of the servo section (Pg. 34)
4. If the player loads and plays a disc normally, and then starts to skip.
 - A. Check the operation of servo section (Pg. 34)
5. If the player goes into the play mode and does not produce a picture.
 - A. Check the operation of the signal processing section (Pg. 50)
 - B. Check operation of the servo section (Pg. 34).
6. If the player plays a disc normally, but produces a poor picture (video dropouts, tearing, etc.)
 - A. Check the operation of the signal processing section (Pg. 50).
 - B. Check operation of the servo section (Pg. 34).
7. If the player has a black and white picture but no color
 - A. Check the operation of the signal processing section (Pg. 50).
 - B. Check the operation of the servo section (Pg. 34).
8. If the player has a good picture but no analog audio
 - A. Check operation of the signal processing section (Pg. 50)
9. If the player has good analog audio but no digital audio.
 - A. Verify the presents of digital audio on the test disc.
 - B. Check the operation signal processing section (Pg. 50).

SYSTEM CONTROL SECTION

LDR300

The system control section controls every function of the laser disc player. In the LDR300 the system control section consists of a mode control microprocessor, and a mechanical control microprocessor (See Fig 21).

The mode control microprocessor in the LDR300 is powered on the instant the AC power cord is plugged in. This allows it to monitor the function keys and the remote receiver. When the power on command is received, the front panel microprocessor turns the power supply on. This supplies power to the other circuit areas of the laser disc player. The mode control microprocessor then decodes the function keys, and the remote receiver data, and sends control information to the mechanical control microprocessor. This communication between the 2 microprocessors is done on 4 data lines. These 4 data lines are shake, X SCK, SO, and SI.

The shake line is pin 45 of IC11 and is the request for data, from both microprocessors. X SCK is pin 40 of IC 11, and is a clock used to time the data transfer. The SO (pin 42) and the SI (pin 41) lines transfer the data between the 2 microprocessors. The mode control microprocessor also controls the reset operation of the other sections in the laser disc player.

The mechanical control microprocessor controls the operation of the different sections in the laser disc player. It decodes the information sent from the mode control microprocessor, and gives the proper commands to different sections of the laser disc player. It also receives data from the different sections and performs the required steps with the data.

After the power up, the mechanical control microprocessor checks the position of the mechanism. This is done

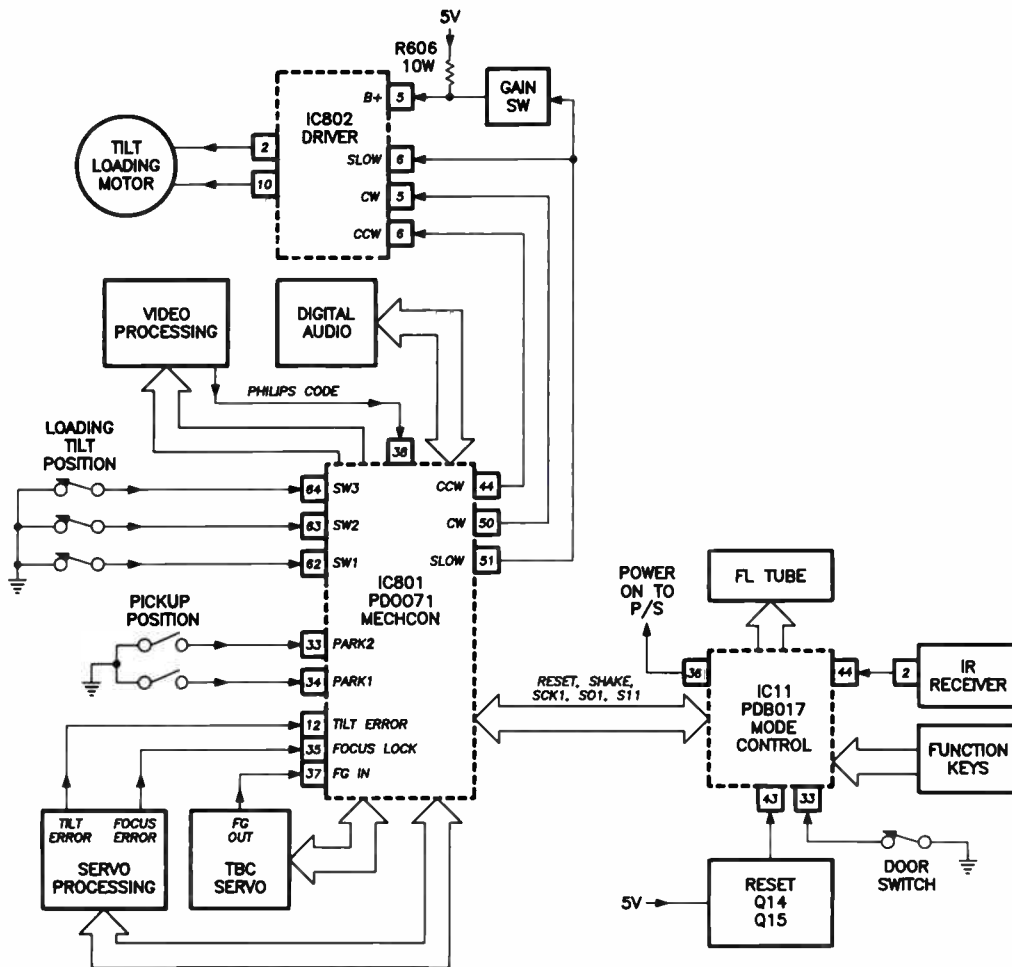

Fig. 21 - LDR300 Syscon

with the tilt/loading position switches. These switches are also used to detect the position of disc tray. When a disc is loaded into the laser disc player, the mechanical control microprocessor sends drive commands to IC 802, to operate the tilt loading motor. The loading/tilt switches are then monitored by the mechanical control microprocessor as the mechanism goes through its different cycles. When the loading sequence is completed, the control signals to IC802 are stopped, stopping the loading motor.

The next step is to start the focus servo, and look for a focus lock signal. If a focus lock is achieved, the spindle motor starts, and the slider motor moves the pickup assembly inward to the inside tracks of the disc. If focus lock is not detected, the pickup assembly is moved forward to a position determined by the position switches. The focus operation is then started once again, and the mechanical control microprocessor looks for a focus lock signal at pin 35. If a focus lock signal is achieved in either position of the pickup assembly, the mechanical control micro uses this information to determine the type of disc loaded into the laser disc player (laser disc or compact audio disc).

The FG pulses from the spindle motor are input at pin 37 of the mechanical control microprocessor. In the mechanical control microprocessor, the frequency of these pulses are monitored for the time taken for spindle motor to reach a predetermined speed. This information tells the mechanical control microprocessor if there is a problem in the spindle motor, and when to turn the tracking servo on. The mechanical control microprocessor also monitors the time taken for the FG pulses to reach the predetermined frequency. Then uses this information to determine whether a 8" or a 12" laser disc is loaded into the player.

To produce the front panel and on-screen displays the mechanical control microprocessor receives data from either video section, or the digital audio section. This data is decoded in the mechanical control microprocessor and sent to the mode control microprocessor to control the front panel and on-screen displays.

With the focus, spindle, and the tracking servos operating, information can be read from the disc. The mechanical control microprocessor now monitors the different section of the disc player for problems. If a problem occurs the mechanical control microprocessor then takes the appropriate corrective action. If the corrective action does not correct the problem, or one of the steps in the start up sequence cannot be completed, the mechanical control microprocessor then places the unit in the stop

mode. This can make troubleshooting and alignment of the laser disc player difficult.

To make alignment and troubleshooting the laser disc player simpler, the mechanical control microprocessor can be placed into a test mode. In the test mode the laser disc player can be stepped through its start up sequence manually, with command issued by the remote control or the front panel key board. To place the unit in the test mode short TP303 to ground, and press the power button. The front panel display will come on with all the segments illuminated. Remove the short at TP303 to complete the operation. The unit will stay in the test mode unit it is powered off with the power button. In the test mode the on screen display and the front panel display indicates the status of the major servos in the laser disc player. The remote receiver commands are also decoded, and displayed in hex decimal code on both displays.

PSLD40

The operation of the system control section of the PSLD40 is very similar to that of the LDR300. The PSLD40 does use a different mode control microprocessor but the operation is the same as the LDR300. The mechanical control microprocessor is the same as the LDR300 except for circuitry changes in the alpha-turn mechanism.

The alpha-turn mechanism in the PSLD40 uses two motors to operate the mechanism. The H load motor moves the disc tray in and out. The V load motor lowers the disc onto the spindle motor, and clamps it into position with the clamper assembly. The V load motor also reclamps the disc when the mechanism is inverted for side B playback. The mechanical control microprocessor controls the drive to both motors, and monitors their position with the horizontal position switches, and the vertical position switches (See Fig 22). IC804 and IC805 receives the drive commands from the mechanical control microprocessor and provides the drive currents to the two motors.

Another circuit area of the mechanical control microprocessor that must be changed due to the alpha-turn mechanism, is the detection of the laser assemblies position. The pickup position switches are monitored by the mechanism control microprocessor at pin 12. The input at pin 12 is 3 voltage levels depending on the location of the pickup assembly. If focus lock is achieved with 0 v at pin 12, the mechanical control microprocessor knows a laser video disc is in the player. If the voltage at pin 12 is 5V when focus lock is achieved, a compact audio disc is

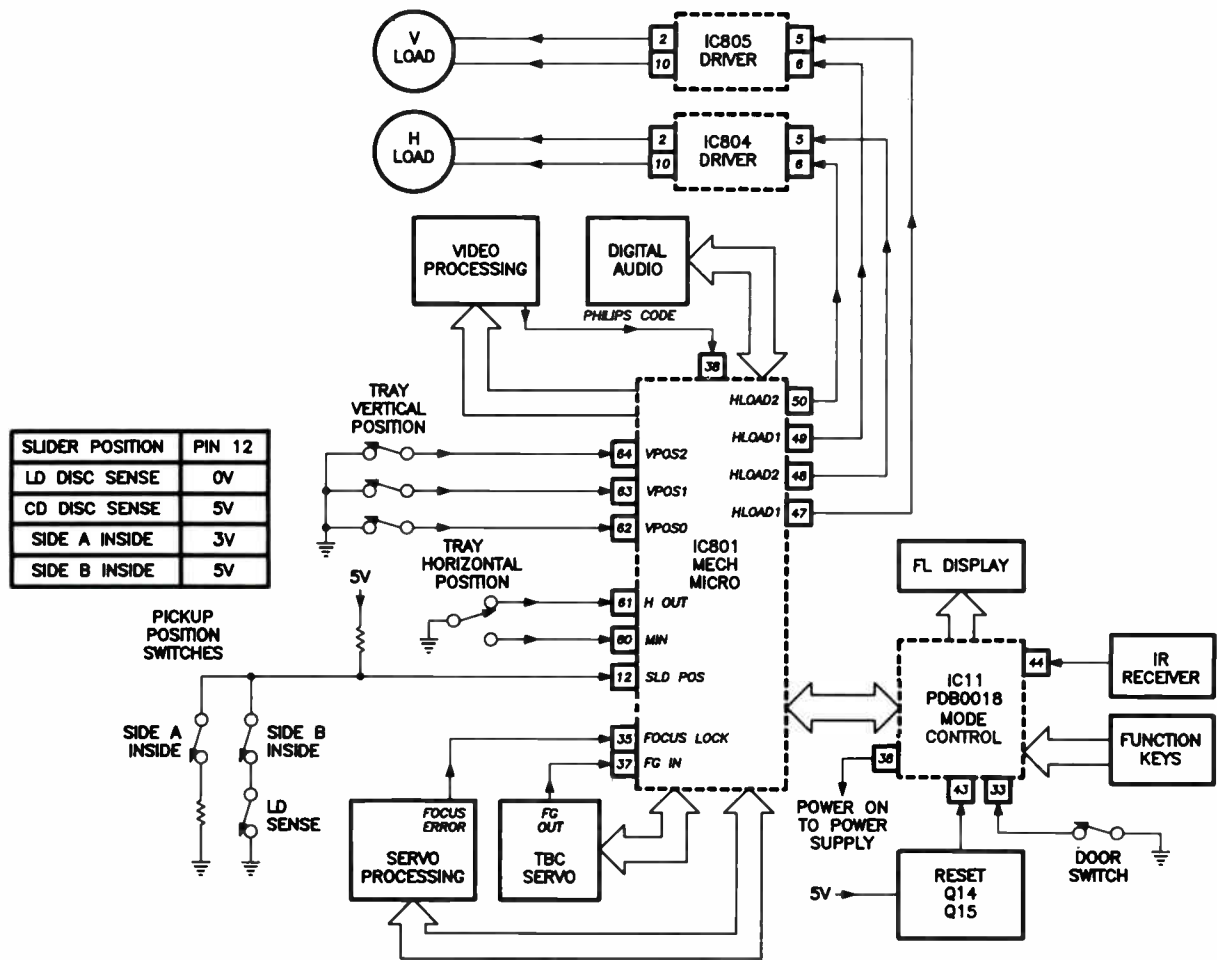

Fig. 22 - PSLD40 Syscon

in the player. Once the focus lock is achieved and the size of the disc is determined, the mechanical control microprocessor moves the pickup assembly inward to the side A inside position switch. This switch stops the inward movement by sending 3V to pin 12 of the mechanical control microprocessor. To play side B of a disc, the slider motor moves the pickup assembly into the inversion mechanism, drives the inversion mechanism, and moves the pickup assembly to the inside of side B. When the inside of side B is reached the side B inside position switch sends 5V to pin 12 of the mechanical control microprocessor. The mechanical control microprocessor then stops the slider motor and looks for a focus lock. When a focus lock is achieved playback of side B is started.

After focus lock the sequence, the control of the different servo sections is done in the same manor as the LDR300.

Service Procedure

1. With the AC line cord plugged in the unit does not turn on.
 - A. Confirm B+ is applied to the mode control microprocessor pin 1 of IC11 (5V).
 1. If not present confirm operation of 5V regulator in power supply.
 - B. If present check for power on command at pin 36 of IC 11 (5V power on, 0V power off)
 1. If present check power supply on off circuitry.
 - C. If not present check for clock signal at IC 11 pin 64 (3V P-P, 6MHz)
 1. If clock signal is not present suspect X11 or IC11.

- D. If clock signal is present check reset line at IC 11 pin 43 for 5V DC.
 - 1. If pin 43 is not 5V suspect reset circuitry.
- E. If 5V is present check operation of the on/off switch, and the interconnect wiring of the on/off switch to IC11.
 - 1. If on/off switch is good suspect IC11.
- 2. If the disc player powers up, but will not load or unload a disc.
 - A. Confirm B+ is applied to the mechanical control microprocessor, IC801 pin 1 (5V).
 - 1. If not present confirm operation of the power supply.
 - B. If B+ is present check IC801 for clock signal at pin 30 (3V P-P, 9MHz)
 - 1. If clock signal is not present suspect X801 and IC801.
- C. If present check for data activity on the communication lines between the mechanical control microprocessor, and the mode control microprocessor, IC801 pins 18,19,20, and 21.
 - 1. If activity is not present suspect IC11, and IC801.
- D. If data activity is present, check for drive voltages to the horizontal and vertical loading motors.
 - 1. If present check for jammed mechanism or defective motors.
 - 2. If not present confirm operation of IC805, IC804, and IC801.
- 3. If the disc player loads disc starts to spin spindle motor and stops
 - A. Confirm the disc is correctly clamped onto the spindle motor.
 - B. Confirm operation of the servo section (Pg. 34).

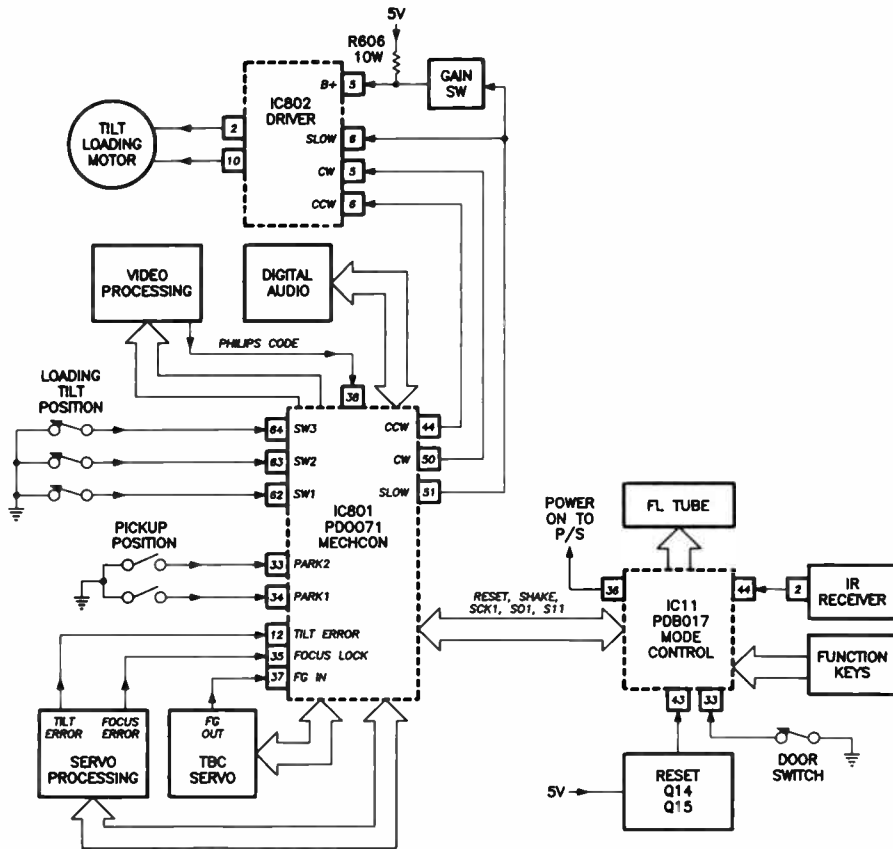

LDR300 Syscon (Repeated)

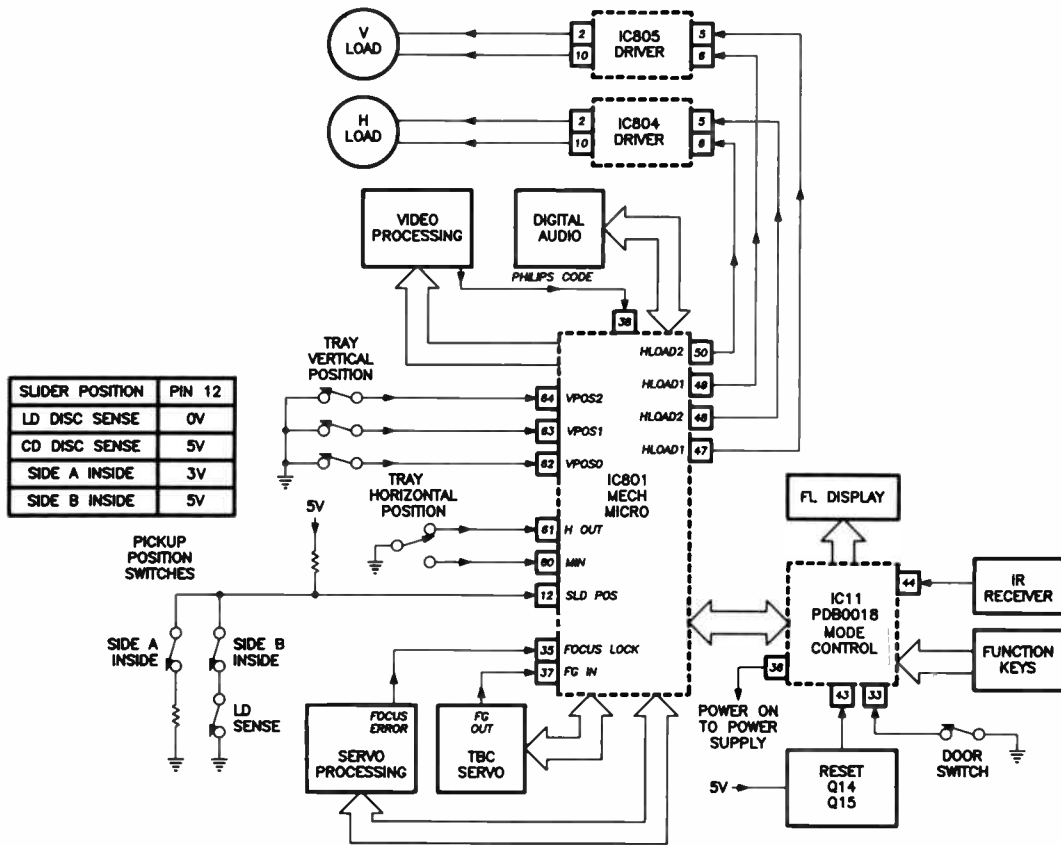

PSLD40 Syscon (Repeated)

SERVO SECTION

The servo section for the LDR300 has 5 servo circuit areas (the PSLD40 has 6 servo circuits) that are turned on, and monitored by the mechanical control microprocessor. These servo circuits are;

1. Focus servo
2. TBC (Time Base Corrector) servo
3. Tracking servo
4. Slider servo
5. Tilt servo
6. Height servo (PSLD40 only)

The Failure of any one of these servo sections can cause a variety of symptoms, from no playback to loss of color. One of the most effective methods of isolating a problem in the servo section is by using the test mode. The test mode gives the technician some control over which servo areas are turned on and off. The operation of the test mode is given in appendix A. To troubleshoot the servo section, place the unit in the test mode and load a disc into the machine. Press the play button on the front of the player, or the remote.

1. If the disc player does nothing
 - A. Suspect the focus servo on Pg. 34.
2. If the disc rotates, but the speed is unstable
 - A. Suspect TBC servo on Pg. 46.
 - B. Suspect focus servo on Pg. 34.

If the disc rotates and a picture is produced, press the play button a second time. This closes the tracking servo loop and the player should play normally.

1. If the disc player does not play normally and produces a still picture.
 - A. Suspect tracking servo on Pg. 39.
2. If the disc player plays normally for awhile, and then starts to skip.
 - A. Suspect tracking servo on Pg. 39.
 - B. Suspect slider servo on Pg. 41.
 - C. Suspect tilt servo on Pg. 43.

3. If the disc player advances the pickup across the disc (looks similar to the disc player being in the scan mode)
 - A. Suspect the tracking servo on Pg. 39.
 - B. Suspect the slider servo on Pg. 41.
4. If the disc player plays normally but the picture quality is poor.
 - A. Confirm operation of the signal processing section Pg. 50.
 - B. Suspect the focus servo on Pg. 34.
 - C. Suspect the tilt servo on Pg. 43.
5. If the disc player has a good picture but there is no color or unstable color.
 - A. Confirm operation of the signal processing section Pg. 50.
 - B. Suspect the TBC servo on Pg. 46.
 - C. Suspect the tilt servo on Pg. 43.

Focus Servo

The opto electrical IC (OEIC) in the pickup assembly monitors the laser beam, and develops error signals to keep the beam focused on the disc. The amount of laser light striking each sensor of the OEIC is used to develop 2 signals.

The first signal is generated by adding the outputs of all the B sensors of the OEIC together. This develops a focus sum signal at the inverting input of IC602 (see fig 23).

The second signal is developed by adding output of sensors 2 and 4 of the OEIC. This signal is then added to the inverted focus sum signal, from pin 2 of IC 602. The resulting signal is the focus error signal, which is applied to the inverting input, IC602, pin 7.

The focus error signal is then supplied from pin 8 of IC 602, to the CD and LD equalizers. These equalizers compensate for different focus characteristics in the CD and LD discs. IC601 selects the correct input for the type of disc being played in the machine, based on a

PICKUP ASSEMBLY

MAIN BOARD

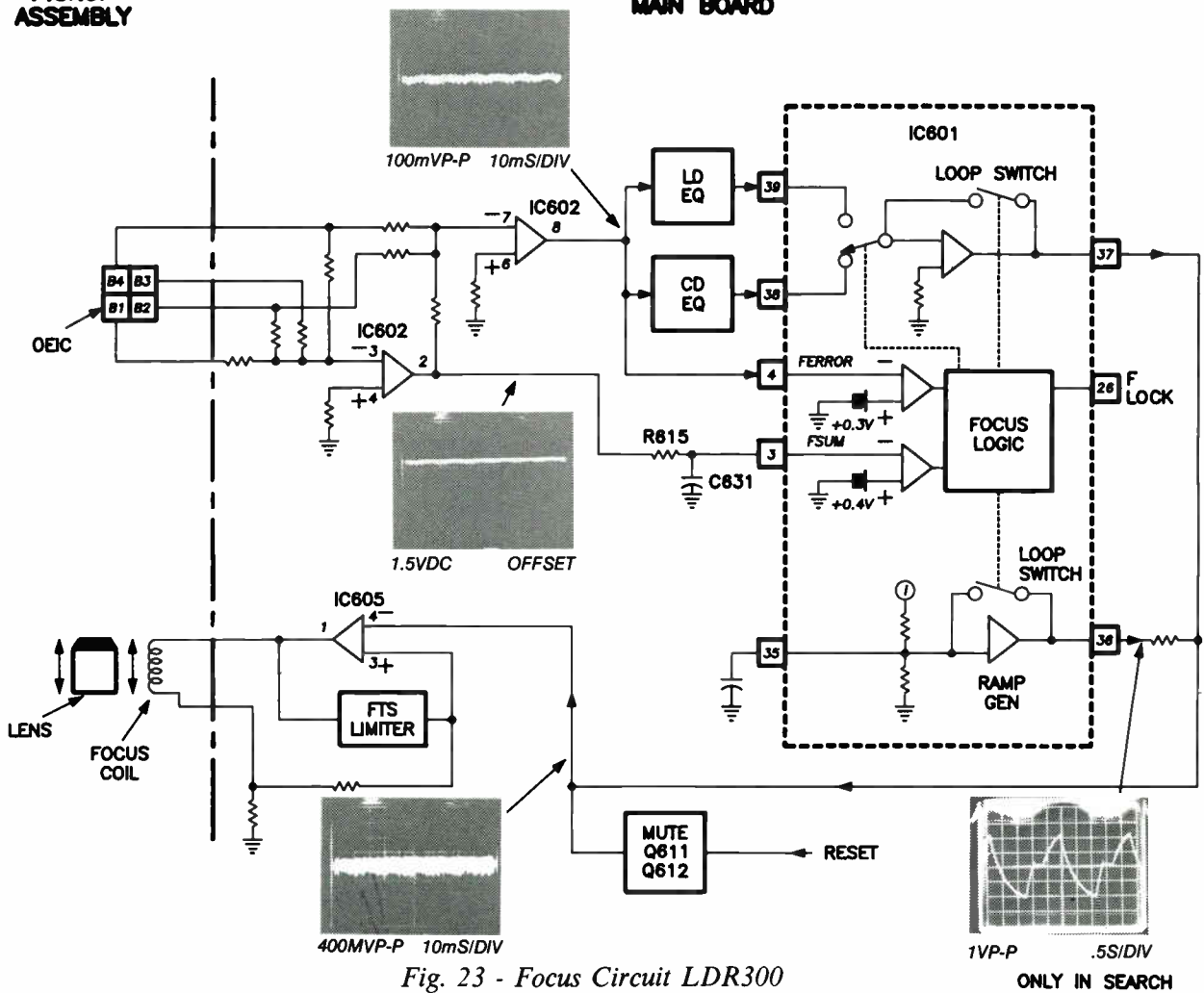

Fig. 23 - Focus Circuit LDR300

command from the mechanical control microprocessor. If the focus loop switch is closed, the focus error signal is equalized and sent out on pin 37, as the focus drive signal. The drive signal is converted to a drive current in IC 605, and used to drive the focus coil. The FTS limiter is used as a protection circuit for the focus coil. The focus drive signal is monitored for frequencies above 2 KHz. If these frequencies are present, the FTS limiter reduces the gain of the focus drive amp IC 605. These higher frequencies can damage the focus coil in the pickup assembly, if sustained for too long of a period. The DC level on the return of the focus coil is also monitored to reduce the gain of IC 605. This prevents a high DC offset from destroying the focus coil. The focus drive signal is also muted during reset of the microprocessors. This protects the focus coil from possible damage during power up of the power supplies.

To close the focus loop switch inside IC 601 the logic section in IC601 looks at 2 inputs;

1. Focus sum signal at pin 3 of IC 601
2. Focus error signal at pin 4 of IC601

For these inputs to be correct the laser beam must be focused on the disc.

When a focus on command from the system control microprocessor is received, the logic in IC601 starts a ramp generator in IC 601. This ramp signal exists IC 601 at pin 36, and is injected onto to the focus drive signal. This ramp varies from +1.5V to -2.5V for approximately 1.7 seconds. This pulls the focus lens in the pickup assembly through its operating range, to look for

an in-focus condition. An in-focus condition is determined by the focus sum signal at pin 4 of IC 601 and the focus error signal at pin 3. A in-focus condition is detected when the focus sum signal at pin 4 reaches .4V, and the focus error voltage crosses the .3V threshold. When these condition are met the focus loop switch will be closed. When the focus loop switch is closed, the ramp generator in IC 601 is turned off, and a focus lock signal is sent to the mechanical control microprocessor. If during playback the focus sum signal drops below .4V, the focus search process resumes again.

The focus servo in the PSLD40 is the same as the LDR300, except for the control of the ramp generator in IC601 (see fig 24). In the LDR300 the ramp generator is controlled by the focus logic section in IC 601. The ramp generator in the PSLD40 is turned on with the laser diode on signal from the mechanical control microprocessor. This is a low that turns Q611 off, and allows C643 to charge and generate the ramp. The ramp generator is turned off when the focus lock command is given to the mechanical control microprocessor. This lock command is a low from IC601, pin 26, and keeps C643 from charging through D612.

Service Procedure

To check the focus system for a focus lock, place the unit in the test mode and load a disc. Press the play button once and check the voltage at pin 26 of IC601. If the voltage is 0V the focus system has achieved focus lock. If the voltage remains at 5V focus lock has not been achieved.

1. If pin 26 of IC601 remains at 5V check.
 - A. The disc surface for scratches and foreign materials.
 - B. The laser lens for dust and foreign materials. If necessary clean the lens with procedure in appendix C.
 - C. The laser diodes output level, see procedure in appendix B.
 - D. The search operation of the focus system. To do this place the unit in the test mode without a disc in the machine. Press the close button, and then the play button. Observe the focus lens for a up and down movement.

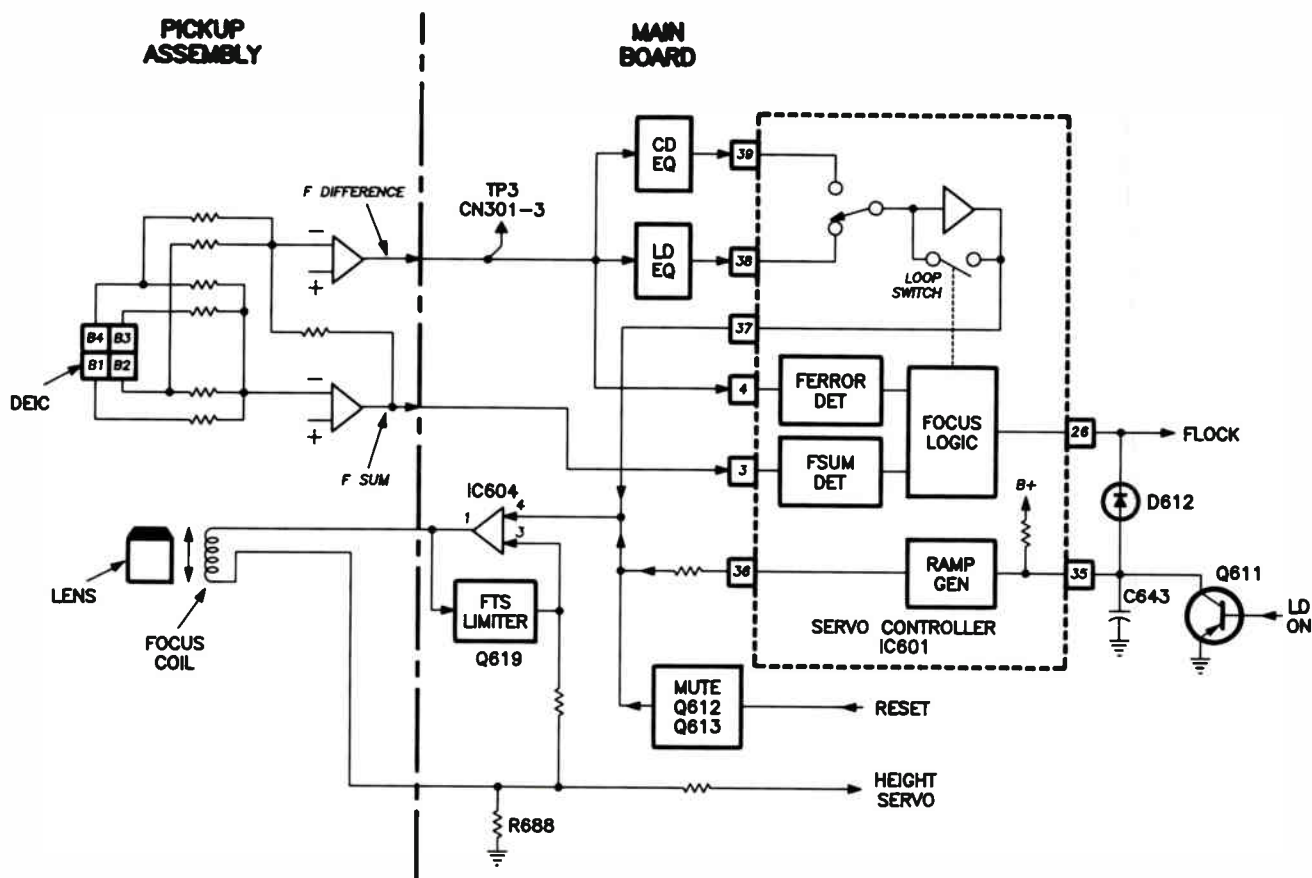
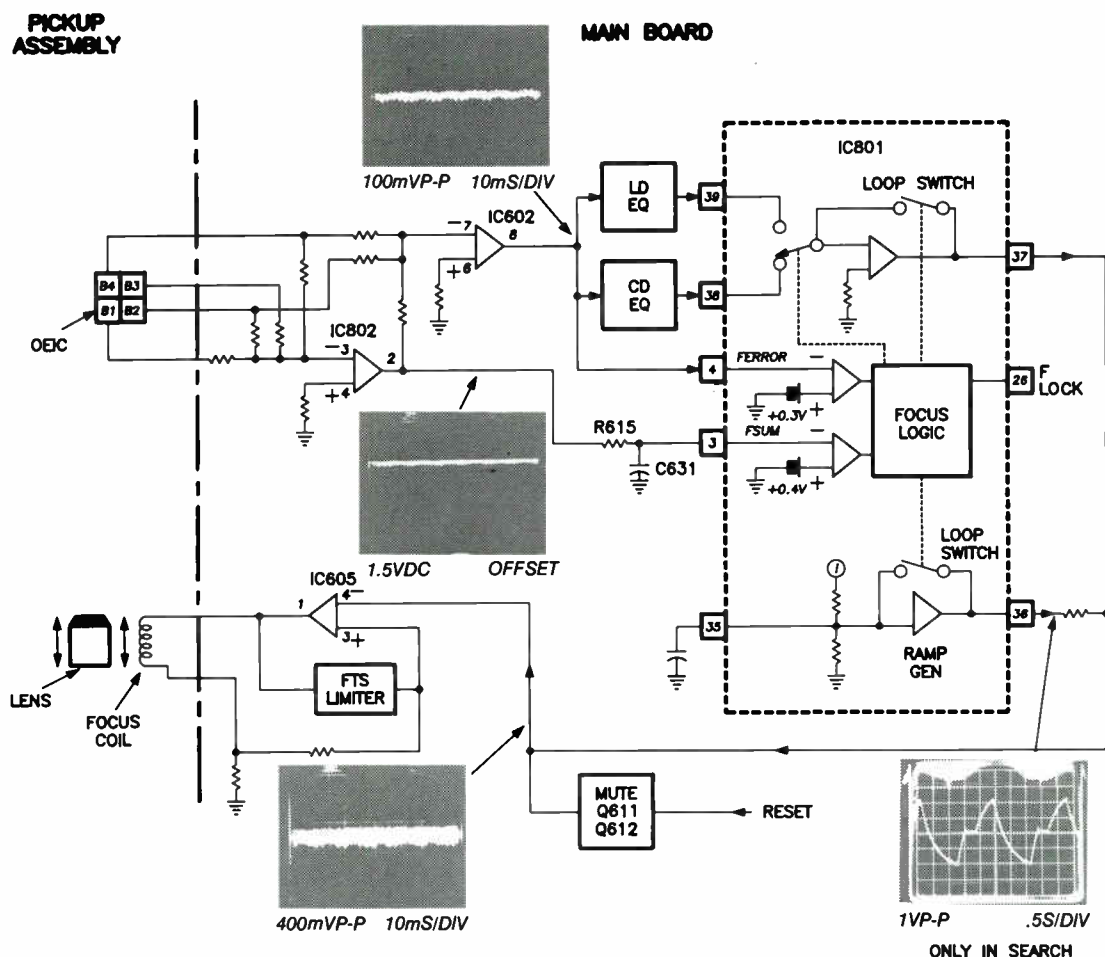

Fig. 24 - Focus Servo PSLD40

1. If lens is not moving up and down, check for ramp signal at IC601 pin 36. If present troubleshoot focus drive circuitry. If missing troubleshoot the ramp generator in IC601.
- E. If the lens is searching up and down, place the unit in the test mode and load a disc into the machine. Press the play button, and with an oscilloscope monitor the DC level at pin 3 of IC601 (the focus sum input). This voltage must be over .4V DC to achieve focus lock.
1. If the focus sum signal is not over .4V DC confirm operation of IC602 and the OEIC.
- F. If the focus sum voltage goes over .4V DC, with an oscilloscope monitor the DC level at pin 4 of IC601 (focus error input). When the pickup is searching for a focus lock this signal will vary. For the focus system to operate the focus error signal must pass through 0V DC +/- .3V.
 1. If the focus error signal does not vary confirm the operation of IC602 and the OEIC.
 2. If this signal does vary and passes through 0V DC, suspect IC601.
 3. If the focus error voltage does vary, but does not pass 0V DC. Suspect the Height servo (PSLD40 only), and the laser output level.



Focus Circuit LDR300 (Repeated)

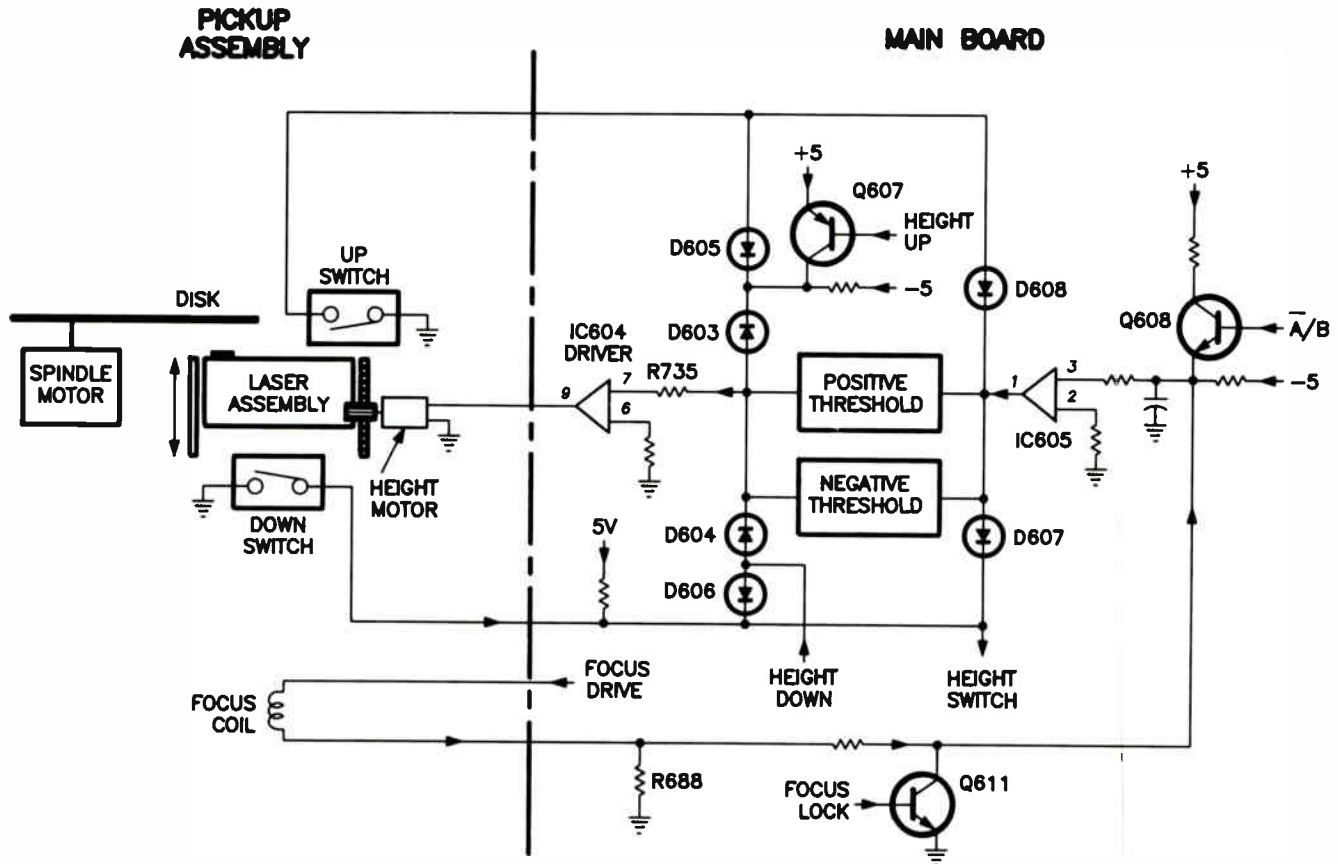

Fig. 25 - Height Servo PSLD40

Height Servo

The height servo in the PSLD40 keeps the focus lens within its optimum working distance from the disc. When the player is first turned on, the height servo moves the pickup assembly to its lowest point. After loading is completed the height servo lifts the pickup assembly to get within operating range of the focus system. The pickup assembly is also lowered during side changes to prevent damage of the laser assembly.

During normal playback the DC level on the tracking return line is coupled to IC605 pin 3 (see fig 25). It is amplified in IC605 and sent to the positive and negative threshold detectors. These threshold detectors block signals below $\pm 0.6V$ to keep within the operating limits of the height servo. The error signal is then sent to IC604 to develop the drive for the height motor. Transistor Q611 is used to disable the height servo till focus lock is achieved. The focus lock signal then turns Q611 off, and allows the focus return signal to control the pickup height. Transistor Q608 is used to invert the DC offset of the error signal during inverted operation of the pickup assembly (side B playback). This inversion of the DC offset reverses the direction of the height motor. If this was not done the error signal would drive the pickup assembly in the wrong direction.

The mechanical control microprocessor controls the up and down operation of the height motor during loading, unloading, and side changes. When a disc is first loaded into the player, the pickup assembly is moved from its lowest position to a point where focus lock can be achieved. This is done by applying a 5V to the base of Q607 turning it off. This 5V is supplied from the mechanical control microprocessor. With Q607 turned off, a negative voltage is supplied to IC604 pin 7. This will drive the height motor and lift the laser assembly. The height up switch limits the travel of the pickup assembly in the up direction. When closed by the laser assembly, the negative drive voltage forward biases D605 and removes the drive to IC604, stopping the motor. D608 is used to stop the up movement of the height motor during normal servo operation. When the height switch is closed, any negative drive from IC605 pin 1 is removed by D608.

To lower the height motor 5 volts is applied from the mechanical control microprocessor. The 5 volts forward biases D604 and applies a positive voltage to IC604 pin 7. This positive voltage drives the height motor and lowers the laser assembly.

The down switch limits the travel of the pickup assembly in the down direction. When the down switch is closed the drive to pin 7 of IC604 is removed by D606. In normal operation when the down switch is closed D607 prevents driving the pickup assembly lower. The mechanical control microprocessor monitors the down switch. When the down switch is closed, the mechanical control microprocessor stops sending the down command to the height servo.

Service Procedure

1. If the height motor does not lower the pickup assembly during power up, and side changes check;
 - A. IC801 pin 5 for 5V
 1. If not present suspect IC801.
 2. If present connect the positive lead of a DVM to IC604 pin 7, and the negative lead to anode of D603. During the down operation the meter should read -165mV .
 - A. If present confirm the operation of IC604 and the height motor.
 - B. If not present check D604, and the down switch.
2. If the height motor does not lift the pickup assembly before focus search starts.
 - A. Confirm the presence of 5V at IC801 pin 4.
 1. If not present suspect IC801.
 2. If present, connect the positive lead of a DVM to IC604 pin 7, and the negative lead to the anode of D603. During the up operation the meter should read 165mV DC .
 - A. If present suspect IC604 and the height motor.
 - B. If not present suspect D603, Q607, and the up limit switch.

Tracking Servo

The tracking servo keeps the laser beam centered on the track of pits as the disc rotates. The tracking error signal from elements A and C of the OEIC are added and buffered in IC 101 (see fig 26). The output of IC101 is then applied to the CD and LD equalizers. The laser disc player having already determined what type of disc is being played, selects the correct input to be applied to the tracking loop. If the tracking loop is closed, the error signal is equalized with the appropriate feed back loop, internal to IC601. Exiting from pin 10 the tracking error voltage is converted into current in IC604. This current signal is then used to drive the tracking coil in the pickup assembly. The tracking coil moves the lens in the pickup assembly from side to side. This keeps the laser beam striking the center of the row of pits. The return line from the tracking coil is used as feedback to drive the slider servo.

In order for the tracking loop in IC601 to close, some conditions must be met. The tracking logic block must receive the proper inputs from the zero cross comparator (IC 601 pin 6), and on track detection from the focus servo (IC 601 pin 5). When both these signals are present the tracking loop will close.

The tracking servo is also used for some of the special effects in the laser disc player. IF the laser disc player is placed in still pause, the tracking servo bumps the laser beam back one track every revolution. This keeps the laser beam on the same track of information as the disc rotates.

The scan operation is also controlled by the tracking servo loop. In both the LDR300 and PSLD40 the scan has two speeds. When scan is first started the player scans at low speed for approximately 5 second, then goes into high speed scan. When the laser disc player is in slow speed scan the tracking servo bumps the laser beam ahead approximately 2 tracks. In the high speed scan the laser beam is bumped ahead by at least 5 tracks.

In still pause the laser beam is bumped back one track every revolution. This keeps the laser beam scanning the same track of information. The actual bump is timed to the vertical sync interval, to keep a stable picture on the television. When still pause is enabled the mechanical control microprocessor sends a jump trigger pulse to pin 27 of IC601.

The logic in IC601 sends a drive pulse from pin 12 to the tracking coil. This drive pulse will bump the laser beam back one track of information. Q603 is also turned on to momentarily ground the focus sum input, disabling the tracking servo loop. The purpose of this is to keep the tracking servo from pulling the laser beam back onto same track. The focus error signal (IC 601 pin 6) is used during the bump sequence to keep the laser beam from bumping more than one track. The error signal at pin 6 is monitored for a crossover point, which indicates that a track of information has been crossed by the laser beam. At that instance the logic section in IC 601 issues a braking pulse to stop the laser beam on that track of information.

In the scan mode the laser beam is pulled across many tracks of information. To do this the tracking servo is

momentarily opened and then closed. This cycle of opening and closing the tracking loop is done as long as the player is scanning. The scan command is sent to IC601 at pin 13. The polarity of the signal at pin 13 also determines the direction of the scan (forward or reverse). At the same time the scan signal is present at pin 13, the tracking off signal is opening the tracking loop, by turning on Q603, and Q604. A jump pulse is now sent out on pin 12 to bump the laser beam. Because the tracking loop is open at this point the laser beam crosses several tracks information. The track off signal now allows the tracking loop turn back on. At this point the frequency of the error signal at pin 6 is monitored. When it drops below a stipulated frequency a brake pulse is sent to the tracking coil and the tracking loop is closed. This lets the laser beam track the information on the disc to momentarily produce a picture. Then the whole process is repeated until scan operation is stopped by the operator.

Pin 25 of IC601 provides track count information to the mechanical control microprocessor during scan operations. This signal also informs the mechanical control microprocessor of excessive disc eccentricity due to disc misclamping. If a misclamping condition occurs the mechanical control microprocessor then places the player in the stop mode.

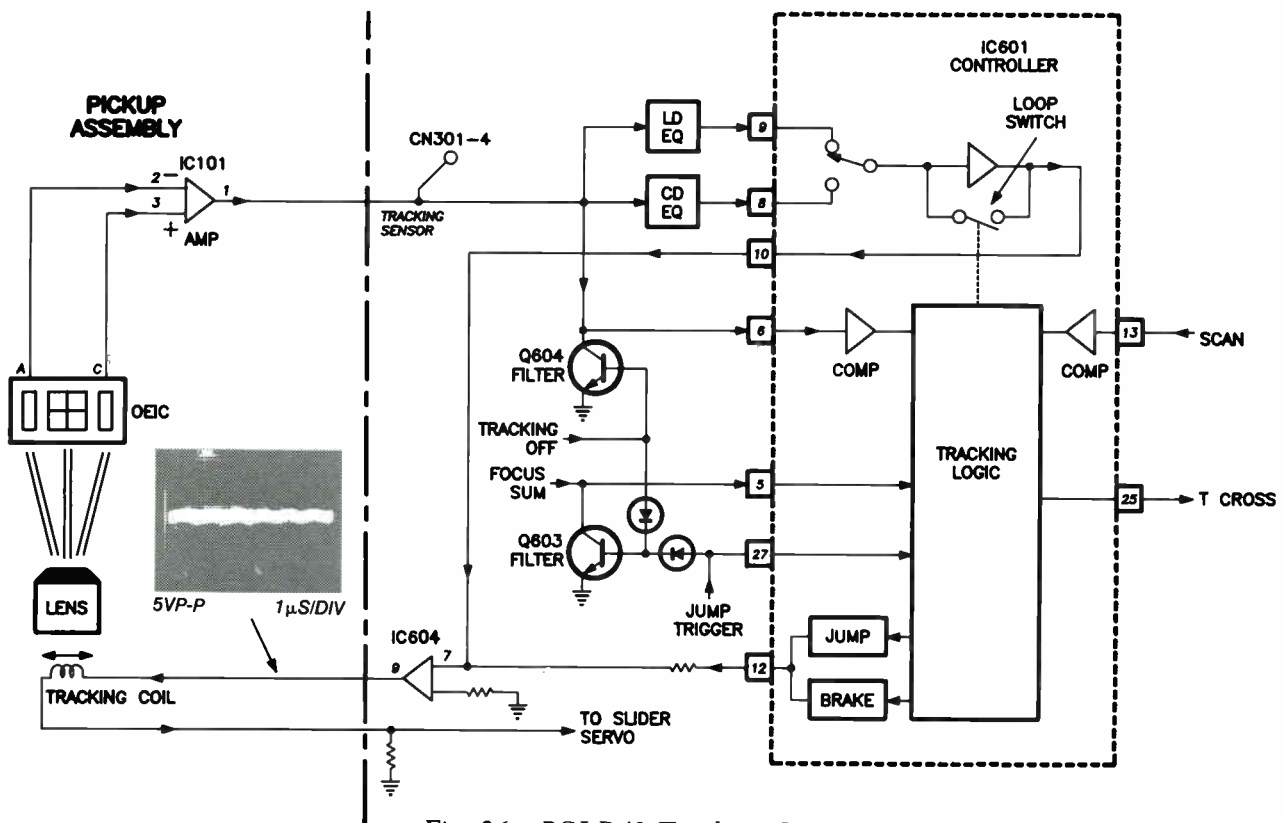

Fig. 26 - PSLD40 Tracking Servo

Service Procedure

1. No tracking servo operation.
 - A. Place unit in the test mode and load a disc into the machine. Press the play button once and confirm focus sum signal at IC601 pin 5. This signal should be approximately .5V P-P
 1. If not present confirm operation of Q603.
 - B. If the signal is present confirm tracking error signal at IC 601 pin 6. This signal should be approximately .5 V P-P.
 1. If this signal is not present check Q604, and IC101.
 - C. If the tracking error signal is present, press the play button once to close the tracking servo loop. Check tracking correction signal at pin 10 of IC 601. NOTE: On the RCA test disc # 202442 this signal was 1V P-P.
 1. If this signal is missing suspect IC601.
 2. If this signal is over 3V P-P suspect IC604 and the tracking coil in the pickup assembly.

Slider Servo

The tracking servo does not have enough range to keep the laser beam tracking the information on an disc as it spirals outward. The slider servo monitors the DC level on the return line of the tracking coil, and moves the laser assembly to minimize it. This keeps the tracking servo within it's operating range throughout the discs.

The DC level on the return line of the tracking coil is applied to pin 16 of IC601 (see fig 27). In IC 601 the DC level goes through phase compensation, and is routed to the slider comparators for for pulse width modulation. The comparators in IC 601 use separate positive and negative going sawtooth waveforms to detect the DC component on the tracking return signal. The logic in IC601 starts the sawtooth generators and the PWM signal. When the DC component of the tracking signal intersects with either of the sawtooth waveforms, the PWM signal is stopped. This changes the pulse width of the PWM signal as the DC level on the tracking return line varies. The PWM signal is then sent to the servo logic block and used to turn on and off drive to the slider motor. In playback, pin 18 of IC601 sends the

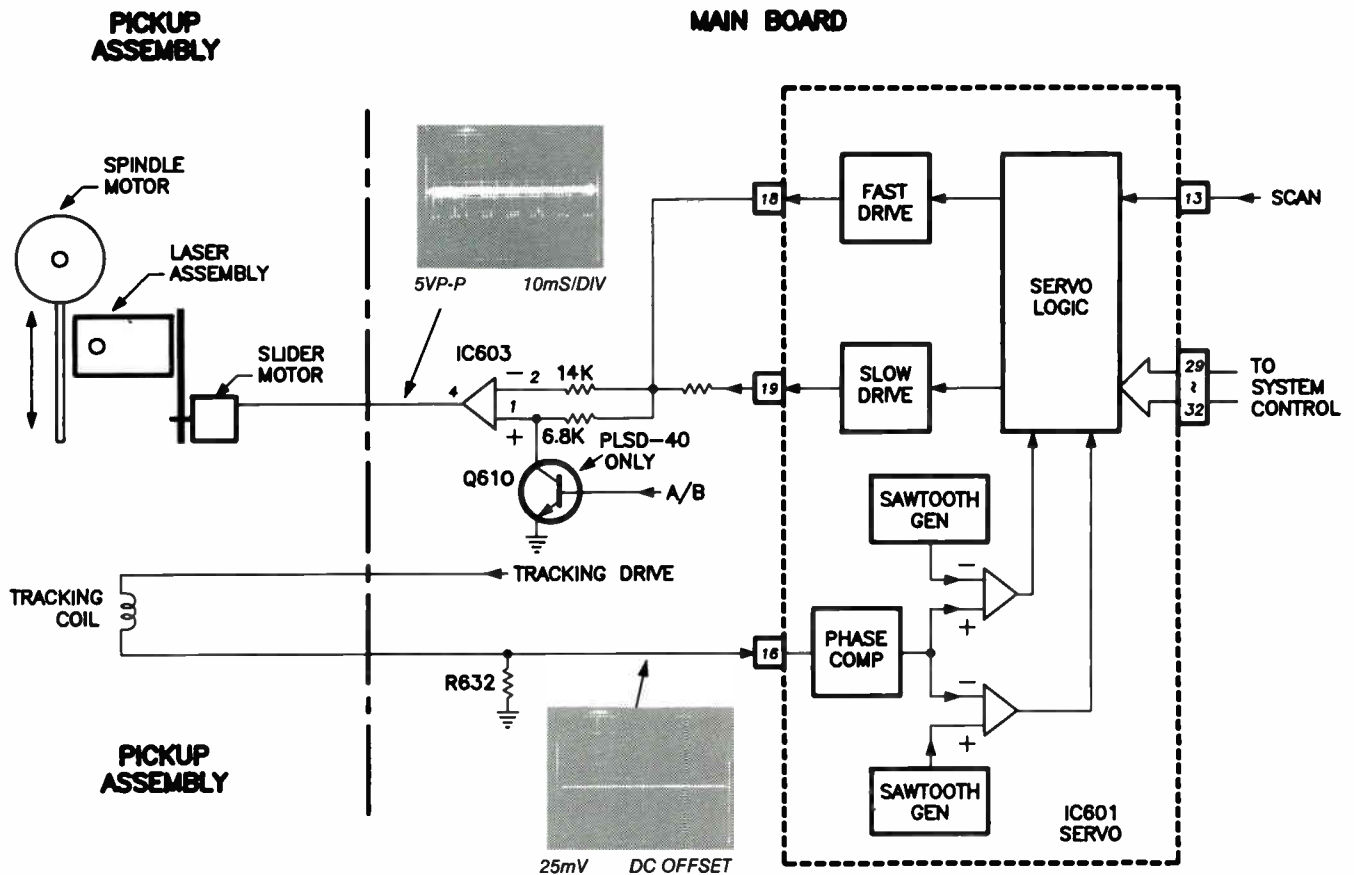
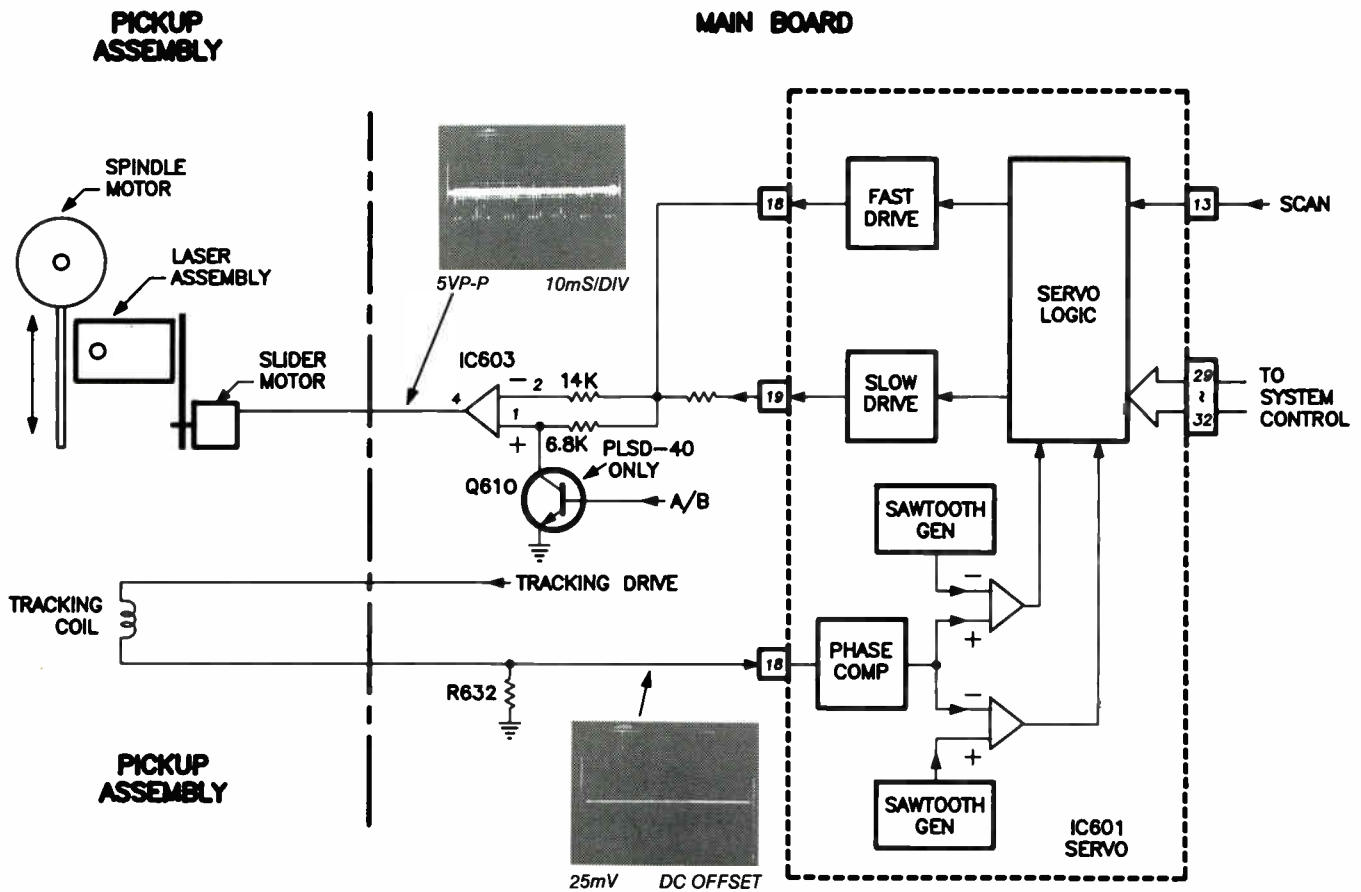

Fig. 27 - PSLD40 Slider Servo



PSLD40 Slider Servo (Repeated)

drive pulses to the slider motor. During low and high speed scans pin 19 is used with pin 18 to send additional drive to the slider motor. These drive pulses are buffered in IC601 and sent to the slider motor.

In the PSLD40 the slider motor must reverse directions to play side B of a disc. This is done with Q610 which is controlled by the mechanical control microprocessor. During playback of side A Q610 is turned off, and pin 1 of IC603 is used as the input to the driver. Pin 1 is the non inverting input to IC603, so any signals applied to it will be the same polarity at the output. When Q618 is turned on by the mechanical control microprocessor pin 1 is disabled by Q610 and the input to IC603 switches to pin 2. Pin 2 is the inverting input and will invert any signal applied to it. This inverts the drive signal going to the slider motor reversing it's direction.

Service Procedure

1. No slider operation

- A. With the unit in the test mode, move the pickup assembly with the scan buttons.
 1. If the pickup does not move check pins 18 of IC601 for drive pulses (1V P-P).
 - A. If present suspect IC603 (IC606 in LDR300) or slider motor.
 - B. If not present suspect IC601.
- B. If the slider motor moves with the scan buttons, put the unit into the test mode load a disc into the machine. Press the play button twice to put the unit in play mode with the tracking servo closed.

1. Check for tracking return signal at pin 16 of IC601. This signal should have less than 70mV of DC offset.

A. If more than 70mV suspect IC601.

Tilt Servo

The tilt servo keeps the pickup assembly and the disc surface at a 90 degree angle. If the tilt servo does not operate the picture on the television may have cross talk, and color instability.

For the tilt servo to operate a sensor is mounted close to the laser lens on the pickup assembly. This sensor uses 1 IR (Infrared) transmitting diode and 2 IR receiving diodes, mounted on either side of the transmitting diode (see fig 28). The transmitting diode sends a IR signal to the surface of the disc. The receiving diodes detect the level of the reflected IR signal from the surface of the disc. The 2 receiving diodes are connected so the phase of the received signal is 180 degrees out of phase with each other. If the disc is not warped the signal level the

receiving diodes detect will be the same. If the disc is warped the receiving diode that is the closest to the disc will have a larger output than the diode that is farther from the disc. The error signal from the diodes is added at IC601 pin 22. When the two diodes receive the same amount of signal, the tilt error is zero. If one diode is closer than the other diode, the error signal will then be the amplitude difference between the 2 diodes. The amplitude and polarity of the error signal depends on which diode is closer to the disc surface.

The total error signal is then sent to the mechanical control microprocessor, IC801 pin 12. In the LDR300 the same motor that operates the loading mechanism also operates the tilt mechanism. After loading is complete and the disc is in play, the loading motor continues to operate, positioning the tilt mechanism. The mechanical control microprocessor monitors the tilt error and by changing the direction of the loading motor rotation varies the tilt of the pickup assembly. The tilt/loading motor is driven by IC802, and the direction is controlled by the level at pins 5 and 6. Pin 4 of IC802 is used to slow the motor down for the tilt operations.

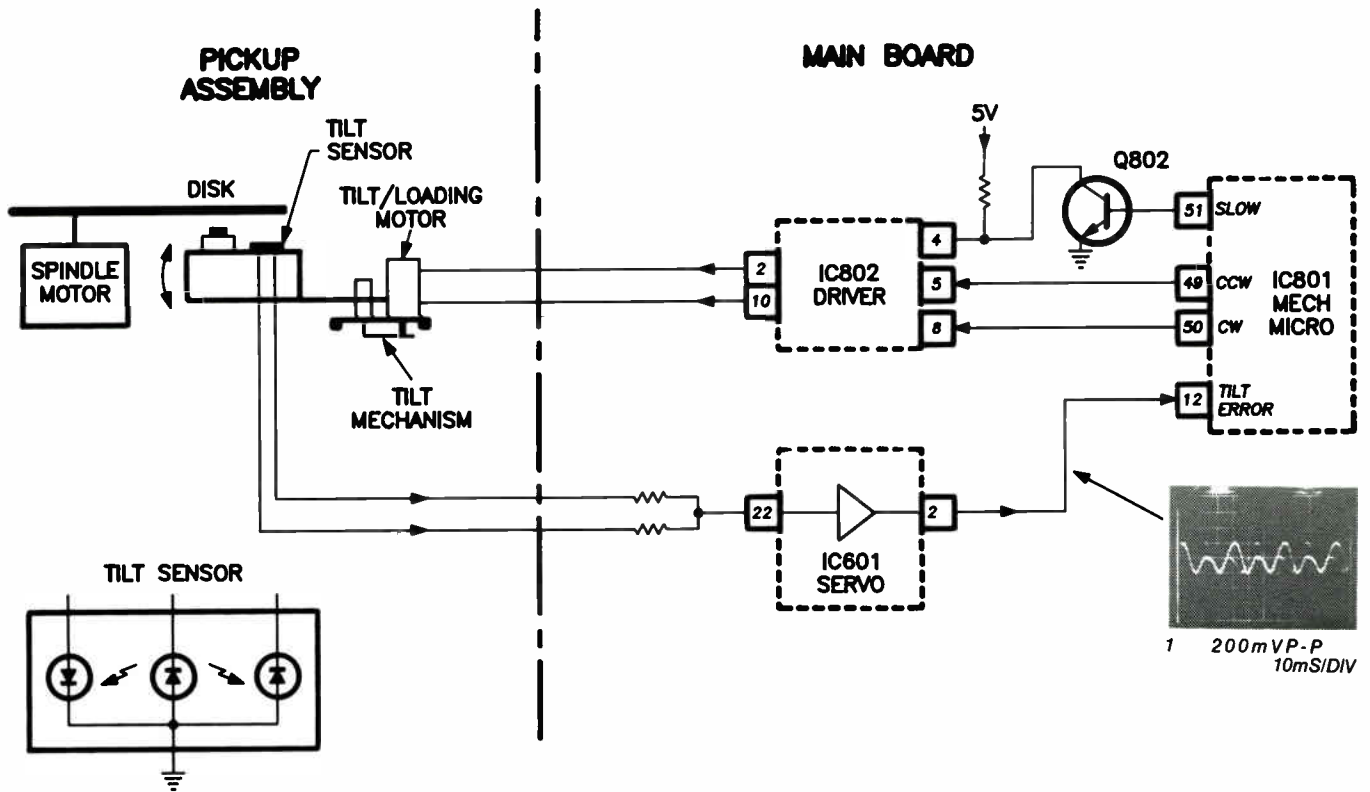

Fig. 28 - LDR300 Tilt Servo

Tilt Servo PSLD40

The tilt servo in the PSLD40 uses a dedicated tilt motor (see fig 29). The tilt error signal from the tilt sensor is buffered and supplied to IC601 pin 22. The comparators in IC 601 determine if the tilt error is great enough to close the loop switch and drive the tilt motor.

If the tilt error is greater than $\pm 26\text{mV}$, the loop switch will close, supplying drive to the tilt motor. Once the loop switch is closed, comparator 2 opens it when the error signal drops below $\pm 23\text{mV}$, stopping the drive to the tilt motor. The drive signal for the tilt motor is sent to the motor driver, IC602 pin 3.

NOTE: The tilt servo in both the LDR300 and PSLD40 is turned off before the end of the disc. This is done to prevent the tilt sensor from transmitting off the edge of the disc.

Service Procedure

LDR300

To check the operation of the tilt servo in the LDR300 place the laser disc player in the test mode, and load a disc into the machine. Press the play button twice to put the unit in the play mode with the tracking servo closed. Pressing the chapter/track buttons on the front of the unit, will move the tilt motor through it's operating range.

1. If the tilt motor does not move check Motor drive commands from IC801 pins 49, and 50. Depending on the direction of the motor rotation, either pin 49 or 50 will be pulsed from 5V to 0V.
 - A. If pins 49 or 50 are not pulsed suspect IC801.
 - B. If the pins are pulsed, suspect the tilt/loading motor, or IC802.

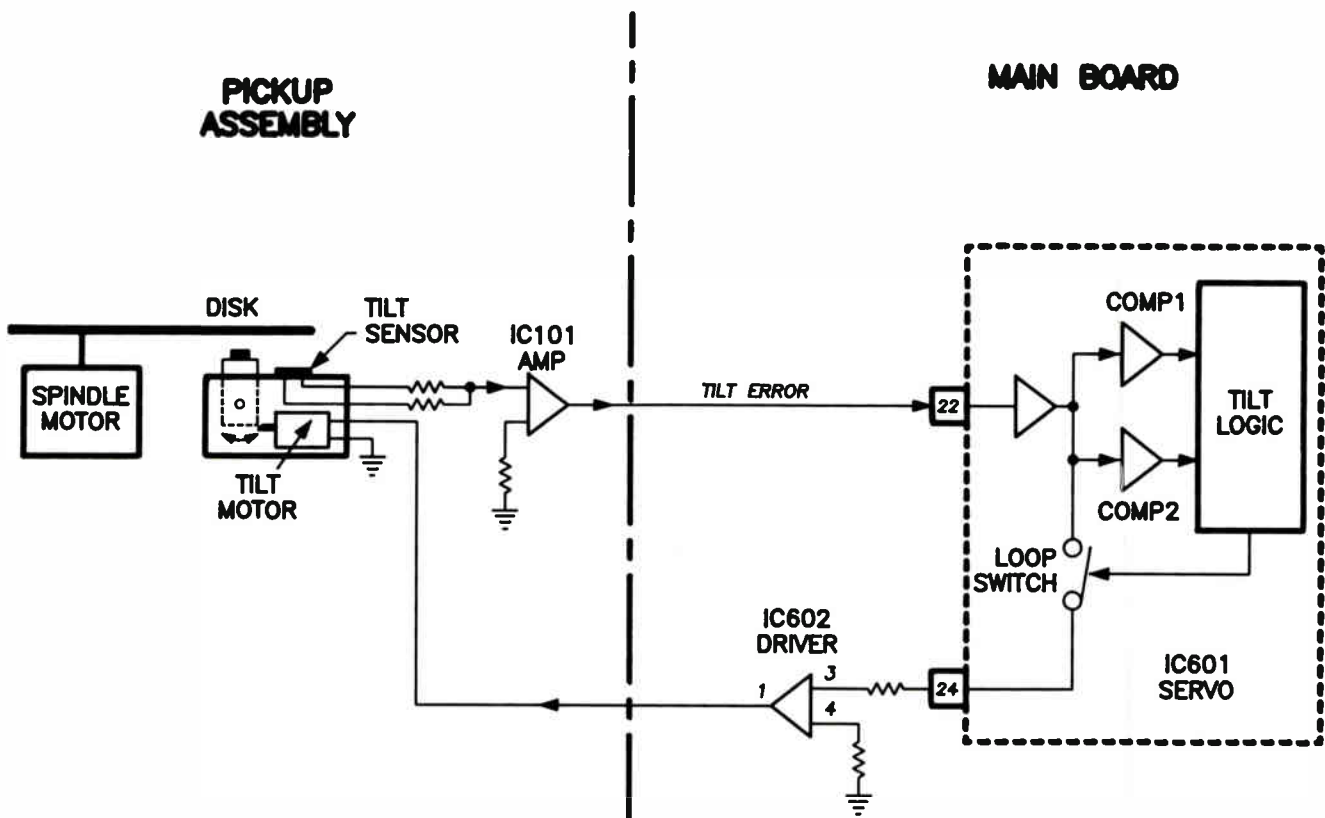
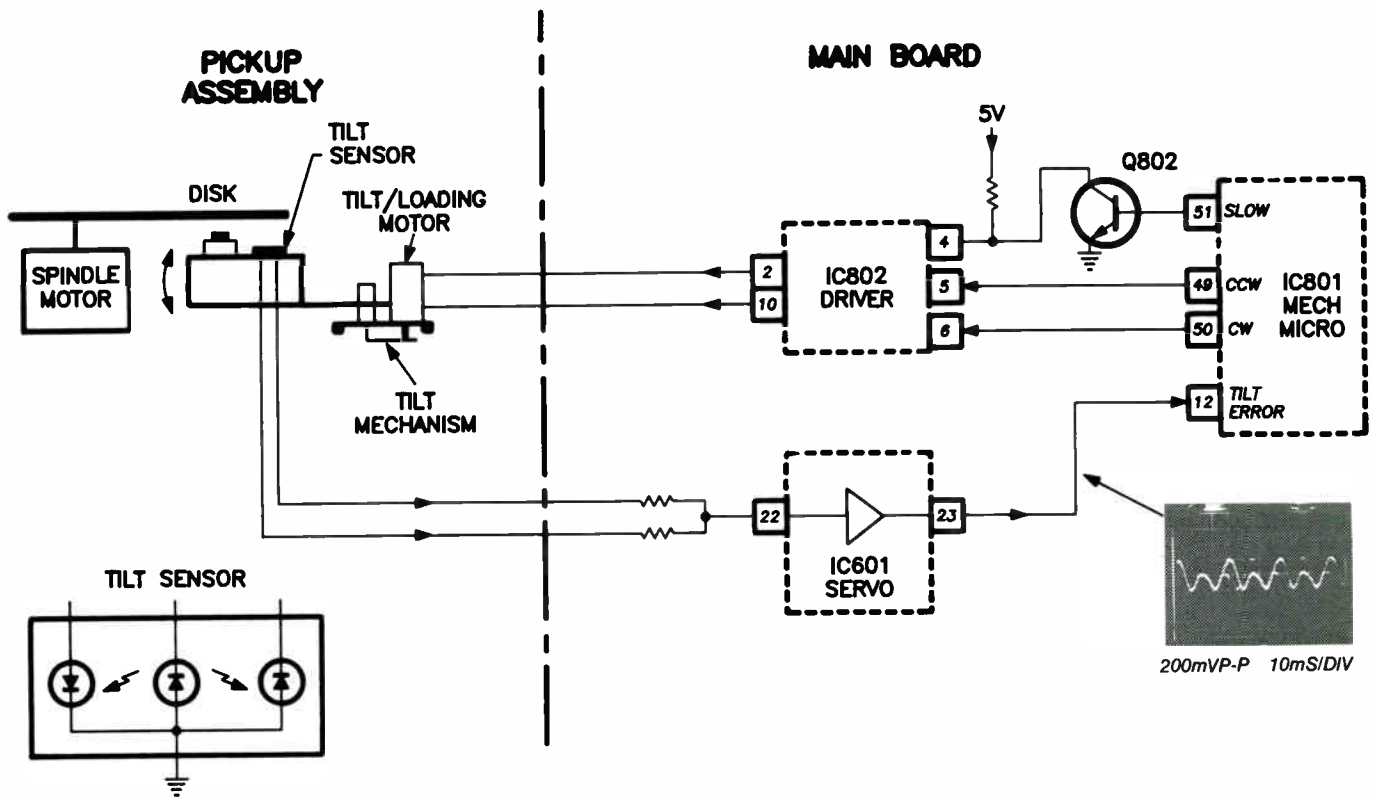

Fig. 29 - Tilt Servo PSLD40



LDR300 Tilt Servo (Repeated)

2. If the tilt/loading motor operates when the track/ chapter search buttons are pressed. With an oscilloscope check the DC level at pin 12 of IC801, while moving the tilt/loading motor through its operating range. The level at pin 12 should vary from 0V DC to 5V DC depending on the position of the motor.
 - A. If the level does not vary suspect the tilt sensor and IC601.
 - B. If the level does vary suspect IC801.

- A. If this level is greater than +/-26mV, check IC601 pin 24 for drive to IC602. The voltage at pin 24 can vary from 0 to 5V DC depending on the amount of error voltage at pin 22 of IC602.
 1. If the voltage at pin 24 is greater than .5V DC suspect IC602 and the tilt motor.
 2. If the voltage at pin 24 is less than .5V DC suspect IC601.

PSLD40

1. To check the tilt servo in the PSLD40, in the play mode check the DC offset on IC601 pin 22. If the tilt servo is operating correctly this level should be less than +/-26 mV DC.

Time Base Correction Servo

The TBC (Time Base Correction) servo corrects for eccentricities in the disc centering. These eccentricities change the speed the information is being read from the disc. If these speed changes are not corrected for, horizontal jitter and chroma instability develop. The low frequency eccentricities are corrected by adjusting the speed of the spindle motor. High frequency eccentricities are corrected in the video section with the time base error signal, and the VPS (Video Phase Shifter) error signal. These correction signals are developed by comparing the phase of horizontal sync, and chroma burst, to a reference oscillator internal to IC901.

Horizontal sync pulses are supplied from the video section to IC901 pin 36 (see fig 30). These pulses are compared with a horizontal reference signal developed in IC901. This reference signal is developed by dividing the

oscillator in IC901 (14.31818MHz) by 910. The phase difference between the horizontal sync pulses, and the reference signal determined by the phase comparator in IC901. The phase comparator develops a error voltage which will be added to the burst error signal.

The burst error signal is generated by comparing the chroma burst phase with a chroma reference signal generated in IC901. This reference signal is generated by dividing the oscillator in IC901 (14.31818MHz) by 4. Difference in phase between the chroma burst signal and the reference signal develops an error signal. This error signal is sent to two location in the laser disc player. The first location is to the video processing section to provide the VPS error signal. This signal is used to correct the chroma signal for the residual time base errors that cannot be corrected for by the video time base corrector. The second location the burst error is added to the hori-

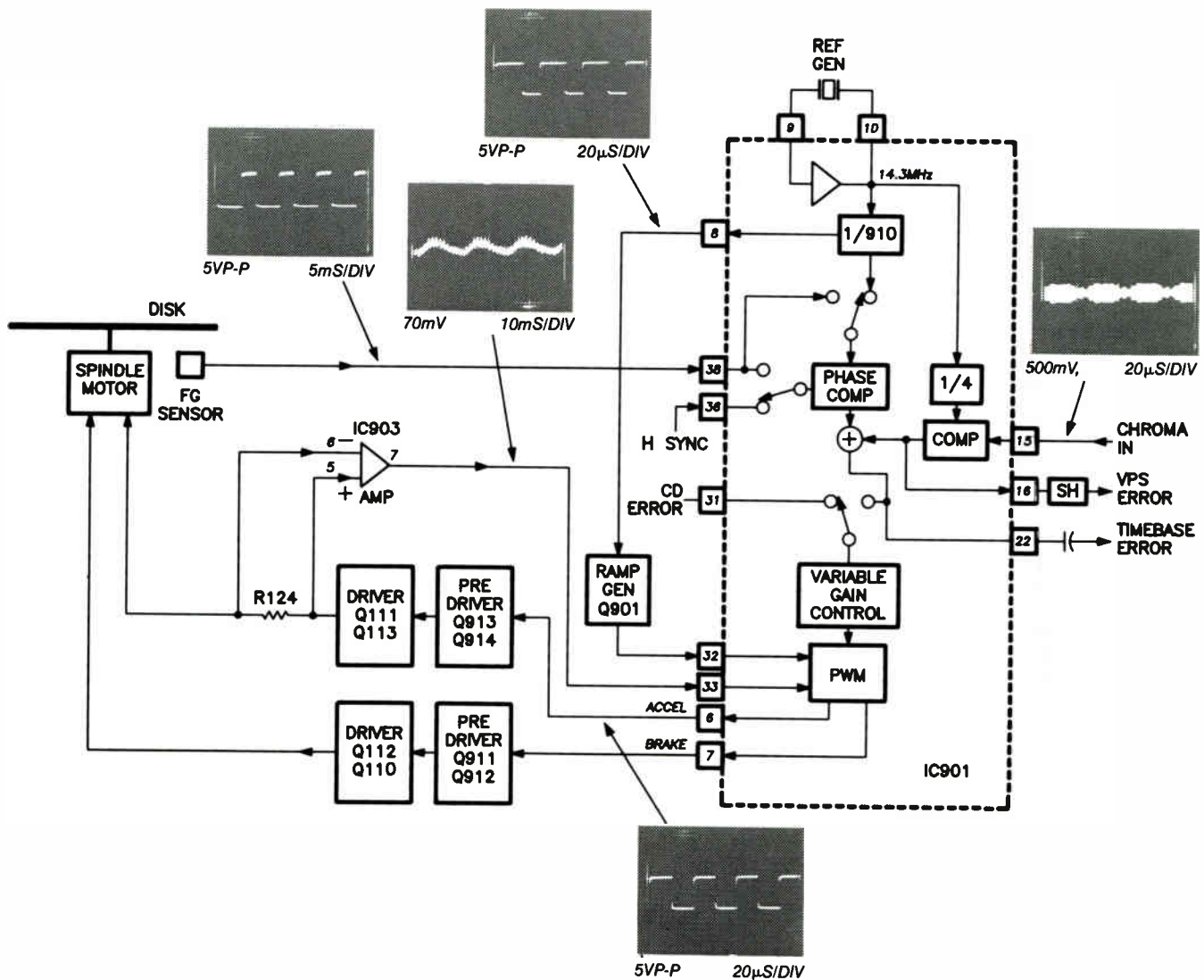

Fig. 30 - LDR300 TBC Servo

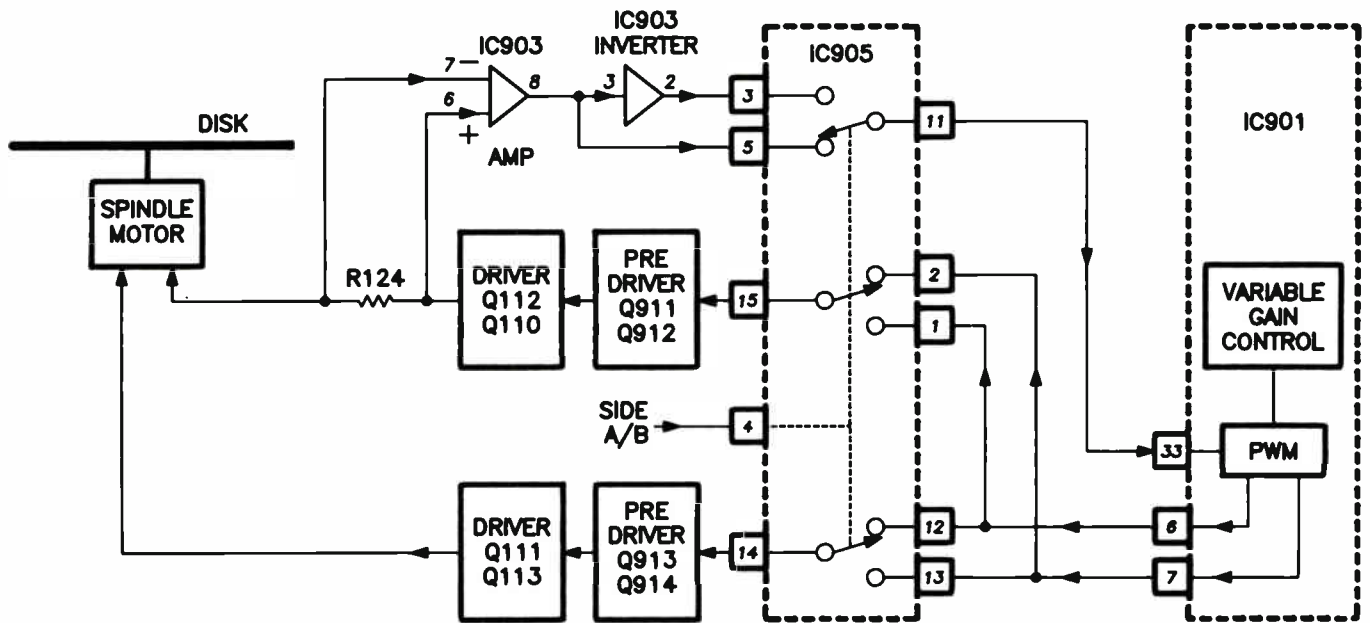

Fig. 31 - PSLD40 Spindle Drive

zontal time base error, to make the total time base error signal. The total time base error signal is capacitively coupled to the video processing section, to control the delay time of a variable delay line. The total time base error is also direct coupled in IC901 to the variable gain control.

The variable gain control in IC901 is used to control the amount of amplification of the time base error signal. The amplification of the time base error signal is reduced when playing the slower speeds of a CLV disc. The output of the variable gain control is sent to the PWM to control the speed of the spindle motor.

When the laser disc player is playing a compact audio disc the variable gain control input is switched from using the time base error signal, to using the CD error signal. This signal is generated in IC201 of the digital audio section.

The FG pulses supplied at pin 38 of IC901 are used during the start up process of the spindle motor. When the spindle motor is first started rotating horizontal sync, and chroma burst signals are not available. The mechanical control microprocessor switches the input of the phase comparator from the horizontal sync pulses, to the

FG sensor pulses. When the spindle motor is at a predetermined speed the mechanical control microprocessor switches IC901 back to comparing the horizontal sync pulses. This allows the spindle motor to get close to the correct speed before using the signals from the video processing section.

The Pulse Width Modulator (PWM) in IC901 uses two signals to control the spindle motor speed. The first signal is a ramp signal that is developed from the output of a 14.5MHz oscillator between pins 9 and 10. This reference signal is first divided by 910 and output at pin 8 of IC901. This signal is then applied to Ramp Generator Q901. The ramp signal output of Q901 is used as a reference for the PWM generator inside IC901. The second signal is the total time base error from the variable gain control. These two signals are used together to control the pulse width of the spindle motor drive signal (ACCEL) at pin 6 of IC901. If the spindle motor must increase in speed the pulse width of the drive signal increases. If the spindle motor must decrease in speed the pulse width of the drive signal decreases. A feedback signal is developed from the voltage drop across R124 and is used to vary the drive signal that is applied to the spindle motor. This is necessary in order to accommodate the different sizes of discs.

The PWM circuit within IC901 also develops a braking signal to stop the spindle motor rotation. This is done when going from play mode to the stop mode. This signal is output from pin 7 of IC901 and sent to the predriver transistors Q911 and Q912, and drivers Q110, Q112.

The PSLD40 changes the direction of the spindle motor rotation when side B of a disc is played. To do this the drive circuitry of the PSLD40 is changed by adding IC905 (see fig 31). IC905 is a switch that switches the PWM drive signals, to reverse the rotation of the spindle motor.

The polarity of the return current also changes when the spindle motor is reversed. The return current in the PSLD40 is amplified and inverted by IC903. Both inverted and non inverted current signals are applied to IC 905 pin 3, and 5. The proper polarity signal is then selected by IC905 and sent to the PWM in IC901.

Service Procedure

1. No spindle motor rotation.
 - A. Confirm focus servo has obtained a focus lock. A low at IC601 pin 26, if not present check focus servo.
 - B. Check for PWM signal at pins 6 of IC901. This signal should be 5V P-P with a pulse width of approximately 50%.
 1. If PWM signal is present, troubleshoot spindle motor drive circuitry; Q913, Q914, Q111, and Q113.
- C. If PWM signal at pin 6 is not present check for ramp signal at IC901 pin 32. This signal should be 400mV P-P at 15.734KHz.
 1. If present suspect IC901.
 2. If not present check for clock signal at IC901 pin 8. This signal should be a 5V P-P squarewave, with a frequency of 15.734KHz.
 - A. If present suspect Q901.
 - B. If not present suspect IC901.
2. If the spindle motor rotates a full speed after focus lock is achieved.
 - A. Check FG pulse at pin 38 of IC901. These pulses should be 5V P-P.
 1. If present suspect IC901.
 2. If not present suspect FG sensor on spindle motor.
3. If the spindle motor rotates but the speed varies when playing a disc.
 - A. Check for presence of horizontal sync pulses at pin 36 of IC901. These pulse should be negative going 5V P-P.
 1. If not present, troubleshoot signal processing section.
 - B. If horizontal sync is present, check for the presence of chroma burst signal, at pin 15 of IC901. This signal should be 400mV P-P chroma.
 1. If not present, confirm operation of the signal processing section.
 2. If present suspect IC901.

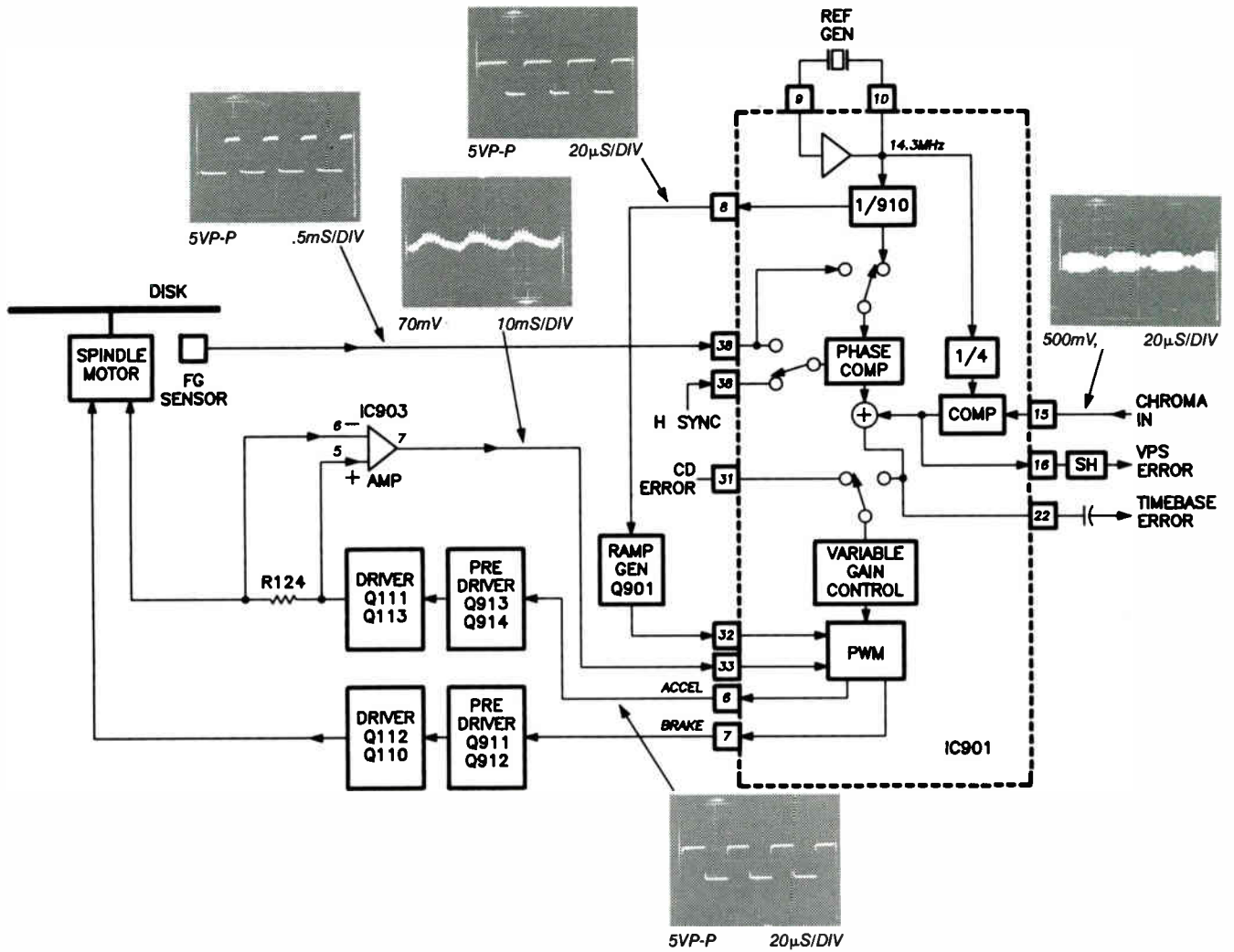

LDR300 TBC Servo (Repeated)

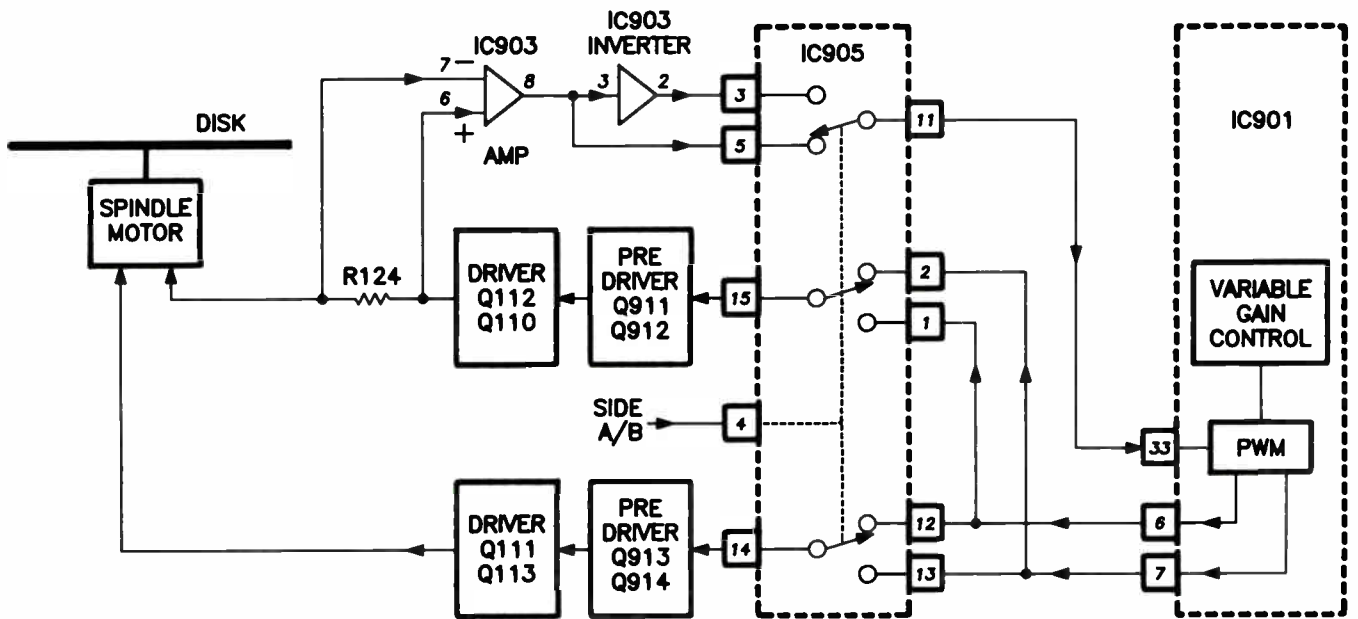

PSLD40 Spindle Drive (Repeated)

SIGNAL PROCESSING SECTION

Video Section

The RF signal from the pickup assembly is applied to pin 53 of IC401 (see fig 32). The RF signal is corrected to boost the high frequencies lost in the optics of the pickup assembly. After correction the RF is then split into 2 signals; one is used for demodulation, and the second signal is used for drop-out detection.

The signal to be demodulated is band pass filtered and sent to pin 49 of IC401 for demodulation. The demodulated video signal is output from pin 44 and low pass filtered, before it is sent to the input of the drop-out detector switch, pin 40. If a drop-out is detected in the RF signal at pin 55, the drop-out switch inserts a delayed video signal. The video signal is delayed by IC402 and returned to the drop-out switch at pin 42 of IC401. The drop-out compensated signal is then sent out of IC401 at pin 38. The video signal is now sent to IC403 for time base error correction.

IC403 is a variable delay line, the delay time is determined by the clock signal at pin 12. This clock signal is generated by a voltage controlled oscillator (IC404), which is controlled by the time base error signal, from the TBC servo. The time base corrected video is sent out of IC404 at pin 1.

After low pass filtering the video signal is once again sent down 2 paths. The video signal is applied to pin 34 of IC401, where the Philips code is extracted from the vertical sync interval and sent out on pin 27 to the mechanical control microprocessor. Also at pin 34 the horizontal and vertical sync signals are separated and sent out on pins 35, and 36. In the second path, the video signal is applied to pin 26, clamped, and sent out at pin 25 for VPS (Video Phase Shift) correction. The VPS circuit remove the minor time base errors that can affect the chroma stability.

After VPS correction the video signal is sent to pin 15 and 16 of IC 401 for noise reduction. At pins 15 and 16,

the video signal goes through high limit and low limit filters to separate cross talk, and audio beat interference.

The cross talk, and audio beat interference is then added to the video signal at pin 10, were they are subtracted out. The video signal is sent out on pin 8 to IC 405, the OSD (On-Screen Display) IC. IC 405 adds on screen data and sends the composite signal to the video out jacks on the rear of the unit.

Service Procedure

1. No video out
 - A. Check for video signal at pin 44 of IC401. This signal should be 2.5V P-P.
 1. If not present confirm RF signal at IC401, pin 53. This signal should be 100mV P-P.
 - A. If not present suspect pickup assembly and RF amplifiers.
 - B. If signal is present at pin 44 check for video signal at the output of the DOC, pin 38 of IC 401. This signal should be 1V P-P video.
 1. If not present suspect IC401 and IC402.
 - C. If video signal is present at pin 38 check for video signal at IC 403 pin 1. This signal should be 1V P-P.
 1. If not present suspect IC404, and IC403.
 - D. If present check for video at OSD IC405 pin 13. This signal should be 2V P-P.
 1. If not present suspect IC401.
 2. If signal is present suspect IC405 and video out circuitry.

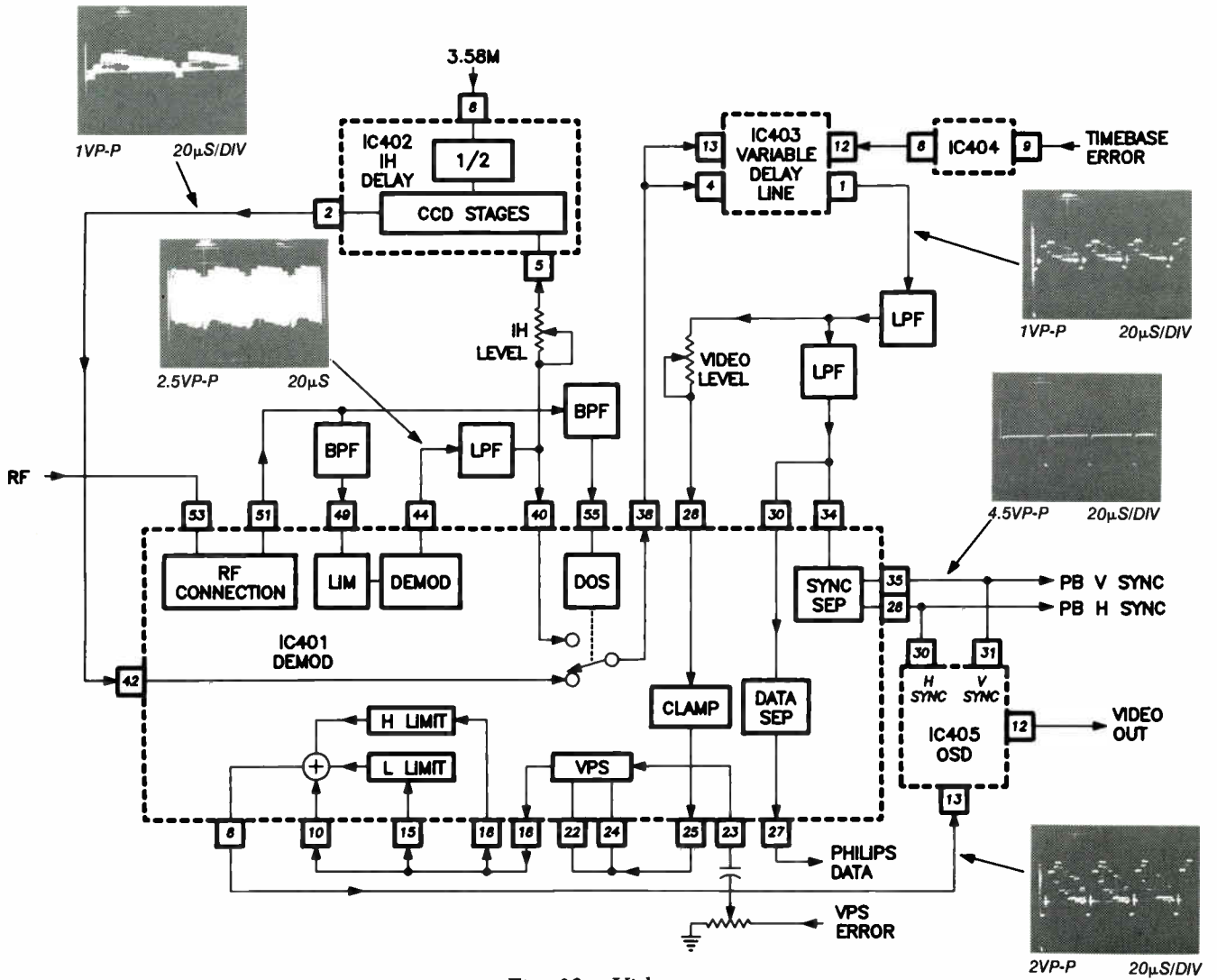

Fig. 32 - Video

Digital Audio

The RF signal from the pickup assembly is split into 2 separate RF correction circuits (see fig 33). One circuit is for the playback of CD's, and the other circuit is for the playback of laser discs (LD). The mechanical control microprocessor selects which correction circuit is used, and switches IC 205 to the correct position. The correction circuits are needed to boost the high frequencies of the RF signal. High frequencies are attenuated in the optics of the laser assembly. The CD RF correction consist of Q201, Q202, and Q203, which are tuned amplifiers to boost the high frequencies of the RF signal. The RF correction circuits for LD is more complex, since the RF characteristics of LD is slightly different than that of CD. In LD RF correction, the RF signal is passed through a 1.75 MHz low pass filter to attenuate any analog video or analog audio RF signals. Transistors Q204, Q205, Q206, provide the required boost for the high frequencies.

After RF correction the selected RF signal is applied to a ATC (Asymmetric Tracking Compensator) circuit. The ATC prepares the RF signal for digital conversion by removing the varying DC offset that is riding on the

RF signal. The ATC circuit eliminates the offset by automatically tracking the shifting DC baseline and cancelling it out. Without the ATC, the process of converting an RF signal to a digital signal would be less accurate. Consequently, the digital signal converted from the RF signal will not reproduce the signal recorded on the disc.

After ATC correction, the RF signal is sent to IC 201 for demodulation. The RF signal is then demodulated and stored into RAM inside IC201. During demodulation the control data and the frame sync data, are separated from the digital signal. The control data is sent to the mechanical control microprocessor, where it is decoded to provide the display information. The sync data is used to control the loading speed of the data being loaded into internal RAM of IC201. With the data now loaded into IC 201 RAM, it must be unloaded from the RAM to the digital filter. The data transfer between the decoder IC (IC201) and the digital filter (IC202) must be synchronized and data transferred from IC202 and IC203 must also be synchronized. To provide the synchronization a master clock is used. This clock is generated in IC203 using pins 30 and 31. The clock is then applied to IC202 at pin 2, and IC203 pin 53.

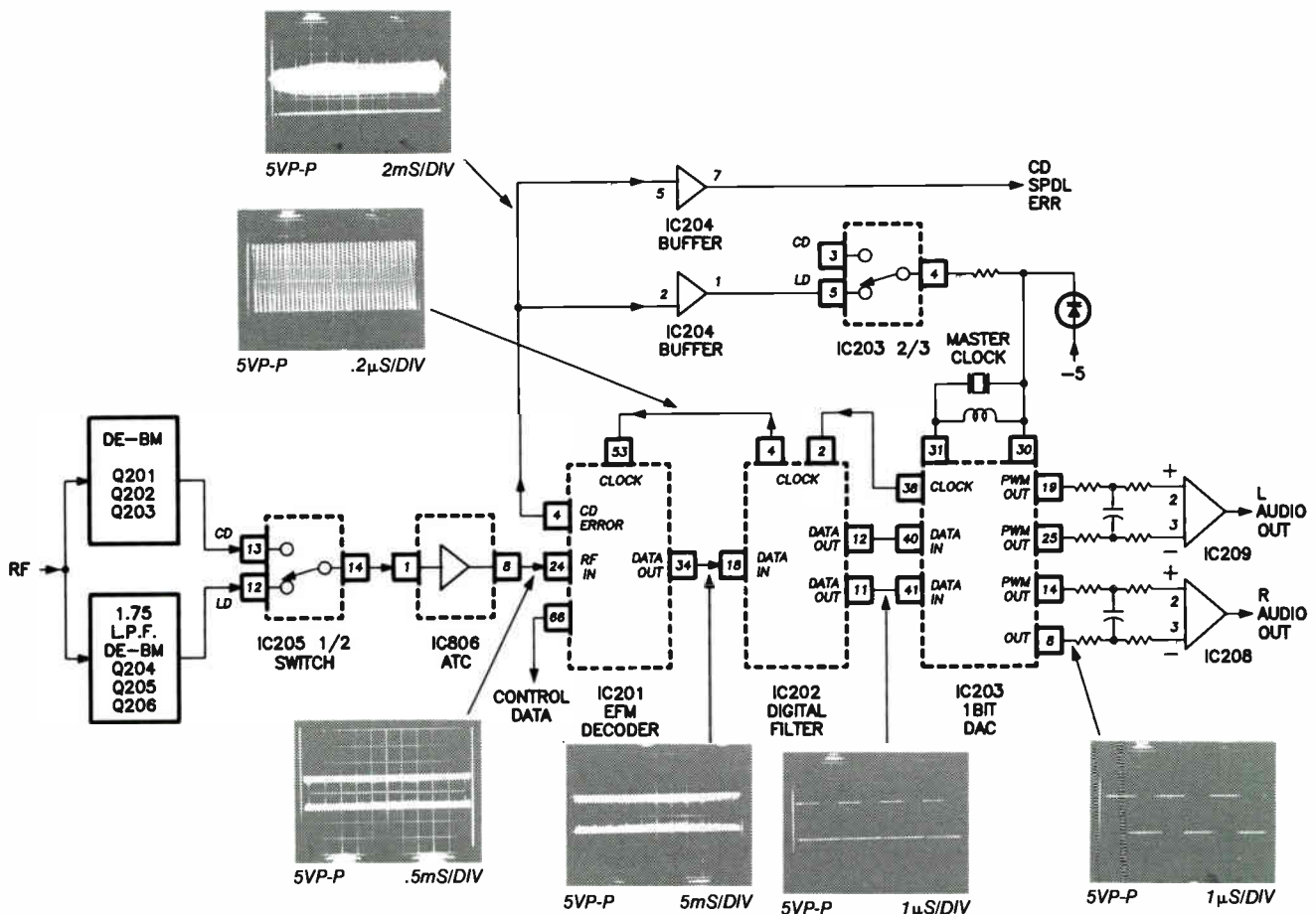

Fig. 33 - Digital Audio

In IC203 the phase of the master clock and the phase of a PLL (internal to IC 203) are compared. The PLL internal to IC203 is synchronized by the sync data. The difference between the 2 signals is then sent out of IC 203 at pin 4. When the laser disc player is playing a compact disc this data is used as a error signal in the TBC servo. When playing a laser disc this signal is coupled via IC203 back to the master clock to control the frequency. The reason for this is to synchronize the data being read into RAM with the data being read out of RAM. When playing a compact disc the master clock at IC203 set to a fixed frequency. The synchronization of the read in and read out operation is accomplished by controlling the speed of the spindle motor. The data demodulated in IC201 is sent out on pin 34 to the digital filter.

The purpose of the digital filter is to remove any noise created during the mastering process. This noise is generated during the analog to digital conversion process. The removal of this noise during playback is accomplished by sampling the 16 bit audio word at a rate that is 8 times the rate of the original sampling frequency (44.1KHz). This process is referred to as "Oversampling". By oversampling at 8 X 44.1KHz (352.8KHz), the noise created during the analog to digital conversion process is now spread over a wider frequency range. This frequency range is from 0 Hz to 88 KHz. By spreading the noise over a wider frequency range there is less noise in the audio frequency range (0 Hz - 20KHz). The output of the digital filter is right channel data (pin 11) and left channel data (pin 12).

The right and left channel data is applied to IC203, the 1 bit digital-to-analog converter (DAC). In the DAC the right and left channel data is converted to pulse width modulated signals. These signals from the data are sent out on pins 8,14,19, and 25.

These signals are filtered out and buffered by IC208 and IC209. The analog signals are then sent to the analog/digital switch, and the output of the switch to the jacks on the rear of the unit.

Service Procedure

No digital audio

1. Confirm digital RF signal at IC201 pin 24. This signal should be 5V P-P.
 - A. If not present, suspect IC205, IC206, and RF correction circuits.
2. If RF signal is present check for clock signal at IC201 pin 53 (5V P-P, 17MHz)
 - A. If not present check for clock signal at pin 31 of IC203 (4V P-P, 17MHz).
 1. If present suspect IC202.
 2. If not present suspect IC203.
3. If clock signal is present check for data out of IC201 at pin 34 (the data level should be 5V P-P).
 - A. If not present suspect operation of IC201.
4. If present check for data activity on pins 11 and 12 of IC202 (5V P-P).
 - A. If not present suspect the operation of IC202.
5. If data activity is present at IC202, confirm the presence of PWM signals at IC203 pins 8,14,25,19. The signal should be 5V P-P and the pulse width should vary.
 - A. If not present suspect operation of IC203.
6. If the PWM signal is present check, for analog audio signals at pin 1 of IC208 and IC209. This signal should be 1V P-P.
 - A. If not present suspect IC208 and IC209.
 - B. If present suspect audio output circuitry (see analog audio section of this manual for troubleshooting procedure).

Analog Audio

The analog audio processing for the LDR300 and the PSLD40 are the same. The play back RF signal from the pickup assembly is separated from the video RF signal by bandpass filters (see fig 33). After filtering, the RF signal is applied to another bandpass filter F351, which separates the 2 audio carriers (2.3 MHz, and 2.8MHz). The two carriers are then sent to pin 41 and pin 2 of IC 351. In IC 351 the RF signal is applied to a limiter and a demodulator. The audio signal after demodulation is time base corrected. This is done with the time base error signal (from IC 901, pin 22, of the TBC servo) applied to pin 27 of IC 351. IC 351 inverts this error signal and adds it to the demodulated audio. This cancels any time base errors riding on the analog audio signal. After error correction the audio signal leaves IC 351 (pins 9 and 34) and enters the IC 351 at the drop-out compensator.

Drop-out compensation is provided in 2 stages. The first stage of drop-out compensation detects any level changes in the RF carrier. The second stage of drop-out compensation detects high frequency noise generated by carrier level changes to small for the first stage of drop-

out compensation to detect. The input signal for the second stage of drop-out detection is pins 8 and 35 of IC 351. If drop-outs are present in either stage of detection, a stored value of audio is substituted in the area of the drop-out.

After drop-out compensation the audio signal is applied to the mode switch in IC 351 at pins 12 and 31. The mode switch selects which channel of audio is to be sent to the noise reduction stages. It has three modes of operation, left channel audio only, right channel audio only, and right and left channel, these modes are selected by the mechanical control microprocessor (See Table In Fig. 33).

The selected output of the modes control section is sent through CX noise reduction. In the CX noise reduction system the high level audio signals are compressed in the record process, and expanded during playback. This increases the dynamic range and the signal to noise ratio of the audio signal. The processed audio signals exits IC 351 at pins 21 and 22. The analog audio signal passes through the analog/digital switch, and is supplied to the audio output jacks or RF converter (LDR300 only).

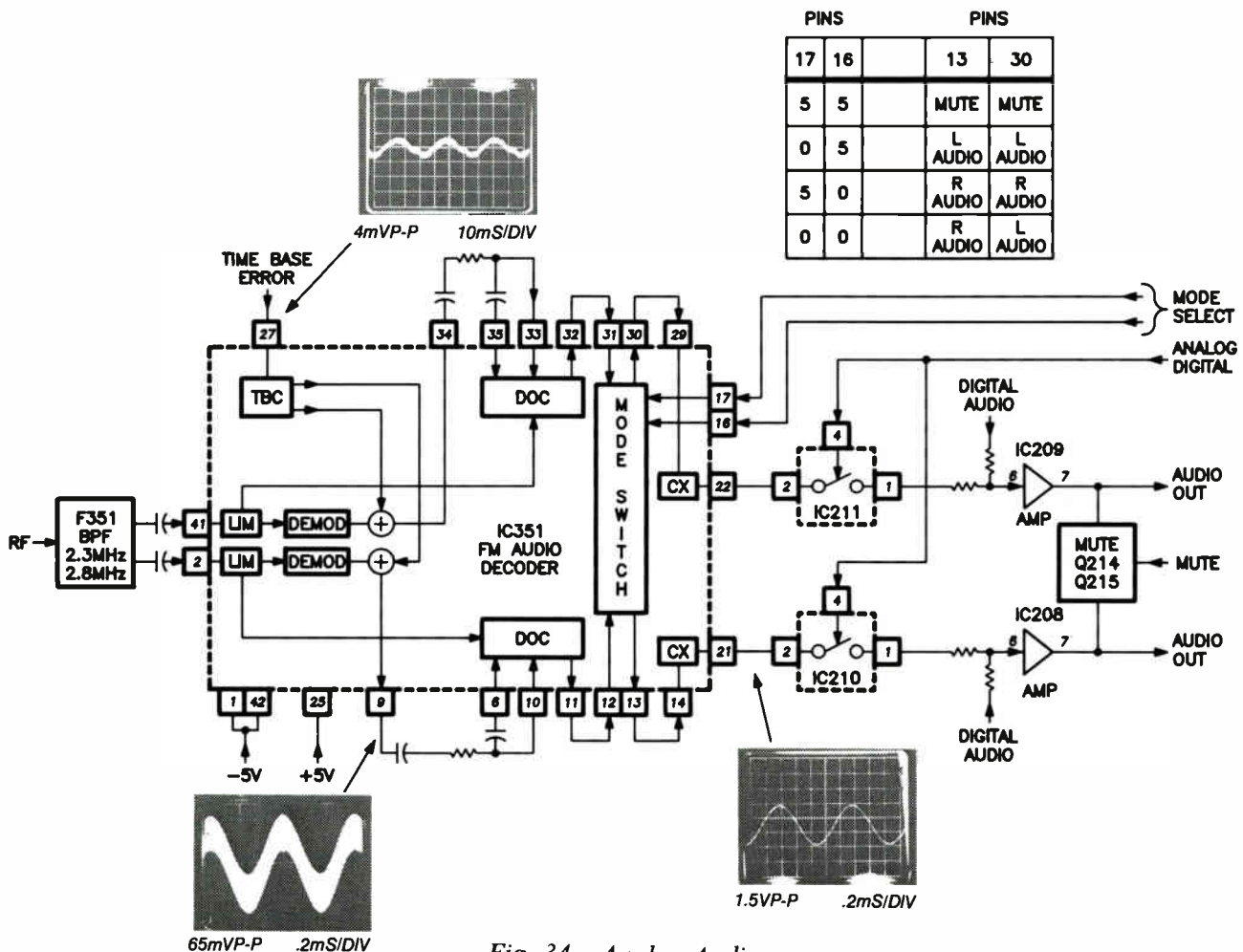

Service Procedure

No analog audio

2. Check for RF signal at pins 2 and 41 of IC351. This signal should be approximately 200mV P-P.
 - A. If not present suspect F351.
3. If the RF signal is present, check for an audio signal at input to the mode switch in IC351(pins 31,12). This signal should be 500mv P-P.
 - A. If signal is not present suspect IC351.
4. If present, check an audio signal at IC351 pins 21, and 22. This signal should be approximately 1.5V P-P.
 - A. If signal is not present check the voltage levels on pins 16 and 17 of IC351. Compare these levels to the table in Fig 34 to determine if IC351 or the mechanical control microprocessor (IC801) is defective.
5. If the signal is present check for audio signal at pin 1 of IC211 and IC210. This signal should be 1.5V P-P.
 - A. If the signal is not present check switching voltage on pin 4 of IC211 and IC210. In the analog audio mode pin 4 should be 8V. In the digital audio mode the voltage on pin 4 should be -8V.
 1. If the voltage at pin 4 is incorrect, suspect IC801.
 2. If the voltages are correct, suspect IC211, IC210.
6. If the signal is present at IC211 and IC210, suspect; IC208 and IC209, and Q214, Q215.

APPENDIX A

Test Mode Initiation LDR300, PSLD-40

To enter the test mode:

1. Remove the top cover and disc tray.
2. Short TP303 (Main circuit board) to ground.
3. Turn the instrument on.
4. Confirm that all segments of the fluorescent display are lit.
5. Remove the short from TP303.

Test Mode Cancellation

To exit the test mode, turn the instrument off.

Test Mode Operation

When in the test mode, the player may be operated using either the remote transmitter or the front panel buttons. However, some keys have different functions in the test mode than they do in normal operation. Refer to Tables 1 and 2 for further details.

Function	Player Status	Key Operation	Remarks
Open Tray	Stop mode.	▲	
Close Tray	Tray open.	▲	
Stop	Play mode.	■	<ul style="list-style-type: none"> • Stop disc rotation. • Open TRK servo.
Play	Disc placement and tray closed.	▶	<ul style="list-style-type: none"> • Starts up with the TRK servo open. • Starts up with tilt neutral. • The disc type (LD/CD/CDV) is determined when playback starts at the SLDR position during startup.
TRK Servo Open/Close	Play mode.	▶	<ul style="list-style-type: none"> • Each time the PLAY button (▶) is pressed, the TRK servo will open or close.
Still	Play mode. TRK servo closed.	 (Remote control key)	<ul style="list-style-type: none"> • Each time the STILL button () is pressed, the player will switch between the PLAY and STILL modes.
SLDR REV SCAN	Play mode.	◀◀	<ul style="list-style-type: none"> • Press and hold down the key. • With the TRK servo open, the pickup can be damaged if the SLD moves further inward than the read-in area on the disc. Do not allow the SLD to move further inward than the read-in area.
SLDR FWD SCAN	Play mode.	▶▶	<ul style="list-style-type: none"> • Press and hold down the key. • With the TRK servo open, the pickup can be damaged if the SLD moves further outward than the read-out area on the disc. Do not allow the SLD to move further outward than the read-out area.
TILT Neutral	Power switch ON.	EDIT	
TILT Servo On	Play mode.	RANDOM PLAY	
TILT Minus TILT Servo OFF	Play mode.	◀◀	<ul style="list-style-type: none"> • Press and hold down the key.
TILT Plus TILT Servo OFF	Play mode.	▶▶	<ul style="list-style-type: none"> • Press and hold down the key.
Screen Display ON/OFF	Power switch ON.	PGM Key	
Frame Search	Play mode.	+10 Key ↓ 0 - 9 Key ↓ ▶	<ul style="list-style-type: none"> • In the PLAY mode, press the +10 key. (The player will standby for the frame no. entry.) • Use the numeric keys to enter the frame no. Then press the player's PLAY key to search. • After the search is completed, the player will return to the operation mode before the search was performed.
LOAD Motor Rotation Clockwise Counterclockwise	Tray open.	▶▶ ◀◀	

Table 1 - Key Operations (Test Mode) LDR300

Function	Player Status	Key Operation	Remarks
Open Tray	Stop mode.	▲	
Close Tray	Tray open.	▲	
Stop	Play mode.	■	<ul style="list-style-type: none"> • Stop disc rotation. • Open TRK servo.
Play	Disc placement and tray closed.	▶	<ul style="list-style-type: none"> • Starts up with the TRK servo open. • Starts up with tilt neutral. • The disc type (LD/CD/CDV) is determined when playback starts at the SLDR position during startup.
TRK Servo Open/Close	Play mode.	▶	<ul style="list-style-type: none"> • Each time the PLAY button (▶) is pressed, the TRK servo will open or close.
Still	Play mode. TRK servo closed.	 (Remote control key)	<ul style="list-style-type: none"> • Each time the STILL button () is pressed, the player will switch between the PLAY and STILL modes.
SLDR REV SCAN	Play mode.	◀◀	<ul style="list-style-type: none"> • Press and hold down the key. • With the TRK servo open, the pickup can be damaged if the SLD moves further inward than the lead-in area on the disc. Do not allow the SLD to move further inward than the lead-in area.
SLDR FWD SCAN	Play mode.	▶▶	<ul style="list-style-type: none"> • Press and hold down the key. • With the TRKG servo open, the pickup can be damaged if the SLD moves further outward than the lead-out area on the disc. Do not allow the SLD to move further outward than the lead-out area.
TILT Servo On	Play mode.	RANDOM PLAY	
Height Minus TILT Servo OFF	Stop mode.	◀◀◀	<ul style="list-style-type: none"> • Press and hold down the key.
Height Plus TILT Servo OFF	Stop mode.	▶▶▶	<ul style="list-style-type: none"> • Press and hold down the key.
Screen Display ON/OFF	Power switch ON.	PGM key	
Frame Search	Play mode.	+10 key ↓ 0-9key ↓ ▶	<ul style="list-style-type: none"> • In the PLAY mode, press the +10 key. (The player will standby for the frame no. entry.) • Use the numeric keys to enter the frame no. Then press the player's PLAY key to search. • After the search is completed, the player will return to the operation mode before the search was performed.

Table 2 - Key Operation (Test Mode) PSLD40

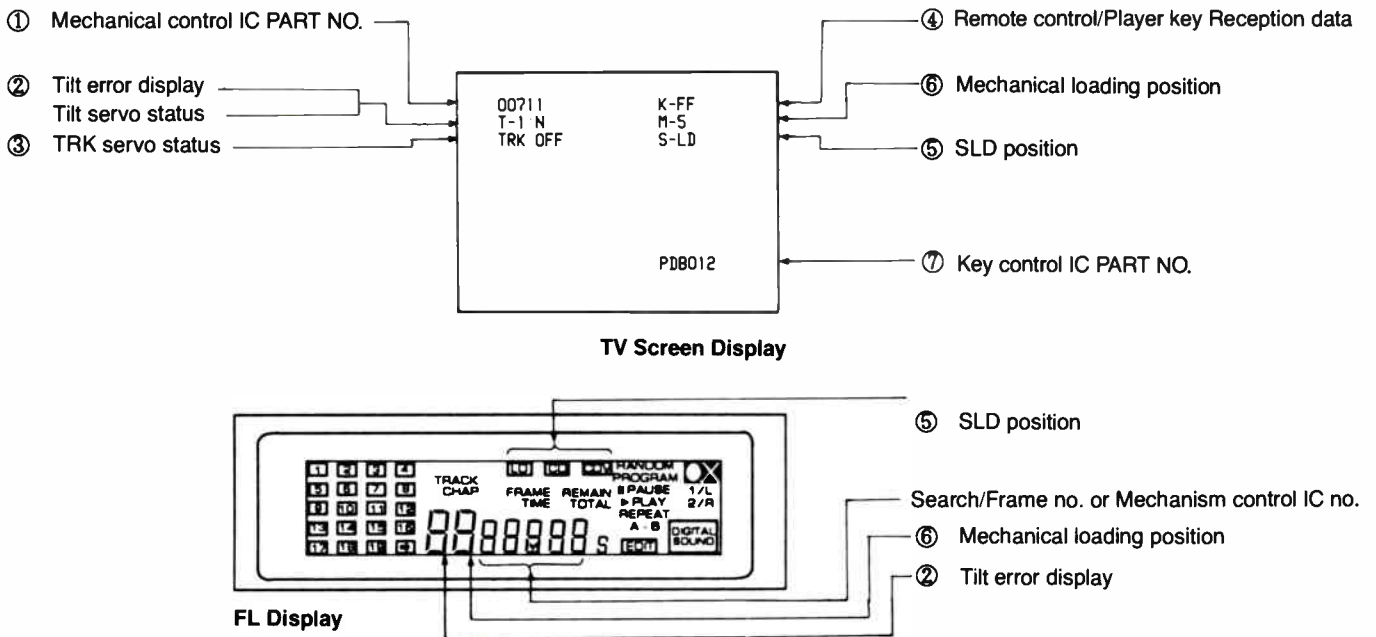

Fig. 1 - TV Screen/Front Panel Displays (Test Mode)

TV Screen And Front Panel Displays

An example of a typical TV screen and front panel (fluorescent) display is shown in Figure 1. The TV display appears when the player is turned on. The front panel display appears after the first command is received during test mode. An explanation of each display follows.

1. Mechanical Control IC Part No.

The part number for IC801 (Main circuit board) is indicated on both the TV screen and the front panel display. Example: part no. PD0071A is displayed as 00711.

2. Tilt Error Display/Tilt Servo Status

The status of the tilt servo is indicated on the TV screen and front panel display. TV display information is coded as follows:

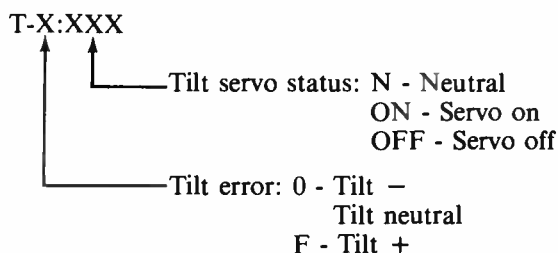

3. Tracking Servo Status

The status of the tracking servo is indicated on the TV screen and is coded as follows:

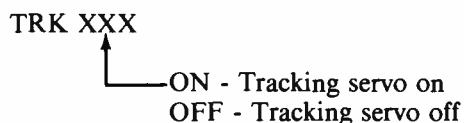

4. Key Reception Data

The code for keyboard commands (remote or front panel) is indicated on the TV screen and is coded as follows:



5. Slider Position

Slider position is indicated on the TV screen and front panel display. TV display information is coded as follows:

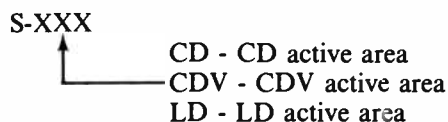

6. Mechanical Loading Position

Mechanism position is indicated on the TV screen and front panel display. TV display information is coded as follows:

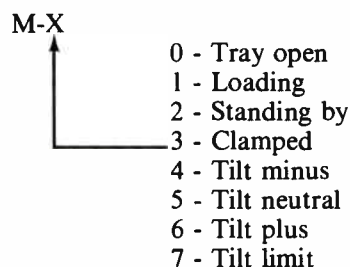

7. Keyboard Control IC Part No.

The part number for IC11 (Display circuit board) is indicated on the TV screen.

CODE	FUNCTION	CODE	FUNCTION	CODE	FUNCTION	CODE	FUNCTION	CODE	FUNCTION	CODE	FUNCTION
00	0	10	F-SCAN	20		30	(10)	40	(CHAPT)	50	R-STEP
01	1	11	R-SCAN	21		31	(11)	41	(FRAME)	51	
02	2	12		22		32	(12)	42	CHP/FRM	52	F-SKIP
03	3	13	CHP/FRM	23		33	(13)	43	SEARCH	53	R-SKIP
04	4	14		24		34	(14)	44	DISPLAY	54	F-STEP
05	5	15		25		35	(15)	45	CLEAR	55	R-MULTI
06	6	16	STP/OPN	26		36	OPN/CLS	46	SPEED -	56	
07	7	17	PLAY	27		37	STOP	47	SPEED +	57	
08	8	18	PAUSE	28		38	PLY/PAS	48	REP-A	58	F-MULTI
09	9	19		29		39	EDIT	49	(2/RCH)	59	
0A		1A	(POWON)	2A		3A	INTRO	4A	(STEREO)	5A	
0B		1B	(POWOFF)	2B		3B	RANDOM	4B	(1/LCH)	5B	
0C	DGT/ANL	1C	POWER	2C		3C		4C	PROGRAM	5C	
0D		1D		2D		3D		4D		5D	
0E	CX	1E	AUD.MON	2E		3E		4E		5E	(TEST)
0F	TV/LDP	1F	+10	2F		3F		4F		5F	(ESC)

Table 3 - Key Reception Data Coding

APPENDIX B

PSLD40, LDR300 Laser diode output Confirmation.

1. Remove the top cover and disc tray from unit.
2. Place unit in the test mode.
3. Connect a DVM across R714 for the LDR-300, R119 for the PSD-40.
4. Without loading a disc into the player, place the player into the play mode.
5. The DVM should indicate 675 mV DC +/-50mV. If laser power is not within this range adjust, VR1 for the proper level.

CAUTION; The laser diode emits invisible infrared radiation, which is dangerous to the eyes. When servicing the laser disc player do not look directly into the laser lens.

APPENDIX C

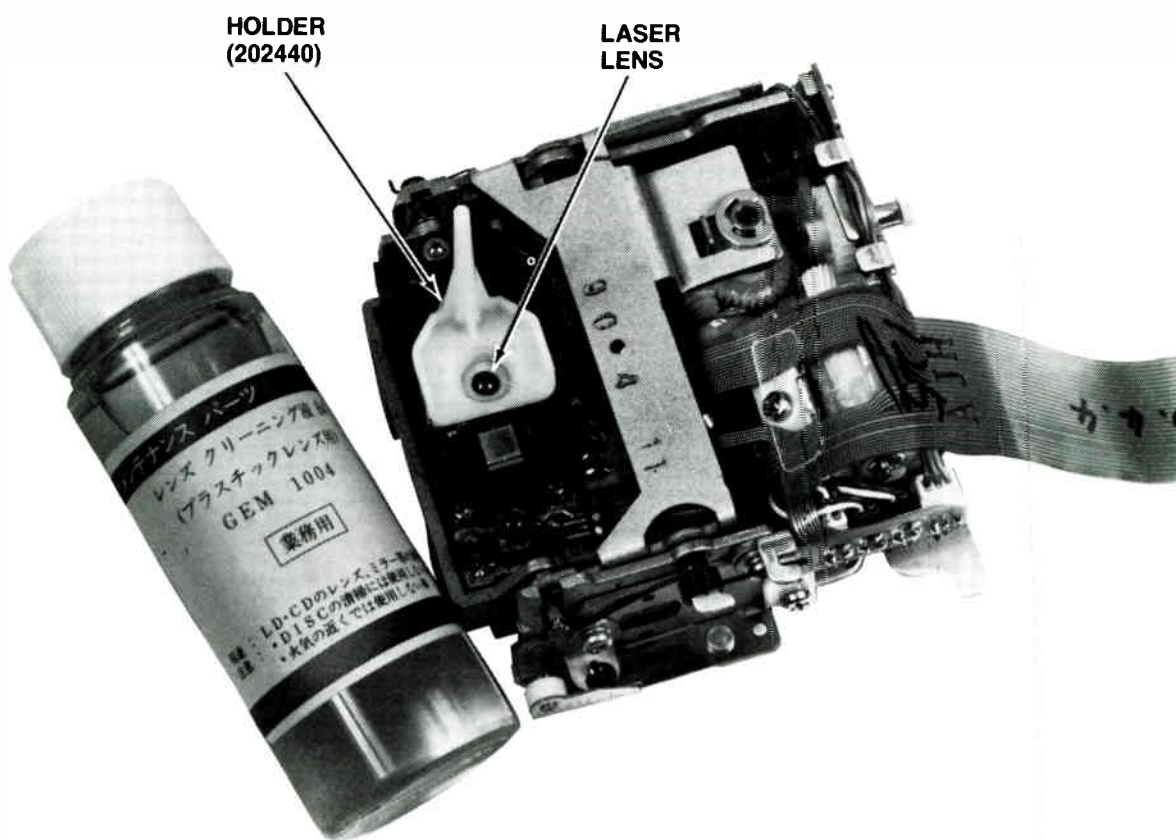

Laser Lens Cleaning

1. Remove top cover and disc tray to gain access to the pickup assembly.
2. Secure laser lens position by placing holder (202440) on lens.

Caution; The laser lens is mounted in the pickup assembly by the focus and tracking coils. Extreme caution must be taken when moving, and handling the laser lens, to avoid damaging the coils.

3. With a cotton swab apply cleaning fluid (202441) to the laser lens, and dry.

APPENDIX D IC201 DIGITAL AUDIO DECODER

PIN No.	SYMBOL	I/O		DESCRIPTION
1	FCOR	I		Focus OK input terminal. This is used for the SENS output and the servo auto sequencer.
2	FSW	O	Z 0	Spindle motor's output filter switching output.
3	MON	O	1 0	Spindle motor's ON-OFF control output.
4		O	1 Z 0	Spindle motor's servo control.
5	MDS	O	1 Z 0	Spindle motor's servo control.
6	LOCK	O	1 0	H output when GFS undergoes sampling LH at 460 Hz. L output when there is L eight consecutive times.
7	NC			
8	VCOO	O	1 0	Oscillation circuit output for the analog EFM PLL.
9	VCOi	I		Oscillation circuit input flock = 8.6436 MHz for the analog EFM PLL
10	TEST	I		TEST pin. Normally GND.
11	PDO	O	1 Z 0	Charge pump output for the analog EFM PLL.
12	Vss			GND
13				
14	NC			
15				
16	VPCO	O	1 Z 0	PLL charge pump output for variable pitch.
17	VCKi	I		Clock input fc center = 16.9344MHz from the variable pitch external VCO.
18	Filo	O	A	Filter output (analog) for master PLL (slave = digital PLL).
19	FiLi	I		Filter input for the master PLL.
20	PCO	O	1 Z 0	Charge pump output for the master PLL.
21	AVss			Analog GND.
22	CLTV	I		VCO control voltage input for the master PLL.
23	AVDD			Analog power supply (+5 V).
24	RF	I		EFM input after asymmetry correction.
25	TEST	I		To be GND.
26	TEST	I		To be GND.
27	ASYO	O	1 0	EFM full-swing output.
28	TEST	I		To be GND.
29	NC			
30	PSSL	I		Audio data output mode switching input. "L" series output. Parallel output with "H".
31	WDCK	O	1 0	D/A interface for the 48-bit slot. Word clock f = 2Fs.
32	LRCK	O	1 0	D/A interface for the 48-bit slot. LR clock f = Fs.
33	VDD			Power supply (+5V)
34	DA16	O	1 0	DA16 (MSB) output when PSSL = 1.48 slot serial data (25' COMP) when PSSL = 0.
35	DA15	O	1 0	DA15 output when PSSL = 1.48-bit slot bit clock when PSSL = 0.
36	DA14	O	1 0	DA14 output when PSSL = 1.64-bit slot serial data 25'COMP LSB first when PSSL = 0.
37	DA13	O	1 0	DA13 output when PSSL = 1.64-bit slot bit clock when PSSL = 0.
38	DA12	O	1 0	DA12 output when PSSL = 1.64-bit slot and LR clock when PSSL = 0.
39	DA11	O	1 0	DA11 output when PSSL = 1. GTO output when PSSL = 0.
40	DA10	O	1 0	DA10 output when PSSL = 1. XUGF output when PSSL = 0.

IC201 DIGITAL AUDIO DECODER (CONT.)

PIN No.	SYMBOL	I/O		DESCRIPTION
41	DA09	O	$\begin{matrix} 1 \\ 0 \end{matrix}$	DA10 output when PSSL = 1. XPLCK output when PSSL = 0.
42	DA08	O	$\begin{matrix} 1 \\ 0 \end{matrix}$	DA08 output when PSSL = 1. GFS output when PSSL = 0.
43	DA07	O	$\begin{matrix} 1 \\ 0 \end{matrix}$	DA07 output when PSSL = 1. RFCK output when PSSL = 0.
44	DA06	O	$\begin{matrix} 1 \\ 0 \end{matrix}$	DA06 output when PSSL = 1. C2P0 output when PSSL = 0.
45	DA05	O	$\begin{matrix} 1 \\ 0 \end{matrix}$	DA05 output when PSSL = 1. XRAOF output when PSSL = 0.
46	DA04	O	$\begin{matrix} 1 \\ 0 \end{matrix}$	DA04 output when PSSL = 1. MNT3 output when PSSL = 0.
47	DA03	O	$\begin{matrix} 1 \\ 0 \end{matrix}$	DA03 output when PSSL = 1. MNT2 output when PSSL = 0.
48	DA02	O	$\begin{matrix} 1 \\ 0 \end{matrix}$	DA02 output when PSSL = 1. MNT1 output when PSSL = 0.
49	DA01	O	$\begin{matrix} 1 \\ 0 \end{matrix}$	DA01 output when PSSL = 1. MNT0 output when PSSL = 0.
50	APTR	O	$\begin{matrix} 1 \\ 0 \end{matrix}$	Aperture correction control output. "H" for the R ch.
51	APTL	O	$\begin{matrix} 1 \\ 0 \end{matrix}$	Aperture correction control output. "H" for the L ch.
52	Vss			GND
53	XTAi	I		16.9344 MHz or 33.8688 MHz Xtal oscillation circuit input.
54	XTAO	O	$\begin{matrix} 1 \\ 0 \end{matrix}$	16.9344 MHz or 33.8688 MHz Xtal oscillation circuit output.
55	XTSL	I		Xtal selection input terminal. "L" when it is 16.9344 MHz. "H" when it is 33.8688 MHz.
56	FSTT	O	$\begin{matrix} 1 \\ 0 \end{matrix}$	2/3 divided output of the Xtal oscillation. Fixed during variable pitch.
57	C4M	O	$\begin{matrix} 1 \\ 0 \end{matrix}$	4.2336 MHz output. Changes during variable pitch.
58	C16M	O	$\begin{matrix} 1 \\ 0 \end{matrix}$	19.9344 MHz output. Changes during variable pitch.
59	MD2	I		Digital OUT ON/OFF control. ON when "H", and OFF when "L".
60	DOUT	O	$\begin{matrix} 1 \\ 0 \end{matrix}$	Digital OUT output terminal.
61	EMPH	O	$\begin{matrix} 1 \\ 0 \end{matrix}$	"H" output when the playback disc has emphasis. "L" output when it has no emphasis.
62	WFCK	O	$\begin{matrix} 1 \\ 0 \end{matrix}$	Write frame clock output.
63	SCOR	O	$\begin{matrix} 1 \\ 0 \end{matrix}$	"H" output when the subcode sync SO or SI is detected.
64	SBSO	O	$\begin{matrix} 1 \\ 0 \end{matrix}$	Sub P - W code and serial output.
65	EXCK	I		For SBSO lead out. External clock input.
66	SQSO	O	$\begin{matrix} 1 \\ 0 \end{matrix}$	SubQ 80-bit and PCM peak data 16-bit output.
67	SQSK	I		External clock input for SQSO lead out.
68	MUTE	I		Mute with "H", and cancel with "L".
69	SENS	O	$\begin{matrix} 1 \\ 0 \end{matrix}$	SENS output. Sent to the CPU.
70	XRST	I		System reset. Reset when "L".
71	DATA	I		Serial data input from the CPU.
72	XLAT	I		Serial data from the CPU is latched with the latch input shutdown.
73	VDD			Power supply input (+5V).
74	CLK	I		From the CPU, serial data transfer clock input.
75	SEIN	I		From the SSP, SENSE input.
76	CNIN	I		Track jump count signal input.
77	DATO	O	$\begin{matrix} 1 \\ 0 \end{matrix}$	Serial data output to the SSP.
78	XLTO	O	$\begin{matrix} 1 \\ 0 \end{matrix}$	Serial data latch output to the SSP. Latched during shutdown.
79	CLKO	O	$\begin{matrix} 1 \\ 0 \end{matrix}$	SP serial data transfer clock output.
80	MIRR	I		Mirror signal input. Used with the auto sequencer for jumps exceeding 128 tracks.

APPENDIX E ICII MODE CONTROL MICROPROCESSOR

PIN No.	SYMBOL	I/O	DESCRIPTION
1	Vdd	I	Power supply input (5V)
2			No connection
3			
4			
5			
6			
7	G1	O	FL lighting timing output "H": ON, "L": OFF
8	G2		
9	G3		
10	G4		
11	G5		
12	G6		
13	G7		
14	G8		
15	G9		
16	G10		
17	G11		
18	VDISP	I	FL display power supply input (- 30V)
19	l	O	FL lighting segment output "H": ON, "L": OFF
20	k		
21	i		
22	i		
23	h		
24	g		
25	f		
26	e		
27	d		
28	c		
29	b		
30	a		
31	LAST MEMORY	O	LED lighting output. "H": ON, "L": OFF
32	CD DIRECT		
33	DOOR SW	I	Door switch input. "H": ON, "L": OFF
34	SYNC IN	O	Synchronized REC control input
35	SYNC OUT		Synchronized REC control output
36	POWER ON	O	Power ON/OFF "H": ON, "L": OFF
37	X RESET		PD0071 reset
38	X CS	O	M50554 select
39			No connection
40	X SCK	I/O	Serial data transfer clock
41	SI	I	Serial data input
42	SO	O	Serial data output
43	RESET	I	Reset input
44	SEL IR		Remote control unit input
45	SHAKE		Serial communication start request input
46		O	No connection
47			
48	ACK	O	Serial communication acceptance output
49	KS0	O	Key scan output "H": ON, "L": OFF
50	KS1		
51	KS2		
52	KS3		
53	KS4		
54	KS5		
55	KS6		
56	KIN0	I	Key data input "H": ON, "L": OFF
57	KIN1		
58	KIN2		
59	KIN3		
60	X2		No connection
61	X1		GND (Not used.)
62	Vss		GND
63	OSC2	I	Oscillator (6.0MHz)
64	OSC1	O	

APPENDIX F

IC801 MECHANICAL CONTROL MICROPROCESSOR

PIN No.	SYMBOL	I/O	DESCRIPTION
1	Vcc		Power supply connection (+ 5V)
2	SQ2	O	Analog audio switching signal output terminal. Digital audio is controlled by IC201 (CXD2500Q).
3	SQ1		
4	HEIGHT UP	O	PLSD-40 Height motor control
5	HEIGHT DOWN		
6	X DIGITAL	O	Digital/analog audio switching signal output terminal. This signal switches the signal which is output to LINE OUT and HEADPHONE. When "H", analog audio. When "L", digital audio
7	XLDP		RF modulator switching signal output terminal.
8	XCX		Analog audio CX noise reduction switching signal output terminal.
9	LDON		Laser diode ON/OFF control signal output terminal. When "H" Laser diode ON. When "L" Laser diode OFF
10	MUTE		Audio system mute control signal output terminal. When "L", MUTE OFF. When "H", MUTE ON.
11	NPC LATCH		Digital filter IC (IC202: SM5840AP) control latch signal output terminal.
12	TILT ERROR PLSD-40		I
13	GFS	CD (EFM signal) frame lock signal input terminal. (IC201: Connected to pin 12 of CXD2500Q) When "H", OK. When "L", NG.	
14	XLAT2	O	IC201 CXD2500Q control latch signal output terminal.
15	S12	I	IC201 CXD2500Q subcode data input terminal
16	SO2	O	IC201 CXD2500Q control data output terminal.
17	SCK2		IC201 CXD2500Q control/subcode reading clock signal output terminal.
18	SHAKE	I/O	Mode Control IC (IC11: PDB017) data transmission handshake signal terminal. This terminal is a bidirectional data line. It transmits the timing for the data transfer after the respective microcomputer switches between the output or input mode.
19	S11	I	Mode Control IC data transmission data I/O terminal. SCK1 (pin 21) will be set to the input mode when there is no communications with the Mode Control IC.
20	SO1	O	
21	SCK1	I/O	
22	T.CROSS	O	Tracking error zero cross signal input terminal. This signal monitors the tracking error signal. During track count search, this signal is counted and the slider motor is controlled.
23	SCOR	I	Subcode sync signal input terminal. When this signal is "H", the subcode signal is input from I201 (CXD2500Q). The disc's playback status is also monitored through the existence or no-existence of the signal.
24	SENS		IC901 (HD49403) SPDL servo status monitor signal input terminal.
25	XTBCHLD	O	During TBC servo jump, it is the correction signal output terminal. During a special playback of CAV disc, the signal becomes "L" when there is track jumping. After V sync and a fixed time period, it becomes "H".
26	V-Sync	I	Playback vertical synchronization signal input terminal for LD/CDV. The IC basically operates while in synchronization with this signal. (Trailing edge input) During a special playback mode for a CAV, the signal is the standard for producing the jump training. It is "L" during vertical synchronization.
27	CNVss	-	GND.
28	XRESET	I	Reset signal input terminal. When "L", RESET. When "H", Normal operation.
29	XIN		9MHz clock oscillation input terminal.
30	XOUT	O	9MHz clock oscillation output terminal.
31	N.C.		Unused
32	Vss	-	GND.

IC801 MECHANICAL CONTROL MICROPROCESSOR CONT.

PIN No.	SYMBOL	I/O	DESCRIPTION
33	PARK2	I	The pickup position detection switch input terminals. Being a switch input for mechanism position detection, it detects the pickup's position.
34	PARK1		
35	FOCUS LOCK		
36	1080/2080		
37	FG		
38	DATA		
39	Hsync		
40	Vsync		
41	CAV	O	CAV/CLV switching signal output terminal. (IC201: Connected to pin 17 of PA5010, it is used as the video NR switching signal.)
42	CLVSCAN	O	CLV V sync scan mode signal output terminal. When CLVSCAN is "L", SCANV (pin 44) is inserted to the video signal.
43	SIDE A/B	O	PLSO-40 SIDE A/B
44	SCANV	O	Pseudo V sync signal output terminal for the CLV V sync scan.
45	XVSQ		Blue back switching signal output terminal for the video output. When "H", playback video. When "L", blue back.
46	XRFCORR		RF correction switching signal output terminal. (Connected to IC201 PA5010 pin 52) "H" at the outer periphery of the CAV.
47	H LOAD	O	PLSD-40 loading motor control
48	V LOAD		
49	CCW	O	Loading/tilt motor rotation direction control signal output terminal. The motor's rotational direction and brake mode are selected by pins 49 and 50. Pin 49: Counterclockwise. Pin 50: clockwise.
50	CW		
51	SLOW		
52	J. TRIG	O	Track jump signal output terminal.
53	FTSSCAN	I/O	Signal output terminal for tracking servo stabilization. Normally, it will be HI-Z in the input mode.
54	TOFF	O	Tracking servo operation control signal output terminal. This signal backs up the ON/OFF of the tracking servo operation. When "L", ON. When "H", OFF
55	CD MODE		
56	XLD MODE		Servo equalizer switching signal output terminal. This is switched according to the disc to be played.
57	SO3		Series signal output terminal for the FTS servo IC (IC601: HA11529), the SPDL/TBC servo IC (IC901:HD49403), and the digital filter IC (IC202: SM5840AP).
58	SCLK3		The series signals of these three ICs are the same. They are distinguished by pin 11 (NPCLAT) and pin 59 (LATCH3).
59	LATCH3	O	Latch signal output terminal for the FTS servo and the SPDL servo.
60	HIN		PLSD-40 tray position dect.
61	HOUT		
62	SW1	I	Loading/tilt position detection switch input terminals.
63	SW2		
64	SW3		

APPENDIX G

IC601 SERVO CONTROLLER

Pin No.	Pin Function
1	Vcc: - 5V
2	FOCS ERROR signal input: OP AMP input to which a SW is connected for gain control during SCAN operation.
3	FOCS SUM input: For DISC detection. Comparator input threshold is + 0.4V.
4	Comparator input threshold for the FOCS S-curve detection is +0.3V.
5	Comparator input threshold for MAIN BEAM ON/OFF track detection is +1.2V FOCS SUM input.
6	TRKG ERROR input: Comparator input threshold for TRKG ERROR zero cross detection is 0V.
7	GND
8	TRKG ERROR AMP for CD input
9	TRK ERROR AMP for LD input
10	TRKG ERROR AMP output. TRKG servo phase compensation is connected between this pin and pin 8.
11	Output for switching the TRKG servo loop characteristics during track jump. (Open or Close)
12	Outputs the actuator drive and brake pulse during track jump and the actuator brake pulse during SCAN.
13	FTS SCAN
14	Current setting terminal for TRKG actuator brake.
15	Current setting terminal for pins other than pin 14.
16	TRKG RTN input: TRKG RTN input for SLDR servo.
17	SLDR servo amp output: During play, the SLDR motor is PWM driven and at that time this pin becomes the window comparator input.
18	SLDR drive signal output during play or when high speed slider is in operation.
19	SLDR drive signal output when SLDR in operating at low or mid speeds.
20	Capacitor connected pin for setting the slope of the reference triangular wave for the SLDR motor PWM drive during play.
21	Resistor connected to set comparator threshold for turning off the TILT servo drive.
22	TILT ERROR input: OP amp input.
23	A VR is connected for setting the TILT servo gain with the output of the OP amp from pin 22.
24	Output for TILT motor drive.
25	T-CROSS output: TRKG ERROR zero cross count output.
26	F-LOCK output: "Low" when FOCS lock activated.
27	J-TRIG input: Triggered at startup. "Low" under normal operating conditions.
28	RESET input:
29	LATCH input: Serial interface bus to the system CPU. (pins 29,30,31) Data is latched on the trailing edge.
30	SDATA input: 8-bit serial command data input.
31	SCLK input: clock for serial data transmission.
32	500kHz input: internal logic clock input. About 450 KHz.
33	TEST pin: Normal state is "Low". (Not used.)
34	Pin for setting the injection current used by internal I ² L logic.
35	Capacitor connected pin for setting the lens UP/DOWN cycle when FOCS ON is activated.
36	Drive voltage output for lens UP/DOWN.
37	FOCS ERROR amp output: FOCS servo phase compensation is connected between pins 38 and 39.
38	FOCS ERROR amp LD input.
39	FOCS ERROR amp CD input.
40	Pin with connected offset adjustment VR that uses the uninverted FOCS Error amp input.
41	Op amp output for FOCS gain control. (Not used.)
42	Vcc: + 5V

APPENDIX H

IC 901 TIME BASE CORRECTION SERVO

PIN No.	SYMBOL	I/O	DESCRIPTION
1	SDAT	I	Serial data input from CPU.
2	SCLK		Serial data clock input from CPU. Strobed at the negative edge.
3	LACH		Serial data latch pulse input from CPU.
4	SENS	O	IC internal state sense output. High-impedance when not selected.
5	STOP		Spindle motor ON signal output.
6	MTPL		Spindle motor accelerating signal output (brush motor). Torque generation direction signal output (3-phase).
7	MTMI		Spindle motor decelerating signal output (brush motor). Torque generation signal output (2-phase).
8	RHDO		Reference HD signal output.
9	OSCO		4 fsc reference signal output.
10	OSCI		4 fsc reference signal input.
11	TEST	I	Test pin (OV).
12	RSET		System reset signal input "L" = reset.
13	DGND	-	GND for digital circuits (OV).
14	AGND		GND for analog circuits (OV).
15	PBVI	I	Burst signal input (AC-coupled).
16	AP10		Op-amp 1 output (burst signal time-axis error output).
17	PFDO	O	LPF capacitor pin for HD/FG signal time-axis error smoothing.
18	AP20		Op-amp 2 output (burst signal time-axis error output).
19	AP31	I	Op-amp 3 invert input.
20	AP30	O	Op-amp 3 invert output.
21	AP41	I	Op-amp 4 invert input.
22	AP40	O	Op-amp 4 output (for CCD circuit phase compensation).
23	SW30		Analog switch 3 output (HD/FG control select).
24	AP51	I	Op-amp 5 invert input
25	AVDD	-	Power supply for analog circuits (5V).
26	SW41	I	Analog switch 4 (to discharge capacitor).
27	VREF	-	Reference power supply (Op-amp reference voltage: 2.5V).
28	BUER	O	LPF capacitor pin for burst signal time-axis error smoothing.
29	AP50		Op-amp 5 output (for phase compensation of spindle motor circuits).
30	LPFC	-	LPF capacitor pin for gain control.
31	CDER		CD mode spindle motor control signal input.
32	VRMP	I	Lamp signal input for PWM.
33	VMOT		Spindle motor pin voltage feedback input
34	OFAD		Op-amp offset adjustment input.
35	DVDD	-	Power supply for digital circuits (5V).
36	SYNC		Composite sync signal input (digital signal).
37	RHDI	I	Reference HD signal input. Normally connected to RHDO (pin 8).
38	FG		FG input (digital signal).
39	CLK		Clock signal output for FTS. (447kHz)
40	2FSC	O	2 fsc clock signal output.
41	FSC		fsc clock signal output.
42	PBHD		Playback HD signal output (after dropout compensation).

