

Technical Series HM-90

\$175

Suggested Price



DB55681314

RCA SOLID-STATE

Hobby Circuits Manual

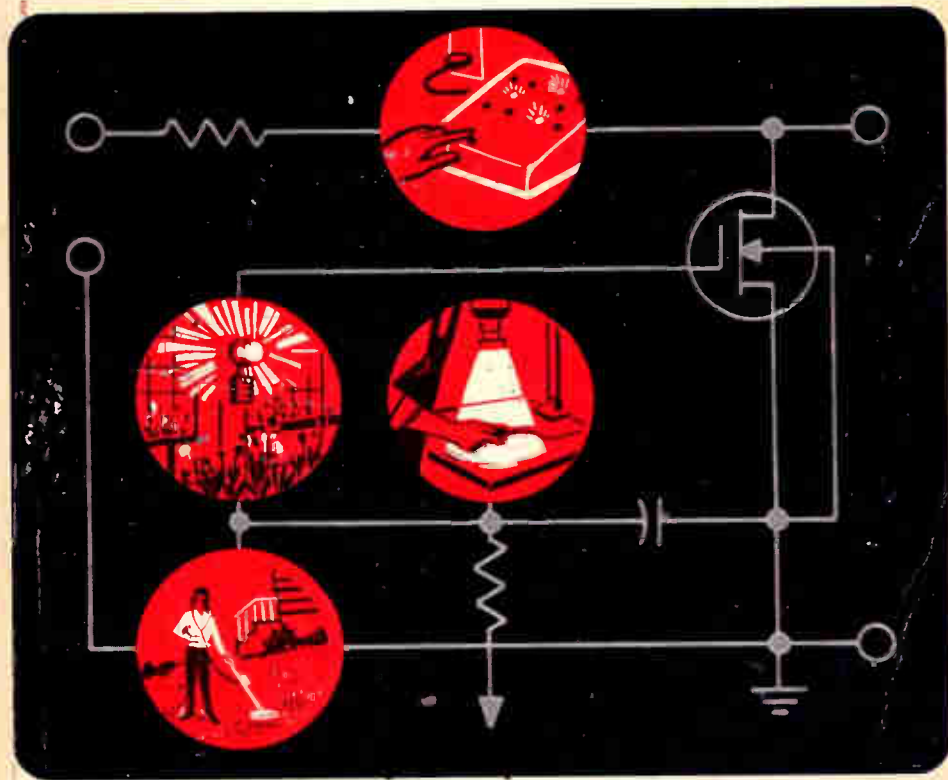

RCA

Contents

Theory and Operation of Solid-State Devices	3
Semiconductor materials, p-n junctions, current flow, silicon rectifiers, bipolar transistors, MOS field-effect transistors, thyristors (SCR's and triacs), integrated circuits, thermistors, photocells.	
General Circuit Considerations	15
Description of the basic circuits used in combination to produce the majority of circuits in the Manual: amplifiers, oscillators, switches, lamp driver.	
Mechanical Considerations	23
Basic construction practices, safety precautions, materials, chassis preparation, soldering, chassis circuit-board wiring, heat sinks, grounding; special handling considerations for transistors, integrated circuits, thermistors, and photocells.	
Testing and Troubleshooting	32
Basic procedures, test circuits for active circuit components, description of professional testing instruments.	
Suggested Circuit Uses	41
Grouping of the circuits into hobby categories: motorist, radio amateur, photographer, music lover, and home owner. Game and novelty circuits are also included.	
Circuits	48
Description of operation, adjustment, special precautions required, and construction for each of the 35 practical circuits.	
Drilling Templates	170
Index	223
List of Circuits	Inside Back Cover

Information furnished by RCA is believed to be accurate and reliable. However, no responsibility is assumed by RCA for its use; nor for any infringements of patents or other rights of third parties which may result from its use. No license is granted by implication or otherwise under any patent or patent rights of RCA.



RCA SOLID-STATE Hobby Circuits Manual

This Manual presents many practical and useful solid-state circuits which can be built by electronics hobbyists ranging from beginners to experts. The operation of each circuit is described in detail, and photographs, schematic diagrams, parts lists, and construction layouts are given. A guide to circuits by area of interest (e.g., amateur radio, photography, audio, etc.) is included to permit easy selection of the most useful circuits for specific applications.

The Manual includes brief descriptions of the theory and operation of the semiconductor devices used in the various circuits (silicon rectifiers, transistors, field-effect transistors, thyristors, and integrated circuits), and of the basic circuit "building blocks" employed. Sections containing construction tips and information on tools required, soldering techniques, testing, and troubleshooting are also included.

RCA | Electronic Components | Harrison, N.J. 07029

*Copyright 1968 by Radio Corporation of America
(All rights reserved under Pan-American Copyright Convention)*

Printed in U.S.A. 6/68



Illustrations of a few useful applications of some of the many circuits in the Manual.

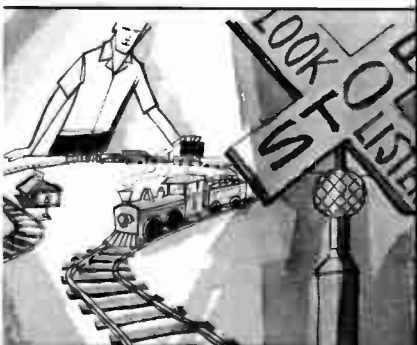
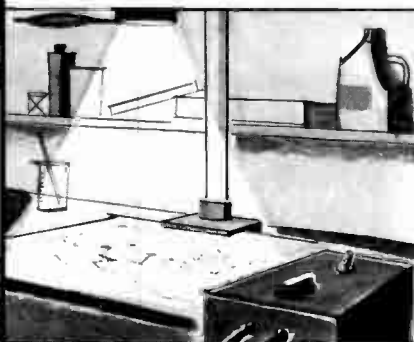
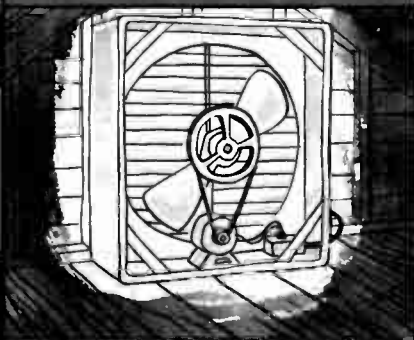

Theory and Operation of Solid-State Devices

SOLID-STATE or semiconductor devices are versatile units that can perform a variety of functions in electronic equipment. Like other electron devices, they have the ability to control almost instantly the movement of charges of electricity. However, in addition, semiconductor devices have many important advantages over other types of electron devices. They are very small and light in weight and have no filaments or heaters; therefore, they require no warm-up time or heating power. Their total power consumption is very low. They are free from microphonic noise and are rugged because of their solid construction.

SEMICONDUCTOR MATERIALS

Unlike other electron devices, which depend for their functioning on the flow of electric charges through a vacuum or a gas, semiconductor devices make use of the flow of current in a solid. In general, all materials may be classified as conductors, semiconductors, or insulators depending upon their ability to conduct an electric current. As the name implies, a semiconductor material has poorer conductivity (more resistance to current flow) than a conductor, but better conductiv-

ity (less resistance to current flow) than an insulator.

The materials most often used in semiconductor devices are germanium and silicon. Germanium is used in many low- and medium-power diodes and transistors. Silicon is more suitable for high-power devices because, among other things, it can be used at much higher temperatures.

The conductivity of semiconductor materials can be increased and controlled by the addition of small amounts of elements known as "dopants" or "impurities." For example, boron might be used as a dopant for silicon. The use of different types of dopants produces either n-type material, which has excess electrons, or p-type material, which has a shortage of electrons in its crystal structure. A position in the crystal structure from which an electron is missing is called a "hole."

P-N Junctions

When a junction is formed of n-type and p-type materials, as shown in Fig. 1, an interaction takes place in which some of the excess electrons from the n-type material diffuse across the junction and combine with the holes in the p-type material. This interaction cre-

ates a small space-charge region (often called the transition region or depletion layer) in the immediate vicinity of the junction. The p-type material in this region acquires a slight negative charge as a result of the addition of electrons; conversely, the n-type material acquires a slight positive charge as a result of the loss of excess electrons.

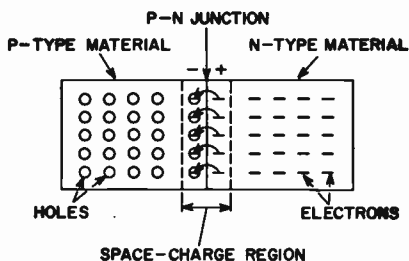

Fig. 1 - Interaction of holes and electrons at p-n junction.

The total effect is that of an imaginary battery connected across the junction having the polarity shown in Fig. 1. In the absence of external circuits and voltages, the voltage difference or potential gradient across the space-charge region discourages further diffusion across the p-n junction and preserves the differences in the characteristics of the two types of materials.

Current Flow

When an external battery is connected across the p-n junction, the amount of current that flows is determined by the polarity of the applied voltage and its effect on the space-charge region. Fig. 2(a) shows a battery connected to produce reverse bias. This connection effectively increases the width of the space-charge region, and the potential gradient increases until it approaches the potential of the external battery; current flow is then extremely small. Under the forward-bias condition shown in Fig. 2(b), the

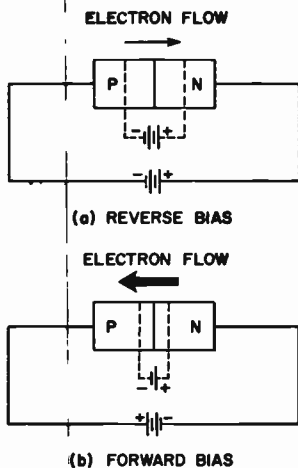

Fig. 2 - Electron current flow in biased p-n junctions.

space-charge region becomes effectively narrower, and the potential gradient decreases to a very low value; electrons then continue to flow as long as the forward voltage is applied.

The positive to negative current flow defined as conventional current flow is satisfactory for use in circuit analysis. However, in the study of semiconductors, it is helpful to think of current flow in terms of electron flow and "hole" flow. Electron current flows from negative to positive; "hole" current flows from positive to negative.

TYPES OF DEVICES

Silicon Rectifiers

Structurally, the silicon rectifier (or semiconductor diode) is a p-n junction; its schematic symbol is shown in Fig. 3. Rectifiers of this type can be operated at ambient temperatures up to 200°C and at current levels as high as 400 amperes, with voltage levels as high as 1300 volts. Parallel or series arrangements of two or more rectifiers can be used to provide even higher current or voltage capabilities.

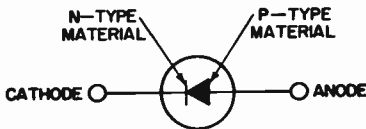

Fig. 3 - Schematic symbol for silicon rectifier.

Because of their high forward-to-reverse current ratios, silicon rectifiers can achieve rectification efficiencies greater than 99 per cent. When properly used, they have excellent life characteristics that are little affected by aging, moisture, or temperature. They can, however, be easily damaged by sudden rises in junction temperature caused by either surges of high currents or excessive ambient-temperature conditions. They are very small and light-weight, and can be made relatively impervious to shock and other severe environmental conditions.

Fig. 4 shows the voltage-current characteristic for a silicon rectifier under both negative-bias and positive-bias conditions. When forward bias is

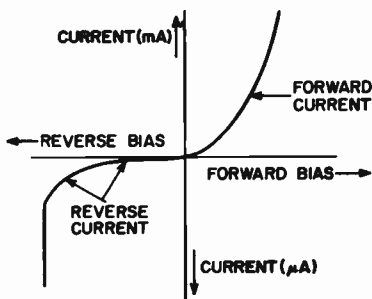

Fig. 4 - Voltage-current characteristics for a silicon rectifier.

applied (anode positive with respect to cathode), the rectifier behaves very much like a low resistance. The forward voltage drop V_f (usually about 0.6 volt) is the potential required to overcome the potential gradient of the space-charge region at the p-n junction. This voltage drop remains sub-

stantially constant as long as the average current in the circuit is within the rated value of the rectifier. However, if the voltage applied to the device is increased (either deliberately or as a result of a voltage surge) to the point where the rated current is appreciably exceeded, the forward voltage drop becomes excessive and the rectifier may be permanently damaged.

Under normal reverse-bias conditions, the rectifier limits current flow to a few microamperes. If the reverse bias exceeds the rated peak reverse voltage (PRV) shown Fig. 4, however, the reverse current increases very rapidly. Any increase in bias beyond the maximum rating may damage the rectifier. More than one diode can be connected in series in a bridge or full-wave circuit to obtain the PRV values required for high-voltage power-supply applications.

A zener diode is a special type of diode designed to maintain the voltage constant across a portion of a circuit in spite of relatively large fluctuations in current input to the zener diode.

Bipolar Transistors

A bipolar transistor can be viewed as two diodes (p-n junctions) connected back-to-back, as shown in Fig. 5. The thick end layers are made of the same type of material (n-type in this case), and are separated by a very thin layer

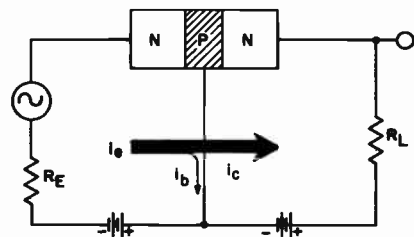

Fig. 5 - N-P-N transistor structure biased for power gain. Arrows denote electron flow.

of the opposite type of material (p-type in the device shown). With a battery connected as shown, the p-n junction on the left is positively (forward) biased and conducts current easily (low resistance); the p-n junction on the right is negatively (reverse) biased and impedes current flow (high resistance). Almost all of the current in the forward-biased junction passes through the thin center region and flows through the reverse-biased junction. The small remaining current flowing through the base determines the degree of current flow through the reverse-biased junction. Because a small amount of current controls a much larger current, a power gain is achieved. This power gain makes the transistor useful as an amplifier and a signal-control (switch) device. (It should be noted that the transistor is a current-amplifying device, rather than a voltage-amplifying device like the vacuum tube.)

The schematic symbols for transistors are shown in Fig. 6. The three electrodes of the device are called the emitter (E), the base (B), and the collector (C). In normal operation the emitter-to-base junction is biased in the forward direction and the collector-to-base junction in the reverse direction. The arrow on the emitter lead identi-

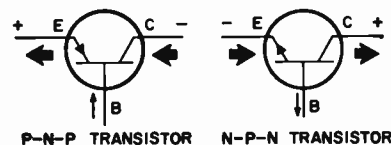

Fig. 6 - Schematic symbols for p-n-p and n-p-n transistors. Arrows denote electron flow.

fies the transistor as a p-n-p or n-p-n type, and indicates the direction of conventional current flow in a circuit. This arrow always points toward the n-type material, and is always in the direction of emitter current flow. The

operation of p-n-p devices is similar to that shown in Fig. 5 for the n-p-n device, except that the bias-voltage polarities are reversed, and electron-current flow is in the opposite direction.

Transistors can be used in three possible circuit configurations: common-base, common-emitter, and common-collector. Diagrams of these three configurations are shown in Fig. 7. In all three configurations the emitter current is the sum of the base and collector currents. Table I lists the properties of the three configurations.

Field-Effect Transistors

Unlike the other transistors described in this book, which are bipolar devices (i.e., performance depends on the interaction of two types of charge carriers, holes and electrons), field-effect transistors are unipolar devices (i.e., operation is a function of only one type of charge carrier, holes in p-channel devices and electrons in n-channel devices).

The operation of field-effect devices can be explained in terms of a charge-control concept. A metal control electrode, which is called a gate, acts as a charge-storage or control element. A charge placed on the gate induces an equal but opposite charge in a semiconductor layer, or channel, located beneath the gate. The charge induced in the channel can then be used to control the conduction between two contacts, called the source and the drain, made to opposite ends of the channel.

In MOS (metal-oxide-semiconductor) field-effect transistors, one or more metal gate electrodes are separated from the semiconductor material by an insulator, as shown in Fig. 8. These insulated-gate electrodes can deplete the source-to-drain channel of active carriers when suitable bias voltages are applied, or can increase the conductivity of the channel without

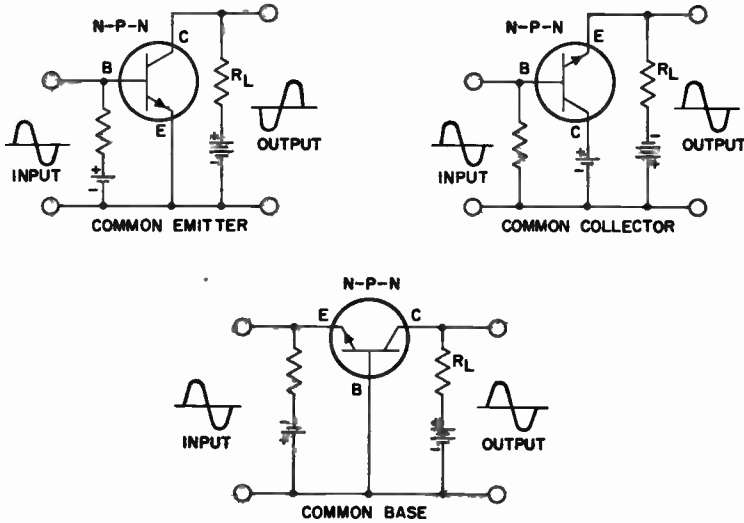

Fig. 7 - Common-emitter, common-collector, and common-base transistor circuit configurations.

Table I.
Important Properties of the Three Transistor Circuit Configurations.

	Common-Base	Common-Emitter	Common-Collector
Voltage Gain	200 or more	200 or more	slightly less than 1
Current Gain	slightly less than 1	approx. 50	approx. 50
Power Gain (Voltage Gain x Current Gain)	200 or more (approx. same as voltage gain)	as high as 10,000	approx. 50 (same as current gain)
Phase Reversal	no	yes	no
Input Signal Applied to	emitter	base	base
Output Impedance (ohms)	high (2000 to 10,000)	high (50 to 50,000)	low (5 to 5,000)
Input Impedance (ohms)	low (10 to 50)	low (20 to 5,000)	high (5,000 to 100,000)
Output Signal Taken From	collector	collector	emitter

increasing steady-state input current or reducing power gain. All MOS field-effect transistors used in the circuits in this book are insulated-gate types.

The two basic types of MOS field-effect transistors are the depletion type and the enhancement type. In the depletion type, charge carriers are present in the channel when no bias

voltage is applied to the gate. A reverse gate voltage is one which depletes this charge and thereby reduces the channel conductivity. A forward gate voltage draws more charge carriers into the channel and thus increases the channel conductivity. In the enhancement type, the gate must be forward-biased to produce the active carriers and permit

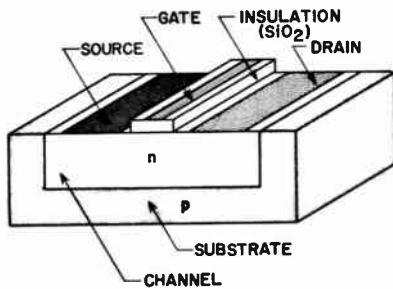

Fig. 8 - Structure of an MOS field-effect transistor.

conduction through the channel. No useful channel conductivity exists at either zero or reverse gate bias. Depletion-type MOS transistors are particularly well suited for use as voltage amplifiers, rf amplifiers, and voltage-controlled attenuators. Enhancement-type MOS transistors are particularly suitable for switching applications.

Because MOS transistors can be made to utilize either electron conduction (n-channel) or hole conduction (p-channel), four distinct types of MOS field-effect transistors are possible. As shown in Fig. 9, the schematic symbol for an MOS transistor indicates whether it is n-channel or p-channel, depletion-type or enhancement-type.

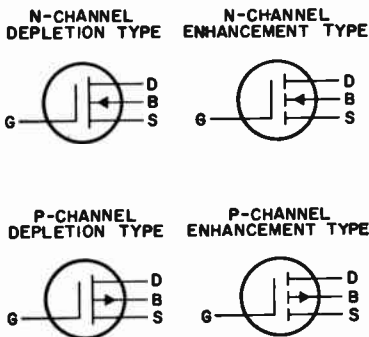

Fig. 9 - Schematic symbols for MOS transistors (*G* = gate, *D* = drain, *B* = active bulk, *S* = source).

The direction of the arrowhead in the symbol identifies the n-channel device (arrow pointing toward the channel) or the p-channel device (arrow pointing away from the channel). The channel line itself is made solid to identify the "normally ON" depletion type, or is interrupted to identify the "normally OFF" enhancement type.

Dual-gate MOS field-effect transistors have two independent insulated gates. The dual-gate transistors exhibit all the features of single-gate field effect transistors, but perform better in certain applications.

Fig. 10 shows a schematic representation of a dual-gate MOS field-effect transistor. The transistor includes three diffused regions connected by two channels, each of which is controlled by its own independent gate.

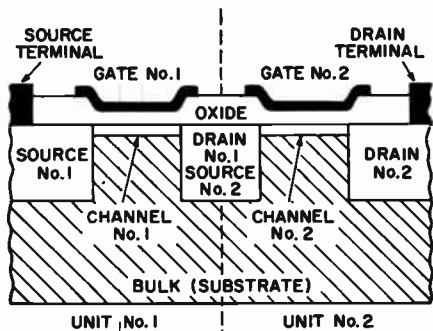

Fig. 10 - Schematic representation of a dual-gate MOS field effect transistor.

Unit No. 1 acts as a conventional single-gate MOS field-effect transistor, with the central diffused region acting as the drain and unit No. 2 acting as a load resistor. Similarly, unit No. 2 can be used as an independent triode with unit No. 1 acting as a source resistor. Fig. 11 shows these configurations from a circuit view-

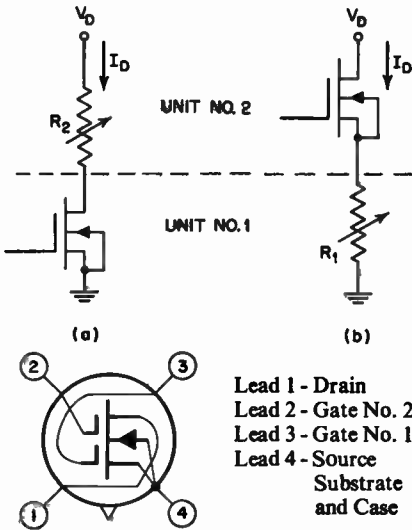

Fig. 11 - Equivalent circuit representation of the two units in a dual-gate MOS transistor and the terminal diagram for the transistor.

point, together with the circuit symbol for the dual-gate unit.

A dual-gate MOS transistor can be cut off if either gate is made sufficiently negative with respect to the source. When one gate is biased to cutoff, a change in the voltage on the other gate is equivalent to a change in the value of a resistance in series with a cut-off transistor.

Thyristors

The term thyristor is the generic name for semiconductor devices that have characteristics similar to those of thyratron tubes. Basically, this group includes bistable semiconductor devices that have three or more junctions (i.e., four or more semiconductor layers) and that can be switched between conducting states (from OFF to ON or from ON to OFF). The two most popular types of thyristors are

the silicon controlled rectifier (SCR) and the triac.

A silicon controlled rectifier (SCR) is basically a four-layer p-n-p-n device that has three electrodes (a cathode, an anode, and a control electrode called the gate). Fig. 12 shows the junction diagram, principal voltage-current characteristic, and schematic symbol for an SCR. A triac also has three electrodes (main terminal No. 1, main terminal No. 2, and gate) and may be considered as two parallel p-n-p-n structures oriented in opposite directions to provide symmetrical bidirectional electrical characteristics. Fig. 13 shows the junction diagram, voltage-current characteristic, and schematic symbol for a triac.

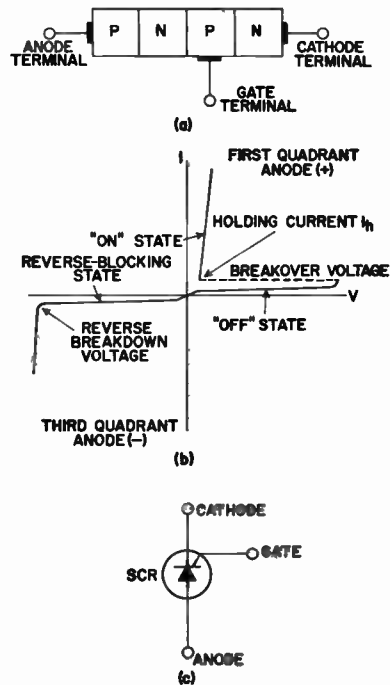

Fig. 12 - Junction diagram (a), principal voltage-current characteristic (b), and schematic symbol (c) for an SCR thyristor.

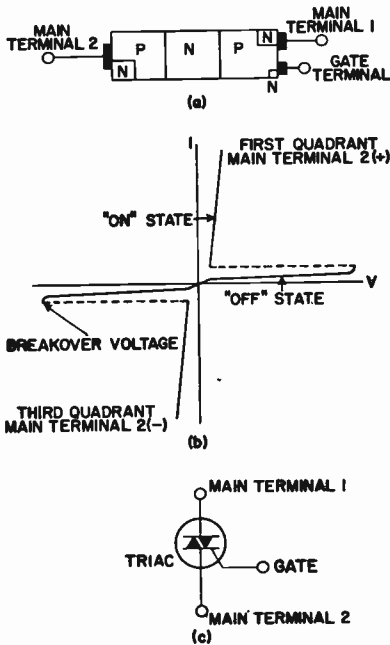

Fig. 13 - Junction diagram (a), principal voltage-current characteristic (b), and schematic (c) for a triac thyristor.

Fig. 12(b) shows that under reverse-bias conditions (anode negative with respect to cathode) the SCR has a very high internal impedance, and only a slight amount of reverse current, called the reverse blocking current, flows through the p-n-p-n structure. This current is very small until the reverse voltage exceeds the reverse breakdown voltage; beyond this point, however, the reverse current increases rapidly. The value of the reverse breakdown voltage differs for individual SCR types.

During forward-bias operation (anode positive with respect to cathode), the p-n-p-n structure of the SCR is electrically bistable and may exhibit either a very high impedance (forward-blocking or OFF state) or a very low impedance (forward-conducting or ON

state). In the forward-blocking state, a small forward current, called the forward OFF-state current, flows through the SCR. The magnitude of this current is approximately the same as that of the reverse-blocking current that flows under reverse-bias conditions. As the forward bias is increased, a voltage point is reached at which the forward current increases rapidly, and the SCR switches to the ON state. This value of voltage is called the forward breakover voltage.

When the forward voltage exceeds the breakover value, the voltage drop across the SCR abruptly decreases to a very low value, referred to as the forward ON state voltage. When an SCR is in the ON state, the forward current is limited primarily by the impedance of the external circuit. Increases in forward current are accompanied by only slight increases in forward voltage when the SCR is in the state of high forward conduction.

An important feature of the SCR is its low power loss as compared with the amount of power it controls. For example, an SCR can control as much as 350 watts with a maximum power loss of less than two watts (3.2 max amperes \times 0.6 volt), an insignificant amount compared to the power loss in a rheostat required to control the same amount of power.

As shown in Fig. 13 (b), a triac exhibits the forward-blocking, forward-conducting voltage-current characteristic of a p-n-p-n structure for either direction of applied voltage. This bidirectional switching capability results because, as mentioned previously, a triac consists essentially of two p-n-p-n devices of opposite orientation built into the same crystal.

The device, therefore, operates basically as two SCR's connected in parallel, but with the anode and cathode of one SCR connected to the cathode and anode, respectively, of the

other SCR. As a result, the operating characteristics of the triac in the first and third quadrants of the voltage-current characteristics are the same, except for the direction of current flow and applied voltage. The triac characteristics in these quadrants are essentially identical to those of an SCR operated in the first quadrant. For the triac, however, the high-impedance state in the third quadrant is referred to as the OFF state rather than as the reverse-blocking state. Because of the symmetrical construction of the triac, the terms forward and reverse are not used in reference to this device.

Thyristors are ideal for switching applications. When the working voltage of a thyristor is below the breakover point, the current through the device is extremely small and the thyristor is effectively an open switch. When the voltage across the main terminals increases to a value exceeding the breakover point, the thyristor switches to its high-conduction state and is effectively a closed switch. The thyristor remains in the ON state until the current through the main terminals drops below a value which is called the holding current. When the source voltage of the main-terminal circuit cannot support a current equal to the holding current, the thyristor reverts back to the high-impedance OFF state.

The breakover voltage of a thyristor can be varied, or controlled, by injection of a signal at the gate, as indicated by the family of curves shown in Fig. 14. Although this family of curves is shown in the first quadrant and is typical of SCR operation, a similar set of curves can also be drawn for the third quadrant to represent triac operation. When the gate current is zero, the principal voltage must reach the breakover value $V(B_0)$ of the device before breakover occurs. As the gate current is increased, however, the value of breakover voltage becomes less until the

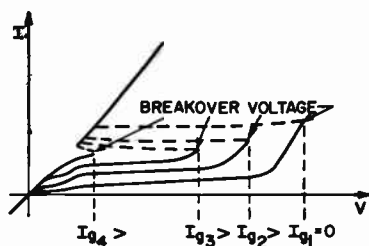

Fig. 14 - Curves showing breakover characteristics of a thyristor for different values of gate current.

curve closely resembles that of a rectifier. In normal operation, thyristors are operated with critical values well below the breakover voltage and are made to switch ON by gate signals of sufficient amplitude to assure that the device is switched to the ON state at the instant desired.

After the thyristor is triggered by the gate signal, the current through the device is independent of gate voltage or gate current. The thyristor remains in the ON state until the principal current is reduced to a level below that required to sustain conduction.

Integrated Circuits

The fundamental requirement of an integrated circuit is that components be processed simultaneously from common materials. A variety of technologies can be used to satisfy this requirement. The technology presently used is based on the silicon planar technology developed for transistors. The basic steps of the silicon process are shown in Fig. 15. The starting material is a uniform single crystal of p-type silicon called the chip. Successive diffusion processing steps permit the introduction of impurities to desired depths and widths in the starting material to form transistors, resistors, and capacitors. Vertical penetra-

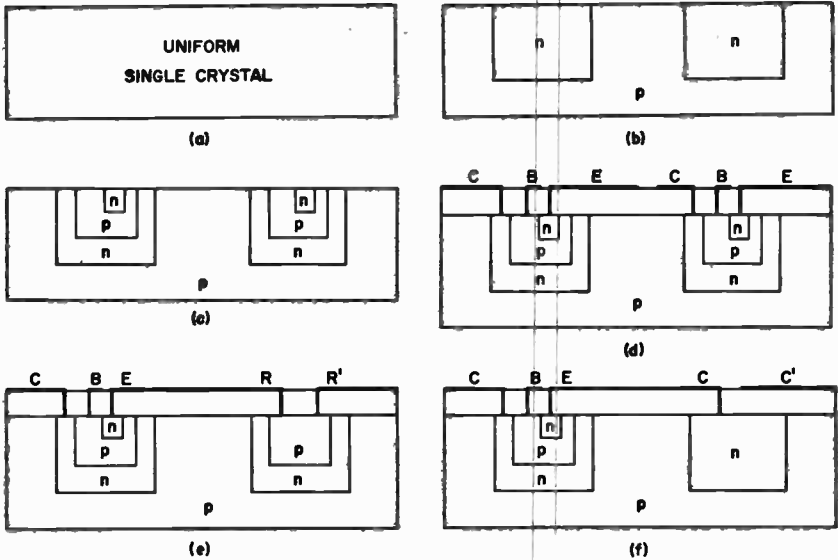

Fig. 15 - Basic steps in integrated-circuit production using the silicon process: (a) silicon wafer used as starting material for an integrated circuit; (b) diffusion of n-type areas to provide isolated circuit nodes; (c) diffusion of additional p-type and n-type regions to form transistors; (d) addition of metallized contacts to transistor elements; (e) connection of contacts to p-type region to form integrated resistor; (f) use of oxide as a dielectric to form integrated capacitor.

tion of the impurities is controlled by the diffusion temperature and time, and lateral control of the diffusions is made possible by combination of the masking properties of silicon dioxide with photo-chemical techniques. The silicon wafer is then coated with an insulating oxide layer, and the oxide is opened selectively to permit metallization and interconnection.

Fig. 16 shows the combination of the three types of elements on a single wafer, together with the equivalent circuit. Fig. 17 shows an enlargement of a completed integrated circuit, the CA3020, together with the corresponding circuit diagram. The callouts on the photograph denote the location of the components shown in the circuit diagram. The actual chip is about 1/4 the size of terminal 4 as shown in the photograph.

Because the basic fabrication proc-

ess for integrated circuits is almost identical with that used to fabricate transistors, transistors formed by this technology are similar to discrete units. Integrated resistors, however, are significantly different from conventional, discrete versions. Discrete resistors are normally made in standard sizes, and different values are obtained by variations in the resistivity of the

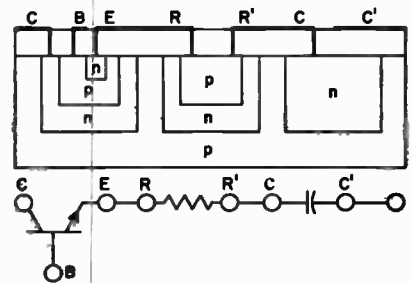

Fig. 16 - Completed silicon chip containing transistor, resistor, and capacitor.

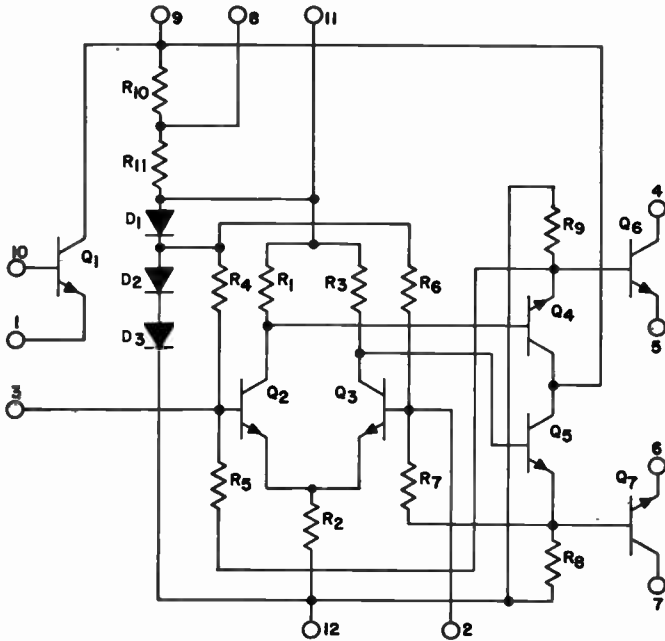
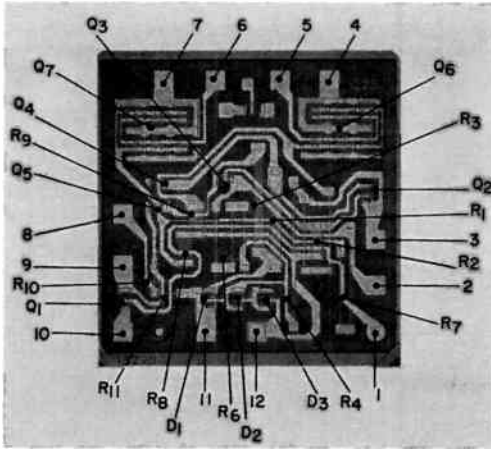

Fig. 17 - Metalization pattern, component location, and circuit diagram for the CA 3020 integrated circuit.

material. In integrated circuits, the resistivity of the material is determined

by the optimum value required for the transistor base diffusion and cannot

be varied to provide different resistance values. Therefore, the value of the resistor depends primarily on the ratio of its length to its width; high-valued resistors are long and narrow and low-valued resistors are short but wide.

The value of an integrated capacitor depends on its area, its dielectric constant, and the thickness of the oxide layer. Because the oxide thickness is kept constant, capacitor values vary directly with area.

SENSORS

Photocells

Fig. 18 shows a typical photoconductive cell, a 1/4-inch-diameter broad-area cadmium-sulfide device. Photocells of this type, which are also known as photoresistors or light-dependent resistors, have a polycrystalline photosensitive surface and are characterized by high sensitivity to visible radiation and moderate speed of response to changes in illumination. The resistance of the cell decreases as the illumination level increases, as shown in Fig. 19



Fig. 18 - Photoconductive cell contained in RCA Add-On Light-Sensor Experimenter's Kit KD2106.

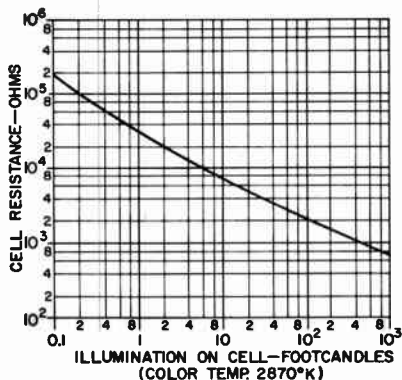

Fig. 19 - Resistance of photocell KD2106 as a function of illumination.

Thermistors

A thermistor is a solid-state device that has a very large, controlled, negative or positive resistance-temperature characteristic. This unique characteristic makes thermistors very useful for applications which interrelate thermal data. Fig. 20 shows resistance-temperature characteristics for three thermistors which have a negative temperature coefficient (i.e., resistance decreases with increasing temperature).

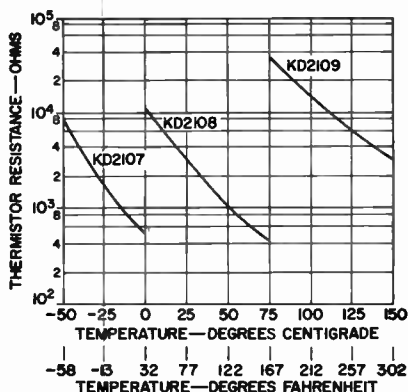

Fig. 20 - Resistance-temperature characteristics of thermistors contained in RCA Add-On Heat-Sensor Experimenter's Kit KD2110.

General Circuit Considerations

THE CIRCUITS described in this chapter are the basic elements of some of a great many electronic circuits in common use. They represent some of the "building blocks" or foundations on which the majority of circuits in this book are constructed. An understanding of the functioning of these fundamental circuits will be of great help in understanding the operation of the practical circuits presented later. The simplified diagrams in this chapter show only the basic configuration for each circuit; component values and construction information are given with the complete practical circuit.

AMPLIFIERS

There are many different types of amplifiers; the type used in any given circuit depends on the application for which the circuit is intended. Power output, load, signal characteristics, and cost are but a few of the many factors that must be considered before an amplifier can be chosen for a particular job.

The circuit in Fig. 21 shows a very basic amplifier; a circuit in which a small current controls a much larger current. Resistor R_1 is the bias resistor; R_2 is the collector load resistor; and capacitor C_1 blocks dc from the output.

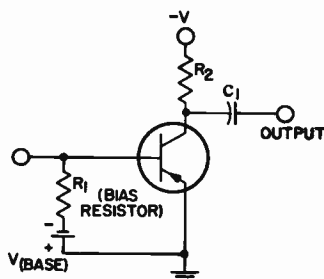

Fig. 21 - A basic transistor amplifier.

The battery voltage establishes, through R_1 , a small current in the base-emitter junction of the transistor. This current is a steady-state current; that is, it flows all the time. The small base-emitter current establishes a much greater current in the collector-emitter junction. The larger current is controlled or voltage-variable resistors of the transistor; the large signal output of the amplifier, therefore, varies with the small input signal.

Additional parts may be added to this basic configuration to improve such qualities as stability and fidelity; however, the principle of operation remains the same.

Voltage Variable Resistor (VVR)

Because the drain-current/drain-voltage characteristic of MOS

transistors remains linear at low drain-to-source voltages, the devices can be used as low-distortion voltage-controlled or voltage-variable resistors (VVR's). The principal advantages of MOS transistors in this application are negligible gate-power requirements and large dynamic range. Fig. 22 shows a voltage-variable resistor circuit using an MOS transistor.

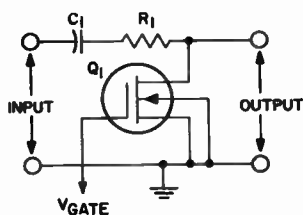

Fig. 22 - A voltage-variable resistor circuit using an MOS transistor.

Series Regulator

A series regulator circuit is essentially a direct-coupled amplifier that is used to amplify an error or difference signal obtained from a comparison between a portion of the output voltage and a reference source. Series regulators maintain a constant voltage output and are used in regulated power supplies. Fig. 23 shows the circuit of a typical series regulator. The reference-voltage source V_R is placed in the

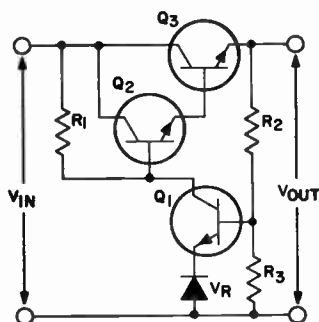

Fig. 23 - A typical series regulator circuit.

emitter circuit of the amplifier transistor Q_1 so that the error or difference signal between V_R and some portion of the output voltage V_{out} is developed and amplified. The amplified error signal forms the input to the regulating element consisting of transistors Q_2 and Q_3 ; the output from the regulating element develops a controlling voltage across the resistor R_1 .

Shunt Regulator

Shunt regulator circuits are not as efficient as series regulator circuits for most applications, but they have the advantage of greater simplicity. In the shunt voltage regulator circuit in Fig. 24, the current through the shunt element consisting of transistors Q_1 and Q_2 varies with changes in the load current or input voltage. This current variation is reflected across the resistance R_1 in series with the load so that the output voltage V_{out} is maintained nearly constant. Transistor Q_1 , the shunt element, must be capable of absorbing all power input to the circuit by the supply when load current is very low.

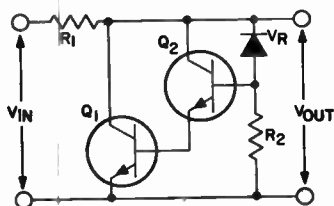

Fig. 24 - A typical shunt regulator circuit.

OSCILLATORS

An oscillator circuit is similar in many respects to an amplifier, except that a portion of the output power is returned to the input network in phase with the starting power (positive or

regenerative feedback) to provide a self-generating or self-repeating current or voltage variation at a definite rate. Oscillators can be made to produce many different waveshapes; the two oscillators described below generate sine waves.

Fig. 25(a) is a transistor version of the Colpitts oscillator. Positive feedback is obtained from the voltage-divider circuit consisting of capacitors C_2 and C_3 in parallel with the primary winding of the transformer. The voltage developed across C_3 is the feedback voltage and is applied to the emitter of the transistor. The frequency and the amount of feedback voltage can be controlled by adjustment of either or both capacitors. For minimum feedback loss, the ratio of the capacitive

reactance between C_2 and C_3 should be approximately equal to the ratio between the output impedance and the input impedance of the transistor. Base bias is provided by resistors R_2 and R_3 ; R_4 is the collector load resistor. R_1 develops the emitter input signal and acts as the emitter stabilizing resistor.

Fig. 25(b) and 25(c) show the MOS field-effect transistor in use in two forms of the Colpitts oscillator circuit. These circuits are commonly used in vhf and uhf equipment. Feedback in the MOS-transistor Colpitts oscillator is controlled by the ratio of C_2 to C_3 . Improved circuit stability is supplied by diode D_1 in Fig. 25(c); the diode provides automatic amplitude control and maintains voltage swings within the capability of the MOS transistor.

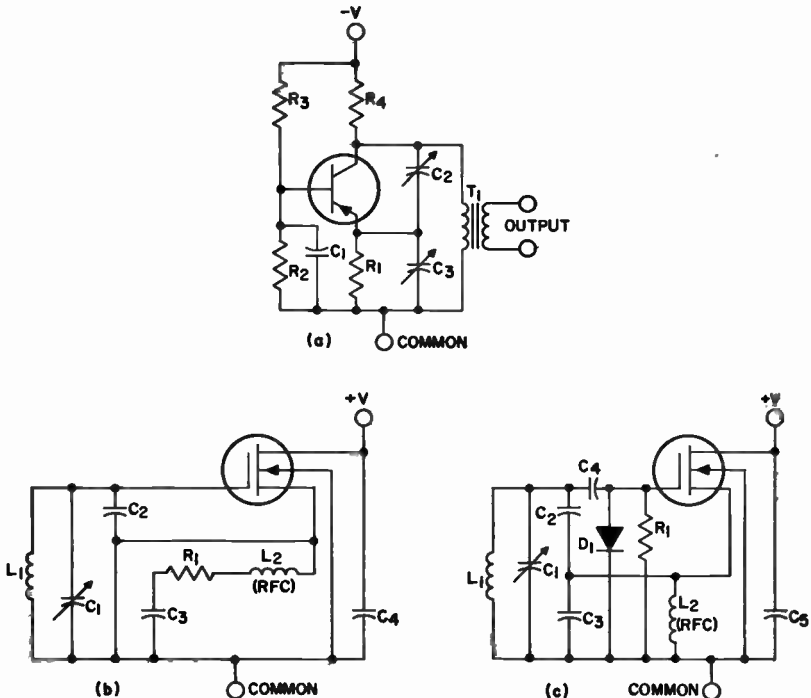

Fig. 25 - Colpitts oscillator circuits: (a) is a bipolar-transistor version, (b) and (c) are MOS field-effect transistor versions.

BASIC TWIN-T BRIDGE OSCILLATOR

The circuit in Fig. 26 represents a basic twin-T bridge oscillator. The oscillator takes its name from the frequency-determining and dc-blocking

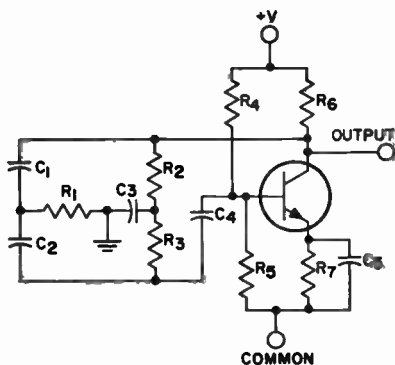

Fig. 26 - A basic twin-T bridge oscillator.

RC network in the left-hand part of the circuit (C_1 , C_2 , C_3 , R_1 , R_2 , R_3). Resistors R_4 , R_5 , R_6 , and R_7 provide the necessary bias conditions for the transistors. Resistor R_7 is the emitter-stabilizing resistor; C_5 , R_5 , and R_7 along with the transistor comprise the transistor amplifier. Capacitor C_4 couples the oscillator signal to the base of the transistor and also blocks dc. Capacitor C_5 bypasses ac signals and prevents degeneration.

SWITCHES

Astable and Monostable Pulsers or Clock Circuits

Astable (free-running) pulsers are oscillators used to generate pulses at specific frequencies in such applications as light flashers, pulse generators, and clock-pulse sources. Monostable ("one-shot") pulsers are used principally for pulse shaping and as time-delay circuits.

The basic astable pulser circuit is shown in Fig. 27. Transistors Q_1 and Q_2 form a regenerative switch. This switch has a very high impedance until it is triggered into conduction; after triggering it has a very low impedance. When power is applied to the circuit, capacitor C_2 charges through the emitter of Q_1 , turning it on and causing the regenerative switch to conduct.

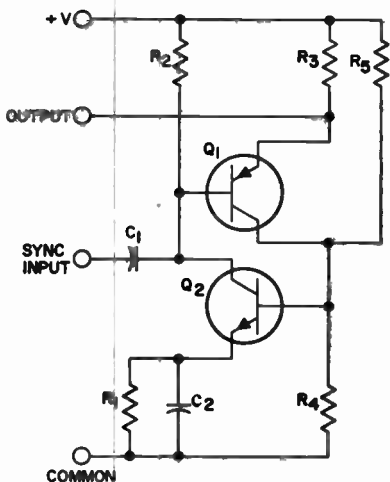

Fig. 27 - The basic astable pulser or clock circuit.

When capacitor C_2 charges, the emitter of Q_2 becomes more negative and turns the regenerative switch off. The high impedance of the switch in the OFF condition causes C_2 to discharge through R_1 . As the charge on C_2 decreases, the emitter of Q_2 becomes less negative and the switch begins to conduct again. This process is repeated as long as power is applied to the circuit.

The basic monostable clock or pulser is shown in Fig. 28. Transistors Q_1 and Q_2 form a regenerative switch similar to the one described above for the astable pulser. When switch S_1 is closed, a voltage is applied across R_5 and the output terminals, and capaci-

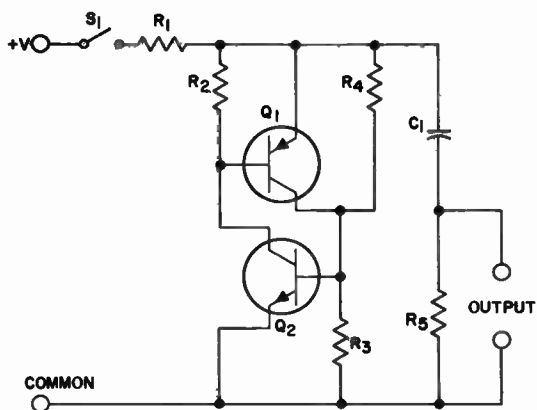

Fig. 28 - The basic monostable pulser or clock circuit.

tor C_1 , starts to charge. When the voltage across C_1 and R_5 together reaches the triggering level of the regenerative switch (which is in parallel with C_1 and R_5), conduction through the switch occurs. C_1 then discharges through R_5 and the regenerative switch. The regenerative switch stays in the conductive state as long as S_1 is closed. Because the voltage across the conducting regenerative switch is very low and because the regenerative switch is in parallel with the $C_1 R_5$ combination, the output voltage is also very low. The circuit will remain in the state described until S_1 is reoperated.

Multivibrator (Astable)

Oscillator circuits that produce nonsinusoidal output waveforms can use a regenerative circuit in conjunction with resistance-capacitance (RC) or resistance-inductance (RL) components to produce a switching action. The charge and discharge times of the reactive elements are used to produce sawtooth, square, or pulse output waveforms.

A multivibrator is essentially a nonsinusoidal two-stage oscillator in which one stage conducts while the other is cut off until a point is reached

at which the conditions of the stages are reversed. This type of oscillator is normally used to produce a square-wave output. In the RC-coupled common-emitter multivibrator shown in Fig. 29, the output of transistor Q_1 is coupled to the input transistor Q_2 through the feedback capacitor C_1 , and the output of Q_2 is coupled to the input of Q_1 through the feedback capacitor C_2 .

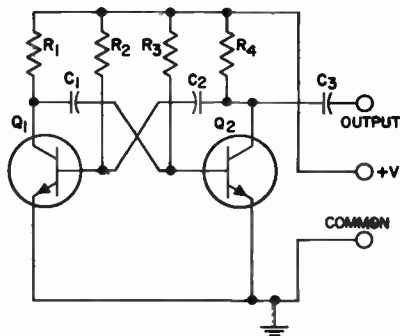

Fig. 29 - An RC-coupled common-emitter multivibrator.

In the multivibrator circuit, an increase in the collector current of transistor Q_1 causes a decrease in the collector voltage which, when coupled through capacitor C_1 to the base of

transistor Q_2 , causes a decrease in the collector current of Q_2 . The resultant rising voltage at the collector of Q_2 , when coupled through capacitor C_2 to the base of Q_1 , drives Q_1 further into conduction. This regenerative process occurs rapidly, driving Q_1 into heavy saturation and Q_2 into cutoff. Q_2 is maintained in a cutoff condition by C_1 (which has previously charged to the supply voltage through resistor R_1) until C_1 discharges through R_3 toward the collector-supply potential. When the junction of C_1 and R_3 reaches a slight positive voltage, however, transistor Q_2 begins to conduct and the regenerative process reverses. Q_2 then reaches a saturation condition, Q_1 is cut off by the reverse bias applied to its base through C_2 , and the C_2R_2 junction starts charging toward the collector supply voltage. The oscillating frequency of the multivibrator is determined by the values of resistance and capacitance in the circuit.

Basic Digital Flip-Flop

The basic digital flip-flop circuit is shown in Fig. 30. The resistor and bias

values of this circuit are chosen so that the initial application of dc power causes one transistor to be cut off and the other to be driven into saturation. Because of the feedback arrangement, each transistor is held in its original state by the condition of the other. The application of a positive trigger pulse to the base of the OFF transistor or a negative pulse to the base of the ON transistor switches the conducting state of the circuit. The new state is then maintained until a second pulse triggers the circuit back to the original state.

In Fig. 30, two separate inputs are shown. A trigger pulse at input A will change the state of the circuit. An input of the same polarity at input B or an input of opposite polarity at input A will then return the circuit to its original state. (Collector triggering can be accomplished in a similar manner.) Capacitors C_3 and C_4 are used to speed up the regenerative switching action. The output of the circuit is a unit step voltage when one trigger is applied, or a square wave when continuous pulsing of the input is used.

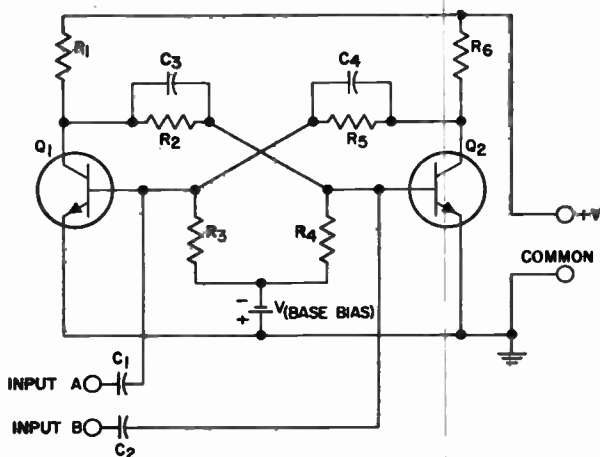

Fig. 30 - A basic digital flip-flop.

NAND Gate

A NAND gate such as that shown in Fig. 31 provides an output when all inputs are applied simultaneously. When a positive input pulse is applied to only one of the transistors in the NAND gate, that transistor turns on; however, conduction cannot occur because the ON transistor is in series with another transistor that is turned off. When positive pulses are applied to both inputs simultaneously, conduction does occur and a negative output is produced. In a NAND gate the polarity of the output is opposed to that of the input; in an AND gate, input and output polarities are the same.

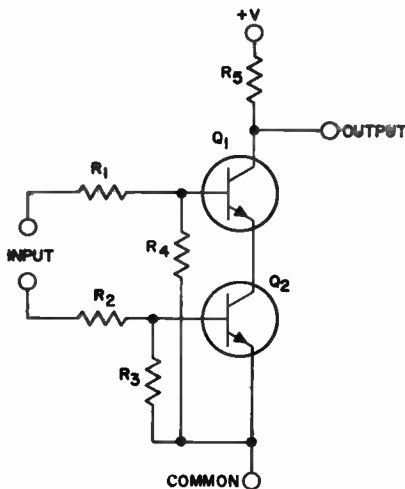

Fig. 31 - A basic NAND gate.

NOR Gate

The circuits in Figs. 32 and 33 are NOR gates. A NOR gate circuit consists basically of a transistor that is held in the OFF state. A positive signal on any of the inputs large enough to turn the transistor on causes the output to go negative or to substantially ground potential. When the output

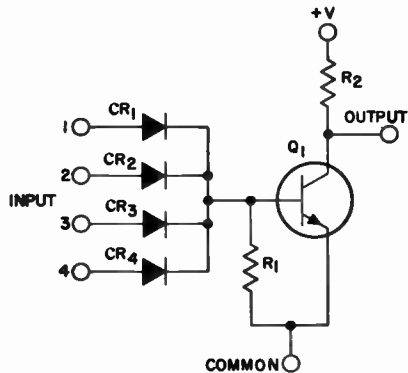

Fig. 32 - A positive-action diode-transistor NOR gate.

polarity is opposite to the input polarity the circuit is a NOR gate; when input and output polarities are identical, the circuit is called an OR gate.

The use of a diode in the positive-action diode-transistor NOR gate shown in Fig. 32 eliminates some of the losses associated with resistive input circuits and thereby increases the number of possible outputs for a given transistor and switching speed. The

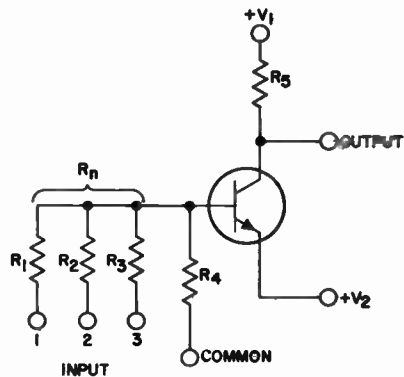

Fig. 33. A positive-action resistor-transistor NOR gate.

diode does not conduct any appreciable current when the input is low. The diode has a high stored charge when

forward-biased; when the transistor is turned off, therefore, the stored charge of the diode compensates that of the transistor.

In a positive-action gate there are only two states, on and off; there is no state in which a limited amount of conduction takes place.

INDICATOR-LAMP CIRCUIT

A positive signal applied to the base of Q_1 in Fig. 34 turns Q_1 on and permits current to flow through R_2 and R_3 . Because R_2 is in parallel with the base-emitter junction of Q_2 , the current passing through it puts a forward bias on Q_2 and causes it to turn on. Conduction through Q_2 lights the lamp, I_1 .

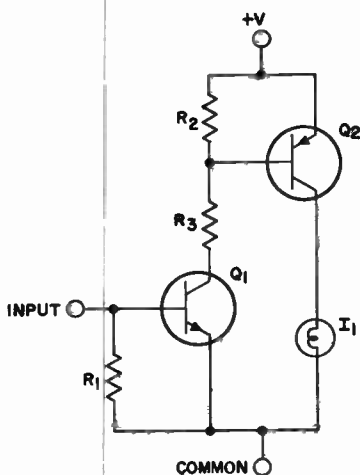

Fig. 34 - An indicator-lamp driver circuit.

Mechanical Considerations

GOOD CONSTRUCTION is important to the satisfactory operation of any circuit. Knowledge of soldering and chassis-wiring techniques and of component-handling and safety precautions is as important to satisfactory circuit operation as is a knowledge of the electrical characteristics of a circuit. This section contains the mechanical information needed by the circuit builder; it should be read thoroughly before work on any circuit is started. A great deal of time and effort can be saved by planning a job thoroughly before beginning construction.

CONSTRUCTION PRACTICES

All of the circuits in this manual can be constructed with hand tools of the type available through any radio-supply, mail-order retail, or hardware store. The greater the variety of tools on hand, the simpler the construction job will be; however, all required work can be accomplished with the basic set of tools listed in Table II.

The continuing satisfactory performance of tools depends on the care they are given. Drills should be sharpened at frequent intervals so that critical cutting angles are maintained. Particular care should be taken of the soldering iron. The iron should not be

Table II.
Tools Required for Circuit Construction

Awl or scribe for marking chassis
Long-nose pliers, 6-inch
Diagonal cutters, 6-inch
Wire stripper
Screwdrivers, 6 to 7 inch, 1/4-inch blade
Screwdrivers, 4 to 5 inch, 1/8-inch blade
Electric hand drill, 1/4-inch or larger chuck, variable speed type is best.
Electric soldering iron, 45 watts, 1/4-inch tip
Center punch for marking hole centers
Straightedge
Files: assortment of flat, round, half-round, and triangular including one large, flat, coarse file and one 1/2-inch-diameter round file.
Drills: assortment including Nos. 32 (0.116 inch diameter), 58 (0.042 inch diameter), and 60 (0.040 inch diameter).
Solder, rosin-core.
<i>Additional Helpful Tools</i>
Bench vise, 4-inch jaws
Taper reamers, 1/2 and 1 inch
Phillips screwdriver
Screwdriver with screw-holding clip and long shank
Nut drivers

run at full voltage for extended periods when it is not being used; if it is abused in this way, burn-out and tip corrosion can result. For stand-by purposes voltage to the iron can be reduced sufficiently by connecting an incandescent

lamp in series with it. The tip of an iron that is not preplated should be cleaned with steel wool after each period of use and should be kept well tinned (coated with solder). A pitted tip should be filed smooth and bright and should be retinned immediately. Preplated tips should not be filed; they can be cleaned after each use with a wet sponge.

Materials

A list of materials required for the construction of each circuit is given with the circuit schematic. Only rosin-core solder should be used in making connections; acid-core solder intended for plumbing and sheet-metal work is not suitable for circuit wiring.

Chassis Preparation

The building of an electronic circuit on a metal chassis is not difficult when the proper tools are used. Aluminum is preferred to steel because of its superior shielding and contact properties and because it is easier to work. However, aluminum cannot be soldered to, and additional wires or bolted-in solder lugs must be used for ground connections.

The recommended positioning of components mounted on circuit boards is indicated on the diagrams included with the circuit write-up. Drilling templates for these circuits are printed in the back pages of this book. It is a good idea to mount each template on cardboard before it is used so that it will not tear readily and become unsatisfactory for repeated use. The template should be fastened securely to the circuit board or chassis before holes are drilled through it. For those circuits not mounted on circuit boards suggested layouts are given where they will help the builder.

Drilling and Cutting Holes

Holes drilled in metal should be located or started with a center punch; the material to be drilled should be held in a vise. Pressure on the drill point should be relaxed when the drill begins to break through. If a two-speed or variable-speed electric drill is used, it is a good idea to shift to a slower speed for large-diameter holes ($3/8$ inch or larger) and just prior to breakthrough in any case. Holes more than $1/4$ inch in diameter should be started with a small drill and enlarged with a larger drill, a reamer, or a rat-tail file. By far the easiest method of hole enlargement is reaming with a tapered reamer; however, a large rat-tail file also makes a good reamer. Enlargement of holes by filing is a tedious process. If the hole is too large to be completed by a larger drill or reamer, a method easier than filing is to drill a series of small holes, as close together as possible, around the inside diameter of the large hole. The center can then be knocked out with a cold chisel and the edge of the hole filed smooth.

When a number of larger holes of the same diameter are to be made, socket punches can be used. Holes in steel plate should be made with an adjustable circle cutter. The cutter should be tried on a block of wood first to make sure that it is set properly.

Square holes may be prepared by drilling small holes inside an edge marking as previously described. Socket hole punches and square punches are of considerable value in making large rectangular openings.

Burrs and rough edges remaining after drilling or cutting can be removed with a file or a sharp knife.

Bending Chassis Material

Metal pieces too large to be cut conveniently with a hacksaw can be

marked with deep scratches (scribed) on either side of the metal along the line of the intended separation. If the sheet is then clamped in a vise and bent back and forth, it will break along the scribed line. If the sheet is bent too far in either direction before weakening occurs, the edge of the sheet may become bent. Rough edges remaining after this operation can be filed away. Bends are made by a similar process but without the scratching or scribing step.

Chassis and Circuit-Board Wiring

Wire to be used in the circuits should be selected with due consideration to the maximum current it must handle and the maximum voltage that its insulation can stand. In this Manual, high-power circuits (such as the SCR circuits) and portions of other circuits carrying high power are wired with No. 16 or No. 18 insulated wire; all other wiring is done with No. 24 insulated wire. "Spaghetti"-type insulation is used on component leads where necessary.

As much as possible, all wiring should be run parallel to the chassis edges, and all bends should be right-angle bends. In addition, all components should be mounted parallel to chassis edges. In both low- and high-frequency work, input and output leads should be kept well separated to avoid feedback effects which can cause unwanted oscillations. In high-frequency-circuit chassis wiring, leads should be kept as short as possible. Fig. 35 shows an example of a well arranged, professionally wired, low-frequency circuit.

The terminals on the circuit boards shown in this book are made of about 1 to 1-1/4 inch of No. 18 wire bent into a "U" shape. The ends of the U-shaped

wire are forced into the terminal holes with enough of the ends projecting through the bottom of the board to allow connections to be made. Terminal ends can be trimmed after soldering is completed.

Soldering

The right amount of heat is important in good soldering. Too little heat will result in a cold solder joint; too much heat can seriously damage a component. The tip of the iron should be kept clean by brushing it frequently with a paper towel. The choice of solder for a particular job is determined by its melting point. 50-50 solder (50% lead; 50% tin) melts at 425°F; 60-40 solder melts at 371°F; 63-37 solder melts at 361°F. 60-40 solder is used in most circuit wiring work.

When transistors, IC's, and crystal diodes are soldered, the lead being soldered should be gripped with pliers close to the unit. The pliers act as a heat path or sink and conduct away damaging heat. If the lead cannot be conveniently gripped with pliers, an alligator clip or commercial heat sink may be used. Components should be mounted in such a way that the leads are protected from mechanical strain.

Before solder is applied, a good mechanical connection should be made by twisting the wire around the terminal post or lug. Soldering should be considered a means for making a good electrical connection, not a mechanical one.

For good heat conduction between the soldering iron and the mechanical joint, a small amount of solder should be applied to the tinned portion of the soldering-iron tip, and this surface should be applied to the joint. The solder is then applied to the joint, but is not brought into contact with the iron; when the solder melts, the joint is properly soldered. This procedure

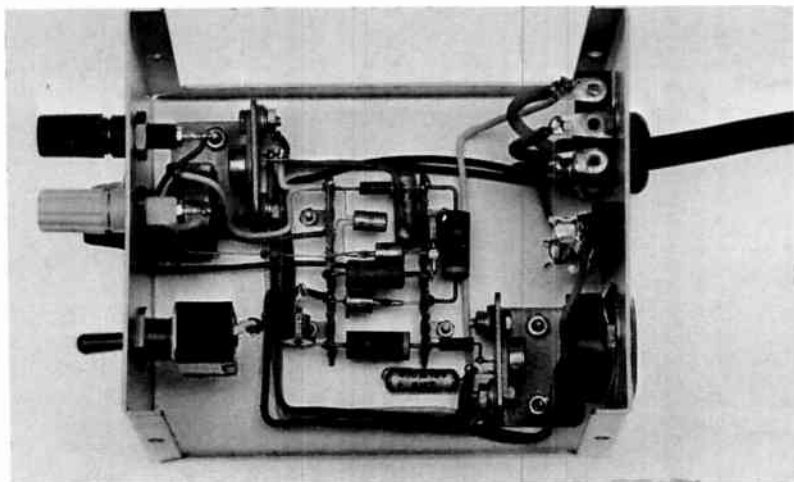

Fig. 35 - A professionally wired low frequency circuit.

avoids a cold solder joint that could cause trouble at some future time. It is a good idea for the inexperienced circuit builder to practice soldering with some pieces of scrap wire.

The stripped ends of heavy solid wire or flexible multistrand wire such as used in line cords should be tinned before the mechanical connection to the lug or terminal is made. This tinning procedure ensures a quick, clean, hot solder joint. Tinning of heavy terminals such as those used on toggle switches is also a good practice. Tinning of ordinary hook-up wire is not necessary.

When a knife is used to strip the insulation from the end of a wire, it should be a dull one so that it will not nick the wire. If diagonal cutters are used, they should be squeezed only tightly enough to cut and pull the insulation. Wirestrippers must be set properly so that the wire being stripped is not nicked. A nicked wire can break and result in an inoperative circuit.

Heat Sinking

The dc power input to a semicon-

ductor device generates heat within the device and raises its temperature. The maximum allowable device temperature rise limits the amount of electrical power input. Because the temperature rise depends not only on how much heat is generated, but on how fast that heat is carried away and dissipated, the amount of input power allowed is closely related to the heat-dissipation methods.

Medium- and high-power transistors are usually so constructed that they can be attached tightly to a chassis or to a heat sink. To aid in carrying heat away from the transistor junction, the collector junction is internally connected to the transistor case in most power transistors. Therefore, when the transistor case is connected to the chassis, the collector is also connected to the chassis, and some provision must be made to prevent shorting out of the dc and ac voltages on the collector. Although it is possible to rearrange the circuit to allow the collector to be at chassis potential, the most usual practice is to insulate the transistor case from the chassis. This insulation must isolate the transistor

from the chassis electrically while providing the least possible interference to the flow of heat from the transistor mounting base to the chassis. Very thin (on the order of a few thousandths of an inch) mica, plastic, or anodized aluminum washers are used for this purpose. When anodized aluminum washers are used, care must be taken to remove any burrs on the transistor or chassis that might cut through the anodizing and destroy its insulating properties. To ensure the best possible heat transfer, a silicone grease or oil can be applied to both surfaces of the washer. The oil or grease fills any voids between the washer and transistor mounting base and the washer and chassis.

In the absence of a suitable metal chassis or in cases in which the device itself cannot be attached to a metal chassis, a heat sink is used. Heat sinks are produced in various sizes, shapes, and materials; they can be flat or cylindrical and can have vertical or horizontal fins attached to them.

Heat sinks also take the form of aluminum angle brackets. The device is normally attached to the angle bracket which is, in turn, attached to but electrically insulated from the chassis by the methods described above.

Grounding

A ground is a common reference point in a circuit; ground potential means that there is no potential difference, no voltage, between the point at ground potential and the earth.

Ground points need not actually be connected to the earth, but if the connection were made, there would be no effect on the circuit. A chassis ground designates a common point in a circuit at which power supplies and metal chassis are electrically tied together.

Good grounds are sometimes very important to proper circuit operation. In an amplifier, for example, the ground minimizes the possibility that changes in the output will be reflected in the input and prevents regeneration. A good ground is one that evidences extremely low resistance and that displays essentially no difference in potential between connections to the same ground point.

Fig. 36 shows the symbols for earth and chassis grounds.

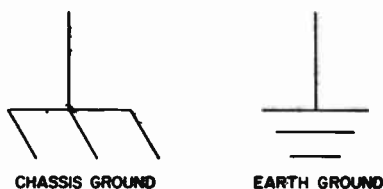

Fig. 36 - Symbols for chassis and earth ground.

SPECIAL HANDLING CONSIDERATIONS

Transistors

The collector, base, and emitter terminals of transistors can be connected to associated circuit elements by means of sockets, clips, or solder connections to the leads or pins. If connections are soldered close to the lead or pin seals, care must be taken to conduct excessive heat away from the seal; otherwise the heat of the soldering operation may crack the glass seals and damage the transistor.

Under no circumstances should the mounting flange of a transistor be soldered to a heat sink because the heat of the soldering operation may permanently damage the transistor.

When the metal case of a transistor is connected internally to the collector, the case operates at the collector voltage. If the case is to operate at a vol-

tage appreciably above or below ground potential, consideration must be given to the possibility of shock hazard and suitable precautionary measures taken.

Transistors should be handled carefully because the semiconductor material inside the case is brittle and can be damaged if the transistor is dropped. A drop of about 4-1/2 inches onto a hardwood surface can subject a transistor to a shock of about 500 times the force of gravity.

MOS Transistors

The performance of MOS transistors depends on the condition of a very thin insulating layer between the control electrode (gate) and the active channel. If this layer is punctured by accidental application of excess voltage to the external gate connection, irreversible damage can occur. If the damaged area is small enough, the additional leakage may not be noticed in most applications. However, greater damage may degrade the device to the point at which it becomes unusable. It is very important, therefore, that appropriate precautions be taken to ensure that the gate-voltage ratings of MOS transistors are not exceeded.

Static electricity represents the greatest threat to the gate insulation in MOS transistors. A large electrostatic charge can build up on the gate electrode if the transistor is allowed to slide around in plastic containers or if the leads are brushed against fabrics such as silk or nylon. This type of charge build-up can be avoided completely by wrapping the leads in conductive foils or fine wire, by use of conductive containers, or by otherwise electrically interconnecting the leads when the transistors are being transported.

A second cause of electrostatic charge damage to the gate insulation

can be traced to the people who handle the transistors. At relative humidity levels of 35 per cent, a person may accumulate an electrostatic potential that could range into the thousands of volts. If such a "charged" person grasps an MOS transistor by the case and plugs it into a piece of test equipment, or in any other way causes the gate lead to contact "ground" before the other leads, there is a good chance that the accumulated electrostatic charge may break down the gate insulation. To avoid this eventuality, those handling MOS transistors should make sure that they are grounded before touching the device.

In most applications, circuit impedances are low enough to prevent any accumulation of electrostatic charge. Thus, although the gate insulation may be damaged by improper handling of MOS transistors before they are connected into actual circuits, thousands of hours of operation under practical circuit conditions have shown that the gate insulation is reliable under the stress of long-term operation within published ratings.

Integrated Circuits

The fabrication of any integrated circuit (IC) involves extreme care. Special handling of the IC from the receipt of raw materials to the shipment of the finished product is the rule. If the IC is to operate satisfactorily in its final application, this same special care must be followed in mounting and soldering. The best method of mounting transistor-can-type IC packages is to bend each lead out from the can slightly so that the lead ends describe a circle as close to the diameter of the mounting or socket holes as possible. Care must be used in bending the leads to avoid breaking them off at the package base. After the leads have been bent, they can be inserted one by

one into the socket or mounting holes.

The tab on the base of the IC designates the location of the highest-numbered lead. If the device is to be inserted into a socket, the tab should be matched with the tab or notch on the socket. If the IC is to be mounted on a printed-circuit board, for example, the leads should first be correctly positioned and inserted into the mounting holes. The top of the IC is then pushed down to move it closer to the board. All leads can then be soldered. Serious damage to the IC can result from incorrect connection of leads.

When an IC lead is being soldered, a pair of long-nose pliers, an alligator clip, or other heat sink should be clamped to it between the soldering iron and the case. The soldering iron used should be small (45 watts); it should be very hot and in contact with a lead for the shortest possible period of time.

Correct polarity should be observed when a battery is installed in a circuit containing an IC; improper installa-

tion could seriously damage the IC

Thermistors

Thermistors are fragile devices that require special handling, particularly when they are being soldered to a mounting or when leads are being soldered to them. Only solder containing silver should be used; attempts to use common lead-tin solder will prove futile and will result in the removal or burning off of the silver coating on the thermistor. The solder recommended is a rosin-core type composed of 70 per cent lead, 27 per cent tin, and 3 per cent silver.

Fig. 37 shows some of the many possible mounting arrangements for thermistors. In mounting A, the thermistor is soldered between a brass cap screw and a flexible lead. This type of mounting is useful at sub-freezing temperatures when one end of the thermistor is electrically connected to the frame or housing of the controlled device. In mounting B, the thermistor is mounted on a large heat sink so that

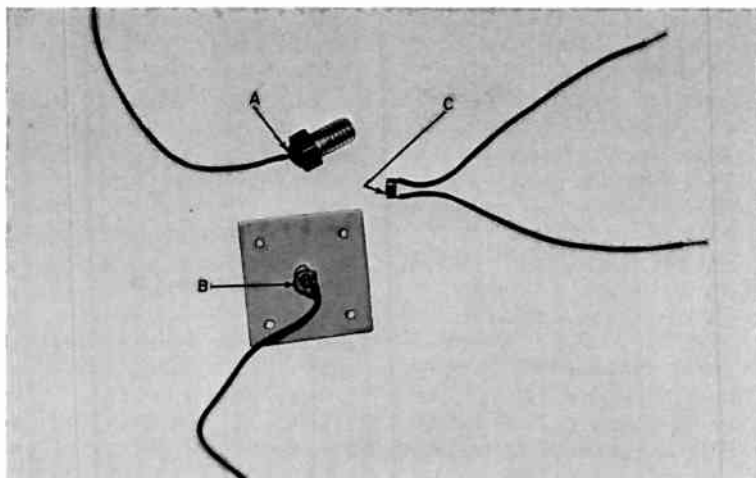

Fig. 37 - A few of the many possible thermistor mounting arrangements.

short-duration, locally directed heat currents do not cause premature triggering of an alarm circuit. (For example, in a freezer, it is not desirable to trigger the alarm each time the door is opened for food removal.)

The soldering technique used in attaching a thermistor to a cap screw is representative of that to be used in all thermistor mounting operations.

The technique is as follows:

1. Place the cap screw, head up, on an asbestos board or a sheet-metal pedestal held in a vise.
2. Heat the cap screw by use of the small blue flame of a butane torch and apply enough silver solder to form approximately a 1/4-inch puddle on the top of the screw head; then remove the heat so that the puddle can solidify.
3. Reheat the cap-screw head until the solder melts. Then remove the heat and, by use of tweezers or long-nose pliers, carefully drop the thermistor on the melted solder and press it against the cap screw head until the solder resolidifies. Then attach the flexible lead to the top surface of the thermistor by use of a small-tip soldering iron. Wipe away any lead-tin solder from the tip of the iron with a piece of cloth before the following steps are taken.
4. Tin the soldering iron and the lead end with silver solder.
5. Place the tinned surface of the soldering-iron tip on the thermistor; apply a little solder to the thermistor to provide better heat conduction. Extra care is necessary at this point; too much heat will melt the solder between the thermistor and the cap screw and may appreciably alter the

characteristics of the thermistor. When a puddle of solder forms between the soldering iron and the thermistor, remove the iron and press the tinned end of the lead lightly into the solder; blow on the joint or fan it so that it cools quickly.

A similar procedure using a torch and a soldering iron should be used in preparing mounting B. A soldering iron is the only tool required to attach leads to a thermistor (mounting C).

Thermistor characteristics can change as much as 20 per cent as a result of the heat of a soldering iron. The original characteristics are restored, however, after the thermistor has been in use for several hours. Excessive heat can cause a wider change in characteristics and therefore requires a longer restoration period.

Photocells

A photocell can be conveniently connected to a circuit by use of a commercially available auto-radio antenna connector, with very little modification. The photocell and an exploded view of the disassembled antenna connector, H.H. Smith No. 1300, are shown in Fig. 38.

The only modification required in the connector is the drilling out of the brass insert in the black bushing nearest the photocell as shown in Fig. 38. In addition, the leads of the photocell should be covered with "spaghetti"-type insulation to minimize the possibility of shorts.

Fig. 38 also shows the completely assembled device ready for use. The connector P₁ is a standard Amphenol microphone connector and the lead is an insulated-shield microphone cable.

SAFETY PRECAUTIONS

Many of the circuits in this Manual

are designed to operate from conventional 120-volt ac household power. Much thought and care has been given to the design of these circuits to make them as safe as possible. However, certain precautions must be taken by the circuit builder to ensure maximum safety.

Three-wire input-power and output-load connectors are recommended; where possible completely enclose all wiring and components. Ground a chassis containing a 120-volt circuit by connecting the pigtail lead on the input plug to the grounded housing of the 120-volt outlet. Always remove this plug from the outlet when the chassis is being serviced. Even if the fuse has blown, internal circuit components may still carry dangerous potentials. If

voltage readings are desired during trouble-shooting, the circuit may be energized; however, it must be remembered that the case of some devices and other areas of the circuit carry dangerous voltages and should not be touched.

A good rule to follow during trouble-shooting of an energized circuit is to keep one hand away from the chassis, in a pocket if possible. It is also recommended that trouble shooting never be undertaken alone. Use safety glasses, especially during soldering; solder splashes are painful and can be dangerous. Also remove rings, bracelets, wristwatches, and the like during troubleshooting because they represent an electrical hazard.

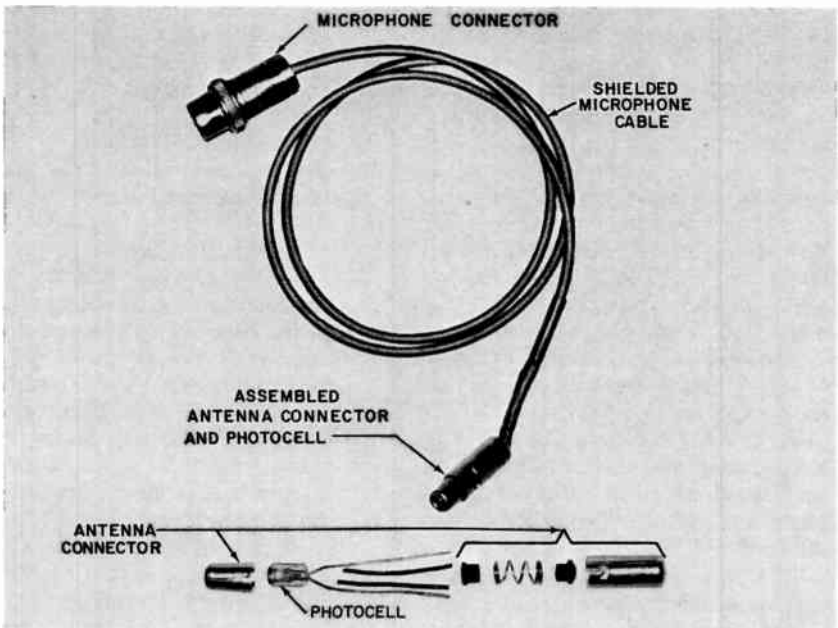

Fig. 38 - Method of mounting photocell for connection to a circuit.

Testing and Troubleshooting

SUCCESS IN troubleshooting the circuits in this Manual is directly related to the circuit builder's familiarity with the instructions presented. The test instruments available and the way in which they are used are also very important factors.

Although waveshapes taken with an oscilloscope are not absolutely essential for troubleshooting, they can be valuable as an aid to understanding the operation of a circuit. Waveshapes taken when the circuits (especially the power-control type) are operating normally can be very useful for comparison purposes when trouble occurs. Waveshapes shown in this book can be taken with an RCA WO-33A oscilloscope or its equivalent; the WO-33A is described at the end of this section. Voltage and current readings can also be very helpful in troubleshooting. The RCA WV-38A Volt-Ohm-Milliammeter (VOM) and the RCA WV-77E VoltOhmyst* are good instruments for such readings. Both of these instruments are also described at the end of this section.

The following checkout procedure is recommended when a circuit is first turned on or when troubleshooting is attempted:

* Trademark Reg. U.S. Pat. Off.

1. Before power is applied to the circuit for the first time, check the wiring for agreement with the schematic and check the load to ensure that it is within the circuit capabilities and is of the proper type.
2. If the circuit fails to operate, visually check the load for any signs of energization, such as the flash of a lamp or the start of a motor.
3. If trouble is evident remove the power-input cord from the power receptacle and check the fuse.
4. If the fuse has blown, recheck the wiring for short circuits; give special attention to the polarity of the electrolytic capacitors and silicon rectifiers.
5. If the fuse has not blown and the load shows no evidence of being energized, recheck the wiring; an open circuit caused by faulty wiring is the most probable cause of the trouble.
6. Voltage and resistance checks by VOM are the next step in isolating the trouble area. If one of the active components (transistors, diodes, or thyristors) is suspected, test it for "go/no-go" operation with one of the tempo-

rary circuits described and illustrated later in this section. (The tests that can be performed with the temporary circuits will only indicate whether the component under test is internally open-or short-circuited; they will not indicate how well or with what gain the component operates in the circuit.) More complete testing of transistor circuits can be accomplished through the use of a transistor tester such as the RCA WT-501A described at the end of this section. If all active components are found to be in working order, check the passive components, resistors and capacitors: capacitors for shorts and leakage, wire-wound resistors and potentiometers for discontinuities. These components, especially new ones that display no visible irregularities, are usually trouble-free and therefore are least likely to be the cause of circuit failure.

7. If the circuit is operating but the performance is not as expected, the trouble might be caused by the fact that the actual value of each component is a little higher or lower than its stated value. If all or substantially all of the components are off in the same direction (either higher or lower,) the sum of the small differences in individual resistance and capacitance might be enough to affect circuit performance. If this problem is suspected, a change to the next higher or lower resistance or capacitance value or the substitution of another component of the same value may produce a significant change in circuit operation. As mentioned previously, success in this type of troubleshooting depends to a

large extent on the experimenter's familiarity with and understanding of the circuits involved.

TEST CIRCUITS FOR CIRCUIT COMPONENTS

The simple, temporary circuits shown in this section are designed to give the typical home circuit builder, who does not have professional-type testing equipment at his disposal, a means of testing circuit components.

Fig. 39 shows a simple "go/no-go" test circuit for silicon rectifier diodes operating at 120 volts. With the connection shown, the lamp operates at half-power. When the switch is closed, the lamp should brighten if the

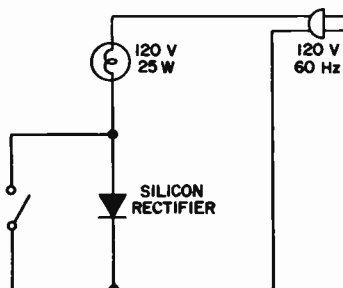

Fig. 39 - "Go/no-go" test circuit for high-voltage silicon rectifiers.

diode under test is good. If there is no change in brightness when the switch is closed, the lamp was burning at full power with the switch open; in this case, the diode is shorted. If the lamp is out with the switch open but lights when the switch is closed, the diode is open.

Fig. 40 shows a "go/no-go" tester for all silicon rectifier diodes in this Manual that operate at low voltages except the 1N34A and 1N270. The test circuit for these two types is shown in Fig. 41.

With a diode connected as shown in Fig. 40 and with the polarity of the battery as shown, the lamp should light; when the polarity of the battery is reversed, the lamp should not light. If the lamp lights regardless of the polarity of the battery, the diode is shorted; if the lamp does not light with either polarity, the diode is open.

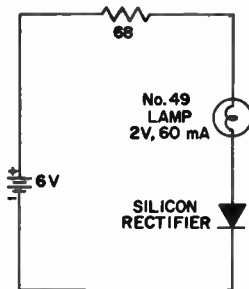

Fig. 40 - "Go/no-go" test circuit for low-voltage silicon rectifiers excluding types 1N34A and 1N270.

When the anode of a 1N34A or 1N270 diode is connected to terminal No. 1 in Fig. 41, the lamp should light if the diode is good; when the anode is connected to terminal No. 3 the light should go off. If the light remains lit regardless of the connection, the diode

is shorted; if the light is off regardless of the connection, the diode is open.

The test circuit shown in Fig. 41 can also be used to test MOS transistors. The base and source should be connected to terminal No. 1, the gate to terminal No. 2, and the drain to terminal No. 3. If the MOS transistor is of the dual-gate type the gates are tested separately. If the lamp lights with the switch open, the transistor is good; if the lamp lights with the switch in either position, the transistor is shorted. If the lamp remains off with the switch closed, the transistor is good; if the light remains off with the switch in either position, the transistor is open.

Fig. 42 shows a "go/no-go" tester for bipolar transistors. The connections shown are for an n-p-n transistor. When the base resistor is connected to the plus side of the battery, the No. 49 lamp should light if the transistor is operative. When the base resistor is connected to the minus side of the battery, the lamp should go out. For p-n-p transistors, the same results should be obtained with the battery polarities reversed.

A quick check can be made of transistors prior to their installation in a

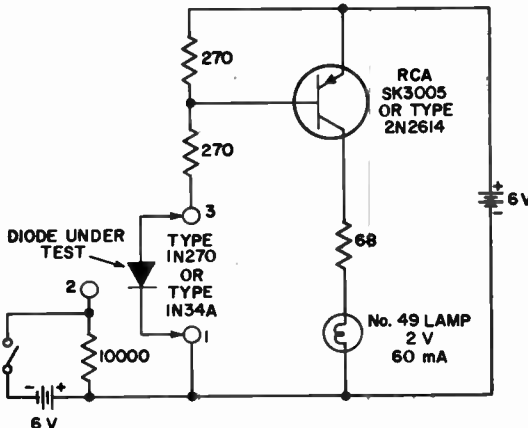

Fig. 41 - "Go/no-go" test circuit for silicon rectifier types 1N34A and 1N270 and MOS transistors.

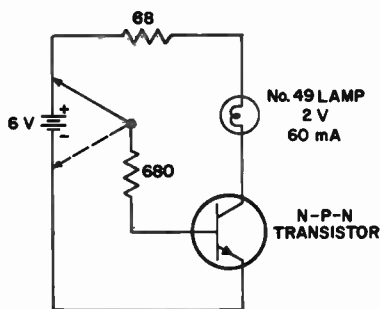

Fig. 42 - "Go/no-go" test circuit for bipolar transistors.

circuit by resistance measurements with an electronic voltmeter such as the RCA VoltOhmyst* described at the end of this section. Resistance between any two electrodes should be very high (more than 10,000 ohms) in one direction and considerably lower in the other direction (100 ohms or less between emitter and base or collector and base; about 1,000 ohms between emitter and collector). It is very important to limit the voltage used in such tests (particularly between emitter and base) so that the breakdown voltages of the transistor will not be exceeded; otherwise the transistor may be damaged by excessive currents.

SCR's can be tested by means of the circuit shown in Fig. 43. When the switch is closed, a current of approximately 20 milliamperes flows through the 25-watt lamp, the 5600-ohm resistor, and the switch; this amount of current is not enough to light the lamp. When the switch is opened, the lamp should brighten to approximately half maximum brightness. Under these conditions, the SCR should be triggered into operation (shunting the 5600-ohm resistor) on each positive half-cycle of input by the 20-milliamperere current flowing in the gate-cathode circuit. If the lamp lights to full

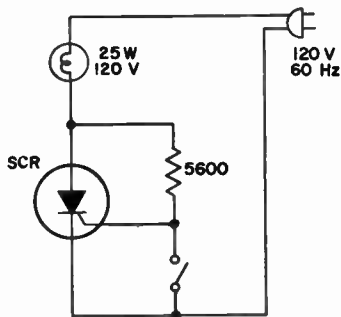

Fig. 43 - Simple test circuit for SCR's.

brightness, the SCR is shorted. If the lamp does not brighten regardless of the position of the switch, the SCR is open.

The test circuit shown in Fig. 44 can be used to check a two-transistor regenerative switch. When the 1000-ohm resistor is inserted in the circuit, the No. 49 lamp lights. If the transistor switch is operating properly, the lamp should remain lighted when the 1000-ohm resistor is removed.

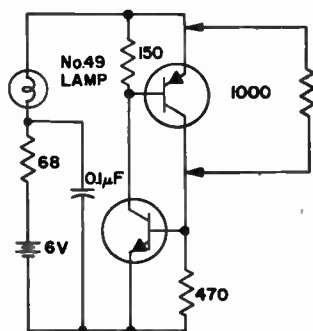

Fig. 44 - Simple test circuit for the two-transistor regenerative switch.

RESISTOR AND CAPACITOR COLOR CODES

Standard color codes indicate the values of resistors and capacitors. Fig.

*Trademark Reg. U.S. Pat. Off.

45 shows common composition resistors and the location of identifying marks; Table III explains the significance of the markings. A resistor with four stripes; yellow, black, green, and silver, respectively, from left to right, is

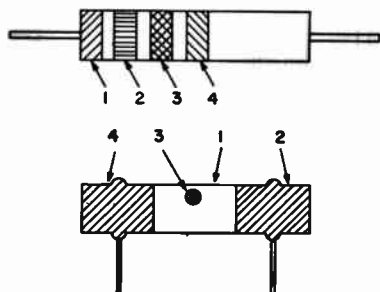

Fig. 45 - Location of identifying marks on common composition resistors: (1) first significant figure of resistance in ohms, (2) second significant figure, (3) decimal multiplier, (4) resistance to tolerance in per cent (no color is $\pm 20\%$).

a 4-megohm resistor with a ± 10 -per-cent tolerance. A resistor with green, blue, and red stripes is a 5600-ohm resistor with a ± 20 -per-cent tolerance.

Fig. 46 shows common types of capacitors and the location of their identifying markings; Table III explains the color-coded markings found on the capacitors. A flat or "postage-stamp" capacitor with 3 dots, left to right, of red, black, and red, has a capacitance of 2000 picofarads or 0.002 microfarad. A capacitor with 6 dots—top row, left to right, of brown, black, black, and bottom row, right to left, of black, gold, green—has a capacitance of 100 picofarads, a tolerance of ± 5 per cent, and a 500-volt rating.

Ceramic capacitors are valued in picofarads. They look much like resistors and are marked with bands (sometimes dots) to denote their char-

Table III.
Resistor/Capacitor Color Codes

Color	Significant Figure	Decimal Multiplier	Voltage Rating ¹ (V)	Tolerance ² (%)		(μF)
Black	0	1	—	-	120	2
Brown	1	10	100	1	1	-
Red	2	100	200	2	2	-
Orange	3	1,000	300	3	-	-
Yellow	4	10,000	400	4	-	-
Green	5	100,000	500	5	5	0.5
Blue	6	1,000,000	600	6	-	-
Violet	7	10,000,000	700	7	-	-
Gray	8	100,000,000	800	8	-	0.25
		(0.01 for ceramic capacitors)				
White	9	1,000,000,000	900	9	10	1
		(0.1 for ceramic capacitors)				
Gold	-	0.1	1000	5	-	-
Silver	-	0.01	2000	10	-	-
No Color	-	-	500	20	-	-

1. Does not apply to resistors or ceramic capacitors.

2. The first column through tolerance 9 applies to non-ceramic capacitors only; the remainder of the column applies to non-ceramic capacitors and resistors. The second column applies to ceramic capacitors valued at more than 10 picofarads. The third column applies to ceramic capacitors valued at less than 10 picofarads.

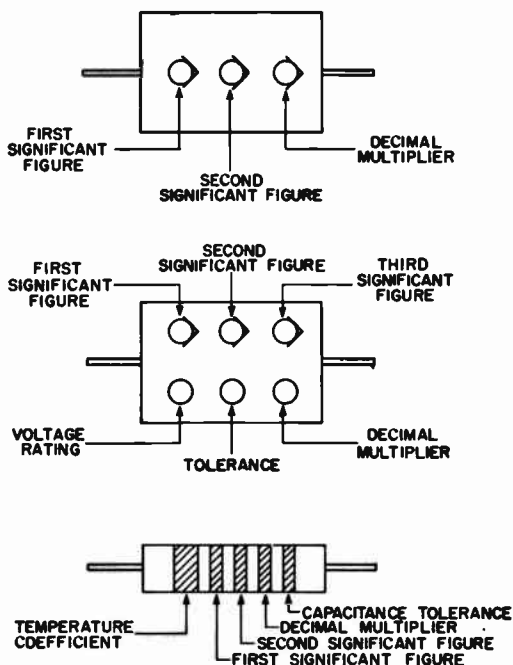

Fig. 46 - Location of identifying marks on common types of capacitors.

acteristics. A capacitor with a broad violet band and successive narrow bands or dots of green, brown, black, and red has a capacitance of 51 picofarads and a capacitance tolerance of ± 2 per cent.

PROFESSIONAL TESTING INSTRUMENTS

Transistor Tester

Convenience and efficiency in the testing and troubleshooting of transistor circuits is possible through the use of the RCA WT-501A, a battery-operated completely portable transistor tester that can measure "beta" at the current level appropriate to a particular transistor. Beta is the common-emitter forward current transfer ratio.

In the common-emitter circuit shown in Fig. 7 the base is the input electrode and the collector is the output electrode. The dc beta, therefore, is the ratio of the dc collector current I_C to the dc base current I_B .

The WT-501A tests transistors out of circuit for dc beta from 1 to 1000, collector-to-base leakage (I_{CBO}) as low as 1.0 microampere, and collector-to-emitter leakage (I_{CEO}) from 20 microamperes to 1 ampere. Reliable in-circuit testing of transistor-current gain is made possible by special low-resistance circuits. The collector current I_C is continuously adjustable from 10 microamperes to 1 ampere so that both low-power and high-power transistors can be tested.

Two sockets are provided on the panel, one socket for n-p-n transistors

and the other for p-n-p transistors. Three color-coded test leads are provided for in-circuit testing, or for use with transistors that do not fit the panel socket.

Additional features include a color-coded panel for simplified operation and a mirror-scale meter to eliminate inaccurate readings due to parallax. Fig. 47 is a photograph of the RCA WT-501A Transistor Tester.

Volt-Ohm-Milliammeter

The RCA WV-38A Volt-Ohm-Milliammeter is a completely portable, all-purpose measuring instrument. It will measure ac sine-wave voltages

from 0.1 volt to 5000 volts, dc voltages from 0.005 volt to 5000 volts, direct currents from 1 microampere to 10 amperes, resistances from 0.2 ohm to 20 megohms, and af output from -20 dB to +50 dB.

Features of this versatile test instrument include a large, easy-to-read meter and a specially designed panel with two-color markings for simplified operation.

A convenient function switch is provided with ac, +dc, and -dc positions. The +dc and -dc positions of this switch reverse the polarity of the test leads. Fig. 48 is a photograph of the RCA WV-38A Volt-Ohm-Milliammeter.



Fig. 47 - The RCA WT-501A Transistor Tester.



Fig. 48 - The RCA WV-38A Volt-Ohm-Milliammeter.

Volt Ohmyst*

The VoltOhmyst WV-77E is designed to measure dc voltages from 0.02 volt to 1500 volts, ac sine-wave voltages from 0.1 volt to 1500 volts, peak-to-peak voltages from 0.2 volt to 4000 volts, and resistance values from 0.2 ohm to 1000 megohms.

Additional features of the WV-77E include separate scales for low ac-voltage measurements to assure accurate readings, a circuit design which allows measurement of ac in the presence of dc and vice versa, and electronic protection against meter burnout. In addition, the resistors in the resistance divider network are protected by a separate fuse.

Fig. 49 is a photograph of the RCA WV-77E VoltOhmyst.

Oscilloscope

The size and weight of the RCA WO-33A 3-inch oscilloscope make it an easily portable instrument, useful in troubleshooting, general waveform analysis, and square-wave and general testing of electronic equipment. The WO-33A is a versatile and reliable instrument, well suited to applications which require a dependable oscilloscope. A scaled graph screen and calibrated voltage source permit direct reading of peak-to-peak voltages.

The sweep-frequency control is continuously adjustable from 15 Hz to 75 kHz. The over-all frequency range of the oscillator is divided into four basic ranges; a vernier adjustment, which overlaps the basic sweep ranges, provides exact adjustment of the sweep frequency.

Fig. 50 is a photograph of the RCA WO-33A Oscilloscope.

*Trademark Reg. U.S. Pat. Off.

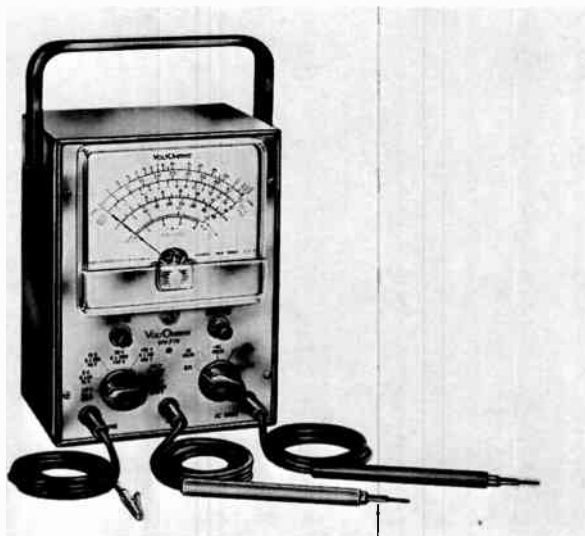

Fig. 49 - The RCA WV-77E VoltOhmyst.



Fig. 50 - The RCA WO-33A Oscilloscope.

Suggested Circuit Uses

THE CIRCUITS in this manual have been designed for maximum versatility; many of them have a range of applications limited only by the imagination and ingenuity of the circuit builder. The following descriptions, then, are to be used only as a guide by those who wish to know what circuit best applies to a certain hobby area. For maximum value from the manual, all circuits should be examined and some thought given to how each could be applied to the area of interest.

MOTORIST

There are four circuits in the *Hobby Circuits Manual* that can be used to advantage by the motorist: the temperature alarm, the tachometer, the bat-

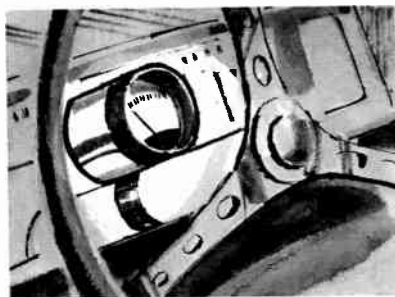

Tachometer

tery charger, and the light minder.

The temperature alarm is very sensitive; when its sensor is mounted outside the car, the alarm signals the driver when road icing conditions exist so that he can adjust his speed accordingly.

The tachometer adds to car engine life by providing an indication of engine speed, an indication that allows the driver to shift a car with a manual transmission at the optimum engine speed or to monitor the shifting of a car with an automatic transmission to

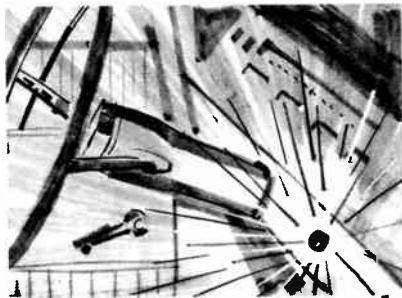

Light Minder

determine whether it is shifting properly. Besides saving wear on the engine, proper shifting saves gas.

The light minder is a particularly good device to have on those days when fog or rain requires that head-

lights be used in the daylight hours. Anyone who has returned to his car after several hours to find the battery dead as a result of his having left the lights on will appreciate the function performed by this device.

The battery-charger circuit contained in the *Hobby Circuits Manual* has a charging rate of 1 ampere and is designed for use with low-ampere-hour batteries such as those used in motorcycles and photoflash units. The charger may also be used to charge automobile batteries but the charging time is longer. If the charger is used at regular intervals, however, it will prove more than sufficient to keep an auto battery up to full charge.

RADIO AMATEUR

There are 13 circuits in the Manual that can be used to advantage by the radio amateur. They are as follows:

Microphone Preamplifier
 Simple Code-Practice Oscillator
 Audio Oscillator
 Semiautomatic Electronic Keyer
 Automatic Keyer
 Frequency-Selective AF Amplifier
 Audio Amplifier
 Audio Mixer, Compressor, and
 Line Amplifier
 Dip/Wave Meter
 Variable-Frequency Oscillator
 VFO Calibrator
 Audio-Frequency-Operated Switch
 Power Supplies

The microphone preamplifier is designed to boost the output of most dynamic microphones to a normal level of 0.5 volt to 1 volt. The preamplifier is compatible with the mixer, compressor, and line amplifier circuit and the audio power amplifier circuit described in this Manual.

The integrated-circuit code-practice oscillator is a simple but useful circuit

that can be used in a code class.

The audio oscillator circuit produces a sine-wave output. This oscillator can be used for code practice, for keying a transmitter through the built-in relay, or for adjusting a linear amplifier.

The semiautomatic key generates a dot or a series of dots depending on how long the paddle-key is held in the dot position; dashes must be made manually. The fully automatic electronic keyer, on the other hand, generates both dots and dashes automatically. The dot repetition rate of both keyers and the dash repetition rate of the fully automatic keyer can be varied by means of a speed potentiometer. Both of these keys make quality code transmission easier.



Audio Oscillator

The frequency-selective audio-frequency amplifier is designed to amplify signals at only one predetermined frequency; at this frequency the voltage gain is about 20 to 30. At other frequencies the gain is approximately unity. This circuit is very useful under conditions of heavy interference because it has the ability to eliminate the side noise and let the desired signal through.

The audio amplifier is a general-purpose unit that can be used around the ham shack in any application that requires an amplifier with a power

output up to 7.5 watts. The amplifier is compatible with all of the circuits in the Manual that require output amplification.

When installed in the microphone circuit, the audio mixer, compressor, and line amplifier allows the transmitter to be modulated at its maximum capability. Maximum transmitter modulation ensures maximum transmission of intelligence.

The dip/wave meter is an extremely useful tool for the radio amateur or experimenter in electronics because it allows him to measure the resonant frequency and consequently the inductance and capacitance of both energized and unenergized radio-frequency circuits. The meter is battery-operated and hand-held.

Control of frequencies from 3.5 MHz through vhf on the amateur bands is possible with the variable-frequency oscillator circuit. The MOS field-effect transistor used in the circuit requires an operating potential of only 10 volts; this voltage can be obtained from an automobile or dry battery through a regulator, or from one of the low-voltage power supplies described in this Manual. Because the MOS transistor generates so little heat, the entire vfo can be enclosed in a box with its tuning coils and capacitors.

The vfo calibrator can be used by a ham operator to calibrate points on a vfo dial that lie outside the tuning range of an amateur-band receiver. A 100-kHz output provided by the calibrator can be used to calibrate receivers and test equipment, such as grid-dip meters.

The most common use of the audio-frequency-operated switch for the radio amateur is to control a radio transmitter. The af switch eliminates the need for manual action and is designed with a slight delay action on turn-off so that pauses in speech will not cause the transmitter to turn off.

Four power supplies are shown; the voltages of two are predetermined and fixed; the voltages of the other two are continuously variable within the rated values of the supplies. The output voltage of the fixed supplies is determined by fixed circuit components. The universal series power supply is designed to provide output voltages from 6 volts to 35 volts; the universal shunt supply provides 6 volts or less. The two continuously variable supplies are designed to deliver voltages in the ranges of 4.5 to 12 volts and zero to 12 volts, respectively. The 4.5-to-12-volt design is the simpler, more economical of the two. The maximum output current for any of these supplies is 1 ampere.

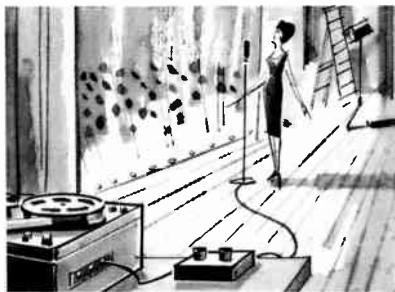

Audio Mixer, Compressor, and Line Amplifier

PHOTOGRAPHER

Of particular interest to the photographer are the universal timer, the enlarger exposure meter, the temperature alarm, the metronome, and the battery-charger circuits.

The universal timer circuit is a very stable, resettable circuit that can be adjusted over a wide range of times. It can be used for precise timing of enlarger exposures, print-development sequences, and other darkroom procedures.

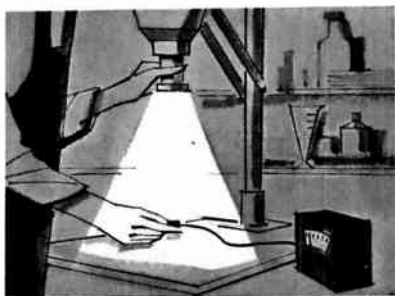

Enlarger Exposure Meter

The enlarger exposure meter makes use of a photocell circuit to permit extremely accurate timing of enlargements. The meter used greatly simplifies the work required to set up the enlarger and to obtain consistently good reproductions.

The temperature alarm can be used to check the temperature of any solution in the darkroom (that is, whether it is warm or cool enough to perform its function satisfactorily). When used in a running-water bath, the temperature alarm will signal a harmful change of temperature instantaneously.

The metronome circuit is a very useful tool in the darkroom because it permits time to be measured audibly. If the "beep" rate of the timer is set at 1 second, the passage of an amount of time can be noted simply by counting the "beeps."

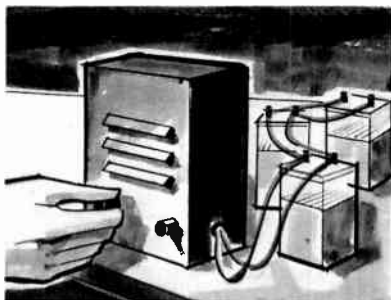

Battery Charger

The battery-charger circuit was originally designed for the prime purpose of providing photographers with a means of recharging the batteries of their portable strobe units. The savings in battery cost realized when the charger is used are substantial. Although this charger can be used to charge auto batteries, its special slow charging rate makes it more applicable to the charging of smaller batteries.

MUSIC LOVER

Seven circuits are described that will add to the enjoyment of music lovers whose delight is in listening, as well as those who prefer to make their own music.

The audio mixer, compressor, and line amplifier circuit permits the audio enthusiast to obtain the uniform audio levels required in the production of very-high-quality tape recordings.

The general-purpose high-fidelity audio power amplifier, when coupled with the phonograph preamplifier circuit, provides a high quality audio system.

The phonograph preamplifier is designed for use with a magnetic pickup capable of supplying an input signal of at least 5 millivolts and has provisions for tape and tuner input. At the 5-millivolt signal level, the pream-



Fuzz Box

plifier delivers an output of at least 1 volt.

The microphone preamplifier was designed to boost the output of a dynamic microphone to a normal level of 0.5 volt to 1 volt. The preamplifier is compatible with the audio amplifier circuit and the mixer, compressor, and line amplifier circuit described in this Manual.

The fuzz box is intended to be used with a guitar; however, it may be used with any instrument whose musical output is electrically amplified. It can be used with the audio power amplifier circuit described in the Manual. The

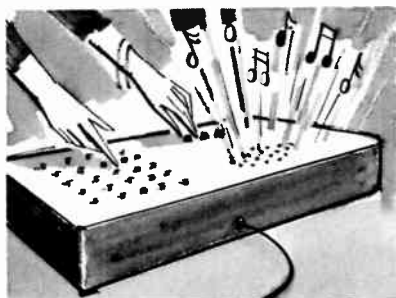

Organ

fuzz box changes the character of the sound produced by an instrument and makes possible the generation of a variety of sounds of which the instrument alone is not capable.

The single-voice organ operates through five octaves and has variable tone character, volume, and tremolo depth controls. A full, rich note is produced that can be amplified by the audio-amplifier circuit to produce a true organ sound.

The electronic metronome replaces the click of the mechanical metronome with a "beep" and makes available a continuous, wide range of time intervals. The electronic metronome has an advantage over the mechanical type in that it does not have to be re-wound.

HOME OWNER

Eight circuits in the Hobby Circuits Manual have been designed with the home owner in mind. These circuits, some for use indoors, some for use outdoors, some battery-operated, and some requiring house power, will make the home owner's life more pleasant by saving steps or unnecessary labor or by adding to the appearance of his home; some circuits also increase the safety of the home.

The temperature alarm, for example, can be used to warn of high tem-

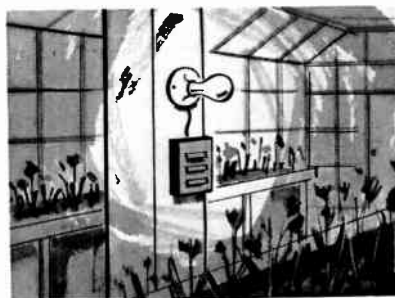

Temperature Alarm

perature in a freezer or low temperature out-of-doors. It can also be used as a fire alarm or to warn of abnormally high temperatures in a furnace room. Because the alarm is provided with a standby battery, it is not dependent upon utility-company power and will continue to operate during a power failure.

The lamp dimmer can be used in the dining, living, or play room to attain the exact lighting level desired. The simplicity of the lamp dimmer makes it extremely easy to build.

The light-operated switch is a particularly versatile circuit that allows lights to be automatically and remotely turned on and off. If the house is left unattended for some time, the switch will ensure that house and yard lights are on during the night. The switch can

also be set to turn on when headlights are shined on the triggering mechanism; in a similar application dock lights may be turned on by a boat owner as he returns to port for the night. In both of these applications the light sensor is mounted at the end of a long tube so that the switching circuit is activated only when the light shines down the tube.

The moisture-controlled switch was originally designed to be used in conjunction with the temperature alarm so that rain-gutter defrosters would be turned on only when ice was present in the gutters. Without the moisture detector the defrosters would be activated every time the temperature fell below freezing whether ice was present or not.



Metal Detector

The metal detector is a handy device for locating underground pipes and for retrieving metal articles lost in sand, grass, or loose earth. The metal detector can also be used for "treasure" hunting by the amateur archaeologist and vacation beachcomber.

The motor speed control is most useful around the shop, where it can be used to adjust and regulate (maintain constant speed under condition of changing load) the speed of drills, buffers, and jigsaws. A power drill operated through the motor speed control can be made to rotate very slowly so that the drill can be used as a power

screwdriver. Floor polishers, hair dryers, and commercial food mixers can also be controlled by this circuit.

The primary use of the electronic flasher is for switching decorative lights or signs on and off to add to their attractiveness. An address sign illuminated by a flashing light is a great help to visitors looking for that address for the first time.

The electronic time delay is useful for activating an auditory device to signal the end of a time interval (e.g., to limit card and chess players to one minute of "thinking time"), or for making another device "wait" for a short time until some action can be taken.

NOVELTY AND MISCELLANEOUS CIRCUITS

The novelty and miscellaneous circuits include games, a hobby model-vehicle control, a siren, power supplies, and the shift register, a circuit that is an integral part of several circuits in the Manual.

The game circuits are the electronic slot machine and the electronic die. The slot-machine game duplicates the operation of the well-known Las Vegas

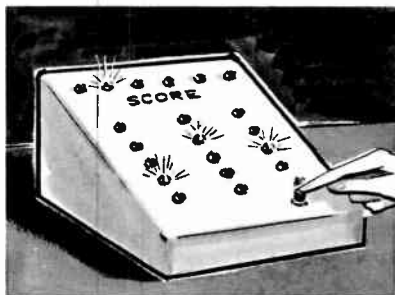

Electronic Slot Machine

model except that a push-button replaces the lever and three vertical columns of lights replace the spinning wheels. Instead of paying off in coin, the electronic slot machine indicates a score through one of six scoring lamps on its face.

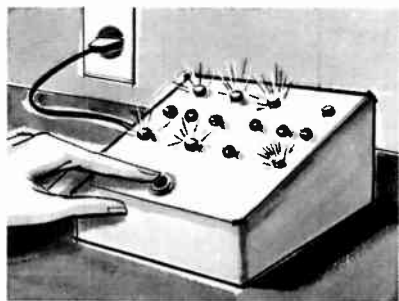

Electronic Dice

The electronic die displays, by means of lights, any of the dot patterns that exist on the faces of a conventional die. If a pair of dice is desired, the single die can be operated twice or a second die can be built.

The siren circuit is battery-operated and can be used in conjunction with a

burglar alarm or as a warning or signaling device. The siren makes a sound similar to that of a police siren but is not as loud.

The model train and race-car speed control provides smooth and continuous control of the speed of model vehicles designed to operate at dc voltages up to 12 volts. Model speed can be adjusted over the complete range from zero to full speed.

Four power supplies are shown; the voltages of two are predetermined and fixed; the voltages of the other two are continuously variable within the rated values of the supplies. The output voltage of the fixed supplies is determined by fixed circuit components. The universal series power supply is designed to provide output voltage from 6 volts to 35 volts; the universal shunt supply provides 6 volts or less. The two continuously variable supplies are designed to deliver voltages in the ranges of 4.5 to 12 volts and zero to 12 volts, respectively; the 4.5-to-12-volt design is the simpler, more economical of the two. The maximum output current for any of these supplies is 1 ampere.

Circuits

CIRCUIT NO. 1—POWER SUPPLIES

Of the four power supplies shown, two provide fixed voltages and two continuously variable voltages within their rated values. In the fixed-voltage supplies, Circuits No. 1 (a) and No. 1 (b), the output voltage can be adjusted to a set value by replacement of certain circuit components with other components of different value. The universal series power supply, Circuit No. 1 (a), is designed for use with electrical cir-

cuits requiring at least 6 volts but less than 35 volts. The universal shunt power supply, Circuit No. 1 (b), is most suitable for applications requiring 6 volts or less.

The exact dc output voltage of a fixed supply is dependent on the regulator circuit, on the transformer used in the transformer-rectifier stage, and on the configuration of that stage. Fig. 51 shows the two transformer-rectifier

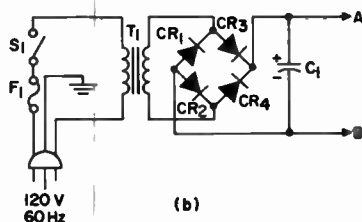
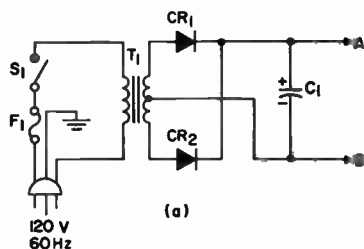

Parts List

C_1 = capacitor, electrolytic, see Table IV for value

CR_1 CR_2 CR_3 CR_4 = silicon rectifier, RCA SK3030

F_1 = fuse, 1 ampere

S_1 = switch, 125 volts, single-pole, single-throw

T_1 = transformer, primary 120 volts, secondary current rating 1

ampere, see Table IV for voltage. If the secondary voltage in Table IV is 6.3 use Stancor No. P-8190 or equivalent; if voltage is 12.6 use Stancor No. P-8130 or equivalent. For all other voltages use Stancor No. TP-4 or equivalent.

Fig. 51 - Transformer-rectifier stages used with the fixed power supplies.

Table IV.
Fixed Power Supply Design Chart

DC Output Voltage	Transformer-Rectifier Stage			Regulator Circuit		
	Transformer Secondary Voltage (V)		C_1 (min) (μ F/9 volts)	Circuit Type	CR_1 Voltage Ratings (V)	R_1 (ohm/watt)
Ckt. 51(a)	Ckt. 51(b)					
3	12.6	6.3	2500/10	shunt	3 forward biased RCA SK3020's in series	5/5
4 1/2	12.6	6.3	2500/10	shunt		3.3
6	20	10	4000/15	shunt	4.7	5/5
9	30	15	4000/15	series	7.5	390/1/2
10	30	15	4000/25	series	10	820/1/2
12	30	15	4000/25	series	11	680/1/2
15	40	20	2500/50	series	13	330/1/2
18	-	22.5	2500/50	series	16	680/1/2
20	-	28.5	2500/50	series	{ 10 and 9.1 in series	1000/1/2
29	-	38	2500/50	series	{ 11 and 11 in series	470/1/2
35	-	40	2500/75	series	{ 15 and 15 in series	1200/1/2
					36	680/1/2

stages; Table IV shows the possible dc output voltages and the regulator circuit (series or shunt) and transformer-rectifier stage to be used to produce each output voltage.

In Fig. 51(a), transformer T_1 iso-

lates and steps down the line voltage, which is then full-wave rectified by diodes CR_1 and CR_2 and filtered by capacitor C_1 . When the circuit shown in Fig. 51(b) is used, the series or shunt circuit receives full-wave rectified ac

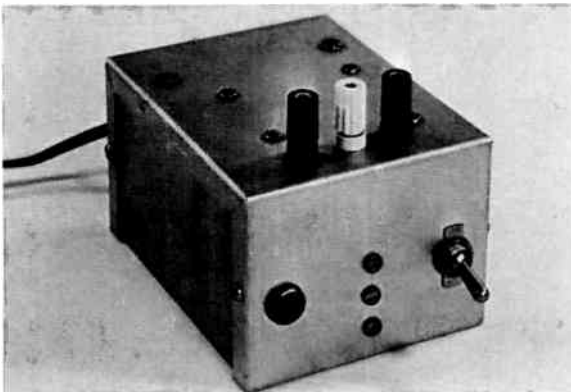

Fig. 52(a) - Fixed power supply.

from a bridge rectifier rather than from a two-diode center-tapped transformer secondary. The bridge rectifier arrangement provides the regulator with a high input voltage. Fig 52 (a) shows a fixed supply.

In the variable-voltage supplies, the output voltage can be varied during operation by means of a potentiometer control. The limited-range variable supply, Circuit No.1 (c), delivers from about 4.5 to 12 volts. The full-range

variable supply, Circuit No.1 (d), delivers any voltage between zero and 12 volts. Fig. 52 (b) is a photograph of a variable supply.

The power supplies are suitable for use with the circuits in this Manual and for many other applications. The specific supply used is determined by the power requirements of the intended application. The maximum output current of any of these supplies is 1 ampere.

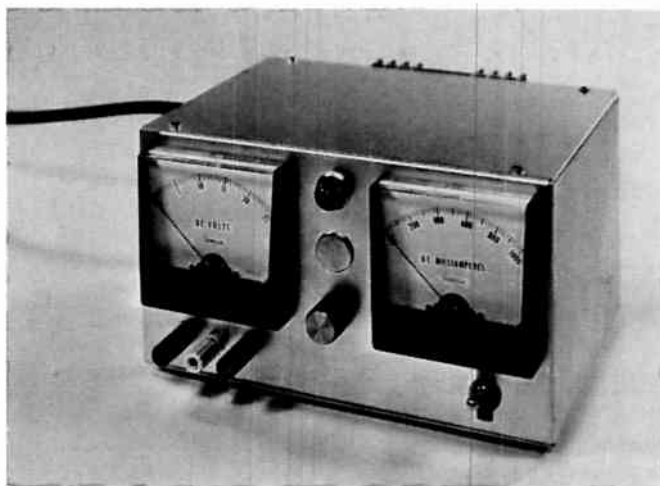

Fig. 52(b) - Variable power supply.

Circuit No. 1 (a) – Universal Series Power Supply

The universal series power supply is a fixed voltage supply that performs best with circuits requiring at least 6 volts and any intermediate value up to a maximum of 35 volts.

The schematic diagram and parts list for the universal series power supply are shown in Fig. 53. The full-wave rectified voltage received from the transformer-rectifier combination of Fig. 51 is applied across the regulator circuit consisting of transistors Q_1 and Q_2 and zener diode CR_1 . The purpose of the regulator circuit is to maintain a constant voltage across the load; without this circuit an increased load would

result in decreased load voltage. The operation of the regulator can best be understood by assuming that a constant voltage exists across the zener diode and the base-emitter junctions of Q_1 and Q_2 under all load conditions. When a decrease in load voltage occurs, through an increase in load current or a decrease in line voltage, the base of transistor Q_2 becomes more positive than its emitter and more base current flows. The increase in base current in Q_2 increases the collector-to-emitter current which, when applied to the base of transistor Q_1 , reduces its collector-to-emitter voltage. This

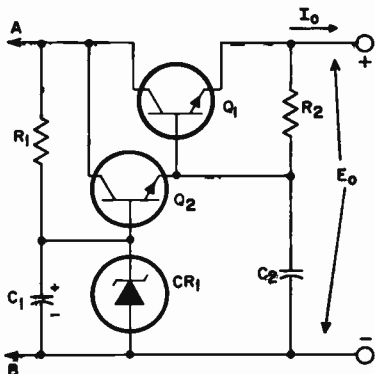

Fig. 53 - Schematic diagram and parts list for the universal series power supply.

Parts List

- C_1 = 100 microfarads, electrolytic, see text
- C_2 = 0.1 microfarad, 50 volts or greater
- CR_1 = zener diode, 1 watt, see Table IV for voltage
- Q_1 = transistor, RCA SK3027
- Q_2 = transistor, RCA SK3020
- R_1 = resistor, 1/2 watt, 10%, see Table IV for value
- R_2 = 220 ohms, 1/2 watt, 10%

action on the part of Q_1 maintains load voltage constant.

When the load voltage increases, through a decrease in load current or an increase in line voltage, an effect opposite to that described above takes place. The base current of transistor Q_2 decreases, resulting in a decrease in its collector-to-emitter current. This collector-to-emitter current is applied to the base of Q_1 and raises its collector-to-emitter voltage, again satisfying the conditions for constant load voltage.

In actual circuit operation, the voltage across the zener diode and the

emitter-base junctions of Q_1 and Q_2 changes slightly with a change in load current. However, because the polarity of the drop across the zener diode is opposite to the drop across the junctions, the effects of each tend to cancel.

The zener-diode and transformer-secondary voltage ratings and the value of resistor R_1 in Fig. 53 depend on the required amounts of load voltage E_o and load current I_o . Table IV shows these values and ratings as a function of output voltage. The voltage rating of C_1 should be higher but as close as possible to the voltage rating of CR_1 .

Circuit No. 1 (b) — Universal Shunt Power Supply

The universal shunt power supply is a fixed power supply designed to perform best when providing 6 volts or less.

The schematic diagram and parts list for the universal shunt power supply are shown in Fig. 54. The principles of operation of the shunt supply are similar to those of the series supply except that a resistor R_1 rather than a transistor is used as the voltage-dropping element. The output voltage is held constant by Q_1 , which regulates the current through, and therefore the

voltage drop across, R_1 .

As in the universal series power supply, load voltage is maintained constant by a regulator circuit composed of a zener diode in series with the base-emitter junctions of transistors Q_1 and Q_2 . As load current increases, the base current of transistor Q_2 decreases and reduces the collector-to-emitter current flowing to the base of transistor Q_1 . This action reduces the collector current of Q_1 so that less current flows through resistor R_1 . When load current decreases, the regulator circuit

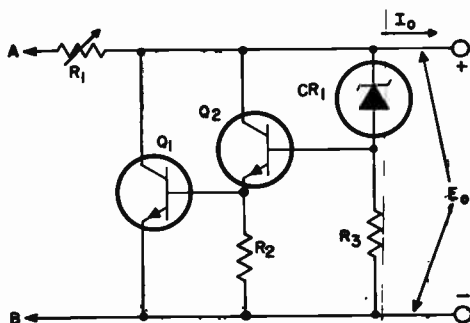

Parts List

- | | |
|-----------------------------------------------------------------|----------------------------------------------|
| CR ₁ = zener diode, 1 watt, see Table IV for voltage | R ₁ = adjustable, 5 ohms, 5 watts |
| Q ₁ = transistor, RCA SK3027 | R ₂ = 180 ohms, 1/2 watt, 10% |
| Q ₂ = transistor, RCA SK3020 | R ₃ = 470 ohms, 1/2 watt, 10% |

Fig. 54 - Schematic diagram and parts list for the universal shunt power supply.

increases the flow of current through resistor R_1 and thus maintains a constant load voltage condition.

The zener-diode and transformer-secondary voltage ratings and the values of resistor R_1 and capacitor C_1 in Fig. 54 depend on the required

amounts of load voltage and load current. Table IV shows these ratings and values as a function of output voltage. R_1 should be adjusted so that it passes a current of 1.15 amperes; an ammeter is required for this adjustment.

Circuit No. 1 (c)—Limited-Range Variable-Voltage Power Supply

The limited-range variable-voltage power supply is a continuously adjustable supply capable of delivering from about 4.5 volts to 12 volts at a maximum current of 1 ampere.

The schematic diagram and parts list for the limited-range variable-voltage power supply are shown in Fig. 55. The voltage-regulating circuit in this supply uses a transistor Q_3 in conjunction with a zener diode. The base of Q_3 is connected to the voltage-control resistor R_4 , which, along with trimmer controls R_3 and R_5 , is in parallel with the load. Therefore, any change in load or output voltage affects the voltage at the base of transistor Q_3 . If the output voltage tends to increase, the base of

Q_3 becomes more positive and more collector current flows. The increased collector current makes the base of Q_2 less positive and reduces the collector-to-emitter current supplied to the base of transistor Q_1 . Reduced base current in Q_1 results in an increased collector-to-emitter voltage drop in Q_1 ; this voltage drop maintains load voltage at the desired level. The opposite effect occurs when the load voltage tends to decrease.

Resistors R_3 and R_5 are used to set the upper and lower voltage limits of the supply; these values normally need be set only once. Screw-driver-adjust trimmer-type potentiometers are the best types for R_3 and R_5 .

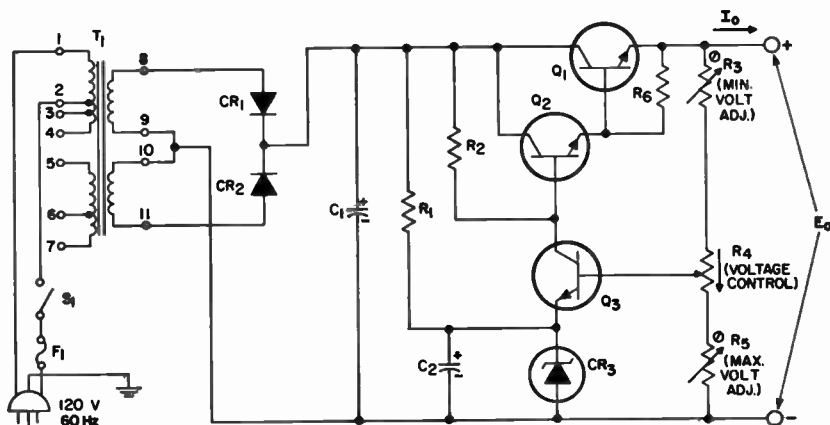

Parts List

C_1 = 5000 microfarads, 25 volts, electrolytic

C_2 = 100 microfarads, 6 volts, electrolytic

CR_1, CR_2 = silicon rectifier, RCA SK3030

CR_3 = zener diode, 3.9 volts, 1/2 watt

F_1 = fuse, 1 ampere, 120 volts

Q_1 = transistor, RCA SK3027

Q_2, Q_3 = transistor, RCA SK3020

R_1 = 6800 ohms, 1/2 watt, 10%

R_2 = 10,000 ohms, 1 watt, 10%

R_3, R_5 = trimmer potentiometer, 5000 ohms, Mallory MTC-1 or equivalent

R_4 = potentiometer, 5000 ohms, linear tape:

S_1 = switch, 120 volts, 1 ampere, single-pole, single-throw

T_1 = transformer, primary 115 volts, secondary 15 volts, 1 ampere, Stancor No. TP-4 or equivalent

Fig. 55 - Schematic diagram and parts list for the limited-range variable-voltage power supply.

Circuit No. 1 (d) - Full-Range Variable-Voltage Power Supply

The full-range variable-voltage power supply is a continuously variable supply capable of delivering up to 12 volts at a maximum current of 1 ampere.

The schematic diagram and parts list for the full-range variable-voltage power supply are shown in Fig. 56. The regulator circuit in this supply receives full-wave rectified ac from a bridge rectifier rather than from a two-diode center-tapped transformer secondary as in the other power supplies

described. This arrangement provides the regulator with a high input voltage. This supply also differs from the others described in that it contains an additional zener diode, CR_6 , connected in opposition to zener diode CR_1 . The transistors in the regulator circuit operate in the same manner as those in the other supplies, but handle twice as much voltage. This voltage does not appear across the load, however, because of CR_6 . The voltage across CR_6 is that across the center taps of the transformer and rectifying diodes CR_1 ,

and CR_2 . The load voltage is equal to the regulator voltage minus the voltage across zener diode CR_6 . When the two voltages are equal, the load voltage is zero. If the regulator-circuit voltage falls below 12 volts, the base-emitter junction of transistor Q_3 becomes reverse-biased and the transistor turns off. As a result, Q_2 and Q_1 also turn off and prevent the load voltage from reversing polarity (becoming negative).

Power-Supply Operation

The power supplies described are self-regulating after the desired output conditions are set through the use of an ammeter and voltmeter. In some applications, it may be desirable to have the ammeter and voltmeter connected as an integral part of the power supply so that output conditions can be monitored.

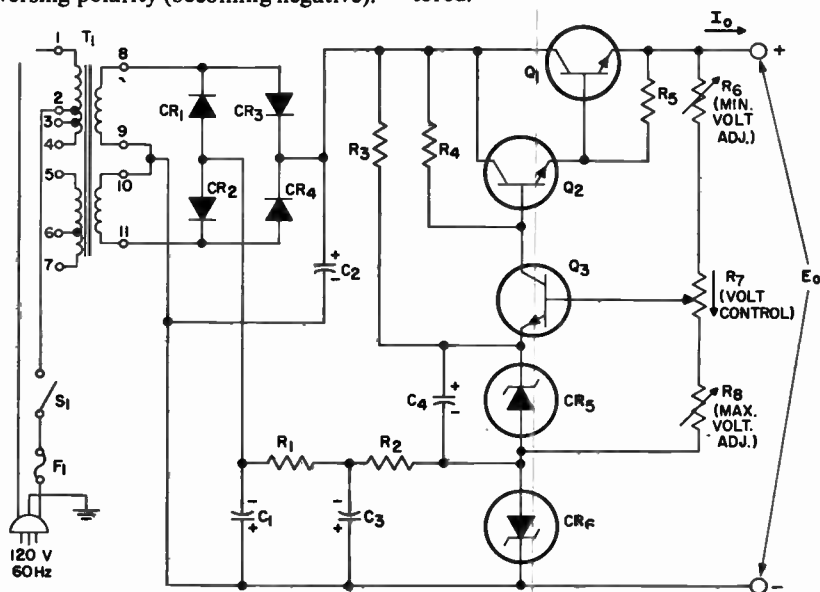

Parts List

$C_1 C_3$ = 500 microfarads, 25 volts, electrolytic

C_2 = 5000 microfarads, 25 volts, electrolytic

C_4 = 100 microfarads, 10 volts, electrolytic

$CR_1 CR_2 CR_3 CR_4$ = silicon rectifier, RCA SK3030

CR_5 = zener diode, 6.8 volts, 1 watt

CR_6 = zener diode, 12 volts, 1 watt

F_1 = fuse, 1 ampere, 120 volts

Q_1 = transistor, RCA SK3027

$Q_2 Q_3$ = transistor, RCA SK3020

$R_1 R_5$ = 220 ohms, 1/2 watt, 10%

R_2 = 470 ohms, 1/2 watt, 10%

R_3 = 6800 ohms, 1/2 watt, 10%

R_4 = 10,000 ohms, 1/2 watt, 10%

$R_6 R_8$ = trimmer potentiometer, 5000 ohms, Mallory MTC-1 or equivalent

R_7 = potentiometer, 5000 ohms, linear taper

S_1 = switch, 120 volts, 1 ampere, single-pole, single-throw

T_1 = transformer, primary 115 volts, secondary 15 volts, 1 ampere, Stancor No. TP-4 or equivalent

Fig. 56 - Schematic diagram and parts list for the full-range variable-voltage power supply.

Construction

For best performance, the supplies should be well ventilated. Transistor Q_1 should be mounted on a heat sink if its maximum power dissipation (determined by multiplying collector current by collector-to-emitter voltage) is expected to exceed 6 watts. Heat sinks are discussed in the section on **Mechanical Considerations**. Maximum power dissipation occurs when the supply is set for minimum output vol-

tage at an output current of 1 ampere.

All power supply transformers should have a dc resistance of at least 1 ohm. If the transformer used has a dc resistance of less than 1 ohm, a 1-ohm, 2-watt resistor should be inserted in series with the secondary. If a center-tapped supply is used, the resistance should be placed in series with the center tap. No special precautions are required if the transformers specified in the parts list are used.

CIRCUIT NO. 2 — SHIFT REGISTER

In a shift register, the successive outputs from the various stages are delayed (or shifted) from those of the preceding stages by a controlled time interval (i.e., the duration between input trigger pulses). These outputs can be used to operate lamps (as shown in Circuits No. 23 and No. 24) or can be coupled through OR gates to establish a timing sequence for various operations of other equipment. If terminal 15 of the circuit (Fig. 57) is connected to terminal 16, the register becomes regenerative and can be used as a ring counter. In a ring counter, each stage follows in sequence as if placed around a circle or ring. Each pulse input to the ring advances the counter one stage; when the last stage is reached, the next pulse activates the first stage. The cycle repeats until input pulses are stopped. The shift register may incorporate as many stages as desired.

Circuit Operation

The schematic diagram and parts list for a 10-stage shift register are shown in Fig. 57. The 10.6-volt dc supply voltage is obtained from two diodes connected in series as shown in Fig. 57. With these voltages applied, switching transistor Q_1 is immediately turned on by the positive voltage

applied to its base through R_3 . One of the register stages must be triggered simultaneously to provide a complete path for the current through the switching transistor.

Each register stage is basically a two-transistor regenerative switch that employs an n-p-n and a p-n-p transistor. If either of the transistors in a register stage starts to conduct, both of them are quickly driven into saturation by the regenerative action of that stage.

When power is applied to the shift-register circuit, capacitor C_3 starts to charge. The charging action provides Q_2 with a base current and turns it on. Q_2 then turns Q_3 on. The stage composed of Q_2 and Q_3 is then in conduction and provides an output at terminal 1. Q_3 conducts through Q_1 . The voltage across R_4 charges C_4 through CR_2 and R_8 . The circuit remains in this state until an input trigger pulse is applied.

To shift the register to the next stage, a negative pulse of 2 volts or more is applied to the base of Q_1 through C_2 . This pulse turns off Q_1 momentarily, interrupts the emitter circuit of Q_3 , and turns that stage off. When Q_1 is off, all stages are nonconducting. When Q_1 returns to its conducting state, the first stage does not turn on because C_3 is fully charged;

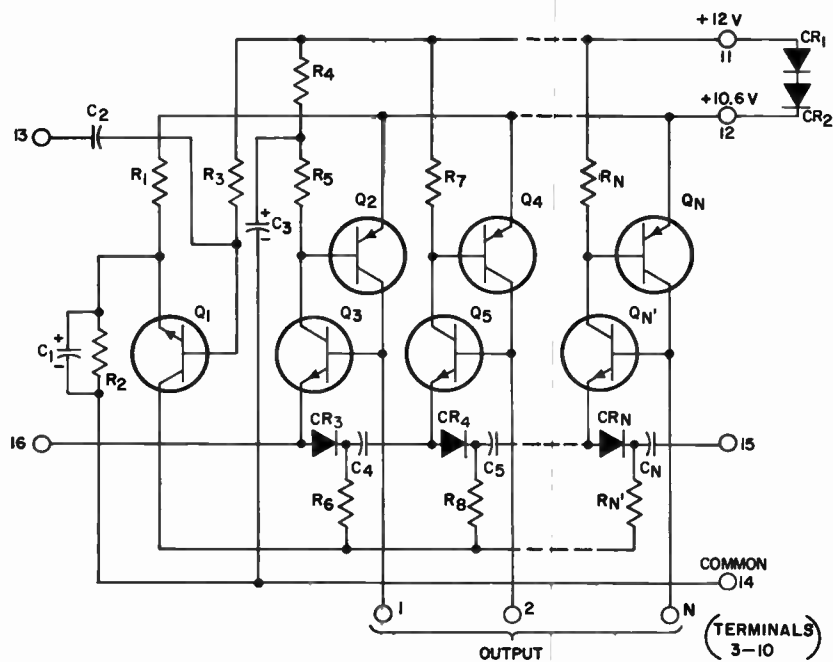

Parts List

C_1 = 100 microfarads, 10 volts, electrolytic

C_2 C_4 C_5 C_N = 0.05 microfarad, 50 volts or greater

C_3 = 10 microfarads, 15 volts, electrolytic

CR_1 CR_2 CR_N = silicon diode, type 1N270

Q_1 Q_3 Q_5 $Q_{N'}$ = transistor, RCA SK3005

Q_2 Q_4 Q_N = transistor, RCA SK3010

R_1 R_7 R_N = 1000 ohms, 1/2 watt, 10%

R_2 = 47 ohms, 1/2 watt, 10%

R_3 = 5600 ohms, 1/2 watt, 10%

R_4 R_5 = 470 ohms, 1/2 watt, 10%

R_6 R_8 $R_{N'}$ = 270 ohms, 1/2 watt, 10%

Fig. 57 - Schematic diagram and parts list for the shift register.

however, the charge on C_4 places a forward bias on the emitter of Q_6 and it turns on. Q_4 is then turned on and produces an output. When Q_4 is in conduction, C_5 charges and ensures that the third stage will trigger with the next input pulse. In this way, the operation of the register is shifted from one stage to the next each time a negative trigger pulse is applied. By interrupting the power and allowing C_3 to discharge, the register can be reset so that operation starts with the first stage.

It is important that the load connected to the outputs (1, 2, N) be 1000 ohms or less. The load current should not exceed 200 milliamperes.

Construction

The drilling template for a 10-stage shift register is shown at the back of this Manual; a component placement diagram and a photograph of the completed circuit board are shown in Figs. 58 and 59, respectively.

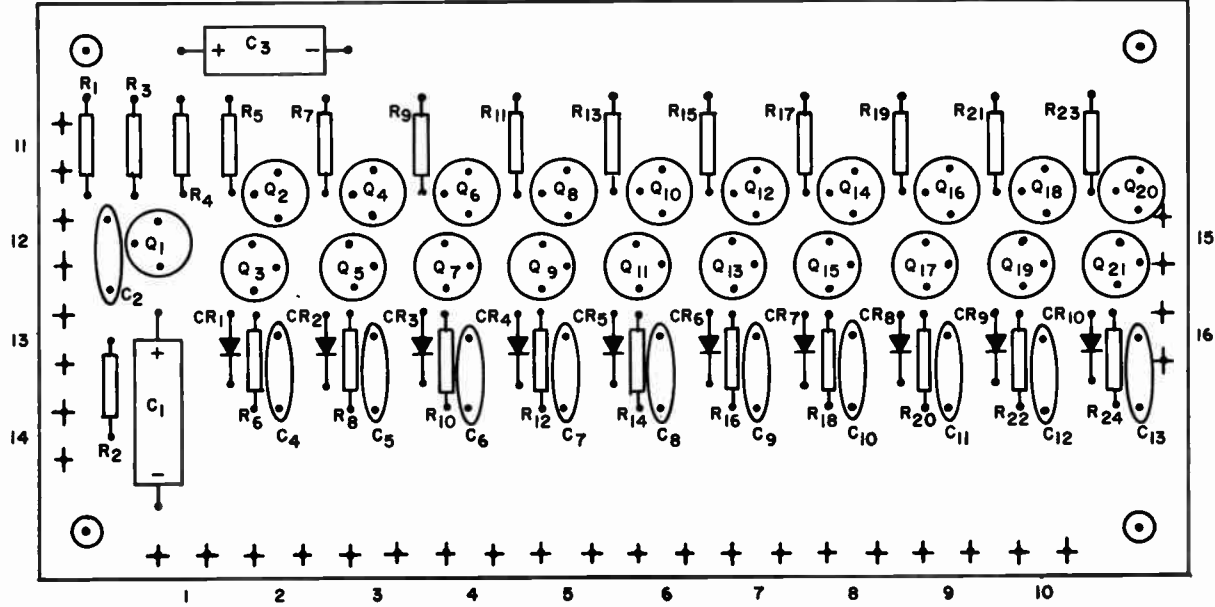

Fig. 58 - Component placement diagram for the shift register.

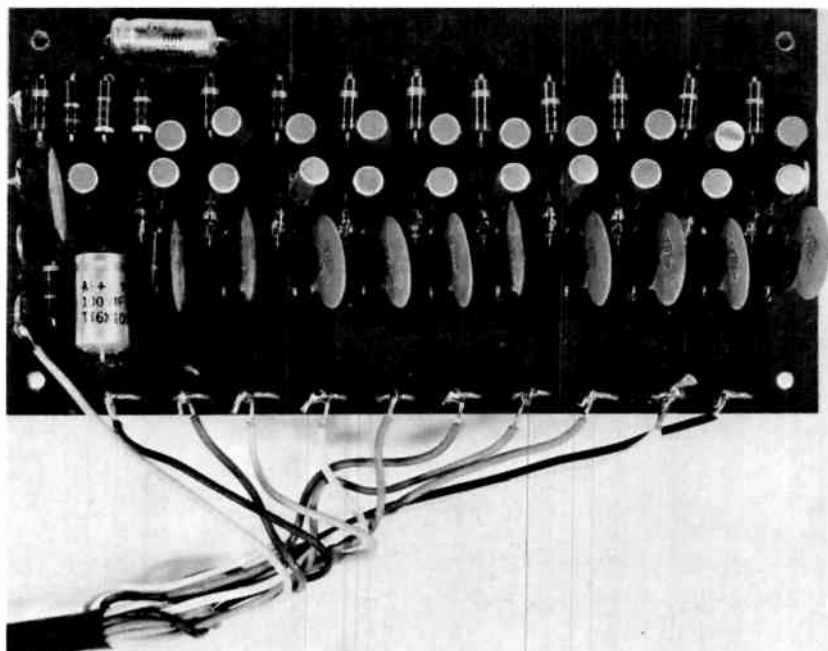

Fig. 59 - Completed circuit board for a ten-stage shift-register.

CIRCUIT NO. 3 — SIMPLE CODE-PRACTICE OSCILLATOR

The simple integrated-circuit (IC) code-practice oscillator is an excellent project for the beginning radio amateur. Construction provides exposure to the use of integrated circuits and practical knowledge of circuit-building techniques; the finished oscillator is a valuable tool for learning the Morse code.

Circuit Operation

The schematic diagram and parts list for the code-practice oscillator are shown in Fig. 60. The heart of the oscillator is the integrated circuit, CA3028. The schematic diagram for the integrated circuit is shown in Fig. 61; all components shown in this diagram are within the integrated-circuit

package. Transistors Q_1 and Q_2 of the integrated circuit comprise a differential amplifier which is driven by a constant-current source Q_3 . The feedback necessary for oscillation is supplied to Q_1 through external capacitor C_1 . The remainder of the resistors both internal and external to the integrated circuit provide proper voltage bias conditions. The current drain for this circuit is approximately 5.5 milliamperes.

Construction

The drilling template for the code-practice oscillator is shown at the back of this Manual; a component placement diagram and a photograph of the completed circuit board are shown in Figs. 62 and 63, respectively.

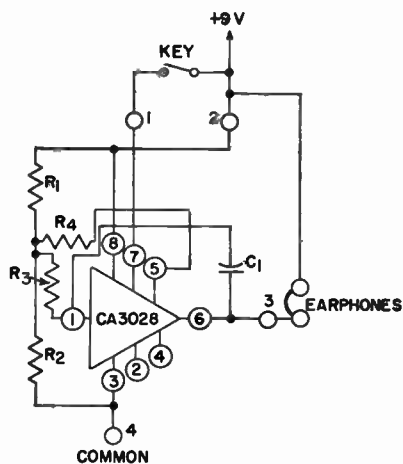

Parts List

- $C_1 = 0.47$ microfarad, 25 volts or greater, 10%
- $R_1 R_3 R_4 = 1000$ ohms, 1/2 watt, 10%
- $R_2 = 2000$ ohms, 1/2 watt, 10%
- Integrated Circuit = RCA CA3028
- Earphones = 2000 ohms, magnetic

Fig. 60 - Schematic diagram and parts list for the simple code-practice oscillator.

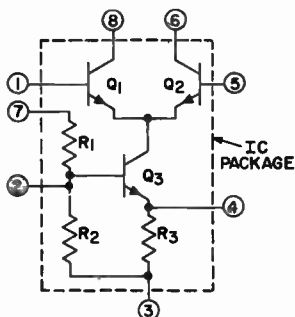

Fig. 61 - Schematic diagram of the CA3028 integrated circuit (all components shown are inside the integrated-circuit package).

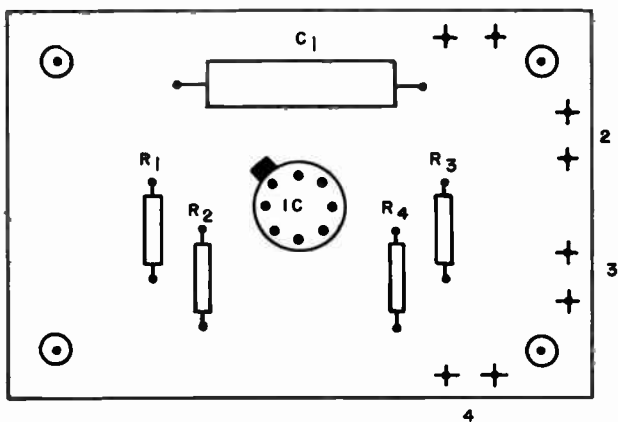

Fig. 62 - Component placement diagram for the simple code-practice oscillator.



Fig. 63 - Completed circuit board for the simple code-practice oscillator.

CIRCUIT NO. 4 — AUDIO OSCILLATOR

The audio oscillator has been designed for code practice; an optional output that can be used to key a relay is provided. The oscillator output tone is a sine wave.

Circuit Operation

The schematic diagram and parts list for the audio oscillator are shown in Fig. 64. Transistor Q_1 , capacitors C_1 , C_2 , C_3 , and C_4 , and resistors R_1 , R_2 , and R_3 form a basic twin-T oscillator (as described in the section on **General Circuit Considerations**). Briefly, transistor Q_1 is a standard audio amplifier; its collector is connected to the twin-T network composed of C_1 , C_2 , and C_3 , and R_1 , R_2 , and R_3 . The output of this network is applied to the base of transistor Q_1 through capacitor C_4 and supplies the

required feedback for oscillation. The output of Q_1 is applied to Q_2 , which is connected into the circuit in a common-emitter configuration (as discussed in the section on **Theory and Operation of Solid-State Devices**). Q_2 provides a power gain and the ear-phone output signal. Potentiometer R_{11} sets the audio level in the ear-phones.

When the circuit is used to key a relay, the hand key is connected through R_8 to the base of Q_2 ; power input should be 12 volts. Transistor Q_2 switches power to Q_1 as well as to the relay. Diode CR_1 protects Q_2 from the high inductive voltages that are present at the terminals of a relay when the relay-coil circuit is interrupted.

When the circuit is used as a code-practice oscillator and a relay is not required, Q_2 , CR_1 , R_8 , and R_9 are omitted, A and B are disconnected,

and the wiring shown by dashed lines in Fig. 64 is substituted.

In the idle state, the current drain for this circuit is approximately 200 microamperes; when keyed, the drain is 7.5 milliamperes.

Construction

The drilling template for the audio oscillator is shown at the back of this Manual; a component placement diagram and a photograph of the completed circuit board are shown in Figs. 65 and 66, respectively.

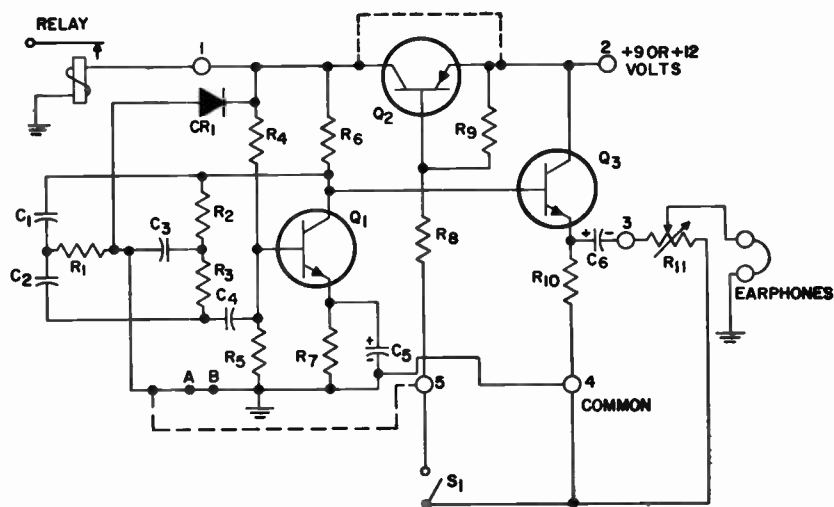

Parts List

$C_1 C_2 = 0.0047$ microfarad
 $C_3 C_4 = 0.01$ microfarad
 $C_5 = 1$ microfarad, 6 volts, electrolytic
 $C_6 = 5$ microfarads, 6 volts, electrolytic
 $CR_1 =$ silicon rectifier, RCA SK3030
 $Q_1 Q_3 =$ transistor, RCA SK3020
 $Q_2 =$ transistor, RCA SK3005
 $R_1 = 10,000$ ohms, 1/2 watt, 10%
 $R_2 R_3 = 47,000$ ohms, 1/2 watt, 10%
 $R_4 = 100,000$ ohms, 1/2 watt, 10%
 $R_5 = 22,000$ ohms, 1/2 watt, 10%

$R_6 = 6800$ ohms, 1/2 watt, 10%
 $R_7 = 2200$ ohms, 1/2 watt, 10%
 $R_8 = 12,000$ ohms, 1/2 watt, 10%
 $R_9 = 470$ ohms, 1/2 watt, 10%
 $R_{10} = 820$ ohms, 1/2 watt, 10%
 $R_{11} =$ potentiometer, 5000 ohms, linear taper
 Earphones = 600 ohms or greater
 Relay = 12 volts, 1350 ohms, Potter and Brumfield No. RS5D or equivalent
 $S_1 =$ telegraph key or switch

Fig. 64 - Schematic diagram and parts list for the audio oscillator.

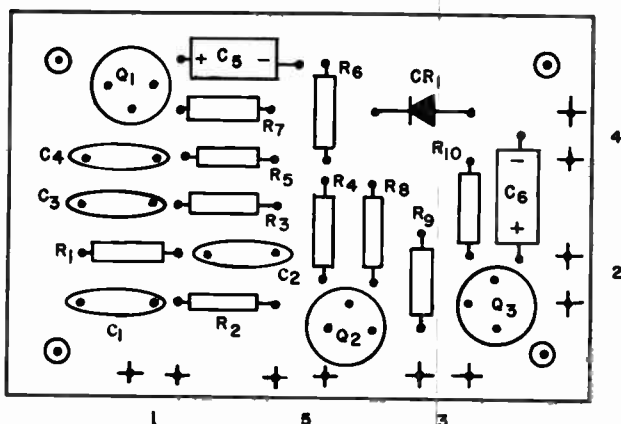

Fig. 65 - Component placement diagram for the audio oscillator.

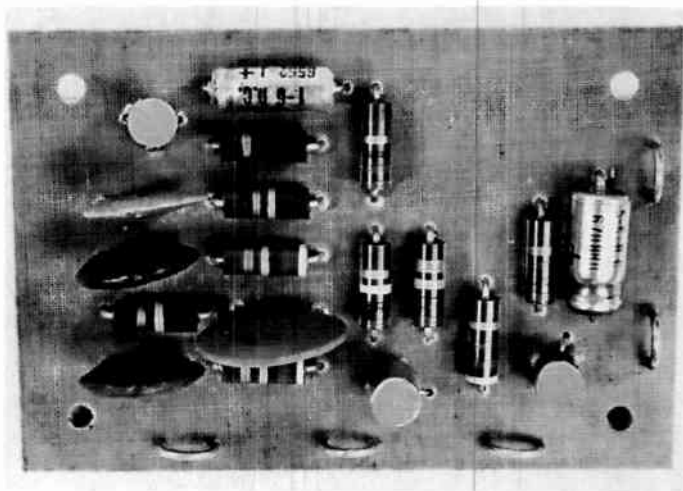

Fig. 66 - Completed circuit board for the audio oscillator.

CIRCUIT NO. 5 — SEMIAUTOMATIC ELECTRONIC KEYS

The semiautomatic electronic Morse-code keyer or "bug" generates a single dot or a series of dots, depending upon how long the paddle-key is depressed; the dash must be made manually. The rate at which dots are generated can be varied.

Circuit Operation

The schematic diagram and parts list for the semiautomatic keyer are shown in Fig. 67. The dot repetition rate is determined by R_4 , C_1 , and the speed potentiometer R_{20} . These com-

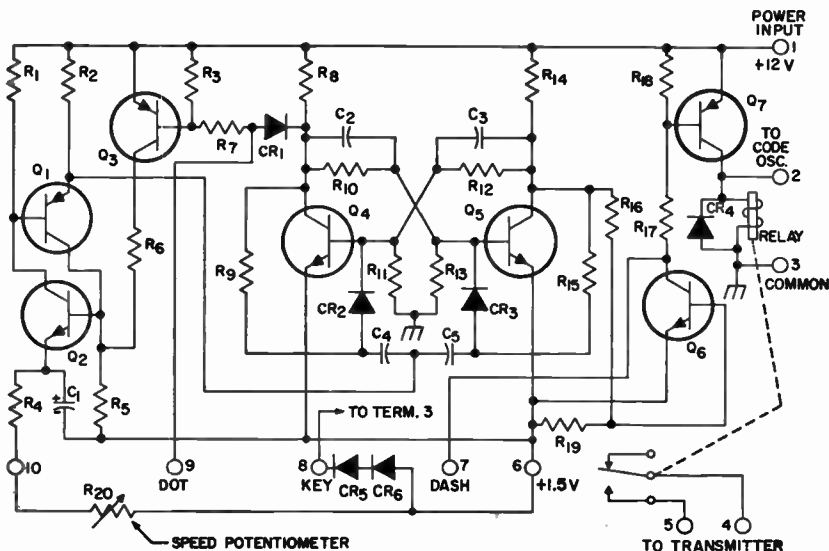

Parts List

C_1 = 5 microfarads, 25 volts, electrolytic

C_2 C_3 = 560 picofarads, 50 volts or greater

C_4 C_5 = 330 picofarads, 50 volts or greater

CR_1 CR_4 CR_5 CR_6 = silicon rectifier, RCA SK3030

CR_2 CR_3 = silicon rectifier, type 1N270

Q_1 Q_3 Q_7 = transistor, RCA SK3005

Q_2 Q_4 Q_5 Q_6 = transistor, RCA SK3020

R_1 = 1000 ohms, 1/2 watt, 10%

R_2 = 180 ohms, 1/2 watt, 10%

R_3 R_{17} R_{19} = 2200 ohms, 1/2 watt, 10%

R_4 = 2700 ohms, 1/2 watt, 10%

R_5 R_{16} = 470 ohms, 1/2 watt, 10%

R_6 = 1500 ohms, 1/2 watt, 10%

R_7 = 39,000 ohms, 1/2 watt, 10%

R_8 R_{14} = 3900 ohms, 1/2 watt, 10%

R_9 R_{15} = 15,000 ohms, 1/2 watt, 10%

R_{10} R_{12} = 33,000 ohms, 1/2 watt, 10%

R_{11} R_{13} = 27,000 ohms, 1/2 watt, 10%

R_{18} = 12,000 ohms, 1/2 watt, 10%

R_{20} = potentiometer, 10,000 ohms, linear taper

Relay = 12 volts, 1350 ohms, Potter and Brumfield No. RS5D or equivalent

Fig. 67 - Schematic diagram and parts list for the semiautomatic electronic keyer.

ponents control the regenerative switch consisting of transistors Q_1 and Q_2 . This switch has a very high impedance before it is triggered and a very low impedance afterward. When the paddle-key is moved to the dot position, the current applied to the base of Q_3

turns it on and permits C_1 to begin charging through the emitter of Q_2 . At the same time, Q_2 turns on and triggers the regenerative switch into conduction. As capacitor C_1 charges, the emitter of Q_2 becomes more and more positive until the regenerative switch is

cut off. When cutoff occurs, the impedance of the regenerative switch becomes very high and C_1 is forced to discharge through R_4 and the speed potentiometer R_{20} . As the charge on C_1 decreases, the emitter of Q_2 becomes less positive and the regenerative switch begins to conduct again. This process repeats itself as long as the paddle-key is held in the dot position. The polarity of the regenerative switch in conduction is such that a negative pulse is applied to the base of transistors Q_4 and Q_5 in the flip-flop. This negative pulse is sufficient to turn on transistor Q_4 ; Q_5 turns off automatically as a result of normal flip-flop action. When Q_5 is off, its collector voltage is applied to Q_6 through R_{16} , and Q_6 turns on. Current through Q_6 activates Q_7 which, in turn, closes the output relay. Diode CR_4 is placed across the relay to protect Q_7 from the high-voltage inductive discharges which occur when current to the relay coil is interrupted and its coil field collapses.

When the paddle-key is released from the dot position with Q_4 off (i.e., when the paddle-key is released at the end of a dot), Q_3 turns off and interrupts the C_1 charging path, with the result that the regenerative-switch pulses that cause the dots are stopped.

CIRCUIT NO. 6 — AUTOMATIC KEYS

This fully automatic keyer produces either dots or dashes continuously for as long as the paddle-key is held in the dot or dash position. The speed of the dots and dashes can be varied to suit the operator. The keyer circuit is composed of a number of the building blocks described in the section on **General Circuit Considerations**: the pulser or clock, the flip-flop, and the lamp driver. The 12-volt supply is needed to power the keyer; eight flash-

When the paddle-key is released from the dot position with Q_4 on (i.e., when the paddle-key is released in the middle of a dot), Q_3 continues to conduct because its base current continues to flow through Q_4 . The regenerative-switch pulses once more to complete the dot cycle. Dot-cycle completion is accomplished when the final regenerative-switch pulse returns the flip-flop to its original state and turns Q_4 , and consequently Q_3 , off.

If instead of batteries a power supply is used to power this circuit, the 1.5 volts needed (shown as an input at circuit-board terminal No. 6) can be obtained from the drop across the two silicon rectifiers CR_5 and CR_6 connected in series, as shown in Fig. 67.

When the paddle-key is in the dash position, the relay is not under the control of a transistor, but operates directly.

The current drain for this circuit is approximately 5 milliamperes.

Construction

The semiautomatic electronic keyer is built on the same circuit board as the automatic keyer, Circuit No. 6. The drilling template for both circuits is shown at the back of this Manual; a component placement diagram is shown in Fig. 70.

light batteries in series or a 12-volt supply such as that described in Circuit No. 1(a) may be used.

Circuit Operation

The schematic diagram and parts list for the fully automatic keyer are shown in Fig. 68. The dot or dash repetition rate of the keyer is determined by speed-control potentiometer R_{20} , which controls the frequency of the

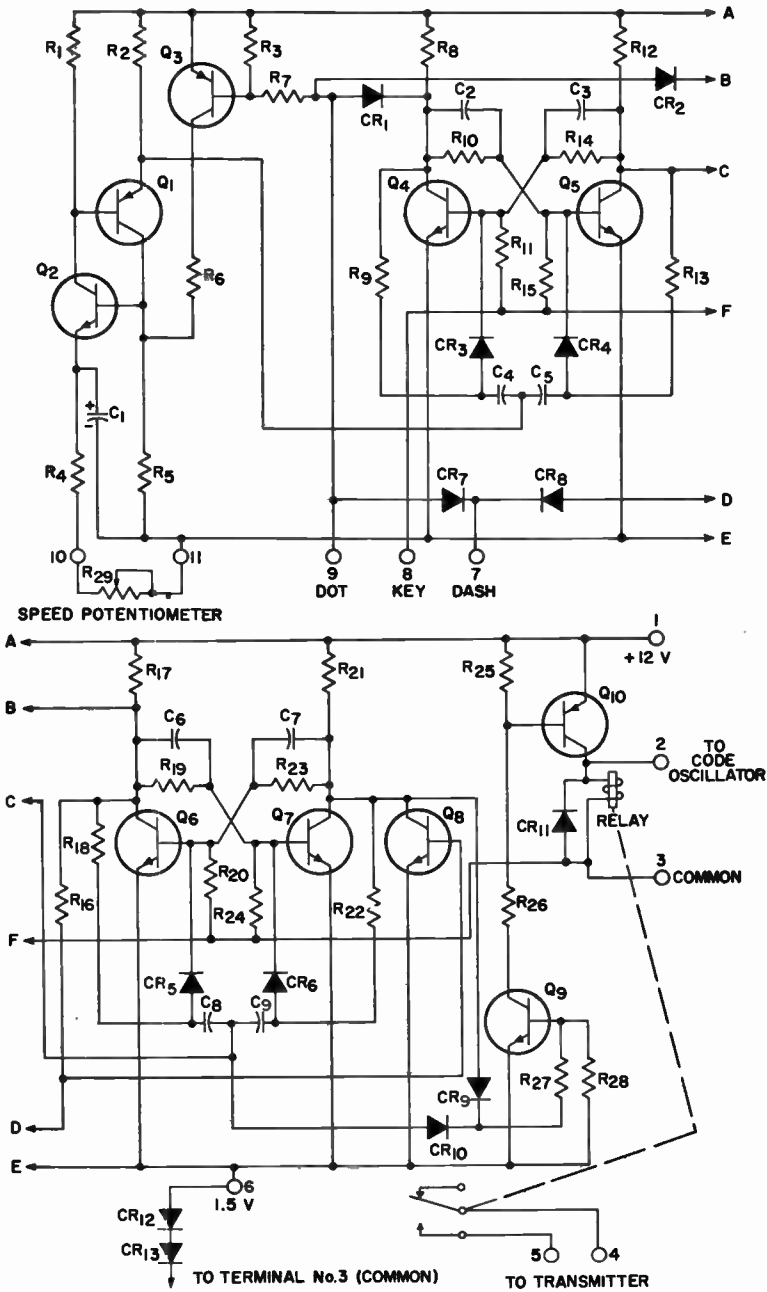

Fig. 68 - Schematic diagram for the automatic keyer.
Parts list on next page.

Parts List

- C_1 = 5 microfarads, 25 volts, electrolytic
 $C_2 C_3 C_6 C_7$ = 560 picofarads, 25 volts or greater
 $C_4 C_5 C_8 C_9$ = 330 picofarads, 25 volts or greater
 CR_1 through CR_{10} = silicon rectifier, type 1N270
 $CR_{11} CR_{12} CR_{13}$ = silicon rectifier, RCA SK3030
 $Q_1 Q_3 Q_{10}$ = transistor, RCA SK3005
 $Q_2 Q_4 Q_5$ through Q_9 = transistor, RCA SK3020
 R_1 = 1000 ohms, 1/2 watt, 10%
 R_2 = 180 ohms, 1/2 watt, 10%
 $R_3 R_{26} R_{28}$ = 2200 ohms, 1/2 watt, 10%
 R_4 = 2700 ohms, 1/2 watt, 10%
 $R_5 R_{25}$ = 470 ohms, 1/2 watt, 10%
 R_6 = 1500 ohms, 1/2 watt, 10%
 $R_7 R_{16}$ = 39,000 ohms, 1/2 watt, 10%
 $R_8 R_{12} R_{17} R_{21}$ = 3900 ohms, 1/2 watt, 10%
 $R_9 R_{13} R_{18} R_{22}$ = 15,000 ohms, 1/2 watt, 10%
 $R_{10} R_{14} R_{19} R_{23}$ = 33,000 ohms, 1/2 watt, 10%
 $R_{11} R_{15} R_{20} R_{24}$ = 27,000 ohms, 1/2 watt, 10%
 R_{27} = 12,000 ohms, 1/2 watt, 10%
 R_{29} = potentiometer, 10,000 ohms, linear taper
Relay = 12 volts, 1350 ohms, Potter and Brumfield No. RS5D or equivalent

pulsar or clock oscillator consisting of transistors Q_1 and Q_2 . When the paddle-key is moved to the dot position (i.e., when terminals 8 and 9 on the circuit board are connected), a current is transmitted to the base of Q_3 ; this current turns Q_3 on. Q_3 in turn activates the regenerative switch consisting of Q_1 and Q_2 and permits C_1 to begin charging through the emitter of Q_2 . As capacitor C_1 charges, the emitter of Q_2 becomes more and more positive until Q_2 is cut off. When cutoff occurs, the total impedance of Q_1 and Q_2 becomes very high and C_1 is forced to discharge through R_4 and the speed-control potentiometer R_{29} . As the charge on C_1 decreases, the emitter of Q_2 becomes less positive and transistors Q_1 and Q_2 begin to conduct again. This process repeats itself as long as the paddle-key is held in the dot or dash position. Q_1 and Q_2 when in conduction produce a negative pulse that is applied to the bases of transistors Q_4 and Q_5 in the flip-flop. This

negative pulse is sufficient to turn off transistor Q_5 ; Q_4 is turned on automatically as a result of normal flip-flop action. When Q_5 is off, current is conducted through R_{13} , CR_{10} , and R_{27} ; this current turns Q_9 on. Current through Q_9 activates Q_{10} which, in turn, energizes the output relay.

The dash flip-flop composed of transistors Q_6 and Q_7 is held inoperative during the dot cycle by the clamping transistor Q_8 which is held in the conductive state by current through R_{17} and R_{16} . Diode CR_{11} is placed across the relay to protect Q_{10} from the high-voltage pulse produced when current to the relay is interrupted and its coil field collapses.

When the paddle-key is released from the dot position with Q_4 off (i.e., when the paddle-key is released during a space at the end of a dot or a series of dots), Q_3 turns off and the oscillator pulses that cause the dots are no longer generated. When the paddle-key is released from the dot position with Q_4

on (i.e., when the paddle-key is released in the middle of a dot), Q_3 continues to conduct and permits the oscillator pulse to complete the dot cycle. This last pulse turns Q_4 , and consequently Q_3 , off, and the oscillator pulses cease.

A dash or series of dashes is produced when terminals 7 and 8 are connected (i.e., when the paddle-key is moved to the dash position). Under this condition Q_3 is turned on by a signal applied to its base through R_7 and CR_7 . At the same time Q_8 is turned off by the grounding of its base through CR_8 . The first pulse from the clock oscillator sets both the dot and dash flip-flops to the output state. Q_3 receives a base signal not only from the paddle-key but from the dash flip-flop through CR_2 and the dot flip-flop through CR_1 . Q_8 receives a dash signal from either the dash or dot flip-flop through their respective diodes CR_9 or

flip-flops are in the no-output state and Q_8 is turned off. If at this time the paddle-key is in the neutral or middle position (circuit-board terminals 7 and 8 disconnected), Q_3 is also turned off and the system returns to its quiescent state. If the key is still in the dash position, the cycle repeats. Fig. 69 shows the voltage and current wave forms at selected points in the circuit. Relay current during a single dash cycle flows for a time equal to three dots and is cut off for a period equal to one dot.

The current drain for this circuit is approximately 20 milliamperes.

Special Considerations

If instead of batteries a power supply is used to power this circuit, the 1.5 volts needed (shown as an input at circuit-board terminal No. 6) can be obtained from the drop across the two silicon rectifiers CR_{12} and CR_{13} connected in series, as shown in Fig. 68.

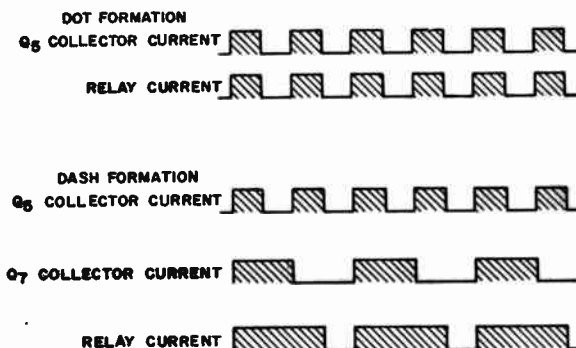

Fig. 69 - Voltage and current waveforms at selected points in the automatic keyer circuit.

CR_{10} . The second pulse from the oscillator sets the dot flip-flop to the no-output state but does not disturb the dash flip-flop, and Q_8 remains in the conducting state. The third pulse sets the dot flip-flop to the output state and the dash flip-flop to the no-output state, and Q_8 remains conductive. When a fourth pulse is developed, both

Construction

The drilling template for the automatic keyer is shown at the back of this Manual. A component placement diagram and a photograph of the completed circuit board are shown in Figs. 70 and 71, respectively.

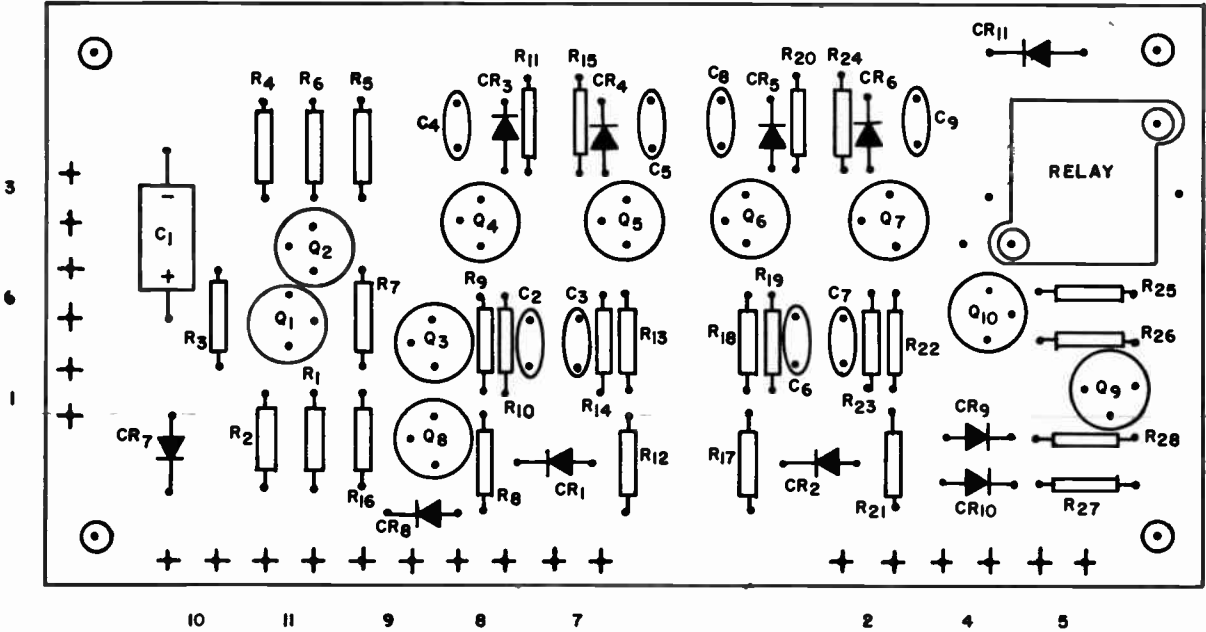

Fig. 70 - Component placement diagram for the automatic keyer.

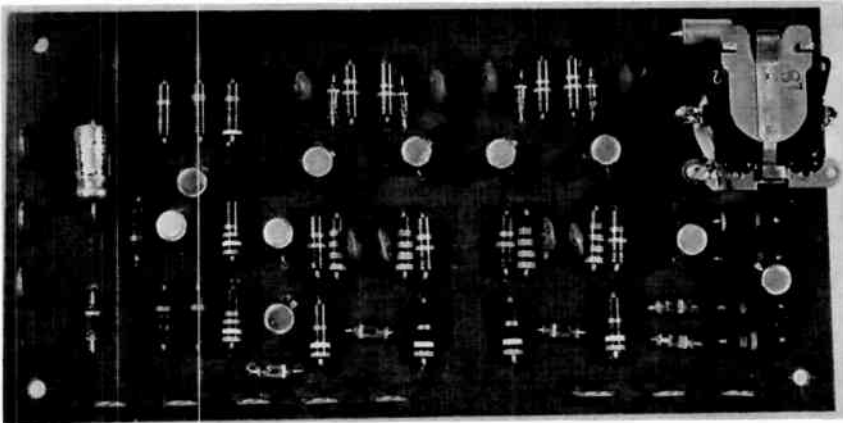

Fig. 71 - Completed circuit board for the automatic keyer.

CIRCUIT NO. 7 — MICROPHONE PREAMPLIFIER

The microphone preamplifier is capable of boosting the output of a dynamic microphone to a 0.5- to 1-volt level. This level is compatible with the mixer, volume compressor, and line amplifier (Circuit No. 8) and the audio power amplifier circuit (Circuit No. 17) described in this Manual.

Circuit Operation

The schematic diagram and parts list for the microphone preamplifier are shown in Fig. 72. The circuit consists of a two-stage direct-coupled amplifier that is stabilized by the use of dc feedback. The circuit works well with dynamic microphones having impedances from 200 ohms to 30,000 ohms.

When the circuit is in operation, base bias current for the input transistor Q_1 is obtained from the emitter of output transistor Q_2 through R_5 . Q_2 obtains its base bias current through the collector resistor of Q_1 , R_3 . This unique bias circuit provides dc feedback for stabilization of the operating points of the transistors. For example,

if the operating current of Q_1 increases, the collector voltage of Q_1 decreases and reduces the voltage of the base of Q_2 . This lower voltage causes a reduction in the operating current of Q_2 . When the operating current of Q_2 decreases, the voltage at the emitter of Q_2 also decreases. This voltage decrease is reflected back to the base of Q_1 , which undergoes a current reduction that offsets the initial increase.

This preamplifier circuit is designed to operate from an 18- to 20-volt source; voltage in this range can be obtained from batteries or from a power supply. The power circuit can be common to the power amplifier. The preamplifier circuit can tolerate voltages greater than 20 volts if R_5 is increased about 400 ohms for every volt above 20 volts. The current drain of the preamplifier is approximately 2.5 milliamperes; the voltage gain is about 1700.

Special Considerations

When the preamplifier is used with a low-impedance dynamic microphone

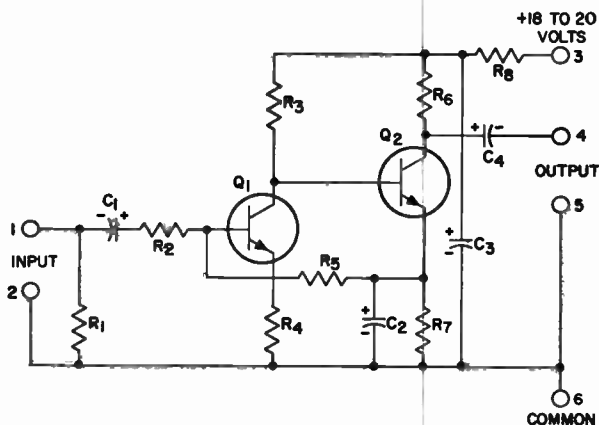

Parts list

C_1 = 25 microfarads, 6 volts, electrolytic

C_2 = 300 microfarads, 6 volts, electrolytic

C_3 = 100 microfarads, 25 volts, electrolytic

C_4 = 20 microfarads, 25 volts, electrolytic

Q_1, Q_2 = transistor, RCA SK3020

R_1 = 220 ohms for low-impedance

microphone 270,000 ohms for high-impedance microphone, 1/2 watt, 10%

R_2 = 10,000 ohms, 1/2 watt, 10%

R_3 = 27,000 ohms, 1/2 watt, 10%

R_4 = 100 ohms, 1/2 watt, 10%

R_5 = 120,000 ohms, 1/2 watt, 10%

R_6 = 3900 ohms, 1/2 watt, 10%

R_7 = 680 ohms, 1/2 watt, 10%

R_8 = 1500 ohms, 1/2 watt, 10%

Fig. 72 - Schematic diagram and parts list for the microphone preamplifier.

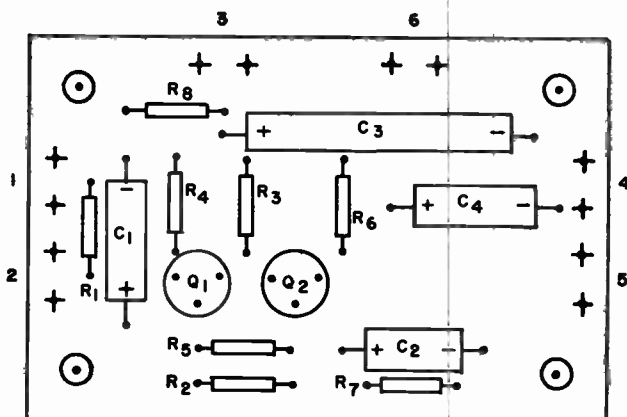

Fig. 73 - Component placement diagram for the microphone preamplifier.

(such as the RCA-HK97 in the low-impedance mode), R_1 should be 220 ohms; when a microphone with an impedance of about 30,000 ohms is used (such as the RCA-HK97 in the high-impedance mode), R_1 should be 270,000 ohms.

Construction

The drilling template for the microphone preamplifier is shown at the back of this Manual; a component

placement diagram and a photograph of the completed circuit board are shown in Figs. 73 and 74, respectively. A single preamplifier circuit fits on a 3- by 2-inch circuit board; two can be built on a 3- by 4-inch board, and three on a 3- by 6-inch board. If the circuit is not constructed on a board, a ground bus should be used to ground the preamplifier to the circuits that follow it at one point only, preferably at the input to the circuits.

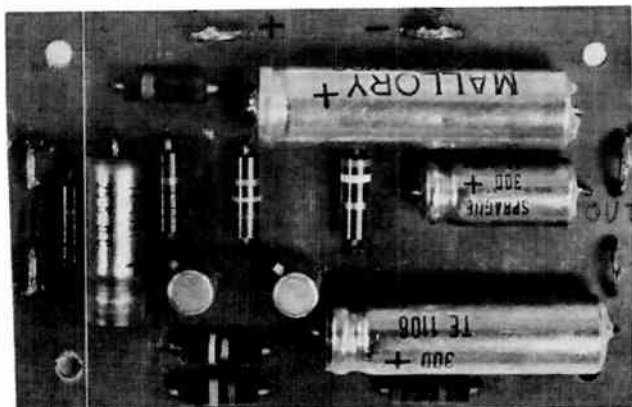

Fig. 74 - Completed circuit board for the microphone preamplifier.

CIRCUIT NO. 8 — AUDIO MIXER, COMPRESSOR, AND LINE AMPLIFIER

The audio mixer, compressor, and line amplifier is an indispensable piece of equipment for the audio enthusiast

who requires uniform audio levels such as are necessary in the production of very-high-quality tape recordings. Fig.

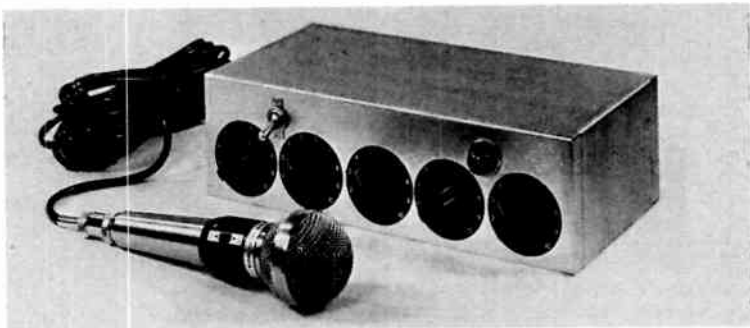

Fig. 75 - A suggested enclosure for the audio mixer, compressor, and line-amplifier circuit.

75 is a photograph of a suggested enclosure for this circuit.

Circuit Operation

The schematic diagram and parts list for the audio mixer, compressor, and line amplifier are shown in Fig. 76. The circuit consists of a four-channel resistive mixer, an MOS transistor (Q_1) that acts as a voltage-variable resistor, a high-impedance MOS transistor amplifier (Q_2), and a two-stage bipolar line driver. The characteristics

of an MOS field-effect transistor that make it useable as a voltage-variable resistor are discussed in the section on **Theory and Operation of Solid-State Devices**; Q_1 operates as described and, with R_6 , forms an incoming-signal voltage divider.

Circuit inputs are designed to be driven by the preamplifier circuit described in Circuit No. 7 or from any source capable of providing a 50- to 1000-millivolt signal. The gain of each input can be controlled by use of a

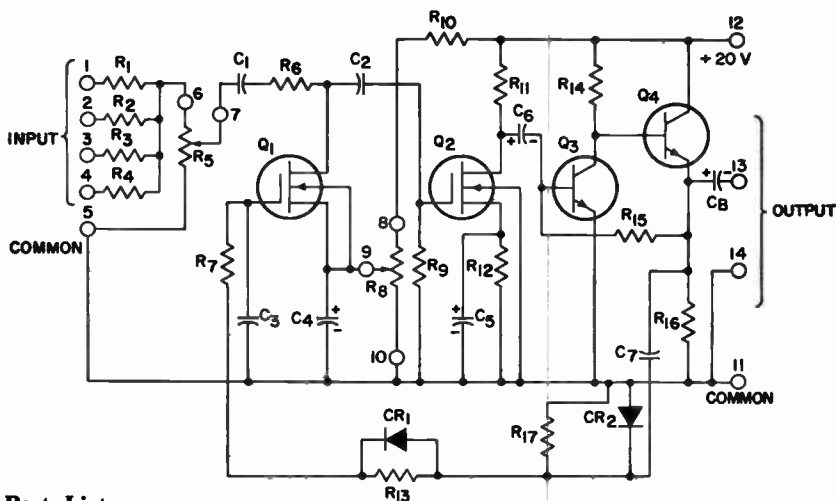

Parts List

$C_1 C_2 C_3 C_7 = 0.1$ microfarad, paper
 $C_4 = 10$ microfarads, 12 volts, electrolytic
 $C_5 = 15$ microfarads, 6 volts, electrolytic
 $C_6 = 5$ microfarads, 25 volts, electrolytic
 $C_8 = 50$ microfarads, 25 volts, electrolytic
 $CR_1 CR_2 =$ silicon rectifier, type 1N270
 $Q_1 Q_2 =$ MOS field-effect transistor, type 3N128
 $Q_3 Q_4 =$ transistor, RCA SK3020

$R_1 R_2 R_3 R_4 R_7 = 100,000$ ohms, 1/2 watt, 10%
 $R_5 =$ potentiometer, 10,000 ohms, audio taper
 $R_6 = 180,000$ ohms, 1/2 watt, 10%
 $R_8 =$ potentiometer, 5000 ohms, straight taper
 $R_9 R_{13} = 1$ megohm, 1/2 watt, 10%
 $R_{10} = 15,000$ ohms, 1/2 watt, 10%
 $R_{11} = 10,000$ ohms, 1/2 watt, 10%
 $R_{12} = 1500$ ohms, 1/2 watt, 10%
 $R_{14} = 1200$ ohms, 1/2 watt, 10%
 $R_{15} = 100,000$ ohms, 1/2 watt, 10%
 $R_{16} = 470$ ohms, 1/2 watt, 10%
 $R_{17} = 2$ megohms, 1/2 watt, 10%

Fig. 76 - Schematic diagram and parts list for the audio mixer, compressor, and line amplifier.

50,000-ohm potentiometer between the output of the preamplifier or other source and the input of the mixer stage. Potentiometer R_6 is the master gain control; it controls all channels simultaneously.

The initial bias voltage for Q_1 is set by adjustment of potentiometer R_5 . When Q_1 is biased off, it has an effective drain-to-source resistance of several megohms. This high resistance allows nearly all of the signal voltage appearing at the potentiometer arm of R_5 to appear at the gate of Q_2 . The signal is amplified by Q_2 and passed to the output-amplifier and line-driver transistors Q_3 and Q_4 . The output signal of Q_4 is rectified by CR_2 and the resultant dc signal is fed back to the gate of Q_1 . The rectified output signal is polarized in such a way that its application to Q_1 reduces the drain-to-source resistance of that transistor. The result is a reduced input to Q_2 and an over-all reduction in amplifier gain. CR_1 is inserted in the feedback line so that the rectified dc signal can be applied very rapidly to the gate of Q_1 and to C_3 . During this application, C_3 is charged at a very fast rate. The discharge time of C_3 is slow because CR_1 forces the discharge current to flow through R_{18} . The product of this

arrangement of CR_1 , R_{18} , and C_3 is a circuit that has a fast attack time and a relatively slow release time. A fast attack time is a very desirable characteristic in a circuit of this type because it provides for immediate reduction in system gain and consequent prevention of the overload that could occur with a loud passage of speech or music. The delayed release time helps to maintain a constant level of output during small pauses in speech or music.

Q_4 is connected as an emitter-follower to provide the amplifier with a low output impedance. The line driver is designed for operation at approximately 1 volt rms into a line of 250 ohms. The circuit can be adjusted so that any input signal level between 50 millivolts and 1 volt will result in an output of approximately 1 volt. Circuit current drain is about 23 milliamperes at 20 volts.

Construction

The drilling template for the audio mixer, compressor, and line amplifier is shown at the back of this Manual; a photograph of the completed circuit board and a component placement diagram are shown in Figs. 77 and 78, respectively.

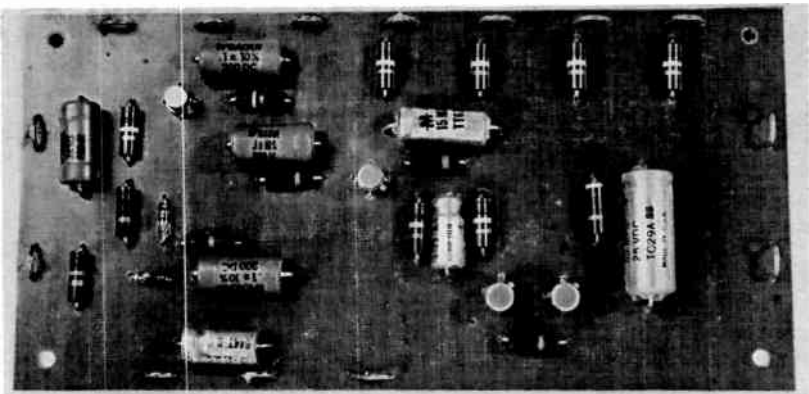

Fig. 77 - Completed circuit board for the audio mixer, compressor, and line amplifier.

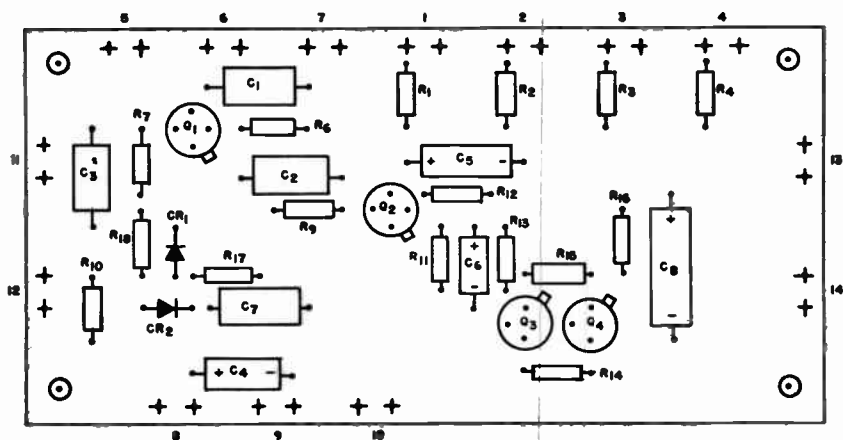

Fig. 78 - Component placement diagram for the audio mixer, compressor, and line amplifier.

CIRCUIT NO. 9 — UNIVERSAL TIMER

The universal timer turns an electrical device off after a predetermined period of time. Because of the high impedance of the MOS field-effect transistor featured in the circuit, electrically and physically smaller, more stable timing capacitors can be used.

Circuit Operation

The schematic diagram and parts list for the universal timer are shown in Fig. 79. When switch S_1 is activated (S_{1a} open and S_{1b} closed), capacitors C_1 and C_2 charge through diodes CR_1 and CR_2 , respectively; the voltage across C_2 is applied to the gate of triac Q_4 through R_6 and R_{13} and turns Q_4 on. The voltage across C_2 is also applied to the timing-circuit elements R_8 and C_4 ; the voltage across R_8 and C_4 (and consequently circuit timing) can be

adjusted by R_8 . C_3 filters the voltage across R_8 and C_4 . When the voltage across capacitor C_4 is high enough, Q_1 starts to conduct and the MOS transistor turns on and places a forward bias on the base-emitter junction of transistor Q_2 . As a result, transistor Q_2 turns on and triggers the regenerative switch composed of transistors Q_2 and Q_3 . When the regenerative switch conducts, it provides a means for the current to bypass the gate of the triac, Q_4 , and the triac turns off, thus depriving the load of power. The timer circuit remains in this state until switch S_1 is opened at least momentarily.

S_1 , a double-pole double-throw switch, is wired so that the C_4 discharge circuit is completed when the line-power circuit is opened. This arrangement allows C_4 to discharge rapidly through R_9 and permits the timer to be recycled almost immediately.

Special Considerations

If a wider range of time periods is desired than can be obtained with potentiometer R_3 alone, a selector

switch may be used to permit various values of R_8 or C_4 to be switched in. Electrolytic capacitors should not be used for C_4 , and R_8 should not exceed 100 megohms; otherwise, an unstable

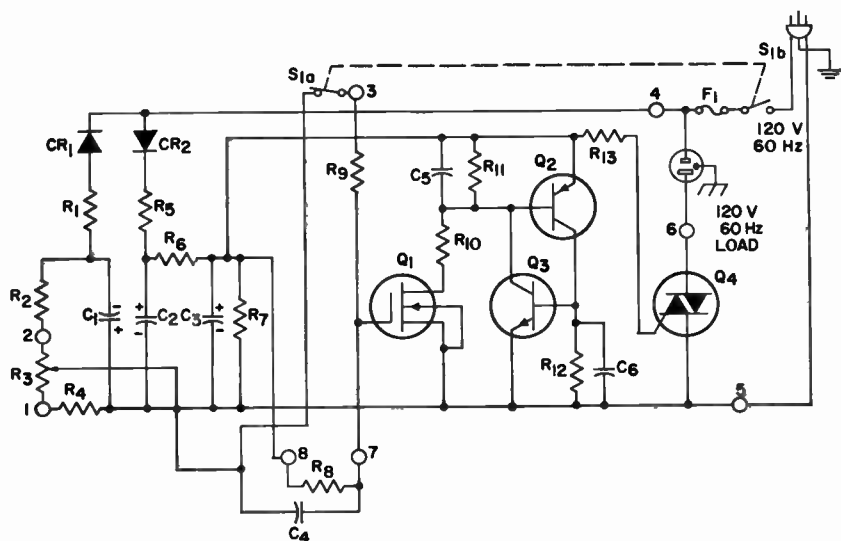

Parts List

- C_1 = 10 microfarads, 200 volts, electrolytic
 C_2 = 10 microfarads, 200 volts, electrolytic
 C_3 = 50 microfarads, 15 volts, electrolytic
 C_4 = 4 microfarads, see text
 C_5, C_6 = 0.01 microfarad, 25 volts or greater, 10%
 CR_1, CR_2 = silicon rectifier, RCA SK3031
 F_1 = fuse, size depends on expected load
 Q_1 = MOS field-effect transistor, type 3N128
 Q_2 = transistor, RCA SK3005
 Q_3 = transistor, RCA SK3020
 Q_4 = triac, RCA 40503 or RCA 40429 (the RCA 40429 may be

used with Wakefield No. NC401K or equivalent heat sink.)

- R_1, R_5 = 100 ohms, 1/2 watt, 10%
 R_2 = 15,000 ohms, 1/2 watt, 10%
 R_3 = potentiometer, 10,000 ohms, linear taper
 R_4 = 1000 ohms, 1/2 watt, 10%
 R_6 = 3000 ohms, 5 watts, 10%
 R_7 = 390 ohms, 1/2 watt, 10%
 R_8 = 4.7 megohms, 1/2 watt, 10%, see text
 R_9 = 5.6 ohms, 1/2 watt, 10%
 R_{10} = 3900 ohms, 1/2 watt, 10%
 R_{11} = 150 ohms, 1/2 watt, 10%
 R_{12}, R_{13} = 470 ohms, 1/2 watt, 10%
 S_1 = switch, 125 volts, double-pole, double-throw, capable of handling the expected load.

Fig. 79 - Schematic diagram and parts list for the universal timer.

circuit will result. The maximum time period attainable (in seconds) is equal to the product of the values of R_8 (in ohms) and C_4 (in microfarads) divided by 1.59.

The amount of power that the timer circuit can handle depends on the ratings of the triac and the type of heat sink used. The RCA-40429 triac can handle a load current of 2.7 amperes without a heat sink; when mounted on a suitable heat sink (Wakefield No. NC401K or equivalent), it can handle 6 amperes. The RCA-40503 is supplied with a factory-attached heat radiator that allows it to conduct a maximum of 3.3 amperes. The section on *Mechanical Considerations* contains a further discussion of heat sinks.

The MOS transistor leads should be shorted until the timing components, R_8 and C_4 , are connected. This precaution prevents damage to the MOS transistor. (See the section on *Mechan-*

ical Considerations for MOS transistor handling techniques).

Construction

One critical feature in the layout of this circuit is the placement of R_8 . This resistor generates heat and should not be located close to other components. The suggested layout shown in Fig. 81 should be used if possible.

A second critical feature involves the placement of the time-determining components R_8 and C_4 . These components and the associated wiring should be shielded as much as possible from dust and dirt that could provide leakage paths and affect circuit timing.

The drilling template for the universal timer is shown at the back of this Manual; a photograph of the completed circuit board and a component placement diagram are shown in Figs. 80 and 81, respectively.

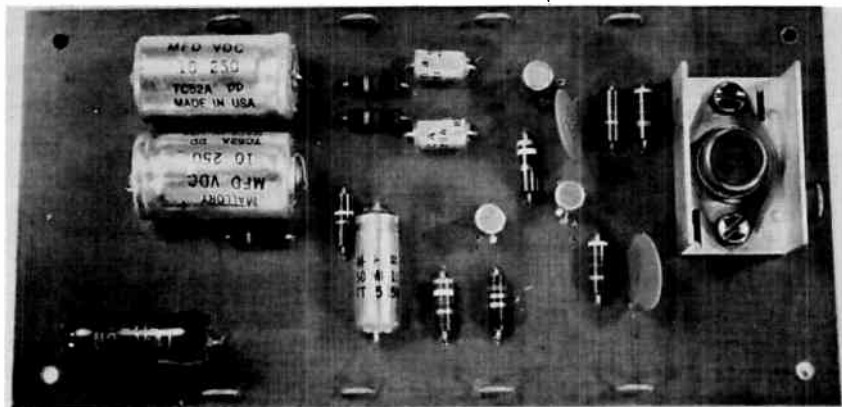

Fig. 80 - Completed circuit board for the universal timer.

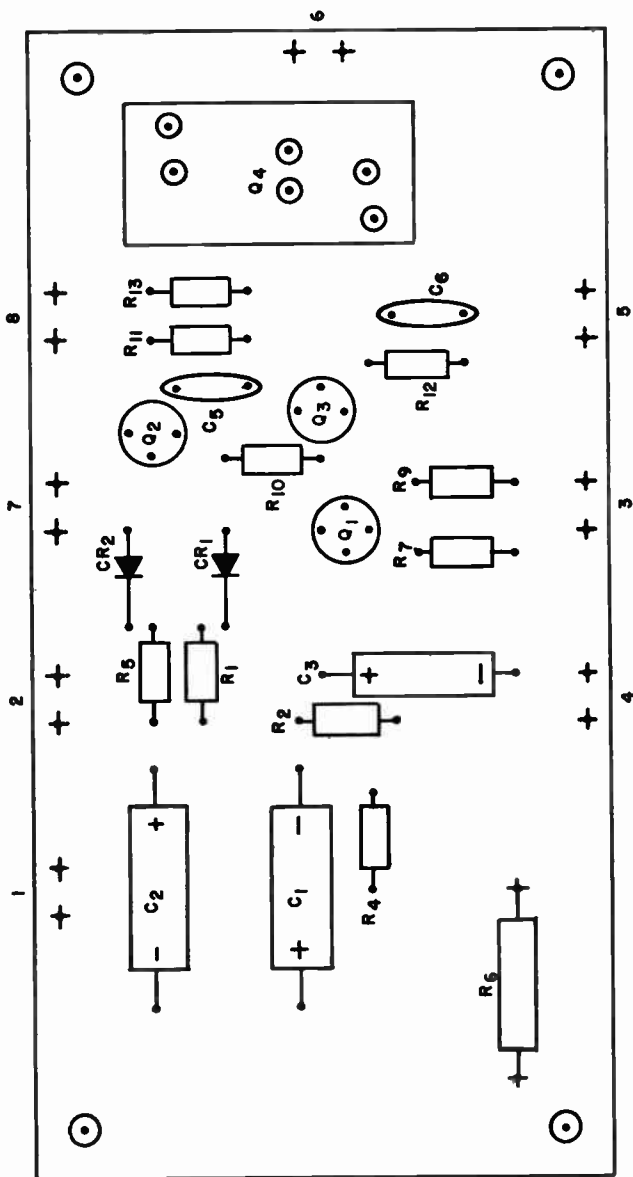

Fig. 81 - Component placement diagram for the universal timer.

CIRCUIT NO. 10 — ENLARGER EXPOSURE METER

The exposure meter, a light intensity meter, provides an excellent means for accurately setting exposure when using an enlarger.

In operation, the required exposure time must first be determined experimentally with a test negative. When this time is established, the photocell of the exposure meter is placed on the

easel over the center of interest and the meter is adjusted for zero deflection. The negative to be printed is then inserted into the enlarger carrier and the iris of the enlarger is adjusted so that zero meter deflection is again attained. The photocell of the exposure meter is then removed and the printing paper is inserted and exposed for the

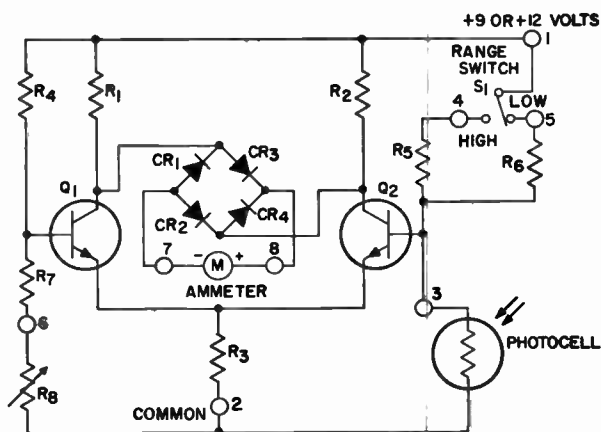

Parts List

CR₁CR₂CR₃CR₄ = silicon rectifier, type 1N270

M = meter, 0 to 1 milliampere, 12 volt, or 0 to 500 microamperes, 9 volt

Photocell = RCA KD2106

Q₁Q₂ = transistor, RCA SK3020

R₁R₂R₇ = 4700 ohms, 1/2 watt, 10%

R₃ = 2200 ohms (12 volts), 3300 ohms (9 volts), 1/2 watt, 10%

R₄ = 47,000 ohms, 1/2 watt, 10%

R₅ = 100,000 ohms, 1/2 watt, 10%

R₆ = 10,000 ohms, 1/2 watt, 10%

R₈ = potentiometer, 50,000 ohms, linear taper

S₁ = range switch, single-pole, double-throw

Fig. 82 - Schematic diagram and parts list for the enlarger exposure meter.

predetermined period of time.

The enlarger exposure meter is equipped with a range switch so that it can accommodate either high- or low-intensity light. On the low scale the meter can be adjusted for zero at light intensities of 0.2 to 6 footcandles; on the high scale, zero deflection is attainable between 6 and 400 footcandles.

Circuit Operation

The schematic diagram and parts list for the enlarger exposure meter are shown in Fig. 82. Transistors Q_1 and Q_2 and resistors R_1 and R_2 form a bridge circuit. The meter connected between the collectors of Q_1 and Q_2 registers zero deflection when a balanced bridge condition is met. The bridge rectifier assembly composed of rectifiers CR_1 through CR_4 permits the meter to record both positive and negative unbalance currents. Resistors R_1 , R_2 , and R_3 are designed for full-scale meter deflection with maximum unbalance current.

Special Considerations

The 9 or 12 volts needed to operate the exposure meter may be obtained from batteries or a power supply. The maximum current drain of the circuit at 12 volts is 3 milliamperes. The maximum current drain at 9 volts is 1.5 milliamperes.

With a 12-volt supply a 1-milliamperemeter movement should be used; for a 9-volt supply a 500-microampere meter movement should be used.

Construction

The drilling template for the enlarger exposure meter is shown at the back of this Manual; a photograph of a completed circuit board and a component placement diagram are shown in Figs. 83 and 84, respectively. Fig. 85 shows a method of mounting the photocell in a block of plastic; the alligator clips are clipped to the appropriate circuit-board terminals.

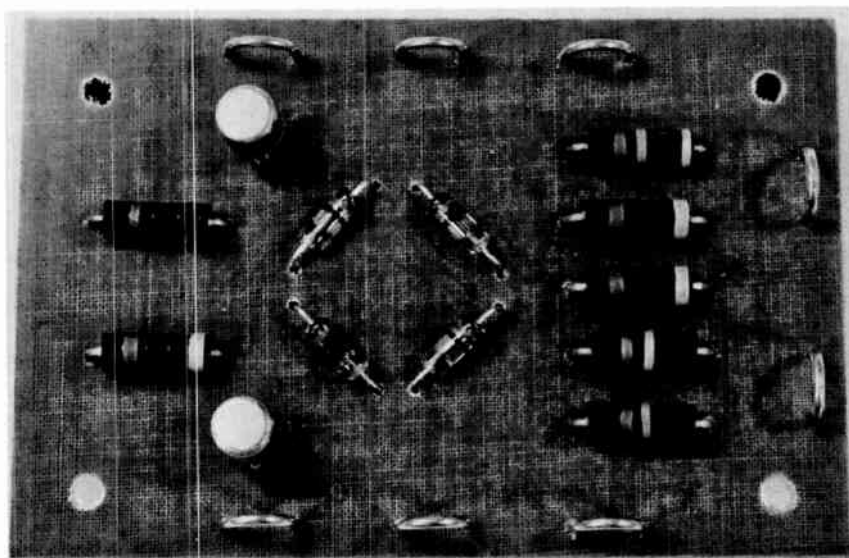

Fig. 83 - Completed circuit board for the enlarger exposure meter.

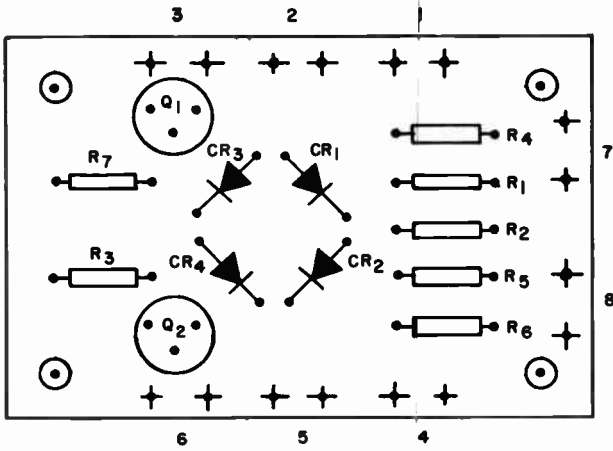

Fig. 84 - Component placement diagram for the enlarger exposure meter.

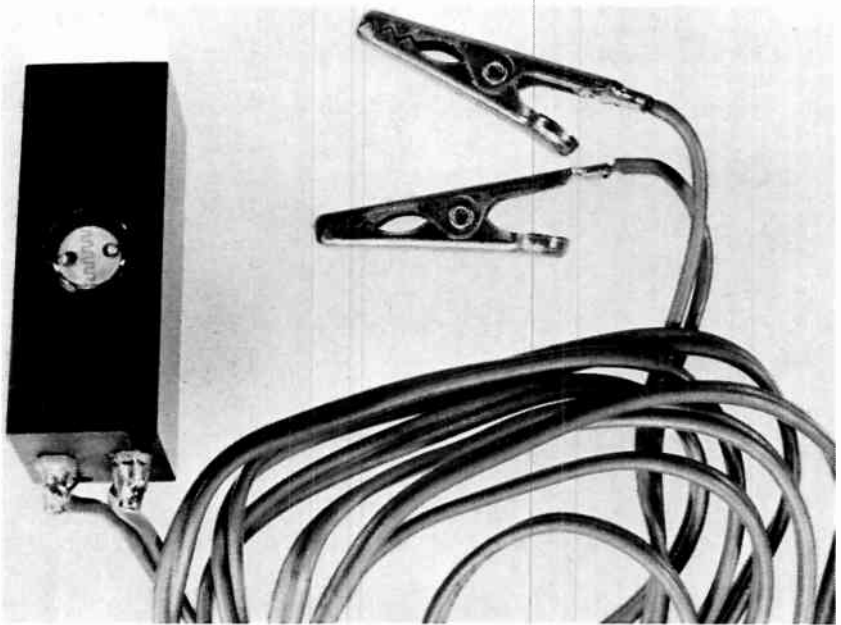

Fig. 85 - A suggested method of mounting the photocell in a block of plastic.

CIRCUIT NO. 11 — LAMP DIMMER

The lamp-dimmer circuit provides continuous control of loads up to 700 watts. With it, incandescent lamps can be set at any level up to their maximum brightness. Fig. 86 shows a suggested enclosure for the lamp-dimmer circuit.

Circuit Operation

The schematic diagram and parts list for the lamp dimmer are shown in Fig. 87. The solid-state device used in the lamp-dimmer circuit is a triac, a

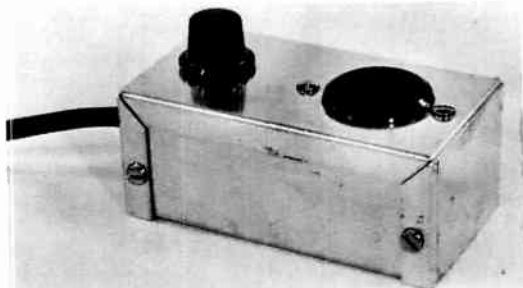
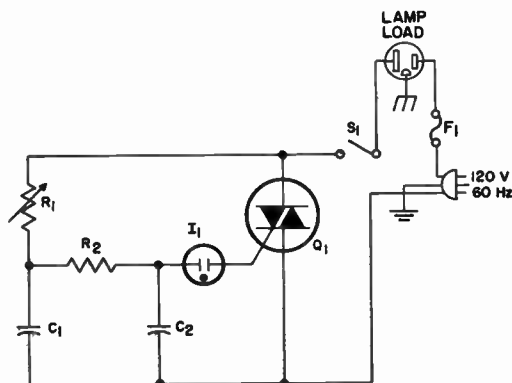

Fig. 86 - A suggested enclosure for the lamp-dimmer circuit.



Parts List

$C_1 C_2 = 0.068$ microfarad, 200 volts,
10%

$F_1 =$ fuse, size suitable to load

$I_1 =$ lamp, neon type NE-83

$Q_1 =$ triac, RCA 40502 or RCA 40429 (the RCA 40429 may be used with the Wakefield No.

NC401K or equivalent heat sink.)

$R_1 =$ potentiometer, 50,000 ohms, 2 watts, linear taper

$R_2 =$ 15,000 ohms, 1/2 watt, 10%, carbon

$S_1 =$ switch, 120 volt, single-pole, single-throw, capable of handling expected load current

Fig. 87 - Schematic diagram and parts list for the lamp dimmer.

type of thyristor that can conduct in either direction and thus permits full-wave control of the load. The triac is triggered into conduction on each half-cycle by a pulse applied to its control lead, the gate. The power delivered to the load is a function of the time in each half-cycle at which the triac is triggered into conduction. The point at which the triac is triggered on each half-cycle is determined by C_1 , C_2 , R_2 , and the potentiometer R_1 . When the capacitors charge to the triggering level of the neon lamp I_1 , conduction into the gate of the triac occurs. The triac then conducts for the remainder of that half cycle.

The RCA-40429 triac can handle 2.7 amperes without a heat sink; the

RCA-40502 triac can handle 3.3 amperes with its factory-attached radiator. At current levels above these values, the triac must be fitted with a heat sink, such as Wakefield No. NC401K or equivalent. Under no circumstances should load current exceed 6 amperes in this circuit. The section on **Mechanical Considerations** contains a discussion of heat sinks. Any radio interference produced by the lamp dimmer can be reduced by use of the L-filter described in Circuit No. 29.

Construction

Because of the small number of components used in this circuit, the layout is left to the circuit builder.

CIRCUIT NO. 12 — TEMPERATURE ALARM

The temperature indicator is an extremely sensitive device that can differentiate fractions of a degree of temperature. A flashing lamp indicates when a predetermined temperature has been reached. Because the circuit can be wired to warn of temperature increases or decreases, it is of practical use as a road-icing indicator for motorists, a frost-warning indicator for farmers, or an indicator to warn of rising temperatures in freezers.

Circuit Operation

The schematic diagram and parts list for the temperature alarm is shown in Fig. 88. The circuit is wired to signal a decrease in temperature below a predetermined level. Transistor pairs Q_4 — Q_5 and Q_6 — Q_7 each form a voltage-dependent regenerative switch. With the circuit wired as shown in the schematic, the triggering level of the Q_4 — Q_5 combination is determined by the thermistor; the triggering voltage of the Q_6 — Q_7 combination is con-

trolled by the sensitivity potentiometer R_{15} and the resistor in series with it, R_{13} . The two regenerative switches are in parallel; both are driven by Q_3 from the same intermittent voltage. Q_3 is switched on and off by the multivibrator composed of transistors Q_1 and Q_2 ; a basic multivibrator is discussed in the section on **General Circuit Considerations**. The intermittent voltage assures that the triggering voltages of the regenerative switches will be sampled once per second so that the switch with the lowest triggering voltage will conduct during the next second. If this sampling were not performed, the first regenerative switch to conduct would continue to do so regardless of the characteristics of the second switch.

As long as the thermistor resistance is lower than that of the R_{13} — R_{15} combination, the triggering voltage of the regenerative switch composed of Q_4 and Q_5 is lower than that of the Q_6 — Q_7 combination and the thermistor-controlled switch conducts, effectively shorting out the regenerative switch

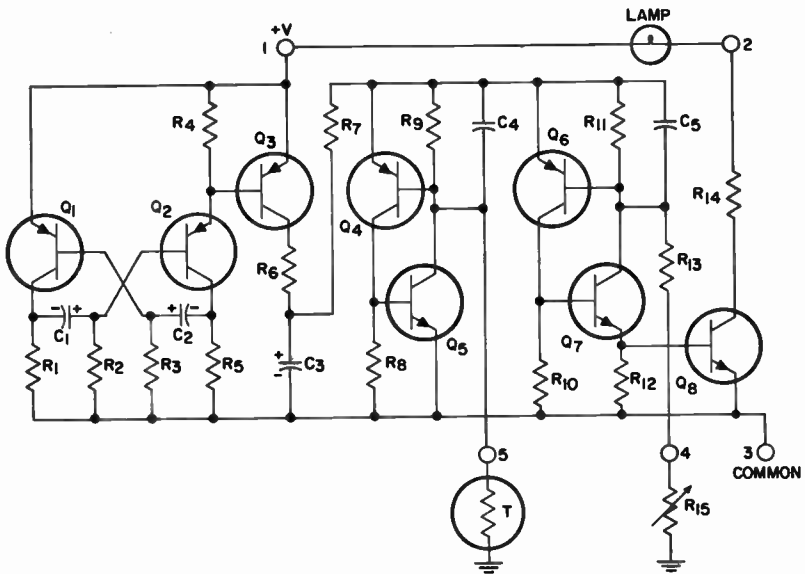

Parts List

$C_1 C_2 = 15$ microfarads, 15 volts, electrolytic

$C_3 = 50$ microfarads, 15 volts, electrolytic

$C_4 C_5 = 0.01$ microfarad

$Q_5 Q_7 Q_8 =$ transistors, RCA SK3020

$Q_1 Q_2 Q_3 Q_4 Q_6 =$ transistors, RCA SK3005

Lamp = No. 47

$R_1 R_5 R_{13} = 1000$ ohms, 1/2 watt, 10%

$R_2 R_3 = 39,000$ ohms, 1/2 watt, 10%

$R_4 = 82$ ohms, 1/2 watt, 10%

$R_6 = 330$ ohms, 1/2 watt, 10%

$R_7 R_{14} = 18$ ohms, 1/2 watt, 10%

$R_8 R_{10} = 470$ ohms, 1/2 watt, 10%

$R_9 R_{11} = 150$ ohms, 1/2 watt, 10%

$R_{12} = 68$ ohms, 1/2 watt, 10%

$R_{15} =$ potentiometer, 10,000 ohms, linear taper

Thermistor = RCA KD2108

(supplied in RCA Kit KD2110)

Fig. 88 - Schematic diagram and parts list for the temperature alarm.

composed of transistors Q_6 and Q_7 . As thermistor resistance increases (through cooling), the triggering voltage of Q_6 and Q_7 approaches and finally becomes less than that of the $Q_4 - Q_5$ combination. When Q_6 and Q_7 are triggered, they short out the $Q_4 - Q_5$ switch and permit current to flow to the base of Q_8 . Q_8 then turns on and conducts current to the lamp. The fact that regenerative-switch triggering voltages depend on the resistance of the thermistor or sensitivity poten-

tiometer means that circuit operation is independent of fluctuations of voltage in the power supply.

To modify the circuit so that the lamp will light with an increase in temperature, it is necessary to interchange the thermistor and the sensitivity potentiometer R_{15} and to connect R_{13} between C_4 and terminal No. 5. The connection between C_5 and terminal No. 4 will be straight wire. The current drain for this circuit averages about 20 milliamperes.

Adjustment and Operation

For adjustment of the circuit so that the indicator lamp will flash when the temperature of interest has been reached, the thermistor is placed in a temperature environment similar to that at which the circuit will be expected to give warning. The potentiometer shaft is then rotated until the lamp just stops flashing. At this point the circuit is set to warn of the temperature of interest.

The schematic diagram and parts list for the temperature-alarm power supply are shown in Fig. 89. The power

supply features a floating battery that insures circuit operation in spite of utility-company power failures. Diode CR₄ isolates the battery from the secondary voltage of T₁. Q₁ does not require a heat sink in this application.

The power supply transformer should have a dc resistance in the secondary of at least 1 ohm. If it does not, a 1-ohm 2-watt resistor should be inserted in series with the secondary. If a center-tapped supply is used, the resistance should be placed in series with the center tap. No special precautions are required if the transformer specified in the parts list is used.

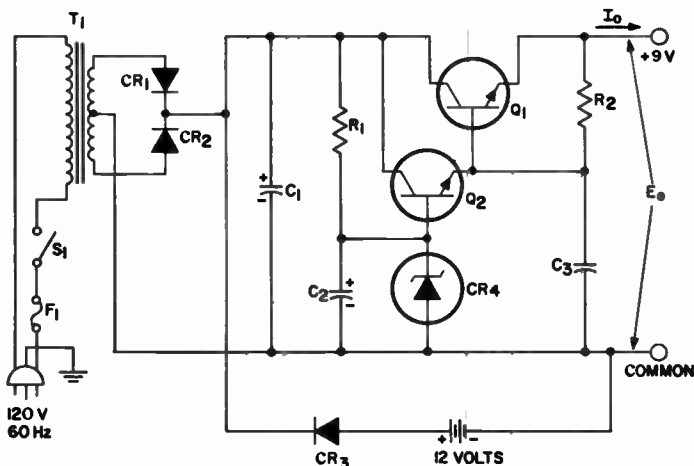

Parts List

C₁ = 4000 microfarads, 25 volts, electrolytic
 C₂ = 100 microfarads, 15 volts, electrolytic
 C₃ = 0.1 microfarad, 25 volts or greater
 CR₁ CR₂ CR₃ = silicon rectifier, RCA SK3030
 CR₄ = zener diode, 10 volts, 1 watt

F₁ = fuse, 1 ampere, 125 volts
 Q₁ = transistor, RCA SK3027
 Q₂ = transistor, RCA SK3020
 S₁ = switch, 125 volts, 1 ampere, single-pole, single-throw
 T₁ = transformer, 115 volts primary, 30 volts secondary with center tap, Stancor No. TP-4 or equivalent

Fig. 89 - Schematic diagram and parts list for the temperature-alarm power supply.

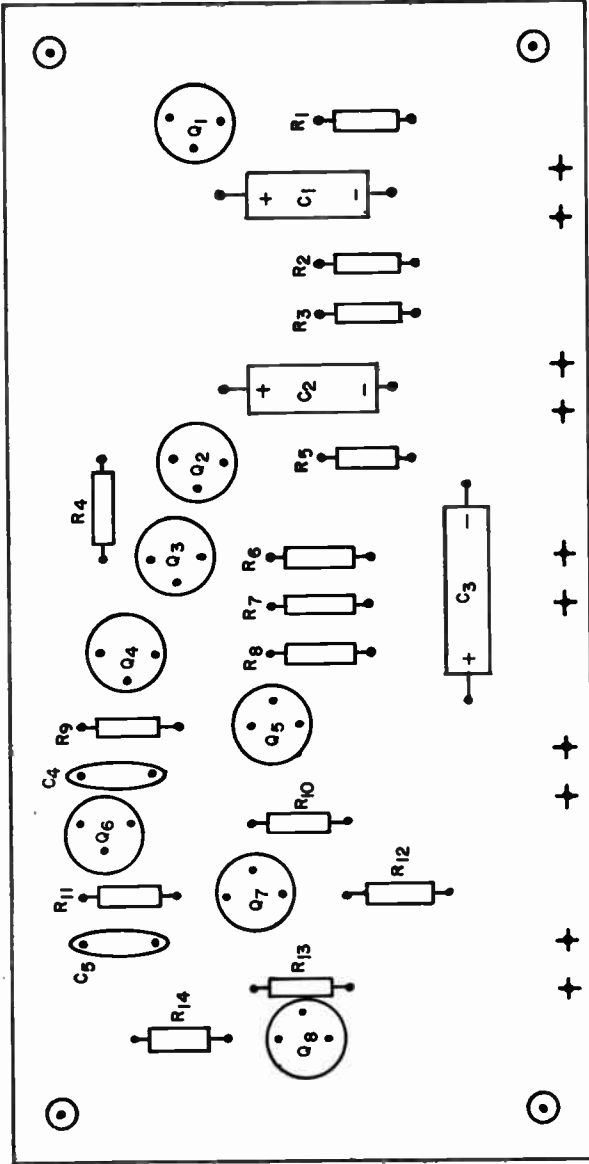

Fig. 90 - Component placement diagram for the temperature alarm.

Construction

No special precautions need be observed in the construction of this circuit except that the physical and electrical size of the sensitivity potentiometer should be determined by the application in which the circuit is to be used. In most applications the thermistor, the sensitivity potentiometer R_{15} ,

and the lamp will not be mounted on the circuit board. Thermistor mounting is discussed in the section on **Mechanical Considerations**.

The drilling template for the temperature alarm is shown at the back of this Manual; a component placement diagram and a photograph of the completed circuit board are shown in Figs. 90 and 91, respectively.

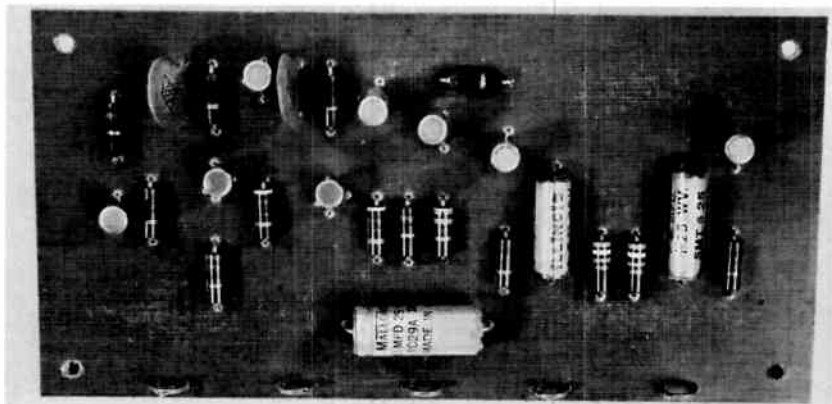

Fig. 91 - Completed circuit board for the temperature alarm.

CIRCUIT NO. 13—POSITIVE-ACTION LIGHT-OPERATED SWITCH

The positive-action photo or light-operated switch can control loads rated at up to 2 amperes. Positive action means that the load is receiving either no power or full power; current to the load does not fluctuate with the amount of light impinging on the photocell. The switch works directly from 120-volt household power, eliminating the needs for batteries. The light level needed to energize the switch can be set by the circuit builder to the value best suited to his application. This switch turns off with an increase in light.

Circuit Operation

The schematic diagram and parts

list for the photo-switch are shown in Fig. 92. Transistors Q_1 and Q_2 form a regenerative switch that exhibits high impedance until the voltage across it reaches a predetermined level. When this level is reached, the switch triggers and its impedance becomes very low. The triggering voltage required is determined by the resistance of the photocell and the setting of the potentiometer R_4 . When the photocell is exposed to light, its resistance decreases and causes an increase in current to the base of Q_2 . When the base current is sufficient, Q_2 conducts and triggers the regenerative switch into conduction. Because voltage

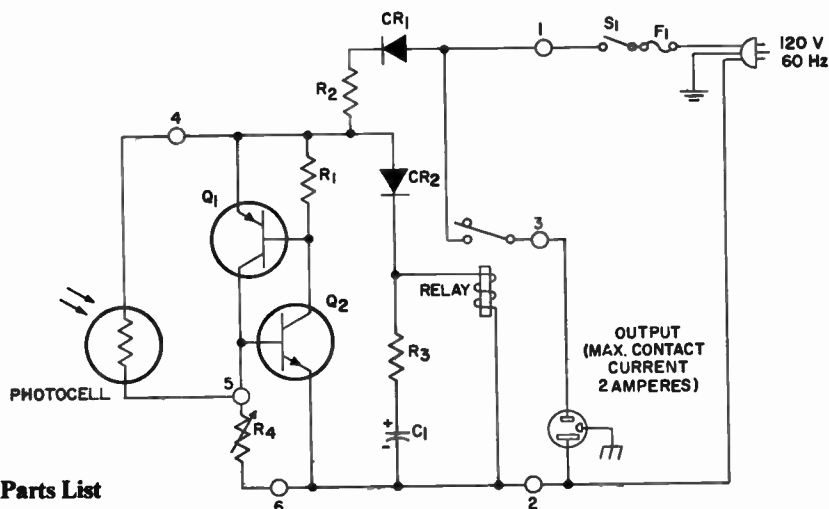

Parts List

C_1 = 5 microfarads, 15 volts, electrolytic

CR_1 = silicon rectifier, RCA SK3031

CR_2 = silicon rectifier, RCA SK3030

F_1 = fuse, 3 amperes

Photocell = RCA KD2016

Q_1 = transistor, RCA SK3005

Q_2 = transistor, RCA SK3020

R_1 = 150 ohms, 1/2 watt, 10%

R_2 = 5600 ohms, 2 watts, 10%

R_3 = 470 ohms, 1/2 watt, 10%

R_4 = potentiometer, 250 ohms, linear taper

Relay = 12 volts, 1350 ohms, Potter and Brumfield No. RS5D or equivalent

S_1 = switch, 125 volts, 3 amperes, single-pole, single-throw

Fig. 92 - Schematic diagram and parts list for the positive-action light-operated switch.

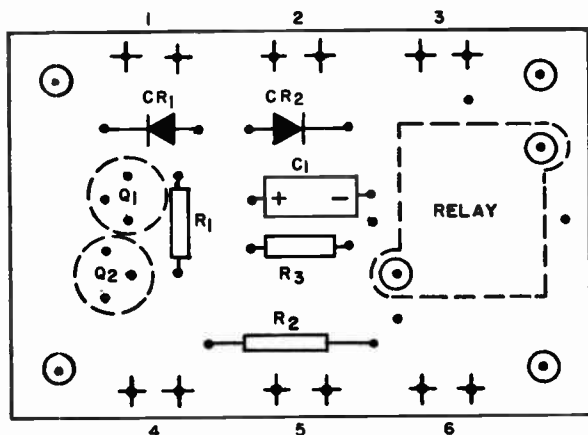

Fig. 93 - Component placement diagram for the positive-action light-operated switch.

across the regenerative switch is half-wave rectified ac (CR₁ is the rectifying diode), the regenerative switch can be triggered on each positive half-cycle. If the photocell is not exposed to light, the regenerative switch will not trigger. The relay which is connected across the regenerative switch operates as long as the regenerative switch is not conducting. As soon as the regenerative switch conducts, the relay releases. The relay

contact rating is 2 amperes.

Construction

The drilling template for the positive-action light-operated switch is shown at the back of this Manual; a component placement diagram and a photograph of a completed circuit board are shown in Figs. 93 and 94, respectively.

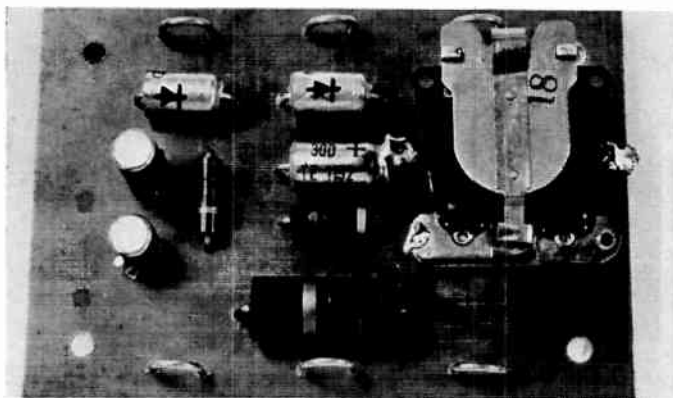

Fig. 94 - Completed circuit board for the positive-action light-operated switch.

CIRCUIT NO. 14 — MOISTURE-CONTROLLED SWITCH

The moisture-controlled switch energizes loads up to 1000 watts when a moisture level predetermined by the user is detected. This circuit cannot be used when the moisture being detected is grounded.

Circuit Operation

The schematic diagram and parts list for the moisture-controlled switch are shown in Fig. 95. The circuit turns on power to a load with an increase in moisture level. Transistor pairs Q₁ — Q₂ and Q₃ — Q₄ each form a voltage-dependent regenerative switch; the function of the switches is to control

the signal voltage to the gate of SCR₂. With the circuit wired as shown in the schematic, the triggering level of the Q₁ — Q₂ combination is determined by the resistance between the probes and R₁₃; the triggering voltage of the Q₃ — Q₄ combination is controlled by the combination of R₈ and R₉. An intermittent 60-Hz voltage, half-wave rectified by CR₂ is placed across the paralleled regenerative switches. The intermittent voltage assures that the triggering voltages of the regenerative switches are tested 60 times per second so that the switch with the lowest triggering voltage will conduct during the next cycle. If this testing were not performed, the first regenerative switch to

conduct would continue to do so regardless of the characteristics of the second switch.

As long as the total resistance of R_{13} and the resistance between the probes is lower than that of the R_8 — R_9 combination, the triggering voltage

of the regenerative switch composed of Q_1 and Q_2 is lower than that of the Q_3 — Q_4 combination and the switch controlled by probe resistance conducts, effectively shorting out the regenerative switch composed of transistors Q_3 and Q_4 . As the total resistance of R_{13}

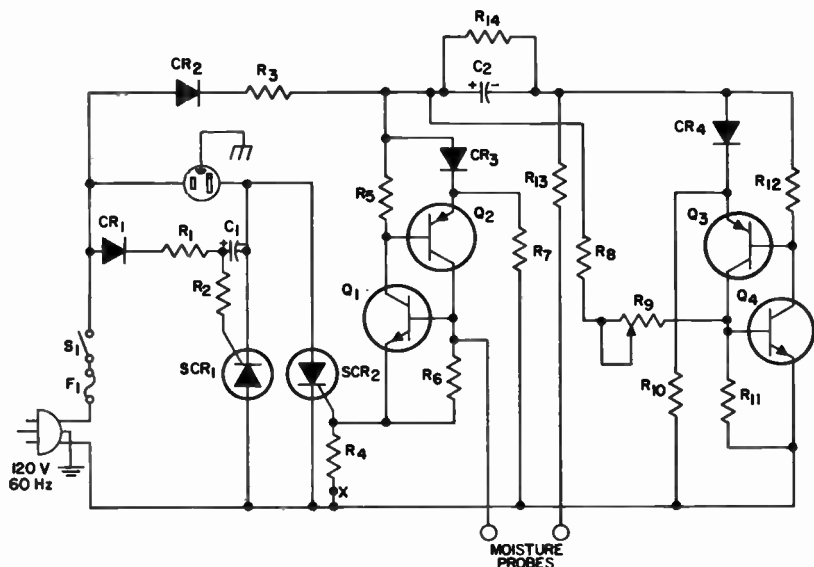

Parts List

C_1 = 10 microfarads, 15 volts, electrolytic

C_2 = 200 microfarads, 6 volts, electrolytic, see text

CR_1 CR_2^* = silicon rectifier, RCA SK3031

CR_3 CR_4^* = silicon rectifier, RCA SK3030

F_1 = fuse, 120 volts, rating determined by the load, maximum 10 amperes

Q_1 Q_4 = transistor, RCA SK3020

Q_2 Q_3 = transistor, RCA SK3005

R_1 R_3 = 4700 ohms, 2 watts, 10%

R_2 = 270 ohms, 1/2 watt, 10%

R_4 = 180 ohms, 1/2 watt, 10%

R_5 R_{12} = 470 ohms, 1/2 watt, 10%

R_6 R_{11} = 1500 ohms, 1/2 watt, 10%

R_7 R_{10} = 22,000 ohms, 1/2 watt, 10%

R_8 = 10,000 ohms, 1/2 watt, 10%

R_9 = potentiometer, 50,000 ohms, linear taper

R_{13} = 1000 ohms, 1/2 watt, 10%

R_{14} = 0 to 250 ohms, 1/2 watt, 10%, see text

S_1 = switch, 125 volts, single-pole, single-throw

SCR_1 SCR_2^* = silicon controlled rectifier, RCA KD2100

*All SCR's and rectifiers are available in the RCA KD2105 Experimenter's Kit. Two Kits are needed.

Fig. 95 - Schematic diagram and parts list for the moisture-controlled switch.

and the resistance between the probes increases, the triggering voltage of Q_1 and Q_2 approaches and finally becomes more than that of the $Q_3 - Q_4$ combination. When Q_3 and Q_4 are triggered, they short out the $Q_1 - Q_2$ switch and permit current to flow to the gate of SCR_2 .

When a sufficient signal is applied to the gate of SCR_2 , it turns on and applies a voltage to the load and the network composed of diode CR_1 , resistor R_1 , and capacitor C_1 , and causes C_1 to charge. During the next half-cycle of voltage, the charge on C_1 is applied to the gate of SCR_1 and turns it on. This process repeats as long as a sufficient signal is applied to the gate of SCR_2 .

When there is no moisture at the probes, the triggering level of the regenerative switch composed of Q_1 and Q_2 becomes high, and the $Q_3 - Q_4$ switch turns on and places a voltage across R_{14} . This voltage drop causes a slight decrease in the firing potential of the $Q_1 - Q_2$ switch and changes the difference between the "turn-on" and "turn-off" moisture levels. Therefore, the sensitivity of the circuit may be varied by changing the value of R_{14} ; for maximum sensitivity R_{14} and C_2 may

be omitted and replaced by a jumper.

Connected as described above, the moisture-controlled switch supplies power to a load with an increase in moisture level. To have the circuit turn off power to the load with an increase in moisture level requires that the junction of R_6 and the emitter connection of Q_1 be moved from the gate of SCR_2 to the lower end of R_4 (point X); the junction of R_{11} and the emitter connection should then be connected to the gate of SCR_2 .

Construction

The full power-handling capabilities of this circuit can be realized only when the SCR's are provided with heat sinks. The RCA KD2100 SCR comes mounted on a heat-sink bracket and is electrically insulated from the bracket.

The type of probe used is a function of the amount of moisture to be detected; liquid moisture can be detected with probes consisting of bare wires. For proper circuit operation the probes should not be grounded through the moisture being detected.

A suggested method of building this circuit in a 3- by 4- by 5-inch aluminum box is shown in Fig. 96.

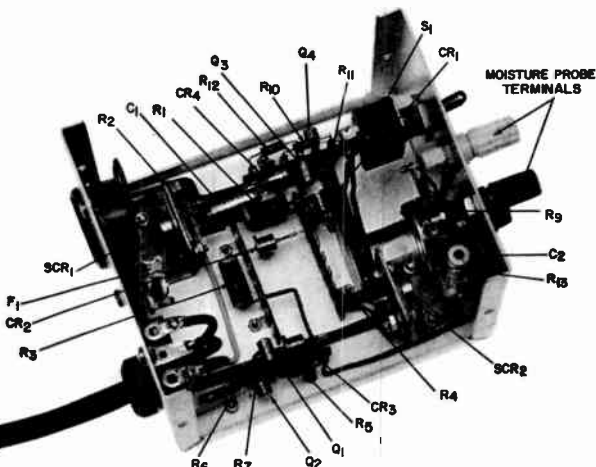

Fig. 96 - A suggested method of assembling the moisture-controlled switch. Components not shown are hidden.

CIRCUIT NO. 15— ELECTRONIC FUZZ BOX

The fuzz box is intended to be used with a guitar; however, it may be used with any instrument whose musical output is electrically amplified. It can be used with the audio power amplifier circuit described in this Manual. The fuzz box changes the character of the sound produced by an instrument and makes possible the generation of a variety of sounds of which the instrument alone is not capable.

Circuit Operation

The schematic diagram and parts list for the electronic fuzz box are shown in Fig. 97. The output of transistor Q_1 , a basic emitter-follower that gives the fuzz box a high-impedance input, is applied to the base of Q_2 . Q_2 is biased at almost cutoff and, therefore, amplifies only half the input signal. Potentiometer R_5 is used to adjust the

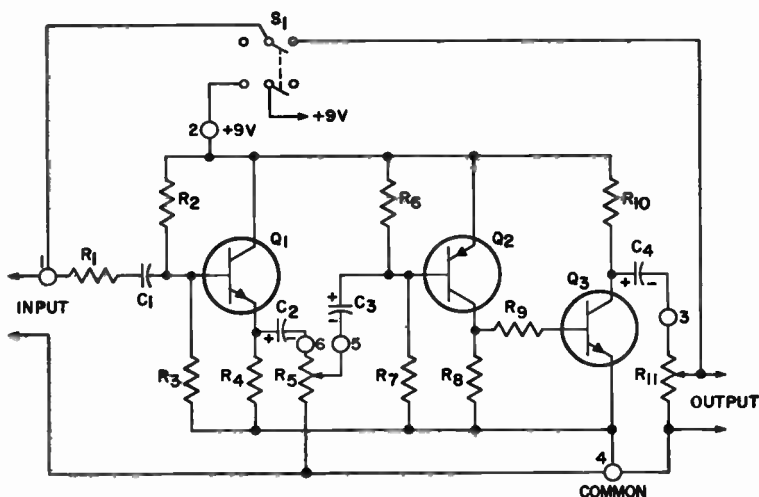

Parts List

C_1 = 0.01 microfarad, 25 volts or greater

C_2, C_3, C_4 = 5 microfarads, 15 volts, electrolytic

Q_1, Q_3 = transistor, RCA SK3020

Q_2 = transistor, RCA SK3005

R_1, R_2, R_3, R_7 = 100,000 ohms, 1/2 watt, 10%

R_4 = 3300 ohms, 1/2 watt, 10%

R_5 = potentiometer, 5000 ohms, linear taper

R_6 = 15,000 ohms, 1/2 watt, 10%

R_8, R_{10} = 2700 ohms, 1/2 watt, 10%

R_9 = 47,000 ohms, 1/2 watt, 10%

R_{11} = potentiometer, 10,000 ohms, linear taper

S_1 = switch, double-pole, double-throw

Fig. 97 - Schematic diagram and parts list for the electronic fuzz box.

input signal level to Q_2 (to approximately 1 volt) and the amount of "fuzz." Transistor Q_3 receives the output from Q_2 through R_9 ; Q_3 is biased in such a way that the top half of the signal input to it is clipped; this clipping action tends to create a square wave. Potentiometer R_{11} is used to vary the output level of the circuit.

The input voltage of this circuit should be approximately 1 volt. The current drain for this circuit is approximately 5 milliamperes.

Construction

In operation, the fuzz box is normally cut in and out as music is being played. When the fuzz box is cut out the musical instrument is connected directly to the amplifier.

The drilling template for the electronic fuzz box is shown at the back of this Manual; a component placement diagram and a photograph of a completed circuit board are shown in Figs. 98 and 99 respectively.

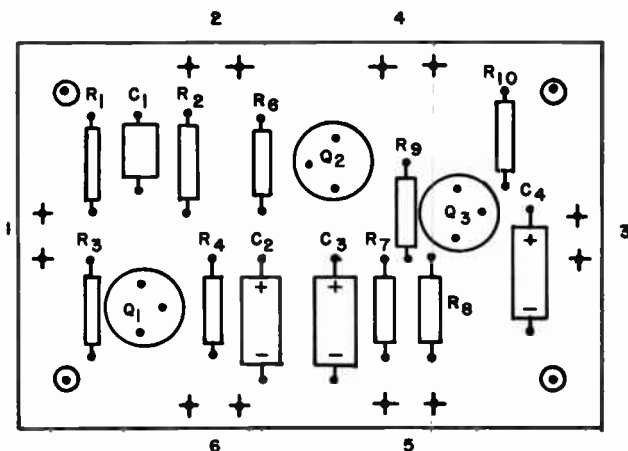

Fig. 98 - Component placement diagram for the electronic fuzz box.

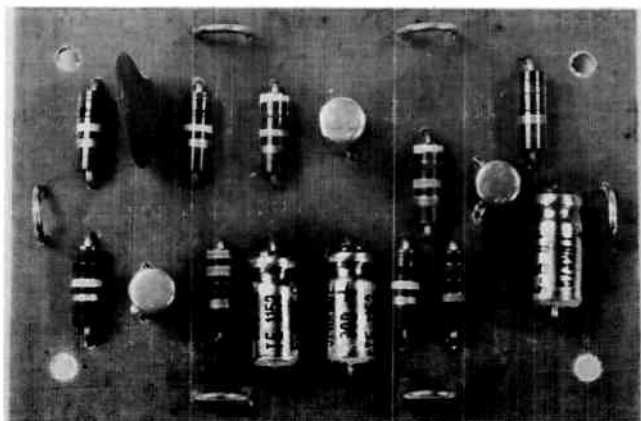

Fig. 99 - Completed circuit board for the electronic fuzz box.

CIRCUIT No. 16 – PHONOGRAPH PREAMPLIFIER

The phono amplifier can be used with the audio power amplifier of Circuit No. 17 to provide an excellent high-fidelity system. The preamplifier is designed for use with a magnetic pickup capable of supplying an input signal of at least 5 millivolts and has provisions for tape and tuner input. At the 5-millivolt signal level, the preamplifier delivers an output of at least 1 volt.

Circuit Operation

The schematic diagram and parts list for the phono amplifier are shown in Fig. 100. Transistor Q_1 is a low-noise transistor and is directly coupled to Q_2 . A frequency-shaping network in the feedback circuit of Q_2 provides frequency compensation when the preamplifier is used with a magnetic phono pickup. The output

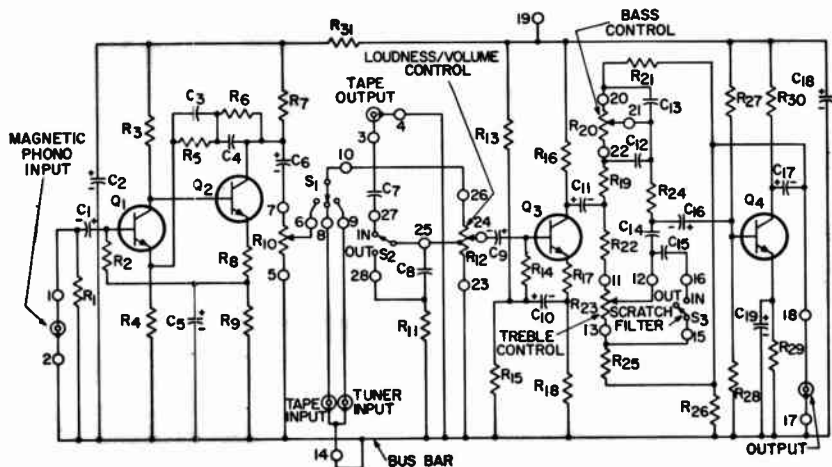

Parts List

C_1 = 2 microfarads, 6 volts, electrolytic
 C_2 C_{17} C_{18} = 25 microfarads, 25 volts, electrolytic
 C_3 = 0.0027 microfarads, 200 volts, paper
 C_4 = 0.01 microfarads, 200 volts, paper
 C_5 = 100 microfarads, 3 volts, electrolytic
 C_6 = 1 microfarad, 25 volts, electrolytic
 C_7 = 180 picofarads, 500 volts, mica
 C_8 = 0.033 microfarad, 200 volts, paper

C_9 = 1 microfarad, 12 volts, electrolytic
 C_{10} C_{16} = 10 microfarads, 10 volts, electrolytic
 C_{11} = 10 microfarads, 25 volts, electrolytic
 C_{12} C_{13} = 0.022 microfarad, 200 volts, paper
 C_{14} = 0.0039 microfarad, 200 volts, paper
 C_{15} = 0.0047 microfarad, 200 volts, paper
 C_{19} = 100 microfarads, 6 volts, electrolytic

Fig. 100 - Schematic diagram and parts list for the phono preamplifier.

Parts List (Cont'd)

Q_1 Q_2 Q_3 Q_4 = transistor, RCA
SK3020

R_1 R_3 = 68,000 ohms, 1/2 watt, 10%

R_2 = 180,000 ohms, 1/2 watt, 10%

R_4 = 470 ohms, 1/2 watt, 10%

R_5 = 27,000 ohms, 1/2 watt, 10%

R_6 = 470,000 ohms, 1/2 watt, 10%

R_7 R_{19} R_{21} R_{24} = 10,000 ohms, 1/2
watt, 10%

R_8 = 82 ohms, 1/2 watt, 10%

R_9 = 1,800 ohms, 1/2 watt, 10%

R_{10} = potentiometer, 100,000 ohms
audio taper, Centralab F1-
100K or equivalent

R_{11} = 8,200 ohms, 1/2 watt, 10%

R_{12} = potentiometer, 250,000 ohms,
audio taper with tap, Cen-
tralab F11-250K or equivalent

R_{13} = 33,000 ohms, 1/2 watt, 10%

R_{14} R_{28} = 18,000 ohms, 1/2 watt, 10%

R_{15} R_{31} = 4,700 ohms, 1/2 watt, 10%

R_{16} = 6,800 ohms, 1/2 watt, 10%

R_{17} = 68 ohms, 1/2 watt, 10%

R_{18} R_{22} R_{25} R_{29} = 1,000 ohms, 1/2
watt, 10%

R_{30} R_{33} = potentiometer, 100,000
ohms, straight taper, Cen-
tralab F1-100K or equiv-
alent, 1/2 watt, 10%

R_{36} = 47,000 ohms, 1/2 watt, 10%

R_{27} = 56,000 ohms, 1/2 watt, 10%

R_{30} = 2,700 ohms, 1/2 watt, 10%

S_1 = switch, single pole, 3-position,
wafer

S_2 = switch, single-pole, double-
throw, toggle

S_3 = switch, single-pole, single-throw,
toggle

circuit of Q_2 contains a level control R_{10} that feeds the loudness control S_2 through the selector switch S_1 . The loudness control, in turn, drives the tone-control circuits of the preamplifier. Tape, tuner, or phono inputs can be selected by means of the selector switch; a connector in the arm of the selector switch permits tape recordings to be made without affecting volume or loudness and vice versa.

Fig. 101 shows the response of the treble and bass tone controls as a function of frequency. Boost of 10 dB and cut of 15 dB are available for deep bass and high treble frequencies. Each control operates independently so that precise tone shaping is possible. When both controls are in the center position, the response is flat; the bass and treble frequencies are equally mixed.

Output distortion is low at all frequencies for any setting of either the bass or the treble tone control. The collector-to-base feedback in Q_3 and Q_4 works with the tone controls to

provide the overall tonal response of the pre amplifier.

Included in the preamplifier is a loudness/volume control switch S_2 . With the loudness control in, lower tones are enhanced at low output levels and a more pleasing sound is produced; when the loudness control is switched out, the volume control attenuates all tones equally, as shown in Fig. 102 (a).

The scratch filter attenuates somewhat the frequencies at which scratch noise from scratched records is most

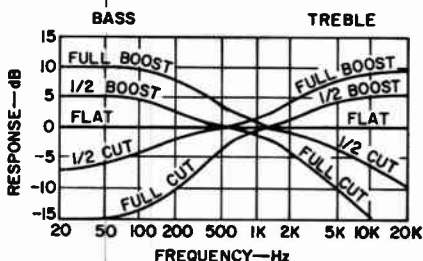

Fig. 101 - Response of treble and bass tone controls as a function of frequency.

prevalent. Fig. 102 (a) shows frequencies attenuated by the scratch filter; S_3 controls the filter. Fig. 102 (b) compares the measured response of the preamplifier with an ideal response.

A magnetic-pickup level control is provided so that the preamplifier does not have to be readjusted when the input is changed from magnetic phonograph to tape, for example.

DC power for the preamplifier can be obtained from a 20-volt power supply or from the audio power amplifier supply (Circuit No. 17) through the RC circuit shown in Fig. 103. A 300-millivolt input level from a tuner or tape recorder is required to produce a 1-volt output; a 5-millivolt input level is required from a magnetic phonograph pickup to produce the same

output. The current drain for the phonograph preamplifier is 7.5 milliamperes at 20 volts.

Construction

To keep the hum level at a minimum, a requirement in any high-gain audio system, a progressive grounding method or common bus has been used. In this system, shown in Fig. 104, a bus wire made from a length of No. 18 wire is connected between the common input and the common output terminals. All grounds of the preamplifier circuit are then connected to this common bus.

If the preamplifier is used by itself, the external ground connection can be made at either end of the bus bar,

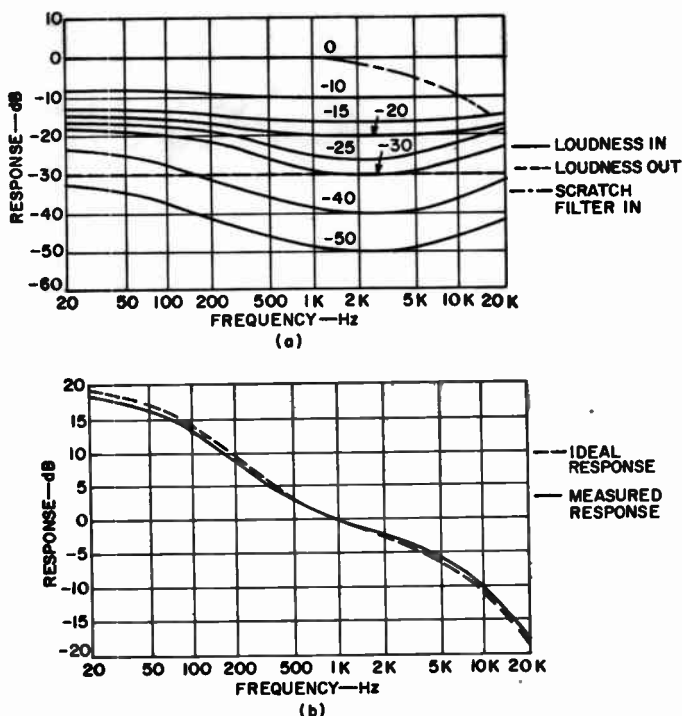

Fig. 102 - (a) Effect of loudness control and scratch filter, and (b) comparison of measured response with ideal response.

whichever produces the lowest hum level. If the preamplifier is used with the audio power amplifier, the preamplifier is grounded through the power amplifier and no physical ground is made to the preamplifier itself.

The drilling template for the phonograph preamplifier is shown at the back of the Manual; a photograph of a completed circuit board and a component layout diagram are shown in Figs. 105 and 106, respectively.

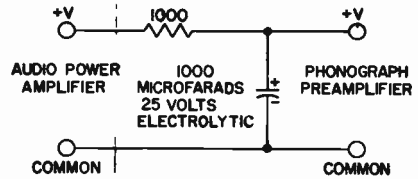

Fig. 103 - RC circuit required to adapt the power supply of the audio power amplifier (Circuit No. 17) to the phonograph preamplifier.

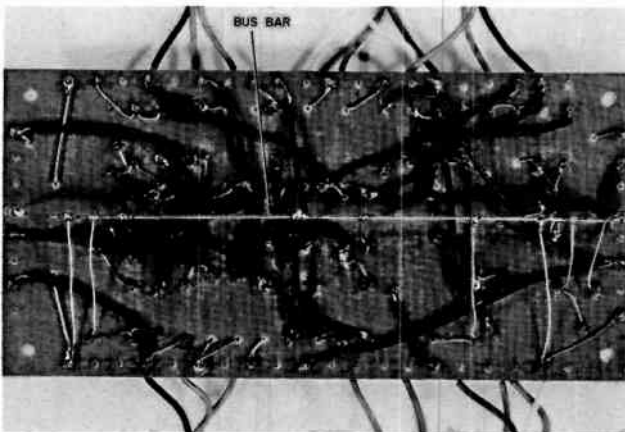

Fig. 104 - Back of phonograph preamplifier circuit board showing bus bar.

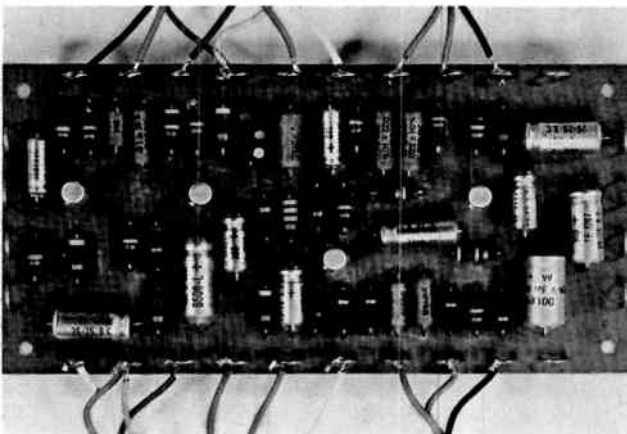

Fig. 105 - Completed circuit board for the phonograph preamplifier.

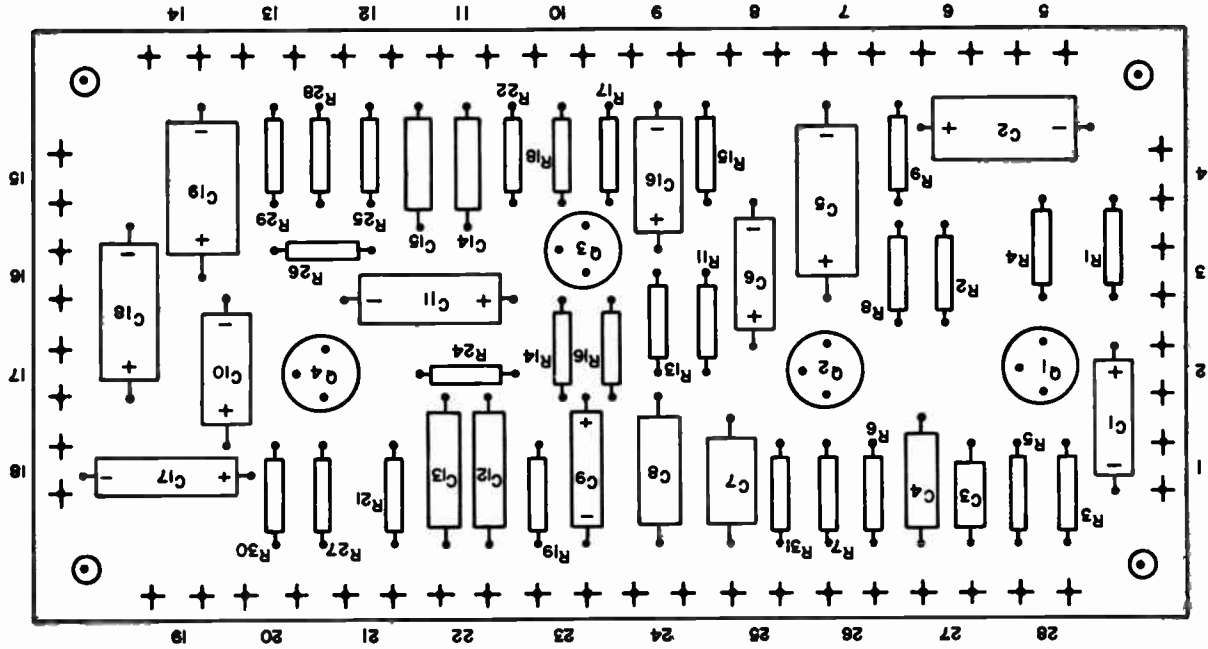

Fig. 106 - Component placement diagram for the photophone preamplifier.

CIRCUIT NO. 17— AUDIO POWER AMPLIFIER

The general-purpose audio amplifier is capable of a power output of 7.5 watts and is compatible with all of the circuits in this manual. A suggested enclosure for the amplifier is shown in Fig. 107.

Circuit Operation

The schematic diagram and parts list for the audio power amplifier are shown in Fig. 108. This circuit is designed for use with the universal series supply (Circuit No. 1(a)); however, the simpler unregulated supply shown in Fig. 109 may also be used.

The output stage of the amplifier is a class B complementary-symmetry circuit that allows the speaker to be driven directly without the need of a transformer. The fundamental operation of a complementary-symmetry circuit can best be understood by examining the circuit conditions at three points in the output-voltage

cycle; the point at which the instantaneous output voltage is zero (the dc condition), the point at which the voltage is peak positive, and the point at which the output voltage is peak negative. It is assumed that the frequency of operation is high enough to prevent a change in voltage across the capacitors during the output cycle.

When no signal voltage is applied to the circuit, the center-point voltage is 12 volts (the center point is indicated on the circuit schematic). The operating-point voltage of the driving transistor Q_2 , and consequently the dc voltage at the center point, is established by the beta and base-to-emitter voltage of Q_2 and the values of resistors R_2 , R_5 , R_6 , and R_7 . The bias voltage that establishes the idling or no-signal current in the output stage is developed across CR_1 . At idle, the diode voltage equals the base-to-emitter voltages of the two output transistors, Q_3 and Q_4 .

When a negative signal is applied to Q_1 , the base current of Q_2 is reduced. The reduction in base current reduces

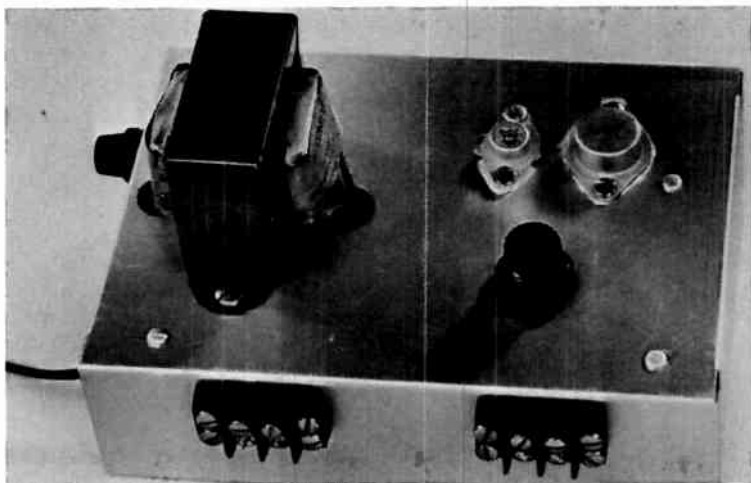
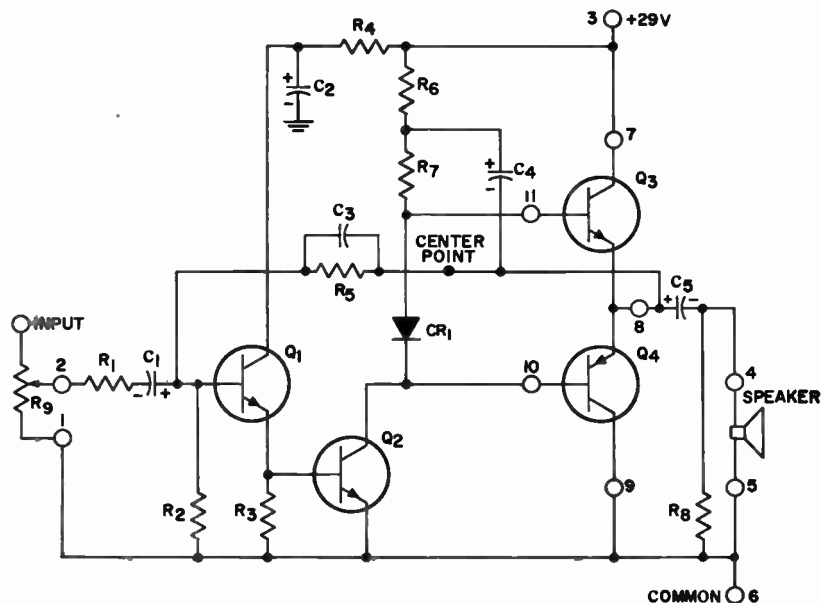

Fig. 107 - A suggested enclosure for the audio power amplifier.

the collector current of Q_2 . Capacitor C_4 maintains a constant voltage and, therefore, a constant current through R_7 . Because of this constant current in R_7 , the base current in Q_3 increases by the same amount that the collector current in Q_2 decreases. Q_3 turns on and applies a positive voltage to C_5 and the speaker load.

When a positive signal is applied to Q_1 , the base current of Q_2 increases. The higher base current, in turn, increases the collector current of Q_2 . Then, because the current through R_7 is constant, the additional current required in the collector of Q_2 flows out of the base of Q_4 and Q_4 turns on. Capacitor C_6 applies a negative voltage



Parts List

C_1 = 50 microfarads, 10 volts, electrolytic
 C_2 = 250 microfarads, 25 volts, electrolytic
 C_3 = 150 picofarads, 50 volts or greater
 C_4 = 500 microfarads, 12 volts, electrolytic
 C_5 = 500 microfarads, 25 volts, electrolytic
 CR_1 = germanium rectifier, type 1N3226
 Q_1 = transistor, RCA SK3020

Q_2 = transistor, RCA SK3024 with heat sink, Wakefield NF209 or equivalent.
 Q_3 = transistor, RCA SK3026
 Q_4 = transistor, RCA SK3009
 $R_1 R_8$ = 1000 ohms, 1/2 watt, 10%
 R_2 = 3300 ohms, 1/2 watt, 10%
 R_3 = 510 ohms, 1/2 watt, 10%
 R_4 = 10,000 ohms, 1/2 watt, 10%
 R_5 = 27,000 ohms, 1/2 watt, 10%
 $R_6 R_7$ = 100 ohms, 2 watts, 10%
 R_9 = potentiometer, 5000 ohms, linear taper
 Speaker = 8 ohms

Fig. 108 - Schematic diagram and parts list for the audio power amplifier.

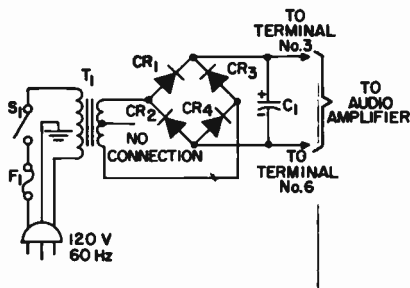

Parts List

C_1 = 1000 microfarads, 50 volts, electrolytic
 CR_1 CR_2 CR_3 CR_4 = silicon rectifier, RCA SK3030
 F_1 = fuse, 1 ampere, 125 volts

S_1 = switch, 125 volts, 1 ampere, single-pole, single-throw
 T_1 = filament transformer, 115 volts primary, 24 volts secondary, Triad No. F-45X or equivalent

Fig. 109 - Simple unregulated supply for use with the audio power amplifier.

across the load through Q_4 . The frequency of the signal and the value of C_5 and high enough so that the voltage of C_5 goes through negligible change during the half-cycle.

Capacitor C_3 reduces the crossover distortion through feedback. An input of approximately 0.5 volt is required for full power output. The current drain for this circuit is about 95 milliamperes with no signal.

Construction

The drilling template for the audio power amplifier is shown at the back of the Manual; a component placement diagram and a photograph of the interior of the suggested enclosure are shown in Figs. 110 and 111, respectively. The layout given is the best for this circuit. Transistors Q_3 and Q_4 are mounted external to the circuit board on a heat sink (Wakefield No. NC401K or equivalent) or on a metal

chassis. The wires connecting Q_3 and Q_4 to the circuit board should be as short as possible so that there is no lead resistance and no possibility of capacitive coupling to other circuits. Transistor Q_2 must be fitted with a heat radiator such as a Wakefield NF209 or equivalent.

The power-supply transformer should have a dc resistance in the secondary of at least 1 ohm. If it does not, a 1-ohm 2-watt resistor should be inserted in series with the secondary. If a center-tapped supply is used, the resistance should be placed in series with the center tap. No special precautions are required if the transformer specified in the parts list is used.

Under no circumstances should the output terminals be shorted when there is a signal applied to the input; a burned-out output transistor can result. To help protect the output transistor a 3/4-ampere slo-blo fuse may be inserted in the output circuit.

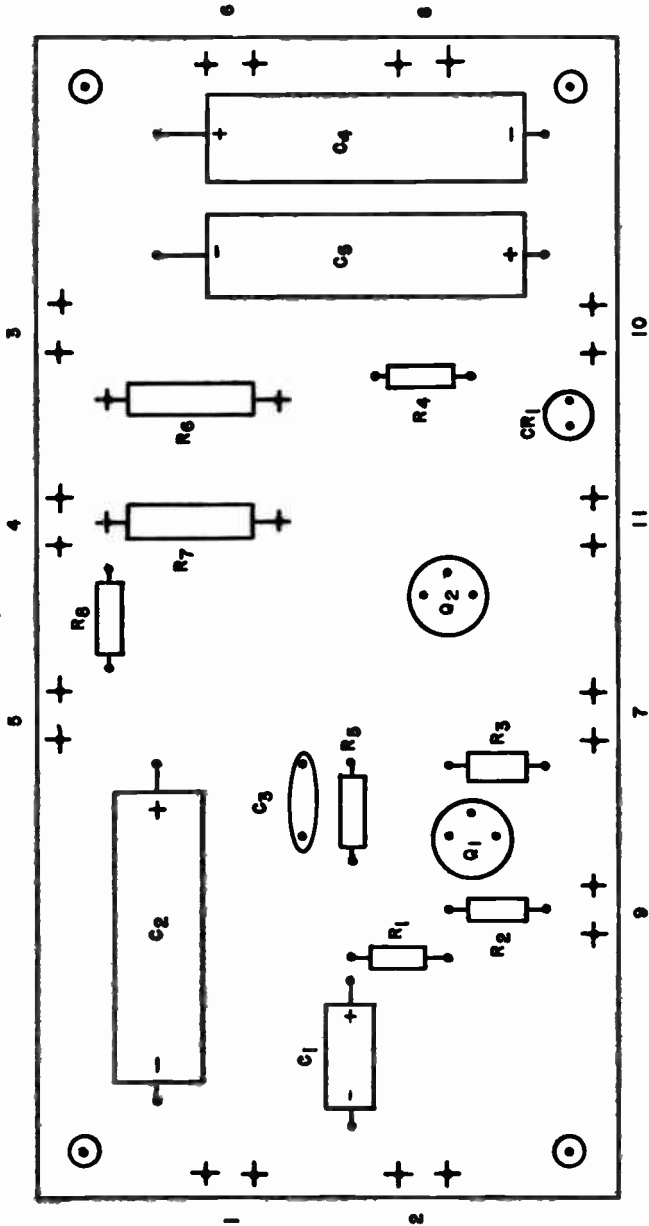

Fig. 110 - Component placement diagram for the audio power amplifier.

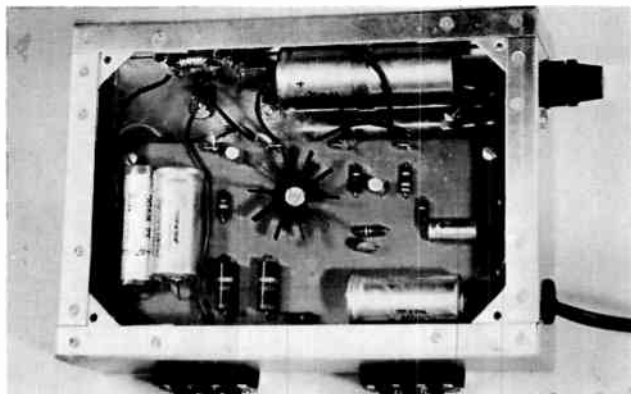

Fig. 111 - The interior of the enclosure suggested for the audio power amplifier.

CIRCUIT NO. 18—ELECTRONIC METRONOME

The electronic metronome produces a series of audible "beeps" at a rate determined by the user. Its most common use is in metering musical cadence, but it may be used in the darkroom to measure time audibly. If the "beep" rate of the timer is set at 1 second, the passage of an amount of time can be noted by counting the "beeps." The electronic metronome has an advantage over the mechanical type in that it does not have to be rewound.

Circuit Operation

The schematic diagram and parts list for the electronic metronome are shown in Fig. 112. Transistors Q_1 and Q_2 form a regenerative switch that has a high impedance until it is triggered, when its impedance becomes very low. When switch S_1 is closed, power is applied to the circuit, C_1 charges through the emitter of Q_3 , and the regenerative switch is turned on instantaneously. Q_1 , the second transistor in the regenerative switch, turns on as Q_2 goes into conduction. Current is then

conducted through C_2 to the base of Q_3 . Q_3 turns on and conducts current to the base of Q_4 , which is in series with the speaker. When Q_4 turns on, it causes the speaker to emit an audible beep. When the charge on C_2 increases, the emitter of Q_1 becomes more positive, turns off the regenerative switch, and stops the flow of current to Q_3 . When the regenerative switch is off, C_2 must discharge through R_3 and R_4 . As the charge on C_2 lessens, the emitter of Q_1 becomes less positive, the regenerative switch is triggered into conduction, and Q_3 receives another pulse. This process is repeated as long as power is applied to the circuit. Each time the regenerative switch conducts, an audible "beep" is produced.

The current drain for this circuit is 20 milliamperes.

Construction

The drilling template for the electronic metronome is shown at the back of the Manual; a component placement diagram and a photograph of a completed circuit board are shown in Figs. 113 and 114, respectively.

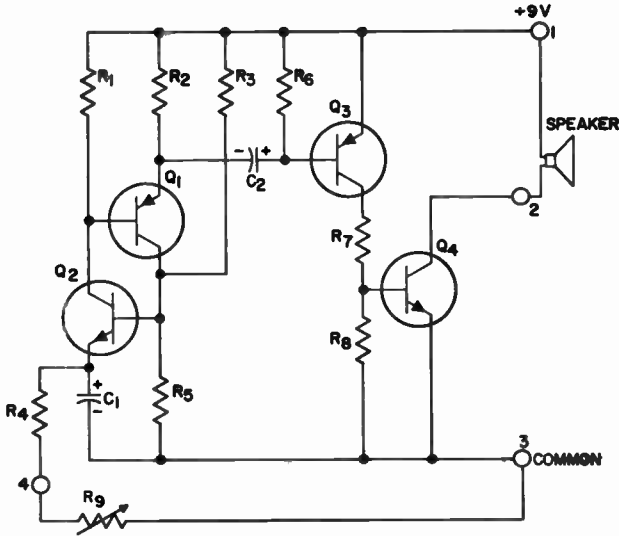

Parts List

- | | |
|----------------------------------------------------|--------------------------------------------------|
| $C_1 C_2 = 20$ microfarads, 12 volts, electrolytic | $R_4 = 3900$, 1/2 watt, 10% |
| $Q_1 Q_3 =$ transistor, RCA SK3005 | $R_5 = 470$ ohms, 1/2 watt, 10% |
| $Q_2 Q_4 =$ transistor, RCA SK3020 | $R_6 R_8 = 150$ ohms, 1/2 watt, 10% |
| $R_1 R_3 = 1000$ ohms, 1/2 watt, 10% | $R_7 = 120$ ohms, 1/2 watt, 10% |
| $R_2 = 68$ ohms, 1/2 watt, 10% | $R_9 =$ potentiometer, 50,000 ohms, linear taper |
| | Speaker = 3.2 ohms |

Fig. 112 - Schematic diagram and parts list for the electronic metronome.

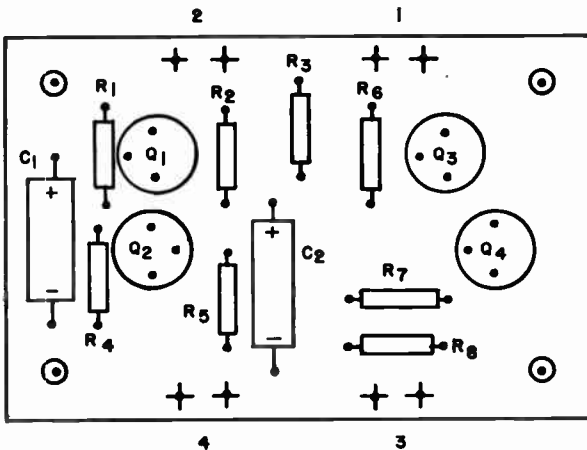

Fig. 113 - Component placement diagram for the electronic metronome.

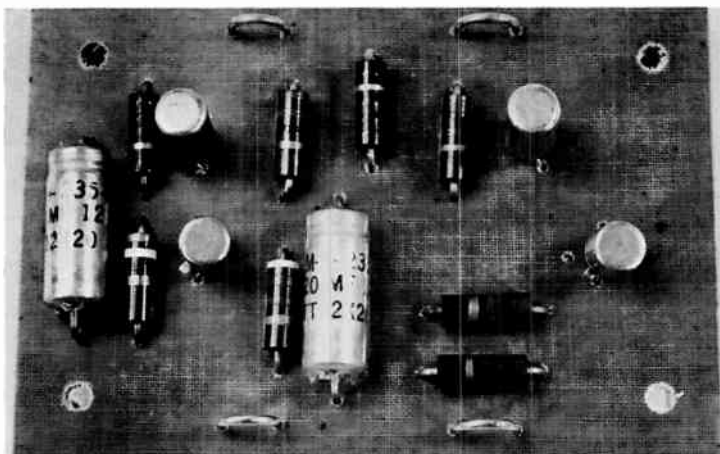

Fig. 114 - Completed circuit board for the electronic metronome.

CIRCUIT NO. 19—SINGLE-VOICE ORGAN

The single-voice organ has a tone that can be varied to simulate the sounds of many musical instruments. Fig. 115 shows the frequency range of

the organ and of the instruments within its range. Fig. 116 shows a photograph of a suggested enclosure for the organ.

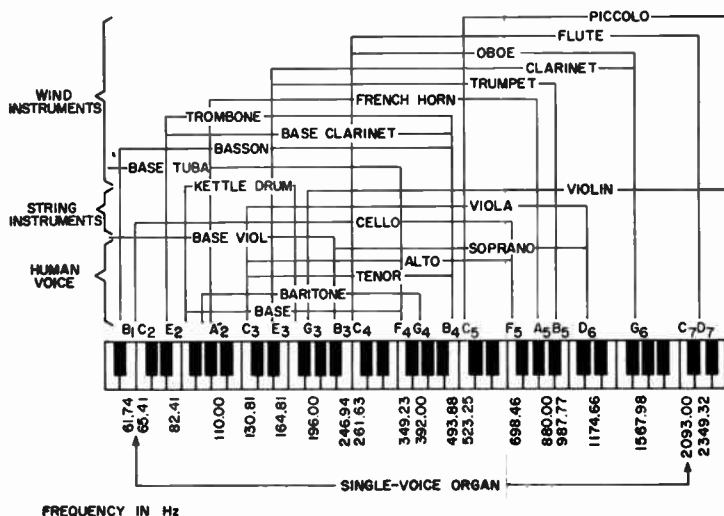

Fig. 115 - Frequency range of the single-voice organ and of instruments within its range.

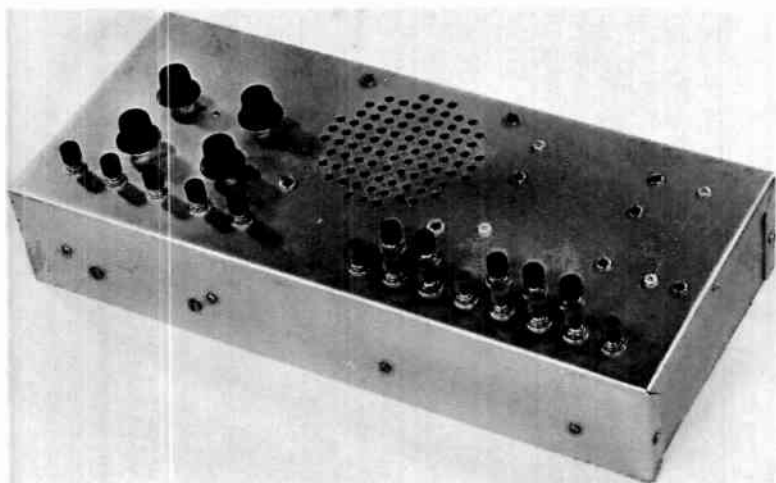

Fig. 116 - A suggested enclosure for the single-voice organ.

Circuit Operation

The schematic diagram and parts list for the tone-generator portion of the single-voice organ are shown in Fig. 117. A pulser or clock oscillator is used to form the basic tones. The mixer-amplifier arrangement (and parts list) shown in Fig. 118 is used in the audio circuit following the tone generator to change the character of the tones through the mixing of two signals: a sawtooth wave taken from terminal 9 and a pulse wave taken from terminal 7. Thirteen series-connected resistors are used in the organ to obtain a chromatic scale; five series-connected capacitors are used so that the tone can be keyed up or down two octaves from the middle octave.

Transistors Q_3 and Q_4 form the basic tone generator; the frequency of this generator is a function of the scale resistor and the octave capacitor

selected. The output of the tone generator is frequency modulated through the application of a very-low-frequency sine wave to the base of Q_4 and the collector of Q_3 ; this sine wave is produced by the twin-T bridge oscillator (which includes Q_1). (The twin-T bridge oscillator is discussed in detail in the section on **General Circuit Considerations**.) The capacitors and resistors of the twin-T bridge have been chosen to produce a tremolo signal of about 6 to 7 Hz. R_6 controls the frequency or depth of tremolo. The voltage on C_7 either aids or opposes the base current that determines the triggering level of the two-transistor switch or tone generator composed of transistors Q_3 and Q_4 . When the voltage on C_7 aids the base current, the triggering level is reduced and the frequency of oscillation and therefore tremolo increases; when the C_7 voltage opposes the current, the frequency and tremolo are decreased.

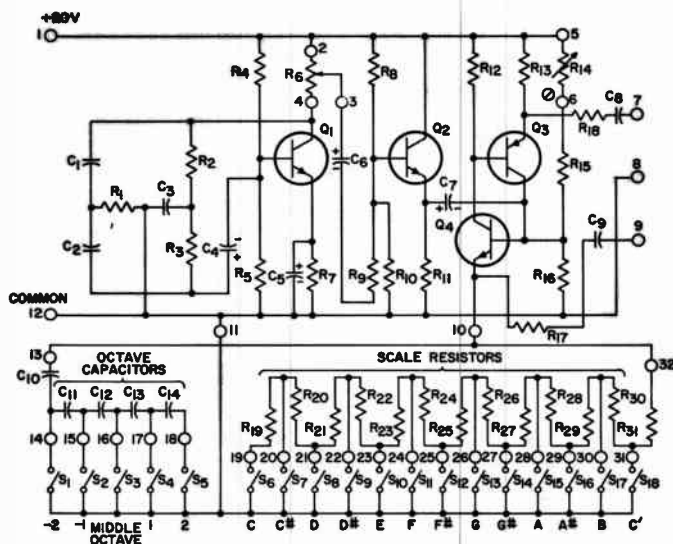

Parts List

- C₁ C₂** = 0.22 microfarad, 25 volts or greater, paper
C₃ C₁₀ C₁₁ = 0.5 microfarad, 25 volts or greater, paper
C₄ = 50 microfarads, 15 volts, electrolytic
C₅ = 100 microfarads, 6 volts, electrolytic
C₆ C₇ = 4 microfarads, 25 volts, electrolytic
C₈ C₉ = 0.1 microfarad, 25 volts or greater
C₁₂ = 0.25 microfarad, 25 volts or greater
C₁₃ = 0.12 microfarad and 0.005 microfarad in parallel, 25 volts or greater
C₁₄ = 0.056 microfarad and 0.0068 microfarad in parallel, 25 volts or greater
Q₁ Q₂ Q₄ = transistor, RCA SK3020
Q₃ = transistor, RCA SK3005
R₁ = 33,000 ohms, 1/2 watt, 10%
R₂ R₃ = 220,000 ohms, 1/2 watt, 10%
R₄ R₈ = 330,000 ohms, 1/2 watt, 10%
R₅ R₁₈ = 100,000 ohms, 1/2 watt, 10%
R₆ = potentiometer, 10,000 ohms, linear taper
R₇ = 3300 ohms, 1/2 watt 10%
R₉ = 270,000 ohms, 1/2 watt, 10%
R₁₀ = 180,000 ohms, 1/2 watt, 10%
R₁₁ R₂₁ R₂₂ = 1000 ohms, 1/2 watt, 10%
R₁₂ = 1500 ohms, 1/2 watt, 10%
R₁₃ = 180 ohms, 1/2 watt, 10%
R₁₄ = potentiometer, 1000 ohms, linear taper
R₁₅ = 1200 ohms, 1/2 watt, 10%
R₁₆ = 470 ohms, 1/2 watt, 10%
R₁₇ = 2.2 megohms, 1/2 watt, 10%
R₁₉ R₂₀ = 1100 ohms, 1/2 watt, 5%
R₂₃ R₂₄ = 910 ohms, 1/2 watt, 5%
R₂₅ R₂₆ = 820 ohms, 1/2 watt, 10%
R₂₇ = 750 ohms, 1/2 watt, 5%
R₂₈ R₂₉ = 680 ohms, 1/2 watt, 10%
R₃₀ = 620 ohms, 1/2 watt, 10%
R₃₁ = 10,000 ohms, 1/2 watt, 10%

Fig. 117 - Schematic diagram and parts list for the single-voice-organ tone generator.

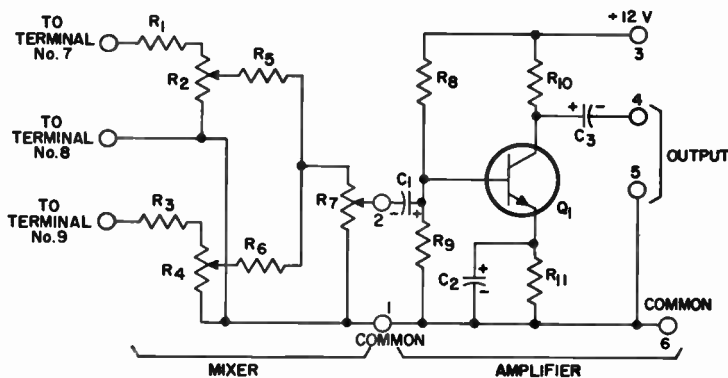

Parts List

C_1 = 15 microfarads, 10 volts, electrolytic

C_2 = 100 microfarads, 6 volts, electrolytic

C_3 = 50 microfarads, 15 volts, electrolytic

Q_1 = transistor, RCA SK3020

R_1 R_3 R_4 R_9 = 100,000 ohms, 1/2 watt, 10%

R_2 = potentiometer, 5000 ohms, linear taper

R_3 = 2.2 megohms, 1/2 watt, 10%

R_4 = potentiometer, 250,000 ohms, linear taper

R_7 = potentiometer, 10,000 ohms, linear taper

R_8 = 330,000 ohms, 1/2 watt, 10%

R_{10} = 12,000 ohms, 1/2 watt, 10%

R_{11} = 3300 ohms, 1/2 watt, 10%

Fig. 118 - Schematic diagram and parts list for the single-voice-organ mixer-amplifier.

The organ is best tuned by comparison with other instruments, such as a piano; R_{14} is the tuning resistor. Two switches must be depressed to obtain a note: a capacitor switch which selects the octave and a resistor switch which selects the note of the scale. The output of the organ may be fed into a radio, TV, or hi-fi amplifier. The RCA KD2112 Integrated-Circuit Kit Amplifier or the amplifier in Circuit No. 17 of this Manual are also suitable.

The current drain for this circuit (not including the amplifier) is approximately 15 milliamperes.

Construction

An easily depressed, normally open, pushbutton switch can be used for the scale and octave switches. The drilling templates for the single-voice organ are shown at the back of this Manual; component placement diagrams for the amplifier, tremolo and tone oscillator, and resistor capacitor boards are shown in Figs. 119 (a) through 119 (d), respectively. Photographs showing board placement within the suggested enclosure are contained in Fig. 120.

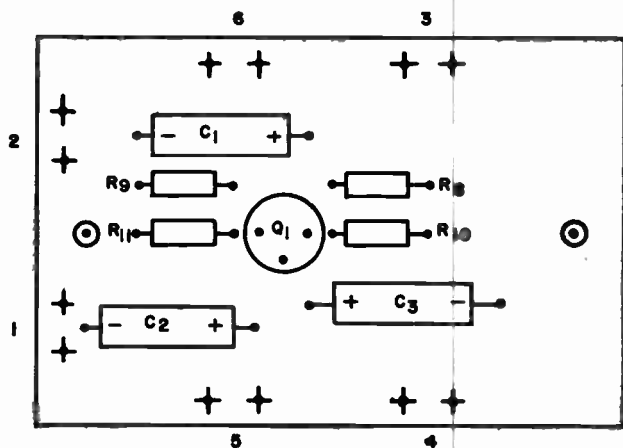

Fig. 119 (a) - Component placement diagram for amplifier.

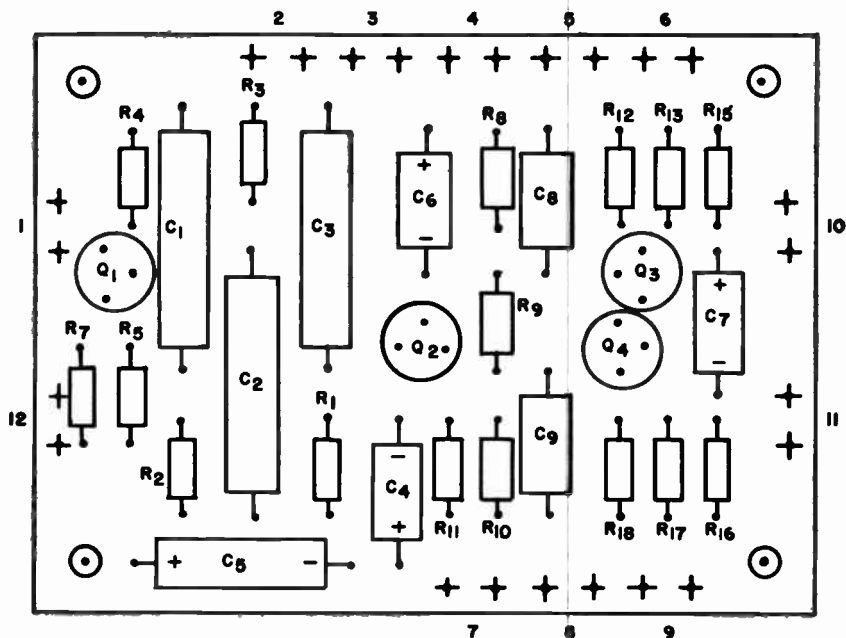

Fig. 119 (b) - Component placement diagram for tremolo and tone oscillator.

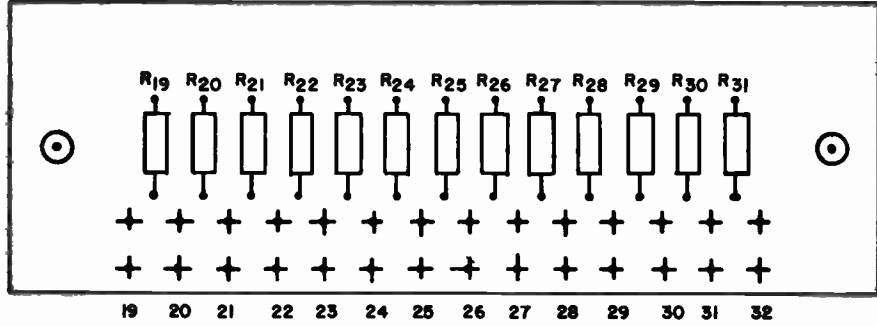

Fig. 119 (c) - Component placement diagram for resistor board.

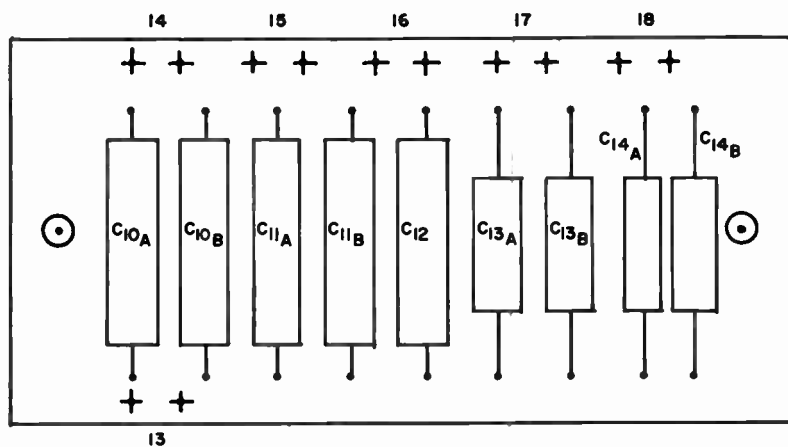

Fig. 119(d) - Component placement diagram for capacitor board.

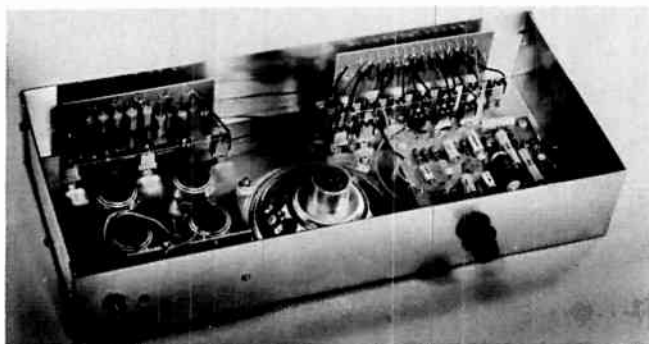
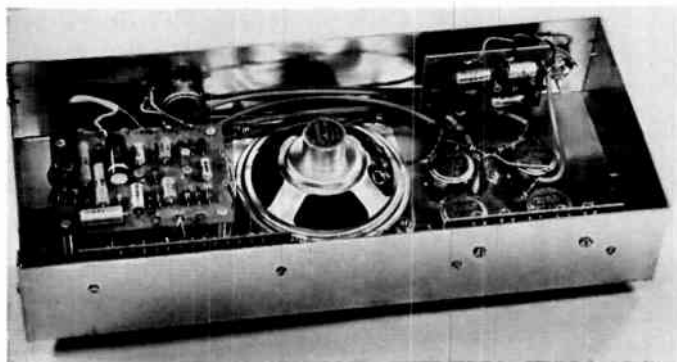

Fig. 120 - Board placement within the suggested enclosure of Fig. 116.

CIRCUIT NO. 20—AUTOMOBILE TACHOMETER

The tachometer circuits are used to indicate the speed, in revolutions per minute, of automobile engines with 12-volt electrical systems. Two circuits are described: one for cars with a negative ground, the other for cars with a positive ground.

Circuit Operation

The schematic diagrams for negative-ground and positive-ground automobile tachometers are shown in Figs. 121 and 122, respectively. The parts list for both circuits is shown in Fig. 121.

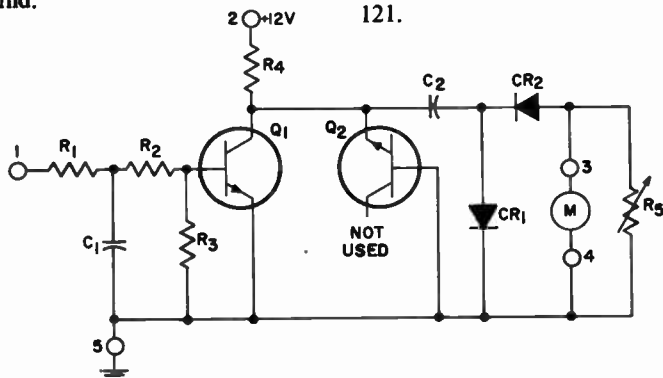

Parts List

C_1 = 1 microfarad, 50 volts or greater

C_2 = 0.5 microfarad, 50 volts or greater

CR_1, CR_2 = silicon rectifier, RCA SK3030

M = milliammeter, 0 to 1 milliamperere range (see text)

Q_1 = transistor RCA SK3025 for

positive ground, RCA SK3020 for negative ground

Q_2 = transistor, RCA SK3020

R_1 = 22,000 ohms, 1/2 watt, 10%

R_2 = 220 ohms, 1/2 watt, 10%

R_3 = 1500 ohms, 1/2 watt, 10%

R_4 = 330 ohms, 1/2 watt, 10%

R_5 = potentiometer, 1000 ohms, trimmer type, linear taper

Fig. 121 - Schematic diagram and parts list for the negative-ground tachometer.

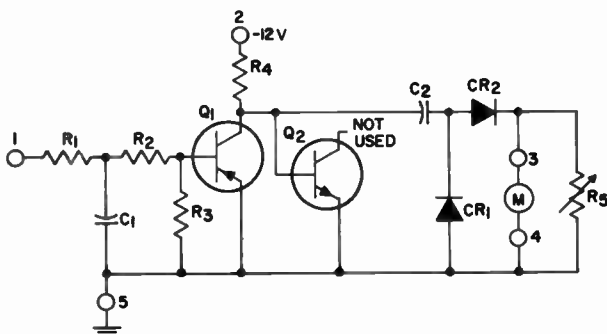

Fig. 122 - Schematic diagram for the positive-ground tachometer. (The parts list for this circuit is shown in Fig. 121).

Both tachometer systems operate on the same principle. Pulses from the distributor points are applied to the base of Q_1 through terminal No. 1. Q_1 turns on and off as the distributor points open and close; capacitor C_1 filters out the "ringing" or voltage oscillations that occur when the points open. Capacitor C_2 , connected to the collector of Q_1 , charges through CR_1 and R_4 when Q_1 is off, and discharges through R_5 , CR_2 , and the meter when Q_1 is on. Meter deflection is proportional to the rate at which the points open and close.

To make the circuits insensitive to the variations in voltage normally present in an automobile electrical system, transistor Q_2 is reverse-biased at the emitter-base junction so that it acts as a zener diode; any 9- or 10-volt, 1/4-watt zener diode may be substituted for Q_2 .

Trimmer potentiometer R_5 is used to calibrate the tachometer. Accuracy of the tachometer circuit can be checked by comparing the revolutions per minute (r/min) reading indicated by this circuit with the reading indicated by a commercial tachometer,

such as that used at service stations.

Both positive- and negative-ground tachometer circuits are configured identically; the only difference in the circuits is the substitution of p-n-p for n-p-n transistors and the reversal of the electrolytic capacitors to accommodate the polarity change.

The full-scale r/min reading of the tachometer is determined by the sensitivity of the meter movement. A 1-milliampere movement will have a full-scale reading of 8,000 to 10,000 r/min; lower r/min readings require a more sensitive meter movement.

Construction

The drilling template for the automobile tachometers is shown at the back of this Manual; a component placement diagram and photographs of completed circuit boards for positive and negative ground systems are shown in Figs. 123 and 124 respectively. The component placement diagram shows the negative ground arrangement. The polarities of the capacitors and rectifiers are reversed for positive ground systems.

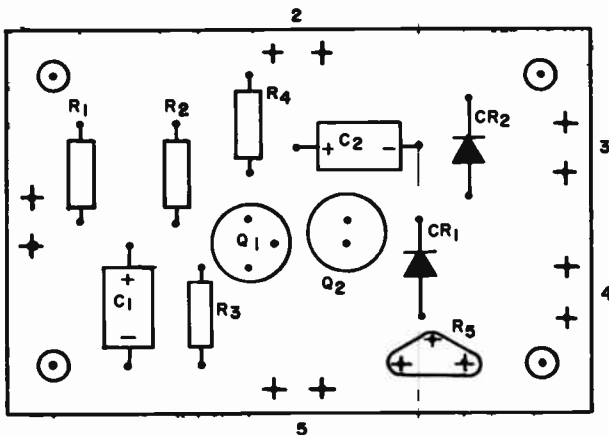

Fig. 123 - Component placement diagram for the tachometer.

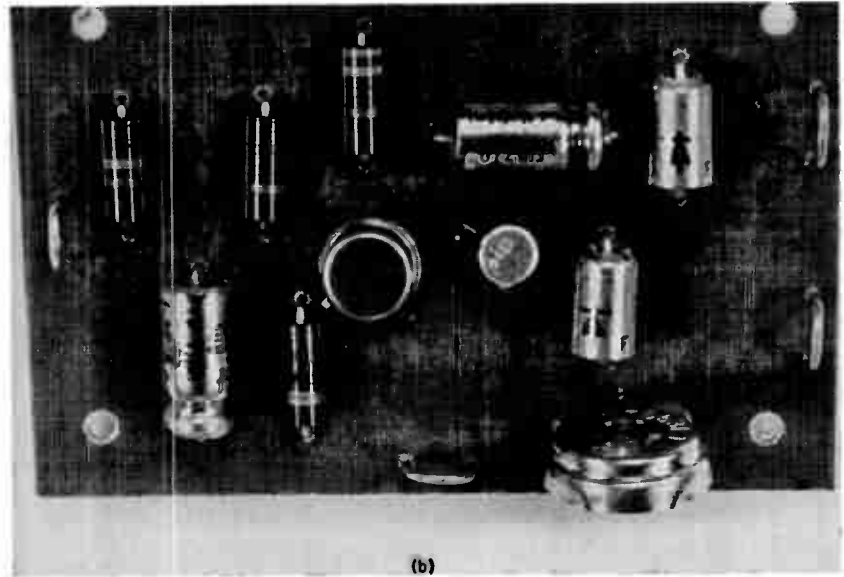
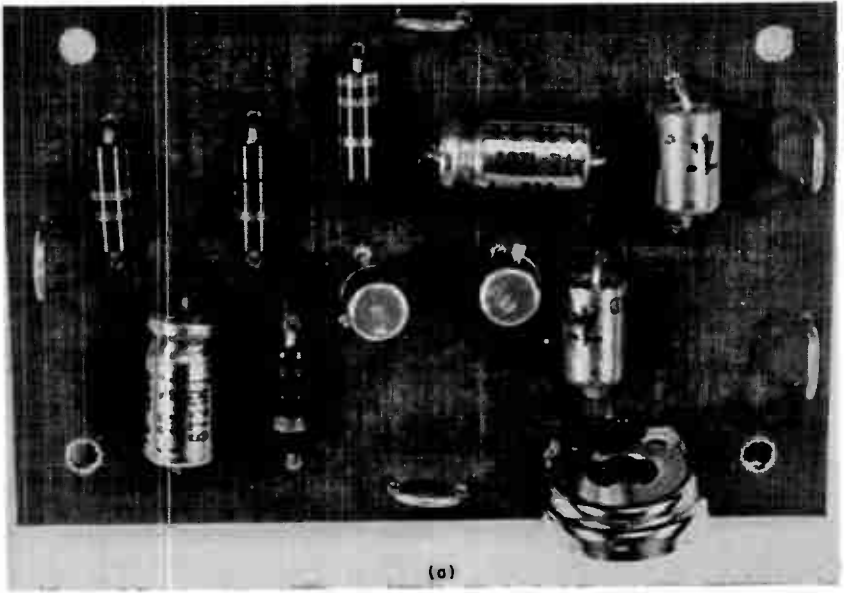

Fig. 124 - Completed circuit boards for (a) positive-ground and (b) negative-ground tachometers.

CIRCUIT NO. 21—BATTERY CHARGER

The battery charger restores to full strength 6-volt lead-acid storage batteries of the type used in motorcycles and photoflash units. The charging rate of 1 ampere per hour is automatically terminated when the battery is fully charged. This charger may be used for automobile or boat batteries if a slow charging rate is acceptable.

Circuit Operation

The schematic diagram and parts list for the battery charger are shown in Fig. 125. The 120-volt line voltage, stepped down to 25.2 volts by transformer T_1 , is rectified by diodes CR_1 and CR_2 and applied to the anode of SCR_1 . Diode CR_3 prevents capacitor

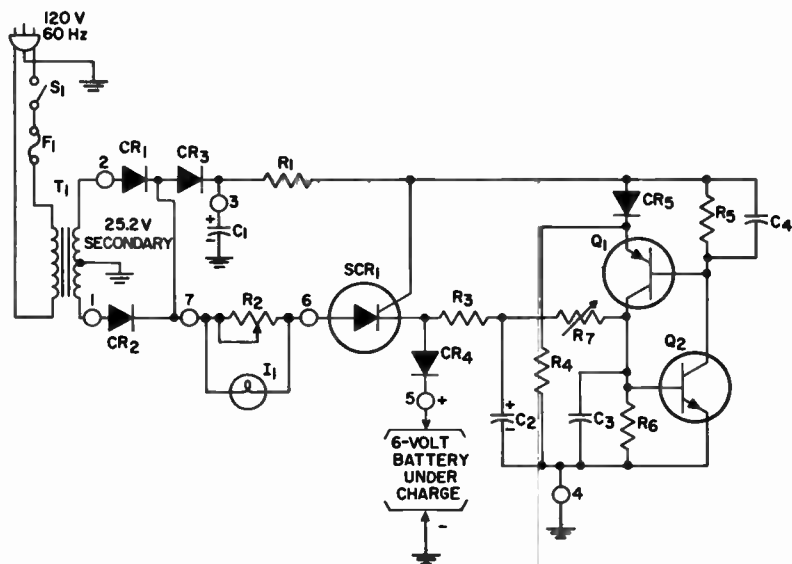

Parts List

C_1 = 500 microfarads, 25 volts, electrolytic

C_2 = 100 microfarads, 12 volts, electrolytic

C_3, C_4 = 0.01 microfarad, ceramic disc

CR_1 through CR_5 = silicon rectifier, RCA SK3030

F_1 = fuse, 1 ampere, 125 volts

I_1 = lamp, No. 47

Q_1 = transistor, RCA SK3005

Q_2 = transistor, RCA SK3020

R_1 = 330 ohms, 1/2 watt, 10%

R_2 = adjustable resistor, 5 ohms, 10 watts, 10%

R_3 = 4700 ohms, 1/2 watt, 10%

R_4 = 10,000 ohms, 1/2 watt, 10%

R_5 = 150 ohms, 1/2 watt, 10%

R_6 = 470 ohms, 1/2 watt, 10%

R_7 = miniature trimmer control, 5000 ohms, Mallory No. MTC-1 or equivalent

SCR_1 = silicon controlled rectifier, RCA SK2100

S_1 = switch, 125 volts, 1 ampere, single-pole, single-throw

T_1 = transformer, primary 117 volts, secondary 25.2 volts at 1 ampere, Stancor No. TP-4 or equivalent.

Fig. 125 - Schematic diagram and parts list for the battery charger.

C_1 , a filter for the gate of SCR₁, from discharging through the anode of the SCR when the battery has reached full charge; diode CR₄ prevents the battery from discharging through the charging circuit when the circuit has been turned off.

The full-charge condition is determined by the voltage-sensing circuit at the right in the circuit schematic. The voltage-sensing circuit, essentially a two-transistor regenerative switch that is triggered into conduction when the voltage across it reaches a level determined by the value of R_3 and potentiometer R_7 , turns off SCR₁ and terminates the charge by making the SCR gate less positive than the cathode.

Potentiometer R_7 can be set by the connection of a fully charged battery or a power supply to the charging terminals of the circuit. The battery used

should be the type that will normally be under charge; the power supply should be set to 7 volts for lead-acid type batteries. With a fully charged battery in the output, potentiometer R_7 is adjusted until the sensing circuit just triggers. Triggering is indicated by extinction of lamp I₁. After a battery has been fully charged and removed from the circuit, the power to the charger should be momentarily interrupted before a second battery is inserted so that the sensing circuit is reset.

It is important that the charging current not exceed the maximum current rating of diode CR₄. Resistor R_2 should be adjusted to 1 ampere or the safe charging rate of the battery, whichever is less. R_2 and R_7 need not be reset unless the circuit is to be used to charge a battery different from the type normally charged.

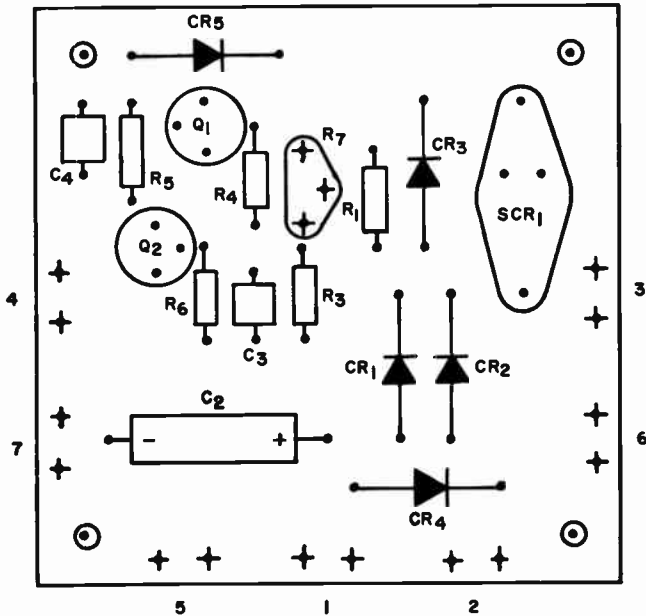

Fig. 126 - Component placement diagram for the battery charger.

The secondary of the transformer used in the charger should have a dc resistance of at least 1 ohm. If it does not, a 1-ohm 2-watt resistor should be inserted in series with the secondary. No special precautions are required if the transformer specified in the parts list is used.

Construction

The drilling template for the battery charger is shown at the back of this Manual; a component placement diagram and a photograph of a completed circuit board are shown in Figs. 126 and 127, respectively.

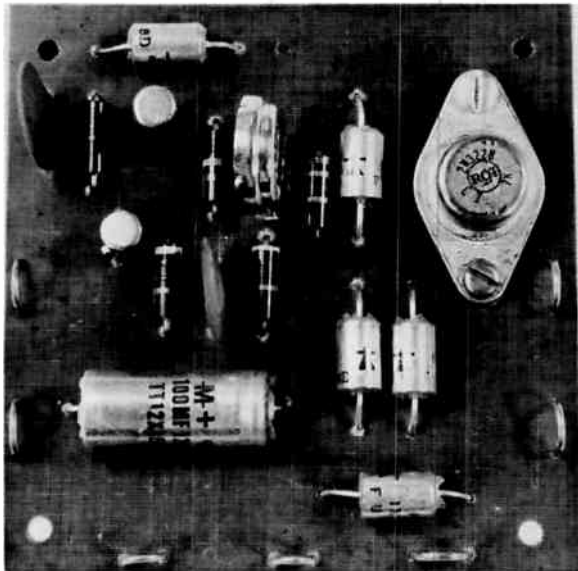

Fig. 127 - Completed circuit board for the battery charger.

CIRCUIT NO. 22—ELECTRONIC SIREN

The electronic siren produces a sound like that of a wailing police siren; the frequency of the wail slowly increases and then slowly decreases as a push-button switch is depressed and released.

Circuit Operation

The schematic diagram and parts list for the electronic siren are shown in Fig. 128. When switch S_1 is closed,

capacitor C_1 begins to charge. As it does so, it makes the base of Q_1 more and more positive and slowly turns it on. Current conducted through transistor Q_1 turns Q_2 on (Q_1 and Q_2 form a direct-coupled amplifier). Part of the output from Q_2 is applied to the input of Q_1 through capacitor C_2 and provides the regenerative feedback that causes the circuit to oscillate. When switch S_1 is opened, C_1 discharges through R_2 and the base of Q_1 . The

"wailing rate" of the siren can be changed by substituting different values of R_1 and C_1 . An increase in the value of R_1 or C_1 lengthens the rate at which the frequency of oscillation increases.

Because battery drain with switch S_1 open is only about 400 microamperes, a power switch is not considered necessary. However, such a switch will

add to battery life.

Construction

The drilling template for the electronic siren is shown at the back of this Manual; a component placement diagram and a photograph of a completed circuit board are shown in Figs. 129 and 130, respectively.

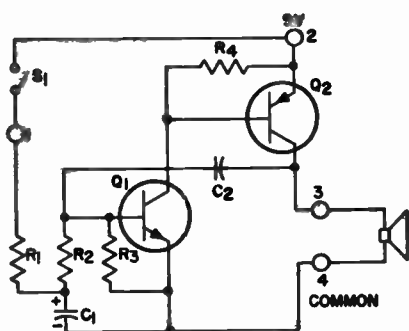

Parts List

- C_1 = 50 microfarads, 12 volts, electrolytic
- C_2 = 0.018 microfarad, 25 volts or greater
- Q_1 = transistor, RCA SK3020
- Q_2 = transistor, RCA SK3005
- R_1 = 27,000 ohms, 1/2 watt, 10%
- R_2 = 68,000 ohms, 1/2 watt, 10%
- R_3 = 56,000 ohms, 1/2 watt, 10%
- R_4 = 470 ohms, 1/2 watt, 10%
- S_1 = switch, any single-pole push-button type
- Speaker = 3.2-ohms or 8-ohms

Fig. 128 - Schematic diagram and parts list for the electronic siren.

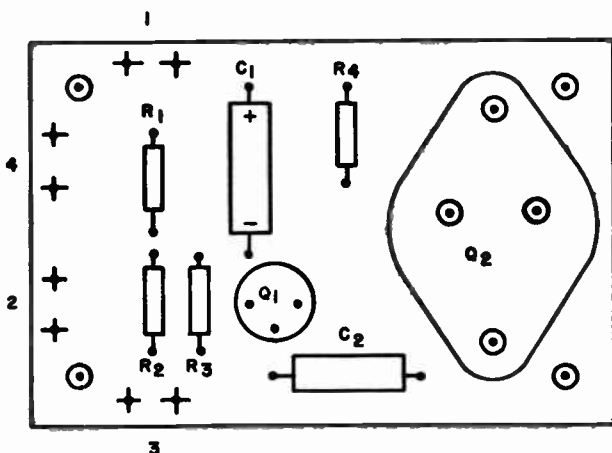

Fig. 129 - Component placement diagram for the electronic siren.



Fig. 130 - Completed circuit board for the electronic siren.

CIRCUIT NO. 23—ELECTRONIC SLOT MACHINE

The completed electronic slot-machine game resembles, functionally, the well-known Las Vegas slot machine except that a push-button replaces the lever and three vertical columns of lights replace the spinning wheels. Each light corresponds to a lemon, cherry, or other symbol found in the conventional machine. Instead of paying off in coin, the electronic slot machine indicates a score through one of six scoring lamps on its face. A suggested enclosure for the slot machine is shown in Fig. 131.

To operate the slot machine, a player depresses the push-button switch momentarily. Each column of lights then starts to flash in sequence; the duration of flashing changes each time the game is played. The maximum time for game completion is approximately four seconds. When the flashing stops, one of the lamps remains lit in each column; the combination of the three lighted lamps is

completely random and determines the score. When no score lamp lights, the score is zero.

The electronic slot machine circuit makes use of the digital circuits described in the section on **General Circuit Considerations**: the NAND and NOR gates, the flip-flop, and the shift register. For this reason the slot-machine circuit represents an excellent means of gaining practical experience in digital circuitry.

Circuit Operation

The electronic slot-machine circuit consists of a series of building blocks; each block is constructed on a circuit board and interconnected as shown in the diagram of Fig. 132. Detailed interconnections for various portions of the circuit are given in Figs. 133, 134, and 135. Detailed schematics for each building block are shown in Figs. 136 through 141. The parts list for each circuit is shown with the schematic.

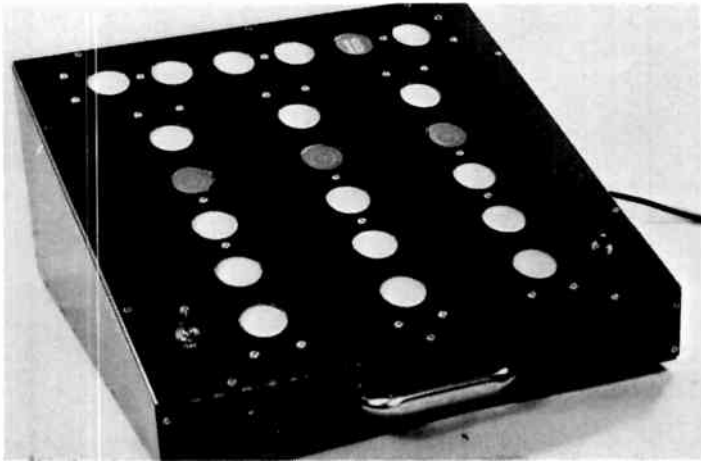

Fig. 131 - A suggested enclosure for the electronic slot machine.

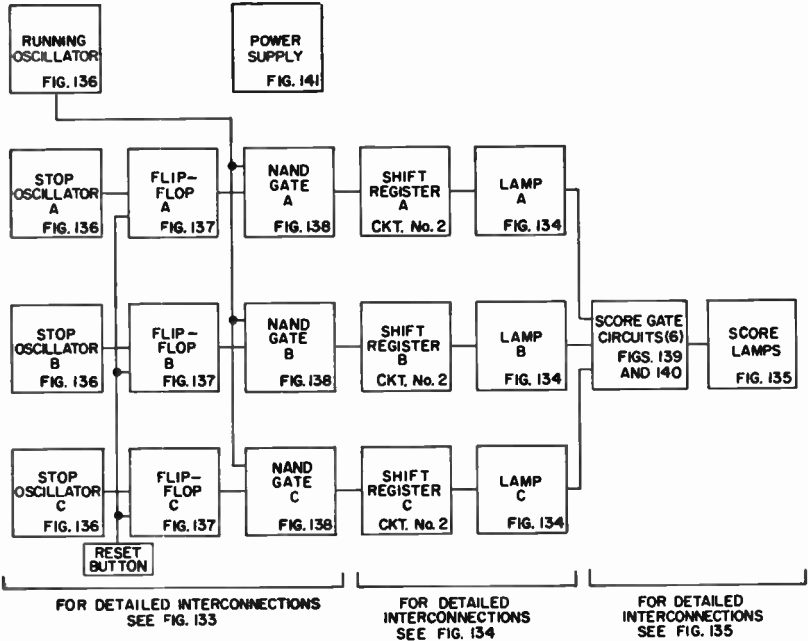

Fig. 132 - Block diagram of the electronic slot machine.

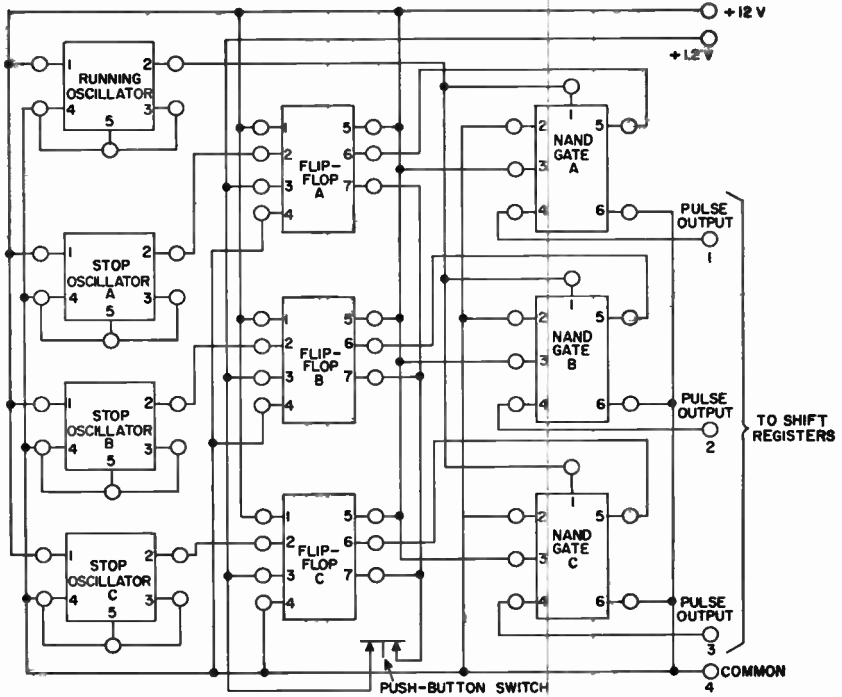
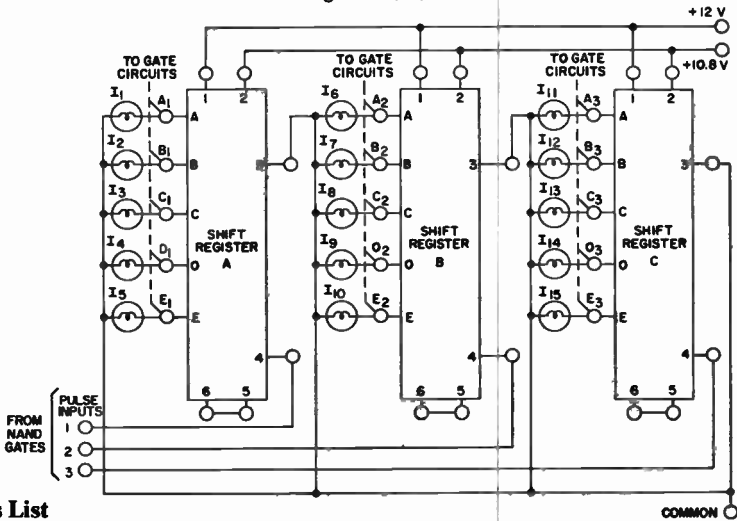

Fig. 133 - Interconnection diagram for the running and stop oscillators, flip-flops, and NAND gates A, B, and C.



Parts List

I₁ through I₁₅ = lamp, No. 47

Fig. 134 - Interconnection diagram for the shift registers and column lamps.

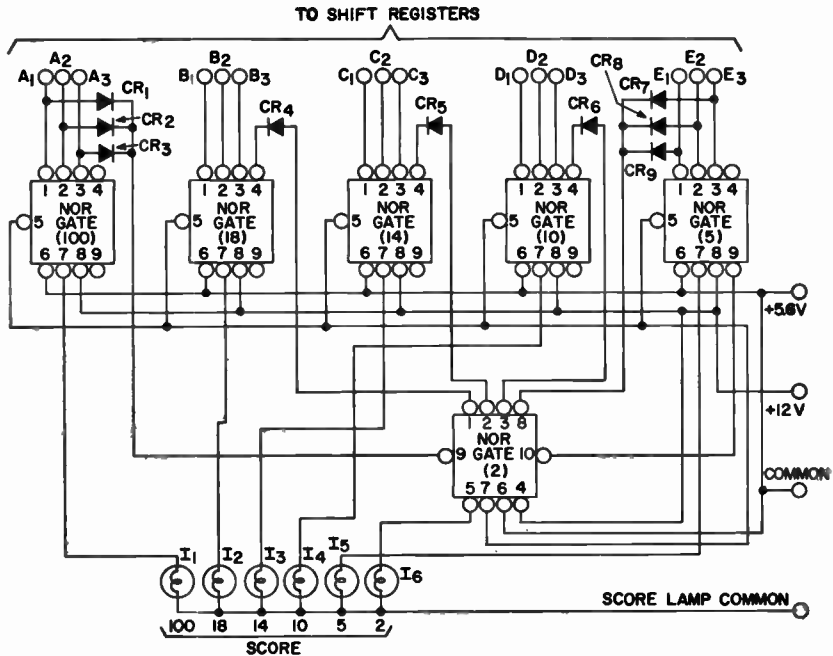

Parts List

I₁ through I₆ = lamp No. 1488

CR₁ through CR₉ = silicon rectifier, RCA SK3030

Fig. 135 - Interconnection diagram for the score gate circuits (NOR gates) and the score lamps.

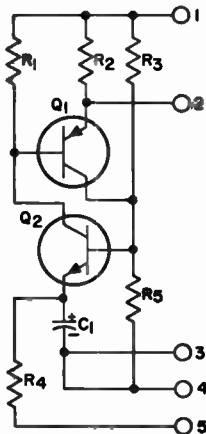

Parts List

Running Oscillator (1 req'd)

C₁ = 2 microfarads, 15 volts, electrolytic

- Q₁ = transistor, RCA SK3005
 - Q₂ = transistor, RCA SK3020
 - R₁ = 1500 ohms, 1/2 watt, 10%
 - R₂ = 47 ohms, 1/2 watt, 10%
 - R₃ = 1000 ohms, 1/2 watt, 10%
 - R₄ = 15,000 ohms, 1/2 watt, 10%
 - R₅ = 4700 ohms, 1/2 watt, 10%
- Stop Oscillator (3 req'd)

- C₁ = 100 microfarads, 15 volts, electrolytic
- Q₁ = transistor, RCA SK3005
- Q₂ = transistor, RCA SK3020
- R₁ = 1000 ohms, 1/2 watt, 10%
- R₂ = 68 ohms, 1/2 watt, 10%
- R₃ = 1000 ohms, 1/2 watt, 10%
- R₄ = 27,000 ohms, 33,000 ohms, 39,000 ohms, one in each of 3 oscillators
- R₅ = 470 ohms, 1/2 watt, 10%

Fig. 136 - Schematic diagram and parts list for the running and stop oscillators.

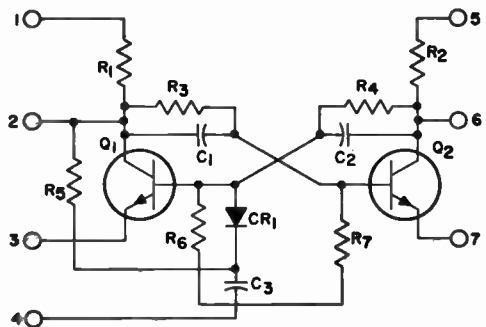
**Parts List**

$C_1 C_2 = 560$ picofarads, 25 volts or greater

$C_3 = 0.01$ microfarad, 25 volts or greater

$CR_1 =$ silicon rectifier, type 1N270

$Q_1 Q_2 =$ transistor, RCA SK3020

$R_1 R_2 = 1500$ ohms, 1/2 watt, 10%

$R_3 R_4 R_6 = 10,000$ ohms, 1/2 watt, 10%

$R_5 R_7 = 6800$ ohms, 1/2 watt, 10%

Fig. 137 - Schematic diagram and parts list for the flip-flops.

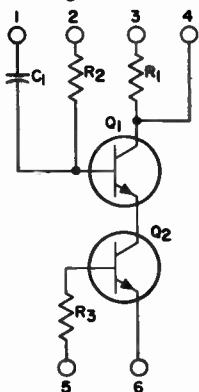
**Parts List**

$C_1 = 0.1$ microfarad, 25 volts or greater

$Q_1 Q_2 =$ transistor, RCA SK3020

$R_1 = 1000$ ohms, 1/2 watt, 10%

$R_2 R_3 = 10,000$ ohms, 1/2 watt, 10%

Fig. 138 - Schematic diagram and parts list for the NAND gates (A, B, C).

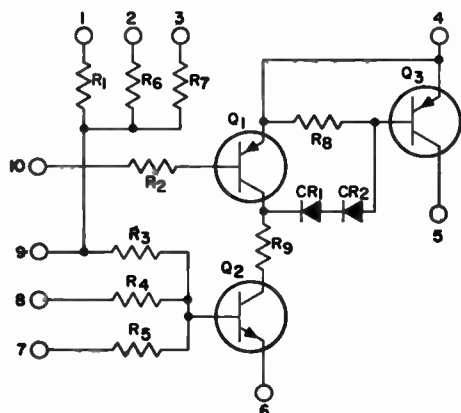
**Parts List**

$CR_1 CR_2 =$ silicon rectifier, RCA SK3030

$Q_1 Q_3 =$ transistor, RCA SK3005

$Q_2 =$ transistor, RCA SK3010

R_1 through $R_6 = 4700$ ohms, 1/2 watt, 10%

$R_2 R_3 R_4 = 4700$ ohms, 1/2 watt, 10%

$R_7 = 3900$ ohms, 1/2 watt, 10%

$R_8 R_9 = 180$ ohms, 1/2 watt, 10%

Fig. 139 - Schematic diagram and parts list for the NOR gate circuit and lamp driver for score 2.

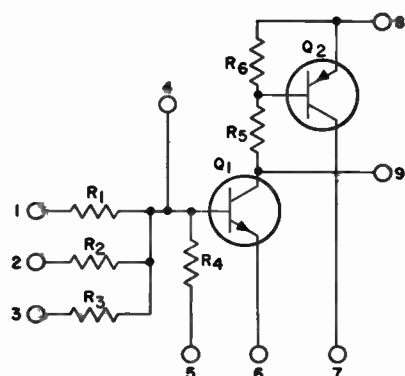

Parts List

- Q_1 = transistor, RCA SK3010
 Q_2 = transistor, RCA SK3005
 $R_1 R_2 R_3 R_4$ = 4700 ohms, 1/2 watt, 10%
 R_5 = 270 ohms, 1/2 watt, 10%
 R_6 = 150 ohms, 1/2 watt, 10%

Fig. 140 - Schematic diagram and parts list for the NOR gate circuits and lamp drivers for scores 10 through 100.

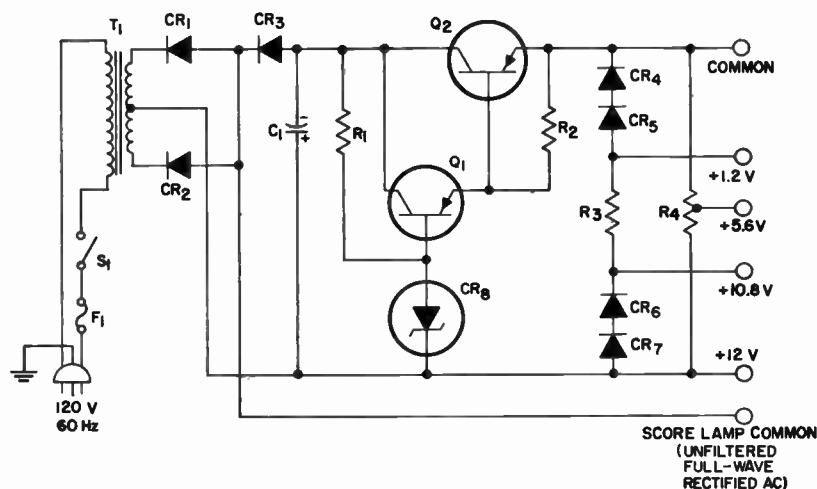

Parts List

- C_1 = 2000 microfarads, 15 volts, electrolytic
 CR_1 through CR_7 = silicon rectifier, RCA SK3030
 CR_8 = zener diode, 13 volts, 1 watt
 F_1 = fuse, 1 ampere, 3AG
 Q_1 = transistor, RCA SK3005
 Q_2 = transistor, RCA SK3009
 R_1 = 1800 ohms, 1/2 watt, 10%
 R_2 = 68 ohms, 1/2 watt, 10%
 R_3 = 470 ohms, 1/2 watt, 10%
 R_4 = 100 ohms, 25 watts, adjustable
 S_1 = toggle switch, single-pole single-throw
 T_1 = transformer, primary 117 volts, secondary 25 volts at 1 ampere, Stancor No. P6469 or equivalent

Fig. 141 - Schematic diagram and parts list for the slot machine power supply.

When power is applied to the circuit, the "running" and "stop" oscillators begin pulsing. The running oscillator pulses at a very rapid rate; the stop oscillators all pulse at a slightly different rate but produce a pulse approximately once every four seconds. The stop and running oscillators continue to pulse as long as power is on.

When the push-button switch shown in Fig. 133 is depressed, the flip-flop circuits assume the output state; their outputs and the pulses from the running oscillator are applied to the gate circuits. Gate circuits with both inputs (running oscillator and flip-flop) satisfied provide an output each time the running oscillator pulses; this output is applied to the shift register which advances the lighted lamp in each column with each pulse.

At this point in the circuit operation, all three columns of lamps are flashing. The score lamps may also flash momentarily at this time as score gate-circuit output conditions are momentarily satisfied. The flashing of the lamps in each column continues until the stop oscillator associated with a particular column pulses once. This pulse can occur, as explained above, at any time up to four seconds after the push-button switch is released. The pulse sets the flip-flop to the no-output state and cuts off the input to the gate.

Because the conditions for gate output are not satisfied, running oscillator pulses are not transmitted to the shift-register.

The shift-register outputs that light the lamps in each column are also applied to the input of the score gates. When the final lighted-lamp combination matches one of the preset scoring conditions, a scoring lamp lights. Table V shows the lamp combinations and associated suggested point values.

Detailed Circuit Considerations

Both the running and stop oscillators shown in Fig. 136 are basically the same circuits, astable pulsers; they differ only in the values of the timing components. The timing capacitor C_1 in the stop oscillator is large compared to the timing capacitor C_1 in the running oscillator. The charging resistors, R_4 , in the stop oscillators must differ slightly to insure a complete random action in the score lamps.

The astable pulser description in the section on **General Circuit Considerations** contains a statement to the effect that the regenerative switch portion of the pulser conducts immediately with the application of power. The pulse conducted consists of a stop pulse in

Table V.
Electronic Slot-Machine Scores

Lamps Lighted	Suggested Score
All first row	100
All second row	18
All third row	14
All fourth row	10
Any two fifth row lamps	5
Any in first row with: {	Any two in second row ... 18
	Any two in third row 14
	Any two in fourth row 10
	Any one in fifth row 2
None of above	0

the negative direction; this pulse is applied to the flip-flop circuits which are in the no-output state when power is applied to the circuit. A momentary depression of the push-button switch places the flip-flops in the output state.

The flip-flop circuit used in the electronic slot machine is the same as that described in the section on **General Circuit Considerations** except that a number of unnecessary components have been omitted. Fig. 137 shows the modified basic flip-flop.

The power supply in Fig. 141 is a modification of the fixed series supply, Circuit No. 1 (a). The slot machine lamps receive full-wave rectified dc through diodes CR_1 and CR_2 . Diode CR_3 keeps C_1 , the filtering capacitor, from discharging back through the lamp circuit, a condition that would increase the ripple voltage output of the supply. Diode CR_3 also permits the use of a value for C_1 that is smaller than would otherwise be possible.

Diodes CR_4 through CR_7 and resistors R_3 and R_4 make available the additional voltage values required by the slot-machine circuit. R_4 should be adjusted so that there are 5.6 volts

across the wiper arm (adjustable tap) and the common terminal.

Construction

Each circuit of the same type in the electronic slot machine uses the same board although the value of one or two of the components may differ. The boards for the same circuit type may be cut and drilled simultaneously; drilling templates are shown at the back of the Manual. Component placement diagrams and photographs of completed circuit boards are shown in Figs. 142 through 146. The list below indicates how many of each circuit type must be constructed.

The push-button switch used to activate the slot-machine game can be any normally closed type.

The completed slot machine shown in Fig. 131 represents but one method of construction. Many other methods are possible and depend on the material used for the chassis, the lamp socket chosen, etc. If desired, a carefully made replica of an actual slot machine can be used to house the electronic counterpart.

Circuit Modules Required

	Number Required	Schematic
Running Oscillator	1	Fig. 136
Stop Oscillator	3	Fig. 136
Flip-Flop	3	Fig. 137
Nand Gates	3	Fig. 138
Score Gate (Lamp I_6)	1	Fig. 139
Score Gate (Lamps I_1 through I_4)	5	Fig. 140
Power Supply	1	Fig. 141
Shift Register	3	Circuit No. 2

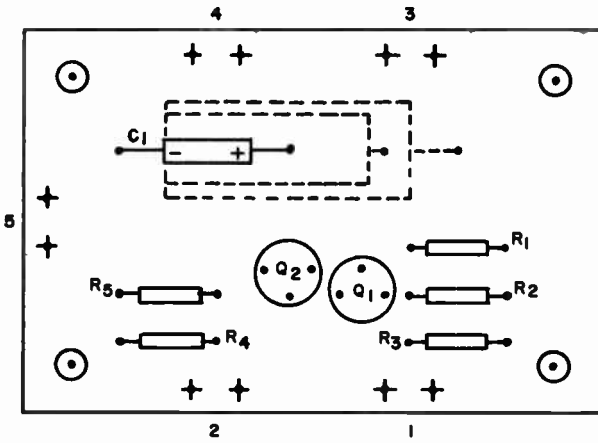

Fig. 142(a) - Component placement diagram for the running and stop oscillators

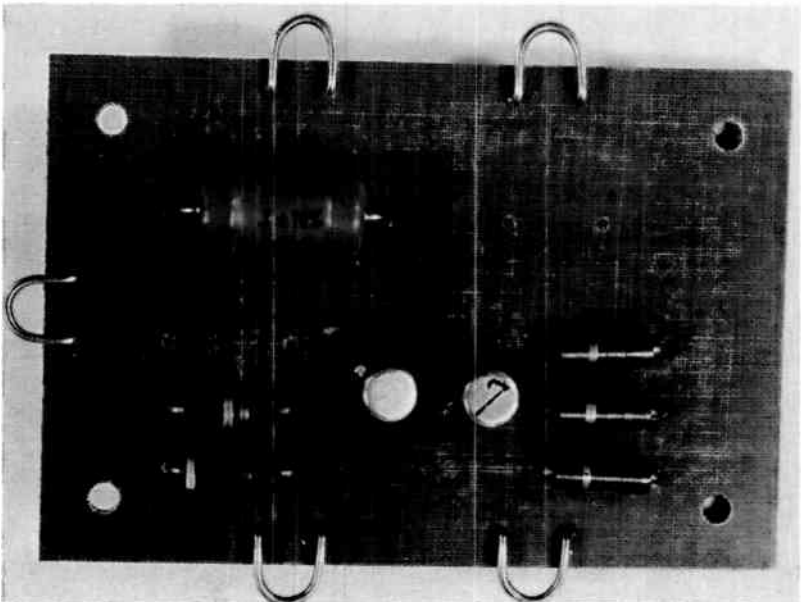

Fig. 142(b) - Completed circuit board for running and stop oscillators.

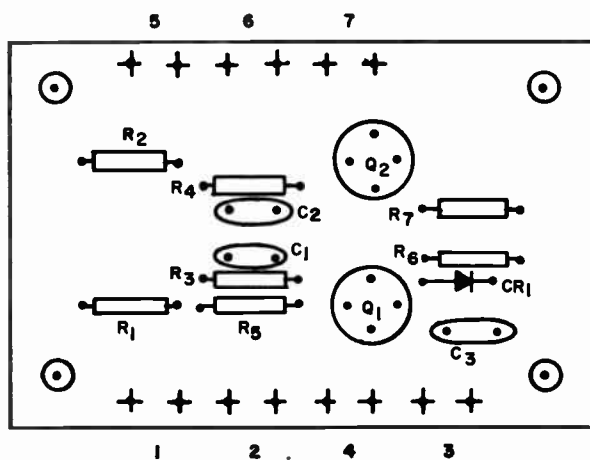

Fig. 143(a) - Component placement diagram for the flip-flop.

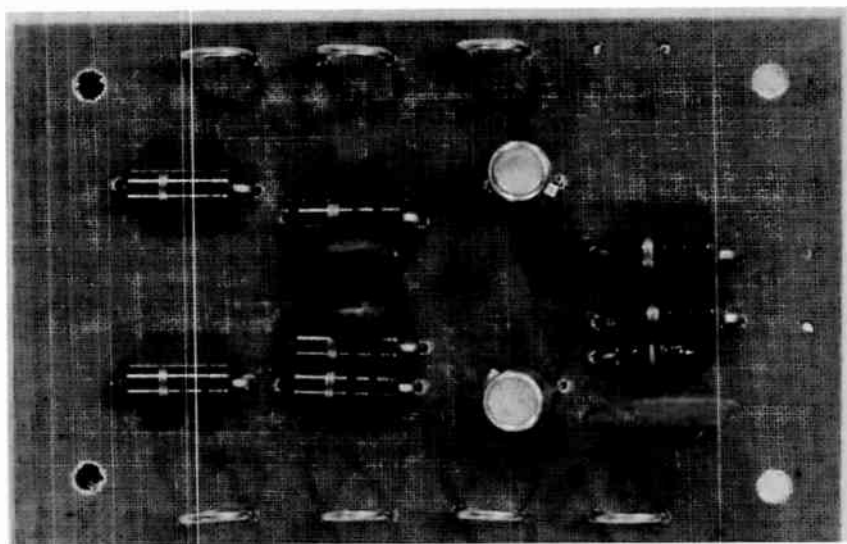

Fig. 143(b) - Completed circuit board for the flip-flop.

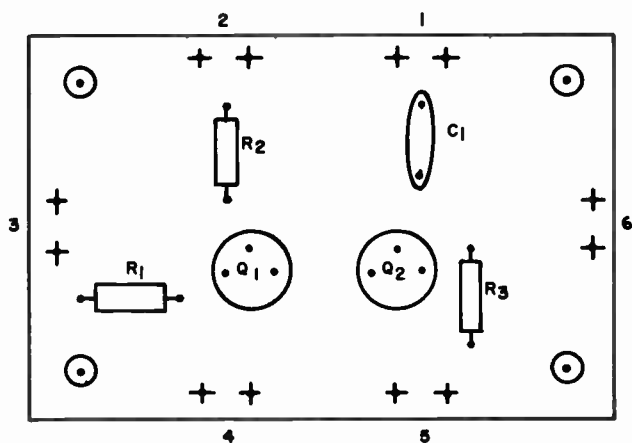

Fig. 144(a) - Component placement diagram for the NAND gates (A, B, C).

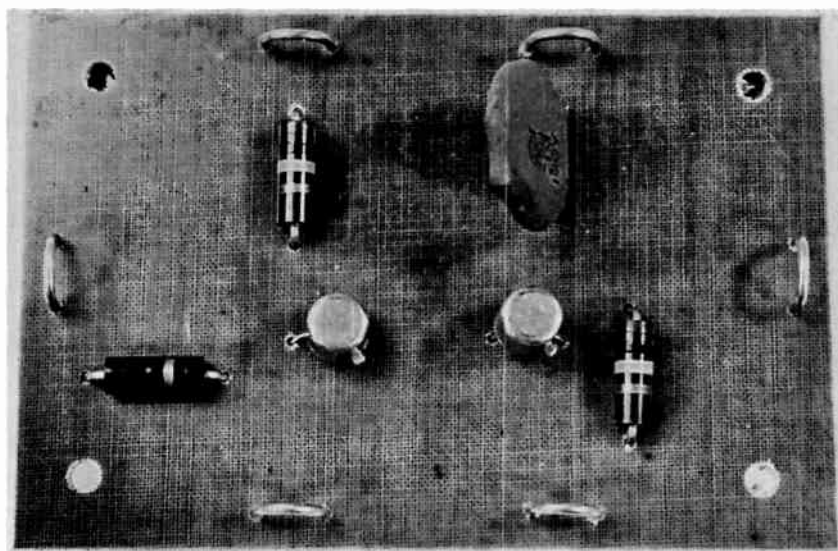

Fig. 144(b) - Completed circuit board for the NAND gates (A, B, C).

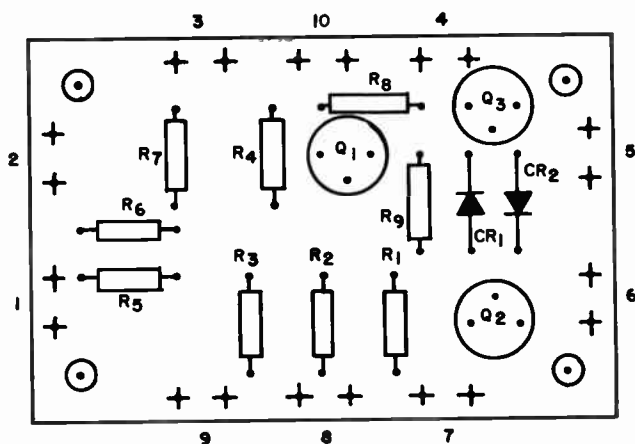

Fig. 145(a) - Component placement diagram for the NOR gate and lamp driver for score 2.

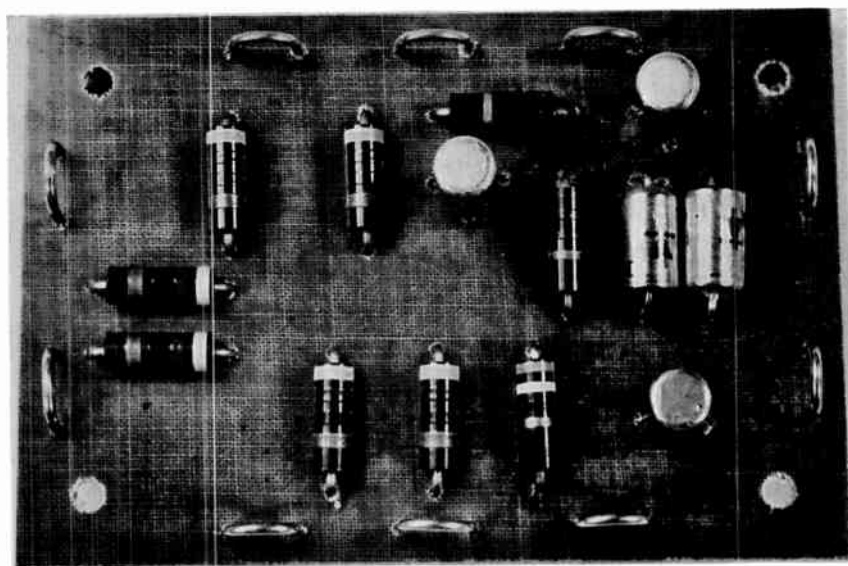

Fig. 145(b) - Completed circuit board for the NOR gate and lamp driver for score 2.

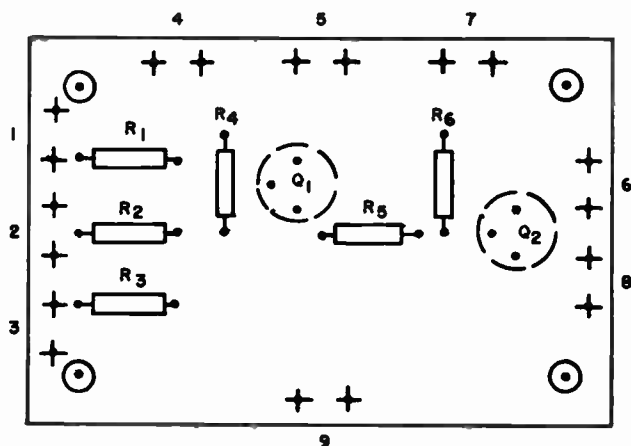

Fig. 146(a) - Component placement diagram for the NOR gate and lamp drivers for scores 10 through 100.

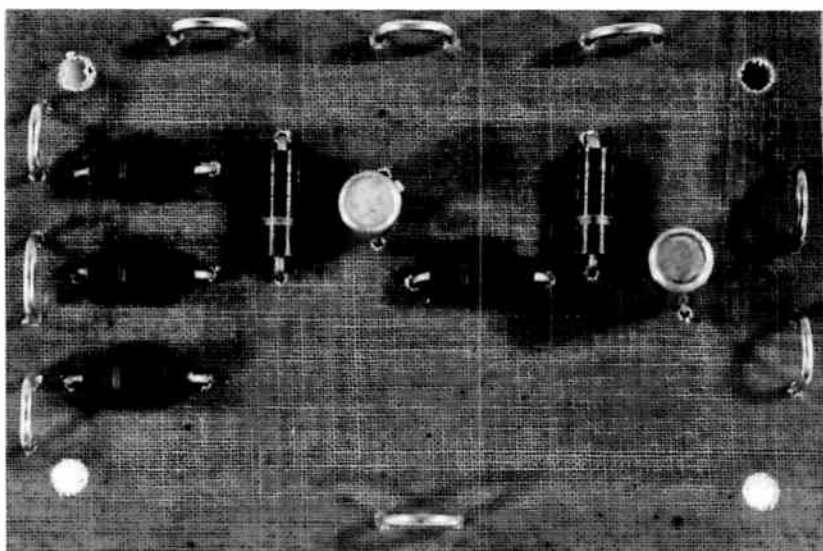

Fig. 146(b) - Completed circuit board for the NOR gate and lamp drivers for scores 10 through 100.

CIRCUIT NO. 24 — ELECTRONIC DIE

The electronic die can display any of the dot patterns that exist on the faces of a conventional die. When the push-button switch is depressed the display lights flash randomly for a few seconds, then stop in a combination representing a number from 1 through 6. If a pair of dice is needed, the single die can be operated twice or a second die can be built; one power supply is sufficient to power a pair of electronic dice. A suggested enclosure for the electronic dice is shown in Fig. 147.

Circuit Operation

The schematic diagrams and parts lists for the electronic die are shown in Figs. 148 and 149.

When push-button switch S_1 (shown in Fig. 148) is depressed, capacitor C_2 charges rapidly to nearly 12 volts; the

resultant current through R_5 is sufficient to start pulser oscillation. The output pulses from the pulser key the shift register (Circuit No. 2) which is connected as a ring counter; i.e., each stage follows the sequence as if placed around a circle or ring. Stage one in the ring generates the number 1, stage two generates the number 2, and so on. Each pulse input to the ring counter advances the counter one stage.

When the push-button switch S_1 is released, C_2 discharges slowly through R_5 and the pulsation rate decreases until oscillation stops. When oscillation has stopped, the arrangement of illuminated lamps on the face of the electronic die remains fixed. The nine-diode "OR" gate shown in Fig. 149 gates the output of the shift register to the lamp drivers and assures that the lamps light in proper sequence.

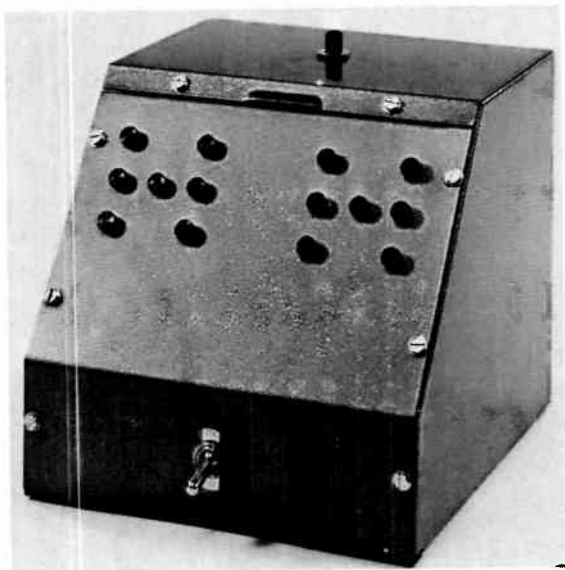
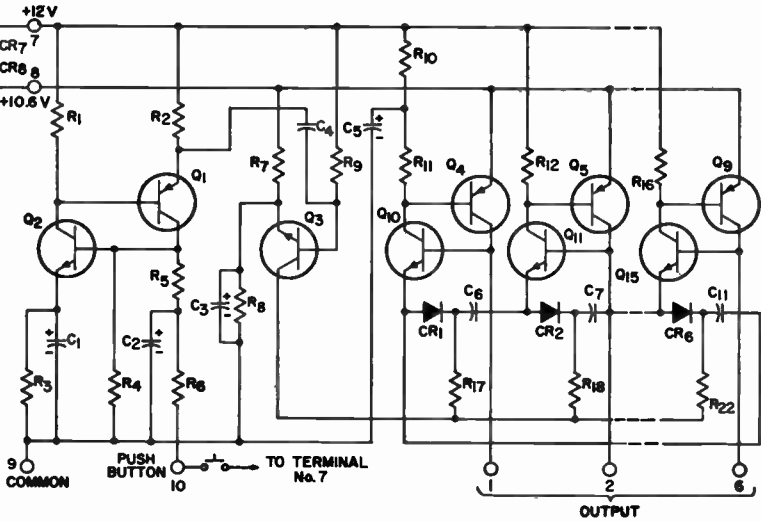

Fig. 147 - A suggested enclosure for the electronic die circuit.



Parts List

C₁ = 1 microfarad, 25 volts, electrolytic
C₂ = 500 microfarads, 25 volts, electrolytic
C₃ = 100 microfarads, 6 volts, electrolytic
C₄, C₅ through C₁₁ = 0.05 microfarad, 25 volts or greater, ceramic
C₆ = 10 microfarads, 25 volts, electrolytic
CR₁ through CR₆ = silicon rectifier, type 1N270
CR₇, CR₈ = silicon rectifier, RCA SK3030
Q₁, Q₄ through Q₉ = transistors, RCA SK3005

Q₂ = transistor, RCA SK3020
Q₃, Q₁₀ through Q₁₅ = transistor, RCA SK3010
R₁ = 1500 ohms, 1/2 watt, 10%
R₂, R₈ = 47 ohms, 1/2 watt, 10%
R₃ = 27,000 ohms, 1/2 watt, 10%
R₄, R₇, R₁₂ through R₁₆ = 1000 ohms, 1/2 watt, 10%
R₅ = 3300 ohms, 1/2 watt, 10%
R₆ = 15 ohms, 1/2 watt, 10%
R₉ = 5600 ohms, 1/2 watt, 10%
R₁₀, R₁₁ = 470 ohms, 1/2 watt, 10%
R₁₇ through R₂₂ = 270 ohms, 1/2 watt, 10%

Fig. 148 - Schematic diagram and parts list for the digital pulser and six-stage shift register.

Fig. 150 shows a modification that must be made to the supply (universal series power supply, circuit No. 1(a))

used to power the electronic die. The modification consists of the addition of diode CR_x between the cathodes of the

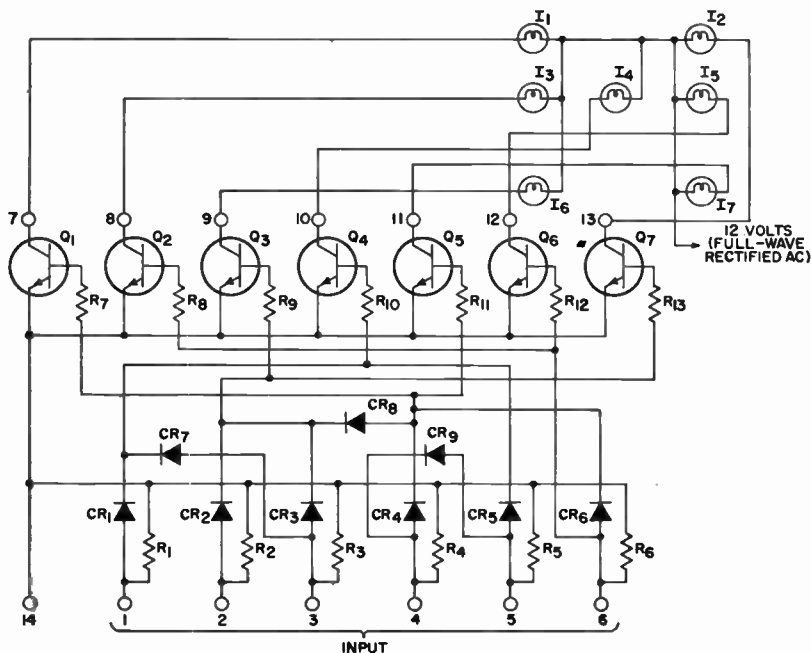

CR₁ through CR₉ = silicon rectifier,
type 1N270

I₁ through I₇ = any 12-volt lamp
drawing 150 milliampers or less

Q₁ through Q₇ = transistor, RCA

SK3020

R₁ through R₆ = 1200 ohms, 1/2
watt, 10%

R₇ through R₁₃ = 680 ohms, 1/2
watt, 10%

Fig. 149 - Schematic diagram and parts list for the indicator-lamp gate and driver circuit.

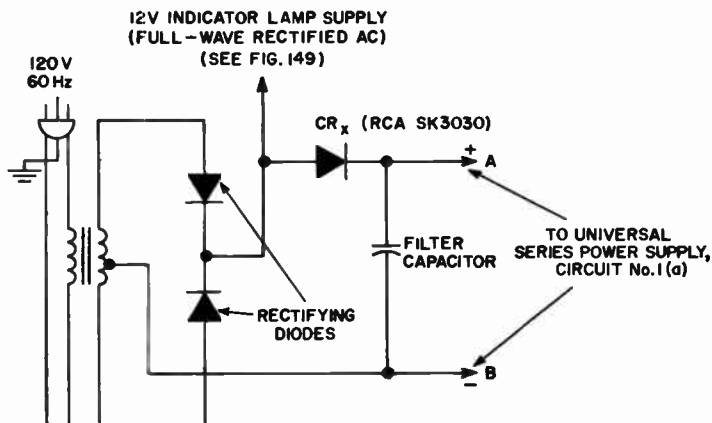

Fig. 150 - Universal series power supply (Circuit No. 1(a)) modified to suit power requirements of the electronic die.

rectifiers and the filter capacitor. Terminal 14 of the die circuit is connected as shown. The electronic-die display lamps receive full-wave rectified current through the rectifying diodes. CR_x in Fig. 150 prevents the filter capacitor from discharging back through the diodes and into the lamp circuit, a condition that would increase the ripple-voltage output of the supply. The presence of CR_x also makes possible use of a C_1 with a smaller electrical capacitance than would otherwise be suitable.

Construction

The design of the electronic die incorporates a power supply and three basic modules: the digital pulser, the shift register, and the lamp module. Drilling templates for these circuits are shown at the back of the Manual; photographs of the completed circuit boards and component placement diagrams are shown in Figs. 151 and 152. The arrangement of components is not critical; a circuit layout different from that suggested may be used.

CIRCUIT NO. 25—METAL DETECTOR

This circuit can be used to locate buried metal objects, such as water or gas pipes, and metal objects such as coins lost in grass, loose earth, or sand. When no metal is near, a steady tone is heard in the headphones connected to the metal detector. When metal is present, the tone either changes or cuts off completely, depending on how the detector is set. The detector locates metal; it does not determine the size or the depth below the surface of that metal.

Circuit Operation

The schematic diagram and parts list for the metal detector are shown in Fig. 153. The circuit consists of two oscillators. The first oscillator, which includes Q_1 , operates at approximately 300 kHz, a frequency determined by inductor L_1 and capacitor C_2 . The second oscillator, which includes Q_2 , operates at a frequency determined by C_{11} and the search coil. L_1 is adjusted so that its frequency of oscillation is

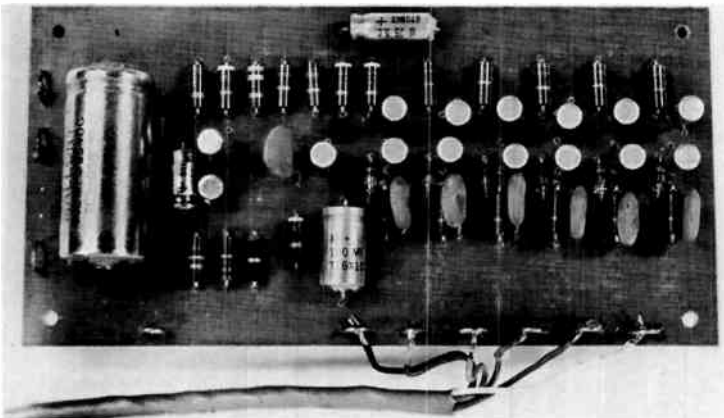

Fig. 151(a) - Completed circuit board for the digital pulser and six-stage shift register.

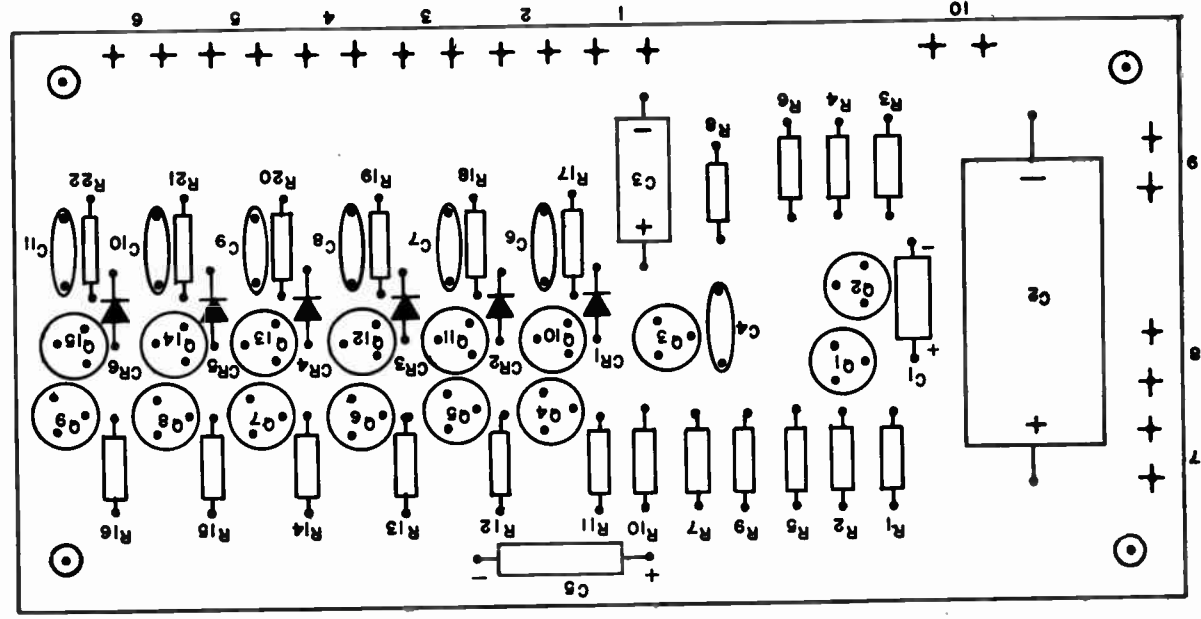

Fig. 151(b) - Component placement diagram for the digital pulser and six-stage shift register.

close to that of the search coil. (The procedure for adjusting L_1 is described below.) The output of the oscillators is fed into a product detector through C_5 and C_6 . The product detector produces an audio signal when there is a difference in frequency between the outputs of the two oscillators. A difference in frequency occurs when the search coil is brought close to a metal object and its inductance, and therefore its frequency of oscillation, is changed. The audio output from the product detector is applied to the base of Q_3 , which amplifies the signal to an audible level.

Adjustments and Operation

With the circuit energized, inductance L_1 is adjusted until a tone is heard in the headphones. Variable capacitor C_{11} , a fine-tuning control, is used as an aid in achieving maximum sensitivity, a condition signaled by a "motorboating" or "putt-putt" sound in the headphones. The detector is then ready for use. As the search coil is passed slowly over the ground and as close to the ground as possible, a change of tone or the cessation of tone indicates the presence of metal. Damp ground may also cause the tone to change, and may

necessitate readjustment of the detector with the search coil held near the ground. The current drain for this circuit is 3 milliamperes.

Construction

The most critical member of the metal detector is the search coil. The coil consists of 12 turns of No. 24 enameled wire enclosed in a 1-foot-diameter loop of 1/4-inch copper tubing. The ends of the loop should be about 2 inches apart at the beginning of search-coil construction and should not be electrically connected. To form the turns within the tubing, one end of the No. 24 wire is fed into one end of the copper tubing and pushed through until it emerges from the other end. The end of the wire that has just emerged is reinserted into the tubing and pushed through as before. This process is repeated until there are 12 turns of wire within the loop. When this task is completed, the loop must be closed so that there is a space of only 1/4 inch between the ends. The loop can be closed by pulling on the ends of the wire within the loop. One end of the wire and the braided conductor of the coaxial cable should then be connected

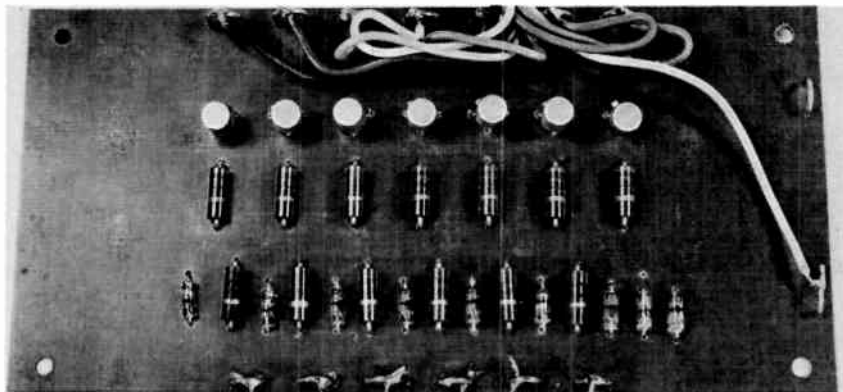

Fig. 152(a) - Completed circuit board for the indicator-lamp gate and driver circuit.

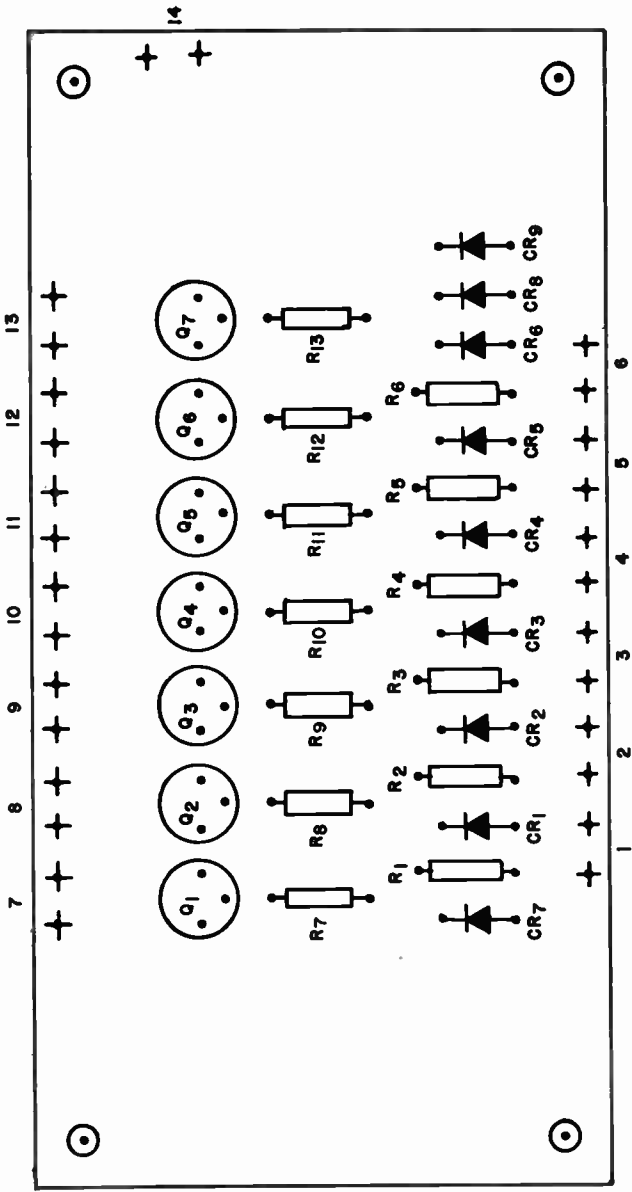
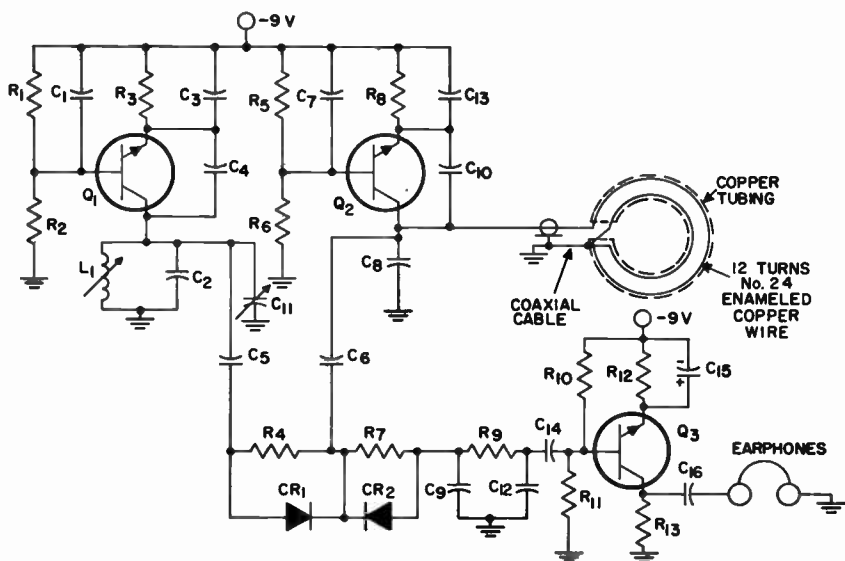

Fig. 152(b) - Component placement diagram for the indicator-lamp gate and driver circuit.



Parts List

$C_1 C_7 C_{14}$ = 0.01 microfarad, 25 volts or greater

C_2 = 1800 picofarads, 25 volts or greater

$C_3 C_{13}$ = 3900 picofarads, 25 volts or greater

$C_4 C_9 C_{10}$ = 0.001 microfarad, 25 volts or greater

$C_5 C_6$ = 0.004 microfarad, 25 volts or greater

C_8 = 680 microfarads, 25 volts or greater

C_{11} = 20 picofarads, variable type, Hammarlund No. MAC-20 or equivalent

C_{12} = 0.02 microfarad, 25 volts or greater

C_{15} = 50 microfarads, 6 volts, electrolytic

C_{16} = 0.1 microfarad, 25 volts or greater

$CR_1 CR_2$ = silicon rectifier, type 1N34A

$R_1 R_5$ = 22,000 ohms, 1/2 watt, 10%

$R_2 R_6$ = 47000 ohms, 1/2 watt, 10%

$R_3 R_8$ = 2200 ohms, 1/2 watt, 10%

$R_4 R_7$ = 1 megohm, 1/2 watt, 10%

R_9 = 68,000 ohms, 1/2 watt, 10%

R_{10} = 10,000 ohms, 1/2 watt, 10%

R_{11} = 91,000 ohms, 1/2 watt, 10%

R_{12} = 680 ohms, 1/2 watt, 10%

R_{13} = 6800 ohms, 1/2 watt, 10%

$Q_1 Q_2 Q_3$ = transistor, RCA SK3020

L_1 = 50 to 140 microhonries, adjustable

Copper tubing: 1/4-inch diameter, 3.14 feet (enough for loop of 1-foot diameter)

No. 24 enameled copper wire: about 40 feet (enough for 12 turns of 1-foot diameter and connections)

Coaxial cable: about 3 feet (exact amount depends on length of handle)

Earphones = 200 ohms

Fig. 153 - Schematic diagram and parts list for the metal detector.

to one end of the copper loop. The other end of the wire should be connected to the center wire of the coaxial cable. Fig. 154 shows a finished search coil.

A handle must then be connected to the search coil as shown in Fig. 154. Metal fasteners should not be used in

the area of the coil. The circuit portion of the detector should be mounted as far as possible from the search coil; a good location is on the upper part of the handle. Layout of the detector circuit is not critical; however, it should be mounted in a metal box as shown in Fig. 155.

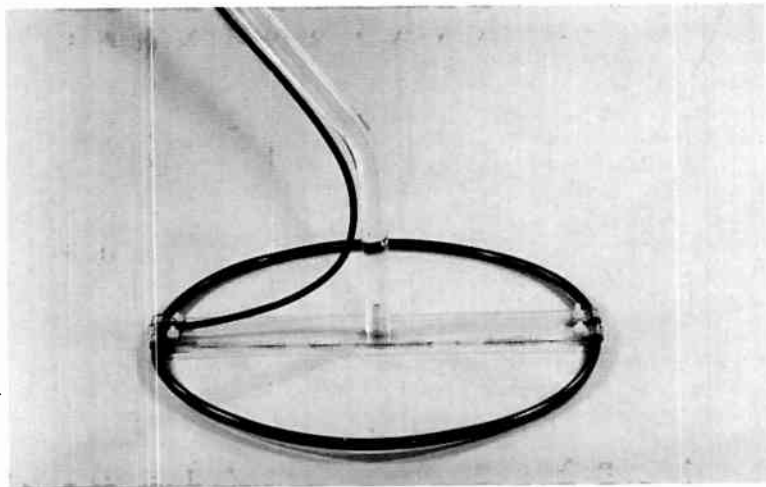

Fig. 154 - A completed search coil with handle attached.

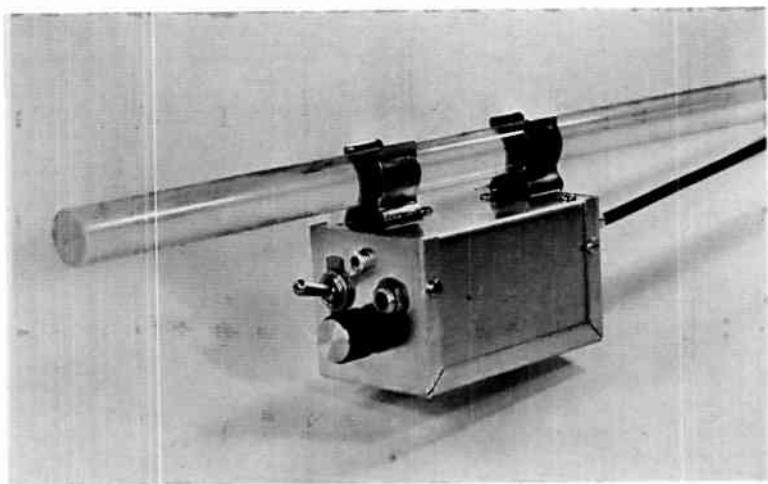

Fig. 155 - A suggested enclosure for the metal-detector circuit.

CIRCUIT NO. 26 —DIP/WAVE METER

One of the most useful instruments available to the electronics experimenter working in rf is the MOS field-effect transistor dip/wave meter. A photograph of the unit is shown in Fig. 156. The meter is essentially an oscillator that can be used to measure resonant frequencies. With the power switch OFF the meter becomes an absorption-type wavemeter that measures the resonant frequency of energized rf circuits; with the power switch ON, the meter measures the resonant frequency of unenergized rf circuits. Then, if the inductance of the circuit is known, the capacitance can be calculated; if the capacitance is known the inductance can be calculated.

In operation, the coil of the meter is placed close to the tuned circuit to be

measured. Capacitor C_1 is then tuned until a movement of the meter needle is observed. If the dip/wave meter is being used to measure an energized circuit, the needle will jump upward slightly when the frequency of the meter oscillator matches that of the LC circuit being measured. If the dip/wave meter is being used to measure the frequency of an unenergized LC circuit, the needle will dip sharply at the point of resonance. If the meter gives no indication a different meter coil should be tried.

Circuit Operation

Fig. 157 shows the schematic diagram and parts list of the dip/wave meter, which is essentially an MOS field-effect-transistor oscillator.



Fig. 156 - A suggested method of assembling the dip/wave meter.

Oscillator feedback is provided by return of the source to a tap on the coil; transistor operating bias is obtained through the bypassed source resistor R_2 . Oscillator rf voltage is rectified by diode CR_1 and measured with the microammeter M . Potentiometer R_3 adjusts the supply voltage to the oscillator and the intensity of oscillations or sensitivity of the dip/wave meter. R_3 also controls the meter reading. C_1 sets the frequency of the dip/wave meter.

Care should be taken when the

dip/wave meter is being operated as a wave meter not to overdrive the circuit to the extent that the field-effect transistor is subjected to greater gate signals than it is capable of accommodating. This condition is encountered when the meter is deflected beyond full scale.

Power is supplied to the dip/wave meter by a 9-volt transistor battery. The current drain for this circuit is 2 milliamperes maximum.

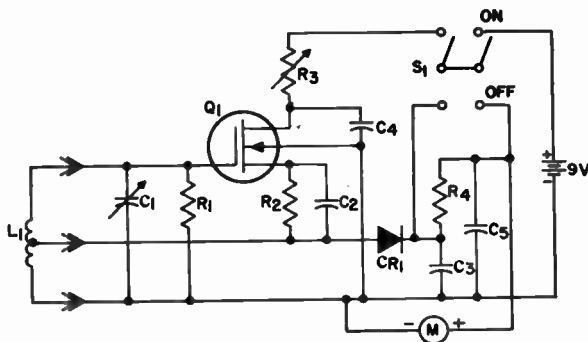

Parts List

Battery = 9-volt transistor type, RCA VS323 or equivalent

C_1 = variable capacitor, 50 picofarads; Hammarlund HF-50 or equivalent

C_2 = 0.01 microfarad, 50 volts or greater, ceramic

C_3 = 0.001 microfarad, 50 volts or greater, ceramic

C_4 = 0.01 microfarad, 50 volts or greater, ceramic

C_5 = 0.01 microfarad, 50 volts or greater, ceramic

CR_1 = silicon rectifier, type 1N914

L_1 = see Table V

M = microammeter, 0 to 100 microamperes

Q_1 = MOS field-effect transistor, type 3N128

R_1 = 47,000 ohms, 1/2 watt, 10%

R_2 = 1000 ohms, 1/2 watt, 10%

R_3 = potentiometer, 10,000 ohms, linear taper

R_4 = 6800 ohms, 1/2 watt, 10%

S_1 = switch, double-pole, double-throw

Fig. 157 - Schematic diagram and parts list for the dip/wave meter.

Construction

The coils used with the dip/wave meter are wound on polyethylene tubing and glued with acrylic cement to a polyethylene bar containing three banana plugs. The ends of the coil are connected to the two end plugs; the

center tap is connected to the center plug. The coil terminals on the dip/wave meter should be recessed so that they cannot be short circuited, a condition that could cause damage to the MOS transistor. A table of typical values is given in Table VI. Fig. 158 shows a number of completed coils.

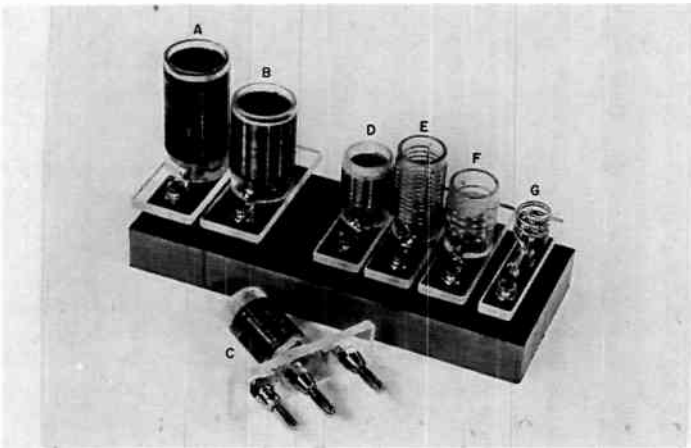

Fig. 158 - Dip/wave meter coils. The coils are described in detail in Table VI.

Table VI.
Dip/Wave Meter Typical Coil Characteristics

Coil*	Inductance (μ H)	Frequency (MHz)		Wire Size	Turns Per Coil	Diameter of Coil (inches)	Length of Coil (inches)	Center- Tap Location (No. of turns from the end)
		Min.	Max.					
A	0.28	1.16	2.25	32 ⁺	120-1/2	1	1-1/2	30-1/4
B	99	2	4.1	30 ⁺	72-1/2	1	1	18-1/4
C	25	3.9	8	28 ⁺	46-1/2	3/4	7/8	12-1/4
D	6.6	7.7	16.1	22 ⁺	19-1/2	3/4	9/16	4-3/4
E	1.7	15.4	32.5	20 [■]	11-1/3	3/4	1	3-1/8
F	0.39	32	66	20 [■]	3-3/4	3/4	1/2	7/8
G	0.16	50	110	12 [■]	3	3/8	1/2	1

*Coils A to D close wound on polyethylene forms; E and F space wound on polyethylene forms; G self supporting. The coils are pictured in Fig. 158.

- + Enameled
- Tin Plated

CIRCUIT NO. 27—VARIABLE - FREQUENCY OSCILLATOR

The variable-frequency oscillator (vfo) circuit can be used with a fixed or mobil radio-amateur transmitter and is capable of excellent performance with minimum frequency drift at frequencies up to and including vhf. Operating potentials can be obtained directly from a 12-volt source, such as an automobile battery, dry battery, or low-voltage power supply (Circuit No. 1(a)). Fig. 159 shows a photograph of the vfo.

Circuit Operation

The schematic diagram and parts list for the variable-frequency oscillator are shown in Fig. 160. This oscillator is basically of the Colpitts type; each of the turning ranges shown in Table VII is band spread over almost all of the turning dial for accurate calibration and resettability. The effect of changes in transistor element capacitance is minimized by use of a voltage

divider consisting of C_4 , C_5 , C_6 , with the transistor connected across C_5 and C_6 . The use of fairly large values for C_5 and C_6 almost completely suppresses the effect of transistor capacitance. A radio-frequency choke L_2 provides the needed low IR drop for the source current of the MOS transistor.

Because the MOS transistor by itself will not provide rectified gate current, a silicon diode, CR_1 , is used in the gate circuit. This diode contributes considerably to the frequency stability of the oscillator by providing automatic bias which tends to compensate for changes in output load and supply voltage.

The vfo output is taken from the source of the MOS transistor through a two-stage negative-feedback amplifier which performs two basic functions:

1. It greatly minimizes the effect on the oscillator of a change in output conditions.



Fig. 159 - Suggested enclosure for the variable-frequency oscillator.

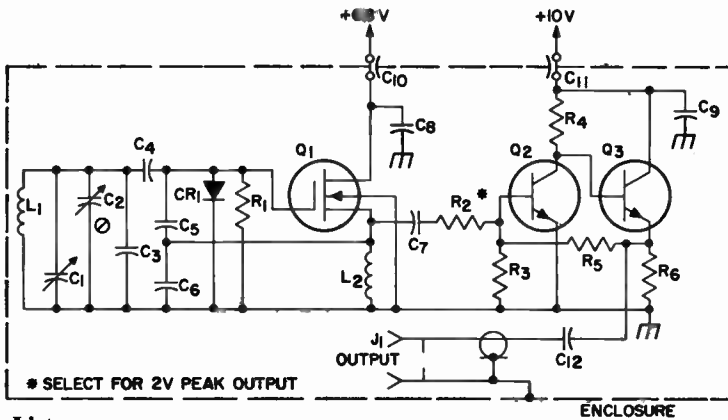

Parts List

C_1 = variable capacitor, high-quality, double-bearing type, Miller 23100 or 23050 or equivalent (See Table VII for value)

C_2 = 25-picofarad air-type trimmer capacitor; Hammarlund APC-25 or equivalent

C_3, C_4, C_5, C_6 = silver mica capacitors, 300 volts (See Table VII for values)

C_7 = 2200 picofarads, 300 volts, silver mica

C_8 = 0.05 picofarad, 50 volts or greater, ceramic disc

C_9 = 0.1 picofarad, 50 volts or greater, ceramic disc

C_{10}, C_{11} = 1500 picofarads, 500 volts, feedthrough type

C_{12} = 0.025 microfarad, 50 volts or greater, ceramic disc

CR_1 = silicon rectifier, type 1N914

J_1 = coaxial connector, chassis-mount vhf type

L_1 = (See Table VII for values)

L_2 = 2.5 millihenries, miniature rf choke, iron core, Millen J300-2500 or equivalent

Q_1 = MOS field effect transistor, type 3N128

Q_2 = transistor, RCA 40245

Q_3 = transistor, RCA SK3020

R_1 = 22,000 ohms, 1/2 watt, 10%

R_2 = 12,000 to 47,000 ohms, 1/2 watt, 10%; select for 2-volt peak output

R_3 = 12,000 ohms, 1/2 watt, 10%

R_4 = 820 ohms, 1/2 watt, 10%

R_5 = 47,000 ohms, 1/2 watt, 10%

R_6 = 240 ohms, 1/2 watt, 10%

Fig. 160 - Schematic diagram and parts list for the variable-frequency oscillator.

2. It provides a convenient means of adjusting the output voltage of the vfo by changing the value of R_2 .

The use of silver-mica capacitors assures a fairly stable temperature characteristic.

Power is supplied to the vfo through two 1500-picofarad feedthrough capacitors. The 10- and 6.8-volt power levels required can be obtained from a modified universal-series supply. The modification is shown in Fig. 161; the universal-series supply is described in

Circuit No. 1 (a).

Construction

The complete vfo should be housed in a 4- by 5- by 6-inch aluminum utility box. The MOS transistor oscillator components of the vfo must be installed in the box with maximum rigidity. This installation can be accomplished by mounting all oscillator components (less the tuned circuits) on a terminal strip (H.H. Smith No. 1070 or equivalent); the two-stage

Table VII.
Tuned-Circuit Data for the VFO

Frequency (MHz)	1.75-1.9	2.5-2.7	3.5-4	5-5.5	8-9
L_1 Inductance (μH)	18.3	9.6	5.4	4.4	2.2
L_1 Total Turns	32	19	17	14-3/4	11-1/2
L_1 Wire Size	24	24	20	20	18
L_1 Turns/Inch	32	32	16	16	8
L_1 Diameter/Inches	1	1	1	1	1
L_1 (B&W No. or equivalent)	3016	3016	3015	3015	3014
C_1 (pF)	75	75	100	50	50
C_2 (pF)	50	50	25	25	25
C_3 (pF)	100	120	100	None	None
C_4 (pF)	470	470	390	390	270
C_5 (pF)	1000	1000	680	680	560
C_6 (pF)	1000	1000	680	680	560

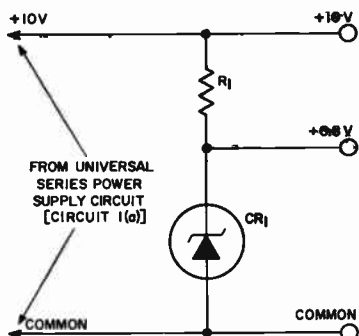

CR_1 = zener diode, 6.8 volts, 1 watt

R_1 = 180 ohms, 1/2 watt, 10%

Fig. 161 - Universal-series-power-supply modification for use with the variable-frequency oscillator circuit.

amplifier can be mounted on a similar strip. This arrangement is shown in Fig. 162. The lower strip in the figure supports the oscillator components; the MOS transistor projects downward from the center of the strip. The upper strip is for the two-stage amplifier; the transistor project upward on either side

of the mounting screw. The short length of coaxial cable runs to the connector on the rear of the aluminum box. The silver-mica capacitors which form part of the tuned circuit must be mounted in such a way that there is no possibility of motion. A photograph of the tuned circuit assembly is shown in Fig 163. In the figure, the tuned circuit is supported by a bent aluminum sheet extending from the front to the rear of the 4- by 5- by 6-inch box. The trimmer capacitor, C_2 , is mounted on the rear wall, as are the coaxial output connector and feedthrough bypass capacitors for the power leads.

A single-pole double-throw switch can be connected in the circuit so that in one position only the vfo power supply is turned on. With the switch in the other position, power is supplied through the main transmitter supply and the vfo is activated by the transmit/receive switch in the transmitter.

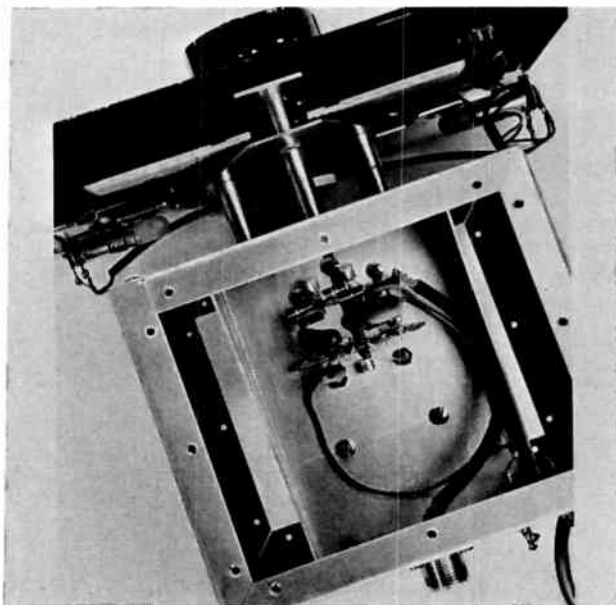

Fig. 162 - Suggested mounting of oscillator and two-stage amplifier components.

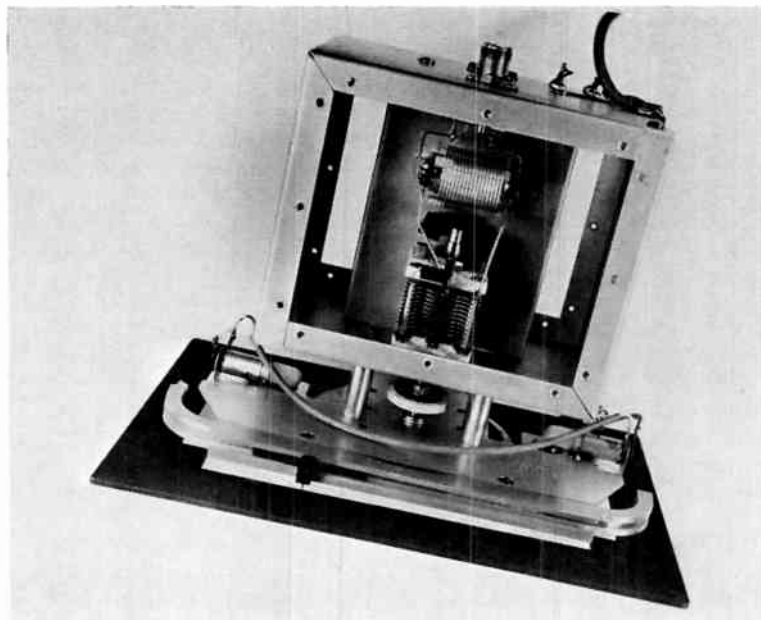

Fig. 163 - Suggested tuned circuit assembly.

CIRCUIT NO. 28—VFO CALIBRATOR

In the vfo calibrator, harmonics of a secondary-standard 100-kHz crystal oscillator are beat with the fundamental, or harmonics, of an external vfo to provide audible signals at definite frequencies across the dial. For example, if this unit is used with a 5.0-to-5.5 MHz vfo, the 100-kHz calibration points are the strongest by far. However, the 50-kHz points are also perceptible and, if proper care is exercised, the 33-, 25-, and 20-kHz points can be detected as well. In practice, the calibrator is permanently connected to the rf line between the vfo and the transmitter. A suggested enclosure for the vfo calibrator is shown in Fig. 164.

Circuit Operation

The schematic diagram and parts list for the vfo calibrator are shown in

Fig. 165. The 100-kHz oscillator, Q_3 , is of the tuned-collector type, with the crystal Y_1 inserted in the base feedback circuit. The 25-picofarad padder capacitor, C_4 (crystal adjust), is connected in series with the crystal so that oscillation can be adjusted to exactly 100 kHz. Capacitors C_7 and C_8 are used as a voltage divider to reduce the coupling to the input of the two-stage wave-shaping amplifier, Q_4 and Q_5 , and thus prevent loading of the secondary-standard oscillator. The two-stage wave-shaping amplifier provides the following advantages:

1. It prevents any reflection of the output load from affecting the frequency of the 100-kHz secondary-standard oscillator.
2. It shapes the output wave so that the harmonics are of greater strength.

The output of the two-stage wave-



Fig. 164 - A suggested enclosure for the vfo calibrator.

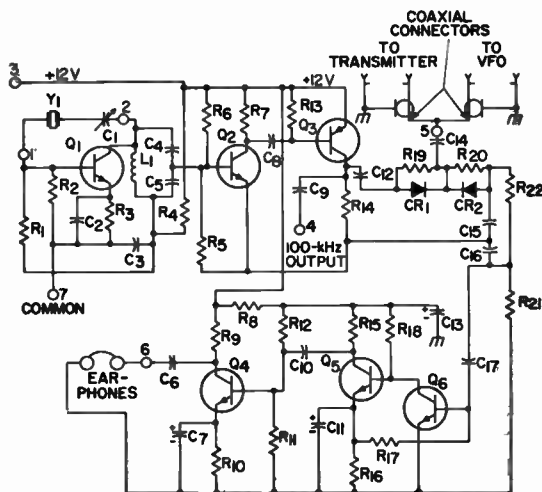

Parts List

C_1 = 25 picofarads, adjustable padder type, air dielectric, Hammarlund APC-25 or equivalent

$C_2 C_3 C_{10}$ = 0.1 microfarad, 25 volts or greater, ceramic

C_4 = 470 picofarads, 500 volts, silver-mica

C_5 = 1200 picofarads, 500 volts, silver-mica

C_6 = 0.25 microfarad, 25 volts or greater, paper

$C_7 C_{11}$ = 50 microfarads, 6 volts, electrolytic

C_8 = 0.001 microfarad, 25 volts or greater, ceramic

C_9 = 100 picofarads, 25 volts or greater, ceramic

$C_{12} C_{15}$ = 0.0022 microfarad, 25 volts or greater, ceramic

C_{13} = 500 microfarads, 15 volts, electrolytic

C_{14} = 22 picofarads, 25 volts or greater, ceramic

C_{16} = 0.05 microfarad, 25 volts or greater, ceramic

C_{17} = 0.03 microfarad, 25 volts or greater, ceramic

$CR_1 CR_2$ = silver rectifier, type 1N34A

L_1 = RF choke, 10 millihenries, Miller 70F-102A1 or equivalent

$Q_1 Q_2 Q_4 Q_5 Q_6$ = transistor, RCA SK3020

Q_3 = transistor, RCA SK3005

$R_1 R_4$ = 82,000 ohms, 1/2 watt, 10%

R_2 = 22,000 ohms, 1/2 watt, 10%

R_3 = 4 700 ohms, 1/2 watt, 10%

$R_5 R_{12} R_{13}$ = 47,000 ohms, 1/2 watt, 10%

R_6 = 120,000 ohms, 1/2 watt, 10%

$R_7 R_9 R_{14} R_{15}$ = 2700 ohms, 1/2 watt, 10%

$R_8 R_{10}$ = 470 ohms, 1/2 watt, 10%

R_{11} = 6800 ohms, 1/2 watt, 10%

R_{16} = 330 ohms, 1/2 watt, 10%

$R_{17} R_{18} R_{21}$ = 10,000 ohms, 1/2 watt, 10%

$R_{19} R_{20}$ = 1 megohm, 1/2 watt, 10%

R_{22} = 68,000 ohms, 1/2 watt, 10%

Y_1 = crystal, Valpey-Fisher type VR-13 or equivalent (calibrated at 100 kHz, service mode)

Earphones = 600 ohms or more

Fig. 165 - Schematic diagram and parts list for the vfo calibrator.

shaping amplifier is connected to one input of a two-diode product detector, CR₄ and CR₅, and the vfo to be calibrated is connected to the other input. The wave-shaping amplifier output is connected in such a way that the unit can be used as a conventional 100-kHz crystal calibrator. The values of the components shown in the parts list have been chosen for a vfo signal of 2 to 3 volts. For larger signals, the 22-picofarad capacitor C₁₇ must be replaced with some type of capacitance or resistive attenuator.

A three-stage audio amplifier consisting of Q₆, Q₇, and Q₈ is used to amplify the extremely low audio output of the two-diode product detector to a comfortable head-phone level.

The crystal socket and the air capacitor used for setting the frequency should be mounted on a small piece of aluminum and attached to one end of the circuit board. If a metal enclosure is used, the circuit board should be separated from it by at least 3/8 of an inch. RF connections to the vfo and transmitter can be made through standard coaxial connectors.

Adjustments and Operation

The adjustment of the 100-kHz secondary-standard oscillator to precisely 100-kHz is easily accomplished by comparison of its harmonic with that of the primary standard, WWV*. For the best beat signal, the 100-kHz output of the calibrator should be loosely coupled to the antenna of the receiver tuned to WWV. Capacitor C₄ should then be adjusted through the crystal-adjustment hole until a zero beat exists between the secondary

standard and WWV. It would be well to wait for the quiet period of WWV's transmission (when there is no 440-Hz modulation) to be absolutely certain that the secondary standard is beating with the carrier and not with one of the sidebands.

The calibrator is very easy to use. It is inserted in the rf line of the vfo by connecting the vfo to the input coaxial connector and the transmitter to the output connector. When power is applied to the unit, a slight hissing noise should be heard in the earphones. This noise indicates that the audio amplifier is active. At, or near, the even 100-kHz points on the vfo, low beat notes should be heard. Calibration of the dial can then be performed by zero-beating the vfo at those points. Lower-volume beats may be heard at the 50-kHz points on the dial, and in most cases it is also possible to hear the 33-, 25-, and 20-kHz beats, especially if the fundamental operating frequency of the vfo is below 5 MHz.

With many of today's amateur-radio receivers designed solely for hamband reception, the vfo calibrator is especially applicable to oscillators operating at frequencies outside the hambands. In addition, the unit can prove very useful for calibrating certain types of test equipment and for allowing the vfo to be used as a hamband frequency meter. The 100-kHz output can be used to calibrate receivers and test equipment such as grid dip meters.

Construction

The 100-kHz crystal oscillator, the two-stage wave-shaping amplifier, the diode product detector, and the three-stage audio amplifier are all assembled on a 3- by 4-1/2- inch phenolic circuit board. This method of construction results in a rugged, compact instru-

**The Radio Amateur's Handbook*. American Radio Relay League, Newington, Conn.

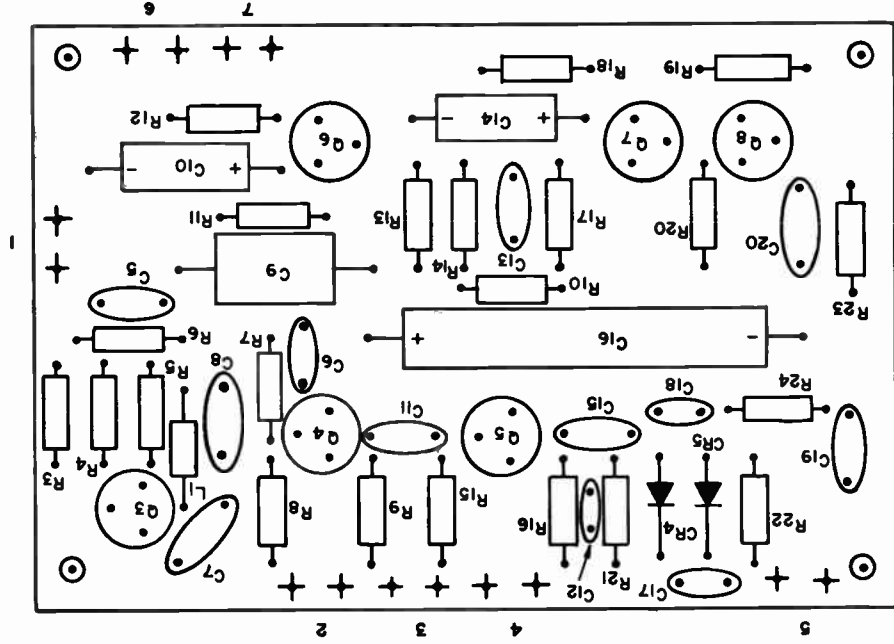

Fig. 166 - Component placement diagram for the vfo calibrator.

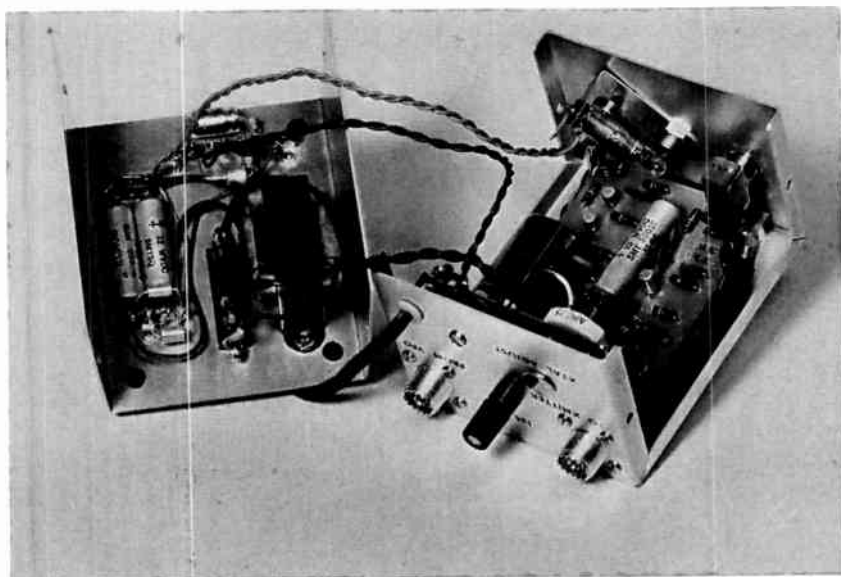

Fig. 167 - The vfo calibrator assembly. Power supply components are mounted on the bottom cover of the aluminum enclosure.

ment. The drilling template for the vfo calibrator is shown in the back of this Manual; a component placement dia-

gram and a photograph of a completed assembly are shown in Figs. 166 and 167, respectively.

CIRCUIT NO. 29—MOTOR-SPEED CONTROL

The motor-speed-control circuit provides both speed control and speed regulation (constant speed under conditions of changing load) for ac/dc universal motors (motors that are series wound). The circuit also provides smooth anti-skip operation at reduced speeds and is useful for adjusting and regulating the speed of power tools, such as drills, buffers, jigsaws; hair dryers; floor polishers; and commercial food mixers. When the circuit is used with a power drill, the speed of the motor can be made slow enough so that the drill can be used as a screwdriver.

The motor-speed-control circuit is suitable for use with motors that have nameplate ratings up to 6 amperes.

Motor speed can be adjusted from complete cutoff to essentially full rated value.

Circuit Operation

The schematic diagram and parts list for the motor-speed control are shown in Fig. 168. Motor speed is determined by the time that one of the SCR's conducts during each half-cycle of ac input. This time is controlled by adjustment of the potentiometer.

When the potentiometer is set for minimum resistance (control knob in maximum clockwise position), capacitor C_4 charges very rapidly and the triggering-voltage level of the two-transistor regenerative switch is

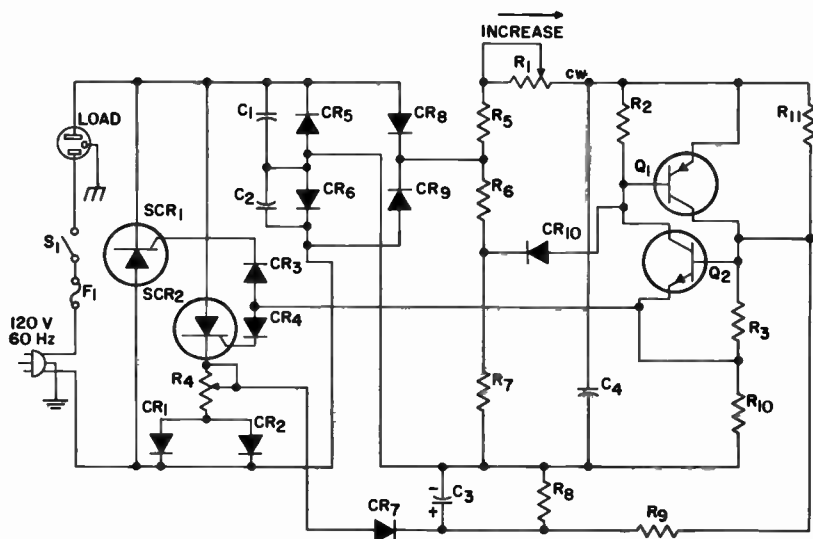

Parts List

C_1 C_2 = 0.01 microfarad, 1000 volts, ceramic

C_3 = 250 microfarads, 6 volts, electrolytic

C_4 = 1 microfarad, 200 volts, ceramic

CR_1 CR_2^* = silicon rectifier, RCA SK3016 mounted in a fuse clip for heat sinking

CR_3 through CR_{10}^* = silicon rectifier, RCA SK3030

F_1 = fuse, 125 volts, 1 ampere, rating depends on intended load

Q_1 = transistor, RCA SK3005

Q_2 = transistor, RCA SK3020

R_1 = potentiometer, 100,000 ohms, 2 watts, linear taper

R_2 = 150 ohms, 1/2 watt, 10%

R_3 R_8 = 470 ohms, 1/2 watt, 10%

R_4 = adjustable resistor, 1 ohm, 25 watts, Ohmite No. 0360 or equivalent

R_5 R_7 = 1000 ohms, 1/2 watt, 10%

R_6 = 15,000 ohms, 1 watt, 10%

R_9 R_{11} = 5600 ohms, 1/2 watt, 10%

R_{10} = 100 ohms, 1/2 watt, 10%

S_1 = switch, 125 volts, 6 amperes, single-pole, single-throw

SCR_1 SCR_2^* = silicon controlled rectifier RCA KD2100

*These components are available in two KD2105 RCA Silicon Controlled Rectifier Experimenter's Kits.

Fig. 168 - Schematic diagram and parts list for the motor-speed control.

reached early in each half-cycle. When the transistors in the regenerative switch start conducting, capacitor C_4 discharges rapidly through the series circuit made up of the transistors and resistor R_{10} . The capacitor discharge

causes a pulse across the parallel circuit composed of R_{10} and the gate circuits of the SCR's. If the anode of SCR_1 is positive with respect to the cathode, the anodes of diodes CR_5 and CR_9 are also positive with respect to

their cathodes and the diodes conduct. A conduction path then exists between the junction of C_4 and R_{10} and the cathode of SCR_1 through CR_5 . The pulse appearing across the parallel combination of R_{10} and the SCR_1 gate circuit (CR_5 , the gate, and C_4) causes SCR_1 to conduct. At the same time, SCR_2 is non-conducting because its anode is negative with respect to its cathode; CR_6 and CR_8 are non-conducting for the same reason. Reverse polarity on SCR_2 , CR_6 , and CR_8 applies a reverse polarity to CR_4 and prevents the pulse from R_{10} from reaching the SCR_2 gate.

During the next half-cycle, the polarity of the power source reverses, and SCR_2 becomes the conducting SCR; SCR_1 becomes the non-conducting SCR.

As the resistance of the potentiometer is increased, the time required to charge C_4 to the triggering potential of the regenerative switch becomes longer, and the pulse is produced later in the half-cycle, or not at all if the charge on C_4 does not reach triggering level. Therefore, the speed of the universal motor can be controlled by the position of the potentiometer knob.

When the mechanical load on the motor is increased, the motor demands more current. The increase in current causes an increase in voltage across the

1-ohm adjustable sensing resistor R_4 . This voltage is fed back through diode CR_7 and resistor R_9 to the base of Q_2 , one of the components of the regenerative switch. The application of this voltage to the base of Q_2 reduces the triggering voltage required by the regenerative switch and causes it to conduct earlier in the half-cycle. Thus, more power is delivered to the motor so that it can maintain a constant speed. Diodes CR_1 and CR_2 prevent current from flowing through R_4 to the feedback network during the half-cycle in which SCR_2 is not conducting. Resistor R_4 is set according to motor nameplate rating or load current; the proper setting for this resistor can be determined from the curve shown in Fig. 169.

Diode CR_{10} is used to prevent improper timing of the triggering circuit when the potentiometer is set high enough so that C_4 does not reach triggering voltage. If the charge on C_1 has not reached triggering potential at the end of a half-cycle, this diode triggers the regenerative switch into conduction so that any residual charge on C_4 is dissipated. The anti-skip circuit composed of CR_{10} and R_7 ensures that each half-cycle of operation starts under the same conditions and thus provides smooth, continuous motor operation.

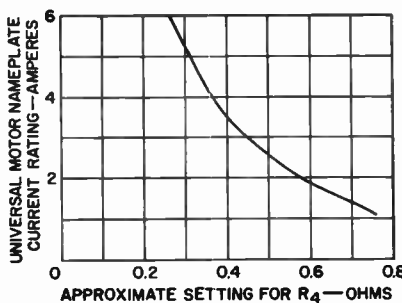

Fig. 169 - Approximate setting of R_4 for various motor nameplate ratings.

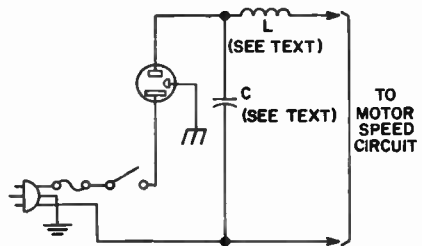

Fig. 170 - Schematic diagram of L-filter connections.

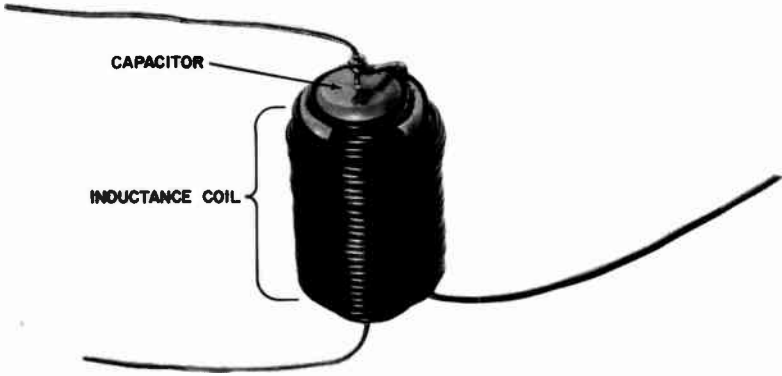

Fig. 171 - Photograph of the L-filter to reduce radio-frequency interference.

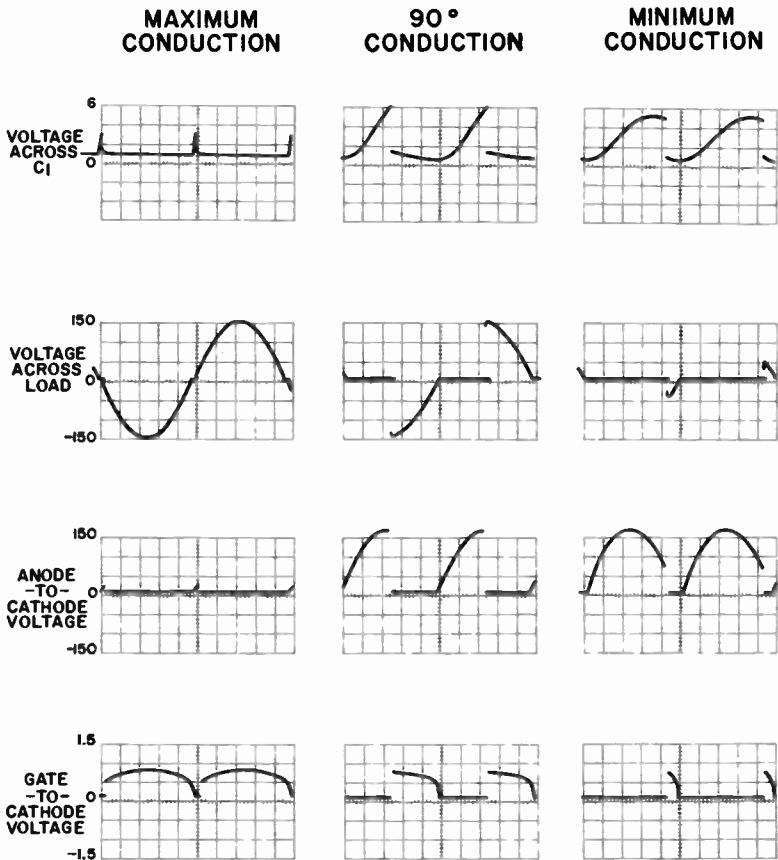

Fig. 172 - Typical waveshapes taken at various points in the motor-speed-control circuit.

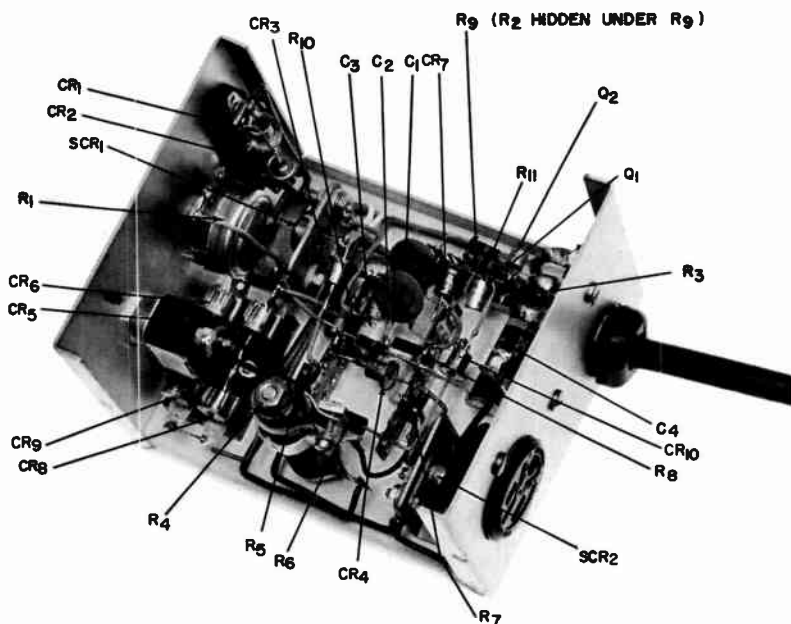

Fig. 173 - A suggested method of constructing the motor-speed control in a 3- by 4- by 5-inch aluminum box.

Adjustments and Special Considerations

This circuit may produce some radio-frequency interference; such interference can be minimized by the installation of an L-filter between the circuit and the voltage source and load as shown in Fig. 170. The filter consists of about 18 feet of No. 18E wire "scramble" or random-wound on a 0.5-inch-diameter rod, and a 0.05-microfarad 200-volt paper capacitor. If desired, the capacitor can be used as the core of the coil instead of the rod. If this method is used, a 600-volt capacitor should be used instead of a 200-volt type. The larger 600-volt capacitor is used only because it provides a better physical core size. Fig. 171 is a photograph of the L-filter.

Operation of single-speed motors at reduced speeds should be limited to relatively short periods. Most motors intended for single-speed operation depend on the air flow provided by a built-in fan to keep the temperature rise within acceptable limits. When the motor speed is reduced, this air flow also decreases, and the motor may become overheated.

The waveshapes shown in Fig. 172 are typical of those present at various points in the motor-speed-control circuit.

Construction

A suggested method of constructing the motor-speed-control in a 3- by 4- by 5-inch aluminum box is shown in Fig. 173.

CIRCUIT NO. 30—MODEL TRAIN AND RACE CAR SPEED CONTROL

The model train and race-car speed control provides continuous and smooth control (from stop to full speed) of most model railroad trains, race cars, and similar "hobby"-type vehicles designed to operate at dc voltage up to 12 volts.

Circuit Operation

The schematic diagram and parts list for the model train and race-car speed control are shown in Fig. 174. The operating speed of the model railroad train or race car with which this circuit is used is determined by the delay involved in triggering the SCR into conduction after the start of each half-cycle of ac input voltage. This delay time, in turn, is controlled by adjustment of the potentiometer R_1 . Because the load and the SCR are in parallel, output voltage is available at the load only when the SCR is not conducting. When the control knob is set to its maximum clockwise position, therefore, maximum delay in triggering the SCR is obtained and maximum speed is attained in the model vehicle.

When switch S_1 is closed, the pulsating direct current from the bridge rectifier charges capacitor C_2 through resistor R_2 and diode CR_5 , and a voltage appears across the output terminals. Under conditions of minimum conduction of the SCR (approximately 55 percent of each input half-cycle of voltage), a maximum voltage of approximately 13 volts is present at the output terminals. As the control knob is turned in a counterclockwise direction, the resistance of R_1 is decreased and the current through R_1 , R_3 , and R_6 charges capacitor C_1 more quickly to the triggering potential of the two-transistor regenerative switch. The switch, in turn, triggers the SCR into

conduction, and the voltage across the output terminals drops to slightly less than one volt when the control knob is in the most counterclockwise position.

Because capacitor C_2 performs an integrating function, the output voltage approaches a steady dc level determined by the relative duration of the "ON" and "OFF" periods of the SCR. The silicon rectifier CR_5 isolates the anode of the SCR from the potential on C_2 so that the capacitor cannot discharge through the SCR when it is triggered into conduction and so that the anode voltage falls to zero and turns off the SCR at the end of each input half-cycle. Resistor R_7 helps to stabilize the operation of the SCR, and also provides a parallel path for discharge of C_1 after the SCR is triggered into conduction. Resistor R_2 limits the current through the bridge rectifier circuit to the maximum allowable value of two amperes in the event of a short circuit across the output terminals.

The parallel arrangement of the load and the SCR in this circuit provides superior control and speed regulation at the operating voltages of model vehicles. The circuit is inherently self-regulating, i.e., it maintains essentially constant speed under varying load conditions. When the mechanical load increases, (e.g., when the vehicle travels on an inclined portion of the track or road), the vehicle motor tends to slow down. The motor current then increases, and the voltage across capacitor C_2 decreases. However, because this voltage is also the potential for the timing circuit (R_1 , R_3 , R_6 , and C_1), the capacitor C_1 charges more slowly and the delay in triggering the SCR is increased. As a result, the output voltage is also increased and the speed is maintained essentially constant.

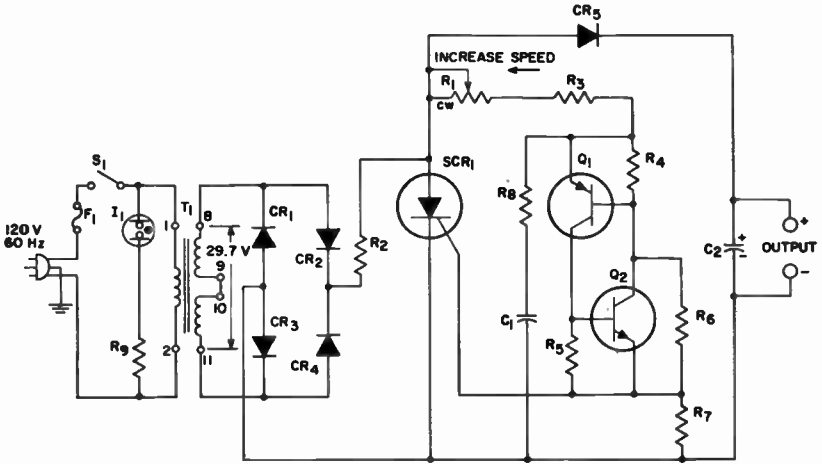

Parts List

C_1 = 1 microfarad, 200 volts, paper

C_2 = 1000 microfarads, 25 volts, electrolytic

$CR_1, CR_2, CR_3, CR_4, CR_5^*$ = silicon rectifier, RCA SK3016, mounted in fuse clips for heat sinking

F_1 = fuse, 125 volts 1 ampere,

I_1 = lamp, neon, NE-2 or equivalent

Q_1 = transistor, RCA SK3005

Q_2 = transistor, RCA SK3020

R_1 = potentiometer, 1000 ohms, 2

watts, linear taper

R_2 = 15 ohms, 60 watts (three 5-ohm 20-watt resistors connected in series)

R_3, R_7 = 100 ohms, 1/2 watt, 10%

R_4 = 150 ohms, 1/2 watt, 10%

R_5 = 470 ohms, 1/2 watt, 10%

R_6 = 1000 ohms, 1/2 watt, 10%

R_8 = 15 ohms, 1/2 watt, 10%

R_9 = 47,000 ohms, 1/2 watt, 10%

S_1 = switch, 125 volts, 1 ampere, single-pole, single-throw

SCR_1^* = silicon controlled rectifier, RCA KD2100

T_1 = power transformer, Stancor No. RT-202 or equivalent

*These components are available in a single KD2105 RCA Silicon Controlled Rectifier Experimenter's Kit.

Fig. 174 - Schematic diagram and parts list for model train and race-car speed control.

Fig. 175 shows the waveshapes across the SCR (from anode to cathode) for one cycle of input voltage at (a) full speed, (b) half speed, and (c) zero speed. At the start of each half-cycle (point 1), the SCR is off. The anode voltage then follows the increasing sine wave until it equals the voltage on capacitor C_2 (point 2). The diode

CR_5 then starts to conduct, and C_2 charges until the SCR is triggered into conduction (point 3) by the timing portion of the circuit. At the start of conduction, the anode drops to 0.6 volt (point 4), the diode CR_5 stops conducting, and capacitor C_2 discharges into the load until point 2 of the next half-cycle.

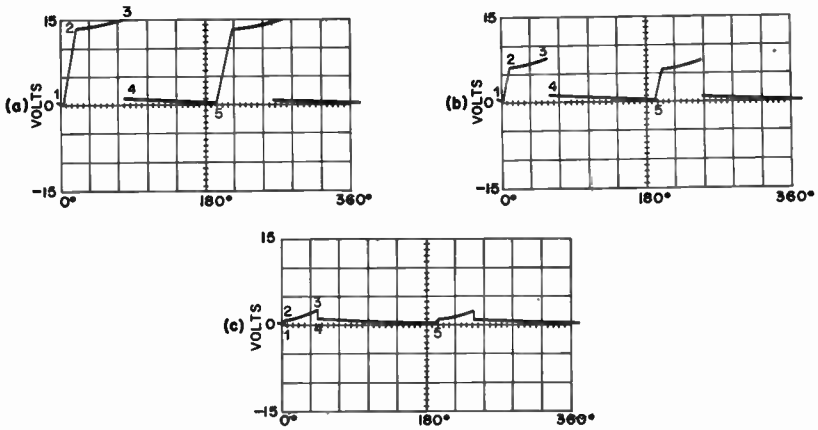

Fig. 175 - Typical waveshapes across the SCR in the model train and race-car speed control at (a) full speed, (b) half speed, and (c) zero speed.

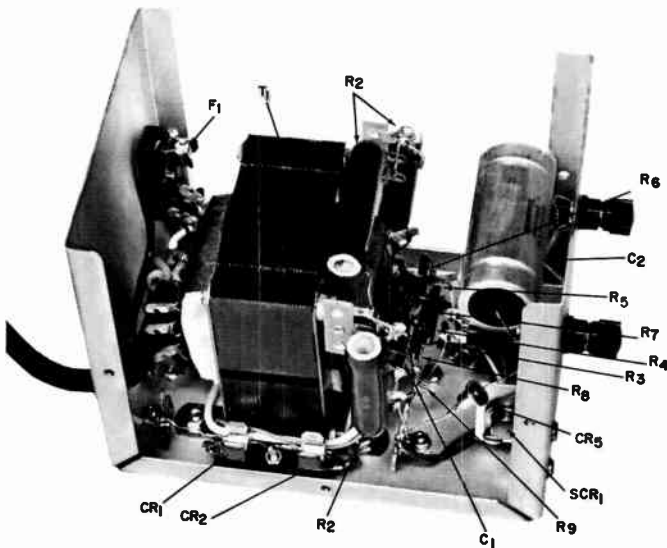

Fig. 176 - The model train and race-car speed control assembled in a 3-by-4-by-5-inch aluminum box. Components not identified are hidden.

The SCR stops conducting when the input voltage drops to zero at the end of the half-cycle (point 5). The load-voltage waveshape is described by the charge and discharge paths of capacitor C_2 .

Construction

Fig. 176 shows a model train and race-car speed control assembled in a 3-by-4-by-5-inch aluminum box.

CIRCUIT NO. 31—ELECTRONIC FLASHER

The electronic flasher circuit supplies power in short on-off pulses to ac/dc devices that have total power ratings up to 240 watts (nameplate current ratings up to two amperes) and that do not use the frame of the device as a ground. The time of each "ON" pulse is fixed at approximately one-half second. The time of each "OFF" pulse can be adjusted to provide the

desired number of "ON" pulses per minute.

This circuit is useful for controlling the flashing of incandescent-lamp loads (e.g., in Christmas-tree decorations, advertising signs, warning signals, and flashing tower lights) and for actuating an auditory device (e.g., an alarm bell).

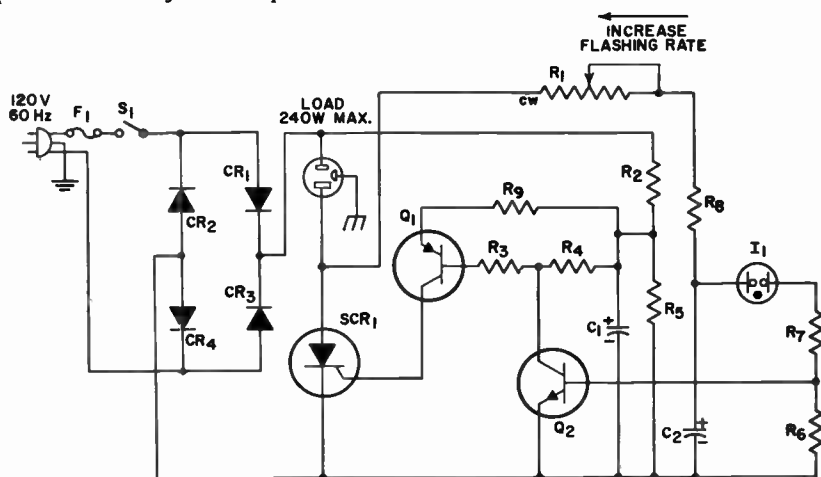

Parts List

C_1 = 50 microfarads, 15 volts, electrolytic

C_2 = 50 microfarads, 150 volts, electrolytic

CR_1 CR_2 CR_3 CR_4 * = silicon rectifier, RCA SK3016 mounted in fuse clips for heat sinking

F_1 = fuse, 125 volts, 3 amperes

I_1 = lamp, neon, NE-83 or equivalent

Q_1 = transistor, RCA SK3005

Q_2 = transistor, RCA SK3020

R_1 = potentiometer, 10,000 ohms, 2 watts, linear taper

R_2 = 3000 ohms, 5 watts, 10%

R_3 R_4 = 2200 ohms, 1/2 watt, 10%

R_5 = 680 ohms, 1/2 watt, 10%

R_6 = 47,000 ohms, 1/2 watt, 10%

R_7 = 4700 ohms, 1/2 watt, 10%

R_8 = 22,000 ohms, 1/2 watt, 10%

R_9 = 150 ohms, 1/2 watt, 10%

S_1 = switch, 125 volts, 3 amperes, single-pole, single-throw

SCR_1 * = silicon controlled rectifier, RCA KD2100

*These components are available in a single KD2105 RCA Silicon Controlled Rectifier Experimenter's Kit.

Fig. 177 - Schematic diagram and parts list for the electronic flasher.

Circuit Operation

The schematic diagram and parts list for the electronic flasher are shown in Fig. 177. The power pulse rate (or the length of time between "ON" periods) is determined by the time required to charge the timing capacitor C_2 to the value required to turn on the neon lamp. The charging time for capacitor C_2 is controlled by adjustment of potentiometer R_1 .

When switch S_1 is closed, the pulsating dc voltage from the bridge rectifier circuit is applied across the load and the parallel combination of the SCR and the resistance-capacitance circuit R_1 , R_8 , and C_2 . Because the SCR is not conducting, load current is negligible. Therefore, the input pulses charge C_2 through resistor R_1 and R_8 , to the firing potential (approximately 80 volts) of the neon lamp. When the neon lamp fires, the current through resistor R_7 (approximately two milliamperes) serves as the input signal to

the base of transistor Q_2 .

Transistors Q_1 and Q_2 are used in this circuit as a two-stage amplifier. Resistor R_6 in the base-emitter circuit of Q_2 ensures that the transistors remain cut off when I_1 is not conducting. The output for the two-stage amplifier triggers the SCR into conduction, and the full pulsating dc input appears across the load (the SCR is a short circuit across R_1 , R_8 , and C_2). Load current continues to flow for practically 180 degrees of each succeeding half-cycle of input signal until C_2 discharges to the extinction voltage of the lamp. (The SCR is actually cut off near the end of each half-cycle and retriggers shortly after the beginning of each succeeding half-cycle by the current applied to the transistors as a result of the storage energy in capacitor C_1 .) When the charge on C_2 is insufficient to maintain conduction in the neon lamp, there is no input to the two-stage transistor amplifier, the flow of gate current to the SCR ceases, and

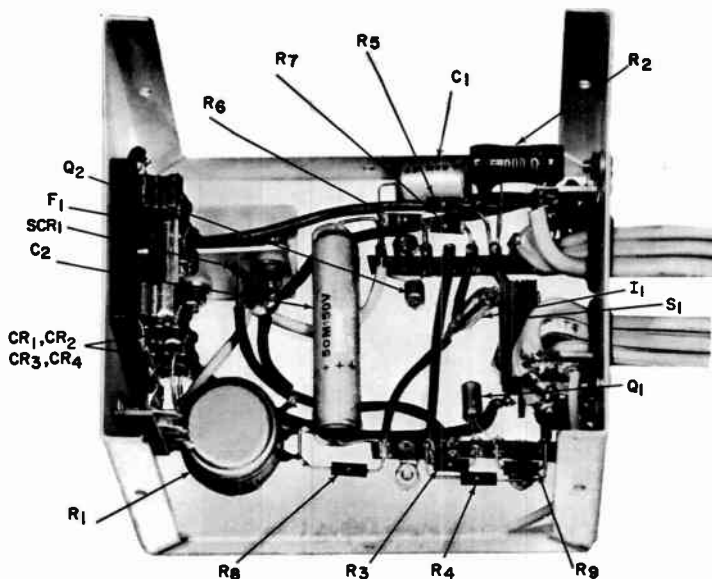

Fig. 178 - The electronic flasher assembled in a 3-by-4-by-5-inch aluminum box.

the SCR is not triggered into conduction on the next half-cycle of input. The load current then drops to a negligible value, and the operating cycle starts again.

Adjustments and Special Considerations

The rate of discharge for C_2 , and therefore the "ON" time for the flasher, is controlled by the value of resistor R_7 ; the value shown in Fig. 177 provides an "ON" pulse of approxi-

mately one-half second. The charging rate for C_2 and therefore the "OFF" time for the flasher, is controlled by means of potentiometer R_1 . For warning-signal applications, R_1 is normally adjusted to provide 40 flashes per minute, with an "ON" time of one-half second and an "OFF" time of one second. Resistors R_2 and R_3 and capacitor C_1 constitute the power supply for the two-stage transistor amplifier; R_4 is a current-limiting resistor for transistor Q_1 .

Fig. 178 shows the electronic flasher assembled in a 3- by 4- by 5-inch aluminum box.

CIRCUIT NO. 32—ELECTRONIC TIME DELAY

The electronic time delay circuit is useful for actuating an auditory device to signal the end of a time interval (e.g., to limit card or chess players to one minute of "thinking time"), or for making another device "wait" for a short time until some action can be accomplished (e.g., getting into the picture before the camera clicks).

The circuit is used to delay the application of power to a load for a predetermined period after the control switch is turned on and can be used with ac/dc devices that do not use the frame of the device as a ground and that have total power ratings up to 240 watts (nameplate current ratings up to two amperes). The delay time can be adjusted from five seconds to approximately two minutes.

Circuit Operation

The schematic diagram and parts list for the electronic time delay are shown in Fig. 179. The delay in turn-on time of the equipment with which this circuit is used is determined by the length of time required for the timing capacitor C_2 to charge to the value

required to turn on the neon lamp NE-83 and trigger the two-transistor switch. This time, in turn, is controlled by adjustment of the resistance of potentiometer R_1 .

When switch S_1 is ON, the full-wave rectified current from the rectifier bridge circuit charges capacitor C_1 through resistor R_2 . The charge on C_1 is held to a peak potential of less than seven volts by the voltage divider formed by resistors R_2 and R_7 . At the same time, the timing capacitor C_2 starts to charge through series resistors R_1 and R_3 . When the charge on C_2 reaches a value of about 80 volts, the neon lamp fires and triggers the two-transistor regenerative switch. The conducting regenerative switch completes the gate circuit through resistor R_4 and triggers the SCR into conduction. The fixed charge on C_1 then maintains conduction in the regenerative switch through the gate of the SCR, and load current continues to flow for the duration (practically 180 degrees) of each succeeding half-cycle of input voltage until S_1 is turned OFF. (The SCR is actually cut off near the end of each half-cycle and retriggered shortly after the beginning of each

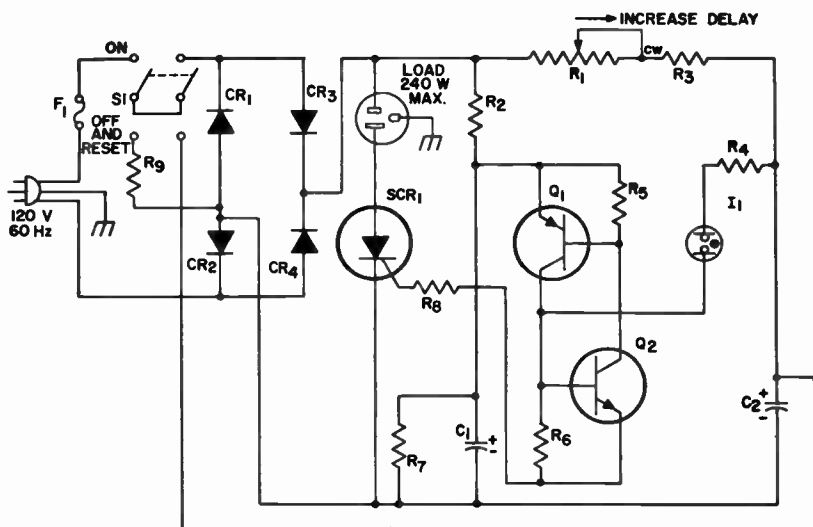

Parts List

C_1 = 50 microfarads, 15 volts, electrolytic

C_2 = 50 microfarads, 150 volts, electrolytic

$CR_1 CR_2 CR_3 CR_4^*$ = diode, RCA SK3016 mounted in fuse clip for heat sinking

F_1 = fuse, 125 volts, 3 amperes

I_1 = lamp, neon, NE-83 or equivalent

Q_1 = transistor, RCA SK3004

Q_2 = transistor, RCA SK3020

R_1 = potentiometer, 1 megohm, 2 watts, linear taper

R_2 = 3000 ohms, 5 watts, 10%

R_3 = 47,000 ohms, 1/2 watt, 10%

R_4 = 10,000 ohms, 1/2 watt, 10%

R_5 = 150 ohms, 1/2 watt, 10%

R_6 = 470 ohms, 1/2 watt, 10%

R_7 = 180 ohms, 1/2 watt, 10%

R_8 = 100 ohms, 1/2 watt, 10%

R_9 = 33 ohms, 1/2 watt, 10%

S_1 = switch, 125 volts, 3 amperes, double-pole, double-throw, toggle

SCR_1^* = silicon controlled rectifier, RCA KD2100

*These components are available in SCR Silicon Controlled Rectifier Experimenter's Kit KD2105.

Fig. 179 - Schematic diagram and parts list for the electronic time delay.

succeeding half-cycle by the current applied as a result of the steady potential on C_1 .) In the OFF position, S_1 discharges C_2 through resistor R_9 and prepares the circuit for the next time-delay application.

Adjustments and Special Considerations

With the values shown in the parts list for R_1 , R_3 , and C_2 , this circuit can

be set for time delays from five seconds to approximately two minutes by adjustment of potentiometer R_1 . Although longer time delays can be obtained by the use of a larger value for the timing capacitor C_2 , it is not economically feasible to obtain delays of much more than five minutes with this circuit.

The exact length of the time delay will depend on the actual capacitance of C_2 . Most electrolytic capacitors are rated on the basis of minimum guaran-

teed value (MGV), and the capacitor used may have a value much higher than its rating. The circuit should be calibrated for various positions of the control knob after the timing capacitor has had a chance to age. Once the capacitor has reached its stable value, the precision of this timer should be well within the requirements of most applications.

Fig. 180 shows the electronic time delay assembled in a 3- by 4- by 5-inch aluminum box.

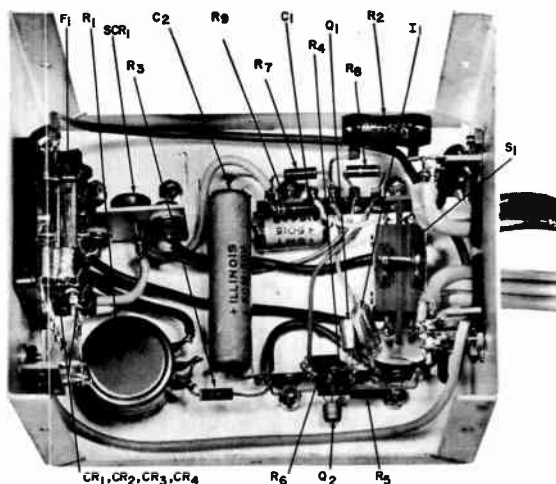

Fig. 180 - The electronic time delay assembled in a 3- by 4- by 5-inch aluminum box.

CIRCUIT NO. 33 — AUDIO-FREQUENCY-OPERATED SWITCH

The audio-frequency-operated-switch circuit can be used to turn on a load rated up to one kilowatt when the sound level increases above a predetermined level. The load continues to receive power until the sound level drops below the predetermined level. The circuit can be activated by an audio signal provided by a preamplifier such as that described in Circuit No. 7; the preamplifier is driven by a microphone. The circuit can be used to control electrical systems, such as alarms,

transmitters, and remote intercoms. It can also be used to measure noise level; in such applications, it activates some device when a predetermined noise level is reached. The level of input to this switch should be approximately 1 volt. The RCA Experimenter's Kit, KD-2112, contains all parts needed to make an integrated-circuit amplifier that will satisfy the input preamplifier requirements of the audio-frequency-operated switch.

Circuit Operation

The schematic diagram and parts list for the audio-frequency-operated switch are shown in Fig. 181. The audio- or radio-frequency signal applied to the input terminals in rectified by CR₅ and CR₆. The resulting signal is applied to the base of Q₁ through the potentiometer R₁. The amount of noise required to activate the circuit can be controlled by adjustment of the potentiometer. The signal applied to the base of Q₁ causes it to

conduct provided that the emitter of Q₁ is positive. The current conducted by Q₁ charges C₂ through the charging path CR₃, CR₄ and R₄.

On the following half-cycle, the charge on capacitor C₂ is applied to the gate of SCR₂ and turns it on; a voltage is thus placed across the load. The load voltage is also applied to the combination of CR₁, R₂ and C₁, and causes the capacitor to charge. The charge on C₁ turns on SCR₁ during the next half-cycle. This process repeats as

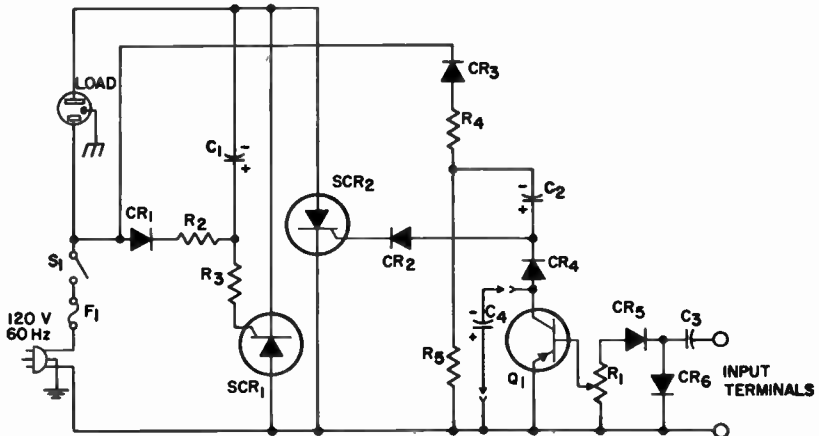

Parts List

- | | |
|-------------------------------------------------------------------------------------------------|----------------------------------------------------------------------------------|
| C ₁ C ₂ = 10 microfarads, 15 volts, electrolytic | R ₁ = potentiometer, 5000 ohms, 2 watts, linear taper |
| C ₃ = 0.1 microfarad, 25 volts or greater | R ₂ R ₄ = 4700 ohms, 2 watts, 10% |
| C ₄ = 10 to 100 microfarads, 12 volts, electrolytic, to increase release time | R ₃ = 270 ohms, 1/2 watt, 10% |
| CR ₁ CR ₂ CR ₃ CR ₄ = silicon rectifier, RCA SK3030 | R ₅ = 470 ohms, 1/2 watt, 10% |
| CR ₅ CR ₆ * = silicon rectifier, type 1N34A | S ₁ = switch, 125 volts, 15 amperes, single-pole, single-throw toggle |
| F ₁ = fuse, 125 volts, ampere rating depends on load | SCR ₁ SCR ₂ * = silicon controlled rectifier, RCA KD2100 |
| Q ₁ = transistor, RCA SK3005 | |

*These components are available in two RCA Silicon Controlled Rectifier Experimenter's Kits KD2105.

Fig. 181 - Schematic diagram and parts list for the audio-frequency-operated switch.

long as there is a sufficient audio- or radio-frequency signal present at the input terminals to cause Q_1 to conduct.

When the signal is removed, Q_1 becomes nonconductive; the charging path for capacitor C_2 is thus opened. If C_2 cannot charge, SCR_2 cannot turn on. The result is an open circuit to the load. Because there is no voltage across the load, capacitor C_1 cannot obtain the charge it needs to turn on SCR_1 during the next half-cycle. Therefore, both SCR 's remain off until another signal is received at the input terminals.

The release time, or the time that it takes for the switch to turn off after the

input signal ceases, can be increased so that the switch does not open during momentary interruptions (e.g., between syllables). This increase in release time is accomplished by connection of a capacitor between the emitter and the collector of Q_1 . Values of capacitance up to 100 microfarads (15 volts) can be used.

Construction

The photograph in Fig. 182 shows the audio-frequency-operated switch assembled in a 3- by 4- by 5-inch aluminum box.

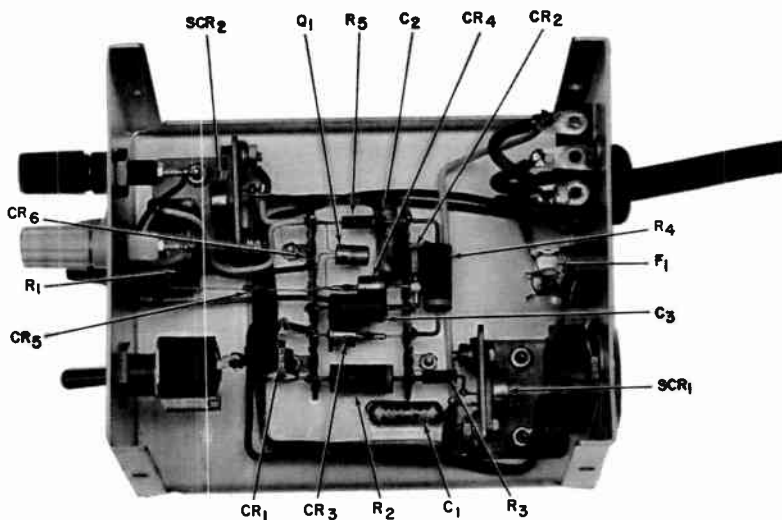

Fig. 182 - The audio-frequency-operated switch assembled in a 3- by 4- by 5-inch aluminum box.

CIRCUIT NO. 34—FREQUENCY-SELECTIVE AF AMPLIFIER

The frequency-selective af amplifier amplifies signals at only one predetermined frequency. At that frequency the voltage gain is 20 to 30; at other frequencies the voltage gain is unity or

less. Circuits of this type are useful in screening out undesirable side signals when copying code or for identifying the frequency of a particular signal.

Circuit Operation

The schematic diagram and parts list for the frequency-selective af-amplifier circuit are shown in Fig. 183. Potentiometer R_8 controls the level of the feedback signal; potentiometer R_7 is used to adjust or peak the twin-T bridge to the desired frequency. Transistor Q_1 acts as a basic audio amplifier. Part of the output of the amplifier is applied to the twin-T bridge oscillator through C_3 . At the predetermined frequency, where most gain occurs, the filter passes the ac at a phase angle that

assures positive feedback. The feedback, adjusted by R_8 , is added to the incoming signal and causes it to increase.

With the component values shown in the parts list, the frequency of the bridge oscillator and the frequency selected for amplification is approximately 1000 Hz; Table VIII shows values of C_5 , C_6 , and C_7 required for other typical frequencies.

The current drain for this circuit is approximately 1.5 millamperes. The maximum input signal is 0.1 volt rms.

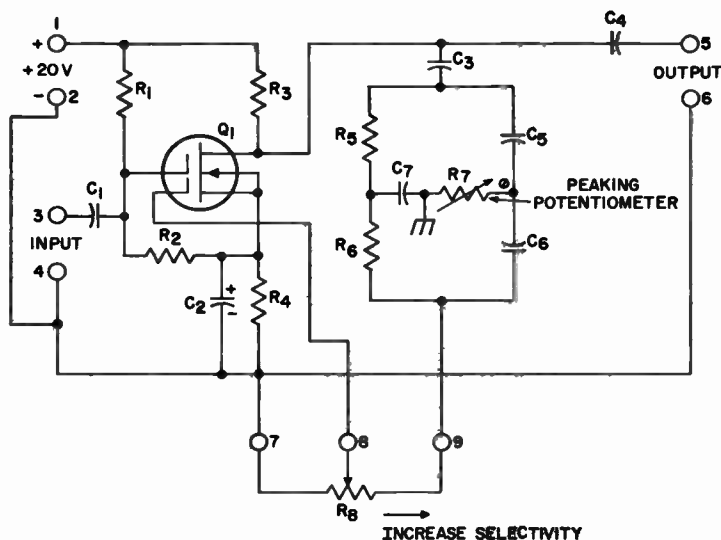

Parts List

C_1 C_3 C_4 = 0.1 microfarad, 25 volts or greater

C_2 = 10 microfarads, 6 volts, electrolytic

C_5 C_6 = 680 picofarads, 25 volts or greater

C_7 = 1500 picofarads, 25 volts or greater

Q_1 = MOS field-effect transistor, type 3N141

R_1 = 1 megohm, 1/2 watt, 10%

R_2 = 100,000 ohms, 1/2 watt, 10%

R_3 = 6800 ohms, 1/2 watt, 10%

R_4 = 1200 ohms, 1/2 watt, 10%

R_5 R_6 = 220,000 ohms, 1/2 watt, 10%

R_7 = potentiometer, 250,000 ohms, linear taper

R_8 = potentiometer, 1 megohm, linear taper

Fig. 183 - Schematic diagram and parts list for the frequency-selective af amplifier.

Table VIII.
Frequency-Selective AF Amplifier Bridge Capacitor Values
for Various Frequencies

Approximate Frequency (Hz)	C_1, C_4 (pF)	C_7 (pF)
150	5600	12,000
300	2700	6200
600	1300	3000
1200	680	1500
2400	330	750
4800	160	360
9600	82	180

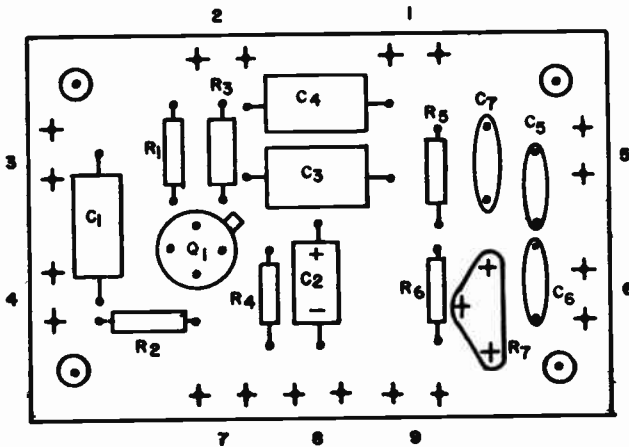

Fig. 184 - Component placement diagram for the frequency-selective amplifier.

Construction

The only special care required in the building of this circuit is in the handling of the MOS transistor. The procedure outlined in the section on **Mechanical Considerations** must be

followed. The drilling template for the frequency-selective af amplifier is shown at the back of the Manual; a component placement diagram and a photograph of a completed circuit board are shown in Figs. 184 and 185, respectively.

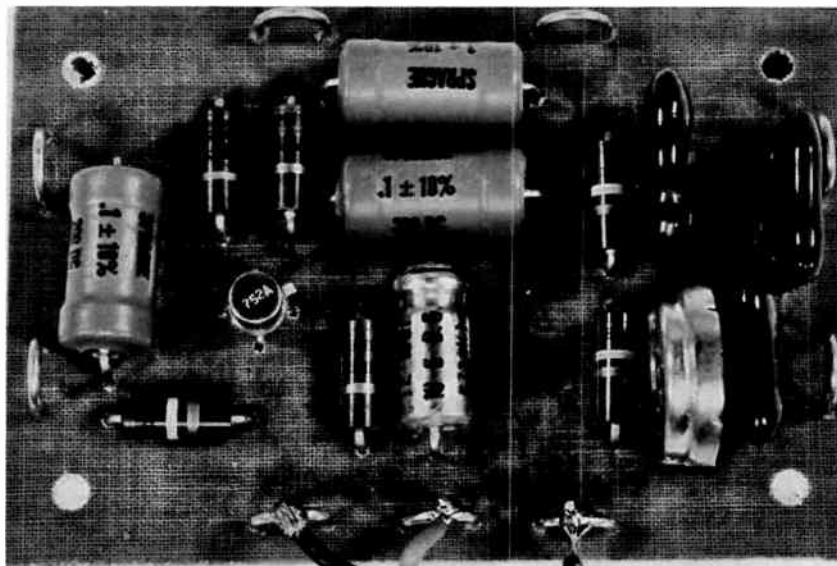

Fig. 185 - Completed circuit board for the frequency-selective amplifier.

CIRCUIT NO. 35—AUTOMOBILE LIGHT MINDER

This circuit sounds an alarm if the lights of a car are left on when the ignition is turned off. The alarm stops when the lights are turned off. When the lights are intentionally left on for a period of time, the alarm can be defeated so that no warning sounds. The alarm then sounds when the ignition switch is turned on as a reminder that the system has been defeated and that the switch should be returned to its normal position.

Circuit Operation

Schematic diagrams for a positive-ground and a negative-ground light minder are shown in Fig. 186. The circuit is essentially an oscillator that obtains its supply voltage from two possible sources, the ignition system or the light system of the car. In the normal mode of operation, the ignition

system is connected to the collector circuit of Q_1 and the light system is connected through CR_1 to the emitter of Q_1 . When the ignition switch is on, the collector of the transistor is at the supply voltage. If the lights are on at the same time, the transistor emitter is also at the supply voltage. Because both the emitter and the collector are at the same voltage, the circuit does not oscillate and no alarm sounds. When the ignition is turned off, the collector is returned to ground through R_1 and C_1 , but the emitter remains at the supply voltage and provides the necessary bias for the circuit to oscillate. Turning the lights off removes the supply voltage and stops the oscillation.

In the defeat mode of operation, the ignition system is connected through CR_1 to the transistor emitter; the light system is completely disconnected. The lights can then be turned on without

the alarm sounding. When the ignition is turned on, it supplies the necessary voltage to the transistor emitter to cause the alarm to sound.

When the alarm is sounding the

light-minder current drain is 23 milliamperes; when the alarm is not sounding the current drain is 3 milliamperes.

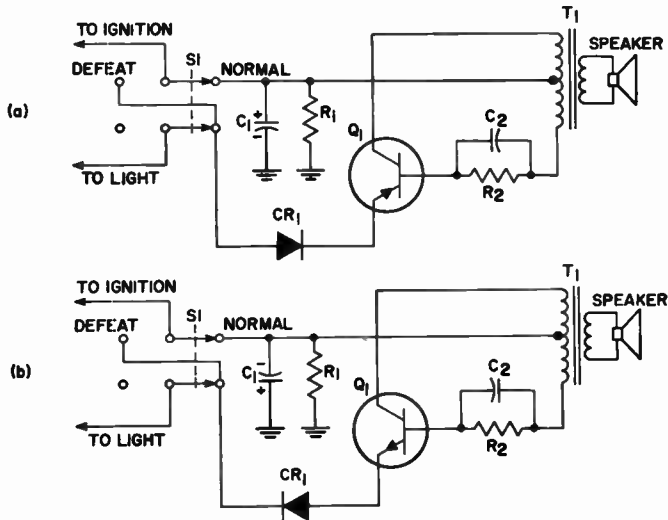

Parts List

C_1 = 30 microfarads, 25 volts, electrolytic

C_2 = 0.22 microfarad, 25 volts or greater

CR_1 = silicon rectifier, RCA SK3030

R_1 = 15,000 ohms, 1 watt, 10%

R_2 = 680 ohms, 1/2 watt, 10%

Q_1 = transistor, for negative-ground system, RCA SK3005;

for positive-ground system, RCA SK3020

S_1 = switch, double-pole, double-throw

Speaker = 3.2 ohms

T_1 = Output transformer, primary 500 ohms center tapped, secondary 3.2 ohms, Stancor No. TA-42 or equivalent

Fig. 186 - Schematic diagram and parts list for the automobile light minder: (a) negative ground system, (b) positive ground system.

Drilling Templates

The following pages contain full-size drilling templates for many of the circuits in the Manual. It is a good idea to mount each template on cardboard before it is used so that it will not tear readily and become unsatisfactory for repeated use. The template should be

securely fastened to the circuit board before holes are drilled through it. A key to the symbols used on the templates is interspersed among the following pages. A list of templates is given below.

Template	Page No.	Template	Page No.
Ten-Stage Shift Register	171	Single-Voice Organ Capacitor Board.....	199
Simple Code-Practice Oscillator ...	173	Automobile Tachometer	199
Audio Oscillator	173	Battery Charger	201
Automatic Keyer	175	Electronic Siren	201
Microphone Preamplifier	177	Electronic Slot Machine Running and Stop Oscillator.....	203
Audio Mixer, Compressor, and Line Amplifier	179	Electronic Slot Machine Flip-Flop	203
Universal Timer	181	Electronic Slot Machine NAND Gates (gates A,B,C)	205
Enlarger Exposure Meter	183	Electronic Slot Machine NOR Gate (2 score)	205
Temperature Alarm	185	Electronic Slot Machine NOR Gates (scores 10 through 100)	207
Positive-Action Light-Operated Switch	187	Electronic Die Digital Pulser and Six-Stage Shift Register	209
Electronic Fuzz Box	187	Electronic Die Indicator-Lamp Gate and Driver	211
Phonograph Preamplifier	189	VFO Calibrator	213
Audio Power Amplifier	191	Frequency-Selective AF Amplifier	215
Electronic Metronome.....	193		
Single-Voice Organ Amplifier.....	193		
Single-Voice Organ Tremolo and Tone Oscillator	195		
Single-Voice Organ Resistor Board	197		

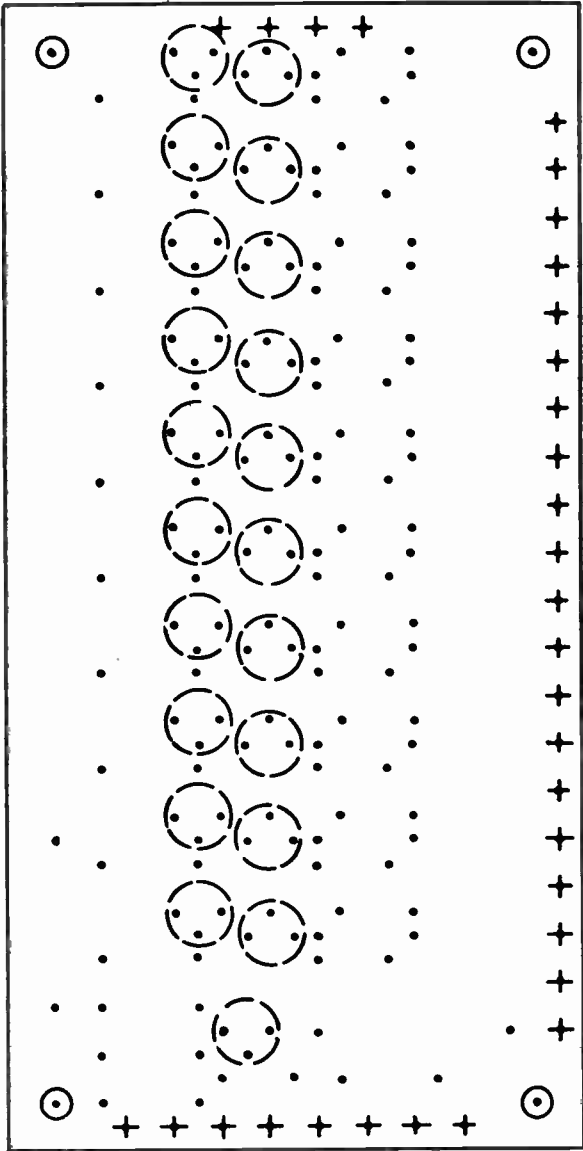

Ten-stage shift register; Circuit No. 2; 3- by 6-inch board.

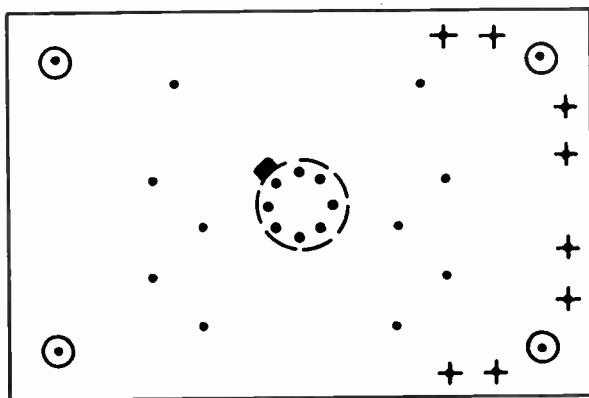

Simple code-practice oscillator; Circuit No. 3; 2- by 3-inch board.

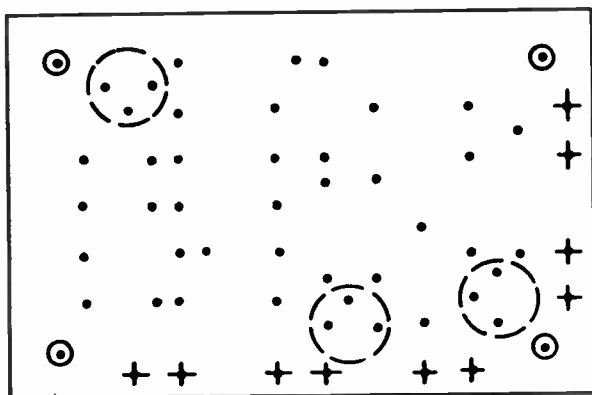

Audio oscillator; Circuit No. 4; 2- by 3-inch board.

KEY TO DRILLING SYMBOLS

- No. 60 drill (0.040 inch)
- + No. 58 drill (0.042 inch)
- ⊙ No. 32 drill (0.116 inch)

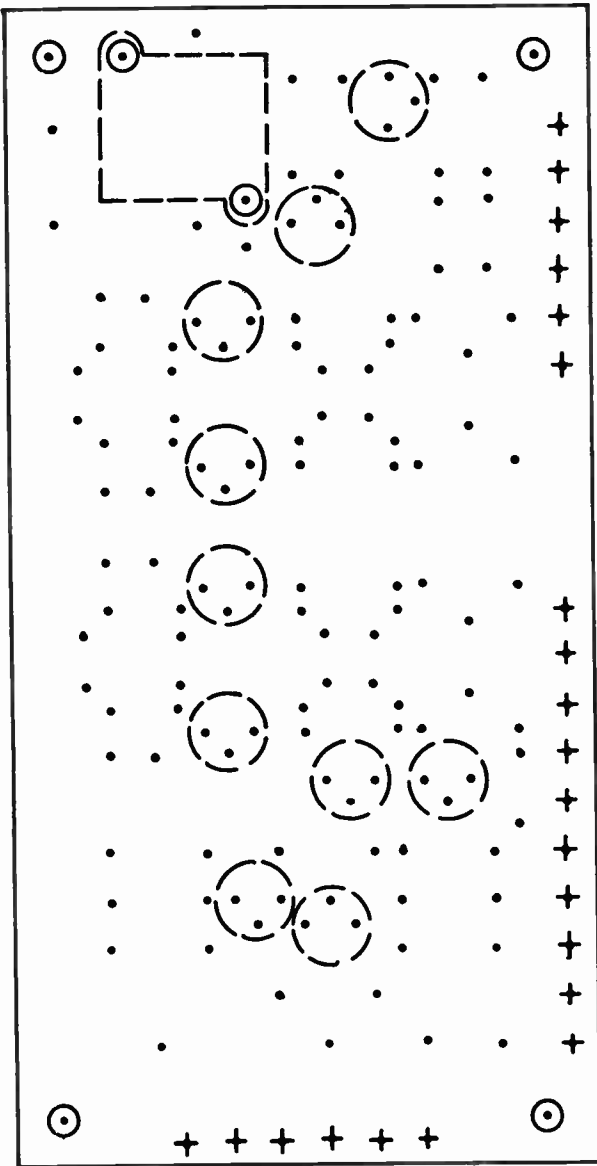

Automatic keyer; Circuit No. 6; 3- by 6-inch board.

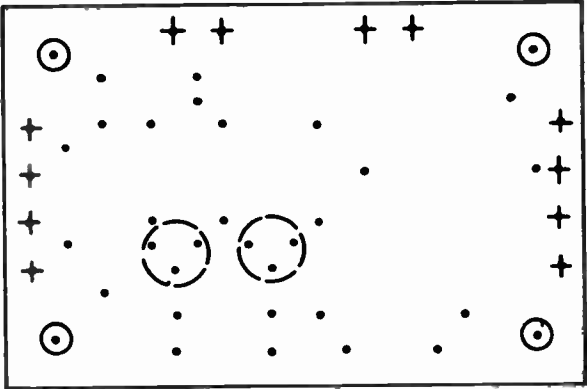

Microphone preamplifier; Circuit No. 7; 2- by 3-inch board.

KEY TO DRILLING SYMBOLS

- No. 60 drill (0.040 inch)
- + No. 58 drill (0.042 inch)
- ⊙ No. 32 drill (0.116 inch)

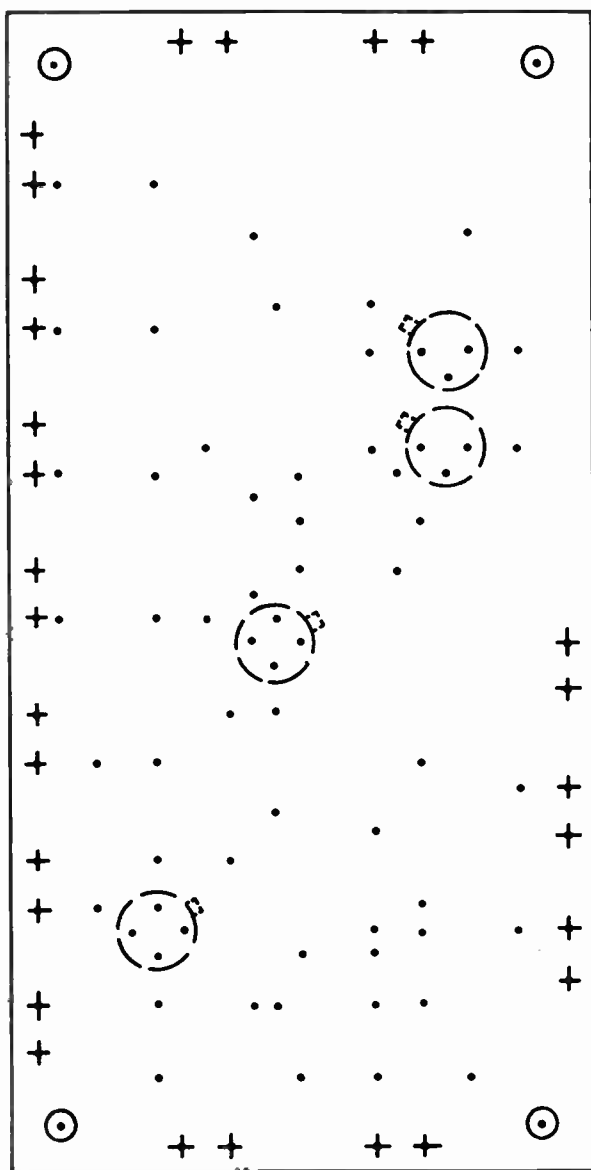

Audio mixer, compressor, and line amplifier; Circuit No. 8; 3-by 6-inch board.

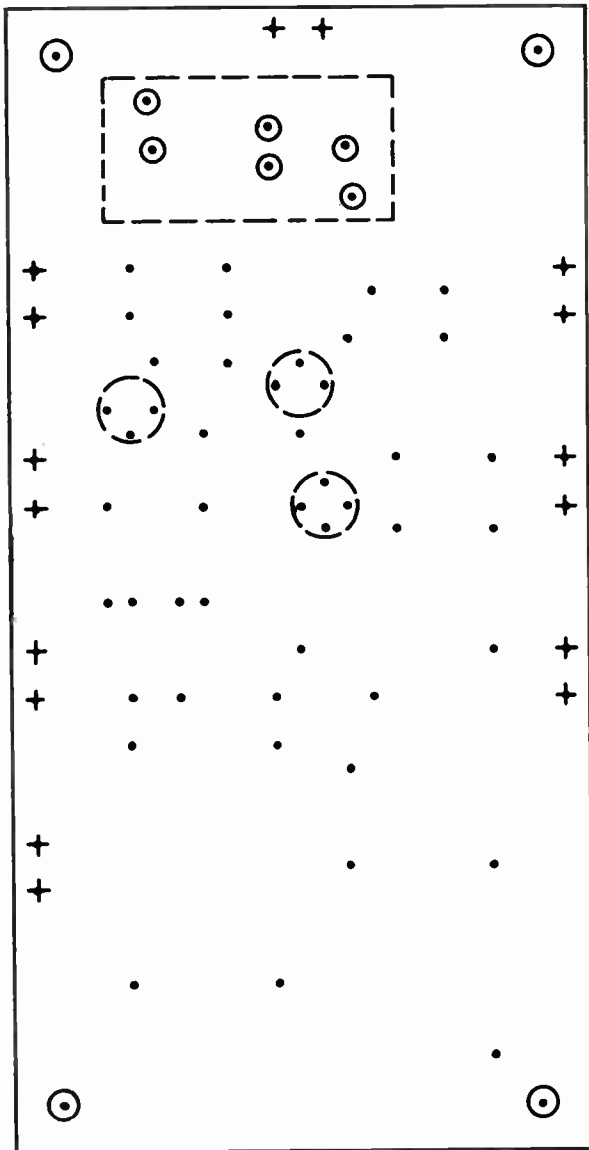

Universal timer; Circuit No. 9; 3- by 6-inch board.

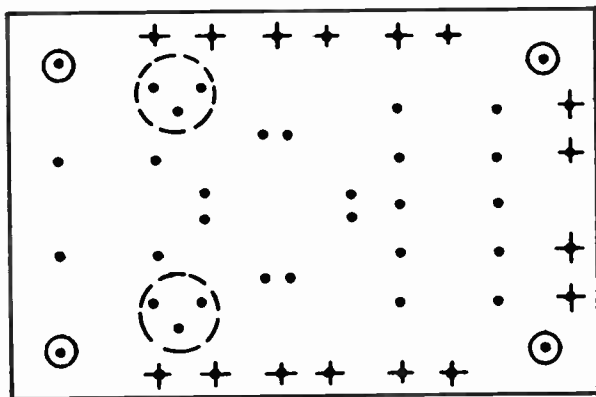

Enlarger exposure meter; Circuit No. 10; 2- by 3-inch board.

KEY TO DRILLING SYMBOLS

- No. 60 drill (0.040 inch)
- + No. 58 drill (0.042 inch)
- ⊙ No. 32 drill (0.116 inch)

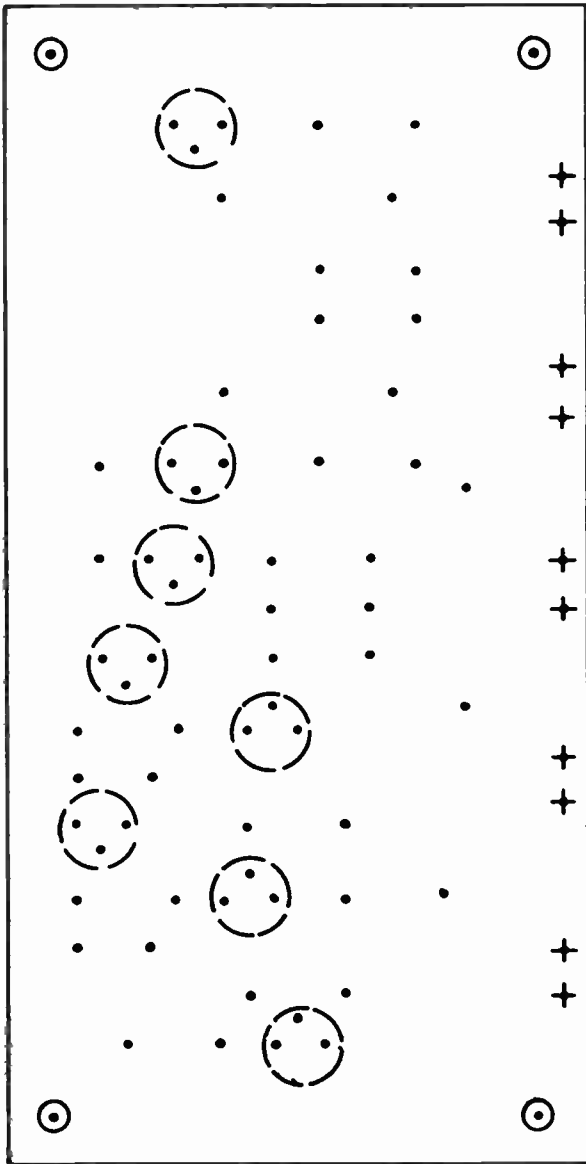

Temperature alarm, Circuit No. 12; 3- by 6-inch board.

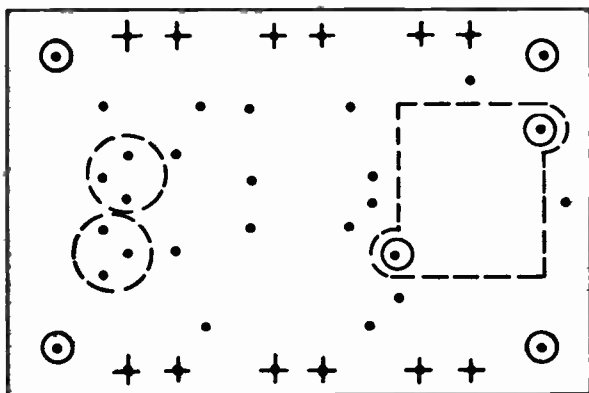

Positive-action light-operated switch; Circuit No. 13; 2- by 3-inch board.

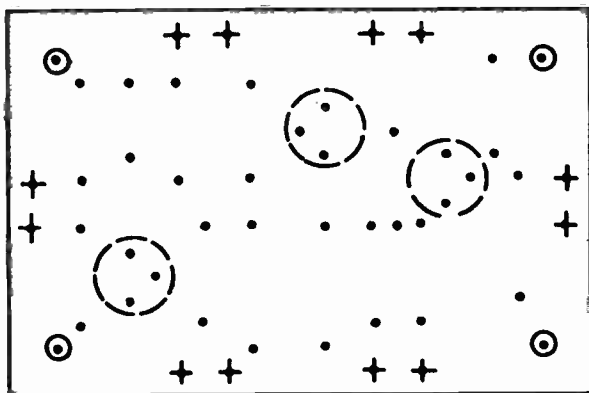

Electronic fuzz box; Circuit No. 15; 2- by 3-inch board.

KEY TO DRILLING SYMBOLS

- No. 60 drill (0.040 inch)
- + No. 58 drill (0.42 inch)
- ⊙ No. 32 drill (0.116 inch)

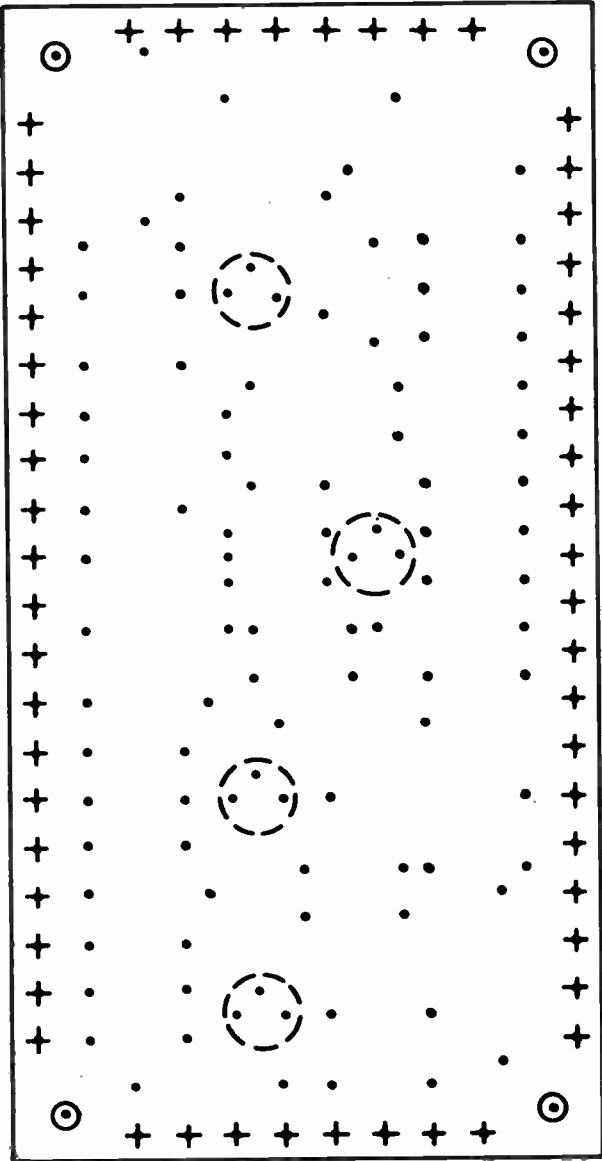

Phonograph preamplifier; Circuit No. 16; 3- by 6-inch board.

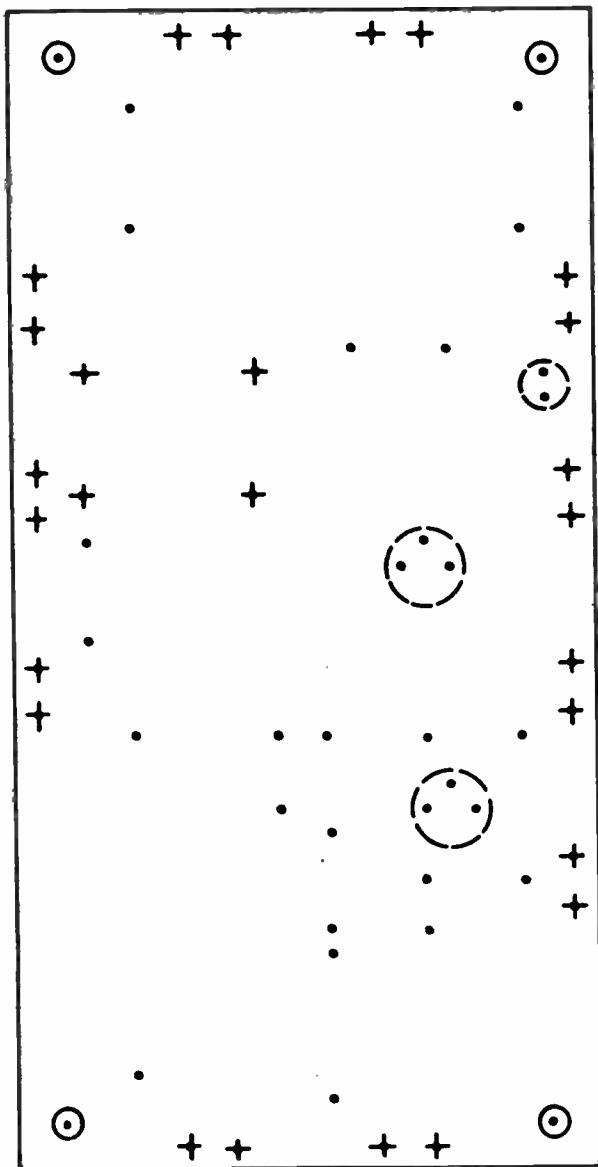

Audio power amplifier; Circuit No. 17; 3- by 6-inch board.

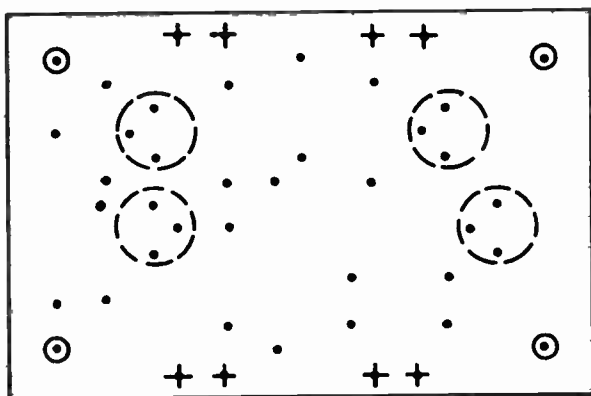

Electronic metronome; Circuit No. 18; 2- by 3-inch board.

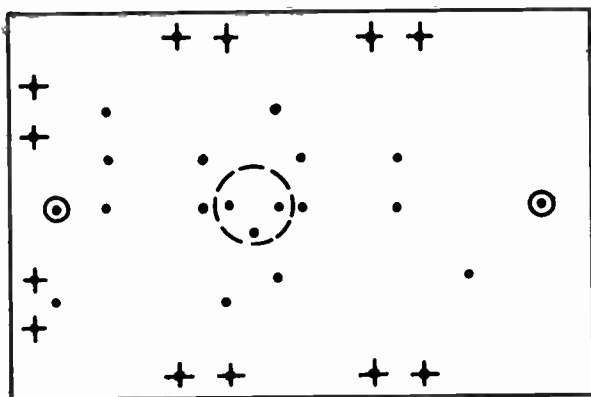

Single-voice organ amplifier; Circuit No. 19; 2- by 3-inch board.

KEY TO DRILLING SYMBOLS

- No. 60 drill (0.040 inch)
- + No. 58 drill (0.042 inch)
- ⊙No. 32 drill (0.116 inch)

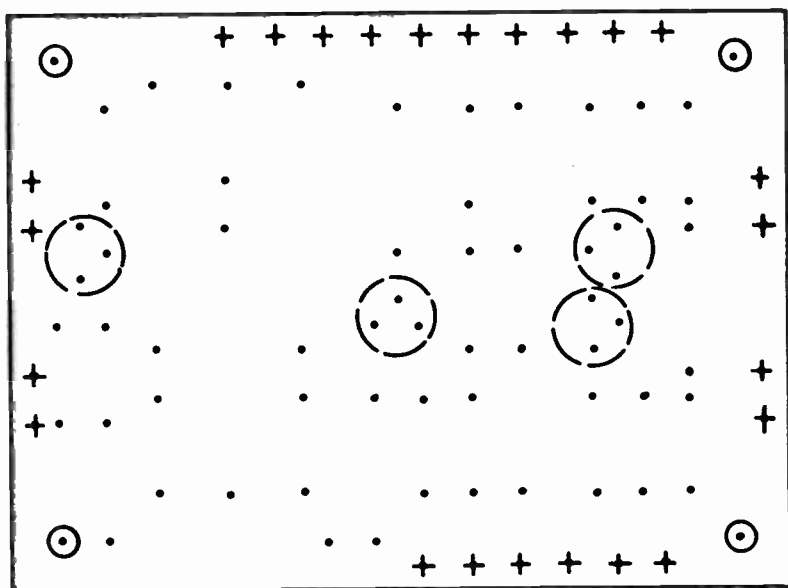

Single-voice organ tremolo and tone oscillator; Circuit No. 19; 3- by 4-inch board.

KEY TO DRILLING SYMBOLS

- No. 60 drill (0.040 inch)
- + No. 58 drill (0.042 inch)
- ⊙ No. 32 drill (0.116 inch)

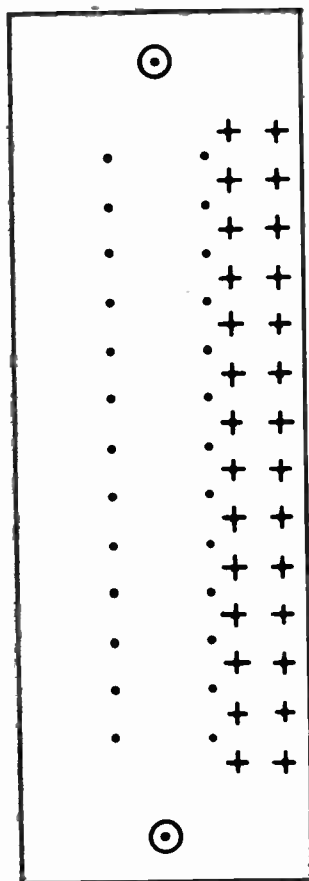

Single-voice organ resistor board; Circuit No. 19; 1-1/2 by 4-1/2-inch board.

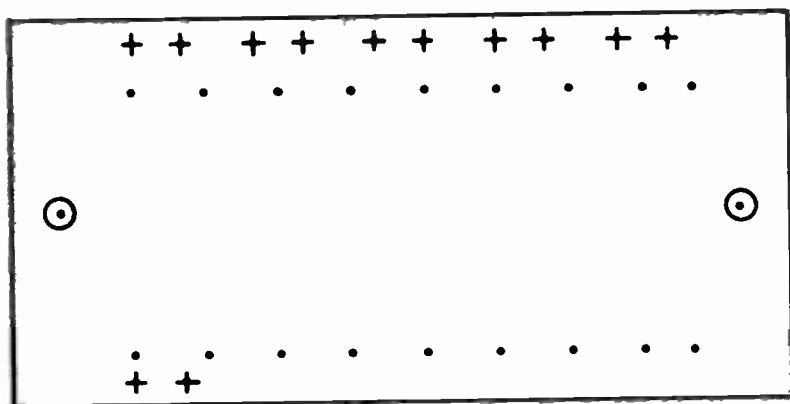

Single-voice organ capacitor board; Circuit No. 19; 2- by 4-inch board.

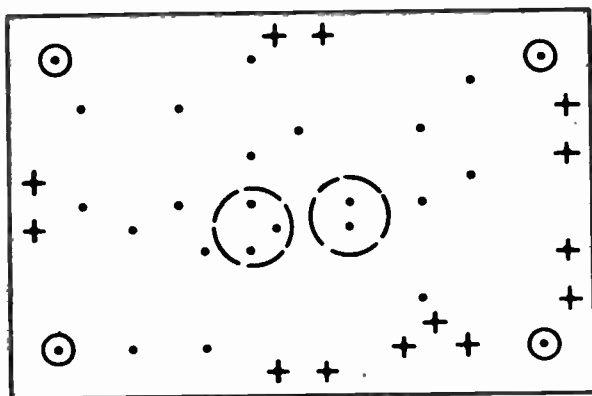

Automobile tachometer; Circuit No. 20; 2- by 3-inch board.

KEY TO DRILLING SYMBOLS

- No. 60 drill (0.040 inch)
- + No. 58 drill (0.042 inch)
- ⊙ No. 32 drill (0.116 inch)

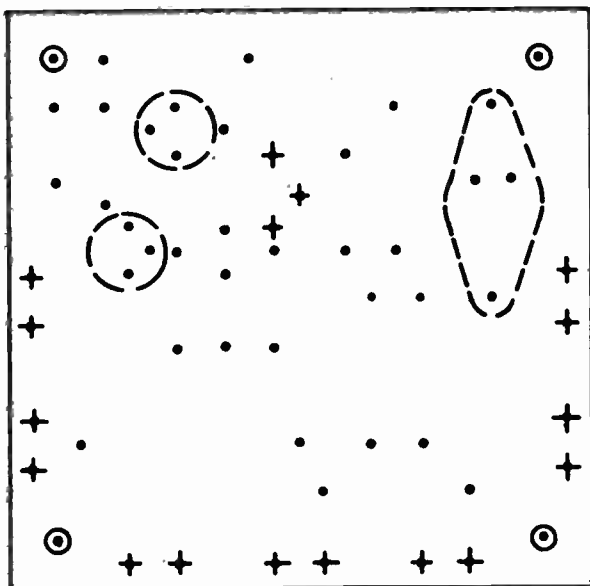

Battery charger; Circuit No. 21; 3- by 3-inch board.

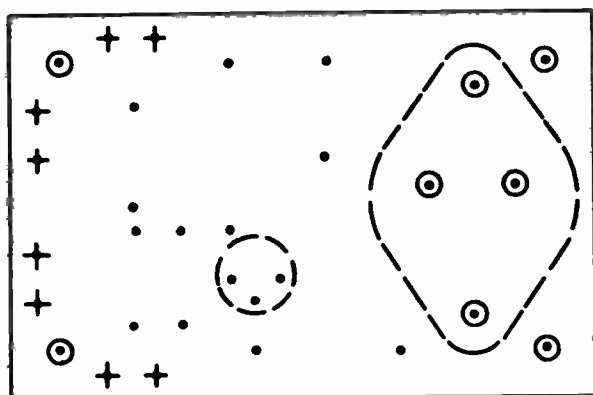

Electronic siren; Circuit No. 22; 2- by 3-inch board.

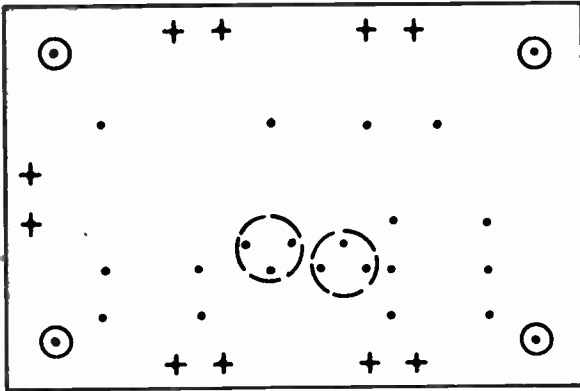

Electronic slot machine running and stop oscillator; Circuit No. 23; 2- by 3-inch board.

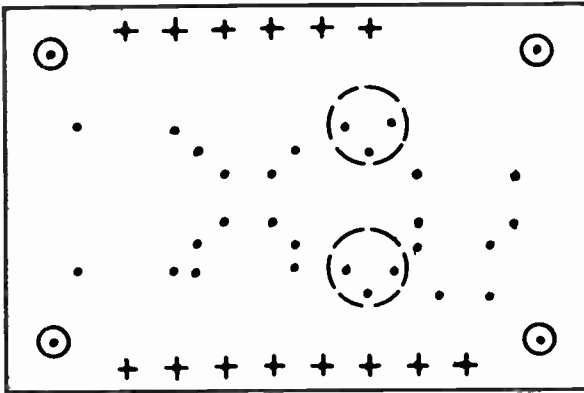

Electronic slot machine flip-flop; Circuit No. 23; 2- by 3-inch board.

KEY TO DRILLING SYMBOLS

- No. 60 drill (0.040 inch)
- + No. 58 drill (0.042 inch)
- ⊙ No. 32 drill (0.116 inch)

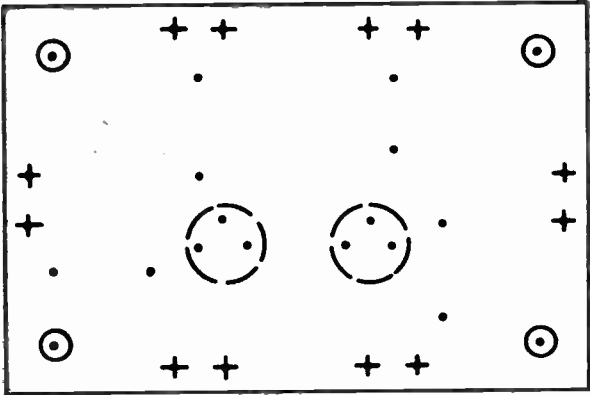

Electronic slot machine NAND gates (gates A,B,C); Circuit No. 23; 2- by 3-inch board.

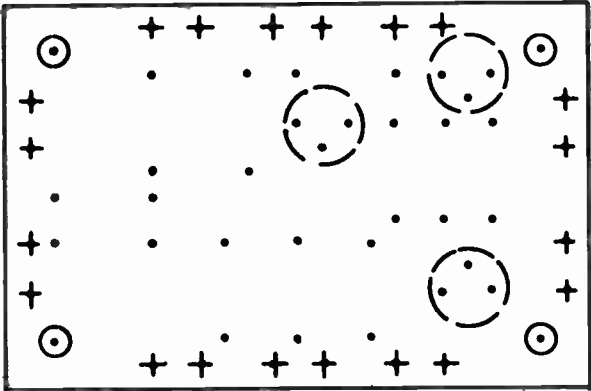

Electronic slot machine NOR gate (2 score); Circuit No. 23; 2- by 3-inch board.

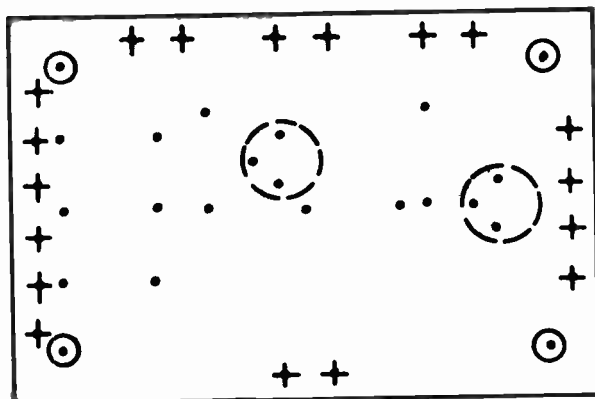

Electronic slot machine NOR gates (scores 10 through 100); Circuit No. 23; 2- by 3-inch board.

KEY TO DRILLING SYMBOLS

- No. 60 drill (0.040 inch)
- + No. 58 drill (0.042 inch)
- ⊙ No. 32 drill (0.116 inch)

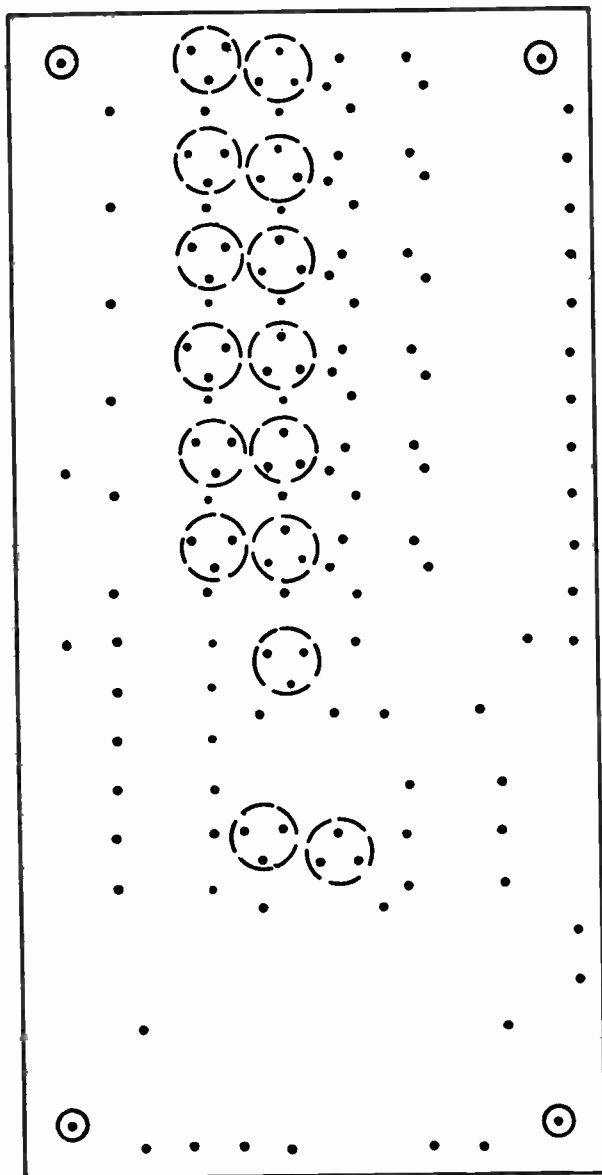

Electronic die digital pulser and six-stage shift register; Circuit No. 24; 3- by 6-inch. board

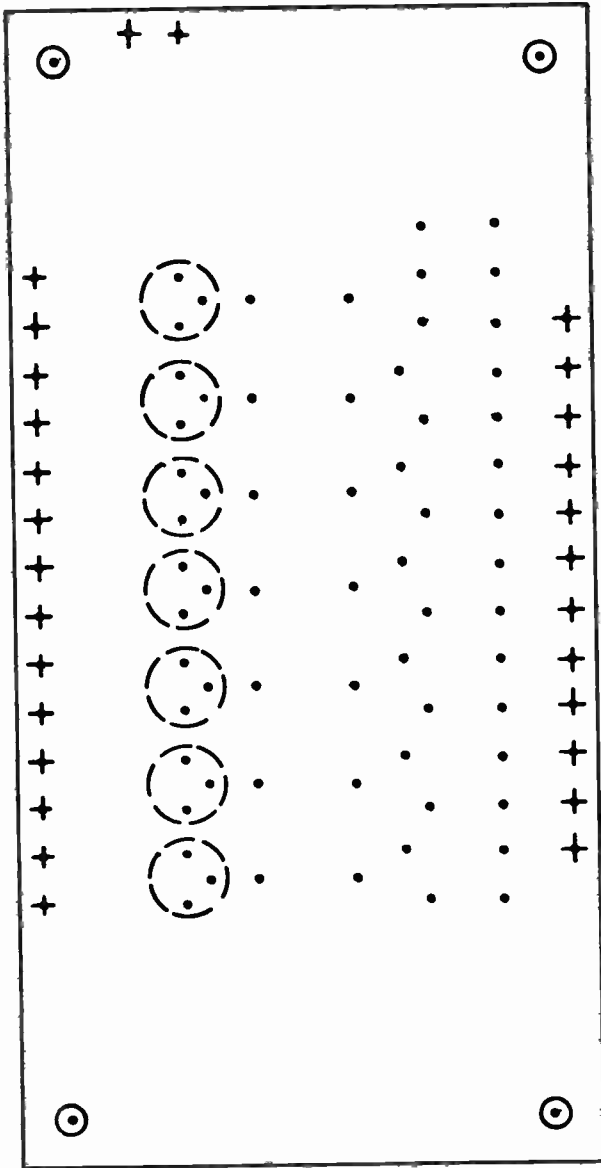

Electronic-die indicator-lamp gate and driver circuit; Circuit No. 24; 3- by 6-inch board.

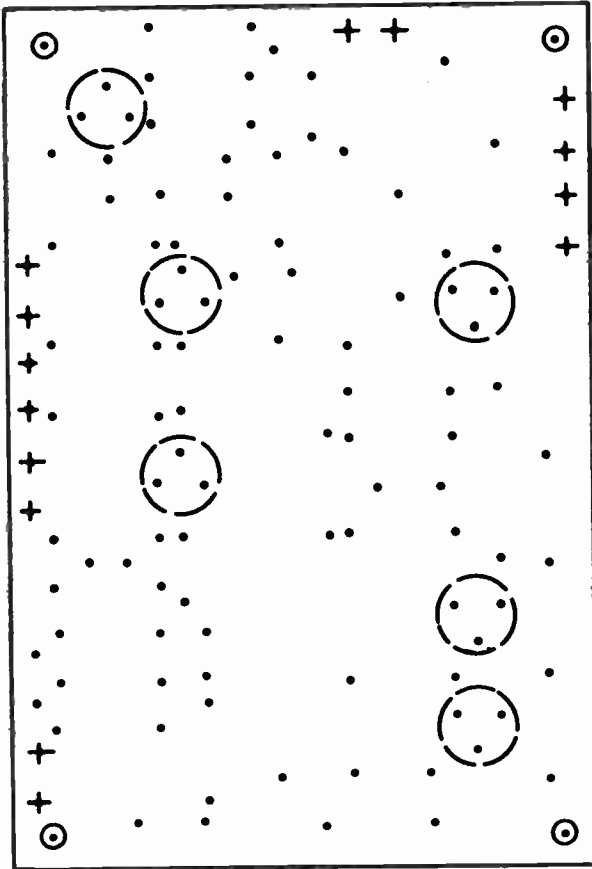

VFO calibrator; Circuit No. 28; 3- by 4-1/2-inch board.

KEY TO DRILLING SYMBOLS

- No. 60 drill (0.040 inch)
- + No. 58 drill (0.042 inch)
- ⊙ No. 32 drill (0.116 inch)

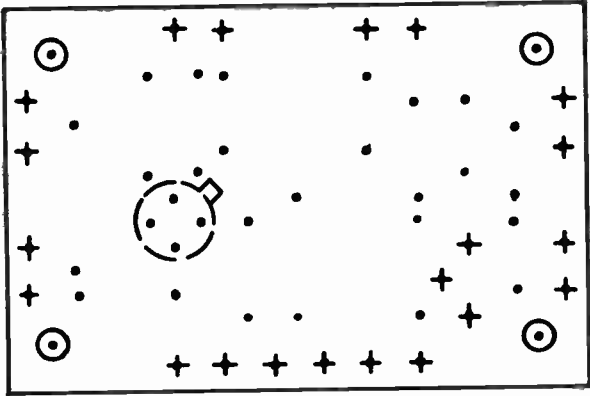

Frequency-selective af amplifier; Circuit No. 34; 2- by 3-inch board.

KEY TO DRILLING SYMBOLS

- No. 60 drill (0.040 inch)
- + No. 58 drill (0.042 inch)
- ⊙ No. 32 drill (0.116 inch)

RCA Technical Publications

on Electron Tubes, Semiconductor Products, and Batteries

COPIES of the publications listed below may be obtained from your RCA distributor or from Commercial Engineering, Radio Corporation of America, Harrison, N. J.

Electron Tubes

● **RCA ELECTRON TUBE HANDBOOK—HB-3** (7 $\frac{3}{8}$ " x 5 $\frac{3}{8}$ ")—Five 2 $\frac{1}{4}$ -inch-capacity binders. Contains over 6000 pages of looseleaf data and curves on RCA receiving tubes, transmitting tubes, cathode-ray tubes, picture tubes, photocells, phototubes, camera tubes, ignitrons, vacuum gas rectifiers, traveling-wave tubes, premium tubes, pencil tubes, and other miscellaneous types for special applications. Available on subscription basis. Price \$20.00* including service for first year. Also available with RCA Semiconductor Products Databook SPD-100 at special combination price of \$30.00.*

● **RADIOTRON° DESIGNER'S HANDBOOK—4th Edition** (8 $\frac{3}{4}$ " x 5 $\frac{1}{2}$ ")—1500 pages. Comprehensive reference covering the design of radio and audio circuits and equipment. Written for the design engineer, student, and experimenter. Contains 1000 illustrations, 2500 references, and cross-referenced index of 7000 entries. Edited by F. Langford-Smith. Price \$7.00.*†

● **RCA PHOTOTUBE AND PHOTOCCELL MANUAL—PT-60** (8 $\frac{1}{4}$ " x 5 $\frac{3}{8}$ ")—192 pages. Well-illustrated informative manual covering fundamentals and operating considerations for vacuum and gas phototubes, multiplier phototubes, and photocells. Also describes basic applications for these devices. Features easy-to-use selection chart for multiplier phototubes. Data and performance

curves given for over 90 photo-sensitive devices. Price \$1.50.*†

● **RCA RECEIVING TUBE MANUAL—RC-26** (8" x 5 $\frac{1}{4}$ ")—656 pages. Contains technical data on more than 1400 receiving tubes for home-entertainment use. Includes six easy-to-read text chapters that provide basic information on electron-tube operation, ratings and characteristics, and applications. Also features a detailed application guide for receiving tubes; quick-reference charts for replacement and discontinued RCA receiving tubes, black-and-white and color picture tubes, and voltage-regulator and voltage-reference tubes; and a Circuits section that includes schematic diagrams, descriptive writeups, and complete parts lists for 36 practical electron-tube circuits for a wide variety of applications. Price \$1.75.*†

● **RCA TRANSMITTING TUBES—TT-5** (8 $\frac{1}{4}$ " x 5 $\frac{3}{8}$ ")—320 pages. Gives data on over 180 power tubes having plate-input ratings up to 4 kw and on associated rectifier tubes. Provides basic information on generic types, parts and materials, installation and application, and interpretation of data. Contains circuit diagrams for transmitting and industrial applications. Features lie-flat binding. Price \$1.00.*†

● **RCA INTERCHANGEABILITY DIRECTORY OF INDUSTRIAL-TYPE ELECTRON TUBES—ID-1020-H** (10 $\frac{7}{8}$ " x 8 $\frac{3}{8}$ ")—12 pages. Lists more than 2300 basic type designations for 22 classes of industrial tube types; shows the RCA Direct Replacement Type or the RCA Similar Type, when available. Single copy free on request.

● **RCA INDUSTRIAL RECEIVING-TYPE TUBES—RIT 104F** (10 $\frac{1}{2}$ " x 8 $\frac{3}{8}$ ")—24 pages. Concise technical data on over 200 types used in military, industrial, and commercial equipment. Includes application guide, chart of prototype versus similar RCA industrial types, interchangeability list of domestic versus RCA replacements, terminal diagrams, and socket and connector information. Price 25 cents.*

● **RCA RECEIVING TUBES AND PICTURE TUBES—ERT-1275M** (10 $\frac{1}{2}$ " x 8 $\frac{3}{8}$ ")—56 pages. Contains classification chart, application guide, characteristics chart, and base and envelope connection diagrams on more than 1300 entertainment receiving tubes and picture tubes. Price 40 cents.*†

● **RCA INTERCHANGEABILITY DIRECTORY OF FOREIGN vs. U.S.A. RECEIVING-TYPE ELECTRON TUBES—ERT-197E** (8 $\frac{3}{8}$ " x 10 $\frac{1}{2}$ ")—8 pages. Covers approximately 800 foreign tube types used principally in AM and FM radios, TV receivers, and audio amplifiers. Indicates U.S.A. direct replacement type or similar type if available. Price 10 cents.*

● **RCA NUVISTORS—INDUSTRIAL AND MILITARY—NIT-140**—28 pages. A guide for communication equipment designers, researchers and experimenters. Describes design features and performance characteristics. Contains characteristic charts, curves, socket information, dimensional outlines, and terminal diagrams. Price 35 cents.*

● **RCA PERIODICALLY FOCUSED TRAVELING-WAVE TUBES—ICE-204**—56 pages. Contains theory of operation, design features, and performance characteristics of RCA periodically focused traveling-wave tubes. Price 50 cents.*

● **RCA RECEIVING TUBE AND PICTURE TUBE SUBSTITUTION GUIDE—ERT-198**—Price 25 cents.*

● **RCA PHOTOMULTIPLIER AND IMAGE TUBES—PIT-700** (10 $\frac{1}{2}$ " x 8 $\frac{3}{8}$ ")—36 pages. Includes concise data on RCA photomultiplier tubes, gas and vacuum

photodiodes, sockets and shields for phototubes, and dimensional outlines for photo and image tubes. Price 60 cents.*

● **RCA PHOTOMULTIPLIER TUBES FOR NEW-EQUIPMENT DESIGN—PIT-703**—16 pages. Reviews some of the applications of photomultiplier tubes. RCA's wide selection is demonstrated by a composite graph of spectral responses; a matrix of spectral response designations versus configuration further assists in preliminary selection of tube types. Additional characteristics are tabulated to help narrow the choice. Price 35 cents.*

● **RCA PICTURE TUBE PRODUCT GUIDE—COLOR AND BLACK & WHITE—PIX-300B**—24 pages. Includes interchangeability chart and characteristics chart on all industry types where RCA has a replacement for both black-and-white and color picture tubes. Basing diagrams and illustrations depicting safety features are also included. Price 30 cents.*

● **PRODUCT GUIDE FOR RCA POWER TUBES—PWR-506B**—40 pages. Contains tabulated data on all RCA power tubes in order of type designation within each general class of service. Includes maximum ratings, temperature ratings, heater or filament requirements, outline drawings, and basing diagrams. Price 30 cents.*

● **RCA INDUSTRIAL TUBES PRODUCT GUIDE—TPG-200C** (10 $\frac{1}{2}$ " x 8 $\frac{3}{8}$ ")—28 pages. Covers all RCA industrial-tube product lines. Gives a brief description of each product line together with quick-selection data. Single copy free on request.

● **RCA STORAGE TUBES AND CATHODE-RAY TUBES—STC-900B**—16 pages. Contains technical information on RCA storage tubes, special-purpose kinescopes and oscillograph-type cathode-ray tubes including display-storage tubes, radechons, scan-conversion tubes, flying-spot tubes, monitor, projection, transcriber, and view-finder kinescopes; as well as data on fluorescent screens. Price 20 cents.*

● **RCA TRAVELING-WAVE TUBE CLASSIFICATION CHARTS—MWD-101C—4** pages. Contains catalog-type data. Single copy free on request.

● **RCA PENCIL TUBE CLASSIFICATION CHARTS—MWD-102B—4** pages. Contains catalog-type data. Single copy free on request.

● **RCA CAMERA TUBES—CAM-600A—26** pages. Contains classification charts, defining data and typical characteristic curves for RCA image orthicons and vidicons. Camera tubes recommended for new equipment design are highlighted. Price 50 cents.*

● **VIDICONS—CAM-700—16** pages. Supplies tube selection guidance and data on RCA vidicons for commercial, educational, industrial, and military service. Also included are tube replacement information and typical vidicon characteristic curves. The information contained in this publication supersedes the vidicon section of the booklet CAM-600A. Price 30 cents.*

● **TECHNICAL BULLETINS—**Authorized information on RCA receiving tubes, transmitting tubes, and other tubes for communications and industry. Be sure to mention tube-type bulletin desired. Single-copy on any type free on request.

Semiconductor Products

● **RCA SEMICONDUCTOR PRODUCTS DATABOOK—SPD-100.** Two loose-leaf binders for standard 8½" x 11" data booklets with more than 900 pages of data and curves on RCA semiconductor devices such as transistors, silicon rectifiers, and semiconductor diodes. Available on a subscription basis. Price \$15.00* including service for first year. Also available with RCA Electron Tube Handbook HB-3 at special combination price of \$30.00.*

● **RCA SILICON CONTROLLED RECTIFIER EXPERIMENTER'S MANUAL—KM-71 (8¾" x 5¾")—136** pages. Contains 24 practical and interesting control circuits that can be built with a complement of active devices available in kit

form. Includes photographs, schematic diagrams, and descriptive writeups. Also includes brief descriptions of solid-state components used (rectifiers, transistors, SCR's) and short section on troubleshooting. Price 95 cents.*†

● **RCA SILICON POWER CIRCUITS MANUAL—SP-50 (8¼" x 5¼")—416** pages. Contains design information for a broad range of power circuits using RCA silicon transistor, rectifiers, and thyristors (triacs and SCR's). Gives design criteria and procedures for applications involving rectification, supply filtering, power conversion and regulation, ac line-voltage controls, rf power amplifiers, and control and low-frequency amplifiers. Shows design and practical circuits. Price \$2.00.*†

● **RCA TRANSISTOR MANUAL—SC-13 (8¾" x 5¾")—544** pages. Contains up-to-date definitive data on over 770 semiconductor devices including tunnel diodes, silicon controlled rectifiers, varactor diodes, conventional rectifiers, and many classes of transistors. Features easy-to-understand text chapters, as well as tabular data on RCA discontinued transistors. Contains over 40 practical circuits, complete with parts lists, highlighting semiconductor-device applications. Price \$2.00.*†

● **RCA TUNNEL DIODE MANUAL—TD-30 (8¾" x 5¾")—160** pages. Describes the microwave and switching capabilities of tunnel diodes. Contains information on theory and characteristics, and on tunnel-diode applications in switching circuits and in microwave oscillator, converter, and amplifier circuits. Includes data for over 40 RCA germanium and gallium arsenide tunnel diodes and tunnel rectifiers. Price \$1.50.*†

● **RCA SEMICONDUCTOR PRODUCTS GUIDE—SPG-201D (10½" x 8¾")—44** pages. Contains classification chart, index, and ratings and characteristics on RCA's line of transistors, silicon rectifiers, semiconductor diodes, and photocells. Price 75 cents.*

- **RCA DIFFUSED-JUNCTION SILICON RECTIFIER STACKS AND BRIDGES—SRS-300—10 pages.** Contains technical data on RCA's diffused-junction silicon rectifier stacks and bridges. Characteristics of basic rectifier circuits are also given to assist in selection of proper RCA rectifier device. Price 20 cents.*
- **RCA SMALL-SIGNAL SILICON N-P-N TRANSISTORS—SST-210—8 pages.** Contains technical data on 2N2102 family of silicon transistors including high-voltage types, very-high voltage types, linear-beta types, and general types. Also includes quick-reference guide. Price 20 cents.*
- **DESIGN OF TRANSISTOR SWITCHING CIRCUITS FOR DATA-PROCESSING EQUIPMENT—CTG-161—42 pages.** Gives design considerations for a variety of transistor switching circuits for data-processing equipment such as logic gates, flip-flops, and memory drivers. It includes a review of switching theory, design procedures, methods of specifying characteristics and ratings for computer switching transistors; examples of design procedures; typical circuits using RCA transistors; and a complete listing of RCA Computer Transistors with ratings, characteristics, and performance data. Price 75 cents.*
- **RCA MOS FIELD-EFFECT TRANSISTORS PRODUCT GUIDE—MOS-160—20 pages.** Includes comprehensive data on RCA dual insulated-gate and single insulated-gate MOS FET's in easy-to-find format plus background information on MOS construction and application. Price 20 cents.*
- **HEAT-SINK GUIDANCE FOR RCA THYRISTORS USING TO-5 AND "MODIFIED TO-5" PACKAGES—SCR-501—6 pages.** Application guide on heat-sink methods for RCA thyristors. Single copy free on request.
- **RCA HOMETAXIAL BASE SILICON POWER TRANSISTORS—HBT-400A—18 pages.** Contains data, dimensional outlines and theoretical information on homotaxial-base silicon power transistors. Price 30 cents.*
- **RCA LOW-NOISE COMMUNICATION-TYPE TRANSISTORS—CTG-165—** Contains quick-selection graphs and charts and capsule data for RCA Bipolar Transistors and MOS Field-Effect Transistors for Low-Noise VHF and UHF Communication and Industrial Instrumentation Applications. Includes special characteristics curves showing quick-selection chart containing curves, G_p (dB) and NF (db) vs. f (30 to 1000 MHz) for each listed transistor type. Single copy free on request.
- **MOUNTING HARDWARE FOR RCA INDUSTRIAL SEMICONDUCTOR DEVICES—MHI-300—4 pages.** Contains mounting information for RCA industrial transistors, thyristors, and rectifiers. Single copy free on request.
- **RCA RF POWER TRANSISTORS—RFT-700B—6 pages.** Contains data, selection guide, and a quick-selection graph on RCA "overlay" transistors. Single copy free on request.
- **RCA PHOTOCELLS—SOLID-STATE PHOTOSENSITIVE DEVICES—CSS-800A—32 pages.** Contains detailed and updated information on RCA cadmium-sulfide and cadmium-sulfo-selenide photoconductive-cell characteristics, an extended section on photoelectric measurements, a new section describing design, new circuits, and an extension replacement guide. Price 35 cents.*
- **RCA PHOTCONDUCTIVE CELLS—** File No. 312—8 pages. Contains descriptive material, characteristic curves, and classification charts on RCA cadmium-sulfide and cadmium-sulfo-selenide brood-area photoconductive cells. Single copy free on request.
- **RCA SILICON POWER TRANSISTOR APPLICATION GUIDE—ICE-215—28 pages.** For designers of industrial and military equipment. Discusses ratings, stability conditions, parameters and equivalent circuits. Includes design procedures and specific design equations for several transistor circuits. Price 50 cents.*
- **SILICON VHF TRANSISTORS APPLICATION GUIDE—ICE-228—20 pages.**

For designers of industrial and military equipment. This guide describes the capabilities of RCA silicon vhf transistors for application at frequencies up to 300 MHz. Includes typical circuits for the 2NF1491 family of silicon vhf transistors. Maximum ratings and characteristics are included. Price 50 cents.*

● **RCA THYRISTORS (SCR's AND TRIACS)—SCR-500A**—22 pages. Contains tabulated data, classification charts and dimensional outlines for all-diffused silicon thyristors. Price 40 cents.*

● **RCA TOP-OF-THE-LINE SOLID-STATE REPLACEMENT GUIDE—SPG-202-E**—48 pages. Lists 31 RCA "Top-of-the-Line" SK-Series replacement semiconductor devices which can replace more than 9600 types of transistors, integrated circuits, and rectifiers used in entertainment electronic equipment, including U.S.A. industry-standard (EIA) types, foreign types, and types identified only by device-manufacturers' part numbers. Price 15 cents.*

● **TRANSISTORIZED VOLTAGE REGULATOR APPLICATION GUIDE—ICE-254**—12 pages. Discusses transistorized voltage regulators of the series and shunt types. Includes design considerations, step-by-step design procedures, and the solutions to sample design problems. Price 20 cents.*

Integrated Circuits

● **RCA LINEAR INTEGRATED CIRCUITS—IC-41** (8¼" x 5½")—352 pages. Contains basic principals involved in design and application of linear integrated circuits—includes description of silicon monolithic fabrication process—derivation of design equations and performance criteria—schematic diagrams, operating characteristics, and performance data for RCA multiple-function silicon integrated circuits for a variety of linear applications. Price 2.00*†

Batteries

● **RCA BATTERY MANUAL—BDG-111** (10½" x 8¾")—68 pages. Contains in-

formation on dry cells and batteries carbon zinc, mercury, and alkaline types. Includes battery theory and applications, detailed electrical and mechanical characteristics, a classification chart, dimensional outlines, and terminal connections on each battery type. Price 50 cents.*†

● **RCA BATTERIES—BAT-134H** (10½" x 8¾")—36 pages. Technical data on 146 carbon-zinc, alkaline, and mercury batteries for consumer and industrial applications. Includes replacement information for 4000 portable radios, and cross-references 860 domestic battery types to their RCA replacements. Price 35 cents.*†

Test and Measuring Equipment

● **INSTRUCTION BOOKLETS** — Illustrated instruction booklets are available for all RCA test instruments at the prices indicated below.

- WA-44A (Audio Signal Generator)\$0.50*
- WA-44C (Audio Signal Generator)1.00*
- WO-33A (Super Portable Oscilloscope)1.00*
- WO-88A (5-in. Oscilloscope) ...0.75*
- WO-91A (5-in. Oscilloscope) ...1.00*
- WO-91B (5-in. Oscilloscope) ...1.00*
- WR-36A (Dot-Bar Generator) .0.50*
- WR-46A (Video Dot/Crosshatch Generator)1.00*
- WR-49A (RF Signal Generator)0.50*
- WR-49B (RF Signal Generator)1.00*
- WR-50A (RF Signal Generator)1.00*
- WR-51A (Stereo FM Signal Simulator)1.00*
- WR-52A (Stereo FM Signal Simulator)1.00*
- WR-61B (Color-Bar Generator)1.00*
- WR-64A (Color Bar/Dot/Cross-hatch Generator)1.00*
- WR-64B (Color/Bar/Dot/Cross-hatch Generator)1.00*

WR-67A (Test-Oscillator)	0.25*	WV-65A (VoltOhmyst†)	0.25*
WR-69A (Television/FM Sweep Generator)	1.00*	WV-74A (High Sensitivity AC VTVM)	0.75*
WR-70A (RF-IF-VF Marker Adder)	0.75*	WV-75A (VoltOhmyst†)	0.25*
WR-86A (UHF Sweep Generator)	0.50*	WV-76A (High Sensitivity AC VTVM)	0.75*
WR-99A (Marker Calibrator) . .	1.00*	WV-77A (VoltOhmyst†)	0.25*
WT-100A (Electron-Tube Micro Mho Meter)	1.75*	WV-77B (VoltOhmyst†)	0.25*
WT-100A (Electron-Tube Micro Mho Meter, Ser. No. 1001 and over)	2.00*	WV-77E (VoltOhmyst†)	1.00*
WT-100A (Tube Chart 1CE-163)	3.00*	WV-84C (Ultra-Sensitive DC Microammeter)	0.75*
WT-110A (Automatic Electron- Tube Tester)	0.75*	WV-95A (Master VoltOhmyst†)	0.25*
WT-110A (1CE-174 Card Punch Data)	0.25*	WV-97A (Senior VoltOhmyst†)	0.75*
WT-110A (1CE-234 Card Punch Data)	1.00*	WV-98A (Senior VoltOhmyst†)	1.00*
WT-115A (Color Picture Tube Tester)	0.50*	WV-98B (Senior VoltOhmyst†)	1.00*
WV-37A (Radio Battery Tester)	0.25*	WV-98C (Senior VoltOhmyst†)	0.50*
WV-37B (Radio Battery Tester)	0.25*	195-A (VoltOhmyst†)	0.25*
WV-38A (Volt-Ohm- Milliammeter)	0.50*		

* Trade Mark Reg. U.S. Pat. Off.

* Prices shown apply in U.S.A. and are subject to change without notice.

† Suggested price.

Index

- Amplifiers** 15
Audio-Frequency-Operated Switch (Circuit) 163
Audio Mixer, Compressor, and Line Amplifier (Circuit) 71
Audio Oscillator (Circuit) 60
Audio Power Amplifier (Circuit) 98
Automobile Light Minder (Circuit) 168
Automobile Tachometer (Circuit) 111

Base 6
Battery Charger (Circuit) 114
Bipolar Transistor 5

Channel 6,8
Chassis 24
Chassis Ground 27
Chip 11
Circuit Boards 24
Circuits, List Back Cover
Clock Circuits 18
Collector 6
Color Codes 35
Colpitts Oscillator 17
Common-Base Circuit 7
Common-Collector Circuit 7
Common-Emitter Circuit 7
Complementary Symmetry 98
Construction 23
Conventional Current 4
Current 4
Current Flow 4,6

Depletion Layer 4
Depletion-Type MOS Transistor 7
Die (Circuit) 131
Dip/Wave Meter (Circuit) 140
Dopant 3
Drain 6,8
Dual-Gate MOS Transistor 8
 Handling 28
Earth Ground 27
Electron Current 4
Enhancement-Type MOS Transistor ... 7
Enlarger Exposure Meter (Circuit) 78

Feedback 17
Field-Effect Transistor (See MOS Field-Effect Transistor)
Flasher (Circuit) 159
Flip-Flop 20
Forward Bias 4,6,7
Forward Blocking Current 10
Forward Breakdown 10
Forward Breakover Voltage 10
Frequency-Selective AF Amplifier (Circuit) 165
Fuzz Box (Circuit) 91

Gate 6,8
General Circuit Considerations 15
Grounding 27

Heat Sinks 26
Hole 3
Holding Current 11
Home Owner (Circuits) 45

Indicator-Lamp Driver 22
Integrated Circuits 18
 Handling and Mounting 28
 Circuit Application 58
 Soldering 29

Junction 3

Keysers (Circuits)
 Automatic 64
 Semiautomatic 62

Lamp Dimmer (Circuit) 81

Mechanical Considerations 23
Metal Detector (Circuit) 134
Metronome (Circuit) 102
Microphone 71
Microphone Preamplifier (Circuit) 69

Model Train and Race-Car		
Speed Control (Circuit)	156	
Moisture Controlled Switch (Circuit) ...	88	
MOS Field-Effect Transistor	6	
Circuit Application	71, 74, 140, 143	
Motor Speed Control (Circuit)	151	
Motorist (Circuits)	41	
Multivibrator (Astable)	19	
Music Lover (Circuits)	44	
NAND Gate	21	
Negative Bias	6	
NOR Gate	21	
Novelty (Circuits)	46	
N-Type Material	3	
OR Gate	21	
Oscillators	16	
Oscilloscope	39	
Phonograph Preamplifier (Circuit)	93	
Photocells	14	
Circuit Application	78	
Handling and Mounting	30	
Photographer (Circuits)	43	
Positive Action	21	
Positive-Action Light-Operated Switch (Circuit)	86	
Positive Bias	6	
Potential Gradient	4	
Power Supplies (Circuits)	48	
Pulsers	18	
P-Type Material	3	
Radio Amateur (Circuits)	42	
Radio-Frequency-Interference Filter ...	153	
Regenerative Switch	18	
Testing	35	
Reverse-Bias	4,6,7	
Reverse Blocking Current	10	
Reverse Breakdown	10	
Ring Counter	55,131	
Safety Precautions	30	
Semiconductor	3	
Sensors	14	
Series Regulator	16	
Shift Register (Circuit)	55	
Shunt Regulator	16	
Silicon Controlled Rectifier	9	
Testing	35	
Silicon Rectifiers	4	
Testing	33	
Simple Code-Practice Oscillator (Circuit)	58	
Single-Voice Organ (Circuit)	104	
Siren (Circuit)	116	
Slot Machine (Circuit)	118	
Soldering	25	
Source	6,8	
Space-Charge Region	4	
Substrate	8,9	
Suggested Circuit Uses	41	
Switches	18	
Tape Recording	71	
Temperature Alarm (Circuit)	82	
Testing and Troubleshooting	32	
Test Instruments	37	
Theory and Operation of Solid State Devices	3	
Thermistors	14	
Handling	29	
Thyristor	9	
Breakover Characteristics	11	
Time Delay (Circuit)	161	
Transistor		
Bipolar	5	
Dual-Gate MOS	8	
Handling	27	
Integrated	11	
MOS	6	
Testing	35, 37	
Unipolar	6	
Transition Region	4	
Triac	9	
Circuit Application	74, 81	
Current Capabilities	76	
Twin-T Bridge	18	
Universal Timer (Circuit)	74	
Variable Frequency Oscillator (Circuit)	143	
VFO Calibrator (Circuit)	147	
Voltage Variable Resistor	15	
Volt-Ohm-Milliammeter	38	
Volt-Ohm Meter	39	
Waves Shapes	32	
Wire Sizes	25	
Zener Diode	5	
Circuit Application	50	

Index of Circuits

Circuit No.	Description	Page
1.	Power Supplies	48
2.	Shift Register	55
3.	Simple Code-Practice Oscillator	58
4.	Audio Oscillator	60
5.	Semiautomatic Electronic Keyer	62
6.	Automatic Keyer	64
7.	Microphone Preamplifier	69
8.	Audio Mixer, Compressor, and Line Amplifier.	71
9.	Universal Timer	74
10.	Enlarger Exposure Meter	78
11.	Lamp Dimmer	81
12.	Temperature Alarm	82
13.	Positive-Action Light-Operated Switch	86
14.	Moisture-Controlled Switch	88
15.	Electronic Fuzz Box	91
16.	Phonograph Preamplifier	93
17.	Audio Amplifier	98
18.	Electronic Metronome	102
19.	Single-Voice Organ	104
20.	Automobile Tachometer	111
21.	Battery Charger	114
22.	Electronic Siren	116
23.	Electronic Slot Machine	118
24.	Electronic Die	131
25.	Metal Detector	134
26.	Dip/Wave Meter	140
27.	Variable-Frequency Oscillator	143
28.	VFO Calibrator	147
29.	Motor Speed Control	151
30.	Model Train and Race-Car Speed Control . . .	156
31.	Electronic Flasher	159
32.	Electronic Time Delay	161
33.	Audio-Frequency-Operated Switch	163
34.	Frequency-Selective AF Amplifier	165
35.	Light Minder	168

RCA