A thick black line drawing of a vomit splat, starting from the top center, curving down to the left, then curving back up to the right, and finally curving down to the right. The background is a dark green grid.

HOW TO GET
THE MOST
OUT OF YOUR
VOM

Tom Jaski

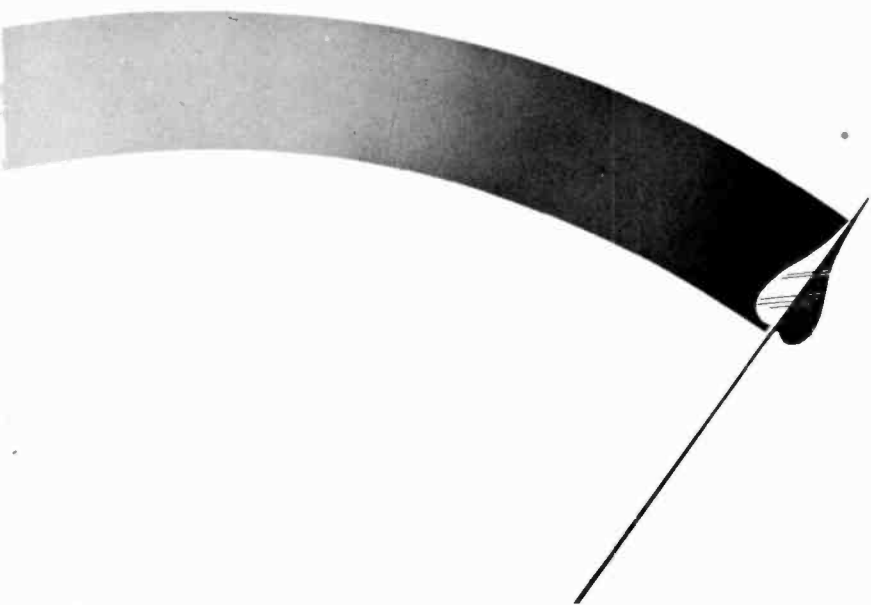

HOW TO GET THE MOST OUT OF YOUR
VOM

TOM JASKI

registered professional engineer
state of california

GERNSBACK LIBRARY, Inc.
NEW YORK 11, N. Y.



© 1960 Gernsback Library, Inc.
*All rights reserved under Universal,
International and Pan-American
Copyright Conventions.*

Library of Congress Catalog Card No. 59-12027

contents

chapter

page

1

The basic meter in the vom 7

The principle of the d'Arsonval type movement. Sizes and shapes of basic meters. Forces of attraction and repulsion between magnetic poles. Homogeneity of the magnetic field. Why we use external resistances. Accuracy of the meter. Calibration accuracy. Why and how we change meter scales. Nonlinear meter scales. Protecting the meter. Determining the rating of a meter. Balancing the meter. Moving counterweights. Selecting a meter.

2

Multirange meters 19

How to measure range. How to determine internal resistance. Making multirange current meters. Changing the meter range. Making low-resistance shunts. Establishing standards. Making voltmeters and multirange voltmeters. Making series resistors. Switching arrangements. Making ac voltmeters. Meter rectifiers. Finding the rms value. Using series resistors for ac and dc. Ac vs dc scales. Calibration of ac voltmeters. Ac calibration methods.

3

Ohmmeters and voltohmmeters 41

Series and shunt type ohmmeter circuits. Potentiometer type ohmmeter. Calibrating ohmmeters. Building your own instrument. Selecting the ranges required. Making meter scales. Photographic equipment. Applying decals. To buy or to build? High-accuracy ohmmeter. Increasing accuracy. Full-scale adjustment. Zero adjustment. High R test. Pin-jack vom. Voltage and current circuits. The Ayrton shunt circuit. Ohms network. Galvanometer. Calibrating the galvanometer.

4

Kit type vom's 71

Soldering. Rosin-core solder. Wiring. Choosing the kit. Meter sensitivity. Types of kits. Reverse-polarity switch. Using external multipliers. Output-measuring circuit. How to read decibel scales. What a logarithm is. The JND ("just noticeable difference"). Ratios. Point of reference. Exponentials. Relationships between power and voltage ratios and db's. Relationships between ac voltage and db scales. Pictorial wiring diagrams. Tools.

5

Commercial vom's 89

Variety of models, ranges and sensitivities. Full-wave bridge rectifier. Clamp-on ammeter adapter. Advantage of larger instruments. Switch doubles meter sensitivity. Thermal-compensating circuit. Germanium diodes protect meter. Separate test-lead jack for high-voltage and high-current ranges. A 100,000-ohms-per-volt meter. "Meter-open" position. Selecting an instrument. Imported instruments. Operation of the vom.

6

Extending ranges and making accessories 103

Measuring higher voltages. The high voltage probe for dc. The high-voltage probe for ac. Measuring lower voltages. Adding current ranges. Measuring higher resistances. Building the extender. Measuring lower resistance. Using ampere scales for measuring low resistance. Measuring capacitance. Using the vom to measure capacitance. The Morecroft method for electrolytics. Measuring inductance. Measuring rf voltages. Measuring power. Ac power.

7

Making practical measurements

127

Measuring with an "insensitive" meter. Testing batteries. Using the vom to check storage batteries. Checking B-batteries. Checking hearing-aid batteries. Checking transformers. Finding turns ratios and voltage ratings. 400-cycle transformers. Checking output transformers. Checking rectifiers and diodes. Identifying and checking transistors. The mystery component. Tube filaments. Appliance repair. Expanded scale for the vom. Detecting small changes in direct current and ac voltage.

8

The vom as a basic meter

145

The vom as a null detector. Wheatstone bridge. Null detection using a grid-dip oscillator. Grid-dip adapter. Lecher wire null detector. Vacuum-tube voltmeter adapter. Amplification for the vom. Transistor current amplification. Field-strength measurements. Calibrating the field-strength meter. Transistor tester using the vom. Checking vacuum tubes with the vom. Tube-emission test. Transconductance test. Amplification test.

9

The vom as a service instrument

167

The vom in ac-dc receiver servicing. Checking series filaments. Checking B-plus voltage. Checking the oscillator. Signal tracing and alignment. Checking AVC. Signal interference. Locating microphonic tubes. Using the vom in FM and TV. Adjusting the linearity coil. Audio amplifier in a TV set. Portable radios. Transistor receivers. Batteries. Testing power transistors. The vom in hi-fi. Tape recorder. Printed-circuit problems. Transmitters.

10

Miscellaneous applications

193

Measuring L and C. Measuring inductance by the parallel-resonance method. Measuring inductance by the series-resonance method. Using a nomograph. Using the capacitance scales to measure inductance. Phase-angle determination. Time measurements with the vom. The vom in the garage. Checking distributor timing. Regulator adjustment. The vom in the laboratory. Measuring the concentration of a solution. Level indicator. Measuring temperature.

Index

219

introduction

THERE are many possessions in life we see so frequently that we take them for granted. Like the modern automobile, we even manage to use them relatively efficiently, at least up to a point.

The volt-ohm-milliammeter or vom is one of these items. Many technicians and engineers learn how to use it for a limited number of measurements, without really understanding its versatility. Here then we want to tell you what the voltohmmeter consists of, how and why it works, what uses can be made of it, how to adapt it for other purposes not usually known, how to care for the instrument, how to check it for accuracy, how to use it in the many ways it *can* be used in servicing and constructing electronic equipment of all kinds.

It is absolutely no exaggeration to say that the vom is the instrument most frequently used by professional service technicians, engineers and maintenance men. From radio and TV repair to such fields as automotive electrical repair, the advantages of the vom are almost automatically realized and used without much conscious thought. It is for many the handiest instrument available, the first they will turn to in their work.

Vom's come in many sizes, shapes, ranges and price classes, and we will have something to tell you about the selection of the proper instrument for your purposes. But they all have similar characteristics in that they are applicable to many measurements (because of their many ranges) and they they need no power source, in contrast to their more expensive cousins, the vacuum-tube voltmeters. Incidentally, following trade practice, the vom (in this book) is variously referred to as an ohmmeter, multitester, multimeter and volt-ohm-milliammeter.

The fact that a vom needs no power source is one of its greatest advantages. For example, the marine radio technician, who must service small-craft radio equipment is not likely to find a 117-volt power source for instruments; thus whatever he carries he must be able to use without power. The mere fact that the instrument

must be carried around a lot, requiring ruggedness and light weight, again recommends the vom.

Then, too, the vom can be relatively inexpensive, and is the first instrument to be purchased or built by the ham, experimenter and hobbyist. It can, for them, form the basis of many other instruments, and we will tell you something of how this is done. Laboratories, rather than purchase many single-range instruments, often use many vom's, when their accuracy is sufficient. In this way they save a great deal of money since they have "many" instruments available in one case.

Besides the commercial units, there are many types of vom kits, and we will take a look at those. In addition there are a number of ways of building your own vom with basic instruments. The ranges of the vom can be extended, to read higher voltages, higher resistances and, in many cases, lower voltages without necessarily making a vtvm out of the instrument. We will discuss the various ways of doing all this.

The vom of course has some limitations. There is, for example a finite, and not always very high, input resistance to the instrument, so that it may present a load to the circuit to be measured. This and the effects you may have to consider will be discussed in some detail. The ac ranges of the instrument may have some limitation as to frequency, so that the unit may become less accurate at higher frequencies, and may not be very useful at very high frequencies.

Because it is a rugged and multipurpose instrument, some compromise has had to be made with accuracy and, although the vom is certainly sufficiently accurate for almost all practical purposes, it must not be regarded as a laboratory standard, unless it is especially calibrated for this. There is, too, the disadvantage that generally, as the higher resistances are measured, the scale becomes more crowded, more difficult to read. This can be avoided in expensive bridge type instruments only. But there is a saving grace. You can use the vom to build your own resistance bridge.

Several books could be written on *specific* applications of the vom: we have limited this one to the most useful and general practical applications, hoping that when you have finished reading it, you will have gained new skills and a new respect for this jack-of-all trades in the electronics and electrical world.

TOM JASKI

the basic meter in the vom

THE basic meter in all voltohmmeters is the well known moving coil or d'Arsonval type movement, named after the French physicist Jacques Arsene d'Arsonval. As early as 1882, this scientist made an instrument which he called a "reflecting galvanometer." Instead of a pointer, the instrument had a small mirror attached to its coil. The mirror reflected a beam of light and, as the coil and mirror turned, the reflected beam turned with it. A scale mounted at some distance from the mirror showed a spot of light traveling from one position to another. The amount of travel indicated the rotation of the coil and, therefore, the current through it.

The first question we can ask of course is, "What makes the coil rotate?" Let us begin with magnets. Magnets have two poles, North and South, named after the poles of the earth. Two poles which are alike—the North poles of two magnets, for example—repel each other, and two poles which are opposite, a North and a South, attract each other.

We have learned by experience (we cannot *really* explain it) that when we pass an electric current through a coil of wire, the coil becomes a temporary magnet with a North and a South pole. If we suspend such a coil (on pivots) in a magnetic field (supplied by a permanent magnet) the coil (Fig. 101) will tend to rotate when we pass a current through it. The temporary North pole is attracted to the South pole of the permanent magnet and repelled by its North pole. The opposite happens to the temporary South pole. If we make the coil turn against a spring, the spring will

resist more as we rotate the coil. To make the coil turn more we must send a stronger current through it, creating greater attraction and repulsion forces in the field.

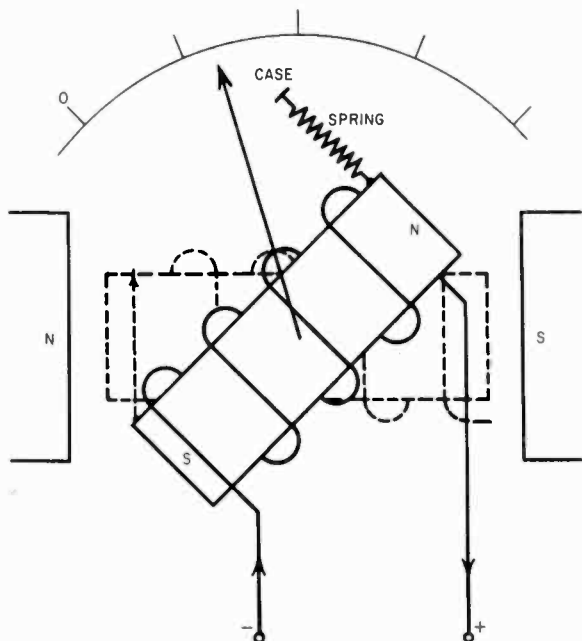

Fig. 101. The principle of the d'Arsonval meter is a rotating coil in a magnetic field. The coil is wound on a rectangularly-shaped aluminum bobbin mounted between the poles of a permanent magnet. The meter works because of the forces of attraction or repulsion between magnetic poles.

Thus, the coil's rotation is directly proportional to the current through it for a given magnetic field strength. When we turn off the current, the coil, pulled back by the spring, will resume its original position. If we were to reverse the current, the coil would rotate in the opposite direction. Thus we must always make sure the current in a d'Arsonval meter goes in only one direction, so that the pointer will deflect to the right, and not to the left.

It takes a lot of refinements to make a d'Arsonval movement from the crude idea of Fig. 101, but the principle is all there. One refinement is that we make the field of the magnet in which the coil rotates as uniform as possible. This is done by shaping the pole pieces so that the coil can rotate just inside of them. The space between the poles contains a soft-iron cylinder, which just

allows the coil to rotate around it. This is shown in Fig. 102-a. This homogeneity or "sameness" of the field assures that the contribution of the magnetic field to the rotation of the coil is always

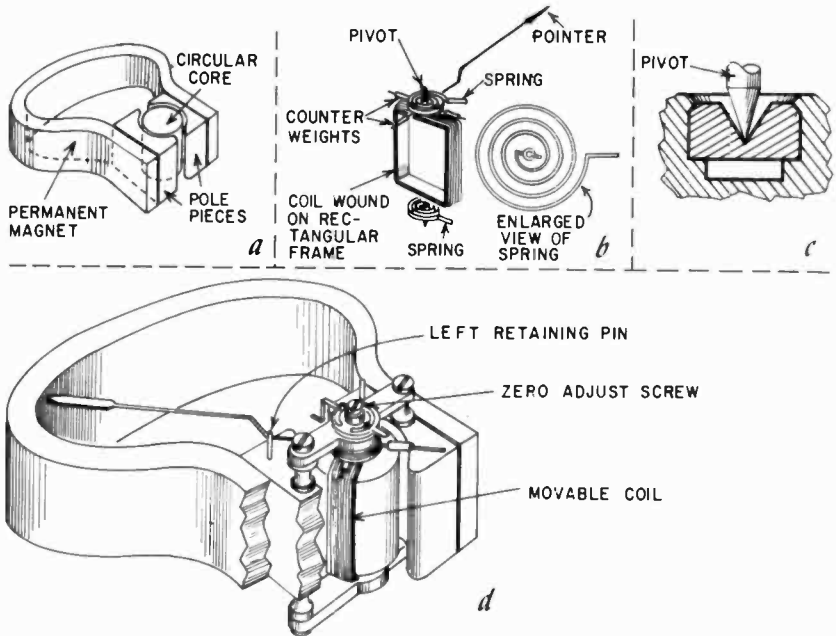

Fig. 102. Interior view and construction details of the moving-coil meter. A well-constructed meter is a precision instrument. The internal resistance of the meter is the dc resistance of the coil wound on the bobbin.

exactly the same, making the rotation the indication of the amount of current in the coil only. (Sometimes, for special reasons, this is not done, but in vom's we always have "linear" meters.)

The coil is mounted on small shafts which are supported in jewel bearings (see Figs. 102-b and -c). The springs are two small bronze spirals which are also used to carry the current to the coil.

To be useful, the coil must have a pointer. The longer the pointer is, the easier it is to read the rotation of the coil. Theoretically, we can make the coil itself perfectly symmetrical, and it would make no difference in which position we used it. But with the long pointer attached to it, the meter would tend to deflect simply from the weight of the pointer. We could counteract this by using strong springs, but then the meter would show a different reading for the same current, when held with the face horizontal

or vertical. In one case, gravity would not help, and in the second case it would.

The only alternative is to counterbalance the weight of the pointer so that the meter will show exactly the same deflection for the same current in all positions. We do this with little weights

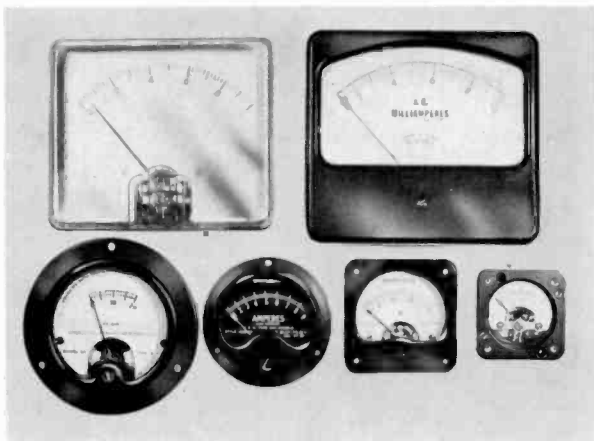

Fig. 103. Basic meters are available in many sizes and shapes. As an indication of size, the unit shown at the top left is a 4-1/2-inch rectangular type; that at the bottom left is a 3-inch round while the one at the bottom right is 1-5/16-inches square.

on a crossarm, shown in Fig. 102-b. By positioning these small weights for exact balancing, we can make the meter read precisely the same in all positions, even upside down.

The magnetic field created in any coil is proportional to the current through it and to the number of turns in the coil; this is what we call *ampere turns*. If we wind more turns on the coil bobbin, it will take less current to get the same amount of coil rotation or pointer deflection. With more turns in the coil, the meter will be more *sensitive*. The coil is made with very thin wire, and this wire has quite a bit of resistance. Sensitive meters have a higher coil resistance. We call this *internal* resistance to avoid confusion with other resistances we will use with meters.

Instruments can be selected for their sensitivity. But we must remember that one thing does not change much from meter to meter and that is the friction in the bearings. For very sensitive meters, the bearings must be more precise, reducing the friction. Some meter bearings are as accurate as and have the same quality as watch bearings, making the meters very expensive and also quite delicate.

Meters may also be selected for their size. Fig. 103 shows some of those available. The larger the meter, the longer the pointer, and thus the easier it is to read accurately. But, again, when we have a long pointer, a relatively small force could bend it, and the large meters are, therefore, more delicate than the smaller ones.

Even if you buy a factory-made instrument, you will be concerned with the sensitivity of the meter in it, for the resistance of the unit (which will "load" the source you are measuring) will be a function of the sensitivity of the meter.

Why we use external resistances

Deflection is proportional to the current through the coil, and *only* the current. As a meter, then, it can measure only current,

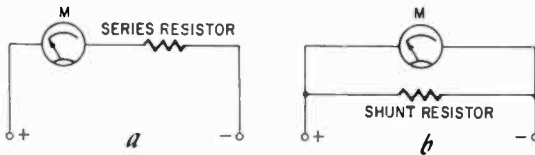

Fig. 104. To measure voltage (a) we use a series resistor to reduce the amount of current flowing through the meter coil. To measure a large current (more than can be permitted to pass through the meter) we shunt part of it through a resistor in parallel with the meter (b). Series and shunt resistors are changed by a range switch on the front of the *van*.

and only as much current as will deflect the pointer the entire scale length. This is a very limited amount at best. Should we want to measure voltage, we will have to measure the current this voltage creates in the coil. Usually this will be much more than the coil can handle. The pointer will bend against its stop, and eventually the coil would get hot and burn. We can reduce the current by putting an *external* resistance in series with the coil, thus reducing the current according to Ohm's law. The more sensitive an instrument is, the more resistance it will need externally. We will discuss in the next chapter how much resistance to use.

Let us look at another way to reduce the current in the meter coil. When we were interested in measuring voltage, it did not matter exactly what the current was so long as it was *proportional* to the voltage, and we could read the deflection of the pointer on the scale as *voltage*. But suppose we want to measure current of a greater magnitude than the meter coil can handle. We might get another meter, but there is a simpler way. We can let only a

part of the current go through the meter, and the other part we send through a resistor. This resistor, which we call a shunt, must be in parallel with the meter. With a shunt, we can make any moving-coil meter capable of "reading" a larger current than its coil can handle. Fig. 104 shows the two basic situations schematically.

Accuracy of the meter

There are several kinds of accuracy with which we are concerned. Some of these are inherent in the basic meter. The first of these is what is called "repeatability," meaning that the meter shows exactly the same deflection for the same kind of current. This depends on the smoothness of the bearings and other mechanical features, such as the springs, etc. Repeatability is a built-in characteristic and is generally quite good. Full-scale repeatability accuracy of a meter is often within 1%.

Next, if we consider the factors which determine deflection, you can see that if the magnets in meters vary a little bit in their strength, the meters will also vary a little bit in their indication of current. Thus, here is another item of accuracy, which we call *calibration* accuracy. For example, a 50-microampere instrument may actually deflect full scale with only 48 μa . There are two ways to do something about this kind of accuracy. In the example mentioned, we could supply the meter with a new scale, which reads 48 microamperes full scale. Or we could shunt the meter with a resistance of such a value that, when the meter reads 50 μa , 50 μa is actually going through the combination of meter and shunt. Both methods are used to provide calibration accuracy for meters, although the latter is more often used commercially.

In a voltohmmeter, calibration accuracy will be a function, not only of the meter itself, but also of all the external resistances used with it. The more accurate our resistances, the greater the calibration accuracy. This is something which we can control.

Why and how we change meter scales

One reason for changing meter scales was mentioned—changing *calibration*. Meters are basically current-measuring instruments, and so their scales are made to read current in microamperes, milliamperes or amperes. But suppose we want to read voltage only. It would then be much more convenient to have a scale reading in volts. What's more, frequently we like to read voltage in steps of 3 to 1, in other words, as 1 volt, 3 volts, 10 volts, 30 volts and so on. In that case, we would need at least two scales, one with

a number of divisions which is a multiple of 10, and one with a number of divisions which is a multiple of 3.

New scales for meters can be made in many ways. You can draw them on paper and paste them over the old scale. Or you can make them photographically. You can even buy meter scales and decals to make new scales. Whichever way the scale is made, to install it, the meter must be opened up, the existing scale removed, modified or replaced.

This is a rather delicate job. First, you must remove the screws that hold the movement in its case. Do this only on a bench which

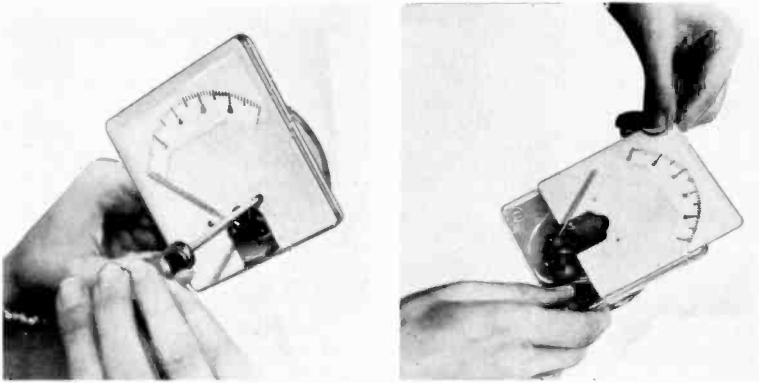

Fig. 105. The meter face is generally fastened to the meter movement by two small machine screws. These are being removed as shown at the left. After the screws have been taken out, slide (do not lift) the meter face out as shown in the photo at the right. This job must be done carefully or the meter pointer will be bent.

is spotlessly clean, for particles of dirt or dust which get into the movement are extremely hard to clean out. Worse, if there are any iron particles about, they will be attracted to the magnet and become almost impossible to remove.

After the movement is out of the case or, in some meters, after the cover is removed, the next step is to take out the two screws that hold the meter scale in place. The scale is usually a thin sheet of brass with the scale printed on it. Next, carefully slide out the scale, and do whatever modification you need to do on it. The last two steps are shown in Fig. 105.

After changing the scale, the whole thing has to be put together again. This is delicate work, for the pointers in meters are made from a very thin piece of aluminum, not much thicker than foil, and are easy to bend. Once bent, they are very difficult to straighten, partly because the cross-section of a pointer is not flat,

but curved for strength. So be very careful with the pointer. When you work on a plastic-front meter (Fig. 105) be very careful not to scratch the front face; scratches will mar the meter permanently, for there is no good way to remove them.

Since the need to change scales on meters is so common, one manufacturer has designed a meter on which the scale and face

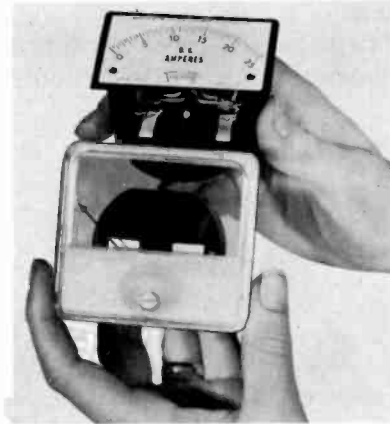

Fig. 106. This meter is designed for easy interchangeability of scales. (Triplet Electrical Instrument Co.)

can be changed easily. The same scale can be used with different movements or, the same movement with different scales (Fig. 106).

Sometimes you may need several scales at once, depending on the ranges you choose. The selection of the proper scales with the choice of accessory resistors will be discussed in Chapter 2. Here, in Fig. 107, we show some of the scales you might have to use. The divisions in the 3, 30 and 150 scales are multiples of 3; in the 1, 5, 500 scales, multiples of 5. The logarithmic scale is used for decibels, which is a logarithmic function and which we will later discuss in detail.

Still other kinds of scales are needed for resistance measurement. These are what we call nonlinear scales: the divisions at one end are not the same length as on the other. The reasons for this will become clear when we discuss ohmmeter principles. Sometimes other scales, such as the low-voltage scales on a meter, are nonlinear, due to certain characteristics of the rectifiers involved.

Notice that all the scales shown encompass a total angle of only 90° . In Fig. 102-d the supports are shown for the coil bearings

above and below the magnet. There are also supports for the central core, which are part of the cut-away section and therefore not shown. Obviously the pointer could not pass by these supports

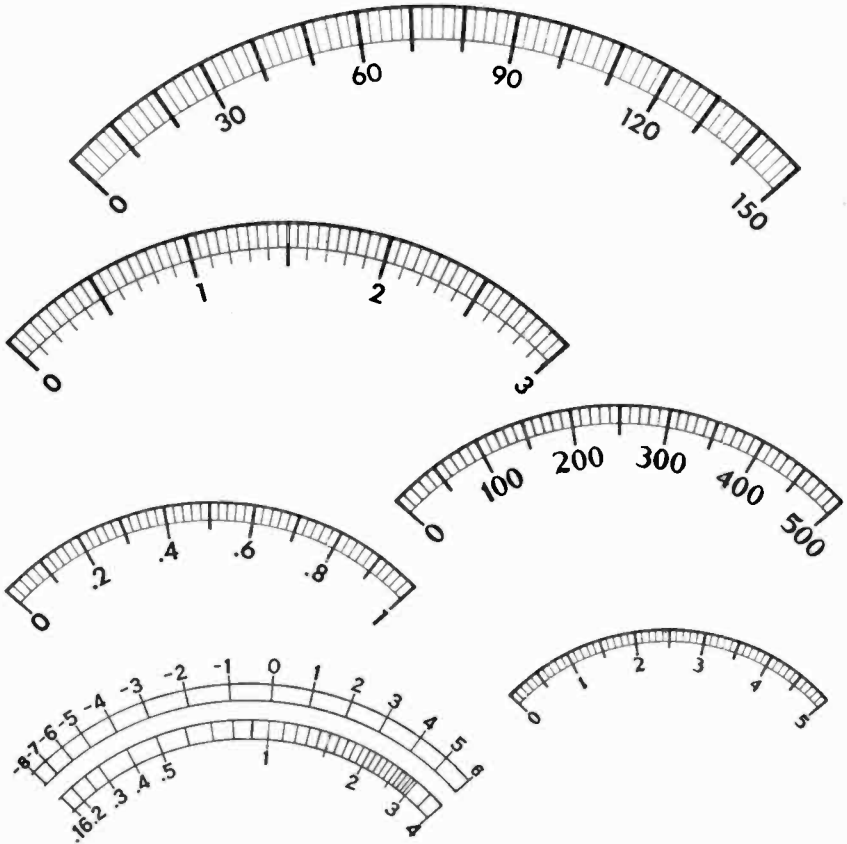

Fig. 107. Representative types of scales used with the vom. These fall into three different categories: linear, nonlinear and logarithmic. Linear scales are used for measuring voltage and current, nonlinear scales for measuring resistance and logarithmic scales for db. (Only linear and log scales are shown here.)

for the bearings, nor the coil by the support for the central core, so the rotation of the coil is restricted to less than 100° . Some special meters have been designed to rotate as much as 240° , but these are large rugged panel types not generally used for unit instruments.

Protecting the meter

Because of the delicacy of the pointer and the thinness of the coil wire in a meter, we will want to include some sort of protec-

tion for the movement. Mechanical protection is not easily built in. If you drop a meter it will probably never be the same.

Electrical protection is much easier to come by. We can simply fuse the meter. This is common practice for expensive sensitive instruments. Fuses are available for as little as 2 milliamperes. For a sensitive instrument this may sound a high value, but these are very fast acting fuses and will blow before serious damage is done to the meter. Often meters are protected by being connected in the circuit in such a way that the bare meter terminals never are available to the outside; in other words, there is always a series resistor or shunt present. This can be detected, for example, when you have an instrument with a 200-microampere movement, yet the lowest current rating of the voltohmmeter is 250 μ a or some other higher value.

The rating of a meter is easily determined from the instrument's specifications. These usually state that the meter is so many ohms per volt. This means that, on a specific scale, the total resistance of the instrument is the voltage rating of that scale multiplied by the listed ohms per volt. For example, a 20,000-ohms-per-volt meter means that, on the 1-volt scale, the meter will have a total resistance of 20,000 ohms. From Ohm's law then you know that the instrument has a $1/20,000 = .00005$ ampere, or 50-microampere, meter.

Balancing the meter

Normally, all meters are carefully balanced at the factory. But, when the meter undergoes a certain amount of handling, as when scales are changed or when the meter is moved around a good deal while being built into a cabinet, it is possible for the coil and pointer combination to get out of balance. This is easy to ascertain. If the meter points exactly to zero when the face is horizontal, hold it up with the face vertical. Now rotate the meter slowly and see if the pointer changes position from the zero mark. If it does, the meter is out of balance. If the unbalance is minor, say one division, it would hardly pay to experiment with the balancing. But if the unbalance is serious, you may have to consider balancing. However, if the balance weights are cemented in place it is a job for an expert.

Balancing is not difficult, but it is a delicate and possibly tedious task. Start with a spotlessly clean bench, and remove the meter from its case. In Fig. 108, we have redrawn the balancing cross also shown in Fig. 102. Weight A counterbalances the weight of

the pointer when it is in a horizontal position, and the combination of A, B and C together counterbalance it in any other position. With the meter face vertical and with the 0 mark and the pivot in a horizontal line (see Fig. 108-b), observe the pointer. If it sags off scale, weight A must be moved *out* from the pivot. If the pointer moves *up scale*, weight A must be moved *in* toward the pivot. When this balancing is precise, rotate the meter to the position shown in Fig. 108-c. Now if the meter pointer moves to the

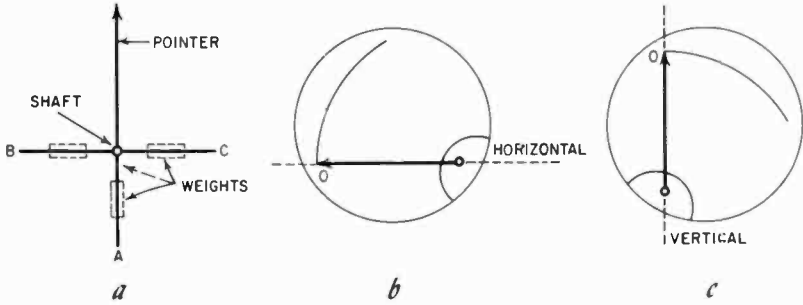

Fig. 108. Tiny weights are used to counterbalance the pointer. The first illustration (a) shows the general relationship of the weights to the pointer. The pointer should rest on the zero mark when the meter is in either the horizontal position (b) or in the vertical position (c).

left, off scale, either weight B must be moved in toward the pivot or weight C out from the pivot. It does not matter which, since the effect of either is the same in terms of balancing moment at the pivot. However, it is best to keep the distances of the counterweights from the pivot approximately equal.

After this you may have to repeat the first balancing. Be sure in any case to check it. These balance arms are extremely delicate, so be careful how you go about moving the weights. They can be pushed along the arm with the tip of a small screwdriver. Hold the pointer cross in one position by the balancing arm A, *not by the pointer!!* After balancing, you probably will also have to reset the zero adjustment. This is easily done from the front of the meter, after the movement has been replaced in its case. When replacing the movement, be sure that the zero-adjustment pin slips between the sides of the zero-adjustment bracket. This bracket changes the zero position by changing the fixed attachment point of the top spring a little, thus altering the tension of the spring, which pulls the coil and pointer with it (see Fig. 102).

Selecting a meter

Although many excellent factory made types and kit types are available, you may decide to build your own voltohmmeter. The problem of selecting a meter immediately arises. This is not only a technical choice, but also involves the problem of how much you are willing to spend.

There are so many possible choices of meters that only a few general rules can be set down. First of all, do not buy a meter of greater sensitivity than you need. The more sensitive, the smaller the load on the circuit—but one disadvantage is the great resistance which will be needed for higher voltage ranges, since precision resistors of higher values will also be more expensive.

The size of the meter must be considered. If you want accuracy and readability, the largest meter is just good enough. But the instrument will then also be large. If you want a rugged, handy pocket instrument, the meter will have to be small, and you will sacrifice some accuracy in your measurements. If you want reasonable accuracy and yet portability, a 3-inch round or 4-inch rectangular meter is about the best choice.

Making your own voltohmmeter is a lot of fun, but also a lot of work, and you will not be able to save any money over the kit type instruments offered. But if you need special ranges, you will find in the following chapters all the information you will need to build many kinds of vom's.

A word of caution: Whenever building any equipment including a meter, avoid inserting the meter until the last possible moment, thus avoiding damage to the delicate meter or scratches to its face if it happens to have a plastic front.

multirange meters

THE basic meter we have discussed can be used to build many measuring instruments. The choice will depend on what is to be measured, but you will always have to have certain information about the meter you are going to use. You will need to know its full-scale range and its internal resistance. These can be established with very simple tools. Fortunately, the majority of d'Arsonval meters come in standard ranges. Once you have established the *approximate* full-scale range of the meter, you can with confidence assume it is the next standard range. These standard ranges are: 20, 50, 100, 500 microamps (occasionally you may encounter a 10- or 30- μ a instrument, but these are rare); 1, 2, 3, 5, 10, 15, 25, 50 and 100 milliamperes. Anything over 5 ma is unsuitable for vom's, and even that is high. But the ranges are listed because you may have to recognize *unsuitable* meters as well. If you buy a new meter, you will certainly know its range and probably also its internal resistance. But if you find a meter in surplus or salvage one from a used piece of equipment, you probably will know neither.

How to measure range

To measure the approximate range of a meter, all you need is a fresh flashlight cell and a handful of resistors. As shown in Fig. 201, connect the resistors in series with the meter, beginning with the highest resistance, until you have obtained nearly full-scale deflection. Start with the highest resistor to prevent overloading the meter and possibly damaging it.

By referring to table 2-1 you can determine the range of the meter. (For example, if a meter deflects full scale with 3,000 ohms in series, it is a 500- μ a unit.) Be sure to observe polarity marks

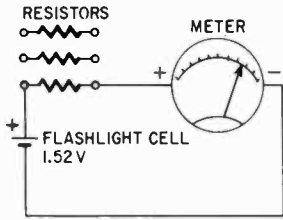

Fig. 201. You can determine the full-scale range of your meter by using the appropriate series resistors.

on the meter. These will appear on or near the terminal studs; the positive pole will be marked with a +. On the battery cell, the center small rod is always the +.

How to determine internal resistance

To find the internal resistance of the meter, use similarly simple tools. A fresh flashlight cell is the first one. A fresh cell always has

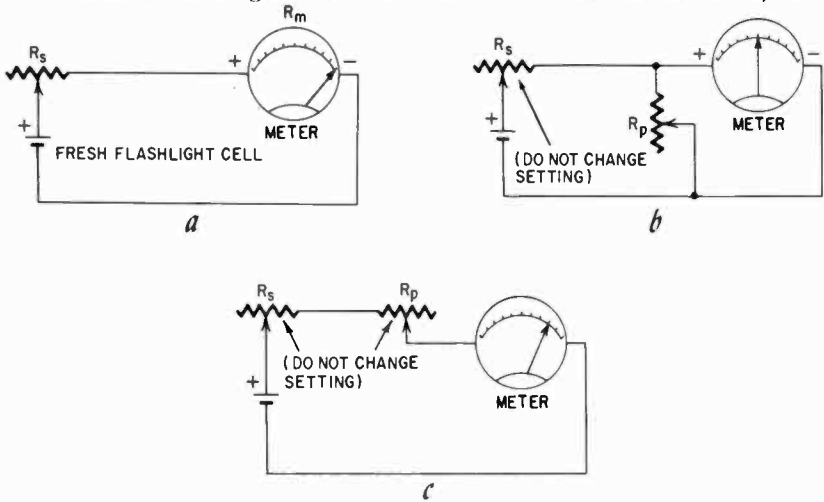

Fig. 202. Steps in finding the internal resistance of a meter. First (as shown in a) adjust R_s for full-scale deflection. Now add R_p (see b) and adjust for half-scale deflection, but do not touch the setting of R_s . Finally (drawing c), put R_s and R_p in series with the meter and then read the deflection.

a voltage of 1.52. This varies practically not at all and, with the small loads you will be applying, it can be used intermittently for hours without losing much of its voltage.

Next you will need two potentiometers. One (R_s in Fig. 202) must be at least the same value as the resistor shown in table 2-1

for that particular meter. Thus, for a 500- μ a meter the rheostat or potentiometer should be at least 3,000 ohms. You will probably use a 5,000-ohm pot for this. The other one, which we will call R_p , must be about the resistance you believe the meter to have.

Table 2—1. Series resistors and current ranges for full-scale deflection

meter range	resistance in ohms for full scale at 1.52 volts
20 microamperes	75,000
50 "	30,000
100 "	15,000
200 "	7,500
500 "	3,000
1 milliampere	1,500
2 milliamperes	750
5 "	300
10 "	150
15 "	100
25 "	60
50 "	30
100 "	15

Table 2—2 shows some of the common values for popular brands of meters. You can see that for one range the internal resistance does not vary too much. For 500 μ a this is 80 to 500 ohms. For R_p we would then select a potentiometer of 500 ohms.

Table 2—2. Approximate internal resistance of representative meters

make	microamperes					milliamperes			
	20	50	100	200	500	1	2	5	10
Burlington	—	1,150	1,150	330	225	46	—	10	5
Emico*	—	—	—	—	—	900	—	1,250	430
General Electric									
type DO-41	2,000	2,000	1,600	360	250	70	30	7	4
Marion									
53 SN	1,750	1,750	1,000	500	300	50	—	10	5
Shurite	—	—	—	—	—	1,000	—	3,475	870
Simpson	—	2,000	2,000	1,000	200	46	—	23	7
Triplett	—	1,770	900	360	156	55	—	8.5	3.1
Weston									
type 301	1,520	1,140	600	660	195	105	27	5.7	2.0
Weston									
type 801	—	900	1,100	400	80	80	—	2.4	1.25

*These are *not* d'Arsonval type instruments. Note the increase in internal resistance.

Now proceed as illustrated in Figs. 202-a, -b and -c. First, as in Fig. 202-a, adjust the potentiometer until you get exactly full-scale deflection. Now add R_p in parallel with the meter, as shown in Fig. 202-b, and adjust R_p for exactly half-scale deflection on the meter, leaving the adjustment of R_s strictly alone. Some of the current will be going through the potentiometer and, when the meter shows half the current, the current through the potentiometer will also be half, and thus its resistance will be exactly equal to the meter's internal resistance. But we still have to determine what it is.

This we do next by connecting R_s and R_p in series with the meter, as shown in Fig. 202-c. The adjustment of the two potentiometers *must not be changed when you do this*. Divide the battery voltage, 1.52, by the meter full-scale current in amperes. Now read carefully what the meter deflection is. Next, divide the voltage by the current noted on the meter, also in amps. Subtract the second figure from the first, and *the difference is twice the meter's internal resistance*. Here's an example of how this works:

Suppose you have a 500- μ a meter. As in Fig. 202-a, adjust R_s for full-scale deflection. You now have in the circuit both R_s and the meter resistance, which we will call R_m . The current (.0005 amps) goes through both: $1.52 / .0005 = 3,040$ ohms, or $R_s + R_m = 3040$. Next suppose in Fig. 202-c you read the meter at 0.9 of full-scale, or 450 microamperes. $R_p = R_m$, therefore $R_s + 2R_m = 1.52 / .0045 = 3,377$ ohms. We can expand this to read $R_s + R_m + R_m = 3,377$ ohms. Since $R_s + R_m = 3,040$ ohms we can substitute this and we then have $3,040 + R_m = 3,377$. Transposing, we have $R_m = 3,377 - 3,040 = 337$ ohms.

The accuracy of this measurement depends on two things: how fresh the flashlight cell is, and how accurately you can read the scale of the meter. In Fig. 203, a scale is shown which might be used in a 500- μ a meter; the arrow near the 5 shows what your second reading would have looked like. The other arrow is shown to explain how to read the meter as accurately as possible. The scale has five major divisions, each of which represents 100 μ a. Each major division is divided into five equal parts, and thus each of these divisions represents 20 μ a. Because the second arrow is shown in the fourth major division, the first digit to read is 3. The arrow is also two-thirds of the way in the first small division, which is then $2/3$ of 20, or about 13.3 μ a. Round this figure off and, with the pointer in this position, you would read 313 μ a.

There are other ways of determining the internal resistance of meters, but they presuppose the availability of other meters calibrated and ready to use. For example, with an ohmmeter you could simply read the resistance of the shunt, R_p , after you had adjusted it for half-scale deflection on the meter. On the other hand, the method discussed requires nothing but one standard—a fresh flashlight battery—and some careful work in reading the meter.

Making multirange current meters

Most meters in use actually indicate currents other than their original range, by means of shunts and other accessories. If you

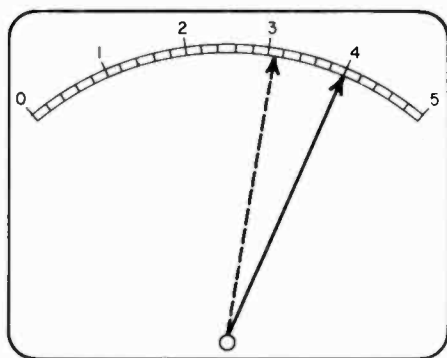

Fig. 203. How accurately you determine the internal resistance of a meter depends in part on how carefully you read the meter scale. The type shown here is linear. Each small division has a value of 20 microamperes. Full-scale deflection is 500 microamperes.

consider the economics of it, the reason becomes obvious. With a 1-ma meter we can read ranges of 1, 10, 100 ma and 1 amp, or more, simply by using an inexpensive external shunt. The manufacturer therefore needs to make only 1-ma movements for all these ranges, and can do it more economically by far.

To make a meter indicate half the current from the same supply or to extend its range to twice the original value, shunt the meter with a resistance exactly equal to its internal resistance. Similarly, to make a meter usable on a range five times as large, bypass 4/5 of the current through a shunt. The meter takes 1/5, and the ratio between the shunt and meter resistances is the reciprocal of the current ratio, or 1 to 4. In other words, the shunt

must be $1/4$ the resistance of the meter. For 10 times the original range, the shunt must then be $1/9$ the meter's internal resistance.

Changing the meter range

Knowing the internal resistance, you can figure any shunt needed to change the range of the meter. For example, let's consider the 1-ma movement in Table 2-2 that has an internal resistance of 46 ohms. To make a 10-ma unit out of it, we would shunt it with $46/9$, or 5.11 ohms.

There are several ways to obtain such a resistance. We could buy one for example. Another way would be to make the shunt. In this case, if you made it from copper wire, use 15 feet, $8-5/8$

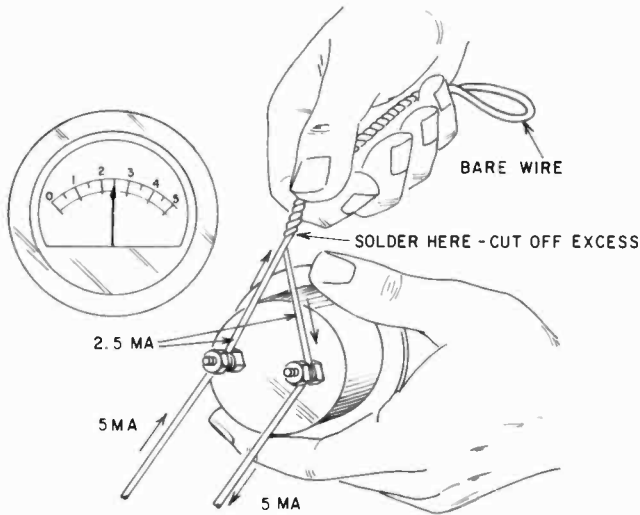

Fig. 204. One method of making a low-resistance shunt. With current passing through the meter, twist the bare wire forming the shunt until the meter passes the correct amount of current.

inches of No. 34 AWG wire, which at room temperature would have very nearly 5.1 ohms resistance. But there is the problem of "at room temperature." If the temperature varied considerably, so would the resistance of the copper wire. For this reason, precision resistors are wound from a wire called Manganin, which is hardly affected by temperature and has about 400 times as much resistance as copper, making it much easier to use. Manganin, or its cousin, Nichrome, which is just about as good, can be obtained from electrical supply houses, but is not otherwise generally available. However, for making a few shunts, you will need only a

small quantity, and you can obtain some from an appliance repair shop by asking them for burned-out toaster, flatiron and heater elements. They are made from Nichrome or similar wire.

Particularly if you intend to make the meter read very high currents in comparison with its original range, you may have to make your own shunts. To make a 1-ma meter read 1 ampere full scale, you must bypass 999 ma. In other words, your shunt would have to be $46/999$, or .046 ohms approximately. You will not find a ready-made precision resistor to do this job. You'll have to make it yourself.

Making low resistance shunts

To make such a low-resistance shunt you can use several methods. One is illustrated in Fig. 204. A copper wire has been attached to each meter terminal, and the wires twisted together, while

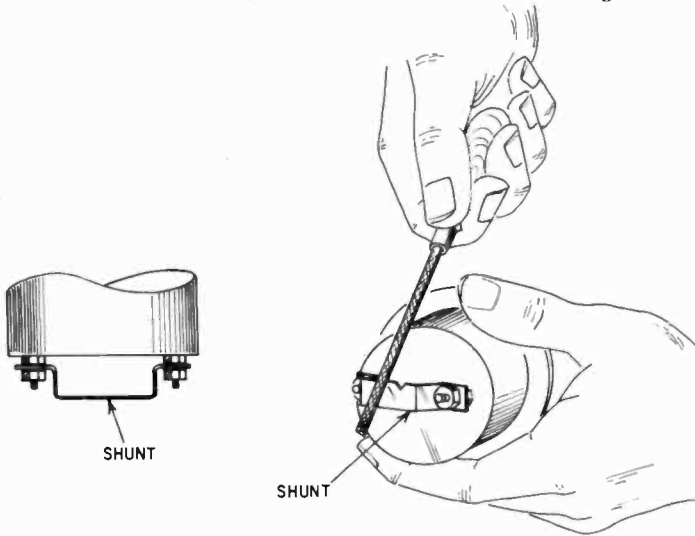

Fig. 205. The shunt must be able to pass its current without an increase in temperature. A substantial shunt is needed for heavy currents (several amperes or more). A copper bar makes a good shunt. Keep filing the bar until the meter reads the correct amount of current. Drill minimum clearance holes for mounting the shunt on the meter. This will permit maximum copper contact between the meter and the shunt. Use flat washers on both sides of the clearance hole on the shunt.

a current goes through the meter. When the wires have been twisted enough, the meter will show the correct current, and you can solder the twisted ends and cut off any excess wire. If you were to make, say, a 1-amp meter this way, you'd calculate the

approximate length of wire needed and make the two pigtails somewhat longer. Then use a current of 1/2 ampere or some such value, and twist the wires together until the meter reads the exact value of the current you are applying.

Notice that in Fig. 204 only one continuous wire is used. This prevents the danger of opening the shunt while the heavy current is on. Opening the shunt under those conditions might well burn out the meter.

Another way to make a heavy shunt accurately is shown in Fig. 205. Here the meter terminals have been paralleled by a heavy wire or bar. With a small file, the cross-section of the bar can be diminished. As it is reduced, the resistance goes up, until the meter reads the correct current value. This method is used only when the shunt is already quite close; it would not be practical to file away half the bar to make the shunt exact.

Notice the essential difference in these two methods. In the first case the shunt has *more* resistance than needed, in the second case *less* than the final value. The latter method is sometimes used commercially to calibrate shunts for very accurate indication.

Establishing standards

How would you establish an accurate current of these magnitudes, say 0.5 amp or more? This is really quite simple. Start with a freshly charged auto battery, which is capable of delivering hundreds of amps for short periods if necessary. At 68°F (what we like to call room temperature) and at a specific gravity of 1.280, which is about normal full charge, a three-cell storage battery will have a voltage of 6.363v. This can be a standard. To get a known current, use a wirewound 25-watt resistor of 12 ohms or thereabouts.

If you do not have such a resistor handy, an appliance such as a flatiron or similar heating-element unit can serve as a resistor. (Be sure it doesn't have an ac thermostat in it.) The manufacturer will have marked the current (at 117 volts) on the device. From this you can calculate the resistance and then work out the current at 6.363 volts, using Ohm's law. The markings of such appliances may not be accurate, so use several, checking one against the other and averaging the difference. A 1-amp meter, for example, seldom needs great accuracy anyway, unless you are doing scientific experiments. In that case, buy a resistor of known value.

Another way to solve the shunt problem also takes advantage of standard resistors. Suppose you have a meter, which has an

internal resistance of 77 ohms. Now suppose also that you make this meter read on a 10 times and a 100 times range. You can obtain resistors of 1 and 11 ohms exactly. Since $99 \times 1 = 99$ and $9 \times 11 = 99$, we could use these shunts nicely if our meter had an internal resistance of 99 ohms. But it has only 77. So to make matters right we add a 22-ohm resistor in series with the meter, "inside" the shunt. This now causes the exact amount of the current we want to go through the meter, $1/9$ or $1/99$. It does not matter how we achieve this; the meter will read accurately. This scheme is illustrated in Fig. 206. Thus, if we had to change meters

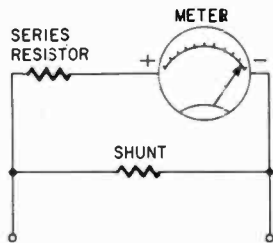

Fig. 206. A small series resistor can be included to modify the internal resistance of the meter to permit the use of shunts having a convenient resistance value.

in midstream, we would simply change the little series resistor to fit in the new meter, provided of course it has an internal resistance of less than 99 ohms.

Changing shunts

It is not convenient to change shunts for a multirange setup all the time, so arrange the meter and shunts with a switch, as shown in Fig. 207.

INTERNAL RESISTANCE 70Ω
1 MA METER

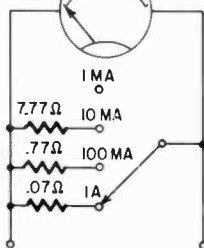

Fig. 207. Switched multirange current meter. Remember to include switch contacts and leads to the resistors as part of the shunt. The meter should be disconnected while switching current ranges, unless the switch is of the shorting type.

Here then is a multirange ammeter or milliammeter, as the case may be, and you now have all the information you need to make either from your basic meter, whatever its range and internal resistance.

Making voltmeters and multirange voltmeters

Let us analyze the necessity of using series resistors with meters to make them read voltage. Suppose we try the 1-ma meter we used before. It had an internal resistance of 46 ohms. If we connect this to a 1.52 volt battery, and ignore the internal resistance of the battery, the current would be $1.52/46 = .033$ amp, or 33 milliamps, 33 times as much as the meter can take. That is why we would put in a series resistor, and you can quickly see what value it would have to be. To reduce this current to 1 ma for 1.52 volts, we need a total of 1,520 ohms. The external resistance should then be $1,520 - 46$, or 1,474 ohms.

We cannot ignore the meter's internal resistance in this case, for the resistance is more than 3% of the total. If we did, our meter would be 3% off. But if we made a scale for 15 volts and ignored the meter resistance, the error would be only 0.3%, and on a 150-volt scale this is really very little. Therefore, when building a voltmeter from a basic meter, the series resistors for the lower ranges must be made with greater accuracy than the others. In this case, for example, with the 1-ma meter, we would use resistors of 1,474, 15,000 and 150,000 ohms, respectively, for those three scales. These can be easily arranged with a switch, as shown in Fig. 208.

The simple way to calculate the value of these resistors is to multiply the voltage range by 1,000 and divide by the meter full-scale range. Thus, if the meter is a 500-microamp unit which we want to provide with a 30-volt range, divide 30,000 by 0.5 (ma) and you come up with a series resistance of 60,000 ohms. It becomes obvious that a meter resistance of 200 ohms is not going to make very much difference; actually not even enough to detect on the scale!

Making series resistors

Series resistors are much easier to make than shunts. Almost any value can be made by adding resistors in series, or by paralleling one or more resistors. Use the standard flashlight cell as a basic calibration source or you can, of course, use a number of them. Thus, for a 1.5-volt scale you would use only one, but a 15-volt scale would use four, which would be a fraction over 6 volts. This would get almost half scale on a 15-volt scale and would provide a good calibration point. For a 100-volt scale, at least 20 of them are required to get up to only 30 volts, and this

would be cumbersome and, eventually, expensive. But because series resistors are what they are, you could calibrate for a 15-volt scale, again calibrate for a 15-volt scale, and add the two resistors together. In this way you can calibrate series resistors for a 30-volt scale—or any multiple of 15 volts—with care, with only four flash-light cells.

Switching arrangements

There are two basic ways of connecting a multirange meter with its switch and resistors. One is shown in Fig. 208-a and the other in Fig. 208-b. The difference is that in the first case the

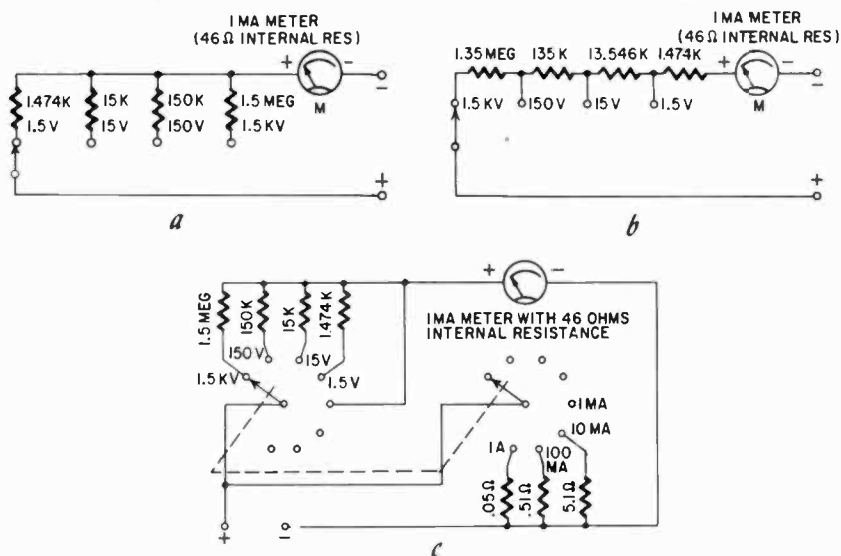

Fig. 208. Switching arrangement (drawing a) for series resistors to obtain a multi-range voltmeter. An alternate arrangement (b) is used in some commercial meters for reasons of economy, but has no particular advantage for the home-built instrument. The combination multimeter (c) uses shunt resistors when on the current range and series multiplier resistors for measuring voltage. The range switch in this example is made up of two wafer sections of a rotary switch, mounted on a common shaft.

resistors can be standard values, while in the second they always are odd values because the lower-range resistors are subtracted from the total for the higher ranges. However, if you are in the process of matching resistors anyway, one method is as good as another.

Table 2-3 shows common values of series resistors for meters of different ranges. Note in the column for the lowest range that

the meter internal resistance must be subtracted, whatever it may be. This table is arranged for the switching scheme used in Fig. 208-a.

It is entirely possible to join a multirange current-switching system with a multirange voltage-switching system for one meter,

Table 2—3. Values of "multiplier" series resistors for commonly used scales and various meter ranges

range full scale (volts)	meter sensitivity					
	microamperes			milliamperes		
	50	100	200	500	1	5
1	20,000	10,000	5,000*	2,000*	1,000*	200*
1.5	30,000	15,000	7,500	3,000*	1,500*	300*
2.5	50,000	25,000	12,500	5,000*	2,500*	500*
3	60,000	30,000	15,000	6,000	3,000*	600*
5	100,000	50,000	25,000	10,000	5,000*	1,000*
6	120,000	60,000	30,000	12,000	6,000	1,200
10	200,000	100,000	50,000	20,000	10,000	2,000
12	240,000	120,000	60,000	24,000	12,000	2,400
15	300,000	150,000	75,000	30,000	15,000	3,000
25	500,000	250,000	125,000	50,000	25,000	5,000
30	600,000	300,000	150,000	60,000	30,000	6,000
50	1,000,000	500,000	250,000	100,000	50,000	10,000
60	1,200,000	600,000	300,000	120,000	60,000	12,000
100	2,000,000	1,000,000	500,000	200,000	100,000	20,000
150	3,000,000	1,500,000	750,000	300,000	150,000	30,000
250	5,000,000	2,500,000	1,250,000	500,000	250,000	50,000
300	6,000,000	3,000,000	1,500,000	600,000	300,000	60,000
500	10,000,000	5,000,000	2,500,000	1,000,000	500,000	100,000
1,000	20,000,000	10,000,000	5,000,000	2,000,000	1,000,000	200,000
1,500	30,000,000	15,000,000	7,500,000	3,000,000	1,500,000	300,000

* Meter internal resistance should be subtracted.

ending up with the familiar multimeter, with the exception of the resistance-measuring ranges, which will be discussed in the next section. Fig. 208-e shows a combination multimeter. Usually we would also have other functions, which we must yet discuss. Instead of switches, simple pin jacks could have been employed, requiring the user to insert the test lead in different jacks for different ranges. This is done, even commercially, but is not so economical that it merits much consideration, except for making the instrument extremely compact.

Making ac voltmeters

From our early discussion of the d'Arsonval meter, you may remember that this meter depends on the magnetic field created around the coil. Should we apply an alternating current to the coil, the magnetic field would reverse itself as many times as the current. The coil and pointer have considerable inertia, and they could not possibly follow such alternations. Consequently this meter refuses to indicate anything when we try to measure ac with it. To do so, we must first turn the ac into dc.

Meter rectifiers

This is done, as everywhere else, with rectifiers. They need only be very small rectifiers, since we will be dealing with very small meter currents. Some essential facts about rectifiers must be considered in relation to meters. One is that rectifiers are not perfect. Metallic rectifiers always have some reverse current, even if this is very small in a good rectifier. Thus, if we used the scheme shown in Fig. 209-a, we would deflect the meter with each positive pulse of current, and we would subtract a little from that with

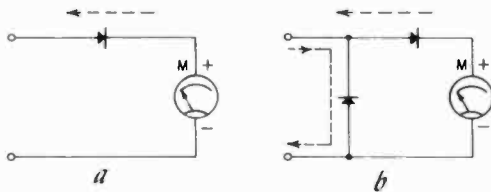

Fig. 209. The illustration at the left shows the meter used with a half-wave rectifier. The arrangement at the right has an advantage in that it reduces the amount of reverse current through the meter.

each negative pulse. This could be made more efficient by using the scheme shown in Fig. 209-b, where the other rectifier presents a low-resistance path for the ac when the negative half-cycle arrives. This would prevent most of the reverse current.

When we pass such a rectified ac through a meter, the meter will stay in one place as long as the current is on, because the meter has a lot of inertia in its mechanically moving system of coil and pointer. But actually the current through the coil wanes and waxes regularly, and even is zero for as long a time as it is on altogether. Thus, with a half-wave rectifier, the energy required to keep the meter deflected (remember that $\text{time} \times \text{current} =$

of series resistors. Here we have indicated the series resistors for dc for the particular meter drawn, but we cannot sensibly indicate the series resistors for the ac ranges because we cannot calculate them. They depend too much on the characteristics of the rectifier.

Using separate series resistors has the advantage that we need not draw as many scales on the meter face. This means that, in general, we can read the scales more accurately because as scales get closer to the pivot point, they become shorter. To some extent, this makes up for the inaccuracy of nonlinearity at the lower end of the scales. Of course, it costs more to put in extra resistors and switch points.

Since we cannot calculate the ac series resistors, we must either depend on the recommendations of the rectifier manufacturer, if given, or we must establish the values empirically by cutting and trying. For this you will need accurately known ac voltages. (We will discuss this more fully under calibration.)

Ac vs dc scales

On practically all vom's, the ac scales are printed in red, so that they can be clearly distinguished from the dc scales. Sometimes, even though separate scales are used, the manufacturer uses the same *numbers* to avoid too much crowding of the face. This can be done by shifting the ac scales somewhat by an extra shunt across the meter switched in when the ac is used, so that the figures come closer together on the two scales. An example of scales using the same numbers is shown in Fig. 212.

Vom's seldom have one or more alternating-current ranges. The reason is that to use the d'Arsonval meter we must rectify the ac, but to measure it as current we must put it in series with the meter and so we would no longer be supplying ac to the load. One manufacturer gets around his dilemma by making ac current ranges from ac voltage ranges by measuring the ac voltage developed across the special current resistors built into the instrument. Although the scale will read ac current the instrument is actually measuring ac voltage developed because of the current. Most instruments do not have ac current ranges, in part because they are needed less than the others.

Calibration of ac voltmeters

The calibration of ac voltmeters is usually done at 60 cycles. This is not the highest frequency which can be measured with the instrument, but there is a limit, set by the characteristics of the rectifier and the impedances in the circuit, as well as the

capacitances. There are no real capacitors to deal with, but only a stray capacitance—the effect of a number of components close together with insulation in between. Some high-quality instruments are usable to 500 kc with good accuracy, and this is about as much as you'd expect from them anyway.

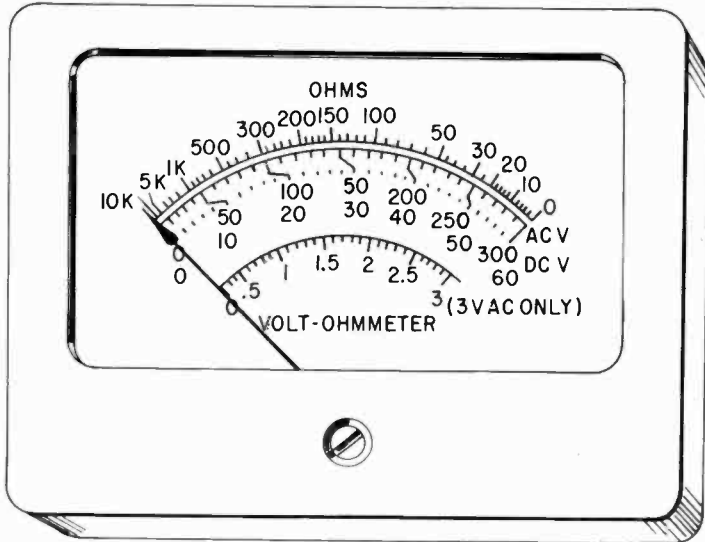

Fig. 212. Volt-ohmmeter scale using the same digits for the ac and dc scales. Note the compression of the ac scale at the low end, and the separate ac scale for low voltage.

To calibrate ac voltmeters then, you will need *known* ac voltages, and this is not as easy as it was with dc, where we had batteries to rely on.

Ac calibration methods

One practically standard source of voltage is the 117-volt power line. Your utility company can sometimes tell you what the voltage is in your area.¹ Then to obtain other voltages you could use voltage dividers made from accurate resistors. This has one complication: when you shunt the low resistor in the divider with the meter, series resistor and rectifier, you will in effect lower the voltage; and since you are in the process of *determining* the ac series resistors, you cannot allow for this drop exactly. Only if you use a very sensitive instrument, in which the series resistor on the low

¹ Your utility company may not always be able to give you the exact voltage. The voltage on both sides of distribution transformers will vary with load. Voltages inside the house or building will also fluctuate.

scales is still very high in comparison with your lower voltage-divider resistor, can you ignore this inaccuracy. (This is analogous to the dc situation in which the meter resistance could not be ignored on the lower scales, unless you had a very sensitive meter.)

Fortunately there is a fairly simple solution to this problem,

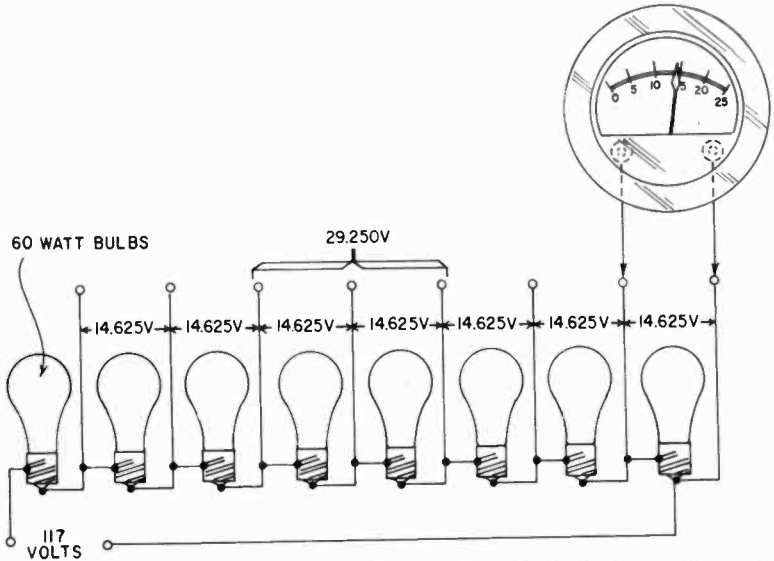

Fig. 213. The line voltage, plus a number of electric-light bulbs, can be used for calibrating the ac scale of a vom.

again using very simple tools. Ordinary light bulbs are machine made and, when you get bulbs from the same manufactured batch, they are surprisingly close in tolerance. They vary less than a percent or so in resistance value. If you take a number of, say, 60-watt bulbs and put them in series across the line, they will glow barely if at all, but you can be quite confident that each will have the same voltage across it, all the same fraction of the line voltage.

In Fig. 213, each bulb has 14.625 volts across it. This can be used to calibrate scales from 15 to about 30 volts, tapping off higher points in the chain for higher voltage scales. But be sure your light bulbs are all the same, and all from the same box.

This method of calibration need not take the meter parallel resistance into account because the light-bulb resistance is so much less that the meter circuit has no significant effect. The cold resistance of a 60-watt bulb is about 15 ohms. Even a 1-ma meter would need, on its 1.5-volt scale, 1,500 ohms resistance, and on its

INVOICE



Gernsback Library, Inc

154 WEST 14th ST., NEW YORK 11

**BILLS
PAYABLE
WITHIN
10 DAYS**

FOR HOW TO GET THE MOST
OUT OF YOUR V.O.M.

KEEP THIS PART OF STUB FOR YOUR RECORDS

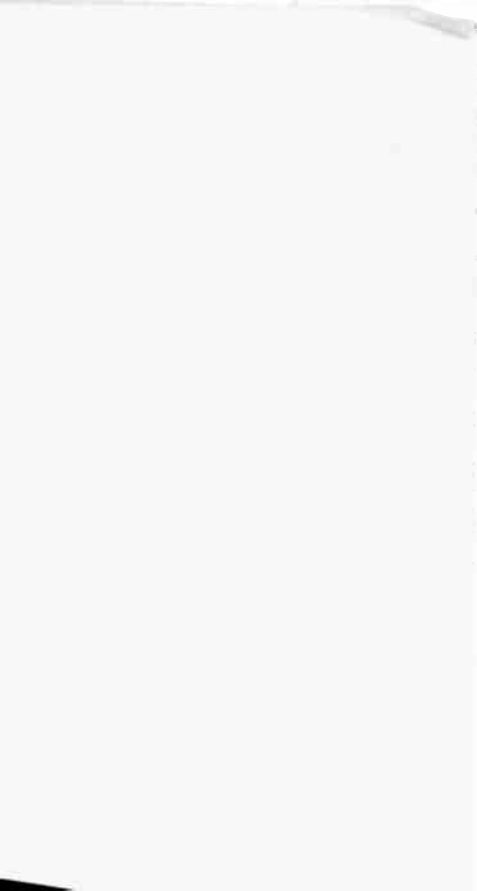

15-volt scale 15,000 ohms. Obviously this is not going to affect the voltage across the 15-ohm light bulb materially.

Better calibration can, of course, be obtained through comparison with a precision-calibrated instrument. But the method described here can be readily used by those who wish to build an ac voltmeter and do not have expensive calibration instruments for comparison purposes.

Another way would be to take a multi-tap transformer to someone who has an accurate instrument, measure the transformer

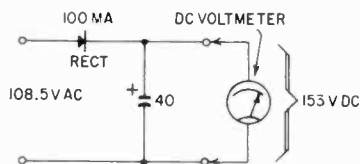

Fig. 214. Method for determining the amount of line voltage if the ac scale of your meter has not been calibrated. Read the peak voltage as dc (by using a rectifier and filter) and then divide this amount by 1.41.

voltages exactly and use these as standard voltages. Then you have to make sure that the 117-volt primary voltage was exactly the same in both cases. Each method has its own errors.

The final accuracy of your instrument will depend on how carefully you work, how well you select your "standards" and how good your meter is. In calibrating with light bulbs, for example, a careful calibration job would call for exchanging the bulbs after the first calibration and doing the job again; and so on, at least five or six times, averaging out any error that might be present because of differences in the bulbs. If five or six calibrations with bulbs from different positions in the chain give the same result, you can be fairly sure that your accuracy is very good, within the limits of your knowledge about the line voltage.

If you cannot get accurate information about the local line voltage from the utility company, there is a simple way you can measure it, provided you have first calibrated the dc portion of your instrument. If you take a good selenium rectifier and a large electrolytic capacitor and put them across the line, the dc to which the capacitor is charged, in the absence of a heavy load, is what is known as the peak value of the ac voltage, which is 1.41 times the effective voltage. Thus, if you measure with the dc meter range a voltage of 153 across the capacitor (the meter is not a serious load),

the ac line voltage is $153/1.41 = 108.5$. The capacitor (see Fig. 214) must be very large, at least $40 \mu\text{f}$, and the rectifier at least 100 ma to allow you to ignore the meter load and the leakage of the capacitor.

Making a supersensitive meter

Not so long ago, the 20,000 ohms-per-volt vom was used for most shop work, with a vtvm for high-impedance measurements. Today multimeters with sensitivity ratings of 100,000 ohms per volt are standard equipment in many shops. They do not need external power, like the vtvm, and are usually more compact and easier to carry. They have no tubes to age and affect calibration, and need no warmup period. The input resistance is equal to that of a 10-megohm vtvm on the 100-volt range and exceeds it on higher ranges.

A 100,000-ohms-per-volt dc voltmeter can be made around a $10 \mu\text{a}$ dc meter, one multiplier resistor for each range, and a selector switch. The diagram in Fig. 215 shows such an instrument.

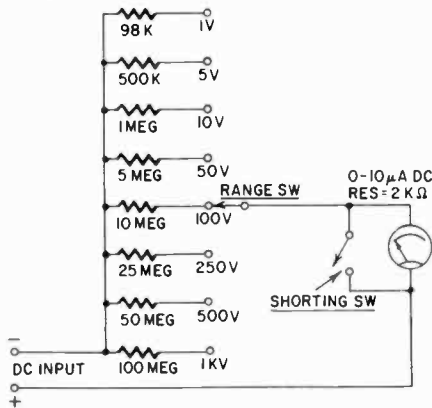

Fig. 215. A 10 microampere meter can be used as the basis for constructing an instrument having a sensitivity of 100,000 ohms per volt.

To find the correct multiplier resistance for each range, multiply the ohms-per-volt sensitivity by the full-scale voltage for the range. If the multiplier resistance is less than 100 times the internal resistance of the meter, subtract the meter resistance from the calculated value of the multiplier for greater accuracy.

Construction precautions

In constructing this or a similar meter, observe these precautions:

1. Insulate the terminals from the panel with high-grade polystyrene or ceramic material.

2. Use a high-grade ceramic-wafer range selector switch and do not touch the ceramic any more than absolutely necessary. After wiring, clean the ceramic with carbon tet or lacquer solvent.

3. If the meter is to be used on a metal panel, be sure to so specify when ordering it.

4. Use special instrument type resistors for values above 50 megohms. Do not touch the bodies of the resistors. After soldering, clean them with a solvent recommended by the resistor manufacturer.

5. Make the case as nearly airtight as possible to keep out dirt and moisture.

6. Keep the shorting switch closed when the meter is not in use, to protect the delicate movement from shocks.

7. Observe the following for extreme precision or laboratory-type accuracy in the instrument you are planning to build:

a. Select a meter with a mirrored scale. Always read the meter from directly in front of the instrument so the reflected image of the pointer and the pointer itself are lined up. Thus, when the eye is in the proper viewing position, the reflected image is not visible. This eliminates errors caused by parallax.

b. Multiplier and shunt resistors should have a tolerance of at least 1% and greater accuracy is recommended.

c. If wirewound resistors are used for ac ranges, be sure they are a non-inductive type. Otherwise, they will be reactive and can cause errors.

8. Whenever possible, leave the meter installation until the last step in the construction. Chassis are handled roughly during construction and the meter may be damaged by jolting or its face broken or scratched.

9. Never store instruments with plastic-faced meters in cabinets with acetone, paint removers and other service and industrial chemicals. Fumes from many of these compounds will attack the meter face, eroding it so it crazes and becomes opaque.

10. Never wipe the meter face with a dry cloth while the instrument is in use. Friction may develop an electrostatic charge

capable of producing large errors in the readings. When a meter cannot be zeroed or its needle tends to stick, the trouble may be caused by a heavy electrostatic charge on its face. If a charge develops on the meter face, discharge it by breathing heavily on the glass or by treating it with an antistatic compound used for cleaning phonograph records.

The very first command about using meters is that they are delicate instruments and must be treated as such. This cannot be emphasized too much, particularly if your livelihood depends on the availability of your meter. An instrument, once dropped, even though it may appear to be functioning well enough, should be regarded with some suspicion, and the various calibrations should be checked with appropriate sources as soon as possible. For example, if you have a meter with a permanent shunt, a strong shock may disconnect it and, although the meter seems to function well, it will indicate high on all its ranges, without any obvious indication something is wrong until you check it against a standard source, such as a fresh flashlight battery.

An alternative method to building an ultra-sensitive vom (such as the one described here) is to use a less sensitive vom in conjunction with an external amplifier. Read the section entitled "amplification for the vom" beginning on page 154 in Chapter 8. See also the description of the pin-jack vom beginning on page 63 in the next chapter. In this instrument, a basic 40- μ a movement, with the help of a transistor amplifier, can be used to measure currents as small as 1 μ a.

ohmmeters and voltohmmeters

IN Chapter 2 we discussed multirange current and voltmeters in general. A good deal remains to be said about these before the matter of construction has been taken care of, but first we must consider resistance measurements, the last function of the vom.

There are three basic ohmmeter circuits, each with its peculiar advantages and disadvantages. The first (Fig. 301) is called the *series* circuit. The deflection of the meter depends upon the resistance in the circuit. If we short the terminals and adjust the

Fig. 301. This is the basic circuit for a series type ohmmeter.

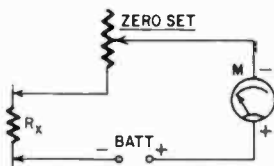

potentiometer for full-scale deflection of the meter, and then insert an unknown resistance across the terminals, the meter will deflect less. The reduction in deflection will be proportional to the inserted resistance.

One real advantage of this circuit is its simplicity. Its disadvantage is that the scale of such a meter will be crowded on both the low and high ends.

But this is not its only disadvantage. Consider what happens when we adjust for zero with a fresh battery. If we use a 1-ma meter, then we know we must have about 1,500 ohms in the circuit

for full-scale deflection. The battery in the circuit is 1.5 volts. At full scale the meter will draw 1 ma. The required resistance is:

$$R = \frac{E}{I} = \frac{1.5}{.001} = 1,500 \text{ ohms}$$

An unknown resistance of about 1,500 ohms would then give us half-scale deflection. When the battery has aged and provides only 1.2-volts, we again adjust for full deflection, which now requires only 1,200 ohms in the circuit. Next, if we again test a 1,500-ohm resistor, we will get a good deal less than half-scale deflection.

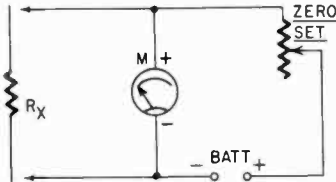

Fig. 302. Fundamental circuit arrangement for a shunt type ohmmeter.

Consequently, the series ohmmeter can be calibrated only for one particular battery voltage. In part, but not entirely, the drop in voltage is made up by an increase in internal resistance of the battery. The series ohmmeter is not very useful as a battery-powered instrument. If we provide it with a dependable ac power supply with rectifier, it can be used, if you wish to put up with the crowded scale. In general, the series ohmmeter is not used commercially.

The next logical circuit configuration would be a *shunt* ohmmeter circuit, shown in Fig. 302. It uses the principle that was discussed in making shunts for current meters. When the meter is adjusted for full-scale deflection, any resistance we put in parallel with the meter will decrease the deflection. Note the difference between this reading and that of the series meter. In the series meter the less the resistance, the less the drop in meter reading. Here the smaller the resistance, the greater the drop in the meter reading. For the series meter, the zero point is at the right, while the shunt meter has its zero point at the left.

The shunt ohmmeter is a useful instrument for measuring very low resistances only. Fig. 303 shows the difference in the two scales, the top scale for the shunt circuit, the bottom scale for the series type circuit. The shunt type ohmmeter is not found in commercial or kit type meters, but is sometimes made by hobbyists and experimenters to measure low-value resistors.

The shunt meter has one serious disadvantage. When not in use, the meter circuit will remain across the battery and will cause it to discharge.

Next we have the potentiometer type of ohmmeter, and this circuit is used by virtually all manufacturers of commercial vom's. See Fig. 304. The meter and the zero-set potentiometer are connected across a standard resistor. When the terminals are shorted

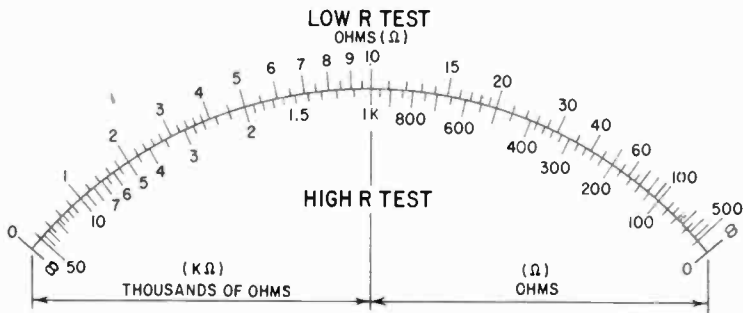

Fig. 303. This illustration shows the difference between shunt and series ohmmeter scales. The upper scale is for the shunt type; the lower for the series. The shunt ohmmeter is suitable only for measuring low resistances. Both scales have crowded areas. Note that the location of the zero point is different for each scale.

for zero setting the meter, the meter circuit reads the battery voltage and again is adjusted for full-scale deflection. When we insert an unknown resistance between the terminals, the meter will deflect less, since the voltage created across the standard resistance will be less. In fact, it will be a proportion (of the battery voltage) which depends on the unknown resistor, and we can calibrate the scale in ohms for this unknown.

Now it is obvious that when we change standard resistors, say to one 10 times higher, that the scale will also read 10 times the

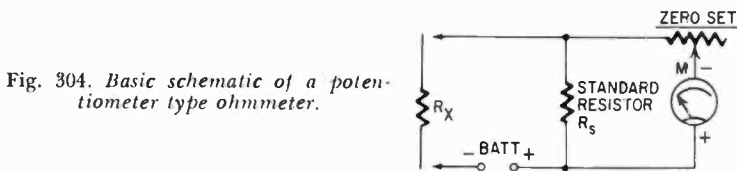

Fig. 304. Basic schematic of a potentiometer type ohmmeter.

resistance—with some reservations. One of these is that the meter circuit must have a high resistance in comparison with the standard, or the shunting effect of the meter will change the range. It is not always possible to make the meter such a high-resistance circuit, and the standard resistors will not always be an exact multiple of the lower ones. We must also consider that the battery is not without internal resistance. Therefore, when we short the terminals, we do not have the exact voltage that is across the standard resistor but we have slightly less. However, when these are compensated for, we can have an almost exact overlapping of scales;

in commercial vom's the same scale is generally used for all ranges. A few instruments use the shunt type meter for the lowest range, and in that case they have a separate scale for it.

But this is not the only problem. Another concerns battery voltage. Consider the simplified diagram of the vom resistance-measuring circuit shown in Fig. 305. Here the lowest range has 11.5 ohms

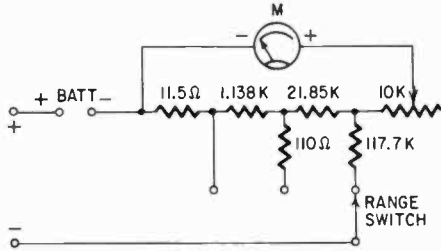

Fig. 305. Simplified schematic of a potentiometer type ohmmeter circuit used in a commercial kit. The battery, multiplier and standard resistors are switched simultaneously. The battery switch is not shown.

for a standard resistor, and the next range (100 times as large) has 1,138 ohms plus 11.5 or 1,149.5 ohms. Now if we were to continue in this way, the next "standard" would be about 115,000 ohms. To get half-scale deflection we would need about 25 microamps, since the instrument has a 50- μ a meter. But, unfortunately, if we insert 115,000 ohms in series with a 1.5-volt battery, we would not get enough current for half-scale deflection; we would get only about 14 μ a. To remedy this, the highest range uses a different battery—a 6-volt one. But we do not want to use the 6 volts across our standard resistor, for this would mean we would have to change range on the voltmeter circuit.

The solution is to put the multiplier, not in the meter circuit, but in the battery circuit instead, which gives us the configuration of resistors and switching shown here. Not shown in the basic diagram is the fact that we also switch batteries. However, the point of importance here is that the meter can obtain the necessary 25 μ a for half-scale deflection since we now have 6 volts across about 225,000 ohms, and this is more than ample.

The potentiometer circuit configuration is common in vom's. Usually the lower ranges are made with standard resistors which are multiples, except for the necessary compensation for meter and battery internal resistances, but the higher ranges deviate from this pattern in the manner shown in Fig. 305.

There are other ways to measure resistance; in fact, there are

much more accurate ways than with ohmmeters, which give only close approximations. One simple method is the measurement of current from an exactly known voltage source, in the manner of the series ohmmeter, but without bothering with any zero-set system. Then each time the resistance must be calculated from the current reading. But this, although perhaps accurate, is cumbersome, hence the demand for ohmmeters. However the system can be used with the meter current ranges when unusually high resistance must be measured.

The meter can also be used as the null detector in a bridge circuit for the measurement of resistance. Commonly, ohmmeters of the potentiometer type are sufficiently accurate for service and experimental work. Most manufacturers decline to give an accuracy guarantee of less than 5% on the resistance measurement, particularly since only half of the scale is legible enough for such accuracy. When using an ohmmeter of the potentiometer type, it is

Fig. 306. Method of calibrating unknown resistors using a fresh battery and an accurate current meter.

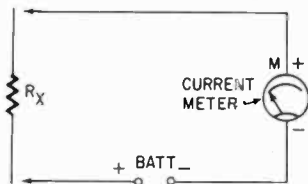

customary to select the range in such a way that the resistance to be measured falls in the right-hand 60% of the scale, where the divisions are the largest and the reading is the easiest and most accurate.

Calibration of ohmmeters can be done in two ways. An ohmmeter can be compared with another, using potentiometers to get different readings. If another ohmmeter is not available for comparison, a number of standard resistors can be used for checkpoints on the scale, and the more points that are marked, the more accurate the ohmmeter will be. But, again, if standard resistors are not available, you can go to work with the same simple tools used for constructing shunts and series resistors. The series current method can be used to determine with good accuracy the values of "standards" to calibrate the potentiometer type circuit. Again you must make sure you have a fresh battery, for this is now your standard. (See Fig. 306.)

Conversely, if you cannot be sure of your voltage, but have one accurately known resistor, you can use this to measure your voltage—if you know the meter's internal resistance (which you can measure, as shown in Chapter 2) and if your known resistance is

high enough so you can ignore battery internal resistance. Battery internal resistance for dry cells usually runs between a few ohms when they are new to about 14 to 20 ohms when they are thoroughly aged. It also varies with different manufacturers, and we cannot set one certain figure as the internal resistance of a battery. It can be measured, however, if you know the exact internal resistance of a meter, (it must be a sensitive type), the exact voltage of a battery in open circuit and the exact resistance of a precision resistor. Then, when you put these in series, the meter *should* read current which you can compute with Ohm's law. In actuality it will not; there will be some slight discrepancy, due to the battery's internal resistance. It usually is not a serious factor.

One difficulty in making your own ohmmeter is the necessity of calibrating a scale right on the meter. This requires that you have the meter open for the calibration procedure. This can be circumvented by making an accurate calibration table, keeping an accurate record of the current readings on the meter and drawing the scale from this all at once. Another alternative is not to provide a separate ohms scale on the meter at all, but to keep the calibration in the form of a curve, which shows current readings for many values of resistance on all the ranges available.

Fig. 307-a shows a typical home-made vom with a 55-ohm internal resistance meter, and Fig. 307-b shows the resistance calibration curves for the instrument. The ohmmeter circuit here is a shunt type meter on the low range and a series type meter on the high range. During calibration, and also of course during repeated use, the zero setting must be frequently checked, for the accuracy of the whole measurement will depend very much on this accurate zero setting. This is the "repeatability" aspect of measurement.

Building your own instrument

The decision as to what type or class of instrument you want to build is something only you can decide, but we can give some broad general considerations of what might be needed for certain kinds of work.

A meter such as that shown in Fig. 307 would generally be insufficient for service and repair work, but it would do nicely for the experimenter who does not plan to build high-performance receivers or sensitive instruments of other types. The 1-ma instrument would, however, be too much of a load on such circuits as detector, discriminator or avc circuits and could not very well be used for alignment in these cases. For this, a meter with at least 20,000 ohms per volt is needed; in other words a 50- μ a meter

should be used. If you have a more sensitive instrument, such as a 10- μ a meter, it can be used just about anywhere where normally a vacuum-tube voltmeter would be called for. (Most manufacturers list operating voltages as measured with a vvm, not a vom.)

Cost is another important consideration. Obviously the expense of the basic meter is the biggest item. Incidentally, it will be difficult for you actually to beat the price of kit type meters, unless you have a lot of usable parts or even a usable meter on hand. It is possible for kit manufacturers to offer their kits at such eco-

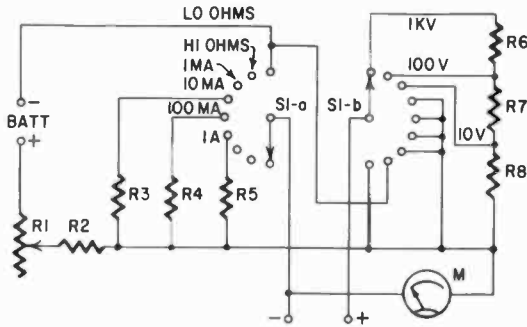

Resistors: R1—2,000 ohm wire-wound variable; R2—3,000 ohms, ½ watt; R3—10 ma shunt, 6.11 ohms; R4—100 ma shunt, 0.555 ohm; R5—1,000 ma shunt, 0.055 ohm; R6—1,000 volt multiplier, 0.9 megohm, ½ watt; R7—100 volt multiplier, 90,000 ohms, ½ watt; R8—10 volt multiplier, 10,000 ohms, ½ watt. (All resistors should have a minimum tolerance of 5%.)
 Meter: 0.1 millimeter.
 Battery: 4.5 volts.
 Switch: 9-point, 2-pole selector.

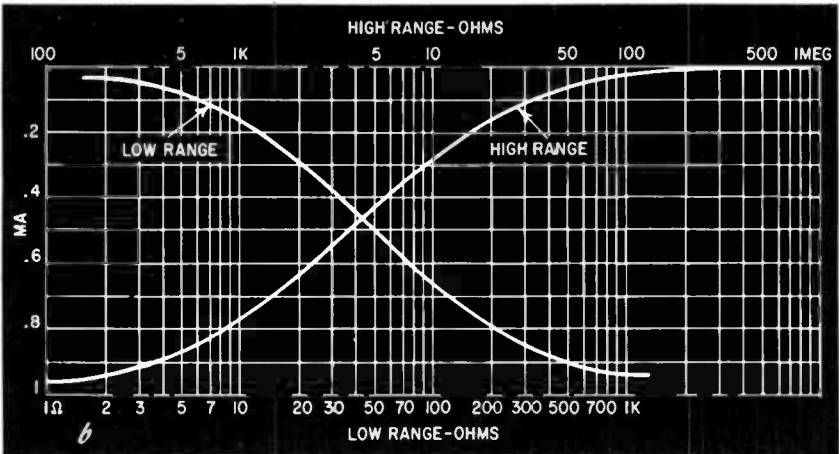

Fig. 307. Simple vom (a) designed around a meter having an internal resistance of 55 ohms. The lower illustration (b) shows calibration curves for the ohms ranges of the instrument. These curves can be kept separately or used as the basis for calibrating a special scale on the meter.

nomical prices because they buy their parts in fantastic quantities. If you have to start from scratch with parts, it might be advisable for you to read chapter 4, describing kit type instruments, before launching on your own construction plans. Only if you have some justification for building your own, such as having parts available or requiring ranges not generally offered, or just because you'd like the fun of building your own (although it may cost as much as a kit) should you proceed. A packaged kit will not only save you money, but unless you have the skill and the equipment, your home-built vom will not have the professional appearance of the kit.

But once you do decide to build, the first matter to decide is the ranges required; the choice of a basic meter is based on this. Or working the other way around, with an available meter, determine what are the most extreme ranges possible. From there you can go on to calculating the necessary series and shunt resistors, the switching required, the box to house the affair in, the terminals, and last but not least, the method of marking the front panel, and how to make meter scales for your basic meter.

If you have or intend to get only a 1-ma meter, the instrument in Fig. 307 is about the best you can do as far as ranges are concerned. The application of such an instrument will seldom call for other ranges. For a more sensitive meter you can construct a circuit such as that shown schematically in Fig. 308. This instrument uses a 50- μ a meter with 1,000 ohms internal resistance. The design circumvents the most complicated switching problems, and uses a switch only as a function selector. Ranges are selected by a number of pin jacks, one for each range. The function switch selects the ac and dc voltage ranges, the current ranges and the resistance measurement.

There were three important reasons for building the instrument as shown. First, the meter was available, salvaged from a pH-measuring instrument at very little cost. The pin jacks obviated the need for a relatively expensive multi-point switch and also saved a great deal of space. And the low-voltage range was desired for the reading of thermocouple voltages. The low-resistance scale was included mainly because other ohmmeters in the shop adequately cover all but such a low scale.

Several features in this circuit are of interest. The current ranges are provided with what is known as an Ayrton shunt circuit, so designed that the meter always has a ring of resistors in parallel with it, providing *some* protection against overloading of the

meter. The Ayrton type shunt is computed with the following formula:

$$R_t = \frac{R_m + R_{st}}{n}$$

in which R_t is the resistance between taps, R_m the meter's internal resistance, R_{st} the total shunt resistance and n the range multiplier. The lowest range, 50 μ a, of course, does not get any shunt, and this range is used with the switch in the "voltage" position.

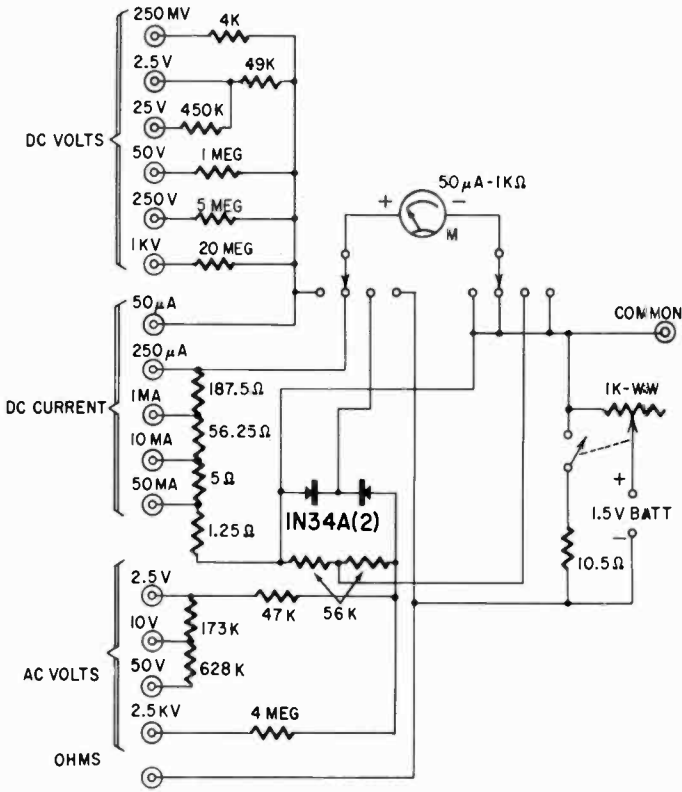

Fig. 308. Schematic for a vom built around a meter having a full-scale deflection of 50 microamperes and an internal resistance of 1,000 ohms.

The lowest of the *higher* current ranges is 250 μ a, and this determines the total shunt around the meter. You need no formula to determine that this must be 250 ohms for a 1,000-ohm internal resistance meter. The next total shunt resistance *between pin jack and common* is then $\frac{1,000 + 250}{20} = 62.5$; next 6.25 and 1.25. The

resistances are made up cumulatively, calling for 1.25, 5, 56.25 and 187.5 ohms, between pin jacks, as shown in the diagram.

The resistance section is a simple shunt type meter, with the meter shunted down for 10 ohms midscale. This requires an 11.1-ohm shunt, but the additional resistance in the leads and switch contacts necessitated the use of a resistor labeled 10.5 ohms (*whatever its exact value was*). No other ranges were desired, and the switch to disconnect the shunt was mounted on the potentiometer.



Fig. 309. This home-made unit was designed for a 50-microampere meter.

With a separate switch, another range 100 times as large (1,000 ohms midscale) would have been automatically obtained with the switch off. The switch is necessary to avoid discharging the battery when the instrument is not in use.

Rectifiers used for the ac voltages were 1N34A's, also because they happened to be on hand. The range resistors were determined empirically. With other 1N34A's other resistors might be needed since the diodes are not all alike. However, the use of 1N34A's has one advantage over copper oxide rectifiers: there is very little compression of the scale, and only at the very lowest end. So little in fact that, when the meter resistors for the ac range

were selected, they were chosen so that full-scale ac and dc would use the same scale. This holds down to about 10% of the scale, where it should not be read in any case.

Fig. 309 shows the completed instrument. Scales were obtained photographically from another vom by a method which will be described shortly. The meter chosen had the same progression of 2.5, 5 and 10. No ohms scale was made; a separate ohms calibration curve is pasted on the side of the meter.

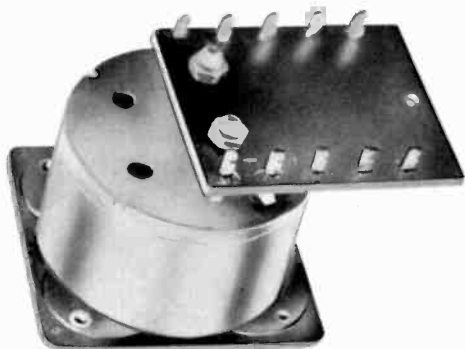

Fig. 310. The mounting board, held in place by the meter studs, is a good support for the resistors and rectifiers in the instrument. The mounting lugs on the board should be properly spaced to accommodate components without excessive crowding. Make sure that clearance holes in the board for the studs are large enough so that no strain or twisting force is placed on the meter.

There are many ways to make your own vom, starting with a great variety of basic meters and almost any ranges you desire, provided the basic meter is capable of them. Construction can be kept simple, as the instrument illustrated, or it can be made complex, as in commercial instruments using a single switch to select all functions.

Do not mount the meter in the box until the last possible moment, to avoid damage to the meter. Plastic boxes of the proper size are available, and with these and the white decals available for marking terminals, switches and potentiometer, a professional look can be given to the instrument with careful work. Resistors need not necessarily be high-precision units if you have some way of selecting resistors from a large supply. Accuracy of resistors can be obtained by using several in series and parallel. Or you can approximate with the nearest standard resistance value. For example, a 56-ohm resistor is a standard item, and the 56.25-ohm

resistor required in the homemade instrument shown is less than $\frac{1}{2}\%$ larger. This sort of discrepancy would be less than a line thickness on the scale of the meter.

Physical construction of the meter can also be varied a lot. It is advisable to use a box which is large enough to hold all components comfortably; crowding parts is an invitation to short circuits or poor workmanship. Never apply heat to meter terminals; many of them have soldered connections on the inside of the studs. Make the meter connections to lugs of the proper size, and *after* soldering these, place them on the meter studs. Never apply heat in any serious amount to diodes used for meter rectifiers. Mount all parts securely. You can often use the switch contacts or pin jacks for mounting multiplier resistors. If not, a good method of construction is to attach a mounting board to the meter studs, and use the mounting board for holding the resistors and rectifiers. (See Fig. 310.)

Making meter scales

One of the most sensible approaches to building your own instrument is to make the ranges fit available scales. Making or changing scales on a meter is one of the most tedious and difficult jobs in building the instrument. By looking at a scale, you can determine whether it is a series, shunt or potentiometer type ohms scale, remembering that the series scale is crowded on both ends, the shunt scale has the zero point on the left and the potentiometer scale is crowded only on the left end (and has the zero on the right, like the series scale). Thus, if you find a meter which already has an ohms scale, make the ohm ranges fit the scale, rather than vice versa. This is not as difficult as it sounds; in a potentiometer, series and shunt scale, half-scale indicates the resistance in the meter circuit.

If you must make new scales there are a number of ways of going about it, but only a few *good* ways. If you have a scale which must be specially calibrated, make a calibration curve and then from this draw a scale which is several times as large as the final product. A large scale is easier to draw and, when you reduce it photographically, any errors are likewise reduced, and so are any irregularities in the lettering. This is a very good way to produce *any* scale if you will remember that the instrument pointer covers an arc of 90° . Naturally, the scale is a part of a circle.

Another good way, using photography, is to start with scales on another meter, or in a book such as this. Fig. 311 is a reproduction

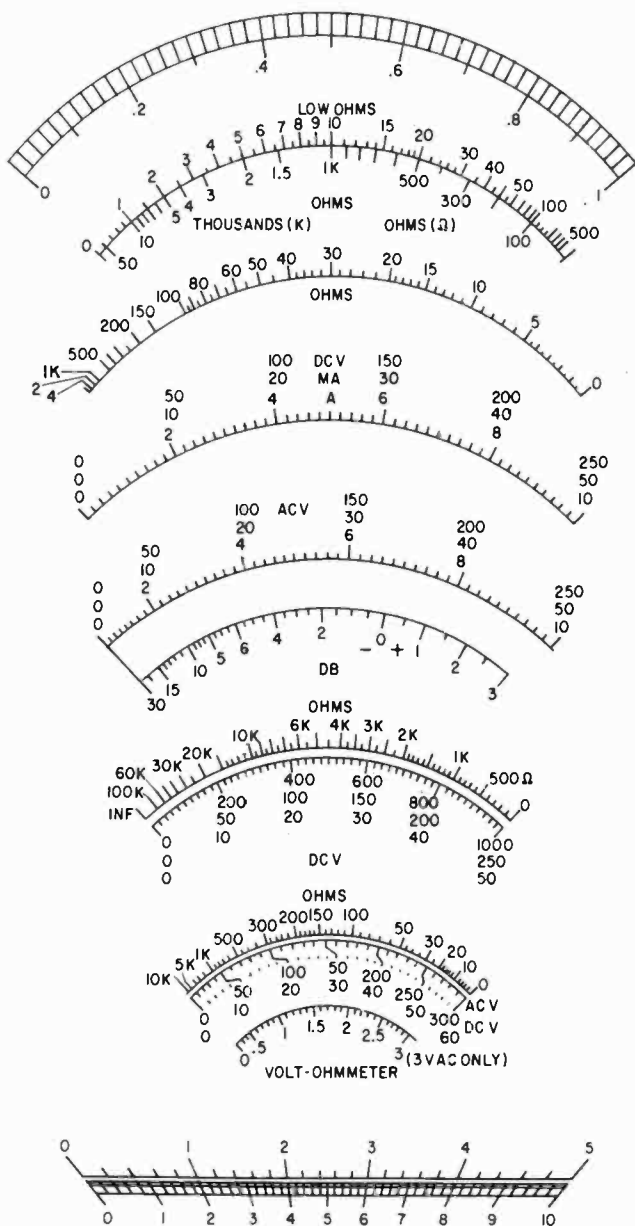

Fig. 311. Various types of vom scales used in commercial instruments.

of a number of commercial vom scales. Photograph the page and print each scale to the size which you need. Then combine them by cutting them out, after printing, pasting them up together and then rephotographing, after which they can be printed together in the proper size for the meter. For film you could use a contrast Ortho film or a commercial film, with D-11 developer, or Kodalith Ortho film. The Kodalith is available in only 5 x 7 and larger, and for a smaller camera would have to be cut.

If you have a roll-film camera, but can focus at close range with a closeup attachment, a Verichrome film with D-11 developer should give usable results. Focus is very important, so is contrast. To get the best contrast, whatever you are photographing must be very well lighted. Also a hard Kodabromide paper should be used, preferably F-5, developed to maximum contrast, but *not* ferrotyped. Glossy dial surfaces would reflect too much light. Dry the paper between blotters.

If you do not have photographic equipment, you might be able to find an amateur photographer who will be happy to copy the scales for you, or you might get it done professionally. This is not expensive, but will raise the cost of your instrument.

If you are a careful and neat draftsman, it is quite possible to draw scales directly, even small ones, which cannot be distinguished from printed scales, by using Leroy or Wrico lettering guides for the numbers. But this is comparatively difficult and time-consuming, and you will probably draw several scales before you have a satisfactory one.

Perhaps the simplest way to make new scales for meters is to use decals. Techni-Cals (Darling Laboratories, Costa Mesa, Calif.) are books of decals with letters, figures, scales etc. appropriate to a certain class of devices. One book contains various meter scales. There are two kinds of decals—black (No. 506 B) and white (No. 506 W).

Decals are easy to apply. The desired decal is cut out with scissors, soaked in water, then slid off the backing paper onto the scale panel. Most meters have a brass scale panel which is painted on both sides with flat white. In that case you can simply turn over the old scale and apply the new decal to the back of the plate. If the underside of the plate is not painted, you should paint either it or the front to provide a black or white base for the decal (white for the black decal and black for white-on-black scales). After the decal has dried, the lacquer base of the decal can be dissolved by applying a little lacquer thinner to the decal sur-

face. The decal must be thoroughly dry, or the surface will crumple up and break up the lettering.

To buy or to build?

Earlier in this chapter we mentioned the desirability of buying a kit if you want to build your own vom. The advantages of a kit — its economy and professional appearance — aren't factors to be disregarded casually. And yet there may be times when, in the face of these reasons, you may wish to build your own. You may want a vom with certain features not to be found in either a kit or a complete unit, or you may wish certain vom functions, but not others.

The two instruments to be described come within such a classification. One is an ohmmeter using both the series and shunt circuits mentioned at the beginning of the chapter. The other is a vom incorporating a transistor. The methods used in the design and construction of these testers, plus the one described on page 47, can act as a guide for others you may want to construct.

High-accuracy ohmmeter

The simple direct-reading ohmmeter circuit, which is really an extension of a continuity tester, is extremely useful for making resistance checks where the high-order of accuracy obtainable by using bridge methods is not required. It has an advantage over the bridge because it does not need manipulation of calibrated components to obtain a balance before the answer can be calculated; the required value appears as a direct reading on the ohmmeter scale.

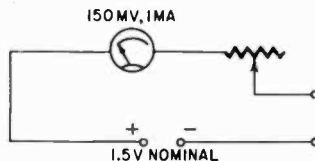

Fig. 312. *Simple direct-reading ohmmeter circuit.*

It is surprising, however, to find that many ohmmeter circuits use arrangements where the accuracy is unnecessarily dependent upon a specific supply voltage, whether this comes from a battery or the power line. Whichever source of voltage is used, it is desirable that the accuracy of the instrument be almost independent of supply-voltage variations within a workable range.

As an example suppose the ohmmeter, built around a milliammeter with full-scale deflection of 1 ma, is to use a dry-cell unit

nominally rated at 1.5 volts. When brand-new these cells give a voltage of practically 1.6, and they can probably be used until the voltage falls to 1.2 before they become seriously unreliable. A circuit for such a meter is shown in Fig. 312. This is a simple series circuit (of the type described on page 41) where equal current flows through each component.

To consider the accuracy of any ohmmeter calibration, the easi-

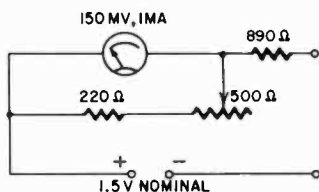

Fig. 313. *Increased-accuracy series ohmmeter circuit, using a 220-ohm resistor in series with a 500-ohm potentiometer to cover the necessary range.*

est method is to consider what value of resistance will give exactly half-scale reading. In this example, when the battery voltage is 1.6, the total resistance of the circuit to give full-scale deflection of 1 ma, with the terminals short-circuited for zero adjustment, will be 1,600 ohms. Having set the zero point, an external resistance equal to this will reduce the reading to half scale. So, for maximum battery voltage, the half-scale reading should be 1,600 ohms. But on page 42 we called your attention to the fact that when the battery drops to 1.2 volts, the total series resistance for full-scale current deflection, with terminals short-circuited, will drop to 1,200 ohms, so the half-scale reading should then be 1,200 ohms.

The question comes, what reading should be put on the scale at this point? Probably 1,500 ohms, because this is based on a battery voltage at the nominal value of 1.5. But the range of zero adjustment necessary to use the battery over its workable range of voltages means that the value indicated as 1,500 ohms may be anything between 1,200 and 1,600, according to the conditions of the battery.

Increasing accuracy

Fig. 313 shows a circuit that reduces this possible error. We start by deciding that the center scale reading is going to be 1,000 ohms. This means that the total resistance in the circuit, with the terminals short-circuited, must also be as near as possible to 1,000 ohms. At the maximum battery voltage, this will allow a current of 1.6 ma, while at the lowest battery voltage the current with the termi-

nals short-circuited will be only 1.2 ma. So the meter shunt must be arranged to pass from 0.2 to 0.6 ma at full-scale deflection for zero adjustment range.

Assuming the meter has a full-scale voltage drop of 150 millivolts (resistance of 150 ohms), then the shunt resistor, to pass 0.6 ma, corresponding to the maximum battery voltage, should be 250 ohms; while to pass 0.2 ma, it must be 750 ohms. Using the nearest practical values, a fixed 220-ohm resistor in series with a 500-ohm potentiometer provides the necessary range of coverage.

Now to work out the value of the series resistor: First we need to know the resistance of the meter with its shunt. The actual meter resistance, in this example, is 150 ohms. At maximum battery voltage, when the meter shunt is 250 ohms, the parallel combination of 150 with 250 ohms is about 94 ohms. For the lowest battery voltage condition, the parallel combination, of 150 ohms with 750 ohms, rises to 125 ohms. To ease the figuring, say the variation is from 95 to 125 ohms. Then the average value of the meter with its shunt is 110 ohms. This would be subtracted from the total circuit resistance of 1,000 ohms, which leaves 890 ohms for the series resistor.

In practice, then, the total circuit resistance varies from 985 ohms at maximum battery voltage zero setting to 1,015 ohms when set for minimum battery voltage. So the center-scale reading will always be within 1.5% of its calibrated value.

Accuracy can be increased still further by making the fixed series resistor a greater proportion of the total circuit resistance, using a higher nominal battery voltage so full-scale deflection is still possible. Suppose, for example, three 4.5 volt batteries are connected in series to give 13.5 volts nominal; these batteries will have extremely long life with a maximum current drain of only a little over 1 ma for full-scale deflection. A terminal voltage variation from, say 11 to 14, could be allowed. The supply voltage is approximately 10 times the previous figure, so the total series resistance in the circuit, to determine the nominal center-scale reading, could be 10,000 instead of 1,000 ohms. Subtracting the mean value for the instrument with its zero adjuster shunt of 110 ohms, this means the series resistor should be 9,890 ohms, and the variation of total circuit resistance is now only .15% from its average value of 10,000 ohms. Using the high battery voltage, the inaccuracy due to battery voltage variation is thus much less than the probable inaccuracy in the original calibration of the milliammeter.

Both these circuits are for what we described earlier (Fig. 301) as the "series" ohmmeter circuit, because the resistance to be measured is connected in series with the meter and its supply voltage. It is obvious from the values we have given that it is suitable for measuring relatively high resistances, but could not easily be used to measure such resistances as speaker voice coils, which would give a reading indistinguishable from a short-circuit.

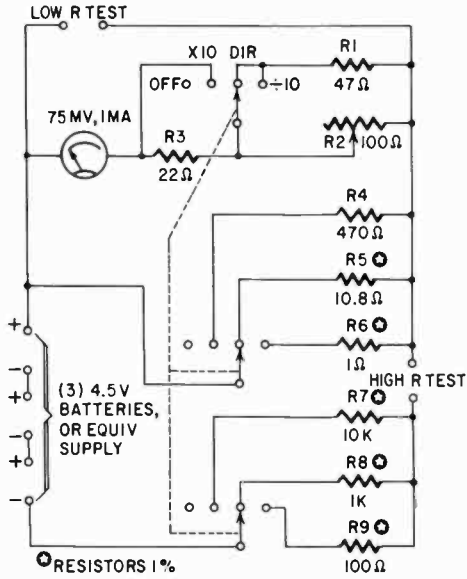

Fig. 314. Accurate multirange ohmmeter, featuring a simplified circuit and a minimum number of contacts in the switching arrangement. Note that a 75-mv meter is used in this instrument.

For this purpose a better instrument is the shunt-reading ohmmeter, shown earlier in Fig. 302. In this circuit the instrument is adjusted to full-scale deflection with the terminals open-circuit. When a resistance is connected to the terminals it provides a shunt for the meter, and gives half-scale reading when the external resistance is approximately equal to the internal meter resistance.

Note the word "approximately." Some books omit it in describing this instrument. Assuming that the battery voltage comes from the original single cell of nominal voltage 1.5, and the instrument is still the 150-mv, 1 ma full-scale job, then at the nominal battery voltage, with no resistance connected, there will be 150 millivolts across the meter and a 1.35-volt drop across the series resistor. When the meter is shunted with a resistor to bring it down to half

scale, there will be only a 75-millivolt drop across it, so the drop across the series resistor must rise to 1.425 volts, which means the current must have risen from 1 ma to nearly 1.1 ma. If the shunting resistor, connected to the terminals, is equal to the meter resistance, this current will be equally divided between them, so the reading will be about 0.55, instead of 0.5 as would be the case according to the statement usually given. To produce half-scale reading a resistor of slightly lower value must be used.

In practice half-scale reading is produced when the external resistance connected is equal to the combined parallel resistance of the meter with any internal shunts, and also with its series feed resistor, as viewed from the terminals of the instrument (regarding the battery resistance as zero).

Now we have the basic requirements for producing an instrument whose accuracy is not to be too dependent on the battery voltage.

The adjustment for full scale, which is zero ohms for the series type or infinity for the shunt type, must adjust the balance of current in the circuit associated directly with the meter movement, without appreciably altering the internal resistance as seen from the instrument terminals.

Using a higher battery voltage improves the possibility for the series instrument. This is true also in the case of the shunt instrument, because the series resistor, although variable, is then always much higher than the meter's own resistance.

Whatever circuit is used, its range is somewhat limited compared with the wide range of resistance values encountered in practice. To extend the useful range of an instrument it would be good to have a multirange ohmmeter with an accuracy similar to that achieved by multirange testers for voltage and current. Fig. 314 shows a circuit¹ which has the following useful features:

1. Circuit simplicity — a minimum of special resistors that have to be adjusted to fit the scale.
2. A minimum number of contacts in the switching arrangement.

The latter is particularly important for the lower range readings, because contact resistance can often ruin a reading. In this instrument the number of switch contact decks is reduced by using a strap across the high resistance test terminals for the ranges using the shunt ohmmeter principle.

¹ Designed by Norman H. Crowhurst

Zero adjustment

A single variable resistor is used for zero adjustment. Some may feel that it would be an advantage to have an independent zero adjustment for each range, so that changing the range does not make it necessary to readjust for zero. Circuits devised to do this usually have the disadvantage that each adjustment interferes slightly with the others, unless extra switching is employed to disconnect from the circuit the variable resistors not in use. This would increase the number of switch contacts necessary.

In this circuit a variation from that of Fig. 313 is used for the zero adjustment, to enable the same variable resistor to serve all ranges, and to avoid the use of low-value variables, which can cause poor reliability.

With the 3-pole switch in the " $\times 10$ " position, the instrument has a center-scale reading of 10,000 ohms, using the HIGH R TEST terminals. To obtain this the series resistor R7 should be just under 10,000 ohms. A 1% resistor of 10,000 ohms should serve here, trimmed, if desired, by setting the instrument to give center-scale reading with a standard resistor of 10,000 ohms. The instrument shunt has a fixed value of 470 ohms (R4), while the zero adjust is a series resistor (R2) of 100 ohms maximum, that varies the voltage drop across the meter branch at full-scale deflection and so varies the current bypassed by the 470-ohm shunt.

The other two switch positions — the direct reading and the " $\div 10$ " position — give the instrument center-scale readings of 1,000 ohms and 100 ohms respectively. The standard resistors for these ranges are also about 1,000 ohms and 100 ohms (R8 and R9). 1% resistors can be used here, being trimmed to the correct value by obtaining a center-scale reading with a resistance standard of 1,000 ohms and 100 ohms respectively. For these ranges, the meter shunts are R5 and R6, which also serve as resistance standards for the two lowest ranges, using the shunt-ohmmeter principle. For series-ohmmeter operation, the zero adjustment provides — at full-scale deflection — a path for the current exceeding the 1 ma that goes through the meter. On the " $\div 10$ " position the total current at full-scale deflection is about 135 ma, so, to conserve battery life, the instrument should never be left in this position for longer than is necessary to take a reading.

The meter that forms the basis of the instrument shown has a resistance of 150 ohms. This was chosen to allow the circuit to be applied to use an old type of meter with some useful life still left in it. Modern meters of 1-ma rating have a lower resistance, or

alternatively, for the same resistance a more sensitive meter can be obtained. The limiting factor for the high range is the voltage drop necessary to give full scale deflection through 10,000 ohms. With a more sensitive meter — for example a 500-microampere job — the same circuit can be used with only half the battery voltage (say 6 volts' worth) and much longer battery life. To use the same circuit with a 1-ma meter of lower resistance value, the simplest method is to build out the meter resistance to suit the values given, so the effective resistance of the meter with a series resistor comes to 150 ohms. This avoids the necessity of recalculating all the circuit values. If a 200-microampere meter should be handy, the circuit could be revised slightly to make it work on only 3 volts' worth of battery. The revision would consist of increasing the resistance values of the zero adjuster and associated switch connections somewhere between two and five times. R4 would also need increasing. The aim in selecting these values is to minimize the readjustment necessary when the range is changed.

For the shunt-connected ranges, giving center-scale readings of 10 ohms and 1 ohm, the positions marked DIR and " $\div 10$ " are used, with the HIGH R TEST terminals strapped together to give full-scale reading. The resistance to be measured is then connected to the LOW R TEST terminals.

To obtain the correct values for the "standards" R5 and R6 on these ranges: R5 is calculated so that with the average full-scale setting of R2, the combined resistance made up of R5, R8, and the meter branch all in parallel is 10 ohms. This procedure is simpler for R6, because the other branches, R9 and the meter branch, are both much higher in value than 1 ohm — the required combined value in this case, for absolute accuracy. If the low-value resistors R5 and R6 are not available, they can be made up of resistance wire.

As with the series arrangement, the lowest range should be used only long enough to check for full-scale deflection and then to measure the required resistance. Carelessness about this precaution will quickly dispose of a set of batteries.

This can be overcome, for bench work, by using a rectified supply from the power line. A step-down transformer to give an output voltage of 15 to 20, using a metal rectifier to give the right dc output, will provide an energizing supply for this ohmmeter. The method of zero adjustment will still render it practically independent of supply-voltage variations. Values of R1, R2, and R3 may need adjusting to suit the exact voltage used; also the

values of R7, R8, and R9 may need modifying slightly, due to the effective internal resistance of the supply. This can be calculated by measuring the reduction in dc output voltage from the supply when the maximum full-scale current on the lowest range is drawn from it. Dividing this current value into the drop in output volt-

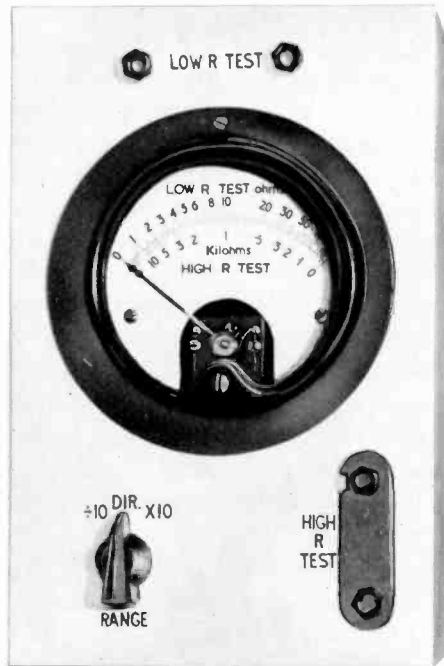

Fig. 315. High-accuracy ohmmeter. The zero control is screwdriver adjusted through a hole in the case.

age it produces will give an effective internal resistance. For example, if the current is 140 ma, and the voltage drops from 16 to 13.2, a difference of 2.8, the internal resistance is 2,800 divided by 140, or 20 ohms. This resistance should be subtracted from the values given for R7, R8, and R9, particularly the last, to keep the center-scale reading correct.

Using the convenient center-scale reading of multiples of 10, the instrument will have a scale of the type shown earlier in Fig. 303, the scale marked HIGH R TEST being used for the readings using series-ohmmeter connections on the upper three ranges and the scale marked LOW R TEST for readings on the shunt-ohmmeter circuit used for the two lower ranges, when the HIGH R TEST terminals are strapped together.

The strap for the HIGH R TEST terminals can be made from a

metal strip, with two holes drilled to fit the terminal spacing. One of these holes is then slotted out sideways, so the strap can be held by the other hole to one terminal, being clamped on the remaining terminal, or released, according to whether the LOW R TEST OR HIGH R TEST is being used.

A photo of the front of the ohmmeter is shown in Figure 315. The zero control is screwdriver adjusted through a hole in the case.

With television, high-fidelity audio, and other electronic equipment demanding closer-tolerance resistors, this high-accuracy ohmmeter is a valuable test instrument.

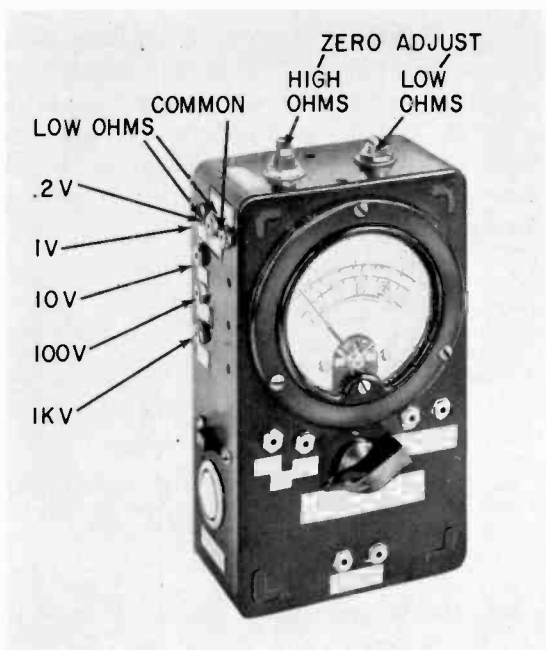

Fig. 316. Pin-jack vom using a 40- μ a basic meter movement (25,000 ohms per volt).

Pin-jack vom

Although used in electronics, the vom can be considered non-electronic, since it does not use tubes or transistors. But this limitation can be overcome by using these components to increase the sensitivity, hence the range, of the vom.²

The basic vom has important advantages over a vtvm, being more compact and not depending upon a line power supply. Fur-

² More examples of meter amplifiers are given in chapter 8.

thermore, there is no warmup period and there are no tubes to age. If, in addition, the instrument has high sensitivity, it compares favorably with the vtvm in the matter of high input resistance. For example, with a $10\text{-}\mu\text{a}$ movement an instrument has an input resistance of 100,000 ohms per volt. This totals 10 megohms on a 100-volt scale, which approximates the input resistance of a conventional vtvm.

Here is a multimeter³ using a $40\text{-}\mu\text{a}$ basic movement (25,000 ohms per volt). A number of interesting features were incorporated. The instrument uses phone pin-jacks. (See Fig. 316.) A multipole rotary switch is usually expensive, difficult to wire, and is often the source of mechanical trouble. A low current range was included to measure dc in the order of $1\ \mu\text{a}$. This uses a transistor amplifier. There are high and low ohms ranges, and two low ac volt ranges. The low ranges are useful when experimenting with junction transistors. There are 15 different ranges altogether. The beauty of the pin-jack arrangement is that more circuits can always be added if desired; the only thing necessary is space on the meter box for additional pin-jacks.

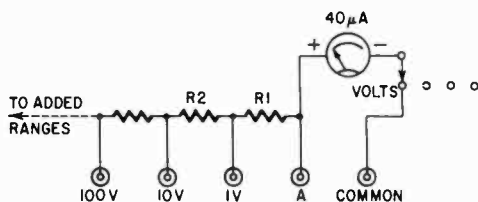

Fig. 317. Voltage-range circuit of the multimeter shown in Fig. 316. This circuit is in use when selector switch is rotated to the VOLTS tap.

Voltage

Fig. 317 shows the voltage range circuit. It is in use when the selector switch is rotated to the VOLTS tap. To design the volts range we must know the *ohms-per-volt* value for the particular d'Arsonval movement to be used. If the meter has a full-scale sensitivity of $10\ \mu\text{a}$, it requires a total series resistance of 100,000 ohms to measure a full scale of 1 volt. This means that the meter is a 100,000-ohms-per-volt unit. In the same way, a $20\text{-}\mu\text{a}$ meter is a 50,000-ohms-per-volt unit.

If you have a $20\text{-}\mu\text{a}$, 2,050-ohm meter, a series resistance of 50,000 ohms is required for every volt (full-scale) you wish to measure. Therefore, in Fig. 317 you need 50,000 minus 2,050 ohms

³ Designed by I. Queen

for R1. For R2 you need a resistor that will drop 9 additional volts. At 50,000 ohms per volt, this comes to 450,000 ohms. In the same way you can easily calculate all other series resistors. Of course you may not wish to have ranges as marked in Fig. 317. You may prefer 5 volts, 25 volts, or any other. In any case, the computation

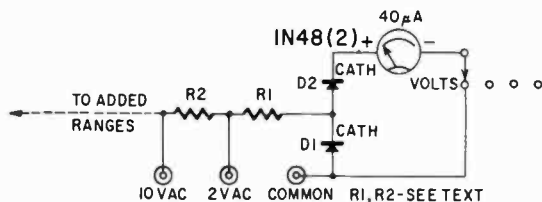

Fig. 318. Circuit for measuring ac volts. This instrument has only two low ranges — 2 volts and 10 volts.

is the same. You may include as many ranges as you have room for pin-jacks. The ranges you choose, however, should correspond to the markings on the meter scale. If your full-scale reading is 15, you will probably want to use 1.5 volts, 15 volts, 150 volts, etc.

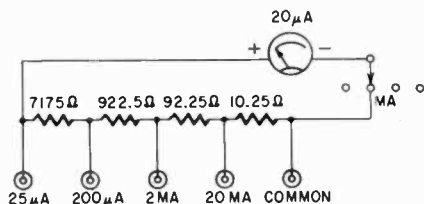

Fig. 319. The Ayrton shunt circuit, used for measurements of current. A ring of resistors shunts the meter at all times.

To measure volts in Fig. 317, one test lead is plugged into the COMMON or minus pin-jack; the other lead is inserted into the desired voltage pin-jack.

For ac volts, use the circuit shown in Fig. 318. This particular instrument has only two low ranges — 2 volts and 10 volts. These have been found very valuable for transistor output measurements. A pair of crystal rectifiers are used across the meter. One half of the ac wave is passed through the meter. The other half is shunted by a crystal and does not flow through the meter. (When the COMMON pin-jack goes positive, D1 is conductive and D2 is blocked. Thus current flows through D1 and not through the meter.) The resistors for these ranges must be found by experiment. This meter has a 40-μa movement. It requires a 2,700-ohm

resistor for R1 and 82,000 ohms for R2. The meter resistance is 5,000 ohms.

To measure ac volts, the range switch is left in VOLTS as for dc measurement. The leads are plugged into the COMMON and desired ac volt pin-jack. The rectifiers across the meter have no effect on the other meter ranges.

Current

Measurements of current are made by using the Ayrton shunt circuit (Fig. 319). The meter is shunted at all times by a ring of resistors. One test lead is inserted into the COMMON ma pin-jack, the other into the desired current pin-jack. (The formula for the Ayrton shunt circuit was given earlier and appears on page 49.)

Fig. 319 shows a network which can be used for a 20- μ a movement with a meter resistance of 2,050 ohms. First we must decide

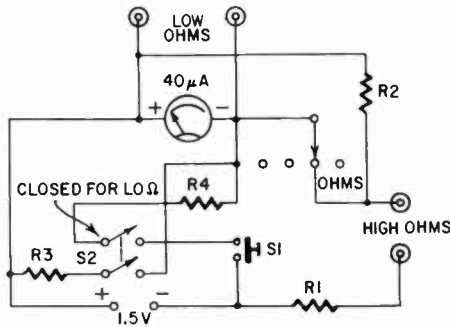

Fig. 320. Circuit for measuring ohms. Dpst slide switch S2, when closed, damps the meter movement while the instrument is handled, preventing the needle from bouncing around.

on the lowest current reading we want. Let it be 25 μ a. We must then shunt 5 μ a around the meter and permit the other 20 μ a to flow through it. If the shunt resistance is four times the meter resistance, the requirements are met. Therefore R_{st} must be 8,200 — we know that R_m is 2,050 ohms. In this case n equals 1.25. For n equals 10 (full scale reading of 20 μ a) R_1 is 1,025 ohms, etc. In this way, the remainder of the network can be calculated. As with volts, we can add as many ranges as we desire, the only limiting factor being the space we have for more pin-jacks.

One question may come up here. The constructor may wish to use the lowest possible current range, for example, 20 μ a in the previous case. This is not possible with a ring shunt. To do this, switch the instrument to VOLTS to disconnect the shunt, and insert

your test leads into pin-jacks which connect directly to the meter terminals. These are shown as jacks "A" and "COMMON" in Fig. 317.

Ohms

The ohms network is a little more complicated than either current or voltage circuits (Fig. 320). Of course the meter you use must carry ohms scales, as well as volts and ma.

To design the *high* ohms network, note the ohms reading that corresponds to meter midscale. In this particular meter it happens to be 30,000 ohms. With HIGH OHMS pin-jacks shorted we want full-scale (or zero ohms) deflection. With 30,000 ohms across the pin-jacks we want mid-scale reading. Obviously we need an ohm-meter circuit having a total internal resistance of 30,000 ohms (this includes meter resistance). This circuit can be traced in Fig. 320 as follows: R1 is the series resistor, in series with the HIGH OHMS pin-jacks (when the selector switch is on ohms), the battery, and the meter. When the pin-jacks are shorted we want the battery to drive full-scale current through the meter. When 30,000 ohms is placed between the pin-jacks we double the total series resistance, therefore we halve the meter current.

This completes the high-ohms circuit except for one problem. What if the series resistance (30,000 ohms for our particular meter) is not correct for securing full-scale deflection? It may be too large or not large enough. In our own case it was not large enough. If you calculate the flow due to 1.5 volts through 30,000 ohms you will get 50 μ a, yet we are using a 40- μ a meter. Then all we have to do is add a shunt, R2. If R2 is 4 times as large as the meter resistance (5,000 ohms) it would pass 10 μ a when the meter flow is 40 μ a. This satisfies all conditions and our high-ohms range is complete. On the other hand, it is possible for the series resistor R1 to be too large. It may not permit sufficient current to fully deflect the needle. Then the battery voltage must be increased. Add cells until R1 is just right or until it permits too much current flow through the meter. Then add a shunt as just described.

For convenience, R1 is shown as a single unit. However, it should be composed of a variable portion and a fixed portion. Thus we can compensate for an aging battery. The variable resistor may be about 20% of the total. In this case, R1 should be 26,000 ohms because the meter (5,000 ohms) is shunted by R2 (20,000 ohms). The solution was to use a 24,000-ohm fixed resistor in series with a 5,000-ohm potentiometer. The potentiometer is adjusted by shorting the pin-jacks and setting for full-scale deflection.

The low-ohms circuit includes a push-button switch S1 and a dpst slide switch S2. On this range, zero ohms is at the extreme left and the scale reads upward. Again note the ohms reading that corresponds to mid-scale on the meter. In this case it happened to be 16 ohms. This gives the value of R3, a shunt resistor placed across the meter terminals and the low ohms pin-jacks, when S2 is closed. With the push-button switch, S1, also closed, R4 permits current flow from the battery into the meter. With the LOW OHMS pin-jacks left open, this current must be sufficient to produce full-scale deflection. Then if we place 16 ohms across the jacks we find that the reading drops to mid-scale as required. The smaller the resistance across the pin-jacks, the lower the meter reading.

Now for the design work. In most cases R3 is so much lower than the meter resistance that the latter may be ignored. In any case we want the resistance across the pin-jacks to equal the mid-scale ohms reading (16 ohms). The limiting resistance, R4,

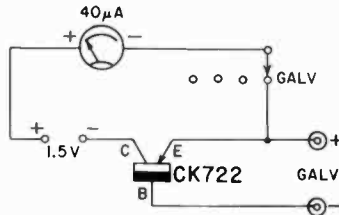

Fig. 321. Galvanometer circuit for measuring weak currents or voltages. High accuracy is not required here, but high sensitivity is.

produces full-scale deflection when the pin-jacks are left open. Calculate the total current flow when the meter shows full-scale deflection. The meter would pass $40 \mu\text{a}$, of course. The 16-ohm shunt would pass $5000/16$ or 312 times as much. This is 12.5 ma, so we may ignore the very much smaller meter flow. How much series resistance do we need to permit 12.5 ma from a 1.5-volt battery? The answer is 125 ohms, of which we already have 16 ohms between the meter terminals. Therefore R4 should be about 110 ohms. As before, it should be partly variable. A 91-ohm fixed resistor in series with a 30-ohm potentiometer was used. To adjust this range, leave the pin-jacks open and adjust R4 for full-scale deflection. Be sure S2 is closed and depress the push-button when you make the measurement.

The slide switch serves another useful purpose. When left closed it places 16 ohms across the meter. This damps the move-

ment and prevents the needle from bouncing around while the instrument is being handled. This is not necessary when the meter is used for volts, ma, or high ohms.

Galvanometer

This range measures weak currents or voltages. High accuracy is not required for most of these measurements, but high sensitivity is. Fig. 321 shows the schematic. The input current or voltage is impressed across the GALV pin-jacks.

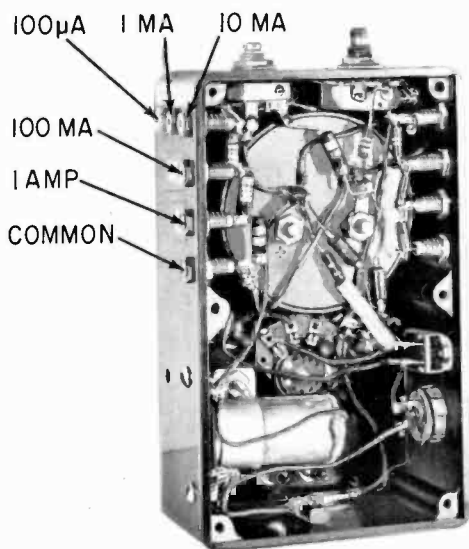

Fig. 322. Interior view of multimeter having four functions: volts, current, ohms and galvanometer. Common terminal, used for volt range, requires no shunt or external circuit across the meter.

Present-day transistors don't have uniform and identical collector current flow. For the galvanometer application, the transistor should show low current when the input terminals are left open. This eliminates the need for an auxiliary circuit to balance out and zero the meter deflection when no input is applied. The transistor used here shows only $4\text{-}\mu\text{a}$ collector current with the terminals open.

To calibrate the galvanometer range, apply various known currents between base and emitter. The emitter is the positive termi-

nal. Linearity will not be perfect but it should be very good. This instrument shows a $4\text{-}\mu\text{a}$ deflection for each μa fed to it, giving an easy and convenient method for increasing the sensitivity of a dc meter.

To read volts, add a resistor in series with the negative (base) lead. Use a 1-megohm series resistor, and the meter will deflect approximately $4\text{ }\mu\text{a}$ for each volt applied. For better accuracy, draw a curve or chart plotting μa meter deflection vs μa input (or volts input). To increase sensitivity, use a larger collector battery.

This multimeter has four functions: volts, current, ohms, and galvanometer. Ordinarily this would require a 4-position, single-pole switch, not a very common part. Use a 3-position switch for this purpose such as a Centralab unit with 4 terminals. Originally the tap could contact only 3 of them, the "common" terminal being excluded. By filing off the stop, the movable tap could also touch the common terminal — and we have a 4-position switch. This common terminal is used for the volt range, the only one that does not require a shunt or external circuit across the meter. (An interior view of the completed instrument is shown in Fig. 322).

kit type vom's

ALTHOUGH there are many makes of kit instruments on the market, there isn't a great variety in types. Generally the choice is limited between a sensitive 20,000-ohms-per-volt meter and the "utility" type tester which may have a 1-ma or 400-micro-ampere meter. Actually, when you buy an instrument in kit form, you have, after careful assembly, the equivalent of a good quality commercial unit. Most kit manufacturers put out both the service type instrument and the smaller, less versatile one, and some of them are available in wired form as well.

Building a kit type instrument is not difficult. The assembly procedure has been broken down into simple single steps of assembly and wiring. Generally the instructions provided with it are clear and understandable though they may vary in presentation. Some manufacturers assume that the individual who is going to assemble a complicated instrument is already well versed in electronics construction, and does not need over-simplified directions. Others begin by assuming that the individual can read and identify numbers, and nothing more, and make the instructions simple enough for anyone to follow, so long as he is capable of reading at a reasonably advanced level.

Parts quality in kits is generally good, possibly even higher than in some commercial instruments. Assembly is the largest single cost item in manufacture and, since the kits eliminate this factor, the considerable saving is passed on to the customer. This gives the manufacturer more leeway in choosing quality parts. The parts are bought in tremendous quantities, giving a price advan-

tage there. In many cases it is impossible for an individual to purchase the separate parts, even at wholesale prices, for the cost of the entire kit, which includes instructions and well-designed front panels. It is possible to give a home-built, home-designed piece of equipment the same kind of professional look that you can get in kits, but it is time-consuming and sometimes expensive to achieve. Even where it is possible to duplicate the parts for less than the kit price, there is this item of appearance, and the additional advantage that all metal parts are drilled, punched and formed.

Regardless of the form of instruction, a certain sequence of recommended procedure has been found by experience to be the best in all cases of kit construction.

1. Read over the entire instruction manual once.
2. Unpack, identify and check on the parts list all items in the kit. This will familiarize you with all the components, and will account for all parts, or disclose those which are missing (a rare event).
3. Assemble the various units of the instrument, checking each step as it is listed in the manual.
4. Solder and wire all parts, checking each step. The sequence of wiring has been carefully determined in the factory by repeated assembly of the kits by different technicians. Seldom will the various steps contain any "illogical" or impractical sequences.
6. Before final assembly, check each soldered or "to-be-soldered" joint. Sometimes assembly steps call for soldering to be deferred until a later time in the wiring. It can happen that you may overlook the soldering of a joint.
7. After final assembly and before the instrument is tested, double-check all the wiring. A good way to do this is to read once again all the steps in the manual, or at least to check all the items to see that all of them have been done.
8. Test the equipment by using all the highest ranges first. Any mistake will then show up with the least likelihood of damage to the basic meter.

Soldering

Of great importance in building kits is the skill in soldering that the builder may have. Practically all kits manuals contain some discussion on how to make a proper soldering joint. If you are not experienced at soldering, you would do well to get some wire, solder and a soldering iron and to do some practice solder-

ing first. Many beginners use either too much solder, or too much heat, making the solder too liquid, so that gravity will tend to flow it away from a joint. Solder at the proper heat level will barely flow and it will always move toward the point of greatest

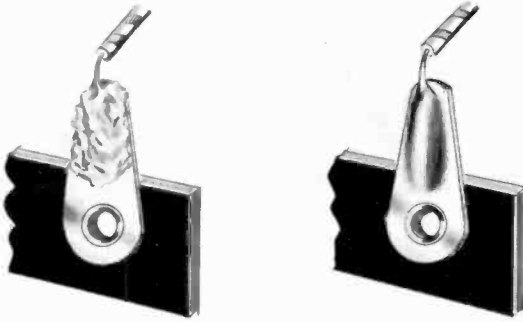

Fig. 401. The difference between a poor solder joint (left) and a good solder job (right). Use the minimum amount of solder and heat the joint until it is hot enough to melt it. Don't carry solder to the work on the tip of the iron.

heat. If you remember this, it will make the solder's ornery behavior seem more logical. Where a part or a terminal or a wire is thickest, it will heat more slowly, but it will soon maintain more heat and consequently draw solder.

Fig. 401 shows the difference between a properly soldered and an improperly soldered joint. On the bad joint, the solder appears rough and granulated; on the good joint, it is smooth and fills all the crevices. Where the manufacturer specifies to make the joint mechanically solid even without solder, this should be done. Even a good solder joint may not be able to take the stress of vibration or other physical forces on it.

A joint is made mechanically solid by wrapping the wire at least one turn around the terminal (as shown in Fig. 402) before soldering. There are some arguments against this, but these hold principally for temporary joints. For example, in testing and making up shunts, you might have to unsolder and resolder a joint several times. Wrapping would be nothing but a nuisance.

All kit manufacturers have a hard and fast rule about the solder that can be used. They insist, and with good reason, on rosin-core solder. No other flux may be applied to any kit part. Other fluxes sold in solder or for soldering are corrosive, and will eventually cause trouble in the kit. Manufacturers declare their guarantee of the instrument null and void if they detect any other than rosin

flux in the construction of a kit sent to them for troubleshooting or repair. If you have a solder which has a flux core and if you are not absolutely sure it is rosin, get some new solder before you

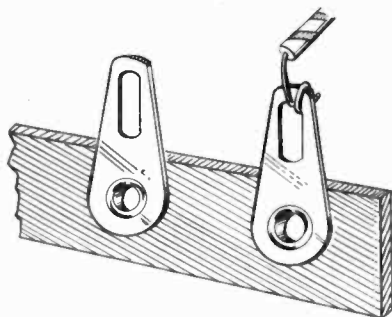

Fig. 402. The purpose of solder is to make a good electrical connection. Solder has little mechanical strength. Wrap the wire around the joint securely before soldering. Both the joint and the wire must be clean.

wire your kit. Its cost is little enough that it is not worth jeopardizing your kit's guarantee to save a few pennies.

The guarantee on kits extends also to the original condition of the parts, and if they can detect (and they usually can) that a part has been mistreated, you will lose the guarantee on that part and will have to pay for its replacement.

Wiring

Wiring of the kit should be done neatly, but it is not necessarily a good idea to dress your wires together—this may increase stray circuit capacitances and reduce the frequency response—follow the instructions! All ends of wires should be neatly clipped off at the solder joint, but it is much better to make the joint so that no ends are sticking out to be clipped off.

Choosing the kit

Selection of the type of kit you need is dependent on the type of work you expect to do with it. If you are going in for serious radio service work, audio or TV repair, or advanced experimentation, you will need one of the 20,000-ohms-per-volt kits. If you expect to do some checking of electronic circuits but mostly want to have a handy portable instrument around, small, and with enough ranges to handle all your measurements, whether in the house, about the automobile or the kid's electric train, the simpler 1,000-ohms-per-volt meter will be best. If you intend to specialize

primarily in appliance repair you will want to have a ready means for measuring wattage but you will not be concerned about sensitivity or measuring very low voltages and very high resistances.

Types of kits

Having discussed some of the generally applicable rules for assembly, let us look at one of the kit type instruments in a little more detail. Most kits also have large pictorial assembly plans supplied with the construction manual. If you hang these up in front of you, you will find they will help speed your work, making it easier on the eyes. It may also help prevent mistakes.

Fig. 403 shows an instrument that is slightly larger than equivalent commercial meters, because some of the assembly tricks used in commercial meters are not feasible in kit type instruments.

Fig. 404 shows the complete schematic. The ranges for voltage



Fig. 403. Volt-ohm-milliammeter constructed from a kit. (Heath Co.)

are 1.5, 5, 50, 150, 500, 1,500 and 5,000 ac and dc. Current ranges are 150 microamperes; 15, 150, 500 milliamperes and 15 amperes. Resistance ranges are $R \times 1$, $R \times 100$ and $R \times 10,000$ with 150, 1,500 and 150,000 ohms center scale. These are representative ranges and generally what are offered in 20,000-ohms-per-volt meters. The instrument has one unusual feature: a reverse-polarity switch for the dc voltage and current ranges. This is a convenience and safety feature. It allows much faster switching of terminals when the polarity needs to be reversed.

Fig. 405 shows the dc voltage circuit of the instrument. The

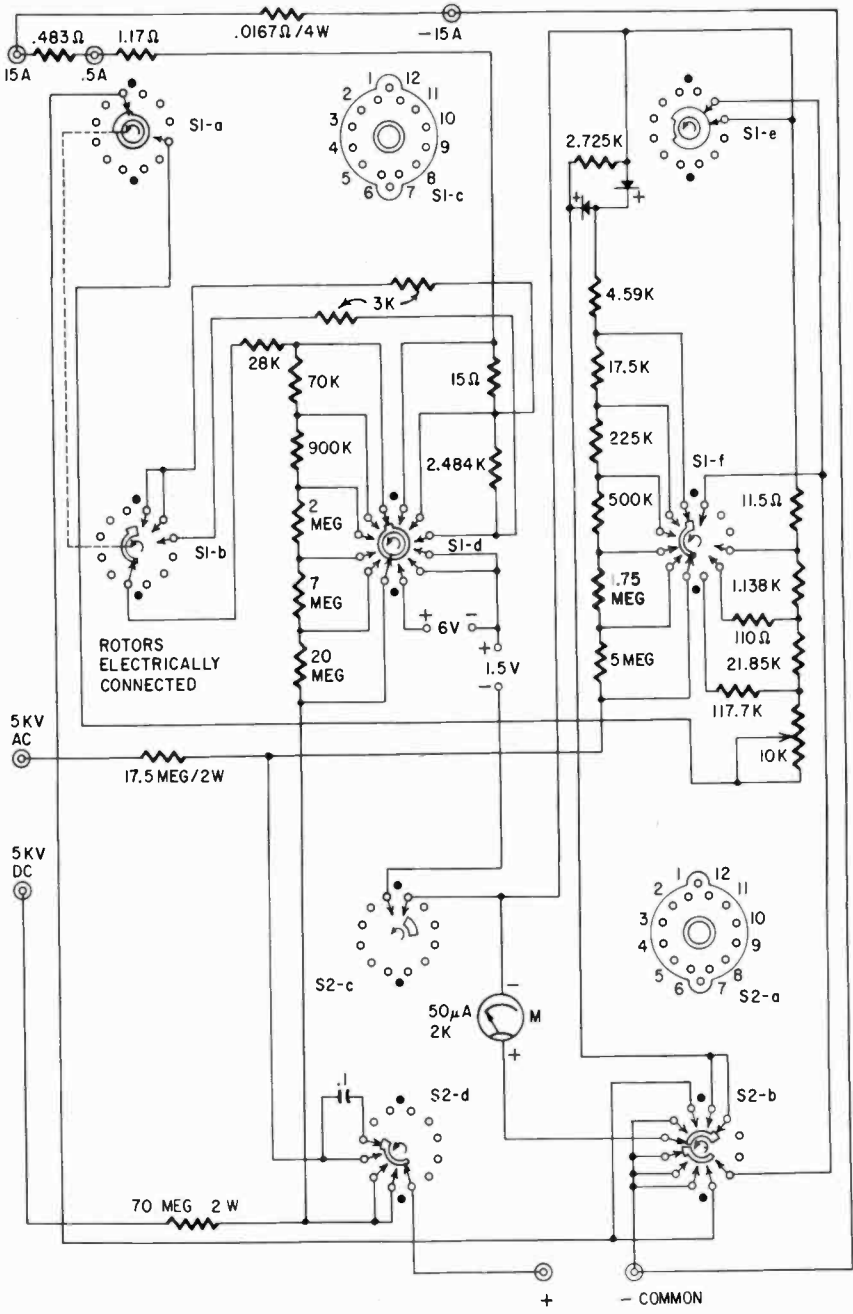

Fig. 404. Complete schematic of the vovm illustrated in Fig. 403. This is a 20,000 ohms-per-volt unit (dc) and 5,000 ohms-per-volt (ac).

meter is a 50-microampere movement having an internal resistance of 2,000 ohms.

Fig. 406 shows the ac voltage ranges. The instrument has an ac voltage sensitivity of 5,000 ohms per volt. Fig. 407 shows the current-ranges. This is the Ayrton type of shunt circuit discussed

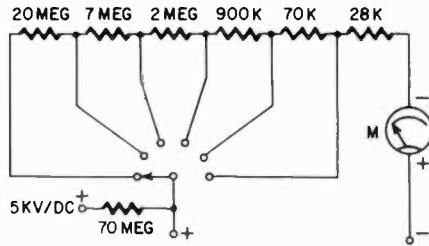

Fig. 405. This is the dc voltage circuit of the vom whose schematic appears in Fig. 404. The resistors are connected as series multipliers.

in detail in Chapter 3. Notice that here there is an additional series resistance in the meter circuit, which keeps the meter circuit resistance high and allows, if ever necessary, replacement of the meter and subsequent recalibration. Separate jacks are provided for 0.5- and 15-amp ranges to avoid heavy current through the switch contacts, which are not rated for it.

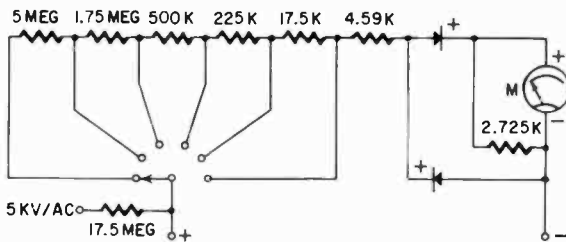

Fig. 406. Ac voltage circuit of the vom in Fig. 404. The multiplier arrangement is similar to that used for dc, except for the use of the rectifier diodes and the shunt resistor across the meter.

The resistance-measuring circuit for this meter was discussed in some detail in Chapter 3. Fig. 408 shows the simplified circuit again. You will remember the reason for the "external" multipliers was the need to use a higher-voltage battery on the high range.

Next we come to a feature not yet discussed at all. This is the output-measuring circuit and its scales. Fig. 409 shows the basic

circuit, which is essentially the same as the ac voltage circuit, but with the 0.1-microfarad capacitor in series with the terminals.

How to read decibel scales

Let us first sidetrack a little and explain what a logarithm is and how it is derived. A logarithm (often abbreviated as log) is a way of writing the exponential to a power. If 10^2 (which is 10×10) = 100, then we can write $\log_{10} 100 = 2$. This means that

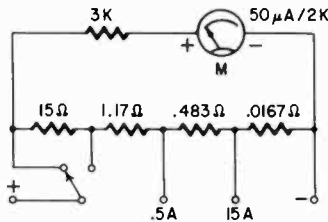

Fig. 407. Current ranges of the vom of Fig. 404. This is an Ayrton shunt circuit.

the base (10 in this case) must be raised to the second power (10^2) to give the number 100. This is a useful form of notation for it allows us to add exponentials and get answers to multiplication problems in a simple way. Thus: $\log_{10} 100 = 2$. Also, $\log_{10} 1,000 = 3$. And quite conveniently: $\log_{10} (100 \times 1,000) = 2 + 3 = 5$.

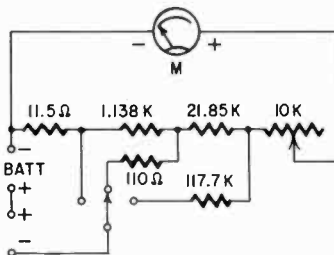

Fig. 408. The resistance-measuring circuit of the vom of Fig. 404.

Let us see if this is true. $100 \times 1,000 = 100,000$ or, to write it another way, $10^2 \times 10^3 = 10^5$, meaning 100,000 is 10 multiplied by itself 5 times. And this is the way we use logarithms. To make it convenient, tables have been worked out giving logarithms for all numbers.

Long ago, telephone engineers, experimenting to find out how much they would need to increase the power in a telephone re-

ceiver so that a listener could detect that the sound was louder, found a certain amount would just be noticed. Logically they called this the "just noticeable difference," an expression which persists in psychology laboratories today. They also found that this JND could be expressed as a logarithmic function of the ratio of two power levels; the *before* and *after* increase.

Logarithms obviously turned out to be a handy way of expressing such an increase, since you could at any time *add* these loga-

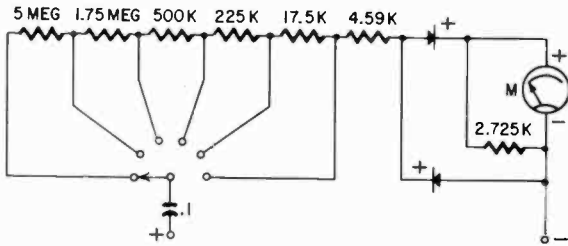

Fig. 409. This output circuit is similar to the ac voltage arrangement shown in Fig. 406. The .1- μ f capacitor is a blocking unit. As in the case of the dc voltage circuit, the resistors are series multipliers. Note the arrangement of the diodes. These are connected as shown previously in Fig. 209 (Chapter 2).

arithmic functions and still accurately express a product. Thus, if one sound had many times the power of another, you could use the logarithm and say there was so much *difference* in the power level. This log function then was given the name of bel. To make it a handier figure, it was divided by ten and called a *decibel*¹ (deci means one-tenth).

The telephone engineers next determined that the *difference* in power levels could be expressed as:

$$10 \log_{10} \frac{P_2}{P_1} \text{ decibels (db)}$$

If we say that there has been a gain in power of 10 decibels, we can say:

$$10 \log_{10} \frac{P_2}{P_1} = 10.$$

and thus:

$$\log_{10} \frac{P_2}{P_1} = 1.$$

This means that the logarithm of the ratio of power level P1 and power level P2 is 1, or that, to get the number, we must raise 10

¹ And it turns out that 1 decibel is a "just noticeable difference."

to the first power or 10^1 . This is of course 10, meaning that 10 decibels have made the sound just 10 times as "loud."

Let's try another example. Say we have a gain of 30 db. Then:

$$\log_{10} \frac{P_2}{P_1} = \frac{30}{10} = 3.$$

This means that we have to raise 10 to the third power, (10^3) and we know this is 1,000. If we have a gain of 30 db, the power in the second case is 1,000 times as much as the power in the first. In other words, a 60-db *gain* means one thing is 10^6 or 1,000,000 times as great as something else. But suppose the sound is described simply as 60 db's, then what does it mean? Well, to be able to measure power sensibly, we must always deal with a logarithmic function of a *ratio*. A *ratio* requires *two* numbers, and if we agree that we will always use the same number for one of these two, then an answer in db's will always mean the same thing to various people. Therefore, engineers decided to use one specific *point of reference* to give them an easy way to obtain a ratio. This point of reference has varied from time to time, but as generally used now it is 1 milliwatt in 600 ohms. It must be in 600 ohms, because with a meter such as a vom we can measure only ac voltage, and power is a product of current and voltage. To get the current out of this, we simply agree to always develop the voltage across the same impedance. Knowing that the reference point is 1 mw in 600 ohms, and being told that some amplifier puts out 30 db, you will know at once that this amplifier has an output of 1,000 times 1 mw, or 1 watt. And you will also know that this 1 watt will develop a voltage of 24.5 in the 600 ohm impedance (from Ohm's law).² Now we are at home base, for we can measure ac voltages with the vom.

And the manufacturer has made matters even simpler, by adding a db scale on the meter. Using the 1.5 volt range on the meter shown in Fig. 403, if the meter indicates about 0.7746 volts, it also shows 0 db, since at 1 mw, 0.7746 volt will be developed in a 600 ohm impedance. Switching to the 5-volt range, you will see that, when the meter again reads 0 db, you are actually measuring a voltage of about 2.45. This works out to correspond to 10 db. We have them shifted, and must add "exponentials," so that, when we

² $W = E \times I$ and $I \times R = E$. Since R is 600, then $I = \frac{E}{600}$. W is 1 watt. $W = \frac{E^2}{R}$
 $= \frac{E \times E}{R}$. But since $W = 1$, we have $1 = \frac{E^2}{600}$. Transposing, we get $E^2 = 600$.

By taking the square root of both sides we will have $E = 24.5$ volts ac.

use the 5-volt range, 10 db must be added to the reading. Table 4-1 shows the addition for this particular instrument.

Table 4-1. Relationship between ac voltage and db scales

ac volt scale	db scale
0-1.5 volts	Read db directly
0-5 "	Add 10 db to the reading
0-50 "	" 30 "
0-150 "	" 40 "
0-500 "	" 50 "
0-1,500 "	" 60 "

Manufacturers do not all use the same reference point. Some prefer to use another—0.6 milliwatt, developed in 500 ohms. This is an older standard. Of course, for it the db scale is different with respect to voltage. For the same db number you read more than twice the voltage. Convert to 1 milliwatt in 500 ohms by adding -8 db.

What happens when you must read output across a lower impedance, such as a speaker voice coil? A correction must be made, and we must add:

$$10 \log_{10} \frac{600}{Z}$$

where Z is the actual impedance of the speaker. Table 4-2 shows the additions to be made for speaker voice coils of different impedance. But remember, the speaker must be exactly matched to the amplifier actually to read the power levels correctly. To correct for 0.6 milliwatt in 600 ohms (the correction for 500 ohms was shown previously), we must use the correction for impedance.

Table 4-2. Corrections to be made in output readings across low-impedance speaker coils

speaker impedance	Add to db reading on meter with 1 mw in 600 ohms reference
3 ohms	23 db
4 "	22 "
8 "	19 "
16 "	15 "

In calculating the voltage developed across the resistor at a certain wattage (or db), we used the square of the voltage. And

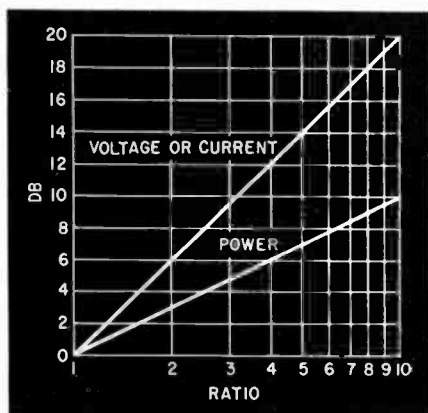

Fig. 410. Power and voltage (or current) ratios vs decibels.

in logarithmic terms, using the square of something means that the log is twice as large. The relation between the db scale and the voltage is the square root of that relation and the power. To state it in another way, the power relation is the square of the voltage relation, which in terms of db and ratio works out as

- () Refer to Figure 10 for the following wiring.
- () Connect a bare wire from B13 (NS) to S1F7 (S).
- () Connect a bare wire from A15 (NS) to S1F8 (S).
- () Connect a bare wire from A17 (NS) to S1F9 (S).
- () Run a bare wire from B17 (NS) to S1E10 (NS).
- () Run a bare wire from B23 (NS) to S1E10 (S).
- () Connect the black wire of the meter rectifier to B23 (NS).
- () Connect a bare wire from B18 (NS) to S1D10 (S).
- () Connect a bare wire from A18 (NS) to S1B10 (S).
- () Connect a bare wire from B20 (NS) to S1B11 (S).
- () Connect a bare wire from A21 (NS) to S1D11 (S).
- () Connect a bare wire from B22 (NS) to S1D12 (S).
- () Connect the red wire of the meter rectifier to A23 (NS).
- () Refer to Figure 11 for the following wiring.
- () Connect the yellow wire of the meter rectifier to B1 (NS).

Fig. 411. Excerpt from an instruction book for a vom kit. (Heath Co.)

just half. Fig. 410 shows the relationships between power and voltage ratios and db's. Plotted on semilog paper, these look like straight lines.

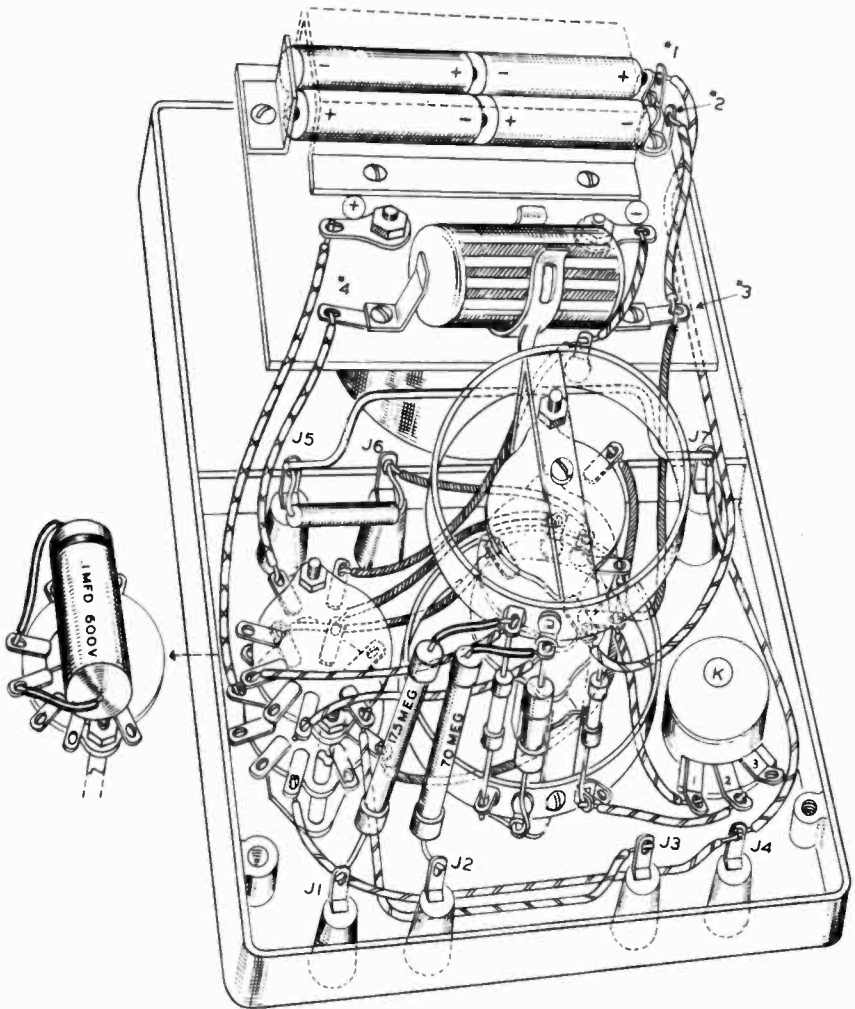

Fig. 412. Type of pictorial supplied with a vom kit. (Heath Co.)

If you read the voltage scales as well as the db scales, you may find the addition of a round number of db's as you change scale may not be perfectly accurate. But consider that if you drop 1 db from the addition you only lose 1 milliwatt, and you can see that extreme accuracy is not required.

Assembly instructions

Fig. 411 is a short section of the instructions which actually come with the instrument shown in Fig. 403 and you can see that they are stated in single, unambiguous steps. NS stands for "no solder" when another wire is expected to be put on the same terminal, and S stands for "solder" when all the wires have been put on the terminal. This particular section is concerned with the



Fig. 413. Front view of a smaller type of vom.

wiring of the range switch, and the clear drawing accompanying it is also shown. Fig. 412 shows one of the overall pictorials supplied to make the wiring job easier. These pictorials are also provided in a large version to hang on the wall.

Sometimes the instrument is not as complicated, and the wiring can be shown completely in one pictorial; for example, the less sensitive instrument, illustrated in Fig. 413. Its interior views (Fig. 414) picture the complete wiring of the instrument. The schematic that goes with this is diagrammed in Fig. 415, which shows at the bottom the same kind of breakdown into single function circuits as was given earlier.

The low ohms range is a potentiometer range, but the high

ohms range is, in effect, a series-type ohmmeter circuit. Notice that the meter in this instrument is a 400-microampere unit, but that in both current ranges it is never directly connected to the circuit without a shunt.

Ranges for the tester are 10, 30, 300, 1,000 and 5,000 volts ac and dc; 0-3000 and 0-300,000 ohms; 10 ma and 100 ma. These ranges were clearly designed for general utility and not specifically for electronic service work.

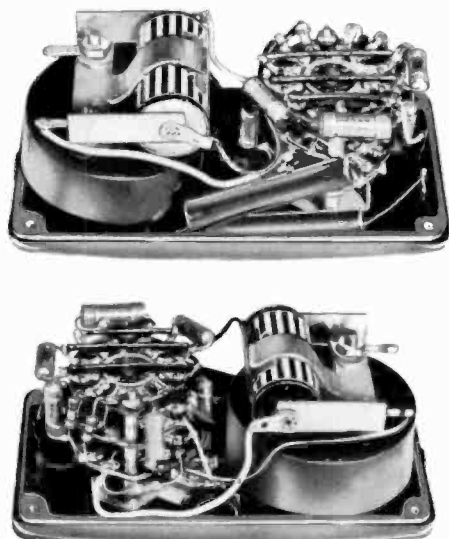

Fig. 414. Two interior views of the compact vom shown in Fig. 413.

Another instrument supplied in kit form is illustrated in Fig. 416. This has a pictorial similar to those described earlier but entirely different kinds of instructions are supplied with the kit. In place of the verbally explicit instructions, these kits come with simple lists of steps, as typified by the section shown in Fig. 417. Here the step number is listed, then the part or wire, and the instructions say from where to where this must be installed, with a reference to the pictorial to be used. Here the reference C means "do not solder" and S means "solder." This type of instruction obviously requires a little more experience in electronic assembly, although special or difficult wiring or assembly points are given more explanation. Incidentally, this is a common approach to instructions, and, once you get used to it, the directions are not difficult to follow.

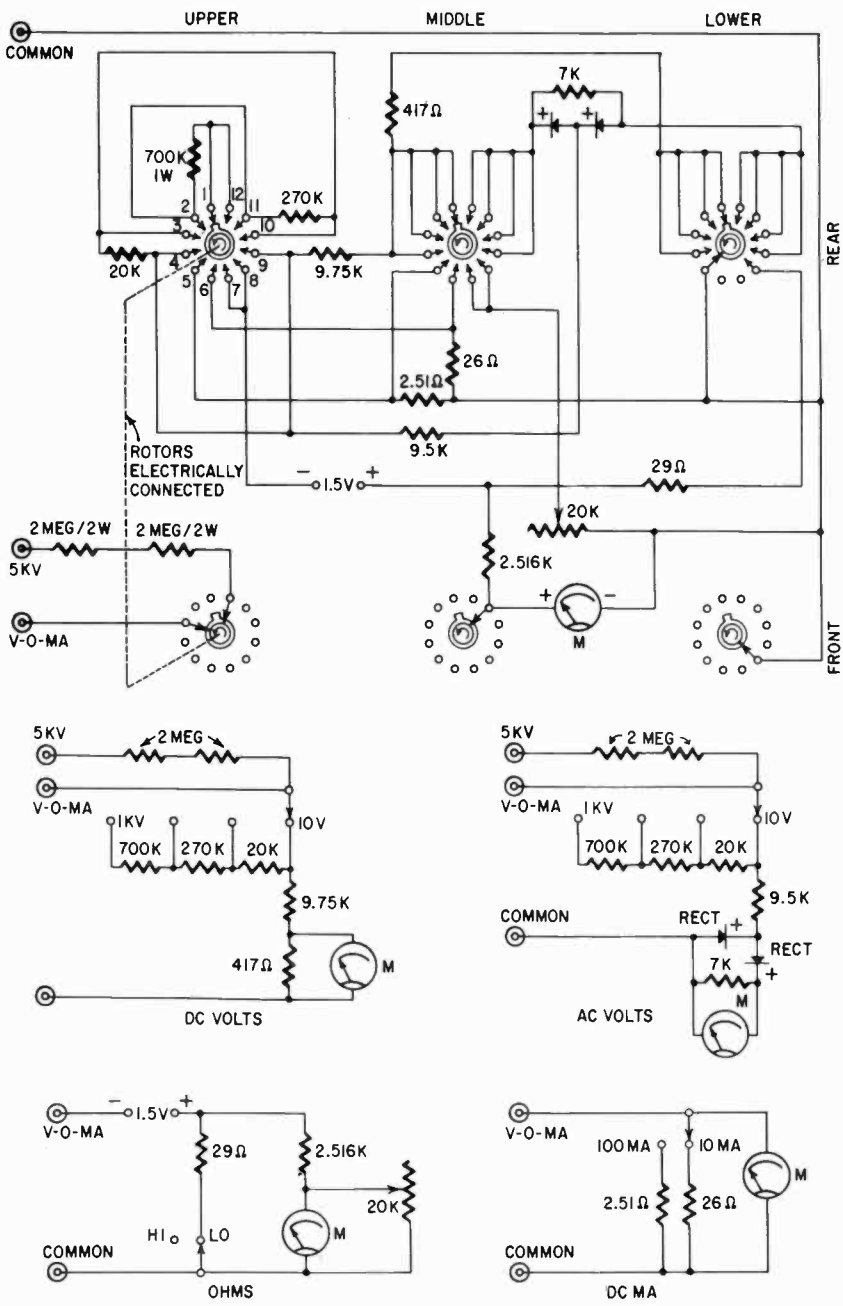

Fig. 415. Schematic diagram of the vom of Fig. 413. The smaller schematic are simplified versions of each of the functions.

Tools

None of these kits call for the use of any special tools. A medium or small screwdriver, a pair of pliers and a soldering iron will just about handle the work. An additional pair of small side cutters and a simple wire stripper will speed it a little. No special calibration tools are required. The fresh flashlight battery is used



Fig. 416. This is a vom having a sensitivity of 20,000 ohms per volt. It was constructed from a kit. (Allied Radio)

to test the low-voltage dc ranges, and the manual recommends the use of a filament transformer for checking the ac voltage function. Dc ranges are checked by drawing an appropriate amount of current for each range from a small battery through a series resistor. Ohms ranges need only be checked with their test leads shorted to see if the meter can be set to zero, which is *on the right-hand side of the scale*.

If you have wondered why these kits, which include everything but the solder, do not contain this last item, the answer is that this is a legal matter. Providing *almost* everything to build an instrument prevents some kinds of litigation.

There are many makes of kit type vom's, but essentially they are supplied in the three classes we have discussed, and those we

have covered are representative of the products offered. Building kits is a lot of fun, and you will own an instrument on a par with

RESISTOR BOARD WIRING					
✓ Step	Sym.	Description	From	To (Length)	Remarks
1-1	R8	res, 7500 ohm	R6-1(S)	H25-10(C)	Fig. 3
1-2	H27	wire, bare	H25-10(C)	S1-B4(S)	Fig. 3
1-3	R9	res, 40K ohm	H25-10(S)	S1-B3(C)	Fig. 3
1-4	R10	res, 200K ohm	S1-B3(S)	H25-9(C)	Fig. 3
1-5	H27	wire, bare	H25-9(C)	S1-B2(S)	Fig. 3
1-6	R11	res, 1-375K ohm	H25-9(S)	H25-6(C)	Fig. 3
1-7	R11	res, 1-375K ohm	H25-6(S)	S1-B1(S)	Fig. 3
1-8	H26	wire, hook up	S1-BR(S)	7"	Fig. 3, thru H25-12
1-9	R1	res, 11.5 ohm	S1-A1(C)	H25-4(C)	Fig. 3, spag.
1-10	H26	wire, hook up	H25-4(S)	H25-13(C)	Fig. 3
1-11	R2	res, 1138 ohm	H25-13(C)	H25-2(C)	Fig. 3
1-12	H27	wire, bare	H25-13(S)	S1-A10(S)	Fig. 3
1-13	R3	res, 110 ohm	H25-2(C)	S1-A11(S)	Fig. 3
1-14	R5	res, 21.85K ohm	H25-2(S)	H25-14(C)	Fig. 3
1-15	R4	res, 117.7K ohm	H25-14(C)	S1-A12(S)	Fig. 3
1-16	H26	wire, hook up	H25-14(S)	4 1/4"	Fig. 3
1-17	H26	wire, hook up	R7-1*	S1-A1(S)	Fig. 3
1-18	H26	wire, hook up	S1-AR1(S)	S1-AR2(C)	Fig. 3
1-19	H26	wire, hook up	S1-AR2(S)	6"	Fig. 3
1-20	H27	wire, bare	R6-2*	S1-B5(S)	Fig. 3
1-21	H26	wire, hook up	H25-7(C)	6 1/2"	
1-22	R23	res, 100 ohm	H25-7(S)		

Fig. 417. Sample instruction sheet for wiring the kit shown in Fig. 416.

some of the best commercial equipment. It is certainly a lot less trouble, and more economical than designing your own.

commercial vom's

IN contrast to kit type instruments, which generally come in only a few sizes, commercial types appear in a great variety of models, ranges and sensitivities. Some kits are also available in wired

Fig. 501. One of the smallest commercial instruments available. It has a sensitivity of 10,000 ohms per volt on both ac and dc (Simpson Electric Co.)

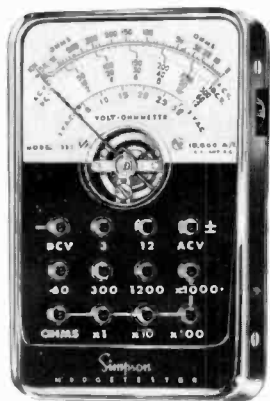

form for a somewhat higher price. A properly wired kit should have at least the same quality as a factory wired unit.

There is no practical way to divide or classify volt-ohm-milliammeters except by size and sensitivity. But some of these instruments are both small and sensitive. For example, the unit shown in Fig. 501 is about the smallest of this type available. The 100-microamp meter gives the instrument 10,000-ohms-per-volt sensitivity on both ac and dc. Making the unit so small has required some sacrifice. This is a pin-jack type of instrument, with some internal function switches operated by the ends of the pin studs.

The studs are partially threaded, making changing ranges somewhat slow. The ranges of the instrument show clearly in the photo, and you can see there is no current measurement feature available. Ohms mid-scales are 120, 1,200, 12,000; the maximum legible resistance measurement is 10 megohms.

Fig. 502 shows the schematic diagram of the entire instrument. Its basic simplicity is obvious. Notice the internal switches,

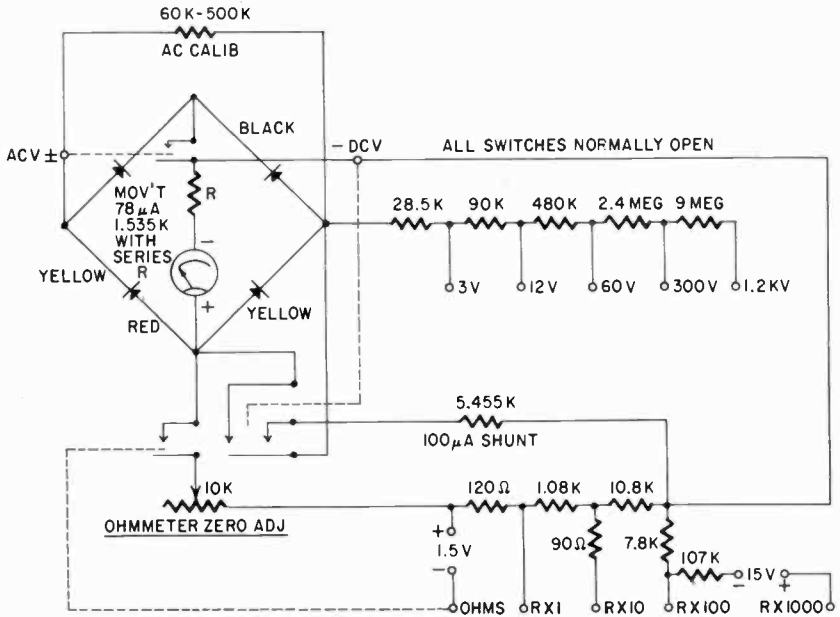

Fig. 502. Circuit diagram of the tester shown in Fig. 501. The internal switches are operated by the test-lead pin jacks. The ohms range is extended to $R \times 1,000$ through the use of a 15-volt battery.

operated by the insertion of test-lead pins. Another somewhat unusual feature is the full-wave bridge rectifier, allowing the same sensitivity on both ac and dc.

Very slightly larger, but with several more ranges is the model shown in Fig. 503. This instrument has, in addition to the voltage and the ohms ranges, four current ranges—0.6, 6, 60 and 600 milliamps. The basic meter is a 50-microamp movement: sensitivity is 20,000 ohms per volt on dc; 5,000 on ac. The ranges are switch-selected, a convenience seldom encountered in instruments this small. Mid-ranges of the ohms scales are 200, 2,000, 20,000 and 200,000. The tester is actually equivalent, in ranges, to most full-size vom's. In Fig. 503, the vom is shown in combination with a

clamp-on ammeter adapter. This adapter is, in essence, a transformer with a core which can be opened, so that it can be clamped



Fig. 503. Volt-ohm-milliammeter with a clamp-on transformer attachment. (Triplet Electrical Instruments Co.)

around a cable or wire, making the cable the primary of the transformer, one single turn only.

Fig. 504 shows the schematic of this clamp-on transformer attachment. Its output is connected to the vom, and this is set to the 3-volt ac range. Current ratings of the model are 6, 12, 30, 60, 120 and 300 amperes. The adapter can be used with any vom which has 5,000-ohms-per-volt sensitivity on ac and a 3-volt scale.

Neither of the units shown in Fig. 501 or Fig. 503 have db scales. But because an output measurement is simply an ac voltage check, using the conversion curves shown in Fig. 505 you can convert the ac voltage reading to db's for any of the three references normally in use—0.6 mw across 500 or 600 ohms and 1 mw across 600 ohms.

The accuracy of this type of instrument is generally about 2% to 3% of full scale for dc measurements and 5% of full scale for ac. This is the accuracy guaranteed by the manufacturer, but in

actually most instruments do better than that. They should, for 5% of full scale means that this is independent of the position of

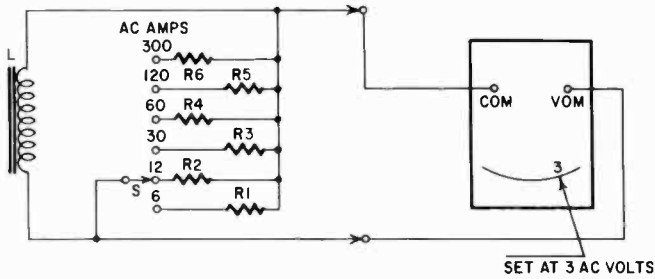

Fig. 504. Schematic of clamp-on transformer attachment of the vom in Fig. 503.

the pointer on the scale. Thus, if you are reading 2 volts on the 2.5-volt ac scale, you may actually have 1.875 or 2.125 volts. But if you read 0.25 volt, the actual voltage may be 0.125 or 0.375, and

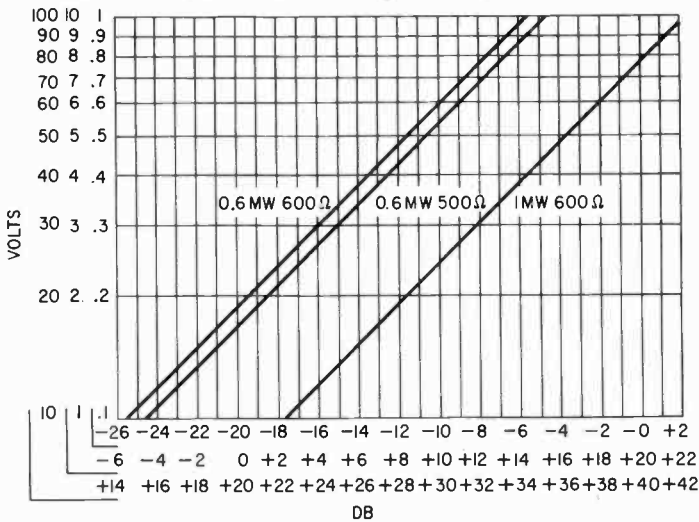

Fig. 505. Conversion curves used for converting the ac voltage reading to db's.

this may make quite a difference. For this reason, it is always recommended to use the range which will give the highest deflection for that voltage.

One way to cut down possible error is to read as long a scale as can be available, and this is one advantage of the larger instruments. The scale of the 4½-inch meters in larger vom's is almost twice as long as in the small pocket instruments.

A typical vom of the larger size is shown in Fig. 506. Similar in ranges, sensitivity and size is the model shown in Fig. 507. These

Fig. 506. Typical vom in the larger-size group. (Simpson Electric Co.)



20,000-ohms-per-volt instruments are the type most often used in radio and TV service; they are general all-around useful tools.

Fig. 507. Vom similar to Fig. 506 in ranges, sensitivity and size. (Triplet Electrical Instrument Co.)



Fig. 508 shows the circuit diagram of the vom illustrated in Fig. 507. This, as you can see, is an instrument of the type we have already discussed extensively. The ac rectifier is the familiar half-wave bridge. A convenient feature is S2, a polarity-reversing switch.

Fig. 508. Circuit diagram of the vom in Fig. 507.

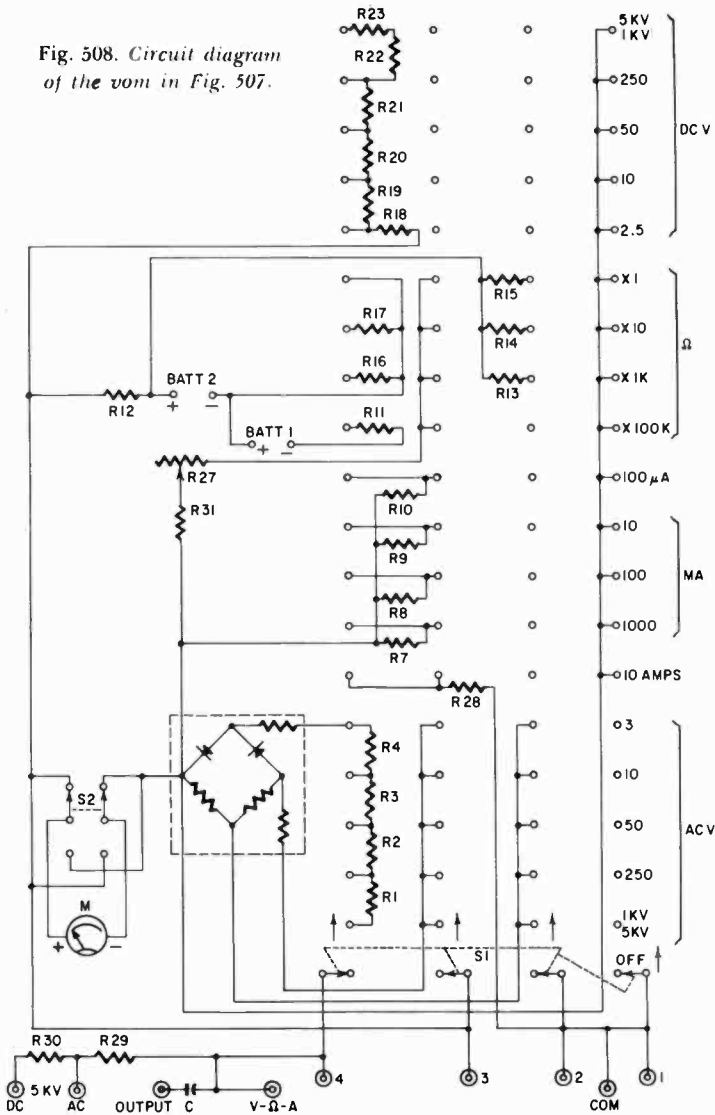

This instrument does not use the Ayrton type shunt on the current ranges, but rather individual shunts for each range.

A somewhat more luxurious and a much more accurate instrument is the one shown in Fig. 509, with its diagram in Fig. 510. This instrument has twice the voltage ranges for ac and dc by virtue of a switch, S2, which allows a change of meter sensitivity. On the "normal" ranges, those shown on the range-selector switch,

switch S2 is in the (V-Ω-A) position (not as shown). Then the meter sensitivity on dc is 10,000 ohms per volt and, on ac 5,000 ohms per volt. With S2 in the position shown, the meter indicates just half the voltage. In other words, the 12-volt scale now becomes a 6-volt scale, the 60-volt scale becomes a 30-volt scale and

Fig. 509. This accurate vom has twice the voltage ranges for ac and dc by using a switch which allows a change of meter sensitivity.



so on. This allows the user always to select a scale on which the voltage will deflect the meter near the top, making for greater accuracy. Having, in effect, twice as many ranges affords twice the opportunity to use a large deflection.

In Fig. 511-a, the "normal" meter circuit is shown in simplified form, and in Fig. 511-b the same range for the $\frac{V \cdot A}{2}$ scale. In the "normal" range, the meter is shunted by resistor R18 to half its deflection and half its sensitivity. R25 is included to allow for the use of the same double system on both ac and dc.

Figs. 511-c and d show the "normal" and "sensitive" positions of the ac voltage range in a simplified schematic. Again you can see that the meter is shunted, this time by R19, while R25 is in series with the meter and R24 in series with the rectifier. This instrument uses a 40-microamp meter; 120 mv, in other words, with an internal resistance of 3,000 ohms. However, the lowest current range (in the $\frac{V \cdot A}{2}$, the sensitive position) is 60 μ a, and the meter is always shunted by a resistor.

Millivolts can be read on this meter simply by using the lowest current-range setting of the selector switch, at which reading the meter shows 120 millivolts full scale with S2 in the "sensitive"

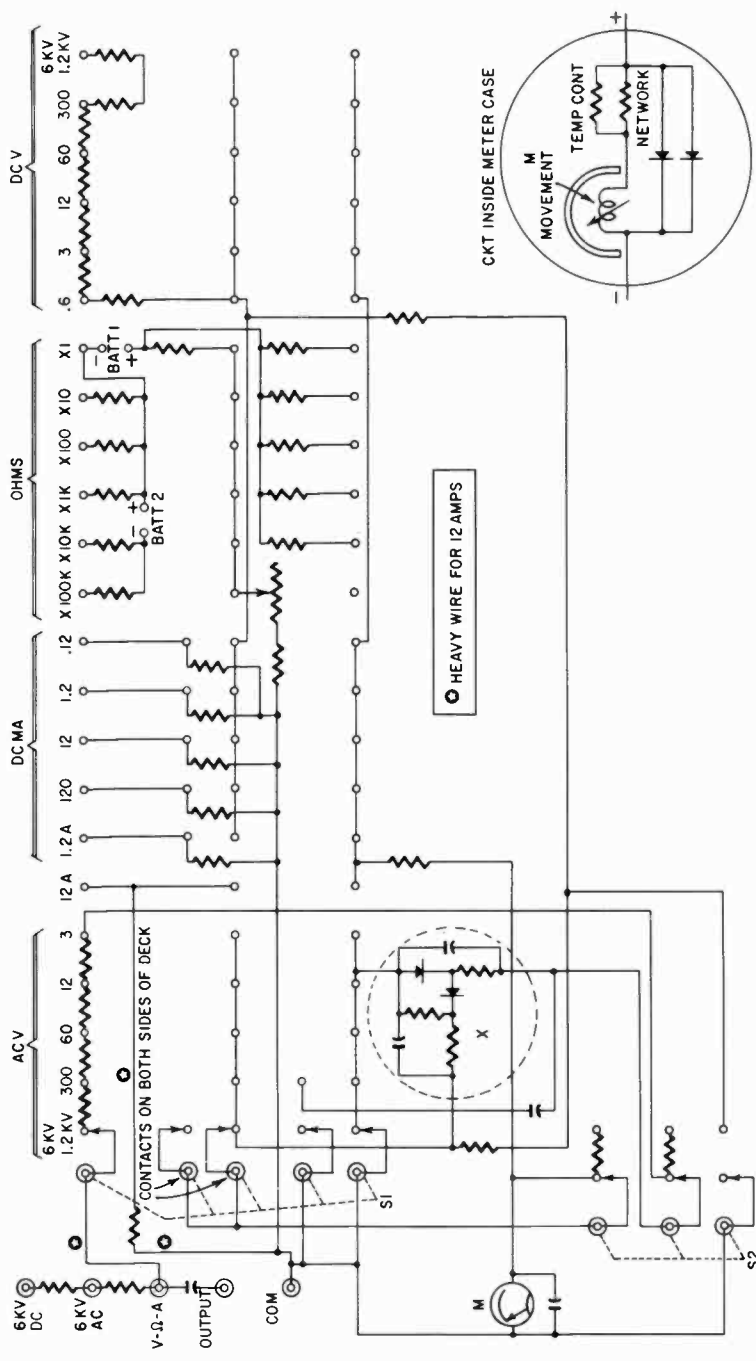

Fig. 510. Circuit diagram of the vom shown in Fig. 509. Switch S2 changes meter sensitivity, providing twice the voltage ranges for ac and dc.

position. In the normal position of S2, with the selector still in the 0.12-ma range, the instrument will read 240 mv full scale.

In the diagram, Fig. 510, an insert shows a circuit inside the meter. This consists of two items. In the first place there is a thermal compensating circuit, consisting of two resistors carefully

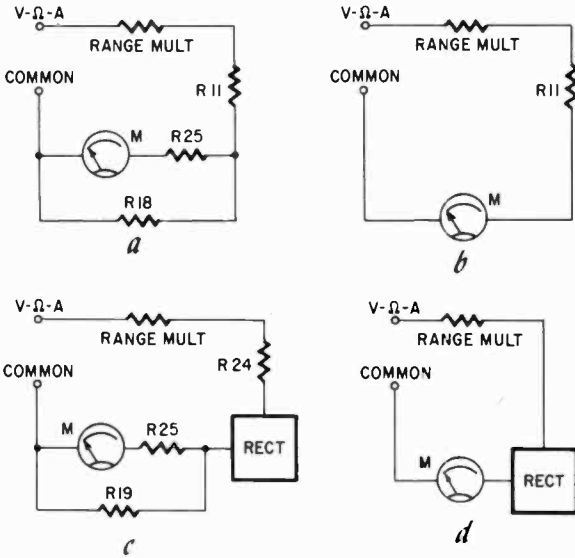

Fig. 511. A simplified diagram (a) of "normal" ranges for dc voltage for the meter shown in Fig. 509. A simplified schematic (shown in b) with switch S2 (refer to Fig. 510) in the $[V \cdot A]/2$ position, removing the meter shunts and giving double the range sensitivity. The ac voltage circuits (c) as they appear in the "normal" position, with meter shunts. The ac voltage ranges as they would be (d) in the "sensitive" position of switch S2.

selected for their temperature characteristics. Now if the shunts of the meter should get warm, and the meter shows a higher current than normal because the shunt resistance rises, this difference is made up by the increase in the resistance of these special resistors, so that the meter indication remains the same. For the voltage ranges, this circuit is of little importance since the resistors in series with the meter are so high that a small change will not materially affect accuracy. But a change in the current shunts, of course, will matter.

The second circuit shown in the meter case consists of two special germanium diodes. These have a high forward as well as back resistance, but have the characteristic that when a high voltage

beyond a certain point is applied, the diode temporarily breaks down and shunts the meter for that moment with a very low resistance. There is one for each polarity, and they are protection for the meter. These meters have been subjected to 1,000 times their normal load without the least damage.



Fig. 512. This 100,000-ohms-per-volt meter features a 10-microampere movement. (Simpson Electric Co.)

Other features making this meter a more useful instrument in the laboratory or shop is the availability of external shunts, allowing it to measure up to 30 amperes of direct current. External shunts can of course be made for *any* meter, but they are not always offered as a standard accessory.

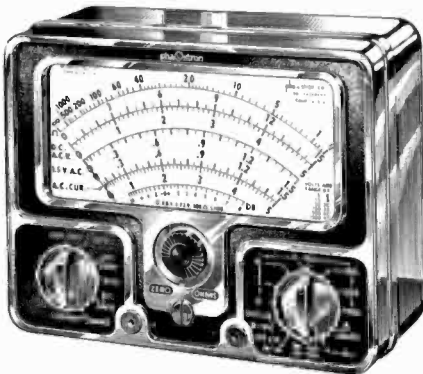

Fig. 513. Less conventional in circuitry, this vom includes current ranges in ac. (Phaostron Instrument and Electronics Co.)

Notice that in many of these meters the extra high voltage range has a separate test-lead jack, and so do the high current ranges. The high current ranges, as mentioned before, are designed this way to avoid heavy currents through the switch contacts, while the high voltage range is so arranged to avoid having to insulate all the

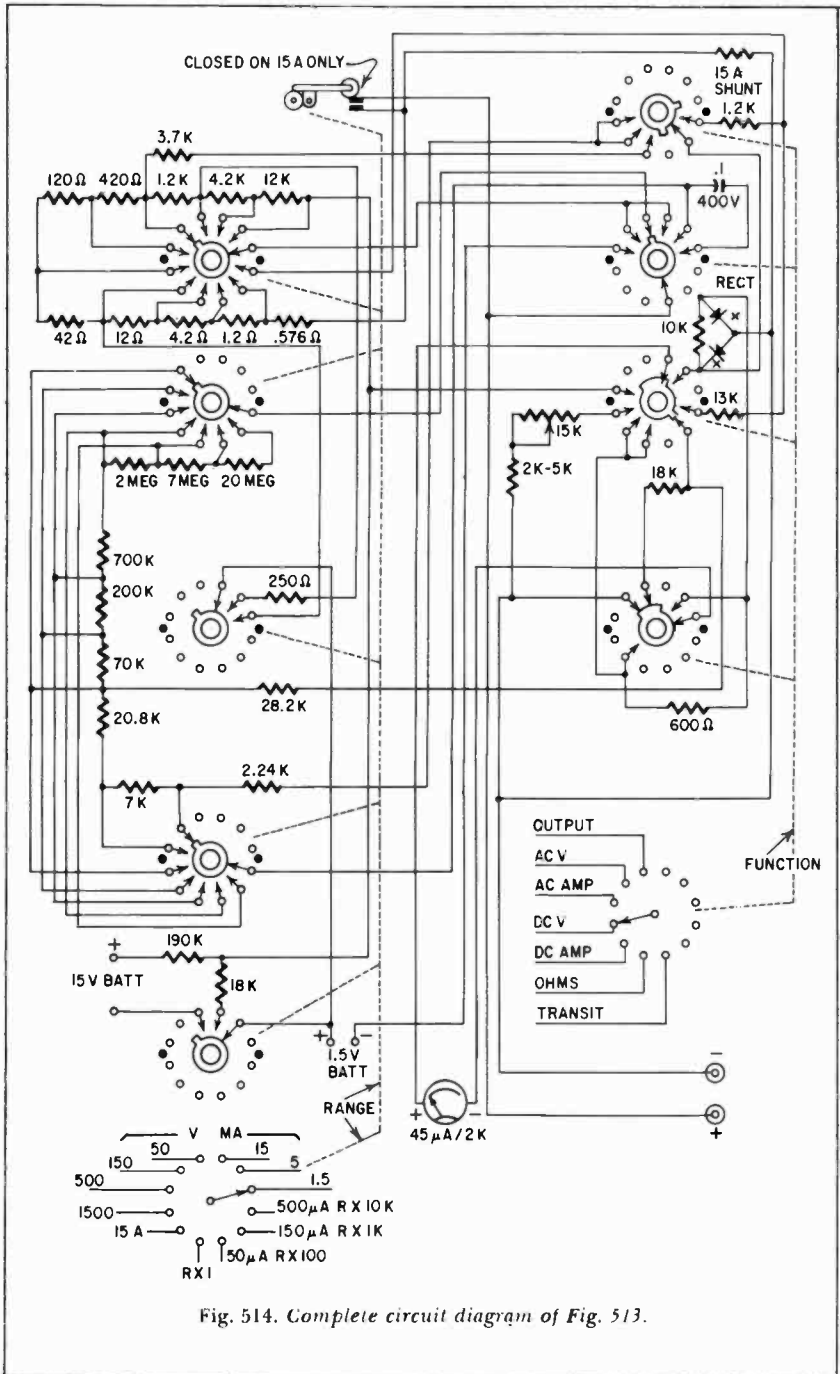

Fig. 514. Complete circuit diagram of Fig. 513.

switch sectors for such a high voltage. With a separate jack and multiplier, only one point need be insulated, the jack itself (and of course the test lead).

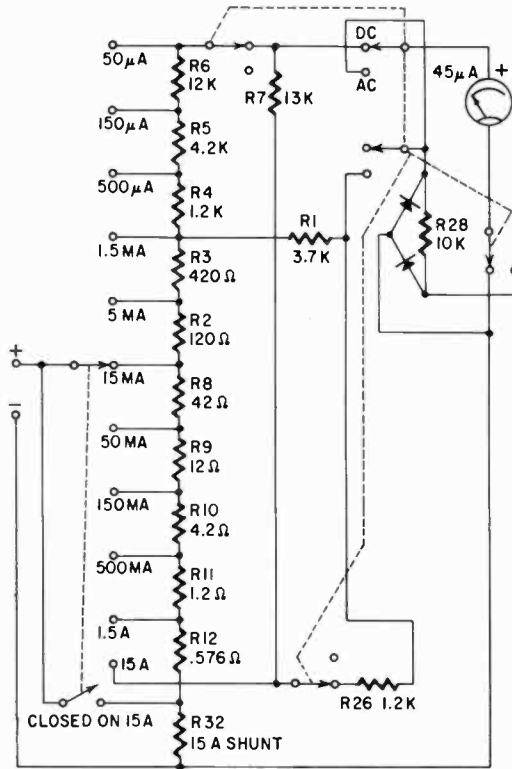

Fig. 515. Current circuit diagram for ac of the vom in Fig. 513.

Sometimes you will also see a separate jack for the lowest current range. This is a simplification with an added advantage. With a separate jack for the lowest current range, in which the meter is virtually unprotected, the operator cannot by mistake put the current through the meter when switching; he has definitely to disconnect the test lead and reconnect it, a procedure which may give him enough pause to think of what he is doing.

Fig. 512 shows one of the 100,000-ohms-per-volt meters presently on the market. It has a sensitive 10-microampere movement, and in addition is a large 7-inch meter with almost 6 inches of scale length. It is a beautifully designed instrument which will compete

in service work with many vacuum-tube voltmeters, but has the advantage that it does not require a power source. For the ohms scales it has the usual dry batteries but, because of its sensitive meter, it is possible to measure resistance up to 200 megohms, with 1.8 megohms center scale. The ranges are clearly marked on the switch-position indicator built into the meter face. In addition, there is a "meter-open" position, which prevents any accidental contact of the test prods from damaging the meter. Apart from the very high values of the multipliers, the circuit for this instrument is conventional.

Less conventional in circuitry is the volt-ohm-milliammeter shown in Fig. 513. This is one of the very few instruments on the

Fig. 516. Typical kit-type multimeter available in wired form. (Electronic Instrument Co.)



market which include current ranges in ac. This is accomplished by measuring the ac voltage developed across shunt resistors. The complete circuit diagram is shown in Fig. 514 and the current circuit for ac in Fig. 515. Notice in Fig. 514 that the instrument seems to have very few resistors by comparison with other comparable vom's. This results from careful design, which allows the use of the same resistor values on the alternating current ranges and the resistance-measuring ranges, for example, and the same multipliers for ac and dc voltages. The rectifier is a full-wave circuit. Sensitivity is 20,000 ohms per volt on dc and 5,000 on ac. The meter is a 45- μ a unit, appropriately shunted. The lowest current range is 50 μ a.

Selecting an instrument

What has been described in this chapter so far is just a sampling of instruments on the market. It is obviously impossible to show even a good complete cross-section of all of those available. Besides the many excellent domestic volt-ohm-milliammeters, many good instruments at competitive prices are being imported. Whatever instrument you purchase, though, uses all the principles we have discussed, and on the basis of what you now have in the way of information about meters it should be easier to select the proper one for your work.

One type not shown in the lineup, for example, is the less-sensitive commercial instrument equivalent to the kit type meters we discussed. Some kit type meters are also offered in wired form by the manufacturer. A typical example is shown in Fig. 516. This instrument also has current ranges for ac and uses a 400- μ a meter. Sensitivity is 1,000 ohms per volt (shunted meter) on both ac and dc, and the instrument has a special low ohms scale with 55 ohms center scale.

Which meter you select for your job will depend entirely on your budget and the demand of the job. If your vom is going to be your constant tool, used on every job, you will want a meter which can do all you need it to do. An inadequate instrument would, in the long run, cost you money by forcing you to make inaccurate measurements and guesses, and by generally slowing your work. The additional investment in a better meter is often justified. On the other hand, if your major activity involves appliances, an occasional use of the meter, or simple continuity checks etc., there is no point in investing a great deal of money in a sensitive instrument. An intelligent choice is up to you.

Operation of the vom

Every kit type instrument and commercial vom will come equipped with complete operating instructions. Most of them also include the instrument schematic, and some of them even break down the circuit to show each function in detail. Practically all show how to use the instrument for the measurements indicated on the scales, and many of them also show how to measure other items, such as the capacitance of a limited range of capacitors, etc. This particular subject we will discuss in subsequent chapters.

extending ranges and making accessories

NO vom can be economically made which can measure *everything*, and both manufacturer and user must, at some point, determine its limitations. This does not mean that forever thereafter it is limited to certain ranges, nor that it would have to be remodeled drastically. Many of the means for instrument modification (such as extending ranges) can be used externally. Some of these are offered commercially, but all of them can, with some care, be home-made.

Measuring higher voltages

One of the most common tests beyond the vom's normal range is the measurement of high voltages, found in scopes, transmitters and special electronic equipment. To provide the necessary higher value of multiplier resistor, and to make it a convenient accessory to use, this resistor can be built into a probe especially designed to protect the user from high voltages. Commercially these probes are offered so that the range of the vom can be extended to as much as 60 kilovolts.

It isn't practical to try to cover all ranges adequately with a single probe; remember that the recommended method of reading the vom is to get as much deflection as possible. For this reason as many as three probes for higher dc voltages and two for ac are needed. These can come in ranges of 10, 25 and 50 kv for dc; 10 and 25 kc for ac high-voltage measurements. (Some vom's are designed to measure as much as 6,000 volts dc without the need for an external probe.)

The high voltage probe for dc

What does such a probe consist of? It is nothing more than a precision resistor of very high value, matched to the input resistance of the instrument. On any range the measurement must be made to deliver an exact multiplication of the scale values. Consider, for example, dc volts on a 20,000-ohms-per-volt meter. The total resistance in the circuit on the 2.5-volt range would be 50,000 ohms. To read, say, 10 kv using a resistor which does not go out of sight in resistance value, you would want a total of 200 megohms. For this a 200-megohm resistor would be accurate enough, the meter and multiplier resistance of the instrument being very insignificant. The resistor, for convenience and safety, is enclosed in a plastic case which, for these voltages, usually has either ribs on the end to prevent flashover of the high voltage to the operator's fingers or an extended handle to make it safer to use. Fig. 601 shows a typical high-voltage probe.

Since most high-voltage supplies such as those in TV sets can deliver current in microamperes only, or at the most a milliamperere or so, it would not be profitable to try to make high-voltage probes for anything but sensitive instruments, preferably at least 20,000 ohms-per-volt. Anything less than that might load the source sufficiently to lower the voltage and give a false reading.

It is feasible to make the resistor, such as the 200-megohm probe just described, from 10 20-megohm units, but remember that the resistors, if they are from the same batch, can very well have the same error, and this error will be multiplied by 10 also. Make certain that your resistors are accurate originally, or measure them as accurately as possible, so that you can either add or eliminate some resistance to obtain accuracy.

The high-voltage probe for ac

High-voltage probes for ac are made in the same way, provided you can assume that the frequency at which they are to be used is one at which the rated ohms-per-volt of the instrument is valid. At higher frequencies, you may have to know the impedance of the instrument on the range you wish to use. (The method for determining this will be described later.) Certainly, through the audio range you can expect that your vom will maintain its accuracy and, for some commercial instruments, well beyond this.

Make certain that the insulation around the probe is sufficient to withstand the high voltage. For 10 kv at least 2 inches of clean phenolic or Plexiglas-type plastic should separate the high

voltage from your hand, with proportionately greater distances for higher voltages.

The ranges of vom's are almost always sufficient to cover everything but very high voltages. However, if an intermediate point is needed, the process of obtaining it is the same, except that not so much high-voltage insulation is required.

Measuring lower voltages

Since the vom is a current meter in the first place, converted for measuring voltages by adding series resistors, there is no reason why the process cannot be extended to include lower voltages by using the lowest current range of the instrument together with an external multiplier resistance. For example, in a 20,000-ohms-per-volt meter the basic movement is a 50- μ a unit. If the internal

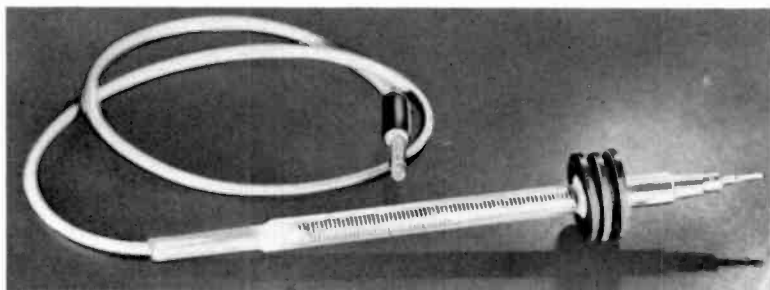

Fig. 601. Home-made high-voltage probe. The purpose of the ribs is to help protect the user against high-voltage arc-over. The resistor (or resistors) in the probe act as an external series multiplier. For use with a probe of this sort, the vom should have a minimum sensitivity of 20,000 ohms per volt.

resistance of this meter is 2,000 ohms, voltages as low as 100 millivolts can be measured by using the meter directly. Proportionately higher voltages would then require small series resistors. Thus the same meter would have a full-scale range of 250 millivolts with a series resistor of 3,000 ohms (5,000 ohms minus the meter resistance). With such low series resistors, the meter resistance must be taken into account. If the meter circuit resistance is not known, you can determine it by the same method described in detail in Chapter 2.

Adding current ranges

Naturally, there is no way to make the instrument read a lower current than the basic meter rating, unless we amplify the current. One method was described in Chapter 3 and will also be shown in a later chapter. The meter ranges can be extended tremen-

dously by making external shunts for the vom. All that is needed is a resistor of the proper value, some short leads to attach it to the meter, and two jacks to plug in the test leads of the instrument. Fig. 602 shows a home-made external shunt. It can be mounted in a small utility box to give it a neat appearance, and marked with the current range for which it is designed. To

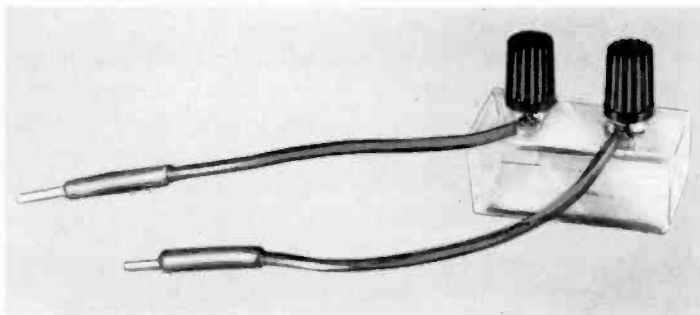

Fig. 602. Home-made external meter shunt for the vom. It consists of a plastic box with a resistor inside, two binding posts and short leads to the meter. The leads form part of the shunt resistance and must be calculated as such. This has an advantage in that you can adjust the shunt to its proper value by trimming the length of the leads.

determine the shunt value, treat the entire meter circuit (whatever it may contain internally) as the basic meter, and determine the proper shunt value by the half- or part-deflection method as explained for the basic meter in Chapter 2.

External shunts are made by some manufacturers of commercial vom's. One instrument has a shunt which will extend its current-measuring capability up to 100 amperes dc.

The clamp-on ammeter described previously can be used to provide current ranges down to 6 amperes ac. To make your own clamp-on ammeter is a difficult and exacting job, and is not recommended. Fortunately, there are simpler ways to provide your own current ranges for ac.

A current will develop a voltage across a pure resistance which is exactly proportional to the current and the resistance. There is really no such thing as a pure resistance, since even a straight wire has some inductance, but for practical purposes we can regard most resistors as pure enough over a wide frequency range. To measure alternating currents, then, we need precise resistors capable of carrying (without undue heating) the currents we need to measure. The wattage rating of the resistor should be many times the power to be dissipated in it, unless we make a low

temperature coefficient resistor of Manganin wire. A 100-ohm resistor, with 10-ma, rms alternating current through it will develop 1 volt rms. Thus, on a 3-volt scale, we could read from 0 to 30 ma ac.

However, this method has a practical limit. Were we to try to measure the current through a 6.3-volt pilot bulb in this way we would find that the bulb would light only dimly (if at all) on a 6.3-volt supply. To measure bulb current, the bulb must get normal voltage. This we can do by using a higher supply voltage and adding series resistance until the voltage across the bulb measures 6.3, then changing our test leads to the standard and measuring the voltage across it, and from that we can calculate the current normally required by the bulb. The method is illustrated in Fig. 603. The lower the lowest available ac voltage

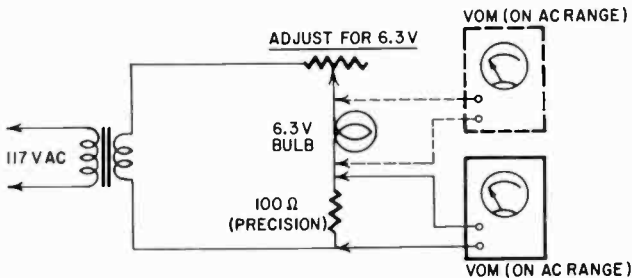

Fig. 603. Measuring alternating current using the ac voltage ranges of the vom. The bulb and the fixed precision resistor are in series. The transformer is a step-down type but must be able to supply enough voltage to take care of all the IR drops. Most vom's do not have a provision for reading alternating current directly.

range on our meter, the better it will be for measuring alternating currents by this method, provided we maintain accuracy.

In most commercial meters, the ac section is not accessible to the outside of the instrument, so to circumvent the lowest ac multiplier you would have to dig into the instrument and provide a separate connection. This cannot be recommended, particularly on an expensive commercial meter.

Measuring higher resistances

The usefulness of almost any vom can be increased with a simple, easily built range extender.

At the beginning of Chapter 3 we described the operation of two basic circuits — series and shunt. In the series version the

battery, meter and some resistance are connected in series between the test leads. The circuit is open until an unknown resistor is connected across the leads. This completes the series circuit, the current flow depending upon the battery voltage and circuit resistance. The meter reads full scale with the leads shorted. (The zero adjustment is made to an exact full-scale reading.)

The meter will read half-scale when the test probes are connected to an external resistance equal to the internal resistance of the ohmmeter. *This half-scale reading is the true criterion of the sensitivity of the instrument.* Any ohmmeter, regardless of sensitivity, reads from zero to infinity. But, when the internal resistance is equal to the external resistance, the current will be half the full-scale value and will show the reading at which the scale is most spread out and therefore most useful.

This method is accurate for practically all purposes for which a meter would be required in radio-TV service work. But it is worth noting that a slight error is introduced, because the resistance of a meter with a shunt connected across it is lower than that of a meter alone. This error is usually less than 1%.

The other circuit, the shunt version, shows exactly the same action in reverse. In it the circuit is closed all the time, and full-scale current flows through the meter except when an unknown resistance is connected across the test leads. Lower values of unknown resistance shunt more of the current, the meter reading zero when the leads are shorted. In this circuit also, we get a half-scale reading when the external resistance is equal to the internal.

In the series circuit (refer to Fig. 301 on page 41 of Chapter 3) the internal resistance is equal to the total resistance of the battery, meter and variable resistor. In the shunt circuit (see Fig. 302 on page 42 of Chapter 3) it is the value we see looking in through the test leads and is equal to the parallel combination of the meter resistance and the series combination of battery and rheostat resistance.

To increase the sensitivity of the series circuit add more battery voltage and more internal resistance so that you still get a full-scale reading when the leads are shorted. You can make up this battery and resistance in a separate package, convenient to handle and use.

Although it is less obvious, the same thing is true of the shunt circuit. In both cases the improvement will be proportional to the increase in voltage and resistance.

The first step is to examine the ohmmeter. Determine which circuit it uses, the battery voltage on the highest scale and the half-scale ohms reading. This is the point where the meter movement shows half-deflection. For a 10-times increase in sensitivity, 9 parts more each of voltage and resistance must be added in the same proportions. For an increase of 100 times, 99 parts more of each.

Building the extender

The simplest sort of range extender is shown in Fig. 604. It is intended for use with an ohmmeter using a 4.5-volt battery and

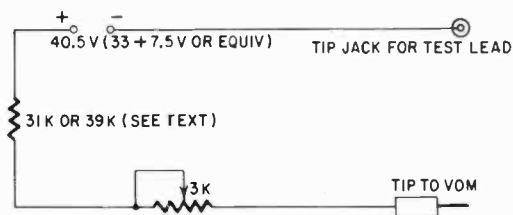

Fig. 604. Range extender for use with an ohmmeter using a 4.5-volt battery and a shunted 1-ma meter, and having a mid-scale sensitivity of 3,600 ohms.

shunted 1-ma meter, and having a mid-scale sensitivity of 3,600 ohms. The addition of a 3,000-ohm resistor and 40.5-volt battery (in series-aiding) provides a 10-times increase in sensitivity, to a mid-scale reading of 36,000 ohms. The total voltage and the total resistance of the circuit are now each 10 times as high. For the probably more common series type ohmmeter the resistance should be 39,000 ohms, and the constants will have to be varied for instruments using other meters, battery voltages, etc. For example, the resistance values would be doubled with the same voltage if the meter were a 500- μ a type, and an ohmmeter with a 1.5-volt battery would be multiplied 10 times by adding an external voltage source of 13.5. With a 1-ma meter, this would mean about 12,000 ohms fixed resistance and a 3,000-ohm potentiometer in series. Multipliers for ohmmeters with unknown internal circuits can be found by experiment, being careful not to use too much battery or too little resistance at the start. A little time spent changing resistors may save an expensive meter.

There are several ways to make a vom read resistances above its highest range, and they are very simple ways. One of them is illustrated in Fig. 605, a simplified diagram of an ohmmeter circuit.

Suppose that the battery in this circuit is 6 volts, and that the meter on its highest range reads 180,000 ohms mid-scale. This means that the meter circuit contains 180,000 ohms. If you add an external battery and an external resistance of 180,000 ohms, you can still zero set the meter but then you have exactly doubled

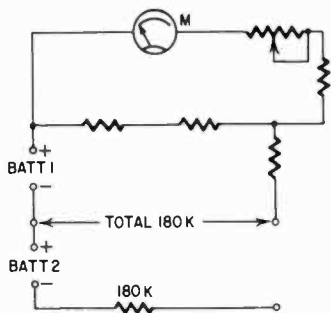

Fig. 605. Method for reading high values of resistance. The vom is set on its lowest current range and is connected to a high-voltage dc source. To protect the meter, set it on a high-current range and work the range switch back until you begin to get a deflection on the meter. A safer method would be to increase the amount of high voltage gradually.

its range. And for greater multiplication you can use higher battery voltages and greater resistors on the outside.

For very high resistances, this method becomes somewhat impractical. In such a case, simply follow the scheme shown in Fig. 606. If the meter has 50 μ a as its lowest range you can com-

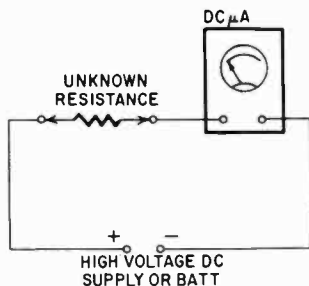

Fig. 606. Method for reading very high resistances. With a battery or dc supply of 500 volts, you can accurately read 50 megohms.

fortably and fairly accurately read a current of 10 μ a. This means that with a battery of 500 volts, or a dc supply of that amount you can accurately read a resistance of 50 megohms. Or, if you want to squeeze a bit, reading 5 microamperes, a resistance of 100 megohms. If that is not enough, you have to use a higher voltage supply, but handle the test leads carefully. Only for devices such as ionization chambers and electrometers and to design high-

volts. The resistors are in proportion, which produces the proper ratio of 1.5 volts to 10 megohms. No zero adjuster is used on the highest scale; instead, series resistors are selected so that the short circuit reading will be approximately correct. In fact, the rheostat may be omitted from any of the circuits shown if they are adjusted carefully and if the original ohmmeter has a good range of zero adjustment.

Above 100 megohms we rarely deal with the resistance of conductors. We usually measure the resistance of insulators that have significant voltage and temperature coefficients. Surface moisture also enters, particularly as dirty surfaces often carry perspiration salts from handling as well as other substances which draw moisture from the air. Consequently, insulation resistance measurements cannot be compared, repeated or even specified except in terms of test voltage, ambient temperature and atmospheric humidity. And even then, a repeatability within 5% or 10% is good.

In building the unit of Fig. 608, the tip jacks must be well insulated by locating them in a panel of good insulating material like polystyrene, with an inch or two of creepage path to metal. A range switch must be specially designed; ordinary switches have too little clearance and may even have cracks between laminations to hold films of moisture or dirt. Special resistors are required. A variable zero adjustment is not too easy to make, but the zero can be brought slightly on-scale by adding series 10- or 22-megohm resistors at the supply end where they are easier to insulate. Insulators and resistors should be handled with clean gloves and care to avoid fingerprints and scratches.

Measuring lower resistance

There is nothing you can do to the built-in ohmmeter circuit to change it for reading a lower resistance range, but you can again use the current ranges of the meter. For example, if your meter has a current range of 10 amperes full scale, send a 10-ampere current through it. Maybe this is not exactly 10; maybe it is only $8\frac{1}{2}$ amperes. Next, take a known resistor (which you can measure on your ohms ranges) and put it in series with the meter and the reading is now, say, 5 amperes. The ratio of R_m (meter resistance) and $R_m + R$ is $5 \div 8.5$. If this resistor is 20 ohms, we could then calculate the meter resistance as:

$$\frac{R_m}{R_m + 20} = \frac{5}{8.5}$$

or: $8.5 R_m = 5 R_m + 100$
and

$$R_m = \frac{100}{3.5} = 28.6 \text{ ohms}$$

This would then be the meter resistance in the circuit. This is an unrealistic figure (it will always be less on the 10-ampere range, more likely something like 0.02 ohms) but the example would be more difficult to follow with such figures.

Suppose you do find an internal resistance on the 10-ampere range of 0.02 ohm? Send 5 amperes through the meter, and then parallel the meter with a low unknown resistor, so that the reading drops to 3 amperes. What is the unknown resistor value? The meter current is now $3/5$ of the original current, so the resistor must be passing $2/5$. The ratio of the meter resistance and the unknown is $2/3$ and the unknown is $3/2 \times .02 = .03$ ohm; that is, *if your voltage remained exactly the same.*

If you use an auto battery or a heavy-duty low-voltage supply for your source, you can have reasonable confidence that the voltage, and thus also the current, did not change. But suppose the total current did become less due to a sagging supply. Say it was only 4 amperes. Then the resistance would actually be $3/1 \times .02 = .06$ ohm, twice as much as you would be figuring! Obviously, this must be avoided. The supply must be capable of delivering this current with no change in voltage.

With a dependable current source, however, the vom high current ranges can be used to read very low resistances indeed, without special gimmicks or scales. All that is needed is to take advantage of the vom's many possibilities. In a case such as this, the current will have to be supplied (in most cases) through a heavy resistor. Make sure the resistor can carry the current and does not heat unduly, or this again would introduce error. With an auto battery supplying 6 volts, you would need about 1.2 ohms to get a 5-ampere current. The resistor would have to dissipate $5 \times 5 \times 1.2 = 30$ watts (I^2R). If you have a resistor of 25 watts which is wound from a wire with a good temperature coefficient, it will probably do if you read quickly. Remember, you may find a heater or flatiron element which can supply the necessary wire for this, or you can use a length of fairly heavy

coiled wire. In the example using an auto battery and the 10-ampere range on the meter, you actually are making a slight error. In the first case, you have .02 ohm in the circuit in series with 1.2 ohms and, in the second case, the two parallel resistors, which works out to .012 ohm. Your total current in the second

Table 6-1. Using ampere scales for measuring low resistance

for meters having
20,000 ohms per
volt (50 μ a),
2,000 ohms internal
resistance

meter reading	(resistance) 10-ampere scale	(resistance) 1-ampere scale	(resistance) 500-ma scale
10	∞	∞	∞
9.75	.39	3.9	7.8
9.5	.19	1.9	3.8
9	.090	.9	1.8
8	.040	.4	.8
7	.0233	.233	.466
6	.0150	.150	.30
5	.01	.1	.2
4	.00666	.0666	.1332
3	.00428	.0428	.0856
2	.00250	.0250	.05
1	.00111	.01111	.02222
0	0	0	0

for meters having
1,000 ohms per volt
(1 ma), 46 ohms
internal resistance

meter reading	(resistance) 10-ampere scale	(resistance) 1-ampere scale
10	∞	∞
9.75	.1794	1.794
9.5	.0874	.874
9	.0414	.414
8	.0184	.184
7	.01071	.1071
6	.0069	.069
5	.0046	.046
4	.00306	.0306
3	.00197	.0197
2	.00115	.0115
1	.00051	.0051
0	0	0

Note: any test leads used are included in resistance measured.

case is a little more, but the difference is less than 1%, so perhaps this is close enough. If not, you can adjust the ratio to take account of this small difference, but the odds are that you are not reading your meter carefully enough for such close figuring. The higher your voltage and series resistor, when you are reading such high currents and low resistances, the less the error due to the actual resistance change in the circuit when you parallel the unknown with the meter. If, in this case, you had used a 12-volt battery and a 2.4-ohm resistance, the difference would have been less than $\frac{1}{2}\%$. Surely you can ignore that.

Here then is a way to measure, with a standard vom, very low resistances. Table 6-1 shows how the values work out for a typical meter if you start with full deflection and reduce it to half with a parallel unknown resistor. Other values would, of course, be proportional.

If you choose this way of measuring very low resistances, you must also be conscious of the dissipation the unknown resistor must have, but it generally is not very high. In our example, it was $2 \times 2 \times .03 = .12$ watt, and that can be dissipated by a very small resistor indeed.

There are other ways of measuring low resistance, but unless you are willing to set up a special bridge-type circuit, this technique, using only the vom, a good current supply and a heavy duty resistor, is about the simplest and most convenient.

Measuring capacitance

It might come as a surprise, unless you have a commercial vom with detailed instructions on the subject, that you can use your vom for measuring capacitance. Although not as simple as measuring voltages, for you must convert an ac voltage reading into capacitance, the process is not difficult. The reason it can be done is that a capacitor has a definite resistance at a definite frequency.

It takes some energy to charge and discharge a capacitor with an alternating current applied to it. Some energy has to be *dissipated* in the capacitor. The reactance varies with the frequency; it is low at high frequencies and high at low frequencies. This may sound backward, until you think of the fact that the energy at low frequencies is dissipated over a longer time each half cycle, and thus there is more opportunity for it to dissipate.

The reactance of the capacitor, or capacitive reactance as it is called, relates to the frequency as follows:

$$X_c = \frac{1}{2\pi fc}$$

in which c is the capacitance, f the frequency and π the well known 3.14 which we use in calculating dimensions of a circle. It is fairly easy to measure capacitance, since we can measure the reactance by determining the voltage developed across it at any one frequency.

The method is illustrated in Fig. 609. The alternating current

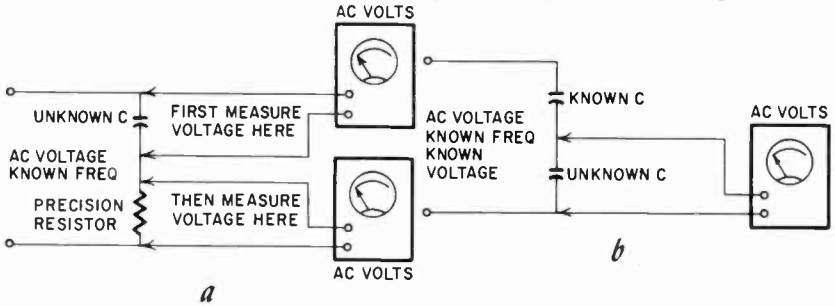

Fig. 609. The vom can be used to measure capacitance. The reactance of the capacitor is determined first. When this is known, the capacitance can be found from the standard formula for capacitive reactance or from Table 6-2. In the first circuit (a), the voltage across the capacitor is compared with that across a known value of precision resistor. In the other circuit (b), a capacitor whose value is known is used as the comparison standard.

is passed through the capacitor and an accurately known resistor, and the voltages across the resistor and the capacitor are compared. These voltages are not in phase, but this does not matter, since you are measuring the voltages one at a time, and only the voltage developed across one element. But don't simply measure one and subtract it from the supply voltage, for then the phase will make a difference.

From the voltage, you can work out the capacitive reactance in ohms, and from this calculate the capacitance with the formula. You have, of course, a stable frequency available—the 60-cycle power line. This is generally held accurate to within $\frac{1}{4}$ cycle by the utility company, and this is close enough for these measurements. Table 6-2 shows the capacitive reactance for a number of popular-size capacitors at various frequencies.

There are several other ways of working out the capacitive reactance in ohms. If your meter has a current range for ac, simply measure the current through the capacitor from a known voltage source, and thus obtain the capacitive reactance. In effect, you

are doing what we have just described, but now the standard resistance is built into the meter. In fact, many manufacturers of such meters calibrate a scale for capacitance (at 60 cycles) directly on the meter scale.

Another way to measure capacitance is to replace the resistor with a known capacitor, as shown in Fig. 609-b. Then you will not have to change the meter test leads, for now you know that the two voltages are in *phase*, and you can get the capacitance more directly if you know the supply voltage. Just subtract the measured voltage from it, and the remainder is across the known capacitor. Then the ratios of the capacitors is the inverse of the voltage ratios. Remember that in the formula for capacitive reactance the letter *c* appeared in the denominator, meaning that the impedance (and thus also the voltage developed across

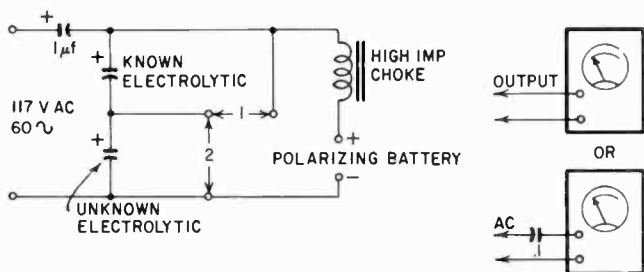

Fig. 610. Method for measuring the capacitance of electrolytics. It may be necessary to put a blocking capacitor in series with the *vom*.

it) will be *smaller* when the capacitor is *larger*, hence the *inverse* ratio. When you use this method, say across the power line, be sure to start with the 250-volt ac range on your meter. In case the unknown capacitor is shorted, this would then prevent damage to the meter.

A word of caution. Do not attempt to use this method for measuring electrolytic capacitors. They would be damaged by the applied ac, or you might damage your meter.

To measure electrolytics we can use essentially the same principle, but we must use a little more complicated setup, (Fig. 610) invented by Morecroft. The two capacitors, one known and one unknown, are both electrolytics, of approximately similar values. The measurement becomes difficult to make accurately if the units have a capacitance ratio of more than 4 to 1.

Table 6-2. Capacitive reactance at different frequencies

Audio frequencies							
capacitance (microfarads)	REACTANCE IN OHMS						
	30 cps	60 cps	100 cps	400 cps	1000 cps	5000 cps	
.00005	—	—	—	—	—	—	637,000
.0001	—	—	—	—	1,590,000	318,000	
.00025	—	—	—	1,590,000	637,000	127,000	
.0005	—	—	3,180,000	796,000	318,000	63,700	
.001	—	2,650,000	1,590,000	398,000	159,000	31,800	
.005	1,060,000	530,834	318,000	79,600	31,800	6,370	
.01	531,000	265,000	159,000	39,800	15,900	3,180	
.02	263,000	132,500	79,600	19,900	7,960	1,590	
.05	106,000	53,083	31,800	7,960	3,180	637	
.1	53,100	26,500	15,900	3,980	1,590	318	
.25	21,200	10,584	6,370	1,590	637	127	
.5	10,600	5,308	3,180	796	318	63.7	
1	5,310	2,650	1,590	389	159	31.8	
2	2,650	1,325	796	199	79.6	15.9	
4	1,310	663	398	99.5	39.8	7.96	
8	663	332	199	49.7	19.9	3.98	
16	332	166	99.5	24.9	9.95	1.99	
20	262	133	80	20	8	1.6	
25	212	106	63.7	15.9	6.37	1.27	
35	152	86	45.5	11.4	4.55	.910	
40	131	66	39.8	9.9	3.9	.8	

Radio frequencies							
capacitance (microfarads)	REACTANCE IN OHMS						
	175 kc	465 kc	550 kc	1000 kc	1500 kc	2000 kc	
.00005	18,200	6,850	5,800	3,180	2,120	1,590	
.0001	9,100	3,420	2,900	1,590	1,060	795	
.00025	3,640	1,370	1,160	637	424	319	
.0005	1,820	685	579	318	212	159	
.001	910	342	290	159	106	80	
.005	182	68.5	57.9	31.8	21.2	15.9	
.01	91.0	34.2	28.9	15.9	10.6	8.0	
.02	45.5	17.1	14.5	7.96	5.31	3.95	
.05	18.2	6.85	4.79	3.18	2.12	1.59	
.1	9.10	3.42	2.89	1.59	1.06	.80	
.25	3.64	1.37	1.16	.637	.424	.319	
.5	1.82	.685	.579	.318	.212	.159	
1	.910	.342	.289	.159	.106	.080	
2	.455	.171	.145	.0796	.0531	.0398	
4	.227	.0856	.0723	.0398	.0265	.0199	

The values of capacitance and reactance shown above are common, but not all-inclusive. Values of reactance not listed can be found through simple proportion. For example: a capacitor of 50 μf would have one-half the reactance of the 25 μf capacitor listed.

A 100- μf capacitor would have one-fourth the reactance of the 25- μf unit. This holds for all frequencies.

In series with the capacitors are two items. In one leg, connected to the ac we see a paper capacitor, of 1 or 2 μf . In the other leg, there is a high-impedance inductor and a battery. The battery is necessary to polarize the electrolytic capacitors, since these do not act the same when they are not polarized. Polarizing takes only a few milliamperes' current, so the battery does not have to be large. But it should have at least about 6 volts, preferably more. The inductance is included, because the internal resistance of a battery is not great, and thus the battery would shunt across the capacitors and ruin the measurement. The inductance must be a high value. You can use the primary of an output transformer. This will have an impedance of about 2,500 to 10,000 ohms but will not significantly affect the capacitance measurement.

Now you can see why we need the paper capacitor. It avoids ruining the battery with an applied ac capable of delivering a large current and avoids pumping dc into the ac source.

With this setup, you can now measure the ac voltages developed across the capacitors. You must, because of the charging current from the battery, have the proper polarity on the electrolytic capacitors. They are marked with a + and a - or "pos" and

Fig. 611. *Technique for checking the leakage current of an electrolytic capacitor.*

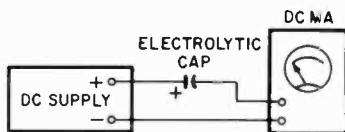

"neg" on the can or paper sheath. When you measure the ac voltage developed across the two capacitors, unless your meter has a capacitor in series with the ac ranges, it will probably deflect from the *battery only*. In that case, you must use either the OUTPUT ranges or connect another capacitor in series with the meter.

When you have done all this, the capacitance of the unknown electrolytic can be determined from an inverse relationship. In other words, the ratio of the known capacitor is the inverse of the ratio of the voltages developed across the two. Thus, if you apply 117 volts to the ac terminals (and use a 1- μf unit for the series capacitor) and if you have one capacitor which develops, say, 2 volts ac across its terminals and you know it to be 50 μf , then if the other capacitor develops 4 volts ac you know it is

only $\frac{1}{2}$ of 50, or 25 μf . The accuracy of this method depends partially on how well you know the *known* capacitor value, for this is now your standard.

One way to get around this is to use several capacitors all marked with the same value. Check each one against the unknown and then average the readings.

There are ways, of course, to calibrate an electrolytic capacitor for a standard. Although they are not very complicated, the measurement of electrolytic capacitors is not so important that we need bother with it. The way in which electrolytics are used does not call for a critical value.

The Morecroft method can be used with a calibrated setup as well, *without* a known capacitor, and this is the way it is used in production testing of electrolytic capacitors. But unless you intend to check hundreds of electrolytic capacitors each week, there would be no point in going to all this trouble. In production work, an ac milliammeter is used to measure the current through the single capacitor directly, and an ac voltmeter to measure the ac voltage across it. From these two values the impedance and hence the capacitance can be determined. The ac milliammeter will then be calibrated in-capacitance directly. This is getting out of the area of vom's and we will leave it at that. But at least you know where the method of checking electrolytic capacitors originated.

One more item about electrolytic capacitors: check the leakage current. This is done with the normal working voltage applied to the capacitor and a dc meter in series (Fig. 611). A good electrolytic capacitor will show 0.3 to 0.9 milliamperes of leakage current¹ per μf per volt. Some poorer ones, but still usable, show up to 1.5 ma per μf per volt. More than this should make you seriously suspect the capacitor or even reject it. A capacitor which shows no leakage is either open or completely dry, and should be tossed out.²

Measuring inductance

We can measure inductance by the same method as capacitance

¹ This value is for standard-size units used in ac-dc sets. Tantalum units, used in miniature portables, have a maximum leakage of .07 microampere per μf per volt. Aluminum foil subminiatures have a leakage of 0.1 microampere per μf per volt.

² Good electrolytics that have been stored idle for a long period of time will show high leakage. Reform these before testing.

but we can now work with direct ratios. Inductive reactance is given by:

$$X_L = 2\pi fl$$

in which pi is again 3.14, f the frequency and l the inductance.

The methods are shown in Figs. 612-a and b. But there is an element of error which must sometimes be taken into account. Inductances are not always wound from wire which will give them the least dc resistance and, if we have such an inductor, a considerable voltage might be developed as a result of the dc resistance. This is not in phase with the inductive voltage, and the

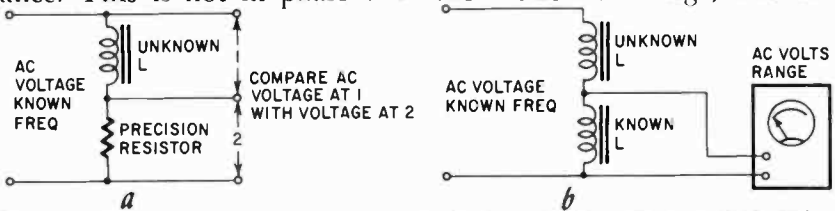

Fig. 612. The value of an unknown inductor can be found by using a method similar to that for finding unknown capacitance. Either a known value of inductance or resistance can be used as the comparison component.

total voltage developed may be a result of these two items. We can find this voltage either by making a vector diagram or by doing some arithmetic. The vector method is shown in Fig. 613. The resistance of the coil is measured using the ohmmeter section of the vom. This is drawn as a horizontal line. You will have to decide on the units you want to use. For example, you may wish to let 50 ohms equal 1 inch, or 100 ohms equal 1 inch, etc.

Now draw a vertical line from the point marked O. This line can be any reasonable length—say, two to three times the distance of the horizontal line. Using the setup shown in Fig. 612-b, calculate the apparent reactance. The value of this reactance will be in ohms. As far as we are concerned, though, it will represent a line whose length is determined by the values chosen for the horizontal line. For example, if we had decided earlier to let 100 ohms equal 1 inch and we had calculated an apparent reactance of 250 ohms, we could say that this is equivalent to a line 2.5 inches long.

Starting at point A in Fig. 613, draw a line of this length between the horizontal (base) and vertical lines. At the point of intersection with the vertical line, write the letter B as shown in the illustration. The distance between B and O on the vertical

line is the true reactance. Let us suppose that this distance is 1.5 inches. Using the scale we had set up, (100 ohms = 1 inch) the true inductive reactance would be 150 ohms.

For example, suppose the dc resistance is 30 ohms, and we find from the developed voltage an apparent inductive reactance of 50 ohms. Then with our method we will find that the *actual* inductive reactance is only 40 ohms. We must use this to calculate the inductance with the formula

$$l = \frac{X_L}{2\pi f}$$

Or, if you are good at geometry, you can use the Pythagorean theorem and find true reactance by taking the square root of the difference of the squares of the two measured values:

$$X_{L(\text{true})} = \sqrt{50^2 - 30^2} = 40.$$

There is a limit to the inductive reactance measurable with 60 cycles. To measure small inductances you will have to use a much higher frequency. But good commercial vom's can be

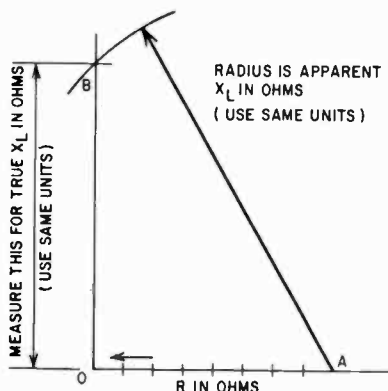

Fig. 613. When a coil has a high value of resistance, an allowance must be made for this resistive component.

used up to several hundred kc's, and you can actually measure such things as broadcast coils if you use a high enough frequency. At those frequencies, since there is usually very little wire in the coil, you can ignore the resistive component.

It is easier to measure inductive reactance with higher frequencies because the voltage developed across an inductance is

greater, as you can read from the formula. The greater the frequency, the greater the inductive reactance and thus the voltage across it. Here is then another use for the vom.

Measuring rf voltages

Most commercial meters are good up to several hundred kilocycles. At higher frequencies, the reading becomes increasingly less accurate as the frequency goes up. But there is a remedy. You can rectify the rf and measure the resulting dc. This is done with the circuits shown in Fig. 614. These can be built into a probe

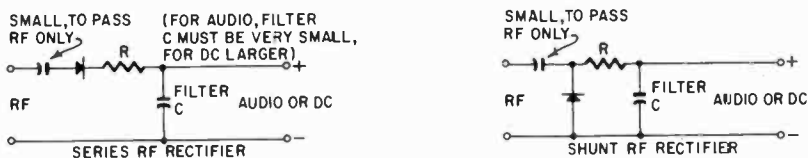

Fig. 614. The ac section of a vom is not suitable for measuring rf. Higher frequencies can be measured by rectifying and filtering them. A series (left) or a shunt rf probe (right) can be made for use with the vom.

if you so desire. Here the measurement made depends on the size of the resistor (R) and the capacitor (C); that is, the time constant of the circuit. If the time constant is large enough, the instrument will read a dc voltage equivalent to the peak of the

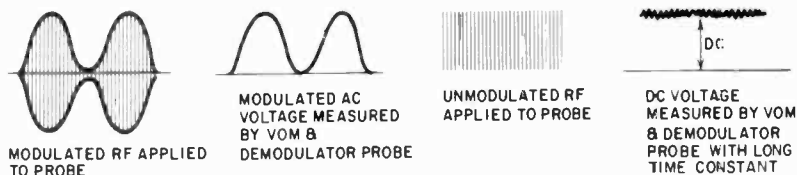

Fig. 615. Waveshapes showing measurements of modulated and unmodulated rf voltages.

rf wave, whether this is modulated or not. If the time constant is much smaller, but still large for the rf, the instrument can be used to read the modulation voltage on the ac scales. The two situations are illustrated in Fig. 615.

Whether you measure the dc or modulation voltage depends on the choice of circuit elements. With a large filter capacitor, the time constant increases. With a large input resistance the time constant also increases. Unfortunately, there are only a few places, such as in transmitters, where the rf voltage to be measured is sufficiently high to provide an adequate response of

meter and probe, so that other measuring devices are usually needed, such as sensitive vacuum-tube voltmeters and oscilloscopes.

Measuring power

Sometimes it is very informative to know how much power a device is consuming. This can be measured in several ways, one of which is using a wattmeter. However, with the vom we can also measure wattage in a number of situations. The simplest of these is where we can measure current and voltage applied to a dc device and from this calculate the wattage. There are two possible errors in this. When you apply the current through the current range of the vom, the actual voltage at the device will be a little less than with the vom out of the circuit. The difference is the voltage drop in the meter shunt. Here we have a case where we would prefer, when dealing with high currents, not to read the meter at its highest deflection, but rather at a lower one. In other words, with a large shunt (lower resistance) and thus less drop in the shunt. Wattage readings do not always demand great accuracy, but this thought might be of use when they do require precision. Wattage, remember, in dc is volts \times amps.

Ac power

Now what about ac? Here we can only measure what is called voltamperes. It is the same as wattage only when the power factor of the device is 1, unity. This is so only if the device is purely resistive or if the power factor has been corrected. The power factor is a figure which indicates by how much the voltage and current are out of phase. In a resistive device with ac applied, the voltage and current rise simultaneously, and are in step or in phase. In a capacitive device, the charge takes time to build up, consequently the current is already going fairly strong when the voltage finally rises, and in this case we can say the current "leads." This we can express as a "power factor," the "cosine" of the angle the voltage and current would make if their values were represented as vector lines.

In an inductive device, the magnetic field counteracts the current change, by what we call a counterelectromotive force (emf) resulting from the magnetic field which is being built up. Here the voltage is already maximum while the current is still struggling to build up. As a result the voltage "leads" the current, and this too we can express as a power factor, or cosine function. Because

the current and voltage are not respectively, maximum and minimum at the same time, we must take this into account when we calculate watts from these values. Thus:

$$W = E \times I \times \cos \theta$$

where $\cos \theta$ is the power factor we have been talking about. This depends on whether a device is inductive, capacitive or resistive.

There is no good way to measure power factor with a vom, except by first measuring the inductance or capacitance of the circuit. Fortunately, these measurements often are not so critical that we cannot take a fairly good approximation knowing that certain devices almost always have the same range of power factor, unless they are being misused. Thus, an electric motor usually has a power factor varying between 0.65 and 0.75, a transformer of good quality a power factor of approximately 0.95 and a synchronous motor usually nearly 1. If you measure voltamperes on, say, an amplifier or a radio or TV set with transformer, you are very close indeed to the equivalent in dc wattage. On a transformerless TV, with series-string tubes, or an ac-dc radio, you are even closer. You already know how to measure alternating current with a vom and, since the vom has ac voltage scales, from these again you can measure wattage. If you do this frequently, make a calibration curve for the particular resistor with which you measure the current, and whatever standard voltage you use (for example, 117) so you can very conveniently read wattage in this way almost directly.

The power factor is useful measurement in service work, for often you can determine faults in equipment this way. For example, a transformer with shorted turns inside is ordinarily very hard to detect but, if you find that the transformer uses considerable energy when there is no load at all on it, you can suspect that it has shorted turns. Similarly a motor which, without load, uses more current or more wattage than a similar motor of the same horsepower rating may well have shorted turns in the armature or field coil.

A shorted turn in a component such as a power transformer or a flyback unit is hard to detect because the overall resistance of the affected winding is barely changed, the reduction in resistance being so slight that it cannot be detected with ordinary measuring instruments such as the vom or vtvm. Thus, if a check of the transformer's resistance shows it to be in agreement with the manufacturer's figures, it does not necessarily mean that the trans-

former is in perfect condition. Furthermore, the short cannot be found by visual inspection except in those extremely rare cases where the fault exists in the outside winding of an open transformer.

Other uses of the vom

There are many other ways to extend the ranges of the vom beside those we have discussed in this chapter, but these ways invariably involve some *active* circuit, contrasted with the *passive* ones we have been considering. Thus, to measure lower currents and lower voltages, we can use some form of amplification. We will discuss this when we consider the use of the vom as the "basic" meter in other devices.

You know now how to measure many values not normally considered as a part of the vom, such as higher currents and voltages, extremely low and very high resistances, capacitance and inductance. Now let us see how this knowledge can come in handy in actual applications, in practical service or how it can be put to work in experimental use.

making practical measurements

THERE are many kinds of measurements for which the vom is either directly usable or for which some simple addition can be made external to the meter. But an instrument which does not have sufficient internal resistance or sensitivity can possibly load the source (such as the plate or screen of a tube) so that measurements (such as voltage) might well be false readings. Now suppose you have nothing but an insensitive instrument. This could be a vom with a 1-ma meter having only 1,000 ohms per volt. How can you still make accurate measurements?" This is not nearly so difficult as it sounds, if you have a vom with several ranges.

Measuring with an "insensitive" meter

Suppose you have a source (Fig. 701-a) which has an internal resistance of R_i and a voltage V , and let us also suppose you want to measure the emf across a resistance R_a in parallel with this source. But your meter drops the voltage somewhat, as a result of its loading action. Say the voltage drops, on one range, to V' . For this range, select the voltage scale on your vom which gives a usable reading, but with the possibility that it could also be read on the next lower range. For example, if the voltage were 8, and you have both 10- and 30-volt ranges on your meter, the 30-volt range is the one you'd read V' on. Now read the voltage on the next lower range, and call this V'' . This will not be the same portion of V' , because we are now going under the assumption that the meter loads the circuit. Thus it would load the circuit *more* on the *lower range*. The voltage would read even more below the actual value than on the higher range.

The voltage difference, $V - V'$ (which we can call v) can be regarded as a voltage in series with the meter. It is used to drive the current through the internal resistance (R_i) of the source and the parallel resistor R_n (Fig. 701-b). Ignoring the voltage V , we will

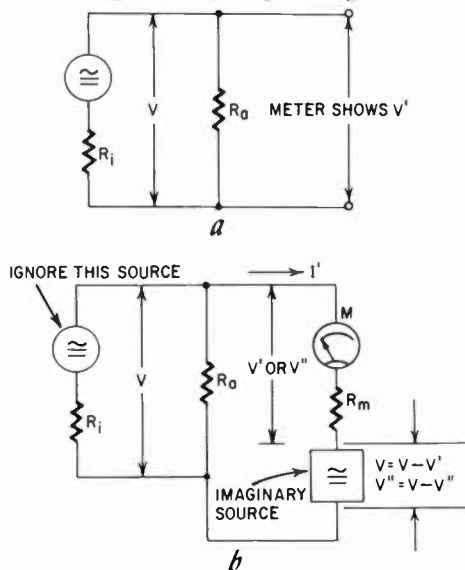

Fig. 701. The vom may not indicate the correct amount of voltage because it may load the circuit being checked.

simply look at the source as if it were nothing but an internal resistance. This sounds odd, but we'll come to a solution of the problem soon. The meter indicates the voltage V' , and the current through it is:

$$I' = \frac{V'}{R_m}$$

in which R_m is the meter's internal resistance. Now our imagined source must drive this current through R_i and R_n in parallel. The resistance of the parallel resistances is:

$$\frac{R_i \times R_n}{R_i + R_n} = R_c$$

and the voltage $v = I' \times R_c$.

If we do the same thing on the next range down, the voltage $V - V''$, will represent a second reading we can call v'' . This again we can consider as before and the value of $v'' = I''$ (the current through the meter *now*) $\times R_c$.

These two voltage differences, v and v'' are related just as their proportion V'/R_{m1} and V''/R_{m2} (in which the values R_{m1} and R_{m2} are the meter resistances on the two ranges) because:

$$I' = \frac{V'}{R_m} \text{ and } I'' = \frac{V''}{R_m} .$$

If we now divide the values v and v'' :

$$\frac{V - V''}{V - V'} = \frac{v''}{v}$$

then we find that the resistances R_c cancel and the result is:

$$\frac{V''}{V'} \times \frac{R_{m1}}{R_{m2}} = \frac{V''}{V}$$

Of course, the ratio R_{m1}/R_{m2} is exactly the ratio of the meter ranges, and this ratio we call Q . We can now rewrite the equation above as:

$$\frac{V - V''}{V - V'} = \frac{V''}{V'} \times Q$$

If we solve this simple equation for V , we find that

$$V = \frac{(Q - 1) V''}{Q - V'/V''}$$

This still looks pretty complicated, but note that we now have a relationship expressed strictly in values we *know*. We have eliminated all such terms as internal meter resistance, internal resistance of the source, current through the meter, and even the difference voltage. We can measure V'' and V' and we know Q . Thus by measuring the sagging voltage source on two ranges of the meter we can come to an accurate measurement of the voltage of the source, regardless of the load on the yom.

For example: suppose you have a meter with a 12- and a 30-volt scale. This amounts to a Q of 2.5 (the quotient of the ranges). If we connect the meter to a source, and on the 30-volt scale measure a value of 12 volts, and then turn the meter to the 12-volt scale and measure 8 volts there, then:

$$V = \frac{(2.5 - 1) 12}{2.5 - 12/8} = \frac{1.5 \times 12}{2.5 - 1.5} = 18,$$

and our actual voltage would be 18. Note that we need know *nothing* about the meter, nor about the source. We need know only the ratio Q of the two ranges, and read the voltage on both.

Fig. 702 is a nomogram designed to accommodate most standard

meter-range ratios. Example 1, the dotted line, shows the problem we worked out. Let's try another one.

Suppose on a 300-volt scale, we read 90 volts and on the 150-volt scale, 60. Now $Q = 2$. We locate in the nomogram the set of scales labeled $Q = 2$. On one of these (also labeled V'), we find the point 9 (if a scale does not read far enough, multiply all scales with the same number—in this case 10) and on the $Q = 2$ scale labeled V'' (at the bottom) we find point $V'' = 60$. By connecting the two points with a line and extending it to intersect the vertical line (dotted line called "example 2"), we find that the actual voltage is 180.

The nomogram is equipped for scale ratios of 2, 2.5, 4 and 5, since we seldom encounter greater or other ratios in meters. For those who are mathematically inclined we include simply the fact that the scales are on lines at the right angles, and that the V' scale always bisects the right angle between the V and the V'' scales.

If you are not interested in making your own scales, simply use the formula if you run across odd scale ratios as you might, for example, in home-built instruments.

Here, then, is a method to read accurately with an insensitive meter a voltage which should be read with a more sensitive meter having higher resistance. But note that it can also be applied as a correction on readings made with a high-resistance (20,000-ohms-per-volt) voltmeter. For example: suppose on the 300-volt range of such a meter we read 82 volts, and on the 150-volt scale, 78. Then, if we have no reason to suspect inaccuracy in the instrument, we find the line shown as "example 3" in the nomogram, and read the actual voltage as 86.

Of course, with an instrument which has an accuracy of 3% full scale, this is cutting matters pretty fine, and you may well be mistaking inaccuracy for loading. But if this is not a *consistent* error in different situations, preferably including one where you *know* loading makes little difference, you can accept this correction. If your voltage source is a very low impedance one, such as a battery, you can accept it more easily.

The correction we have shown here works equally well for ac and dc, and in fact for ac at any frequency for which the meter response remains accurate, so long as we can assume that there is no phase shift in the current or voltage. If the phase shift in one range is different than in the other, as it would be if we measured with an inductive or capacitive circuit (in place of R_n), then our

correction is no longer accurate. It is, of course, possible to set up a special nomogram for these instances, but only if you were to deal with the same kind of measurement every day would such a thing be profitable. And in that situation you could probably afford a more sensitive meter to do the job without correction.

Testing batteries

In the radio and automotive fields, testing batteries is one of

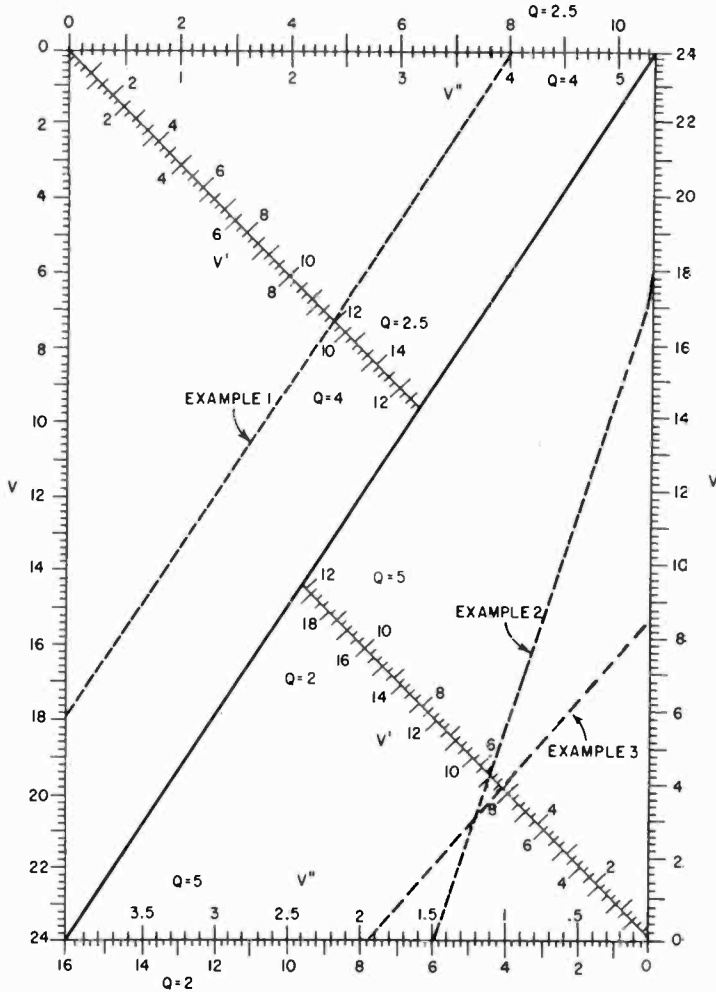

Fig. 702. Nomogram to compensate for loading by the vom, with out requiring data on meter resistance, etc. For higher figures than the scales, simply multiply all scales by the same number, whether this be 2, 3, 5, 10, etc.—whatever is needed to reach the appropriate voltage readings.

the most often used and most needed tests. You may have seen special battery testers in a garage or shop, but you can do the same thing with a vom if you are willing to make a number of simple accessories. Although a battery tester is not exactly a vom or can't even be considered a multimeter, it may help you to understand how such a tester is made and functions.

Fig. 703 is a pictorial of a battery tester. The circuit diagram is shown in Fig. 704. Designed especially for testing A- and B-batteries, it is *not* designed or intended for checking auto batteries.

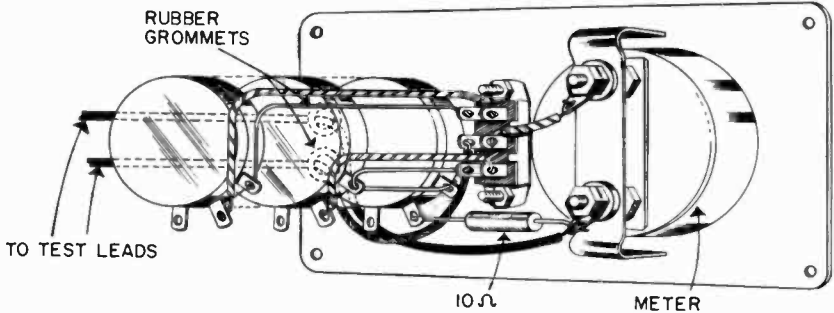

Fig. 703. Pictorial diagram of a battery tester. This exploded view shows the relationship of the components to each other, and the required wiring. A pair of color-coded test prods (red and black) are connected to the two wires marked "to test leads." (Heath Co.)

The meter, a 15-ma instrument, is put in series with a 10,000-ohm potentiometer for testing B-batteries. This allows testing with up to 15 ma, sufficient to tell whether a B-battery is going to sag under the load. In practice a B-battery is seldom called upon to deliver much more than this amount.

For testing different-voltage B-batteries we would, of course, prefer to change the load resistor, and for this reason a potentiometer is used. On the front of the meter there is a scale, and the series resistance is adjusted in accordance with the B-battery voltage marked on this scale. The entire 10,000 ohms would be used for batteries of 180 volts and up, but not many batteries over 150 volts are used. It is possible to overload the tester with a 300-volt battery capable of delivering 15 ma or more, but as always, there has to be a limit on the instrument somewhere, dictated by practical economics.

The A-battery section is similar, except that here the meter is in series with a 1,000-ohm potentiometer and this combination is shunted by a 100-ohm pot and 10 ohms in series. This means that the lowest shunt for the meter is 10 ohms and, since the basic

meter has a resistance of 92 ohms, the meter is capable of reading 150 ma. For example, a 1.5-volt battery would be tested with about 150-ma load, normal for that voltage. Higher-voltage batteries would of course get a similar load, since the series resistor is set higher as well as the shunt. Thus, with a voltage setting of 8 volts, the series resistor would be 500 ohms and the shunt about

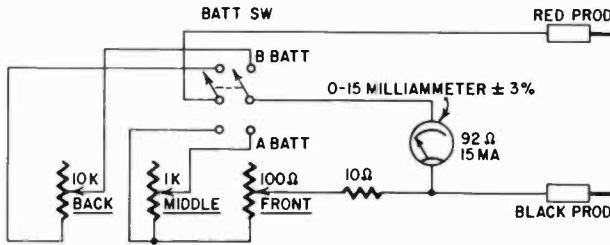

Fig. 704. Schematic diagram of the battery tester shown in the previous illustration. (Heath Co.)

50 ohms, more or less. The current drawn is about $8/500 = .016$ amperes, or 16 ma. The shunt allows the meter to read approximately 35 ma so that a good battery will show about halfway deflection on the meter, and a very good battery a little more. These figures are only approximate and illustrative.

Using the vom to check storage batteries

To make your own accessories to test batteries, all you need is your vom and a means of loading the battery. Let's start with a problem child first.

An auto battery should be capable of delivering about 50 amperes continuously for several minutes without showing much drop in voltage. For this, on a 2-volt cell, you would need a resistance of about 0.04 ohm. This is easy to make, for 21½ feet of No. 10 copper wire—if it is bare—has exactly 0.04 ohm of resistance and can carry almost indefinitely a current of 50 amperes. All you need then is to coil this wire (to save space) and provide some means of connecting it to the battery.

Fig. 705 shows how you can make this connection easily. Two small file handles each have a piece of 20-penny nail inserted in them, with the point sticking out. The No. 10 wire is soldered to the nails; test leads from the vom are clamped onto the ends of the No. 10 wire left sticking out, and there you have a first-class tester for 6- and 12-volt auto batteries, to be tested cell by cell.

The meter is set to read the voltage of each cell. Whenever the

tester is applied to the battery, it should be held there for at least 15 seconds. If in that time the battery voltage drops more than 20%, the battery should be charged or replaced if it has just been charged. The 20-penny nails must be pushed into the terminals

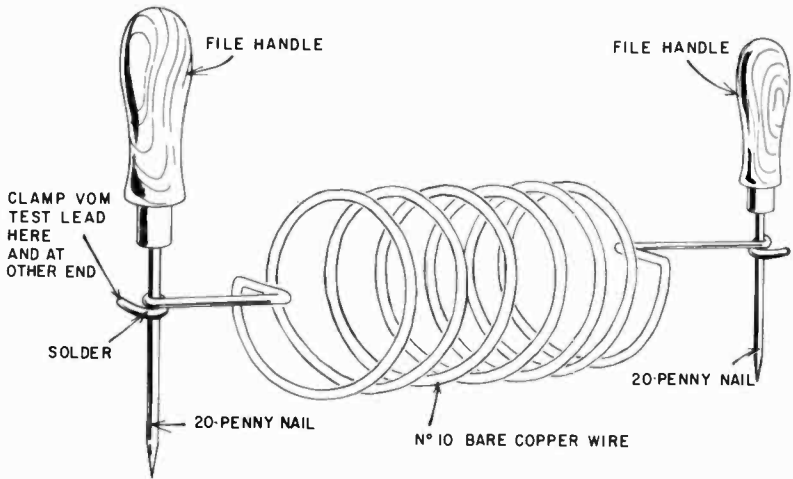

Fig. 705. This is a simple home-made accessory that permits the use of the vom as an auto battery tester. This unit puts a direct short circuit across the battery. Allow about 15 seconds for the test, but not longer. A heavier wire than No. 10 is a move in the right direction, but do not use a lighter gauge since it will become quite hot and may burn out.

with considerable force to make adequate contact with the lead battery terminals.

Other battery testers are simple to understand. You will not need to make shunts for your meter since it is more than likely that it has adequate current ranges. If it does not, Chapter 6 tells how to make additional shunts. Series resistors must be calculated so that the appropriate current will flow. Here is a cue: the current for a 1.5-volt A-battery must be about 150 ma, and so on up to about 15 ma for the 15-volt unit. To make a more severe test, simply put on a heavier load to increase the current.

Checking B batteries

The manufacturer usually specifies the normal full-load current of a battery. For B-batteries this is a great deal less than for heater supplies. If you have, say, a 90-volt battery in a portable receiver, the best way to test is with the receiver *on*. If the battery shows less than 70% voltage under full load (in this case, 63 volts), it needs

replacement. (Portables are so designed that they will operate satisfactorily with 70% to 80% of the battery voltage.)

Checking hearing-aid batteries

Similarly, hearing-aid batteries should be tested in the hearing aid with the instrument turned on. Most radio-supply house catalogs will show not only the current and voltage but also the milli-ampere/hour rating.

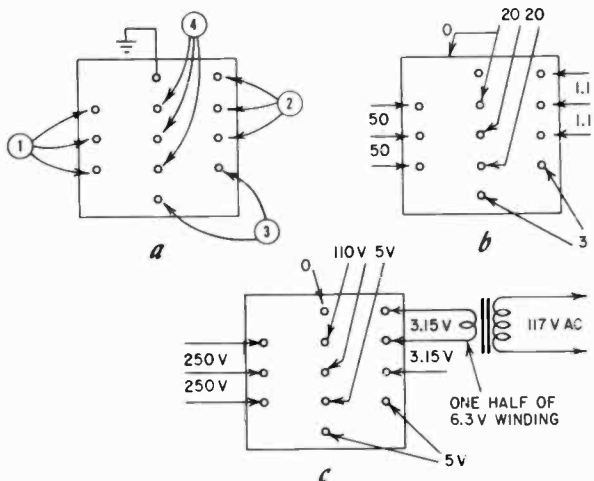

Fig. 706. An unknown transformer can be identified with the help of the vom. Using the resistance scales of the vom, group the transformer terminals (a) by making a continuity check. If the resistance is high enough, you will be able to locate the center tap. Next, check the resistance of each winding (b) which may identify center taps and approximate voltage class. Finally (c) apply a low voltage across one winding and measure the voltage across the others which will identify the winding. Note that the primary here is tapped for two voltages, as it often is on military equipment.

Checking transformers

Transformers are available in many shapes and sizes, new as well as surplus, and they are one radio component not too readily identified as to values and connections. Quite often the leads of the transformer will get painted or covered with black wax, so the color coding becomes indistinct, or the terminals on potted transformers will be marked with pretty numbers which give absolutely no clue as to the voltage, connections, etc. But, fortunately, if you have a vom and a low-voltage ac supply, such as from a filament transformer, you can soon work out the problem.

Checking power transformers

Assuming that we are going to work on a power transformer, the first step is to make a continuity check of the wires or terminals. You can then group them as shown in Fig. 706-a. If you are dealing with wire leads, it is a good idea either to tag the wires or to twist those which belong together, so you can recognize the pairs or groups.

Next, check the dc resistance between the wires that show continuity. You are not specifically interested in making a precise measurement of the windings, just in their *relative* resistance, because by this means you can identify the approximate voltage range of the windings. You will want to know particularly if there is no measurable resistance between terminals, for then they might be common to the same winding end.

While checking the resistance on the windings, you may be able to determine which of the three connections on a winding is the center tap. The resistance between it and either one of the others is always less than that between the other two (Fig. 706-b).

Finding turns ratios and voltage ratings

Finally, to identify the turns ratios, and *perhaps* the voltage ratings of the windings, apply a small ac voltage to the winding which measures low in resistance, and then measure the ac voltage developed across the other windings. For example, let us say you put a voltage of 3.15 across one of the windings. Then the winding which produces a 55-volts ac is likely to be a 110-volt winding, etc. If this winding turns out to develop 69.3 volts, it may still be the 110-volt winding: you have simply put the 3.15 volts across a 5-volt winding instead of a 6.3-volt one.

In this way, as shown in Fig. 706-c, you can gradually work out the voltage ratings for all windings, for in radio work these are almost certainly standard. You may deal with 2.5-, 5-, 6.3- and 7.5-volt filament windings, but of these only the 5 and 6.3 are now common.

400-cycle transformers

If you find that the transformer does not check out on the standard voltages at all, yet you have reason to believe that it is nevertheless a power transformer, then you may be dealing with a surplus 400-cycle type. These will show unusually *low* voltages on 60 cycles. If you were to try to use a 110-volt, 400-cycle winding on a 110-volt, 60-cycle current, the winding would almost certainly burn out since its impedance would be too low.

A transformer must always have at least four terminals, unless

it is an autotransformer, used for stepping voltages up or down without isolating them from each other. Autotransformers in radio work are relatively rare, so if you find a transformerlike device with only three terminals, it is most likely a center-tapped choke. If it has only two, it is definitely a choke. If a transformer with only four terminals does not give a standard voltage ratio, it may be either an output transformer or some special job. You are not likely to confuse interstage with power transformers since the former have a much higher impedance, and thus much higher dc resistance also.

Checking output transformers

An output transformer may show only a fraction of an ohm on the speaker side, or it may show quite a bit. If the resistance is high, it may be an output-to-line transformer. Of course this method is not entirely foolproof if you have something absolutely unknown and strange in your hands, but usually you can at least get some idea of the unit you are dealing with.

The primary impedance of an output transformer can vary anywhere from 2,000 to 25,000 ohms. If you can guess reasonably accurately at the output impedance, which may be something like 3.2, 4 or 16 ohms, then you can determine the primary impedance *approximately* from the turns ratio, which is about the same as the voltage ratio. Thus, if the voltage measured across the primary reads 100 times the voltage applied to the secondary, then your turns ratio is about 100 to 1. The impedance, though, is approximately the *square* of the turns ratio, since the impedance depends on the inductance and the formula for inductance contains the *square* of the turns. If you have an output transformer of 3 ohms, secondary impedance, and the turns ratio is, say, 50 to 1, then your primary impedance is $50 \times 50 \times 3 = 7,500$ ohms. Of course, with any vom, you don't have to make a *guess* at the impedance, primary *or* secondary, you can measure it, as we showed for inductance. If you measure the impedance of a transformer, remember to leave the other windings *open*. With the possibility of identifying windings, determining turns and voltage ratios and winding impedance, the transformer is not likely to remain a mystery for long. And all this with a vom and only a very few simple accessories!

Checking rectifiers

The vom can give you an immediate and rapid check-out on germanium, silicon and selenium diodes and rectifiers. You can determine their condition and their polarity using the ohmmeter

section. When you check items such as rectifiers, you should be aware of the battery polarity in your meter. In most commercial instruments, the ohmmeter section is so circuited that the red terminal is also the positive in the ohmmeter circuit. But not always; some instruments have this reversed. The meter instructions will provide you with this bit of information. In the following we will assume that the red terminal is positive.

As you connect the prods of the ohmmeter section of the vom to a rectifier, you should read a high resistance one way and a relatively low resistance the other. The low-resistance value varies between 20,000 and 50,000 ohms and the high-resistance should be at least 400,000 to several megohms; in other words, a ratio of at least 20 to 1. It does not matter too much what the lower value is, but a ratio of 20 to 1 is a good minimum standard to adopt. With anything less, the rectifier will be inefficient.

Notice that with the red test prod on one side you read high, on the other side low. The side which gives a high reading is the negative side (see Fig. 707). This, then, quickly determines the polarity. If a rectifier is shorted, it will give a low reading both ways. If it is open it will give a high reading both ways.

Most selenium rectifiers are built for 130-volt service, and have about five or six "plates." The plates are nothing but cooling fins for the junctions. Less fins indicate a low-voltage rectifier.

Checking diodes

Germanium and silicon diodes are checked the same way, but there is a class of germanium diodes which have comparatively low values for each reading. So, if you get low readings but a large ratio, the diode may be OK. These diodes are built especially for high-frequency work, mostly microwaves, where the nonlinear characteristic of the semiconductor is more important than its rectifying capacity. For example, a 1N22 will show about 250 ohms low and 5,000 ohms high. Notice that the ratio is still 20 to 1.

Merely knowing that the rectifier is not shorted and that it has a high forward-to-backward ratio does not guarantee that it will give optimum performance, but it will almost always do this. A very few rectifiers measure all right, yet fail to deliver their rated current. Most of these cases can be traced to loose junctions, and nothing can be done about them.

Identifying and checking transistors

A transistor is a semiconductor device. We can regard it as a pair of diodes, back to back. Thus, a transistor should have a high for-

ward-to-back ratio the same as a diode, between its emitter-to-base and collector-to-base junctions. Since P-type semiconductor material has a "shortage" of electrons (a place to which the electrons will flow) the low reading should be obtained with the "+" or red prod on the collector and emitter of a p-n-p transistor; the opposite is true of an n-p-n unit. The ratio of forward and back resistance varies all over the lot for production transistors, but for really good ones it should be better than 20 to 1. Some first-class units will measure 20 ohms one way and several megohms the other.

The forward-to-back resistance test is just a qualitative check of whether the transistor is open, shorted or normal; for a measurement of just how good the transistor is, you need more than

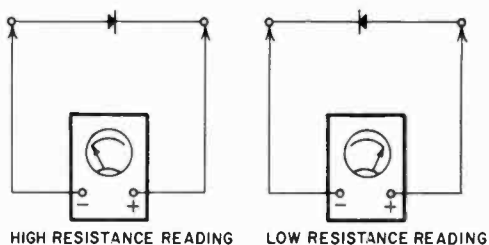

Fig. 707. The vom can be used to check germanium, silicon and selenium diodes and rectifiers.

a vom. In a later chapter some of the simplest transistor checkers will be shown, using the vom as its basic meter. At this point, you can use the vom only to check the transistor for faults and for type.

The mystery component

It sometimes happens that you will find among your components something that looks as though it might be a resistor or a capacitor or maybe even an encapsulated inductor. How can you identify this mystery part! If you check for resistance, it shows infinite, but not being sure, you would not throw it out as an open resistor. Checking its capacitance, you don't seem to get a reading either. What is it?

Most likely it is a very very small capacitance in the order of a few micromicrofarads, maybe even less than 1 $\mu\mu\text{f}$. And if you remember that the reactance of a capacitor goes down as the frequency goes up, the way to discover if this is a small capacitor is to measure the ac voltage you can get through it from an audio oscillator. For 1 $\mu\mu\text{f}$, a 5,000-cycle frequency at a few volts should give you

a very readable measurement on the low ac scale of the vom. If the device is an open resistor, more than likely you will not get a reading at all; the capacitance of burned-out carbon ends is so small it cannot be measured with a vom even this way.

Sometimes you will encounter a similar situation in oscillator coils. Checking out a coil, you may find that one of the terminals, even though it has a wire connected to it, does not give a reading to any other terminal. In this case you may be dealing with a coil in which a few turns of wire, wrapped around the main coil, serves as a capacitive coupling to the grid of the oscillator tube, and actually *does not* have a second connection.

A somewhat similar situation may be encountered in power transformers or modulation transformers, which may have what is called a Faraday shield. This is made in the form of a winding between primary and secondary, because this is a good economical way to make it, and has only one connection. A Faraday shield keeps high-frequency power-line interference from getting into whatever device the transformer may be in, or vice versa to keep the device from sending high-frequency interference out over the power line. The transformer lead to the Faraday shield is often bare, tinned, stranded wire.

Tube filaments

With vacuum tubes about the only thing you can check is continuity of the filaments. That is, without auxiliary apparatus, which we will discuss later. It is also possible to check for element shorts, but this test should be made with the tube warmed up. Use the setup shown in Fig. 708, in which the filament receives its rated ac filament voltage. The tube is allowed some time to get warm, and the vom is then used to check one element after another. Connect one lead of the vom to the cathode, as shown. Connect the other lead to each tube element (via the socket) in turn. As you make the connection, tap the tube gently and watch the meter. You can use the rubber-end of a pencil, but tap the tube. Don't wallop it! If the meter reads, you have a short.

Other tube tests require more external apparatus.

Appliance repair

In appliance repair, the vom will be employed chiefly as a continuity tester, using the lowest ohms range.

Since most modern vom's have also a very-high-resistance range, they can also be useful for insulation tests. The resistance to frame or ground on a motor should be at the very least several megohms,

and preferably over 10. The insulation resistance of many devices will depend partly on the humidity, and thus you may read different amounts on different days but, if they are all high, there is no danger. Good insulation values are particularly important on equipment used in the bathroom and kitchen, since the user is likely to stand on a damp floor or come into contact with damp surfaces. Electric shavers, waffle irons, toasters, flatirons, portable

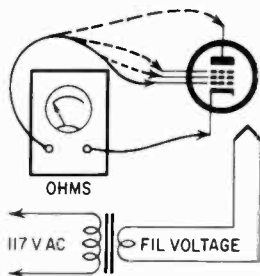

Fig. 708. Checking a tube for element shorts with the filament heated.

heaters, mixers and blenders and electric frying pans should have very high insulation resistance.

The vom's ohms ranges may help locate a break in a heater element or lampcord. Its voltage ranges can help you locate a blown fuse quickly. With the meter set on the 150-volt ac range or higher, you can locate the blown fuse by testing on either side of the fuse socket, with some lamp or appliance switched "on" in every circuit in the house. The fuse which has a voltage across it is the open one. If the two connections to the fuse are not available, the fuse can be checked for continuity, but then each one checked must first be removed from its socket.

Some household appliances refuse to function properly when the line voltage is low. For example, refrigerator, washing machine or dryer motors may never quite reach enough speed to "kick out" the starting winding, overheating the motor. When unusual noises come from the appliance, such as a repeated on and off clicking noise, check the line voltage with your vom; it may be all you need to locate the trouble.

Expanded scale for the vom

An expanded scale means a scale which covers just a portion of the voltages you are dealing with. This is useful for observing small variations in such voltages, as a result of temperature, load-

ing or some other factor which changes in time. The method is simple, as you can see from Fig. 709. The voltage to be checked is connected to one side of the meter, while a bucking voltage is connected on the other side. Now the meter needs measure only the *difference* between the two voltages, and a lower scale can be used. For example, if we want to determine the change in a 100-volt source, and we use a 67.5- and a 30-volt battery in series, we will actually be measuring 2.5 volts, and the meter scale for that range can be used. Now a change of 1 volt will result in a meter deflection of almost half-scale. This voltage change would be barely visible on the 250-volt scale which we would otherwise have had to use.

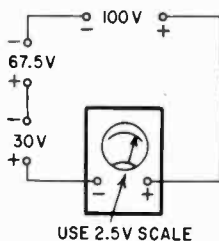

Fig. 709. Expanded (40 times) reading of variations in voltage.

Detecting small changes in direct current

The same principle can be used to observe small changes in current (Fig. 710). The bucking battery counteracts the meter deflection as a result of the current through the shunt, and by this trick we can use a lower range for the current measurement.

For example, let us suppose we want to measure the change in a 10-ma current. If we send this through a shunt for, say, a 100-microampere meter which has about 1,000 ohms internal resistance (a 100-mv meter, in other words), we would have to use the 10-ma range to get exactly 100 mv at the meter terminals, giving full deflection. This shunt would be a little less than 10 ohms. Were we to push this current through a shunt 10 times as large, and bucked out all but 100 mv of the voltage generated across this shunt, we would still have only 100 mv at the meter, and full-scale deflection. If the current changed to 11 ma, we would be generating 1,100 mv, but bucking out only the same as before; in other words, a 100-mv change at the meter. You can easily see then how sensitive this system would be.

We must make sure, of course, that the shunt for the lower range is capable of accepting this larger current, and that the shunt is not so high in resistance that its inclusion is going to change the current in the entire circuit. If you make sure that the shunts can take the current, or if you are willing to use external shunts, you can in this way enlarge the sensitivity of your meter by simply making it read a difference voltage.

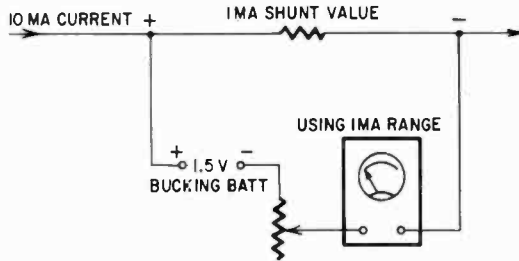

Fig. 710. Expanded (10 times) reading of variations in current.

Detecting small changes in ac voltage

This could also be used for ac, *provided* the voltages used for the compensation were of the same frequency and *precisely opposite in phase*. If we are dealing with 60-cycle power frequencies, where the phase reversal can be a simple reconnecting of a power transformer winding, then we are in business—provided the change we wish to observe is not going to be materially affected by power-line voltage changes. For example, if we have a regulated ac supply and use this to feed both the device and the comparison voltage source, in the proper phase, we could use this system. But, as you see, the conditions which must be imposed rather limit this technique for ac.

For resistance-variation measurement, if we try to set up a circuit for a comparable “difference” measurement we will inevitably end up with a bridge circuit. This we will discuss in another chapter, for here the meter becomes part of a system, not the system subsidiary to the meter.

The vom and you

There is quite a general tendency to regard the vom as an instrument of very limited capabilities, particularly if the unit has a rating of only 1,000 ohms per volt. Part of this is due to the growing popularity of the vtvm with its considerably higher input impedance. But, as we have shown here, the limitations of the

so-called insensitive vom should possibly be ascribed to the user. In this chapter, and elsewhere in this book, we have shown that the vom has a much greater utility than is generally recognized, but this utility is dependent upon the skill of the user.

No claim is made that the "out of the ordinary" uses of the vom described in the various chapters are the total sum of what the vom can be expected to do. These simply represent a small sampling of what the vom can accomplish in the hands of a skilled technician.

the vom as a basic meter

THE vom can be used (since it contains a suitable meter) as the basic indicator in many instruments. It is, of course, possible to use it in almost *any* instrument which needs a meter. But this would probably tie up the vom at just about the same time you needed it for some other application.

In the shop, though, and in the ham shack, many instruments highly essential to operation or service work are used only once in a while, comparatively speaking. This does not mean that they are nonessential but, if you can avoid tying up money in such instruments, they are all the more worth while to keep around for when you need them.

There are also times when you may need greater sensitivity or perhaps greater input resistance than is possible with the vom, yet these instances may not be sufficiently numerous to warrant the purchase of a vacuum-tube voltmeter. In this chapter we will show instruments which are, on the average, used infrequently, yet are relatively important and certainly handy to have around. We will use only the vom for the basic meter, showing all that it can do in this sense.

The vom as a null detector

A null detector locates a null, a point of zero deflection, a point of no voltage and no current through the meter. This type of indication has certain advantages. It tells us, for example, when two values are equal. Its most common use is in bridge circuits. In the last two chapters you learned how to extend meter ranges to

measure values not normally included in the scales. In one way this was done with simple accessories; in another we made the instrument more sensitive by reading a difference voltage only. For resistance, there is no such simple way; we must use some kind of a bridge circuit.

The most famous of bridge circuits is the familiar Wheatstone

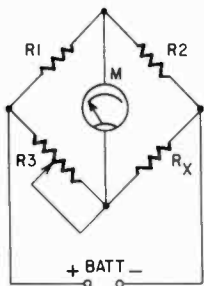

Fig. 801. Simple Wheatstone bridge circuit using the vom as a null detector.

bridge (Fig. 801). Four resistors (R_1 , R_2 , R_3 and R_x) are shown circuitwise in the form of a square, with a battery attached to two corners and a meter, originally a galvanometer connected to the other two. Looking at the top leg, you can see that the corner at which the meter attaches has a voltage which is the result of the divider R_1 , R_2 across the battery. If we make the *ratio* of R_3 and the unknown R_x the same as the ratio of R_1 and R_2 , then the voltage at the other meter terminal will be the same portion of the battery voltage, and the meter will indicate nothing, a null.

We have then the equation:

$$\frac{R_1}{R_2} = \frac{R_3}{R_x}$$

or:

$$R_x = \frac{R_2 \times R_3}{R_1}$$

If we make R_3 adjustable and choose R_1 and R_2 in such a way that their ratio is *approximately* the same as we expect the ratio of the other two to be, then we can very exactly adjust R_3 to the *precise* ratio. If R_3 is a calibrated potentiometer having a scale, or if it consists of a series of precision resistors which we can progressively switch, then we can adjust it and read the value of R_x closely. If we make the ratio of R_1/R_2 large, then we must also make R_3 large compared to R_x .

Since we are always limited in our adjustment to finite decrements (meaning we can never adjust smoothly, always in small

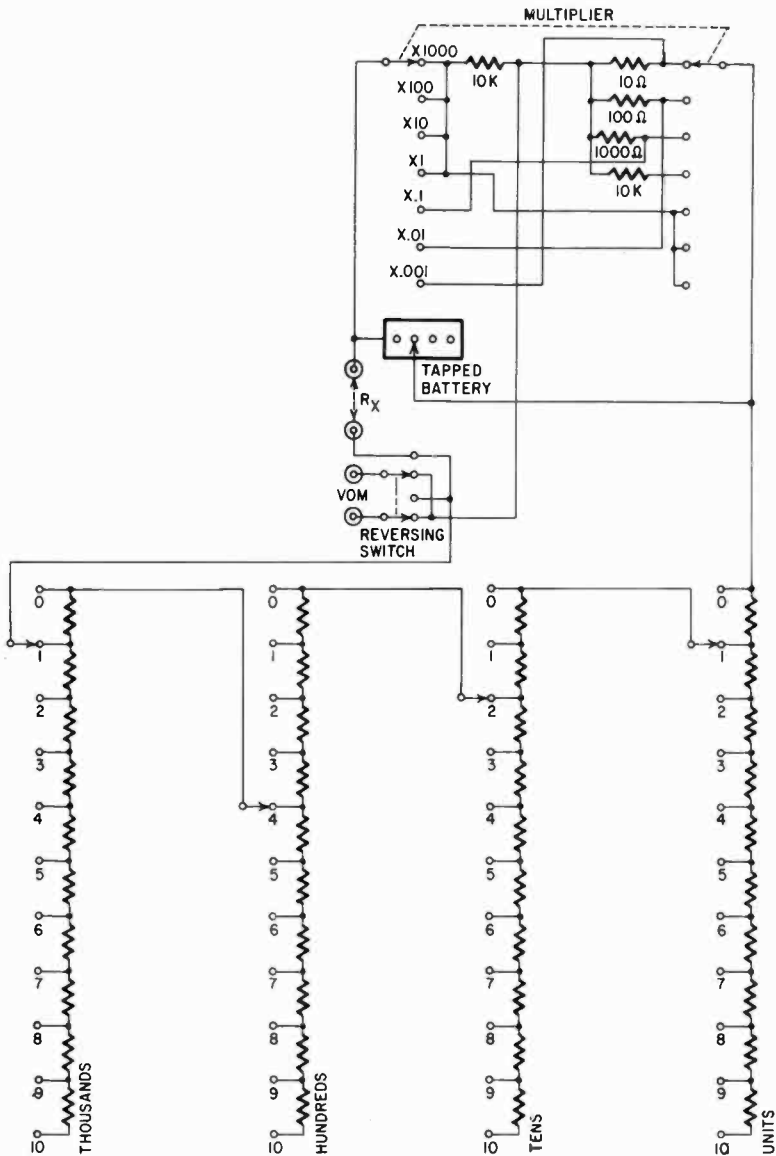

Fig. 802. Complete circuit of a Wheatstone bridge which can use the vom as a null detector. The unknown resistor is placed across the terminals marked R_x . The reversing switch is needed since the meter in the vom is not a zero center type. If, in using this instrument, the meter pointer starts to move to the left, put the reversing switch in the opposite position. The large group of tapped resistors in the lower part of the circuit are equivalent to R_3 in Fig. 801. When the bridge is balanced, the meter pointer should read zero, since, with a state of balance, no current flows through the meter. For a final adjustment, the range switch on the vom should be set to read the smallest amount of current.

steps) even on the best potentiometer, the larger R_3 is, the more precisely we can adjust it, since we can take smaller steps, comparatively speaking. Our approach is similar to the one we used for increasing the sensitivity: we develop the situation where a small *difference* gives us a great amount of deflection on the meter.

Usually a Wheatstone bridge is a complete instrument, enclosed in a box, and R_1 and R_2 are made up so that their ratio is expressed in multiples of 10 — 1, 10, 100, 1,000, etc. This limits the number of resistors needed for R_1 and R_2 and makes the switching simple. R_3 will then be a series of steps representing units,

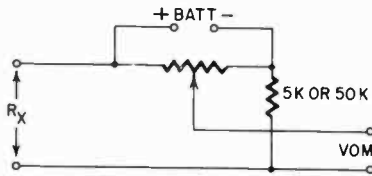

Fig. 803. Simpler form of home-constructed Wheatstone bridge for use with the vom. The potentiometer, which can be a 100,000-ohm wire-wound unit, represents R_1 and R_2 as in Fig. 801. The fixed resistor, 5,000 or 50,000 ohms is R_3 .

10's, 100's, etc., all marked in such a way that we can read at once the value of R_x when the bridge is in balance.

Fig. 802 shows a complete Wheatstone-bridge circuit. The meter will deflect one way or the other, depending on whether R_3 is too large or too small for the proper ratio with R_x . Therefore, if you plan on using the vom for the meter, it should have a reversing switch. If not, such a switch must be provided in the bridge box.

Normally a bridge galvanometer is also provided with shunts, so that when the bridge is badly out of balance the meter will not be damaged. In a vom, shunts are already present, of course, in the current ranges. However, if you shunt the 10-ampere circuit across the bridge, you make it a very insensitive device. So, when we use the vom for a bridge null indicator, the best way to start is on the *voltage* range, which is capable of measuring the bridge battery voltage. This is the very maximum indication which can be expected. When the bridge is near balance, as when the meter on that range shows no deflection to speak of, you can then switch to the next lower voltage range, and after that to

the low current ranges, where the vom is in its most sensitive position. Thus you can balance the bridge with almost as much sensitivity by using a 20,000-ohm-per-volt vom as by using an expensive galvanometer.

If your measurement problems don't warrant buying a complete bridge, yet you must frequently know accurately the value of resistors within a limited range, then you can make a simplified version of the bridge with one accurately calibrated potentiometer and a few known precision resistors (Fig. 803). The calibrated potentiometer is a 100,000-ohm wirewound unit, which

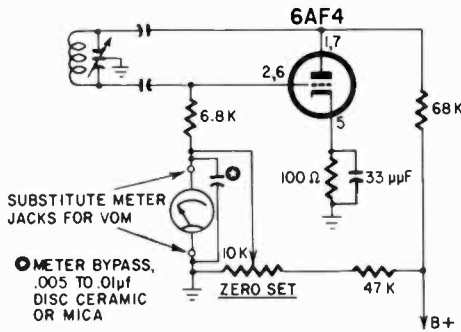

Fig. 804. The vom can be used as a substitute for the meter in a grid-dip oscillator. The vom will then act as a null indicator. Use the lowest possible current range on the meter that will give the maximum swing in toward the null. The meter is most sensitive on the low current ranges.

is used for R1 and R2. For R3 you will need precision resistors of 50,000 and 5,000 ohms. Then you can read accurately between 500 and 500,000 ohms. But the accuracy will depend to a great extent on how large, clear and accurate the scale for the potentiometer is. It can be marked directly in values for R_x .

The Wheatstone bridge is unsuitable for very high and for very low resistances. With an ohmmeter or with the current ranges of the vom you can measure very high resistances with an accuracy which is usually sufficient for practical purposes. For very low resistances, a Kelvin double bridge is used. But this must be specially constructed. With careful work the shunt method described earlier usually provides enough accuracy (with sufficient care) to keep the circuit from loading the battery too much.

Null detection in a grid-dip oscillator

The vom can also be used for a grid-dip oscillator or grid-dip oscillator adapter. A small handy instrument, the grid-dip oscilla-

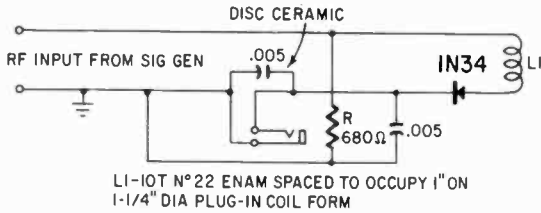

Fig. 805. Schematic of the grid-dip adapter to be used with the vom and a signal generator. A jack is used to permit easy removal of the vom when it is to be used for other work. Use the minimum current range that will give a suitable indication. This will be a null-type of operation.

tor consists of an oscillator tunable by a variable capacitor. The oscillator is made to cover many bands by means of plug-in coils. The oscillator has a meter in its grid circuit. When the coil is brought near a tuned circuit, and adjusted to resonate with this circuit, there will be a sudden dip in grid current, due to the absorption of the energy by the tuned circuit. Thus it supplies a usable minimum or null indication.

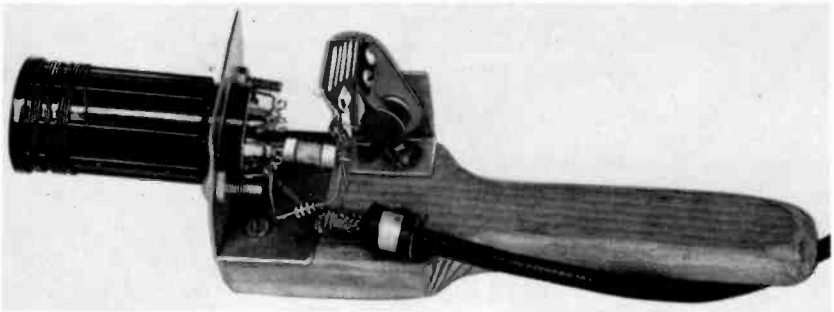

Fig. 806. Photo of the grid-dip adapter whose circuit appears in Fig. 805. The signal generator is connected to the adapter through a small length of coaxial cable. The long handle and the metal base plate of the coil help eliminate hand-capacitance effects.

Fig. 804 shows the circuit of a grid-dip oscillator. A vom with the proper range, in this case 500 μ a, can be substituted for the built-in meter. Many amateurs build their grid-dip oscillators to use their vom's. A jack must be supplied for connecting the meter.

You can even go a step further and, instead of using the

specially built oscillator, use your rf signal generator and the vom for indication. This surely is the minimum expenditure for a grid-dip instrument. Fig. 805 is the schematic for the instrument in Fig. 806. The signal generator supplies the rf, through the small ceramic capacitor and diode. The diode rectifies the current for measurement by the dc ranges of the vom. In practice, the coil is loosely coupled to the tuned circuit and, when resonance is obtained, a drop in current will be noted due to the loading of the signal generator. If the generator does not have enough output, the dip will be somewhat indistinct. It may be possible to increase your rf signal generator's output by putting a jumper across the series output resistor found in many generators. In some commercial models this series resistor is built into the output cable.

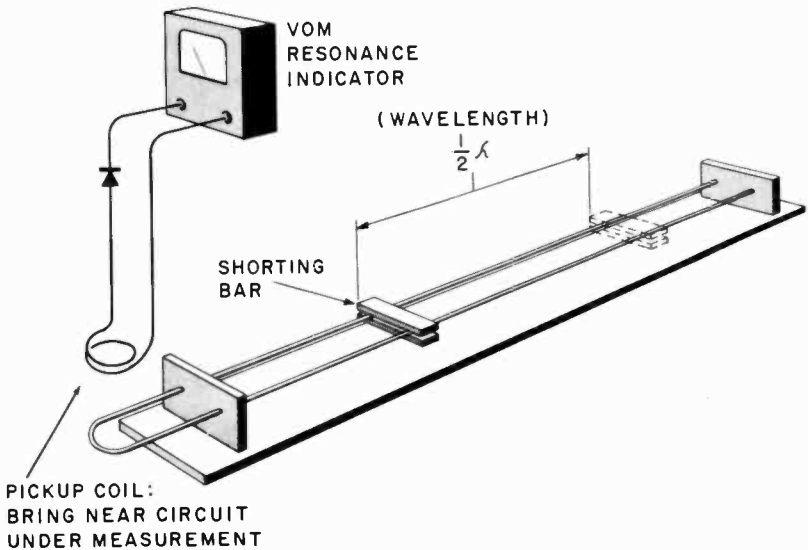

Fig. 807. The vom can be used with a pair of Lecher wires as a null indicator. A point-contact silicon diode can be used as the rectifier. Types such as 1N21B, 1N23A, 1N23B or 1N82 are suitable. The pickup coil can be an air-wound unit of one or two turns.

In any case, the dip adapter must be connected by coaxial cable to the generator, particularly for use at the higher frequencies.

Lecher wire null detector

Another null-detection application of the vom can be its use with Lecher wires (Fig. 807). These are a set of parallel wires used to check high-frequency oscillators. The parallel wires are shorted by a bar which can be moved the length of the wires. The

transmission line formed by the parallel wires will (when energized by an oscillator through the pickup coil) have standing waves on its length.

Using a resonance indicator, in essence similar to the grid-dip oscillator, you can find two points for the bar at which the Lecher wires will absorb a large amount of energy. These points are separated exactly a half-wavelength of the measured radiation

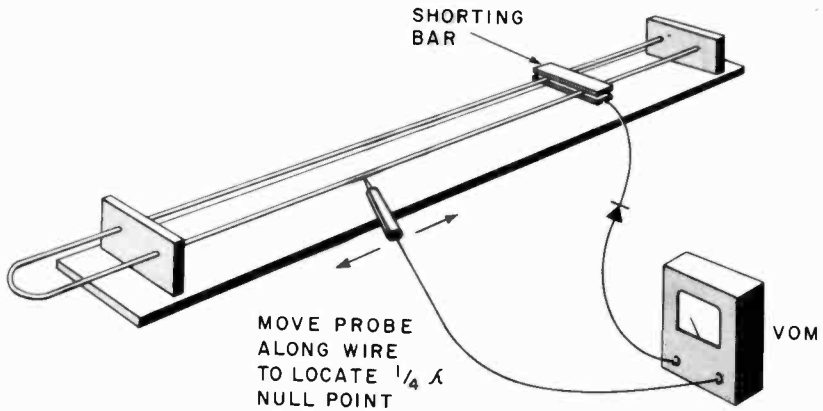

Fig. 808. Method of using the vom to locate a quarter-wavelength null point on the Lecher wire system. The shorting bar must be at the resonance point.

and thus, by carefully measuring the distance between them and dividing this figure (in meters) into 150, you get an answer in megacycles.

The vom is connected through a crystal diode to a simple coil of one or two turns, which should suffice to give almost full-scale deflection on the 50- μ a scale, even from a receiver oscillator.

Another way to use the vom in this setup is particularly handy if the Lecher wires are too short to show two dip points for a particular frequency. Since standing waves have points of high and low voltage, it should be possible to find also a point of low voltage a quarter-wavelength away from a high-voltage one. The procedure is illustrated in Fig. 808.

Using the shorting bar, one dip point is located, indicating resonance at that point. Now the vom leads are connected as shown, with the diode in one leg. When the prod is moved along one of the wires away from the shorting bar, a point will be encountered where the reading of the meter will suddenly drop to virtually nothing. This is a null point, a quarter-wavelength from

the shorting bar, and once again the exact frequency can be determined.

Because the ac ranges of the meter are not usually sufficiently responsive to uhf, we use a crystal diode and the dc (current) ranges of the meter. A small capacitor in parallel with the meter will increase the reading somewhat, but will also make the dip show up a little more slowly, due to stored energy in the capacitor.

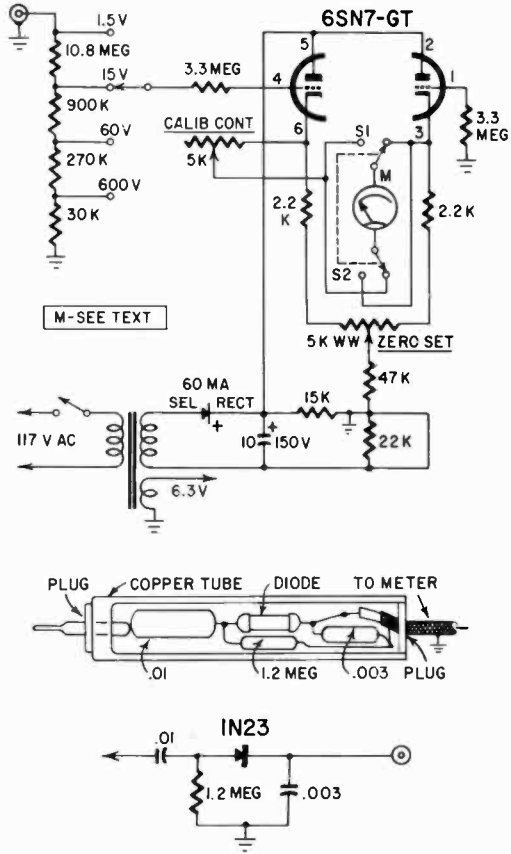

Fig. 809. Vacuum-tube voltmeter adapter which can use the vom and the probe which is needed with it.

A 20,000-ohms-per-volt instrument is almost certainly needed for this kind of work, although a 1-ma movement can sometimes be used if the power of the generator is great enough. Transmitters usually emit enough for the 1-ma meter or handy-tester type of instrument.

Amplification for the vom

The vom can be made more sensitive by using some form of amplification. There are many possibilities in this area. We can use voltage amplification and thus make a vtvm out of the vom, or we can use transistor current amplification and make the instrument a very sensitive current meter. (See also page 68, Chapter 3.)

Fig. 809 is a simple example of such a vtvm circuit. The schematic is shown for a $500\text{-}\mu\text{a}$ movement, but much greater sensitivity can be had by using a $50\text{-}\mu\text{a}$ unit. The meter as shown has ranges of 1.5, 15, 60 and 600 volts. With a $50\text{-}\mu\text{a}$ meter, after recalibration, these would become 0.15, 1.5, 6 and 60 volts, and for

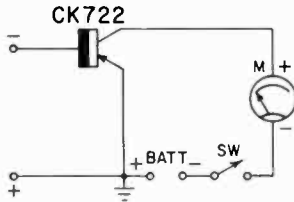

Fig. 810. Elementary transistor current amplifier.

higher voltages the vom should be switched to a higher range. However, remember that the calibration may have to be individually adjusted for each range, since the difference in resistance of the ranges would change the operating point of the two triode sections.

As shown, the vtvm is capable of measuring only dc voltages, since the meter movement would not respond to ac appearing at the cathodes of the tube. However, an ac probe can be built with the instrument (Fig. 809).

The meter in Fig. 809 must be specially calibrated, since there will be a noticeable difference between ac and dc readings.

However, a separate set of multipliers could be designed for ac so that the same scales of the meter can be used without recalibration, although the lower portion of the scale in ac measurements is not likely to be linear.

A circuit could be constructed similar to that shown in Fig. 809 which could make use of the ac ranges of the vom, but there would be a considerable sacrifice in sensitivity. With the proper calibrating and multiplying resistors, you may be able to achieve conformity of the ac voltage measurements with the ac scales on your vom which would make the entire setup more accurate and

convenient. This would have to be worked out for your particular vom, and it depends on the ac scales shown on it.

Transistor current amplification

The transistor is basically a current amplifier and is well suited for some simple current amplifiers which can be constructed to give your vom much more sensitivity. A step beyond this would be taking advantage of current amplification to make a sensitive

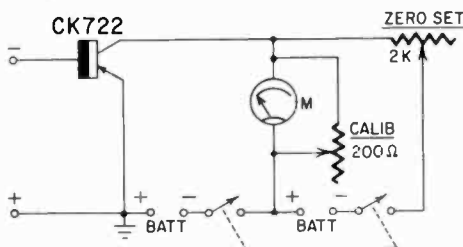

Fig. 811. Transistor amplifier for the vom supplied with a zero setting circuit and a calibrator to match one of the vom scales. The vom is used in place of the position occupied by the meter.

voltmeter which uses the vom as its basic instrument. Fig. 810 shows the simplest form of current amplifier which can be built.

If you use a 1-ma movement, you can have a current meter which is, in effect, equivalent to a 10- μ a meter, very sensitive indeed. Take advantage of its sensitivity by making it into a voltmeter with 100,000-ohms-per-volt resistance. Fig. 811 illustrates the circuit diagram, but in place of the 1-ma meter shown you can use your vom.

With a 20,000-ohms-per-volt meter, you could build an even more sensitive voltmeter, but there is a practical limit to what you may need. There is also one other problem . . . the element of instability: the effect of temperature on the transistors. Thus, by merely holding one of them between thumb and forefinger, you can warm it enough to get almost full-scale deflection. Therefore, transistors in this kind of a circuit must be mounted so that they are either well ventilated and assume room temperature, or well insulated so that they are not much affected by room-temperature changes. In either case, it is necessary to check the ZERO SET each time you take a measurement. Also, do not leave this meter connected to the source for any great length of time, for the current flowing through the transistors may, in time, warm them

enough to change the reading. It is nice to have such a sensitive meter, but the penalty is the extra care it needs.

The circuit of Fig. 811 has the obvious disadvantage that the meter will always indicate some current. This problem has been solved in the circuit shown in Fig. 812. A calibrating potentiometer has also been included so that the deflection of the meter can be standardized for one of the meter scales.

The maximum gain obtainable with this kind of current ampli-

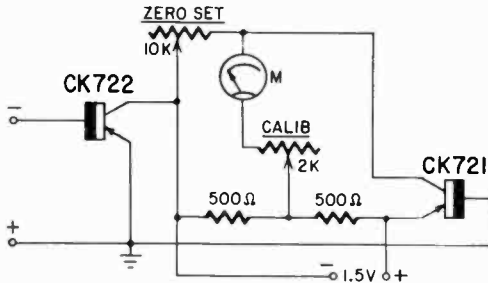

Fig. 812. High gain transistor amplifier for the vom. This circuit has zero set and calibration controls. The disadvantage of this circuit is that it is susceptible to temperature changes.

fier is about 20, depending somewhat on the transistor used. Some very good transistors may give a gain as high as 50. Whatever the gain for the one you build, you will probably "calibrate" the circuit down to an even multiplication of some vom scale, so probably you will be using the 10, 20, 25 or 30 gain figure. Consider that this amplifier, which can be built very compactly, can turn the 50- μ a scale of your vom into a 2- or 5- or even a 1- μ a scale, or, if you have a less sensitive instrument with a 1-ma meter, it can make this instrument as sensitive for current measurement as a 20,000-ohms-per-volt unit, at very little expense.

You can carry this process a step further, and use two transistors to get really high current amplification, as in the circuit shown in Fig. 813. The transistors are cascaded to produce a gain of about 100 or more, and thus you can obtain a sensitivity of 0.5- μ a *full scale* for a vom with a 50- μ a scale. This is a sensitivity well beyond that ordinarily needed in service work, but might be useful for changing the vom into a sensitive field-strength meter.

A circuit which uses a different approach is that shown in Fig. 814. A very sensitive arrangement, it does not have one of the major disadvantages of the previous circuit—the tempera-

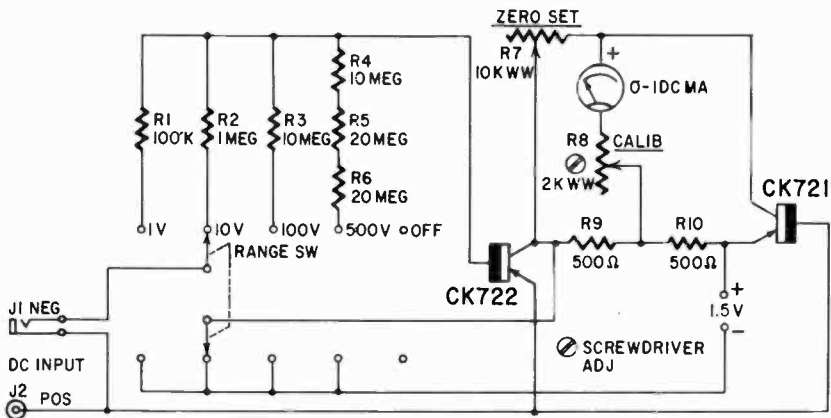

Fig. 813. Sensitive voltmeter using transistors which can be designed for the vom as its basic meter. The sensitivity of this instrument becomes so great that it can be used as a field-strength meter, when the vom is a 20,000-ohms-per-volt type.

ture effect. If the transistors are reasonably matched (and we can assume that they will reach the same temperature rise) the accuracy of the instrument should be affected little or not at all by temperature changes. As shown here the circuit is designed for a 50- μ a scale. The original circuit was designed for a 20- μ a meter, and for this it would of course show much more sensitivity.

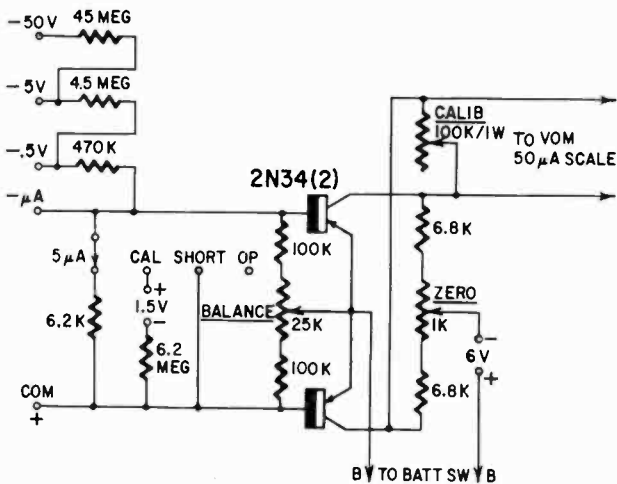

Fig. 814. Balanced transistor amplifier for the vom does not have the temperature problem encountered in single-ended amplifiers. This assumes that both transistors are reasonably well matched. This circuit is for use with a vom having a sensitivity of 20,000 ohms per volt.

Similarly we can amplify the signal to make a more sensitive null detector out of the vom. With a $50\text{-}\mu\text{a}$ scale, the circuit of Fig. 815 can be used. Because it shows rectification before energizing the meter, this will be your clue to the fact that this null

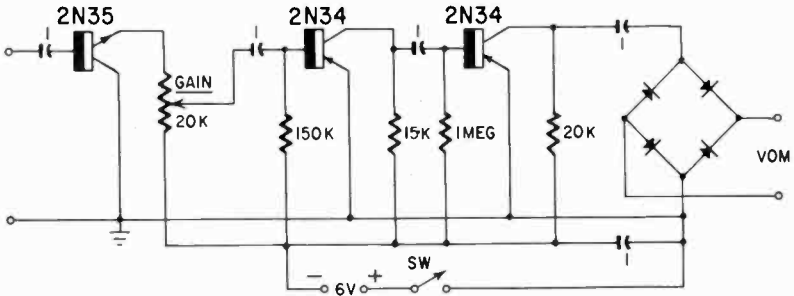

Fig. 815. Sensitive ac amplifier for the vom to be used as a null detector in ac bridge circuits, or to increase the ac sensitivity of the instrument.

detector is designed for ac only. The Wheatstone bridge discussed earlier can be used with ac as well as dc; the reason that it is usually used with dc is the fact that originally the circuit was designed for sensitive dc galvanometers.

There are a number of bridge type circuits using ac which are useful for measuring capacitance, inductance and resistance values. We studied the null detector here because it is the natural companion to the very sensitive dc voltmeters using transistor current amplification.

Field-strength measurement

A popular use for the vom, field strength measurement, can be approached in several ways. If you are close to a source of radiation, it may be unnecessary to tune the field-strength measuring circuit carefully. You may be able to obtain *comparative* readings with such a simple arrangement as Fig. 816. Here the 1N21 diode is shunted across the meter leads, and the meter turned to its lowest—possibly the $50\text{-}\mu\text{a}$ scale. With a grid-dip oscillator several feet from the meter, this should provide almost full-scale deflection.

This circuit is unsuitable for uhf, since the test leads of the meter are too long and the circuit will probably be resonant to a much lower frequency. In this case, special short meter leads can be made to reduce the wavelength of the meter circuit. However, in measuring uhf field strength, you will probably be more

interested in picking up the radiation from a specific source, and tuning should be used.

For this a somewhat more elaborate circuit is needed. A typical tuned field-strength meter is shown in Fig. 817. Notice its similarity to a grid-dip oscillator tuned circuit. Many gdo's are indeed used

Fig. 816. An extremely simple type of field-strength meter. This is suitable only in areas having high signal strength.

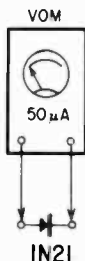

as field-strength meters with the power turned off, but the meter circuit is not always sensitive enough to indicate low-level radiation.

To make the field-strength meter more sensitive, we can employ two methods. Which you select depends on the sensitivity desired. One method is to make the antenna longer or more efficient, but this is not always a good procedure if you are dealing with high-frequency radiation. The other is to make the meter circuit much more sensitive, and for this you can use any of the transistor amplifiers already discussed. Simply interpose the transistor amplifier between the tuned circuit (with rectifier) and the meter.

For the uses to which field-strength meters are generally put by the amateur or experimenter, it will not be necessary to calibrate the meter accurately. Only in the determination of interference strength, as carried out by the FCC, would we need a calibrated meter. The meter would then be calibrated in microvolts per

Fig. 817. Field-strength meter with the vom used as the indicator.

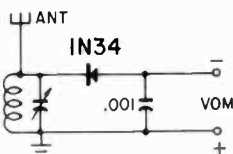

meter; i.e., in microvolts generated on an antenna exactly 1 meter long. However, most amateurs and service technicians use field-strength meters for such purposes as orienting and positioning antennas, detecting antenna radiation patterns, and indicating whether an oscillator is operating, and all of these are relative measurements only.

If you must calibrate your field-strength meter, there are two ways in which you can proceed. One is to compare the readings on your meter with those of a calibrated meter, which is usually owned by such companies as the manufacturers of dielectric and induction-heating equipment or the producers of diathermy

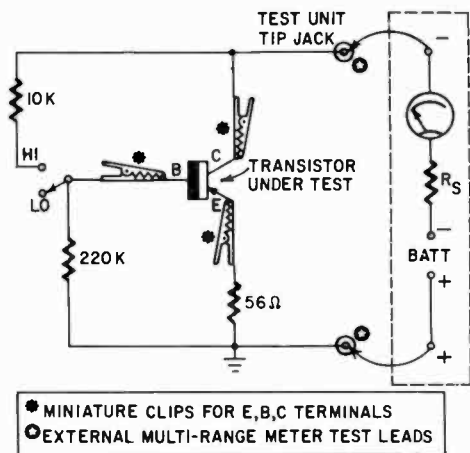

Fig. 818. Simple transistor checker using the vom for a battery as well as a meter. Miniature clips are used to attach the tester to the leads of the transistor. The function selector on the vom should be set to read resistance, usually low ohms.

equipment. These people must make their installations conform to FCC rules with respect to interference, so most of them are equipped to make accurate measurements. Another way is to provide the meter with a calibrated signal at the precise frequency by a signal generator. The generator is then connected to the antenna input of the field-strength meter through a dummy antenna, which, in effect, is nothing more than a resistor and capacitor so arranged and chosen that they represent the same impedance as a normal antenna for the meter.

Transistor tester using the vom

Earlier we showed how transistors could be identified and accepted or rejected on the basis of their backward-to-forward ratios of their junctions. But nothing was said about the actual performance of the transistor, which is dependent on these ratios. The basic requirements are simple. The transistor's ability to amplify is a measure of its response to a change in base current

with a larger change in collector current. This can be checked by the simple device shown in Fig. 818 and a vom.

The transistor is clamped into the alligator clips, and the meter turned to a resistance position, probably the low-resistance range, although this depends on the ranges of your vom. In effect, the resistance range provides for the transistor check a battery and a series resistor which will protect both the meter and the transistor. In the LO position of the switch on the tester, the current through the transistor base is zero, except for leakage through the emitter-base junction and the 220,000-ohm resistor. This leakage should be included to give a more realistic measurement of the performance.

With the switch in the HI position, the current in the transistor base circuit will be determined by the 10,000-ohm resistor. The collector current will now be much larger than before. The two readings indicate the effectiveness of the transistor. Strictly speaking the ratio of the two divided by the change in base current is not equivalent to the transistor beta (current amplification) but

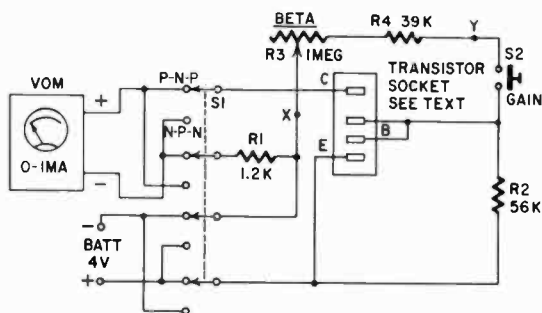

Fig. 819. Direct reading transistor checker using the vom as the basic meter. A vom having a sensitivity of 1,000 ohms per volt is adequate for this job. Table 8-1 is a calibration chart for this checker.

it is close to it. The second figure includes the current through the base and the voltage divider, which would have to be subtracted to obtain beta. But these currents are very small by comparison.

A good transistor for audio amplification should show a ratio of at least 8 to 1 and anything less than 6 to 1 indicates a poorly functioning transistor. If both readings are very low, the transistor may have excessive resistance in the forward direction; if both are high, the transistor may be nearly shorted.

The main advantage of this simple transistor checking adapter is just that—it is simple to make and use. Many other adapters can be made using the current range of the vom for indication, and using an external battery and external resistances.

A particularly useful tester is the one shown in Fig. 819. It uses the same principle: a change of collector current is measured as the base current is changed. But here the change is always made a fixed ratio, and the resistor required to make this ratio the same is calibrated directly to read the beta of the transistor. This tester uses the 1-ma range of the vom, but you have your option of using this 1,000-ohms-per-volt type of meter or one with greater sensitivity.

A special adapter with alligator clips can be made to accommodate power transistors. Fig. 820 shows the adapter, while Table

Table 8—1. Calibration of the checker shown in figure 819

Beta	Resistance	Beta	Resistance
	(X to Y)		(X to Y)
	(ohms)		(ohms)
5	40,000	30	240,000
6	48,000	40	320,000
7	56,000	50	400,000
8	64,000	75	600,000
9	72,000	100	800,000
10	80,000	125	1.0 megohm
15	120,000	150	1.2 megohms
20	160,000		

8—1 shows the calibration of the potentiometer for marking the beta range on the potentiometer scale. With switch S1 in the proper position for an n-p-n or p-n-p transistor, and the transistor plugged in, read the leakage current through the transistor first. Now depress switch S2 and adjust the reading on the meter to be exactly 0.5 ma *more*, and the scale on the potentiometer will indicate the beta of the transistor. In one operation you learn its amplifying ability and its leakage properties.

There are many other types of transistor testers but any of them can use the vom as meter.

Checking tubes with the vom

The vom with some auxiliary equipment can be used to check any radio or TV tube for any of its characteristics which are of importance to use. You can build a regular device for this, or you can set up each time you wish to check a tube. It all depends on

how often you expect to test tubes and how much convenience you expect to create for yourself.

Checking tubes with the vom is not at all difficult once you know how to go about it. We have already discussed tube-filament continuity and a check for shorts.

The next most common test is testing a tube for emission. To do this we must ask the tube to deliver saturation current, which, depending on the tube, varies from 45 to 250 ma. But it is not

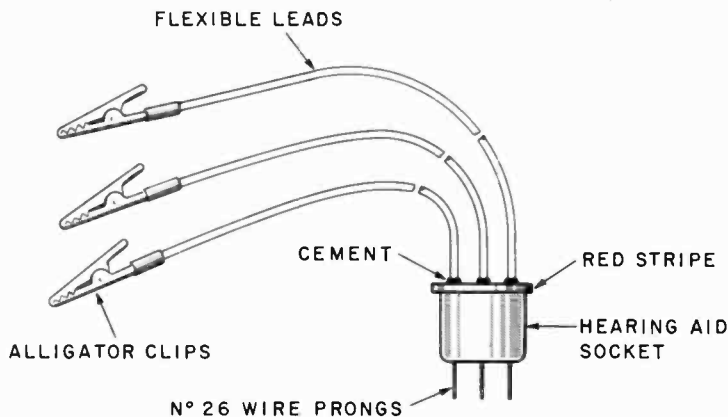

Fig. 820. Plug for testing power transistors, designed to go with the tester of Fig. 819. The plug is made from a miniature hearing-aid socket with the pins removed and wires inserted in place of the pins. Use a stripe of red paint or fingernail polish as a guide on both the tester and adapter sockets.

difficult to figure out what it should be if you first check a tube which you know is performing well and compare its reading with

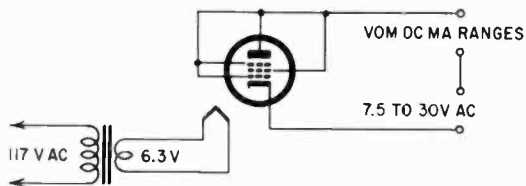

Fig. 821. Method of making an emission test with the vom. All the tube elements (except the cathode) are tied together, so the tube is tested as a diode. This test is a check on the condition of the cathode.

the tube under test. Generally tubes such as 6V6 and 6L6 output types have over 200-ma saturation current, while rf amplifiers such as the 6AU6 and 6BH6 will show about 60 ma. In-between

types, such as dual triodes 12AX7, 12AU7, and the 12AT7 will supply about 60 to 80 ma of saturation current.

The process is very simple. The diagram is shown in Fig. 821. All the tube elements, other than the filament and cathode, are tied together, and the meter is put in series with the tube and a relatively low-voltage ac supply. This should be about 30 volts or less for most tubes, although rectifier tubes may need as much as 70. The meter is used on the 1-amp, 500-ma or 250-ma scale, depending on what you have available. For some tubes, the 100-ma scale will be sufficient. The emission, which is as much current as the tube can possibly produce, is a direct indication of the state of the cathode. If this emission current is less than about 60% of what your healthy tube puts out, the tube should be replaced.

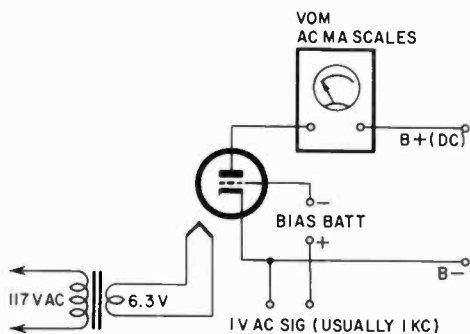

Fig. 822. How to make a transconductance test with the vom. If the vom cannot read alternating current (and it usually cannot) obtain this information indirectly by measuring the ac voltage drop across a known standard resistor in series with the plate.

The next most interesting test is that for transconductance. Again the tube must be supplied with filament current, but now we need some dc supplies to provide proper voltages for the elements and for the grid a 1-volt ac signal. The signal voltage can be anything from 60 to 1,000 cycles. Finally, we will need to measure ac milliamperes with the vom.

The diagram is shown in Fig. 822. The measure of transconductance is the *change* in plate current with a 1-volt *change* in grid voltage. By applying ac to the grid, you can immediately read the change in ac on the plate, since now the grid voltage changes from 0 to 1 volt rms.

With the proper dc voltage on the plate (rated voltage), the

transconductance will be exactly 1,000 times the meter reading in micromhos if you use a 1-ma ac scale, and proportionately more if you use a higher scale. Thus, a 10-ma ac scale would read 1/10,000 of the transconductance in micromhos, etc.

Several other tube tests can be made with your vom. One of them, the power output test, also requires an ac milliampere measurement, and one, the amplification test, an ac voltage measurement. The power output test is seldom performed.

The amplification test circuit is shown in Fig. 823. Again a signal voltage is applied to the grid, and the resultant ac voltage at the plate, developed across the plate resistance, is measured.

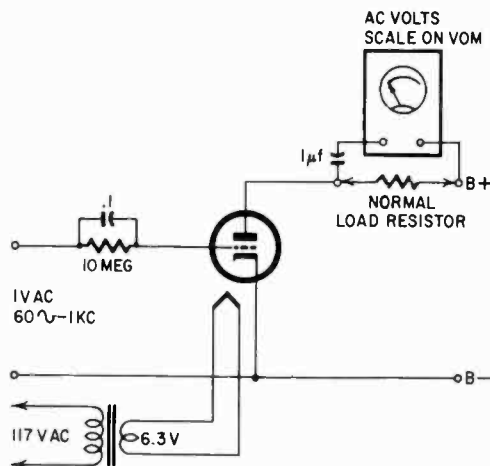

Fig. 823. Amplification test using vom ac voltage scales. When testing pentodes, the screen should get normal screen voltage. The amount of B plus must also be what the tube will get in actual use.

This is a direct figure for amplification, since the signal on the grid will be made 1 volt again. In other words, the meter reading in volts is the amplification. Sometimes this test is substituted for the transconductance test, and you can see that, if we measure the voltage across a fixed value resistor, this voltage will be proportional to the ac developed, and thus proportional to the transconductance. But it is not exactly the same, for in the transconductance test there is no other load resistor besides the meter, while in the amplification test we use a normal load resistor for the tube.

Other tests are for gas and interelectrode capacitance. For the

first, you need a meter reading only a few microamperes and, with the transistor-amplified vom described earlier in this chapter, this can certainly be done. The process is to apply a bias to the tube until the tube is cut off, and then to measure the grid current of the tube with a sensitive microampere meter, while the plate has a normal voltage on it. The theory is that, while the tube is cut off through a high grid bias, no electrons can pass from the cathode to plate, so whatever electrons reach there must come from the grid, and this would not take place unless the tube is gassy.

Interelectrode capacitance is simply the measurement of the very small capacitances between the elements. Usually these are too small to be measured with a vom, unless you calibrate the vom to measure small capacitances with the series ac method used in identifying "mystery components" (see Chapter 7). Measurement of interelectrode capacitance is seldom necessary except in vhf and uhf circuit design, and then you can usually rely on the manufacturer's figures.

There are many other ways to make the vom serve as the basic meter in instruments. Those we have shown here are intended to be guides only to help you decide how you want to incorporate provisions for using the vom with instruments which normally have their own meter. Remember one thing: when you have your meter tied up, you cannot use it for anything else. If you want to make an instrument using the vom which must be used simultaneously with some other measurement, it would probably pay to build a meter into the instrument permanently.

Some solve this problem another way. Notice that many of the instruments described have as their basic meter a 1-ma unit. Therefore some experimenters acquire, besides their vom, several 1-ma meter movements which can be used for various instruments, and they rely upon the vom when sensitivity is needed.

the vom as a service instrument

IN the beginning of this volume, we called the vom the most frequently used instrument of the service technician. Its versatility and possibilities are now a familiar story. Not only does the instrument have a large variety of useful scales, but there are many simple and inexpensive ways to extend its capabilities. The vom, moreover, is compact, relatively rugged and easily carried.

It is, because of its characteristics, the most valuable instrument for a variety of service and maintenance people, whether they are industrial electricians, TV repair men, electronic-organ service technicians or laboratory engineers. It is feasible, and usually necessary, to provide a range of instruments for the service or laboratory bench, but it is neither feasible nor particularly necessary to carry such an assortment along on a service job. In this chapter we will take a look at *what is measured*, the meaning of the readings taken with the vom, so that you will get some insight into its multitudinous applications. Many problems can be made a great deal less difficult with the aid of a good vom, provided the user knows and understands what is being measured, what such measurements mean in terms of the function of the equipment. Since it is obviously impossible to talk about *all* possible applications of the vom, we have selected those of most general interest. Simultaneously we will mention some of the vom's limitations. It is not *always* possible to make readings entirely meaningful, and to allow direct interpretation of the results in terms of equipment function.

The vom in ac-dc receiver servicing

By far the majority of receivers in use in our country are the small ac-dc transformerless types. These often have a "hot" chassis, so the first use of the vom is to make certain that you are not working on something which can be dangerous. Although 117 volts ac is not always fatal, it certainly can be.

You have removed the set from the cabinet, set it on the bench and plugged in the line plug and turned on the switch. (Replace

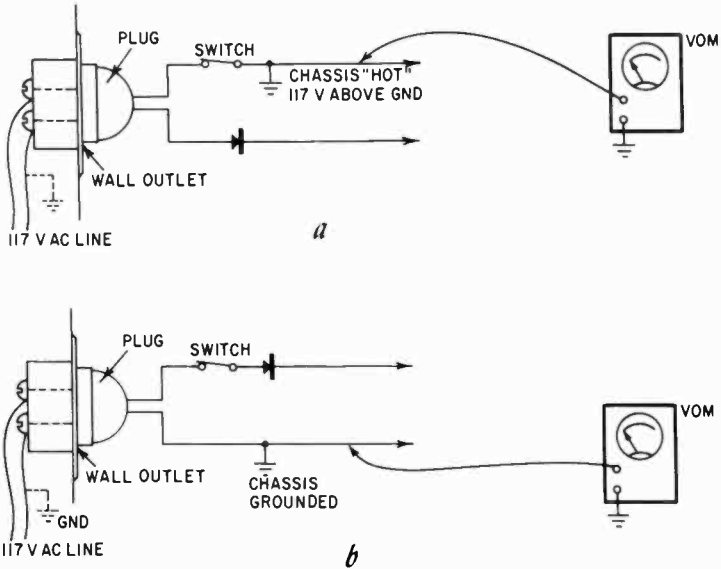

Fig. 901. With the vom set on the 150-volt ac scale, check to make sure that the chassis isn't "hot."

the knobs as soon as the set is out of the cabinet but *before* the set is plugged in.) Now, with the vom on its 150-volt ac scale, establish whether the chassis is "hot." (See Fig. 901.) Practically all 117-volt power lines have one side grounded; if the line plug of the receiver is in the outlet correctly, the chassis will show no voltage to ground. Ground can be a waterpipe in the vicinity or, if the building meets electrical-code specifications, the outlet box itself must be grounded, and you get a ground connection there. If the chassis shows a voltage one way to the outlet box metal and not the other, the box is properly grounded. Work on the set only with the plug inserted so that no voltage shows on the chassis.

Checking series filaments

Since in these transformerless sets the tube heaters are con-

nected in series, the entire string will refuse to light if one tube is out. This tube can be quickly located if you use the same ac scale (150-volts) on the heater pins of each tube. For octal tubes these are usually pins 2 and 7, (with a few exceptions), for minia-

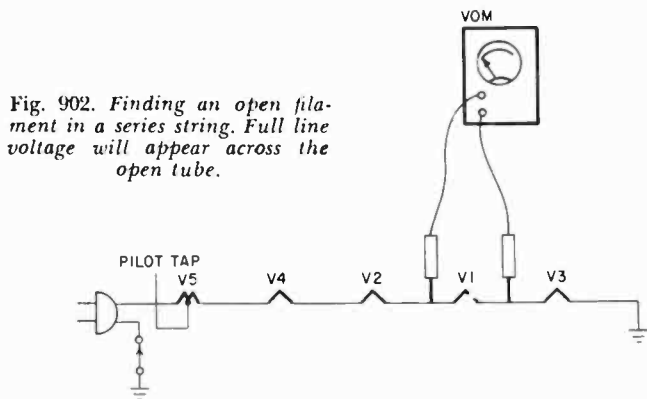

Fig. 902. Finding an open filament in a series string. Full line voltage will appear across the open tube.

ture 7-pin tubes ordinarily 3 and 4 and 4, 5 and 9 on the 9-pin tubes. Pin No. 9 is the center tap of the heater. In series sets with 12-volt tubes, this tap would probably not be used.

Fig. 902 shows such a string of tubes. With the vom you can locate the faulty tube quickly, since the entire 117 volts ac will appear across this tube. You could also take out one tube at a

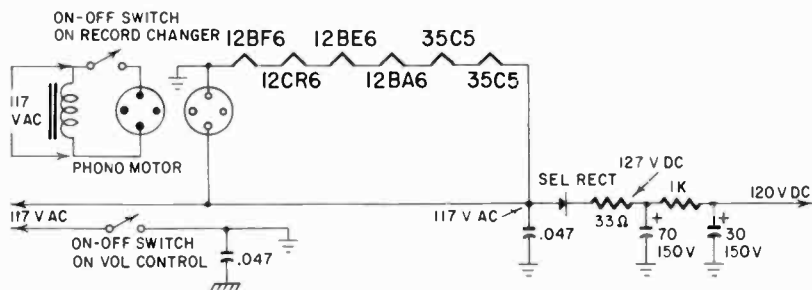

Fig. 903. Power supply setup for an ac-dc receiver.

time and check it for heater continuity on the low ohms range of the meter.

Some series-string sets also have a resistor in series with the tube heaters. If the tubes are all OK, but do not light, look for and check this resistor.

Checking B-plus voltage

If all the tubes light yet a set does not work, check to see if

there is power supply voltage. (Fig. 903.) Use the dc scales, starting with at least the 500-volt or 300-volt one. If the power supply voltage in an ac-dc set reads much less than 120 the filter capacitor is defective or the rectifier is probably not operating properly. Coincident with low voltage when the filter capacitor is out, there is usually a clearly audible hum in the set.

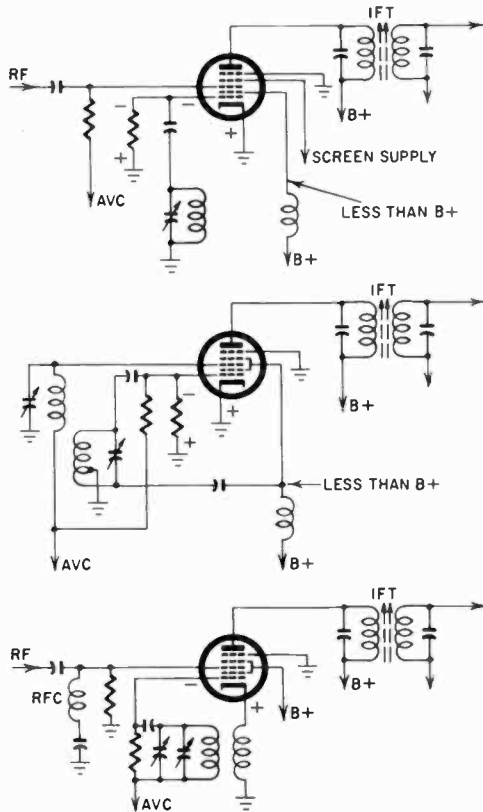

Fig. 904. Some very different-looking converter circuits. Polarity and voltage points are indicated when checking for oscillator function using the vom.

A quick test for filter capacitor function is to connect the meter prods to the chassis and B-plus and turn the set off. If the voltage drops to zero at once, the filter capacitor is finished and should be replaced. If the voltage is low but drops very slowly, or at least not very fast, the rectifier tube probably has lost emission.

Checking the oscillator

If the plate voltage is OK, tubes light and there is a barely audible hum in the speaker to show that the output circuit and the speaker are at least functioning, make a quick check to see if the set oscillator is working. If it is, a small positive voltage should appear at the oscillator cathode of the converter tube. Fig. 904 shows check points on some common receiver oscillator circuits.

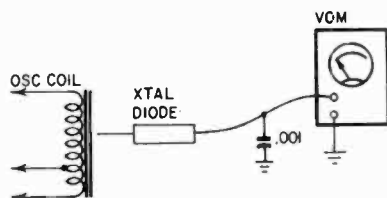

Fig. 905. A crystal diode and a vom set on its most sensitive scale can be used to check for oscillator operation.

Another way to check the oscillator of a receiver quickly was explained in Chapter 8 under field-strength measurement. For this you need only clamp a crystal diode onto your test leads, switch the meter to its smallest current (microampere) scale and

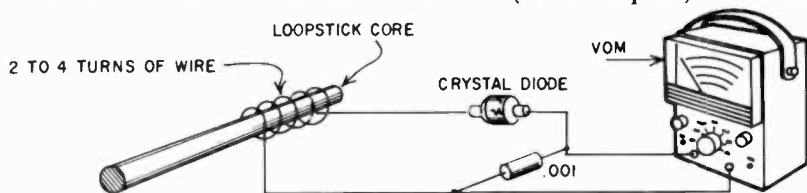

Fig. 906. Simple probe to check for oscillator function without connecting to the circuit.

put the test-lead "probe" in the vicinity of the oscillator coil. (Fig. 905). If the oscillator is working, you will get a considerable deflection on the meter.

An oscillator probe for the vom, easy to make and which functions at uhf as well, is shown in Fig. 906. A ferrite rod can be obtained from a loopstick antenna. (Incidentally, if you've ever wondered why these things are called loopsticks when they in no way resemble loops, it is because they exhibit the same directional characteristics as loop antennas.) The probe consists of a few turns of fairly heavy wire around the rod, a semiconductor diode and a capacitor. Brought near an oscillator this probe will show as much as 200 μ a deflection on a vom. It is sensitive enough,

with a 50- μ a meter, to show the presence of rf in other parts of the circuit.

Signal tracing and alignment

Most ac-dc sets can be signal-traced by touching each successive grid in the set with a metal object such as a screwdriver. If you hear an audible click in the speaker, the stage is probably working. But this is not always a reliable method. A signal generator injecting an af or rf signal would be better. This is almost certainly needed when you wish to align a set. If only the if needs to be aligned, the vom can be a handy indicator for proper set alignment. Of the several ways to connect the vom for this, the simplest is to attach it as an output meter across the speaker voice coil. Then, with the volume as low as possible yet giving a definite deflection on the meter, adjust the trimmers on the if transformers for maximum output. Do not try this procedure with an FM tuner or receiver. The adjustment of the if's in these is much more critical and requires the use of the appropriate if signal, 10.7 mc.

Another method of using the vom for alignment is to connect it from ground or chassis to the screen grid of an if tube (or rf, if the set has one) provided the screen grid is fed through a dropping resistor. When the strength of the signal increases, the avc voltage also rises. This reduces the amount of screen current and as a result there is less of a voltage drop across the screen resistor. The voltage at the screen will rise. Use this for an indication of maximum signal.

Plate voltage at all the tubes is the next quick check, and for this you would use the high-voltage dc range of the vom. If any plate has exactly the same voltage as the B-supply, you can be reasonably sure this tube is not functioning, for even an if transformer winding will drop the plate voltage a certain amount. (This is shown in Fig. 907.) Tube nonoperation can be caused by a variety of defects, but the most common ones are burned-out cathode resistors or open grid resistors. Check these with the set turned off and the meter on the appropriate resistance ranges.

If the vom shows large positive voltages on the grids of any of the tubes, you can be almost sure the preceding coupling capacitor is leaking and must be replaced. This would also be indicated by excessive drop of the plate voltage across the preceding plate load resistor.

Checking avc

Proper functioning of radio receivers of the superheterodyne type also requires avc. The avc voltage is developed by the second detector or a separate diode detector usually in the same envelope.

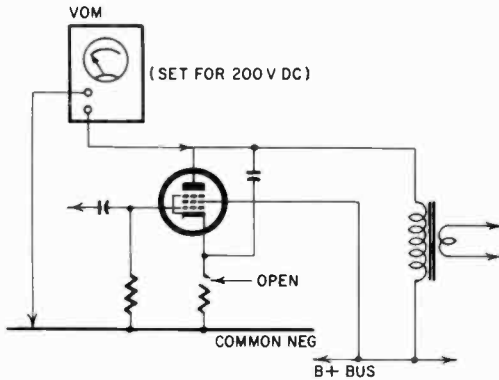

Fig. 907. An open cathode resistor means full B+ on the plate of the tube. The same amount of voltage will appear on both sides of the load.

On a strong transmitter signal, this voltage should amount to as much as 10 to 12. This is a negative signal applied to the ground end of the grid section of rf and if transformers, to avoid overloading the stage with a strong signal. (See Fig. 908.) If this voltage is absent, the set exhibits what is known as "blasting." When you tune a station it will suddenly come in much stronger than expected, and it will be almost impossible to receive even a relatively weak broadcasting station without serious distortion. The loss of avc can result from leaky avc capacitors.

The avc method used in most receivers calls for relatively large capacitors. These store the energy provided by the signal so that, when the signal drops for a short period, it does not immediately decrease the avc voltage. If it did, the set would sound either very "flat" with all passages, loud or soft, coming out the same, or it would show a "wagging" signal, an excessive hunting of the avc trying to keep up with signal-strength variations. Both conditions can result from dried-out or open avc capacitors. If the vom shows a rapidly varying voltage on any of the avc points, with the set tuned in on a station and left there, some of the avc capacitors are either open or too small.

Incidentally, this is one method of hooking up an S-meter, a meter which can be used to measure signal strength but is most

often simply employed as a tuning indicator. Avc voltage is a sure indication of maximum tuning and, where you have "difficult-to-tune" stations, you could use your vom this way, simply hooking it to the avc circuit to tune for maximum voltage. Use a 20,000-ohms-per-volt (minimum) vom for this test.

Signal interference

Fig. 909 shows two types of wave traps. These are tuned to eliminate a particular frequency. The series circuit in Fig. 909-a does this by showing a very low impedance to the unwanted signal,

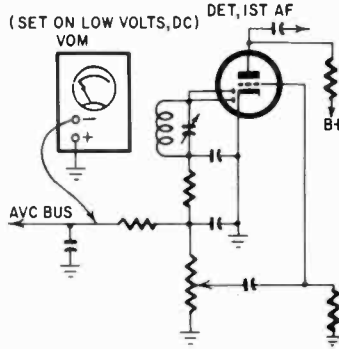

Fig. 908. Method of checking avc with a vom.

bypassing it to ground. The parallel wavetrap, working in a completely opposite manner, shows a very high impedance and does not allow much of the signal to enter into the receiver. Which-ever you use depends on the situation; the series wavetrap reduces the set's sensitivity on adjacent frequencies, but the parallel wavetrap (Fig. 909-b) is less effective. These traps are used, for example, near a transmitter antenna, which might put out such a strong signal that it is heard all over the dial.

To tune the wavetrap, simply connect the vom to an avc point, tune the receiver to the offending station and adjust the trap for minimum indication on the meter. This is sometimes the only possible procedure if the signal is strong enough to saturate the receiver audio in spite of the avc.

The appearance of a station on several points on the dial may not always be a sign you need a wavetrap. It may be, for example, lack of selectivity of the if's or a weak oscillator. There are two ways in which signal interference can take place. There is what is

known as "image" frequency. Let us say you have the set tuned to 550-kc signal and the if is 450 kc. The signal from the oscillator may come in and interfere. Your reception is disturbed by the "image" of the 1450 kc station; although your tuning circuit *should* reject this station it *enters the if circuits*, creating interference there.

There is also what is called "double-spot" appearance of stations. This can happen when a signal at 1450 kc also generates an if at 450 kc (where it would create an interfering image). In *double spot* reception, the *strong* 1450 kc signal generates the second "spot"

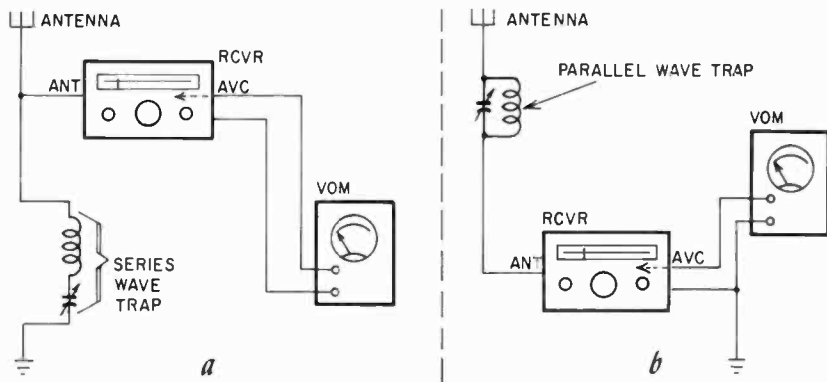

Fig. 909. Two kinds of wavetraps that can be tuned by connecting the vom to the avc circuit.

in the converter rf grid circuit by heterodyning with the oscillator signal radiated by this tube. Receivers with rf amplifiers that do not radiate do not have double spot reception. Whatever we do to prevent image reception will also cure double-spot reception. Most frequently this can be cured by proper rf and if alignment of the receiver.

Locating microphonic tubes

The usual method of locating a microphonic tube is to tap each in turn until a "boing" is heard in the speaker. However, some tubes are so microphonic that they sound off no matter what part of the chassis is tapped. One way of locating these tubes is to connect the vom (set to read voltage) across the plate, screen or cathode resistor (as shown in Fig. 910) and then tap it. Microphonism is indicated when the meter flickers as the tube is tapped. When testing power output tubes, keep the volume turned down to eliminate the effects of microphonics in earlier stages.

Using the vom in FM and TV

Problems similar to those in AM receivers are encountered in FM tuners, with a few basic differences. For example, you can align an FM if strip with an AM oscillator, and connect the vom to the discriminator or ratio detector. But in this case you must tune for a *minimum* signal, with the generator set for the intermediate frequency. In FM, when the signal is exactly on frequency (if)

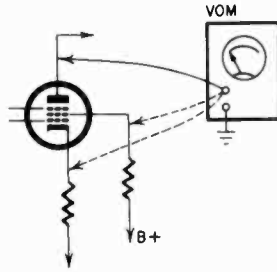

Fig. 910. Use the vom to locate a microphonic tube. Connect as shown and tap the tube lightly. Watch the vom for erratic behavior of the meter pointer.

the AM will not show up, but when the signal (or, conversely, the if transformers) is off resonance, the AM will pass: the more off resonance, the more AM signal will pass. So tune for minimum signal. Of course, better alignment methods of FM if strips call for a sweep generator and oscilloscope. But a creditable job can be done with an AM test generator and the vom if the job is done with extreme care.

A properly functioning FM receiver does not respond to AM, but this is a function of the limiter before the second detector. Thus, if we inject an AM carrier signal on, say, the mixer, and take the signal off for the vom with a demodulator probe in the stage *before* the limiter, we can do a very accurate job of aligning these if's. The limiter if can also be aligned this way without the limiter tube in its socket, if we apply the signal to the input of the limiter transformer. Fig. 911 shows such a demodulator probe.

TV intermediate-frequency amplifiers must handle both the picture carrier, which is AM, and the sound carrier, which is FM and 4.5 mc away from the AM. TV if transformers must have a very broad response. With the exception of the last one, the sound if, these can also be adjusted with an AM oscillator and

the vom connected to the video detector. Let us warn you, though, that proper TV alignment is very difficult without a sweep generator and scope.

Adjusting the linearity coil

The millimeter function of a vom can be used for speedy adjustment of the linearity coil (if the TV set has one). Clip the meter leads across the terminals of the fuse in the B-plus line going to the horizontal output circuit. Adjust the linearity coil for

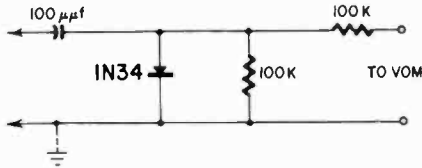

Fig. 911. A demodulator probe is needed for rf or if signals when aligning receivers with the vom.

a minimum reading. That's all! Naturally, the fuse is removed when the meter is connected.

Audio amplifier in a TV set

The audio section of a TV set is no more complicated than that of a broadcast receiver. In the audio section, one particularly useful measurement is the bias voltage on the cathode of the output tube. A low bias voltage will lead to distortion. This could be caused by loss of emission in the tube or by drying out of the bypass electrolytic capacitor.

When servicing the audio portion, voltage measurements will again give clues to shorted or leaking capacitors, open resistors, etc.

If a set is completely dead, the job starts from the back. Check the speaker first. Touching the voice coil with the meter prods with the meter on the low ohms range should give a clearly audible click in the speaker. From there, the next check point is the grid of the output tube, then the sound detector or the second detector. The vom is adequate instrumentation to service all of the audio section of any receiver.

Special adapters are sold which will make service work much easier. These are tube bases (in seven-and nine-pin miniature and octal bases) with a socket on top. Between the socket and the base are short switches with exposed contacts. With these you can test the performance of a tube in its circuit, for you can measure

voltages on any tube element during operation and, by opening the small switches, measure current to any element.

Sometimes when you use the vom to measure a voltage on one of the elements in a set which has been inoperative, the set will suddenly come to life. This is a sure indication of something wrong with the return to that circuit, usually an open resistor. On the other hand, you may find that in a set which operates poorly, that connecting the vom across two points will decrease the output or even stop the set from operating altogether.

Now this is no definite sign that something is wrong in the circuit. If you were measuring, for example, negative grid bias on a tube and using the 1.5-volt scale (which would be appropriate) you might then also short the grid to ground through such a low resistance that it would cease to operate. Similarly, an oscillator which is operating marginally may suddenly cease when you apply the test prods to measure its voltages. It may even shift frequency. Many oscillators are voltage-sensitive to a certain extent and when the voltage is further lowered by the vom the deviation may get worse.

Portable radios

Portable radios present special problems. Servicing techniques used with these sets are slightly different from those used with home or auto radios. Several additional points must be checked to see that the finished job meets the necessary standards.

Tubes in a portable are checked the same way as ac heater tubes, and they need not be supplied with dc for the filament. The filament is, of course, the cathode also. Alignment of portables is no different from any ac receiver.

However, when we get into combination sets usable on either ac, dc or battery, the story is different. Here special switching circuits are used to change over from the ac or dc supply to the batteries.

Fig. 912 shows the filament circuit of a typical ac-dc battery portable. This one is simple compared to some. Notice that the filaments are circuited in a particular order. This assures that the "cathode" of the output tube has, for bias, the drop across all the other filaments.

In some sets there are separate resistors from points between the filament connections to ground. When you encounter these, they are there for the same reason — to adjust the bias voltage for one of the tubes to the required value, without requiring the use

of all the filament for the ground return. Thus checking filaments is complicated by these separate resistors, which might lead you to believe that a filament connection is all right. Actually, you are

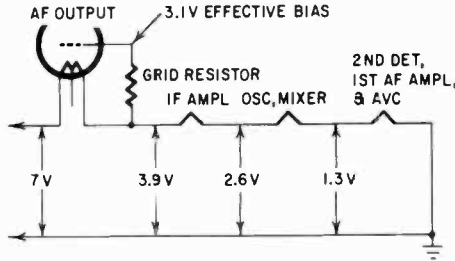

Fig. 912. Arrangement of the tube filaments in a portable receiver. The voltages shown are approximate and are read with respect to B-minus.

measuring the grounding resistor, a puzzling situation, until you remove the tubes and test them separately.

One source of trouble in such portables is the switch which changes over from power supply to batteries. If it has poor contacts, the filament current in the tubes may be reduced. In such battery-operated tubes, the functioning of the tube is strongly dependent on the proper filament current and the filament

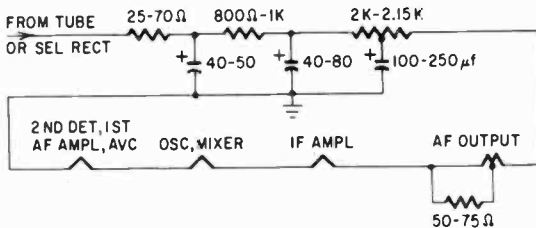

Fig. 913. Basic circuit of the power supply of a typical three-way portable.

does not have the long-time thermal storage that the ceramic-encased ac cathodes have. Any variation in filament current will immediately change the electron emission from the filament.

When the set is used on either ac or dc, the filaments are supplied from the dc supply through a separate dropping resistor (Fig. 913). Some portables have a dual rectifier with one of the cathodes assigned to supply just the filament current for the tubes. In others, there is a transformer for ac operation, with a bridge type dry rectifier. The latter cannot be used on dc.

In the dc position, the filaments and the B-plus are still supplied through the rectifier, and the plate voltage will be somewhat lower — 110 volts dc. If the filter capacitors are very large, they may manage to store a little extra energy and the plate voltage may be about 120, while on dc there will be only 110 volts in the first place. Thus, if your vom indicates, when the set is on dc, that the plate and filament voltages are a little low, this is no reason to suspect immediately that something is wrong with the set.

Notice in Fig. 913 that after the dropping resistor no large filter capacitor is shown in the filament circuit. In some sets there is. If you should pull out a tube beyond this capacitor, it will allow the capacitor to charge to the full B-plus voltage and, when the tube is reinserted, the filament will promptly flare up and die.

Never pull tubes out of a battery portable with the set turned on (but not working) with the vom on its lowest range. It may well cost you a meter. Even in the filament circuits of portables always start with the meter on the range which can accommodate the highest voltage that can occur in the set.

Remember, too, that ac-dc portables are transformerless and may have a "hot" chassis when used on the power line.

Transistor receivers

This is another class of receivers which merits special notice. Here we are dealing with oscillators which are even more touchy about proper voltages, so check for oscillator function with a probe which does not need to touch the circuit. As a matter of fact, the oscillator in transistor radios is the most troublesome section, and many fail to operate if the transistor is anything but optimum.

Alignment of a transistor receiver is different. Usually the transformers are single-tuned, meaning there is only one slug, while the transformer secondary is not always actually at resonance. The alignment procedures of tube and transistor radios are similar though, and the vom can be used to measure the detector output for maximum signal strength. Transistor receivers are much more critical with respect to proper voltages than tube sets, and they must be measured with greater care, considering in all cases the possible loading by the vom.

Checking oscillation

We can seldom test directly the unwanted oscillation. The small changes in voltage on even the local oscillator do not permit

direct measurements as in a tube set. Indirect methods must be used.

A wavemeter is a good way to test for oscillation. Couple it loosely to the detector input, although far more tightly than to pick up an ordinary if signal. Kill the local oscillator with a jumper or a capacitor across its tuning plates if these are hot. With no signal applied to the set any indication on the wavemeter indicates oscillation.

A handy wavemeter circuit is shown in Fig. 914. It is made up of a ferrite antenna, a tuning capacitor and a trimmer capacitor in series with a switch. The switch connects the trimmer or padder

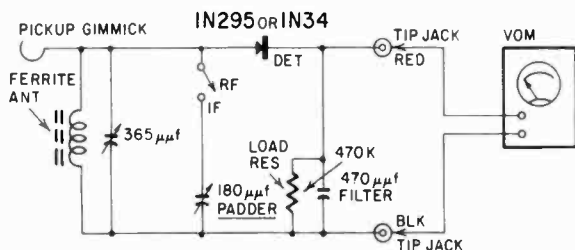

Fig. 914. The vom can be used with this external circuit to check for unwanted oscillation in a receiver. Set the vom on its lowest dc voltage scale.

for if measurements. (The wavemeter can be used with the switch open for oscillator checking if desired.)

The vom, set on its lowest dc range, is connected to the two tip jacks and acts as an indicator. The gimmick is simply a piece of flexible wire. In use, about three turns are wrapped around the lead or lug from the last if transformer to the detector (diode or transistor). With a printed circuit, hold the gimmick lead in parallel with that from the if transformer. The variable capacitor is tuned to the if with the switch closed. Any meter reading indicates oscillation. When the cause of the oscillation is found and eliminated, the meter will not indicate.

The avc or agc may be used if the fixed voltage is known. Appreciable departure indicates oscillation. In a transistor radio, the avc may go either positive or negative from some fixed value and can control the base, collector or emitter of the controlled stage. Use this test with these limitations in mind.

Sometimes, the presence of oscillation can be detected by a change in voltage at the detector after checking with the schematic or a similar radio.

Batteries

The fact that batteries in transistor radios have a long life increases the possibilities for corrosion and leakage, with consequent poor contact and malfunctioning. Mercury batteries particularly, unless of the completely sealed type, show a tendency to corrode right at the battery terminal. If you remove a battery of this type from a portable or transistor set and then check it, the reading with the vom may be misleading. By cleaning the terminals well, you may find that the battery is good after all. Don't throw it away after a casual measurement. Replace or recharge batteries which measure less than 75% of their rated voltage under load (with clean contacts). It is possible to recharge many kinds of dry batteries at least several times.

Use your vom to measure the voltage of recharged batteries. Don't take it for granted. A voltage which is only a little too high may damage, not only the transistors in the set, but even the electrolytic capacitors, which are usually of very large capacitance and very low voltage. Here again observe the rule of not pulling transistors with the set on; inductive or capacitive "kick" might be enough to ruin the transistor. Be especially careful how you use an ohmmeter around transistor sets. If the battery voltage of the meter is in some way added to the voltage of the set's battery, the resulting higher voltage may do more damage while you are trying to discover what is wrong.

On the other hand, some of the large capacitors in the set may have enough "bounce," even when you think they are discharged, to give the meter an unmerciful kick, particularly on the ohms ranges. In an electrolytic capacitor, the nature of the electrolyte is such that it may actually recover some charge in the capacitor even after it has been thoroughly shorted when you discharge it. The larger the capacitor, the more likely is this to happen. Always check first with the voltage ranges to see that there are no stray capacitor charges sitting in the set, before going to work with the ohmmeter section.

In transistor sets, be especially certain of your battery polarity. If the battery plug is not polarized, wrongly inserted batteries can damage transistors and the low-voltage electrolytic capacitors. The vom can be used to establish polarity, if you aren't sure of it. Most sets have the battery position clearly marked, but a few do not.

Testing power transistors

One of the quickest checks for abnormal operation of power transistors is to test for collector voltage. If this voltage is low and all other conditions seem normal, the transistor should be tested for low gain and internal leakage. This is done with the ohmmeter section of the vom. Disconnect the base and emitter leads from their circuit connections, leaving the transistor bolted firmly to its heat sink. It might be a good idea to check for shorts between the transistor case and the chassis after disconnecting the output transformer's primary.

Check the ohmmeter's polarity. Most service type instruments have a positive lead to the red or ohms jack, but some differ. Set

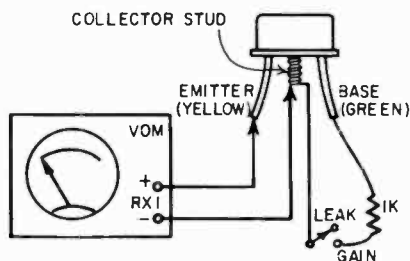

Fig. 915. Setup for checking power transistors with the vom.

the instrument on $R \times 1$, and *leave it there!* On this scale, only a small battery is used. Some instruments use as much as 22.5 volts on higher ranges, and this can harm transistors.

Connect the ohmmeter's *negative lead* to the collector stud and the positive lead to the emitter. A zero ohms reading, dead short, indicates a shorted transistor. If a fairly high reading is shown, the transistor is probably OK. A low ohmage reading indicates a leaky transistor or the possibility that the transistor is still too hot. Wait a few minutes and recheck.

For a final test, connect a 1,000-ohm resistor between the base and the collector stud (Fig. 915). The meter should now show a decided *decrease* in resistance, and should read less than 50 ohms. If not, the ohmmeter polarity may be wrong — recheck. If the reading is more than 50 ohms with the 1,000-ohm resistor connected, either the base lead is open or the transistor has very low gain and should be replaced.

The vom in hi-fi

One of the first jobs for the vom in hi-fi that comes to mind is

the phasing of speakers. Whether you use stereo or monophonic reproduction, if you use more than one speaker, they must be properly phased or the sound will be acoustically distorted.

Phasing speakers with the vom is very simple. Using the low ohms range, the battery in the vom will cause the cone of the speaker to deflect either one way or the other if you apply the test prods to the voice-coil connections. As you do this, note whether the cone moves in or out, and mark the terminal which was connected to the red test prod. When you check the second speaker, switch prods until the speaker cone behaves in the same way. Again mark the connection of the red test prod. When the speakers are used together, on the same set, you must then observe your polarity marks. This is true whether the speakers are in series, parallel or connected through a crossover network (Fig. 916).

With some tweeters (for example, electrostatic units) this polarity check is neither possible nor needed. Since like charges repel, when a voltage swing from the output tube goes up (more positive), the diaphragm of the speaker will move *in* because this puts a negative charge on the grounded plate. Thus, if you use an electrostatic speaker in your system, it must be phased so that the cone speakers will also move *in* when the signal has a positive swing.

Some diaphragm tweeters are hard to check because the diaphragm moves so very little. However, if you remove the horn and stretch a piece of a toy balloon over the narrow horn mouth, the motion of the diaphragm can be observed. Do not stretch it too tightly, but make sure that the balloon rubber is airtight around the mouth.

The proper phasing of speakers is most important in stereo, since the sound in both channels is the *same* set of sound waves, moving in the same direction. Therefore, we want to reproduce it that way also.

Stereo is recorded through identical amplifiers, and to reproduce it with full stereo effect it should be amplified through systems which are as nearly the same as possible, if not in actual physical similarity, then at least in a functional sense. When the equipment is built in duplicate for both channels, there is no serious problem. You simply have to observe the proper phasing of the speakers and the setting of the controls (they must be the same). But if you use two very dissimilar channels, such as an

FM and an AM radio, this setup has several problems which the vom can help you solve for maximum stereo benefit. First of all, since you have different amplifiers, you can adjust the speaker output to approximately the same level with the output function of the vom. Connect the vom to each of the speaker voice-coil connections in turn, and set for approximately the same output level. If the speakers differ very much in size, or even if they are the same size, this does not actually guarantee that the acoustical

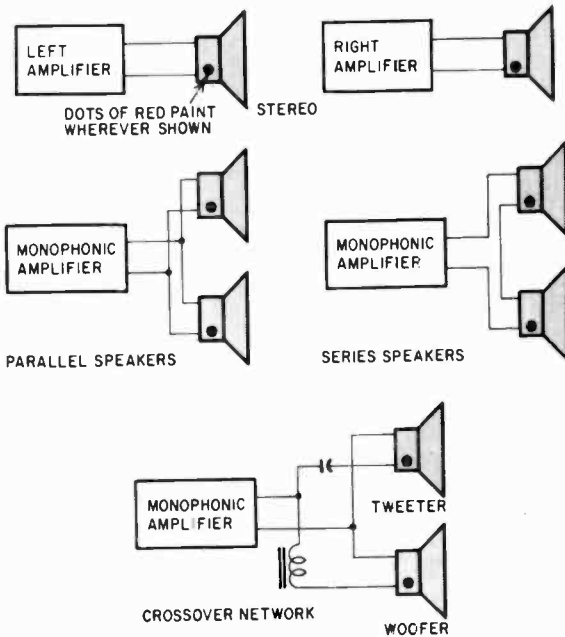

Fig. 916. No matter what speaker arrangement the audio or hi-fi system uses, always observe speaker polarity — as checked by the vom.

output will be the same, since there is a lot of difference in speaker efficiency. But at least it will be an approach, and you can make allowances for various speaker sizes. If you use one of the sensitive transistor amplifiers for your vom which were described earlier, then you can connect a microphone to the meter through a diode (you'll be measuring ac), and, at the same distance from the speakers, compare the voltages generated by the microphone. Adjusting the controls for the same average deflection on the meter will assure you of identical *acoustical* output of the two dissimilar channels.

Phasing of such a set of speakers in different cabinets is also something of a problem, but one which is fortunately simple to solve with a little gimmick, a strip of paper. Cut a strip of paper about 1 to 2 inches wide, and hang it in front of a speaker, about $\frac{1}{8}$ inch away from the grille. Watch the strip move on heavy passages, when you turn up the volume. Now face the speaker with the other one, about $\frac{1}{4}$ inch apart, and turn up the program volume to about the same level (see Figs. 917-a,-b). If your speakers are phased properly, the strip will hang almost perfectly still; if the speakers are out of phase, the strip will move wildly. Speaker phase can be reversed simply by transposing the voice-coil connections.

It is not sufficient in this case to disconnect one side of the voice coil and observe the cone motion. If you do this, and mark voice-coil polarity, you have to do something more. Reconnect the voice coils to their transformers, and connect one side of the voice coils together or, if they are grounded, connect the chassis of the sets together. (*Careful!* In ac-dc sets, make sure the chassis are both "cold.") If the output transformers as well as the voice coils are of the same polarity (phase), and you connect the output section of your vom between two equally marked voice-coil connections on the two sets (Fig. 917-c), then you should measure no, or very little, voltage if the sets each produce about the same voltage across the voice coil. With opposite polarity, there would be about twice the voltage of one. But this procedure is useless unless you have first marked your voice coils for polarity.

Checking push-pull balance

Output stages in push-pull amplifiers must be carefully balanced, and many amplifiers have a balancing potentiometer in the grid circuit which can be used to make the final balance. Some of these also have jacks in the cathode circuits, so that the dc flowing through each half of the output transformer primary can be adjusted to exactly the same value. This prevents dc magnetization of the core which can cause distortion. If no jacks are available, you can use the volts ranges of the vom instead of the current ranges, and check the voltages on the grids or cathodes. If it is impossible to achieve balance, it may be that small differences in tube characteristics and components are adding up, so try swapping output tubes to see if balance can be obtained that way. If not, you'll be better off starting with a new set of balanced tubes.

Lack of balance in the output stage might be a result of lack of balance earlier — in the phase splitter, for example — and a quick check with the vom across the plate and cathode load resistors of the phase splitter will tell you about this.

Tape recorders

Interesting problems arise in servicing tape recorders. Tape recorders have a bias oscillator, which may be operating anywhere from 20 to 100 kc depending on the recorder. Inexpensive ones use a bias from 20 to 30 kc. These oscillators can be checked with the type of probe using a diode, but they are usually pretty husky oscillators and an ac voltage across the bias winding in the tape head should be measurable. The bias oscillator is on only when

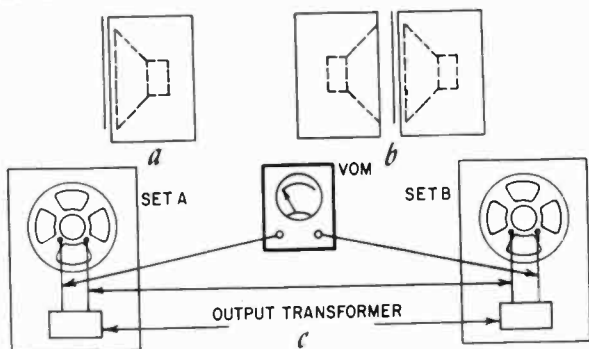

Fig. 917. Method of checking speaker phasing.

the unit is in the record position. It usually has several safety interlocks which prevent it from operating, and incidentally erasing the tape, when it is not desired.

In some recorders the lockout takes a different form. The bias oscillator tube finds double use in recording, as an oscillator; in playback, as an output amplifier. These circuits have complicated switching, and experience has shown that these switches can be a major source of trouble. Thus, a careful continuity check with the low ohms range of the vom may often lead you immediately to the source of trouble.

With a tube removed (and the amplifier off, with power-supply capacitors discharged) a check of the resistances from the tube pins to ground should tell you a great deal. Grid circuits should have the appropriate resistance to ground and, if the meter kicks

to near zero, then rapidly rises to, say, a 50,000-ohm resistance, suspect the coupling capacitor ahead of the tube position being checked. On the other hand, this is the correct behavior for the supply to the screen grid, say, in an output circuit, since the screen usually has little resistance in its supply.

If the plate or screen shows less than 5,000 ohms to ground, you have a short on your hands. If the resistance to ground shows high enough, but there isn't the first low kick and then the gradual rise of resistance, your electrolytics may be done for.

A cathode bypass capacitor is not that easily tested. This check is best done with the amplifier on and a signal going through. If the cathode voltage varies with the signal, the capacitor is at least insufficient, if not inoperative. Use the dc voltage ranges of the vom for this test.

Speaker matching

One recurring problem in audio, whether it be hi-fi or public-address systems, is matching the speaker to the output transformer. There is always a stepped arrangement; that is, you have a choice of maybe 4-, 8-, 12-, 16-, and 20-ohm taps on the transformer, not a continuous change. Thus, if you can determine approximately the best tap, this is the best you can do in matching to that particular amplifier. This can be done fairly directly. When the transformer and speaker are matched perfectly, there is the maximum transfer of energy; in other words, voltage times current is the greatest. If you arrange to measure both the voltage and current across the speaker (Fig. 918), and multiply each current measurement with its voltage measurement, the combination which gives the highest product is the best match.

To do this, you must provide a steady signal to the amplifier, turn up its volume to maximum and take your various measurements, being sure to turn down the amplifier when changing taps. The small 0.5-ohm resistor inserted in the circuit is removed later, and it also causes some mismatch, but much less than the difference between taps on the transformer. If the amplifier produces, say, 20 watts, this means, in a series circuit of 8 ohms in the power transformer and 8 ohms in the speaker, the rms current would be 1.25 amperes. This through a 0.5-ohm resistor would create 0.6 volt ac, enough to read clearly on a 2.5- or 3-volt scale. The voltage would increase, as the impedance tap is higher, and the current would decrease. But in the power measurement, the

current is squared (I^2R) so neither the highest current nor the highest voltage is the proper match; only that point at which the product of the two is highest. With five or six taps on the transformer, it won't take long to calculate which produces the best power output in the speaker.

Many "tricks" of the trade really require only common sense and some knowledge of what circuit elements will do. Thus, we must remember that when we get the vom ohms ranges across a large capacitor, electrolytic or paper, it will gradually charge to the battery voltage in the vom. When we check the resistance of small capacitors (not electrolytics), their resistance should measure in the hundreds of megohms to be in good condition: but even if it does, that is no guarantee that the capacitor will not

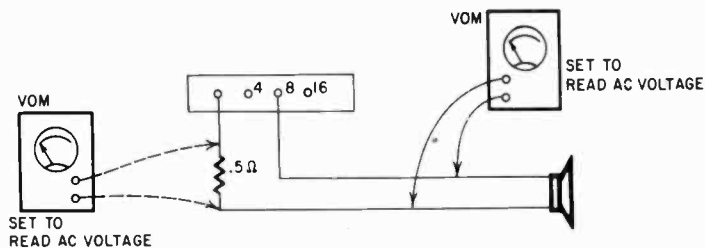

Fig. 918. The vom can be used for checking the impedance match between the speaker and the output transformer of the amplifier.

break down under a higher operating voltage. Here is one case where the vom can provide a false picture. Electrolytics with rated working voltage applied should pass about 1 to 1.5 ma per microfarad maximum. Anything more than that indicates deterioration and anything less than 0.5 ma should lead you to suspect a dried out capacitor. It is good practice, even before turning on a set or an amplifier which is in for repair, to make a complete resistance check, particularly of the power supply components. This may reveal a short which could soon damage other parts. Voltage checks of power supplies with the equipment on are the next logical step in investigating inoperative equipment.

Printed-circuit problems

Printed circuits have been finding their way into audio equipment, transistor radios and TV receivers on a rather large scale—and bringing with them certain problems characteristic only of printed circuits. When a circuit board is flexed, as it may be when removing tubes from it or replacing them, the possibility always exists of cracking the circuit lines. These cracks may be minute, invisible to the naked eye, but sufficient to interrupt the circuit or, worse, to interrupt it intermittently. Such hair-line breaks

can be found rapidly with the low ohms range of the vom, since the normal resistance of a circuit conductor is usually written several places to the right of the decimal point. Any resistance over 0.1 ohm in a circuit line indicates that the line is either starting to develop a fine crack, or is in some other way corroding or deteriorating, and careful inspection of such a line with a magnifier is necessary.

Another bugaboo of printed circuits is the eyelets sometimes used for attaching components or to connect circuit lines on two sides of a board. Many of the processes used on circuit boards involve acids and other strong chemicals which are basically corrosive. If just a microscopic bit of this kind of chemical has been left on the copper before the eyelets are inserted, trouble may develop, even though to the eye the connection appears properly soldered. Again, ohmmeter checks may indicate this but, to be really certain, use the shunt-ohmmeter system described earlier for measuring very low resistances.

The third kind of problem showing up in printed wiring is insulation trouble. If any moisture condenses on a printed-wiring board, there is the possibility of electrolysis which may deposit conductive salts on the surface of the board's insulation and eventually cause breakdown. If two circuit lines are connected through a low resistance, this may not be serious, since current will always take the path of least resistance. But if two such lines are not in any way connected, electrolysis may have serious consequences. The best medicine here is preventive. Check the board with the high-resistance range of the ohmmeter. If your meter goes up to 100 megohms, for example, and you can get *some* deflection when measuring lines which are supposed to be isolated, trouble can develop. Sometimes it can be prevented by a thorough cleaning of the board. Do not use any solvent on printed-wiring boards. Solvents leave deposits which are as bad as dirt but in a different way. A dry clean rag should give all the cleaning needed. After cleaning, measure the insulation again. Use, if necessary, one of the methods described earlier for measuring very high resistance.

If circuit lines are broken, the best remedy is to solder (with a low-heat iron) a short piece of wire across the break. If circuit lines are beginning to show low isolation resistance, the board can often be saved by taking a very sharp little knife and cutting a shallow groove between the lines. This disturbs the glazed surface, and it should be restored with a lacquer or special silicone coating.

Transmitter servicing

The vom is as handy in transmitter servicing as in receiver work, and has a few additional applications in it. Fig. 919 shows a partial transmitter schematic, mostly the final amplifier and the oscillator-driver. The tuning of the transmitter can be done with the current ranges of the vom. Notice that, in the power amplifier cathode, the manufacturer has installed a jack and it is here you can measure the total amplifier cathode current with the current ranges of the vom. In tuning an amplifier, assuming that the oscillator is working, crystal controlled and on the proper frequency, the current in the power amplifier, without the antenna

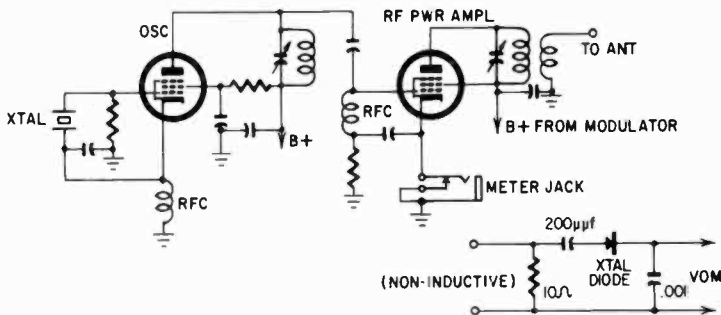

Fig. 919. Partial schematic of a typical transmitter. Adjustment of the final stage can be done with the vom connected to the meter jack.

connected, is adjusted for a *minimum*, since at that point the tuned plate is at resonance and has its greatest impedance.

The final tuning of the transmitter includes the tuning of the antenna. This requires an rf ammeter, and usually the measurement is made with a thermocouple type. But again we can put the vom to work if we use a noninductive resistance, small capacitor and a diode to convert antenna current into a small dc voltage. When this procedure is used, remember that the antenna will be tuned a trifle shorter than it should be, but the difference will not be significant.

A quick check of transmitter modulation can be made using the vom. With the transmitter tuned and on, but unmodulated, measure the current in the antenna. Now with a steady note supplied to the modulator microphone, the meter reading should increase 22½% for exactly 100% modulation. For less increase you are undermodulating and not taking advantage of the transmitter's capabilities; with more than 22½% change in reading, you are overmodulating and causing distortion in the signal.

In transmitter work, the vom really comes into its own as a field strength meter and can serve, for example, as a monitor. A

simple tuned circuit, diode and vom wavemeter, set up in the vicinity of the transmitter, will serve to indicate if the transmitter is radiating. Moreover, it will give a check on frequency deviation, since there is nothing in such a simple circuit which can change the reading except if the frequency of the transmitter changes and the circuit is no longer in resonance with the transmitter. Modulation of the transmitter will be evidenced by an increased reading on the field-strength meter.

The vom as a field-strength meter can also be used to determine the radiation pattern of the antenna. Circling the antenna, note the meter reading at regular intervals, say every 10 feet. This need not be a calibrated reading, only a relative one. When the notations of such readings are plotted, and the points of equal reading connected by curved lines, the pattern of the antenna will emerge.

Servicing the modulator of a transmitter is so similar to servicing an audio amplifier that no additional comment is necessary. However, remember when working on transmitters that the FCC frowns on tests while radiating and that most of the work on the transmitter must be done without an antenna or with a dummy. The dummy antenna is simply a series circuit of a noninductive 10-ohm resistor and a 200 μf capacitor. Remember too, that the voltages in the transmitter are likely to be higher than in a receiver, so always protect your meter by starting your readings on the highest ranges.

In this chapter we have been able to indicate some service applications of the vom. Others will no doubt occur to you as the need arises, and as your familiarity with the instrument grows. And some of them are already so common and familiar that they need not be used as illustrations. In the next and last chapter we will discuss the use of the vom in somewhat less familiar ways and situations, but nevertheless generally useful ones, with some further hints on how to care for your instrument.

miscellaneous applications

A PART from the service uses of the vom in radio, TV and hi-fi, there are many others for which it is handy, and some for which it is indispensable. Necessarily these cover many items in areas where we would not normally think of the vom as a fitting tool. You will undoubtedly think of still others as you become more familiar and accustomed to working with the vom.

Some measurements we have described can be made in a more sophisticated manner, and there will be a few sections on these. And, although serious repair of the basic instrument in the vom should be done by a competent instrument repair service, you can do a number of things to keep yours in good shape, and these will be listed.

Measuring L and C

In an earlier chapter we discussed the measurement of inductance and capacitance by methods which compared the unknown with a standard resistor at a particular frequency, or with another inductor or capacitor. These are reasonably accurate methods, but they are not always easy to do for small values of inductance and capacitance, where higher frequencies must be used. Also, we can't always be sure that the meter does not contribute to the circuit values in some way. To get around this, we can try another method which hinges on the fact that, for a particular frequency, there will be only one capacitance which resonates with a given inductance, and vice versa.

Either series or parallel resonance can be used. In a series arrangement, the total impedance of the circuit will be the least at

resonance, while in a parallel circuit it will be highest. If we wish to learn the inductance of a certain coil and we have a capacitor (whose value we know) available in approximately the right range, then by varying the frequency and tuning for resonance, we can discover the resonant frequency, and from this calculate the unknown.

This method depends on several factors. First of all, you must have a good resonance indicator. The vom in combination with a small capacitor and a diode will serve for that; but you must also know the exact frequency used, and for this you will be dependent on the accuracy of a signal generator. Fortunately, there are many ways to calibrate a signal generator; for example, by using a receiver and tuning it to a broadcast station and then tuning the signal generator until it produces its modulated tone on top of the station, and other such easy methods.

Measuring inductance by the parallel resonance method

Fig. 1001 shows the principle used for measuring an unknown inductance with a known capacitance by the resonance method. What we have here is a parallel resonant circuit with the signal generator tuned for the *highest* indication on the meter.

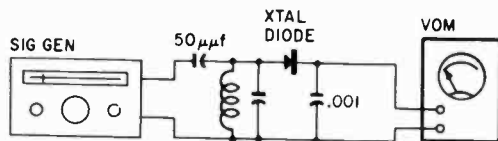

Fig. 1001. *Measuring inductance or capacitance with the vom, using the principle of parallel resonance. The vom should be set on its lowest dc voltage range. Set the signal generator attenuator for maximum signal output.*

The crystal diode will rectify the voltage developed across the parallel circuit, consequently we will want to set our vom to read dc volts. The .001-μf capacitor is an rf bypass, so that the voltage reaching the vom will be dc essentially.

You may run into some difficulties when trying this arrangement on the higher frequency ranges of the signal generator. Many generators use harmonics of the lower frequencies to get to the upper ranges. This technique is a good one but it does mean that the rf output of the generator is much weaker at higher frequencies. Whenever possible, use the lower scales of the signal generator. A coil and capacitor combination will resonate at many different frequencies, depending on the setting of the capacitor

(if variable) and the positioning of the coil slug (if it has one). A safe procedure is to try to have the variable capacitor as completely meshed as possible (giving maximum capacitance) and the tuning slug of the coil turned in. The best position for the slug is so that it is at the center of the coil. This is the maximum inductance position. Turning the slug so that it is all the way inside the coil form is no assurance that it is in the correct position. Doing this sometimes pushes the slug *out* of the coil, thus lowering the inductance.

When running this test, try to use a sensitive vom. One of the devices described earlier to increase the sensitivity of the instrument would be helpful. Also, be sure to set the attenuator of the generator for maximum output.

Measuring inductance by the series resonance method

In Fig. 1002 the same measurement is made with a series circuit, but notice that the diode now is in series with the circuit elements, and again you tune for *maximum* deflection on the meter.

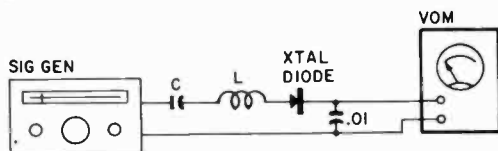

Fig. 1002. Using the vom and series resonance to measure inductance or capacitance. The signal generator should be set for maximum output; the vom on its lowest dc voltage range.

When you know the frequency, you need two formulas, one for the inductive reactance and one for the capacitive reactance:

$$X_L = 2\pi fL \text{ and } X_C = \frac{1}{2\pi fC}$$

At resonance these two values will always be equal, and thus we can get L and C on one side of the equation:

$$L \times C = \frac{1}{(2\pi f)^2}$$

So for any frequency that you read on the signal generator dial, you can calculate the product of L and C, and then simply divide by the known value, whatever that is.

A "capacitor or inductance of about the right value" means one which would have approximately the same magnitude of reactance at some reasonable frequency where it might be used.

Thus, if you made the capacitance large enough, you could probably measure the inductance of a broadcast frequency coil at audio frequencies, but your method would be so lopsided that you would not get an accurate measurement. If, instead, you measured it at broadcast frequencies or thereabouts with a capacitor of about 500 μf , you would get a rather good measurement.

Using a nomogram

Since this combination of inductance and capacitance is very common in electronics, we usually can find a nomogram that takes all the work out of the calculation. See Fig. 1003 on the facing page.

To determine a resonant frequency construct a straight line between the left-side values of L and C. Read the resonant frequency on the left side of the f scale. For a more exact solution construct a second straight line between the right side of the L and C values, using the significant figures of L and C. Read the significant resonant-frequency figures on the right side of f. Decimal location is in accordance with the left-side solution. To convert from frequency to wavelength construct a horizontal straight line through the value of frequency on the left-side f scale. Read wavelength on the left λ scale. Similarly construct a second horizontal straight line through the value of frequency on the right side of the f scale. Read significant figures on the right λ scale. The horizontal condition can be observed in both cases by equal intercepts on the L and C scales.

As an example, find the resonant frequency and wavelength of a circuit containing 1-mh inductance and .002- μf capacitance. Construct a straight line from 1 mh on the left side of the L scale to .002 μf on the left side of the c scale. This will give us about 100 megacycles at the intersection of this line with the left side of the f scale. At this intersection construct a horizontal line. Estimate 3 meters on the left λ scale.

For a more exact solution construct a straight line from the bottom 1 on the right side of the L scale to 2 on the right side of the C scale. Read about 112 mc on the right side of the f scale. (For more exact reading use interpolation scale insert.) Construct a horizontal line through this intersection and read 2.67 meters on the right λ scale. Using the top 1 on the right side of the L scale would obviously be wrong since it would be incompatible with the first solution.

What we have said so far will give you an indication of how the

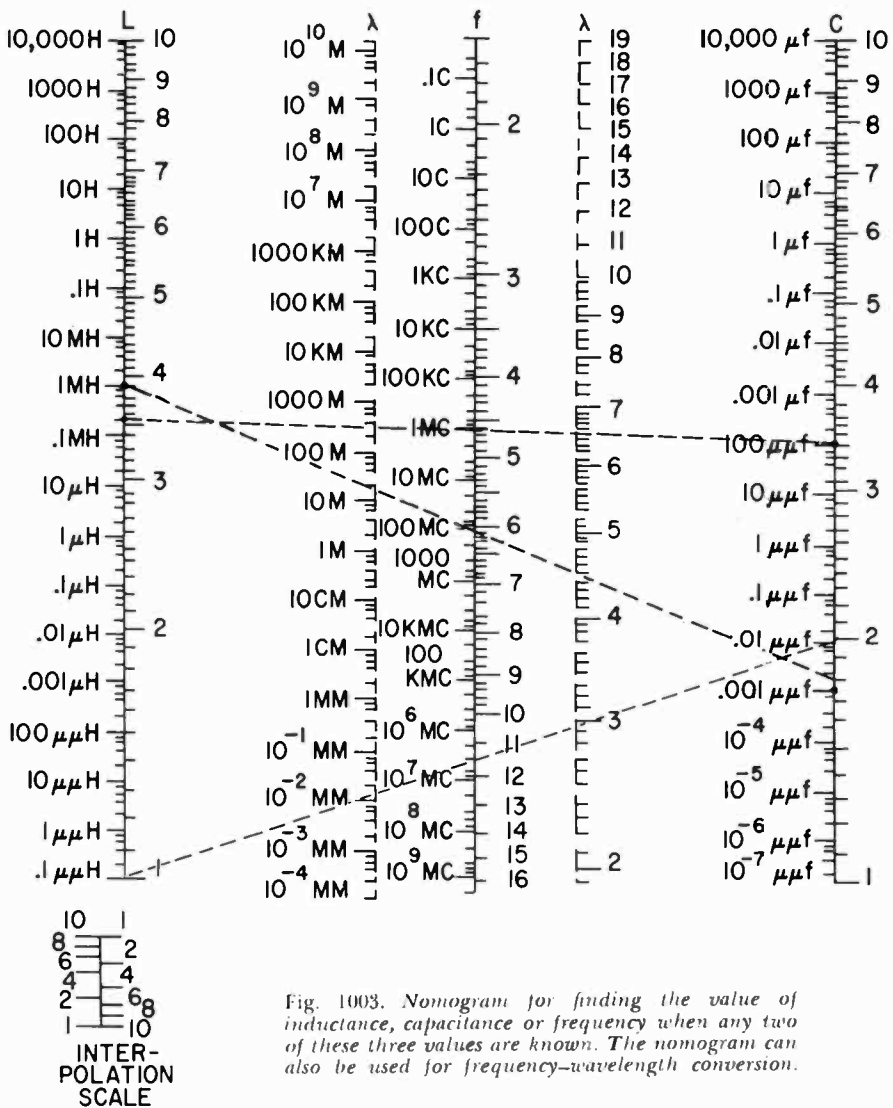

Fig. 1003. Nomogram for finding the value of inductance, capacitance or frequency when any two of these three values are known. The nomogram can also be used for frequency-wavelength conversion.

chart works. If we have three unknown factors, and know any two of them, we can always find the third. Thus, knowing the values of inductance and capacitance, we can easily determine the frequency at which this combination will resonate. But if we know the frequency (our signal generator tells us that) and we know the value of inductance we are using, we can get the value of capacitance from the chart in Fig. 1003. Similarly, if we know the

frequency and the value of capacitance, the chart will give us the value of inductance.

As an example, let us say that you have a 100 μf trimmer and that our vom gives us a peak reading when we set the dial of the generator to 1 mc. On the chart we connect these two points with a straight line and on the left side of the L scale we can read the values of inductance as approximately 0.2 mh.

In Figs. 1001 and 1002, the circuits have been shown connected directly to the generator. This is not a necessity. If you use a grid-dip oscillator, in which the coil is exposed, you need only bring the parallel resonant circuit near the coil to get an indication.

Using the capacitance scales to measure inductance

Some vom's come equipped with capacitance scales. With a little arithmetic these can be used to measure the inductance of coils having a low resistance. Using the ohmmeter section of the vom, measure the resistance of the coil. Make a note of the reading. Do not disconnect your test leads, but switch the selector on the vom so that it is set to read capacitance in microfarads. The inductance of the coil can now be found by using this equation:

$$L = \frac{\sqrt{X^2 - R^2}}{377}$$

In this case, X is the capacitive reactance at the line frequency which we are assuming to be 60 cycles. We get the number 377 in the denominator of the equation by multiplying $60 \times 2\pi$.

To see how we use this method, let us suppose you have an unmarked choke coil. You measure its resistance and find it to be 30 ohms. When you check the choke using the capacitance scales of the vom, you find that you get a reading of 10 μf . To find the capacitive reactance of a 10 μf capacitor at 60 cycles use a capacitive reactance chart such as the one shown on page 118. This is a handy thing to have. If not, then calculate the reactance using this old standby:

$$X_c = \frac{1}{2\pi fc}$$

In this case the reactance comes out to be 265 ohms. This is X in our equation.

$$L = \frac{\sqrt{265^2 - 30^2}}{377} = 0.7 \text{ henry}$$

Keep in mind, though, that this is the maximum inductance of our choke. The inductance will be affected by the amount of dc flowing through the coil.

If, in measuring the resistance of the coil you find that it is very small compared to its inductive reactance, then you can ignore the resistance. You can do this if the inductive reactance is about ten times as much as the resistance. In such cases the formula for inductance simplifies to:

$$L = \frac{X}{377}$$

Phase-angle determination

Determining phase angle is a little trickier than some of the measurements described, but it is entirely feasible with a vom, provided you understand what is happening in the circuit.

Because it takes time to charge a capacitor, the current in a circuit containing capacitance will show the greatest change when the voltage across the capacitor is still low. This means that, at any time, the current may have reached a maximum value well before the voltage comes up to its maximum value. In other words, the current "leads" the voltage in a capacitive circuit. We represent this by vectors, which are simply arrows drawn for convenience in calculations, and we usually draw them through an origin about which they can rotate.

In an inductance, the opposite happens. When we apply a voltage to a coil the magnetic field created causes a counter-emf to be generated which delays the current from reaching its maximum value as fast as the voltage. We say that the current "lags" behind the voltage or that the voltage leads the current.

This phase angle (amount of lag or lead) between current and voltage cannot be measured directly, but we can measure values which will allow us to construct the phase angle graphically by means of vectors in some cases.

Consider, for example, the circuit in Fig. 1004. Here we show a transformer with a split secondary, and a capacitor across one half of this secondary. We know that this capacitor will change the phase angle of the voltage in that half. But how much? Normally the voltages in the two halves of such a split winding will be equal and opposite in phase, which in terms of vectors would be two arrows of equal length and in opposite directions (Fig. 1005-a). But if we add the capacitance shown, one of the

vectors rotates just a little, as in Fig. 1005-b. Now if we were to measure the voltage across each half (ignoring the possibility of resonance), we would measure the same voltage in both halves.

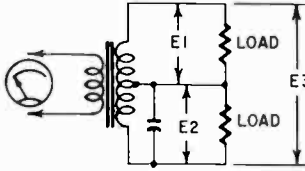

Fig. 1004. Because of the presence of the capacitor, the voltages across the two halves of the secondary winding will no longer be exactly 180° out of phase.

But, if we measure the two together (E3 in Fig. 1004), we find that the two don't add up to the arithmetic sum of E1 and E2. This is due to phase shift.

In Fig. 1005-c we show how such values would add up as vectors. What you would actually measure for E3 is E3'. If we can measure

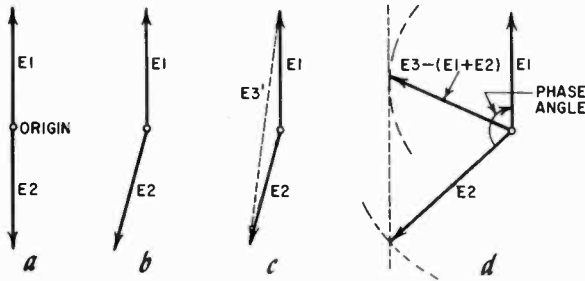

Fig. 1005. Vector relationships of the circuit of Fig. 1004. Without the capacitor (a) the vectors are 180° out of phase. The capacitor shifts the phase of the voltage (b). The vectors can be added algebraically (c). Method of finding the phase angle (d).

E1, E2 and E3, we can find the phase angle as shown in Fig. 1005-d. First, put down a value E1 represented by a certain length, say 1/4 inch per volt. Now take a compass and set it for the difference between E3 and the sum of E1 and E2, $E3 = (E1 + E2)$ and draw the arc shown. Next, just barely touching the arc draw a line parallel to the line representing E1 and tangent to the circle we have drawn. Now set your compass for the value of E2 in the same units, and draw an arc from the same origin as before. Where this second arc crosses the line parallel to E1, draw E2. Then with a protractor (or with trigonometry if you are skilled in this), you can measure the phase angle between the two voltages. Notice that the voltages E1 and E2 do not necessarily have to be equal for you to use this procedure. So long as you represent each value

as a vector in the same kind of units, whether this is 1 inch or $\frac{1}{2}$ inch per volt or what have you, you will end up with the true vectors representing the phase angle between the two. You will not be able to tell which leads which unless you look at the circuit and remember that a voltage in a circuit with capacitance is naturally "behind" one which has inductance only.

In industrial electronic circuits capacitors are often used to get a phase shift for reasons of control. In the circuit of Fig. 1006-a we show a capacitor and resistor in series. Our "phase-shifted" voltage would be taken off between the two; in other words, E2. To know just how much we are shifting phase, we again make the same three measurements, and draw the two vectors as shown in Fig. 1006-b. Start with E1 and then draw an arc with the compass set at

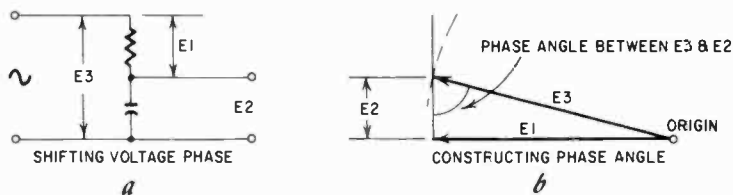

Fig. 1006. Capacitors are often used to shift the phase of a voltage (a). The angle (b) indicates the amount by which the phase has been shifted.

the value for E3. Where this intersects the vertical line drawn at the end of E1, you can measure the value of E2 to check and then draw in E3. Now the angle indicated is the angle of phase shift accomplished with the capacitor.

We could go on and further complicate matters by using an inductance and a capacitor. However, we are still talking about the vom, and the only other thing we will say about vector diagrams is that in resonance the two vectors of capacitance and inductance will be exactly opposite, exactly 180° out of phase.

Time measurements with the vom

If we use a circuit such as shown in Fig. 1007 and charge a capacitor through a resistor, the voltage across the capacitor will rise gradually if both the capacitor and the resistor have high enough values. It can take a number of seconds for the voltage to reach a stable point. However, this point will depend on the relationship between the input resistance of the vom and the charging resistor, for, as shown, the capacitor will ultimately receive a voltage which is a proportion of the total resistance.

Unfortunately this type of circuit does not charge linearly, but according to the well-known capacitor charging curve. The time

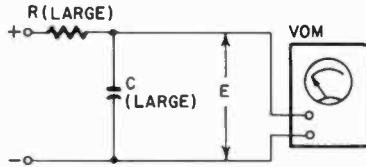
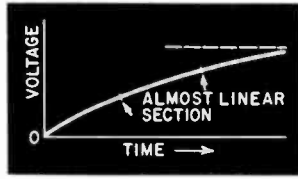

Fig. 1007. The voltage across C will rise slowly, giving E as a measure of time.

units would have to be calibrated because, on the low part of the scale the voltage time units would be large and at the top they would be small.

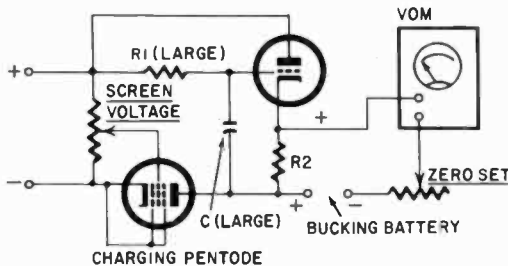
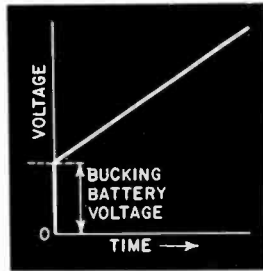

Fig. 1008. Linear time measurement, using the *vom*.

But with a simple additional circuit we can make this curve almost perfectly linear, and this is shown in Fig. 1008. Here a

pentode is used to charge the capacitor. This assures constant current in the circuit, while the cathode follower prevents the vom from discharging the capacitor. Using a cathode follower, we would find an initial voltage on the cathode, but this can be bucked out as shown. No values are indicated in the circuit because they depend to a great extent on tube characteristics. However, the order of resistances is also dependent on time and the size of the capacitor. For several seconds' rise, if C is about 4 μf , then R1 should be approximately 5 megohms and R2 approximately 47,000 ohms. But these values may be changed to suit the individual tubes, available voltages and the size of the capacitor in the circuit.

The vom in the garage

There are a number of uses for the vom in the garage. First, there is the check on the condition of the auto battery, which we

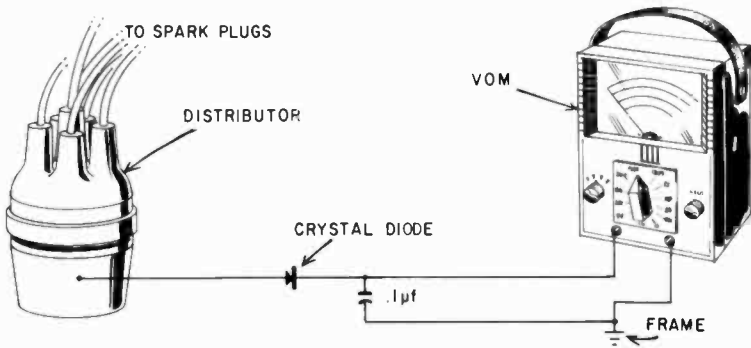

Fig. 1009. The vom can be adapted for use as a temporary tachometer.

discussed before. Then there are such self-evident applications as a check of wiring insulation, continuity checks, etc.

The vom can also make a fine temporary tachometer, useful for adjustments that have to be checked several times at different rpm's—carburetor adjustments, for example. The circuit is shown in Fig. 1009. The pulses are obtained from the low-voltage contacts of the distributor and integrated in the .1 μf capacitor. With a 6-volt system, a reasonable deflection can be expected on the 25- or 30-volt scale on a 20,000-ohms-per-volt meter. The voltage is proportional to the number of pulses; in other words, the rpm's of the motor, the voltage of the battery and the dwell time of the contacts. The vom must be calibrated with a mechanical tachometer, but for a single car the calibration holds quite well if the

breaker dwell timing is not changed. And a mechanical tachometer needs to be held against the rotating shaft or some such part, while an electronic one leaves both hands free for other work.

A somewhat better tachometer is shown in Fig. 1010. The circuit is essentially the same, but here a microswitch is used instead of the distributor breaker. The microswitch is set up so that

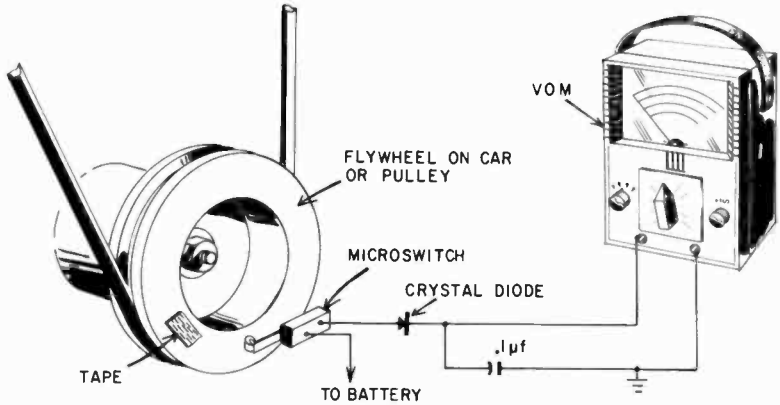

Fig. 1010. This temporary tachometer is independent of dwell time.

a small piece of tape stuck to the flywheel or a pulley lifts the arm once per revolution. If you always use tape having the same width, you need not worry about dwell time, and the device can be calibrated. The microswitch should be a rather rugged type with a roller, for this is heavy-duty operation for such a switch. Do not keep it on the flywheel any longer than necessary. One such separate switch worked quite successfully when attached to a bracket which was held in place in the automobile by a strong Alnico magnet.

Checking distributor timing

The vom can also be used to set the distributor timing. All cars have a timing mark somewhere on the flywheel, the driving pulley for the fan or on the ring gear. When this mark is lined up with a mark on the frame, the breaker contacts are just opened, firing the plugs. If you connect the vom as shown in Fig. 1011, you can readily tell when the breaker contacts open, and adjust the position of the distributor to make this point come at the right moment. Usually this must be set for a specific cylinder, generally the first mentioned in the firing order. For this you can refer

either to numbers stamped on the engine block or to the manual, if any, which comes with the car. Timing is changed by the position of the distributor and dwell time by the opening of the breaker contacts. The sooner the contacts open and the more

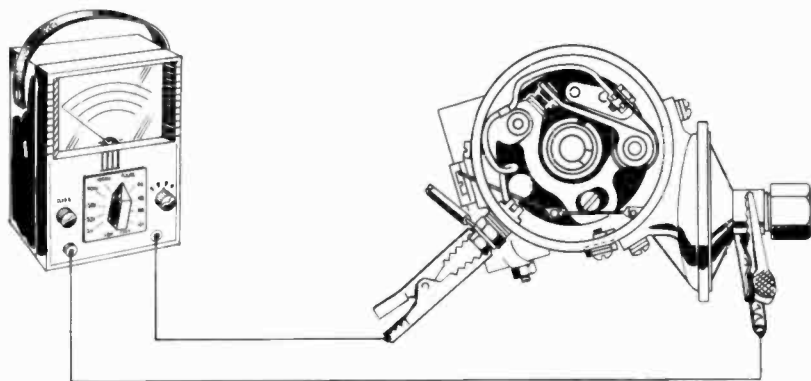

Fig. 1011. Setting distributor timing with the vom.

they open, the smaller the dwell time. The spark discharge will have more energy when the dwell time is greater. In this operation the car can be cranked by the starter if you pull the center high-voltage lead off the coil so the plugs won't fire and the engine start up while you're working on it. Ignition must be on; otherwise there would be no voltage at the distributor.

Regulator adjustment

Another check point in an automobile where the vom can be used is the regulator adjustment and the generator current. Many late-model cars no longer have an ammeter, only a red light to show when the generator is not charging the battery, but you will never know from that how much the generator is charging. For that you'll have to check its output at different rpm's. This is simply a current measurement, but you'll need to have a 20-ampere (or higher) range for the meter. Earlier we showed how to make shunts to extend the meter to higher current ranges.

Associated with the generator is the regulator, which does not allow the battery to be connected to the generator until the latter produces enough voltage to be certain of a charging current to the battery. This is a differential device, checking the generator voltage against the battery voltage and, if the former is enough higher, contacts close and lock in. The differential should be quite

small. At a speed of 2,500 rpm (generator speed), the generator should put out enough voltage (about 7 to 7.5 volts) to cause the regulator to close its contacts. If it does not, the contacts may be stuck. When the generator voltage drops below 6.3, the regulator should open. Regulators on most cars control the current as well as the voltage at which the contacts close and some are quite tricky to adjust, if adjustable at all; but at least you can quickly locate the source of trouble if your battery is not being charged.

The vom in the laboratory

Depending on what kind of laboratory you may be working in, the vom can be a handy instrument for many purposes. For

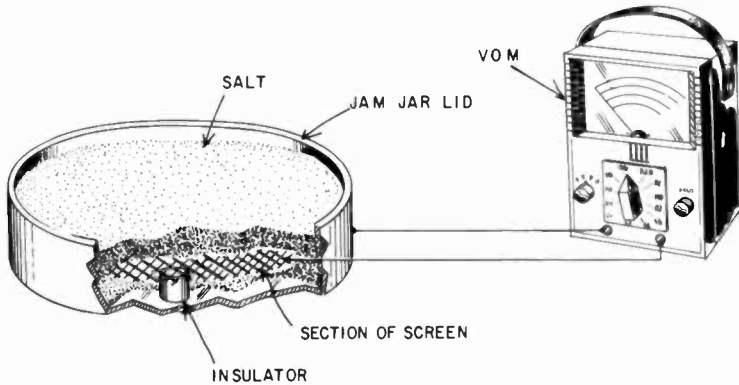

Fig. 1012. Simple humidity meter using the vom. Start with salt which has been heated to remove any traces of moisture. You will need to experiment with the spacing between the electrodes, as well as with the correct resistance range to use.

example, in many lab measurements the relative humidity is an important parameter of whatever experiment is going on. A humidity measurement can be made with the simple arrangement shown in Figs. 1012 and 1013. The lid, which acts as one electrode, is filled with ordinary kitchen salt to cover the little screen or grid which forms the other electrode. Naturally, the screen and the lid of the jam jar are insulated from each other. The resistance between the two is a measure of the amount of moisture absorbed by the salt from the air.

This kind of humidity meter has one disadvantage: the salt will eventually saturate, and then must be heated to return it to normal. If you can set the apparatus up so you can place a small flame under it when you feel the salt needs to be dried out, this is

one way of restoring the humidity meter. If not, simply dump the salt and start over.

A better and more stable humidity meter is shown in Fig. 1013. Here the sensitive elements are two thermistors, one in the air and the other inside a wick which soaks up water from a glass. Because of the greater cooling of the wet thermistor due to small

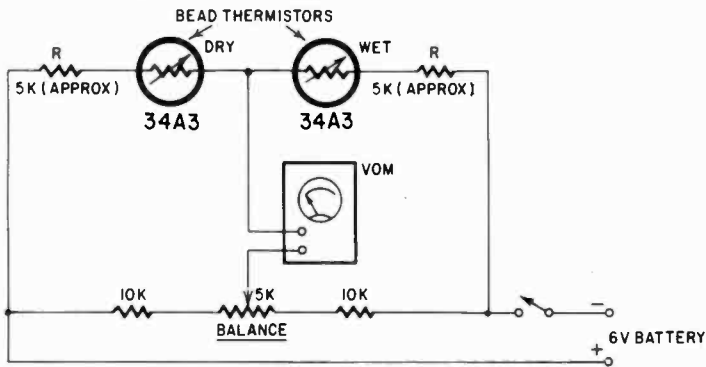

Fig. 1013. This is a more precise humidity meter. The two resistors (R) must be selected to obtain a reasonable balance. The "wet" thermistor should be covered with a wick which sits in a glass of water.

air currents and evaporation of the moisture in the wick, the two thermistors and the vom will indicate what is, in effect, a temperature difference, but one which is related to the moisture of the "dry" thermistor. Thus the "wetter" this one is, the less difference in the temperature and the greater the humidity. Zero set is adjusted when the wet bulb thermistor is out of the water and its wick dry. Notice that this is a bridge-type circuit, with approximately equal resistance in the legs, so that any temperature effects on these resistors is mostly compensated for. The relationship between wet and dry temperature difference and humidity can be obtained from tables in physics handbooks and air-conditioning texts.

Measuring the concentration of a solution

Every solution and suspension of matter in a liquid has its own characteristic conductivity, and from measurements made with a pair of inert electrodes you can pretty accurately determine the concentration of a solution, if you know what the values should be. There are charts in chemical handbooks which tell

you what they must be. The setup is simple: the two electrodes can be platinum wire or some other noble metal (separated by a plastic spacer) at a fixed distance from each other and always submerged exactly to the same depth. The resistance measured this way with the vom is your indication of the concentration of the solution, and can also be an index of its purity. For example, drinking water is tested this way for possible solids suspended in it and salts dissolved in it; boiler water is checked for "salinity" in the same way.

The same electrodes, if you are sure your liquid is constant, can also be used for level measurement, since the depth to which the electrodes are submerged will change the resistance measured. The measurement of conductivity must be made fairly rapidly, since the electric current from the battery in the vom may dissociate some solutions and start a film or gaseous covering on one of the electrodes, changing the reading. A better way is to use a bridge type circuit in which the solution would get no current through it if the bridge remains balanced.

Level indicator

In a similar manner, with a bridge circuit, the vom can be used to make a very accurate level indicator for the lab. The bridge potentiometer is supplied with an arm and float, and the unbalance of the bridge circuit is indicated by the vom. Fig. 1014 shows this application.

The same idea of employing a bridge circuit with a potentiometer can, of course, be made to indicate *any* mechanical position. A simple potentiometer circuit with a dc voltage source and a vom can be used directly to show position also. If the potentiometer is one which can rotate through 360° , you can use it for a continuous position indication in a circular motion. There are some potentiometers on the market which are made for such a purpose, but their winding is continuous and to use them this way you'll have to interrupt the winding in one place and attach leads.

Measuring temperature

Temperatures in the lab can be indicated by thermistors using the same circuit we showed for the humidity indicator, but leaving out the wet wick. In that case the instrument is automatically compensated for ambient temperature and would indicate a temperature rise directly. Another method using the vom for indicat-

ing temperatures is with the aid of thermocouples. Thermocouples consist of two dissimilar wires which, when heated, will develop a voltage across their junction. This voltage is usually not more than about 50 mv but, on a 50 μ a scale of a vom with 20,000-ohms-per-volt sensitivity, this gets the needle up half-scale. If you want a more sensitive instrument, one of the transistor amplifiers will do the job. In this case you need dc amplification.

A third method for using the vom to indicate temperatures in the lab is with the help of a temperature resistance "bulb." This

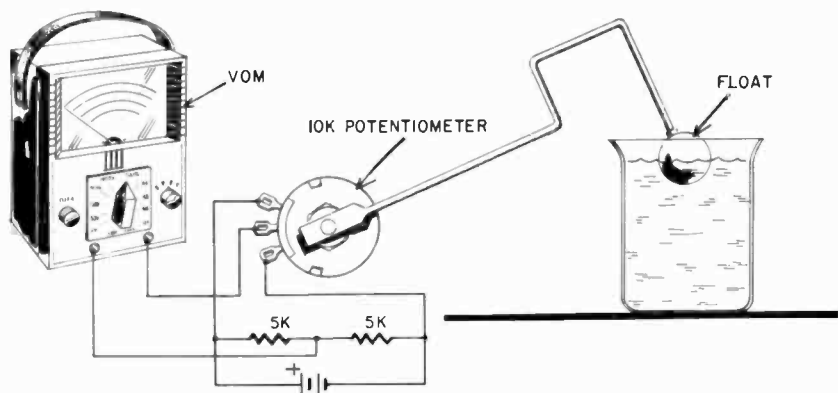

Fig. 1014. How to make a sensitive level indicator using the vom. The potentiometer can be supported by a metal U-bracket fastened to a wooden base. The "sensitivity" of this system will be determined by the length of the arm going from the potentiometer to the float and by the setting of the range selector of the vom.

is a bobbin full of wire, generally with a large temperature coefficient. Copper wire is used, but platinum wire has a more linear change with temperature, and nickel wire has greater resistance change per unit of temperature change. The "bulb" can be made in various shapes and resistance values, depending greatly upon the needs, the dimensions required, the possible protection needed, etc. Resistance bulbs cannot be used for temperatures beyond the capabilities of the insulation, and for this reason most of them are used up to about 250° F, but wire with special heat-resisting insulation is available for higher temperatures. The vom is ideal for this kind of measurement, since it has resistance scales ready-made. A calibration curve for temperature can be made with the help of a good thermometer, but also simply with a temperature/resistance change curve for the particular metal used. Physics handbooks will contain the necessary information.

Sensitive balance

A very sensitive balance can be made from a butterfly capacitor, using the vom as a null indicator, but this must be used in an ac bridge. Since the vom's ac scales are by no means the most sensitive part of the instrument, better results are obtained with diode rectifiers and the microamp scales. The idea is shown in Fig. 1015.

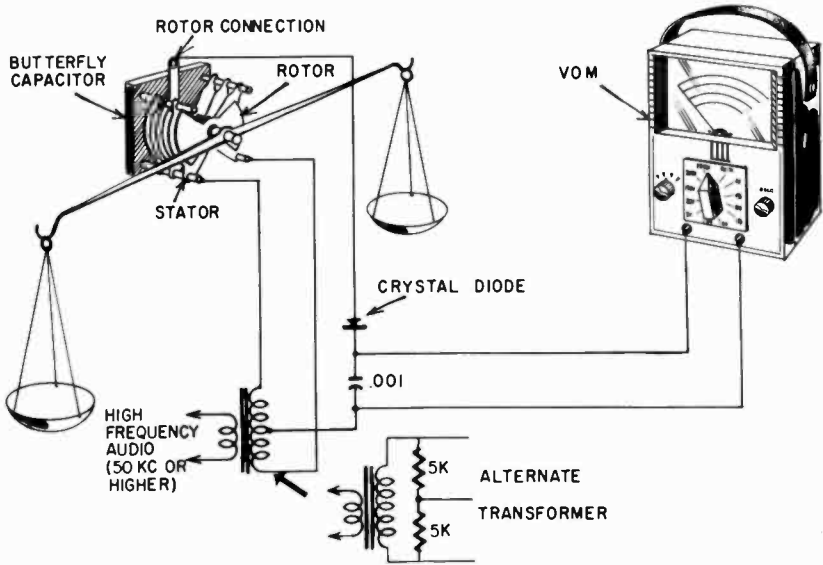

Fig. 1015. Sensitive balance using an ac bridge, the vom and a butterfly capacitor. Use the largest butterfly capacitor you can obtain. An alternate transformer setup is shown in the event that a center-tapped transformer isn't available.

Most butterfly capacitors are supplied with ball bearings and rotate very easily. An arm fastened to the shaft can carry the weights and balance scales. The circuit is again a bridge circuit, but this time with a low-voltage ac supply and diodes for rectification.

The sensitivity of this arrangement depends partially on the circuit values, but of course also on the length of the arms, their weight and the friction in the ball bearings. The swinging arm should be slung very slightly below the center of the shaft. This gives the arm a slight tendency to come to rest in a balance position. Without this, it would never come to rest completely. However, this arrangement detracts from the sensitivity just a little. If you want maximum sensitivity, you can depend on the scales to lower the center of gravity a little, and arrange the arm exactly

in the center of the shaft. The setup can be made even more sensitive by using a transistor null-detector amplifier for the vom, but you will find that the electrical sensitivity soon exceeds the mechanical excellence of the shaft supports, and irregularities in the ball bearings will begin to show up as sudden little jumps in the meter.

Measuring viscosity

Measuring with a vom the current supplied to a small dc motor can give us a measure of the viscosity of a liquid, if the shaft of the motor is supplied with a little paddle which rotates in the liquid, but of course here we must make sure that the paddle is always fully submerged. This, in effect, is the principle used in some commercial viscosity meters. If you want only a temporary relative viscosity indicator, the vom can serve nicely for this purpose.

Photometric measurements

The vom can be used in simple photoelectric circuits for all kinds of photometric measurements. Thus, not only absolute amounts of light, but also such items as density of photographic



Fig. 1016. Simple photometric circuits using the vom.

negatives, density of liquids in glass vessels, reflection of surfaces and the relative light output of phosphors can be measured. For the so-called photovoltaic cells, nothing more is needed than the cell and the vom. These cells have been in use for many years in photometers for photographic purposes and usually are made of cesium oxide. The later photovoltaic cells are the silicon type of semiconductor material, so-called solar batteries, which put out a lot more voltage than the cesium oxide cells.

For the photoemissive and photoconductive cells, (the latter is usually cadmium sulfide), a battery is also needed. This generally needs to be more than is available in the vom resistance ranges, where 15 volts is about the maximum. The cadmium sulfide cells usually need about 40 volts, and the vacuum-tube type about 90. Fig. 1016 shows the two circuits, which, as you can see, are very simple indeed.

The "transistor" photocells on the market are of two kinds, both photoconductive and photoemissive cells being manufactured. These use the same kind of a circuit with lower voltages, often not more than 1.5. With transistors, polarity is important, since reverse polarity can destroy the cell. Polarity is also important in vacuum-tube type cells: with the wrong polarity the cell will not function, but it is not destroyed, as the semiconductor cells are.

Biophysical measurements

There are many other kinds of measurements for which the vom can be used in the laboratory. For example, it can be used for psychophysical measurements. One of these is the measurement of skin resistance. This is often done with a bridge circuit, which will, of course, register changes quite drastically. For this you would set up a bridge where the unknown is approximately 40,000 to 60,000 ohms. Contact with the skin can be made with two small glasses with electrodes in them, with the glasses filled with a saturated salt solution. Ordinary kitchen salt will serve.

Most biophysical measurements deal with such small values that the vom cannot be used without amplification. Some of the sensitive amplifiers we have discussed can be used, but generally more amplification is needed, hence it will be more profitable to use some other kind of instrument.

Checking electrolysis

One miscellaneous use for the vom is checking for electrolysis. When dissimilar metals are in contact in an electrolytic medium, there will almost certainly be electrolysis, since the two metals will form a battery of sorts. Electrolysis will be particularly encountered on boats; it will show up even in fresh water. The vom can tell you whether any voltage is present. This may only be a fraction of a volt, and the vom will show *something* but even a little is too much. If the meter deflects at all on its most sensitive scale, electrolysis is taking place.

Ground resistance

Many installations using electronic and medical equipment need very good grounds, in some cases for electronic reasons and in others for safety. The low-resistance scale can be used to measure ground resistance.

Ground resistance is extremely important in transmitter installations and it is usually specified that the ground must have a

resistance of less than 5 ohms. The way to measure it is to use a temporary rod near the ground rod, driven approximately the same depth, and then to measure the resistance between the two. Each ground rod will then have approximately half the resistance. To make the reading more meaningful, the extra rod should be moved around in a radius of several feet, and readings taken in various places to get an average. Ground resistance varies a good deal during the year; in fact specifications usually demand that the ground be measured at the time of delivery of the job.

There are several other methods of measuring ground resistance, all of them more involved than the one we have described, and the details can be found in an electrical engineering handbook. Once you have established a good ground it can also serve to discover electrolysis voltages on pipes, simply by measuring for a voltage difference between the ground and the pipe. If you can get a deflection on the lowest voltage scale of the vom, you can be sure the pipes will not last very long.

The vom in industry

Naturally, when we take on big areas, as we have been doing in discussing vom applications, there will be a great deal of overlap. Thus, many of the things said about receiver and transmitter as well as amplifier servicing are applicable to industrial situations. For example, an industrial sound system is no different than any other PA system with the possible exception that in industry it is likely to be larger and require more power and also more maintenance. The uses for the vom in industrial maintenance work are so numerous that even mentioning them all would occupy an entire volume.

Industrial recorders

One of the first applications which comes to mind is the servicing of industrial recorders, which generally involve servo type amplifiers. These are often somewhat different from other kinds of amplifiers. Many of them operate with ac directly on the plates of the tubes and, understandably, they will function only when the voltage swings positive. In these cases there will always be a balancing system, so that the voltages rise and fall in two tubes 180° out of phase, and something will happen only if there is a difference in these voltages, and then only on the positive half-cycles. This is mentioned only so you will not begin by assuming that the amplifier must necessarily have a dc plate voltage, which

you would fail to measure with the dc ranges of the vom (Fig. 1017).

Many industrial controls use thyratrons, gas type tubes, and these are in a class by themselves. When you encounter thyratrons, you'll not fail to notice it for practically all of them glow with a bright purple when they are conducting. This glow results from the ionized gas in them, and this gas will stay ionized as long as there is even a low positive voltage on the anode. Thus, thyratrons will always operate with ac on the plates and even on the grid. The most common way of controlling the current passed through a thyratron is by shifting the phase of the ac voltages on the plate and grid relative to each other. But, although the thyratron has ac applied to it, remember that it will actually pass a pulsating direct current since the electrons in the tube can go in only one direction, from the cathode to the anode. We have here the unusual situation that you have to measure applied plate voltage with the ac ranges and yet plate current must be measured with a dc range.

Also you should consider that the current measured this way is not equivalent to straight dc and that the peak current is considerably higher than will be indicated by the meter. What its actual value is cannot be measured with a current meter and, besides, it would depend on the length of time of the cycle the tube remains conducting. Peak current would have to be measured indirectly, with a resistance across which you'd measure the integrated voltage with a diode and capacitor. If the meter load is high enough, the meter will indicate almost the peak voltage developed across the resistor, the same as it would indicate almost the peak voltage across the power line.

In industry you would also service such devices as the thermistor and thermocouple temperature arrangements, and you already know how to use the vom in those cases. Temperature bulbs are also very common.

Checking rf equipment

Rf is encountered in industry when dielectric and induction heating are used. It may take forms that are not at once obvious. For example, small bag-sealing machines are now made which don't show any obvious rf equipment, yet they use a well concealed generator in the dielectric manner. When rf is generated for industrial purposes, there isn't much reason to use filtering in the power supply. After all, with proper design, all the rf stays

within the machine area. In fact, a field-strength meter made with a vom can be used profitably here for detecting stray fields, which might require extra shielding on the machine.

A similar situation prevails with induction heating. Be careful to keep the meter itself well out of the induction work-coil field;

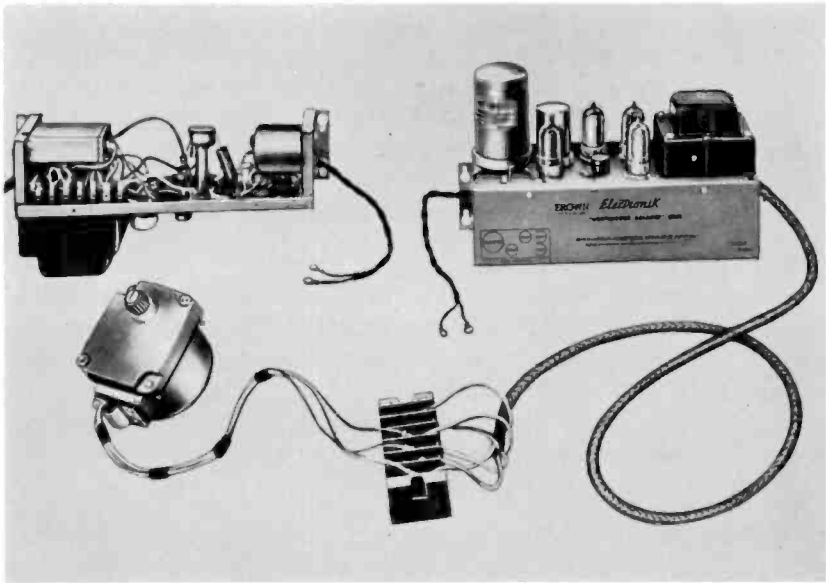
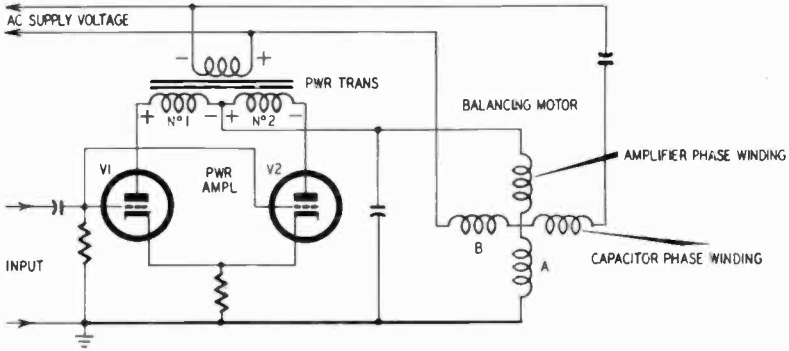

Fig. 1017. The circuit diagram shows a partial servo schematic. Each of the tubes supplies a half-cycle of ac to the motor windings. The photograph shows a typical servo amplifier. This unit has ac voltage on the plates of the output tubes. (Minneapolis-Honeywell Regulator Co.)

or you might find the metal inside the plastic case fused into a neat lump of alloy. Dielectric and induction generators are adjusted almost exactly like transmitters and their circuitry is very

similar, but take note of the fact generally, no filters are used, and thus the plate power supply is pulsating dc. However, for supplying generators of any size, three-phase current is usually employed, and the resulting pulsating dc will appear very nearly like a dc voltage on the meter.

Testing relays

The vom can be used to check relays, encountered everywhere on the industrial scene. You can check the proper making or breaking of the contacts and the continuity, resistance and insulation values of the coils. In dc relays, corrosion of the coil wire is a common fault. This is hard to detect, except that the relay will show a tendency to close or open more slowly. Where a relay exhibits this characteristic and the voltages on the coil are normal, you can detect shorted turns by comparing the dc resistance of the coil with another coil for the same type relay. These coils are automatically wound by machine and usually very closely similar so that, if you set up the two coils in a bridge type circuit, with the vom as a null detector, obvious differences should show up very readily.

The industrial electronics and electric uses for the vom include many other areas than the few samples we have mentioned, but space does not permit further discussion. Wherever electrical values must be measured, the most likely instrument to turn to is the vom because of its many ranges and capabilities.

Caring for your meter

The most obvious care for the vom is not putting it where it can fall. Nor should it be subjected to the extremes of cold and heat, or to strong ac magnetic fields, moisture, dirt and grease, and serious vibration. All too often, the vom is treated with disrespect, yet the user demands all kinds of performance and accuracy from his instrument, no matter what he has done to it.

Meter out of balance

If the meter shows signs of being out of balance, as you can readily determine by turning the instrument sideways and upside down and laying it flat, a specialist should be the one to rebalance it unless you have the skill, patience and inclination to spend a lot of time on the job.

Battery replacement

The resistance-range batteries will need periodic replacement, although with average use once a year is about as often as this

needs to be done. But even if a battery needs no replacement, check it for corrosion at least once a year and preferably twice. The corrosion products from a battery are highly conductive and could easily short other parts of the circuit if they are allowed to "grow" on the battery, as you have probably seen in flashlights which have been damp. The need for battery replacement can be detected easily; the meter refuses to allow zero setting. But even before that, if a meter shows serious discrepancies when you measure a resistance on two different ranges, the battery is weakening. Accuracy of the resistance ranges can be checked with some standard or precision resistance, but remember that there is really nothing you can do about it except use fresh batteries, which might improve accuracy somewhat.

Cleaning the meter

A slightly damp rag with a little detergent can be used to clean the voin case and meter face, but be sure it is only *slightly* damp. A wet rag will certainly do more harm than good. Use no solvents, thinners or even carbon tet on the meter. Most of them leave an oily film or a deposit which is hard to remove. Periodic dry dusting is the best preventive against gathering dirt on the meter. Never leave a meter with a plastic face exposed to direct sunlight for long periods of time. If you like to have the sun shining in your shop, put the meter where the sun does not get at it. Consistent exposure to strong sunlight will discolor the plastic face and will very likely fade the lettering on the scales, making the meter difficult to read.

Checking the test leads

A periodic check should be made of the test leads. If the leads show cracks, replace them. If they feel too flexible at the plugs and prods, check to see if the strands of the flex wire are beginning to break. If so, cut the wire back an inch or so, peel the insulation and reconnect to the plugs. Make sure the contact surface of the plugs is always clean. If there is any corrosion or dirt, clean them with some very fine steel wool (*not near the meter*). Be sure to remove any steel-wool remnants. Remember that the test leads must be considered part of your meter and that poor contact, frayed leads and poor insulation on the leads all can contribute to lack of accuracy.

Cleaning wafer switches

Trouble is sometimes caused by the contacts of the meter switch. This is a tricky part to clean, and this must not be done unless you are certain this is the source of the trouble. If it *has* to be done, some very fine sandpaper cut into narrow strips and pasted to kitchen match sticks can be used to rub the contacts clean. But use no pressure on the delicate contacts beyond what is absolutely needed for the sanding. Blow out all particles carefully. Most often you will find that the contacts are silver-plated on good quality meters and, since these are wiping contacts, the wipe of the switch will very probably keep them clean enough.

Don't expect too much from your meter. You have an instrument which is a reasonable compromise between versatility and accuracy. The manufacturer's guarantee of 2% of full-scale accuracy is almost always exceeded. But the vom is not intended as a precision instrument in the first place. It is intended as a tool with a great many uses, and as such is the most tool you can buy for your money in any class.

index

A		
A- and B-Batteries, Testing	132	
Ac:		
and Dc Voltage Ranges, Combination Multimeter With	33	
Calibration Methods	35	
Cathodes, Ceramic-encased	179	
Circuit, Formula for Wattage in	125	
Current Ranges in	98	
-dc Transformerless Receivers	168	
High voltage Probe for	104	
Power, Measuring	124	
Voltage and Db Scales, Relationship Between	81	
Voltage, Detecting Small Changes in	143	
Voltmeters, Calibration of	34	
Voltmeters, Making	31	
Volts, Circuit for Measuring	65	
vs Dc Scales	34	
Accuracy:		
Calibration	12	
Increasing	56	
of Measurement of Internal Resistance	22	
Accurate Multirange Ohmmeter	58	
Acoustical Output	185	
Adapter:		
Clamp-on Ammeter	91	
Grid-dip	150	
Vtvm	153	
Adding Current Ranges	105	
Adjuster, Zero	112	
Adjusting the Linearity Coil	177	
Adjustment, Zero	60	
Ammeter Adapter, Clamp-on	91	
Ampere Turns	10	
Amplification:		
for the Vom	154	
Test	165	
Transistor Current	155	
Amplifier, Servo	215	
Antenna:		
Dummy	160	
Loopstick	171	
Radiation Pattern	192	
Appliance Repair	140	
Applying Decals	54	
Arrangements, Switching	29	
Audible Hum in Speaker	171	
Audio Amplifier in Tv Set	177	
Auto Battery	133	
Auto Battery Source Supply	113	
Autotransformers	137	
Avc Capacitors, Leaky	173	
Avc, Checking	173	
Ayrton Shunt Circuit	48	
Ayrton-type Shunt	49	
B		
Balanced Transistor Amplifier	157	
Balancing Potentiometer	186	
Balancing the Meter	15	
Basic Meter:		
Cost	47	
in the Vom	7	
Ranges Required	48	
Basic Ohmmeter Circuits	41	
Batteries	182	
Batteries, Mercury	182	
Batteries, Recharged	182	
Battery:		
Auto	133	
Loading the	133	
Polarity	182	
Polarity in the Meter	138	
Replacement	216	
Tester	132	
B Batteries, Checking	134	
Beta, Transistor	161	
Bias Oscillator	187	
Biophysical Measurements	212	
Blasting	173	
Board, Mounting	51	
B-plus Voltage, Checking	169	
Bridge Galvanometer	148	
Bridge, Wheatstone	146	
Bucking Voltage	142	
Building the Extender	109	
Building Your Own Instrument	46	
Burned-out Cathode Resistors	172	
Butterfly Capacitors	210	
C		
Calibrating Unknown Resistors	45	
Calibrating With Light Bulbs	37	
Calibration:		
Accuracy	12	
Methods, Ac	35	
of Ac Voltmeters	34	
of Ohmmeters	45	
Capacitance:		
of Electrolytics, Method for Measuring	117	
Measuring	115	
Scales, Using to Measure Inductance	198	
the Vom Used to Measure	116	
Capacitive Reactance	116	
Capacitive Reactance:		
at Different Frequencies	118	
Chart	198	
Formula for	116, 195	
Capacitor, Reactance of	116	
Capacitor, Variable	195	
Capacitors, Electrolytic, Polarizing	119	
Capacitors, Butterfly	210	
Caring for Your Meter	216	
Cathode Resistors, Burned-out	172	
Center-tapped Choke	137	
Ceramic-encased Ac Cathodes	179	
Changing:		
Meter Scales	12	
Shunts	27	
the Meter Range	24	
Charges, Stray Capacitor	182	
Chart, Capacitive Reactance	198	
Chassis, "hot"	168	
Checker, Transistor	160	
Checking:		
Avc	173	
B Batteries	134	
B-plus voltage	169	
Diodes	138	

Distributor Timing	204	Decibels	80
Electrolysis	212	Decibels vs Power and Voltage Ratios	82
Electrolytic Capacitor Leakage		Defective Filter Capacitor	170
Current	119	Demodulator Probe	176
Hearing-aid Batteries	135	Detecting Small Changes in Ac Voltage	143
Oscillation	180	Detecting Small Changes in Direct	
Output Transformers	137	Current	142
Power Transformers	136	Diaphragm Tweeters	184
Push-pull Balance	186	Difference, Voltage	128
Rectifiers	137	Different Frequencies, Capacitive	
Rf Equipment	214	Reactance at	118
Series Filaments	168	Diode, Crystal	171
the Oscillator	171	Diodes:	
Test Leads	217	Checking	138
Transformers	135	Germanium and Silicon	138
Tube for Shorted Elements	141	Germanium, Special	97
Tubes with the Vom	162	Direct Current, Detecting Small	
Choke, Center-tapped	137	Changes in	142
Choosing the Kit	74	Direct-reading Ohmmeter Circuit	55
Circuit:		Direct-reading Transistor Checker	161
Ayrton Shunt	48	Dissipation, Energy	115
for Measuring Ac Volts	65	Distributor Breaker	204
for Measuring Ohms	66	Distributor Timing, Checking	204
Galvanometer	68	Double Bridge, Kelvin	149
High-ohms	68	Double-spot Reception	175
Low-ohms	68	Dropping Resistor	172
"Normal" Meter	95	"Dry" Thermistor	207
Ohmmeter, Direct-reading	55	Dummy Antenna	160
Ohmmeter, Potentiometer-type	43		
Ohmmeter, Series-type	41	E	
Ohmmeter, Shunt-type	42	Effective Internal Resistance	62
Output-measuring	77	Elaborate Range-extending Method	111
Resistance, Total	57	Electrolysis, Checking	212
Series-type Ohmmeter	85	Electrolytic Capacitors, Polarizing	119
Thermal Compensating	97	Electrons, "shortage" of	139
Zero Setting	155	Electrostatic Speaker	184
Circuits, Converter	170	Emf (counterelectromotive force)	124
Circuits, Ohmmeter, Basic	41	Emission Testing	163
Clamp-on Ammeter Adapter	91	Encapsulated Inductor	139
Cleaning the Meter	217	Energy Dissipation	115
Cleaning Wafer Switches	218	Energy, Maximum Transfer of	188
Collector Current	161	Establishing Standards	26
Collector Stud	183	Expanded Scale for the Vom	141
Combination Multimeter with Ac and		Extender, Building the	109
Dc Voltage Ranges	33	Extender, Range	107
Commercial Vom's	89	Extending Ranges and Making	
Comparison Component	121	Accessories	103
Component, the Mystery	139	External Resistance	11
Conductors, Resistance of	112	External Shunt, Home-made	106
Construction Precautions	39	External Shunts	98
Construction, Sequence of Procedure			
for Kit	72	F	
Continuity, Filament	140	Factor, Power	124
Continuity, Heater	169	Faraday Shield	140
Control, Zero	63	Faulty Tubes, Locating	169
Conversion Curves	91	Ferrite Rod	171
Converter Circuits	170	Field-strength Measurement	158
Copper Bar Shunt	25	Field-strength Meter	157
Corrections in Output Readings Across		Filament Continuity	140
Speaker Coils	81	Filaments, Tube	140
Cost of Basic Meter	47	Film, Kodalith Ortho	54
Counterbalancing the Pointer	17	Filter Capacitor, Defective	170
Counterelectromotive Force (emf)	124	Finding:	
Crossover Network	184	the Rms Value	32
Crystal Diode	171	Value of Unknown Inductance	120
Current:		Turns Ratios and Voltage Ratings	136
Collector	161	Formula:	
Measurements	66	Capacitive Reactance	116, 195
Meter, Switched Multirange	27	Inductive Reactance	121, 195
Meters, Multirange, Making	23	Wattage in Ac Circuit	125
Ranges, Adding	105	Forward-to-back Resistance Check	139
Ranges in Ac	98	Four Hundred-cycle Transformers	136
Saturation	163	Frequency Deviation	192
Curves, Conversion	91	Frequency, Resonant	194
		Full-wave Meter Rectifier	32
D			
D'Arsonval Meter	8	G	
Db Scales	91	Galvanometer:	
Dc, High-voltage Probe for	104	Bridge	148
Dc vs Ac Scales	33	Circuit	68
Decals, Applying	54	Range	69
Decals for Meter Scales	54		
Decibel Scales, How to Read	78		

Gas and Interelectrode Capacitance Tests	165	Construction, Sequence of Procedure for	72
Generator, Signal	194	-type Meters	47
Generator, Sweep	176	-type Multimeter in Wired Form	101
Germanium and Silicon Diodes	138	-type Vom's	71
Germanium Diodes, Special	97	Kits, Types of	75
Good Solder Joint	73	Kodalith Ortho Film	54
Grid-dip:			
Adapter	150		
Oscillator	149		
Oscillator, Null Detection in	150		
Grid Resistors, Open	172		
Ground Resistance	212		
Grounding Resistor	179		
H		L	
Half-scale Reading	59, 108	Laboratory, the Vom in the	206
Hearing-aid Batteries, Checking	135	Larger-size Vom	93
Heater Continuity	169	Leakage Current, Checking Electrolytic Capacitor	119
Heating Equipment, Induction	160	Leaky Avc Capacitors	173
Heavy-duty Low-voltage Source Supply	113	Lecher Wire Null Detector	151
Hi-Fi, the Vom in	183	Lecher Wires	151
High:		Level Indicator	208
Accuracy Ohmmeter	55, 62	Light Bulbs, Calibrating with	37
Forward-to-backward Ratio	138	Linear Time Measurement	202
-gain Transistor Amplifier	156	Linearity Coil, Adjusting the	177
-ohms Circuit	68	Loading the Battery	133
-R Test Terminals	60	Locating Faulty Tubes	169
High-voltage Probe:		Locating Microphonic Tubes	175
for Ac	104	Lockout	187
for Dc	104	Logarithm	78
Home-made	105	Loopstick Antenna	171
Typical	104	Low:	
Higher Resistances, Measuring	107	-level Radiation	159
Higher Voltages, Measuring	103	-ohms Circuit	68
Home-made External Shunt	106	-R Test Terminals	61
Home-made High-voltage Probe	105	-resistance Shunt, Making a	24
Hot Chassis	168	Resistance, Using Ampere Scales for Measuring	114
How to:		Temperature Coefficient Resistor	107
Determine Internal Resistance	20	Lower Resistance, Measuring	112
Measure Range	19	Lower Voltages, Measuring	105
Read Decibel Scales	78		
Humidity Meter	207		
I		M	
Identifying and Checking Transistors	138	Magnets	7
Image Frequency	175	Making:	
Impedance Match	189	Accessories and Extending Ranges	103
Increased Accuracy Series-ohmmeter Circuit	56	Ac Voltmeters	31
Increasing Accuracy	56	Low-resistance Shunts	24, 25
Inductance:		Meter Scales	52
Finding the Value of Unknown	120	Multirange Current Meters	23
Measuring	120	Practical Measurements	127
Using Capacitance Scales to Measure	198	Series Resistors	28
Induction Heating Equipment	160	Supersensitive Meter	38
Inductive or Capacitive "Kick"	182	Voltmeters and Multirange Voltmeters	28
Inductive Reactance, Formula	121, 195	Maximum Transfer of Energy	188
Inductor, Encapsulated	139	Meaning of Vom Readings	167
Industrial Recorders	213	Measuring:	
Instrument, Building Your Own	46	Ac Power	124
Instrument, Selecting an	102	Ac Volts, Circuit for	65
Insulation Trouble	190	Capacitance	115
Internal Resistance:		Concentration of a Solution	207
Effective	62	Higher Resistances	107
Accuracy of Measurement	22	Higher Voltages	103
How to Determine	20	Inductance	120
Interpolation Scale	196	Inductance by Parallel Resonance Method	194
Inverse Ratio	117	Inductance by Series Resonance Method	195
J		L and C	193
Jack and Multiplier, Separate	100	Low Resistance, Using Ampere Scales for	114
Just Noticeable Difference	79	Lower Voltages	105
K		Lower Resistance	112
Kelvin Double Bridge	149	Ohms, Circuit for	66
Kit:		Power	124
Choosing the	74	Rf Voltages	123
		Temperature	208
		Viscosity	211
		Wattage	125
		with an Insensitive Meter	127
		Measurement, Field-strength	158
		Measurement, Repeatability Aspect of	46
		Measurements:	
		Biophysical	212
		Current	66
		Making Practical	127

Photometric	211	High-accuracy	55, 62
Voltage	64	Polarity	183
Mercury Batteries	182	Scales, Shunt and Series	43
Meter:		Ohmmeters, Calibration of	45
Balancing the	15	Ohms:	
Basic, Ranges Required	48	Network	67
Battery Polarity in the	138	-per-volt Value	64
Caring for Your	216	Reactance in	118
Cleaning the	217	One Hundred Thousand Ohms-per-volt	
Cost of Basic	47	Meter	100
Field-strength	157	Open Grid Resistors	172
Humidity	207	Operation of the Vom	102
in the Vom, Basic	7	Oscillation, Checking	180
Measuring with an Insensitive	127	Oscillation, Unwanted	181
Moving-coil	9	Oscillator:	
-open Position	101	Bias	187
out of Balance	216	Checking the	171
Physical Construction of	52	Grid-dip	149
Plastic-front	14	Null Detection in Grid-dip	150
Protecting the	15	Probe	171
Range, Changing the	24	Other Uses of Vom	126
Rectifier, Full-wave	32	Output-measuring Circuit	77
Rectifiers	31		
Scales, Changing	12	P	
Scales, Decals for	54	Parallel:	
Scales, Making	52	Resonance Method, Measuring	
Selecting a	18	Inductance by the	194
Supersensitive, Making a	38	Unknown Resistor	116
the D'Arsonval	8	Wave Trap	174
Meters, Kit-type	47	Phase:	
Meters, Multirange	19	Angle Determination	199
Method:		Shift	130, 200
Elaborate Range-extending	111	-shifted Voltage	201
for Measuring Capacitance of		Splitter	187
Electrolytics	117	Voltages in	117
for Reading Very High Resistance	110	Phasing of Speakers	184
the Morecroft	117	Photometric Measurements	211
the Vector	121	Pin-jack Vom	63
Methods, Ac Calibration	35	Point of Reference	80
Micromhos	165	Pointer, Counterbalancing	17
Microphonic Tubes, Locating	175	Polarity:	
Microphonism	175	Ohmmeter	183
Microswitch	204	Reversing Switch	93
Mid-scale Sensitivity	109	Speaker	185
Modulated and Unmodulated Rf		Polarizing Electrolytic Capacitors	119
Voltages	123	Poles, North and South	7
Monitor	191	Poor Solder Joint	73
Morecroft Method	117	Portable Radios	178
Mounting Board	51	Position, "Meter-open"	101
Movement, Supersensitive 10 μ amp	98	Potentiometer, Balancing	186
Moving-coil Meter	9	Potentiometer-type Ohmmeter Circuit	43
Multimeter, Combination, with Ac and		Power:	
Dc Ranges	33	Ac, Measuring	124
Multimeter, Kit-type, in Wired Form	101	and Voltage Ratios vs Decibels	82
Multirange Current Meters, Making	23	Factor	124
Multirange Meters	19	Measuring	124
Multiplier Series Resistors, Values of	30	Output Test	165
Multipliers, Series	77	Supply Voltage	170
Mystery Component	139	Transformers, Checking	136
		Transistors, Checking	183
		Printed Circuit Problems	189
N		Probe:	
Network, Ohms	67	Demodulator	176
Nomogram, Using a	196	Oscillator	171
Nomogram to Compensate for Loading		Two hundred-megohm	104
by Vom	131	Typical High-Voltage	104
Normal Meter Circuit	95	P-type Semiconductor Material	139
North and South Poles	7	Push-pull Balance, Checking	186
Null:		Pythagorean Theorem	122
Detection in Grid-dip Oscillator	150		
Detector, Lecher Wire	151	Q	
Detector, the Vom as a	145	Q (Quotient of the Ranges)	129
		Quarter-wavelength Null Point	152
O			
Ohmmeter:		R	
Accurate Multirange	58	Radiating Transmitter	192
Circuit, Direct Reading	55	Radiation, Low-level	159
Circuit, Potentiometer-type	43	Range:	
Circuit, Series-type	41	Extender	107
Circuit, Shunt-type	42	-extending, Elaborate Method	111
Circuits, Basic	41	Galvanometer	69
		How to Measure	19

Measuring	19	Separate Test-lead Jack	98
Required in Basic Meter	48	Sequence of Procedure for Kit Con-	72
Ratio	80	struction	
Ratio:		Series:	
High Forward-to-backward	138	Filaments, Checking	168
Inverse	117	Multipliers	77
Square of the Turns	137	-ohmmeter Circuit, Increased Ac-	56
Ratios, Scale	130	curacy	28
Reactance:		Resistors, Making	33
Capacitive	116	Resistors, Using Separate for Ac	
Formula for Capacitive	116	and Dc	195
Formula for Inductive	121	Resonance Method, Measuring In-	169
in Ohms	118	ductance by the	41, 85
Reading, Half-scale	59, 108	String Sets	174
Receivers, Ac-dc Transformerless	168	-type Ohmmeter Circuit	167
Receivers, Transistor	180	Wave Trap	168
Recharged Batteries	182	Service Instrument, the Vom as a	191
Recorders, Industrial	213	Servicing, the Vom in Ac-dc Receiver	215
Recorders, Tape	187	Servicing, Transmitter	169
Rectifier, Meter, Full-wave	32	Servo Amplifier	140
Rectifiers:		Sets, Series String	139
Checking	137	Shield, Faraday	141
Meter	31	Shortage of Electrons	152
Selenium	138	Shorted Elements, Checking a Tube for	
Regulator Adjustment	205	Shorting Bar	43
Relative Resistance	136	Shunt:	49
Relays, Testing	216	and Series Ohmmeter Scales	48
Repair, Appliance	140	Ayrton-type	25
Repeatability Aspect of Measurement	46	Circuit, Ayrton	190
Resistance:		Copper Bar	42
Check, Forward-to-back	139	-ohmmeter System	27
Effective Internal	62	Shunts:	98
External	11	Changing	24, 25
Internal, Accuracy of Measurement	22	External	
Internal, How to Determine	20	Low Resistance, Making	
-measuring Circuit	78	Signal:	
of Conductors	112	Generator	174
Relative	136	Interference	172
Total Circuit	57	Tracing and Alignment	173
Resistances, Measuring Higher	107	S-Meter	
Resistors, Method for Reading Very		Solder:	
High	110	Joint, Good	73
Resistor:		Joint, Poor	74
Dropping	172	Purpose of	72
Grounding	179	Soldering	
Low Temperature Coefficient	107	Solution, Measuring the Concentration	207
Unknown	147	of	190
Unknown, Parallel	116	Solvents	113
Resistors, Calibrating Unknown	45	Source Supply, Auto Battery	
Resistors, Series, Making	28	Source Supply, Heavy-duty Low-	113
Resonant Frequency	194	voltage	7
Rf:		South and North Poles	
Ammeter, Thermocouple-type	191	Speaker:	
Equipment, Checking	214	Audible Hum in	171
Voltages, Measuring	123	Matching	188
Voltages, Modulated and Unmodu-		Polarity	185
lated	123	Voice Coil	172
Rms Value, Finding the	32	Speakers, Phasing of	184
Rod, Ferrite	171	Special Germanium Diodes	97
S		Square of the Turns Ratio	137
Saturation Current	163	Standards, Establishing	26
Scale:		Stereo	184
Expanded, for the Vom	141	Storage Batteries, Using Vom to Check	133
Interpolation	196	Stray Capacitor Charges	182
Ratios	130	Supersensitive Meter, Making a	38
Scales:		Supersensitive 10 μ amp Movement	98
Ac vs Dc	34	Sweep Generator	176
Db	91	Switch, Polarity-reversing	93
Meter, Decals for	54	Switched Multirange Current Meter	27
Meter, Making	52	Switching Arrangements	29
Ohmmeter, Shunt and Series	43	System, Shunt-ohmmeter	190
Types of	15		
Types of Vom	53	T	
Selecting a Meter	18	Tachometer, the Vom as a	203
Selecting an Instrument	102	Tape Recorders	187
Selenium Rectifiers	138	Techni-Cals	54
Semiconductor Material, P-type	139	Terminals, High-R Test	60
Sensitive Balance	210	Terminals, Low-R Test	61
Sensitivity, Mid-scale	109	Tester, Battery	132
Separate Jack and Multiplier	100	Testing:	
		A- and B-batteries	132

Emission	163	Voice Coil Connections	184
Power Transistors	183	Voice Coil, Speaker	172
Relays	216	Voltage:	
Tests, Gas and Interelectrode Capacitance	165	Bucking	142
Theorem, Pythagorean	122	Difference	128
Thermal Compensating Circuits	97	Measurements	64
Thermal Storage	179	Phase-shifted	201
Thermocouple-type Rf Ammeter	191	Power Supply	169
Thermocouples	209	Voltages:	
Time Constant	123	in Phase	117
Time Measurements with the Vom	201	Measuring Higher	103
Transconductance Test	164	Measuring Lower	105
Transformer, Unknown	135	Measuring Rf	123
Transformerless Receivers, Ac-dc	168	Modulated and Unmodulated Rf	123
Transformers:		Voltampers	124
Checking	135	Voltmeters:	
Checking Output	137	Ac, Calibration of	34
Four-hundred Cycle	136	Ac, Making	30
Transistor:		and Multirange Voltmeters, Making	38
Amplifier, Balanced	157	Vom:	
Amplifier, High Gain	156	Amplification for the	154
Beta	161	as Field-strength Meter	192
Checker	160	as Null Detector	145
Checker, Direct Reading	161	as Service Instrument	167
Current Amplification	155	as Tachometer	203
Receivers	180	Basic Meter in	7
Tester Using the Vom	160	Checking Tubes with the	162
Transistors, Identifying and Checking	138	Expanded Scale for	141
Transmitter:		in Ac-dc Receiver Servicing	168
Modulation	191	in Garage	203
Radiating	192	in Hi Fi	183
Servicing	191	in Industry	213
Trimmers	172	in Laboratory	206
Tube, Checking for Shorted Elements	141	Larger-size	93
Tube Filaments	140	Meaning of Readings	167
Tubes, Locating Faulty	169	Measuring Wattage with a	125
Tuning Slug	195	Nomogram to Compensate for	
Tweeters, Diaphragm	184	Loading by the	131
Twenty-penny Nails	134	Operation of	102
Two Hundred-megohm Probe	104	Other Uses of	126
Types:		Pin-jack	63
of Kits	75	Scales, Types of	53
of Scales	15	Time Measurements with	201
of Vom Scales	53	Transistor Tester Using the	160
Typical High-voltage Probe	104	Used to Measure Capacitance	116
		Using it in Fm and Tv	176
U		Vom's, Commercial	89
Unknown:		Vom's, Kit-type	71
Inductance, Finding the Value of	120	Vtvm Adapter	153
Resistor	147		
Resistor, Parallel	116	W	
Resistors, Calibrating	45	Wafer Switches, Cleaning	218
Transformer	135	Wagging Signal	173
Using:		Wattage, Formula for in Ac Circuit	125
Ampere Scales for Measuring Low		Wattage, Measuring with a Vom	125
Resistance	114	Wave Trap, Parallel	174
Capacitance Scales to Measure Inductance	198	Wave Trap, Series	174
Nomogram	196	Wave Traps	174
Separate Series Resistors for Ac and Dc	33	Wavemeter	181
Vom in Fm and Tv	176	Wet Thermistor	207
Vom to Check Storage Batteries	133	Wheatstone Bridge	146
		Wired Form, Kit-type Multimeter	101
V		Wires, Lecher	151
Value, Ohm-per-volt	64	Wiring	74
Values of Multiplier Series Resistors	30	Z	
Variable Capacitor	195	Zero:	
Vector Method	121	Control	63
Vector Relationships	200	Adjuster	112
Very High Resistances, Method for Reading	110	Adjustment	60
		Setting Circuit	155