

RADIO-CRAFT LIBRARY N^o. 5

HOW TO BECOME A RADIO SERVICE MAN

How to Get Started and How to Make Money
in Radio Servicing

with

Complete Constructional and Technical Data

by *Louis Martin*



PUBLISHED BY
GERNSBACK PUBLICATIONS, Inc.
99 HUDSON ST - NEW YORK

The 1935 (volume 2)

Official AUTO-RADIO SERVICE MANUAL

\$2.50 List



Over 240 Pages Printed on Special Thin "Bible Paper"

Over 500 Illustrations

Flexible, Looseleaf Leatherette Cover

HERE NOW—is the second volume of the OFFICIAL AUTO-RADIO SERVICE MANUAL—the 1935 Edition.

With so large a number of new auto-radio sets placed on the market by different manufacturers, the 1935 OFFICIAL AUTO-RADIO SERVICE MANUAL becomes an essential part of Service Men's equipment. Remember, there are nearly 1,800,000 auto-radio sets in use today.

THERE IS ABSOLUTELY NO DUPLICATION OF MATERIAL BETWEEN THE 1933 EDITION (VOLUME I) AND THE NEW 1935 EDITION (VOLUME II). THE MATERIAL IS 100% NEW.

Every radio man connected in any way with the booming auto-radio business needs a copy of the 1935 OFFICIAL AUTO-RADIO SERVICE MANUAL. It contains only auto-radio service "dope."

HERE ARE HIGHLIGHTS OF THE 1935 AUTO-RADIO MANUAL.

240 pages crowded with diagrams, service material and other essential data required for proper servicing of new auto-radio receivers. Included are diagrams of sets which appeared during 1934, and which were not included in the supplement to the first edition.

Complete schematic diagrams, chassis layouts, voltage tabulations and servicing instructions are included for practically all sets. "Under-side" tube symbols are also included to facilitate the job of servicing the sets.

Instructions are included with many sets telling how to suppress stubborn cases of ignition interference. This includes the newest "suppressorless" sets—and what to do when interference is encountered with this type of set.

Details on how to make installation in "turret-top" cars are included. The different methods used by car makers and set manufacturers are listed with the individual circuits and service information.

The index contains the listing of sets which were published in the first edition, as well as the sets which appear in the new volume. This information helps the Service Man to locate the circuit and details for any receiver that has been made.

The book is bound in a handy, flexible leatherette cover. To be sure the pages are sturdy, to withstand constant use, the book will be printed on a special "bible" stock. This is a very durable, but thin paper. The book printed on this paper can be easily rolled to fit into your pocket or slipped in the service kit.

Here is a Partial List of Sets Covered

Atwater Kent Mfg. Co.
Audiola Radio Co.
Autocrat Radio Co.
Belmont Radio Corp.
Century Radio Products Co.
Chevrolet Motor Corp.
Chrysler Motor Corp.
Colonial Radio Corp.
Crosley Radio Corp.
Delco Appliance Corp.
Detrola Radio Corp.
Emerson Radio & Phonograph Co.
Fada Radio & Electric Corp.
Ford Motor Corp.
Ford-Majestic
Franklin Radio Corp.

Galvin Mfg. Corp.
General Electric Co.
General Motors Corp.
Graham-Paige Motors Corp.
Grigsby-Grunow Co.
Chas. Hoodwin Co.
Howard Radio Co.
Hudson Motor Car Corp.
International Radio Corp.
Karadio Corp.
P. R. Mallory & Co.
Montgomery Ward & Co.
National Company, Inc.
Noblitt-Sparks Industries, Inc.
Philco Radio & Television Corp.
Pierce Airo, Inc.

RCA Manufacturing Co., Inc.
Sears Roebuck & Co.
Sentinel Radio Corp.
Sparks-Withington Co.
Stewart Radio Corp.
Stewart-Warner Corp.
Stromberg-Carlson Tel. Mfg. Co.
Transformer Corp. of America
United American Bosch Corp.
United Motors Service, Inc.
U. S. Radio & Television Corp.
Wells Gardner & Co.
Wilcox-Gay Corp.
Rudolph Wurlitzer Mfg. Co.
Zenith Radio Corp.

Send remittance of \$2.50 in form of check or money order for your copy of the 1935 OFFICIAL AUTO-RADIO SERVICE MANUAL. Register letter if it contains cash or currency. THE MANUAL IS SENT TO YOU POSTAGE PREPAID.

GERNSBACK PUBLICATIONS, Inc. 99PR HUDSON STREET
NEW YORK, N. Y.

**--for the real
servicing "dope"
you can't find a
better book!**



NO other radio book is comparable to the 1935 OFFICIAL RADIO SERVICE MANUAL. In contents, in style of printing, in grade of paper, in illustrations, there has never been published such a comprehensive volume.

The 1935 Manual contains over a thousand pages—yet it is only 1¼ inches thick because it is printed on a special Bible stock which is an exceptionally good stock, yet one of the thinnest and most durable papers. This 1935 Manual is the most authentic and elaborate service guide ever used in the radio industry. Service Men and dealers who use this

1935 Manual are astonished by finding in it such a wealth of profitable service information which has never been published before.

Contents of the 1935 Manual

Over 1,000 pages full of diagrams and essential information of manufactured receivers—only data of real use in servicing is included. This new Manual is really portable since it will be extremely thin and light as well. ● Volume V continues where the preceding manual left off. ● Many circuits of old sets are included. ● Service Men know every set has certain weak points which are really the cause of trouble. Wherever the information could be obtained, these weaknesses with their cures are printed right with the circuits. This is an entirely new and valuable addition to the Manual. ● All the latest receivers are included—all-wave sets, short-wave sets, auto-radio sets, midget and cigar-box sets, etc., as well as P.A. amplifiers and equipment, and commercial servicing instruments. ● The cumulative index is even more complete than before: including cross-reference to sets sold under different names and type numbers. ● Volume V includes resistance data; socket layout; I.F. data; and voltage data. ● Tube data on latest tubes. ● Free question and answer service—as included in our last three manuals.

OVER 1,000 PAGES
Over 3,000 Illustrations

Flexible, Looseleaf Leatherette Covers

Size 9x12

Yet only 1¼" thick

Send remittance of \$7.00 in form of check or money order for your copy of the 1935 OFFICIAL RADIO SERVICE MANUAL. Register letter if it contains cash or currency. THE MANUAL IS SENT TO YOU POSTAGE PREPAID.

GERNSBACK PUBLICATIONS, Inc.

99PR HUDSON STREET

NEW YORK, N. Y.

What Others Say about this Manual:

Norfolk, Va.

I received the OFFICIAL RADIO SERVICE MANUALS ordered as per my letter of March 26, 1935 in good order.

I am very well pleased with same as it is a very valuable Radio Service data reference and guide.

Arthur J. Freney.

Detroit, Mich.

Received your 1935 OFFICIAL RADIO SERVICE MANUAL and certainly is something to rave about. It's great.

A. Hedke.

Stillwater, Maine

I have received the 1935 Manual, and I am very much pleased with my investment.

Franklin J. Holmes.

Swift Current,

Saskatchewan, Canada.

I beg to acknowledge receipt of my 1935 issue of the OFFICIAL RADIO SERVICE MANUAL.

Your Manual is fine, and would not be without any of them. The Manuals may be improved for Canadian use.

A. M. Ford.

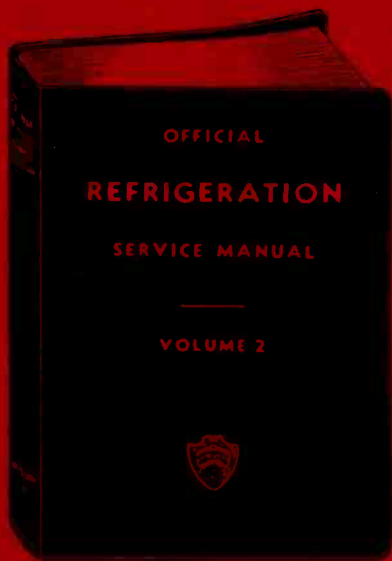

THIS IS THE ONLY COMPLETE
REFRIGERATION SERVICE
MANUAL EVER PUBLISHED - - -

*Entirely New Material
from Cover to Cover!*

\$5.00 NET

VOLUME TWO

OF THE *Official*
OVER 352 PAGES
OVER 300 DIAGRAMS
Complete Service Data
Flexible Looseleaf Binder

REFRIGERATION SERVICE MANUAL

This Manual forms a companion and supplement to the previous OFFICIAL REFRIGERATION SERVICE MANUAL (Volume 1), since all data in the 1935 volume is entirely new.

The OFFICIAL REFRIGERATION SERVICE MANUAL was the first refrigeration Service Manual ever published—and now this new volume has been prepared so that they both form a comprehensive library of information on this rapidly growing refrigeration industry.

This edition is printed on a Special Bible Stock which is extremely thin, yet durable. The special grade of paper makes the new Refrigeration Manual much easier to handle.

Detailed information on servicing; outlines of theory and methods of operation; instructions for the handling of refrigerants; charging systems; diagnosing troubles; trouble charts; electrical hook-ups; charges of oil and refrigerant in different models; advice on the selection of oils; placement and temperature required by foods; valve settings; compressor construction, faults, overhauling; estimating coil and machine loads; are encompassed in this new volume of refrigeration servicing.

List of Contents in the Second Volume of the "Official Refrigeration Service Manual"

History
Food Preservation
Theory and Fundamental Laws
Methods of Refrigeration
Refrigerants, Lubricants and
Brines
Handling, Testing and Storage
of Refrigerants
Compression Systems of
Refrigeration
Liquid Throttle Devices and
Valves
Refrigeration Systems
Electric Control Devices
Compressors, Types, Seals,
Valves, Capacities, Service

Evaporators and Cooling Units
Service Tools, Equipment and
Tool Manipulation
Commercial Unit Specifications
and Service
Household Unit Specifications
and Service
Servicing Refrigeration
Apparatus
Servicing Low Side Float
Valve Systems
Servicing High Side Float
Valve Systems

Servicing Expansion Valve
Systems
Servicing Thermostatic Valve
Systems
Servicing Restrictor and
Capillary Tube Systems
Charging Systems with
Refrigerant
Electrical Service; Motors,
Fuses, Hookups
Service Kinks
Estimating Refrigeration Loads,
Coil and Machine Sizes
Miscellaneous Data

Send remittance of \$5.00 in form of check or money order for your copy of the OFFICIAL REFRIGERATION SERVICE MANUAL (Volume 2). Register letter if it contains cash or currency. THE MANUAL IS SENT TO YOU
POSTAGE PREPAID.

GERNSBACK PUBLICATIONS, Inc. 99PR HUDSON STREET
NEW YORK, N. Y.

CHAPTER 1

The Small, Independent Service Man

A MAN enters the radio service business because he believes it to be the most likable and most profitable business that he is capable of running. In this chapter we will deal with the man who has not sufficient money available to open an impressive store, and who desires pointers on how a small business is to be run, the least amount of apparatus necessary, and the probable income to be secured.

In the first place, a man who has no capital will, in all probability, use his home as the place to conduct the business. This is not detrimental because in the radio service business, nearly all contacts are made either by telephone or mail—the customer never entering the place of business.

Apparatus Required

The next question that arises is that of test equipment. Of course, the more test equipment at hand, the better the service that can be rendered, although there is a minimum amount necessary. For instance, every shop should have an analyzer. This need not be expensive nor elaborate, but merely sufficient to obtain all current and voltage readings. The instrument described in this book may be used until business warrants something more elaborate.

The R.F. (radio frequency) oscillator is the next piece of equipment that should be added. In another chapter in this book there is described an extremely inexpensive oscillator—in fact, it may easily be built with very few parts usually found around the shop; even if parts must be purchased, the total cost would not exceed about three dollars; in many cases it may be built for much less. The intermediate frequency and audio-frequency oscillators may also be built, although they are not absolutely essential, and it is well for the small independent Service Man to defer their construction until he has built up a reasonable amount of business. Thus far, the analyzer is the only essential piece of test equipment

that should be had before opening up a radio service business.

Hand tools are, of course, a necessary addition to any service organization. An elaborate collection is not necessary, but for the man who is in doubt as to those which are desired, the following list is suggested:

One neutralizing adapter (4 prong, UX);

One neutralizing adapter (5 prong, UY);

One small hand drill with assorted drills; several small files;

One hammer;

One pair high resistance telephone receivers;

One electrician's knife;

One pair diagonal cutting pliers;

One pair long nose pliers;

One pair 6-inch side cutting pliers;

One non-metallic screw driver;

One large screw driver;

One small screw driver;

One electric soldering iron; rosin-core solder;

One roll of friction tape;

Assortment of nuts, bolts, screws, etc.;

One roll solid No. 18 push-back wire;

Two non-metallic socket wrenches;

One set small open-end wrenches.

The above are essential to clean-cut servicing although many Service Men have their own ideas on just what tool is necessary for a certain job. The following list is also suggested as additional material which should be carried or kept in the shop, depending upon local conditions.

One small bottle wood alcohol;

One bottle household ammonia;

One small piece of cheese cloth;

One small bottle vaseline;

One small bottle furniture polish;

One dentist's hand mirror;

One small hydrometer in carrying case;

One small flashlight, fountain pen type;

Seven small fixed condensers—

.0001, .001, .006, .0025, .01, .5, 1.0, 2.0 mfd.;

Eight grid leaks, varying in size from .1 to 10 megs.;

Two glass insulators, several "Nail-it" knobs;

Five carbon resistors, 500, 700, 800, 1000, and 2000 ohms;

Six variable wire-wound resistors, 2000, 5000, 10,000, 25,000, 50,000, and 100,000 ohms;

One roll aerial wire;

One roll lead-in wire;

One small blow torch.

Many men contemplating entering the service field, no doubt, have had mechanical experience before, so that the above list of material will be very familiar. In general, it will be found that only a few additions are necessary to the above list in order to have a complete set of "radio" tools.

Getting Business

The small man with only about fifty dollars available has a little problem before him when it comes to getting business. Ordinary means such as newspaper advertising cannot be used for very obvious reasons. It is the purpose of this section to suggest ways and means of advertising (which is the only means one can get business) so that the greatest number of desirable people may be reached for the least expenditure of money.

The very first thing that should be done is to install a telephone. The initial deposit is small compared with the results secured by its use. While additional rules and regulations may be laid down, the reader may doubt the validity of some of the methods suggested. For this reason the author has decided to quote from some actual articles that have been published by that excellent Service Man's magazine, *Radio-Craft*. These letters and articles are reproduced with their kind permission.

The following has been abstracted from an article which appeared recently in *Radio-Craft*, entitled "The Business End of Radio Servicing," by George K. Graham.

It should be noted that the methods used by Mr. Graham are absolutely applicable to the small Service Man; no

large outlay of money is necessary, and the results are certainly satisfying.

"The writer has met Service Men of all kinds and types; some are successful, some are not. A peculiarity he has noted is that the successful ones usually know the least about technical radio; while those who are more technically inclined do not seem to get fair prices for their work. The reason may be that the over-technical radio man is so engrossed with radio itself that he forgets he is in the servicing business primarily to make money.

Go After Business

"Promotion work can be successfully applied to radio service work and will give handsome returns. Your prospects are the people who bought battery sets years ago, and who are constantly patching them up to keep them going, those who bought the earlier electric sets, and those who have had their newer machines long enough to have passed the guarantee period. A large percentage of set owners have purchased their radio receivers from a dealer but will, through some misunderstanding (usually over credits, etc.), make a practice of having them repaired by some outside man. You may as well be the man to do this work for them.

"Right now, in your own town, some one is wondering whom to call for radio service. Make it your business to reach these people. True, not every one you come in contact with needs service right now; but you know that tubes, condensers, resistors and transformers, etc., have a definite life. Set owners will need service sometime. Make them acquainted with your business; not after they have had service done elsewhere, but before, in time for you to get the job. Get to these people first, tell them your story, leave your name with them—then when they do need service they will think of you. Your business will be in direct proportion to the number of contacts you have previously made.

"A good plan to follow is a combination of telephone canvassing and direct-mail advertising. You can call at least twenty-five people a day and offer them a free radio inspection. Your method of approach may be somewhat like this:

'Hello Mr. Brown this is Mr. Jones the radio man. I have just started in the radio service business and in order to become acquainted with the people in town I am offering a free radio inspection. I will be glad to come to your home and inspect your radio, test the tubes, and check the antenna and ground installation. How long have you had your radio, Mr. Brown?'

'You say your machine is a year and a half old? By the way, Mr. Brown, have you had the tubes tested lately? You know that sometimes you can get better reception if you rearrange the tubes in your set. I will be glad to stop up and test the tubes for you and try to get the best reception possible. I am doing this just as a sample of my work; so that when you do need service you know where to call.'

'If he agrees to allow you to inspect his set, make an appointment and **KEEP** it.

If not, continue, and say:

'Well, Mr. Brown, I am glad to hear that your radio is working satisfactorily and, so that you will know where to call, I am going to mail you my telephone number and address.' Experience has shown that twenty-five telephone calls will net, on an average, eight inspections; and, of these eight customers there should be no difficulty in selling four of them at least some tubes or other accessories.

Keep After It

'Don't be afraid to do a little extra work. It won't be necessary after your business has come to the point where you have enough daily calls to keep you busy. But, until then, keep right at your promotional work.

'The next day after your phone conversation mail your prospect a card or letter telling him your story all over, giving your telephone number. Follow this up with a second letter, impressing him with the desirability of having his radio checked before it really gives trouble. Sell him the idea of having his set put in good shape before trouble really develops and denies him his radio for a few days. Stress the idea

that 'An ounce of prevention is worth a pound of cure.'

"While these letters will not give immediate results, they are doing their bit to sell your customer the idea of calling you the next time he needs service. After the second letter, two weeks later, mail your customer a post card, giving him a reminder that you are still waiting to serve him. Continue this card system at least once a month. Call the people on the phone regularly until they get to know you. Remember, too, that before you entered the business they were having their radio taken care of by someone else,

MRS. MARY SMITH,
Baldwin Place,
Oceanside, L. I.

Dear Mrs. Smith:

A Stradivarius violin worth twenty thousand dollars is musically valueless without a little ten-cent chunk of rosin to rub on the strings. A Rolls-Royce costing sixteen thousand dollars won't budge an inch without six little spark plugs costing seventy-five cents a piece.

So you see, when you stop to think about it, the little things are tremendously important. Which brings us to our subject: Is your Radio working satisfactorily—or is it just working? Why be satisfied with anything short of perfect Radio reception when it is so easy to get the best out of your Radio?

Just call Rockville Centre 701. One of our highly skilled Radio experts will call at your home and inspect your Radio, test the tubes, check the installation, all **FREE OF CHARGE**. Why not take advantage of this offer? You owe it to yourself and your family to see that your Radio is giving the satisfaction it is designed to give. Why let some minor accessory cheat you out of this real Radio enjoyment? Don't delay. Take advantage of this offer. We await your call.

Yours for Radio enjoyment,
GRAHAM BROS.

A brief, pithy service sales letter

it is your job to sell them the idea of calling you.

"Do not make it a practice to use price as the bait, use reliability and promptness as your main selling points. Ask your old customers for the names of their friends and follow these names up in the same manner except that you can mention the friends' name and in that way make the conversation more personal.

"Your follow-up letters and cards can be cheaply mimeographed and, if you send out twenty-five pieces of mail a day, you will be able to keep at it. This

system is much better than mailing a broadside of, say, a thousand pieces of mail once, and then forgetting about it. Make this follow-up system a religion.

✓ "After you have serviced a set for one of your customers send them a thank-you letter, emphasizing the fact that you are interested in their well-being from a Radio standpoint. Make them feel that you are interested in them, not only in their money. Make your contacts serve you by showing the people that you are conscientious.

Dear Mr. Jones:

Is your radio working satisfactorily—or is it just working—!

Perhaps you have been using your radio for the past six months or so without having it checked. It may be that just a tube or some minor accessory is standing between you and complete radio enjoyment.

No matter what radio receiving set you own—no matter if it is electrically or battery operated—no matter if it be old or new, your receiver does require attention. Perhaps we can be of service to you; and we will appreciate your consideration.

"Those Serve Best who serve with sufficient knowledge and sincerity of purpose." We are radio service specialists with sufficient knowledge and sincerity of purpose to insure you of complete radio satisfaction. We deal in radio facts instead of radio promises and hopes. We are capable radio engineers and our radio knowledge is at your disposal.

Let us look out for your radio interests. Call Rockville Center 701. Our inspection and advice costs you nothing. Why not call now and have your radio set inspected before trouble develops!

At your service,

GRAHAM BROS.

An introductory letter, such as Mr. Graham used in his "get-acquainted" campaign.

How to Sell New Tubes

✓ "A very good method that has been used with considerable success in following up these free inspection calls—and regular service calls for that matter—is to have your service kit, tools, etc., in a suitcase large enough to hold the test kit, tools and at least a set of tubes for the particular type of receiver you are servicing at the time. When you are in the customer's home, ask them how long they have had their machine, what previous trouble they have had, etc.; this will give you a general idea of just what may be wrong.

"The first thing to do is to examine the machine in its present condition.

Proceed to take the customer's tubes out of the set, and place them to one side; then insert the full new set of tubes, explaining to your customer that you always check the set with your own tubes; as this save time and trouble in case a tube should burn out during the testing. After you have tested the machine and rectified any difficulties that may have been present, take your tube tester and test the customer's tubes, carefully noting any that may be weak.

"Now, with your own tubes in the set, tune in one of the weaker stations; and then remove your tubes, one by one, replacing them with the customer's tubes. If he has any weak tubes, he will immediately see that there is a difference in results with good tubes in the set; and the task of selling him new ones will be much lighter. Remember that the manufacturer designed the set to work with perfect tubes and it is your duty to see that the set has just that; your customer will thank you after he sees the difference in results. As ninety percent of the radio public have been sold on the idea that tubes are the most important part of a radio, you can capitalize the idea and make it pay you handsome dividends.

"The practice of having the tubes with you will save you many a sale; because sometimes, while you are running back to the store, the customer gets a chance to change his mind, and may decide to run the set just as it is. Get the job done as quickly as possible and cash in on the interest the customer has in his set at the moment. Later on, something else will captivate his attention; remember the old adage of chain and department stores—"They never come back." Very few of the customers, who say they will call when they can afford the tubes, will call you back. But, if you are tactful and persistent, you can sell them the tubes while you are right on the job.

Mistakes to Avoid

"Of course, it goes without saying that you will only ruin your business if you attempt to force tubes and accessories on people who do not actually need them. But, if a man has weak tubes in his machine and is cheating himself out of real radio enjoyment, it is your duty to him to show him and

convince him that his radio can be greatly improved. This idea does not involve tubes alone, but covers any other item that the customer may need to make his reception perfect. Some owners do not know just what their receivers can do; they will go along with only halfway results. Show these people just what the possibilities are, and you will make a success of the business. Their friends will notice the difference, and this will bring you much greater returns in new business.

"In servicing receivers that have some major defect, such as a burnt-out transformer, it is good general practice never to spend more than thirty

Dear Radio Owner:

We are reminded of a story told about the late P. T. Barnum, the famous circus magnate and practical joker. It seems that, while he was giving one of his shows in the rural sections of the country, Mr. Barnum decided to add a "FREE" attraction to his already famous circus. This attraction was a highly decorated doorway marked, "FREE EXIT." When our country friend entered the doorway and passed through, he found himself outside the grounds and was faced with the necessity of paying another admission to re-enter the grounds to see the show.

FREE RADIO SERVICE is usually worth just what is asked for it—nothing. Many of the residents of this and other suburban localities purchase their Radios from large chain stores located in nearby cities. These large Radio outlets advertise FREE SERVICE.

Out of fairness to the large stores, we must remember that the largest portion of their customers are located in the big cities near to the stores. To these customers the big stores do give prompt, efficient service; but what happens to the service calls from the suburban towns?

Put yourself in the place of one of these big stores. Close at hand you have 90 percent of your service work; the other 10 percent is spread throughout a circle a hundred miles in diameter. To do one service call in the suburbs takes as much time as do ten calls nearby. What is the natural consequence of this condition? The suburbanite has to wait until the service department has enough calls out his way to warrant sending a man to his locality.

To YOU, a suburbanite, this means waiting days—sometimes weeks, for service, and the most expensive Radio is useless unless it is giving entertainment—that's what you bought it for. It is not necessary to wait for service.

Yours for complete Radio enjoyment,
GRAHAM BROS.

A sales letter urging the value of prompt service when it is wanted.

Dear Patron:

We wish to thank you for having given us an opportunity to be of service to you. We realize that a successful business can only be built on good will. Our interest in your Radio does not cease with the mere collection of the service charges. It is our earnest desire to have each machine serviced by us, act as an advertisement of our business. Now that your Radio has been placed in good working order, it will be to your advantage to keep it in this condition. You can easily and inexpensively do this by taking advantage of our monthly inspection.

This inspection service consists of a thorough checking of your Radio and all the accessories once a month. This procedure greatly reduces the repair bills that are inevitable when a Radio is neglected. The total yearly cost of this inspection service is less than it would cost to replace one part in your Radio. It has been our experience that most people do not give any attention to their Radio unless it has actually stopped working. Many times during the course of our regular inspection we can detect trouble and prevent it from doing serious damage to your machine. If it were only for the sake of having your Radio always in operation when needed, it would be worth the price asked for this inspection.

May we offer you this service at the amazingly low price of \$1.50 per call? This will include checking the tubes and re-activating any that may be weak, checking the aerial installation, speaker, power unit, or other accessories, testing the speaker for tone, and making any minor adjustments that may be necessary. If you wish to take advantage of this offer, return the enclosed card and we will enter your name on our inspection list.

May we again thank you for your patronage and solicit your continued good will, and that of your friends!

Yours for Radio Satisfaction,
GRAHAM BROS.

A "bread-and-butter" letter sent after making a first call.

minutes' time on the machine in the customer's home. They have an idea that you must find the trouble immediately. The average customer dislikes very much to have his radio torn apart in front of him. Take the set to the shop where you can work in peace, and do a much better job.

"A hard and fast rule, never to be broken is: never, under any circumstances, take the customer's tubes with you when you take a machine to the shop for repairs. This will save you many an unpleasant scene when you have found that there are defective tubes in addition to the trouble you have just repaired. If the customer's tubes have not left his home, there can

be no question as to whether or not they are his tubes. After you return a set from the shop you can proceed as outlined above, and often make an additional tube sale."

No one will dispute the fact that Mr. Graham is not only a radio Service Man, but also a business man. While it may not be advisable, due to lack of sufficient financing, to mail twenty-five letters a day, nevertheless the same idea may be followed on a much smaller scale. The idea of the manner in which to obtain business, however, is there.

Mr. J. P. Kennedy offers some interesting methods of obtaining business. He not only states the methods that brought in trade, but also discusses some which proved to be failures. Some of the circulars sent by Mr. Kennedy are included as a suggestion.

(Published in a recent issue of Radio-Craft.)

"The first problem requiring thought was to reach the greatest number of people with the message, not only that a radio Service Man was available, but that they needed this particular Service Man right now. Under the mistaken idea that low prices would get the results, five hundred government post cards were printed and sent out offering service at one-third the regular rate of \$1.50 for a limited time. The idea practically failed. The "something-for-nothing" people were the only ones that called; and they wanted more for their fifty cents than two ordinary calls would entail.

"The next idea had more merit and certainly more profitable results. The radio page of our leading local paper was such an uninteresting sheet that most of the radio advertisers requested other locations to make their copy effective. 'Let's write something of interest for that page, something that will consistently attract readers who, in turn, will see the ads.' That idea appealed to the editor. He offered to run free with my name at the head, a daily column on radio, if I would supply the copy.

"A question and answer column seemed the logical medium and, as enough questions would not come in to supply the daily assignment, it would be necessary to write not only the answers but the questions. To make them appear genuine, fictitious initials could be sign-

ed. It took six hours of typing to prepare the first two weeks' copy. The idea clicked instantly. Actual fan mail began to come in with real questions. People began to ask, 'Who is this chap, Kennedy?' Sensing that query, I ran ads, tying in with the column, with my picture and suitable copy. The calls for service were increasing daily.

A Direct-Mail Campaign

"There are a large number of wealthy people in this city (South Bend, Indiana). Their trade and good will was the next objective. Tortured with staid mimeographed advertising, that went in the waste basket, these people are the hardest to reach. Personal calls are impossible with countless butlers, maids and private secretaries to block reaching their superiors.

"Personal letters seemed the only solution. They must be sent in plain envelopes on plain white paper, with no letter head that would betray their commercial aspect. They must have human interest, discreet flattery, the personal touch, and a dynamic compact message—high-pressure stuff. Everyone who has lived in a given community, for a few years, knows at least the big civic and industrial characters. If not, almost any old citizen can supply not only the names but countless stories and incidents about these prominent people. There is your material. A typical letter is reproduced here.

Use of Good Printing

"An important part of a Service Man's equipment is a good business card. Taking advantage of the methods used by politicians to get their personality across to the voters, I resorted to a business card bearing my own picture and a minimum of printed material. The more simple and unique the card is, the more dignified and effective it is with the most desirable class of trade.

"Study the business cards of successful firms and men. Ask yourself what appealed to you in a particular card; take that idea and use it in your own card. Color, discreetly used, distinguishes a card. I use two straight blue lines (despite the extra cost of a second run by the printer) to get away from the conventional black, yet employ a cool color that will not distract



The "ad" at the left was less successful than that in the center, which introduces "human interest."

the eye of the reader from the printed matter. I consider this card on a par with any other form of advertising I could give a prospective customer.

"To supplement the business card, a personal letter of appreciation goes to every new acquaintance I make. It apparently does no harm to flatter new friends; they remember you long after you have forgotten them.

"Studying the successful method of selling employed by allied industries, I took the idea of the persistent Fuller Brush salesman and reworked it to sell service. The addresses of houses having an aerial could be secured by merely walking down the street. The city directory supplied the names of the occupants of these homes. I selected ten a day and mailed a government postcard bearing my picture and a message.

"This announcement has been gaining entrance to 70% of the homes it is sent to. True, it costs time and energy to make these free calls; but half of those called on need new tubes, lightning arrestors, tone controls or actual repairs and—believe it or not—they buy them and average you \$1.50 to \$2.00 per call. The days when you could sit around the shop, and wait for the calls to come in, have passed. There is plenty of business if you go after it.

"I tried an interesting experiment in selling lightning arrestors. The weather reports were watched carefully for an announcement of an approaching thunder storm; and an ad was then run with a scare headline in italics. **Not a single call resulted from the ad!**

"The copy was changed, a little personal family interest was injected; and not only was a stock of slow-moving lightning arrestors sold, but I obtained the opportunity to sell tubes and other accessories on the same call.

"The natural question other Service Men will ask, when they finish reading this article, is: 'How much is Kennedy making with all these advertising stunts? How big is the city he's in?'

"The business will average \$10.00 a day profit or return for labor while you work. Being human, I take a day off occasionally for a little golf; devote a few evenings a month to social affairs; oversleep some mornings; attend the weekly meetings of the Kiwanis Club and take part in any civic affairs that call for volunteers. (That's real publicity plus the satisfaction of doing a good turn.) South Bend is an industrial city of slightly over 100,000 population, with a fine friendly group of people and with the well-known University of Notre Dame at its northern boundary.

"The leading radio concerns have dis-

What's Wrong With Your Radio?

BY J. P. KENNEDY,
Instructor of Radio and Service
Engineers.

My Grebe set was one of the first electric outfits using an A and BC eliminator. The set has stopped through the tubes light gets very hot. When an eliminator tube gets hot or shows a purple glow around it, it nearly always means it has burned out in your power supply block.

Profit by Experience

OF 2,000 OTHERS, CALL
J. P. Kennedy's
Radio Service
Ph. 3-2414 418 W. LaSalle

**OUR COMPLETE KNOWLEDGE
OF RADIO MEANS MINIMUM
COST OF REPAIR.**

J. P. KENNEDY'S
Radio Service
Ph. 3-2414 418 W. LaSalle

What's Wrong With Your Radio?

BY J. P. KENNEDY,
Instructor of Radio and Service
Engineers.

What problems are likely to be met with in moving a set to a lake resort and installing it there? First, if it is an electric, the same voltage and frequency current supply you employ in the city must be available (Vicinity near Grand Rapids, Mich., and Gary, Ind., may have 25-cycle supply instead of the 60-cycle supply.)

\$10.00 FREE

If We Can't Repair Your
Radio Set

**J. P. KENNEDY'S
RADIO SERVICE**

Ph. 3-2414 418 W. LaSalle

What's Wrong With Your Radio?

**J. P. KENNEDY'S
RADIO SERVICE**

Ph. 3-2414 418 W. LaSalle

A combination of publicity and advertising with small space—"bullets"—frequently repeated. Larger newspaper advertisements are shown below at the left.

tributors located here who supply all the standard merchandise needed, without delaying you with shipping and burdening you with express bills. A minimum stock can be carried, because of the ease of securing additional supplies.

"Other, less-aggressive Service Men are going broke here; so, unless you can bring in new and more effective ideas for selling service, stay in your own home town.

"One ten-by-ten room in my home contains my desk, phone, service bench, and shelves for spare parts and supplies. No sets are brought in that can be repaired in less than an hour in the owner's home. All my equipment is hand-made. Careful workmanship and technical accuracy make my instruments as important in the eyes of my customers as their more expensive ready-made counterparts. Besides, after designing and building an instrument, I know how to use it."

Of particular interest to readers of this book is the final paragraph of Mr. Kennedy. Note that a ten-by-ten room in his own home is used for the shop.

While many of the methods described by Mr. Kennedy duplicate those used by other independent Service Men, the fact remains that those methods produce results, and it is results that count.

Besides the methods outlined above, there are many other ideas that may be incorporated in the service business in order to stimulate business. Repro-

418 West LaSalle Avenue,
South Bend, Indiana
March 17, 1932.

Mr. John Riley,
605 E. Howard Street,
South Bend, Indiana.

Dear Mr. Riley:

Have you ever had a person who sold you merchandise or service take a personal interest in your satisfaction after they secured your money?

A few years ago, I had the pleasure of repairing your Bremer-Tully radio. The gracious manner in which I was treated by both yourself and your charming wife left a pleasing memory. The air of culture and refinement that pervaded your home inspired me to exert my best efforts and utmost skill in repairing your radio.

Not hearing from you since, I presume your set has been working satisfactorily, but really it should be carefully gone over at least once a year. Tubes don't last forever. Improvements are available, such as static modifiers, better known as tone controls, new quick heating tubes and more efficient lightning arresters.

I am interested in your satisfaction. Without knowing of these improvements, you might be talked into buying a new set, while your present set can be brought up to date at a fraction of the cost of a new machine. I want your friendship and the good will of your friends. This can only be obtained by serving your interests to the best of my ability. In other words, I want your radio service business. May I have it?

(Signed) J. P. KENNEDY,
J. P. Kennedy's Radio Service.

Phone 3-2414

One of Mr. Kennedy's diplomatic letters. A little blarney, and then a business touch.

duced below are a few well worthwhile ideas that have been suggested

in a number of editorials of Radio-Craft by Mr. Hugo Gernsback. It would be well for the Service Man to follow the suggestions offered.

"Under present economic conditions, the Service Man and the radio replacement industry are rendering a big service to the country; because it has been frequently observed that the owner of a radio set (which cannot be repaired) will go without a radio rather than buy a brand new one, even though he can trade in the old set. We believe it is far better that an old set should be reconditioned and put into shape, so that the set owner is satisfied for the time being, than that he should learn to go without a radio and, eventually, be lost to the entire radio trade. This situation is not so impossible as some might think, for it has happened too often with many disgusted set owners; and it is about time for the radio industry to wake up to this condition.

"A conservative estimate, from reliable sources, places the number of battery-operated receivers still in use, in this country, considerably over 5,000,000. While practically all of them are today hopelessly out of the running (when we compare them with the present-day A.C. models) many still give satisfactory, even excellent reproduction; although they are a nuisance to their owners, as far as the battery end is concerned.

Of the 5,000,000 battery sets, it is safe to say that considerably over 70 percent are in homes which are wired for alternating current; and a small

percentage of other homes are supplied with direct current . . .

"There are on the market, today, any number of low-priced power packs which can be bought cheaper now than at any time during the past and are, without a question of a doubt, much cheaper right now than they will ever be again. The reason is that very few new power packs are now built; while those on the market are, in many instances, really distress merchandise. Of course, there are some new packs manufactured (to which we, personally, would give the preference if we had to do the job); but the drawback of these, at the present time, is that they run into quite a sum of money and, except where the owner of a battery-operated set has quite an expensive model, from which he does not wish to part, it will as a rule be difficult to make a sale of an installation incorporating a newly-manufactured power pack.

"The wide-awake radio man, who wishes to cash in on the situation outlined above, should find out how many battery-operated sets there are in his community, and how many of them are in homes where electric current exists. This should not be difficult to find out; and even a house-to-house canvass during the dull season might bring in a handsome harvest.

"In the city, in apartment houses the easiest way to get information is from the janitor or superintendent. Usually a cigar will do the trick, and the names of the set owners can be had readily. Personal solicitation of the set owners is then not necessary. The



Telephone 3-2414

J. P. Kennedy
418 West LaSalle Avenue
South Bend, Indiana

J. P. Kennedy's Radio Service

Mr. Kennedy's calling cards. Note his picture which gives the card that "personal touch."

thing can be accomplished best either by a telephone call in the evening, when the owner is home; or otherwise by letter, although the telephone method is the best.

"In the country the conditions are somewhat simpler because information as to who has a set is easier to get and practically every radio man knows his prospects or can easily get a list. Here again the telephone system is the best to get the owner's attention which, when followed up by personal solicitation, should net quite a few orders.

"The radio man should explain to the set owner that, for a reasonable amount of money, it is now possible to convert his battery set to an excellent A.C.- (or D.C.-) operated set, doing away with both storage and "B" batteries. Of course, there are any number of sets on the market that use "eliminators" of one kind or another; and it may be stated that most of these "eliminators" today are anachronisms. They require constant care and usually contain an acid solution, that has ruined many a good rug and woodwork. With the modern power pack all this is done away with; and the talking points on the power pack are so great that, if the set owner is made to realize what it is all about, he will usually consent to have the set converted for power operation.

"Of course, a change-over to electric operation necessitates also the purchase of a number of new tubes and in this the radio man will cash in too; as, no doubt, the owner will be willing to buy the tubes from him.

"In every case, it is most important that the set owner be informed that, by converting his set from battery to power operation, he will get (as a rule) much better results as to volume, and he will be saved the bother of batteries. If the radio man can prepare a little calculation, showing that the change-over will actually save its cost in operating expenses within six months or less, the set owner can usually be sold on the idea of having the change made immediately.

"While a battery set thus converted may not be as good as a modern set designed for A.C. operation, yet it will do the work satisfactorily and certainly as well, if not better, than the orig-

inal battery set. Incidentally, the radio man will get the good will of the owner and, when economic conditions change, which they always do sooner or later, the set owner will be a good sales prospect for a modern set. And, as every radio man realizes, it is the long pull that counts. Once you get the good will of the community or the neighborhood, the rest will be easy; and a steady income is assured.

"Radio dollars do not tend to grow on trees. You have to go and look for them, exactly as for any other kind of dollars. When times are difficult, like the present, and people do not spend as freely as of yore, a certain amount of ingenuity is needed in order to get extra sales. For that reason, the up-to-date Service Man these days does not content himself with just servicing sets, which is his trade. Of course, if there are enough sets to be serviced, it is certain that the Service Man will find no cause for complaint. If, on the other hand, he has a limited clientele, whose sets do not happen to require servicing, there is still a good deal of money to be made from extra efforts, which have nothing to do with servicing itself, strictly speaking.

"When things are dull, the radio Service Man can easily become a radio salesman and supply his customers with all sorts of radio merchandise; and, if you once have an entree to the customer, it is usually an easy matter to 'sell' your prospect.

"Most of the sets made prior to 1931 contained no Pentodes. It should not be difficult to convince a set owner of the better quality, greater volume, etc., that can be had through the use of the new Pentodes. It is no trick at all, with most sets, to change them over from the old-type tubes to Pentodes at a decent profit to the Service Man. Most set owners, these days, cannot afford to get new sets; but they welcome having their sets brought up to date, if it can be done.

"In a recent issue of *Radio-Craft* there was described a new "Tune-A-Lite," also known under the trade name of 'Flashograph.' This new tuning device is an elongated neon tube, which is already built into several 1932 sets. The main idea is that the neon bulb flashes to the highest point when the

set is in resonance with a certain station. This is a brand new device that is sure to interest the average set owner. In the near future it will be possible to buy a complete Tune-A-Lite section that can be attached to the outside of the radio set, and it will also be possible, with a little cabinet work, to fit one into a present-day set. A demonstration of such a light is sure to make a sale.

"I have spoken before of short-wave adapters. Now-a-days, people wish to tune in foreign countries direct, and get the thrill of hearing the European and other world broadcasts that fill the air. A large amount of such adapters are already to be had, listing from low prices up to the more expensive models. If the Service Man carries one of these adapters with him, and shows the owner how comparatively simple it is to tune in a foreign program, the sale can easily be made.

"Electric (A.C.) clocks are becoming the rage all over the country. They are not only cheap, but they keep time most accurately. The consumption of current is almost nil. An ideal position for such a clock is on top of a radio set; and many Service Men are making slight structural changes in existing cabinets, to fit electric clocks into the standard receivers. A sample of the clock, carried around and demonstrated, will frequently result in a sale.

"Then, of course, tone controls, of which many can be had, and at reasonable prices, are still good sellers. They take but a few minutes to install; and a simple demonstration to your prospect nearly always results in a sale. There seems to be a certain reluctance, in most people, when it comes to listening to lectures and talks over the radio. In most sets not equipped with tone controls, the talk is usually sharp and brilliant. This, the tone control can 'mellow down,' and thus make the talk far more agreeable to the individual taste. One Service Man reports that four out of five demonstrations result in sales.

"The itch for distance seems to be on the increase, even on the long-wave broadcast set. For a time, most people wished only to get local programs; now it seems they are hunting for distant stations again, if the many letters that we receive are a true indication of this. As a rule, successful 'DX' (long-distance) reception pre-supposes a good aerial. A large proportion of present aerials were installed in a hurry, and are not good in the electrical sense. Set owners who use indoor aerials, and light-socket connector aerials, should be sold on the idea that their set will give them far greater volume if a good hundred-foot outdoor aerial—providing there is sufficient room—is installed.

"Then, there is, of course, a tremendous market for line-noise filters. Radio set owners who live in apartment houses, if they have a sensitive set, know that they will get a click every time a light is switched on in the house. Then there are disturbances from refrigerators, vacuum cleaners and a host of other appliances. There are now on the market a number of efficient noise filters, and an up-to-date Service Man should always carry a few with him. Once the prospect understands what it is all about, he will not hesitate to spend a few dollars if he knows that his reception will be relieved of a great deal of man-made static.

"I have only sketched a few of the more obvious ways in which the Service Man can pick up dollars right and left, if he only goes after them. There are, of course, many other methods which he will find if he uses his head."

Stress has been placed, in the foregoing discussions, on the advisability of rewiring old receivers to accommodate the new advances in radio. This is of particular importance to the small business man who must continually devise new methods of letting the people know that "here is a service organization that knows what is going on in radio."

CHAPTER 2

Advanced Commercial Aspects

IT is probably the hope of every Service Man to own his own business. Many men, having previous business experience, enter into it with full knowledge of the various factors that determine success or failure. It is the purpose of this chapter to treat some of the business essentials that must be anticipated before any large investment is made.

Location

Obviously, a man expects to do enough business when once established, not only to make a living, but to "put a little on the side." With this factor definitely settled, the next question is one of location. It is clear that the answer to this question is not the same for urban as for suburban localities; consequently, only general considerations can be given.

In a large city, such as New York, Chicago, Philadelphia, etc., two people may live next door to one another for years, and yet not know of one another's existence. In a large city, therefore, if one is to run a shop for the service of radio sets exclusively, a good location is by no means necessary, as in all probability all sets will be called for and delivered by the organization, the customer never entering the shop. If, on the other hand, the business is to be of the sales-service type, then a location that is suitable is not easy to find.

Several busy neighborhoods in which stores are known to be empty should be watched very carefully day and night, and if possible, a rough estimate of the number of people passing per day should be obtained. The neighborhoods should also be investigated as to the class of people living in the vicinity, since this may determine the charges that the store-owner must fix. If the neighborhood houses a poor class, then the charges must be small in order to obtain business. This means a very small overhead on the part of the business man. If the neighborhood

is an exclusive one, then the rates must be increased in proportion to the overhead.

In large cities, exclusive and non-exclusive apartment houses may be adjacent to one another so that the line of demarcation may not be very great. In general, however, a medium-class section is selected so that the advantage of dealing with either type of clientele is afforded.

A desirable location is not the only thing that determines the location of a store—the rental must also be considered. From a knowledge of the type of location, a fairly accurate estimate of the gross income must be determined. This may not be an easy matter, but by a judicious investigation of similar stores in the vicinity, a fair approximation may be obtained.

From this approximate figure, the gross profits must be estimated. In a service shop that will handle sets and parts as accessories, the profits derived directly from the sales should not be considered in our gross profits for the reason that the organization is to be essentially a service concern, and therefore any profits that are derived outside of the service field may be termed "Additional Profits." With a fair approximation of the gross profits, the maximum rental that should be paid should not exceed 20 percent of that figure.

Thus, suppose a very small business is to be considered in which the estimated gross profit per month is \$300. Now 15 percent of \$300 is \$45 which is the maximum rental that should be paid. It must be understood that this figure of \$45 must also include light and power. Thus \$255 per month is left for the owner. This \$225 is entirely independent of any money that might be made by virtue of the sale of apparatus. If \$45 is the rental decided upon, then a store offering the most advantages for that rental should be secured.

Some landlords demand a lease from one to three years, this lease having a clause calling for a deposit of one month's rent as security which is returnable at the termination of the lease. This sum should be counted as part of the investment of the store.

Overhead

Every store has certain fixed expenses that must be met regardless of the volume of business that is done. These expenses are called overhead expenses and, of course, must be reduced to a minimum.

The question of rent, light, and power was discussed in the previous section and therefore will not be entered into again. Most service organizations are equipped with at least one car, and the rent, gas, and oil used must also be considered. This expense must be deducted from the gross profits mentioned above. During the servicing of receivers certain small items such as solder, depreciation of tools, wear and tear on the car, and insurance of the car should also be deducted from the gross profits. Over the course of a year, the above items may be computed, and a monthly figure deduced. This monthly figure should be held in reserve until such a time as payment becomes necessary.

Test equipment is another thing that must be considered. The initial cost of the apparatus should be counted as part of the investment of the shop, but when they are discarded from time to time as new and more modern apparatus is installed, the cost should be deducted from the gross profits monthly. What this really means is, for example; a new test panel may cost \$50 to build; and the life is estimated at about one year. The fifty-dollar investment should be divided by twelve in order to know the cost per month, which in our problem is \$4.17. In one year, then, the cost of the equipment will have been returned and may be used for more apparatus. This is equivalent to borrowing the money to pay for the apparatus, and paying it back monthly.

A certain amount of the gross profits, about 5 percent, should be set aside for breakage, subscriptions to magazines, stationery, books, files, and

any other incidental expenses that may arise from time to time.

Salaries

The question of salaries is a moot one. The writer knows of four different service organizations that use four different methods of paying the help. These four methods will be discussed in turn, and the conclusions left to the reader, since the method depends upon local conditions.

One method is to pay Service Men a straight salary, regardless of the amount of apparatus they sell, or the number of service calls they make. Off hand, this sounds unfair to the Service Man, but it really is not. When some firms hire a man, they expect him to do everything within his power to further the interests of the Company. They believe that just because a man works late for a few nights, he should not demand additional remuneration; for, when legal holidays arrive, the man does not work, but receives pay for it just the same. There is a great deal of merit in this reasoning. It is the writer's belief that most technical men want a fixed salary, regardless of how much or how little they work. Such men are also aware of the fact that if they prove valuable to the organization, they will be rewarded by an increase in salary. If they are not valuable, the concern cannot make money, and when this condition occurs, the Service Man will undoubtedly find himself out of a job.

The cry may be raised that with the straight salary method of payment, a man who is exceptionally good, receives about the same salary as one who is just passable. This is true and undisputable. A firm cannot expect to have a number of men all of the same calibre. An average must be struck, and this average must be high enough so that the firm can make a reasonable profit on their investment. When business is slow, and it becomes necessary to lay off a certain fraction of the men, the best ones will remain.

The salary and commission method is by far the most widely used today. Service Men are paid a small salary and a commission on all the apparatus that is sold and a certain percent of the

price of each service call. This method has the distinct advantage that the bonus offered acts as an incentive toward getting more work done per man than would be obtained without the bonus. Of course, there are some men who do not profit by such an inducement since they do as much as possible all the time, regardless of the method of payment. Such men, however, are hard to find, and as a consequence, the commission method has been adopted by many concerns.

Certain unscrupulous Service Men, in their desire to make money, attempt to sell customers apparatus that, even in the wildest of dreams, cannot aid the receiver. They are soon found out, with the result that such men find their firms making changes in personnel.

The third method of payment is that of commissions alone. The service organization maintains no men on its regular staff. The names and addresses of men living in widely scattered sections of the town are on file, and when a call is received from a certain locality, the man nearest the service call is informed either by telephone or telegraph. In this manner the customer is assured of speedy service; the firm is assured of a low overhead expense; and, last but not least, the Service Man makes money.

Payment may be made on the total sale of equipment plus an additional fixed fee for the call; or a flat percentage of the total job. This method has rather obvious advantages, but many disadvantages. Firstly, a very large number of competent Service Men must be had on file; second, these men must be available on short notice; third, each man must carry a stock of apparatus which is the property of the firm, in anticipation of a reasonably complex service job; fourth, a Service Man may not receive sufficient income to warrant serious consideration.

With slight changes, however, the plan may be made very profitable for all concerned.

The fourth method is rather unique, but has some very excellent features. A service station is widely advertised, but the space in the service station is rented to independent Service Men. All calls that are received are divided evenly among the men, in the order in which

they are received. Thus, over a period of time, all men receive the same number of calls. Once a man calls on a customer, that customer is his, and cannot be turned over to anyone else regardless of whose turn it is to receive a call, unless the customer specifies to the contrary.

Space may be rented with or without equipment, the rent with equipment being slightly greater. All parts are purchased from the owner who is in a position to offer very substantial discounts due to the large quantities in which the apparatus may be purchased. Stenographic and telephone service is available at no additional cost. Monthly meetings are held, during which the policy of the "company" is discussed. Only suggestions may be made to the owner, since he may be considered the "landlord," but if the suggestions are reasonable they are adopted.

Of course, each Service Man makes it his business to find as many customers as possible; they are entered on a card which is filed in the office. When a call is received, the card is consulted, and if the customer has been visited by one of the men before, that man receives the call. If not, then the call is given to the man who is "in line."

Technical meetings are held, and the opinion of the various members, concerning problems, customers, etc., are obtained. This has proven to be a very valuable asset in some cases. With this method every man is his own boss, but if the calibre of his work or his character is such as to be detrimental to the "Company" he may be dispossessed by a majority vote.

The owner receives, in some cases, in addition to the rent, a certain percentage on every new call that is received.

The author would like to see more of the above method of handling a service business. It is one of the fairest, to both the Service Man and the owner, of which he is aware.

Literature and Files

It is not only advisable, but the duty of every Service Man to read technical literature. All available catalogues, pamphlets, books, and magazines that can be afforded, should be purchased.

They should be accurately catalogued and filed away. All material that is consulted often should be filed in a hard-covered binder and kept at hand at all times. Circuit diagrams should be filed separately according to both the name of the manufacturer and the model number.

There are available at the present time a number of "manuals" that contain diagrams of almost every receiver manufactured. One of these should be procured and kept for ready reference. A number of men have two of these manuals, one for the shop and one for the tool kit; this is advisable when it can be afforded. A good idea is to jot down the troubles that are encountered in all of the receivers serviced every day. This forms a diary which is of invaluable assistance when attempting to recall the peculiarities of a receiver that was serviced some time back.

A very complete filing system is of paramount importance. The history, charge, dates serviced and condition of every set should be kept and filed in alphabetical order, so that when a call is received, the customer's card may be rapidly consulted for the entire pedigree of the set, which, in some cases, is just as vital as knowing the cause of a certain trouble before repairing it.

Advertising

A man may have a fortune in diamonds in his possession, but if he does not let anyone know he has them, he may starve to death. People cannot know that a certain man is in the service business unless he lets them know. It is the purpose of advertising to tell people that you are ready to serve them.

In the large cities, newspaper advertising has not been used to any great extent. This is mainly due to the fact that a Service Man serves only his immediate vicinity, and therefore a city-wide advertisement, while it would be helpful to a large organization, costs too much for the small man. He must, of necessity, adopt a less expensive means of advertising. Certain newspapers have weekly sections that are devoted exclusively to radio broadcasting. The man who wants his radio serviced is sure to look there for the nearest

repair station. Such advertising is recommended for any organization, regardless of size, that intends to increase its business. A small box, telling the people what you do, when you do it, and how much you charge, is sufficient for all practical purposes.

In small or middle-sized towns, circulars have been used with very excellent results. The circular may be a small card advertising the fact that you are in business and in a position to offer good service at a reasonable cost.

The owner of one organization says that he has 20,000 of them printed at a time. He has small boys distribute them after school and Saturdays at a cost of about \$.50 to \$1.00 per thousand. He receives, on the average, about 20 answers per thousand cards. This, he says, is sufficient to keep him busy all year round. When business is slow, he distributes a large number, but when it picks-up again, he reduces the distribution. In this manner he manages to keep business at an even level without the necessity of constantly hiring and firing Service Men. Every Service organization should have them.

Several hundred form letters mailed each week is also a very excellent means of obtaining business. Names and addresses of families, which may be secured from local dealers for whom service work is done, can be obtained as described in the previous chapter and used as a mailing list. The form should be changed from time to time and mailed again. Just because a person does not reply the first time is no indication that he will not reply to the second.

Once a clientele has been built up, the problem changes to one of keeping them rather than getting them. Periodically, a "reminder" should be sent telling the customer that at such-and-such a date their radio set was serviced and that in all probability it needs looking over. This will be done at a minimum charge of one dollar, or if the customer will bring the set to the shop, there will be no charge for an inspection. The minimum fee, it might be explained, is for traveling time only, and not for the inspection. The customer is then aware of the fact that you still remember him and in all probabil-

ity, if he thinks that his set is in need of repair, will call you. Keeping in touch with a customer is one of the most important jobs of any service organization.

Free Tube Testing

One of the most important means of obtaining business is the free testing of tubes. A large sign displayed in the window to the effect that tubes may be brought in and tested free of charge will attract a great number of people. This should also be advertised in the "reminders" and circulars that are sent out.

The tubes should be tested in full view of the customer, so as to minimize any doubt that might exist in his mind as to the validity of the test. This is an important point and the psychological aspects go a long way toward making a sale. The sale of tubes provides an excellent source of constant income, and nothing should be done that would tend to diminish this sale.

Window Display

In a strictly service shop, there is no need for an elaborate window display; but when sales of radio sets and parts are a substantial part of the income, then the window arrangement is the one item that impresses the customer before he enters the store.

The window should contain an assortment of receivers and accessories that are attractive; each item having a neat placard indicating the price, make, and number of tubes, in the case of a receiver; and, the name of the item and the price in the case of accessories. The window should have enough apparatus in it so as to give it a rich appearance. A large window half full of apparatus is far worse than a small window that is filled.

The above does not imply that the window should resemble a warehouse, but rather that it should convey a cozy appearance that invites entrance. All parts should be arranged so that they are clearly visible from all angles; a window blocked with bargain signs instills skepticism and is not in accordance with good business practice. In a transient location it is good, but where one must depend upon repeat business, it is not advisable.

Another important item is the lighting of the window. To attempt to save money by cutting down on window lighting is false economy. There is nothing more attractive than a well lighted window radiating its cheerfulness into the street. Window lighting does more to attract attention than anything else. Once a person is attracted, he is a prospective customer. Looking at the situation from another angle, it might be said that poor lighting actually drives away customers. The window should be kept spotless at all times and should give the appearance that business is excellent, although you may be on the verge of bankruptcy.

Special Methods

There are several unconventional methods which are used to advertise a service business. A number of companies have constructed a complete microphone and phonograph system in a small truck, rent it to political clubs during election, rent it to moving picture houses in the vicinity, use it at fairs, important broadcasts, speeches, announcements, free music, or at any time where it is desirable to attract the attention of a number of people in the streets. This method is as yet novel, and therefore the investment that is made is a good one. It should not cost more than six or seven hundred dollars to completely build such a truck, but when it is realized that about fifty dollars per day is obtained by renting it, it can be seen that the cost will be recovered in a very short time.

One half of each side of the truck is devoted to a sign advertising the company who is renting it, while the other half of each side displays the name of the owner of the truck. Thus, the service station receives advertising at the same time that it is rented.

Current models of radio receivers are placed in it and demonstrated at various locations in the town. In this manner, the public not only sees the latest radio models, but also hears them, without the obligation of going into a store. Many cases have been reported where sales have been made from the truck itself. A sign might be shown stating that the equipment inside has been designed and built by the "so and

so" service station. This instills confidence regarding the technical ability of the service concern.

The renting of public address systems to dance halls, churches, private people, morticians, etc., is a very profitable source of income. The necessary apparatus consists essentially of one or two microphones, a double turntable, phonograph records, an amplifier, loudspeakers, wire, etc. All the equipment may be connected by means of plugs and jacks so that an installation can be made in a very short time. Installations of this type bring in as much as twenty-five to seventy-five dollars per day, depending upon the length of time the apparatus is to be in use, the size of the room or rooms, difficulty of installation, etc. This phase of radio certainly should not be neglected.

Since sound motion pictures have come into vogue, people have become aware of the fact that records of their own voice may be made easily and cheaply. This has caused a number of enterprising radio men to install sound recording apparatus in their stores, the charges for which are very nominal—25 cents to a dollar and a half per record, depending upon the quality desired. In summer beach resorts a very excellent business may be done, and the profit, with the prices quoted above, is enough to make one sit up and think. Sound recording apparatus may also be used to record weddings, speeches, important broadcasts, etc., at special prices.

It will not be very long before 16 mm sound motion pictures (for the home) will be available. This is one time to prepare yourself for real profits. The idea of taking pictures with the actual sound on 16 mm film is virgin, but it remains for some wide-awake Service Man to start such a station in his locality.

INVESTMENTS

When a man wants to open a service shop, he usually has a certain amount of money to invest, and his problem is to determine the most profitable distribution. After making the initial surveys of a possible location, and renting the store, the next problem is one of fitting it up.

The store should preferably be divided into two sections; the outer section or office being the first, and the rear of the store the second. The office should consist of a desk, several chairs, a file, telephone, and any other accessories that would lend an atmosphere to it. A business-like appearance is very essential here.

The rear room should be a sort of den—very personal and handy. Shelving should be provided for keeping a small stock; a work bench big enough to easily handle a very large set should be constructed. This table should have the proper draws for tools; proper closets for housing special test equipment, and, if possible, should be located near a window. Besides a few other odds and ends that may be desirable, the shop is complete.

While an elaborate office is very impressive, the cost is excessive in comparison with the income. When a customer enters a service shop, he does so for the sole reason that he wants his set repaired, and does not care whether it will be fixed in an old shack or in a mansion. When a man enters your service shop you do not have to sell him; he knows that his set is defective and calls to ask you to fix it. In a store that specializes in sales, the problem is different. A man enters because he wants to buy something, and it is up to you to sell him. An impressive store is therefore absolutely essential. A small, neat office is all that is necessary for a service station.

The repair room must be kept in a neat orderly manner. The writer has spent years in commercial radio laboratories, and realizes the ease with which a laboratory may go "haywire." Once it does, it takes three times as long to find anything as it would take were everything in order. A certain time during each day must be devoted toward keeping everything in their respective places.

All of the furniture described above, including the painting and lighting fixtures should not exceed \$200.00 for a store whose gross profit is estimated to be \$300.00 per month.

Stock

It is impossible for any service station to carry a complete stock of parts

that would be suitable for any repair job. However, there are some parts of radio receivers that may be replaced with others of different manufacture without impairing the quality of the work the slightest amount. Such parts are the condensers and resistors. Every receiver uses them, and they break down very often, so that a complete assortment of condensers and resistors should always be kept on hand. It may happen that a customer wants to have some of the tubes removed from his set and others, of more recent design, substituted. In doing this job, the Service Man may remove several resistors from the receiver which cannot be used in view of the constants of the new tubes that are to be inserted. There is no reason why these resistors cannot be used again in another job for which they are suited. Of course, they should be thoroughly tested by having rated current flow through them for several hours, at the end of which time they should be tested for their resistance values. The same holds true for replacement condensers—they can be used in another receiver, provided they are in perfect condition. In this manner the stock is increased from time to time without the expenditure of any money. —

A good assortment of tubes, transformers, chokes, wire, etc., should always be had, not only for test work, but for actual replacement. An investment of about \$200.00 should be sufficient for stock which includes several of each type of tube in common use.

The Analyzer

In another chapter of this book there is described a simple set analyzer for the beginner. This was designed for four prong—three-element tubes only, since it was designed for simple battery sets. By the addition of another five-prong socket in the analyzer connected as shown in Fig. 59, it may be used with three-element five-prong tubes. The plug should also be changed to the five-prong type and an adapter used when four-prong tubes are to be tested. A sketch of the adapter is illustrated in Fig. 60.

Since the analyzer now contains a five-prong socket, it may be used for

testing screen-grid tubes. Another lead is added to the cable and soldered to a small cap which connects to the screen-grid lead in the set. The other end of this lead, in the analyzer, connects to the five-prong socket in the tester as shown in Fig. 61.

As conditions are now, the meter in the analyzer of Fig. 38, will read reversed when thrown on the "grid voltage" tap. In order to rectify this, another set of contacts may be added (it usually is present in the rotary switch as purchased) and connected as indicated in Fig. 62. By depressing the "50 volt" bias button with the switch SW1 on the new sixth set of contacts, the additional 50,000 ohm resistor is automatically inserted, which increases the range of the meter on this tap to 100 volts. The measurement of screen current may be made without any additional changes by setting SW1 on the first set of contacts. The connections necessary for the testing of most pentodes is the same as for four-element tubes and consequently may be performed with this tester.

To measure A.C. filament voltages, all that is necessary is to connect an A.C. meter directly across the heater contacts on the five-prong socket. This should be connected in series with a switch so as to facilitate its disconnection when so desired.

We now have an analyzer that measures filament voltage (A.C. and D.C.); plate voltage; plate current; screen voltage; and screen current. Control-grid voltage may be easily measured by connecting a switch (S.P.D.T.) as shown dotted in Fig. 38. When this switch is thrown to the left, control-grid voltage is measured on the same tap as "grid voltage." The analyzer is now as complete as necessary for all ordinary testing.

Besides the analyzer, a modulated Radio Frequency oscillator of the type described in chapter 5 may be used. This is a very important piece of apparatus and should not be omitted from the list of necessary test equipment. It is exceedingly simple and should not cause much difficulty. The oscillator circuit is known as the Hartley type, which, no doubt, is familiar to most Service Men. If it is found that the output voltage is not sufficient for all

ordinary purposes, the volume control resistor may be changed to a higher value. Tests indicate that it delivers sufficient output for most of the sensitive receivers now in use.

One or two precautions regarding its use will not be amiss. It should be kept as far from the receiver under test as possible—sufficient room should be allowed in designing the bench for this—and all leads from the oscillator to the receiver should be shielded in copper braid. If necessary, the shield and one of the leads should be grounded. Whether this is necessary or not must be determined by trial. In any case, the receiver should not pick up the oscillator when it is not connected to the set.

With the increase in superheterodyne receivers, the intermediate frequency oscillator described costs so little to build, that no up-to-date service organization should be without one. As pointed out in another chapter, such an oscillator is absolutely necessary when lining up "supers." For convenience, it might be stated that a 125-turn honeycomb coil, tapped at the center will do for the 850-microhenry inductance.

All three oscillators may be combined in a single case, if so desired, at a cost of no more than \$20.00. To bring the oscillator up-to-date, it might be desirable to add a 1 ma. meter in series with the grid lead. When the set is tuned to resonance with the oscillator, the reading of the meter will decrease; this aids in obtaining an exact condition of resonance.

The cost of three oscillators, the set tester, and all necessary hand tools, should not exceed \$75.00. This price, however, is subject to the quality of the apparatus that is purchased; it may on the average, exceed this value or fall short of it by about \$25.00.

Conclusion

A man with a little experience in radio should not be afraid to go in business. Probably about 90 percent of all troubles found are due to poor tubes. It must not be inferred from this that no knowledge is necessary—on the contrary, besides the technical end, there is the business aspect to think of. The tendency is to devote more time to the

business end than the technical end; while this necessary in some cases, it should not be habitual.

One of the greatest faults with technical men is that, in general, they are not business men. A man may have the knowledge to repair any set brought to him, but if he cannot get sets to repair he must give up his business. While it is true that technical brains can be hired, that is no excuse for the owner of a small business to decide that he is justified in stopping the study of radio.

First, the fundamental theory of radio should be studied rigorously. When this has been completed, either through correspondence schools, resident schools or by self education, the more advanced refinements of the art should be tackled. At about this time the student should start to construct simple receivers. Every possible characteristic should be noted and remembered. The more complicated electric receivers should not be constructed at once—for then, the student will learn nothing. Every advance in the art should be followed carefully. The characteristics of new tubes should be studied and compared with their older brothers. This should be done for business as well as for technical reasons.

When the pentode appeared on the market, there were thousands of people who wanted them installed in their receivers—people who wanted to better their receivers because they could not afford to buy new ones. The Service Man who had kept up-to-date had no trouble in changing over receivers to use this new tube; but the man who had to wait until someone showed him how to do it, lost a good deal of money and potential future customers.

The author has received numerous letters from men who knew nothing at all about radio and want to know how to go about learning it. Ten years ago it was a simple matter to connect up a one tube receiver by following the pictorial diagrams that were published at that time. However, ten years in radio is a long time; the art has advanced so rapidly, the receivers now so relatively complex, that a pictorial diagram is more confusing than a schematic. No knowledge of Ohm's Law is necessary in order to wire a re-

ceiver, but to properly service one, it is sometimes very essential. For the above reasons, one cannot hope to learn radio within a reasonable time by self education unless he has had preliminary training. This training may be obtained, either by correspondence or by resident courses, in any one of the recognized schools throughout the country. More information can be secured in three months of blackboard instruction than by two years of self-educat-

tion at home. Correspondence courses are so planned now that a remarkable amount of knowledge can be absorbed in a short space of time—but such courses are for men who actually want to learn and are willing to devote a few evenings a week to real conscientious study.

It must be remembered that “—he who lacks knowledge lives in hope, but he who has knowledge lives hopefully.”

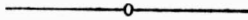

CHAPTER 3

The Radio Set

AS is well known, a radio set is a device that is used for the reception of broadcasting signals. This broad and elementary definition is applicable to any and all devices that are capable of producing sound that is being transmitted by radio. Now the energy that reaches the aerial of a radio receiving set is extremely minute, a fairly strong signal being about twenty-millionths of a volt! Obviously, to attempt to operate a relatively heavy device as a loud speaker with such a small voltage is impossible; and consequently, means must be taken to increase the strength of the signal before it can operate a loud speaker. Suppose it is amplified sufficiently, then no sound would be heard for still another reason.

The wave of a broadcasting station is likened to that of the magnetic field surrounding a horseshoe magnet, which we are all familiar with; the only difference being that the strength of the broadcasting wave varies, this variation taking place about a million times a second; superimposed on this rapid variation is the actual music or speech that must be heard. It is clear that if the wave as received is applied to the speaker itself, it would be totally unable to respond to the rapid variations and therefore no music or speech would be heard. The second problem then, is to separate the variations of the speech or music from that of the station-wave that carries it. It is the speech (or music) wave that must be amplified and applied to the speaker.

Radio-Frequency (R. F.) Amplification

In a small, simple receiver, it is possible to connect the aerial to the first-tube, which separates the broadcasting wave from the one which it is desired to hear. Telephone receivers may then be connected in the set and a simple one-tube receiver is made. Such a receiver is only capable of receiving sta-

tions of only a few miles distant, and furthermore, it will be difficult to receive one station when another close-by is "on the air." In order to make a receiver more sensitive, i.e., receive stations further away, it is necessary to amplify (increase the strength of) the signal many times before the separation takes place. A system that is so connected as to amplify the signal before the separation takes place, is called a RADIO-FREQUENCY AMPLIFIER.

A radio-frequency (R.F.) amplifier may consist of one or more tubes, each tube being called a stage of amplification, and furthermore, may or may not be adjusted to the station it is desired to hear. In nearly all present-day receivers, all the R.F. stages are adjustable (tuned) so that each one contributes toward separating one station from another. Thus, the addition of R.F. amplification obviates both of the difficulties mentioned above, i.e., discriminates between stations and increases the strength of those desired. Experience indicates that it is impractical to increase the number of tuned R.F. stages above three.

Apparatus Required

One of the first problems that confront the man who desires to become a Service Man is how the connections to the receiver are to be made. Every manufacturer or designer of a receiver has his own idea of just how it should be done, so it is suggested that directions be followed very closely if good results are to be obtained.

Figure 1 shows several means by which the aerial of a set may be connected to the first R.F. amplifier tube. At A, a device called a resistor is connected directly between the aerial and ground. When a current of electricity flows through a wire, this wire offers a certain amount of opposition to the flow of current. Silver, for instance,

offers the least opposition than any other metal; copper offers the next-least amount of opposition, while such metals as iron, german-silver, and carbon offers a greater amount of opposition than either silver or copper. This opposition, in electrical terms, is called

the station flows through the primary coil P (the primary is the coil to which energy is applied) which sets up a voltage, exactly similar to the broadcast wave, across coil S, which is the secondary (the secondary is the coil from which energy is taken).

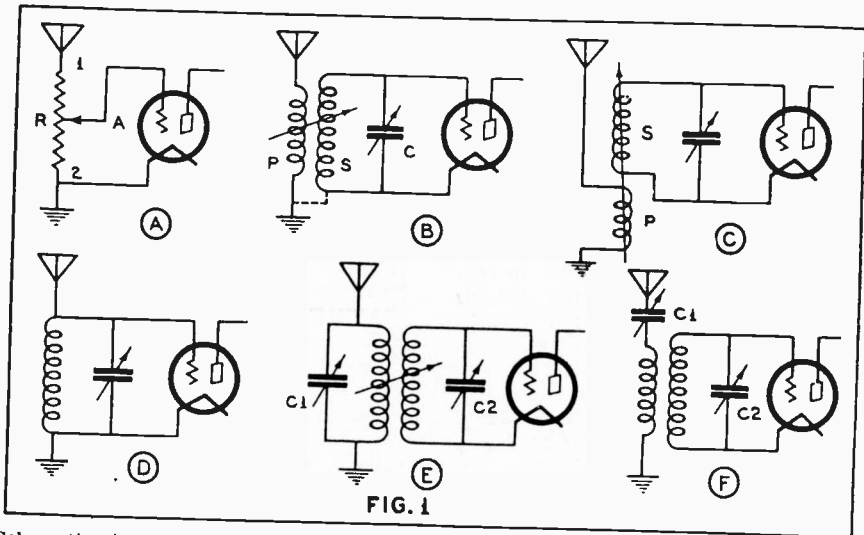

FIG. 1

Schematic circuits of six different types of antenna circuits. Those shown at A and D are known as "direct coupled" while those at B, C, E, and F are known as "inductively coupled" types. Fig. 1-1 shows the pictorial representation of the above.

ed resistance, and a device which offers resistance to the flow of current is called a resistor. It is clear that for the same amount of current to flow through two wires of unequal resistance, a greater voltage must be applied to the greater resistance.

All signals "on the air" flow down the resistor to the ground. When the arm is at point 1, the signal is greatest and when it is at point 2, it is weakest (nearly zero); by moving the arm between points 1 and 2, the strength of the station may be varied at will. It will be noticed that this means of coupling (coupling is merely the transferring of energy) has no provision for separating one station from another. This is its main disadvantage, but it provides a very easy and effective means of varying the strength or volume of a signal after it is once tuned in.

At B, is shown another means of transferring the broadcast's station energy to the first R.F. tube. The energy of

A tuning condenser connected across S (C in Fig. 1B) selects the station desired. As indicated by the arrow, the distance, and hence the energy, induced in S by P may be varied at will. This method enjoys the distinct advantage that only the desired signal gets past the first tube, assuring the operator of good selectivity. (Selectivity is the ability of a set to separate one station from another.) In most receivers, the position of P is fixed in the most desirable location, eliminating one control from the receiver.

Practically the same arrangement is shown at C. In this case, the location of P is at one end of S rather than near the center, and furthermore its construction is a little different, as will be seen later.

At D, the famous single-circuit tuner is shown. At one time, this arrangement was conceded to be the most sensitive available. It still is, for that matter, but for various reasons is no longer used. In the first place, due to

its direct connection in the antenna circuit, it is very broad (receives one station over a large portion of the tuning dial). Secondly, the position of the dial for any given station varies as the length and position of the antenna varies; thus on a windy night, if such a coupling method were used, the signal would fade in and out, due to the fact that the wind shakes the aerial wire, which of course, is undesirable. Where great signal strength is necessary, and selectivity is to be sacrificed, this type of connection is used.

In E of the same figure another coupling method is shown. It is seen that two tuning condensers are used—C1 and C2. The object of this method is to tune both the aerial circuit and the tube circuit, thus securing additional selectivity and signal strength. It has two disadvantages which make

fact that the condenser C1 is in series with the aerial instead of being in parallel (across) with coil P. It is to be used when the aerial is very long and an additional control is not a disadvantage.

Which of the above types one should use depends upon the particular taste of the designer; but it would be well for the experimenter to build a small receiver and try each for himself.

The Detector

It was stated before that in order for a signal to be heard, the speech or music must be separated from the carrier wave. (The carrier wave is that portion of the signal upon which the speech or music is superimposed. The speech or music is referred to as the audio-frequency signal.) In the early days of radio, crystal detectors were

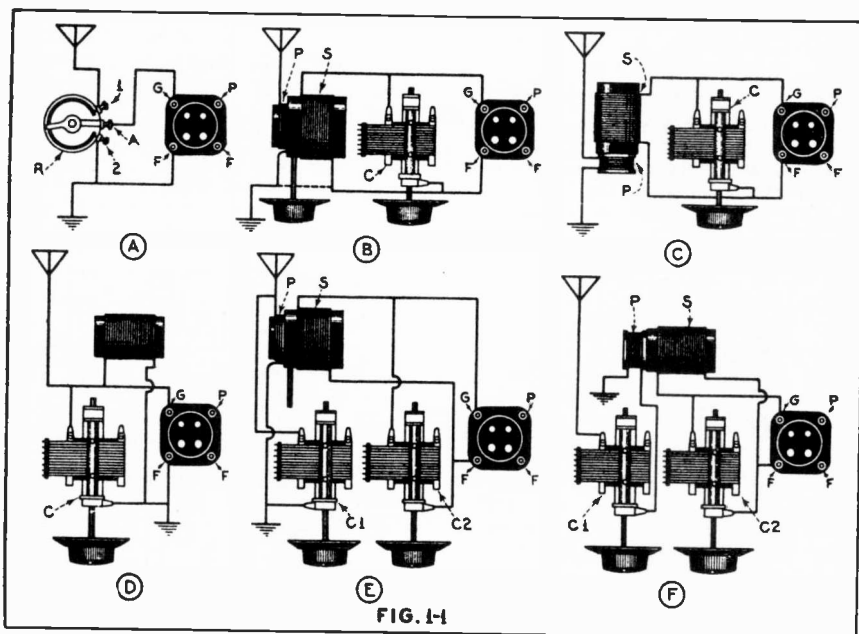

FIG. 1-1
Pictorial representation of the antenna systems indicated in Fig. 1. The lettering in this figure correspond to those of Fig. 1.

its use somewhat undesirable; first, it adds an additional control (C1) to the receiver; and second, with a very long or a very short aerial only a few stations may be tuned in due to the presence of C1.

At F, an arrangement is shown which is similar to that at E except for the

used to do the separating or detecting of the broadcasting wave, and therefore it was called a detector. At the present time, vacuum tubes are used for that purpose and therefore they, too, are called detectors. Without a detector, no signals could be heard regardless of their strength, and, there-

fore, it is a very important part of every radio receiver.

A simple radio receiver which may

the local stations will be received at once with this method since there is no means provided for separating them. Figs. 3, 4, and 5 show three other methods of connecting crystal receivers. It should be noticed that the tuned circuits are substantially the same as described for the tube circuits above. For home construction, the secondaries of the coils should consist of 60 turns of No. 20 B&S wire on a 2-inch tube, the primaries may consist of about 30 turns of the same size wire, wound as described above.

As the book progresses, different radio circuits will be described. For the present we will confine our attention to the different methods used to connect tube detectors so one may know the detector circuit from any other. The tubes, in the majority of cases, look the same regardless of whether they are detectors or amplifiers; the only way one may know the different parts of a receiver is by the method of connection and the values of the parts used.

Figure 6 illustrates four general methods used to connect detectors. At A, the tuning coil of an R.F. unit is connected to the detector tube through

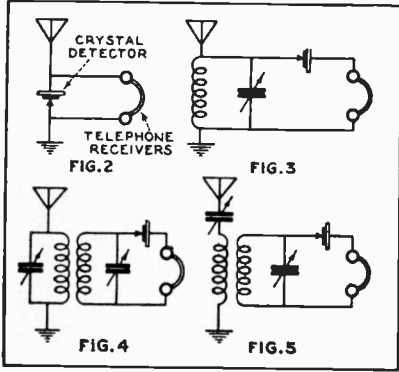

Schematic circuits of four different crystal receivers.

be used for the reception of local stations is shown in Fig. 2. All signals striking the aerial pass through the crystal which rectifies (merely another word for detects) the signal allowing the audio-frequency part to flow through the telephone receivers. All

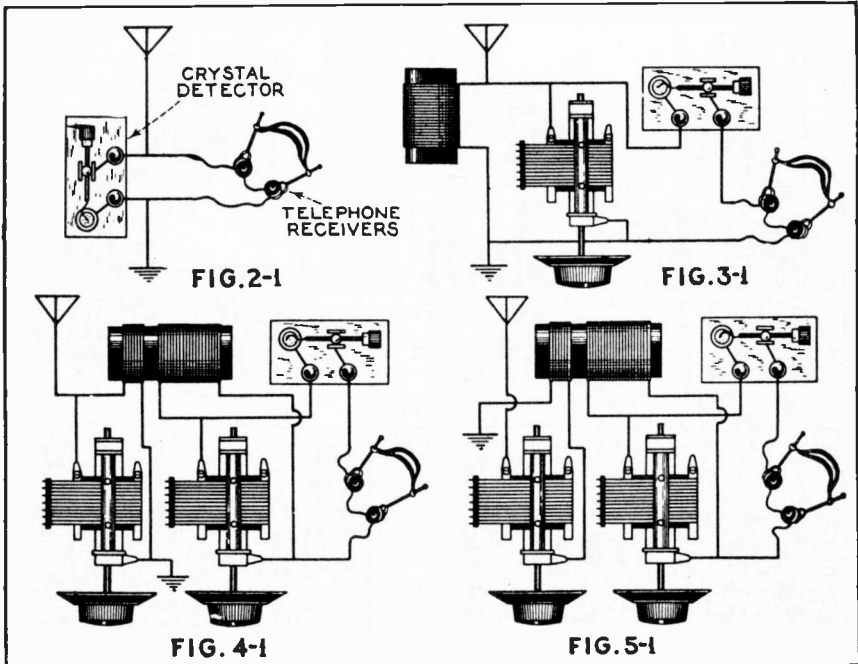

Pictorial representation of Figs. 2, 3, 4, and 5, above.

a condenser C2 and a resistor R1. This method of connection is known as the grid-leak and grid-condenser method, so called because during the operation, an electric charge is accumulated in

connected that detection of the signal takes place without the use of condensers or resistors.

At D is shown a variation of the method used at C, which is called a

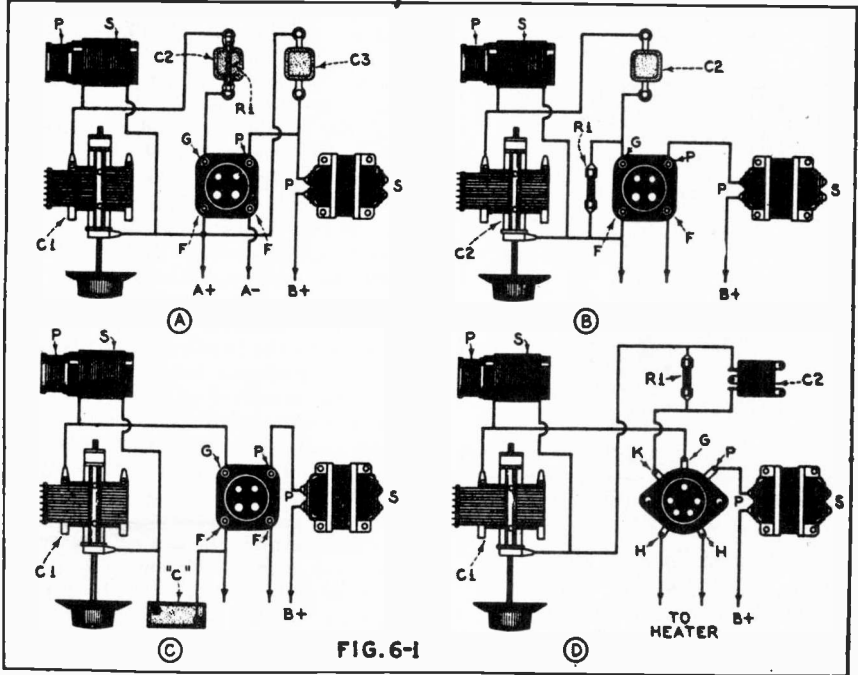

Pictorial representation of the four detector circuits of Fig. 6.

condenser C2 which leaks off through resistor R1. This method of detection is one of the most sensitive known and has reigned supreme for many years. It has several disadvantages which obviate its present use. It is only sensitive on weak stations, on the stronger ones it distorts considerably. The tone quality depends upon the value of C2 and R1; with use, the values change, especially with poor parts, and the receiver suffers accordingly. With present-day highly sensitive receivers, the signal strength applied to such a tube would give results that are unrecognizable from the original.

At B the same arrangement is employed but the grid-leak R1 is connected from grid to filament instead of across the grid condenser. The value of C2 is usually about .00025 mfd. and R1 about 2 megohms (2 million ohms).

At C is shown a radically new detector circuit. A small battery is so

power or linear detector. The quality of output is better for strong signals than that for the methods described

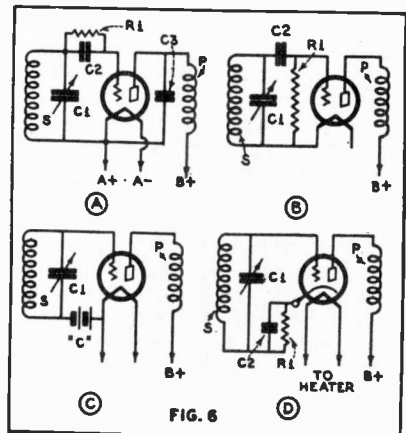

Four types of detector circuits.

above and therefore is more suitable for present-day receivers.

Later on, a more detailed discussion of this part of a radio receiver will be given in a discussion of the details of **Audio Frequency amplifiers**.

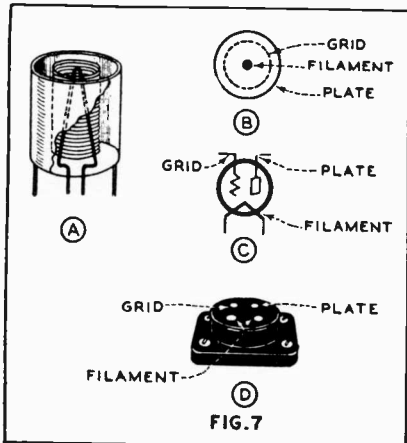

Elements of a three-element tube and socket.

The Audio Amplifier

We have seen so far, that an R.F. amplifier is necessary in order to increase the sensitivity and selectivity of a receiver, and a detector is used for obtaining the signal to be heard from the broadcasting station-wave. In order to make the signal to be heard as loud as desired, an **AUDIO AMPLIFIER** is necessary.

A complete discussion of audio amplifiers will be given in the latter part of this book, but suffice it to say that it is undesirable to use too many stages of such amplification since distortion is bound to occur. In fact, present receivers use only one stage of audio amplification fed from a power detector of the type described above.

To the man who knows a little about electricity, theory is not essential in order to service some receivers, so that more time will be devoted to a discussion of the various parts of a radio set, and, which is far more important to the beginner in radio, how one may recognize one part from another.

The Vacuum Tube

In its essential form, a vacuum tube is an evacuated glass vessel which con-

tains three essential elements—a grid, a filament, and a plate—for a three element tube. A cut-away view is shown in Fig. 7 and a diagram in Figs. 7B and 7C.

The filament is the V shaped thread of metal, the grid is the circular arrangement of wires and the plate or anode is the solid piece of metal surrounding the other two elements. Their relation to one another is indicated in Fig. 7B, and their schematic arrangement in Fig. 7C. The grid and filament is called the **input circuit** and the plate and filament is called the **output circuit**; the signal is fed into the tube via the grid and filament, and is removed (amplified) from the tube via the plate circuit. All apparatus connected to the input of the tube is called the external input circuit and all apparatus connected to the plate is called the external plate circuit. In some cases it is quite clear that only the external circuit is under consideration, so that the latter will be referred to as merely the plate circuit.

The filament is heated by means of a battery or transformer which is connected to the tube through prongs at the base of the tube. In order to facilitate connections and to support the tube, a socket is used which is similar to that shown in Fig. 7D. The battery is connected to the socket as indicated in Fig. 8A and shown schematically in

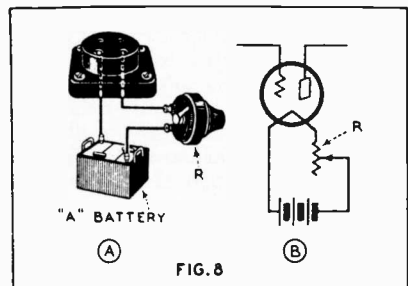

Pictorial and schematic diagram of filament connections.

Fig. 8B. The "A" battery is the one that heats the filament; it is connected in series with the filament through the resistor R which is used for regulating the filament voltage.

The external grid circuit must be connected to the grid and filament of the tube as stated above; the socket

connections are shown in Fig 9A and the schematic diagram (which is its equivalent) in Fig. 9B. If an antenna and ground and a pair of telephone receivers be connected as shown dotted, a one-tube receiver will be had.

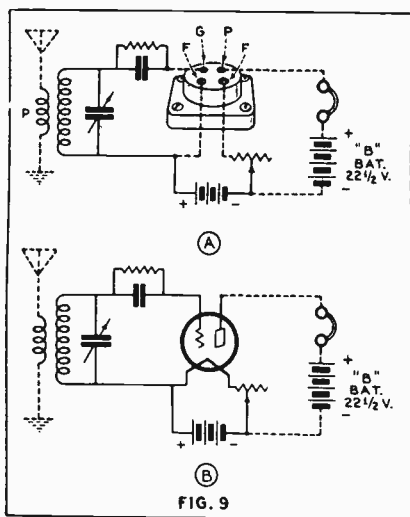

FIG. 9

Input and output circuits of a tube.

Particular notice should be paid to the fact that there is a "B" battery inserted in the circuit. In order for a tube to function properly, it is necessary always to connect a battery between the plate and the output circuit as indicated; furthermore, the plate should always be connected to the positive side of the battery and the filament to the negative. The tube will not function if the "B" battery connections are reversed. This is one of the first points to check when troubleshooting on a radio set, especially one that uses batteries.

Recent advances in the vacuum-tube field brought forth the four and five element tubes. The physical construction of the four-element tube is the same as the three-element described above, with the exception of the insertion of another grid interposed between the input or control grid and the plate.

The theory of the vacuum tube is an extremely complicated treatise, but a brief explanation of what actually goes on inside is helpful in determining the action of the circuit to which it is connected.

The filament of a tube, as stated above, is heated by means of a battery, in a manner that is similar to that of the ordinary incandescent lamp. When it reaches a certain temperature, the filament gives off small particles of negative electricity which are called electrons. These electrons being negative, are attracted to the positively charged plate, since as we all know, like charges repel and unlike charges attract. It is because this stream of electrons (which are evaporated from the filament in exactly the same manner that water evaporates when it is boiling) must be attracted to the plate, that the "B" battery with its positive terminal connected to the plate, must be used. Thus, if the "B" battery voltage were reversed, the plate would repel the electrons instead of attracting them and the tube would not work.

In a three element tube, the grid is placed between the filament and the plate so that all the electrons must pass through the grating of the grid in order to reach the plate. Now if the grid is made positive it will increase the flow of electrons to the plate and if it is made negative, it will decrease the flow of electrons. It is clear, then, that the condition of the grid (whether

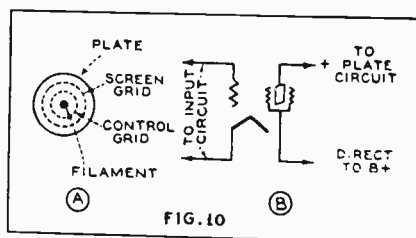

FIG. 10

Elements of a screen-grid tube.

it is positive or negative) determines the amount of electrons flowing to the plate. Because of this controlling action of the grid which is connected to the input circuit of the tube, it is called the control grid. In other words, that grid in the tube which is connected to the input circuit is called the control grid, regardless of where the other grids connect.

To aid the tube, an initial voltage, obtained by means of a battery or a resistor, is connected to the grid. This voltage is very important and determines whether the tube is an amplifier

or a detector. This voltage is called the "C" voltage or "C" bias.

The arrangement of the tube elements is depicted in Fig. 10A and its schematic circuit in Fig. 10B. The tube is so constructed that the control grid connection is made to a small cap on

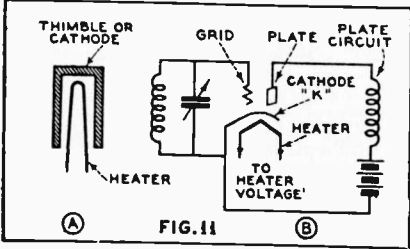

Circuit of heater and cathode connections.

the top of the tube, the screen grid (the other grid is called a screen grid) connection being made to the same prong of the socket as the input grid of the three-element tube.

Because electric receivers must have the tubes operate from alternating current, certain tubes have been designed with a slightly different filament arrangement than that discussed above. The filament is there as before, only now we will call it a heater; surrounding this heater, but insulated from it, there is a thimble which actually emits the electrons which work the tube. Now it should be remembered that the heater is connected to a source of potential exactly as described above, only the external grid and plate circuits are made to this thimble or cathode in exactly the same manner as they were made to the filament described above. This is indicated in Fig. 11A and B.

This heater may be used in three-, four-, or five-element tubes depending upon the design. Five element tubes are constructed exactly the same as the four-element described above, with the addition of a third grid internally connected to the filament. Its presence, therefore, does not directly change the outline given above.

From the above, it will be realized that a theoretical knowledge is not necessary in order to construct or service some receivers because the fundamental circuit is the same in every receiver. This point will be discussed further later on.

The purpose of the vacuum tube, as stated above, is to amplify or detect a signal, depending upon its type of connection. It will be instructive now, to discuss the R.F. units used in radio sets and then the units used in audio work.

R.F. Units

Since the external input circuit of any vacuum tube is fundamentally the same, the only difference between an R.F. and an A.F. unit is in its construction. Fig. 12 shows a schematic diagram of a two stage R.F. amplifier which directly precedes the detector tube. All filament and "B" battery connections have been omitted for the sake of simplicity but they are given in another section of this book.

An examination of the input circuits (that circuit which is connected between grid and filament) of the tubes will show that they are all the same as the aerial circuits discussed above. If a type B (Fig. 1) antenna coil is used, the primary P is usually wound with about 10 turns of No. 22 wire either at one end or spread over the entire secondary. The secondary S is wound with about 60 turns of the same size wire on a 2 in. diameter tube. The only thing that separates the primary from the secondary is air, no iron being used in R.F. transformers. Fig. 13 shows a pictorial layout of a typical R.F. transformer, connected in the one-tube set described above. The

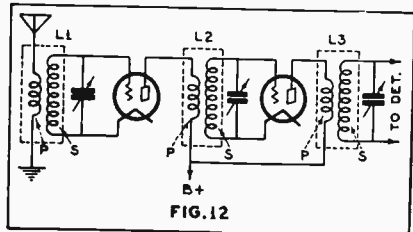

Antenna and R.F. coils.

transformer is light, small, and is usually mounted above and away from any metal parts of the set. In some cases it is enclosed in a can or shield in order to isolate it from the rest of the receiver. In this respect, R.F. transformers are easy to recognize. They may vary slightly in size or shape, but

their general appearance and the notable absence of iron distinguishes them from any other parts of the set.

The primary P of transformers L2 and L3 look exactly the same as the antenna coil L1 described above, with the exception that the number of primary turns are different (usually not

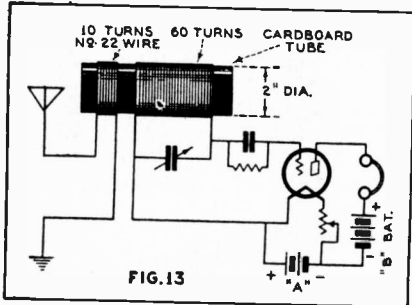

FIG. 13

Semi-pictorial diagram of a single tube receiver.

quite as many). These coils may be purchased in a set of three and are accurately matched in order that the tuning condensers, connected across each, may be "lined up."

The Tuning Condensers

The tuning condensers used in radio work consist essentially of a set of spaced stationary plates between which are meshed a similar set of rotary plates as shown in Fig. 14. As the shaft is turned to the right, more and more of the plates mesh and the greater the capacity; the opposite is true when turned to the left. Connection to the grid of the tube is made from the stationary or stator, and to the filament from the rotor. Such tuning or variable condensers are always associated with R.F. coils in any radio set.

Resistors and Fixed-Condensers

The small resistors and fixed-condensers (non-variable, they have a fixed capacity) are the same regardless of where they are used, consequently, besides stating that the resistors are about one inch in length, one-quarter inch in diameter and of different colors (see standard RMA color code reproduced elsewhere in this book) little may be said of them. They are usually made of carbon or else are wire wound; either may be used, depend-

ing upon the type specified by the manufacturer.

The fixed condensers are usually about one inch square, have two metal lugs, one projecting from either end, and have their capacity stamped on the face. They may easily be recognized by the mfd. which follows their capacity rating (mfd. means microfarad).

A.F. Units

The mode of connection of A.F. units is exactly the same as for the R.F. units described above; the only difference being in their size. A.F. transformers are used to couple one tube to another in the manner shown in Fig. 15, which, it will be seen, is exactly the same as described above. No tuning condenser is necessary across the secondary of this transformer since the station has been tuned-in by the R.F. unit, and it remains for the A.F. unit to amplify all of the signal that is applied to it by the detector.

Such transformers are usually wound on an iron core as shown in Fig. 16. The primary is wound with several thousand turns of very fine wire, just a little thicker than a hair; directly over it and insulated from the primary, is wound the secondary which consists of

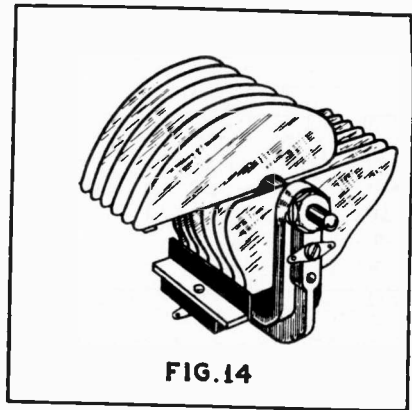

FIG. 14

A typical variable condenser.

about twice or three times as many turns as the primary and is wound with still thinner wire. Such units cannot be constructed at home with the expectation of securing satisfactory results. An A.F. transformer is heavy and completely covered with a metal

shield. The various terminals P, +B, G, and F, are clearly marked. No trouble should be experienced in recognizing this unit. Its representation in diagrams is always accompanied by thin, straight lines between the primary and secondary, which indicate the presence of iron, and the presence of iron always means an audio unit.

A choke coil or merely a choke is a device that is inserted in a circuit in order to prevent current (A.C. only) from flowing through the circuit in which the choke is inserted. Thus, if an A.F. choke is inserted in series with the plate lead of an A. F. amplifier tube, no A.F. signal will pass through it, and therefore no signal will be heard. In a similar manner, if an R.F. choke be inserted in the plate lead of an R.F. amplifier, no signal will be heard. A.F. chokes should only be used in A.F. circuits and likewise, R.F. chokes should only be used in R.F. circuits. They should never be interchanged.

Construction of R.F. Chokes

An R.F. choke consists of several hundred turns of very fine wire, usually wound on a spool or a bobbin of wood (similar to the type used on sewing machines). It has no iron and therefore is light; the spool being about one inch in diameter. The primary coil in C (of Fig. 1) is an R.F. choke and

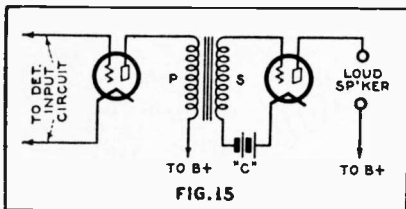

Connections of an A.F. transformer.

is mounted as shown in Fig. 17. It is usually wound with No. 28 or 30 B & S wire and has two terminals protruding. Its connection is always indicated in the diagram of the set.

Construction of A.F. Chokes

Audio-frequency chokes are heavy massive affairs wound with several-thousand turns of enameled wire on a thick (about one square inch in cross-

sectional area) core. It, too, has two terminals from which connections may be made, but there can be no confusion between this and an R.F. unit. If confusion does arise, it is between an A.F.

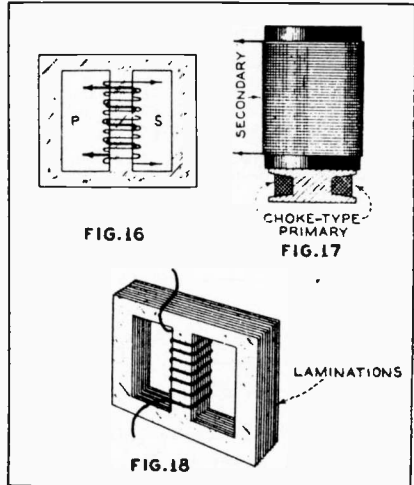

Upper left, A.F. transformer construction. Upper right, R.F. transformer construction. Below, A.F. choke construction.

choke and transformer. One may tell the difference between them, however, by the fact that a choke has but two terminals while the transformer has four; also, of course, the label may be consulted when in doubt. A pictorial view of a typical A.F. choke is shown in Fig. 18. The method of connection will be described during the course of the book.

The Power Unit

Ever since the advent of electrically operated receivers, there must be connected or housed in the set certain pieces of apparatus that are used to take the place of the "A" and "B" batteries formerly used. These pieces of apparatus, when built in a unit, are called the power unit.

Since ordinary radio sets require "B" voltages of from 20 to 500, means must be provided to raise the ordinary 110-volt light-lines to the required value. To accomplish this, a device called a power transformer is used. In its essential form it consists of a large core of iron wound with several coils of wire. One coil connects directly to the

light line, and therefore is called the primary. Another, very much larger winding, is wound directly over the primary with smaller wire (about No. 28). From this winding the high voltage necessary for the "B" supply is obtained. This winding is called the high-voltage secondary. To supply the voltage necessary for the heaters of certain tubes, smaller windings (called low-voltage secondaries) are used. A pictorial representation of these windings is given in Fig. 19A and a schematic diagram in Fig. 19B. In certain cases a tap (another word for a connection) is taken from the center of the high voltage winding as shown.

Now that the proper voltage has been obtained for the "A" and "B" supply, the next problem is to convert the high voltage A.C. into high voltage direct

current and 60 times a second it is negative. As we have seen, the tube will not work when the plate is negative—only when it is positive. The result is

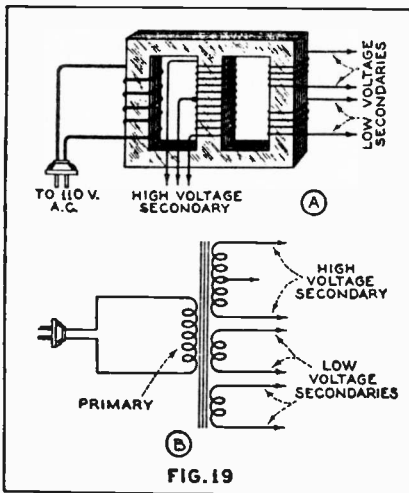

Pictorial and schematic connections of a power transformer.

current (D.C.). This is accomplished by means of a rectifier tube. A power rectifier tube is similar to the three element tube described above, but has no grid—just a filament and a plate. The filament is lit by means of a low-voltage secondary of the power transformer and is connected as shown in Fig. 20.

Now in normal operation, the voltage across the secondary of the transformer changes from positive to negative 120 times per second. Thus, 60 times a second the plate of the tube is posi-

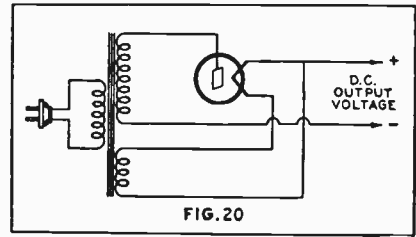

A half-wave rectifier circuit.

tive that the voltage has one part of it chopped off—that part that is applied to the tube when the plate is negative. Since only half of the voltage is used, the circuit is a half-wave rectifier.

To utilize all of the voltage that is applied to the tube, a slightly different type of tube is used. It has two plates instead of one—and is connected as indicated in Fig. 21. The outside terminals of the high-voltage secondary connect to both plates of the tube and the center-tap is the negative of the D.C. voltage output. With this arrangement, when the plate of one tube is positive, the plate of the other is negative, and vice versa. With this connection, both halves of the voltage are used.

The Filter Unit

Since the output voltage of the rectifier varies in strength, some means must be used to smooth it out, or make it unvarying in amount so that it is equivalent to batteries which it is replacing. In our discussion of A.F. chokes, it was stated that they are used whenever A.C. or varying currents are to be suppressed, they may then be

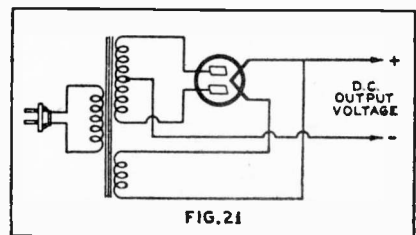

A full-wave rectifier circuit.

used to advantage as shown in Fig. 22. To further increase the smoothing or filtering action, large condensers are connected as shown dotted in Fig. 22. In order to make the voltage output stable, a resistance is connected from the "+B" to the "-B" as shown dotted in the same figure. This resistor is called the bleeder resistor.

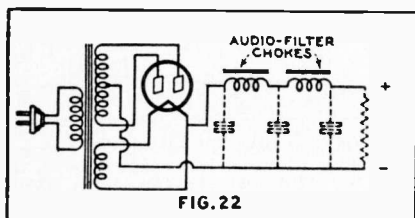

A typical filter circuit.

The summation of the entire action may be graphically illustrated by reference to Fig. 23, which is self-explanatory. With the above apparatus, it is possible to obtain an output which is substantially the same as that obtained from batteries.

The Loud Speaker

It is clear that if sound is to be heard, there must be something present in the radio set that will generate the sound and emit it. This is the purpose of a loud speaker.

Surprising as it may seem to some people, sound is nothing more than a motion (to and fro) of the air particles between the source of sound and the ear. The rapidity with which the air moves determines the pitch or frequency of the sound, while the amount of air moved determines the loudness of the sound. A loud speaker, then, must be capable of taking the output of a radio set and cause the air to move in a to and fro motion in direct accordance with the signal to be heard. That part of the speaker which moves the air back and forth is called the diaphragm.

Probably the simplest speaker with which we are all familiar is the telephone receiver that we use in our home or office, a cross-section of which appears in Fig. 24. A permanent magnet (similar to an ordinary bar magnet) is mounted vertically as indicated by M. Stretched over this, and separ-

ated from it by a few thousandths of an inch is the diaphragm D. A coil of wire is wound over M and connected to the output of a radio set as indicated in previous diagrams. The effect of the signal is to magnetize and demagnetize (which really means making stronger and weaker) the magnet M above and below the strength it has when no signal is received; this in turn attracts the diaphragm to a greater and less extent in direct accordance with the signal, as indicated by D' and D". Since the diaphragm is a disc about 2 inches in diameter, it pushes the air in front of it back and forth, so that when the ear is placed directly in front of a small opening in the case, sound is heard. The same principle applies to the so-called magnetic speakers which are nothing more or less than the simple receiver described here with a large paper diaphragm. The large diaphragm pushes more air, and hence gives a greater volume output. It should be recalled though, that to get more sound output, more must be applied, so that the telephone receiver described is only used when weak stations are being listened to.

The Dynamic Speaker

The speaker unit described above has several disadvantages. In the first place, when a strong signal is being

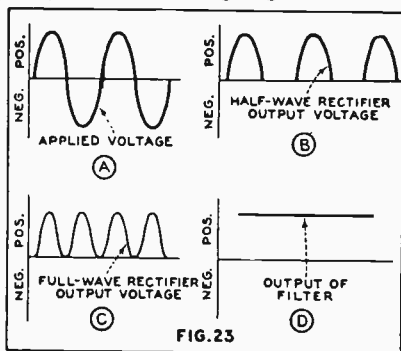

At A, applied A.C. voltage; at B and C, half- and full-wave output voltage; at D, the D.C. output.

received, the diaphragm vibrates so much that it hits the magnet and "rattles." Second, the permanent magnet is very unstable and causes the speaker in time, to weaken necessitating replacement. Third, the quality of the music

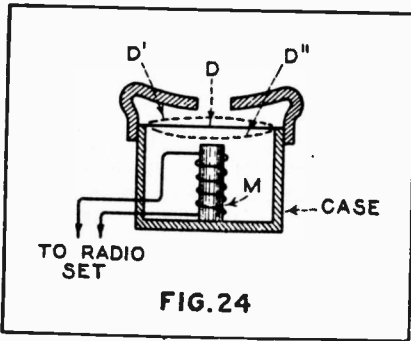

FIG. 24

A cross-section view of a simple telephone receiver. The coil, wound over magnet M connects to the output of the receiver.

or speech is not very good with strong signals. To obviate the above effects, a new type of speaker has been developed and is used to the exclusion of all other types in present receivers—the dynamic speaker.

The first requirement of such a speaker is that no permanent magnets are used, a cross-section of such a unit is shown in Fig. 25. A large, heavy, iron case (M) is built in the form of a cylinder with a large center portion MN. Over this center portion is wound many turns of fine wire (similar to that of an A.F. choke), the terminals of which connect to a D.C. source of supply. This source may be batteries, a separate rectifier, or in many cases this winding (called the field) is used as one of the chokes in a filter unit. In any event, the bar MN is magnetized. Over one end of the bar, but separated from it, is placed a small coil, wound with a few turns of fine wire; this coil is called the voice coil and connects directly to the output of the radio set. When a signal is impressed across the terminals of the voice coil, it generates a magnetic field (exactly similar to that of the field coil); this field is varying according to the variations of the signal and reacts with the steady field to produce motion of the voice coil. Now, rigidly attached to this voice coil is a large cone-shaped piece of paper

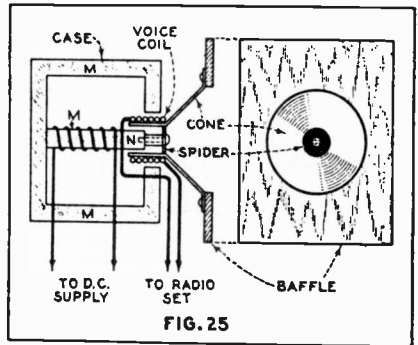

FIG. 25

Cross section view of a typical dynamic speaker. To the right is shown the baffle board which is always used with such speakers.

which is called the cone; this cone moving with the voice coil to produce sound.

A signal of almost any strength may be applied to such a speaker, the limitations only being the horizontal distance the voice-coil can move, which is about one-eighth of an inch. The quality obtained from such a speaker is excellent on large volume and is in no way comparable to the magnetic speakers described.

The cone is centered on the bar by means of a spider shown in the figure; if the cone is off center, the speaker will rattle. The easiest way to center a cone is to loosen the screw in the center of the spider and move the voice-coil from side to side until the rattle stops on the strongest signal that can be tuned in.

In order to increase the response of the very low notes, a large board is attached to the cone by means of brackets as shown in the right-hand sketch of Fig. 25. This board should be at least one foot in length on each side in order for it to be effective. This board is called a baffle and is to be found on every radio set using a dynamic speaker.

Connections from the voice-coil to the final tube in the set is usually made by means of an output transformer which is described in another section of this book.

CHAPTER 4

Semi Technical Data

Semi Technical Data

THERE does not seem to be any definite line of demarcation between any two allied professions. The problems of the mechanical engineer are, at times, those of the electrical engineer. In the development of most electrical equipment, mechanical engineers are usually called upon to develop, perfect or criticize the work of the electrical engineer. It is in this manner that the final product receives the attention of men who are specialists in their field.

There is no piece of apparatus that is perfect; every device (especially if it is equipped with moving parts) requires attention at some time or other, and radio apparatus is certainly no exception to this rule. The necessity for repairing radio apparatus is too obvious to require consideration, and it is the job of the Service Man to effect the repair.

In most radio sets, defective parts, when located, may be easily replaced with similar units, but there are instances where similar replacement parts are not available, and it is in such cases that the ingenuity of the Service Man is called into play. He must possess the knowledge to recognize the problem at hand, decide on a solution and predict the results. At times, when the problem is strictly a servicing one, the solution is not difficult, but when it involves a mixture of psychology, statesmanship, engineering, economics and time, the term "Service Man" is misleading. His technical decisions must conform with accepted practice, and oftentimes the finished repair job is better than the original.

Present Possibilities

Radio, television and home talking movies are the three main sources of revenue for the Service Man, for the reason that every receiver sold requires attention at one time or another. A

radio receiver is no longer a luxury but a necessity, and as such, a consistent demand for Service Men has been created.

Television is said to be "just around the corner" (although the authors fail to state which corner). It is the author's opinion that the status of television is the same as radio was in 1923. People then accepted radio reception with an air of hopefulness, created a demand for radio receivers and competition advanced the art.

During the intervening years between 1923 and 1932, the public has become educated to the possibilities that the future holds in store for them and, consequently, refuses to accept television in its present stage. However, television-parts manufacturers are doing a good business at the present time, which indicates that it will not be long before it becomes one of the major industries in the electrical field. Service Men will do well to acquaint themselves with the advances made in television. When it is generally accepted, it promises to be a tremendous source of income for those engaged in its manufacture, sale or service.

Talking pictures swooped down upon the theatre with amazing rapidity, displaced the silent picture and also to some extent the legitimate stage, and bids fair to be a permanent feature for some time to come. It is only natural then, that talking pictures in the home should be desirable. At the present time, small 16 mm projectors are available with and without sound accompaniment. The output of the pick-up (sound on disc is assumed) usually connects directly to the audio amplifier of the radio set, so that it becomes the business of the Service Man to possess a knowledge of sound recording as well as radio in order to complete his "radio" education. At least one manufacturer is placing on the market a 16 mm. projector with sound on film. This product should stimulate the sound

talking pictures in the home to a greater extent than the former method. A slight knowledge of optics, screens, illumination, etc., should be added to the Service Man's store of knowledge in order to effectively service home talking equipment.

Future Outlook

With the above facts in mind, it is not difficult to predict future possibilities. The fields of radio, television and home talking pictures are so interwoven that it is impossible to speak of one field without reference to the other. With proper advertising it is easy to see that the future of radio is very bright indeed.

There seems to be a misleading rumor to the effect that the radio business is "slow" during the summer months. While this was true ten years ago, it is not indicative of present conditions. The radio business is not considered good during the summer for the simple reason that people are not home during the summer. With the advent of the automobile receiver, however, this difficulty is obviated. With present day high signal-to-noise ratio receivers, the problem of static interference is minimized, and in the future, will probably be eliminated altogether. With a little effort, the radio business may be made to be an "all year round" proposition.

Requirements of a Service Man

Of all the requirements of a Service Man, that of technical knowledge is paramount. Contrary to some opinions, a Service Man obtains a livelihood by what he knows rather than by what he does. It does not take much knowledge to replace a defective transformer in a receiver, but to know which transformer to replace may, at times, require considerable skill. Regardless of any other qualities a man may possess, his opinion is held in high esteem among fellow Service Men if he "knows his stuff."

Personality is an important factor that enters into the success of a Service Man. Suppose, for example, a man, in an answer to a service call, is informed that a certain receiver is "noisy." Upon investigation he finds that it is due

to interference caused by an oil-burner motor in the cellar, and informs the customer of his findings. This customer may or may not believe him, and may or may not give him the job of eliminating the interference, depending upon the manner in which the subject is approached and the personality of the Service Man. A magnetic personality instantly instills confidence, and confidence is an all important factor in building up a business. A Service Man should be pleasing, neat, well-dressed and attempt to convey the air of a physician rather than that of a laborer; for after all, a Service Man must sell the customer on the idea that he (the Service Man) is right and that his word is law—not by ferocity and sarcasm but by a consistent, diplomatic, pleasing approach that is indicative of sure knowledge. This point is extremely important, especially for the man who desires to build up his own business.

Circuit Diagrams

A circuit diagram is merely a means of conveying knowledge. In order to

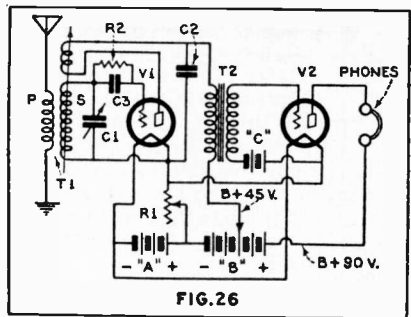

Schematic circuit of a simple 2-tube regenerative receiver.

indicate how certain pieces of equipment are connected, each and every part of the equipment is represented by a symbol and the symbols are connected together by lines which represent wires. In this manner the mode of connection of the apparatus is indicated.

Suppose, for example, it is desired to translate a simple two tube diagram into words. Consider the circuit of Fig. 26. As can be seen, it consists of two tubes, a multiplicity of coils, con-

densers and telephone receivers. Let us examine in detail just what the various parts mean.

The antenna and ground connect to the two ends of a coil marked P. This is the primary coil of the radio-frequency transformer T1. All the energy collected by the antenna is in the coil P. By induction it generates a voltage across the coil S; this voltage operating the tube V1 and in turn V2, amplifying the signal until it is loud enough to hear. Now in order to obtain the greatest amount of response, the coil S must be tuned to resonance with the signal, and this is accomplished by the condenser C1.

In America, the broadcast stations cover the band from 550 to 1500 kc. (kilocycles), and thus it becomes necessary to have the coil S and the condenser C1 of such size that they can tune over this band easily. The antenna coil (or primary coil) P is merely used for the purpose of collecting sufficient energy to actuate the tube; if it is too large, the set will tune "broad" and if it is too small, it will produce a small or weak signal. Just how the primary is designed depends upon the particular receiver in use, and it is not the purpose of this book to enter into design considerations. All that it is necessary to know (so far as reading diagrams is concerned) is that the primary is not ordinarily tuned. The coil and condenser (called the tuned circuit) connects to the grid and filament of the tube through the grid-condenser C3 and the grid-leak R2, which are necessary in order for the tube to detect.

The plate of the tube connects through a coil to the primary of the audio-frequency transformer T2. In simple terms, the coil T has two connections after it is wound, the beginning of the coil and the end. One of these connections goes to the prong of the tube socket marked "P" and the other to the terminal of the A.F. transformer marked "P". In other words, when the symbol of a device shows three terminals, then there must be at least three wires going to that device; if not, then the diagram should be checked carefully for errors.

During the author's many years as an instructor, he has found one method

of indicating how diagrams should be read that seemed to be very comprehensible. It can easily be appreciated by the reader that although it is easy to point out how a particular diagram should be read, it is impossible to explain how all radio diagrams should be read unless general rules are laid down.

Fortunately, the input circuit of any vacuum tube is generally the same regardless of whether it is an oscillator, amplifier or detector. Stripped of unessential details, the input circuit of any tube may be represented by Fig. 27. It is seen that a coil L is connected directly between the filament and the grid. Whether the coil has a condenser across it or not has nothing to do with the interpretation of the diagram immediately, the fact remains that between the grid and filament of the tube there must be connected a circuit; whether this circuit is a resistor, or an inductance has nothing to do with the fact that there must be a continuous circuit between the grid and filament. This point is extremely important and should be carefully borne in mind when tracing diagrams.

The same requisite is true of the plate circuit; regardless of what path one must trace through the plate circuit, there must be a complete circuit between plate and filament. It is evident that in a three element tube the filament is the common point from which all voltages are measured. In pictorial form, the grid and plate circuits may be shown as in Fig. 28. With a true appreciation of the above statements, one is able to fathom the most complex radio receiver diagrams used in modern receivers.

Let us see how the above holds true in analyzing the two tube set of Fig. 26. Starting with the grid of V1, we pass through R2 (and of course C3, although C3 does not offer a continuous path for D.C. and therefore should not be considered) then through winding S of the R.F. transformer T1 and back to the filament. Thus, the first prerequisite is satisfied. From the plate of V1 we pass through the primary of the A.F. transformer T2 to the "B" plus tap, through the "B" battery and resistor R1 to the filament. Thus, the second prerequisite is satisfied. Con-

sidering tube V2, we pass from the grid through the "C" battery to the filament; from its plate through the phones and "B" battery, through R1 to its filament. In all of the above cases, it is absolutely essential that we trace from the grid of a particular tube to its filament and from the plate to its filament. In this manner each tube may be considered a distinct and separate unit, and may in general be studied in detail without reference to any other tube.

Advanced Circuit Study

The simple circuit of Figs. 27 and 28 will be used as the foundation upon which all additional data rests.

One problem which most Service Men have difficulty with is the determination of just what resistor or resistors are used to obtain "C" bias for a given tube. Again we may apply a simple rule, which if followed, will make the solution of the most complex circuit

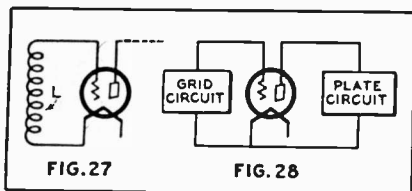

Left, input circuit; right, block diagram of input and output circuit of a tube.

relatively easy. It may be stated definitely that the voltage included between the grid return and the filament (or the heater in the case of heater type tubes) constitutes the "C" bias for that tube. Thus in the circuit of Fig. 29, resistor R is the grid circuit, 4 being the grid lead, 3 being the grid return; lead 3 connects directly to point 2. Since the "C" bias is the voltage between the grid return and the filament, then the bias must be the voltage across R1, or between points 1 and 2. The plate current flows between plate and filament and hence point 1 is positive with respect to point 2, or point 2 is negative with respect to point 1. The same holds true for the filament current and hence the grid return is negative with respect to its filament. In ordinary operation, no current flows in the grid circuit and hence through R, therefore

there is no voltage across R. The potential of the grid is thus the same as its grid return, with the result that the actual grid voltage ("C" bias) is the drop across R1. If the polarity of the "A" battery were reversed, the grid

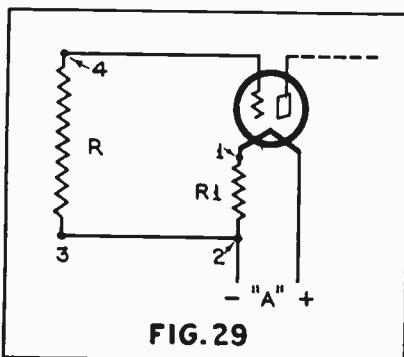

Typical input circuit showing grid-bias resistor.

would be positive with respect to the filament since the filament current is usually far greater than the plate current. In modern receivers, the "C" bias is determined solely by the plate current, so that the direction of filament current has no bearing on the subject.

Let us consider a more complex circuit such as that illustrated in Fig. 30. The plate currents of both V1 and V2 must flow from the "B" plus through the tube to the cathode (heater tubes being used now for the sake of variation) and then through R1 (from point 2 to point 1) in order to reach the "B" minus. The "C" bias for both tubes

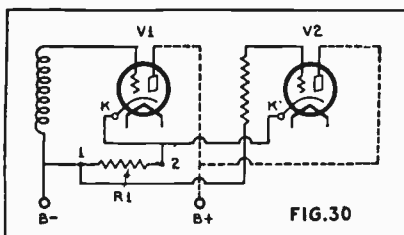

Diagram showing how two tubes obtain their bias from a single resistor.

is then the voltage drop across R1 and is equal to the value of R1 in ohms multiplied by the sum of the plate currents of both tubes.

It is now a very easy matter to show how a modern automatic volume control functions. When a signal is too loud, it may be reduced by making the grids of the amplifier tubes more negative. This may be done automatically

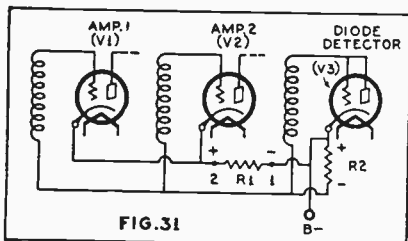

FIG. 31

Connections showing the principle upon which one type of automatic-volume control works.

by causing the plate current of a diode (two element) detector to flow through a resistor, and having this resistor in series with the grid return leads of the amplifier tubes. This is illustrated in Fig. 31.

The plate currents of both V1 and V2 must flow through R1 in order to reach "B" minus. The current through the diode, (when a station is tuned in) must flow through R2 as well as R1. Now the "C" bias for any tube was defined as the voltage between the grid return and its particular cathode. Trac-

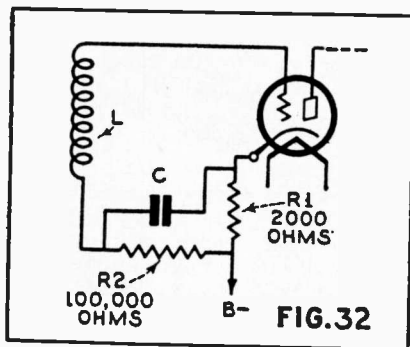

FIG. 32

Input circuit showing the use of a grid-filter.

strength, and hence a smooth control of volume is automatically secured. Other systems use a separate tube to secure the desired result, but the fundamental theory of operation is the same.

It should be particularly noted that we determined how the automatic volume control functioned and analyzed the grid circuits of three tubes by merely following the simple rule outlined above. The plate and power circuits were not shown for the sake of clarity, and in analyzing diagrams only one circuit should be investigated at a time anyway, so that the simplified diagram shown in Fig 31 is indicative of what one should concentrate on when studying radio diagrams.

Grid Filters

A very interesting case illustrating the general rules outlined above is found in the study of grid-circuit filters. In high grade audio amplifiers, it is desirable to keep the signal actuating a certain tube entirely within the tube circuit. This is especially useful in high-gain amplifiers where the slightest feed-back may cause oscillations.

Consider the circuit of Fig. 32. From our previous analysis we know that the grid-bias resistor is R1 and, let us say, is about 2000 ohms. The signal impressed across the coil L actuates the tube and therefore should be as great as possible. Now the effect of the grid-bias resistor is to reduce the signal voltage applied between the grid and cathode, so that it is necessary to shunt the resistor R1 with a condenser whose reactance (the opposition to flow of current of a condenser) at the lowest frequency to be received is about one-tenth the value of R1. In audio amplifier work, this may mean the use of a very large (and consequently expensive) condenser. If we now insert a large resistor R2 in the circuit as shown, then the condenser may be made very much smaller by virtue of the fact that the resistance path from the grid return to the cathode is deliberately made larger by the insertion of R2.

Since the value of the reactance of the capacity should be one-tenth the value of the resistance R1, then it can be made about one-tenth the size that it would have if R2 were not there due

ing through the grid returns of both V1 and V2, we find that the total voltage between their grid returns and their cathodes is the sum of the voltages across R1 and R2. The voltage across R2 varies directly as the signal

to the insertion of R2, and at the same time do the same amount of filtering. Resistor R2 does not contribute to the "C" bias because the plate current does not flow through it; it (the plate current) returns to the "B" minus immediately upon leaving R1. It should be pointed out that the grid circuit of the tube consists of L, C, and R2. The plate circuit may also have a filter for the same reasons as discussed for the grid circuit.

At this time a few pointers regarding the construction of receivers are in order. First, all grid and plate leads should be as short and as direct as possible; this is very important in modern receivers. Second, all leads carrying A.C., such as filament leads, should be twisted. When twisted, the magnetic field of one lead neutralizes the field of the other, resulting in an external field of practically no strength. The power unit should be kept as far from the A.F. end of the set as possible in order to avoid induction.

Uses of Voltmeters and Ammeters

In the early days of radio broadcasting, Service Men had but two pieces of test equipment—a voltmeter and a milliammeter. The receivers were simple in those days and consequently additional apparatus was considered unessential and in some cases slightly unethical. With the advent of the electric receiver, however, design advanced to such a stage that it became almost impossible to intelligently test a receiver unless some means was employed to measure all voltages and currents both accurately and swiftly—hence the modern set analyzer.

To attempt to describe a simple tester without illustrating in detail the theory upon which it functions would be unwise. Therefore we will devote some time to a discussion of some of the problems encountered in measuring work and then proceed to show how they may be minimized.

Suppose it is desired to measure the grid voltage of a tube connected as shown in Fig. 29. Now grid voltage is measured between the grid and the filament (or the cathode in heater-type tubes) and therefore it is necessary to insert the voltmeter between points 1 and 4. If this is done, a reading will

be obtained, but not the true reading. The reason will be apparent when the same circuit is redrawn as in Fig. 33. The "C" bias resistor has been replaced by the battery E which, let us say, has a voltage of 6. If the voltmeter is to read correctly, it too must read 6 volts. Usually the resistor R has a value of about 1,000,000 ohms; if the grid circuit is that of an audio amplifier, the resistance of the secondary of the transformer may be about 100,000 ohms. Let us assume the latter figure.

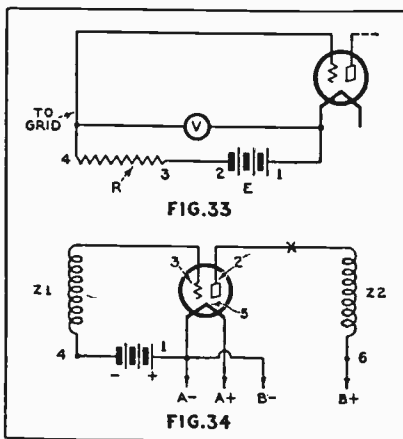

Above, circuit showing the connections of a grid circuit voltmeter. Below, typical 1-tube receiver.

If a low resistance voltmeter is used (100 ohms per volt), then the meter will have a resistance of only 1,000 ohms if the 10-volt scale is used. The current flowing in the circuit would be 6 divided by 101,000 or .000059 amperes. The voltage drop across R is 5.9 volts, leaving a voltmeter reading of only .1-volt. If a high resistance meter is used, with a value of 1,000 ohms per volt (a total resistance of 10,000 ohms for the 10-volt scale) the reading of the voltmeter would be .55 volts. It is seen then, that the higher the resistance of the meter, the more accurate the reading obtained.

It is not practical to make meters with a resistance greater than 1,000 ohms per volt, so that in circuits having a high resistance, the correct bias can never be measured. In R.F. and

.6 Ten ths
.06 Hundred ths
.006 Thousand ths

detector stages, where the secondary of the transformer has practically no resistance, it is possible to obtain correct readings. In cases of circuits having a high resistance, the grid bias may be accurately measured by removing the chassis and connecting the voltmeter across the bias resistor R1 in Fig. 29.

The same trouble holds true for the plate circuit—actually true readings can never be obtained if the load (output circuit) has a high resistance. The drop in voltage in the plate circuit will never be as much (in percent) as in the grid circuit; for instance, if the true plate voltage (measured from plate to filament—or cathode) is 100 volts, and the voltmeter reads 75 in a fairly high resistance circuit, then it may be assumed that the plate voltage is correct. Extreme precision is not justified in service work—accuracy of about 10 percent is close enough for all purposes.

From the foregoing, it is clear that for ideal voltage measurements, the resistance of the voltmeter should be much higher than the resistance across which it is connected. A good rule to remember is that the resistance of the meter should be at least ten times the resistance of the circuit being measured.

The Ammeter

Just as the voltmeter is used for measuring voltage, the ammeter is used for measuring current. The movements of the meters are the same, the only difference being that a high resistance is connected in series with the movement in the case of the voltmeter, and a low resistance connected across the movement when it is to be used as an ammeter. This point will be discussed in greater detail later on.

The ammeter being a low resistance unit that is connected in series with the circuit through which the current is to be measured, it might seem that its location in the circuit is arbitrary. This is only true when its resistance is low as compared with the rest of the circuit; when the current through the circuit is small; and, if a voltmeter is used, the current that is consumed by the meter is not recorded by the ammeter.

The above statement regarding the placement of the ammeter is not really important in radio service work, but it was mentioned because it accounts for some of the errors that occur in some types of measuring instruments.

The Milliammeter

Unlike power work, the currents involved in radio are very small, being in the order of thousandths of an ampere rather than amperes. To effectively measure such small currents, meters are required that are rather sensitive, being called milliammeters, since they measure thousandths of an ampere instead of amperes. When calculations are performed, care should be taken that the decimal point be placed in the proper place, else erroneous results will be obtained. For example, when using 6 milliamperes (abbreviated mills, or ma.) in a calculation, it always should be written 6/1000 or .006 amp.

Very little can be said regarding the location of the milliammeter in any radio circuit other than being placed in series with the circuit through which the current is to be measured. Its resistance is usually small compared with the remainder of the circuit and hence no appreciable error is encountered by its use. As a preliminary step toward constructing a simple analyzer, let us show how the two instruments mentioned above may be used to locate trouble in a typical radio set.

Locating Troubles With Voltmeters and Ammeters

Meters are used in service work for the purpose of locating trouble. This does not imply that the meters indicate where the trouble lies, but they act as a means to localize the search. Modern radio sets are so complicated that unless a means is used to suggest the source of trouble, the Service Man will find himself guessing; and guess work is one of the most frequent causes of unsatisfactory service work.

It will first be shown how meters are used in a single stage amplifier, then in a complete radio set, and finally how they may be incorporated in a simple tester.

Suppose that, in servicing a receiver, a particular amplifier stage, illustrated in Fig. 34, is to be tested. Only six possible measurements may be made;

first, plate voltage; second, plate current; third, grid voltage; fourth, grid current; fifth, filament voltage; sixth, filament current. If all of the above measurements conform with the values stated by the manufacturer, then the trouble does not lie in any of the plate or grid circuits, and the attention of the Service Man should be concentrated elsewhere.

Plate Voltage Measurements

To measure plate voltage, all that is necessary is to place the negative terminal of the voltmeter at point 1 and the positive terminal at point 2. The meter should then indicate a certain value. (In all of our voltmeter measurements, the use of a high resistance meter will be assumed.) If the reading of the meter is far below the value recommended by the manufacturer of the set, the resistance of Z2 should be measured independently, and the results checked with the value specified by the maker. If the resistance of Z2 does not conform (within about 10 percent) with the rated value, then it should be replaced at once. If it does conform, then in all probability the current drain of the voltmeter is sufficient to reduce the reading of the meter although the actual value, when the meter is not connected, is correct. It is evident at this point that the interpretation of the meter reading is of paramount importance, as an erroneous interpretation may cause the Service Man to perform additional unnecessary tests.

If the stage being tested is one of the R.F. amplifiers, then the actual voltage will be about the same as the read voltage; if it is an audio stage, then the actual voltage may be from 10 to 75 percent greater.

If no voltage reading is obtained, then either the "B" plus power is not connected or the load resistance Z2 is open. The power supply may be tested by connecting the voltmeter across points 1 and 6. If a reading is obtained, then Z2 is open and should be replaced. It is wise to check the continuity of Z2 separately at this point to check the previous tests.

Obviously, if the voltage reading is correct, the attention of the Service Man should be directed elsewhere. Certain manufacturers have sufficient fore-

sight to realize the problems of the Service Man and publish the voltage readings as they are read, assuming a definite meter resistance.

Plate Current Measurements

Assuming that the plate voltage is correct, the plate current should then be measured. This may be done by connecting the milliammeter in series with the plate circuit, as shown in Fig. 34 at point X. The meter should then read normal plate current. If the reading conforms with the value specified by the maker of the set, then plate circuit measurements are finished. If not, then (1) it may be too high or (2) too low.

If the plate current is too high, with normal plate voltage, the "C" bias may be wrong, the filament voltage too high or the tube defective. Methods of test to ascertain which of them is causing the trouble will be given in their proper sequence.

Measurement of Grid Voltage

To measure grid voltage, connect the positive terminal of the voltmeter to point 1 and the negative terminal to point 3. It should be noticed that the polarity of the voltmeter is the reverse of that used when measuring plate voltage.

The interpretation of the meter reading is exactly the same as for the plate voltage measurement above. To check for the actual value of bias, connect the terminals of the meter to points 1 and 4. In our case, since a battery is used for the bias, the actual value can be measured.

While the measurement of grid current is desirable, it is not absolutely essential to good servicing. With the proper negative bias on a tube, it should not draw current; if it does, the value of current means nothing to the Service Man, except that the tube is defective and must be replaced. This, however, may be determined just as rapidly, although with more inconvenience and less expense by testing the tube separately.

Filament Voltage Measurements

Very little can be stated regarding the measurement of filament voltage. The terminals of the meter should be connected across points 1 and 5. Its value may then be adjusted (in battery

receivers) by merely varying the rheostat setting.

Filament current measurements are usually not required, as the proper emission may be obtained (or nearly so) by keeping normal filament voltage applied to the tube.

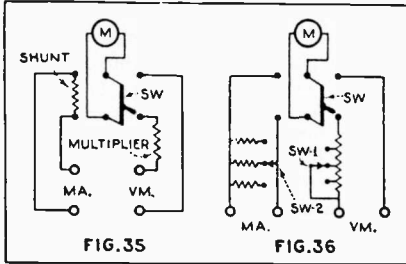

FIG. 35

FIG. 36

Left, how a single switch may be used to operate a single meter as either a voltmeter or an ammeter. Right, additional resistors for extending the range of the meter.

While six different measurements are possible, only four are desirable, namely, plate voltage and current, grid voltage and filament voltage. Before a test is made, the Service Man should determine from service manuals, previous experience, etc., just what the results of the test should be; the tests being made for the sole purpose of ascertaining whether they do or do not agree.

It should be particularly noted that the meter readings do not indicate where the trouble lies. They are merely an aid to finding the cause of the trouble—and the only aid that may be obtained at the present time.

Meter Scales

One fact should have been apparent to the reader by this time. Voltage and current measurements were made and no mention was made of the scale of the meter. The grid voltage may be about 20 volts, while the plate voltage may be 300; the plate current of a certain tube may be 2 ma. while that of the adjacent tube may be 35 ma. It therefore becomes necessary to adopt means of changing the range of the meter for different tubes, circuits, etc. It is also possible to use one meter as both a voltmeter and a milliammeter, the change from one to the other being effected by switches.

Multipliers and Shunts

Unfortunately, space does not allow a theoretical discussion of the use of multipliers and shunts. For our purpose, a multiplier may be defined as the resistance that is inserted in series with the movement of a meter in order to

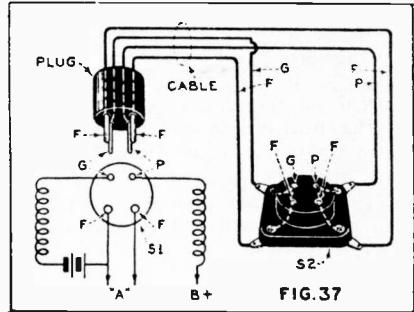

FIG. 37

Circuit illustrating the principle of the analyzer.

read voltage, and a shunt may be defined as the resistance that is connected across the movement of a meter in order to read current. Thus in Fig. 35, by manipulating the switch SW, the meter may be made either a voltmeter or an ammeter. By throwing the terminals are used; when thrown to the left, the milliammeter terminals become available.

To obtain different ranges, various multipliers are connected in the circuit, each corresponding to a different range. The same holds true for the various milliammeter scales. Thus in Fig. 36, three ranges of voltages and currents may be read with a single meter.

CONSTRUCTION OF A BEGINNER'S ANALYZER

A radio set analyzer, in its simplest form, is nothing more than a meter arranged with a multiplicity of switches for the purpose of placing the meter in any desired position in the circuit. It is realized, of course, that in a commercial receiver the various points referred to in Fig. 34 are not accessible and therefore a plug and socket arrangement is necessary.

Figure 37 illustrates the manner in which a plug may be used to advantage. The socket S1 is in the set to be tested and S2 is in the analyzer. It is easy to see that although the socket connections to S1 are not accessible, they may be reached by means of the plug and analyzer socket S2. The meter with its attendant multipliers and shunts are then connected in such a manner that all voltage and current readings may be secured at will. With the analyzer described only D.C. voltages and currents may be read since only a single D.C. meter will be used.

A complete diagram of connections of the analyzer is given in Fig. 38. A rotary switch is used for selecting the measurement of plate voltage, plate current, grid voltage, grid current and filament voltage.

Description of the Analyzer

The four leads marked "to set" connect to the P, G, F and F prongs of the plug which may be made from an old tube base. With the rotary switch SW1 on the two left contacts, grid current is measured. In measuring

this current, two scales are available, 1 and 5 ma. By depressing SW9, the 1 ma. scale is used and by depressing SW 10, the 5 ma. range is available.

The second set of contacts on the rotary switch measures grid voltage. Here, three scales are available, 0-5, 0-20, and 0-50 volts. The lowest range may be obtained by depressing SW11, the medium range by depressing SW12 and the highest range by pressing SW13.

The third set of contacts on the rotary switch measures filament voltage. In this instance, two ranges are available. 0-5 and 0-10 volts. Either scale may be obtained by depressing either SW7 or SW8.

The fourth set of contacts facilitates the measurement of plate voltage. Three voltage scales are available, 0-50, 0-100 and 0-500. Any scale may be obtained by depressing SW2, SW3, or SW4, which correspond to the three scales above.

Plate current measurements may be made by rotating the switch to the fifth set of contacts. Two current scales are available, 0-5, and 0-50 ma. They may

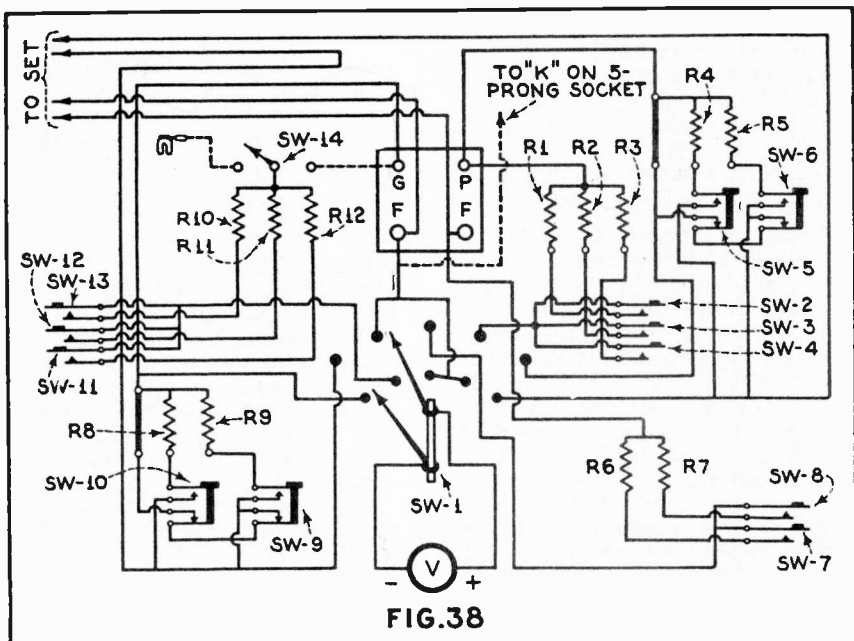

Complete schematic diagram of a simple tester. SW-14 is thrown to the right for three-element tubes and thrown to the left for control-grid measurements on screen-grid tubes. A single meter is used for all measurements in this tester.

be obtained by pressing buttons SW5 and SW6.

This analyzer is suitable for battery operated receivers where there is no A.C. filament potential to measure, no five prong tubes, and where nothing but set analysis is required. For the beginner it is highly recommended, as it gives a deeper insight into the functioning of analyzers than would be obtained by a description of a more complicated tester. Its simplicity of construction, low construction cost, and simplicity of operation should appeal to the man who wants to learn by first grasping the fundamentals and then logically proceeding to the more complicated. It is not intended for the man who wants to build "Rome in a day."

Values of Parts

One Jewell 0-.5 ma. meter (internal resistance 140 ohms);

Two 5,000 ohm resistors, R10, R6;

One 10,000 ohm resistor, R7;

One 20,000 ohm resistor, R11;

Two 50,000 ohm resistors, R1, R12;

One 100,000 ohm resistor, R2;

One 500,000 ohm resistor, R3;

One 140 ohm resistor, R9;

Two 35 ohm resistors, R8, R4;

One 3 ohm resistor, R5;

Eight S.P.S.T. push-type switches;

Four D.P.S.T. push-type switches;

One double pole, 5 point rotary switch;

Cable, wire, a socket, analyzer plug.

Use of the Simple Set Tester

Suppose, for example, it is desired to test a simple battery operated receiver of the type depicted in Fig. 26. The first thing that should be done is to place the receiver in operating condition by applying normal filament, plate and grid voltages to the set. The plug of the analyzer should be placed in the socket V1 of the set, and the tube that originally was in V1 should be placed in the socket of the analyzer. With the rotary switch at the extreme left, grid current measurements should be made with the 1 ma. scale being used. In all probability no reading will be obtained because the grid current is far too small to be measured by such a meter.

The rotary switch should then be moved to the second set of contacts and

the 5-volt scale button depressed. Here again a very small reading will be obtained because of the presence of the high grid-leak resistance R2. If R2 be shorted, a reading equal to the value of the filament voltage will be obtained since the meter in the analyzer is automatically connected to the negative terminal of the filament and the grid return lead in the set to the positive terminal. If no reading is obtained, and the condenser C1 is good, then coil S is open circuited. A reversed reading will be obtained if the "A" battery terminals are reversed.

The measurement of filament voltage is obtained by rotating the switch SW1 (in the tester) to the third set of contacts. The value of this voltage may be made correct (if it is not so) by merely varying the resistance of R1.

The plate voltage may be measured by rotating SW1 to the fourth position. The 0-50 volt scale button should be depressed since the plate voltage is only 45 on this tube. Actually it will read slightly less due to the voltage drop in the primary of the transformer T2. A reading of about 40 volts will usually indicate normal plate voltage. If no voltage reading is secured, it may be due to an open tickler coil, an open circuit in the primary of the A.F. transformer T2, lack of proper "B" connections, or a shorted condenser C2. All of the tests necessary to perform in order to determine the defective unit will be described in the following section.

Plate current may be measured by placing SW1 in the fifth position. With the applied voltage normal, the correct plate current should be obtained. If not, then the tube, in all probability, is defective and should be replaced. Methods of testing tubes will be described in a following chapter. The test of the first stage is now complete and the second is ready to be checked.

The tube from the analyzer is replaced in the socket of the set and the positions of the analyzer plug and tube V2 are now interchanged exactly as in the first case. The same procedure is followed but the results will not be the same as before because of the difference in the bias and plate voltage applied.

When the grid voltage is measured, a very low or a slightly reversed reading may be obtained. This is due to the manner in which the "A" battery has been connected in the diagram. The plus of the "C" battery is shown connected to the plus of the "A" and therefore the meter in the analyzer is reading the difference between the two voltages. If the "A" connections are reversed during this reading, a very large bias reading will be obtained because the meter is now reading the sum of the two voltages. This point should be carefully borne in mind when testing battery sets, and the diagram of Fig. 26 was drawn especially to emphasize this point. The effect of the high resistance of the secondary of the transformer T2 should also be remembered when testing this stage.

With the voltage and current readings obtained, the function of the tester is completed and it remains the problem of the Service Man to interpret the results. No intelligent interpretation is possible without a wiring diagram of the receiver on hand. When a particular voltage is too low, the diagram should be consulted immediately. In the testing of V1 (Fig. 26) a very low voltage on the plate may be obtained. After deducting the probable voltage drop in the primary of T2, the reading may still be too low to be normal. A test of the battery voltage and all soldered joints may show nothing wrong. The man without a diagram would, at this point, be "stuck" but the one who had foresight to procure the diagram of the receiver before testing it, will immediately see that a partially shorted plate bypass condenser C2 will cause a considerable drop in voltage and a possible burnout of the primary of T2.

Testing the Coils

There are two types of coils used in radio sets, air-cored and iron-cored. Either type may be open, partially shorted or entirely shorted. Now most analyzers have, as an integral part of the device, a continuity tester or ohmmeter. This is nothing more or less in its essentials than a voltmeter V connected in series with a small battery, as shown in Fig. 39. With terminals 1 and 2 shorted, the voltmeter

reads the battery voltage; which is the same as the full-scale deflection of the meter. If a resistance R is inserted between terminals 1 and 2, the voltmeter reads less than the battery voltage, because of the voltage drop in R, the resistance being measured. The more resistance between 1 and 2, the less the meter reads. This makes it possible to mark or calibrate the scale of the voltmeter directly in ohms, so that, when a resistance is connected between points 1 and 2, the meter reads a certain figure which is the value of the resistance in ohms so connected.

The coil to be tested is connected to points 1 and 2 of the ohmmeter. If the meter reads nothing at all (0), then the coil is defective. If the meter does read, it is difficult to tell whether the coil is partially shorted or is good, un-

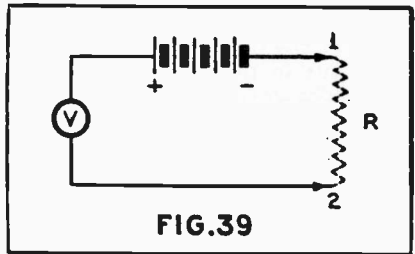

FIG.39

Simple diagram of an ohmmeter.

less the resistance of the coil is known. For instance, an R.F. transformer is wound with only a few turns of wire, and consequently its resistance is low. An ohmmeter test then, can only indicate when the coil is open or closed.

On the other hand, a large iron-cored coil is usually wound with many turns of wire and may have a resistance of several hundred or several thousand ohms. In this case, the Service Man cannot tell the difference between a partially-shortcd coil and a good one, unless he knows the approximate resistance of the coil when good. This may be usually found in the service notes of the radio set, or, if there is a similar coil in the same or another set, the resistance of one may be compared with the resistance of the other. Coils should be tested, not only for shorts and open circuits, but also for a "ground" (short circuit) to cores.

Notes

In many cases, the cores of chokes, transformers, etc., are grounded to the frame of the set (which is usually at ground potential.) The coils themselves are above ground potential, so that a coil grounded to its core constitutes a short-circuit.

Fortunately, however, when a coil in a radio set is defective, it usually is either open or has a dead short; so that the continuity tester is all that is necessary to locate defective ones.

Testing the Condensers

When a condenser is good it should do two things: (1) it should not allow D.C. to pass through it, and (2) it should therefore accumulate and hold a charge, when its rated D.C. voltage is applied. When a condenser is leaky it allows D.C. to pass; so that, to test for a leak in a condenser, all that is necessary is to connect the terminals of the condenser to the ohmmeter. The needle of the ohmmeter should move a little (due to the flow of current into the condenser necessary to charge it if the capacity is large), and then return to its normal position and stay there. If it does not return to its normal position, but stays somewhere on the scale, then the condenser is leaky and should be discarded.

It is perfectly possible for a condenser to test O.K. on the small voltage used in the ohmmeter, but break down completely when normal voltage is applied. To test a condenser completely, the rated D.C. voltage should be applied for a few moments, and then removed. The condenser should be allowed to stand charged for a few moments, and then discharged. If a spark occurs during discharge, the condenser is good, if there is a weak spark or none at all, the condenser is defective.

The above statement applies only to condensers of large capacity, about $\frac{1}{4}$ to $\frac{1}{2}$ mf. and larger. For the smaller sizes, the continuity test described above is sufficient, being enough to determine whether the condenser is shorted or not. It is perfectly possible for a condenser to open, even though it is

a rare occurrence; an open condenser is one which passes neither D.C. nor A.C. This is usually due to broken or unsoldered leads from the condenser plates to its terminals. To locate an open in a condenser of small capacity is practically impossible. For condensers of large capacity, the methods described above for testing condensers may be used to advantage.

For the electrolytic type of condenser, the rated D.C. voltage may be applied. A milliammeter connected in series with the condenser and the source should read not more than .5 ma. per microfarad capacity of the unit. Thus an 8 mf. electrolytic condenser should have not more than 4.0 ma. passing through it, if it is to be considered O.K.

It is very useful to be able to measure condenser capacity. This may be done very easily by connecting a small copper-oxide rectifier in series with a D.C. meter and a source of A.C. potential. The condenser to be measured is also connected in series with the arrangement. The greater the capacity of the condenser, the greater the reading of the meter. In this manner the scale of the meter may be calibrated to read directly in microfarads, provided that the same A.C. source of potential is always used.

Testing Resistors

Testing resistors really involves (as far as radio service work is concerned) only the measurement of the value of the resistance. If the result of the measurement is within 10 percent of the rated value of the unit, it may be considered O.K. If it is far from the 10 percent tolerance, then it should be discarded. Care should be taken, when replacing a resistor in a receiver, that it is able to dissipate the heat fast enough; if it cannot do so, the resistor may burn out due to excessive overload.

In the chapter to follow, there will be described complete test equipment for the more advanced Service Man.

CHAPTER 5

Advanced Service Data

EVEN though the equipment described in the preceding chapter is sufficient for the servicing of the more simple battery receivers, it is not complete enough for a thorough check of modern superheterodynes. It is suitable for the embryo Service Man who feels the necessity of becoming acquainted with up-to-date test methods but who is not willing to make a large investment in apparatus that he feels he will not be able to use.

For the Service Man who has had sufficient experience to recognize the need for advanced equipment, and for the beginner who believes that a certain amount of experience will be gained by building modern test equipment, this chapter is dedicated. Complete construction details accompany every description.

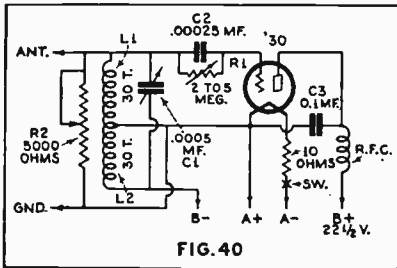

FIG. 40

Complete schematic circuit of a simple R.F. oscillator. All values are marked on the diagram.

The R.F. Oscillator

In the early stages of radio servicing, the broadcasting station was used to conduct all tests. If it so happened that no stations were operating at the time, then it was impossible to conduct any tests. During periods of SOS, even at the present time, it is impossible to intelligently conduct a test on a receiver. Even though a reliable station is on the air, the continuous change in volume that accompanies a selection that is being rendered makes the test-

ing of receivers unreliable. It is for the above reasons that an artificial transmitter (oscillator) should be used by the Service Man.

The R.F. oscillator is used for the creation of a signal of any desired strength and wave length that is suitable for the broadcast band i.e., from 550 to 1500 kc. A complete schematic diagram of such an oscillator is shown in Fig. 40.

One of the most important features of the oscillator illustrated in the above-mentioned figure is its utter simplicity. It is portable using a '30 type tube, a small 22½-volt battery for plate potential and a 2-cell flashlight "A" battery. The entire arrangement may be placed in a single carrying case, the inside of which should be thoroughly shielded to prevent radiation (giving off energy) from the coil itself. It is designed to cover the broadcast band from 550 to 1500 kc. The particular wave length desired may be obtained by merely rotating the tuning condenser C1. The variable grid-resistor R1 is used for the purpose of securing any pitch note desired. While this feature may easily be done away with, it is desirable in instances where the fidelity (quality) of the audio amplifier in the receiver is to be checked. The output of the oscillator may be adjusted by varying the arm of the potentiometer R2. This adjustment will be found to be particularly useful when testing receivers of different sensitivities.

The coil consists of 60 turns of No. 20 or 22 silk or double cotton covered wire wound on a 2 inch diameter form tapped at the center. The coil should be raised a reasonable distance above the shield in order to prevent excessive loss and a consequent loss of efficiency. Under no circumstances should the "B—" terminal be connected to any of the "A" terminals, for this would

short circuit the feed back coil and cause the oscillator to stop functioning. An R.F. choke is placed in the plate circuit of the tube in order to keep the radio-frequency power in the oscillator itself, and not let it wander out into the "B" battery leads from which radiation might take place.

Discussion of Circuit

While the dynatron oscillator might be described, it was not for the reason that the present type of four element tubes have their plates blackened so as to reduce secondary emission, the effect of which is to cause a peculiar bend in the plate voltage—plate current curve. It is this bend that causes the tube to oscillate, and since the shape of the bend varies with different

the oscillator corresponds to the frequency of the broadcast station. This operation is repeated for stations of different frequencies. A curve is then plotted, the horizontal lines corresponding to the dial setting of the oscillator and the vertical lines to the corresponding frequency of the broadcasting stations. In this manner the frequency of the oscillator for any setting of its dial may be determined at a glance.

The I. F. Oscillator

In lining up superheterodyne receivers, it is desirable, as will be seen later, to first be sure that all the intermediate frequency transformers are tuned to their rated frequency. This may be accomplished only by a separate oscillator tuned to the intermediate frequency. Such an oscillator may, of course, be incorporated in the same case as the R.F. oscillator described above.

This has not been done for several reasons. First, there may be men who already have R.F. oscillators, but who contemplate building an I.F. oscillator—obviously, then, the composite unit would be undesirable for such men. Second, not all service jobs require the use of an I.F. oscillator, and consequently, it would increase the weight of the equipment that must be carried if a single larger unit were described. Third, if certain Service Men feel that they are not classed under the two categories above, they may incorporate both oscillators at will.

Figure 41 shows the schematic diagram of an I.F. oscillator that is designed for an I.F. of 175 kc. This frequency is not made variable because practically all broadcast receivers in use today have their intermediate frequency amplifiers tuned to 175 kc. Furthermore, the cost and the size of the oscillator is reduced by keeping the oscillator tuned to a constant frequency.

As may be seen from the diagram, the fundamental circuit is exactly the same as the R.F. oscillator; the only difference being in the sizes of the tuning coil and condenser. The condenser is shown fixed, but it might well be variable, or else may be made to consist of a fixed capacity of .00075 mfd. and a small variable condenser of

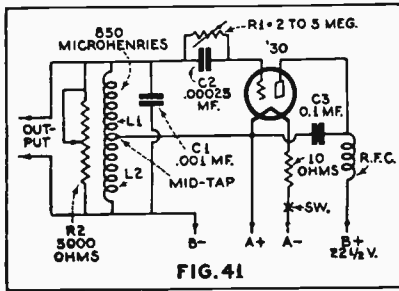

Complete schematic diagram of an I.F. oscillator. Note the similarity between the diagram above and that shown in Fig. 40.

tubes, the oscillator is not as stable with the present type '24 tubes as it was with the older type tubes.

The oscillator described is a very stable one and the output will not change appreciably with different tubes, although it is a good idea to keep one tube for the oscillator alone.

The oscillator may be marked or calibrated in the following manner: Tune a radio set to a broadcast station of known frequency (most newspapers give the frequency of broadcast stations in the vicinity), and then disconnect the aerial and ground from the set. Start the oscillator by closing the filament switch SW and connect the ANT. and GND. posts of the oscillator to the receiver. Then turn the tuning knob (leaving the tuning of the set constant) until the note of the oscillator is heard in the loudspeaker. The number on the dial of

.00025 mfd. connected across it. In this manner, the frequency of the oscillator may be varied slightly to compensate for discrepancies in circuit constants. As may be readily seen, the R.F. and I.F. oscillators may be com-

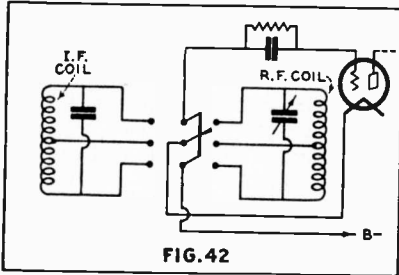

FIG. 42

Switching arrangement showing how a single tube may be used for the two oscillators.

bined in a single unit; the change from one frequency range to the other being effected by means of a switch as shown in Fig. 42. The method of using the oscillator will be fully described later.

The Audio Oscillator

The possession of an audio oscillator seems to be the ambition of a great many Service Men. Why they do not possess one is beyond the comprehension of the author, since many interesting experiments and tests may be made with one. The diagram of connections is exactly the same as that of Fig. 41 with the following changes:

Coils L1 and L2 are the secondary and primary, respectively, of an ordinary low-ratio audio transformer, the grid leak R1 should be made variable from 0 to 10 megs., the choke R.F.C. should be increased to 15 henries, R2 should be increased to 500,000 ohms, and the bypass condenser C3 should be changed to 2 mfd. Variation of the audio frequency pitch is secured by merely varying the size of the grid leak. Almost any range of audio frequency may be secured by changing the size of either C2 or R1, the greater either one is made, the lower the frequency generated.

The Output Meter

For frequencies above 100 cycles, the ordinary A.C. meter is useless. For this reason, there have recently been placed upon the market small, dry rec-

tifiers that are capable of handling very small currents efficiently. Several of these may be obtained and connected in a bridge arrangement as shown in Fig. 43. The resistance R is adjusted until the meter reads full scale with a loud signal impressed. In most cases it has a value of 5,000 ohms.

Many manufacturers make their dry disc rectifiers available ready for a bridge connection. In such cases, the meter should be connected as shown in Fig. 44. The meter M is a D.C. milliammeter. The advantage of this method of connection lies in the fact that if the arrangement is to be used for reading current, the resistor R is short circuited and the terminals are connected in series with the circuit through which the current is to be measured. This instrument can be put to many uses as will be seen later.

The Regenerative Receiver

The circuit discussed in Fig. 26 is called a regenerative receiver for the simple reason that part of the energy in the plate circuit is fed back to the grid circuit via a coil (called the tickler). The energy so fed back adds to the signal being received with the result that the strength of the output increases as the energy fed back increases. A limiting point is reached when the energy fed back becomes so great that the tube begins to oscillate (acts as a transmitter); when this occurs, the signal is weak and distorted. The object, then, is to adjust the coupling between the tickler and the secondary of the R.F. transformer until maximum strength is received—if the coupling be advanced beyond this point, the tube will break into oscillation. This value of coupling is very critical, and

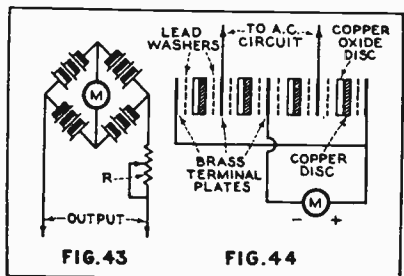

FIG. 43

FIG. 44

Left, Bridge connections of a dry rectifier. Right, Internal connections of the rectifier.

therefore the tuning of such receivers must be done with some dexterity. The effort is compensated by the additional gain that is secured—about equal to one stage of well designed R.F.

When tuning such a receiver, the tickler should be advanced until the receiver oscillates. The tuning dial should be rotated until a squeal is heard; this indicates the presence of a broadcast station. The coupling should be loosened a little and the tuning dial returned until the station is loudest, although it still may be distorted. The coupling is again loosened and the dial again returned. This process is repeated until a point is reached where the station comes in loud and clear—until the set just stops oscillating.

Because the tuning of the set is affected by changes in the position of the tickler (because of the change in coupling), receivers employing regenerative detectors cannot have their tuning condensers ganged. This point is a decided disadvantage—in fact, it is for this reason that present-day receivers do not employ regeneration.

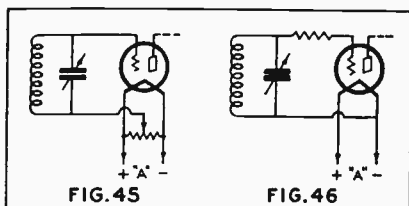

Two methods of controlling oscillations.

An advantage of the regenerative receiver is the fact that since the feed back tends or has the same effect as decreasing the resistance of the tuned circuit, it tunes sharper than a receiver not employing such feed back. However, this does not mean that it will discriminate between stations to a greater extent than other types of receivers; for it must be remembered that it is only sharp on the particular frequency to which it is tuned, and on no other.

A careful Service Man would require but a small amount of practice in order to fully appreciate the advantages to be gained by the use of regeneration. For short-wave work (in receivers

that are not superheterodynes) it is used to the exclusion of all others.

The Tuned R.F. Receiver

Radio frequency amplification, as is well known, increases the sensitivity of a receiver, while audio amplification increases the volume output. For reasonable distant reception, then, a certain amount of R.F. gain is desirable. The amount of amplification per stage (when three-element tubes are used) cannot be increased above a certain amount because energy is fed back from the plate circuit to the grid circuit via the internal capacity of the tube. As in the regenerative receiver, when this energy is great enough, the tube breaks into oscillation. To obtain a reasonable amount of gain, means must be adopted to minimize the effect of the feed back.

One of the earliest methods was to place a 400 ohm potentiometer across the filament terminals and connect the grid return to the arm of the potentiometer as shown in Fig. 45. When the arm was near the positive terminal of the filament, the resistance (grid to filament) of the tube decreased to such an extent that a great deal of the energy fed back was dissipated in this resistance; thus the tube ceased to oscillate. Rotating the arm toward the negative terminal increased the resistance and consequently the sensitivity of the receiver until it started to oscillate. In this manner, a control of the sensitivity and of the volume was secured. This method had to be discarded when amplifier design called for the insertion of a "C" battery, and when tubes were made with very high vacuums which increased the grid-filament resistance of the tube to such an extent that a reasonable control of oscillation could not be obtained.

A second method used to control oscillation, and one which is still in existence in some receivers, is to place a resistance in series with the tuned circuit and the grid as shown in Fig. 46. This resistance is usually made 800 ohms, which value does not detract from the sensitivity to a marked degree. No manual control is necessary, and, which is far more important, it functions independently of the frequency to which the set is tuned.

In view of the fact that feed back is caused by the grid-filament capacity of the tube, a receiver tends to oscillate more on the shorter waves (higher frequencies) than on the longer ones. This means that such a receiver is more sensitive on the shorter waves than on the longer ones, engineers have therefore taken means to equalize the response over the entire broadcast band. With the methods of controlling oscillation shown in Figs. 45 and 46, the position of the arm (in Fig. 45) had to be changed every time the receiver was tuned, and, in Fig. 46, the response on the higher wave lengths was decreased because of the presence of the resistor, since it was not usually required at the higher wave lengths. For the above reasons a system of neutralization was invented which obviated both of the methods described.

The Neurodyne

In the neurodyne method of balancing out the feed back, a small condenser C2 (Fig. 47) connects from the grid of the tube to be neutralized to a tap on the secondary of the transformer of the succeeding tube. Part of the energy in the grid circuit (the signal) flows through the small capacity C2 to the small coil L2, which, as stated before is part of the secondary of the R.F. transformer. The remainder of the signal is amplified by the tube and appears across L1. The two coils, L1 and L2, being coupled, neutralize one another, so that the effect of the feed back is nil.

In neutralizing a receiver (whether it be an I.F. or an R.F. stage) one of the filament prongs of the tube used in the stage being neutralized is cut so that the tube does not light (a burned-out tube cannot be used). A signal is tuned in, which will be heard because of the capacity of the tube, and then the neutralizing condenser C2 (which is about 50 mmf.) is adjusted slowly until the signal cannot be heard. The tuning of the set is again adjusted until the signal is heard and again it is balanced out. This is continued until the signal is completely balanced out. It may so happen that the signal cannot be balanced out completely; in which case the balancing condensers

are adjusted for a minimum response. This procedure is followed for all the stages in the amplifier, the process being repeated at least twice.

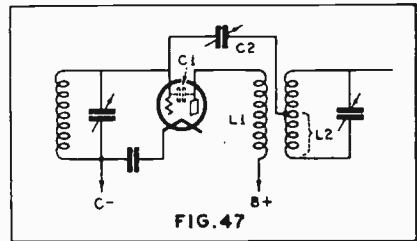

FIG. 47

Diagram showing the connections of the neutralizing condenser C2.

Another method of neutralization is the so-called Rice method. The method of connection is illustrated in Fig. 48. The theory underlying this method is simpler than for the one outlined above. The tuning coil L is tapped in the exact center as shown. Energy is fed from the plate to the grid via the internal capacity of the tube C1. Now since the coil is tapped in the exact center, the capacity of C2, the balancing condenser, is made equal to the capacity C1, by balancing the stage just as for the neurodyne method described above. When this condition exists, the voltage induced in L1 due to the capacity of the tube is equal to that induced in it by coil L2, which derives its energy from the plate circuit via C2.

Because a symmetrical arrangement of coils and condensers are used in the Rice method, the setting of C2 is, theoretically at least, independent of frequency. This is not true of the neurodyne method since the action depends upon mutual induction. It is regrettable that space does not permit a more lengthy discourse on this subject.

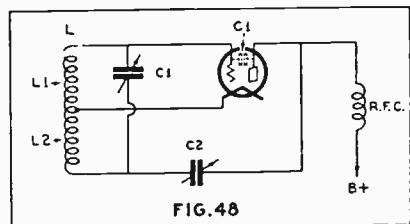

FIG. 48

Diagram illustrating the Rice method of balancing.

There are, of course, many more methods of neutralizing and balancing receivers, but in the fundamental concept, they are all the same—the object being to balance out the effects of capacity feedback. Since the advent of the four element tube, with its very small (comparatively) grid-plate capacity, balancing schemes have been discarded; and, it is the writer's belief that in the future the trend in tube design will be toward a decrease in tube capacities, which will mean the elimination of most of the troubles now encountered in receiver design.

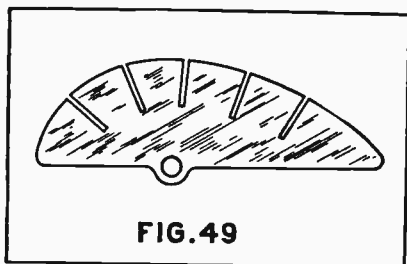

FIG. 49

A typical rotor end-plate in a variable condenser.

Lining the Tuning Condensers

With present model radio sets, single-control tuning is used to the exclusion of all others. It is therefore necessary, in order for maximum signal strength to be obtained and for a minimum of interference to be received, that all the tuning condensers in the receiver be tuned to the same frequency at any setting of the dial. Receivers that are out of line are bothered with interference, tune broadly and in some cases receive the same station at two or three points on the dial. This latter condition must not be confused with the "double-hump" reception which occurs when the volume control is turned too high on some types of screen-grid receivers. For the purpose of lining the tuning condensers in a set, there are connected across the tuning condensers small auxiliary or "padding" condensers. These are adjusted, by the method to be described later, until the signal is loudest. This type of adjustment does not hold for any setting of the condenser, so that many manufacturers construct the last plate in the tuning

condenser in sections, such as illustrated in Fig. 49. Each section is adjusted for a particular setting of the condenser, and, consequently, the tuning elements may be "lined-up" at all settings of the dial.

Another method that is used to some extent is a "bridge" arrangement depicted in Fig. 50. The tuning condenser is C1, while C1A, C2, and C2A are adjusting condensers. With low settings of C1, the parallel effect of C1A is large, and therefore C1A is used to line the unit at the low wave lengths, say 1500 kc. At the higher wave lengths, C2A is adjusted (C2 being fixed), since it is in series with the tuning condenser.

There is one general method in "lining up" receivers. The antenna and ground are removed from the set, and the ANT. and GND. posts of the R.F. oscillator are connected to the receiver. The plate lead to the detector (first detector in a superheterodyne) is broken and a low range (0-2 ma.) D.C. meter is inserted. The set is tuned to a low wave length, and then the oscillator dial is turned slowly until the meter shows the highest reading (in the case of a grid-leak and grid-condenser detector, turn the oscillator dial until the reading is at minimum). Adjust the signal output of the oscillator until the meter reads half scale, and then retune the set carefully until a maximum reading is secured. This latter precaution is taken in order to be sure that the set is tuned to the same frequency as the oscillator. The proper balancing condenser is now turned slowly until the reading is maximum (or minimum, depending upon the detector). The balancing or padding condensers on the second, third, etc. stage are then ad-

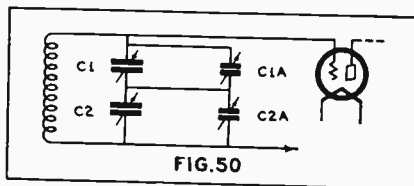

FIG. 50

Connections of padding condensers.

justed in the same manner. If at any time the pointer of the milliammeter goes off scale, then the output of the

oscillator should be reduced. This procedure should be gone over at least twice in order to secure satisfactory results. The dial of the set should now be tuned to the high wave bands and exactly the same routine followed. In cases where only one padding condenser in each R.F. stage is present, only one wave-length adjustment is possible, and the dial of the set should be tuned to the middle of the scale and the balancing done there.

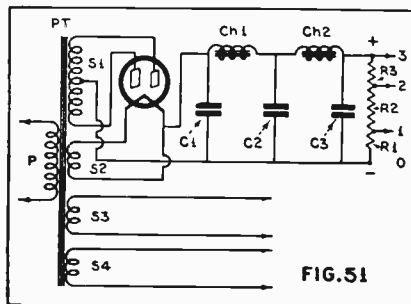

FIG. 51

Circuit showing the connections of a typical full-wave rectifier and filter system.

If it is inconvenient to break the plate lead, an analyzer may be used, the lowest scale on the meter being used. If the Service Man is in possession of an output meter, then it may be connected across the primary of the output transformer, and used in exactly the same manner as the milliammeter described above.

The Power Unit

The power unit of any receiver consists essentially of a power transformer, a rectifier tube, two chokes, three filter condensers, and a bleeder resistor, as indicated in Fig. 51. Several taps may be taken from the resistor as shown. Suppose that trouble is suspected in the power unit. How should one test it? The defects may be outlined in the following manner:

R1 Shorted

Set not connected to power unit, no voltage between 0 and 1; all other voltages higher than normal with set connected or not connected to power unit.

R1 Open

Set connected, voltage from 0 to 1, higher than normal; set disconnected

from power unit; voltage from 0 to 1, very high; 0-2, high; 0-3, high.

R2 Shorted

Set connected, voltage between 1 and 2 zero; set disconnected from power unit; voltage between 1 and 2, zero; all other voltages high.

R2 Open

Set connected, voltage between points 1 and 2 high; set disconnected from power unit, voltage between points 1 and 2, very high; 0-1, zero; 0-2, high; 0-3, high.

R3 Shorted

Set connected, voltage between 2 and 3 zero, all other voltages high; set disconnected from power unit; voltage between 2 and 3, zero; all other voltages high.

R3 Open

Set connected, voltage between 2 and 3 high; set disconnected from power unit; voltage from 0-1, zero; from 0-2, zero; from 0-3, high.

C3 Shorted

No voltage in set, CH.1 and CH.2 hot, rectifier tube red, transformer hot.

C2 Shorted

No voltage in set, CH.1 hot, CH.2 cool, rectifier tube red, transformer hot.

C1 Shorted

No voltage in set, CH.1 and CH.2 cool, rectifier tube very hot, transformer very hot.

CH.1 or CH.2 Partially Shorted

Voltages in receiver high, A.C. hum apparent.

CH.1 or CH.2 Grounded

Symptoms the same as for when C2 or C3 is shorted.

The effect of an open power transformer is simply a lack of voltage on the rectifier tube. A partially shorted secondary is noticed by a hum in the receiver; hot transformer, especially surrounding the section that is shorted; and reduced output voltage.

Superheterodyne Receivers

Because of the fact that R.F. amplifiers break into uncontrollable oscillation when too much gain is attempted, mainly because of inter-electrode capacity, a very ingenious scheme has been invented that minimizes the tendency to oscillate. Since the feed back through a tube diminishes as the fre-

quency is lowered, Major Armstrong suggested the idea of having a local oscillator in a receiver that will react with the incoming signal in such a manner that the resultant signal is reduced in frequency. This new signal may now be amplified in the usual manner, and, because of the diminished frequency at which amplification is now taking place, the amount of amplification that may be obtained in an amplifier without oscillation can be increased.

It is clear, then, that in order for a resultant low frequency to be generated, the frequency of the local oscillator must differ from that of the desired signal by an amount equal to the low-frequency at which amplification is to take place. This low frequency is called the intermediate frequency and is abbreviated I.F. A distinct advantage of such a receiver is the fact that the intermediate frequency may be kept the same regardless of tuning of the set over the broadest band, and consequently no tuning condensers are required in the I.F. amplifier stages. In this manner the number of tuned elements may be reduced to a minimum although the number of pre-detector stages of amplification is large.

A general description of the modern superheterodyne is as follows: A signal is received by the antenna and amplified by one or two stages of R.F. amplification. An oscillator, having its tuning condenser on the same shaft as the R.F. tuning condensers, generates a voltage at a frequency differing from the signal frequency by the I.F., which in modern receivers is 175 kc. In the grid circuit of the tube following the R.F. amplifier, which is called the mixer, demodulator, or first detector, the oscillator voltage is connected in series with the signal voltage, and the resultant voltage actuates the tube. Now this tube must be used as a detector in order that the signal that appears in the plate circuit be the difference between the two—hence the name, first detector. The signal is now amplified by two or three stages of I.F., rectified by a second detector, and then fed to the audio amplifier.

From the above brief description, several important facts present themselves, which are as follows:

(1) How may the I.F. transformers be adjusted to their rated intermediate frequency?

(2) How may the oscillator be adjusted so that the difference frequency is always constant, i.e., 175 kc.

(3) What procedure should be followed in lining up a "super"?

Without entering into a lengthy technical description of why a certain procedure is necessary, let it be stated that first it is imperative that the I.F. transformers be lined by means of a separate oscillator; second, the R.F. tuning condensers lined, and third, the oscillator condenser adjusted.

How to Line the I.F. Stages

First, remove the oscillator and all the R.F. tubes from their sockets, leaving only the first detector, the I.F., the second detector, and, if desired, the audio amplifier tubes in their sockets. Connect the two terminals of the separate I.F. oscillator to the grid and cathode terminals of the first detector, after first disconnecting the secondary of the R.F. transformer of the first detector tube. A milliammeter is next connected in series with the plate of the second detector, or an output meter may be connected across the terminals of the output transformer as previously described under "Lining up the R.F. Stages."

The oscillator is then tuned to 175 kc. and the "trimmer" condensers are tuned on each of the I.F. transformers in turn, until the reading of the meter is a maximum (or a minimum if a grid-leak and grid-condenser detector is used). This process should be repeated at least twice in order to insure accuracy. In cases where it is inconvenient to remove the secondary of the transformer feeding the first detector, the two terminals of the oscillator may be connected to a small coil of about five turns, and this coil coupled closely to the grid coil of the first detector.

With the I.F. transformers correctly lined, the tubes may break into oscillation (even at 175 kc., especially if three-element tubes are used). The next procedure is to neutralize each stage in the same manner as described for R.F. stages; and, when this is completed the lining-up process should be repeated. The entire routine may have

to be gone over several times before the amplifier is acting normal, but the effort will be compensated by the very stable results secured.

Lining the Oscillator Condenser

With the I.F. units in line, the next procedure is to adjust the R.F. tuning condensers; which is accomplished in the manner previously described. It is apparent that when the I.F. units and the R.F. condensers are in line, maximum signal strength will be obtained when the oscillator frequency is separated from the signal frequency by exactly 175 kc.

Now this intermediate frequency of 175 kc. may be obtained either with the oscillator 175 kc. above or below the signal frequency. Modern practice dictates that it shall be tuned above the signal frequency in order to minimize interference.

Our milliammeter is again connected in the plate circuit of the second detector, all the tubes in the receiver are inserted, and the R.F. oscillator terminals connected to the ANT. and GND. posts of the receiver in the usual manner. The receiver is tuned to a low wave length, the oscillator tuning condenser is loosened from its shaft and slowly rotated until maximum response on the meter is noted. The R.F. tuning condensers are then rotated slowly to determine if there is any increase in response, and should be left at the maximum point. It might be wise to tune carefully the external oscillator at this time to be sure of a maximum deflection of the meter.

The oscillator condenser in the receiver is turned very slowly for maximum response. Two points on this condenser will be found. Choose the one with the minimum meshing of condenser plates. The same procedure is followed for a higher wave length.

The receiver is now "lined up" and "ready to go".

The Audio Amplifier

The methods to be followed in servicing an audio amplifier are exactly the same as for the R.F. amplifier heretofore described. The fundamental purpose of such an amplifier is to increase the strength of the signal after it is rectified. It does not increase the sensitivity of a receiver—as many peo-

ple are lead to believe. Just because a set has enormous volume, does not mean that it can receive distant stations. The amount of amplification that may be desired is limited by two factors; the size of the room and the noise level. The latter factor is controllable only by very careful design, which is beyond the scope of this book.

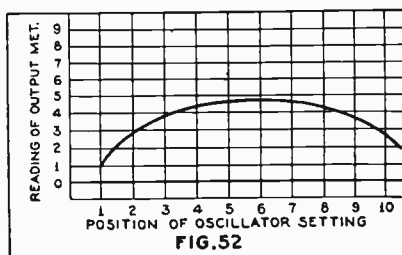

FIG. 5.2

Response curve of an audio amplifier.

An interesting experiment that the experimenter or Service Man may perform is to compare the quality of output of different amplifiers. All the apparatus that is required is an audio oscillator, such as described in this chapter, and two output meters. The output of the audio oscillator is connected across the primary of the first A.F. transformer; all the tubes may be left in their sockets if so desired. One output meter is connected directly across the output of the oscillator and the other is connected across the voice coil of the speaker or across the primary of the output transformer.

The oscillator is adjusted for a low note, the lowest possible, and the reading of the first output meter noted. The volume control on the oscillator should now be adjusted for a convenient reading with a reasonable response from the speaker. The reading of the second output meter is noted and jotted down on a piece of paper. The pitch or frequency of the oscillator is raised a little, and the volume control adjusted until the reading of the first output meter is exactly the same as before; the reading of the second output meter is again noted. This procedure should be followed until the entire audio frequency has been covered—say from 50 to 5000 cycles per second.

The results should be plotted on a chart as illustrated in Fig. 52. If the amplifier is a good one, the curve should appear somewhat as illustrated. When comparing amplifiers, another similar

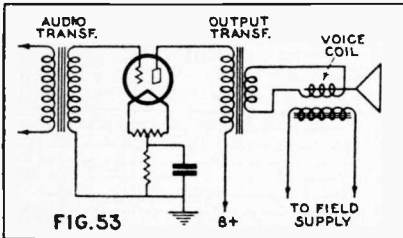

Connections of a standard audio amplifier showing the location of audio and output transformers.

curve is drawn, but care should be taken that corresponding positions of the oscillator's volume control, for every setting, is used in both cases, or else the comparison will mean nothing.

With all leads to the output meter as short as possible, some very interesting results may be obtained.

Conventional Audio Amplifiers

Practically all audio amplifiers are equipped with output transformers. Their use is necessary, not only because the D.C. component of the plate current flows through the transformer instead of the speaker, but also because the impedance (combination of resistance and reactance) of the voice coil of the usual dynamic speaker is far too low to be directly inserted in the plate circuit, a transformer must be used to raise this impedance to the required value—twice the tube's impedance in three-element tubes and one-fifth the impedance in pentodes. The schematic diagram of the usual amplifier is indicated in Fig. 53.

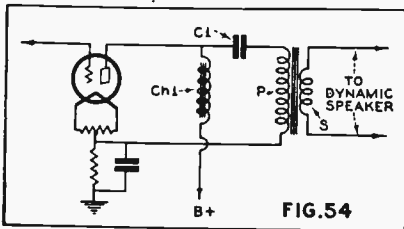

A parallel-fed output stage. The condenser C1 may resonate with the primary of the output transformer to any desired audio frequency.

In certain cases where it is desirable to tune the amplifier in order to increase the response of a certain frequency, a choke is inserted in the plate circuit as indicated in Fig. 54. The

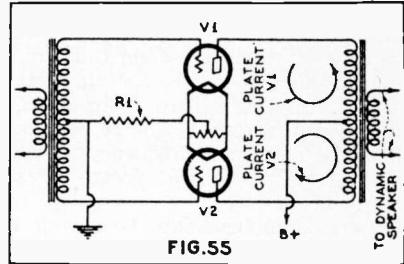

Typical push-pull amplifier.

value of condenser C1 together with the inductance of the primary of the output transformer is tuned to the resonating frequency. Another advantage of this method of connection is the fact that the D.C. component of the output does not flow through the transformer. This is distinctively advantageous where a slightly excessive amount of flux (magnetism) in the core is liable to cause saturation of the core, with a consequent reduction in inductance.

A push-pull connection, Fig. 55, is very popular at present due to the fact that the even harmonics generated in the tube when it is distorting, cancel out; and consequently, the load impedance may be made equal to the tube impedance and greater output secured. It should be noted that the plate currents of each tube flow in opposite directions through the output transformer and therefore the D.C. flux in the core is always zero. This permits the use of

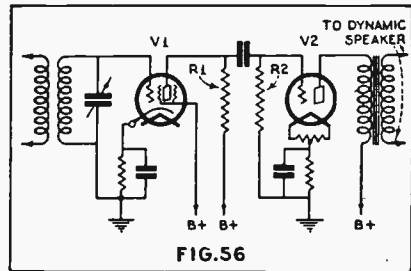

A screen-grid power detector feeding into an audio amplifier.

a better grade of iron than is possible when D.C. flux is present. Another important feature is the fact that there is no bypass condenser necessary across the "C" bias resistor. An elementary examination of the theory of this type of amplifier will show that when the plate current of one tube is increasing, then the plate current of the other is decreasing by the same amount and at the same rate; the net current through the resistor at all times being constant; no bypass condenser is therefore necessary.

Detectors

In some types of receivers the output of a linear detector feeds directly into the power tube as shown in Fig. 56. This is a resistance-coupled stage and is used only when a screen-grid tube is

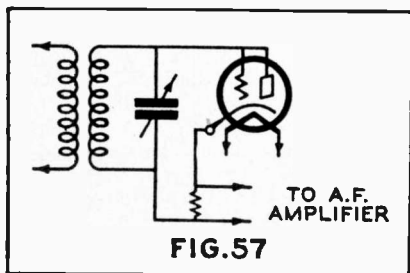

Connections of a two-element detector. Note the similarity between this and the half-wave rectifier used in the power unit.

the detector. It is more economical to use a coupling transformer when a three-element tube is the detector because of the additional gain that is secured. The remainder of the circuit is self-explanatory.

The old adage "History repeats itself", seems to hold true in radio as well as in the academic subjects. In 1914, before the broadcast era, two element detectors were being used. Now in 1932 they have come into vogue as the latest in receiver design. The simple schematic circuit is illustrated in Fig. 57. A three-element tube with its grid and plate connected together is used as the detector. Note the lack of plate voltage and the unique method of connection.

Its brother, the Duo-Diode has just been introduced at this writing. The schematic circuit is depicted in Fig. 58.

It is simply a full-wave rectifier similar to the '80 type used in the power unit.

With the brief description of the above types of detectors, the question naturally arises as to why they are used. When radio was in its early stages, the factor of sensitivity was greater than any other. Engineers were at work constantly to develop more sensitive receivers, and they surely have accomplished their purpose. With the sensitivity problem settled, they turned their attention to quality, and no one will deny the fact that remarkable strides have been made along this direction recently.

One of the contributions to this improvement in quality was the elimination of one of the audio stages. The

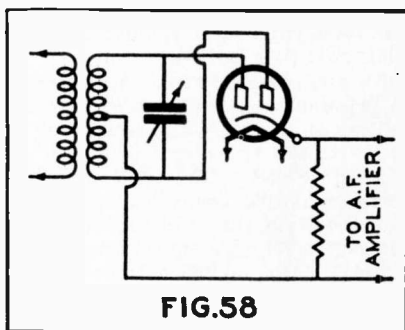

The duo-diode detector—a full wave rectifier.

more amplification in the audio end of the receiver, the greater the distortion. Since present receivers have sufficient gain in the R.F. stages for all practical purposes, and since the "linear" detector is capable of handling this large voltage, there is no need for two stages of audio amplification.

The diode and Duo-Diode detectors are capable of handling far more voltage without distortion than any other type, and therefore are used in very sensitive receivers. For very weak signals they are worthless. However, modern receivers have sufficient gain to obviate the latter difficulty.

THE ANALYZER

Figure 38 depicted an analyzer that was suitable for testing 4-prong tubes. In view of the rather extensive use of 5-prong tubes, it was thought advis-

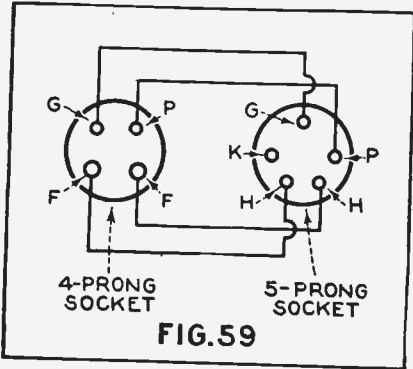

The five-prong socket on the right connects to the four-prong socket as shown in order to test heater-type tubes.

able to include an additional socket for testing these tubes. At the same time, additional connections may be added in order to test screen-grid tubes. Fig. 59 shows the diagram of connections of the additional fifth socket.

As may easily be seen by reference to the diagram, the "heater" prongs of the 5-prong socket are connected directly to the "filament" prongs of the 4-prong socket. The grid and plate connections are connected together as shown. Note that the "K" (cathode) connection remains unconnected. It goes directly to the switch as shown in Fig. 38.

Since the plug of the analyzer has but four prongs, an adapter must be used when 5-prong tubes are to be tested. It is desirable to change the analyzer cable for a 5-wire type; the connections being indicated in Fig. 60. With this new cable, a 4-prong adapter must be used when testing 4-prong tubes.

For testing screen-grid tubes, a sixth wire must be added to the cable, as

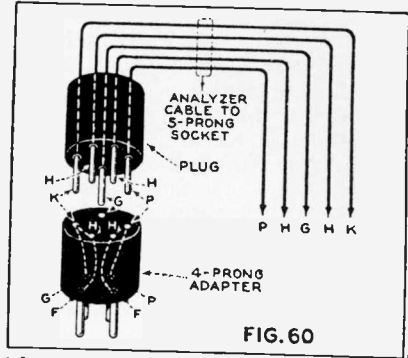

Adapter and cable used for testing heater-type tubes. Also see Fig. 61 below. The adapter used in both figures is the same.

shown in Fig. 61. This cable may be added to the five-wire cable described above, if desired. The adapter for testing 4-prong tubes is the same as shown in Fig. 60. The only change between the cable of Fig. 60 and that of Fig. 61 is the addition of another wire connected to caps designed to fit the plug on the top of the tube.

Since screen-grid tubes are being tested, means must be provided to measure the screen-grid voltage and current. The additional contacts necessary are indicated in Fig. 62. A 50,000-ohm resistance has been added in order to increase the range of the meter. The rotary switch, SW.1 in Fig. 38, usually has more than the required amount of contacts, so that the additional change may easily be made.

For the measurement of screen-grid current, SW14 in Fig. 38, is thrown to the left. This connects the grid multipliers and shunts to the screen-grid of the tube as shown, which also connects to the screen-grid wire leading from the cable as shown in Fig. 61.

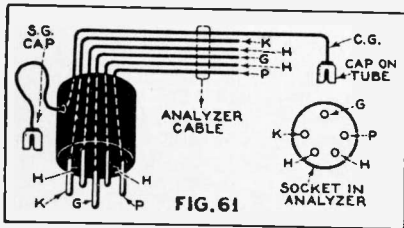

Analyzer cable used for testing screen-grid tubes. The cable leads are marked and correspond to the socket markings also given.

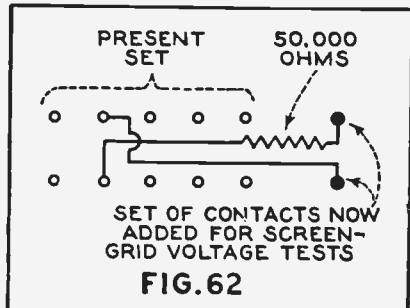

Additional set of contacts used for screen-grid voltage tests.

**--for the real
servicing "dope"
you can't find a
better book!**



NO other radio book is comparable to the 1935 OFFICIAL RADIO SERVICE MANUAL. In contents, in style of printing, in grade of paper, in illustrations, there has never been published such a comprehensive volume.

The 1935 Manual contains over a thousand pages—yet it is only 1¼ inches thick because it is printed on a special Bible stock which is an exceptionally good stock, yet one of the thinnest and most durable papers. This 1935 Manual is the most authentic and elaborate service guide ever used in the radio industry. Service Men and dealers who use this

1935 Manual are astonished by finding in it such a wealth of profitable service information which has never been published before.

Contents of the 1935 Manual

Over 1,000 pages full of diagrams and essential information of manufactured receivers—only data of real use in servicing is included. This new Manual is really portable since it will be extremely thin and light as well. ● Volume V continues where the preceding manual left off. ● Many circuits of old sets are included. ● Service Men know every set has certain weak points which are really the cause of trouble. Wherever the information could be obtained, these weaknesses with their cures are printed right with the circuits. This is an entirely new and valuable addition to the Manual. ● All the latest receivers are included—all-wave sets, short-wave sets, auto-radio sets, midget and cigar-box sets, etc., as well as P.A. amplifiers and equipment, and commercial servicing instruments. ● The cumulative index is even more complete than before: including cross-reference to sets sold under different names and type numbers. ● Volume V includes resistance data; socket layout; I.F. data; and voltage data. ● Tube data on latest tubes. ● Free question and answer service—as included in our last three manuals.

OVER 1,000 PAGES
Over 3,000 Illustrations

Flexible, Looseleaf Leatherette Covers

Size 9x12

Yet only 1¼" thick

Send remittance of \$7.00 in form of check or money order for your copy of the 1935 OFFICIAL RADIO SERVICE MANUAL. Register letter if it contains cash or currency. THE MANUAL IS SENT TO YOU POSTAGE PREPAID.

GERNSBACK PUBLICATIONS, Inc.

99PR HUDSON STREET

NEW YORK, N. Y.

What Others Say about this Manual:

Norfolk, Va.
I received the OFFICIAL RADIO SERVICE MANUALS ordered as per my letter of March 26, 1935 in good order. I am very well pleased with same as it is a very valuable Radio Service data reference and guide.
Arthur J. Freney.

Detroit, Mich.
Received your 1935 OFFICIAL RADIO SERVICE MANUAL and certainly is something to rave about. It's great.
A. Hedke.

Stillwater, Maine
I have received the 1935 Manual, and I am very much pleased with my investment.
Franklin J. Holmes.

Swift Current, Saskatchewan, Canada.
I beg to acknowledge receipt of my 1935 issue of the OFFICIAL RADIO SERVICE MANUAL. Your Manual is fine, and would not be without any of them. The Manuals may be improved for Canadian use.
A. M. Ford.

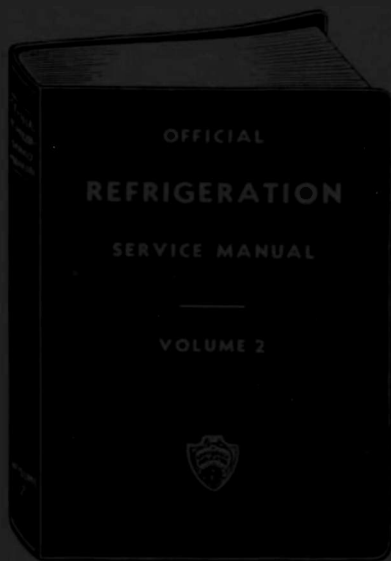

THIS IS THE ONLY COMPLETE
REFRIGERATION SERVICE
MANUAL EVER PUBLISHED - - -

*Entirely New Material
from Cover to Cover!*

\$5⁰⁰ NET

VOLUME TWO

OF THE *Official*
OVER 352 PAGES
OVER 300 DIAGRAMS
Complete Service Data
Flexible Looseleaf Binder

REFRIGERATION SERVICE MANUAL

This Manual forms a companion and supplement to the previous OFFICIAL REFRIGERATION SERVICE MANUAL (Volume 1), since all data in the 1935 volume is entirely new.

The OFFICIAL REFRIGERATION SERVICE MANUAL was the first refrigeration Service Manual ever published—and now this new volume has been prepared so that they both form a comprehensive library of information on this rapidly growing refrigeration industry.

Detailed information on servicing; outlines of theory and methods of operation; instructions for the handling of refrigerants; charging systems; diagnosing troubles; trouble sheets; electrical hook-ups; charges of oil and refrigerant in different models; advice on the selection of site; placement and temperature required by foods; valve settings; compressor construction; faults; overhauling; estimating coil and machine loads; are encompassed in this new volume of refrigeration servicing.

This edition is printed on a Special Hulse Book which is extremely thin, yet durable.
The special system of paper makes the new Refrigeration Manual most easy to handle.

List of Contents in the Second Volume of the "Official Refrigeration Service Manual"

History
Food Preservation
Theory and Fundamental Laws
Methods of Refrigeration
Refrigerants, Lubricants and
Brines
Handling, Testing and Storage
of Refrigerants
Compression Systems of
Refrigeration
Liquid Throttle Devices and
Valves
Refrigeration Systems
Electric Control Devices
Compressors, Types, Seals,
Valves, Capacities, Service

Evaporators and Cooling Units
Service Tools, Equipment and
Tool Manipulation
Commercial Unit Specifications
and Service
Household Unit Specifications
and Service
Servicing Refrigerating
Apparatus
Servicing Low Side Float
Valve Systems
Servicing High Side Float
Valve Systems

Servicing Expansion Valve
Systems
Servicing Thermostatic Valve
Systems
Servicing Restrictor and
Capillary Tube Systems
Charging Systems with
Refrigerant
Electrical Service: Motors,
Fuses, Hottings
Service Kits
Estimating Refrigeration Loads,
Coil and Machine Sizes
Miscellaneous Data

Send remittance of \$5.00 in form of check or money order for your copy of the OFFICIAL REFRIGERATION SERVICE MANUAL, Volume 2. Delivery takes 10 to 15 working days if necessary. THE MANUAL IS SENT TO YOU POSTAGE PREPAID.

GERNSBACK PUBLICATIONS, Inc. 49PR HUDSON STREET
NEW YORK, N. Y.