

\$3.45

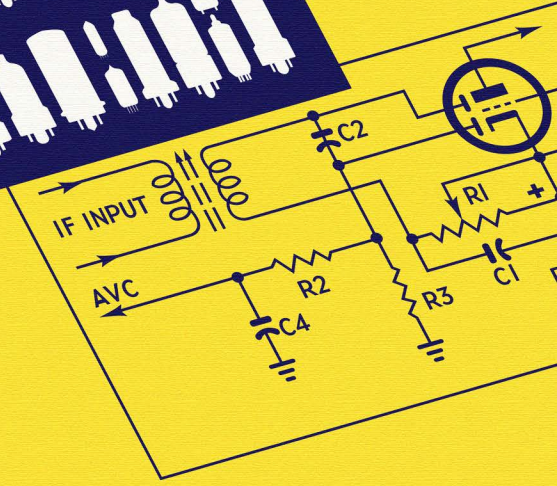

TUBES AND CIRCUITS

George J. Christ



GERNSBACK LIBRARY

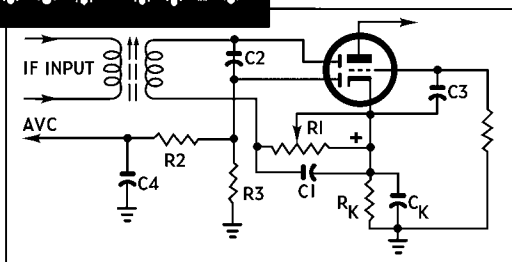
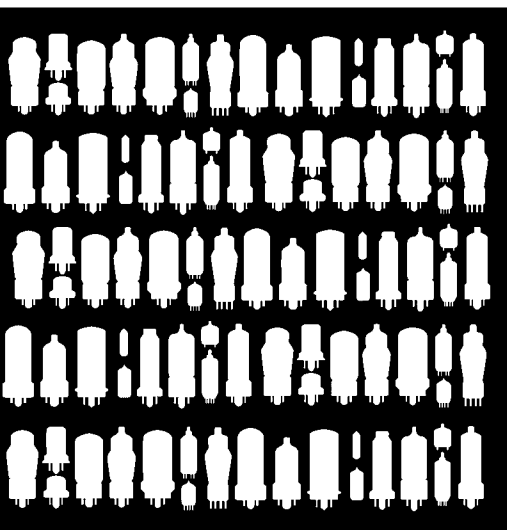

TUBES AND CIRCUITS

GEORGE J. CHRIST

*Adjunct Assistant Professor
of Applied Science
New York University*

*Transmission Engineer—
New York Telephone Company*

**GERNSBACK LIBRARY, Inc.
New York 11, N. Y.**



© 1960 Gernsback Library, Inc.
All rights reserved under Universal
International, and Pan-American
Copyright Conventions.

Library of Congress Catalog Card No. 57-9008

contents

chapter

page

1

Electronics 7
Boundaries of electrical conductors. Electrons in motion. Electrical pressure. Electron emission. "Free" electrons. Thermionic emission. Pure tungsten emitters. Thoriated tungsten cathodes. Emission surplus. Vacuum-tube cathodes. Oxide-coated emitters. Secondary emission. Electron multiplier. Field emission. Cold-cathode gas tubes. Photoelectric emission. Control of electrons in motion. Electrostatic deflection. Magnetic deflection. Legend.

2

Vacuum-tube characteristics 19
Diodes. Space-charge effect. Temperature saturation. Static plate resistance. Triodes. "Turned-back" electrons. Static characteristics. Amplification factor. Transfer characteristics. Amplification. Dynamic resistance. Tube merit. Mutual conductance. Load lines. Grid-leak resistance. Dynamic curves. Phase shifts. Dynamic plate resistance. Kirchhoff's first law. Tetrodes. "Instability" range. Pentodes. Suppressor grid. Changing plate currents and grid voltages.

3

Vacuum-diode applications 43
Power supply rectifiers. Half- and full-wave rectifiers. Voltage doubler. Ripple factor. Peak inverse voltage. Bleeder and voltage divider. Regulation. High-voltage power supplies. TV flyback system. Boost B-plus voltage. Autotransformer high-voltage system. Vibrator power supplies. Diode detectors. AM detection. AVC. Discriminator. Phase shifts. Deviation ratio. Ratio detector.

4

Vacuum-tube amplifiers 69
Triode amplifiers. Power amplification. Distortion. Class-A amplifiers. Power diagram. Plate efficiency. Class-AB amplifiers—push-pull operation. Parallel operation. Class-B operation. Class-C amplifiers. Transformer-coupled amplifiers. Pentode amplifiers. Cutoff characteristics. Video amplifiers. Coupled circuits. Power pentodes—beam power tubes. Phase inverter. Negative feedback. Cathode follower. Input admittance. The limiter. Grid-bias arrangements.

5

Vacuum-tube oscillators 127
Sine-wave oscillators. Grid-leak bias. Intermittent oscillation. Frequency stability. Electron-coupled oscillator. Tuned-plate-tuned-grid oscillator. Colpitts oscillator. Crystal oscillators. Frequency multiplication. The crystal oscillator in TV. Reactance tube. R-C oscillators. Sawtooth generator. Blocking oscillator. The multivibrator. Pulse generators. Peak-clipping circuit. Sync separator. Dynatron or negative-resistance oscillators.

6

Miscellaneous applications 145

Dc restorer. Agc. Amplitude modulation. Grid modulator circuit. Triode detectors. Plate and grid detection. Regenerative detector. Gated amplifiers. Color killer and gated amplifier. Bandpass amplifier. Burst amplifier. Reactance tube. Hartley oscillator. Automatic frequency control. Phase-splitting network. Mixers and converters. Triode-pentode mixer. The gated-beam detector. Quadrature coil. Limiter and quadrature grids.

7

Multi-purpose tubes 161

Duo-diodes. Automatic frequency control. Triple diodes. Combined AM detector and FM discriminator. Duo-triodes. Oscillator-mixer. Duo-diode triodes. Triple-diode triodes. Diode-tetrodes. Audio drivers. Triode tetrodes. Diode pentode. Agc amplifier and detector. Triode pentodes. Color killer and bandpass amplifier. Dual pentode. Combined agc amplifier, sync separator and noise gate.

8

Gas tubes 167

Cold-cathode diodes. Field-emission principle. "Townsend discharge." Gas ionization. Thermionic gas diode. Space charge. Gas molecules. Saturation. Cathode sheath. Positive-ion sheath. Gas diode rectifiers. Plasma. Ignitor anode. Mercury-arc rectifier. Peak inverse voltage rating. Glow discharge. Thyratrons. Relay or trigger tube. Sawtooth oscillators. Gas-tube relaxation oscillator.

9

Photoelectric emission 173

The cathode-ray tube. Electrostatic deflection. Electromagnetic deflection. Electron-ray tubes. Fluorescent targets. "Shadow" electrode. Photoelectric tube. Captive electrons. Light spectrum. Cesium-, sodium- and rubidium-coated cathodes. Lithium phototube. Image orthicon. Principle of secondary-emission multiplication. Target mosaic. The color kinescope. Special color phosphors. Miscellaneous picture tubes for color TV.

10

Industrial applications 183

Basic control circuits. Phototube-controlled thyatron circuit. Phototube-controlled triode circuit. Light-pulse-sensitive phototube. Counting circuits. Automatic door openers. Repeating control circuits. Thyatron critical grid-voltage. Thyatron firing point. Phase difference. Phototube-controlled thyatron circuit (the Photo-Troller). Electronic timing. Thyatron and control relay timing circuit.

introduction

IN this scientific age, we are constantly confronted with new products, the result of perhaps years of development by our engineers. In electronics, the majority of these, ranging from the electronic brain or pilotless plane to the house radio or TV set, function because the tiny electron is under man's control; it follows instructions and pursues the course to which it is assigned. Control over the electron is exercised primarily in radio tubes, and their many applications make it necessary to have a tube manual of the various types. Each has its particular place in a circuit and each requires certain specified operating voltages for proper operation.

Practicing technicians, through experience, may recognize circuit troubles that follow similar patterns and so they easily clear the condition by tube parts or replacement. The unusual trouble such as poor quality, difficult tuning, picture distortion in TV etc. may not be easy to find unless the technician has a thorough understanding of what to expect from each tube in the circuit. A trial-and-error method may not work. Even though the tube is good, it cannot do its job if the *proper* voltages are not applied or the tube is improperly loaded.

On the assumption that the practicing technician either needs or would like additional working knowledge of electronic circuits and the basic theory behind their operation, this book covers the subject of electron tubes and circuits with emphasis on the practical approach. The reader is taken step by step through the theory of electron behavior, the first part of the book covering basic electronics and how the electron behaves under the influence of heat, electric or magnetic fields. The method by which electricity is converted into light as well as the phenomenon of converting light into electricity are also considered broadly at first and then in some detail later. While the first three methods of activating electrons is important, the fourth, having to do with light, is perhaps the one which is most evident in its application to the home TV set and of course the TV camera tube at the studio. The importance of understanding these fundamentals is stressed by referring to practical applications. Thus, by becoming thoroughly familiar with basic circuit theory, the reader finds it easier

to understand the more involved circuits discussed later in the book. The TV set itself combines many facets of electron circuit theory and, with color television a reality, such basic understanding is essential.

Before getting into a detailed discussion of more complicated circuits, the basic characteristics of electronic tubes are discussed in the early chapters, starting with the simple diode and progressing through multi-element tubes. Their applications to practical circuits are covered by direct reference to data taken from tube manuals. The various tube types listed in manuals are discussed and the need for many of the same type and many different types are explained. For example, both triodes and pentodes may be classified as audio, radio-frequency or video amplifiers while at the same time they may be classified as voltage or power amplifiers. The need for many of the multi-element tubes is explained and the reason for their use in a typical circuit is also covered. Improper use of tubes and other components in electronic circuits may cause distortion; the reason for and reduction of distortion is also discussed. The fact that the electron tube can amplify is the basic characteristic that enables it to "oscillate" in a circuit so designed and this principle is made use of extensively in radio and TV circuits.

Electron tubes with a small amount of inert gas inserted in the glass envelope are called "gas" rather than vacuum tubes. This type functions entirely differently from vacuum tubes and must be treated separately. The basic theory of operation is covered along with circuit application. The tube with gas added becomes a switch rather than an amplifier, thus presenting a new concept. Detailed discussion on phototubes with particular reference to television camera tubes and cathode-ray picture tubes are covered in some detail to give the reader a complete picture of how the live show at the studio can be watched at home on the picture tube at the same time that it is happening. Use of the cathode-ray-tube principle has been adapted for memory storage and this new device is explained from a practical point of view. Industrial application of electronics for photoelectric control is discussed in the final chapter in the book to give the reader a basic understanding of industrial applications of electronics.

The entire book discusses basic theory by adhering closely to the practical side of the problem and it is hoped that the text can serve as a ready reference to the technician who wishes to base his knowledge of radio circuits on a thorough understanding of fundamental principles. The most complicated electronic circuit can always be broken down into its component parts, which in themselves are relatively simple combinations of resistance, capacitance and inductance combined in tube circuits. The technician who is thoroughly grounded in basic principles finds himself better qualified to clear circuit troubles by a logical, straightforward analysis of the circuit.

GEORGE CHRIST

electronics

ELECTRIC current flow has long been identified as a movement of electrons. Before the age of electronics a flow of current was thought of as confined to electron movement within the boundaries of electrical conductors. Under these limitations, man learned how to make the electron work for him by directing its flow to such apparatus as electric lights and electrical machinery. As long as the electron was held within the limits of the conductor, man had no difficulty. When it escaped its metal boundaries, the electron became troublesome. It could make its own path and produce arcing between conductors or parts of electrical apparatus. The "loosed" electron was uncontrollable and chose its own rampant path in much the same way that a flash of lightning in an electrical storm finds its own unpredictable route between the clouds and ground.

These phenomena were the earliest evidences of electronic conduction in space. It remained for scientists to release the electron deliberately at will and control its motion before electronics, as we know it today, could be born. This becomes quite evident when we consider the definition of "electronics" as the science of dealing with the conduction of electricity through solid-state materials, vacuum or gas.

Perhaps the earliest form of controlled electronic conduction was found in the arc lamp where the arcing was deliberate and confined within the lamp itself. But it was not until many years later that the electron was put to use in a wide variety of ways. By harnessing the electron, wide ranges of power came under control, from the low-level signal input to a radio receiver to the extremely high power generated in a mercury-arc rectifier.

Electrons in motion

When an electron moves, it produces a current flow, the motion of the electron itself being the electric current. In electrical circuit conductors, "free electrons" associated with the individual atoms of the metal are the particles that move when an "electrical pressure" (voltage) is applied. These electrons are elementary negatively charged particles and are very light in weight. Because their charge is extremely high compared to their weight (very high ratio of charge to mass), the electron is able to act with extreme agility, making it possible to start or stop an electric current in a circuit in as small a time interval as a fraction of a microsecond.

The number of free electrons within the metallic atom determines the conductivity of the metal; the greater the conductivity, the greater the number of free electrons. Insulators have very few free electrons. Because electrons are negative particles, they repel each other and consequently acquire a random motion within the relatively narrow confines of their own or adjacent atoms. When a potential is applied to a closed electrical circuit, the negatively charged electrons "spurt" toward the positive side of the applied voltage. Because the electron is so very light and can move very swiftly, it would like to take off immediately and arrive at the attractive positive potential within a fraction of a microsecond. However, the electron finds conditions very crowded—other electrons are in the way—so the best it can do is follow the general trend of about a few centimeters in a second, eventually reaching the positive terminal of the battery or power supply.

The number of electrons that pass along the conductor in a given length of time is a measure of the amount of current flow. If the potential of the circuit is increased, the electrons move faster and cause a greater current flow. A conductor with less conductivity (higher resistance) has less electrons to move and even though the same voltage is applied, the current is less.

Although the rate of travel of electrons is relatively slow, the first shove or pulse (which is really the first evidence of current flow) is felt instantaneously when the circuit is closed. This may be more readily understood if we compare conditions in the wire or conductor with the situation in a crowded bus or railroad train. If the standees are packed in tightly and the man at the rear wishes to get off and starts pushing, the person facing the door would immediately be pushed out the door if the people in between offered no resistance to the initial shove. So it is in the conductor but to a much greater degree. The crowded electrons are almost weightless and offer no resistance to the initial surge when the circuit is closed. Consequently the pulse on closing the circuit is instantaneously transmitted from one end of the circuit to the other. If it weren't for this inherent characteristic of circuit behavior, the generation of pulses for use in various electronic circuits such as television would not be possible.

Electron emission

"Free electrons" are confined to the conductor itself and do not escape from the metal. They are completely surrounded by other negatively charged electrons and acquire a random motion, moving aimlessly about within the confines of the conductor, repelling each other. Under normal static conditions, when no potential is applied to the circuit, the free electrons do not move very far from their parent atom because its positive nucleus acts as the basic attractive force.

As the random motion of the free electrons in the atoms near the metal surface forces them toward the surface, they find themselves pulled back by the positive force of the nucleus because there is no attraction beyond the metal. The action is similar to a ball attached to an elastic band; the farther the ball stretches the elastic, the greater the force to pull it back. In this manner, the electron remains under the influence of its own or adjacent positive nucleus until it attains enough speed to overcome this restraining force. The limiting effect which prevents the free electron from escaping the metal boundary can be looked upon as a surface barrier which acts to hold the electron within the confines of the metal. Speeding up the electron's motion (giving it more energy) enables it to pull away from the influence of the positive nucleus of the atom and break through the surface barrier to the surrounding space where it can be put to use. Because the electron must break loose from the metal where it is held by piercing this surface barrier, the job would be made easier if a metal with a low surface-barrier resistance were used. In practice, the radio tube does just this. However, there are several ways to release the electron. Not only is the electron given more energy but the metal surface itself can be treated. A special metallic surface can be used to make it a little easier for the electron to escape.

Thermionic emission

There are a number of ways to give the electron more energy but the use of heat is by far the most common. When the temperature of a metal is raised, the energy of some of the electrons increases, giving them enough speed to break through the surface barrier and escape. They are literally "boiled off" the metal. The liberation of electrons by this method is called *thermionic emission*. Practically all receiving type tubes with the exception of a few cold-cathode types utilize this method of emitting electrons.

To put the emitted electrons to work, they must be free to move under proper direction. Depending on the job to be done, small or great quantities of current must be provided; hence the number of emitted electrons may be either small or enormous. The best way to do the job is to enclose the electron source, in this case the emitter

itself, within a glass envelope and except in special cases completely evacuate all gas. (Radio tubes, of course, are constructed in this manner.)

The emitter, one of the electrodes of the vacuum tube, is called the cathode and the electrons may be boiled off by heating it either directly or indirectly. Directly heated cathodes, called filaments, use a material that must be a relatively good conductor but as such is inherently a poor emitter of electrons. Hence filament type tubes must be operated at high temperatures to emit a sufficient number of electrons. Indirectly heated cathodes, on the other hand, do not carry any current, hence do not have to be good conductors. Therefore these indirectly heated or *heater* type cathodes can be made of a material that will emit large quantities of electrons at lower temperatures with no regard for their electrical conductivity.

Vacuum-tube applications are many and varied and the amount of power handled can be as little as a few milliwatts or as much as several kilowatts. The number of electrons emitted determines the current and hence the power-handling capacity of the tube. In tube design, emitter materials capable of yielding great numbers of electrons when heated to specified temperatures are suitable for use in transmitting tubes where large amounts of power are required. Conversely, receiving type tubes which require much less current can use a metal or combination of metals that will deliver a smaller but adequate number of electrons.

Tungsten emitters are used extensively in high-power vacuum tubes. Because tungsten is a relatively poor emitter, it is used as a directly heated filament whose temperature is raised to a very high value (about 2500°K) to provide enough emission. The filament is heated to a white glow, requiring a relatively large amount of filament power. However, it is very rugged and is only used in large transmitting tubes where small traces of gas may be present. In these tubes, the electrons traveling through the tube may collide with small particles of gas, breaking other electrons free from the gas molecules and making the molecules slightly positive. The relatively heavy gas molecules, (or ions) now positively charged, "bombard" the tungsten filament which is the only type emitter capable of withstanding the bombardment with no damage.

Thoriated tungsten cathodes emit electrons over a thousand times more efficiently than pure tungsten heated to the same temperature. Therefore, thoriated tungsten can be operated at a much lower temperature than pure tungsten and is usually heated to about 1900°K—a yellow glow. The cathode itself is made from tungsten that has been coated with a thin layer of thorium only about one molecule deep. Thus, if the emitter fails, it can be reactivated. These cathodes can be used in high-voltage transmitter tubes also, but only if all gas is completely removed from the tube. In practice, because such

cathodes are relatively efficient emitters, more than enough electrons are always boiled off.

Oxide-coated emitters are used in all heater type tubes as well as practically all other tubes in radio receivers. They consume relatively little power and are the most efficient. The emitter is a mixture of barium and strontium oxides coated on the surface of a nickel alloy cylinder surrounding an insulated heater element. When heated properly, this cathode will emit large numbers of electrons at a temperature of only about 1100°K when the emitter develops a dull red glow. As with the thoriated tungsten filaments, oxide-coated emitters are always designed to furnish considerably more electrons than are required to produce the necessary current flow. The importance of this "emission surplus" will become evident in later chapters.

Vacuum-tube cathodes

The electron emitter or cathode may be heated directly or indirectly. The indirectly heated cathode, used to the greatest extent in radio circuits, is called the *heater* type. Because high temperatures

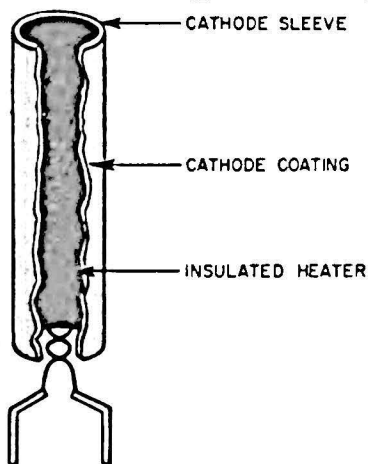

Fig. 101. The indirectly heated cathode is electrically isolated from the heating element (heater).

are unobtainable by this method of radiant heating, the heater is made of oxide-coated materials. The cathode heater (Fig. 101) consists of a metal sleeve with a heating element placed inside and insulated from it. Because it can emit enough electrons at a relatively low temperature and low power consumption, the heater type of cathode has an advantage over the directly heated cathode. The heating element is made of low-resistance material, while the heater which

carries no current can be high-resistance material with high emission characteristics. Furthermore, with a heater type tube, alternating current can be used in the heating element to heat the cathode indirectly without causing the noise or hum to which directly heated types are susceptible.

Another advantage of the indirectly heated cathode is that it reaches approximately the same temperature over its entire surface and will emit electrons uniformly since the potential is the same over its entire surface. Due to its construction, the indirectly heated cathode can be located closer to the grid than the directly heated filament, a physical advantage which permits higher tube amplification. The heater type of tube is used in almost all radio receiving circuits.

The use of filament or directly heated cathodes is limited to special circuits or circuit components, paradoxically where either very large or very small powers are involved. Because the tungsten cathode is used in transmitters where very large amounts of power must be handled, filament type tubes are required. On the low side of the power scale, filament tubes are also used in almost all battery-operated radio sets where power consumption must be held to a minimum. A few rectifier tubes also use filament type directly heated cathodes.

In tubes with large power-handling capacity, where ac is used to heat the emitter directly, the filament must be heavier and sturdier than in tubes where only dc is used. Ac fluctuations along the length of the filament tend to cause uneven electron emission which may produce hum. The filament is ribbon-shaped to minimize this effect. A flat ribbonlike filament structure tends to heat more uniformly, thus offsetting the tendency toward uneven electron emission. This shaped filament also provides a much larger "emission area" than the conventional wire type filament and with much less material.

On the other side of the power scale, directly heated type tubes used in low-power battery-operated sets are designed to operate with only a 1.5- or 2-volt filament battery voltage with low current consumption, and therefore a conventional wire structure is used. Some battery-operated radio receivers are designed to use an alternating voltage source also. In such cases, the dc filament voltage is supplied through dropping resistors and filters or from a separate rectifier and filter network.

Secondary emission

With thermionic emission, the free electrons in the metal are stimulated directly by heat and are literally boiled off. Once the electron is released, because of its light weight, it can travel at tremendous speeds if given the opportunity. Although very small, electrons can acquire enough momentum in traveling toward a positive potential to cause appreciable damage when striking an object unless proper

care is taken in tube design to prevent it. Electrons can travel with such speed that they release other electrons from the material they hit. In some cases, this characteristic is made use of in radio-tube design.

High-speed electrons can strike a metal hard enough literally to chip away a few other free electrons from within the metal itself. This results from the fact that the high-speed electron forces itself through the metal surface, burying itself in the atomic structure. As the electron slows down and stops, it gives up large amounts of energy to the surrounding free electrons. The electrons near the surface take on the released energy of the incoming particles enabling them to escape into the surrounding space. Depending upon the force of the oncoming or primary electron, several electrons are usually removed. Electrons thus released are called *secondary* electrons and this action, known as secondary emission, adds to a total number of electrons in the immediate area. Once free, the released electrons mingle with the oncoming primary electrons in the space and join them in seeking a positive potential. Secondary emission occurs to some degree in practically all radio tubes. In vacuum tubes, the released or primary

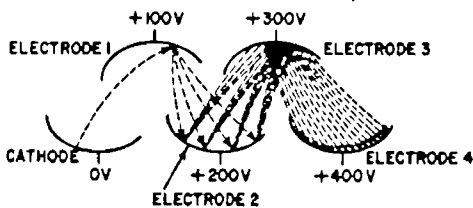

Fig. 102. The electron multiplier depends upon secondary emission for much of its action.

electrons produce secondary electrons when they strike the positive electrodes. In tubes filled with gas, the electrons produce secondary electrons from the gas itself.

The electron multiplier

A direct application of secondary emission is the electron multiplier which generates large increases in current. As electron motion constitutes current flow, the greater the number of electrons moving in one direction the greater the current. This applies to electron motion whether in conductors or in a vacuum. Being negative, the electron moves toward the highest positive voltage and the electron multiplier makes use of this electron characteristic as indicated in the simple application of Fig. 102. The primary electron strikes the first and nearest electrode (or plate) hard enough to put four or five secondary electrons into motion. Each of these secondary electrons in turn becomes a primary electron in traveling to electrode 2. This electrode

is more attractive than electrode 1 because of its higher potential. This same process continues successively to plates 3 and 4 as the electron current builds up through the multiplier. In some multipliers this process is carried to the point where the number of electrons (and therefore the current) is increased 100,000 times.

Secondary emission of this type which utilizes the plate or plates of electron tubes is deliberately produced and the "extra" electrons are guided in specified paths. Sometimes the production of secondary electrons is undesirable and can cause considerable damage. For example, high-speed electrons may accidentally strike the supporting insulation or the glass walls of tubes. In high-voltage tubes, the violent bombardment of the glass tube walls by electrons that stray from the appointed path can release secondary electrons from the glass itself. Having lost negative electrons, the glass becomes positive and attracts more and more stray primary electrons. If this process is allowed to continue, the glass "spot" becomes more and more positive to the point where the great number of arriving primary electrons heat the glass and literally burn a hole in it. This must be prevented in tube design by providing focusing shields to direct the primary electron stream to the plate.

Field emission

Considering the basic premise that the electron cannot break the surface barrier and escape from the metal unless it can acquire enough energy from outside sources, we might visualize an external force strong enough actually to pull the electron away from its parent atom in the metal. Contrary to types of emission where the electron itself is "activated" or energized to break through the metal, with field emission, nothing is done to the electron itself.

In a metallic substance, we have regarded the surface of the metal as a barrier which prevents the electron from escaping under normal conditions. Actually this barrier can be looked upon as having some measure of thickness. When an electrode with a positive voltage is brought near the metal, an electric field is produced between it and the metal, and the thickness of the surface barrier is effectively reduced. As the positive potential is increased, the electric field becomes strong enough to weaken the surface barrier of the metal making it thin enough to permit the free electrons to escape with no more energy than that which they always exercised in their normal random motion.

As in the case of thermionic emission, the source of the electrons is called the cathode and the positive plate is called the anode. Tubes designed to emit electrons in this manner are called cold-cathode tubes. However, the cold-cathode tube which utilizes this method of emission is not a vacuum tube but rather one which contains a small amount of inert gas. Tubes such as the 0B3, 0C3 and 0D3 are cold-

cathode gas tubes of this type. Even with gas however, the initial electron flow is generated entirely by field emission.

Photoelectric emission

Photoelectric emission, as its name implies, is a process in which light energy is converted to electrical energy. With this type of emission, free electrons in certain metallic substances receive enough energy when exposed to light to enable them to break through the surface barrier and escape to the surrounding space. These free electrons are activated by units of light energy called photons. The familiar photoelectric cell used in special control circuits works on this principle. The camera tube in television studios also uses the same technique. Just as with thermionic emission, certain metals do a better emitting job than others. Some metals are more sensitive to the blue end of the spectrum than others. In other words, the number of electrons emitted depends on the frequency as well as the intensity of the light.

Most metals are more sensitive to the blue end of visible light than to the red and the type metal selected for a particular application depends on how the tube is to be used in a given electronic circuit. For example, artificial light from a tungsten incandescent

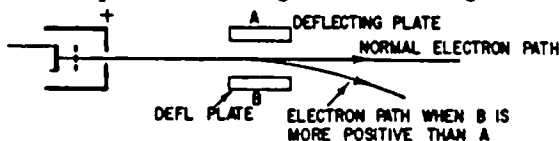

Fig. 103. Simplified diagram of the control elements of a cathode-ray tube such as commonly used in oscilloscopes.

lamp radiates most of its energy at the red end of the light spectrum. Therefore a photosensitive tube made from a metal sensitive to the blue end of the spectrum would give very little response.

Photoelectric emission in the TV camera tube is entirely different even though the end result is the same, i.e., light energy to electrical energy. Different degrees of brightness must be registered to provide the correct contrast at the TV receiver. In other words, the registered response at the camera tube which is eventually reconstructed at the home TV set must reproduce electrically what the human eye sees.

Control of electrons in motion

Up to now our discussions have centered about the various methods of releasing the electron from a metal structure. Once released, the electron must be controlled. It can be directed in straight lines at different speeds or its path can be curved. Because the electron is a negatively charged particle, it hastens to reach a positive polarity, per-

haps the positive plate of a vacuum tube or the positively charged face of a TV picture tube. A moving electron is an electric current and therefore produces a magnetic field of its own. Its path can be deflected by an external magnetic field by interaction of the two fields. Therefore, the magnetic field acts on the moving electron. On the other hand, an electron can be deflected by an electrostatic field whether it is moving or not.

With the exception of special applications in gas tubes, the electron, when set in motion, must be given a free rein. It must be allowed to travel an unimpeded path by completely evacuating all gases from the route. This is done in all vacuum tubes. In the ordinary cathode-ray vacuum tube the boiled-off electrons are set in motion by the electrostatic fields of positive anodes. Once in motion the electron can be further influenced by an additional electric field at right angles to the direction of motion or by a magnetic field.

Electrostatic deflection

In the cathode-ray tube used in oscilloscopes, the electron stream is deflected electrostatically by deflecting plates which are mounted along the electron path as shown in the simple diagram of Fig. 103. The components shown normally make up the electron gun of the oscilloscope. The gun uses four deflecting plates, of which only two are shown in Fig. 103 for simplicity. Each pair of plates is capable of producing positive or negative potentials at right angles to the direction the electrons are traveling, thus pulling the electrons back and forth horizontally or up and down vertically in accordance with the magnitude of the applied voltages. Although the lightweight electrons acquire very high speeds under the influence of the positive anodes they can be pulled out of line as indicated in Fig. 103. As the deflecting voltages on plates A and B are varied, the path of the electron will be altered either vertically or horizontally. This action produces a trace across the face of the tube.

Magnetic deflection

Magnetic fields also affect electrons but only when the electrons are moving. Thus the cathode-type tube just discussed could use magnetic deflection. To understand how this type of deflection works, remember that electrons in motion constitute electric current flow whether the motion occurs in metallic conductors or in space. Electric currents generate magnetic fields, hence external magnetic fields react on the electron-generated fields and exert either a repelling or attractive force. For example, if an electron is projected into a magnetic field but perpendicular to it (Fig. 104) it will be deflected from the field by a force at right angles to the electron motion. In this case, the field generated by the electron beam is into the paper above the path and out from the page below the stream line. Thus the net weakened

field below the electron path will divert it downward, forcing it to follow a curved path until it is completely rejected from the field.

This interaction of fields can be used for focusing and deflecting electron paths as in television picture tubes. For example, if the elec-

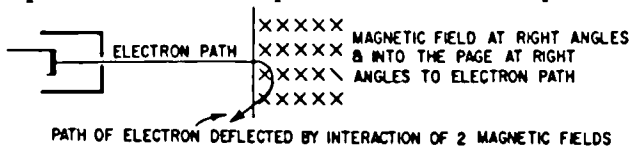

Fig. 104. Magnetic fields can be used to influence the path of an electron beam.

tron is traveling in the same direction as the magnetic field, its own magnetic field will be at right angles to the external field and both fields will have no effect on each other. (Fig. 105-a.) However, if the

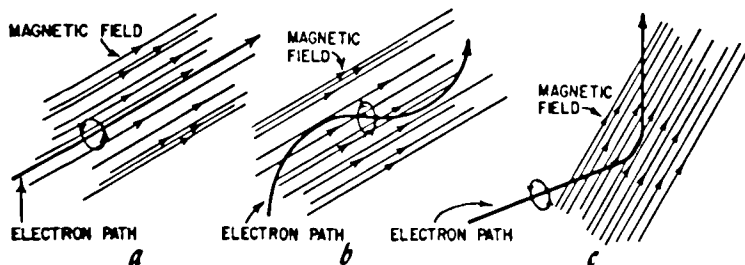

Fig. 105. A more detailed view of how a magnetic field influences an electron beam: a) field and electron follow same path; b) electron beam enters field at an angle and is ultimately forced into a convergent course; c) electron beam is deflected by magnetic field.

electron is moved through the magnetic field at an angle to it (Fig. 105-b), the fields will interact and a force will be exerted on the electron to form its course, ultimately into a convergent instead of divergent one. A similar action takes place in electric motors where the interaction of the armature current field and pole fields cause rotation. Here, however the conductors have to move bodily instead of allowing free individual paths for the electrons.

If the direction of the external magnetic field is changed as in Fig. 105-c, the path of the electron can be deflected just as with electrostatic deflection. By using two coils mounted at right angles to each other (as in a TV receiver) and by varying the direction of their magnetic fields back and forth and/or up and down, the electron stream can be directed to different points on the screen of the picture tube as required.

The face or screen of the TV picture tube (or cathode-ray tube in an oscilloscope or radar set) is coated with a powdered chemical (phos-

phor) that fluoresces or emits light when bombarded by the electron stream. Thus, when the beam is moved across the screen it traces a pattern of light that is determined by the instantaneous amplitudes of the currents flowing in the deflecting coils or yoke in an electromagnetically deflected system or the voltages applied to the plates in an electrostatic type tube.

Legend

Beginning with vacuum-tube characteristics in the next chapter, letters and associated subscripts will be used to identify tube or circuit operating characteristics. These are listed here as a convenient form of reference.

- C_o Coupling capacitor
- C_f feedback capacitance
- C_g grid capacitor
- C_{gk} grid-to-cathode capacitance
- C_k cathode bypass capacitor
- C_{pk} plate-to-cathode capacitance
- C_s shunt capacitance
- C_{sg} screen bypass capacitor
- e_b dynamic plate voltage
- E_b dc plate voltage (static)
- E_{bb} fixed battery supply voltage for plate
- E_g fixed (static) grid voltage (or fixed negative grid bias)
- e_g dynamic grid voltage (signal voltage)
- e_i input voltage
- e_o output voltage
- e_p primary (transformer) voltage
- E_r ripple voltage
- e_s signal voltage (also transformer voltage, secondary)
- E_{sg} voltage on screen grid
- g_m transconductance or mutual conductance
- i_b dynamic plate current (ac component of plate current)
- I_b dc plate current (static)
- i_p primary current
- i_s secondary current
- L_p primary coil
- L_s secondary coil
- P_o output power
- R_b plate resistance (static)
- R_g grid resistor
- R_k cathode resistor
- R_L load resistance (also effective load)
- r_p plate resistance or impedance (dynamic)
- R_{sg} screen grid resistor
- μ amplification factor

vacuum-tube characteristics

OF the many methods that can be used to release electrons from a metallic substance, thermionic emission is the most popular. Strangely enough, electron emission by heat was first noticed quite accidentally by Thomas A. Edison while experimenting with incandescent lamps. In one of his experiments he observed that if a carbon-filament lamp was constructed with an additional electrode (with a positive voltage on it) current would flow in the circuit of the added electrode. This phenomenon was called the *Edison effect* and was not put to use until years later when Professor Fleming developed the *Fleming valve*, which was really the first vacuum tube. The simplest of radio tubes contained two electrodes; a heated cathode which emitted electrons and a positive anode which acted as a collector, or plate. This tube was the forerunner of present-day diodes.

Diodes

The basic principle of operation of the diode applies to all vacuum tubes, even multi-element types, hence it is important that its functioning be clearly understood. In previous discussions of thermionic emission, we learned how free electrons were "boiled off" the cathode. In fact, up to a point, the hotter the cathode becomes, the more electrons are boiled off. However, if the electrons had no place to go—that is, if there were no positive anode to attract them away from the cathode—the electrons would become so "bunched" in the vicinity of the cathode and the space would become so crowded that any additional emitted electrons would be repelled by this negative charge in space and be forced back to the cathode. With a positive anode (or plate), many electrons would leave this negative "space charge," flow to the anode and produce a current flow in the anode circuit. The space

vacated by the moving electron would immediately be filled by a newly boiled-off electron, thus maintaining a constant current flow.

This action within the glass envelope of the diode can be more clearly understood by referring to Fig. 201 which shows how the emit-

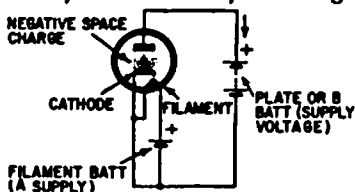

Fig. 201. Space-charge effect in a simple diode. The path of current flow is indicated by the arrow.

ted electrons are bunched about the cathode and how the current flow is maintained, effectively creating a closed circuit. The amount

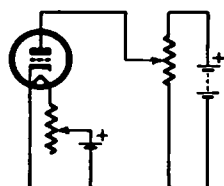

Fig. 202. A circuit used to study the results of varying cathode temperature and plate voltage.

of current that flows in this circuit is directly related to the number of electrons reaching the anode. Because the flow of electrons is limited, the space between the electrodes has resistance. If this "resistance" did not exist, the electron flow between the electrodes would be infinite since the low resistance wiring in the anode circuit of Fig. 201 is the

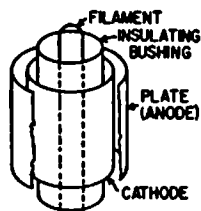

Fig. 203. Physical arrangement of the electrodes of a simple diode.

only resistance to the current flow. The number of electrons attracted to the positive anode depends upon the magnitude of the anode voltage; i.e. the greater the positive voltage, the greater the current.

If the cathode were not heated to the proper temperature, the number of emitted electrons would be limited and, in such case, an increase in anode potential could conceivably not produce an increase in current. Therefore, the electron flow or plate current can be considered dependent upon cathode temperature as well as anode potential. Studies have been made to show the effect of each, using a circuit similar to Fig. 202 arranged to vary the cathode temperature or plate voltage. Fig. 203 shows how a diode is constructed and indicates the physical arrangement of the electrodes.

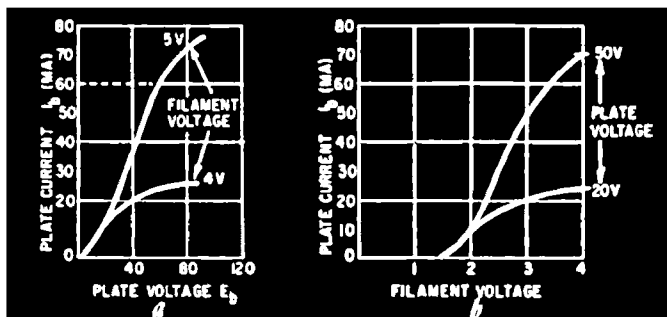
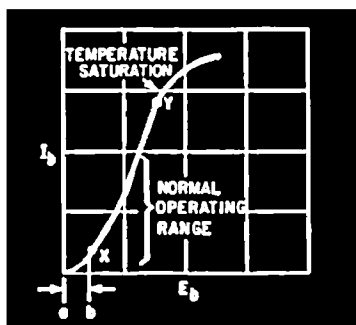

Fig. 204. Cathode temperature (filament voltage) and plate voltage are two factors which limit tube performance: a) when plate voltage is raised while cathode temperature is constant, temperature saturation occurs; b) result of varying cathode temperature while plate voltage is constant.

If the cathode is maintained at a certain temperature while the voltage on the plate is gradually raised, the electron flow will increase up to the point where there are not enough electrons boiled off to "meet the demand." The voltage becomes so high that there

Fig. 205. Relationship between I_b and E_b determines vacuum tube performance. X-Y is the normal operating area of the tube.



are not enough electrons to form a space charge. This limitation is called *temperature saturation* and is clearly shown in Fig. 204-a. If the temperature is further increased, the saturation point is raised. For example, if the tube is operated with a plate voltage of 60, Fig. 204-a shows us that 5 volts must be applied to the filament to prevent saturation; i.e., to develop all the current that is needed by boiling off enough electrons to maintain a negative space charge.

Fig. 204-b shows the opposite effect. The plate voltage is held constant and the filament voltage (cathode temperature) is increased. This set of curves also shows a leveling off effect. However, in this case it is due to the fact that the negative space charge has been properly formed but the positive voltage is insufficiently attractive to take all the electrons that are emitted.

In normal tube operation, a negative space charge must be maintained for proper circuit functioning because the actual plate current should be directly related to the anode voltage—there must always be a sufficient supply of electrons to suit the demand for current on the part of the positive plate. Thus, within the design limits of the tube, a space charge always exists and the tube never reaches temperature saturation. Diodes perform in accordance with their design characteristics, differing from one another in the amount of current that can be handled or the maximum anode voltages that may be used.

The basic relation between plate current and plate voltage must also be considered. Fig. 205 is a typical diode characteristic curve showing the effect an increasing plate voltage (E_b) has on the plate current (I_b). With such a tube, the manufacturer specifies the filament voltage necessary to provide an ample supply of electrons under proper operating conditions and limits the voltage that should be applied to the plate. As indicated, the normal operating region is well below the saturation point and is limited by the maximum permissible anode voltage at point Y. Note the curvature at low values of plate voltages (between points a and b) brought about by space-charge effects. This comes about because at low plate voltages the strong space charge tends to "smother" the attractive force of the plate, at least until it reaches point X where the changes in plate current become directly proportional to plate voltage changes.

The limiting effect on electron flow in a vacuum-tube circuit can be represented as a resistance, R_b . This resistance causes dissipation which manifests itself as heat on the plate of the tube. It results from the fact that the fast-moving electrons, on striking the plate, transfer their energy of motion into heat. This effective resistance is called the *static plate resistance* and its value is the ratio of the plate voltage to the plate current (E_b/I_b).

If an external resistance R_L is added to the diode circuit as shown in Fig. 206, the current would then be limited by both resistances R_L and R_b and the power lost in the tube would be $(I_b)^2(R_b)$. If we assume that the voltage appearing across R_L is to be put to work by using it as a source for driving another circuit the diode would serve no purpose. If a driving voltage were required, it could be obtained directly from the battery without wasting power in the tube. However, if an alternating voltage were used in the circuit of Fig. 206 in place of the supply voltage or battery E_{bb} as shown, the circuit could be put to work. Electrons will only flow to the plate of the tube when it is positive with respect to the cathode. Therefore, if an alternating voltage were applied to the plate, the electrons would only flow to the plate when it is positive but not when it is negative, thus developing an unidirectional current through R_L . This would then develop a dc potential across R_L which would be pulsating rather than of a constant value because the current flows in pulses. Thus

the diode is a rectifier and as such has many applications. It is used in power supplies where, with a proper combination of resistance (or inductance) and capacitance, alternating voltages are converted to dc voltages of fairly constant amplitude with little ripple. The detector of broadcast-band receivers makes use of this characteristic of the diode to rectify alternating voltages. The discriminator or ratio detector of an FM or TV receiver also depends upon the diode.

The diode, then, is an important link in the chain of functions of

Fig. 206. The addition of load resistor R_L allows the diode to be put to work when the plate supply is ac. The circuit is that of a basic rectifier.

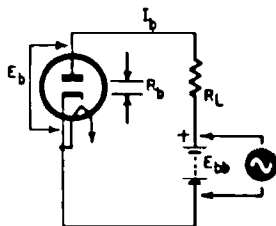

most electronic circuits. Circuit components such as resistance, inductance and capacitance work hand in hand with the diode and these components must be properly selected to insure correct circuit functioning.

Triodes

With adequate emission, the negative space charge formed between the cathode and plate acts as a sheath which repels additional elec-

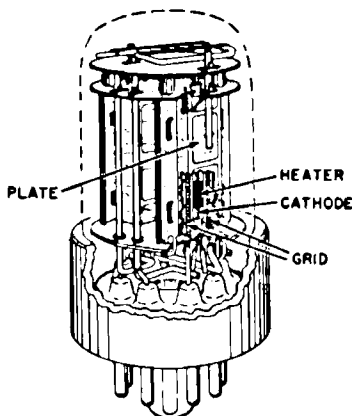
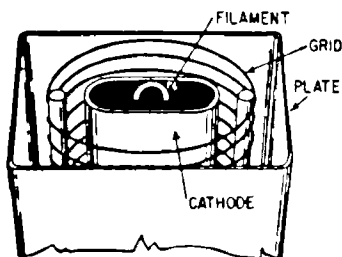

Fig. 207. Electrode placement of a typical triode. Note the relationship of the grid to the cathode and plate.

trons trying to leave the cathode. If the plate is positive, electrons move out of the space charge and flow to the plate. New electrons from

the heated cathode fill in the gaps in the space charge and thus a current flow is produced. The ability of the space charge to control the flow of electrons to the plate was soon recognized as a characteristic that could be utilized to produce amplification. Early tests indicated that if a third electrode were inserted between the cathode and the plate and if kept at a negative potential, could exert a repelling force on the electron flow just as the space charge does. As a result, a tube was constructed with a third electrode so arranged that the electrons could pass through.

Fig. 207 gives a picture of the relative positions of the electrodes in a typical triode. The grid structure varies from a spiral winding type to one that has a very fine mesh. Fig. 208 gives a few samples of var-

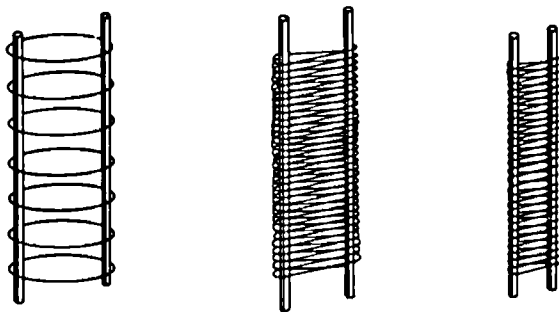

Fig. 208. Grids are formed in a variety of ways, from a simple spiral winding to a fine screenlike mesh.

ious types of grids, constructed to permit electrons to pass through them to the plate. Being negative, the control grid does not attract any electrons to itself, but repels them. However, a few electrons traveling from the cathode to the plate and headed straight for a part of the control grid may strike it head-on and cling to it. In operation, such electrons find their way back to the cathode circuit through an external resistor.

Under the usual condition of operation, the grid is kept at a negative potential with respect to the cathode. The plate with its positive polarity attracts the negative electrons. With a negatively charged grid injected into the electron path, the electrons are slowed down, some sufficiently to be turned back, while others have enough speed to pass through and on to the plate. Those which are turned back do not take part in the current flow in the plate circuit. The negative grid reduces the plate current.

These "turned-back" electrons could be recovered by increasing the positive polarity of the plate, thus giving the electrons more speed to overcome the negative grid voltage and increasing the plate current. Because the plate is farther away from the cathode than the con-

trol grid, the positive voltage on it would have to be increased a great deal to offset a relatively small negative voltage on the control grid. This operating characteristic of the triode results in amplification. The amount of amplification is determined by the construction of the tube; that is, the relative positions of the tube electrodes. Since there are many electrode combinations which might yield different results, it is no wonder that tube manuals list many triodes, each with different characteristics designed for a particular type of operation.

Static characteristics

Each tube type has a set of operating characteristics which indicate

Fig. 209. Test circuit used to determine the static characteristics of a triode.

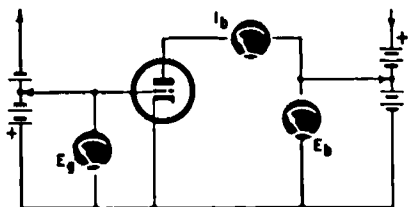

how much plate current will flow with various values of plate and grid voltage. These so-called *static characteristics* are determined by

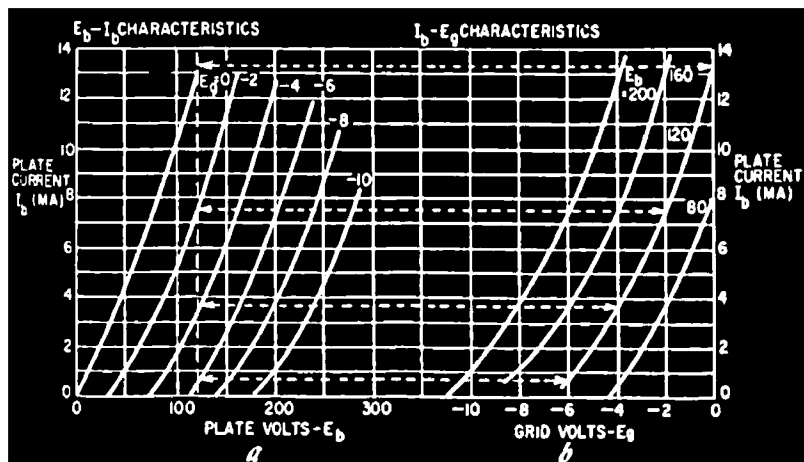

Fig. 210. Plate characteristics of a typical triode: a) $E_b - I_b$ family of curves; b) $I_b - E_g$ curves are commonly called transfer characteristics.

the manufacturer by using a circuit arrangement similar to Fig. 209. In this circuit, the tube is operated with various values of fixed negative grid bias and the plate current is read as the plate voltage is varied. A series of curves is thus determined for the tube under test.

Fig. 210-a shows such a set of curves for a typical triode. Note that, as the polarity of the grid is made more negative, a larger plate potential is required to produce an initial current flow. However, it is interesting to see that once the current becomes greater than about 2 ma, regardless of the grid potential, incremental increases in plate voltage

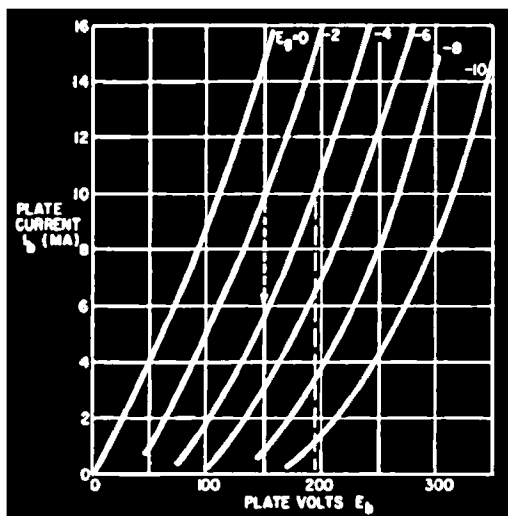

Fig. 211. Determining transconductance from E_g - I_b curves.

produce practically the same incremental increases in plate current over the remaining length of the curve, as shown in the fact that the curve slope is almost constant. Moreover, not only is the slope of each curve relatively constant, but all curves have approximately the same slope. This typical tube characteristic merely means that, if a tube is operated within its specified range of values, changes in plate or grid voltage will cause almost the same changes in plate current, regardless of the exact values of grid or plate voltage. Since the effectiveness of a tube is related to changes of voltages and currents, this similarity of curve slopes becomes an important factor in tube operation,

Before pursuing this discussion further, it might be well to consider a second set of tube characteristic curves. Referring again to Fig. 210-a, the curves show how the plate current varies with changes in plate voltage while the grid voltage is held constant at various values. Changes in plate current could also be measured by changing the grid bias values and holding the voltage at the plate constant. If this were done, curves similar to those of Fig. 210-b would result. As a matter of fact, the curves in Fig. 210-b could be derived directly from those in a. For example, if a dashed line is drawn on the curve of Fig.

210-a where $E_b = 120$ volts, the points at which it intersects the grid voltage curves indicate the same current values shown on the 120-volt curve of b. Similar checks could be made at other plate voltages. Thus, because the curves of Fig. 210-b can be derived from the information of Fig. 210-a, they are called *transfer characteristics*. Tube manuals always show the E_b-I_b static characteristics because they contain all the information needed to learn how the tube will perform. On the other hand, the E_g-I_b transfer characteristics are seldom drawn except where tubes are specifically designed for power amplification.

Amplification

Getting back to the E_b-I_b tube characteristic curves, the effect of changes in plate current, with changes in plate or grid voltages, can be read directly from the curve. For example, refer to Fig. 211 which shows the tube characteristics for a triode. If the tube is operated at a plate voltage of 150 and the grid bias set at -2 volts, 10 ma will flow in the plate circuit. If the negative grid bias were increased to -4 volts, the plate current would drop to 6 ma if the plate voltage were maintained at 150. However, if a bias of -4 volts were used, the plate voltage would have to be increased to about 195 to restore the plate current to 10 ma. Thus, a change of either 2 volts on the grid or a change of 45 volts on the plate produces the same change in plate current. We might reason, therefore, that as far as the plate circuit is concerned, a 2-volt change in the grid circuit produced the same effect in the plate circuit as a 45-volt plate voltage change. The effect is amplification and in this case, the ratio

$$\frac{\text{change in plate voltage}}{\text{change in grid voltage}} = \frac{45}{2} = 22.5$$

Because of the similarity of the curve slopes, the same amplification ratio would be obtained at other grid bias values. Therefore, under the normal operating ranges of a tube, the amplification of the tube is shown mathematically as

$$\mu = \frac{\Delta E_b}{\Delta E_g} \quad (1)$$

where μ is the amplification factor, ΔE_b the change of the plate voltage and ΔE_g the change of grid voltage.

Dynamic resistance

Changes in plate current caused by grid voltage changes are limited by the flow of the electron stream itself. This resistance to the variations in electron flow is called the dynamic or ac plate resistance. Mathematically, it is the ratio of the rate of change of plate voltage,

corresponding to a change of plate current, as the grid voltage is held constant, or

$$r_p = \frac{\Delta E_b}{\Delta I_b} = \text{dynamic plate resistance} \quad (2)$$

Here again the dynamic plate resistance can be derived directly from the static characteristic curves. For example, in Fig. 211, with a grid bias of -2 volts and a plate voltage of 150, 10 ma flows in the plate circuit. Changing the plate voltage to 100 with -2 volts still on the grid reduces the plate current to 5 ma. Hence, a 50-volt plate voltage change produced a 5-ma plate current change or

$$r_p = \frac{\Delta E_b}{\Delta I_b} = \frac{50}{.005} = 10,000 \text{ ohms}$$

Tube merit

There is still a third and very important tube characteristic to be considered. The merit of a tube lies in its ability to develop changes in plate current when the grid voltage is changed. Whether these changes are large or small, the effectiveness of the tube is measured by the change of current that can be produced in the plate circuit. Tube merit is determined by the ratio of the change of plate current to a change in grid voltage. For example, in Fig. 211, with a plate voltage of 150, a change of grid voltage from -2 to -4 will decrease the plate current from 10 ma to 6 ma—a 4-ma change. This effect on current is expressed as

$$g_m = \frac{\text{change in plate current}}{\text{change in grid voltage}} = \frac{\Delta I_b}{\Delta E_g} \quad (3)$$

and, since it depends on the curve slopes, it is likewise a tube constant which changes as the curve slope changes. Because the ratio of current to voltage is the inverse of resistance, this ratio is a form of conductance. The term used to define this ratio is called *transconductance* or *mutual conductance*. It is usually measured in terms of micromhos, and its symbol is g_m .

Referring to the ratios derived from Fig. 211.

$$g_m = \frac{.004}{2} = .002 \text{ mhos} = 2,000 \text{ micromhos}$$

Load lines

The discussion so far has centered around tube characteristics and constants and how these are derived from circuits similar to Fig. 209. Such a circuit cannot be used for practical amplification. To put the

tube to work, the circuit must be arranged to permit the application of an input voltage. Also the current variations produced in the plate are useless unless the current is fed through a resistance, so as to de-

Fig. 212. The basic circuit of a triode amplifier.

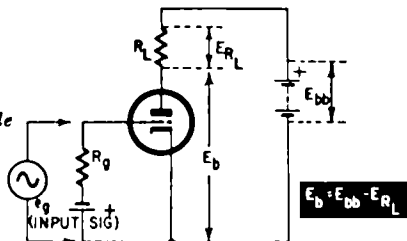

velop a voltage, which can then be used as a further driving source, for another tube or perhaps a loudspeaker.

A circuit as shown in Fig. 212 satisfies these requirements. The resistance in the grid circuit provides a load across which the input

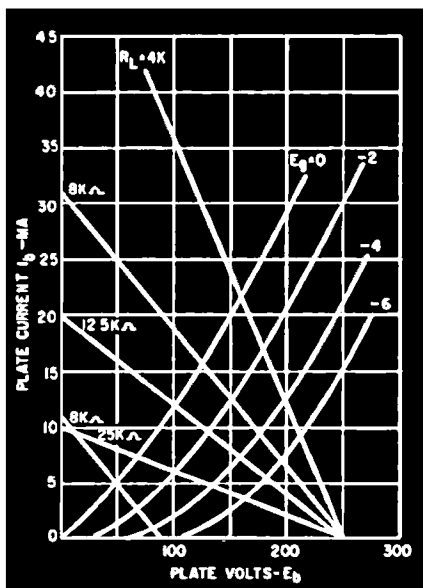

Fig. 213. E_b - I_b curves with load lines added for various values of R_L .

signal voltages can be applied. It also provides circuit continuity in the grid circuit so that electrons accidentally collected on the grid can leak off to the cathode or to ground on their way back to the cathode. This resistance is identified as R_g , the *grid-leak resistance*.

As long as the grid is biased negatively, placing resistance in the grid circuit has no effect on the grid voltage. With a negative grid, no electrons are attracted to it and, as far as the grid-cathode circuit is concerned, it acts as an open circuit. Because there is no voltage drop across R_g , the bias voltage appears at the control grid in full strength.

In a given circuit (Fig. 212) with a fixed supply voltage E_{bb} , adding the resistance R_L (load resistance) to the plate circuit increases the total resistance and reduces the current. This means that the plate voltage E_b is no longer the same as the supply voltage but is equal to the supply voltage less the voltage drop across the load resistance. For example, with no load resistance, the curves of Fig. 211 tell us that with -2 volts on the grid and 150 volts at the plate, the plate current would be 10 ma. If the tube were put to work as shown in Fig. 212 where a load resistance R_L is inserted, the added resistance in the plate circuit would lower the plate current and drop the voltage at the plate. The voltage left at the plate might very well be too small for proper tube operation if the load resistance is too high.

This can be corrected by increasing the supply voltage or reducing the load resistance or both. However, there is a practical limitation to how much these can be increased or decreased. To learn how a circuit, such as Fig. 212 will function it is necessary to adjust the static characteristics to dynamic curves. This can be accomplished relatively simply by constructing a load line on the static characteristic curves of the tube.

Fig. 213 shows characteristics similar to Fig. 211 but with load lines added. Before going into a detailed discussion of how the load lines are positioned, it might be well to refer to the circuit of Fig. 212 again. The load resistance has the same effect in the plate circuit as it would in any electrical circuit where Ohm's law is followed. This states that an increase in voltage is accompanied by a proportionate change in current. Hence, the equation or performance of resistance R_L in the plate circuit can be represented as a straight line on the E_b - I_b characteristic curves. Since any two points on a straight line will fix its position, determination of the points of intersection with the voltage and current axis is all that is necessary to draw the load line for a particular value of load resistance. Fig. 213 shows that the voltage axis intersection occurs when the plate current is zero. With a supply voltage present, this condition can only result when the tube is cut off. Thus, there is no potential drop in the load and the voltage appearing at the plate is the supply voltage E_{bb} .

The current axis intercept must be at a point where the voltage at the plate is zero. In theory this could occur only when the plate-to-cathode circuit is short-circuited and R_b would be zero. (This of course is only theoretically possible, but it satisfies the condition for determining the R_L load line.) With R_b short-circuited, the current in the plate circuit is maximum and may be calculated as follows:

$$I_b = \frac{E_{bb}}{R_L}$$

By using these rules, a series of load lines may be constructed for a given tube. However, the selection of the proper load resistance in a particular amplifier circuit is controlled by several factors such as the magnitude of the input signal to be handled, the available supply voltage, the power output required and the degree of distortion that can be accepted. Selection of the load resistance in a circuit is therefore of prime importance to proper circuit operation.

Several load lines are shown in Fig. 213 for different values of load resistance. The lines were constructed assuming a 250-volt supply¹.

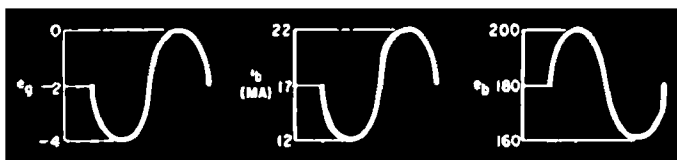

Fig. 214. Phase shifts which occur when an alternating voltage is applied to the grid of a triode.

Load lines for 4,000, 8,000, 12,500 and 25,000 ohms have been drawn. Note how the line slope decreases as R_L is increased, indicating that current changes, under the influence of an incoming signal, will decrease with higher load resistances. An 8,000-ohm load line drawn with a 90-volt supply is also shown. Note that it has the same slope as the 8,000-ohm load line at 250 volts. This is so since load line slope is determined entirely by the ratio of current to voltage.

The "start point" or operating point is found at one of the points of intersection of these load lines with the various characteristics. For example, the 250-volt 4,000-ohm load line tells us that if we operate with a grid bias of -2 volts about 17 ma will flow in the plate circuit and the voltage at the plate will be about 180. If the load resistance is increased to 12,500 ohms (but using the same bias) the plate current will drop to about 9.8 ma with a voltage of about 135 at the plate.

With higher negative biases on the grid, plate currents are reduced but voltages at the plate are increased. For example, still using a load of 4,000 ohms and a grid bias of -2 volts, the plate current is 17 ma and the voltage at the plate is about 180 as mentioned earlier. If the grid voltage is increased to -4 volts, by following the load line the curve tells us that the plate current decreases to about 12 ma while the voltage at the plate goes up to about 200. Thus, as the grid voltage becomes more negative the voltage at the plate becomes higher. The grid and plate voltages change in opposite directions or are said

¹In practice, recommended values of supply voltage are obtained from tube manuals.

to be 180° out of phase with each other. If this change of grid voltage from -2 to -4 were brought about by an ac signal voltage with a 2-volt peak, fluctuation of current in the plate circuit would produce a corresponding voltage variation at the plate opposite in phase to the grid voltage. This phase shift is shown more clearly in Fig. 214 illustrating the plate current and voltage variations derived from the 4,000-ohm load line of Fig. 213. Note that, as the grid voltage decreases (becomes more negative), the plate voltage increases (becomes more positive). The plate current varies from a mean of 17 ma to a maximum and minimum of 22 and 12, respectively, while the plate voltage starts at about 180 and changes from a peak of 200 to a minimum of about 160.

Once the operating point is set, the fixed values of grid bias, plate voltage and plate current lose their importance because the function of amplification is dependent upon *changes* or more specifically the effect of ac input voltages on plate current and plate voltage. In fact, the tube circuit could be redrawn in the form of Fig. 215, its ac circuit equivalent, where r_p is the dynamic plate resistance (resistance to ac) and R_L the load resistance. The applied voltage is $-\mu e_g$ the voltage generated within the tube itself and is merely the input signal voltage to the tube multiplied by its amplification factor. This voltage is shown as negative to indicate the phase shift through the tube. Since the tube output voltage is obtainable across R_L only, it follows that the voltage drop in the tube itself is lost. If i_p is written for only the ac component of the plate circuit current (that is, the sine-wave variation of plate current produced by the input signal) the tube output voltage e_o is $i_p R_L$. With an input signal voltage of e_g , therefore, the circuit amplification is e_o/e_g .

$$\text{But since } e_o = i_p R_L$$

$$\text{amplification} = \frac{i_p R_L}{e_g} \quad (4)$$

However from Kirchhoff's first law, the voltage round the loop of Fig. 215 must satisfy the relation,

$$\mu e_g = i_p r_p + i_p R_L = i_p (r_p + R_L)$$

$$\text{amplification} = \frac{e_o}{e_g} = \frac{i_p R_L}{e_g}$$

we can multiply numerator and denominator by μ :

$$\text{but } \mu e_g = i_p (r_p + R_L)$$

$$\frac{\mu i_p R_L}{\mu e_g}$$

$$\frac{\mu i_p R_L}{i_p (r_p + R_L)}$$

cancelling i_p in the numerator and denominator, we have:

$$\text{amplification} = \frac{\mu R_L}{r_p + R_L} \quad (5)$$

This equation shows that the circuit amplification is dependent upon the ratio of r_p to R_L and seems to indicate that as R_L is increased the tube circuit amplification increases. However, for this to be the case, the dynamic plate resistance would have to remain constant. This does not happen; r_p does not remain constant over the entire range of the characteristic curves because, as the load is increased beyond certain limits, the dynamic plate resistance becomes very high and distortion results.

In summary, then, the triode follows specific laws and functions in a properly loaded circuit:

- (1) Plate current depends on both the voltage at the grid and the voltage at the plate.
- (2) Plate current changes are in phase with grid voltage changes caused by the input signal.
- (3) Current changes acting through the load resistance produce voltage changes on the plate which are opposite to or 180° out of phase with the grid voltage.

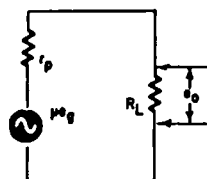

Fig. 215. An equivalent circuit of a triode amplifier.

Because the voltage at the plate decreases when the grid voltage becomes less negative (increases in a positive direction), the plate voltage attracts less electrons and thus tends to change due to the grid. Thus, the current is less than it would have been had the plate remained constant. This can be demonstrated simply by referring to Fig. 213. For example, with a supply voltage of 250 and a bias voltage of -4 , the total current change with a 2-volt peak input signal is about 15 to 31 ma when there is no load in the plate circuit. With 8,000 ohms in the circuit, this current change is reduced to 7.5 to 12.5 ma because the effect of changes in plate voltage is coming into play. With no load, the voltage at the plate remains at 250 even though the plate current changes.

Because its operation is affected by changes in plate voltage, the triode is limited in the amount of amplification it can produce. Recognizing this limitation with the triode, tube engineers considered the possibility of designing a tube whose operation, over a normal range, would be insensitive to voltage variations at the plate. The tetrode,

the first tube to accomplish this objective, was the forerunner of present-day high-mu tubes. The triode was not abandoned, of course, for there are many circuits where certain triode characteristics such as relatively high current carrying capacity and low dynamic plate resistance are needed. Its use and application were directed to circuits where power rather than voltage amplification was required.

Tetrodes

Variations in plate voltage when an input signal is applied to the grid of a tube is a fundamental requirement of all vacuum tubes when the plate circuit contains a load resistance. The tetrode makes these plate-voltage variations practically ineffective in controlling the plate current by injecting a second grid in the tube space between the first or control grid and the plate. This second grid, constructed as a mesh or grid somewhat like the control grid, allows the majority of

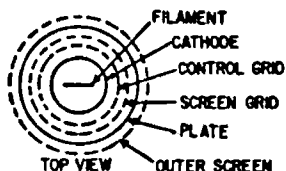

Fig. 216. Electrode structure and placement of a tetrode.

electrons to pass through to the positive plate. By applying a positive potential to this second grid, it effectively shields the cathode and first grid from the plate, hence is called the *screen grid*. Because the net surface area of the screen grid is relatively small, the proportion of electrons that it collects is negligible compared to the plate. Fig. 216 shows a picture of the electrode structure.

The screen grid, located as it is between the cathode and plate, has

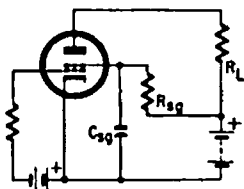

Fig. 217. Typical tetrode circuit.

“first call” on the electrons in the space charge. In fact, it functions in much the same way as the plate in a triode (except, of course, it gathers much less current). Hence, variations in grid voltage produce variations in screen current. However, since the tube output is not obtained from the screen circuit, i.e. the screen does not require a load resistance as such, the voltage at the screen can be held constant, by applying a potential through a voltage-dropping resistor in a practical manner as in Fig. 217. Note that in Fig. 217, the dropping

resistor R_{sg} must be bypassed by capacitor C_{sg} whose capacitance is large enough to hold the screen grid voltage constant with cyclic variations in voltage drop across R_{sg} . Otherwise, the screen voltage would change with screen current variations and the amplification would be reduced as with the triode.

The tetrode as an amplifier performs in accordance with its design constants. As with the triode, the constants μ , g_m and r_p are determined by the same ratios of current and voltage. Static characteristic curves, however, differ widely from the triode because of the screen grid. As with the triode, these curves show the relationship between the plate current and plate voltage with different values of grid voltage. But because the plate current is also dependent upon the screen grid voltage, tube performance in terms of i_b vs e_b apply with a fixed value of screen grid voltage only. If the screen voltage is changed, a different set of curves will obtain from this fact. It would appear that a series of characteristic curves for various screen voltages is needed to

Fig. 218. Circuit for determining the characteristics of a tetrode.

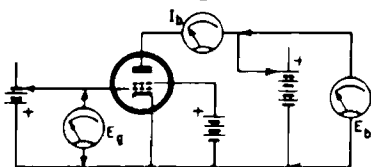

learn all about the operating characteristics of the tube. In practice, however, this is not always necessary.

Because of the action of the screen grid, the tetrode develops plate-current variations which are relatively independent of the plate voltage. However, the action of this same screen grid makes for instabil-

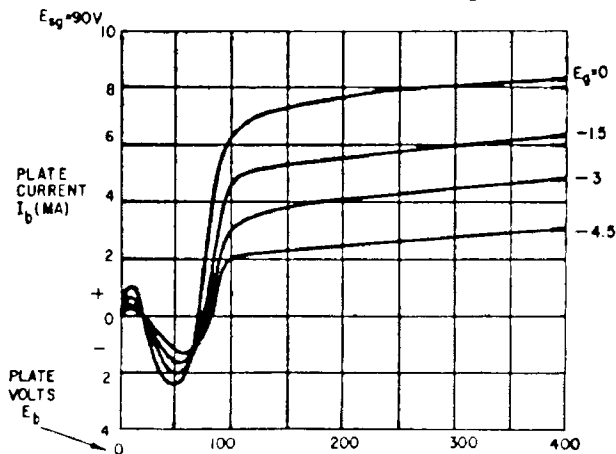

Fig. 219. Characteristic curves of a typical tetrode voltage amplifier.

ity of operation if the applied voltages are not properly controlled. The tetrode was abandoned in favor of the pentode with the addition of a third grid which eliminated this characteristic and at the same time retained the much-wanted characteristic of relative independence of plate current on plate voltage.

However, despite its drawbacks, the tetrode is once again finding a place in every-day electronics. Its plate resistance is such that it makes an excellent device for feeding transistor output stages in hybrid radios. The efficiency gained through proper impedance matching more than makes up for the circuit precautions necessary. Television manufacturers, too, have *rediscovered* the tetrode. In portable sets where the number of individual stages is limited, the tetrode is often used as a high-gain low-noise converter.

Static characteristics for tetrodes are obtained in the same manner as for triodes. Fig. 218 shows a typical circuit arrangement with the screen voltage held constant while the grid or plate voltage is varied. Fig. 219 shows a family of characteristic curves for a typical tetrode voltage amplifier. Note how the plate current begins to increase as the plate is made slightly positive but starts to decrease as the plate voltage is further increased, indicating that the plate actually emits electrons, losing more than it gains, until finally a point is reached where further increase in E_b results in a steady increase in plate current. The region of the curve up to the point where the plate voltage reaches about 100 is the unstable part of the characteristic and operation in this region would be abnormal.

To explain what is happening in the tetrode circuit and to account for the peculiar characteristic curve, consider a circuit with a screen grid voltage of 90. With no voltage on the plate, all electrons traveling through space flow to the screen grid. When a small positive potential is applied to the plate, some electrons are attracted by the screen, a few stay with the screen and the rest pass through. Those that do not strike the screen directly but pass through are pulled back to the screen by its positive attraction. Those that are traveling at a very high speed are carried far enough past the screen to be attracted to the slightly positively charged plate, causing a flow of plate current. However, as the plate voltage is further increased, the velocity of these few electrons that get by the screen is so great because of the added attraction of the plate that they strike the plate hard enough to cause it to emit secondary electrons. The secondary electrons "bounced off" the plate find themselves in the space between the plate and screen grid and because of the greater attractive force of the screen, whose voltage is higher than the plate, flow to it. The plate circuit actually loses current.

This process continues as the plate voltage is increased and it loses more and more secondary electrons until the voltage on the plate is high enough to gather some of the secondary electrons to itself. As

shown in Fig. 219, this occurs with about 60 volts on the plate. The plate loses still more electrons than it gains until its voltage is about equal to the screen voltage at which time it begins to gain electrons. As the plate voltage is increased, the plate current rises almost proportionally up to the knee of the curve, at which point practically all the secondary electrons return to the plate.

Inspection of Fig. 219 shows that for plate voltages above 100 the curves are almost horizontal, indicating that changes in plate voltage have very little effect on the plate current. Therefore, if the tube were operated in this range, the circuit would function satisfactorily. Actually, however, circuit component variations or tube aging might allow the operating range to slip into the unstable region. In practice this occurred very frequently and the result was very unsatisfactory. This quickly led to the development of the pentode which elim-

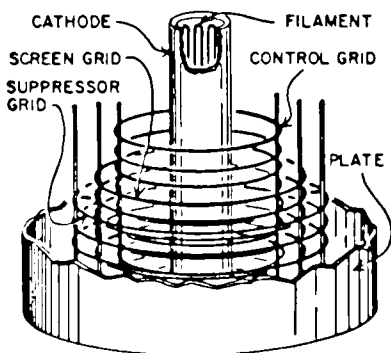

Fig. 220. Position of electrodes in a pentode. Note the relative position of the three grids.

inated the "instability range" while maintaining the desirable characteristic of working with a plate current practically independent of plate voltage.

Pentodes

In the pentode, the combined attractive force of both the screen and plate produced secondary electrons as before. However, by placing a third meshlike grid between the screen grid and plate but with the same potential as the cathode, it was found that the plate secondary electrons were shielded from the screen or were "suppressed" and forced to return to the plate. Thus, the third grid is called the *suppressor grid*. Fig. 220 shows the physical arrangement of the three-grid five electrode tube called the pentode.

As with the tetrode, the electron flow is controlled primarily by the control grid and screen voltages but, with the pentode, the plate circuit gathers all secondary electrons as well as those boiled off the cathode and passed through the screen to the plate. Fig. 221 shows

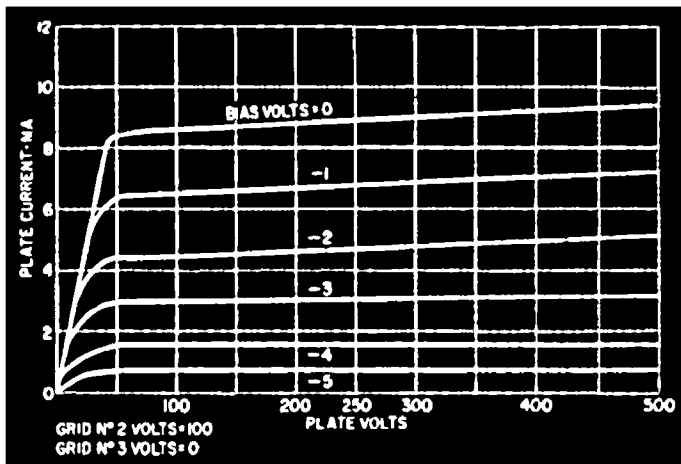

Fig. 221. Static characteristic curves of a typical pentode.

the I_p - E_b characteristics of a typical pentode. Note that the "fold" in the curve which occurred with the tetrode has been eliminated. The series of curves shows how the plate current varies with changes in plate voltage at different values of grid bias voltages. Note, however, that this group of curves applies only when the screen voltage is 100. With a different value of screen voltage, the characteristic curves, while having the same general shape, would indicate different values of current.

As with the triode, these curves are called *static characteristic curves* and indicate how the tube performs with various dc voltages applied to its electrodes. The three basic tube constants μ , r_p and g_m are likewise derived from these curves.

Pentode functioning is based on "changes" i.e. changing grid voltages and changing plate currents. Referring to Fig. 221, plate current changes are relatively independent of plate voltage changes beyond the "knee" of the curves. These occur at plate voltages above 75 with zero grid bias and above 50 volts with higher biases. In practice, the tube is operated so that variations in plate voltage, caused by changes in plate current and input signal, cover a range which is always above the knee of the curve.

By operating above the knee of the curve plate current variations are controlled almost entirely by the signal voltage because the voltage at the plate changes only slightly. Since the tube constants μ , g_m and r_p are derived from the characteristic curves, if the slopes of the various curves are different from one another in their respective operating ranges, the tube constants will be different for different operating voltages. For example, in Fig. 221, the slopes of all the

curves are slightly greater near the knee at about 80 to 100 volts than at higher operating voltages, say about 250–300 volts. In addition, the slope of the zero bias curve is slightly more than the curve with a bias of -3 or -4 volts.

Referring again to Fig. 221 and assuming a grid bias of -1 volt, the dynamic plate resistance can be found from the curve and is very high. For example, with a change of plate voltage from 100 to 200, assuming that the curves can be read with a fair degree of accuracy, the dynamic plate resistance can be calculated:

$$r_p = \frac{\Delta e_b}{\Delta i_b} = \frac{200 - 100}{(6.9 - 6.75) (10^{-8})} = \frac{100}{(.15) (10^{-8})} = 666,600 \text{ ohms}$$

Again with -1 volt on the grid and over this same operating range, a very small change in grid voltage would have produced the same change in plate current as did the 100-volt change in plate voltage. In fact, while it is almost impossible to read the curve closely enough it appears that about 0.1-volt change in grid voltage would give us the same 0.15-ma current change and therefore, very approximately,

$$\mu = \frac{\Delta e_b}{\Delta e_g} = \frac{100}{0.1} = 1,000$$

The pentode, therefore, has a high amplification factor but the same characteristic that results in a high μ also yields a high dynamic plate resistance. Both go hand in hand. With such a high plate resistance to begin with, the pentode is limited in the amount of current it can handle and therefore finds its greatest use as a voltage amplifier.

The remaining tube constant—mutual conductance g_m —also can be derived from the characteristic curves. Since with -1 -volt grid bias, a change of about 0.1 in the grid voltage caused a 0.15-ma change in plate current, the mutual conductance:

$$g_m = \frac{\Delta i_b}{\Delta e_g} \quad \text{then}$$

$$g_m = \frac{(.015) (10^{-8})}{0.1} = 1,500 \text{ micromhos}$$

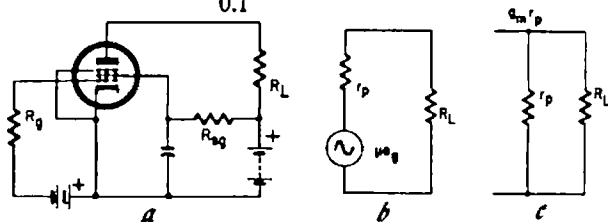

Fig. 222. Pentode amplifier circuit and equivalents: a) simple pentode circuit; b) equivalent circuit is similar to that of triode; c) more accurate representation shows r_p and R_L in parallel.

With regard to the changes in tube constants with different operating voltages, reference to Fig. 221 again will show why this is so. For example, if the operating range were shifted from the plate voltage range of 100–200 to 250–350, inspection shows that the curves are flatter at the higher voltage values. This means, of course, that the change would be less and therefore less grid voltage change would be required to match the change in current. Therefore, the dynamic plate resistance and amplification factor are almost double their previous values, but the mutual conductance is almost the same.

As with the triode, the pentode is put to work by adding a grid-leak resistance to the input or grid circuit and a load resistance to the plate circuit. A typical pentode circuit is shown in Fig. 222-a where the load and grid-leak resistances have exactly the same functions as in the triode. Fig. 222-b shows the electrical equivalent of the pentode circuit, using exactly the same form as the triode. Likewise, the circuit amplification is dependent upon the relation between the load resistance R_L and the dynamic plate resistance r_p or

$$\text{Amplification} = \frac{\mu R_L}{r_p + R_L} \quad (6)$$

However, because the amplification factor μ is so high, it is not

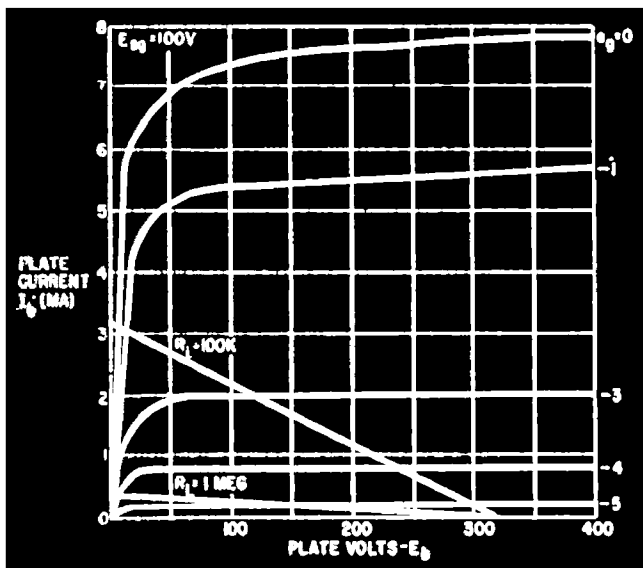

Fig. 225. I_b - E_b curves for a pentode. The load lines are constructed for $R_L = 1$ megohm and 100,000 ohms.

necessarily important to select a load resistance that is as high or higher than the dynamic plate resistance as was done with the triode. Also, both the plate resistance and amplification factor vary considerably at different points on the curves. Even a load resistance one-tenth the average plate resistance would give substantial amplification. Moreover, use of a load resistance that is too high may result in a plate current that is too small.

Tube manuals do not generally list the amplification factor (μ) of pentodes. We can get this information indirectly by knowing the relationship that exists between transconductance, dynamic plate resistance and amplification factor. Thus:

$$\mu = g_m r_p \quad (7)$$

Because, under normal operating conditions, the plate current is relatively independent of changes in plate voltage, the pentode may be looked upon as a *constant-current* device and amplification may be expressed in terms of g_m rather than μ as in (7).

$$\text{Amplification} = \frac{\mu R_L}{r_p + R_L}$$

$$\text{but } \mu = g_m r_p$$

We can now substitute $g_m r_p$ in place of μ :

$$\text{Amplification} = \frac{g_m r_p R_L}{r_p + R_L} \quad (8) \quad \text{but} \quad \frac{r_p R_L}{r_p + R_L}$$

is the expression for two resistances r_p and R_L in parallel. Therefore, the equivalent circuit for the pentode shown in Fig. 222-b can be redrawn as shown in Fig. 222-c where r_p and R_L are shown in parallel and $g_m r_p$ is the amplification factor.

Fig. 224. The variable spacing of the grid wires results in a tube having a remote cutoff characteristic.

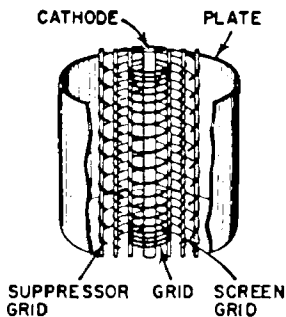

Load lines can also be plotted on the pentode characteristic curves. Fig. 223 shows a set of typical characteristic curves for a pentode with several load lines included. With a plate supply voltage of 320, if a 1-megohm load resistance is used, the Y-axis intercept would be about

0.32 ma and the operating range of the tube would be considerably reduced. In fact, the only intercept obtainable within the normal operating range with 1 megohm and 320 volts occurs with a grid bias of -5 volts and even then the operating point would permit only about 0.2-ma plate current. Such a low value of current would result in minute plate current changes with input signal voltage. Therefore, if operated at this point at all, the input signal would have to be very small.

On the other hand, with a load resistance of 0.1 megohm, a grid bias voltage between -3 and -4 could be used, depending upon the size of the signal to be handled and the amount of variation in plate current that could be permitted.

These curves, of course, only apply when the screen voltage source is 100. Different currents would result from other values of screen voltage and load resistance. Because the screen acts like the plate of the triode, selection of the proper screen voltage for a given condition can best be determined by referring to the transfer characteristics. Details regarding these curves and the method of using them become quite involved and are therefore reserved for Chapter 4 where the pentode is put to work in several practical circuits.

The pentode is looked upon primarily as a voltage amplifier. However, some voltage-amplifier pentodes are better suited for rf than for audio and are therefore so classified. Pentodes are also classified as sharp, remote or semi-remote cutoff tubes. The sharp-cutoff pentode has a relatively sharp slope to its transfer characteristic while the remote-cutoff type reaches the cutoff point gradually, its transfer characteristic approaching zero current in a long sweeping curve. The remote-cutoff tube is sometimes called a *variable-mu* tube because the curve, not being a straight line, develops a changing μ as it goes from maximum to zero current. The control grid of this type tube is especially constructed to give this effect and Fig. 224 shows how the wires in the grid change their spacing over the length of the structure.

Because of its delayed cutoff, the variable- μ tube is useful where a changing grid bias is needed and a considerable operating range is required. In Chapter 4 the remote-cutoff tube is put to work in circuits where agc is used.

vacuum-diode applications

THE diode is most useful as a rectifier and detector. As such it plays an important part in radio and TV circuits. In power supplies it converts alternating into unidirectional current. In AM radios and in some TV sets it finds its place as a detector. In TV and FM receivers

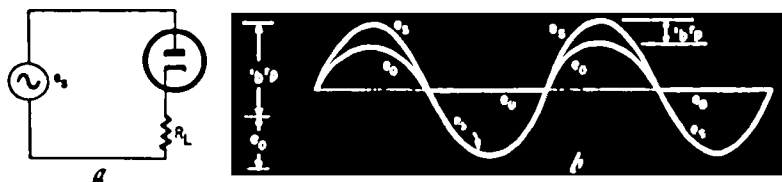

Fig. 301. The half-wave rectifier is one of the most common types in use: a) simplified rectifier circuit; b) output waveform.

the diode, as a demodulator, is an essential part of the discriminator or ratio detector circuit.

Power-supply rectifiers

The plates and screens of vacuum tubes require constant dc potentials. Most radio receivers are ac-powered—they are connected to the 110–120-volt house supply—therefore a rectifier is used to change the alternating into a unidirectional voltage. The simplest and most widely used method in ac-dc sets is half-wave rectification (high-voltage supplies in TV sets also depend on this technique).

The half-wave rectifier

When an ac voltage e_s is applied to a diode (Fig. 301-a), a unidirectional voltage is developed across the load R_L with a pattern represented by e_o in Fig. 301-b. The peak of the rectified voltage is less

than the peak of the applied voltage e_a . The difference between them represents the voltage drop within the tube. The output voltage e_o consists of half-wave pulses since the diode rectifies only one half of the incoming wave.

Although it is unidirectional, the output voltage of the rectifier cannot be used directly as a source of plate or screen voltage. The tubes must be operated with a constant dc voltage so that electron flow

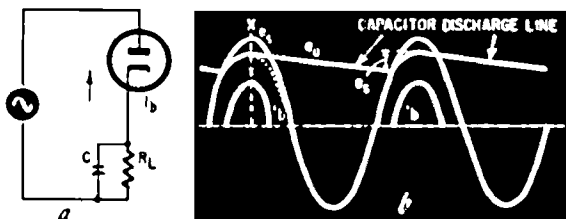

Fig. 302. In use, a filter must be added to the half-wave rectifier: a) basic rectifier circuit; b) output waveform.

remains constant unless changed by the action of the control grid. Therefore the output of the rectifier diode requires filtering to produce a constant rather than a varying voltage.

The addition of capacitor C across R_L (Fig. 302-a) provides a simple filter circuit. The pulse of current (i) flowing through R_L during the positive part of the cycle develops a voltage drop across the load resistor and charges capacitor C . As the positive potential at the plate of the tube increases, the capacitor charges to the peak value of the voltage across R_L . When the plate current decreases, the capacitor discharges through R_L , tending to maintain a constant voltage across it. For example, assume that curve e_o in Fig. 302-b represents the voltage across R_L as the plate current increases. When the voltage reaches point X and starts to decrease, the voltage across R_L goes down as shown by the dashed line. Capacitor C , having acquired a peak charge, discharges through R_L at a rate shown by the solid line, preventing the output voltage from dropping to zero.

The slope of the capacitor discharge line is controlled by its size and the value of R_L and the amplitude E_r indicates how good the filtering job is. The ideal objective is a completely smooth, unidirectional output and the magnitude of E_r is a measure of the ripple present.

In practice, load resistor R_L may be physically nonexistent, the actual diode load being a parallel combination of all the tubes in the receiver plus a bleeder if used (Fig. 303). Filtering action depends upon the value of capacitor C and the inclusion in the filter circuit of additional resistors and capacitors.

Half-wave rectification is most commonly used in inexpensive power supplies such as those found in table-model radios. These receivers are designed to operate from either an ac or dc source.

Fig. 304 shows a typical power supply for a five-tube superheterodyne receiver. The plate and the cathode of the 35W4 act as a half-wave rectifier. The large electrolytic capacitors do the filtering job in conjunction with the 1,200-ohm resistor. The voltage across the input 50-

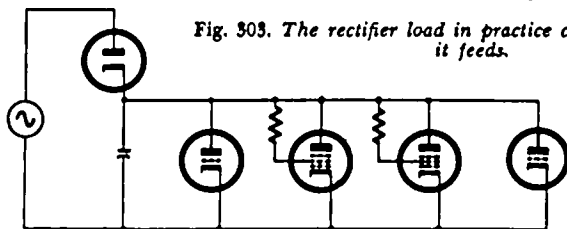

Fig. 303. The rectifier load in practice consists of the tubes it feeds.

μf capacitor is greater than at the terminals of the 30- μf capacitor but contains a larger ripple component. This higher voltage is often used

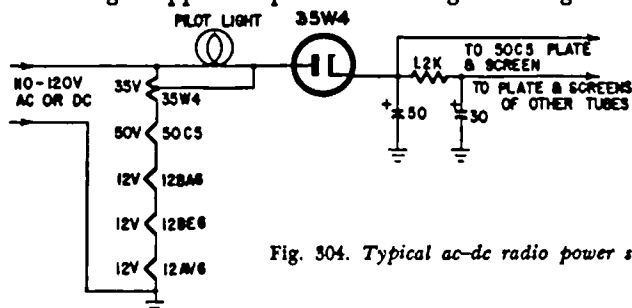

Fig. 304. Typical ac-dc radio power supply.

in a circuit such as the output stage where the higher hum level of the voltage is not so important.

If the power source is dc, the circuit will work, provided the positive side of the source is connected to the rectifier plate. Then, with the plate of the 35W4 at a constant positive potential, the electrons will flow in a steady stream across the tube rather than in pulses, and no rectification takes place. With dc the circuit is free from hum, but may contain other low-frequency noise and the filter circuit is still useful.

If the plug is reversed in the socket (with the negative side going to the 35W4 plate), no current flows through the diode and the receiver is inoperative. The tubes will light, however, for the series circuit through the heaters remains intact—The heater voltage does not depend upon the polarity of the power line. However, because the heaters of all five tubes are in series, if one tube burns out none of them will light. Since all of them are across 110-120 volts, they must all receive the same amount of current and the sum of their voltage drops must approximate the line voltage. In this case the sum is 121 volts (rms) which means that with a lower line voltage a smaller amount of current will flow through the heaters.

The tuning-dial light (pilot light) is connected across one half of the 35W4 heater so that the light and part of the heater are in parallel and the entire combination is in series with the plate. The voltage drop across half of the heater stabilizes the voltage applied to the pilot light. If it burns out, the circuit remains operative. When the set is first turned on, the light will glow very brightly before dimming to its normal brilliance. This occurs because of the initial surge of current through the 35W4 plate to charge the large filter capacitors.

Voltage doubler

Fig. 305 shows a simple voltage doubler using two rectifier tubes. The circuit rectifies both halves of the line voltage through a special arrangement. Even though a transformer is not used, the circuit will operate only with ac and cannot be used with a dc power line.

When the plate of tube V1 is positive with respect to the cathode, the circuit is completed from X through V1, capacitor C1 to Y, charging

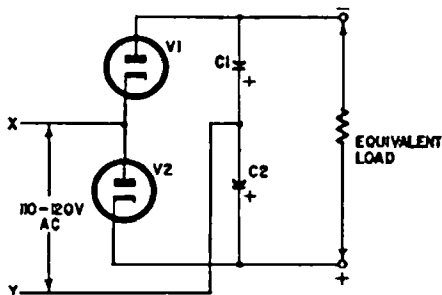

Fig. 305. Basic voltage-doubler circuit.

ing C1 to the peak value of the line voltage. On the next half cycle, when the plate of V2 is positive, the circuit is completed from Y through capacitor C2 and tube V2 to X, charging C2. Since the capacitors are in series, the rectified output voltage is the sum of the voltages across them. This is about double the value of the line voltage.

When a load such as that presented by the plates and screens of other tubes is connected across the output, the current drawn from the capacitors tends to lower the terminal voltage. Therefore the doubler has poor voltage regulation and is seldom used in circuits requiring more than 50-75 ma.

Full-wave rectifiers

The most widely used power source in high-quality electronic systems is the transformer type full-wave rectifier. Beside the advantage of higher output due to the use of a stepup transformer, a larger load can be handled and a better filtering job done by using both halves of the ac sine wave.

The simple full-wave rectifier circuit of Fig. 306-a illustrates the basic principles. The tube shown is a dual-plate unit with a single

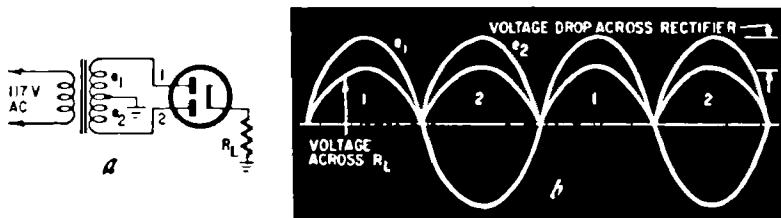

Fig. 306. The full-wave rectifier: a) rectifier circuit; b) output waveform.

cathode. When plate 1 is positive, electrons flow through the tube from the cathode to that plate, completing the circuit through one half of the transformer winding, to ground and back to the cathode through the load R_L . When plate 2 is positive, it attracts electrons which flow through the second half of the transformer winding to ground. This current continues to the cathode through R_L , flowing in the same direction as before. Fig. 306-b shows the rectified waveform.

The voltage developed when plate 2 is positive appears in the same direction as that of plate 1. As with the half-wave rectifier the peak voltage available across R_L is less than the ac input voltage by an amount equal to the internal voltage drop of the tube. This voltage drop varies with the rectifier tube used and the load on it.

The design of the power-supply circuit—including the type of filter used, the type of tube selected and the input voltage required—depends upon the voltage and current needed, the amount of ripple or hum that can be tolerated and the degree of regulation necessary. The filter circuit itself has an important bearing on the output voltage, and the best way to understand how power supplies function is to examine a system where both the output voltage and the degree of ripple must be taken into account.

Ripple factor

Filter circuits are normally designed with either a capacitor or choke input. Sometimes the filters are multisectional but usually consist of a choke and one or two capacitors. Chokes are often used instead of a resistor (as in the case of a half-wave rectifier) because they do a better filtering job. A resistor serves only to control the discharge action of the filter capacitor while a choke resists changes in current and plays a much more active part in the filter circuit.

Fig. 307 shows a typical full-wave rectifier with capacitor input (a) and a choke-input (b). Using a capacitor and inductor in the filter circuit takes advantage of the fact that each can store energy which can be used to smooth the dc pulses. The capacitor smooths the voltage variations and the choke smooths current.

With capacitor input the voltage waveshape at the output resembles that shown in Fig. 307-c and the choke input filter produces the wave-

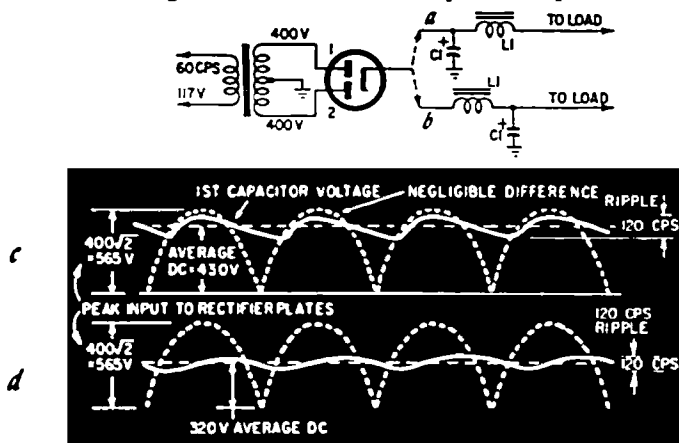

Fig. 307. Different types of filters can be used with the full-wave rectifier: a) capacitor input filter; b) choke input filter; c) waveform produced with capacitor input; d) waveform produced with choke input.

form illustrated in Fig. 307-d. The capacitor input filter produces a higher ripple with sharp and abrupt variations while the choke input circuit develops less ripple with smoother variations but considerably less voltage. In both, the fundamental frequency of the ripple is twice the input frequency, or 120 cycles.

The effectiveness of each filter is measured by the ratio of the rms value of the fundamental component of the ripple voltage to the output voltage. This ratio is called the *ripple factor*. For a capacitor input filter the ripple component can be prevented from reaching other sections of a radio receiver by adding a second capacitor and perhaps another choke. Additional sections can also be added to a choke input filter.

A capacitor input filter is generally used when the current needed is relatively low. With a low load current the capacitor discharge time is fairly long, the low current being equivalent to a high resistance and consequently a long time constant. Therefore, the voltage output does not vary to a great extent from its peak value.

On the other hand, with a choke input filter the changes in current pulses through the rectifier tube are opposed by the choke. Current flows through the choke at all times even though the current through the tube falls to zero as it abruptly changes from one plate to the other. By delaying the buildup of current, the choke input filter produces a much lower output voltage—the average dc load voltage is only about 65% of the peak of the ac applied to the plates of the tube.

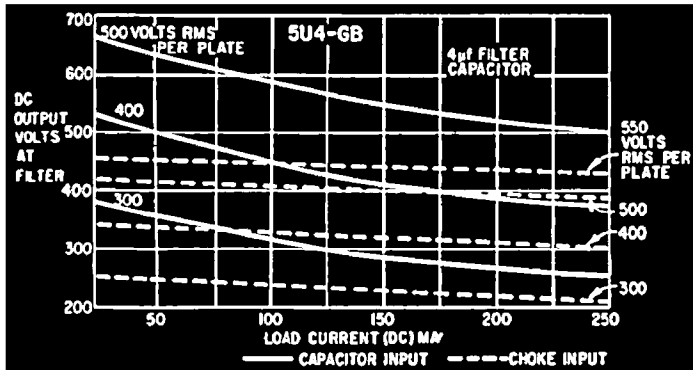

Fig. 308. Curves such as these are often used to indicate a rectifier tube's performance under varying conditions.

The higher the dc resistance of the choke the lower the output (for a given input) becomes.

These differences can be readily understood by referring to Fig. 308, which shows the characteristics of the 5U4-GB full-wave rectifier. Assuming that this tube is used in the circuit of Fig. 307 and that a dc voltage of 450 is required, about 550 volts rms per plate is required if a choke input filter is used. The slope of the dashed lines indicates that the 450 volts obtainable at a 100-ma load drops only to 430 volts if the load is increased as much as 250 ma.

If a capacitor input filter is used, a smaller transformer is required. The curves of Fig. 308 indicate that for a 100-ma load about 400 volts rms per plate is needed. This is 150 volts less than for a choke input filter. However, regulation is much poorer—if the load is increased to 250 ma, the output drops from about 450 to about 380 volts.

An analysis of the voltages at various points in the circuit will clarify the operation of the full-wave rectifier. Assume that a power transformer capable of delivering 400 volts per plate is used. With a load of 150 ma and a capacitor input filter, the dc input to the filter is about 430 volts average (Fig. 307-c). However, with choke input the voltage is only 320. The 430-volt output seems to be greater than the 400-volt ac input, but this is not the case. Remember that the peak of the ac wave is $400 \times \sqrt{2}$, or 565 volts. Figs. 307-c and 307-d also show the shape of the dc output at the other side of the filter.

Peak inverse voltage

Another important factor which must be considered in the design of a power supply is the *peak-inverse-voltage* rating of the rectifier used. Arcing can occur between adjacent elements of the tube if the voltage difference between them is greater than the limits specified by the manufacturer. For example, in Fig. 307, when plate 1 is con-

ducting, plate 2 is negative and reaches its most negative point when plate 1 is at its positive maximum. At that time, when plate 2 is, say, 565 volts below ground, the cathode is about 20–30 volts more positive than the above-ground average of 430 volts. A difference voltage on the order of 1,000 volts exists between electrodes. The 5U4-GB is designed to withstand a peak inverse voltage of 1,550 and, therefore, the selected example is well within the tube's limits.

Bleeder and voltage divider

The good voltage regulation characteristics of the choke input filter exist only under normal conditions of operation where a substantial load current is maintained. If the circuit for which the power supply is designed requires only a few ma, the choke becomes ineffective as a filtering device. A choke functions because of its ability to resist changes in current and, if the current is very low to begin with, it can't change very much. At some point the choke will not keep current flowing through the diode all the time and the voltage-averaging action breaks down. When this occurs, the capacitor at the other end of the choke takes over and the regulatory action of the choke is lost.

In circuits where the load current may become very low, a bleeder circuit is added to the output of the filter. The bleeder is a resistance or series of resistances connected across the output of the filter. The total resistance is such that the current drain of the bleeder is not less than one-tenth the maximum load current. The value of bleeder current depends a great deal on the choke used; the larger the inductance, the smaller is the amount of bleeder current required.

Many bleeders are used as voltage dividers to supply various voltages from a single source. The divider may be engineered very simply by following a few basic rules.

Suppose a power supply furnishes 300 volts at 100 ma, and voltages of 250, 180 and 100 are needed for the various stages of a particular circuit. A four-section bleeder to supply these voltages is required (Fig. 309).

Assuming that the bleeder current should be 10% of the load current, then 10 ma must flow through the bleeder. This additional current must be added to the load current, giving a total load of 110 ma.

Very often the voltage divider consists of a single wirewound resistor with a wattage rating high enough to dissipate the heat generated.

Because the individual load currents pass through their respective bleeder resistors, each component must be shunted by a capacitor large enough to bypass all ac originating in its portion of the radio (or other) circuit. The capacitors shown in Fig. 309 are typical of such bypass arrangements.

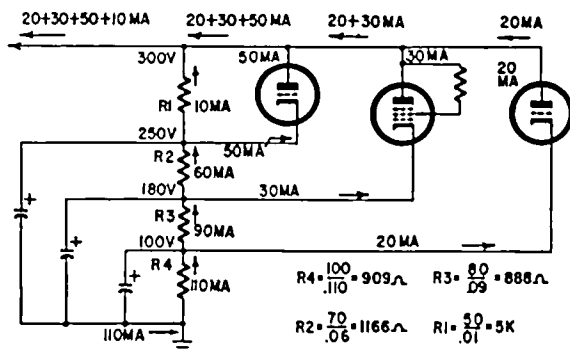
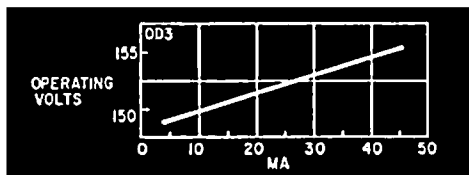

Fig. 309. Four-section bleeder and voltage divider used to supply various voltages and currents from a single power source.

Regulation of low-voltage power supplies

Under ordinary circuit conditions additional regulation of the power supply is usually not required. However, in some circuits the load on the power supply may change rapidly and to a large degree. In such cases, voltage-regulator circuits are added to the power supply.

Fig. 310. Characteristic curve of a typical gas diode.



The type used depends upon the magnitude of variations of the load current and how much correction is needed.

One of the simpler regulator circuits employs a gas diode. Typical of these is the 0D3, used where a constant 150 volts is needed. This tube is a cold-cathode type which uses no heater. It relies upon the establishment of an electric field to pull the electrons from the cathode. From the cathode, they travel at a high speed (dependent upon the potential applied) toward the plate. As they travel, they strike gas molecules in their path hard enough to knock other electrons from the gas, producing secondary emission. When it loses an electron a gas molecule becomes a positive ion, which hurries to the negative cathode. In its course it strikes other molecules, releasing more and more electrons and creating more ions. The end result is a surge of current—positive ions to the cathode, electrons to the anode—accompanied by a gaseous glow within the tube. Once this condition is established, the tube tends to maintain a constant voltage drop across its electrodes regardless of how the load current changes. This voltage

is determined by the electron velocity necessary to maintain the ionization.

Assume, that a constant voltage of 150 is to be maintained across the OD3. The characteristics shown in Fig. 310 indicate that the OD3

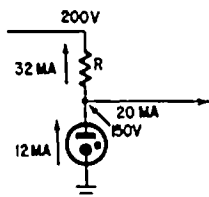

Fig. 311. Simple gas-diode regulator circuit. R is a dropping resistor.

can regulate voltages within the range of 150–155, and that it can carry between 5 and 45 ma. The tube requires 180 volts to get it started.

Assuming that for best regulation 12 ma should flow through the tube, Fig. 310 indicates that the voltage drop across the tube is 150. With a 200-volt supply and a load of 20 ma, a dropping resistor is needed to lower the voltage to 150. This resistance is computed to be

$$\frac{200 - 150}{.020 + .012} = \frac{50}{.032} = 1,560 \text{ ohms which is shown as R in Fig. 311}^1.$$

For higher voltage regulation these tubes may be placed in series (Fig. 312). If V1 and V2 were each a OD3, this arrangement would provide regulation for 300 volts. In this case R is designed in the same manner as with a single tube.

While gas-diode regulator tubes are suitable for use in circuits where nominal load fluctuations occur, they are not designed to handle wide variations of load such as might occur in on-off keying of CW signals or where the load might vary as much as 100–200%.

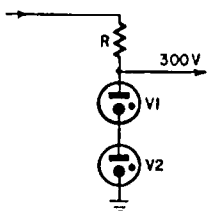

Fig. 312. To provide regulation of higher voltages, gas tubes are sometimes placed in series.

For such special applications, a series-regulated type of circuit is used. The load current is supplied directly from the cathode circuit of a power amplifier tube. Fig. 313 illustrates a circuit which makes use of this arrangement but which also includes gaseous diodes. This circuit compensates for a change in load current plus any fluctuations in the ac line voltage.

If the load decreases, the output voltage increases, making the grid

¹ A more detailed discussion of gas tubes is presented in Chapter 8.

of V2 less negative, thus increasing its plate current. Increased current flow through resistor R2 (which is large with respect to the plate resistance of V2) increases the negative bias on V1. This produces an

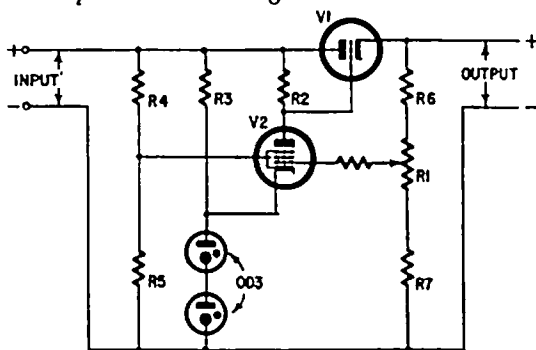

Fig. 313. This regulator circuit also provides means to account for fluctuations in the ac line voltage.

increase in the plate-cathode voltage drop, reducing the output voltage. The desired output to be regulated is controlled by arriving at

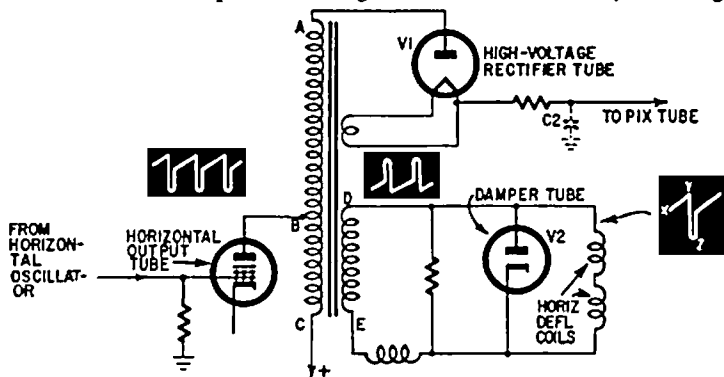

Fig. 314. Typical flyback high-voltage supply. This type of high-voltage system is used in many TV sets.

the proper position on R1. Voltage-regulator tubes stabilize the cathode potential of V2 so that potential variations between the grid and cathode are dependent only upon changes in the output. A change in input voltage produces the same effect because a variation in the voltage drop across R4 and R5 also changes the current flow through V2.

High-voltage power supplies

So far, discussions on power supplies have centered on the most familiar types used in radio receivers or amplifiers where the maxi-

mum voltages required are several hundred volts. In TV sets, however, potentials can reach 16,000 to 25,000 volts. Although the voltages required to accelerate the electron beam in the picture tube are very high, the load current is low and is measured in microamperes. The power supplies previously discussed handle fairly large load currents and are rather bulky. With low load currents, however, the high-voltage supply requires relatively small component parts of light weight.

The high-voltage supply does not use the 60-cycle ac line as its source. Instead, a relatively high frequency generated within the TV set is used. This makes it easier to filter the rectified dc component.

TV flyback system

One of the many types of high-voltage power supplies used in TV receivers is the transformer-coupled flyback system illustrated in Fig. 314. It uses the output of the horizontal oscillator of the receiver to trigger high-voltage peaks which are then rectified.

Since the electron beam of the cathode-ray tube must scan the screen fast enough to trace a picture, the scanning rate is high. Therefore, these pulses which are used to move the beam across the tube are repeated at a rapid rate—15,750 times per second. These rapid pulses from the horizontal output tube (which amplifies the horizontal oscillator output after it has been shaped into the proper kind of sawtooth wave) are passed through windings B-C of the transformer to the secondary and then to the deflection coils. During the horizontal trace period a sawtooth current passes through the deflection coils (this is the period between X and Y). This causes a magnetic field to build up around them. During the retrace period the current drops abruptly (Z), inducing a high-amplitude transient voltage in the coil. This pulse is then "kicked" back into the secondary D-E. During this retrace period the horizontal deflection coils are, in effect, acting as a high-voltage generator. This high-amplitude pulse is stepped up through the transformer, returning it to the primary where it appears as a peak voltage, measuring thousands of volts, across the entire primary A-C.

The pulse is applied to the high-voltage rectifier V1 which changes the transient voltage into dc. The rectified pulses are fed through a resistance-capacitance filter.

Even though the pulses occur at a fairly rapid rate, the transient voltage itself is a sharp pulse of extremely short duration. Therefore, the spacing between the pulses is relatively long and, to maintain a constant dc output voltage, the charge on filter capacitor C2 must be maintained during this interval. However, at a frequency of 15,750 cycles, capacitors on the order of 500 μmf are large enough.

Diode V2 connected across the deflection coils is known as the damper tube and plays an important role in the high-voltage system. In Fig. 314, while the horizontal output tube is cut off during the retrace period Y-Z, the sudden collapse of the field about the deflec-

tion coils causes the secondary of the transformer to oscillate at the resonant frequency of the circuit formed by the inductance and distributed capacitance of the winding. The first half-cycle of the pulse constitutes the retrace period Y-Z. The next half-cycle of oscillation is

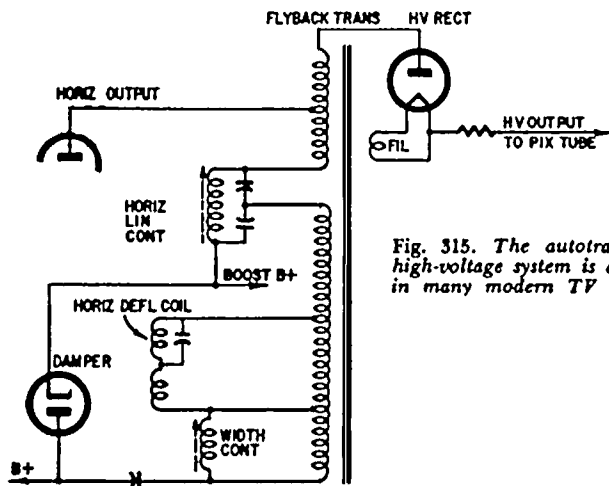

Fig. 315. The autotransformer high-voltage system is also used in many modern TV receivers.

positive and, if the damper tube were not present to short this pulse, a series of transient oscillations would occur, carrying over into the trace period and causing a distorted picture. By preventing the development of the first positive half-cycle, the damper tube prevents the formation of succeeding cycles.

While not shown in Fig. 314, many receivers use the energy diverted through the damper tube to reinforce the high-voltage pulse to the picture tube. Several methods are used to obtain this boost voltage. In some cases the voltage developed across a cathode resistor and capacitor in the damper is added to the plate circuit of the horizontal driver between the lower portion of the transformer primary and B plus. In other systems a capacitor bridged from the cathode of the damper to the low-voltage power supply stores energy during the retrace period when the damper tube conducts and releases it to the driver during the trace period, boosting its output.

Autotransformer high-voltage system

Because of its simplicity and economy the autotransformer type of high-voltage supply is popular. The basic action of the circuit is similar to the flyback system except that the use of the autotransformer permits connecting the damper tube effectively in series with the transformer winding to obtain additional high voltage. The plate of the damper tube in this type of circuit (Fig. 315) is connected to the low-

voltage power supply. In this manner the supply voltage is added to the boost voltage obtained from the damper tube.

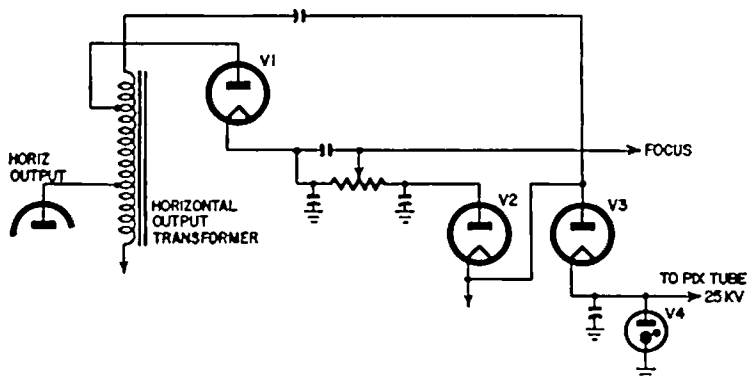

Fig. 316. *V4 is the voltage regulator in this simplified system.*

In color TV, changes in picture content vary the current drain from the high-voltage source. Any change in output voltage from the rectifier varies the brightness of the entire picture as well as the focus and overall size. Therefore, some measure of regulation is necessary. One method which uses a gaseous regulator is similar to the voltage regulators described earlier. Fig. 316 shows a typical high-voltage power supply in which such regulation is used.

The regulator tube *V4* is a metallic cylinder filled with hydrogen. It acts like the gas tubes described earlier but a much higher voltage is needed to fire the tube. Once fired, it is sustained at the voltage to be regulated. In this circuit, as the voltage output from *V3* attempts to rise, the current drain through *V4* increases. The increase in the total current from the high-voltage rectifier tube (load plus *V4*) increases the voltage drop through the regulator so that the voltage at the output remains constant.

Another type of regulator is shown in Fig. 317 in which a triode (*V4*) is used for regulation. The triode is bridged across the 25-kv high-voltage output while the cathode is connected to a 200-volt point on the low-voltage power source. Since the grid receives its input from a resistance network in the rectifier circuit, its voltage is sensitive to any variation in output voltage. Thus, if the high-voltage rises due to less current drain from the picture tube, this increase appears as an increase in positive polarity at the grid, increasing the current drawn by *V4*. This offsets the loss at the picture tube, maintaining a constant load and therefore constant voltage. If the current drawn by the picture tube increases, the reverse occurs.

Vibrator power supplies

Thus far all of the power supplies discussed utilize a commercial

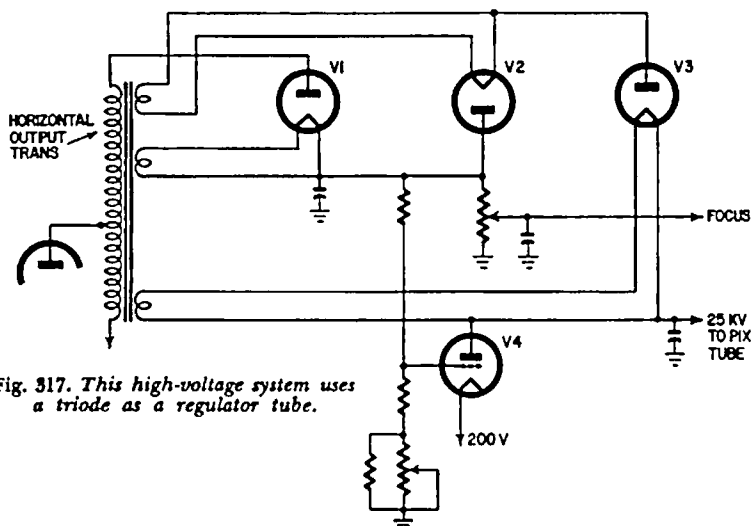
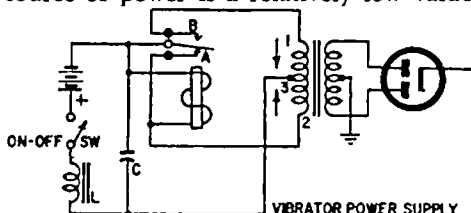

Fig. 317. This high-voltage system uses a triode as a regulator tube.

or self-generated source of ac, which is rectified and filtered. The familiar full- and half-wave rectifier tubes are often used in conjunction with a vibrator. When the source of power is a relatively low value

Fig. 318. Typical vibrator power supply.



of dc, something must be done to raise the voltage before it can be used. A transformer will not do this job. An electromechanical device, the vibrator, is often used for this purpose.

Fig. 318 shows a simple vibrator circuit. When the switch is closed, the electron flow is through half of the transformer winding 2-3, then through coil L and switch SW back to the battery. Current through the relay coil closes contact A, which shorts the relay, causing it to release. The sudden release of the armature makes it kick over to contact B, routing the current through the other half of the transformer winding 1-3. This current changes the polarity of the transformer winding. The cycle then begins over again and will continue as long as the switch is closed. The armature moves from contact A to contact B several times a second and the alternating voltage produced is stepped up by the transformer and applied to a full-wave rectifier.

The output of the vibrator is not a sine wave but a series of sharp

peaked waves whose magnitude depends upon the inductance of the choke L and the stepup ratio of the transformer. A good filtering job must be done to minimize the ripple voltage. Generally a two-section filter is used.

Constant making and breaking of the vibrator contacts causes a certain amount of arcing to occur and is a source of rf interference. Choke L and capacitor C are arranged to eliminate the interference partially. Connecting capacitor C between the armature of the relay and the center tap of the transformer primary allows it to bypass rf generated at either contact. The choke offers a high impedance to the flow of rf beyond the capacitor. Another coil and capacitor across the secondary (not shown) complete the rf filtering.

Diode detectors

In addition to the diode's function as a power supply rectifier in radio and TV receivers, it is used to separate the basic intelligence radiated from the transmitter to the receiver.

AM detection

An amplitude-modulated carrier is shaped as shown in Fig. 319. The process of modulation at the transmitter is such that the audio signal is imposed upon the carrier so that the amplitude variations of the carrier occur at a rate directly proportional to the frequency of the

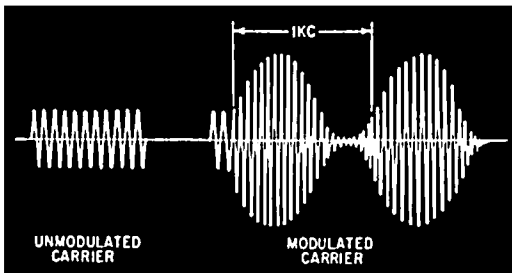

Fig. 319. Typical unmodulated and amplitude-modulated carrier waves.

audio variations. The magnitude of the carrier peaks is directly related to the amplitude of the audio. The relationship between the audio power and the power of the carrier is called the modulation percentage.

In practice, the modulated carrier wave is irregular in shape because the audio signal is made up of frequency components comprising a range of well over 5,000 cycles. Diode function, however, is the same whether the audio is a complex wave or a single-frequency wave of constant amplitude. For the purpose of this discussion, the modulated carrier arriving at the input to the diode is assumed to resemble the wave shown in Fig. 319.

The application of an amplitude-modulated signal to a diode

circuit results in rectification, one half of the carrier being cut off. The variations and amplitude of the remaining half-wave pulses form an envelope pattern which is, in fact, the audio signal itself. In Fig. 320 the input signal produces half-wave current pulses through the load resistor R_L . If capacitor C were not in the circuit, the voltage pattern would look exactly like the waveshape of the current pulse at A. However, with C in the circuit, filtering action takes place and the voltage pattern across R_L closely resembles the audio signal at B. The

Fig. 320. Simplified detector showing waveforms at various points in the circuitry.

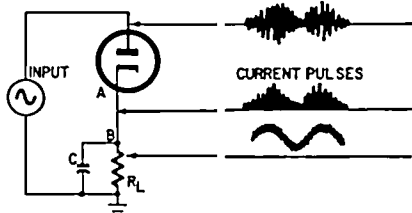

result is not a pure audio signal because small carrier ripples are still present in the wave. This additional carrier is filtered or bypassed prior to audio amplification.

The ideal detector reproduces the exact intelligence applied at the transmitter. Failure to do so causes distortion; the audio output contains new frequencies not in the original signal. Therefore, selection of the proper diode load resistor and capacitor is most important.

Fig. 321. If the filter time constant is too long, severe distortion results from clipping.

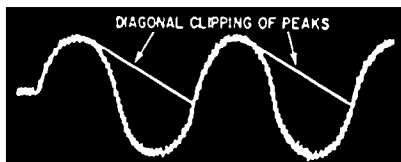

The R-C portion of the detector circuit has two closely related functions. The relative values of resistance and reactance affect the discharge time of the capacitor, hence the degree of distortion. Considering first the relationship between R_L and C , the voltage across C can die away only as fast as the charge can leak through R_L . If R_L and C are made large in value so that the capacitor discharge time is long, (to flatten rf ripples in the audio signal) there is severe distortion. (Fig. 321). (The discharge time is so long that it carries over the trough of the audio signal, actually "clipping" the peaks of the audio.)

The value of R_L compared to the plate resistance of the diode determines the detection efficiency, which must be high to hold distortion to a minimum. For high plate efficiency, R_L must be large in respect to the diode plate resistance. With a high load resistance the power absorbed in the tube is a smaller part of the energy in the input signal. With R_L at least 20 times r_p the diode efficiency is 80%. If R_L is increased to as much as 100 times the plate resistance, the efficiency

will rise to about 95%. Capacitor C must be as small as possible to offer a high reactance to the highest audio frequency. It should bypass the carrier only and not the audio. As small as it is, however, its capacitance must be about 10 times the diode plate-to-cathode capacitance so that most of the reactive drop will be across the tube, leaving only a small part to appear across C. This puts the value in the order of 50 to 150 μf .

R_L should have a resistance of about three times the reactance of C at the highest audio frequency to be handled. For example, suppose

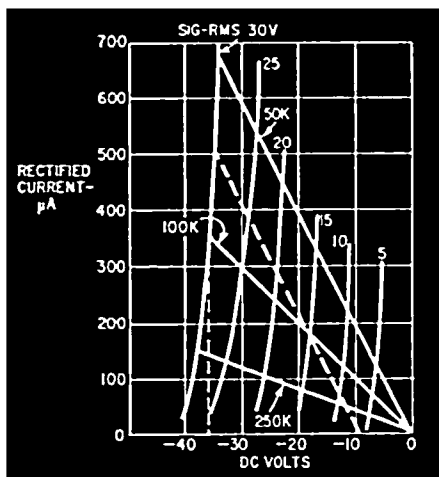

Fig. 322. Typical diode characteristics with various values of load resistances.

the circuit of Fig. 320 used one half of a duo-diode. The tube manual would show diode characteristics for different values of load resistance with various input signals. Fig. 322 is typical. With a 100,000-ohm load resistance, an input signal of 15 volts rms would deliver about 180 microamperes, producing 18 volts across R_L . With 100% modulation, the maximum input voltage is 2×15 , or 30 volts rms, equivalent to an output voltage of 36. Since the minimum voltage is zero, the dc potential varies from 36 volts to zero, for an average of 18. The voltage variation across R_L is ± 18 , proving that the diode is linear.

When the diode is put to work (when its output supplies the first audio amplifier), the grid circuit of the audio stage "loads down" the detector. If the grid resistor of the audio amplifier were 100,000 ohms, the net diode load would become 50,000 ohms. If a new load line were drawn (shown dashed) through the operating point, the dc voltage would vary from 34 maximum to about 9 minimum. This indicates that, where the minimum value should be zero, it actually goes no

lower than 9 volts, giving considerable distortion. Because of this biasing effect, the minimum is reached at about 5 volts rms. So the troughs between 0 and 5 do not get reproduced at all, being completely flattened.

Simple avc

The diode detector circuit permits the addition of simple avc (automatic volume control) compensating for wide differences in carrier signal strength by changing the bias of the rf or if amplifier tubes (or both) in the radio receiver circuit.

Tube amplification is the ratio of a change of plate voltage for a given change in grid voltage. With changes, we are really dealing in

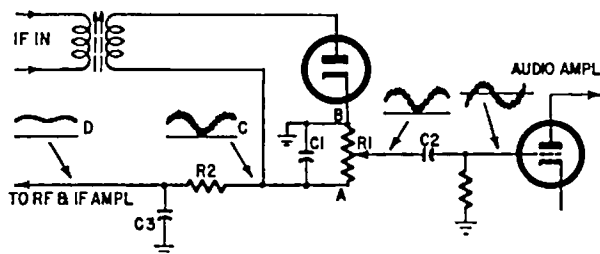

Fig. 323. Simple automatic-volume-control circuit and associated waveforms.

curve slopes, and the slope of a tube characteristic determines its constants. Considering tube transfer characteristics, the curves bend when approaching cutoff even though they are relatively straight up to and perhaps slightly beyond the zero bias point. A change in tube bias will shift the operating point along the transfer characteristic. This shift could be large enough to reach the point where the curve slopes, and hence the amplification changes. The application of a varying bias (such as avc voltage) will vary the gain.

In Fig. 323, a diode detector is arranged for avc operation. The input to the diode is from the if stage of the radio receiver. The load resistor is a volume control potentiometer. The output wave contains the audio signal with a carrier ripple. However, because the current pulses are unidirectional, the output is not a true ac wave but varying dc with an ac component superimposed upon it. By putting capacitor C2 in the potentiometer output circuit, the dc is blocked and ac only is applied to the grid of the audio amplifier. In fact, C2 acts like a coupling capacitor in a resistance-coupled amplifier circuit. The voltage applied to the audio stage can be varied by R1. Turned all the way to point A, the input is maximum. Turned to B, minimum output is obtained.

The dc component is not constant but varies in proportion to the rectified signal, as shown at C. Since this voltage is to be used as a

bias voltage it must be a constant average of the total variation. R2 and C3 take care of this part of the job. Their time constant is such that the wave is smoothed out as shown at D, supplying a constant bias voltage.

The dc component is really the amplitude of the carrier signal itself. With a strong signal, the entire modulated wave is larger and the dc component is greater. Since the dc component varies directly with the strength of the carrier signal, the negative bias applied to the amplifier stages varies. Because a strong signal produces a large negative bias, it reduces the amplification of the if and rf stages to which the bias is applied. With weak carrier signals, the reverse is true; the output volume of the receiver is controlled automatically by the carrier signal itself. In some cases, particularly in shortwave reception where a high degree of rapid fading is common, it is desirable to design the avc circuit to follow signal variations closely. For example, if the R2-C3 time constant is too long, a strong signal burst will charge the capacitor to a relatively high value, which will remain high when the signal fades to a lower signal strength. On the other hand, too short a time constant would not provide enough smoothing effect and the avc will "follow" low audio frequencies, causing a bass loss.

With the avc circuit just discussed, some value of bias is always applied to the amplifier tubes. This may be a disadvantage when the

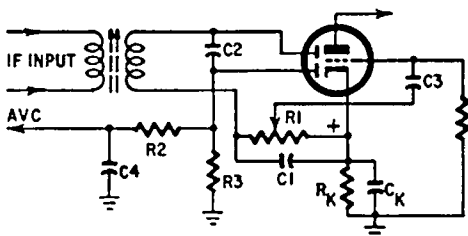

Fig. 324. Delayed automatic-volume-control circuit.

radio receiver is tuned to a weak signal. If the bias could be removed entirely for weak signals, maximum amplification would be obtained. This can be achieved if the avc circuit is arranged to supply a negative bias only when the incoming signal reaches a certain level. In other words, the avc can be delayed.

Delayed avc

In Fig. 324, the negative bias generated in the avc circuit must first overcome a fixed positive potential. The tube used in the circuit is a duo-diode-triode, with plate 1 acting as the diode detector and plate 2 wired to produce the delay feature. The triode section utilizing plate 3 acts as the first audio amplifier. The diode detector load resistance R1 and capacitor C1 are the same as in the simple avc circuit. However, the cathode is not grounded directly but is connected

to ground through a bias resistor R_K with a bypass capacitor, C_K . Diode plate 2 supplies the avc voltage which is developed across R_3 . With no carrier, the cathode is above ground by the amount of voltage drop (about 3 volts) through R_K (due to plate current flow in the

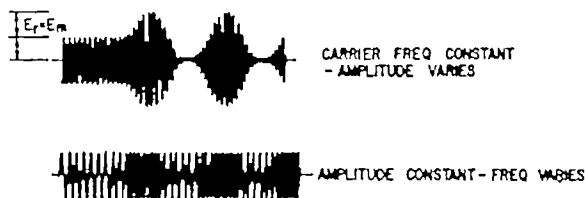

Fig. 325. Comparison of amplitude-modulated and frequency-modulated waves.

triode section of the tube), and diode plate 2 is negative with respect to the cathode by this same amount. This condition exists as long as there is no current flowing through R_3 .

When a carrier signal is applied to the diode, plate 1 functions as a diode detector supplying the audio signal to the triode section via C_3 . The voltage appearing at plate 1 is applied to plate 2 by coupling capacitor C_2 , but no current flows from the cathode to plate 2 because it is negative with respect to the cathode. Until the voltage is high enough to overcome the negative bias produced by R_K no voltage will appear across R_3 . When plate 2 reaches that point, the complete circuit will consist of a rectified flow of current from cathode to plate 2 through R_3 and R_K back to the cathode. The rectified voltage will appear across R_3 , making point X negative with respect to ground. R_2 and C_4 take care of the filtering as with simple avc. Thus, avc is not applied for weak signals and comes into play only when the signal is large enough to overcome the preset fixed bias.

Diodes as FM detectors

The diode has an important job to do in the FM receiver also. It is used in two types of circuits which perform the same function—the discriminator and the ratio detector.

The waveshape or characteristic of the frequency-modulated wave can be understood by comparison with the AM-modulated carrier. With the AM wave, the amplitude is varied in accordance with the modulating audio signal. The amount of amplitude change is determined by the loudness or power of the audio wave. The frequency of amplitude fluctuation corresponds with the modulating audio frequency. By direct analogy, the frequency of the FM carrier is varied at a rate determined by the frequency of the audio signal while the amount of frequency change or frequency deviation from normal is directly related to the strength or power in the audio signal. Fig. 325 illustrates these types of modulated carriers.

Discriminator

The problem of demodulation that must be solved in the FM receiver is the conversion of frequency variation into voltage variation. To accomplish this task, straight rectification, such as is done with the diode detector, is not the answer. The FM wave has no amplitude variation, hence rectification cannot separate the audio from the carrier.

In searching for a circuit to do the job, consider the ordinary resonant or tuned circuit. Such a curve with its sloping sides on either side of the resonant frequency offers a range of operation over which frequency changes result in current or voltage changes. However, the discriminator uses a different method and performs these functions with excellent results.

In Fig. 326, the frequency-modulated carrier from the limiter is applied to a duo-diode through a set of resonant circuits tuned to the center frequency. This combination of coupled resonant circuits and duo-diode with resistance and capacitance load is known as a discriminator.

To analyze properly the function of the discriminator, consider first the effect of the induced voltage in the secondary of the transformer, neglecting for the moment the voltage applied directly through C5. The output of the limiter is coupled to the secondary of the tuned transformer which is directly connected to the plates of both diodes. Voltages applied by the secondary to each diode are therefore 180° out of phase with each other at all times. Because point M is the electrical center of the secondary coil, the voltages applied to each plate are equal as well as 180° out of phase and are represented as e_1 and e_2 . Without any connection through C5 to the transformer secondary each

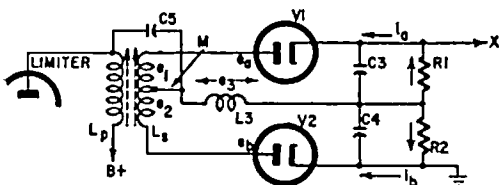

Fig. 326. The discriminator is often used as an FM detector.

of these voltages would act on their respective diodes, causing current pulses to flow alternately through each diode as its plate becomes positive. With identical diodes, the voltage developed across equal resistors R1 and R2 would be equal and of the same polarity. Even though these current pulses are 180° out of phase, capacitors C3 and C4 hold the charge so that, under the condition just described, point X and ground are at the same potential—there is no voltage from X to ground.

In this process, current pulses flow through L_3 during each cycle because the circuit is common to both diode plates.

The foregoing discussion indicates that the discriminator output voltage is zero (point X to ground) as long as the voltages applied to each diode plate are equal. This is true regardless of the phase relationship between the voltages because output capacitors C_3 and C_4 tend to hold the voltage output of each tube section constant. However, a third voltage e_3 , applied directly to the transformer secondary, must be taken into account. This voltage adds vectorially to the induced voltage in the secondary so that the actual voltage applied to each plate is the vector sum of two voltages. The questions to be answered then are, what is the phase relationship of e_3 with e_1 and e_2 , and how does it combine with each to give the desired results?

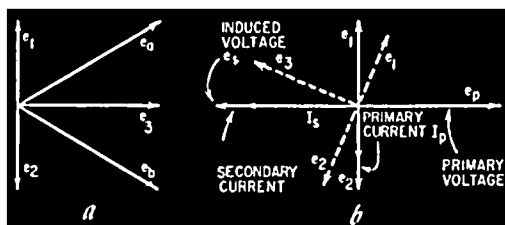

Fig. 327. Phase relationships within the discriminator circuit: a) voltage relationships; b) results of voltage and current vector addition.

There is no question regarding the phase relationship between e_1 and e_2 . Since they are each on opposite ends of the transformer secondary, they are *always* 180° out of phase with each other. Voltage e_3 , however, is of the same polarity as the primary and, as shown in Fig. 327-a, is 90° out of phase with both e_1 and e_2 . This 90° relationship may be readily understood when we remember that the transformer secondary is coupled to the primary by a mutual inductance.

The secondary is a series resonant circuit as far as the induced voltage is concerned. At resonance, secondary current is in phase with the induced voltage. However, because of its reactance the voltage across the capacitor (C_5) lags the secondary current by 90° . Since the primary current lags the primary voltage by 90° (because of the inductive reactance of the coil) the induced voltage in the secondary must lag the primary current by 90° . The primary and secondary currents are therefore 90° out of phase. Since the voltages in each winding are each 90° out of phase with their respective currents, they are in turn 90° out of phase with each other. The primary voltage e_p is 90° out of phase with both e_1 and e_2 (Fig. 327-b). The voltages applied to the diodes are the vector sums e_a and e_b of Fig. 327-a.

When the carrier is modulated, its frequency shifts above and below the center frequency. When it shifts upward, the reactance of the

capacitor decreases and that of the coil increases. Since the inductive reactance predominates, the secondary circuit is inductive and the secondary current lags the induced voltage by some angle (Fig. 327-b). Since the induced voltage always lags the primary current by 90° , the secondary current lags the primary by 90° plus some angle. Secondary voltages are 90° out of phase with the secondary current and are therefore no longer 90° out of phase with the primary voltage for e_s .

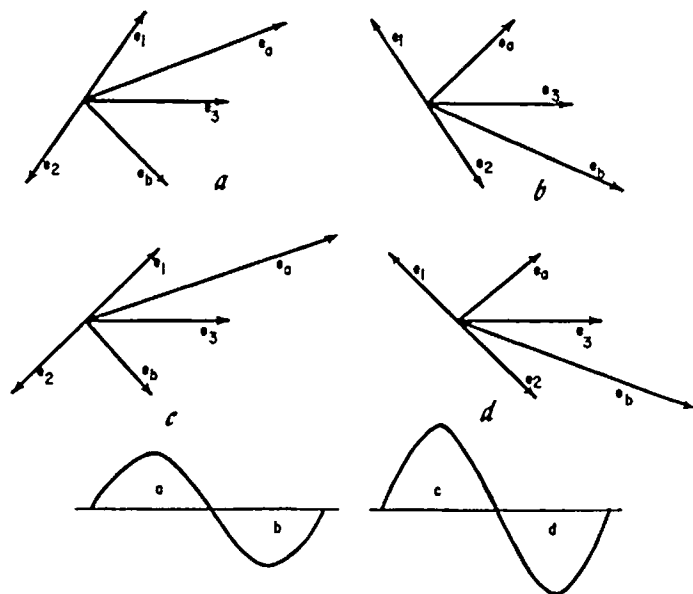

Fig. 328. The phase shifts which occur in the discriminator result in audio waves at its output: a) the positive half of a sine wave in vector form; b) the negative half of the same wave; c) this vector diagram represents the positive half of a wave of greater amplitude than that shown in a; d) the negative portion of a wave of equal amplitude.

The phase shift of e_1 and e_2 with respect to e_3 is indicated in Fig. 327-b. The vector sums of $e_1 - e_3$ and $e_2 - e_3$ are no longer equal and the resultant voltages e_a and e_b are different— e_b being greater than e_a . Rectified voltages through the diode sections are no longer equal and a difference voltage appears at point X of Fig. 326. In this case point X is negative with respect to ground.

When the carrier shifts to a lower frequency (during the other half of an audio cycle) the phase relationships are opposite, with the secondary current leading the induced voltage. The net result is an increase in e_a and a net difference voltage at X, positive to ground.

Thus variations in carrier frequency result in variations of the

voltage at point X in direct proportion to the audio frequency. Fig. 328 shows how the shift in phase of e_a and e_b results in a shift of polarity at X.

Deviation ratio

If the audio frequency is 1,000 cycles, the received frequency will vary above and below the carrier 1,000 times per second. If the audio were 5,000 cycles, the frequency change would occur 5,000 times per second. Because the frequency change of the carrier is directly related to the power or amplitude of the audio signal, there is a practical relationship between this frequency deviation and the maximum audio-frequency amplitude to be handled. The ratio of these two frequencies is called the deviation ratio and for broadcast work is usually in the order of 5 to 1. Actually, the greater this ratio is, the greater will be the signal-to-noise ratio. On this basis, in FM broadcasting, if high-quality transmission is required and audio frequencies as high as 15,000 cycles are to be transmitted, the carrier frequency would shift $5 \times 15,000$, or 75,000 cycles. However, in voice broadcast work, such as in the various bands used by taxicabs, police, etc. where the highest audio frequency need be no greater than about 3,000 cycles, a frequency deviation of 15,000 cycles is all that is necessary to produce a similar signal-to-noise ratio.

As a final consideration, to do a good job, the discriminator should produce an audio wave that is the exact replica of the transmitted wave. The discriminator, if it is to handle a deviation ratio of 75,000 cycles, must be linear over the entire range; that is, its output voltage variations must be directly proportional to the carrier-frequency deviations. Since the voltages that reach the diode plates are related to the output of the mutually coupled resonant circuits, the tuned circuits must be made flat over the frequency range to be handled by selection of proper values of load resistors (R_1 and R_2 of Fig. 326). Moreover, for a proper balance at the output of the discriminator, R_1 and R_2 should be as equal as possible and both diodes should be identical.

Ratio detector

The ratio detector used in some FM receivers acts somewhat as a discriminator but performs its function in a different manner. As shown in Fig. 329, mutually coupled tuned circuits supply the input to the dual diode. But in this case the diode sections are connected in series and voltage e_b , fed from the transformer primary to the secondary, is lower in magnitude than it was in the case of the discriminator. This is done because, when taken directly from the plate as with the discriminator, the load on the preceding amplifier is increased. With the discriminator, this loading effect is negligible because the preceding amplifier is operated as a limiter which functions normally with relatively low impedance loads. With the ratio detector, however, the preceding tube is a normal if amplifier with no limiting

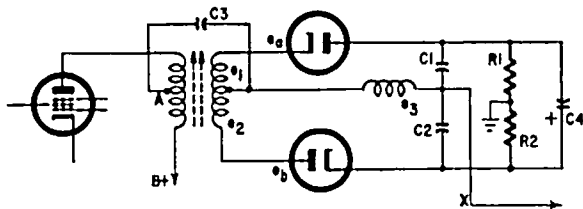

Fig. 329. The ratio detector is another often-used FM demodulator.

action and requires a relatively high-impedance load. By tapping off the primary circuit at point A as shown (instead of from the plate of the preceding tube in the discriminator circuit) the high-impedance load on the preceding amplifier is maintained.

Since the phase relationships between e_1 , e_2 and e_3 are the same as with the discriminator, resultant voltages e_a and e_b are produced in exactly the same manner. However, in this case, current flows through both plates at the same time and only when e_b is positive and e_a negative in relation to each other. In effect, R_1 and R_2 are in series and the voltage drop across both is held constant by capacitor C_4 . Because C_1 and C_2 are also in series across C_4 , the sum of their charges must always be the same as the sum of the IR drops across R_1 and R_2 and the voltage across C_4 .

Because the preceding amplifier is not a limiter, the incoming signal to the detector is subject to amplitude variations of the carrier. However, because the combination of R_1 , R_2 and C_4 has a long time constant, the voltage across them (including C_1 and C_2 in series) is held at a constant value and the ratio detector tends to do its own limiting. Even though the voltages e_a and e_b act in series in the circuit, they differ from each other when the carrier is frequency-modulated. However, the voltage applied to C_1 develops a charge dependent upon e_a , and the charge on C_2 depends upon e_b , since each is in the local circuit of each diode section. Therefore, the charges across C_1 and C_2 vary as the carrier is frequency-modulated but their sum is held constant by C_4 .

Because the voltage drop across R_1 and R_2 is held constant, the potential between the center of C_1 , C_2 and R_1 , R_2 varies in proportion to the difference in charge between C_1 and C_2 . Since this difference in charge is proportional to the difference between e_a and e_b , the resultant voltage between X and the midpoint of R_1 and R_2 (ground) is the audio signal itself. Thus, the ratio detector converts frequency variations to voltage variations while at the same time acting as its own limiter.¹

¹ Tubes other than diodes are often used as FM detectors. The gated-beam discriminator (quadrature-grid FM detector) is discussed in the chapter on miscellaneous applications, page 160.

vacuum-tube amplifiers

THE amplifying property of vacuum tubes is directly related to the control grid because of the ability of this electrode to produce large changes in plate current while requiring little or no current itself. The triode and pentode (including beam power tubes) are amplifiers and the variety of circuits in which they can be used seems unlimited.

Triode amplifiers

The triode is the simplest of all amplifiers since its plate current is influenced by only three electrodes: the cathode, control grid and plate. The triode can be put to work by applying the proper bias to the grid and inserting a load in the plate circuit. The equivalent circuit of the triode can be represented as in Fig. 215 in Chapter 2. The amplification of the tube is related to the ratio of R_L to r_p , as indicated in formula 6, page 33, in Chapter 2.

If R_L is made high enough (about 10 times the dynamic plate resistance) the amplification of the circuit will be very close to the μ of the tube. Actually, it doesn't work that way because increasing R_L too much introduces other limitations. Too high a load resistance reduces the operating current so that the dynamic plate resistance increases and the tube functions at a point which produces severe distortion.

Fig. 401 shows the characteristics of a representative triode (having a μ of 20) plus several load lines. Assuming a supply voltage of 250, under normal operating conditions a load of 8,000-10,000 ohms could be used. With a dynamic plate resistance of 7,700 ohms, a load of 8,000 ohms results in an amplification of 10.8 (equation 6). In Fig. 401, the triode with an 8,000-ohm load and a grid bias of -2 volts operates with a plate current of about 12.4 ma. The application of

a 2-volt peak input signal varies the plate current between a maximum of 15.2 ma and a minimum of 9.6. The current variations appear to be symmetrical, changing 2.8 ma on either side of the mean of 12.4. This lack of distortion (within the accuracy of the graph) results from the fact that the load line intercepts the characteristic curves on the straight-line portion of the I_p - E_b curves. As the plate current is varied, the voltage at the plate changes from 129 to 175, or ± 23 volts from the operating voltage of 152. The plate voltage reaches maximum value when the plate current is lowest.

The amplification properties of the triode are limited because of this change in plate voltage when a signal is applied to the grid. If the plate voltage had remained at 152 (a condition that could occur

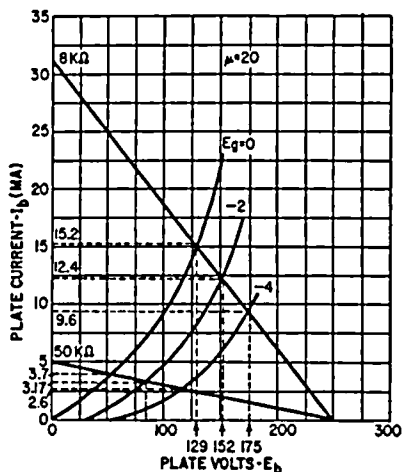

Fig. 401. The operating point of a vacuum-tube amplifier can be determined from its characteristic curves. The plate curves for a typical triode are shown.

only if $R_L = 0$) the 2-volt grid swing would have changed the current 21 ma in one direction and 6.5 in the other, giving a total peak-to-peak current change of 14.5 ma instead of 5.6.

If a load of 50,000 ohms instead of 8,000 is used in an effort to increase amplification, then from equation 6:

$$\text{Amplification} = \frac{20 \times 50,000}{7,700 + 50,000} = 17.3$$

The solution assumes that the value of r_p remains at 7,700, but strict adherence to the equation does not take into account any changes which can be caused by using various inputs or grid bias voltages. Because the dynamic plate resistance does change, all conditions must be considered before the formula is used. Since all information re-

garding tube operation is contained in the characteristic curves, the *real* amplification can be derived directly from them for any condition of operation. Equation 6 applies only if typical operating values are used. However, when working with specific current and voltage values taken from the characteristic curves (Fig. 401) it is often difficult to use the graph accurately, especially when the working region is in the low-current portion of the characteristic.

To determine the amplification with a 50,000-ohm load, data can be taken directly from the curves, which will take any change in dynamic plate resistance into account. Since the amplification of a tube must be equal to the ratio of the output voltage (e_o) to the input signal (e_g):

$$\text{Amplification} = \frac{e_o}{e_g} \quad (9)$$

To find the change in plate current with a 2-volt peak input signal and a -2-volt bias, data must be obtained from Fig. 401. The 50,000-ohm load line crosses the -2-volt bias curve at a point where the current is 3.17 ma. The 2-volt peak input will vary the current from 2.6 to 3.7 ma, or an ac peak change of 0.57 ma. Using these values in equation 9, the amplification

$$A = \frac{0.57 \times 10^{-3} \times 50,000}{2} = 14.25$$

or less than the value derived directly (see page 70) where a dynamic plate resistance of 7,700 ohms was assumed. This indicates that the plate resistance has changed; otherwise the solutions of the equations would have been the same.

To find the new value of r_p in the low-current region, assume that the grid bias is held at -2 volts. A current change of 1 ma produces a plate change of 17 volts, indicating that the dynamic plate resistance is double the value when a load of 8,000 ohms is used, or

$$r_p = \frac{17}{.001} = 17,000$$

Using equation 6 with this new value of r_p , the amplification becomes

$$\frac{20 \times 50,000}{17,000 + 50,000} = 14.9$$

which is very close to the value obtained by using equation 9.

However, with an 8,000-ohm load where the operating current is 12.4 ma and the tube functions on the straighter portions of the curves, the amplification calculated by using equation 6 is valid. To verify this let us calculate the amplification using equation 9. In Fig. 401, the 8,000-ohm load line crosses the -2-volt grid curve at 12.4 ma. The 2-volt input signal results in a peak alternating current at the plate of 2.8 ma, therefore

$$\text{Amplification} = \frac{.0028 \times 8,000}{2} = 11.2$$

which is fairly close to the value which can be computed directly from formula 6.

Thus far we have discussed manipulations of the characteristic curves and how they can be used to determine the behavior of tubes under specific operating conditions. Actually, a great deal of this work is done by the tube manufacturer and the resistance-coupled charts in tube manuals present the necessary data for specific operating voltages and load resistances. These charts indicate tube performance with various values of R_L , bias, input signal, output voltage, etc.

We assumed in the foregoing discussion that R_L was the only load on the tube. However, the dynamic or ac load consists of the entire output network. In Fig. 402 the real load on the first tube is made up of R_L , C_c and R_p . Therefore in resistance-coupled charts the value of R_p is specified.

Power amplification

At the present time, the beam power tube and the power pentode¹ are generally used as power amplifiers, primarily for reasons of

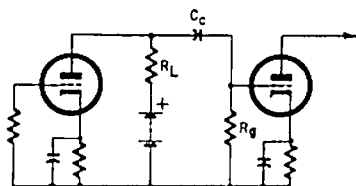

Fig. 402. The true load on an amplifier consists of resistive and reactive components.

economy. (The beam power tube is covered later in this chapter.) As power amplifiers these tubes have a higher power efficiency than the triode—they require lower input signals to produce equivalent power. Therefore, one or more stages of voltage amplification can be omitted—a decided advantage in low-cost equipment. The triode, nevertheless, has characteristics which make its use as a power amplifier highly desirable. It has a relatively low dynamic plate resistance and can develop large plate current changes in a properly designed circuit.

The power amplifier must be capable of producing large current changes in a load such as a speaker. The triode is capable of fulfilling this requirement and its use covers a broad range from special applications in audio amplifiers² to high-power use in radio transmitters.

Since the power amplifier works with large amounts of plate current, the dc resistance of the plate circuit must be kept low so that little dc voltage is lost. This enables the voltage at the plate to be very near that of the plate supply. However, the tube must be properly loaded from an ac standpoint—the tube's dynamic load must be of

¹ Tube manuals make a clear distinction between power pentodes and beam-power tubes. The tube symbols for both types are identical, although the power pentode uses a suppressor grid and the beam-power tube has beam-forming plates.

² Power pentodes in which the screen grid is connected to the plate are considered as triodes.

the correct value to insure good operation. Both of these requirements can be met by using transformer coupling (Fig. 403) where the dc resistance of the primary winding is relatively small and the tube is properly loaded by R, which is reflected through the transformer.

Fig. 403. The plate-load requirements of a power triode can be met with transformer coupling.

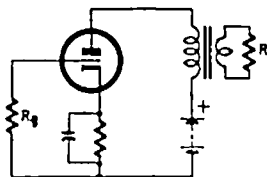
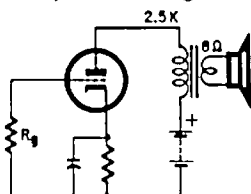

Fig. 404 shows a power amplifier stage using a triode supplying an 8-ohm speaker. Because this tube requires a load of 2,500 ohms, a transformer is used which has the proper turns ratio to make the 8-ohm load look like 2,500 ohms from the primary side. Using a trans-

Fig. 404. The speaker and output transformer form the load for this power amplifier.



former in this manner makes it part of the load so that its inherent inductances (incremental and leakage) as well as the capacitance between windings become part of the total load impedance. These reactive components tend to produce frequency distortion which can be minimized by proper design. Proper selection of circuit components may even be used to make these reactive components function to advantage.

Distortion

The problem of amplitude distortion, is closely related to the fundamentals of power amplifier design. The power amplifier is arranged to produce as much power as possible and the problem of distortion arises from the fact that the input signal can drive the plate current into the curved portions of the characteristic. The output power, dependent upon the alternating component of the plate current in the load, may be determined by the equation

$$P_o = i_b^2 R_L \quad (10)$$

where i_b is the ac component and R_L is the effective load on the tube. An increase in either I_b or R_L will increase the output power. Increasing R_L , however, will reduce the operating plate current and may require a reduction in driving voltage to prevent severe distortion. A direct increase in input signal voltage to increase i_b may also produce severe distortion because the signal departs from the straight-

line portion of the characteristic curve. Thus, the maximum power obtainable from a power amplifier must take into account the amount of tolerable distortion. The decision as to whether R_L is to be increased or decreased or whether the input signal should be increased must be based upon the operating characteristics of the tube.

A typical power triode's characteristics are shown in Fig. 405. Both the I_b-E_b (Fig. 405-a) and transfer characteristics (Fig. 405-b) are illustrated. The tube has a dynamic plate resistance of about 800 ohms, a μ of 4.2 and a relatively high g_m of 5,250 micromhos. Load lines are shown for values of 500, 1,000, 2,000 and 5,000 ohms at a plate supply of 300 volts.

When working with power amplifiers, it is more convenient to use the transfer characteristics because they indicate the position of the input signal on the dynamic transfer curve. The effect of an increase

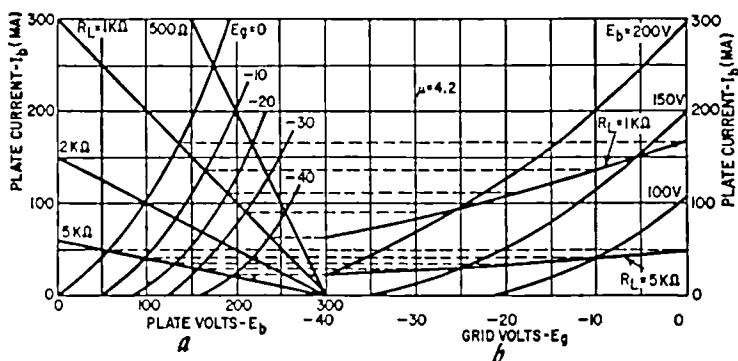

Fig. 405. Characteristic curves for a typical power triode: a) I_b-E_b curves; b) transfer characteristics.

in the input signal voltage on the amplitude can be more easily visualized. The transfer characteristics in Fig. 405-b are plotted for plate voltages of 100, 150 and 200 on a static basis, and dynamic curves for 1,000 and 5,000 ohms. The dynamic curves have less slope and curvature than the static curves. The greater the load resistance, the flatter the curve. Since the grid voltage variations are reflected through the tube by the dynamic load line, the curves show that the greater the load resistance, the lower the amplitude of the plate ac component. On the other hand, the flatter curve is also straighter and as a result the output contains less distortion.

In Fig. 406-a only the dynamic transfer characteristics are shown. Note that the cutoff point for all of the curves is around -70 volts. Also the section of all the curves in range of grid bias from -10 to -60 volts is nearly a straight line. This indicates that if an operating bias of about -25 volts is used, an input signal with a peak of 25

volts could be handled with a minimum amount of distortion since the tube is functioning on the straightest portion of the curve.

In transferring the input signal through the tube, incremental changes in plate current are produced as the grid bias is changed. With a 1,000-ohm load the current changes are greater than with a 5,000-ohm load because the 1,000-ohm curve is not as flat as the others. Apparently there is a certain criterion which must be looked for—greatest output power vs least distortion. Both of these are affected by the load impedance, plate voltage and operating bias.

Class-A amplifier

Power amplifiers designed to operate with minimum distortion are called class-A. In class A, the grid is never driven positive nor beyond the projected cutoff point in the opposite direction. In Fig. 406-a, for example, because all the curves have almost the same cutoff point, a grid bias of about -25 volts is suitable for all loads, provided the signal is kept within the limits of class-A operation.

The maximum output power from any electrical device is obtained when the load resistance equals the internal resistance of the source. With the power amplifier, maximum output power is obtained when the load equals the dynamic plate resistance. However, if this value is used more distortion results (because of the greater curvature of the characteristic) than if a larger resistance were used. But too large a load resistance reduces the power output. Therefore, as a compromise, *maximum undistorted power* is obtained in a triode when load resistance is twice the dynamic plate resistance. With the proper input voltage the tube then functions as a class-A power amplifier. The dynamic curves of Fig. 406-b emphasize this point. The curve for $R_L = 2r_p$ is straighter than the curve for $R_L = r_p$. On the other hand, when $R_L = r_p$, the steeper slope results in greater power outputs.

The current and output power values with several load resistances, a grid bias of -25 volts and an input signal of 25 volts peak are shown in table 4-1. The current values can be read directly from the dynamic transfer characteristic.

Table 4-1. Power output for different values of load resistance

Load resistance (ohms)	i_b (ma)	Power output (watts)
800	110	2.0
1,000	100	1.8
2,000	60	1.5
5,000	30	0.6

The Ohm's law formula for the calculation of power output is $(i_b)^2 R_L$. Taking a load of 800 ohms as an example, the plate current is 110 ma for a bias of -25 volts. An input signal of 25 volts peak will swing the bias from 0 to -50 volts. With the bias reduced to zero by the signal, the plate current rises to 185 ma. At the other extreme, when the sum of bias and signal voltage reaches -50 , the plate

current decreases to 45 ma. The difference between these two extremes is the current value that is used in calculating output power. Since the current is expressed in ma, we divide by 1,000 (or multiply by 10^{-3}) to convert the current to amperes. The current (in amperes) must be divided by $2\sqrt{2}$ since we are working with peak-to-peak values. For a load of 800 ohms, we would get:

$$P_o = \left(\frac{185 - 45}{2\sqrt{2}} \right)^2 800 \times 10^{-3} = 2.0$$

Where the emphasis is on distortionless output rather than on maximum power, the load resistance and grid bias can be adjusted to suit the circuit condition, depending upon the magnitude of the input signal. For example, curve *c* (Fig. 406-b) can handle a larger input signal than curve *b* by selecting a higher negative bias. If the signal voltages are within the range of curve *b*, a lower resistance can be used. Thus, if maximum output is desired and a normal amount of distortion can be tolerated, the load resistance should be equal to the dynamic plate resistance and the grid bias set to handle the specific signal.

In practice, it is sometimes necessary to deviate from the class-A pattern. For example, in Fig. 406-b, with curve *a* the circuit can handle a peak signal of 30 volts. If a signal greater than this is applied to the tube (say, 35 volts) and if the same circuit constants are maintained, the current wave or output signal will be distorted, each peak being slightly flattened when the tube is driven into the curved portion of the characteristic. If the bias is increased to -35 volts to eliminate the distortion on the positive peak of the signal, the negative peak becomes more severely distorted. Changing the load resistance and operating the tube on curve *c* to remedy this sacrifices power output. Thus, other means must be used to reduce the distortion of the wave as it is transferred through the tube.

Assume that the peak signal to be amplified is 35 volts. When the load resistance is equal to twice the dynamic plate resistance, changing the operating grid bias to -35 volts prevents the signal from driving the grid positive. But reference to Fig. 407-a shows what happens to the negative peak. It is much flatter than a sine wave while the positive half is more pointed. This distortion is caused by driving the grid into the curved portion of the characteristic, thus creating a second harmonic 90° out of phase with the fundamental (Fig. 407-b).

Calculation of distortion

The amplitude of the second harmonic determines the major part of the distortion and, being an even harmonic, can be cancelled. However, severe distortion such as that caused by driving the signal beyond cutoff contains other harmonics which are almost impossible to eliminate. Efforts to control distortion are directed toward the reduction

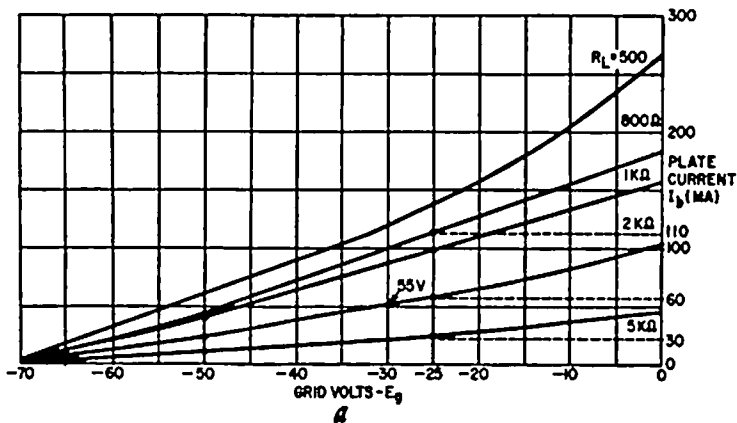
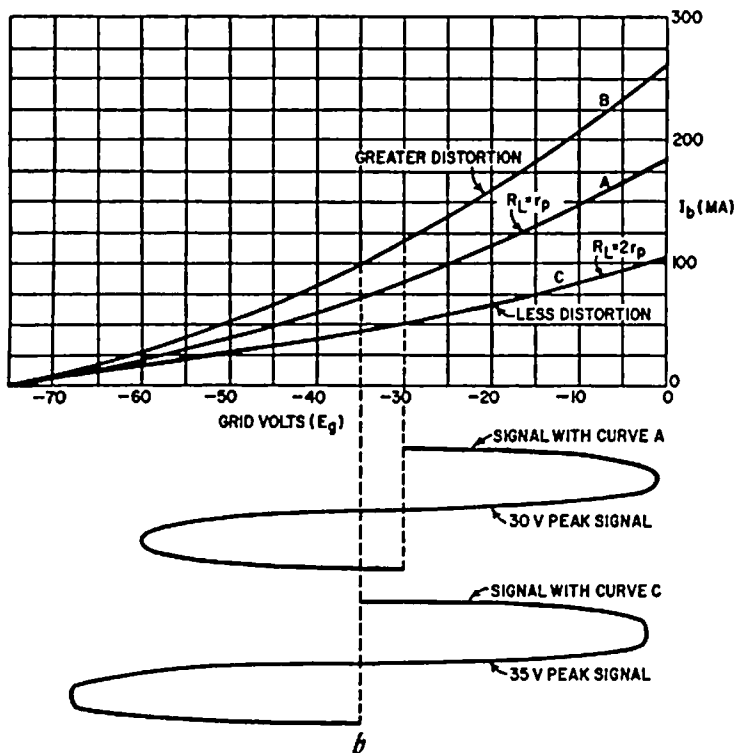

Fig. 406. Transfer characteristics of a power triode: a) because of the relatively flat nature of the curve, class-A operation is possible with several values of load; b) it isn't always possible to operate a tube class-A—all of the curves shown will produce distortion or power loss.



of even harmonics and in high-quality amplification the reduction of third- and other odd-order harmonics must be undertaken as well.

Getting back to the second harmonic of Fig. 407-b, distortion, as

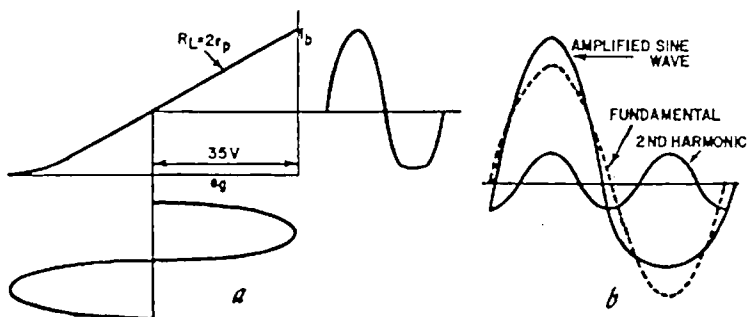

Fig. 407. Distortion can occur without the tube drawing grid current: a) too high a signal for a given bias produces distortion; b) the flattening of the negative peak of the output current produces second-harmonic distortion.

listed in the tube manual or as a characteristic of any power amplifier, is classified in terms of percentage. Before studying methods of eliminating second and other harmonics, the reader must be familiar with the method by which the percentage distortion of an amplifier can be calculated. In Fig. 408, which shows a transfer characteristic for a 2,000-ohm load, a plate current variation from 103 to 13 ma (because

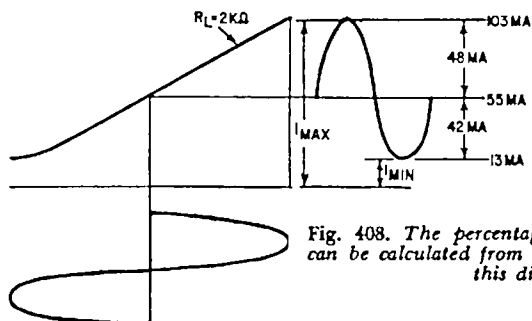

Fig. 408. The percentage of distortion present can be calculated from the figures appearing in this diagram.

the operating point is 55 ma, the positive peak of the ac component is 48 while the negative peak is 42), the second-harmonic distortion is:

$$\frac{\frac{1}{2} (i_{b\max} + i_{b\min}) - I_b}{(i_{b\max} - i_{b\min})} \times 100\% \quad (11)$$

the percent harmonic distortion

$$\frac{\frac{1}{2} (103 + 13) - 55}{(103 - 13)} \times 100\% = \frac{58 - 55}{90} = 3.3\%$$

Power diagram

A power diagram is a set of characteristics with a load line and is

used to extract power information. Fig. 409 shows the characteristic curves of a triode redrawn from Fig. 405.

If we assume a load of 2,000 ohms and a bias of -30 volts, the operating plate current is 55 ma with a plate voltage of 190. The dc power lost in the load is the voltage drop across the resistance times the current (squared) through it. This power is the product of the operating current and the dc voltage drop in the load. In Fig. 409 this is OA times AC which is the area of the rectangle OACB. The total input power supplied to the plate circuit is the operating current times the plate supply voltage, or $I_b \times E_b$. This is equivalent to the total rectangular area PDBC. The difference between these values is the power consumed in the tube itself, which obviously is the rectangular area PDOA.

With a peak input signal of 30 volts the plate current varies from 55 to 13 ma, represented by OX in the diagram. At the same time the voltage across the load changes from 190 to 275, equivalent to XY on the diagram. The ac power loss in a resistance is I^2R , or EI where E and I represent rms values of voltage and current. Since OX and XY represent peak values the power is:

$$\frac{OX}{\sqrt{2}} \times \frac{XY}{\sqrt{2}} = \frac{(OX)(XY)}{2} = \text{the area of triangle OXY}$$

This power, shown as the area of OXY, is the usable power output. This is in addition to the dc power lost in the load previously shown to be equal to rectangle OACB. Therefore, the total power is the sum of both. Since the average current has not changed as the input signal was applied (it only varied above and below the operating point) you may wonder where this extra power came from. The plate supply voltage is the only source of power and that has not changed. Remember that the energy from the power supply or the total input power was divided between power in the load and power in the tube plate. If the power increases, the power loss in the tube itself must have decreased.

This can be checked by using the curves in Fig. 409.

Dc power from power supply	=	PC \times CB = 300 \times 55 \times 10 ⁻³	= 16.5 watts
Dc power in load (no input signal)	=	OA \times AC = 55 \times 10 ⁻³ \times 110	= 6.05 watts
Dc power in tube (no input signal)	=	OA \times AP = 55 \times 10 ⁻³ \times 190	= 10.45 watts
Maximum ac voltage across load with 30-volt peak signal	=	275 - 190	= 85 volts
Maximum ac current through load with 30-volt peak signal	=	55 - 13	= 42 ma

$$\begin{array}{l} \text{Ac power in load} \\ \text{with 30-volt peak} \\ \text{signal} \end{array} = \frac{85 \times 42 \times 10^{-3}}{2} = 1.79 \text{ watts}$$

$$\begin{array}{l} \text{Net power lost in} \\ \text{tube when 30-volt} \\ \text{peak signal is ap-} \\ \text{plied} \end{array} = 10.45 - 1.79 = 8.66 \text{ watts}$$

As a further check the usable ac power output can be calculated from the basic relationship $i_b^2 R_L$. Thus:

$$i_b = \frac{\mu e_g}{r_p + R_L} \quad (12)$$

$$P_o = \frac{\mu^2 e_g^2 R_L}{(r_p + R_L)^2} \quad (13)$$

The plate resistance r_p is the inverse slope of the characteristic curve, or $r_p = \Delta e_b / \Delta i_b$. From Fig. 409, therefore, using the curve for a -30-volt bias,

$$r_p = \frac{220 - 180}{90 - 37} = \frac{40}{53 \times 10^{-3}} = 755 \text{ ohms}$$

$$\text{then, power output} = \frac{(4.2 \times 30 \times 0.707)^2 \times 2,000}{(755 + 2,000)^2} = 2.08 \text{ watts}$$

which is close to the value obtained earlier. The slight difference is due to errors in reading small values on the curve.

Plate efficiency

While class-A operation is ideal from the standpoint of distortion it makes a basically inefficient amplifier. In the preceding example a total of 16.5 watts was needed to derive a useful power output of just about 2 watts. Since the class-A amplifier is designed for high-quality output, the power loss is a secondary consideration.

The effectiveness of utilizing a part of the power supply to obtain output power is called *plate efficiency* and is defined as the ratio of useful output power to input, or total power consumed in the plate circuit. For example, in the case just discussed, the amplifier had a plate efficiency of only $2.08/16.5 \times 100 = 12.6\%$.

Class-AB amplifiers—push-pull operation

Power amplifiers which deviate from the high standards of class-A operation are classified in different categories, depending upon the power output desired. For powers in the order of 10 to 15 watts, the high quality of class-A operation can be retained by connecting two

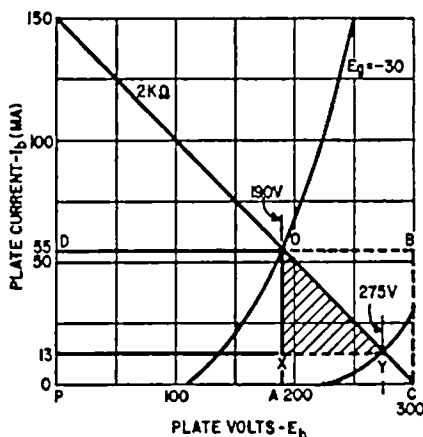

Fig. 409. This power diagram is based on the characteristic shown in Fig. 405.

tubes in push-pull (Fig. 410). This type of circuit is called a class-AB amplifier and handles more power because the tubes are driven harder—an input signal normally beyond the range of a class-A amplifier is used. (Push-pull can, of course, be used for any class of operation, A, B or C.)

To understand fully the operation of a push-pull amplifier consider the circuit of Fig. 410 and assume that the tubes used have the same characteristics as those explored as class-A amplifiers.

The plate operating currents of tubes V1 and V2 flow through the transformer in opposite directions. When these currents are equal, the magnetic fields created by each will be in opposite directions and will cancel. With no residual magnetism, the ac fields created when an input signal is applied do not saturate the transformer core. Because of this, less core iron is required. Moreover, with the plate supply connected as shown, hum currents originating in the rectifier also cancel.

When a signal is applied to the push-pull amplifier, one half of the input voltage drives each tube. This means that, not only can each tube be excited harder but the total input can be doubled. This indicates that the tubes are in series as are their outputs. In Fig. 410 when the grid of V1 is at its most positive point the grid of V2 is at its most negative value because the ends of the transformer secondary are 180° out of phase. A half-cycle later these conditions are reversed. Therefore, as one tube is "pushed" to its maximum value of plate current the other is "pulled" to its minimum value.

As the plate current increases in V1 and decreases in V2, a net difference appears which induces a voltage in the secondary of the output transformer and is applied to the load. As the tube currents alternately increase and decrease, the total current in the common

supply circuit at X is constant because the increase in current through one tube is offset by the decrease in current through the other. The plate supply does not experience the ac fluctuations originating in

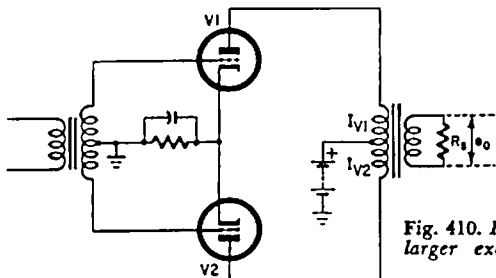

Fig. 410. Push-pull permits the use of a larger excitation voltage than single-ended operation.

the plate circuits of the individual tubes. Thus, under proper operating conditions, the push-pull amplifier cannot be responsible for regeneration through the power supply.

On the assumption that each tube should be operated for maximum power output, the load on each tube should be equal to its dynamic plate resistance. Therefore, the total impedance across the primary of the output transformer must be twice the dynamic plate resistance of a single tube. To suit this condition and allow for the impedance ratio of the transformer (n_p/n_s), the total impedance is calculated as:

$$2r_p = \left(\frac{n_p}{n_s} \right)^2 R_L \quad (14)$$

Assume a condition in which the balanced tubes are driven by a 70-volt peak input, a 35-volt peak input being applied to each. If the grid bias on each tube were -35 volts and they operated on the

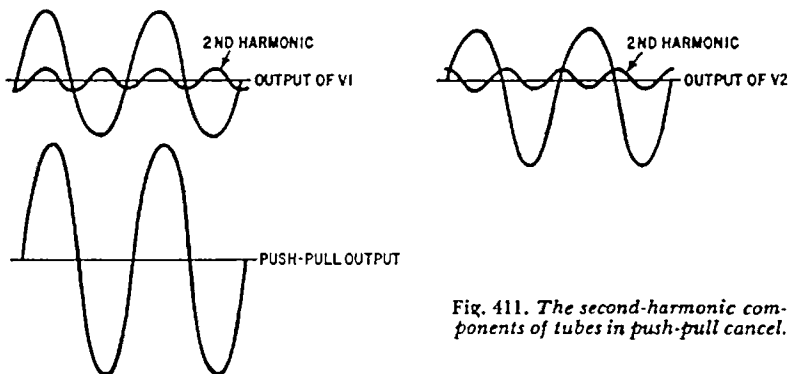

Fig. 411. The second-harmonic components of tubes in push-pull cancel.

negative curved portion of the characteristic (Fig. 407), a second harmonic would be generated. However, because the tubes operate 180° out of phase, the second harmonics and all other *even* harmonics

are canceled (Fig. 411). Not only is the combined output of both tubes a pure sine wave with no distortion, but because the tube outputs are in series, the total is twice that of either tube.

Fig. 411 does not show how these second harmonics are truly 180° out of phase. This is more clearly brought out in Fig. 412 where the dynamic transfer curves for V1 and V2 are drawn 180° out of phase. As the input signal is applied, the P-portion of the signal produces a flattened current wave in V2 and an elongated wave in V1. On the other hand, the N-portion of the signal causes the opposite effect. Since these output waves are in series, the combined output is free of a second harmonic because it has been canceled.

All this assumes that odd harmonics are not present and therefore all distortion is eliminated by push-pull operation. In practice, however, there are odd harmonics with the third being the most prevalent. With the existence of a third harmonic, there is distortion regardless of push-pull operation. Therefore, for typical operating values of power amplifiers, a certain percentage of harmonic distortion is always shown (even with class-A) in tube manuals. However, this percentage is always less with push-pull than with single-tube operation under similar conditions.

Parallel operation

In some cases the primary consideration is an increase in output power. To take care of this power requirement, two or more power tubes can be connected in parallel. Such a process increases the output power but has no effect on the percentage of distortion. Contrary to push-pull operation, two identical tubes connected in parallel will provide twice the output of a single tube for the same input signal voltage and will also double the distortion. (The percentage of distortion remains the same because both output voltage and distortion are doubled.)

Fig. 413 shows how two tubes can be connected in parallel. The load resistance is about half of what it would be for single-tube operation. To check the operation of each tube, the regular e_p-i_p characteristic for a single tube is used, but the values of plate current must be doubled.

Class-B operation

When larger values of power are handled, as at radio transmitting stations, larger efficiencies than those afforded by the class-AB amplifier must be realized. Remembering that the efficiency of an amplifier is calculated from the ratio $i_b^2 R_L / I_b E_b$, an increase of plate alternating current or a decrease in effective input power will raise the efficiency. Both of these methods for increasing efficiency are used when the power tube is connected for class-B. When operated this way, the tube is biased to "projected cutoff;" that is, the point where the dynamic

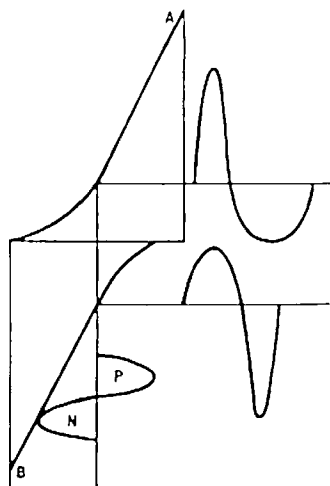

Fig. 412. This dynamic curve shows the cancellation of second-harmonic distortion in a more graphic manner.

transfer characteristic would cross the zero current axis if it continued in a straight line.

Fig. 414 shows an input signal with a peak value equal to the pro-

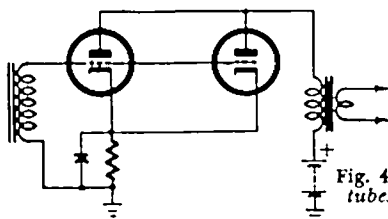

Fig. 413. To obtain high output power, two tubes are sometimes connected in parallel.

jected cutoff bias. The current output wave is severely distorted, containing practically only one-half the input signal. Under this condition, such a circuit *must* be worked in push-pull to restore the other half of the signal and, if both tubes are identical in performance,

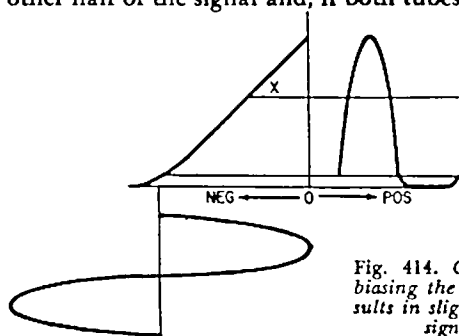

Fig. 414. Class-B operation is achieved by biasing the tube to projected cutoff. This results in slightly more than one-half the input signal appearing at the plate.

the distortion in the output is substantially reduced but still is considerably greater than with class-A. In some instances with class-B operation, the signal may be large enough to drive into the positive grid region.

Class-B improves efficiency because high input signal voltages can be used to produce high values of plate current. Furthermore, by operating at projected cutoff, the average power taken from the power supply is less because current flows through each tube for little more than a half-cycle. Each tube, therefore, delivers power to one half of the output transformer primary for a half-cycle. This is electrically the same as having one tube delivering power to half the primary for an entire cycle.

Class-C amplifiers

The pursuit of higher-efficiency operation led to the development of the class-C amplifier. This type is reserved for rf circuits only and in practically all cases is used in radio transmitters. The class-C amplifier, like the class-B, takes advantage of the basic relationship between power output and plate circuit power input in acquiring high efficiency. By operating the tube *beyond* cutoff and with a signal voltage that drives into the positive grid region of the tube characteristic, extremely high output powers are obtainable. Since the tube is biased beyond the cutoff point, plate current flows for less than half a cycle. Power is drawn from the supply source only when an output pulse is delivered. Therefore, the average power consumed is relatively low.

Since current flows for less than a half-cycle, operating the tubes in push-pull does not restore the original signal because part of the cycle is lost. Therefore, the class-C amplifier is not used in audio work and the highest efficiency that may be realized for an audio amplifier is only that obtainable with class-B.

The class-C amplifier finds its niche at the radio transmitter where extremely large amounts of power in the order of 50–100 kw are handled. Where high values of power are generated, the operator cannot afford to waste any more power in plate dissipation than absolutely necessary. If a single frequency (such as a carrier) is to be amplified, the power amplifier may be operated on a class-C basis, provided the plate load consists of a parallel-resonant circuit. The current pulses energize the parallel (or tank) circuit which is resonant at the carrier frequency. These "less-than-a-half-wave" positive pulses store energy in the tank which returns the pulse within its own resonant circuit during the negative half of the carrier cycle in much the same way that a flywheel converts pulses of energy from a steam engine into a steady flow of power. This process is repeated each cycle.

The length of the plate-current pulses is controlled by the grid

bias. The greater the bias beyond cutoff, the less will be the length of pulse. Since a half-wave pulse is 180° , the bias is adjusted to produce current pulses lasting for 120° – 150° , equivalent to efficiencies of about 60% to 80%. Waveshapes of current and voltages as they appear in the portions of the circuit are indicated in Fig. 415.

The output of the class-C amplifier is rich in harmonics, particularly the second, and in practice harmonic filters are used to reduce them so that their radiation is kept to a minimum.

Transformer-coupled amplifiers

The foregoing discussions on triodes have centered on the tube as a power amplifier. Interest has been focused on tube function, with various loads, biases, magnitudes of input signals and their effect on amplitude distortion. Use of a transformer, however, adds reactive components to the load on the tube, which results in frequency distortion unless measures are taken to minimize their effect. For this reason, transformer coupling is not widely used in audio voltage amplifiers because resistance coupling gives a much better frequency response. In transistor receivers, however, transformer coupling is used for impedance matching and to obtain the voltage stepup not obtainable with resistance coupling.

In power amplification where large currents are used, the transformer with its low dc primary resistance is responsible for only a small drop and the voltage at the plate is almost as high as the power supply voltage (when no input is applied to the tube). Moreover, by selecting a transformer with a proper turns ratio, the tube can be properly loaded regardless of the impedance of the load. Transformer coupling, for example, is almost always necessary between power amplifier tubes and speakers.

When transformer coupling is used between stages, the inductance of the transformer affects the frequency response, causing it to fall off at both the low and high ends of the band. The distributed capacitance of the secondary winding also has some effect on the high-frequency response.

At medium and high frequencies, the impedance contributed by the transformer is high and therefore does not affect the total load on the tube. At low frequencies, however, the shunt reactance due to primary inductance is low, reducing the net load on the tube compared to the load at medium frequencies, resulting in a reduction in amplification. This occurs because the tube has a low load impedance compared to the dynamic plate resistance (as shown in equation 6) and the output voltage is low. Therefore, the lower frequencies in the audio band are not amplified as much as the medium or high frequencies.

Inherently, transformers allow a certain amount of field leakage between windings, which manifests itself as *leakage inductance*. This inductance acts as a series impedance between the tube and the load.

Fig. 415. In class-C operation slightly less than one-half the input wave appears at the plate. However, the original waveform is restored by the tank circuit.

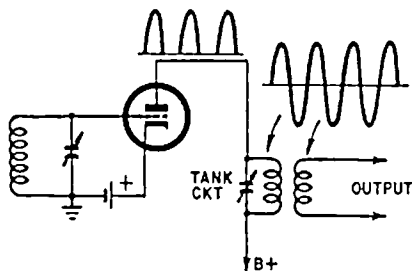

Its effect at low and medium frequencies is negligible because, as a series inductance, its reactance is so much lower than the impedance of the load and its voltage drop is so small that practically all of the tube output appears across the load. However, at the high frequencies, the reactance is large enough to develop a substantial voltage drop, reducing the voltage applied to the load. Hence, the output drops off at the high-frequency end of the band. The distributed capacitance between windings in the secondary tends to form a resonant circuit with the leakage inductance, thus offsetting the undesirable effect of the leakage inductance. This resonant effect can be critical and transformers used for coupling in audio circuits are designed so that this winding capacitance will resonate with the inductance at the proper frequency.

For good frequency response, the transformer must have a high primary inductance so that its reactance is high with respect to the plate resistance of the tube at low as well as at medium frequencies. To obtain a high primary inductance, the transformer should have a large core of high-quality magnetic material. The core should have an air gap just large enough to prevent saturation without lowering the incremental inductance too much.

To take care of the high-frequency response, the leakage inductance must react with the secondary-winding distributed capacitance to create resonance at a frequency in the higher part of the band to offset the series-reactance effect of the leakage inductance. However, since the capacitance acts in shunt with the load, it has a tendency of its own to reduce the high-frequency response as well as to offset the leakage inductance. Therefore, the net effect on the frequency response depends on the Q of the transformer at the resonant frequency. This circuit Q is the ratio of the reactance due to the leakage inductance and winding capacitance to the primary and secondary circuit resistances. Ideally, a circuit with a Q of about 1 at the highest frequency to be passed produces the best results.

When transformers are used for interstage coupling in voltage amplifiers, these same reactive components affect the overall amplification.

Pentode amplifiers

One of the primary functions of the pentode in modern electronic systems is to amplify voltage. Because of its high amplification factor, it is well suited for amplifying small signal voltages such as are picked up by the ordinary radio receiver, TV or the low-level output of a microphone in an audio system. The total amplification necessary in these cases requires several stages where either transformer or R-C coupling may be used.

Like the triode, the amplification of the pentode is dependent upon the ratio of i_b to e_p but, because at the plate current is relatively independent of the voltage at the plate, the pentode is termed a *constant-current* device. Hence, the voltage amplification may be represented as

$$\text{Amplification} = g_m R_{eq} \quad (15)$$

$$\text{where } R_{eq} = \frac{r_p R_L}{r_p + R_L}$$

If several stages of voltage amplification are used, the load on the tube no longer consists of just the plate load resistor R_L but also includes all other resistances and reactances in parallel with it. For example, the R-C circuit of Fig. 416 shows the total load R_L in parallel with the series combination of C_c and R_g . These added components reduce the effective load on the tube and lower the amplification. Moreover, the reactance of the capacitor which is now part of the shunting circuit will vary with frequency and thus presents different

Fig. 416. As with the triode, the pentode amplifier is loaded by a combination of resistive and reactive components.

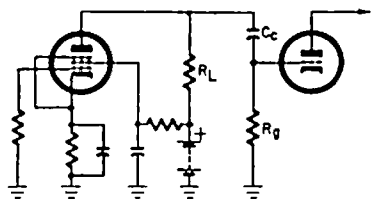

loads to the tube at different frequencies, causing frequency distortion.

Before looking into this program of frequency distortion, consider the basic characteristics of the pentode itself. We can start with a sharp-cutoff pentode. Its static characteristics with several load lines are shown in Fig. 417. Load lines for .047, 0.1 and 1 megohm are shown for an amplifier circuit with a 300-volt plate supply. Considering, first, the hypothetical case where the load is zero (no load connected in the plate circuit), the voltage at the plate remains constant as the grid voltage is varied. If a grid bias of -1 volt is assumed and an input signal of 1 volt peak is applied to the tube, the plate current would vary from a norm of about 7 ma to a peak of about 9.25 and a minimum of 4.8 ma, a current change of just over 2 ma either side of the steady-state value, with little amplitude distortion. However, with

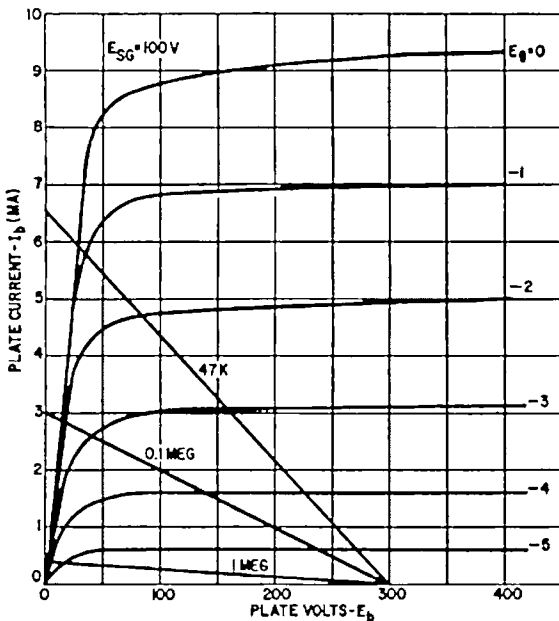

Fig. 417. Characteristic curves of a typical pentode.

a load of 47,000 ohms in the circuit, the operating plate current would drop to 5.3 ma and the voltage at the plate to about 25. In this case, with the same input signal the current increases to a peak of 6 ma and decreases to a minimum of about 4.6. The output is severely distorted because the operating point lies below the knee of the curve. If this same load resistance were maintained, but the bias were dropped to -2 or -3 volts, the distortion would be considerably reduced. For example, with a -2 -volt bias, the operating current would drop to about 4.7 ma but the current would change from about 5.8 to 3.1 ma with a 1-volt peak signal. This amounts to a current increase of 1.1 ma and a current decrease of 1.6 ma, indicating a slight amplitude distortion. Use of a -3 -volt bias would reduce this distortion because the current changes would then be 1.6 and 1.5 ma, respectively, from a 3.1-ma norm.

To determine the amplification of such a circuit, the plate resistance and amplification factor must be known. These constants can be derived from the static characteristic curves but with pentodes such a procedure is very difficult. As a case in point, assuming that a 3-volt bias must be used, it is almost impossible to determine voltage and current changes with any degree of accuracy because the curve slopes are so very small, almost horizontal, beyond the knee of the curve. To determine r_p it is necessary to derive the ratio i_b/e_b directly from

the curves by observing the change of plate current produced by a change in plate voltage. Changes in plate voltage vs changes in grid voltage must also be derived from the curves to determine the value of μ . With such small slopes to deal with, the accuracy of the results is questionable. For this hypothetical pentode the tube manual might specify a plate voltage of about 250 and a dynamic plate resistance of about 1.5 megohms. The amplification factor is about 2,500. Using equation 6, the amplification of the circuit with a 47,000-ohm load is

$$\text{Amplification} = \frac{2,500 \times 47,000}{1,500,000 + 47,000} = 76$$

Since the rms value of the input signal is $1 \times 0.707 = 0.7$ volt, the output is $76 \times 0.707 = 54$ rms volts across the 47,000-ohm load resistance, if the assumed values of μ and R_L are correct.

The voltage peak across the load produces a corresponding change in plate voltage which may be verified directly from the characteristic curves. For example, with a load of 47,000 ohms, the plate varies from about 160 volts to about 90, a change of 70 volts, as the grid varies between -2 and -3 volts.

An attempt to increase the output by handling a larger input signal voltage would cause distortion. Besides, a 54-volt output is more than is needed to drive most power amplifiers in use. Increasing the load resistance to, say, 100,000 ohms to avoid distortion would not help if a 1-volt peak signal were used. With a 3-volt bias, the 1-volt peak signal would drive into the range of the curve below the knee. Increasing the bias to -4 volts would not eliminate the distortion for the same reason, and larger biases would not give enough range of operation since the 1-volt peak signal would then drive into cutoff.

Therefore, the pentode amplifier is limited in the size of signal it can handle. This means that the amplification ratio of the pentode circuit (not μ , the amplification factor) is held to relatively low values when input signals of $\frac{1}{2}$ to $\frac{3}{4}$ volt are to be amplified, because the load resistance must be relatively low compared to the plate resistance to prevent distortion.

Where smaller signals are used, such as in the microvolt or millivolt range, full advantage of the higher load resistance can be taken without fear of distortion if the proper grid bias is selected. In the example used, the 100,000-ohm load with a -4 -volt bias would be entirely satisfactory. In fact, with a 0.5-megohm load, small signals could be amplified to produce net amplification ratios in the order of 800—a 1-millivolt input signal would become 0.8 volt at the output.

Another fact that must be considered is the effect of the screen voltage on the tube performance. The characteristics shown in Fig. 417 apply only when the screen grid voltage is 100. With lower screen voltages, the series of curves would show lower plate currents. There are

Fig. 418. Average transfer characteristics for a pentode amplifier showing curves for five different values of screen grid voltage.

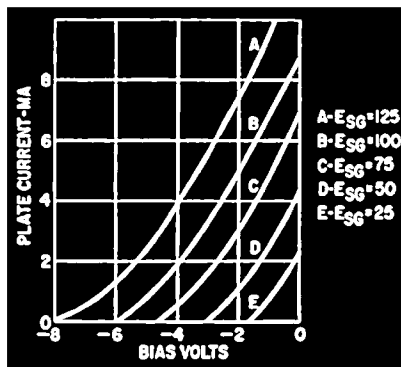

many combinations of screen and grid voltages that may suit a given case and, rather than show a set of I_b-E_b characteristics for many values of screen voltage, it is simpler to draw average transfer characteristics (Fig. 418). To check, note that where the screen voltage is 100, the plate current readings at each value of grid bias correspond exactly with those shown in Fig. 417 where the plate supply voltage is 300.

The curves can be used directly to determine variations in current with different input signal voltages and here the effect of distortion is obvious. Note also that, even though these curves are derived from the I_b-E_b static characteristics, it is proper to work directly from them because the voltage at the screen is kept constant by being connected directly to the supply voltage or bypassed with a capacitor if supplied through a screen resistor. In such a case the resistance in the screen circuit has no effect on the voltage at the screen as any ac component in the screen is bypassed.

If the screen voltage were only 25 a bias of about -1 volt would be required. Current variations would be in fractions of a milliampere. For resistance-coupled amplifiers, therefore, because there are many voltage combinations, tube manufacturers have already worked out the operating details for various signal voltages, load resistances, bias and plate supply voltages. These data may be found in the resistance-coupled charts in the tube manual. For example, for the 6SJ7, the chart states that if the plate supply voltage is 300, a load resistance of 0.1 to 0.5 megohm can be used but the plate current must be limited by restricting the voltage applied to the screen. With a load of 0.1 megohm, the plate dc is held to only 0.5 ma by applying only 55 volts to the screen. The bias is a little over -1 -volt to handle a 0.1-volt signal with less than 1% distortion.

If a 0.5-megohm load is used, however, the current must be reduced to lower the IR drop in the load so that enough voltage is left on the plate to enable the tube to function above the knee of the

curve. Therefore, with an R_L of 0.5 megohm, the tube requires only 25 volts on the screen and a bias of -1 volt. Only about 0.4 ma will flow in the plate with such a small value of operating current, but the IR_L drop is low enough, even with a 0.5-megohm load, to allow 60 volts at the plate, which is above the knee of the curve. Because the range of operation is so small, more distortion can be expected and in this case amounts to about 2–3% instead of less than 1% where the load was only 0.1 megohm. Thus, it follows that any attempt to derive more output from radio circuits, whether it be in the form of overdriving the tube or increasing the load resistance, can result in more distortion.

Remote, or sharp-cutoff characteristic

Because of these characteristics, the pentode is often used as a voltage amplifier in all types of electronic circuits. In audio circuits R-C coupling is generally favored, particularly where high fidelity is desired. As an rf amplifier, however, mutual or impedance coupling is used. In the tube manual, practically all pentodes are classified as rf types on a sharp- or remote-cutoff basis. Some are special types suitable for frequencies up in the 300–400-mc band and others have characteristics suitable for TV circuits.

Sharp-cutoff tubes have transfer characteristics which cut off rather sharply. With such tubes, the curve slopes are relatively steep and the current decreases to zero at a fairly constant rate as the bias is increased negatively. However, *remote-cutoff* or so-called *variable-mu* tubes have transfer characteristics whose slopes are rather long and sweeping, reaching the cutoff point gradually and producing a net variable slope which decreases as the negative bias is increased. Because the slope of the curve is a measure of the amplification factor, the variable slope produces a variable mu.

A transfer characteristic curve for a variable-mu tube is shown in Fig. 419. Note how the slope of the static curve varies and how the bias must be reduced to about -35 volts before the current is almost entirely cut off. With such a characteristic, a larger current variation would result if the grid bias were -5 volts than if it were about -20 with a given input signal. This is brought out by the plate current waves corresponding to the same grid swing in each case. With a given load on the tube, more amplification is obtained when the bias is -5 volts than when it is -20 because, even with a fixed load resistance, the tube characteristic maintains its curvature. Thus, in an avc circuit, if the bias is varied by action of the incoming rf signal, the stronger signal will produce a greater negative bias and thus reduce circuit amplification. In practice, the bias slides back and forth along the tube characteristic, constantly adjusting the tube gain as rf carrier strength varies.

Both miniature and regular pentodes are constructed for either

remote- or sharp-cutoff operation, with the remote-cutoff tube used principally in if and rf stages where AVC is applied. Sharp-cutoff tubes are used where low-level input signals are handled and high-voltage amplification is desired.

Frequency distortion in amplifiers

Our discussions on pentode tubes thus far have been concerned principally with their basic characteristics and function in simple one-stage circuits. In practice, an audio circuit designed to amplify the

Fig. 419. Transfer characteristic curve for a variable- μ tube.

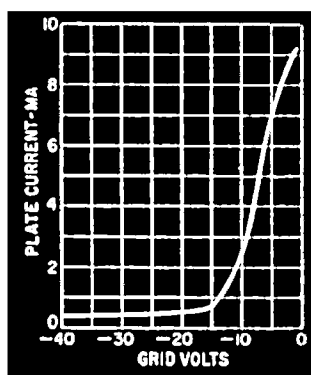

output of either a microphone or record player may require several stages of voltage amplification to drive a power stage which in turn drives a speaker. The goal in audio work is the faithful reproduction of the input signal. This objective can be attained only if all of the

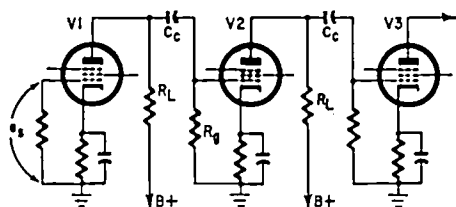

Fig. 420. Resistance coupling is favored over transformer coupling for audio voltage amplification.

complex frequency components of voice or music are amplified equally as the complex wave progresses through the amplifier and if no new frequencies are created in the amplification process. Only then will the amplifier be doing a "hi-fi" job.

Amplitude distortion is created within the tube itself by the formation of new frequencies—harmonics of the fundamental. Even though measures are taken to avoid this, it still is possible to produce an output which is distorted from a frequency standpoint through care-

less or improper design of the voltage amplifiers in the audio circuit. If the circuit components of the amplifier include capacitances and inductances whose impedance varies with frequency, the output from one stage to the next will not be the exact reproduction of the input signal. Such variation results in frequency distortion, and it follows that limited use of reactive components in audio amplifiers, or adequate correction for them when they are an inherent part of the circuit, will result in the least amount of distortion. Accordingly, resistance coupling as contrasted with transformer coupling is favored in audio voltage amplification. A pentode circuit of this type is shown in Fig. 420.

To analyze the resistance-coupled amplifier properly and determine the sources of frequency distortion, it is necessary to consider each stage as a separate entity. The resistance-coupled amplifier of Fig. 420 can be separated into its component amplifier sections, one part of

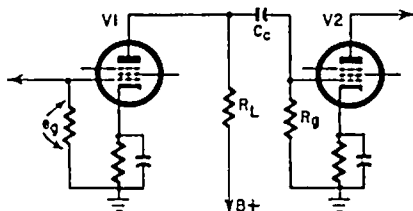

Fig. 421. One part of the R-C amplifier of Fig. 420. Load resistance R_L is shunted by the series combination of C_c and R_g , which affects tube loading.

which is redrawn in Fig. 421. In this circuit, the load resistance R_L is shunted by the series combination of C_c and R_g which affects the tube loading. The tube load also is influenced by the distributed capacitance to ground of the circuit wiring (C_w) and by the interelectrode capacitances (C_{pk} and C_{gk}) the combined effect of which is to place an additional parallel path across the load resistance. To study the effects

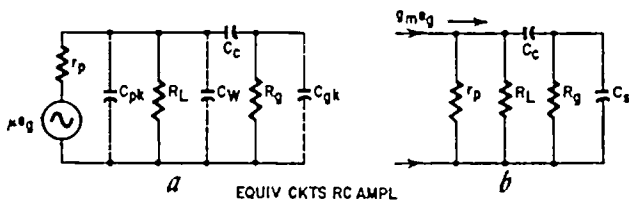

Fig. 422. Single-stage section of Fig. 421, redrawn as equivalent circuit (a) where input signal is represented as voltage μe_s in series with plate resistance and (b) represented in terms of g_m instead of μ .

of all these components better, the actual single-stage section of Fig. 421 is redrawn as in Fig. 422-a where the input signal is represented as the voltage μe_g in series with the plate resistance. In considering this equivalent circuit, however, it may be seen that for all practical purposes shunt capacitances C_{pk} , C_w and C_{sk} can be considered as one capacitance since they are all in parallel with R_L . Since the pentode is normally considered a constant-current generator, the circuit can be represented in terms of g_m instead of μ . Taking these factors into account, then, the equivalent circuit can be redrawn in the form of Fig. 422-b where all the shunt capacitances are lumped together as C_s .

With all resistances effectively in parallel, a reduction in size of any one of them will reduce the circuit amplification. Even if r_p , R_L and R_g are all held at high values, the combined shunt capacitance C_s will reduce the tube amplification at higher frequencies. Series capacitor C_c , however, acts as a voltage divider. If its reactance is high enough at the low-frequency end of the audio band, its voltage drop will take away some of the voltage intended for R_g , which is used as an input to the next stage.

In short, because the circuit contains both series and parallel reactive components, the amplifier output over both the low- and high-frequency portions of the audio band will be lowered.

In a properly designed audio voltage amplifier circuit, the values of all three resistances are usually large so that their combined impedance is high enough to give good amplification. Under this condition, the reactance of the shunt capacitances is large enough over the middle range of frequencies to have a negligible effect on the tube loading. In addition, the series or coupling capacitor is large enough so that at the middle frequencies it presents a relatively low reactance to the circuit. As far as the medium frequencies are concerned, the coupling capacitor may be considered a short circuit and

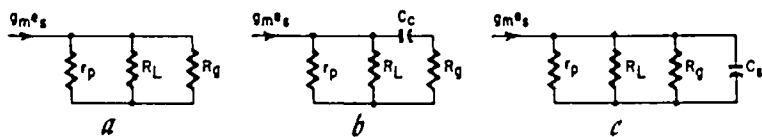

Fig. 423. Fig. 422-b redrawn in (a), where circuit is comprised of resistance only. (b) Equivalent circuit at low frequencies. (c) Equivalent circuit showing C_s , which affects the high frequencies.

Fig. 422-b can be redrawn as shown in Fig. 423-a where the circuit is comprised of resistance only. Using the formula for amplification on a constant-current basis, the gain in the middle-frequency range can be written

$$\text{Amplification (middle frequencies)} = g_m R_{eq}$$

where R_{eq} is the equivalent resistance of r_p , R_L and R_g , in parallel. R_{eq} in this case includes the grid resistor of the following tube.

At the low-frequency end of the spectrum, the reactance of the shunt capacitances C_s are high enough to be ignored if their reactance is high at the middle frequencies. However, the series capacitor C_c must be taken into account because its reactance is greater. If its low-frequency reactance is high, an appreciable voltage drop across the capacitor will divide the voltage output from the tube so that less of the voltage drop across R_L is applied to R_g for use in the next stage. Therefore, the equivalent circuit at low frequencies can be represented as in Fig. 423-b where no shunt capacitances are shown but capacitor C_c plays a prominent part. Since the voltage input to the next tube appears across R_g , the amplification of the low audio frequencies compared to the middle frequencies is controlled by the reactance X_c of the coupling capacitor C_c . It is therefore appropriate to show the gain of the low frequencies in terms of the middle-frequency gain because the ratio of the two is a measure of the frequency distortion. (The middle-frequency gain is based on deriving the best output with no amplitude distortion.) Hence, from Fig. 423-b, the low-frequency gain can be written as:

$$\text{gain at low frequencies} = \frac{g_m R_{eq}}{\sqrt{1 + (X_c/R_T)^2}} \quad (16)$$

where $g_m R_{eq}$ is middle-frequency gain, X_c the reactance of C_c at a particular frequency and

$$R_T = R_g + \frac{R_L r_p}{R_L + r_p}$$

Once the mid-frequency amplification is determined, the reduction in gain at any frequency in the low end of the band can be computed.

At high frequencies, the reactance of C_c can be neglected because, if it is low enough to be considered as a short circuit at the mid-frequencies, it certainly is negligible at the higher end of the band. C_s , however, begins to have a profound effect on the high frequencies because its decreasing reactance drops the load on the tube, reducing the output. In the equivalent circuit of Fig. 423-c, C_s must be shown. Here again, the high-frequency amplification can be calculated in terms of middle-frequency gain and, because the capacitive reactance X_s is a shunt capacitance in parallel with all the resistances, the output is a function of the ratio of X_s to R_{eq} or

$$\text{Amplification at high frequencies} = \frac{g_m R_{eq}}{\sqrt{1 + (R_{eq}/X_s)^2}} \quad (17)$$

where R_{eq} is the parallel combination of all resistances and X_s is the reactance of the shunt capacitances at a particular frequency.

The gain over the entire audio band may be computed at each

individual frequency if all the circuit components are known. The values of amplification thus obtained could be plotted on a curve with gain as the *ordinate* and frequency as the *abscissa*. Such a characteristic is called a *response curve*.

This would be a long and tedious process, however, and perhaps not necessary if an overall response curve were desired, because the reactance factors change proportionately with frequency. Since the primary value of such a curve is that it may be used for determining the overall frequency performance of the circuit, it is necessary only to plot gain in terms of the ratio of the low and high frequencies to the mid-frequency at a few points. A typical response curve for an audio range up to 10,000 cycles for an R-C amplifier with an R_L of 0.5 megohm is shown in Fig. 424. The effect of varying C_c and C_s is also indicated. Note that the overall response of curve A is not too good for such a circuit, the frequency deviation increasing rapidly below about 100 cycles at the low end and above 3,000 cycles at the high end.

An increase in capacitance of C_c should improve the low-frequency response and Fig. 424 shows this effect. With a C_c of .005 μf , the response at 20 cycles is just about half that at mid-frequency. If the capacitance is increased to say, .01 μf , or doubled, equation 16 tells us

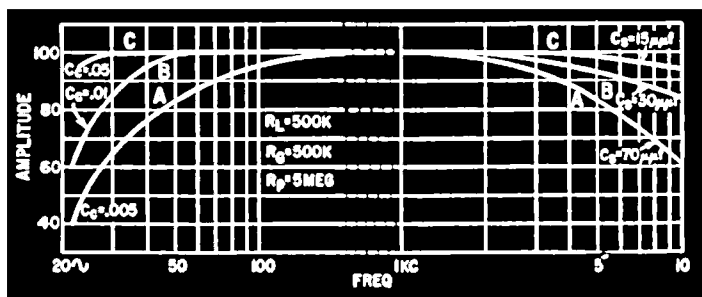

Fig. 424. Frequency-response curves of a resistance-coupled amplifier.

that the response ratio at 20 cycles would be improved to about three-fourths of the mid-frequency gain. These values may be checked by calculations as follows:

$$\frac{\text{Low-frequency gain}}{\text{Mid-frequency gain}} = \frac{1}{\sqrt{1 + (X_c/R_T)^2}}$$

Therefore with $C_c = .005 \mu\text{f}$

$$X_c = \frac{1}{2\pi f_c} = \frac{10^6}{6.28 \times 20 \times 5 \times 10^{-3}} = \frac{10^6}{0.628} = 1.6 \text{ megohms}$$

$$R_T = 0.5 + \frac{0.5 \times 5}{0.5 + 5} = 0.95 \text{ megohm}$$

$$\text{Gain ratio} = \frac{1}{\sqrt{1 + (1.6/0.95)^2}} = \frac{1}{1.95} = .51$$

with $C_c = .01 \mu\text{f}$ $X_c = 0.8 \text{ megohm}$

$$\text{gain ratio} = \frac{1}{\sqrt{1 + (0.8/0.95)^2}} = \frac{1}{1.3} = .76$$

Similar calculations would verify the curve shown where C_c is $.05 \mu\text{f}$.

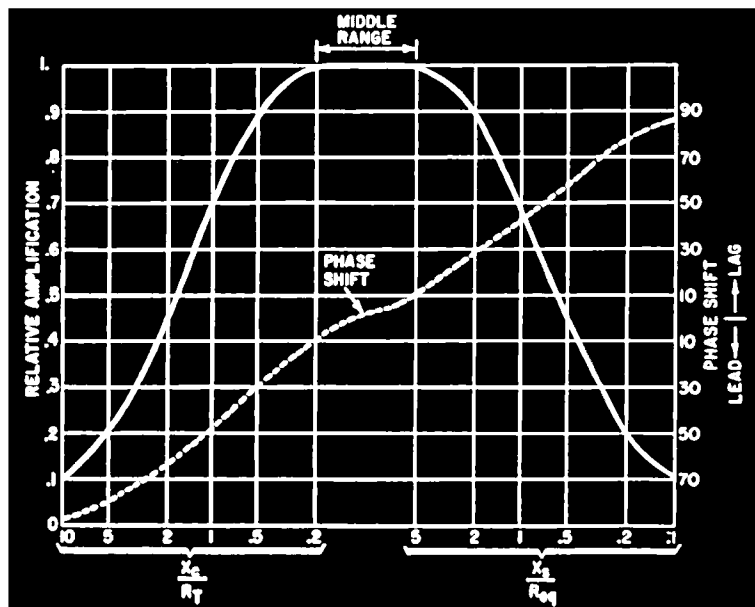

Fig. 425. Universal amplification curve used to determine the overall response of an amplifier. Phase-shift curve (broken line) is included.

The high-frequency response of the curve in Fig. 424 can be improved by lowering the value of C_s and these curves can also be verified by computation. If the capacitance is reduced to as little as $15 \mu\mu\text{f}$, the response curve C is practically flat up to 10,000 cycles.

Since C_s is not a fixed capacitance but rather the combined shunt capacitance of the wiring and interelectrode tube capacitance, it cannot be changed as easily as coupling capacitor C_c . Any reduction in C_s must therefore be made by reducing distributed capacitances. This is done by careful wiring, (keeping all leads as short as possible) and by using pentodes which normally have low interelectrode capacitances.

In audio circuit work it is often advantageous to determine the overall response of an amplifier quickly. This may be done by plotting a so-called universal amplification curve (Fig. 425). Assuming the response at the middle frequencies to be unity, the low-frequency amplification will be 70% when $X_c = R_T$. Likewise, at the high frequencies, the response will be 70% when $X_s = R_{eq}$. Once having determined R_{eq} and R_T , their ratio to X_s and X_c can be found for any frequency. In fact, the amplification can be estimated at frequencies which are multiples or submultiples of the frequency where $X_c = R_T$ or $X_s = R_{eq}$. Table 4-2 gives the relative amplification of resistance-coupled amplifiers and serves as a basis for determining the universal amplification curve of Fig. 425.

The universal curve of Fig. 425 includes a phase-shift curve, which is shown as a broken line. At low frequencies, where the series capacitor C_c is effective, the circuit is capacitive; that is, the current leads the voltage. The angle of shift in the low-frequency end is related to the ratio X_c/R_T and naturally increases as X_c increases, approaching 90° at very low frequencies. When X_c is equal to R_T (amplification 70% of mid-band) the phase shift is 45° and when it is twice R_T the angle becomes 60° .

At the higher frequencies, the reverse is true; the phase shift is negative rather than positive, producing a lagging current. Here as with the low frequencies, when $X_s = R_{eq}$, the phase shift is 45° and other ratios produce different angles of phase shift.

The difficulties encountered in correcting for those components which cause frequency distortion in resistance-coupled amplifiers increase as the frequency range increases. An attempt to increase the

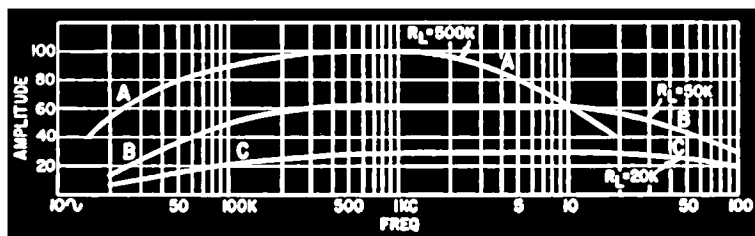

Fig. 426. These curves show the effect of reducing the value of the load resistance. high-frequency amplification range to 15,000 cycles is more difficult than if 10,000 cycles were the limit. Remembering that the complete amplifier is the combination of several amplifier sections, this difficulty becomes more pronounced the broader the frequency band to be amplified.

There are practical limits to how much improvement can be obtained by changing C_c and C_s . Therefore, other steps must be taken.

For example, in Fig. 424, curve A is flat over a very narrow band from about 100 to between 2,000 and 3,000 cycles. Even with curve C, which may be hard to reach because of the difficulty in holding C_s to only 15 μmf , the response is good only to 10,000 cycles. However, if load resistor R_L were dropped to a lower value, the entire characteristic would drop to some new reference point, tending to "flatten" the overall response at the higher frequencies.

Table 4-2. Relative amplification of resistance-coupled amplifiers

low frequencies		high frequencies	
Frequency	Relative amplification	Frequency	Relative amplification
$5f_1$	0.980	$0.2f_2$	0.980
$2f_1$	0.895	$0.5f_2$	0.895
f_1	0.707	f_2	0.707
$0.5f_1$	0.477	$2.0f_2$	0.447
$0.1f_1$	0.10	$10.0f_2$	0.10

where f_1 equals the frequency at which X_c equals R_T and f_2 the frequency at which X_s equals R_{eq} .

Fig. 426 shows the result of reducing R_L in the basic circuit used for the curves of Fig. 424. (Curve A corresponds to curve A in Fig. 424.) When the load resistance is reduced to 20,000 ohms, the overall response curve is practically flat to 100,000 cycles, plenty good enough from this standpoint for an audio amplifier.

However, the net amplification, instead of being in the order of 100 (as with a 0.5-megohm load), would be only about 5.

A reduction of R_L to, say, 0.1 megohm together with a change in C_s results in a flat characteristic for audio frequencies and the total response, while reduced, can be made up by adding a stage or two. In other words, to obtain a flat response over the audio range from, say, 50 to 15,000 cycles, proper manipulation of C_c , C_s and R_L gives the desired results.

Video amplifiers

To the video amplifier in the TV receiver falls the task of amplifying a range of frequencies which stretch through the audio spectrum into the rf band. The frame frequency of 30 cycles which is the frequency at which the full interlaced picture is flashed on the picture tube is the lowest value that must be handled. The picture components reach frequencies as high as 4.5 mc. To obtain a flat characteristic over such a broad band, special measures must be taken.

To begin with, all the measures taken for high-fidelity amplification in audio amplifiers must be applied—wiring capacitances are kept

at a minimum and tubes with very low interelectrode capacitances and high transconductance are used. Even if the load resistance is made relatively small to improve the overall frequency response, substantial voltage amplification is obtained because of the high plate-current changes developed. For example, the 6AG7 (a tube used in the early days of TV) has a g_m of 11,000 micromhos. With a load resistance of only 10,000 ohms, even though the plate resistance is about 130,000 ohms (and ignoring the following grid resistor) the voltage amplification would be

$$g_m R_{eq} = 11,000 \times 10^{-6} \times \frac{10,000 \times 130,000}{10,000 + 130,000} = 93$$

approximately.

Contrast this with the sharp-cutoff pentode with an r_p of 5 megohms which gave a net amplification of only 4 with a 20,000-ohm load.

These measures are not enough to cover the wide band necessary in video amplification; frequency-correction devices must be applied. Considering first the low-frequency end of the video band, to improve the 30-cycle response, the voltage drop across the coupling capacitor should be small as compared to the drop in grid resistor R_g . At 30 cycles the reactance of a .005- μ f capacitor is over a megohm. With a grid resistance of 0.5 megohm, two-thirds of the tube output voltage would be lost in the capacitor. Even if the capacitance were increased to, say, .05 μ f, the voltage lost in the capacitor would be almost 20% of the tube output—too much for good response. Any further increase in the capacitance of C_c is limited by the fact that the physical size of the capacitor provides a large shunt capacitance path between the grid of the second tube and ground. Moreover, the larger the capacitor, the greater the chances of dc leakage from the plate of the first tube to the grid of the second.

The size of the grid resistor in general cannot exceed 0.5 megohm because of the grid characteristic of the tube. The only solution is to compensate for the effects of this capacitance by adding appropriate components to the circuit. In Fig. 427, a capacitor and resistor in parallel are connected in the plate circuit. At the lower frequencies, the reactance of $C1$ increases, thus increasing the total load impedance on the tube. The circuit is designed to provide enough increase in amplification to offset the larger voltage drop across C_c . In other words, the compensating network increases the gain of the tube by the same amount that the reactance of C_c decreases the voltage applied to R_{eq} .

To select values of $R1$ and $C1$ for such a network, their direct relation to C_c and R_g , which in effect form another network, must be taken into account. To be effective at low frequencies only, the impedance of $R1$ should be high with respect to the reactance of $C1$ at the lowest frequency to be passed, say, 30 cycles. The gain of the

Fig. 427. A capacitor (C1) and a resistor (R1) are connected in the plate circuit to act as a compensating network.

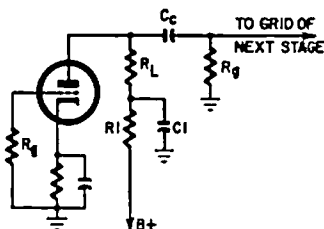

amplifier, then, is affected only at the low frequencies because at the higher frequencies C1 tends to short-circuit R1, making it ineffective in increasing the amplification.

The gain of the R-C amplifier at the middle frequencies with no compensation by definition is equal to $g_m R_{eq}$. In a video amplifier, where R_L is much lower than either r_p or R_g the amplification can be written as $g_m R_L$. Similarly the low-frequency gain can be written

$$\text{Low-frequency gain} = \frac{g_m R_L}{\sqrt{1 + (X_c/R_T)^2}} = \frac{g_m R_L R_T}{\sqrt{R_T^2 + X_c^2}}$$

However, since R_L , a component of R_T , is small compared to R_g , R_T effectively becomes equal to R_g . Therefore, the approximate formula for low-frequency gain in a video amplifier may be written

$$\text{Low-frequency gain} = g_m R_L \frac{R_g}{\sqrt{R_g^2 + X_c^2}} \quad (18)$$

With the compensating network (where R1 is much larger than X_1) added to the circuit, the overall gain becomes

$$\text{Gain} = g_m \left(\frac{R_L}{\sqrt{R_L^2 + X_c^2}} \right) \left(\frac{R_g}{(\sqrt{R_g^2 + X_c^2})} \right)$$

which by manipulation of the constants can be changed to

$$\text{Gain} = g_m R_L \left(\frac{R_g}{\sqrt{R_g^2 + X_c^2}} \right) \left(\frac{\sqrt{R_L^2 + X_c^2}}{R_L} \right)$$

Comparing this equation with the amplification at the middle frequencies the product of the terms in brackets must equal unity if the low-frequency gain is equal to the mid-frequency gain. Equating these gains to unity results in the following relationship:

$$R_g C_c = R_1 C_1$$

which can be used to determine the proper value of C1.

The resistance component R1 is neglected in these calculations because it has a value of about 10 times the reactance of C1 and is there-

fore effectively bypassed. However, because the connection of a high resistance into the plate circuit may tend to drop the voltage at the plate to too low a value, R_1 can be made only as high as these restrictions permit.

Improving the high-frequency response beyond what can normally be accomplished, by reducing all shunt capacitances to a minimum or by using a low value of load resistance, is more involved than improving the low-frequency response. Since the combined shunt capacitances C_s are responsible for the poor high-frequency gain, the addition of inductance L in series with R_L in the plate circuit (Fig. 428-a) will tend to offset the effects of C_s . Actually, the inductance forms a

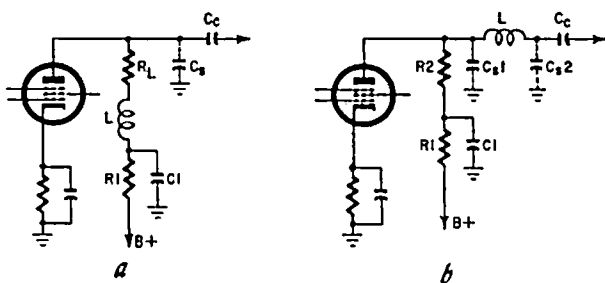

Fig. 428. Adding inductance L in series with R_L in the plate circuit (a) tends to offset the effects of C_s . Series peaking (b) gives a greater increase in gain than the shunt type, as in (a).

parallel-resonant circuit with C_s and proper compensation can be had if the inductance is chosen to be resonant with the combined effects of C_s at a frequency about 1.4 times higher than the highest to be passed.

High-frequency correction by "shunt peaking" does not produce a flat curve but one which is peaked at the resonant frequency and then falls off rather rapidly. Series peaking (Fig. 428-b) gives a greater increase in gain than the shunt type. The series inductance L has no effect at the low frequencies but develops a high impedance at the higher frequencies because its reactance increases. However, inductance L is resonant with shunt capacitances C_{s1} and C_{s2} (distributed capacitances associated with each tube and considered separately instead of as one capacitance C_s as before) at different frequencies.

One resonance occurs between L and C_{s2} which tends to boost the voltage at the junction between them. A second resonance occurs between the three components: the reactance of L exceeds that of C_{s2} and so the effective reactance looking into L is inductive; this differential inductive reactance is then resonated by the capacitive reactance of C_{s1} in parallel. This tends to boost the voltage at the input junction. When the circuit is correctly adjusted, these fre-

quencies are quite close together and the resulting output is very flat up to the higher resonant frequency.

Transformer and mutual-coupled circuits

The resistance-coupled amplifier (with and without compensation) has been thoroughly discussed from the standpoint of frequency distortion. The difficulties encountered in producing a flat frequency

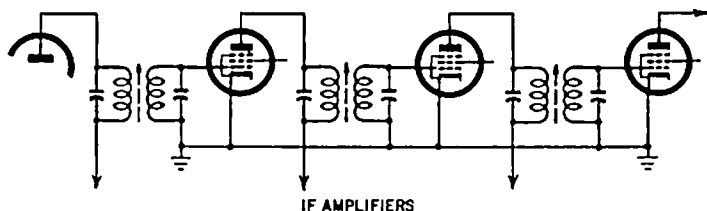

Fig. 429. A form of transformer coupling. Pentodes are used because the coupling device is a parallel-resonant circuit.

response arise from the fact that a very large audio or video band is being amplified. With transformer coupling of audio voltage amplifier stages, the problem of obtaining a flat response is just as involved. There is no coupling capacitor to contend with but the shunt capacitances are still there and the transformer, with its several reactive components, presents an additional problem. Because transformer-coupled amplifiers are more expensive than R-C-coupled types, they are generally used in special cases. Pentodes make use of resistance coupling because, being high-impedance devices, they must work into higher load impedances than a transformer can present.

Mutual coupling in the if stages of radio and TV receivers might be considered a form of transformer coupling and, in these cases, pentodes are used because the coupling device is a parallel-resonant circuit (Fig. 429). Parallel-resonant circuits present a high impedance to the tube and the high-impedance pentode does a very satisfactory job. With this type of coupling, where the if transformers are factory-adjusted to be resonant over a given band, the effect of the distributed capacitance of both wiring and tube electrodes is absorbed as part of the capacitance of the resonant circuit. This capacitance is automatically taken care of by adjusting the trimmers when lining up the if's. In such a circuit the response is essentially "flat" over the frequency band to be passed, because the band (in broadcast-band receivers, about 8 kc) is a small part of the actual if carrier frequency of about 455 kc.

In TV receivers a band of about 3-4 mc instead of 8 kc must be passed. For such a relatively broad band, "flat" response is not as simple as in the standard broadcast receiver. To facilitate the solution of this problem, the if amplifier stages are usually stagger-

tuned. In a circuit such as Fig. 429, the transformers are not tuned to the same frequency. The first and third stages are tuned to one frequency and the second and fourth stages (if any) to another. The response of an individual stage is not very broad but the overall amplification tends to be flat with a double hump at each end and a valley in the center of the band. By carefully adjusting, say, the second and fourth stages, it is possible to bring the "valley" to the level of the entire curve.

In triode audio amplifiers, with straight transformer coupling, the reactive components of the transformer itself must be taken into account. The primary inductance of the transformer acts as an inductive shunt, in parallel with the tube load and reduces the output at the

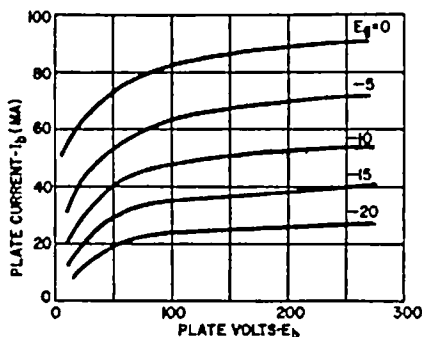

Fig. 430. The characteristics of the power pentode are much more curved than the triode's.

low frequencies. The other component—the leakage inductance—acts as a series reactance between the tube and the load, reducing the amplification at the high-frequency end of the band. The distributed winding capacitance appears as a shunt across the load also.

To live with these basic characteristics, the transformer selected must have a high primary inductance and low leakage. The winding capacitance is an inherent part of the transformer and should resonate with the leakage inductance at a frequency at the top end of the band, thus compensating for the falling off otherwise caused by the leakage inductance. The secondary should have many more turns than the primary to step up the voltage to the grid of the next tube.

With a given-size core, the total number of turns, both primary and secondary, is fixed because of space limitations. With a high turns ratio, the primary must have relatively few turns for a high primary inductance. To increase the primary inductance, the core has to be made larger. The larger size results in more leakage inductance and distributed capacitance. These resonate at a lower frequency—probably within the audio band itself—and produce a hump and sharp

dropping off, spoiling the high-frequency response. The increase in leakage inductance can be controlled by carefully interleaving the primary and secondary windings but this process increases the distributed capacitance, which might neutralize the benefits obtained.

To do as good a job as possible, the transformer must have a large core of high-quality magnetic material with an air gap only large

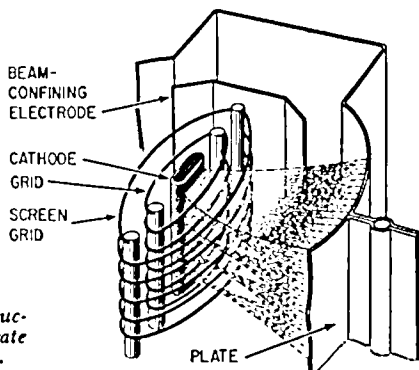

Fig. 431. Beam power tube construction. The heavy dashed lines indicate high-density space charge region.

enough to prevent dc saturation and not reduce the incremental inductance. The stepup ratio should not be too high, otherwise frequency response will be sacrificed. Skillful interleaving of the windings can sometimes reduce the leakage inductance without too much increase in their distributed capacitance.

Power pentodes—beam power tubes

A few pentodes have been designed for power amplification. These are commonly used in the output stages of power radio receivers. (The 6K6-GT with an output in the order of 3 watts is one example.) But why, then, use the power pentode instead of a triode that is capable of delivering more power? The reason is that a pentode requires a much smaller driving voltage than a triode, thus saving perhaps one stage of amplification. However, the characteristics of the power pentode are much more curved than the triode's. Unlike the voltage amplifier pentode, the I_b - E_b curves do not rise steeply to the knee of the curve but slope off gradually (Fig. 430). This gradual transition is caused by the suppressor, which tends to produce a variable- μ action. Thus the power pentode produces more harmonics than the triode and, because the resulting amplitude distortion contains a substantial third harmonic, push-pull operation does not help very much. Because the pentode is much more efficient than the triode, it is generally used where economy is important.

Beam power tubes such as 6V6-GT, 50C5 and 6L6-GB, while not pentodes in the true sense of the word, function circuit-wise as pentodes but are capable of delivering considerable power. In the

beam tube (Fig. 431) the electron stream is concentrated by a pair of deflecting plates and directed toward the plate in a well-defined beam. Also, physically, the distance between the plate and screen is large so that the high-speed electrons bounce the secondary electrons from the plate, but not far enough for them to be attracted to the screen. Thus, a negative space charge is created between the screen and the plate (near the plate), which acts exactly as the suppressor of the ordinary pentode.

The beam tube can be classified as a power pentode because it has the same fundamental characteristics. However, contrary to the power pentode, the beam tube's characteristics closely resemble those of the regular voltage-amplifier pentode. As the plate voltage is increased the plate current rises sharply to the knee of the curve, at which point there is an abrupt change in slope to the region where the current is relatively independent of plate voltage. Compare the characteristics of the 6L6 beam tube in Fig. 432 with those shown in Fig. 430. The beam power tube produces less distortion than the power pentode. In fact, when operated beyond the knee of the curve, the beam tube produces less third-harmonic distortion than the power pentode while still retaining its high efficiency as well as the advantage of requiring only a small driving voltage. Second-harmonic distortion is relatively high but this, of course, can be reduced by push-pull operation.

The method of obtaining the output power and calculating the distortion for the beam tube is practically the same as with triodes. For example, assuming that a 6L6 is to be operated on a single-tube basis, not push-pull, and with an operating plate voltage of 250, a load resistance of 2,500 ohms should be used for about a 14-volt peak input signal. If it is assumed that the operating bias is -14 volts, the load line must cross the -14 -volt point at an E_p of 250 volts. To determine the plate supply voltage needed with 250 volts at the plate and a bias of -14 volts, the slope of the load line must be drawn. Since the slope of the line is the ratio E_b/I_b , then an arbitrarily selected value of E_b will determine I_b .

$$\text{Thus} \quad 2,500 = \frac{E_b}{I_b} = \frac{500}{I_b}$$

$$\text{then} \quad I_b = \frac{500}{2,500} = 200 \text{ ma}$$

Using the 500-volt and 200-ma intercepts, curve A then determines the slope of a 2,500-ohm load line.

This line does not intercept the operating point P' corresponding to a grid voltage of -14 and plate voltage of 250. Drawing a second line B through P'', parallel to the first, appears to give the desired load line. For this case, a supply voltage of about 430 is needed. However,

a check of the signal-handling capacity of this operating point must be made before it is accepted. A 14-volt peak signal will vary the current from a peak of about 150 ma to a low of about 25. Obviously there is serious distortion—the negative peak of the wave is seriously rounded.

In practice the operating bias is reduced to about -12.5 volts so that an abnormal negative pulse will not run the tube so near cutoff.

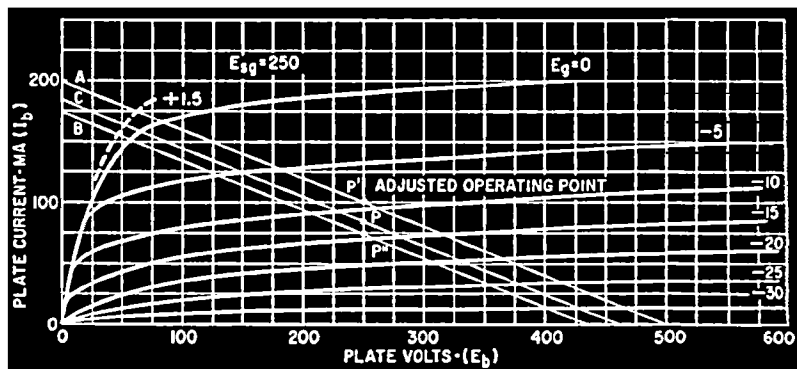

Fig. 432. Plate-voltage, plate-current characteristics of the 6L6 beam power tube.

In this case, with a 14-volt peak signal, the grid would be driven to -26.5 volts and even a slight signal increase will still give enough leeway without cutting the tube off.

On the positive peak, grid current will flow ($-12.5 + 14.0 = 1.5$ volts) but this does not present any problems because the 6L6 is designed to permit some flow of grid current. Therefore, if a new load line C is constructed through the operating point corresponding to a grid bias of -12.5 volts, the voltage intercept indicates that a plate supply of about 460 volts is required.

By analyzing the positive and negative swings of the grid bias, it will be noted that some distortion is present, even when operating on curve C, allowing for errors in reading the small scale, with an input of 14 volts peak. For example, the current appears to vary from a mean of about 85 ma to a peak of about 165 and a minimum of about 30—an 80-ma change in the positive direction and a 55-ma change in the negative, a peak difference of 25 ma. This results in second-harmonic distortion of

$$\frac{\frac{1}{2} (165 - 30) - 85}{165 - 30} \times 100\% = \frac{67.5 - 85}{135} \times 100\% = 13\%$$

This can be cancelled by push-pull operation.

Special circuit arrangements in amplifiers

The circuit designer is constantly balancing the cost of high quality or fidelity against the efficiency of the circuit. In power amplifiers, to obtain more output the tube is driven harder, causing amplitude distortion. To reduce or eliminate this distortion, a second tube is added (or a double tube is used) and wired in push-pull. This involves higher costs because, not only is a second tube needed, but also an input transformer must be provided. The transformer occupies more space on the chassis and in addition must be carefully selected so that it will be a minimum source of distortion. Design engineers, aware of these factors involving the use of transformers, finally devised a method of providing push-pull operation without them. With this method, resistance coupling is used and the circuit is designed so that it may be applied to a driver stage as well as to the input to the power stage. Such a *phase-inverter* circuit can be used with triodes or pentodes.

Phase inverter

The phase inverter does just what it says, it "inverts" the phase of the incoming signal and permits it to drive two tubes 180° out of phase with one another, without the use of transformers. Because one side of the output of an amplifier is grounded (usually at the power supply), it cannot be connected directly to both grids of two tubes connected in push-pull. By using a circuit similar to Fig. 433-a, however, phase inversion is accomplished.

In this circuit R_k and C_k are the common-cathode bias resistor and bypass capacitor for both tubes, providing the same negative bias for each. Considering V1, the full output voltage is applied to it and the amplified output appears across R_{L1} . This output is transferred through coupling capacitor C1 to R_{g1} , the grid resistor of the next tube. So far, nothing has happened to V2. Before considering how tube V2 functions, a polarity check through V1 should be made. For example, at the instant the grid of V1 is becoming less negative (application of the positive peak of the input signal), the plate is becoming less positive, therefore shifting the phase through the tube. This "negative" polarity also appears at the grid resistor. By taking a tap from R_{g1} and connecting it to the grid of V2, this "negative-going" signal will make the grid more negative and its plate more positive. The plate of V1 is the opposite polarity of V2 and each tube, therefore, is being fed 180° out of phase to the other, the same as with the transformer push-pull circuit.

Not only must the tube outputs be 180° out of phase, but the input voltages for the output tubes must be of the same amplitude so that the second harmonics of each tube will be cancelled. Obviously, if the voltage across R_{g1} is greater than that across R_{g2} , the second-harmonic components will not cancel exactly and a net distortion factor will

remain. Since the input e_s is tapped from R_{g1} , the voltage can be adjusted to be the same as e_s , even though the voltage applied to the

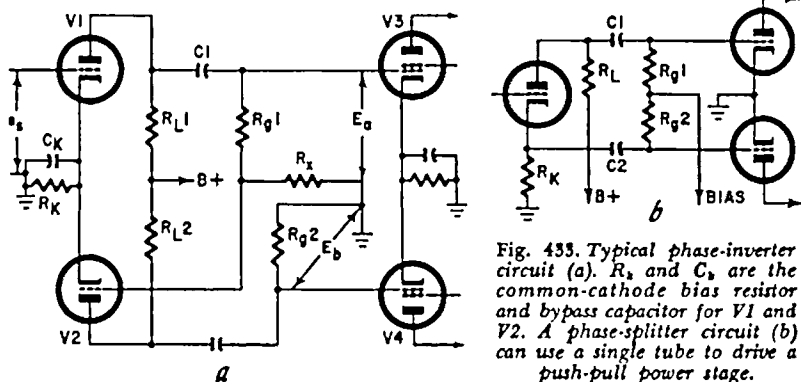

Fig. 433. Typical phase-inverter circuit (a). R_K and C_K are the common-cathode bias resistor and bypass capacitor for V1 and V2. A phase-splitter circuit (b) can use a single tube to drive a push-pull power stage.

whole of R_{g1} is too high for the purpose. This is accomplished by making the ratio of the tap resistance R_x to the total R_{g1} equal to the voltage amplification of V1. If the voltage amplification of tube V1 were 10, it could mean that an input of 1 volt would appear as 10 volts across R_{g1} , which, say, is 0.5 megohm. Thus, a 1-to-10 resistance tap or, in this case, 50,000 ohms would provide 1 volt at the input to tube V2 also.

As with the push-pull amplifier, both tubes should have the same characteristics. Also, load and grid resistances must be equal so that each tube circuit develops the same output voltage.

In many cases, it is desirable to use a single tube to drive a push-pull stage. Fig. 433-b shows a phase-splitter (inverter) containing a resistance R_K in the cathode circuit equal to load resistance R_L . Since both resistors are in the plate circuit (R_K is in the cathode circuit which is part of the plate circuit) the ac voltages developed across each resistance are equal. Since the cathode is 180° out of phase with the plate, the cathode tap will be 180° out of phase with the ac voltage appearing across R_L ; hence, the phase inversion. The voltages applied to each of the grid resistances will be equal and 180° out of phase with each other and, therefore, can be used to drive a push-pull stage.

The single-tube phase splitter is simpler than the two-tube type but has the decided disadvantage of producing no voltage amplification.

Cathode resistor R_K is common to both the grid and plate circuits. Therefore, plate-current variations in the cathode develop an ac voltage across resistance R_K . This voltage, which is also in series with the grid circuit, acts to depress the grid component of the circuit, thus tending to nullify the amplified voltage which would be generated in the plate circuit if R_K were not present. This process of reducing the net amplification of the circuit by effectively feeding all or part of the

output of an amplifier back into the grid circuit in such a way that it opposes the input signal is called *negative feedback*.

Negative feedback

With the single-tube phase splitter, the resultant negative feedback can be looked upon as a by-product of the inversion process. The function of R_k in this case is to provide inversion. However, negative feedback has a very important place in special amplifier circuits for its own sake. In circuits where it is used, the amount of feedback is controlled and the gain of an amplifier is reduced, but seldom to as great an extent as with the phase splitter.

Sometimes the feedback is carried over several stages of amplification rather than kept within the single-tube circuit. In other cases selective feedback is used so that not all the frequencies are fed back in the same proportion.

The basic theory of feedback should be thoroughly understood. Ordinarily, the amplification of a simple circuit with an input signal of e_x is

$$A = \frac{e_o}{e_x}$$

where e_o is the output voltage (Fig. 434).

If a portion of the output is fed back into the input in such a way that it opposes the input voltage, the output voltage will be considerably less. By representing the feedback in terms of a percentage of the output, the new value of amplification can be derived. In Fig. 434, if the input signal e_x has added to it a fraction β of the amplified output e_o , then if β is considered negative when the feedback voltage opposes the input, the new input becomes $e_x - (-\beta e_o) = e_x + \beta e_o$, which in turn is amplified A times. This new output must still be equal to e_o , or

$$\begin{aligned} A(e_x + \beta e_o) &= e_o \\ \text{then } e_o &= Ae_x + \beta Ae_o \\ \text{and } e_o(1 - \beta A) &= Ae_x \end{aligned}$$

$$\text{or } \frac{e_o}{e_x} = \frac{A}{1 - \beta A} = K = \text{Amplification with feedback} \quad (19)$$

From this it can be seen that if the term βA is very large, the amplification becomes practically equivalent to

$$K = -\frac{1}{\beta} \quad (20)$$

This means that the effective amplification of such a circuit is dependent only upon the fraction β of the output that is superimposed upon the input and is practically independent of the amplifier gain itself. This is so because, when the feedback is large, the external sig-

nal voltage is not very different from the feedback voltage itself. Under this condition, a small change in amplification brought about by, say a plate and screen supply voltage variation, would change the factor βA quite a bit and thus increase or decrease the net input to the amplifier in such a way as to offset the original change in amplification

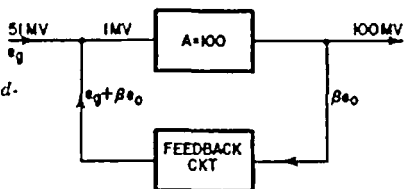

Fig. 434. Basic theory of negative feedback.

caused by the plate supply variations. The feedback amplifier produces a relatively stable output, automatically correcting for variations produced within the amplifier circuit itself.

To understand this more clearly, assume in Fig. 434 that the net input signal e_n to the amplifier is 1 mv, that the amplifier has a gain of 100 and the feedback is as much as 50%. The feedback factor would then be 100 times 0.5 = 50 = βA (remember $-\beta$ is negative). For a net amplifier input of 1 mv, therefore, the input signal to the amplifier would have to be 1 + 50 = 51 mv. Thus, with 50% feedback, the net amplification of the circuit has been reduced from 100 to

$$K = \frac{100}{1 - (100 \times -50)} = \frac{100}{51} = 1.96$$

Circuit fluctuations affecting the overall gain of the circuit are minimized with a large feedback factor. To check this statement, consider the above case where $A\beta$ is large. If the basic circuit amplification were cut in half, say from 100 to 50, the net input to the amplifier would have to be 2 mv instead of 1 mv as before ($2 \times 50 = 100$, $A = 50$). It would therefore be necessary to increase the input from 51 to 52 mv to develop the same output. Thus, only 2% change in effective overall amplification would result if the basic amplification were changed as much as 50%.

The negative-feedback amplifier, therefore, tends to be a stable device which compensates for variations in amplification within its own circuit. The total gain lost is made up by adding stages of amplification. The feedback amplifier, however, functions also to control amplitude distortion to some extent and to compensate for frequency-distortion effects. Amplitude distortion is generated within the amplifier, usually in the output power stage where the tube is driven into the curved portions of the characteristic. This distortion appearing in the output is also fed back into the input 180° out of phase with the original input and, of course, is reduced along with the overall amplification.

To understand the effects of feedback on distortion, assume that the distortion originating in the amplifier and appearing in the output without feedback is represented as d . The output of the amplifier without feedback can then be pictured as made up of two components, an amplified signal voltage and a distortion voltage which equals $e_o + d$. With feedback, the factor d is reduced to a lower value D but, since we can assume that the input signal was adjusted to give the same output e_o with distortion, the new output would be made up of the components $e_o + D$. If β is the feedback factor, then the new input would be equal to $e_r + \beta (e_o + D)$ which, when amplified, would become $A [e_r + \beta (e_o + D)]$. In passing through the amplifier, however, another distortion component would be picked up, hence

$$\begin{aligned} e_o + D &= A (e_r + \beta e_o + \beta D + d) \\ &= A e_r + \beta A e_o + \beta A D + A d \\ \text{or } A e_r + d &= e_o + D - \beta A e_o - \beta A D \\ &= e_o (1 - \beta A) + D (1 - \beta A) \end{aligned}$$

by regrouping,

$$A e_r = e_o (1 - \beta A), \text{ becoming } \frac{e_o}{e_r} = \frac{A}{(1 - \beta A)}$$

which is the basic formula for amplification with feedback, and

$$d = D (1 - \beta A) \text{ or } D = \frac{d}{(1 - \beta A)} \quad (21)$$

which shows that the distortion with feedback is really the distortion without feedback divided by the factor $(1 - \beta A)$.

In summary, when $A\beta$ is large, the amplification is very stable and amplitude distortion originating in the amplifier is reduced to a minimum.

Negative feedback may also be put to use to compensate for variations in amplification over the frequency band. In audio work it is used to alter the overall frequency response of the amplifier. When this is done, the feedback circuit is selective and the feedback network is designed to provide the feedback factor with different values over the frequency band. For example, if more high frequencies than low are fed back to the input, the gain at the high end of the band will be less than at the low end, all other things being equal.

The circuit of Fig. 435 shows a two-stage amplifier with voltage feedback. In this circuit, tube V1 has two cathode resistors, R_{k1} and R_r , but only R_{k1} is bypassed by capacitor C_{k1} . Thus R_r produces negative feedback within the first amplifier stage itself. A connection is also established between point X in the cathode circuit of V1 and the plate of V2 through the R1-C1 network, establishing a second source of feedback voltage.

In the amplifier circuit (Fig. 435) assume that the negative half of

the input signal is applied to the grid of V1. At that instant, the cathode circuit at point X will become more negative while the plate of V1 becomes more positive. This positive polarity at the plate, transmitted through C_c , makes the grid of V2 more positive (less negative) also. The polarity at the plate of V2 becomes negative (less positive) and this negative-going signal is applied to point X in the cathode circuit of V1 via R1 and C1. The negative polarity applied to point X tends to lower the voltage at that point. Because the voltage that matters to the tube is that from grid to cathode, a negative voltage from

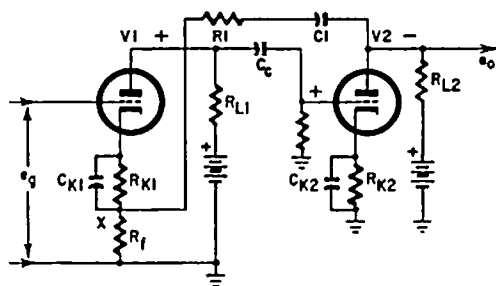

Fig. 435. Amplifier circuit using selective feedback to alter the overall frequency response.

cathode to ground is the same as a positive voltage from ground or grid to cathode. Thus both the first and second negative pulses at the cathode are negative feedback.

R_1 and R_f and their relation to one another determine the amount of feedback voltage.

This type of circuit may be used for selective feedback to alter the overall frequency response. The network R_1 and C_1 can be arranged to feed back more high frequencies than low and thus increase the response at the low-frequency end of the band. The reactance of C_1 compared to the overall impedance of the feedback circuit determines the degree of selective feedback. If the reactance of C_1 at low frequencies is high compared to the circuit resistance, less low-frequency feedback voltage will appear across R_f and the overall low-frequency amplification will not be reduced as much as that of the highs.

A three-stage amplifier with feedback is shown in Fig. 436. The feedback voltage is taken from the cathode of V3 and applied to the cathode of tube V1 at point X. By tracing the polarities through the amplifier stages, it can easily be seen that negative feedback is developed across R_{k1} as with the two-stage amplifier of Fig. 435. Note also that the pentode screens must be bypassed directly to the cathodes so that the feedback voltage will not be applied to the screen also. The

omission of the cathode bypass capacitors in V1 and V3 develops feedback within these tubes in addition to the main feedback from V3 to V1.

Oscillation with negative feedback

When applying negative feedback over several stages, always make sure that in the process positive feedback is not produced at the extreme ends of the audio-frequency band being amplified. A glance at the formula $K = A / 1 - \beta A$ indicates that, if the feedback factor $A\beta$ is positive and equal to or greater than unity at any frequency, then the denominator becomes zero or negative and the amplification K becomes infinite, resulting in oscillation. In other words, even though

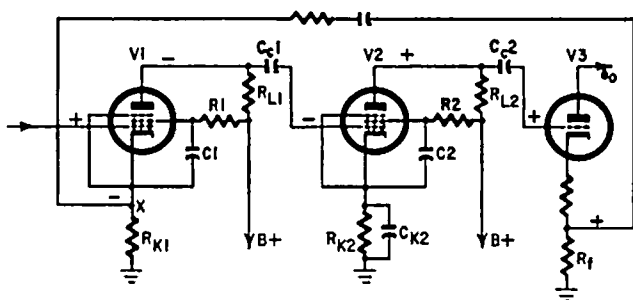

Fig. 436. A three-stage amplifier. Phase shifts within the amplifier can cause positive feedback, resulting in oscillations.

the circuit is arranged for negative feedback and develops negative feedback over most of the audio band, phase shifts occurring within the amplifier (see the universal amplification curve of Fig. 425) at extreme ends of the band may actually cause positive feedback.

To understand how such a situation might develop in a three-stage amplifier (Fig. 436), the overall frequency characteristics of the amplifier must be considered. Fig. 425 shows that the phase shift varies either side of the norm at the middle frequencies where reactive components of the circuit are small in relation to the resistive components. In the three-stage amplifier, if all stages are assumed to have the same voltage amplification, Fig. 425 shows that the total phase shift will reach 180° (60° for each stage) at the frequency where the amplification per stage has dropped to half the mid-frequency gain.

The polarities of Fig. 436 show that the voltage appearing across R_f is 180° out of phase with that at point X. Frequencies off mid-band, however, are not of the same phase because of the reactive components of the circuit and the size of these components with respect to the resistance of the amplifier circuit determines the amount of the phase shift. Suppose in this case, the gain at 100 cycles in each of the three stages is half the amplification at 1,000 cycles. Since the universal

amplification curve of Fig. 425 shows that the phase shift per stage is 60° , by the time the 100-cycle frequency reaches R_f it has undergone an additional shift of 180° so that its (100-cycle) polarity is really negative rather than positive. Feeding this negative polarity back to point X brings it in phase with the cathode-circuit polarity instead of out of phase. Thus, positive, not negative, feedback may result in some cases which *may* cause oscillation. Positive feedback does not always result in oscillation. The amount of energy fed back is also an important factor.

In the case under discussion, where the 100-cycle amplification is half the gain at 1,000 cycles, the 100-cycle gain through the entire three-stage amplifier would be $\frac{1}{2} \times \frac{1}{2} \times \frac{1}{2} = \frac{1}{8}$, the gain of the 1,000-cycle frequency. Thus, if oscillation is to be avoided, even though the feedback is positive at 100 cycles, the feedback factor βA at the mid-frequency must be less than 8. If it is 8 or more, the amplification with feedback would be

$$K = \frac{A}{1 - (8 \times \frac{1}{8})} = \frac{A}{0} = \infty$$

If a greater degree of feedback were desired, the feedback factor of 8 being too small to provide the desired stabilized output, one of the stages would have to be very flat with good response at, say, 100 cycles. With an amplification of one of the stages near that of 1,000 cycles, the phase shift would be nearly zero and the total phase shift through the amplifier would be a little over 120° instead of 180° as before.

Another method of accomplishing the same result would be to start with the feedback factor desired and work back from there. Assuming that an overall feedback factor βA of 100 is desired, the overall frequency response must be good enough over the entire band so that K is positive and finite at all frequencies. Fig. 425 shows that the amplification falls to 0.1 when the phase shift is about 85° . Thus, for two stages at that frequency, the phase shift would be 170° and the gain would be $1/10 \times 1/10 = 1/100$ the mid-band amplification and βA would drop to unity. Oscillations are not possible for these two stages because the total shift is only 170° and oscillations cannot build up. The third stage, therefore, must be made flat enough so that the total shift through the amplifier does not reach 180° .

Cathode follower

The cathode follower is in fact a circuit wired for 100% feedback and in a way resembles the inverter of the single-tube phase-inverter circuit. In this circuit (Fig. 437) the load resistance is in the cathode circuit only, with no resistance in the plate circuit itself, thus producing a feedback factor of 100%. The cathode follower has no gain since its voltage amplification must always be less than unity.

Amplification was described earlier by equation 5 on page 33. In

considering the functioning of the cathode follower, the phase shift of the signal through the tube (which has no bearing on the actual gain of the tube) must be taken into account. Equation 5 may then be rewritten as:

$$A = \frac{-\mu R_L}{r_p + R_L}$$

while the amplification with feedback has been derived as

$$K = \frac{A}{1 - \beta A}$$

Hence, with the cathode follower having a load resistor R_k , the amplification can be written as

$$K = \frac{\frac{-\mu R_k}{r_p + R_k}}{1 - \frac{-\beta \mu R_k}{r_p + R_k}} = \frac{-\mu R_k}{r_p + R_k + \beta \mu R_k}$$

since with the cathode follower $\beta = 1$.

$$K = \frac{-\mu R_k}{r_p + R_k (\mu + 1)} \quad (22)$$

From this it may be seen that the amplification of the cathode follower must be less than unity.

Because the output is taken from the cathode, the output impedance is relatively low, usually in the order of 500 to 600 ohms, but may be as low as 170 ohms in some cases. The impedance of such a circuit can be derived very easily if certain assumptions are made. At frequencies below 2 mc where reactive components may be neglected, the impedance of the cathode-follower circuit may be written

$$Z = \frac{r_p R_k}{r_p + R_k (\mu + 1)} = r_p \frac{R_k}{r_p + R_k (\mu + 1)}$$

but since the amplification of the circuit is

$$K = \frac{\mu R_k}{r_p + R_k (\mu + 1)}$$

then

$$Z = \frac{r_p K}{\mu} = \frac{K}{g_m} \quad (23)$$

Since the amplification is less than 1 and most tubes have a transconductance in excess of 1,200 to 1,300 micromhos, the impedance is less than 850 ohms and, if the tube g_m is higher, the impedance can be as low as 170 ohms. Thus, the cathode follower makes a good device for transforming a high-impedance to a relatively low-impedance, acting much like an impedance-matching transformer. Because it has

no gain, its input capacitance is low and its input impedance high. Even though there is no voltage gain, the combination of high input impedance and low output impedance with no impairment in frequency response makes the circuit useful as an impedance-matching

Fig. 437. A cathode-follower circuit.

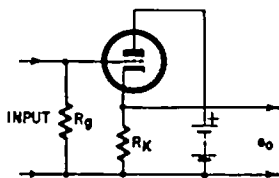

device. No transformer is capable of passing the wide band of a video signal as well as this type of circuit.

Because of its low output impedance, the cathode-follower circuit is capable of developing considerable power amplification even though it is a very poor voltage amplifier. This characteristic is an important by-product in the video amplifier circuit.

Input admittance

In our discussions of R-C coupled amplifiers, the effect of the interelectrode capacitances on the load of the preceding tube was mentioned and considered in combination with the other shunt capacitances. These interelectrode capacitances differ in magnitude with

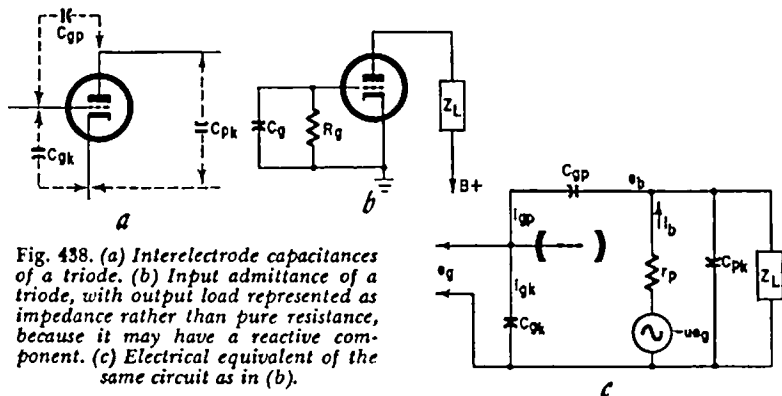

Fig. 438. (a) Interelectrode capacitances of a triode. (b) Input admittance of a triode, with output load represented as impedance rather than pure resistance, because it may have a reactive component. (c) Electrical equivalent of the same circuit as in (b).

different type tubes. For example, the input capacitance of pentode tubes (used generally in R-C amplifier circuits) for all practical purposes is equal to the grid-to-cathode and grid-to-screen capacitances with the plate not considered in the tube input because the grid-to-plate capacitance is negligible. With triodes, however, such as in the power stage of audio amplifiers, or in high-power tubes in radio transmitters, plate-to-grid capacitance becomes an important factor in circuit performance.

In Fig. 438-a, the interelectrode capacitances of a triode are shown. Obviously, the grid-to-cathode capacitance C_{gk} acts as a direct shunt across the input while C_{pk} is part of the tube output and has no effect on the input impedance. However, the grid-to-plate capacitance C_{gp} affects the input impedance and becomes very important because the ac voltage at the plate is always considerably higher than the grid voltage in addition to being out of phase with it, causing a capacitive current to flow between these electrodes. The amount of current flow depends, of course, on the capacitance and the potential difference between the electrodes. Since the load resistance R_L determines the voltage at the plate, when R_L is large enough to produce appreciable amplification, the potential difference between the plate and grid is much higher than the input signal voltage, resulting in a large flow of current through this capacitance.

Because this input impedance is affected by the load on the tube, the current that flows through the grid-to-plate capacitance is directly related to the load impedance. If the load is a pure resistance, the phase relationship between the current and voltage in the plate circuit will be such that the input impedance or rather, its reciprocal, input admittance, will be a pure capacitance. However, if the load impedance has a reactive component (that is, the plate voltage is not in phase with the plate current), the input admittance will have a resistive component. In other words, not only will the grid-to-plate circuit reflect capacitance to the input, but it will also appear to have a resistive component.

Fig. 438-b shows the input admittance of a triode as a resistance in parallel with a capacitance, with the output load represented as impedance rather than pure resistance because it may have a reactive component. Fig. 438-c shows the electrical equivalent of the same circuit. In this circuit the input admittance consists of two circuits in parallel, one path through C_{gk} and the other through C_{gp} in series with the output circuit. The current through the grid-to-plate capacitance is due to the vector difference between voltages e_g and e_b .

Part of this output circuit — C_{pk} and Z_L — is the load on the tube and affects the basic plate circuit. Since the net effect of C_{pk} and Z_L is to make the plate circuit capacitive, e_b , which is determined by the drop in the total plate circuit impedance, must lead μe_g by some angle ϕ and thus leads the input voltage e_g by $180^\circ + \phi$. The voltage difference across the grid and plate is therefore $e_g - e_b$, where e_b is $(180^\circ + \phi)$ out of phase with e_g . With this voltage as a source of potential, the current i_{gp} flowing through the grid-to-plate capacitance (Fig. 438-c) would be

$$i_{gp} = \frac{e_g - e_b}{X_{gp}}$$

where X_{gp} is the reactance of the plate-to-grid capacitance.

The current flowing through the first path would be

$$i_{gk} = \frac{e_g}{X_{gk}}$$

where X_{gk} is the reactance of the grid-to-cathode capacitance. Thus the total current would be

$$i_{gp} + i_{gk} = i_t = \frac{e_g}{X_{gk}} + \frac{e_g - e_b}{X_{gp}} = e_g \frac{1}{X_{gk}} + \frac{1}{X_{gp}} - \frac{e_b}{e_g X_{gp}}$$

and the total input admittance would be

$$\frac{i_t}{e_g} + \frac{1}{X_{gp}} - \frac{e_b}{e_g}$$

which may be rewritten as

$$\frac{1}{X_{gk}} + \frac{1}{X_{gp}} (1 - A) \quad (24)$$

where $e_b/e_g X_{gp}$ is the amplification of the tube alone.

In the relationship expressed in equation 24, the $1/X_{gk}$ and $1/X_{gp}$ components appear as pure capacitance and hence the currents flowing through the capacitive reactances X_{gk} and X_{gp} are 90° out of phase with the input voltage e_g . However, the third component $e_b/e_g X_{gp}$ may have a resistive component as well as being a function of the tube amplification. If the plate load impedance is a pure resistance so that the plate current i_b is exactly 90° out of phase with the voltage e_b at the plate, this third term will be a pure capacitance with no resistive component.

Since the capacitances of all these components affect the input admittance of the amplifier circuit and this total capacitance is a function of the tube amplification, then from equation 24 the total input capacitance of the circuit is shown as

$$\text{input capacitance } C_1 = C_{gk} + C_{gp}(1 + A) \quad (25)$$

which is considerably larger than the sum of the individual interelectrode capacitances. Using this formula, then, if a 6C5 tube were used in the circuit, by obtaining the interelectrode capacitances from the tube manual and assuming an amplification of 15, the input capacitance would be

$$C_1 = 2.4 + 2(1 + 15) = 34.4 \mu\mu\text{f}$$

In considering the effect of a resistive component as part of the input admittance, if the plate load impedance is a pure resistance, the current is exactly 90° out of phase with e_b , which is the characteristic of a pure capacitive circuit. A phase difference other than 90° between i_b and e_b of course indicates the presence of resistance. If Z_L

in Fig. 438-c is capacitive, the plate current i_b , which must always be in phase with e_r , the signal voltage, will lead the voltage at the plate by 90° plus some angle Y . The plate voltage e_b , will, therefore, lead the input e_r by an angle less than 90° . Where the plate load Z_L is inductive, the opposite is true: the current will lag the voltage at the plate, which, in turn, will lead the input by an angle greater than 90° , indicating the presence of a *negative* resistance.

Positive and negative resistive components may perhaps be more readily understood if the currents and voltages are shown vectorially. If the load impedance is a pure resistance, the plate current will be in phase with e_b . This is represented vectorially in Fig. 439-a where the plate current and voltage as well as the generated voltage μe_r in the plate circuit are shown. The current i_{pk} flowing through C_{pk} will be 90° ahead of e_r and it is so shown. The current through the plate-to-grid capacitance will lead the difference voltage ($e_r - e_b$) by 90° also. Since e_r and e_b are in phase, this current will lead e_r by 90° also and thus the total current i_t , the vector sum of i_{pk} and i_{pk} , will lead e_r by 90° , indicating a pure capacitive input. This condition obtains as long as the plate load impedance is a pure resistance.

However, if the plate circuit is inductive, the current and voltage relationships will change. In Fig. 439-b, i_b is still in phase with e_r because it represents the electron stream which is acted upon directly by

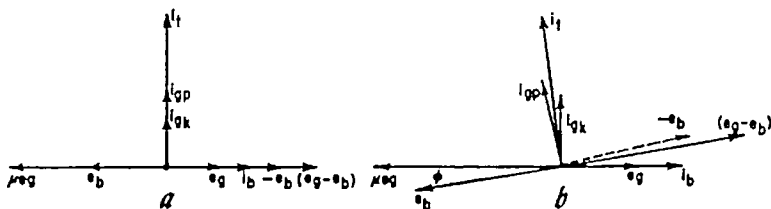

Fig. 439. Vectorial relationships of currents and voltages. When load impedance is a pure resistance (a), the plate current will be in phase with e_b . When plate load is capacitive (b), e_b appears in the second quadrant because it lags the plate current.

e_r . In this case, e_b leads i_b because of the inductive load by an angle ϕ , instead of being in phase as before. The plate voltage e_b must then lead e_r by $180^\circ + \phi$ and the voltage difference ($e_r - e_b$) feeds current back into the input circuit. Because the reactance between the plate and grid is a pure capacitance C_{gp} , the current flowing from plate to grid must lead this voltage by 90° . As indicated in Fig. 439-b, this current i_{gp} will lead the input signal e_r by an angle ϕ greater than 90° . From the standpoint of the input circuit, this current i_{gp} combines vectorially with the pure capacitive current i_{pk} and the total i_t appears in the second quadrant, indicating a negative resistance component as well as a capacitive one. A negative resistance, of course,

indicates a positive feedback which, if large enough, can cause oscillation. This negative resistance is made use of deliberately to produce oscillation in some circuits.

When the plate load impedance is capacitive rather than inductive, e_b in Fig. 439-b appears in the second quadrant because it lags the plate current. This swings current i_{kp} into the first quadrant, which, of course, seems like a positive resistive component to the input signal voltage e_r .

When the load impedance is a pure resistance, all currents are 90° ahead of the input signal voltage (Fig. 439-a). The input admittance, therefore, appears as a pure capacitance.

While this negative resistance effect is used in some oscillator circuits, it can be annoying and may even cause some damage in circuits designed primarily for amplification. If this unwanted positive feedback is large enough—as it may well be in large power tubes at transmitting stations where parallel-resonant circuits are used in the grid and plate circuits—oscillation of considerable amplitude can result. In such cases, the plate tank circuit may not be resonant at exactly the carrier frequency being amplified and it will therefore have a reactive component, the plate current not being exactly 90° out of phase with the plate voltage. Such a condition produces a positive or negative

Fig. 440. The Hazeltine system neutralizes positive feedback. The voltage deliberately fed into the grid through C_n and L_n is at the bottom of the output transformer and is 180° out of phase with e_b .

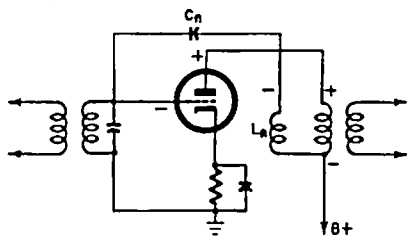

input resistance. Where the possibility of positive feedback exists, the effect of the grid-to-plate capacitance is neutralized by making an electrical connection from the output to the input circuit in such a way that a second current will flow through the grid circuit 180° out of phase with the current flowing through the grid-to-plate capacitance. Such a process is called *neutralization* and is a must at all transmitters.

In lower-powered circuits where triodes are used, this problem of negative resistance is more bothersome than damaging, because extraneous oscillations or "squeals" may develop. Several methods have been devised for neutralizing this feedback and one of the methods used is the Hazeltine system shown in Fig. 440. The voltage deliberately fed into the grid through C_n and L_n is at the bottom of the output transformer and thus 180° out of phase with e_b , which is responsible for the positive feedback.

The limiter

Pentodes when used as voltage amplifiers are normally operated so that the output signal is not distorted, particularly in audio amplification. In frequency-modulation receivers where amplitude variations superimposed upon the received carrier signal must be discarded, the pentode amplifier is arranged to produce the same output voltage regardless of the voltage variations in the input signal. The amplifier output is therefore limited and distorted but this distortion is not important as it does not affect the makeup or quality of the audio signal.

The limiter in the FM receiver is the pentode amplifier located directly before the discriminator or ratio detector. The frequency-modulated carrier, when picked up at the receiver, has acquired noise pulses which appear as amplitude variations superimposed upon the carrier. These amplitude variations, such as static pulses or any other disturbance not in the original signal, can be removed by merely chop-

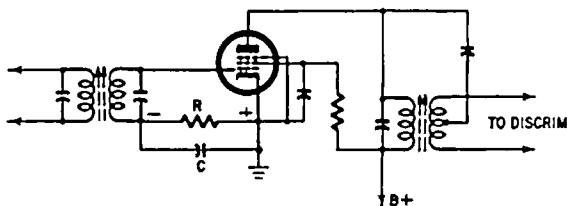

Fig. 441. Typical limiter used in FM receivers.

ping off the peaks. The pentode amplifier can be arranged to do this job when wired as a limiter where low plate and screen supply voltages and grid-leak bias are used.

Fig. 441 shows a limiter typical of FM receivers. With no resistance in the cathode circuit, the tube is not normally biased but, with the combination of R and C in the grid circuit, the tube acquires a bias when the grid draws current. The tube used in this case is a sharp-cutoff pentode.

To understand how the limiter works, assume that the screen and plate voltages are selected so that the weakest signal will "saturate" the tube. If this "saturation" occurs when the signal reaches a peak of, say, 4 volts, the screen voltage must be low enough so that the tube will be cut off with a bias of about -4 volts. According to the transfer characteristics of Fig. 442, the tube cuts off at about -4 volts when the screen has about 75 volts applied to it. With zero bias, the maximum plate current is in the order of 6.3 ma. Assuming that the initial input signal is about 5 volts peak, the initial pulse of the signal acting on the tube at the instant it is not biased would cause grid current to flow. Current flowing through R would, of course, produce a negative

polarity on the grid, which would be maintained by C during the negative half of the wave when no grid current flows, because of the relatively large time constant of R and C. The circuit is arranged so that grid bias is self-adjusting to always create the same amplitude variations in the output. To do this, the grid must always draw grid current during part of the cycle to replenish the bias. In Fig. 442 the input signal always "kicks" the grid into the positive region so that the bias is maintained. Even though the amplitude of the signal varies from the normal 5-volt peak the grid bias adjusts itself so that the tube always draws grid current. Although the output wave is severely clipped and subject to high harmonic distortion, the frequency is the same. However, since the audio information is not in the form of amplitude variations of the carrier and the basic carrier frequencies have not been disturbed, the distortion thus caused by the limiter has no effect. Moreover, since these carrier "pulses" are fed into a parallel-resonant circuit, the sine-wave characteristics are restored and are constant in amplitude.

To make the limiter function properly, it must be saturated by the weakest signal and the if amplifier preceding it must deliver the needed voltage to do this at all times. If the incoming signal is not large enough to swing the limiter to saturation, noise will get through to the output. As the receiver is tuned between stations where there is no carrier to saturate the limiter, the noise can get through because it takes over the limiter action.

To guard against the undesirable possibility of not always saturating the limiter, the pentode could be operated at a lower plate and screen voltage so that the tube would be cut off at a lower grid bias. However, there is a practical limit to this because operation within a narrower range will result in smaller current pulses which may not be large enough to drive the discriminator. Because of this possibility, if a limiter is operated with lower plate, screen and bias voltages in an effort to make sure that it will always be saturated, even with the weakest signal, it is fed into a second limiter which in turn supplies the input to the discriminator. By operating two limiter stages in cascade, the first one takes care of the severe amplitude variations while the second stage removes any residual variations that might be carried through when a weak signal is received.

Grid-bias arrangements

Practically all of the amplifier circuits discussed thus far have operated with a negative bias on the grid. For the most part this bias was obtained from a cathode bias resistor which, by action of the plate (and screen) current, made the cathode positive with respect to the grid. This is by far the most popular method of obtaining grid bias because it is derived within the circuit itself and a separate source of bias is not necessary.

Fig. 442. Average transfer characteristics of a typical FM limiter. The tube cuts off at approximately -4 volts with 75 volts applied to the screen grid.

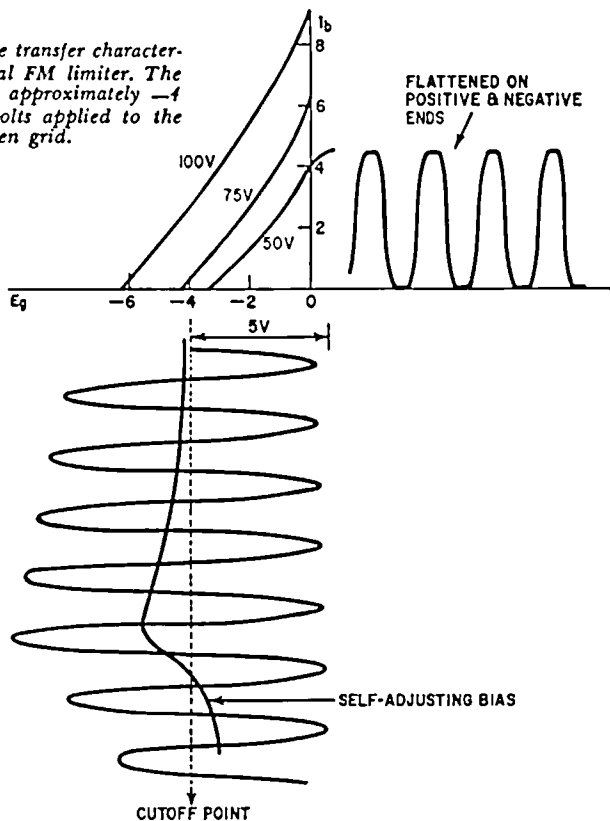

Another method of self-biasing is the one described in the foregoing limiter discussion where the tube biases itself by drawing grid current when the grid becomes positive. The more grid current the circuit tends to draw, the greater the bias becomes.

In large power tubes which require very high negative biases, a separate power source must be used and this can be obtained by using a conventional C-battery or by tapping a voltage divider at a point negative with respect to the cathode. A few methods for obtaining grid bias are shown in Fig. 443. Sometimes a fixed negative bias is obtained directly from a rectifier (Fig. 443-c). By obtaining the voltage from the plate rather than the cathode side of the rectifier tube, a potential which is negative with respect to ground can be obtained.

Other methods of obtaining grid bias are used for special cases but those shown are the most popular. The important thing to remember in all such circuits is that, regardless of the method used, the circuit

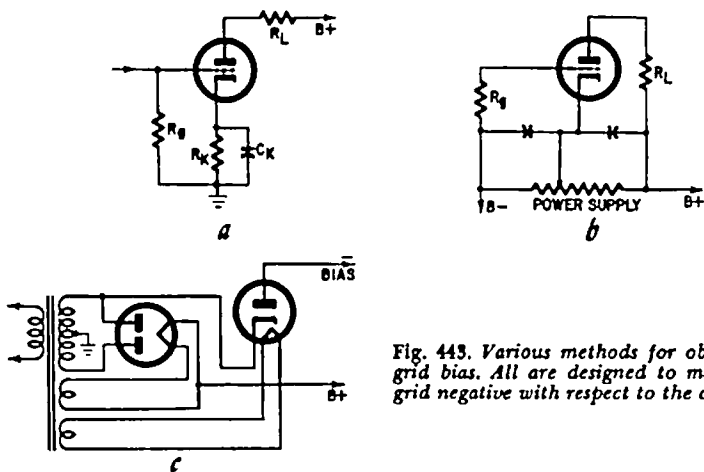

Fig. 443. Various methods for obtaining grid bias. All are designed to make the grid negative with respect to the cathode.

designer is endeavoring to make the grid negative with respect to the cathode. Potential differences to ground or to the chassis have no relation to this unless either the cathode or grid is connected to ground. For example, in Fig. 443-a the grid has zero potential with respect to the chassis but the cathode is above ground and thus the grid becomes negative with respect to it. Similarly, by tracing the individual circuits shown, it is seen that all other methods also develop grid bias negative with respect to the cathode.

vacuum-tube oscillators

SINCE the power required in an amplifier input is much less than that at the output, a tube can be made to supply its own input. If 1 volt is applied to the input of an amplifier with an amplification of 10, its output is 10 volts. If the entire 10-volt output is fed back into the input, in such a way that it adds to the original signal, the new input becomes 11 volts and the output 110 volts. On the second trip around, this total is again added to the input until the "round-robin" buildup causes oscillation.

It might be reasoned that after the first round (when the 10 volts are returned to the grid) the original 1-volt input could be removed and the tube would continue on its own until the circuit went into oscillation. Such a phenomenon occurs only if enough energy is fed back initially to overcome circuit losses—in other words more energy must be fed back than originally supplied.

Since the entire feedback path has reactive components, circuit losses vary with frequency, and oscillation occurs at that frequency which is accompanied by the least loss.

In other words, the circuit resonates in much the same way that plucking a violin string sets it into mechanical oscillation at its natural resonance—the frequency at which the losses incurred by setting the string in motion are the smallest. In this case, oscillation dies down—the note is heard for a very brief period unless energy is supplied by plucking the string again.

With the vacuum-tube oscillator, however, oscillation continues because the plate supply is a source from which energy is drawn to overcome the circuit losses. Such a circuit may be looked upon as a power converter which changes dc energy into ac.

Vacuum tube oscillators have many applications in radio and TV circuits. They are used in transmitters to generate carrier frequencies and in superheterodyne receivers (including TV) to help produce a

constant intermediate frequency. In general, oscillators may be placed in two broad categories: L-C, which generate sine waves; and R-C which generally produce nonsinusoidal waves.

Sine-wave oscillators

In the sine-wave oscillator (as in all others) the circuit is deliberately designed to produce oscillation by feeding back enough energy to overcome circuit losses at some specific frequency.

Fig. 501-a is a variation of the Hartley oscillator, which uses L-C resonant circuits. The output from the plate of the tube is fed back to the tuned circuit in the grid through C_f . Positive feedback is accomplished even though the plate voltage is 180° out of phase with that at the grid. Point X at the bottom end of the inductance is 180° out of phase with point Y which is connected to the grid. Thus, feeding the output voltage back to the input at point X produces positive feedback. The plate circuit portion of the coil X-O acts as the primary winding of a transformer and induces a voltage in the grid circuit via the secondary O-Y, which adds to the voltage already appearing at the grid. The coil is shunted by capacitor C, forming a parallel-resonant circuit. The alternating flow of electrons in this tank circuit is caused by a constant exchange of energy between the capacitive and inductive components. Resistor R_g and capacitor C_g maintain the proper bias on the grid.

In Fig. 501-b, electrons flow to the plate and around the circuit through the power supply to ground and back through the coil to the cathode. At the instant the power supply is activated an instantaneous

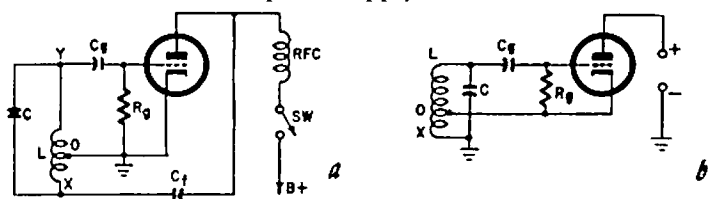

Fig. 501. Two forms of the Hartley oscillator. A feedback capacitor (circuit a) is used for feedback. In the other arrangement (circuit b) the plate current is permitted to flow through part of the tank coil.

pulse causes a rapid rate of change of current through the coil, which develops a large magnetic field, inducing a voltage which opposes the initial flow of current. This momentary disturbance is enough to set the circuit off.

The magnetic field starts to collapse almost immediately and in doing so charges capacitor C. When it has completely collapsed, capacitor C is completely charged. It then begins to discharge through the coil in an attempt to equalize the voltage on its plates, sending current back into the inductive branch in the same direction as the initial flow. The cycle repeats itself and continues to do so as long as the

energy transferred between the branches of the resonant circuit does not diminish.

If it were not for the plate supply, this energy would diminish, reducing or damping the oscillations until they died out. Each swing through power-consuming components, such as the resistance in the coil and the capacitor "rubs" away some energy. The power supply replenishes it in much the same way as a spring supplies the power to overcome friction in a mechanical oscillator, the pendulum.

Grid-leak bias

The oscillator of Fig. 501 has no fixed or cathode bias, even though a circuit which supplies its own input naturally drives the grid positive, increasing the electron flow in both plate and grid to the point where the tube can be damaged. Some form of bias, therefore, is necessary to keep these currents within bounds. Grid-leak resistor R_g and capacitor C_g do this job by maintaining negative bias on the grid.

As shown in Fig. 502, the plate current starts to increase rapidly into the positive grid region of the curve at the instant the switch is closed.

Fig. 502. Grid-leak bias automatically adjusts to the needs of the oscillator.

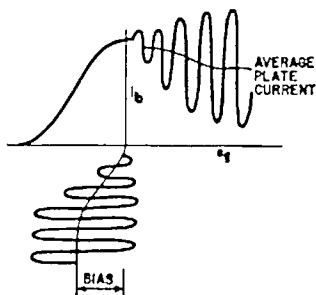

However, the inductance of the primary winding of the coil O-X prevents current from building up too rapidly because it is opposed by the induced voltage in the coil. This voltage appears as a positive one on the grid which begins to draw current. The current flows through the grid circuit and develops an IR drop through R_g , which makes the grid negative—eliminating the grid current and reducing the plate current. Even though at this instant the grid bias is zero it rapidly begins to go negative. Therefore, in Fig. 502 a slight negative bias is indicated at the very start of oscillation.

The first negative-going *kick* in the tuned circuit drives the grid more positive during the second cycle. Following pulses are increased, as more and more energy is transferred between L and C in the tuned circuit, until a point of stability is reached where all the pulses are of the same magnitude. This occurs when the grid bias reaches a fixed value. The average plate current also decreases while the oscillator is finding its operating point. When oscillating, the tube always draws grid current during a short part of the cycle.

With self-bias the oscillator is self-sustaining; once started it will continue as long as the circuit is activated, unless some component fails. Any momentary reduction in the amplitude of oscillation (perhaps caused by power fluctuations) which tends to make them die out is automatically compensated for. A reduction in amplitude results in insufficient driving power to force the grid positive. If it "misses" a positive peak, the negative bias begins to drop toward zero, enabling a less positive peak to drive the grid into the positive region again. When reaching a stabilized point, the output is lower, but the oscillator continues to function because the grid bias is still replenished on each cycle.

If the values of R_g and C_g are not properly selected, the oscillator will not perform correctly. If the time constant of the R-C combination is too large, compensation for variations in the amplitude of the oscillations does not occur rapidly enough to keep the circuit functioning. The long time constant cannot hold the grid negative, and successive pulses become lower and lower until oscillation dies out. The circuit then remains inactive until the grid-leak capacitor gradually discharges through R_g and bias is reduced to the point where oscillation can begin again. This action is called *intermittent oscillation* and can occur at an audible or an rf rate. Reducing the value of R_g , C_g , or both will cure a condition of this nature.

Frequency stability

The resonant circuits in the L-C oscillator determine its frequency. Therefore, they are also (for the most part) responsible for frequency stability. The high-Q resonant circuit permits oscillation at one particular frequency because of its sharp tuning. Any reduction in circuit Q flattens the resonance curve and permits oscillation over a band of frequencies. Since Q depends upon circuit resistance, the load on a circuit can be represented as a resistance which consumes power—the more power the oscillator has to supply, the more subject it is to frequency *instability*. Therefore, when high power is required, the oscillator is usually used to drive a power amplifier. In this way a tube (generally a voltage amplifier) can be used as an oscillator from which a nominal amount of power is drawn. Loading, therefore, has a negligible effect and stability is easily obtained.

Additional measures such as the use of temperature-compensated circuit components also help to insure stability. The voltage amplification of the tube circuit is kept stable by keeping the load constant. In many cases r_p is prevented from varying by regulating the power supply, thus maintaining the operating point of the tube. These steps help to keep the input capacitance (admittance) of the tube constant. Any change in admittance affects frequency and, since it is a function of amplification, any shift in the tube's operating point will produce instability.

Electron-coupled oscillator

To obtain power from oscillator circuits and still maintain maximum stability, electron-coupled oscillators (Fig. 503) are often used. In this circuit the screen grid acts as the plate of a triode. Small cur-

Fig. 503. The electron-coupled oscillator provides amplification of the signal produced.

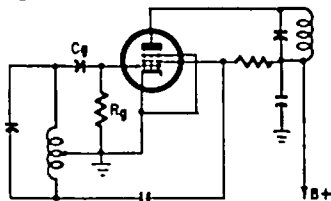

rent fluctuations appearing at the screen are fed back to the grid to maintain oscillation. The remaining electrons—the greater part of the space charge—go to the plate of the tube and deliver the output power. Since the plate functions as part of an amplifier circuit, the oscillations

Fig. 504. A tuned-plate-tuned-grid oscillator.

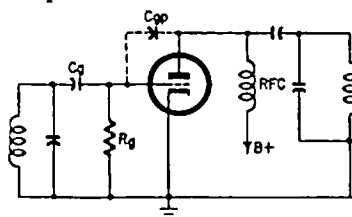

developed in the screen-grid circuit are delivered with increased amplitude. Actually, the plate current is controlled by the screen, which acts on the electron stream, converting it to an oscillating stream instead of the normal fluctuating flow.

Tuned-plate-tuned-grid oscillator

A tuned-plate-tuned-grid oscillator is shown in Fig. 504. The grid circuit contains a resistance-capacitance combination R_g-C_g to sustain oscillation. However, because there is no physical connection between the plate and the grid (as in the Hartley oscillator), the positive feedback loop is not readily apparent. This type of oscillator relies on the interelectrode capacitance between plate and grid to provide the necessary feedback path. In Fig. 504 capacitor C_{gp} (in dashed lines) represents this capacitance.

Although an ac path is established by C_{gp} , it cannot be assumed that oscillation will result. Since the voltage at the plate is 180° out of phase with the grid, it would seem that negative rather than positive feedback would occur. However, positive feedback from plate to grid results if the input resistance is negative. This condition results when the plate circuit contains an inductive component. The circuit oscillates when the plate resonant circuit is tuned to a slightly lower frequency than that of the grid circuit. The frequency is determined by

the tuned circuit having the higher Q . If the plate circuit Q is higher, the resonant curve is sharp and oscillation favors the frequency of this circuit. When this occurs, the grid resonant circuit with a lower Q responds over a wide band of frequencies well within the range of the plate circuit.

Colpitts oscillator

The Colpitts oscillator (Fig. 505) is often used as the local oscillator in TV and VHF superheterodyne receivers. The circuit resembles the Hartley except that feedback is obtained by tapping the capacitive rather than the inductive portion of the resonant circuit. The amount of feedback is determined by the relative size of capacitors C_1 and C_2 , with C_2 commonly much larger than C_1 . When the circuit is activated, the flow of electrons starts charging capacitor C_2 in the plate circuit

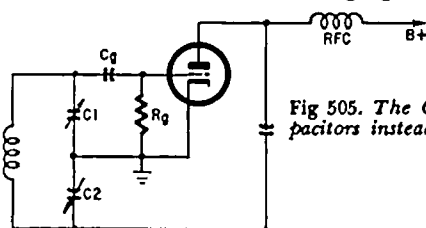

Fig 505. The Colpitts oscillator uses tapped capacitors instead of the tapped coil used in the Hartley type.

and the charge is transferred to the grid circuit, C_1 making the grid momentarily positive. Grid current begins to flow, developing negative bias and the R_g-C_g combination acts to maintain it as energy is transferred back and forth within the tuned circuit.

Frequency is determined by the resonant circuit consisting of the coil and capacitors C_1 and C_2 . C_1 serves as the tuning capacitor which varies the frequency of the oscillator within a range determined by C_2 and the coil. When used in a radio receiver C_2 is a variable capacitor so that the range of frequencies covered can be adjusted.

Variable capacitor C_1 is always on the same shaft as the variable capacitor tuning the rf section of a superheterodyne receiver. As the resonant frequency is changed when tuning stations, the frequency of the oscillator must be changed proportionately so that the intermediate frequency remains constant. Thus (considering the broadcast band for simplicity) while the tuning capacitor is covering 550–1,600 kc (a frequency change of about 3 to 1), the oscillator section—in order to maintain the intermediate frequency of 465 kc over the entire band—must cover 1,015–2,065 kc. Since this ratio is 2 to 1, the capacitor used to tune the rf signal has a greater range to cover than that used in the oscillator circuit. The presence of C_2 in the circuit permits the oscillator capacitor C_1 to meet this requirement.

For example, in the broadcast receiver, to cover a 3-to-1 frequency range the variable capacitor in the rf section must have a 9-to-1 capac-

itance range because frequency is inversely proportional to the square root of the capacitance ($f_0 = 1/2\pi\sqrt{LC}$). On this basis a capacitor with a range of 20 to 200 $\mu\mu\text{f}$ would do the job. In the oscillator section a 4-to-1 capacitance range is required and, if the variable capacitor has a range of 20 to 100 $\mu\mu\text{f}$, a 5-to-1 range would result. The oscillator would not track properly under these conditions. In other words the intermediate frequency of 465 kc would not be maintained over the entire band. By placing a padder of about 400 $\mu\mu\text{f}$ in the circuit (C2 in Fig. 505) the capacitance range is reduced to 20 to 80 $\mu\mu\text{f}$, a total range of 4 to 1 as desired.

The Colpitts oscillator is used widely in commercial applications because one end of each capacitor is grounded and thus can be mount-

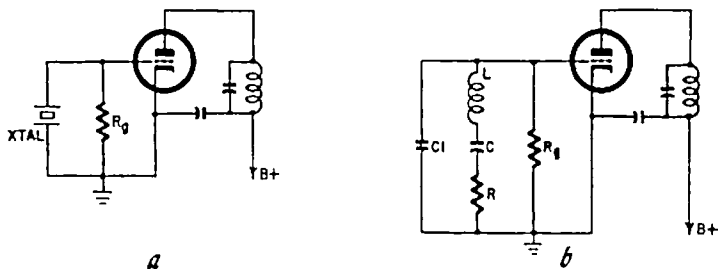

Fig. 506. Crystal oscillators are often used where extreme accuracy is required: a) a simple crystal oscillator; b) equivalent circuit.

ed directly to the chassis. In addition, the coil requires no tap—only two leads must be handled. This is particularly convenient in all-wave receivers where coils are switched for various frequency bands.

Crystal oscillators

Where the greatest degree of stability is desired, such as at transmitting stations, the crystal oscillator is used.

The crystal determines the frequency because of its piezoelectric effect. If a slab of quartz is mechanically compressed (or twisted), a voltage appears across it. Conversely, if a voltage is applied across it, its dimensions change. If an alternating voltage is applied, the crystal vibrates at its natural resonant frequency, which depends on the thickness of the slab and the angle at which it was cut from the mother crystal. Just as a violin string sounds the same note whether it is plucked lightly or vigorously, the crystal vibrates at the same frequency independently of the amplitude or frequency of the applied voltage. However, because the crystal's mechanical resonance determines the frequency produced, its natural resonance may vary with temperature changes which affect its physical dimensions. Thus, when extreme frequency stability is required, crystal oscillators are run under controlled temperature conditions.

A simple crystal oscillator circuit is shown in Fig. 506-a. The crystal

replaces the tuned circuit usually placed between grid and cathode. Actually the crystal is electrically equivalent to an inductance in series with a capacitance and resistance, the entire circuit being shunted by the capacitance between the plates which hold the crystal. Fig. 506-b shows the crystal oscillator redrawn in its equivalent circuit form. L and C are in series resonance and represent the mechanical resonance of the crystal.

At a frequency slightly higher than the natural resonant frequency, the net reactance of L and C is slightly inductive with the inductance high enough to resonate with C1, the interelectrode capacitance. The combination forms a parallel-resonant circuit, with the L-C-R circuit as the inductive and C1 as the capacitive branch. Because of the high Q of the circuit, it has a high impedance. The current circulating through the crystal (not through the tube) is maximum at resonance, maintaining the crystal vibration at a high level.

The crystal is equivalent to a high-Q circuit because of the extremely high L-to-R ratio. In fact the circuit Q is much higher than that obtainable with a regular tuned circuit. This is one of the primary reasons for the excellent frequency stability of the crystal oscillator.

Because they are subject to mechanical damage if too much current is forced through them, crystal oscillators are limited to low power outputs. This is particularly true at the higher frequencies where the crystal slabs are cut very thin. Additional amplifiers (called buffers) are always used to secure a larger output when necessary.

Since the frequency developed by a crystal depends on its physical dimensions, there is a practical limit to the highest fundamental frequency that can be generated. It is on the order of 10 mc, although frequencies as high as 20 mc have been reached.

Crystals can also be made to oscillate at a frequency which is a multiple of the fundamental. Known as overtone operation, frequencies as high as 100 mc have been reached.

Frequency multiplication

When more than nominal power is required at relatively high frequencies, the crystal oscillator output is fed directly into a buffer amplifier. The immediate effect is to increase the amplitude of the wave produced by the crystal. However, by connecting a resonant circuit to the output of the buffer, it can be made to amplify frequencies other than the fundamental. If a 1-mc crystal oscillator is used to feed a buffer amplifier tuned to the second harmonic, the output becomes 2 mc. The buffer (primarily a voltage amplifier) can then be used to drive a class-C amplifier, the output of which is rich in harmonics. This amplifier could be tuned to a higher harmonic, such as the fourth, and will produce an 8-mc signal. By cascading buffer and multiplier stages, further frequency multiplication is possible.

When frequency multiplication is used, it is very important that the fundamental frequency produced by the oscillator does not vary, since

the variations are also multiplied. Thus a 1-mc crystal oscillator whose frequency is multiplied 100 times for FM broadcast purposes would develop a deviation of 1 mc if the oscillator frequency changed by only 1%.

The crystal oscillator in TV

In color TV the color information is transmitted as sidebands of a 3.58-mc carrier which has been suppressed. To permit demodulation

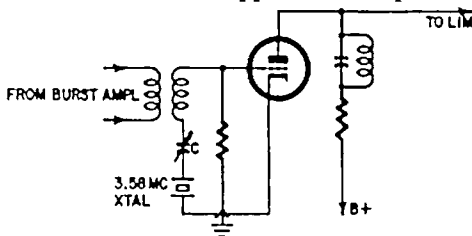

Fig. 507. A simplified crystal ringing circuit.

the carrier signal must be reinserted. Because the phase relationships of the various signals are important the locally generated "carrier" must be not only on frequency but also of proper phase.

One type of circuit used to perform this function is the crystal ringing circuit shown simplified in Fig. 507. The crystal oscillator is kept

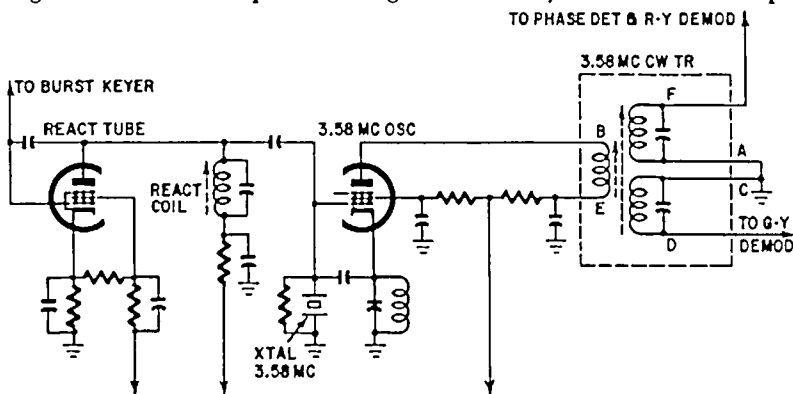

Fig. 508. This crystal oscillator is used with a reactance tube which maintains the proper frequency.

on frequency and properly synchronized by the color burst signal which appears at the start of each horizontal trace. This pulse activates the crystal and helps it to "ring" or oscillate at the proper rate.

Because this is a high-Q circuit oscillation continues with little reduction in amplitude between each succeeding burst. Trimmer capacitor C is used to compensate for slight variations in crystal manufacture which can cause frequency errors of several hundred cycles.

The crystal oscillator is followed by a limiter which smooths out any amplitude variations that occur. Phase-shift networks, beyond the limiter, make the necessary phase adjustments.

Another circuit which uses the crystal oscillator is illustrated in Fig. 508. The 3.58-mc crystal oscillator is used in conjunction with a reactance tube which controls the frequency as required. The incoming voltage is the result of a frequency and phase difference between the locally generated "carrier" and the color burst. The reactance tube is wired so that it acts like a capacitance bridged across the crystal. The signals which are applied to its plate and grid vary its capacitive reactance thereby changing the frequency of the crystal oscillator.

R-C oscillators

Many oscillators in use today, particularly since the development of commercial TV, use combinations of resistance and capacitance (R-C) rather than inductance and capacitance (L-C) to generate repetitive pulses or oscillations. The characteristic buildup or decay of currents and voltages in R-C circuits is made use of in pulse-generating or

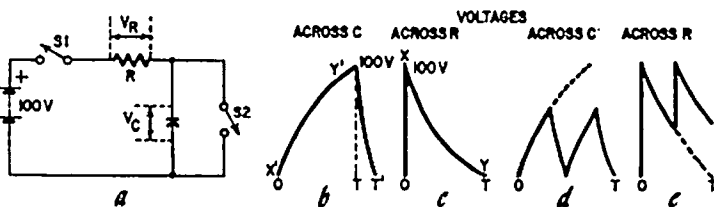

Fig. 509. R-C oscillators are often used in TV sweep circuits: a) simplified R-C oscillator (in practice the switches are replaced by a tube); b) waveform produced at the instant S_1 is closed; c) decay of voltage across R; d) voltage across C; e) voltage across R.

trigger circuits. Oscillator circuits using particular combinations of R and C are fixed in frequency by the time constant of the R-C combinations. In general, R-C oscillators are used to produce nonsinusoidal waves, while the L-C is used primarily for sine waves.

The sweep systems of TV receivers often rely on R-C oscillators to generate the voltages required to sweep the electron beam across the face of the picture tube. In the simple R-C circuit of Fig. 509-a, at the instant switch 1 is closed, the capacitor begins to charge exponentially to 100 volts along curve X'-Y' in the interval O-T (Fig. 509-b). The instantaneous current through R produces an initial voltage of 100 across R at the instant the switch is closed. This voltage then decays exponentially as indicated by X-Y in Fig. 509-c, until capacitor C is fully charged and the current flow stops. This occurs in the time interval represented by O-T which corresponds to the time interval in b. The length of time required to charge C depends upon the time constant of the R-C circuit. If switch 1 is held

open and switch 2 closed, the capacitor discharges quickly through the short circuit, as indicated in the interval T-T' in Fig. 509-b. If switch 2 is opened when the capacitor is fully discharged and switch 1 again closed, the cycle is repeated.

Continuing this process produces a series of voltage waves across R and C similar in shape to those just described, with the wave across R classified as a differentiating wave and that across C as an integrating wave.

The charging cycle of the capacitor is not linear, so, if the capacitor is permitted to reach its full charge before discharging, the resultant wave is not truly sawtoothed in shape, because the buildup portion is exponential and far from a straight line. By cutting the charging cycle the capacitor is discharged before any marked curving can occur (Figs. 509-d, -e).

A practical application of this principle is shown in Fig. 510 where the circuit is activated by short rectangular pulses and a vacuum tube is used instead of a switch.

The grid of the tube is biased beyond cutoff so that it is normally nonconducting. At the instant the circuit is activated by turning on the power supply (with no pulse applied), capacitor C charges through load resistor R_L . Before the capacitor is fully charged, a positive pulse is applied to the grid which allows the tube to conduct.

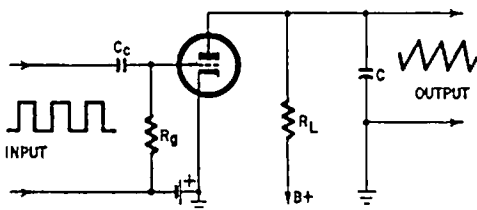

Fig. 510. High-frequency R-C oscillator. A square-wave pulse is used to trigger the circuit.

Capacitor C discharges rapidly through the tube because the resistance of the tube is lower than that of R_L . In this type of circuit the values of C and R_L must be carefully selected to insure rapid discharge of the capacitor, for the incoming pulses occur at a rapid rate and if the discharge rate were not rapid enough the charge would hold over from one pulse to another. To insure that the sawtooth is nearly linear the supply voltage must be high so that the required voltage rise is large enough for proper circuit operation even if the capacitor is allowed to charge to only 5% of the total voltage.

In TV circuitry, a local oscillator may be used to generate the pulses which activate the sawtooth generator. The oscillator itself is synchronized by pulses received from the transmitter. The local oscillator

generates pulses of sufficient amplitude to activate the sawtooth generator.

In Fig. 511, tube V2 and its circuit are the sawtooth generator. The grid activating pulse is derived from V1, which functions as an oscillator, the output of which is also a sawtooth wave.

In this application V1 is called the blocking oscillator because it interrupts itself at regular intervals. Positive feedback is obtained through transformer action which drives the grid positive during the oscillating cycle. To analyze how this circuit functions, assume that the grid of V1 is driven slightly positive via its own feedback path. This increases the plate current, which drops the plate voltage, tending to

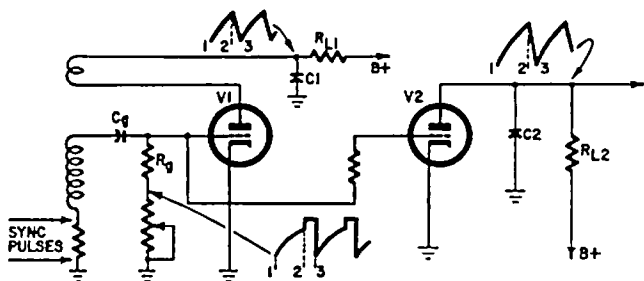

Fig. 511. Tube V2 is the sawtooth generator. It is triggered by the pulses produced by V1, a sawtooth oscillator.

make the grid still more positive in relation to the plate. This increase in positive grid potential increases the plate current again. In other words, plate current increases rapidly until the tube becomes saturated, at which time further increases in positive grid potential no longer affect the plate current and positive feedback ceases. The grid voltage collapses rapidly, reducing the plate current and increasing the plate

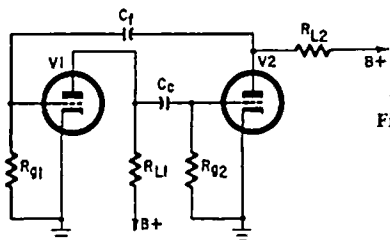

Fig. 512. A simple multivibrator circuit.

voltage, which therefore produces reverse action. This action makes the grid negative and drives it beyond cutoff, causing capacitor C_c to acquire a high negative charge. This capacitor begins to discharge through R_g , decreasing the negative bias until the tube begins to conduct and the cycle is repeated.

The wave thus produced is sawtoothed in shape and is used to acti-

vate V2, which shapes it into a true sawtooth wave. Thus it is V2 which is really the sawtooth generator. The shape of the pulse derived from V1, while repetitive, is irregular and the only portion of it used is the pulse portion which occurs when the tube conducts. The frequency of the pulses is determined by the time constant of R_g-C_g .

The pulses and waves have been divided off into corresponding periods of time in Fig. 511. Period 1-2 represents the part of the cycle when V1 is cut off, but the grid, which has been driven far beyond cutoff, is becoming less negative as C_g discharges through R_g . At the same time that this is going on, V2 is cut off and both C_1 and C2 are charged through R_1 and R_{L2} , forming the sawtooth waves indicated by the plate current buildup in both tubes. When the decreasing grid bias finally passes the cutoff point and plate current begins to flow, the change in plate potential builds up rapidly through the positive feedback path, driving the grid more and more positive until saturation is reached. This occurs during the part of the cycle indicated between 2-3. As the tubes conduct, capacitors C_1 and C2 discharge rapidly, forming the retrace path of the sawtooth wave. The tubes are cut off again and the cycle is repeated.

Since a sawtooth wave is also developed across capacitor C1 (tube V1), the need for V2 may be questioned. Because a linear sawtooth

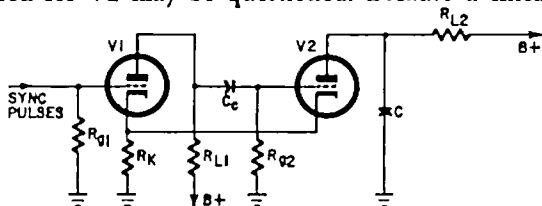

Fig. 513. Multivibrators of this type are sometimes used in TV.

wave is desired, the time constant of R_{L2} and C2 must be large, and discharge tube V2 is designed to handle it. Any attempt to operate V1 with a large time constant would cause the plate voltage to fall to an extremely low value, resulting in unstable operation.

Although, in practice, the oscillator is self-sustaining, a synchronizing pulse is used to keep it in step with the trace pulse from the transmitter.

The multivibrator

The multivibrator is often used as a source of sawtooth waves. The circuit uses two tubes, usually triodes in a single glass envelope (duo-triode), which rely on feedback between them to produce oscillation. A simple multivibrator is shown in Fig. 512. V1 drives V2 and positive feedback is obtained through capacitor C_c . Assuming that minute circuit variations produce a slight shift in potential on V2's grid, the resultant amplified increase in voltage appears almost instantaneously

on the grid of V1. As this occurs, the drop of plate potential in V1 brought about by the increased plate current moves the grid voltage of V2 in a negative direction until the tube is cut off. This happens instantaneously. Capacitor C_r is thus fully charged and begins to discharge through R_{r1} and R_{L2} , making the grid of tube V1 negative until it is cut off. Then the process reverses.

In TV work, a more practical application of the multivibrator is that of Fig. 513. A cathode resistor R_k , common to both tubes, is used and capacitor C acts only in conjunction with R_{L2} . If it is assumed that the grid of V2 is cut off but is becoming more positive, it reaches a point where its plate current starts flowing. The plate voltage decreases and the cathode voltage increases, making the grid of V1 effectively more negative and raising the plate voltage of V1. A further increase in the grid voltage of V2 increases the plate current of V2. This action occurs almost instantaneously so that the plate current of V2 reaches saturation immediately. When this happens, the process reverses, leaving the plate current of V1 at a constant maximum and no voltage change is reflected through C, which has just been charged by the grid current in tube V2. R_{r2} begins to lose its negative potential, repeating the cycle.

Every time V2 conducts, C discharges through the tube, providing the return trace of the sawtooth wave. While the tube is cut off, C charges through R_{L2} . Since the length of the sweep is a function of the length of time the tube is cut off, changing the value of R_{r2} will change the frequency of the sawtooth wave to a limited extent. The sawtooth wave, of course, appears across C or R_{L2} .

Pulse generators

Multivibrator circuits are usually synchronized to insure that cycling occurs at a regular rate. In TV the sawtooth generators must be kept in step with the transmitted signal to insure a proper scanning sequence. (The circuit of Fig. 513 requires an input pulse to V1.) These sync pulses need not be of a particular shape but may be any pulse sharp enough to keep the generator in step. Almost any type of short pulse or triangular wave would be satisfactory. Other circuits may require a square-wave input rather than a sharp pulse.

The simple circuit of Fig. 514—a peak-clipping circuit using diodes—can be used to develop waves which are nearly rectangular. The harder this circuit is driven, the more closely the output resembles a square wave. The output can then be amplified and applied to another clipper to increase the sharpness of the square-wave pulses.

In the TV system, pulse techniques are developed to a fine degree. The picture itself is transmitted with a series of superimposed pulses. The signal contains a rectangular blanking pulse which interrupts it during the horizontal return trace along with the very important synchronizing pulses.

Three synchronizing pulses are used—equalizing, horizontal and vertical. Each pulse is of a different length and amplitude, but all of them are rectangular. They consist of a fundamental frequency upon which low- and high-order harmonics are superimposed. Since the leading edge of each pulse is the control portion—critically timed at the transmitter—it is important that it be a straight line.

The rectangular pulses which are part of the video signal are subject to distortion in the video amplifier. The distributed capacitance (which is so troublesome in audio and video amplifiers because it affects the higher frequencies) tends to distort the amplified rectangu-

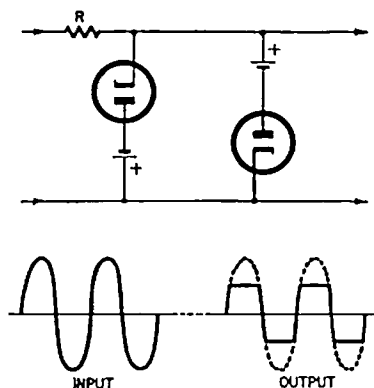

Fig. 514. Peak-clipping circuit using two diodes.

lar pulses by preventing the leading edge from building up instantaneously to form a straight line. Fig 515 shows what might happen as the pulse is amplified—the leading edge of the square wave, which

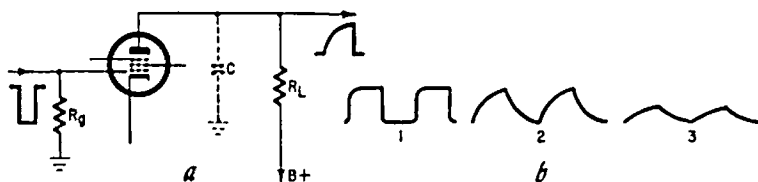

Fig. 515. A rectangular pulse is often distorted by the limited response of an amplifier; a) leading edge of pulse is rounded; b) a relatively good response (1); a poor output (2); long time constants produce severe distortion (3).

contains the high-frequency components and controls the pulse timing is distorted. This occurs because of the long time constant between distributed capacitance C and resistance R_L (Fig. 515-a) which causes C to charge slowly even when the flat top portion of the pulse is

received. The video circuit is designed to accommodate this type of wave by using a low value of R_L and by keeping shunt capacitances to a minimum.

Since low shunt capacitance and relatively low loads are required for good overall frequency response in a video amplifier, square-wave pulses can be used to check the high-frequency response. A loss in high-frequency gain will appear as a loss in the steepness of the leading edge of the rectangular wave. Fig. 515-b shows how the pulse may look on an oscilloscope as the high-frequency response becomes increasingly poor. In Fig. 515-b (1) a good output is illustrated while (2) shows a poor output. If the time constant is exceptionally long, the waveshape indicated in (3) would result.

After the synchronizing pulses are separated from the composite

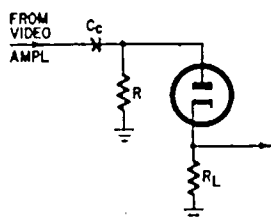

Fig. 516. A diode used as a sync separator.

signal in the TV receiver, they are reformed before being used to drive the horizontal or vertical sawtooth oscillators. This can be done because the sync pulses form the highest level of the entire video signal. A tap is taken from the video amplifier and the pulses may be fed

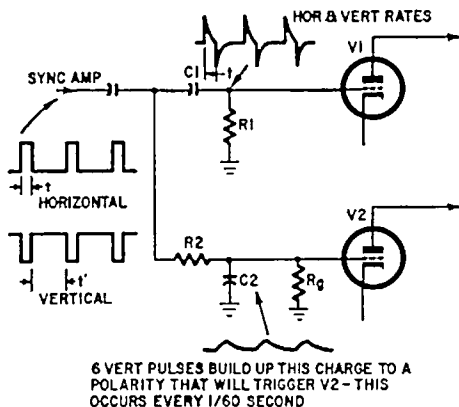

Fig. 517. Simple circuit showing how horizontal and vertical pulses are separated.

into a diode wired as in Fig. 516. With C_c and R selected for a long time constant, the incoming positive pulse charges C_c through the

diode. The capacitor immediately discharges through R, making the plate of the diode negative with respect to the cathode and ground. It takes another sync pulse to overcome the negative plate. In this manner, only the high-level sync pulses are passed through the tube and hence are separated from the video signal. Other methods are used but all are based on this principle.

The sync pulse itself is a composite signal inasmuch as it may be horizontal or vertical. Horizontal scanning is more rapid than vertical, occurring 15,750 times a second as opposed to 60 a second. Therefore, while the horizontal oscillator relies on a sharp rapid pulse to make it function properly, the vertical oscillator functions at a much more "gradual" rate. In Fig. 517 the composite horizontal and vertical sync pulse is fed to an R-C network and then to their oscillators. The

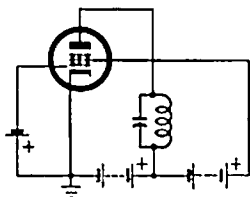

Fig. 518. A dynatron oscillator.

signal made up of horizontal and vertical pulses, is modified by C1-R1, a differentiating circuit, and C2-R2, an integrating circuit. As indicated, the short horizontal pulses generate positive and negative spikes across R1 which are used to synchronize the horizontal oscillator. The longer vertical pulses also generate spikes which keep the oscillator synchronized during the vertical retrace. From the standpoint of the vertical oscillator, these pulses could be combined into one long single pulse which would satisfy the timing requirements. However, they are broken up for the sake of maintaining horizontal synchronization.

The longer vertical pulses also react on the integrating circuit R2-C2, which has a long time constant. Thus, six vertical pulses in sequence build up a charge across C2 to a maximum 60 times a second. The voltage obtained is sufficient to trigger the vertical oscillator. Fig. 517 also shows how these voltages appear at the input to each oscillator.

Negative-resistance oscillators

Negative resistance can be defined as a phenomenon which produces an increase in plate current with a decrease in voltage. The tetrode displays this characteristic when it is operated in the low-voltage region.

Fig. 518 is a circuit which makes use of this characteristic. The tuned circuit is in the plate and the screen voltage is adjusted so that

it is greater than that at the plate. Therefore, the operating point of the tube is at the center of the negative-resistance point. When the negative resistance is great enough to offset the positive resistance caused by the parallel-resonant circuit in series with the plate, oscillation takes place. In this oscillator, if the grid bias is set so that the tube just about oscillates, variations due to power supply fluctuations which normally affect frequency have no effect. The circuit produces a high degree of stability, the output being a pure sine wave. Oscillators of this type are sometimes used in special test circuits where they can be kept on the threshold of oscillation at all times.

miscellaneous applications

IN radio and TV circuits vacuum tubes are used to perform their basic functions—rectification, amplification and oscillation. However, in some cases these functions are combined or altered so that they are not easily recognizable as such; in others they are channeled into unsuspected directions. Some tubes use special internal construction to permit the intermixture of several functions to produce needed effects. Then again, familiar tubes are often used in what may seem to be “unusual applications.” Most often it turns out that the unusual application is simply an unexpected use of the tubes’ familiar characteristics.

Dc restorer

Although the dc restorer is no longer found in modern black-and-white TV sets, it still has wide application in color. Essentially, it is used to restore the reference level of the composite signal before it is applied to the picture tube.

When the televised scene at the transmitter changes, say, from that of a well lit room to that of a street at dusk, there is an overall shift in the relationship between the peaks of the signal and the dc reference level. However, because the unidirectional but varying signal at the receiver has been stripped of its reference point by reactive components in the circuitry, steps must be taken to reinsert this “brightness reference.”

To do this the video amplifier in the receiver must cause the bias on the picture tube to vary with a change in the average illumination of the televised scene if true reproduction is to be had. This bias can be looked on as a dc reference level which rides up and down on the signal as the average brightness of the scene changes.

A simple circuit to restore the brightness level is shown in Fig. 601, where the video signal minus the dc component is fed to the picture tube through C_c . Resistor R_g is large enough to prevent the diode from loading the grid of the picture tube. R_2 is of a high enough value so that the circuit R_1 - C_1 and the diode have a much higher impedance than R_L and therefore a negligible loading effect on the video amplifier.

Plate current flow through R_L controls the voltage at the plate of V1 which, in this case, is about equal to that at point X. A composite video signal, the peaks of which are the synchronizing pulses, will reduce the voltage at X in proportion to the peak of the video signal charging C_1 . This charging current reduces the negative bias on the picture tube by effectively shorting R_2 . When the diode V2 conducts, this resistor is shunted by its relatively low resistance and

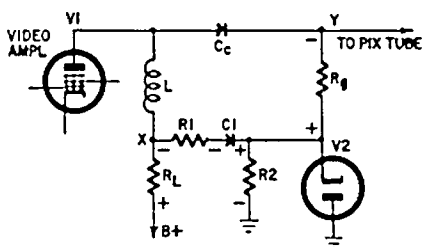

Fig. 601. Typical dc restorer circuit.

the voltage drop from Y to ground is reduced, lowering the picture tube bias. The lower the bias on the picture tube the brighter is the average picture illumination. Thus the action of the diode effectively restores the dc reference level to the signal.

Between pulses the diode does not conduct and the dc level is maintained by the time constant of R_1 - C_1 so that the rate of discharge of C_1 through R_1 controls the bias between peaks.

Although this somewhat simple system is more complex in color TV—three restorers are used, one for each primary color—the basic function is quite similar—the diodes are used to help restore the average dc level of a varying signal.

Automatic gain control

In the ordinary radio receiver, most detector circuits are arranged to provide automatic volume control to compensate for variations in carrier signal strength. In TV circuits the arrangement for performing a similar function for the picture is called agc (automatic gain control). While agc and avc produce the same end result, video agc acts on *signal peaks* while audio avc functions on the *average* strength of the carrier.

The composite video signal contains the synchronizing pulses along

with the picture and audio information. With a constant signal strength, the brightness of a scene varies changing the overall level of the video signal, but the sync pulses always reach the same amplitude (Fig. 602-a). If the carrier strength changes however, the level of the entire signal drops, including the sync pulses (Fig. 602-b). Therefore the agc circuit is arranged to function on the sync pulse levels rather than on the average signal level, or brightness.

A simple agc system using a diode to develop the negative bias which controls the gain of the if and rf stages is shown in Fig. 603.

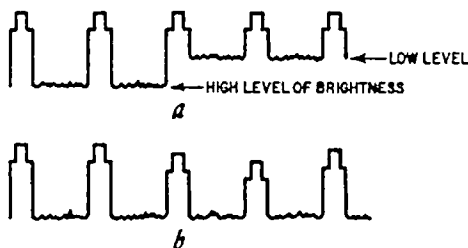

Fig. 602. (a) Video signal level changes as scene brightness changes, but sync pulses always reach the same amplitude. (b) Level of entire signal drops, including sync pulses, when the carrier strength drops.

This circuit obtains its input by tapping the video detector signal through C_c . The signal causes the tube to conduct, charging C_c . The amount of charge on the capacitor is determined by the peak of the sync pulse. Resistor R_1 is large enough to prevent C_c from discharging any noticeable amount between peak intervals. Thus a negative potential becomes available at the output for application to the controlled tubes.

Changes in average brightness do not change this negative potential because the sync pulses reach the same level at all times except when

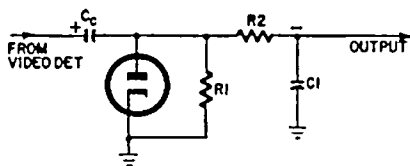

Fig. 603. Typical diode agc system for developing the negative bias to control the gain of the if and rf stages.

the carrier signal fades. Then they too decrease. The output from the diode becomes lower, and less negative bias is applied to the controlled stages, increasing their gain.

In modern TV receivers where lightness and portability are important factors, simple systems such as described are often used. How-

ever, in many sets other agc systems are used. Some of them have an agc amplifier before the agc diode to increase the level of bias obtainable. Others use a more complex system called keyed agc which is discussed on page 151.

Amplitude modulation

In radio broadcast work, the carrier signal, as its name implies, is the agent on which the audio rides to the receiver (the carrier is discarded after the wanted information is removed). In amplitude modulation the amplitude of the carrier is varied, whereas with frequency modulation the frequency of the carrier is changed by the amplitude fluctuations of the audio.

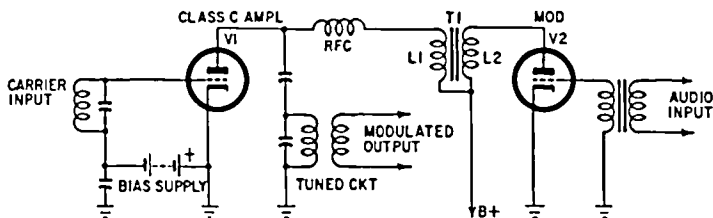

Fig. 604. Typical plate-modulated amplifier.

The most generally used method of producing amplitude modulation is through *plate modulation*. Triodes are often used for this purpose. In Fig. 604, a typical plate-modulated amplifier, the ac output of the audio power amplifier—the modulator—forms part of the voltage applied to the plate of the class-C amplifier. Audio-frequency variations in the plate circuit of V2 are transferred to the plate circuit of V1, the carrier amplifier, via the transformer T1, which is in series

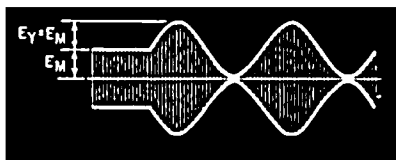

Fig. 605. With 100% modulation, the carrier will extend from zero to twice the original carrier amplitude, E_M . The increase in amplitude is shown by E_Y .

with the plate supply of V1. These variations add to or subtract from the dc applied to the amplifier in direct proportion to the audio supplied by the modulator. Thus the voltage peaks of the carrier pulses are greater when the total plate voltage (plate supply plus positive audio peak) is highest and lowest when the net plate voltage is reduced to its minimum. These pulses activate the tuned circuit

which restores the negative halves of the sine waves and produces a balanced output.

The wave shape of Fig. 605 is due to the combination of three frequencies (1,000, 1,001 and 999 kc) where the modulating 1,000-cycle audio signal creates two additional carrier frequencies called the upper and lower sidebands. The power in the audio signal lies en-

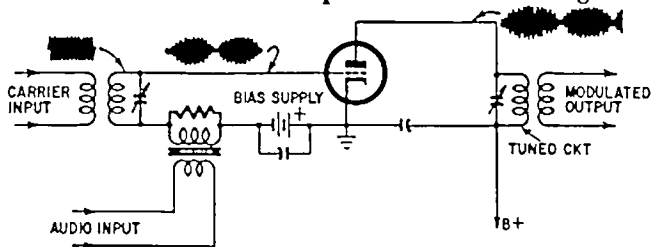

Fig. 606. Typical grid-modulator circuit.

tirely within the sidebands and with 100% modulation the sideband power is half the carrier power.

Plate modulation, although simple and efficient, requires a great deal of audio power. In TV systems where the video signal amplitude modulates the carrier, this modulating power is difficult to obtain. Therefore grid modulation which requires negligible audio power is used. However, it is not as efficient as plate modulation and results in only a slight power saving.

A simple grid-modulator circuit is shown in Fig. 606. The amplifier is not as efficient for it must operate on the linear portion of the tube's characteristic. The output of the carrier amplifier contains the audio signal, and any distortion in the amplifier would distort it too.

Triode detectors

Triodes are occasionally used in radio circuits as detectors. Diode detectors, of course, produce no gain; they only rectify. The triode when used as a detector amplifies the input signal as well as rectifying it, thus performing two functions simultaneously. However, the triode as a detector has some important limitations and is therefore used only in special applications.

If a triode is biased to cutoff (as in class-B operation) the tube will function to amplify one half of the carrier pulses and the plate circuit will register plate current pulses only (Fig. 607). The average value of plate current varies in accordance with the modulation envelope and thus produces the audio signal. If the output circuit is filtered (Fig. 607), only the audio signal will appear at the output transformer. The detection accomplished by this method is called *plate detection*.

This type of detector does not load the preceding amplifier as does

the diode. However, because the output depends on the average value of a series of plate pulses, it lacks sensitivity—it cannot handle low-level signals. Because of the curvature of the tube characteristic at its operating point, it develops more distortion than the diode. When strong signals are received, operation is more linear but, with a high percentage of modulation, distortion occurs as the troughs of the envelope are driven into the curved portion of the tube's characteristic.

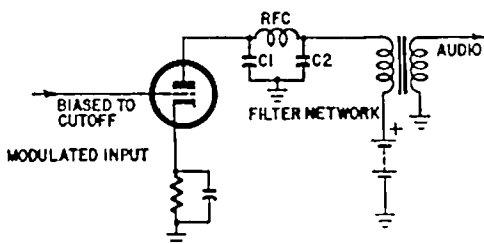

Fig. 607. Plate-detection circuit, using a triode as a detector and an amplifier.

To overcome the shortcomings of plate detection, triodes are sometimes operated so that grid detection takes place. In Fig. 608, grid-leak resistor R_g and capacitor C_g function like the load of a diode detector with one stage of amplification. The input signal drives the grid positive, forcing it to draw current. This develops a negative potential

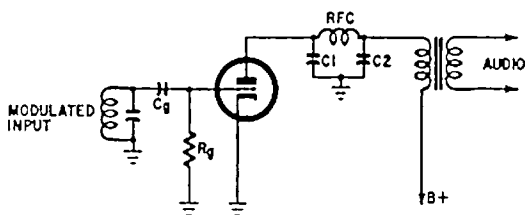

Fig. 608. A triode being operated so that grid detection takes place.

across R_g , which capacitor C_g tends to maintain. The R_g - C_g combination thus develops an average bias which varies in accordance with the audio signal; the stronger the signal the greater the bias. The grid is self-adjusting and the bias slides along the characteristic curve as the signal strength changes. The filter circuit is arranged to remove the rf variations in voltage while permitting the audio voltage variations to go through. Because rectification occurs in the grid circuit, the grid-leak detector cannot handle high-level input signals and, while similar to the diode detector in other respects, it is not satisfactory from the standpoint of power-handling capacity.

Regenerative detector

In a variety of specialized uses, triodes, pentodes and gas tubes are often used as regenerative detectors. (One of the most common applications, in a modified form known as a superregenerative detector, is in lightweight, relatively high-frequency radio control receivers). Fig. 609 illustrates a regenerative detector. Essentially it is a grid-leak detector in which the signal is fed from the output of the triode to

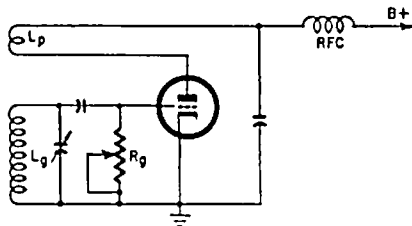

Fig. 609. A triode being used as a regenerative detector.

the grid circuit. This positive feedback results in a great deal of amplification, so that low-level signals can be received with a minimum of circuitry.

The amount of positive feedback must be less than the input so that the net output will increase without forcing the tube to break into oscillation. The amount of feedback is controlled by the amount of coupling between L_p and L_g or by making R_g a variable resistor as shown in Fig. 609.

Gated amplifiers

Although, in practice, pentodes are used as gated amplifiers, their action can best be explained by using triode examples. The gated or keyed amplifier is found in both color and black-and-white TV, where it is put to a variety of uses. One of the most common is in the agc circuits of modern receivers.

Keyed agc

While the rather simple circuit of Fig. 603 performs the basic agc functions, it is not an ideal system and is used where economy and simplicity are primary considerations. Noise bursts riding in on the sync pulses tend to increase the bias on the controlled stages, producing variations in the brightness of the televised picture which should be avoided. This random noise and its untoward effects can be a nuisance to the viewer and at its worst can make the received image unintelligible.

A more elaborate and often used circuit avoids this effect by making use of the fact that noise pulses are of short duration and are often

completely eliminated by the shaping circuits in the sweep stages of the receiver.

In the keyed agc circuit shown in Fig. 610, the agc keyer tube receives its plate voltage from a width coil, magnetically coupled to the horizontal-output transformer. Thus the plate receives its voltage in the form of flyback pulses.

The control grid of the keyer tube is directly coupled to the plate circuit of the video amplifier. Although the control grid receives the composite signal consisting of video information and sync pulses, the

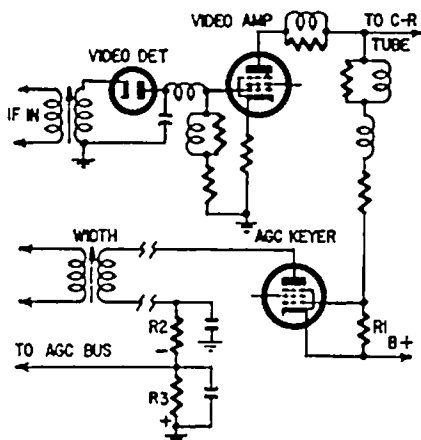

Fig. 610. Keyed agc circuit. The agc keyer tube conducts only during the time interval of flyback pulses received from the horizontal-output transformer.

keyer tube conducts only during the time the plate is made positive by the pulses received from the horizontal-output transformer. In this way the current passing through the keyer tube is controlled primarily by the strength of the sync pulses.

The agc keyer tube current passes through the width coil winding and also through R3, developing a voltage across this resistor in proportion to the strength of the sync pulse level. This voltage is filtered and fed back to the controlled stages.

Because of the direct-coupled connection between the keyer control grid and the video amplifier tube, we have B plus voltage on the grid. To keep the grid negative with respect to the cathode, the cathode is returned to a somewhat higher B-plus point.

Color killer and gated amplifier

Another special application of triodes is found in the color section of sets in which the color-killer tube functions to prevent spurious

color signals from reaching the picture tube when the incoming signal is transmitted in black-and-white.

Color sets are arranged to function whether the signal is color or black-and-white, without any adjustment on the part of the viewer. When a color program is received the set must separate the various colors associated with the signal. Each of the three primary colors used has a separate amplifier which functions when the proper color is received. When a black-and-white signal is tuned in, these color

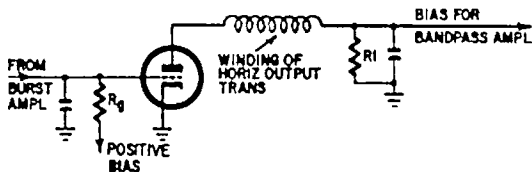

Fig. 611. A triode color-killer circuit. In this circuit, the color killer is inserted before the bandpass amplifier.

amplifiers must be disabled. The function of the color killer is to bias the color amplifiers to cutoff when no color is received and to become inactive itself when a color signal is present. Moreover, the disabling process must be applied to the color amplifier during the horizontal retrace period so that spurious effects do not mutilate the picture.

The picture information gathered from the video amplifier is fed to a bandpass amplifier which passes both black-and-white and color information. In some circuits the color killer is inserted before the bandpass amplifier, in which case it disables it. In other circuits the color killer follows the bandpass amplifier and must disable the individual color amplifiers.

Consequently, several color-killer circuits have been devised. Fig. 611 shows one in which the bandpass amplifier control voltage is obtained from the color killer.

The grid of the color killer is activated by the color signal while the plate receives positive pulses from the winding of the flyback transformer. Although the involved circuitry preceding the color killer is not shown, it receives its actuating pulse from the first video amplifier (as does the bandpass amplifier) and feeds into a set of detectors which in turn supply the voltage fed into the grid of the color killer.

The voltage at the color-killer grid is highly negative when a color signal is present and hence the tube is cut off even though a positive pulse is applied to the plate. With no plate current flowing, no voltage is developed across R1 and no negative bias is developed for application to the bandpass amplifiers.

With no color signal, the voltage applied to the color-killer amplifier is slightly positive and the tube becomes active each time its plate receives a positive pulse. The plate current, in passing through R1,

develops enough negative voltage to bias the bandpass color amplifier to cutoff.

Another type of circuit used acts in an opposite manner. The circuit of Fig. 612 functions so that, when no color signal is received, no bias is applied to the color-killer tube and it conducts with each positive pulse at the plate. The resultant current flow develops a negative charge across C1 and this, added to the -2.5 -volt bias, is

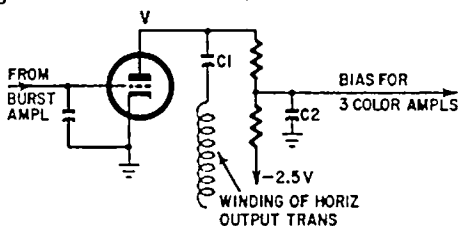

Fig. 612. This color-killer circuit acts in an opposite manner from the one in Fig. 611. Here, the bandpass amplifier precedes the color killer.

enough to bias the color amplifiers directly. (The bandpass amplifier precedes the color killer in this circuit).

When a color signal is received, the voltage at the color-killer grid is negative enough to prevent current flow in the plate circuit even when the tube receives positive pulses. The only voltage appearing across C1 is -2.5 volts, which is insufficient to prevent the color amplifiers from operating.

The action of the color killer is to trigger the amplifier with which it is associated—either to disable or activate it. This gating action is performed via the control grid.

Since the video amplifier contains all the color and black-and-white components, it is necessary to separate the color from the monochrome. This is usually done at the video stage by feeding the entire signal to the bandpass amplifier from one section of the video amplifier and recovering the black-and-white signal from another section by passing the video signal through a set of filters designed to trap the color frequencies.

The output of the bandpass amplifier is then passed through the detectors and filters to separate the color components which eventually appear as voltages which control the red, green and blue elements of the picture tube. Since picture quality depends upon the detail obtainable, spurious signals must be prevented from reaching the picture tube during the retrace periods of the scanning beam. Therefore, the bandpass amplifier must be disabled during this period and, since the control grid is already used for the color killer, some other element is used to disable the tube during the retrace period. As shown in Fig. 613, the bandpass amplifier is a pentode, and the

screen grid is used for this purpose. The disabling pulse is taken from the flyback transformer, the circuit being arranged so that a negative voltage of sufficient magnitude to cut off the tube is applied to the screen.

The principle of gating amplifiers is also used in the sync sections of TV receivers. A pulse from the horizontal transformer is used to

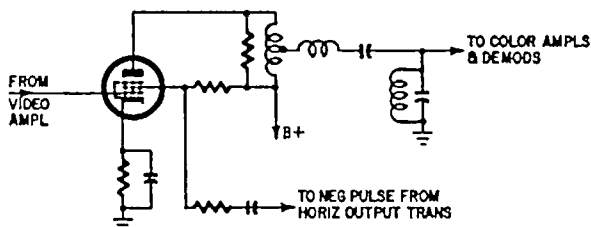

Fig. 615. A pentode bandpass amplifier. To prevent spurious signals from reaching the picture tube, the screen grid is used to disable the tube during retrace periods.

activate the color burst amplifier. The tube is allowed to conduct just long enough to pass the color burst during the retrace period. In other words the pulse from the flyback transformer disables the bandpass amplifier and at the same time activates the color burst amplifier. In some circuits this is accomplished by adding positive pulses to the cathode circuit of the burst amplifier, driving the cathode positive (with respect to the grid) to cut off the tube.

Reactance tube

In many of the triode uses outlined, pentodes can be used with equal or greater efficiency. However there are some jobs for which pentodes, because of their characteristics and multiple elements, are particularly suited. The pentode can be made to function in some circuits where, strictly speaking, it does not perform as a voltage amplifier. One of these important "extracurricular" applications is as a reactance tube in TV and FM systems. In FM it is used at the transmitter where it functions as a variable reactance to frequency-modulate the carrier. In TV reactance tubes perform as automatic-frequency-control devices for regulating horizontal oscillators.

In FM transmission the carrier frequency must bear the audio information with all of its component variations in frequency and amplitude to the receiver. This is done by varying the frequency of the carrier above and below its arbitrary center frequency.

Fig. 614 illustrates a Hartley oscillator to which has been added an additional variable capacitor C_m (a capacitor-type microphone in this basic illustration). It is parallel with C_1 , so that the normal frequency is determined by the capacitance of both.

If the normal frequency of the oscillator (center frequency of the FM carrier) is 100 mc, then the oscillator must be able to swing to

either side of this center frequency. Capacitor C_m can be arranged so that its capacitance is changed by the spacing between its plates. Moving the plates back and forth will then change the frequency of the oscillator.

The amount of space between the capacitor plates will determine the frequency of the oscillator. If we were using sound to activate the capacitor, the spacing between its plates would be determined by the amplitude of the signal.

The number of times a change in the spacing of the capacitor plates takes place will affect the rate of change of the oscillator frequency. Again, if we were using a sound wave to activate the capacitor plates the rate of change of the oscillator frequency would be in direct proportion to the frequency of the signal.

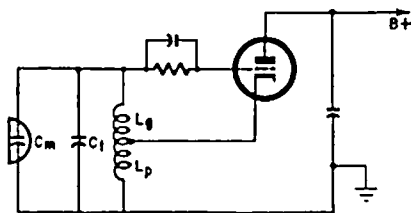

Fig. 614. Typical Hartley oscillator to which has been added an additional variable capacitor C_m .

Therefore if C_m were a capacitive microphone, the frequency of the oscillator would change in an amount and at a rate determined by the amplitude and frequency of the audio signal.

However, this would be an inefficient system, limited by the mechanical construction of the microphone. We know that the frequency of an oscillator can be controlled by varying either the inductive or capacitive components in its tuned circuit. Since a circuit is reactive when the current is out of phase with the voltage (it leads when the circuit is capacitive, lags when inductive) any component which will develop a leading or lagging current can be substituted for a capacitor or inductor.

In FM broadcasting the modulation of the carrier is accomplished by a reactance tube which is a triode, tetrode or pentode connected across the tuned circuit of an oscillator so that it simulates a variable reactance. Fig. 615 illustrates a circuit using a pentode. The tuned circuit of oscillator V2 is bridged by reactance tube V1. The series network formed by resistor R and capacitor C is connected across the tank circuit. The reactance of C is very small compared to the resistance of R (at a frequency of 50 mc the reactance is about 600 ohms). Thus the current flowing through this network is essentially in phase with the voltage in the tuned circuit.

The voltage e_c developed across C lags the current i_t through the entire circuit by 90° and also lags e_t , which is in phase with i_t , by 90° . Since e_c is applied to the control grid, the plate alternating current of V1, which is in phase with e_c , must also lag e_t , the tank voltage, by 90° . Thus, because V1 with its network develops a current flow which lags the voltage by 90° , the reactance tube appears to the tank circuit as an added inductance. This inductance must be taken into

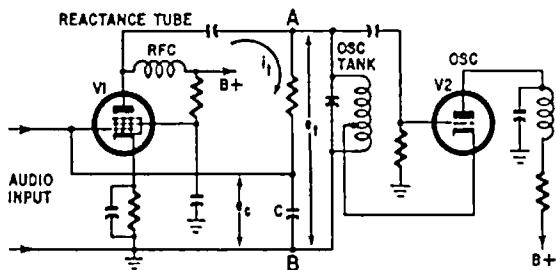

Fig. 615. In this method for obtaining frequency modulation, the reactance tube is shunted across points A and B of the tank circuit of a Hartley oscillator.

account when determining the resonant frequency of the tank circuit.

Means must be provided to change this reactance in direct proportion to the audio frequency. With the audio signal connected to the control grid as shown, the plate current varies with changes in the grid voltage. Suppose that the audio input is 1,000 cycles and that the positive half of the cycle is beginning. The grid moves in a positive direction, increasing the plate current. Since this current is inductive,

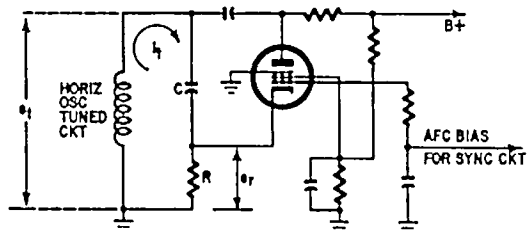

Fig. 616. Typical automatic-frequency-control circuit. R and C are the components of a phase-splitting network.

ductive, it appears to the oscillator as an added inductance. To balance the added inductive current the frequency of the oscillator goes up, increasing the capacitive current and decreasing the inductive current. When the negative half of the audio signal is applied, the reverse is true. The higher the amplitude of the applied signal, the greater is the shift in frequency. With this method, the carrier can be directly modulated by electronic means.

Automatic frequency control

A typical afc circuit is shown in Fig. 616 in which R and C are the components of a phase-splitting network. In this case, because the components used are different, the reactance tube is not originally

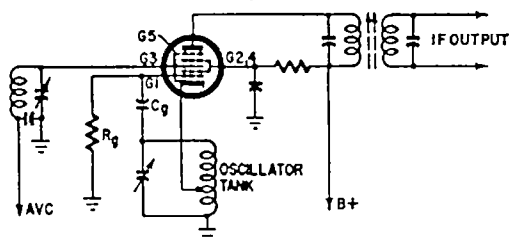

Fig. 617. A 6BE6 pentagrid converter. In this tube, the oscillator is part of the tube circuit.

equal to an inductance. Because R is very small in respect to C, the entire R-C network is reactive with i_p leading the tank voltage e_t by almost 90° . The voltage appearing across R provides the tube with cathode bias. Because a bypass capacitor is not used, negative feedback is developed and the plate current variations of the oscillator are 180° out of phase with the voltage drop across R. Since this voltage e_r is 90° ahead of e_t , the plate current lags e_t by 90° and the network appears once more as an inductance.

As long as the oscillator (horizontal oscillator in this case) is in phase with the incoming sync pulses, the tube rides along as a constant reactance. However, when there is a difference in phase—if the oscillator gets out of step with the incoming pulses—dc bias is applied to the control grid to increase or decrease the current as determined by the oscillator frequency. A change in current will result in a change in the oscillator frequency and move it into step with the incoming pulse.

Mixers and converters

Most radio receivers today use the heterodyne principle to effect sharp tuning. Superheterodyne reception requires the production of an intermediate frequency which is constant regardless of the frequency of the incoming signal. A local oscillator is arranged so that its frequency varies with the tuning of the receiver to a particular carrier. The output of the oscillator is mixed with the incoming signal so that the difference frequency becomes the intermediate frequency.

This mixing process or frequency conversion can be accomplished in several ways by using specially constructed converter or mixer tubes. Usually with a converter the oscillator is part of the tube circuit. In a mixer an external oscillator circuit is used.

The most popular of these tubes is the 6BE6 pentagrid converter shown in Fig. 617. This tube may be thought of as two pentodes in

series. For example, grid 1 acting as the control grid generates the local oscillator frequencies through the feedback path of grid 2, the first screen grid. Grid 3, the injector grid, acts as a secondary control grid which influences the electron stream produced by grids 1 and 2. Grid 3 with its input signal, the carrier, reacts on the electron stream which

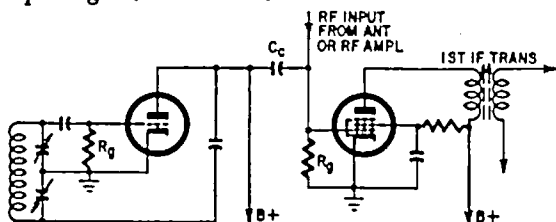

Fig. 618. Triode-pentode mixer circuit. The oscillator is a Colpitts. The voltage produced by the local oscillator and that supplied by the antenna (or a preceding rf stage) are used to modulate the control grid of a pentode. Of the four main frequencies appearing in the plate circuit of the pentode, the difference frequency is selected to act as the intermediate frequency.

continues to the plate of the tube carried by the attraction of grid 4, the second screen. Grid 5 is the suppressor and performs its normal function. Grids 1 and 2 can be looked on as a portion of one pentode and grids 3 and 4 as the second, with 5 acting as the common suppressor.

The action of the converter is not as complex as it looks. The first two grids act as an oscillator in conjunction with the cathode. With a signal of 1,000 kc the oscillator frequency will be, let us say, 1,455 kc. Since grid 2 and grid 4 are tied together this frequency appears on grid 4. The 1,000 kc signal is applied to grid 3. The oscillator signal and the rf signal are attracted to the plate of the tube. In the process we get sum and difference frequencies with the result that signals of 1,000 kc, 1,455 kc, 2,455 kc and 455 kc appear at the plate.

The plate circuit of the converter contains a tuned circuit in the form of the 1st if transformer. This circuit, which is resonant at 455 kc, rejects all of the other frequencies at the plate of the converter. Thus, only the wanted signal (in this case 455 kc) is amplified.

A triode-pentode mixer of the type commonly found in TV and FM receivers is illustrated in Fig. 618. Although the triode oscillator and pentode mixer are shown separately they are often found in the same tube envelope. Mixing action is a straightforward process. The oscillator frequency and the rf signal are both fed to the grid of the pentode which is biased to function on a non-linear portion of its curve. The signals are mixed—sum and difference frequencies produced—and the output is taken from the plate of the tube. Again the signal of the proper frequency is selected by the tuned circuit in the plate of the mixer.

The gated-beam detector

Where low cost and simplicity of operation are primary considerations the gated-beam tube has found wide application as an FM detector and limiter. The use of this specially constructed tube reduces

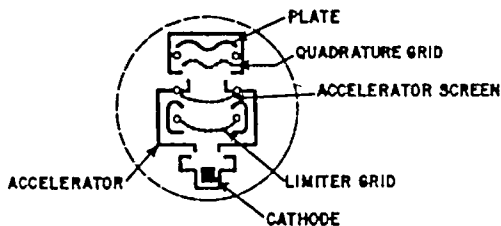

Fig. 619. Internal view of the 6BN6 tube, commonly used in TV audio sections.

the number of components in an audio system. It eliminates the detector transformer as well as several limiter stages. Other advantages are that it provides good noise rejection and is fairly easily aligned.

An internal view of the 6BN6 (a tube commonly used in TV audio sections) is shown in Fig. 619. The tube contains a cathode, two grids, an accelerator element and a plate. Fig. 620 shows a typical circuit using the tube.

The incoming FM signal is applied to the *limiter* and *quadrature* grids. The construction of the tube is such that the phase of the FM

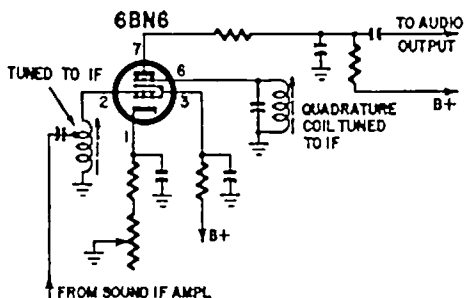

Fig. 620. A typical circuit using the 6BN6 gated-beam detector.

signal on one grid is different from that on the other. The phase difference varies with the frequency deviation of the signal. Since the grids control the amount of current that flows in the plate this difference is converted into corresponding amplitude variations. The frequency characteristic of the signal is never lost since the rate of change of the frequency of the incoming signal is reproduced as the frequency of the amplitude variations in the plate circuit.

multi-purpose tubes

PRACTICALLY all modern radio and TV receivers use space-saving multi-purpose tubes. Duo-diodes, duo-triodes and triode-pentodes are but a few of the many combinations in use today. Modern techniques and materials have made the list of multi-purpose tubes

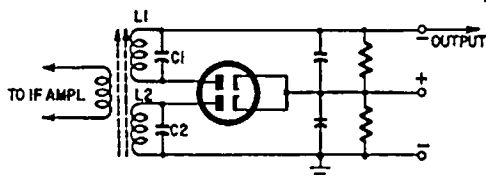

Fig. 701. A duo-diode used as an automatic-frequency-control tube.

one of limitless possibilities. By combining similar or different tube types in a single envelope, highly efficient and economic circuits not otherwise possible have come into daily use.

The first step toward the combination tube was taken when the half-wave rectifier (single diode) was made into the full-wave rectifier (two diodes in one envelope). The 5U4-GB is a tube typical of this type.

Duo-diodes

Aside from the full-wave rectifier, the duo-diode is found in many services. It is used as an FM detector (the 6AL5, a duo-diode whose units are shielded from each other, is sometimes used in this application), horizontal discriminator, afc discriminator and in other circuits where an advantage can be gained by having two diodes close together. In Fig. 701, for example, a duo-diode is used as an afc tube. Two tuned

circuits—one for each diode—are fed by a tap taken from an if stage. The first tuned circuit is resonant at a frequency slightly higher than the if, the second slightly lower. At the intermediate frequency the voltages through each diode cancel—they are 180° out of phase and of equal

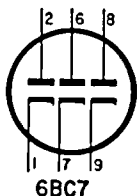

Fig. 702. Each diode of this 6BC7, used in color TV as a dc restorer, handles one of the primary colors.

amplitude. A shift in the intermediate frequency in either direction produces a difference voltage at the output, which is applied to a reactance tube which in turn adjusts the frequency of the local oscillator.

Although a system such as this would be used only where great precision of operation is required, it serves to illustrate one of the varied uses of a duo-diode.

Triple diodes

Fig. 702 illustrates a triple diode, the 6BC7, a tube used in color TV as a dc restorer. Each diode handles one of the primary colors (red, green and blue) and functions to maintain the average color illumination.

Another function of the triple diode is as a combined AM detector and FM discriminator (or ratio detector) in AM-FM radios. Appropriate sections of the tube are switched into the circuit, depending

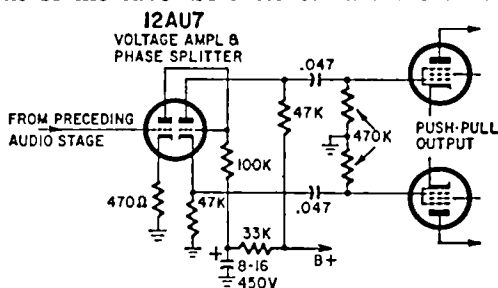

Fig. 703. A duo-triode 12AU7, used as a voltage amplifier and phase inverter in an audio circuit.

upon the nature of the signal received. Triple diodes are sometimes incorporated into one envelope with other tube types.

Duo-triodes

The convenience of placing two triodes within a single envelope is so great that this is one of the most widely used combinations. The applications of this type of tube are almost limitless. In push-pull audio stages, where small amounts of power are required, they make

excellent output tubes. Because of the independent action of each section, the tubes can be used for many dual-purpose functions, such as that of combined vertical oscillator and output tube in TV. Another use is as a voltage amplifier and phase splitter in audio systems. Fig. 703 shows a 12AU7 in an audio circuit. Notice that the plate of the voltage amplifier is directly coupled to the grid of the phase splitter. One of the advantages of this arrangement is the elimination of the coupling capacitor—a frequency-sensitive reactive component.

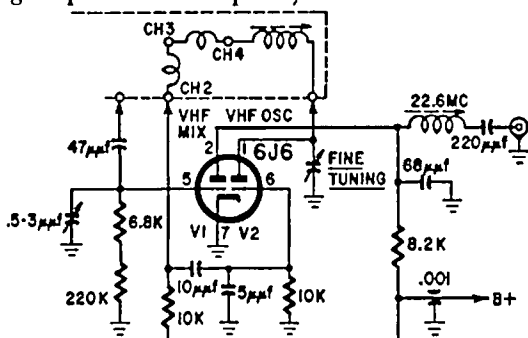

Fig. 704. The 6J6 duo-triode makes an excellent oscillator-mixer because of its common cathode.

Some duo-triodes are specifically designed for high-frequency work, where they form excellent rf amplifiers because of their low noise characteristics. They are also often used as mixers and oscillators. The 6J6 makes an excellent oscillator-mixer because of its common cathode. In fact it cannot be used in the same manner as the 12AU7 because of this feature. In Fig. 704, coupling between the oscillator and mixer is accomplished through the cathode. The oscillator frequency is injected into the electron stream between cathode and plate, which is also the electron path of V1, which in turn contains the input signal. The output consists of the mixed frequency. Other duo-triodes used for high-frequency service are the 6BQ7-A, 6BZ7 and 6BC8.

Duo-diode triodes

The duo-diode triode finds wide application in the radio receiver as a detector, first audio amplifier and avc tube. Fig. 705 shows the 6AV6 in a circuit of this type. One interesting feature is the way in which bias is achieved. In any tube the grid is hit by a number of electrons as they pass from the cathode to the plate. Even when the tube is operated class-A a certain amount of grid current is produced. Often this current is so small that it cannot be measured with normal instruments. In this case the current is on the order of 0.1 microampere. However, because of the high resistance in the grid circuit, this small current results in a voltage drop which is used to bias the tube. The

6AV6 requires about 1 volt on its grid. This is produced by the 0.1-microampere current which flows through the 10-megohm resistor.

Triple-diode triodes

The popularity of the AM-FM radio receiver and the dual nature of the signal in television have made tubes such as the 6T8 popular. In radio, the tube is used as an FM detector, first audio amplifier and AM detector. The triode section is used as the first audio ampli-

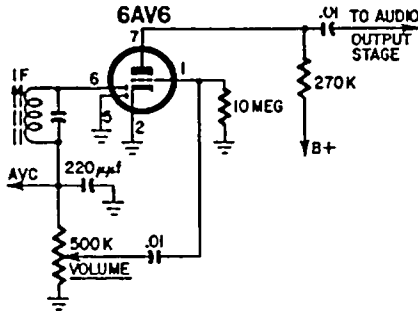

Fig. 705. The 6AV6 duo-diode triode, used as a detector, first audio amplifier and avc tube in radio receivers.

fier which is common to both the AM and FM sections of the set. The diodes are switched in and out of the circuit, depending on the nature of the signal. In TV, two of the diodes are used as a

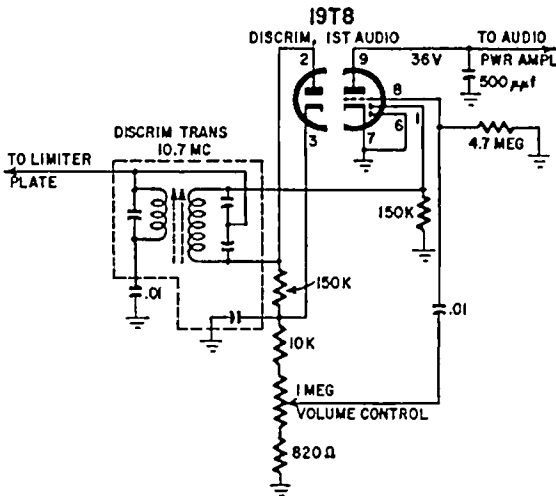

Fig. 706. This multi-purpose tube acts as an FM detector and audio amplifier.

ratio detector and the triode as the first audio amplifier. The third diode can be left unused or wired as an agc clamp. In the circuit shown in Fig. 706, the tube functions as a discriminator and first audio amplifier. In this application, the unused diode plate is grounded. (Except for filament voltage, the 19T8 is similar to the 6T8.)

Diode-tetrodes

Tubes such as the 12EM6 (diode-tetrode) and the 12J8 (duo-diode tetrode) are finding some application in automobile radios. The tubes are designed to function with only 12 volts applied to the plates so that they can be operated directly from the automobile battery. The diode sections are used for detection and avc while the tetrodes are used as audio drivers. The tetrode is of special value when transistor output stages are used because impedance-matching problems are minimized.

Triode-tetrodes

Triode-tetrodes such as the 6CQ8 are found in the modern TV receiver. They are used as oscillator-mixers, with the tetrode acting as the mixer section. The low noise characteristic of the tetrode makes it particularly suitable for this function. Close control of component values and modern manufacturing methods virtually eliminate the tetrode's undesirable instability.

Diode-sharp-cutoff pentode

Another often used tube is the diode-pentode which can double for the diode-triode in many applications. The pentode can be used as the first audio amplifier while the diode performs as detector. However, because pentodes have several characteristics which triodes lack, tubes of this type can be used as if amplifiers and detectors. In Fig. 707 the 6AS8 (a diode-sharp-cutoff pentode) is shown in a circuit where it

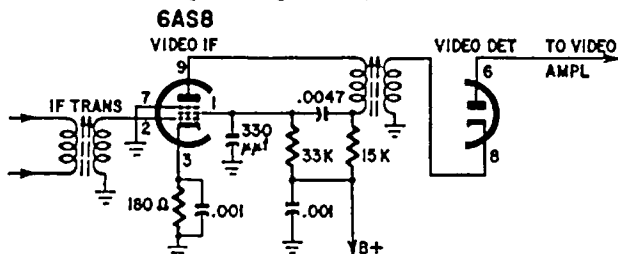

Fig. 707. The 6AS8 diode-sharp-cutoff pentode, shown in a circuit as a video if amplifier and video detector.

functions as a video if amplifier and video detector. Diode-pentodes are also found in agc circuits where the pentode is used as the agc amplifier and the diode as the detector.

Triode-pentodes

Triode-pentodes such as the 6AN8 have special applications in color sets where the tube performs as a color killer and bandpass amplifier in the color sync section. As described previously, the color killer (triode) develops the bias which disables the bandpass amplifier (pentode) when no color signal is received.

Another common use is as a combined oscillator and reactance tube where the pentode is wired as the reactance stage.

Often triode-pentodes will be found functioning in two widely separated sections of a TV set. Tubes such as the 6U8-A (often used as an oscillator-mixer) can be found functioning as an audio if (pentode) and vertical oscillator (triode).

Dual pentodes

An unusual multi-purpose tube is the 6BU8, a dual pentode with separate plates and suppressor grids, but with the cathode, control and screen grids common to both elements (Fig. 708).

The tube can be used as an agc amplifier, sync separator and noise gate simultaneously, eliminating the need for the separate stages used to perform these functions in many TV sets. Part of one section of the

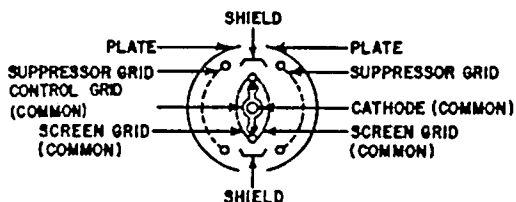

Fig. 708. Multi-purpose tubes sometimes share electrodes. In this case the tube has a common cathode, control grid and screen grid.

tube is used as a gated (keyed) agc amplifier. The suppressor grid in this instance functions as the control grid as far as signal is concerned. The operating point of the tube(s) is determined by the bias applied to the common control grid. The other section of the tube (plate and screen) is used as a sync separator. Noise gate action is a function of the entire tube. When noise pulses ride in on the sync pulses, the tube is cut off since these pulses are applied to the control grid. Since noise is a random pulse which seldom appears on more than a few consecutive sync pulses, the receiver does not have a chance to get out of step with the sync pulses and the oscillators continue to function despite the momentary interruption.

gas tubes

THE electronic circuits with which most people are familiar use vacuum tubes almost exclusively. Except for the few cases in which a gas tube is used as a rectifier or voltage regulator, the operation and circuit applications of these tubes are unfamiliar.

Cold-cathode diodes, such as the 0C3 and 0D3 utilize the principle of field emission. When a strong electric field is applied to a

Fig. 801. Curve showing the magnitude of current in a cold-cathode diode as voltage is increased.

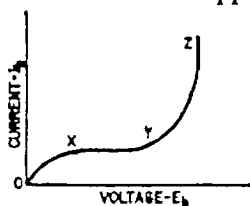

metallic surface, it literally pulls electrons from it. Therefore, electron activity in this case is not due to heat—hence the name cold cathode.

Cold-cathode diodes

Because the thermionic gas-filled diode functions differently from the cold-cathode type, each must be discussed separately. Perhaps the simpler of the two is the cold cathode.

The magnitude of the current in a cold-cathode diode is due to the combined effects of electrons and positive ions. If a voltage is applied to two metal electrodes (fairly close together in a glass envelope containing a small amount of inert gas) and it is gradually increased, the current flow between the electrodes will change.

At first a slight increase in current is obtained (Fig. 801). Then it remains constant with any further increase in voltage until point Y, at which the current increases rapidly.

The current increase from 0 to X is not caused by electron emission from the cathode but rather by the small amount of ionization of the gas always present, regardless of applied voltage. The increase of potential in the 0-X range merely causes more and more positive and negative gas ions to flow to the electrodes. In the range X-Y the current is constant because the flow of ions remains unchanged, being independent of anode potential, which is still not high enough to break down additional gas molecules into ions.

When point Y is reached, the speed of the electrons traveling to the anode is high enough to break up gas molecules in their path, producing more electrons and positively charged ions. This process increases rapidly (Y-Z) as more and more secondary ions are produced until point Z is reached, where the multiple effects are so intense that the current increases almost without limit. The Y-Z part of the curve is called the "Townsend discharge" and it is in this region that the cumulative effects of ionization take place. Here the newly liberated electrons speed on to the anode, producing new electrons each of which produces new ions. At the same time that the electrons are breaking up the gas molecules, the new ions (made positive by losing electrons) travel toward the cathode, liberating other molecules in their path.

An extreme increase in current is experienced at the breakdown point when the current flow becomes self-sustaining. This point varies for different tubes and depends upon the gas used, its pressure and temperature and the spacing of the electrodes. The type of metal used also influences the breakdown point.

When breakdown occurs, the tube glows as much as the tube design allows. In voltage regulators where the current is small, the glow may occur only in a portion of the tube. In tubes such as those used in neon signs, the glow is deliberate in order to create light and is almost uniformly distributed over the entire tube length. The voltage drop across the tube in this condition varies slightly with large current changes. Therefore the current must be externally controlled to keep it within bounds once breakdown occurs. If it is not controlled an abnormal glow results and the cathode will be overheated and perhaps destroyed by the heavy bombardment of positive ions. If the concentration of current near the cathode becomes great enough, arcing will occur between the cathode and anode, destroying both electrodes.

Thermionic gas diode

The hot-cathode gas-filled diode does not require high anode voltages to start electron flow. The cathode emits electrons freely, forming a space charge from which they pass to the anode when a positive potential is applied to it. In a vacuum diode small traces of gas cause a flow of current that varies in direct relation to the amount of gas left in the tube. In some critical applications where tube operation

depends upon a specific characteristic curve, this can be undesirable. For example, Fig. 802 shows typical I_b - E_b curves for a vacuum diode containing varying amounts of gas. Curve A is the characteristic of a diode with the curve carried beyond the saturation point at X.

Fig. 802. Typical plate-current-plate-voltage curves for a vacuum diode containing varying amounts of gas.

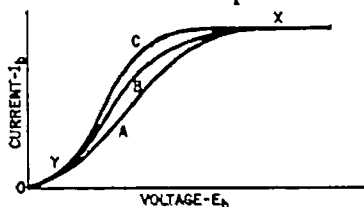

With larger amounts of gas, the rate of current increase becomes greater in the Y-X region because of the production of ions from gas molecules. This increase occurs for two reasons: the ion flow adds directly to the current, and the negative space charge is partially neutralized by the positive ions flowing to the cathode. Once saturation is reached, the traces of gas have no effect on the curve. Hence curves A, B and C converge at X. Moreover, the gas has no effect in the O-Y portion of the curve because the voltage is too low to cause ionization.

In a gas tube in which fairly large amounts of gas are deliberately added, the current and voltage relationships are quite different. In Fig. 803, curve A of Fig. 802 is drawn to a much larger scale and not carried to saturation (in gas diodes, the current in the O-Y region is extremely low in relation to the total diode current). The current in the gas diode (curve D) would increase without limit if it were

Fig. 803. Curve A of Fig. 802 is drawn to a much larger scale and not carried to saturation.

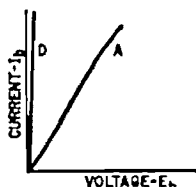

not controlled by external circuit resistances. At breakdown, the anode voltage has practically no control over the current. In thermionic gas tubes, this voltage is in the order of 10-20. Thus, if a gas tube is placed across a voltage source greater than the breakdown voltage, the tube acts like a short circuit.

The interelectrode space of a gas tube is divided into two specific regions. The first extends a short distance from the cathode and is called the *cathode sheath*. When the tube conducts and the cathode is surrounded by positive ions, this region is called the *positive ion sheath*. The rest of the interelectrode space from the edge of this region to the anode is called the *plasma*. When breakdown occurs, boiled-off electrons are sped into the plasma by the positive ion sheath

and positive ions from the plasma fall to the cathode. The positive ions in the plasma formed by the bombardment of gas molecules by the high-velocity electrons move so slowly that they are balanced out by the free electrons and cause a net charge of zero in the plasma. In this way almost all of the voltage drop between anode and cathode occurs in the small space charge called the sheath.

Because of their large current-carrying capacity, gas-filled diodes are used for rectification where high currents are involved. In such circuits the cathode must be heated to full emission before the anode voltage is applied. If anode potential is applied before the cathode is hot, the voltage drop across the tube is excessive, causing breakdown and damaging the tube.

In some types of gas diodes, such as those used in battery chargers, the gas pressure is relatively high. This pressure decreases the rate of burnoff of the cathode, permitting the tube to be run at a higher temperature. If the pressure is too high, however, breakdown may occur because of the peak inverse voltage rating of the tube. Such tubes can be used only at low voltages.

When very large currents are to be handled, mercury-pool cathodes are used. The mercury pool itself is not an electron source and the arc (current flow) is started by other means. Once started, the arc concentration produces mercury vapor, providing a conducting path between the electrodes. Electrons are emitted while the arc is active and they flow to the anode. The mercury vapor continually condenses on the sides of the tube and flows back into the cathode pool, replenishing itself. This type of rectifier is extremely rugged and, because of its high current-carrying capacity, can handle high overloads of short duration without damage.

Many commercial mercury-arc rectifiers use a separate anode called the *ignition anode* to start the arc. This small anode, with a positive dc voltage applied to it, is plunged into the mercury pool when the tube is started. It is quickly removed by spring action, causing an arc which is immediately transferred to the excitation anodes of the rectifier.

In some mercury-arc rectifiers excitation is accomplished in a different manner. An *ignitor* anode, which is a high-resistance element, is used to start the tube. It can be used repeatedly on each positive half-cycle of an applied voltage. The ignitor is kept in contact with the mercury pool and, each time a positive voltage is applied, a tiny spark appears at the junction of the anode and the mercury cathode. The hot spot created by this action releases electrons in the form of an arc.

Thyratrons

The thyratron is a gas triode with enough gas pressure to permit firing with a normal value of plate voltage and having a grid which

can be biased to prevent firing until a desired instant. In practice, the thyatron is often used as a triggering device since the tube can be kept from conducting by applying a high negative grid bias. If a high positive pulse is fed to the grid, the tube will fire. Once this takes

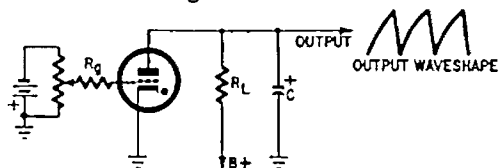

Fig. 804. Typical thyatron used as a sawtooth oscillator.

place, the grid no longer controls the tube—the negative space charge and grid are completely overcome by the positive ions of the glow discharge. The current flow is limited by the external impedance of the plate circuit and can destroy the tube if it is not controlled.

The thyatron because of its no-go/go nature serves as a relay or trigger tube and not as an amplifier even though it has a control grid. As a relay it is extremely fast but must be reset before it can be used again. After triggering the anode voltage must be removed

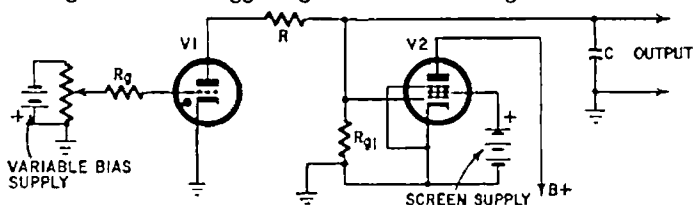

Fig. 805. A thyatron being used in conjunction with a pentode.

to stop the current flow before the grid can regain control. An ac voltage applied to the plate (and cathode) would permit resetting the tube during each negative half-cycle.

Since, by varying the grid bias the firing time of the thyatron can be delayed or advanced by will, the tube is often used in control applications.

Sawtooth oscillators

Thyatrions can be used as sawtooth oscillators in place of high-vacuum tubes (Fig. 804). The voltage across the capacitor (the output voltage) rises exponentially until the charge reaches the point at which the thyatron fires (the firing point being determined by the grid bias). When the tube conducts, it acts as a low resistance through which capacitor C discharges rapidly. The voltage on the tube is reduced by this action to a point at which conduction ceases. The process then repeats itself. The sweep frequency is adjusted by

changing the grid bias. This type of circuit is sometimes called a gas-tube relaxation oscillator.

In Fig. 805 a thyatron is used in conjunction with a pentode. Capacitor C is charged through V2 at a constant rate. The voltage across it, which is also the voltage across the thyatron, increases uniformly along a straight line. This is because the pentode's plate current is independent of its plate voltage and, therefore, as the plate voltage drops while C is charging, the current through the tube remains uniform. The voltage across C is applied to the thyatron. When it reaches the proper value the tube fires and capacitor C discharges. Resistor R serves to limit the current through the tube. Because the current increases uniformly with respect to time rather than exponentially as in Fig. 804, the sawtooth wave approaches the ideal.

The firing point of the thyatron can be controlled by varying the bias on the grid of the tube. In effect this also controls the amplitude and shape of the sawtooth wave.

photoelectric emission

ELECTRON emission is grouped into four general categories: thermionic, secondary, field and photoelectric. Photoelectric emission produces electricity from light by a process in which electrons are emitted from specially treated surfaces. The reverse process (light from electricity), while not photoelectric emission in the true sense, is closely related to it.

Modern TV, an important part of our everyday lives, depends upon both processes. The camera tube at the studio interprets the televised scene as electric impulses which are reassembled in the receiver and converted back into light by the picture tube.

Where the transfer of energy between electricity and light is involved, materials of several types are used, depending upon the requirements of the circuit. Materials which emit light when bombarded by electrons consist of nonmetallic phosphors which are fluorescent. In the reverse application, materials which emit electrons when exposed to light are used. They are usually metallic with specially treated surfaces.

The cathode-ray tube

The process of converting electricity into light—as in the TV picture tube—is based on the principle that a moving electron contains a certain amount of kinetic energy which is converted into luminescence when a phosphor material is struck. In the cathode-ray tube, a stream of electrons is sent headlong into the phosphor-coated surface of the tube, causing it to fluoresce at the point of contact.

The electrons emitted from the indirectly-heated cathode (Fig. 901) are attracted forward by a positive potential, but are under the control of a grid in much the same way as in the ordinary vacuum tube.

The problem is to focus the electron stream into a fine beam and speed it up so that it strikes the fluorescent screen hard enough to get a sharp point of light.

The control grid is a metal cylinder surrounding the cathode. The grid has a metal diaphragm in it with a small aperture which acts as the first lens. The electrons go through the hole only, forming a beam.

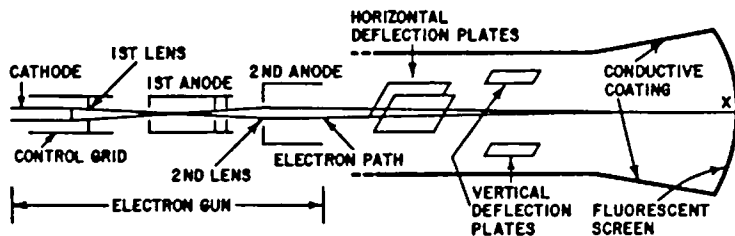

Fig. 901. Internal view of cathode-ray tube using electrostatic deflection.

The cylindrical first anode has several apertures (diaphragms with small holes) which act on the electron stream and help to direct it into a narrower beam. This anode is at a positive potential and speeds the electrons toward the screen by focusing the stream into a pinpoint. The second anode, also cylindrical, determines the final velocity of the electrons, speeding them on their way so that they will strike the screen hard enough to cause fluorescence. Thus, the first anode is the focusing anode and the second the high-voltage electrode. The inside of the glass walls of the tube are lined with a conductive coating which is connected to the second anode. This coating, at a high positive potential, collects the secondary electrons knocked off the fluorescent screen by the electron beam. In Fig. 901, note the path of the beam and how the cathode lens together with the first anode cause a crossover within the first anode cylinder in exactly the same way that a picture is inverted in an ordinary camera. This combination of electrodes—cathode, grid and first anode—is called the *electron gun*.

Horizontal and vertical deflection plates move the electron beam side to side and up and down by creating electrical fields through applied voltages. Assume that with no voltage applied to the plates the beam appears in the center of the screen at point X. If a fixed potential is applied to the horizontal plates,¹ the spot will move horizontally toward the positive plate and will then appear off center. A similar movement of the spot occurs when a voltage is applied to the vertical plates. Only in this case, it will move up or down rather than to one side.

¹ The terms horizontal and vertical deflection plates (or more simply, horizontal and vertical plates) refer only to the effect these plates have on the electron beam. Physically, the vertical deflection plates are mounted horizontally; the horizontal deflection plates are mounted vertically.

If an alternating voltage is applied to the horizontal plates (a sine or sawtooth wave), the spot moves back and forth rapidly, appearing as a horizontal line on the screen. If, at the same time, another alternating voltage is applied to the vertical plates, the horizontal trace will be pulled apart, rising and falling in step with the amplitude variations of the vertical deflection voltage. If a 1,000-cycle sine wave is applied to the vertical plates and a sawtooth voltage of the same frequency to the horizontal, a single cycle of the sine wave will appear

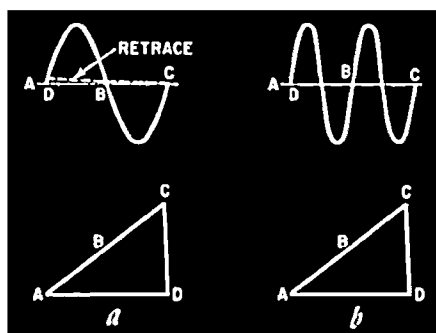

Fig. 902. Relationship between a sine wave and the time base applied to a cathode-ray tube.

on the screen. As the electron beam is pulled from left to right by the application of an increasing potential difference on the horizontal plates (corresponding to the straight-line rise in potential of the sawtooth wave), the beam is drawn upward to a maximum and downward to a minimum, corresponding to the sine-wave voltage on the vertical plates. At the instant that the vertical voltage completes its sine-wave cycle, the sawtooth reaches its positive peak and instantaneously returns to zero in time to meet the next sine-wave cycle. Thus, the single-cycle sine wave appearing on the screen is really a series of traces superimposed upon one another. If the sine and sawtooth waves get out of step, the screen will show a series of transient traces.

By adjusting the frequency of the sawtooth wave (time base), wave-shapes of frequencies in the rf range can be observed. By making the time-base frequency half the frequency to be observed, two cycles will be seen.

Fig. 902 shows how the time base and the return trace appear with respect to the observed signal. In *a*, the sawtooth and the sine wave are of the same frequency; in *b*, the sawtooth is half the frequency. In these cases, the return time is fast enough so that it can barely be seen on the screen. In television, however, the tube must be cut off during each retrace period. It is such a high-speed system that the return trace

could be seen and it would interfere with the picture. Also, although the basic principles are the same, the television picture-producing circuitry is much more complex.

The electron beam in a TV cathode-ray picture tube is not a steady one. It is modulated by the video signal to produce various intensities of light. Moreover, the horizontal deflection circuit is activated by a sawtooth generator which must be synchronized with the horizontal scanning rate of the camera tube at the transmitting station. The vertical circuit is triggered by a sweep oscillator (the oscillators associated with the deflection systems of cathode-ray tubes are commonly

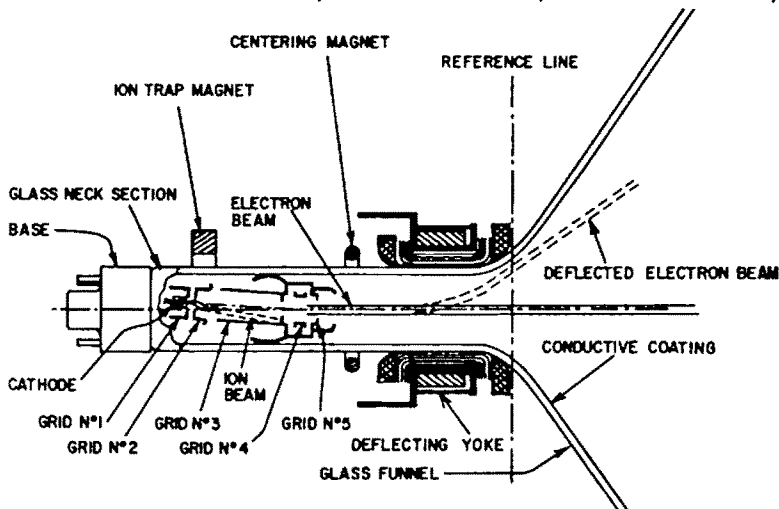

Fig. 903. Cross-section of magnetically deflected TV tube. Note how the electron beam is moved through the use of magnetic fields generated by the deflection coils.

called sweep oscillators or generators) which functions at a much lower frequency to coincide with the speed at which the electron beam must move to "paint" the picture from top to bottom.

To meet the demand for larger pictures by home viewers, magnetic deflection proved more desirable than the electrostatic system (which is still used in oscilloscopes and other equipment). Receivers today use magnetic fields for horizontal and vertical deflection.

Fig. 903 shows a cathode-ray tube with magnetic deflection coils. The cathode and grid structure, acting as the first lens, is about the same as in an electrostatic system. However, the first anode of Fig. 901 has been replaced by an accelerating grid, which acts like the first anode and speeds the electrons (this grid does no focusing). The second anode is the conductive coating on the inside of the glass envelope. In some units, focusing is accomplished by a permanent magnet which

forms a field in the same plane as the electron beam, squeezing it into a thin line. Many picture tubes today use electrostatic focusing, accomplished by a special anode within the tube.

No matter which focusing method is used, beam deflection is caused by magnetic fields. The field produced by the deflection coils is at right angles to the electron path and can be easily used to deflect the beam. When the vertical coils in the deflecting yoke are activated (Fig. 903) the magnetic fields interact, displacing the beam as shown. When the horizontal coils are activated, the beam is deflected to the left. Both actions and the relative position of the electron beam depend on the rise and fall of current within the deflection coils. This current originates in the sweep circuits of the TV set.

If either of the horizontal or vertical oscillators or coils fail, the raster will be lost. If the video amplifier fails so that no signal reaches the picture-tube grid, the face of the tube will light up (the raster will be present) but no picture will appear. If the high-voltage supply fails, the raster itself will not be present.

Electron-ray tubes

Cathode-ray tubes convert electrical energy into light and electron-ray tubes do the same thing, but are used for quite a different purpose. The indicator tube is one of the simplest applications of the electricity-to-light principle. In this type of tube, electrons are not focused into

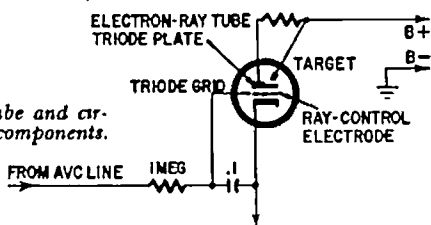

Fig. 904. A 6E5 electron indicator tube and circuit, with its triode and target components.

a beam but flow toward the target at random. The indicator tube is used in many radio sets to facilitate tuning. Photosensitive tubes thus used are called electron-ray tubes and the 6E5 is typical. They are constructed with fluorescent targets which glow when bombarded.

When used in a circuit, the indicator often requires a dc amplifier to provide enough voltage to control the tube. A tube such as the 6E5 contains a control triode within the same envelope as the indicator. Fig. 904 shows a 6E5 tube with its triode and target components. The input voltage originates in the avc circuit of a radio. The tube has a common cathode, with the current to the plate of the triode section controlled by the avc bias applied to its control grid. The electron flow to the target is controlled by the voltage on the triode plate, which is internally connected to the ray-control electrode. Electrons emitted from the cathode strike the target, causing it to glow with a faint green

light. When the control grid of the tube is at the same polarity as the target, the tube will glow over most of the target area but, as the grid is made more negative, fewer electrons reach the target, diminishing the glow.

The electron-ray tube circuit in a radio is arranged so that when the AVC bias is least negative (when the receiver is not tuned to a station), the triode section of the tube conducts a large amount of current and the voltage at the plate is minimum. This potential is transferred to the indicator grid and a minimum flow of electrons to the target results.

The opening and closing of the "eye" is produced by a "shadow" electrode (ray-control element). When this electrode is less positive than the target, electrons are repelled by it and do not reach the portion of the target in the shadow of the electrode. This shadow varies from about one-third of the target area (when the electrode is most negative) to zero (when the target and control element are at the same potential). The grid of the triode section controls the shadow electrode.

Although the 6E5 tube is frequently used, the modern trend has been to smaller tubes of the miniature type. One such tuning indicator is the EM84/6FG6. This tube has a rectangular indication pattern

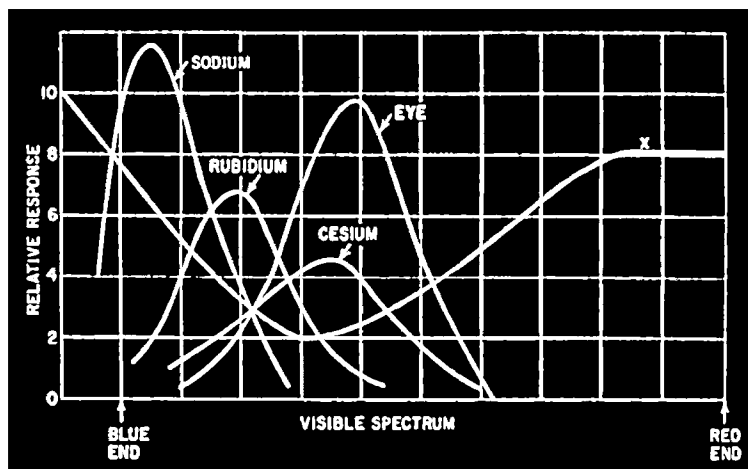

Fig. 905. The response of various photosensitive elements to the light spectrum.

and is for use in broadcast receivers and tape recorders. The blue-white pattern changes in length with signal strength. Unlike other indicator tubes, the pattern of the EM84 is displayed, not on a shaped electrode, but on the inner surface of one side of the tube envelope, which is coated with a fluorescent substance. The tube is a nine-pin miniature type.

Photoelectric tube (phototube)

The photoelectric tube and TV camera tube perform the reverse function of converting light into electrical energy. The energy (electrons) released may be used to operate relays as with the photocell. On the other hand the released electrons may be discarded and not used, as in the camera tube.

Electron emission, regardless of how it is produced, is brought about by imparting enough energy to a captive electron to permit it to escape

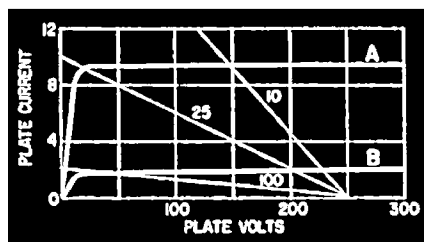

Fig. 906. Plate characteristics of a typical phototube. Two current curves are shown to indicate action of the tube with various intensities of light.

from its parent atom. In some materials, light provides enough energy to free an electron from its surface. The amount of emission depends upon the intensity of the light (the number of photons which strike the surface in a given time interval). The color of the light also has an effect on the photoelectric current. Tests indicate that for most metallic surfaces, blue light causes a greater current flow than red light of the same radiant power.

In the photoelectric tube, the electrons emitted from the specially-treated cathode create a closed-circuit current flow in much the same way as in an ordinary vacuum tube. The cathodes are coated with cesium, sodium or rubidium. Fig. 905 shows the relative response of these elements over the visible spectrum. Since some photoelectric tubes are supposed to react to light in the same way as the human eye, the response of the eye at various frequencies is also plotted on the same graph. Note that although the response of cesium is not as great as the other metals, it resembles that of the human eye.

It is important that the material used will respond properly to the light source in a particular application. For example, light from a tungsten lamp lies predominantly in the red and infra-red portions of the spectrum. Little power is radiated at the blue end, and a phototube using lithium would produce very-low-level response.

Because most of our artificial light sources are tungsten lamps, efforts are made to extend the response curve of phototubes into the red regions. The application of a thin film of cesium and cesium oxide on

silver improves the response to light from a tungsten lamp. Curve X in Fig. 905 is the response curve of this type of surface.

Phototubes may be either high-vacuum or gas-filled, but the internal electrodes are usually arranged similarly. A typical vacuum phototube

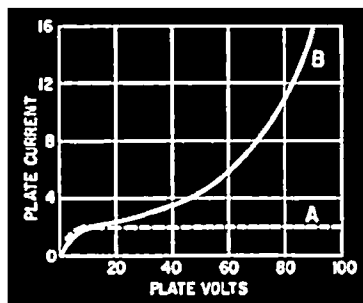

Fig. 907. Plate curve showing how the addition of gas affects the action of a phototube.

is constructed with a large cathode and a small anode, so that the anode will not interfere with the passage of light to the cathode. Fig. 906 shows the characteristics of a typical tube of this type. The curves show the tube performance with different load resistances. The current is directly related to the intensity of the light falling upon the tube. Curve B is a plot of current for light intensity one-fifth that of A. The current of A is about five times that of B. In either case, as the anode voltage is increased current rises rapidly to a saturation point, at which point no further increase occurs. In a high-vacuum phototube, the space charge plays an important part because the currents are so small—they are measured in microamperes.

Because of the small current output from the vacuum phototube, gas-filled tubes have been made to increase the available current. Addition of the proper amount of gas will change the characteristic curve from say, A to B, in Fig. 907. Curve B resembles the characteristic of a gas-filled thermionic tube, the sudden rise in current being due to ionization of the gas. However, the anode voltage is not permitted to rise above 90 in this case so that breakdown will be prevented.

Because the anode voltage is held below the breakdown point, a glow discharge does not occur and the tube cannot be damaged. The total amount of current emitted from the gas phototube is actually no more than with the vacuum type. But the gas-filled tube is much more sensitive. However, it is not as quick-acting and is less linear. The loss of speed of response is due to the slow-acting ions, which take more time to reach the cathode than the electrons do to reach the anode.

The image orthicon

By utilizing the principle of secondary-emission multiplication, the

image orthicon camera tube permits the televising of a scene which is very dimly illuminated.

The tube, shown in Fig. 908, is made up of three main sections. The scene to be televised is projected by an optical lens onto a photo-sensitive cathode, which in turn emits electrons in proportion to the light intensity. This action is similar to that of the ordinary photoelectric cell, except that the cathode is not evenly illuminated over its entire surface.

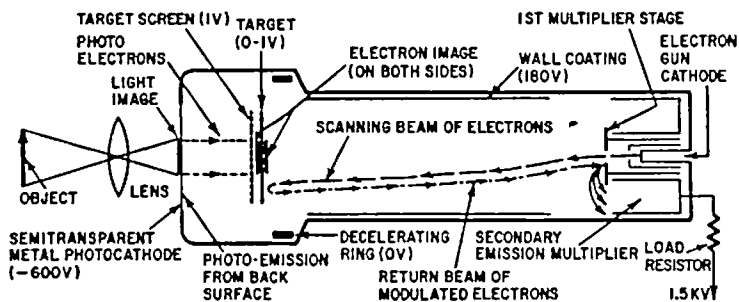

Fig. 908. Cross-section of image orthicon camera tube. This type of tube is almost universally used in commercial TV broadcasting.

Electrons emitted from each incremental portion of the cathode are sped toward a target mosaic under the influence of a positive target screen. The beam is kept in a straight line by a magnetic focusing field. The electrons strike the mosaic target hard enough to cause secondary emission. Thus, the tiny elements of the mosaic are charged in proportion to the number of electrons each is caused to emit. The mosaic is, therefore, left with a charge pattern which is directly related to the light variations of the scene. In effect, the picture has been amplified to a certain extent in the image section of the tube.

The electron gun in the rear of the tube generates an electron beam of relatively low velocity (in this case, the electrons need not strike the target with force as it is already emitting secondary electrons). The main purpose of the beam is to set up a pattern of scanning. As shown in Fig. 908, the electrons are routed to the target and then back again. The returning beam contains the picture information. The electron speed is arranged so that a target element with no positive charge will repel an electron in the beam and return it to the multiplier. If the target element is positively charged, electrons from the beam will fall upon it until the charge is neutralized, at which time the beam will be turned back. The returned beam, therefore, varies in intensity as electrons are absorbed by the target. The modulated beam is then amplified before being fed to the external circuit.

The color kinescope

The same principles are used in a color picture tube as in a black-and-white unit, except that the speeding electrons strike phosphors which emit blue, green or red light.

Since all color combinations originate with the three primary colors (when dealing with light, the primary colors are as stated and are different from those used when mixing pigments), they can be used to derive any shade. It is this principle which forms the basis of color TV as we know it today.

The color kinescope is a cathode-ray tube whose inner surface is coated with uniform layers of special color phosphors. The red phosphors are applied first, the green spots next and then the blue. This process of applying phosphor is repeated over the entire surface of the front of the tube so that it is made up alternately of red, green and blue phosphors. The materials used are generally silver-activated zinc sulphide for blue, manganese-activated zinc orthosilicate for green, and manganese-activated zinc phosphate for red.

The color tube is constructed with a fine meshlike screen between the phosphor surface and the electron gun. This screen (called a mask) contains several hundred thousand apertures and is mounted so that each opening lines up with the different color phosphors. The electron-gun assembly consists of three individual guns, each emitting an electron beam to excite its corresponding color phosphor.

The relative intensities of each beam are controlled, permitting the mixing of primary colors to produce a wide range of colors and shadings. In operation, the three electron beams approach the screen at different angles, with the mask permitting each beam to strike only the proper portion of the phosphorescent screen.

The individual electron guns are complete assemblies in themselves. The electron beams are arranged to converge at the center of the mask. Each gun section is adjusted to produce convergence synchronized with the scanning so that the beams converge over the entire surface of the face of the tube. By adjusting the guns so that the three beams come together at any given point on the mask, the proper color combination is obtained at a given instant.

Information in the video signal directs the modulation of each of the beams so that if a red dot is received, only a red dot will be activated in the picture tube.

Other color picture tubes which operate on different principles have been invented. The Lawrence and the Apple tubes use only a single electron gun. However, at the present time, the three-gun tube is in general use.

industrial applications

THE electron tube (gas-filled and vacuum) is widely used in industry. High-current rectifiers controlled by electronic timers are used in modern welding. Electronic speed control devices and electronic eyes count, sort and grade materials and products.

Control circuits

Circuits used in industry range from simple triggered relays to massive arrays of complex circuitry which may supervise an entire process

Fig. 1001. Basic control circuit using a triode in conjunction with a phototube.

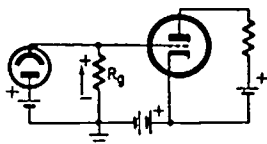

from raw material to finished product. Actually, the simple circuits have much in common with their more complex brothers—they both use basic principles to control an operation. The function of the control circuit is primarily to vary current. When used in conjunction with a relay, it acts as an electronic switch which may start or stop a mechanical operation, or perhaps it may adjust the speed of a motor.

One of the simplest types of control circuits is similar to the one in Fig. 1001, in which a triode is used in conjunction with a phototube. An increase in illumination will increase the plate current of the triode by increasing the electron flow through R_g . The grid of the tube becomes less negative, increasing the plate current.

In some applications, the thyatron instead of a vacuum triode is used with a phototube. In Fig. 1002, the circuit is designed to effect an instantaneous application of dc through a relay, which may be arranged either to open or close an external circuit. The grid bias

on the thyatron is negative enough to prevent firing. However, when the phototube is illuminated, the increased voltage drop across R_g reduces the grid bias, allowing the tube to fire and energizing the

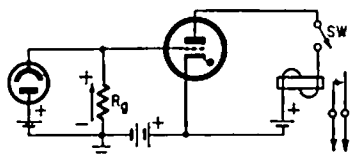

Fig. 1002. Typical phototube-controlled thyatron circuit. Note position of relay in gas-tube plate circuit.

relay. After the tube fires, the circuit is locked because the grid no longer controls the tube. Even if the light is removed from the phototube, the relay remains operative and can be released only by opening the switch.

Control circuits such as these are used in locations where light is always present. Therefore, the basic circuit must be modified to act only on a sudden change of illumination. In Fig. 1003, the bias on the

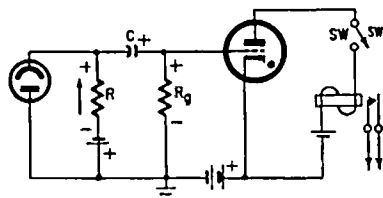

Fig. 1003. Light-pulse-sensitive phototube circuit. A sudden increase of light triggers the relay.

thyatron is sufficient to keep it from firing even though normal illumination falls upon the phototube. If a sudden change of illumination occurs, the pulse of current through R develops a voltage surge which is transmitted through capacitor C to the grid, decreasing the bias of the thyatron to the point at which it will fire. Plate current flows through the relay only when the light intensity is great enough to fire the thyatron.

Fig. 1004 shows a circuit which is triggered by a drop in light intensity. Normal illumination develops a large current flow through R and a correspondingly high voltage drop which keeps the grid of the thyatron negative. Because no current flows in the grid circuit, capacitor C is charged to approximately the same potential as the drop across R . When the illumination on the phototube is suddenly decreased, the voltage across R drops and the potential of C changes rapidly, reducing the bias on the thyatron and permitting it to fire. Circuits such as these form the building blocks of counting circuits and are often used as automatic door openers. They also find wide application as burglar alarms.

Repeating control circuits

All of the circuits discussed require resetting before they can be

used again; once the thyatron has fired, the only way it can be stopped is by interrupting the tube's circuit. By applying an ac rather than a dc voltage to the plate, the thyatron fires and turns off at regular intervals. The plate voltage is negative for half a cycle and plate current flows only during the positive portion of the cycle. As the voltage applied to the plate increases during the positive half-cycle, the grid bias must be made more negative to prevent firing until the appropriate moment. The series of bias voltages which correspond to varying values of plate voltage are known as the *critical grid voltage*

Fig. 1004. Sudden decrease of light intensity operates this circuit.

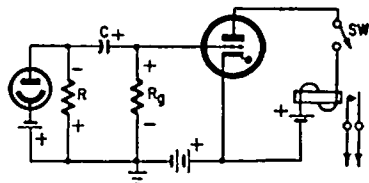

of the thyatron. In Fig. 1005-a, the dotted curve A indicates the negative bias necessary to overcome the increase in plate voltage as the positive portion of a sine-wave cycle is applied to the plate. Once this critical voltage is known, the grid bias can be appropriately altered to control the length of time that plate current will flow.

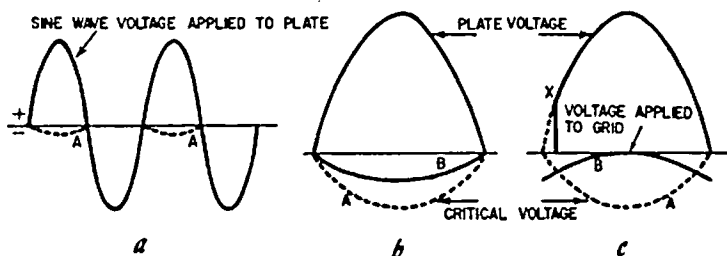

Fig. 1005. Repeating circuit: (a) dotted curve indicates negative bias needed; (b) curve B indicates what happens when ac is also applied to thyatron grid; (c) point X indicates firing point of thyatron.

If ac is applied to the grid also (curve B, Fig. 1005-b) it can be used to control the firing time of the tube and hence, the average plate current. If the grid bias is 180° out of phase with the plate voltage, but never greater than the critical voltage, plate current flows for the full length of the half-cycle or 180° , and the average current is maximum. If the grid voltage is out of phase with the plate voltage by some other value, the tube will not fire until point X (Fig. 1005-c) is reached. The firing point of the thyatron can also be changed by varying the amplitude of the ac voltage applied to the grid.

This ability to vary the firing point of the thyatron not only per-

mits the tube to be cut off after it fires, but is used in many rectifier circuits arranged so that the firing point of the tube is automatically adjusted to produce voltage regulation. Fig. 1006 shows how the control over the firing time is measured in terms of a phase difference between the grid and plate voltages. When the grid voltage leads the

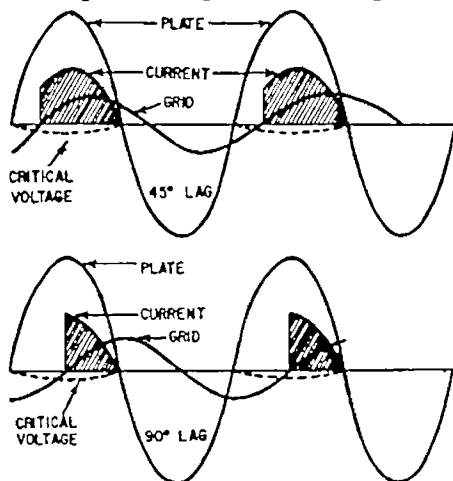

Fig. 1006. Control over firing time of thyatron is measured in terms of phase difference between voltages applied to the plate and grid.

plate voltage, it exercises no control because it is positive at the beginning of the plate voltage wave so that conduction begins and nullifies grid control. Therefore, by shifting the phase of the grid voltage to as much as 180° lagging, the average plate current can be controlled from almost zero to the maximum half-cycle current.

The circuit of Fig. 1007 shows a phototube-controlled thyatron in which the firing is controlled by ac voltages. The circuit is that of a commercial unit, the Photo-Troller, manufactured by Westinghouse. The relay operates when the phototube is inactive.

The voltage applied to the grid of the thyatron is obtained from secondary winding C, but is shifted by some angle since it is tapped from R2 of the R2-C2 combination. When the phototube is nonconducting, the grid voltage leads the plate voltage and the relay is operated.

When the phototube is slightly illuminated, the current through R1 charges C1. During the next half-cycle, C1 discharges, altering the grid polarity. The grid voltage changes from A to B (Fig. 1008). The firing of the tube is therefore unaffected by low-level illumination.

However, if the light is strong enough, the phototube current will charge C1 to a relatively high value. When it discharges, the grid bias becomes more negative so that the voltage reaches the points indicated

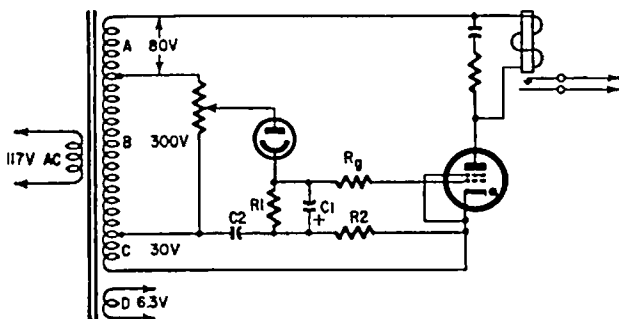

Fig. 1007. Phototube-controlled thyatron circuit in which ac voltages control firing time. (Photo-Troller courtesy of Westinghouse).

by curve C in Fig. 1008, which are well below the critical grid voltage. Thus, the tube will not fire and the relay will drop out as soon as the R-C combination across it is discharged. This combination serves to hold in the relay between successive conducting half-cycles.

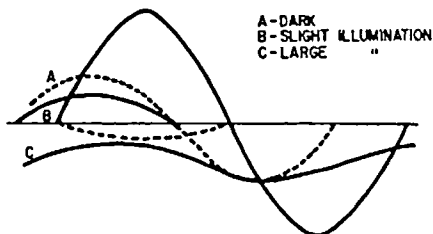

Fig. 1008. Effects of varying degrees of light intensity on circuit of Fig. 1007.

Electronic timing

Timing circuits are extensively used in industrial control circuits. A simple, often-used arrangement consists of a single thyatron and

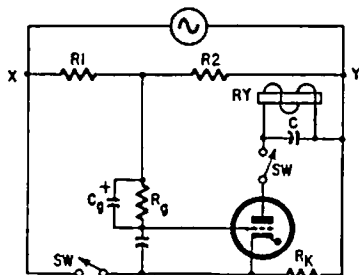

Fig. 1009. Simple thyatron and control-relay electronic timing circuit.

control relay (Fig. 1009). When the switches are open, the ac voltage applied to the voltage divider is fed to the grid by utilizing the voltage

drop across R_2 . Under this condition, the tube functions as a diode, the grid conducting current only during that part of the cycle when X is positive, charging C_g as shown.

When the switches are closed, the cathode is connected to point X and the plate to Y through the relay winding. The grid voltage now consists of the ac voltage across R_1 plus the dc charge on C_g acquired while the switch was open. In effect, the bias voltage which cuts off the tube is a high negative value superimposed on the relatively low ac fluctuations across R_1 . With the switch closed and C_g no longer receiving a charge, C_g begins to discharge through R_g at a speed determined by the time constant. As it discharges, the ac fluctuations from R_1 continue and the tube remains inoperative until the com-

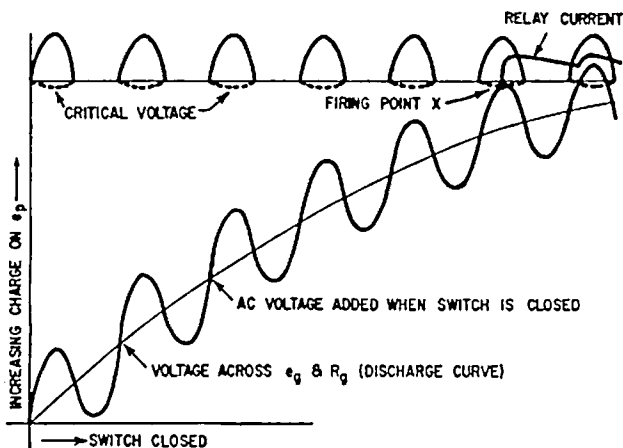

Fig. 1010. Graphic representation of what happens in Fig. 1009. Ac superimposed on dc charge of capacitor C_g finally reaches point X , where it fires the tube.

bined ac and dc bias reaches the critical grid voltage. The thyatron then fires, energizing the relay which performs its appointed function.

Fig. 1010 is a graphical representation of what happens. The ac superimposed on the dc charge of capacitor C_g finally reaches point X , where it fires the tube. The heavy negative charge controls the grid bias even though an ac voltage is superimposed upon it. The slope of the curve is determined by the time constant of C_g and R_g and the interval between closing the switch, and the firing of the tube also depends upon it.

Once operated, the relay remains energized until the switch is opened, when capacitor C_g again charges to its maximum value. This recharging cycle is not instantaneous and, in the usual circuit, is about 10% of the discharge time of the capacitor.

A		
Abscissa	97	
Ac Plate Resistance	27	
Admittance, Input	119	
Agc:		
Keyed	151	
Keyer Tube	152	
System, Diode	147	
Am Carrier Waves	58	
Am Detection	58	
Amplification	27	
Amplification:		
At High Frequencies	97	
Curve, Universal	100	
Factor	27	
Power	72	
Amplifier:		
Bandpass	154	
Burst	153	
Class-A	75	
Frequency Distortion	94	
Load, Triode	73	
Percentage Distortion	79	
Amplifiers:		
Class-AB	81	
Class-C	85	
Gated	151	
Pentode	88	
Resistance-Coupled	95	
Transformer-Coupled	86	
Triode	69	
Video	101	
Amplitude Distortion	73	
Amplitude Modulation	148	
Anode, Ignitor	170	
Anode Voltage, Magnitude of	20	
Applications, Vacuum-Diode	43	
Automatic:		
Door Openers	184	
Frequency Control	158	
Frequency Control Circuit	157	
Gain Control	146	
Autotransformer, High-Voltage System ..	55	
Avc, Delayed	62	
Avc, Simple	61	
B		
Bandpass Amplifier	154	
Basic Rectifier Circuit	23	
Basic Voltage Doubler Circuit	46	
Bass Loss	62	
Beam, Electron	176	
Beam-Power Tubes	107	
Bias, Grid-Leak	129	
Bleeder:		
Circuit	50	
Current	50	
Resistors	50	
"Boiled-Off" Electron	20	
Boost Voltage	55	
Brightness Reference	145	
Burglar Alarms	184	
Burst Amplifier	153	
C		
Calculation of Distortion	78	
Capacitor Input Filter	48	
Carrier Waves, AM	58	
Carrier Waves, Unmodulated	58	
Cathode:		
Follower	117	
Follower Circuit	119	
Ray Tube	173	
Sheath	169	
Temperature	21	
Cathodes, Heater-Type	10	
Cesium	179	
Characteristic Curves, Pentode	89	
Characteristic Curves, Triode	74	
Characteristics:		
Static	25	
Transfer	27	
Triode Tube	26	
Choke Input Filter	48	
Circuit:		
Basic Voltage Doubler	46	
Grid Modulator	149	
Pentode Amplifier	39	
Phase-Inverter	110	
Phototube-Controlled Thyatron	184	
Plate-Detection	150	
Triode Color-Killer	153	
Circuits:		
Control	183	
Filter	47	
Mutual-Coupled	105	
Voltage-Regulator	51	
Class:		
A Amplifiers	75	
AB Amplifiers	81	
B Operation	84	
C Amplifiers	85	
Clipping Circuit, Peak	141	
Cold-Cathode Diodes	167	
Color:		
Killer and Gated Amplifier	152	
Kinescope	182	
Phosphors	182	
Colpitts Oscillator	132	
Conductance, Mutual	28	
Conductivity of Metal	8	
Constant-Current Device	41	
Control Circuits	183	
Control Circuits, Repeating	184	
Counting Circuits	184	
Coupling, Resistance	94	
Coupling, Transformer	73, 105	
Critical Grid Voltage	183	
Crystal Oscillators	133	
Current and Voltage Vectorial		
Relationships	122	
Current, Bleeder	50	
Currents, Hum	82	

Curve, Phase-Shift	100	Electrons, Secondary	13
Curves:		Electrons, "Turned-Back"	24
Dynamic	75	Electrostatic Deflection	16
Static	75	Electrostatic Focusing	177
Cutoff, Projected	85	Emission:	
D		Area	12
Damper Tube	54	Electron	9
Dc Restorer	145	Field	14
Deflection:		Photoelectric	15
Colls, Magnetic	176	Secondary	12
Electrostatic	16	Surplus	11
Magnetic	16	Thermionic	9
Delayed Avc	62	Emitters, Oxide-Coated	11
Demodulation	64	Equivalent Circuit, Triode Amplifier	93
Demodulator, FM	68	Even Harmonics	83
Detection:		Extraneous Oscillations	123
AM	58	F	
Grid	150	Factor, Amplification	27
Plate	149	Factor, Ripple	47
Detector:		Feedback:	
Gated-Beam	160	Negative	112
"Loading Down" the	60	Negative, Oscillation with	116
Ratio	67	Selective	115
Regenerative	151	Field Emission	14
Superregenerative	151	Fields, Interaction of	17
Detectors, Diode	58	Fields, Magnetic	17
Detectors, Triode	149	Filter:	
Deviation Ratio	67	Capacitor Input	48
Diagram, Power	79	Choke Input	48
Diode:		Circuits	47
Agc System	147	Two-Section	58
Detectors	58	Filters, Harmonic	88
Gas	51	Firing Point, Thyatron	171, 185
Sharp-Cutoff Pentode	165	Flat Response	106
Tetrodes	165	Fleming Valve	19
Thermionic Gas	168	Flyback System, TV	54
Diodes	19	FM Demodulator	68
Diodes:		FM Detectors, Diodes as	63
as FM Detectors	63	Focusing:	
Cold-Cathode	167	Electromagnetic	176
Triple	162	Electrostatic	177
Directly-Heated Cathode	11	Shields	14
Discriminator	64	Free Electrons	8
Discriminator Phase Relationships	65	Frequency:	
Distortion	73	Correction Devices	102
Distortion:		Multiplication	134
Amplitude	73	Stability	130
Calculation of	78	Full-Wave Rectifiers	46
Third-Harmonic	108	G	
Distributed Capacitance, Secondary		Gain, Low-Frequency	97
Winding	87	Gain, Middle-Frequency	96
Divider, Voltage	50	Gas:	
Doubler, Voltage	46	Diode	51
Dual Pentodes	166	Diode Regulator Tubes	52
Duo-Diode Triodes	163	Filled Thermionic Tube	180
Duo-Diodes	161	Gated:	
Duo-Triodes	162	Amplifier, Color Killer and	152
Dynamic:		Amplifiers	151
Curves	75	Beam Detector	160
Plate Resistance	33	Generators, Pulse	140
Resistance	27	Grid:	
Transfer Curves	83	Bias Arrangements	125
Dynatron Oscillator	143	Detection	149
E		Leak Bias	129
Edison Effect	19	Leak Resistance	29
Effect, Space Charge	19	Modulator Circuit	149
Electrical Pressure	8	Quadrature	160
Electrode Structure, Tetrode	34	Structure	24
Electromagnetic Focusing	176	Voltage, Critical	185
Electron:		Gun, Electron	174
Beam	176	H	
"Boiled-Off"	20	Half-Wave Rectifiers	43
Coupled Oscillator	131	Harmonic Filters	86
Emission	9	Harmonics, Even	83
Gun	174	Harmonics, Odd	83
Gun, Single	182	Hartley Oscillator	156
Indicator Tube	177	Hazeltine System	123
Multiplier	13	Heater-Type Cathodes	10
Ray Tubes	177	High Frequencies, Amplification at	97
Electronic Timing Circuits	187		

High-Mu Tubes	34	Sawtooth	171
High-Voltage Power Supplies	53	Sine-Wave	124
High-Voltage System, Autotransformer ..	53	Oxide-Coated Emitters	11
I			
Ignitor Anode	170	P	
Image Orthicon	180	Parallel Operation	83
Impedance-Matching Device	119	Peak-Clipping Circuit	141
Improving High-Frequency Response ...	104	Peak Inverse Voltage	49
Indicator Tube, Electron	177	Pentode:	
Indirectly-Heated Cathodes	11	Amplifier Circuit	39
Inductance, Leakage	87	Amplifiers	88
Input Admittance	119	Characteristic Curves	89
Interaction of Fields	17	Static Characteristic Curves	38
Interelectrode Capacitances, Triode ...	119	Pentodes	37
Interleaving of Windings	107	Pentodes, Dual	166
Intermittent Oscillation	131	Percentage Distortion, Amplifier	79
Inverse Voltage, Peak	49	Phase:	
Inverter, Phase	110	Inverter Circuit	110
K			
Keyed Age	151	Relationships, Discriminator	65
Keyer tube, Age	152	Shift Curve	100
Kinescope, Color	182	Shifts	81
"Knee" of the Curve	38	Splitter, Single-Tube	112
L			
Leakage Inductance	87	Phosphors, Color	182
Light-Pulse-Sensitive Phototube Circuit ..	184	Photoelectric Emission	15
Light Spectrum	178	Photoelectric Tube	179
Limiters	123	Photons	15
Load Lines	28	Photo-Trolley	186
"Loading Down" the Detector	60	Phototube:	
Low-Frequency Gain	97	Circuit, Light-Pulse-Sensitive	184
M			
Magnetic:		Controlled Thyatron Circuit	184
Deflection	16	Plate Characteristics	179
Deflection Coils	176	Vacuum	180
Fields	17	Plasma	169
Magnetism, Residual	81	Plate:	
Magnitude of Anode Voltage	20	Characteristics, Phototube	179
Manganese-Activated Zinc Orthosilicate ...	182	Curves, Triode	70
Manganese-Activated Zinc Phosphate ...	182	Detection	149
Mask	182	Detection Circuit	150
Maximum Undistorted Power	75	Efficiency	81
Metal Conductivity	9	Load Requirements, Triode	73
Middle Frequency Gain	96	Resistance, Ac	27
Mixers and Converters	158	Positive Ion Sheath	169
Modulation, Amplitude	148	Power:	
Mosaic Target	181	Amplification	72
Multiplier, Electron	13	Diagram	79
Multivibrator	139	Supplies, High-Voltage	53
Mutual Conductance	28	Supplies, Vibrator	56
Mutual-Coupled Circuits	105	Supply Rectifiers	43
N			
Negative:		Supply, Superheterodyne Receiver ..	45
Feedback	112	Tubes, Beam	107
Feedback Oscillation with	116	Pressure, Electrical	8
Resistance Oscillators	143	Primary Colors	182
Space Charge	21	Projected Cutoff	85
Neutralization	123	Pulse Generators	140
O			
Odd Harmonics	83	Pure Sine Wave	83
Optical Lens	181	Push-Pull Operation	82
Oscillation, Intermittent	130	Q	
Oscillation with Negative Feedback	116	Quadrature Grid	160
Oscillations, Transient	55	R	
Oscillator:		Ratio Detector	67
Colpitts	182	Ratio, Deviation	67
Dynatron	143	Ray-Control Element	178
Electron-Coupled	131	R-C Oscillators	136
Hartley	156	Reactance Tube	153, 157
Sawtooth	138	Receiver, Superheterodyne	45
Sweep	176	Rectifier Circuit, Basic	23
Oscillators:		Rectifiers:	
Crystal	133	Full-Wave	46
Negative-Resistance	143	Half-Wave	43
R-C	138	Power Supply	43
P			
Regenerative Detector	151	Regulator Tubes, Gas-Diode	52
Remote-Cutoff Characteristic	41	Remote-Cutoff Characteristic	41
Remote-Cutoff Tubes	42, 93	Remote-Cutoff Tubes	42, 93
Repeating Control Circuits	184	Repeating Control Circuits	184
Residual Magnetism	81	Residual Magnetism	81
Resistance:		Resistance:	
Coupled Amplifiers	95	Coupled Amplifiers	95
Coupling	94	Coupling	94
Dynamic	27	Dynamic	27
Grid-Leak	29	Grid-Leak	29

Resistors, Bleeder	50	Transformer:	
Response, Flat	106	Coupled Amplifiers	86
Response, Improving High-Frequency	104	Coupling	73, 105
Restorer, Dc	145	Q	88
Retrace Period	54	Transient Oscillations	53
Ringing Circuit, Crystal	135	Transient Voltage	54
Ripple Factor	47	Triode:	
Rubidium	179	Amplifier Equivalent Circuit	33
S		Amplifier Load	73
Saturation, Temperature	21	Amplifiers	69
Sawtooth Oscillator	138, 171	Characteristic Curves	74
Scanning Rate	54	Color-Killer Circuit	153
Screen Grid	34	Detectors	149
Second Harmonic	78	Interelectrode Capacitances	119
Secondary:		Pentodes	166
Electrons	13	Plate Curves	70
Emission	12	Plate-Load Requirements	73
Emission Multiplication Principle	180	Regulator Tube	57
Winding Distributed Capacitance	87	Tetrodes	165
Selective Feedback	115	Transfer Characteristics	77
Shadow Electrode	178	Tube Characteristics	26
Sharp-Cutoff Tubes	93	Triodes	23
Sheath, Cathode	169	Triodes, Duo-Diode	163
Sheath, Positive Ion	169	Triple-Diode Triodes	164
Shields, Focusing	14	Triple Diodes	162
Shunt Peaking	104	Tube:	
Silver-Activated Zinc Sulphide	182	Cathode-Ray	173
Simple Avc	61	Damp	54
Sine-Wave Oscillators	128	Gas-Filled Thermionic	180
Sine Wave, Pure	83	Merit	28
Single Electron Gun	182	Photoelectric	179
Single-Tube Phase Splitter	112	Reactance	155, 157
Sodium	179	Remote-Cutoff	42
Space:		Triode Regulator	57
Charge	19	Variable-Mu	52
Charge Effect	20	Tubes:	
Charge, Negative	21	Beam Power	107
Stability, Frequency	130	Electron-Ray	177
Static:		Sharp-Cutoff	93
Characteristics	25	Tuned-Plate-Tuned-Grid Oscillator	131
Curves	75	Tungsten Lamps	179
Plate Resistance	22	"Turned-Back" Electrons	24
Superheterodyne Receiver Power Supply	45	TV Flyback System	54
Superegenerative Detector	151	Two-Section Filter	58
Suppressor Grid	37	U	
Sweep Oscillator	176	Undistorted Power, Maximum	75
Sync Separator	142	Universal Amplification Curve	100
T		Unmodulated Carrier Waves	58
Tank Circuit	87	V	
Target	178	Vacuum-Diode Applications	43
Target Mosaic	181	Vacuum Phototube	180
Temperature, Cathode	21	Variable-Mu Transfer Characteristics	
Temperature Saturation	21	Curve	93
Tetrode Electrode Structure	34	Variable-Mu Tubes	42, 93
Tetrode Voltage Amplifier	35	Vectorial Relationships, Currents and	
Tetrodes	34	Voltages	122
Thermionic:		Vibrator	57
Emission	9	Vibrator Circuit	57
Gas Diode	168	Vibrator Power Supplies	58
Tube, Gas-Filled	180	Video Amplifiers	101
Third-Harmonic Distortion	108	Voltage:	
Thoriated Tungsten Cathodes	10	Divider	50
Thyratron:		Doubler	46
Circuit, Phototube-Controlled	184	Regulator Circuits	51
Firing Point	171, 185	W	
Grid	185	Windings, Interleaving of	107
Thyratrons	170	Z	
Time Base	175	Zinc:	
Timing Circuits, Electronic	187	Orthosilicate, Manganese-	
Transconductance	28	Activated	182
Transfer:		Phosphate, Manganese-Activated	182
Characteristics	27	Sulphide, Silver-Activated	182
Characteristics Curve, Variable-Mu	93		
Characteristics, Triode	77		