

SHORT WAVE BEGINNER'S BOOK

25
¢

PUBLISHED BY

**SHORT
WAVE
CRAFT**

98 PARK PLACE

NEW YORK

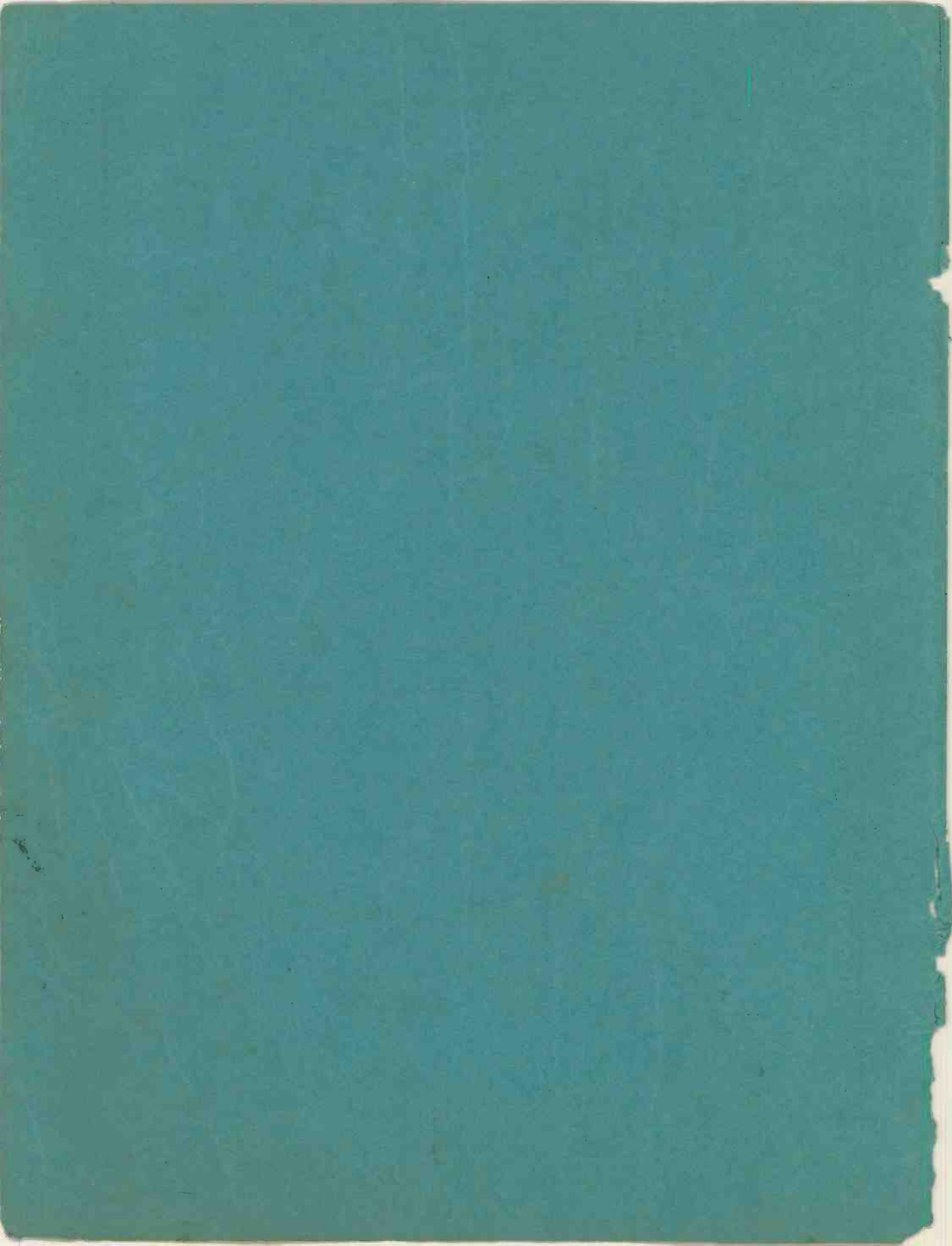

SHORT WAVE BEGINNER'S BOOK



Including

A Complete Course of Instruction in Short Waves
Details for Making S-W Aerials
A Complete Beginner's Set
Coil Winding Data
Operating Kinks



Published by **SHORT WAVE CRAFT**
98 Park Place, N. Y. City
1933

P R E F A C E

● In compiling this volume, we have endeavored to include information on every subject that will interest the Beginner in short waves. By following the instructions given for building and operating short-wave receivers, the reader is assured of complete success—for the authors are all expert in the short-wave field and some are world famous.

We have carefully sought to keep the information as simple as possible, without leaving out essential data. For this reason, some of the articles are extremely simple in their scope, while others are more complicated. It is recommended that the beginner read over all of the material and then review the more complicated subjects as a knowledge of the subject is attained.

C O N T E N T S

Introduction, by <i>H. Gernsback</i>	3	Short Wave Operating Hints, by <i>M. Harvey Gernsback</i>	22
Getting Started in Short Waves, by <i>C. W. Palmer</i>	4	Coupling the R.F. Stage to Detector	23
Schematic Symbols—Radio's Shorthand	6	Audio Amplifiers for S-W Sets	23
A Few Facts About Short-Wave Coils, by <i>A. Benneweg, Jr.</i>	8	Methods of Coupling to Speakers, by <i>M. H. Gernsback</i>	24
Novel S-W Coil Ideas	9	Aerials for Short-Wave Receivers, by <i>C. W. Palmer</i>	26
The Beginner's S-W Receiver, by <i>C. W. Palmer</i>	10	Good Antenna Design, by <i>Arthur H. Lynch</i>	28
The Beginner's Set Gets an Amplifier, by <i>C. W. Palmer</i>	12	Some Things You Don't Know About Aerials, by <i>Don C. Wallace</i>	30
Smoothing Up The Regeneration Control, by <i>R. J. Slack</i>	14	Learning the Code, by <i>John L. Reinartz</i>	32
New Kinks For the S-W Set, by <i>Rex E. Lovejoy</i>	15	Home-Made Antenna Coupling Condensers, by <i>M. H. Gernsback</i>	34
Which Regeneration Scheme? by <i>M. H. Gernsback</i>	16	A Panel Mounting S-W Coil Assembly, by <i>W. G. Wheat</i>	35
Tuning the Short-Wave Receiver, by <i>C. W. Palmer</i>	18	A Meter-Kilocycle Conversion Chart	35-36
How To Make Worth-While Audio Ampli- fiers, by <i>Louis Martin</i>	20		

THE SHORT-WAVE BEGINNER

— Introduction —

By HUGO GERNSBACK

● EVERY year a new crop of short-wave enthusiasts embark upon the exciting adventure of listening to the entire world by means of the short waves. Conservative estimates, collected from various sources during the past few years, show conclusively that between 30,000 and 40,000 new members join the short-wave fraternity annually, and it is a proven fact that most of them start in the fall months, when the nights become longer and the weather cooler. That is the time when the home experimenter becomes interested and when his enthusiasm is at the highest pitch.

Every Broadcast Listener a Short-Wave Prospect

When the broadcast craze first hit the public, between 1922 and 1923, millions developed the itch for "distance" and believe it or not, there are still several hundred thousand broadcast listeners in this country alone who nightly sit up with their sets and fish for distant stations. Sooner or later a good percentage of these will take to the short waves and many will build their own receivers.

I have no fault to find with those short-wave beginners who start out with a manufactured set which they bought complete, ready to operate. There are, of course, any number of excellent sets of this description on the market, and they are becoming increasingly popular with the public. These enthusiasts cannot of course be termed beginners, in the strictest sense of the word; neither can they be called experimenters, although they experience exactly the same thrills as that large body of short-wave experimenters who "make their own."

Home-Made Short-Wave Sets Cost Little

Not everyone can afford to buy a manufactured set these days, and we find therefore a high percentage of radio-mechanically inclined people who wish to have the inde-

scribable thrill of building a set themselves, thereby gaining an insight into the mysterious workings which they might not otherwise get. In due time they will, of course, buy factory-made sets, but the present discussion concerns those who wish to start from scratch and work their way up by easy stages.

At present-day prices anyone with a lean pocketbook can afford to buy the few parts with which a one- or two-tube short-wave set can be built. A one-tube set can be assembled for as little as \$5.00, including batteries and phones, while a good two-tube set can be built at a cost of \$8.00 and up. If you have spare radio parts lying about, the cost will be even less.

While a good two-tube set will, under fair circumstances, pull in stations from all over the world, it is well for the beginner to realize that there are certain requirements which must be met in the operation of short-wave sets in general.

In the first place, a set that may work good in your friend's house may not perform nearly as well when transported to your own. The reason for this is bad "location." Conditions in the open country or in the suburbs are generally better than in crowded cities, although there are notable exceptions to this rule. Ground and aerial conditions have a lot to do with good reception when it comes to receiving overseas stations. As a rule, the man in an apartment house should have a much longer aerial than his country cousin; so if your set does not "perk" immediately, try and change the aerial. Sometimes changing the aerial in either direction, that is, from east-west to north-south, will also make a surprising difference.

Nullifying the Effect of Man-Made Static

Of course, the apartment house experimenter—and this holds true of those living in the suburbs also—is bedeviled by a good deal of

local "man-made" static. This can be better gotten around by using a "transposition" type lead-in from the aerial binding post of the set to the aerial flat-top, leaving only the horizontal aerial exposed to the radio waves. The flat-top should be at least 20 to 30 feet above roofs, trees, etc.

The Greatest Asset of the Beginner—Patience

You have to get used to the idiosyncracies of your set. Every short-wave receiver has its own little "bugs" to which you must become accustomed, and you must know them to get the best results. It is unusual to pull in every country on the globe the first night after you have finished your receiver. It would take you some time, even if your set is operating at its best. In the first place, the station you may be fishing for may be off the air. Second, you may not have the right time, because it takes you a while to figure out and translate foreign time into your own, due to time differences.

The beginner must become acquainted with the different faint whistles in the earphones, because some of the faintest whistle-like sounds can be built up into good signals, if you learn how to do it! The broadcast listener, of course, is the greatest sinner when it comes to tuning a short-wave set. It takes him some time before he understands that moving the condenser a thousandth of an inch will tune in or tune out a station. In short-wave tuning, your hand must become accustomed to exceedingly fine and careful motions.

Of course, you will not expect to obtain the same results from a junk set that can be gotten from one that is carefully built, with all connections carefully soldered and with the insulation of the entire set of the best. Always remember that the energy which comes in over your aerial is less than the millionth part of a fly-power, and you cannot afford to waste much of this power due to insulation losses.

GETTING STARTED IN SHORT WAVES

By C. W. PALMER

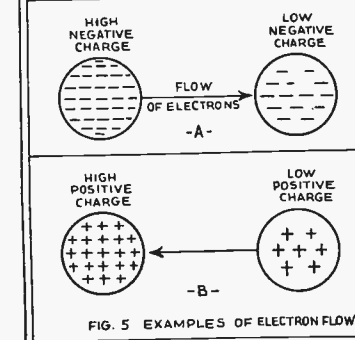
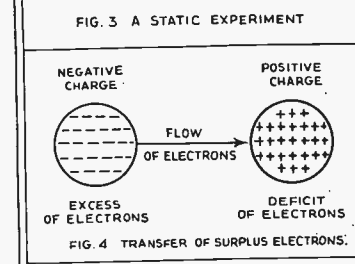
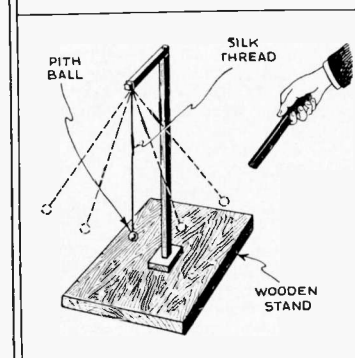
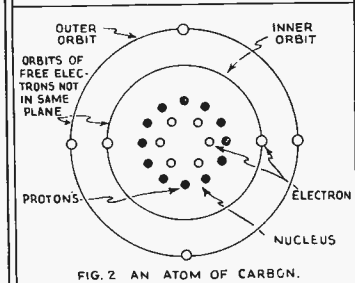
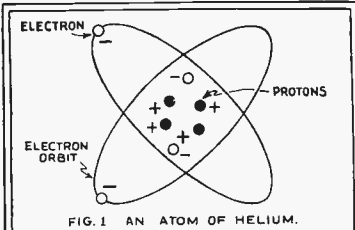

The diagrams above illustrate the basic electrical conditions occurring in the structure of certain atoms; also electron flow.

● THE man who is interested in building short-wave receivers and listening to the local and distant broadcasts has been at a distinct disadvantage up to the present, as there has been no direct source of information to instruct him on how to get started. Even for the fan who is fairly well versed in radio from the usual broadcast angle, it is still a difficult task to become familiar with the peculiarities of the short waves.

It is the purpose of this book to help this class of radio enthusiasts. For the benefit of those who have a very limited knowledge of radio, we will assume that the reader is entirely unfamiliar with the subject. Therefore, we beg those more fortunate readers with some past experience to be patient if we spend undue time in explaining every technical word and expression.

To understand how radio signals are received, it is necessary to have a knowledge of electricity—the basis of radio. Suppose, then, we start by considering the subject from the very beginning.

Electrons

Matter is any substance having weight and volume. The air we breathe, the water we drink and the earth on which we live are all forms of matter. Matter of all kinds is composed of tiny specks which have been called atoms. These atoms, in turn, are made up of a number of still smaller particles of two kinds, and in order to start out with the right foot, we will give these particles their correct names—electrons and protons. The electrons are tiny charges of negative electricity, and the protons are charges of positive electricity. Do not make the mistake made by some people when thinking about electrons and protons. They do not carry the electricity; they are the electric charges. If a negative charge of electricity were divided into many small charges, eventually a minute charge would be reached that could no longer be divided. This final division would be an electron. So much for the electron and proton.

Normally, each atom contains a definite number of electrons and protons, in such a combination that the charges just equal each other. The atom is then said to be uncharged or neutral. Figures 1 and 2 show examples or normal atoms. However, if a force is applied to the atom, some of the electrons will be pulled away from it and it will have an excess of positive electri-

city compared to the remaining negative charges. Conversely, if a force is applied in the opposite manner, too many electrons are present in the atom and it is said to have a negative charge.

We can perform an interesting experiment at this time, to illustrate the effect of charging a body. For this experiment we need a rod of hard rubber (some fountain pens are made of this material), a glass rod, a piece of silk cloth and a small piece of pith from a corn cob. We suspend the pith on a silk thread, as shown in Fig. 3. Then we rub the glass rod vigorously with the silk cloth and bring it near the pith ball. It will be found that the pith ball will follow the glass rod—it is attracted by it. Then we allow the rod to touch the pith ball and notice that it now repels it. Now rub the rubber rod and bring it near the pith ball—it attracts it.

The glass rod receives a positive charge when rubbed and the rubber rod receives a negative charge. This is the reason why we notice the difference in their actions on the pith ball. From this experiment, we learn that two like charges repel (the pith ball and the glass rod were both positive when they were allowed to touch) and unlike charges attract (the positively charged pith ball was attracted by the negative rubber rod).

Conductors and Non-conductors

Some materials, such as gold, copper, silver, brass, aluminum, etc., present very little opposition to the passage of electric currents. Others, such as cotton, silk, rubber, wood, mica, etc., will not readily pass a current. The first class of substances is called **conductors**. The atoms of most metals apparently do not have a very strong hold on the electrons which make up their negative charge. An external force can easily remove some electrons or add some to the normal number. The second class of substances mentioned is known as **non-conductors**. They have a strong hold on the electrons and will not readily change from their neutral state.

Potential

We have learned that like charges repel each other and unlike charges have an attraction for each other. If we translate this into terms of electrons, it will read: electrons repel each other but attract protons, and similarly, protons repel each other but attract electrons. Apparently the feeling of the protons and electrons is mutual.

If we charge a body with negative electricity (add electrons) a stress or strained condition is set up in that body by the electrons repelling each other. Some of these "free" electrons move to the surface of the body to get away from the others. The more electrons we put into the body, the greater becomes the force of the electrons trying to escape. This force which tends to return a body to neutral is called a "potential." The same effect is noticed in a body from which electrons are removed.

To illustrate the effect described, suppose we refer to Fig. 4. The two balls shown are charged, one negatively and the other positively. If we touch these balls together, the excess electrons in the negative one will rush to the positive one. It follows directly from this that a current will flow, as we already explained that electrons are electric charges. Several other examples of current flow are shown in Fig. 5. At A, the left copper ball has a higher negative charge than

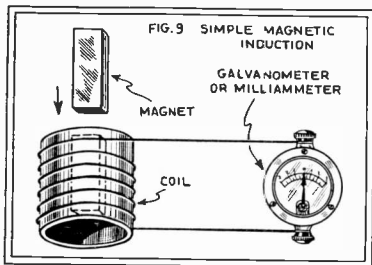

Magnetic induction is demonstrated by plunging the steel magnet into the coil.

the right one, causing a current to flow from left to right. At B, the left copper ball has a higher positive charge than the right one and a current will flow right to left—the right ball has more electrons than the left one.

It will be noticed that the electrons move from negative to positive and since we know that electrons are electricity, it follows that the current is also from negative to positive. A number of years ago, before we knew as much about electricity as we do now, physicists experimenting with it decided that the current flowed from positive to negative and this illusion has been passed down to the present time and is still commonly used. We must keep this discrepancy in mind as it is important in understanding the operation of vacuum tubes and other electric devices.

The difference in potential, as that shown in Figs. 4 and 5, is measured in volts. Because a difference in potential always causes a current to flow, we sometimes call it an electro-motive force (E.M.F.) Current strength, that is, the number of electrons passing through an electric conductor per second, is measured in amperes.

Resistance

We have found that the current flowing through an electric circuit is dependent on the potential. We also learned that some materials will carry a current (lose and gain electrons) more easily than others. The opposition that a conductor offers to the passage of a current is known as resistance. The resistance depends on the kind of material, the length of the conductor and the cross-sectional area. To be exact, the resistance increases directly as the length of the conductor. A standard unit of resistance has been set up and is called the ohm, in honor of the noted German physicist, George Simon Ohm.

If we analyze the above information, we learn that the current depends on the volts and also on the resistance. In 1827, George Simon Ohm put this relationship into terms of arithmetic and it is known as Ohm's Law. There are three forms of Ohm's Law. The first tells us that the current in a circuit is equal to the potential (volts) divided by the resistance (ohms). The second tells us that the resistance in a circuit is equal to the potential (volts) divided by the current (amperes), and the third tells us that the volts equal the amperes times the ohms. We will learn the application of these three formulas as we progress further into the subject of short-wave radio.

Production of an Electric Current

In the foregoing discussion, we have referred to a force (E.M.F.) that would cause electrons to be separated from atoms and move through a conductor to other atoms. This E.M.F. can be maintained by means of a battery or a generator. The former consists of plates of certain materials immersed in certain solutions that cause a chemical action, resulting in the production of free electrons at one of the plates. We will not go into the details of these chemical actions at this time. The interested radio fan can find this information in books on electricity or batteries. Several

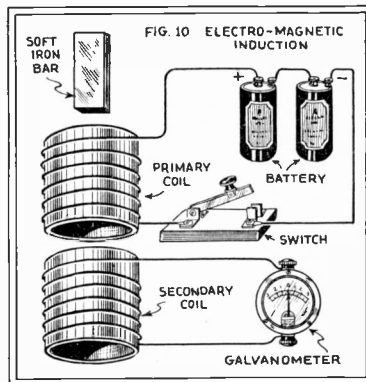

To demonstrate the basic laws of induction.

common types of batteries are shown in Fig. 6.

The other common source of E.M.F. is a generator which depends on the effect of induction and magnetism. We already encountered the effects of induction when we noted that the pith ball was attracted by the glass rod, even though it was not touching it in any way. Inductive actions are very important in radio, in tuning coils, transformers, etc.

Magnetism

When a current flows through a conductor, two principal effects can be noticed. The first is that heat is produced. The current encounters a certain opposition (resistance) in the conductor and part of the electric energy is used up in overcoming this "frictional" resistance. The energy used up in this manner makes itself evident in the form of heat.

The second effect is known as magnetism and we can best illustrate this by considering Fig. 7. This illustration shows a coil of wire wound around a bar of soft iron. A current from a battery is flowing through the coil. While the current is flowing, the iron bar will be found to have the power of

(Continued on Page 17)

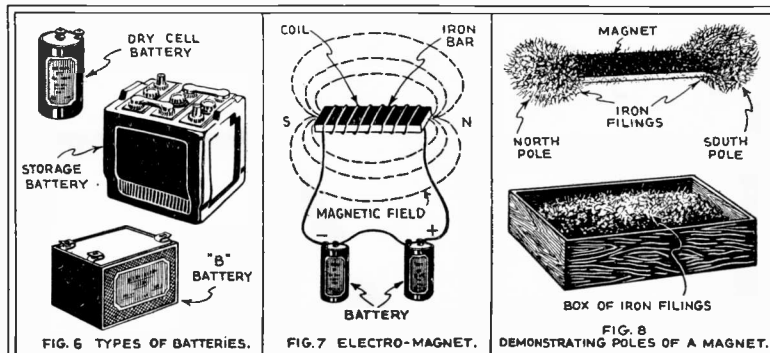

Three types of batteries; an electromagnetic circuit; and the poles of a permanent bar magnet.

SCHEMATIC SYMBOLS — RADIO'S SHORTHAND

The Symbols

● **AERIAL:** This symbol represents the ordinary type of outdoor aerial used with most receivers, although it may also be employed to represent indoor or underground aeriels and those with special characteristics such as noise reduction, etc. The loop or coil aerial is shown directly below the extended type. This symbol is used to represent both the flat spiral and the square (box) types ordinarily used.

Ground: The standard symbol for a ground connection or "earth," as it is sometimes called, is shown below the aeriels. This symbol indicates connections made to the grounded chassis of a receiver as well as the actual connection to the water pipe or other form of ground. The counterpoise symbol appears next. A counterpoise is a group of wires suspended below the aerial a few feet above the ground and insulated from it. It is commonly used for transmitters and in a few cases for receivers, especially where the soil is dry or sandy so that it is difficult to obtain a good "ground."

Condensers: Several symbols for condensers of different types are shown. The first represents fixed capacities and pictures of both the mica and the paper insulated varieties are given. The symbol for both is the same. Next is the variable air-insulated condenser of the ordinary rotary type. This is usually represented by two parallel lines with an arrow running diagonally through, but in some cases, the moving or rotating plates are indicated by a curved arrow instead of the flat parallel lines. Below the variable condenser is the "ganged" condenser, which is simply a number of variable air condensers connected on a single shaft for tuning more than one circuit with a single dial. The last condenser symbol is the "condenser block" or group of capacities in a single metal case, which are used primarily for the filter circuits of A.C. power units.

Inductors: The standard symbol for coils of any type is shown first. In this form, the coil is understood to have an air core (no iron or other metal) and may be either a radio frequency tuning coil or an R.F. choke, as the picture shows. When the two air-core coils are placed together, they are coupled and the unit becomes an R.F. coupling coil or transformer, commonly used for coupling the aerial to the first tube in a set or one R.F. tube to another.

The next in order is the continuously variable inductance or, as it is generally termed, the "variometer." This consists of two R.F. coils coupled closely together and arranged so that their inductances may either aid each other or work

A Simple Explanation of What the Symbols Are and How They Are Used.

in opposition. Below the variometer is a tapped coil. Sometimes it is desirable to change the size of a coil. This is accomplished by bringing leads out from the winding at the desired points; the coil is then said to be "tapped."

Following the tapped coil are several symbols indicating coils with iron cores. The presence of the iron is indicated by the three parallel lines placed either through the spiral (the coil) or adjacent to it. The first is a single iron core coil—commonly known as an A.F. (audio or low frequency) choke coil. We run across this coil in A.F. amplifiers and power units. When two coils are coupled together with an iron core, we have a transformer—either an A.F. coupling transformer or one used for power supply purposes. A special type of A.F. transformer is shown at the top of the second column; it is the push-pull transformer with a tap at the center of one of the windings, so that two tubes may be connected opposite each other.

Resistors: A number of special types of resistors are pictured next. The first is an ordinary fixed resistor of any value; below this is a variable resistor with an arm to make contact at any point on the resistance wire. A special type of variable resistor is the potentiometer or "voltage divider," shown next.

Circuit Connections: Wires that cross but are not connected are shown schematically by making a semi-circular bend in one. Wires that cross and are connected together are shown with a black circular intersection — a distinct round dot.

Crystals: Two types of crystals are used in radio equipment. First is the crystal rectifier or detector, which is still found in some receivers, although its use has diminished in recent years. This is shown first. Next is shown the piezo-electric crystal, which consists of a specially cut piece of quartz or other special crystal. It is used to keep transmitters in tune and has been used in one special type of receiver to make tuning extremely sharp.

Switches: Numerous types of switches have been used in radio receivers; some of the most common are illustrated. The first is the toggle switch; second is the selector switch; and the third is the knife switch, which may have any number of blades and may have contacts on either one or both sides.

Fuse: Two types of fuses are shown: the screw type such as

those used in your house fuse box and the cartridge type. They are both shown by the same symbol.

Batteries: The symbol for a battery consists of alternate long and short lines. The long ones indicate the positive pole and the short ones the negative. Three types of batteries used in radio receivers are shown—the storage battery, the dry cell and the "B" battery.

Phonograph pickup: The popularity of radio amplifiers for phonograph amplification has created a demand for a symbol covering the magnetic pickup employed for coupling the phonograph to the radio.

Loudspeakers: Both magnetic and dynamic speakers are pictured. The magnetic speaker is shown with its permanent magnet and the field-coil or electromagnet of the dynamic speaker is indicated beside the "voice coil." The difference between the two is obvious from the symbols.

Microphones: or telephone transmitter which usually takes the form shown in the chart for radio broadcasting and transmitting is shown by a form that resembles the ordinary telephone transmitter and is frequently labeled "mike."

Jacks: Three types of phone jacks are depicted. The first is the "single circuit type" which merely provides connections for the headphones. The second type is the "double circuit jack" which disconnects the last tube from the circuit when the phones are used in the detector or first stage. (This method of connection was very popular a few years ago.) The last type is the filament-control type that turns off the filament of the power tubes when the phones are inserted in a previous stage.

Headphones: The phone symbol is simply a copy of the actual phones and needs no explanation.

Voltage Regulator Tube: In some A.C. receivers a special tube is provided to prevent changes in the voltage of the supply line from affecting the reception or endangering the apparatus. This tube contains a special type of filament.

Terminals: In the next two sections are shown several devices used to provide connections to parts of the receiver. The first is the "binding post" or terminal which accommodates the end of a wire and connects it to parts of the set. Next we have the phone tip jack that grips a phone tip and connects it to the output of the set. The third connector is the common power-plug and receptacle found in house wiring.

Meter: This is the symbol used to indicate the use of a meter such as a voltmeter, ammeter, milliammeter, etc. The letter indicates the type of the meter.—"A" stands for ammeter, "M" for milliammeter, "V" for voltmeter, etc.

Chart of Radio Symbols

	AERIAL			PUSH-PULL AUDIO TRANSFORMER			SINGLE CIRCUIT JACK	
	LOOP ANTENNA			FIXED RESISTOR			FILAMENT CONTROL JACK	
	GROUND			VARIABLE RESISTOR			HEAD PHONES	
	COUNTER-POISE (CP)			VOLTAGE DIVIDER (POTENTIOMETER)			VOLTAGE REGULATOR TUBE	
	FIXED CONDENSERS			WIRES NOT CONNECTED			BINDING POST	
	VARIABLE CONDENSER			WIRES CONNECTED			TIP JACK	
	CONDENSERS OPERATED ON ONE SHAFT "GANGED"			CRYSTAL DETECTOR			PIEZO-ELECTRIC CRYSTAL	
	CONDENSER BLOCK			SWITCH (POWER OR FILAMENT-SINGLE-POLE, SINGLE-THROW SW.)			THREE ELEMENT TUBE ("TRIODE")	
	R.F. COIL (MAY BE R.F. CHOKE)			SINGLE-POLE MULTI-THROW SWITCH			TWO ELEMENT ("DIODE") TUBE RECTIFIER FOR POWER SUPPLY OR DETECTION	
	R.F. COILS COUPLED (R.F. TRANSFORMER)			DOUBLE-POLE DOUBLE-THROW SWITCH			FULL-WAVE RECTIFIER TUBE	
	VARIOMETER (CONTINUOUSLY VARIABLE R.F. COIL)			FUSE			THREE ELEMENT TUBE, A.C. HEATED CATHODE TYPE ("TRIODE")	
	TAPPED R.F. COIL			BATTERIES			SCREEN GRID TUBE ("TETRODE")	
	AUDIO FREQUENCY COIL. (MAY BE A.F. CHOKE)			PHONOGRAPH PICK-UP			VARIABLE-μ SCREEN GRID TUBE	
	TRANSFORMER (MAY BE A.F. TRANSFORMER, P.W.R. TRANS. OR FILAMENT TRANS.)			MAGNETIC SPEAKER			DYNAMIC SPEAKER	
	MICROPHONE (TRANSMITTER)			POWER PENTODE TUBE			POWER PENTODE TUBE	

A FEW FACTS ABOUT SHORT-WAVE COILS

By A. BENNEWEG, JR.

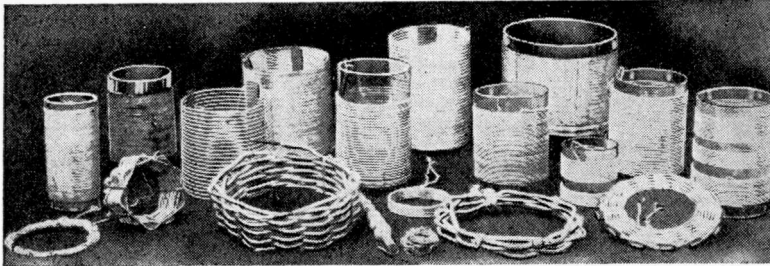

A number of different forms of short wave coils.

● RADIO experimenters who build their own short-wave receivers, particularly those experimenters who are new to the game, are at a loss to know exactly how to make short-wave coils having the lowest possible losses. A large number of the short-wave receivers in use contain a relatively small number of tubes, so that there is considerable advantage in using low-loss coils. The amplification-per-tube is also relatively small at short waves, so it becomes apparent that coils giving greater amplification from existing sets are desirable.

Short-wave coil design is quite a study in itself. Much valuable information can, of course, be gathered by "try it again" methods; but, as in any line, the experiments must be directed by a certain knowledge of theory. Theoretical studies are very valuable to any experimenter, since theoretical knowledge serves to guide one, saving considerable time, and aiding in an interpretation of the results discovered. This article deals with some of the simple theories underlying short-wave coil design. Common methods used to construct short-wave coils will also be considered in detail.

Short-wave coils are "good" or "bad," depending upon the losses within them. In some uses for coils, the losses within them are not of importance, since the loss factor does not enter. However, the most important use for coils, to the short-wave fan at least, is in tuned circuits. In such circuits, especially where high amplification is essential, the losses within the windings of the coils, and the forms upon which they are wound, are of considerable importance. In any tuned circuit, the loss in the variable condenser is usually relatively unimportant but the losses in the coil are large in comparison. One worries about the losses in

short-wave coils because the amplification usually depends upon the coils. When good coils are used, the amplification is high. If a set is insensitive, such as one discovers at frequencies in the neighborhood of five meters, the chances are that the coils are bad! A little simple theory will show why such losses exist.

One loss in short-wave coils, perhaps the most familiar one, is that due to so-called "skin effect." Radio frequency currents tend to flow on the surface of a wire. The effective cross-section of the wire is reduced, and the resistance of the wire therefore increases. The current flows on the surface of the wire because the inductance is less at the wire surface and therefore the reactance (engineer's term for "resistance to flow of alternating current"; it is like ordinary "resistance" in direct current circuits) is less, the current preferring the path of least resistance. Of course, the action in a coil is considerably more complicated than the action within a simple straight wire. Nevertheless, the effect is similar, giving an increase in resistance as the frequency is increased. That is one source of loss in short-wave coils.

Another source of loss is that due to eddy currents. Eddy currents are currents which flow in every direction in general and no direction in particular, being due simply to the nature of the peculiar electrical "breeze" associated with coils in which a high-frequency current is flowing. Any electrical current consists of a stream of billions upon billions of electrons. Each electron has associated with it an electro-static field which acts across space. These fields are capable of exerting forces on neighboring electrons, causing them to move in the direction of the strongest field. Since these fields perform the weirdest acrobatics under the influence of the high-frequency alternations, it is clear that all sorts of electrical breezes proceed in different directions inside and around short-wave coils. It is as if each electron was supplied with a tiny electric fan; obviously, with the electrons proceeding in various directions, the electrical breezes within short-wave coils are something complicated! It is no wonder that a great number of electrons are blown in the wrong direction!

It must be remembered that any flow of electrons constitutes an electric current. So, if some electrons are caused to move in the "wrong" direction, interference is caused with the "main" current flow and an effective resistance is created. If all the electrons within a coil behaved absolutely alike, a much greater effective current would result, which is an apparent reduction in the resistance of the coil itself.

In Fig. 1, a greatly enlarged portion of a section of a radio coil is shown. This illustration shows, by arrows, that electrons flowing in adjacent wires exert forces on each other, causing complicated electrical phenomena. No extraordinary results would be obtained if the

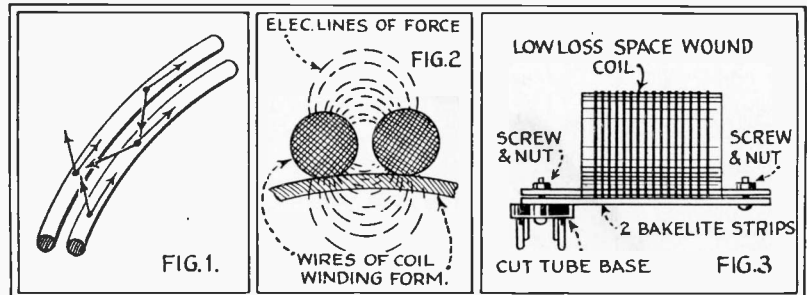

The action about the turns of short-wave coils and at the right, an effective design for short-wave plug-in coils.

flow of electrons in all turns of a coil was constant; however, difficulties arise because high-frequency currents constantly reverse their direction, speeding up and slowing down, or accelerating and decelerating. Such changing currents cause induced currents in adjacent wires which tend to flow oppositely. In Fig. 1, only two wires are shown; in an actual coil, one can imagine how complicated these electron fields become! Eddy currents, then, are random currents which may aid the main current flow, but generally hinder it, causing an apparent increase in resistance within the wire constituting the coil's winding.

Another important source of loss at high radio frequencies is dielectric loss. The form upon which a coil is wound has an effect on the coil's losses because the electric lines of force find it easier to proceed through a solid dielectric than they do through air. Because of the higher dielectric constant of solid dielectrics, the capacity between the turns of a coil is increased. This effect would not be particularly troublesome if the dielectric used as a winding form were perfect; and at short waves, however, solid dielectrics are far from perfect.

The effect of an imperfect dielectric is to cause a heat loss. The dielectric is subjected to strains at a radio-frequency rate, since the current direction is constantly changing; at one instant the dielectric is strained in one direction (see Fig. 2), and, after a lapse of time (dependent upon the frequency), the strain is reversed. This effect causes a loss within the form itself. Dielectric loss can be overcome by winding the turns of a coil further apart (so that the field-strength in the dielectric is reduced), winding the coil on a thinner material, or selecting a special dielectric which has low losses at high frequencies. The "perfect" coil would be air supported, that is, "wound on air"; obviously this is impossible. However, space-wound, coils are popular for short-wave work because of their low losses.

From the foregoing it is apparent that the wire in a coil must be of a certain size; if it is too large, the eddy current loss will be increased; if it is too small, the resistance will increase. For every coil diameter there is a best size, and the larger the diameter, the larger one may make the wire size for the same amount of loss.

For all-around short-wave use, two inches is a good diameter to use. Coils should be space wound for lowest losses.

For two-inch coils, No. 20 wire is a good size; the coils when wound are also quite sturdy.

Needless to say, it takes considerable work to test all kinds of short-wave coils, especially when

they are wound by hand. Several kinds of coils are shown in the photograph herewith. It will save the constructor considerable time if he will construct coils like the one shown at the extreme right in the picture. This is a space-wound solenoidal coil made of No. 20 wire. It is wound on a thin celluloid frame, two inches in diameter. This type of winding is popular for short-wave use, as it consists of the usual primary, secondary and tickler windings. Other interesting kinds of coils (not so effective for short-wave, however) are also shown in the photo. Note the large basket-weave coils; these were quite popular for short-wave use several years ago.

The construction of the space-wound coils is not difficult. A collapsible form is constructed of a wooden cylinder about two inches in diameter. The celluloid sheet is wound on the form, cemented into a cylinder and the wire is wound on and spaced. The wire is then given a thin coating of a low-loss cement such as collodion. This

holds the wire securely in place. The form can then be removed and the coil remains self-supporting. Those wishing to construct such coils can purchase coil kits. Others may desire to construct their own winding forms.

If one must use the above coils for plug-in, a simple mounting arrangement is shown in Fig. 3. Two strips of bakelite, arranged as a clamp, are mounted on a tube base. This base may be either a 4- or 5-prong. For only primary and secondary coils, the 4-prong base will serve, while a 5-prong base is needed for primary, secondary and tickler connections.

Using a .0001-mf. condenser, the specifications of two-inch diameter coils of No. 20 wire (with a space between turns equal to the wire diameter, except the largest coils) are as follows:

			Wavelength
Primary	Secondary	Tickler	Range
5	3	4	16-26
5	6	5	23-39
7	13	5	37-80
9	36	5	76-160

NOVEL S-W COIL IDEAS

● HERE is a free hand drawing of a method I am using for fastening the ends of large wire on my short-wave coils. Fully realizing that it is a hard matter to wind coils with large wire and secure the ends in such a manner as to have the turns drawn tight, I set about to find a way that would be easy, and this sketch illustrates the result.

Taking two pieces of No. 16 wire, I bent a ring on one end of each wire (scraping the ends and priming with solder before bending the ends into a circle) large enough for No. 12 wire to pass through. Then I measured the wire from the hole in the coil form to the tube prong, allowing about one inch to stick through. I cut off, cleaned and primed this end with solder. The wire was then drawn through the hole in the coil form and passed through the hole in the tube prong, drawn tight and soldered fast. After allowing enough space on the coil form for the required number

of turns on the coil, I then bored another hole for the second wire and the same procedure was followed, placing this wire like the first one. Chas. Q. Free.

Simplest Low-Loss Coil Form

● PROBABLY one of the simplest and best low-loss coil forms is shown in the accompanying illustrations. This particular design was suggested in a recent British patent and appeared in *Experimental Wireless* in London. The coil is wound in sections in the slots formed, the tube or cylinder being made of varnished impregnated paper, or it may be of fiber, bakelite, micarta, etc. The uncut portions, B, serve to support the coil sections, while each unit is permanently held in place by the slot walls.

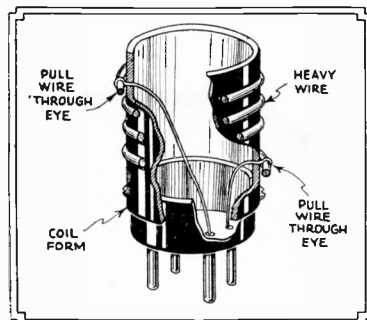

An effective method for anchoring heavy wire on coil forms.

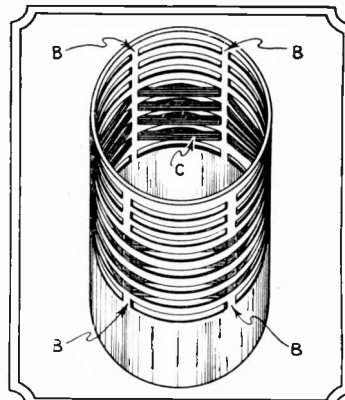

A clever way in which to make a "low-loss" short-wave coil form.

THE BEGINNER'S S-W RECEIVER

By C. W. PALMER

● SOME of our readers may notice that the circuit of the set shown herewith is the old favorite "three-circuit tuner" so common to radio set builders of the early days of broadcasting. We must not think for this reason that the set is not a particularly good one. In fact, surprising as it may seem, the same circuit with occasional modifications is used by 80 or 90 per cent of present-day short-wave fans and amateurs. One of the attractive things about short-wave radio is that the simplest apparatus suffices for even the greatest distances.

In building our receiver, we will follow a definite plan. First, we will make a simple and economical one-tube set working from batteries. Then, we will construct an amplifier to increase the volume of the programs so that a loud speaker may be used.

So much for our plans for the future. The problem at hand is to make our short-wave set. To construct any mechanical device, we must have tools, so before continuing further we will collect those required. Figure 1 shows a typical layout of radio tools. It will be noticed that the list includes a hacksaw, a soldering iron (electric preferred), a hand drill and a number of different sized machine drills, a screw-driver, a heavy pair of pliers, a pair of cutters, a pair of long-nose pliers, several files, a knife with heavy blades, a center-punch, a hammer and a pair of tweezers. While all these tools are not essential, it is well to remember that even the best mechanic cannot do good work without correct tools and most of the ones listed above may be found in the household tool box.

A short-wave receiver consists of a number of individual parts, each of which has a distinct use. First, there is a tuner. This consists of a coil of wire of a definite size and a condenser. The condenser is a device which stores electricity and it has several uses in radio reception. The use in this case is rather complicated, but for the present we will accept the explanation that a coil and a condenser will permit the signals from one station to be received and all others to be rejected. In other words, if the dimensions of either the coil or the condenser are variable, we can select any station at will. In a subsequent chapter, we will learn how the tuner can select stations in this way.

The condenser used for tuning consists of a number of flat metal plates in two groups, one arranged to rotate within the other. The two sets of plates are electrically

separated (insulated) from each other. This instrument is known as a variable condenser. Another type, called a fixed condenser, consists of pieces of tin-foil or aluminum foil separated by mica or waxed paper. The latter are used when it is not necessary to vary the size (capacity) of the condenser.

The next part of the radio set is the vacuum tube, which detects the signals. Radio signals are electric currents that change their direction of flow extremely fast—even more than 1,000,000 times each second. That is to say, if the current starts to flow in a wire from left to right, it immediately reverses and starts from right to left. This is known as an alternating current; when it reverses as fast as mentioned, it is called a radio-frequency current.

Now, this radio-frequency current is received in the tuner and is passed on to the detector. Our ears cannot hear the sound caused by anything vibrating faster than about 10,000 to 15,000 times per second and in order to hear the music sent in the form of radio-frequency (high-frequency) currents, we must first reduce the number of reversals of current to low frequencies. This is accomplished by the use of the vacuum tube. Here again, we will accept the explanation without trying to understand how it is accomplished.

The sounds from a radio set are electric currents changed into air vibrations which we hear as music, speech, etc. The device which changes the electric currents into sound is the head phone or loud speaker. When the sounds are not very loud, head phones are employed, and when sufficient sound is available to fill a room, a loud speaker is employed. They operate in very much the same manner, except that the loud speaker is made heavier to carry stronger currents and produce more sound.

In the above explanation of radio reception, we have not tried to learn how each part acts. We are only trying to become familiar with the parts used, so that the task of building our set will be less difficult. Later, we will spend some time learning how each part acts and why it is used.

A complete list of the parts needed for the set is given below. The names of the manufacturers of the parts used in the author's set are listed for the convenience of those who wish to copy the receiver exactly. Other makes may be used, if good apparatus of the correct values can be obtained more conveniently. However, as the mounting of the parts and the po-

sitions of the connections for wires may be different in other makes, it is advisable to use the specified parts.

- 1 .0001-mf. variable condenser, National ST100, 180° Equitune (C1).
- 1 .001-mf. fixed condenser (with grid leak clips), Polymet (C2).
- 1 .00025-mf. fixed condenser, Polymet (C3).
- 1 0.5-mf. by-pass condenser, Polymet (C4).
- 1 Aerial coupling condenser (made at home) (C5).
- 1 2-megohm grid leak, Lynch (R1).
- 1 20-ohm rheostat with switch, Carter (R2).
- 1 50,000-ohm variable resistor, Clarostat type P10 (R3). (Regeneration control.)
- 1 4-prong tube socket, Pilot type 216.
- 1 Vernier dial, Kurz-Kasch.
- 12 Binding posts, Eby Junior.
- ¼ Pound No. 22 double silk covered wire, Cornish Wire Co.
- 1 Box No. 600 Braiddite hook-up wire, Cornish Mfg. Co.
- 1 Type 30 tube, Triad.
- 1 45-volt "B" battery, Burgess Battery Co., type 10308.
- 2 Dry cells, Burgess Battery Co., type 6.
- 1 Pair of head phones, Trimm.
- 1 Panel bakelite or similar material, 5 x 8 inches, Insuline Corp. of America.
- 1 Strip of bakelite 4 x 1 inch, Insuline Corp. of America.
- 8 inches of bakelite tubing, 2-inch diameter, Insuline Corp. of America.
- 1 Wooden baseboard 8 x 8 x ¼ inch thick.
- 6 Brass angles with 1-inch arms.
- 1 Strip of stiff bus-bar.
- Miscellaneous screws, soldering lugs, etc.

When all the parts are obtained, the panel may be drilled to hold the tuning condenser C1, the rheostat R2, and the regeneration control R3. The positions of the mounting holes, as well as the two holes for the brass angles that secure the panel to the baseboard, are shown in Fig. 2. In drilling the panel, care should be taken to press lightly with the drill so that the panel will not be cracked. The size of each hole is indicated in the illustration.

When we have mounted the three controls on the panel, we can drill the baseboard. Fig. 3 shows the positions of the holes. As a wooden board is employed, we do not have to drill holes for mounting the apparatus. Round head wood screws will suffice for this purpose.

In order to cover all the short-wave bands a number of different coils are needed. As these coils must be interchanged from time to

(Continued on Page 25)

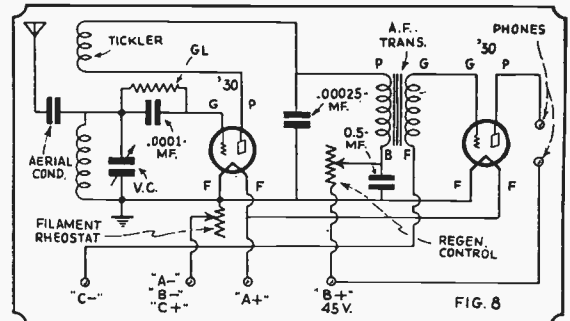
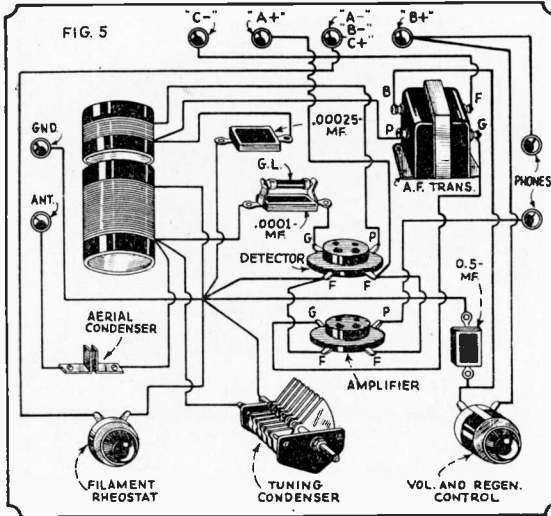

Schematic and picture wiring diagrams of the beginner's short-wave receiver with A.F. amplifier added.

THE BEGINNER'S SET

An audio amplifier to increase the volume of the one-tube set

● IN THE article describing the Beginner's one-tube set, we learned how the vacuum tube can be used to change the extremely high frequency (radio waves) to low frequency currents that are needed to operate a loud speaker or head-phones. There is another important use for the vacuum tube. This is to increase the volume of the sounds received, so that a loud-speaker can be used, and so that the far distant stations can be heard with sufficient volume to be understood.

To utilize the vacuum tube as an amplifier, we must connect it in a certain manner and use several other parts, as we shall see. The ordinary type of receiving tube contains three elements—the filament, the grid and the plate. The filament, when heated, throws off electrons. These electrons hit the plate and as we will remember from the article, on page 4, the flow of electrons is also a flow of current. By placing the correct voltages on the plate and the grid by the use of batteries, the grid can be made to

control the number of electrons flowing to the plate.

Then if the output of the detector is connected to the grid of the amplifier tube, the signal received can be used to control the current flowing in the plate of the amplifier tube. In this way, the current in the latter tube changes with each change in the detector and as the current in the amplifier is larger than that in the detector, greater volume can be obtained.

Several amplifiers can be connected after the detector to further increase the volume; at this time, though, we will content ourselves with adding a single tube.

To couple the detector tube to the amplifier, some device must be used to permit the tube to be used efficiently and to separate the battery leads in the two circuits. There are three common systems of accomplishing this separation. The first and most universal is known as the transformer method. The second is called the resistance coupled method and the third is the impedance system.

Transformer Coupling Method

We will recall that if two coils are coupled together and a current is flowing in the first, a current will also flow in the second whenever a change takes place in the applied current. This action is known as induction and is used in radio tuners and in transformers. The transformer consists of two coils (a primary and a secondary) with an iron core between them. The iron core increases the inductive action and makes the device more efficient for low frequency currents. This is shown in Fig. 1.

Now if we look at Fig. 2, we will see how the transformer is employed to couple the detector tube to the amplifier tube. It will be noticed that the primary of the transformer is used in place of the phones that were formerly in the detector plate lead. The secondary is then wired to the grid of the amplifier and finally the phones are connected in the plate wire of the amplifier tube.

The advantage of the transformer system over the two other circuits

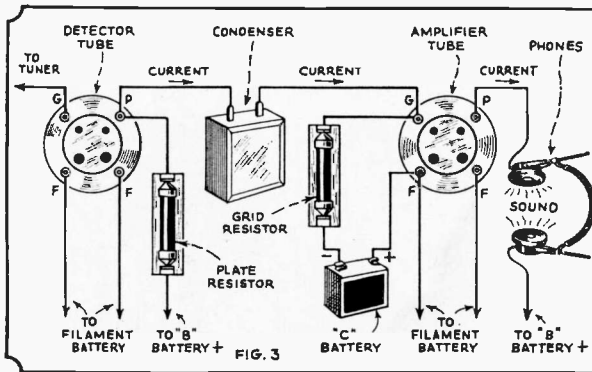

Wiring diagram of resistance-coupled audio amplifier stage and detector.

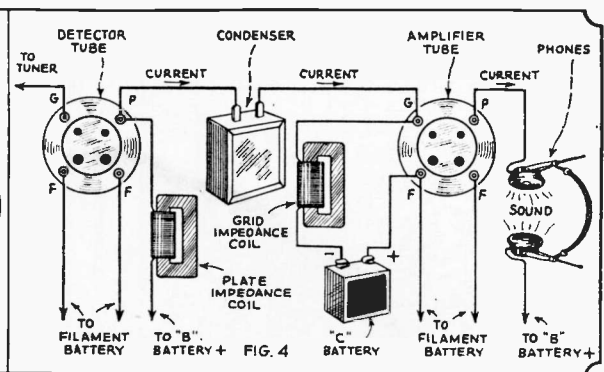

Impedance-coupled detector and amplifier stages.

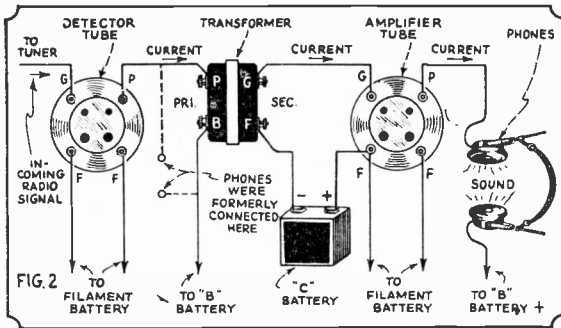

Picture diagram showing typical transformer-coupled A.F. amplifier.

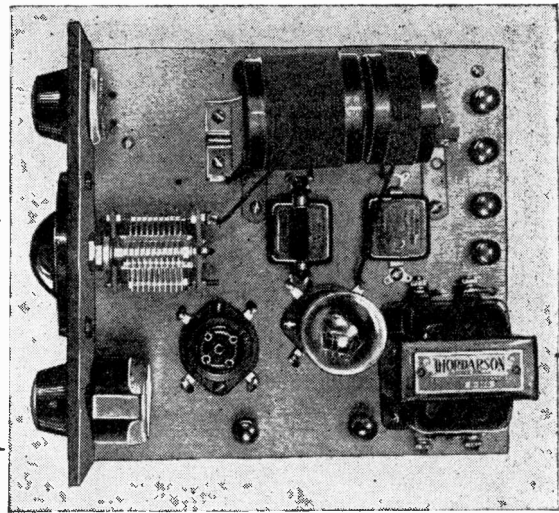

GETS AN AMPLIFIER

By C. W. PALMER

to be explained is that the voltage of the signals in the detector is increased or stepped-up, as it is commonly called. This is a well known property of the transformer which is used extensively in radio and electrical work. One every-day application of the voltage step-up or step-down principle is in the electric light lines, where the current is carried at 550 volts or more and is stepped-down in transformers to the commonly used 110 volts.

In the amplifier that we will build for our Beginner's Receiver, transformer coupling will be employed. However, in order to understand how the other systems work, we will discuss them briefly.

Resistance Coupling

If the transformer in Fig. 2 is replaced with a condenser and two resistances of the correct values, a suitable coupling will result that is known as the resistance method. We found some time ago that a condenser stores current and that it will pass an alternating current but not a direct current. This is the property that is utilized in the resistance coupled amplifier. The

condenser is connected between the detector plate and the amplifier grid. The resistances prevent the signal from being short-circuited through the batteries. These resistances must be of such a value that the current from the "B" and "C" batteries can be impressed on the plate and grid respectively, but still be high enough so that the signals are carried from the plate to the grid. Figure 3 shows the circuit for the resistance amplifier.

Impedance Coupling

The impedance-coupled amplifier is similar to the resistance amplifier in that a condenser is used to couple the two tubes together. The difference lies in the fact that instead of using plate and grid resistors, coils with a large number of turns and iron cores are used. This is not the same as transformer coupling, as the two coils are not coupled inductively, but are entirely separate.

The operation of the impedance amplifier is also similar to the resistance amplifier, in that all the amplifying is done in the tubes.

It has advantages over the former amplifier, though, in certain respects. The coils are made with a sufficient number of turns so that the audio frequency currents that make up the signals cannot pass. However, the resistance of the coils to the passage of the battery current is much less than that for the resistance coupled method. This permits the use of fewer batteries, for the same amplification. There are other advantages in a well-designed impedance amplifier in the quality when very loud signals are required. However, as the reasons for these actions are rather complicated, we will not attempt to explain them. The resistance coupled amplifier has one good point in its favor, and that is that both the low and high notes that make up good music are amplified with the same intensity for medium volume. Unless the transformers or the impedance coils are very well designed, the quality will not be as good in the latter amplifier.

The circuit of an impedance am-

(Continued on Page 29)

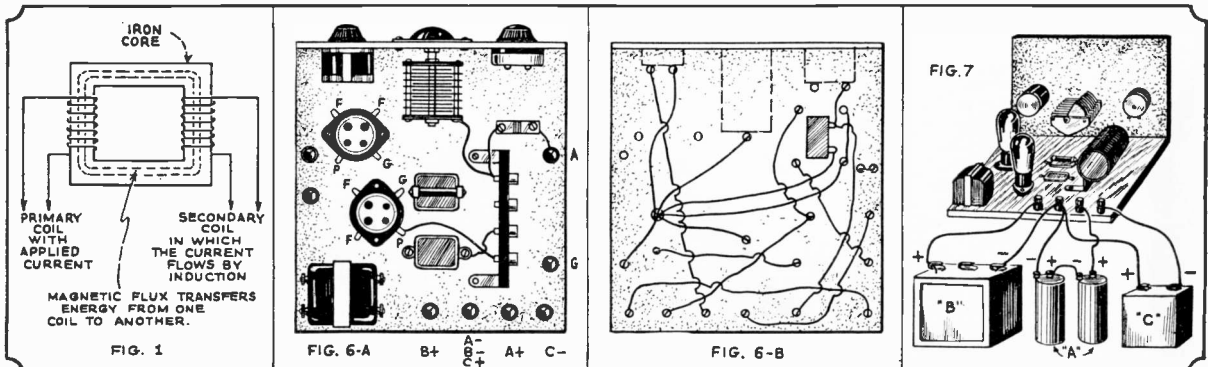
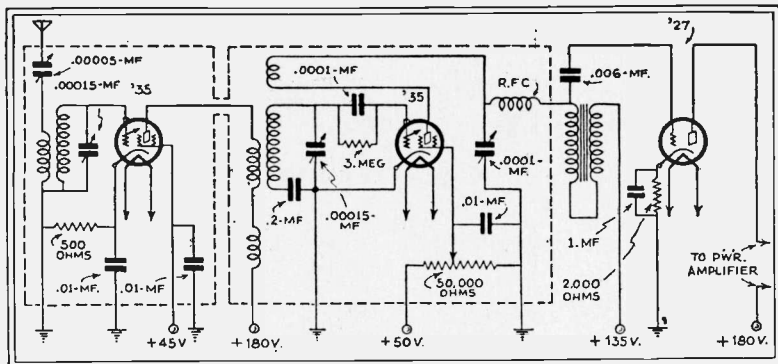

Fig. 1 shows action in A.F. transformer; 6A shows layout of A.F. and detector stage apparatus on subpanel.

6B—Wiring on under surface of the one stage A.F. and detector receiving set; Fig. 7—Battery connections.



Smoothing Up The Regeneration Control

By R. J. SLACK

● MUCH has been said and written as regards capacity versus screen-grid voltage control of regeneration; they both have their merits. The capacity method allows a quieter and smoother control, but has the disadvantage of disrupting the tuning, especially on the higher frequencies.

It is claimed that the new 35 tube, when used as a grid-leak detector plus screen-grid regeneration control, has the ability to hold its critical point much steadier when this arrangement is employed. However, I use a combination of the two methods, by employing a variable voltage to the screen and a .0001-mf. variable in the plate circuit of the 35 detector, thus allowing the screen-grid voltage to be set at its peak operating value (and it has one) and retaining the smooth and gradual features of the condenser.

This adds another control that looks worse on paper than in practice, because the screen-grid voltage knob is just an auxiliary and need rarely be touched when once set, except on extremely weak signals, when every bit of efficiency counts.

When a greater than necessary number of turns are on the tickler coil and the screen-grid voltage is adjusted to its correct value, the tube will "plop" in and out of regeneration. The only alternative is to reduce the number of turns on each coil until the correct number is found.

If possible, separate plate and filament transformers should be used. I wound my own filament supply transformer and when finished it delivered 2.75 volts without a load and I immediately concluded that a 3-tube load would bring it down to "about" the correct value. It did—about. For the next month my set "plopped" until I finally exhausted everything

else and measured the heater voltage (under load). It read 2.6 volts. After connecting a 40-watt bulb in series with the primary and reducing the voltage to 2.3, everything began to function again.

When changing over a Super-Wasp circuit from conductive to inductive coupling as per diagram A, I encountered a terrific tunable hum and this was solved by combining the Super-Wasp with the National arrangement as per diagram B.

I believe that it is universally agreed that the R.F. plate voltage does not belong on the detector grid condenser. A very slight leakage across this condenser results in erratic behavior of the set and an annoying interlocking between circuits results.

Another prolific source of trouble exists in the method employed in grounding the various apparatus. Each R.F. stage should be completely isolated in its own aluminum or copper can and the different parts inside the can should be grounded as per diagram C, with D and E as second and third choice, respectively. This of course also applies to the detector can.

All "B" voltage leads from set to power-pack should be shielded. A piece of ordinary BX conduit cable with regular wires and wrapping removed is large enough to hold these. Also, don't forget to ground the metal sheath to B-minus. It is also good practice to enclose the 110-volt A.C. leads from the power-pack to line in this cable, if at all near R.F. portion of set. I don't believe there are many cases of inductive hum resulting from proximity of aerial to A.C. lines. However, this can be determined by simply removing aerial from set.

All connections should be soldered with rosin and not acid core solder.

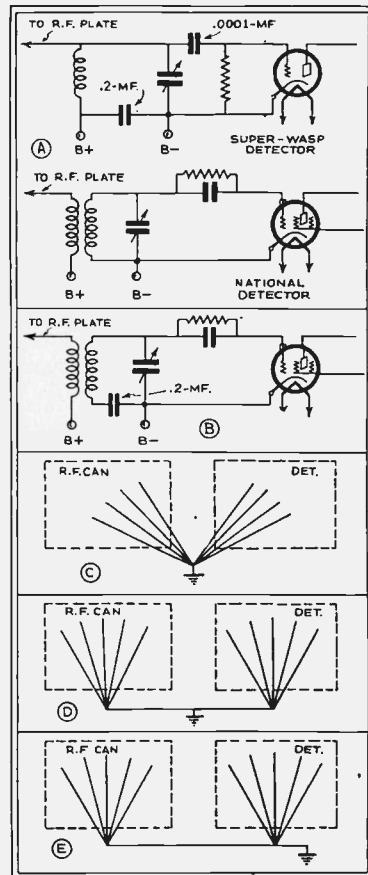

Diagrams above show improved form of detector circuit as worked out by Mr. Slack; C, D, and E show optional methods of "grounding."

A.C. filament leads from set to pack should be as short and direct as possible, twisted, and not smaller than No. 10 wire. A good A.C. voltmeter should be used to measure the voltage to the heaters of the tubes while under load, and this should come mighty close to the manufacturer's recommended voltage.

The trend in short wave receiver design as in broadcast receivers is fewer controls and gadgets. This works out very well in a broadcast receiver employing numerous R.F. stages, but in the average short-wave set with its lone little R.F. stage, I don't care to sacrifice my set's sensitivity for simplicity achieved by ganging controls. A casual glance at F will reveal at least five controls. The average "ham" operator will raise his hands in holy horror at this, but it so happens that I am interested solely in tuning in short-wave broadcasts and want every last bit of efficiency when hunting for VK2ME, etc.

NEW KINKS FOR THE S-W SET

By REX E. LOVEJOY

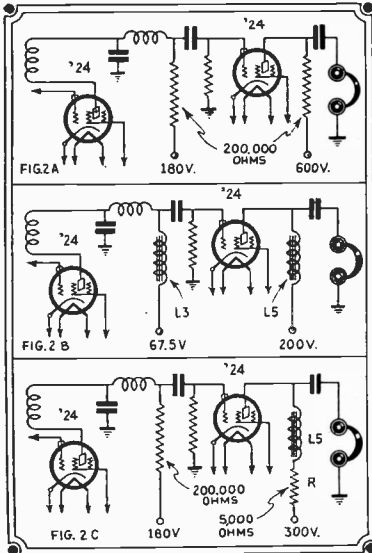

Figures 2A, B, and C, above, show several ways in which to connect a low impedance so as to match the output tube.

● THE ideal amateur receiver should have at least five qualities: namely, (1) Selectivity, (2) Low noise level, (3) Sensitivity, (4) Volume, (5) Ease of operation.

In order to keep the noise level conveniently low, a great number of tubes should not be used, for tubes have a characteristic of creating noise within themselves. Further, if a number of tubes are employed, there is more probability of the interlocking of the fields of different stages, thereby setting up hums, whistles, et cetera, and raising the noise level in general, as well as lowering the efficiency. The general effect of such interlocking of fields can be eliminated only by very careful shielding and laying-out of the whole receiver.

If the number of tubes is to be restricted, those tubes used must be necessarily of comparatively high amplification factor, to bring the volume to the desired level.

Ease of operation limits the number of tuned circuits. The smoothness of operation, as well as the sensitivity, are determined by the circuit and the tubes involved.

The receiver illustrated in the schematic diagram of Fig. 1 has all of the desirable characteristics to a very satisfactory degree. The screen-grid detector employed is highly sensitive and control of regeneration through the screen-grid is quite conventional and known for its smoothness.

The object of merit is the use of a 24 tube as an audio amplifier. The 24 has an amplification factor, or "mu," of 400 and picks up readily the very weakest of signals from the detector. The type 27 tube, commonly used, has a mu

of 8, and the 47 pentode, a mu of 52. By comparison it is realized why a 24 is very much superior to either of the other types.

To realize maximum gain from any circuit, the load impedance must match the plate-to-filament impedance of the tube. With the screen-grid tube, this impedance of the plate is of comparatively high order. Obtaining a load impedance to match may be accomplished in one of several ways, as illustrated in Fig. 2.

Resistance coupling is used in Fig. 2A. This system works nicely but has the disadvantage of requiring about 600 volts to the resistor in the last stage. This is evident, for the resistors are in the neighborhood of 200,000 ohms.

Fig. 2B gives an impedance-coupled system which is very satisfactory. By experiment it was found that if the primary and the secondary of an ordinary audio transformer were connected in series and the whole unit used as shown, the impedances obtained were very nearly correct. L3 and L5 are both audio transformers of ordinary design.

In Fig. 2C is shown another variation where a combination of inductance and resistance is used. This circuit has the same disadvantage of Fig. 2A, but to a smaller extent. The voltage required is about 300 volts. In this circuit, L5 is a output choke designed for use with a 45 power amplifier. R is approximately 5,000 ohms.

Since most receiver power-packs have an output of about 200 volts,

the circuit in Fig. 2B was adopted.

In the completed receiver, Fig. 1, C1 is a midget condenser cut down to two plates, double-spaced. C2 is a similar condenser, cut down to three plates, single-spaced, and is used for tuning. C3 is a 23-plate, 0.00015 mf. midget used for "lump" capacity for centering the amateur bands. It is mounted on the base of the subpanel. Once adjusted, it is left undisturbed.

A variable-mu, or 35, tube is used as detector T1, because of its very nice performance as a regenerative detector, although a 24 may be used almost as well. R1, Fig. 1, may need to be changed for different tubes.

C5 should not be any larger than 0.00025 mf. for maximum volume and the potentiometer R2 must be by-passed by C7, a 1 mf. condenser, to remove noise. The grid-leaks for the 24 audio tube and the detector, R3 and R1, are not critical and several values should be tried and the ones giving most volume and smoothest regeneration should be used. It is absolutely necessary to by-pass R4 with a 1 mf. condenser, designated as C9.

Any coil and condenser combination can be used for the detector circuit. If home-made coils are used, after the band has been located, the tickler L2 should be cut down or increased until oscillation just starts when the screen-grid of the detector is at a potential of about 21 volts. This adjustment is quite important, for volume is 50

(Continued on Page 19)

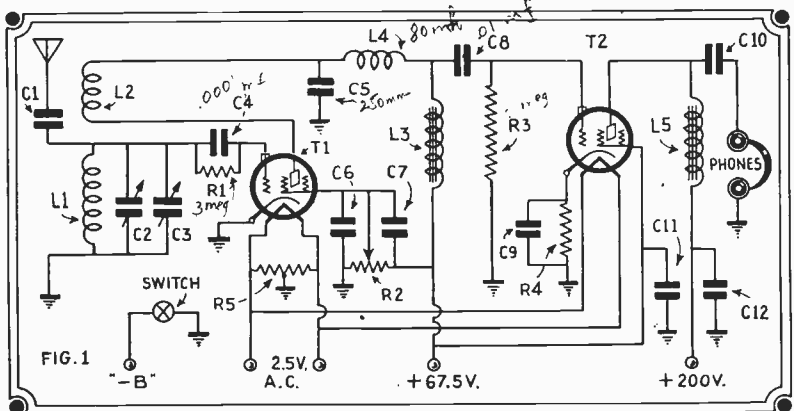

Complete wiring diagram of short wave receiver especially designed for operation on the amateur bands of 20, 40, and 80 meters and providing smooth and efficient reception of code and phone signals on these bands.

WHICH REGENERATION SCHEME?

By M. H. GERNSBACK

● ONE of the most important factors in short-wave receiver design is regeneration control. Unless a set has an efficient method for controlling regeneration it is well nigh useless. A discussion of various methods of control and their advantages and disadvantages will be undertaken in this article.

Detector systems using three-element tubes such as types 99, 01A, 30, 26, 27 and the new 56 will first be discussed. For simplicity, all diagrams will show grid returns to cathode, which is equivalent to A-minus filament in battery sets. Figure 1 shows the simplest system of control, by mechanical movement of the tickler coil with respect to the grid coil. This method is now obsolete, as it is very critical in adjustment and causes quite a noticeable detuning effect on the detector tuning control. Figure 2 shows a method that was once considered the best possible for short-wave work. It is used but little at present, as it also is fairly critical in adjustment and causes detuning. It is simply a parallel plate feed system similar in principle to the method of isolating the plate current from an A.F. transformer primary in audio amplifiers.

The control shown in Fig. 3 merely varies the voltage applied to the detector plate by means of a variable resistor. This control is likely to be very noisy and in addition it gives only rough control, together with detuning effects, all of which makes it unsatisfactory for high efficiency. In Fig. 4 is shown a method which, although it has negligible detuning effects, is not very satisfactory because of its critical and not always noiseless operation. Figure 5 illustrates what is probably the most generally used form of control. If carefully designed it will usually prove a very quiet and smooth form of control. Noisy variable condensers cause trouble frequently and in addition there is a pronounced detuning effect.

Figures 6 and 7 illustrate two entirely different methods of control. The exponents of the scheme shown in Fig. 6 claim that it is free from detuning effects, is very quiet in operation and gives a very smooth control of regeneration. The method of control illustrated in Fig. 7 also gives very satisfactory results, according to reports. We have not yet experimented with it, however, so we are not able to give definite statements as to its merits, but it is certainly worth a trial.

Recently quite a number of set builders have advocated the use of screen-grid and R.F. pentodes in the detector stage. These tubes, when properly used, give much stronger signals than triodes and offer much more efficient methods of controlling regeneration. All of the methods of control discussed under three-element tubes may be used with these tubes and will

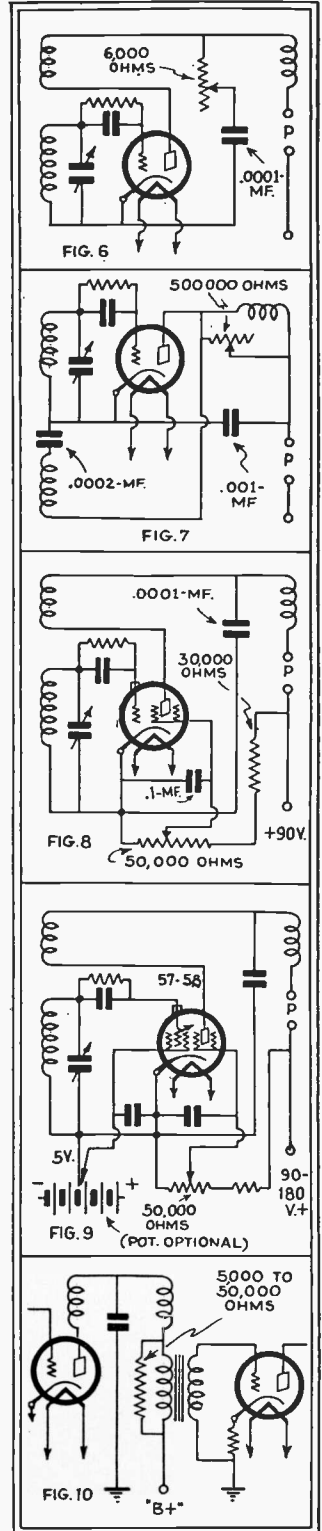
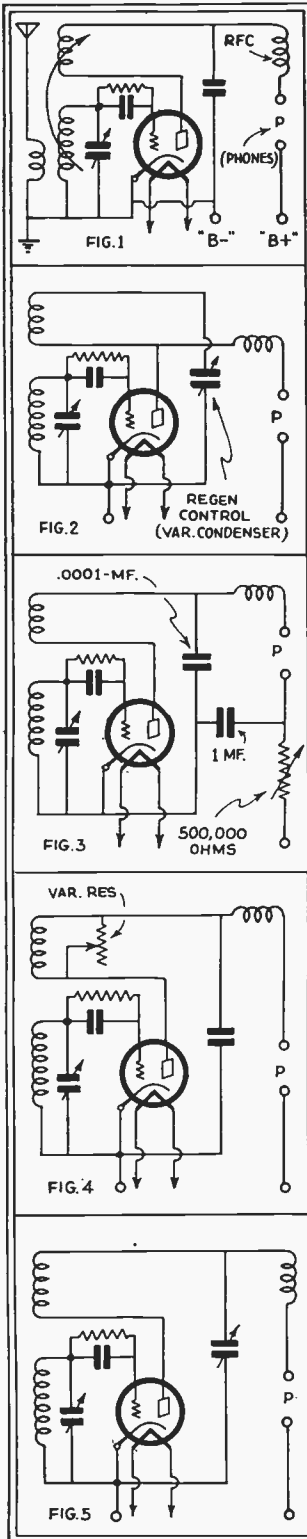

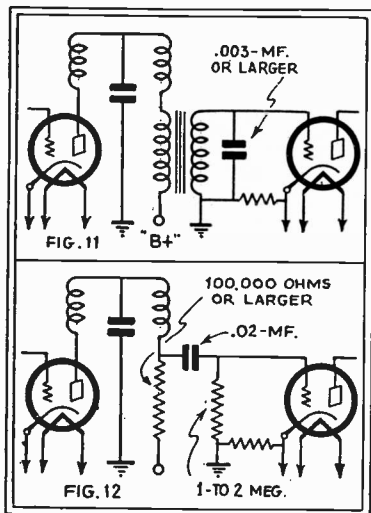

Reducing threshold howl in transformer and resistance coupling.

give much stronger signals. There is a much better system of control for these tubes, by varying the potential applied to the screen-grid. This method gives very fine control with none of the objectionable features of the methods of control described above. Figure 8 shows how the screen voltage is varied by a potentiometer. A variable-mu tube used as detector in this circuit will give even better control than an ordinary screen-grid or pentode tube.

The use of the R.F. pentode as detector has only recently been considered, because of lack of R.F. pentodes in the open market. This tube should prove even more effi-

cient as a detector than the screen-grid tube, especially when provision is made for varying the potential on the suppressor grid as well as on the screen grid. The suppressor grid potential should be adjustable so that positive as well as negative potential may be applied. This control need only be adjusted when first operating a receiver, as once the best point is found there is no further need of adjustment unless tubes or the circuit is changed. We would like to hear from experimenters as to what results they have had using these new tubes. (See Fig. 9.)

One of the most troublesome things in a regenerative detector system is threshold howl—a strong audio frequency howl which occurs just before the receiver goes into oscillation. As the period just before oscillation is the most sensitive of operation, threshold howl effectively ruins a receiver's efficiency. The reasons for threshold howl are not very well understood, but there are several methods of eliminating it. Figures 10 and 11 illustrate methods of curing this condition when a transformer is used for coupling to the audio amplifier. Both of these methods result in reduction of volume, but they are necessary if the receiver is to function properly.

If resistance or impedance coupling is used between detector and audio system, threshold howl is not present. This is the most satisfactory method, as the systems illustrated in Figs. 10 and 11 affect the audio response. Figure 12 shows a resistance coupling system. It is necessary to apply at least 180 volts to the plate of the detector, due to the drop in the resistance. Figure 13 is a form of impedance

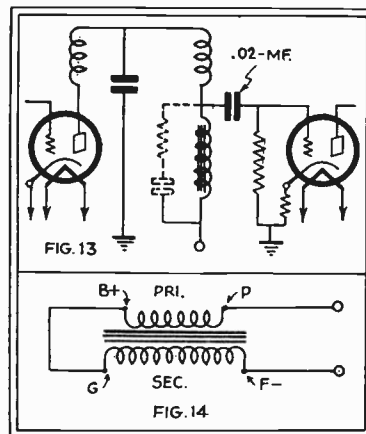

Impedance coupling and a suitable way to obtain the correct impedance.

coupling. This is the best method for all-around use, as the voltage drop through the plate impedance is very slight and a fairly low plate voltage may be applied to the detector. When using a screen-grid or pentode tube as detector, it is almost imperative to use the impedance method, due to the high plate impedance of these tubes. By connecting the primary and secondary of an A.F. transformer in series as shown in Fig. 14, a satisfactory plate impedance may be secured. It may be necessary to shunt this impedance with a resistance in series with condenser, as shown by the dotted lines in Fig. 13. This is to cut the high note response. It is also possible to use a high impedance choke coil in place of the audio transformer.

attracting small pieces of iron and steel. When the current from the battery is not flowing, the iron bar no longer attracts the iron pieces. Thus we can see that the current passing through the coil of wire has given it a new property which we call magnetism, and since it has this property only when the electric current flows, we call it an electromagnet.

Now, if we replace the soft iron bar with one of hard steel and allow the current to flow for some time, we will find that the steel will attract the pieces of iron even when the current flow has stopped. We have now made a permanent magnet. A careful examination of the soft iron bar will show that it also retains a small amount of magnetism, although in a smaller degree than the steel. The steel is said to have a higher degree of retentivity than the iron.

If we drop a permanent magnet into a box of iron filings, we will notice that there are two places on the magnet to which the most filings cling. See Fig. 8. These plac-

GETTING STARTED

(Continued from Page 5)

es near the ends of the steel bar are called the poles of the magnet. One pole is called the north pole and the other the south pole, or more accurately the north-seeking pole and the south-seeking pole, for if we suspend the magnet from a thread, it will swing around until the north-seeking pole faces the north and the south-seeking pole faces the south. This is the effect used in the magnetic compass.

Magnets and magnetism are used in a number of different ways in radio receivers. Headphones and loud speakers contain magnets. The transformers used in radio amplifiers depend on magnetism. Even the actual transmission and reception of the radio waves depends on magnetic principles.

Induction

One of the greatest discoveries in electricity was the fact that a magnetic field in motion will cause a movement of electrons which we know as an electric current. If we connect a coil of wire across an

indicating instrument (such as a galvanometer, which indicates the presence of current) and run a permanent magnet through it, as shown in Fig. 9, the needle of the galvanometer will move, indicating the presence of current in the coil. The needle of the meter will quickly return to the zero position when the magnet is at rest in the coil. Then if we draw it out again quickly, the galvanometer needle will again move, but this time in the opposite direction. It will be found that the faster the magnet is moved, the greater will be the deflection.

If we substitute a piece of unmagnetized steel for the magnet there is no current indicated. The difference between the magnet and the steel is the presence of the magnetic lines of force surrounding the former. This experiment shows that whenever a conductor is placed in the presence of a moving magnetic field, a current is produced. This current is caused by induction.

(Continued on Page 22)

TUNING THE SHORT-WAVE RECEIVER

By C. W. PALMER

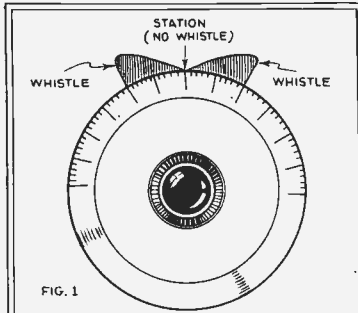

FIG. 1

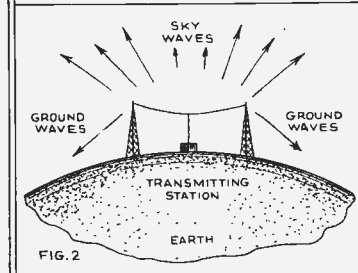

FIG. 2

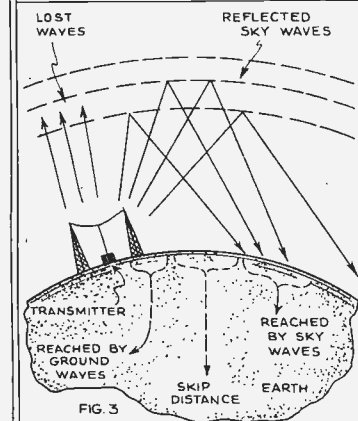

FIG. 3

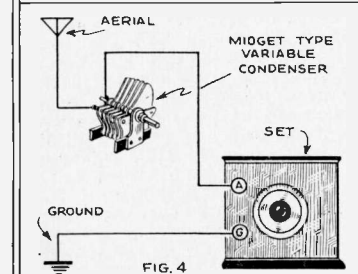

FIG. 4

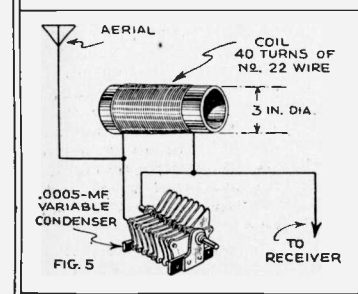

FIG. 5

● THE knack of operating a short-wave receiver correctly is usually learned only after considerable trying on the part of the operator, whether he is a beginner or a "dyed-in-the-wool" veteran. Each receiver acts a little differently from any other and we must find the best way to handle our set, by continuous trying.

Probably more short-wave sets fail to give satisfaction because of incorrect handling than for any other reason. The novice invariably manipulates the tuning dials much too rapidly. Due to the fact that several stations may often be tuned in and out within the space of one division on the tuning dial, it must be turned very slowly even with a vernier dial, or the stations will be passed by without being heard. The ability to turn the dials slowly and patiently must be acquired. We are all used to the regular broadcast receivers which may be tuned roughly until the station is heard and then adjusted to the best point. This habit of tuning the latter receivers makes the task of correctly tuning our short-wave set even more difficult.

Two Methods of Tuning

There are two methods of tuning regenerative receivers. (The Beginner's Receiver is a set of this type.) The first way is to set all controls such as the volume control, antenna series condenser, etc., at the point where the loudest music is heard on local stations. Then advance the regeneration control (volume control on the Beginner's Set) until the set drops into oscillation. We will remember from a previous explanation that the set is oscillating when a slight hiss is heard which suddenly stops with an abrupt click as we turn the regeneration control to the right. The period where the hissing noise is heard is known as **regeneration** and the set is extremely sensitive when operated in this condition. If we turn the regeneration control until the set is oscillating and then turn the tuning dial, a whistle will be heard whenever a broadcasting station is passed. This whistle is caused by the oscillation of the receiver (which is just like a miniature transmitter) interfering with the waves sent out from the broadcasting station. When the whistle is heard, all we have to do is to turn the regeneration control back until the set passes the point of oscillation and is regenerating. We

may also have to slightly readjust the tuning dial to obtain the greatest volume.

If the incoming signal is fairly strong, we will find that the program comes through clear and free of the whistle. However, if the signal is weak, the whistle will dominate the voice or music and clear signals will not be heard. In this case, the "zero-beat" method of tuning is more satisfactory.

To tune by the "zero-beat" method, turn the regeneration control until the set just passes into oscillation. Then tune the set very carefully until it is at the critical point between the two whistles which identify the presence of a station, at which it will be found that no whistle is heard. At this point there is no whistle because the signal generated by the receiver corresponds exactly to that of the broadcasting station and they do not interfere with each other. Figure 1 illustrates zero-beat tuning.

You can tell when the point of zero-beat is reached by turning the tuning dial slightly to one side or the other. The slightest deviation on either side will cause the whistle to reappear. Zero-beating is an excellent means of fishing for weak or far distant stations, as the set is in a very sensitive condition when oscillating. Many distant stations that you cannot hear at all when the set is regenerating can be tuned in with sufficient strength to at least identify them, if you zero-beat them.

Time Differences

When trying to receive distant or foreign stations, the difference between the time at the locality of the receiver and the transmitter must be remembered.

It is possible to receive great distances on short waves with very simple equipment. However, to receive these far-away stations, intelligent handling of the receiver is necessary. For instance, it would be rather foolish for us to listen for a station in Paris that signs off at 12 midnight at a time later than 7 p.m. in New York, for it is 12 midnight in the former city at this time.

Greenwich Time is the system of time accepted in all countries to have a world standard. Greenwich Mean Time is noon at the moment when the mean sun passes over the meridian of Greenwich, England. Standard Time is the time

accepted over a large area, such as Eastern Standard Time, which covers the east coast of the United States. The true local time may vary almost an hour in this area, even though the accepted time is the same in any part.

The meridian of Greenwich, England, has been taken as the prime meridian and there are twenty-four standard meridians around the earth, differing by 15 degrees longitude east and west. These meridians were established in order that the time in any part of the earth may correspond in minutes and seconds with the Greenwich time, although the hours vary one hour forward or back for each meridian east or west of Greenwich. In the United States the standard times are: Eastern, 75 degrees west (five hours slower than Greenwich); Central, 90 degrees west (six hours slower); Mountain, 105 degrees west (seven hours slower), and Pacific, 120 degrees west (eight hours slower).

A very useful time conversion chart may be obtained by sending 10 cents in coin to the Superintendent of Documents, Government Printing Office, Washington, D. C., for a copy of Miscellaneous Publication No. 84, entitled "Standard Time Conversion Chart."

Skipping and Fading

A transmitting antenna sends out radiations which move in straight lines, as shown in Fig. 2. The waves which travel along the surface of the earth are called ground waves and those which are directed upward are the sky waves. Actually the ground and sky waves are identical, except for the direction of travel. The ground waves follow the surface of the earth and pass through mountains, cities, forests, etc., and are slowed down and weakened by these obstructions. This weakening effect is so strong that the ground waves are practically non-existent at 500 miles, depending of course on the wavelength and the power used. It is evident that if the ground waves alone were heard in our receivers, long distance transmission would be out of the question.

The sky waves do not travel in straight lines indefinitely, for if they did they would never return to the earth and would not affect our sets. According to the Heaviside layer theory, there exists around the earth's surface, at varying heights, an enveloping layer of ionized gas. This ionization may be caused by radiations of electrons or ultra-violet light from the sun. In any event, this layer is thought to be present around the earth. When the sky waves reach it, they are reflected from it as shown in Fig. 3 in a similar manner to the way light rays are reflected by a mirror.

This reflecting layer explains skipping. As seen from Fig. 3, the receiver may be located so far from the transmitter that it does not receive the ground waves. If the reflected sky waves return to the earth beyond the location of the receiver, no signal will be received. This reflection may also explain fading, for if the reflecting layer is not constant, the point at which the reflected wave hits the earth may vary, causing the signals to keep fading and returning.

Fringe Howl

A great many short-wave receivers are troubled with a condition known as fringe howl which prevents their correct operation. When the regeneration is increased just under the point of oscillation, the receiver starts to howl or hum. This trouble is not very prevalent in sets without amplification, but when the receiver uses two audio frequency stages, it often becomes unmanageable.

Increasing the amount of regeneration will stop it, but it is sometimes desirable to operate the set just under the point of oscillation. One simple method of eliminating the trouble is to connect a resistor of about 100,000 ohms (the grid leak type) across the secondary of the first audio transformer.

Dead Spots

A great many short-wave sets are troubled with so-called dead spots or points on the dial at which the set will not oscillate.

In the first article of this series, we found that if a coil was placed in the proximity of another coil which was connected to a source of current, a current would also be picked up in the second coil. This may be expressed in the following manner: If a coil is coupled to a second coil with a current flowing, the first will absorb energy from the second.

This is what happens at the dead spots. For some reason, a circuit tuned to that particular frequency is absorbing current from the coils of the set. The trouble is most commonly caused by the aerial being tuned to that frequency and the energy is absorbed in the antenna system.

The solution to the problem is evident. The aerial must be tuned to a different wavelength at which there are no stations. This may be done in any one of three ways. The first is to change the dimensions of the aerial, either making it longer or shorter. This is not always practical, both because of structural difficulties and also because it is difficult to know what length will eliminate the trouble. It would be very disappointing to find that the wavelength of the aerial had been shifted to another waveband where stations might be received.

The second method is to connect a small variable condenser in series with the aerial lead, in order to tune it to another point on the scale at which no stations are heard.

The third method is to tune the aerial to an entirely different waveband, by connecting a coil and a condenser in the aerial circuit. A coil such as the one described in the article last month for eliminating broadcast interference will be suitable. It may be used for the dual purpose of changing the fundamental wavelength of the antenna and also stopping broadcast interference, by tuning it to the point where the broadcast station disappears and the oscillation returns. The dimensions of this wave-trap are repeated in Fig. 5 for the benefit of the reader.

per cent greater at a potential of 21 volts than at any other. Tube-base coils were used in the original receiver and the approximate number of turns is given in the table under Fig. 1.

C11 and C12 are 1 mf. by-pass condensers and may be placed in the power-pack or in the receiver proper.

The panel should be of aluminum, copper or brass, to eliminate body capacity effects, etc. A metal sub-panel is advisable, with filament wires below it and all other wiring above. A non-metal subpanel can be used; if the filament wires are twisted together and kept as far

NEW KINKS

(Continued from Page 15)

from other wiring as possible, induced hum will not be noticeable.

List of Parts

- C1, C2—See text for details.
- C3—0.00015 mf. variable midget condenser (23 plates).
- C4—0.0001 mf. fixed condenser.
- C5—0.0001 or 0.00025 mf. fixed condenser.
- C6, C8, C10—0.01 mf. fixed condensers.
- C7, C9, C11, C12—1 mf. fixed condensers.
- R1—3 megohm grid leak.

- R2—0.100,000 ohm potentiometer.
- R3—2 megohm grid leak.
- R4—400 ohm bias resistor.
- R5—20 ohm center-tapped resistor.
- L1, L2—Tube-base coils.
- L3, L5—Audio transformers—primary and secondary windings in series (see text).
- L4—Radio-frequency choke, about 80 millihenries.

Tube Base Coil Data			
No. 30 S.S.C. Wire			
Number of turns			
Band	L1	L2	
80 m.	25	11	
40 m.	12	9	
20 m.	5	7	

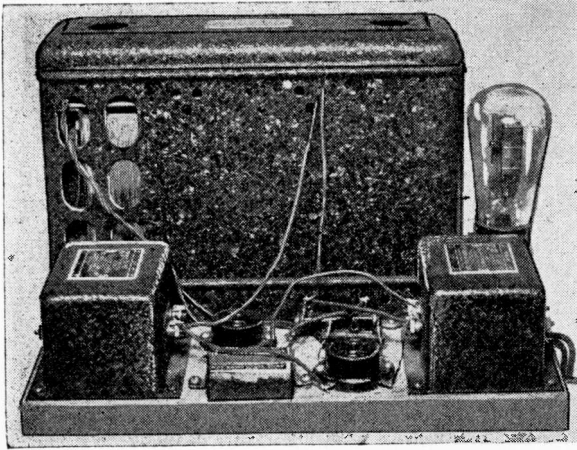

HOW TO MAKE AUDIO

By LOUIS MARTIN

After all—just what kind of audio amplifier shall we build for our short-wave receiver? Shall it be of the resistance, impedance, or transformer coupled type? Should we utilize the new 56 and '47 tubes? Is one A.F. power-stage better than two ordinary amplifier stages, and why?

● RECENTLY the writer visited the home of a radio writer who was conducting a comparison between five well-known short-wave receivers. Some of the sets were equipped with audio amplifiers and therefore have good loud speaker response on foreign stations; however, there were two that had very sensitive R.F. amplifiers but were not equipped with sufficient audio gain to permit decent loud speaker reception.

In order to place the receivers on a more equitable basis the amplifier pictured in Fig. 1 was built "on the spot." It consists of an input push-pull transformer feeding two 47's in push-pull — nothing more, nothing less; but it sure made reception interesting.

Since then, it has occurred to the writer that every S.W. station should have at least one audio amplifier on hand to operate or test any R.F. chassis on hand. In the discussion to follow, the advantages and disadvantages of several types of audio systems will be analyzed.

The Resistance-Coupled Amplifier

The simplest of amplifier systems is the straight resistance-coupled unit depicted in Fig. 2. As may be seen by reference to the figure, coupling between stages is effected by resistances and condensers, no transformers of any sort being used, with the exception, of course, of the output transformer.

While this class of amplifier cannot boast of high gain, nevertheless it has many desirable features upon which its popularity has been founded. In the first place, it is the most economical class of amplifier one can build; secondly, the quality of reproduction cannot be equalled by any other type of amplifier unless the very highest grade of parts obtainable are used; thirdly, the space occupied is very small and the unit can fit almost anywhere.

All values are given in the diagram of Fig. 2. The coupling re-

sistors should be of the 1 (one) watt size, not so much because of the actual heat they generate, but because they may be heated by other parts of the set such as the rectifier, etc., and therefore be called upon to dissipate safely .75-watt although they are only generating .2-watt of heat. The .01-mf. coupling condensers should be tested for leakage with 300 volts D.C. before using them. The rating of a reliable manufacturer may sometimes be relied upon.

The gain of this amplifier should be sufficient to operate a loud speaker from the usual S.W. receiver output. If, however, the gain of the amplifier is to be varied, then the grid resistor of the 47 may be in the form of a potentiometer as shown in the diagram. All filter and bypass condensers are of the dry electrolytic type because of their low cost, small size, and high capacity.

If a magnetic speaker is used, then a 30-henry choke must be used in the filter circuit; if a dynamic speaker is used, then the choke may be removed and the speaker field used in its stead. No attempt has been made to give a layout, as most men have the equipment in the "junk box" and will probably use it.

While this amplifier is designed to operate from a screen-grid detector, it may, by changing the size of the 100,000-ohm input resistor to 50,000 ohms, be used with the usual R.F. tuner having a 27 (or the more recent 56 which is the same as the 27, except for the filament current, in the detector stage).

The Impedance-Coupled Amplifier

The diagram of the impedance-coupled amplifier is exactly the same as the resistance-coupled unit of Fig. 2 with the exception that the coupling resistors are replaced by audio chokes; 200 henry chokes being substituted for R1 and R2, and, for real good reception, 500 henry units for R3 and R4. The

primary of any good audio transformer has an inductance of about 200 henries, but the 500 henry "brutes" may be a little difficult (or costly) to obtain. However, if one is not worried so much about quality, primaries of old audio transformers (with the secondaries burnt out) may be used for R1, R2, and R4.

The "fly in the ointment" may be that four primaries are not in the "box," so that to make the amplifier as practical as possible, the resistors R3 and R4 may be left as shown in Fig. 2, but the chokes substituted for R1 and R2. This diagram is shown in Fig. 3. The construction of the power unit is the same as that of Fig. 2, therefore repetition is not made.

This amplifier, properly called an impedance-resistance coupled amplifier, has most of the advantages of the amplifier of Fig. 2 but not some of its disadvantages. First, due to the use of relatively low-resistance chokes in the plate circuit, a higher voltage may be applied to the plate of the 56 than in the resistance-coupled amplifier; second, due to the use of chokes in the plate circuit, the actual gain per stage is greater than if resistors were used; third, the quality of response is about as good as a resistance-coupled amplifier, especially if low resistance, high impedance chokes are used. Another advantage of the amplifier of Fig. 3 over that of Fig. 2 is the fact that impedance-coupled amplifiers have less tendency to motorboat than resistance-coupled amplifiers.

One thing that may prove to be a disadvantage is the ability of the chokes to pick up hum from the power unit. This may be obviated by shielding either the choke, the power unit or both; or by rotating the choke with respect to the power unit; or, again, by separating both.

This amplifier is well worth while building for the man with high ideals and a small purse.

WORTH-WHILE AMPLIFIERS

The Transformer-Coupled Amplifier

The author was never an advocate of high-gain audio amplifiers for radio receivers. By this is meant that more than two stages should never be used, but the maximum gain per stage should, of course, always be realized. For high gain per stage and good (but not excellent) quality the transformer-coupled amplifier should always be used.

For the average short-wave receiver two stages of transformer-coupled tubes is too much because of the following reasons:

Most receivers of modern design use a detector that amplifies in itself (unlike those of five years ago) so that an additional stage should give excellent volume on most stations. For stations too weak to be heard on the speaker with only one stage of audio the headphones should be used, for an additional audio stage would only tend to make matters worse.

As the number of audio stages is increased, the noise level increases—and at a greater rate than the number of stages. Anyone who has ever constructed three or four stage audio amplifiers for radio work will bear this out.

Additional instability such as microphonic noise, oscillation and poor quality increase tremendously as the number of stages is increased above two.

Every piece of equipment that is added to an amplifier distorts the quality. The more apparatus added, the worse the quality becomes. This is one of the main reasons why present-day tubes have a high gain—so that the number of stages may be reduced to one, as will become evident by an inspection of any modern broadcast receiver.

For an amplifier suitable for use with a short-wave receiver, any of the preceding types are excellent, and for those who prefer the transformer-coupled type, a single, push-pull stage is recommended as being the simplest and most efficient of its type for the purpose. Figure 4 is a schematic of such a circuit.

It is not unlike the standard units used for radio work, and may easily be built in a few hours. Shielded cabinets and neat wiring are not requisites for good reception; good apparatus and careful wiring are far more important. As before, the power unit of Fig. 2 is used, the only change being in the size of the grid-bias resistor—now 225 ohms instead of 450 ohms as shown. Also, the 25 mf. bypass condenser across this resistor may be omitted.

That the gain obtained from this single stage is sufficient for all ordinary purposes was borne out in tests conducted by the writer—for it is the schematic of the circuit used in the amplifier shown in Fig. 1.

The input circuit of the amplifier under discussion may only be used when the output tube of the receiver is of the 27 type. If the amplifier is to be used with a set whose output tube is of the high impedance or screen-grid type, then the input circuit must be revised slightly as shown in the insert of the figure.

Conclusion

It will be noticed that in all of the diagrams given, tubes of the 24 type were not used. The reason for this is not difficult to see. For one, the gain of the amplifier would be too great for the purpose for which it is intended; second, the input to such tubes must be small because (1) the grid bias is small and (2) a large signal would overload the second stage.

Since the use of a larger power tube than the 47 is certainly not justified, then a tube of the 56 type must be used when good all-around reception is desired.

The above, however, is a matter of opinion. For cases where a high-gain, two-stage amplifier is desirable, as, for instance, in conjunction with a single-tube tuner, the circuit of Fig. 5 is suggested. As before, the power unit is the same as that of Fig. 2, the only change being in the first stage.

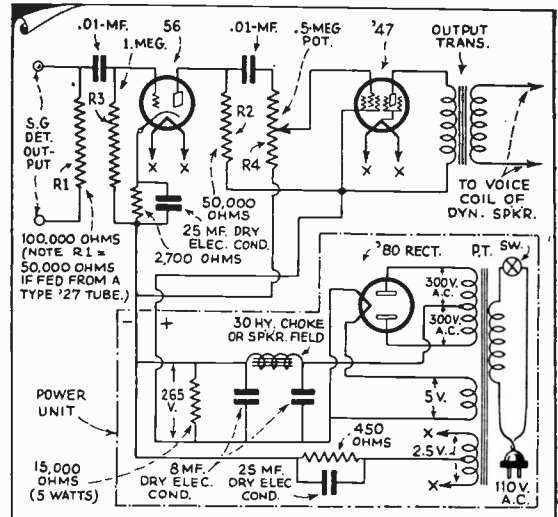

FIG. 2 RESISTANCE COUPLED AMPLIFIER

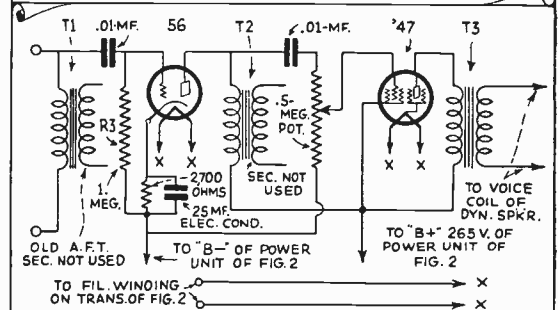

FIG. 3 IMPEDANCE COUPLED AMPLIFIER

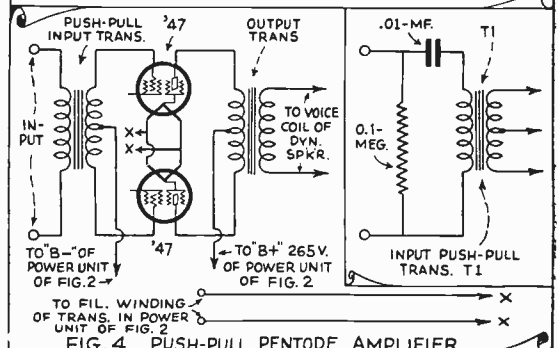

FIG. 4 PUSH-PULL PENTODE AMPLIFIER

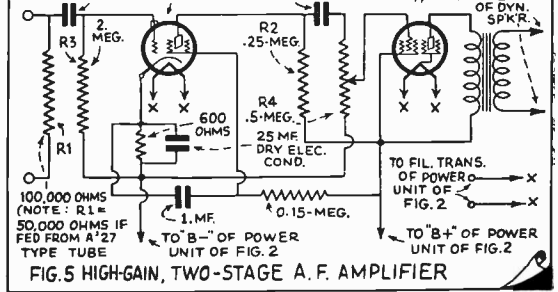
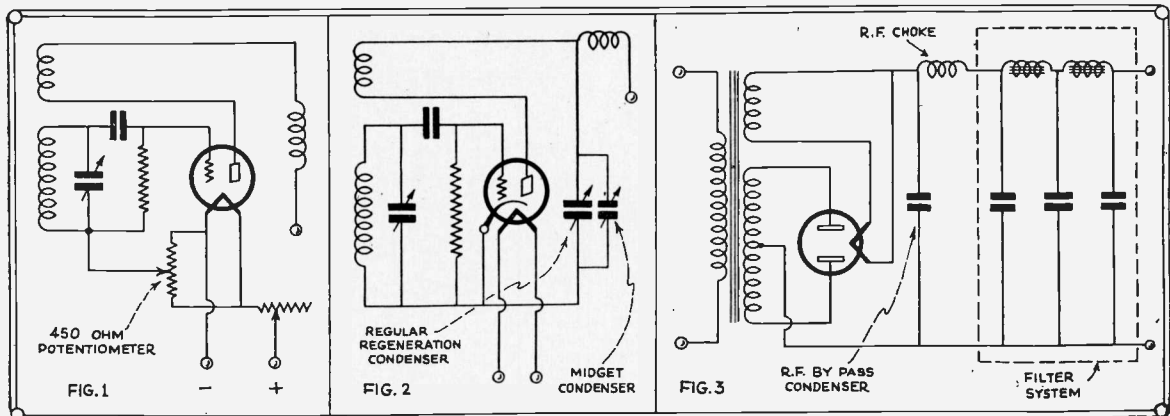

FIG. 5 HIGH-GAIN, TWO-STAGE A.F. AMPLIFIER



SHORT-WAVE OPERATING HINTS

By M. HARVEY GERNSBACK

1. MICROPHONIC hum in a short-wave receiver is not always caused by faulty tubes. A defective variable condenser is often the cause of violent microphonic hum. This trouble can sometimes be remedied by re-spacing the plates of the noisy condenser. If this procedure is not possible it will be necessary to replace the condenser.
2. When shielding a short-wave set be sure that the coils are at least one inch away from the shields. If it is possible to have even greater spacing so much the better. When the coils are too close to the shields there is sure to be a large loss in efficiency.
3. When using for a detector a filament type tube supplied with pure D.C., it is often possible to obtain smooth regeneration control by connecting a potentiometer across the filament terminals of the tube and bringing the grid return to the slider arm of the potentiometer (see diagram).
4. When using a variable condenser to control regeneration in a

short-wave receiver very fine adjustment of regeneration can be secured by shunting the regeneration condenser with a small variable condenser. A midget condenser having 2 or 3 plates should prove very satisfactory (See Diagram).

5. Always make sure that all by-pass condensers used in the R.F. and detector circuits of a short-wave receiver are of non-inductive construction. If they are not they are next to useless.

6. When using a stage of radio-frequency amplification utilizing a screen grid tube, it is worthwhile to try several tubes before making a final installation, as these tubes are less uniform in construction than triodes.

7. A.C. hum in a short-wave receiver using battery substitutes is often difficult to eliminate. Certain types may be cured by placing an R.F. choke with suitable R.F. by pass condensers in the "B" supply unit's filter circuit. This should precede the filter system (see diagram).

8. Always have several grid leaks on hand as there is a great difference in performance between various sizes and the size on the label cannot always be trusted.

9. When using a set with plug-in coils it may happen that the set is less sensitive over that portion of the tuning range where the variable condenser used for tuning is near maximum capacity. If this is the case it is possible to wind an extra plug in coil with its winding increased 40 to 50 per cent over that of the coil mentioned above. By this method the frequencies which were received when the variable condenser was near maximum using the first plug in coil will be tuned in near the minimum capacity of the variable condenser when the extra plug in coil is used in place of the regular one. The sensitivity of the receiver is better when less condenser capacity is shunted across the tuning coil and therefore better reception will be had. This particular kink was used very successfully on the Pilot "Super Wasp" set.

A similar action can be obtained if the magnetic field is produced by a current instead of a permanent magnet. Suppose we wind two coils and place them end to end as shown in Fig. 10, one coil being connected to the galvanometer and the other to the battery, with a switch to open the battery circuit. When we close the switch, the galvanometer indicates a momentary current. Then open the switch again and the galvanometer needle shows another current, opposite to the first.

If we insert a piece of soft-iron through the coils, the action is the same as before, but much stronger. This is the principle of the tuning coils and transformers used in radio reception. It will be noticed that we did not move the coil as we did

GETTING STARTED

(Continued from Page 17)

the magnet. The magnetic field, building up in the coil when we closed the switch, gave the necessary "moving" field to induce the current in the second coil or the secondary, as it is called.

Direct and Alternating Current

Up to this time, we have limited our discussion to currents flowing in one direction in a conductor. This type of current is known as direct current. It will be remembered that when the magnet was plunged into the coil and withdrawn, the current reversed its direction when the magnet was withdrawn. To state this in another way, we can say that the direction of the current was alternating in

one direction and then in the other. This type of current is known as an alternating current.

Alternating currents are used extensively in radio. In fact, the radio waves themselves are alternating currents which reverse very fast, in the neighborhood of 1,000,000 times per second or even more. Currents which have a frequency (reverse their direction of flow) of less than 10,000 cycles (complete reversals) per second are known as audio frequencies, and those over 10,000 cycles per second as radio frequencies.

It is suggested that the reader perform the various experiments in this discussion in order to fix the facts firmly in mind, as these principles are all directly applicable to the operation of radio apparatus.

COUPLING R.F. STAGE TO DETECTOR

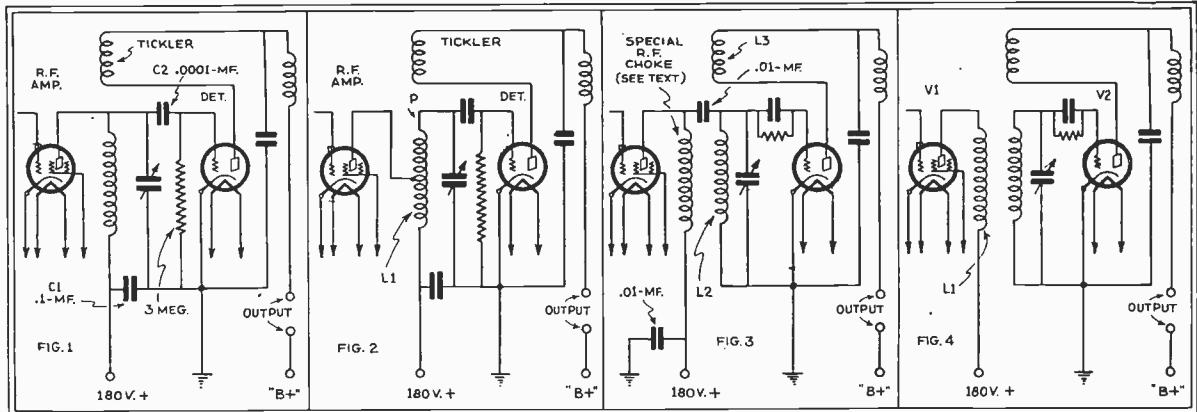

Tuned plate impedance coupling.

● ONE of the most popular types of short-wave receivers in use today consists of a tuned stage of R.F. amplification followed by regenerative detector and an audio amplifier.

In this article we shall discuss different methods of coupling an R.F. amplifier to a regenerative detector.

One of the simplest methods makes use of a tuned plate imped-

Here impedance coil, P, has tap.

ance. This method was very popular in the past, as it required only a 4-prong socket for the plug-in coils and in addition it simplified coil construction, as only two windings are used, tickler and plate impedance. A circuit of such a system is illustrated in Fig. 1. This method gives good results with certain reservations. Unless condensers C1 and C2 have good insulation, noisy reception will be experienced. Then, too, the tuning con-

R.F. plate separated by choke.

ditioner has a potential difference of 98 to 250 volts existing between rotor and stator, depending on the voltage applied to the R.F. tube's plate.

Efficient coupling with three-coil coupler.

In Fig. 2, a slight variation of this circuit is illustrated. The plate of the R.F. tube is connected to a tap on the plate impedance L1; this tap may be a center tap. Several taps should be made on the

(Continued on Page 33)

AUDIO AMPLIFIERS FOR S-W SETS

● MANY set constructors give little attention to the design of the audio amplifier for a short-wave receiver, as they believe that it will have little effect on the final results. This is a mistaken idea, because a good audio system will make a great difference in any set's performance.

In general, more audio amplification is required for loud speaker operation of a short-wave receiver than is usual in a broadcast receiver. Signals are usually much weaker and in addition there is liable to be quite a bit of background noise. The ideal audio system should possess a substantially flat frequency response to insure good quality of reception and it also should be constructed in such

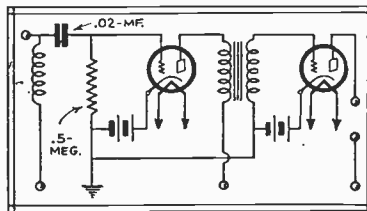

Fig. 1—One of the simplest audio amplifier systems. a manner that its response can be altered. By this it is meant that there should be compensating devices included in the circuit by which the relative amplification of the different audio frequencies can be raised or lowered with respect to each other. In brief, the ampli-

fier should have a carefully designed system of "tone control."

Figure 1 shows a simple audio system capable of giving very fine reproduction. Its chief drawback is that in most cases there is not enough volume for loud speaker operation.

By using a screen grid or R.F. pentode in the first audio stage and an output pentode in the second stage, it is possible to produce an amplifier giving good quality, together with ample volume. Such a system is illustrated in Fig. 2. By means of switch SW-1 the amplification of low frequency notes can be raised or lowered as desired. By adjusting potentiometer R4 the high frequency response can be raised or lowered.

(Continued on Page 33)

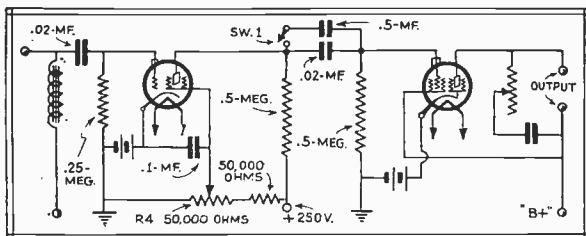

Fig. 2—Desirable A.F. amplifier employing SG tube in first stage and pentode in output stage.

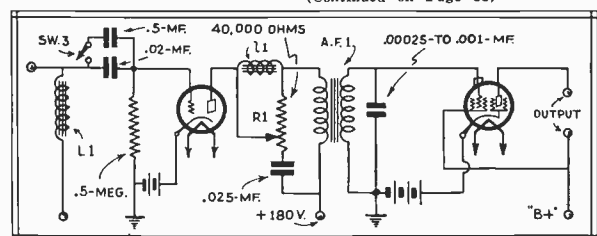

Fig. 3—Showing audio frequency amplifier with scheme for adjusting the frequency response.

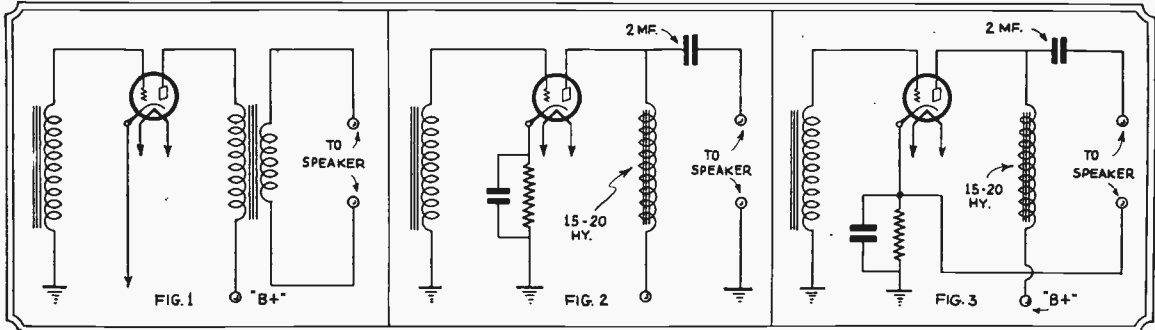

Fig. 1. Connecting speaker by transformer. Fig. 2. Coupling with choke and condenser. Fig. 3. Still another choke-coil coupling.

Methods of Coupling To Speakers

By M. H. GERNSBACK

● ONE of the most important, but strangely neglected, points to be considered in the design of a short-wave, or for that matter any type of receiver, is the method of coupling the loud speaker to the output tube of the set. If this point is neglected much of the care put into the design of the receiver is wasted. Failure to utilize a suitable method of coupling will result in lack of volume, mediocre quality of reproduction and in some cases violent distortion and instability.

It is the intention of the writer to discuss this problem in a critical manner from the standpoint of practical results.

First of all, why is an output coupling device necessary? An output unit serves two purposes. The first is to prevent the plate current of the output tube from passing through the delicate windings of the loud speaker. This plate current is quite considerable and if allowed to circulate in the coils of the speaker would demagnetize the speaker and possibly burn the windings out. If the output tube does not consume more than 8 milliamperes in its plate circuit, it is not necessary to protect the speaker windings in this manner.

The second purpose of the output unit is to match the impedance of the plate circuit of the power tube to the impedance of the voice-coil of the speaker. The impedances of different types of speakers cover wide ranges. The average magnetic speaker has an impedance of 2000 or 3000 ohms, while the voice coil in a dynamic usually has an impedance of from 1 to 10 ohms. Quite a difference between the two types! In the light of these figures it is obvious that some sort of coupling device is absolutely necessary between the speaker and tube to adjust these wide differences.

Two General Coupling Schemes

There are two general types of coupling in use. The first is by means of a transformer placed between the speaker and the tube. The primary of the transformer is designed to conform to the plate impedance of the tube, while the secondary matches the impedance of the speaker. The transformer method is essential when using a dynamic speaker, as it is impractical to use any other method, due to the low impedance of the speaker's voice coil. The secondary of the transformer must have an impedance equal to that of the voice coil.

A discussion of the value of the primary impedance will be undertaken in a later paragraph. A diagram of the transformer type of coupling is shown in Fig. 1.

The second type of coupling makes use of an A.F. choke coil and a fixed condenser. The choke coil is placed in series with the plate lead of the output tube. The size of this choke varies with the type of tube used, but for the ordinary triode having a plate impedance of two or three thousand ohms a 15 or 20 henry choke should be sufficient. A fixed condenser of about 1 mf. should be connected to the plate terminal of the tube. The other side of this condenser is one terminal for the loud speaker. The other loud speaker terminal is taken to the ground of the receiver. If the receiver is operated from the light line and the bias for the output tube is secured by voltage drop in a resistor connected in series with the cathode of the tube and ground better low note response will be assured by returning the loud speaker terminal to the cathode of the output tube instead of to the ground. See Figs. 2 and 3 for complete details. The output of this type of coupling is suitable

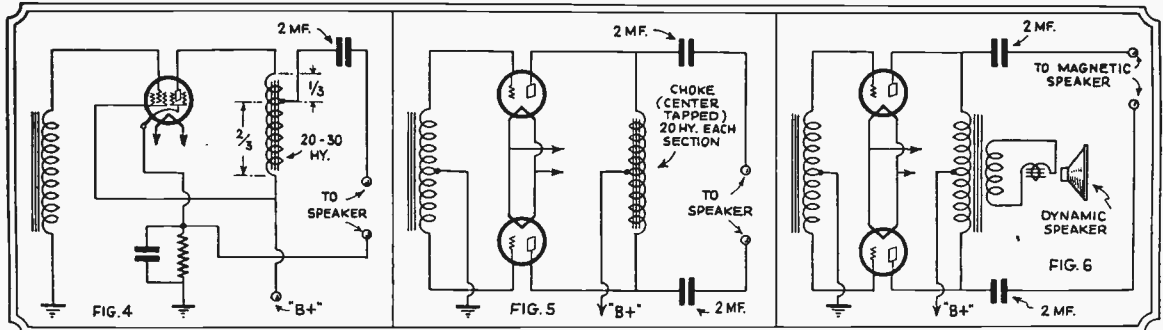

Fig. 4. Pentode coupled by tapped choke. Fig. 5. Push-pull coupling through choke. Fig. 6. Operating two speakers at once.

only for a speaker of fairly high impedance, not less than 2000 ohms. It is useful for this reason with magnetic speakers and headphones.

When a pentode is used in the output stage the most common coupling method is to use a transformer. This transformer must have a much higher primary impedance than that used for a triode. If a tapped choke is available the choke method of coupling can be used. The choke should be tapped one-third of the way from one end. The total inductance of the choke may be about 20 or 30 henries; the plate of the tube should be connected to the end of the choke nearest the tap. The other end of the choke goes to "B" plus. A 2 mf. condenser is connected from the tap to one terminal of the loud speaker. The other terminal of the loud speaker goes either to ground or cathode, as with the triode tube. This method of coupling for a pentode has been used but little in this country but is very popular in England. See Fig. 4.

time, they are made in such a way that the changes can be made easily. A bakelite strip 4 inches long and 1 inch wide is equipped with four binding posts and mounted on the baseboard with brass angles. Stiff pieces of wire (bus-bar) are fastened on the coils and these wires are secured in the four binding posts. The mounting strip is shown in Fig. 4. In drilling this strip, be very careful not to crack the bakelite.

The remainder of the parts may now be screwed into place on the baseboard as shown in the layout, Fig. 5. Finally, the panel is fastened to the baseboard with the two wood screws and the set is ready for wiring.

The binding post at the front of the coil mounting strip, marked 1, is at the "grid" end of the tuning coil. It is connected to the stationary (fixed) plates of the tuning condenser C1 by a piece of hook-up wire. One end of the grid condenser C2 is also connected to the binding post 1. A wire is soldered to the soldering lug on the condenser and the other end is soldered to the binding post. A third connection is made from this same binding post to the aerial terminal through condenser C5. This condenser is formed of two brass angles mounted on the baseboard, facing each other, but not touching. There should be a space of about 1/16 inch between them. The exact size of the angles and the spacing between them is not critical, so we may use approximate dimensions.

A number of the wires of the set are connected together and grounded to the "Ground" binding post. To facilitate making these connections, a machine screw is passed through the baseboard, below binding post 2 of the coil mounting. A

Push-Pull Output

When the output stage is push-pull type it is also possible to use either choke or transformer coupling. Figure 5 illustrates a simple method of coupling a magnetic type speaker to the output of a push-pull stage. See Fig. 5. This method may also be used where a transformer is used in the output of the amplifier. If the transformer has a low-impedance secondary for the voice coil of a dynamic speaker, it is possible to add a magnetic type speaker in this way. See Fig. 6.

The methods of determining the impedance of a transformer for the output tube is quite involved, but for triodes the usual value of the load impedance is approximately twice the value of the internal impedance or A.C. plate resistance of the tube. If a tube has an internal impedance of 1900 ohms the load impedance will be about 3800 ohms. This is not an exact figure but is close enough. In the case of the pentode this relation does

not exist. The load impedance of a pentode tube is always much less than the tube's A.C. plate resistance.

The following chart gives the recommended load impedances for a number of generally used tubes. All values are for use where the tubes are operating at the plate voltages mentioned. It is necessary or course that the correct grid bias be applied to the tube.

Load Impedance		
Tube	ohms	Plate Volts
10	10200	425
12, 12-A	10800	180
20	6500	135
31	5700	180
33	700	135
38	13500	135
45	3900	250
45	4600	275
46 (Class A)	6400	250
46 (Class B)	5800 (for 2 tubes)	400
47	7000	250
50	4350	450
71, 71-A	5350	180

THE BEGINNER'S S-W RECEIVER

(Continued from Page 10)

connection is made to a soldering lug under the head of the screw to this post. By referring to the picture layout of the under side of the set, Fig. 6, the wires connecting to this screw may be readily seen. One side connects from the rotary plates of the tuning condenser C1; another from one of the terminals of the rheostat R2; a third runs from the bypass condenser C4, which is fastened to the under side of the baseboard; still another wire connects to one side of the condenser C3; another connects to one of the F binding posts on the tube socket and the last wire runs from the screw to the "Ground" binding post of the set.

The remaining wires are as follows: The third binding post from the front on the coil mounting is wired to the remaining soldering lug on condenser C3 and through the baseboard to the back phone terminal. The fourth post on the coil mounting connects to the P terminal on the tube socket. The lug on the other side of the grid condenser C2 is connected to the terminal G on the tube socket which is adjacent to it. A wire is soldered to the other angle of the condenser C5 and connects to the aerial binding post. The front phone terminal connects to one of the soldering lugs on condenser C4 which is also connected to resistor R3 with a wire through a hole in the baseboard. The resistor R3 is equipped with three terminals. The center one and one of the outer terminals are used and the third one is left open. The second terminal on this resistor is soldered to a wire which connects to the right hand binding post at the rear of the set.

The center binding post of the three at the back of the receiver is connected to one side of the rheostat R2 and the left hand binding post is connected to the other F terminal of the tube socket. This completes the wiring of the receiver. It is advisable to check the wiring to be sure that all the wires have been connected. This can be done most readily by marking off the wires on the diagram with a colored pencil as the wires are checked off.

The coil forms are made of short lengths of two-inch tubing cut from the eight-inch piece obtained. They are all 1 1/2 inches long, except the largest, which is two inches long. To cut the tubing, measure off the 1 1/2-inch length with a ruler and wrap a strip of paper several times around the coil at the desired point. Then with a pencil, a straight line may be marked around the tube.

The lengths can then be cut off with a hacksaw and the edges smoothed off with a file. Two holes are then drilled near the edges, directly opposite each other, to permit the insertion of small screws for holding the ends of the wire and the mounting "legs." The legs are simply pieces of stiff wire (bus-bar) bent around the screws and spaced to fit in the mounting strip binding posts.

The coils are all wound with No. 22 double silk covered wire. All the coils are wound in the same direction, and each coil should be centered on its form. There are six coils numbered in the following table according to the number of turns.

Coil No. 1.....	45 turns
" " 2.....	18 "
" " 3.....	12 "

(Continued on Page 29)

AERIALS FOR SHORT-WAVE RECEIVERS

By C. W. PALMER

Why the Aerial Is Used

● AT THE broadcasting station the antenna system (aerial and ground) is used to create the electromagnetic radiations that we call "radio waves," which travel out into space. For this reason, transmitting aerials are designed so that a maximum amount of power is radiated. At the receiving set, on the other hand, the function of the antenna is to act as a circuit in which the passing waves from the broadcasting station may be picked up. The waves that make up the signals from the transmitting station cause corresponding high frequency alternating currents to flow up and down through the circuit between the aerial and ground, which really forms the plates of a large condenser (like the plates of the variable condenser in a set). This effect is shown in Fig. 1.

Types of Antennas

A number of forms of antennas have been devised for transmitting and receiving, some of which are generally useful and others which have special characteristics that adapt them to a particular use. However, we are not particularly interested in the latter now, and we will consider only those of general use for short-wave reception.

Figure 2 shows three simple forms of antennas. At the left is the vertical type, consisting of a single wire suspended vertically in the air. This type of aerial receives equally well in all directions. At the center of the illustration is the T-type aerial, consisting of a wire suspended horizontally with a vertical connecting wire (called the lead-in) at the central point. Antennas of this type receive best from the two directions of the ends of the horizontal wire. At the right of Fig. 2 is the inverted L-type aerial, commonly used because of the convenience of erecting it. It receives best from the direction of the lead-in. For most wavelengths, the directional effects of these three aerials are not very pronounced; however, on certain wavelengths, especially on certain very short ones, the directional effect of the inverted L is quite marked.

In Fig. 3 are shown two other less common types of aerials. The left one is the horizontal V-type, which receives best from the direction of the lead-in. The other is known as the umbrella type be-

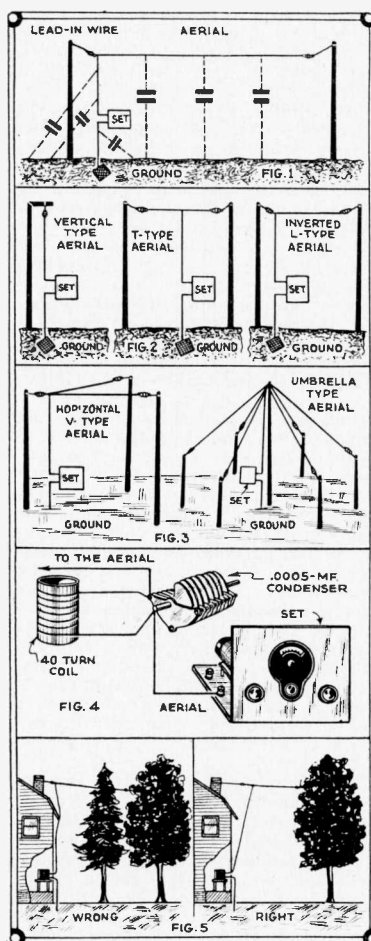

Illustrating various simple types of short-wave aerials suitable for receiving purposes.

cause of its resemblance to the ribs of an umbrella. This type is much less common than the others because of its complicated structure. It is used more frequently for transmitting, because of its low resistance and also because it sends equally well in all directions.

The Antenna Installation

Any attempt to set down rules for making an aerial of definite dimensions would be foolish, as we can all see. Every antenna installation presents different conditions;

thus it is perfectly easy to say that the ideal aerial for general short-wave reception is one 50 feet long and 100 feet high, but it may not be practical to follow these instructions because of the surrounding layout of buildings, etc. In crowded locations, such as city apartment houses where one encounters difficulties because of the presence of other aerials and finds no convenient support for the contemplated one, the best judgment must be exercised.

The writer has found that the horizontal type of antennas are preferable to the vertical types. In one particular case, it was found that a horizontal 30-foot wire of the T type would bring in stations 200 miles away with several times the intensity possible with a vertical wire of the same dimensions.

In building an aerial for our Beginner's Short-Wave Set, it may be found that greater signal strength is obtained if we use a short aerial of about 25 or 30 feet total length for the two smallest tuning coils. A few of us may also be unfortunate enough to have trouble in getting the set to oscillate on certain parts of the dial with one or more of the tuning coils. In this case, if the length of the aerial is changed slightly, this trouble will disappear. The difficulty is due to the natural wavelength of the antenna being tuned to one of the wavelengths at which we desire to receive a station. In this case, the aerial absorbs so much energy from the set that it cannot oscillate.

While we are talking about trouble with our receiver, a few of us may be unfortunately located quite near a large broadcast station operating on the broadcast band and may have difficulty in tuning it out. A simple but effective cure for this interference is a wave trap. The trap is simply a coil and a variable condenser which will tune to the wavelength of the broadcast station. It is connected in the aerial lead-in wire. A suitable coil which will tune over the entire broadcast wave band consists of 40 turns of No. 22 wire wound on a coil three inches in diameter. The condenser may be any variable condenser of about .0005 mf. (23 plates). Figure 4 shows how the wave trap is made and connected in the aerial lead-in. All that is necessary is to tune the condenser slowly while listening to

the receiver. At one point the broadcast station will either disappear entirely, or nearly so. So much for the trouble in our set.

To return to the construction of antenna systems, in Fig. 5 we find two illustrations of a typical aerial installation. At the left is shown how NOT to do it and at the right is illustrated the correct way. It will be noticed that the correct aerial is kept clear of all obstructions and that the lead-in is removed from the building. The aerial wire should be suspended as far away from nearby electric light and power wires as possible. If it is in a direction at right angles to is practical, the wire should be run such wires, also those of trolley lines, electric railways, etc., from which electrical disturbances might be picked up. In this case the lead-in should be taken off the end furthest from the source of the disturbance.

We must also be careful to keep the aerial away from metal roofs, gutters, leaders, steel framework, etc., since these grounded objects absorb the radio energy and leave very little for the antenna.

The Lead-In

As we explained in Fig. 5, the lead-in wire should be kept some distance from the wall of the building. It must never be allowed to touch the metal cornice or leader at the edge of the roof, for these are grounded. It is a good plan to bring the aerial wire directly into the set. In this way, no difficulty is encountered with connections becoming loose or corroded. Figure 6 shows a method of bringing the wire down at the lead-in end without making a joint.

Two systems for bringing the lead-in wire into the building are commonly employed. The simplest way is to bring it through the nearest window, using a special insulated lead-in strip which is sold for the purpose. These strips consist of a flat conductor about 1/2-inch wide covered with a flexible

Do you know the best type aerial for your set and your location? Read this simple explanation.

insulating covering. The strip is placed under the window so that it will close. The end of the lead-in is connected to the outside terminal and a wire is connected to the inside terminal for the purpose of connecting to the set. It is well to solder the two wires to this strip to prevent corrosion from increasing the resistance of the aerial. This method is illustrated in Fig. 7.

The other method that is used to carry the lead-in into the building consists of a hollow porcelain bushing similar to those used for certain types of electrical wiring. A hole is drilled through the wall, slanting down to the outside, as we can see by referring to Fig. 8. The purpose of this down slant is to prevent rain water from entering the tube. The lead-in wire is passed through this tube and is connected directly to the set. Of course, in brick buildings the latter method is rather difficult, so the window strip is more commonly used. Another method is that described by Mr. H. Gernsback, which involves the use of two small copper foil leaves glued opposite each other on the window glass.

The Ground Connection

For both the aerial wire and the ground lead, a wire of not less than No. 14 should be used. In order to get good results, we must keep the resistance of the antenna system as low as possible. It is a good plan to use enameled wire so that the wire will not become corroded, as this would cause an increase in the resistance.

The ground connection should provide an electrical connection of as low a resistance as possible to the earth, since the earth acts

as one of the large plates formed by the antenna system. We can easily understand that if the ground is not good, the aerial is not good either. The importance of a good ground connection cannot be too strongly emphasized.

A water pipe which forms part of a water supply system installed in the ground usually makes an excellent ground, since the pipe makes a direct contact with the earth for a long distance. It is well to note that the water pipe grounds are approved by the Board of Fire Underwriters, as they are usually more efficient than the average artificial or homemade variety of ground connections.

In making the connection between the ground wire and the pipe, it is advisable to use a ground clamp, as a wire wrapped around the pipe may become corroded and a poor connection will result. A ground wire connected to a simple strap-type ground clamp is shown at the left of Fig. 9. In order that we may be sure of a good connection, it is necessary to file or sandpaper any paint or rust from the pipe. Another type of clamp that is tightened by a screw to the pipe is shown at the right of the illustration.

When it is not possible to use the water pipe, in places where the water is not piped to the house, a copper plate, a bucket or other large metal object may be sunk in a well or cistern.

Another way is to bury a copper plate about two feet square in moist earth. In general, the greater the number of well grounded objects that we can connect to the ground lead, the better will be the reception, especially on the very short waves. This difference may not be noticed particularly on the nearby stations, but it will certainly be noticed in the reception of distant stations.

A suitable approved lightning arrester should always be used with any aerial, as the Underwriters' rules require it.

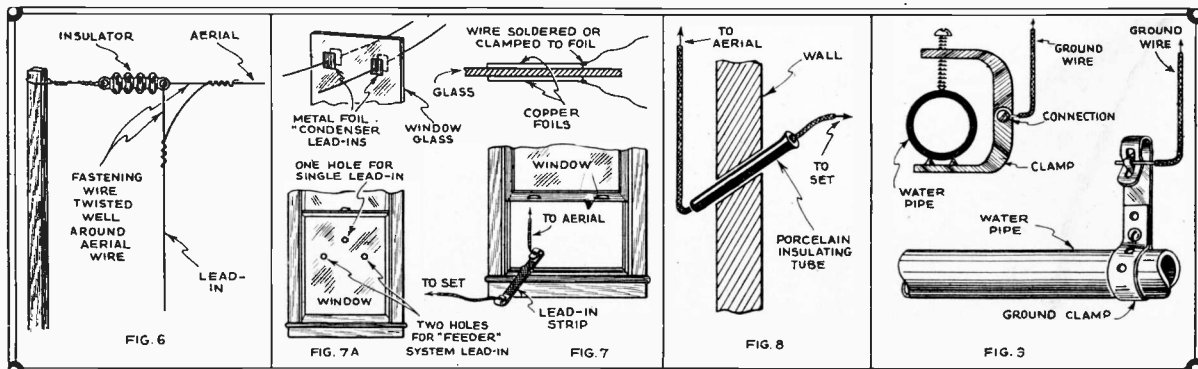

Various details worth watching out for in constructing short-wave receiving antennas.

GOOD ANTENNA DESIGN

By ARTHUR H. LYNCH

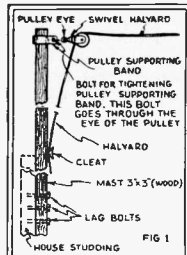

Fig. 1—Type of mast used by the author for ten years. 3"x3" wood, painted every three years with gray marine paint as a protection against the weather. Mast can be held against the house by lag screws into studs or ordinary bolts may be used.

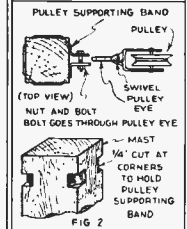

Fig. 2 — Enlarged view of the section shown at Fig. 1, showing mastic corners of mast cut to hold pulley wire or rope. Commercial type hooks are available in the chain stores very cheaply; see figures below. Iron parts are best painted to give weather protection.

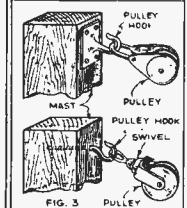

Fig. 3—Top view of the mast pulley-hook and assembly. A good pulley supporting band can be made from a regular ground clamp. Slip the pulley eye over the bolt used to hold it before the bolt is put through the band itself.

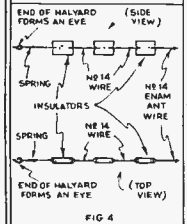

Fig. 4—Two views of the "free end" of antenna system. The insulators are especially thin, for short-wave requirements. No. 14 copper wire ties the insulators together. The wire is coiled on itself and soldered. The wires should not be longer than 6\"/>

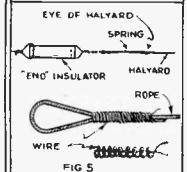

Fig. 5—Assembly at the extreme end of the antenna. We see the last of the three insulators, the tie wire connecting it to the spring and the tie wire joining the spring with the eye of the halyard.

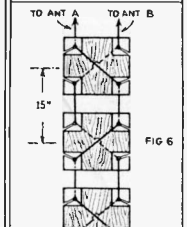

Fig. 6—Note carefully how transposed antenna leads are run to the receiver. Leads pass through transposition blocks as shown to prevent twisting. "A" enters the block at the upper rear, while "B" enters the block from the upper front side.

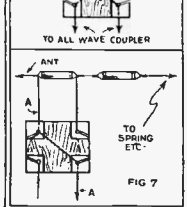

Fig. 7—Simple single wire antenna with transposed lead-in taken from one end. "A" passes through the TRP block and joins directly to the flat-top. "B" ends at the lower TRP block and "A" then goes to the receiver.

Fig. 8—Shows the "cage" type of antenna. It has great "pick-up" range without being directional. Total length about 75 ft., using several insulator spreaders as shown. Weights keep the antenna from swaying and twisting.

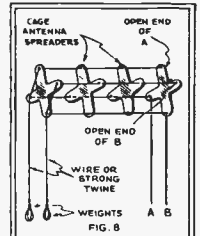

Fig. 9—Method of connecting extreme "cage" spreader to the regular aerial insulating system. Note that two tie wires are run in the form of a braid, from the grooves on the spreader to the first antenna insulator.

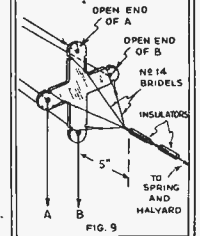

Fig. 10—Absorption is prevented by keeping the transposed lead-in well away from the building. Two insulators are secured to the end of a 1 1/2" x 1 1/2" pine stick 3 to 4 ft. long, supported by a shelf-bracket.

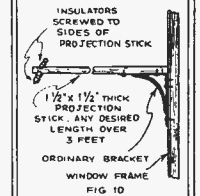

Fig. 11—Typical arrangement of dipole antenna with transposed "noise-eliminating" lead-in. It is almost useless to employ one of the newest "anti-static" shielded receivers, unless you also use one of these new transposed lead-in arrangements.

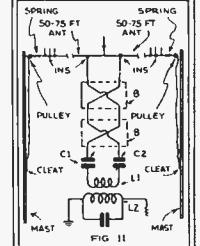

Fig. 12—The Lynch "All Wave" Automatic Antenna Coupler, which couples any of the new antenna systems with transposed lead-ins, to any receiver. Variations in wavelength are compensated for by changing the position of the Lynch coupler inside the first RF coil of the receiving set.

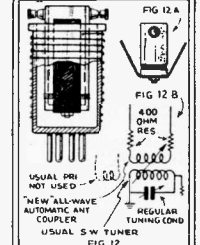

Fig. 13—This picture shows how the author mounted an aerial mast on his house. The mast being well painted and lag-screwed to the stud or bolts may be used.

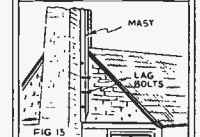
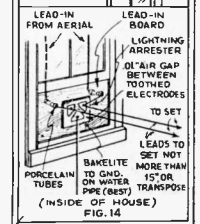

Fig. 14—A very good design for a lead-in board, which may be made in two halves, is here shown. The lightning arrester can be bought or made. Two holes may be drilled through the window glass if desired.



● SOMEONE has said that a good antenna is as good as a stage of radio frequency amplification. I do not remember who made the remark, but I do know that it was intended to refer to broadcast reception. It is even more apropos of short waves and it is still more desirable where television reception is desired. It is to be regretted that most manufacturers and practically all experimenters have not given this important subject the attention it deserves. Perhaps, to paraphrase the older quotation, we might say that a good antenna is the best and cheapest form of amplification.

In general, a good antenna for broadcast reception may not prove very satisfactory for either short waves or television. On the other hand, an antenna which is suitable for short wave reception is also suitable for broadcast reception. We will, therefore, consider the entire proposition from the short wave point of view.

Regardless of the particular type of antenna we are to construct—and there are a great many varieties, it should be remembered that it will give the best results if it is as high and as long and as free from surrounding objects as possible.

Another important consideration of the antenna system, is that it should be as thoroughly insulated as possible. The insulators chosen for this important part of the receiving system should be as free from high-frequency losses as possible and should be designed to avoid the accumulation of moisture. It is sometimes thought that glazing of insulators accomplishes this purpose. This is true, to an extent, but it is equally true that very satisfactory insulating materials have their resistivity reduced in direct proportion to the amount of glazing applied to them. It should also be remembered that, though some special glass makes highly desirable insulating material, it is not cheap. When glass insulators may be had for a few cents, it may generally be assumed that they are made of a quality of glass which is not desirable for short wave use. Some cheap glass contains lead and it may be realized that its resistivity is not very high. Insulators made of cheap glass and porcelain will work fairly well on

the broadcast wavelengths, but they are not suitable for use where the best results are desired on the short waves.

Considering, therefore, that we have determined upon the type of antenna which we are to use and that we have found a suitable place to install it as high and as free from all surrounding objects as possible, we are confronted with the problem of getting all the energy from the antenna to the receiver itself, without permitting the lead-in to pick up any interference. This is accomplished very easily by the use of a transposed lead-in. The accompanying illustrations give all the details. Keep the transposed lead-in three or more feet from the building, by means of the

projection insulators, shown in Fig. 10.

It is highly desirable, therefore, to have the leads from the place where entrance to the room is made to the contact with the receiver just as short as possible. If it is impossible to keep these leads very short, they should be transposed, in just the same fashion as the outside portion of the lead-in. In fact, more interference is picked-up inside of apartment houses than is picked up outside.

We now come to the important matter of connecting the transposed lead-in to the receiver itself. A very ingenious scheme has been developed for doing this job. It is

the result of the combination of several coupling systems which have been in use at several of the important commercial receiving stations for some time. The coupler itself is shown in Fig. 2. It is nothing more than a suitable moulding which acts as the housing for the antenna coupling coil and the balancing resistance units which make up the coupler proper. It will slide right into almost any regular coil form and it requires no adjustment for changes from one wave band to another. The two legs of the antenna are automatically balanced by the action of the metallized resistors, while the shift from one wave band to another is accomplished by securing the correct degree of coupling.

Coil No. 4.....	8 turns
" " 5.....	6 "
" " 6.....	4 "

The grid or "tuning" coil is inserted in binding posts No. 1 and 2 of the coil mounting. The plate or regeneration coil is inserted in binding posts No. 3 and 4. The coils can be used as either grid or plate coils, but the following combinations are ordinarily employed:

Meters	Grid Coil	Plate Coil
190-100	No. 1	No. 3
100-60	No. 2	No. 4
70-45	No. 3	No. 4
50-28	No. 4	No. 5
28-18	No. 6	No. 5

The next point in the installation of the set is the construction of

THE BEGINNER'S SET

(Continued from Page 25)

the aerial and ground. The aerial consists of a wire about 50 to 100 feet in length suspended on the roof or in any other convenient way. The ends of the wire must be insulated by placing glass or porcelain insulators between the wire and the support. The wire brought down from the aerial to the set must be insulated as carefully as the aerial itself, if good results are to be obtained.

The ground consists of a wire wrapped tightly around the water pipe or steam pipe. The pipe

should be sandpapered so that a good contact can be made.

Our set is now ready for operation. Turn the rheostat about half way up and rotate the regeneration control knob until the set goes into oscillation. This is a phenomenon easy to recognize by the click and hissing sound after a certain point is passed in turning the knob. The point where oscillation begins is the most sensitive operating point for the receiver. Now, if we turn the tuning dial slowly, re-adjusting the regeneration control to keep the set at the point of oscillation, we will find the locations on the dial for various stations.

plifier is shown in Fig. 4. The similarity to the resistance amplifier is quite evident.

The "Beginner's" Amplifier

Now, we will consider the problem of adding an amplifier to our one-tube set.

First, we will need a few more parts than we used in the first set.

- 1 Audio transformer, Thordarson R260.
- 1 4-prong tube socket, Pilot type 216.
- 1 Type 30 tube, Triad.
- 1 4½-volt "C" battery, Burgess Battery Co. type 2370.
- 1 Binding post, Eby Junior.

When the parts are all procured the changes can be made. The transformer is mounted at the right-hand side at the back. To place this unit, one of the binding posts must be moved, as we used as wide spacing as possible between these terminals in the original set. Half way between the two left-hand binding posts, drill another hole for the one that we removed and the same distance to the left of the extreme left-hand one, drill another hole for the extra terminal.

Next, mount the transformer at the point indicated in the photographs, with the terminals marked P and B to the left. Then drill four holes for the wires from the transformer terminals through the baseboard, as close to the terminals

THE BEGINNER'S AMPLIFIER

(Continued from Page 13)

as convenient. Then mount the new tube socket between the detector tube and the tuning condenser, slightly to the right as shown. The socket terminals should be placed so that the G and P binding posts are to the back. Then drill four holes through the baseboard for the wires from the socket.

Now that the parts are all in place, the wiring can be changed. First remove the wires that must be changed. These consist of the following: The wire from the plate coil to the phone binding post is removed. The wire from the other phone terminal that was connected to the .5-mf. condenser and the regeneration control is removed. The wires on the two remaining battery binding posts of the original set are taken off, as they must be shifted around.

Wiring the Amplifier

The wiring of the amplifier can now be started. Connect a wire from the plate coil and .00025-mf. condenser to the P terminal on the transformer. Now connect a wire from the B terminal of the transformer to the oscillation control and .5-mf. condenser. Next connect a wire from the G binding post on the transformer to the G post on the amplifier tube socket, and one

from the F post of the transformer to the binding post at the extreme left at the back (looking from the front of the set). This is for the negative terminal (-4½) on the "C" battery. Connect a wire from the P terminal on the amplifier tube socket to the front phone binding post, and one from the back phone post to the battery binding post at the extreme right. Another wire from the volume control that we removed from the former right-hand binding post also connects to this right-hand post. This is the connection made to the positive "B" battery terminal (+45). The second battery post from the right, looking back from the point of the set, is the negative "A," negative "B" and positive "C" (-A, -B, and +C). This terminal is connected to the left terminal on the filament rheostat, and was formerly the center of the three battery binding posts.

The third battery post from the right is the "A" positive (+A) and it is connected to the rear filament terminal on the detector socket. An additional wire is now run from this socket terminal to the left-hand filament terminal of the amplifier socket. The right-hand filament terminal of the amplifier is connected to the front filament terminal of the detector socket.

SOME THINGS YOU DON'T KNOW ABOUT S-W AERIALS

By DON C. WALLACE

● FEW people realize what a pronounced improvement in reception is had from the use of a properly designed short-wave antenna system. It must be correctly laid out, correctly built and correctly installed in the proper place.

The best location for an antenna is on or over vacant property. A "back lot" antenna is superior to one that is stretched across the housetops. The unusually large network of house-wiring, all of which is directly, inductively or capaci-

differ from the traditional. This article deals with the successful and practical compromise of antenna systems that are within the reach of all.

The Size of Wire to Use

In order named are the practical sizes of antenna wire which are best suited for short-wave reception:

1. No. 6, No. 8 or No. 10 solid copper enameled wire for the flat top portion and No. 12 enam-

will be so far advanced as to lower the efficiency of the antenna.

In the early days of radio, Saturday was antenna cleaning day. Several of the more enthusiastic would lower the antenna and polish the wires with steel wool. Steel wool was not pleasant to handle and a pair of old leather gloves was donned to prevent the fine particles of steel wool from entering the flesh of the hands.

Theoretically, the corrosion of copper wire, if sufficiently corroded, is just as good an insulator as an enameled coating. But too often the corrosion is unevenly distributed and, therefore, of uncertain effectiveness. Consequently, enameled covered wire is ideal for a short wave aerial.

Other coverings may be used, such as rubber, weatherproofing, paraffin cloth, cotton or silk, or any other covering of a good insulating quality.

The span of copper is all-important, the covering of the wire of secondary importance. The covering for portable aerial of station W6ZZA is a double layer of silk cloth woven over a large number of strands of carefully cut-to-size loop wire. Both the flat top portion and the feeder system use this kind of wire. One of the feeder wires is green silk covered loop wire, the other feeder is brown, making it easy to prevent the feeders from becoming entangled when the portable aerial is erected on a hotel roof after dark. This flexible loop wire is not as good as enameled wire but it permits of speedy installation and enables the operator to wind the antenna around the lid of a cigar box when it comes time to check out of the hotel.

It is repeated that solid copper wire is specified for short-wave aerials. Stranded wire offers more surface, lower resistance to the R.F. currents on the broadcast band. But it is not as good as solid wire for short-wave reception. This is because the higher frequencies (short waves) alternate so many times per second that certain losses are introduced when uneven-surfaced wire is used. The high frequencies tend to jump from wire to wire (stranded wire is twisted) rather than to follow the twists of the wire. Solid copper wire eliminates this "jumping" tendency, thus making an easier path for the flow of currents. Therefore, solid copper wire is recommended.

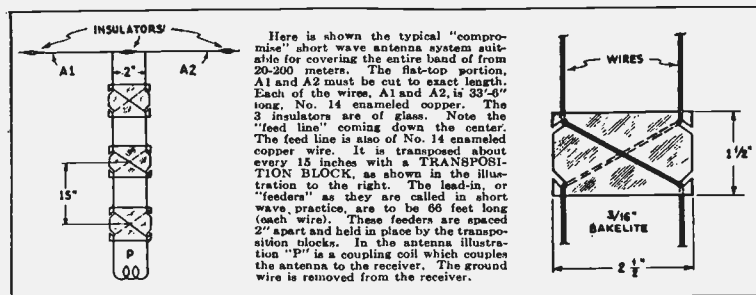

A typical short-wave aerial using a transposition lead-in.

tatively coupled with all of the electrical devices in the city, picks up noises which are inherent in the wiring system but which are not picked up a few yards distant.

Too many treatises on antenna systems deal with the subject in a vague, general manner. Actual dimensions are left to guesswork. This article gives exact dimensions, their importance being such that the success of short-wave reception depends upon them to a greater extent than the average experimenter is aware of. A surprisingly large number of new stations will be heard if the proper short-wave antenna system is used.

The dimensions and placement of the antenna are more important than the kind of wire used. The ideal antenna wire is that of the largest size, consistent with the ability to erect and permanently suspend it in the proper place. Conditions too often do not permit the use of large wire, neither will the pocket book afford it. A compromise must be made. Radio, in all its branches, is a compromise . . . between convenience, cost, time, ease of construction and operation, availability of material, knowledge of the subject, inherent inhibitions against things "new" or those that

eled wire for the feeder system.

2. No. 12 solid copper enameled wire for both the flat top and feeder system.
3. No. 14 solid copper enameled wire for both the flat top and feeder system.

Wire smaller in size than No. 14 is not strong, mechanically. It will not permit of "full stretching" when pulled taut. As a last resort No. 16 enameled wire could be used with perfectly satisfactory results. In general it is suggested that No. 12 wire be used for spans of more than 100 feet and No. 14 for spans of less than 100 feet. Enameled wire is the more practical to use. Radio frequency currents have a tendency to travel on the surface of the wire. Bright new copper wire would be best if it could be made to retain its shiny finish. The R.F. (Radio Frequency) currents travel with minimum loss on a bright surface, the antenna system radiates with greatest ease, and maximum efficiency is the result. However, corrosion on the surface of the wire will increase the resistance to these minute R.F. currents and within 48 hours the corrosion

These details may seem commonplace and "finicky" to some. But it must be remembered that improvements and corrections in radio design multiply rapidly.

A 2408% Increase in Efficiency

If we make a 2% improvement in the kind of antenna wire used, a 2% improvement in antenna insulation, a 2% improvement in antenna dimensions, a 2% improvement in antenna placement, a 2% improvement in antenna coupling to the receiver, a 2% reduction in noise pick-up, a 2% improvement in receiver coil design, a 2% improvement in the tuning condenser, a 2% improvement in the grid leak, a 2% improvement in the shielding, a 2% improvement in the placement of the receiver in its housing, a 2% improvement in the radio frequency choke coil, a 2% improvement in the tube and coil sockets and contacts, we will then have a total improvement 2x2x2x2x2x2x2x2x2=2048%.

A 2% improvement in six of these places, or 2x2x2x2x2=32%, will not be perceptible to the human ear. Individually, these 2% improvements will result in no audible increase in volume, individually they are of no consequence. Collectively, the sum total of 2048% is what counts. This increase in efficiency will enable you to hear more stations, from more countries, with more volume and with greater ease. It is evident, therefore, that these little 2% increases, when multiplied, are of far-reaching importance in the total effectiveness of the completed receiver. Additional increases in efficiency are gained from the proper insulation of the antenna.

An antenna designed to deliver utmost performance at a certain frequency (wavelength) operates at peak efficiency only if tuned to its exact wavelength. At other wavelengths it does not deliver the same efficiency. Improper or poor insulation not only tends to distort the actual dimensions of the antenna but the antenna actually does not know where it terminates. Poor insulation is partly conductive. Thus the antenna has no definite terminating point. Like other things in radio, there is a difference of opinion as to the merit of various well-known insulating materials and the proper placement of the insulation. In practice we cannot resort to the last word in insulation because it is awkward, expensive and troublesome and the improvement which it offers over and above the accepted and commonplace method of insulation is not of sufficient importance to detract from the effectiveness of the properly designed all-around short-wave antenna system.

Insulating Materials

The best insulating materials for antenna are silk, linen, cotton, or

woven strands of these materials. They should be free from coloring because the base of all coloring is of a conductive nature. When silk, linen or cotton become wet the impurities in the material, plus the natural impurities in the air, introduce conductiveness and a consequent lowering of the insulating qualities of the material. The quality of insulation can be preserved by boiling the material in vaseline. In time the sun will melt the vaseline and the useful life of our "perfect insulator" is from six months to one year.

Obviously, this perfect insulator is not practical and once more we resort to the time-worn radio compromise by using glass for antenna insulation.

Those who can afford to pay a little more for better insulators are advised to use PYREX. Good porcelain, finely grained, well baked and completely glazed, is the next best thing to use. Glass is the nearly perfect insulator and is an ideal compromise for short-wave antenna. Glass insulators can be procured from your parts supply house.

As a possible alternative a maple dowel stick can be used. It should be from 3/8" to 1/2" in diameter, one foot in length, boiled for an hour or two in paraffin. Like the vaseline-boiled linen insulator, these dowel sticks are at the mercy of the weather, dust and soot particles will accumulate on the dowel surface and the effectiveness of the insulator is then considerably reduced.

Portable W6ZZA uses cotton string for insulation. A ball of string is thrown over an elevator shaft or penthouse, hoisted to the top of a flag pole or attached to some other convenient support. Because the cotton string is used but once it is not affected by rain or moisture and a negligible amount of soot and dirt will accumulate on its surface. Cotton string makes a perfect short-wave antenna insulator, most convenient in its application, will retain its insulating qualities for an entire week. Given a quick jerk it will break easily and down comes the aerial. The aerial is then rolled over the lid of a cigar box and thrown into a suitcase when checking out of the hotel. But this cotton string insulation is intended for portable use only.

Glass, being our perfect compromise for a permanent antenna installation, can be had in the form of insulators 3" in length. The standard Pyrex Glass insulator is of that length. Longer glass insulators can be used.

Points to Watch when installing S-W ANTENNAS

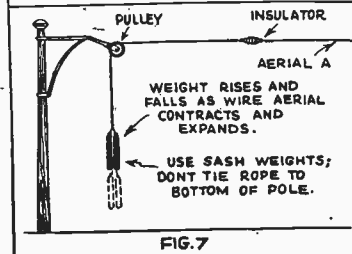
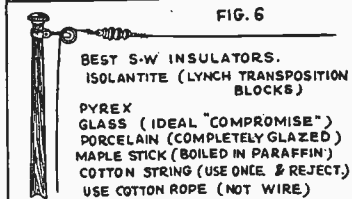
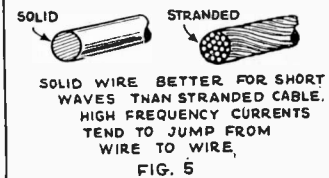
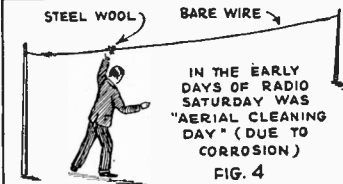
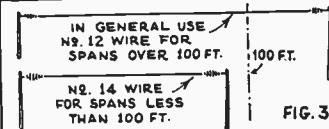
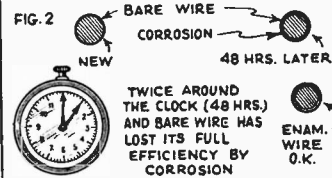
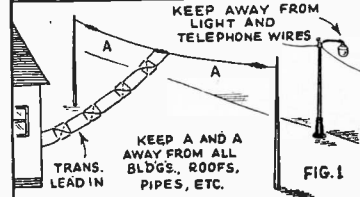

LEARNING THE CODE

By JOHN L. REINARTZ

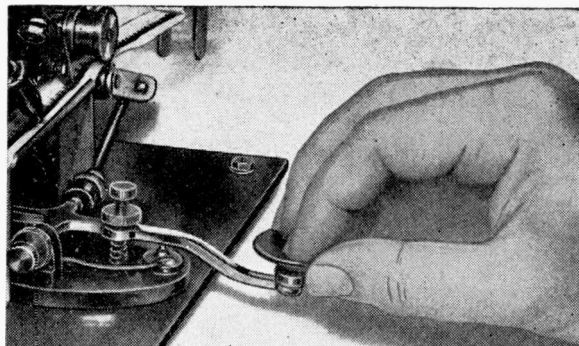

Illustrating correct position for gripping the key.

● ONE of the greatest mysteries to the uninitiated is how an amateur can make head or tail out of the jumble of dots and dashes that he hears in the ear phones. When one has learned how to read these dots and dashes it is quite an accomplishment; to read them at great speed is an art. Sometimes one meets an operator who can read the code, read a book and carry on a conversation at the same time. Edison was also one of these. All of us cannot be Edisons, so we won't be able to do all this at the same time, but we can learn how to read the code so that we may be able to obtain an operator's license and also be able to sit in and take our turn at the key and converse through the ether.

During the great war it fell to my lot to teach the code to several classes of future radio men for Uncle Sam. This was a splendid experience and indicated to me why some of us have such a hard time trying to get the hang of it. Time after time some student would be able to get as far as 5 words per minute and then be stuck, at times getting to the point of giving it up. At first it was a case of individual instruction to get by this 5 word per minute point, only in some cases to have the thing repeat itself at 7 or 8 words per minute. Always in a case of this

kind the student would be one who had a hard time trying to remember which letter in the alphabet followed the preceding one or which letter preceded the one to follow. It was so bothersome that I finally hit upon the stunt of starting a new student in to learn the alphabet both forward and backward before he was allowed to sit in and listen to a transmission.

This is what I want you to do if you really wish to learn the code. Go right after it; learn to say Z Y X W V U as well as A B C D E, even to be able to go on both forward and backward from any letter that may come to your mind, like M, say M L K J I or M N O P Q R and so on to the beginning or the end of the alphabet. When you are able to do that, it will be time enough to see what a key is like.

When the time comes when you think you are ready to read the code, get some one to do the sending for you. It is all too easy to learn how to send the characters that go to make up the letters of the alphabet, much easier than it is to copy them down when they are being sent by some one else. It is

much too early in the game to try to do the sending, anyhow. You won't be able to make the characters so they will sound like what they are supposed to. Get some one, even if it has to be your sister.

While you are looking for some one to send to you, look over the International code and get an idea what the letters become. You will see that A becomes . — and B becomes — . . . C — . . . D — . . . E . F . . . G — . . . and so on, dots and dashes being used to indicate a letter, these dots and dashes are usually spoken of as dit and dah, so you send A as dit dah, and B as dah dit dit dit, and C as dah dit dah dit and D as dah dit dit. The reason for this is that it really sounds that way when you listen to someone's transmission, the dots being very short and sounding like dit, while the dashes are longer and sound like dah, depending somewhat on the tone of the signal.

Now that you are acquainted with character A, go through the entire alphabet and memorize the rest of them. When someone says C you should be able to say — . — . dah

INTERNATIONAL MORSE CODE AND CONVENTIONAL SIGNALS

A . —	R . . .	S — — — —	PERIOD	FROM (OE)
B — . . .	S . . .	O — — — —	SEMICOLON	INVITATION TO TRANSMIT
C — . . .	T —	A' (GERMAN)	COMMA	(GO AHEAD)
D — . .	U . . .		COLON	WARNING—HIGH POWER
E .	V . . .	AorA (SPANISH-SCANDINAVIAN)	INTERROGATION	QUESTION (PLEASE REPEAT AFTER...)
F	W — —	CH (GERMAN-SPANISH)	EXCLAMATION POINT	INTERRUPTING LONG MESSAGES
G	X — —	E	APOSTROPHE	WAIT
H	Y — —	(FRENCH):	HYPHEN	BREAK (BK) (DOUBLE DASH)
I . .	Z	N (SPANISH)	BAR INDICATING FRACTION	UNDERSTAND
J	1	o (GERMAN)	PARENTHESIS	ERROR
K	2	U (GERMAN)	INVERTED COMMAS	RECEIVED (O.K.)
L	3	Q (GERMAN)	UNDERLINE	POSITION REPORT (TO PRECEDE
M	4		DOUBLE DASH	ALL POSITION MESSAGES
N . .	5		DISTRESS CALL	END OF EACH MESSAGE (CROSS)
O — —	6		ATTENTION CALL TO PRECEDE	TRANSMISSION FINISHED
P	7		EVERY TRANSMISSION	(END OF WORK) CONCLUSION
Q	8		GENERAL INQUIRY CALL	OF CORRESPONDENCE

[TO BE USED FOR ALL GENERAL PUBLIC-SERVICE RADIO COMMUNICATION. (1) A DASH IS EQUAL TO THREE DOTS; (2) THE SPACE BETWEEN PARTS OF THE SAME LETTER IS EQUAL TO ONE DOT. (3) THE SPACE BETWEEN TWO LETTERS IS EQUAL TO THREE DOTS; (4) THE SPACE BETWEEN TWO WORDS IS EQUAL TO FIVE DOTS.]

dit dah dit and not have to stop and think for a minute or more. You won't be ready to listen to any transmission until you are able to associate these dit dah things with the letter that they represent. You are now able to do two things; say the alphabet over both forward and backward and to transform the letters into dit and dah. Until you have mastered this part of the job of learning the code do not attempt to copy a transmission.

Unless you live way out somewhere you will find an amateur in your town or city. If you have not already made his acquaintance do so at once; you will find him a regular fellow whether he is fourteen or forty. Tell him that you are in need of someone to send the code so that you may have practice at receiving, ten to one he will arrange that you will receive this instruction. Be sure that who ever will do this for you will start off nice and slow. Two or three words per minute is fast. At first it will be necessary to have letters only sent with lots of time in between each letter. Get the hang of associating the dit dah with the letter it represents. Write it down as the letter and not as the character or dit dah. Do it the right way while you are at it, otherwise you will have to undo it at a later date.

About the time you are able to receive at the rate of 5 words of 5 letters each per minute, you will have spent several weeks at two hours a day, so if you are not getting on any faster than that

do not feel bad, as it is the average rate of learning. In a month you will do ten words per minute. About that time it will be safe for you to try your hand at the key. You will then know how a character should sound. Do not slur the dots and dashes. Make them distinct; allow the proper space between the dots and dashes. None of us uses the same time interval; that becomes part of the individual. Make the dash much longer than the dot, three to four times. It makes it sound lots nicer and it will also be easier to read.

Do not make the mistake of running the words together. Remember that some one else has to read what you send. As a rule the shorter the space between the characters themselves, the better the whole sounds. Have the dot or dash follow quickly. Make the dot as short as you can, follow with a short space and then make the dot if one follows nice and short; if a dash follows make it plenty long at first. When you have attained speed you will automatically cut down on its length.

In case you are so located that you are not able to get in touch with an amateur and you have no one who is able to send dots and dashes for you, there is still a way out. Look through the radio magazines and find a device called the Telepex, which consists of a clock work which drives a tape containing the dots and dashes. This can be run at any speed within reason, both fast and slow. One or

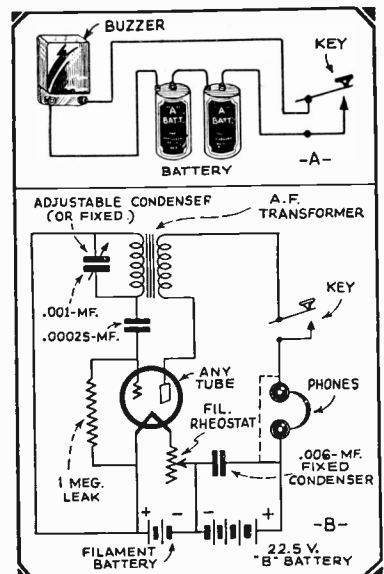

Diagrams above show simplest buzzer code practice set; lower diagram, more elaborate practice set. more tapes can be purchased with the device. When connected with a battery it will teach you the code. As the short or long characters come under a finger it makes contact with the metal over which the paper runs. This closes a circuit of battery and tube and we have another sending device which does not get tired.

coil between center and the "P" end. This plate terminal of the R.F. tube should be tried on these various taps experimentally for best results. Here the plate impedance L1 is being used as an auto-transformer. It will give slightly greater sensitivity than the circuit in Fig. 1, but entails extra strain on the coil.

Another type of coupling which makes use of a separate plate impedance is illustrated in Fig. 3. It will be seen that the plate system of the R.F. tube is entirely separated from the grid circuit of the detector. The plate impedance should be an RF. choke. This choke MUST have low distributed capacity. It should preferably be wound single layer; however, a sectional

DETECTOR COUPLING

(Continued from Page 23)

winding may be used, with at least three sections. Quoting from an article by R. William Tanner, writing in a past issue of SHORT WAVE CRAFT concerning the construction of such a choke, he says:

"A very efficient choke can be constructed by cutting six slots, separated 1/8-inch, in a 3/4-inch wooden dowel; these should be about 3/16-inch deep. A total of 600 turns of No. 36 enameled wire is required; 100 turns per slot."

This circuit is highly efficient because the plate load more nearly approximates the plate impedance of the R.F. tube. L2 and L3 are the plug-in grid and tickler wind-

ings.

Probably the most efficient method of coupling is to use inductive coupling between the plate of the R.F. tube and the grid of the detector. This method is illustrated in Fig. 4. There is no possibility of leakage from the plate of V1 to the grid of V2. The primary, L1, should have an impedance as high as possible consistent with good selectivity. The ideal method would be to employ a one-to-one ratio transformer. However, the selectivity would be very poor, so the primary should have fewer turns. The ratio of turns between primary and secondary should be approximately 3 to 5. At frequencies above 10,000 kc., the ratio should be about 4 to 7.

When using a screen grid or pentode tube as a regenerative detector, the inductive coupling method will give much quieter operation than the other systems.

Figure 3 illustrates what is probably the best scheme of adjusting frequency response. It consists of a resonating system so designed that it will be resonant towards the upper end of the audio band.

A. F. AMPLIFIERS

(Continued from Page 23)

As the circuit is shunted across the input to transformer A.F.-1, the frequencies near the resonance point of the trap circuit will be by-passed to ground and hence will not appear in the output of the amplifier. By adjusting potentiometer A1 it is possible to alter the resonant frequency of the trap circuit. Low note response is boosted by closing SW-3.

Push-pull circuits do not offer any particular advantages in short-wave work, as the amplitude of signals is rarely sufficient to cause overloading of a single type 45, 47 or 42 tube in the output stage. If the receiver uses battery tubes, such as 31, 33, 38, 41, it may be advantageous to use push-pull or even "push-push" (Class B) amplification in the output stage to secure adequate undistorted output for speaker operation.

HOME-MADE ANTENNA COUPLING CONDENSERS

By M. HARVEY GERNSBACK

The short-wave fan will find these home-made condensers very efficient and the cost practically nil.

● ONE of the most important considerations in the design of a short wave receiver is the method of coupling the set to the antenna system. There are two coupling methods generally in use, as most fans know: inductive coupling and capacitive coupling. For the present we shall confine our attention to a discussion of simple methods of effecting a suitable coupling me-

ing and cutting out two pieces $\frac{1}{2} \times 2$ inches; each piece should be bent to form a right angle bracket. The bend should be at a distance of one inch from each end so that the resulting pieces will be in the form of right angle brackets with each leg one inch long. In one piece drill a hole in one of the legs to pass a screw. The size of the hole may be as desired to fit whatever

and last of all a 3 inch piece of brass tubing, with an inside diameter slightly larger than the outside diameter of the spaghetti tubing.

Two holes should be drilled in the bakelite block, $\frac{1}{4}$ inch from each end to pass the two screws. Two pieces of bus bar each $2\frac{1}{2}$ inches long should be cut and two pieces of spaghetti two inches long also. A loop is made in one end of each

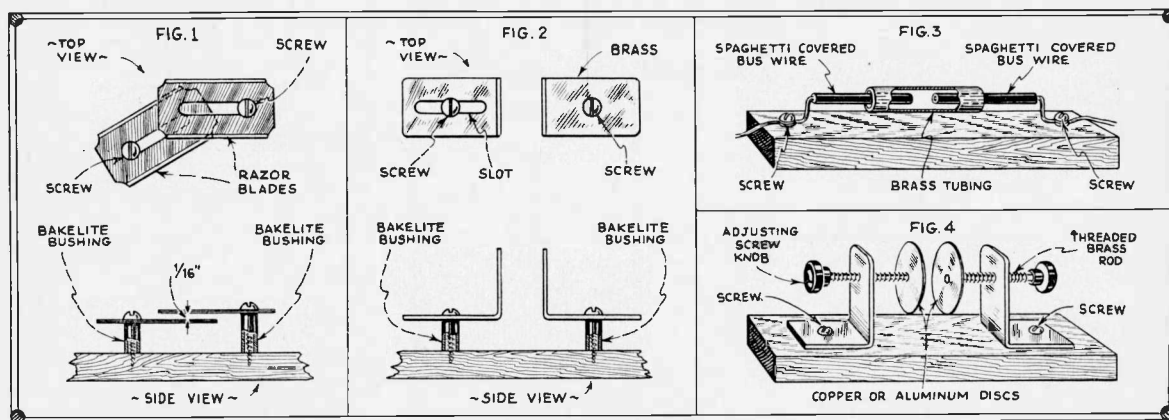

Fig. 1, at left shows how to make an antenna coupling condenser from old safety-razor blades. Fig. 2—Another simple and practical design involving the use of two right-angle brass or other metal members, one of which is slotted for adjusting the capac-

ity by use of capacitance. All of the methods discussed here are, of course, only home made "gadgets," but they are all just as effective as the ordinary midget variable condenser seen in a commercial outfit.

The first coupling device serves a double purpose; it acts as a coupling condenser and it is also the answer to what to do with old razor blades. The condenser consists of two safety razor blades mounted on top of each other with an insulating spacer in between. The blades should preferably be of the new type with stampings in them. The stampings can be used for passing screws through. The blades used by the writer were Gillette's, but almost any type will do. The blades should be spaced about $\frac{1}{16}$ of an inch apart and one should be free to be rotated in order to vary the capacity of the unit (See Fig. 1).

Another simple condenser can be constructed by taking two pieces of aluminum, brass or copper sheet-

screw the constructor has on hand. In the other piece a slot $\frac{1}{2}$ inch long with the ends of the slot $\frac{1}{4}$ inch in from the ends of the leg should be cut. The width of the slot should be sufficient to pass a screw the same size as the screw to be used in the other bracket. The two brackets should be mounted as shown in Fig. 2. The capacity can be varied by sliding one of the brackets back and forth by means of the slot in it. The illustration should be self-explanatory. Do not make the brackets any smaller than specified or the capacity of the condenser will be too small to secure good results.

Another type of condenser is really nothing more than the old "neutrodon," which was a familiar part of the original neutrodyne sets of nine years ago. A bakelite block $5 \times \frac{1}{2} \times \frac{1}{16}$ inches should be secured; also six inches of bus bar wire, six inches of spaghetti tubing that will fit over the bus bar very snugly, two small screws of half inch length and nuts to fit them,

Fig. 3 shows how to utilize the old neutralizing condenser principle. Fig. 4—Still another simple type which can be made from odds and ends to be found in your "scrap-box." The base should be of first-class insulation.

piece of bus large enough to pass the screws. The spaghetti is then slipped over the bus, completely insulating it with the exception of the loops. The rest of the construction is illustrated in Fig. 3. It is important that the distance between the two pieces of bus is about $\frac{1}{8}$ of an inch.

The condenser illustrated in Fig. 4 consists of two right angle brackets of brass with one leg $\frac{1}{2}$ inch long and the other two inches long. The width of the brackets may be $\frac{1}{2}$ inch. In the $\frac{1}{2}$ inch legs a hole should be drilled for passing a mounting screw. In the two inch legs holes should be drilled $\frac{1}{4}$ inch from the end of the legs. These last holes should be tapped so that brass threaded rods may be screwed through. On the end of each rod a disc of copper or aluminum two inches in diameter is soldered. The two discs form the plate of the condenser and by screwing or unscrewing the brass rods the capacity may be altered.

A PANEL MOUNTING S-W COIL ASSEMBLY

By W. G. WHEAT

This Method of Assembly
Facilitates Interchanging
Coils.

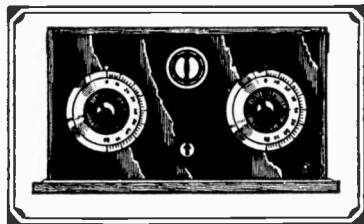

Fig. 1—Plug-in coils can just as well as not be mounted in a handy position such as between the tuning dials, as here shown.

● THE following method of mounting a coil on the panel of a short wave receiver was worked out after the writer had almost jerked his receiver off the table a number of times when removing the plug-in-coil with which it was equipped.

A new panel of aluminum was procured along with several Pilot coil forms, the kind with the ring-hold, to facilitate handling.

First cut a hole in the upper center of the panel, as shown in Fig. 1. This hole is one and seven-eighths inches in diameter.

Next procure a piece of black bakelite or celeron tubing two inches in diameter and three inches long. This is for the sleeve which holds the coil socket assembly. When in position it also acts as dust shield, thereby keeping dust from creeping into the set around the coil opening.

A piece of three-sixteenths inch hard rubber or bakelite, two inches or so square is next procured, and, lastly, a five-prong Pilot tube socket.

Fig. 2 shows the mechanical details of construction.

- (a) is the bakelite sleeve.
- (b) is the short wave coil form.
- (c) is the Pilot tube socket.

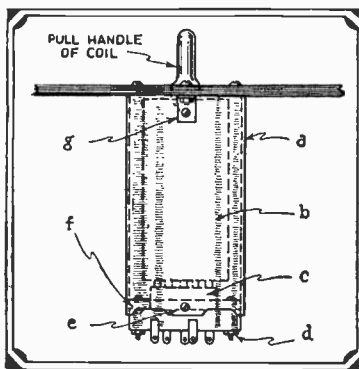

Fig. 2—shows side view of S-W coil mounting assembly.

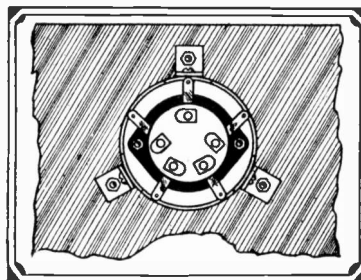
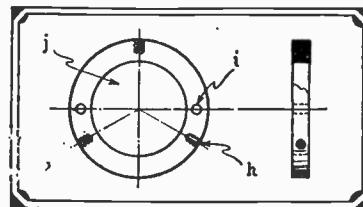

Fig. 3—shows a back view of the coil socket assembly.



The rings for removing the coils from the receptacle may be made in this way.

- (d) is mounting bolt holding socket to rubber ring—two required.
- (e) is the offset flange to strengthen the sleeve where the bolt passes through to hold ring in position.
- (f) is the hard rubber or bakelite ring cut to fit inside the sleeve snugly.
- (g) is one of the three metal brackets which hold the sleeve to the panel.

Fig. 3 shows a back-view of the assembly.

Fig. 4 shows the socket mounting ring.

- (h) is one of the threaded holes in the ring. They should be 4-32 thread or smaller. In drilling and tapping these holes clamp the rubber or bakelite, at these points, in a vise and then proceed; this prevents splitting the material.
- (i) is the hole to take coil socket bolt.
- (j) is the section cut out to fit the upper portion of the socket.

This type of assembly is very handy and works nicely, eliminating the necessity of raising the lid of the cabinet to remove the coil.

THE METER-KILOCYCLE CONVERSION CHART

● THE conversion table on page 36 is highly accurate because it has been worked out by the factor 299,820. Most tables used up to this time are based on the factor 300,000 which introduces an error.

The table is entirely reversible—for instance 100 meters is equal to 2,998 kilocycles or 2,998 meters is equal to 10 kilocycles. Any quantities not included in the table may

be read by shifting the decimal point—to the left for wavelength and to the right for frequency. The shift is therefore in opposite directions.

The factor 299,820 is based on the speed of a radio wave which is the same as that of light, or 299,820,000 meters per second. By dropping the last three ciphers the answer is given in kilocycles (thou-

sands of cycles) instead of cycles.

The frequency in cycles may easily be determined if the wavelength is known, by dividing the latter value into the factor 299,820. And the wavelength in meters may be calculated if the frequency in kilocycles is known by dividing the frequency into the same factor.

(Prepared by Bureau of Standards, Department of Commerce.)

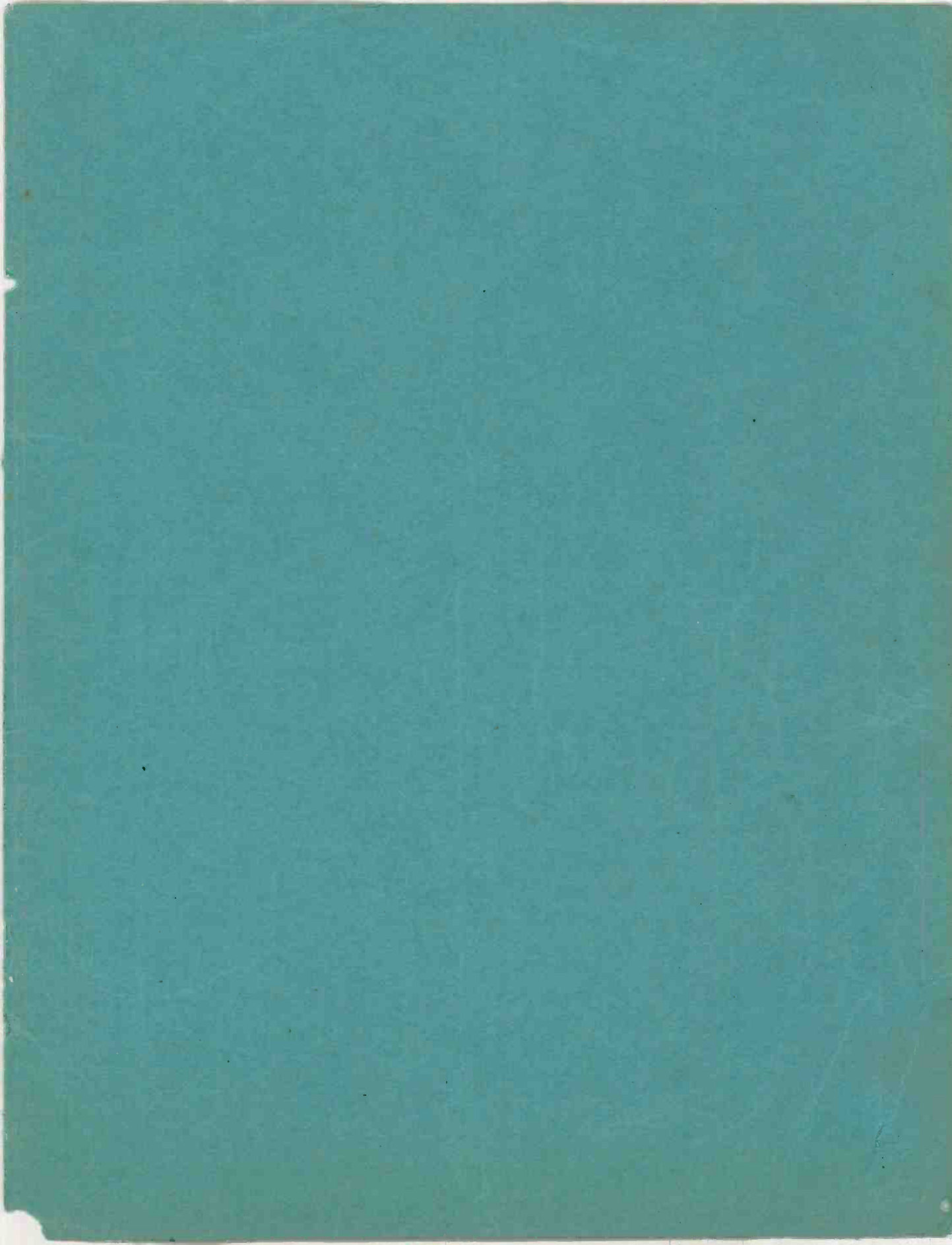

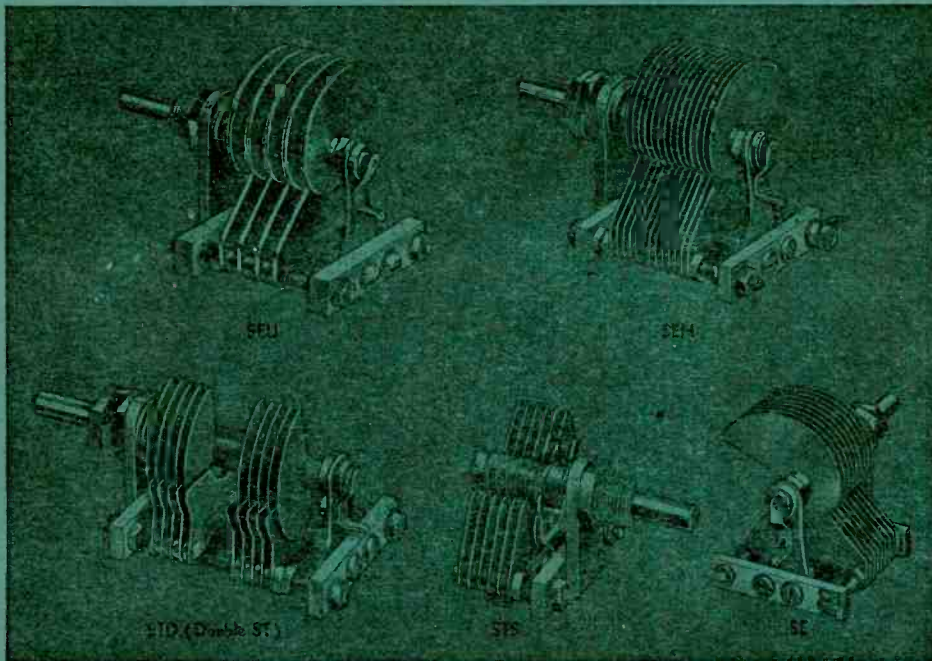

SHORT WAVE CONDENSER

Compact, highly efficient, and utterly reliable, these little condensers embody every refinement that years of specialization in short wave design have shown to be desirable. Isolantite stator insulation, thick non-resonant aluminum plates, constant impedance rotor connections, and insulated main bearings are but a few of the details which, combined with the best materials and fine craftsmanship, provide the ultimate in performance.

The condensers shown on this page are representative of the extremely complete line of NATIONAL short wave parts, including dials, plug-in coils, transformers, chokes and other equipment, all of uniform high quality.

We shall be pleased to mail a copy of our FREE General Catalog No. 210 to short wave constructors.

Catalog Type No.	Capacity in Mmf.	Air Gap	Plate Shape	Rotor Plates	Stator Plates	Depth behind Panel	List† Price
SE- 50	50	.026	270° SFL	6	5	2 3/4"	\$3.00
75	75	.026		8	7	"	3.25
100	100	.026		10	10	"	3.50
150	150	.026		15	14	2 3/4"	3.75
200	200	.0175		14	13	2 1/2"	3.75
250	250	.0175		16	16	2 3/4"	4.00
300	300	.0175		20	19	2 3/4"	4.00
335	335	.0175		22	21	2 3/4"	4.25
SEU- 15	15	.055		3	3	"	2.50
20	20	.055		4	4	"	2.75
25	25	.055	5	4	"	2.75	
ST- 50	50	.026	180° SLW	6	5	2 3/4"	\$1.80
75	75	.026		8	7	"	2.00
100	100	.026		10	10	"	2.25
150	150	.026		15	14	2 3/4"	2.50
200	200	.0175		14	13	2 3/4"	2.75
250	250	.0175		16	16	2 3/4"	3.00
300	300	.0175		20	19	2 3/4"	3.25
335	335	.0175		22	21	2 3/4"	3.50
STN- 18	18†	.065		4	3	1 3/4"	2.00
STHS- 15	15	.0175		2	1	1 3/4"	1.40
25	25	.0175	2	2	"	1.50	
50	50	.0175	4	3	"	1.60	
STD- 50	50*	.026	6*	5*	2 3/4"	3.50	
STHD-100	100*	.0175	7*	7*	"	4.50	
SS- 50	50	.026	180° SLC	5	4	2 3/4"	\$1.80
75	75	.026		7	6	"	2.00
100	100	.026		9	8	"	2.25
150	150	.026		12	12	2 1/2"	2.50
200	200	.0175		11	10	2 3/4"	2.75
250	250	.0175		13	13	2 3/4"	3.00
300	300	.0175		16	15	2 3/4"	3.25
350	350	.0175		18	18	2 3/4"	3.50
SSN- 18	18†	.065		3	3	1 3/4"	2.00
SSS- 20	20	.0175		1	2	"	1.40
30	30	.0175	2	2	"	1.50	
50	50	.0175	3	3	"	1.60	
SSD- 50	50*	.026	5*	4*	2 3/4"	3.50	
SSHD-100	100*	.0175	5*	5*	2 3/4"	4.50	
150	150*	.0175	8*	8*	"	5.00	
2SE- 100	100*	.026	270° SFL	10	10	5"	\$5.50
2SEH- 200	200*	.0175		14	13	"	6.50
2SEH- 335	335*	.0175		22	21	"	6.75

* Per Section † 3000 Volt Rating ‡ Usual Trade Discounts Apply



NATIONAL COMPANY, INC., MALDEN, MASS.