

The Cathode-Ray Oscilloscope



By GEORGE ZWICK

Gernsback Library

No. 40

75 Cents

The
CATHODE-RAY
OSCILLOSCOPE

by

GEORGE ZWICK, B.E.E.

*Associate Member, Institute of Radio Engineers
Instructor, Radio and Television, Madison Institute, Inc.*



Gernsback Library No. 40

PUBLISHED BY

RADCRAFT PUBLICATIONS, INC.

25 West Broadway,
New York 7, N. Y.

COPYRIGHT, 1949

BY HUGO GERNSBACK

All Rights Reserved

First Printing—May 1949

Second Printing—July 1949

Third Printing—May 1950

Fourth Printing—September 1951

The Cathode-Ray Oscilloscope

PREFACE	5
CHAPTER 1...A.C. MEASUREMENTS	7
Direct current (d.c.) and alternating current (a.c.) A.c. as a variation of an electrical quantity with time. The ordinary meter, a.c. and d.c. Measurement of an average value of a varying voltage or current. Observation of variation at any one instant, instantaneous values. The cathode-ray tube, a visual indicator of instantaneous values.	
CHAPTER 2...THE CATHODE-RAY TUBE	14
Conversion of electron energy into light. The luminescent coating. The cathode-ray tube. The electron gun. Arrangement of elements. Function of the gun. Analogy of an optical system. Deflection of the spot, sweeping. Deflecting systems, electrostatic and electromagnetic. The electrostatic deflection system. Tracing by a moving spot of light.	
CHAPTER 3...SWEEP SYSTEMS	24
Vertical deflection, usually by signal. Horizontal deflection, by sweep voltage. Sixty-cycle sweep. External sweep voltage. Internal sweep voltage, the saw-tooth oscillator. The gas-discharge-tube type. The multivibrator. The blocking oscillator. Synchronization, locking.	
CHAPTER 4...A TYPICAL CATHODE-RAY OSCILLOSCOPE	36
The c.r. tube. Accelerating and focusing power supplies. The sweep generator. Horizontal and vertical amplifiers. Details of various controls on c.r.o. panel. Operating the oscilloscope.	
CHAPTER 5...PRACTICAL APPLICATIONS OF THE CATHODE-RAY OSCILLOSCOPE	46
Alignment of intermediate-frequency amplifiers. Differences between AM and FM procedures. The frequency-modulated signal generator and its use for alignment. Peak i.f. alignment of a.c.-d.c. midget receivers. Band-pass or flat-topping alignment in high-quality receivers. How to align the FM discriminator. I.f. alignment in FM receivers. Band-pass alignment of 3-winding i.f. transformers. Slope detection. Use of the marker or "pip" oscillator for band-pass alignment. The ratio detector and its alignment procedure. Alignment of low-gain, non-limiter type of FM discriminator. Alignment of television i.f. channels. The wide-band, pre-war type of i.f. channel. The staggered i.f. system. Television trap alignment. Judging quality of response curves. Judging Oscillation from the appearance of i.f. response curve. R.f. alignment of AM receivers. R.f. alignment of FM receivers. Television receiver front-end alignment. Reason for alignment for audio instead of video in television receivers.	

Audio output measurement. Calculation of voltage gain. Calculation of power output. Plotting audio response curves. Logarithmic vs. linear response-curve plotting. Peak a.c. measurements. Measurement for saw-tooth amplifier balance. Horizontal and vertical oscillator-amplifier checking. Magnetic deflection circuits, checking and patterns. Checking synchronizing pulses. Synch separation checking. Measurements in ham transmitters. 100% modulation patterns. Detecting overmodulation. Checking undermodulation. Trapezoidal and envelope modulation patterns. Distortion due to overmodulation. Regeneration in class C stage. Neutralizing class C stage. Regeneration in i.f. amplifiers. Audio-frequency distortion. Location of a.c. hum. Hum in the horizontal-deflection circuits of a television receiver. Hum in the vertical circuits. Hum in the video circuits. Effects of hum on audio circuits. Location of source of hum. Hum in power-supply circuit. Hum in circuits other than power supply. Values of permissible a.c. hum in various points of power supply. Elimination of hum by parts placement and wire "dressing." Synchronizing and clipping circuits. Insufficient clipping. Wrong clipping. Auto radio vibrator supply systems. Effects of too small a buffer condenser. Excessive buffering. Proper contact spacing and its effect on output. Synchronous vibrator output pattern. Determining frequency of an unknown e.m.f. Lissajous figures. Frequency ratio patterns. Checking phase shift. Phase angle between different voltages. Phase shift in audio amplifiers. Phase shifter for 60 cycles, for use with sweep generator for television and FM i.f. alignment.

Fig. 109—Photo courtesy Allen B. Du Mont Laboratories.

Preface

THIS book was written primarily for the radio serviceman and the newcomer in radio whose background is not an engineering degree, but a simple course in radio fundamentals, perhaps Signal Corps electrical experience or possibly only a correspondence course in radio. The material, as simply presented as one could ask for, is devoid of all complicated mathematics and engineering theory. The author believes that, if the student understands the *fundamental* workings of this very important instrument, he will, as his general radio experience widens, also get to understand this instrument in greater detail and thoroughness. For the time being, this book will help him to understand the instrument and how to use it intelligently and to prepare himself for further study of cathode-ray tubes and their applications in television and allied fields.

Although simplicity is a major feature of this work, it was not intended to make this an ABC of radio servicing. A rank beginner with only slight familiarity with Ohm's Law may stumble too often, as he "reads" this book, to find it very helpful. But even he will find this volume more and more useful as his knowledge expands. At the other extreme, the advanced radioman with a thorough background in a.c. theory and electronics, may often be bored by the apparently elaborate elementary explanations. However, both of these groups are small minorities in the radio service field. The vast majority of servicemen, who, in our opinion, rely too often on past practical experience only, should benefit greatly from this work. For, instead of being almost solely dependent on past case histories for *what* to do in a particular case, the serviceman, with the aid of this book, will know *why* he does certain things, thus combining experience with judgment, and being able to devise particular methods for best doing particular jobs.

It is important to study the subject in an orderly manner. To turn to Chap. 5 to discover how to use the 'scope, without first having studied Chaps. 1 through 4 on what the 'scope is and how it works, is like trying to operate a complex lathe or milling machine by simply referring to the instruction sheet, or like attempting to prepare a rare dish without any experience other than holding an open cookbook in one's hand.

While this book cannot be called nontechnical, it is a simple, but logical, technical explanation of the why and how of the oscilloscope. With a fair amount of study of the preliminary chapters, the student will be able to operate the instrument quickly, intelligently, and enjoyably. He will be able, if he is a serviceman, to use the 'scope profitably. Without intelligent, efficient use, the instrument becomes a hindrance and is soon discarded. With proper understanding, the 'scope becomes one of the most important service tools for FM, television, and other high-fidelity equipment. It saves time, money, and temper.

Chapter 1

A.C. Measurements

THE cathode-ray tube is one of the most versatile electronic instruments in use today. Its applications beyond the field of radio are extremely wide and important. To the engineer, ham, serviceman, and radio-minded hobbyist, these nonradio phases are of minor interest. Our purpose is to explain, in as simple terms as possible, the uses of the tube in a complete instrument called an *oscilloscope* as applied only in radio and closely allied fields.

While the oscilloscope may be used to measure any voltage or current, a.c. or d.c., its most important application is in the measurement, observation, and study of alternating currents of frequencies varying from a few cycles per second (power frequencies), through audio frequencies, to radio frequencies in the megacycles. For d.c. measurements, simple meters of the D'Arsonval or vacuum-tube type are adequate, and are often preferred for their simplicity, except in special cases such as the observation of superimposed a.c. voltages.

To understand the advantages of the oscilloscope for a.c. measurements, let us review briefly the elements of both a.c. and d.c., particularly the *differences* between these two types of current.

Direct current, as its name implies, flows in one direction only. Its amplitude may change from time to time, but its polarity never does. A source of d.c. such as a storage battery or a dry cell, is capable of supplying different amounts of current, depending on the resistance connected to it. Should the value of the resistance increase, or the value of the voltage decrease because of battery wear, the current will decrease. However, current-flow *direction* will remain the same, from minus to plus, regardless of changes in the amount of current flowing or the time elapsed. Thus, for example, a source of a constant value of voltage, such as a generator or a battery, measuring 120 volts, would be

shown graphically as in Fig. 101. Similarly, a steady current of 40 milliamperes would appear on a graph as in Fig. 102. It is sufficient to measure these only once to be able to state accurately their values, not only at the time of measurement, but all the time, until a change in the circuit is made for the purpose of changing the voltage or current.

With a.c., however, the story is completely different. Just as the two characteristics of amplitude and polarity or direction can be used to

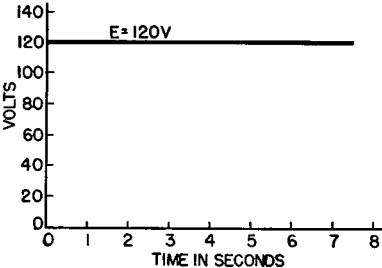

Fig. 101—Graphic representation of steady d.c. voltage (120 volts), with respect to time.

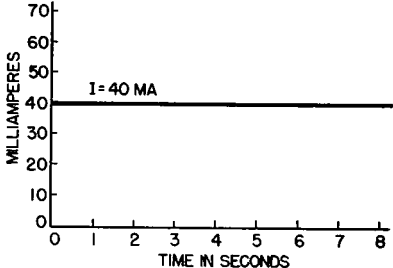

Fig. 102—A steady direct current of 40 milliamperes, presented graphically, with respect to time.

identify d.c., so will the following two features serve to identify positively and unmistakably alternating voltage or current. The first and simpler of the two is the regular, periodic reversal of polarity. Thus, a 60-cycle current would increase from zero to maximum in the positive direction, decrease back to zero and continue to a maximum negative value, and return to zero, 60 times each second. If we were to use a zero-center voltmeter, the pointer would start from center, swing to the left and back to zero during the first half-cycle, to the right and back to zero during the next half-cycle, again to the left, etc., as indicated in Figs. 103 and 104. However, no pointer could swing back and forth fast enough, even at the comparatively low frequency of 60 cycles per second, to keep up with these polarity reversals. And the human eye could not follow such quick movements, even if the pointer were capable of making them.

The second outstanding characteristic of a.c. is the continuous variation in the magnitude of the voltage or current. The value is never the same from one instant to the next, although the values repeat periodically. For example, an a.c. voltage having a maximum value of 120 volts starts at zero, rises to +120, decreases to zero, reverses polarity, rises to -120, decreases to zero, and so on, over and over. Compare this voltage, illustrated on Fig. 105, with the 120 volts illustrated in Fig. 101.

Fig. 105 shows the a.c. cycle, or the complete repetition of the variation, as it really occurs in time. On this graph, the line 00''' represents the elapsed time from the moment the circuit was closed. Point

0 indicates the moment the switch was turned ON. As time passes from 0 to 0', the voltage rises from zero to +120 volts (maximum) at point A, then falls back to zero at point 0'. Next the voltage rises again, but in the *opposite* direction, until it reaches -120 volts (maximum) at point B, and again decreases to zero at point 0''. This completes *one cycle*. From point 0'' to 0''' the cycle repeats itself, duplicating the original variation from 0 to 0'. We have now shown two complete cycles of a.c., 120 volts maximum. While it is quite simple to represent a.c. voltages or currents on paper, it is impossible to have a meter whose pointer could follow these variations. We must find another way to observe a variable voltage.

A few words about a.c. meters. We all know that there are meters for a.c. measurements. These, however, do not measure the voltage at any one instant, because of the inertia of the moving element. They do indicate a value which is called the r.m.s. (root mean square), which, for a voltage such as in Fig. 105, is approximately 70.7% of the maximum value. Thus, for the a.c. discussed above, which went *up to* 120 volts at points A, A', B, and B', the meter would only read 70.7% of 120, or approximately 84.8 volts. While this r.m.s. value is important, being the value used for all calculations of power, etc. (the 110-volt a.c. line in our homes has such an r.m.s. value, its peak being approximately 155 volts), it is nevertheless an arbitrary value, and does not tell much about the nature of the variation of the a.c. It remains for the oscilloscope to show the a.c. as it varies, at any instant of observation, and throughout its cyclical variation.

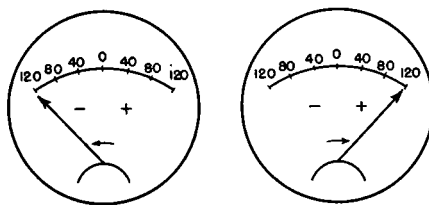

Fig. 103 and 104—If it were possible to follow the movements of the needle on a zero-center meter connected to 110 volt a.c., the needle would be seen to swing alternately to left and right, as current reversed each half cycle.

Complete a.c. variations or cycles such as shown in Fig. 105 are often called *waves*, because they resemble waves on graphs as well as on a cathode-ray screen. A brief description of the most common of the various types of a.c. variations or waves occurring in radio applications follows:

First, and most important as well as most common of the a.c. wave forms, is the *sine wave*. It appears approximately like Fig. 105, and is

typical of all our commercial a.c. as well as most r.f. and a.f. signal generators. It is called a *sine wave* because it varies (increases and decreases) in the same manner as the geometric quantity called a *sine*.*

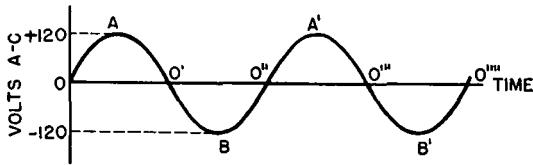
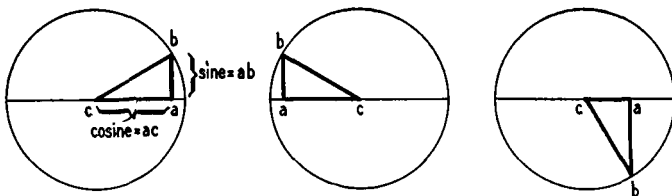

Fig. 105—Most common of the a.c. wave forms—the *sine wave*. The voltage (or current) rises and falls in successive positive and negative directions during each cycle.

The first important factor to remember is that the value measured by an a.c. voltmeter is approximately 70.7% of the maximum or peak of this wave. Another way this is often expressed is that the peak value of the sine wave is $\sqrt{2}$ (1/.707) times the r.m.s. value, or the value read by the ordinary a.c. voltmeter. The importance of this is quite obvious when we consider the fact that any electrical or radio component which operates on a certain a.c. voltage, say 110 volts, must be able to withstand 1.41 times 110 volts, or approximately 155 volts peak. Thus a condenser which was designed to withstand up to 150 volts is still liable to fail on a commercial 110-volt line. The second important thing to remember is the fact that the sine wave has generally been accepted as the standard by which other wave shapes are judged. In the great majority of cases, specifications for equipment, insulation, etc., will be given in terms of sine-wave a.c.

The second type of variation in the order of importance is the saw-tooth a.c. wave, which gets its name from its appearance (see Fig. 106). It is very widely used in oscilloscopes, radar equipment, television circuits, and many other types of measuring apparatus. The ideal saw-

*NOTE: Geometrically, the sine and cosine of an angle may be explained as follows: Draw a circle and its diameter. Draw any radius at an angle to the diameter. From the end of this radius draw a vertical line to the diameter. In the triangle formed, the vertical line is called the *sine*, and the horizontal side of the triangle is called the *cosine*. See sketch for examples. As the radius is drawn in different positions around the circle, the vertical line will vary in length, showing how the *sine* varies as the angle between the two radii varies. An alternating voltage or current which varies in instantaneous value as the sine of an angle varies is called a *sine-wave ac*.



tooth wave has a straight-line (usually called *linear*) rise, as shown by the diagonal lines on Fig. 106, and a quick, abrupt decline along the vertical lines on the same figure. In practice, a saw-tooth wave may not look quite as linear as shown here, but only the most linear portion of the rise of the wave is used for the applications mentioned. We shall

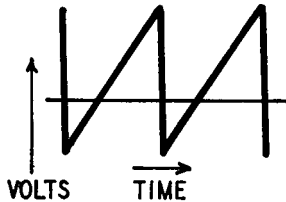

Fig. 106—Second type of variation in wave form—the saw-tooth a.c. wave..

say more about this type of a.c. wave in Chapter 3, in connection with cathode-ray sweep circuits.

The third type of a.c. wave of interest to us is the *square wave*. It is shown in its ideal form in Fig. 107 and derives its name from its square-sided appearance. In reality, it is a rectangular wave, but the word “square” is commonly used. Notice the two important characteristics of this wave. The first is the abrupt and steep rise and fall. In this diagram, these are actually *instantaneous*. In practical cases, the sides are not quite vertical, looking more like Fig. 108, but are still very steep. The second feature of this type of a.c. wave is the flatness of the top of the wave. There is no variation in height for the duration of the half-cycle, just as in ordinary d.c. While a square wave is not often used for its own sake, it is extremely useful in alignment and measurement circuits and as a source of many different types of a.c. pulses used in cathode-ray applications.

The structure of the square wave, despite its rather simple appearance, is extremely complex and quite difficult to analyze. Theoretically, the square wave consists of a large number of sine waves of different frequencies, magnitudes, and phases combined into one. In practice, there are a number of different square-wave generators, to meet the requirements of particular circuits as well as of general test equipment apparatus.

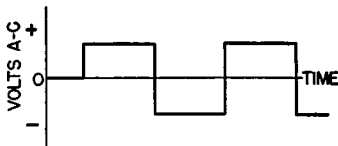

Fig. 107—Third important type of wave form—the square wave. This is idealized form.

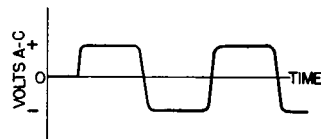

Fig. 108—In practice the sides of the square wave are more like those shown.

There are many other variations of a.c. waves ; however, the three types mentioned above are the most important to the radioman. The others may be studied as the need for them arises.

From the foregoing example it is apparent that alternating voltages and currents cannot be identified by either their magnitudes or their averages alone. While the *average values* of a square wave and a saw-

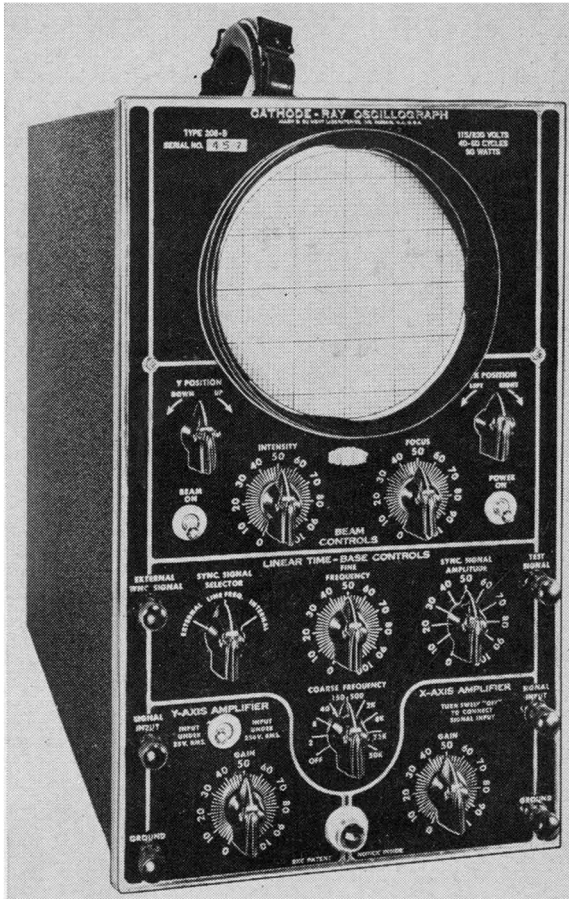

Fig. 109—Typical Cathode-Ray Oscilloscope.

tooth wave may be the same, the *shapes* of these two waves and their *instantaneous* values differ very much. Yet an a.c. meter would read *the same voltage in both cases*. Since we are concerned with the differences in appearance and behavior of these different types of a.c., the ordinary meter is of little use. As an illustration, let us consider the type of a.c. generated by a microphone picking up a 400-cycle sine wave. If this

sine-wave a.c. is fed into an amplifier, the output (which may feed a loudspeaker) should be a greatly magnified sine wave. In other words, the amplifier is intended to serve as a faithful, distortionless enlarger. Should distortion take place, however, the output will be magnified, but it will no longer have the shape of a pure 400-cycle sine wave. Rather will it be a combination of the original and other sine-wave frequencies produced by the nonlinearity of the circuit. This may be compared to a photographic enlarger, which, due to some internal defect, distorts the features of a person, although it enlarges it to the desired size. The only way we can examine the output of the amplifier is by the use of such a visual indicator as the cathode-ray oscilloscope.

Briefly, the cathode-ray tube may be compared to a screen on which a point of light traces the various patterns which are to be studied. It is necessary only to have that point of light follow the variations in the voltage or current we wish to examine, in order to produce a picture of that variation on the c.r. screen. Since we are discussing electric currents, not just light, it is necessary to convert these currents into light by means of a *fluorescent* surface. This is usually a mineral coating on glass, which has the property of glowing whenever electrons strike it. There remains only one other requirement, and that is to keep the trace of the voltage or current on the screen long enough for the eye to see it. Although the voltage or current variations occur much too fast to impress the human eye, it is possible, with the aid of so-called sweep circuits, to give the *illusion* of slowness or even to stop the motion altogether for the purpose of measurement or photography. Thus, no matter what the frequency of the a.c. being observed, it is possible, by means of a suitable sweep circuit, to produce a motionless trace or picture on the screen by superimposing identical traces one upon the other many times per second, the number depending on the frequency.

To understand more fully the operation of the all-important sweep circuits, as well as the structure, theory, and operation of the cathode-ray tube itself, turn to Chapter 2.

A photo of a complete oscilloscope appears in Fig. 109.

Chapter 2

The Cathode-Ray Tube

WE have already stated that the purpose of the oscilloscope is to permit visual observation of the behavior of alternating voltages and currents. This requires a conversion of electric current, or electrons in motion, into light. To accomplish this, a *luminescent* substance is used.

Let's define some of the terms in connection with cathode-ray screens. *Luminescence* is the ability of a body to convert invisible energy into light at temperatures less than that of incandescence or

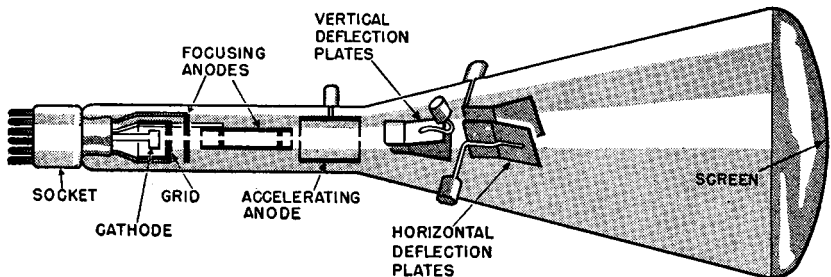

Fig. 201—Cross-section of cathode-ray tube, with principal parts indicated. These are an electron gun, a means for deflecting the electron beam, and a fluorescent screen.

white heat. Thus, electron bombardment of a luminescent surface produces light. When the light ceases immediately after the bombardment stops, the characteristic is known as *fluorescence*. When the glow persists after the excitation has stopped, we refer to the luminescence as *phosphorescence*. The materials for the screen coating are chosen for the color of light emitted, as well as the duration of the afterglow. Some very common screen coatings are willemite, for a green-blue color, zinc oxide for a violet glow, zinc sulfide for light blue, and so on. These, however, are details determined by the particular use of the tube. Regardless of the type of screen coating or tube application, the fundamental method of operation remains the same.

A cathode-ray tube may be considered as consisting of three major units: an electron gun for producing a narrow beam of electrons, or *cathode rays*; a means for deflecting the beam or spot, by application of

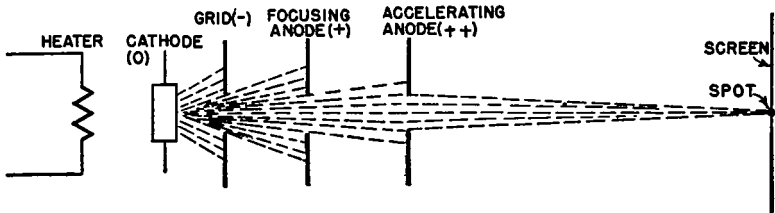

Fig. 202—Arrangement of heater, cathode, grid, focusing and accelerating anodes, in cathode-ray tube. Electron beam focuses on fluorescent screen at right.

voltage or current to the deflecting mechanism (deflection yoke or deflection plates); and a fluorescent screen which glows when struck by the electron beam. The electrodes or elements, in their order of physical arrangement, and their functions are as follows (see Fig. 201):

I. Electron Gun

Heater—Operated from a low-voltage source, 6.3 volts for the most common types, the heater is used to bring the cathode to emission temperature.

Cathode—When the heater is ON, the cathode will give off electrons, just as the cathode in an ordinary tube.

Control Grid—This element performs the same function as the control grid in any vacuum tube: it regulates the amount of electron flow from the cathode. In addition, it is so shaped that the electrons which are allowed to pass are forced to go through a small opening to concentrate the beam.

First or Focusing Anode—This anode has a positive potential as does the plate of an ordinary vacuum tube, except that this plate

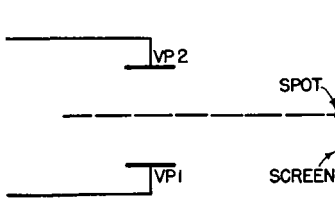

Fig. 203—With zero voltage on deflecting plates, beam strikes in center of screen.

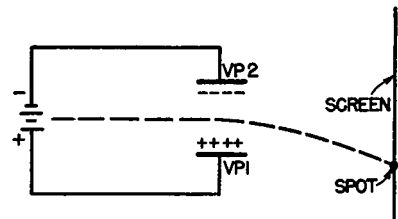

Fig. 204—With deflection plates + and - as indicated, beam strikes below center.

acts as a lens which intercepts electrons which approach it at too great an angle, and accelerates, because of its positive potential, those electrons moving through the opening. This produces a

focusing action which may be controlled by adjustment of the positive potential applied to this element. Since the element is not intended merely to attract electrons toward itself, as is an ordinary vacuum-tube plate, but instead to bunch or focus them and speed them on toward the screen, the element is called a *focusing anode*.

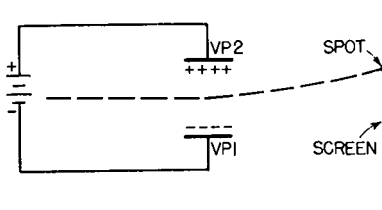

Fig. 205—When plate *VP2* is positive and *VP1* negative, beam strikes above center.

Second or Accelerating Anode—This high-voltage plate has for its main function the speeding up of the electrons in order that they may strike the screen with sufficient velocity to cause emission of light. The voltage is usually not adjustable. Again the structure of the element makes for beam concentration. See Fig. 202.

Intensifier Anode—In some types of c.r. tubes (particularly DuMont) there is also a third anode called an *intensifier*. The function of this element is to increase the brilliance of the trace on the screen. It is not a fundamentally required element or one widely used. The structure is rather unusual, being a metallic coating inside the glass near the face of the tube.

The electron gun provides a point of light on the screen, usually in the center, although it may be near either the extreme

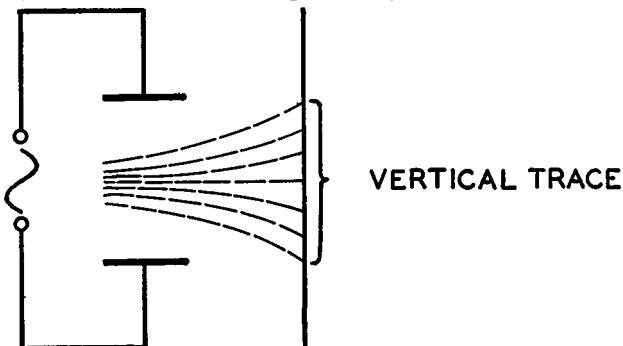

Fig. 206—If a.c. is applied to the vertical deflecting plates, the beam will move up and down as indicated by the dotted lines, producing a vertical line.

left or right edge of the screen in some tubes. In the latter case, the gun structure is designed for *off-center* location of the spot.

II. Deflection Elements

Beam deflection can be accomplished by two different methods in c.r. tubes. The *electromagnetic-deflection* type of tube, found

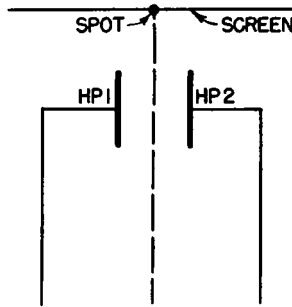

Fig. 207—Action of horizontal deflection plates HP1 and HP2 in c.r. tube; with no voltage between plates, beam strikes in center.

mostly in larger models of television receivers, radar viewers, and some laboratory oscilloscopes, uses a magnetic field for electron deflection. A pair of coils, fitted over the neck of the c.r. tube, carries the currents required for proper beam deflection. In some of these tubes, focusing also is done by a coil, instead of by the focusing anode. Others use *electrostatic* focusing and electromagnetic deflection. However, these types are not very common in service oscilloscopes, and we shall not go into further detail about them here.

The *electrostatic-deflection* type of cathode-ray tube commonly used in service instruments contains two pairs of plates, one

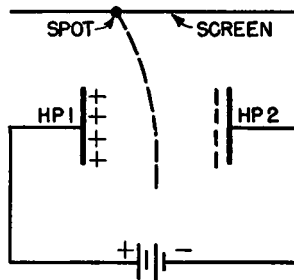

Fig. 208—With horizontal plate HP1 positive with respect to plate HP2, the beam strikes left of center.

pair being horizontal and the other vertical. Each pair of plates is either parallel and/or slightly divergent toward the screen end

of the tube. See Fig. 201. The horizontal pair of plates, positioned somewhat like the ceiling and floor of a room, are the *vertically deflecting* plates, since they are used to swing the beam up or down. The other pair, placed like two opposite walls of a room, are the *horizontally deflecting* plates, causing the spot to move left or right. The voltages to be studied are applied to these two sets of plates, causing the beam or spot to deflect in step with the variations of the test voltages.

III. Target or Screen

This is the tube face, which emits light when struck by fast-moving electrons.

Just as there are different methods of beam deflection, so there are many different varieties of electron-gun design. The type that is most common, and most likely to be encountered, will be discussed here. You will have no difficulty understanding the operation of any other type, once you have a clear picture of the theory and operation of the gun dealt with in this book.

Let's follow the electrons from the time they leave the cathode until they strike the screen:

- 1—The *heater* raises the temperature of the cathode until a stream of electrons is emitted.
- 2—The *cathode* is the real electron-emitting element. It differs from the usual cathode in that the emitting surface is confined mostly to the area facing the opening in the grid.

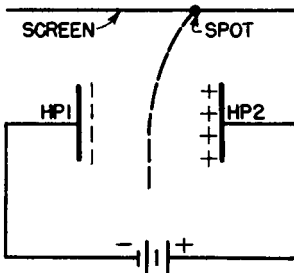
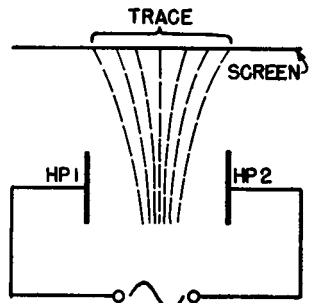

Fig. 209—Here plate HP1 is negative with respect to HP2, and beam strikes to right of center

Fig. 210—If a.c. is applied across the horizontal plates HP1 and HP2, beam swings back and forth and a horizontal line appears on the screen.



- 3—The *control grid*, which generally surrounds the cathode, is operated at a negative potential with respect to the cathode, very much like the control grid of an ordinary vacuum tube. This bias is adjustable, so that the *intensity* of the electron stream can be varied as required. The control is usually called the *intensity* or

brightness control and is set for a comfortably bright trace on the c.r. screen.

- 4—The *first or focusing anode* also has a variable voltage supply, but it is positive with respect to the cathode. It will therefore *accelerate*, not retard, the electron stream. Its physical structure (somewhat like a cylindrical can with a hole in each end) is such that it tends, by intercepting electrons not traveling along the axis of the tube, to bunch or focus the electron stream passing through it.

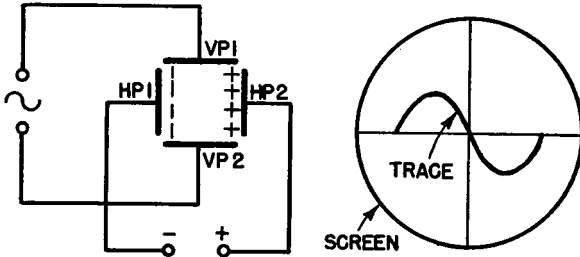

Fig. 211—With sine-wave a.c. on the vertical plates and steadily increasing d.c. on the horizontal plates, a sine wave form appears on the screen.

- 5—The *second or accelerating anode* speeds up the beam, so that the impact on the screen will be of sufficient velocity to cause adequate light emission. This anode is also positive with respect to the cathode, but of a higher potential (about 750 to 1,000 volts for a 3-inch tube), and is not adjustable. The physical structure is similar to that of the first anode, except that it has a larger diameter and, as a result, the beam is further focused and accelerated.
- 6—The two pairs of *deflection plates* are located between the second anode and the screen. They serve both as centering electrodes, enabling the operator to move the spot to the center of the screen (they may also be used to place the beam at any other point along the horizontal axis of the screen, if that is desired) and as signal electrodes. The test voltage applied to these plates will move the beam in step with the variations of the test voltage. These plates may further be thought of as two condensers, one having its plates in a vertical position (for horizontal deflection) and the other condenser being in a horizontal position (for vertical deflection).

To illustrate the functions of these deflecting plates, let us look at Figs. 203, 204, and 205 showing the effect of the vertically deflecting pair. Fig. 203 shows no voltage on the plates; hence there is no change in the direction of the beam. The spot is in the center. Fig. 204 shows

the upper plate VP2 negative with respect to the lower plate VP1. As a result, the electron stream, being negative, is repelled by the upper plate and attracted by the lower. Due to the high speed, the beam will still travel forward, but it will veer downward. The spot will therefore strike the screen at a point *below* the center. Fig. 205 shows the polarity of the plates reversed, with the spot striking the screen *above* the center.

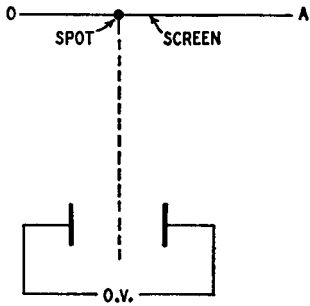

Fig. 212-a—With zero potential on the deflecting plates, the beam will strike the center of the screen.

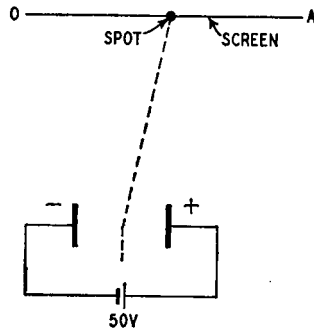

Fig. 212-b—With 50 volts negative charge on left plate, beam moves a proportionate distance across screen toward A.

If, instead of the battery potential shown, an a.c. voltage were applied to the vertical plates, the beam would move up or down as fast as the a.c. on the plates reversed. This would produce a trace such as shown in Fig. 206, the height of the spot on the screen at any instant being proportional to the value of the a.c. voltage at that instant.

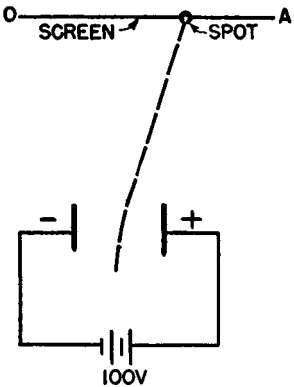
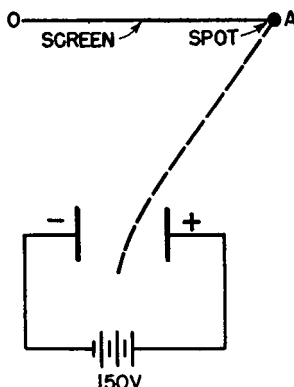

Fig. 212-c--With left plate 100 volts negative, beam moves 2/3 way across screen.

Fig. 212-d--Here left plate is charged 150 volts negative. Beam now moves all way across the screen.



The horizontal plates have a similar effect on the spot, only in the left-right direction, as illustrated in Figs. 207, 208, and 209. An a.c. applied to these plates would produce a horizontal line on the screen as in Fig. 210.

If we were now to apply an a.c. sine wave to the vertical plates (for convenience, we shall refer to the *vertically* deflecting plates merely as

vertical plates and to the horizontally deflecting pair of plates as horizontal) and a *steadily increasing* d.c. potential to the horizontal plates, as shown in Fig. 211, the resulting pattern will be a sine-wave a.c. While the vertical plates swing the spot up and down in accordance with the rise and fall of the a.c. cycle, increasing the voltage on the horizontal plate moves the electron stream horizontally across the screen and therefore permits the beam to trace the sine-wave "picture" on the screen. In other words, this sweeping action prevents successive points of the up-and-down trace from overlapping, and spreads them out instead.

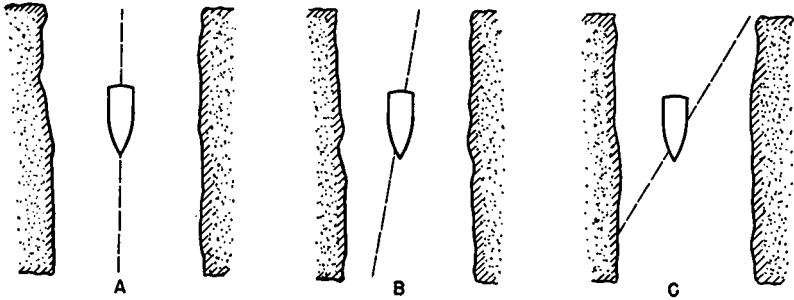

Fig. 213-a—Boat moving downstream; no cross wind. b—Same boat, with a breeze from right shore. c—Same boat, but with a strong wind from right shore.

And the speed with which the trace moves across the screen depends on the rate of change of voltage applied to the horizontal deflecting plates.

We now have a system of *scanning* or tracing any voltage on the c.r. screen by applying the voltage to be observed to the vertical plates while a *suitable*, varying d.c. potential is applied to the horizontal plates, as was done in the example above.

We have seen how the electron gun of the cathode-ray tube can produce a spot of light on the fluorescent screen. Let us assume that this point or spot of light is initially located at the center of the screen, as shown in Fig. 212-a. If we wish to move this spot across the screen from left to right along line OA, we have to supply a force which will "bend" the electron stream (which is our spot of light) in such a manner that it will move in the left-to-right direction.

To understand fully why this force is necessary, we need but recall two fundamental facts. The first is the law of attraction and repulsion, which states that charges of *like* polarity *repel* each other, while those of *unlike* polarity *are mutually attracted*. It also follows that the force or strength of such attraction or repulsion depends directly on the strength of the charges (or the number of particles of one polarity in excess of the number of those of opposite polarity). The second fundamental fact is that every electron is a particle of matter, having mass

(usually called weight) and, when in motion, kinetic energy. Just as a physical body such as a baseball in motion requires a force to change its direction, so does the electron in motion if it is to change its course. The first law also tells us that the direction in which the electron will veer or deflect depends on the direction of the deflecting force. Fig. 213 shows the behavior of a boat on a stream. As long as there is no cross wind, the boat moves in its original downstream direction. But as soon

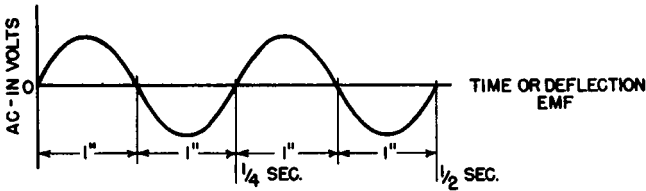

Fig. 214—Illustrating two cycles of alternating current, under a uniformly increasing deflection voltage.

as the wind blows in the direction shown, the boat, in spite of its set course, will move *diagonally* across the stream. Furthermore, the stronger the wind, the more windward will the direction of the boat be.

Similarly, the electron in motion, under the force of the focusing and accelerating potentials, follows a straight path to the screen. When it passes between a pair of plates having no potential difference between them, the electron proceeds on its course. But, if the left-hand plate is made negative with respect to the right-hand plate, then the electron will be pushed over to the right-hand (more positive) side, at the same time still moving forward. The amount of veering or deflection will depend on how great the differences of potential (or polarity) between the two plates is. For example, a potential of 150 volts will deflect the stream much more than a potential of 50 volts. Fig. 212-d illustrates this phenomenon.

Another important thing to remember is that the deflection is directly proportional to the deflecting force. If a force of 50 volts will deflect the electron 1 inch on the screen, then 150 volts will deflect it three times as far, or 3 inches. In other words, the deflection is *linear*. See Figs. 212-b, c, and d.

As indicated in Fig. 211 if the potential on the horizontal plates is increased at a uniform rate and a sinusoidal voltage is applied to the vertical plates, a sine wave will be traced on the screen. For example, suppose the sine-wave frequency is 4 cycles per second, or one cycle per $\frac{1}{4}$ second. Suppose further that the potential on the horizontal plates increases from zero to maximum in $\frac{1}{2}$ second, and the distance the beam travels in the horizontal direction is 4 inches. Referring to Fig. 214, it is evident that exactly two sine waves will be traced on the screen in $\frac{1}{2}$ second. This is the case only when the voltage on the horizontal plates

increases at a *uniform rate from zero all the way to the maximum*. However, should this voltage rise at a uniform rate for the first $\frac{3}{8}$ second only, and rise at a slower rate for the remaining $\frac{1}{8}$ second, the result would be as follows: The first three inches of sweep across the screen, corresponding to the first $1\frac{1}{2}$ cycles, would be the same as the first $1\frac{1}{2}$ cycles of the previous case. During the fourth inch of horizontal travel of the spot more than $\frac{1}{2}$ cycle will be traced, because of the slower rate of voltage increase, the whole pattern looking like Fig. 215. This trace is not a true reproduction of the wave applied to the vertical plates, indicating instead a compressed half-cycle, which is

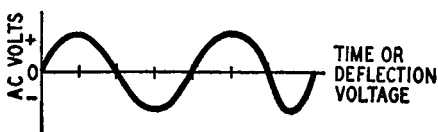

Fig. 215—Same two cycles illustrated in Fig. 214, but with *uniform voltage changes during the first $1\frac{1}{2}$ cycles, and a decreasing voltage change during the fourth half-cycle.*

equivalent to a change in the frequency of the wave being measured. A sweep of this kind could give misleading information, especially when one is observing unknown wave shapes. Unless the observer knew that the oscilloscope was not linear, he might suspect a perfectly good piece of equipment of being defective and causing the distortion.

We must have, as far as practically possible, a *linear* horizontal-deflection voltage (commonly called *sweep voltage*). To see just how such a linear voltage is produced, let us turn to Chapter 3.

Chapter 3

Sweep Systems

WE can summarize the requirements of the sweep voltage for pattern tracing across the c.r. tube as follows:

- 1—To move a spot of light across the screen, a deflecting voltage is required.
- 2—Uniform speed of motion of the spot requires a uniform rate of rise of the deflecting voltage. (The voltage must keep on increasing to a certain value, depending on the diameter of the screen, in order to be able to deflect the spot farther and farther from its starting point.)
- 3—If the spot is to return to its starting position at the end of its deflection across the screen in time to begin tracing a new cycle, the voltage must decrease *rapidly* to zero.

Or, briefly stated: *The deflecting voltage must increase at a uniform rate to its maximum value, then fall abruptly to zero.* Such a voltage is commonly called a *saw-tooth voltage* (because its wave shape is similar in appearance to the teeth of a saw).

There are many types of saw-tooth voltage generators. The most common are the gas-discharge type, the multivibrator type and the blocking oscillator, the latter two being of the vacuum tube variety.

In all these generators the operation depends on the charging (building up of a potential) of a condenser in series with a resistor.

When a condenser is first connected across a source of e.m.f. (see Fig. 301) the potential difference across the condenser is zero volts. A stream of electrons rushes around the path from the negative side of the battery to the upper condenser plate, and from the lower condenser plate to the positive side of the battery. The upper condenser plate becomes, by comparison, excessively negative and the lower plate excessively positive. This is equivalent to saying that a potential difference, or voltage, exists between the two plates, this voltage increasing as the excess of electrons on the upper plate increases. Another way of stating the same thing is to say that the current is flowing *into* the condenser and building up a charge. During the initial

period after closing the switch, the high surge of current tends to charge the condenser very rapidly, building up a potential across its plates in opposition to the potential of the charging battery. This retards

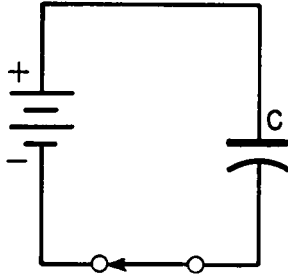

Fig. 301—A condenser connected across a battery; at instant of switch closure no voltage exists across condenser. Gradually, a current flows into the condenser and a voltage builds up across it.

further flow of current into the condenser, slowing the building up or the voltage across the condenser. But as the voltage slowly increases, the current flow into the condenser decreases until finally, when the voltage across the condenser is equal in magnitude to the source voltage, no further current flows, and the condenser is said to be fully charged.

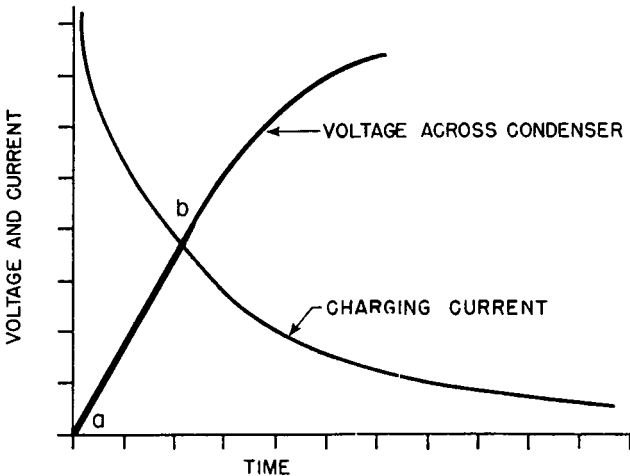

Fig. 302—Charging of a condenser. Note how voltage rise starts at a high rate and rises at a uniform rate to "b", after which the rise begins to taper off.

Fig. 302 shows the approximate charging-current curve for a condenser as well as the e.m.f. build up. Observe the following:

- a. The *current* into the condenser starts off at a high rate, then tapers off to almost zero.
- b. The voltage across the condenser similarly builds up rapidly at first, continues to increase at a slower and slower rate, until it almost stops increasing near the maximum value.

Now let us examine the *voltage* curve. Notice that the first portion (heavy line) is steep and almost straight. This means that during the interval ab the e.m.f. rises at a *very uniform rate*. After that, the rise still continues, but at a progressively slower rate, hence the curvature.

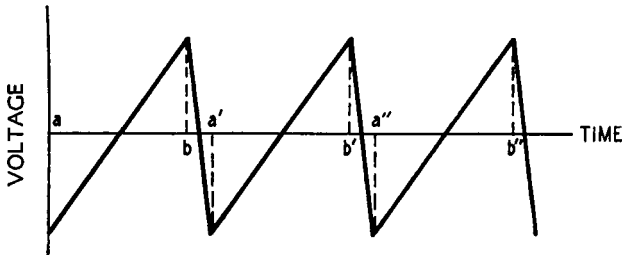

Fig. 303—Time intervals of a saw-tooth wave generator: $a-b$, $a'-b'$, $a''-b''$ represent scanning time; $b-a'$, $b'-a''$ represent "fly-back" time.

It is the straight portion of this curve that is utilized in a saw-tooth voltage generator. All that is necessary is a means of stopping the rise just before curvature begins and of repeating this rise from a to b as often as required. For example, if we wish to sweep the sine-wave a.c. of Fig. 211 (page 19) 20 times per second, we need but generate 20 voltage rises each second such as the one between a and b on Fig. 302. In other words, the rate of the condenser charge (and discharge, of course, although we are concerned with the charging cycle only) would be 20 per second. However, in order to repeat the path ab , we must restore the condenser to its original condition at time b . Thus, if the voltage at time $a = 0$ and at time $b = 15$, then, for the example outlined, the condenser would repeat the following cycle 20 times per second: first, rise from zero to 15 volts at a uniform rate; second, immediately thereafter drop suddenly to zero; third, start rising from zero to 15 volts again. Fig. 303 illustrates this example.

In addition to the major requirement that the saw-tooth voltage be linear, in order to sweep the spot across the screen at a uniform rate, it is also necessary that the spot return almost instantly to the left-hand or starting position on the c.r. screen, in order to repeat the cycle. Since the spot returns as soon as the deflecting voltage is removed, the saw-tooth voltage must decrease to zero as rapidly as possible after reaching the maximum value. In Fig. 303, the time ab , $a'b'$, $a''b''$, etc., is called the *scanning time*, this being the interval during which the e.m.f. rises and therefore causes the spot to scan the c.r. screen. The time

ba', b'a", etc., is called the *retrace* or *flyback* time, meaning the time during which the e.m.f. drops to zero and the spot "flies" back to its original starting position. Note that the flyback time is much *shorter* than the scanning time (usually about one-tenth).

Saw-Tooth Generators

Fig. 304 shows a simplified version of the gas-triode (type 884), saw-tooth generator. The tube is similar to any other triode, except that it is not a vacuum tube. It contains a small amount of inert gas, which ionizes under a sufficiently high potential and becomes conducting; i.e., the gas atom will lose an electron, leaving a positively charged ion. Under normal conditions, when the gas is not ionized, negligible current flows through the tube. However, when fully ionized by the application of a sufficiently high voltage, called the *ionization potential*, or breakdown voltage, the gas becomes so highly conducting that the tube acts almost like a short circuit from plate to cathode. (Value of this voltage depends upon the type of gas, its pressure, and some circuit characteristics.)

In the circuit of Fig. 304, the plate voltage is supplied in series with resistor R_p . The grid voltage is at some negative value, this value determining the plate voltage at which the tube will ionize or break down. The value of plate voltage is the "firing potential". The supply voltage E_b is usually higher than the firing voltage. The cycle is approximately as follows:

When the supply voltage is connected, the condenser C charges in series with resistor R_p . As soon as the voltage across the condenser

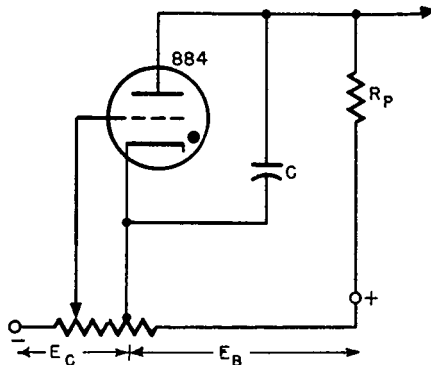

Fig. 304—Basic gas triode saw-tooth generator.

reaches the breakdown voltage, the tube starts conducting and acts as a short circuit across the condenser. This reduces the voltage to a value below that required for ionization, and the tube no longer conducts.

The condenser then begins to charge again, repeating the cycle. A saw-tooth voltage has thus been generated, its rise corresponding to the charging of the condenser C and its decline taking place when the condenser discharges during the period of ionization.

The frequency of the charges and discharges depends on how long a charging time (duration of deflecting voltage in the case of the c.r.

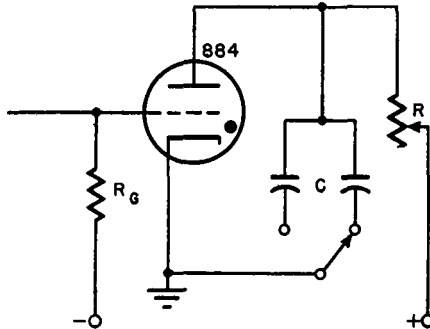

Fig. 305—Gas triode oscillator, including variable charging resistor and condenser.

tube) is required. This in turn determines the size of the condenser C and the value of resistor R_p . The larger these components, the longer the time and, therefore, the lower the frequency. In actual practice, different condensers are switched into the circuit for different frequencies, while the resistor is a potentiometer (see Fig. 305).

The Multivibrator

A second type of saw-tooth generator is the *multivibrator*. In its simplest form it looks like a 2-stage, resistance-coupled amplifier, to which a coupling condenser has been added from the plate of the output tube back to the grid of the input tube (see Fig. 306). In this circuit, a rise in current in tube A causes an increase in negative bias on tube B. This continues until plate current of tube A is maximum and that of tube B is minimum. When this condition has been reached, condenser C_b discharges through the grid resistance R_{gb} of tube B, making its grid less negative. At the same time, the bias of tube A is being increased until current cutoff, while plate current in tube B increases. The tube functions are thus reversed. The time of one half-cycle varies with the time constant $(R_{pa} + R_{gb}) C_b$, that of the other half-cycle with the time constant $(R_{pb} + R_{ga}) C_a$. A condenser placed across the plate circuit of tube B would charge up during the time the bias increases on that tube, then suddenly discharge when the bias abruptly drops to minimum. Thus we again have the saw-tooth voltage rise. There are a number of variations of this basic circuit in use in oscilloscopes and television receivers.

The Blocking Oscillator

A third popular type of saw-tooth generator is the *blocking oscillator*. In Fig. 307, a transformer couples the plate and grid circuits of the same tube. A rise in plate current thus makes the grid more positive, further increasing the plate current in a very short time. But, as the

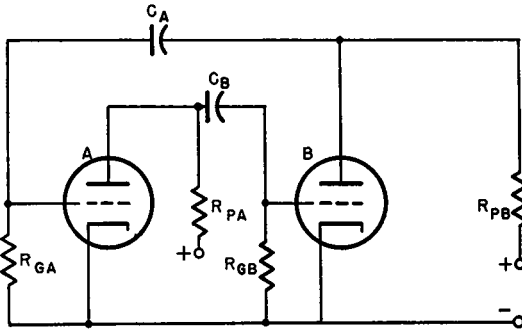

Fig. 306—Basic multivibrator circuit. Except for C_A , this circuit resembles an ordinary 2-stage amplifier.

grid goes positive, grid current flows, producing a negative bias which will rapidly decrease the plate current to zero. The tube is then said to *block*, meaning that the plate current has been cut off. Here again we have the essential requirements for a saw-tooth generator: a sharp pulse of plate current (corresponding to the discharge time of the condenser) followed by a period of cutoff (no plate current), during which time the condenser charges in saw-tooth fashion. Fig. 308 shows the plate current and grid voltage during one cycle of operation of the blocking oscillator. Note that the plate current pulses are very sharp and of short duration. During this time, the grid voltage builds up due

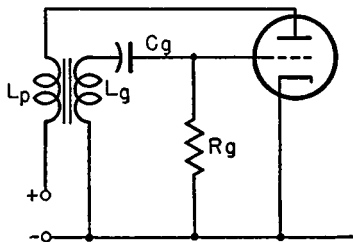

Fig. 307—Basic diagram of a blocking oscillator.

to grid current flow, increasing the bias to cut off at point a. From point a to point b on the curve the condenser slowly discharges through the resistor, until, at b, the grid voltage again allows the plate current to

rise for the beginning of the next cycle. A simple diagram of the blocking oscillator is shown in Fig. 309.

In all such types of oscillators, the saw tooth is produced in approximately the same manner, i.e., by allowing a condenser to *charge gradually and uniformly to a predetermined voltage in a predetermined time* (except in the blocking oscillator, where the saw-tooth action is produced by the uniform discharge of a condenser). This charging constitutes the first part of the oscillator cycle. It corresponds to the active or *scanning* period during which the spot of light is swept across the cathode-ray screen. The second part of this cycle is the sudden discharge of the condenser and the decrease of the scanning voltage to zero; it corresponds to the flyback time, during which the beam jumps back quickly and almost invisibly to its starting position to be ready for the next line. The duration of the first (charging) part is approximately 90 percent of the total cycle time, allowing roughly 10 percent for flyback. This is one reason why the flyback trace is so dim on the c.r. screen.

As stated above, both the maximum voltage to which the condenser is allowed to charge and the time of charge are predetermined. This time, which determines the frequency of the saw-tooth voltage, depends primarily on the size of the charging condenser and of the resistor through which the grid condenser must discharge. In Fig. 305, variation of either R or C, or both, changes the frequency of the oscillator.

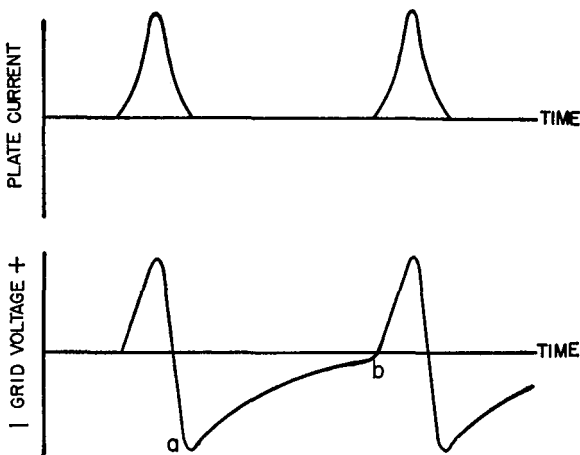

Fig. 308—Plate current and grid voltage variations during one cycle of blocking oscillator.

In Fig. 306, the same result is achieved by varying R_{gb} and C_b . In Fig. 309, R_2 and C_2 are the major frequency-determining factors. In all three of these typical oscillators, which incidentally are all audio-

frequency generators, the tunable elements are R and C. They are the counterparts of L and C, the tuning-condenser-and-coil combination of the common *radio-frequency* oscillators. There are other factors which

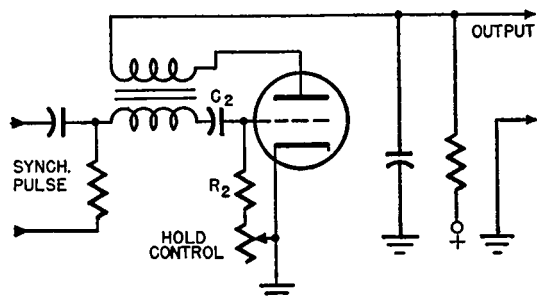

Fig. 309—Typical blocking oscillator circuit.

more or less influence the frequency of R-C oscillators, such as supply-voltage variations, etc., but these are of comparatively minor significance.

Synchronization

While the factors mentioned determine the frequency of an R-C oscillator, there are others which affect the frequency of oscillation. Since the latter are themselves variable, the resultant frequency will therefore vary. Thus it cannot be said with any degree of certainty that the same setting of the dial will produce the exact same frequency every time. Under these conditions, it is said that the oscillators are *free-running*. Both the frequency of the saw teeth as well as their magnitudes may vary somewhat from time to time and even from cycle to cycle. Very often, however, it is necessary to have an *exact* frequency saw-tooth wave, for observing and photographing wave shapes or for television receiver deflection. Even a minor variation of either the frequency or the magnitude of the saw-tooth voltage is sufficient to cause a wave to drift across the c.r. screen, making observation difficult and photographing impossible. In television reception, a similar drift is certain to result in severe distortion. Since this drift is due to the non-uniform operation of the sweep generator, frequency and magnitude of the saw teeth must be controlled in some manner. This control is called *synchronization* or *locking*. Simply stated, the frequency of the sweep oscillator is controlled by a source outside of its own circuit. Thus, if an accurately controlled and maintained frequency is applied to the input of a sweep generator, this accurate external signal will *time* the local oscillator at the same point in each cycle, making all the cycles equal in size and spacing, hence of constant frequency.

One might wonder at this point, and justly so, whether the controlling or synchronizing pulse itself is absolutely reliable. The answer is quite simple. It is not very important that the frequency be exact from the viewpoint of absolute standards. Rather it is important that the local frequency be as nearly the same value as the control frequency as possible. Thus, if the frequency of sweep of a television transmitter varies within reasonable limits, no apparent effect on the received picture will be noticed *as long as the receiver sweep oscillator varies exactly the same way as the transmitter oscillator*. The same is true in the case of any oscillographic application.

Fig. 310 illustrates free oscillations as well as synchronization or locking. During the initial period AB, the saw-tooth characteristics depend entirely on the local conditions of the oscillator and it is said to be free-running. The individual teeth are longer as well as less frequent. From point B on, the saw teeth appear smaller in size as well as higher in frequency (closer together). Notice that a sine-wave a.c. potential has been applied to the same circuit (the grid) in which the local oscillations take place. This sine wave causes corresponding variations in the plate circuit of the same tube, thus stopping every saw-tooth cycle (the charging cycle) at exactly the same time, the positive value of control voltage reducing the grid voltage enough to cause the tube to fire sooner than it would without any control voltage. Points D, E, and F now become the peaks of the saw teeth, instead of points D', E', and F'. This produces cycles of shorter duration as well as of greater frequency. Any external voltage of the desired frequency may be applied to the free-running sweep oscillator to provide locking or synchronization, thereby obtaining the exact frequency desired from our local sweep generator.

The decrease in the *amplitude* of the generated saw teeth is of no great significance. In most cathode-ray measurements, as well as in television reception, a horizontal amplifier is provided which, in conjunction with a gain control, can *amplify* the saw-tooth input to any desired value, meeting the requirements of the circuit. The necessity for this amplifier is obvious. In Chap. 2 we saw that a certain deflecting potential (sweep voltage) is required to move the spot across the screen. Any voltage below that value will deflect the beam only part of the way, resulting in a smaller, compressed picture; while an excessive deflecting potential will run the beam off the screen, around the side of the tube, resulting in loss of part of the picture. The *gain control* of the horizontal amplifier is therefore used to obtain the correct value of sweep-voltage input to the deflecting circuit of the c.r. tube. We shall discuss a typical circuit in the next chapter.

Returning to the subject of synchronization, let us assume that we wish to observe the wave form of a 600-cycle supply. Referring back to Chap. 2, we can say that, if the spot is moved across the screen once

for every cycle of our test voltage, we will observe one cycle. During the time the spot moves from zero position upward, then back to the zero position, then downward, and finally back again to its starting position, the sweep voltage moved or swept this spot all the way across the screen. Had the motion of the spot across the screen been faster, it would not have had time to complete a cycle in the up-down direction. As a result, the trace would have been spread out too much on the screen. On the other hand, had the sweep voltage caused the spot to move across the screen much more slowly, it would have traced more than one complete up-down cycle. Thus, if the sweep voltage is 600 cycles and the test frequency also 600 cycles, one complete cycle will appear on the screen. Should the sweep frequency decrease to 150 cycles, we would see four cycles of the test voltage. Similarly, a 200-cycle sweep would produce three cycles on the screen. Since we seldom observe less than one complete cycle, the lowest frequency that can be studied is the same as the lowest saw-tooth frequency (about 10 cycles).

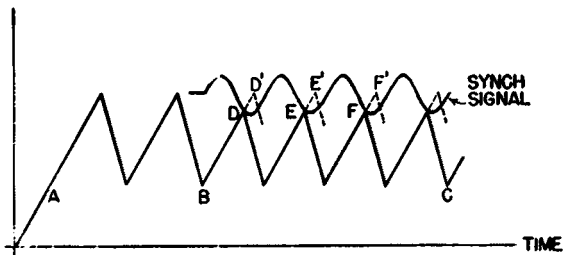

Fig. 310—Free oscillations and synchronization. From A to B, no synch signal is applied. From B to C, the sine wave synch pulse “stops” each saw tooth at the same point. Points D', E' and F' show where the saw tooth might have been without synchronization (dashed lines.)

The highest unknown frequency may be a few times as high as the highest sweep frequency. Thus, for a maximum sweep frequency of 40,000 cycles, we can observe a test frequency up to about 200,000 cycles, in which case five cycles would appear on the screen. A 320,000-cycle test voltage would produce eight complete cycles on the screen. This cannot be carried too far, since it becomes difficult to study the wave form when too many cycles appear on the screen. There are other limitations on the maximum frequency that can be studied. We shall mention them in due time.

The saw-tooth wave is important, not for its own sake as a type of voltage variation encountered in radio work, but as an aid in viewing other waves in which we have a direct interest. A sine-wave a.c. is a good example of such a wave. The sine wave is the standard a.c. wave form. All other wave shapes are more or less complicated variations of this fundamental type. In advanced circuit theory, calcula-

tions pertaining to complex a.c. waves are made by the standard procedure of resolving the complex wave into a number of component waves, each of these being a simple sine wave.

However, most a.c. potentials studied on the c.r.o. are not simple sine waves. While most r.f. and a.f. signal generators produce nearly pure sine-wave voltages, the e.m.f.'s most generally studied are much different. Consider an audio amplifier. Almost all the speech and music handled consists of very complex and apparently irregular wave shapes. (See Fig. 311.) However, since it would be extremely difficult to study such a complex wave on the c.r. screen, we resort to a simple but satisfactory expedient, and one that produces a wave much simpler to analyze. We use a standard test wave shape, such as a square wave or a sine wave. The conclusions arrived at through the study of such a standard test wave are equally applicable to complex waves, since, as pointed out previously, complex waves are merely combinations of sine waves of different frequencies, amplitudes, and phases.

The less common of the two standard test wave shapes mentioned above is the square wave, shown in Fig. 312. Although more difficult to produce and analyze, the square wave provides a more accurate check on the response of an amplifier, especially where wide-band, uniform frequency response is desired. This is because the square wave is a

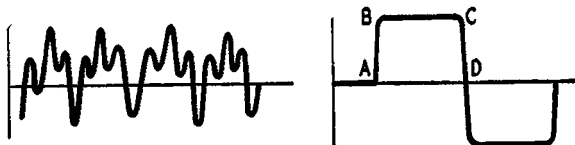

Fig. 311 (left)—Appearance of an actual sound wave on the 'scope (1000 cycle tone containing harmonics). Fig. 312 (right)—A square wave. Parts A-B and C-D would be altered if the high frequency response were poor. Part B-C would serve as a check on the frequency fidelity.

combination of a fundamental plus many harmonics, thus combining both high- and low-frequency characteristics. When a frequency-response test is made using this wave, the fidelity with which the square wave is reproduced in the amplifier is a good indication of both extremely high- and extremely low-frequency responses. Thus, if in Fig. 312 the steep sides *ab* and *cd* of the wave are duplicated without any change (distortion), it indicates good high-frequency response. Poor response at these frequencies would result in distortion in this part of the cycle. Either the sides would slope gradually instead of being steep, or the sharp, right-angle corners of the original wave would be rounded off, etc. The quality of the low-frequency response can be judged from the flat portions of the cycle, denoted by *bc*. As mentioned earlier, the square wave is but a special case of a sine wave. It is, in fact, a fundamental sine wave combined with a number of higher-frequency sine

waves. As a test instrument, the electronic square-wave generator is rather complicated in design and limited in use. For laboratory use, however, it is practically indispensable.

Intensity Modulation and Markers

The beam or spot in a cathode-ray tube is usually of constant intensity or brightness. This is determined by the cathode emission, grid bias, and accelerating potentials of the tube. The horizontal and vertical deflecting plates simply move the spot across the screen in a manner dictated by the potentials applied across these deflecting plates. If, for any reason, the *intensity* of the beam should vary, the pattern on

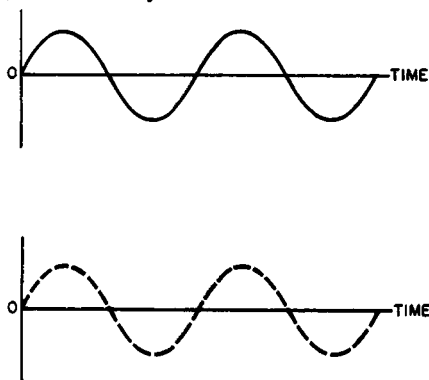

Fig. 313 (above)—C.r. tube traces a sine wave of constant beam intensity. The brightness is uniform over the cycle. Fig. 314 (below)—An intensity-modulated c.r. trace of sine wave. The beam was interrupted or extinguished approximately 12 times during each cycle.

the screen would also vary, but *only in the degree of illumination*. The shape would not be altered at all. Thus, in Fig. 313, we see two cycles of a sine wave of constant beam intensity. Fig. 314 shows the same two cycles, with the trace broken into dashed lines. The electron stream was interrupted about 12 times during the cycle by biasing the grid of the c.r. tube to cutoff as many times. In practice, we would simply have to feed a signal to the grid of the cathode-ray tube (not unlike the signal fed to the television receiver picture tube) of a frequency approximately 12 times higher than the frequency of the test voltage. Although such a dotted trace may not be very common in service work, the superimposed marker or *pip* is quite common in wide-band FM and television alignment. By means similar to the example just given, it is possible to put one or more markers on a wave or band on the c.r. screen, to indicate band width or locations of certain peaks. We shall see later, in the chapter on applications of the c.r.o., specifically how these markers are helpful in aligning FM and television i.f. channels, discriminators, etc.

Chapter 4

A Typical Cathode-Ray Oscilloscope

THE cathode-ray oscilloscope described is typical of most service instruments of this type. Except for special additions and modifications, most other 'scopes are very similar in arrangement, design, and even circuit connections. The more expensive instruments for laboratory use have higher deflection sensitivity, wider frequency response and other refinements, adapting them to study of a wider range of voltages.

Fig. 401 shows the complete schematic diagram of a 3-inch c.r.o. For our purpose, we have divided this diagram into four subunits, marked A, B, C, and D and identified as follows:

- Unit A—vertical amplifier,
- Unit B—horizontal amplifier,
- Unit C—sweep generator,
- Unit D—power supply.

Let us first examine each unit, after which we shall see how the complete assembly operates. Fig. 401-A shows the vertical amplifier. It is a 6SJ7 triple-grid amplifier, operated as a pentode. The gain of the stage is approximately 50. The input circuit is quite conventional, not unlike the input to an audio amplifier. C_1 is the d.c. blocking condenser, to prevent a high positive d.c. potential from being applied to the grid. Since it is usually a 400-volt condenser, care must be taken not to connect a test signal of higher voltage to this amplifier. Should it be necessary to examine a test point at higher potential, an additional condenser of sufficiently high working voltage should be connected in series with the V terminal. THE VERTICAL GAIN control R_1 is the usual 0.5-megohm potentiometer acting as a signal input control. The cathode and screen circuits are quite conventional. The lead from the cathode marked INT. SYNCH. will be explained later in the discussion of the complete assembly. The plate circuit deserves some comment, since

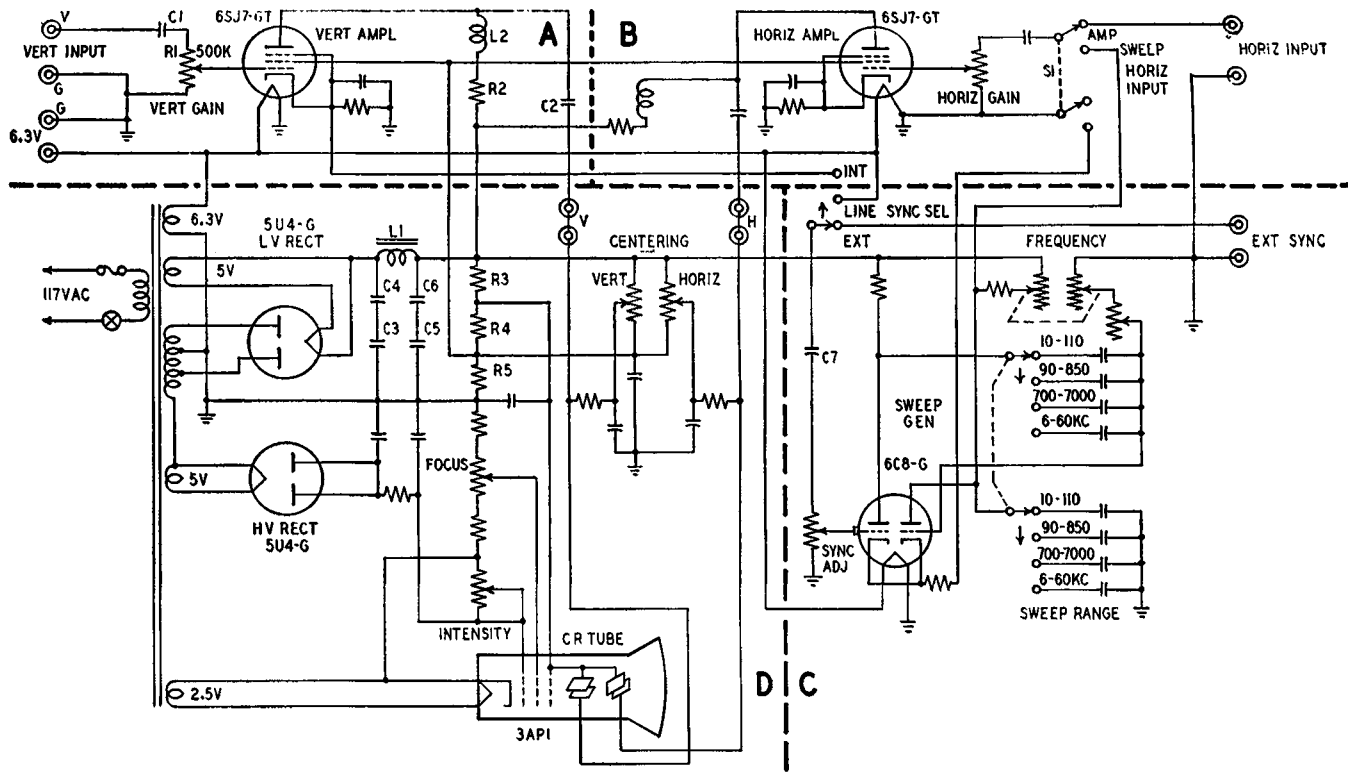

Fig. 401—Complete schematic diagram of a 3-inch Cathode-Ray Oscilloscope. Section A, Vertical amplifier; B, Horizontal amplifier; C, Sweep generator; D, Power Supply.

it differs from the usual audio amplifier. The difference lies in the peaking coil L_2 in series with the plate load resistor R_2 .

As stated in Chap. 3, the vertical amplifier may be called upon to handle frequencies three or more times higher than the highest sweep frequency. Assuming a 60-kilocycle maximum for the sweep generator, as is the case in this instrument, the signal or test frequency may be as high as 180 kc. The ordinary resistance-coupled amplifier, for comparison, handles frequencies up to only about 15 kc. Since the c.r.o. is a measuring device, it is important that all frequencies being observed be amplified equally. Should the higher frequencies (or any others, for that matter) be amplified less, the 'scope would give a false indication of poor high-frequency response in the instrument being tested, while in reality it is the oscilloscope that is at fault. This decrease in response at high frequencies is mainly due to the shunt capacitances of the amplifier tube and stage. Placement of components and wiring are an added factor, tending to increase this shunting effect. Let us see how this shunting effect comes about.

We know that plate-to-grid capacitances in pentodes are extremely small, being roughly .005 $\mu\mu\text{f}$. However, grid-to-cathode (C_{gk}) and plate-to-cathode (C_{pk}) capacitances range much higher, usually about 2 to 5 $\mu\mu\text{f}$ for the grid, and as high as 10 or 12 $\mu\mu\text{f}$ for the plate. These capacitances are, in effect, shunt condensers from grid and plate to cathode or ground. At audio frequencies (below 15 kc) their shunting effects are generally slight enough to be negligible. At higher frequencies, such as the 180 kc in our vertical amplifier, these condensers become low-impedance paths to ground. As a result, the amplifier shows a decrease in output at higher frequencies. A common method of correcting this high-frequency loss is through the insertion of peaking coils, such as L_2 (see A), in series with the plate load of the particular amplifier. These coils tend to counteract the shunting effect of the capacitances, as outlined below.

From fundamental a.c. theory we know that the reactance of a condenser decreases with increase in frequency ($X_c = \frac{1}{2\pi fc}$ — the higher the value of f , the lower the value of X_c), while the reactance of a coil increases as the frequency increases ($X_l = 2\pi fL$ — the higher f , the higher X_l). We also know from vacuum-tube characteristics that for any given tube and circuit, the output increases as the plate load resistance R_l increases. With these two basic facts in mind, we can understand the function of the peaking coil.

At low frequencies, the shunting effect of C_{gk} and C_{pk} is negligible. At the same time, the a.c. resistance of the peaking coil L_2 in the plate circuit is also negligibly low. This makes the plate load approximately equal to R_2 or 68,000 ohms. We shall consider the output at

these frequencies as normal. At medium-high frequencies, the reactance of C_{gk} and C_{pk} decreases as the coil reactance increases. As the frequency further increases, these effects continue in the same directions, X_c decreasing and X_L increasing, the combination behaving as a parallel resonant circuit. Were it not for the resistor, R_2 the L-C circuit would have a peak at a single frequency, as is the case with parallel resonance. However, the resistor acts as a loading device, reducing the selectivity and flattening the response. With a suitable peaking coil for a particular tube, resistor, and frequency range, the circuit can be made substantially flat over the required range of frequencies.

The only other component to be noticed in Sect. A is the blocking condenser C_2 . This is necessary since the output (plate) of the amplifier feeds one of the deflecting plates in the cathode-ray tube, which plate is also at a certain d.c. potential required for *centering*. The condenser C_2 must be large enough to offer a low impedance to the lowest frequencies found in the output of the *vertical* amplifier.

The *horizontal* amplifier shown in Sect. B is, with the exception of the d.p.d.t. switch S_1 , identical to the vertical amplifier. This switch makes it possible to amplify either the output of the local sweep generator or the external signal fed to the HORIZ. INPUT terminals. Although the sweep-generator frequencies are considerably lower than those encountered in the vertical amplifier, the peaking in the plate circuit of the horizontal amplifier is nevertheless necessary, since it may be desired to feed an external sweep voltage of much higher frequency into the horizontal input terminals (d.p.d.t. switch in the AMP position). With S_1 at SWEEP, H input is from the saw-tooth output of the internal oscillator. This will be referred to again when viewing the entire diagram as a complete unit.

Section C is the diagram of the sweep generator or saw-tooth oscillator of the multivibrator type, using a double triode. Its general operation is as described in Chap. 2 for saw-tooth generators. The controls and their functions are as follows:

I. SWEEP RANGE—This dual control serves as a *coarse* frequency adjustment, and might be compared to a band switch in a multiband receiver. It selects the range of frequencies between which the oscillator may be tuned with the aid of the *fine* frequency control. The lower half of this dual control switches in different values of capacitance from the output plate to ground. Notice that the larger values of capacitance are used in the lower-frequency bands, and vice versa. This condenser is, in effect, the load or output impedance, across which the saw-tooth voltage appears. The upper half of this control switches in different values of coupling condensers, from the first triode plate to the grid of the output triode. Since the time constant of this coupling

circuit largely determines the frequency of the multivibrator, a large change in the value of this coupling condenser results in a proportionate change in the output frequency.

II. FREQUENCY—This control is a dual potentiometer, the right-hand half varying the grid resistance of the second triode while the left-hand unit varies simultaneously the second triode plate voltage and output condenser charging current. The proportioning of the size of the condensers being switched in and the values of the potentiometers is such that the potentiometers vary the frequency within the limits of the band set by the SWEEP RANGE control. Thus, in position 2, for example, the range is set for a band of between 90 and 850 cycles. The *fine* control will then tune the oscillator to any frequency between 90 and 850 cycles per second.

III. SYNCH ADJ—This control looks exactly like the common gain control in an audio amplifier grid, but it is used as such only when an external signal is fed to the multivibrator for synchronizing purposes. As you will recall, a free-running saw-tooth generator, whatever its type, tends to be unstable, varying somewhat above and below the desired frequency. Since for most oscillographic (and television) purposes an *exact* frequency is required for stability of pattern, a synchronizing or timing pulse is applied to the grid of the oscillator, this synchronizing pulse setting off or timing each generated cycle at exactly the same point. It might be called a precision *cycle timer*.

In our diagram, the SYNCH ADJ potentiometer varies the amount of this timing pulse fed into the grid of the first triode. This is important, since the minimum amount of synchronizing voltage is desirable. An excessive amount of synchronizing signal tends to change or distort the output of the saw-tooth generator.

IV. SYNCH SELECTOR—This three-position switch allows three different sources of synchronizing voltage to be used as required. We will return to this switch later in this chapter.

The final section of the c.r.o. is shown in Sect. D and again in Fig. 402. This is the combined low- and high-voltage power supply. Theoretically, this unit consists of two supplies: one having an output of about 250 volts d.c. for the amplifiers and oscillator, the other giving around 750 volts d.c. at a current of about 1 milliamperes for the cathode-ray tube. In practice, however, as shown on this diagram, the two supplies are combined in the interests of simplicity and economy. A single power transformer supplies all the heater, low, and high voltages. The heater voltages are quite conventional and need no comment. The high-voltage system consists of the usual center-tapped winding, feeding the plates of the upper 5U4-G. This in conjunction with L_1 , C_3 , C_4 , C_5 , C_6 and bleeder resistors R_3 , R_4 , and R_5 forms

the typical and familiar full-wave power supply. The higher voltage for the cathode-ray tube is obtained as follows: A second high-voltage winding, not center-tapped, is connected in series with the lower end of the center-tapped winding. The other end of this second winding goes to the cathode of the second rectifier. This is also a 5U4-G, but with both plates tied together, forming a half-wave rectifier. Since the current requirements of this supply are extremely low (below 1 ma) and the voltage is used for the cathode-ray tube only, complete filtering is not necessary. Hence, half-wave rectification and small condensers are adequate. As a result, no center-tapped transformer is required, further saving materials, space, weight, etc. Since a 250-volt supply already exists, the half-wave winding need but supply the additional voltage required, usually not over 500 volts for a 3-inch cathode ray tube. The additional load on the 250-volt supply due to this series connection is negligible, being only about 1 ma. Fig. 402 shows the complete voltage

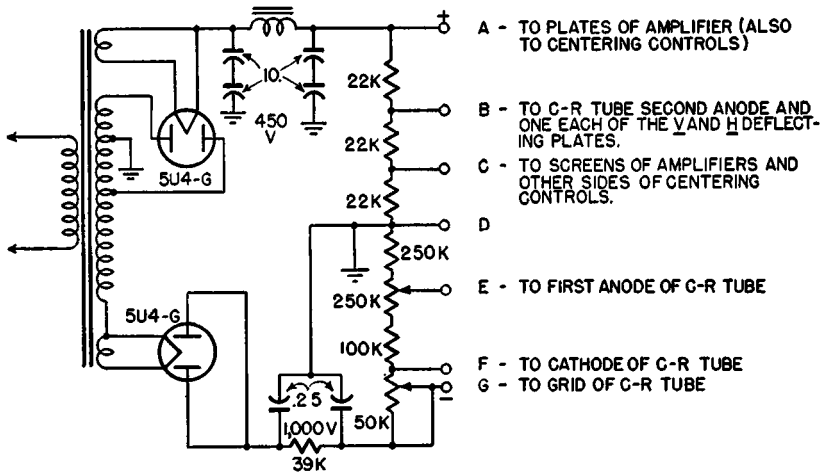

Fig. 402—Simplified schematic of dual power supply. (First figure is voltage to ground; second is voltage to negative end of power supply). Point A +250, +750 v; B +175, +675 v; C +100, +600 v; D 0, +500 v; E (Focus) -200 to -400, +100 to +300 v; F -450 to -500, 0 to +50 v; G (INTENSITY) -500, 0 v.

output system, with polarities marked to indicate relative voltages at various elements of the cathode-ray tube. Notice that the two rectifiers are in series with each other. The cathode of the upper 5U4-G is the highest positive point of the whole system. Next, in the downward direction, comes the higher, and then the lower plate of the same rectifier. Further down is the cathode of the second 5U4-G, and finally, the lowest point in the system is the plate (two plates tied together) of the lower rectifier.

Let us now examine how this supply feeds the various circuits of the oscilloscope. Points A and D are the high and ground points, respectively, in the low-voltage system. Point A feeds the plates of the amplifiers and sweep generator, at approximately 250 volts. Point C, about 80 volts above ground, supplies the screens of the amplifiers. The total current consumption here is about 30 milliamperes. The high-voltage supply, about 750 volts, is between points A and G. Starting with the lowest point, the control or signal grid of the cathode-ray tube goes to point G, while the cathode connects to point F at a small potential above the grid. By means of the INTENSITY potentiometer, the resistance and consequently the voltage drop between points F and G may be varied, thus varying the negative bias on the control grid. This controls the electron beam and also the brightness, and indirectly the *size* of the spot. The first anode, referred to earlier as the focusing anode, goes to the slider of the potentiometer called FOCUS. By varying the positive potential on the first anode, the spot may be brought into sharp focus, resulting in a sharp spot on the screen. The second anode goes to point B, next to the highest potential point in the whole system. This is the accelerating anode and is operated at the highest potential of all the cathode-ray tube elements. Observe also that one each of the horizontal and vertical deflecting plates go to the same point as the second anode. Each remaining plate goes to the slider of a potentiometer marked CENTERING. There are two such potentiometers, one for vertical and the other for horizontal centering. Since each slider can vary the potential of the plate connected to it above and below the potential of the other plate of the pair, the spot may be moved to the left or right, above or below the center of the screen, as required.

It is interesting to note that although the second anode is about 675 volts above the grid, it is only about 175 volts above ground. In some 'scopes the positive end of the high-voltage supply is grounded, putting the grid about 750 volts below ground. This is both a convenience and a safety precaution, since it puts some of the control shafts at chassis potential. However, it does not affect the operation of the 'scope, since the voltage distribution to, and the potentials of, the various elements are still as required.

Discussion of the Complete Cathode-Ray Instrument

Having discussed the various units that go into the making of a cathode-ray oscilloscope, we shall now examine the complete assembly. Referring again to Fig. 401 showing the complete schematic diagram of a popular 3-inch instrument, we shall discuss the few remaining controls and circuit details not covered in the analyses of the partial diagrams.

The 6.3-v output terminals may serve as a source of heater potential for some other tube or tubes used in conjunction with the 'scope.

For example, they may be used where a sample of a.c. of the same characteristics as the synchronizing potential is required for an auxiliary instrument.

The pairs of terminals marked V and H in the center of the diagram are for use when neither horizontal nor vertical amplification is desired. Normally, they are bridged by a wire jumper, as shown. When direct signal connection to the deflection plates is desired, the jumpers are removed, and the signal is connected between the lower of the two posts and ground. Fig. 403 shows these connections as viewed from the outside. They are usually at the back of the oscilloscope case. However, since most signals require amplification before being applied to the deflection plates, these direct connections are seldom used.

Just below the 6SJ7 horizontal amplifier is the switch marked SYNCH SELECTOR. This switch offers a choice of three different sources of synchronizing pulses for locking the sweep generator. Observe that the rotor contact or arm of this switch connects in series with a blocking condenser to the input grid of the sweep generator (through the SYNCH ADJ control). The condenser is approximately $0.25 \mu\text{f}$, sufficiently large for any low-frequency a.c., blocking d.c. only. The SYNCH ADJ control, in turn, varies the amount of signal input to the saw-tooth generator, different amounts being required for locking at different signals and frequencies.

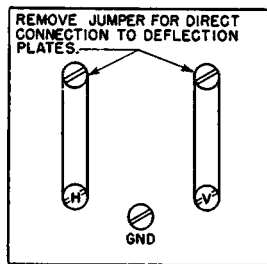

Fig. 403—Typical terminal strip for direct connection to deflection plates of c.r.o. tube (when V and H amplifiers are not used). These are high-voltage terminals and should be thoroughly protected from accidental contact.

The EXTERNAL position of this selector switch connects to a pair of binding posts, shown on the right-hand side, marked EXT SYNC. This is used when some other type of synchronizing voltage is desired for sweep timing. Often this may be a standard audio oscillator, which is more precise or otherwise more desirable.

The INTERNAL setting of the sweep selector connects to a portion of the output of the vertical amplifier. Since this amplifier handles the test signal, internal synchronization always means that the sweep generator is timed by, and in accordance with, the actual signal being examined. This is perhaps the most common method of synchronization.

The LINE position uses the 60-cycle supply as a source of synchronizing potential. Notice that it connects to the 6.3-v a.c. of the heater circuit. This source is often used, since most commercial 60-cycle supplies are very stable and reliable, both with regard to frequency and wave shape. A simple use of this would be the checking of the accuracy of calibration of an oscillator at 60 cycles, or an integral multiple thereof, up to about 600 cycles. We shall discuss this method in detail in the next chapter.

The switch just to the right of the 6SJ7 horizontal amplifier selects one or the other of two methods of operation. In the AMP position, the horizontal input signal is fed to the horizontal amplifier and then to the horizontal deflecting plates. This is the case when an external sweep voltage other than the local saw tooth is used for horizontal deflection of the beam. Notice that in such a case the saw-tooth oscillator is *not* used at all. As a matter of fact, it is made inoperative, since the lower half of the switch actually opens up the cathode-to-ground-path of the 6C8-G.

In the SWEEP position, the c.r.o. is used in the most common manner. The cathode of the saw-tooth oscillator is connected to ground for normal tube operation. The output of the sweep generator is now fed to the H-amplifier input. This amplifier, in turn, feeds the horizontal deflecting plates of the c.r. tube.

Let us now sum up all the functions and controls of the c.r.o. by actually listing their operation in a typical case. Assume that we wish to examine the frequency and wave form of a 100-cycle audio oscillator. The procedure would be as follows:

1. Plug the c.r.o. into the proper a.c. outlet — 115 v, 60 cycles in this case. Turn it ON by means of the ON-OFF switch on the INTENSITY control knob.
2. After allowing about 30 seconds for warming up, turn the same control further clockwise until a sufficiently bright trace appears on the screen.
3. Adjust FOCUS control (varying the positive potential on the first anode) until the spot is as small and sharp as possible.
4. Turn the H centering control until the spot is midway between the left and right edges of the screen. Similarly, turn the V centering control until the spot is halfway between the top and

bottom of the c.r.o. screen. The spot is now both in center and in correct focus.

5. Set SWEEP SELECTOR switch to SWEEP, since we are going to use the internal saw-tooth generator for sweeping.
6. Set RANGE switch to either 10-110 or 90-850, either setting enabling us to obtain 100 cycles. Adjust horizontal gain until the spot is swept across the screen in a horizontal direction. It will not move up or down, since no vertical deflecting e.m.f. is present.
7. Connect the 100-cycle generator output to the vertical input terminals of the c.r.o. Adjust the vertical gain for proper vertical deflection on the screen. Since the signal input is approximately 100 cycles, it is necessary to adjust the saw-tooth frequency to approximately 100 cycles. This is done with the FREQUENCY control. A single cycle will now appear on the screen. In order to synchronize exactly or lock the trace on the screen, we merely set the SYNCH ADJ control so that sufficient signal voltage, taken from the output of the vertical amplifier, is fed to the saw-tooth generator. The correct setting is evidenced by the stopping of the picture.

As mentioned earlier, it may often be desirable to have two, three, or even more cycles on the screen for better observation. To observe simultaneously four cycles of our 100-cycle test voltage, set the SWEEP RANGE to the first (10-110) position and adjust the fine control until the saw-tooth generator produces about 25 cycles per second, as shown by the appearance of 4 cycles on the screen.

In conclusion, a few words of *caution*. They are extremely important, actually a matter of life or death. In all instruments where cathode-ray tubes are used, there is the danger of shock and even death from the high potentials. A 3-inch instrument may have a supply of 750 v or more. A 5-inch 'scope may run up to 2,000 volts, while a 10-inch television receiver may operate at up to 10,000 volts! Some television receivers on the market today carry a lethal potential of 25,000 to 30,000 volts! In a great many commercial oscilloscopes, the H and V terminals shown in the center of the diagram in Fig. 401 are too often left exposed on the backs of instruments. Many a serviceman has received a bad shock or even narrowly missed electrocution by attempting to move, lift, or otherwise handle the instrument on the bench with the switch ON. These terminals should be adequately covered against accidental contact. Remember, *your life may depend on it!*

Chapter 5

Practical Applications of the Cathode-Ray Oscilloscope

WE are now ready to outline actual service uses of the c.r.o. in the service shop or laboratory. Having studied the whys and wherefores of the instrument, one can now proceed to apply the scope *intelligently* to actual problems.

For the purpose of simplification, we shall divide all the applications of the oscilloscope into these major groups:

- Group I—alignment,
- Group II—measurement,
- Group III—trouble shooting.

Group I includes the following:

1. Visual peak alignment of narrow-band receivers, such as a.c.-d.c. sets, inexpensive, average-quality console receivers, etc.;
2. Flat topping or band-pass alignment of higher-quality console receivers;
3. Wide-band alignment of FM intermediate-frequency channels;
4. Correct alignment of FM discriminators;
5. Alignment of television i.f. channels;
6. Proper staggering for desired bandwidth and response curve shape in television i.f. channels using this type of i.f. system.

The fundamental difference between the old method of peak alignment and the visual method is the fact that the “by ear” and even the output-meter system gives an indication only of the *magnitude* of the output voltage, without much regard for frequency. The modern visual alignment method allows the observer actually to *see* the shape of the response curve and thus judge the output at *any* and *all* of the frequencies in the desired band. The importance of this cannot be over-emphasized; it is an absolute *must* in FM and television alignment,

making the difference between good fidelity and unbearable distortion in FM sound channels, and between excellent detail and very poor quality of a television picture. Since we wish to observe a *band* of frequencies, instead of the single-frequency peak of old-time alignment, a different type of signal generator is required—the frequency-modulated sweep generator.

The frequency-modulated signal generator, or, as it is more commonly called, the sweep generator, is essentially a signal generator that varies periodically above and below any chosen center frequency. As an example, when such a signal generator is set to, say, 465 kc, with a sweep of ± 5 kc, it will generate a sequence of frequencies all the way from 460 to 470 kc. Furthermore, it will repeat this sequence in a regular, periodic manner. If this sequence is repeated fast enough, say, at least 30 times per second, we will observe on the cathode-ray screen a *band* of frequencies 10 kc wide, extending from 460 to 470 kc. Since many an i.f. channel is 10 kc wide, we are thus observing simultaneously the complete i.f. channel, just as it is intended to operate in an actual receiver.

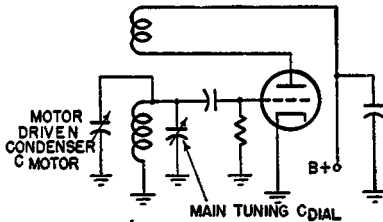

Fig. 501—Oscillator section of motor-driven FM signal generator.

Of the several varieties of sweep generators on the market, one of the simplest and most easily understood, although no longer popular, is the rotating-condenser type. A motor, driven at a fixed speed of perhaps 3,600 r.p.m. (60 cycles per second), is coupled to the rotor of a small tuning condenser. This condenser is in parallel with the main tuning circuit of the oscillator so that, when the condenser is half-meshed, the oscillator frequency is the nominal or center value. As the rotor unmeshes, the circuit frequency shifts upward; and an increased meshing of the rotor causes a downward shift of the center frequency.

Figs. 501 to 504 illustrate these cases. Fig. 501 shows a part of the signal generator tuned circuit. The motor-driven condenser is part of this tuning system, so that with the condenser at 50 percent of its maximum capacitance the output frequency is 465 kc. The response curve of this single-frequency curve might be shown as in Fig. 502-a. As the motor tunes the condenser from 50 to 100 percent of capacitance, the frequency shifts from 465 kc to 460 kc and traces a curve that may be represented as shown in Fig. 502-b. This curve is nothing more

nor less than a shifting of the single-frequency curve of Fig. 502-a from right to left. Since this shifting of frequency happens in a very short time, we see the complete curve on the screen (Fig. 502-b). Were the

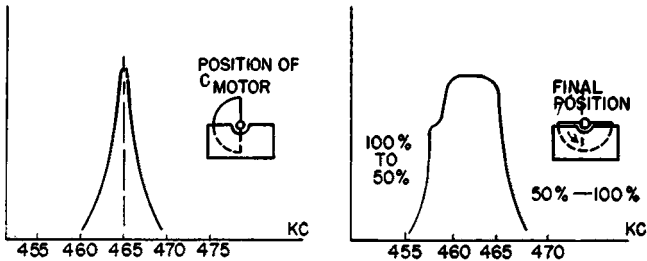

Fig. 502-a (left)—Response curve at 50% setting of motor driven condenser. Fig. 502-b (right)—Response curve plotted during time motor-driven condenser swings from 50% to 100% of capacitance. During time of return of condenser from 100% to 50%, the above curve will be repeated and will overlap original curve.

condenser allowed to remain in the maximum-capacitance position, the curve would look like Fig. 502-a, except that it would be located at 460 kc instead of at the original 465-kc position. But as the condenser continues to rotate from its maximum position back toward the starting value (50 percent meshed), the oscillator output exactly repeats the response curve at 461, 463 and 465 kc and all the values between these points. Thus the curve just generated is being *retraced* and *completely overlapped*. As the condenser continues to rotate toward the minimum-capacitance position, a similar response curve will be generated, this time starting with 465 kc and going to 470 kc at minimum capacitance. Fig. 502-c shows the result. Further rotation from minimum back toward half-meshed position will repeat and overlap the curve just generated. Now if the speed of condenser rotation is high enough, both curves will be seen simultaneously. Fig. 503 shows the over-all response curve for a complete 360-degree rotation of the motor (1/60 second).

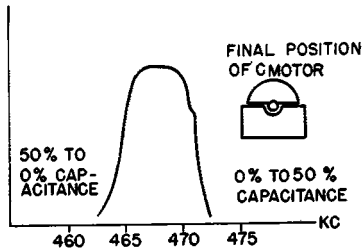

Fig. 502-c—Response curve during the unmeshing of the condenser plates, from 50% to 0% and back to 50%.

We now have two complete response curves on the screen. We need only increase our sweep frequency sufficiently to superimpose

these two curves for alignment observation. Thus, if the rotor frequency is 60 cycles per second, a c.r.o. sweep of 120 cycles would give us single image response. (The c.r.o. sweep would scan the screen twice in 1/60 second, at the same time that the sweep oscillator generates two complete response curves.) Fig. 504 shows the resultant single response curve.

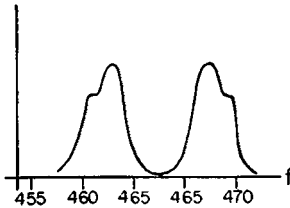

Fig. 503—Overall response curve for 360 degrees rotation of motor-driven condenser. Motor frequency... 60 cycles (3600 r.p.m.); c.r.o. sweep frequency... 60 cycles.

A word about the symmetry of the curves. It seldom happens that the response curve is 100 percent symmetrical, since amplifiers are not *exactly* linear for *all* frequencies. That is why we have shown a little hump to one side of the curve, to illustrate the directions in which the curves are generated. When superimposing these two curves, the overlap will be not quite 100 percent. However, for all practical alignment purposes, it is sufficient to have the peaks coincide.

There are other means of sweep generation, some mechanical, others electronic. They differ only in method, not in results. The electronic method is the most used in modern instruments.

We shall mention and briefly explain two of the most popular types. The first (RCA), utilizes a method somewhat similar to the motor-driven condenser system described above. A push-pull oscillator has part of its tuning capacitance in the form of a split-stator, concentric plate condenser. Physically, the condenser is somewhat like two cylindrical cans, the smaller fitting inside the larger one. One of these,

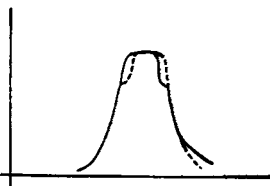

Fig. 504—Combined trace; superimposed response curves. Motor frequency... 60 cycles c.r.o. sweep frequency... 120 cycles.

the stator, is cut lengthwise, and the two halves insulated from each other. Each of these sections goes to one end of the oscillator circuit. The second "can", in one piece, is electrically grounded, and physically fastened to a modified form of a speaker voice-coil assembly. When the voice coil is energized, not unlike an ordinary loudspeaker, the "rotor can" moves with the voice coil, similar to the paper cone of a speaker. This motion in and out of the split-stator can causes a varia-

tion in the capacitance, and consequently the frequency, of the push-pull oscillator. The result is a frequency modulated output. Since the voice coil is usually operated from a 60-cycle source, the modulation frequency is 60 cycles. Furthermore, since the amount of voltage to the voice coil is adjustable, the distance the "rotor" will move is also varied, just as the strength of an audio signal varies the distance of motion of the speaker cone. With the change in the distance of motion of the rotor, the capacitance of the split-stator condenser also changes, resulting in a variation in the sweep bandwidth. In the actual instrument, the dial is marked not in voltage input to the voice coil (which incidentally is 0 to 120 volts), but in sweep bandwidth (megacycles), usually from zero to 10 mc.

Another common method of producing frequency modulated signals is the reactance modulation system. This method is based on the fact that in certain tubes it is possible to vary the transconductance (G_m) of the tube through variation in grid bias. This results in a fairly wide variation in the tube plate current. This plate current may be d.c., or a.c. of any desired frequency, including r.f., depending on the manner of operation of, and the signal input to, the tube.

In a practical reactance modulation system, the r.f. oscillator which we wish to frequency modulate is coupled to the reactance tube. Thus, the input to the tube, and consequently its plate current, is r.f. When we next apply a signal to the grid of the reactance tube (usually 60-cycle a.c., although any other frequency may be used), the tube is said to be modulated. The r.f. plate current will now vary in accordance with the grid input. Furthermore, the plate circuit is so arranged that this variable r.f. current is made to flow through the tank circuit (frequency determining LC circuit) of the oscillator. This is equivalent to varying the value of L or C of the oscillator tuning system, and the frequency will now vary above and below the nominal frequency in accordance with the a.c. signal applied to the grid of the reactance tube. The degree of variation, corresponding to the bandwidth of the sweep generator, is governed by the magnitude of the reactance tube grid voltage. The final result is therefore an FM sweep generator of variable sweep width, as required for different types of alignment procedures.

While on the subject of reactance modulation, it is well to briefly mention the use of this principle in connection with a.f.c. (automatic frequency control). This feature is finding widespread use in modern television synch circuits, and even in automatic television tuning systems (Philco). At first glance the purpose of reactance modulation in these examples seems to be just the opposite of the application described above. But although in the case of synch a.f.c. or automatic tuning, reactance modulation is used to *prevent* frequency changes, there

is no basic contradiction between sweep generation and a.f.c. application of reactance modulation. In *both cases*, reactance modulation is used to *change* the oscillator frequency. However, in the case of synch circuits and automatic tuning, the change is calculated to cancel an accidental frequency shift, due to stray pulses, temperature drift, etc. Thus, when an oscillator "wanders off" from its nominal frequency, the reactance modulator—a f.c. system *shifts* the frequency *back to normal*. The circuit is so designed that no frequency shifting will occur as long as the oscillator is on frequency. This simply requires a discriminator circuit, which produces no bias in the reactance modulator at the correct frequency, and a corrective bias of proper magnitude and polarity at *off-frequency* operation of the oscillator.

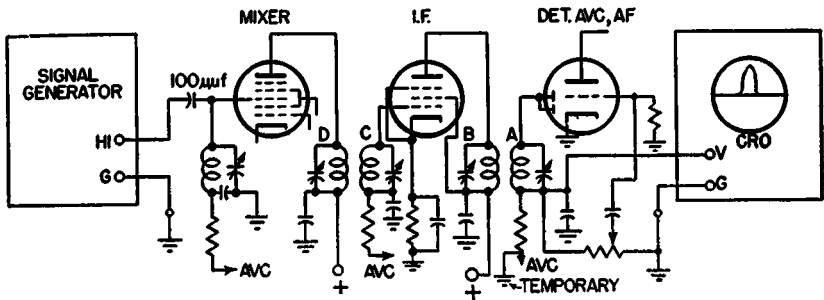

Fig. 505—Typical set-up for a.c.-d.c. midget receiver peak alignment.

Procedure for Peak Alignment

Let us now illustrate actual cases of visual alignment. Fig. 505 shows a typical setup for peak alignment of an a.c.-d.c. midget. Although various manufacturers will differ in methods and locations of input signal and output indicators, the differences are not fundamental, and therefore these typical examples will be generally satisfactory.

The detailed procedure is as follows:

1. Allow equipment (including receiver) to warm up for at least 10 minutes.
2. Disconnect antenna and connect output of signal generator between mixer grid and ground.
3. Short circuit the oscillator output by grounding oscillator tuning condenser, removing tube if separate oscillator and if heaters are not in series.
4. Short circuit a.v.c. voltage by grounding a.v.c. bus, or by any other convenient means.
5. Connect vertical c.r.o. input between points V and G across receiver audio input.

6. Set generator center frequency to specified receiver i.f. Set sweep to 10 kc.
7. Set c.r.o. controls for proper focus, adequate intensity, and adequate V and H gain.
8. Set sweep frequency, both coarse and fine, until a single image appears.
9. Align trimmers A, B, C, and D in that order, until curve is as high as possible, consistent with good symmetry and smooth edges. (Beware of jagged sides!)
10. Remove shorts from oscillator and a.v.c. circuits.

Since this is not a high-fidelity receiver, peak alignment is all that is called for.

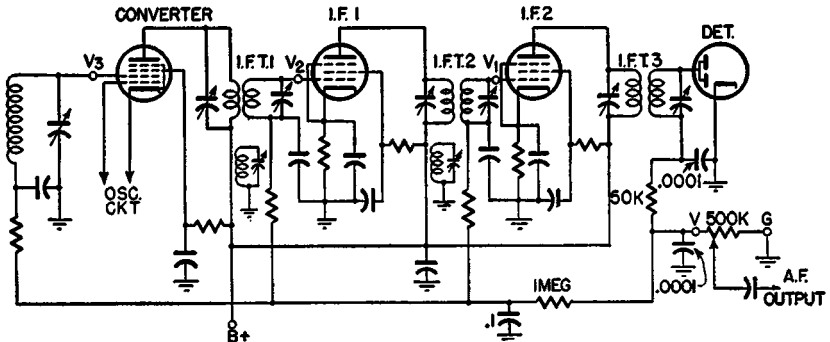

Fig. 506—Typical i.f. amplifier of a good quality receiver. Generator connection points: V_1 , V_2 , V_3 , each to ground. Note: Third winding in first and second i.f.t. is sometimes used as a means of obtaining wide-band response. See text.

CAUTION! Many small a.c.-d.c. sets have the chassis *above* ground potential and a.c. pickup is likely. However, with a series condenser at the input, it is much simpler to align with the oscilloscope than with an output meter. A fine a.c. ripple on the response curve does not prevent proper alignment, as it often does with aural or even meter alignment.

Band-Pass or Broad-Band Alignment

In this category fall most medium- and high-priced console AM receivers. The procedure is more elaborate and exacting. Assuming an a.c. set having two i.f. stages, proceed as follows:

1. Allow equipment to warm up sufficiently.
2. Short circuit the antenna input, oscillator, and a.v.c. circuits, as before.

3. Connect vertical input of the c.r.o. to the second detector load resistor, points V and G on Fig. 506.
4. Set 'scope controls (such as intensity, focus, gain, etc.) for normal conditions of operation. Readjust later, as required.
5. Set sweep frequency on the c.r.o. to about 120 cycles, or twice the signal generator sweep frequency, if that is other than 60 cycles. In some sweep generators there is an outlet or binding post (may be labeled "CRO Sweep" or "Sweep Synch", etc.) which supplies a sample of the modulation voltage used to obtain the FM in the generator. When this voltage is fed to the "H-Input" terminals of the CRO, while the internal saw-tooth generator of the 'scope is switched off, positive synchronization of the pattern is always obtained. This is the most satisfactory of all types of sweep voltages, since it provides automatic synchronization.

NOTE: See Fig. 631, page 109, for details of a simple 60-cycle, external sweep source providing much better locking than the 'scope's internal synch circuit. To use the unit, connect it to the horizontal input terminals. Turn off internal sweep. Use the unit only if the generator has no synch outlet.

6. Connect output of sweep generator between grid and ground of last i.f. tube (points V_1 and G on Fig. 506), and adjust generator output for normal-size pattern. Readjust the V and H gain controls on the 'scope to suit.
7. Align secondary and primary trimmers in this order on this stage for best overlapping of response curves, as outlined previously.
8. Move the generator input back to the grid of the first i.f. tube (points V_2 and G on Fig. 506). Readjust the signal generator output for proper-size pattern.
9. Realign *this stage only* as previously, for best superimposed traces. Do not change the alignment of the last stage!
10. Repeat this procedure with converter stage, feeding generator output to points V_3 and G on Fig. 506.

The response curves for the average good console will look like Fig. 507, while those for a band-pass receiver will be similar to Fig. 508. Figs. 509-a and b show improperly aligned response curves, resulting in cutoff at one end or the other of the band.

For a receiver having more than two stages of i.f. [rare except in FM and television (TV) receivers], the procedure remains the same, re-

peating the steps outlined above for every i.f. transformer, in the same order as before.

There are a number of receivers in which the i.f. band width and flat-topping is controlled by a third tuned circuit in the i.f. can, called a tertiary, a trap, or a loading circuit. However, since these are rare in AM broadcast receivers and more common in FM and television sets, we shall discuss them in connection with the alignment procedure for FM and TV receivers.

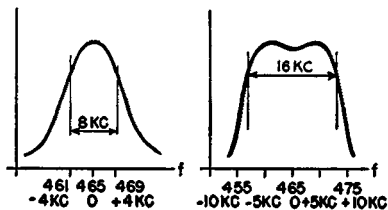

Fig. 507 (left)—Response curve of a medium-quality receiver; band-width is about 8 kc. Fig. 508 (right)—Response curve of a high-fidelity receiver; band-width is approximately 16 kc.

So far we have discussed visual alignment in those cases where a 'scope as an output indicator is either helpful (not absolutely necessary, as in the case of the peak adjustment of a.c.-d.c. midsets) or fairly essential (in the case of the broad-band or so-called high-fidelity receivers). The visual method in these cases is a time-saver and, to a certain degree, makes for a better alignment job. However, a fairly satisfactory alignment would have been possible with just a signal

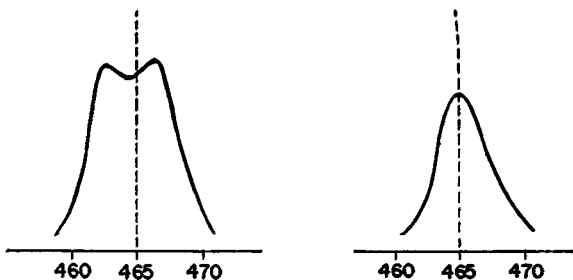

Fig. 509-a (left)—Incorrect alignment (double response curve) as evidenced by "dip" of curve not falling on the center frequency. Fig. 509-b (right)—Incorrect alignment (single response curve) resulting in "non-symmetrical" sides of curve.

generator and an ordinary output meter. In the cases to follow, the c.r.o. method is absolutely essential. Distortion, oscillation, side-band cutting, and poor picture quality in the case of the television receiver,

are almost certain to result from any attempt to align by ear or output meter.

We shall first outline the procedure for FM sets, covering both the FM broadcast receiver and the sound channel of all television sets.

In FM broadcasting the transmitted signal swings over a band or ± 75 kc. But the FM sound channel of a TV station has a swing of only ± 25 kc. As a result the FM broadcast receiver must have a minimum flat bandpass of 150 kc, compared to 50 kc for the FM sound section of the TV receiver. However, when aligning either type of set the procedure is identical. The signal generator is set for a sweep of 200 to 600 kc, far wider than either type of receiver's pass band.

As mentioned earlier, the FM i.f. channel is very much like the high-fidelity AM channel, except for the greater band width in the case of FM. However, the usual second detector of the AM set is now replaced by a *discriminator*, a modified type of audio detector in which only deviation from the carrier frequency (above and below)

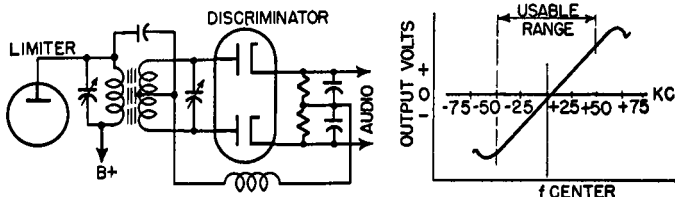

Fig. 510 (left)—Typical discriminator circuit. Fig. 511 (right)—Response curve of a discriminator with 60-cycle c.r.o. sweep. Cross lines are scale lines on the c.r.o. screen.

produces output. Fig. 510 shows a typical discriminator, while Fig. 511 gives the response curve for such a detector.

FM Discriminator Alignment

To align the FM Discriminator :

1. Disable the high-frequency oscillator and allow a warm-up period of at least 10 minutes.
2. Set the sweep signal generator to the proper intermediate frequency for the receiver under test. Set sweep to about ± 100 to ± 200 kc. If possible, consult the manufacturer's data for exact bandwidth setting of sweep.
3. Connect output of signal generator to points G1 and GND on Fig. 512, the input to the last limiter stage (assuming the i.f. has not yet been aligned). In the case of sets using no limiter stages as such, the generator is fed to the grid circuit of the last i.f.
4. Connect vertical scope input to points V and GND in Fig. 512. This is the input to the first audio stage.

5. Set scope controls for proper pattern. Briefly, they are:

Adjust INTENSITY control for adequately bright trace.
 Adjust FOCUS control for sharp trace on c-r screen.
 Switch internal sweep to OFF position. Connect sweep source from either the sweep generator if it has a sweep output terminal, or from 60-cycle sweep source described in Fig. 631, page 109, to the 11 - INPUT terminals of the c.r.o.

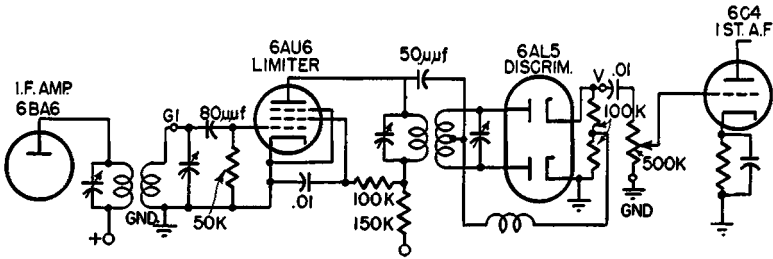

Fig. 512—Last i.f., limiter (may be one or two stages), discriminator and first audio of an FM receiver. Points of input and output connections are indicated.

Adjust horizontal and vertical c.r.o. gain controls for a good-sized pattern on the screen.

6. Align discriminator transformer primary and secondary slugs or trimmers until pattern is approximately as in Fig. 511. You will notice that the linearity and symmetry of the curve will depend largely on the primary adjustment. The secondary adjustment will determine the center frequency (zero output) position.

In connection with step 6 of the discriminator alignment, it might be helpful to briefly explain the reasons for this alignment procedure. Most of the discriminators in use today, including the ratio detector type (except for the Philco Locked-In Oscillator type which we shall explain later), use the center-tapped secondary type of discriminator transformer. They all have two main objectives in common: First, to tune for maximum i.f. signal input to the discriminator, since this produces the maximum output. Second, to tune for minimum output

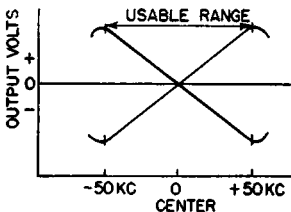

Fig. 513—Double response discriminator curve results from 120-cycle sweep.

(preferably zero) at the center frequency, this corresponding to an unmodulated carrier. Since the discriminator is a type of a band-pass

stage, extending both above and below the center frequency of the i.f., the alignment should produce the correct, *symmetrical* bandpass on opposite sides of the midpoint. Furthermore, since this midpoint is the center frequency, or the nominal i.f. of the signal, at which no modulation exists, any appreciable output at this point would be incorrect. Hence the secondary alignment for proper phase and equal voltages in each half of this secondary, resulting in a *net zero* output.

A more common type of discriminator response curve is shown in Fig. 513. This is obtained when c.r.o. sweep is 120 cycles instead of 60. It is somewhat easier to align, as dissymmetry and improperly located intersection are easier to see. To align with this pattern, proceed as above, except that the symmetry of *both* curves is now obtained with the primary tuning, while intersection at the center (resonant) frequency will be obtained by tuning the discriminator secondary.

Another method of tuning FM detection that is sometimes found in less-expensive FM and television sets is called *slope detection*. However,

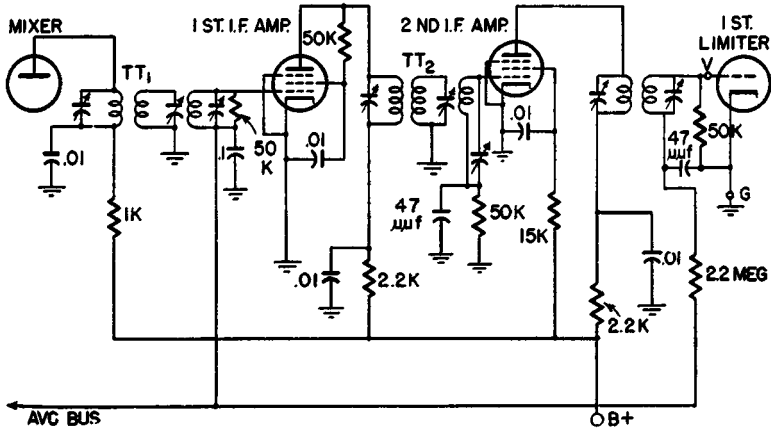

Fig. 514—FM wide-band i.f. channel. Band-width is obtained by means of tertiary "traps" TT_1 and TT_2 .

since it is essentially a modified i.f. alignment, we shall discuss it as a part of i.f. alignment procedure.

FM I.F. Stages

In contrast to amplitude-modulated receivers, whose i.f. band is anywhere from 3 to 10 kc, the frequency-modulated receiver requires a band of from 50 to 250 kc for high-fidelity performance. There are three fairly common methods of achieving this band width. The first is illustrated in Fig. 514, where the interstage i.f. transformers have a tertiary tuned winding. It is this tertiary setting that determines the band width of this stage, by acting as a load on the stage. Since the

“Q”, or sharpness of a response curve decreases with the loading of the circuit, any device which takes power from the circuit (shunt resistor, rectifier or absorption trap) will therefore “load” the system and flatten the curve, giving wider frequency response. A parallel tuned circuit such as this tertiary will absorb the greatest amount of energy from the circuit when tuned to the frequency of the circuit. Being adjustable in frequency, the tertiary can be made to draw more or less current from the circuit, thus enabling the serviceman to adjust to the desired bandwidth in the stage.

The second type of FM i.f. channel, shown in Fig. 515, has a standard type of tuned primary, tuned secondary transformer, with the addition of shunt or loading resistors across primary and secondary windings. These resistors reduce the sharpness of the curve, resulting in wider and flatter response curves. The lower the values of these resistors, the wider the response curve.

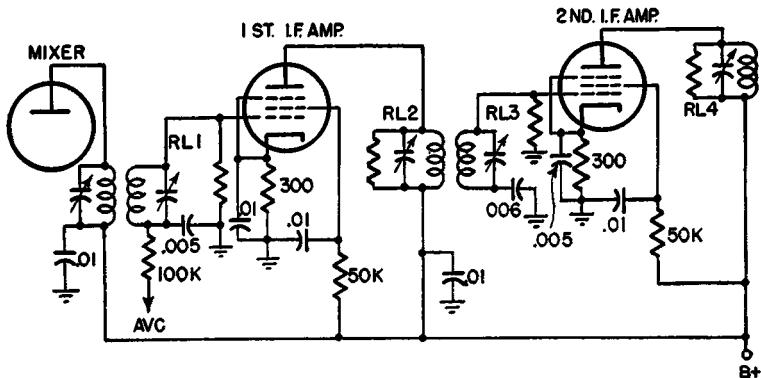

Fig. 515—Another type of wide-band FM i.f. channel, utilizing standard type i.f. transformers with loading resistors. Primaries and secondaries are tuned to approximately the same frequency.

The third type of wide-band i.f. is the stagger-tuned system. The circuit looks like an ordinary i.f. channel (Fig. 515 without the loading resistors). Band width in this system depends on the proper peaking of the primary and secondary tuned circuits to *different* frequencies within the desired band-pass of the amplifier. These different frequencies are so chosen as to provide an *overall* flat response within the limits of the i.f. channel. Many television receivers use this type of wide-band i.f. system.

To align the 3-winding type of i.f. channel:

1. Disable the high-frequency oscillator and allow time for the equipment to warm up.
2. Set signal generator to correct center frequency.
3. Set generator sweep to ± 50 to 300 kc.

4. Adjust 'scope controls for suitable pattern.
5. Connect vertical 'scope input between points V and GND on Fig. 514. This assumes that the limiter input stage has been lined up as previously described.
6. Apply signal generator output between first i.f. grid and ground. (See manufacturer's specifications for condenser, if any, in series with the high side of the signal generator. Usually, .05 μf is suitable for the last i.f. stage, and 50 μf for the others.)
7. Align the primary and secondary of the last i.f. transformer for maximum vertical deflection (peaks).
8. Align tertiary for maximum band width, or flat topping, of the response curve. *Do not widen the band beyond the point where vertical deflection begins to decrease sharply.*
9. Shift the signal generator to the grid circuit of the mixer stage and reduce generator output until pattern on the screen is of the proper size.
10. Repeat alignment as for the last stage.

If there are more than two stages of i.f., the procedure is repeated for each additional stage.

Slope Detection

This type of FM detection is found in some commercial receivers, both FM and television, which have no limiter stages and therefore do not have the noise-reducing properties of true FM receivers. Fortunately, the alignment procedure is extremely simple. But first a word about the operation of the slope detector.

Referring to Fig. 513, you will recall that the center frequency or

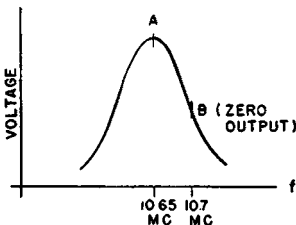

Fig. 516—Slope detection. The last i.f. transformer is peaked off the nominal center frequency. Correct alignment is indicated when the center frequency (10.7 mc) falls on point B.

crossover point is a point of zero audio output. Any deviation in frequency (due to modulation) above or below the center results in audio output. The slope detector approximates this condition. In Fig. 516 is shown an ordinary i.f. response curve. Even in wide-band FM circuits, this is

not more than 150 kc. wide. For ordinary AM reception, the center frequency is naturally at the peak of the curve, with shifts either above or below that frequency resulting in decreased output. To simulate FM detection (discriminator action) peak the i.f. channel feeding the detector to a lower frequency than the center frequency specified, so that, instead of falling at point A, the nominal frequency falls at point B, about halfway down the slope of the curve. Any frequency deviation due to modulation will now increase the amplitude in one direction and decrease it in the other. We thus have achieved the essential requirements of discriminator action—a voltage variation proportional to frequency deviation, the usable portion of the wave being practically a straight line.

The specific procedure for this alignment is as follows:

1. Carry out all the alignment steps as in band-pass AM alignment up to and including step 10, which is the alignment of the first i.f. transformer.
2. Reconnect the signal generator input across the grid circuit of the *last* i.f. stage (points V_1 and G on Fig. 506.)
3. Using a calibrated c.r.o. screen (most 'scopes come equipped with a plastic screen fitted over the cathode-ray tube, with 1/10-inch square ruled lines) or a frequency marker or pip, if the signal generator has provision for frequency marking,* locate the frequency halfway down the slope of the response curve (see Fig. 516). As an example, let us assume the peak of the response curve to be 10.7 megacycles, a common frequency in FM sets in use today. The frequency halfway down the slope might then be 10.65 mc. The span from peak to the halfway mark would then be 50 kc.
4. With the signal generator marker set to 10.65 mc, realign *only this last stage* for peak output at 10.65 mc.
5. Leaving the pattern on the 'scope, shift the marker dial on the sweep generator to 10.7 mc, and notice whether the pip falls approximately halfway down the slope. Retune the stage to 10.65 mc or thereabouts until the center frequency falls midway down the slope.

* Most modern sweep generators contain, in addition to the regular signal generator, a marker oscillator which can be superimposed on the main trace to locate exact frequency of any spot on the main response curve. It usually appears as a jagged portion of the main curve, somewhat as shown on Fig. 523. By means of an auxiliary dial, accurately calibrated in frequency, this marker or pip can be put anywhere on the main curve. It serves as a frequency vernier for all signal generator dial settings. In some generators there are two such marker dials, enabling the user to set the high and low ends of the band or any other two points on the response curve.

A somewhat quicker and simpler method of slope detection alignment is to:

1. Align complete i.f. channel as outlined for band-pass sets.
2. Reconnect signal input to grid circuit of last i.f. stage as before.
3. Set marker dial to the center i.f. frequency.
4. Realign *only this stage* until the marker falls halfway down the slope of the response curve.

This latter method is preferable, since it obviates the necessity of determining the band width of the stage or the i.f. channel.

Ratio-Detector FM Receivers

Another type of FM discriminator is the *ratio detector*, which functions as a combined FM discriminator and AM noise limiter-rejector. Its advantages are obvious. Since this detector alone takes care of noise suppression, limiter stages are unnecessary. The i.f. stages preceding this ratio detector are therefore operated as normal, full-gain i.f. am-

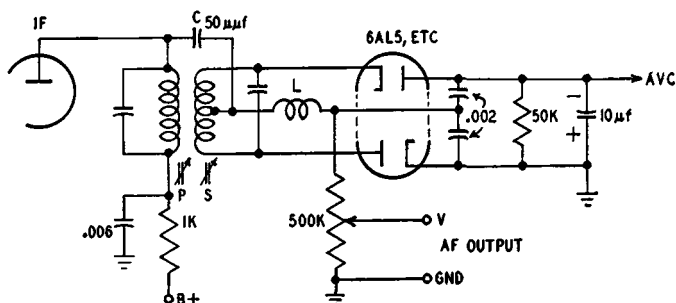

Fig. 517—A typical ratio detector. Where *C* is omitted, the winding *L* is placed near the primary, so that the induced voltage across *L* is substantially the primary voltage.

plifiers. The alignment of the ratio detector is somewhat critical, but, if general procedure is adhered to and specific manufacturers' suggestions are followed, alignment is both quick and easy.

It is relatively easy to identify the ratio-detector type of discriminator. Instead of connecting to the two plates of the discriminator diodes, as in the case of the standard discriminator, the ends of the discriminator transformer secondary connect one to a plate and the other to a cathode of the two diodes. Thus the two diodes are connected *series-aiding* through the secondary (plate No. 1—to transformer—to cathode No. 2—to plate No. 2—to load resistor—to cathode No. 1). See Fig. 517.

Another distinguishing feature of the ratio detector is the heavy bypassing of the load resistor ($10 \mu\text{f}$). The coupling condenser from the

plate of the preceding i.f. plate to the center of the discriminator transformer secondary is omitted in some cases, and the coil L is inductively coupled to the transformer primary. Still other versions of the ratio detector have somewhat different diode output circuits. The alignment procedure, however, is substantially the same in all of them. It involves two main steps:

First, the primary of the transformer is tuned for *maximum voltage* across the *whole* secondary.

Second, the transformer secondary is tuned for *maximum balance* between the two halves. This is usually a *minimum-output* adjustment, since the *difference* between the two component voltages of the secondary is an indication of unbalance. The smallest value of this difference indicates least unbalance.

The specific alignment procedure for the ratio detector of Fig. 517 is to:

1. Allow the usual warmup time for the equipment, including the receiver.
2. Set signal generator to center frequency of the i.f. (10.7 mc for most FM sets, 21.25 mc or the manufacturer's given value for the FM in television receivers). Set sweep to a little more than the specified i.f. bandwidth (usually ± 25 kc for TV sound channels, ± 75 kc for FM receivers). The manufacturer's specifications should be consulted wherever possible, since there are some exceptions to the general rule. Philco, for example, has an i.f. bandwidth approximating 0.5 mc in their television sound channel, necessitated by the automatic tuning system and the a.f.c. Connect generator output across grid of last i.f. stage.
3. Connect vertical input to 'scope across audio load resistor (point V and ground on Fig. 517).
4. Adjust c.r.o. controls for adequate-size pattern of the type shown in either Fig. 511 or 513.
5. Detune trimmer or slug of the discriminator transformer secondary as far as possible.
6. Align primary circuit (P on Fig. 517) for maximum linear span of curve (see Fig. 511).
7. Align secondary circuit (S on Fig. 517) for balance or cross-over at the center frequency. If the signal generator has a marker frequency dial, set the marker to the center frequency and adjust for equal response on both sides of the marker; otherwise use the calibrated celluloid screen on the cathode-ray tube for the same purpose.

Should the output of the signal generator be inadequate for sufficient output indication, the following modification of the alignment may help: Connect output of signal generator across the grid circuit of one of the earlier i.f. stages, or even the mixer, and proceed with the alignment as above. It is advisable, however, to check the tuning of the discriminator transformer alone, if that is possible. Then the signal generator is moved back toward the mixer, one stage at a time, observing the output curve in each case for maximum swing and correct crossover.

There are a number of variations of this method of alignment, such as modified methods of feeding the signal and various connections of the output indicator, but these are almost always specified by the manufacturer. The basic purpose and method is correct in all cases, and follows the procedure outlined.

Philco Locked-In Oscillator Detector

This type of FM detector is entirely different from the other types mentioned, operating on a basically different principle. This is a form of synchronization, the principle of which can briefly be stated as follows: When an external signal of approximately the same frequency as a local oscillator is properly and adequately injected into such an oscillator, the latter will "lock-in" with the signal, and, within small limits, follow the frequency of the signal. In the Philco FM receivers, detection is achieved approximately in this manner: A tube of special design, the FM1000, has an arrangement of elements similar to a pentagrid converter. The cathode, grid 1 and grid 2 are connected in a modified Colpitts oscillator, this type being very popular at the television and FM frequencies. Grids 3, 4, 5 and the plate are connected very much like the ordinary converter. The main difference in connection is the fact that the oscillator tank circuit and the "mixer" output, or plate circuit, constitute what looks like a primary and secondary, respectively, of an i.f. transformer. In addition, the plate return consists of an R-C circuit which functions as the audio load circuit.

In operation, the oscillator is set to the i.f. center frequency (9.1 mc in the Philco), while the last i.f. stage feeds a signal of the same center frequency to the injector grid (No. 3) of the FM1000 tube. The plate circuit of this tube is also tuned to 9.1 mc. The local oscillator will now lock-in with the incoming i.f. signal and follow the latter in frequency changes. But, as the i.f. shifts due to modulation, the local oscillator also changes frequency, causing, in this particular circuit, a change in the plate current of the FM1000. This plate current, varying in step with the i.f. deviation, flows in the load resistor in the plate return of the tube, producing audio output in accordance with the original modulation. Amplitude variations have but little effect on the oscillator, since the latter is "held" by the incoming frequency. Therefore this detector inherently rejects noise.

To align this type of detector, it is but necessary, after the i.f. alignment is completed, to tune both the primary (oscillator) and secondary (plate circuit) to the i.f. center (9.1 mc here). The detailed steps are as follows:

1. Allow equipment to warm up as usual.
2. Connect signal generator with output of unmodulated r.f. of correct center frequency (9.1 mc in Philco) in series with a $0.1 \mu\text{f}$ condenser between grid and ground of the last i.f. tube.
3. Short circuit plate winding of the detector i.f. can.
4. Connect 'scope across grid circuit of final audio stage.
5. Set c.r.o. sweep for highest frequency possible.

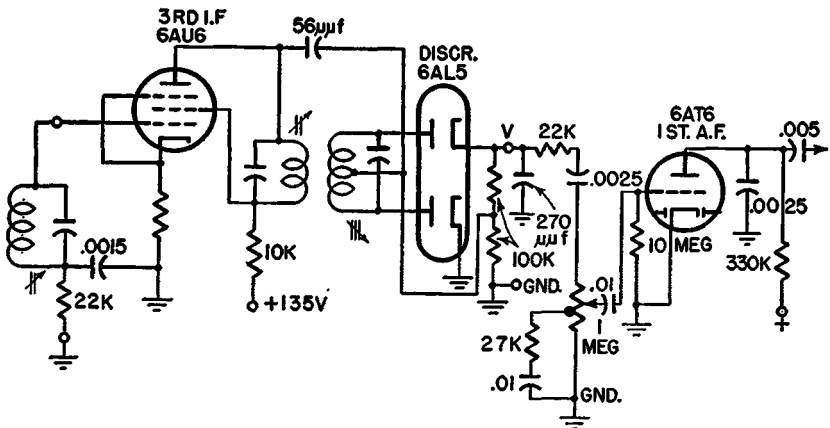

Fig. 518—Non-limiter type of discriminator. The i.f. stages are operated at low gain, providing adequate limiting.

6. Adjust horizontal and vertical gain controls for a good-sized pattern. The vertical gain may have to be set at maximum, due to the poor response of the 'scope at the high frequencies.
7. Align oscillator trimmer (primary) for zero beat. This will be evident by a gradual rise in the vertical deflection on the 'scope, with a corresponding decrease in the frequency to less than 1 cycle on the 'scope. The final pattern for *zero beat* will be almost a straight horizontal line.
8. Remove short-circuit from secondary and align *secondary only* for the same result as in 7. This completes the alignment.

Non-Limiter Discriminator

Another version of discriminators found in a number of cheaper television (sound channel) and FM receivers is shown in Fig. 518. The discriminator proper is conventional in every respect. There is no limit-

ing in the receiver. It is possible to operate an i.f. channel at low gain and reduced screen potentials, thus approximating limiter action (with additional stages where necessary) in order to minimize amplitude modulation (characteristic of most noise) when the desired signal is *precisely tuned in*. The alignment in this case is very similar to that given for the regular discriminator. However, we shall outline it here as applied to Fig. 518.

Alignment of Low-Gain, I.F., Non-Limiter Discriminator

1. Disable the high-frequency oscillator and allow equipment to warm up.
2. Set generator at proper i.f., sweep width at ± 100 to 200 kc.
3. Connect output of signal generator across grid circuit of third i.f. stage.
4. Connect c.r.o. vertical input between points V and Gnd.
5. Align primary slug of discriminator transformer for symmetrical appearance of curves (see Fig. 513).
6. Align secondary slug for crossover at center frequency.

In other words, this type of set is treated *exactly* like the ordinary, limiter-discriminator type of FM set. Simply forget the absence of limiter stages as such, and consider the limiting action built in the i.f. stages.

Alignment of Television I.F. Channels

Before proceeding with this important phase of servicing a *television receiver*, let us recall a few important facts:

First, while AM sound receivers have a band width of approximately 10 kc and FM receiver band width may reach an extreme of 150 kc, the average television receiver band width runs from 3,000 to 6,000 kc. This is about 40 times as wide as the FM sound channel, and over 500 times as wide as the ordinary AM channel!

Second, since such an extreme band width requires special circuits and procedures, both the test equipment and the alignment procedure must be excellent. Any old signal generator won't do! (Some manufacturers have attempted to simplify this problem by outlining a procedure calling for average-quality equipment and only fair technical knowledge, but this is not the solution. It is no more than a stop-gap method or a second-best solution. Foolproof, permanently prealigned, high-fidelity i.f. channels simply do not exist, except in some over-enthusiastic advertising copy.)

Lastly, both the nature of the transmitted signal and the fact that results are *seen*, not heard, makes it vital to follow established general methods, as well as specific manufacturers' directions.

The equipment required for proper *television* i.f. alignment consists of:

1. *A stable signal generator*

- (a) covering the i.f. range of the various commercial receivers on the market today (7 mc to 30 mc is adequate at this writing);

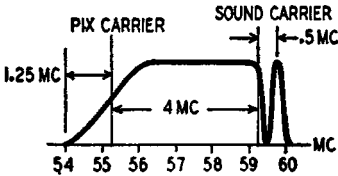

Fig. 519—Typical television channel (Channel No. 2) at the input to the mixer.

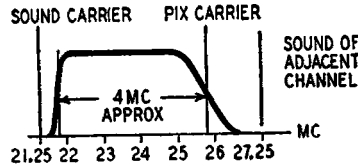

Fig. 520—Video i.f. response at the input to the i.f. amplifier. (Any channel.)

- (b) having a sweep frequency range of from zero to at least 6 mc;
- (c) having a marker frequency source over the complete tuning range.

Since the same instrument will also be used for front-end alignment, (r.f., mixer, and oscillator), the frequency and marker ranges should extend all the way up to 250 megacycles to cover the oscillator frequency for the highest station, channel 13, 210-216 mc. With an i.f. of 30 mc, the oscillator frequency may have to be approximately 246 mc.

- 2. *A high-grade cathode-ray oscilloscope*, having good frequency response at the television i.f. bands, preferably with an r.f. probe for use up to 250 mc.
- 3. *An audio oscillator* having good wave form and frequency range up to *at least* 15,750 cycles, which is the horizontal sweep frequency now in use.
- 4. The usual service instruments, such as an output meter, vacuum-tube voltmeter, or high-sensitivity voltohmmeter (20,000 ohms per volt or better).

The television channel, as established by the Radio Manufacturers' Association and generally in use in the United States, looks like Fig. 519:

- 1. The over-all band width is 6 mc.
- 2. The picture carrier is 1.25 mc above the low-frequency end of the channel.

3. The sound carrier is 5.75 mc above the low-frequency end (0.25 mc below the top of the channel).
4. The carriers are 4.5 mc apart.
5. The low-frequency end of the channel is a uniformly sloping line, approximately at 45 degrees.
6. The high-frequency end of the band is a sharp, near-vertical line.

In order to receive this combined sound and picture signal, the front end of the receiver must have sufficient band width to admit nearly the whole channel, or at least 5 mc. Otherwise, side-band cutting of sound or picture, or *both*, may result. We shall say more about this under r.f. alignment.

When this incoming *band of frequencies* is combined with the local oscillator in the mixer stage, the output or the intermediate frequency is also a *band*, but transposed in position as shown in Fig. 520. Notice that this looks like a mirror reflection of the incoming signal shown in Fig. 519. Since we are concerned with the i.f. alignment, we shall look on the c.r.o. screen for a picture as much as possible like Fig. 520. The extent to which this result is achieved depends upon the design of the i.f. circuits. However, since the serviceman is little concerned with design and primarily with correct operation of manufactured circuits,

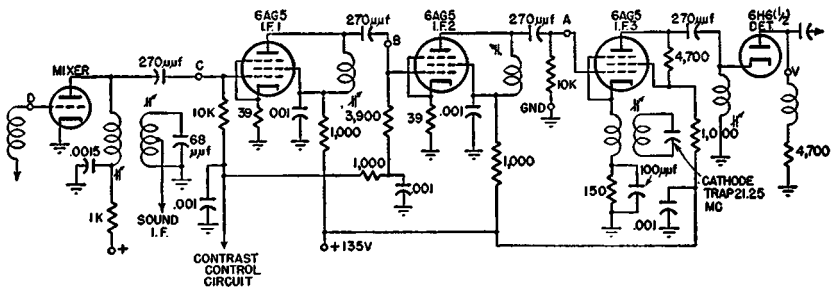

Fig. 521—Typical impedance-coupled, 3-stage staggered i.f. system.

it may be safely said the extent to which the specified bandpass is obtained depends *almost entirely* (barring defects in the circuit) on the care and effort taken by the serviceman in the alignment of the tuned circuits.

Two I.F. Systems in Use

There are two main systems of i.f. design in use today. One is the wide-band or band-pass system in which each stage is designed for full-band or near-full-band width. This is rather complex to design, expensive to manufacture, and difficult to adjust. In a few cases, but not as a rule, the i.f. cans are non-adjustable. The other type, more in favor

in most recent television receivers, is the stagger-tuned system in which a number of tuned circuits contribute to produce the over-all band width required. Being less expensive to design and produce, this system is favored by many television receiver manufacturers.

Fig. 521 shows a 3-stage i.f. channel of a modern set. Note the following interesting features:

1. The i.f. amplifier stages are *impedance-coupled* instead of transformer-coupled. Tuned inductances are in the plate circuits, ordinary resistors in the grid circuits.
2. Parallel L-C circuits called *wave traps* are used to extract images and other undesirable frequencies from the picture channel.
3. Another of these traps is used to extract the audio i.f. from the mixer output, this i.f. signal then continuing in the conventional

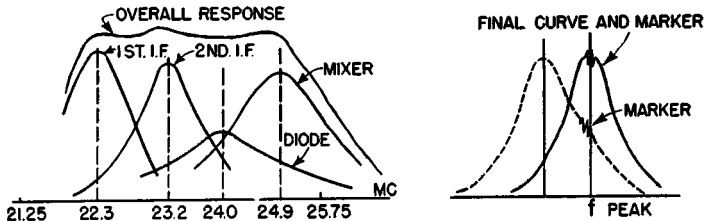

Fig. 522 (left)—Stagger response and resultant overall curve. Individual response curves are peaked to contribute to the desired overall response. Fig. 523 (right)—Dashed line shows response curve prior to correct alignment. Marker is “placed” where peak should fall. Solid line curve shows final alignment, with marker at peak.

manner to the discriminator and audio circuits. These traps are discussed further under alignment.

In aligning such an i.f. amplifier, various circuits are peaked to different frequencies, so that the over-all effect is the desired i.f. band. Taking Fig. 521 as an example, we would align the 4 circuits as follows:

Mixer output	24.9 mc
First i.f.	22.3 mc
Second i.f.	23.2 mc
Diode detector	24.0 mc

The individual curves and the over-all band are shown in Fig. 522. Notice that the sharpest tuned circuit is the first i.f. stage, operating at fixed bias. This circuit is therefore aligned at the low-frequency end of the band in order to produce the steep side in the final curve. Next comes the second i.f., in which the *contrast control* (bias) varies the

selectivity to a certain small degree. This is peaked next, at 23.2 mc. The mixer, a fairly broad circuit, is at the high-frequency end of the band, to give the desired 45-degree slope. Finally, the diode-detector stage is placed between the second i.f. and the mixer. Being the widest-band circuit, the detector stage is used to fill in the low portion or dip in the over-all curve. The resultant band may thus be made very nearly like the ideal flat-topped band desired. Of course, the exact adjustment frequencies, as well as the sequence of stages, will depend upon individual manufacturers and their specific instructions should always be followed for best results. The alignment procedure outlined, however, is very typical of modern practice and will serve in many cases.

To align the i.f. amplifier of Fig. 521, proceed as follows:

1. Disable the high-frequency oscillator and allow equipment to warm up for at least 10 or 15 minutes.
2. Set controls on oscilloscope for adequate pattern.
3. Connect vertical c.r.o. terminals across output of video detector (V and ground). (If 'scope has high-frequency probe, see alternative procedure.)
4. Set main frequency dial on the sweep generator to the approximate i.f. of the particular stage being aligned.
5. Set sweep range to 4 megacycles (unless specific manufacturers' instructions indicate a different sweep width).
6. Connect output of sweep signal generator across grid circuit of third i.f. tube, point A and ground.
7. Set marker dial on sweep generator to 24 mc as accurately as possible.
8. Align trimmer or slug on last i.f. can until peak coincides with marker. See Fig. 523.
9. Move signal generator output leads back one stage to point B and ground. Set *contrast control* on receiver about halfway. Readjust c.r.o. controls for suitable-size pattern.
10. Set marker frequency to 23.2 mc and align second i.f. coil until peak coincides with marker pip. Do not touch previously aligned slug.
11. Shift generator output to grid circuit of first i.f. (point C and ground). Do not change contrast setting. Adjust generator output for correct size of pattern on c.r.o. screen.
12. Set marker frequency to 22.3 mc and align first i.f. slug or trimmer until peak falls on marker, as previously.

13. Shift generator to mixer grid, reduce signal generator output to suit, set marker dial to 24.9.
14. With generator across point D and ground, align mixer coil (video) until peak of curve falls on marker.

The complete i.f. amplifier should now be correctly aligned. However, if the resultant curve differs considerably from the typical response curve of Fig. 520, repeat the above alignment procedure, shifting the various marker settings slightly one way or the other, depending on the appearance of the curve, to obtain the desired over-all band. For example, should there be a dip in the curve at 23.0 mc and a rise at 23.5 mc (see Fig. 524), it would indicate that the second i.f. peak is too far away from 23.0 and too close to 24. To correct this, realign the second i.f. at about 22.7 mc. These errors are usually due to either inaccurate settings of the marker dial or careless alignment. Ordinarily, a single alignment according to directions will produce satisfactory results.

Alternative Alignment Procedure, Observing Output of Each Stage Separately

If the serviceman has a cathode-ray instrument with a high-frequency probe for the vertical amplifier (or at least a vacuum-tube volt-

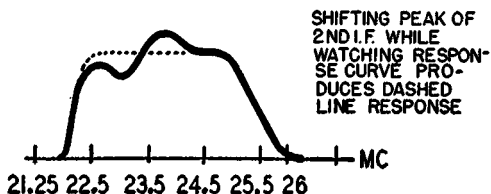

Fig. 524—Improperly aligned stagger system. If the second i.f. is peaked at too high a frequency, the rise at 23.5 mc would appear as shown. Realigning this stage at a somewhat lower frequency would level off the curve. Overall response should be observed while realigning.

meter with a similar high-frequency probe), he can align each stage individually by connecting the vertical 'scope input across the output of the stage being aligned in each case, instead of the detector output. Since in the latter case the cumulative effect of all the i.f. stages is observed, there is some chance of confusing the effects of different adjustments. Aligning the second stage may appear to increase the response at a portion of the curve not at the frequency of the second stage. However, proper care in locating markers and peaking will minimize such difficulties.

The alignment of the nonstaggered i.f. channels (prewar RCA, Crosley, etc.) is actually simpler and faster than the stagger alignment, since all stages are set for approximately the same band width and the same frequency range. Here, again, manufacturers' bulletins are very helpful, as they give *specific* data for the *particular* set in question. For most cases, however, the general procedure outlined here will serve.

Fig. 531 shows a typical i.f. channel of the *nonstaggered* type. Alignment procedure is approximately as follows:

1. Disable the high-frequency oscillator and allow equipment to warm up.
2. Set oscilloscope controls correctly.
3. Connect vertical input terminals of 'scope across detector load resistor.
4. Set sweep generator to approximate center of i.f. channel (10 mc for prewar receivers, 23 to 27 mc for new sets).
5. Connect generator output across grid circuit of last i.f. stage.
6. Locate markers on c.r.o. screen at the frequencies specified by the manufacturer for that particular stage.
7. Align trimmer or slug for maximum response. Consult service data for those cases in which response curves are shown. Otherwise strive for maximum output consistent with flat frequency response.
8. Shift sweep generator back to grid of next-to-last i.f. stage. Set the markers and repeat alignment procedure of step 7.
9. Repeat the above procedure on all stages all the way back to the mixer grid. The curve now on the screen will be the final *over-all* i.f. response curve.
10. Check the curve for the three important characteristics of a television i.f. system: flatness of the top of the curve, steepness of the low-frequency end, and correct sloping of the high-frequency end.

In most cases of this type of i.f. amplifier, there is only one adjustment per stage. In some cases there is none, the circuits having been designed for permanent band pass (fixed-tuned). Any difficulty in obtaining the correct band-pass response in such cases should be treated as a trouble-shooting problem, not as a matter of misalignment. A defective coil winding, resistor, or condenser in the stage is likely to be the cause of the trouble.

Trap Alignment

Trap alignment is really part of the i.f. alignment. However, since it applies to most i.f. systems, it is treated separately, after the various i.f. adjustments have been discussed.

Due to the nature of television channel allocations, carrier locations in the channels, and the design of some television receiver front ends, image interference and sound interference with the picture are fairly common. To eliminate these, tuned circuits, often called *traps*, are used. These traps are coupled to the i.f. circuits being interfered with, and are tuned to the frequency of the interfering signals. The undesired frequencies thus absorbed by the wave traps are kept out of the i.f. channel.

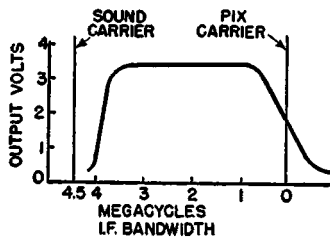

Fig. 525—An ideal i.f. response curve.

The procedure for trap alignment is:

1. Have equipment completely set up as for normal video i.f. alignment.
2. Set signal generator to frequency indicated for the particular trap. This is almost always shown in the diagram next to the trap.
3. Adjust trimmer or slug of trap for *minimum* signal on the c.r.o. screen. If more than one trap is tuned to the same frequency, align all of them for *minimum* on the 'scope across the detector load resistor.
4. Keep on increasing the output of the signal generator and re-tuning the trap for *minimum* output.
5. Repeat procedure for other traps and rejection frequencies, increasing input from signal generator in each case until you are sure the *lowest* output has been obtained at the trap frequencies.

Usually there will be two different trap frequencies, but the adjustment procedure is the same in both cases.

Judging Response Curves; Adjustment for Proper Response

Fig. 525 shows what might be called an ideal response. Since the height of the flat portion of the curve is uniform, in this case 3.5 volts for all frequencies up to 4 mc (except for the sloping portion near the carrier end), there will be uniform response or output for all frequencies of video modulation. Actually this condition is extremely difficult to obtain without a large number (six or more) of low-gain i.f. stages. In practice, therefore, a compromise has to be made, both at the expense of over-all band width as well as uniformity of response. Thus, a commercial television receiver might have a total band width of only 2.5 to 3 megacycles. Furthermore, the response can vary up and down within reasonable limits. Fig. 526 shows a typical response curve of a moderately priced television receiver. First of all, the band is only about 3 mc wide, adequate for most home entertainment use except for very large area pictures. Also, the response varies along the frequency band, rising toward the high end and dipping near the middle of the band. The dashed curve on the same picture indicates very poor response in the middle range of frequencies, indicating probable misalignment of the receiver. The final result of a response such as this would be rather poor detail on the television picture tube.

Another fact worth mentioning is that in many receivers the shape of the response curve will vary to a lesser or greater degree as the bias setting of the i.f. stages is varied. This adjustment is called the *picture* or *contrast* control. Because of these factors, certain precautions must be taken during alignment of the video channel:

1. Unless unavoidable, do not turn the contrast control more than halfway up, since it will not be turned up any further under operating conditions in all but the poorest signal areas.
2. Do not attempt any adjustment, not even touching up, of the i.f. channel without the oscilloscope. Remember, the customer will judge the picture by eye, not by output meter. In those few cases

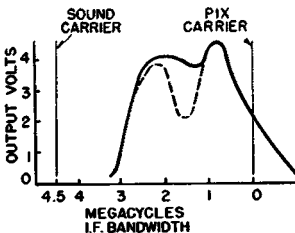

Fig. 526—Solid line shows a typical i.f. response curve for a small (7 inch) television receiver. The slight dip is permissible. The dashed line shows poor response at the middle.

where the manufacturer designed the circuit for adequate alignment with the output meter, the manufacturer's procedure is the one to follow.

3. If the gain of a receiver is low, do not attempt to boost it by

narrowing the band. The problem, if the receiver is not defective, is *signal input*. Check the antenna system or add a pre-amplifier.

4. Wherever possible, get data on response curves and for specific realignment from the manufacturer. He knows exactly what the receiver can do and how best to achieve the desired results.
5. In stagger-tuned systems, each stage is most effective over a certain portion of the i.f. band (see Fig. 522). When correcting bad response of any particular portion of the curve, first refer to the alignment information to ascertain which stage is responsible. Thus, in Fig. 526, the bad dip of the dotted portion of the curve is due to low output of the middle of the band. Looking back to Fig. 522, we see that this portion of the curve corresponds to the second and third i.f. stages. After checking these stages for normal tube operation, check the center frequencies of these tuned circuits, using the sweep generator markers. Then realign *one stage at a time*, watching the c.r.o. screen for improvements. Similarly, if the right-hand edge of the same response is very steep instead of sloping as it should, the mixer stage alignment should be investigated. Of course, this applies to a stagger system of the type shown in Fig. 522. As different manufacturers stagger their i.f. stages differently, always check the specific alignment information for the particular receiver in question.
6. A stable, nonoscillating amplifier should produce a smooth trace on the oscilloscope. If the trace is fuzzy or jagged (zig-zag lines forming the trace), it is an indication of some form of oscillation or stray pickup. If the oscilloscope is not defective and the high-frequency oscillator of the receiver has been temporarily disabled (as it should always be for i.f. alignment), the trouble probably lies in an oscillating i.f. stage. Reducing the *contrast* will clear this up, but this is not a remedy; it is only an indication that the i.f. channel is the offender. The trouble must be cleared up, so that the contrast may be turned up as required for normal operation, without causing oscillation. Some slight oscillation with the contrast at maximum is permissible, since this is not a normal manner of operation for a receiver.* Although oscillation is really trouble-shooting procedure, it is nevertheless mentioned here because it so often occurs in the

*Note: Be careful not to confuse the jagged portion of the response curve, due to the marker, with accidental oscillation. It is quite easy to determine whether the marker is responsible simply by turning off the marker frequency generator, or by varying the marker frequency and observing whether the jagged part of the curve moves. If it does not move, some cause other than the marker is responsible.

process of intermediate-frequency alignment. We shall have more to say about this when discussing trouble shooting with the cathode-ray oscilloscope in the next chapter.

7. As a final check, observe the quality of the picture on an actual signal. This should always be done before a receiver is given a final O.K.

R.F. Alignment - AM Receivers

It is assumed that the i.f. channel has been properly aligned. We may therefore reconnect the receiver high-frequency oscillator and connect our oscilloscope to the detector load resistor or the grid circuit of the first audio amplifier. The detailed procedure for alignment is:

1. Allow equipment to warm up.
2. Set receiver dial near the high-frequency end of the band, about 1400 kc for the broadcast band, proportionately high for any short-wave band.
3. Set signal generator to same frequency as the receiver dial. Set modulation to 400 cycles.
4. Set c.r.o. controls for normal pattern (internal sweep).
5. Disconnect antenna and ground and connect signal generator output across antenna input terminals.
6. Connect vertical c.r.o. terminals across detector load resistor or first audio grid circuit.
7. Align oscillator condenser trimmer of the receiver for maximum output on c.r.o. Should the r.f. and mixer circuits be *very far* off, a slight readjustment of these circuits might be required before the oscillator can be satisfactorily aligned. However, for most commercial receivers this will not be necessary.
8. Align mixer and antenna stage trimmers, in that order, for maximum amplitude.
9. Shift receiver dial and signal generator frequency to a point near the low-frequency end of the band, usually 600 kc for the broadcast band.
10. Align the receiver oscillator *series padder only* for maximum output. Do not touch the antenna or mixer trimmers at this setting of the dial.
11. Repeat steps 2 through 8, as the 600-kc padder adjustment may react back on the high-frequency end, throwing the latter slightly out of adjustment. This completes the r.f. alignment.

With the alignment completed, the receiver dial has been tied down at two points near the extremes of the band. It will now track

satisfactorily over the entire dial. That is why the oscillator alignment is most critical and should be done with utmost care. While slight detuning or misalignment of the r.f. stages will cause loss of *gain only*, oscillator misalignment or detuning will invariably result in improper dial calibration as well as distortion due to side-band cutting.

R.F. Alignment of FM Receivers

With the exception of these three items, r.f. alignment of FM receivers is similar with AM receiver alignment.

1. The sweep frequency should be set to ± 50 to 300 kc.
2. The alignment frequencies should be determined from the manufacturer's data, (just as in the case of the AM short-wave bands), since different design factors require tying down the oscillator at different frequencies in different receivers.
3. The vertical input of the 'scope should be connected either to the grid-return resistor of the first limiter (point A and ground in Fig. 512) or, if that resistor feeds an a.v.c. line, across the *ungrounded* cathode resistor of the discriminator, after the other

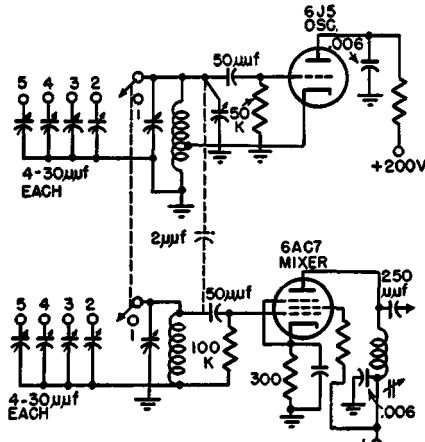

Fig. 527—Mixer-oscillator in which shunt capacitance is used to tune to lower frequency channels. Channel No. 1 is highest; No. 5 the lowest.

cathode is disconnected (Fig. 512, point V and ground). After alignment, the broken cathode lead should be reconnected. 'Scope adjustments are the same as in Band-Pass Alignment (P. 52).

R.F. Alignment of Television Receivers

The requirements for r.f. alignment of a TV receiver are somewhat different. The front end must pass a band at least 4.5 mc wide,

since it is a common channel for both video and audio and the two carriers are 4.5 mc apart (see Fig. 519). Actually, the band should be 5.25 to 6 megacycles wide. In most sets, each television station, or channel, as it is commonly called, must be individually aligned, as would a push-button position in a broadcast set or as a short-wave band in a multiband receiver. Proper adjustment means, not only maximum output in the desired band, but also sufficient rejection (minimum output)

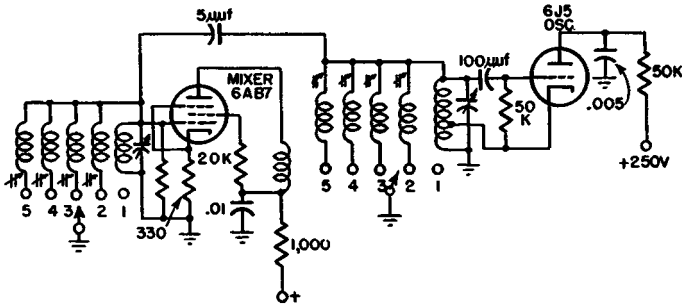

Fig. 528—Shunt coil method of band-switching. No. 1 is the lowest, No. 5 the highest frequency channel.

at the edges of the band for the prevention of interference from adjacent channels.

To align the various channels, the order in which the channels are set depends on the particular type of tuning system used. If, as shown in Fig. 527, additional capacitance is switched in the circuit when going from the highest- to lower-frequency channels, align *highest*-frequency channel first, follow with the next lower one, and so on down to the lowest-frequency station. Be sure not to touch any higher-frequency trimmer when aligning the lower-in-line station.

If shunt inductances are used in changing stations, as shown in Fig. 528, these are switched across the lowest-band inductance. In this case align the *lowest*-frequency station first, then the next higher one, and so on to the highest channel. Again, align only the circuit for the particular station in question. This is important, since the inductance and/or capacitance of the station first being aligned is used on all stations, as well as for the first station only. Where individual tuned circuits are used for the various stations, alignment may be performed in any order desired, not unlike the setting up of push-buttons in an ordinary broadcast receiver. See Fig. 529.

If series-inductance switching is used for tuning (1946-47 RCA, etc.), then the highest-frequency channel is aligned first, since this inductance will be in the circuit for all other stations, in addition to the incremental inductance added in each particular station to lower the frequency. Fig. 530 illustrates this method.

In all of the above cases the alignment procedure is as follows:

1. Allow equipment to warm up.
2. Set oscilloscope controls as for i.f. alignment.
3. Connect vertical 'scope terminals across output of video second detector. This contains the rectified output of the mixer stage. If the oscilloscope has an r.f. probe (self-contained rectifier), the probe may be connected across the mixer plate circuit.
4. Set signal generator to approximately the midpoint of the channel. For channel 4, 66-72 mc that would be 69 mc. Set sweep to 6 mc.

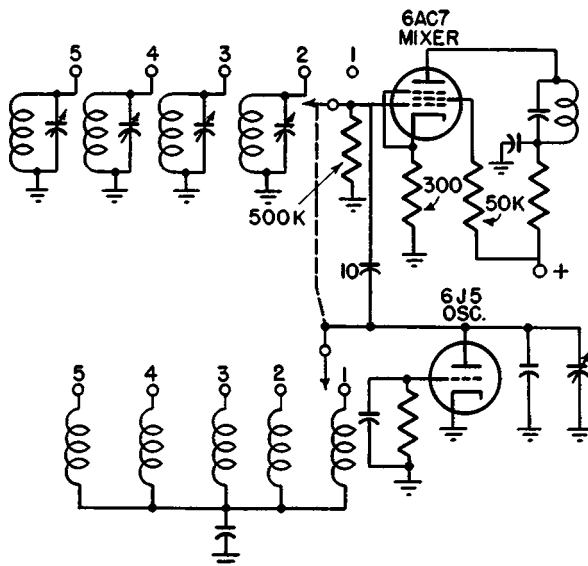

Fig. 529—Front end of a television receiver using individual coils for each band. The alignment may be done in any sequence.

5. Connect signal generator output to antenna terminals of receiver and adjust generator output for normal-size pattern on the c.r.o. screen.
6. With marker dial, locate the edges of the band on the 'scope screen. For channel 4 the markers will be at 66 mc and 72 mc, respectively.
7. Align r.f. and mixer trimmers (or slugs, as they are more likely to be) for maximum response of the curve. Don't touch i.f. alignment slugs.
8. Transfer the vertical c.r.o. terminals to the sound channel detector load resistor, as in the case of FM receiver alignment.
9. Set fine tuning control of receiver approximately midway between extremes of rotation.

10. Align oscillator trimmer or slug for maximum output on 'scope screen. This indicates maximum audio output and hence correct oscillator setting for both video and sound.*

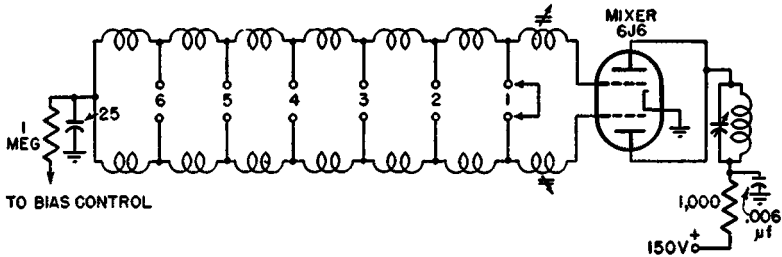

Fig. 530—Simplified diagram of mixer stage, using series inductances for channel switching. The oscillator uses a similar arrangement.

11. Repeat above procedure for all the other channels in the order outlined above.

The above alignment is all that is necessary for a receiver equipped with an r.f. stage ahead of the mixer. No final touching up is required after installation. However, a number of receivers on the market have

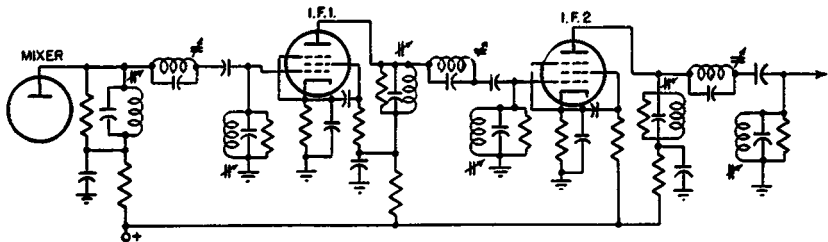

Fig. 531—Semi-fixed tuned, non-staggered, i.f. channel. The coil slugs are adjustable but seldom require it, because of extremely wide-band design. (Pre-War set).

no *preselector* stage, the antenna feeding the mixer stage directly. In such cases, a final touching up of the mixer circuit will probably be necessary after the set has been installed.

* Note: The reasoning behind step 10 in aligning for sound instead of video is as follows: The standard RMA television channel contains both the video and audio carriers, spaced exactly 4.5 mc apart. (Refer to Fig. 519). Since television receivers contain but one mixer-oscillator for both carriers, the resultant i.f.'s will necessarily be spaced exactly 4.5 mc. The receiver sound and video i.f. channels are therefore aligned 4.5 mc apart, and the oscillator must therefore be tuned to the correct frequency which will "throw" the two i.f.'s into their present channels. However, since the video channel is up to 40 times as wide as the audio (4 mc vs. 100 kc maximum), a slight detuning of the oscillator is sufficient to make the audio i.f. output of the mixer different from the frequency to which the sound i.f. channel is tuned. As a matter of fact, the sound may be completely lost. The video output, however, would suffer only very slightly from the same slight detuning of the oscillator, since this channel is very broad. But once the oscillator is tuned to produce the correct audio i.f. output, the video output is certain to be there, even if negligibly detuned.

Chapter 6

Measurements Using the Cathode-Ray Oscilloscope

THE measurement of both a.c. and d.c. voltages with the cathode-ray oscilloscope is becoming increasingly important. While the ordinary D'Arsonval meter and the vacuum-tube voltmeter can be used in many instances, they are sometimes much less satisfactory than the c.r.o. Among the shortcomings of the ordinary meters may be listed:

1. Inability to indicate distortion,
2. Inability to distinguish between different types of components that make up a single resultant voltage,
3. Effect of changing the operating conditions of the circuit they are measuring.

There are other disadvantages, but these will suffice to illustrate the point. Consider, for example, the measurement of *audio output*, usually done with a sine-wave or square-wave input to the amplifier. Now, while every serviceman knows from practical experience that overloaded amplifiers cause distortion, no output meter shows distortion satisfactorily. Should the gain or power output of an amplifier be calculated on the basis of maximum voltmeter reading, it is likely that the output contains an excessive amount of distortion (harmonics, etc.). Thus the true, usable output is not known. With an oscilloscope, however, it is a simple matter to adjust the amplifier, not for just maximum output, but for maximum *usable* output—*undistorted output*, as it is generally referred to. This is the only output that counts, in most audio applications.

Another example of the advantages, and even near-indispensability, of the c.r.o. is in the tracing, location, and analysis of *hum*. This is extremely important in video sweep and signal circuits. Again a voltmeter *may* be used: it will locate an a.c. component (hum) in a d.c. supply, but it will give little or no indication as to frequency, source, etc., of the hum. An oscilloscope will easily locate the offending voltage, indicate its magnitude, frequency, and any other characteristics the voltage may have, thus pointing to the source of the trouble and suggest-

ing the simplest remedy. In terms that no serviceman can fail to understand, the c.r.o. will save time, temper, and money.

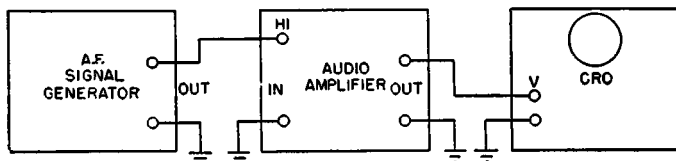

Fig. 601—Set-up for audio gain or frequency response measurement.

Let's consider specific cases, outlining procedures and indicating the advantages of the 'scope in each application.

Audio Output Measurement (Fig. 601)

1. Allow equipment to warm up.
2. Set the audio signal generator to the desired frequency* and the output control for a suitable output voltage—0.1 volt for *over-all* amplifier gain checks, up to 3.5 volts for single stage gain measurements. In any case, adjust for suitable-size pattern on the screen.
3. Set the generator output impedance as required—high output impedance when feeding directly into the grid of a tube, low impedance for primary of an input transformer.
4. Calibrate the vertical amplifier of the oscilloscope.†
5. Connect vertical input terminals of the c.r.o. across the speaker transformer (output transformer) voice-coil winding.

* For an *output check only*, use 1,000 cycles, the standard test frequency in audio measurements. With some equipment, a 400-cycle test may be specified. This frequency is the standard modulation frequency in test oscillators. For a complete response-curve check, all frequencies between 20 and 15,000 cycles may be used. See response-curve test later in the chapter.

† To calibrate the vertical amplifier, proceed as follows:

1. Put calibrated scale over the cathode-ray screen. Scale is usually graduated in 0.1-inch squares.
2. With a reliable voltmeter, measure an available small a.c. voltage. The 6.3 heater voltage may conveniently be used.
3. Apply this measured a.c. to the vertical input of the c.r.o. Assuming the voltage to measure 4.6 volts, adjust the vertical gain control until deflection is 46 divisions. The screen is now calibrated for 0.1 volt per division. *Do not touch the gain control after this calibration!* For different scale ranges, the procedure is similar. Thus, a 125-volt *measured* input, covering 50 scale divisions on the 'scope, indicates a sensitivity of 2.5 volts per division.

Where absolute voltage values are required, the calibrating voltmeter must be accurate. While the ordinary a.c. voltmeter is not much better than 5% in tolerance, the same meter may be checked on any scale, or portion of a scale, against a more precise instrument. Once so checked, the meter is nearly as accurate as the standard against which it was calibrated. For gain or response measurements the *absolute* accuracy of the meter is of little consequence. As long as the same meter is used to calibrate the c.r.o. screen *and* the input to the amplifier from the a.f. signal generator, the gain calculations will be accurate.

6. Increase gain control on the amplifier until wave-form distortion begins to show. This is the maximum undistorted output obtainable.
7. Read the output voltage on the c.r.o. screen, and calculate the gain by dividing this output voltage by the input voltage from the signal generator.

Example :

Input-voltage 0.1 v
 Screen calibration 0.1 v per division
 Output reading 36 divisions = 3.6 v

$$\text{Gain} = \frac{\text{output}}{\text{input}} = \frac{3.6}{0.1} = 36.$$

For *power* output calculations, square the value of output voltage and divide by the voice-coil impedance. To be exact, only the power-consuming component of the voice-coil impedance should be used in the calculation. However, the error involved is very small.

Example :

Output voltage 3.6 v
 Voice-coil impedance 4 ohms

$$\text{Power output } P = \frac{E^2}{R} = \frac{(3.6)^2}{4} = 3.24 \text{ watts.}$$

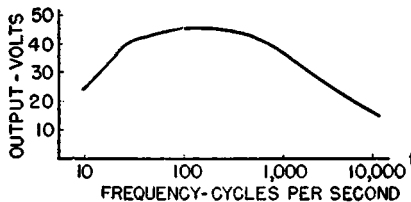

Fig. 602—Response curve of a poor-quality audio amplifier.

Audio Response Curve

Since audio-frequency sweep generators are not very common, it is necessary to plot a curve of output voltage versus individual frequencies, in order to get the *over-all* frequency of an amplifier.

The procedure for obtaining the response curve is very similar to the output measurement procedure just outlined. The audio signal generator should have a range of from 20 to 20,000 cycles. The output attenuator should either be calibrated in volts (or millivolts) or be easily measurable. To run a response curve, proceed as follows :

1. Set up the equipment for audio output measurement.

2. Calibrate the screen of the 'scope.
3. Keeping the output level of the signal generator constant throughout the test (with regular checks, using a voltmeter), feed the various frequencies to the input of the amplifier in approximately logarithmic order—from 20 to 100 cycles in 10-cycle steps, from 100 to 1,000 in 100-cycle steps, from 1,000 up in 1,000-cycle steps. At 10,000 cycles the steps may be increased to 2,000 or 3,000. You will probably find the calibration of the dial of the signal generator will automatically suggest this type of frequency-interval selection.
4. Read and record all output readings.
5. Plot a response curve of audio output vs. frequency, as shown in Fig. 602. This curve is in terms of audio *voltage*. Since audio variations are more significant in terms of units of *loudness*, it is desirable to convert the curve just plotted into db. As 1,000 cycles is the accepted standard audio test frequency, variations are generally plotted in comparison with the audio level at 1,000 cycles, giving the *ratio* of any level to the 1,000-cycle level. Using comparative voltages, the formula is:

$$\text{db} = 20 \log_{10} \frac{\text{voltage at any frequency}}{\text{voltage at 1,000 cycles}}$$

Should the relative *powers* be known, the formula becomes:

$$\text{db} = 10 \log_{10} \frac{\text{power at any frequency}}{\text{power at 1,000 cycles}}$$

A final word in regard to *response measurement*. Sometimes an amplifier may behave quite normally for most frequencies, yet distort badly on a certain few frequencies. An ordinary output voltmeter may very often skip over these few troublesome points, but the cathode-ray instrument will indicate them, as well as resonance at certain frequencies, by a steep rise in output. The serviceman should distinguish between a *gentle rise* in output over a certain part of the spectrum and a rather *sharp peak* or *series of peaks* in the band. The former indicates very common behavior in audio amplifiers which are *not designed for absolutely flat response* with no rise or fall whatsoever. The latter is an indication of resonance at certain frequencies, regeneration, and even oscillation—all undesirable characteristics in an audio amplifier that call for trouble shooting and correction.

Peak A.C. Voltmeter

One of the most useful applications of the oscilloscope is in the measurement of *peak* a.c. voltages. Although there are some peak-

reading vacuum-tube voltmeters on the market, they are rather uncommon. The cathode-ray oscilloscope, because it shows the a.c. wave as it really occurs, is a very handy device for the measurement of signal voltages to grids of amplifiers, oscillator output measurements, and similar applications. The procedure is quite simple and requires little further detailing, since it is contained in many of the tests outlined in Chap. 5. A brief outline will be given here:

1. Calibrate the vertical amplifier of the 'scope.
2. Connect the vertical input terminals across the voltage to be measured, *in the same manner as during calibration* (series condenser, if one was used, vertical gain control unchanged, etc.).

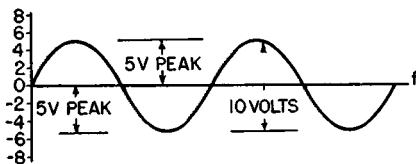

Fig. 603—Illustrating meaning of "peak-to-peak" a.c. voltage. R.m.s. value is 3.6 volts approximately. Peak-to-peak value is 10 volts.

3. Read the total voltage between positive and negative peaks on the screen. See Fig. 603 for example.
4. Divide by 2 the value obtained in step 3, since the peak voltage was taken *twice* in the peak-to-peak measurement.

It is possible to read the voltage in step 3 from the center or zero line to *either* of the peaks, in which case *no division* would be necessary. However, this method is often inaccurate, for it may be difficult to determine the exact position of the zero line. Sometimes the zero line shifts up or down with the application of a signal. Taking the peak-to-peak value and dividing by 2, brings the measurement much closer to the exact value by reducing the error in reading and in determining the position of the zero line.

Saw-Tooth Amplifier Balance

A very important use of the oscilloscope is the measurement of sweep voltages in television receivers, particularly in smaller receivers in which electrostatic deflection is used. In these sets, multivibrators are used as sweep-frequency generators, followed by dual-tube, *balanced* amplifiers. (See Fig. 604.) If, due to either a defective tube, or component, the amplifier output is unbalanced or distorted, severe picture distortion or crowding of one side of the picture will result. A simple check with the oscilloscope will quickly locate unbalance.

To check such a system without the use of the 'scope would be impossible, since voltage measurements alone give no indication of

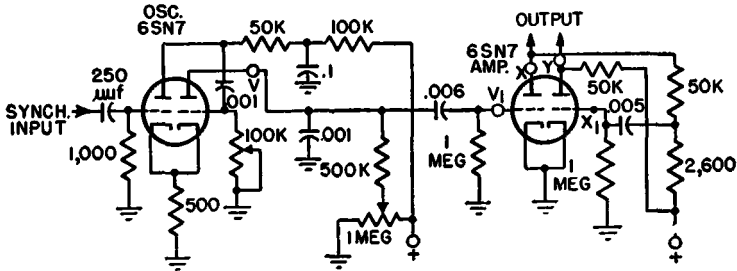

Fig. 604—A 15,750-cycle multivibrator and amplifier. This is very common in the less expensive television receivers.

distortion, unbalanced output, nonlinearity, etc. With the 'scope, the procedure is both simple and effective.

Horizontal Oscillator, Television Receiver

1. Allow equipment to warm up.
2. Connect vertical input to c.r.o. between *output* plate of multivibrator and ground (point V and ground on Fig. 604).
3. Adjust c.r.o. controls for normal pattern on the screen.
4. Set 'scope sweep to approximately 4,000 cycles. Since the horizontal oscillator operates at 15,750 cycles, approximately 4 cycles will appear on the screen.

NOTE: It is advisable to make this test with the oscillator at 15,750 cycles. If for any reason the horizontal hold control has been disturbed, it can be reset by tuning in a station and adjusting the hold control until the picture stops moving across the screen. Another method is to match this against an audio signal generator set to 15,750 cycles.



Fig. 605—Saw tooth as it should appear on the c.r.o. screen. The flyback lines should be very faint. The zero line (X-axis) should not be visible at all. The ends of the teeth should not be rounded off.

5. Observe output wave form on oscilloscope. It should look almost exactly like Fig. 605. If any marked differences exist, the

multivibrator circuit is at fault. Both the components and potentials should be checked.

6. Move the vertical oscilloscope terminals to the grid of the first amplifier (V_1 in Fig. 604). Check appearance of saw tooth. If any distortion exists, the coupling condenser is probably defective. The size of the saw tooth at this position should be about the same as in step 5.
7. Repeat the test at the plate of the first amplifier (X in Fig. 604), the grid of the second amplifier (X_1 in Fig. 604), and the plate of the second amplifier (Y in Fig. 604). Distortion at any of these test points indicates a defect in either a component or a tube, or both. Of course, in going from the grid of a tube to the plate of the same tube, an *increase* in the size of the saw tooth should occur, due to the *gain* in the tube.
8. Compare the size of the saw tooth at the first and second amplifier plates. *They should be the same size* within about 3%. Any greater discrepancy will result in crowding of one portion of the picture. Trouble shooting and correction are in order, until the plates are balanced.



Fig. 606—Saw-tooth wave shape of current in deflection yoke.

Vertical Amplifier, Oscillator

The procedure is exactly the same as for the horizontal circuit, except that the sweep frequency is 60 cycles, instead of 15,750. The c.r.o. sweep should be set as low as possible, preferably around 20 cycles. At frequencies below 20, the flicker becomes objectionable and makes observation difficult.

Magnetic-Deflection, Wave-Shape Checking

In the larger television receivers (and even in some of the better 7-inch sets) electromagnetic deflection is used. Here the current wave shape in the yoke is a saw-tooth, while the applied voltage looks like Fig. 607-c. However, the procedure for wave-form checking is practically the same as in the electrostatic system. A simple guide to correct wave shapes is shown in Figs. 607-a through c. Beginning with Fig. 607-a, we see first the output wave form of the blocking oscillator described in

Chap. 3, the pulse at the grid of the discharge tube (Fig. 607-b), and finally the output of the discharge tube (Fig. 607-c) which is the input to the deflecting yoke.

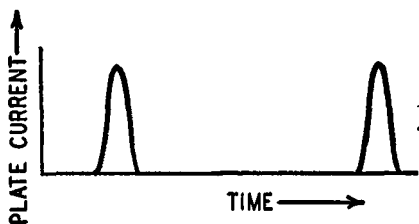

Fig. 607-a—Plate current pulse as a result of grid voltage shown in Fig. 607-b.

To examine these wave shapes on the 'scope, set its sweep to about 20 cycles for the vertical-deflection circuits, and about 4,000 cycles for the horizontal. Then connect, in sequence, the vertical input terminals between ground and 1, plate of oscillator output, 2, plate of discharge tube (if it is a separate tube) and finally, 3, across the deflecting yoke.

Any serious deviation from the standard patterns should be cause

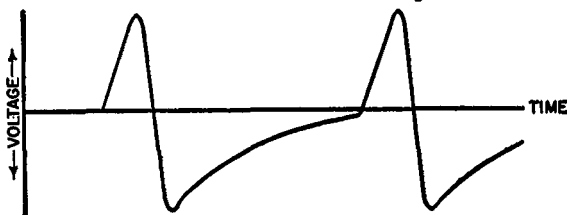

Fig. 607-b—Shape of blocking oscillator and discharge tube grid voltage curve for two cycles of operation.

for investigation of the particular circuit, since deviation will cause distortion, nonlinearity, etc., on the television screen.

Checking Synchronizing Pulses

Another check which *must be done with the oscilloscope* is the observation of synchronizing pulses and the pulse-clipping action in the television receiver. *Inadequate* clipping will appear in the form of

Fig. 607-c—Voltage across deflecting yoke which will produce a current in the yoke like that of Fig. 606.

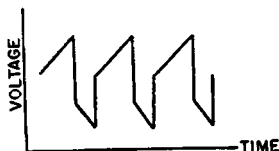

waviness of the test pattern (as well as the picture), indicating that video signals are allowed to enter the sweep circuits. *Improper* clipping may result in poor holding (picture drift). The synchronizing pulses, instead of the video signal, are clipped, leaving little or no sync pulses at the input to the sweep generating circuits.

Fig. 608 shows the various types of video-synch signals. In Fig. 608-a, the combined video and synch signal is shown. In Fig. 608-b we see the signal after *correct* clipping—the synch pulse without the video. Wrong clipping, in which the synchronizing pulse has been removed and the video left, is shown in Fig. 608-d.

To check these phenomena with the oscilloscope, set up the equipment as for horizontal or vertical pulse viewing. Then, with the aid of Fig. 608, view the pulse at the following points by applying the vertical input terminals to:

1. Output of the video amplifier—this should show the combined signal. (Fig. 608-a)
2. Output of the synch amplifier—clipping takes place here, hence the video should be substantially removed. (Fig. 608-b)

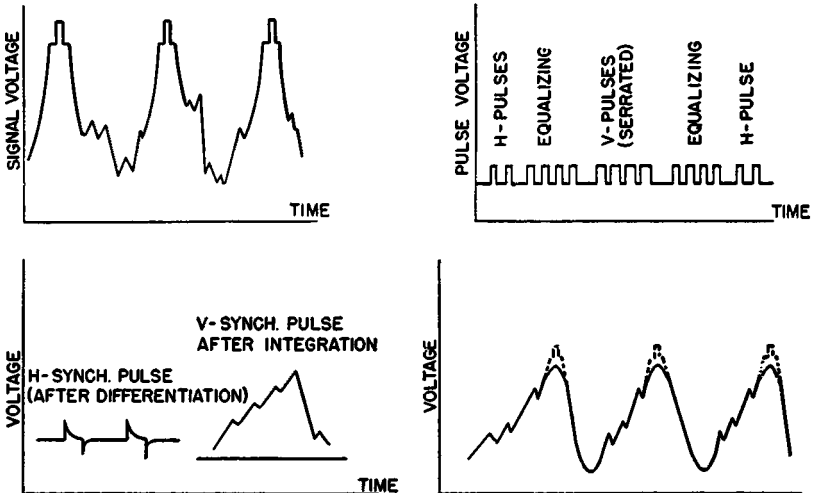

Fig. 608-a (upper left)—Combined signal (video and synch) after detection.
 Fig. 608-b (upper right)—Synch pulse after clipping (output of clipper stage.)
 Fig. 608-c (lower left)—Input to horizontal and vertical sweep oscillators.
 Fig. 608-d (lower right)—Wrong clipping. Here the synch pulses (dotted) have been removed, leaving only the picture signal. Result—no picture “locking”.

3. Output of synch separator—both pulses (H and V) appear here *without* the video.
4. Input to the horizontal oscillator—only the horizontal pulse should appear. (Fig. 608-c.)
5. Input to the vertical oscillator—this will show the vertical synch pulse only. (Fig. 608-c)

Remember, that individual variations in manufacturers' designs may call for somewhat different techniques. The best advice in addition

to the information in this book is: Follow manufacturers' procedures as far as possible. They save time and trouble.

Percentage Modulation, Ham Transmitters

There are two main types of test patterns used in checking *modulation percentage*. Both are easy to obtain and the choice is entirely with the individual user. It is often advisable to check by both methods, since neither one alone shows to best advantage in all cases.

The *modulation-envelope* method is the simpler of the two. The pattern obtained depends on the oscilloscope sweep, and requires only one type of signal to be picked up from the transmitter. To check for the modulation envelope:

1. Allow equipment to warm up.
2. Wind a small coil of fairly stiff, self-supporting wire (No. 18 bell wire will do nicely) and couple it to the modulated amplifier tank circuit. Connect the open ends of this coil to the vertical input terminals of the 'scope. See Fig. 609 for details.
3. Set horizontal and vertical gain controls on the 'scope for proper picture size. Also, adjust size by varying coupling of pickup coil to tank circuit. Use fairly loose coupling for best results.
4. Set sweep frequency for about one-third the modulating frequency. If the audio is 600 cycles, for example, the sweep should be approximately 200 cycles. Incidentally, if the modulating

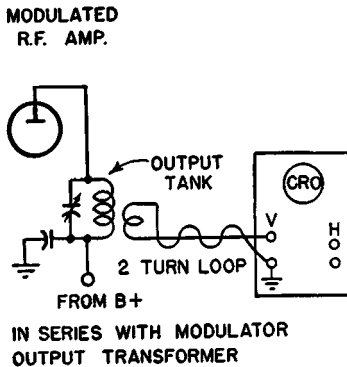

Fig. 609—Method of coupling to c.r.o. for the "modulation envelope" method of percentage modulation checking.

frequency is a *steady note*, there will be no difficulty in correctly adjusting the modulation. With ordinary speech, modulation is not constant, thus making it difficult to adjust for the proper

level. Any tone below 4,000 cycles will be satisfactory. Adjust c.r.o. synch control for pattern locking on the screen.

5. Increase or decrease audio gain, as may be required, until the minimum carrier amplitude is zero. See Fig. 610-b. This is indicative of 100% modulation. Overmodulation is indicated by gaps on the c.r.o. screen (as in Fig. 610-c), while undermodulation appears as in Fig. 610-d, the carrier being above zero. For comparison, Fig. 610-a shows the carrier intact, without modulation. Fig. 610-b, c and d represents modulation by complex waves. Pure tone (sine-wave) modulation would have produced sine-wave modulation envelopes, assuming no distortion.
6. As a final check, remove the steady audio-modulating note and substitute the microphone. Speak into the mike in a normal tone of voice. The modulation envelope should vary between

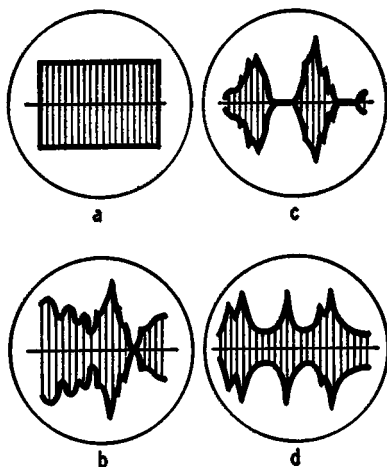

Fig. 610-a—Carrier without modulation. b—Carrier 100% modulated (minimum amplitude zero). c—Over 100% modulation—note blank space along zero axis. d—Under 100% modulation: carrier never reaches zero at audio frequencies.

Figs. 610-a and 610-b, indicating modulation up to, but not exceeding 100%. Average modulation levels should always be below 100%. However, since the proximity of the microphone to the speaker has an effect on the modulation (audio output), no exact procedure can be given for all cases. A good suggestion, and one which is always safe (overmodulation may cause spurious radiations which are prohibited by law) is to whistle a steady note into the microphone. Only at the loudest level should the modulation kick up to 100%. In other words, keep the mike gain control set so that, with the microphone kept at the usual distance from the speaker, the loudest steady note barely reaches 100% modulation.

For *trapezoidal-pattern* modulation checking, the procedure is the same as for the envelope method outlined above, except that you:

1. Set the oscilloscope sweep generator to OFF.

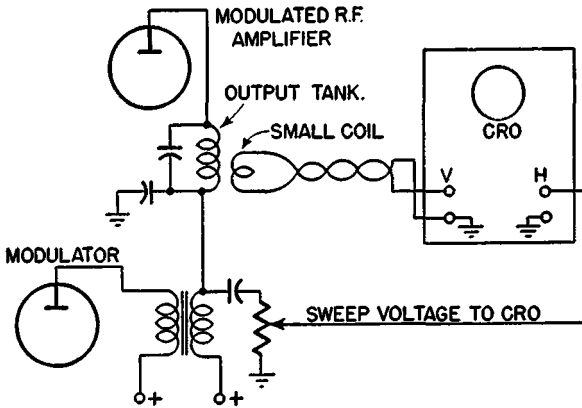

Fig. 611—Method of coupling to c.r.o. for trapezoidal pattern modulation check.

2. Feed a portion of the modulating voltage to the horizontal input terminals of the c.r.o. This can be a small audio voltage taken across a suitable resistor in the modulator circuit. See Fig. 611 for details.
3. Adjust 'scope controls for normal pattern.
4. With a steady note into the microphone (or any other input to the modulator, such as a phonograph record), observe the pattern on the cathode-ray screen. Figs. 612-a through d show various stages of modulation from zero to over 100%.
5. Make a final check with the microphone, as in step 6 of the modulation-envelope procedure above. Remember, 100% modulation is a level *seldom* to be reached, and *never* to be *exceeded*!

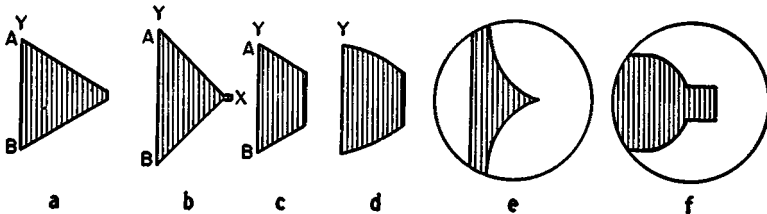

Fig. 612—Trapezoidal patterns. a—100% modulation; b—over modulation; c—under-modulation; d—amplitude distortion; e—regeneration in class-C stage; f—another form of evidence that regeneration is present.

Here are a few common transmitter troubles and methods of detecting them. The setup for the following cases is the same as for the

modulation checks just concluded. We shall use the trapezoidal test pattern for analysis.

Distortion, Over- and Undermodulation

Using the trapezoidal method of testing modulation, 100% modulation, overmodulation, and undermodulation are illustrated in Figs. 612-a, 612-b, and 612-c, respectively, while amplitude distortion is shown in Fig. 612-d. In Fig. 612-a 100% modulation is indicated by the trapezoid in which the maximum height AB is twice the height of the unmodulated carrier. Overmodulation results in length AB being more than twice carrier height, while the width of the trapezoid is foreshortened, as in Fig. 612-b. In undermodulation, the height is shorter than twice the carrier, while the width, although foreshortened, does not reduce to a point. See Fig. 612-c.

In practice, where complex waves rather than pure sine waves are the usual modulating voltages, overmodulation is the more troublesome, since it causes spilling over into adjacent frequency channels, particularly on the downward modulation peaks. As shown in Fig. 612-b, upward overmodulation increases the height of AB, while downward overmodulation causes an extension along the horizontal axis x.

To remedy overmodulation in the downward direction, reverse the connections to *any one* winding of an audio transformer. This reverses the phase of the modulating voltage. In addition, reducing the audio input is a general remedy for overmodulation. Where a pure sine wave instead of a complex audio voltage is used for modulation, reducing the audio alone is sufficient, since in this case there is no unbalance between positive and negative modulation peaks.

Regeneration in a Class-C Stage

Regeneration in a class-C stage may be due to a number of faults, such as no neutralization or faulty bypassing. On the 'scope screen, evidence of regeneration may be a distorted trapezoidal pattern, as in Figs 612-e and 612-f. When regeneration is due to faulty bypassing, it is best to leave the setup intact and replace *one at a time* the suspected components until the trouble clears up. Should bad neutralization be responsible, the procedure is somewhat different. In such a case, proceed as below (neutralizing an r.f. amplifier) and check the pattern after neutralization is completed.

Neutralization of the Class-C R.F. Stage

1. Set up the equipment as for modulation envelope test.
2. Remove source of modulation.
3. Open the plate supply to the stage being neutralized.
4. Connect the oscilloscope vertical terminals in series with a 100- μmf condenser across the plate tank of the same stage.

5. Connect the horizontal input terminals through a similar condenser across the grid circuit of the same stage.
6. Tune the grid circuit for *maximum* horizontal deflection.
7. Tune the neutralizing condenser for *minimum* vertical deflection.
8. Repeat steps 6 and 7 until the neutralizing condenser tuning produces *as nearly zero* vertical deflection as possible.

Figs. 613-a and 613-b show, respectively, a neutralized and an unneutralized stage. Fig. 613-c shows a double-frequency pattern (second harmonic) usually due to either improper plate and grid potentials or incorrect tuning, or both. A check on voltages as well as retuning is indicated in such a case. Improper tuning of the plate circuit may sometimes give rise to *phase shifts*, as illustrated in Figs. 613-d and 613-e. Ordinary voltmeter or r.f. ammeter measurements in such cases are obviously useless. The oscilloscope is the *only* simple means of detection as well as correction of such "bugs" in amateur equipment.

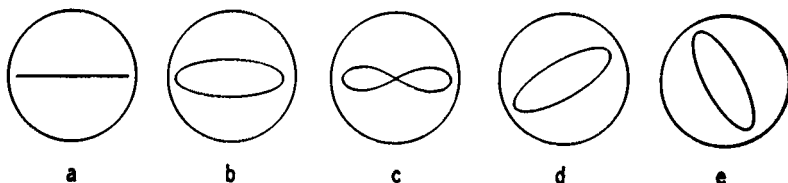

Fig. 613-a—Neutralized class-C r.f. stage pattern. b—Unneutralized class-C stage. c—Presence of second harmonic, due to improper potentials or detuning. d and e—Improper tuning of plate circuit.

Trouble Shooting With the Cathode-Ray Oscilloscope

The first half of this chapter was directly concerned with measurement, which is actually a form of trouble shooting. A measurement made, either to check the correct operating conditions of a circuit or to locate a fault, is truly a trouble shooting procedure. Thus, in checking modulation and neutralization, we are really trouble shooting the modulator, r.f. amplifier, and other stages. The examples that follow are further instances of the same general type, except that they assume trouble to exist and then proceed to locate the trouble and apply remedial measures.

Regeneration in I.F. Amplifiers

Regeneration is common to both video and audio i.f. circuits. Open bypass condensers, poor ground connections, defective or inadequate shielding, and overcoupling produce regeneration. In the audio channel this may result in some "hash", distortion, or otherwise poor quality of sound output. Except in severe cases, it will not, however, make reception impossible. But in video, even mild i.f. regeneration is sufficient to ruin the picture beyond usefulness.

To check for i.f. distortion, set up the equipment as for i.f. alignment, stage by stage. That means that the last i.f. stage is checked first, then the preceding one, and so on all the way back to the mixer. With the equipment so set up:

1. Feed a signal to the grid circuit of the stage.
2. Observe the pattern on the 'scope. If the sides of the response curve are fuzzy or jagged (see Fig. 614-b), either regeneration or oscillation is present, depending on the degree of departure from the smooth curve of Fig. 614-a.
3. Move the input signal back toward the mixer one stage at a time and repeat this observation in each case.

NOTE: Where an i.f. gain control exists, as in the case of a television contrast control, set it *nearly all the way up* (toward maximum gain) to determine whether regeneration exists in this weak-signal position. **A**

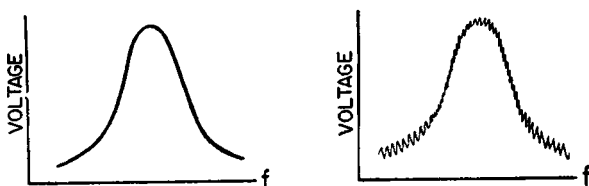

Fig 614-a—(left)—Normal i.f. pattern. Smooth line is evidence of no oscillation. b (right)—Fuzzy or jagged outline, indicating regeneration or oscillation in an i.f. amplifier.

slight trace of regeneration with the control at *maximum* is permissible, however, since a signal of acceptable strength will never require this setting. Conversely, any signal so weak as to require maximum setting of the contrast control is probably too poor for minimum acceptable results.

The remedies for regeneration are varied. It is always advisable to work with the schematic diagram on hand, as well as any other manufacturers' data that may be available. In general, the following items should be investigated:

1. Cathode, screen, and plate-return bypassing.
2. Excessive voltages at these elements, particularly on the screen and plate.
3. Missing or poor shielding.
4. Poor ground connections. (A poor *common ground* between the various pieces of test equipment and the receiver may give rise to regeneration. Of course, this is a false alarm, but can cause a lot of grief before it is discovered. Grounding must be good, preferably at one point, on the receiver chassis.)

5. Overcoupling.
6. Excessive signal input.

Remedial steps should be taken *one at a time*, with the setup intact and while observing results of the remedies, as they are applied, on the screen of the cathode-ray tube. While regeneration may be detected on a plate milliammeter or a voltmeter, the use of these instruments instead of the 'scope involves a lot of experience and care. Even then it is a hit-or-miss method. In comparison, the oscilloscope is all but infallible.

Audio-Frequency Distortion

A defect in an otherwise good stage can cause over-all distortion. This differs from uneven response, which was discussed earlier. When an amplifier distorts on most or all frequencies, then a cure at any one standard frequency will cure the amplifier for all frequencies. To analyze such a defect:

1. Allow equipment to warm up.
2. Apply a *standard* wave to the vertical input of the c.r.o. A *square-wave* generator is very useful here, but a sine wave will be satisfactory. If no audio oscillator is available, use 60-cycle a.c. for this standard pattern (the 2.5-or 6.3-volt heater supply of the amplifier will do very well).
3. Observe the wave shape at various settings of the oscilloscope vertical gain control. This will provide a fidelity check on the vertical amplifier, indicating whether any distortion is due to this source. If the pattern looks like a good sine-wave shape, then proceed to the next step. Otherwise, the vertical amplifier needs attention, before it can be used for trouble shooting in another piece of equipment.
4. Apply the sine wave (or the square wave, if that is used) to the input of the amplifier under test, being careful to keep the applied signal level within the maximum rating of the amplifier. Observe the output wave-shape. If this pattern differs considerably from the pattern obtained in step 3, the amplifier is distorting.
5. Repeat step 4 with individual stages of the amplifier, feeding the signal to the grid circuit and connecting the vertical c.r.o. input terminals across the plate circuit of the same stage, until the offending stage is located. Unless the power supply is at fault, the chances are that only one stage is responsible. Where the fault lies in a common circuit such as the power supply, then ordinary voltmeter-ohmmeter analysis will locate the trouble.

The following listing of different types of distortion gives the causes and the resulting oscillograms.

Fig. 615-a—a normal sine wave, either as it appears before amplification or at the output of a distortionless amplifier.

Fig. 615-b—the same sine wave with some distortion. The flattening of the positive peak is generally due to overloading of the amplifier.

Fig. 615-c—more severe distortion, both on the positive and negative peaks. If there is no defective component in the circuit, the fault is almost always overloading. Reducing the input signal will cure the trouble.

Fig. 615-d—a form of distortion generally due to a shorted cathode bypass condenser. When two tubes in push-pull are involved, the trace will appear as in Fig. 615-e.

A very common fault in old amplifiers which have had considerable service is a leaky coupling condenser at the grid of any stage. Fig. 616-a shows the circuit of the stage. If the oscilloscope's vertical terminals are

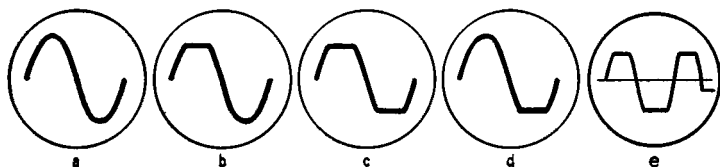

Fig. 615-a—Normal sine-wave a.c.; no distortion. b—Flattening of positive peak due to overloading. c—Distortion of both positive and negative peaks. Overloading is the cause, not a defect in the amplifier. d—Distortion due to a shorted cathode bypass condenser. Grid is driven positive. Reduction of input will not improve this wave shape. e—Same condition as at d, except for two tubes. Here, too, reduction of signal input will not help.

connected between point A and ground, and a normal pattern appears, it means that the input signal is not distorted. Moving the high side of the vertical input from point A to point B will include the coupling condenser in the circuit. A leaky coupling condenser C will cause the curve illustrated by the dashed lines in Fig. 616-b. This is shown for a condition of overload, when the grid would normally go positive. The obvious remedy is to replace the offending condenser.

Another cause of audio distortion is mismatching load impedance to the output tube impedance. For normal conditions of loading, the output sine wave, either at the plate of the output tube or across the speaker voice coil, should look almost exactly like the input wave form, or a perfect sine wave. When mismatching is severe, one of the following two results is likely:

1. If the loading is insufficient (too high a load impedance on the tube), the wave appears very sharp, as in Fig. 617-a.
2. If excessive loading is the cause, as when the load impedance is too low for the particular tube, the output wave shape will be rounded off, appearing somewhat like Fig. 617-b.

Location of A.C. Hum

Hum location is of great importance in video circuits, since the a.c. hum present in the power supply finds its way into the sweep circuits

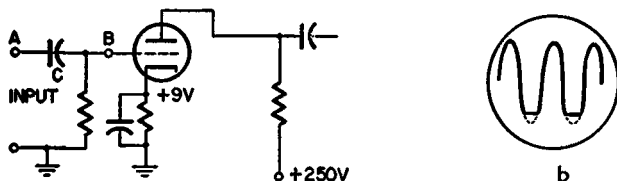
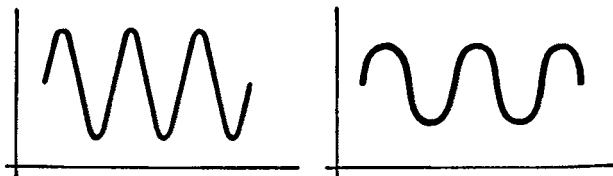

Fig. 616-a (left)—Partial diagram of an audio stage, showing how a leaky coupling condenser *C*, will keep the grid from going positive and flatten out the curve on the peaks. *b* (right)—A normal stage will have an output as shown for overload conditions. A leaky coupling condenser will prevent the grid from going positive, thus giving the curve as shown by the dotted lines.

and ultimately modulates the picture itself. The result may be a very slow shifting of the picture across the screen. It can be observed best with the antenna disconnected, or with the contrast control all the way



Figs. 617-a and -b—Distortion due to improper load matching on final amplifier. *a* (left)—Effect of too light loading (high impedance). *b* (right)—Too heavy loading (low impedance, or partial short) on the output amplifier.

off. The rectangular illuminated area on the picture-tube screen, called the *raster*, will have wavy sides instead of straight edges. Fig. 618-a shows the appearance of a normal raster, while that shown in Fig. 618-b illustrates the effects of a.c. in the sweep circuits (note the wavy edges). This is primarily due to a.c. in the *horizontal*-deflection circuits.

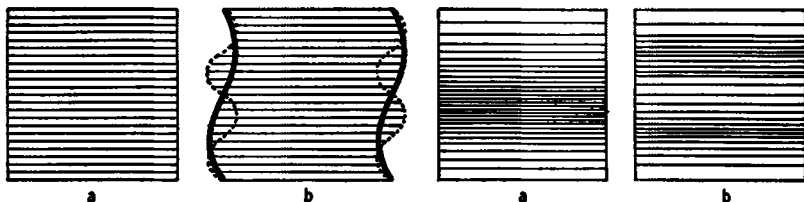

Fig. 618—A.c. hum in horizontal deflection circuits of TV set: *a*—Normal screen. *b*—Hum (solid line is 60 cycle, dotted line is 120 cycle).

Fig. 619—Hum in vertical deflection circuits of TV set: *a*—60-cycle hum. *b*—120-cycle hum produces twice as many condensations and rarefactions.

When stray a.c. finds its way into the *vertical*-deflection circuits, the effect appears as unevenly spaced horizontal lines, as shown in

Fig. 619. Compare this with Fig. 618-a, in which the lines are uniformly spaced, indicating a normal raster. Under conditions of actual picture reception, such variation in the spacing of the lines will result in vertical crowding of one portion of the picture, alternating with stretching of the adjacent portion. This, of course, produces distortion. In addition, when lines are crowded or overlap, the details contained in such lines are superimposed on each other with a resultant loss of sharpness and detail.

Another effect of a.c. getting into d.c. circuits is a partial *blacking out* of the picture. Fig. 620 shows the result of a.c. getting into the video amplifier circuits.

In audio circuits, particularly those with good low-frequency response, excessive a.c. in d.c. circuits (supply, bias, etc.) may result in objectionable hum, although this is not very common either in small

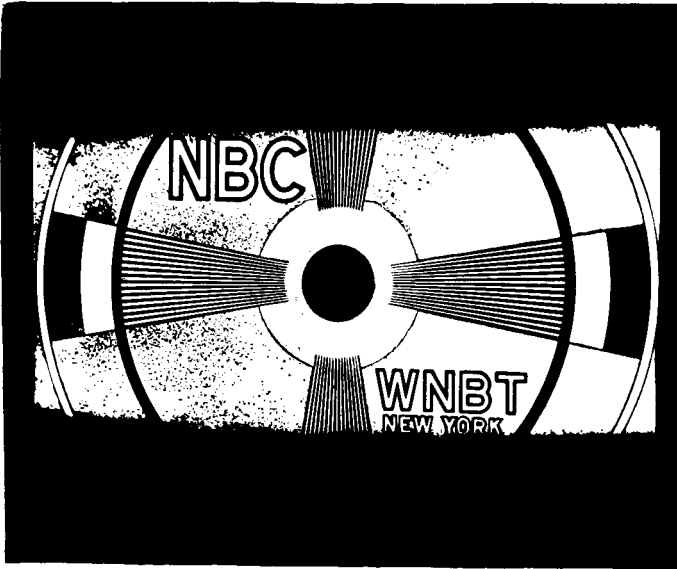

Fig. 620—Result of excessive a.c. hum in video amplifier.

a.c.-d.c. receivers or even in the television receiver audio channels of the less expensive variety, the latter sets having rather poor response at 60 and 120 cycles.

In all the above cases, the ordinary meter might possibly be used to measure the incremental a.c. superimposed on the d.c. However, this is just as complicated a procedure as it is unreliable. The oscilloscope is both quick and handy for locating the source of trouble, as well as for observing the effects of the remedy used in any particular case. The procedure is generally as follows:

1. Allow equipment to warm up.

- Set the c.r.o. sweep generator to about 20 cycles to permit convenient observation of both 60 and 120 cycles. Set the gain as required in each case.
- Connect the ground connection of the 'scope to a good ground point on the receiver or amplifier in question. If this connection

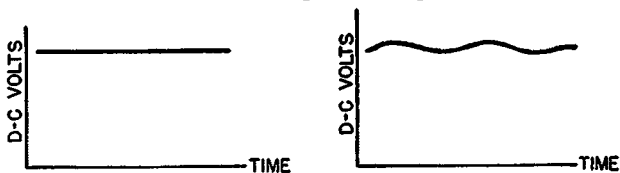

Fig. 621-a (left)—Normal, well-filtered d.c. output of a rectifier system. Fig. 621-b (right)—Ripple on the d.c. output, due to poor filtering.

is not good, a.c. hum not due to any defect in the equipment may appear. Connect the high side of the c.r.o. vertical input, in series with a 0.25- μ f condenser if the point on test is more than 500 volts above ground, to various points in the B-supply system.

- With all 'scope controls properly set, observe the trace on the screen. A good d.c. supply will have a straight-line output, as shown in Fig. 621-a. If a sufficient amount of a.c. exists, a trace like Fig. 621-b will result.

Hum in the Power Supply Proper

Before outlining specific test points and remedies, a few words of caution are in order: The vertical amplifier of the oscilloscope may have a very high gain in some cases. Because of this, a very slight trace of waviness in the oscillogram of Fig. 621-b is not necessarily an indication of trouble. If the 'scope gain control is set at or near maximum, a very *negligible* amount of a.c., which is always present in rectified a.c. supplies, may cause a wiggle on the screen. Familiarize yourself with the behavior of the vertical amplifier before making these a.c. hum tests. Once you know the equipment, you will be able to tell readily which is a normal trace and which has excessive a.c. modulation. In general, the following are permissible a.c. voltages (maximum) measured at the various points in the power supply system, as indicated in Fig. 622:

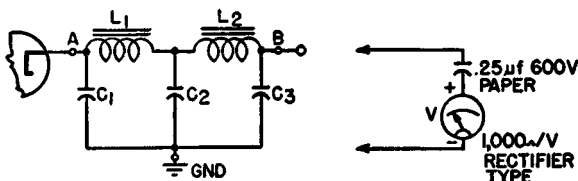

Fig. 622—Typical rectifier filter system; for choke input C_1 is omitted. Voltmeter may be used instead of 'scope.

- Output of rectifier, full-wave condenser input (point A, Fig. 622)

5-15

2. Output of rectifier, half-wave condenser input (point A, Fig. 622) 10-30
3. Same as setup 1, except choke input (point A, Fig. 622) 70-100
4. For no-load conditions, in above cases ... 20% of values above.
5. After the filter, any of above cases (point B in Fig. 622) approximately 0.5 or about 0.1% of the total voltage. This would give about 0.25 volt a.c. in a 250-volt supply, 1 volt in a 1,000-v supply, etc. To measure the above a.c. components, either the calibrated 'scope method may be used (see note, p. 81), or a rectifier-type a.c. voltmeter of about the correct range, *in series with* a high-grade paper condenser of 0.25- μ f capacitance may be placed across the same terminals where the 'scope was located in the above tests. However, *observation* with the 'scope is recommended as a simple way of locating hum as well as determining the severity of the a.c. modulation. It may be stated with a high degree of certainty that once the operator has become well acquainted with the c.r.o. and has learned to judge quantitatively the significance of a particular amount of a.c. modulation on the screen, he will seldom if ever revert to the voltmeter for this type of work.

Causes and remedies of power supply hum are few and usually easy to locate. A leaky filter condenser, an open filter condenser, or a shorted filter choke, the latter being rather rare—each and all of these will cause excessive hum. We did not bother to list a *shorted* filter condenser, since in such a case there will be other, much more obvious, consequences (low voltage, overheating, damage, etc.) with which every

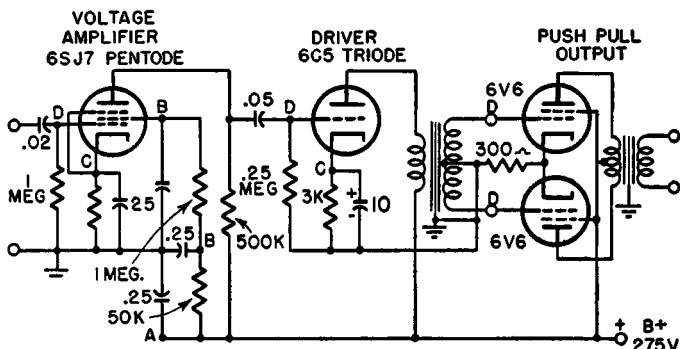

Fig. 623—Typical high-gain audio amplifier, showing sources of output hum, due to a.c. at the points indicated.

serviceman is familiar. A somewhat less obvious, yet fairly common, source of hum is *overloading* the power supply. As a check of this condition, the 'scope will show very little difference in hum content before

and after the filter choke. In some cases of severe overload, the choke may be jumped or shorted out of the system without materially increasing the hum. The remedy, if the load requirement cannot be reduced,

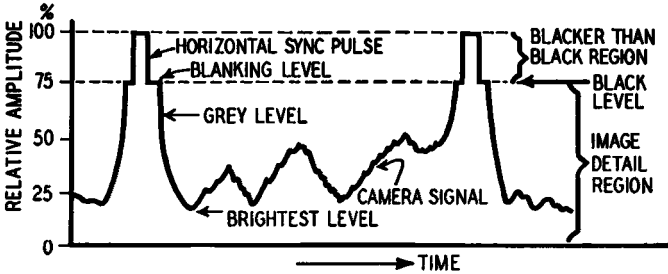

Fig. 624—One line of standard RMA video signal (negative polarity system).

is to substitute a heavier (larger inductance at the rated current) filter choke.

Hum Outside the Power Supply

Not all a.c. hum finding its way into the d.c. circuits originates in the power supply. Sometimes a well-filtered power supply will be blamed for faults in other parts of the circuit. A small amount of a.c. picked up from the heater wiring, pilot lamp, or similar a.c. circuit will get into the cathode bias or grid circuit of a sensitive amplifier, be amplified in the plate circuit of the same tube, and perhaps be carried along and be further amplified to excessive proportions in other parts of the circuit. Tubes with excessive heater-cathode leakage can cause hum in some critical circuits.

Fig. 623 shows a portion of a circuit (receiver or amplifier) in which the a.c. hum is not traceable to the power supply. Assuming that defective tubes have been eliminated, the following points should be checked for presence of a.c., in the same manner as the power pack was traced above:

1. Plate return (point A), check for faulty bypass condensers.
2. Screen supply (points B), check for faulty bypass condensers.
3. Cathode circuits (points C), check for faulty bypass condensers.
4. Grid circuits (points D). This is perhaps the most troublesome circuit for a.c. pickup, because of its sensitivity. Check for hum *with no signal* applied. Placement of components, of wires (dressing), etc., is extremely important here.

The above troubles may be particularly annoying in large multitube receivers, video and FM amplifiers, and similar equipment where high gain and crowding of parts is likely to occur. In service work, where

commercially designed equipment is to be repaired or maintained, the fault generally will not lie in poor design. Rather it will be found to be a *defective component*. Therefore it is very helpful to use all the available service data supplied by the manufacturer. Lacking such information, the serviceman should at least avail himself of a schematic diagram before tackling a complex, multitube set. When even that is not available, the general procedures outlined here, coupled with the serviceman's experience and fundamental knowledge, should prove adequate to cope with the problem.

A final note of caution: remember that modern FM and television receivers are very carefully designed, almost to the point of individual "tailoring". Therefore, although the original design is sound, severe circuit changes may accidentally be brought about when replacing a defective component or wiring. Make the utmost effort to *replace both parts and wiring as exactly as possible* in their original positions. Unless this is heeded, such difficulties as hum, oscillation, detuning, and many others are, not only possible, but probable.

Improper Video Clipping

This may be a very troublesome matter in *television* receivers. To understand the problem, let us first explain the clipper function. The video signal reaching the receiver contains both picture detail and synchronizing information. This latter information appears as pulses or pips at the extreme high end of the combined signal (see Fig. 624). Somewhere after detection these two signals have to be separated, the picture detail going to the video amplifier circuits and then to the grid of the picture tube, while the synch pulses are fed to the horizontal and vertical sweep oscillators. The process of clipping involves removal of all picture detail from the synch pulses, so that only timing information will be fed to the sweep generators.

While correct clipping requires removal of all the picture detail without destroying the synch pulses, there are two possible sources of difficulty in this problem. *Insufficient clipping*, caused either by a defective tube or other component, will leave too much of the picture detail with the synch pulse. This will ultimately result in a fine, irregular waviness of any straight line on the picture, such as the vertical wedges of the test patterns. Or, in trade lingo, "video is getting into the synch."

Wrong clipping, although less common in manufactured receivers, may be caused by a phase reversal between the video detector and the synch circuits, such that the pulses are clipped instead of the video. The result is very poor synchronization or none at all. The picture will not stay locked, but drifts up and down or across the screen.

Fig. 624 shows the combined signal. Inadequate clipping simply means that the signal is fed to the sweep oscillator substantially as it appears in the figure. A normal synch signal, after correct clipping,

looks like Fig. 608-b, page 88. Should the wrong end of the signal be clipped, the pulses would be removed and the video left intact to be passed on to the synch amplifier and then to the sweep oscillators. This is illustrated in Fig. 608-d. The result, as has already been stated, is a drifting picture, evidence of poor synchronization, or complete lack of synchronization.

To trace the signal with the oscilloscope :

1. Allow equipment to warm up.
2. Set 'scope for normal pattern viewing.
3. Set sweep for approximately 5,000 cycles. This will allow viewing of about 3 lines on the screen.

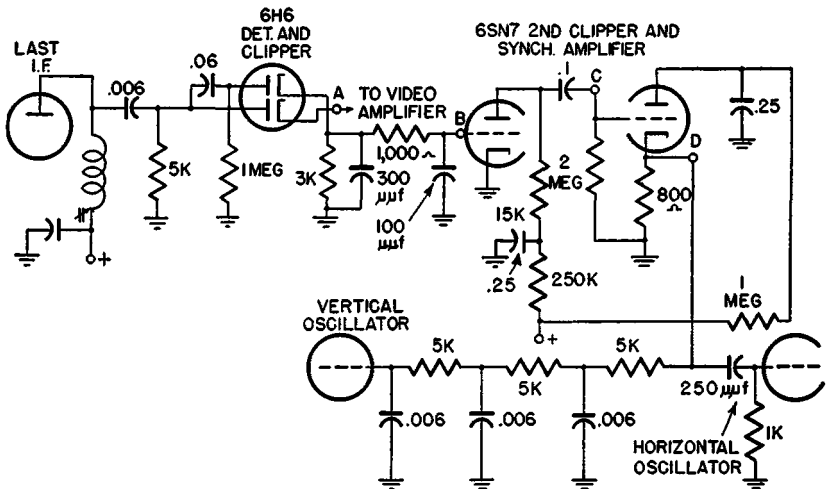

Fig. 625—Diagram of a typical detector-clipper-amplifier feeding the H and V oscillators.

4. With the ground terminal for the vertical input making a good ground connection on the receiver, touch the high side to points A, B, C, D (Fig. 625) in the order listed, and observe the results. At point A, the signal should be intact, as in Fig. 624. At point B, if all is well, the clipped signal should have most of the video removed. Point C should show the pulses only, as in Fig. 608-b. Point D will show the same pulse after amplification.

Auto Radio Vibrator Supplies

One of the most important applications of the oscilloscope is the checking and correction of faults in auto radio vibrator systems. In spite of the fact that it is almost impossible without a c.r.o. to service properly this most common job in the shop, too few servicemen have ever taken advantage of this instrument. Such difficulties as chronic rectifier failures, short-lived vibrators, low output voltages, and noisy receivers are almost beyond the ability of the multimeter to diagnose. Yet the

oscilloscope will locate these faults with little expenditure of time or effort.

Briefly, a defective buffer condenser can cause low voltage output, bad arcing, and damage to the vibrator, rectifier tube, and even the power transformer. Similarly, improperly adjusted vibrator contacts can cause most of the above, in addition to noise in the receiver.

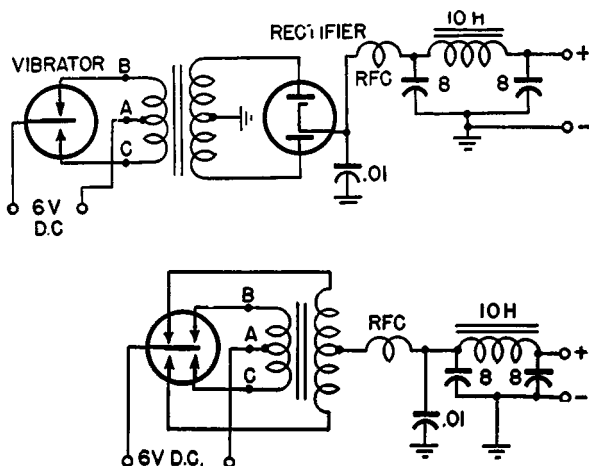

Fig. 626-a and b—Simplified diagrams of a non-synchronous vibrator power supply (upper) and a synchronous type (lower).

Fig. 626 shows a portion of the vibrator supply system. With the circuit in normal operating condition, and the vertical input to the 'scope across points A and B or A and C (*not to ground!*), the voltage pattern should look like Fig. 627-a. The c.r.o. sweep frequency for this test should be about 40 or 50 cycles, giving about 3 or 4 cycles on the screen. Note that the wave is substantially square, with no steep peaks or rounded corners. This indicates a correct value of buffer condenser and proper contact spacing.

Fig. 627-b indicates either too small a buffer condenser or a complete lack of buffering. This will usually be accompanied by low output voltages. If an exact duplicate replacement cannot be made, the substitute chosen should bring the wave shape as closely as possible to that shown in Fig. 627-a.

Fig. 627-c shows the effect of too large a buffer condenser. The lagging edge of the wave is rounded off. A very common defect in old vibrators is poor contact due to pitted contacts and chattering. The resultant wave looks somewhat like Fig. 627-d. Careful dressing and readjustment of the spacing of the contacts will remedy most of this difficulty, although it may be more convenient as well as more economical to replace such a vibrator with a new one. However, where replace-

ment cannot be made for any reason, the above procedure will make the old unit serviceable for quite a while longer.

Fig. 627-e shows the wave form for a normal vibrator of the *synchronous* (self-rectifying) type. The sharp pips in this case are no indication of a defect as was the case in Fig. 627-b. They are due to the opening of the secondary, or rectifying, contacts in synchronism with the primary breaker points.

When adjusting vibrators, slightly different vibrator frequencies in different receivers require variations in contact spacing as well as buffer capacitances. Since manufacturers do not encourage vibrator repairing, it is difficult to outline precise adjustment procedures. However, the above directions and sample patterns are typical of most common practices, as well as of good design and operating conditions. Where a repair has to be made and no other specific instructions are available, the outline given will prove sufficiently helpful to achieve satisfactory results.

Determining Frequency of an Unknown E.M.F.—Lissajous Figures

The tracing of various patterns and the identification of unknown frequencies are extremely useful applications of the cathode-ray oscilloscope. Such problems as determination of hum frequency, interference frequencies, etc., are quite simple once the fundamental steps are clearly understood.

There are two main methods of curve tracing: One method traces the unknown wave, applied to the vertical input of the 'scope, by the linear sweeping of the self-contained, saw-tooth oscillator. This is the most common method of observation on the 'scope. The second method although less common, is very useful for determining unknown frequencies and phase relationships. This latter method makes use of the *Lissajous figures*. The first method is only as accurate as the sweep

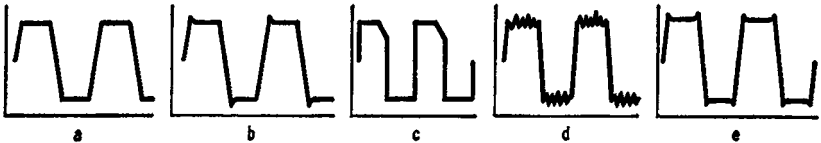

Fig. 627-a—Normal wave shape for non-synchronous vibrator. b—Too small a buffer condenser (or none at all). c—Too large a buffer condenser. d—Pitting, and chattering contacts. Can cause low output and poor regulation. e—Normal wave shape for synchronous vibrator.

generator of the 'scope, while the second may use an external, calibrated frequency standard, and is therefore more accurate.

From the various discussions earlier in this book, the reader should be quite familiar with the saw-tooth method of observation. Briefly, it presents the wave shape of the unknown voltage or current as it actually develops in the circuit, without comparison to any standard wave. The

Lissajous figures method compares the unknown with a standard wave. The procedure is simply to connect the unknown voltage (frequency unknown) to the vertical amplifier input terminals, and a standard frequency voltage (most often 60 cycles) to the horizontal amplifier input. The sweep generator is turned off.

Fig. 628 shows a number of typical Lissajous figures. In Fig. 628-a, both voltages are of the same frequency (60 cycles). A perfect circle results. If the unknown frequency is somewhat distorted, instead of being a pure sine wave, the circle will have a ragged outline. Of all Lissajous figures, the circle is the simplest. The ratio between number of vertical and horizontal loops determines the ratio of the standard frequency to the unknown. Here the ratio is 1:1, and hence both frequencies are the same. When the ratio is 2:1, as illustrated in Fig. 628-b, the unknown frequency is 30 cycles. Similarly reasoning, Fig. 628-c shows a ratio of 1:5, with an unknown frequency 5 times that of the standard, or 300 cycles. Figs. 628-d and e show, respectively, a 6:1 and a 5:3 ratio, making the unknown frequency 10 cycles in the first case and 36 cycles in the latter. Fig. 628-f denotes an unknown frequency of 72 cycles, the ratio being 5:6, meaning that the unknown is $\frac{6}{5}$ of the standard frequency of 60 cycles.

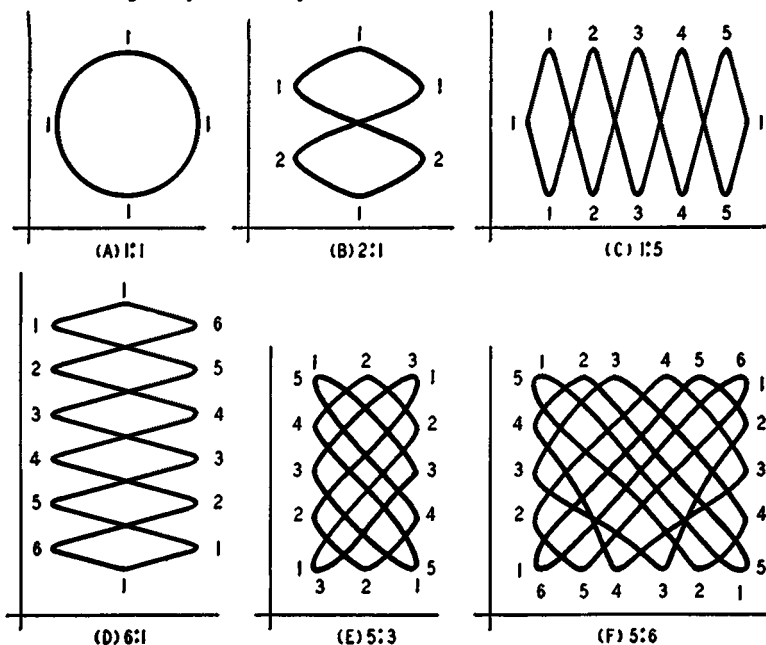

Fig. 628—Lissajous figures for different frequency ratios.

It is not absolutely necessary to use 60 cycles in these comparison tests. Any other known frequency will do equally well. However, since 60 cycles happens to be very readily available, and since (and this is

very important) the accuracy of the commercial 60-cycle frequency usually is extremely high, this is a most logical frequency to use as a standard.

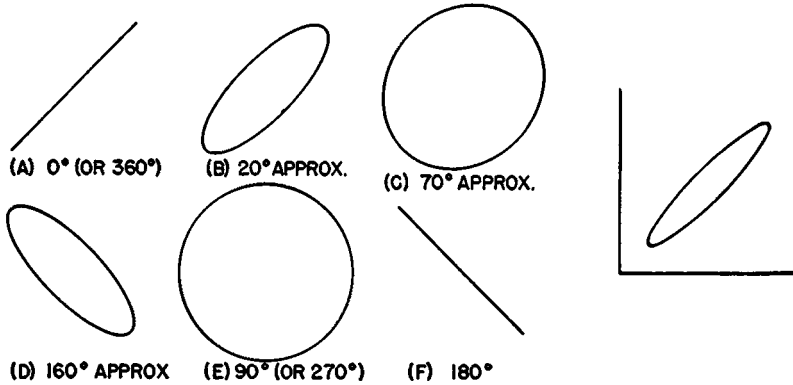

Fig. 629 (left)—Phase shift patterns and approximate values. Fig. 630 (right)—Negligible phase shift in an amplifier (10 to 15 degrees). This will vary somewhat with frequency.

The general method in calculating frequency ratios is as follows: Count all the loops along the vertical edge of the pattern. Similarly count the number of loops along the horizontal edge of the pattern. Note that the loops along the horizontal edge are produced by the voltage applied to the vertical plates, while the loops along the vertical edge are produced by the horizontal voltage. Dividing the number of vertical edge loops by the number of horizontal edge loops will give the ratio of the standard to unknown frequency. Thus in Fig. 628-f there are six loops along the horizontal edge and five loops along the vertical edge. The ratio of the vertical to horizontal loops is therefore 5:6, and the unknown frequency is therefore 6/5 of 60, or 72 cycles.

Another very useful application of the Lissajous figures is in the determination of *phase angles* between signals of the same frequency. This is particularly important in checking phase shift in high-quality audio amplifiers, the type of distortion called *phase-shift distortion*. This means that the amplifier has a phase delay between input and output. When this phase shift is small, say under 20 degrees, the resultant distortion is rather negligible. However, severe distortion will result from large angle shifts or, and this is the most common difficulty, from *different amounts of shift at different frequencies*.

In outlining the procedure for checking phase shift, we shall first indicate the general procedure for determining phase-angle differences between *any two voltages*. Such a phase difference is not necessarily an indication of any defect. Phase-angle differences between voltages are quite common and normal. In the amplifier, we are checking for phase *shift in the same voltage* due to the nature of the unit. More particularly,

we are concerned with *differences in the angle of shift at different frequencies*.

To check for phase difference between any two voltages, proceed as follows:

1. Allow equipment to warm up.
2. Set c.r.o. controls so that spot is in the exact center of the screen. The calibrated plastic screen is necessary in this case.
3. Set the horizontal and vertical c.r.o. gain controls for exactly the same deflection. This can be done by alternately applying one of the unknown voltages to the horizontal input and the other to the vertical input, adjusting the vertical or horizontal gains in each case for the same number of divisions of deflection on the screen. *Do not change these settings after they are made.* If frequency is high, say over 50 kc, the signal should be applied *directly* to the deflecting plates of the 'scope, and the individual voltages adjusted for equal deflection on the c.r.o. screen.
4. Observe the resultant pattern on the screen. If the two voltages are in phase, a straight line at 45 degrees will result. A slight difference in phase will produce a very thin ellipse at about 45 degrees. (See Figs. 629-a and 629-b.) Increasing angles of shift are illustrated in Figs. 629-b to 629-f, with the values of angle indicated in each instance.

Two reminders are in order: First is the matter of *drift*. If both frequencies are absolutely steady, the pattern will be stationary. Should one of the voltages vary slightly or drift, the pattern will go through a slow phase cycle from 0 to 360 degrees, and then repeat this over and over. The second reminder, although it is quite easy to determine the phase angle from the figures, as shown in Fig. 629, it is generally sufficient for practical purposes to *see* whether the angle is large or small. This is usually the case in amplifier phase-shift testing, where the angle of shift is not likely to be very great.

The procedure for checking phase shift in an audio amplifier is somewhat different:

1. Set up the equipment as for checking phase difference between voltages. Since we are going to use audio frequencies, the 'scope amplifiers may be used.
2. Connect output of the test amplifier to the vertical c.r.o. input terminals. Connect the input of the amplifier to the horizontal 'scope terminals. In this way the same signal that is fed to the test amplifier will also be applied to the horizontal-deflection circuit of the 'scope.
3. Connect audio oscillator to the input of the test amplifier. Adjust 'scope or test amplifier gains for equal vertical and horizontal deflection, using same method as in step 3 above.
4. Observe pattern on the 'scope. In most cases the result will be a thin ellipse, since only a small phase shift usually exists (Fig.

630.) Should the ellipse be much wider, compare it with the patterns shown in Fig. 629 to determine the approximate angle of phase shift.

5. Vary the frequency of the audio oscillator through the audio range (30 to 12,000 cycles is sufficient for most amplifiers) and observe the phase shift at different frequencies.

You will notice that there is no *drift* of the pattern, since the same source of e.m.f. (and the same frequency, of course) is used for both the horizontal and vertical scope amplifiers.

A final note on *phase shift*. Fig. 631-a is a simple phase-shifting device used as a sweep source in connection with wide-band i.f. alignment, such as in television amplifiers. Since most frequency-modulated sweep generators use 60 cycles as the sweep frequency, the simple instrument shown here enables the user to apply to the horizontal c.r.o. terminals the same frequency voltage as that used for frequency sweep-

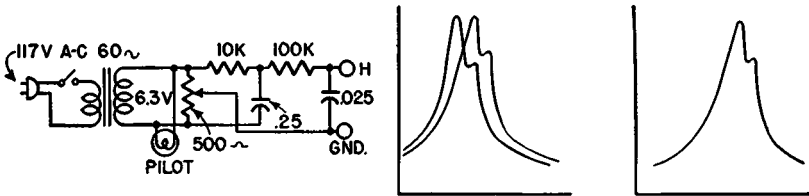

Fig. 631-a (left)—Simple phase shifting device (60 cycles) for use as the horizontal sweep source in FM and TV alignment. b (center)—Double pattern due to slight shift (phase control not adjusted). c (right)—Phase control properly set. A single pattern results.

ing inside the signal generator. In practice, the output terminals of the unit shown are connected across the horizontal input of the cathode-ray oscilloscope. Without any adjustment of the potentiometer, the likelihood is that two patterns, somewhat out of phase, will appear on the 'scope screen, as shown in Fig. 631-b. The potentiometer should now be adjusted until the two traces *overlap* as far as possible, since this is the easiest pattern to view for alignment purposes. However, regardless of the degree of overlap, the pattern will be locked in any position in which it is left for the duration of the test.

Index . . .

A.c.:		Blocking Oscillator	29
Average Value	12	Cathode Rays	15
Definition	8	Cathode-ray Tube:	
Peak Value	10	Deflection Elements	17
R.m.s. Value	10	Electron Gun	15
Waves	10	Target (Screen)	18
Accelerating Anode	16, 19	Charging-current, Condenser	24
Adjustment, Synch	40	Charging of Condenser	24, 27
Alignment:		Checking:	
Band-pass i.f.	52	Horizontal Oscillator: TV Receiver	85
Discriminator	56, 64	Sweep Circuits; TV Receiver	84
Improper (Response Curve)	54	Vertical Oscillator; TV Receiver	86
Locked-oscillator FM Detector	64	Wave Shape in Magnetic-deflection	
Non-staggered TV i.f. Channel	71	TV Sets	86
Peak i.f.	51	Class-C Transmitter Stage, Regen. in	92
Precautions; TV i. f.	73	Clipping, Improper Video	102
Ratio Detector	62	Condenser:	
R.f.; AM Receivers	75	Charging Current	24
R.f.; FM Receivers	76	Charging of	24, 27
R.f.; TV Receivers	76	Voltage Curve	26
Slope Detector	60	Control:	
Stagger-tuned TV i.f. Amplifier	69	Centering	42
Trap	72	FOCUS	42
TV i.f. Circuits	65	FREQUENCY	40
3-Winding i.f. Channel	58	Grid; c.r. Tube	15
AM Receiver, r.f. Alignment	75	INTENSITY	42
AM Set, Response Curve	53	Setting Oscilloscope	44
Amplifier:		SWEEP RANGE	39
Balance, Saw-tooth	84	SYNOH ADJUST	40
Horizontal	39	SYNOH SELECTOR	40
Horizontal Sweep	32	VERTICAL GAIN	36
I.f. regeneration in	93	Curve (See <i>Response Curve</i>)	
Oscillating i.f.	74	Cycle (a.c.), Definition of	8
Saw-tooth	84	D.c., Definition of	7
Stagger-tuned TV i.f.	67	Decibels, Computing Gain in	83
Stagger-tuned TV i.f.; Alignment of	69	Deflection:	
Vertical	86	Electrostatic	17, 19
Wide band TV i.f.	67	Elements	17, 19
Anode:		Electromagnetic	17
Accelerating	16, 19	Plates, Direct Connection to	43
First	15, 19	Plates, Function of	17, 19
Focussing	15, 19	Detection, Slope	59
Intensifier	16	Detector, Philco Locked-in Oscillator	63
Second	16, 19	Direct Connection to Deflection plates	43
Audio:		Discriminator:	
Frequency Distortion	95	Alignment	55
Gain, Calculating	82	Non-limiter; Alignment	64
Output Measurement	81	Distortion:	
Power Output Calculation	82	Audio-frequency	95
Response Curve Plotting	82	Saw-tooth Amplifier	84
Automatic Frequency Control	50	Over- and Undermodulation;	
Average Value of Wave	12	Transmitters	92
Band-pass:		Phase-shift	107
I.f. Alignment	52	Electromagnetic Deflection	17
Receiver Response Curve	53	Electron:	
Beam:		Beam; Action of	22, 23
Electron; Action of	22, 23		
Intensity	35		

Gun	15	Linearity of Saw-tooth Wave	11
Electrostatic Deflection	17, 19	Lissajous Figures	105
Elements, Deflection	17, 19	Loading Resistors, Effect of	58
Figures, Lissajous	105	Location of Hum	97, 99, 101
Firing Potential	27	Locked-oscillator FM Detector	68
First Anode	15, 19	Locked-oscillator FM Detector Alignment	64
Fluorescent Screen	13, 14	Luminescence	14
Flyback (Retrace) Time	27	Magnetic-deflection TV set, Wave- shape Checking in	86
FM:		Markers	85
Discriminator Alignment	55	Measuring a.c. Peak Voltages	88
I.f. Stages	57	Meters, a.c.	9
Locked-Oscillator Detector	63	Modulation:	
Locked-Oscillator Det. Alignment	64	Envelope Pattern; Checking	90
Ratio Detector	61	Over- and Under-; in Transmitters	92
Ratio-detector Alignment	62	Percentage; Ham Transmitters	89
Receivers; r.f. Alignment	76	Motor-driven Condenser FM Generator	47
Signal Generators (See <i>Sweep Generators</i>)		Multivibrator	26
Slope Detection	59	Neutralization of Class-C Transmitter Stage	92
Focusing Anode	15, 19	Non-limiter Discriminator Alignment	64
Free-running Oscillator	31	Oscillating i.f. Amplifier, 'Scope Pattern	74
Frequency:		Oscillator:	
Comparison with Standard	106	Blocking	29
Control; Automatic	50	Free-running	31
Determining Unknown e.m.f.	105	Gas-triode	27
Ratios; Calculating	106	Horizontal; Checking in TV Receiver	85
Saw-tooth; Generator	28	Oscilloscope:	
Use of 60-cycle as Standard	106	Principal Units of	86
Gain:		Range Required for TV i.f. Tests	86
Calculating Audio	82	Output, Measurement of Audio	81
Computing; in Decibels	83	Peak:	
Gas-triode Oscillator	27	A.c. Volts; Measuring	88
Generators:		I.f. Alignment	51
Saw-tooth (See <i>Blocking Oscillator, Gas-triode Oscillator, Multi- vibrator</i>)		Peaking Coils	88
Sweep	47	Phase:	
Gun, Electron	15	Angles; Determining	107
Ham Transmitters, Percentage Modulation	89	Shift Distortion	107
High-frequency Probe, Use of	69, 70	Shifter; Circuit for	109
Horizontal:		Philco Locked-oscillator Detector	68
Amplifier	39	Phosphorescence	14
Deflecting Plates	14, 17, 20	Potential, Ionization	27
Oscillator; TV Receiver Checking	85	Potentiometer, INTENSITY	42
Sweep Amplifier	32	Power:	
Hum:		Gain in db; Computing	83
In Power Supply	99	Output Calculation; Audio	82
Location of	97, 99, 101	Supply	40
Outside the Power Supply	101	Supply Hum	99
I.f.:		Supply, Vibrator; Checking	103
Amplifiers; Regen. in	93	Probe, High-frequency; Use of	69, 70
Stages; FM	57	Pulses, Checking Synchronizing	87
Stagger-tuned TV	67	Range, Sweep	89
Systems; TV	67	Ratio Detector	61
Transformer; Tertiary Winding	57	Ratio Detector Alignment	62
Band-pass TV	67	RCA Sweep Generator	49
Instantaneous Value	11	Reactance Modulator Sweep Generator	50
Intensifier Anode	16	Regeneration:	
Intensity:		In Class-C Transmitter Stage	92
Beam	35	In i.f. Amplifiers	93
Modulation	35	Resistors, Loading; Effect of	58
Potentiometer	42	Response Curve:	
Ionization Potential	27	AM Set	53
Judging TV i.f. Response Curve	73	Audio; Plotting	82

Band-pass Receiver	53	Pulses; Checking	87
Typical TV Receiver	73	Selector	43
Improper Alignment	54	Signal	40
Sharpness of; Effect of Circuit Loading on	58	Synchronizing Sweep Gen. and 'Scope ..	53
Symmetry of	49	Television: (See <i>TV</i>)	
TV i.f.; Checking	73	Tertiary Winding i.f.; Effect of	57
TV i.f.; Judging	73	Tertiary Windings i.f. Channel; Aligning	58
Retrace (Flyback) Time	27	Time, Scanning	26
R.f. Alignment:		Transmitters, Neutralizing Class-C Stage	92
AM Receivers	75	Trap Alignment	72
FM Receivers	76	Trapezoidal Pattern Modulation Checking	91
TV Receivers	76	TV:	
RMA Standard Television Channel	66	Channel; R.M.A. Standard	66
R.m.s. Value of a.c.	10	I.f. Alignment Precautions	73
Saw-tooth:		I.f. Circuits; Aligning	65
Amplifier Balance	84	I.f. Response Curve Checking	73
Generator Frequency	28	I.f. Systems	67
Generators (See <i>Blocking Oscillator, Gas-triode Oscillator, Multi-vibrator</i>)		I.f. Tests; 'Scope Range Required ..	66
Voltage	24, 26	Receiver; Horizontal Oscillator Check	85
Wave	10	Receiver; r.f. Alignment	76
Scanning:		Receiver; Series-Inductance r.f. Switching	77
Action	21, 22	Receiver; Shunt-Inductance r.f. Switching	77
Time	26	Receiver; Typical Response Curve ..	73
'Scope (See <i>Oscilloscope</i>)		Receiver; Vertical Oscillator Check ..	86
Screen, Fluorescent	13, 14	Sweep Circuits; Checking	84
Selector, Synch	43	Vertical:	
Shape of Wave	10	Amplifier; Oscilloscope	86
Sharpness of i.f. Response Curve; Effect of Circuit Loading on	58	Deflecting Plates	14, 17
Signal:		Gain Control	86
Synch	40	Oscillator; TV Receiver, Checking ..	86
Generator Connection for FM Discrim. Alignment	55	Vibrator Power Supply, Checking	103
Generator for TV Alignment	66	Video:	
Sine Wave	10	Carrier Width	66
Slope Detection, FM	59	Improper Clipping	102
Slope Detector Alignment	60	Voltage:	
Sound Carrier Width (TV)	66	Curve; Condenser	26
Square Waves	11, 34	Sweep	24
Stagger-tuned:		Wave:	
TV i.f. Amplifier; Aligning	69	Average Value	12
TV i.f. Amplifiers	67	Linearity	11
Sweep:		Saw-tooth	10
Frequency Control	39	Shape	10
Generator; RCA	49	Shape Checking; Magnetic-deflection TV Sets	86
Generators	47	Sine	10
Generator; Motor-driven Condenser	47	Square	11
Range	39	Wide-band:	
Voltage	24	FM i.f. Amplifiers	57
Symmetry of Curves	49	TV i.f. Amplifiers	67
Synch:			
Adjustment	40		
Oscillator	31		